

Birla Central Library

PILANI (Jaipur State)

Class No :- 744

Book No :- J 71M

Accession No :- 20392

MECHANICAL DRAWING

MECHANICAL DRAWING

A TREATISE ON THE DRAWING OF MECHANISMS
AND MACHINE DETAILS, INCLUDING THE MAK-
ING OF DIFFERENT CLASSES OF DRAWINGS,
THE DIMENSIONING, READING, AND CHECKING
OF WORKING DRAWINGS, NUMBERING AND
FILING SYSTEMS FOR DRAWINGS, AND GENERAL
DRAFTING-ROOM PRACTICE

BY
FRANKLIN D. JONES

THIRD EDITION

NEW YORK
THE INDUSTRIAL PRESS
LONDON: THE MACHINERY PUBLISHING CO., LTD.

1841

COPYRIGHT, 1920, 1931, 1941
BY
THE INDUSTRIAL PRESS
NEW YORK

PRINTED IN THE UNITED STATES OF AMERICA

PREFACE

Many books on mechanical drawing have covered such subjects as geometrical drawing problems, orthographic projection, the development of intersecting surfaces, etc., but the application of these principles and the real object of mechanical drawing as related to machine and tool manufacture has been dealt with vaguely, in many instances. The student has been taught certain details, but he has not been given a clear conception of the work of draftsmen and designers in the drafting-rooms of machine-building plants. This book presents the subject in a way that will enable the student to understand what the term "mechanical drawing" really means in its broadest sense, the essential features of modern drafting practice, and the difference between the mere representation of a design by a suitable drawing and the more valuable work of originating and developing the design itself.

A special effort has been made to secure a well-balanced treatise in which the various elements of mechanical drawing are dealt with according to their relative importance. For instance, little space is given to lettering, because making fancy letters in numerous styles is not the work of a draftsman in a well-managed drafting-room, although this subject has been greatly emphasized in many books. The aim has been to present methods which are in actual use rather than exercises in drawing which do not conform to the practice in manufacturing plants. An elaborate drawing of a bevel gear with all of the teeth accurately reproduced may be an attractive and impressive feature in a text-book on mechanical drawing, but it is misleading, because working drawings are not made in that way. This book, in its arrangement and scope, is based on the assumption that it is essential for the student of mechanical drawing — whether in school or in shop — to understand the purpose of drawings as applied to machine and tool construction, how various mechanical devices may be represented

by means of drawings, the necessity of making drawings which completely and clearly show what they are supposed to, and the relation between *drawing* and *designing*. Special attention has been given to the dimensioning of drawings and to the importance of using printed instructions or any legitimate means of making a drawing entirely clear to the men in the shop.

In dealing with the numerous details of the draftsman's work, an effort has been made to present methods which are sanctioned by common usage and to explain the reasons for the more important variations in practice. To accomplish this the methods and systems of many of the representative drafting-rooms were studied, and much valuable information was also secured from articles pertaining to different features of drafting practice which have been published in *MACHINERY*.

F. D. J.

CONTENTS

CHAPTER I

DRAWINGS AND THEIR USE IN MACHINE AND TOOL CONSTRUCTION

	PAGES
General Uses of Drawings — The Work of the Draftsman — Why Draftsmen Should Understand Manufacturing Methods	1-9

CHAPTER II

PROJECTION AS APPLIED TO MECHANICAL DRAWING

Orthographic Projection — Number and Arrangement of Views — Examples of Projection Drawings.....	10-26
---	-------

CHAPTER III

MECHANICAL DRAWING INSTRUMENTS AND MATERIALS

Instruments for Drawing Straight Lines and Circles — T-Square and Triangles — Protractors — Scales — Drawing- boards — Paper and Other Materials.....	27-69
---	-------

CHAPTER IV

HOW DESIGNS ARE ORIGINATED AND PROCEDURE IN MAKING DRAWINGS

Preliminary Work in Designing — Different Classes of Drawings — Scale Drawings — Kinds of Lines Used — Tracing.....	70-97
---	-------

CHAPTER V

SECTIONAL VIEWS AND THE READING OF DRAWINGS

Examples of Sectional Views — Use of Section Lines — Prin- ciples Governing Reading of Mechanical Drawings.....	98-129
--	--------

CHAPTER VI

METHODS OF DIMENSIONING WORKING DRAWINGS

Rules for Dimensioning—Designating Tolerances on Drawings—Designating Angles and Tapers—Tabulated Drawings 130-167

CHAPTER VII

INSTRUCTIONS ON WORKING DRAWINGS AND
PROCEDURE WHEN CHECKING

Use of Symbols and Abbreviations—Explanatory Notes—Titles—Lettering—Checking Drawings Systematically 168-181

CHAPTER VIII

PRINTING PROCESSES AND APPARATUS FOR
PRINTING, WASHING AND DRYING

Making Prints for Shop Use—Methods of Drying and Ironing Prints—Changing Blueprints—Mounting Blueprints.. 182-196

CHAPTER IX

ENGINEERING STANDARDS AND DRAWINGS OF
MACHINE DETAILS

Screw Threads and Their Standards—Conventional Methods of Representing Screw Threads—Pipe Fittings—Keys—Gear Drawings..... 197 234

CHAPTER X

DESIGNING OR LAYING OUT CAMS

Laying Out Cams for Uniform Motion, Intermittent Motion, Crank or Harmonic Motion, and Uniformly Accelerated Motion—Different Types of Cams..... 235-256

CHAPTER XI

GEOMETRICAL DRAWING PROBLEMS AND THE
DEVELOPMENT OF INTERSECTING SURFACES

The Ellipse, the Helix, Involute and Cycloidal Curves—Sheet Metal Pattern Drawing..... 257-272

CHAPTER XII

DRAFTING-ROOM SYSTEMS, EQUIPMENT AND
ARRANGEMENT

Filing Systems — Card Indexes — Recording Changes — Lists of Parts — Arrangement of Drafting-room and Its Lighting.....	273-309
---	---------

CHAPTER XIII

SKETCHING AND PERSPECTIVE DRAWING

Making Sketches without the Use of Instruments — How Perspective Drawings are Made — Isometric Drawing.....	310-337
--	---------

MECHANICAL DRAWING

CHAPTER I

DRAWINGS AND THEIR USE IN MACHINE AND TOOL CONSTRUCTION

WHEN any new or improved form of tool or machine is being developed, its general arrangement and the principle governing its operation or use may be quite clear in the mind of the inventor or originator, and he may proceed with the actual work of construction, guided only by a mental picture of the device. Many simple tools or appliances could be, and some are, produced in this direct way, but it is evident that such a method of procedure is greatly restricted. It is often easier for the originator of a new type of mechanism to build it with his own hands than to attempt, simply by verbal description, to give some one else a clear enough mental picture of the device to enable him to construct it. This direct method of construction is, of course, impracticable as applied to regular manufacturing. In the first place, it would be impossible to originate many of the more complicated mechanisms by simply forming a mental picture of them. The basic principle of the device and possibly its general arrangement might be entirely clear, but in order to determine the exact relation of the various parts when they are all properly proportioned and assembled, it is necessary to make a fairly accurate drawing. Such a drawing not only shows the arrangement of the mechanism as a whole, but greatly assists the designer, in many cases, in the development of the idea. Frequently the mental picture is distorted and, when an accurate drawing is made, it is apparent that changes are necessary either in the form and size of one or more parts or possibly in the entire arrangement of the mechanism.

General Uses of Drawings. — The method usually followed by inventors and designers in originating new or improved mechanical appliances is to make a drawing of whatever plan or idea is to be developed. When this has been done, a clear conception of the form and often of the practicability of the device represented by the drawing may be obtained not only by the originator of the idea but by others who understand drawings and are able to “read” them. Drawings, then, as applied to the manufacture of tools and machines, serve several important purposes. First, they assist in the development of a plan by enabling the inventor or designer to see clearly the relation of different parts to one another and whether or not the desired motion or effect may be obtained. Second, drawings make it possible for the originator of a plan to convey the idea to others readily. Third, they show to those who are actually to construct the device, the proportions of its different parts and their relation when properly assembled. Finally, drawings are useful as records of what has been done and make it possible to reproduce whatever tool or mechanism is represented on the drawing.

The Work of the Draftsman. — In the manufacture of various kinds of mechanical tools and equipment, the work to be performed may be divided into four branches: (1) Originating entirely or in part the general type of device to be constructed and the principle governing its operation; (2) designing the mechanism in accordance with established mechanical principles and in such a way that the different parts will be strong enough to resist any stresses to which they may be subjected; (3) making drawings such as are needed in the actual work of construction; and, (4) making, fitting, and assembling the different parts. In the study of mechanical drawing, it is essential to understand the relation of these four branches of work to one another, because a draftsman may simply make drawings according to the ideas of others, or he may have more or less to do with originating the plan. Some draftsmen are also able to determine the proportions of different parts and

many of them control, to some extent, the method of manufacturing. In a restricted sense, a *draftsman* makes drawings of appliances originated by an *inventor* or *designer*. The designer may be an inventor or vice versa, and he is always a draftsman and is capable of making mechanical drawings. The draftsman, however, is not necessarily a designer and may know little or nothing about the principles governing the design of machinery or tools.

It is evident, then, that a man is valuable in the designing department in proportion to his ability to originate, design, and develop useful and practical appliances. It is also apparent that the name "draftsman" has a broad meaning and may include anyone, from a man who can make a drawing to scale from a free-hand sketch to a man who can design as well as draw a complicated automatic machine. The first is regarded simply as a draftsman, while the second one is a designing draftsman, who can create. Properly designated, the first man is a draftsman, while the second is a designer. This distinction, however, is not usually made except in salary, and anyone working on drawings (not tracings) is known by the general term of draftsman. If the work is restricted to the making of tracings, the one doing it is commonly known as a *tracer*. A designer must be a specialist, because it is impossible for one man to know how to design mechanical devices for any and all purposes, and there is no known rational method of design which can be studied in the same way as one might study mathematics or physics.

What the Draftsman Should Know. — In taking up the study of mechanical drawing, it is important to know what is involved in becoming a designer or draftsman who, instead of simply making drawings of the plans of others, is capable of original work. To begin with, the ability to originate or improve plans and designs may be developed by studying what others have accomplished. It frequently happens that the principle governing the operation of one device may be applied to some other mechanism which is used for an entirely different purpose. In this way, the original idea is made more

useful and of greater value because it is utilized for more than one purpose. While this is not original work in the exact meaning of the term, the fact is that very few mechanical appliances are absolutely originated by one man; moreover, it may not always be advisable in machine design to attempt to be entirely original, but rather to apply what is definitely known to be sound in theory and practice. This does not mean that the inventor or designer should not think for himself nor that he should deliberately appropriate the ideas of others, but simply that one should proceed cautiously when attempting to improve or change entirely some commonly accepted method or principle which has been thoroughly tested in practice.

The draftsman whose work is not confined merely to drawing lines on paper, must have a knowledge of mechanical laws, the various well-known methods of transmitting and modifying motion, and how to proportion parts of tools and machines so that they will resist the stresses to which they are subjected. Many worthless designs have been the direct result of ignorance of fundamental mechanical principles. Another requirement is a knowledge of the art of drawing, which is the principal subject dealt with in this book. While a draftsman, to be successful, must know more than how to make mechanical drawings, nevertheless this is an important part of his work, because drawings which do not *clearly* represent the object drawn are a source of trouble and are liable to cause serious mistakes. Delays in the pattern shop and machine shop are often due to poor drawings which are lacking either in dimensions, in the arrangement and number of the views, or in some other respect.

Why Draftsmen Should Understand Manufacturing Methods. — A fourth requirement in connection with the work of designing is a knowledge of manufacturing methods. Other things being equal, the draftsman excels who is capable of designing parts which are as simple and free from complications as possible and which are, therefore, cheaper to manufacture. The competent designer not only thinks of

the operation of a tool or mechanism, but carefully considers the work of the patternmaker, molder, machinist, and toolmaker. It is much easier, of course, to draw lines on paper than to form the parts which the lines represent, in wood, iron, and steel; yet this simple fact is often disregarded and many designs and inventions have been discarded because the cost of manufacturing was unnecessarily high. Since a simple change on a drawing will often greatly reduce the work in the pattern shop, the designer should understand the principles of patternmaking and molding. A knowledge of machine shop practice is even more important, and for this reason experienced machinists and toolmakers who take up drafting work find that their shop training is invaluable, especially when designing tools, jigs, or parts which require considerable machine work. The draftsman who has not had actual experience in the shop should consult with machinists, patternmakers or others who may be able to supply valuable information. When making special tools, such as jigs, milling fixtures, etc., for reducing the cost of the work, the foreman or workman should not only be consulted, but should usually have a deciding voice as to what should be made. The men who use the tools often know better than the draftsman what is needed.

The machinist and shop foreman, being constantly with the work, know which are the expensive operations, when there is difficulty in fitting, where the clearances are so small as often to become interferences, and other facts of importance in developing a good design. A method that has been used with excellent results is for each foreman and responsible workman to have a blank stub-book with the pages numbered and provided with suitable printed headings. In this book all suggestions are written and the perforated leaves are removed and sent to the chief draftsman, the stub being kept as a memorandum for the shop man. These leaves are sorted when received, and those requiring immediate attention are investigated; others are filed under the respective machines until another lot is to be built, when the suggestions are con-

sidered collectively. The workmen are not only at liberty to use these books, but are held accountable if they allow troubles to exist on the machines they build, and do not report them. In this way, advantage is taken of the mechanical knowledge stored up in the minds of the men.

Mechanical Drawings and Their Application.—A mechanical drawing is a representation on paper of a machine, machine part, tool, or other object used in the mechanical industries, that is to be made from metal, wood, or other material, and it may show either the form or shape to which a machine part is to be made, or the relation of a number of parts to each other in order to indicate how these parts are to be assembled; hence, a mechanical drawing may be used to represent anything from a locomotive to a small machine screw. These drawings are generally made on a drawing-board by using either a drafting machine for straight and angular lines, or a T-square in conjunction with triangles, and also a protractor for some angular lines. Certain auxiliary instruments are also required, such as compasses, dividers, scales, ruling pens, etc. Some drawings are made without the use of special instruments. These are known generally as “free-hand drawings” or “sketches.” The “drawing instruments” referred to are distinguished from “drawing materials” which include the various kinds of paper, cloth, pencils, ink, and other supplies.

Classification of Mechanical Drawings.—Mechanical drawings may be classified under two main headings, *outline drawings* and *working drawings*. Outline drawings merely show the general appearance and over-all dimensions of machines and devices and are used mainly in catalogues and for representing the general features of a machine to prospective purchasers. Working drawings are used in machine shops and pattern shops in the building of machines and tools. Some working drawings, known as *general* or *assembly drawings*, show all the parts of a machine or mechanism, in their proper position and relation to each

other. The principal dimensions may or may not be given on drawings of this kind, which are used by the assemblers and erectors in the fitting and assembling of machine parts that have already been made in other departments of the shop. The second class of working drawings, known as *detail drawings*, give all the dimensions and complete information as to the form of separate machine parts or of sections composed of several parts. The dimensions on working drawings indicate the sizes of all parts requiring machining operations, and such drawings should also contain complete information regarding the material from which parts are to be made and the treatment they are to undergo — such as hardening, case-hardening, etc. The assembly drawings are generally made to a much smaller size or scale than that of the actual machine or tool, while the detail drawings are made either full size, or to as large a scale as possible.

A working drawing must convey to the eye of the workman a clear idea of what the designer wants made. It should be so complete that, when it passes into the shop, no further questions or explanations will be necessary; hence, a complete working drawing contains all the necessary information as to materials, treatment, limits, fits, finish, etc., that the shop man requires.

Mechanical drawings do not represent an object in the form of a picture — that is, they do not show the object in the same way as it would appear to the eye of the observer. A drawing made to appear exactly as it would when viewed from a certain point is known as a *perspective drawing*, and the mechanical draftsman is seldom required to represent machines or machine parts in this way. He conveys his ideas by much simpler and better methods than this and, in making working drawings, uses what is known as *orthographic projection*, or simply *projection*. Many mechanical drawings do not appear to the untrained eye to represent the true form of an object — that is, they do not always look like the object, as would a picture for instance, — because certain methods of representing machine parts have been adopted, by means

of which drawings can be made much more rapidly and the exact form and dimensions can be indicated more accurately than if the true perspective form were reproduced. As an example, screw threads are not ordinarily drawn in the way in which they actually appear to the eye, but a much easier and quicker way of representing them is used.

General Views and Detail Drawings. — When it is desired to make a drawing of a machine already constructed, each part is measured and sketched separately, and all necessary dimensions are placed upon the sketch; then these parts are assembled, so to speak, in the form of a general drawing. On the other hand, if it is desired to design a machine, a general drawing with the parts in place is made, and then the dimensions of the various parts are determined and the extent to which they must be machined by turning, planing, milling, drilling, reaming, tapping, etc. The different parts or small units consisting of several parts, or of a great many parts in some cases, are drawn separately, at least in sufficient detail to show clearly what is wanted.

In the general views, outlines are drawn of such details as are thought essential to clearness. If the machine, tool, or other device is not complicated and consists of a relatively small number of parts, a general drawing may be sufficient, but if there are a great many separate parts, separate working drawings of these details are necessary. If all the details of a complicated design were drawn on the general view, there would be so many lines that it would be difficult, if not impossible, to show clearly the form and size of each part. The smaller detail drawings are also much more convenient for shop use.

A mechanical drawing should show clearly the form and dimensions of the part it represents. Every line should stand for some definite thing; and when lines cannot express the ideas in a direct and unmistakable manner, abbreviations, symbols, and printed notes should be used so that the patternmakers or machinists who are to use the drawings will be able to work without other instructions. Each note

should consist of concise sentences and should be placed close to the part to which it refers, in order that it may be easily read and understood. The different views should be arranged so that they clearly represent the object drawn, and a reasonable degree of neatness in the drawing of lines and in lettering is also desirable.

Why a Knowledge of Mechanical Drawing is Essential. — Every man engaged in the mechanical trades who has aspirations toward advancement must, at least, learn how to “read” or understand mechanical drawings; and in order to obtain a complete knowledge of the reading of mechanical drawings, it is necessary to know, in a general way, how to make them. A man who cannot make accurate and understandable sketches according to the methods of mechanical drawing is seldom able to read any except the simplest drawings; hence, the importance of the study of mechanical drawing. Drawing may be called a universal language, and the mechanic who cannot read drawings or blueprints is handicapped in his trade almost as much as if he could not read or write. The knowledge of how to make sketches and drawings is also an exceedingly useful accomplishment to a man who, as foreman or superintendent, has to direct the activities of others. The importance of understanding the principles of mechanical drawing, therefore, is apparent and it should be clearly understood that not only draftsmen must understand these principles, but every mechanic who wants to read drawings rapidly and accurately.

In order to read a working drawing, it is necessary that one be familiar with the conventional methods commonly used to represent parts, material, finish, etc., and that one understand in what respects mechanical drawings differ from perspective drawings or photographs, which represent the object as it appears to the eye. To the inexperienced, a working drawing may appear like a conglomeration of lines which do not represent clearly what they are intended to show, but the man who understands such drawings will have a mental picture of the object drawn.

CHAPTER II

PROJECTION AS APPLIED TO MECHANICAL DRAWING

THE mechanical drawing of a machine part or a combination of parts forming a complete mechanism is usually composed of two or more separate views, each representing a different side of the object drawn. The number of separate views on the drawing depends upon the number actually needed to show clearly the general shape of the piece and all important dimensions such as the lengths and widths of different parts, the shape as seen from different sides, and, in brief, whatever information concerning the form and dimensions is needed for reproducing the mechanical device which the drawing represents.

Perspective drawings which show objects just as they appear to the eye are useful, especially when the idea is merely to show the general shape of whatever part is represented. The use of such drawings in books and periodicals as a means of illustrating various objects is, of course, common. In mechanical work, and especially wherever machinery is constructed, drawings are used which are quite different in appearance from the ordinary perspective drawings. A perspective drawing may show two or three sides of an object on one view, the same as a photograph. While a mechanical drawing does not resemble a perspective drawing in appearance, it does show the form of the object and usually much more clearly and accurately than a perspective drawing, provided the mechanical drawing is understood.

Orthographic Projection. — Mechanical drawings are based on a method of drawing known as “orthographic projection.” In order to illustrate simply this method of drawing, assume that some object is held in the hand on the same level as the eyes and is turned so that the front side, top side, and end

are each seen successively. These different views will then correspond practically to the different views of the same object as represented by a mechanical drawing made according to the orthographic projection method. In other words, if three sketches or separate views were made, showing the outline of the object as it appeared when seen from the three different positions, such views would correspond to those on a mechanical drawing of the same piece. While these different views would all be drawn on a flat sheet or on a plane surface, they are practically the same as those that would be obtained if the object drawn were held in the hand and were turned

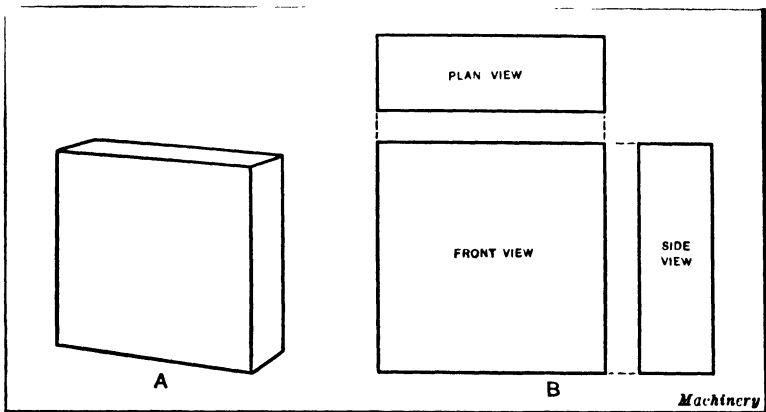

Fig. 1. (A) Perspective Drawing of a Rectangular Block. (B) Mechanical Drawing of a Rectangular Block

first to one position and then the other, in order to show the different sides as just described, except that many mechanical drawings are arranged to show parts and shapes that would be concealed when actually looking at the object itself.

These mechanical drawings, which are composed of views representing different sides of a machine part, tool, or some other mechanical device, show the length, breadth, and thickness of various portions of the piece accurately, which is a great advantage in mechanical work, because the chief purpose of most mechanical drawings is to represent mechanical devices so clearly and accurately that they may readily be

reproduced in iron and steel. It must not be inferred from this that drawings are made so accurately that the pattern-maker, machinist, and toolmaker can measure them in order to determine the required dimensions at various places. This method of determining the dimensions is unnecessary, because an important part of the draftsman's work is to place on the drawing all necessary dimensions expressed either in feet, inches, or fractional parts of an inch, depending upon the size of the work and the degree of accuracy required.

Comparison of Perspective and Mechanical Drawings. -- The relation between an ordinary perspective drawing and a mechanical drawing made according to the orthographic projection method, is illustrated in Fig. 1, which shows, at *A*, a perspective view of a plain rectangular block, and at *B*, a mechanical drawing consisting of front, plan, and side views. The side view is practically the same as though the right-hand side of the block were removed and turned around so as to be in line with the front side. Similarly, the plan or top view represents the upper side of the block, as though it were swung upward to a vertical position and in the same plane as the front and side views. The front view shows that this side of the block is square, but by simply referring to this view alone, it is impossible to determine whether or not the block is a cube with sides of equal width, or a block of rectangular form. The side and plan views show, at a glance, that the block is not a cube and that its sides are of rectangular shape. Each view represents the block as it would appear when seen squarely from that particular side, and it is quite evident that, when one view has been drawn, as for example the front view, lines may be projected to the other views for locating them properly, as will be explained and illustrated by practical examples.

This drawing, at *B*, Fig. 1, is a very simple example of orthographic projection. Either style of drawing shown in Fig. 1 might be used to represent such a plain piece as this block. For instance, if steel blocks of a certain size were required, the necessary dimensions could be placed on the per-

spective drawing and this could be used by a machinist as well as a properly dimensioned drawing made according to the orthographic projection method, but when a part is of irregular shape, and especially if several pieces are combined to form some kind of a mechanism, the separate views representing the front and, perhaps, the side and top are much superior to a perspective drawing. In fact, perspective drawings would not be at all practicable for most of the work represented by mechanical drawings.

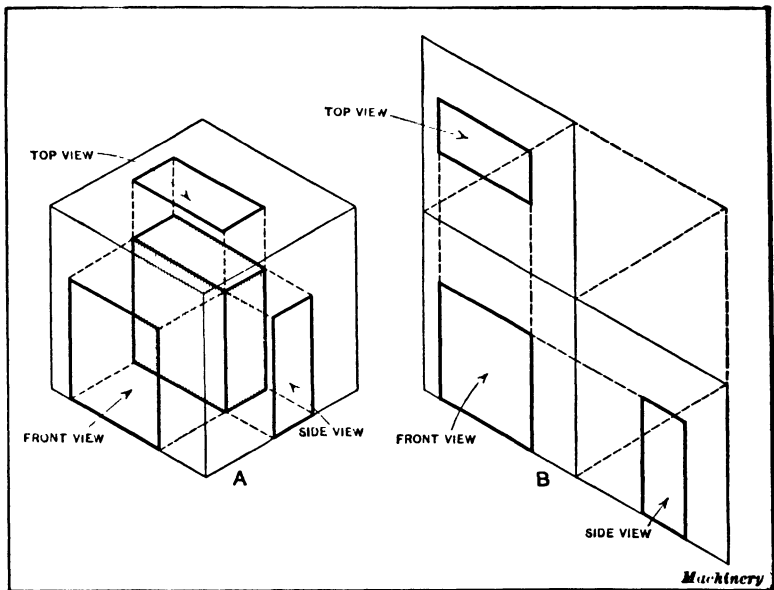

Fig. 2. Diagram illustrating Principle of Orthographic Projection

Principle of Orthographic Projection Method.—As it is essential for the mechanical draftsman to understand thoroughly the principle of orthographic projection, this method of drawing will be further explained. To begin with, the representation of a plain rectangular block by means of separate views showing the shape as seen from the front, top, and side, will again be considered, because a simple object of this kind illustrates the principle better than a drawing of some complicated mechanical device. At A, Fig. 2, this

block, which is shaded, is represented as being enclosed by a box formed of glass sides. Now, if lines were extended or projected from the four corners of the block to the front of the box, as illustrated by the dotted lines, and these four points were joined as shown by the full lines, the square thus drawn would correspond to the front view. In the same way, if the corners of the side were projected to the side of the box and a rectangle drawn, this would correspond to the side view of the block. The top view is represented as being projected up to the top side of the box in a similar manner. These three views now represent a mechanical drawing made according to the orthographic projection method, but they lie in three different planes and on an actual drawing it is, of course, necessary to place all three views on a flat sheet or so that they all lie in one plane. If it is assumed that the top and right-hand side of the glass box are hinged at the front edges, and that they are turned so as to lie in the same plane as the front side, the views will then appear as shown at *B* or in the same relative positions as the three views illustrated at *B*, in Fig. 1.

It will be understood that diagram *A* is intended merely to illustrate the principle of orthographic projection and that, in actually making a drawing of this block, the front view would ordinarily be drawn first to whatever size the block happened to be or to some reduced scale; then lines would be extended or projected for locating the end lines of the side and top views. The rectangles would then be completed by drawing lines representing the sides on both the top and side views, the distance between these lines corresponding to the thickness of the block.

Number and Arrangement of the Views. — A mechanical drawing may show only one side of an object or it may be composed of two or more views. Two or three views are the usual number, although four may be needed and sometimes it is necessary to add separate views of important details. These detail views are frequently used to show some part which is not represented clearly enough in the general views.

If a single view representing only one side of the part drawn is sufficient to show clearly all that is required in making this part, additional views would be useless and the time required for drawing them would be wasted.

When there are two or more views, it is evident that if they have been simply drawn on a sheet of paper in haphazard fashion or without regard to their respective locations, the drawing may be very confusing, because it will not be apparent which view represents the front of the object and which ones show the shape and size of the piece as seen from the top and end. In other words, the relation between the views and the part they represent will not be apparent in all cases. For this reason, the views of mechanical drawings are arranged according to a definite plan. In the United States, the general practice is to place the top view above the front view, and the end view next to whatever end it represents. For example, if a view of the left-hand end is considered preferable to a view of the right-hand end, this end view is placed to the left of the front view, thus indicating, that it represents the left-hand end or side. If it were considered advisable to show both ends, then a right-hand view would be placed to the right of the front view. In some instances, a bottom view is needed, in which case it is placed below the front view.

The view obtained by looking at the object from above is known as a *plan* view; that obtained by looking at the object from one of its sides and showing a vertical face is known as an *elevation*, and it may be either a *front elevation* or an *end elevation* (also known as *side elevation*), depending upon whether the view is of the front or side of the part drawn.

In the case of a simple object like a bolt, screw, or washer, one view is sometimes sufficient, but in most cases two or three views are required, as previously mentioned. The number of views depends upon the shape of the object and the purpose of the drawing. For example, a screw would be shown from the side, and an end view might be drawn to show the shape of the head. In the case of a shaft, an end

view might be included with a side view to show its circular form, or the location and size of keyways or attached parts.

Third-angle and First-angle Projection. — It is generally the practice to represent a machine detail in the position that it will occupy in the machine for which it is intended, instead of showing it upside down or in some other position. When the views are placed with the plan above the front elevation, the right-hand end view to the right and the left-hand end view (when drawn) to the left, this is known as *third-angle projection*. In European countries, it is frequently the custom to use what is known as *first-angle projection*. With this method, the front elevation is placed at the top, the plan view, at the

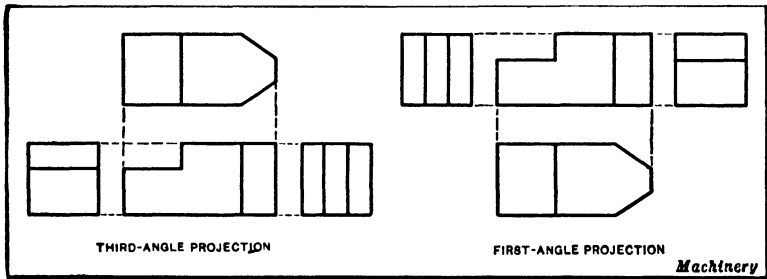

Fig. 3. Comparison of Third-angle and First-angle Methods of Projection

bottom, the right-hand end view at the left, and the left-hand end view at the right. (The difference between these two methods is illustrated in Fig. 3.) The first-angle projection is also generally employed in architectural and structural work, as in drawings of bridges, etc.

The Study of Different Types of Drawings. — The mechanical draftsman must understand the relation between different views and what they represent. He must also know what views are required to show properly and clearly, by the projection method, the form of any mechanical device for which a drawing may be required. In order to become proficient in the art of making good mechanical drawings and in interpreting or reading existing drawings, it is necessary to understand the underlying principles and then, by exercising judgment, to apply these principles to the different problems

and conditions that may arise. There are no inflexible rules that can be laid down and used as a guide either in making drawings or as a means of understanding them, but by studying first very simple drawings and then those that are more complex, the various methods of representing practically any mechanical device will be apparent. The principal point to bear in mind when making mechanical drawings is that they are to serve as a guide in producing whatever part is drawn. For this reason, the draftsman should, as far as possible, consider the drawing from the viewpoint of the patternmaker and machinist who will use it.

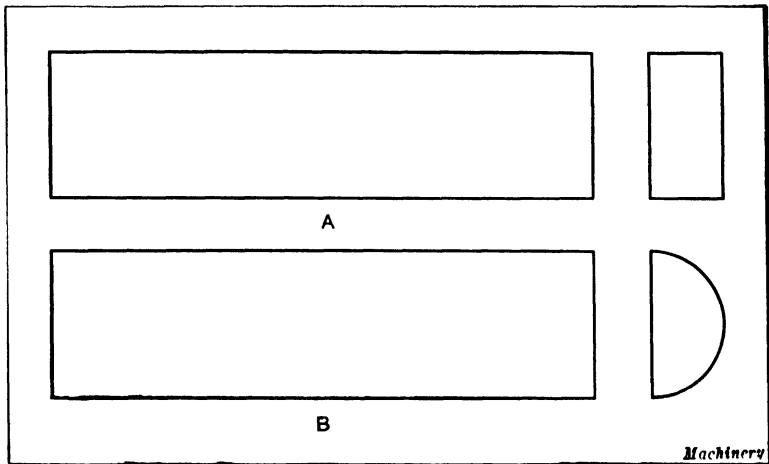

Fig. 4. Simple Example of Projection

Simple Examples of Orthographic Projection. — Since the best way for the student of drafting practice to become familiar with mechanical drawing methods is by studying drawings of various kinds, examples representing distinct types will be considered, beginning with the simplest forms. At *A*, Fig. 4, is shown a drawing of a short bar of rectangular shape. The view to the left is meaningless until it is combined with the end view. The latter shows at a glance that this bar is rectangular in cross-section. The sketch *B* in the same illustration represents a half-round bar as is clearly illustrated by the end view.

Figure 5 represents a drawing of a small cast-iron block which has a circular boss projecting from one side. If the view to the left were the only one shown, there might be doubt as to what the circle represents; although if it were shaded, as will be explained later, the fact that the circle

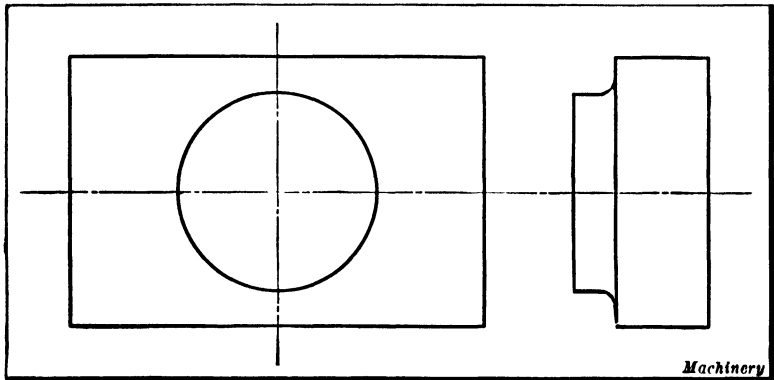

Fig. 5. Another Example illustrating the Relation of Different Views

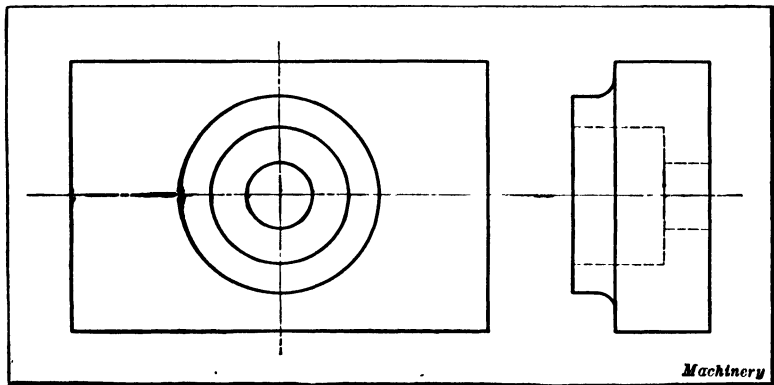

Fig. 6. Illustration showing Use of Dotted Lines for representing Concealed Surfaces

represents a boss and not a hole might be shown quite clearly. Even if this much were known, the height of the boss and the thickness of the block could not be indicated by this single view; but when an end view is added, the proportions of the entire casting are clearly revealed.

Before continuing with the examples illustrating different types of drawings, the use of dotted lines on drawings as a means of representing interior and concealed surfaces should be explained, since these lines appear on a great many drawings.

Use of Dotted Lines to Show Interior or Concealed Surfaces. — A great many of the castings, forgings, and other parts used in the construction of mechanical devices have holes, recesses, and ports or other interior passages of various shapes which may be partly or entirely hidden from view, especially on a drawing formed only of lines representing exterior surfaces. To illustrate how interior surfaces are

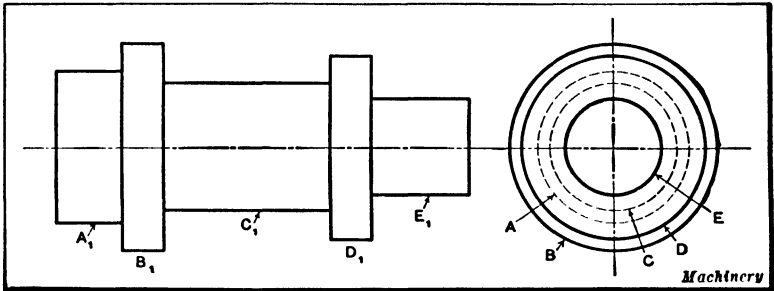

Fig. 7. Another Example illustrating the Use of Dotted Lines

shown, a casting is illustrated in Fig. 6 which is similar to the one shown in Fig. 5, except that it has an opening extending through the center of the boss. In the view to the left (Fig. 6), there are three concentric circles, and by referring to the end view, it is easy to determine just what each circle represents. The outer circle is the outline of the boss, as in the preceding case; the next circle represents the large part of the hole, and the smallest circle, the small part of the hole. The depth of the large section is also shown clearly by the dotted lines.

The use of dotted lines is further illustrated in Fig. 7, which shows a circular pin having five different diameters. By referring to the end view, it will be noted that there are three circles formed by continuous lines, and two formed by dotted

lines. The relation between these full and dotted circles, and the sections shown by the side view to the left, is indicated by corresponding reference letters. For instance, the outer circle *B* represents the larger collar *B*₁; the circle *D* represents the collar *D*₁; the dotted circles *A* and *C* represent the sections *A*₁ and *C*₁, respectively; and circle *E* represents *E*₁. The circles *A* and *C* are dotted because both the parts they represent are concealed or lie back of the collars when the pin is seen from the right-hand end. If part *A*₁ were larger than *B*₁, then circles *A* and *B* would both be formed

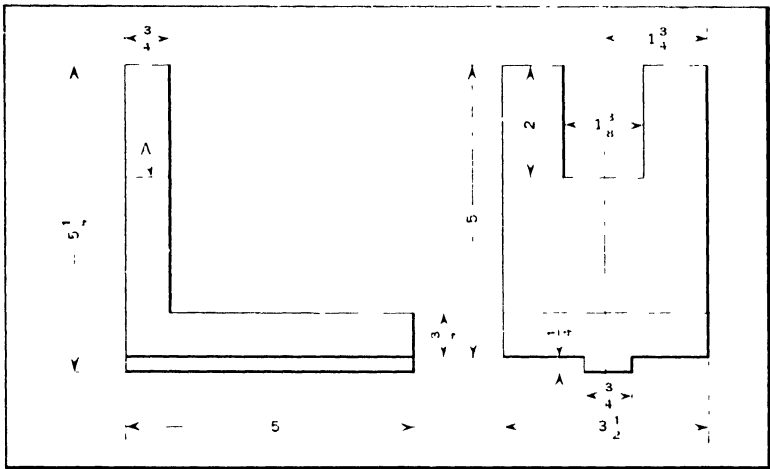

Fig. 8. A Drawing requiring only Two Views

by continuous or full lines, assuming, of course, that the end view were placed on the right-hand side, as in this case.

Dotted lines representing either interior surfaces or parts which are back of some other section are found on almost all mechanical drawings. In a great many cases, however, the shape of an interior opening or of a concealed surface is shown by one or more sectional views instead of using dotted lines. The use of sections is explained in Chapter V.

Drawings Requiring Only Two Views.—A great many drawings of simple parts require only two views. Some drawings of this kind have already been referred to. The

small rectangular block shown in Figs. 5 and 6, which has a circular boss projecting from one side, is represented very clearly by two views. If a plan view were added to the drawing, it would not show anything other than what is represented by the two views given. In this case, however, a plan or top view might be substituted for the end view. If the sides of the block were tapering instead of being parallel, then a plan view would be needed to show the tapering sides, but it would not be necessary to show an end view. From this it will be inferred that when there are only two views, the two sides are shown which represent the part to the best advantage. In some cases, front and plan views are needed, and in others, front and end or side views.

Another drawing requiring only two views is shown in Fig. 8. This drawing is of a cast-iron knee and it contains all the dimensions of the knee. The view to the left shows that the vertical part of the knee is square with the base, and it shows the height and width of the vertical section as well as the length and thickness of the base. The dotted line at *A* also indicates that there is an opening through the vertical part, but without an end view, it would not be possible to tell anything about the shape of this opening. By referring to the end view, it is evident that the opening or slot is rectangular in shape and that it is $1\frac{3}{8}$ inches wide and 2 inches deep. This end view also shows that the base of the knee has a projecting section or "tongue" $\frac{3}{4}$ inch wide and $\frac{1}{4}$ inch deep. With a drawing of this kind, a patternmaker could easily make the pattern needed for producing the casting, and then this same drawing could be used by the machinist when planing those surfaces which must be finished accurately to the given dimensions.

Drawings Requiring Three Views. — Mechanical drawings composed of three separate views of whatever part is shown are very common, especially in the case of shop drawings of machine details, tools, etc. Sometimes a third view is added merely to make the drawing clearer and more easily understood than one having only two views, but in many instances

three views are absolutely necessary in order to show every part of the object in its true form. An example illustrating why three views are sometimes required is shown in Fig. 9. This drawing represents a cast-iron knee which is the same as the one previously referred to, except that it has an oblong slot through the base which is surrounded by a boss of similar shape. In this case, if the top or plan view were omitted,

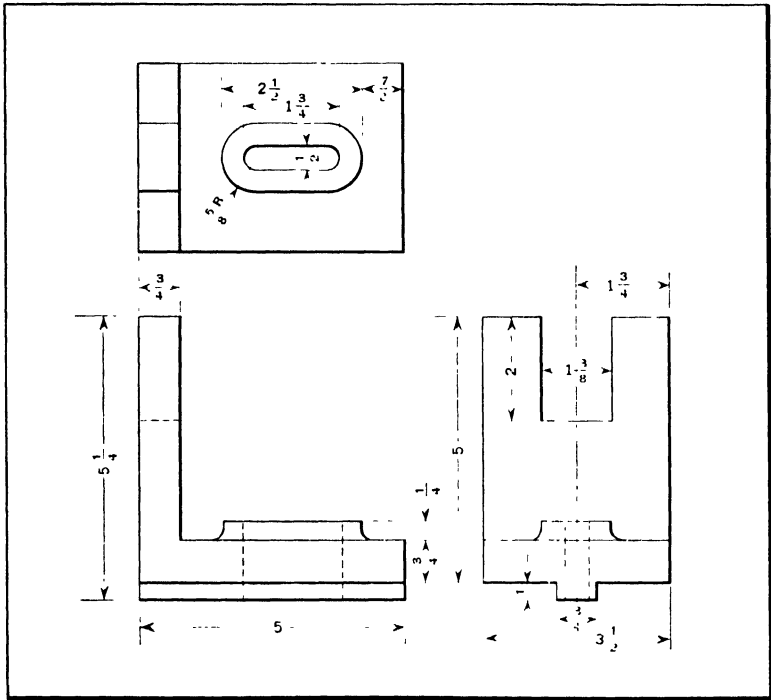

Fig. 9. A Drawing requiring Three Views

the two remaining views would show the length and width of the boss and of the opening through the base, but it would not be possible to determine whether or not the boss and opening were rounded at the ends or square, although it would, of course, be reasonable to assume that they were rounded. By adding a plan view, one can see at a glance the exact shape of the opening and the boss which surrounds it.

Another piece which requires three views to represent it fully is shown in Fig. 10, which is a drawing of a drop-forging. The dotted lines in the front view show that there is an opening through the forging, and the plan view shows that this is a slot having rounded ends. If there were only a plan view, it would not be possible to determine the shape of sections *A*, *B*, and *C*, but by referring to the end view, it is clear that the part *A* is square and parts *B* and *C* circular in cross-section. As the circle *D* is solid and not dotted, this indicates that it represents the end *C* and not the part *A*. On the contrary, if part *A* were circular and *C* square, then part *A* in the end

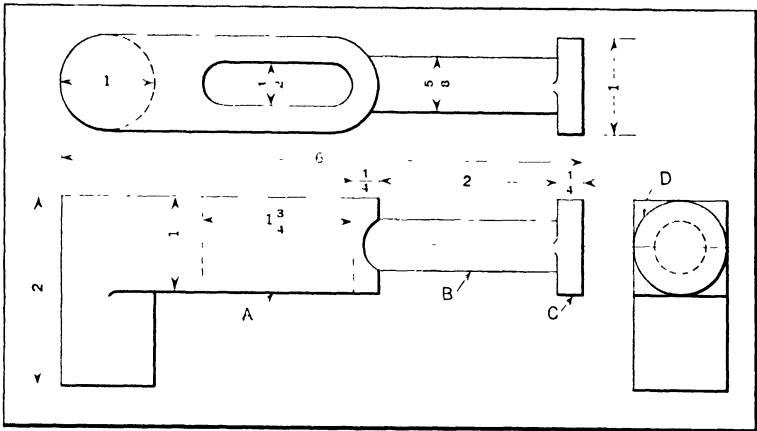

Fig. 10. A Drop-forging represented by Three Views

view would be concealed by part *C* and the circle *D* representing it would be dotted. This end view illustrates the importance of dotted lines, and shows how even a slight change of the kind mentioned may modify the shape of a part as represented by the drawing.

The cast-iron intake manifold shown in Fig. 11 is part of a gasoline engine, and is still another example illustrating a drawing requiring three views. The need of three views in this case is quite apparent. The front view shows the curvature of the pipe in a vertical plane, but its curvature in a horizontal plane is not shown at all by this view. The plan

view illustrates how the main branch curves at each end, but it does not show the complete shape, and it is necessary to add an end view. By referring to these three views, it is clear that the manifold has round flanges at *A* and a round-cornered diamond-shaped flange *B*. The shape of flange *B* is shown in the plan view where dotted lines are used to represent that part which is concealed beneath the main branch of the manifold. The bosses or lugs *C*, *D*, and *E* should also be referred to in the different views, as they illustrate how such details are represented. As this manifold is a hollow casting, the passageways are shown by dotted lines.

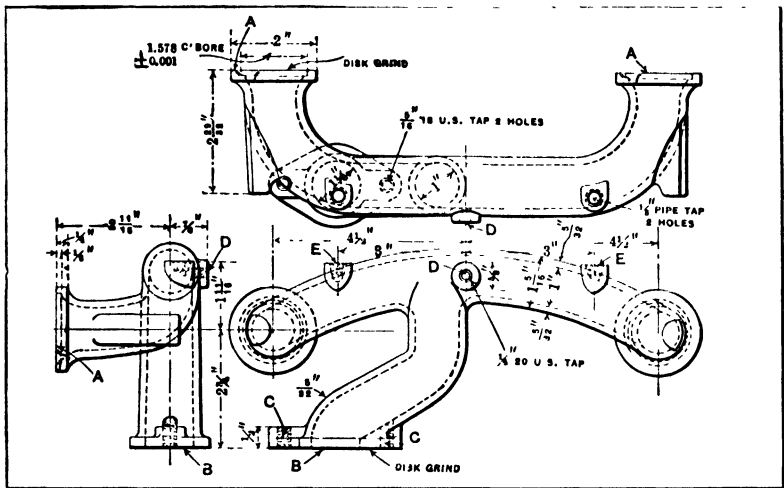

Fig. 11. Drawing of an Exhaust Manifold

Auxiliary Views of Inclined Surfaces. — According to the method of projection illustrated by the diagram *A*, Fig. 2, the three planes upon which the front, side, and top views are projected are at right angles to each other and each plane is parallel to that surface of the block the outline of which is projected upon it; moreover, each view represents the true size of that particular side, because every line or edge on the block is parallel to the plane upon which it is projected.

In drafting practice, it is often necessary to make a drawing of some casting or forging which has inclined surfaces or

parts that would not be shown in their true proportions by views of the kind previously referred to; hence, it is necessary, in many cases, to draw auxiliary views which show the inclined part just as though it were projected upon a plane parallel to it. One or two examples will serve to illustrate the idea more clearly.

Figure 12 shows the drawing of a small casting that has an inclined or beveled side in which there is a recess and hole.

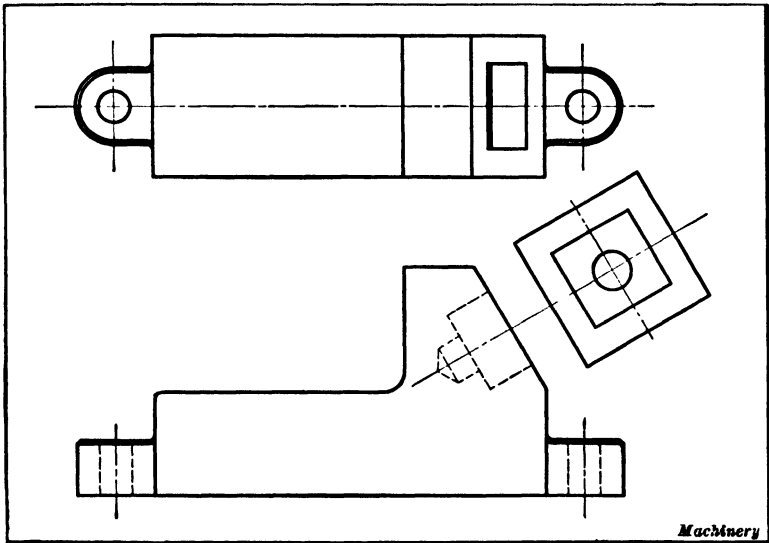

Fig. 12. Illustrating Use of Auxiliary View of Inclined Surfaces

The plan view does not show this inclined part clearly nor in its true proportions, because the inclined edges, as seen in the plan view, are foreshortened or less than their actual length; but by drawing an auxiliary view, as shown, which represents the inclined part of the casting as it would appear when seen squarely and not at an angle, the true form is clearly represented. This auxiliary drawing is simply a plan or top view of the inclined part of the casting, or, in other words, it corresponds to the view that would be obtained if the lines were projected upon a plane parallel to the beveled surface.

The bellcrank shown in Fig. 13 also has an auxiliary view. The two arms of the bellcrank are at an angle of 60 degrees, and they are offset. Now if both arms were alike, the auxiliary view would not be needed. It would simply be necessary to give the dimensions for one arm, as shown in the

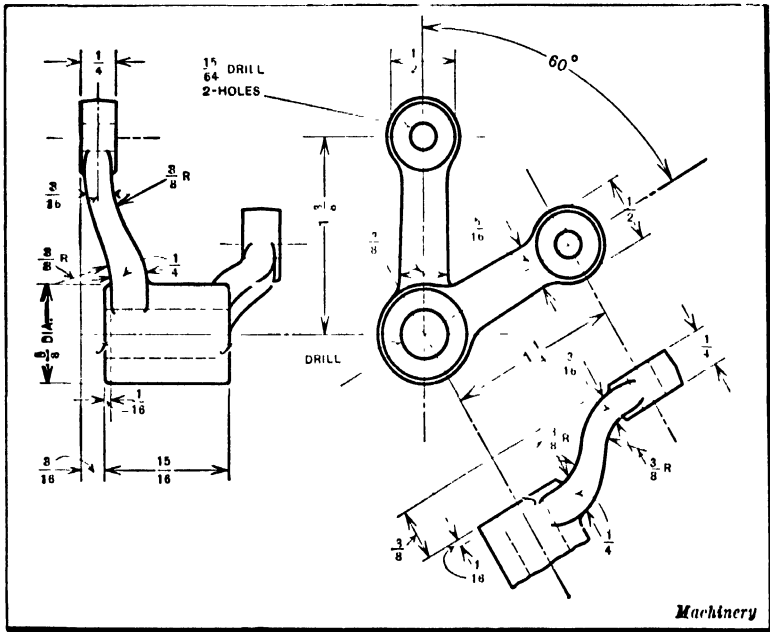

Fig. 13. Drawing of a Bellcrank

left-hand view, and then place a note on the drawing explaining that the other arm is a duplicate. In this case, however, a special detail drawing is needed. As will be seen, it shows the inclined arm just as if it were viewed squarely from the side; consequently, the length of the arm and the curves are represented in their true length and form.

CHAPTER III

MECHANICAL DRAWING INSTRUMENTS AND MATERIALS

MECHANICAL drawings should be fairly accurate, particularly when the drawing is relied upon to show the relative location of certain parts of a mechanism. While the drawing itself should have all important dimensions marked on it so that it need not be measured to obtain sizes, nevertheless a drawing which is accurately proportioned is usually desirable and often necessary. Any error in the calculations employed to determine the dimensions of members composing a mechanism may be detected by a correctly proportioned drawing, and accuracy is especially desirable for drawings of complicated mechanisms.

To obtain the required degree of accuracy, it is necessary to use mechanical drawing instruments which include types for drawing straight lines, circles, and lines at given angles in accordance with required measurements. This chapter does not deal with the different special constructional features of various grades of drawing instruments or with the use of special tools employed only rarely by draftsmen, but it is a general review of the types ordinarily required in making mechanical drawings and of the methods of using the various instruments.

Pencil and Ink Drawings.— It is common practice to make pencil drawings on paper first and then copy the pencil drawings in ink on some transparent material, such as tracing paper or tracing cloth placed over the pencil drawing. The inked drawings, commonly called “tracings,” are then used to make any required number of prints or reproductions for use in the shop. In order to have the lines show clearly and distinctly on the print, it is necessary that the inked lines on the tracing be fairly heavy. While the making of tracings

and prints is the most common method, the pencil drawing is sometimes inked in directly on the paper. This method, for instance, is often used in making patent office drawings. In either case, the making of pencil and ink drawings requires the use of instruments especially designed for drawing straight lines and circles, and means of securing the proper proportions between the different parts represented.

The Ruling Pen. — Most drawings are composed largely of straight lines which are drawn by using the straight edge of a T-square or a triangle as a guide for the pen or pencil. In

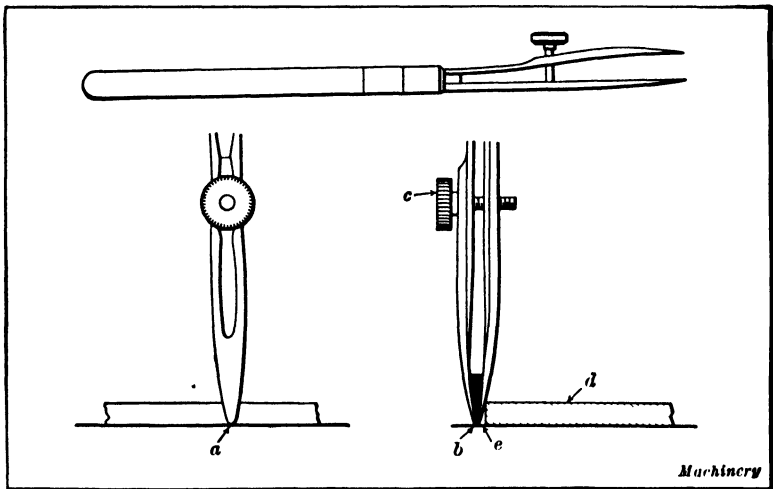

Fig. 1. Ruling Pen for drawing Straight Lines

the case of ink drawings, the instrument used is known as the "ruling pen." The ruling pen, Fig. 1, has two steel blades having points or "nibs" which are rounded as shown at *a*. The nibs or points should have fairly sharp edges, and should be of equal length and of the same form. The space *b* between the points contains the ink (which is represented by the solid black portion) and the width of this space determines the width of the line drawn; the space can be varied for drawing fine lines or heavy lines of uniform widths, by means of the adjusting screw *c*. The pen should be held so that both points rest on the paper, and it is necessary that they be

equally sharp in order to produce fine lines. The square or triangle which is used to guide the ruling pen in drawing straight lines is represented by d . It will be observed that the ruling pen is guided only by the top edge or corner of d and that there is a space e between the point of the pen and the lower corner of d . This space is necessary in order to prevent the ink from causing blots by coming into contact with the guide d . It is evident that the distance e must be kept uniform during the entire stroke of the pen in order to

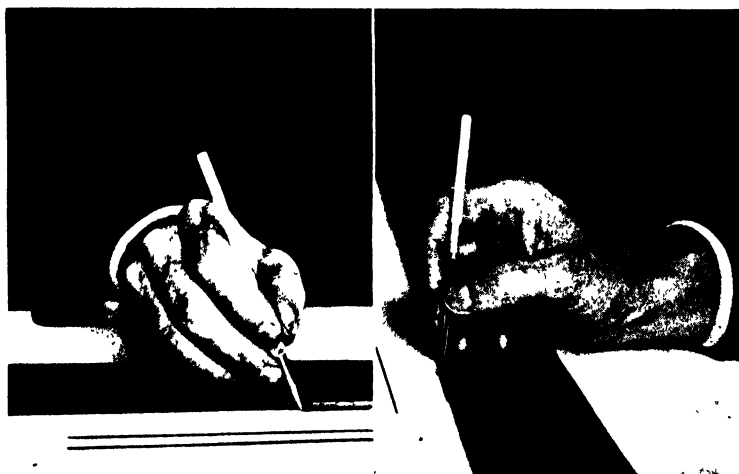

Fig. 2. Method of using Ruling Pen

produce a straight line and also to prevent either of the points of the pen from leaving the paper.

The ruling pen is filled with ink by inserting the quill of the ink bottle stopper between the pen points. Care must be taken not to put too much ink into the pen, and it is preferable to place the ink bottle so that the pen can be filled without holding it over the drawing-board. When the pen is filled in this manner, no ink should be found on the outside of the pen blades; however, if any ink should accumulate on the outside of the blades, it should be removed with a piece of linen cloth before attempting to use the pen. Ruling

pens should be carefully cleaned after using as ink, if allowed to dry on them, will cause corrosion. The inside of the blades should be wiped frequently before refilling.

Drawing Straight Lines. — In Fig. 2 is shown a front and a side view of a ruling pen held by the hand in the correct position for drawing straight lines. Only a little practice is required in order to enable anyone to draw straight lines neatly and rapidly. Horizontal straight lines should always be drawn from left to right, care being taken to hold the rul-

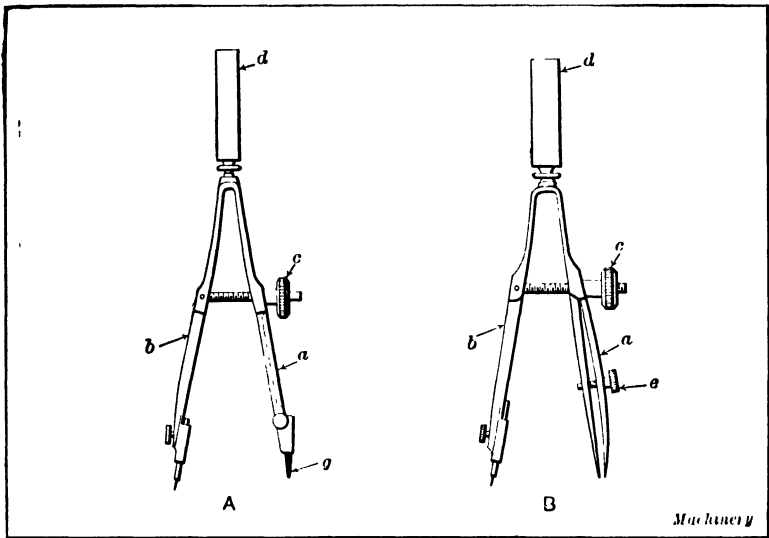

Fig. 3. (A) Bow Pencil. (B) Bow Pen

ing pen in the straight upright position during the entire stroke. With the exception of very short lines, a full arm movement should be used. When within about one half inch from the point at which a line is required to terminate, the full arm movement should be discontinued and, with the tips of the fingers resting upon the top of the straightedge, the pen should be brought to a stop at the desired point simply by the motion of the fingers which hold it.

During the entire stroke in which the arm movement is used, the fingers should touch the top of the straightedge lightly in

order to steady the hand. The pen should not be gripped too tightly and should be held in contact with the straight-edge with only sufficient force to prevent it from leaving the guiding edge. The pen is usually inclined in the direction in which it is moving as indicated in Fig. 2. Some draftsmen, however, prefer to hold the pen in a perpendicular position. Short lines should be drawn with the finger motion only, such as used at the end of the full arm movement.

Instruments for Drawing Circles. — The instrument used for drawing circles depends somewhat upon the size of circle

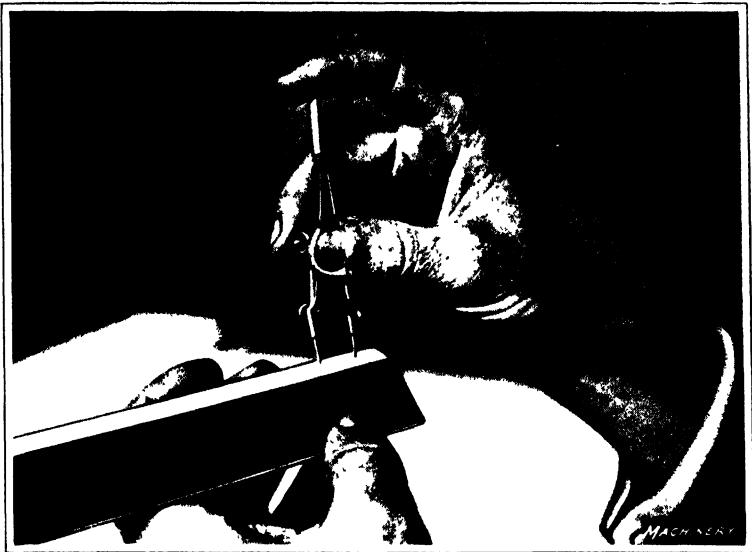

Fig. 4. Setting Bow Pencil to a Given Radius

to be drawn. The spring *bow pencil* and spring *bow pen* are ordinarily used to draw circles up to $1\frac{1}{2}$ or 2 inches in diameter. The construction of spring bow instruments varies slightly, but they are all alike in their more important details. They consist essentially of two steel legs *a* and *b*, as shown in Fig. 3, which are so constructed that a spring tension forces their lower ends apart against the adjusting nut *c*. Handle *d* provides a convenient means of holding the instrument when

adjusting it or when drawing circles. The leg *b* of the spring bow pencil shown at *A* is fitted with a steel bar which terminates in a fine steel point, and the leg *a* is so constructed that a piece of lead *g* can be secured in the position shown. The lead and the needle point should be so adjusted that the handle *d* is perpendicular to the paper or drawing-board when the needle point is set in the paper and the pencil point rests on the paper in the position shown. The needle point has a shoulder which allows the point to pierce the paper only a short distance.

With the exception of the leg *a*, the spring bow pen shown at *B* is the same as the bow pencil. The leg *a* is fitted with a pen for drawing circles in ink. The pen is similar to the ruling pen and the distance between the points or "nibs" can be adjusted by the screw *e*.

Drawing Circles with Spring Bow Instruments. — When drawing circles to a given diameter, the bow pencil is usually set to the radius of the circle by placing it on a suitable scale. The instrument should be held in the position shown in Fig. 4, and the thumb and middle finger should be used to turn the nut which adjusts the distance between the needle point and the pencil point. When drawing a circle, the hand should be raised until the thumb and index-finger assume the position shown in Fig. 5. The circle is then drawn by rolling the handle of the instrument between the thumb and index-finger in a clockwise direction. The handle should be inclined slightly in the direction of rotation. The center of the circle is ordinarily located at the intersection of two center lines. If the center is at some other point, a small circle drawn free-hand with a lead pencil about the center prick mark will enable its position to be located quickly when making the tracing. The bow pen is usually set by adjusting it with reference to the circle drawn in pencil.

Some draftsmen make a practice of changing the setting of spring bow instruments by pressing the points of the instruments together with the thumb and index-finger of the left hand, and spinning the adjusting nut with a finger of the

right hand. In this way, the instrument can be quickly closed or opened to the maximum capacity. This method is used only to obtain approximate adjustment and the final setting should always be made with one hand alone, as previously described.

The Compass. — The compass is used for drawing circles that are too large to be made with the bow pencil or bow pen. At *A*, Fig. 6, is shown a compass with pen in place and the needle point properly adjusted. The instructions on the

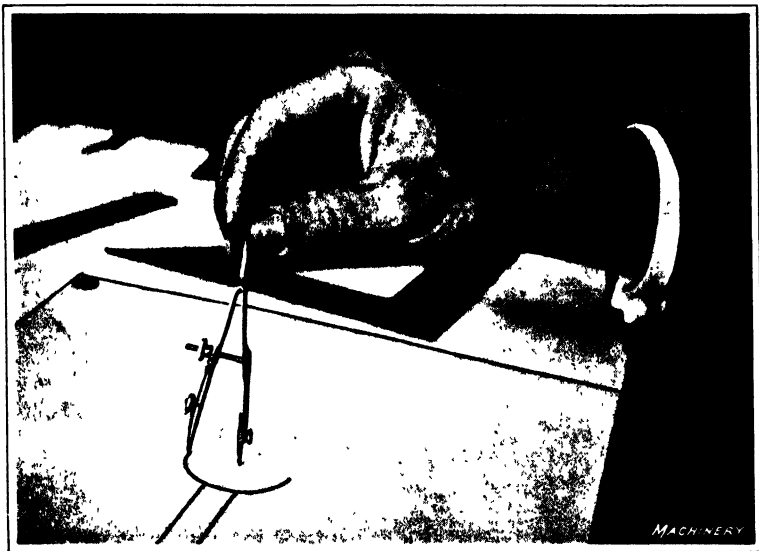

Fig. 5. Drawing a Circle with a Bow Pen

care of the ruling pen also apply to the pen used in the compass. The needle point should be adjusted so that the point of the pen is even with the shoulder on the needle-bar as shown. The needle-bar should be locked in this position where it should remain permanently. The pen point can be readily removed and replaced by the pencil point shown at *C*, when pencil lines are required. The lead should be adjusted to agree with the setting of the needle point. When circles larger than about 3 inches are to be drawn, the points of the compass should be adjusted at the joints, as shown at *D*, in

order to bring these members perpendicular to the paper or drawing-board. The extension bar shown at *B* is used in drawing circles which are too large to be drawn with the compass when equipped only with the pencil point or pen point. This lengthening bar is inserted between the leg of the compass and the pen or pencil point.

Drawing Circles with the Compass. — As the compass is frequently used, the correct methods of handling this im-

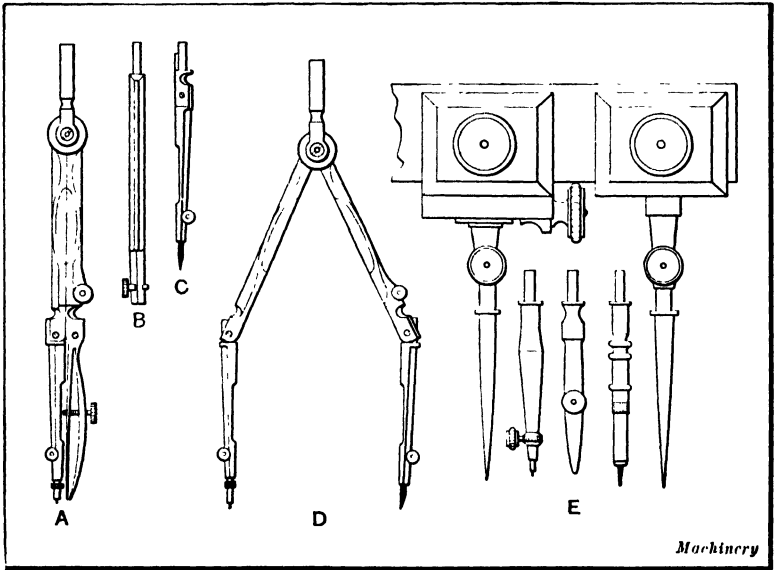

Fig. 6. Compasses for drawing Circles which are too Large for the Spring Bow Instruments

portant instrument should be acquired. When the compass is picked up, the thumb should be placed in the position shown in Fig. 7. This position permits the instrument to be readily opened by pressing with the thumb and middle finger into the chamfered section. When the compass is opened a sufficient amount, the fingers of the right hand will naturally assume the position shown in Fig. 8. When it is held in this position, the opening of the compass can be readily continued for setting the points to coincide with graduations on a scale. This enables the draftsman to make all adjustments required

in drawing circles up to about 3 inches radius, with the right hand alone. For larger circles, the compass should be opened and closed by the same method, but the thumb and index-finger of the left hand should be used to bring the jointed sections into such a position that they will both be perpendicular to the paper as shown at *D*, Fig. 6. The final adjustment is then made by using the fingers and thumb



Fig. 7. Position of Hand for opening Compass readily when it is picked up from Drawing-board

of the right hand alone, the instrument being held as previously described in connection with Fig. 8. When drawing a circle, the position of the hand is changed so that the top or handle of the instrument will be held between the thumb and index-finger, the same as the bow instrument is held in Fig. 5. The circle should be drawn by rotating the instrument in a

clockwise direction. In drawing heavy ink circles, it is usually necessary to begin the rotative movement before allowing the pen point to touch the paper, as otherwise the ink may leave the pen and cause a blot. In Fig. 9 is shown the method of using the compass equipped with a lengthening bar for drawing circles that are too large to be drawn with a compass alone. When



Fig. 8. Setting Compass to Given Radius

the lengthening bar is employed, the instrument should be held by both hands.

Beam Compass. — Circles beyond the range of an ordinary compass are drawn with the beam compass shown at *E*, Fig. 6. This is the usual type of beam compass and consists of a beam or strip of hard wood carrying two heads provided with needle points, a pencil-holder, and pen. When a pencil or pen is being used, the head carrying the needle point is usually clamped at one end of the beam or bar while the one carry-

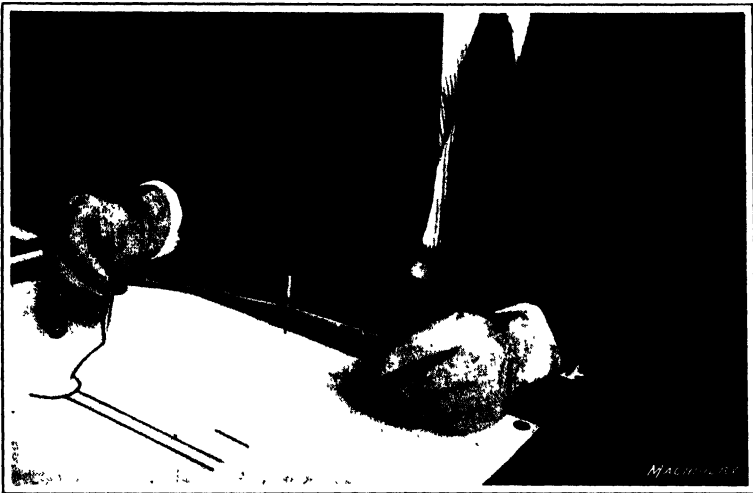

Fig. 9. Drawing an Arc of rather Large Radius by using Compass and Lengthening or Extension Bar

ing the pencil-holder or pen is adjusted at any point along the beam that may be required for the radius of the arc or circle to be drawn. Only a small section of the beam is shown in the illustration.

Dividers. -- Dividers are used for dividing circles or straight lines into equal parts and for transferring measurements from a scale to the drawing. For making small and very fine divisions, the spring bow dividers shown at *A*, Fig. 10, are used. The construction is similar to that of the bow pen and bow pencil, the only difference being that both legs terminate in sharp needle points. The method of holding and adjusting

the spring bow dividers is essentially the same as that for the bow pen and bow pencil. The fine adjustment provided on the spring bow dividers makes them particularly adapted for making divisions requiring a fair degree of accuracy, such as is often required in dividing a circle into any number of equal parts.

Dividing a Circle into a Given Number of Equal Parts. — When the distance between the points is set as nearly as pos-

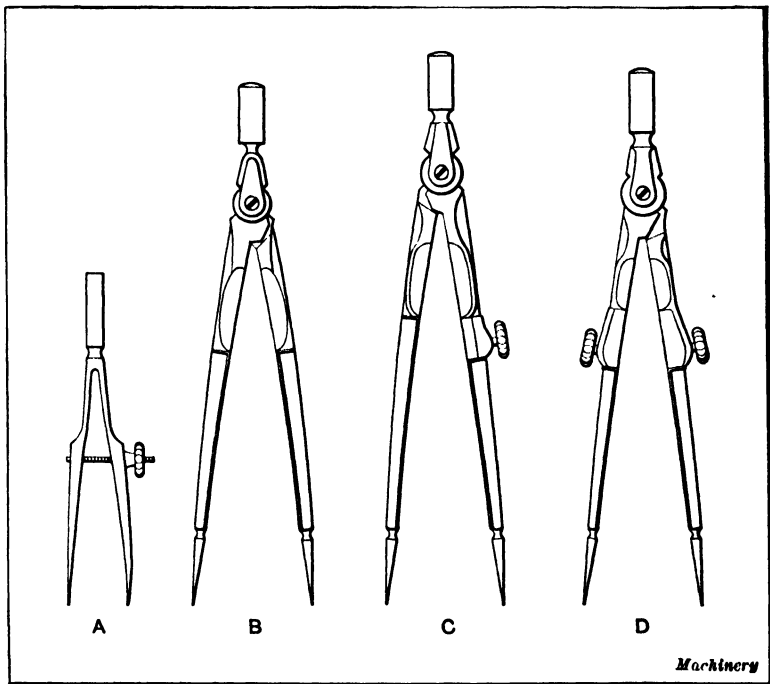

Fig. 10. Different Kinds of Dividers

sible to the length of one of the required spaces, by either estimate or scale measurement, the line or circle should be spaced off by a trial division. The spacing should be done in the usual way, except that the points of the instrument should not be pressed into the paper. When spacing or dividing lines or circles, the dividers should be held between the thumb and forefinger, each point of the dividers being moved

alternately along the line to be divided. If the trial division proves that the instrument is properly set to make the required number of equal spaces, the spacing can be done by pressing down on the instrument with just sufficient force to make easily distinguished prick marks. If the spacing does not come out even, open or close the instrument a distance equal to the amount of error divided by the number of divisions and make another trial division. Repeat this operation until the instrument is so adjusted that the line can be divided exactly as required.

Plain, Hairspring and Combination Dividers. - - The plain dividers shown at *B*, Fig. 10, are used for making divisions beyond the capacity of the spring bow dividers. This instrument consists of two steel members joined at the top by a friction joint similar to that of the ordinary compass. The lower ends of the dividers have very sharp steel points for making small prick marks. The dividers should be opened, closed, and adjusted by the fingers and thumb of the right hand alone just as in the case of the compass.

The type of dividers shown at *C*, Fig. 10, are known as hairspring dividers. In this type of dividers one leg is made solid while the other is hinged or jointed and is provided with an adjusting screw that permits of very fine adjustment.

The dividers shown at *D* are formed by replacing the needle point and pen or pencil point of the ordinary compass with solid steel points. These divider points are not often used as most draftsmen have either plain or hairspring instruments.

Proportional Dividers. — Proportional dividers are useful when enlarging or reducing drawings by direct measurement, and for dividing a circle into equal parts. They are made with two entirely separate legs, which have steel points at each end and are joined to each other by a screw and thumb-nut sliding in a slot formed in each leg, as shown in Fig. 11. The pivot screw passes through a sliding block formed of two parts, each fitting the slot in its respective leg, so that the joint, or pivot, of the instrument can be placed at any point desired. Thus the double-pointed legs form practically

two dividers, the relative lengths of the legs of which are adjustable at will. If the pivot screw is so placed that its distance from one point is one third of the entire length of the leg from point to point and is clamped in that position, the dividers are set at a proportion of 1 to 2; that is, if the divider legs are opened until the points of the shorter leg are one inch apart, the points of the longer will be two inches apart. By shifting the position of the pivot screw, any other relative proportion can be obtained. The position of the pivot screw is determined by graduations upon the legs, to which a single line upon the sliding block may be adjusted. When it is desired to enlarge or reduce a drawing, the scale of graduations marked "lines" is used; the scale marked "circles" is used when it is desired to divide a circle into a number of

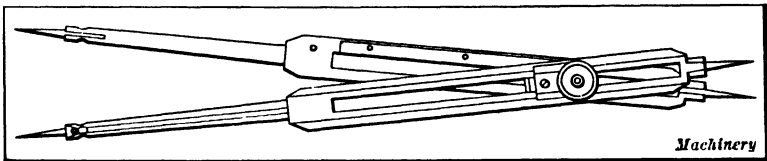

Fig. 11. Proportional Dividers

equal parts, the diameter of the circle being measured by the large end of the dividers. In mechanical drafting, this instrument is not ordinarily used.

The T-square. — Since most drawings consist principally of horizontal and vertical lines of various lengths, a convenient means of drawing them is necessary. Horizontal lines are usually drawn by guiding the pen or pencil with the edge of a T-square blade. The T-square consists primarily of a thin ruler or blade which has a head secured to it at one end. The head is usually fixed at right angles to the ruling or working edge of the blade. This type is shown at *A*, Fig. 13. The head is held against the edge of the drawing-board with the left hand. The T-square shown at *B* has a swivel or pivoted head that may be secured in any desired position by a thumb-nut. This type of T-square is sometimes equipped with a protractor for setting the head at any required angle.

In Fig. 12, the T-square is shown in its normal position on the drawing-board. Ordinarily all horizontal lines are drawn by the aid of the T-square which is moved as may be necessary. The head is always held in contact with the left-hand edge of the board either by the method shown or as indicated in Fig. 15.

Triangles. — Vertical lines are usually drawn with the aid of triangles which are generally used in connection with the T-square. There are two types of triangles that are commonly used by mechanical draftsmen. These two forms are

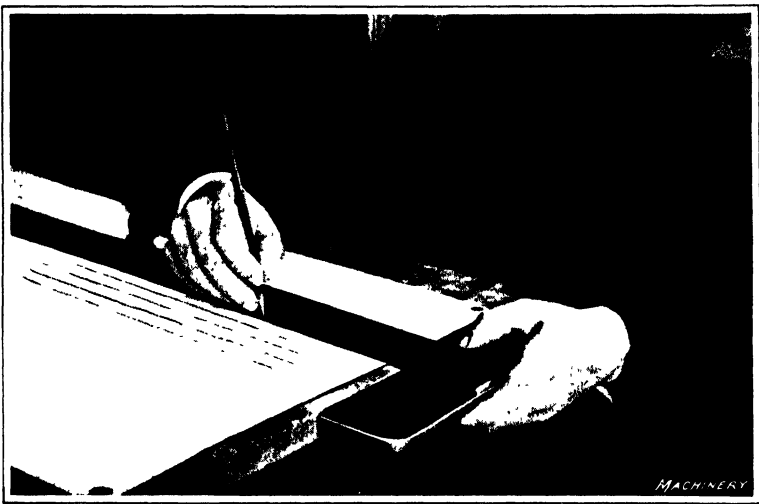

Fig. 12. Drawing a Straight Line by using T-square to guide Pencil

shown at *A* and *B*, Fig. 14. The one shown at *A* is commonly called the 45-degree triangle and has one angle of 90 degrees and two angles of 45 degrees. The triangle shown at *B* is usually called the 60-degree triangle and has one angle of 90 degrees, one of 30 degrees, and one of 60 degrees. Triangles are usually made from $\frac{1}{8}$ to $\frac{1}{4}$ inch in thickness and from 3 to 15 inches in length, according to the size of drawing for which they are to be used. They are made of celluloid and of various kinds of hard wood, hard rubber, or similar substances. The celluloid ones are transparent and are preferable.

Straight lines may be drawn at right angles to the hori-

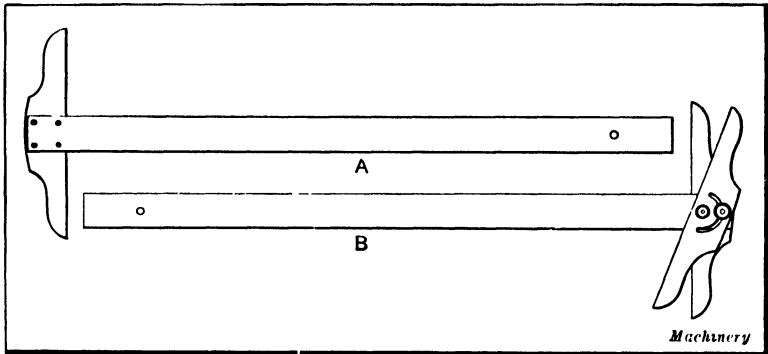

Fig. 13. T-squares of Fixed-head and Adjustable Types

zontal edge of the T-square or at angles of 45 degrees, 30 degrees and 60 degrees by placing the triangles in the positions indicated by the dotted lines in Fig. 14. In Fig. 15 is shown the correct position of the hands in drawing vertical lines. This position permits the triangle to be held in contact with the T-square and it also enables the draftsman to keep the head of the T-square in contact with the edge of the drawing-board. The 45-degree triangle is almost universally employed for cross-sectioning or cross-hatching sectional drawings.

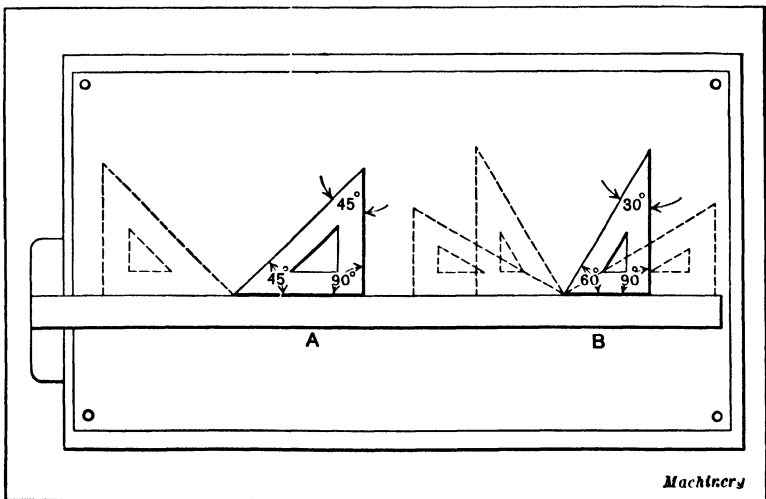

Fig. 14. Triangles in Different Positions on T-square

There are various special instruments designed for cross-sectioning, but experienced draftsmen usually prefer to use the plain 45-degree triangle for ordinary work. For special work, triangles having different angles are used, but nearly all of them have one angle of 90 degrees. The 60-degree triangle is used principally for drawing hexagons, such as are required in representing bolt heads, etc.

The size of a triangle is determined by the length of the side of the right angle, the longer side being measured in the



Fig. 15. Drawing a Vertical Line by using T-square and Triangle

case of the 30- by 60-degree triangle. The different angles which can be laid off by using the 45- and 30- by 60-degree triangles singly and in combination are shown by the illustration, Fig. 16, which is self-explanatory.

Protractors. — The protractor is used to measure or set off angles of any required number of degrees. The protractor shown in Fig. 17 is a type often used by draftsmen. It is made from celluloid and includes one half of a circle. Some protractors are provided with an arm pivoted at the center which can be swung around the circle (see Fig. 18). The

smaller protractors are divided into degrees, while larger ones show half or quarter degrees. Those with a swinging arm like the one shown in Fig. 18 are usually provided with a vernier scale by which small fractions of degrees, such, for example, as 1, 3, or 5 minutes, are read.

Irregular Curves. — Irregular curves, sometimes called “French curves,” are required in drawing curved lines other

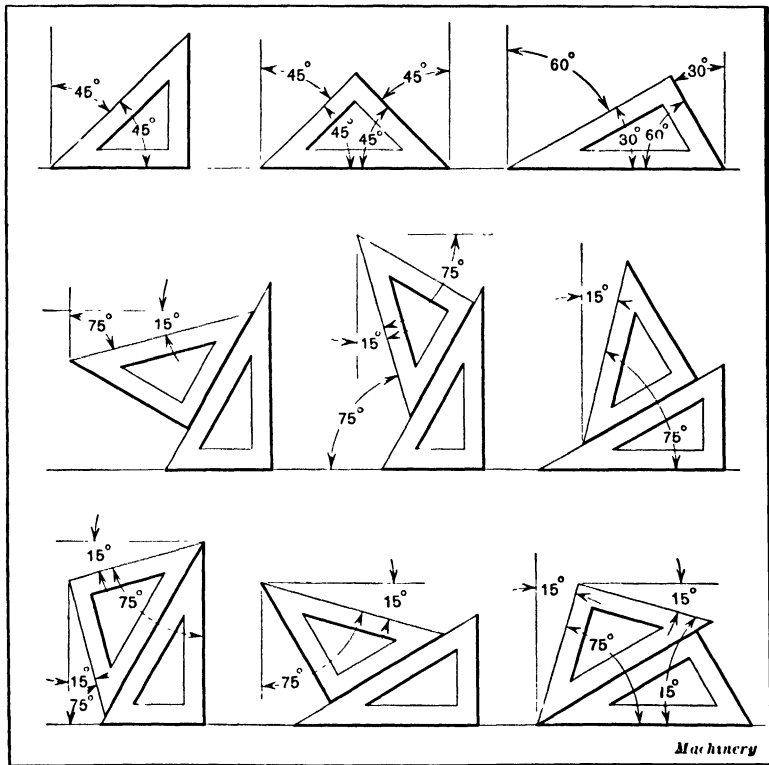

Fig. 16. Different Angles which may be laid off by using the 45- and 30- by 60-degree Triangles

than circles or arcs. Curves are generally made of celluloid and in a great variety of sizes and forms. The curves may be parts of ellipses, spirals, parabolas, or other curves. For special purposes, they are made of any curve called for by the drawing to be made. Typical curves are shown in Fig. 19.

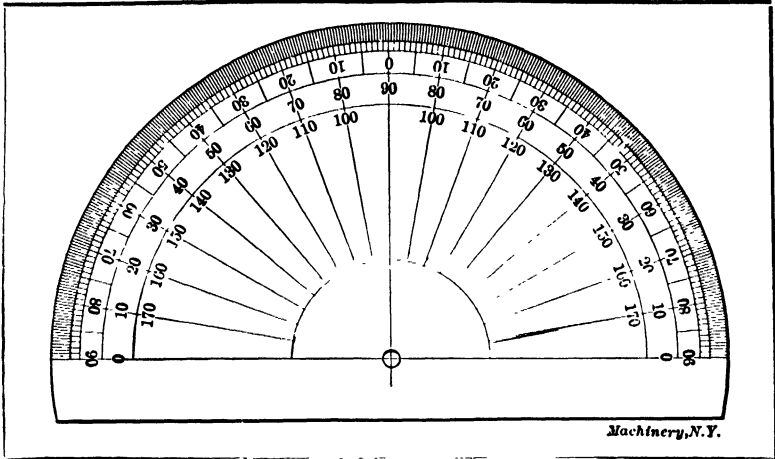

Fig. 17. Simple Form of Protractor

One elliptical and one spiral curve will serve for general purposes. In practice, the points through which a curved line is to be drawn are located and then the edge of the irregular curve is made to coincide with as many of these points as possible and a smooth line drawn; then the curve is applied to as many more of the points as possible and the curved line continued, this process being repeated until the entire irregular curve is drawn.

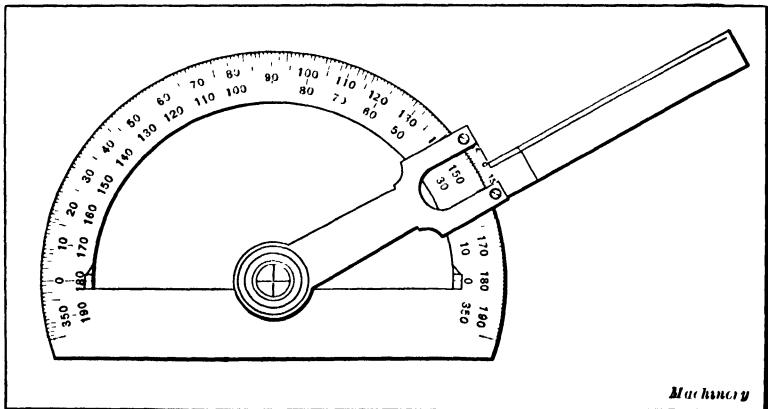

Fig. 18. Protractor having a Pivoted Arm and Vernier Scale

Many curved lines drawn by means of the irregular curve require that the same parts of the instrument be used on each side of a center line. The regularity of the curve drawn and the degree of symmetry will depend upon the accuracy with which the irregular curve is located in corresponding positions on opposite sides of the center line. One method of locating the irregular curve is by making pencil marks on the curve to indicate the section used. The instrument can then be reversed and this section used to draw the corresponding curve on the opposite side of the center line. A convenient method

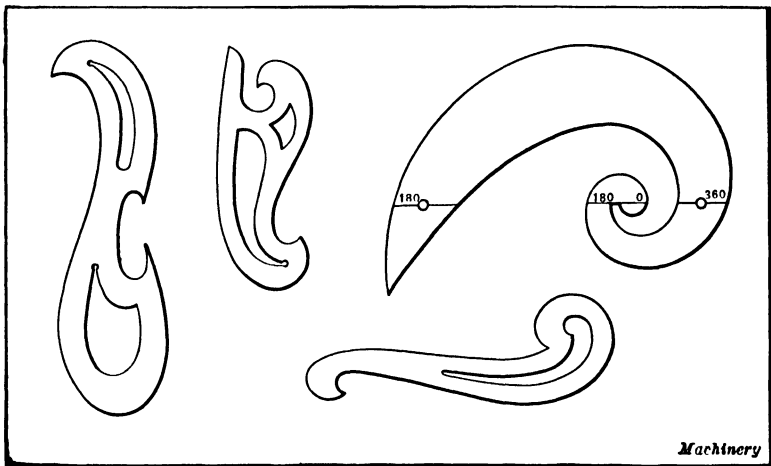

Fig. 19. Irregular Curves used for drawing Curved Lines other than Circles or Arcs

of drawing a symmetrical figure which requires a right-hand and a left-hand curve on each side of a center line, is illustrated in Fig. 20.

As can be seen, there is a hole about $\frac{1}{16}$ inch in diameter in each end of the curve. In use, the curve is laid on the drawing, the locations of the holes are marked with a pencil point, and the desired curve drawn on one side. On the center line of the piece to be drawn, select two centers, as *A* and *B*, and from these centers locate the positions of the holes in the opposite sides. Place the curve in the reversed position with the holes in the curve over these points. The method is simple; in fact, it takes a much longer time to explain it than to follow it.

There is only one condition under which the end of a curve can be joined to another curve (or to a straight line) so that the two lines will join neatly together, and that is where both the lines are tangent to the same radius where they join. In any other case, there will be a break or sharp place which will be apparent to the eye, and further, a piece made after the drawing will not be so strong as though the curve joined evenly. There is a simple way to obtain this desired end and that is to draw at various points on the irregular curves, radial lines (or in the case of concave curves, prolongations of

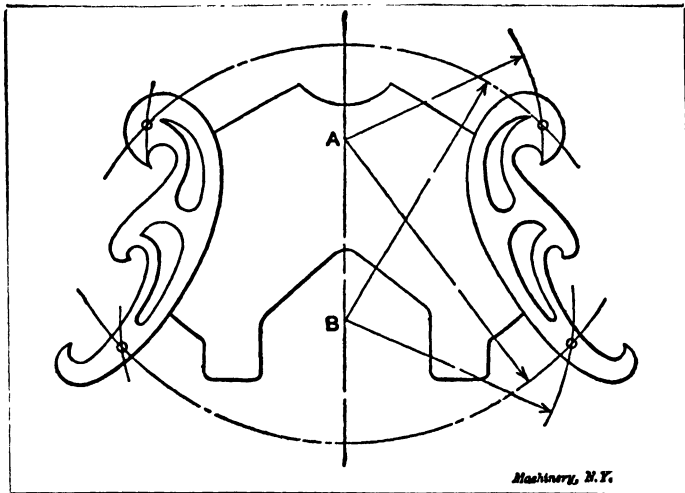

Fig. 20. Method of drawing a Symmetrical Figure requiring Right-hand and Left-hand Curves on Each Side of a Center Line

radial lines) which are at right angles to the tangents of the curves at the points chosen. Figure 21 shows an irregular curve on which radial lines perpendicular to the tangents are drawn. The curves drawn at the lower part of the illustration indicate how neatly curves may be joined when the radial lines are used as guides.

Celluloid Templates.—Where the same work must be frequently drawn, templates made from some light, easily cut material not only facilitate the drawing but make the work uniform. While paper or cardboard may be used for tem-

porary work, the most satisfactory templets are cut from celluloid about 0.01 inch thick. A dark tint is preferable to white, because of its greater contrast with the drawing paper or tracing cloth. The templet shown at *A*, Fig. 22, is for drawing bolt heads and nuts; lines must be ruled on this to assist in the correct placing on the center line of the part in the drawing. The templet for machine handles of the more common size (see sketch *B*) will also be found useful; in this

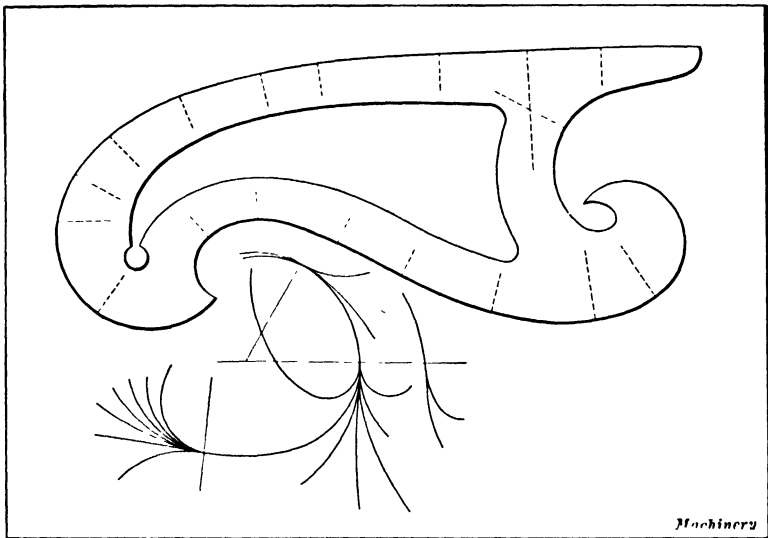

Fig. 21. Method of drawing Curves which are Tangent to the Same Radius where they join together

case, only half of the design is cut out of the edge of the templet; the other half of the drawing is made by placing the templet on the opposite side of the center line.

Scales Used by Draftsmen. — Ordinarily the draftsman's scale is either flat with beveled edges or triangular with the flat sides relieved by semicircular grooves. The flat form of scale shown at *A*, Fig. 23, has both edges beveled to an acute angle so that the graduations and figures are easily read. While the flat scale has two faces upon which graduations can be made, the triangular scale shown at *B* has six faces for graduations. The type shown at *B*, however, has certain

disadvantages one of which is the difficulty often experienced in locating any particular scale. The type shown at *A* is preferred by most draftsmen as it lies flat upon the drawing-board and permits either scale to be located quickly.

There are two general classes of graduations. The first consists of graduations for "full size" drawings, which are drawings made the same size as the actual parts they represent; the second covers graduations that are adapted for drawings made on a scale much smaller than the parts represented. In the first class, the inches may be divided into

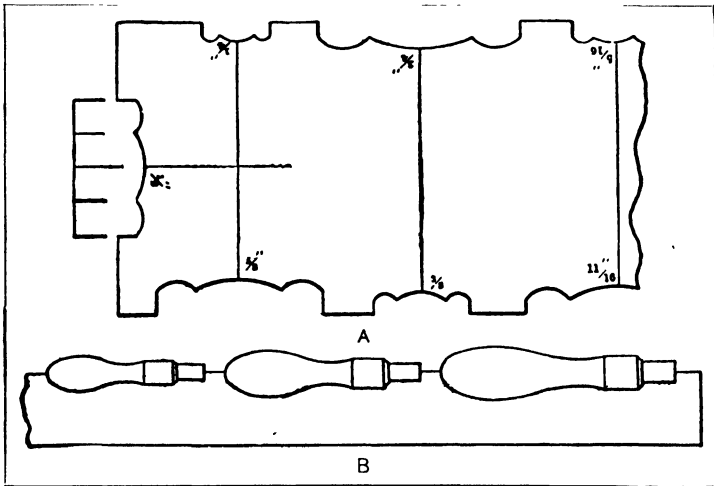

Fig. 22. Celluloid Templates for drawing Bolt-heads and Machine Handles

eighths, sixteenths, thirty-seconds, and sixty-fourths, or in tenths and hundredths; in the second class, the main graduations represent feet, and one foot on these reduced scales may actually measure $1\frac{1}{2}$ inch, 3 inches, or some other fractional part of a foot. The use of scales will be explained fully in a following chapter.

Set of Drafting Tools.— The selection of the proper tools or instruments is very important. Few draftsmen agree fully as to what constitutes a complete set of tools, or about the best construction of the various appliances. It is also evident that the draftsman must be guided somewhat by the

class of work he is doing. Certain tools which may be required by the work carried out by one designer may not be of any use to another. In general, however, the requirements are fairly similar, and in the following is given a specification of a complete set of tools purchased by an experienced draftsman, for his own use. Undoubtedly his judgment and experience may give some valuable suggestions as to the selection of the tools needed by any draftsman.

In the set to which reference is made, the three bow instruments are $3\frac{1}{4}$ inches long with center adjustment. The bow

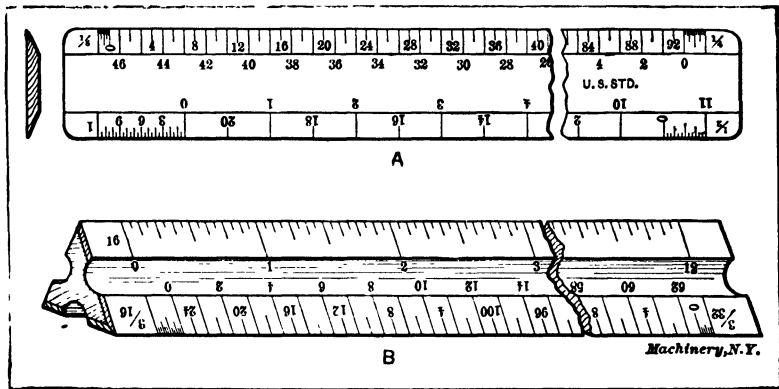

Fig. 23. Scales used by Draftsmen

pen will draw perfect circles from less than $\frac{1}{32}$ inch diameter to $3\frac{3}{4}$ inches diameter. There is one $3\frac{1}{2}$ -inch pencil compass with fixed pencil and needle points, and a $5\frac{1}{2}$ -inch pen compass with fixed pen and needle points, and hairspring adjustment. The pencil compass is small, because it is preferable to use trams for all pencil work beyond its limits, but the pen can be used to advantage in the $5\frac{1}{2}$ -inch size. The hairspring adjustment on it is a great convenience, although by no means necessary. The two ruling pens are 5 inches and $5\frac{1}{2}$ inches long. The trams consist of a tubular German silver bar in three sections, held together by long slip joints, and will work to a radius of 50 inches. Both heads slide on the bar, being clamped in the desired position with thumb-screws, and the points are adjustable in either head. The delicate adjust-

ment is of the swinging lever type, which is the only satisfactory one for trams. There are two divider points, and pen, pencil, and needle points. The whole instrument is very stiff and light and has a bar long enough for all ordinary work.

Most draftsmen prefer the transparent triangles. A good selection consists of a 16-inch, 30 and 60 degrees, a 10-inch, 30 and 60 degrees, and a 5-inch, 45 and 45 degrees, for all ordinary work. A set of flat scales is far superior to the ordinary triangular scale. This particular set comprises 7 scales, $\frac{1}{4}$, $\frac{3}{4}$, 1, $1\frac{1}{2}$, 3, 6, and 12 inches = 1 foot. These scales are of the reverse bevel type, and both sides of each scale are graduated the same, but read from opposite ends. With this arrangement, it is never necessary to do more than turn the scale over to have it reading in the desired direction. The divided foot on the $1\frac{1}{2}$ - and 3-inch scales is marked 2-4-6 etc., instead of the usual 3-6-9, which makes it easier to find the desired point. The 6-inch scale is fully divided into sixteenths and the 12-inch, into thirty-seconds. Scales of this kind, however, are made only to order by the firms manufacturing draftsmen's scales. A slide rule, a protractor, and a couple of curves complete the set of tools.

Drafting Machine. — The term "drafting machine" has been applied to a special instrument which is designed to take the place of the T-square, triangles, scale, and protractor, in order to facilitate the work of drafting. The drafting machine illustrated in Figs. 24 and 25 consists primarily of two parallelograms, a protractor, and a square having graduated ruling edges. The two parallelograms joined together constitute an arm which, when anchored to the drawing-board as shown, gives the protractor and square a parallel motion about the drawing. This form of parallel motion permits either zero point on the ruling edges to be placed instantly at any point on the drawing by a single direct movement, due to the fact that the arm formed by the parallelograms is similar to the human arm. Thus the action is the same as when the hand is moved to any position.

Starting from zero, a line can be drawn along the graduated

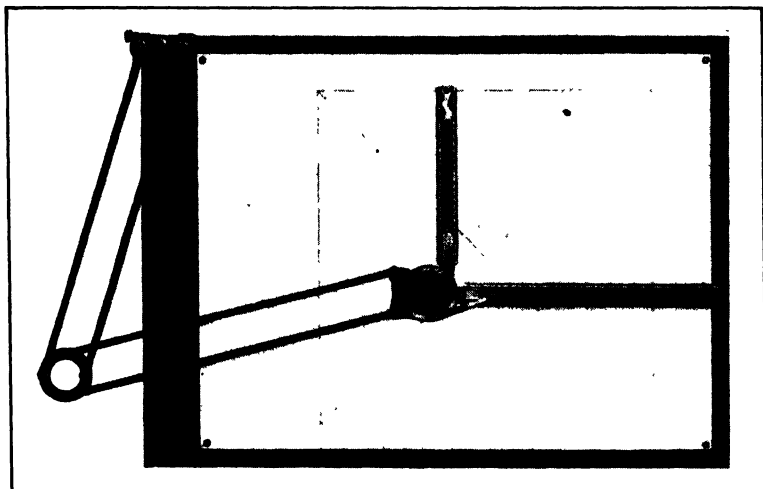

Fig. 24. Universal Drafting Machine

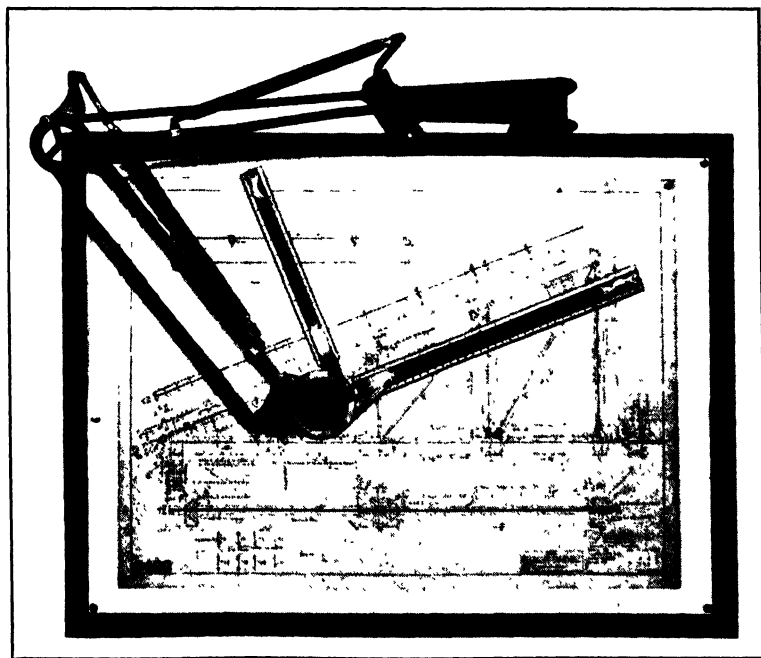

Fig. 25. Drafting Machine counterpoised with Springs for Use on Board placed in Vertical Position

ruling edge to just the exact length required. Thus in drawing a straight line to any required length, there is no changing from a ruling edge to a scale edge and there is no over-running end to be erased or redrawn. The zero on the scale is simply moved to position by a single direct movement of the hand which controls the instrument, while the other hand is left free to draw the line its exact length. The square is used for the reason that as soon as a line is drawn, another line at right angles to it is usually required. Considerable

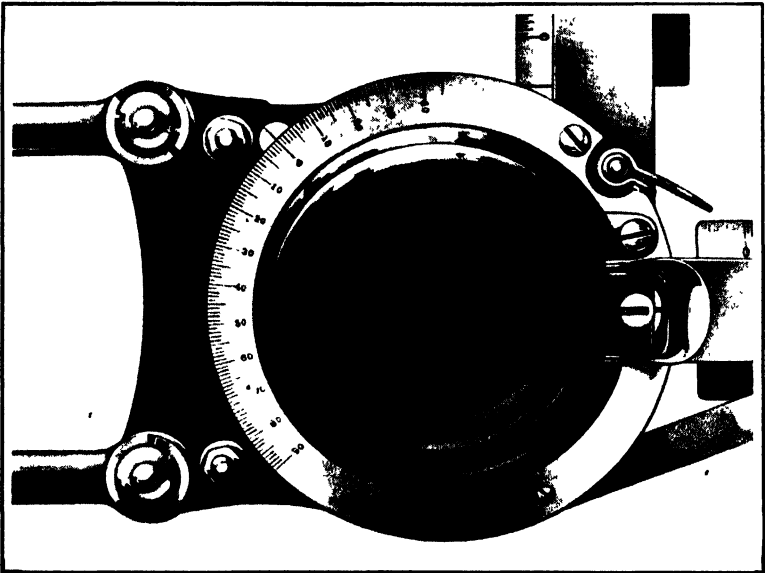

Fig. 26. Protractor of Drafting Machine

time and attention is thus saved, particularly in angular work. The blades of the square are interchangeable for all graduations. Straightedges can be inserted in place of the scales when inking in drawings or tracings.

A conveniently arranged protractor permits the square formed by the two scales to be set at any given angle. The square, when set at an angle as shown in Fig. 25, has the same parallel motion about the board as when set at zero. This feature is of great advantage when making drawings of

angular work. No matter what the angle may be, it is a simple matter to set the protractor, move the zero on the scale to position, and draw the line the exact length. In Fig. 26 is shown the protractor. The centrally located wood handle is of such a shape that it fits into the hand nicely. An automatic stop makes it unnecessary to read or clamp the protractor at the most frequently used angles. For instance if it is required to set the square at an angle of 30-degrees with the horizontal, it is only necessary to press the thumb-latch shown at the right of the wood handle and rotate the handle a sufficient amount to allow the latch to drop into a recess which automatically and accurately locates the square at the required angle. From this it will be seen that the protractor is the controlling center of the instrument. The handle is held in the left hand which controls all of the motions of the machine, thus leaving the right hand free for drawing lines.

As the draftsman becomes accustomed to placing the zero on the scale in position by a single direct movement of the left hand and drawing the line just its exact length with the right hand, he steadily gains in concentration and speed, which results in a high degree of efficiency. Protractors of special design can be obtained for architectural work or map drawing and can be equipped with a vernier which reads to minutes. The type shown in Fig. 24 is the one ordinarily used in the drafting-room for making drawings of the ordinary size when the board is placed on a table or stand in the usual horizontal or inclined position. The instrument shown in Fig. 25 is equipped with a counterpoise and is used when the board is held in a vertical position. For very large drawings, the counterpoised instruments are equipped with special holders that enable them to be moved to any position on the board without affecting their accuracy of alignment. The drafting machine illustrated is made by the Universal Drafting Machine Co., Cleveland, Ohio.

Drawing-boards. — The kind and variety of the equipment used by mechanical draftsmen vary somewhat according to

the number of drawings made, their size, and the general conditions under which the work is done. For instance, the student of mechanical drawing may use simple and inexpensive equipment which would be entirely inadequate in the drafting-room of a machine building plant where it is essential to use all modern appliances that facilitate the work of the designing department. When drawings are made on a small scale, the drawing paper is attached by means of thumb-tacks to a drawing-board which may be supported on a table or desk; in most drafting-rooms regular drawing tables are used. These

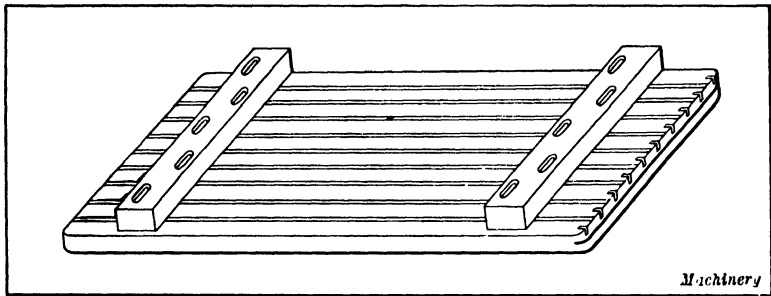

Fig. 27. Drawing-board having Hardwood Cleats on Back to prevent Warping

drawing tables are practically drawing-boards mounted upon some form of stand which is usually arranged to permit adjusting the board.

The principal requirements of a drawing-board are that the top surface be smooth and that at least one of the edges be straight, in order to form a suitable guide for the head of the T-square. The drawing-board should be made of well-seasoned soft pine and be formed of strips glued together edgewise. Some boards have end pieces fitted across the end of the board by a tongue and groove. The best drawing-boards have hard-wood cleats secured to the back of the board to prevent warping. The back of a board having these cleats is shown in Fig. 27. The screws which hold the cleats pass through oblong holes containing metal bushings that fit closely under the screw-heads and yet allow the screws to move freely in case the board contracts. Grooves are sunk in the board

on the under side. These grooves take the transverse strength out of the wood to allow it to be controlled by the ledges, leaving at the same time its longitudinal strength nearly unimpaired. To make the working edge perfectly smooth, allowing easy movement of the T-square, a strip of ebony is let

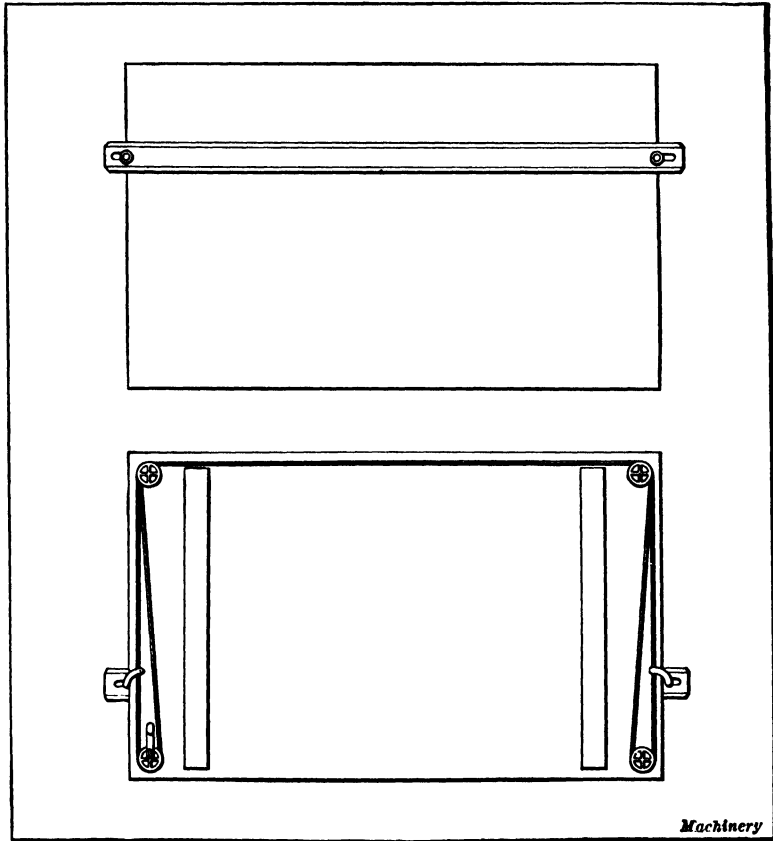

Fig. 28. Drawing-board equipped with Parallel Attachment

into one end of the board. The strip is sawed apart at about every inch to allow for contraction of the board.

Parallel Attachment for Drawing-boards. — Some drawing-boards and tables intended especially for drafting are provided with what is known as a “parallel attachment.” This attachment consists principally of a straightedge (see Fig. 28)

which is used in place of a T-square. The straightedge provides means of drawing parallel lines and it is used to locate the triangles for drawing vertical lines in the same manner as a T-square. The continuous cord to which the ends of the straightedge are fastened passes over pulleys at each corner of the board. This cord is so arranged that the straightedge will maintain its horizontal position when raised or lowered

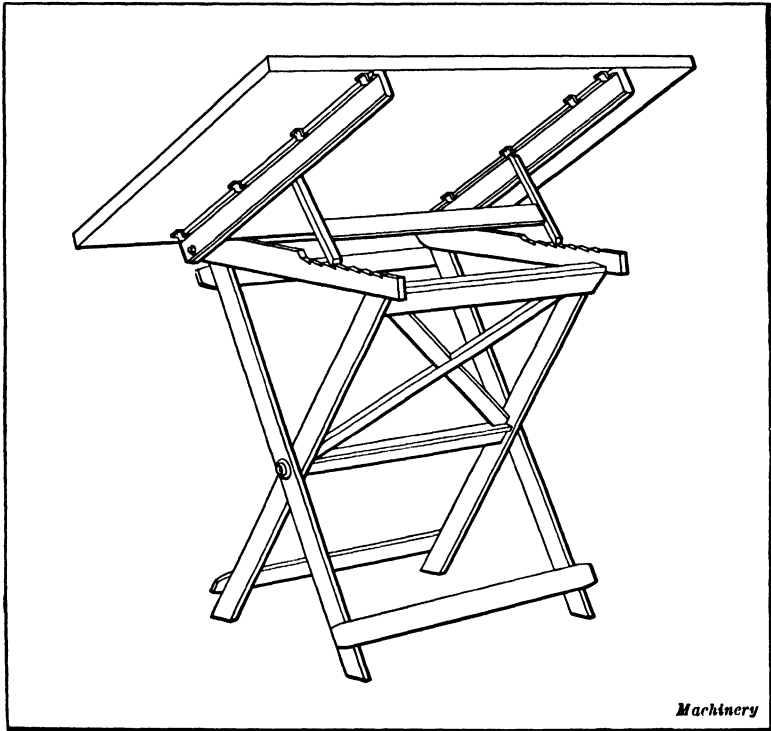

Fig. 29. Adjustable Drawing Table

to any position on the board. The straightedge of the attachment illustrated may also be set at an angle or be removed readily if the use of a T-square is preferred.

Drafting Tables. — The tables used in drafting-rooms may be non-adjustable or adjustable. The adjustable type is now used extensively and most of these tables may be adjusted for height and also for changing the inclination of the table.

The method of obtaining the adjustment and the general arrangement varies considerably on different makes.

A simple design of drafting table is shown in Fig. 29. This is a folding type which may be adjusted to different angles. The drawing-board is held at the desired inclination by supports which engage notches or teeth formed on the cross-pieces of the frame. The drafting table illustrated in Fig. 30

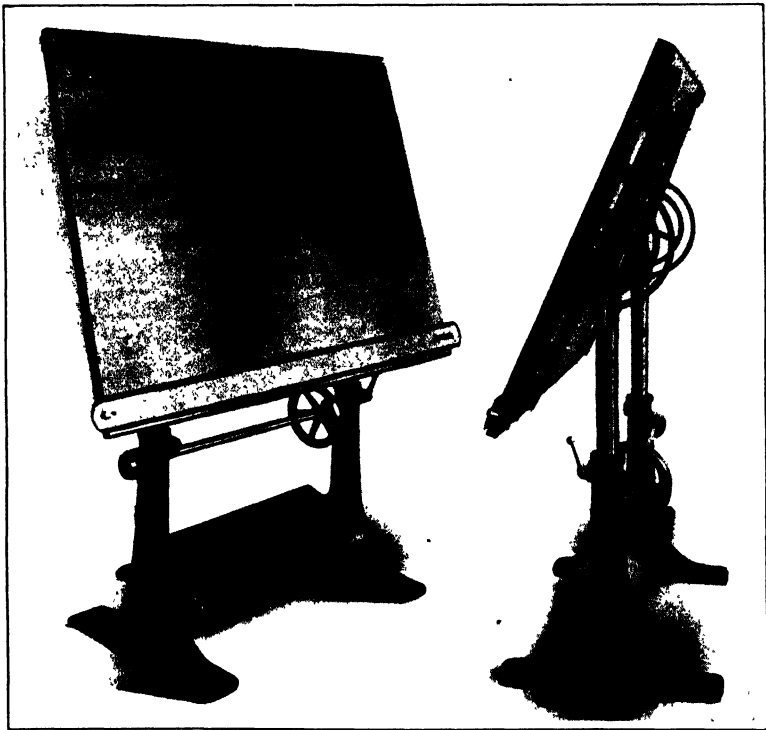

Fig. 30. Another Type of Adjustable Drawing Table

has both vertical and angular adjustments. The front and side views clearly show the construction. The board is firmly secured to cast brackets which are pivoted to the vertical supporting members. The table is rigidly held in an angular position by tightening the hand-lever shown in the view to the right. This lever binds against a segment of the support-

ing bracket and it is threaded to a long bolt, the head of which clamps the bracket on the opposite side. The table is adjusted vertically by the handwheel shown. This wheel is mounted on a cross-shaft having pinions at each end, which engage teeth cut on the supporting legs. The board is equipped with a parallel attachment.

Drawing Paper. — As most mechanical drawings are first drawn in pencil and then traced in ink upon transparent cloth or paper, the paper used for the pencil drawing need not be as expensive as the paper that would be required for making a finished drawing in ink. There are a great many kinds and qualities of drawing paper manufactured to suit the great variety of uses to which it is put, since drawings vary from pencil sketches to the shaded ink drawings used for illustrating purposes. In former years, drawing paper was mostly made in sheets of certain arbitrary sizes, those in most common use being as follows: Medium, 17 by 22 inches; Imperial, 22 by 30 inches; and Double Elephant, 27 by 40 inches. The quality marked "Whatman" is still used when an extra good quality is wanted. The thickness of this paper varies according to the dimensions of the sheet; that is, the larger the sheet, the thicker it is. Two different surfaces are furnished: smooth, or "hot pressed" (marked HP), and rough, or "cold pressed" (marked CP), the latter having a considerably roughened or "grain" surface. There are many other kinds and qualities of drawing paper of all grades, sizes, and prices, and of both foreign and domestic manufacture, which are used for mechanical drawing. Drawing paper in sheets is used to a much greater extent in schools and by artists and other free-hand draftsmen than by mechanical draftsmen. The reasons for this are that very large sizes of sheets are seldom required by the former classes of draftsmen, that paper in sheets is more conveniently stored in drawers than if it is in the form of rolls, and that it is more easily procured in small quantities.

There are a variety of colors, or rather tints or shades of drawing paper from clear white to buff, gray, terra cotta, and the natural manila tints. While the artist uses those tints

which best suit the character of the work, the mechanical draftsman is governed by questions of utility. Pure white paper is not usually as agreeable to the eyesight as paper having a slight cream or ecru tint. A slight tint shows the effect of dust less than pure white, and it is not so easily soiled. It is more difficult, however, to trace a penciled drawing made on buff or cream-colored paper than it is one made on white paper. On account of the variety of sizes of sheets needed by the mechanical draftsman, paper manufactured in rolls is usually preferred, as sheets of any desired dimensions may be readily cut from the roll.

American Standard Sizes for Drawings.—The recommended standard trimmed sheet sizes of drawing paper and cloth are shown by the table. The standard sizes shown by the

Size, Inches				Metric Size, mm.			
<i>A</i>	8½ × 11	<i>D</i>	22 × 34	<i>A</i> ₀	841 × 1189	<i>A</i> ₄	210 × 297
<i>B</i>	11 × 17	<i>E</i>	34 × 44	<i>A</i> ₁	594 × 841	.15	148 × 210
<i>C</i>	17 × 22			<i>A</i> ₂	420 × 594	.16	105 × 148
				<i>A</i> ₃	297 × 420		

left-hand section of the table, are based on the dimensions of the commercial letter head, 8½ × 11 inches, in general use in the United States. The use of the basic sheet size 8½ × 11 inches and its multiples permits filing of small tracings and folded blueprints in commercial standard letter files with or without correspondence. These sheet sizes also cut without unnecessary waste from the present 36 inch rolls of paper and cloth.

For drawings made in the metric system of units or for foreign correspondence it is recommended that the metric standard trimmed sheet sizes be used. (Right-hand section of table.) These sizes are based on the width to length ratio of 1 to $\sqrt{2}$.

In the case of paper sold in sheets the prices are fixed at so much per sheet, or per quire of 24 sheets. Occasionally the price is given per ream of 480 sheets. If sold in rolls of so many yards, the price is fixed by the yard; if sold by the weight, at so much per pound for whatever the roll may weigh,

as the rolls will vary somewhat from the standard weight. Continuous or roll drawing paper is made in almost as great a variety of qualities, thicknesses, and tints as that which comes in sheets. Usually, however, such drawing paper is either of pure manila and of the natural color, or of a mixture of manila and other materials, and slightly tinted, the tints running toward buff and terra cotta.

Manila Paper. — The surface of manila paper is made either very smooth and glossy or with a slight grain. As the smooth finish is made by running it between heated calender rolls it does not usually lie flat upon the drawing board, but has a tendency to buckle or rise in numerous places. A smooth surface manila paper is, therefore, not nearly as convenient for doing the pencil work of a drawing as that having a slight “grain” or roughness. There is a tendency of the pencil to slide over the surface without making a distinct line, unless the pressure applied to it is considerable, or unless the pencil is much softer than those which the draftsman is in the habit of using. Of course, the point of a soft pencil wears away much faster than a hard one and, therefore, requires more attention to keep it in proper condition. Another difficulty is that the smooth surface is liable either to stain or to become rough under the action of the erasing rubber. It is, however, a very strong paper, and its price is moderate. Manila drawing paper with a rough or “grain” surface is well adapted to either pen or pencil work, and works well under the erasing rubber. The slight tint of the surface is an advantage to the eyesight of the draftsman. It is generally purchased in rolls.

Eggshell Drawing Paper. — Eggshell drawing paper is one of the best papers made for drawings. It withstands a good deal of hard usage while being made and much rough usage afterward. While it is made in sheets of the usual sizes, it is more often obtained in continuous rolls. On account of the high price of this paper, these rolls usually contain only 10 yards each. The surface of this paper, as its name indicates, somewhat resembles the surface of an eggshell, except that

the small depressions forming the grain are deeper and quite pronounced. The surface is very hard and takes either pencil or ink readily, and will stand almost any amount of erasing.

Mounted Drawing Paper. — Mounted drawing paper is drawing paper strengthened by being mounted on cloth, or having a backing cloth pasted to it. This process is usually confined to the more expensive kinds of white and slightly tinted drawing papers, and generally to those in large sheets or rolls. Such paper is used for maps and plans that are intended to withstand much handling and hard usage. Mounted drawing paper is used only occasionally for mechanical drawings.

Bristol Board. — Bristol boards are a high quality of cardboard, made by pasting several sheets of high-grade linen paper together so as to form the thickness required. After pasting, they are subjected to a heavy pressure, and present a very smooth surface for ink work. The thickness of bristol boards is indicated by the number of sheets pasted together to form the "board." Hence, they are called 2-sheet, 3-sheet, 4-sheet and 5-sheet, the last being the thickest usually made. The 3-sheet bristol board is specified by the United States Patent Office as the proper material to use for patent drawings.

Cross-section Paper. — Thus far all the drawing papers mentioned have been those with absolutely blank surfaces. There is, however, a large class of drawing papers on which preliminary lines in two directions, at right angles to each other, are ruled as a valuable aid to the draftsman in laying out his work. These are known as cross-section papers. Strictly speaking, cross-section paper is that in which the horizontal and vertical ruling is spaced at the same distance apart, there being, for example, eight or ten lines to the inch. When this ruling is so made that the horizontal spaces of the ruling are fewer than the vertical, it is properly called profile paper. In this case the vertical ruling is 20, 25, or 30 to the inch. Cross-section paper is used for making sketches, diagrams, etc., and for free-hand work; the ruling is of great assistance in properly proportioning the parts. It is also largely

used in the plotting of graphic charts and similar work. It is nearly always white.

Profile paper is used by civil engineers for representing the profile or cross-section of grades, cuts, embankments, excavations and the like. This paper is made in sheets 16 by 20 and 17 by 22 inches, and also in continuous rolls. For the use of railway surveyors, the profile paper is made in continuous strips, folded between covers in book form; these books are called profile books.

Tracing Paper. — The principal feature of ordinary tracing paper (thin, transparent paper) is its cheapness. However, it is useful for temporary work or when there is to be very little handling of the tracing. So-called "onionskin" paper is much used for tracings. While not as transparent as ordinary tracing paper, it is much stronger.

Parchment paper may be used as a drawing paper. The entire work of the drawing, both pencil and pen work, may be done on it, and the drawing may then be used the same as an ordinary tracing for producing blueprints. By the use of this paper only one drawing is made, instead of a drawing and tracing as with the usual methods.

Tracing Cloth. — Tracing cloth is largely used for regular tracings that must be handled a great deal. It is made of finely woven and very smooth cloth coated with a preparation of Canada balsam to give it a fine surface for the use of the pen, and also to render it transparent. One side is smooth and glossy while the opposite side has a dull finish. This peculiarity is known as "dull back"; the tracing cloth can be purchased with a gloss surface on both sides if desired. It is possible to use it for a preliminary pencil drawing, to be afterward inked in by working upon the dull side, although this is not usually practiced except for simple work in which comparatively few lines are needed. Tracing cloth is nearly always sold in continuous rolls, 24 yards long and 30, 36, or 42 inches wide.

General Considerations in Selecting Drawing Paper. — In selecting a suitable paper for a certain work there are several

requirements which should be kept in mind, and which may be enumerated as follows: The paper should be of such a tint as to be agreeable to the eyes of the draftsman. It should be possible to stretch the paper readily so that it lies flat on the drawing-board. Where much pencil work is to be done, as in designing, the paper must stand the frequent use of the erasing rubber, and it must take pencil lines easily, even if a pencil as hard as 6H is used. If the drawing is to be finished in ink, the quality of the paper must be such as to take ink readily, without wrinkling where the ink lines are made. The thickness and texture of the paper should be uniform over the entire surface. A good drawing paper should be of such a surface as not to absorb liquids too readily, but not to repel them at all. If the surface is repellent, inks or colors are liable to rise in small blotches on parts of the ink line and leave an insufficient quantity of ink to make a good line at other points. While all these qualities will not be likely to be found in any one paper, a paper should be selected embodying as many of them as possible.

In selecting a proper medium for tracing, the draftsman must be guided by the conditions of the work. These conditions will ordinarily be as follows: For temporary drawings, and when but a few blueprints are to be made, ordinary tracing paper will be used; if the tracing is to be used for a large number of blueprints, or for permanent use as a record, it should be made on good tracing cloth. If a drawing as well as a tracing is wanted quickly, or if the drawing is to be of a comparatively temporary nature and considerable pencil work with the usual erasures is expected, parchment paper may be used.

Bruning BW Paper.— This paper is used in making positive prints directly from the original or without the use of a negative. This sensitized paper, after exposure in the usual manner, is developed by means of a developing solution of the proper strength. These positive prints, with black lines on a white background, are said to be easier to

read and check. The white background also facilitates the writing of notes or the making of changes.

Ozalid White Prints.—The Ozalid white prints, which have dark lines on a white background, are produced directly from the original tracing and by a dry development process. Dry ammonia vapors are used for developing the exposed prints, instead of a developing liquid or solution. Several advantages are claimed for this dry development. The prints are true to the scale of the original; cut sheets can be utilized readily, eliminating trimming waste; a finished print is available in two simple steps of exposure and dry development, and when the print emerges from the machine it is dry and ready for immediate use.

Transparent Paper, Cloth, and Foil.—Ozalid transparent materials (paper, cloth, and foils) provide transparent duplicates of originals from which subsequent prints can be made, thus eliminating redrawing. These subsequent prints are made in the same manner as the standard Ozalid prints. The Ozalid transparent paper, cloth and foils develop a sepia-colored line which has exceptional covering power; consequently, the Ozalid white prints made from the transparent material retain the details of the original. Additions or changes are made easily on Ozalid transparent duplicates in either pencil or ink. Such a revised or corrected transparent duplicate actually constitutes a new original. Lines on all Ozalid transparent duplicates are removed easily by a corrector fluid or mechanically by the "block-out" method.

Ozalid Light-Sensitized Foil.—A sensitized foil for duplicating tracings has been developed. Copies of tracings are made on this foil in the same manner as on ordinary Ozalid print paper. A foil print can be made of an original drawing having weak lines and a smudgy background. From the new foil print, paper prints can be made which will have strong lines and clear backgrounds.

The base material of the foil is cellulose acetate and is non-inflammable, strong, and permanent. A clear foil,

0.005 inch thick, is made with a glossy finish on both sides. Another foil, 0.0075 inch thick, has a mat finish on one side that will take pencil and ink lines. The image is embedded in the foil and is not affected by light or washing. The block-out method or "Ozolid corrector fluid" can be used to block out on the foil copy that portion of a design to be changed. The desired changes can then be made on the foil in pencil or ink. The transparency of the foil permits as many as six layers to be used in producing a composite print showing group details of all six foil copies.

Pencil Tracing Cloth.—This cloth is intended for pencil lines, and prints made from a pencil tracing are said to compare favorably with ink tracings. A commercial pencil drafting cloth is known as "Pencil-Tex." This material is similar in appearance to fine tracing cloth, the velvety surface having a remarkable affinity for pencil leads of all degrees of hardness. Even the hardest pencils will leave a sharp, uniform dense line. This intensification, together with a glass-like transparency, is said to make possible the production of blueprints with the sharp contrast of prints made from ink tracings.

Opaque Drafting Fabric.—This fabric is somewhat similar to ordinary tracing cloth but it is covered with an opaque surface. In making a drawing on this material, the draftsman works with a pointed steel tool instead of a pencil; this tool is used exactly as a pencil would be and scrapes away the opaque surface along the lines which make up the drawing. This exposes the transparent fabric to permit the passage of light. In making blueprints from such drawings, the method of procedure is exactly the same as where ordinary tracings are used, but as the lines are transparent and the remainder of the drawing opaque, the resulting blueprint has blue lines on a white background.

Thumb-tacks.—Thumb-tacks are used to fasten drawing paper and tracings to the drawing-board. The head, which is the shape of a round disk, is slightly crowned

on the top and has a very thin edge. This permits the T-square to slide over the head smoothly. Many thumb-tacks have steel points which are attached to brass or German silver heads. Four different sizes having heads varying from $\frac{5}{16}$ to $\frac{5}{8}$ inch in diameter are shown at *A*, Fig. 31. The $\frac{1}{2}$ -inch size is extensively used. The tack shown at *B* has a beveled edge. At *C* is shown an inexpensive tack which is stamped from one piece of steel, the point being bent down

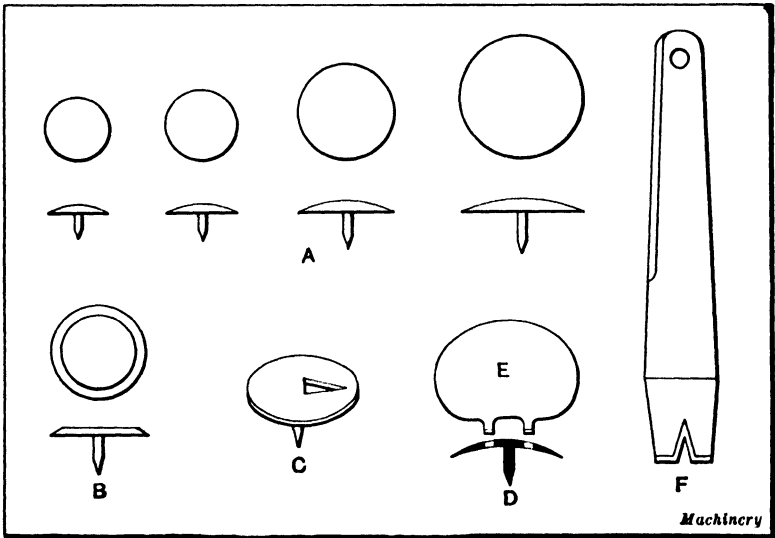

Fig. 31. Thumb-tacks for holding Paper or Tracing Cloth to Drawing-board

from the head of the tack. At *D* is illustrated what is known as the "center-pull thumb-tack." This steel tack is turned from solid metal. It has a thin head with a knife edge and the T-square straightedge rides over the head very easily. The special puller *E* which engages two holes in the head makes it easy to pull the tack out straight. At *F* is shown a common type of thumb-tack puller. The end used for pulling thumb-tacks has a beveled V-shaped groove which can be slid under the thumb-tack head.

Drawing Pencils. — Drawing pencils are usually made of hexagonal form to prevent their rolling off an inclined draw-

ing board. They are made in different degrees of hardness, the softer grades usually being indicated by the letter B following a number and the harder grades by the letter H following a number. The following is the complete list of the degrees of hardness made by some of the well-known manufacturers: 6B, 5B, 4B, 3B, 2B, B, HB, F, H, 2H, 3H, 4H, 5H, 6H, 7H, 9H. Some manufacturers, however, have a different system of designating the degree of hardness, but this is the method usually employed.

Many draftsmen use a 5H or 6H pencil on all shades and grades of drawing paper. The hardness of lead should be varied somewhat for different papers to make the drawing visible through the tracing cloth. In most drafting-rooms, the papers used have a coarse-grained surface and are either white, buff, or cream color. Experience has shown that on the white drawing paper a 5H pencil makes lines which may be seen readily through the tracing cloth, but on the buff color paper a 4H should be used, and on the deeper shades a 3H is desirable. Since a much greater pressure can be secured in making lines with a lead pencil than with a pencil compass, the lead in the compass should always be one degree softer than the pencil. If this method is followed, all drawings will have good black lines, which will lessen the strain on the eyes, especially in making tracings.

Sharpening Drawing Pencils. — In order to produce neat pencil drawings, it is necessary to keep the pencils properly sharpened. There are two methods of sharpening lead pencils for mechanical drawings: the round or conical point and the flat or chisel point. The rounded point shown at *A* and *B*, Fig. 32, is always used for lettering and dimensioning when a pencil is used. Some draftsmen use the round point for all ordinary drawing and employ the chisel point shown at *C* and *D*, only when very fine lines are required. The chisel point, being thinner, can be used to produce more lines without re-sharpening than the conical point can. In sharpening the pencil, the lead is given either a conical or chisel point by rubbing on sandpaper or a file.

Ink Used by Draftsmen. — A good India ink should be used for all mechanical drawings. It can be purchased in small bottles equipped with a quill filler attached to the cork. A good quality of ink will flow freely and dry quickly. Water-proof drawing ink is to be preferred in most cases. The bottle must be kept corked to prevent evaporation. If the ink becomes too thick and does not flow freely, it may be diluted with a few drops of water. Prepared drawing inks of various colors may be obtained, but they find limited use in

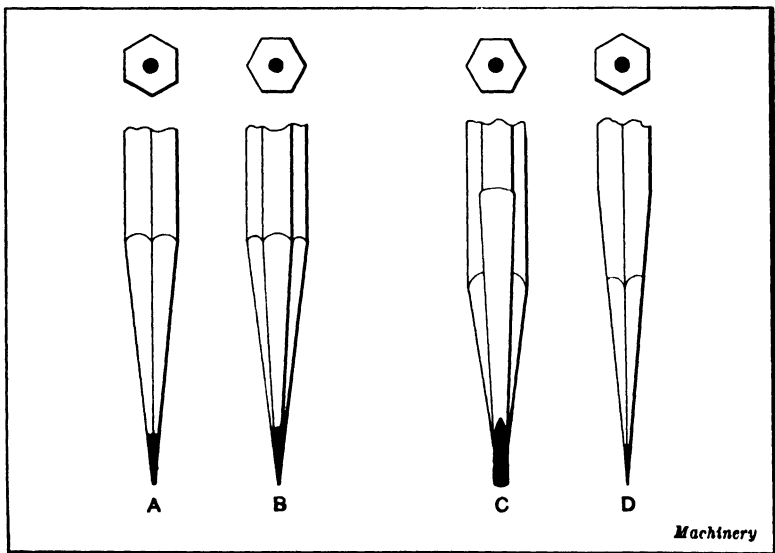

Fig. 32. Methods of sharpening Pencils

ordinary drafting-room work. Red ink is sometimes used in making center lines and dimension lines on tracings, but this is not the general practice and, if followed, the blueprinting must be carefully done in order to have the lines show distinctly.

Ink produced from India or Chinese sticks was employed by draftsmen previous to the introduction of prepared ink. The Chinese stick or the India ink is prepared by grinding with a small quantity of water.

Erasing Pencil and Ink Lines. — Draftsmen should have the proper equipment for making erasures on paper or trac-

ing cloth, as mistakes are unavoidable. The usual form of pencil eraser is made from soft pliable rubber. The rubber ink eraser is made from rubber which has very fine sand or pumice stone incorporated into it. When it is desired to restrict the erasure to a limited area, an erasing shield made from a thin plate of some material such as steel, brass, celluloid, or paper should be used. It has openings or holes cut in it of various shapes and sizes. When this shield is used, an opening of the required size and shape is placed over the portion to be erased, and the rubber eraser applied to the opening. A steel erasing knife is also used to erase ink lines from paper or tracing cloth. An oilstone should be used to sharpen the edges when they become dull. When using the erasing knife care should be taken to keep the blade perpendicular to the paper or tracing cloth and only a very light pressure should be exerted on the drawing. The action of the cutting edge should be confined to the ink alone and the surface of the paper or tracing cloth should be scratched as little as possible. The erasing knife is particularly useful in erasing heavy lines and, if it is used with care, good results may be obtained.

The usual practice in erasing heavy ink lines is to use the erasing knife until the line has nearly disappeared, then an ordinary rubber ink eraser and finally a soft rubber pencil eraser. After an ink erasure has been made, the surface of the paper or tracing cloth should be rubbed with a piece of soapstone. The soapstone resizes the surface and prevents the ink from penetrating the paper or cloth, thus causing blots when drawing ink lines over the erased surface. If heavy lines are required to be drawn over an erased surface it is usually a good plan to produce the required weight of line by drawing a series of very fine lines instead of one heavy line, allowing the ink to dry each time, before drawing the succeeding line.

CHAPTER IV

HOW DESIGNS ARE ORIGINATED, AND PROCEDURE IN MAKING DRAWINGS

THE work done in the drafting-room includes the origination and improvement of mechanical devices, and the making of drawings that will enable these various forms of mechanisms to be constructed. The work of origination may be, and often is, due to the combined efforts of several men, or it may be confined largely or entirely to one man. Frequently the basic idea or principle is thought out by a designer, chief draftsman, or sometimes by a shop foreman or superintendent. This idea or conception of a new device is, according to a common method of procedure, first represented by a sketch which may be simply a crude drawing made free-hand. Then the next step is to make an accurate drawing in order to obtain a better idea of the relation of different parts, and finally, if the design is approved, working drawings are made which are the ones needed in actually constructing the device. Those who originate new forms of mechanisms may consider their time too valuable for making drawings other than the preliminary sketches such as are used to show the draftsman what the general requirements are. The draftsman, however, who makes drawings that agree in regard to the original features with sketches furnished him, is often relied upon to do more or less original work, especially in developing and perfecting the various details of the design.

Preliminary Work in Designing a New Mechanism. — The work of developing the design of any mechanical device depends very largely upon the nature of the device and its purpose. Some forms of mechanical apparatus are simple as far as their operation is concerned, and little time or thought is expended in deciding how the parts are to be arranged, but

perhaps the proportioning of these parts to withstand safely the stresses to which they will be subjected in actual service, involves careful calculations. A hoisting mechanism, consisting of a train of gears and with shafts subjected to bending and torsional stresses, illustrates this general type of apparatus.

Then there is another general group of mechanical devices which differs from the class just referred to, in that few, if any, calculations for stress are required, because the parts are not subjected to loads or stresses worth considering; nevertheless, the origination of the design may be difficult. Take, for example, the case of a machine which must be complex in order to perform mechanically some difficult operation. The adding machine, for instance, is a very complicated mechanism which was exceedingly difficult to design because of the intricate mechanical actions required. Very little power, however, is needed for operating a machine of this kind, and the stresses on the different parts are small, so that the big problems confronting the designer were those pertaining to mechanical action.

In the design of apparatus for generating power, another class of problems is encountered. For instance, in the design of steam engines, an essential part of the work is to develop an engine which will be economical in operation, or one using the least possible amount of steam per horsepower. If pumping machinery, air compressors, etc., are considered, it is apparent that physical laws which affect the operation of such equipment must play an important part in the development of the designs.

Another branch of designing work which is quite different from those mentioned has to do with the design of various kinds of tools used in machine building plants. Such tools include the general group known as machine tools and also the smaller equipment used in conjunction with them. For instance, various classes of machine tools, such as turret lathes, screw machines, drilling, milling, and grinding machines, etc., require special cutting tools and work-supporting devices. The designer of such tools must necessarily understand manu-

facturing methods, and he is often an expert on machine shop practice; in fact, draftsmen or designers specializing in this work are frequently "graduates" of the shop.

Now it is quite evident that a designer cannot be an expert in all branches of work, because the field is so large and advances so rapidly that no one mind can grasp all of the essential facts. The natural result has been the development of specialists in machine design just as there are specialists in surgery. For instance, there are designers who work exclusively on some general class of machinery, such as special automatic machinery; power plant equipment; jigs, fixtures, and gages; machine tools; and other general groups which might be mentioned. The draftsman who is equally competent in any plant regardless of the nature of the work is one who does not originate, but merely copies on paper or tracing cloth what the specialist has planned for him.

To be able to draw and understand drawings is like being able to read a language; it is merely a beginning for the man who is primarily interested in machine design. Many students of mechanical drawing do not understand what is involved when they begin to study this subject, and that is why an attempt has been made at the beginning of this book to show clearly the relation between the mere drawing of lines on paper and the much greater and more valuable work of actually creating new or improved forms of mechanical apparatus. The making of the drawing, however, is an essential step, but drawing alone should be regarded as merely one part of the draftsman's stock in trade. Reference has already been made to some of the other subjects that he should understand.

What Mechanical Drawings are Based on.—When a mechanical drawing is to be made, the draftsman usually has a certain amount of information and data or figures given him as a basis or guide in making the drawing. This information, as before mentioned, may be in the form of a sketch on which important dimensions are marked, especially if the design is different from any that has preceded it. If some

existing design is to be improved, the draftsman may work from drawings of it, making whatever changes have been suggested or those that seem desirable. In some cases, a drawing is required of a machine or tool either because the original drawings are not available, or because the device has been constructed without proper drawings. A common method of procedure in this case is first to make one or more sketches of the device and then use these sketches (which should contain all important dimensions) when making an accurate drawing.

A great many drawings are made by experienced draftsmen without any preliminary sketches or any information other than an order from the chief draftsman or some other official for the drawing of a device adapted for a certain purpose. For instance, in the design of drill jigs, milling fixtures, etc., a competent draftsman may simply know what kind of a piece is to be held in the jig or fixture and the nature of the machining operation. He then proceeds to work out a design which conforms to approved practice in the design of such equipment. A draftsman capable of such work is a designer in this particular field, although he may not be competent to do work requiring a general knowledge of mechanical engineering subjects.

Uses of Different Classes of Drawings. — The draftsman should understand clearly the uses of different classes of drawings and their relation to one another, because there are several distinct types of drawings which serve different purposes. Most of the mechanical devices shown on drawings are composed of different parts which are assembled to form the complete mechanism. Now if the number of parts is relatively small, it is evident that the shape and size of each part might be clearly shown on a single drawing consisting possibly of two or three views; but when a mechanism is more complicated and is formed of many different shafts, levers, gears, etc., if an attempt were made to show all of these on one drawing, the result would be a mass of lines which, in some instances, would be so closely spaced and interwoven that the drawing could not be used as a guide when constructing the mechanism.

It is frequently necessary, therefore, to make separate drawings which show the details more clearly than a complete drawing of the entire machine. There are then general or assembly drawings, and detail drawings.

Classes of Assembly Drawings. — An assembly drawing may show a machine in outline merely to illustrate its general arrangement (the side elevation, Fig. 1, illustrates this type

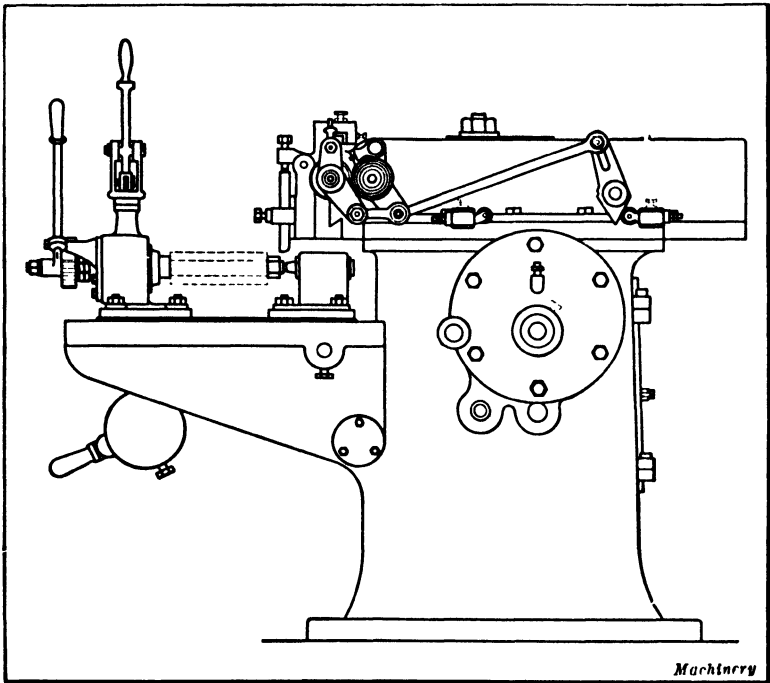

Fig. 1. Side Elevation of a Nut-planing Machine — An Example of an Outline Drawing

of drawing), or the assembly drawing of a comparatively simple mechanism may contain all the necessary dimensions, in which case it is a “working drawing,” the latter term being applicable to any drawing which contains the necessary dimensions and instructions for constructing whatever the drawing represents.

When the design of a new machine is being developed, an assembly drawing is commonly made first, because it shows

the relation between different parts and assists the designer in working out his plans. This assembly drawing, which is a preliminary design, is frequently made full size unless the mechanism is too large to permit of doing this. There is often an advantage in having this first drawing full size, especially when it is important for the designer to be able to see the various details clearly, and particularly when there are numerous parts which are likely to interfere when the mechanism is in operation, owing to small clearance spaces. This preliminary assembly drawing is not always confined to one machine, but it may show several different kinds of apparatus forming a complete plant and possibly the necessary piping, etc.

After the assembly drawing is finished, the drawings of details are made, and then an assembly drawing may be required in the erecting shop to show the machinist who assembles various parts just how they are arranged. The preliminary design, which is drawn in pencil, may be traced and blueprints made for use in the shop, but frequently another assembly drawing is made to a smaller scale, so that it may be placed on a sheet of standard size. This would be done if the preliminary design were too large for actual use in the shop. If this second assembly drawing is made by referring to the dimensions on the various detail drawings, errors in the dimensions of the details may be discovered since the different units forming the complete drawing will not go together properly. An assembly drawing for use in the erecting shop usually contains the principal dimensions, as, for example, the center-to-center distance between important shafts and whatever general dimensions might be needed in properly assembling the different units forming the complete machine. When making a drawing of this kind, the draftsman should not necessarily show by dotted lines all concealed parts, because frequently they would be useless and simply complicate the drawing and make it confusing. In some cases, it is necessary to show by dotted lines the location of certain important details for the guidance of men in the assembling department.

These details might be within the bed of the machine or in some other concealed location, and perhaps the use of dotted lines would enable their position to be shown very clearly, thus avoiding a separate view of the entire machine.

When the assembly drawing is merely an outline of the machine, it may be intended as the catalogue illustration or to show the purchaser of the machine how it should be set up. Some drawings of this kind are used to show the location of foundation bolts, so that the foundation can be built before the machine arrives. Other outline drawings are used to show the relation between the machine and the overhead works, as in the case of a belt-driven grinder. Another purpose of an outline assembly drawing is to enable the user of a machine to identify different parts. For instance, if the separate parts or units of the machine are numbered on the outline drawing, these numbers can be used when ordering new parts instead of attempting to name or describe them. These numbered drawings are sometimes found in manufacturers' catalogues.

When Detail Drawings are Required. — Whenever a mechanical device is formed of so many parts that a drawing showing all of them assembled would be confusing, separate working drawings of different important units or details are made. A detail working drawing may show only one casting, forging, or other piece, or the detail drawing may represent a certain group of parts which form some unit in the complete machine. For instance, a separate drawing might be made of a gear-box for changing the speed of a machine tool. By making a separate drawing of a unit of this kind, different views of this particular unit can be shown and to a larger scale than would be possible on a drawing which showed the complete machine. When the different views on the drawing of the gear-box are provided with all necessary dimensions, they show the men in the shop just how that particular gear-box is to be constructed. This is an example of a detail working drawing. Frequently several small details are shown on one sheet, even though these parts may not belong together

when assembled, but a separate sheet for each independent detail or group of parts forming the independent unit is desirable.

Sizes of Drawings. — Mechanical drawings may be made to full or “life size” or they may be drawn to a reduced scale. While it is necessary to make drawings large enough so that all of the details may be seen easily, it would obviously be impracticable to draw all kinds of machinery full size because, even in the case of machines of moderate size, very large and unwieldy drawings would be the result. These large drawings are not only inconvenient to handle in the shop, but it is an awkward procedure to make them, merely because of their size and the difficulty of reaching to various parts of large drawings across the drawing-board.

It is customary in different drafting-rooms to adopt certain standard sizes for sheets of drawing paper or tracings, and then select a suitable sheet size for each drawing. The present American Standard consists of the basic sheet size $8\frac{1}{2}$ by 11 and its multiples. Many manufacturers have also used the following sizes: 24 by 36 inches; 18 by 24 inches; 12 by 18 inches; 9 by 12 inches.

Sheets of these sizes have been adopted because they can be cut from commercial rolls of drawing paper, tracing cloth, and blueprint paper with little waste. It will be noted that when the 24- by 36-inch sheet is cut in half, it forms two 18- by 24-inch sheets, and the latter forms two 12- by 18-inch sheets. The smallest size given is sometimes called a “sketching sheet,” and it is made by cutting a 12- by 18-inch sheet in half. The larger sheets are intended for the assembly drawings or for detail drawings of complicated parts which must be drawn to a fairly large scale in order to show all of the small details. Many of the smaller details may be drawn full size, but the larger details and the assembly drawings are almost invariably drawn to a reduced scale. For instance, a large detail drawing may be one half or one fourth the actual size of the detail represented, and it may be necessary to reduce the assembly drawing to one eighth, one twelfth, or even one sixteenth of the actual size.

At one of the large automobile plants, five different sizes of sheets are used. The first is the standard letter size, $8\frac{1}{2} \times 11$ inches. All other sizes are developed from the first size; that is, all are multiples of $8\frac{1}{2}$ by 11 inches, or of one of those dimensions. No. 1 sheet is always made with a wide blank margin at the left on the short dimension, and a narrower uniform blank margin on the other three sides. The drawing or sketch is placed on the paper to read lengthwise of the sheet. Sheet No. 2 is 11 by 17 inches, with a wide blank margin at the left on the short dimension, and a narrower blank margin on the other three sides. The drawing is made to read lengthwise of the sheet. Sheet No. 3 is 17 by 22 inches, sheet No. 4, 22 by 34 inches, and sheet No. 5, 34 by 44 inches, with the same arrangement of margins.

Another plan is to use only sheet No. 2, which is 11 by 17 inches, drawing large objects to a reduced scale on this size sheet, with a statement of the scale used on the sheet margin, so that the drawing will be readily understood. This method would do away with the necessity of having different sized sheets, and all of the books for shop use would be made up with one size of sheet. In making drawings of such parts as crankcases, cylinders, etc., they would be drawn to a reduced scale with only the machining dimensions placed on the sheet. Pattern drawings would be made full-size, and would be kept in the drafting-room for factory reference. One or two large drawings might also be placed in the tool-room or at some other convenient point, for reference after a job has been started. All of the drawings in regular use, however, would be 11 by 17 inches.

How to Use a Draftsman's Scale. — When drawings are made full-size, a scale is used which is graduated in inches and subdivisions of an inch, in the usual manner. This scale is also used for half-size drawings or those drawn to a scale of 6 inches = 1 foot. The half-inch divisions on the scale are then considered the same as inches, and the sixteenth divisions correspond to eighths of an inch on the half-size drawing. If a half-size drawing is too large to go on a standard sheet

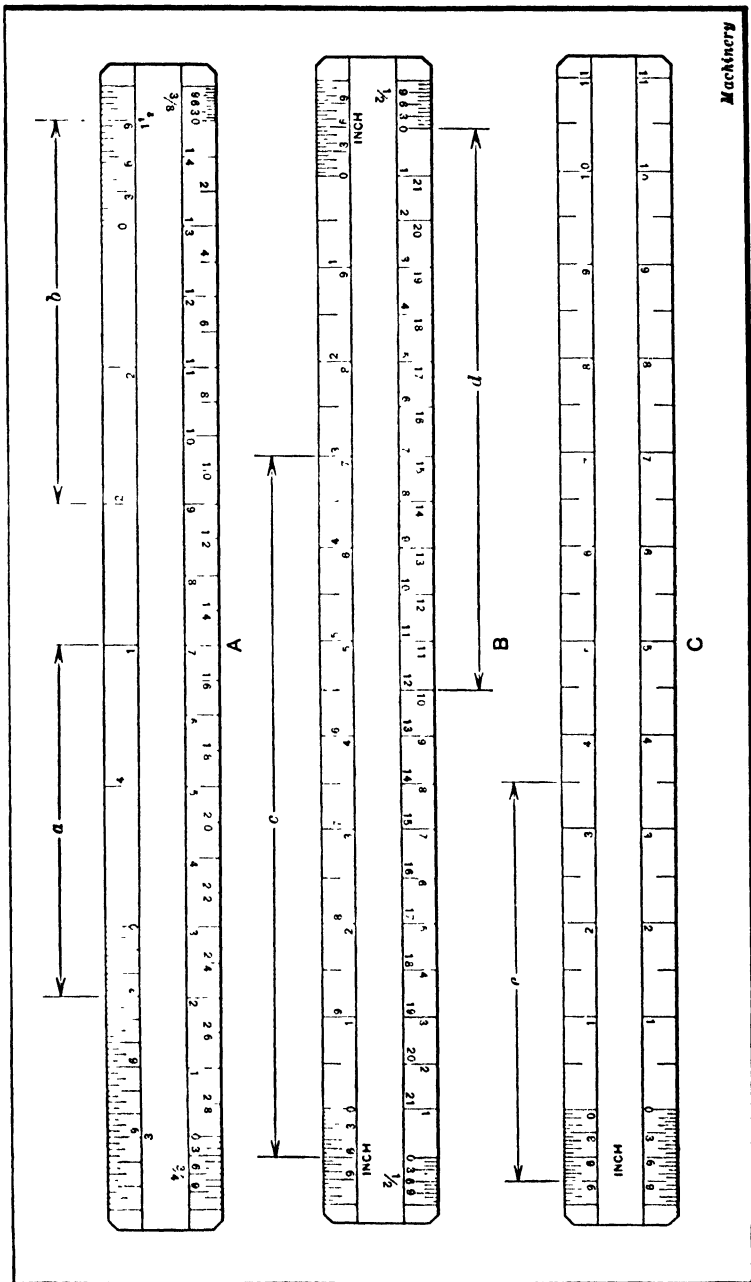

Fig. 2. Draftsman's Scales with Different Sets of Graduations, including Scales of $\frac{3}{8}$ Inch, $\frac{1}{2}$ Inch, $\frac{3}{4}$ Inch, 1 Inch, $1\frac{1}{2}$ Inches, and 3 Inches per Foot

and a still greater reduction of size is required, then a scale having special graduations is used. The reduced scales generally used on mechanical drawings are as follows:

Scale of 6 inches = 1 foot ($\frac{1}{2}$ size)

Scale of 3 inches = 1 foot ($\frac{1}{4}$ size)

Scale of $1\frac{1}{2}$ inch = 1 foot ($\frac{1}{8}$ size)

Scale of 1 inch = 1 foot ($\frac{1}{16}$ size)

Scale of $\frac{3}{4}$ inch = 1 foot ($\frac{1}{16}$ size)

A draftsman's scale which has four sets of graduations, representing $\frac{3}{8}$, $\frac{3}{4}$, $1\frac{1}{2}$, and 3 inches to the foot, is illustrated at *A*, Fig. 2. The graduations representing $1\frac{1}{2}$ and 3 inches to the foot are on one edge and those for $\frac{3}{8}$ and $\frac{3}{4}$ inch to the foot, on the other edge. The method of reading and using one of these scales will be explained considering first the scale of 3 inches to the foot. This scale is on the upper edge at the left, as seen in this particular illustration. A length of 3 inches along this edge is divided into twelve equal parts representing inches and each of these inch divisions is further divided into eighths. This 3-inch section of the scale is considered the same as though it were 1 foot long, since it represents a length of 1 foot on the reduced scale of the drawing. It will be noted that the zero mark is at the right-hand end of the scale instead of being at the left, and that the numbers 3, 6, and 9, representing inches, read from the zero mark to the left. The divisions to the right of the zero mark, however, which represent feet, read from left to right, the readings in each case being away from the zero mark. With this arrangement, the number of feet and inches can be read directly. The arrow *a* is equivalent to a measurement of 1 foot 3 inches, and illustrates how the scale is read. Incidentally a scale divided in this way is known as an "open-divided scale" to distinguish it from the "full-divided" or "chain" scales used by civil engineers, which have equal divisions and subdivisions extending along the whole length of the scale, so that only one set of graduations can be placed along one edge.

The scale of $1\frac{1}{2}$ inch to the foot starts at the opposite end of the same edge, and the numbers representing feet are placed

between those for the 3-inch or $\frac{1}{4}$ -size scale. The arrow *b* is equivalent to a measurement of 2 feet 9 inches, as will be seen by examining the scale graduations. When two sets of divisions or two different scales are placed on one edge as in this case, one must be double the other. For instance, $1\frac{1}{2}$ inches and 3 inches to the foot may be placed together and $\frac{3}{8}$ and $\frac{3}{4}$ inch per foot are on opposite edge of the scale illustrated at *A*, Fig. 2. The meaning of the different numbers opposite the graduations on the lower edge of the scale will

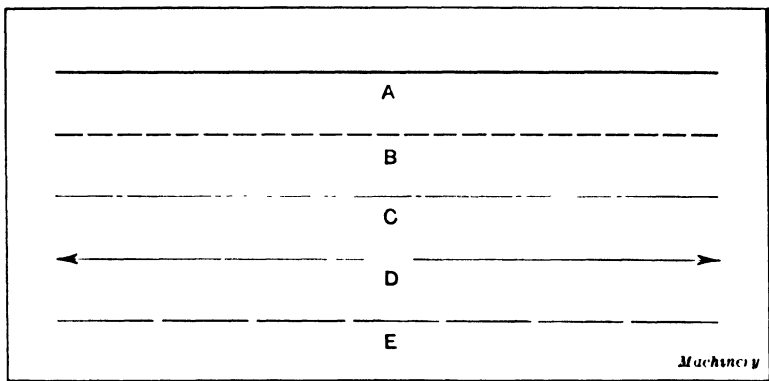

Fig. 3. Different Kinds of Lines used on Drawings

now be apparent, since the arrangement is similar to that described.

The scale illustrated at *B* has only one set of graduations on each edge, the scale on one side being 1 inch to the foot and on the other, $\frac{1}{2}$ inch to the foot. The arrow *c* is equivalent to a reading of 7 feet 6 inches on the inch scale and the arrow *d*, a reading of 12 feet on the half-inch scale. Still another type of scale is shown at *C*. Both edges of this scale are graduated to 1 inch to the foot. The advantage of using a scale of this kind is that it is not necessary to turn it around in order to bring the right scale into position, as would often be the case with the scale shown at *A*, which has four sets of divisions.

Different Kinds of Lines. — Mechanical drawings are composed of lines which vary both in form and width, some being

full or unbroken, while others are dotted or have some other form. If all the lines were alike, there would not be sufficient contrast between different parts represented by the drawing, and it might be difficult to understand fully the arrangement of a mechanism. Since clearness is vital in mechanical drawings, several different kinds of lines are used to assist the draftsman to make a drawing which can be more easily read or understood. Unfortunately, there is no universal standard governing the kinds of lines to use on mechanical drawings. While the visible outline of an object is always represented by full or unbroken lines and concealed parts by dotted lines, practice varies in regard to the dimension lines and some of the others.

Lines in Common Use. — The lines illustrated in Fig. 3 are in common use and conform with approved drafting practice. The width of the full line *A* for representing all visible details varies somewhat according to the size and purpose of the drawing. Such lines on a tracing might be $\frac{1}{32}$ inch wide, but perhaps not more than half this width if the ink lines were drawn directly on the paper, as is sometimes done. The dotted line *B*, which is used to represent concealed parts of surfaces, is usually formed of a series of short dashes about $\frac{1}{8}$ inch long, separated by short spaces, as shown in the illustration. When drawing with these dotted or broken lines, the spacing is governed entirely by the eye or by judgment, no attempt being made to make the dashes and intervening spaces conform to given lengths.

A center line is shown at *C*. This is another form of line which may be considered standard, as it is used by practically all mechanical draftsmen. The dimension line *D* is used to show how far and from what points a given dimension extends. This is a full line, but much lighter than the visible outline *A*. A space should always be left approximately in the center of the dimension line, to receive the figure representing the dimension. The arrow-heads at each end of the dimension line should preferably be made about as shown in the illustration, or with the lines forming the arrow-head placed rather

close to the dimension line. Some draftsmen make arrow-heads which flare out considerably and present a very unsightly appearance. While this is a minor point, if a drawing contains numerous dimensions and the arrow-heads are poorly made, the general appearance of the drawing will be greatly impaired.

The extension or reference line *E*, Fig. 3, is formed of rather long dashes and is used to mark the limits of a dimension. Unbroken light extension lines are also commonly employed. An extension line is placed at each end of the dimension line in order to show exactly where on the drawing the dimension applies; that is the extension lines are placed directly opposite the surfaces between which the dimension is given and the dimension line is drawn between them. The arrow-heads of the dimension line come into contact with the extension lines, thus showing clearly where the dimension applies. A small space should be left between the extension lines and the lines of the drawing proper. Short extension lines are simply one continuous line, and in some drafting-rooms all extension lines are continuous and the same as the dimension lines in width.

These extension or reference lines are also called "witness" lines in some drafting-rooms. They are not always used in conjunction with dimension lines, as this is not necessary, because the dimension lines frequently extend directly between center lines or the lines of the drawing itself. Some draftsmen use light unbroken extension lines and a form similar to that shown at *E* for the dimension lines. The object of using broken lines for the dimensions is to secure a greater contrast between these lines and the lines of the drawing proper. It is more convenient, however, to draw the unbroken dimension lines, and when they are made lighter than the outlines of the drawing, there is no difficulty due to lack of contrast. Still another variation in practice is represented by the use of dimension lines similar to the form shown at *E*, except that the dashes are separated by double dots. It would be desirable if differences in practice did not exist and the American Standard were adopted generally; as this

is not the case, the draftsman must be governed by standards of the plant or drafting-room where he is employed. The methods of using the different lines referred to are shown in illustrations found in various parts of the book.

Shade Lines on Drawings. — The working drawings used in machine building plants are almost invariably unshaded, but some other drawings have shade lines in order to make the object appear in relief or stand out from the paper. The illustrations in technical periodicals are often shaded, the idea being, in many cases, to show the form of the object as clearly as possible in a single view. All Patent Office drawings are shaded and sometimes shading is applied to assembly drawings of machines, particularly when they are merely intended for purposes of illustration. As draftsmen may be required to make these shaded drawings, the methods of shading will be explained.

One method of shading is simply by using light and heavy lines to represent the outline of the object. In order to secure a more pronounced shading effect, closely spaced parallel lines are sometimes used to make curved surfaces appear curved, as on a wood engraving. The first method is illustrated by the diagrams in Fig. 4. As will be seen by referring to this illustration, heavy shade lines usually represent the bottom and right-hand edges, it being assumed that the light strikes the paper from the upper left-hand corner at an angle of 45 degrees. It is easy to determine which surface is on the shaded side by placing a 45-degree triangle upon the T-square and assuming the hypotenuse to be the ray of light.

When shade lines are used, each view is shaded independently of the others, but the lower and right-hand sides are shaded in all the views. The shade line should preferably be drawn outside the surface that it bounds. Dotted lines are never shaded, neither is a line common to two surfaces when both surfaces are visible. By referring to Fig. 4, it will be noted that shading for a hole is on the upper left-hand side. A boss projecting above the surface would be shaded on the lower right-hand side, and then it would not be mistaken for

a hole. At *A* is a square block, hollow in the center. The outer shade lines show that the block is raised above the surface of the paper, and the location of the inner lines shows that the center of the block is hollow. At *B* is shown how the block would be shaded if at an angle of 45 degrees. Since the projection of a ray of light is supposed to be at 45 degrees,

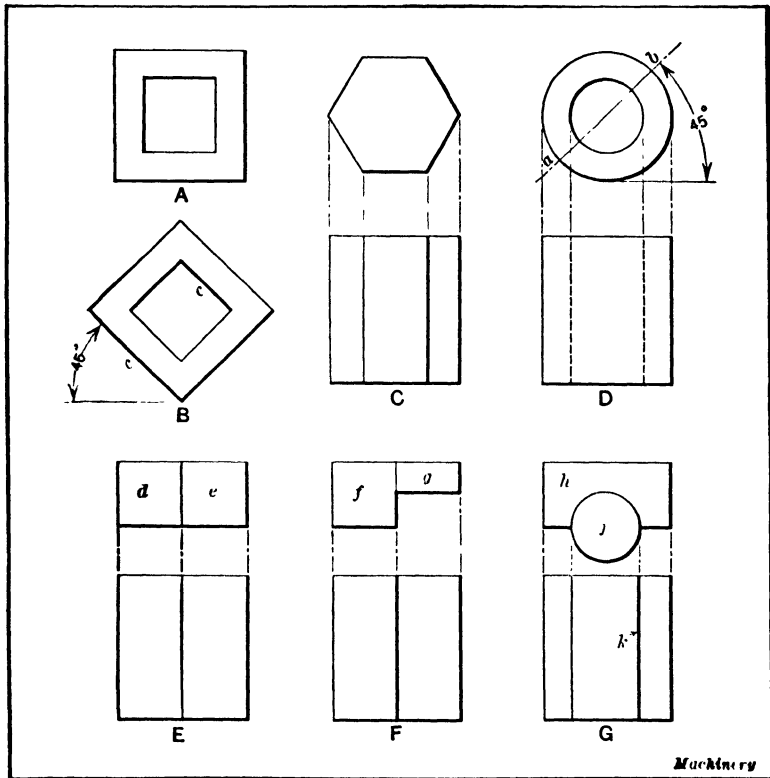

Fig. 4. Diagrams illustrating the Use of Shade Lines

there is no logical reason why the lines parallel to *cc* should not be shaded instead of *cc*; but the figure looks well as drawn. At *C* is the shading for a hexagonal prism, and at *D*, for a hollow cylinder. The shading on the top view of *D* starts at the 45-degree line *ab*, gradually increases, and then diminishes to nothing when it again reaches the line. At *E* are

two blocks *d* and *e* of the same size. No shade line would be drawn between them; but at *F*, where blocks at *f* and *g* are of different thicknesses, the shade line would be necessary. At *G* the block *h* is recessed for the cylinder *j*. It may be shaded as shown, although some draftsmen might prefer to leave off the shade line *k* in the lower view.

The short section of pipe shown in Fig. 5 has been shaded by means of closely spaced parallel lines, which gradually fade out, thus making the pipe and fitting appear cylindrical. This method of shading is often seen on Patent Office drawings.

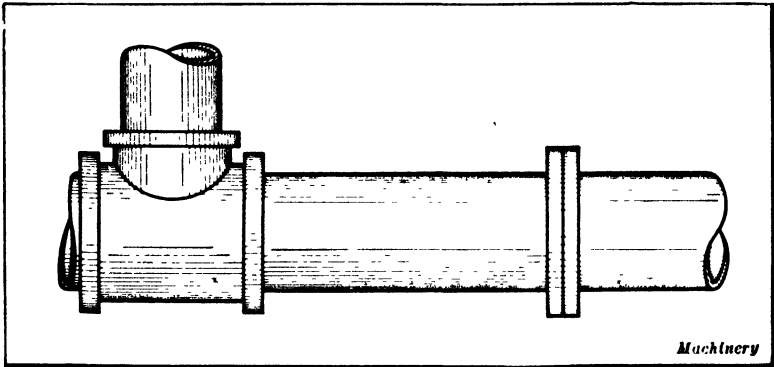

Fig. 5. Another Method of Shading, intended to give the Pipe and Fitting a Cylindrical Appearance

Making the Pencil Drawing. — The making of the pencil drawing, which is usually traced afterward on transparent cloth, is a very important part of the draftsman's work, because it is an actual representation of the design and must be drawn quite accurately or in the proper proportions. The tracing, which is made later, is simply a copy of the pencil drawing and making the tracing requires much less experience and knowledge than making the pencil drawing. While this pencil drawing should be fairly accurate, no attempt is made to have lines terminate exactly at intersecting points merely to secure neatness of appearance. In fact, pencil drawings often have quite a "sketchy" appearance, even though the various lines are located accurately.

The first question to be decided is the scale or size of the drawing. Usually the size of the sheet must conform to one of the standards adopted by the plant for which the drawing is to be made; hence, the scale of the drawing must be selected accordingly. If a half-size drawing is a little too large, a scale of 3 inches to the foot would be used instead, and if the latter were still too large, the drawing would usually be made to $1\frac{1}{2}$ inch per foot. In order to locate the different views to the best advantage, it is frequently advisable to make a very light free-hand outline sketch which conforms approximately to the amount of space each view will require. The work is then started by drawing the most important lines of the principal view or the view which will be of the greatest assistance in locating lines on the other views. The principal view may be defined as the one which represents the characteristic shape of the part to be drawn. The center lines are drawn first, because it is the general practice to lay off other important lines from the center lines, which may be considered as the foundation or framework of the drawing. This drawing of the center lines first applies to any symmetrical part. It is essential to make the pencil lines heavy enough so that they can be seen easily through the tracing cloth. The pencil drawings should not be made too neatly as this is a waste of time. There is no reason why the draftsman should take pains with the lettering, cross-sectioning, and the general appearance of a pencil drawing. The cross-section lines may be drawn free-hand, the neat finishing touches being left to the tracer.

Making Tracings. — When a tracing of a pencil drawing is to be made, a sheet of tracing cloth, which corresponds approximately in width and length to the standard size sheet, is placed over the pencil drawing and is held in position by thumb-tacks. The tracing cloth is glazed or smooth on one side and dull on the other. The tracing may be made on either side, but it is the general practice to use the unglazed side, because it takes ink more readily than the smooth glossy side. Moreover, pencil lines may be drawn more readily on

the dull side in case this is necessary. When a fine neat tracing is desired, the glazed side should preferably be used, as the lines are somewhat sharper when the ink is applied to a smooth surface. The glazed side also collects less dust and ink lines may be more easily erased from it.

The cloth should be stretched evenly over the surface of the pencil drawing and the surface of the cloth should be rubbed with some pulverized chalk, soapstone, or one of the special preparations used for this purpose, as this causes ink to flow more readily upon the surface of the cloth. After the chalk or other substance has been rubbed in lightly with a dry rag, the tracing cloth is wiped clean and then the ink lines are drawn.

Small tracings are held by a thumb-tack in each corner, but large tracings should preferably be held by eight tacks. If the following procedure is adopted, the cloth may easily and quickly be placed on the drawing-board without wrinkling: Put the first tack in the middle of the top margin of the cloth. Then smooth the cloth with the palm of the hand downward to the middle of its bottom margin, and fasten it there with a tack. This makes the cloth taut vertically through the middle. Now, smooth out from the center to the middle of one of the side margins, fasten with a tack at this point, and repeat for the other side. The cloth is now tacked at the middle of each of its edges. Finally, smooth out the cloth from the center to each corner and tack there. As the cloth is always smoothed from the center outward, no wrinkle or fullness is left.

Order in which Ink Lines Should be Drawn. — The ink lines on a tracing should not be drawn in haphazard fashion, because by proceeding in an orderly manner the tracing can be made more rapidly and easily. As a general rule, the center lines are drawn first, and then the circles and arcs such as are used to represent the fillets in corners, etc. The reason for drawing the circles and arcs before the straight lines is that ordinarily it is easier to join straight lines to the curved lines neatly than to follow the reverse order. The horizontal

straight lines are next drawn, beginning at the top of the drawing and inking in the various lines as the T-square is moved toward the bottom of the drawing. In this way, the T-square is prevented from sliding over the lines before the ink has had time to dry. The next step is to draw the vertical lines, which is generally done by guiding the ruling pen with a triangle held against the T-square. When drawing these vertical lines, the order should be from the left side of the drawing to the right. The dimension and extension lines are next drawn, and then the section lines, provided any part of the drawing is shown in section. As the dimensioning of drawings and the use of sections are very important features of drafting practice, these subjects will be dealt with separately in a following chapter.

Tracing cloth is affected considerably by atmospheric changes, and whenever possible, the entire drawing should be finished on the same day on which it is started. If this cannot be done, it is advisable to finish one of the views on the tracing instead of partially finishing all the views.

The ink lines which form the drawing or tracing proper may all be of uniform width or they may vary to secure a shaded effect, as explained previously in the paragraph headed "Shade Lines on Drawings." Whether shading is done or not, all lines should be heavy enough to reproduce clearly on the blueprint. Perhaps the best way for the beginner to obtain an idea of line width is to examine existing tracings and compare them with their blueprints. After the different views on the tracing have been finished, any explanatory notes that may be required are added and also such features as the border line and title. When pencil drawings are made on thin paper, which is a rapid method sometimes employed, care should be taken to use a soft pencil and make heavy clean-cut lines that will reproduce well on the blueprint.

Using Bond Paper instead of Tracing Cloth. — Thin bond paper is in many respects better than tracing cloth for drawings to be blueprinted. It permits the making of a neat looking drawing, pencil drawings can easily be made on it, a heavy

pencil drawing will blueprint nicely from it, and it is cheaper than cloth. Besides, tracing cloth does not lie in drawers as well as bond paper. When tracings are folded and creased across the lines of the drawing this shows on the blueprint. There is no trouble on this score with bond paper, and if for no other reason than this many have decided in its favor. Drawings can be inked more accurately by inking the original pencil drawing than by tracing, and it can be done more rapidly, which is another advantage for bond paper.

In many drafting-rooms, with the exception of drawings that must be repeatedly and frequently blueprinted, they make no tracings. Such as they make are made largely for the reason that they blueprint more rapidly. Another reason for tracing is that, if the original drawing was used to blueprint from too often, it would soon become worn out and unfit to make another copy from without much labor. For standard erecting plans, etc., it is preferable to make tracings on cloth and keep the original carefully, as in the course of years it is likely to need alterations.

From smooth and semi-transparent drawing paper one can get a first-class blueprint in about two and one-fourth times the number of minutes required for tracing on cloth. The drawing is laid out in pencil, then the useless lines are erased with a piece of "artgum," which leaves the surface in good condition for inking. When the drawing is inked it is done; there is no tracing to be made. When making a drawing upon which a great deal of time is to be spent such as the design of a new machine, the paper is dampened and the edges are glued to the drawing-board. When dry it presents a surface which is smooth and which is not affected by any atmospheric changes and moisture which buckle and wrinkle any drawing paper under ordinary conditions.

Making Changes on Bond Paper Drawings. — Changes on bond paper drawings can be made much more easily than in the case of tracing cloth. The pieces or parts to be changed are cut out and a new piece is pasted in and redrawn. The draftsmen soon become so expert at this that a piece $1\frac{1}{2}$ inches

square can be cut out and another pasted in, in less time than it could be erased from tracing cloth. The piece to be changed is first squared off and cut out with a knife. This is then laid over another piece which is made $\frac{3}{8}$ or $\frac{1}{8}$ inch larger than the piece that has been cut out and the edges of this new piece are glued all around with ordinary library paste; it is then pasted on the reverse side of the drawing. The blueprint will be rather light around the edges of the patch, but this only indicates to the shop man where the changes have been made, and is rather an advantage than otherwise.

Another method of making changes on bond paper drawings is as follows: When drawings have to be patched, a sheet of clean paper is laid under the part to be changed, which is removed by cutting with a sharp knife. The knife passes through both sheets of paper, thus providing a patch to fill the opening at the same time. To fasten this to the main body of the drawing, a piece of transparent paper spread with clear mucilage is used, if the patch is small. If of considerable size, the joint is neatly covered with thin strips of gummed transparent paper about $\frac{1}{8}$ inch wide. The advantage of this method is the smoothness of surface produced. The patch is flush with the main body of the drawing paper and the drawing instruments pass over the joint between the old and new portions without difficulty. It would be especially useful in cases where alterations are made on thick drawing paper. When neatly done with a sharp knife, the joint in such cases is almost invisible.

Special Drawings for Patternmakers. — It is the practice of most shops to make a working drawing of a casting, which suffices for both the patternmaker and the machinist. The patternmaker gets a blueprint and often from a maze of lines picks out those which pertain to the pattern. The patternmaker usually decides the amount of stock necessary for finish and, if the drawing is rather complex, he often loses time in distinguishing pattern dimensions from those necessary for machining operations. Drawings intended for use in both pattern shop and machine shop may also confuse the

machinists who work repeatedly on this piece, and who are compelled to use a drawing bearing a lot of pattern dimensions. Very often, too, these drawings are made at a reduced scale, which may be inconvenient for the patternmaker, especially when a full-size drawing shows the form or proportions more clearly.

This practice of making special drawings for the patternmaker has been adopted by several machinery manufacturers. According to one plan, these special drawings are made full size, and the amount of finish is decided in the drafting-room. No blueprint is furnished, but a buff paper drawing is made, and when the pattern is completed, the drawing is indexed and placed on file. This method has the following advantages: The full-size drawing gives the draftsman a better idea of proportions. By making the pattern drawing first and using this together with the assembly drawing when making details for the shop, the chance of error is much reduced. This is because a pattern drawing must be more thoroughly developed than a shop drawing. The making of several sections and an elevation or two not necessary to the machinist, often brings to light interferences which would otherwise escape notice.

It might be said that the other method of making combined drawings would accomplish this. It is, however, impracticable to make such pattern drawings as complete as they should be. It is the lot of the patternmaker to form many irregular curves. When the drawing is full size, he may prick through the paper and define a line on a thin board which, when cut to the line, is a correct templet for the curve.

Patternmaker's Blueprints. — It is sometimes customary to make two tracings in order to secure separate drawings for the pattern shop and machine shop, but the following method has the advantage of requiring only one tracing. A finished tracing is made containing all dimensions both for the patternmaker and machinist. The dimensions for the machinist are inked in as usual, but the pattern dimensions are put in with a soft lead pencil. Several prints are taken from the tracing while in this condition, one furnished the pattern shop, and

as many filed away as desired. The lead pencil dimensions are then erased and the tracing is ready for making prints for the machine shop. In this way the patternmaker can readily understand and pick out his figures, and the machine shop print is kept free from unimportant dimensions which often cause considerable trouble.

Commercial Side of the Draftsman's Work. — Machine designers should aim to develop a knowledge of commercial conditions, to acquire the business man's point of view in working out designs of machines. It has been well stated that an engineer is a man who not only designs and builds safely, but who also produces a machine that is adapted to manufacturing needs at a cost commensurate with the service the machine is to render. One of the best known machine tool designers in the United States, who later became an executive of one of our largest machine tool plants, said that the great failing of most machine designers was their lack of appreciation of the element of cost. "Anybody," he said, "can design a machine to do almost anything, if he can spend all the money necessary; but it takes a real designer to so design a machine that it can be built and sold at a profit."

The most successful machine designers are those having the idea of cost uppermost in their minds, so that while working out the design they constantly take into consideration the commercial requirements referred to. The competent designer aims to originate mechanical devices that are reduced to their simplest form, because he knows that every unnecessary screw, pin, wheel, or lever increases the first cost, and possibly the upkeep. He also considers carefully the manufacturing problems, such as are encountered in the pattern shop, machine shop, or foundry. A machine may be simple in its arrangement, perfect in its mechanical action, and have every part proportioned to resist safely all working stresses, but still be greatly lacking in design. The drawing of lines on paper is so much easier than forming in iron or steel the parts that the lines represent that the inexperienced designer does not always see his drawing from the manufacturing point of

view. The cost of originating a design that may be drawn on paper in a few hours or days is usually insignificant when compared with the actual manufacturing costs which follow and often extend over a period of years. If a 100 per cent increase in the designing cost will reduce the manufacturing cost even 1 per cent, or less, this additional expense may yield a very high return.

Value of Cooperation between Designing and Manufacturing Departments. — The value of cooperation between the designing and manufacturing departments is not always fully recognized, especially by the young engineer. What the shop men think of a new design is usually worth knowing. Frequently, a shop foreman or the men under him are able to suggest changes that simplify their work without reducing the effectiveness of the design as a whole. While engineering training and ingenuity are essential in the drafting-room, a machine designer is successful in proportion to his ability to simplify both the design and the methods of production. The best designer is one who aims for both mechanical and commercial success in whatever he originates or develops.

A good draftsman and designer should be acquainted with the work of the patternmaker, molder, blacksmith and machinist. He should have a general knowledge of the principles of patternmaking so that his designs will not involve useless expense in the making of patterns; of molding, so that he will not be designing parts almost impossible to mold or on which there would be time wasted, unnecessary expense in coring out, or other operations which might be avoided if the design were made to conform to good practice in the foundry; of blacksmithing, so that the forging operations will not be unnecessarily difficult or expensive; of the machinist's work, so that the parts will be easily machined and all possible hand work avoided. The draftsman should also be competent to give the dimensions in such a manner that they will be the ones needed by the machinist in getting out his part of the work. He should plan in his mind *how* the parts will go together, starting from the foundation and following through

the assembling of all of the parts till the machine is completed. In short, the draftsman must be able to follow the work intelligently throughout the whole factory.

A knowledge of machine shop practice is of especial importance. The draftsman should carefully consider how every casting or forging should be machined to enable the work to be done efficiently. While designers naturally think of finished surfaces, bearings, drilled and tapped holes, recesses, etc., there are many who do not consider the matter from the viewpoint of economy.

The analysis of manufacturing problems as they come up in design is something like this: Can the part be machined readily? How? On what type of machine? Can the various members be assembled without difficulty? When it is decided that the work can be machined on some of the standard tools, many designers do not consider it necessary to go into the subject further, unless they have had practical experience in tool design and manufacturing. There are many important points in connection with machine designing that materially affect the cost of manufacture, such as the location of holes that must be drilled and tapped, general shape of the casting or forging, whether projecting lugs should be a part of the casting or be attached to it, use of temporary flanges or lugs for holding or driving, the coring of internal grooves or recesses to avoid machining, etc. Of course, the effectiveness of a piece of mechanism must be the first consideration, and the weight, strength, and even general appearance are important points that must be considered; in fact, the methods of manufacturing may, in some instances, be secondary, but it is essential to study them carefully.

Improving a Design after Mechanism is Constructed. — A drawing which is to furnish directions regarding the manufacture of a part of some standard machine that has been thoroughly tested and has reached the manufacturing stage, should contain specific information regarding the size, finish, material, etc.

In the development of a new mechanism on the drawing-

board, however, there is a definite limit to the ideas that can be laid out in the drawing. After a design has been carried so far on a drawing-board, it is often essential that a model be made. The making of this model will no doubt bring out ideas that will make it advisable to redesign the mechanism on the drawing-board. Thus it is essential that the closest cooperation exist between the makers of the experimental mechanism and the engineering department. Also, no pains should be spared to acknowledge the value of an idea submitted by a man in the shop who may know little about machine design, but nevertheless be able to suggest changes that will improve the design. If, in a mechanic's opinion, some improvements over the method shown on the drawing can be effected, his ideas should be considered. There are instances where four, five, or six machines are built before one is fully satisfactory, but each one develops improvements. A drawing was required to start the first one, so the real purpose of the drawing was to make the start. When the machine is satisfactory, the drawings are corrected for record and duplication. It is important to remember that the drawing is a means to an end and not the end sought — a point sometimes lost sight of by draftsmen and by technical students.

Property Rights in Engineering Drawings and Data. — The relations of the draftsman and engineer as regards his proprietary right in the designs which he creates, is closely allied with that of ownership of patents which originate during the work carried out by the draftsman. The subject may be divided into four principal questions, as follows:

1. May a draftsman make blueprints from his own drawings embodying his own computations, and take these home with him or away with him when he leaves his job? May he do this with the drawings of his fellow workers? These will enhance his value to any subsequent employer. Are they *his*?

2. Suppose he bought his own paper, and did his printing at home on Sundays and holidays, so that his records were not made at his employer's expense? Does this change anything?

3. Suppose that this same information, tables of sizes and proportions, design data and standards, are in note-books. May the draftsmen copy these, and carry such priceless information gathered through years of wage-paying and experiment with him to his next place, and perhaps to a competitive concern?

4. Can an improvement in a process, or a new process or an improved design, or a new mechanical movement be patented by the draftsman for himself, while he is working for an employer on a similar problem, and be used to hold up his employer until the parties can agree as to the terms?

The accepted answer, emphasized by decisions of Court, and embodied in codes and standards of professional ethics, is that drawings and data belong to the employer, and the engineer or draftsman may not take them away with him. The reasons back of this practice include: (1) The shop furnished the plant — rent, heat, light, tools, etc. — where these ideas were conceived. (2) The shop presented the problem — without this the invention or the design would never have been created. (3) The shop furnished antecedent knowledge and acquired experience, which molded the creation, and prevented mistakes and waste. (4) The shop furnished experimentation, actual or precedent, which gave the creation its practical or commercial shape. (5) For many creations, the shop furnished or will furnish the manufacturing facilities which the inventor would otherwise have to struggle to find or pay for heavily elsewhere. (6) For many creations, the shop furnishes the selling or marketing facilities of its commercial organization.

Again, the draftsman or engineer may contract by a signed instrument to give shop or manufacturing rights to the employing shop, while retaining the right to sell or license to outside parties. Or, again, this principle may be made applicable to patents which relate to the employer's business, while patents in no way related thereto may be expressly excluded, and the employer stands as an outsider would in relation to purchase or license.

CHAPTER V

SECTIONAL VIEWS AND THE READING OF DRAWINGS

AN object may sometimes be more clearly represented on a drawing by showing the cross-sectional shape. This is done by imagining the object to be cut as though it were literally cut apart by means of a saw; a drawing is then made which represents the exposed edges and surfaces. An outline drawing of a globe valve is shown at the left in Fig. 1, and a sectional view to the right, which shows the valve as it would appear if split vertically through the center. The interior parts might be represented by means of dotted lines, but in this case, as in many others, a sectional view is much clearer. (The dimensions are omitted on these drawings to avoid a confusing mass of lines.) All parts cut by this *section plane* or *cutting plane* are shown by parallel "section lines" drawn at an angle of 45 degrees. As a rule, these lines are about $\frac{1}{16}$ inch apart, but they are usually spaced entirely by the eye; the general tendency is to space the lines too closely together at first, and then to increase the space between them as the lengths of the lines increase.

The arms of pulleys and gears are not section-lined, and if the cutting plane passes through the axis of a solid part like a shaft or bolt, which is one of the details of whatever part the drawing represents, ordinarily the shaft or bolt is not sectioned, thus making the drawing easier to read. Sections are usually made parallel to, or coinciding with, the long axis or length of the object, or at right angles or oblique thereto. They are then known as *longitudinal sections*, *right* or *cross-sections*, and *oblique sections*, respectively. When an object is supposed to be cut into two similar parts (as in Fig. 1), the view obtained by looking in a direction at right angles to the cut surface is called a *full section*. A view that shows

the object cut in to the center on two planes at right angles to each other is called a *half section*.

The cutting plane may be assumed to lie at any angle necessary to bring out the details most clearly; or a sectional view may represent an object as though it were cut through a part of the distance on one plane, and the rest of the way on another plane, either higher or lower, as may be required. All

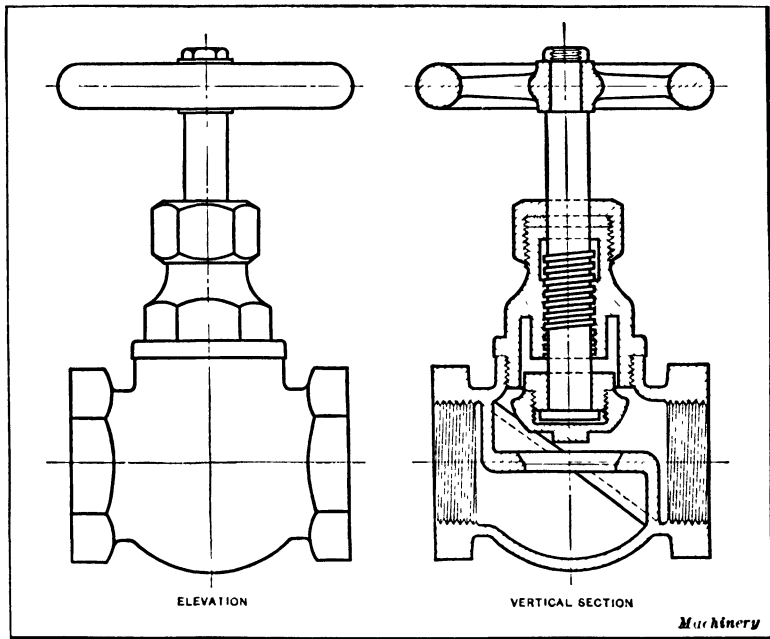

Fig. 1. Outline Drawing and Sectional View of a Globe Valve

that is necessary to have the view clearly understood is to draw a line through one of the views of the piece, indicating just where the sectional view is supposed to be taken, and then to make a note on the drawing to that effect.

Examples of Sectional Views. — In Fig. 2 is shown a side view of a handwheel and two kinds of sectional views. As the wheel is symmetrical, it is quite unnecessary to draw more than half the wheel in the side view, although the whole wheel may be drawn if desired. It is here represented as though

cut in two along its diameter on the line *ab*. This line should be a dash-and-dot line, as shown, and not a solid one. One of the uses of a dash-and-dot line is as a center line where a piece is symmetrical, and its use here would indicate that the half of the wheel not drawn was like the part that was drawn, even if it were not otherwise apparent.

Above the center line *cd*, of one sectional view, the shapes of the rim and hub are shown by dotted lines, since they would

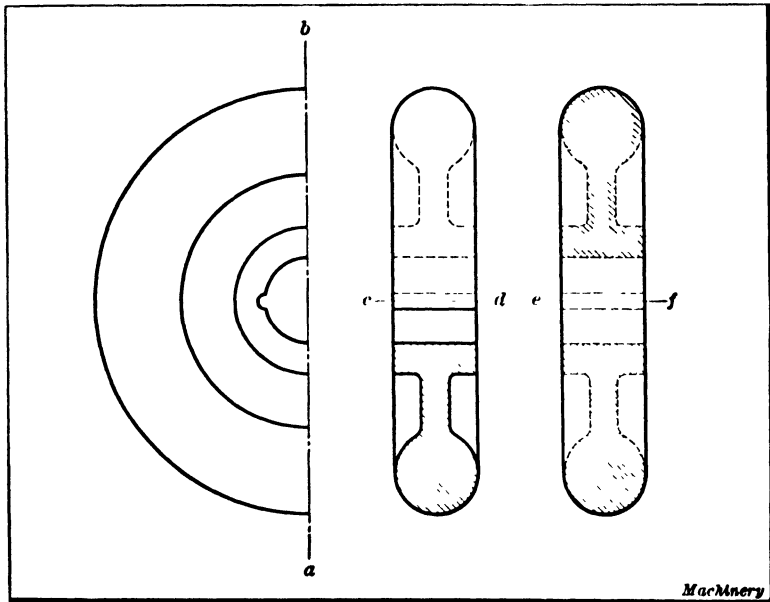

Fig. 2. Different Methods of indicating the Shape of a Section

not be visible to an observer who held the wheel so that he looked directly at the edge or rim. Below *cd* is a sectional view taken along the line *ab* of the side view.

To the extreme right, are shown two methods of drawing what are termed "dotted sections." The sections are supposed to be taken on the line *ab* as before, but cross-sectioning is done by dotted lines, indicating that the shape of the section would be as shown, but that the parts in front of it have not actually been cut away. This is a very convenient method to adopt at times. For example, in showing a milling ma-

chine knee and saddle it would enable one to represent the knee and saddle as they actually appeared, and also to show a sectional view of the mechanism under the saddle and inside the knee. If, on the other hand, the view were drawn as though the knee were actually cut through, one would not form an idea of its exterior appearance unless another view were drawn. It will be noted in the figure that the dotted lines extend clear across the section, as drawn below *ef*, and only along the edge of the section above *ef*.

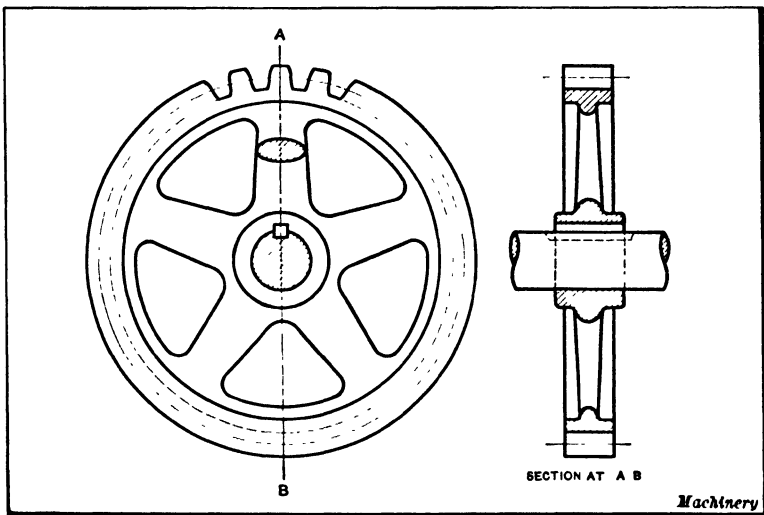

Fig. 3. Conventional Method of showing a Section of a Spur-gear Wheel

In Fig. 3 are two views of a gear wheel. The one at the left side is a side view, and to show the shape to which the arms are to be formed, a sectional view of one of the arms is drawn in this view. The end of the shaft is supposed to be broken off and is sectioned.

The right-hand sectional view is taken along the line *AB*. It will be noted that the shaft and key are not sectioned. The method followed in such cases is usually to section the castings or inclosing parts, such, for example, as the hubs, rims, etc., of a wheel, but not inclosed parts like shafts, rods, bolts, keys, etc. A bushing being both an inclosed and inclos-

ing part might or might not be sectioned, individual judgment dictating the method here as elsewhere. This gear has five arms, and the line AB cuts through one of them only. They are not sectioned in the right-hand view, and two opposite arms are drawn as though both of them lay in the plane of the paper. While this is not correct, it is the method usually

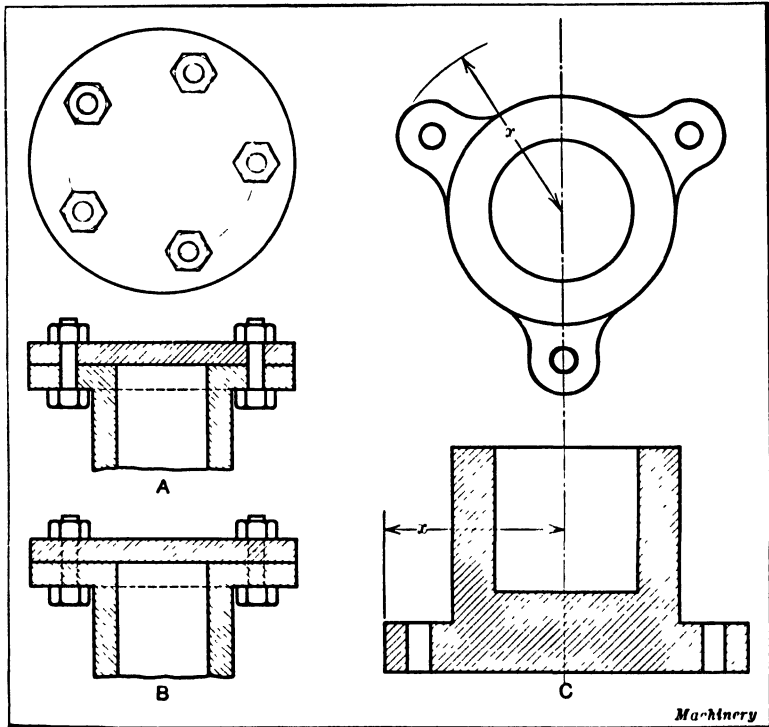

Fig. 4. (A and B) Two Methods of sectioning Parts bolted together. (C) Section of a Casting having Three Lugs

followed. The method of representing the gear teeth in sectional views is generally as shown. (The common methods of drawing gears will be dealt with in Chapter IX.)

Sectional and top views of a cylinder or pipe on which a blank flange is bolted are shown at A and B in Fig. 4. There are five bolts, and the plane in which the sections are taken would cut through only one of them. Most draftsmen, how-

ever, would draw the sectional view as indicated at *A*. The bolts are shown as though both were in the plane of the section, and these bolts are not sectioned, but are drawn in full. It is not necessary to show more than two of the bolts, since it would detract from the clearness, and the top view shows plainly how many bolts there are. Some draftsmen think bolts drawn in this way are too prominent, and prefer to represent them in sectional views as shown at *B*. This method also has the sanction of fairly common usage. When two pieces of the same material join, the section lines incline in opposite directions, as shown at *A* and *B*.

Sketch *C*, Fig. 4, is another example of a figure that is not symmetrical in all respects. It shows two views of a step bearing having three ears or lugs for bolting it to its baseplate. In making a sectional view of such a piece the cutting plane is supposed to pass through the lugs in most cases, and, according to common practice, the sectional view would be made symmetrical, and the distance x in the lower view, from the center of the piece to the outer end of each lug, would be made equal to the distance x in the upper view.

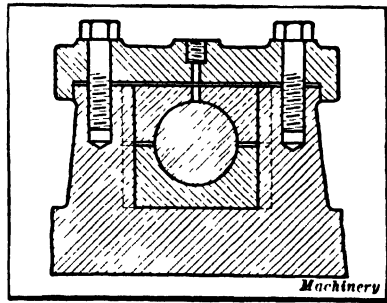

Fig. 5. Use of Section Lines to indicate Different Kinds of Metal

Section Lines.—When an object is cut by a section plane, the section lines show whether it consists of one or more pieces. Because the lines are uniform and run in the same direction at *C*, in Fig. 4, it is known that this part consists of only one piece. The change in the direction of the lines in Fig. 5 indicates different parts. If parts cut by the section plane are made of different materials, the style or arrangement of the section lines may indicate the general class of material. In Fig. 5 the section lines show that the

Section Lining and Material	Section Lining and Material		
	Cast iron.		Electric windings, electro magnets, resistance, etc.
	Steel.		Concrete.
	Bronze, brass, copper and compositions.		Brick or stone masonry.
	White metal, zinc, lead, babbitt and alloys.		Marble, slate, glass, porcelain, etc.
	Aluminum and aluminum alloys.		Earth.
	Electric insulation, Vulcanite, fibre, mica, Bakelite, etc. Show solid for narrow sections.		Rock.
	Sound or heat insulation. Cork, hair-felt, wool, asbestos, magnesia, packing, etc.		Sand.
	Flexible material. Fabric, felt, rubber, etc.		Water and other liquids.
	Fire brick and refractory material.		Wood. Across grain With grain

Fig. 6. American Standard Symbols for Section Lining

shaft, the bearing blocks and the outer part are made of different materials. The chart in Fig. 6 shows the American Standard section lines and the different materials that they represent. Since many kinds and grades of materials

are now used for machine parts, section lines are a general guide only. The particular section lines shown in the accompanying chart are in general use but there is some variation in different plants, especially for materials other than cast

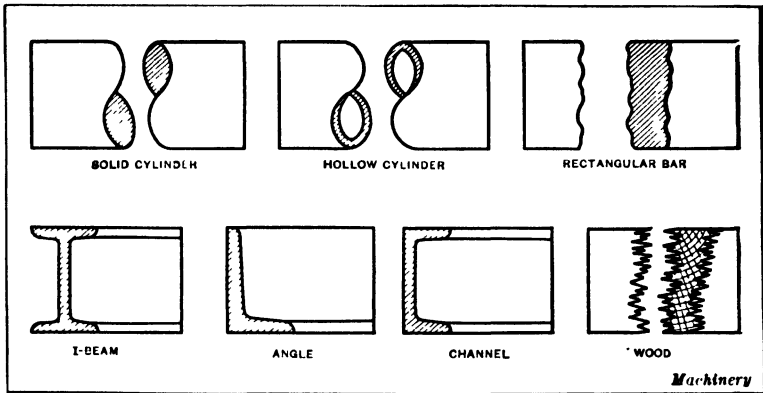

Fig. 7. Broken Sections and Structural Shapes

iron and steel. Indicating materials by means of section lines assists in making drawings clearer or more readable. Section lines also mark clearly the sectioned surface so that it can be distinguished readily from the rest of the drawing.

Broken Sections.—In Fig. 7 are shown methods of representing bars and rods, shafting, structural beams, etc., when

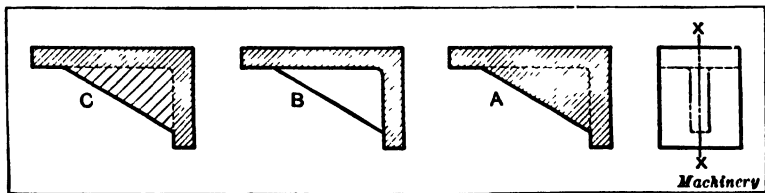

Fig. 8. Three Methods of representing Sectional Views of Bracket in Plane *xx*

it is not convenient to show their whole length on the drawing. These pieces may be drawn as long as the limits of the drawing will allow, and then are broken as indicated, to show that the full length of the piece is not represented. The nature of the break indicates the cross-sectional shape. Drawing a broken section often permits using a larger scale. When

placing the dimensions on the drawing, the full length is, of course, given. When drawing I-beams, angles, channels, etc., either the approximate shape of the section or the accurate shape is shown on the end.

Sectional Views of Ribbed Parts. — The purpose of any drawing is to be useful, and to this end care should be exercised in the use of conventional or common methods of representing parts in drawings so that they will not be misleading. Just as orthographic projection cannot be strictly adhered to in all cases, so conventions are not universally applicable. Perhaps in no instances do more conventions appear than in the representing of ribs and in the sectioning of symmetrical

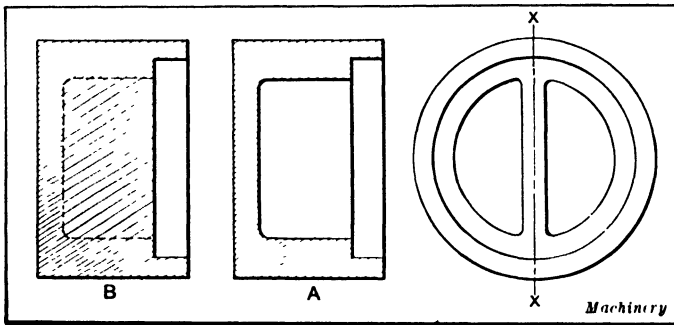

Fig. 9. Two Methods of showing Section of Casting having a Central Rib

and ribbed constructions. A number of cases are illustrated and comments are made on the various methods of representation. These are only types, and are not intended to cover every possible case, but simply to illustrate possible correct solutions of typical cases.

Sectional views on planes passing through ribs will be considered first. Figure 8 shows a bracket with a section taken on the line X-X. The true section is shown at A, the dotted lines indicating the flanges, but it is hardly necessary to say that no draftsman would think of using such a representation. A generally accepted method is shown at B, in which the plane of the section is assumed to have been moved forward until it is in front of the rib. Another method which is

sometimes used is shown at *C*, where alternate section lines are omitted from the rib. It will also be observed that in this case the flanges are shown by dotted lines instead of full lines, as the section is taken through the rib. The wider spacing indicates the presence of a rib of small thickness.

Figure 9 represents an object having a rib as shown in the view at the right. The section on *X-X* as ordinarily represented is shown at *A*, where it will be observed that the presence of the rib is not so evident as it was at *B*, Fig. 8. The view *A*, Fig. 9, would be the same if there was no rib. It is sometimes necessary to show such an object in one view, and it is for such cases that the treatment indicated at *B* is found desirable. One view with such a representation would clearly indicate the fact that there was a rib. However, this treatment of a rib is often convenient and desirable in other cases, as shown in Fig. 10.

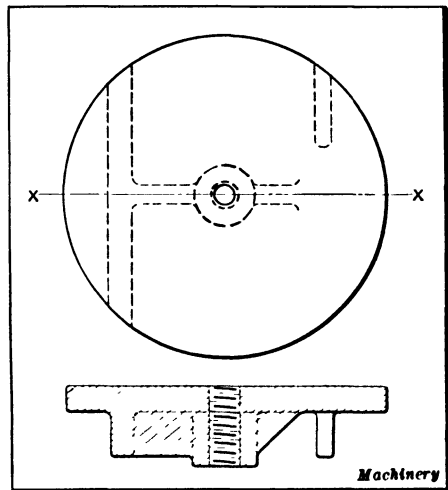
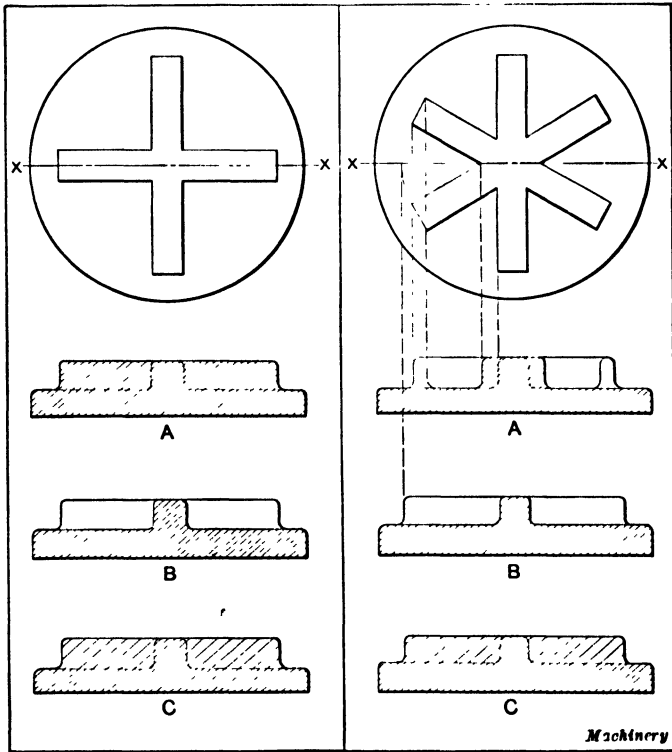

Fig. 10. Sectional View of Plate having Ribs and a Central Hub

Note that the outline of the ribs where double sections are used is shown by dotted lines where they join the rest of the object.

Figures 11 and 12 show ribbed flanges. At *A*, Fig. 11, is shown the true section on *X-X*, which some draftsmen use, but the representation at *B* is more generally acceptable, and would be considered the correct one to use. The alternate method shown at *C* is also a correct representation, but is hardly necessary for such cases. At *A*, Fig. 12, is shown a cross-section on *X-X* which is projected, but it is not as evident as the representation shown at *B* which would generally

be considered the correct one. The cross-sections at *B* or *C* might be used without the top views by simply giving the number of ribs in a note, and this would not be likely to lead to any misunderstanding. The representation at *A* would not be as clear. The vertical projection lines in Fig. 12 serve to show the method of obtaining the views *A* and *B*. The



Figs. 11 and 12. Methods of cross-sectioning Ribbed Flanges—Methods *B* and *C* Represent Good Practice

objection to the method shown at *A* is that the ribs do not appear in their true length. The objection to the representation at *A*, Fig. 11, is that it indicates undue solidity.

Sectional Views which are Symmetrical.—The subject of symmetrical parts, as far as sectioning is concerned, is closely related to the drawing of ribbed parts in section. Figure 13 shows a section on *X-X* at *A*, in which the lugs are projected.

The lug lying on $X-X$ is treated as a rib and is not sectioned, although the use of section lines is correct and they would be used by many draftsmen. At B is shown another method sometimes used. Figure 14 shows the treatment of a similar object, A being the true section on $X-X$ and B an alternative method

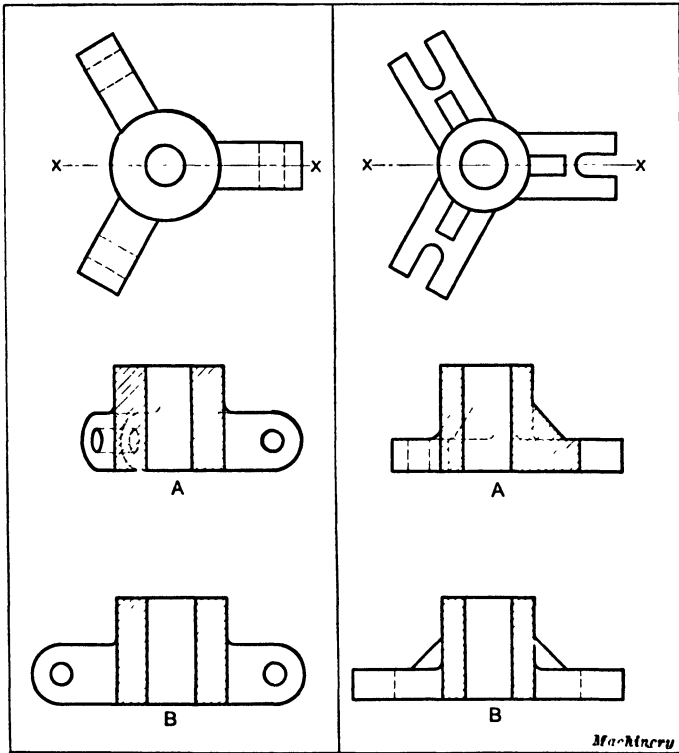

Figs. 13 and 14. Two Kinds of Cross-sectional Views

of representation. Figures 15 and 16 show the treatment of circular objects with arms, A being the incorrect and B the correct representation in each case. The alternate method shown at C is another correct representation of the object shown in Fig. 15. The projection lines show the method of obtaining the sections.

A similar condition arises in representing the holes in flanges, and C in Fig. 17 shows the correct method in such

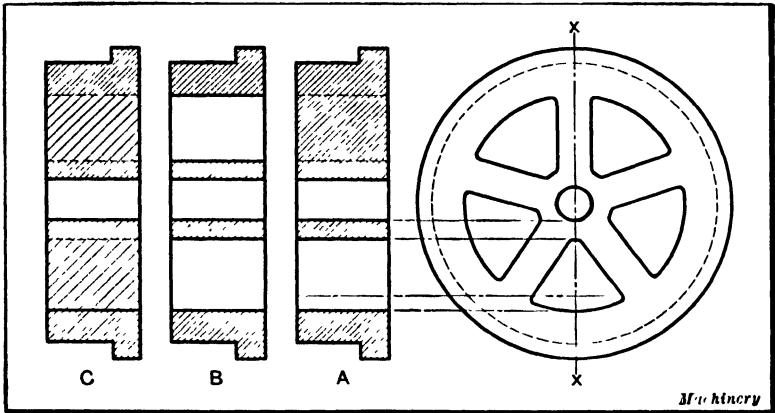
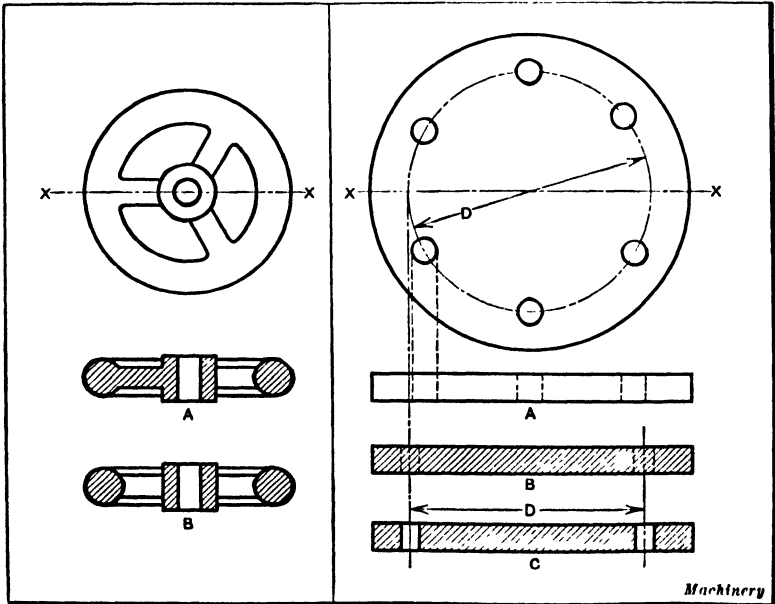

Fig. 15. Other Examples of Symmetrical Cross-sectioning

cases, where the distance between the holes is made equal to the diameter of the circle of drilling regardless of projection. At *A* is shown the true projection, which is misleading. At *B* the holes are shown dotted, the centers of the holes being the



Figs. 16 and 17. Cross-sections of a Handwheel— Sections of a Flange having Equally Spaced Holes

true distance apart. This is a correct representation and is often used when none of the holes are on the plane of the section. Keyways and pins will be considered in the same manner. In Fig. 18, *A* shows the projected section of the hub with the keyway, while *B* is the representation often used to preserve symmetry. At *A*, Fig. 19, is shown the projection of a hole through a shaft for a pin, and *B* and *C* are acceptable representations of this piece, even though the end view remains the same.

The object in all cases is to give a representation which will most clearly convey the idea. To this end symmetrical objects should appear symmetrical, and the true size should

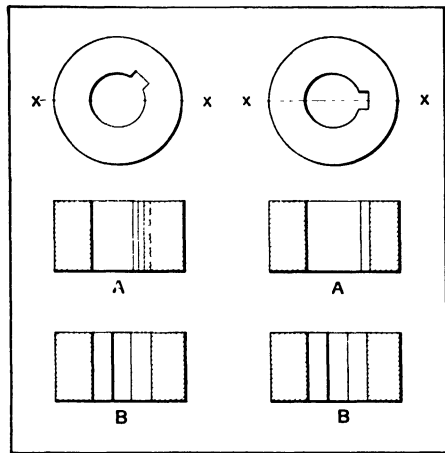

Fig. 18. Methods of showing Keyways in Cross-sectional Views

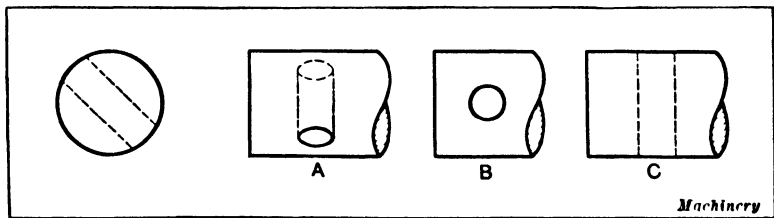

Fig. 19. Methods of showing Transverse Holes in a Shaft

be shown in preference to a foreshortened one. Holes should appear round, and diameters should appear in their true length.

Showing Part of Drawing in Section. — The general shape of a piece is often brought out more clearly by showing half of a drawing in section. A simple example is illustrated in Fig. 20 which represents the rear wheel hub of an automobile.

As will be seen, the sectional view extends down only to the center line. This part section shows very distinctly the shape of the hub; the exterior view below the center line shows the threaded end to better advantage than would a complete sectional view. While a complete section could be used to represent a simple part of this kind, in some cases an exterior view of one half of a piece, which also requires a sectional view, is very essential.

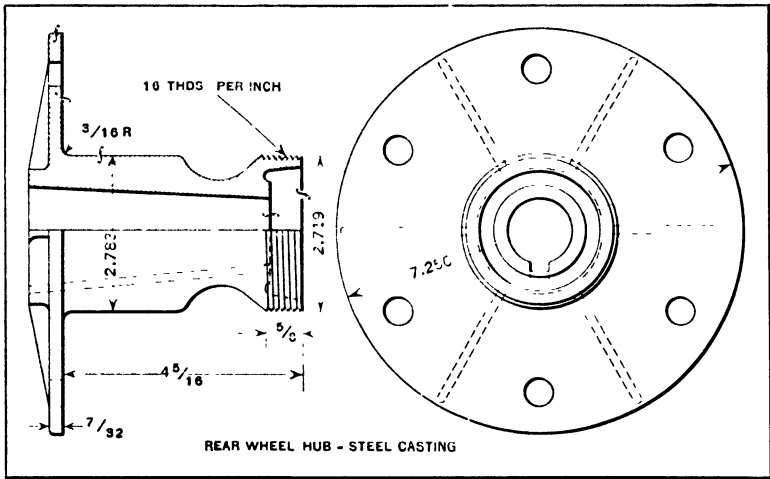

Fig. 20. Automobile Wheel Hub which is shown partly in Section

Another example of a part section is shown in Fig. 21, which illustrates a conical shaped "cinder pot" having flanges at each end and a bottom plate bolted to the lower flange. The sectional view to the left of the center line shows distinctly the shape of the flange which, as will be noted, is not so clearly revealed by the exterior view at the right. On the other hand, the right-hand half of the drawing shows the stiffening ribs better than the sectional view. A working drawing of this pot might have a plan view showing the number of ribs and bolts, but frequently such information, especially in the case of simple drawings, is given by notes. For instance, this pot might have the number of bolts and ribs marked on it in order to avoid a plan view.

Sectional Views of Important Details. — There are no general rules governing the sectioning of drawings except the rule that sections should be used wherever they make the drawing a clearer and better representation of the object drawn. In many instances, sectional views of important details are shown, the idea being to show certain essential parts, just as sections are cut out of some models used for demonstrating purposes, to show the interior arrangement. In this way, the drawing is made to bring out distinctly some part

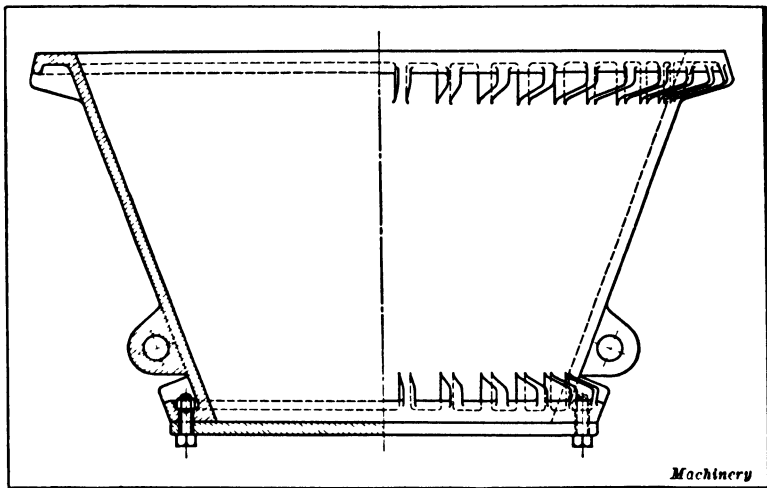

Fig. 21. Another Example of a Drawing shown partly in Section

of a mechanism which would be rather obscure if not shown in section. One example is illustrated in Fig. 22. This view shows the mechanism for revolving or indexing the turret on a Gridley single-spindle automatic. In this case, part of the worm and worm-wheel is shown in section, and that part of the machine containing the plunger which engages the notched indexing-disk or wheel. The sectional view of the worm shows the form and arrangement of the details much better than would have been possible without a section. The advantage of a sectional view through the index-plunger housing is also apparent. These part sections are very commonly employed in mechanical drawings, and the draftsman must be

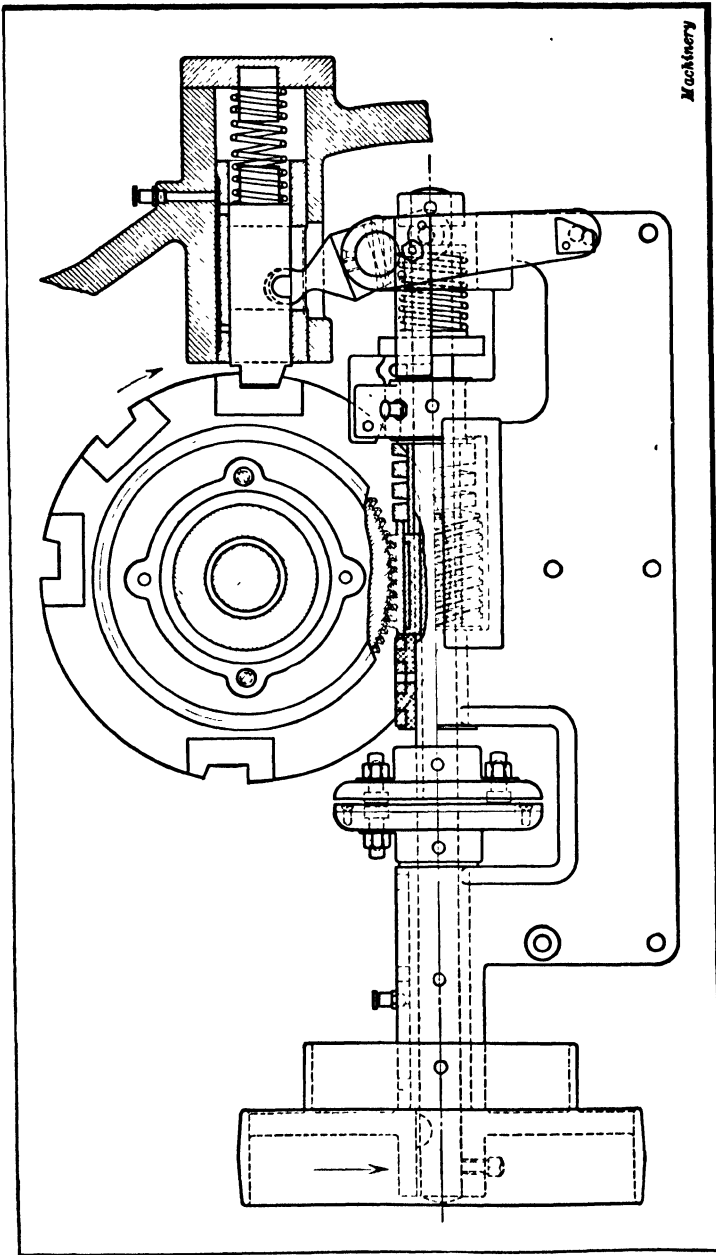

Fig. 22. Example illustrating how Sectional Views of Important Details are shown on Some Drawings

guided somewhat by judgment in determining when sectional views are preferable.

Indicating Position of Part Shown in Section.—The relation between a sectional view and some other view such as a plan or elevation, is not always apparent unless the location of the section is indicated in some way. Furthermore, two or more sectional views of the same part are often required. It is evident that the sectional view of the globe valve (Fig. 1) shows the valve as it would appear if cut in halves vertically through the center, but the relation between the different views on drawings which are a little more complicated is not always as apparent, and the relation between the section and other parts of a drawing is frequently shown by marking on one view the section or cutting plane represented by another sectional view, which is marked in a similar manner to identify it.

Figures 23 and 24 show different views of a steering gear case. (While these views are shown on two separate illustrations in order to reproduce them on a larger scale, they all belong to one working drawing.) Upon reference to Fig. 23, it will be noted that the sectional view is marked "Section *A-A*." By referring to the plan view, the location of the cutting plane *A-A* may be seen, as this plane is represented by the line ending with arrows and marked with a letter *A* at each end. The arrows show which side of the sectioned part is represented by the sectional view. These arrows are not always used, but they often tend to facilitate reading a drawing. The sectional view just referred to is taken in a vertical plane, whereas the one shown in Fig. 24 represents a view in a horizontal plane. This latter section is marked "Section *B-B*," and by referring to the elevation, or side view, beneath it, the line *B-B* shows that the section represents the casting as it would appear if cut through the center horizontally along this plane.

Section Representing more than one Cutting Plane.—Most sectional views represent the part as though it were cut straight through on one plane, which may or may not

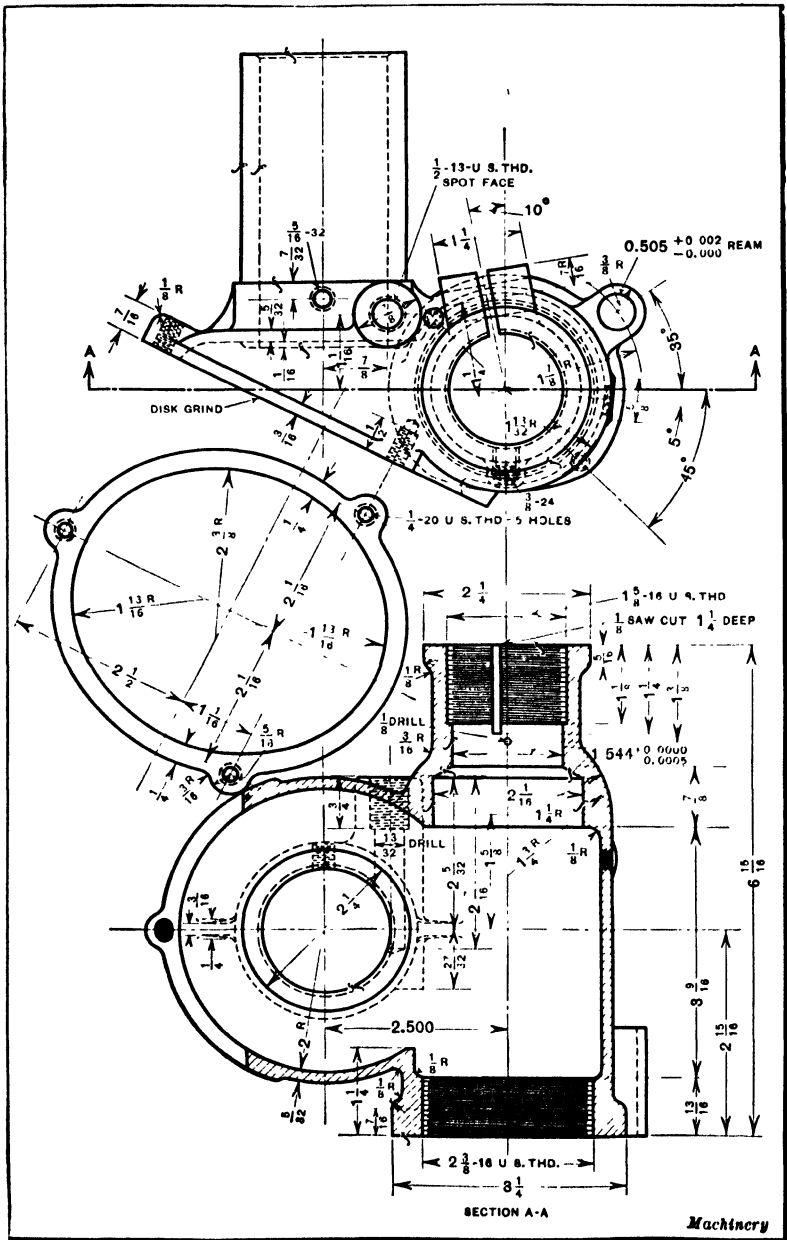

Fig. 23. Automobile Steering Gear Case — Note how Relation of Sectional View to Plan View is indicated

Machinery

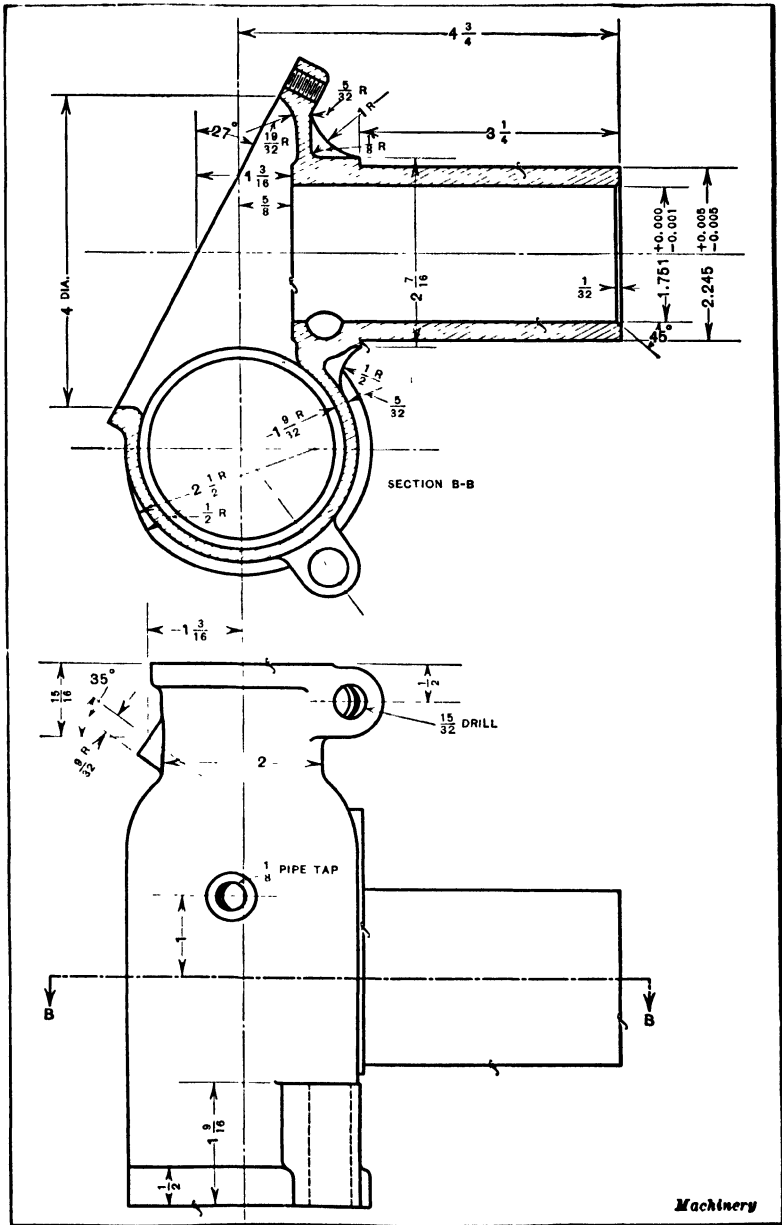

Fig. 24. Additional Views of Automobile Steering Gear Case illustrating how Position of Sectional View is indicated

coincide with the center line; but sometimes the cutting plane is assumed to pass through the part to a certain point and then change its direction. An example is shown in Fig. 25. The view at the left, marked "Section A-A," represents the section along the cutting plane A-A as indicated on the right-hand view. As will be seen, this cutting plane extends vertically down to the center of the circular part of the casting

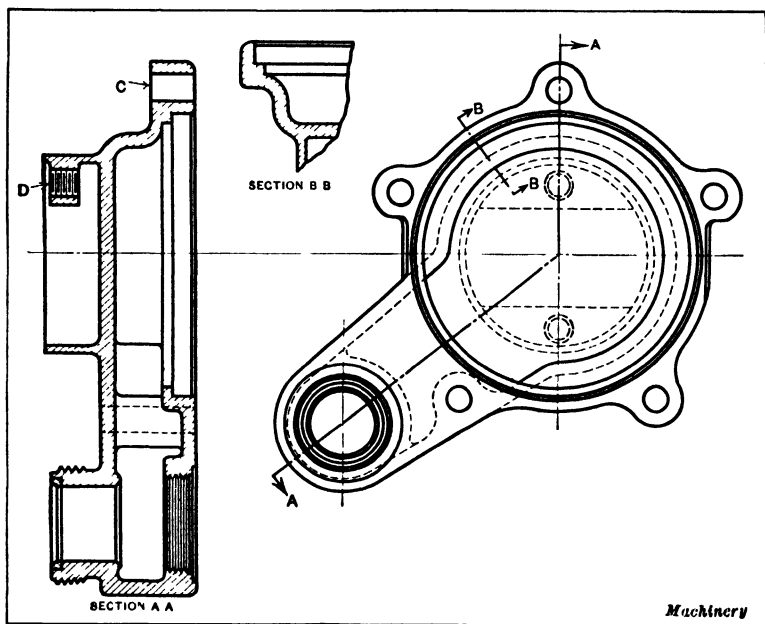

Fig. 25. Sectional View representing more than One Cutting Plane

and then continues at an angle through the extension projecting from the lower left-hand side. The advantage of making the drawing this way is that the important features are clearly shown in one sectional view. For instance, the lugs at C and D are shown, and then by drawing in section the projecting part, the general shape of the entire casting is brought out much better than by merely representing the section as it would appear if the cutting plane passed straight through the casting either vertically or at an angle. While the sectional view to the left is not a true drawing according

to the projection method of making mechanical drawings, it does show clearly the shape of the casting, which is the essential requirement. A separate detail section, marked on the drawing "Section B-B," is included to show the cross-sectional shape of the casting between the bolt lugs, the location of this detail section being represented by the line B-B on the right-hand view.

If the cutting plane changes its direction, more than two letters may be used, to show clearly the different points at

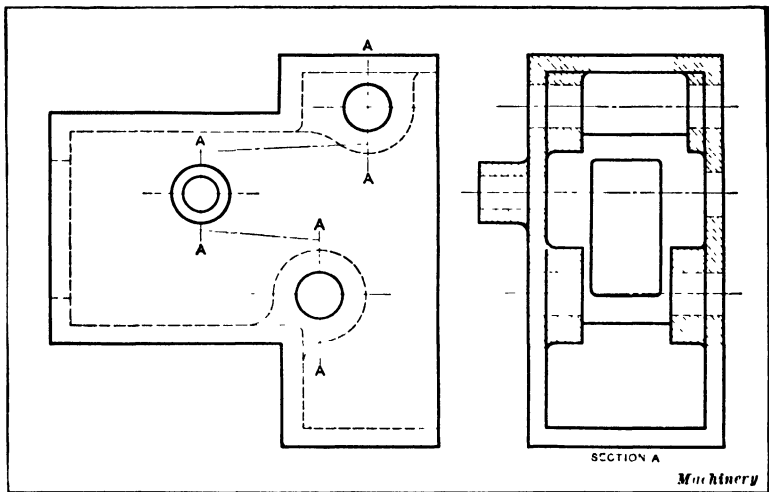

Fig. 26. Another Method of denoting Sections on Drawings

which changes occur. For instance, a sectional view such as the one shown in Fig. 25 might be marked "Section A-B-C," these three letters being placed on the right-hand view to show the path followed by the cutting plane. The letter *B* would, in this case, be placed at the point where the vertical cutting plane changes its direction. A letter at each end of the line representing the cutting plane usually shows clearly, however, the position of the cutting plane.

Another method is to use one letter only for any particular section, every change in the direction of the cutting plane being denoted by the same letter, as illustrated by Fig. 26.

The location of the lines and letters on the view to the left shows that the sectioned part (see right-hand view) represents sections in three different planes. Incidentally, this illustration shows a feature of drafting practice not used by draftsmen as much as it could be advantageously; i.e., showing the cross-sections by means of dotted lines instead of full lines. This use of dotted lines enables the object to be drawn in full lines as though it were not illustrated in section, so that in the same view sections on any parallel plane may be represented without interfering with the remainder of the drawing.

Showing Sections without Use of Section Lines. — The evenly spaced section lines which are used on most drawings to indicate cross-sections, are not employed by some draftsmen, because this method of representing sections is considered tiresome and wasteful of time. Another method of showing cross-sections is as follows: A tinting ink is used made from ordinary black Higgins ink with sufficient alcohol added to thin it. A test may be applied to some white paper. When the ink dries a light brown, it is of the proper consistency. This ink or paint is applied to the reverse side of the tracing on the parts which are to be shown in section, using a small camel's hair brush. On the blueprint this sectional view shows a cloudy bluish white, which is very readily distinguished. The main use of tinting ink is on all large full-sized sections, such as the beds of machines. The tinting ink is not applied *all over* the cross-section if the latter is large, as the cloth would be injured by the shrinkage that would result. A border of ink, about $\frac{3}{4}$ inch in width, is painted around the outline of a large section.

Another method, equally simple, which gives very similar results, is merely to rub over the parts shown in section on the back of the tracing with a soft pencil. On the blueprint this will also show as a bluish white. The pencil method has an advantage over the ink or paint method, as the latter has a tendency to wrinkle the tracing cloth if the thin ink is applied too liberally.

While the ink or pencil methods of sectioning require little

time, regular cross-section lines are preferable for most drawings. The bluish-white color for representing sections on a blueprint is likely to cause trouble, for that same bluish white may be produced by a tracing which has become spotted with water -- a thing which happens quite frequently where the sun exposure method of printing is used.

Reading Mechanical Drawings. — The expression “reading a drawing” simply means obtaining a clear understanding of it, by referring to the different views. Experienced draftsmen, machinists, toolmakers, and patternmakers are all able to read drawings, although it does not follow that they could make a suitable drawing. Everyone can understand an ordinary perspective drawing, because it represents the object as it would actually appear to the eye, but a mechanical drawing with its different views, numerous full and dotted lines, dimensions, symbols or abbreviations is comparatively complex, although it shows to the trained eye a great deal more than would be possible, in most cases, by a perspective drawing. The first step in learning how to read drawings is to study elementary mechanical drawing principles. When the student understands the use of different views for representing different sides of a mechanical device and the use of other features common to mechanical drawings, such as dotted lines to represent concealed parts, sections, and the meaning of certain abbreviations, the ability to read drawings is soon acquired with practice. The best plan is to begin with simple drawings and then practice reading more complex ones, securing as great a variety as possible.

General Procedure when Reading Drawings. — When reading a drawing, it is advisable to visualize the object as far as possible, or see it in the mind's eye as it would appear when constructed. This is where the imagination comes into play somewhat and also the ability to grasp readily the relation between the different views by glancing from one view to the other. For instance, if there are front, plan, and side views, these separate views on the drawing are combined mentally so that the mental picture corresponds to that of the object

itself. Students of mechanical drawing are sometimes puzzled when attempting to read a drawing, because they expect every drawing to conform exactly to certain rules, and forget that a draftsman may not always make a drawing which is theoretically correct, if, by some variation from the usual practice, he can represent the object more clearly. A section on one side of a center line may represent a different cutting plane than a section on the other side of the same center line, in

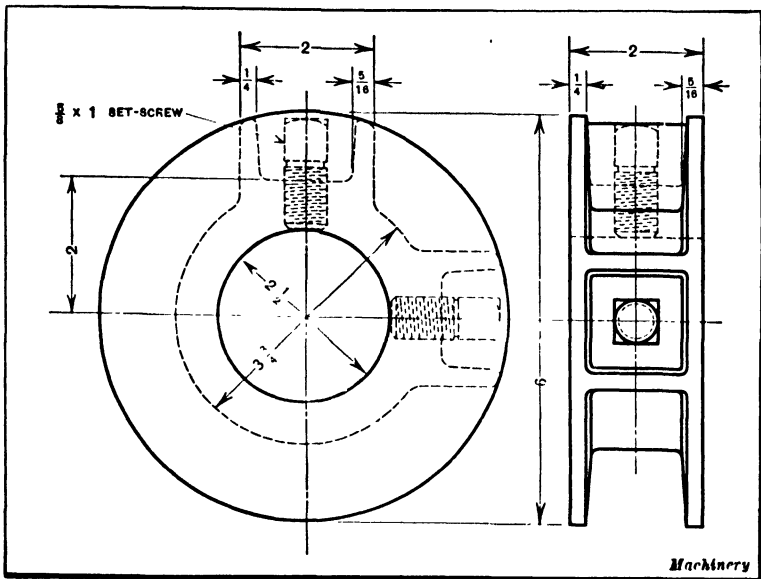

Fig. 27. Drawing of a Flange Collar

order to show in one view the arrangement or shape of interior passages or other features. By carefully observing the lines on different views which represent the corresponding parts, such variations will be detected readily and understood.

When the general shape or arrangement of the object shown on the drawing is clear, at least as far as the main features are concerned, the details and the dimensions should be observed. When studying the details, it is frequently necessary to glance from one view to another. For instance, it may be impossible to determine whether a circle on one view repre-

sents a hole or a projecting boss of circular shape, until the corresponding lines on another view are observed. If the drawing is rather complex, there may be some doubt as to the relation between lines on different views, in which case a straightedge or T-square is sometimes used to project points from one view to another in order to determine definitely whether certain lines represent the same part. Dividers can also be used for this purpose, the method being to compare

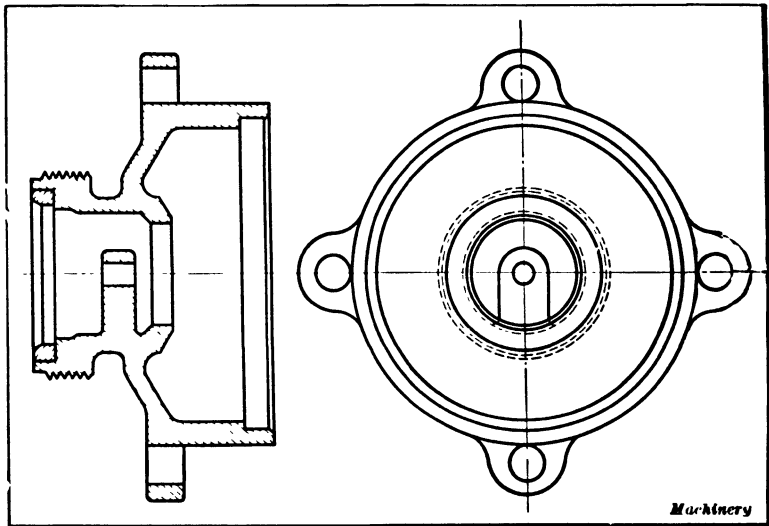

Fig. 28. Sectional and End Views of a Small Casting

the distance between the lines on different views and a common center line.

Examples Illustrating how to Read Drawings. — A few concrete examples will be considered to illustrate just how drawings are read and the points to be observed in understanding thoroughly what they represent. A very simple drawing is shown in Fig. 27 which represents a flanged collar. The side view shows clearly that this collar contains two set-screws located 90 degrees apart, and that the heads of these set-screws are within some form of pocket. The right-hand view shows clearly that this is a square pocket. Incidentally, the object of designing a collar in this way is to avoid accidents

by so inclosing the set-screws that they cannot catch the clothing, in case a workman should come into contact with the collar while the latter was attached to a revolving shaft.

Another simple type of drawing is shown in Fig. 28. It is evident that the sectional view represents a section on the vertical center line. This sectional view shows that a lug projects into the central passageway and the right-hand view shows clearly the shape of this lug. The sectional view also shows that a ring having a beveled edge is inserted in a recess formed in the threaded end of the casting. The fact that this ring is a separate part is indicated by the section lines which incline in the opposite direction from the others. It will be noted that the section lines in both cases are the same, and according to the usual custom, these evenly spaced parallel section lines represent cast iron. It does not follow, however, that the inserted ring is of cast iron, because it is the practice in many drafting-rooms to specify by a note on the drawing what kind of material is to be used instead of relying upon different kinds of section lines which may, in some cases, be misunderstood, since there is no universal standard governing their use. On a working drawing of this part, the kind of fit between the ring and casting should also be indicated. If the ring is a press fit, as in this case, the allowance for the fitting should also preferably be given.

The drawing reproduced in Fig. 29 represents the external brake-band anchor of an automobile. The left-hand view shows that there is an elongated hole in the casting, and the dotted lines of the right-hand view show that this hole extends through the casting. The dotted lines in these two views also show that there is a hole located at right angles to the one just referred to. The sectional view above shows very clearly these two openings, and also the shape of the casting in a plane *A-A*. This drawing illustrates the use of printed instructions. When the patternmaker receives the drawing, he notes that the elongated hole, which is 1 inch long and $\frac{3}{4}$ inch wide, is to be cored. Consequently, it is necessary to make, in addition to the pattern, a suitable core-box. The

drawing also shows that the hole extending at right angles to the one to be cored is drilled out with a $\frac{13}{8}$ -inch drill. The

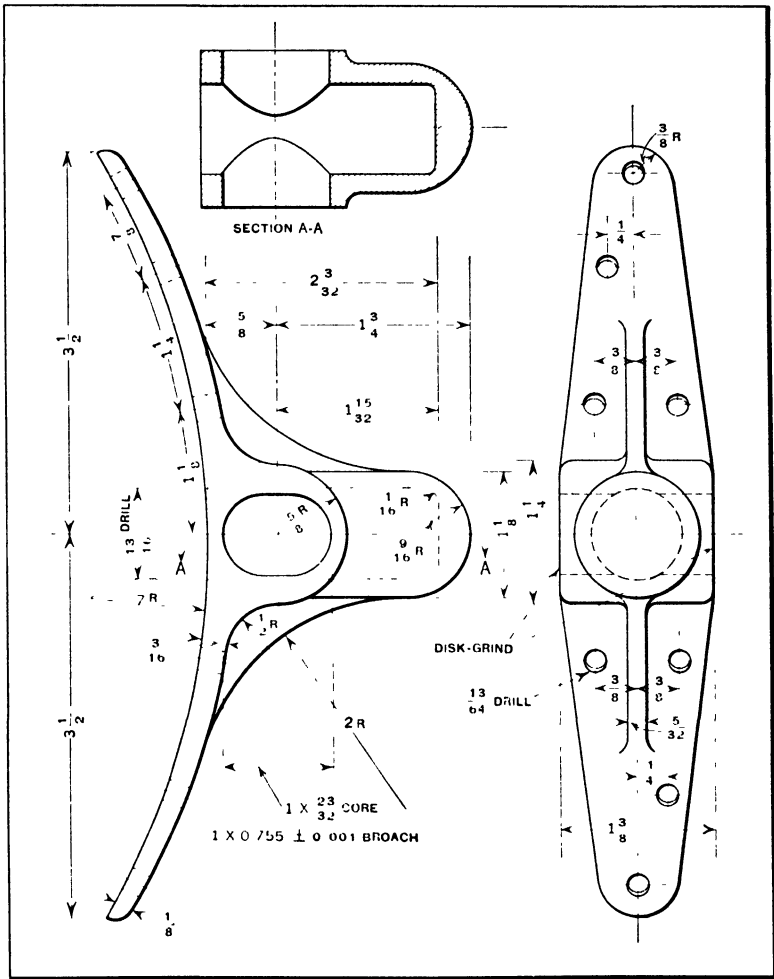

Fig. 29. Drawing of a Brake Band Anchor

fact that the elongated hole is to be broached is also indicated, and the method of finishing the sides of the casting, which in this case are to be disk-ground. The radius of the main part of this casting is given as 7 inches, and the zig-zag radial line shows that the center of the arc is on the center

line of the casting. The use of these zig-zag lines for radial dimensions is common, because, in many cases, if the radial line were extended out to the point where the center is actually located, it would be beyond the limits of the drawing. For this reason, the radial lines are frequently drawn zig-zag fashion merely to show from which center line the arc is struck.

The drawing of a crane hook of 10 tons capacity is shown in Fig. 30. This drawing illustrates a simple method of showing cross-sectional shapes without using separate sectional views. In this case, the right-hand sectional view shows that

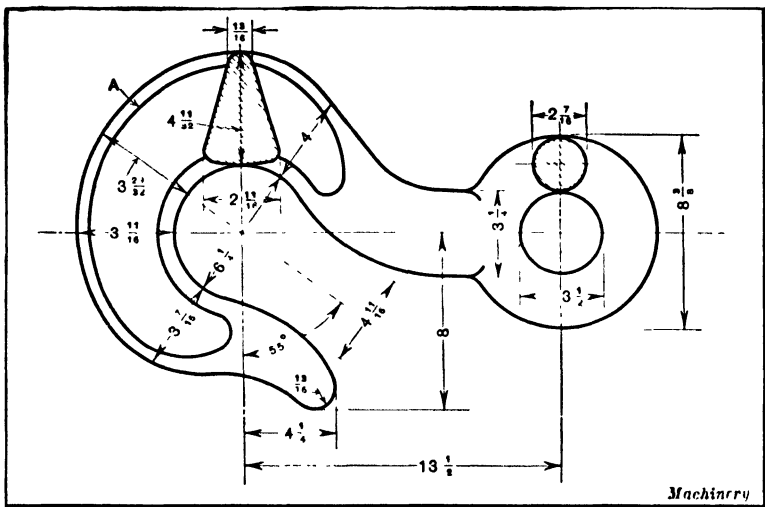

Fig. 30. Simple Method of showing Cross-sectional Shapes by placing Sectional Views directly on Drawing

the eye of the hook is of circular cross-section and the other sectioned part shows that the hook is somewhat V-shaped. The particular part of the hook which is given this V-shaped form is indicated by the line *A*, which represents the limits of the flattened surface. This method of placing cross-sections right on another view and at the point where the section is taken, is often resorted to and is not only convenient, but frequently shows the shape of the object more clearly than would separate views.

The drawing reproduced in Fig. 31 is more complicated

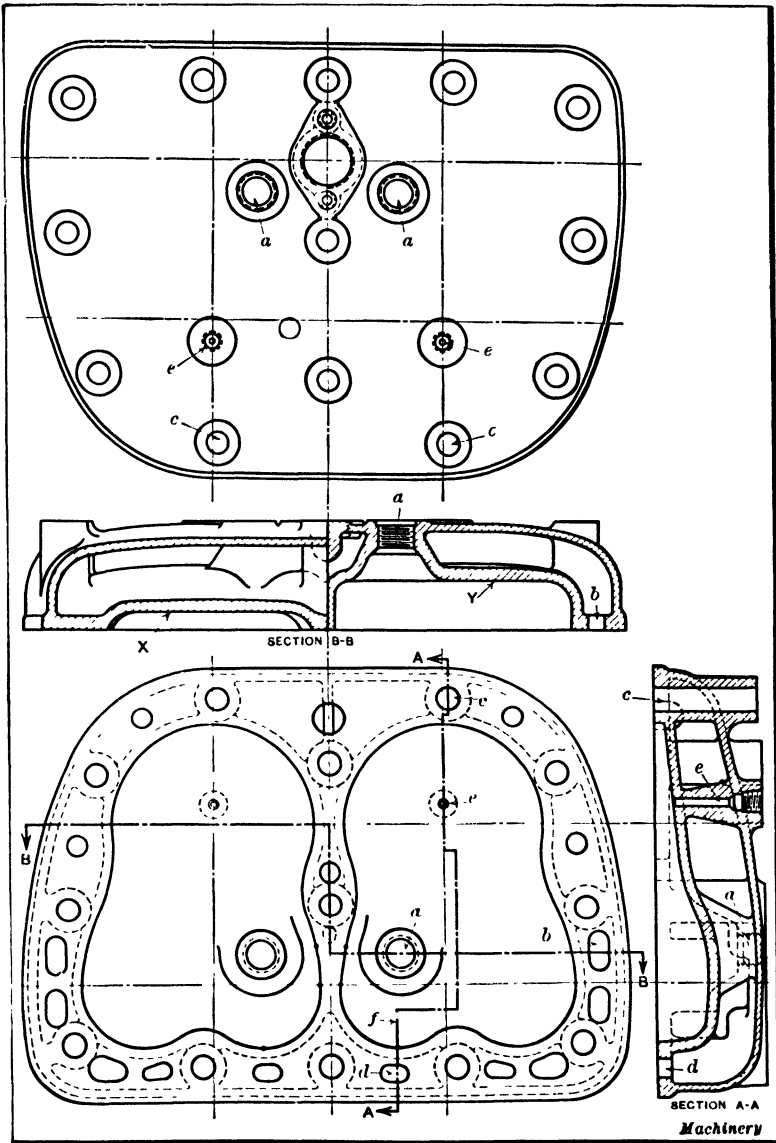

Fig. 31. Drawing of Cylinder Head Casting which illustrates Certain Points in the Reading of Drawings

than those previously referred to, and illustrates several interesting features. As it was necessary to reduce this drawing

greatly in order to show it on a book page, the numerous dimensions on the working drawing were omitted. The drawing represents the cylinder head casting of a gasoline engine. The different views, named in the order in which they appear and beginning at the top of the illustration, are as follows: A plan view, a sectional view, a bottom view, and another sectional view. A glance at these different views shows at once the general shape of the head. In making this drawing, the most important part of the draftsman's work was to show clearly the form and arrangement of the interior passages, which is done by the two sectional views in conjunction with the dotted lines on the bottom view. It will be noted, however, that the sectional views are not confined to one cutting plane. The heavy dot-and-dash line $B-B$ on the bottom view shows clearly the two planes represented by the section $B-B$ above the bottom view. The fact that this section is not in one plane is indicated by the abrupt change in the form of the interior passages, which occurs at the center line. The right-hand half of section $B-B$ shows that the cutting plane passes through a tapped hole a and by referring to line $B-B$ on the bottom view the location of this hole is indicated. The shape of the opening b in the sectional view is also shown by referring to the bottom view. The section $A-A$ represents four different planes, as indicated by line $A-A$ on the bottom view. The section first passes through the center of bolt hole c and is then shifted to coincide with the center of the circular space on the under side of the head. The cutting plane is again shifted to the right to a more central point, and then over to a plane which passes through opening d . By changing the cutting planes in this way, a sectional view $A-A$ is obtained, which shows a great deal more about the shape of the casting than would a section representing one plane.

In attempting to read this drawing the student will be assisted by referring to the small reference letters which represent the same parts on the different views. A study of these views will show that the casting is of the same shape on each

side of the vertical center line. For instance, if the section *B-B* were taken in one plane, the sectional view would be the same on each side of the center line. Therefore, instead of duplicating the view, each half of the section is taken in different planes. As will be seen, the under side of the head at *X* is much lower than the under side at *Y*, which is in a different plane, and by referring to the section *A-A*, the curvature of the head which causes this difference in height in section *B-B* is shown. Of course, on the working drawing, the radii of these curves and all other necessary dimensions are given together with whatever explanatory notes are needed.

The few examples which have been referred to are intended to indicate in a general way the method of procedure when reading drawings. The student should practice reading the other drawings reproduced in this book and also drawings or blueprints obtained from as many different sources as possible.

CHAPTER VI

METHODS OF DIMENSIONING WORKING DRAWINGS

AS most mechanical drawings are used in the pattern shop, machine shop, or forge shop to show the workmen exactly what is required, these working drawings should contain all necessary dimensions and, in addition, whatever instructions may be needed to make every operation entirely clear. While it might be possible to measure an accurate drawing and in this way obtain the dimensions within fairly close limits, such a method, even when applied to simple parts not requiring great accuracy, would be very unsatisfactory, and often result in serious errors; but even if this method of obtaining dimensions by the direct measurement of drawings were practicable, it is much better to place all important dimensions on the drawing where they can be seen readily because, when a drawing is properly dimensioned, it shows exactly what is required. While it is usually desirable to make a drawing quite accurate, an inaccurate working drawing, properly dimensioned, is much superior, as a rule, to an accurate one which is not dimensioned or does not include all the dimensions needed in the shop. Even a rough free-hand sketch would ordinarily be better than a drawing made accurately but without adequate dimensions and instructions. In fact, a large percentage of the work done in machine shops and tool-rooms must be made so accurate that dimensions expressed in figures are absolutely necessary. The chief purpose of the drawing itself is to show to which parts or surfaces the given dimensions apply.

When the dimensions are being placed on the drawing, the draftsman should keep in mind all of the different manufacturing or machining operations that will be required, and place the dimensions on the drawing in such a manner that

the workmen will be able to proceed without asking questions. A knowledge of shop practice is helpful to the draftsman in dimensioning drawings, as well as in other ways.

General Methods of Dimensioning Drawings. — When dimensions are less than a certain amount (which varies in different drafting-rooms), the common practice is to express them in inches, but if the dimensions exceed this amount, they are usually given in feet and inches. For example, if twenty-four inches is the amount or the dividing line, twenty-two inches would be written 22", or simply as 22, without the double accent sign, which represents inches. If the dimension were, say, three feet five inches, instead of writing 41", it would be written thus: 3 ft. 5 ins.; 3 ft. 5"; or 3'-5". In one case, the word "feet" is abbreviated, and in the other, it is represented by a single accent mark. When the latter method is employed, a dash should be placed between the figures so they will not be mistaken for one number. For example 3'5" might be read 35". If the dimension is equivalent to a whole number of feet, it is common practice to place a zero after the dimension to show unmistakably that it is correct and that the inches were not omitted. Thus, 4 ft. 0 ins., or 4'-0". If the dimension is four feet one half inch, it would be written: 4 ft. 0½ in., or 4'-0½".

In some plants, all dimensions of 36 inches or less are expressed in inches; in other plants the limit may be either 48 inches or the American Standard of 72 inches. There are some exceptions to this use of feet and inches. For example, the stroke of a steam engine is given in inches, regardless of its length, and the same is true of the length of the wheel-base of an automobile or locomotive. When all the figures on a drawing represent inches and not feet and inches, the figures are often given without double accent signs to indicate inches. When the dimension is either a whole number and a fraction or simply a fraction alone, a common fraction or a decimal fraction may be used. This point will be considered later.

The dimension is ordinarily placed in a space left at the center of the dimension line, as at *A*, Fig. 1, but sometimes it

is placed outside of the extension lines, as illustrated at *B*, provided the space between extension lines is small. The extension lines should not quite touch the lines of the drawing. Most dimension lines are either horizontal or vertical, and the dimensions for the vertical lines are usually placed so as to be read on the right-hand side of the drawing, as illustrated in Fig. 2. On some drawings, however, these vertical dimensions are placed so as to be read from the bottom of the sheet the same as the horizontal dimensions. It will be noted that the dimension lines are parallel to the side on which the dimension is given.

It will be understood that the dimensions on a drawing indicate the actual size, the scale of the drawing not being con-

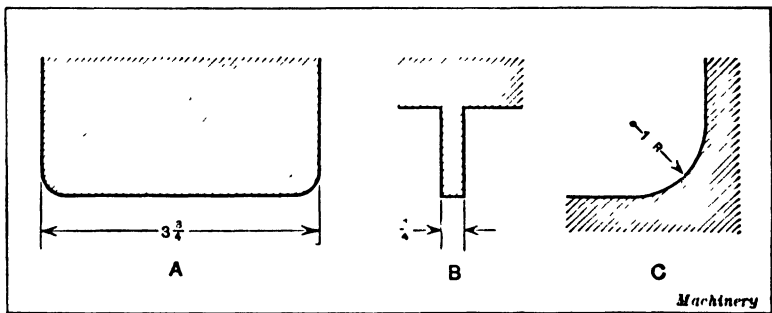

Fig. 1. Methods of using Dimension Lines

sidered. The dimensions also indicate the finished size and, in the case of castings or forgings, allowance must be made in the pattern shop and forge shop for machining operations. Most patternmakers work from drawings which give the finished dimensions, and they allow on the pattern whatever is considered necessary for the machining operations. Special drawings for patternmakers, however, are sometimes furnished.

Most dimensions and dimension lines are placed outside of the drawing proper where there is a clear space and where they are not so liable to be confused with the lines of the drawing itself. In a great many cases, however, the dimensions must be placed within the outline of the drawing. In

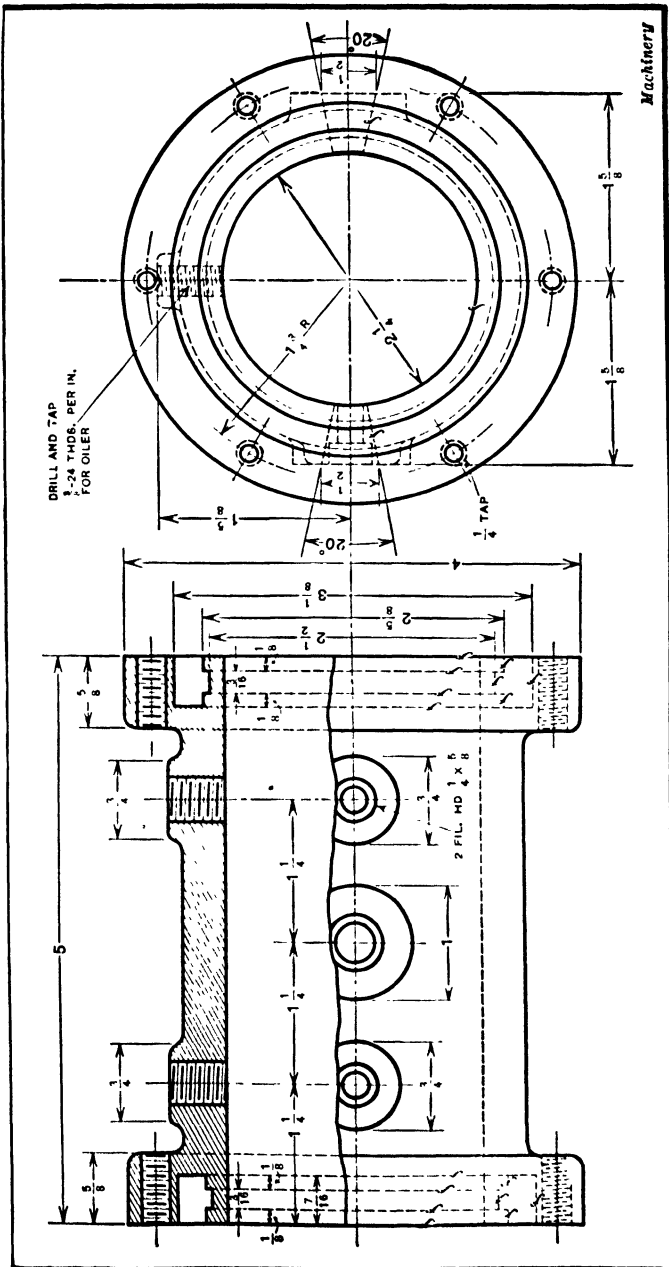

Fig. 2. Working Drawing of a Cast-iron Bearing-box

fact, it is often preferable to have them right on the drawing and close to the dimensioned parts. When a dimension is placed on a sectional view, a clear space should be left for the dimension by omitting the section lines around it. One of the lines of the drawing should never be used in place of a dimension line, as this would lead to confusion. It is also bad practice to use a center line as a dimension line.

The dimension line for the radius of an arc has an arrow at only one end (see sketch C, Fig. 1) and the dimension is followed by the abbreviation "R." or "Rad.," indicating radius. When dimensioning circles, the diameter should be given instead of the radius, the latter being used only for arcs of circles. When indicating the distance between two circular parts, the dimension from center to center should always be given.

If there are several dimensions in a row, the over-all dimension should be included as a rule. This point will be considered more fully later. The shorter dimensions are placed nearer the outline of the drawing or within the over-all dimension line. When a piece has several different diameters throughout its length, as, for example, a shaft with shoulders of different sizes, the diameters should be given on the side rather than on the end view, because they show more clearly just which section any particular dimension applies to. This general rule also holds good for such parts as castings having holes or openings of different sizes.

Dimensions should be placed on that view which shows most clearly the part of the drawing to which the dimension applies. Dimensions of the same part should not be repeated on different views because if changes have to be made some of the duplicate dimensions may be overlooked; moreover the number of lines on a drawing should be reduced as far as possible for the sake of clearness. The essential point is to give all dimensions that are necessary without useless repetition. Another important point is to give dimensions which are related to surfaces from which a workman can and should measure directly, as this not only facilitates the work in the shop, but tends toward greater accuracy.

Standard Rules for Dimensioning Drawings.—The following rules are from the American Standard for drawings and drafting-room practice:

General Rules: All drawings must be so dimensioned that the parts shown thereon can be made without the necessity of scaling the drawing. The dimensions should include those sizes and distances which are worked to in actual shop or constructional operations and should be so given that computations will not be necessary.

Dimensions should not be duplicated on various views or a single view, except where they will add to the clarity of the drawing, and no more should be given than those required to produce the part.

Common and Decimal Fractions: Dimensions of parts that can be measured or that can be produced with sufficient accuracy by using an ordinary scale should be written in units and common fractions. Parts requiring greater accuracy should be dimensioned in decimal fractions.

Dimensions in Inches or Feet and Inches: Dimensions up to and including 72 inches should preferably be expressed in inches, and those greater than this length, in feet and inches.

Where dimensions call for accurate machining with small tolerances, it is recommended that the total dimension be given in inches and decimal fractions.

In structural drawing all dimensions of 12 inches and over should be expressed in feet and inches.

In automotive, locomotive, sheet metal and some other practices all dimensions are specified in inches.

Symbols for Inches and Feet: The symbol (") is used to indicate inches and common and decimal fractions of an inch. When all dimensions are given in inches the symbol is preferably omitted. A note may be placed on the drawing stating that all dimensions are given in inches.

The symbol (') is used to indicate feet and fractions of a foot. Dimensions in feet and inches should be hyphenated, thus 4'-3"; 4'-0 $\frac{1}{2}$ "; 4'-0".

Dimension Lines: Fractions should be written with the division in line with the dimension line. A dimension line must not pass through a dimension figure. If unbroken lines are used, as in common practice in structural drawing, the dimensions are placed above the line. When fractional dimensions of less than one inch are given, the numerator should be placed above the dimension line and the denominator below.

All dimension lines and their corresponding numbers should be placed so that they may be read from the bottom or right hand edges of the drawing. All dimensions should be placed so as to read in the direction of the dimension lines.

When there are several parallel dimension lines, the figures should be staggered to avoid confusion.

Dimensions should be given from a base line, a center line or a finished surface that can be established readily.

Over-all dimensions should be placed outside the intermediate dimensions. In dimensioning with tolerances, if an over-all dimension is used, one intermediate distance should not be dimensioned.

Angles: In dimensioning angles, an arc should be drawn and the dimension placed so as to read from the horizontal position. An exception is sometimes made in the dimensioning of large areas when the dimensions are placed along the arc.

Dimensioning Circles: A dimension indicating the diameter of a circle should be followed by the abbreviation "D" except when it is obvious from the drawing that the dimension is a diameter. The dimension of a radius should always be followed by the abbreviation "R." The center should be indicated by a cross or circle and the dimension line have one arrow-head.

Dimensioning Holes: Holes which are to be drilled, reamed, punched, swaged, cored, etc., should have the diameter, given preferably on a leader, followed by the word indicating the operation, and the number of holes to be so made.

Dimensioning with Tolerances: Accurate dimensions which are to be established with limit gage or micrometer, should be expressed in decimals to at least three places and the drawing should give the limits between which the actual measurements must come. For external dimensions the maximum limit is placed above the line and for internal dimensions the minimum limit is placed above the line. This method should be used for smaller parts and where gages are employed extensively.

A second method, used for larger parts and where few gages are employed, is to give the calculated size to the required number of decimal places, followed by the tolerances plus and minus, with the plus above the minus, as $8.625D \begin{matrix} +.000 \\ -.002 \end{matrix}$.

Examples of Dimensioned Drawings.— In the dimensioning of drawings, there are no inflexible rules which can be laid down, and it is necessary for the draftsman to exercise his judgment and experience. The method of dimensioning should be planned or thought out very carefully, just as the method of machining the work itself is planned. Figure 2

represents the working drawing of a cast-iron bearing box. This drawing illustrates some of the features of dimensioning which have been referred to. As the sectional part shows, this casting has an annular recess in each end, and in each recess there is a shallow groove. This drawing illustrates the point regarding the placing of diameters on the side view instead of on the end view. In this case, the bore of the casting is marked on the end view, where it shows very clearly that the dimension ($2\frac{1}{2}$) applies to the inner diameter. While it would be possible to place the various other diameters on this end, the relation between them and the different surfaces is shown much more clearly on the side view. This drawing also illustrates the advantage of placing some of the dimensions within the outline of the drawing proper, as, for example, those representing the diameters of the bosses in the side view and the distances between these bosses. The total length of the casting is given at the top of the drawing so that the pattern-maker or machinist will not have to do any adding. To further simplify dimensioning, all screw hole dimensions are given in notes.

Another example illustrating methods of dimensioning is shown in Fig. 3, which illustrates a steel part of odd or irregular shape. As the illustration shows, this piece has curved sections of different radii, and in dimensioning the drawing, it is necessary to give not only the radii but dimensions showing their centers. For instance, the center of the $4\frac{1}{8}$ -inch radius is located $1\frac{3}{8}$ inches from the horizontal center line and $5\frac{7}{8}$ inches from the vertical center line. The $2\frac{1}{2}$ - and $2\frac{3}{4}$ -inch radii are each struck from a vertical line, which is $1\frac{7}{8}$ inches to the left of the vertical center line. The $5\frac{1}{4}$ -inch radius shows that the length of the curved section at the left should be determined with reference to the $\frac{7}{8}$ -inch hole. When the center of an arc is not definitely located by dimensions, this shows that the location should be such that the arc joins neatly with the lines at each end.

Drawings of Parts for which Tolerances are Specified. — In the manufacture of machine parts, perfection is impossible,

although, with the machines and the precision measuring tools now available, it is practicable to finish work that is within exceedingly close limits of a given size. In ordinary manufacturing practice, however, such extreme refinement is unnecessary, and since it is also expensive, the modern method

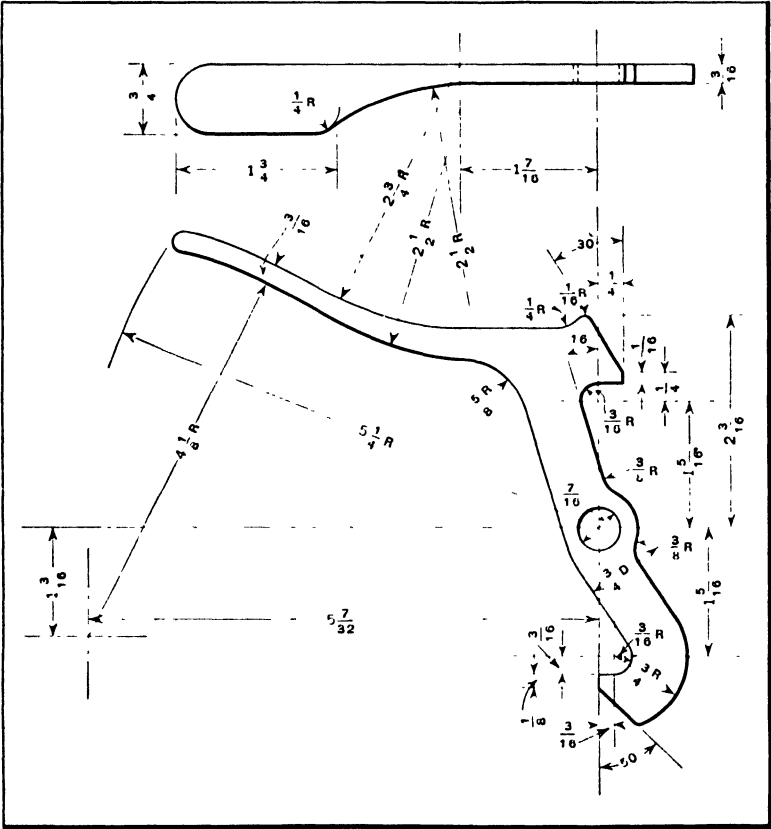

Fig. 3. Example illustrating Methods of indicating Radial Dimensions

of constructing machinery and tools is to adopt certain tolerances or allowable errors. The various parts forming the machine are then finished to some dimension which is within the minimum and maximum dimensions allowed. By the adoption of this method, parts can be produced which are accurate enough to serve all practical purposes, but not need-

lessly accurate, since the cost of production increases rapidly as the tolerance or allowable error is reduced.

If a dimension is given on a drawing and nothing is said about the tolerance, the usual assumption is that the part does not need to be finished very accurately, because most drawings of castings, forgings, or other pieces which are not regarded as precision work usually have plain dimensions and no tolerances are specified. Therefore, when a dimension is given without a tolerance, the degree of accuracy secured in a finished part may depend upon the judgment of the man doing the work. In order to avoid any misunderstanding regarding the degree of accuracy necessary for various classes of machine parts, tools, etc., the allowable errors or tolerances are usually given on the drawings of work which is considered in the precision class. The general practice, however, is not to specify tolerances for the rougher or less accurate work, although a few concerns give tolerances even though the work may be quite inaccurate.

What Tolerances are Based on. — In dimensioning drawings which require tolerances, it is necessary to decide in the first place what tolerances should preferably be allowed. This is a branch of work which requires considerable experience, and a draftsman or designer who has spent many years making drawings for interchangeable work might not be able to specify the proper tolerances, especially for some new form of mechanism, because the tolerances depend upon the class of mechanism and the degree of accuracy necessary in order to secure satisfactory operation. Very often draftsmen, especially if inexperienced, specify tolerances that are much smaller than they should be, because this is considered safe practice. The difficulty with this method is that the cost of manufacture is often greatly increased without improving the quality of the product, because when the tolerances are not so large that they interfere with the operation or durability of the mechanism, they do not affect the quality.

In view of the fact that tolerances depend upon the nature of each part and its purpose, the man in an organization most

competent to decide what tolerances should be allowed for a new mechanical device, might be the chief draftsman, the shop superintendent, or someone else. In any case the decision should not be regarded as final until the actual operation of the mechanism has demonstrated that the parts are neither too loose nor unnecessarily accurate. The exact methods of machining and gaging each piece are other factors which enter into this problem and make it more complex. The draftsman should understand why tolerances are allowed, what they are based on, and how they should be indicated on drawings, even though he may not always be competent to decide what tolerances should be adopted.

It is often assumed that draftsmen who have had considerable experience and who know something about shop practice are capable of specifying the tolerances and that the tool and gage designers can use these same tolerances without modification. It is not practicable, however, for a draftsman, or even an experienced designer, to give the proper tolerances in all cases, especially if some new form of mechanism is being designed. If the draftsman specifies tolerances that are too small, the mechanism may operate satisfactorily, but in order to machine the work to the degree of accuracy specified, impracticable machining and gaging methods might be necessary, thus greatly increasing the cost of production. Many manufacturers who did government work during the war had great difficulty because tolerances were unnecessarily small.

Relation between Tolerances and Manufacturing Methods.

—As the determination of suitable tolerances is of great importance in manufacturing all machinery and tools, according to the interchangeable plan, this subject should be thoroughly understood. The first principle to bear in mind is that the tolerances are directly related to the purpose and action of the mechanism and that they should be as large as possible and not unnecessarily small. When tolerances are established with this principle in mind, the manufacturing costs, to say nothing of the initial cost of special tools, can be greatly reduced.

While the tolerance must be based primarily upon the purpose and action of the mechanism, it is also essential to consider the methods of machining and gaging. While tolerances may be given for some dimensions, such as the sizes of holes, shafts, screw-thread diameters, or other work which will be located for machining and gaged by methods known beforehand, it is impracticable to say what the tolerances should be for more complicated work until the exact method of gaging and machining it has been decided. The procedure outlined in the following has been employed to advantage by the Pratt & Whitney Co., in making drawings for accurate work: After a mechanism has been designed to perform whatever function is required, the design is not considered complete, but is analyzed to see if it cannot be changed so as to reduce the cost of manufacture without impairing the effectiveness of the working of the mechanism. When the design has been simplified as much as it can be without interfering with the functioning of the device, other modifications may be made if they will permit the use of better tools or gaging methods.

The assembly and detail drawings for very accurate work have the general dimensions but without tolerances, except, possibly, temporary ones to give the tool and gage designers a general idea of what is required. In some instances, a certain tolerance might be absolutely necessary in order to insure the proper operation of the device, in which case it would be placed on the preliminary drawing. The tool and gage designers cooperate with each other until all the tool and gaging equipment has been designed or selected. It is essential in connection with this work that the dimensions be related to points on the work that are naturally adapted for gaging and locating purposes. When all of the tolerances have been determined by considering the functioning of the device and practical means of machining and gaging it, these tolerances are placed upon the tool drawings.

Working Drawings without Tolerances. — A great many working drawings have the dimensions given in inches and fractional parts of an inch, but without tolerances. On such

drawings common fractions are used, such as $\frac{1}{2}$, $\frac{1}{4}$, $\frac{1}{8}$, $\frac{1}{16}$, $\frac{1}{32}$, or $\frac{1}{64}$ inch. Examples of this method of dimensioning are shown in Figs. 2 and 3. One not familiar with drafting practice might infer that a part dimensioned in this way was to be made as closely as possible to the given dimensions, and that when less accuracy were required, this would be indicated by specifying tolerances. But, according to the general custom, when the dimensions are expressed by common fractions, it is understood that no great degree of accuracy is required, and when drawings are for parts which must be accurate and, perhaps, interchangeable, decimal fractions are then used and the tolerances are generally given.

The objection to the first method is that it is indefinite and allows considerable latitude for individual judgment, unless it is understood that a certain error is allowable when no tolerance is given. Even if a length need not conform to a given dimension within $\frac{1}{8}$ inch, there is good reason for specifying this tolerance on the drawing, because the workmen will then know what is required, but at the present time this is not the general practice when the drawings are for work which is not considered in the precision class. When a fractional dimension is not accompanied by a tolerance, it is the general rule in many shops to allow a tolerance of plus or minus 0.010 inch. If the dimensions must be within closer limits, the tolerance is specified.

Basic Dimension. — The basic dimension or size of a machine part is the theoretical or nominal standard size from which variations are made. For example, a shaft may have a basic diameter of 2 inches, but a maximum variation of minus 0.005 inch may be permitted. The minimum hole should be of basic size in all cases where the use of standard tools represents the greatest economy. The maximum shaft should be of basic size in all cases where the use of standard purchased material, without further machining, represents the greatest economy, even though special tools are required to machine the mating part.

Meanings of the Terms "Limit," "Tolerance," and "Allowance."—The terms "limit" and "tolerance" and also "tolerance" and "allowance" are often used interchangeably, but each has

a distinct meaning and refers to different dimensions. As shown by the illustration, Fig. 4, the *limits* of a hole or shaft are its diameters. *Tolerance* is the difference between two *limits* or limiting dimensions of a given part, and the term means that a certain amount of error is tolerated for practical reasons. *Allowance* is the difference between limiting dimensions on mating

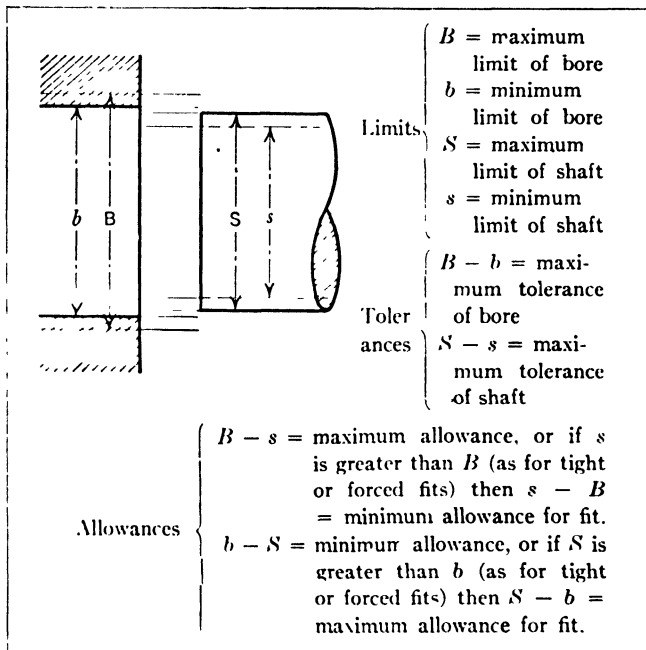

Fig. 4. Diagram Showing Difference Between "Limit," "Tolerance" and "Allowance"

parts which are to be assembled either loosely or tightly, depending upon the amount allowed for the fit.

Unilateral and Bilateral Tolerances. — The term "unilateral tolerance" means that the total tolerance, as related to a basic dimension or size, is in *one* direction only. For example, if the basic dimension were 1 inch and the tolerance expressed as $1.00 - 0.002$, or $1.00 + 0.002$, these would be unilateral tolerances, since the total tolerance in each case is in one direction. If the tolerance were divided, so as to be partly plus and partly minus, it would be "bilateral." Thus, $\begin{matrix} +0.001 \\ -0.001 \end{matrix}$ is an example

of bilateral tolerance, because the total tolerance of 0.002 is given in two directions.

Tolerance Standardization in Different Countries. — National standard systems of applying tolerances have been established in the United States, Austria, Germany, Great Britain, Holland, Sweden, and Switzerland. All national standards, except the British, are based exclusively on the unilateral system of tolerances. The British standard gives both the unilateral and the bilateral systems, recommending the former. The national standards, with the exception of the American, the British, and the Dutch, give both the basic hole and the basic shaft systems. The United States and Great Britain have adopted the basic hole system, Holland the basic shaft system exclusively.

Relation of Tolerances to Limiting Dimensions and How Basic Dimension is Determined. — The absolute limits of the various dimensions and surfaces indicate danger points, inasmuch as parts made beyond these limits are unserviceable. A careful analysis of a mechanism shows that one of these danger points is more sharply defined than the other. For example, a certain stud must always assemble into a certain hole. If the stud is made beyond its maximum limit, it may be too large to assemble. If it is made beyond its minimum limit, it may be too loose or too weak to function. The absolute maximum limit in this case may cover a range of 0.001 inch, whereas the absolute minimum limit may have a range of at least 0.004 inch. In this case the maximum limit is the more sharply defined.

The basic size on the drawing is that limit which defines the more vital of the two danger points, while the tolerance defines the other. In general, the basic dimension of a male part such as a shaft, is the maximum limit which requires a minus tolerance. Similarly, the basic dimension of a female part is the minimum limit requiring a plus tolerance. There are, however, dimensions which define neither a male nor a female surface, such for example as dimensions for the location of holes. In a few cases of this kind, a variation in one direction is less dangerous than a variation in the other. Under these conditions, the basic dimension represents the danger point, and the

unilateral tolerance permits a variation only in the less dangerous direction. At other times, the conditions are such that any variation from a fixed point in either direction is equally dangerous. In such a case, the basic size represents this fixed point and tolerances on the drawing are bilateral.

When Allowance Provides Clearance Between Mating Parts.—When one part must fit freely into another part as a shaft in its bearing, the allowance between the shaft and bearing represents a clearance space. Obviously the clearance varies widely for different classes of work. The minimum clearance should be as small as will permit the ready assembly and operation of the parts, while the maximum clearance should be as great as the functioning of the mechanism will allow. The difference between the maximum and minimum clearances defines the extent of the tolerances. In general, the difference between the basic sizes of companion parts equals the minimum clearance, and the term “allowance,” if not defined as maximum or minimum, is commonly applied to the minimum clearance.

When “Interference of Metal” is Result of Allowance.—If a shaft or pin is larger in diameter than the hole into which it is forced, there is interference between the parts. The metal surrounding the hole is expanded and compressed as the shaft is forced into place. Car axles and various other parts are assembled in this way.

If interchangeable parts are to be forced together, the minimum interference establishes the danger point. This means that for force fits the basic dimension of the shaft or pin is the minimum limit requiring a plus tolerance, while the basic dimension of the hole is the maximum limit requiring a minus tolerance.

Methods of Expressing Tolerances on Drawing.—There are several different methods of indicating tolerances on drawings. The two most common methods are as follows:

1. The maximum and minimum limiting dimensions are given. Example: $\frac{2.250}{2.246}$. This method, according to the

American Standard, should be used for smaller parts or where gages are employed extensively. For *external* dimensions the maximum limit is placed above the line and for *internal* dimensions the minimum limit is placed above the line.

2. A second method which, according to the American Standard, is used for larger parts and where few gages are employed, is to give the basic size followed by the plus and minus tolerance with the plus above the minus. Example: $6.25 \pm \begin{smallmatrix} 0.000 \\ 0.004 \end{smallmatrix}$. This tolerance is *unilateral* or in one direction only from the basic or desirable dimension of 6.25 inches. If the tolerance is *bilateral* or divided relative to the basic dimension, the dimension previously given might be written as follows: $6.25 \pm \begin{smallmatrix} 0.002 \\ 0.002 \end{smallmatrix}$.

Many draftsmen combine the plus and minus signs and only give half of the total tolerance. For example, 2.250 ± 0.003 . This means that the diameter is 2.250 either plus or minus 0.003. The first method is somewhat more definite, and it would be necessary when the tolerance is not equally divided as is sometimes the case. Example: $2.250 \pm \begin{smallmatrix} 0.002 \\ 0.001 \end{smallmatrix}$. The two limiting dimensions might also be given for a bilateral tolerance. For example, $\frac{2}{2} \frac{253}{217}$. When the limiting dimensions only are given, it is impossible to determine whether the tolerance is unilateral or bilateral, although in this particular case one might guess that the basic dimension is 2.250.

Dimensioning Drawings to Insure Obtaining Required Tolerances.—In dimensioning the drawings of parts requiring tolerances, there are certain fundamental rules that should be applied.

Rule 1. In interchangeable manufacturing there is only one dimension (or group of dimensions) in the same straight line which can be controlled within fixed tolerances. This is the distance between the cutting surface of the tool and the locating or registering surface of the part being machined. Therefore, it is incorrect to locate any point or surface with tolerances from more than one point in the same straight line.

Rule 2. Dimensions should be given between those points which it is essential to hold in a specific relation to each other. The majority of dimensions, however, are relatively unimportant in this respect. It is good practice to establish common location points in each plane and to give, as far as possible, all such dimensions from these points.

Rule 3. The basic dimensions for interchangeable parts should be, except for force fits and other unusual conditions, the "maximum metal" sizes (maximum shaft or plug and minimum hole.) The direct comparison of the basic sizes should check the danger zone, which is the minimum clearance condition in the majority of cases. It is evident that these sizes are the most important ones, as they control the interchangeability, and they should be the first determined. Once established, they should remain fixed if the mechanism functions properly and the design is unchanged. The direction of the tolerances, then, would be such as to recede from the danger zone. In the majority of cases, this means that the direction of the tolerances is such as will increase the clearance. For force fits, the basic dimensions determine the minimum interference, while the tolerances limit the maximum interference.

Rule 4. Dimensions must not be duplicated between the same points. If dimensions are duplicated, changes are liable to be made in one place and not in the others. It causes less trouble to search a drawing to find a dimension than it does to have them duplicated and more readily found but inconsistent.

Rule 5. As far as possible, the dimensions on companion parts should be given from the same relative locations. Such a procedure assists in detecting interferences and other improper conditions.

Examples of Correct and Incorrect Dimensioning. — The upper drawing, Fig. 5 shows a common method of dimensioning a part such as the stud shown, but one that is bad practice. It violates the first and second rules. As the dimensions given for the diameters are correct, they are eliminated from the discussion. The dimensions given for the various lengths are wrong: First, because they give no indication as to the essential lengths;

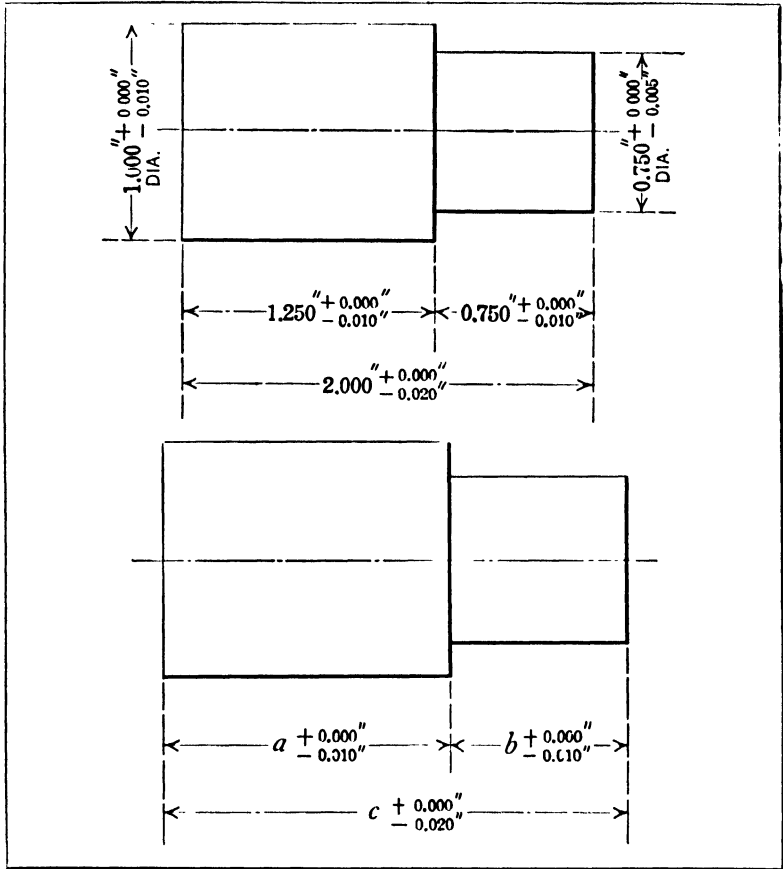

Fig. 5. An Example of Incorrect Dimensioning

second, because of several possible sequences of operations, some of which would not maintain the specified conditions.

The lower view, Fig. 5, shows one possible sequence of operations indicated alphabetically. The main dimensions are represented by letters a , b and c so they can be referred to more conveniently. If we first finish the dimension a and then finish b , the dimension c will be within the specified limits. In this case, however, the dimension c is superfluous. If we first establish c and then b , the dimension a may vary 0.030 instead of 0.010 inch as is specified. If we first finish the over-all length c , and

then the length of the body a , the stem b may vary 0.030 inch instead of 0.010 inch as specified.

If three different plants were manufacturing this part, each one using a different sequence of operations, it is evident from the foregoing that a different product would be received from each plant. The example given is the simplest one possible. As the parts become more complex, and the number of dimensions increase, the number of different combinations possible and the extent of the variations in size that will develop also increase.

The correct way to dimension this part if the length of the body and the length of the stem are the essential dimensions is to give dimensions a and b . If the length of the body and the length over all are the most important give dimensions a and c . If the length of the stem and the length over all are the most important give dimensions b and c .

Arrangement of Dimensions for Locating Holes. — When it is necessary to locate several holes on a drawing, or possibly a large number, the dimension lines may be arranged in different ways; there is no general rule which may be followed under all conditions simply because the dimensions are primarily for the use of the machinist or toolmaker, and there is a close relationship between the method of dimensioning and the method of doing the work. The form or shape of the part in which holes are required and the degree of accuracy necessary are also points to be considered. A drawing with the dimensions arranged in a certain way might be entirely satisfactory in one shop or tool-room and not in another, where the measuring or tool equipment is different. A few simple examples will illustrate the principle underlying different methods of dimensioning and the relation between these methods and the work of the shop man.

The diagram A , Fig. 6, shows a rectangular plate which is dimensioned according to the following plan: First the principal hole a is located from the adjacent edges of the plate. From this main hole a (which might be any hole that is considered the most important) the other holes are located by dimensions placed between horizontal and vertical center

lines intersecting the different holes. (The diameters of the holes have been omitted in this and the other illustrations so that the different methods of arranging the hole-locating dimensions will stand out more clearly.)

While dimensions arranged as shown at *A* enable each hole to be located, it is necessary to add the dimensions to obtain some center-to-center distances as, for example, the distance

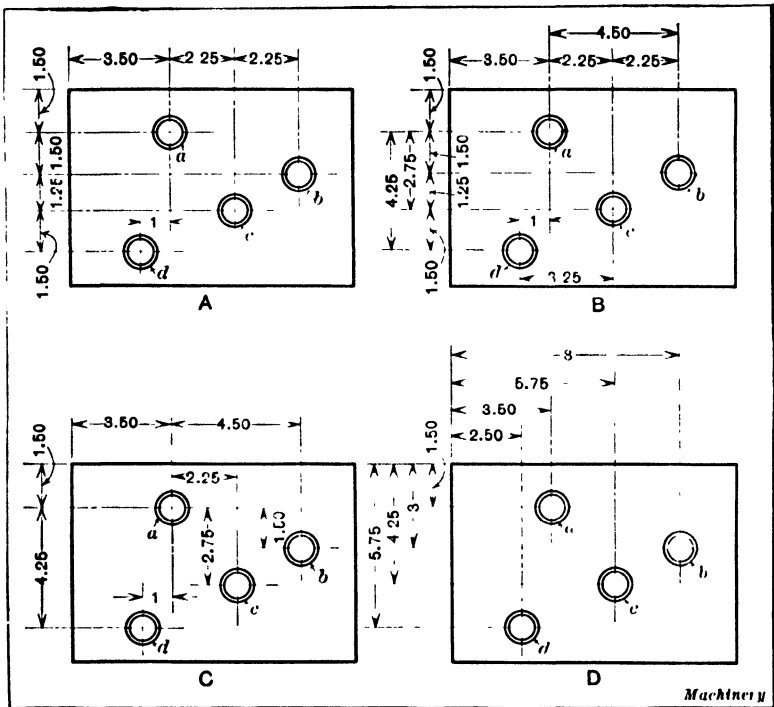

Fig. 6. Different Methods of Dimensioning for Locating Holes

between the center lines of holes *a* and *b*. This might be considered an objection on a drawing used in the manufacture of duplicate parts, but of little consequence when a drawing is used by a toolmaker in the production of one or, at most, a few plates. Opinions differ in regard to points of this kind, which accounts in part for the various methods of dimensioning found on drawings made in different drafting-rooms.

The advantage of the method shown at *A* is that the number of dimensions used is reduced to a minimum and if changes are to be made, the work is simplified; both of these features are very important, especially when a drawing is complex and represents a part having a large number of holes located irregularly. The drawing at *A* is also clear and not likely to be misread.

A modification of the method shown at *A* is illustrated at *B*. In this case, additional dimensions have been placed on the drawing, the object being to give all center distances directly so that addition of dimensions will not be necessary. Many draftsmen would contend that this method of dimensioning is superior to that shown at *A*, but in making such comparison the purpose of the drawing should be considered. While dimensions for locating only four holes might preferably be arranged as shown at *B*, if there were many holes the drawing would be needlessly complex and confusing, because of the use of both over-all and center-line to center-line dimensions.

The method of dimensioning shown at *C* differs to some extent from the others referred to, as all dimensions are direct from vertical and horizontal center lines intersecting the principal hole. For instance, the horizontal distances from the vertical center line to holes *b*, *c*, and *d* are given and also the vertical distances from the horizontal center line to holes *b*, *c*, and *d*. A method of dimensioning master plates, which is similar in principle, will be dealt with later.

Base-line Method of Dimensioning. — A fourth method of dimensioning, shown at *D*, Fig. 6, is sometimes called the "base-line" method, because all dimensions are direct from two finished edges, each of which serves as a base. This method is applicable when the work has finished edges at right angles to each other, and plates of irregular shape may be mounted on an auxiliary plate having such edges. The dimension lines of all four methods that have been referred to are at right angles to each other, and in no case have dimensions been given to show the center distance between the

holes in a straight line. This right-angle method, as it might be called, is practicable for many classes of work, because the adjustments made by the machinist or toolmaker when locating the work for drilling and boring are frequently in two directions at right angles to each other, the machines or other work-holding equipment being arranged in this way. The direct center-to-center distance, however, is often required, which indicates that the method of arranging the dimensions on a drawing may be very closely related to shop and tool-room practice.

Basing System of Dimensioning on Shop or Tool-room Methods. — The relation between the method of dimensioning and the particular method of doing the work in a shop or tool-room is an important point for the draftsman to consider. If a number of holes are to be drilled and bored in a plate, the latter may be located for each hole by adjusting the machine table in two directions at right angles to each other. These adjustments can be made very accurately on precision jig boring machines which have proved efficient for all classes of work requiring the drilling and boring of holes to given center-to-center distances within close limits. Special vernier scales are also used at times to secure more accurate adjustments than would be possible with a plain scale. For instance, these verniers are sometimes applied to milling machines which are used for boring jig plates or other precision work. Holes are also located in work of the precision class, either by the so-called button method, the size-block method, or the disk method. When these methods are employed, the accuracy obtained does not depend upon the adjustment of a machine slide which may be controlled by an inaccurate screw.

Briefly, the button method consists in attaching to the work very accurate cylindrically shaped buttons or bushings which are held in place by small screws tapped into holes that are smaller than the holes required, and are located approximately where the holes are needed. These buttons are first set very accurately according to the dimensions given on the

drawing; then one button after another is set exactly concentric with the spindle of a bench lathe or any suitable machine, by using some form of indicator, and the different holes are bored in successive order. The use of buttons enables the toolmaker to locate the holes very accurately because he can measure by a micrometer or vernier caliper just how far the buttons are apart, so that the method is positive. The relation between this button method and the system of dimensioning will be considered a little later.

The size-block method consists in adjusting the plate in two directions at right angles to each other, and standard size blocks are used to determine the amount of adjustment instead of relying upon a machine table, even though the latter may have a graduated dial reading to thousandths of an inch. One method of using size blocks is as follows: Two parallels are accurately located at right angles to each other and the size blocks are placed between the parallels and the edges of the work to secure whatever horizontal and vertical adjustments are necessary. If the plate does not have square finished edges, it may be mounted on an auxiliary plate and the size blocks are then inserted between the parallels and this auxiliary plate. If the work is being bored in a lathe, it is held against an accurate faceplate, and after each hole is drilled and bored, the plate is shifted in two directions at right angles to each other by inserting size blocks conforming to the required dimensions. The draftsman should understand, at least in a general way, these locating methods, particularly if he is to make drawings of precision work that must be located by them.

The disk method, which is often used in connection with watch work and other small precision work, is so called because the holes are located by means of disks instead of buttons. These disks are accurately ground to such diameters that when their peripheries or edges are in contact, the center of each disk will coincide exactly with the position of the hole to be bored. In order to locate a hole, the disk — which is temporarily attached to the work — is first set exactly con-

centric with the lathe spindle by using a test indicator, and then this disk is removed for drilling and boring the hole. The other holes are then located in the same manner. These different methods of locating work have been referred to because they are closely related to different methods of dimensioning drawings, as will be more apparent after studying the following examples.

Considering now the relation between the method of dimensioning and the method of doing the work, it will be apparent that if a jig plate were dimensioned as shown in Fig. 6 it would be adjusted in two directions at right angles to each other for locating the holes, because horizontal and vertical dimensions are given. If the work were located simply by adjusting the table of, say, a milling machine and the hole *a* were drilled and bored first, the table might then be adjusted horizontally and vertically to correspond to the location of hole *b*. Then it would again be moved horizontally and vertically for holes *c* and *d*, respectively.

If the drawing were dimensioned as at *C*, the vertical and horizontal center lines could each be considered as the zero line and all adjustments be made directly from them. Suppose, for instance, that the adjustments of the machine table were used, the movements being indicated by graduated dials. If these dials were set at zero when the machine was properly adjusted for boring hole *a*, the adjustments for all of the other holes could then be obtained by direct readings, and this same principle would apply in case the size blocks were used. A drawing dimensioned as at *C* would be more convenient than one dimensioned as at *A*, because the former gives the dimensions relative to the zero positions.

Center-to-center Dimensions for Locating Holes. — While any of the drawings illustrated in Fig. 6 could be used for locating the work, either by adjusting the compound slides of a machine table or by means of the size-block method previously described, if the button method were employed, the dimensions could be arranged so as to be more convenient and useful to the toolmaker, provided it were considered neces-

sary to check the center distances by direct measurements, which is usually the case with precision work. If the work had two finished edges at right angles to each other and the base-line method of dimensioning (illustrated at *D*, Fig. 6) were practicable, the buttons could then be set easily by placing the work on a surface plate with first one edge and then the other in contact with the surface plate, so as to measure in both directions by using a vernier height gage. As the total distance to each hole is given, the height gage could be set

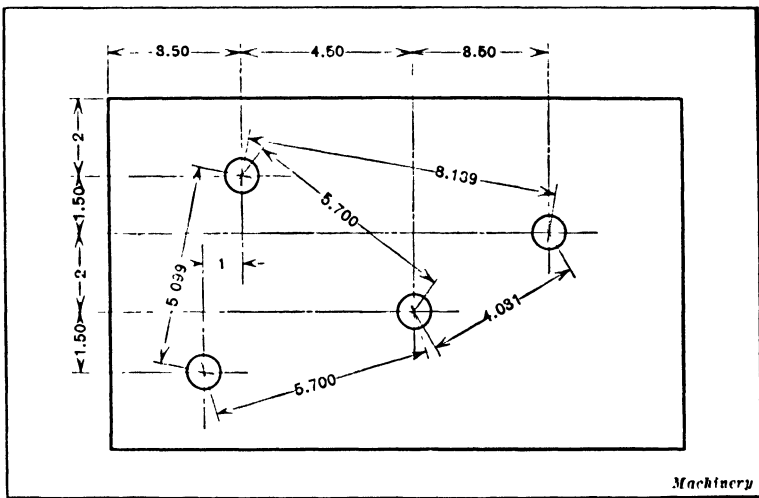

Fig. 7. Drawing on which Center-to-center Distances between Holes are given to avoid Calculations in Tool-room

by referring directly to the dimensions. But after setting the buttons by this method, the toolmaker would have to calculate the center-to-center distance between the holes, if it were considered necessary or desirable to check the location of the buttons by direct measurement. Any of the drawings shown in Fig. 6 give the lengths of two sides of a right-angle triangle, from which the length of the hypotenuse may be determined in order to check the center-to-center distance by direct measurement.

The drawing shown in Fig. 7 has these center distances, and for this reason is more convenient for the toolmaker when

measurements over the buttons are required. These center distances might, of course, be included on drawings dimensioned according to any of the methods illustrated in Fig. 6. When checking the distance between two buttons, the usual method is to measure the over-all dimension or the distance from the outside of one button to the outside of the other. The center-to-center distance, however, should always be given on the drawing. The toolmaker then adds to this dimension an amount equal to the diameter of whatever size buttons are used, all buttons for any one job being of the same diameter. The center-to-center distances are also needed when the holes are located by the disk method. If a jig plate or master plate has a large number of holes, the center distances of only those holes which must be very accurately located might properly be given on a separate view or diagram, which would show clearly just where great accuracy is necessary. A knowledge of the conditions governing each case must be considered and the aim of the draftsman should be to help the shop man whenever possible even though this involves departing occasionally from customary practice.

Cross-slide and Angular Methods of Dimensioning. — Two methods of dimensioning drawings, known, respectively, as the "cross-slide" and "angular" methods, are sometimes utilized in connection with drawings of master plates or other precision work, particularly when it is necessary to locate a series of irregularly spaced holes. Master plates are often used to insure locating, with great accuracy, a number of holes in several duplicate plates. These master plates are used by watch manufacturers and also by toolmakers and model-makers. Two methods of dimensioning which have been applied to the making of watch master plates, are illustrated diagrammatically in Fig. 8 which illustrates the principles involved.

The cross-slide method of dimensioning is shown at *A*. As will be seen, the drawing has horizontal and vertical center lines and each hole is located relative to these center lines by giving the horizontal and vertical dimensions. These dimen-

sions, in each case, represent the total distances from the center lines to the hole. When the dimensions for the master plate are given in this way, it is because the draftsman knows that the plate is to be located for boring each hole by adjusting it in two directions at right angles to each other. In one of the large watch factories, a special bench lathe faceplate having compound slides is sometimes used for drilling and boring master plates. The cross-slides are located at right

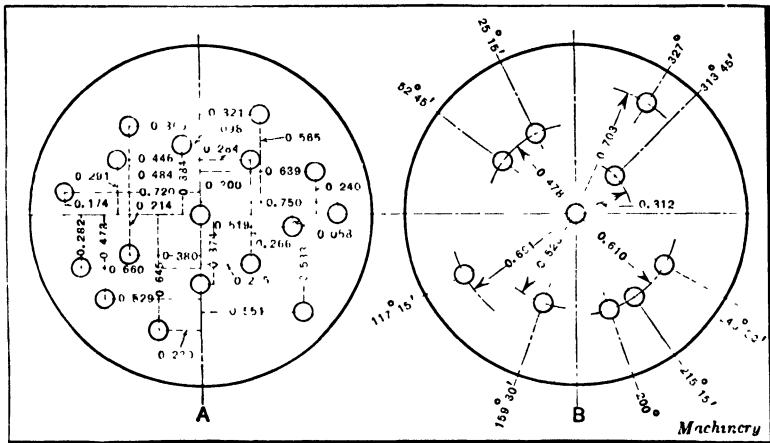

Fig. 8. Two Methods of dimensioning Master Plates such as are used in Watch Manufacture

angles to each other and are equipped with micrometer screws which afford a rapid and accurate method of adjusting the plate.

The angular method of dimensioning shown at *B* in Fig. 8 is considered superior to the cross-slide method in some cases. All holes that are the same distances from the center are connected by an arc, and the location of each hole is determined by the radius of its arc and the angle in degrees and minutes between the hole and a vertical center or zero line. The fixture for holding the master plate dimensioned in this way must, of course, be arranged both for radial and angular adjustments, and if considerable accuracy is necessary, a vernier should be used in conjunction with the degree graduations,

Some of the holes in watch plates do not need to be located with the degree of precision required in some other classes of work, and when there are several series of holes each located on the same arcs or at the same radial distances, the angular method of locating them is very convenient. For example, if two holes are located 0.293 inch from the center and another series of four holes is located 0.495 inch from the center, the plate is first adjusted radially 0.293 and is then set to correspond to the angles between the two holes on this arc. If the four holes mentioned are the next in order, the slide is adjusted radially to the 0.495 position, and then in an angular direction for locating each of the holes on this arc. The same procedure is, of course, followed for all of the other holes, and this is a very convenient and rapid method for the class of work to which it is applicable.

There are certain holes in watch master plates which are not located by either the angular method or the cross-slide method, as a more positive and accurate way is required. Such dimensions as the "depthings" of the train and the escapement usually require locating a certain hole accurately from two other holes or points. These dimensions may be secured from some other master plate or model, or they may be arrived at by computation. For operations of this kind, the location of the master plate for drilling and boring is frequently controlled by means of the disk method, which has already been referred to. When the button method is employed, as in the case of larger master plates than are used for watch work, the center-to-center distances should be given on the drawing, as mentioned before, and a separate view may be preferable containing only these center dimensions, particularly if there are many closely spaced holes and other dimensions with little room for all of them on one view.

Designating Angles and Tapers. — The dimensions of angles may be given in degrees and minutes, in which case the dimension line is an arc with its center usually at the intersection of the two lines forming the angle, as shown at *A* in Fig. 9. If the angle of a conical part is given, it may be the

included or total angle as at *B* or one half the included angle, which is the inclination of one side relative to the axis as at *C*. The angle, however, is not always given relative to the axis as will be explained later in connection with Fig. 10.

The inclination of a tapering plug or hole might be expressed either in degrees, in inches of taper per foot, by a name and number, or by giving the diameter of the large and small ends of the tapering part. The practice varies considerably and depends somewhat upon the amount of taper and whether or not it conforms to some standard. When the taper is very small, the taper in inches per foot is often given and the diameter at one end. The tapers of tool shanks and sockets are

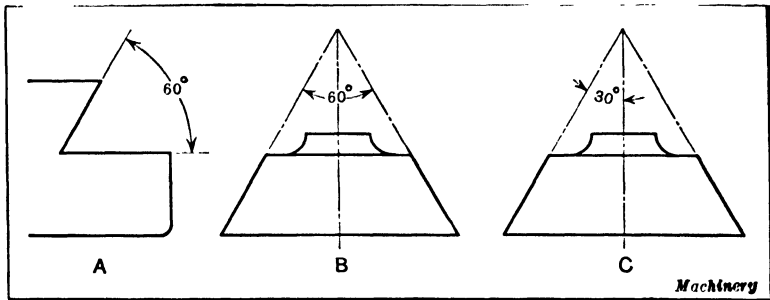

Fig. 9. Designating Angles on Drawings

indicated by name and number. For instance, if the tapering end or shank of a reamer were marked "No. 4 Morse taper," this would mean that the No. 4 size of the Morse standard was required. The Brown & Sharpe and Jarno are other well-known standards for tapers. The various numbers and their corresponding dimensions are listed in engineering handbooks. Gages which conform to the different numbers are ordinarily used in shops handling work of this kind, so that it is not necessary to give the actual dimensions on the drawing.

Sizes of taper pins, such as are used for doweling parts together or for securing collars or hubs to their shafts, are also designated by numbers. These numbers for the generally accepted standard range from No. 0 to No. 10, and sizes

smaller than No. 0 are, according to the practice of the largest maker of taper pins in the United States, indicated by zero marks varying from No. 00 to No. 000000. These sizes below No. 0, however, do not conform to a universally recognized standard. Incidentally the numbers indicate the diameters of pins at the large ends and the length of the pin varies to suit conditions.

Specifying Angles that Conform to Machine Graduations. — The preferable method of designating angles depends some-

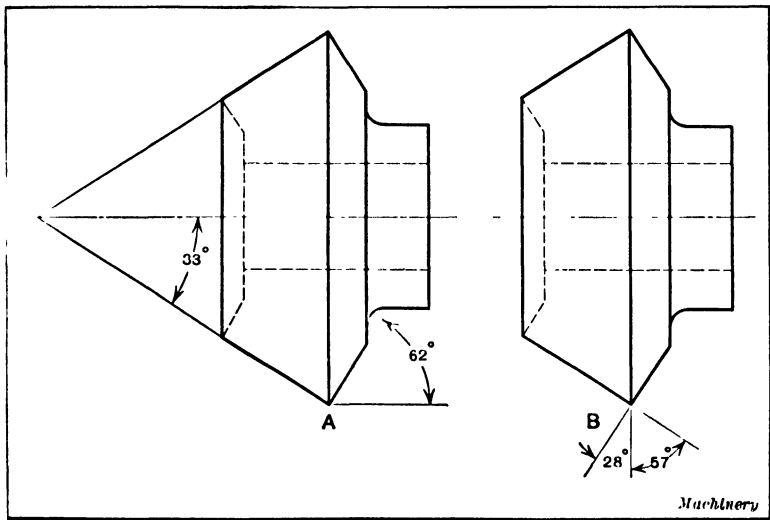

Fig. 10. (A) One Method of giving the Face and Edge Angles of a Bevel-gear Blank. (B) A Drawing of the Same Bevel-gear Blank with Angles given which conform to Machine Graduations

what upon the way the work is to be handled. As a general rule, angles should be given which correspond to the angular graduations on whatever machine parts need to be adjusted for machining the tapering surfaces. This point is illustrated by a comparison of sketches *A* and *B*, Fig. 10, which represent a bevel pinion blank. On sketch *A* the angle of the conical face, relative to the axis, is given as 33 degrees, which is one half the included angle, and the inclination of the beveled edge is given with reference to a line parallel with the axis. If this blank is to be turned on an engine lathe, the compound

slide would not, of course, be set to 33 degrees, but to 57 degrees when turning the conical face, and if the bevel edge is also turned by means of the compound slide, the latter would be set to 28 degrees, and not to 62 degrees. If these angles were given as illustrated at *B*, they would then correspond to the angular position of the tool-slide as represented by its graduations, which is preferable for the shop man. While it is a simple matter to determine what the position of the compound slide should be when the angles are given as shown at *A*, the fact remains that many machinists are puzzled and are obliged to ask questions when the angle on the drawing does not show directly the angular position of a machine slide.

Angles are given in degrees and minutes when a fractional part of a degree must be indicated on the drawing. Thus $14\frac{1}{3}$ degrees would be written $14^{\circ} 20'$. If the graduations on a machine tool are in degrees, it is possible, of course, to judge one half or one fourth of a degree quite closely. For instance, if the angle specified were 74 degrees 45 minutes and the machine graduations were in degrees only, which is the common method of graduating on ordinary machine tools, the tool-slide could be set to 74 degrees plus three fourths of a degree quite closely, but when angular work is in the precision class, as in toolmaking and gage-making practice, either a gage or a sine bar is employed instead of relying upon the setting of a machine slide, although some machines and fixtures designed for accurate work have vernier attachments for the angular graduations.

Tabulated Drawings. — In plants where small tools or relatively simple mechanical devices are manufactured, which vary in regard to size but are all of the same general form, what are known as "tabulated drawings" are used. A drawing of this kind does not have the dimensions marked directly on it, but letters are used instead and the corresponding dimensions are given in a table which accompanies the drawing. Such drawings are not as convenient to work from as those having the dimensions on them and errors are more easily

made with tabulated drawings, so that this plan has not been adopted very generally for shop or working drawings. The tabulated drawings, however, are convenient for reference purposes. An example of a tabulated drawing is shown in Fig. 11. This drawing represents three views of a pivoted clamp intended for the use of toolmakers. This clamp is made in four different sizes, as indicated by the numbers to

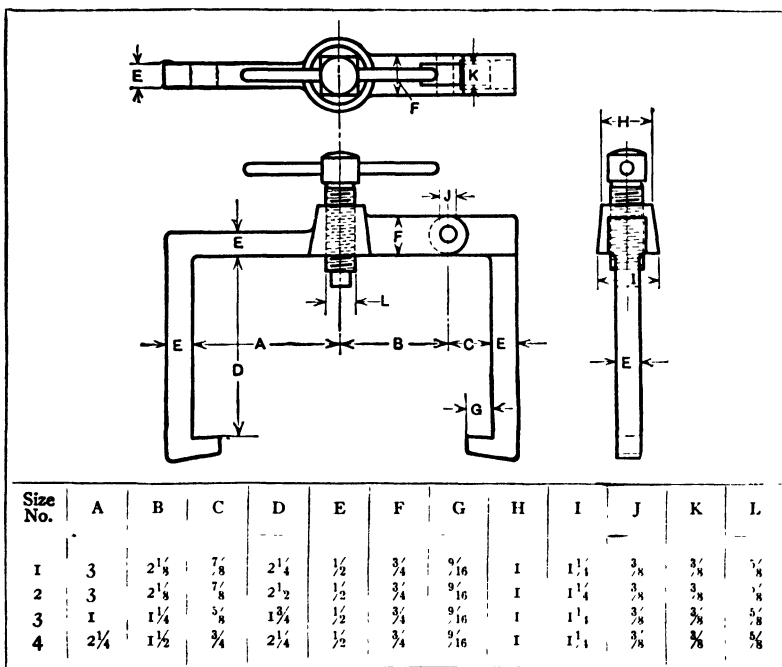

Fig. 11. Tabulated Drawing for Toolmaker's Clamps of Different Sizes

the extreme left in the table, and the figures beneath the different letters represent the dimensions corresponding to these letters on the drawing.

Tabulated Tool Drawings.—In all large factories doing considerable tool work, as in the automobile line, there are many tool drawings which are of similar design but of varying dimensions. These tool drawings are principally of small tools, such as reamers, taps, arbors, gages, etc. Various

methods are in use to prevent a duplication of drawings and at the same time provide the shop with adequate information for manufacturing the tools. One of the most simple of these in common use is to have a large sheet, showing at the top a drawing of the tool wanted, with letters designating the various dimensions. The tabulations are filled in with all the necessary dimensions and give complete information as to sizes; then, when an order is issued for any tool shown on the drawing, the entire sheet is blueprinted and all entries are crossed out except those required.

This method, however, has its disadvantages, one of which is that in a short time the sheet becomes so crowded with figures that a draftsman, in looking it over, may pass by the dimension wanted and make an additional entry through failure to note the original. Another difficulty is that a draftsman cannot picture in his mind's eye just how the tool will look when completed. This is a serious fault, which has resulted in several freakish and unworkable tools being made. The tabulations also confuse the toolmakers and are objectionable to most of them.

Another system in vogue is to use the master tabulated sheet in the tool designing department only, and a blocked-in blueprint in the tool-room. Then, when an order is issued for the tool-room, the various dimensions are copied from the master tabulated sheet and entered on the corresponding blank spaces on the blueprint which is then sent to the tool-room as a working drawing. The confusion caused by the use of the previously mentioned system is eliminated when this method is used, but the other disadvantages remain, with the additional fault that mistakes are likely to be made in copying the entries on the print. These could be prevented by checking, but this entails additional work. Again, on some of the tools it is necessary to note an exceptional treatment, such as hardening, grinding, polishing, etc. To mark this on the master sheet would require a footnote or something similar. In filling out the blocked-in prints, these notes are sometimes ignored, resulting in an incorrect tool. Another drawback to

the system is that it is necessary to search for a desired entry, owing to the fact that the entries are recorded in the order of issuing them and not according to size, which is the information needed by the drafting-room in looking up data for any new work.

Individual Tracings of Tools. — In order to eliminate all the objections and at the same time maintain a correct record of tools of this kind, the following system has been established with good results in one of the country's largest automobile factories. An individual tracing (see Fig. 12) is made of

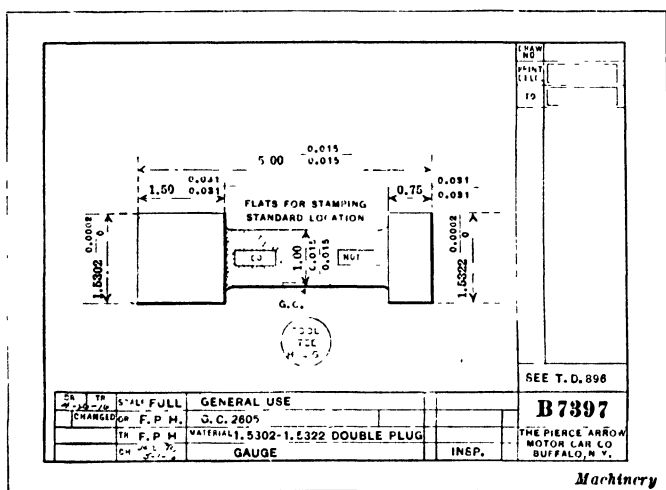

Fig. 12. Drawing of a Plug Gage

each tool, and although this may seem unnecessary, it is really not as big a proposition as it appears, as most of the drawings are simple. In the lower right-hand corner above the drawing number of the individual sheet, the number of the master sheet is recorded. The important dimensions (which are usually the diameter or length) as well as the number of the individual drawing and the distinguishing mark of the tool, are entered on a slip of paper and placed in a Rand visible file which is used as a permanent record.

The construction of the panel units in this file is such that the celluloid tubes can be readily moved about and replaced

or removed entirely, as desired. The units used are hung on rings erected on a central standard. These rings have a number of holes in which the hinges of the panel units swing. The rings can be changed and larger ones substituted, so that more panels can be used when necessary, and expansion can thus be readily taken care of as the index grows. The method of making the entries is extremely simple, as they can be made in less than a minute on the typewriter and are easily read. The slips are filed in order of size, so that any entries can be found in a minimum amount of time. Should an entry be canceled, it is a slight matter to remove the slip and advance all remaining entries to fill the vacant space. This system works out very well without any of the disadvantages incident to the method mentioned in the foregoing and, being capable of expansion, it may be continued indefinitely.

It has been found by experience that in order to have tools made that are suitable for manufacturing a certain part, it is necessary for the draftsman to make an individual drawing of each, in order to obtain the correct proportions. This necessitates at least a pencil drawing to scale, from which the dimensions may be transferred to the master sheet. To make a tracing of this tool drawing does not require more than an hour or so. In a factory the size of the one using the system referred to, the number of orders for these so-called tabulated tools is so large that the amount of time consumed in entering the dimensions on a blocked-in print would soon be considerably greater than that required to make a tracing. These tracings are checked and placed in a file so that they can always be used for reference. There is also an added advantage if some existing tool is to be used, as this can be easily determined by reference to the tracing. This is more apparent on manufacturing than on inspecting tools, but as the system mentioned covers 106 different types, something equally satisfactory for all must be used, which requirements are filled by this system.

Dimensions on One Drawing for Parts of Different Sizes.

— When a certain part is to be manufactured in several dif-

ferent sizes, dimensions for these various sizes are sometimes placed on one drawing, instead of using a tabulated drawing and to avoid making an original tracing for each different size. An example is shown in Fig. 13. This particular piece is required in six different sizes, which are designated by numbers 1 to 6. As will be seen, the dimensions for each size are numbered to correspond with the number of the part. For instance, in this case the over-all length of the smallest size, or No. 1, is $3\frac{1}{8}$ inches, whereas the largest size, or No. 6, has

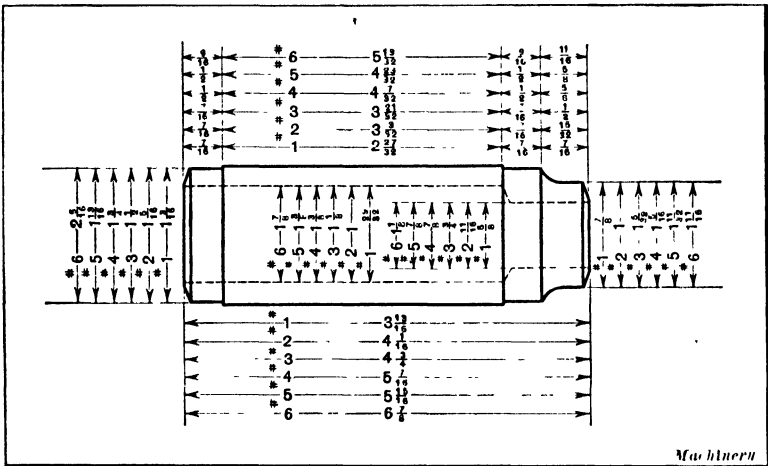

Fig. 13. Dimensions on One Drawing for Parts of Different Sizes

an over-all length of $6\frac{7}{8}$ inches. This method is practicable for simple parts provided the number of different sizes wanted is relatively small. If there were many sizes, difficulty would be experienced in finding room for the dimensions, especially on certain parts of the drawing where only a small amount of space is available. Sometimes, when there is insufficient room for the dimensions of interior surfaces, extension lines are used to permit placing the dimensions of holes, recesses, etc., outside of the limits of the drawing proper, but such an arrangement may prove confusing.

Another way to avoid making more than one original drawing of different sized parts which are the same, or practically

the same, in design, is as follows: The dimension lines are placed on the original tracing, but all dimensions which vary for parts of different sizes are omitted. Instead of the dimensions, solid black circular dots are drawn on the tracing and these form white spaces on the blueprints. A blueprint is made for each size, and the correct dimensions for each particular size are marked with ink in the blank spaces. The object of this plan is, of course, to avoid making more than one original tracing. Any dimension or information which applies to all of the different sizes is marked on the tracing, blank spaces being left only for dimensions which vary.

Drawings Dimensioned according to Metric System.—

When drawings are dimensioned according to the metric system of measurement, all dimensions are expressed in millimeters. The reason for not expressing the dimensions in decimeters or meters is the possibility of mistakes due to misplacing decimal points. No matter what the dimension is on a drawing showing machinery or machinery parts, the dimension is expressed in millimeters. This often means numbers of five figures, but the rule is invariable. The practice as regards scales is to use full $\frac{1}{5}$ and $\frac{1}{10}$ scales; if necessary, $\frac{1}{20}$, $\frac{1}{50}$ and $\frac{1}{100}$ scales may be used, but $\frac{1}{2}$, $\frac{1}{4}$, $\frac{1}{8}$ and other binary division scales are not recommended.

CHAPTER VII

INSTRUCTIONS ON WORKING DRAWINGS AND PROCEDURE WHEN CHECKING

MECHANICAL drawings frequently require, in addition to the complete dimensions, instructions in the form of either symbols, abbreviations, or explanatory notes. The object of such instructions may be to indicate the kind of finish desired, the method of heat-treatment, the kind of thread, the type of tool to use, as, for example, whether a drill or a reamer will finish a hole accurately enough, and any other information needed to make a drawing complete, both as a guide to the men in the shop and as a record of how the part is made. Abbreviations which have not become standard and are not generally understood, are objectionable and it is preferable to write out the word or expression so that the drawing will be self-explanatory.

Symbols and Abbreviations Used on Mechanical Drawings.—Only standard or generally recognized abbreviations should be used on drawings. Whenever there is a doubt, a note is preferable to an abbreviation or symbol because clearness is more important than brevity.

- $1\frac{1}{2}$ "—6NC—2.....American Standard screw thread — $1\frac{1}{2}$ inch, 6 threads per inch, National Coarse Series, Class 2 ft.
- $\frac{3}{4}$ "—16NF—3LH....Screw thread of National Fine-thread series, Class 3 ft, left hand. Threads right hand if not marked LH.
- U. S. S.United States Standard screw thread. Replaced by American Standard but U.S.S. still on many drawings.
- U. S. F.United States Standard thread *form* but not the standard number of threads per inch.
- NS.....Special threads of American National Form.
- NPT.....American Standard taper pipe thread.

NPS.....	American Standard straight pipe thread.
Csk80°.....	The abbreviation Csk (or C'sink) means countersink—in this case countersink having angle of 80 degrees.
$\frac{1}{8} \times 45^\circ$ Ch.....	Chamfer or bevel corner or edge indicated, to width of $\frac{1}{8}$ inch and to an angle of 45 degrees.
6 P.....	The letter P means diametral pitch of gear teeth or cutter. D. P. may also be used; thus 6 D. P.
8 P. D.....	A pitch diameter (P.D.) of 8 inches; applied to various classes of gearing.
4.262 C.P.....	A circular pitch (C.P.) of 4.262 inches. The circular pitch system is usually applied to large teeth.
S A E 2320.....	A Society of Automotive Engineers standard steel; number indicates general class of steel.
C.R.S.....	This is the abbreviation for "cold-rolled steel." (Such steel actually is cold drawn through a die.)
M.S.....	Machine steel or "machinery steel"—a low-carbon steel often used for parts of machines.
C.I.....	Cast Iron. This term is very indefinite and modern practice is to give specific information.
Gr.....	An abbreviation for <i>grind</i> , meaning that surface indicated is to be finished by grinding.
Hrd. and Gr.....	Means that part indicated is to be hardened and then finished by grinding.
<i>f</i>	Commonly placed across on line of drawing to show that surface is to be finished.
206 Brin.....	Hardness of material shown by Brinell test—206 Brinell in this example.
18 C Rock.....	Hardness of material as shown by Rockwell test, using C scale in this case.

Finish Marks.—What are known as "finish marks" are placed on drawings to show what surfaces need to be finished. The letter "*f*" is almost invariably used. This letter is placed with the cross-bar on the intersection of the line representing the surface to be finished. A drawing which has a number of these finish marks is shown in Fig. 2, Chapter VI, and illustrations will be found in other chapters. The letter should always be placed across the line so that it will be noticeable and the cross-line of the letter should preferably intersect that line on the drawing which represents the

surface to be finished. The practice of some concerns is to use the capital letter "F" with the foot resting on the line indicating the surface to be finished.

Finish marks are not always placed on drawings, because they are considered unnecessary. These marks will frequently be found on drawings of cast-iron parts and forgings to show clearly which surfaces are to be machined and which ones are to be left rough. Finish marks would be unnecessary on many drawings, because it is evident that certain, or all, surfaces require machining.

Symbols which Indicate Kind of Finish.—It is the practice in some drafting-rooms to use symbols which not only show what surfaces are to be finished, but indicate the kind of finish desired. For instance, the kind of finish may be designated by numbers; thus, the expression "No. 1 finish" might mean that the surface should be turned; "No. 2 finish," that it should be ground; "No. 3 finish," that it should be ground and polished; "No. 4 finish," that it should be ground and lapped. These numbers are selected arbitrarily and their use is not governed by any fixed standard.

According to the American Standard, a surface to be machined or "finished" from unfinished material such as a casting or a forging, should be marked with a 60-degree "∇," the bottom of the "∇" touching the line representing the surface to be machined or finished. A code figure or letter should then be placed in the opening of the "∇" to indicate the quality of the finish desired. The meaning of these code figures or letters should then be indicated by notes at the bottom or side of the drawings.

Instruments have been developed for indicating definitely the quality of finish on machined surfaces so that the degree of finish or smoothness can be controlled. One type of instrument shows the average height of surface irregularities and another instrument produces on a chart a graphic record of surface quality.

Explanatory Notes on Working Drawings.—Some of the

common mistakes made in using drawings could be avoided by a more liberal use of explanatory notes wherever mistakes were likely to occur. A drawing should tell its own story without the aid of an interpreter. If it needs an interpreter, it is seriously lacking. Standardization of practice in the making of mechanical drawings would be desirable, and also uniformity in conventions. The use of conventions, however, is sometimes misleading, because no matter how well they are commonly understood by the drafting fraternity, the conditions in modern shops will always lead to mistakes. Many men are employed in machine shops who have had no mechanical training and, consequently, have never studied mechanical drawing. Conventions are Greek to many machine operators and they must have the aid of the foreman or someone else to explain them. Notes in English are generally understandable and should, therefore, be employed in preference.

Explanatory notes are used to designate the kind of material, as, for example, machine steel, tool steel, cold-rolled steel, or steel of a certain carbon content. When several pieces of one kind are needed, the number of duplicate ones required is noted on the drawing. These explanatory notes also relate to different kinds of small tools that are to be used, such as drills, reamers, and counterbores; thus the number or size of the drill and the size of the reamer, if used, are given. If punched bolt holes are considered good enough in connection with parts made of sheet metal, and close-fitting bolts are not necessary, the holes may be marked "punch 9/16 inch for 1/2-inch bolts." If holes are to be cored instead of being drilled this would also be noted so that the patternmaker need not inquire about this point. As screw threads are represented on drawings by conventional methods, and do not show the kind of thread, this is indicated by a note. For instance, a hole might be marked "tap 3/4-10NC," which means that an American Standard tap of 3/4-inch size is to be used. The number of threads per inch

usually is given, even when the pitch is standard. When the pitch is not standard, the number of threads per inch should always be given. If the thread is an American Standard form, but is not standard in regard to the number of threads per inch, it might be marked " $\frac{3}{4}$ -14NS," the symbol NS meaning National Special. The taper of the shank of a tool such as a reamer would, if standard, be designated by a number applying to that particular standard, as for example, a "No. 4 Morse taper." These examples indicate the kind of information which is given in the form of short explanatory notes.

Titles on Drawings and Records Required.—Mechanical drawings are given titles which are commonly placed in the lower right-hand corner of the tracing, usually within a ruled inclosure. This title generally includes the name of whatever part or mechanism is shown on the drawing, the firm name and address, the drawing number, the date the drawing was approved, and the initials or other means of identifying those responsible for the drawing, such as the checker and engineer who approved the design. A symbol, usually consisting of a letter and number combined to represent the type and size of the machine on which the detail shown on the drawing belongs, is often included in the title and other identifying numbers and information.

In Fig. 1 is shown the standard title used on drawings of one large plant; these titles are printed on blank sheets of tracing cloth, ready for the draftsman. A "T" is placed in the lower right-hand corner of the title and in the lower left-hand corner of the tracing; this stands for Thurlow (Thurlow Works). The drawing number is placed next to this letter so that when finished it will read T-1524, etc.

The arrangement of titles and the use of symbols, letters, etc., varies in almost every drafting-room, and the draftsman should become familiar with whatever system of recording tracings and machine parts has been established by his employer. The system may be very simple or quite complex,

depending upon the size of the plant and the variety of its products. In addition to means of locating and identifying drawings, the parts represented by them may require numbering for identification, and lists of parts or bills of materials are also in common use. Systems of designating parts by symbols or numbers and the purpose of part lists are explained in Chapter XII.

Stamping or Printing Titles. — The title of the drawing is usually lettered by hand, but to save time and also secure neat titles of uniform materials, the title may be stamped or printed on the tracing (see Fig. 1). Blank spaces may be left

REVISED		AMERICAN STEEL FOUNDRIES								
		THURLOW WORKS—CHESTER, PA.								
		SPACE FOR TITLE								
			DRAWN	TRACED	CHECKED	SCALE		FOLIO NO.	EQUIPMENT NO.	PRINT ISSUED
						DATE				
						RECOMMENDED				
						APPROVED				
						Works Engineer				
						AUTHORIZED				
Works Manager										

Fig. 1. Example illustrating the Title of a Drawing

for names and numbers which are filled in for each drawing, or the entire title may be set in type and printed when a printing press is used. The best results are obtained by using a printing press for printing the border line and title on the various sized sheets of tracing cloth which have been adopted as standard. Sometimes an ordinary rubber stamp is used, although this method, while simple and inexpensive, is inferior to printing. One large concern has a stamp with spaces for the name of the part drawn, material specifications, heat-treatment, if any, required, the initials of the draftsman, checker and tracer and a space for the symbol number.

Another method of avoiding hand lettering on titles is by using stencils which are cut out of tin or copper sheets. A stiff short brush should be used. In order to do the stenciling

neatly, moisten the brush with a little water and rub it along a stick of ink until it cannot absorb any more. The brush should never be dipped into a saucer of ink or the ink applied with a pen. Draftsmen sometimes cut their own stencil plates by using a stiff drawing paper and applying a coat of varnish to the upper surface.

Lettering. — Many of the books on mechanical drawing have emphasized the importance of lettering, and in most

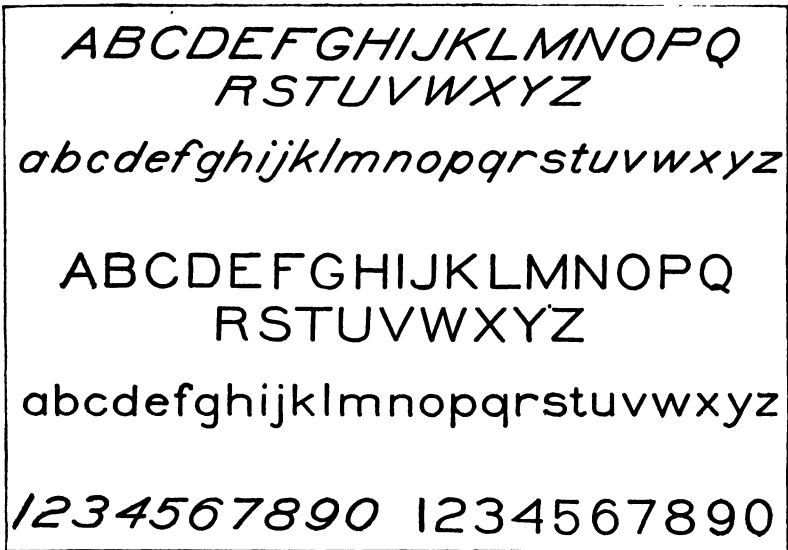

Fig. 2. Styles of Lettering used on Most Drawings

books previously published, considerable space is given to this subject and various styles of letters are illustrated, ranging from the small sizes to large designs which are supposed to be drawn accurately by the use of instruments. In actual practice, these different styles are seldom, if ever, used. The chief requirements are to do the lettering neatly and so that all words are legible and easily read. Lettering is usually done free-hand by using either an ordinary writing pen or a special lettering pen. The slanting Gothic style of letter illustrated in the upper part of Fig. 2 is in very general use. The capital letters are employed for titles and headings, and

the small letters for notes and instructions, or wherever the larger letters are unnecessary. This is known as a "single-stroke" style which does not mean that the pen is not lifted from the paper in making the letters, but that the line width is obtained with one stroke of the pen. With practice, letters of this kind can be made quite rapidly without sacrificing neatness or legibility. Some draftsmen prefer the vertical style of lettering also shown in Fig. 2. The letters are more round or open than the slanting Gothic letters but practically the same otherwise. The slanting and vertical figures are also shown in this illustration. The large "built-up" or drawn letters are seen occasionally on the titles of drawings — especially large sizes — but in most drafting-rooms the drawing of letters mechanically is considered a waste of time. When the title is printed or stamped on the tracing, as explained in a preceding paragraph, very little lettering is necessary unless notes are required on the drawing.

Why Errors on Drawings are Costly. — A drawing may be pleasing to the eye, but if the dimensions are inaccurate or the drawing is misleading it is useless for practical purposes. A mistake on a drawing may be the cause of much loss both in money and time, especially in a factory where manufacturing is done on a large scale. For example, suppose four hundred machines of a kind are to be built. Patterns have been made from the drawings and sent to the foundry for castings, which are made as fast as the facilities in the foundry will allow. The whole order might be filled before any of the machines are assembled, and if there has been an error on the drawings, some of the pieces may not fit into their places and may require the making over of one or more parts; this will delay the erecting and result in extra expense for producing new castings, machining them, fitting them to their places, etc., thus delaying work all along the line — all of which might have been avoided if a certain figure had not been wrong on the drawing, an arrow point placed at the wrong line, or some other error made.

It is customary in most factories to build a sample machine

and test it before the design is approved and manufacturing orders issued to the shop. This first machine not only shows possible defects and errors in the construction, but it may show how improvements can be made. Frequently a desirable change will be thought of while building the sample machine that would not have been noticed on the drawing.

While the drawing must be correct it should also be legible and neat. Under the head of legibility comes the clearness of the drawing or the conveying of the idea that is in the designer's mind. The placing of the views, sections and projections and the arrangement of dimensions, notes, etc., has much to do with the legibility of the drawing. Clear lines neatly joined, well-formed figures and letters, well-arranged dimensions, notes, etc., are among the essentials to neatness.

Checking Drawings. — After drawings have been completely finished and contain all the necessary dimensions, symbols, abbreviations, notes, etc., it is the general practice to check them. The object of checking is not only to locate any errors that may have been made in the dimensioning, but to discover defects of any kind which should be remedied. A competent checker may suggest changes in design or in the method of manufacture. The checking may be done by the chief draftsman or by one or more experienced draftsmen who have been assigned to this work. In smaller drafting-rooms, the draftsmen often check each other's drawings, but a man should not check his own drawing, if this can be avoided, because he is not so likely to detect his own mistakes as someone else.

The tracing is generally used when checking, although some prefer a blueprint from the tracing. When using a blueprint, all corrections or changes may be indicated on the print in red pencil, and all figures that are correct may be checked with, say, a yellow pencil. After all changes have been approved, the changes indicated in red are made on the original prints which are afterward compared by the checker with the blueprint to see if all changes have been made correctly. This checked blueprint may also be filed away for reference purposes in case there is any doubt as to who is to blame.

After a tracing has been checked, the initials of the man checking it and the date should be placed on a space provided.

Checking Lists. — The checking of the drawings should be done in a systematic way, and checking lists are often issued which show just what requires checking or, at least, the essential details of this work. These lists are prepared partly with reference to the product of the plant or the conditions peculiar to it, although many items found in checking lists apply regardless of the class of work. A typical checking list follows. In using this list, or a similar list, items should be checked in whatever order is given, to avoid missing any of them.

1. Is the size of sheet correct?
2. Are the title, scale, drawing number, model, number required, etc., correctly given?
3. Is there a sufficient number of views to show the piece correctly?
4. Are full and dotted lines shown in their proper places?
5. Are dimensions properly located?
6. Are all required tolerances properly given?
7. Are views shown correctly as to right and left hand?
Are even numbers used for right-hand patterns and odd numbers for left-hand?
8. Is the design correct in principle?
9. Is it what is needed and can nothing better be suggested?
Can it be made cheaper?
10. Is the drawing correct to scale, and are those dimensions not scaling correctly underlined?
11. Are arrow-heads neatly and properly shown and have any been omitted?
12. Is all necessary information given, and are all dimensions "tied up"?
13. Are all dimensions given in decimals where required?
14. Are tapped holes shown correctly?
15. Are "f" marks shown where needed?
16. Is the proper draft provided for all patterns and forging dies?
17. Are all corners provided with rounds or fillets?

18. Is a note given in regard to counterboring, spot-facing or other finish for screw-heads?

19. Are all bosses large enough?

20. Are all parts of proper strength?

21. Are detail notes provided regarding heat-treatment, polishing, electro-plating, etc.? Are such notes correct?

22. Are parts marked "grind," where needed?

23. Are all given dimensions correctly figured?

24. Will the piece properly fit parts with which it is to be assembled, and will it work without interference?

25. Is clearance provided for wrenches and screwdrivers?

26. Is there clearance provided to allow for all variations and tolerances?

27. Are proper oil-holes provided, and is there a sufficient number of them?

28. Are all parts provided with a sufficient number of threads of proper pitch for the material used?

29. Is the allowance for driving and running fits expressed in thousandths of an inch, and are the parts marked with their tolerances?

30. Are developed lengths of parts shown?

31. Are parts to be ground "necked" to provide clearance for the wheel when grinding?

32. Is provision made on all drill jigs, fixtures, etc., for the removal of burrs and chips?

33. Are the name, material and pattern number correct for each piece?

34. Has proper consideration been given to the subsequent attachment of other parts?

35. Is the material cross-sectioned according to standards?

36. Has the following information been given regarding springs: Temper, gage number and decimal diameter of wire, number of coils, initial tension, inside diameter and length in compression?

37. Is it shown on dies where they are to be ground?

38. Is clearance provided for the leaf swing on jigs and fixtures?

39. Can the bosses shown be drawn from the sand?
40. Are you willing to stand responsible for any errors noted above, if this drawing is sent into the factory?
41. Have you signed this drawing as "checked"?

Checking List for Punch and Die Drawings. — The checking list which follows applies more especially to drawings for punch and die work. This list was compiled with the idea of making it brief, as it is intended to be used in conjunction with more complete instructions. The sole object of the list is to call instantly to the mind of the checker the requirements of the standard practice. This list is subject to more or less modification, according to the practice and working conditions of different drafting-rooms, and it is divided into five sections headed: "Design and Approval"; "Assembly"; "Details"; "Title"; and "General Requirements."

Design Approval:

1. Authorization, requisition, memorandum, blueprint, sketch or sample.
2. Yearly requirements.
3. Grade of tool.
4. Method of operation.
5. General and specific requirements of departments.
6. Harmony in design, compared with other up-to-date tools.
7. General design.

Assembly:

1. Views and projections.
2. Work to be easily placed in die.
3. Work to be easily removed from die.
4. Same gaging points on succeeding operations.
5. Parts to be readily machined and assembled.
6. Interference of moving parts, slides, etc.
7. Burr side of blank in proper relation.
8. Provision for grinding.
9. Stripping and knockout devices to be adequate.
10. Clearance for slugs and burrs.
11. Setting pins.

12. Safety pins for unsymmetrical blanks.
13. Punch height to clear work during forming operation.
14. Size of punch shank to be standard.
15. Relation of shut height to available presses.
16. Size of dowel-pins and standard screws.

Details:

1. Views and projections.
2. Views of details placed in same relative positions as assembly.
3. Detail to check with assembly.
4. Easily machined.
5. Easily assembled.
6. Easily hardened without liability to check.
7. How fastened in place.
8. Scaling and calculating of dimensions.
9. Intermediate dimensions.
10. Over-all dimensions.
11. Limits.
12. Size and location of holes.
13. Finish marks.
14. Grinding marks.
15. Detail number.
16. Name.
17. Number of pieces required.
18. Material.
19. Hardened.
20. Ground.
21. Forging.

Title:

1. Class and type of punch and die.
2. Part number.
3. Model number.
4. Scale.
5. Initials.
6. Drawing number.
7. Date drawn.
8. Date traced.

General Requirements:

1. Neatness and clearness.
2. Crowding of views, details and notes.
3. Lettering.
4. Lines.
5. Section-lining.

The different men in the drafting-room use all or part of this list, as required. The designer uses the section on "Assembly." The head of the division or department uses the sections under the headings "Design Approval," and "Assembly." The detailer uses the portion under the headings "Details," "Title," and "General Requirements." The tracer need pay attention only to the section of "General Requirements," after which the checker uses the complete list with the exception of "Design Approval." It is understood that before a list of this kind can be used successfully, detailed instructions in separate form must be given to the draftsmen, covering all the parts to which attention is called in this list.

Standardization of Drawings. — A common cause of mistakes and misunderstandings in manufacturing is the lack of uniformity of practice in making drawings. Difficulty from this source is often experienced in jobbing shops which bid on contracts after having studied the drawings submitted. Frequently these drawings leave much to inference and imagination, but it is a serious matter to bid on a product in the belief that a certain standard of manufacture is required when a higher or a lower one is wanted. If the contractor assumes that the standard is too high, he probably bids too high, and if he assumes that it does not call for high-grade work, his bid may be too low for making a living profit.

The work of standardization should include fixing conventions, the adoption of uniform methods of indicating limits and tolerances, the placing of dimensions, the uses of dotted and broken lines, etc. — in short everything which makes a drawing a conveyor of specific instructions for making a part.

CHAPTER VIII

PRINTING PROCESSES AND APPARATUS FOR PRINTING, WASHING AND DRYING

THE original tracings of mechanical drawings are not intended for shop use, because they are a permanent record and would soon be soiled and perhaps lost if sent to the pattern and machine shops. The general method of securing reproductions of tracings suitable for shop use is by a process similar to that of the photographic printing process. There are several different kinds of prints, but the most common is known as a "blueprint" because it has white lines on a blue background. There are also prints which have white lines on a dark brown background, and also positive prints with either black or blue lines on a white background. These various prints are made on different kinds of paper which have been prepared for the purpose, and which may be obtained from any concern dealing in drafting-room supplies.

Making Blueprints.—The process of making blueprints is simpler than making prints from photographic negatives. The blueprint paper, after exposure, may be immersed in water only or in both water and a potash solution. For sunlight printing, the tracing is placed in a printing frame which may be quite similar to the printing frames used in photography, except that it is usually much larger. One of these printing frames is illustrated in Fig. 1. The frame is provided with a plate of glass and a removable back formed of sections that are hinged together so that one or more sections may be swung back for examining the blueprint, if necessary. Beneath the back of the frame there is a thick pad which serves to hold the tracing and blueprint flat

against the glass. The back, in turn, is held firmly in position by cross-bars provided with flat springs. In the illustration, one of these bars is shown removed and that section of the frame at the extreme right is turned upward.

The tracing is first placed in the frame with the inked-in side next to the glass. Then the blueprint paper is inserted with the sensitized face next to the tracing. After the frame is closed and locked, the tracing and the sensitized paper back of it are exposed to the light for a length of time de-

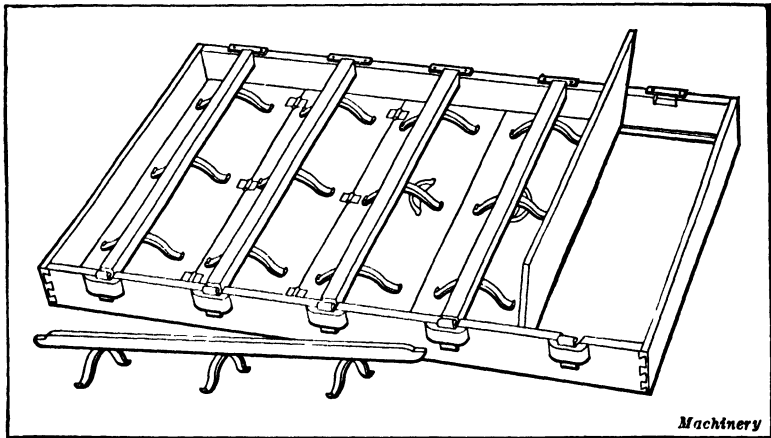

Fig. 1. One Type of Printing Frame used for making Blueprints

pending upon the kind of paper used. After exposure, the sensitized paper is removed and immersed in water. Almost immediately, white lines appear corresponding to the black lines on the tracing. This is due to the fact that the exposure to light has a certain effect on the chemicals which form the coating of the blueprint paper. The result is that those parts of the paper which have been protected from the light by the black lines turn white when the paper is washed in water, and the exposed part changes to some shade of blue. If the exposure has not been long enough, a light shade of blue is obtained and, if it is too light, the blueprint will not be clear and distinct, because there is not enough contrast between

the background and the white lines forming the drawing. On the other hand, if the exposure has been prolonged too much, the blueprint may be entirely spoiled.

Printing frames of the general type used for solar or sun printing are often provided with a wheeled carriage, the frame being held in position by trunnions so that it can readily be turned over and be held at any angle which will give the best light during exposure. Many drafting-rooms which rely on solar printing have one or more printing frames which, with the carriage, are mounted on a track so that the frames can easily be pushed out through a window in order to secure better light. Whenever possible, the printing frame should be exposed to the direct action of the sunlight.

Negative and Positive Prints.—There are two general classes of prints which may be defined as negative and positive. An ordinary blueprint with white lines on a blue background represents a negative, whereas the original tracing used in producing the blueprint is a positive. Van Dyke prints with white lines against a brown background are also negatives. Processes have been developed for obtaining positive prints directly from the positive originals. These positive prints may have black, blue or dark red lines on a white background. The object in obtaining positive prints is to make reading and checking easier and, in addition, the white background facilitates the writing of notes.

Blueprint Paper.—Blueprint papers vary in regard to sensitiveness and length of exposure required for printing. The papers requiring a longer exposure are the most satisfactory in regard to quality and the appearance of the prints. The sensitive rapid-acting papers are intended for use where prints are required quickly or where a strong light is not available and a sensitive paper is necessary. These “quick” or “rapid” papers need to be handled more carefully than those that are less sensitive in regard to protection from light and dampness before exposure. Blue-

print paper comes in rolls which may vary in width from, say, 30 to 54 inches and in length from 10 to 50 yards. Blueprint cloth may also be obtained. These cloth prints will withstand rough handling and are especially desirable for use out of doors or wherever ordinary paper prints would be easily torn.

The Bruning BW Process.— With this process a black and white positive print is obtained directly from a positive original or without the use of a negative. The first step consists in exposing the BW paper and the original tracing in a printing machine the same as in making an ordinary blueprint. The exposed paper is then developed by applying a thin film of developing solution. When the print emerges from the machine or attachment, it is a fully developed black and white positive and is ready for use. The BW paper is made especially for this process.

Ozolid White Print Process.— This positive process produces dark lines on a white background but by means of dry development or without the use of developing liquids. A heater vaporizes an ammonia solution, thus causing dry ammonia vapors to rise. The sensitized print material is developed by these vapors. As the ammonia vapors rise to the top of an evaporating tank, they develop the Ozolid print material as a rubber belt conveys it over perforations in the tank top. The printing and developing operations may be combined in one machine. The original and sensitized print material are held in contact with a glass cylinder so that tracing, sensitized material and solution all revolve at the same rate of speed. When the Ozolid print emerges from the machine, it is dry and ready for immediate use.

Transparent Duplicates.— Ozolid transparent duplicates, from which an unlimited number of subsequent prints can be reproduced, are made in the same manner as standard Ozolid working prints. Additions or changes may be made readily on these transparent duplicates using either pencil or ink. A transparent duplicate thus revised constitutes a

new original that is easily obtained. Furthermore, white prints incorporating such revisions or changes may be obtained from the altered transparent print even though the original drawing remains unchanged.

Machines for Making Blueprints, White Prints, or Other Copies of Tracings.—Machines for making prints from original cloth or paper tracings have been highly developed. Some of these machines are small types for use where the amount of printing is comparatively small. There are also larger and more complete printing machines designed for maximum production in large plants requiring numerous prints. Machines of the latter type may be arranged for printing, washing and drying, all in one continuous operation. With all of these machines, some form of electric light is used for printing instead of natural light or sunlight; consequently, prints can be made at any time of the day or night, regardless of weather conditions, which is a decided advantage over the solar printing method.

Printing machines vary considerably in regard to general arrangement and constructional details. For example, there are vertical and horizontal designs, different types of lamps, different methods of traversing the tracings and print paper through the machine, and variations in connection with certain other details, as indicated by the descriptions to follow. Since there are variations in the opacity of the original cloth and paper tracings, and also in the sensitivity of printing papers, all machines require some means of adjustment either in printing speed and length of exposure or in light intensity, or both, to avoid either under-exposure or over-exposure. It is impracticable to describe all of the equipment on the market, but the following descriptions of typical designs indicate characteristic features of different types or designs.

Bruning Printing Machine.—A compact design of machine is illustrated in Fig. 2 (Model 55). This machine, like other models and makes, operates either with cut sheets or rolls

of print paper. When a roll is used for printing continuously while successive tracings are inserted, the roll is mounted below the feed table at the front and the paper automatically feeds into the machine as the tracings are inserted by the operator. Inked tracings can be printed at the rate of 12 to 15 feet per minute. The operating speed is shown by an indicator at the front of the machine. The light for printing is from a 55-watt mercury vapor quartz lamp. This lamp is within a revolving 9-inch Pyrex cylinder which is in contact with tracing and print paper during the period of exposure. The print and tracing return at the top of the machine, the tracing entering a tray on the top of the print in the same position as occupied when inserted in the machine; hence, reprinting does not require reversal of the tracing. This machine may be connected either with A.C. current of 220 volts, 60 cycles, or 220 volts, 50 cycles.

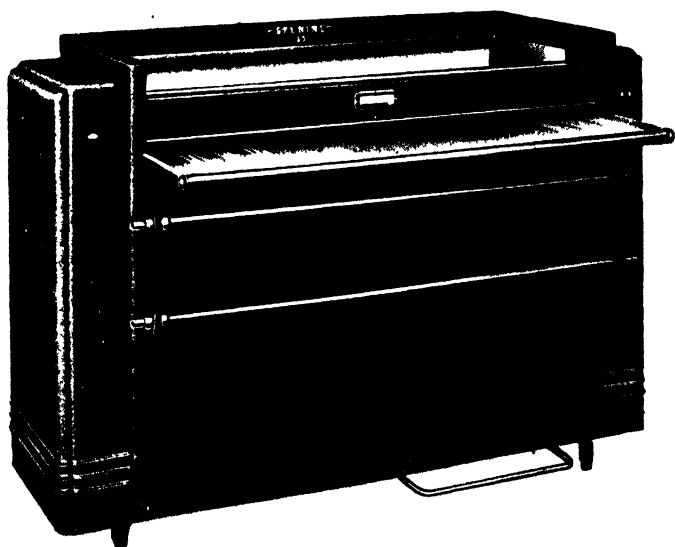

Fig. 2. Bruning Model 55 Printing Machine

Ozalid White Print Machine.— This machine (see Fig. 3) is for making Ozalid white prints which consist of dark lines on a white background. The original tracing and sensitized print material are held in contact with a glass cylinder which revolves around a stationary, high-pressure, mercury vapor lamp. The glass cylinder, tracing and sensitized material all revolve together or at the same rate of speed. An adjustable light shade may be used to vary exposure without change of printing speed. The latter may also be varied by means of the hand control knob seen at the left side of the machine. Ozalid white prints are produced by dry development, without washing, fixing, or drying. The printer and dry developer are combined in the Model F machine (Fig. 3) which produces white prints in less than two minutes. The development which follows

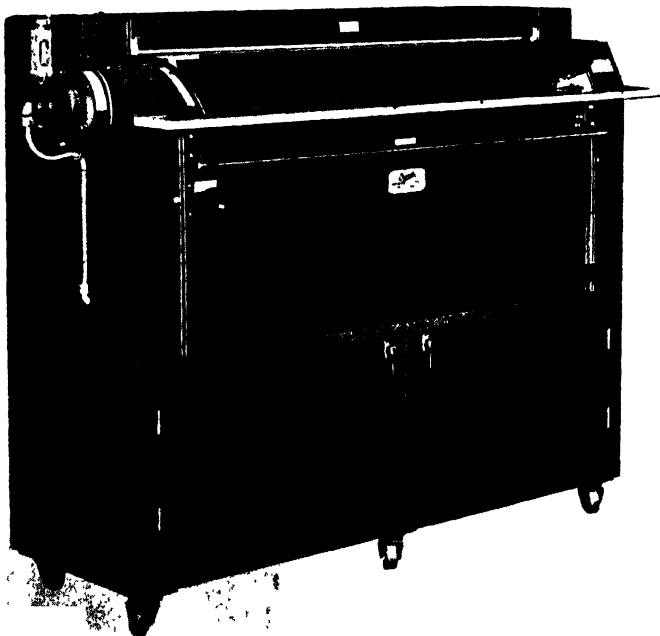

Fig. 3. Ozalid Model F White Print Machine

printing is due to dry ammonia vapors which rise from an ammonia solution subjected to heat. This machine has a printing speed up to 56 inches per minute, a developing speed of 30 inches per minute, and a width capacity of 42 inches. It is wired for 200 to 235 volts A.C., 60 cycles.

Pease Continuous Mercury Vapor Tube Printer.—This machine (Model 7) is a horizontal type for exposing blueprints, brown prints, and direct-process prints. When operating continuously or when making single prints in cut sheet sizes, tracings and sensitized paper are fed into the machine at the front over a feed table and onto an endless fabric band which carries them upward, around, and through the machine in close contact with a curved section of highly polished plate-glass where exposure takes place. Illumination is from mercury vapor tubes. Three of these tubes permit printing speeds of 2 feet per minute, and four tubes increase the speed to 2½ feet per minute, using good tracings and either a fast blueprint paper or a direct-process paper.

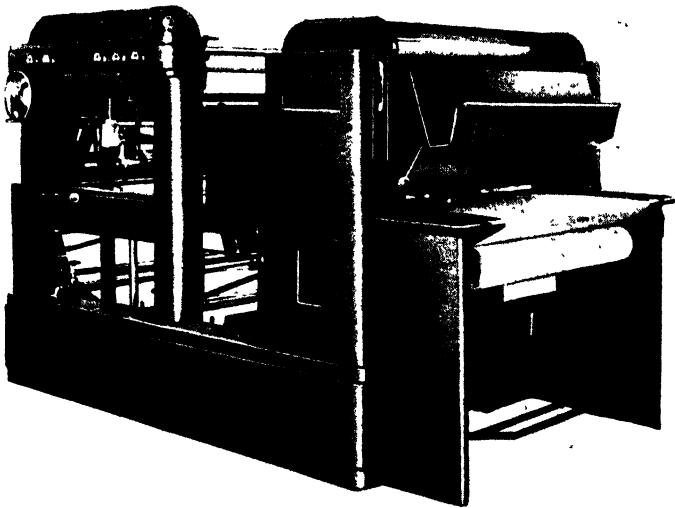

Fig. 4. Pease Model 23-16 Continuous Blueprinting Machine

The Pease Model 22-16 continuous blueprinting machine (Fig. 4) consists of a Model 22 printer used in conjunction with a Model 16 washing and drying machine. This machine has been developed to meet the needs of commercial blue- printers, industrial plants, and government departments whose production requirements do not necessitate the high speed of the Model 22 but who do want the features incorporated in the latter machine.

Outstanding features include sliding contact, which smooths out inequalities present in tracings and gives $24\frac{3}{4}$ inches of uninterrupted exposure area; three-speed lamp control, which allows the lamps to be operated at 10, 15, or 20 amperes, as desired; and actinic arc lamps which furnish uniform light emission.

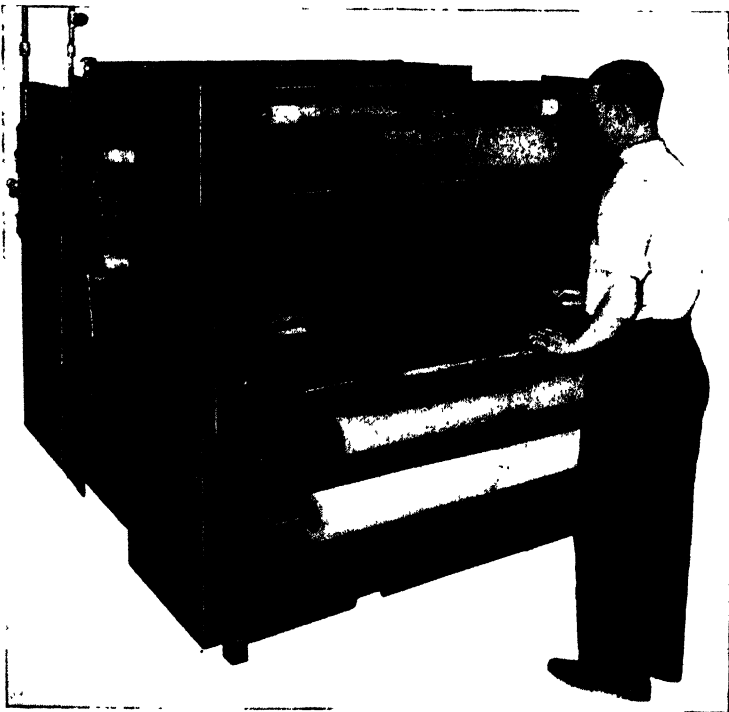

Fig. 5. Shaw Combination Printing, Washing and Drying Machine

Shaw Combination Printing, Washing and Drying Machine.—This machine (Fig. 5) may be used for making blueprints, blue-line prints, or Van Dyke negatives. The illustration shows the combined printing, washing, potashing, and drying equipment combined in one unit for continuous operation. The width capacity is 42 inches, and the speeds may be varied from 9 inches to 12 feet per minute.

The washing unit receives the exposed prints when they leave the printing unit. As the prints enter the top of the washer they receive the first water wash for removing chemicals. From the washing unit they enter the potash bath, and then receive a second water wash, after which they continue down a long inclined drop to a large tray at the bottom of the washer, where they receive a continued puddle bath. The prints, as they leave the lower wash tray, proceed upward for a distance of 24 inches. This permits some of the surface water to drain back into the tray before the prints enter the two wringer rollers. Finally, the prints enter the drying unit, where they pass around the surface of two revolving copper drums heated by either gas or electricity. Two felt-covered rollers, which have an ironing effect, cause the prints to leave the dryer in a smooth, shiny condition. From this point, the prints travel over two gripper rollers to a winding roller, after which they are ready for the shearing operation.

Revolute Combined Printing, Washing and Drying Machine.—A Revolute machine (Model 3H) which exposes, develops and dries in one continuous operation, has a Pyrex glass cylinder which rotates with tracings and print paper, and at the same rate of speed. The light is supplied by stationary arc lamps within the cylinder. The machine may be used for blueprints, Van Dykes, black-and-white prints, or reproduced tracings. The paper, after exposure, is first submerged in a fresh water bath; next, front and back water sprays develop the paper further; then the paper is again submerged in a water bath. This is followed by a chemical

bath, a potash bath being used for blueprints and a "hypo" for Van Dyke prints. In changing from blueprints to Van Dykes, the guiding rollers at this point are merely shifted so that the paper passes through the hypo bath instead of the potash bath. A third fresh water bath follows and then a final water spray front and back. Excess water is next removed by a squeegee roller. The paper then passes over six aluminum drying cylinders. The printing speeds can be varied from a few inches to over 20 feet per minute by means of a mechanical feed-changing mechanism.

Developing Machines.—Some machines are designed expressly for developing. These may be arranged to attach to a printing machine if desired. Fig. 6 shows a developing machine for use in the Ozalid process of producing positive type prints directly from the original copy. After exposure to light in a blueprinting machine, the positive print with black lines on a white ground is dry-developed in the machine shown. Dry-development is accomplished by applying controlled dry ammonia fumes to the sensitized surface

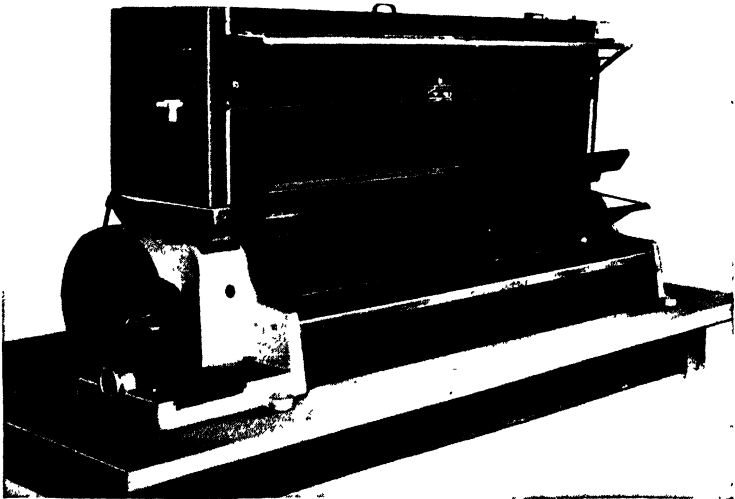

Fig. 6. Developing Machine

of the exposed material as previously explained. As no liquids touch the prints, they remain true to the scale of the original copy. The type of developing machine shown in the illustration (Type 1000) is built in two sizes, for materials 42 and 54 inches wide. This machine has a developing speed of 32 linear inches per minute. The Type 3500 high-speed developing machine is designed for production developing of either cut sheets or roll material. It has a maximum capacity of 16 linear feet per minute, and is designed for attachment to either of two makes of high-speed printers now on the market. This machine is also built in two sizes, to accommodate materials 42 and 54 inches wide.

Method of Hanging Blueprints after Washing.—If a printing, washing and drying machine is not available, blueprints, after washing, may be dried by simply hanging them on a line or on racks so that the water will drain off by gravity. When blueprints are dried in this way they are often hung up so that the lower edge is in a horizontal position. This method is not a good one, because when a print is hung so that the lower edge is practically level, the water will gravitate to this edge and hang there in globules, and the print will not be perfectly dry at this edge for hours; and in almost every case the edge is discolored. The best way to hang blueprints for drying is to place them so that the lower edge is at an oblique angle with the horizontal; then the water will gravitate to the lowest corner. There will be no accumulation of water at other points, and the drying will be far more rapid than in the case when the sheet is hung level. This is a very small detail of drafting-room work, but it is of considerable consequence, both as regards time and the appearance of the blueprints.

Blueprint Drying Rack.—The special drying rack illustrated in Fig. 7 is made of wood and has about thirty-six slots, of the shape shown, cut in its under side; one side of each slot is vertical and one inclined at an angle of about 60 degrees to the horizontal, the two sides being connected by a

circular arc. Each slot contains a small hardwood ball, which naturally tends to fall to the bottom or mouth of the slot. The width of this part of the slot, however, is less than the diameter of the ball, so that the latter cannot drop out. Hence, instead of dropping out, the ball exerts a pressure on each side of the slot so that when the end of a blueprint is placed in position against the vertical face and the ball is allowed to fall to the bottom of the slot, the pressure exerted on the vertical face is quite sufficient to hold the print in place. To prevent the balls from falling out of the slots sideways, wires are secured to the rack opposite the middle of each slot, as shown in the illustration.

The two principal advantages possessed by this piece of apparatus are: (1) The facility with which the ball is flipped up out of the bottom of the slot to release the blueprint. (2) The fact that the water is allowed to drain off the print without defacing it in any way whatever. This rack is intended for small and medium sized prints, but it can also be employed in drying large blueprints, though in this case it would be advisable to use two racks and suspend the prints from two points, in order to keep them as flat as possible.

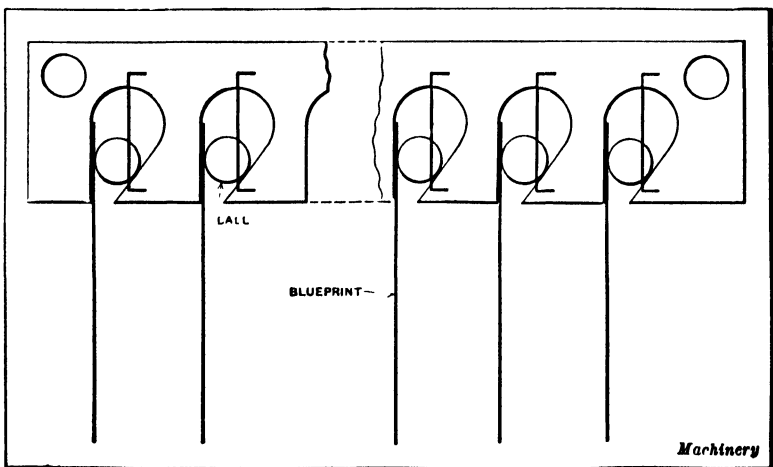

Fig. 7. Rack for holding Blueprints while drying

In this case, the two racks should be placed on an adjustable frame so that different sizes of prints could be accommodated. One of the racks could be fixed in position and the other made movable, one being arranged so that it is a little higher than the other. This precaution allows the prints to be so arranged in the racks that the bottom edges of the prints are not quite horizontal; the water on the prints will then flow to one corner and so drain away more readily than if the edges were horizontal.

Drying Blueprints Rapidly.—A simple type of quick-drying apparatus consists of an A-shape frame having a sheet-iron covering on one side with a trough at the lower end for catching the water which runs off from the prints. A print to be dried is placed against this sheet-iron tray and the water is removed from it quite rapidly by scraping the surface of the print with a rubber squeegee similar to the kind used for cleaning windows. This drying frame may be provided with some means of heating the interior.

Mounting Blueprints.—Blueprints are sometimes mounted to make them more durable. For mounting, any good grade of cardboard, or a piece of sheet fiber about 1/16 inch in thickness and a little larger than the print, will be found satisfactory. The first step in mounting the print is to give both sides of the sheet of fiber or cardboard a coat of orange shellac and then set it up on edge to dry. After the shellac is thoroughly dry, a second coat should be applied to the side on which the blueprint is to be mounted. Then apply a similar coat of shellac to the back of the blueprint and allow the blueprint and mount to stand until the shellac is nearly dry, i.e., until the surfaces are so sticky that when touched with the finger tip, the mount can almost be lifted from the table. The blueprint should then be placed upon the mount and thoroughly rubbed down first with the hands and then with the roller. After allowing the mounted print to stand for four or five hours to allow the shellac to set thoroughly, one or two coats of white shellac should be applied over the

entire surface of the blueprint to give it a glossy appearance and to protect it from grease and dirt. The prints must be thoroughly dry before applying the white shellac.

Mounting Blueprints on Cloth.—Blueprint cloth is often used in preference to paper when prints are to be used out-of-doors or are subject to rough handling. These prints are made directly on the specially prepared cloth. If ordinary paper blueprints are to be mounted upon cloth, the cloth should be soaked in water and then thoroughly wrung. The cloth should then be unfolded, shaken out, fastened to a drawing-board, and covered with flour or starch paste. This should be well rubbed into the cloth. The superfluous paste should be worked to the center of the board and then scraped off with the hand and returned to the basin. This process should be repeated until the paste is evenly spread all over the cloth. The blueprint should then be dampened on the back with a sponge and be placed in the correct position on the cloth. It should then be rubbed gently but firmly with a large blotter, until one half is fastened to the cloth; the other half is then treated in the same manner. Any air bubbles that may appear can be pricked with a needle.

Blueprints from Typewritten Copy.—It is sometimes required to make a typewritten copy from which a number of blueprints may be made, but if one attempts to make such blueprints from an ordinary typewritten sheet, the result is usually unsatisfactory because the purple or blue ink commonly used on typewriter ribbons offers very little resistance to the passage of light. The result is that the blueprint has a weak and "washed-out" appearance. If, however, the stenographer takes two pieces of black carbon paper and places them face to face with a piece of thin white paper between, and then proceeds to write the copy in the ordinary way, it will be found that the letters, which are black and written on both sides of the sheet, are practically impervious to the passage of light. From a copy prepared in this manner, good clean-cut blueprints can be made.

CHAPTER IX

ENGINEERING STANDARDS AND DRAWINGS OF MACHINE DETAILS

A GREAT many small parts or details are frequently used in the construction of mechanical devices, even when the design is not particularly complex, and it is necessary for the draftsman to know how to represent these details clearly and by methods which have been adopted to avoid useless and tedious work. For instance, screw threads are represented by certain common or "conventional" methods, as they are called, which make it possible to show a threaded section easily without attempting to draw a thread as it actually appears. The customary methods of drawing gears also illustrate this feature of drafting practice. Thus, the teeth of a spur gear are commonly represented by dotted circles instead of attempting to draw the tooth outlines, as explained more fully later. In addition to these conventional methods, there are certain standards which have been adopted, and also commercial parts are used more or less in the construction of machinery and tools. It is necessary for the draftsman to distinguish between the parts that are made special and those parts which are standard and perhaps purchased from other manufacturers.

The standards which have been adopted for screw threads are the most important and the draftsman should be familiar with them. These screw thread standards vary in different countries and also for some special classes of work. They are so well established that all the principal standards are given in engineering handbooks. The tendency is to increase this work of standardization of machine details, because it results in greater economy in the production of machinery. Standardized machine parts can be made up and kept on hand for immediate use or, in some cases, they may be pur-

chased in quantities from manufacturers equipped with special machinery adapted for the economical production of such parts. It is not only necessary for the draftsman to be familiar with the different machine details and conventional methods in general use, but to understand how and where to employ them.

Screw Thread Details. — As the screw and nut are used on almost every kind of mechanical device, the representation of screw threads is necessary on practically all mechanical drawings. Various forms of threads have been developed and some of these forms have become so generally used in

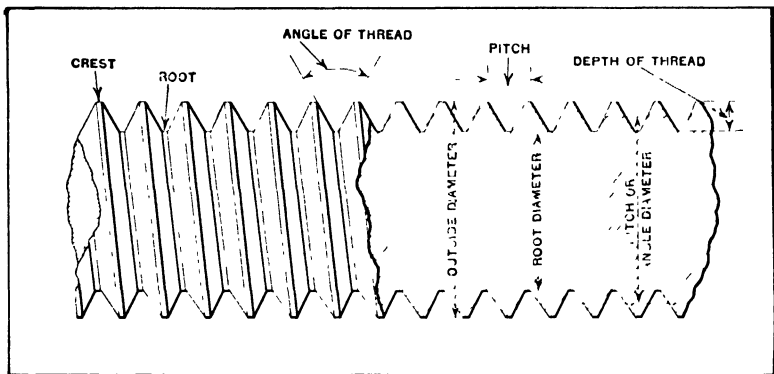

Fig. 1. Drawing showing Meaning of Various Terms which are applied to Screw Threads

different countries or for certain purposes that they are now termed "standard." The screw thread in most general use in the United States is the American or U. S. Standard. A profile of the American Standard thread is the same as that of the U. S. Standard, but the American Standard system includes numbered (machine screw) sizes in addition to the larger diameters, a "coarse" and a "fine" series of pitches and a system of tolerances and allowances for different classes of fits.

Fig. 1 shows some of the common screw thread terms. The outside diameter is sometimes called the major diameter and the root diameter the minor diameter. The pitch diameter is equal to the outside diameter minus the depth of the thread.

Pitch and lead.— Pitch and lead are two expressions that are often confused. The word *pitch* is often, though erroneously, used in place of “number of threads per inch.” The pitch is the distance from center to center of two adjacent threads as indicated in Fig. 1. The *lead* of a screw thread is the distance the screw will travel through a nut if turned around one complete revolution. It is evident that for a single-threaded screw the pitch and lead are equal. In a double-threaded screw, as indicated in Fig. 2, the lead equals twice the pitch and in a triple-threaded screw, three times

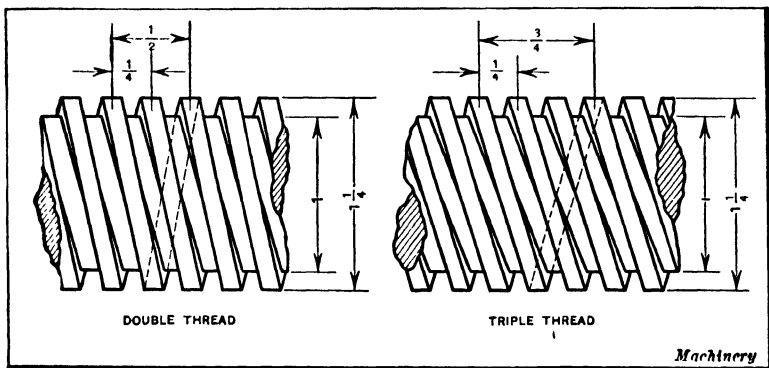

Fig. 2. Double and Triple Threads of the Square Form

the pitch. The definitions given for pitch and lead should be strictly adhered to, as great confusion is often caused by improper interpretation of these terms.

Designating Multiple Threads.— Confusion is caused by indefinite designation of multiple-threaded screws. Sometimes the lead and the class of thread are given, thus: “ $\frac{1}{2}$ -inch lead, double,” which means a screw with a double thread. When cutting such a thread the lathe is geared for two threads per inch, but each thread is cut only to a depth corresponding to four threads per inch, and after one thread groove is finished, the work is indexed 180 degrees before cutting the second thread groove. This same thread might be designated by giving both the lead and the pitch in order to avoid any misunderstanding, thus: “ $\frac{1}{2}$ -inch lead, $\frac{1}{4}$ -inch pitch, double

thread." It is also well to mention whether the thread is right hand or left hand, R. H. or L. H. being used ordinarily.

Representing Screw Threads on Drawings. — In drawing screw threads of any kind, the exact form of the thread as it appears to the eye or a correct orthographical representation of the thread is seldom shown for the reason that it would require an undue expenditure of time to draw the helical curves that are required to show the true form of any thread. Many simple methods of representing screw threads have come into use from time to time. Mechanical drawings differ somewhat in regard to such features, although the American Standard for Drawings and Drafting Room Practice includes screw thread representations for bolts and threaded parts.

All the methods used to represent screw threads will not be referred to, but rather the ones most commonly used. Each method has perhaps some feature which makes it particularly adapted for certain purposes. Nearly all of the conventional methods in common use, such as are employed to represent small screw threads, etc., are not intended to show the form or shape of the part from the pictorial point of view. For instance, in the case of a thread, an explanatory note is used ordinarily to indicate the kind of thread and its pitch. This method eliminates an endless amount of tiresome work that would otherwise be required. When parts are threaded with standard taps or dies, the size of the tap or die and the length of the required thread are usually all the information needed on the drawing in addition to the conventional method used to represent the thread. The tap or die controls the form and pitch of the thread and, when threads are cut in a lathe, the machinist uses gages for determining the shape or form of the thread, and he needs to know the diameter and pitch or the number of threads per inch so that the lathe can be properly geared. It is, therefore, evident that no particular advantage is derived from a drawing which represents the actual outline of the thread when suitable notes are provided, unless it is some special form of thread which can be cut only by making special tools.

Drawing Square Threads. — At *A*, Fig. 3, is shown a true drawing of a square screw thread, which is given here simply to show the appearance of a screw thread represented in this manner. The draftsman seldom uses this method of representing a screw thread on mechanical drawings; however, it is sometimes desirable to show a thread in this way on patent drawings, catalogues, etc., where the pictorial effect is important. When this is required, the rules for drawing the helix given in Chapter XI should be referred to.

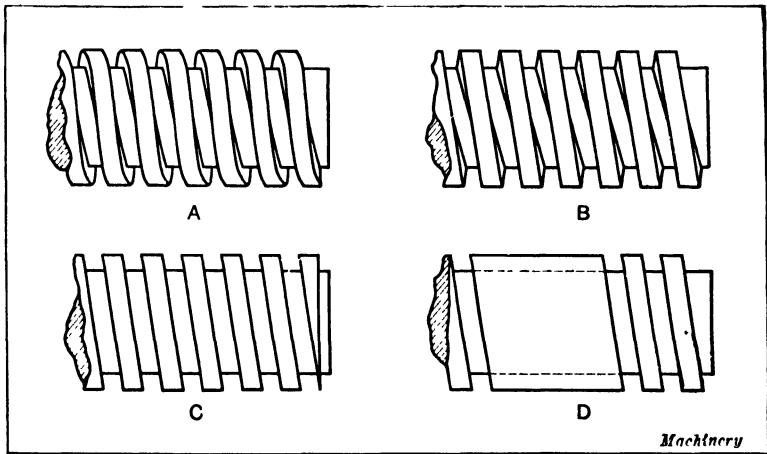

Fig. 3. Different Methods of representing a Square Thread

At *B*, Fig. 3, is illustrated a method of drawing square threads which in appearance closely approximates the exact method. This method is too elaborate, however, for ordinary purposes and the simpler method illustrated at *C* is more generally used. When a thread of considerable length is to be shown, unnecessary work is avoided by drawing two or three threads at each end of the threaded section and simply indicating the intermediate portion of the thread by dotted lines representing the bottom or root of thread as shown at *D*.

Simpler methods than those already shown are often used and, when square threads of very small diameter are to be indicated, it is perhaps preferable to represent them by one of the methods illustrated at *C*, *D*, *E* and *F*, Fig. 4. Of course

an explanatory note must accompany the drawing giving all information as to pitch, lead, etc., as otherwise it would ordinarily be supposed to represent the American or U. S. form of thread, assuming the drawing were made in the United States.

Common Methods of Representing Screw Threads.—In Fig. 4 at *A* and *B* are shown two threads represented by straight lines which, as in the case of the square screw thread shown at *B*, Fig. 3, represent the thread approximately as it actually appears. This method of drawing a thread is not generally

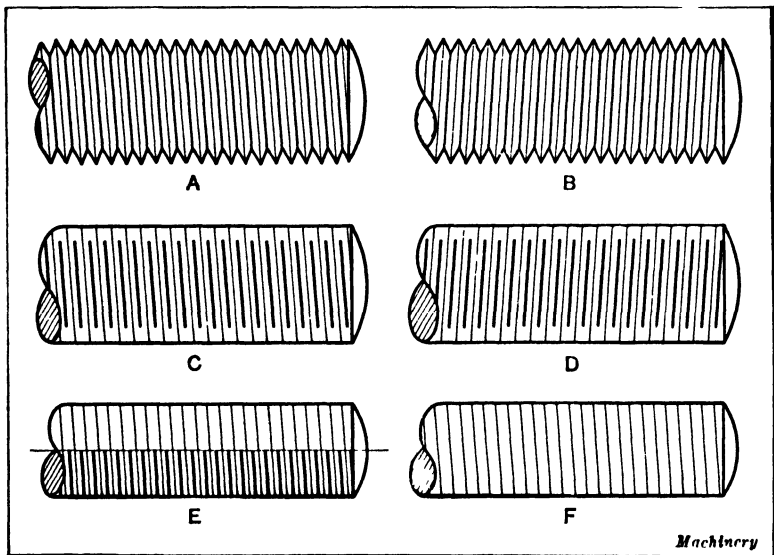

Fig. 4. (*A* and *B*) Right-hand and Left-hand Screw Threads (*C*, *D*, *E*, and *F*) Conventional Methods of representing Screw Threads

used in making mechanical drawings but is given here chiefly to show the difference between a right-hand and a left-hand thread. The thread represented at *A* is a right-hand thread and that at *B* is a left-hand thread. A screw having a right-hand thread as shown at *A* will advance into a threaded hole when turned in a clockwise direction, and a screw having a left-hand thread as shown at *B* will enter a threaded hole when turned in a counter-clockwise direction or in a direction opposite to that in which the hands of a clock turn.

A much simpler method of representing screw threads than that shown at *A* and *B*, and perhaps the most commonly employed method, is that shown at *C* and *D*. In this case, *C* represents a right-hand thread and *D* represents a left-hand thread. Although this method of indicating right- and left-hand threads is technically correct, the drawing itself should not be depended upon to show the difference between right- and left-hand threads. When a left-hand thread is required, it should be so stated on the drawing. If no note is given specifying right- or left-hand threads, it is understood that a right-hand thread is required. The use of the method shown at *C* to represent right-hand threads, and that shown at *D* to represent left-hand threads, is not restricted to the V-thread but is generally employed to represent screw threads of all forms. The light lines are intended to represent the top or the extended portion of the thread, while the heavy lines are intended to represent the bottom of the recess or groove between the raised portions of the thread. In using this method of representing screw threads the draftsman usually draws the light lines first, making the spaces between the lines as uniform as possible, usually by judging the distance as the triangle is moved to each successive position. After the light lines are all drawn in, the heavy lines may be drawn midway between the light lines as shown.

Mechanical drawings for ordinary purposes do not require accurate spacing of the lines which represent the threads, but continued practice in drawing threads usually develops the draftsman's skill to a point where it becomes second nature to space the lines quite accurately and with considerable speed. The spacing ordinarily need not be in accordance with the actual pitch of the thread, and in indicating very small threads the spaces can be made equal to two or three times the actual pitch. Many draftsmen make a practice of drawing the lines which represent the threads, at a slight angle. It is also common practice to draw these lines at right angles to the axis of the screw. This practice is recommended because it enables the draftsman to use the T-square

or T-square and an ordinary triangle to much better advantage. When large threads are to be shown or an exceptionally accurate drawing is required, the lines representing the threads may be spaced with dividers and faint pencil guide lines drawn to indicate the depth of the thread so that the heavy shade lines may be all drawn to uniform lengths. Instead of using heavy lines to represent the bottom of the thread, as shown at *C* and *D*, Fig. 4, it is the practice in some drafting-rooms to make all the lines of uniform width.

The method of drawing screw threads shown at *E* perhaps requires less time and care to produce neat appearing screw threads, than any of the other methods described, due to the fact that the center line and the line representing one side of the screw form guide lines that determine the length of the heavy lines as shown. It is not necessary, however, to make these lines heavier. It is customary to draw the short lines on the right-hand side of vertical screws and on the lower side of screws shown in a horizontal position on the drawing, as it gives the appearance of shading. One of the simplest methods of representing screw threads is shown at *F*, Fig. 4. This method is recommended for very small threads. The lines can, of course, be drawn at right angles to the axis of the screw or be inclined as shown in the illustration.

Representing Threads in Holes.—Some of the most common methods of representing threads in holes are shown in Fig. 5. The upper and lower views show, respectively, the methods of representing threaded holes in plan and elevation, or as seen from the top and side. At *A* is shown the simplest plan view of a threaded hole, and this method is generally used. The method shown at *B* is identical with that shown at *A* except that the conventional method of shading holes is used to strengthen the pictorial effect. The method shown at *C* is also intended to give a shaded effect, but it is not generally employed. Other variations are shown at *D* and *E*.

The side view *A* shows one of the most common methods of representing screw threads in concealed holes. It will be

noted that this method is similar to that shown at *C*, Fig. 4, to represent an external screw thread. Practically the only difference is that dotted lines are used instead of light and heavy full lines. Screw threads in holes are always represented by dotted lines, except in the case of sectional drawings such as are shown at *D* and *E*, Fig. 5. At *B* is shown a method which many draftsmen consider good practice for screws of all diameters. In representing very small screws by this method, the draftsman frequently draws the dotted

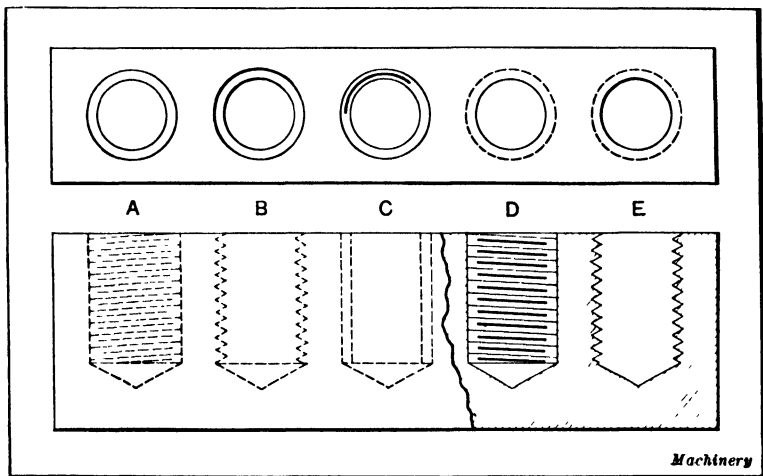

Fig. 5. How Threads in Holes are represented on Drawings

lines free-hand in order to save time. If large threads or particularly accurate drawings are required, guide lines and the 60-degree triangle can be used to represent the actual outline of the thread. The method shown at *C* is perhaps the simplest and easiest for representing threaded holes and is particularly recommended for threads of small diameter. At *D* is shown the conventional method of representing a sectional view of a hole. The alternate long and short cross lines representing the thread may be drawn at right angles to the axis instead of being inclined as at *A* and *D*. The inclination at *D* is in a direction opposite to that of the hidden lines shown at *A*. The reason for this is that the

threads at the farther side of the hole only are visible in the sectional drawing. At *E* is shown another method which is sometimes preferred when very large threads are to be drawn. When no great accuracy is required, method *E* can be used to show small threads by drawing the lines free-hand, using perhaps faint guide lines to determine the top and bottom of the threads. When a thread of large diameter is represented by this method, its pictorial effect may be improved by drawing lines which represent the top and bottom of the thread at the back of the hole. The thread will then have an appearance similar to that of the screw shown at *B*, Fig. 4, and the sectional view of an internal left-hand thread will have an appearance similar to that of the right-hand screw thread shown at *A*.

Screws and Bolts. — Screws and bolts may be divided into a number of classes, each of which is particularly adapted to a certain kind of work. A draftsman should not only be familiar with the different classes but should know how to employ them to advantage in designing machines. Screws and bolts have to a certain extent become standardized and, as various standards are employed in different shops, the draftsman should ordinarily specify such standards as are kept in stock. The different classes used in machine construction are known as machine screws, cap-screws, studs, set-screws, and bolts. These general classes include different forms or types which are distinguished by variations of the shape of the head and other details mentioned later.

American Standard Screw Threads. — This standard is the U. S. Standard expanded into a more complete screw thread system which includes tolerances and allowances for different classes of fits. The form of thread profile which is designated as the American (National) form, is the same as the U. S. Standard profile. Two thread series have been adopted, one being coarse and the other fine. (See Table 1.) The coarse thread series is the present United States Standard, supplemented in sizes below $\frac{1}{4}$ inch by a part of the standard established by the American Society of Mechanical Engineers in 1907. The fine thread series for the diameters in Table 1, from $\frac{1}{4}$ inch to 3 inches

inclusive, is in accordance with standard formerly known as the S. A. E. "Regular Screw-Thread Series," and below $\frac{1}{4}$ inch the fine-thread series is supplemented by the fine-thread series previously established by the American Society of Mechanical Engineers. The American Standard also includes an 8-pitch, 12-pitch and 16-pitch thread series.

Table 1. American Standard Coarse-and Fine-Thread Series

Sizes	Basic Major Diameter (Inches)	Coarse Series Threads per Inch	Fine Series Threads per Inch	Sizes	Basic Major Diameter (Inches)	Coarse Series Threads per Inch	Fine Series Threads per Inch
0	0.0600	..	80	$\frac{3}{4}$	0.7500	10	16
1	0.0730	64	72	$\frac{7}{8}$	0.8750	9	14
2	0.0860	56	64	1	1.0000	8	14
3	0.0990	48	56	$1 \frac{1}{8}$	1.1250	7	12
4	0.1120	40	48	$1 \frac{1}{4}$	1.2500	7	12
5	0.1250	40	44	$1 \frac{1}{2}$	1.5000	6	12
6	0.1380	32	40	$1 \frac{3}{4}$	1.7500	5	..
8	0.1640	32	36	2	2.0000	4 $\frac{1}{2}$..
10	0.1900	24	32	2 $\frac{1}{4}$	2.2500	4 $\frac{1}{2}$..
12	0.2160	24	28	2 $\frac{1}{2}$	2.5000	4	..
$\frac{1}{4}$	0.2500	20	28	2 $\frac{3}{4}$	2.7500	4	..
$\frac{5}{16}$	0.3125	18	24	3	3.0000	4	..
$\frac{3}{8}$	0.3750	16	24	3 $\frac{1}{4}$	3.2500	4	..
$\frac{7}{16}$	0.4375	14	20	3 $\frac{1}{2}$	3.5000	4	..
$\frac{1}{2}$	0.5000	13	20	3 $\frac{3}{4}$	3.7500	4	..
$\frac{9}{16}$	0.5625	12	18	4	4.0000	4	..
$\frac{5}{8}$	0.6250	11	18

S. A. E. Screw Thread Standards.—The Society of Automotive Engineers, Inc. (S. A. E.), standard screw thread series are given in Table 2. A comparison with Table 1 will show that the pitches of the "coarse" and "fine" series of both the American and S. A. E. Standards are alike. The Extra-Fine Series is an S. A. E. Standards only. The S. A. E. Standard, like the American Standard, includes three series of uniform pitches, one having 8, another 12, and still another 16 threads per inch throughout the range of diameters. There is also an S. A. E. special-pitch series (not included in table). The S. A. E. Standard thread form or profile is the same as the American Standard.

Table 2. S. A. E. Standard Series of Screw Threads

Size	Basic Major Diam.	Threads Per Inch					
		Coarse (NC) Note 1	Fine (NF)	Extra Fine (EF) Note 2	8 Thread Series Note 2	12 Thread Series Note 3	16 Thread Series Note 4
0	0 0600	..	80				
1	0 0730	64	72				
2	0 0860	56	64				
3	0 0990	48	56				
4	0 1120	40	48				
5	0 1250	40	44				
6	0 1380	32	40				
8	0 1640	32	36				
10	0 1900	24	32				
12	0 2160	24	28				
1/4	0 2500	20	24	32			
5/16	0 3125	18	24	32			
3/8	0 3750	16	24	32			
7/16	0 4375	14	20	28			
1/2	0 5000	13	20	24		12	
9/16	0 5625	12	18	24		12	
5/8	0 6250	11	18	24		12	
1 1/16	0 6875					12	
3/4	0 7500	10	16	20		12	16
1 3/16	0 8125					12	16
7/8	0 8750	9	14	20		12	16
1 5/16	0 9375					12	16
1	1 0000	8	14	20	8	12	16
1 1/16	1 0625					12	16
1 1/4	1 1250	7	12	18	8	12	16
1 3/16	1 1875					12	16
1 1/2	1 2500	7	12	18	8	12	16
1 5/16	1 3125					12	16
1 3/8	1 3750	6	12	18	8	12	16
1 7/16	1 4375					12	16
1 1/2	1 5000	6	12	18	8	12	16
1 9/16	1 5625					12	16
1 5/8	1 6250				8	12	16
1 11/16	1 6875					12	16
1 3/4	1 7500	5		16	8	12	16
1 13/16	1 8125					12	16
1 7/8	1 8750				8	12	16
1 15/16	1 9375					12	16
2	2 0000	4 1/2		16	8	12	16
2 1/16	2 0625					12	16
2 1/8	2 1250				8	12	16
2 3/16	2 1875					12	16
2 1/4	2 2500	4 1/2		16	8	12	16
2 5/16	2 3125					12	16
2 3/8	2 3750					12	16
2 7/16	2 4375					12	16
2 1/2	2 5000	4		16	8	12	16
2 5/8	2 6250					12	16
2 3/4	2 7500	4		16	8	12	16
2 7/8	2 8750					12	16
3	3 0000	4		16	8	12	16

Note 1. The Coarse (NC) series continues by 1/4-inch steps or increments up to 4 inches diameter.

Note 2. The Extra Fine (EF) and 8-pitch series continue by 1/4-inch increments up to 6 inches diameter.

Note 3. The 12-pitch series continues by 1/8-inch increments up to 4 inches diameter and by 1/4-inch increments from 4 1/4 to 6 inches diameter.

Note 4. The 16-pitch series continues by 1/8-inch increments up to 4 inches diameter.

Machine Screws.—The term “machine screw” is applied to various forms of small screws, but is generally understood to mean a screw which ordinarily is inserted in a tapped hole in a machined part and which has a slotted head to receive a screwdriver. Machine screw sizes formerly were designated entirely by numbers, but the present American Standard has numbered sizes up to $\frac{1}{4}$ inch and then fractional sizes up to the largest size of $\frac{1}{2}$ inch. Fig. 6 shows the commonly used shapes of heads and the names conforming to the American Standard. The nominal length of the machine screw is indicated in each case by the dimen-

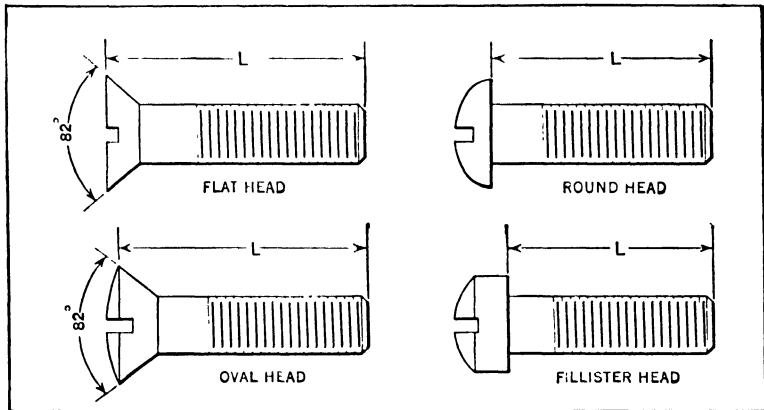

Fig. 6. Different Classes of Machine Screws Included in the American Standard
Dimension L is the Nominal Length

sion L . Machine screws usually are designated by giving the number (or fractional size) and pitch. For example, a No. 10-24 means a No. 10 size having 24 threads per inch.

The American Standard machine screws include the sizes in Table 1 up to $\frac{1}{2}$ inch, and the pitches for both coarse and fine-thread machine screws are the same as given in Table 1. Approximately 80 per cent of the machine screws manufactured are in the coarse-thread class.

Machine Screw Applications.—The flat-head machine screw *A*, Fig. 7, is used when the head must be either flush or

slightly below the work surface. Ordinarily it is unnecessary to show screw heads accurately on the drawing. The dimensions, however, may be obtained from an engineering handbook. Oval head machine screws (often termed "French" head screws), are used in place of the regular flat-head type, if a more finished appearance is desired. Their heads are countersunk so that the oval edge is flush with the work surface. Round head machine screws are used largely for small work and for sheet metal equipment. Their heads protrude above the work, as at *B* Fig. 7.

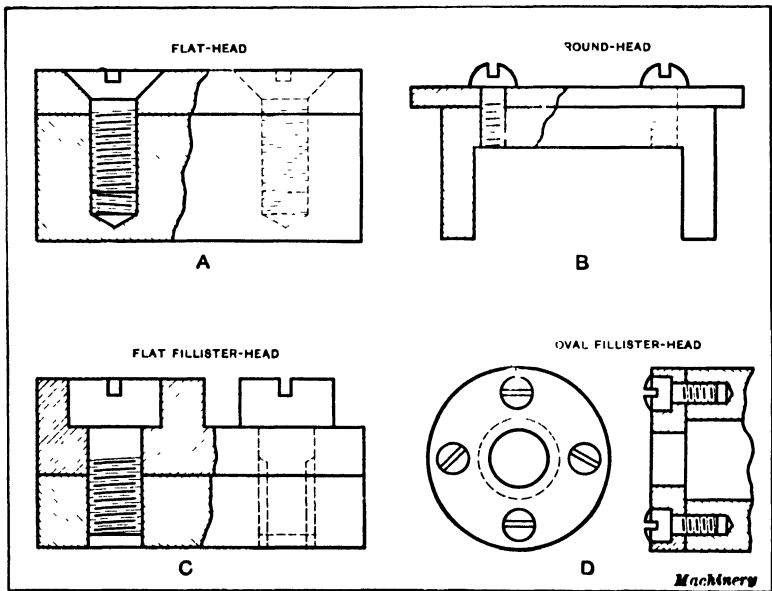

Fig. 7. Typical Applications of Machine Screws

Fillister-head screws are used largely on machine work where heavy screws or bolts are not required. The screw at *C* is a flat fillister head and is generally set *flush* with the work or a little below the surface. The counterbored hole to receive the head is a little larger than the head to allow for any eccentricity. These screws are sometimes used without countersinking the work. The oval fillister head at *D* is used more extensively than the flat fillister head. The present American standard does not include the flat fillister head and the oval form is classed

merely as "fillister head." The oval projects above the surface of the work. When a number of machine screws are equally spaced, it is common practice to include a note stating size and number of the screws required. For example, on the drawing this may be written, "4 No. 3-56 oval fillister head," which means that four equally spaced oval fillister head screws are required.

Cap-Screws. — Cap-screws are inserted in tapped holes like machine screws, but they are made in larger sizes and are generally used for heavier work. Many cap-screws have slotted heads like machine screws, but hexagonal heads intended to

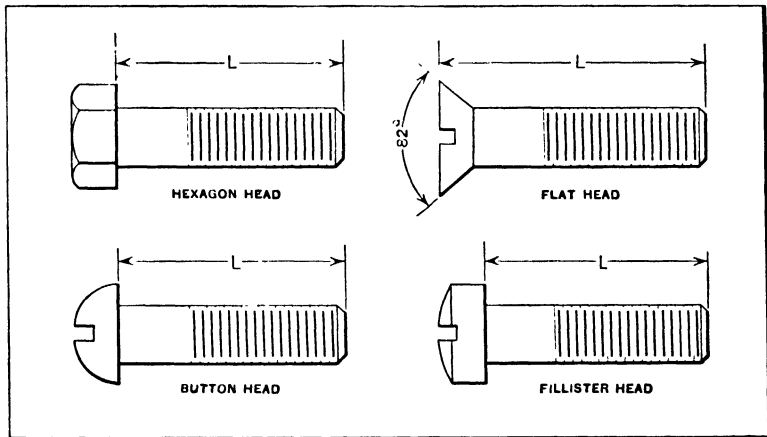

Fig. 8. Names given to American Standard Cap-screws. Dimension L is the Nominal Length

receive a wrench instead of a screw driver are frequently used. The term "tap-bolt" is also applied to screws of this class.

Cap-screws, except for certain special applications in automotive work, etc., have the coarse series of threads (Table 1) which is the same as the U. S. Standard. The American Standard cap-screws range in diameter from $\frac{1}{4}$ inch to $1\frac{1}{4}$ inch. The S. A. E. Standard includes both a coarse and a fine series of pitches which are the same as the two series of pitches given in Table 1 for diameters from $\frac{1}{4}$ inch to $1\frac{1}{4}$ inches, inclusive. Fig. 8 shows the names applied to American Standard cap-screws. The slotted head cap-screws have the same names as machine

screw-heads of similar shape, excepting the "button head" cap-screw which is of the same general form as the "round head" machine screw. Dimension L indicates the nominal length.

Machine Bolts. — Many types of bolts have come into use for various purposes and some of the most commonly employed types have been standardized. The difference between a bolt and a screw, according to the generally accepted meaning of the term, is that nuts are used on bolts whereas screws are inserted into tapped holes; there are exceptions, however, to this general classification. When a bolt is used to connect two pieces, a hole is drilled through both pieces large enough to

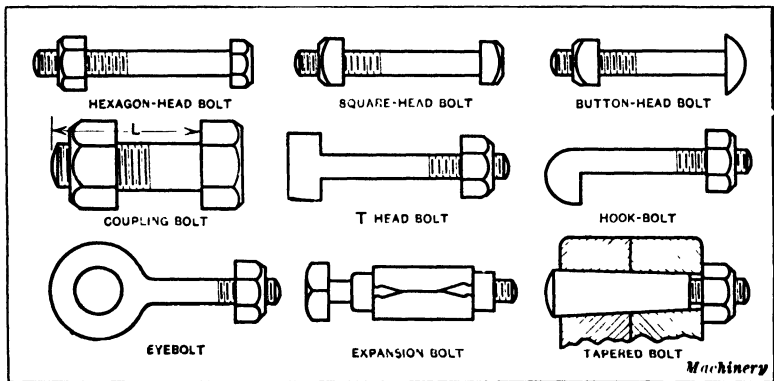

Fig. 9. Various Forms of Bolts

receive the body of the bolt, and the nut is screwed either directly against one part or against a washer placed between the nut and the work, thus clamping the two pieces firmly together between the bolt head and the nut. The hole through which the bolt passes may be slightly larger than the diameter of the bolt or the bolt may be accurately fitted in the hole to prevent lateral movement of the part instead of relying entirely upon the friction resulting from the pressure of the nut.

Bolts are classified according to the shape of the head. Some of the principal forms are shown in Fig. 9. The hexagonal and square types are used in machine construction and for a wide variety of purposes. The button form is applied to a miscel-

laneous class of work, especially when it is desired to improve the finish where the bolt head protrudes. The T-head bolt is extensively used for clamping castings and forgings to various kinds of machine tools. The T-shaped heads of the bolts engage T-slots which extend along the table of the machine. After the bolt head is inserted in the T-slot it is given a quarter turn so that the projecting lugs forming the T hold the bolt in place. The hook-bolt is a special form having a hook-shaped head. It is used for clamping narrow pieces which would be weakened excessively by drilling. The eyebolt is so named because the head forms a loop or "eye" which may be used in different ways. They are used principally to provide a means of attaching a chain or hook to heavy machine tools, motors, etc. Expansion bolts are used for such purposes as attaching a pipe-hanger bracket or other part to a wall or ceiling of brick or concrete when a through bolt cannot be employed. Bolts of this type are made in quite a variety of designs. The nominal size represents the diameter of the bolt proper and not the diameter of the casing or expansion member.

Bolt and Nut Standards. — The dimensions of bolt heads and nuts have for many years conformed to certain standards but there have been different standards and also some revisions which have caused a great deal of confusion. Many believe that the United States Standard is in general use in the United States because of the name given to this standard and also because the U. S. Standard tables are found in the various engineering handbooks. The U. S. Standard which was established in 1876 was the first real attempt to standardize nuts, but its use at the present time is restricted to a few industries. For a number of years the so-called Shop Standard was the one generally used by bolt and nut manufacturers. In 1924 an international conference on bolt and nut standardization was held in New York under the auspices of the American Engineering Standards Committee (now American Standards Association). According to the American representatives at this conference, the United States Standard at the time mentioned represented less than 3 per cent of the production in the United States. The

bulk of the production, excepting in the automobile and agricultural machinery industries, conformed at the time to the Shop Standard. In 1927 the Bolt, Nut and Rivet Manufacturers Association adopted the Manufacturers Standard for rough and semi-finished square and hexagonal nuts in $\frac{1}{4}$ - to $1\frac{1}{4}$ -inch sizes, inclusive. An American Standard was also approved by the American Standards Association in 1927. According to the Manufacturers Standard, nuts for $\frac{5}{8}$ - and $\frac{3}{4}$ -inch bolts were $\frac{1}{16}$ inch wider across the flats than the American Standard, to allow using hot forged nuts; otherwise the Manufacturers and American Standards were alike excepting that the latter covered bolt diameters up to 3 inches, inclusive. Later the American Standard was revised by increasing the width across flats of $\frac{5}{8}$ -inch nuts from $\frac{15}{16}$ inch to 1 inch; the nominal thickness of $\frac{9}{16}$ nuts was also increased from $\frac{31}{64}$ to $\frac{1}{2}$ inch. Both of these increased dimensions conformed to the Manufacturers Standard. The latter has been discontinued and the Bolt, Nut and Rivet Manufacturers Association have adopted the American Standard. It is evident from the foregoing that the standardization, even of such important elements as bolt heads and nuts, has been subject to considerable change, so that it is important for the draftsman and designer to keep in touch with changes and developments of this kind to safeguard against using some standard which may be obsolete or at least not in general use.

Proportions of the American Standard Bolt Heads.— The American Standard includes both “regular” and “heavy” bolt heads and nuts. Regular bolt heads and nuts are for general use and heavy bolt heads and nuts are applied where a larger bearing surface is desired.

Regular bolt heads: Widths across flats of unfinished and semi-finished heads = $1\frac{1}{2}D$ adjusted to nearest sixteenth-inch size. Height of head = $\frac{2}{3}D$ for unfinished heads. Widths across flats of finished heads = $1\frac{1}{2}D$ excepting $\frac{1}{4}$ - to $\frac{5}{8}$ -inch sizes, the widths of which = $1\frac{1}{2}D + \frac{1}{16}$. The height of finished heads = $\frac{3}{4}D$ (D = bolt diameter). The term “unfinished” means not

machined on any surface; "semi-finished" means machined under the head only; "finished" means machined on all surfaces.

Proportions of American Standard Nuts: There are regular and heavy nuts in unfinished, semi-finished and finished grades.

Regular Nuts: Widths across flats of regular nuts = $\frac{1}{2}D$ excepting to $\frac{1}{4}$ - to $\frac{5}{8}$ -inch sizes, the widths of which = $1\frac{1}{2}D + \frac{1}{16}$ inch.

Heavy Nuts: Widths across flats = $1\frac{1}{2}D$ plus $\frac{1}{8}$ inch (adjusted to sixteenths) for unfinished, semi-finished and finished nuts.

U. S. Standard Bolts and Nuts: The United States Standard has been superseded by the American Standard Heavy Bolt Heads and Nuts which are similar. The American Standard Heavy Bolt Heads and Nuts have the same widths across the flats as the U. S. Standard.

Set-Screws.—The principal difference between a set-screw and a cap-screw is that the former bears on its point, whereas a cap-screw bears on its head. Set-screws are generally used to prevent relative motion between two machine parts, as, for example, when a set-screw passes through a tapped hole in the hub of a pulley and bears against a shaft which drives the pulley. Keys are preferable to set-screws for locking pulleys, gears, etc., to their shafts, and for similar work, although set-screws may serve the purpose when not subjected to heavy loads; they are used principally on the cheaper grades of machinery. Set-screws are not only used for locking parts together, but also as a means of obtaining slight adjustments, either to eliminate unnecessary play by means of gibs, or for changing the location of a tool or other part. On account of the danger caused by the projecting head of set-screws, hollow or "safety" set-screws are now used extensively. These have a square or hexagonal hole in the end for a wrench, instead of a projecting head.

Different Forms of Set-Screws.—The different forms of set-screws most commonly employed in machine work are shown in Fig. 10. It will be observed that these differ as to the shapes of the ends and heads. They are made in other combinations, those shown with heads being made in headless forms and vice versa. Set-screws may be obtained in various lengths to meet requirements. The types of set-screws used for some applications are made from

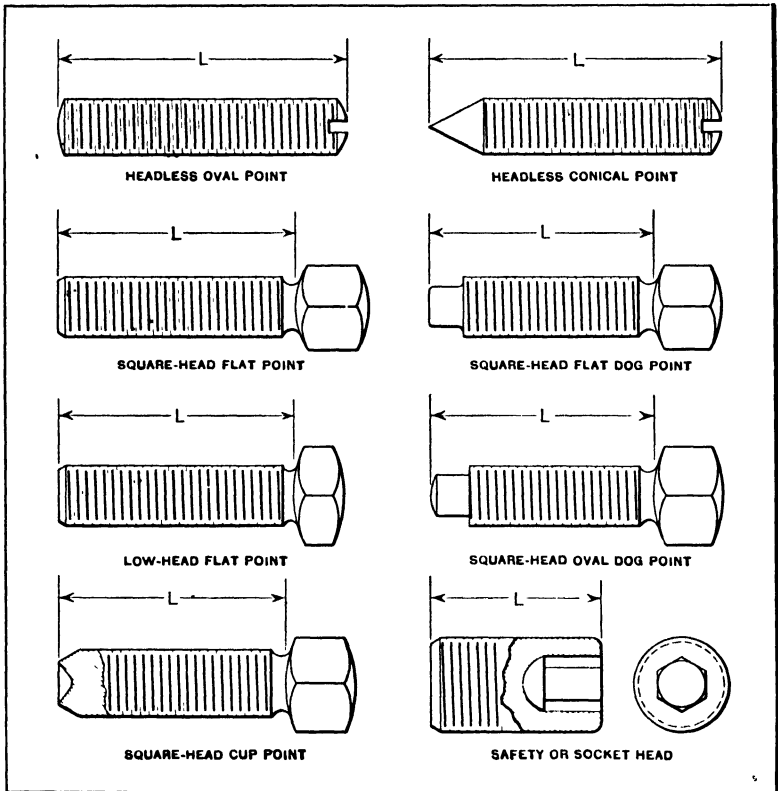

Fig. 10. Different Classes of Set-screws. Dimension L indicates Nominal Length

steel and hardened all over, while some are provided with soft heads and hardened points.

The square-head flat-point set-screw is commonly employed in chuck and fixture work to prevent movement. This type was originally used to hold small pulleys, gears, etc., in place on shafts; however, the danger caused by the projecting heads on moving parts has resulted in the more general use of headless set-screws for this class of work. The low-head flat-point type is often used in place of square-head set-screws when only a small amount of clearance for the head is available. The headless round-point set-screw is used very largely with jig or fixture work as an adjustable stop. Check-nuts are quite fre-

quently used on headless set-screws to prevent any change in location, the same as on the other types. When provided with conical or cup points this type is frequently used in a collar to prevent its rotation on a shaft. When a conical-point set-screw is used for this purpose, the shaft is countersunk to receive the point. The angle formed by the conical point is generally 60 to 70 degrees, although this angle varies to a considerable extent in the products of various manufacturers. The cup point requires no countersinking operation as it imbeds itself in the metal by the pressure exerted when tightening the screw. The dog-point or pivot-point type of set-screw is often used when the end is liable to become upset or enlarged as the result of numerous applications of pressure. It is also used in place of a key to prevent rotation when a longitudinal movement of a gear or pulley along a splined shaft is required. The socket flat-point set-screw is used in place of the square-head flat-point type and it is rapidly replacing the other types, especially where a strong set-screw is required on moving parts. This type is also provided with different type points and can generally be used for any class of work requiring set-screws. The dimensions of commercial set-screws may be obtained usually from the manufacturers catalogue.

The American standard set-screws have nominal screw thread diameters ranging from $\frac{1}{4}$ inch to $1\frac{1}{2}$ inches, and the pitches are the same as the American coarse-thread series.

Studs or Stud-bolts. — Stud-bolts have a thread at each end. They are extensively used to hold cylinder heads, steam chest covers and similar parts, in position. The threaded section *a* Fig. 11 of the stud usually is screwed into the stationary part to which the removable cylinder head or other part is attached as illustrated by the sectional view. The stud differs from a cap-screw in that the nut is substituted for a solid head. Studs are generally considered preferable to cap-screws, especially on heavy machinery in which the attached part must be frequently removed. The thread of the end *a* is usually made a little over size to make it fit tightly in the tapped hole. When set into cast iron, the length of the threaded end should be at least $1\frac{1}{4}$

times the diameter of the stud. The threaded portion b on which the nut is screwed is made of any length to meet requirements, and for some purposes it is made a sufficient length to enable two nuts to be used instead of one, thus providing means of fastening and locking the piece in place. In drawing studs, the conventional method of representing screw threads is generally used.

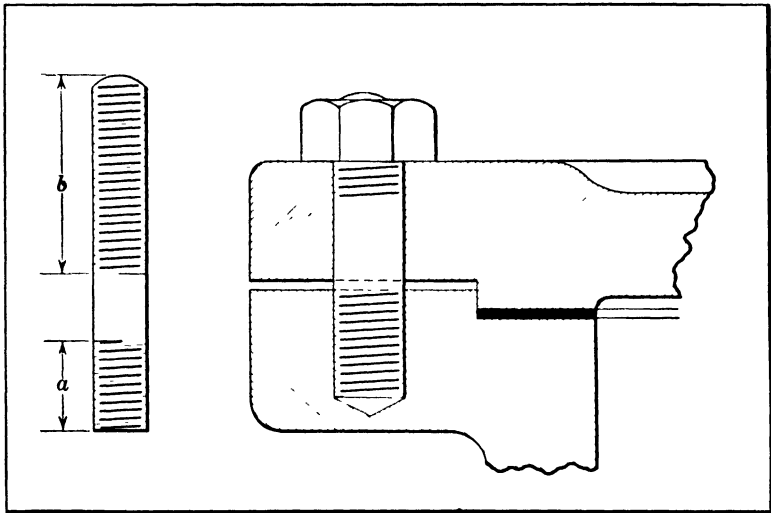

Fig. 11. A Stud or Stud-bolt and Typical Method of Using

Machine Keys. — A key of the type commonly used in machine construction consists ordinarily of a piece of steel, either square or rectangular in cross-section, which is inserted into a keyway or keyseat formed partly in a shaft and partly in the hub of a gear, pulley, or other part which, by means of the key, is driven positively and prevented from rotating relative to its shaft. While keys are used primarily to prevent relative rotation between shafts and such parts as pulleys, gears, etc., they also prevent axial movement in many cases, owing to the frictional resistance between the keyed parts. The type of key that may properly be employed in any case naturally depends somewhat upon the class of work for which it is intended.

The so-called *saddle key* A Fig. 12, does not enter a slot in

the shaft, but is curved on the under side and is slightly tapered on top so that when driven into place the shaft is gripped by the frictional resistance. The *sunk key B* is the most common type. This is of rectangular section and engages a groove or slot formed both in the shaft and hub of the gear or pulley. The *flat key C* is a rectangular shape which, for some classes of work, bears upon a flat surface formed on one side of the shaft. The draw or *gib key* is a sunk key which has a head by means of which it can be removed. The *round tapered key D* is simply a taper pin which is driven into a hole that is partly in the shaft and partly in the hub; this form is used for light work. The

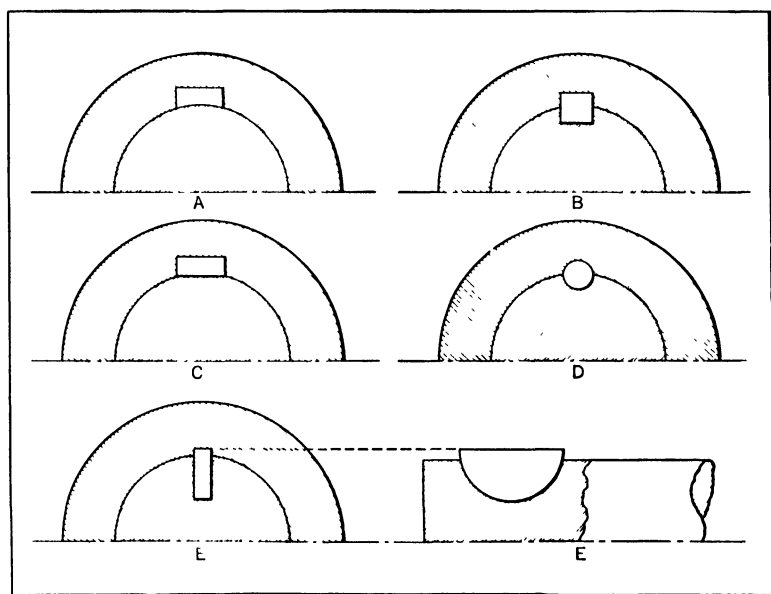

Fig. 12. Different Types of Machine Keys

name *feather* or *spline* is applied to a key which is fixed to either a shaft or hub, as when a gear must be driven by a shaft, but at the same time be free to slide in a lengthwise direction. The *Woodruff key E* is a section of a disk, the part which enters the shaft being circular. The common method of designating Woodruff key sizes has been by the use of numbers but the nominal size, according to the latest S. A. E. standard, is indi-

cated by giving the key thickness and the diameter of the key stock. For example a $\frac{1}{8} \times \frac{3}{4}$ key is $\frac{1}{8}$ inch thick and is made from $\frac{3}{4}$ -inch stock.

The width of an ordinary sunk key ordinarily is equal to about one fourth of the shaft diameter and the thickness, when a flat key is preferred to the square form, is usually about one sixth of the shaft diameter; these proportions are varied somewhat by different manufacturers. The taper of American standard square and flat keys is $\frac{1}{8}$ inch per foot.

Wrought Pipe. — Wrought-iron and steel pipes are made in three different thicknesses, known as *standard*, *extra strong*, and *double extra strong*. The actual outside diameter is the same, the increased thickness of the wall merely decreasing the internal diameter. The term "wrought-iron pipe" is often used indiscriminately to designate all butt-or lap-welded pipe whether made from wrought iron or steel, but the term *wrought pipe* is preferable for designating either steel or wrought-iron pipe. A large percentage of the wrought pipe now used is made of steel. When wrought-iron pipe is desired the term "genuine wrought iron" or "guaranteed wrought iron" should be used, as otherwise the manufacturer will invariably supply steel pipe.

The size of iron and steel piping is specified in terms of the nominal inside diameter excepting for the large sizes, as noted later. For standard pipe (See Table 3) the actual inside diameter is usually greater than the nominal, especially on the smaller sizes, but in the extra strong, and especially in the double extra strong pipe, the internal diameter is less than the nominal size. The thickness of the wall and the weight per linear foot of piping varies on account of the difficulty in securing uniformity in the process of manufacture. It is assumed to be permissible for standard weight pipe to vary from 5 per cent above to 5 per cent below the standard weight. A class of pipe known as *merchant* pipe, which is ordinarily carried by jobbers, is almost invariably from 5 to 10 per cent under the nominal weight. In specifying pipe, therefore, it should be stated whether "merchant," full weight, extra strong, or double extra strong pipe is required.

Formerly wrought iron was preferred for the best classes of

Table 3. National American Briggs Standard Pipe Thread.

Diameter of Pipe			No. of Threads per Inch	Length of Effective Thread	Outside Diameter at Small End of Thread	Root Diameter at Small End of Thread	Reamer Diameter at Large End of Reamed Hole
Nominal Diameter	Actual Inside Diameter	Actual Outside Diameter					
$\frac{1}{8}$	0 269	0 405	27	0 264	0 393	0 334	0 345
$\frac{1}{4}$	0 364	0 540	18	0 402	0 522	0 433	0 445
$\frac{3}{8}$	0 493	0 675	18	0 408	0 656	0 568	0 583
$\frac{1}{2}$	0 622	0 840	14	0 534	0 816	0 701	0 721
$\frac{3}{4}$	0 824	1 050	14	0 548	1 025	0 911	0 932
1	1 049	1 315	$11\frac{1}{2}$	0 683	1 283	1 144	1 169
$1\frac{1}{4}$	1 380	1 660	$11\frac{1}{2}$	0 707	1 627	1 488	1 514
$1\frac{1}{2}$	1 610	1 900	$11\frac{1}{2}$	0 724	1 866	1 727	1 753
2	2 067	2 375	$11\frac{1}{2}$	0 757	2 339	2 199	2 227
$2\frac{1}{2}$	2 469	2 875	8	1 138	2 820	2 620	2 662
3	3 068	3 500	8	1 200	3 441	3 241	3 289
$3\frac{1}{2}$	3 548	4 000	8	1 250	3 938	3 738	3 789
4	4 026	4 500	8	1 300	4 434	4 234	4 287
$4\frac{1}{2}$	4 506	5 000	8	1 350	4 931	4 731	4 786
5	5 047	5 563	8	1 406	5 491	5 291	5 349
6	6 065	6 625	8	1 513	6 546	6 346	6 406
7	7 023	7 625	8	1 613	7 540	7 340	7 402
8	7 981	8 625	8	1 713	8 534	8 334	8 400
9	8 941	9 625	8	1 813	9 527	9 327	9 398
10	10 020	10 750	8	1 925	10 645	10 445	10 521
11	11 000	11 750	8	2 025	11 639	11 439	11 519
12	12 000	12 750	8	2 125	12 633	12 433	12 518

work, but records of installations and tests have demonstrated that steel pipe is equal to wrought-iron pipe for general work and, according to some authorities, resists corrosion, in the average case, as well as wrought iron; the steel pipe is also cheaper than wrought iron, and according to one estimate 90 per cent of the wrought pipe made in the United States is of steel. The term *galvanized pipe* is applied to ordinary wrought pipe which has been galvanized. The abbreviated expression *O. D. pipe*, which is found in manufacturers' catalogues, is applied to large wrought pipe, the nominal size of which is designated by the outside diameter instead of the inside diameter as in the case of smaller sizes. It is common practice to designate the nominal sizes of all pipes above 12 inches by giving the outside diameter, although

this is not an invariable rule. The National Tube Co. designates all pipes above 15 inches inside diameter, by the outside diameter. The nominal sizes of boiler tubes also indicate the outside diameter.

Standard Pipe Thread. — The American standard taper pipe thread, also known as the American Briggs standard and as the Briggs standard, is a 60-degree vee thread, truncated equally top and bottom by an amount equal to 0.033 times the pitch of

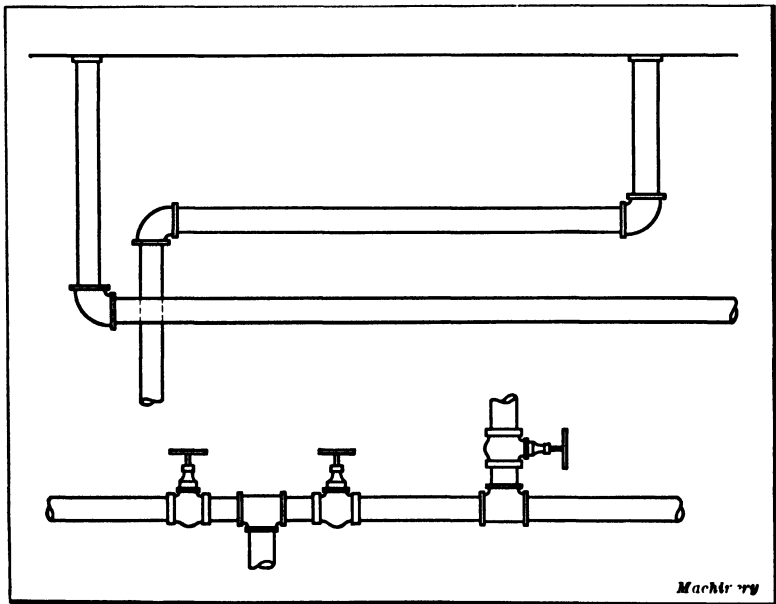

Fig. 13. Examples of Pipe Drawings

the thread. The taper of the thread, on the diameter, is $\frac{1}{16}$ inch per inch or $\frac{3}{4}$ inch per foot. The thread depth equals $0.8 \times$ pitch of thread.

Pipe Fittings. — Different sections of pipe are connected by "pipe fittings," such as elbows, tees, crosses, flanges, unions, couplings, etc. The size of a fitting corresponds to the nominal size of pipe for which it is intended. The smaller pipes are commonly joined by some form of screwed connection, such as a coupling or union, but for sizes above 6 inches, flanges which

are held together by bolts are in common use. Several standards have been adopted at different periods for governing the diameter and thicknesses of flanges and the diameter of the bolt circle, as well as the size and number of bolts. The present standard for flanged fittings is known as the American standard. The draftsman engaged on work which requires piping should secure tables covering the sizes of different classes of fittings and other data required in connection with the installation and laying out of piping. Tables for different classes of flanged fittings will be found in *MACHINERY'S HANDBOOK*.

Drawings of Piping. — Small sizes of piping are sometimes represented diagrammatically by a single heavy line, but the

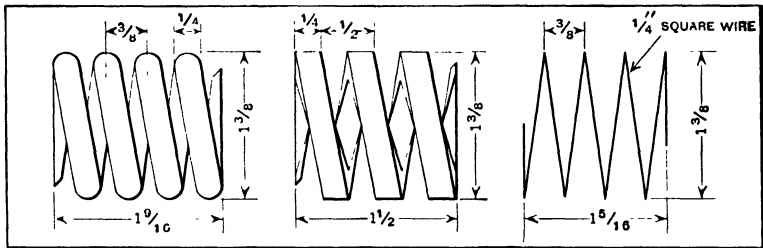

Fig. 14. Drawing of a Helical Spring made of Round Wire

Fig. 15. Drawing of a Helical Spring made of Square Wire

Fig. 16. Simpler Method of Drawing Spring: note gives Wire Size

larger sizes are usually drawn as illustrated in Fig. 13. The upper illustration represents pipes which are connected with a tank, and the lower illustration shows valves in connection with a pipe drawing. When an entire layout of piping is to be represented in a single view, the isometric form of drawing is often very convenient. The principle governing this method of drawing is explained in Chapter XIII. When the diameter of wrought iron or steel pipe is given on a drawing, this corresponds to the nominal diameter as given. This nominal diameter is approximately equal to the inside diameter of 1 inch pipes and larger, excepting the *O. D.* pipe previously referred to. The inside diameters of pipes below 1 inch are somewhat larger than the nominal diameter.

Drawing Helical Springs. — Several conventional methods are in use in drafting rooms for representing helical springs.

Three of these methods are indicated in Figs. 14, 15 and 16. In Figs. 14 and 15 the curvature of the springs is represented by straight lines to facilitate the making of the drawing. Though these views are not true representations of the springs, they bear a close resemblance to them. Even these methods, however, entail a good deal of work which may be largely eliminated by employing the simpler method indicated in Fig. 16 where the outline of the spring is represented by one continuous line. It is quickly drawn and a note giving the wire size, together with the other dimensions, meets practical requirements.

Drawings of Gearing. — Draftsmen should understand the principles governing the design and action of gearing, because gears of some kind are used on such a large variety of mechanical devices. The types of gearing in common use include spur gears, bevel gears, spiral gears, and worm-gears. The points to consider in the design of gearing are: The type of gear to use; the relative sizes or diameters of meshing gears to secure the required speed ratio; the size or pitch of the teeth so that they will be strong enough to transmit the required power; and the shape or arrangement of the body of the gear itself.

The type of gearing to use depends upon such factors as the relative locations of the shafts and the reduction or increase of speed required between the driving and the driven shafts. The gear diameters are, of course, determined with reference to the speed ratio necessary and the pitch of the teeth depends upon the strength needed to transmit the power without danger of breaking the teeth. The body of the gear may simply be in the form of a disk or there may be a hub and rim connected by either a web or by means of arms or spokes. It is evident that the design of gearing is too broad a subject to be covered in a book dealing primarily with drawing; hence, the common methods of representing gearing on drawings will be explained and illustrated, but the subject of gear design and the proportioning of gears for withstanding stresses and transmitting a given amount of power will not be considered. The student of drafting practice, however, should study this subject separately, owing to the extensive use of gearing.

Methods of Drawing Spur Gears. — Working drawings of spur gears, as they are usually made, do not show the gear as it actually appears, because the making of such a drawing would require considerable time and it would not be any better for shop use than the simpler drawings which are employed. The conventional methods of representing gears differ somewhat in various drafting-rooms, just as in the

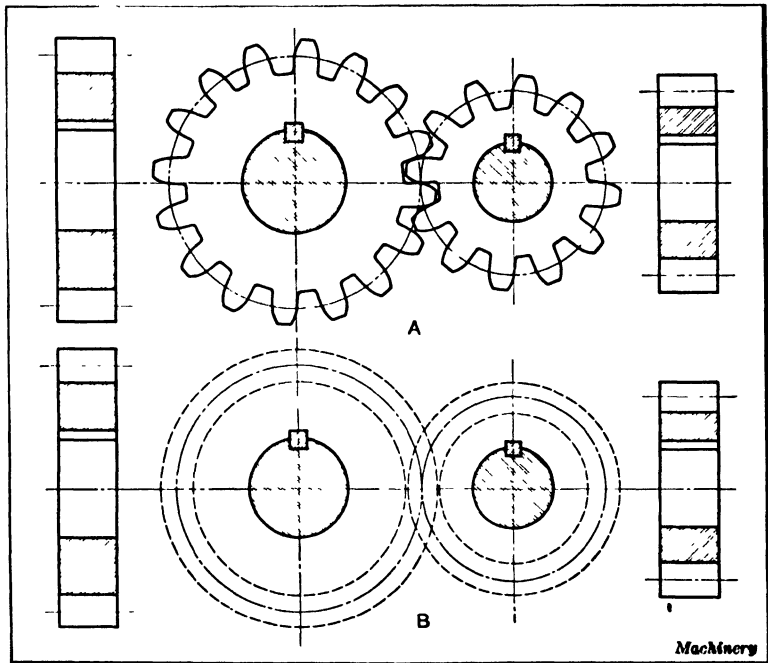

Fig. 17. (A) Drawing of Gear with all the Tooth Outlines shown. (B) Simpler Method of representing Gear which serves all Practical Purposes

case of screw threads, but these differences in practice pertain to minor details. Drawing A, Fig. 17, shows two spur gears in mesh, and in this case the curvature or outline of each tooth is represented. It is evident that to draw in all of these teeth, even though the tooth curves are only approximately correct, requires considerable time, and is also unnecessary on a working drawing. Therefore, the teeth are either omitted entirely on a working drawing, as shown at B, or sometimes

a few teeth are drawn in at the point where one gear meshes with the other. It will be noted that the teeth are represented by dotted circles. The diameter of the outer circle corresponds to the outside or blank diameter of the gear, and the inner circle, to the bottoms of the tooth spaces. The dot-and-dash circle between these dotted circles is known as the *pitch circle*. When the diameter of a spur gear is referred to, it is always understood to mean the diameter of the pitch circle, and it is the relation between the diameter of the pitch circles of two meshing gears which determines their relative speeds. When a drawing shows two gears in mesh, the pitch circles are always in contact.

The outer circles are sometimes drawn solid instead of using dotted circles. For instance, the outlines of three or four teeth may be drawn to the approximate shape at the meshing point, and then the remainder of the outer circle be represented by a solid line. If some gears are located back of others, as in a compound train, and solid circles are dotted to represent the concealed parts of the gear rims, which may be an advantage in showing the relative locations of the gears, especially if it is not convenient to include an end view. It will be understood that Fig. 17 is intended merely to show the difference between an actual representation of gearing and a common or conventional method of illustrating gears on working drawings. On a regular working drawing the sizes of the gears and the pitch of the teeth would, of course, be given together with other necessary dimensions and information; then a drawing of the kind illustrated at *B* is just as useful to the machinist who has to cut the gear as a true drawing which shows the curvature of each tooth.

Working Drawing of Spur Gears. — Most gears are made either of cast iron or of steel. The cast-iron gear may have a solid web or a thin section between the hub and the rim, or it may have arms or spokes, the latter being used for the larger sizes. Many small gears are made of steel, especially if they are intended for hard service. The steel gears of larger sizes are usually made from forgings or, if quite

small, they may be turned from bar stock. The term "gear blank" is applied to any gear before the teeth are cut. When making working drawings of gears, the draftsman considers these points. For instance, if the gear is to be cast and is to have spokes, dimensions will be needed by the patternmaker which would not be required on a simpler form of gear.

The amount of work necessary in designing a gear varies somewhat according to the size and type of gear and is also affected by the class of service the gear is intended for. For instance, a small steel gear which is to transmit little power may simply be in the form of a disk, and calculations for determining the pitch of the teeth or the proportions of the gear body are unnecessary. On the contrary, if a large gear is required for severe duty, the designer must carefully consider the pitch and strength of the teeth as well as the proportions of the different sections, such as the arms in the case of a cast-iron gear. The student of drafting should understand clearly the relation between these problems in design and the making of the drawing itself.

In order to illustrate the important points to consider when making working drawings of spur gears, a practical example will be considered. Suppose two spur gears of 6 diametral pitch are to be located on shafts which are 12 inches apart as measured between centers, and that the speed ratio of the shafts is 2 to 1. The problem is to determine the size of each gear and to make a working drawing which gives all the information necessary for making the gears.

As the center-to-center distance is 12 inches, the total diameters of both gears equal $2 \times 12 = 24$ inches. Now, as the diametral pitch is 6 (which equals the number of teeth for each inch of diameter) it follows that the total number of teeth in both gears equals 24 times the diametral pitch, or $24 \times 6 = 144$. Since the speed ratio is 2 to 1, one gear must be twice as large in diameter as the other and have twice the number of teeth; therefore, in this case, one gear has 48 teeth and the other, 96 teeth ($96 + 48 = 144$). Their respective pitch diameters which are obtained by dividing the number

of teeth by the diametral pitch, equal 8 and 16 inches ($48 \div 6 = 8$ and $96 \div 6 = 16$). The outside or blank diameter of a spur gear is obtained by adding 2 to the number of teeth and dividing the sum by the diametral pitch. In this example, the outside diameter of the large gear equals $\frac{96 + 2}{6} = 16.333$ inches, and the outside diameter of the small gear equals $\frac{48 + 2}{6} = 8.333$ inches. The whole depth of the teeth is found by dividing 2.157 by the diametral pitch and

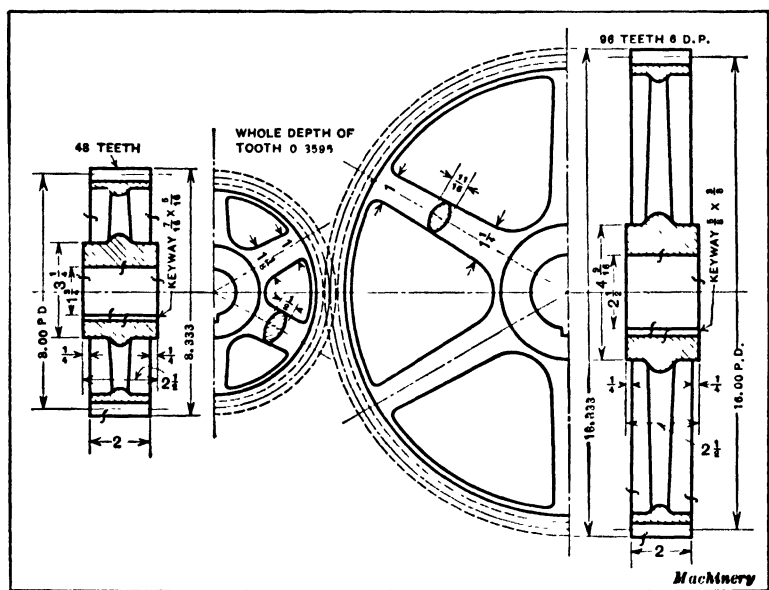

Fig. 18. Working Drawing of a Spur-gear Drive

equals, in this case, 0.3595 inch. This is the amount that the cutter is fed in radially when cutting teeth (assuming that the gear blank is turned to the correct diameter), and it should preferably be given on a working drawing.

Designers often use simplified formulas for proportioning such parts of a gear as the hub, rim, and spokes in case the gear is of that type. Such formulas are found in some hand-

books and also in works on machine design. For instance, in the case of the gear shown in Fig. 18, certain dimensions are obtained by dividing constants by the diametral pitch. These constants have been found by experience to give the right proportions, and the designer's calculations are thus greatly simplified. If an attempt were made to calculate the exact sizes according to the theories governing the proportioning of parts to withstand certain stresses, the calculations in many cases would be extremely complex and the final results would not be as satisfactory in many instances as are obtained by the simpler and more rapid methods.

It is not necessary to give dimensions or information on a working drawing pertaining to the curvature of the gear teeth, because the exact form of the teeth is controlled by the gear-cutting process. Practically all gears used at the present time have teeth of the involute form, so that this is assumed to be the case and need not be specified on a working drawing unless a special tooth form is desired. It is advisable for the draftsman to understand in a general way at least, how tooth curves are originated; therefore, the methods of drawing involute curves and also the cycloidal curves which formerly were used for gear teeth are explained in Chapter XI.

Many gears have what is known as the "stub tooth." Such gears are used in automobile transmissions and in other forms of mechanism which are subjected to severe service and are required to have exceptionally strong teeth. According to the method introduced by the Fellows Gear Shaper Company, the stub gear tooth is based on two diametral pitches; thus, if the pitch of a gear on a working drawing is given as $\frac{8}{6}$ pitch (also written 6-8 pitch), this means that the height of the tooth conforms to 8 diametral pitch whereas the thickness, number of teeth, and pitch diameter are based on 6 diametral pitch. It is evident, therefore, that the tooth is thicker in proportion to its height than a standard tooth. According to the system of R. D. Nuttall Co., the tooth dimensions are based upon the circular pitch, the addendum being equal

to 0.250 times the circular pitch, and the dedendum equal to 0.300 times the circular pitch.

Drawings of Bevel Gears. — Bevel gears are often represented on working drawings as though they had plain or smooth conical surfaces instead of teeth (as illustrated at *A*, Fig. 19). This method is more likely to be employed when the bevel gears are shown on the drawing as a detail or part of a complete mechanism which is represented by the drawing. A working drawing, however, could also be made in this way, provided the necessary data for cutting the gears were given

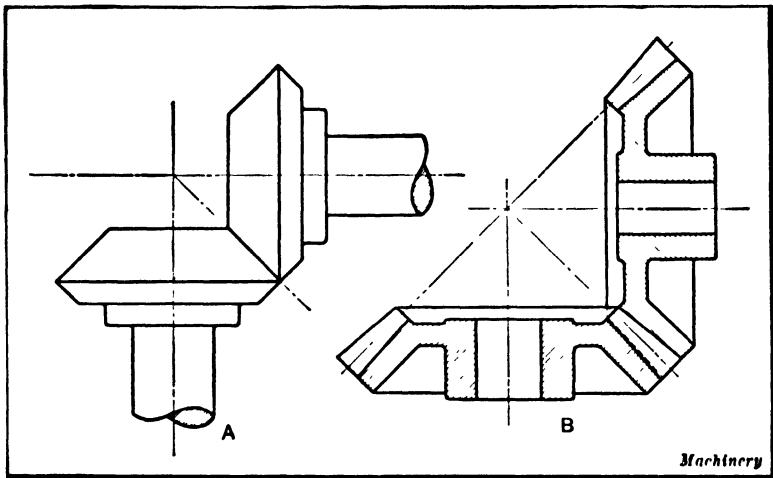

Fig. 19. Two Methods of representing Bevel Gearing

in the form of notes. A common method of representing bevel gears on working drawings is illustrated at *B*. This is simply a sectional view, and, when properly dimensioned and accompanied by certain notes, it gives all the information necessary for making gears.

As a practical example of bevel gear drawing, assume that two shafts at right angles to each other are to be connected by gearing of 3 diametral pitch having a ratio of 4 to 1 between the driving pinion and the driven gear. The smaller gear (commonly called the *pinion*) is to have 15 teeth, and a working drawing is required for cutting the gears with a formed

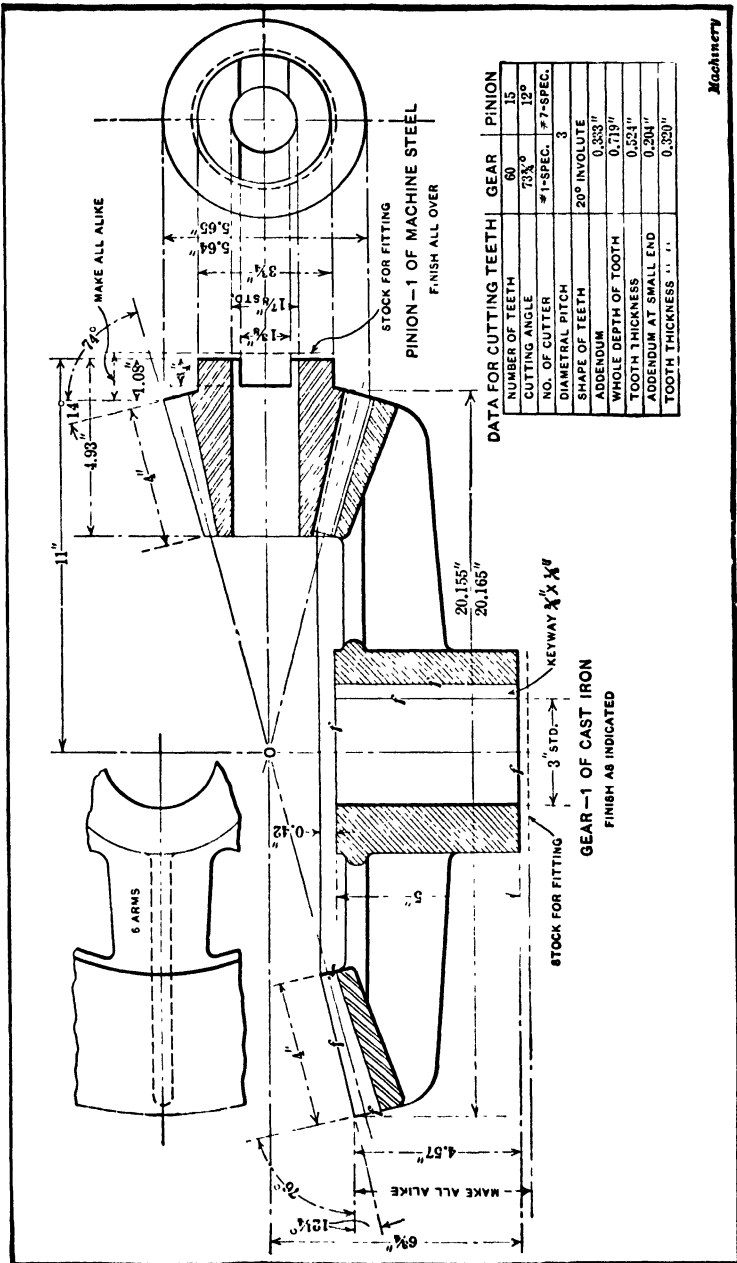

Fig. 20. Working Drawing of Bevel Gears which are to be cut with Formed Milling Cutter

Machinery

milling cutter. As the ratio is 4 to 1, the large gear will have 60 teeth. With these figures available, the required angles of the tooth faces, the diameters and other dimensions can be determined by the rules or formulas found in handbooks and in treatises on gearing. (See MACHINERY'S HANDBOOK.) Before the bevel gear blanks are turned, it is necessary to determine their diameters and the angles of the conical faces, and before the teeth can be cut, the angles at which the blanks must be held in the machine are required. In addition, various other dimensions and information are necessary on the working drawing, as illustrated in Fig. 20, which shows a drawing for the particular combination of gearing referred to. This drawing includes, in addition to a sectional view of the gear and pinion, a detail plan illustrating the shape of the arm and web, and also an end view of the pinion showing the cross driving slot which is used in this case instead of a key because the pinion is so small.

Some of the information required in cutting the gear is given in tabular form in preference to placing the figures directly on the drawing. It will be noted that the face angle of $12\frac{1}{4}$ degrees and also the face angle of 76 degrees are given with reference to a line at right angles to the axis of the gear; consequently, these angles correspond to the angles at which the machinist would set a compound rest for turning these surfaces in a lathe. It will be noted that on each hub a certain amount of stock is allowed for fitting, as indicated by the dotted line. No dimension is specified on this particular drawing, but instead the drawing is marked "make all alike." The object of making them all alike is to avoid resetting in the gear-cutting machine when cutting the teeth in a certain lot or number of gears.

Drawings of Worm-gearing. — A detail drawing of a worm and worm-wheel is shown in Fig. 21. The worm is not shown in position, as an end view would then be obtained. These two sectional views with the accompanying notes give all the information necessary. The distance from the center of the worm-wheel to the center of the worm, when the latter is in

position, is given on the drawing of the worm-wheel, and in this case is 4.672 inches. The ends of the blank for the worm are turned down to a diameter of 1.813 inches, which corresponds to the root diameter of the thread and serves as a guide for depth when cutting or milling the thread. The pitch of the worm and the circular pitch of the worm-wheel are, of

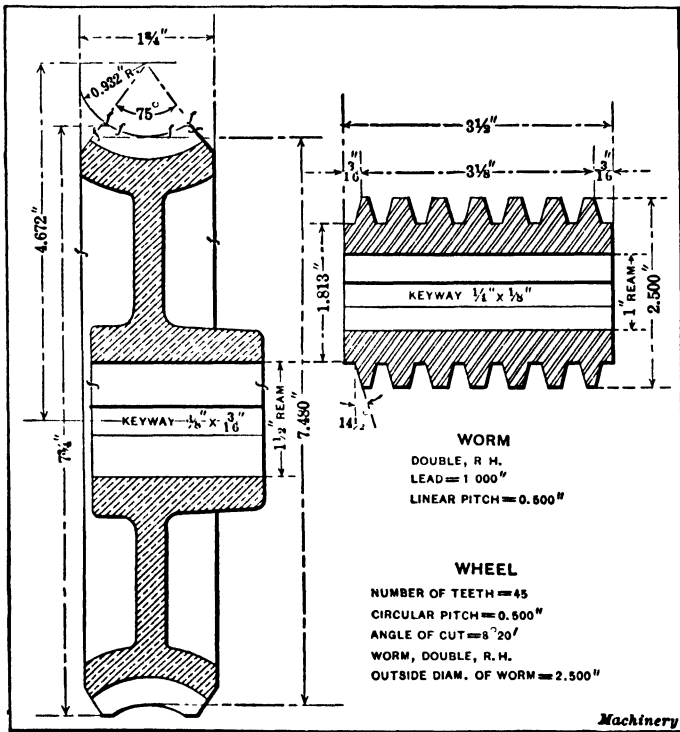

Fig. 21. Working Drawing of a Worm and Worm-wheel

course, always the same. A side view of the worm-wheel is sometimes included, particularly if the wheel is large and has arms or spokes. The notes on the drawing explain that the worm has a double right-hand thread and the lead and pitch are given. The notes for the worm-wheel give the number of teeth, circular pitch, the angle at which the wheel is held for gashing the teeth, etc. This angle for gashing would not be necessary in case the wheel were hobbled directly from the

solid on a machine designed for this work and having a geared drive.

Drawings of Spiral Gears. — When two spiral gears are shown in mesh on a drawing, the teeth are simply represented by lines drawn diagonally but without attempting to incline them accurately. The information for cutting the gear is usually given partly in connection with the drawing itself, and partly in the form of notes. The drawing of a single spiral gear may be similar to the kind just mentioned, or it may be a sectional view and appear like the sectional view of a spur gear, the information needed for cutting the gear being given in notes. The drawing of a spiral gear should include, in addition to the outside diameter and other dimensions of the blank itself, the number of teeth; the tooth or helix angle (angle between tooth and axis of gear); whether the gear or helical tooth grooves are right hand or left hand; the diametral pitch of the cutter to use; the lead of the helix or spiral; and the whole depth of the cut. The combination of gearing to use for obtaining the required lead may also be included.

CHAPTER X

DESIGNING OR LAYING OUT CAMS

CAMS are used on different classes of automatic machinery and on various other mechanical devices, usually to secure mechanical movements which could not be obtained readily, if at all, by other forms of mechanism. Most cams rotate and the driven member has either a straight-line sliding movement or a swinging motion. Some of the most complex machines in existence are governed in their operation largely by means of cams which can be designed to give almost any action required. A cam has curved working surfaces which are laid out in accordance with whatever mechanical movement is necessary. The body of the cam may be in the form of a plate having a curved edge or it may be cylindrical and have a groove of the proper curvature cut into the cylindrical surface. These two general classes of cams are the most common although certain other forms are used. When laying out a plate cam, the problem is to determine the shape of the edge and, in the case of a cylindrical cam, the curvature of the cam groove which engages a roller on the follower and gives it the necessary movement. The motion of the follower may be uniform or it may gradually increase and then gradually diminish. The motion may also be irregular, as for example, when the follower has several periods of motion and rest during a revolution of the cam. In order to design or lay out cams, it is necessary to know how these different motions may be obtained by giving the working edge or groove of the cam the proper curvature.

Designing a Cam for Uniform Motion. --- The laying out of a cam for imparting a uniform motion to the follower will be illustrated by taking as an example a cam which causes the follower to rise a certain distance and then descend to the

starting point. The diagram *A*, Fig. 1, shows one half of the cam curve and illustrates the method of laying out this curve to secure a uniform motion. The center or axis of the cam is represented at *a* and the follower, at *c*. The follower in this case is shown as a pointed rod, although in actual practice it is provided with a roller which bears upon the working edge of the cam, as will be explained presently. The vertical center line is first drawn and then a semicircle is described

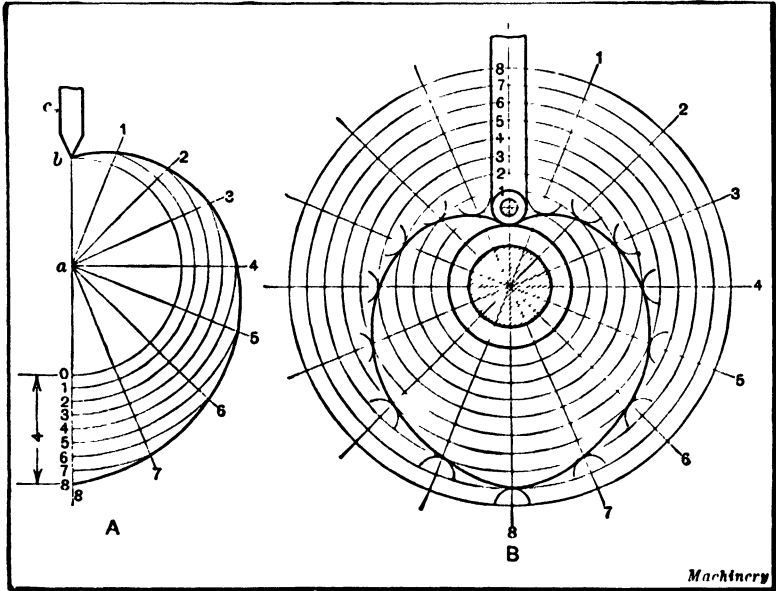

Fig. 1. Method of laying out a Heart Cam for a Uniform Motion

about center *a*. In this case, the semicircle has a radius *ab*, point *b* representing the lower end of the stroke of the follower. Assuming that this stroke is to be 4 inches, this distance is laid off on the center line and is divided into any convenient number of equal parts, the number in this case being 8. The semicircle is also divided into the same number of parts. With *a* as a center, next describe an arc from division 1 on the center line intersecting radial line 1. Then describe an arc from division 2 intersecting radial line 2, and so on. These various points of intersection coincide with the curve of the

cam which is drawn through them. The other half of the curve (not shown in the illustration) is constructed in the same way.

Cam Lay-out for Roller on Follower. — The general method of constructing a follower is to place a hardened steel roller at its end which bears on the edge of the cam as indicated by the diagram *B*, Fig. 1. The reason for using the roller is to reduce friction. Now the curve laid out as described in connection with diagram *A* represents the path followed by the center of the roller; therefore, when a roller is used, the working edge of the cam must be inside of the curve shown at *A* an amount equal to the roller radius. Diagram *B* illustrates how the entire cam curve is laid out when a roller is used. The method followed is the same principle as described in connection with diagram *A*. In actually designing this cam, a circle representing the camshaft would be drawn first and then a larger circle for the hub of the cam. The center of the follower roller is next located at its lowest point which, in this case brings the roller into contact with the hub at one point so that the cam will not be larger than is necessary. In this example, the distance equivalent to the stroke of the cam happens to be laid off above the center of the roller, merely as a matter of convenience, instead of below the center of the camshaft as at *A*. The stroke is divided into a certain number of parts, the number in this case being 8. A series of concentric circles is then drawn through these division points and one half of the outer circle is divided into eight parts or into the same number as the stroke of the follower. From the point where the circle from division 1 intersects radial line 1, describe an arc equal to the radius of the cam roller; similarly, from the point where the circle through division 2 intersects radial line 2, describe another arc equal to the roller radius, and continue describing these arcs with the intersecting points as centers, as indicated by the illustration. The cam curve is then drawn tangent to this series of arcs. Cams of this general class are commonly known as "heart cams" because of their shape. The follower is pushed upward

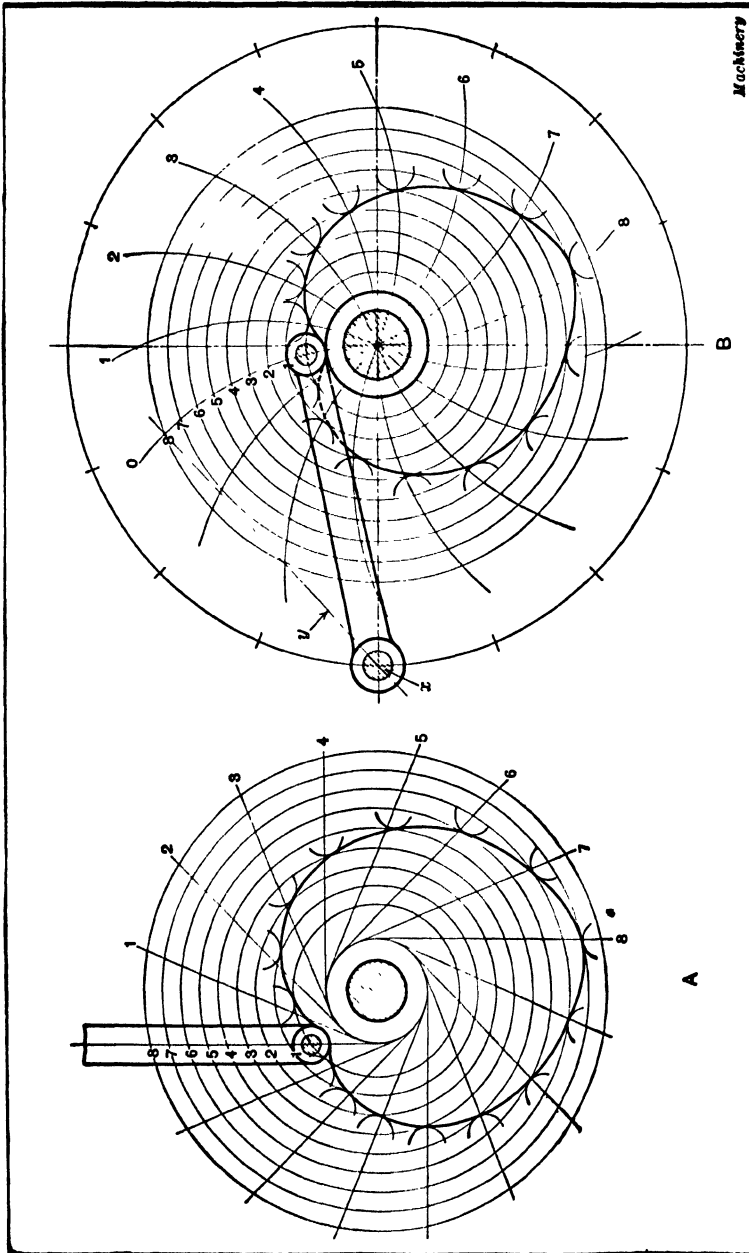

Fig. 3. (A) Method of laying out Cam when Follower is Off Center. (B) Design of a Heart Cam which is to operate a Pivoted Follower

positively by the cam, but it either descends by its own weight or is held in contact with the cam by a spring.

Cam Lay-out when Follower is Off Center. — In some cases the follower is offset relative to a vertical center line intersecting the axis of the camshaft, as illustrated by diagram *A*, Fig. 2, and then the method of laying out the cam curve is modified somewhat. A distance on the center line of the follower equal to the stroke is divided into a certain number of equal parts as in the previous example and these parts are numbered as before. From the center of the camshaft a series of concentric circles is drawn through these division points, and the outer circle is divided into twice the number of parts as the number of follower stroke divisions. A smaller base circle is also drawn from the center of the camshaft, which is tangent to the center line of the follower. Now instead of drawing radial lines as in the preceding examples, a series of lines is drawn from division points 1, 2, 3, etc., on the outer circle, which are tangent to the base circle. Arcs having a radius equal to the radius of the follower roller are then drawn from the points where these tangential lines intersect the concentric circles of like number, the same as described in connection with diagram *B*, Fig. 1.

Cam Lay-out when Follower is Pivoted. — The follower of a cam is frequently in the form of a lever which is pivoted at the end opposite the cam roller; consequently, the follower swings about the pivot as the cam revolves and the center of the cam roller moves along the arc of a circle. The method of laying out the cam for a pivoted follower is illustrated at *B*, Fig. 2. The follower is pivoted at *x* and its upper position is indicated by the center line *y*. The arc representing the path followed by the center of the cam roller would, if extended, intersect the axis of the camshaft. In order to lay out this cam curve, concentric circles are drawn through division points laid off on the stroke line of the follower as before. A large circle is then described about the center of the cam, which intersects the center *x* of the follower pivot. This circle is divided into 16 equal parts, or into twice as many

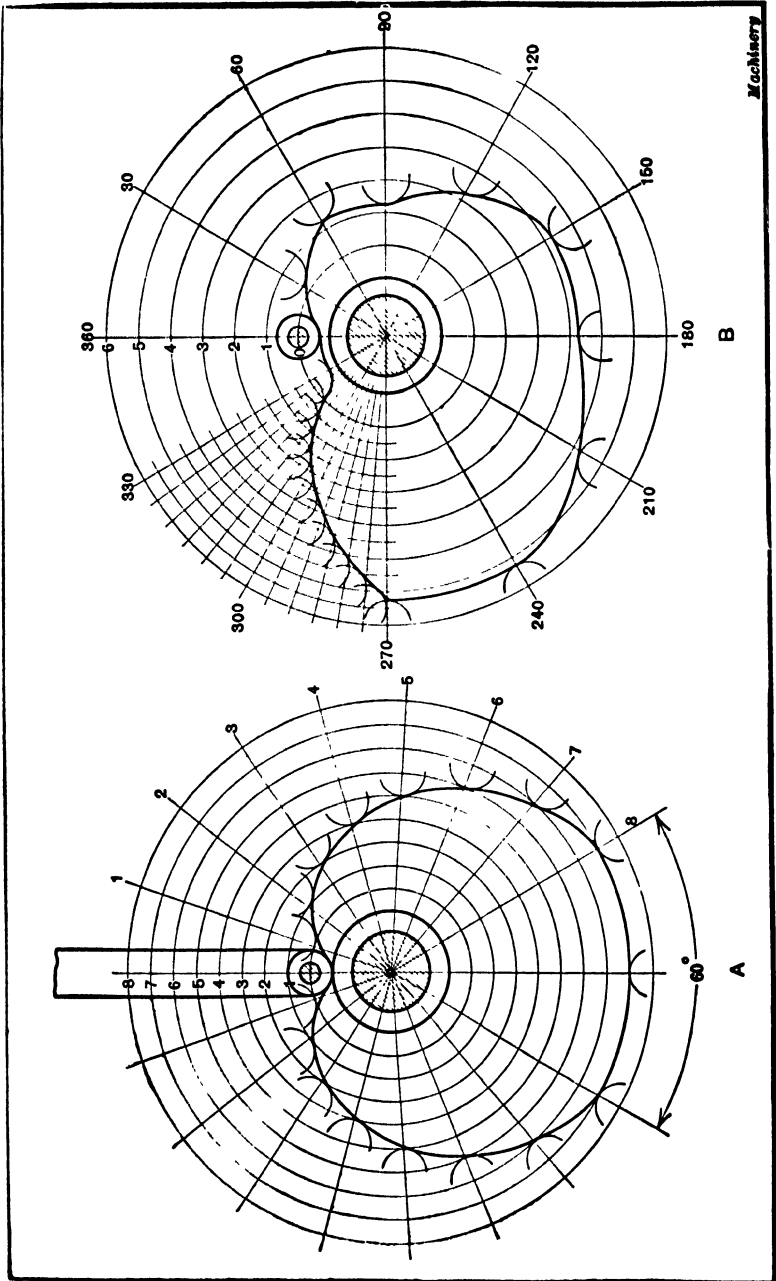

Fig. 3. (A) Cam which has a Dwell or Period of Rest Equal to 60 Degrees. (B) Cam which imparts an Intermittent Motion to the Follower

divisions as the follower stroke line. With a radius equal to the length from center x to the center of the follower roller, arcs 1, 2, 3, etc., are described from the division points on the outer circle. The points of intersection between these arcs and the concentric circles of like number, are then used as centers for describing the small roller arcs which are tangent to the cam curve.

Cam which has a Dwell or Rest Period. — The follower of a cam does not always move continuously but may remain stationary during part of the cam's revolution. Diagram *A*, Fig. 3, illustrates how a cam is laid out to allow the follower to remain stationary during 60 degrees of the cam's revolution. This rest period occurs at the top of the stroke, the follower being moved upward the full distance during 150 degrees of the cam's rotation; it then remains stationary during a movement equal to 60 degrees, and then descends to the starting point. The stroke line of the follower is divided into a number of equal parts, as in the previous case, and concentric circles are drawn through these division points. Radial lines which are 60 degrees apart or 30 degrees from the vertical center line, are next drawn as indicated by the arrow marked "60 degrees." These lines represent the beginning and the end of the rest period and this part of the cam is concentric with the camshaft. That part of the outer circle not included between the sides of the 60-degree angle is divided into twice the number of equal parts as the number of division points on the follower line, there being 8 divisions for the 150-degree "rise" and a like number for the return curve. The cam curve is now laid out as described for previous examples.

Cam Designed for Intermittent Movements. — The follower of a cam frequently has an irregular or intermittent movement with possibly several rest periods during one revolution of the cam. An example of a cam designed for giving the follower an intermittent motion is shown by diagram *B*, Fig. 3. The total movement of the follower is assumed to be 6 inches as indicated by the six divisions on the vertical center line

passing through the center of the roller. This cam is so laid out that the follower will rise 2 inches during 60 degrees of cam rotation, then rest during 30 degrees of rotation; there are two additional upward movements of 2 inches during 60 degrees of cam rotation, each followed by rest periods of 30 degrees; the follower then returns to the original or starting position during 60 degrees and remains there during 30 degrees of cam rotation. In designing cams of this kind it is convenient to divide the different movements of the follower according to the number of degrees of cam rotation as just described. As the periods of motion and rest are all 60 and 30 degrees in this case, the outer circle is divided into twelve parts of 30 degrees each. The stroke of the follower is also divided into six equal parts in this case, and concentric circles are drawn through these division points. The cam curves are then laid out in the manner previously described. As the roller is to rise 2 inches in 60 degrees of cam rotation, the intersecting points between circles 1 and 2 and the 30- and 60-degree radial lines are used as centers for describing the roller arcs. As the follower is to rest during 30 degrees of cam rotation after rising 2 inches, that part of the cam curve between the 60- and 90-degree lines is concentric. In the same manner the entire cam curve is completed. It will be noted that that part of the circle between the 270- and 330-degree divisions is divided into twelve parts and a similar number of radial lines are drawn. Arcs are also drawn between the concentric circles so that the number of radial lines corresponds with the number of circular lines. In this way, twice the number of centers are obtained for describing the roller arcs and consequently the contour or curve of this part of the cam can be laid out more accurately. Greater accuracy was considered necessary at this point because of the abruptness of the cam curve. In the practical designing of cams, the number of division points and circles must be regulated somewhat in accordance with the accuracy desired, which in turn depends upon the type of the cam and its contour. Thus the stroke, in this case, might have been divided into a greater number of divisions than six.

Design of a Face Cam. -- All of the cams previously referred to have been of the type having curved edges which bear against the roller of the follower; hence, the follower is either held in place by its own weight or is assisted by means of a spring. This arrangement, however, is not always practicable, because a positive drive in both directions may be desirable or necessary. One method of obtaining a positive drive is to make the cam in the form of a disk having a groove

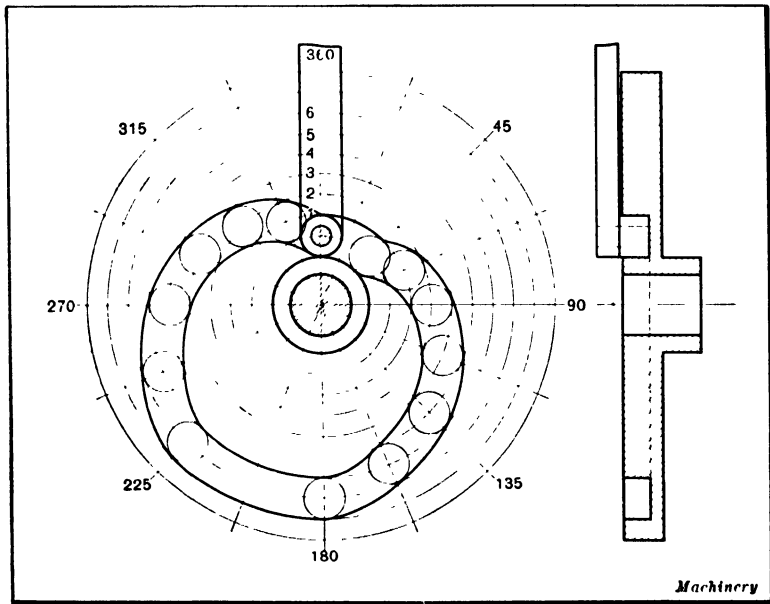

Fig. 4. Lay-out of a Face Cam which has a Groove engaging the Follower Roller

of the required curvature cut into its face. The roller of the follower engages the groove as illustrated in Fig. 4 so that it is positively driven. This style of cam, which is sometimes called a "plate-groove cam," is laid out in the same manner as the plate or "periphery cams" previously referred to, except that a series of circles is drawn to represent different positions of the cam roller instead of the series of arcs, and then the curvature of the cam groove is drawn tangent to the inner and outer sides of these circles. This particular

cam has two rest periods each equal to 45 degrees of cam rotation. The periods of rise and fall are each equal to 135 degrees and each of these periods is divided into the same number of equal parts as the number of divisions on the stroke line.

Plate Cams Arranged for Positive Drive. — The face cam is not an ideal type because the outer and inner edges of the cam groove tend to rotate the roller in opposite directions

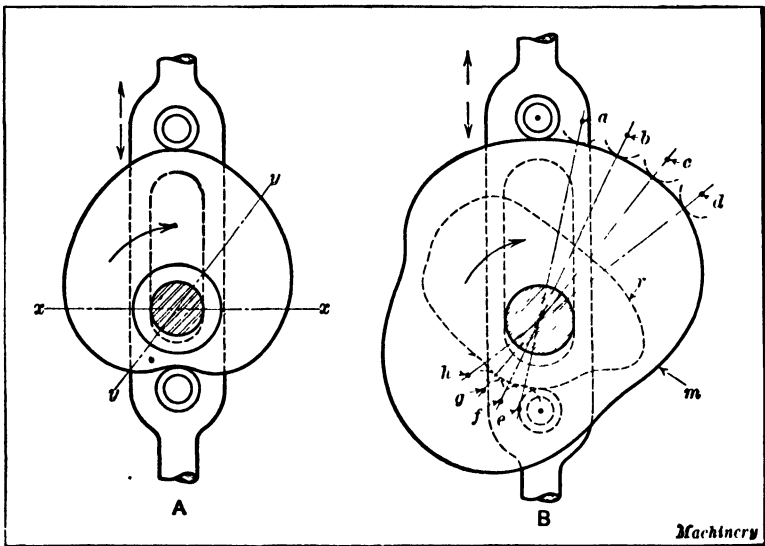

Fig. 5. (A) Follower equipped with Two Rollers for obtaining a Positive Drive. (B) Illustrating Use of a Special Return Cam

and the roller is also reversing constantly as it comes into contact with first one side of the groove and then the other; consequently, both the cam and roller are worn by the resulting friction, particularly if the speed is rather high. To avoid these defects, some plate cams have followers equipped with two rollers in order to secure a positive drive. An example is illustrated at A, Fig. 5. Since the distance between the rollers remains constant, the cam must be designed so that the distance between any two points on the edge, as measured along some center line $x-x$ or $y-y$, will be the same, which is

necessary on account of the unvarying distance between the rollers. The term, "constant diameter cam," is sometimes applied to this type. The follower in this example is slotted to clear the camshaft which acts as a guide. Another kind of follower is in the form of a rectangular yoke which surrounds the cam; hence, the name "yoke cam" is applied to this type. These cams having rollers engaging both sides can be designed to give a definite motion only during 180 degrees of rotation, because the curvature of the remaining half must be such

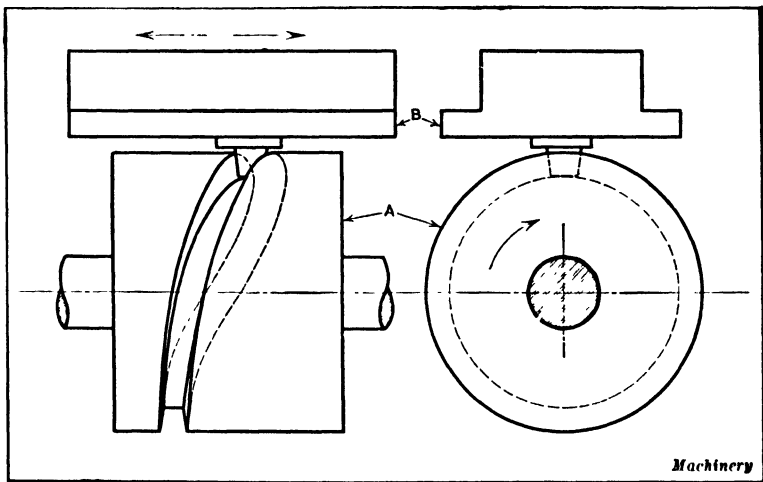

Fig. 6. A Cylindrical or Barrel Cam

that the distance, as measured along any line intersecting the camshaft axis, will be the same at all points; furthermore, the curve of this remaining half, which represents the path of the follower roller, should not be nearer the camshaft axis than the curve for the first 180 degrees of cam rotation, because this will increase the motion of the follower.

Use of a Return Cam. — By using a special return cam in addition to the main cam, as shown at *B*, Fig. 5, the limitations of the type of cam drive illustrated at *A* may be avoided. The follower may be placed between the main cam *m* and the return cam *r* and have rollers on opposite sides. When designing a cam drive of this kind, the main cam is first laid out to

give the desired motion. From various points as *a*, *b*, *c*, *d*, etc., which represent the center of the cam roller in different positions relative to the main cam, radial lines are drawn and centers *e*, *f*, *g*, *h*, etc., are located diametrically opposite and at a distance equal to the center-to-center distance between the rollers. By describing roller arcs from these latter centers, the contour of the return cam is determined.

Design of a Cylindrical Cam. — Cylindrical or “barrel” cams, as they are sometimes called, are used when the motion of the follower is parallel to the axis of the cam, although this type may also operate a pivoted follower. The diagram, Fig. 6, illustrates a cylindrical cam *A* which, as it revolves, imparts a reciprocating motion to the slide *B* that is assumed to be mounted in suitable ways. The stroke of the slide is equal to the distance measured parallel to the cam axis from the center of the curve at its extreme left-hand position, to the center at the extreme right. The cam curve may be laid out directly upon the cylindrical surface of the cam blank, but if a draftsman does the work, the usual procedure is to lay out a development of the curve and then transfer it to the cam. The development of the cam curve corresponds to the shape of the curve as it would appear if laid out upon a flat surface.

The general method of laying out a cylindrical cam is illustrated diagrammatically in Fig. 7. The rectangle shown at *A* is a development of the cylindrical cam surface, the height being equal to the length of the cam, and the length equaling the circumference of the cam. Upon this development a curve is drawn representing whatever shape will give the follower the required motion. This curve represents the path traced by the center of the follower roller. The principles governing the design of cam curves will be explained in detail later. At present we shall assume that the curve is completed and that this curve is to be projected to the drawing of the cam which is shown at the left in Fig. 7. A circle representing a plan view of the cam is drawn and half the circle is divided into a certain number of equal parts, the number

in this case being six. The base line of the development *A* is then divided into twice the number of parts as the half circle or, in this case, into twelve. Vertical lines are drawn from these division points from the base line of the development and other vertical lines are projected downward from the division points on the plan view. Horizontal lines are drawn from the points of intersection of the vertical lines at *A* and the cam curve, so that these horizontal lines intersect the vertical

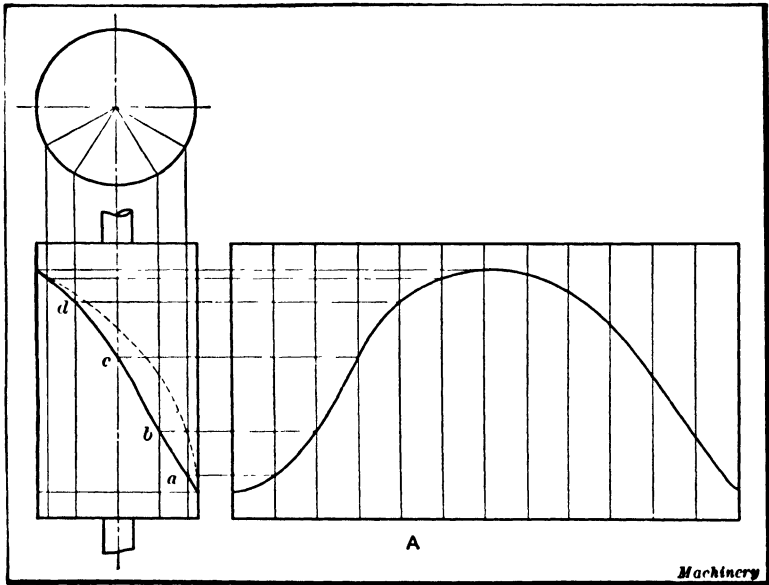

Fig. 7. Lay-out of a Cylindrical Cam

lines drawn from the division points on the circle. The points *a*, *b*, *c*, *d*, where the vertical and horizontal lines intersect, indicate the path of the cam curve. That part of the curve on the rear side of the cam which is indicated by the dotted line is laid out in the same way, except that the horizontal lines are drawn from the points where the right-hand half of the cam curve on development *A* intersects with the vertical lines.

The development of a cam curve such as the one illustrated at *A* may be transferred to the cylindrical cam body by wrap-

ping the drawing itself about the cam and then marking various points along the curve upon the cam surface by means of a small prick-punch. From this curve, which is the center line of the cam groove, the groove itself is laid off to the required width which depends upon the diameter of the cam roller. In order to reduce the friction and wear, the groove and roller of a cylindrical cam should be tapering.

Cam Curves for Avoiding Shocks at High Speeds. — Some cams must be so designed that the follower is given a certain definite motion during the revolution of the cam. Heart cams are simple examples of this type as they are designed to give the follower a uniform motion throughout the cam's revolution. The cam shown at *B*, Fig. 3, is another example. In this case the follower has certain periods of rest and of motion during each revolution. When the follower does not require a certain kind of motion and the only condition is that the follower move a given distance during either a complete revolution or a part revolution of the cam, it is very essential to give the cam a curvature that is conducive to smoothness of operation, especially if the speed of rotation is rather high. The cam curves referred to in preceding examples give the follower a uniform motion from the beginning to the end of its stroke; this uniform motion, however, is suitable only for comparatively slow speeds because, if the speed is increased beyond a certain point, shocks occur at the beginning and end of the stroke. To avoid these shocks and to secure smoothness of operation, other cam curves are employed. One of these is known as a *simple harmonic motion* and it corresponds to the motion derived from the well-known Scotch yoke or slotted cross-head, the follower being gradually accelerated to the maximum velocity and then gradually retarded. An action that is quite similar is obtained from an ordinary crank and connecting-rod, provided the latter is very long. Another form of cam curve which is even better than the harmonic motion curve is designed to give a *uniformly accelerated motion*. The follower is accelerated from rest to maximum velocity and then retarded again at a uni-

form rate which might be one inch per second, two inches per second, etc. In a slowly moving mechanism it might not be of much importance whether the cam operated the follower with a uniform motion, a simple harmonic motion, or a uniformly accelerated motion; but when the speed of the cam is relatively high, the cam curvature must, if possible, be laid out to start and stop the follower as easily as possible to avoid shocks. Cams for high rotative speeds are designed

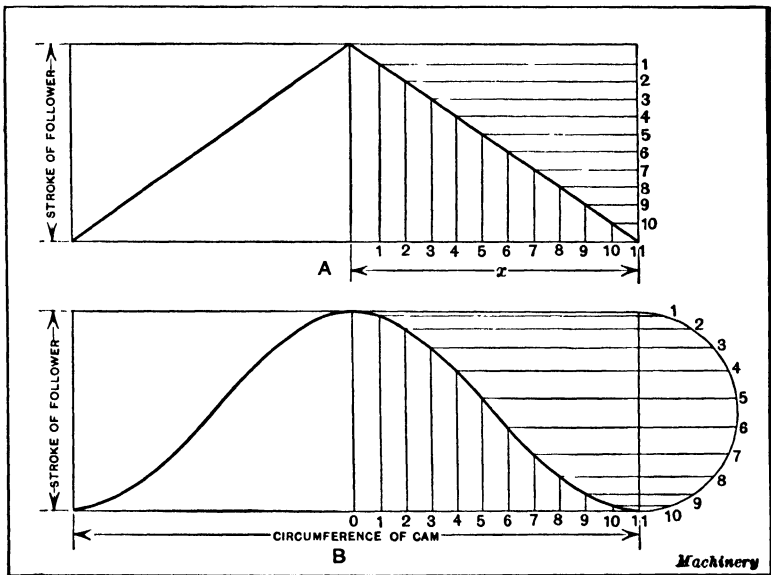

Fig. 8. (A) Cam Curve for Uniform Motion. (B) Crank or Harmonic Motion Curve

to start the follower gradually, increase the speed to maximum near the middle of the stroke and then gradually reduce it as the end of the stroke and the point of reversal are approached.

Comparison of Uniform and Harmonic Motions.— The difference between a uniform and a harmonic motion is illustrated very clearly by the diagrams in Fig. 8. The development of a line representing a uniform motion is illustrated at A. The rectangle represents part of the surface of a cylindrical cam, the height being equal to the stroke and the length

to the cam's circumference. If the cam were to be designed for an absolutely uniform motion, a distance x equal to one half the cam circumference would first be divided into a certain number of equal parts. The vertical line equal to the length of the stroke would then be divided into the same number of parts. The intersecting points of vertical and horizontal lines drawn from these divisions would represent the path followed by the cam roller which, as will be seen, is a straight diagonal line for a uniform motion. Now, when the roller reaches the end of its stroke, it immediately starts downward at the same rate of speed and the result would be a shock unless the cam were operated very slowly. These shocks at the beginning and end of the stroke may be modified by curving the cam groove at the points of reversal, although this would shorten the stroke unless an allowance were made for the curved portions.

The diagram *B* illustrates the simple harmonic motion curve which gives a much smoother action than the one designed for uniform motion. As will be seen, this curve passes through the intersecting points between horizontal and vertical lines. The vertical lines are drawn from equal division points laid off on a line equal in length to one half the cam's circumference; the horizontal lines, instead of being equally spaced, are drawn from division points on a semicircle, the diameter of which equals the stroke of the cam.

Cam Curvature for a Uniformly Accelerated Motion. — If the speed of a cam is to be unusually high and a cam curve is desired that will give the smoothest operation, a curve known as a parabola is somewhat better than a curve giving a simple harmonic motion. In a uniformly accelerated motion, the distance which a body moves at the end of a given number of time units varies as the square of the number of such units. For example, if a body has a uniform acceleration of 2 inches per second, and D equals the distance, then $D = \frac{1}{2} \times 2 \times (1)^2 = 1$ for the first second; $D = \frac{1}{2} \times 2 \times (2)^2 = 4$ for the next second, and so on. Uniformly retarded motion obeys the same law. Cam curves which are based on

this law should preferably be used for cams designed for high rotative speeds, because the velocity of the follower increases uniformly from the beginning to the middle of the stroke, and then decreases uniformly; but with a crank curve the acceleration and retardation are slightly irregular.

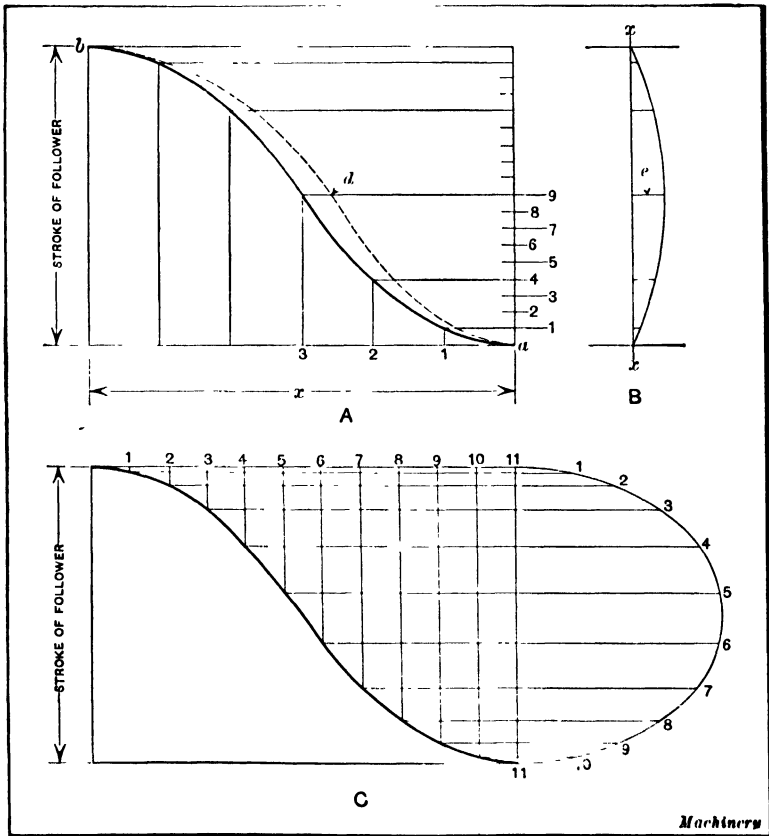

Fig. 9. Methods of laying out Cam Curves for a Uniformly Accelerated Motion

Laying out a Curve for Uniformly Accelerated Motion. — The method of laying out a curve for obtaining a uniformly accelerated motion is shown by diagram A, Fig. 9. This diagram shows only one half the curve, since the part for the return stroke is similar. The first step is to divide line x of the diagram or chart which, in this case, has a length equal

to one half the cam circumference, into any convenient number of parts, the number in this case being 6. One half of these division points are then numbered from right to left as at 1, 2, and 3. The square of this number (3) or 9 equals the number of parts that one half of the vertical line representing the cam stroke should be divided into. Vertical lines are now drawn from division points 1, 2, and 3 on line x and horizontal lines from divisions 1, 4, and 9 on the vertical or stroke line. The points of intersection between these vertical and horizontal lines coincide with the curve which is drawn through them. This part of the curve, which is one half of the curve for the forward stroke, gives a uniformly accelerated motion. It will be noted that vertical line 2 intersects with horizontal line 4, which is the square of 2, and that vertical line 3 intersects with horizontal line 9, which is the square of 3. The reason for this is, as previously explained, that a body having a uniformly accelerated motion passes over a distance during any number of time units equal to the square of the number of such units. That part of the curve for the uniformly retarded motion is laid out as just described. It will be noted that the horizontal lines above the central division number 9 are spaced to correspond with those below it, or are the same distance from it. If a diagonal line is drawn between corners ab , it will represent the path of a follower which has a uniform motion.

Modification of Curve for Pivoted Follower.— It is assumed that the cam curve shown at A , Fig. 9, is intended for a follower which has a straight-line motion parallel to the axis of the cam. If the cam roller is attached to a pivoted follower it will be necessary to modify the curve somewhat as indicated by the dotted line. The simple method of determining how much to change the shape of the curve, is illustrated at B . The vertical line $x-x$ represents the axis of the cam and the arc represents the path of the roller on the follower. From the points 1, 4, 9 (Diagram A), and corresponding points above point 9, lines are drawn between the vertical line $x-x$ and the arc. The cam curve is then moved to the

right an amount determined by the lengths of these lines between $x-x$ and the arc. For instance, point d for the modified curve is located to the right a distance equal to the length of line e . This modification of the curve compensates for the circular motion of the follower.

Ellipse Method of Drawing Curve for Uniformly Accelerated Motion. — Diagram C, Fig. 9, shows how a cam curve may be drawn which is a close and satisfactory approximation for the uniformly accelerated motion curve. One of the horizontal lines representing one half the cam's circumference is divided into a certain number of equal parts and vertical lines are drawn from these division points. The horizontal lines which intersect with these vertical lines, thus indicating the path of the cam curve, coincide with divisions on an ellipse instead of using a semicircle as in the case of diagram B, Fig. 8, which shows a curve for simple harmonic motion. It is evident that the kind of cam curve depends upon the proportions of the ellipse. The ratio of the major axis to the minor axis should be $1\frac{3}{8}$ to 1 or 11 to 8.

Plate Cam Having Uniformly Accelerated Motion. — The method of laying out a plate cam so that the motion is uniformly accelerated and retarded is illustrated at A, Fig. 10. This method is the same in principle as previously described in connection with diagram A, Fig. 9. Only one half of the cam curve is shown as the other half is similar and is laid out in the manner to be described. This cam is to move the follower, during one half a revolution, a distance indicated by the arrow marked "stroke of follower." The stroke points are laid off on the vertical center line. A circle of any convenient radius is next drawn and one half the circumference is divided into a number of equal parts; the number in this case is 6, which corresponds with the 6 divisions on line x of diagram A, Fig. 9. As 90 degrees represents the angle through which the motion is uniformly accelerated on the forward stroke, and as one fourth the cam circumference is divided into three parts, one half the cam stroke is divided into the square of 3, or into 9 parts and the remaining half,

into 9 parts. With the axis of the camshaft as a center, arcs are struck from points 1, 4, and 9. The intersections of arc 1 with radial line 1, of arc 4 with radial line 2 and of arc 9 with radial line 3, are points on that part of the cam curve which gives a uniformly accelerated motion on the forward stroke. The remaining part of the curve shown by diagram A is for uniformly retarding the motion and passes through the intersecting points of arcs drawn from divisions above the central

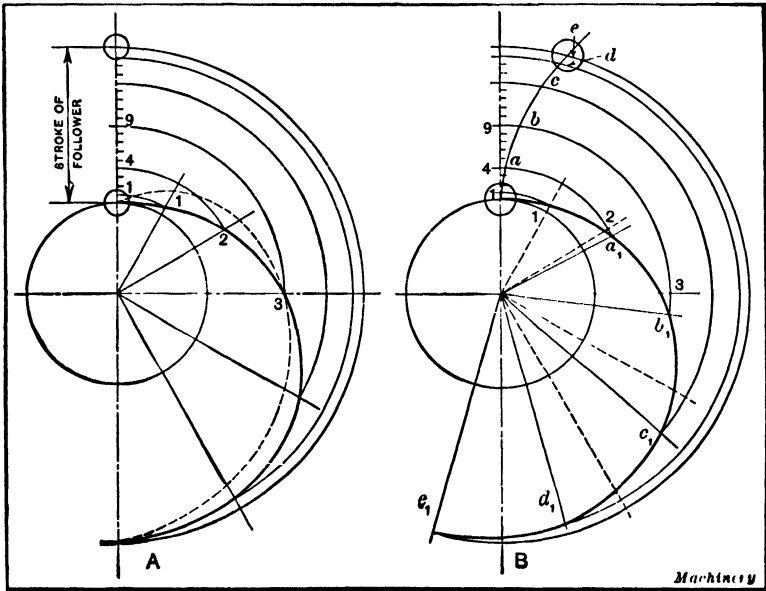

Fig. 10. Plate Cams designed for Uniformly Accelerated Motion

point 9 corresponding to divisions 4 and 1. It will be understood that this cam curve represents the center line of the path followed by the cam roller. When a follower is pushed upward by a cam of this type and then falls by its own weight, theoretically it should remain in contact with the cam because the principle of uniformly accelerated motion is the same as that of a falling body; in practice, however, the friction and inertia of connected parts would probably prevent the follower from remaining in contact with the cam during the return movement unless the speed of rotation was quite slow.

When the follower is pivoted and its motion is along an arc as shown at *B*, Fig. 10, the curve is laid out as described in connection with diagram *A* except that the radial lines which are intersected by the arcs are advanced somewhat. The equal divisions of the half circle corresponding to the radial lines shown at *A* are represented by dotted lines at *B*. The radial line a_1 is advanced a distance $2a_1$ equal to the distance $4a$ between the vertical center line and the arc of the follower.

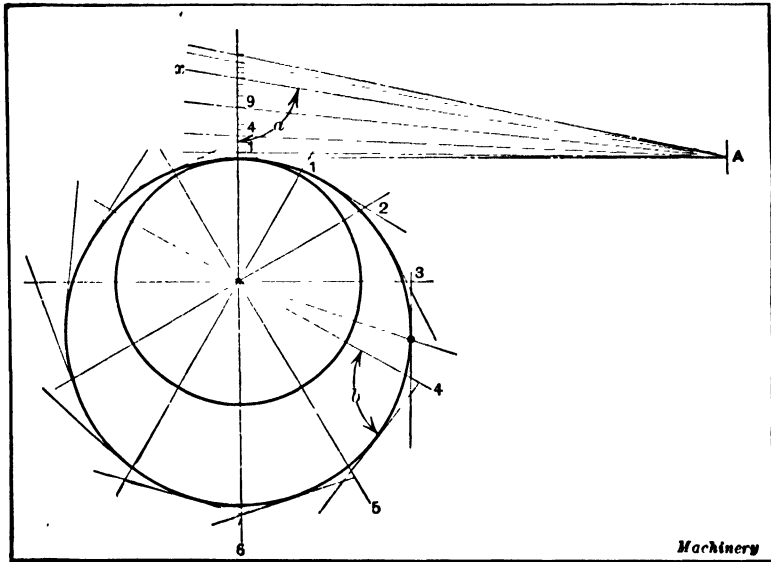

Fig. 11. How a Cam is laid out when it operates a Tangential Follower

Similarly radial line b_1 is advanced a distance $3b_1$ equal to $9b$, and the advance of lines c_1 , d_1 , and e_1 is determined in the same manner.

Plate Cam Having Tangential Follower. — The followers of some cams have straight or flat surfaces which are in a tangential position relative to the working edge or surface of the operating cam. The follower may be pivoted at one end (as indicated by the diagram, Fig. 11) or it may operate in guides and have a straight-line sliding motion. The pivoted follower will be considered first, the pivot being represented at *A*

Fig. 11. A distance equal to the stroke is first laid off on the vertical center line as in preceding examples, and one half the stroke is divided into 9 equal parts in this case, which is equal to the square of the number of divisions in one fourth of the circle. If the follower is to swing about A as a center, it will assume positions 1, 2, 3, etc., as the radial lines 1, 2, 3, etc., swing around to a vertical position. The points of intersection 1, 2, 3, and so on, on the radial lines are found just as described in connection with diagram A , Fig. 10, but instead of drawing the cam curve through these points, straight lines representing the edge of the follower must be drawn from them. The angle between any straight line and its corresponding radial line must be equal to the angle which the radial line makes with the follower when it swings around to the vertical position. For instance, when radial line 4 is in a vertical position, the follower will be at x ; therefore, angle b should be equal to angle a . After this series of lines is drawn from points 1, 2, 3, 4, etc., the cam curve is drawn tangent to them. Now, if the follower instead of being pivoted moves up and down with its working face always parallel to the first position, then all of the angles b between the radial and straight lines will be right angles. The working surface of a cam having a tangential follower must be entirely convex because any concave sections of the curve would not come into contact with the follower.

CHAPTER XI

GEOMETRICAL DRAWING PROBLEMS AND THE DEVELOPMENT OF INTERSECTING SURFACES

MECHANICAL draftsmen should know how to construct the different geometrical figures and curves which are used in drafting practice. The draftsman's methods of constructing certain of these geometrical figures differ from the procedure explained in many text-books, both on geometry and mechanical drawing, because the draftsman uses instruments that enable the work to be done more rapidly. While such figures as the square, hexagon, octagon, and many others may be constructed by means of a straightedge and compass, the draftsman's method is simplified by using the T-square and triangles or possibly a universal drafting machine. For example, the sides of a hexagon are drawn by using the 30-60-degree triangle and without first dividing a circle by means of a compass; or if one line must be perpendicular to another, it is drawn by using a T-square and triangle, rather than by the slower methods which are explained in books dealing with plane geometry. While these geometrical principles should be thoroughly understood, only a few of the more important problems will be considered in this chapter, as it is assumed that most of the users of this book are familiar with simple problems, such as bisecting a line, erecting a perpendicular to a line at a given point, etc. Moreover, there are many text-books which may be referred to for this elementary information.

Drawing an Ellipse. — When a circle is represented on a drawing in an oblique position, which is quite common, it has the form of an ellipse. There are several ways of drawing an ellipse, some being accurate and others approximate but rapid. The draftsman ordinarily has the maximum and

minimum dimensions of the ellipse, which are known, respectively, as the major axis and minor axis.

An accurate method of drawing an ellipse is illustrated in Fig. 1. Two circles are first described from a given center. The diameter of the larger circle is equal to the major axis of the ellipse, and the diameter of the smaller circle is equal to the minor axis. From various points, as at A , B , and C , on the outer circle, radial lines are drawn which intersect the inner circle at a , b , and c . Horizontal lines are drawn from the points a , b , and c , and vertical lines from the points A , B ,

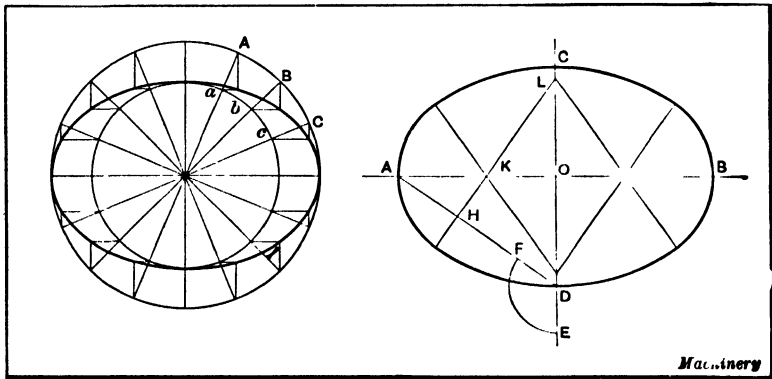

Fig. 1. Accurate Method of drawing an Ellipse

Fig. 2. Approximate Method of drawing an Ellipse

and C . The intersections of these horizontal and vertical lines are points on the curve of the ellipse which is drawn through them.

Approximate Method of Drawing an Ellipse. — Many of the methods of drawing an ellipse approximately are complicated and difficult to practice, and some of them do not give good results unless the ratios of the major and minor axes are within certain limits. Figure 2 illustrates a simple way of drawing an ellipse, which is sufficiently accurate for many purposes. The distance AB represents the major axis and the distance CD , the minor axis. First draw the diagonal line AD and then locate point E a distance from O equal to one half the major axis; then, with D as a center, describe

the arc EF . Point H is next located midway between A and F and a perpendicular line HL is drawn, thus locating points K and L . From these two centers, the large and small arcs for forming one half of the approximate ellipse are described. The centers for forming the other half of the ellipse are located in a similar manner.

Straightedge or Trammel Method of Drawing an Ellipse. — The method of drawing an ellipse, illustrated at the upper

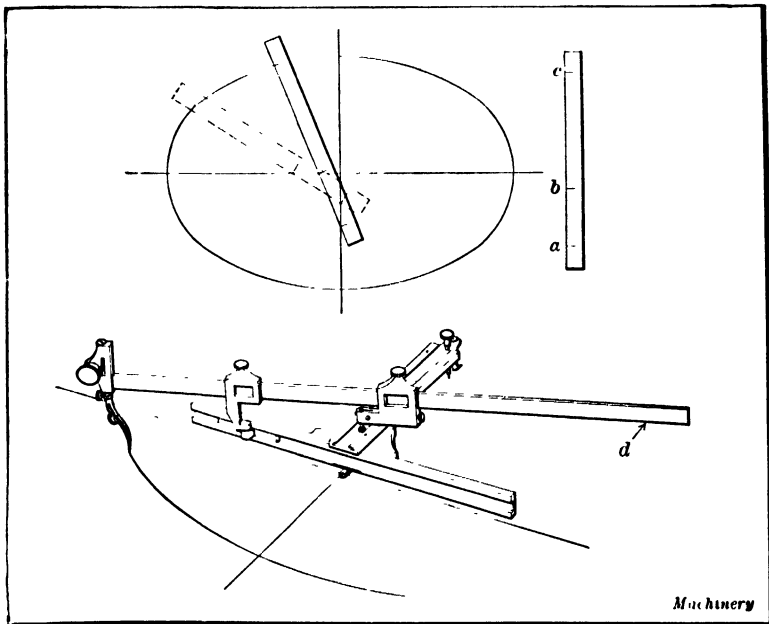

Fig. 3. Straightedge or Trammel Method of drawing an Ellipse — The Ellipsograph

part of Fig. 3, is accurate and illustrates the principle governing the operation of the ellipsograph shown in the same illustration. On a straightedge, which may be made of a strip of stiff drawing paper, three lines, a , b , and c , are located. The distance ac equals one half the major axis of the ellipse to be drawn, and the distance bc , one half the minor axis. Horizontal and vertical center lines are first drawn, and then various points on the ellipse are located by moving the straightedge along from one position to another, keeping line b on the

major axis and line *a* on the minor axis. For instance, when the straightedge is in the position shown by the dotted lines, point *c* coincides with the path of the ellipse and it also coincides with the ellipse when the straightedge is in any other position, provided points *a* and *b* are in line with their respective horizontal and vertical center lines. When drawing an ellipse by this method, various points are first located and are marked by a series of dots opposite graduation *c* for different positions of the straightedge. A draftsman's curve is then used to draw the ellipse through these various points.

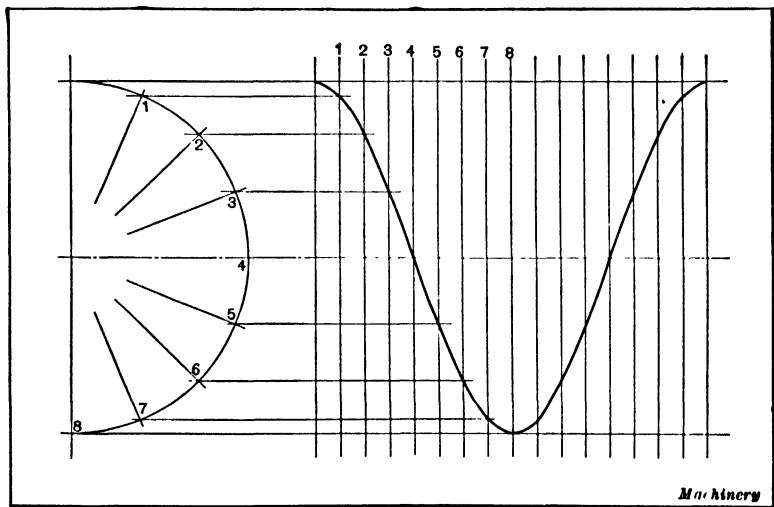

Fig. 4. Method of constructing a Helix

The ellipsograph shown in the lower part of Fig. 3 has a graduated bar *d* (graduations not shown) and is adjustable for drawing ellipses having major axes varying from $\frac{1}{2}$ up to 22 inches. Such an instrument is desirable if this work must be done frequently. Several other devices operating on this same principle are in use. Sometimes a beam trammel having three points instead of two is used in conjunction with a square. In this case, two of the points corresponding to graduations *ab* (Fig. 3) are held in contact with a square, while the third point describes the ellipse. Of course only

one fourth of the ellipse is drawn at a time, and then it is necessary to shift the position of the square.

Construction of a Helix. — The helix, which is frequently but incorrectly referred to as a “spiral,” is represented by the curve of a screw thread. The method of drawing a helix is illustrated in Fig. 4. One half of the circumference of the cylinder, on the surface of which the helix is to be described,

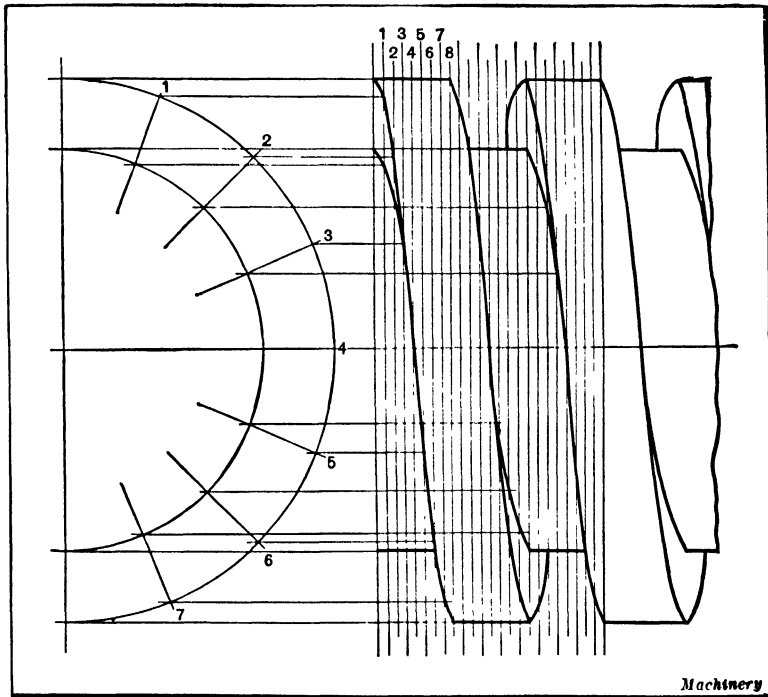

Fig. 5. Representing a Large Square Thread by drawing Accurate Helical Curves

is divided into a number of equal parts. In this case there are eight divisions as shown at the left-hand side of the illustration. One half the lead of the helix (the lead equals the distance that the helix advances in one revolution) is divided into a similar number of equal parts. Horizontal lines are next drawn from the division points 1, 2, 3, etc., on the circle and vertical lines from the other division points. The intersections between the horizontal and vertical lines which are

numbered alike, represent points on the helical curve, as the illustration shows.

The application of this method to the drawing of a large square thread is shown in Fig. 5. In this case there are two helical curves, one representing the outer edge of the thread and the other the inner corner or root; therefore, two half circles are drawn. The radius of the larger circle is equal to the outside radius of the screw, and the radius of the smaller circle is equal to the radius of the screw at the root of the thread. The intersecting points for the outer edge of the thread are obtained by projecting lines from the outer circle,

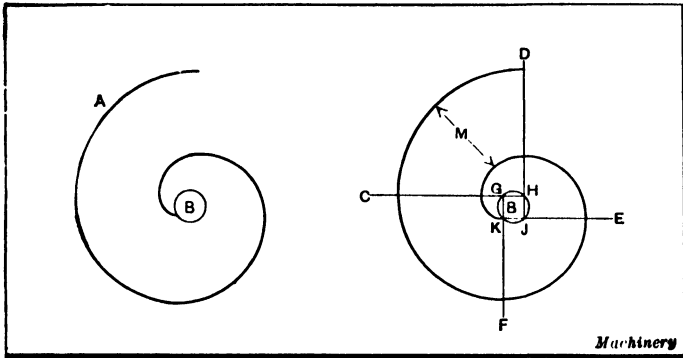

Fig. 6. Diagrams illustrating the Involute Curve

whereas the points along the inner helix are obtained by projecting lines from the smaller circle. If a number of threads were to be drawn, as might be required on a drawing used for illustrating purposes, paper templets could first be laid off by the method illustrated in Fig. 5 and these templets used for drawing the helical curves on the different threads.

The Involute Curve. — The involute curve (or, simply, the involute) may be defined as a curve which may be traced by a point, as a pencil, fixed to the end of a flexible cord, when unwound from the surface of a cylinder. This curve is represented by the line *A* in Fig. 6; *B* is the generating cylinder or circle from which the cord is supposed to have been unwound. For ordinary purposes this curve may be approxi-

mately drawn with a generating circle of a given diameter by the following method (see the right-hand figure): Within the generating circle *B* inscribe a square, extending the lines forming its sides, as shown, to *C*, *D*, *E* and *F*. With the point *G* as a center, and the distance *GK* as a radius, scribe an arc extending from the line *FG* to the line *CG*. With *H* as a center, extend the compass to the point where the last arc ended on the line *CG*, and continue the curve to the line *DH*. With *J* as a center, and the radius extended to the intersection of the curve on the line *DH*, continue the curve to the line *EJ*. Continue these operations until a spiral of sufficient length has been produced.

If this curve is generated on a large scale a greater number of basic lines, as *CG*, *DH*, etc., should be made, so as to increase the accuracy of the curve. It should be understood that an accurate involute curve

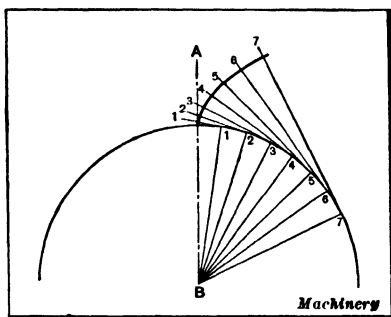

Fig. 7. How to draw an Involute Curve accurately

cannot be described with the compass, since no part of it is the arc of a circle. In drawing this curve mechanically, for instance, as a curve on large wood pattern work, a generating cylinder of wood of proper diameter is used, and around this is placed a very fine copper wire, to the end of which a drawing pencil is fastened. By this means very accurate work can be done. It may be well to state that, mathematically, the diameter of the generating circle multiplied by 3.1416 will give the distance between one convolution and the next, as shown by the distance *M*.

Drawing an Involute Curve Accurately. — The involute curve is the basis of the involute system of gearing, although on ordinary gear drawings it is not necessary to draw the tooth curves accurately, and they need not be drawn at all. In many cases the gear teeth are represented by dotted circles

the diameters of which equal the pitch diameter, outside diameter, and root diameter. If a few teeth are drawn where the two gears mesh, the draftsman does not attempt to draw the curves accurately, as this is not necessary since the shape of the teeth is governed by the gear-cutting process.

Figure 7 illustrates how a small part of an involute curve may be accurately drawn in case this should be necessary. The generating circle in this case is comparatively large. The intersection of the vertical center line AB with the generating circle marks the beginning of the involute curve from this point; toward the right a number of equal spaces are laid off and these are numbered from left to right. Radial lines are drawn from each of these points to the center B of the generating circle. By using a straightedge and a 90-degree angle, tangent lines at right angles to each of these radial lines are drawn. These tangents are given numbers corresponding to the numbers of the radial lines. With point 1 on the generating circle as a center, and the distance from this point to the vertical center line as a radius, that part of the involute curve between the generating circle and tangent line 1 is described. Then with point 2 on the generating circle as a center, and with the distance from this point to the termination of that part of the curve just drawn, as the radius, that section of the involute curve extending between tangent lines 1 and 2 is described. By proceeding in the same manner and using points 3, 4, 5, etc., on the generating circle as centers, the remainder of the involute curve is generated. When laying out an accurate curve, it is essential, of course, to use a very sharp-pointed pencil and to draw the curve on a smooth surface. In the application of this method, there may be from twelve to twenty tangent lines in one fourth of the circumference of the generating circle, although only from one fifth to one eighth of the circle may be required for generating an involute curve of the desired length.

Drawing Cycloidal Curves. — If a circular disk is rolled along a straightedge, a point on the disk will describe a curve known as a *cycloid*. If this disk or “generating circle” is

rolled upon the outer surface of another disk, a given point will describe an *epicycloid*; if the disk is rolled around the inner surface of a ring, the point will describe a *hypocycloid*. These epicycloidal and hypocycloidal curves are the basis of the cycloidal system of gearing, which has been largely replaced by the involute system.

The Epicycloid. - To describe an epicycloid upon a given circle *AB* (Fig. 8) with a generating circle *C* proceed as follows: Through the centers of the given circles draw the

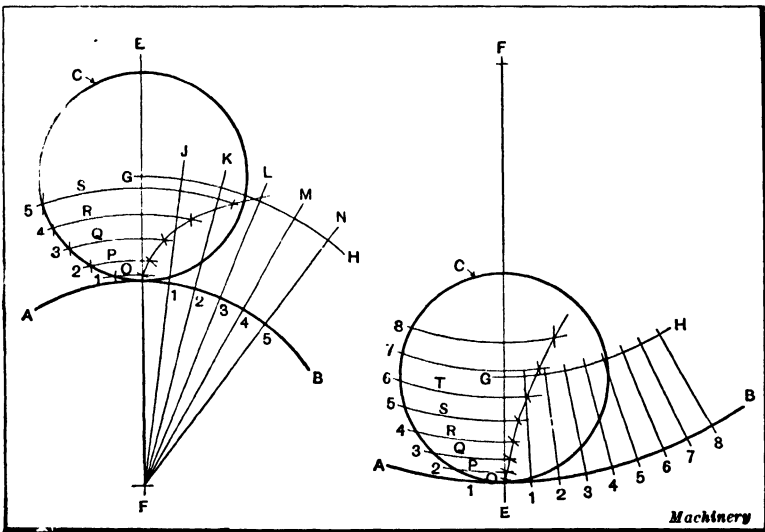

Fig. 8. Generating an Epicycloidal Curve

Fig. 9. Generating a Hypocycloidal Curve

vertical line *EF*, the intersection of which with the circles determines the beginning of the required curve. From this point lay off toward the left on the generating circle *C*, and toward the right on the given circle *AB*, a number of equal distances, numbering the points 1, 2, 3, etc., as shown. Through the center of the generating circle, and with the center *F* of the given circle as a center, describe the arc *GH*, upon which the center of the generating circle will travel as it rolls along. Through the points 1, 2, 3, etc., on the given circle draw the radial lines *J*, *K*, *L*, etc., intersecting the arc *GH*. Through

the points 1, 2, 3, etc., on the generating circle, and with F as a center, describe the arcs O, P, Q, R , etc. With the radius of the generating circle C , and the intersections of the radial lines J, K, L , etc., with the arc GH used successively as centers, describe short arcs intersecting the arcs O, P, Q , etc. These intersections are points on the required epicycloidal curve.

The Hypocycloid. — A hypocycloid is generated in the same manner as an epicycloid, except that the generating circle rolls on the inside of another circle. It is constructed as follows: Draw the vertical line EF (Fig. 9) through the centers of the given circle AB and the generating circle C , the point of intersection of this line with these circles determining the beginning of the required curve. With the center F of the given circle AB as a center, describe the arc GH passing through the center of the generating circle C . Divide the generating and given circles into equal spaces, and through the points on the given circle draw radial lines intersecting the arc GH . With the center F of the given circle as a center, describe the arcs O, P, Q, R , etc., passing through the points 1, 2, 3, etc., on the generating circle. With the radius of the generating circle C , and the intersections of the radial lines with the arc GH used successively as centers, describe short arcs intersecting the arcs O, P, Q, R , etc. These intersections are points on the required hypocycloidal curve.

Development of Intersecting Surfaces. — The use of the term "development" in connection with drafting practice may be illustrated by considering a practical example. If a steel sheet forming one section of a boiler is unrolled and flattened, it will represent a development of that particular section. If the rolled sheet formed a cylindrical part of the boiler, the development of this sheet would be a rectangle, or possibly a square. When one cylindrical body intersects or is fitted to another, the edges which fit together have a certain curvature, as seen on a development of the intersecting surface. When the cylindrical bodies are formed of sheet metals, it is necessary to determine the shape of this curve

when the sheet is flat or before it is rolled to shape. A pattern may be laid out first which represents a development of the sheet, and then the steel plate may be cut to the shape of this pattern or templet so that, when it is rolled to cylindrical form, it will accurately fit the other cylindrical body. Such patterns are used in boiler shops and in other places where parts are made from sheet metals.

The usual problem is to lay out a development of the intersecting surfaces from a drawing of the finished object. Certain allowances have to be made in actual practice for forming

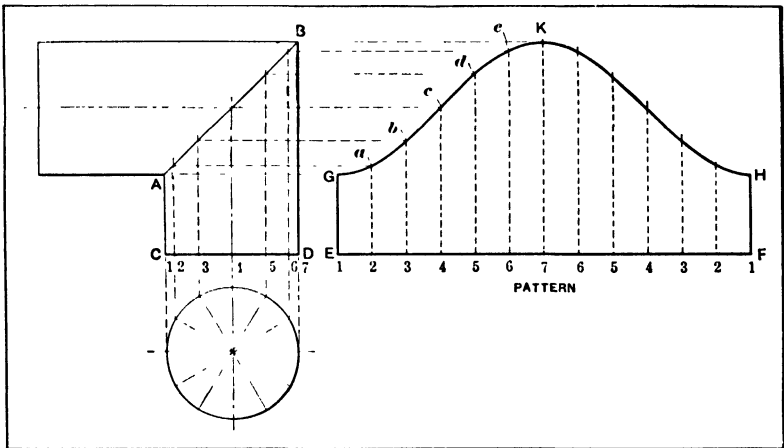

Fig. 10. Development of the Pattern for an Elbow

lap joints for riveting parts together, and it may be necessary also to allow for changes in length, due to bending of the sheets when the latter are comparatively thick or heavy. These allowances will not be considered in explaining the methods of developing patterns, the assumption being that the edges butt together at the joints.

Development of an Elbow. — An elbow, such as is formed of two cylindrical pipes which intersect at right angles to each other, is a typical example of sheet-metal pattern development. An elbow of this kind is shown at the left in Fig. 10. It is assumed that both sections of the elbow are of the same diameter. The diagonal line *AB* represents the joint

as seen in the side view. If one of these sheets is unrolled or flattened, it will appear as shown to the right in the illustration. The problem is to determine the shape of the curve *G, K, H*. The first step is to divide the end view or circle corresponding to the size of the elbow into a number of equal parts, which should preferably be divisible by 4. The number of divisions depends upon the degree of accuracy required in developing the curve. From these division points, vertical lines are drawn which intersect with the diagonal line *AB*.

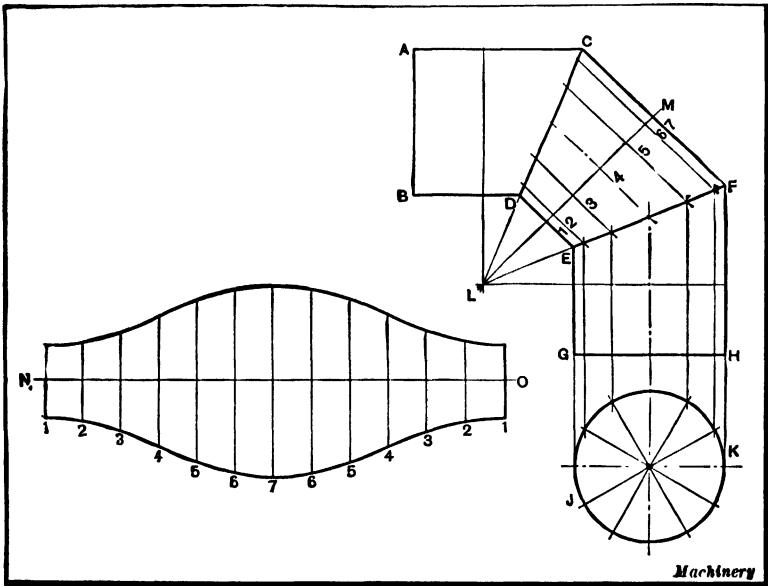

Fig. 11. Development of a Three-piece Elbow

The base line *EF* of the pattern or development is made equal to the circumference of the elbow, neglecting any allowance for a lap joint, and the height *EG* and *FH* is equal to length *AC*. Line *EF* is next divided into as many equal spaces as the circle, or into twelve equal spaces in this case. Vertical lines are then drawn through each of these division points on line *EF*. The point where line No. 2 from the circle intersects line *AB* is now projected over to line No. 2 on the development; thus locating one point *a* of the curve. In this

same manner, the other points b , c , and d , etc., are located. In other words, the vertical distances $2a$, $3b$, etc., are equal to the distances between the base line CD and the diagonal line AB on lines 2, 3, 4, etc. After the points in one half of the curve GK are located, the corresponding points on the remaining half are determined in the same manner and the curve is then drawn through these locating points.

Development of a Three-piece Elbow. — A three-piece elbow is illustrated in Fig. 11, and the problem in this case is to develop a pattern for the central section. A circle representing an end view of one section of the elbow is first divided

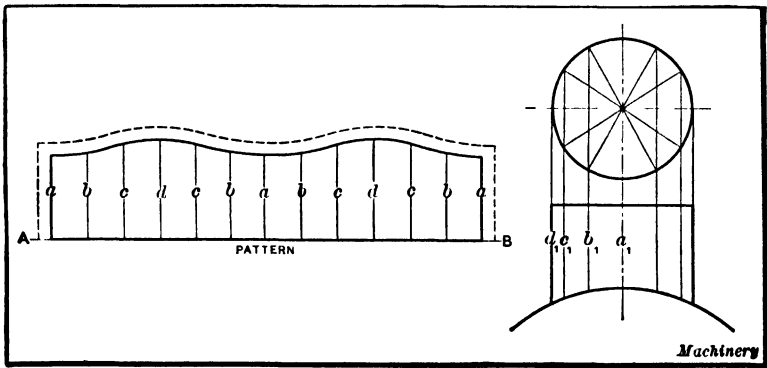

Fig. 12. Development of the Pattern for the Dome Sheet of a Boiler

into a number of equal divisions, as in the preceding example, and radial lines are drawn through these points. Vertical lines are also drawn which intersect with line EF , and through these points of intersection other lines are drawn parallel to the sides DE and CF . After a center line NO is drawn, a distance is laid off equal to the circumference of the elbow, and this distance is divided into as many equal spaces as the circle which, in this case, is twelve. A center line LM is also drawn which bisects the angle formed by the sides CD and EF . The distance between this center line and the line EF as measured on lines 1, 2, 3, etc., is transferred to the development, care being taken to lay off the distance in each case on lines which are numbered alike. In this way points for the

lower edge are determined, and as the upper edge is similar, it is simply necessary to lay off the same distances above and below the center line *NO*. The principle of this "parallel-line" method of development is applied in many of the practical problems encountered in sheet-metal pattern-drafting.

Intersecting Cylinders of Unequal Diameter. — A problem in pattern development, which is the same in principle as the

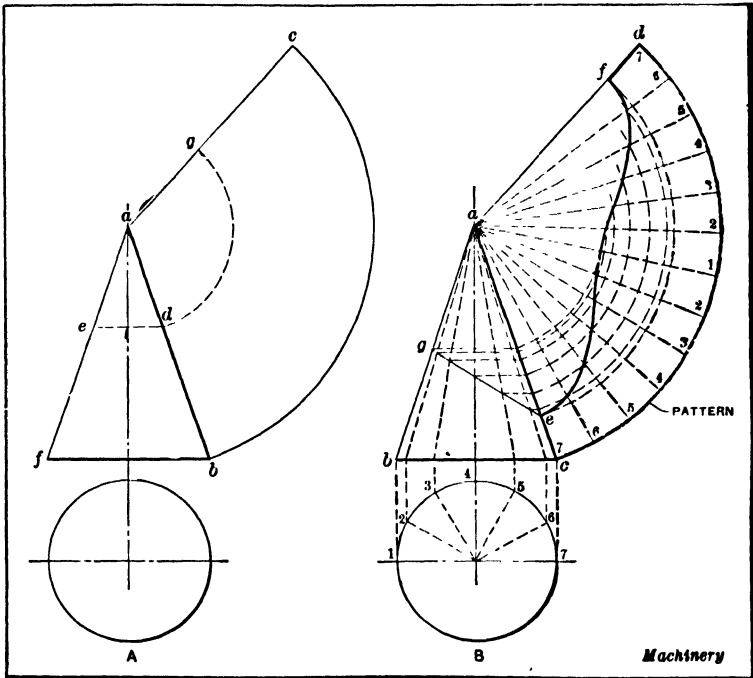

Fig. 13. The Radial-line Method applied to a Pattern Development

ones previously referred to, is illustrated by the diagram, Fig. 12, which shows how the pattern for the dome sheet of a boiler is laid out. In this case, the cylindrical dome is much smaller in diameter than the boiler. A circle representing a plan view of the dome is divided into a number of equal spaces as before, and vertical lines are projected downward from the intersecting points. A distance equal to the circumference of the dome is laid off on line *AB*. After dividing this line

into the same number of equal spaces as the dome circle and drawing vertical lines from these division points, line a is made equal to line a_1 , line b equal to line b_1 , etc. After laying off line d , the next line c on the pattern is made equal to c_1 , the next equal to b_1 , and so on. The other half of the pattern is then laid out in the same manner. The dotted line around the pattern indicates the allowance that would be made for a lap or flange by means of which the dome would be riveted to the boiler shell.

Development of Conical Shapes. — All of the developments referred to previously have depended upon measurements of distances on parallel lines projected from equal division points on a circle. When the development is of a conical body, radial lines are employed instead of parallel lines. If the development of a cone were required, it would simply be necessary to describe an arc having a radius equal to the length of the side ab of the cone (see diagram A , Fig. 13) and a length bc equal to the circumference of the base of the cone. Straight lines from points b and c at the extremities of the arc to the apex a complete the development. The flat surface $dgc b$ represents the development of a frustum of a cone having sides $fedb$.

The diagram B , Fig. 13, shows the development of a cone intersected by a plane ge which is at an angle with the base bc . One half the circle representing the end view of the base is first divided into a number of equal parts, the number in this case being six. Vertical lines are drawn from these points which intersect the base line bc , and from these intersecting points the lines are extended to the apex a . The arc cd which forms part of a complete development of the cone is divided into twice the number of spaces as the semicircle representing the cone base. Radial lines are drawn from these division points on arc cd to the apex a . On these radial lines points are located which correspond to the curvature from e to f . The intersecting points between line ge and the lines extending from the apex to the cone base are projected to the side ac by drawing horizontal lines as shown. At the termination

of each horizontal line, an arc is struck from the apex *a* as a center. That arc which represents the continuation of line No. 1 from the base should intersect with line No. 1 on the development; the arc which is a continuation of line 2 on the base should intersect radial line 2 on the development, and so on for the other numbers. The curve is then drawn through these various points of intersection. If the pattern developed in this way were rolled to cylindrical form, it would have a circular base and an inclined top edge, as indicated by the section of the cone *bgcc*.

CHAPTER XII

DRAFTING-ROOM SYSTEMS, EQUIPMENT, AND ARRANGEMENT

IN every drafting-room it is necessary to have some system that will make it possible to locate readily and to identify all drawings and records, in order to supply the shop quickly with whatever information may be needed, and also to enable duplicate machines to be constructed at any time. The system generally includes a method of filing tracings, card indexes for locating them readily, a record of blueprints which have been sent out, and other features, the system varying somewhat according to the size of the drafting-room and the variety of existing drawings and records.

The drafting-room may also include in its organization men who are competent to direct manufacturing operations and to specify on "operation sheets" just how each part of a mechanism is to be machined, so that the shop man can confine his attention to the actual work of construction. The reason for the adoption of this practice is to avoid having the same kind of work done in various ways and according to the ideas of different men, the object being to specify what seems to be the best method, after the conditions in each case have been carefully studied. Owing to the special forms of tools and fixtures now used, the designer (often with assistance from the shop) must of necessity control or determine beforehand how such tools are to operate, since the design of such special equipment is based upon the method of operation. The drafting department, however, may or may not decide as to the order of operations and machines to be used when standard tools are employed. The relation between the drafting and manufacturing departments varies widely and depends upon the size of the plant, the nature of the product manufactured,

and the ideas of the management in regard to methods of planning and controlling manufacturing operations.

Just how extensive the system of a drafting-room needs to be depends largely upon the variety of the work manufactured and to what extent the activities of the draftsmen extend beyond the work of machine design and mechanical drawing. This chapter will deal with some of the different methods of recording, locating, and identifying drawings or patterns, and of increasing the effectiveness of the drafting-room either by means of its system, arrangement, equipment, method of lighting, or any other features which tend to promote the work of the draftsmen.

General System of Filing Drawings. — As it is the customary practice to use at least two or three different sizes of drawings, tracings of the same size are usually filed together, because it is inconvenient to find them when large and small sheets are placed together in a drawer, unless the drawer is large enough to take different sizes which are separated by partitions. According to a common method, the different standard sizes of sheets which have been adopted are represented by letters placed beside the drawing number. For instance, if the standard sizes are 24 by 36 inches, 18 by 24 inches, 12 by 18 inches, and 9 by 12 inches, the letter A might represent the 24- by 36-inch size, the letter B, the 18- by 24-inch size, etc. The drawing number which accompanies the letter may also indicate the location of the drawing in the filing cabinet. To illustrate, suppose the number of a drawing is B₃₁₅. In this case, the letter B shows that the drawing is an 18- by 24-inch size, the first figure of the number shows that it is in drawer No. 3, and the remaining figures, that it is the fifteenth drawing in this particular drawer. Possibly the drawing would be placed in a folder marked with the name of the machine for which the drawing was made. If the drawing happens to be a detailed view of a part used on more than one machine, blueprints are made and marked "record prints." These prints are then filed the same as the tracings wherever this particular detail is required. In this way, a

complete set of drawings for each machine is always on hand and convenient for reference. Instead of designating the size of the drawing by a letter accompanying the drawing number, certain blocks of numbers may be assigned to each size. The range of numbers allowed for each size is large enough to last for years. With this system, the size of the drawing

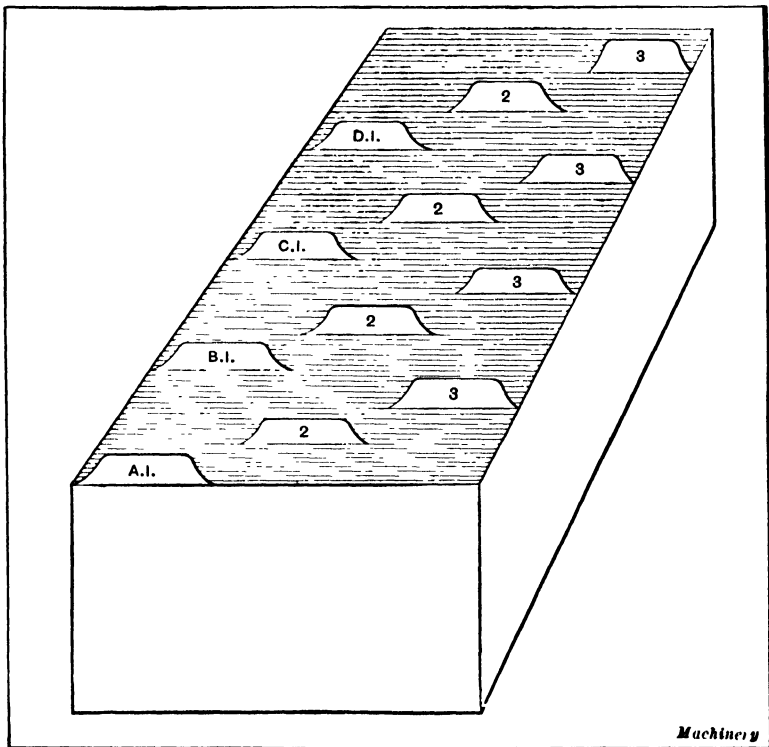

Fig. 1. A Numerical Card Index for Drawings

number indicates the size of the sheet, to one who knows the sizes corresponding to the different blocks of numbers.

Card Index for Locating Drawings.—When a great many drawings are filed in a cabinet, it would usually be difficult to locate different tracings without some system of indexing, and for this reason what are known as “card indexes” are commonly used. These indexes serve the same purpose as

the index of a book. The system of indexing suitable for one drafting-room may not exactly meet the needs in another where different conditions exist in the plant. For this reason, the particular systems referred to may not be directly applicable in all cases, but the general principle can be applied with whatever modifications may be necessary.

A common form of index consists of cards which represent the drawings and which are filed according to some order. One form of card index is illustrated in Fig. 1. This is sometimes called a "numerical index" because the cards are filed with reference to the letters and drawing numbers in consecutive order. All the cards for drawings of the "A" size are placed back of the marker card A, the cards for the "B" size are placed back of the marker card B, and so on. If the number of a drawing is B₃₁₅, the card for this drawing would be filed in section B and after card No. 3 (see Fig. 1). These cards should be numbered consecutively and in advance to avoid the possibility of having the same number on two drawings, as this index must be referred to before numbering a drawing.

For example, if a size A drawing for drawer No. 2 is to be numbered, and by referring to the index under A₂ it is found that A₂₁₀ is the last number used, this shows that the drawing should be No. A₂₁₁. This number is placed on the drawing, and on the index card is printed the name of the part represented by the drawing, the date, the pattern or piece number, and possibly other information, such as the name or symbol of the draftsman, the checker, as well as special remarks when necessary. This form of card index enables one to locate readily any drawing, provided the number is known. When it is necessary to locate the drawing by referring to the name of the part drawn, a different card index is used.

Card Index Based on Classes of Machines. — The greatest difficulty in devising a satisfactory index system for drawings is encountered in shops which handle a great variety of work. On the contrary, the problem is relatively simple in the draft-

ing-rooms of shops where the product is limited to only one or, perhaps, a few standard machines or tools which are manufactured in large quantities. In order to provide a more complete system of indexing than would be available where only a numerical index is used, many drafting-rooms have a card index arranged alphabetically with reference to the different classes of machines or tools represented by the drawings. This system may be used in conjunction with the

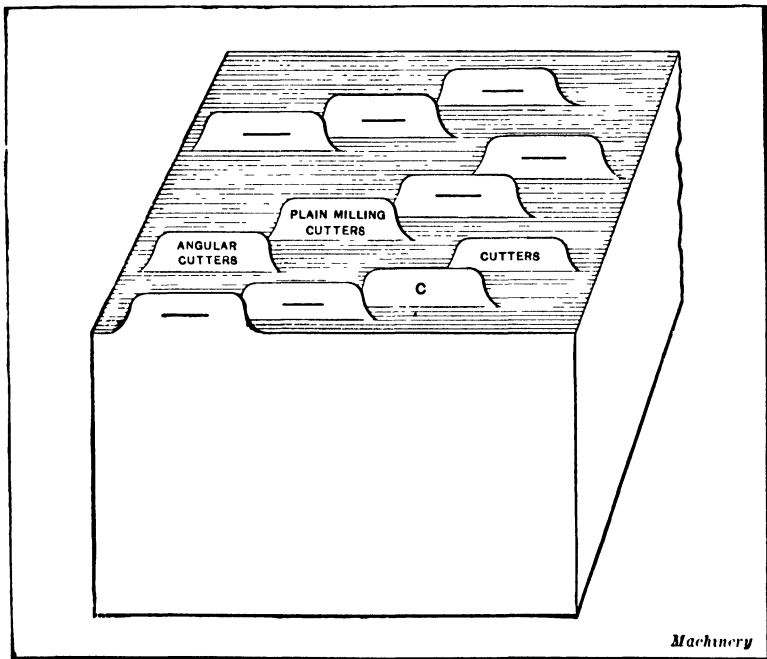

Fig. 2. Card Index based on Classes of Tools or Machines

numerical index previously described, or it may be considered satisfactory without an additional index arranged according to drawing numbers.

Figure 2 illustrates how the card index is arranged when the cards are filed with reference to different classes of tools or machines. This particular illustration shows that part of the file which is used for cutters. In this case, the cards for drawings of all classes of cutters are placed back of the head-

ing "Cutters"; sub-headings should be added to the index if the variety of cutters is great enough to warrant subdivision. In the same way, the cards for machines should be filed according to the general classes of machines represented, and all the attachments for such machines should be indexed under the heading of the particular machine for which the attachment is intended. For instance, the card for the dividing head of a milling machine should be indexed under "milling machine" and back of the subdivision marked "dividing head."

Special tools, such as jigs and fixtures, that are used for manufacturing operations on parts of standard machines and

Drawing No. A-612	Date March 6, 1905
Drawn by M. C-r	Checked by Potter
Casting Detail:	
Special head for #2	
Blank & Blank Milling Machine.	
Piece No. 656	
Remarks: For construction see A-109.	
For milling hexagon nuts.	

Fig. 3. A Typical Index Card

tools are indexed in the same divisions as the parts on which the operations are to be performed. For example, the fixture for drilling the dividing head of a milling machine would be indexed under "dividing head" back of the main division headed "milling machine." Whenever it is difficult to decide under which heading a certain tool or fixture should be indexed, it is advisable to make out two or more cards and place them in those parts of the file where they are most likely to be looked for.

Figure 3 shows a typical index card. The piece number given on the card is also the pattern number if the part is a casting. When the pattern numbers are marked not only on the drawing, but on the index card, a special index of pat-

terns is not needed, although it is convenient and in many cases necessary to be able to tell from the number of the pattern for what machine or tool this pattern was used. For this reason, a book or pattern register should be provided in which the pattern numbers are arranged in succession, the number being entered in the book as soon as the drawing is made.

Card Index for Jobbing Shop. — In a jobbing shop handling a general line of repair work, and possibly building new machinery, there should be some system of keeping records of machines and parts of machines sent out, as well as of the drawings. In most shops of this kind, some of the work is made according to blueprints or sketches supplied by the customer, and other work is made from drawings obtained from the drafting-room of the jobbing shop. Similarly, the patterns may be obtained from a customer or be made by the firm. This system should be so arranged that the drawing for any part of any machine may be readily found if the customer's name is known. There should also be a complete index of all patterns, drawings, outside blueprints, etc., to avoid a duplication of work in connection with future orders.

According to the system to be described, when an order is received from the customer it is written out on a form, duplicate copies of which are sent to the pattern shop, boiler shop, machine shop, or wherever work is to be done. We will suppose that this order is for a machine to be made to the firm's own drawings. The drawing office then, on receipt of this order, makes out a production sheet on bond paper forms, giving name and number required of each part, drawing number, pattern number if a casting, and material of which it is made. This production sheet should include everything required such as bolts, nuts, oil-cups, gaskets, split pins, name-plate and every detail, no matter how small. In the case of forgings it should give, in addition to drawing number, the length and size of bar required to make it. The required number of prints should then be made from the production sheet. The order number, name of customer, date issued and

number of machines required (the production sheet should always be made out for one machine only) should be marked on the prints, and not on the original, as this may be used again later, on other orders. One print should then be sent to the stores department, to order the material from, and one to each department having work to do on that order. Also one print should be filed away as a record under the order number, preferably in an envelope, together with any special specification or other matter referring to that order only; these should be kept in numerical order and be stored in a fireproof vault, but in a convenient place for reference. The original can now be altered to suit any future orders or improvements in design without affecting the record of that order. Any alterations to the drawings for subsequent orders are also made in such a way that there is a record of the original dimensions.

How Index is Used for a Duplicate Order. — To duplicate any part of an old order, there is a card index of the production sheet prints that are filed under their order numbers. These cards are indexed alphabetically under the customer's name which is placed on the card near the top edge. The body of the card has columns headed as follows: Order number — Name of machine — Size — Machine number — Drawing number. This card is filled out for each order for that particular firm. Therefore, given the customer's name, we can, by consulting this index, find the order number under which the machine was built, and by referring to the production sheet print for that order number, the drawing numbers are found.

The column for size makes it unnecessary to refer to two or three production sheet prints. For instance, if an order is received for a set of grate bars, the same as supplied previously with a 48-inch boiler for Brown & Co., then Brown & Co.'s card is referred to and the 48-inch size is located. In another column opposite this size will be found the order number, and from the production sheet print for that order number we can secure the pattern number and number re-

quired. If the size were not marked on the card and if a number of boilers had been built for that firm, it might be necessary to refer to several production sheet prints before finding the one for the 48-inch boiler.

The "machine number" column is used in case a customer sells his machine to someone else, the number being stamped on the nameplate of the machine. The "drawing number" column gives the assembly drawing number and may save time if one wanted only an assembly drawing, but it is primarily intended for orders such as stacks, smoke connections, etc., which require only one drawing. No production sheet is made for such orders, a bill of material on the drawing giving all information required.

The original production sheets have a card index with alphabetical guide cards, and are indexed under the name of the machine, as boiler under B. The production sheets are numbered in successive order, as made. The shop drawings are indexed alphabetically under the name of the part. These drawings are numbered and filed consecutively as made, and are given the suffix A or B. A is the large size (18- by 24-inch) and B the small size (9- by 12-inch). The A and B drawings are numbered and filed independently of each other. Each part of a machine is on a separate card, and the cards are rewritten from time to time to keep the parts on the card in order of size, the smallest size being at top.

If the order should be to make a machine to the customer's blueprints, these prints are numbered consecutively, starting with the number after that given to the last blueprint on the previous order, and giving it the suffix C or D, as 125-C. The suffix C indicates that the patterns shown on that print are our property, and the suffix D indicates the reverse. These prints are folded and put in envelopes bearing the same number, and are filed away in consecutive order, the C and D prints being in separate drawers. The C prints are indexed with our own A and B drawings, so that we have on the cards a complete list of all sizes of patterns or designs of that particular part. The D prints are indexed under the name of

the part. The column for print number on the index card is for the number given the print by the customer, and under the heading "Name of firm," is the name of the customer or owner of the print; these two columns are for purposes of ready identification. The foregoing is only a bare outline of the system, but it will be sufficient to show its cheapness and adaptability to the work required of it.

Limiting the Volume of the Card Index. — While the card index has proven a valuable aid in facilitating the drawing-

Class Milling Machine Fixtures Subdivision Fixtures for parts of Multi-spindle Drills FIXTURES FOR FEED RACKS				
No. of Drawing	Date Issued	Draftsman	Description	Date Superseded
2716	6-13-1904	Smith	For 4-spindle drill, $1\frac{3}{8}$ center distance	12-31-1905
3563	9-27-1905	Leland	For 3-spindle drill, $1\frac{3}{8}$ center distance
4716	12-30-1905	Leland	For 4-spindle drill, $2\frac{1}{2}$ center distance
4719	12-31-1905	Leland	For 4-spindle drill, $1\frac{3}{8}$ center distance

Fig. 4. Index Card intended to reduce Volume of Index

room work, it is apt to become rather voluminous, however, if the business is a growing one, and even though one may add all the card index guides possible, dividing the index into classes and subdivisions, there will invariably be some subdivisions that will contain more cards than are convenient to look through every time a drawing is to be found. For this reason a system based upon a principle of classification will make the index less voluminous and also permit a saving

of time when looking up a drawing. It has been the usual practice to make one card for each drawing indexed. This is not necessary, however, so long as there will always be a certain number of drawings of the same kind of tools or articles that can conveniently be listed on the same card. The card reproduced in Fig. 4 shows plainly the principle employed in regard to using the index guides, having first guides for general classes, and then for subdivisions. On the third line of the card is given the general name of the class of articles for which the drawings on this card are made. It will be seen that by means of this system the card index can be easily reduced to a fraction of its original volume. The average life of a drawing is rather short, and still, as superseded drawings have often to be referred to, it is well to systematize the drawing-room so that the superseded drawings are kept on file with the regular ones, but marked "superseded," and with the date the reissue took place. In order to save unnecessary delay in looking up a drawing, the date when the drawing was superseded should also be marked on the card in the index. With the exception of these remarks, the picture of the card will explain its purpose, and its general usefulness.

Record of Blueprints. — In some drafting-rooms, a complete record is kept of all blueprints which are sent to the shop or to the customer. A special card index may be used for this purpose, there being one card for each tracing. These cards are marked with the drawing numbers and are kept in numerical order. When a blueprint is sent to the shop, the name of the one receiving it is recorded on the card bearing the number of the tracing. In this way, it is possible to determine easily where every blueprint of a certain drawing can be found. Some system of keeping track of blueprints is especially desirable in a manufacturing plant where improvements and changes in the designs and details are constantly being made. For instance, if several hundred blueprints are constantly being used in various departments, it is essential to know where all the blueprints are, in case changes are to be made.

The practice in some plants is to provide each department with a complete book of blueprints for each type of machine manufactured. According to one system, when a change is made on a drawing, a new blueprint is made to supersede each blueprint in the factory. When a blueprint is issued from the drafting-room, a card is filled out. On this card, the name of the part is entered, the drawing number, and the date the blueprint is delivered to the department which received it. When a change is made on the tracing, this card index shows where the blueprints are and in the column marked "change" is noted the date when the new blueprint is delivered and the old one is returned. If for any reason it is not necessary to change the blueprint, in some departments a check mark, asterisk, or some other symbol is placed in the column marked "change," instead of the date, and a similar mark is made on the back of the card where the reason is noted. For instance, if the drilled hole in a casting is to be enlarged from $\frac{1}{2}$ inch to $\frac{9}{16}$ inch, it would not be necessary to change the blueprint in the pattern shop, as each department has its own blueprint. When a department no longer needs a particular set of blueprints, this set is returned to the drafting-room and the date is marked on the index card under the heading "returned."

When blueprints are sent away to customers or to other concerns, a separate card index may be used to show how many prints are out, and where they may be found. These cards are arranged with the customer's or the firm's name in alphabetical order. In order to safeguard against the loss of valuable drawings in case of fire, record blueprints should be made of all tracings and be kept in a fireproof safe or vault. Whenever changes are made on the original tracings, care should be taken to see that these record blueprints are also changed, so as to be kept up to date.

Record of Sketches.—Draftsmen and especially machine designers often make free-hand sketches, and in conjunction with this there may be dimensions or other data which are worth keeping for future reference. It is the practice in

some drafting-rooms to draw these sketches with a copying ink or a copying pencil, and then reproduce them in a special copying book used for this purpose. While these sketches may be indexed on the index pages of the copybook, when there are several books, a card index for the sketches is convenient. These cards may be arranged according to the name and kind of tool or machine or with reference to the names of customers. If a sketch is sent to the shop, it is noted in the copybook to enable the sketch to be located, if desired.

In many drafting-rooms, the draftsmen are provided with a notebook in which all estimates and calculations are made, but it is often difficult to locate the information or data required when one of these books has been used for some time and a mass of calculations has accumulated. A preferable method is to place such information and data on separate cards which form an individual record for each draftsman.

General Rules and Instructions. — One of the essential features of a good drafting-room system is the adoption of a number of general rules such as will be particularly valuable for new draftsmen who are not familiar with the various local standards, etc., which may have been adopted. The information should cover such points as the sizes of drawings, methods of dimensioning, including the adopted method of expressing tolerances on drawings, the way various degrees of finish are indicated in case this method is in use, information regarding the use of cross-sectional lines, lettering, etc.

In some drafting-rooms, in addition to general instructions, what are known as "data sheets" are issued. These sheets are intended to give the draftsman information and data pertaining particularly to the material used in whatever products are manufactured. For instance, there may be a list of the stock of steel carried in stock, including the sizes, shapes, and qualities. These data sheets may also contain information regarding stock patterns, examples and explanations of certain formulas commonly used in the design of the company's products, and in general, all data which has a particular bearing on the designer's work in that particular plant.

Record of Changes on Drawings. — As manufacturers are continually improving their products, the drafting-room must change its drawing, lists of parts, etc. Under no conditions, though, should a drawing be changed by any one unless authorized by the chief draftsman, and then the change must be made on the detail, assembly, and list tracings, and all prints made from these tracings. Changes are also required in the patterns and special tools, where these are affected. A record of the changes must be made in a file or book kept for that purpose. As a rule, changes are made only before a new lot of the product is begun, unless the change is of such a nature as to demand immediate attention. For this reason the foremen of the different departments, and sometimes the men, are provided with books in which they record errors, suggested changes, etc., and then send them to the drafting-room.

Before making any changes on a drawing, the draftsman should place before him a list of all the places in which the change must be made and then check off each place as the changes are made. Large changes should be sketched on detail paper before they are made on the tracing. Sometimes a comparatively simple change, like shortening the over-all length of a complicated casting will entail considerable labor. This may be avoided by changing only the dimensions and either underlining or enclosing them in small heavy circles which show that the dimensions are out of scale, so that the drawing will not measure correctly. Where the change is $\frac{1}{2}$ inch or less, the lines need not be altered nor a circle placed around the figures. Sometimes when an error has been made in the shop, a deviation from the drawings will save a large amount of costly labor and material, but the change must be recorded for future reference either in making repairs or in case some attachment or extra part is to be designed for the machine.

In some drafting-rooms, records of the changes are kept on the drawing. This may be done by having two columns, headed "Revisions"; one of these shows the location of the

change, the other shows the date. In this case, all changes made at one time are given a letter, for example A, which is placed in a circle alongside each change. Then the letter and a number showing the number of changes that bear that letter are entered in the first column and the date is entered in the second.

The method of making records of alterations should be standardized, because workmen shift about a great deal, and all alterations should be uniform. When several different systems of noting alterations are used, it is impossible for a man to understand all of them without considerable explanation, and, of course, no man likes to confess ignorance of a drawing if he is used to working with drawings. At one of the large automobile plants, when a figure is changed, a lower case letter is placed alongside the figure changed. This letter is surrounded by a circle on the tracing and the same letter occurs again where notation of alterations is made. Here the letter is followed with the figure as it originally read, followed by the date and initials of the man who made the correction. In this manner all changes can be so recorded as to enable one to find the dimension as it was prior to the change, and also to discover when and who made the change. If this system were uniform for all drawings, there would never be any confusion in regard to alterations.

Issuing and Storing Blueprints.—In shops where the manufacture of duplicate parts is done on a relatively small scale, a single set of blueprints may be issued, this set following the work from one department to another. Such a plan would not be suitable for a large plant manufacturing a great many duplicate machines at one time, and in such cases the different departments are supplied with sets of blueprints so that work on a given lot of machines can be carried on at the same time throughout the factory. Some manufacturers prefer to have all blueprints for a given type or design of machine bound together in a book or pack, there being as many duplicate books as are required by the different departments. The advantage of this method is that a complete set of prints

is always at hand and the continual replacement of lost prints is not necessary, as is the case where loose prints are used.

A record of the location of these blueprint books is kept in the drafting-room. In some cases, separate prints may be used, as, for example, in the screw machine department. While most blueprints are unmounted, it is the practice in many shops to mount them either on some kind of cardboard, wood, or possibly on thin steel plates. A thin material is preferable because the blueprints require much less storage space. Another plan is to issue separate blueprints to the workmen and also a complete set of prints bound together for the use of the machine shop foreman or superintendent. Blueprints after being used are filed away in some shops, whereas, in others, they are destroyed. When blueprints are soiled and torn considerably while in use, it is preferable to make new ones when they are again needed. The extent to which blueprints are injured depends, of course, upon the length of time they are kept in the shop, and upon the kind of work done.

In shops manufacturing duplicate machines, the blueprints are often stored in the tool store-rooms and are given out in exchange for checks, the same as tools. It is the practice in one of the large locomotive plants to use blueprints for reference purposes instead of the tracings. The object of this method is to avoid injuring the original tracings by constant handling. An extra blueprint is made of each tracing on which there is a large letter R, and also the following note: "This is a record print and must be treated as an original and returned to vault promptly."

Systems of Designating Parts by Symbols and Numbers. — There are various ways of designating machine and tool parts by numbers and symbols, such as are found on mechanical drawings. A common method is to identify each type of machine by a letter, and then add to the letter a number indicating the size. For instance, D might represent drilling machines, L, lathes, etc., and by combining a letter and number, as, for example, L-36, the symbol for a 36-inch lathe would be obtained. Serial numbers are also assigned to dif-

ferent parts of the machine; if 25 were the serial number of the lead-screw of a 36-inch lathe, the complete symbol would be L-36-25. This symbol (L-36) could also be used to identify the patterns. The relation between numbers may indicate the relation between parts; thus, if 30 is the serial number of a shaft, 31 may designate a bushing which is assembled on the shaft. When the numbers are arranged in this way, they enable the assembler to understand more readily the detailed drawings, since they show which parts go together.

Classification of Parts by Numbers or Symbols.— The numbers or symbols assigned to different parts may indicate in a general way what the parts are made of or their location in a complex mechanism which is divided into several groups or sections. Sometimes the size or a number simply indicates whether the part it represents is a casting or a steel part. For instance, steel parts may be given numbers below 500 and castings, numbers above 500. This idea has also been expanded so that the symbol shows quite definitely the nature or purpose of the part it represents.

A method that has been adopted at a plant manufacturing adding typewriters is to indicate by the size of the number whether the part is a shaft, a collar, any screw machine product having a hole, a casting, a drop-forging, a punched part, a machine screw, etc. Thus, the numbers from 0 to 9 represent shafts; from 10 to 29, studs, pins, screws, and so on. Numbers from 90 to 99 are reserved for miscellaneous parts not in the general classes mentioned. In addition to these numbers, letters are used to show to what general group or part of the mechanism any detail belongs. For instance, A represents the accumulator mechanism; B, the base frames and certain other parts; C, the carriage, etc. According to this system, if the symbol A-6 were used, this would show that the part represented was a shaft of the accumulator mechanism. When more than one operation is required, a number may be added to the symbol to show the number of the operation; thus, if numbers between 50 and 74 represent punched parts, then the symbol A-52-2 on the drawing of

a die shows that this die is used for the second operation on a punched part for the accumulator mechanism. This system with more or less modification could be applied to other lines of manufacture.

Lists of Parts. — What are known as “lists of parts” or “bills of material” are frequently used in conjunction with mechanical drawings. The part list shows what parts or materials are needed in the construction of a mechanism and serves as a record for future reference. This list is sometimes placed right on the drawing, or it may be on one or more separate sheets. These sheets are usually typewritten or printed forms that are filled in, or the lists are traced and are filled in on blueprints of these tracings. As various classes of materials are used in machine construction, such as castings, forgings, parts turned from bar stock, and parts purchased outside, such as machine screws, oil-cups, etc., the part lists are often classified, particularly if a great many parts are needed. For instance, there may be one part list for all of the castings required, a second list for parts made from bar stock, and still another list for purchased parts, such as machine screws, bolts, oil-cups, etc. A typical list of parts gives the name of the machine or mechanism for which the parts are required, the size, and whatever numbers or symbols may be needed for identifying it. In addition there are the name and number of each part and whatever information is needed in ordering, or to form a complete record. For instance, on a list of bar stock parts, the information would include the number wanted, the kind of steel or other material, the total length, and the form of the section.

These part lists, which are filed for future reference, are of great value when another lot of machines is to be constructed, as they show the stock-keeper the kind and number of purchased parts needed, and enable the work of ordering castings, etc., to proceed without delay and without guesswork as to what is actually required.

Operation Sheets. — When a new mechanical device is to be manufactured in a large plant, an operation sheet, or what

is sometimes called a general plan, which designates the various operations to be done from start to finish, is sent into the shops where the fixtures, gages, jigs, or tools are made. This operation sheet is valuable in showing what jigs, fixtures, tools, or gages are needed first. Thus each device follows in its regular sequence and a jig to be used on the seventieth operation will not be made before a jig used on the fifty-eighth operation. The equipment and manufacturing methods are clearly brought out before all concerned, and anything causing a fluctuation in the daily output can be easily localized and readily adjusted. Operation sheets are summaries of each standard part of the product, and from them arrangements for the manufacture of other devices are often possible at a much smaller expense than would otherwise be the case.

The value of this sheet is increased by placing on it sketches of the article with each operation completed. Then the jig or fixture maker sees immediately what his fixture or jig is desired to accomplish; oftentimes the man who makes the working drawings gets incorrect data or fails to put in every detail. As these sketches show each successive operation, they assist greatly in demonstrating the locating points and giving such other data as are often thought unnecessary until the jig or fixture is being made.

Multiple System of Drawing Sizes. — In order to economize in tracing cloth and paper, many drafting-rooms have been in the habit of using what is known as a "multiple system" of sheet sizes. For instance, in one case the largest sized tracings and blueprints which are required are 36 by 24 inches, and these large sheets form the basis of all smaller sized tracings and blueprints by a direct method of subdivision, smaller sized sheets being 24 by 18, 18 by 12, and 12 by 9 inches. As far as the complete using up of tracing cloth and blueprint paper is concerned, such a method of cutting up large sheets is admirable; but in filing tracings and blueprints, and when mailing blueprints in connection with engineering specifications, etc., there is an advantage in having a uniform size and one conforming to the $8\frac{1}{2}$ - by 11-inch standard size sheets

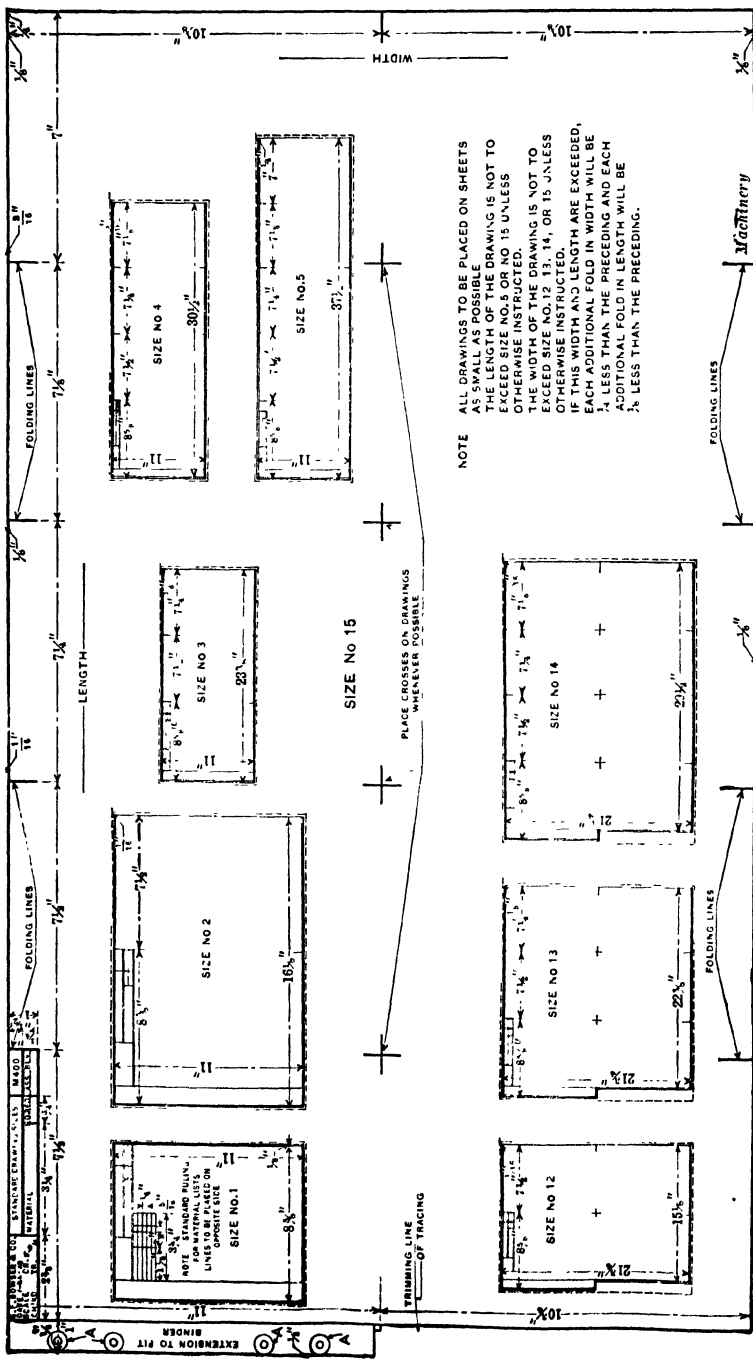

Fig. 5. Diagram showing Different Sizes of Sheets, the Location of Folding Lines and the Extension which enables the Blueprints to be held securely in a Binder

of business stationery. A practical method of maintaining this standard size in the case of large drawings is by a method of folding.

In the plant of S. F. Bowser & Co., Fort Wayne, Ind., blueprints of working drawings are generally made on sheets of about the size of the standard business stationery. For small shop drawings, blueprints $8\frac{1}{2}$ by 11 inches in size are ample to meet all requirements; but in cases where larger sheets are necessary, these are made in multiples of the basic size, so that they may be folded up and mailed with letters and specifications, making a neat package which will fit into an ordinary envelope with the letter unfolded. To facilitate folding blueprints to the standard $8\frac{1}{2}$ - by 11-inch size, the tracings are made with index-marks on them to indicate the points at which the prints should be folded.

Provision for Folding Blueprints. — Figure 5 shows the layout for different sizes of tracings that are used and the way in which “folding lines” are provided to show how to fold the blueprint made from the tracing. It will be seen that the sheet size numbers are 1, 2, 3, etc., for sheets measuring 11 inches from top to bottom, and 12, 13, 14, etc., for sheets measuring $21\frac{3}{4}$ inches from top to bottom. For sizes designated by numbers higher than 10, the 2, 3, 4, etc., indicate the width of the drawing, while the 10's digit indicates that the height is $21\frac{3}{4}$ inches. For a drawing still larger than any of those shown in Fig. 5, the same system of numbering is used; for example, a drawing $44\frac{3}{8}$ inches wide by $32\frac{1}{4}$ inches long would be called size No. 26, the 6 denoting the number of folds right to left and the 2 indicating that there are three folds from top to bottom.

How the Folding is Done. — In folding a blueprint, the bottom is first folded under, and then, starting at the right-hand side, the print is folded under continuously until the last fold has been made. The tracings are ruled with a slight taper at the top edge of the sheet, starting from the left-hand edge; this taper is $\frac{1}{8}$ inch per fold, although $\frac{1}{4}$ inch is the maximum taper which is allowed for the entire length of a

sheet. The top edge was tapered in this way so that, when the sheet is folded, the corners will not project. After a sheet is folded, the corner will be located from $\frac{1}{8}$ to $\frac{1}{4}$ inch below the top of the outside sheet, thus allowing the folded blueprint to be turned over more easily when looking for a print in a binder.

The spacing of the folding lines for different sizes of blueprints is clearly indicated in Fig. 5, and in the case of the No. 15 size of sheet, it will be seen, reading from left to right, that these lines are spaced $7\frac{1}{2}$, $7\frac{1}{2}$, $7\frac{1}{4}$, $7\frac{1}{8}$ and 7 inches, respectively, while from top to bottom the spacing is 11 and $10\frac{3}{4}$ inches. The reason for having the distance between folding lines decrease by regular intervals from left to right and from top to bottom is that in folding up a blueprint the bottom of the sheet is first folded under, and then, starting at the right-hand side, the sheet is folded under until it has been reduced to the unit size of $8\frac{1}{2}$ by 11 inches. Decreasing the distances between folding lines as indicated makes the sheet fold flat, while it would be bulky if the folding lines were uniformly spaced.

Filing the Folded Blueprints. — Another advantage resulting from the application of this system of folding prints to a uniform size is in maintaining blueprint files in the drafting-room, in the offices of the company's engineers, and in any other places where a complete set of blueprints is required. When the blueprints are folded they are ready for binding in the standard loose-leaf binders used for maintaining various files of data written on the regular business paper. The way in which binding is effected will be most readily understood by referring to Fig. 5, which shows the outline of a complete blueprint provided with an extension to fit into the binder. At the left-hand side of the upper section of the print there is an extension one inch in width, which is punched with four holes to fit the type EA-3-R loose-leaf binders made by the John S. Moore Corporation, of Rochester, N. Y. Should it happen that a print is punched badly and has to be repunched, or if the blueprint is accidentally torn at the points where the

binder pins pass through the holes, the blueprint does not have to be discarded. In such cases, use is made of Dennison's No. 2 gummed rings, which are pasted around the holes, thus making the blueprint even stronger than when it was new. The arrangement of these guard rings is shown at *A*.

Attention has already been called to the practice of starting at the right-hand side of the sheet and folding under continuously. The real object of adopting this method of folding is to obtain a folded print which acts like a single leaf when mounted in one of the loose-leaf binders.

The border line, "folding lines," and a space ruled for insertion of the title, drawing number, etc., are printed on the sheets of tracing paper. Particular attention is called to the position of the title, drawing number, etc., which are in the upper left-hand corner of the blueprint so that when the sheet is completely folded up in a binder, this title and drawing number appear on each folded sheet as successive sheets are turned over in the binder, without unfolding the sheets.

Two files of blueprints in binders are maintained in the drafting-room, one of these being arranged numerically according to the drawing numbers, while the other has the blueprints classified according to the parts which are shown. In the latter file, prints from all drawings of stuffing-boxes, valves, pump plungers, etc., are arranged together according to this classification, so that, if it is required to locate a drawing of a given part without knowing the drawing number, the task is greatly simplified by referring to this file.

Specifying Standard Commercial Parts. — In making out bills of material for assembly drawings, difficulty was sometimes experienced through failure of draftsmen to use the proper commercial names in specifying parts which it was their intention should be used in assembling. To correct this undesirable condition, each standard commercial part used was given a drawing number. In handling this work, the catalogues of all manufacturers from whom such parts as bolts, nuts, washers, set-screws, etc., were purchased were gone over by the drafting department and lists of the proper com-

mercial names of these parts were made with a drawing number assigned to each.

These lists were copied on the typewriter on $8\frac{1}{2}$ - by 11-inch sheets of tracing paper with a reversed carbon paper on the back, and these made clear blueprints for the use of the draftsmen in making up bills of material, so that any given part could be specified by its drawing number, thus practically avoiding any chance of mistakes being made. These blueprints giving numbers of commercial parts are placed in binders and put in the file of blueprints, which is arranged numerically, although there is a slight difference in the arrangement of these prints. The drawing number is the same as the part number, which is believed to be a much simpler method than having different numbers for the drawing and the part. Ordinarily, there is an individual blueprint for each number, but in the case of commercial parts, blueprints are arranged with twenty numbers on each, in order to economize space.

There are many parts used in the products made by S. F. Bowser & Co. which are of the same design and general dimensions, although one individual dimension may vary for different cases. For instance, use is frequently made of pieces of $\frac{3}{4}$ -inch wrought-iron pipe which are threaded at both ends, and all dimensions of such pieces are the same, except the total length. In all such cases, a blueprint of the part is made with the variable dimension indicated by a letter, and pieces of each different length used are assigned different drawing numbers. These blueprints are made up with more than one drawing number to a page, with the variable dimension tabulated beside the drawing number under a letter which indicates this dimension. This practice of putting anywhere from one to twenty numbers on a sheet is not at variance with the idea that the drawing and part numbers are the same, because in such cases it is assumed that a single drawing has as many drawing numbers as the number of parts shown.

Record of Assembled Units. — Many pieces are used which are termed “partial assemblies” in turning out completed

products at the Bowser plant. These partial assemblies comprise two or more pieces which are made in the factory, assembled, and placed in stock ready to be drawn out upon the requisition of the assembling department. Each of these so-called "partial assemblies" is assigned a drawing number, just as if it were an individual part, and in making up bills of material on assembly drawings of complete products, the drawing number of the partial assembly is used as if it were a single piece; then, to avoid the possibility of confusion, a double star is placed in the column devoted to the specification of the material from which parts are made. In this way, the assembling department sees at once that drawing numbers with these stars placed beside them are partial assemblies, and so there is no danger of confusion.

Method of Filing Tracings which Eliminates Card Index. — For filing tracings where the system of cutting large sheets into halves, quarters, etc., is employed for making various sizes of tracings, a number of cabinets of different dimensions are required if the tracing files are to be kept in orderly fashion. The same is true of the different sized tracings required for making blueprints according to the $8\frac{1}{2}$ - by 11-inch system of sizes which has been described, but a very satisfactory solution of the filing problem has been worked out. A majority of the tracings of working drawings are of the $8\frac{1}{2}$ - by 11-inch size, and all of these tracings are filed numerically by their drawing numbers in standard business letter filing cabinets. Cabinets with other sized drawers are provided to take the larger tracings, but, in order that their location may be readily ascertained, the file of $8\frac{1}{2}$ - by 11-inch tracings is made complete through the insertion of the upper left-hand section cut out from blueprints of all other sized tracings, which gives the title of the drawing and is filed numerically by the drawing number of the tracing. On this section of the blueprint there is written with a red pencil the size of the tracing and its location in other sizes of cabinets required for the preservation of the larger tracings. Consequently, reference to a single file at once shows the exact location of any tracing that is re-

quired. This method enables the required tracing to be located in less time than it would take if it were necessary to refer first to a card file to ascertain the location of the required tracing, and it also makes it unnecessary to maintain such a card file.

Replacement of Obsolete Prints. — In every plant engaged in building machinery or in any other line of engineering work, it frequently happens that certain minor details of an existing design are required to be changed, but frequently the changes are such that they may be made on the original tracings without requiring entirely new tracings to be made. In working out the new drafting-room system for the Bowser plant, provision has been made for keeping a record of all changes of this kind made on old tracings, and also of cases where entirely new tracings were found necessary. There are certain departments in the factory to which new blueprints of changed tracings must be sent to replace obsolete prints in the files in these departments; and it is the duty of the drafting-room to see that such prints are sent out just as soon as they are ready, together with a written notification of the change which has been made in the design.

At the time the new print is delivered, the obsolete print must be taken by the messenger and returned to the drafting-room. Each department to which a new blueprint is sent receives the written notification concerning the change in the machine detail shown by the print. This work of preparing notifications for the different departments to which blueprints are sent is handled by a stenographer. A card file is kept on 5- by 8-inch cards, which constitutes a complete record of all blueprints that are sent out to the shop, and of all changes in design that are made on tracings. This card file refers not only to prints of parts which go into the latest products, but also the parts that have been declared obsolete as a result of certain changes in design. There is a separate card in the file for each drawing, and on the reverse side of the card spaces are provided for recording the sending out of blueprints and the return of obsolete prints from each department to which

new prints are sent. This guards against any department keeping obsolete prints in its files and making parts from such prints through mistake. When the print represented by a given card in the file is declared obsolete, a small star is stamped in the upper right-hand corner of this card and a new card is made out for the print in question. Each card is marked in its upper right-hand corner with the drawing number of the part shown by the blueprint, and it will be apparent that there may be several cards of the same number, each having the star stamped in the corner with the exception of the last card of the given blueprint number, which represents the blueprint that shows the part in its latest form.

On these cards there is a ruled space on which is typewritten a statement of the changes made in the design shown by the print; and each time a change is made on a design, requiring a new card to be made out to record this change, the card is marked with the number of changes that have been made in the design of the part shown by that blueprint. These cards are in sets, there being one for the drafting-room record file and one paper sheet for each department which must receive a new blueprint and notification of the changes in design of the part shown by the print. There is also one sheet of paper for the stenographer's use in taking dictation from the chief draftsman concerning the changes made in the design, and this sheet of paper is ruled with lines like the ordinary stenographer's notebook, so that the usual positions above and below the line may be used in writing the notations in shorthand. After taking dictation concerning the changes in design in each blueprint, the stenographer tears off from the pad the top sheet on which the stenographic notes were made and all sheets on which notifications to department heads will be typewritten, together with the drafting-room record card on which a typewritten statement of the change in the blueprint will be recorded. Tearing off the complete set of sheets is an easy matter, because the girl simply runs her thumb over the edge of the pad and catches the card, which is torn off with the paper sheets that are above the card.

Carbon paper is placed between each of the lower sheets so that all of the notification sheets and the drafting-room record card may be slipped into the typewriter and written at one time. At the bottom of each of the notification sheets sent out to the factory with new blueprints, there is a slip separated from the main sheet by a perforated line. When the new print is delivered to the department, the old print is taken out of the file in that department, and a receipt signed for the new print on the slip at the bottom of the notification sheet. This receipt is then torn off the main sheet and clipped to the obsolete print, so that both may be returned to the drafting-room office. A record of the delivery of the new print and return of the old one is then made on cards in the drafting-room file, and the old print and receipt are destroyed. The double entry on the back of a drafting-room record card serves to indicate that the card refers to an obsolete print, thus serving as a check on the small star stamped in the upper right-hand corner to indicate the same thing.

Drawing-room Equipment and Arrangement. — The equipment and arrangement of a modern drawing-room is shown in Fig. 6 as an example. The main room is made large in order that there will be sufficient space for the equipment without the danger of overcrowding. At the same time the room should be well heated and ventilated, and should preferably face the north in order to secure the steadier light which is always obtained from that direction. It is a well-known fact that the light secured from this direction does not cast the conflicting shadows due to the different positions of the sun during the day that the light obtained from any of the other three directions does. The north wall of the building should be given up to window space, so that plenty of light can be obtained. It is always desirable for right-handed persons to have the light coming from the left, and with this fact in view it is well to arrange the drawing tables *B* so that when the draftsman is at work he faces the east.

At the east end of the main room, according to the arrangement illustrated, will be found files *C* and cases *D* running the

full width of the room, in which drawings, tracings, pencil sketches and supplies are kept. The files are arranged on each side of the supply cases and extend toward the center for about two fifths of the width of the room. The supply cases *D* are arranged between the files *C* and are about half their size. The file cases consist of seven sets of files, as shown in Fig. 7 at *b*, *c*, *d*, *e*, *f*, *g* and *h*, respectively. A card index, *a*, which is very valuable to a drafting-room, is arranged at the top of the case. The file *b* is reserved for blueprints of parts, and assemblies of standard products of the plant, file *c* is for tracings, file *d* for original drawings, file *e* for duplicate

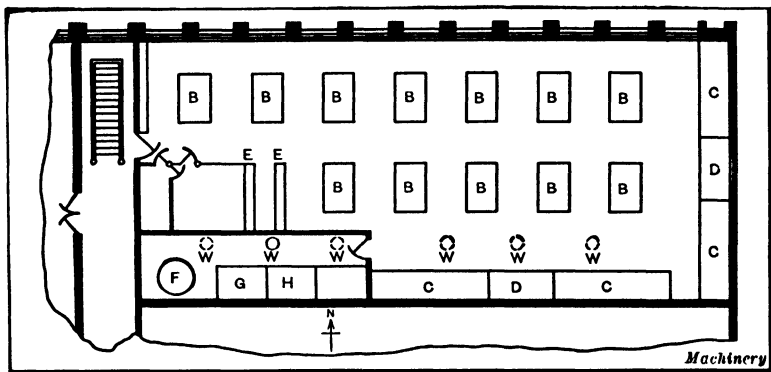

Fig. 6. Plan of a Drafting-room showing an Approved Arrangement

sketches, and file *f* is for foreign blueprints, that is, blueprints which have been obtained from other companies. The file *g* is for obsolete drawings and prints that are retained for reference. There are eight rows of these files and the drawings of the different years are placed in separate rows, thus making them easily accessible and easy to find.

The supply case *D* consists of two sets of drawers in which supplies, such as tracing cloth, paper, ink, pencils, erasers, etc., are stored. The top of the supply case is constructed of such a height that it also answers the purpose of a table, which will be found very convenient when consulting any of the drawings or prints in the files. On the south side of the room is found another set of files similar to the one just described.

The sample cases *E*, in Fig. 6, are arranged at the west end of the room. These cases consist of several drawers and two or three small cabinets, and are intended as a place to store defective castings, patterns, new parts, etc., which are used for reference by the draftsmen from time to time.

One of the principal features of the modern drawing-room is the portion set apart for the blueprinting work. This room should be of light-proof construction and should be equipped with all of the modern improvements which have been invented for the process of blueprinting, such as blueprinting machines, steam driers, washing pans, etc. The location of the blueprinting machine is at *F*, the steam drier at *G* and the washing pans at *H* in this particular illustration.

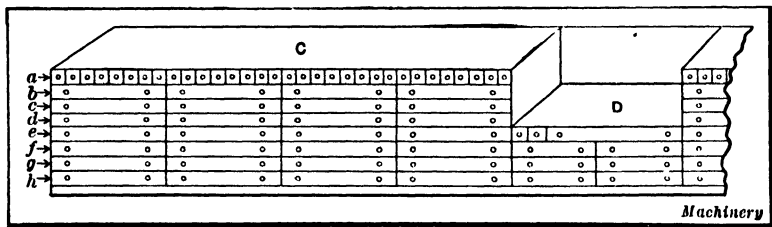

Fig. 7. Arrangement of Files and Supply Cases

The chief draftsman's or engineer's private office is located directly in front of the blueprint room. It is advisable for the head of the department to have a room separated from the drawing-room, where he can discuss his business problems with his employes in private. All of these rooms should be large and well ventilated. The roof should be equipped with a number of ventilators *W*, in order that a good circulation of air can be obtained. The illustrations shown here are a combination of the lay-out and equipment of several of the drafting-rooms in use at the present time in a number of the most modern plants in this country.

Drafting-room Lighting. — Few classes of work call for more active and constant use of the eye than that of the draftsman. The necessity for continual distinction of fine lines and details and the use of finely divided measuring scales and delicate

instruments warrants a system of illumination free from all features likely to produce eye fatigue and eye strain, and capable of promoting ease and comfort in such work. The problem is not altogether one of providing light of high intensity. Too much light may be as harmful as insufficient light. The following information on this subject was contained in an article in the *Electric Journal* by C. E. Clewell, a specialist on lighting.

The general requirements for drafting-room lighting are: Good and sufficient light for each person; uniform distribution of light provided by lamps in such numbers and so arranged as to furnish illumination which is satisfactory without regard to the arrangement of tables; an arrangement of lamps that will avoid glare and subsequent eye strain; a system which will furnish illumination on the drawing-boards with a minimum of shadow effect when using instruments and ruling devices; an intensity of illumination which will permit the discernment with ease of fine lines and detail, and which will be sufficiently penetrating for tracing work.

Prevalent Methods of Lighting. — Numerous methods have been used for the lighting of drafting-rooms, some of which possess several of the features outlined above, but they seldom fulfill all requirements. For example, one method of drafting-room illumination is that in which one or two light units provided with reflectors are placed close to the work. This system, casting an intense light on the paper, is not uniform, however, and it is necessary to change the units when the position of desks is shifted, wiring modifications often being called for in such cases. A system of this kind produces a glare from the surface of certain kinds of paper with subsequent eye fatigue. It should be further noted that the resulting shadows are excessive and this requires a continual shifting of the work or lamps and a consequent delay and annoyance.

In an investigation of drafting-room lighting, tests were made in a typical room with bays 16 by 20 feet and a ceiling height of 11 feet 6 inches. A sectional view and floor plan of

such a bay, together with the lighting arrangement, is shown at the left in Fig. 8. This typical drafting-room contained an average of four tables per bay and could accommodate four persons per bay. The room was originally equipped with large light units spaced on an average of from 8 to 10 feet apart and mounted 10 feet above the floor or about 5 feet 6 inches above the drawing-boards. The complaints from the use of this lighting scheme were threefold: (1) The illumination was not uniform, the intensity on some desks being higher

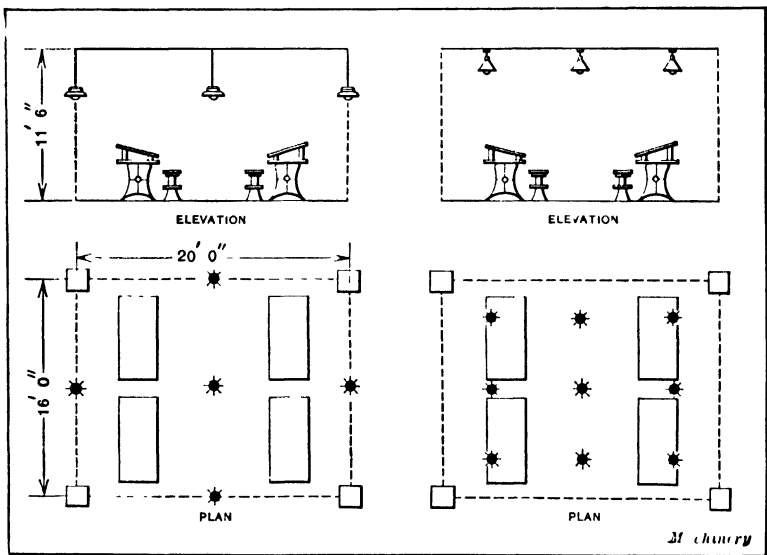

Fig. 8. Bay of Drafting-room lighted with Large Lamps — Bay lighted by Nine Smaller Lamps

than on others. (2) The low mounting height of the lamps, together with the large size of the units required to furnish sufficient light, caused those working in certain positions to suffer from excessive eye strain, both from the glare of the light source and from the reflected light on the papers. (3) Shadows from the small number of light units were dense and required a constant shifting of the ruling devices so as to receive the light on the work at the proper place.

The problem was to provide illumination possessing all the

requirements previously outlined, and with features of such excellence as to be satisfactory in all respects for a class of work which rightfully calls for superior lighting facilities. The study of the requirements will show that uniformity, the absence of shadows, and the reduction of glare are the conditions most difficult to obtain. Several methods were given thorough trial before the final scheme was chosen.

Illumination Experiments. The first step in an attempt to eliminate the defects of the lighting system shown at the

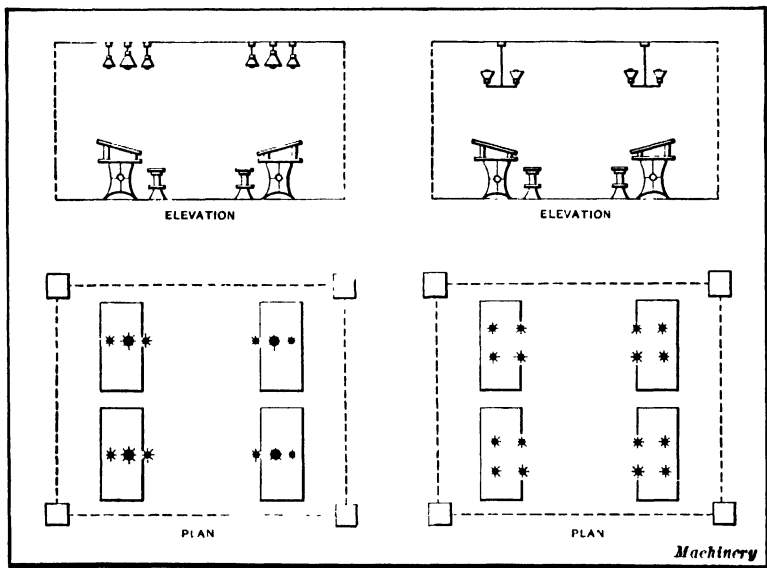

Fig. 9. Bay lighted by Four 100-watt and Eight 40-watt Lamps—Arrangement finally adopted consisting of Sixteen 40-watt Lamps

left in Fig. 8 was the installation of nine units somewhat smaller than those originally used, arranged as indicated at the right in this same illustration. Certain draftsmen were set to work in this trial bay. From the beginning the following items were observed: The intensity was excellent, the light uniform, and the glare inappreciable. It soon became apparent, however, that the shadows cast by the large number of units were an objectionable feature. In drawing circles and in the use of the divider generally, some nine shadows

standing out in all directions from the instrument and apparently rotating when a circle was described produced confusion and annoyance. This feature naturally gave rise to considerable complaint and led to the suggestion that the shadows might be diminished by the use of more units arranged in groups for a given floor space.

As a second experiment, twelve units in four groups were arranged as shown at the left in Fig. 9, the system being made up of four 100-watt and eight 40-watt tungsten lamps per bay. Draftsmen were then placed in this bay so as to work under the light for some days. The same trouble was experienced with shadows in excessive numbers, as was the case in the first trial, the effect being even more noticeable, due to there being twelve lamps per bay instead of nine as before. The lack of uniformity was even more noticeable in this scheme, since each cluster can be considered as one light source as far as independence of desk locations is concerned, and the superiority of nine over four light sources or groups per bay was demonstrated.

Other arrangements which were given trial were as follows: One bay was provided as an extreme case with 21 units scattered over the ceiling. Here the shadow effect was perhaps somewhat offset by an excessive intensity, but the use of lamps in such numbers would be prohibitive in point of economy.

An arrangement of four 250-watt tungsten lamps per bay, equipped with broadly distributing reflectors, was tried. While possessing some good points, this arrangement made use of units entirely too large for the ceiling height. Calculations were made to determine the minimizing of shadow effect in large rooms by the use of broadly distributing reflectors rather than those of a more concentrating type. This involves the building up of intensity at a given point by the light furnished by many distant light sources rather than depending entirely upon the light from one overhead unit. A man leaning over his work will cast a deep shadow, cutting off nearly all of the light if provided by one unit overhead and little or

none from distant units; whereas, if the units are provided with broadly distributing reflectors, such shadows will be far less noticeable.

An Approved System of Lighting. — The plan finally adopted consisted of the use of sixteen 40-watt tungsten lamps per bay arranged in clusters of four each and in an inverted position on the fixtures. (See the right-hand diagram, Fig. 9.) The primary object in this scheme was the attainment of a light free from the shadows found in previous trials. Various types of reflectors and fixtures as well as the effective mounting height of the lamps above the floor were successively tried. With the ceiling freshly painted a yellow tint so as to present a coefficient of reflection of about 0.7, the following items were observed: Opaque reflectors which transmitted all the light coming from ceiling reflection, while providing a shadowless illumination, did not furnish a sufficient intensity for the work in question. The reflectors seemed to give the best results when mounted in a vertical position pointing upward, rather than when mounted in an angular position. Reflectors of a softly diffusing quality of glass and furnishing a considerable amount of transmitted light to the work, seemed to fulfill all the requirements as outlined above. Each draftsman, irrespective of desk or table location, received a good and sufficient light. This light was uniform and was made soft and free from glare by a glass reflector, providing excellent diffusion and a soft yellow tint. The shadows were eliminated and with the use of the correct size of lamp an intensity of proper value was provided throughout the room. This system has been in service long enough to show that, within the limitations of ceiling height and types of units and reflectors available, a very satisfactory result has been obtained. It is of interest to note that the number of watts per bay with this last scheme was practically the same as that found in the original installation. Hence the superior results were obtained not by an extravagant installation but by a carefully arranged plan of the equivalent number of watts in another form.

Varying the Intensity of the Light. In such a lighting installation as that just described it is likely that different intensities of the artificial light may be needed at different portions of the day and evening. At first thought the usual conclusion is that more artificial light is required at night than on cloudy days. Experience shows the reverse. During the day the eye is subjected to a stimulus from daylight intensities which are ordinarily many times greater than the intensities of artificial light commonly used. In the daytime this causes the pupil of the eye to be in a contracted state so that it requires a greater intensity on the object than is necessary when the eye is relaxed as at night. Thus on a cloudy day, when the daylight is insufficient, a greater intensity of the added artificial light is necessary to produce a satisfactory illumination on the working surface than at night. If the lighting system has been designed for an intensity suitable when used in conjunction with some daylight, it is quite possible that the intensity will be too high for comfort at night. Some way of changing the intensity of the light without destroying its uniform distribution is therefore desirable. If lamps be turned out here and there at random for the purpose of reducing the intensity to the proper value at night, the uniformity of the light is apt to be destroyed. One method of varying the intensity, without destroying the uniformity of the light, consists in installing the lamps in groups, and turning out a part of the lamps in each group. This affords different intensities without disturbing the uniformity. Often, however, the lamps are not in groups.

The tungsten lamp possesses one feature which can be used to advantage in varying the intensity, whatever the number and arrangement of lamps. From the normal voltage of the lamp to about fifteen or twenty per cent below normal, the light of the tungsten lamp maintains its characteristic white color. The voltage on such a lighting system may be reduced by means of a transformer arranged with a number of secondary taps to give voltages below normal, thus permitting a change from normal intensity to lower values without notice-

ably affecting the white quality of the light. This scheme has been used and furnishes a convenient method of varying the light intensity without destroying the uniformity of distribution.

Adjustable Drop-light and Reflector. — The most common system of artificial illumination in drafting-rooms is by means of drop-lights and reflectors, either 16- or 32-candlepower lamps being used. One 16-candlepower lamp scarcely gives sufficient light for the usual size of drawing-board, and a 32-candlepower lamp gives a light which is too concentrated and glaring, thus causing a reflection from the tracing, which is

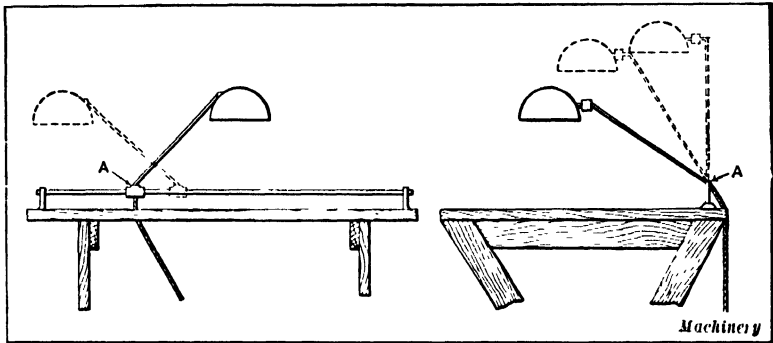

Fig. 10. Light held in Adjustable Bracket

injurious to the vision. It has been found that two 16-candlepower lamps are preferable. One of these should be placed at the extreme left and the other a little at the right of the center of the board. If one of the lamps casts objectionable shadows, it can be turned out temporarily. The adjustable lamp fixture illustrated in Fig. 10 is designed to eliminate the use of two lights. It consists of an arm and reflector mounted upon a rod at the back of the drawing-board. There is a universal joint at *A* which permits the lamp to be placed in any position. The connection is with a floor socket and there should be sufficient length of cord to permit the lamp to be adjusted along the rod.

CHAPTER XIII

SKETCHING AND PERSPECTIVE DRAWING

PENCIL sketches are commonly used by almost everyone engaged in mechanical work. The inventor and designer frequently use rough sketches in developing new appliances, the mental picture being transferred to paper so that it becomes clearer. Sketches assist in developing an idea, and they often reveal faults, or show that the idea is entirely impracticable. A number of sketches are often made to illustrate different solutions of the same problem. During the preliminary steps in the development of a design, free-hand sketches may serve the purpose about as well as accurate drawings, and the former are preferable since they can be made quite rapidly.

Another important use of sketches in mechanical work is to show the form and arrangement of existing devices, such as tools, machine details, or a complete mechanism. The original drawings of a machine may have been destroyed by fire or lost; if new ones are needed, rough free-hand sketches are frequently made first, because it is not convenient for the draftsman to make the scale drawings directly from the machine. After one or more sketches have been made, all important parts of the machine are measured, and these measurements are marked on the sketches, which are then used by the draftsman as a guide for making a more complete and accurate drawing.

Sketches are used universally to illustrate ideas of a mechanical nature. For instance, whenever there are discussions on mechanical subjects, a pencil and paper are generally required to show by a drawing or sketch what cannot be explained clearly by words alone. While the ability to sketch

is essential to the draftsman or designer, at least some skill in sketching is also useful to the man in the shop. The machinist or toolmaker often relies upon a sketch to illustrate some existing tool or mechanism, or as the means of representing what is considered, at least, to be a new or improved device or method. Drawing has sometimes been referred to as the "language of the shop," and inability to draw or sketch is often a great handicap to the shop man.

Experienced machinists and toolmakers usually know more or less about mechanical drawing methods owing to the continual use of blueprints in the shop. They understand what the different views represent, or are able to "read" a drawing. Practice in the reading of various kinds of drawings tends to teach the methods of making mechanical drawings, so far as the number of views required and their arrangement is concerned; but the actual making of a neat drawing or sketch, especially without the use of instruments, requires practice and the understanding of a few simple principles. It is the purpose of this chapter to give a few hints on sketching to shop men who are already familiar with the projection method of drawings, and also to draftsmen who find it difficult to make satisfactory sketches. It is a mistake to suppose that neat sketches can be made only by those having a special talent in that direction. Most machinists and toolmakers can become fairly proficient in sketching if they are willing to practice, and it is important to remember that the amount of practice necessary can be reduced greatly if the proper methods are followed.

An Important Principle in Sketching. — The real difference between a poor sketch and one that is neatly executed is that a poor sketch is composed of crooked lines which are not of the right length or do not bear the proper relation to one another, while in a good sketch the reverse condition obtains. Now, most mechanical drawings, whether they represent a complicated mechanism or some simple part, consist largely of straight horizontal and vertical lines, which vary as to length and as to their location relative to one another. The

first step, then, in acquiring skill in sketching without the aid of instruments, is to learn how to draw fairly straight lines, and the next step is to make lines of the right length and place them where they belong. That sounds easy and, in fact, it is not as difficult as many imagine.

A finished sketch may appear complex and difficult just because it is composed of many different lines. The drawing of a few lines would not seem difficult, but when many lines are combined to form a complete drawing, the making of such a sketch is considered almost impossible by many mechanics who have never considered themselves handy with a pencil. Now the fact is that a sketch which is formed of a mass of lines may be drawn almost as easily as a much simpler one, except that more time is required. If two straight lines can be drawn on a sketching pad, there should be no difficulty in drawing four, eight, or any required number of lines, which is an important point to bear in mind. It is, in fact, a principle which applies not only to drawing but to building machinery and to a thousand and one other activities. If each detail of the work is carried on correctly, the completed job, whether it be a sketch or a complex machine, will finally be the result. The appearance of the completed work may prove rather deceptive. It may seem to the inexperienced as hopelessly difficult when it is, in reality, merely an aggregate of simple details put together in the right way.

Most drawings, as was said before, are formed largely of straight lines that are perpendicular to one another. Some drawings also have a number of circles or arcs of circles, and there may also be lines at various angles to each other, and irregular curves. It is evident that one who can draw these lines, especially the straight ones, with fair accuracy, without using mechanical drawing instruments, has at least a good chance of becoming reasonably proficient in the art of sketching. Locating and proportioning the lines is another essential requirement. These two general features of sketching will be dealt with.

Drawing Straight Parallel Lines. — It is preferable when sketching by the method to be explained to use a pad having a cardboard back to make it rigid. The size of the pad is not important, although an 8- by 10-inch size will be found convenient for most sketching. A good exercise with which to begin is that of drawing straight parallel lines. An easy method of doing this is illustrated in Figs. 1 and 2. The pencil is guided, as it is drawn across the paper, by one finger which slides along the edge of the pad. Either the little finger

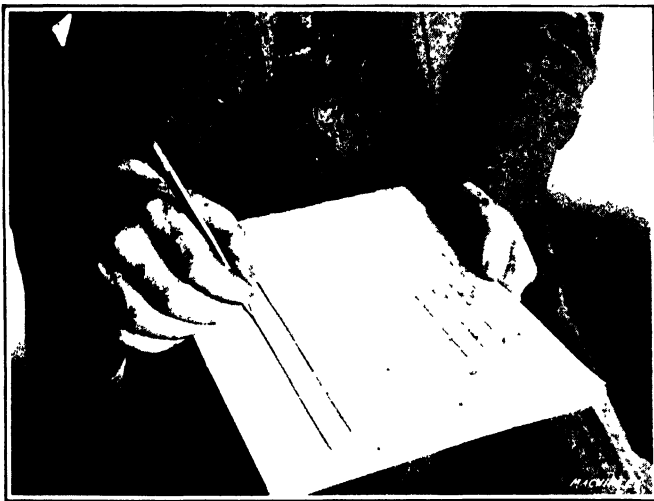

Fig. 1. Drawing Straight Parallel Lines by guiding Pencil from Edges of Sketching Pad

or the ring finger next to it is used to guide the pencil, depending on the distance from the edge of the pad to the line to be drawn. Unless the line is very close to the edge — say less than one inch — the little finger should be used (see Fig. 2). As the little finger follows the edge of the pad, the ring finger slides lightly over the top surface of the pad and supports the hand. By adopting this simple method, lines that are practically straight and parallel can be drawn with a little practice, and the movement of the pencil can be quite rapid without impairing the straightness of the lines; in fact, a



Fig. 2. End of Little Finger is held against Edge of Pad so that Pencil will follow Straight Line

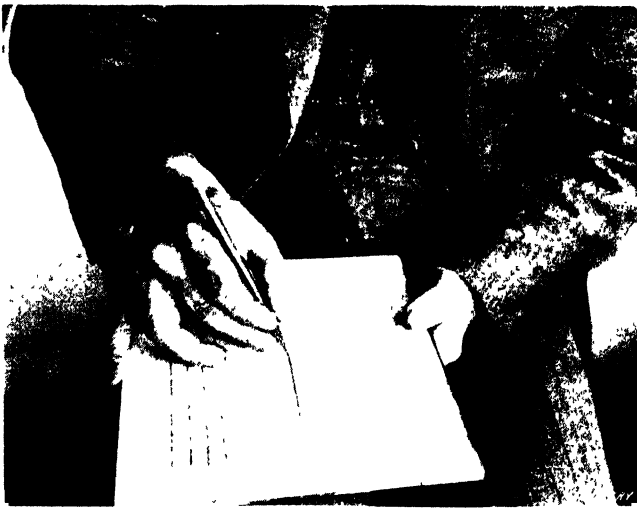

Fig. 3. Drawing Straight Line which is located near Center of Pad

somewhat rapid stroke is preferable. This method will be found decidedly superior to the common way of attempting to draw a straight line by a series of short follow-up strokes.

After it has become easy to draw straight lines near the edge of the pad, the pencil should be moved nearer the center as shown in Fig. 3. This exercise is a little more difficult because the pencil is farther from the guiding finger. The pencil is held at different distances from the edge of the pad simply by separating the guiding finger more or less from the remainder of the hand. When making a sketch, that edge of the pad nearest the line to be drawn should ordinarily

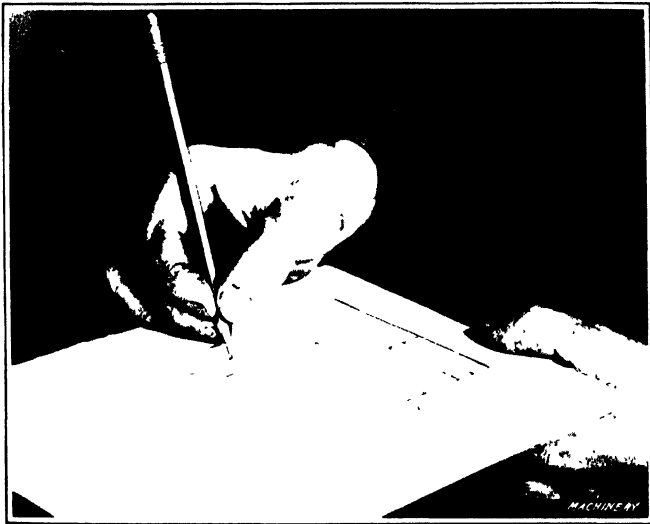

Fig. 4. Lines drawn at Right Angles and in Different Positions by guiding Pencil from the Four Edges of the Pad

be used for guiding, and in this way the entire surface of the pad can be covered, if it is not over eight or ten inches wide.

The next exercise should be that of drawing lines of various lengths at right angles to one another, as illustrated in Fig. 4. The pencil is guided by the little finger the same as before, and the end of the pad is used as well as the side. These exercises should be continued until the drawing of lines by this method becomes natural and easy. Simple figures, such as squares and rectangles of different sizes, should be drawn next to obtain practice in the matter of locating the lines properly and getting them somewhere near the right length.

This next step is a little more difficult than the first because drawing a lot of miscellaneous lines is much easier than making a drawing of some definite object.

How to Proceed when Making a Sketch. — If the shape of a casting or forging or the arrangement of some mechanism is to be shown by a sketch, the lines which form it must be properly proportioned, their length and location agreeing approximately with the size and location of the different surfaces or parts which they represent. Success in this branch of the work is achieved partly by method and partly by practice. Some sense of proportion is also needed, but most machinists are good judges of short distances and should be able with practice to proportion a sketch accurately enough if the right method is adopted. It is important to draw the main parts first and then the details, because the proper proportions and locations are secured more easily in this way.

In order to illustrate some of the points to be observed when sketching and the general method of procedure, one or two practical examples will be given. As an illustration, suppose a sketch similar to the one shown in the upper part of Fig. 5 is to be made. The first thing to decide is how and where to begin. It would be possible to start in several different ways. For example, we could first draw the collar at the right-hand end, then the threaded end at the left, and finally connect these sections by drawing the long horizontal lines, but it is quite evident that this would not be the best way to proceed. The proper way would be first to draw a center line, then the principal lines, and finally the smaller details. Center lines are not always needed in sketching, but as a rule they enable the different parts, even of a simple sketch, to be more accurately located relative to each other. Take, for example, the sketch of a gas engine crankshaft shown in the lower part of Fig. 5. In this view, it is desirable to have different bearings approximately in line. To accomplish this, three parallel and equally spaced center lines extending lengthwise of the shaft should be drawn first. If these lines are drawn fairly straight and are spaced about equally, the

crankshaft can be sketched around them easily. This shaft could also be sketched without center lines by first drawing lightly three sets of double parallel lines. The two lines in the center serve as a guide for aligning the shaft bearings, and the outer lines serve to locate the crankpin bearings. The shaft is then drawn in heavier lines by beginning at one end and finishing each crank successively.

It is neither necessary nor advisable to guide the pencil from the edge of the pad for drawing all straight lines. This

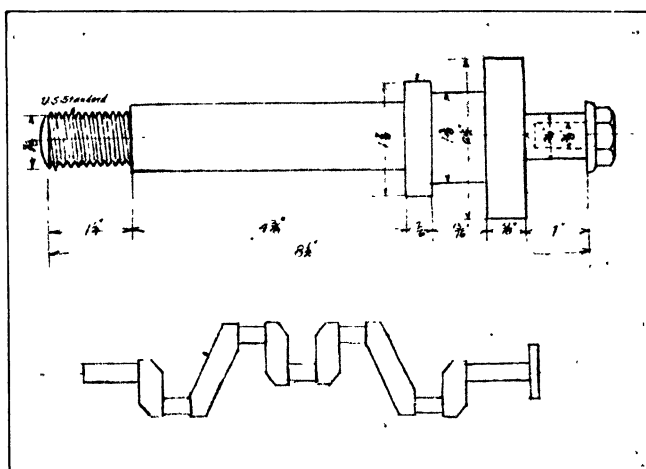

Fig. 5. Sketches illustrating Methods of Procedure

would be an awkward way to draw the numerous short connecting ends which form the smaller details on many sketches. The pencil should be guided only when drawing the longer lines which form the principal part of the sketch. For instance, when sketching the crankshaft, the pencil should be guided while drawing the center lines or the light parallel guide lines, but the cross-lines are so short in this instance that they could doubtless be drawn to better advantage, without attempting to steady the hand from the edge of the pad. A sketch of this kind could be made easily on cross-sectioned paper, but such paper may not always be at hand, and a plain pad is just as good for many purposes. The cross-sectioned paper with its

guide lines accurately spaced is excellent when it is of especial importance to make a sketch accurately to scale.

Whenever possible, only one view is shown on a sketch, even though two views might be considered necessary on a working drawing. Many parts are understood to be round or of circular cross-section by mechanics, and an end view is not needed or, in some cases, an explanatory note may be

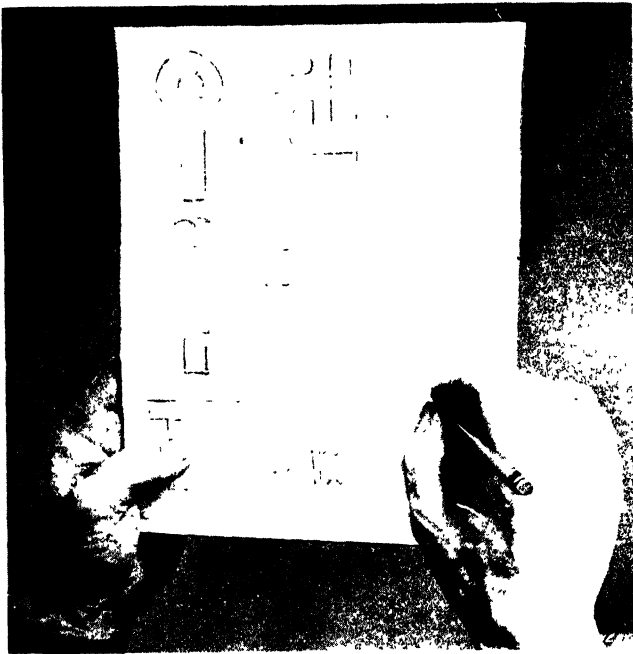

Fig. 6. Sketching Small Details — An Exercise in drawing Lines and in proportioning Parts

added to the sketch to avoid an extra view. If one section of a circular piece were of special shape or had a slot cut in it, an additional view might be advisable.

The sketching of small details such as are shown in Fig. 6 is good practice and should precede the making of larger sketches. When starting the sketch it is often advisable to draw very light guide lines which serve to block out the principal parts of whatever object is being drawn. Such guide

lines, as a rule, will greatly assist in proportioning the sketch and make it possible to complete the sketch with little or no erasing. When simple details can be drawn readily, sketches of larger and more complicated parts should be made. The example shown in Fig. 7 represents an engine cross-head and one end of a connecting-rod. These sketches illustrate the important point that plain straight lines which are parallel and at right angles to one another form a large part of most

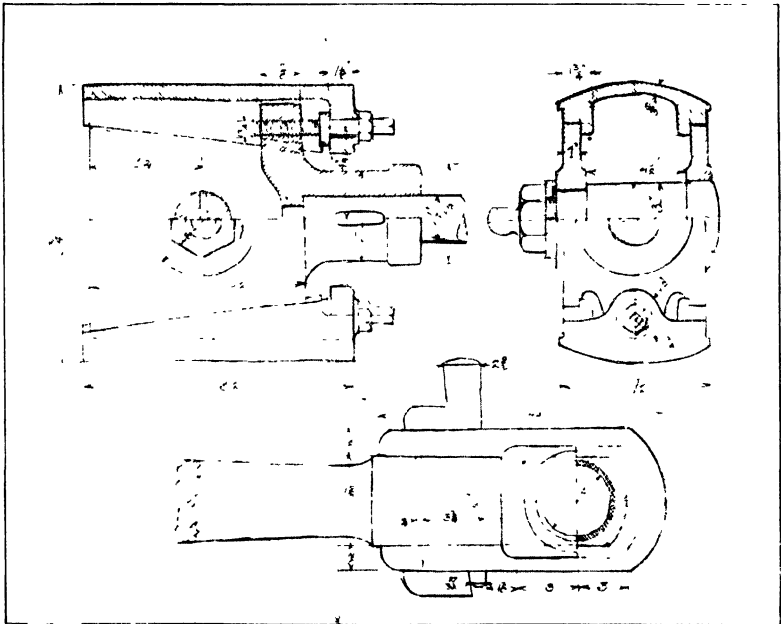

Fig. 7. Engine Details — Note how Straight Horizontal and Vertical Lines predominate in these Sketches

sketches. There are doubtless many mechanics who do not believe that they could make sketches, even after considerable practice, which would be as well proportioned as those shown in Fig. 7; and yet knowing how to draw straight parallel lines by guiding the pencil from each of the four edges of the pad is practically all that is necessary in making sketches of this kind, aside from the ability to judge distances between lines and the relative lengths of lines.

When lines are at an angle with the sides of the pad and the finger cannot be used for guiding the pencil, a good way to draw such lines is to look at the point on the paper where the line is to end and then move the pencil quite rapidly toward this point. When drawing lines of this sort, a bold and fairly rapid stroke is better than a slow, hesitating movement. The eyes should be fixed on the place where the line is to end instead of following the pencil point. With a little practice, diagonal lines that are quite straight can be made in this way.

Proportioning the Parts of the Sketch. — When a mechanical drawing is being made, the length and position of the lines depend upon measurements; but when making a sketch of some mechanical device or machine part, judgment regarding the relative sizes of the different details is needed to secure the proper proportions, although, as previously mentioned, one's judgment can be greatly aided by proceeding in the proper way. As an illustration, assume that a sketch is to be made which represents a side elevation of a planer. A good way to begin this sketch would be first to draw the long lines representing the bed, by guiding the pencil from the edge of the pad. The length of the lines would be governed entirely by the size of sketch wanted. The vertical lines which represent the front side of the housing would then be drawn to a height proportional to the length of the bed. That is, if the housing of the planer being sketched is judged by the eye to be about one half as high as the bed is long, the height of the vertical lines should be one half the length of the horizontal lines. Other important parts can be proportioned in the same way. After the large parts have been sketched to about the correct proportion by this comparative method, it will be found quite easy to draw the details somewhere near the right size. This idea, as applied to sketches generally, may be summarized as follows: Draw the long or "foundation" lines first and then it will be comparatively easy to sketch in the details.

There is a decided advantage in making the principal lines fairly accurate and straight, not so much to secure neatness

as accuracy of proportion. A drawing can be quite rough and "sketchy" and still be a good representation of the part drawn, provided the proportion is somewhere nearly correct. This is illustrated by the fact that when a mechanical drawing which has been made by the use of instruments is traced free-hand on transparent paper, the lines may be rough and uneven, but the drawing has a good appearance, nevertheless, because the proportions are accurate.

Free-hand sketches should not be relied upon too much, particularly when they are used in originating new forms of

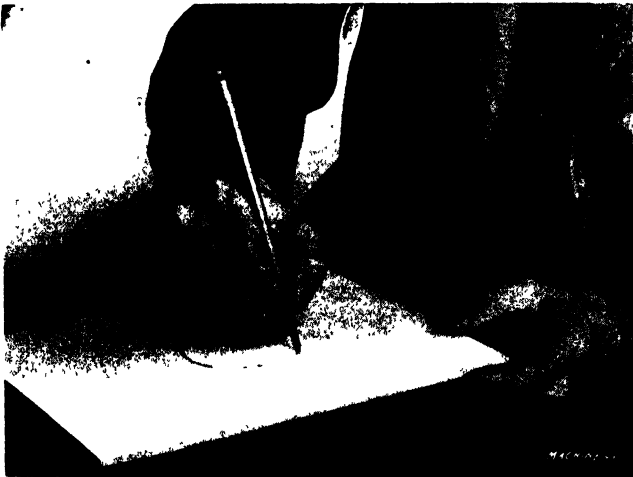

Fig. 8. Drawing a Circle by turning Pad beneath Pencil which is pivoted between Knee and Little Finger

mechanism or designs which are rather complex. As every machine designer knows, sketches are often very deceptive. Sometimes a certain design or arrangement seems to be entirely practicable, when seen as a crude sketch, but a drawing which is accurate to scale shows clearly that some other plan must be adopted. For this reason, any method of sketching which tends toward greater accuracy without waste of time is desirable.

Drawing Circles without Instruments. — Thus far nothing has been said about drawing circles, and unfortunately some



Fig. 9. Joint of Little Finger used as Pivot when drawing the Larger Circles



**Fig. 10. Top View of Pad upon which Circle is being drawn—
Note Accuracy of Circle**

sketches require circular as well as straight lines. It is rather difficult to draw, free-hand, what, even in the spirit of charity, might be called a circle; but circles can be drawn quite satisfactorily by the method illustrated in Figs. 8, 9, and 10. The circle is drawn by turning the pad around instead of the pencil. The pad is supported on the knee, and the little finger of the hand holding the pencil, supports the hand and should be directly over the knee to act as a pivot



Fig. 11. Drawing Arc of Large Radius by using Elbow as Pivot

for the pad. The end of the finger may bear against the pad, as shown in Fig. 8, but for the larger circles some prefer to form a pivot by bending the finger so that the first joint rests upon the pad as in Fig. 9. It is necessary to apply some pressure in order to prevent the hand from shifting relative to the pad which is turned around by the other hand. Figure 10 shows how accurately a circle may be drawn by this simple method. Circles of different diameters may be drawn by

varying the distance between the pencil and the little finger. This method of drawing a circle is very convenient, although it requires some practice. Quite accurate circles may also be drawn by this method upon a single sheet of paper. The latter is placed upon a table or board and is slowly turned about the point where the little finger holds the paper in contact with the board.

When a large circle forms a prominent part of a sketch it is better to draw it first, as the other details can then be located and proportioned with reference to the circle. For

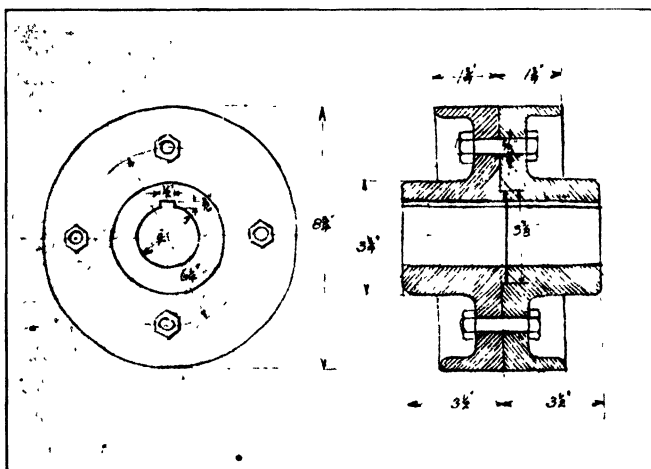

Fig. 12. Sketch of Flange Coupling

example, when making a sketch of the coupling shown in Fig. 12, the circle representing the outside of the coupling should be drawn first. A center line is then drawn through the circle, and in this way the sectional view is located quite accurately in relation to the circle. If an attempt were made to draw the center line first and then the circle, it might prove difficult to locate the center of the circle exactly on the center line when the circle is drawn by the method illustrated in Figs. 8 and 9. The sketch of this coupling, as well as the other sketches shown in connection with this article, were drawn by following the methods described.

The gearing sketch shown in Fig. 13 is another example intended to illustrate the possibilities of drawing circles without the use of instruments. A simple sketch of this kind might be much less accurate than the one shown and still meet all practical requirements, although if a neat and well-proportioned sketch can be made without special effort and unnecessary waste of time, it is certainly preferable. Besides, as pointed out before, a reasonable degree of accuracy is often

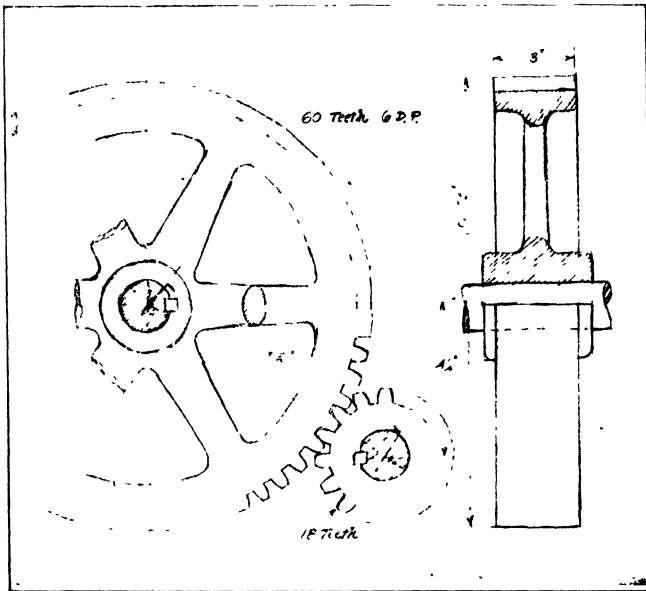

Fig. 13. Sketch of Spur Gear and Pinion

essential. The outer circle or arc representing the outer ends of the gear teeth in Fig. 13 does not vary more than about $\frac{1}{32}$ inch from a true arc on the original sketch, and it was drawn by the method previously described. When making a sketch of this kind, it is easy to locate the side view at the right by simply drawing light projection lines across from the end view.

If an arc of quite large radius is required, the elbow can be used as a pivot for the pencil, as demonstrated in Fig. 11.

The elbow rests upon a table or desk and the pencil strikes an arc having a radius which is about equal to the length of the forearm. This method was employed for drawing the curved lines which form the body of the jack shown by the

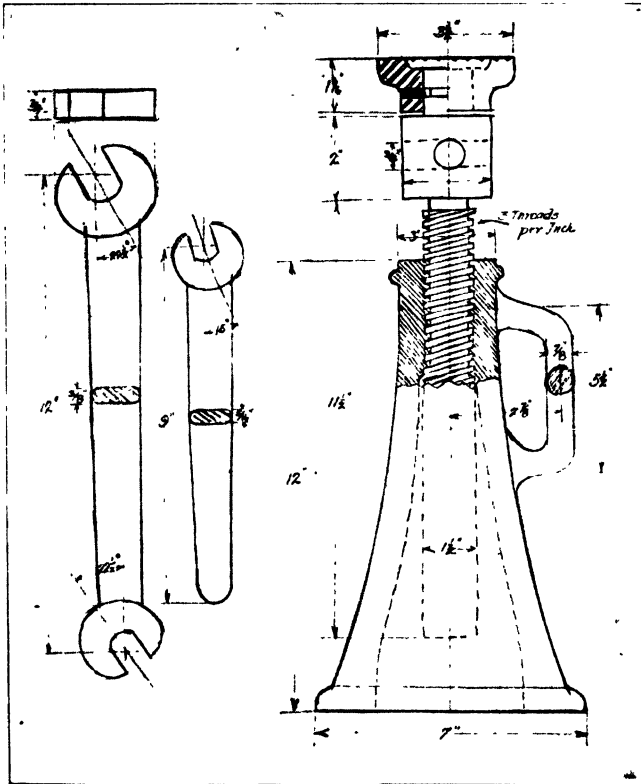

Fig. 14. Sketch of Wrenches and Screw Jack — Curved Lines of Jack Body are drawn by Method illustrated in Fig. 11

sketch, Fig. 14. After drawing a center line and lines representing the top and base of the jack body, these arcs are struck and then it is easy to fill in the smaller details and secure a well proportioned sketch.

Use of Sketches in Tool and Jig Design. — Tool designers use sketches to advantage when laying out tools, jigs, or fixtures for new work. For instance, in connection with

turret lathe practice, rough sketches are often made to show possible arrangements of the toolꝑ in order to determine as quickly as possible the most effective method of making whatever part is to be produced. Any special arbor chuck or work-holding fixture would also be included in the sketch. In many cases, these rapidly drawn sketches, especially if fairly accurate, serve the same purpose as accurate scale drawings.

When developing the design of a jig or fixture, sketches are particularly valuable. Often a sketch which is made in a few minutes shows that an idea which seemed at first thought to be good, is entirely impracticable. On the contrary, if the design appears to be satisfactory, a scale drawing showing the exact arrangement of the different parts can be made from the sketch by a draftsman who has not had the experience or training to develop original designs. As the design of many special tools and of jigs and fixtures depends upon the shape of the work, the preliminary sketches should be made around a drawing of the part for which the tool or jig is intended. Ink or a colored pencil may be used for this outline drawing of the work to secure greater contrast with the sketch of the tool or jig itself. It may be advisable to make a fairly accurate drawing of the work. Sometimes cross-sectioned paper is especially useful when developing the designs of new tool equipment, in order to insure greater accuracy in sketching. The squares on the paper serve as units of measurement and the sketch may be drawn almost as accurately as when instruments are used.

Perspective Drawings. — Perspective drawings are frequently used in machinery catalogues, in technical magazines or books, and for other purposes when the main object is to show a picture of a mechanism rather than an accurate representation of it as seen from different sides. An example of a perspective drawing is shown in Fig. 15. This drawing shows part of the mechanism of an automatic screw machine. It illustrates the arrangement of some of the gearing and other parts very clearly, and for this purpose is superior to a mechanical drawing. Perspective views of this kind are often

used in conjunction with the written description of a mechanism to represent pictorially the relation between important parts.

The elementary principles governing the construction of perspective drawings are illustrated in part by the sketches in Fig. 16. If the rectangular shaped object shown were observed with the eyes on the same level as the "horizon line" ab , the object would appear as shown by sketch A ,

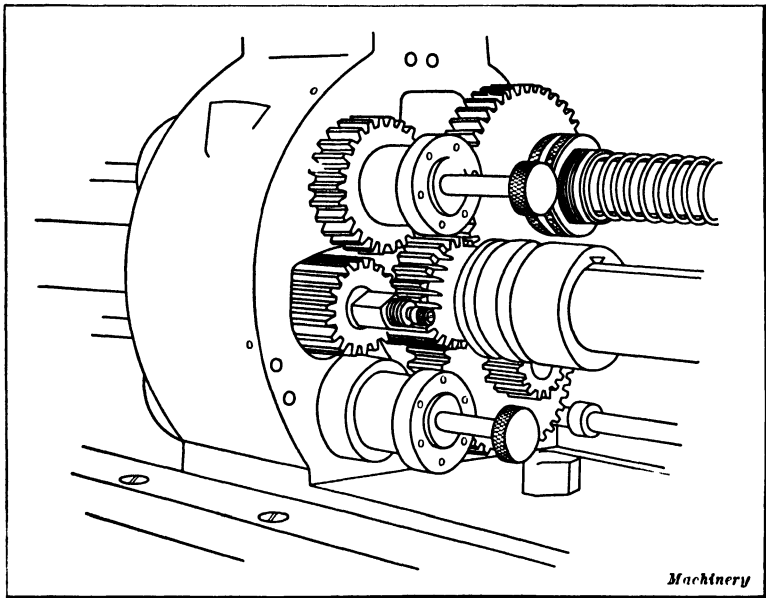

Fig. 15. Perspective Drawing used to illustrate Part of the Mechanism of an Automatic Machine

but if it were seen from the level indicated by line cd , the appearance would change, as shown by sketch B . It will be noted that lines on the object which are actually parallel gradually converge, because in this case the object is seen at an angle; as the parallel lines recede, they naturally appear to incline inward or toward each other. If these lines are extended on a drawing as shown by the dotted extension lines, they will intersect at a given point. Thus one group of horizontal lines intersect at b in sketch A and the other group

intersect at *a*. These points where the lines meet are known as “vanishing points” and their position relative to the object depends upon the position of the horizon line and the position of the object itself. The object shown in Fig. 16 is inclined so that the front edges and sides are not parallel to the “picture plane” or the plane of the paper; consequently the lines converge toward the respective vanishing points. This vanishing of lines which recede from the picture plane is the basis of perspective drawing. It will be noted that the vertical lines are parallel, which is due to the fact that they are parallel to the picture plane. The horizontal lines would also be

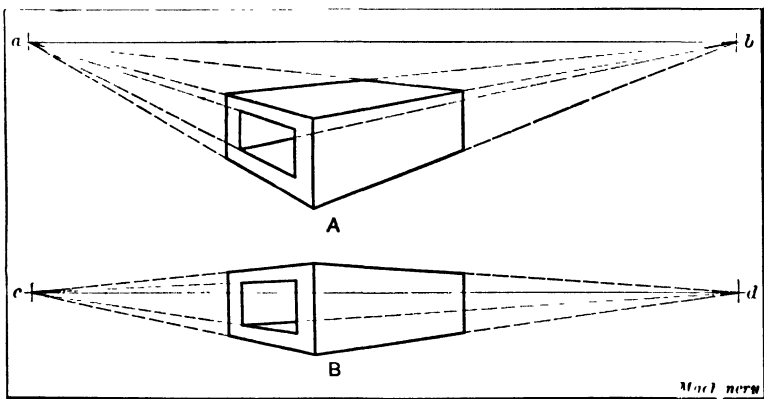

Fig. 16. Simple Diagrams illustrating the Principle of Perspective Drawing

drawn parallel, if they were parallel to the picture plane. It is because of this vanishing or receding effect of the lines on a perspective drawing that the impression of distance is given by such drawings.

Most perspective drawings, such as are used in machinery catalogues, etc., are drawn in such a position that the surfaces of one end, one side, and the top of the object are seen and the principal horizontal lines of the drawing vanish at two points, as in the case of the simple example shown in Fig. 16. Such a drawing is defined as a “two-point perspective” to distinguish it from the “one-point perspective” which represents an object in such a position that one of the

principal groups of horizontal lines is parallel and the lines of the other group incline toward the vanishing point.

All perspective drawings are not made strictly according to the rules governing perspective. These modified forms are sometimes the result of merely judging the location of certain lines, or of the vanishing points; the perspective may also be deliberately changed to represent more clearly some detail which would otherwise be partly or entirely concealed.

Method of Making a Perspective Drawing. — The theory of perspective is that, if rays or straight lines were extended from points on the object to the eye of the observer, and if the picture or perspective drawing were interposed in the right position, the lines would coincide with points on the drawing corresponding to similar points on the object itself. This fact will be more apparent by referring to Fig. 17. In this illustration, which shows how a perspective drawing is made, a plan view of a die-block is drawn at the upper part of the illustration, and beneath this plan view there is a line AA . The method of making the perspective drawing will doubtless be clearer, if the student first thinks of this line AA as the edge of a pane of glass placed perpendicular to the plane of the paper, and the point E as representing the eye of the observer.

Now, if straight lines are drawn from each important point on the plan view to the "point of sight" E , it is apparent that these lines will intersect the flat glass surface. For instance, line CE intersects it at D ; line FE , at G , and so on for all the other lines which might be drawn. It is also evident that if a perspective view of this die-block were drawn upon the flat surface of the glass plate, the edge of which is represented by line AA , point C would be located at D on the drawing, point F , at G , point H , at I , etc. When actually making a perspective drawing, since the latter is in the same plane as the plan view, these points, such as D , I , and G , are first located at line AA and are then projected downward, thus establishing certain lines and points on the perspective view.

The first step is to draw line AA and the plan view which

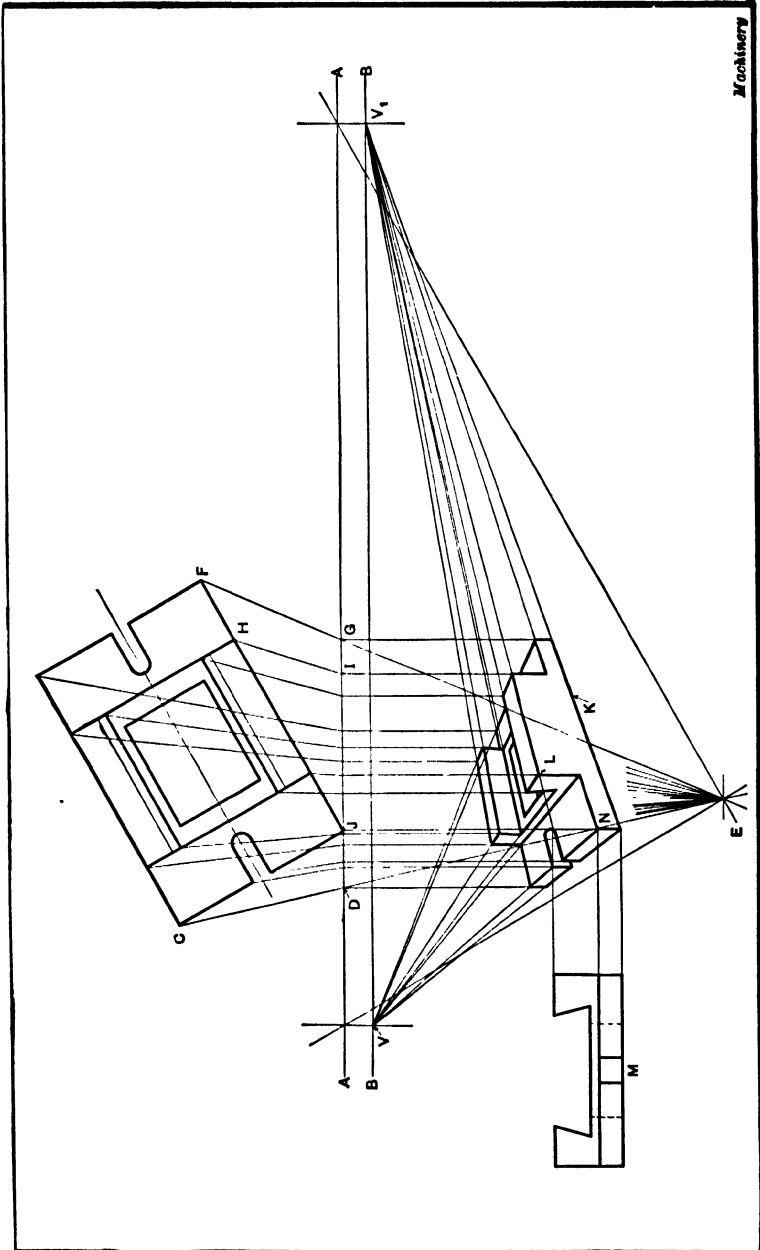

Machinery

Fig. 17. Method of making a Perspective Drawing of a Die-block

is placed at any desired angle. In this case side JF in the plan view is located at 30 degrees from line AA , so that the perspective drawing will show the side and end surfaces. The line AA is drawn close to the plan view, because if this line were considerably below the plan view, the size of the perspective drawing would be reduced accordingly. For instance, with such an arrangement, the distance between the intersecting points D and G would be less and the entire perspective drawing would be smaller. The point of sight E is next located somewhere below the plan view. It should preferably be some distance from the plan view, as otherwise the perspective will have a distorted appearance. A line is now drawn from E parallel to line JF in the plan view and up far enough to intersect line AA . Another line is drawn from E parallel to line JC , thus establishing another point of intersection on line AA . The horizon line BB is now drawn. The location of this line relative to the plan view and to the point of sight E depends upon what surfaces are to be shown in the perspective drawing. In this case, the horizon line is located considerably above the point of sight; consequently, the perspective view will show the upper surfaces of the die-block. If a view of the bottom surfaces were required, the horizon line would be placed below point E . The lines FE , CE , HE , etc., are next drawn from the various important locating points on the plan view to the point E . These lines need not extend beyond line AA , but they should all incline toward point E . At the points where these diagonal lines intersect AA , vertical lines are extended downward through the space where the perspective view is to be drawn. The vanishing points V and V_1 are located on the horizon line BB opposite the points where the lines from point E intersect AA .

Now that these vanishing points and the vertical lines have been located, the perspective may be drawn readily. The bottom line K intersects the vertical line extending downward from corner J and inclines toward the vanishing point V_1 . It will be noted that all the other lines in this group also incline toward V_1 and terminate at the vertical lines

which extend downward from corresponding points on the plan view. For instance, the line representing one edge of the upper surface of the die-block terminates at L , because the vertical line at L is the one extending downward from the corner corresponding to point L in the plan view. The terminating points of the group of lines which incline toward vanishing point V are also located with reference to these vertical lines projected downward from the plan view. It is necessary to determine the vertical location of these intersecting points, such as N and L . The corner J (see plan view) lies in the picture plane, assuming that line AA represents the edge of this plane; hence, lines in the perspective drawing representing the base of the die-block are located the true distances apart, as measured along the vertical line extending downward from corner J . This is shown by the dotted line projected from the end view M , to point N . This end view is not absolutely necessary in this case, but it has been inserted to illustrate more clearly how a point, such as L , is determined. This point L is not the true distance above the base line K , because it lies back of the picture plane. To locate point L , the true height of the die-block is projected from view M to the line extending downward from J , and then a diagonal line is drawn to the vanishing point V_1 . In this way, the intersecting point at L is determined. This same principle may be applied in locating the lines in a vertical direction on other perspective drawings. Students should practice the making of perspective drawings of different parts shown in orthographic projection, beginning with comparatively simple examples.

Isometric Drawing.—What are known as “isometric” drawings are commonly used in preference to ordinary perspective drawings, especially in connection with mechanical work. These isometric drawings can be made more easily and rapidly than perspective views, and they are used quite extensively for such purposes as illustrating the arrangement of a system of piping or other lay-outs when it is desirable to show in one view all that is necessary for obtaining esti-

mates, or even for the actual work of erection or construction. The difference between a perspective and an isometric drawing will be seen by comparing the perspective drawing of a die-block, Fig. 17, with the isometric drawing of the same die-block in Fig. 18. In the isometric drawing, the two groups of lines corresponding to the horizontal edges of the object do not incline toward vanishing points as in a perspective, but are parallel. The parallel lines representing these horizontal edges are all drawn at an angle of 30 degrees from a

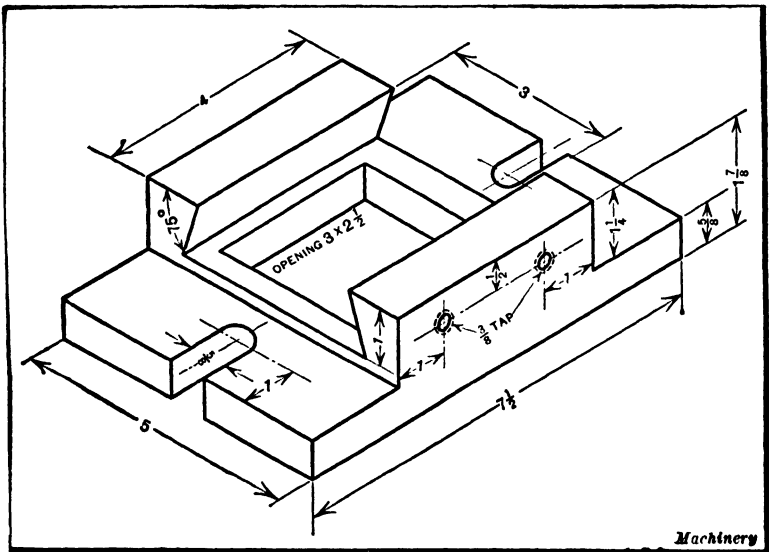

Fig. 18. Isometric Drawing of the Die-block shown in Perspective in Fig. 17

true horizontal line, and they incline upward toward either the right or the left, depending upon whether they represent the end or side of the object.

As shown in Fig. 18, the end lines incline upward toward the left and the side lines, upward toward the right, but they are all at an angle of 30 degrees from a horizontal line and do not converge as in the case of a perspective. These inclined lines and the vertical ones constitute three groups which are used to represent the length, width and thickness of the object in a single view. Any line belonging to one of these three

groups is known as an "isometric line," and all distances on these lines are, according to the usual method, laid off to the true dimensions, although, strictly, the length should be reduced on account of the foreshortening effect an amount equal to a little over 0.8 of the true length.

In order to facilitate the making of isometric drawings, special ruled paper is sometimes used. This paper has, in addition to the regular horizontal and vertical cross-section

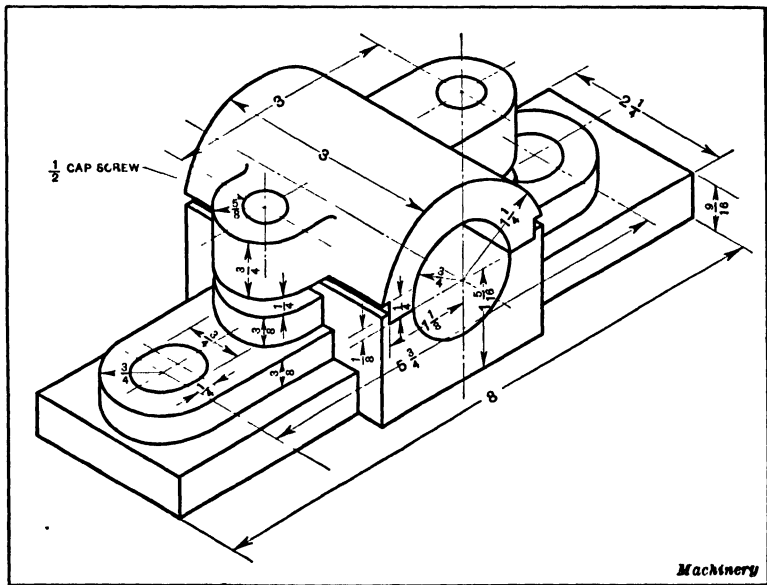

Fig. 19. Isometric Drawing of a Pillow-block

lines, diagonal lines inclining in each direction at an angle of 30 degrees to the horizontal. Such paper is especially desirable for making free-hand sketches. For example, if a sketch of the die-block shown in Fig. 18 were made on an isometrically ruled pad, practically all of the lines could either be traced directly upon the ruled lines of the pad or be drawn parallel to these ruled lines when the latter were not located in exactly the right positions.

Representing Circles on Isometric Drawings. — Circles are represented on isometric drawings as ellipses, as illustrated in

Fig. 19, which shows a pillow-block, and also in Fig. 20 which shows a shaft coupling partly in section. The ellipses on such drawings can be formed quite neatly with a little practice when isometric drawings are made free-hand on ruled pads. If the drawing is to be made by means of instruments, the construction of an ellipse requires more time, although it can be drawn easily by the method to be described, which is accu-

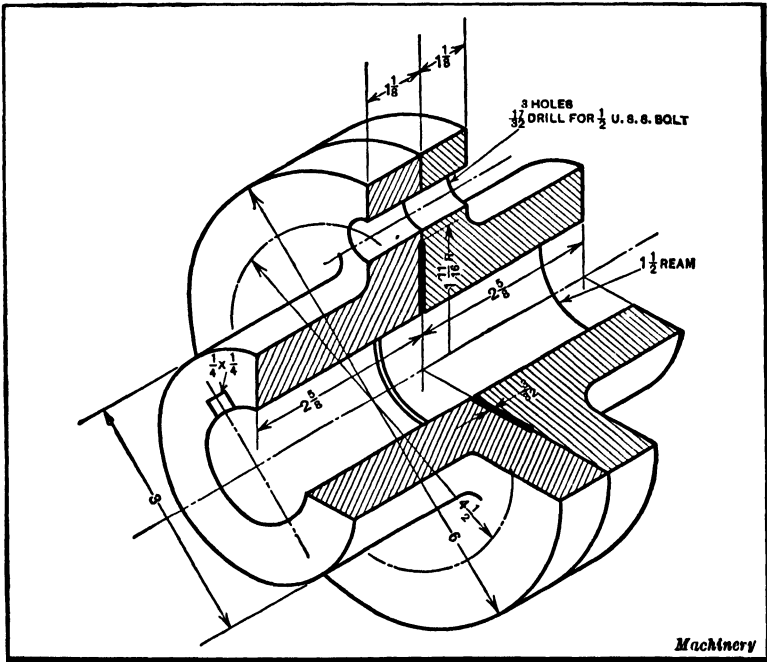

Fig. 20. Isometric Drawing of a Shaft Coupling

rate enough for practical purposes. This method will be illustrated by taking the coupling drawing as an example.

The method of procedure is illustrated in Fig. 21. An isometric drawing of a square is first made, as shown to the right. The length of the sides of this square is equal to the diameter of a circle. The large arcs are drawn from centers *A* and *B* with a radius *R* and the smaller arcs, from centers *D* and *C* with a radius *r*. In this case, two of these diagonal lines are horizontal and the other two are drawn with a 60-

degree triangle. The relation between this square and the drawing of the coupling is shown by the view to the left. It will be noted that the diagonal line intersecting centers *A* and *B* corresponds to the axis of the coupling. In this particular illustration, the ellipse represents the outline of a circular surface (side of the coupling) which lies in a vertical plane. If the circular surface were in a horizontal plane, the same method of drawing the ellipse would be employed, although

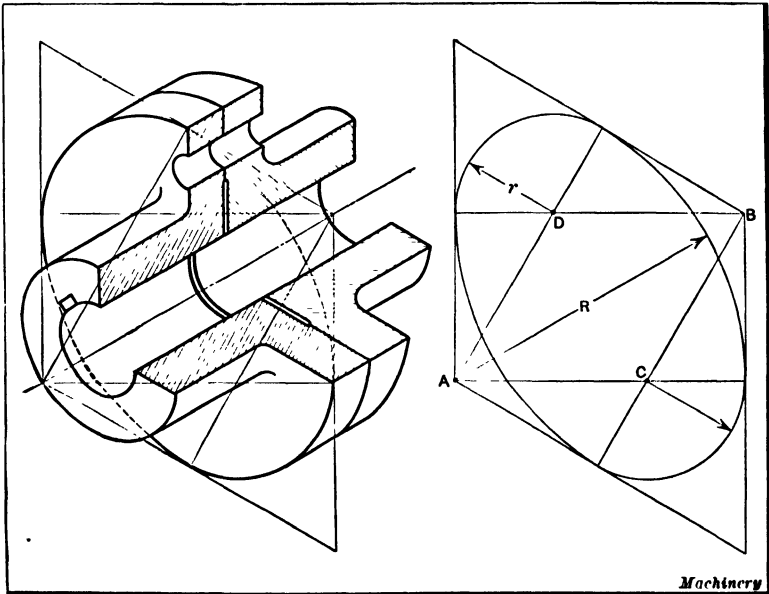

Fig. 21. Method of drawing Ellipses on Isometric Drawings

the square would be in a different position. If Fig. 21 is turned around to the right until the axis of the coupling is vertical, the circular surface will then be represented in a horizontal plane and the relation of the square to the ellipse in this position will be apparent. The diagonal lines of the square will now be at an angle of 60 degrees with the horizontal and they may be drawn by using a 60-degree triangle. These isometric drawings are easily understood and, when properly dimensioned, may be used as working drawings, especially for representing comparatively simple parts.

INDEX

- ABBREVIATIONS**, used on working drawings, 168
- Allowance, tolerance and limit**, defined, 142
- American standard cap-screws**, 211
- American standard machine screws**, 208
- American standard screw threads**, 206
- Angles and tapers**, designating, 158
- Assembly drawings**, classes of, 74
- BASE-LINE**, dimensioning, 151
- Basic dimension**, 142
- Beam compass**, 36
- Bevel gears**, working-drawings of, 230
- Bilateral and unilateral tolerances**, 143
- Blue- and brown-line prints**, 184
- Blueprinting**, electric, 186
- Blueprinting frame**, 182
- Blueprinting machines**, 186
- Blueprint paper**, kinds of, 184
- Blueprints for patternmakers**, 92
- issuing and storing, 287
- making, 182
- mounting, 195
- provision for folding, 293
- record of, 283
- Bolt and nut standards**, 213
- Bolts and screws**, 206
- Bolts, machine**, 212
- American standard, 213
- U. S. standard, 213
- Bond paper**, use instead of tracing cloth, 89
- Briggs standard pipe thread**, table, 221
- Bristol board**, 61
- Broken sections**, 105
- Brown- and blue-line prints**, 184
- CAM** curves for avoiding shocks at high speed, 248
- for harmonic motion, 248
- for uniformly accelerated motion, 248
- modification, pivoted follower, 252
- Cams, cylindrical**, design of, 246
- designing or laying out, 235
- face, design of, 243
- lay-out for roller on follower, 237
- lay-out when follower is off center, 239
- lay-out when follower is pivoted, 239
- plate, arranged for positive drive, 244
- plate, having tangential follower, 255
- plate, having uniformly accelerated motion, 253
- return, use of, 245
- Cap-screws**, 211
- Card index**, see "Index"
- Celluloid templates**, 46
- Center lines**, 82
- Center-to-center dimensions for locating holes**, 154
- Changes on drawings**, record of, 286
- Checking drawings**, 176
- Checking list for die drawings**, 179
- Circles**, dividing into given number of equal parts, 37
- drawn without instruments, 321
- drawn with spring bow instruments, 32
- drawn with the compass, 34
- instruments for drawing, 31
- Classification of parts by symbols or numbers**, 289
- Cloth, tracing**, 62
- Commercial parts**, specifying, 295
- Compass**, 33
- Compass, beam**, 36
- Conical shapes**, development of, 271

- Conventional methods of representing screw threads, 200
- Cost of production, effect on design, 93
- Court decisions as to property rights in engineering drawings and data, 97
- Cross-sectional shapes, simple method of showing, on drawing, 126
- Cross-section paper, 61
- Cross-slide and angular methods of dimensioning, 156
- Curves, cycloidal, drawing, 264
 involute, 262
 involute, drawn accurately, 263
 irregular, 43
- Cycloidal curves, drawing, 264
- Cylinders, intersecting, of unequal diameters, 270
- Cylindrical cam, design of, 246
- D**ESIGNING a new mechanism, preliminary work in, 70
- Designing or laying out cams, 235
- Designs, how originated, 70
 improving after mechanism is constructed, 95
- Detail drawings and general views, 8
- Detail drawings, when required, 76
- Details, sectional views of, 113
 machine, drawings of, 197
 screw thread, 198
- Development of an elbow, 267
- Development of conical shapes, 271
- Dimension, basic, 142
- Dimension lines, 82
- Dimensioned drawings, examples of, 136
- Dimensioning, angular and cross-slide methods, 156
 base-line method of, 151
 drawings to metric system, 167
 drawings, examples of correct and incorrect, 147
 drawings, standard rules for, 135
 drawings when there are tolerances, 145
 working drawings, methods of, 130
- Dimensions, arrangement of, for locating holes, 149
 center-to-center, for locating holes, 154
 on one drawing for parts of different sizes, 165
- Dividers, 36
 plain, hairspring, and combination, 38
 proportional, 38
- Dotted lines, use of, to show interior or concealed surfaces, 19
- Drafting fabric, opaque, 65
- Drafting machine, 50
- Drafting-room lighting, 302
- Drafting-room systems, equipment and arrangement, 273
- Drafting tables, 56
- Drafting tools, set of, 48
- Draftsman, difference between designer and, 3
 value of shop experience, 94
- Drawing-boards, 53
 parallel attachment for, 55
- Drawing-paper, cross-section, 61
 considerations in selecting, 62
 sizes and kinds, 58
- Drawing pencils, 66
 sharpening, 67
- Drawing problems, geometrical, 257
- Drawing-room equipment and arrangement, 300
- Drawings, assembly, classes of, 74
 checking, 176
 filing, general system of, 274
 free-hand, 310
 isometric, 333
 of parts for which tolerances are specified, 137
 perspective, 327
 procedure in making, 70
 sizes of, 77
 special, for patternmakers, 91
 standardization of, 135, 181
 tabulated, 161
 uses of different classes of, 73
- Drying and ironing machine for blueprints, 189

- Drying blueprints after washing, method of, 193
- Duplicate orders, index used for, 280
- ELBOW**, development of an, 267
 three-piece, development of, 269
- Electric blueprinting machines, 186
- Ellipse, approximate method of drawing, 258
 drawing an, 257
 straightedge or trammel method of drawing, 259
- Ellipsograph, the, 259
- Epicycloid, the, 265
- Equipment of drafting-rooms, 273
- Erasing pencil and ink lines, 68
- Errors on drawings, why costly, 175
- Extension or reference lines, 33
- FACE** cam, design of a, 243
- Filing drawings, system of, 274
- Filing folded blueprints, 294
- Filing tracings, method which eliminates card index, 297
- Finish marks, 169
- Finish, symbols indicating kind, 170
- First- and third-angle projection, 16
- Fittings for pipes, 221
- Folding blueprints, provision for, 293
- Follower, cam lay-out for roller on, 237
 off center, cam lay-out for, 239
 pivoted, cam lay-out for, 239
- Frame for blueprinting, 182
- Free-hand sketching, 310
- French curves, 43
- GEARING**, drawings of, 224
 worm-, detail drawing of, 232
- Gears, bevel, working drawings of, 230
 spiral, drawing of, 234
 spur, methods of drawing, 225
 spur, working drawings of, 226
- Geometrical drawing problems, 257
- HAIRSPRING** dividers, plain, and combination, 38
- Harmonic motion, cam curves for, 248
- Helix, construction of a, 261
- Hypocycloid, the, 266
- ILLUMINATION** experiments, 305
- Index, card, based on classes of machines, 276
 eliminated by method of filing tracings, 297
 for jobbing shops, 279
 for locating drawings, 275
 used for duplicate orders, 280
- Index guides, in card index, 282
- Ink and pencil drawings, 27
- Ink used by draftsmen, 68
- Instruments and materials, 27
- Instruments, drafting, set of, 48
- Intermittent motion, cam designed for 241
- Intersecting cylinders of unequal diameters, 270
- Intersecting surfaces, development of, 269
- Involute curve, 262
 drawn accurately, 263
- Irregular curves, 43
- Isometric drawings, 333
 representing circles on, 335
- KEYS**, machine, 218
- LAYING** out a curve for uniformly accelerated motion, 251
- Lead and pitch of screw thread, 199
- Lettering, 174
- Lighting, an approved system of, 307
 for drafting-room, 302
 prevalent methods of, 303
- Limits, designating, on drawings, 145
 drawings of parts having, 137
- Limit, tolerance and allowance, defined, 142
- Lines, different kinds of, 81
 shade, on drawings, 84
- List of parts, 290
- Locating drawings by card index, 275
- MACHINE** bolts, 212
- Machine details, drawings of, 197
- Machine, drafting, 50

- Machines, blueprinting, 186
- Machine screws, 208
- Manufacturing problems, relation to design, 95
- Materials and instruments, 27
- Mechanical drawings, classification, 6
number of views, 14
- Metric system, drawings dimensioned according to, 167
- Mounting blueprints, 195
on cloth, 196
- Multiple threads, designating, 199
- NEGATIVES** and making prints from negatives, 184, 185
- Notes, explanatory, on drawings, 171
- Nut and bolt standards, 213
- OBSOLETE** prints, replacement of, 298
- Opaque drafting fabric, 65
- Operation sheets, 290
- Origination of designs, 70
- Orthographic projection, 10
method, principle of, 13
simple examples of, 17
- PAPER**, for blueprinting, 184
tracing, 62
used by draftsmen, 58
- Parallel attachment for drawing boards, . 55
- Part lists, 290
- Parts, designating by symbols and numbers, 288
- Patternmakers, special drawings for, 91
- Patterns and templets, development of in sheet-metal work, 266
- Pencil drawing, making the, 86
- Pencils, drawing, 66
- Pencil, spring bow, 31
- Pen, ruling, 28
spring bow, 31
- Perspective drawings, 327
method of making, 330
- Pipe fittings, 222
- Pipe threads, 221
- Piping, drawings of, 223
- Plate cams, arranged for positive drive, 244
having tangential follower, 255
having uniformly accelerated motion, 253
- Printing titles on drawing, 173
- Prints, blue- and brown-line, 184
obsolete, replacement of, 298
- Profile paper, 62
- Projection, orthographic, 10
simple examples of, 17
- Projection, third-angle and first-angle, 16
- Proportional dividers, 38
- Proportioning parts of a sketch, 320
- Protractors, 42
- Punch and die drawings, checking list for, 179
- READING** mechanical drawings, 121
- Records, of assembled units, 296
of blueprints, 283
of changes on drawings, 286
of drawings, 172
of sketches, 284
- Ribbed parts, sectional views of, 106
- Rules and instructions, general, for drafting-room system, 135, 285
- Rules, standard, for dimensioning drawings, 135
- Ruling pen, 28
drawing straight lines with, 30
- S. A. E.** standard screw threads, 208
- Scale, draftsman's, use of, 78
- Scales used by draftsmen, 47
- Screws and bolts, 206
- Screw thread details, 198
- Screw threads, representation on drawings, 200
- Sectional views, 98
of ribbed parts, 106
- Section lines, 103
- Sections, broken, 105
representing more than one cutting plane, 115
shown without use of section lines, 120
- Set-screws, 215

- Shade lines on drawings, 84
- Sheet-metal pattern drafting, 266
- Sizes of drawings, 77
- Sketches, how to proceed when making, 316
 record of, 284
 use of, in tool and jig design, 326
- Sketching, 310
- Spiral gears, drawings of, 234
- Springs, drawing, 223
- Spur gears, methods of drawing, 225
 stub-tooth, 229
 working drawings of, 226
- Square threads, drawing, 201
- Standardization of drawings, 135, 181
- Standards and drawings of machine details, 197
- Standard screw threads, American, 206
- Standard screw threads, S. A. E., 207
- Standard tolerance systems, 144
- Storing and issuing blueprints, 287
- Stub-tooth spur gears, 229
- Studs, 217
- Symbols and abbreviations on drawings, 168
- Symbols and numbers, classification of parts by, 289
 systems of designating parts by, 288
- T**ABLES, drafting, 56
- Tabulated drawings, 161
- Tangential follower for plate cam, 255
- Tapers and angles, designating, 158
- Tapped or threaded holes, representing, 204
- Templets, celluloid, 46
- Threads, American standard, 206
 in holes, representing, 204
 multiple, designating, 199
 pipe, 221, 222
 screw, representation on drawings, 200
 square, drawing, 201
- Thumb tacks, 65
- Titles and records required on drawings, 172
- Tolerance, limit and allowance, defined, 142
- Tolerance standardization, 144
- Tolerances, and manufacturing methods, relation between, 140
- Tolerances, drawings of parts with, 137
- Tolerances, methods of expressing, on drawing, 145
- Tolerances, unilateral and bilateral, 143
- Tool drawings, tabulated, 162
- Tools, individual tracings of, 164
- Tracing cloth, 62
- Tracing paper, 62
- Tracings, making, 87
- Tracings of tools, individual, 164
- Triangles, 40
- T-square, 39
- Typewritten copy, blueprinting from, 196
- U**NIDRAFT, 65
- Uniformly accelerated motion, cam curves for, 248
 ellipse method of drawing curve for, 253
- Uniform motion, designing a cam for, 235
- Unilateral and bilateral tolerances, 143
- V**ANDYKE negatives, 184
- Vanishing points in perspective drawing, 329
- Views, number and arrangement of, 14
- W**ASHING, drying, and printing apparatus, 186
- Working drawings, explanatory notes on, 171
 instructions on, 168
 methods of dimensioning, 130
 without tolerances, 141
- Worm-gearing, detail drawing of, 232

DATE OF ISSUE

This book must be returned
within 3, 7, 14 days of its issue. A
fine of ONE ANNA per day will
be charged if the book is overdue.

	70)
	5
	17

PRESCRIBED AS A

TEXT BOOK

Not to be issued without permission.

LIBRARIAN.