

Birla Central Library

PILANI (Jaipur State)
Engg College Branch

Class No :- 690

Book No :- G83M v.2

Accession No :- 31826

Acc. No.

ISSUE LABEL

Not later than the latest date stamped below.

--	--	--

MODERN BUILDING
CONSTRUCTION

MODERN BUILDING CONSTRUCTION

A COMPREHENSIVE, PRACTICAL, AND AUTHORITATIVE GUIDE
FOR ALL ENGAGED IN THE BUILDING INDUSTRY

Edited by

RICHARD GREENHALGH

A.I.Struct.E.

ASSISTED BY MANY SPECIALIST
CONTRIBUTORS



IN THREE VOLUMES —VOLUME TWO

LONDON

SIR ISAAC PITMAN & SONS, LTD.

1948

✓
✓
690
G83M1

v.2
3/826

c/66
e/266
S

SIR ISAAC PITMAN & SONS, LTD.
PITMAN HOUSE, PARKER STREET, KINGSWAY, LONDON, W.C.2
THE PITMAN PRESS, BATH
PITMAN HOUSE, LITTLE COLLINS STREET, MELBOURNE
47 BECKETTS BUILDINGS, PRESIDENT STREET, JOHANNESBURG
ASSOCIATED COMPANIES
PITMAN PUBLISHING CORPORATION
2 WEST 45TH STREET, NEW YORK
205 WEST MONROE STREET, CHICAGO
SIR ISAAC PITMAN & SONS (CANADA), LTD.
(INCORPORATING THE COMMERCIAL TEXT BOOK COMPANY)
PITMAN HOUSE, 381-383 CHURCH STREET, TORONTO



THE PAPER AND BINDING OF
THIS BOOK CONFORM TO THE
AUTHORIZED ECONOMY STANDARDS

MADE IN GREAT BRITAIN AT THE PITMAN PRESS, BATH
D8--(1.8462)

CONTENTS OF VOLUME TWO

		PAGE
TRAINING OF CRAFTSMEN AND SPECIALISTS IN THE BUILDING INDUSTRY	H. BANNISTER A.R.I.B.A., A.R.C.A.	561
ROOF COVERINGS: Slates and Slating; Tiles and Tiling; Finishings; Asphalt and Bituminous Felt Coverings; Metal Roof Coverings	JOHN MILLAR F.S.I., M.I.Struct.E.	565
PLASTERING: Materials; Tools; Lathing and Wall Boards; Plastering Operations; Plasters; Plaster Mouldings	The late DANIEL WALKER	619
PAINTING AND DECORATING: Construction of Paint; Pigments; Painting; Distemper	CHARLES H. EATON F.I.B.D., F.R.S.A.	648
PAPERHANGING: Equipment and Preparatory Work; Wallpaper; Pasting and Hanging	CHARLES H. EATON F.I.B.D., F.R.S.A.	677
GLAZING	CHARLES H. EATON F.I.B.D., F.R.S.A.	693
PLUMBING: Tools; Materials; Pipe Joints; Pipe Bending; Water Supply; Cisterns; Water Fittings; Pipe Fixings; Hot-water Fitting; Water Pressure; Wells and Pumps; Roof Work; Chemical Works Plumbing; Prefabrication	PERCY MANSER R.P., A.R.S.I., <i>Honours Silver Medallist</i> <i>Revised by</i> A. C. MARTIN M.R.S.I.	703
GAS-FITTING: Gas Manufacture; Piping of Buildings; Methods of Measuring Gas; Gas as an Illuminant; Gas for Heating and Cooking; Gas for Heating Water	R. J. ROGERS <i>Chief Superintendent, Fittings Department, City of Birmingham Gas Department</i> <i>Revised and with additions by</i> R. A. WOODROOK	791
ELECTRICAL FITTING: Units and Layouts; Methods of Wiring; Circuits; Accessories, Fittings and Domestic Appliances; Bell and Telephone Work; Wire- man's Tools	The late CHARLES RAPHAEL M.I.E.E. M.Cons.E., F.I.E.S.	814

CONTENTS OF VOLUME TWO—*continued*

		PAGE
BUILDER'S OFFICE AND ROUTINE: Builder's Office; Buying; Accountant and Cashier; Contracts	R. F. GALBRAITH B.Sc. <i>Revised by J. H. BENNETTS</i> A.I.O.B.	840
BOOK-KEEPING, ACCOUNTING, AND COSTING: What is Book-keeping? Cash Book; Practical Summary; Final Accounts	ROBT. G. LEGGE <i>Author of "Builders' Accounts and Costs"</i>	856
ESTIMATING: Methods of Estimating; Cubing; Bricklayer; Pavior, Mason, Slater and Tiler; Carpenter and Joiner; Excavator, Concrete, Specialist Trades; Plumber; Plasterer; Painter, Paperhanger and Glazier; Completing the Estimate	HENRY A. MACKMIN F.S.I., M.I.Struct.E., M.R.San.I. <i>Author of "Builders' Estimates and Data"; Formerly Lecturer on Analysis of Pricing at The College of Estate Management, London, and Head of the Building Depart- ment, Croydon Polytechnic</i>	886
PRELIMINARY OPERATIONS: Preliminary Procedures of Building; Plant; Shoring and Underpinning; Foundations	R. V. BOUGHTON A.I.Struct.E.	921
SUPERINTENDENCE: Personnel; Office Equipment and Methods; Setting-out; Foundations; Concrete; Brick- work; Masonry; Slating and Tiling; Carpentry and Joinery; Smith and Founder; Plumbing, Plastering, Painting and Decorating	P. J. LUXTON <i>Member of the Incorporated Clerks of Works Association</i>	977
DRAINAGE AND SANITATION: Conservancy Systems; Water-carriage Systems; Traps, Chambers, and Gullies; Rain-water Utilization; Drains; Planning Drainage Systems; Internal Fittings; Sewage Purification	HENRY C. ADAMS M.Inst.C.E., F.R.San.I., etc.	1013
HEATING: Heat and Temperature; Methods of Heating; Layouts of Hot-water Systems; Hot-water Heating Apparatus	J. R. KELL A.M.I.Mech.E., M.I.H.V.E., M.Inst.F.	1065
VENTILATION: Properties of Air; Methods of Ventilation; Fans, Design of Ducts; Combined Heating and Ventilation	J. R. KELL A.M.I.Mech.E., M.I.H.V.E., M.Inst.F.	1087
PREFABRICATION	R. GREENHALGH A.I.Struct.E.	1109
EXAMINATIONS AND PROFESSIONAL QUALIFICATIONS	THOMAS CORKHILL F.B.I.C.C., M.I.Struct.E., <i>Double Medallist</i>	1118

INSET PLATES

Types of Coloured Slates	<i>Facing page</i> 565
Pile Foundations	" " 975
Blue-print Working Drawing	" " 977
Flow of Water in Pipes	" " 1078

PRINCIPAL ILLUSTRATIONS IN VOL. II

	PAGE
Slate Splitting	567
Boarding, Felt, Battens, and Counter Battens	571
Centre Nailing	573
Double-ridge Course	574
Graduated Slating	576
Varieties of Tiles	578
Section and Part Plan of Eaves	581
Section Through Ridge and Part Elevation at Verge	583
Lead Ridge	587
Flashings and Soakers to Chimney	593
Coverings and Roof Finishings to Dormer	594
Taper and Parallel Gutters	596
Details of Lead Gutters	597
Cross Sectional Elevation of Cesspool	598
Detail of Skirting on Timber Flat	600
Detail of Outlet through Parapet Wall	602
Methods of Laying Ruberoid	606
Detail of Valley Gutter	606
Alternate Method of Finishing Vulcanite	610
Details of Zinc Work	616
Plasterers' Tools	622
Plasterer Applying Mortar to Hy-rib	627
Double-mesh Herring-bone Metal Lathing	628
Section through Cement Gun	636
Nozzleman Shooting "Gunite" during Reconditioning of Douglas Pier, Isle of Man	637
Trough for Paint Brushes	655
Pound Brush and Sash Tool	656
Burning-off Lamp	657
Shavehooks	658
Stippling Brush	660
Examples of Painted Heraldic Work	670
Method of Combing Plastic Paint	676
Paperhanger's Equipment	679, 680, 681
Trimming Wallpaper with Scissors	686
Wheel Trimmers	686
Hanging Ceiling Paper	688
Types of Lead Cames	697
Types of Glazing Bar	698
Tools for Plumbers	702, 704
Reverberatory Furnace	708
Pipe Joints	714, 716, 723
Oxy-Acetylene Outfit for Lead Burning in Use on Sheet Lead	718
Malleable Iron Fittings for Use with Mild Steel and Wrought Iron Piping	721
Executing Bronze Welds	725
Pipe-bend showing Compressors in Position	727
M.W.B. Filter at Hampton	732
Arrangement of Main Stop-cock and Draw-off Taps	734
Syphon Flushing Cistern with Loose Valve	740
High Pressure Screw-down Bib Tap	745
Ball Valve Details	748
Arrangement of Pipes for a Suburban House	750

PRINCIPAL ILLUSTRATIONS IN VOL. II—*continued*

	PAGE
Storage Cistern and Connections	752
Paterson's Pressure Filter	754
Electrically Driven Pump and Storage Tank	755
Pipe Fixings	757, 758
Tank System	760
Combined System	765
Whitehall Sectional Boiler	766
Methods of Fixing Lead Sheetting to Woodwork of Roof	780
Section Through Drip, showing Capillary Groove	783
Effects of Using Soft and Rigid Flame in Lead Burning	786
Waste, Ventilation and Cold Water Service Pipes Made up Ready for Fixing	788
Waste Pipe Arrangements for one Floor of a Block of Flats	789
Denham Plumbing and Heating System Unit	790
View showing Interior Construction of Dry Meter	798
Construction of Brick Flues and Fireplaces	807
Layout in a Detached House	817
Three-way 15 amp. Fuse-board with Neutral Link for Testing Purposes	824
Distribution Board with Sub-boards on every Floor	827
William White 30-amp. D.P. Switch with S.P. Fuse and Neutral Link	828
G.E.C. Bakelite Ceiling Rose	831
Connections of Simple Bell Transformer	835
Bell and Indicator Connections	836
Tools for Builders	927
Sketch of Bricklayers' Scaffold	929
Bricklayers' Scaffold for High Building	930
Steel Wall Bracket	931
Joint Pins and Patent Couplers	933
Builder's Gantry	936
Constructional Details of Patent Adjustable Steel Gantry	937
Shores and Shoring Details	939, 940, 942, 943, 947, 949, 950, 951
Preparing Grounds for Bases of Structures	960
Designing Bases of Structures	965
Bases of Brick Walls	969
Reinforced Concrete Pile and Beam Foundations	974
Driver for Piles of Moderate Length	975
Earth Closets for Schools	1017
Cesspool Details	1018
Intercepting and Junction Chamber with Doulton's Fitting	1031
Petrol Intercepting Trap	1035
Ince's Apparatus for Separating and Collecting Clean Rain-water	1037
Drainage of Detached House	1049
One Pipe System of Sanitation	1052
Sanitary Fittings	1055
Panelled Bath	1058
Sunken Bath	1059
Septic Tank and Effluent Well for a Small House	1063
Panel Heating	1070
Pump Circulation showing Pump in Return	1076
Types of Radiator	1084
Method of Fixing Suspended Ceiling and Ventilation Ducts from Concrete or Hollow Tile Floor	1090
"Vento" Cast-iron Heater Battery	1098
Self-cleaning Oil Filter	1100
Resistance in Duct Systems	1105
Demountable House	1109
Prefabrication of Homosote Wall Section	1110
Vertical Section showing Construction of Two-storey House by Homosote System	1111
Isometric Sketch showing the General Construction of the Seco House and how the Panels	1111
Support the Loads	1113

MODERN BUILDING CONSTRUCTION

TRAINING OF CRAFTSMEN AND SPECIALISTS IN THE BUILDING INDUSTRY

By H. BANNISTER, A.R.I.B.A., A.R.C.A.

THE basis of proficiency in any craft lies in aptitude, sound training, and diligent study. Assuming that a boy enters a craft of his own choosing, the building industry to-day offers him unparalleled chances of advancement provided he is trained on the right lines. If he is prepared also to master some of the practical and theoretical aspects of other crafts that impinge on, or are related to his own, the opportunities for advancement become even wider. The purpose of this contribution, however, is not to dwell on the opportunities awaiting entrants to the building industry—they are too obvious—but to outline the methods by which craftsmen and specialists can obtain the training that will fit them to grasp those opportunities.

Junior Technical School in Building. This course of training has proved itself, during the last twenty years, and a study of its scope and method will well repay the parent of any boy of thirteen years, which is the age of entry to one of these Technical Schools. The schools of this type generally offer a course extending over three years; but the courses at the schools, which Local Authorities are now establishing throughout the country, are to be of two years' duration only. The work of these schools can be divided into general education and technical education; but in the carrying out of the work in the school, the two parts are carefully woven together to make a complete scheme.

GENERAL EDUCATION. The subjects taken in this section include English, Mathematics, and Science, all of which are taught as in a Secondary School. English includes History, Geography, and Literature; Mathematics is divided into Arithmetic, Algebra, Geometry and Trigonometry; and Science includes Chemistry and Physics. In the teaching of all these subjects, examples and illustrations are chosen from a wide field relating to building.

TECHNICAL EDUCATION. Here, Art and Tech-

nical Drawing are taught, the latter subject being divided into Building Construction and Practical Geometry, including the main crafts of the industry, with the technology that is part of each craft. The trades usually covered are Carpentry, Joinery, Brickwork, Plumbing, and Decoration.

Physical training and games form part of the curriculum, and the students visit works in progress.

The years that a boy attends such a school form an excellent starting point for any future in the industry, and they count as part of an apprenticeship to the individual crafts if a boy wishes to enter one on completion of his training.

Apprenticeship. For the majority of those who enter the industry during the next few years and wish to become craftsmen, the following method of training can be recommended. On leaving the Elementary School they should go direct into a firm of builders as an apprentice to a chosen trade. The Government have appointed a Council to consider this question of apprenticeship, and they have issued a report which will have considerable influence on the development of the system as the industry makes its great expansion.

It is intended in this national scheme of apprenticeship that the master-builder shall be responsible for training in the practical side of the craft, while the Technical School shall be responsible for the theoretical side of his work. One day and two or more evenings will be spent at school for the three to five years of the apprenticeship, by which time the apprentice should be able to pass the final of the City and Guilds examinations in the practice and theory of the chosen craft.

Training of Foreman. A foreman requires a knowledge of building far beyond that of his own craft. He should study Building Construction, Building Materials, Mechanics,

MODERN BUILDING CONSTRUCTION

Steelwork, Builder's Quantities, and Builder's Book-keeping.

BUILDING CONSTRUCTION. This subject has been taught to students in all departments of building for many years, and during that time considerable changes have been made in the method of presentation. To-day the student can get considerable help from books published on the subject; but the time-honoured method of attending lectures, and having exercises in drawing, with independent reading, has much to recommend it. Such a course should extend for at least three years, by which time the detailed knowledge of other crafts in building, added to that of his own craft, should be helpful when his opportunity for promotion comes.

The Carpenter. The material used by the carpenter is still principally wood, but the shop-fitter now also uses metal; and in the erection of prefabricated buildings, concrete slabs, which have been reinforced with steel rods, may have to be erected by the carpenter. In these new developments the carpenter, as well as other craftsmen, has to be prepared to handle new materials, and that often in a new way. This has led to specialists among craftsmen.

In beginning his training, a period of benchwork can be recommended. It will introduce him to the tools he will have to use, and enable him to appreciate accuracy in setting out his work. This might well be followed by work on the erection of buildings on the site, when shuttering for concrete foundations has to be erected, and sometimes designed by the craftsman; then there is the handling of large timbers or steelwork for floors, roofing, and framing.

The Setter-out. With the development of the large-scale joiner's shop which is able to execute large orders, varied in design, there has come into being this pivotal man, the "setter-out." He is also to be found in workshops devoted to shop-fitting for large stores. All the men who become expert in setting-out are first trained as craftsmen, but show a marked ability for reading and interpreting the scale drawings of the draughtsmen, and reproducing them to full size on what is called a "rod." There have, in the past, been no special classes for this, but any student completing the course for his final City and Guilds certificate should be able to do the work required. For students from the shop-fitting section, however, classes have been arranged, and these have proved of value not

only to students, but also to large firms needing the services of a "setter-out."

The Machinist. This very highly-skilled craftsman is found in all types of workshop connected with the manufacture of joinery, but until very recent years no special courses of instruction were organized for him. The gradually-increasing use of the machine in the manufacture of all types of joinery has brought in this specialist, and it is in the workshop with the machines that the apprentice will begin his training. He should not only strive to become skilled in the use of every type of machine used, but should become acquainted with the way in which the work is fitted together in the joiner's shop and erected on the site. Then, if possible, he should attend a course of instruction on machine joinery, where the correct use of machines is taught, with all their varied possibilities, including the use of safety guards. There are regulations by the Home Office in regard to these, and the student should know what they are and how they are applied for his own safety.

The Shop-fitter. This is now a well-organized branch of the building industry. Apprentices have been restricted in numbers and have had to pay a premium, a policy which has had the support of the masters and the men. Boys trained in the Technical Schools are to be found in all departments of shop-fitting. As previously mentioned, a craftsman must be able to use both wood and metal; he must also acquire skill in the use of the "rod," so that when erected his work will be accurate and thus fit into its place. The training, therefore, recommended is, first, an apprenticeship to a firm of shop-fitters, and then attendance for a course of study specially arranged for shop-fitters at a Technical School during the years of apprenticeship.

There are at least three specialists who are among the pivotal men in this industry: the draughtsman and designer, a very small section, but one whose training covers many years; the setter-out, already referred to; and the machinist, who must be a worker in wood and metal.

The Bricklayer. In his training, the bricklayer should become skilful in the use of other materials than bricks: Terra-cotta is often used as a facing material, and therefore the bricklayer would be required to lay it and fit his brickwork to it. Of course, the bricklayer will be able to lay glazed bricks, but he should also be able to set tiles in a bathroom or a kitchen.

Now, all these varied materials require a different technique. Then, as the demands for prefabricated houses and other buildings grow, the bricklayer will need to know how these buildings have to be erected, so that he can direct others. A knowledge of concrete and its reinforcement by mild steel would be required, for correct handling of this material is most important.

But his chief work will be with bricks and mortar, and here there is a rich tradition, for bricks are one of the oldest of building materials. The boy should be apprenticed to a good firm, and during his apprenticeship he should attend a Technical School at least one day a week, and on evenings during the week. He will come to realize the full scope of his work as a bricklayer, which is not just setting bricks in a straight wall at so many an hour. The work of other craftsmen follows that of the bricklayer, and it is, therefore, essential that he should be acquainted with the work of those who do follow him.

Every bricklayer should have a good working knowledge of Geometry, so that the setting-out of any arch in brickwork presents no difficulties. With the modern use of reconstructed stone, the bricklayer has another facing material and one which he must learn to bond in his walls with brick backing. The bricklayer, like other craftsmen, has to face up to modern conditions and requirements, and with such an outlook the prospects are excellent.

The Plumber. Plumbing is one of the most ancient crafts, nevertheless it has responded to modern requirements. Many fittings to-day require a high quality of craftsmanship when they are fitted into their place, otherwise their value is much reduced. The apprentice, therefore, should aim at joining the Institute of Plumbers and thus become a R.P. (registered plumber).

During the last twenty-five years the public has been making increasing demands for a higher standard of Public Health Services, and with this demand the training of the plumber is involved, because without his co-operation and skill the higher standard cannot be reached. It is, therefore, essential that a study of sanitary science should form one of the subjects in all courses of study. This in turn demands a good general educational standard on the part of the apprentice before he leaves school. During his training he will acquire a good knowledge of Geometry and of the varied materials, such as

lead, copper, zinc, iron, and solder, that he will have to use.

The Plasterer. This is a trade with great traditions. A boy wishing to become a plasterer should be apprenticed with a good firm, and should attend day and evening classes so that, along with the practical side of the craft, such as the plastering of straight walls and ceilings, he should learn the artistic side of his work. Here is a list of subjects that he might well study with advantage: History of his craft; architectural styles and how they influence the plasterer's art; mouldings as found in all the styles of architecture; enrichments applied to mouldings; geometry as applied to ceilings, patterns, etc.; natural ornament; clay moulding; plaster casting; fixing of mouldings and enrichments; and casting and moulding *in situ*. If a study of the above subjects is spread over the years of his apprenticeship, the boy will become deeply interested in his craft. The study of materials by the apprentice is most important in connection with plastering, because failure in plaster work is often due to wrong use of materials.

The Painter and Decorator. There is a national scheme for training apprentices to this craft, and during the last twenty years it has done some very good work.

Great improvements have been made during the last decade in the manufacture of materials used by the decorator; but it is still as necessary as ever it was for the craftsman to know his material and what can and cannot be expected of it, so that he can advise his client correctly and thus save disappointment later. The craftsman, in his training, should become acquainted with the correct use and treatment of his tools, both the traditional ones and the modern ones.

Ability to draw is a great asset to any decorator, and every apprentice should have the opportunity of learning. In the process of learning, the apprentice will also gain much useful information connected with his craft. The first that springs to the mind is the varied forms of lettering, ancient and modern. Then, plant and animal forms, both as found in Nature and as used in historic ornament. The most important study for the decorator is colour, for there can be no such thing as a decorator who is colour-blind. This study should take him to Nature to see what she does in her use of colour, and then to its application to colour schemes in the studio and on the job.

MODERN BUILDING CONSTRUCTION

The Heating and Ventilating Engineer. This industry is already well organized and will, in the near future, expand into a most important branch of building. It falls into two sections: design of heating and ventilating systems, and erection of the plant. In training for design, a good general education is necessary, with an emphasis on mathematics. Skill as a draughtsman will also need to be developed. In these days, very elaborate plant is used in keeping a building cool in summer and warm in winter, and the erection of such plant, therefore, calls for skilled craftsmen. Day courses of training have been instituted, but only a start has been made, and more will have to be done in the future for this very important branch of the industry. The same applies to the evening courses, though these have been in operation longer and are more highly developed.

The boy should be apprenticed to a firm of heating and ventilating engineers, and attend such day or evening courses as he is able to. He could reinforce this with the reading of technical papers and such books as have been written within recent years.

The Structural Engineer. This is now one of the professions connected with building, and the training should be on a professional standard.

The first step should be a good educational standard, and, to mark this, "matriculation" should be aimed at. Having passed this examination, the student should enter a school of training for his chosen profession, and apply to his professional society—in this case the Institution of Structural Engineers—to be enrolled as a student.

His course of study will now follow the syllabus of the Institution under the guidance of fully-qualified members of his profession.

The next examination at the end of two years' study will bring him to the Graduateship standard.

If this examination is passed successfully,

then a period of training in a structural engineer's office might follow with advantage, thus giving the student an introduction to business methods, as well as to the more advanced work of his profession. He would continue his studies in all subjects for his final examination by means of evening lectures.

As an alternative to the above, the student could enter a structural engineer's office after passing the Matriculation examination, and continue his studies in the evenings by his own reading and with attendance at lectures, day or evening.

The Chartered Quantity Surveyor. All students in quantity surveying should aim to become members of the Surveyors' Institute, and to do this a student must be trained under a qualified member of the profession, and pass the examinations held by the Institute.

To become a student of the Institute, the candidate must be 17 years of age and have reached a standard of general education, such as a student for a University, and have passed the Matriculation examination or its equivalent. Having entered as a student, he could become articled to a chartered quantity surveyor, and thus begin his office practice. At the same time, he could attend classes and lectures for his first professional examination, in which there are nine subjects. There follows the Intermediate examination, which is held in four divisions; his sub-division would be No. 3, which is for surveyor candidates. There are eight subjects, of which the typical subject is Quantities.

The final examination is also held in four divisions, of which No. 3 is for surveyor candidates, with the typical subject Quantities. There are nine subjects in this examination.

The period of study required for passing these examinations can be considerably shortened by attending a full-time course of study up to, say, the Intermediate standard, and then entering an office for practical experience, not as a pupil, but as a technical assistant.

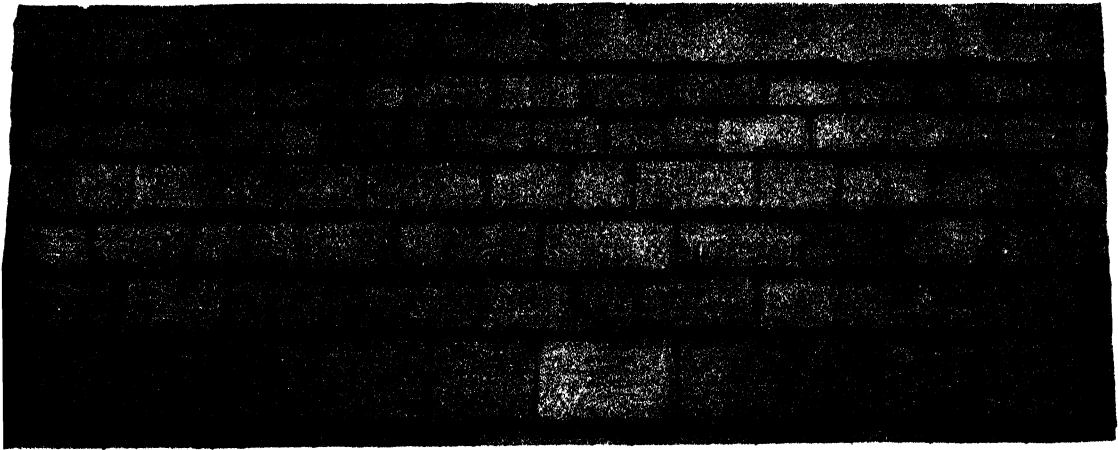

PRECELLY GREEN ROOF IN MIXED SHADES

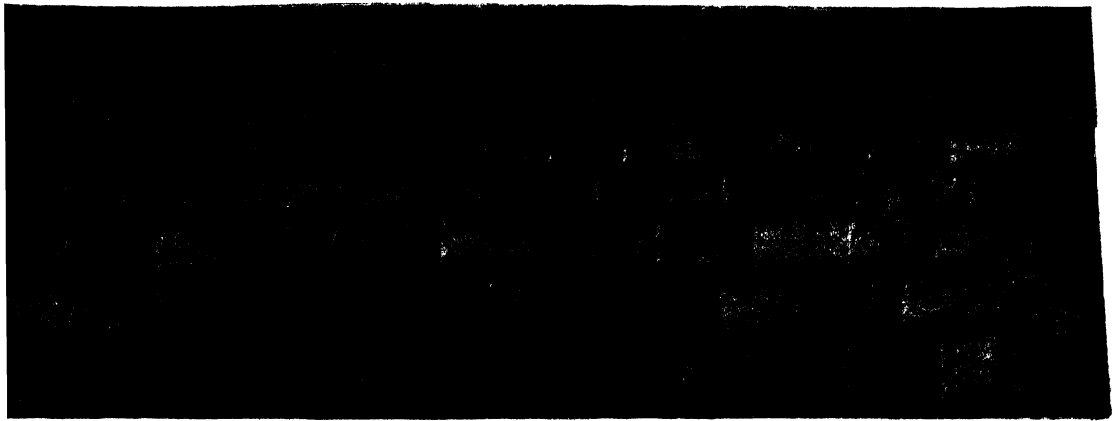

PRECELLY RUSTIC SLATES

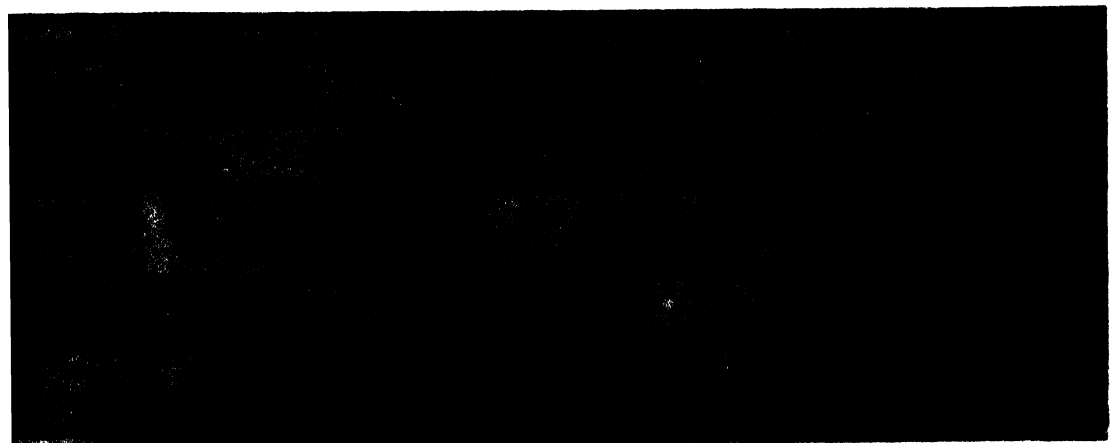

"VRONLOG" RUSTIC SLATES

Roof Coverings

By JOHN MILLAR, F.S.I., M.I.STRUCT.E.

Chapter I—SLATES AND SLATING

Roofing Materials. The materials for covering a roof are determined by the climatic conditions, and by the nature and importance of the building under consideration. Being one of the chief items of construction, the roof must be durable in proportion to the permanence of the building; and where the roof is prominent the roofing

to ft., the pitch is a third. The correct pitch varies in accordance with the nature of the covering (see Fig. 1).

Table I gives the least pitch it is desirable to adopt for the materials in use for coverings.

TABLE I
ROOF PITCHES FOR VARIOUS MATERIALS

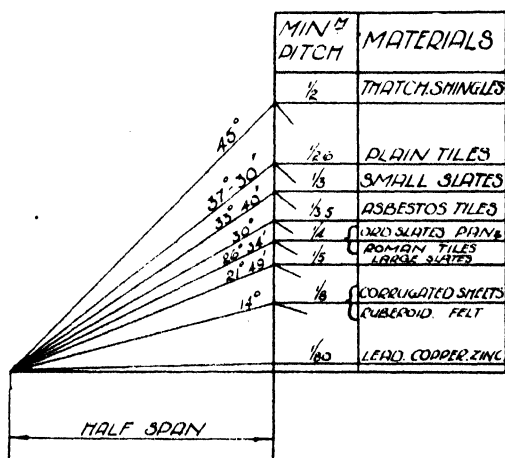

FIG. 1. ROOF PITCHES

materials should, of course, be given consideration from an architectural and aesthetic standpoint.

For coverings the following are in use: slates, tiles, asbestos tiles, and corrugated sheets, corrugated iron, lead, copper, zinc, asphalt, felt, glass, shingles, and thatch.

Poor conductors, such as slates and tiles, make better coverings than those which conduct heat, such as corrugated iron, as they tend to preserve a more equable temperature in the interior of the building.

Pitch. The term *pitch* is applied to the amount of slope given to the sides of the roof, and may be stated either in terms of the number of degrees in the angle which the roof makes with the horizontal, or by the ratio of the rise to the span; thus, for a span of 30 ft., if the rise is 7 ft. 6 in., the pitch is a quarter; if the rise is

Materials	Angle of Inclination in Degrees	Ratio of Rise to Span
Slates (Large)	22	1/4
" (Ordinary)	26-34	1/4
" (Small)	33-41	1/4
Plain Tiles	37-41	1/4
Pan Tiles	26-34	1/4
Roman Tiles	26-34	1/4
Asbestos Tiles	30	1/4
" Corrugated Sheets	14	1/4
Corrugated Iron	14	1/4
Felt	14	1/4
Lead	1/2	1/4
Copper	1/2	1/4
Zinc	1/2	1/4
Asphalt	1/2	1/4
Glass	26-34	1/4
Thatch	45	1/4
Shingles	45	1/4

SLATE

Characteristics. Slate, one of the commonest materials for roofing, is a rock of fine grain and compact structure, formed originally from material transported by water and deposited as fine silt on ancient sea bottoms.

Although a sedimentary rock it has, owing to intense lateral pressure, lost its original bedding plane, and has acquired its characteristic tendency of splitting into thin plates known as *planes of cleavage*, which may be parallel to the original bedding plane, but more usually are at some angle from it (see Fig. 2).

The mechanical theory of cleavage is that the forces acting in a lateral direction have not only contorted the beds, but have so re-arranged the particles as to cause them to lie in a plane perpendicular to the direction of the forces themselves (see Fig. 3).

MODERN BUILDING CONSTRUCTION

Slates are occasionally found with the cleavage planes slightly curved, due to some disturbance after the cleavage planes have been formed. This is termed "wavy cleavage," and the slates are then said to be "yorky."

The original stratification is sometimes discernible either by faint bands of colour on the cleavage surface, or by difference in texture. These bands of colour are not detrimental to the durability of the slate.

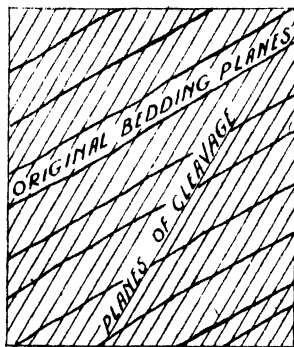

FIG. 2. SLATE FORMATION

Besides the cleavage planes, it is found that there are also other planes of weakness along which the block may be easily divided. These occur in a more or less vertical direction at right angles to the principal cleavage. This tendency is known as *pillaring*, a quality in slate known as "grain."

That the planes of cleavage permit the rock to be split into thin, uniform slabs is an essential characteristic of slate, without which it would

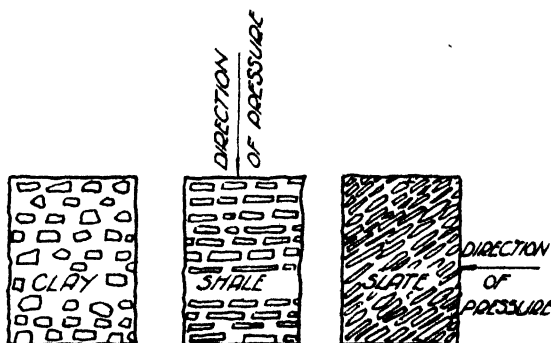

FIG. 3. PLANES OF CLEAVAGE

be of little value as a roofing material. Other characteristics of a good slate are hardness and toughness of structure, uniformity of colour, and an absence of patches. It should give a clear ring when struck with the knuckles, not be greasy to the touch, but somewhat rough, and when it is stood in water to half its depth, the water should not rise more than $\frac{1}{8}$ in., nor, when immersed in water for twenty-four hours, should it absorb more than one two-hundredth

of its dry weight. Other rocks, such as shales and certain kinds of sandstone, differ from true slate in that they possess no planes of cleavage, but only split along the planes of the original bedding. They are used for roofing purposes in some districts, and are hence misnamed slates.

Slate, being derived from clayey rocks, consists essentially of silicates of iron and aluminium which represent nine-tenths of the total mass. These two minerals give to the slate its permanent character. Table II gives the chemical analysis of a few different slates.

TABLE II
ANALYSIS OF SLATE

	OAKELEY		Pre-celly	Tilberthwaite
	Old Vein	New Vein		
Silica (SiO ₂)	55.25	53.40	62.66	50.160
Alumina (Al ₂ O ₃)	24.60	26.67	22.22	17.850
Iron Oxide (Fe ₂ O ₃)	10.40	9.53	6.03	6.750
Lime (CaO)	1.00	0.90	0.06	3.670
Magnesia (MgO)	2.09	1.85	1.22	6.350
Potassium Oxide (K ₂ O)	1.47	1.42	3.21	2.060
Sodium Oxide (Na ₂ O)	0.53	0.52	1.01	3.110
Sulphuric Acid (SO ₃)	0.21	0.23	0.31	0.100
Titanium Oxide (TiO ₂)	•	•	•	1.030
Loss on Ignition (Water)	4.62	4.70	3.88	4.670
Specific Gravity	2.88		2.80	2.775

WEIGHT OF SLATE. Welsh slate weighs 180 lb. per cub. ft., Cornish slate 173 lb. per cub. ft., and Westmorland slate 157 lb. per cub. ft. The estimated weight of roof covering per square of 100 ft. superficial is—

	Firsts	Seconds	Thirds	Randoms
North Wales	4-5 cwt.	7 cwt.	9 cwt.	
South Wales	7 "	9 "		10½ cwt.
Cornish	6 "	7 "		10 "
Lancashire	7½ "	9 "	11 "	
Westmorland	7½ "	9 "	11 "	

PHYSICAL TESTS. The following tests were made on slates taken from the Oakeley quarries. The tests for absorption of water showed that, after being immersed for 2½ hours at 60° F., the weight of the slate was not appreciably or measurably increased. The test for tensile strength gave 8,740 lb. per sq. in., and the resistance to compression measured 31,470 lb. per sq. in.

Quarrying. Slate is obtained by open quarrying or by mining, and in certain quarries is obtained in both ways, according to the dip of the strata. The open workings generally run in galleries, and the underground workings in chambers. In both systems the slate is worked in descending order, commencing at the top.

Whichever of the above systems is employed

and colour into heaps which are termed *bests*, *mediums*, and *seconds*. These are comparative terms and do not always imply that the bests and mediums are better than the nominal seconds. They have reference to texture, thickness, and uniformity of cleavage.

The rule laid down for the splitters in the best Welsh quarries is that for *best* quality slates,



Oakeley Quarries, Ltd.

FIG. 4. SLATE SPLITTING

for reaching the slate, the process of obtaining it is by blasting. In the removal of the rock advantage is taken of any natural joints that may occur, and also of the tendency of the rock to split in certain directions.

SPLITTING. The blocks of slate are taken to the splitting and dressing sheds at the surface, where they are further reduced to slabs about 3 in. in thickness before being placed on the saw tables.

The rough slab is next sawn across one end to give it an even square face for the splitter, who with a broad-edge chisel and mallet carefully splits the reduced slab into sheets (see Fig. 4), which are then cut into slates by a circular dresser.

The slates are now divided into sheets of the required thickness, and sorted according to size

size 22 in. by 12 in., or 22 in. by 11 in., there should not be a greater number than eighteen in 3 in.

Medium quality slates run eleven, twelve, and thirteen to the 3 in., that is, $\frac{3}{16}$ in. for *best* quality and $\frac{1}{4}$ in. for medium quality slates.

The method of splitting or riving the slate in the Westmorland area differs from that employed in the Welsh area. In the Welsh area the splitters sit at their work and, resting the block against the side of their legs, divide and subdivide the block into the required thickness, with a broad, thin chisel and wooden mallet. This is termed "chisel riving." In the Westmorland area hammer riving is generally adopted. In this method the splitters or rivers stand at their work. They use a hammer, one end of which has a cutting edge, and, holding

MODERN BUILDING CONSTRUCTION

the block with one hand, they apply a series of blows with the other along the cleavage plane until the block splits.

DRESSING. After the block has been split to the required thickness, the irregularly shaped pieces are next dressed into roofing slates. The method of doing this varies slightly in different quarries. Some use a machine which is worked by a foot treadle, others use a circular dressing machine with two knives fixed diagonally, and driven by electricity. Along one side of the machine is a notched measuring gauge, into which the slates are placed. The knife, descending or revolving, cuts them to the required size. The edge on the face of the slate which is first struck with the knife shows a clean cut, while the under edge breaks or spalls, giving a rough splayed edge to the slate. This rough splayed edge is on the side of the slate which is termed the "back" when laid, except in the case of the under-eaves slate, which is reversed in order to obtain a close joint along its lower edge, and so lessen the risk of the slates being stripped off by the wind. The punching or drilling of the nail holes is usually done on the building.

SIZES OF SLATES. Table III gives the names and sizes of the various slates obtainable, also their covering capacity.

TABLE III
SIZES, NAMES, AND COVERING CAPACITY OF SLATES

Name	Sizes	Covering Capacity of One Mile of 1,200 Slates. Lap approx. 3 in	Actual No. of Slates Required to Cover One Square (100 sq ft.), 3 in. Lap
Princesses . . .	24 in. × 14 in.	136 yd.	98
Duchesses . . .	24 in. × 12 in.	117 "	115
Marchionesses . . .	22 in. × 11 in.	97 "	138
Countesses . . .	20 in. × 10 in.	78 "	169
Viscountesses . . .	18 in. × 9 in.	62 "	213
Ladies . . .	16 in. × 8 in.	48 "	277
Headers . . .	14 in. × 12 in.	61 "	218
Doubles . . .	12 in. × 6 in.	25 "	533

• VARIETIES

Slate Areas. The principal sources of supply are North Wales, Westmorland, Cumberland, Lancashire, Cornwall, and South Wales.

North Wales. The largest quantity of slates are obtained from this area in bests, mediums, and seconds. The sizes run from 34 in. by 14 in. down to 10 in. by 6 in. They were formerly

sold to the trade in thousands of 1,200 plus 60 extra, but are now sold per thousand net without any extras. Sizes 36 in. by 24 in. are sold by weight. Slates sold by weight are called "ton" slates.

The colours of slate from this area are purple-grey, grey-blue, and blue, and all are excellent metal.

Westmorland and Cumberland. This area produces a slate of a green colour of various shades, among which are light green, dark sea-green, and olive green. The colouring of these slates is derived from the presence of ferrous oxide and magnesia. They are thicker and coarser than Welsh slates, averaging $\frac{3}{8}$ in. in thickness, and are more expensive, but they make a more pleasing roof. The above area embraces North Lancashire, which produces an excellent slate in random sizes for graduated work. The material which forms the slate in this area is not a marine clay, but is largely made up of volcanic ash, and these slates do not possess such a good cleavage as the clay slates.

Cornwall. The slates obtained from Delabole, Cornwall, are very durable, and the quarries are among the oldest in the country. Sized slates are chiefly produced, the colour of which, after a few years' weathering, mellows down to a silver-grey. Thick *randoms* and *rustics* of a green colour can also be obtained. Randoms are slates supplied in mixed sizes. Rustics are slates that have taken on a stained appearance, due to chemical changes along the cleavage planes, which have become slightly open as a result of weathering. They are approximately $\frac{3}{8}$ in. in thickness and are used for diminishing work.

South Wales. This area produces slates of various shades in light, dark, bright, and olive green. Two well-known varieties are Precelly and Vronlog. The former are produced in rustics and randoms, and the latter in standard sizes from 24 in. by 12 in. down to 10 in. by 6 in., and also in randoms and rustics.

Peggies are small slates which vary in length from 9 in. to 14 in.

Good slates are also obtained from Scotland and Ireland, but owing to difficulties of transport they are used locally only.

Foreign Slates. Other countries producing slates are France, America, Germany, and Norway. Many of these slates are of an inferior quality, and careful discrimination should, therefore, be exercised in their choice.

SLATING

The following terms are used in slating—

The *back* is the upper surface of the slate when laid; the under surface is called the *bed*. The part of each course exposed to view is termed the *margin*; and the length of the margin, or the distance between the nail holes of each course, is called the *gauge*.

The top of each slate is termed the *head*, the lower edge the *tail*.

A *course* is one horizontal layer of slates.

The *lap* is the amount that one slate covers the next but one below it; but when the slates are head-nailed, the lap is measured from the nail hole instead of the top of the slate.

The *bond* is the arranging of the slates on the roof, so that no vertical joint of one course is less than half a slate in width from the vertical joint in the course above and below; this is accomplished by introducing a half-slate or a slate and a half-slate at the commencement of every alternate course.

The *eaves* (Fig. 5) is the name given to the lower edge of the roof; and the upper edge, or the line formed by the intersection of the roof surfaces, is called the *ridge*.

The *verge* is the edge of the roof plane at a gable end.

The *hip* is the line of intersection of two roof planes containing an angle greater than 180° ; the *valley* the line of intersection of two roof planes containing an angle of less than 180° .

A *hipped end* is the sloping end of a roof and is generally triangular in shape.

A *double eaves course* is the first course of slates laid on the roof, not exposed to view, and equal in length to the slate to be used minus the gauge. It is introduced to fulfil the condition that, wherever a vertical section is taken through the slates, there shall be two thicknesses of slates, and three thicknesses if taken through the lap.

The *double ridge course* is the last course of slates laid at the ridge, and is of the same length as the double eaves course.

Where battens only are employed, and where greater protection is required, the joints are pointed in cement or hair mortar, to prevent wind and rain from penetrating the roof. This is termed *torching*.

Shouldering is the term applied to the bedding of the top of the slates in hair mortar for about 2 in. wide where the situation is an exposed one.

Rendering is the application of hair mortar

to the underside of the slates when laid on battens, to prevent snow or driving rain from entering at the crevices. The disadvantage of this method is that the bedding tends to attract moisture rather than repel it.

When the building is in an exposed situation, it is preferable to give a steeper pitch and a greater lap than would ordinarily be employed, and to adopt a slate with a rough face.

Slaters' Tools. The slaters' tools are few in number. They consist of a *cutting-iron*, about 2 in. by $\frac{1}{4}$ in. in section and about 1 ft. 6 in. long, with the ends shaped and sharpened for fixing into the block of wood; a *pick-hammer*; an *axe*, or *zax*; a *slate-ripper*; and a *chalk line* (see Fig. 6).

The *axe* is used for dressing the edges of the slate; it consists of a steel blade about 12 in.

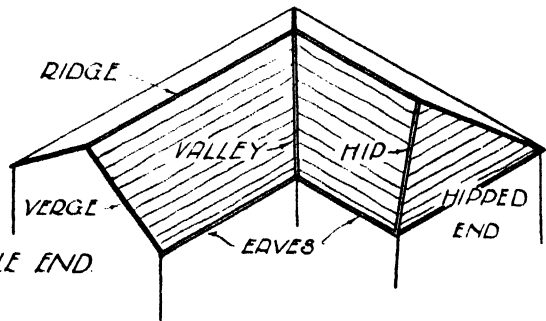

FIG. 5. TERMS USED IN ROOF WORK

long with a spike. The blade is fixed to a wooden handle. The slate is placed on the dressing or cutting iron, projecting over the edge by the amount it is desired to trim off. The axe is then taken in hand, and by a series of sharp blows the slate is trimmed off to the required size. The spike on the back of the blade is used for punching the holes in the slate, the positions of which are marked with a gauge.

The *gauge* is usually a piece of batten with two nails driven through it, at a distance apart to give the position of the nail-holes from the tail of the slate. One nail projects sufficiently to score a line across the slate to mark the level of the nail holes; and then with a sharp blow the holes are punched with the spike. One end of the hammer is used for driving nails; the other end is pointed and used for punching holes in the slate, if necessary, while the work is in progress on the roof. On the side of the hammer is a claw for removing bent or defective nails.

The *ripper* is used to remove broken slates

MODERN BUILDING CONSTRUCTION

by cutting through the nails by which they are held; it consists of a long thin steel blade with a wooden handle at one end, while the other end is widened out sufficiently to form a hook on each side of the blade, so as to grip the nail which it is desired to cut. The tool is passed up below the slate and round the nail, and then with a sharp pull the nail is forcibly cut and the slate withdrawn.

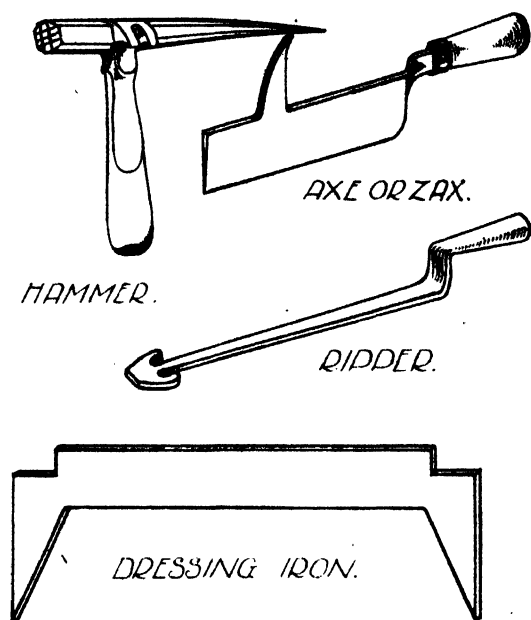

FIG. 6. SLATER'S TOOLS

The *chalk line* is employed for setting out the position of the battens, when used on the roof and also as a guide in fixing the slates.

PREPARATORY WORK

The groundwork of battens, boards, or felt, for receiving the slates may be prepared in several ways, according to the nature of the work in hand and the framework of the roof.

Battens. Where the structure is of timber, battens alone may be employed. They are nailed horizontally across the roof at distances apart according to the gauge required (see Fig. 7). As only half of the width of the battens is used for nailing the slate to, the remaining half affords a support for the top of the preceding course. Battens used for ordinary slating are from $1\frac{1}{2}$ in. to 3 in. in width, and $\frac{3}{4}$ in. or 1 in. in thickness, a usual size being 2 in. by $\frac{3}{4}$ in.

The spacing of the battens will be uniform throughout the roof where regular sized slates

are used, with the exception of the first batten, when centre nailing is employed. The position of the first batten is measured from the front of the fascia to the bottom of the batten, and will be as given in Table IV.

TABLE IV
POSITIONS OF FIRST BATTEN FOR VARIOUS SLATES

Length of Slate	2½ in. LAP		3 in. LAP	
	1st Batten	Remaining Battens	1st Batten	Remaining Battens
24 in.	10¼ in.	10¾ in.	11 in.	10¾ in.
22 "	9½ "	9¾ "	10 "	9¾ "
20 "	8½ "	8¾ "	9 "	8¾ "
18 "	7½ "	7¾ "	8 "	7¾ "
16 "	6½ "	6¾ "	7 "	6¾ "

To fix the battens correctly, a chalk line is struck across the rafters at intervals to suit the gauge of the slating, measuring from bottom to bottom of batten.

Another method employed for setting out and fixing battens on a roof is to cut a piece of batten to serve as a guide; this guide is made to fit in between each row of battens, its length being equal to the gauge minus the width of batten used. Battens are economical, and much used in general work where there is a ceiling below or where ventilation is required.

TILTING FILLET. At the eaves a special batten, called a *tilting fillet*, is fixed. It is $\frac{3}{4}$ in. or 1 in. thicker than the ordinary battens, in order to tilt up the under or double eaves course, so that a proper bed may be formed for the slates above, and at the same time prevent the lifting effect of the wind, by closing the space at the edge of the slates. In some cases the fascia board is utilized for the same purpose in place of the tilting fillet, by being placed higher than the boarding or battens by the amount required to tilt the slates. It is also necessary, for the same reason, to fix a thicker batten at the ridge, in order to give a proper bed to the under ridge slate, and so prevent it from "riding."

Boarding and Felt. A better method is to employ boarding, and to cover it with sheets of one-ply Willesden paper or inodorous sarking felt (see Fig. 8). As these felts are water-proof the risk of decay is negligible. This method gives a more equable temperature to the interior of the building.

A fairly satisfactory method sometimes used in cheap work is to employ two-ply Willesden paper, and place it directly on the open rafters.

Boarding, Felt, and Battens. This is similar to the above method, but with the addition of battens above the felted boarding (see Figs. 9 and 10). The battens provide an air space to

on the felted boarding, running from eaves to ridge, and to nail the slate battens to them. This allows any condensation on the underside of the slates, or water from any cause, freedom

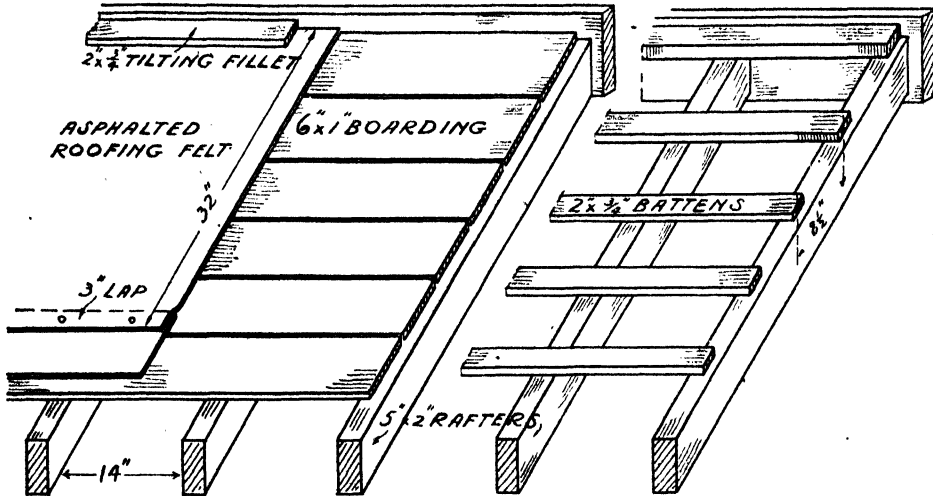

FIG. 8. BOARDING AND FELT

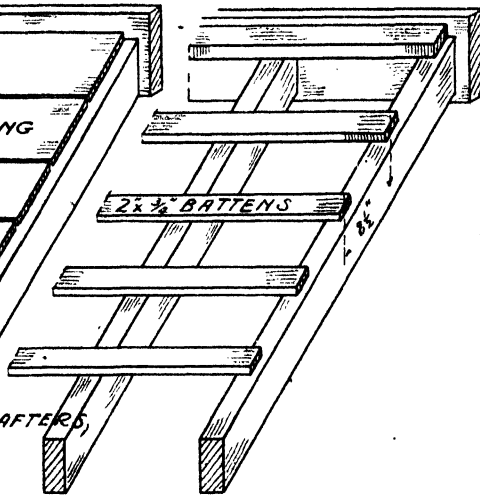

FIG. 7. BATTENING

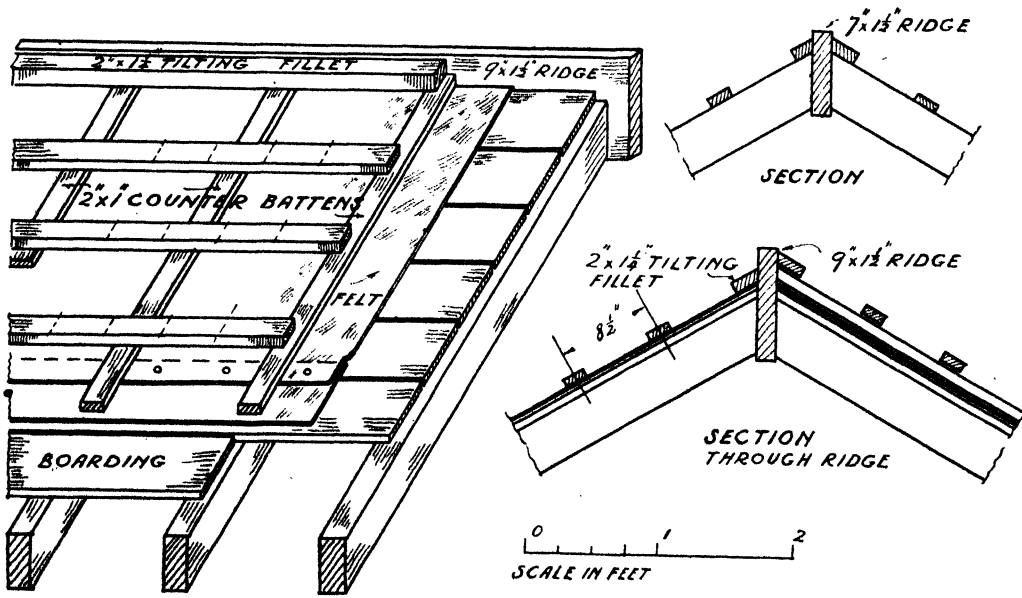

FIG. 9. BOARDING, FELT, BATTENS, AND COUNTER BATTENS

the underside of slates, but there is probably a danger of decay through the lodgment behind the battens of any water that may be driven between the slates.

The best method to adopt is to place 2 in. by 1 in. *counter battens* directly over each rafter

to make its way to the eaves. This method is generally adopted in good class work (see Figs. 9 and 11).

In modern work, roofs are often formed of steel and concrete or steel alone. If the roof is of concrete and slates are used for the covering,

MODERN BUILDING CONSTRUCTION

the battens may be fixed to plugs driven into the concrete, or the slates may be fixed to the concrete direct.



FIG. 10. BATTENED AND FELTED ROOF

When a steel roof is employed to support the covering, and where a more fire-resisting construction is desired, small steel angles take the place of the rafters and battens for securing the slates. For this purpose large slates are more

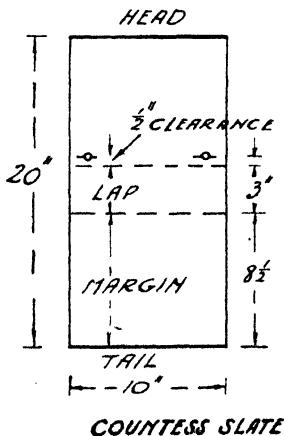

FIG. 12. COUNTRESS SLATE, DRESSED AND HOLED

suitable than small ones, for though they are a little more expensive, their extra cost is more than compensated for because wider spacing of the angles is possible. In this case the slates are fixed with copper wire or long lead nails.

Sorting. The slates are sorted out according to thickness, and piled on their edge for convenience of placing on the roof. The thicker

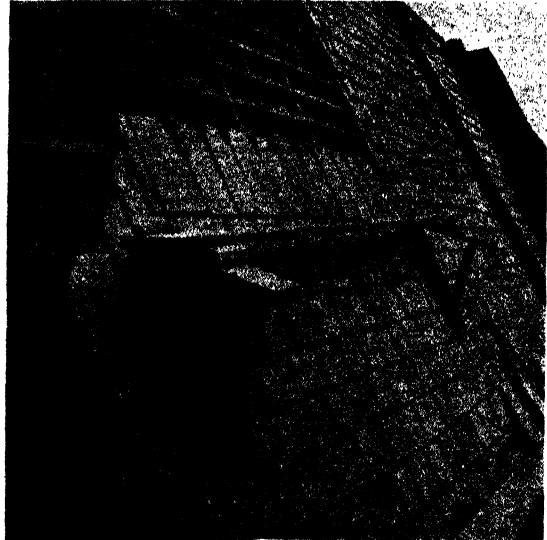

FIG. 11. SLATE BATTENS AND COUNTER BATTENS IN SLATED ROOF

slates are placed at the lower part of the roof, and the thinner ones at the top. When Westmorland or other slates are used for diminishing

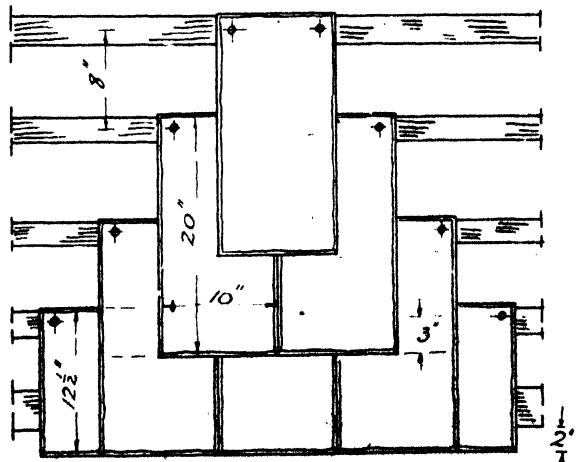

FIG. 13. HEAD NAILING

work, they are sorted out both in respect to thickness and size. The object of diminishing courses is to give to the roof an appearance of greater depth than it really possesses.

Nails. Slating nails are made in various

patterns and of different materials—copper, composition, iron, and zinc. Copper nails, though practically imperishable, are soft and, owing to their cost, are not generally used. Composition nails, made from an alloy of copper and zinc, are the best. Zinc nails are much used in general construction, but they are soft. Nails of malleable iron, galvanized, are also satisfactory and are much in use.

Nails vary in length from 1½ in. to 2 in., according to the size of the slate used. For Princesses, Duchesses, and Countesses slates, and also Westmorland slates, the nails should be 2 in. long and weigh 90 to the pound; for Viscountesses and Ladies, 1½ in. long at 180 to the pound. These nails are made with as thin a head as possible, so as not to project above the surface and interfere with the bedding, or cause breakage to the slate in the course above.

FIXING THE SLATES

For fixing slates, two nail holes are drilled or punched in each. If the slate is to be *head-nailed*, the holes are made 1 in. from the head of the slate; when the slates have to be *centre-nailed*, the holes are made near the centre, at a distance from the tail of the slate equal to the gauge being used plus the lap, plus ½ in. for clearance. In either case, the nail holes are 1¼ in. from the long sides of the slates. A slate-and-a-half-slate may be fixed with three nails, and small slates with a single nail.

Fig. 12 shows a Countess slate dressed and holed ready for fixing on the roof. The punching or drilling is done from the bedside of the slate, a small amount of slate splintering off to form a counter-sinking for the head of the nail.

Head-nailing. Each method has its advantages. In head-nailing, each nail is covered by two thicknesses of slate, so that if one is broken the nail is still protected, but the leverage offered to the wind is greater than if centre-nailed, and repairs to the roof are more difficult. The lap is measured from the nail hole, thus reducing the gauge by ½ in., and more slates are

therefore required per square, making the roof slightly more expensive (see Fig. 13).

Centre-nailing. In centre-nailing, the nail hole is covered by one slate only, but it has a greater protection in that the leverage, as stated above, is much less than in the case of one nailed near

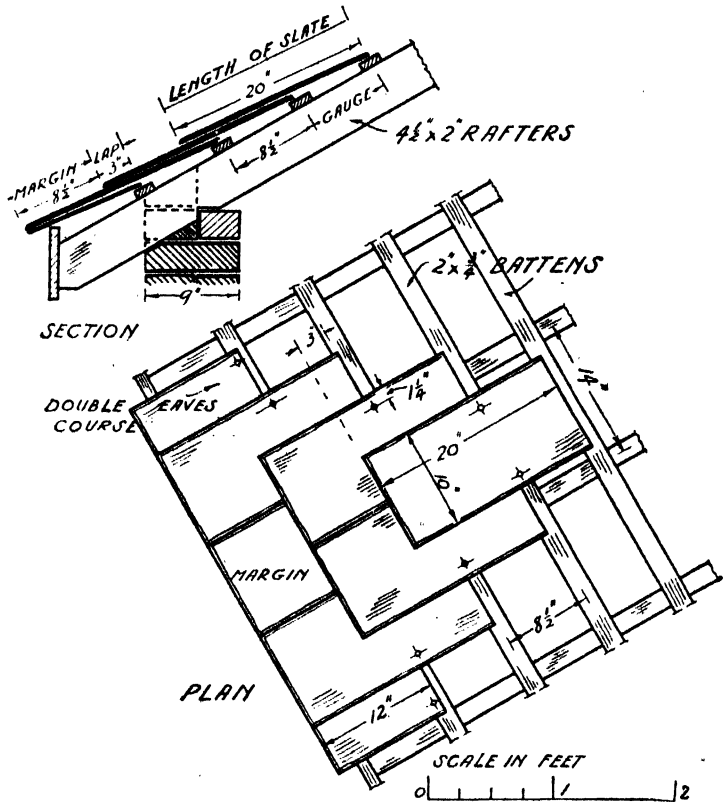

FIG. 14. CENTRE NAILING

the head. Centre-nailing is the method generally adopted (see Fig. 14).

The choice of a suitable slate for the roof will depend on the pitch and the position of the building, the practice being that the steeper the pitch the smaller the slate, and the flatter the pitch the more exposed the roof the greater the lap.

The lap varies from 2 in. to 4 in., a good average being 3 in., the amount usually adopted.

Gauge. Having decided on the lap to be given, the gauge is next obtained by one of the following rules—

When the slate is centre-nailed: *Deduct the lap from the length of the slate and divide by two*; the quotient is the gauge. Thus—

$$\text{Gauge} = \frac{\text{length of slate} - \text{lap}}{2}$$

MODERN BUILDING CONSTRUCTION

When the slate is head-nailed: From the length of the slate, deduct the lap plus the distance of the nail from the head of the slate (usually 1 in.) and divide by two; the quotient is the gauge. This rule may be stated thus—

$$\text{Gauge} = \frac{\text{length of slate} - \text{lap} - 1 \text{ in.}}{2}$$

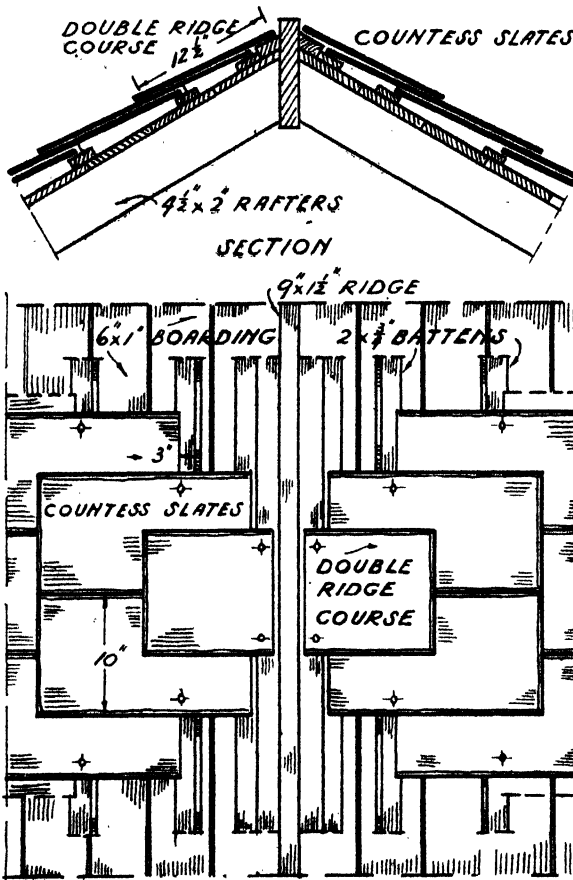

FIG. 15. DOUBLE-RIDGE COURSE

As an illustration, consider a Duchess slate to be laid to a 3 in. lap, centre-nailed; then the gauge will be—

$$\frac{24 \text{ in.} - 3 \text{ in.}}{2} = 10\frac{1}{2} \text{ in.}$$

If the slate is head-nailed, the gauge will be—

$$\frac{24 \text{ in.} - 3 \text{ in.} - 1 \text{ in.}}{2} = 10 \text{ in.}$$

DOUBLE EAVES COURSE. The length of the double eaves course will be the gauge, plus the lap, plus 1 in., the extra inch being to obtain the lap, as this course of slates is nailed at the

head even if the other slates are centre-nailed. Adopting a Duchess slate as before, the length of the double eaves course will be, when the slating is centre-nailed, $10\frac{1}{2}$ in. plus 3 in. plus 1 in.—that is, $14\frac{1}{2}$ in.; and for head-nailed slates, 10 in. plus 3 in. plus 1 in.—that is, 14 in. Sometimes this course is formed by placing an ordinary slate lengthways along the eaves. This is unsatisfactory and should not be allowed.

In order that the nails of the first full course of slates will clear the top of the double eaves course, it is necessary for the nail holes in this course to be at a distance equal to the length of the eaves course, plus $\frac{1}{2}$ in. for clearance, measured from the tail of the slate.

RIDGE COURSE. The last course of slates at the ridge has to be cut to about the same length as the eaves course, so that the last full course will come within $1\frac{1}{2}$ in. from the ridge (see Fig. 15). To obtain this result, the gauge as set out may, if necessary, be slightly modified. As an illustration, suppose a roof slope measures 25 ft. 8 in., and is covered with Countess slates laid to a 3 in. lap. To obtain the exact gauge, reduce the length of the slope to inches, deduct the length of the ridge course (12 in.), and divide by the nominal gauge ($8\frac{1}{2}$ in.). This will give the number of courses, or may be stated thus—

$$\frac{\text{Length of slope} - \text{length of ridge course}}{\text{Gauge}}$$

that is—

$$\frac{308 \text{ in.} - 12 \text{ in.}}{8\frac{1}{2} \text{ in.}} = 34\frac{50}{85}$$

say 35 courses. Now divide the slope length by the number of courses, and the answer will be the gauge. Therefore—

$$\text{Gauge} = \frac{\text{slope length}}{\text{No. of courses}} = \frac{294}{35} = 8.4 \text{ in.}$$

which is approximately $8\frac{2}{5}$ in. The lap is found thus—

$$\begin{aligned} \text{Lap} &= \text{length of slate} - \text{gauge} \times 2 \\ &= 20 \text{ in.} - 8.4 \times 2 \\ &= 3.2 \text{ in., or approximately } 3\frac{1}{4} \text{ in.} \end{aligned}$$

If 2 in. battens are used, a piece $6\frac{3}{8}$ in. long will serve as a guide for fixing the battens.

Open or Spaced Slating is the term employed for slating laid with a horizontal space between each slate (see Fig. 16). This method gives by no means a poor and inefficient roofing, but is rather economical both in material and labour if the work is properly carried out.

A pitch of not less than 26° is recommended, and a spacing of not more than 2 in. between each slate, if a water-tight job is required. In

an exposed position, this construction will not keep out driving snow. It is usually adopted for covering workshops, coal houses, etc. The saving effected on the slating alone, taking a

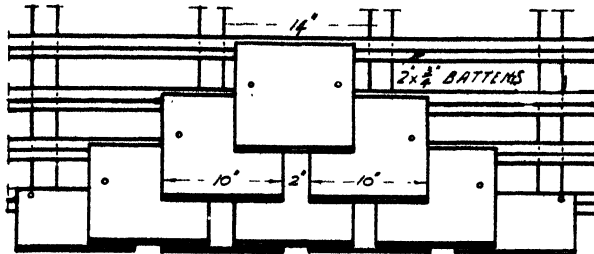

FIG. 16. OPEN SLATING

square of 100 ft. as a basis, and using Countess slates with a 3 in. lap, is—

Ordinary Roofing—

$$\frac{10 \text{ ft.} \times 10 \text{ ft.} \times 144 \text{ in.}}{8\frac{1}{2} \text{ in.} \times 10 \text{ in.}} = 170 \text{ slates.}$$

Open Roofing—

$$\frac{10 \text{ ft.} \times 10 \text{ ft.} \times 144 \text{ in.}}{8\frac{1}{2} \text{ in.} \times 12 \text{ in.}} = 141 \text{ slates.}$$

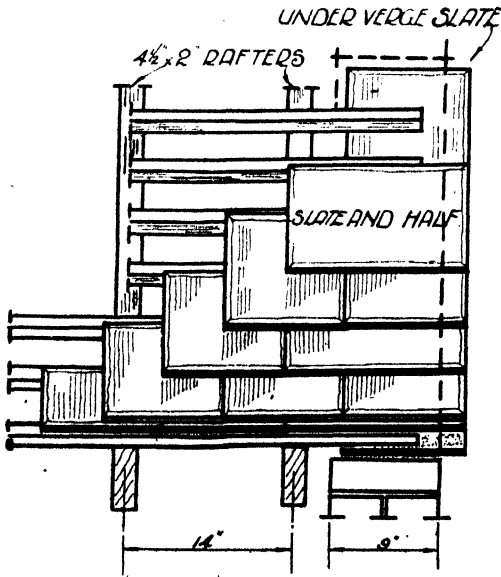

FIG. 17. VERGE

This shows a saving of 29 slates per square or about 17 per cent, a saving in labour in fixing, and less weight to be carried by the rafters.

Glass Slates. These can be obtained of the same dimensions as the ordinary slates which are bonded in with them, and are screwed to the battens. These are not to be recom-

mended for large areas, being suitable only for admitting light to roof spaces, workshops, etc.

Verges. These occur when the slating does not finish against a wall, but is carried over it. They are provided with an additional layer of slates bedded in cement on the wall, to tilt the outside courses of slates so as to divert the water from the edge. The slates project 1½ in. beyond the face of the wall, and the outside courses are bedded and the edges pointed in cement (see Figs. 17 and 18).

Graduated Courses. In laying graduated courses (Fig. 19), the lap is kept uniform, but the gauge is varied to suit the length of the slates, which are sorted out in uniform lengths before the work is commenced. A roof of this kind presents no more difficulty in setting out than an ordinary one. All that is necessary is to put the battens at the required distances, centre to centre, to suit the gauge. The battens are set out by the slater and not by the carpenter, or the slater may supply the carpenter with a "rod" for setting out the work.

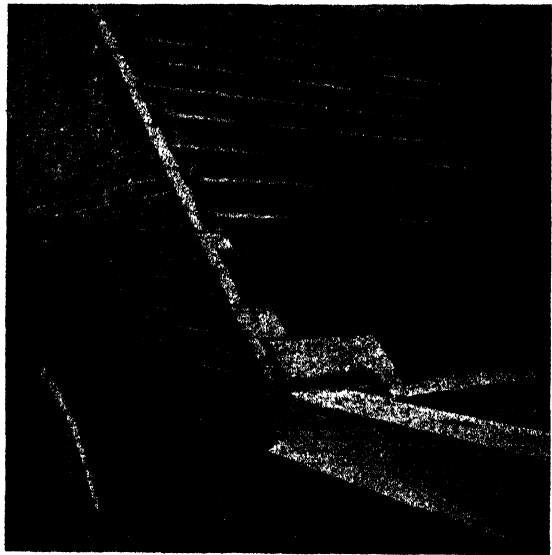

FIG. 18. FINISH TO VERGE OF SLATED ROOF

Irregularly-shaped Roofs. In roofs that are not exactly square, the courses must be kept parallel with the ridge, and any course that is short of the full course placed at the bottom (see Fig. 20). This cutting of the edges of the slates occurs where the span of the roof varies, making one end of the roof longer than the

MODERN BUILDING CONSTRUCTION

other. The setting-out should commence at the ridge, and the spacing of the battens worked towards the eaves.

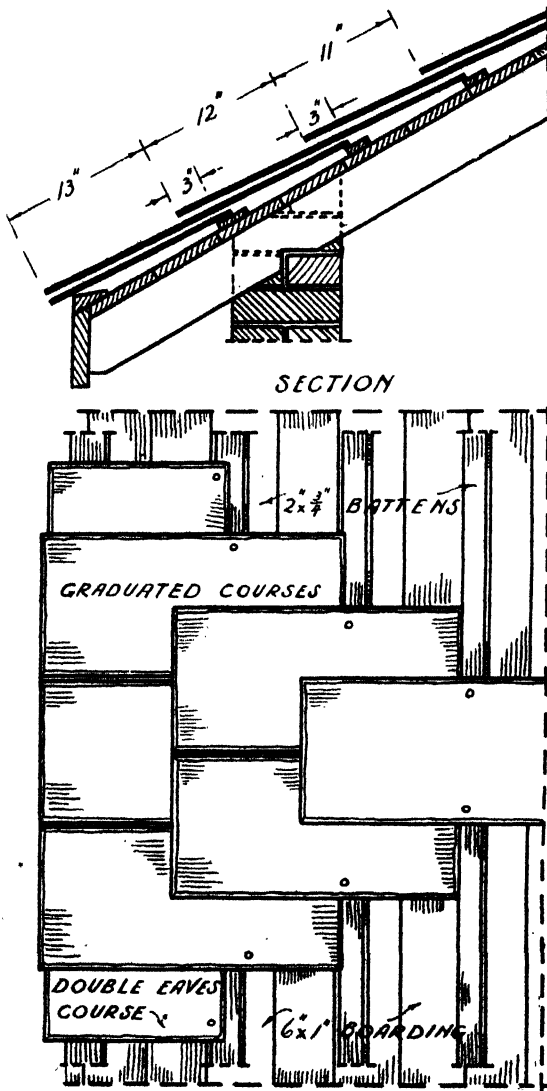

FIG. 19. GRADUATED SLATING

Hung Slating. This is sometimes employed for protecting exposed walls from driving rains, and also as a cure for damp walls. The length of the slate selected should be such that the gauge will be a multiple of a brick in height, so

that the slates may be nailed into the joints; or plugs may be driven into the joints of the brickwork to fix the battens to, which in turn

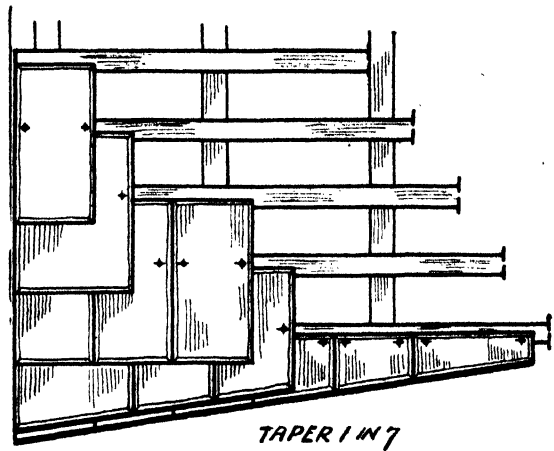

FIG. 20. IRREGULAR-SHAPED ROOFS

carry the slates. It is not usual to carry the slates to the ground, but to finish them with a small cornice at first floor level.

Dormer checks may be covered with slates of a size to course in with the slates on the roof. A lap of $1\frac{1}{2}$ in. is sufficient for all vertical slating.

Ornamental Slating. To relieve the monotony of ordinary slating, the lower edges of the slates are cut to various patterns, the pattern being repeated every three to six courses, or two or

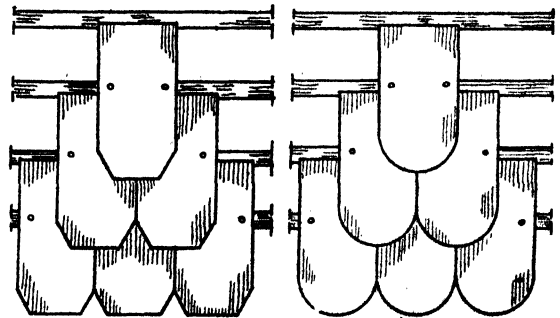

FIG. 21. ORNAMENTAL SLATING

three good combinations of coloured slates may be used for the same purpose. Fig. 21 shows two examples of ornamental slating. The semi-circular ends are not as easy to cut neatly as the simple splayed cuts to the left.

Chapter II—TILES AND TILING

Manufacture of Tiles. Tiles are made from clay. Ordinary clay is formed by the disintegration, or weathering, of igneous rocks, shales, and certain limestones. It contains silica, alumina, and combined water, in various proportions, with impurities in the form of oxide of iron and lime, its composition being dependent upon the character of the rock from which it is formed.

The pits are generally worked open to the sky, but in the Broseley district the clay is in the form of rock and is obtained by mining. It is generally found that the top seams are weak and the deep seams are strong; the clay, therefore, requires careful mixing and blending to make it suitable for tile-making. Owing to their comparative thinness, the material requires careful selection, handling, and burning.

If the clay is too strong, that is, contains too high a percentage of alumina, it requires the addition of, say, ground fireclay to thin it down. A refractory clay, that is, one containing a high percentage of silica, is more suitable, as it is then capable of being burnt to a higher temperature than a strong clay.

WEATHERING. After having been dug, the next operation is *weathering*. Clays differ greatly in the extent to which they are affected by exposure; some are completely disintegrated by standing in the open air for less than a month, whilst others are scarcely affected after years of exposure. Some tile makers consider this process unnecessary for their clay, but it is such an important operation in the production of an efficient and lasting tile, that all clays should be spread out, watered, turned over, and left to weather for at least twelve months.

The clay is next taken and tipped into hoppers containing toothed and plain rollers, which crush and reduce the material into a fine state. It is next placed in an open trough with mixing blades and afterwards thoroughly mixed in a pug-mill, water being added to obtain the required consistency. It should be sufficiently fine to pass completely a 24-mesh sieve.

MACHINE-MOULDING. The material is now ready for moulding, and may be machine-moulded or hand-moulded. In machine-moulding the clay may be in a plastic or in a semi-dry state, but in hand-moulding the material must be plastic.

From the pug-mill the clay is forced through a die, thus forming a long band thicker and wider than the width and thickness required for the finished tile. The forcing of the clay through the die means a reduction to about one-sixtieth of its original bulk, and requires an enormous pressure, which probably produces cleavage lines similar to those in slate, causing the tiles to laminate under the action of alternating frosts and thaws. In addition to this danger there is another. During the passage of the clay through the die, the portion that comes into contact with the sides travels at a different speed, due to friction, to that at and near the centre, thus foliating the tile into a series of very fine leaves.

Another method of moulding employed, and one preferable to the last, is by passing the clay through a set of rollers of the width required, and spaced apart to give the tile its proper thickness after burning. A revolving knife cuts the band of clay into pieces of regular sizes, termed *bats*. These bats are allowed to stand for a few days, after which they are placed in a machine and subjected to a pressure of 20 tons per square inch; at the same time the holes are made and the nibs formed on the tile.

HAND-MOULDING. For hand-moulding, a metal mould is used and it is covered with sand before being filled, to prevent the clay adhering to its sides, and to give to the tile the texture known as *sand-faced*. The mould is formed with two projecting pieces on its edge; these pieces go to form the nibs on the finished tile, and are turned up by the moulder while the clay is soft. The holes are next pierced with a small metal cylinder.

Hand-moulding has the advantage over machine-moulding in that it gives a more homogeneous tile and one less liable to lamination.

With regard to colour, hand-made tiles quickly vegetate and become a natural colour.

DRYING. The process of drying which follows takes from two weeks to eight weeks, according to the plasticity of the clay. The object of drying is to remove the surplus water and thus facilitate handling of the tile. Water is found in two conditions, either as moisture or mechanically mixed with the clay, or in a state of chemical combination.

MODERN BUILDING CONSTRUCTION

Part of the former is evaporated on drying, and the remainder by heating the clay to a temperature of 220° F. The combined water is unaffected until a temperature of 1,100° F. is

reached; at this temperature the clay loses its plasticity and becomes a stone-like mass. The removal of this water is the cause of the shrinkage in the clay, and this should not exceed about 9 per cent. During drying, a slight "camber" is obtained in the length of the tile by placing the tile on a cambered board, or on a shaped bed of sand. This camber is an important quality, as it not only gives a good bedding for

the tile, but reduces capillary attraction to a minimum, and the air spaces thus formed are valuable in assisting evaporation of moisture and in preserving the tile. Tiles are sometimes

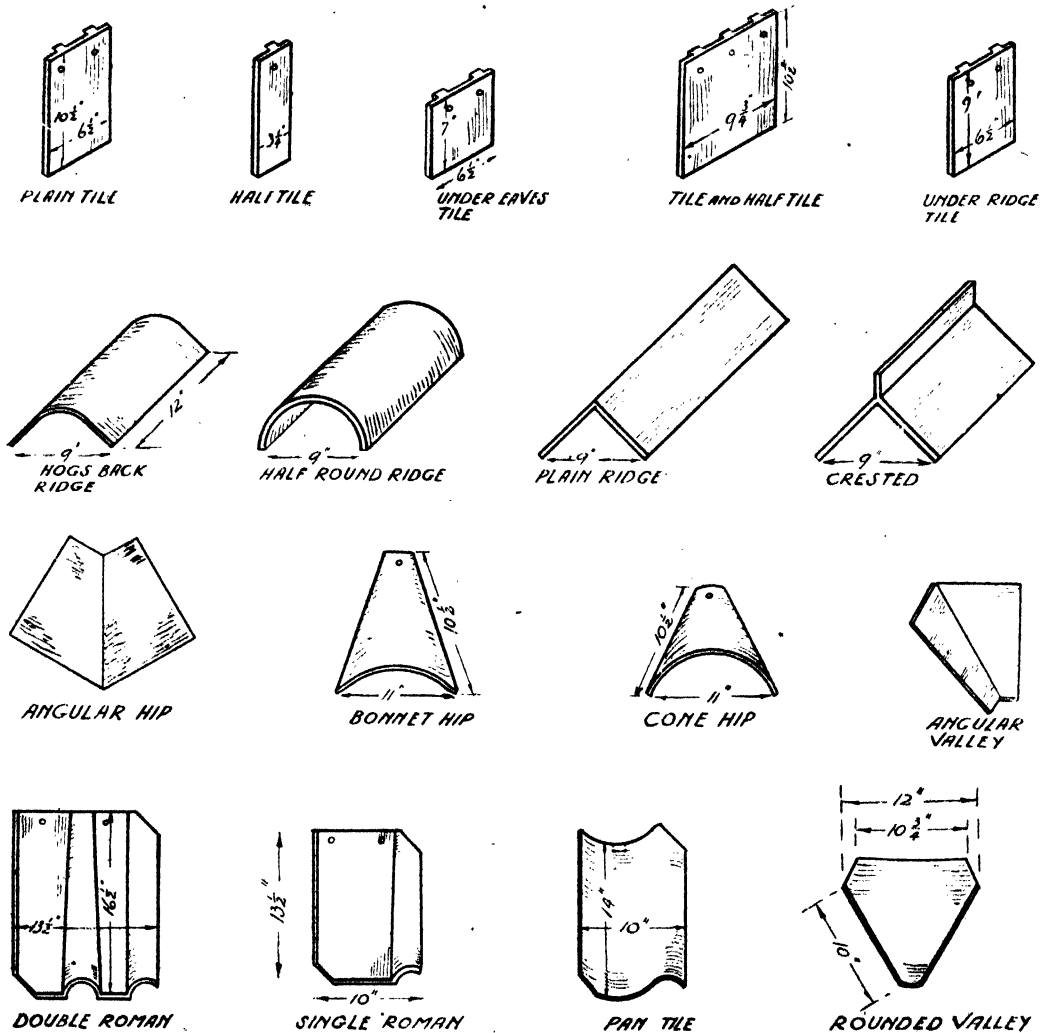

FIG. 22. VARIETIES OF TILES

reached; at this temperature the clay loses its plasticity and becomes a stone-like mass. The removal of this water is the cause of the shrinkage in the clay, and this should not exceed about 9 per cent. During drying, a slight "camber" is obtained in the length of the tile by placing the tile on a cambered board, or on a shaped bed of sand. This camber is an important quality, as it not only gives a good bedding for

found to be curved in their width, but this is due to hard burning.

BURNING. The next operation, and one of the most important in tile making, is the burning, as the weathering qualities of the tiles depend chiefly on sufficient burning. The temperature needed to secure a good roofing tile of satisfactory hardness is between 1,870° F. and 2,100° F.

The heat is applied gradually at first; but the actual burning takes about two days. The greatest heat being at the top of the kiln, the tiles in this position are burnt harder and are darker in colour; while those at the bottom, getting the least fire, are lighter in colour.

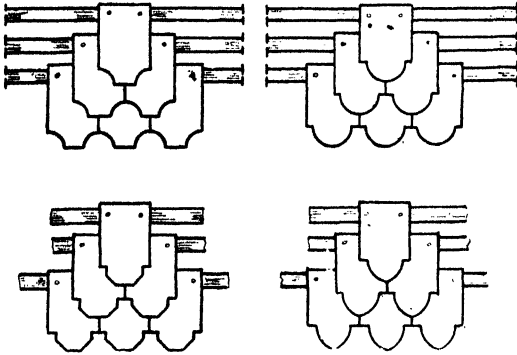

FIG. 23 ORNAMENTAL TILING

There are many shades of colour between these two extremes.

The kiln is left to cool down before the tiles are withdrawn, otherwise the sudden change of temperature would cause the tiles to crack in pieces.

COLOUR. The colour is largely determined by the burning and the amount of oxide present in the clay. There is a wide choice of colours in tiles, ranging from light red to dusty brown, and if used with the right judgment will give variegated tints that make the roofs look very pleasing.

After the tiles are withdrawn from the kiln they are sorted out for colour and quality into three grades: *bests*, *seconds*, and *thirds*.

The principal tile-producing areas are Broseley (Shropshire), North and South Staffordshire, Loughborough (Leicestershire), Berkshire, Kent, Yorkshire, and Somersetshire.

TILING

Of the many varieties of tiles in use at the present time, *plain tiles* undoubtedly make the best and also the most picturesque roof, particularly where hand-made tiles are employed. They are used extensively, with few exceptions, for good-class work, and when properly made will be found to be practically everlasting.

The failure of a good tile roof is usually due to the corrosion of the nails, or the decay of the battens. The tiles measure 11 in. by 7 in. or 10½ in. by 6½ in. by ½ in. in thickness, the latter

size being more in general use (see Fig. 22). They have two nibs on the underside for hanging to the batten, and are laid in a similar manner to that of slates, but being smaller and more porous, they require a steeper pitch (see Table I).

Tiles are sold by the thousand (1,000 only being allowed, and not 1,200 as for slates).

Gauge and Lap. The gauge and lap for tiling are determined in a similar way to that for slating, but no deduction is made in the length on account of the nail hole as in the case of head-nailed slates, the lap being the amount by which a tile covers the next but one below it. The lap generally adopted is 2½ in., which gives a 4 in. gauge. Each tile, therefore, has an effective covering area, when laid to this gauge, of 6½ in. by 4 in., which is 26 superficial inches.

The number of tiles laid to a gauge of 4 in., required to cover a square is given by the formula—

$$\frac{\text{Area of square}}{\text{Width of tile} \times \text{gauge}} = \frac{10 \times 10 \times 144}{6\frac{1}{2} \times 4} = 554 \text{ tiles}$$

It is usual to allow 5 per cent for waste, which gives the total number as—

$$554 + \frac{554 \times 5}{100} = 582 \text{ tiles}$$

If the situation is an exposed one, the gauge should not be more than 3½ in. In this case,

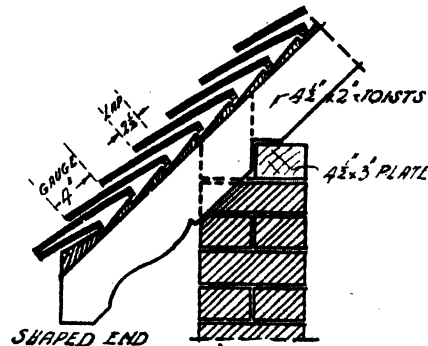

FIG. 24. FEATHER EDGED BOARDING

by the above formula, the number required will be 591 tiles per square.

Variety in Tiling. Variety may be introduced into the work by slightly varying the gauge. If the gauge is, say, 4 in., the gauge rod would be marked, commencing at the eaves, say, 4 in., 4 in., 3½ in., 3½ in., 4½ in., 4 in., 4 in., 3½ in., etc.,

MODERN BUILDING CONSTRUCTION

thus giving the same number of courses without affecting the efficiency of the roof covering, and eliminating the mechanical accuracy often found in modern work. Other means of obtaining variety to the surface in tiling are to use tiles

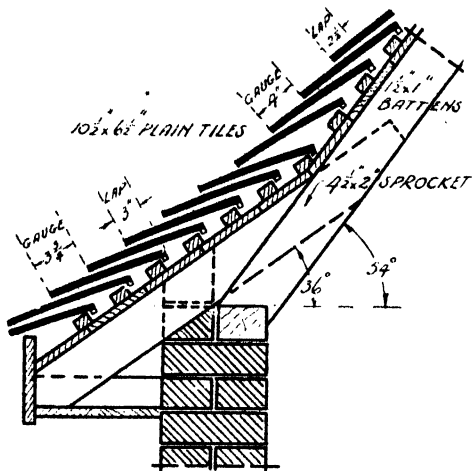

FIG. 25. EAVES FINISHED WITH SPROCKETS

of mixed light and dark shades, or by introducing tiles having their lower ends shaped, as shown in Fig. 23, in bands of three or four courses, between four to six courses of plain tiles.

WEIGHT OF TILES. Tiles weigh, approximately, 21 cwt. per 1,000. The weight, therefore, per square, will be, where a 4 in. gauge is employed—

$$\frac{554 \times 21}{1000} = 11.6 \text{ cwt., approx.}$$

and, if a 3½ in. gauge be adopted, the weight will be 12.4 cwt. per square. This weight, compared with "seconds," or "mediums," in Welsh slating, is nearly double; and, a tile not being impervious to moisture, to this weight must be added the weight of moisture that may be absorbed by the tile, which is anything up to 5 per cent. Owing to this increased weight, stouter rafters are required to ensure a satisfactory roof.

PREPARATORY WORK

The preparation of the roof for plain tiling is similar to that employed for slating, but tiles being a better non-conductor of heat and cold than slates, the use of battens is less objectionable. The sizes of battens used are 1½ in. by 1 in., or 1 in. by ¾ in. In addition to the methods previously described, feather-edged boarding is much in use for tiling at the

present time instead of boarding and battens (see Fig. 24). It is used on the score of economy and is not to be recommended. The boards are cut out of 1 in. thickness of board, which gives approximately ¾ in. at one edge and ¼ in. at the other. For satisfactory work, the width of the board should divide equally into the slope length, and this is obtained in the same way as finding the exact length of the gauge.

Sprockets. These are pieces of timber varying in length from 2 ft. to 3 ft. 6 in., and cut out of timber 9 in. by 2 in. They are placed on the top of each rafter at the eaves, or they may be of the same scantling as the rafters, say, 4 in. by 2 in., from 3 ft. to 3 ft. 6 in. long, and nailed to the side of the rafters, giving a bell-shaped eaves (see Figs. 25 and 26). For this method of eaves finish, a well-known architect, famed for his excellent designs, makes the pitch of the rafters 54°, and that for the sprockets 36°.

A set-square made to an angle of 54° for giving the roof pitch, is simply reversed for the sprocket pitch. While this looks pleasing from an architectural point of view, care must be exercised that the angle at the eaves is not too flat, which, with the increased volume of water

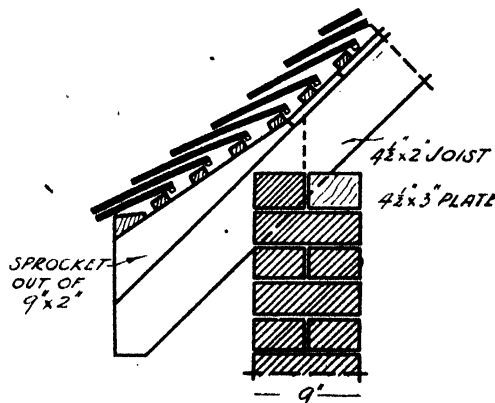

FIG. 26. ALTERNATIVE METHOD OF FINISHING EAVES WITH SPROCKETS

at this point, is often the cause of lamination of the tiles.

FIXING THE TILES

Plain tiles are generally specified to be nailed every third, fourth, or fifth course, and this is quite satisfactory in most cases, but if the building is in an exposed position every tile should be nailed. The nails used are 1½ in. long and preferably made of copper, but these are little employed owing to their expense.

Composition and zinc nails are in more common use. The old method of fixing was by means of oak pegs.

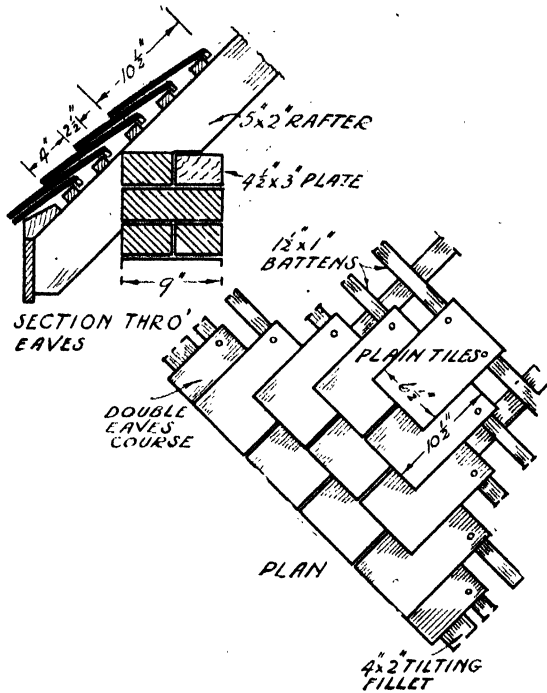

FIG. 27. SECTION AND PART PLAN OF EAVES

Bedding, torching, or rendering to the under side of the tiles should be avoided, and if provision has to be made against extremes of weather, felt and boarding should be employed.

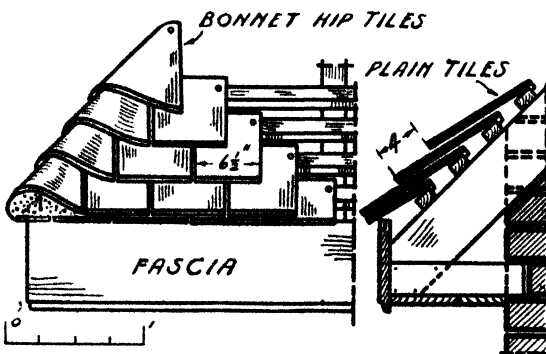

FIG. 28. PART ELEVATION AND SECTION OF HIP, SHOWING BONNET HIP TILES

Eaves. For the under eaves and under ridge course, special tiles are made in order to save cutting. The length of the eaves tile is 7 in., and the length of the ridge tile 9 in. (see Fig. 22).

Section and plan of the eaves, showing application of eaves tile, are shown in Fig. 27

Bond. *Tile-and-a-half Tiles and Half-tiles.* To obtain the bond in the courses, special tiles are made equal in width to tile-and-a-half, that is, 9 1/4 in., and other tiles equal in width to half

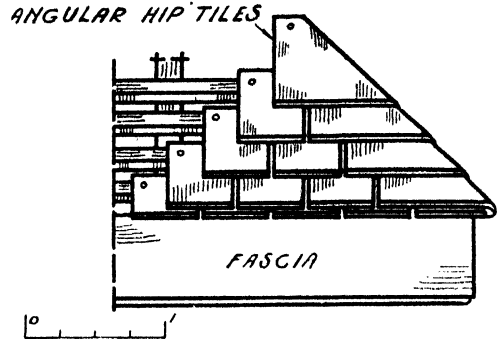

FIG. 29. ELEVATION OF HIP, SHOWING ANGULAR HIP TILES

a tile, that is, 3 1/4 in.; either of these tiles, but for preference the tile-and-a-half tiles, are introduced in alternate courses (see Fig. 22).

Hips and Valleys. For the hips and valleys special, or purpose-made, tiles, termed *hip* and *valley* tiles, are used. The hip tiles may be had *half-round*, *bonnet* (Fig. 28), *cone*, and *angular* (Fig. 29). Of these forms, the bonnet and the

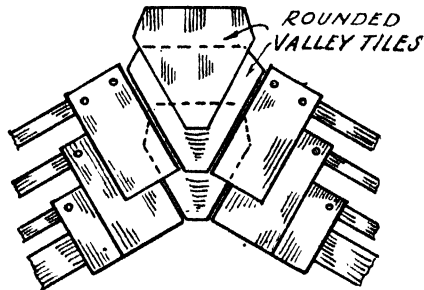

FIG. 30. VALLEYS FORMED WITH VALLEY TILES

half-round make the most pleasing finish, but the latter are somewhat out of scale on small roofs.

Valley tiles may be had in *angular* and *rounded* forms, and should be used in preference to lead, as they look better and the continuity of colour is unbroken. Their application is shown in Fig. 30.

OTHER FORMS OF VALLEYS. The valley may be finished in the form of an *open* or a *secret* gutter, or soakers may be employed and the tiles close-mitred at the angle. For an open gutter (Fig.

MODERN BUILDING CONSTRUCTION

31), a small fillet is placed at the angle, and two tilting fillets, $1\frac{1}{2}$ in. by $\frac{3}{4}$ in. in size, are placed

If a secret gutter is used, the above preparation will apply, except that the tilting fillets will

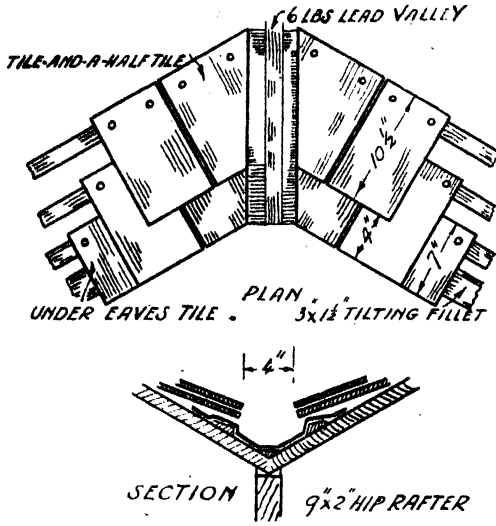

FIG. 31. OPEN VALLEY

parallel to and $2\frac{1}{2}$ in. from the angle, in order to tilt the tiles. The lead is dressed over the

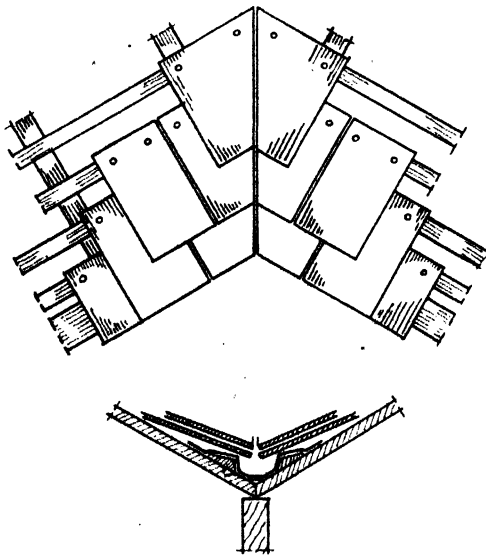

FIG. 32. SECRET GUTTER

valley, and to a height of about 2 in. above the tilting fillet on each side, and fixed. Six-pound lead would be a suitable weight for this purpose. The pieces of lead being cut across the sheet, are in lengths of 7 ft., and are lapped 3 in. at the ends.

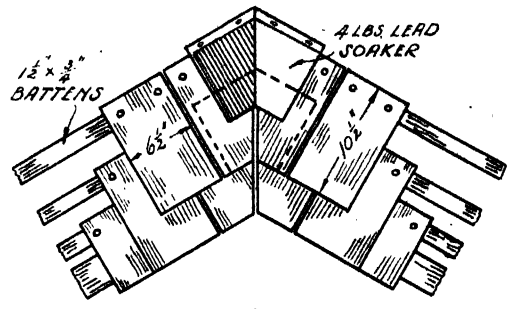

FIG. 33. CUT AND MITRED VALLEY WITH LEAD SOAKERS

be placed nearer the angle and the tiles close up to it, as shown in Fig. 32. This method is not to be recommended, as the gutter is liable to become choked with dirt in a short time.

Another method, not much employed, is the use of soakers placed over the angle, the tiles being close mitred. The tiles adjacent to the angle are tile-and-a-half tiles (see Fig. 33). The soakers extend 4 in. on either side of the angle

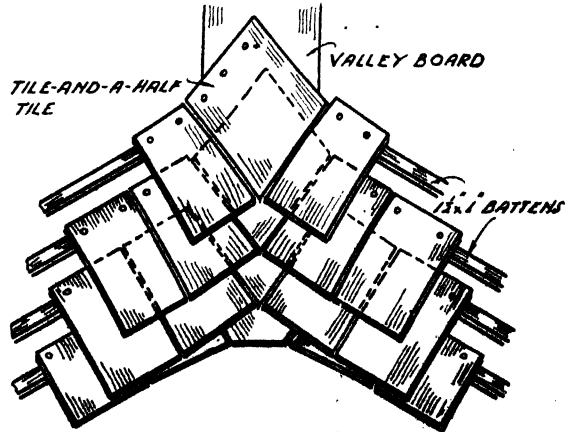

FIG. 34. LACED VALLEY

and are cut parallel to it. In some cases they are made about 2 in. or 3 in. wider at the top. Their length will be equal to the length of the tile plus $1\frac{1}{2}$ in. minus the gauge, that is, $10\frac{1}{2}$ in. + $1\frac{1}{2}$ in. - 4 in. = 8 in.

Other methods employed for covering the valley give *swept* and *laced* valleys. Swept valleys in tiles are formed in a similar manner to that used in random slating, the tiles being cut out of tile-and-a-half tiles.

Laced valleys (Fig. 34) are formed with the

use of tile-and-a-half tiles laid on a 11 in. by 1 in. board, or the valley may be furred out to 14 in. or 15 in. in width, so that the angle is flattened between the roof slopes. The tiles are then laid diagonally up the centre of the valley and nailed. Up to the lower edges of these the plain tiles sweep.

A swept valley is shown in Fig. 35.

Verges. The verges of tiled roofs are formed by a similar method to that used in slated roofs.

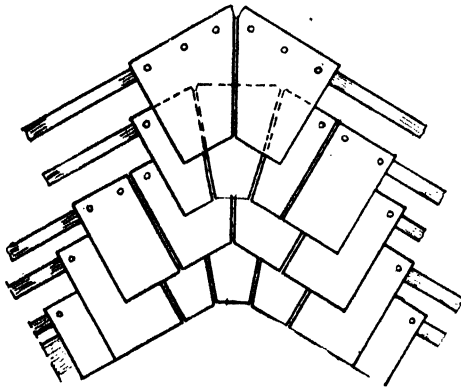

FIG. 35. SWEEP VALLEY IN TILING

A layer of tiles, and in some cases two layers, after being well saturated, are bedded in the wall and made to project 2 in. from it. These tiles should be well bedded in Portland cement and pointed on the external edge. A plain or angular fillet in cement, or a wooden moulding, is placed on the underside of the tiles at the junction of the wall (see Figs. 36 and 37).

Ridges. Ridge tiles may be had either *half-round*, *hog's-back*, or *angular with a cresting*. They measure from 12 in. to 18 in. in length.

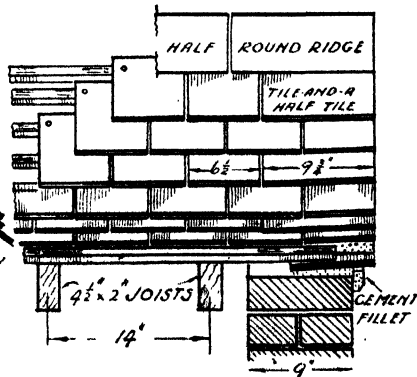
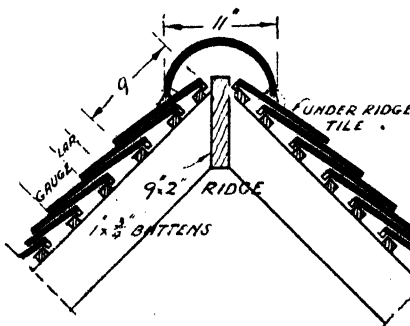

FIG. 36. SECTION THROUGH RIDGE AND PART ELEVATION AT VERGE

These tiles are bedded where the lower edges meet the roof and at their ends (see Fig. 36).

If the ridge of an intersecting roof terminates at a lower level against the roof slope, the junction is finished with a 4 lb. lead saddle piece.

Where the tiles finish against a square abutment, the most suitable treatment to give a watertight job is to use lead soakers and skeleton stepped flashing, or in place of the flashing a fillet of cement. A cement fillet is more suitable

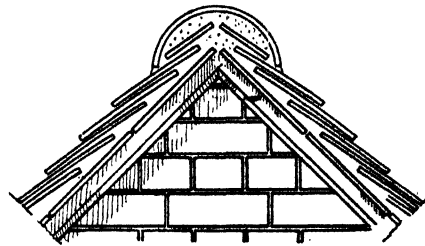

FIG. 37. END ELEVATION OF RIDGE AT VERGE

where tiles are employed as, owing to the roughness of the tiles, a better key is obtained than that afforded by slates.

SPECIAL TILES

Pantiles. These tiles are of a flat-ogee shape in section, and measure 13 1/2 in. by 9 3/4 in., or 14 in. by 10 in. by 3/4 in. thick. They are moulded flat and afterwards bent to shape before burning, a projecting nib being formed on the underside at the head of the tile for hanging to the batten. Nailing is employed only on steep slopes. Battens for pantiling measure 1 1/4 in. thick by 1 in., or 2 in. by 1 in. In some cases, the vertical edges of the tiles are bedded upon counter battens running from eaves to ridge.

MODERN BUILDING CONSTRUCTION

Commencing at the right-hand side of the roof, the tiles are laid in rows from eaves to ridge, without bond, having a lap of 3 in. in their length, and a side lap of from $1\frac{1}{2}$ in. to 2 in.

It should be noted that the lap for these tiles, and for all tiles except plain tiles, is a single one; this lap differs from that given by the formula for slates and plain tiles, in that the tiles in this case cover the tiles in the preceding course by the amount stated, and not the tiles

may be fixed to the top of barge board, and made to project sufficiently far as to cover the joint. Where the walls are carried up above the plane of the roof, the junction is usually covered with a fillet of cement, or pieces of tiles bedded in cement.

These tiles are chiefly used for covering sheds, barns, workshops, etc., and are laid on open battens. They are sometimes used in domestic work, and when so employed the roof should

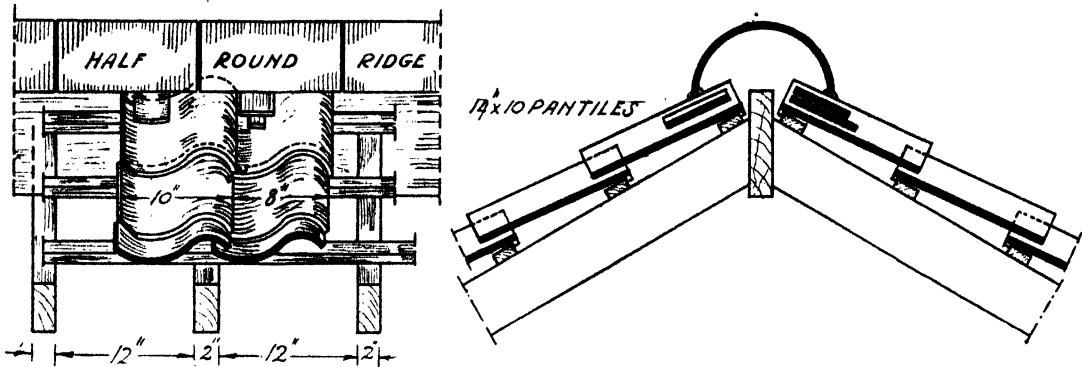

FIG. 38. METHOD OF FIXING PANTILES

in the next course but one, as given in the definition of lap in an earlier chapter.

Owing to their irregular shape and the difficulty in cutting them, especially on the rake, these tiles do not lend themselves to a satisfactory finish to hips and valleys, and therefore should only be used for roofs of simple construction.

Any water falling on the roof gravitates to the concave part of the tile on its way to the eaves, which it reaches, at times, with such a velocity as to splash over the gutter. To obviate this risk, two or three courses of plain tiles are laid at the eaves. This breaks the rush of water from the hollows of the tiles, and distributes it into an even flow into the gutter. When the roof is commenced with pantiles, it is usual to dispense with the tilting fillet.

The ridge is generally finished with a half-round ridge tile which, owing to the wavy lines of the pantiles, rests only on the rolls, leaving a space between the lower edge of the ridge tile and the concave part of the pantile. This space is filled in with one or two pieces of tile, as shown in Fig. 38. This is termed *galletting*.

The verges may be treated in a similar manner to that used for plain tiling, by using a tile undercloak and pointing the edge of the tiles in cement; or a small piece of boarding

be boarded, felted, and battened. When laid with a 3 in. head lap and a $1\frac{1}{2}$ in. side lap, 166 tiles are required to cover a square; and, when given a 2 in. side lap, 177 tiles will be required.

Each tile weighs approximately $5\frac{1}{4}$ lb.; therefore, when laid with a $1\frac{1}{2}$ in. side lap, a square will weigh $7\frac{1}{2}$ cwt. approximately; while, if laid with a 2 in. side lap, the weight will be $8\frac{1}{2}$ cwt. approximately per square.

Other Forms of Tiles. There are many other forms of tiles laid with a single lap; among these are *double Roman*, having two rolls in their width and measuring $16\frac{1}{2}$ in. by $13\frac{1}{2}$ in.; *single Roman*, with one roll, in size $13\frac{1}{2}$ in. by 10 in.; and *corrugated*, measuring $16\frac{1}{2}$ in. by $13\frac{1}{2}$ in. (see Fig. 22). *Spanish tiles*, Fig. 39, are slightly cone shape in their length, which is 14 in. These tiles do not require battens, being fixed direct to the rafters, which are spaced at $8\frac{1}{2}$ in. apart. The *under tile* lies between the rafters, and is fixed thereto with two nails. The *upper tile* covers the rafters and the edges of the under tile, and is made secure with one nail to the rafter. To cover a square 250 of these tiles are required.

Italian Tiles. These are really Roman tiles, but manufacturers called them Italian. They are made in the form of *under* and *over* tiles (see

Fig. 40). The under tile is flat and tapering in plan, with flanges along its longer edges. The over tile is half-round in section, and covers the flanges of the under tile when laid; it is also

natively, coke-breeze blocks, measuring 9 in. by 5 in. by $1\frac{1}{2}$ in., are built into the face of the brickwork between the courses, and the tiles hung to them (see Fig. 42), the blocks being left pro-

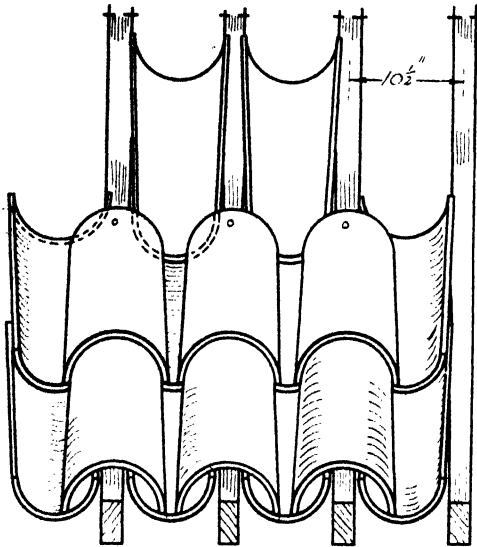

SPANISH TILES

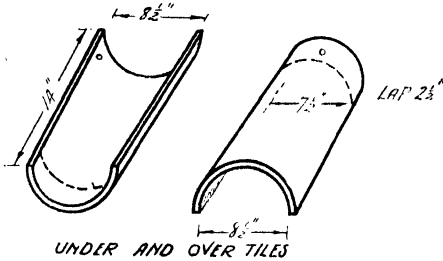

FIG. 39. SPANISH TILES

tapered in its length, so that the end of one tile overlaps the one in the preceding course.

TILE HANGING

Tile hanging construction is used for the protection of walls in exposed positions, or as a covering for thin walls, to give an equable temperature to the interior of the building.

The tiles may be hung to battens, which are fixed by nailing to coke-breeze bricks, built into the walls at regular intervals, or they may be fixed to timber framing where the building laws permit.

Another method is to build the wall brick-on-edge in Flemish bond, and to nail the tiles direct to the mortar joints (see Fig. 41); or, alter-

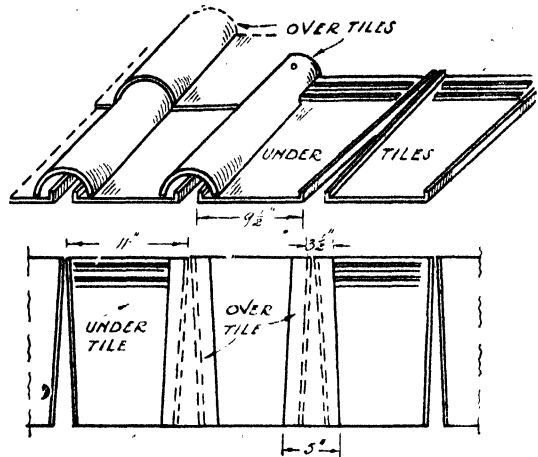

FIG. 40. ITALIAN TILES

jecting for this purpose. This gives a lap of $1\frac{1}{2}$ in., which is generally sufficient for vertical work.

As the woodwork in such positions is liable to decay, the latter methods tend to more permanent work.

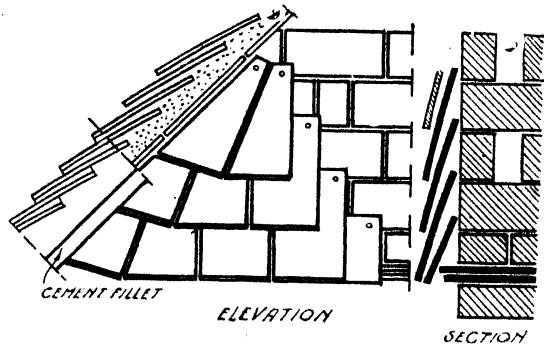

FIG. 41. JUNCTION OF TILE HANGING WITH VERGE

In most cases, vertical tiling is commenced at first floor level, and made to project over a corbelled brick course. All tiles in vertical work are nailed.

If it is desired to cover an existing wall with tiles, the battens may be nailed to wood plugs, driven into the joints of the brickwork at intervals, or the tiles nailed direct to the mortar joints. This latter method is the better,

MODERN BUILDING CONSTRUCTION

providing the mortar joints are sound, but gives an excessive lap.

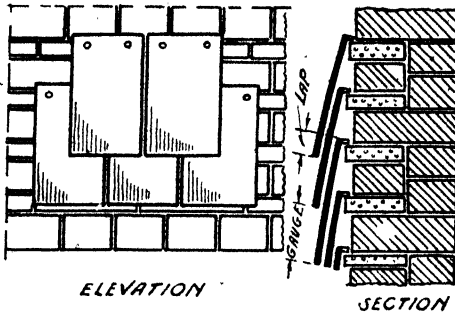

FIG. 42. TILE HANGING

Angle Tiles. Special angle tiles, right and left-handed, are made for the angles, one side

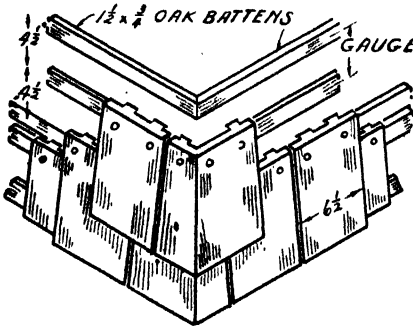

FIG. 43. SQUARE ANGLE IN VERTICAL TILING

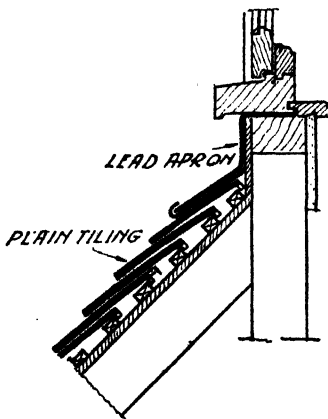

FIG. 44. TREATMENT OF TILING AT SILL

being equal to a tile in width, and the other side to a half-tile (see Fig. 43).

Ordinary tiles may be cut and mitred, and

lead soakers placed underneath across the angle.

Dormer cheeks may be covered with tiles which can be finished flush with the face of the frame, or returned on the face of the same and finished with angle tiles.

Finish of Tiling to Window. Where window openings occur in walls covered with tiling, the junction between the sill and the tiling is covered with a lead apron of 4 lb. lead, fixed to the back of the sill, and dressed down over the tiles (see Fig. 44). The top of the opening is finished with either a moulded tilting fillet, Fig. 45, or by bedding one or two courses of plain tiles over the frame and projecting 2 in. from it. The moulding along the top of the frame may be continued down the sides of the frame, which should be placed flush with the face of the brickwork, to form a stop for the tiling. Where this is not done the end tiles are bedded and pointed in cement.

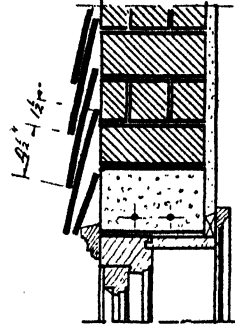

FIG. 45. TREATMENT AT HEAD OF OPENING

The junction of the tile hanging with the verge of a roof necessitates the tiles at this part being cut to the pitch of the roof, and to cut one tile only would result in having no means of fixing it. If, however, a piece is cut off the last two tiles in the course, a nail-hole is obtained in each, and a fixing thereby secured (see Fig. 41).

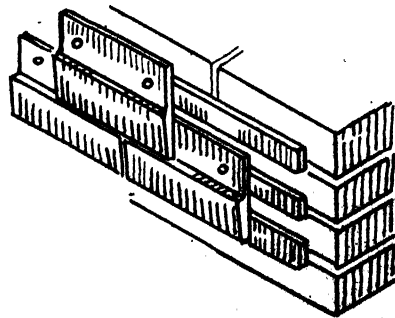

FIG. 45A

Brick Tiles. Fig. 45A shows a type of tile which resembles brickwork when fixed, and has been used in the South of England. This brick tile measures $8\frac{1}{2}$ in. by 6 in. and is hung with a 3 in. lap, as shown, on $1\frac{1}{2}$ in. by $\frac{3}{4}$ in. battens to brickwork or timber framing.

Chapter III—FINISHINGS

Ridges. To prevent any water from making its way to the interior at the joints where two side slopes meet, some form of protection will be required. The most common method adopted in tiled roofs is to cover the ridge with rounded, or other form of tile, bedded at the joints and along the bottom only, where the tile rests on

is usually dressed over a wooden roll 2 in. in height and 1½ in. wide; this roll is rounded on the top and has the sides splayed to 1 in. at the bottom. The bottom of the roll should be on a line with the slating; see Fig. 47.

The width of lead required is about 18 in.; this width allows about 6 in. to lie on each slope

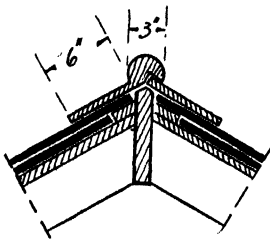

FIG. 46. SLATE RIDGE

the slope. This bedding at joints and bottom allows a circulation of air to the ridge board. These tiles are used in slated as well as tiled roofs, but in most cases do not harmonize with

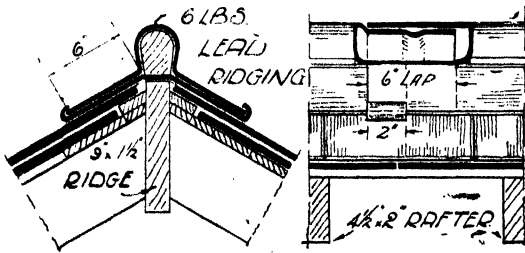

FIG. 47. LEAD RIDGE

the colour of the slate used. This is termed a *tile ridge*; see Fig. 22.

Another method is to employ a *sawn slate ridge*, which is formed with a roll and two wings; see Fig. 46. These ridges are generally made in two pieces, with the roll worked on one wing, and fixed to the ridge board with brass, or copper, screws. Small slate dowels are used in the joints at the roll to give a more secure fixing. The appearance of these rolls is not good.

Lead ridges are not so much used as formerly owing to their cost. When employed, the lead

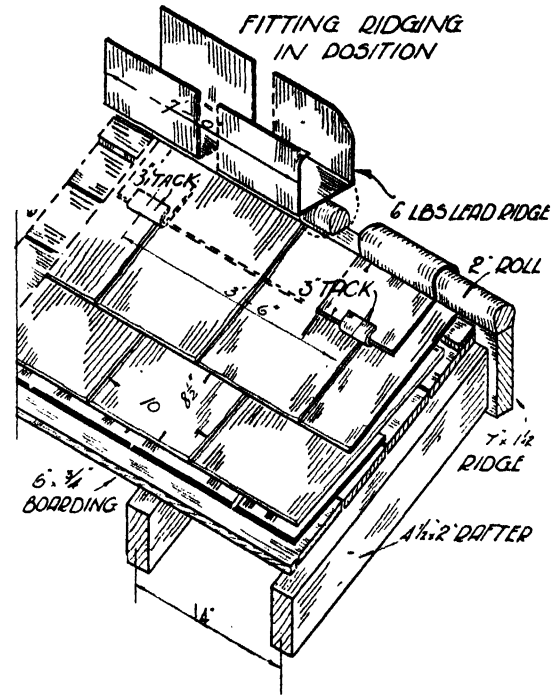

FIG. 48. LEAD RIDGE

of the roof. It is secured with lead tacks placed at intervals of 3 ft. 6 in. along the ridge. These tacks are secured in position, with double-pointed spikes, before the roll is fixed. The spike is driven through the tack into the ridge board, half of it being left projecting to fix the roll. The ridge lead is then dressed over the roll and fixed with the tacks. Fig. 48 shows the ridge lead being fitted, and also the finished ridge.

Where the lead ridge finishes against an abutment, a separate piece, termed a *saddle piece*, is used, Fig. 49, or the roll lead is bossed

MODERN BUILDING CONSTRUCTION

up against the wall $1\frac{1}{2}$ in., and finished with a capping piece; see Fig. 50.

In good class work, a rebate is formed in the roll to take the extra thickness of lead where the lap occurs; this gives a straight line to the

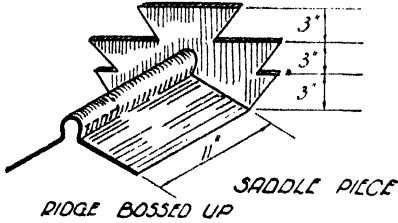

FIG. 49. SADDLE PIECE

ridge. In addition to the rebate, a groove is cut across the roll to prevent water being drawn through by capillary attraction.

Hips. Hips require somewhat similar treatment to ridges, and may be formed in the same

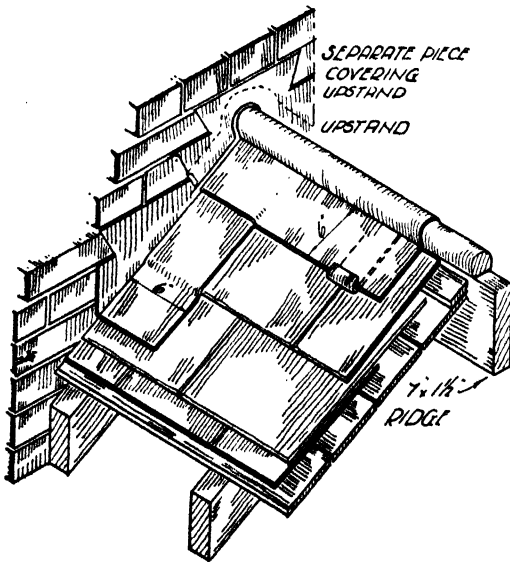

FIG. 50. TREATMENT OF LEAD RIDGE AT WALL END

way as described above, but the slates require cutting on the rake to fit against the hip. If hip tiles are used, it is usual to secure the end tile from slipping by screwing, or driving, into the back of the rafter a piece of wrought-iron turned up at the end. This piece of metal is termed a *hip hook*.

At the junction of the hips with the ridge, the joint is formed with a purpose-made tile, either

plain or ornamental; when ornamental it is termed a *tile finial*. When lead is employed the junction is finished as shown in Fig. 51.

Another method of finishing the hip, which cannot be employed at the ridge, is by cutting

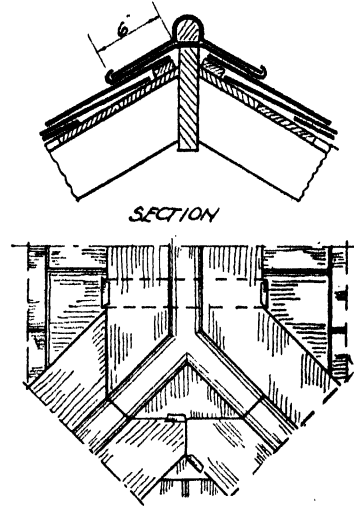

FIG. 51. JUNCTION OF RIDGE WITH HIPS

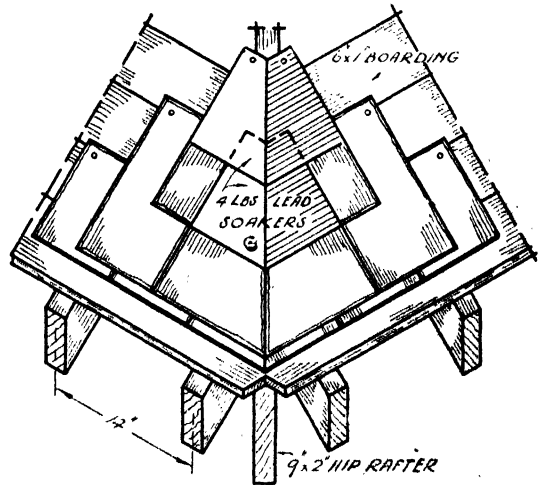

FIG. 52. HIP FORMED WITH SOAKERS

the slates to form a close-mitred hip and placing 4 lb. lead soakers across the joint, Fig. 52, lapped and bonded in with the slates and nailed at the top edge; or a secret gutter can be formed along the hip rafter, giving a watertight joint: see Fig. 53.

The former method of finishing the hip is the best. This particular method is usually adopted where Westmorland slates are used. The pitch

laid in with each course of slates, in a similar manner to that employed for hips; see Fig. 54. The more common method, however, is to

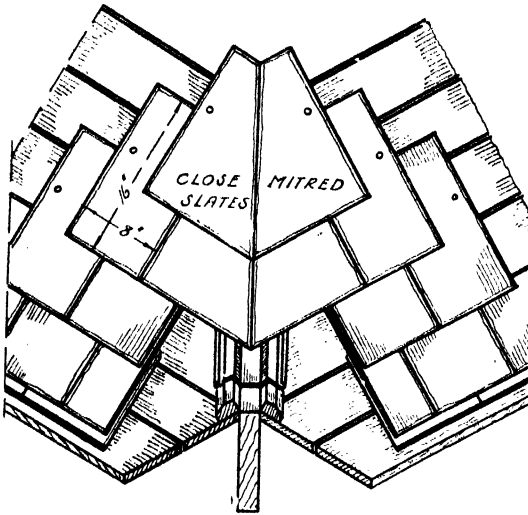

FIG. 53. HIP FORMED WITH SECRET GUTTER

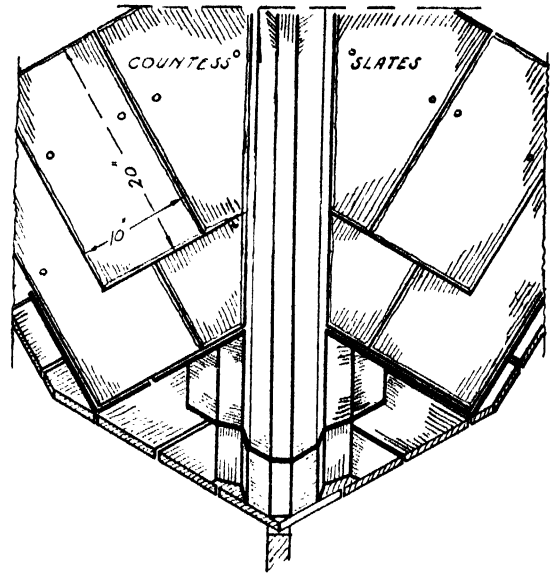

FIG. 55. VALLEY FORMED WITH OPEN GUTTER

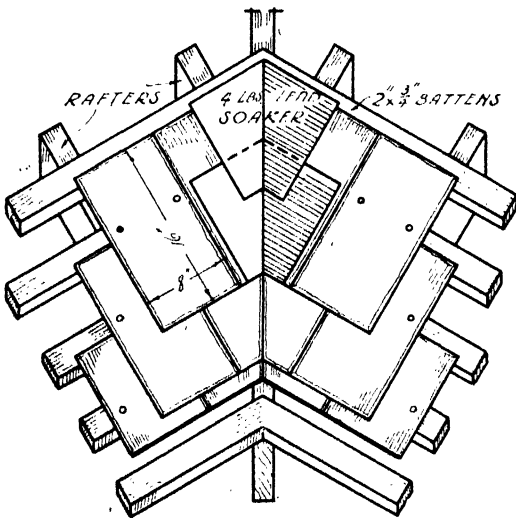

FIG. 54. VALLEY FORMED WITH SOAKERS

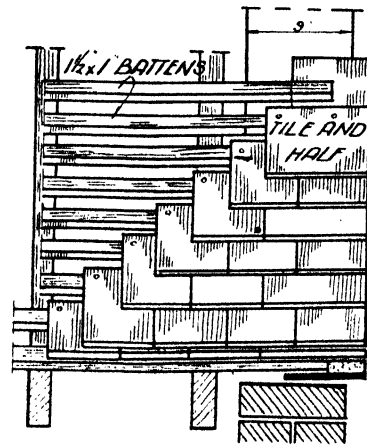

FIG. 56. VERGE TO TILING

should not, however, be less than 45°, nor yet should slates less than 8 in. wide be used. Slates of 8 in. in width give a 12 in. wide slate for slate-and-a-half slate, which can be easily obtained.

Valleys may be finished with the slates close-mitred, and the angle covered with lead soakers,

employ sheet lead. The preparation for the work will be to place two tilting fillets 3 in. or 4 in. from the angle of the valley and parallel to it. This is all that is necessary if the roof is boarded; but if, however, the roof is battened, only valley boarding will be required to a height of about 10 in. on each slope, to form a backing

MODERN BUILDING CONSTRUCTION

for the lead. A small fillet is usually placed at the angle of the valley to take off its sharpness; see Fig. 55.

The lead is cut to 7 ft. lengths and 20 in. in width; it is dressed along the valley and over and beyond the tilting fillets on the slope to a height of 9 in. The ends are lapped 6 in., and the edges nailed with copper nails. These pieces of lead terminate at the ridge, and the point where they meet is covered with a piece of lead, termed a *saddle piece*, which is dressed over the ridge and into the valley on each side. The

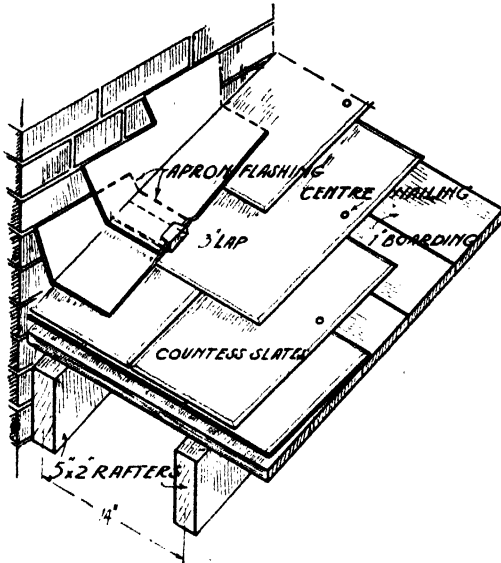

FIG. 57. JUNCTION FORMED WITH APRON FLASHING

slates along the valley are cut on the rake, and should finish flush with the tilting fillet; otherwise, if allowed to project, they are liable to be broken by workmen when making repairs to the roof. Where valleys run as high as the ridge of the main roof, the ridge lead is simply dressed over the valley; or where the hips meet the ridge, the ridge lead is dressed down over the ends of the hips.

Verges (Fig. 56). The method of treatment is similar to that described for slating, page 575.

JUNCTIONS BETWEEN ROOFS AND WALLS

When a roof abuts against a wall, an angle is formed, which it is necessary to protect with sheet lead, or other material, to prevent the rain-water from penetrating the roof at the point of junction. Among the various methods

employed are *single*, or *apron*, flashings; *skeleton*, or *hanging*, flashings; and *soakers*, *cement fillets*, and *secret side gutters*.

APRON FLASHING. Sheet lead makes the best form of joint between the wall and the roof, and may be in a single piece, as an apron flashing. This is about 12 in. wide, half of which lies on the roof, while the remaining half is turned up against the wall, Fig. 57. If the wall is built of stone, a raglet is cut in the stonework about 5 in., or 6 in., from the roof and parallel to it, to receive the upper edge of the lead. This

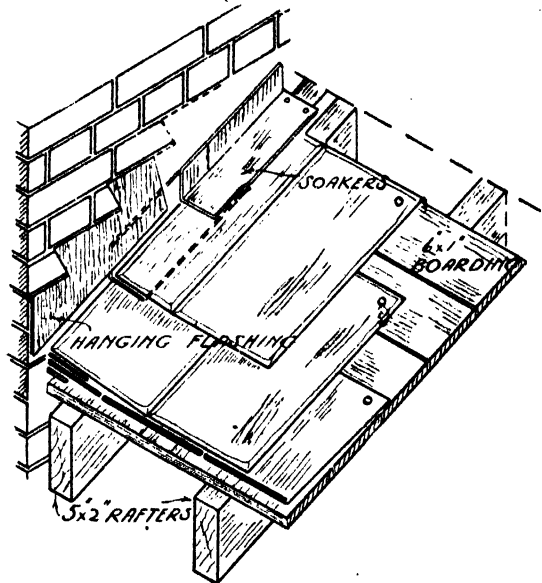

FIG. 58. JUNCTION FORMED WITH SOAKERS AND SKELETON HANGING FLASHING

edge is turned into the raglet about 1 in., and secured with wood or lead wedges, and the joint afterwards pointed in cement. If, however, the wall is built of brick, the upper edge of the lead against the wall is cut in the form of steps, the lower edge of which should finish not less than 2 in. from the roof. A line parallel to the roof plane, cutting these points, is known as the *water line*.

When cutting out the steps in the lead an extra piece, about 1 in., is left on the top edge of each step to be turned into the joints of the brickwork; this lip is afterwards wedged with wedges and pointed in cement, as already described. In all cases where the roof abuts against the wall, a tilting fillet should be provided to divert the water from the wall.

Before the lead is fixed in position, small strips of lead, called *tacks*, about 8 in. or 9 in. long,

and 2 in. to 3 in. wide, are fixed to the battens, or boarding, to secure the part of the lead which lies on the roof. They are placed at 3 ft. 6 in. intervals, and are fixed slightly inclined towards the eaves, to prevent water being drawn along the tack to the inside.

SOAKERS. The best method is to use pieces of lead called *soakers*, which are 7 in. to 9 in. in width, according to the size of the slate used, and in length equal to the gauge of the slate, plus the lap, plus 1 in. for fixing to the woodwork. About 2½ in. of the width is turned up against the wall, while the remainder lies between each course of slates. To protect the edge of the portion against the wall, another piece of lead, called a *skeleton*, or *cover, flashing*, about 6 in. wide, is fixed into the brickwork, or stonework, and dressed down over the soakers

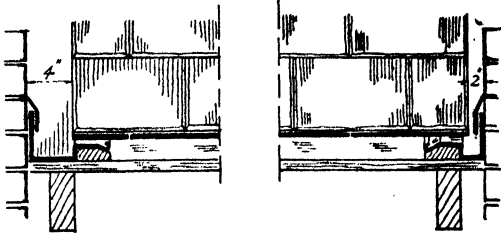

SIDE GUTTER

SECRET GUTTER

FIG. 59

finishing on a line with the slates; see Fig. 58. In this method, the expansion and contraction of the lead is much reduced, as the soakers are almost entirely covered by the slates.

CEMENT FILLET. As a compromise between efficiency and cheapness, a fillet of cement is sometimes used instead of the skeleton flashings to cover the edge of the soakers against the wall, and in some cases zinc is used for the soakers in lieu of the lead.

SECRET GUTTER. Another method is to form a *secret* or *side gutter*, Fig. 59, along the junction, by placing a 3 in. by 1 in. fillet 2 in. or 3 in. from, and parallel to, the wall and lining it with lead. One edge of the lead is dressed over the tilting fillet, and then nailed and weltd. The object of the welt is to stop any water that may make its way under the slates and over the gutter, and direct it towards the eaves. The other edge of the lead is turned up against the wall, and finished with a stepped skeleton flashing; or the gutter may be formed of a single piece of lead, the upper edge stepped and fixed to the wall. This method is also employed along the edge of dormers, the lead on the dormer

cheek being dressed over it. Secret gutters are not to be recommended, as they are liable to become choked with leaves and debris. A cement fillet is often used to form the joint as above. If carefully done, it may remain good over a long period, but it is apt to break off sometimes in pieces. It is better adapted to a tile roof than to a slated roof, as the tiles, owing to their roughness, provide a better key for the fillet (see Fig. 60).

Junction of Roof with Chimney. When a roof plane is intersected by a chimney stack, a watertight junction is formed in the following

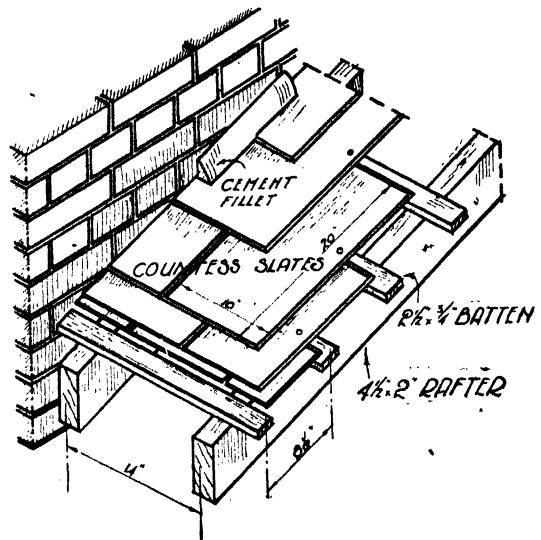

FIG. 60. JUNCTION FORMED WITH CEMENT FILLET

manner. On the lower side of the stack is fixed a piece of lead about 12 in. wide, half of which stands up against the stack and the upper edge turned into the brickwork joint, the remaining half being dressed down over the slates. The lead is made about 6 in. wider than the stack to allow of its being dressed round the angles. This piece of lead is termed an *apron* (see Figs. 61 and 62). The joint at the side of the stack is formed in a similar manner to that already described for a square abutment, that is, with an apron flashing. The flashings are made long enough to be returned at the angles sufficient to cover the apron on the face of the stack about 3 in., the edges being secured with tacks.

On the back of the chimney a small gutter is formed. The lead is turned up against the

MODERN BUILDING CONSTRUCTION

stack about 5 in., and the edge covered with a hanging flashing, this flashing also being turned round the angle and finished over the side flashings. The other edge of the gutter lead is dressed over a tilting fillet and about 9 in. up the roof slope, and the edge nailed with copper nails. The lead is of sufficient length to allow it to be dressed down over the slates, and so make a watertight job.

Skylight Openings. When a skylight or trapdoor is formed in a roof, the junction of the

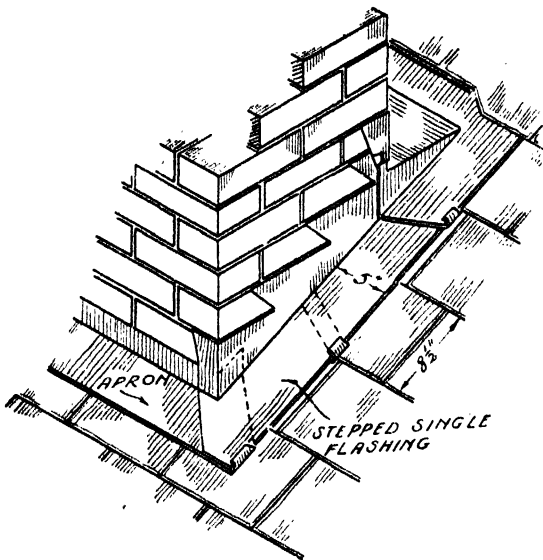

FIG. 61. JUNCTION OF ROOF WITH CHIMNEY SHOWING APRON FLASHING

roof with the sides of the opening require somewhat similar treatment to the junction of a roof with a chimney to render it weatherproof. The lead in this case is in the form of an apron or single flashing, and is made wide enough to be on the roof cover, the vertical side to be dressed over the top of the curb or lining, whichever is used, and to be close copper nailed to it. The frame of the light projects usually 2 in. over the sides, thus forming a weathertight joint.

Dormers, Fig. 63, may be rendered watertight either by being slated or tiled in keeping with the general covering of the roof, or they may be covered with sheet lead. When the slating or tiling is continued below the sill, an *apron* is required at the junction of the sill with the roof, and this is fixed before the window frame is placed in position. This piece of lead is of 5 lb. per super-foot and lies 6 in. on the

slates or tiles. It is taken underneath the sill and turned up 1 in. at the back. It extends about 6 in. beyond the cheeks, and is dressed round the angle into the roof slope.

The first soaker against the dormer cheek is made sufficiently large to be worked over the end of the sill, and it is then termed a *worked*, or *bossed*, soaker. Instead of bossing the end of the soaker over the sill, a groove is cut in the end of the sill, in a line with the face of the frame, so that the lead covering the cheek passes down the front of the frame, through the groove in the sill, and lies over the apron. When this latter method is adopted, the sill should be kept sufficiently high to clear the line of the roof covering. Of the two methods given, the latter is the neater and the better one.

The lead covering to the cheeks is next fixed, the top edge being welted or nailed behind a roll, if one is used, and the edge of the sheet turned on to the face of the frame and finished with a single welted joint, copper nailed.

In addition to the above fixing for the cheeks, it is necessary, owing to the weight of the lead, and as a precaution against its tendency to creep, to provide intermediate supports or fixings at intervals of about 2 ft. to 2 ft. 6 in. apart. This support is obtained by the use of *soldered dots* or *secret tacks* for small areas and vertical *welts* for larger areas. A soldered dot is formed with a brass or copper screw and washer, and then soldered over and wiped flushed, a circular sinking about 2 in. to 3 in. in diameter and $\frac{1}{2}$ in. in depth being taken out of the boarding to allow this to be done. As this sinking leaves only $\frac{1}{4}$ in. in thickness in a $\frac{3}{4}$ in. board at the back of the dot for fixing, additional support is given to the screw by a small piece of wood placed on the inside.

A secret tack is formed by soldering one end of a piece of lead, about 5 in. wide and 9 in. long to the back of the sheet, passing the other end through a slot in the boarding and fixing it on the inside with screws. The slot is made sufficiently wide to allow for any expansion in the sheet due to changes in temperature.

A better method than those described above is to solder a piece of $\frac{3}{4}$ in. diameter lead pipe about 2 $\frac{1}{2}$ in. long to the back of the sheet, at the point where support is required, and to groove the board to receive it. The upper end is then bent and passed through a slot prepared in the boarding, and the end of the pipe *tafted* to hold it in position.

The lower edge of the cheek lead forms the

flashing to the roof soakers, or secret gutter, whichever is employed, and is secured with *bale tacks* as shown. These tacks are employed in lieu of single tacks, as, being stiffer, they hold the sheet much better.

Where the dormer cheeks are large the lead is fixed in several pieces. These pieces should

not exceed about 8 super-feet in area. The vertical joints between the sheets are formed by welded joints, the horizontal joints being lapped and secured with tacks.

The top of the dormer, if comparatively small, may be finished with one piece of lead, but in many cases it is necessary to use rolls to form the

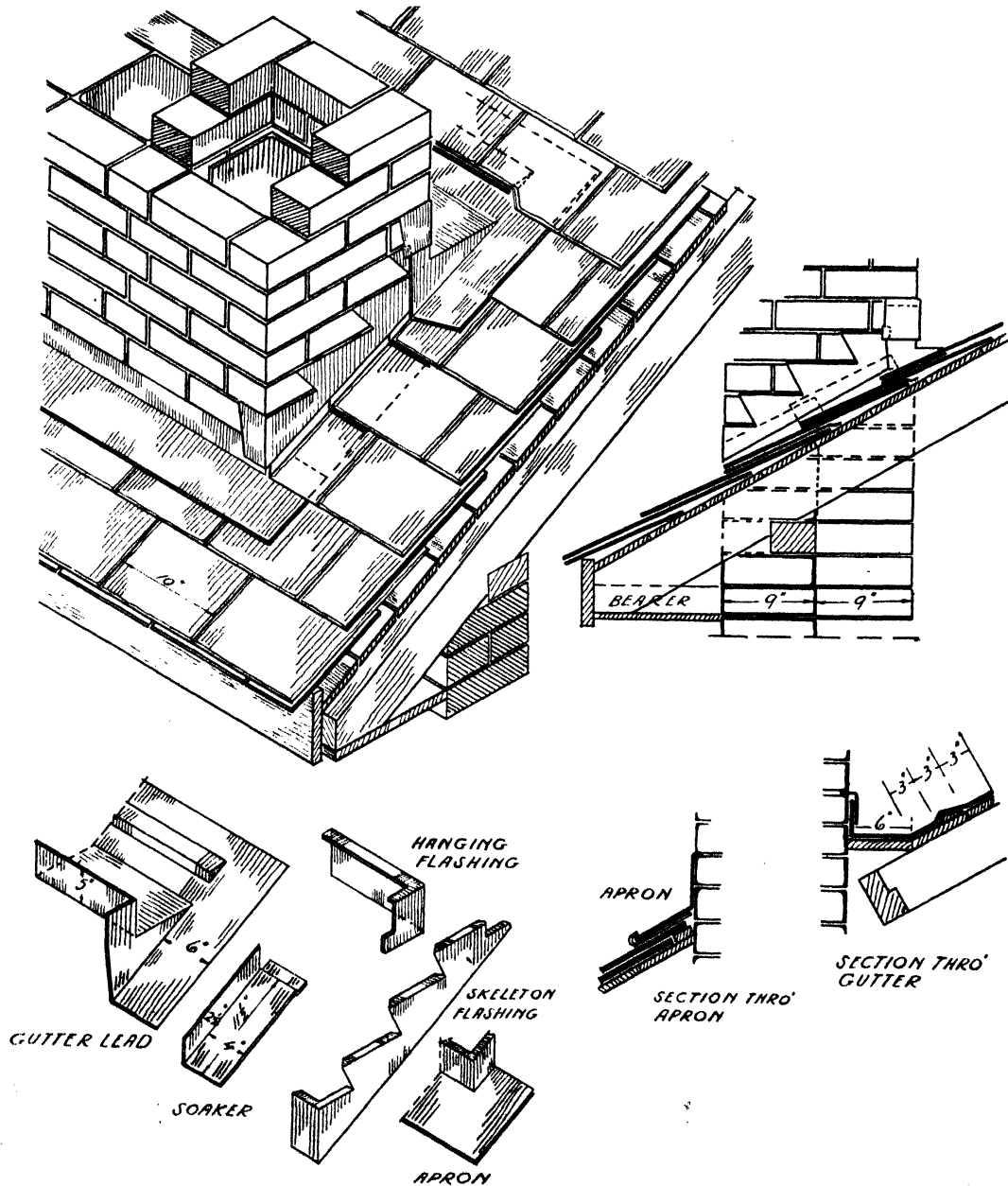

FIG. 62. FLASHINGS AND SOAKERS TO CHIMNEY

MODERN BUILDING CONSTRUCTION

joint along the edge of the sheet. The rolls should be placed not more than 2 ft. 8 in. apart. As 3 in. of the sheet is required to form the undercloak, and 7 in. for the overcloak, this makes up a width of 3 ft. 6 in., which is half the width of a sheet of lead.

The angle between the top of the dormer and the cheek may be left plain, and the top covering

turned down over the sides and front about $1\frac{1}{2}$ in. and close copper nailed. The lead covering to the cheeks is finished behind a fascia and nailed.

A better method is to form the angle with a flat welt and to work into it copper tacks at intervals. This form of tack is termed a *weltd tack*.

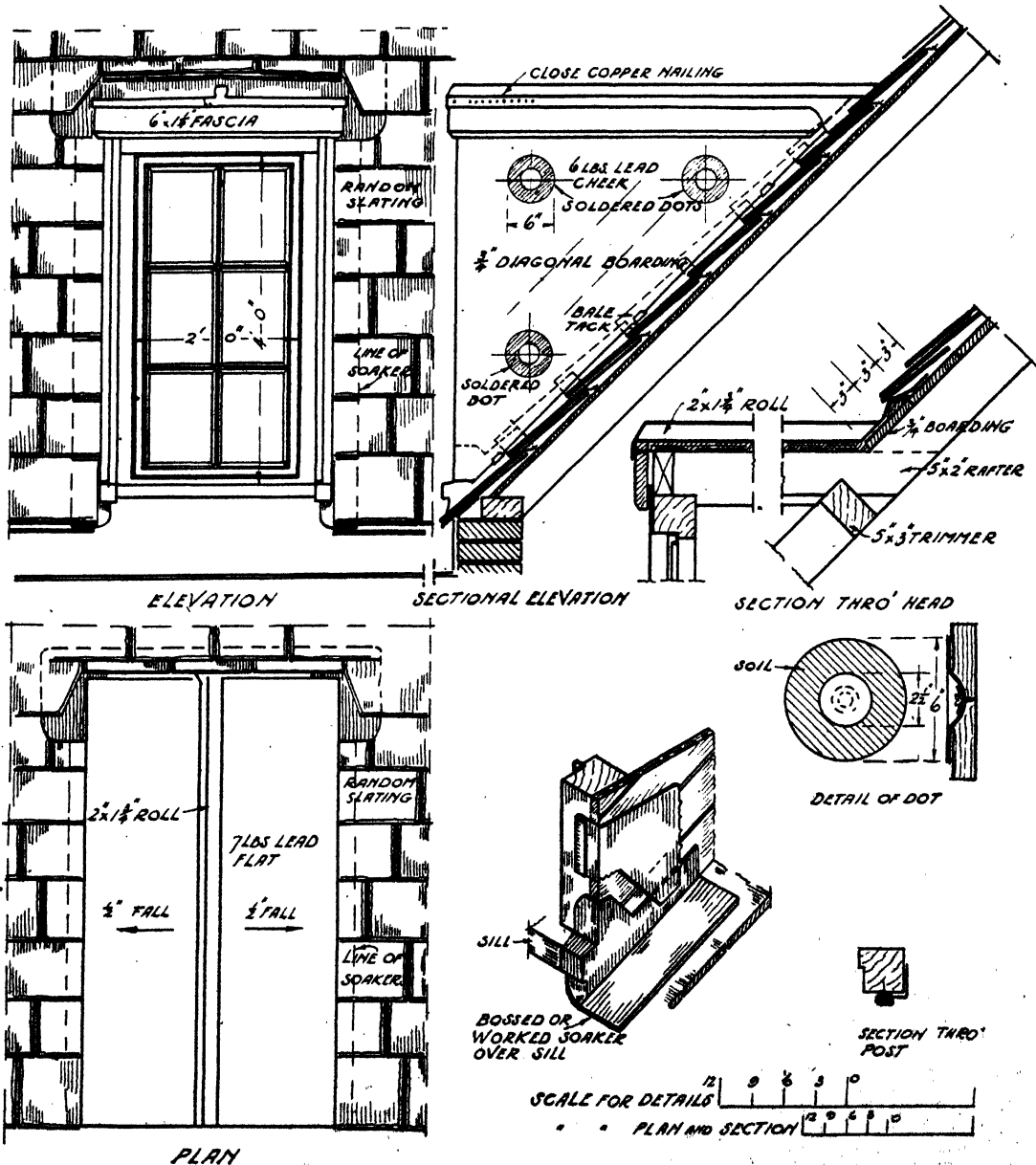

FIG. 63. COVERINGS AND ROOF FINISHINGS TO DORMER

The angle is often finished with a wooden roll and the lead covering dressed over it, the bottom edge being secured with tacks. The tacks are placed in position before fixing the roll. The roll should be well under-cut to assist in keeping the lead in position, while giving freedom for expansion. If, instead of a roll, a moulding is used, the lead covering in this case is turned down and covers only the nosing of the moulding, to which it is copper nailed.

Lead Finishings. The sheet lead used in roof finishings is obtained from the manufacturers in either cast or milled sheets, the former being rarely used in present-day construction.

Milled lead is made in sheets of 7 ft. or 8 ft. in width, and from 30 ft. to 40 ft. in length. It may be had in weights from 4 lb. to 12 lb. per superficial foot.

Lead is greatly affected by heat; it is, therefore, undesirable to fix all edges of the metal. One edge only of a piece of lead should be rigidly fixed, thus allowing the body of the metal to expand and contract according to variations in temperature. Lead is one of the most serviceable metals in use for finishings to roof work. It fits more closely than copper or zinc, and therefore prevents leaks during driving rain. It is used at all junctions of roof planes with walls and chimneys, and is most adaptable as a covering for hips, valleys, ridges, gutters, flats, etc. The weight per foot super for the various parts of a roof are 4 lb. per super-foot for soakers; 5 lb. per super-foot for flashings, aprons, tacks, and secret gutters; 6 lb. per super-foot for hips, valleys, and ridges; and 7 lb. per super-foot for flats, gutters, and cesspool to gutters. (See section on "Plumbing" for fuller information.)

GUTTERS

Gutters are used behind parapet walls and between sloping roofs to carry off the water from them. They may be either *tapering* or *parallel*. Where tapering gutters occur behind parapet walls, they taper on one side only, and are usually termed "parapet gutters." Where they occur at the bottom of roof slopes they taper on both sides, and are known as "tapering," or "V," gutters (see Figs. 64 and 65).

Tapering Gutters are formed on the top of the common rafters, being supported by bearers, which are fixed to each rafter at heights varying to suit the fall; the bearers carry the gutter boarding.

In long gutters it is necessary to introduce

two or more *cesspools*, or outlets, at convenient intervals, to prevent the width of the gutter becoming excessive.

A gutter should run in lengths of not more than 9 ft., and have a minimum fall of 1 in. in 10 ft. The width at the narrowest part should not be less than 9 in. The joints across the gutter are formed with a *drip* not less than 2 in. in depth, as shown in Fig. 66. Along the top edge of the drip, a rebate 1 in. wide is formed, into which the edge of the *undercloak* is finished, and is secured with copper nails. The *overcloak* is carried over the drip and usually lies about 1 in. on the lower gutter, while the part of the lead on the roof side, and on the wall side, extends forward about 3 in., to lessen the risk of water finding its way between the sheets. Some plumbers do not allow the overcloak to project on to the lower gutter, but finish it about $\frac{1}{2}$ in. from the lower gutter, to prevent capillary attraction.

When two adjacent gutters fall in different directions, the joint between the lead sheets is formed with a wooden roll over which the lead is dressed.

The lead forming the gutter is turned up against the wall to a height of about 5 in., and the edge protected with a hanging flashing as shown. The part of the lead on the roof side is dressed over the tilting fillet, which is placed 3 in. above the sole of the gutter and parallel to it, to a height of 9 in. up the roof slope, and fixed with copper nails.

Parallel, or Box, Gutters have their sides parallel, and are formed by placing two pole plates at a distance of not less than 12 in. apart. To support the gutter boarding, small bearers are fixed between the pole plates at intervals of about 16 in., and at heights to suit the fall. The boarding in turn carries the lead lining. Where the gutter is shallow, the lead may be in one piece in width; but, if a deep gutter, the upper edges are finished with a flashing.

At the lower end of the gutter the outlet takes the form of a cesspool and a socket pipe (see Figs. 67 and 68), or the outlet may be in the form of a shoot.

The cesspools to the gutters have a minimum size of 9 in. square and 6 in. deep, and are lined with 6 lb. or 7 lb. lead, bossed out of a single piece, or cut and soldered at the angles, the latter being the more usual way. See section on "Plumbing" for further details.

The water is conveyed from the cesspool to the rain-water head on the outside of the wall

MODERN BUILDING CONSTRUCTION

through a 3 in. or larger diameter socket pipe, which is soldered to the lining of the cesspool, and is usually twice bent in its length. The socket pipe is generally taken from the bottom of the cesspool, but in some cases it is arranged at the angle. This is useful where there is insufficient space under the cesspool, and one bend only is required for the pipe in this method.

The end of the socket pipe should be provided with a galvanized wire domical grating to prevent the pipe becoming choked with leaves and rubbish.

Where the outlet is in the form of a shoot, the lead is dressed over the opening in the wall, its edges being turned up and finished with a flashing.

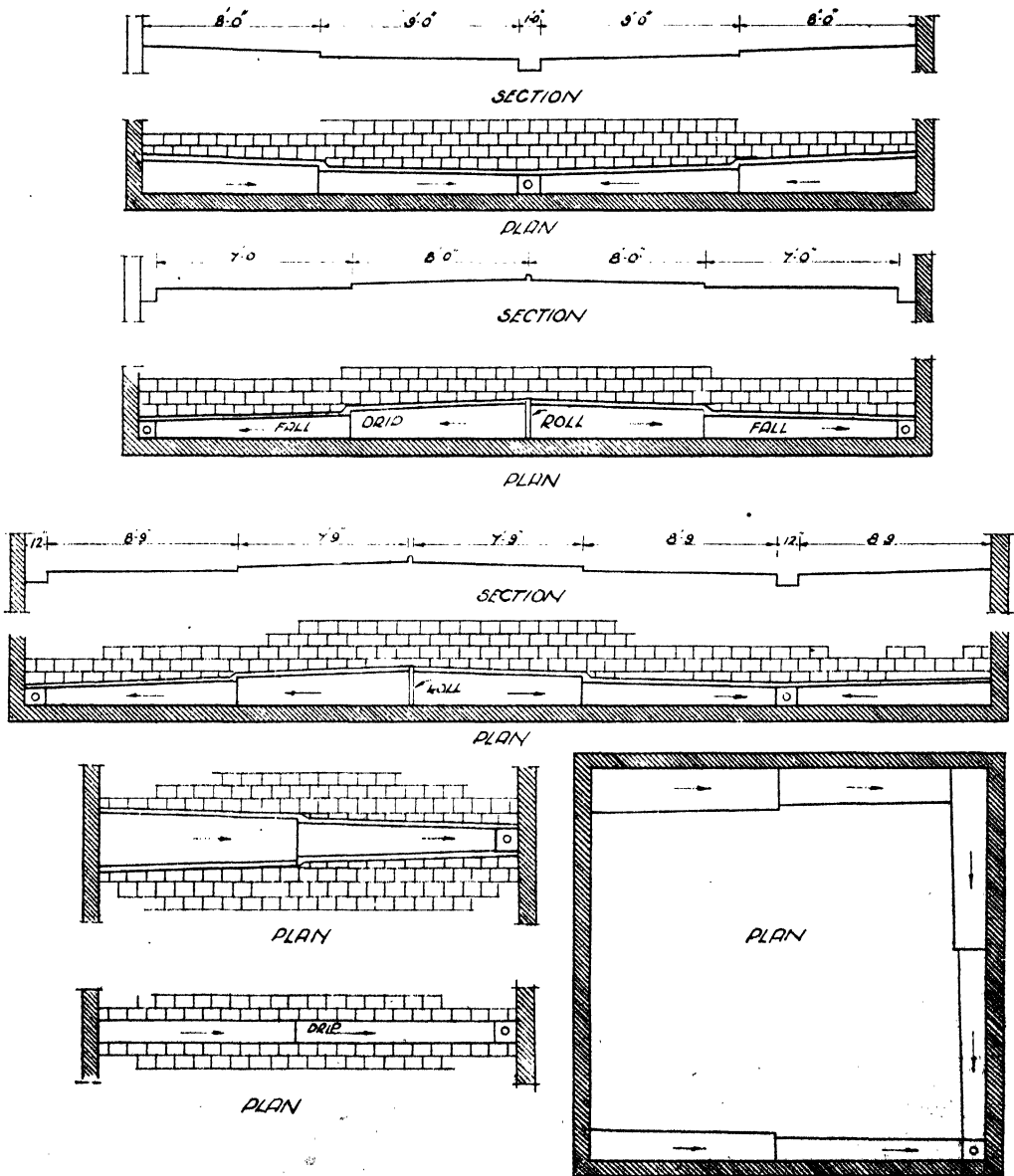

FIG. 64. TAPER AND PARALLEL GUTTERS

The two gutters at the top of Fig. 64 show two methods of arranging a tapering gutter against a wall. In the first method the gutter slopes in both directions to a cesspool in the centre. The second method differs from the first in that two cesspools are employed and are

placed in the corners. This latter arrangement necessitates the use of a roll at the highest level as shown in Fig. 65. Both of these gutters are in four lengths, and are, therefore, suitable for roofs of a maximum length of about 40 ft.

An arrangement for a longer length of roof is

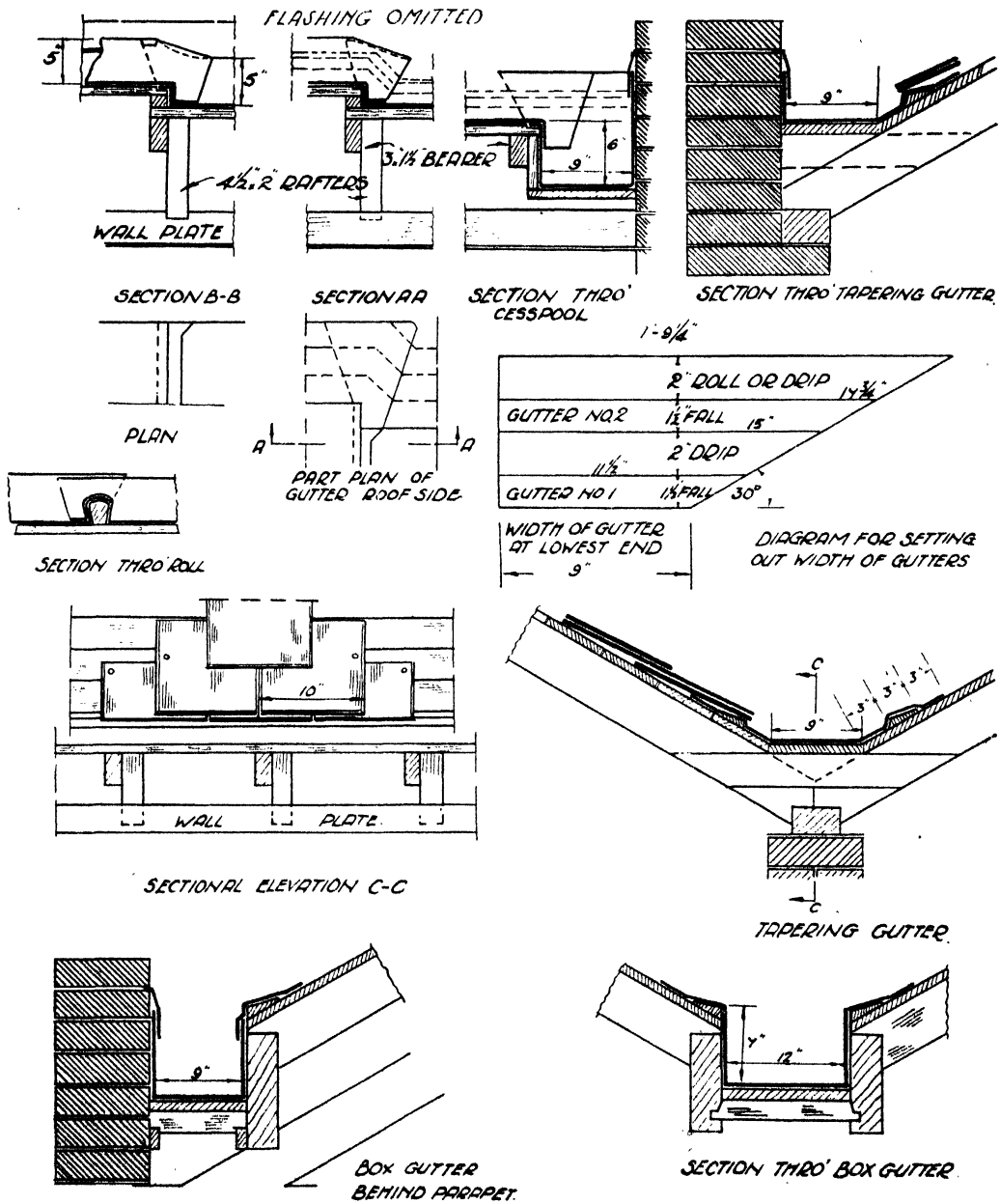

FIG. 65. DETAILS OF LEAD GUTTERS

MODERN BUILDING CONSTRUCTION

shown in the middle of Fig. 65, and this could be conveniently adopted for a roof of 50 ft. in length. The cesspools in this case are placed in such a manner as to prevent the width of the gutter becoming excessive, and therefore more expensive, particularly if the roof pitch is a flat one.

Lengths of gutter do not always work out to the exact length of the sheet of lead in practice, that is, say, 10 ft. as shown, and where this does

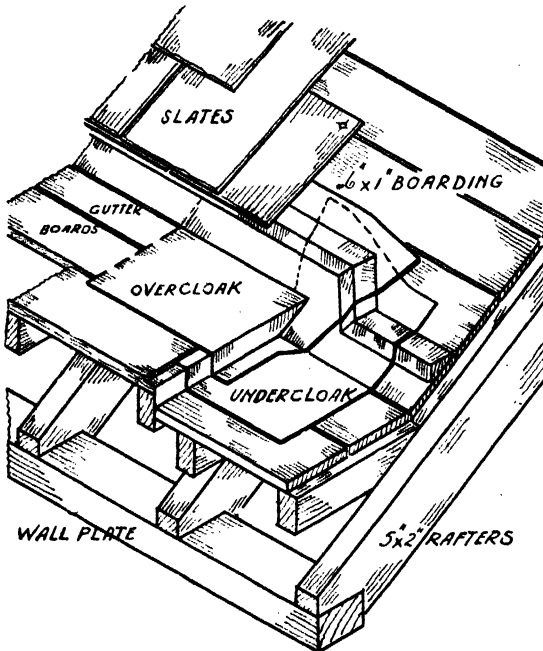

FIG. 66. SHOWING LEAD FINISH TO DRIP

occur the length of each gutter may be reduced, or it may be kept to its maximum length and the last length only shortened. The latter method will be found to be the more economical one.

A box, or parallel, gutter is shown at the bottom left-hand side of Fig. 64. This type of gutter is used between either sloping or flat roofs. It requires more timber but less lead in its construction than one tapering on plan.

The plan at the bottom right-hand corner shows how the guttering would be arranged for a small roof where one point only is available for an outlet.

Snow Boards. Rough frames of wood, termed *snow boards*, are usually placed over these gutters to prevent leakage caused by the accumula-

tion of snow. Snow is liable to slide down the roof slopes and, when snow boards are absent, block the gutter; the water cannot then flow along the gutter and rises up the roof slope, when it is likely to leak between the joints of the slates.

For valley gutters, the snow boards simply consist of bearers, about 3 in. by 2 in. in section and spaced about 6 ft. apart, cut with bevelled ends to lie on the roof slopes. Laggings, about

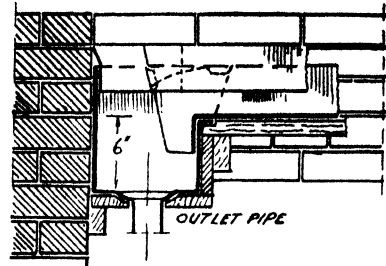

FIG. 67. WALL SIDE OF CESSPOOL

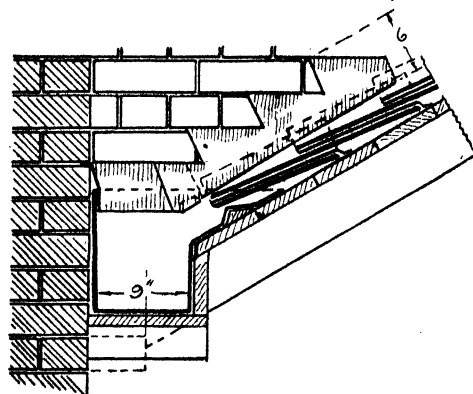

FIG. 68. CROSS SECTIONAL ELEVATION OF CESSPOOL

3 in. by 1 in., are nailed to the top edges of the bearers and are spaced about 1½ in. apart. The snow boards can be made in any convenient lengths, say about 12 ft.

For parapet gutters, the bearers are cut splayed at one end as before to rest on the slates, and the other end of each bearer is supported on a small upright which rests in the gutter. The top end of the upright is usually halved to the wall end of the bearer.

All snow boards should be creosoted so that they will better withstand the effects of the weather.

Chapter IV—ASPHALT AND BITUMINOUS FELT COVERINGS

ASPHALT

THE materials generally used for flat roof covering are: asphalt, bituminous felt, a combination of sheet steel and mastic, lead, zinc, and copper.

Asphalt is defined in British Standard Specifications as natural or mechanical mixtures in which asphaltic bitumen is associated with inert mineral matter. There are many varieties of natural asphalts, but those used in making asphalt for building work are chiefly natural *rock asphalt* and *lake asphalt*. The former is substantially calcareous rock impregnated exclusively with bitumen by natural process.

The principal commercial deposits are the mines at: Val de Travers, Neuchâtel, Switzerland; St. Jean de Maruéjols, Gard and the Seyssel District Ain and Haute Savoie, France; near Ragusa in Sicily; and in Brunswick, Germany.

Lake asphalt is substantially different in character from rock asphalt, and occurs in the form of a surface deposit in Trinidad, British West Indies.

For use in building construction asphalt is prepared in the form known as *mastic asphalt*, which is composed of finely graded mineral matter bound together with asphaltic bitumen to form a coherent, voidless, impermeable mass, solid or semi-solid under normal temperature conditions, but sufficiently fluid when brought to a suitable temperature to be spread by means of hand tools.

While mastic asphalt is also used for road surfacing, it must be distinguished from those forms of asphalt which have to be compacted under pressure. Mastic asphalt acquires stability after cooling to normal temperature. Compressed asphalt tiles for flooring are also used in building work.

Mastic asphalt is prepared in cakes weighing approximately 56 lb. and generally transported in that form to the site of the work, where they are remelted either in a hand-stirred cauldron or in a mechanically agitated mixer.

The principal uses of mastic asphalt are three: (1) Flat roof covering, (2) Damp coursing and waterproofing parts of structures below ground, (3) Flooring and paving.

Special grades are also prepared for more onerous conditions such as where resistance to

acids, oils or other agencies is necessary. Coloured varieties are also available.

The ingredients used in making the various classes of asphalt mastic can be of several kinds, and the bituminous components selected depend upon the purposes the asphalt is designed to fulfil. In acid-resisting mastics, for example, the aggregate itself must be proof against acid attack.

In the more normal grades of material the bulk of the aggregate may be of natural rock asphalt or of unimpregnated limestone. The bituminous components may also be of native origin or may be derived from asphaltic petroleum.

Application. It should be understood that asphaltting is a skilled craft and the proper application of the material must be carried out by expert workmen. Owing to its thermoplastic properties, the efficiency of an asphalt covering is to a considerable extent dependent upon the suitability of the design of associated details of which it forms an integral part, and it is important that such requirements are indicated in specifications and drawings, since the work of other trades may also be involved. It is also important if the asphalt is to be subjected to unusual or special conditions of traffic or wear, that the full details should be supplied to the asphalter at the time he is asked to tender, so that he may know what type of material will be suitable and whether any particular factors must be taken into account.

FALLS. When it is desired that an asphalt roof is to be left free from standing water, a minimum fall should be specified, of not less than $1\frac{1}{2}$ in. in 10 ft. (1 in 80); in the case of concrete, hollow-tile or similar construction, this should be provided by screeding, and in the case of timber roofs by furring, unless the sub-structure is made to falls.

Over concrete, hollow tiles or similar construction, the screeding should be floated to a plane and even surface, without material variation in the degree of slope.

KEYS. Since the unit weight (density) of asphalt is approximately equal to that of concrete, the provision of a suitable key in the foundation is necessary on sloping surfaces.

MODERN BUILDING CONSTRUCTION

In vertical or steeply sloping surfaces, the following provision for keying should be made:

BRICKWORK. Normally it is sufficient for all horizontal joints to be raked out to at least $\frac{1}{2}$ in. and brushed clean. Where, however, the surface of the brick is highly finished, giving an extremely smooth surface, it may be necessary in addition to hack the surface of the brickwork.

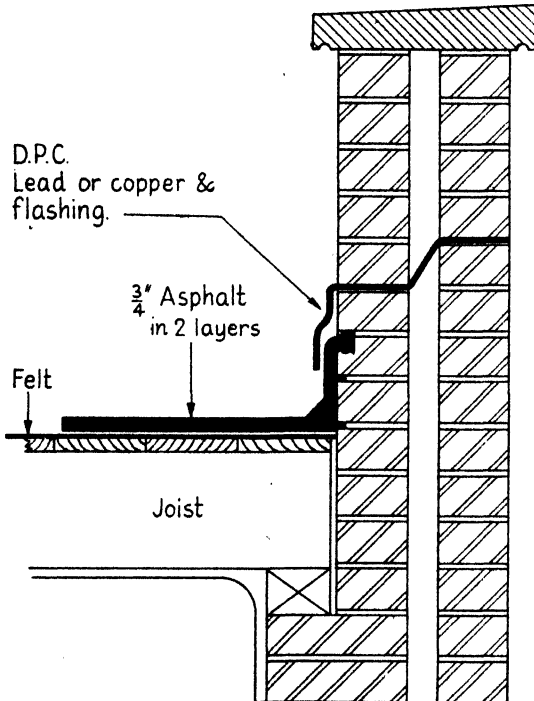

FIG. 69. DETAIL OF SKIRTING ON TIMBER FLAT

The top edge of vertical asphalt (including skirtings), except where such asphalt forms a continuous covering with further work in a non-vertical position, whether over brickwork or concrete, must be tucked into a continuous chase not less than 1 in. by 1 in., the top edge of the asphalt adjacent to the nib being splayed to act as a drip, to avoid rainwater lodging at that point (see Fig. 69).

CONCRETE. While concrete surfaces are sometimes sufficiently rough as they come from the shuttering to provide an adequate key, in general, all vertical concrete surfaces and those with a slope greater than 1 in 10 (approximately 10°), require hacking. Grooves may also be formed in the concrete at approx. 2 ft. centres (see Fig. 70).

METAL. Metal surfaces over or against which asphalt has to be applied, must first be

cleaned, and painted with an appropriate bituminous solution.

TIMBER. On vertical and sloping timber

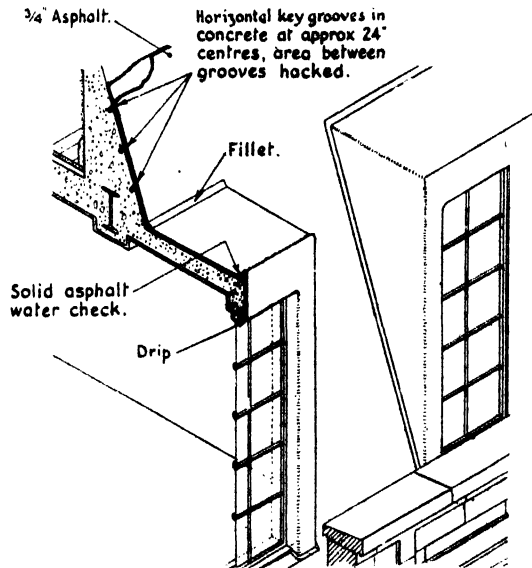

FIG. 70. DETAIL AT ROOF SLOPE

surfaces, and at angles formed by or at junctions with such surfaces, in addition to an interposed membrane, if any, expanded metal lathing, securely fixed by means of staples or other support, should be used to give an adequate key for the asphalt.

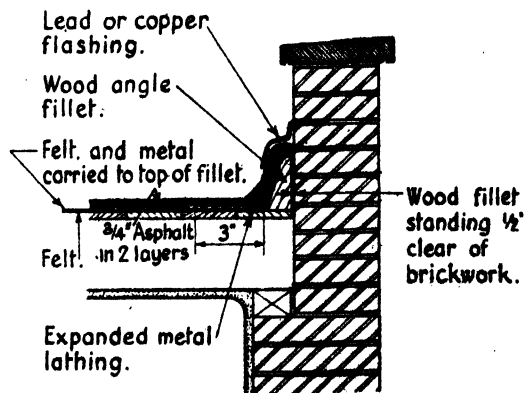

FIG. 71. DETAIL OF SPLAYED SKIRTING TO PARAPET WALL ON TIMBER ROOF

This construction is shown in Fig. 71 and is alternative to the method given in Fig. 69. The strip of expanded metal, which extends about 3 in. on to the flat boarding, gives a better key for the asphalt and forms a better finish at the

angle. Note that in both illustrations the roof boarding is covered with felt to form a satisfactory base for the two layers of asphalt.

OTHER SURFACES. Glazed brickwork, lime-washed, painted or similarly treated surfaces should be wire-brushed and hacked. All washes should be completely removed.

Where asphalt is applied vertically in particularly exposed positions, such as over a brick parapet which may be subject to the full force of driving rain, an additional key such as an expanded metal support may be desirable.

TIMBER ROOFS. With timber roofs, observance of the following points is important, safeguarding against shrinkage, warping, and displacement generally, and consequent weakening or tearing of the asphalt covering: boards and joists should be adequately seasoned and should be completely protected from rain prior to asphaltting; boards should be well nailed with the nails punched in; joists should be stiff and not too widely spaced; adequate ventilation should be provided between roof timbers and ceilings to avoid dry rot; a triangular wood fillet should be secured to the boarding and adjacent to vertical abutments.

UNDERLAYS. Where the foundation is liable to movement through vibration, thermal movement, or other causes, direct contact with the asphalt should be avoided by means of a thin membrane in order to obviate such movement being transmitted to the asphalt.

An underlay may also serve another useful purpose. During the laying of the hot molten mastic, moisture on the substructure will tend to vaporize and set up blowholes in, or through, the molten mastic, some of which may remain undetected. This can be prevented by the provision of a membrane such as black sheathing felt laid loose over horizontal concrete surfaces. On vertical or steeply sloping timber surfaces, the membrane must be fixed by galvanized clout nails. Such interposed underlay is indispensable when asphalt is to be applied over timber; over a thermal insulating medium such as cork or fibre board; over concrete flat where steelwork is slightly below or level with the laying surface, or where concrete has been affected by frost; where concrete is made with a porous aggregate such as clinker, ashes, or breeze.

Fabric underlays and light-metal reinforcements are supplied and fixed by the asphalt contractor.

Thermal Conditions. Thermal conditions within a building have effects on human

comfort, fuel economy and roof stresses. Where precautions for minimizing heat flow are considered to be necessary, it is recommended that provision should be made for a light coloured surface finish.

A white surface will reflect away most of the solar heat received and the following are methods of applying such a finish—

(a) (Temporary). An application by brush or spray of limewash composed of 10 per cent by weight of white tallow added hot to lime putty and mixed with boiling water and screened.

(b) (Reasonably permanent). By embedding white mineral chippings in the asphalt surface at the time of laying, or by application after laying with a suitable adhesive solution.

If areas are designed for traffic, they may with advantage be covered with light weight tiles of good insulating properties, the surface being preferably whitened.

This may normally be all that is necessary for reducing the heat flow in the roof structure, but, where a greater margin of safety is required, or the roof is of large area, some form of insulation may be employed in addition, to reduce the passage of heat. Cork or fibre board if placed between concrete and asphalt mastic will resist transmission of solar heat, about 1 inch of the former being equivalent to a whitened surface; if the insulation is fixed to the underside of the concrete there will be reduction of heat losses from the room below, thus effecting an economy in fuel.

THICKNESS AND NUMBER OF COATS. (Horizontal work includes slopes not greater than 10°. Sloping work includes slopes steeper than 10° but not steeper than 30°, and vertical work includes slopes over 30°).

In roofing work asphalt is normally applied as follows:

(a) On horizontal and sloping surfaces, in two coats, to a total thickness of not less than $\frac{3}{4}$ in.

(b) On vertical surfaces, in two coats, to a total thickness of not less than $\frac{1}{2}$ in.

(c) In roofs designed for special forms of traffic, in two coats to a total thickness of not less than 1 in. the bottom coat being not less than $\frac{3}{8}$ in. and the wearing coat not less than $\frac{5}{8}$ in.

(d) As a horizontal damp-proof course in narrow widths (e.g. through parapet walls) in one coat not less than $\frac{1}{2}$ in. thick. It is desirable that grit shall be beaten into the asphalt immediately after application, and left proud of the surface, in order to provide a

MODERN BUILDING CONSTRUCTION

better key for the mortar below the next course of brickwork.

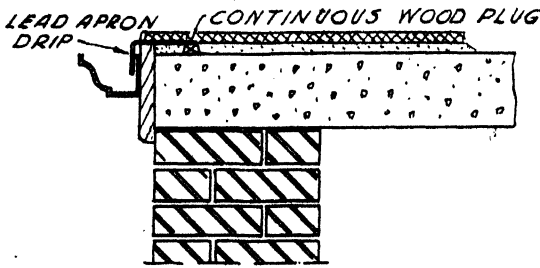

FIG. 72
DETAIL AT EAVES

top edge being raised sufficiently to divert the water from the edge. (See Fig. 73.)

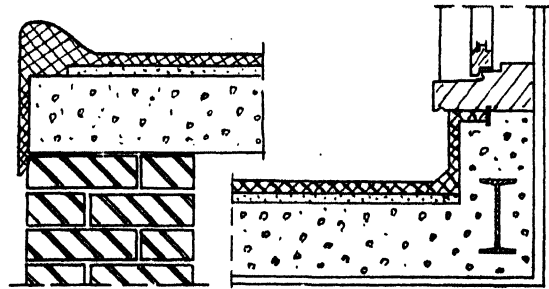

FIG. 73
DETAIL AT VERGES

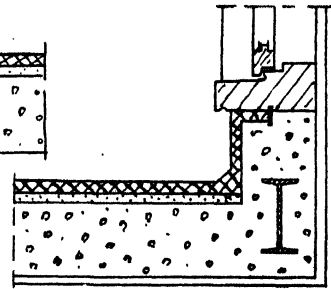

FIG. 74
DETAIL AT LANTERN

(e) Fillets at internal angles in one coat, not less than $1\frac{1}{4}$ in. wide at the face.

(f) Skirtings, drips and other vertical work in two coats.

(g) In all multiple coat work the joints between each layer to be lapped not less than 6 in.

(h) The top coat of flat surfaces and slight slopes exposed to weathering agencies should be well rubbed, immediately after laying, and while the material is still warm, with a suitable sand, special attention being given to the joints of bays.

(j) Where three-coat work is specified, e.g. roof tanks, etc.—

On horizontal and sloping surfaces in three coats to a total thickness of not less than $1\frac{1}{8}$ in.

On vertical surfaces in three coats to a total thickness of not less than $\frac{3}{4}$ in.

Fillets at internal angles in two coats, 2 inches wide at the face.

Eaves. Where a flat roof finishes with an eaves gutter, the asphalt is sometimes turned down on to the vertical face of the wall to form an apron; the lower edge of this apron is splayed back, thus forming a drip. A better method is to finish the edge of the flat with a lead apron drip (see Fig. 72). This should be fixed 3 in. or 4 in. over the flat, nailed and not left loose or laid between the layers of asphalt.

It is best without a welt because this would mean four thicknesses of lead at the junctions, and leave the asphalt covering, which is apt to crack at these joints, too thin.

The internal angles, both horizontally and vertically, should also be provided with a strong asphalt fillet.

Verges. Where the verges occur, the asphalt is dressed over the edge of the gable wall, the

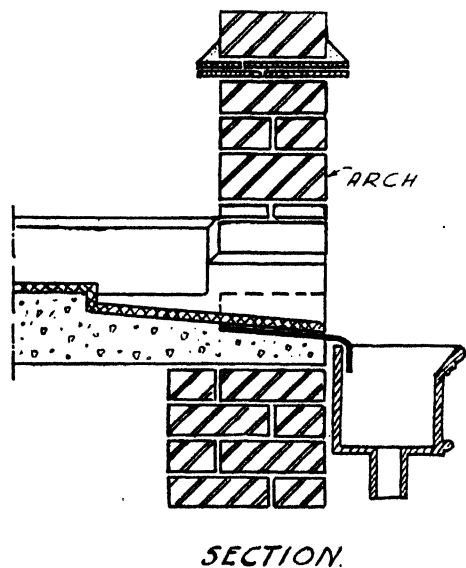

SECTION.

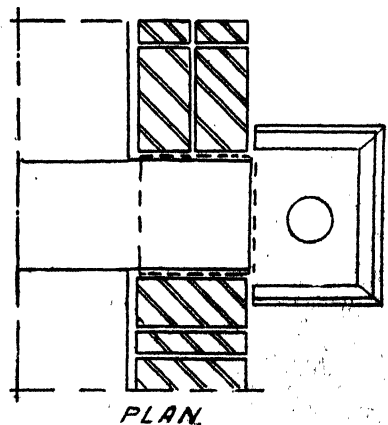

PLAN.

FIG. 75. DETAIL OF OUTLET THROUGH PARAPET WALL

Fig. 74 shows the method adopted in finishing the asphalt where it abuts against a lantern light. The asphalt is carried up the face of the

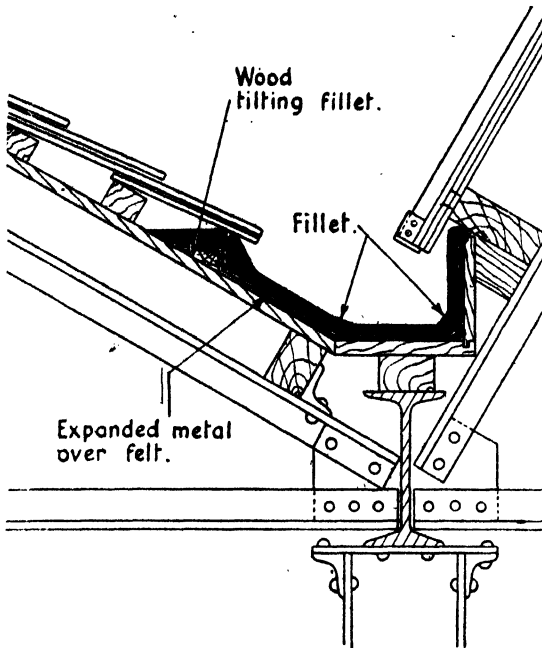

FIG. 76. ASPHALT LINING TO BOX VALLEY GUTTER

curb, turned over on the top, and finished against the water bar. It may be finished in a groove in the underside of the sill, or with a lead flashing, the bed of the sill being rebated in each case.

CHUTES. The flat may be drained by means of a water chute through the parapet wall to a rain-water head. The opening is lined on the sides and bottom, connected with the flat and skirting, and given a fall to the outside to facilitate the discharge of water from the flat. The outer part of the opening is finished with a lead apron, as shown in Fig. 75.

Cesspools are adopted in many cases for the drainage of flats.

Parapet Gutters. Ordinary parapet gutterings may also be covered with asphalt. They are similar to lead-covered gutters except that no drips are required.

Fig. 76 shows a box valley gutter, including solid asphalt tilting fillet, the whole being laid on felt and expanded metal reinforcement.

Figs. 77, 78, and 79 show methods of finishing the asphalt work to flat roofs without parapet

walls. In these cases the asphalt is carried over the projection and finished in a groove.

The Natural Asphalt Mine-Owners' and Manufacturers' Council issues technical publications and gives free advice on all questions relative to the use of asphalt for building purposes.

ROOFING FELTS

Bituminous roofing felts are frequently used as a waterproof covering for flat roofs. These consist essentially of a felt base, made from a

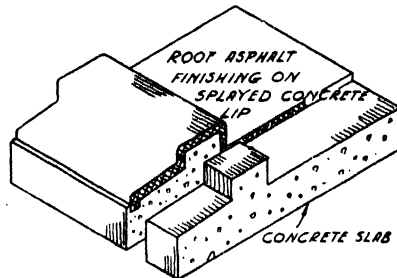

FIG. 77

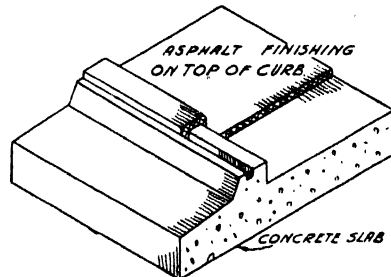

FIG. 78

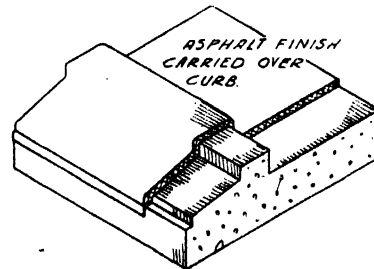

FIG. 79

ASPHALT FINISHES

mixture of fabrics saturated with asphaltic bitumen or fluxed coal tar pitch.

These felts are manufactured in rolls, the average-size being 15 yards x 36 inches, and are applied over the roof in two or more layers

MODERN BUILDING CONSTRUCTION

sealed together with a bituminous medium. A surface finish of mastic asphalt, tar macadam, cement screeding or tiles is often given, and such finish is desirable if the roof is to be trafficked, and also from the aspect of fire resistance. Some of these systems require periodic maintenance.

The type of felt used when no such additional covering is given, is known as Self Finished



FIG. 80 PERMANITE ON BOARDING FIG. 81 PERMANITE ON CONCRETE

Felt, which is coated as well as saturated with asphaltic bitumen, and suitably surfaced with talc mica or the like, to prevent sticking in the roll. The type known as Mineralised Bitumen Felt may also be used, the upper surface being dressed with slate or other mineral granules.

Roofing felts and roof covering systems in which they are embodied are sold under numerous trade names. They differ relatively little in their general characteristics, although

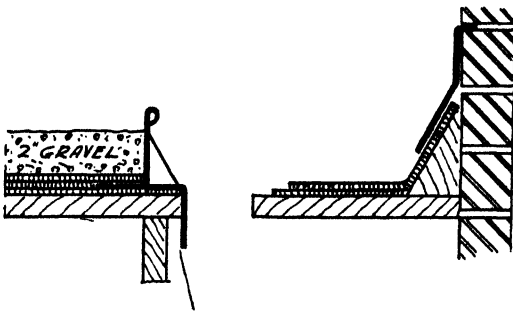

FIG. 82 SECTION AT EAVES

FIG. 83 SECTION AT WALL

certain firms put forward their own particular recommendations with regard to details, some of which are illustrated in the diagrams attached.

Permanite. The Permanite process consists of building up separate layers of flexible sheet asphalt, each layer being sealed with hot bitumen to the previous layer. All joints are lapped and arranged so that the joints in the upper sheets come in the centre of those beneath. It has been found by experience that only two or three layers are needed to secure the necessary strength and resistance. When the last sheet is on, it is coated on top with a dressing of hot

bitumen and clean dry grit embedded. When completed, this makes an admirable roof covering for roofs of light construction, whether boarded, concrete, or sloping. (See Figs 80 and 81.)

EAVES. The eaves may be finished with three-ply blanco self-finished bitumen, felt apron, or

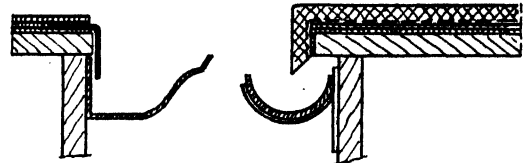

FIG. 84

FIG. 85

SECTIONS AT EAVES

lead (see Fig. 84). The section adjacent to the wall requires a $4\frac{1}{2}$ in. by 3 in. angle fillet, the second layer of Permanite turning up on the fillet and being covered with a flashing. For the eaves, a special zinc curb is fixed where the finish is in gravel. The curb is holed at intervals to allow for drainage of the roof. (See Figs. 80-84.)

Permaphalt Asphalt. "Permaphalt," a combination of "Permanite" sheet asphalt and Mastic Rock asphalt, will be found suitable for roofs of heavy construction which are utilized as roof gardens, playgrounds, etc.

Details of finishings to eaves and verges are shown in Figs. 85, 86, and 87.

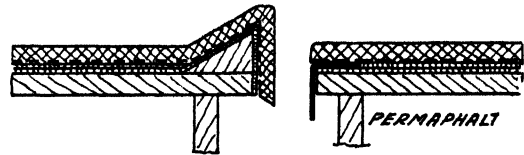

FIG. 86 SECTION AT VERGE

FIG. 87 SECTION AT EAVES

INSULATION. The roof surface may be finished with "Permatiles." These tiles are made with natural granular pumice, washed, graded and separated, mixed with Portland cement, the pumice being used as a base to give the most cellular form possible. The top surface is also formed of pumice finely ground and mixed with cement, so that the whole tile is made of the same material, thus eliminating the possibility of disintegration through variable degrees of expansion and contraction which may occur when two dissimilar materials are used. The tiles are applied *in situ* by being

sealed down with a coating of pure bitumen not only at the bottom but up the sides, the latter forming an effective expansion joint. (See Figs. 88, 89.)

The tiles are 9 in. by 9 in. by 1¼ in. thick, and weigh 64 lb. per yard super. They are heat insulating, light-reflecting, and traffic resistant. From tests made they show that with the standard "Permatile" there is more than

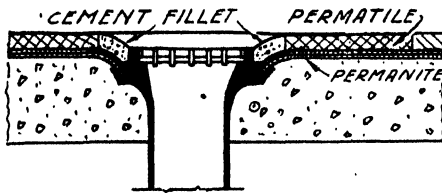

FIG. 88. SECTION OF ROOF OUTLET

30 degree exclusion of heat, as compared with a typical flat roof covering.

WALL FINISH. The finishes at walls, etc., can be devised to suit any special requirements, the sketches showing typical finishes for normal work. (See Figs. 89, 90.)

Where the roof has a surfacing of macadam, it is termed "Permac" roofing.

Ruberoid. This material consists of a fibrous base saturated with an asphaltic bituminous composition chosen on account of its great absorbent and lasting properties so that it may

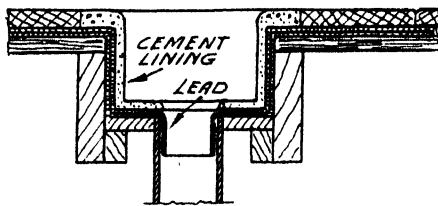

FIG. 89. SECTION THROUGH BOX GUTTER

retain unaltered the maximum amount of Ruberoid compound.

The actual nature of the base varies according to the particular type of Ruberoid. The ingredients of this bituminous saturant are carefully selected to ensure that the composition has high waterproofing and flexible qualities, and that the sheet will remain pliable yet not be soft. The fibre base then receives an outer coating of a hard asphaltic bituminous composition to seal the saturant and to provide a weatherproof surfacing which will require no further treatment after the roofing is laid. The resultant material is extremely flexible and suitable for

use in all climates. Despite its name, this roofing fabric contains no rubber or other short-lived ingredients which would be liable to oxidize or perish.

Ruberoid roofings are adaptable to any shape of roof—flat, pitched or curved on wood or concrete. When laid on concrete the elasticity of Ruberoid prevents it from being affected by any cracks or sagging which may occur in the concrete. An important point, where large roofs are concerned, is the desirability of reducing their total weight, and in this respect Ruberoid proves a most adaptable material. The fact that it is a non-conductor of heat

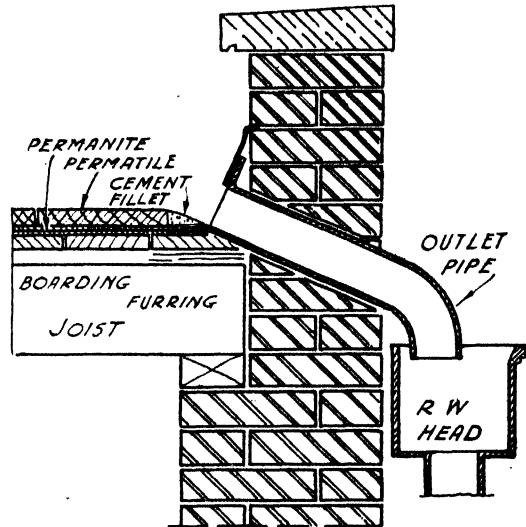

FIG. 90. OUTLET PIPE THROUGH WALL

considerably widens its scope. The method of laying is shown in Figs. 91-94.

Flat roofs roofed with Ruberoid and surfaced with 2 in. of sand or gravel, Rubercrete, Ruco Ruberoid, or Ruberdal specifications, are fire-proof. They comply with the London Building Act and Ministry of Health model by-laws, and are approved by all authorities, including insurance companies.

The Standard Grey Ruberoid roofing is manufactured in three plies or weights—

1-ply Grey (Light)	32 lb. per square
2-ply Grey (Medium)	42½ " " "
3-ply Grey (Heavy)	52½ " " "

The plies are of uniform quality. The first-named is recommended for small buildings that are not exposed to severe conditions. The two-ply is for general roofing, while the heaviest

MODERN BUILDING CONSTRUCTION

type is employed for the roofing of large buildings of all kinds (see Figs. 91 and 92).

Rubercrete, Ruco Ruberoid, Ruberdal. Rubercrete is a built-up roof surfaced with Rubercrete

good drainage. It is recommended that the seams should run with the fall of the roof to avoid holding up water (see Figs. 95, 96, 97, 98).

If the fall can include the whole roof, the

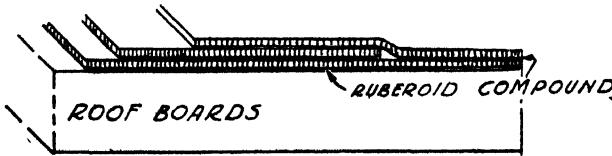

FIG. 91. TWO-LAYER BUILT-UP

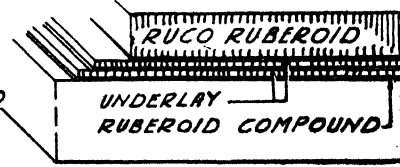

FIG. 93. RUCO RUBEROID ON ASTO ASBESTOS FELT

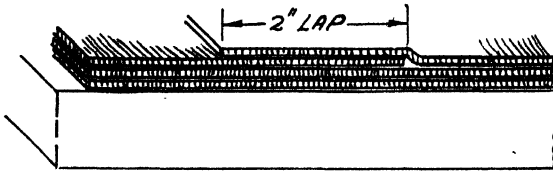

FIG. 92. THREE-LAYER BUILT-UP

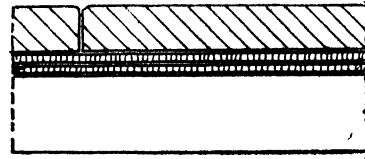

FIG. 94. 12 IN. X 12 IN. X $\frac{1}{4}$ IN. RUBERDAL TILES ON TWO LAYERS OF ASTO ASBESTOS FELT

METHODS OF LAYING RUBEROID

macadam. Ruco Ruberoid is a built-up roof surfaced with Ruco Mastic Asphalt (see Figs. 93, 94, 95). Ruberdal is a built-up roof surfaced with 12 in. by 12 in. Ruberdal tiles. These three grades are suitable for foot traffic (see Figs. 95, 96, and 97).

entire surface may be drained from a single gutter at the back of the building, thereby avoiding pipes and gutters at the front or in the forecourts.

Eaves and verges should be turned over the edge of the boarding and nailed, the edge and

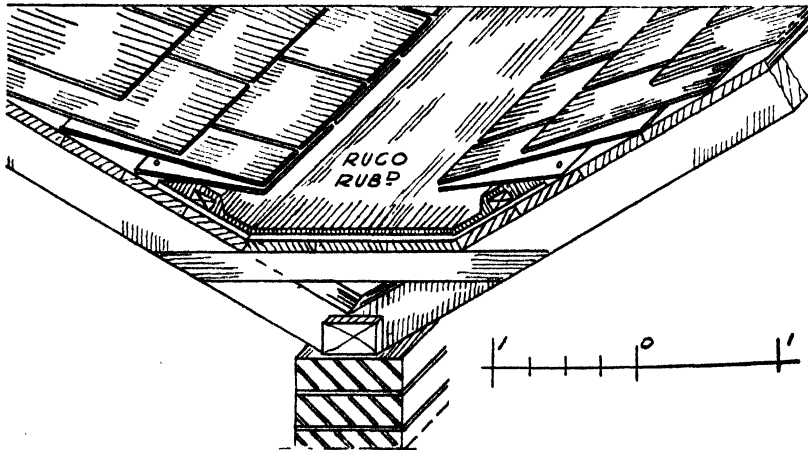

FIG. 95. DETAIL OF VALLEY GUTTER

BOARDING. The roof boarding should be at least $\frac{3}{4}$ in. thick if tongued and grooved, or 1 in. closely butted if plain.

No drips or rolls are required on flat roofs. Roofs and gutters should have the same fall as for lead or asphalt. A fall of 2 in. will provide

entire surface may be drained from a single gutter at the back of the building, thereby avoiding pipes and gutters at the front or in the forecourts.

GUTTERS. Gutters should be covered first. Two layers are advisable, and they should be bedded together with cold Ruberoid mastic or hot Ruberoid compound. (See Fig. 100.)

ROOF COVERINGS

Outlets and cesspools should be lined with lead forming a flange, turned into a rebate in the boarding, and extended around the outlet on the sole of the gutter. The Ruberoid should be bedded over this flange with mastic or compound and turned into the outlet.

PITCHED ROOFS. On pitched roofs, the cover-

tion L5 is for three-layer under-roofing with asphalt finish.

1st layer Astos Asbestos Felt	26½ lb. per square
2nd layer Ruberoid Astos Asbestos Roofing	52 " " "
3rd layer Insulating Paper	6 " " "
Finishing layer ¼ in. Ruco Mastic Asphalt	622 " " "

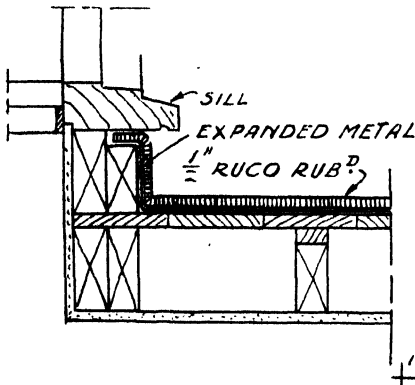

FIG. 96. SECTION THROUGH SILL OF LANTERN LIGHT

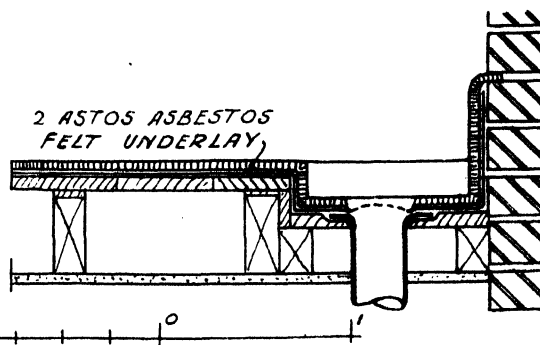

FIG. 97. SECTION THROUGH CESSPOOL

ing should be laid at right angles to the boarding joints and, since boards are usually fixed horizontally, the caves to ridge method of laying the roofing is usual. The ends of the Ruberoid sheet finish at the ridge, and the ridge is finished with a ridge capping. This capping is a strip of Ruberoid 9 in. wide cemented down and nailed.

There are a number of specifications for wood and concrete. The following typical specifica-

The boarded roof surfaces to be prepared to receive Ruberoid. All upstanding edges planed down and nail-heads well sunk.

Concrete roof surfaces to be finished to receive Ruberoid, correctly graded to falls and free from lumps and depressions.

No metal flashings are required because every type of flashing can be carried out in Ruberoid.

Being an excellent non-conductor of heat,

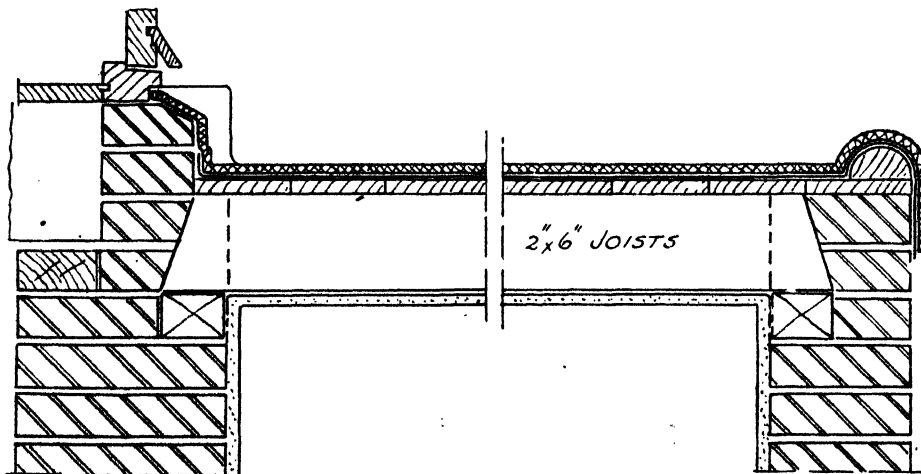

FIG. 98. SECTION THROUGH FLAT ROOF
Showing wood curb

MODERN BUILDING CONSTRUCTION

Ruberoid is unaffected by extremes of temperature and will not run or creep.

Gravel or other materials are not required to protect it from the heat of the sun, and there is no risk of clogged gutters or downpipes.

and elastic substance which, while retaining its elasticity permanently becomes, in the course of time, of a metallic hardness. It is absolutely impervious and offers the most hermetical resistance to water, dust, etc. It consists of

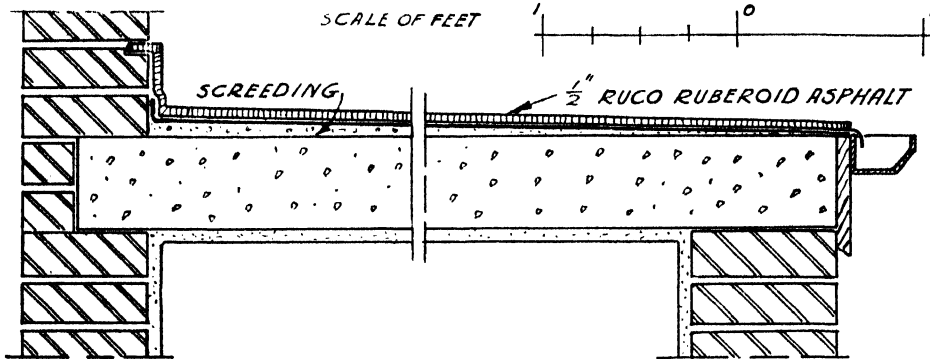

FIG. 99. SECTION THROUGH CONCRETE FLAT ROOF

Ruberoid Insulated Steel Roof. This roof consists of self-interlocking steel units 2 ft. wide and of certain standard lengths.

The units are made in two types, *A* and *B*, each type being made with either two or three channels per unit. The channels of the type *A* units have their ends formed as a spigot and sock joint, while the type *B* units are joggled.

three layers of vulcanite sheet asphalt, each layer being bedded with mastic applied hot, thus combining into a solid mass without joints.

SKIRTINGS. Against vertical faces preparation should preferably be as Fig. 106, but where cost is a consideration, a finish to walls as shown in Fig. 107 could be employed. An improved method of finishing the roof at vertical is by using the "capillary trap and mechanical wedge" (patented). This is shown in Fig. 106.

Where a garden roof is required, 2 in. of

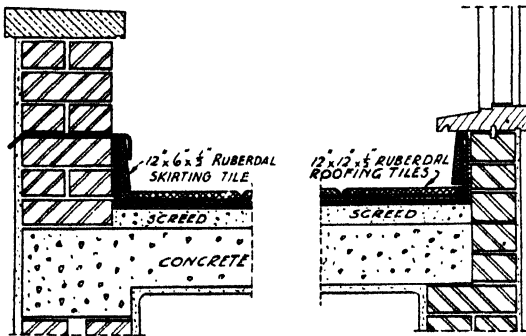

FIG. 100
FINISH AT PARAPET

FIG. 101
FINISH AT LANTERN

RUBERDAL ASBESTOS TILE FINISH

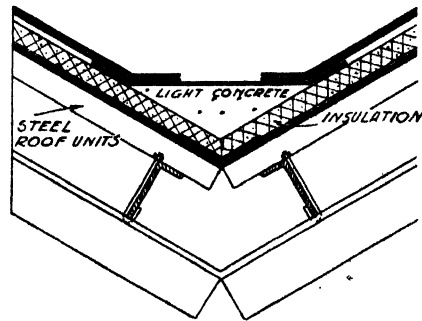

FIG. 102. SECTION THROUGH VALLEY GUTTER

The insulating material is cemented to the roof deck with Ruberoid compound applied hot.

These steel roof units are also used on pitched roofs, details of which are shown in Figs. 102, 103, and 104.

Fig. 105 shows the finish of Ruberoid to a prefabricated eaves.

Vulcanite. This is a bituminous, horn-like

loamy gravel is the best finish, but cement concrete, tiles in cement, or tar macadam can be employed. Proper gravel kerbs must be provided at outlets (see Fig. 108) or eaves, etc., to retain the gravel on the roof as on wood constructed flats. Where a gravel kerb is not employed, a lead under-flashing should be used at eaves or verge to form a drip. Fig. 109 gives

ROOF COVERINGS

a detail of the construction of a chute, and Fig. 108 an outlet pipe through the parapet.

Macasfelt is a system of covering which consists of layers of plastic bitumen asphalt alternating with layers of flexible waterproof sheeting, the whole being covered with a layer of fine asphaltic macadam about $\frac{1}{2}$ in. thick which gives an asphalt-like surface.

The three layers of waterproof sheeting combined with the interlining of bitumen make the roof permanently waterproof, while the maca-

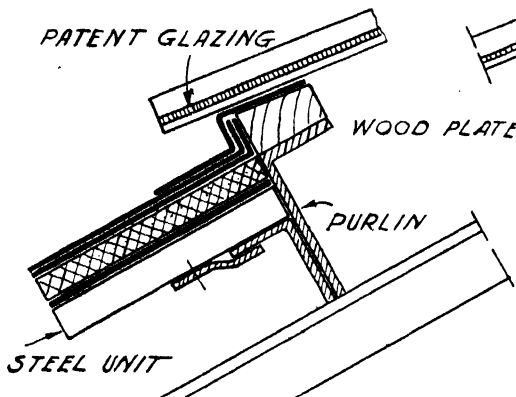

FIG. 103. DETAIL AT FOOT OF ROOF LIGHT

dam finishing layer gives a hard-wearing fire-proof surface not likely to be damaged by any ordinary usage. The macadam also protects the sheeting from the rays of the sun.

The weight of "Macasfelt" consisting of three layers of sheeting, three layers of bitumen,

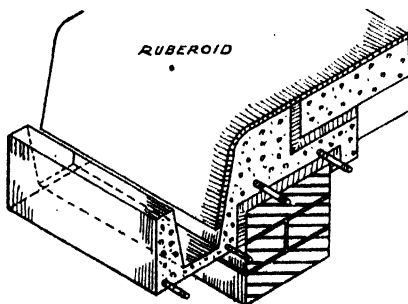

FIG. 105. FINISH AT PREFABRICATED EAVES

and half an inch of macadam, is approximately half cwt. per square yard, and has a total thickness of approximately 1 in.

Thermotile. To obtain the maximum of insulation in flat roofs, the roof is built up of layers of bitumen combined with layers of waterproof

sheeting protected on the surface with special reinforced asbestos tiles 12 in. by 12 in. by 1 in. thick. The approximate total thickness is $1\frac{1}{2}$ in.,

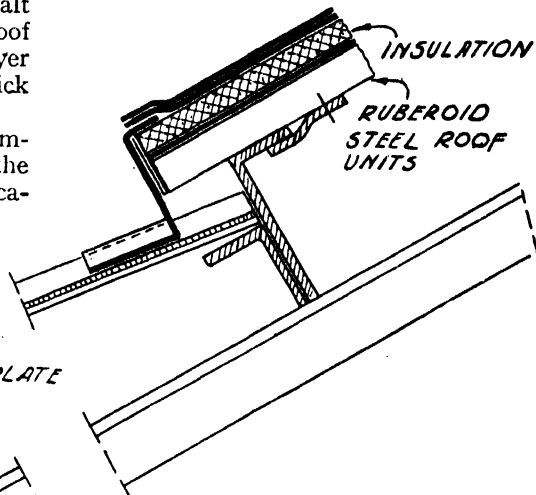

FIG. 104. DETAIL AT HEAD OF ROOF LIGHT

and the approximate weight 8 lb. per sq. ft. This system is known as Thermotile Insulated Flat Roofing, and can be applied to either concrete or boarded flats. Speaking generally, it can be adopted for re-covering existing flat roofs which are defective or lack insulation.

"Durok." Where the cost will not allow for "Macasfelt" to be used, a less expensive cover-

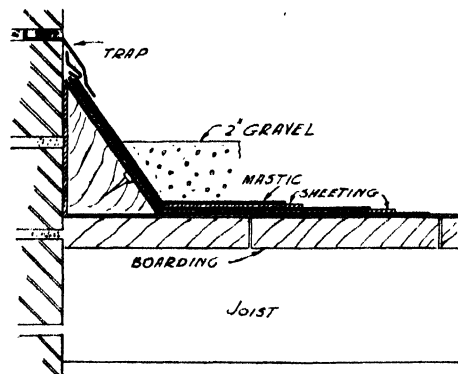

FIG. 106. VULCANITE ROOFING
Showing improved method of capillary "trap"

ing is provided by "Durok." This system of flat-roof covering consists of two layers of "Rok" roofing sealed together with Hard Rok Mastic. It provides a very serviceable roof covering.

Provided reasonable care is taken a "Durok"

MODERN BUILDING CONSTRUCTION

roof should last indefinitely, but an occasional dressing of mastic should be given, say, once every five years.

"Rok" roofing is used for covering ordinary pitched roofs, and may be laid either horizontally (gable to gable) or vertically (ridge to eaves). The horizontal method is simpler and more easily rendered waterproof by inexperienced hands, the joints being made so that they do not obstruct the layer when turned over the

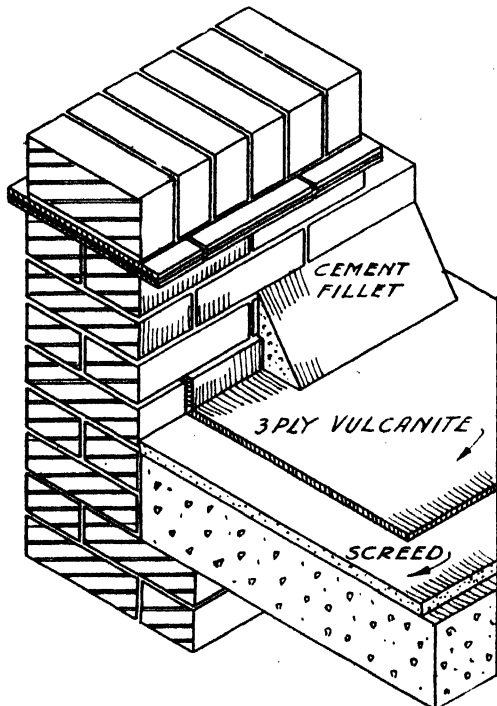

FIG. 107. ALTERNATE METHOD OF FINISHING VULCANITE

ridge, thus presenting a smooth unbroken surface to the driving rain.

In the vertical method, begin at the end of the building away from the direction of the wind. This ensures that driving rain will blow over the joints and not into them.

Each length should overlap the adjoining length 3 in., coated with "Rok" cement, and nailed at a 2-in. spacing $\frac{3}{4}$ in. from the edge.

No roof can be weatherproof unless all joints are carefully lapped, nailed, and sealed. All edges of boards at eaves and elsewhere should be rounded to avoid any risk of cutting the "Rok."

FLASHINGS for brick parapets, walls, and chimneys should be carried out by fixing a 3 in. by 3 in. angle fillet of wood, and dressing the "Rok" up over it and nailing it at the same

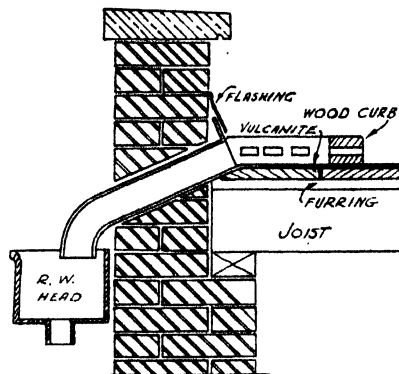

FIG. 108. SECTION THROUGH PARAPET
Showing pipe outlet and wood gravel board

time. A cover flashing of "Rok" should be let into the brickwork and dressed down so as to overlap the upturn of the sheet, and stuck with "Rok" cement, the brick joint afterwards

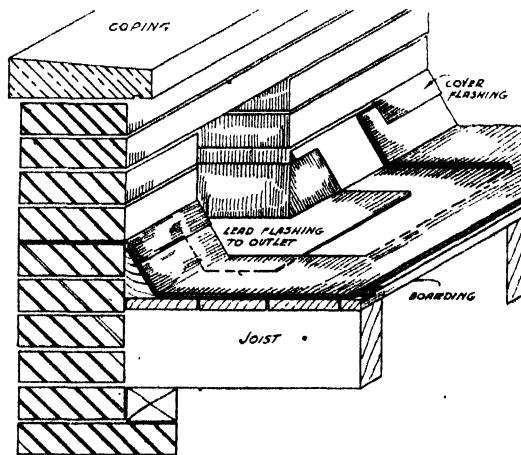

FIG. 109. VULCANITE DETAIL SHOWING LEAD OUTLET

being wedged and pointed in cement. If preferred, metal flashings can be used.

Gutters and valleys should be made of two layers of the "Rok" stuck together, only the under layer being nailed.

Cesspools and outlets should be lined with lead and the "Rok" turned over, nailed and cemented to the sides.

Chapter V—METAL ROOF COVERINGS

CORRUGATED ROOFING

“Ferro-Rok.” This is a combination of steel and “Rok” roofing. The core is specially annealed steel sheet, treated before being immersed in the first coating of bitumen to ensure perfect cohesion of the bitumen and metal. After being immersed in a hot bath of adhesive bitumen, it is then covered with a sheet of “Rok” roofing on each side, and finally coated with a high quality, high melting-point bitumen. To ensure perfect protection for the steel sheet, the upper layer of “Rok” is folded over the edges and sealed on the *underside*.

The sheets have a standard of eight 3-in. corrugations and are supplied in standard lengths from 5 ft. to 10 ft.

The actual width of a corrugated sheet of eight 3-in. corrugations is 2 ft. 2 in., and covers 2 ft. normal with one corrugation side lap, or 1 ft. 9 in. with two corrugations side lap. An end lap of 6 in. is recommended. Ridging, made on the same principle as sheets, is supplied in 3 ft. or 6 ft. lengths by 18 in. girth.

The weights of Ferro-Rok are as follows—

26 gauge	.	.	1.40 lb. per sq. ft.
24 "	.	.	1.60 " "
22 "	.	.	1.87 " "
20 "	.	.	2.10 " "

The maximum spacings of purlins recommended for roofs of 30 degree pitch or over are as follows—

For 26 gauge sheets, 4 ft. 3 in. centres; 24 gauge sheets, 5 ft. 6 in. centres; 22 gauge sheets 6 ft. 6 in. centres, and 20 gauge sheets 7 ft. 3 in. centres. For curved roofs, or for side runners, these spacings may be increased with safety.

The sheets are secured to the purlins or runners by means of standard galvanized fasteners, as used for galvanized sheets—drive screws for wood purlins, or hook bolts for steel purlins.

Drive screws $2\frac{1}{2}$ in. long by $\frac{1}{4}$ in. diameter are sufficient in most cases, but the length of hook bolts is naturally determined by the depth of the leg of the steel angle. To determine the length of hook bolts required, allow $1\frac{1}{2}$ in. more than the leg of the steel angle. Under the head of drive screw, or under the nut of hook bolt, use a galvanized curved diamond steel

washer $1\frac{1}{2}$ in. by $1\frac{1}{2}$ in. Diamond-shaped felt washers are placed under the galvanized diamond washer. This felt washer seals the nail or bolt hole, and prevents corrosion at this point, as shown in detail. Two drive screws or hook bolts per sheet per purlin are usually sufficient except under very exposed or unusual conditions, when the number may with advantage be increased to three, and the number of side bolts may also be increased, spacing at, say, 12 in. centres.

The sheets must always be punched on top of the corrugations. Bolts for ridging should be at not more than 12 in. centres.

With each consignment of sheets is also sent a supply of thick bitumen mastic. The end of each drive screw should be dipped in this mastic, when the driving or screwing will cause the mastic to flush up and seal the ragged edge of the hole left by punching. In punching holes, a very sharp punch should be used and a wood or lead block, shaped to fit into the corrugation, should be placed under the sheet at the spot to be punched. The most effective punch is one tapered from a point to $\frac{3}{8}$ in. diameter in a length of 3 in.

Robertson Protected Metal is a light, strong, building covering which lasts because it is proof against corrosion by acid, alkali and climatic conditions. It is easily handled and can be erected without breakage and without regard to weather conditions. Its long life, its insulating qualities, and the elimination of painting and maintenance costs, save a considerable amount of money. It costs no more than corrugated steel, plus several coats of paint.

Robertson Protected Metal is made by combining steel sheets, asbestos, and three different asphaltic compounds.

The base, or core, is a specially annealed steel sheet thoroughly cleansed of rust, grease, moisture, or any other substance that might interfere with the perfect bonding of the three protective coatings before being immersed in the first asphaltic coating. This coating forms a thick elastic shield, proof against gas and moisture, that entirely encloses the metal. The coating is soft, the asphaltic base being impregnated with oil which helps to keep it “alive”

MODERN BUILDING CONSTRUCTION

and at a maximum efficiency long after ordinary coatings have outlasted their usefulness. This coating is then completely encased with a tough sheet of asbestos felt, thoroughly saturated with asphalt.

This second coat is specially selected asbestos fibre impregnated with an asphalt saturant which is laid over the first coat while it is still hot. The heat and pressure applied is sufficient to bond the steel, the first coat, and the asbestos felt, thoroughly and permanently. The felt

impart a permanent colour. This has the advantage of rendering painting, or other decorative work, unnecessary.

The special aluminium-coloured coating is a fourth outer coat, applied over the sealing coat. It does not add to the protective qualities of the material, and is offered only where a light coloured sheet is demanded. It may be applied on both sides of sheets, or on one side only, with either black or maroon on the other side.

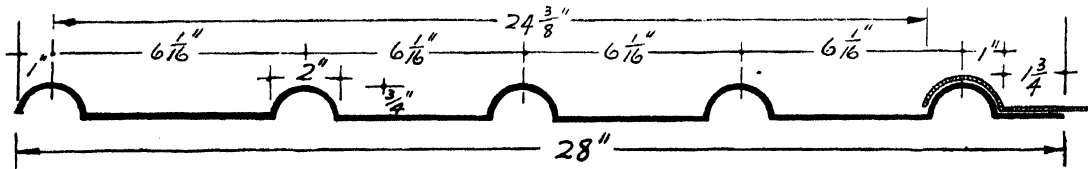

FIG. 110. ROBERTSON MANSARD CORRUGATIONS

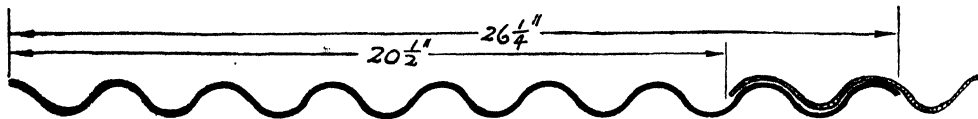

FIG. 111. 8/3 IN. CORRUGATIONS
ROBERTSON PROTECTED METAL

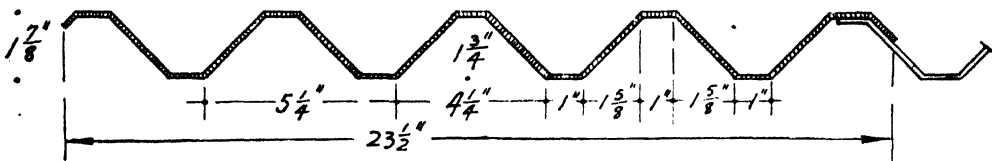

FIG. 112. ROBERTSON V-BEAM SHEET

forms an opaque insulating covering and protects the first coat from light, heat and mechanical abrasion.

The asbestos coat is then protected from destructive weather conditions, and from the softening influence of water or any other moisture, by an exclusively patented sealing coat. This third, or outer coating, is applied to the asphalt-saturated asbestos felt at a high temperature. It forms a tough, thick, elastic, and lasting surface which is water-repellent and corrosion proof, and which allows the material to be handled freely in shipment and erection without damage to the protective coating.

COLOUR. The natural colour of these sheets is black but where maroon is desired, mineral pigments are introduced into the protective coating in the course of manufacture so as to

Robertson Protected Metal has many times the insulating value of corrugated steel.

Mansard Corrugation. Where appearance is of more importance than usual with the ordinary industrial style of structure, the type of sheet known as "Mansard corrugation" will be found suitable. (See Fig. 110.)

Robertson Protected Metal sheets are made in three corrugations all produced from a flat sheet 30 in. wide. They are—

(1) 10 1/2 corrugations of 2 1/8 in. pitch with a corrugated width of 27 1/2 in., and a net covering width of 23 1/2 in. when laid with 1 1/2 corrugations side lap.

(2) Eight corrugations of 3 in. pitch, with a corrugated width of 26 1/4 in. having a net covering width of 20 1/2 in. when laid with two corrugations side lap, or 23 1/2 in. covering width when laid with one corrugation side lap (Fig. 111).

The Mansard corrugated sheet is 28 in. wide with five corrugations and a nominal covering width of 24½ in., and one corrugation side lap.

These sheets are made in 26, 24, and 22 gauges only, and are shown in Fig. 111.

Standard flashings are produced in gauges 26 to 20, in stock lengths of 5 ft. and 10 ft. The weights of these sheets are, approximately, 3.33 lb. per sq. ft. for 26 gauge; 3.86 lb. for 24 gauge; 4.54 lb. for 22 gauge, and 5.38 lb. for 20 gauge.

For corrugated sheets on roofs having a rise of 4 in. or more in 12 in., the following table shows the relationship between gauges and spacing of purlins for the three types of corrugations.

Gauge	10½/2½ in. or Mansard	8/3 in.
No. 26 up to	3 ft. 9 in.	4 ft. 3 in.
No. 24 "	4 ft. 9 in.	5 ft. 6 in.
No. 22 "	5 ft. 9 in.	6 ft. 6 in.
No. 20 "	6 ft. 6 in.	7 ft. 3 in.

For spacing side rails for vertical sheets the above figures may safely be increased by 1 ft.

Curved sheets are provided, either curved throughout their entire length, or curved up at one end. The radius of curvature is limited to a minimum of 15 in., except in the case of Mansard sheets.

V-beam Roofing. Robertson V-beam roofing provides corrugated roofing in its strongest and most economical form (see Fig. 112). It can be depended upon to give years of service under severe conditions. It has a great load-carrying capacity, and sheets of 22 gauge will, with a large factor of safety, carry a 30 lb. live load on a purlin spacing of 7 ft. 6 in. For the same spans and loads, the great strength provided by the V-beam form of corrugation makes it possible to use these sheets in lighter gauges than are required for other types of corrugated roofing. Even more important is the considerable saving in the weight and cost of structural framework that can be effected through the use of Robertson V-beam sheets.

The sheets provide roofs of the same relative stiffness as the ordinary types of corrugated metal sheets provide when employed on the accepted spacings of supports. Robertson V-beam sheets can be used in accordance with the following table of maximum purlin spacings—

24 gauge	.	.	8ft.
22 "	.	.	9 ft.
20 "	.	.	10 ft.
18 "	.	.	11 ft.

A standard sheet is 23½ in. wide and it has a nominal covering width of 21 in. when lapped as shown. The standard lengths of these sheets are from 5 ft. to 9 ft. in half-foot increments, and 10, 11 and 12 ft.

V-beam Roof Deck. Robertson V-beam sheets can be used in combination with other materials to form a roof deck which is capable of overcoming the disadvantage of unprotected steel roofing subject to early disintegration through rust and corrosion. These V-beam sheets provide an ideal deck for insulated and built-up roofs (see Fig. 113).

V-beam sheets give to the V-beam roof deck maximum strength for minimum weight. The weight of the V-beam sheets and the insulating board is approximately only 3 lb. per sq. ft.

The weight of a 4-in. concrete slab is approximately 12 times as great. The weight of the waterproofing is common to both constructions.

The insulating value of V-beam roof deck is high. Tests prove that the coefficients of heat transmission through this construction, expressed in terms of the amount of heat transmitted from the atmosphere on the underside to the atmosphere on the upper side per 1° F. difference in temperature per hour, are—

With ½ in. insulating board 0.313 B.Th.U.'s average.

With 1 in. insulating board 0.216 B.Th.U.'s average.

This insulating value is approximately equivalent to 12 in. concrete.

FIXING. For steel purlins, galvanized hook bolts are used in the manner shown in Fig. 114. These should be of a length 1½ in. greater than the outside leg of the angle. Stock sizes are 3½ in., 4 in., 4½ in., 5 in., 5½ in., 6 in., and 6½ in. by ⅜ in. diameter. Special lengths or diameters are provided to order.

An alternative method of attachment is by means of malleable cast-iron clips.

For wood purlins, special cone-headed galvanized drive screws are recommended. The stock size is 2½ in. by ½ in. with screwed shaft.

With either hook bolts or drive screws, curved diamond galvanized washers 1½ in. by 1½ in. No. 14 gauge should be used on the outside of the sheet. Special diamond fibre washers 1½ in. by 1½ in. should be used between the galvanized washer and the top side of the sheet.

For either steel or wood framing, galvanized side bolts 1 in. by ½ in. with mushroom under-head, should be used with not greater than 15 in. centres. The head of such bolts should be turned

MODERN BUILDING CONSTRUCTION

to the outside of the building, and under the heads there should be a round fibre washer only. Against the nut on the underside of the sheet a flat galvanized washer only should be em-

with two galvanized bolts $1\frac{1}{2}$ in. by $\frac{1}{2}$ in., fixed in a similar manner to roofing. Side lap and end lap bolts should be used exactly as described for V-beam sheets as an ordinary roof.

After fixing the V-beam sheets, the required number of layers of insulating material is next applied. If a single layer of insulating board is used, the insulation is bolted directly to the V-beam sheets in the high parts of the corrugation. If more than one layer of insulating board is used, the layers are first joined together and then bolted to the V-beam sheets. The insulating board is mopped on both top and bottom surfaces with asphalt. The successive layers of built-up roofing are applied in the usual manner.

Flashings for all junctions are made in Robertson Protected Metal.

LEAD FLATS

The construction of lead flats or roofs will be similar to that used for a floor, but the upper surface will be formed with a slight fall to drain off the water. The amount of slope is usually a minimum $1\frac{1}{2}$ in. in 10 ft., but 2 in. or $2\frac{1}{2}$ in. would be preferable. The slope is obtained by furring up the joists, the furring being arranged

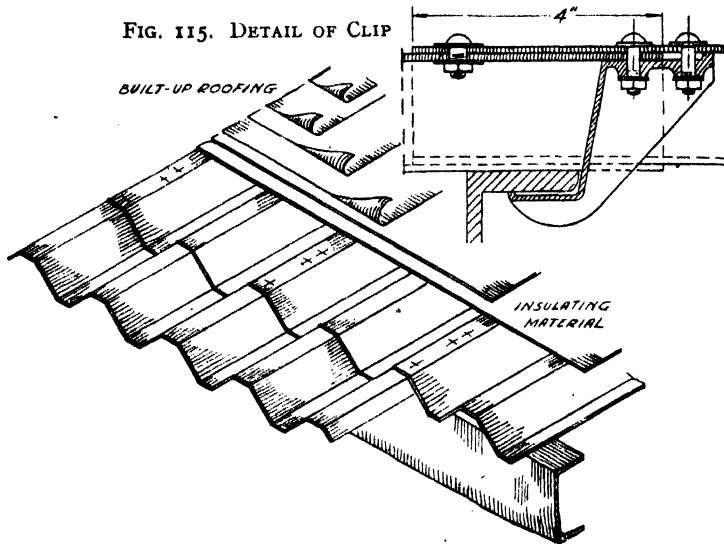

FIG. 113. ROBERTSON V-BEAM SHEET INSULATING MATERIAL AND BUILT-UP WATERPROOFING AS A ROOF DECK

ployed. Similar bolts in alternate corrugations at the end laps are desirable. These fastenings should be thoroughly bedded in a special fibre cement and also be used to seal both sides of the sheets around all fastening holes.

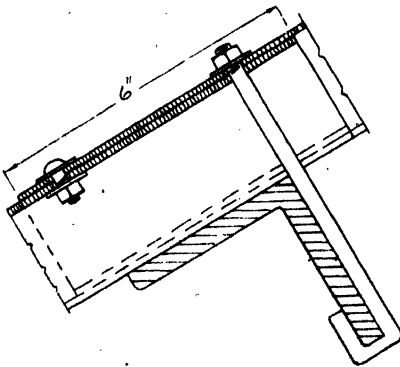

FIG. 114. HOOK BOLT

Where malleable cast-iron clips are used, the purlins should be fixed with their toes pointing up the roof. The clips are equipped with shoulders, as shown in Fig. 115, to make provision for variation in the thickness of the flange of the purlins. The clips are attached to the sheets

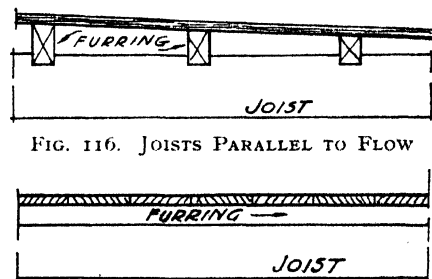

FIG. 116. JOISTS PARALLEL TO FLOW

FIG. 117. JOISTS AT RIGHT ANGLES TO FLOW

parallel to, or at right angles to the flow, whichever arrangement allows the boarding to run in the direction of the flow (see Figs. 116 and 117). These furring pieces are well-spiked to the posts at 15 in. to 18 in. centres. On good work it is often specified that a layer of felt should be placed beneath the lead, and provided the felt used is not too thick, a good job results.

For good class work, the boards should be in narrow widths, 1 in. grooved and tongued.

When rough boarding is used, it should be traversed and its edges shot.

All internal angles should be rounded.

Rolls are required before the lead is placed, their primary object being to divide the roof area into suitable sizes conforming to the width of half a sheet of lead which may vary from 3 ft. 6 in. to 4 ft. 6 in. The former is the size most frequently used, making the length 10 ft.

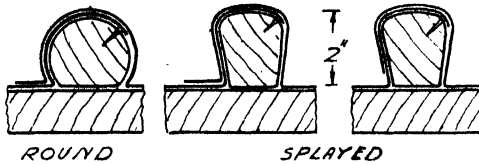

FIG. 118. SECTIONS OF WOODEN ROLLS

SPACING OF ROLLS. Allowing 3 in. for the undercloak and 6 in. for the overcloak, this will give a maximum spacing of 2 ft. 9 in. for the rolls and joints (see Fig. 121). Wooden rolls vary from 1½ in. to 2 in., according to the size of the flat, but for general purposes the 2 in. size is usually adopted. To hold the lead, they are splayed on their sides (see Fig. 118). This type of roll is preferable to the rounded rolls.

DRIPS. Various forms of drips are used to form the joint across the end of the sheet, the one for flats being quite square, and 2½ in. to 3 in. deep. The upper edge of the undercloak

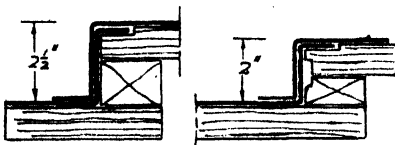

FIG. 119. DRIP. FIG. 120. GROOVED DRIP

is turned up into a rebate 1 in. to 1½ in. wide, and secured with copper nails. The overcloak is carried down the face of the drip and finished on the lower flat a distance of 1 in. (see Fig. 119). Shallow drips should have a capillary groove (see Fig. 120).

Copper nails are the best for all lead work. When fixed 1 in. apart, it is termed "close" nailing, and when fixed at from 3 in. to 8 in. centres it is described as "open" nailing. A complete plan of the flat is shown in Fig. 121.

WEIGHT. Milled lead is described by its weight in lb. per superficial foot, and knowing

the weight of a cubic foot, the thickness for any weight can be found, thus—

If weight is about 710 lb. per cub. ft. therefore

$$710 : 12 \text{ in.} :: 1 \text{ lb.} : x$$

$$\text{or } x = \frac{12 \times 1}{710} = 0.0169$$

say 0.017 in. for 1 lb. For, say, 6 lb., the thickness would be 0.017 × 6 = 0.104 in.

The usual weights specified in ordinary building work are 4 lb. for soakers; 5 lb. for flashings, aprons, etc., for flats.

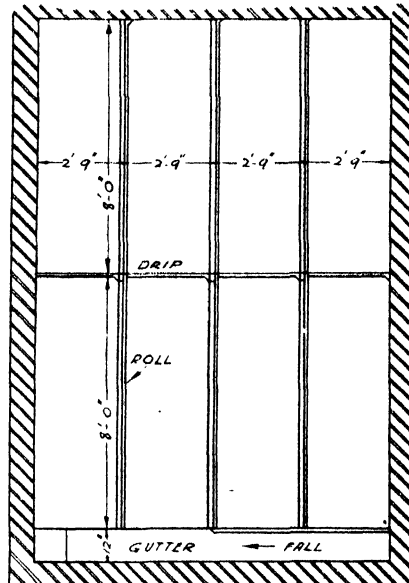

FIG. 121. PLAN OF LEAD FLAT

ZINC ROOFING

Zinc as a roofing material has outstanding advantages. On exposure to the atmosphere, zinc forms its own protective coating, which is a basic carbonate.

WEIGHT AND GAUGE. Zinc is one of the lightest permanent roofs obtainable. The following table gives the weight per square of various gauges of zinc roofing, including cappings, etc.

Zinc Gauge	Weight of Zinc Roofing per square
14 . . .	144 lb.
15 . . .	169 lb.
16 . . .	192 lb.

Sheets are manufactured in lengths of 7 ft. and 8 ft. and 3 ft. width. Other sizes of sheets are obtainable for special orders, but usually at slightly increased cost.

MODERN BUILDING CONSTRUCTION

ROLL CAP. The roll cap system is the one in common use. It enables roofs to be laid, with the exception of a few minor details, without

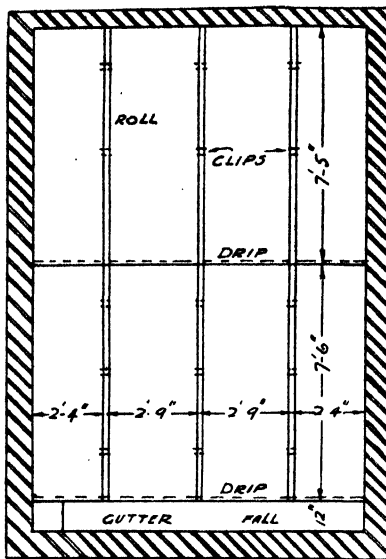

FIG. 122. PLAN OF ZINC FLAT

the use of solder, and makes it possible for the roof to be fixed without nails or screws passing through the exposed surfaces of the zinc. (See Fig. 127).

With roll cap roofing, the sheets are laid over boarding between wood rolls, fixed in the direc-

tion of the fall. The sides of the sheets are turned up against the rolls, and the rolls and turned-up edges covered with zinc capping.

DRIPS. The ends of the sheets are joined either by joints at drips or by welded joints according to the pitch of the roof. Drips are constructed on low pitched roofs and enable weatherproof joints to be made without the use of solder. Welded joints are used on pitched roofs.

HOLDING DOWN CLIPS. Lengths of capping are joined by holding down clips on both flat and pitched roofs. These enable the capping to be joined without nails projecting through the exposed surface of the zinc. (See Fig. 126.)

The lower ends of the capping are finished by forming stop ends, and the upper ends by forming saddle pieces. The turned-up edges of the sheets under these stop ends and saddle pieces are formed into half stops and dog-ears.

Zinc roofs are laid from the eaves upwards. After the sheets are fixed in position, beginning again at the eaves, the capping is fitted.

Flat Roofs. Flat roofs are given the same fall as copper to allow for drainage. If the roof has a fall of less than 1 in 8, drips must be provided, in order to enable weatherproof joints to be made between the ends of the sheets.

DRIPS. The drips are in the form of vertical steps, and should not be less than 2½ in. high. They are spaced according to the length of sheet being used. If the standard 8 ft. sheet is used, drips are spaced at approximately 7 ft. 6 in. centres, 6 in. in the length of each sheet being taken up with folds and beads. If longer sheets are necessary, the spacing of the drips can be increased accordingly.

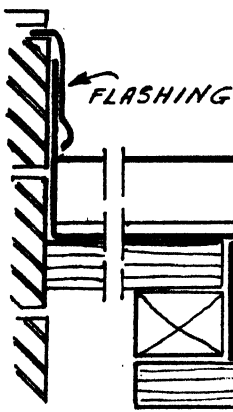

FIG. 124. CROSS SECTION OF DRIP

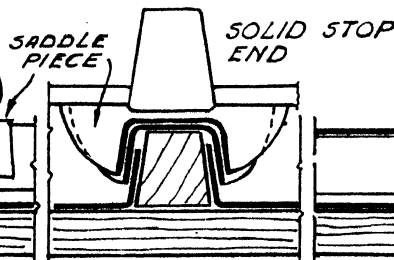

FIG. 123. ELEVATION OF DRIP AND ROLL

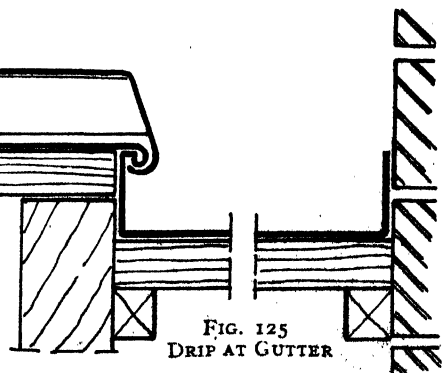

FIG. 125. DRIP AT GUTTER

DETAILS OF ZINC WORK

ROOF COVERINGS

Pitched Roofs. The roof to be covered can be given any pitch since zinc will not creep.

If the roof has a pitch of more than 1 in 8, drips may be dispensed with, and the ends of the sheets joined by means of welded joints. Using 8 ft. long sheets, welded joints occur at approximately 7 ft. 9 in. centres, 3 in. of each sheet being used for the folds of the welts.

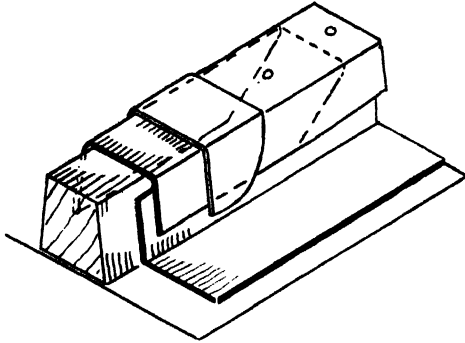

FIG. 126. HOLDING DOWN CLIP

It is not necessary to stagger welded joints, as the thickness of the folds in the side turn-ups is taken up against the wood roll. The joints along the lower ends of the bottom sheets over gutters, etc., are constructed as at drips in flat roofs.

ROOF BOARDING should be well seasoned deal. Oak or western red cedar should not be used because these woods contain substances which may corrode the metal. Boarding should not

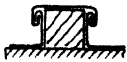

FIG. 127. ROLL

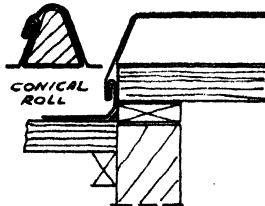

FIG. 128. SECTION THROUGH ROLL AND DRIP

DETAILS OF COPPER ROOFING

be less than $\frac{3}{4}$ in. thick, and should be laid in the direction of, or diagonally across, the fall. Any warping will not then obstruct the flow of water. Felt or paper is laid over the roof before it is covered with zinc.

WOOD ROLLS. The rolls are made $1\frac{1}{2}$ in. high, $1\frac{1}{2}$ in. across the base tapering to $1\frac{1}{4}$ in. across the top. The size varies slightly in practice, but the minimum height is $1\frac{1}{8}$ in. (See Fig. 127.)

Sheets are turned up $1\frac{1}{4}$ in. along each side

against wood rolls, a slight clearance being left between the bottom of the turn-up and the roll for expansion.

Rolls are spaced with a distance stick about 3 in. shorter than the width of the sheet (see Fig. 122), and are cross nailed to the boarding at not more than 21 in. centres with cut nails.

Clips spaced at least every 3 ft. 6 in. are fixed under the rolls by the nails, and are bent to grip the turned-up side edges of the sheets. Each side edge is held by at least two clips.

CAPPING AND HOLDING DOWN CLIPS. Standard capping covers the roll and edges of the sheets and is fixed in lengths of not more than 6 ft. by means of holding-down clips (see Fig. 126).



FIG. 129. PLAN OF COPPER FLAT

Stop ends and saddle pieces at ends of capping at drips are shown in Figs. 123 and 124.

Dog-ears are formed at the corner of sheets where the side turn-up meets the end turn-up. They occur at upright surfaces such as drips and parapet walls (Fig. 125).

FLASHINGS are formed in a similar manner to those in lead work, but they have their lower edge formed with a half bead to stiffen it and so prevent its curling outwards (Fig. 124). Drip at gutter is shown in Fig. 125.

COPPER ROOFING

Sheet copper provides an excellent and highly durable material for roof coverings. It is extremely light, for copper of No. 24 gauge may be considered equivalent to about 6 lb. lead for use in a similar position, a large saving

MODERN BUILDING CONSTRUCTION

of dead weight in the roof. For covering flat roofs or lining gutters, No. 23 or No. 24 gauge is mostly used, but No. 22 gauge is sometimes employed. For step or cover flashings, a lighter gauge would be used, say No. 25 or No. 26. No. 23 gauge weighs 19 oz. per sq. ft. and No. 24 gauge, 16 oz. per sq. ft.

The sizes of sheets used for roofing purposes are 5 ft. 3 in. by 2 ft. 8 in. and 4 ft. by 3 ft. 6 in., both having the same area of 14 sq. ft. These sizes are sold at a basic price per lb. Sheets larger than the basic area will be found to be more economical as they require less jointing, cleats, etc., and less labour. These sheets measure 8 ft. by 3 ft. and No. 24 gauge.

The roof for copper is prepared in a similar manner to that used for lead or zinc. The addition of a layer of felt on the boarding will be found useful in preventing slight irregularities in the boarding. It also prevents condensation forming on the underside of the metal. When laid on concrete roofing, a finish with a cement screed to give an even surface is desirable. On concrete sloping surfaces, the sheets are secured by fixing them to dovetail battens spaced at from 12 in. to 15 in. centres where standing seams joints are adopted. Where wood rolls are used, the battens

are placed at from 18 in. to 24 in.

FALL. For flat roofs the minimum fall should not be less than 2 in. in 10 ft. or 1 in. in 60 in.

ROLLS. The jointing of the edges of the sheets is made over wooden rolls, either square, measuring $1\frac{1}{4}$ in. by $1\frac{1}{4}$ in. (see Fig. 127), or conical, measuring 2 in. by $1\frac{3}{4}$ in. (see Fig. 128). The latter are considered superior and are much in use.

The allowance for forming the joint over rolls is 5 in., that is, 2 in. for the undercloak and 3 in. for the overcloak, the effective width of each sheet being about 3 in. less than its

actual width, e.g. the rolls are generally spaced at 2 ft. 5 in. centres if using 2 ft. 8 in. sheets. (See Fig. 129.) Clips 6 in. by 2 in. are placed under the roll at 2 ft. centres, and folded in between the undercloak and overcloak which is finished with a welted joint along one side of the roll.

The ends of the rolls at the drips are finished with a saddle piece which has its upper edges welted to the edges of the overcloak of the upper flat.

Standing seams are generally used only on pitched roofs. They are liable to become damaged on flat roofs where there is traffic, their usefulness as an expansion joint being spoiled.

Drips are not, as a rule, as necessary in copper roofing as they are in lead roofs, because copper, unlike lead, cannot creep, particularly

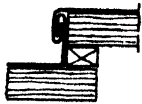

FIG. 130. SECTION THROUGH DRIP

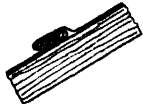

FIG. 131. DOUBLE WELT

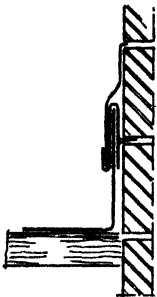

FIG. 132 SECTION THROUGH FLASHING
DETAILS OF COPPER ROOFING

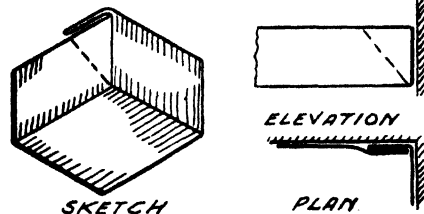

FIG. 133. DOG'S-EAR JOINT

where the fall is a liberal one. However, where the area covered is a large one, it is an advantage to employ them about 10 ft. apart (see Fig. 130).

Where the pitch is not less than 8 degrees, drips may be dispensed with and the joints between the sheets, both vertically and horizontally, made by the use of double welts which should be turned in the direction of the flow of water (see Fig. 131).

Cover flashings are made 6 in. wide and are lapped 3 in. in every 3 ft. The lower edge is formed with a single welt turned backwards in order to stiffen it because, owing to its thinness, it is apt to curl outwards. The clips to secure the bottom edge of the flashing are bent and then doubled twice in order to stiffen them. (See Fig. 132.)

As copper cannot be bossed in the same way as lead, and soldering is inadmissible, it is usual either to welt or dog-ear any upright corners (Fig. 133). If the corners are welted, and not soldered, they would not be watertight. Hence it is usual to dog-ear such corners.

Plastering

By the late J. DANIEL WALKER

Chapter I—MATERIALS

THE craft of the plasterer is of very great antiquity, wattle and daub, composed of reeds and mud, being employed by primitive men to render their crude dwellings more weather-proof and durable. That well-executed plaster work composed of suitable materials is exceedingly durable, when sheltered from the elements, is shown by the excellent state of plastering on the walls of dwellings several thousand years old.

The ability to start and control fires led to the accidental discovery of lime and its properties as a binding material; these properties were quickly appreciated and made use of, shells and chalk being first used to make lime, the discovery of the hydraulic limes and cements following much later. Although the ancients lacked most of our modern quick-setting plasters, yet, by infinite labour and the expenditure of time, they could produce surfaces having a high degree of polish.

PLASTER OF PARIS is so called because of its extensive use in the capital of France, where it was seen and admired in the beginning of the thirteenth century by one of the Tudor kings, and introduced by him into England. Its fire-resisting qualities were quickly appreciated, so much so that after the fire of London it became compulsory as a finish to commercial buildings. Even as far back as the time of the Pharaohs, the Egyptians used plaster of Paris for the construction of fibrous-plaster work.

In these days of high costs, coupled with a shortage of plasterers, the work of the craft is mainly restricted to the production of coverings severe in their simplicity, and of a strictly utilitarian nature. It was not always so, for in the sixteenth century, ornamentation in bold relief ran riot, and rivalled the art of the sculptor.

Many fine examples of ornamental plaster work are still extant, particularly in Great Yarmouth, and in other parts of Norfolk and Suffolk; Holyrood and Buckingham Palaces contain most ornate ceilings in bold relief.

LIME. This is still the most common binding material used by plasterers, where walls are not subject to hard wear or hurried work is not essential. Of late years a ready slaked and finely sifted material, called *Calime*, has been put on the market; it is claimed to be suitable for all purposes to which ordinary lump lime is put, with the added advantages of requiring no slaking and being free from waste.

CHALK LIME. This is so called because it is manufactured by burning chalk; it is suitable only for running into plasterers' putty for setting coats, or for running cornices; in the latter case, it is gauged with the addition of plaster of Paris.

In the past, it was extensively employed for the mixing of *coarse stuff*; but as it sets only on its surface, it should not be so used unless strengthened by the addition of, say, 10 per cent of Portland cement.

STONE LIME. There are various kinds of this lime, differing in the degree of their facility of setting under water, some being feebly and others eminently hydraulic; these are fully described elsewhere in this work.

For plastering, a feebly hydraulic lime is suitable, both for undercoats and finishings; whatever kind is selected will, however, be vastly improved by the addition of a little Portland cement.

The following data regarding stone lime will be found useful—

2 bushels	= 1 bag = 140 lb.
1 yard cube	= 8 bags = 1,120 lb. = $\frac{1}{4}$ ton = 1 load.
36 bushels	= 1 chaldron.

PLASTERERS' PUTTY. This is the term applied to lime which has been slaked and run into a creamy paste; it is used for the composition of plastering mortars, setting stuff, gauged stuff, etc.

By *running* is meant the operation of slaking the lime in a tub or large tank, by immersion in water, until the liquid violently boils and the lime breaks down into a thick milky fluid, which

MODERN BUILDING CONSTRUCTION

is then strained through a fine sieve into a bin, or a wood-lined pit in the ground, where it is left until the surplus water drains away, leaving the putty in a pasty condition. This is left (or should be) for several weeks, so as to afford sufficient time for any unslaked particles which, despite all care, may have passed over with the milk.

Frequently, the labourer who runs the lime throws the core (unslaked lime) on the ground, until the heap attains such dimensions that it must be removed. This is a most mistaken procedure, for particles are apt to adhere to the boots of passers-by and gain access to the prepared mortar, and later cause trouble. The core should be transferred from the sieve to a barrow, and be wheeled to a spoil heap as far distant as possible, and carted from the site at the earliest possible moment. Frequently this waste lime is buried on the site, but there is always the danger that it may be left so near the surface that its ultimate expansion may lift up finished pavings.

The *bin* containing the putty should be kept covered up, not only with the object of preventing foreign bodies falling into the mixture, but to exclude, as much as possible, the passage of air which will cause the formation of an inert scaly crust, due to the absorption of carbonic acid from the atmosphere.

Mixing. Some plasterers contend that it is safe to incorporate the putty with the sand and hair as soon as the putty has been run; this practice should be discouraged, and many architects stipulate that it shall be run from four to six weeks before being mixed. Apart from its liability to cause blows, the putty gets fairly hot (men have been known to heat their tea bottles in slaked lime), and there is the liability of burning the hair in the coarse stuff unless the putty has cooled.

Neither should the putty, even after it has stood for some time in the bin, be mixed up into coarse stuff and used straight away; far better results will be obtained if the mortar be allowed to stand for some days after mixing, as a chemical action seems to take place, resulting in a fatter and smooth working material, less liable to crack than will green mortar; it is said that a silicate of lime forms around the individual grains of sand, improving the composition. The heap should be covered by wet sacks, and then knocked up, with as little water as possible, when wanted for use.

Stone lime mortar should not be allowed to

temper too long, or its setting will be somewhat impaired; but chalk lime may be allowed to temper for weeks, without detriment to its slight setting properties.

COARSE STUFF. This is the material used for the undercoats of walls and ceilings, and it is usually composed of one part of plasterers' putty to two and a half or three parts of clean sand, plus the addition of well-beaten hair or fibre, the amount of which will vary according to the position, more hair being needed for lath-work than for walls.

To mix this coarse stuff, a ring of sand is formed, the putty placed therein, the hair added, and the whole well buffed and raked over until a proper mixture of even consistency is obtained. The determined proportion of hair should be measured and added; this measuring can be done by filling a bushel basket with the beaten hair and ascertaining how many pounds the basket contains, thus giving a guide to the correct amount required per yard cube of mortar.

FINE STUFF. This is an admixture of plasterers' putty and fine, washed sand; it is used for the setting coat of lime plastering. The proportions of sand to putty will vary according to the class of work for which it is intended; generally it is somewhere in the proportions of two or three parts of washed sand to one of putty; this subject will be dealt with later, when describing the various methods of finishing setting coats.

HAIR is added to plasterers' coarse stuff for the purpose of acting as a reinforcement, to afford a support while the material is setting. It should be long, cow or goat hair, well beaten and teased out so as to be free from clots, lumps, grease, or dirt; this beating is done by placing the hair on a strong sieve and beating the material with short sticks, held in both hands, and manipulated much in the same manner as in playing a kettle-drum.

Jute fibre and sisal are materials which have been used with considerable success in America as a hair substitute; *Manilla fibre* is also another substance used for the same purpose.

Hair should never be added to hot lime mortar, as it is liable to be burnt and its strength considerably impaired; here, jute and Manilla fibres score by being practically unaffected by this heat.

Hair is sold in bags of $\frac{1}{2}$ cwt., $\frac{3}{4}$ cwt., and 1 cwt. each, and is put up in three qualities—No. 1, No. 2, and No. 3—the last being the best.

1 bushel of dry unbeaten hair weighs about 14 lb.
1 ft. cube of dry unbeaten hair weighs about 11 lb.

Amount of Hair. Specifications vary greatly as to the quantities to be added, a common practice being to allow 1 lb. of beaten hair to every 3 ft. cube of coarse stuff for walls, and 1 lb. to every 2 ft. cube for lathwork. Care must be taken that the hair is well incorporated and evenly distributed throughout the mass of mortar; it should be added when the material has cooled down, and be well buffed into it by a larry and rake.

A practical test for sufficiency of hair is to lift a shovelful of the haired mortar and observe its tenacity and the length of the portions which overhang the shovel edges.

SAND. The following weights are approximate only, but near enough for all practical purposes—

- A cubic yard of dry sand weighs $1\frac{1}{4}$ tons.
- 1 ton of ditto equals about 22 ft. cube, but 1 ton of wet sand is only about 19 ft. cube.
- A load equals 34 ft. cube, or $1\frac{1}{4}$ yd.
- A bushel of wet sand weighs $1\frac{1}{4}$ cwt.
- A bushel of dry sand weighs 1 cwt. 16 lb.

Formerly, a load equalled one cubic yard, but of late years it has become the practice to deliver a load of $1\frac{1}{4}$ cubic yards.

Shrinkage of Materials. In arriving at the quantities of materials which will be needed for the work in hand, it must be recognized that a yard of dry sand will, after wetting, be found to have shrunk about one-fifth of its former bulk, and where Portland cement is the binding material, this percentage must be allowed for; with lime the case is somewhat different, for the increase in bulk of the lime when slaked somewhat compensates for the shrinkage of the sand.

Preparation of Sand. Plasterers do not like sand which is too sharp, as unless the proportion of lime be considerable, the mortar is apt to be what is known as "short," and difficult to manipulate.

Despite this hankering for a little loam, sand to give the best results must be perfectly free from all earthy matter, and should be washed before use, if there is the slightest doubt as to its cleanliness; it should be obtained from non-tidal waters or from pits; sea sand should not be used, unless the conditions are such as make its use unavoidable. In that case, it should be washed at least twice so as to remove all traces of saline matter, or the work

will be damp in humid atmospheres and tend to effloresce.

By thorough washing, sand otherwise totally unfit for building operations can be made perfectly suitable; where large quantities have to be dealt with, it pays to lay down power-driven sand-washing plant; for smaller quantities, a long V-shaped trough is constructed by nailing two boards at right angles to each other, and forming a sieve in the lower end of the trough. The latter is fixed in an inclined position, and running water led to the upper part; the sand is then thrown into the shoot, and as it is washed down the incline, becomes freed from its impurities; the sand falls through the screen, and the pebbles, running over the meshes, fall in a heap. Usually, however, sand is washed in a tub of water, by immersing each sievelful and giving it a rotary motion.

Care must be taken to renew the washing water frequently, or quite an appreciable amount of mud will collect upon the top of the washed sand.

For cement work, sand should be somewhat coarser in grain than is needed for lime mortar. The nature of the sand used has a very considerable effect in determining the strength of mortar; so much so, that a standard sand is used for cement testing. If the sand be too fine, cracking will result; and if too coarse, it becomes difficult to manipulate and to produce a smooth surface.

For work required as white as possible, *silver sand* is used.

For coarse stuff, ground bricks may be substituted, with excellent results, provided that the brick debris is obtained from well-burnt bricks, and that it be not overground or too finely crushed. Unfortunately, the better the brick, the less likely is it to be used, for the least burnt brick produces the most available rubbish for grinding.

Where mortar mills are used for the production of sand substitutes, it is usual at the same time to mix the mortar therein; in this case, the lime should be previously reduced to putty, and *never* added in unslaked lump form, or "blows" will inevitably result in the finished work.

By "blows" are meant the blisters and lumps due to particles of lime slaking and expanding in the finished plastering.

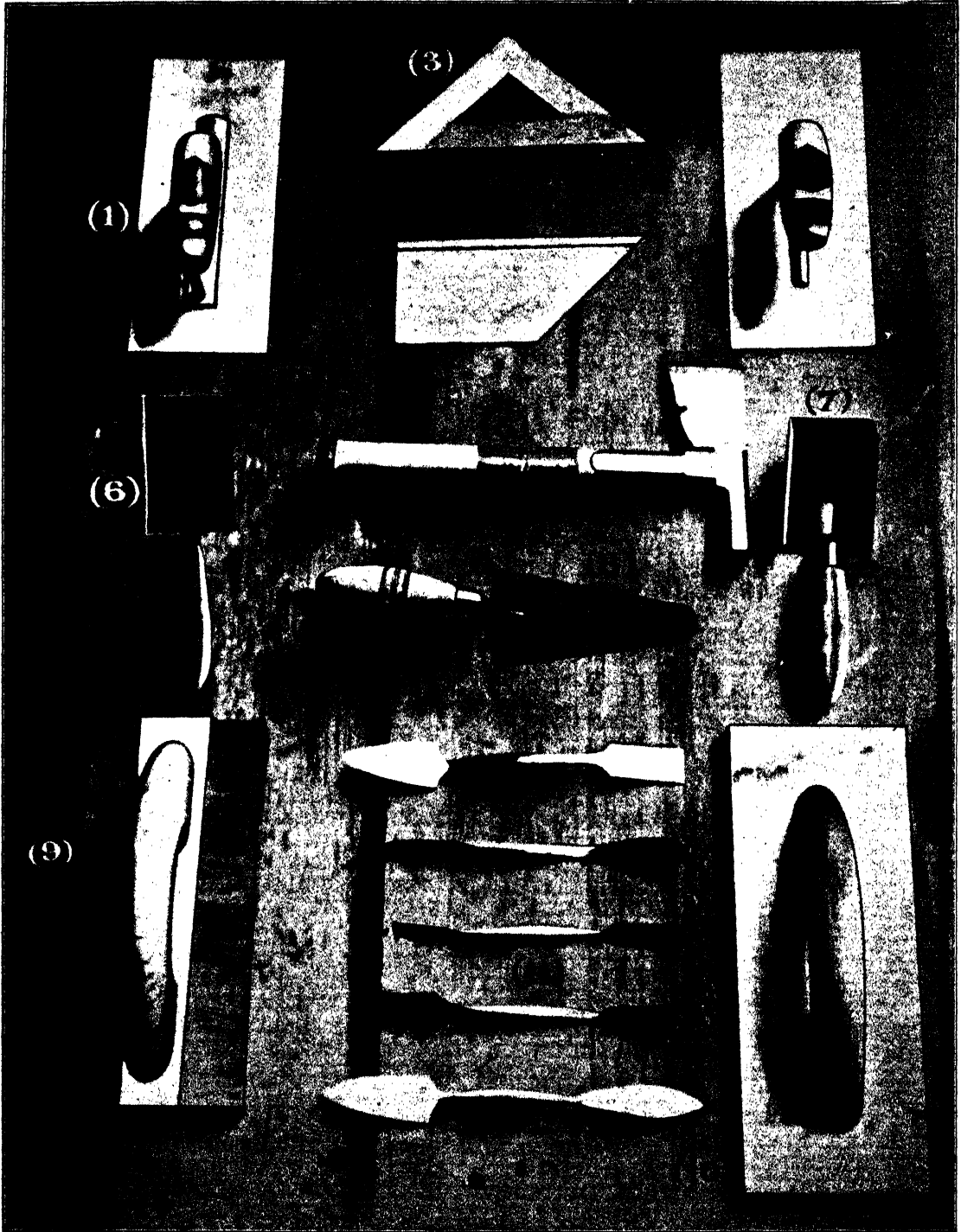

FIG. 2. PLASTERERS' TOOLS

Chapter II—TOOLS

As might be expected from the plastic nature of the materials used by plasterers, their tools consist mainly of trowels and rules, the most important of which are shown in the accompanying illustrations.

FLOATS. Fig. 1 is known as a *Darby*, and is really an elongated form of *float*; it is used for scouring and levelling the surface of wall and ceiling plastering, both in the floating and setting coats, as a preparatory labour to the finishing or laying off thereof. The darby has two handles, and is about 6 ft. to 8 ft. in length, with the handles so arranged that they can be grasped by one operative, but the tool is usually worked by two men; pine is the most suitable wood for its construction; it is a tool usually provided by the employer.

Cross-grained Float. No. 9 shows the tool used for scouring the plastic faces of plaster, after the work has been ruled off by the darby; it will be seen that the handle is fixed to a wood key let into the float at right angles to the grain.

The *Skimming Float* is illustrated by No. 10, and is used for the skimming, or setting, coats, prior to laying off by the steel trowel; in this case the grain of the wood is parallel to the handle.

TROWELS, for laying and finishing the setting coats, are of steel, the handles being supported either by one or two steel shanks, two types of which are shown by Nos. 1 and 2, Fig. 2. It is a matter of choice which tool is preferred, the single-shanked trowel having more give, or spring, than the double-shank.

The *Panel Trowel* is shown by No. 6, and, as its name implies, is used for the finishing of small panels where a larger tool could not be worked. It is also known as a *margin trowel*.

The *Twitcher* is shown by No. 7; it will be seen that its sides stand up at right angles to the blade, which enables it to be run up internal angles, and iron, or smooth, both faces of the returns at the same time.

Gauging Trowel. One form is shown by No. 8; this trowel is made in three sizes and is used for mixing, or "gauging," small quantities of plaster, etc.; needless to say,

it comes in very handy for a variety of other purposes.

The **JOINT RULE**, No. 4, is used for forming mitres worked in position; it is made in various lengths, and with or without a wood handle, or "stock"; this stock gives a firmer grip and does not cramp and chill the operative's hand, as does the plain steel blade.

SMALL SPATULAS, shown in No. 11 in five

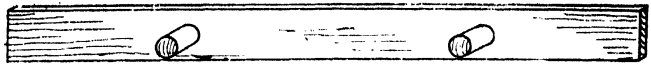

FIG. 1. THE DARBY

different shapes, are for working in positions difficult of access, where a larger trowel would be useless; the ends are shaped like a spoon, trowel, chisel, gouge, or spade; although only five are shown, there are about a dozen shapes available.

SCRATCH TOOLS. These are not illustrated, but resemble the small tools as No. 11, and have curved ends. The edges of these ends are serrated, or formed like saw teeth, and are used to scratch or saw down between mouldings and other places to clean up and reduce unwanted projections.

The **STEEL SQUARE**, No. 3, is a triangle of steel and, like the steel joint rule, shown in No. 4, can be obtained in different sizes.

The **LATH HAMMER**, No. 5, in addition to a driving head, has an axe, for cutting lath ends, etc., and a slot for withdrawing nails.

These illustrations have been photographed from tools supplied by Messrs. Tyzack & Son, Old Street, London, E.

In addition to the wood floats illustrated, smaller ones are used, and are provided with a small wooden handle, which is held by the operative's finger-tips.

DRAGS are thin metal blades having saw-toothed edges, used for producing a scored surface on undercoatings for the provision of a key for the following plastering; they may be used for paring down hard plaster much in the same manner that a mason drags the surface of freestones.

MODERN BUILDING CONSTRUCTION

Among other tools are moulding knives, steel chisels, level, bradawl, chalk line and reel, stock brushes of different kinds, water pots, sieves, larry, rake, mitre box for cutting mouldings, steel compass, plumb rule and bob, running rules, and cornice moulds.

The CHALK LINE is employed for the purpose of "snapping" lines on surfaces, the line being rubbed on a piece of chalk or burnt wood, held taut at each end, whilst another operative lifts it in the centre, and releases it smartly, which results in its snapping sharply on the wall and producing a line thereon.

FLOATING RULES are made of straight-grained pine; they have either square or feather edges, and are used for testing and producing true surfaces on screeds, and from screed to screed. Where feather-edged, the feather, or splayed, edge is not commenced from the face of the rule, so as to form a knife edge, but started about $\frac{1}{2}$ in. back.

The HAWK is a flat piece of wood about 12 in. square, with a round central handle on its underside; this handle is generally screwed to a dovetailed wedge, which is let into the underside of the hawk, and extending its full width, running *across* the grain, so as to stiffen and prevent the curling, or possible breakage of the hawkboard. Some hawks have a cross piece pegged instead of being let into the board, its advantage being that the thickness of the board can be less than one which is keyed, and it is somewhat lighter to handle. The keyed hawk is, however, much stronger and neater, another advantage being that the key can be driven out, and the hawk packed in a smaller space in the tool box.

Except that they are superior in quality, the present-day tools of modern plasterers differ very little from those in use thousands of years ago by the Egyptians, Romans, and Greeks.

The object of the "hawk" is to hold several trowelfuls of plastering mortar, and obviate unnecessary stooping on the part of the operative; many years ago boys were employed to "serve," or replenish, the hawk as its load became diminished, the plasterer giving the cue, by calling out "Serve," as his hawk became empty.

These *hawk boys* are a thing of the past, which is perhaps to be deplored, as their occupation

was often the first step in obtaining a knowledge of the craft.

HOD. Strictly speaking, the hod is not a plasterer's tool, but that of the labourer who attends upon the mechanic; its function is to contain the mortar whilst in transit from the "banker" to the place of use; it consists of a V-shaped receptacle, with one open and one closed end, fixed in a metal crotch shaped like a letter Y, the stem of the Y being hollow to receive the end of an ash handle about 4 ft. long, the whole device being carried on the labourer's shoulder. This long handle serves to support the hod box whilst being loaded, and affords a grip whilst being carried. The hod is often called a "monkey"; its capacity is, roughly, half a bushel.

LARRIES AND RAKES. These, also, are labourers' tools, the *larry* being a metal blade about 9 in. long by 6 in. wide, with an oblong slot in its middle, the blade being fixed to a long ash handle at right angles; it is used to "buff," or punch, the coarse stuff, so that the hair and putty are properly incorporated with the sand; the perforation in the blade allows the tool to pass more easily through the mass as the whole is worked about. The *rake* is a pronged tool set on a long handle, and used to pull and drag the hair mortar about in a somewhat similar manner to the larry.

KNIVES of various shapes are employed for cutting canvas, and for paring and trimming mouldings.

SHALLOW BINS, open on one side and closed by shallow boards on the other three edges, are supported on legs at a convenient height, for the reception of plastering mortar and the gauging of plaster; other shallow boxes are used for the temporary storage and protection of plaster on the scaffolds. Lids should be provided to prevent foreign materials falling in, and to prevent moisture from damaging the dry materials.

There are, of course, many special narrow trowels for panelled and other work, and like all specialized jobs, improvisation comes to the fore when necessity demands; for example, small coved angles have sometimes been formed by using the back of the bowl of a teaspoon.

All tools must be cleaned immediately after use because most plasters set up a rapid rusting action which soon affects the usefulness of the tools.

Chapter III—LATHING AND WALL BOARDS

WOOD LATHS

Rent Laths. Obtained by splitting lengths of straight-grained fir, were at one time almost exclusively used for the support of plastering on ceilings or partitions, but are now exceedingly difficult to obtain, *sawn laths* having displaced them to a very large extent. Rent laths, despite their slight extra cost, are much to be preferred, for owing to their continuous fibres they are much stronger, and their irregularity of surface gives a better key; on the other hand, this unevenness requires a greater thickness of floating to produce a uniform surface. However, where two-coat work is specified, *sawn laths* or expanded metal lathing must be substituted.

Wood laths should be fixed about $\frac{1}{4}$ in. to $\frac{3}{8}$ in. apart; for if closer, the mortar will not penetrate between and curl over to form a proper key; and if spaced too wide, it will be difficult to keep in position until set.

The width of laths should not exceed 1 in., for if over this, the distance between the spaces becomes too great for a proper key.

The substance of laths should be such as to enable them to span firmly from stud to stud, or joist to joist, and to resist the pressure of the operative's trowel.

COUNTER-LATHING. Where the timber supports behind laths are over 2 in. in width, it becomes necessary to pack out the main laths from the supports by means of underlaths, so as to allow the mortar to get behind; this is known as *counter-lathing*.

Wherever a stud partition abuts against a brick wall, or forms a continuation of same, the junction of the two should be covered by means of a strip of metal lath, or a crack will eventually appear, owing to the twisting or shrinkage of the wood.

BUTT AND BREAK. In common work the joining ends of laths are often lapped, but in better class work the ends are butted, and moreover are not all joined upon the same line of support, but so arranged that every 1 yd. or 2 yd. superficial of laths meet on different joists or studs; this is known as "butt and break," and renders the finished plaster less liable to crack.

SIZES OF LATHS. *Fir laths* are sold by the bundle, the contents of which vary in different localities; an ordinary bundle contains 500 ft. run of lath; the lengths vary from 3 ft. to 5 ft., increasing by 6 in. at a time.

Laths are described as *single*, *lath-and-a-half*, and *double*.

Single laths are 1 in. wide by $\frac{1}{8}$ in. to $\frac{3}{16}$ in. thick.

Lath-and-a-half is $\frac{3}{16}$ in. to $\frac{1}{4}$ in. thick.

Double laths are $\frac{1}{4}$ in. to $\frac{3}{8}$ in. thick.

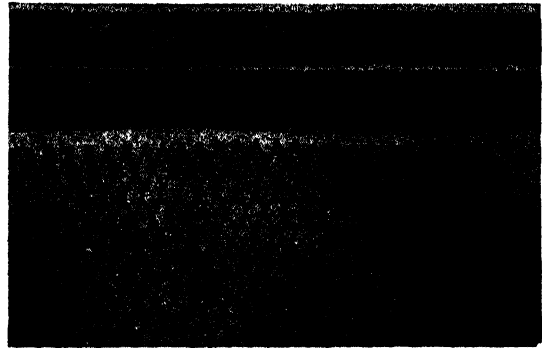

FIG. 3. WOOD LATHING AND METAL LATHING

COVERING CAPACITY. With ordinary spacing a yard super will require 24 laths of 3 ft. length, or 21 laths of 3 ft. 6 in. lengths.

Reference has been made to the difficulty experienced in obtaining rent laths, but at least one firm now supply these in various thicknesses, and in the following lengths—

2 ft., 2 ft. 4 in., 2 ft. 6 in., 2 ft. 8 in., 3 ft., 3 ft. 6 in., and 4 ft.

These lengths are such as to avoid waste, and each bundle contains 300 ft. run, having a covering capacity of about $3\frac{1}{2}$ yd. super.

LATH NAILS. The length will depend upon the thickness of the laths—

Single-lath nails are $\frac{3}{4}$ in. in length and 950 go to 1 lb.

Lath-and-a-half nails are $\frac{7}{8}$ in. in length and 850 go to 1 lb.

Double-lath nails are 1 in. in length and 750 go to 1 lb.

In former times cast nails were used; these

MODERN BUILDING CONSTRUCTION

are now obsolete. The best nails are zinc or galvanized wrought iron.

Wherever plaster of Paris is mixed with the pricking up coat, it is imperative that zinc or coated nails be used, as plaster of Paris or any

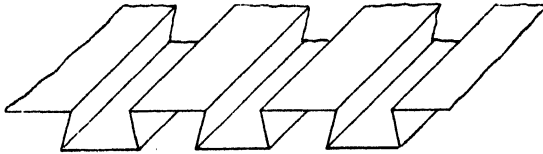

FIG. 4. DOVETAILED METAL SHEETS

cement having this as a base will inevitably set up rust when in contact with raw iron.

Fig. 1 shows two sawn laths and a sample of expanded metal lathing.

METAL LATHING

Metal lathing is far superior for plastering than any type of wood lath; there are various kinds, most of which consist of thin sheet steel cut in different patterns and expanded so as to form a steel mesh, the strands of which are not at right angles to the surface, and thus afford a dovetailed hold for the plastering mortar.

The sheets are supplied in various stock lengths and widths, and of various thicknesses, or *gauge*, each different type and thickness having a definite catalogue number assigned to it. They can be obtained either unpainted or otherwise, galvanized, or coated with a preservative against rust. Special sizes can usually be supplied at short notice, as also can sheets bent to curves or special shapes.

Fig. 3 shows a form of metal lathing supplied by the Expanded Metal Co., and is of the pattern known as "diamond mesh." The long way of mesh (known as L.W.M.) runs along the length of the sheets, and therefore the short way of mesh (S.W.M.) is across the width of sheet.

Whilst the diamond pattern is in general use for plastering support, square patterns are made having meshes 4 in. square and under; this kind is chiefly used for reinforcing concrete, as the diamond pattern prevents pebbles from passing freely through their acute angles.

Wherever metal lathing is liable to come in contact with plaster of Paris, Keene's, Parian, or any other composition having plaster of Paris as its base, the lathing and its fixing staples must be coated or galvanized, or the metal will rust away.

"Jhilmil" Patent Metal Lathing consists of perforated metal sheets made in lengths of 5 ft. by 18 in. to 24 in., and 6 ft. by 12 in. to 18 in. wide. The material affords an excellent key for plaster, is flexible, can be easily cut with shears, is simple to attach, and can be used for cornices, coves, or circular work; studs may be spaced as far as 18 in. centres where this form of lathing is to be used.

Very thin partitions can be made by wiring this metal to light iron supports and plastering both sides of the lathing, the rendering on one side being allowed to set before commencing on the reverse side; some light form of strutting is advisable at the commencement, so as to stiffen and prevent flexing until the mortar sets.

Dovetailed Metal Sheets, Fig. 4, are formed by

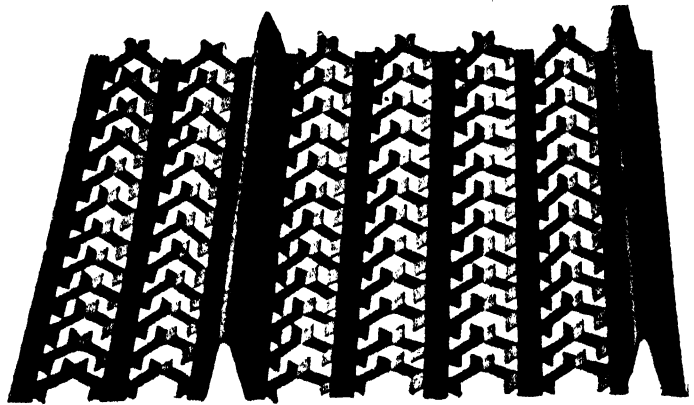

FIG. 5. HV-RIB METAL LATHING

pressing thin sheet steel, so that both sides of the pressed sheet have continuous dovetailed grooves; these sheets when plastered both sides with Portland cement and sand mortar make strong partitions, occupying very little floor space.

Another form of metal lathing is made by Messrs. Hayward Brothers and Eckstein; thin sheets are slit in strips, with uncut portions between each perforation; the slit parts are pushed out so that the lathing resembles the pattern of a wicker basket, giving a firm key for the mortar.

"Hy-rib" is another type of metal lathing; it is stiffened by rigid high ribs. Apart from its use as a support for plastered surfaces, it is used extensively for reinforcement in concrete slabs. Its construction is clearly shown in Fig. 5, which shows half the width of the sheet. It will be seen that the ribs and laths are manufactured from a single sheet of steel, making a complete unit of laths and ribs.

In walls and partitions, Hy-rib does away with the necessity of steel or wood studding. The lath surface is straight and true, and the metal is expanded in such a manner as to provide a perfect key with a minimum of plaster.

The manufacturers advise that the rib should be fixed outwards where this material is used as a reinforcement for the construction of external walls, and that the plastering should be carried out in panels not exceeding 12 ft. in width; the ribs may be fixed either vertically or horizontally. If vertical, twelve ribs may be fastened together as one unit, and if horizontal, four sheets locked together may be found the most convenient unit. Temporary struts are advisable in partition work, where the structural supports are more than 6 ft. apart.

Like most other forms of expanded metal, curved sheets can be supplied to desired radius; special cutters and punches for fastening sheet to sheet are provided.

Hy-rib is manufactured by the Trussed Concrete Steel Co.; their specification for fixing and plastering when intended for use as walls is as follows—

Place all Hy-rib sheets with ribs outwards and mesh surface on interior of wall. Interlock all adjoining sheets of Hy-rib at sides and ends. Sheets must be securely fastened together every 21 in. along the sides, and at every rib at the end by wiring, or by pinching of the lapped ribs with special pincers. Where joints occur between supports, each adjacent joint must be staggered at least 2 ft. Allow a lap of 3 in. where joints occur over supports, otherwise 12 in.

It must be rigidly attached to the steel framing by means of clips or strong galvanized wire, and to wood framing by staples or nails. Such attachments shall be made in the interlocking side laps between sheets, at least every 10½ in. The structure should be so designed, where possible, that the ribs of Hy-rib will extend horizontally.

For plastering the materials should consist of: best English slow-setting Portland cement complying with the British Standard Specification; sand which is free from organic matter, and graded in size from coarse to fine; water-proof paste, approved by the Trussed Concrete Co.; best cowhair, long, and free from grease, well beaten, and separated.

Application of the Plaster. For external work and the first interior coat, the plaster should be composed of Portland cement, one part; sand, three parts. The sand and cement to be mixed together in a dry state, and passed through a sieve till the mass is of a uniform colour; the hair and water to be added, and the whole mixed and applied as rapidly as possible.



FIG. 6. PLASTERER APPLYING MORTAR TO HY-RIB

Hair will only be needed in the first coat, and should be added to the mortar in the proportion of 1 lb. hair to every 3 cub. ft. of mortar, which should be mixed up in small quantities, as required.

Cement mortar should never be allowed to acquire its initial set, before it is used, as if knocked up, that is, reworked, it becomes what is known as "killed," and its ultimate strength seriously impaired.

The first coat is applied to the lathing, preferably commencing at the bottom and working upwards; whilst this coat is still wet, its surface is scratched, or scored, to afford a key for the subsequent coats, which are applied as described elsewhere for wall plastering.

MODERN BUILDING CONSTRUCTION

Partitions formed of Hy-rib should be at least 2 in. thick and should be protected from vibration until set, and from too rapid drying, if

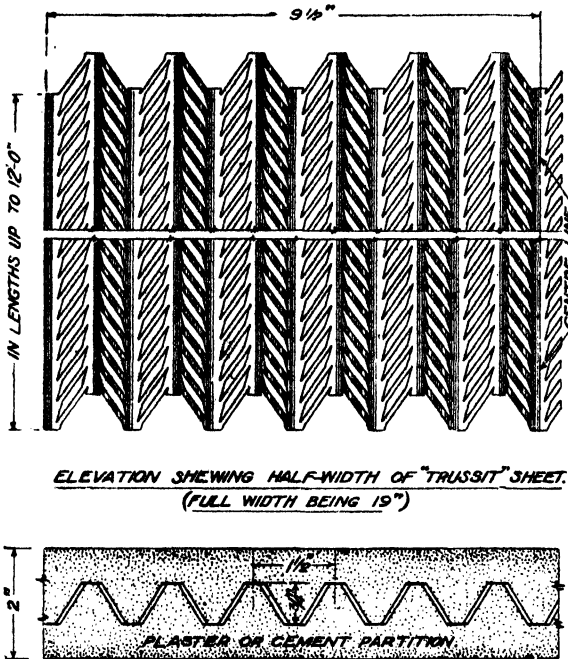

FIG. 7. TRUSSIT METAL LATHING

exposed to the rays of the sun, by means of damp canvas or sprinkling with water.

In walls, partitions, and ceilings formed of Hy-rib, expansion rods $\frac{3}{16}$ in. diameter are advised at about 2 ft. centres wired to the ribs at right angles to their length, and placed on top of ribs.

The specification for the materials is applicable to most forms of metallic lathing.

Fig. 6 is an illustration of Hy-rib as erected for the construction of partitions, and also shows the method of applying the plaster.

"Trussit" is another type of expanded metal sheet designed expressly for the reinforcement of concrete curtain walls and partitions. It offers the maximum resistance to thrust from either side, and being so intimately incorporated with and surrounded by the plaster, it becomes an integral part of the partition wall, instead of merely a support. It is claimed that a wall 2 in. thick, composed of this reinforcement and Portland cement and sand, has ample substance and that it will be sound and fire-proof.

Fig. 7 illustrates the type of metal; it is

made in sheets 8 ft., 10 ft., and 12 ft. long, in three thicknesses of 24, 26, and 28 gauge.

Herring-bone Metal Lathing, Fig. 8, is another form which affords a firm surface for plastering, whilst providing an excellent key; it is supplied in sheets 18 in. wide by 96 in. long, in various gauges, and is manufactured by the Self-Sentering Expanded Metal Co.

Fixing Expanded Metal. Wire staples are usually employed to secure this material to wood studs, or joists, but special clips are also used. Care is necessary to ensure that the metal is fairly taut, for if it bags, or bulges, a greater thickness of plastering will be needed to produce an even surface. If the type is not interlocking at the joints, it becomes necessary to wire the meeting edges, one to the other, at

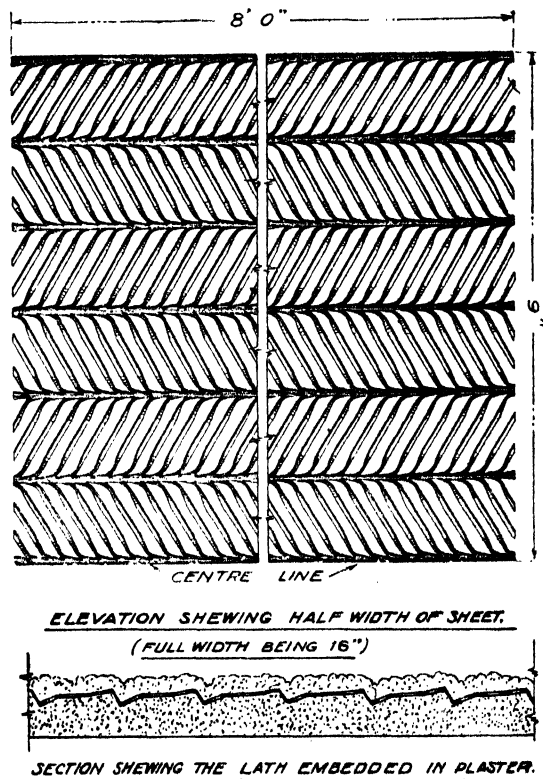

FIG. 8. DOUBLE-MESH HERRING-BONE METAL LATHING

frequent intervals; galvanized iron, or copper wire should be used for this purpose.

Skilfully used, expanded metal has great scope in the economical construction of false ceilings domes, etc.

WALL BOARDS

The modern desire to complete structures as speedily as possible, plus the high cost and scarcity of labour, has led to the introduction of many forms of pre-fabricated wall and ceiling coverings. Nearly all of them are light, warm, and non-heat conducting, but most are inflammable. They can be set with a skimming coat of plaster, finished with a distemper, or left in their natural warm brown colour. A charming panelled effect can also be produced. On ceilings or partitions, they obviate lathing, but nailing-supports must be provided at all edges, cross joints as well as long joints, and unless all edges and the centres of slabs are well-nailed a satisfactory result cannot be obtained.

One disadvantage applies to all wall boards, i.e. that plugging and fixing strips are necessary, and that the cavity behind harbours vermin unless the space is filled with coarse stuff. On the other hand, this space acts like a cavity wall in retaining heat and preventing dampness.

Paramount and Thistle Plaster Board are two types of wall board composed of gypsum plaster sandwiched between an enveloping surface of tough fibrous paper which is moulded to the wet plaster at the same time as the slab is formed. The fibres of the envelope are drawn into the plaster core and a firm bond established without the application of any adhesive.

It is made in thicknesses of $\frac{3}{8}$ in. and $\frac{1}{2}$ in. and in widths 3 ft. and 4 ft. to suit spacing of 12 in., 16 in., and 18 in. centres. As slabs are made in continuous lengths and then cut up to stock lengths, any desired size can be obtained; the stock lengths are 6 ft., 7 ft., 8 ft., 8 ft. 6 in., 9 ft., 10 ft., 11 ft., and 12 ft. While it is an advantage to run the wall board in one length from floor to ceiling, long slabs on ceilings become unwieldy and difficult to handle.

These boards have a high fireproof value and will withstand the flame of a blow-lamp for several minutes before the backing strip is scorched.

As the whole appearance of the finished work depends entirely on the degree of accuracy of the fixed backings, too much care cannot be taken in their fixing. They should be arranged so that the edges of two adjoining slabs meet in the centre of the backing with a gap of from $\frac{1}{8}$ in. to $\frac{1}{4}$ in. This gap should be filled with Joint Filler, preferably covered with Sealer Tape. Ceiling slabs should have heading joints staggered, unless a panelled effect is desired.

Nails should be placed 6 in. apart on ceilings and 9 in. on walls and kept $\frac{1}{8}$ in. back from edges. They must be galvanized otherwise they will be attacked by the gypsum, set up rusty spots, and ultimately destroyed. The nails should be driven well home, making a slight dent with the hammer, but a nail punch should not be used. Any nails which are loose through missing the backings, should be drawn, otherwise they will work through decorations.

These boards can be finished in one coat, or, preferably, in two coat work. After bedding the sealing tape across the joints, level up the slab with the plaster to surface of tape, and when set, finish off with the second coat.

Instructions for Fixing. For ceilings, the scaffold should be arranged at such a height as to give about 3 in. clearance above the head. Support the slabs by means of a tee-square formed by cutting a length of slating batten or a strip of 4 in. \times 1 in. timber about 1 in. longer than the height of room. This can be sprung under the slab with the crosshead under same. The other end being on the floor will hold the slab firmly while nailing. Nail from the centre of the slab and work to the edges. Slabs can be cut with a fine toothed saw, or, if the cut edge is next to the wall, with a knife. The cut should be made through the paper on both sides and broken sharply on a straight edge. Always rub down any loose paper on cut edges, otherwise it will work up in after-treatment.

When wall board is to be fixed over old plastered walls, carefully locate old studs and use a nail long enough to enter well into same. If the plaster is uneven, it is advisable to cut the plaster away down to the old stud, and fix strips of fir standing slightly above the plaster to receive the new slabs. Employ a box galvanized nail in lieu of a wire nail, as this, having a smaller shank than a wire nail, will not injure the slab to the same extent.

When applying wall boards to old brickwork or stone, plug the wall and fix 2 in. \times 2 in. fir backings at 16 in. centres; be sure the backings are firmly plugged. Joint Sealer should be applied by means of a 3 in. semi-elastic scraping knife. Nail heads should be covered over, and plenty of sealer worked into the joint which should then be spread to a 3 in. wide strip. Apply the reinforcing strip as soon as a joint is covered, placing it centrally over the joint and pressing firmly with the spreading knife. Sealer should be used only for very small defects; for larger ones use Joint Filler.

Chapter IV—PLASTERING OPERATIONS

WALL PLASTERING

THREE-COAT work is the usual procedure in good class work except where one of the special plasters is substituted; the various coats are known as *rendering*, *floating*, and *setting*.

The reason for applying three coats is because unless the surface of the wall is unusually true, such a thickness of material becomes necessary that if it were applied in one or two coats it would be difficult to retain the plaster on the wall until set, and cracks would inevitably result. The best work is produced when the minimum amount of stuff that will produce a good even finish is applied.

The finished thickness of the three coats averages from about $\frac{3}{4}$ in. to $\frac{7}{8}$ in., but cases occur when upwards of 1 in. becomes necessary.

Where wood frames and wood skirtings occur, the carpenter should have fixed his grounds before the plasterer begins, and to these the plasterer will have to work, for they govern the total thickness of his coating.

Rendering. Before rendering a wall, the plasterer should make certain that the wall itself is fit for the reception of his material; in other words, that it affords a proper key. Blue brickwork should have the joints well raked out, and if Flettons have been used they should also be raked out, unless the bricks are of the dovetail pattern specially made for plastering upon.

Stock brickwork, as a rule, provides a very good backing for plaster work, but if old and sooty bricks have been inserted, these should be cut out, or if too numerous, should be hacked, and an application of lime and cow-dung be put on and allowed to stand for several days; otherwise brown patches will show in the finished work.

The wall should be well-brushed and wetted, and the rendering roughly applied, that is, it should be left with a rough surface so as to afford a firm key for the floating coat; about an hour after its application it should be scored, or scratched, with a *scratcher*, formed generally of a few pointed laths.

Before applying the next coat, the rendering should be allowed to get dry and hard, and to crack as much as it ever will, for if

all its ultimate shrinkage has not taken place before the floating is done, then this will crack also.

Floating. This is the application of the second coat, which is ruled and "floated" true before putting on the setting coat.

The hard, dry rendering coat is well wetted, the wall plumbed from top to bottom, and ribbons of plastering mortar, called *screeds*, about 3 in. wide and 6 ft. to 8 ft. apart, are run from floor to ceiling, and ruled so as to be true in one vertical plane. At the same time, notice must be taken of the wood grounds, and if these do not coincide with the screeds, one of the two will have to be altered; it may happen that circumstances are such that the plastering will have to be humoured to suit the joinery, and that the screeds cannot be made upright.

The floating coat is now applied and the straight-edge worked on the screeds, to pare off any excess mortar and to discover the hollows which need filling out.

After the bays between each screed have been ruled fair, they should be scoured over with a float, and when the surface has slightly hardened it should be lightly scratched, to form a key for the setting coat; this may be done either with a "scratcher," or by brushing with a stiff yard broom, care being taken not to roughen it unduly, for upon its truth depends that of the setting coat which follows.

Devilling is scratching the surface of floating by means of a wood float through which several nails have been driven so that their points project about $\frac{1}{8}$ in., such a tool being known as a "devil."

The floating must now be left to harden and crack, but must not be left until quite dry, or the setting coat may peel off; it is ripe to receive the setting when it is firm but still "green," that is, slightly moist.

While lime plastering makes sound work, if suitable materials are employed, it can be hardened at very little expense by the addition of 10 per cent of Portland cement in all its coats.

If the work is to be distempered or painted, more care is necessary than if it is to be papered; proper precautions must be taken to avoid

"galls," or untrowelled patches missed by the tool, for it is impossible to rectify faulty work once the setting coat has hardened, without showing a patch or lumpy surface.

The presence of galls can be more readily detected by looking sideways along the wall, and passing the finger-tips over suspected portions.

The floating coat should be damped, and the setting coat applied in one operation from floor to ceiling, or a joint will show; in a long room advantage can be taken of any breaks or projections, and the work jointed in the internal angles of same.

The scaffold must be so arranged as to be far enough away from the wall to enable the trowels to be worked; the gang of men should be distributed so that some work above the others, and so that the strokes of their laying trowels traverse each other's work at the scaffold line; in a very tall room, this may necessitate three tiers of workmen.

Setting. In common work, the setting coat is applied in one layer, but in better class finish it is put on in two, the second following the first immediately, a skimming float being used for the first application, and a laying trowel for the finish coat.

To obtain a high-class finish, the setting coat must be well scoured with a hand float, and next by a cross-grained float, water being sprinkled upon the work by means of a stock brush, then left for a short time to stiffen, again scoured, and finally finished with a steel trowel.

As a rule, the operative who trowels the work follows closely on the one who does the final scouring, and with a damp stock brush in one hand, the polishing trowel in the other, damps and trowels off the work, traversing it in all directions until a satisfactory finish is obtained.

Setting coats should not exceed $\frac{1}{8}$ in. in thickness $\frac{3}{16}$ in. at the most; if more, it will crack, and if less than $\frac{1}{8}$ in. is liable to peel off.

The same objection applies to vertical joints as to horizontal ones, and the length of a wall should, if possible, be finished without a joint, sufficient men being engaged to make this possible; as a rule, in a wall of considerable length, piers or breaks occur and work can be stopped at such points.

The final setting coat should not contain hair, but the addition of a little white hair is an advantage in the first setting coat, and with care will not show through the second one.

Marble dust, sifted and mixed with the final

setting coat, gives a brilliant surface; it should not be added to the setting stuff until it is about to be used, and care is necessary to ensure that the proportions of dust to sand are kept uniform.

Powdered glass, brickdust, and crushed spar are other materials used to colour and enhance setting coats.

GAUGED SETTING. In hurried work, plaster of Paris is mixed with the fine stuff; one plasterer rapidly lays on the material with a skimming float, his mate following on and ruling it off. Fresh material is then gauged, and a thin coat applied by one plasterer and immediately trowelled off by a second, before it can set, care being taken not to overwork the stuff and kill it in the process; the addition of size water delays the setting.

The addition of too large a proportion of plaster will cause cracks, and overworking will lead to peeling and flaking.

EXTERNAL ANGLES. In good work these are run with Keene's cement on a Portland cement backing, but in common work are generally made of the ordinary wall stuff.

If moulded, then the putty (if Keene's is not used) must be gauged with plaster of Paris, and the moulding run by the use of a running mould, worked on screeds, after the removal of which the edges of the moulding are cut true to receive the junction of the setting coat.

Where such angles are cut by the passage of skirting, or dado mouldings, the vertical moulding should be formed first, and later cut away where the horizontal moulding will pass through it, the object of this being to ensure that the vertical moulding will be true and out of "winding"; if, on the other hand, the angle is run in short lengths between floor and skirting, and from skirting to dado capping, and thence to door head or ceiling there is a grave risk of getting it crooked; the writer has seen some very bad examples due to the lack of this precaution.

SKIRTINGS. Where surmounted by a moulding, this forms a good joining place for the work above; but in the case of a Keene's or Portland flush skirting without a top mould, the skirting should be formed, the top cut off to a clean line, and the work above finished to it; never attempt to rub the setting coat into the face of the skirting, or a most messy and unsatisfactory finish will result.

Two-coat Work is very seldom executed in lime plaster, except on the commonest class of

MODERN BUILDING CONSTRUCTION

work, and is performed by combining the rendering and floating coats in one operation, the undercoat being ruled off and at once scoured, finished later with one coat of setting stuff; it is very liable to crack and difficult to finish to a perfectly true surface.

Stucco is the name generally given to external plastering much in vogue in early Victorian days, principally executed in Roman cement and ruled to imitate stone; it certainly had the merit of water-proofing the under-burnt place bricks, of which most of these imposing looking structures were erected.

Where this class of plastering is now carried out, Portland cement is substituted, with, however, the disadvantage that, unless treated with special preparations, it cannot be painted on for several years; reference will be made later to the solution recommended for coating Portland cement which is to be painted.

The cement should be gauged with washed sand in the proportions of three of sand to one of cement. It is applied in two or three coats, well scoured with a cross-grained float, and finally patted with the float so as to remove the scouring marks and bring the sand to the surface, leaving a uniform, flat, sanded finish.

Where it is desired to imitate closely the texture of stone, the work may be completed by a float to which felt has been secured by plaster, the felt being rubbed down on a fine stone to bring it to a level surface; this tool produces a fine face, in which the sand is not prominent.

The washable distempers or water paints now on the market are capable of producing very pleasing results on this surface; or if the surface to be left is uncoloured, lime may be substituted for the cement, although it is advisable to add, say, 10 per cent of the latter to external lime plastering.

TROWELLED STUCCO is the description given to lime plastering specially finished for painting. It is very similar to the best kind of setting previously described, except that the proportions of sand and putty are varied somewhat; the sand is coarser, that is, washed through a sieve having about 12 meshes to the inch each way, the proportions of sand being about $2\frac{1}{2}$ or 3 to one of putty. Considerably more labour should also be put into the work so as to avoid the least trace of irregularity in the finished surface.

The setting coat is worked over with the floating rule in every direction, then well scoured

with the float, allowed to stiffen, and again scoured three times, water being lightly sprinkled on with a stock brush at each operation *except the first coat*, and finally trowelled off in all directions, finishing with up and down strokes until a hard, dense, polished surface results. It is then lightly brushed with a damp, but not wet, stock brush, to remove any traces of "fat" or crumbs left by the edges of the trowels.

BASTARD STUCCO is a finish midway in quality between good setting and trowelled stucco, the proportion of putty to sand being greater; that is, 2 of putty to $2\frac{1}{2}$ parts of washed sand. It is applied in two coats on the floating, once scoured, and trowelled off, and brushed as before. It is, owing to the greater proportion of putty, much more liable to develop fine hair-like cracks.

CEILING PLASTERING

Ceilings should be lathed, pricked up, or rendered, floated, and set, unless of two-coat work.

Rendering, or Pricking-up. The plasterer applies the haired coarse stuff, not in the direction of the laths, nor at right angles to them, but diagonally, forcing the mortar between the laths so that it curls over, and when set, affords a secure key for the following coats; this *pricking-up coat* is the base which sustains the finish, and very great care should be taken that the materials and workmanship are such as will make a sound, lasting job.

The hair must not be stinted, neither must it be short, or the ceiling will ultimately fall; several instances of this have come under the writer's observation in recent years, due to a paucity of lime and hair (short at that) coupled with sawn laths spaced too closely.

Each trowelful of rendering should slightly lap the preceding one, so as to bind or bond to it, and the coat should be as thin as practicable, consistent with a fair surface.

About a "bare" $\frac{1}{2}$ in. is a suitable thickness, and a little Portland cement should be added; plaster of Paris is often used in the pricking-up coat.

When firm, but not unduly soft, it should be lightly scratched in two directions, so that the marks resemble in shape a large spear head, or lozenge, and should preferably be made by a single pointed lath instead of a number, which tend to cut the work up unduly.

Floating. When the pricking-up coat is hard, *but not before*, the floating coat may be applied,

the ceiling being first trued up by dots of plaster as a guide for the screeds on which the floating rule will run.

Coarse stuff for floating ceilings should not be too stiff, or such pressure will have to be applied that the laths may flex, or spring, cracking the rendering coat and weakening the key; here it may be pointed out that ceilings are often cracked owing to the joists not being sufficiently strong to carry the load in the floor above, and the plasterer is not always the culprit.

This floated and well-scoured surface is lightly scored when firm, left to harden and shrink and, like walls, set before it becomes dry; the object to be aimed at is not merely to apply the setting as a distinct and separable layer but to slightly force the particles of the setting into the floating and "marry" up with it.

Setting. Setting stuff for ceilings is often slightly gauged with plaster of Paris, to which size-water should be added so that its setting is retarded, or it will otherwise be overworked and killed, thereby destroying its setting properties.

Plaster of Paris should never be added to mortar containing Portland cement.

Scouring. Too much emphasis cannot be laid on the importance of well scouring both floating coats and setting, provided *always that they be not gauged with plaster of Paris.*

CEMENT WORK

Portland Cement. Next to lime, Portland cement is the most frequently used material for plastering, Keene's cement being a good second. During recent years very great advances have been made in its manufacture, owing to a fuller knowledge of the properties of its component materials, and the finer grinding than heretofore of its particles; this increased knowledge and improved methods result in a very appreciable addition to its final strength.

It can be obtained in quick and slow-setting varieties, and will bear a much larger addition of sand than lime, so much so that the amount of sand is generally limited, for plastering purposes, by the difficulty of obtaining a smooth surface, instead of by its strength.

Special quick-hardening brands are supplied (at an increased price) which prove very useful when plastering has to be applied to walls subjected to water pressure.

Its chief uses for plastering are as backings to receive the finer finish of Keene's and similar cements, or at times as a wall finish in dadoes, skirtings, angles, linings to concrete tanks, man-

holes, benchings, channels, etc., for the carriage of sewage or water, or in positions exposed to the elements, and where exceptional hard usage is anticipated.

Mixed with granite chippings, it makes excellent floors, artificial stone steps, landings, pavings, and concrete partition slabs.

As a wall finish, its dark colour is considered an objection, although this feature can be overcome by the white varieties now on the market. Moreover, unless specially treated, it cannot be painted on for some considerable time, owing to the alkali in the cement combining with and saponifying the oils of the paints applied to its surface, resulting in the paint rubbing or peeling off; the colouring pigments are also affected and rendered fugitive.

Unlike plaster of Paris and its kindred compounds, Portland cement is an excellent preservative of steel, and must be used for the undercoats of these plasters where metal lathing, or any ferrous metal, is the support.

Plasterers' coarse and fine stuffs are vastly improved at a slight expense by the addition of 10 per cent of Portland cement.

A black finish can be obtained by the addition of oxide of black manganese.

There is no objection to the addition of well-slaked lime putty to Portland cement plastering (provided it is not added in excess), and this addition enables a much finer and smoother finish to be obtained with considerably less labour than would otherwise be possible.

Portland cement mortar should be mixed by hand in small quantities as required, and in definite and uniform proportions with sand, or the colour of the work will vary. Neither must it be manipulated after the commencement of its initial set, or its strength will be seriously impaired and its colour changed.

One part of cement to two or three parts of sand is the customary proportions for plastering if putty is added; without putty, more than two parts of sand will render the production of a smooth surface difficult to obtain.

WATER-PROOFING. As a water-proofing material, Portland cement has a considerable vogue; but to be efficient, it is imperative that the sand is clean and free from impurities, such as salt, clay, iron, and earthy matter, and that the proportion of sand to cement be not too great; the work must be sufficiently trowelled so as to close up all interstices, and force the particles into intimate contact with each other. The coating of cement and

MODERN BUILDING CONSTRUCTION

sand must be protected from the rays of the sun until set, and for some days after; neither must there be any risk of damage by frost. Above all, the surface to be coated must be properly prepared, by raking out joints or hacking, so as to give a good key; joints in undercoats should not register or line up with those of the succeeding ones, but be passed at least 6 in., as is usual in asphaltting.

Even at its present high price, Portland cement is really cheap, and in water-proofing operations should not be stinted. It should be mixed not weaker than one part of cement to two parts of sharp washed sand, in small quantities as required.

It is useless to attempt to apply Portland cement to the surface of a whitewashed wall; all traces of whitewash, distemper, or paint must be hacked off until a rough, clean surface is obtained, or failure will result.

All internal angles in work to be water-proofed should be strengthened by being rounded, and the edges of all joints should be brushed and wetted before being made good.

Plasterers are often called in to water-proof vaults, or basements, in old buildings, and experience much trouble by the seepage of moisture through the walls, this causing the mortar to slide or creep down before it can set. Messrs. Kerner-Greenwood, who manufacture the well-known Pudlo brand cement water-proofer, recommend that, in such cases, this seepage can be controlled by driving lengths of iron gas barrel through the wall, so as to tap the surrounding liquid; the ends of the barrel that are inside the chamber should project slightly, to lead the droppings free from the surface, and after the cement work has set these tubes are tapped, or driven, below the finished surface, plugged by corks, and cemented over.

When dealing with basement floors, water if present to any appreciable degree, must be kept under by a sump and a pump; a convenient method is to sink a length of stoneware drain 6 in. in diameter, the socket being below the finished floor line; in this pipe sump the pump hose is inserted, and at the finish of the work the drain is sealed by a drain stopper, and the floor made good. This method will naturally only be adopted if it is impossible to form a sump outside the building.

Water-proofing operations are facilitated and ensured by the addition of one of the various materials marketed for this purpose, for although soap, china clay, tallow, oils etc., have been

advocated, it is advisable to employ well-trying water-proofers, and to follow the maker's instructions and advice in their use.

For the class of work above described, rapid-hardening cement should be obtained, and the setting can be further hastened by the addition of common washing soda mixed with hot water, although it is not wise to add foreign matter to cement unless it is really necessary.

Portland cement is of a strongly alkaline nature and, in drying out, the evaporated moisture brings to the surface alkaline crystals and leaves them as a feathery efflorescence; unless this is removed, or neutralized, they saponify the oil of paint, rendering it tacky and non-drying, and also affect the pigment, causing it to become a dirty brown.

Cement surfaces should not be painted until twelve months have elapsed. If it is imperative that they should be, then the alkali should be neutralized by a wash of dilute spirits of salts, or better still, with chloride of zinc, washed down, and dried before applying paint.

DATA FOR CEMENT WORK. Good Portland cement weighs per foot cube about 75 lb. to 85 lb. when lightly filled into a measure, and about 110 lb. if the measure be shaken so as to consolidate the cement.

Architects and engineers generally accept 1 ft. cube as the equivalent of 90 lb., the modern practice being to specify a definite weight of cement to so many parts of sand, instead of the old practice of proportions by measure.

A bag of cement contains 2 bus. or about $2\frac{1}{4}$ ft. cube, and weighs 2 cwt. Ten bags should, therefore, go to a ton, but eleven bags are usually supplied by the manufacturer, the extra bag being in the nature of a trade allowance; some factors arranged to have a reputed ton sacked up in twelve bags for the retail trade.

Two standard sacks of cement to a yard cube of sand give a mixture approximately of one to six, but the proportions should always be determined by a definite cement measure and a yard, or half-yard, sand box; for small quantities a pail may be substituted.

A foot cube of Portland cement, mixed with a foot cube of sand, will plaster $2\frac{1}{4}$ yd. super 1 in. thick. From this basis, it follows that the same amount of material will cover 3 yd. super $\frac{3}{4}$ in. thick and $4\frac{1}{2}$ yd. super $\frac{1}{2}$ in. thick. If a foot cube of cement is mixed with 2 ft. cube of sand, it will cover 3 yd. super 1 in. thick, from which it follows that the same amount will cover 4 yd. super $\frac{3}{4}$ in. thick and 6 yd. super $\frac{1}{2}$ in. thick.

Roman Cement is a dark brown powder, obtained by burning and grinding nodules of soft brown material found in the London clay; it sets very rapidly, and is therefore useful for tidal work, or where water is encountered. It is weakened very considerably by the addition of sand, and is much inferior in strength to Portland cement, whilst costing considerably more, but has the advantage of being fit to receive paint as soon as set.

Formerly, it was extensively used for external stucco work; its present-day use is, however, very limited—

1 sack contains 3 bus. or 234 lb.
A cask contains 5 bus. and weighs 390 lb.
1 foot cube weighs about 61 lb.

Gauged neat, 1 bus. will cover $1\frac{1}{2}$ yd. super to a thickness of $\frac{3}{4}$ in.

If mixed with a bushel of sand, it will cover $4\frac{1}{2}$ yd. super, $\frac{1}{2}$ in. thick.

Keene's Cement is manufactured by immersing plaster of Paris in a solution of alum, and reburning and grinding the resulting material. It is made in three grades—*coarse*, *fine*, and *superfine*—the latter variety being exceedingly white; a pink Keene's of excellent quality is also marketed.

Keene's cement sets very much more slowly than plaster of Paris, and is capable of receiving a very high polish; it becomes exceedingly hard, and is extensively used for wall finishes, skirtings, dadoes, mouldings, angles to quoins, and panels in door openings, etc.

Setting stuff on lime backings being unsuitable for external angles liable to damage, it is a common practice to round and form them in Keene's on Portland, the Keene's usually being continued at a tangent to the rounded angle in the form of *wings* about 2 in. wide. By "wings" is meant the extent to which the Keene's is continued after the termination of the curve of the rounded angle; many architects specify this finish and material to the angles of window openings. Where the depth of the jamb does not exceed $4\frac{1}{2}$ in., plasterers find it more economical to finish the whole depth in Keene's, instead of limiting it to the 2 in. wing and finishing the remainder in setting stuff.

Keene's, like plaster of Paris, is soluble in water, and therefore unsuitable for external work, unless well painted.

It should receive a priming coat of sharp paint almost as soon as finished, or the evaporation of its moisture will conduct the contained salts to its surface, leaving a feathery deposit,

called "efflorescence," and throw off any paint applied later.

One part of Keene's to three parts of sand may be employed for the rendering and floating coats instead of Portland cement, and is claimed to have the advantage of not being so liable to effloresce as if the backing were of Portland; its disadvantages are that Keene's is more costly and, the backing being softer, is more liable to damage; nowadays Portland is almost universally employed, in the proportions of three of sand to one of cement.

FINISHING COAT. The finishing coat is of neat Keene's, about $\frac{1}{8}$ in. thick; it should not be less, but there is nothing to be gained by making it thicker. No more material should be mixed than is required for the day's work, and when applied must be finished off the same day.

It should be gauged in small quantities a little in advance of its being required, so that there are no idle intervals for the workmen; it should be mixed to a firm, smooth paste and watered down to the desired degree of softness, care being taken to avoid a sloppy mixture.

The work must be so divided or spread amongst a sufficient number of men that jointing occurs only at breaks, where they will be invisible in the finished work; and, like setting stuff, the whole height of the plastered wall should be finished in one operation, unless there are horizontal projections at which a stop can be made.

After a uniform thickness has been applied, the work is ruled off, and allowed to harden slightly before being scoured up; if scoured too soon, the floats are apt to produce hollows. A good test is to press the finger-tips on the work, and see if it is firm enough to prevent the impressions showing.

The coating is then scoured by hand floats worked with a rotary motion, damped as little as possible, the scouring being twice repeated.

The next operation is trowelling the surface with long firm strokes in all directions, repeating this trowelling once again after having traversed the entire surface.

Towards the finishing of the second trowelling, the trowel is slightly inclined so that the edge is brought into play, the pressure being applied upon the downward stroke until the whole surface be brought up to a high degree of polish.

All crumbs or curls of extraneous Keene's must be removed with a joint rule and brush.

Keene's cement quickly sets up rust in unpainted ironwork, and must therefore be kept

MODERN BUILDING CONSTRUCTION

out of contact with this metal, unless painted or galvanized; most forms of expanded metal lathing can be obtained already coated with an anti-rust solution.

1 bus. of Keene's cement weighs 75 lb.
A sack contains 3 bus. and, therefore, weighs $75 \times 3 = 225$ lb., say 2 cwt.
A cask contains 4 bus. and, therefore, weighs 300 lb.
One sack of Keene's mixed neat will cover 20 yd. super $\frac{3}{8}$ in. thick. If mixed with 4 cwt. of sand, it will cover 28 yd. super $\frac{1}{2}$ in. thick.

Cracks in ceilings are frequently specified to be cut out and made good with Keene's; these

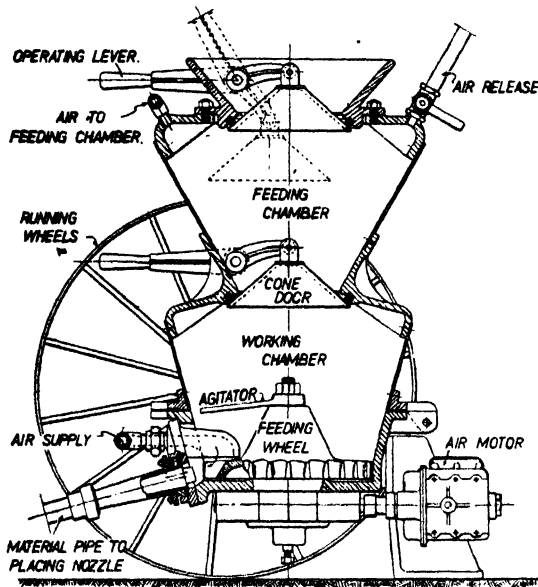

FIG. 9. SECTION THROUGH CEMENT GUN

cracks in floors composed of concrete and rolled steel joists are invariably along the line of the joist, the bottom flanges of which are seldom more than $\frac{1}{2}$ in. above the ceiling line. Such cracks, when opened up, should be undercut slightly, and the sides painted so as to check the suction, or too rapid drying, of the new filling mortar; then be bodied in with Portland cement and finished with Keene's.

Parian Cement is very similar to Keene's, and is produced by immersing plaster of Paris in a solution of *borax* and *cream of tartar*, the mixture being burnt and ground to a fine powder.

It produces a whiter and somewhat harder finish than Keene's, sets more quickly, but if caught before the setting has gone too far, can be knocked up and reworked; here let it be pointed out that reworking *any* mortar or

plaster (except lime) impairs its ultimate strength, in a greater or lesser degree.

The addition of 7 lb. of China clay (*kaolin*) to 1 cwt. of Parian gives the finished work a harder and finer finish, with a better polish than is obtainable otherwise. The clay must be in the form of a fine powder and be thoroughly mixed with the cement, and the whole sifted through a fine sieve so as to intimately mix the two, or the work will be patchy owing to there being more clay in parts.

It is used for the same class of work as Keene's, weighs much about the same, and is put up in similar quantities. Like Keene's, it attacks iron; it is also soluble in water, and useful only for interior work.

THE CEMENT GUN

This is a pneumatic appliance for the delivery of cementing material to surfaces and inaccessible positions. While it can, and is, at times employed to cover wall surfaces, its primary function is for the repair of dangerous or weakened structures.

It delivers the material at a high pressure (up to 80 lb.) forming a dense compact product. In a normal day's work it will cover 100 yd. super an inch thick, provided the work is set out to allow that area to be dealt with. The nature of the repair work on which the cement gun is employed makes it advisable that only men skilled in its use should operate it.

The materials are mixed dry, and wetted at the delivery nozzle by a water pipe controlled by the operator. A rapid-setting cement such as *Ciment Fondu* and a higher grade, clean washed sand are employed, the material in place being known as "gunite."

The machine consists of two hopper chambers superimposed and connected by a cone-shaped valve, so arranged that a continuous rate of feed can be maintained. Air can be admitted to either chamber during feeding and mixing, and a continuous supply kept up while feeding in fresh material. Fig. 9 shows a section through the cement gun.

METHOD OF OPERATION. The dry mix is fed into the upper chamber and falls into the lower one, compressed air is admitted, and the mixture agitated and fed on to an Archimedian screw which carries it to the material feed pipe, while at the same time a powerful stream of air drives it along the delivery hose. The top valve is hand-operated, the feeding chamber being opened for a further mix and then closed.

Air is admitted to the upper chamber and, as soon as the pressures in both chambers become equal, the lower valve opens by its own weight, and the working chamber is replenished. So

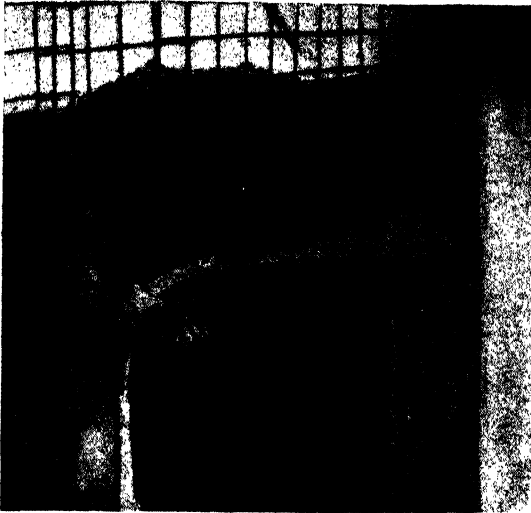

FIG. 10. NOZZLEMAN SHOOTING "GUNITE" DURING RECONDITIONING OF DOUGLAS PIER, ISLE OF MAN
(Note reinforcing fabric)

the cycle of operations is repeated, thus providing a steady flow of material.

Round the nozzle of the delivery pipe is an annular ring provided with a number of fine jets which allow water to impinge upon the dry mix at the moment of delivery, the rate of flow of water and material being controlled by the operator by means of a trigger.

The whole device is mounted on a pair of large wheels, thus making it easily portable. Its action is automatic and fool-proof, long lengths of hose enabling it to be employed in confined spaces.

In applying material, it is essential to keep the delivery nozzle at right-angles to the work and, on account of rebound due to the air employed being at so high a pressure, from 2 ft. to 3 ft. away from it.

EXAMPLES OF REPAIR WORK. Some of the earlier examples of reinforced concrete work carried out in this country have deteriorated from various causes, such as insufficient cover to reinforcement, faulty mixtures, excess of water in mixing, and lack of proper tamping of concrete.

A too wet mix has often been used, and while

this allows the concrete to flow more easily in forms, it weakens the ultimate strength, and in drying produces numerous cavities. Holes as large as 4 in. have been formed by insufficient tamping, thus seriously reducing the strength of the member. Insufficient cover to the reinforcing bars leads to corrosion of the metal and sets up scales and blisters which disrupt the concrete.

When being repaired, if seriously weakened and much of the concrete needs to be cut away, the member is strutted. The defective portions are then removed, the bars scaled with flat-head rotary bits, all dust blown away, the work wetted and cement-mix blown in. Additional reinforcement, see Fig. 10, is often placed round the faulty portions, and fresh cementing material sprayed behind and all round it.

Repairs to such structures are costly and may amount to one-third of the original cost, but short of demolishing the whole and reconstructing it, it may be the only remedy available.

By means of the cement gun, steel chimneys have been coated with a mix applied to the exterior of a reinforcement mesh; tunnels have been treated in like manner; the members of steel bridges protected; sea-walls reinforced and faced; miles of partly collapsed sewers lined with steel tubes and then coated back and inside; rubble piers, as in St. Paul's Cathedral,

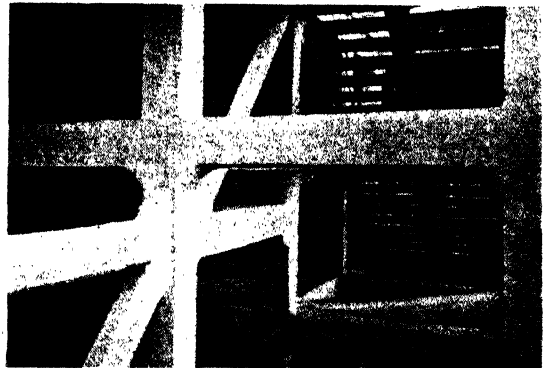

FIG. 11. A RECONDITIONED PORTION OF THE DOUGLAS PIER

reinforced by gunite grouting; storage bins lined and reinforced; retaining walls and reservoirs faced and repaired. There seems, in fact, to be no limit of structural repair beyond the capacity of this machine. Fig. 11 shows the completed portion of the reconditioning of the pier at Douglas, Isle of Man.

Chapter V—PLASTERS

Plaster of Paris, or Plaster, is obtained by burning and grinding a mineral known as *gypsum*, or sulphate of lime, its purest form being the marble known as *Alabaster*.

It forms the base for most of the patent plasters and of Keene's and Parian cements, its chief uses being the production of plaster casts, models, moulds, and for gauging plasterers' putty where moderately quick setting is desired.

Whilst woodwork protected by this material is rendered fire-resisting, it must not be allowed to come into contact with unpainted iron or steel, or it will quickly eat such metals away.

It can be obtained in several varieties, quick and slow setting, coarse and fine, and either pink or white; it must be kept quite dry and protected from damp air until wanted, or it will harden and become useless; for fine work, plasterers usually sift it through muslin.

Setting. This can be retarded by gauging the plaster with water to which size has been added and dissolved, "gauging" being the term applied to the mixing of plaster with water to the desired consistency for use.

The correct proportions of size-water to plaster is a matter for experiment, and varies according to the extent to which it is desired to slow the setting. Stale beer, and also ammonia, will act in the same manner as size.

Setting can be hastened by adding alum water to the gauging water, the proportions being found by experiment. The addition of alum also hardens the plaster, its chief use being for casting enrichments in gelatine moulds so as to cause the cast to set before the heat, engendered by the setting of the plaster, has time to melt and distort the mould; the alum also acts on and hardens the gelatine.

GAUGING PLASTER. This operation if improperly performed will considerably weaken the material.

The plaster should be stored in a box placed on a stand, so as to obviate stooping. Having ascertained the approximately correct quantity required for the particular job in hand, and also about the amount of water it will take up, obtain a "gauge pot" sufficiently large to contain both plaster and water. Measure out

the water into this pot, take the plaster up in a scoop, and sprinkle it a little at a time into the water, and continue until the plaster appears on the top of the water; then quickly stir with a stick until the whole is thoroughly mixed. Roughly, 2 lb. of plaster will take up a pint of water to make a stiff paste.

MEMORANDA

1 ton of plaster contains 10 sacks.
Each sack contains 3 bus. and weighs 2 cwt.
75 lb. is the weight (average) of 1 bus.
A small bag of plaster holds 14 lb.
A cask contains 2½ cwt.

Being soluble in water, plaster is useless for external work.

Sirapite Plaster. This has a plaster of Paris base, is sold in both coarse and fine grades, sets fairly quickly (though much slower than plaster), makes a very good and economical wall covering in two coats, is low in cost, and requires no hair. The undercoat can be made of equal parts of Sirapite and sand, and can be followed up quickly by the finishing coat, which in turn is fit for painting, or papering, within twenty-four hours after being applied; for labour its cost is slightly higher than three-coat work in lime.

Its disadvantage is that, like all hard, dense plasters, it is comparatively non-absorbent, and therefore liable to sweat or condense atmospheric moisture in cold weather.

Sawn laths should be used, as owing to their uniform thickness two-coat work can be finished with less thickness than if rent laths were used. For ceilings or lathed partitions, hair should be added to the first coat. Metal lathing must be coated with anti-rust preservative, or be galvanized. Lath nails must be such as will not rust.

Another of its advantages is that it cuts out all the messy and prolonged operations of slaking and mixing lime plaster; it also gives a more durable surface.

The set being fairly rapid, it must be applied and finished quickly, for if reworked it will be killed and spoilt.

A ton of Sirapite, mixed with an equal volume of sand, will coat 120 yd. super of ¾ in. thickness; and used neat for finishing, will cover

about 300 yd. super. It is suitable only for internal work.

Adamant Plaster. This was invented many years ago in America, and at one time was extensively used in this country; plaster of Paris is its base. It sets moderately quickly, and, as marketed, the mixture for undercoats contains sand, dried glue, and sawdust, together with a small proportion of washing soda and borax; the addition of the dried glue acts in the same manner as size-water in retarding the setting. It is suitable for two-coat work, the finish coat being applied as thinly as possible, and trowelled up with the minimum amount of water.

Basset's Plaster. This is an improved form of Adamant, and the following instructions are given for its application.

For a floating coat for laths and walls, take $1\frac{1}{2}$ buckets of sand, $1\frac{1}{2}$ buckets of plaster of Paris, and one bucket of Basset's composition; mix in a gauge box with water as you would ordinary mortar, then apply to walls, or laths, in a coating not less than $\frac{3}{8}$ in. thick.

For the setting coat, mix the following dry in a box, and pass through a fine sieve: $1\frac{1}{2}$ buckets of plaster of Paris, one bucket of Basset's composition; well sift this mixture and sprinkle into a bucket half full of water until the desired consistency (care being taken not to make it too thin, or sloppy), and well stir with a flat stick.

For backing cornices mix as for floating coats.

For finishing cornices, or to produce a white enamel surface, a plaster is supplied which can be used without any addition; it should be mixed in a bucket, no more being gauged than can be used up in an hour. Wood laths only should be used; the recommended size is $1\frac{1}{4}$ in. wide by $\frac{1}{4}$ in. thick, spaced not more than $\frac{1}{4}$ in. apart.

Nails should be of composition, or galvanized.

Adamant plaster is put up in sacks containing about 155 lb. of the floating material, and will cover about 7 yd. super.

The No. 3 grade for setting coats weighs about 140 lb. per sack, and will cover 30 yd. super.

Basset's plaster scores by enabling local sands and ordinary plaster of Paris to be used in conjunction with their special material, and tends to reduce the cost.

Robinson's Cement has a plaster of Paris base; it is claimed to be one of the best fire-resisting plasters on the market, to be cheaper than

Keene's, and but slightly dearer than ordinary three-coat work.

It is made in three grades, No. 1 being employed for finishing, and No. 2 being mixed with sand for undercoats; it is perfectly white, and can be trowelled to a high polish.

It attacks steel, and is an inside plaster only.

Granite Plaster has a base of gypsum; it can be applied in two coats, both being finished in the same day, and may be papered, or painted, within two or three days after finishing. It is supplied in two forms, one with sand, the other without, so as to allow local sands to be employed. It is an internal plaster, and the same precautions as to steel lathing and iron-work must be taken.

Carton-pierre. This is not a plaster but a material very similar to papier mâché, and consists of finely-pulped paper, preferably such as has been made from white rags mixed with dissolved glue in suitable proportions, plus the addition of fine whiting, strengthened with a small proportion of plaster of Paris added at the moment of casting.

It is used for casts and reproductions; if skilfully handled very fine work can be accomplished, but of late years this branch of the plasterers' craft has gone somewhat out of use. Plaster, or papier mâché, moulds are taken of the object to be copied, and coated with linseed oil, or shellac, to prevent the carton-pierre adhering. The plastic material is firmly pressed into the moulds, piece by piece, reinforced as necessary with fine copper wire, and placed in a warm position to dry. Irregularities caused by the joints of the mould are cleaned up with fine files and scrapers, and the whole surface finished off with the finest glass-paper. Cavities in the back of the casts are temporarily filled with sawdust, or dry plaster, to prevent the cast creeping before the set is complete.

Carton-pierre is exceedingly strong, light, and capable of producing very delicate and beautiful castings.

Scagliola, known in the trade as "Scag," is a method of imitating various marbles by the use of plaster and pigments. The process is a complicated one, needing great care and skill.

Very beautiful work can be accomplished, either by applying the scag in its ultimate position, or working it on slabs and stripping and fixing after set.

Gypsum Plasters. Of late years many plasters of gypsum base have been placed on the market under various names. *Pioneer Plaster* is one of

MODERN BUILDING CONSTRUCTION

them. It has a moderate rate of setting, is free working, and is capable of producing a finish as hard and smooth as Keene's, at a lower cost. Unless the distemper is mixed with "petrifying fluid" instead of water, however, it

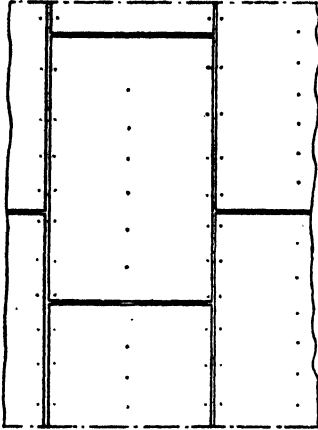

FIG. 12. THISTLE PLASTER LATH, SHOWING METHOD OF BREAKING BOND

is liable to flake in a few months. Despite its close, smooth texture, it does not give rise to condensation even on a cement backing. The backing can, if desired, be composed of $2\frac{1}{2}$ parts of clean sand to 1 of plaster instead of cement. It dries a dark grey.

Thistle Plaster is a similar product which has pronounced fireproof qualities; indeed the fire-resisting qualities of gypsum plaster are one of its chief assets. *Thistle Plaster* is employed for undercoat as well as finish, the makers providing a mixture called "Browning," or backing, which can be had with hair incorporated in it. As suitable hair is not easy to obtain, this is a recommendation.

Only a sand free from saline matter should be used, because any trace of salt in sand is detrimental and has a corrosive action on metal lathing unless it is galvanized or bitumen-coated.

All gypsum plasters are apt to be somewhat quick in setting, but this can be retarded to almost any desired degree by the addition of size water without affecting the ultimate result; the addition of size seems to improve its texture.

Fir, and also metal, lathing is costly, the wood lathing taking an appreciable time to fix, and suitable rent laths being difficult to obtain. A suitable substitute is *Thistle Plaster Lath*

composed of a tough fibrous, specially prepared paper, to which the plaster readily and firmly adheres. It is sold in stock sizes $\frac{3}{8}$ in. thick by 3 ft. wide, by 2 ft. 4 in., 2 ft. 6 in., and 2 ft. 8 in. to suit joist spacings 18 in., 16 in., 15 in., or 14 in. centres.

Galvanized nails $1\frac{1}{4}$ in. long by 12 W.G. should be used, 10 lb. being sufficient for 100 sq. yd. of lath. As with fir laths, the joints should be staggered, see Fig. 12. The makers emphasize that it is necessary to bond the joints with a 4 in. strip of scrim cloth, well-pressed, dry, into a 4 in. strip of plaster, over the joints of the lathing. (See Fig. 13.)

HINTS ON USE OF GYPSUM PLASTERS

Use only clean water, and avoid an excess.

Clean graded sands give greater strength.

Never knock up partly, or fully set plaster; it becomes killed and useless.

Keep all tools clean.

Apply the setting coat while undercoats are green, but delay until all cracking has finished.

Damp backing if dry, but employ as little water as possible, otherwise blisters will rise in the finished coat.

Scratch or devil all undercoats to form a key.

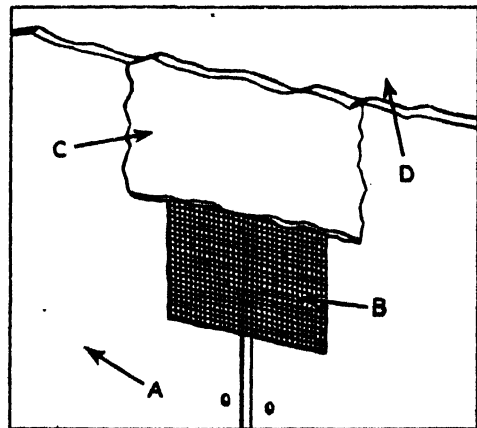

FIG. 13

A. Thistle Plaster Lath; B. Scrim Cloth;
C. Plaster Cementing Scrim to Thistle Lath;
D. Finished Plasterwork.

Leave Portland cement backings to harden for two weeks before setting with plaster.

For two-coat work on plaster boards, use 1 of coarse plaster to $1\frac{1}{2}$ clean grit sand. Finish with fine plaster setting.

On wood laths, the backing should be 1 of haired plaster to 2 parts sand.

On walls, backing should be 1 of coarse plaster to 3 of sharp sand.

With walls of low suction, or hard bricks, and tile (rough, porous), rake joints and use 1 of coarse plaster to 2 parts of sharp sand.

Acoustic Plasters. Various wall plasters which have a sound-damping effect have been introduced. One variety, which appears to consist of finely powdered asbestos mixed with a binder, is applied by a spray of compressed air to a thickness of $\frac{3}{4}$ in. to form a spongy mass the air spaces in which entangle and dissipate sound waves. Being of a soft nature, easily damaged and difficult to repair, it can be used only at such a height as to be above traffic. It dries a sad grey, and any distemper or paint applied to decorate it seriously affects its sound-dampening properties.

Thistle Acoustic Plaster can be applied in a plastic condition on a base of gypsum and sand by any skilled plasterer. It is best finished with a float to a matt surface, employing a cork, wood, or carpet float. On curved surfaces the finishing is best done with a rubber sponge. If the natural grey-white colour is to be tinted, a water-soluble dye is recommended. Full instructions for mixing and applying the plaster are issued by the makers, who claim that it has a 50 per cent sound-deadening effect.

Fibrous Plaster consists of plaster of Paris reinforced chiefly by a coarse canvas known as "scrim," in conjunction with wood laths, wire netting, tow, fibre, sawdust, reeds, slag wool, timber wool, etc. One great objection to wire netting as a reinforcement is the difficulty of cutting the material.

The canvas should be strong, with an open mesh, from $\frac{1}{8}$ in. to $\frac{1}{4}$ in.: any iron wire reinforcement must be galvanized, or the action of the plaster will quickly destroy it. As with plasters, size-water is employed to retard the setting.

Owing to its lightness and fire-resisting properties, considerable use is made of this material on ocean liners, and for masking stanchions, column girders, etc.; even in buildings where weight is a secondary consideration, cornices are cast in the plasterers' shop, and screwed up to walls and ceilings; it is unfit, however, for external work unless kept well painted and dry.

It is extensively used in the form of slabs about $\frac{1}{2}$ in. thick to displace lath and plaster on ceilings. In such cases, the spacing of the ceiling joists must suit the sizes of sheets, and be so arranged that a joist also gives a fixing for the middle of the slab, or the

slabs will be liable to deflect. They require careful handling in transport, unloading, and storage, for unless well reinforced they soon get damaged.

These ceiling slabs have one smooth face, the other being purposely left rough, so as to give a key to the plastering applied after the slabs are fixed. In very cheap work, the smooth side may be fixed downwards, and the joints stopped flush with plaster; but the usual practice is to fix the rough face looking to the floor, the slabs then being floated and set in the usual manner.

Strong galvanized nails of a peculiar pattern must be employed for fixing. These are illustrated in Fig. 14, which shows portions of three slabs; it will be seen that the edges of the slabs are slightly bevelled, and that the joints are about $\frac{3}{8}$ in. wide, so that a body of jointing

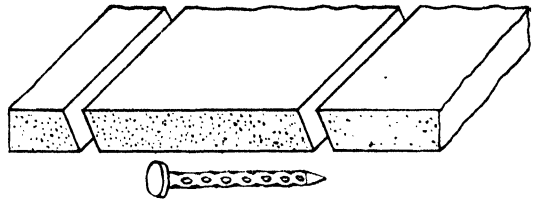

FIG. 14. PLASTER CEILING SLABS

plaster can be inserted; the slabs should on no account be in intimate contact, or cracks may develop.

The following hints are given by one manufacturer of slabs: All bevelled edges should meet in the manner shown, so as to afford a good "key" for jointing, that is one where the jointing mortar would not drop out before setting; the slight bevel helps in this matter. When the slabs are nailed up, these joints should be stopped with haired mortar to which a little plaster has been added.

Owing to the porous nature of the slabs, it is advisable before beginning to "set" to damp the rough surface with clean water in order to stop suction, and then follow on with the finishing as soon as possible. The general method of finishing is to "float" the slabs with one of the patent plasters, or gauged coarse stuff, and set in the same way as ceilings.

The particular type of slab illustrated is reinforced by coarse canvas and wood laths.

The stock thickness is $\frac{5}{8}$ in., lengths and widths being: 3 ft. by 2 ft. 6 in., 3 ft. 3 in. by 2 ft. 6 in., 3 ft. 6 in. by 2 ft. 6 in., 3 ft. 9 in. by 2 ft. 6 in., 4 ft. by 2 ft. 6 in., and 4 ft. by 2 ft.

Chapter VI—PLASTER MOULDINGS

Gelatine is a substance derived from hoofs, hides, fish skins, bones, etc., common glue being a crude form of this material, which is employed by plasterers for the reproduction of mouldings containing undercut members, its pliability enabling the mould to be flexed and removed without injury to mould or casting. When the job is finished, the gelatine can be remelted and reformed, provided always that nothing has been added which would tend to render the jelly insoluble.

Good gelatine is clear and free from any offensive odour; it is, however, liable to be attacked and broken down by minute organisms, which cause mould-like growths, to prevent which such preservatives as carbolic acid are added.

Tannic acid, or chrome alum, are employed to harden the jelly, but, like bichromate of potassium, these prevent the remelting.

When bichromate is added, the jelly is sensitive to the action of light, and it becomes impossible to remelt the compound; this property is taken advantage of in some photographic processes.

Beeswax may be added to toughen, and *glycerine* to prevent the drying of the material; 4 oz. of glycerine to 1 lb. of gelatine are about the correct proportions.

Gelatine should be soaked overnight in clean cold water, the surplus water poured off, the jelly melted in a steam-jacketed vessel, similar to, but larger than, an ordinary glue pot.

It should not be boiled too long or it will be weakened; neither should it be stirred too much, or air will be imprisoned, and cause bubbles and "blebs."

The object to be reproduced must be coated with shellac, or melted paraffin wax, so that the jelly will not stick to it; linseed oil may be employed for the same purpose.

As the jelly is applied in a fluid form, a *case* of clay must be built up around the object, leaving a space of as uniform thickness as possible so that the mould may not be too thick in places, rendering it difficult to flex and withdraw.

After the mould has been formed, its working surfaces must be coated to prevent the plaster

sticking thereto; crude paraffin oil (not commercial paraffin) is very suitable for this purpose.

Moulds are also made of various kinds of *wax*, beeswax being the best, in the proportions of 1 lb. resin to 12 lb. of wax, with sufficient turpentine to soften the mass. The whole is melted over a gentle heat, and fine whiting added to arrive at a suitable consistency; it should be tested whilst melting, so that when cooled, a plastic compound is formed.

Modeller's Clay is sometimes used to obtain a "squeeze," or impression, of a moulding, the clay being applied in thin sheets, backed up by plaster before being removed; the plaster is worked true so that the mould will lie on its back, when placed on a bench.

CORNICES

The term "solid" is applied to moulding and plaster-work formed in the positions they are to occupy, thus distinguishing this class of work from the fibrous precast mouldings and slabs; fibrous plaster workers often refer to the ordinary plasterers as "solid men."

Fibrous. Before fibrous plaster mouldings can be discussed, it is necessary to describe the construction of the moulds which produce both solid and false work.

In both cases, a tool known as a *running mould* must be constructed; its shape and profile will differ according as to whether it is required to form a mould, to *cast* a fibrous cornice, or to *run* a solid cornice in position.

A plasterer's cornice mould, or *horse*, consists of a piece of sheet metal, called the "plate," fixed to a support of wood, known as the "stock." This stock is fixed at right angles to the "slipper," or base board, of the horse. Struts are fixed to stock and slipper to strengthen the mould and serve as handles.

The top front portion of the stock is called the "nib" and the bottom front edge the "toe."

Fig. 15 is an elevation of a running mould for a solid cornice, showing the side upon which the plate is mounted; *N* is the nib, *T* is the toe, *P* is the plate, *K* is the stock, and *S* is the slipper. Fig. 16 shows the reverse side of the mould, the strut, or handle, being shown at *H*. The

completed mould is known as the *horse*, and the construction is called *horsing the mould*.

Small moulds not intended for much use often have the stock merely screwed to the slipper, and "housed" by means of a strip of wood tacked to the slipper on each side of the stock; this is a crude method adopted by plasterers when a carpenter is not available.

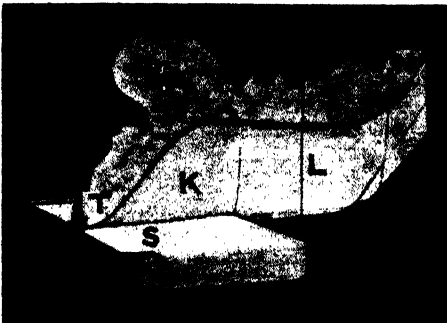

FIG. 15. CORNICE MOULD, PLATE SIDE

A better way is to cut a groove in the slipper, and let the bottom edge of the stock therein, as shown in Fig. 16, a still further improvement being to cut this groove wide enough, and shape it to accommodate a wood key so as to firmly fix the stock.

For a heavy cornice a running mould must be well made and secured, or it will distort in use and produce faulty work.

A further refinement is to armour the two ends of the front edge of the slipper by strips of zinc, which not only protect it, but by packing the main body of the slipper slightly away from the screed on the wall considerably reduce friction, and enables the mould to be worked freely. These strips are shown in Fig. 16.

It will also be noticed in this illustration how the stock is backed off, or bevelled, from the zinc profile so that the surplus material is enabled to free itself as the mould traverses the work. The illustration also shows how the metal plate is fixed with its working edge slightly in advance of the contour of the stock; this projection is greater when coarse material, such as Portland cement and sand is being used, than when fine plaster is the medium employed.

In Fig. 15 a line *L* will be seen on plate and stock; its purpose will be explained presently.

To cut the plate, the outline of the cornice is transferred to a sheet of metal by pricking and connecting the impressions made thereby, and afterwards cutting this metal with a pair of

snips, the outline being cleaned up with fine files until a true profile is reproduced.

Plates are known as *positive* and *negative*, the latter being the reverse contour of the cornice when it is being run solid; the positive is the contour which would produce a mould from which the exact shape of the cornice could be cast, in the case of a fibrous cornice. In Fig. 17 the negative plate would be cut as *N*, and the positive as *P*. The lines *SOL* on *P* are the wall and ceiling lines, and are known as the *striking off lines*.

The dotted line *BB* represents the top of the bench on which the mould for a fibrous cornice would be run, and shows the relation of the plate to the bench.

When the outline of the negative plate for the solid cornice is being transferred from the drawing, the wall and ceiling lines at the top of nib and front of toe should also be produced, so that the line *L*, Fig. 15, can be drawn at right angles to the ceiling line and parallel to the wall face. The object of this line is to enable the mould to be plumbed when fixing the running rules, so that the plate will occupy its correct pitch, or position, to wall and ceiling; as a rule, the vertical members of the cornice are so short that they give very little guide, whereas the prolonged line helps considerably.



FIG. 16. STOCK SIDE OF CORNICE MOULD

For the plate, strong sheet zinc is recommended as not being attacked by the plaster of Paris, as would sheet iron; in theory, iron should set up rust stains in the cornice, yet in practice it does not appear to do so. Zinc has the disadvantage of being more costly, not so readily obtained, and moreover is easily distorted in use by slight knocks or careless handling. For these reasons it will be found that most of the plates are cut from sheet iron, and serve

MODERN BUILDING CONSTRUCTION

their purpose for the limited time they are required.

In the ordinary way, these moulds are only wanted for the particular job in hand; and, therefore, as long as the profile is true and the horse strong enough to last for the time it is required, that is all which really matters; this accounts for the lack of finish and nicety of jointing, shown in the attachment of the strut in Fig. 16.

The strength and tenacity of fibrous plaster is shown by Fig. 18, where it will be observed that the joints of the horse have been further secured by bindings of canvas and plaster of Paris.

Solid, or in situ, cornices, if of appreciable size, require rough bracketing; fibrous cornices score by needing very little, unless of exceptional girth, as otherwise it is sufficient to screw the moulding to the wall and ceiling at its top and

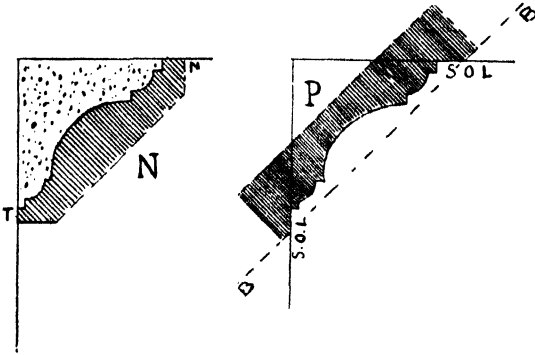

FIG. 17. PROFILES OF POSITIVE AND NEGATIVE PLATES

bottom edges to plugs provided at frequent intervals for this fixing.

Another advantage of fibrous cornices is that the slow and expensive working of mitres is obviated, it being possible to cut and fit fibrous plaster much in the same way that a carpenter mitres wood mouldings, the intersections being quickly made good with plaster. If desired, the mitres can be precast, but considerable care is required in making the moulds.

Fig. 19 shows a wooden running mould for the production of a plaster mould for the casting of a fibrous cornice; the slipper runs along a running rule; the nib *N* is frequently loaded by the application of a mass of plaster, so as to keep it well down and prevent it jumping.

To show the mould clearly, the front portion of the slipper has been partly cut off and one strut removed; it is customary to fix the stock

in the centre of the slipper's length, and to stay it both ways; this construction is better shown in Fig. 18. Comparison with Figs. 15 and 16

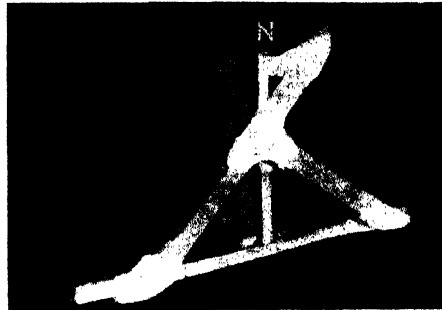

FIG. 18. FIBROUS PLASTER BONDING TO RUNNING MOULD

illustrate the difference in the horses of moulds for fibrous and solid cornices.

Fibrous cornices can be cast in lengths of from 10 ft. to 15 ft., depending somewhat upon their girth, and the difficulty of handling and of transporting from shop to job; the lengths should bear such a relation, to the total length required, as to cut up with as little waste as possible.

When the mould for the cast has set and dried, it must be oiled, greased, or coated with shellac, to prevent the casting sticking to the mould.

There are many preparations used for this purpose; some plasterers prefer to shellac the mould first and then grease it; others rely on the oil or grease alone.

OILING PLASTER MOULDS. Melt a quantity of Russian tallow and add sufficient sweet oil, so

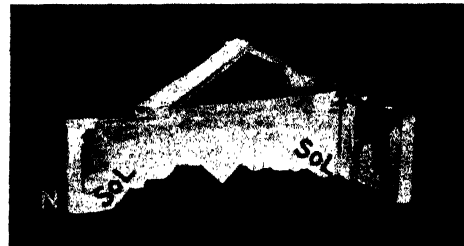

FIG. 19. RUNNING MOULD IN POSITION ON BENCH

that when cool it forms a thin creamy paste, which can be easily applied by a soft brush.

The mould must be well coated, the excess of tallow wiped off. Lard, either neat or mixed with sweet oil, may be substituted for the tallow.

The addition of a small proportion of paraffin oil improves both these mixtures, and prevents the formation of a soapy compound of the plaster and sweet oil. One part of stearic acid to five parts of alcohol may be melted in a steam-jacketed vessel, the compound being well shaken as it cools, the mould being well coated with the cold solution. With the evaporation

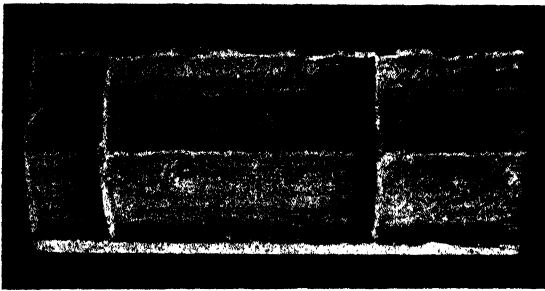

FIG. 20. BACK OF FIBROUS PLASTER CORNICE

of the spirit, the stearine is left in a fine skin over the surface of the mould.

A cheap method is to substitute soft soap mixed with boiling water, but this leaves a very sticky surface, liable to collect dust, etc., and is not recommended.

RUNNING FIBROUS PLASTER CORNICE. The mould being ready and coated with one of the oiling compounds, previously described, the next thing is to prepare the canvas and laths for its reinforcement; Fig. 20 shows the back, and Fig. 21 the front of such a cornice. *Edge laths* of wood are inserted at *E L*, *body laths* at *B L*, with wood *ribs* as *R* at intervals of 18 in. to 24 in.

In Fig. 21 the cornice is broken away to show the edge and body laths; in this case only one body lath is shown, but the number will vary with the design and girth of the moulding.

The girth of the cornice should be ascertained by fitting a piece of string in the mould, and the scrim canvas cut wide enough to allow a lap of 4 in. or 5 in. each side of the mould; that is, if the girth equals, say, 18 in., then the canvas should be cut at least 26 in. to 28 in. wide.

If the length of the cast be greater than that of the canvas, sufficient pieces must be prepared so as to allow at least 6 in. laps in the joins, and everything must be prepared and ready to hand before gauging any plaster. The body and edge laths must be arranged so that no time will be lost in searching for them, and the rib laths cut to shape and sufficient in number for the job.

When fixing the edge laths, it is imperative

that neither lath nor its canvas wrapping projects beyond the striking-off lines which fit against wall and ceiling, or the cornice will not go home to its proper position.

The correct proportions of size-water and plaster being ascertained, fine plaster is gauged and the mould covered to a depth of $\frac{1}{4}$ in. by means of a "splash brush." This application is known as "firstings."

Before all this has been used up, another operative should have prepared the second coating, a greater quantity of size-water being added to delay the setting to a greater degree; this "seconds" is now rapidly splashed over the first coat, applying it to produce a somewhat thicker layer than the "firsting" coat.

The canvas is now quickly laid and pressed on this coat, well tucked into the contour of the mouldings, so as to avoid hollow places, or lumpiness; the canvas will then lie with a selvedge over the edges of the mould, but *no plaster must yet be placed upon these edges.*

The canvas backing is well brushed over with plaster; the body laths dipped in plaster and forced into their positions, and covered by canvas strips sufficiently wide to lap about 3 in. on to the under canvas previously applied.

The edge laths are now coated with plaster, placed on the canvas, and the selvedge brought

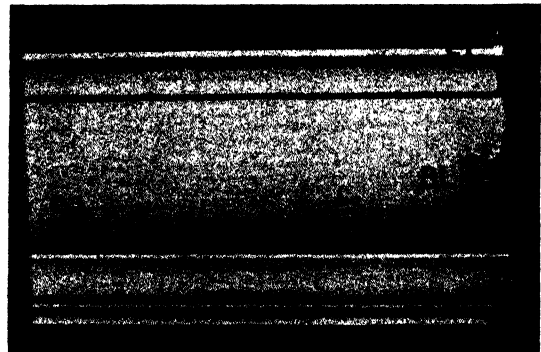

FIG. 21. FRONT OF FIBROUS PLASTER CORNICE, SHOWING LATH REINFORCEMENT

tightly over and coated with plaster, to stick it down to the main canvas; *all surplus plaster must be quickly removed from the striking-off edges*, so that nothing will project beyond these lines.

The spacing of the ribs should have been previously determined, and canvas cut to fit in the panels between the ribs, wide enough to span the surfaces *AA* and *CC* in Fig. 20. This canvas is now laid in the panels, pressed

MODERN BUILDING CONSTRUCTION

into the plaster, and brushed over with the same material.

Ribs are now dipped in plaster and quickly placed in position and covered with canvas, in a similar manner to the body laths, thus completing the casting of the moulding.

From the foregoing it will be seen that speed is essential to the success of the operation, and that it is necessary that all the various materials should be ready and to hand, or failure will result.

Where a moulding is enriched, these may be either cast with the moulding, or cast separately, and stuck on when the moulding is in position ; if cast with the cornice, great care is necessary

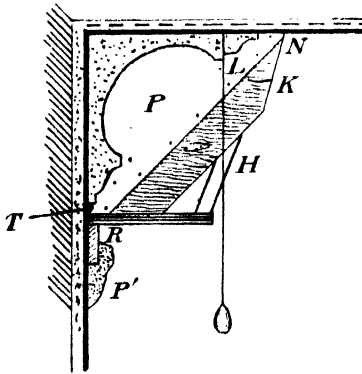

FIG. 22. PLUMBING CORNICE MOULD

to ensure proper spacing, and to make certain that the mould will not shift in the casting.

With such enrichment, gelatine moulds often become necessary, so as to enable the cast to be freed from the mould.

Solid, or in situ, cornices usually require brackets to support and diminish the quantity of material used in their construction ; large mouldings often have a core formed in brick-work, concrete, or stone oversailing constructed to a rough outline of their shape ; this is the usual method for external work, and at times for internal.

Wood brackets, spaced about 18 in. apart, can be fixed to wall and ceiling, laths being applied to form the backing of the cornice. Where the projection is not too great, wood laths are fastened, at a suitable angle, to the wall and ceiling by plaster, and the cornice formed on this support ; this method is known as *Scotch bracketing*.

Fig. 15 shows the type of running mould for solid cornices.

Screeds must now be formed on wall and ceiling, so as to provide a true surface for the front of slipper and top of nib to run along ; a running rule must also be fixed to support the bottom of the slipper.

The wall screed determines the distance of the slipper front from wall, and the running rule its distance from the ceiling.

Screeds are made of coarse stuff strengthened by the addition of plaster of Paris ; where the mould is heavy to run, the face of the screeds can be lubricated with grease, soft soap, black-lead, or French chalk.

The screeds are ruled off and straightened, the cornice mould " offered up " at each end of the wall, in the exact position occupied by the cornice, and marks made on the wall and ceiling screeds at the outside of the nib and bottom of slipper.

A chalk or charcoal line is now snapped on the ceiling screed ; gauged putty is placed on same by one plasterer, whose partner, following behind, works it over with a long rule, until it becomes perfectly true, finally finishing it off by means of a cross-grained float.

In very long rooms, two men traverse the screed with a long straight-edge, first forming the screed on the longest sides, so as to determine the positions of those for the ends of room.

FIXING THE RUNNING RULE. Fig. 22 shows the position the horse will occupy when running the cornice ; the mould is offered up with its nib *N* in tight contact with the ceiling screed, and the toe *T* against the wall screed. The line *L* shown in Fig. 15 is now plumbed, and marks made on the wall screed at the base of the slipper, at each end of the wall, and a line snapped as before. These marks determine the position of the top of the running rule *at the two ends only*. The rule must not be fixed for the whole of its length to the snapped line, which may have sagged slightly, or not be quite parallel to the ceiling.

Ceilings are not always quite true, and the rule must be humoured or adjusted to suit such probable variations.

The horse should be offered up at frequent intervals along the screed, the top of nib being kept to the line on the ceiling, and the toe of the slipper pressed firmly against the face of the wall screed, marks being made to its underside as guides for fixing the running rule.

The running rule can now be fastened to the wall, either by nailing or by dots of plaster, as indicated by *P*¹ in Fig. 22. Plaster dots have

the advantage of not disturbing the plaster work below the cornice, and get over the difficulty of finding joints in the brickwork to receive nails.

Pine is the most suitable material for running rules, which should be planed on one face and top edge; they are usually 3 in. wide by $\frac{1}{2}$ in. thick.

BACKING. The body of the cornice is formed of coarse plaster, putty, and sand; the surface is composed of fine plaster and putty, the proportion varying from equal parts to one of plaster and four of putty, according to the nature of the work.

Once these proportions have been fixed upon, they must be adhered to, and the materials measured to ensure a uniform mixture, or hard and soft places will occur, resulting in difficult running.

Plaster boxes and bins should be provided, with lids to protect their contents.

MUFFING THE MOULD. To run the coarse body of the cornice with the same "horse," it becomes necessary to so alter its outline that it produces

a backing slightly smaller than the finished cornice. This is accomplished by an operation known as *muffing*, or building up the profile of the horse by the addition of plaster laid on the "stock," so that the built-up edge projects about $\frac{3}{16}$ in. beyond the metal plate; *this addition must not be added to the top of nib or front of toe.*

At least two plasterers are necessary to run a cornice, and at times two may be required to run the horse whilst others apply the material.

After the backing, or core, has been formed, the "muff" is removed from the mould edges, and a gauging of fine plaster and putty, containing somewhat less plaster than the undercoat, is applied by brush and trowel, the mould being firmly and quickly run along the entire length of the cornice.

The running rules should now be taken down, and any holes or damage to the wall plaster repaired. The floating coat is then cleaned and damped, so as to prepare it for the application of the setting coat.

Painting and Decorating

By CHARLES H. EATON, F.I.B.D., F.R.S.A.

Chapter I—THE CONSTRUCTION OF PAINT

IN few crafts has there been such a change in the variety and type of materials as in the craft of painting and decorating. Modern materials demand much more technical knowledge than is generally accepted as necessary by the average craftsman. The poor results sometimes obtained, when really first-class materials are used, are due almost entirely to a lack of knowledge and skill on the part of the operative, although the unfavourable conditions that prevail on the average job make it almost impossible for even a well-trained craftsman to execute work of which he can be proud.

Paint may be said to consist of certain solid particles of varying sizes and shapes suspended in liquid or liquids that serve the purpose of allowing the material to be spread as evenly as is required over a surface; the liquid also serves to attach the particles securely to each other, and to the surface upon which the mixture is applied.

Pigments. The solids are called *pigments*, and they may be divided into two classes, *natural* and *artificial*. Pigments are the materials used to give the paint density, body and colour; they owe their individual colour to their ability to reflect or absorb certain rays of light, a matter of selection. Colour, being always dependent upon light, absence of light means absence of colour. The ability to absorb or reflect suitable rays of light and allow the pigment to appear as a certain colour, depends entirely upon the structure and shape of the particles, and their individual chemical composition.

Pigments are generally in powder form, and are ground in a medium which is called the *vehicle*. This medium may be water, or a suitable medium soluble in water, oil or spirit. The greater bulk of pigment used by the decorator is ground in oil, generally *linseed oil*. Pigment and oil are first brought together in a mixing machine, then ground in a mill varying in size according to the quantity of pigment to be handled, the resulting mixture being a stiff paste which

must be packed in an air-tight container to prevent a change taking place, due primarily to the action of air. Pigments for certain special purposes are ground in turpentine, water, or a special medium. The oil (linseed oil) acts as a binder; that is, binds together the particles of pigment and makes it possible to attach them to the surface under treatment. Other mediums, however, may be substituted for linseed oil, as gold size, varnish, or boiled linseed oil. Tung-oil, or Chinese wood oil, is also used by manufacturers. The type of binder varies according to the requirements of the job: in order to make the paste more fluid so that it may be spread with a brush, more oil is added, but there is a limit to the amount, this depending largely upon the purpose for which the paint is to be used; also, paint made entirely with linseed oil and pigment would give a mixture that would dry so slowly, and be so elastic, that in applying it serious difficulties would inevitably ensue.

Thinners. Linseed oil dries by absorbing oxygen from the atmosphere, the process of oxidation of a thin film varying from 24 to 48 hours, according to the temperature. Obviously, if the oil is loaded with a pigment it will take much longer to dry or oxidize; therefore, some other way of securing the required result has to be taken. This is partially obtained by introducing a *thinner*, that is, a material that will serve to thin the mixture so that the oil film may take to itself the necessary amount of oxygen in a shorter period of time. Turpentine is generally used for this purpose, and *American turpentine* is the most suitable. *White spirit* is a rectified mineral spirit, and is commonly described as *turpentine substitute*. It is being increasingly used, and is satisfactory where reliable brands are employed.

Turpentine, or turpentine substitute, dries almost entirely by evaporation. Certain difficulties and defects that develop in connection with paints have been wrongly credited to the use of turpentine substitute; there are circumstances in which it has an advantage over pure

turpentine, though it should be observed that the best and most efficient thinner is pure American turpentine.

Driers. A normal mixture of pigment, binder, and thinner does not, however, give all that is required. The drying time of paint can be largely regulated by adjusting the proportion of binder and thinner; the varying of the quantity of pigment may also effect an advantage in drying, but there are limits. A certain quantity of pigment is essential for a definite purpose; if the binder is reduced beyond a certain proportion, the structure of the film may disintegrate in an unreasonably short time; alternatively if the percentage of thinner be too high, the quantity of binder may be reduced more than will serve to hold together the film. In order to correct this, and to allow for the retention of the right proportion of all the ingredients, it is necessary to add something which will dry the paint film in a sufficiently short space of time to suit industrial requirements. This is brought about largely by introducing materials which, by their action, cause the oil to absorb oxygen more rapidly than it would in the natural sequence of things. The materials used for this purpose are called driers. The materials generally used are chiefly compounds of lead or manganese, that is, litharge, lead acetate, lead borate, lead oxide, manganese dioxide, manganese sulphate, manganese borate, manganese oxalate, and cobalt salts. These materials are, in their pure state, very powerful drying agents, and are sold to the trade in various forms known as *patent driers*, *liquid oil driers*, and *terebine*.

Patent driers consist of a drying agent, such as the above-named, with sulphate of lime, chalk, sulphate of barium, or barytes, introduced as extenders or reducing agents, the whole being ground in oil to a stiff paste. When the original package has been opened, the contents should be covered with oil to prevent a skin forming through oxidation. The pure materials are so strong in themselves that some system of reducing is necessary so that it may be possible for the craftsman to proceed with reasonable safety.

There is no standard formula for drying materials, each varying according to the knowledge, understanding, and commercial instincts of each particular manufacturer. The absence of a standard allows the introduction of quite unreasonable quantities of extenders or reducing agents, which extend the basic pigment of the

paint and so interfere with the elasticity of the paint film that cracking may result. It is wise, therefore, to become familiar with driers of a reliable manufacture and understand the particular kind suitable for various types of paint. It is unwise to use patent driers in dark paints; although it should be practically colourless, the slight colour of the reducing agent will impair the brilliancy of rich colour.

Liquid Oil Drier consists of a drying medium mixed with oil, slightly thinned with spirit; a little resinous matter is also added. The oil—the greatest volume of material in this type of drier—renders it much more safe to use, the danger from a slight excess not being nearly so great as with other types of driers. Oil, adding as it does to the elasticity of the paint film, is more uniform and reliable in its action. Being transparent, it does not affect the colour of the paint into which it is introduced. Liquid oil driers may be regarded as the safest and most easy to use for all general purposes.

Terebine consists of the drying agent reduced chiefly with spirit; a little resinous matter and oil are, however, introduced, without which the drying agent would settle and remain solid at the bottom of the vessel while in store. Care should be taken to see that this has not happened, or it may transpire that, when the material is used, only spirit and a little oil are added to the paint instead of a requisite amount of drier. Terebine, in actual use, is not nearly so safe as one would wish; it tends toward increasing the risk of cracking of the paint film. In drying, the spirit evaporates, leaving behind the drier and resinous matter.

Gold Size consists of gum, red lead, litharge, copperas, and oil, the whole mixture being incorporated in a process of boiling. It is used chiefly as a binder and drier in the manufacture of flat paints. An excess of this material will cause cracking, particularly when the previous coat of paint contains much oil.

Powdered Driers. Some manufacturers prepare driers in powder form, but their use is not to be recommended. The addition of a powder that cannot be properly incorporated is bad; paint would be gritty, and in addition to this there is the greater risk of the powder falling in patches, and so causing a lack of uniformity in the film established with such a mixture. By properly balancing the ingredients, a suitable paint can be prepared for each application and each type of finish.

Chapter II—PIGMENTS

It has already been seen that pigments fall into two main classes: natural, and artificial. Further, some pigments definitely co-operate with the vehicle, or binder, while others are quite inert, and a few appear actually to retard or delay the process of oxidation.

The white pigments may be regarded as the most important, because among them are those which most favourably co-operate with the vehicle, and also form the basis of many coloured paints. All the white pigments may be regarded as having individual qualities that render them particularly suitable to individual types of work. Some afford a means of providing, either in themselves or in co-operation with other pigments, adequate protection against decay; others are proof against an atmosphere laden with chemical fumes; others are of great value because their great density affords a means of easy obliteration when a change is to be made in the colour of a surface; still others combine, in part, all three qualities, that is they offer reasonable resistance to weather and foul atmosphere, and they obliterate quite satisfactorily.

There is a special class of materials which should be included in the list of white pigments; these materials, of themselves, have little body or even durability, but are used as extenders to render the physical condition of paint more suitable, or to act as reducing agents or adulterants, in order to bring the material within a certain limit of cost. The builder, however, may not consider it necessary to know too much about these things, his main concern generally being confined to the question of the description being a fitting one for the material. If he wishes to know more, adequate safeguards are available as a result of the work of the British Standards Institution, who have drawn up set formulae for paints suitable for almost every class of work, thus enabling the architect to specify that the paint shall conform to the British Standards Institution specification, and the builder to see that the material conforms to this specification.

Manufactured White Pigments. The names of the principal white pigments are white lead, zinc oxide, lithopone, titanium dioxide, and

antimony oxide, all of which are produced by chemical means. Barytes, whiting, terra alba, French chalk, China clay, and white earth, occur in nature in a more or less pure state, requiring little preparation by the manufacturer to render them suitable for his purpose. It is these latter pigments that are used as extenders; they are all practically inert, but each has a special function to fulfil when introduced, with other materials, into paint, and should not always be regarded as adulterants.

WHITE LEAD. White lead is obtained as a result of treating, by various processes, the metal lead, and is a double compound, *carbonate and hydrate of lead*. It is a colourless substance of very considerable opacity. For centuries there was only this white pigment, and but one method of manufacture, commonly known as the *Old Dutch Stack Process*. Other time-saving methods have been introduced, however, but the product has a physical difference.

White lead is regarded as poisonous, and, when introduced into the human system, acts cumulatively, causing, in the first instance, *colic*, commonly known as *painters' colic*; this, if neglected, develops into a type of paralysis known as *plumbism*, which is a notifiable disease. Generally, it may be stated that poisoning by white lead is caused by dust being allowed to pollute the atmosphere during the process of rubbing down painted surfaces, or by personal neglect, such as dirty hands and clothing, the finger nails frequently secreting particles of lead, which get transferred into the system with food, etc. Efforts have been made to improve matters by making it compulsory to damp the surface with a sponge, then rub down with a *waterproofed* abrasive, but the regulations are often ignored.

White lead when produced is in the form of a white powder attached to the core of the lead strip from which it is converted. It is sprayed with water, so that dust may not be distributed, and kept wet during intervening processes. Ultimately it is put into an enclosed mill into which linseed oil is gradually introduced. The water displaces the oil and a stiff paste results. It is in this form that white lead is usually sold to the trade. When a keg is opened, the material should be covered with oil

or water; but if the latter is used, care should be taken to see that the pigment is free from all trace of water before making it into paint. If oil is used, it may be difficult to make paints that dry without gloss (i.e. *flattening*), from which oil, except the grinding oil, must be excluded.

The pigment, if properly prepared and mixed with a suitable vehicle, as linseed oil and turpentine, is wonderfully durable, and may be mixed with other pigments with but few exceptions, these being pigments that contain sulphur or similar compounds. In a foul atmosphere, for example, a sulphur-laden atmosphere, as in the neighbourhood of gas works, the pigment quickly changes from white to grey. Its opacity, or hiding power, is very good, due largely to its high specific gravity, which is about 6.47. It weighs about 175–180 lb. per cub. ft., and when ground to a stiff paste absorbs 8 or 9 per cent of oil. Its covering power, that is, the area covered by a given quantity, is not so good as that of other materials, this being due to its weight. White lead made by some processes appears to require more oil than when made by other processes. White lead co-operates well with the oil, and actually assists in its oxidation.

ZINC OXIDE, or oxide of zinc—frequently called *zinc white*—is made from metallic zinc (*spelter*). It was first brought to prominent notice in France by Courtois, of Dijon, about 1781. Sorrol, in 1834, while carrying out experimental work in connection with the galvanizing of metals, made certain discoveries which resulted in the commercial production of the pigment, and in 1841, extensive furnaces were erected at Grenelle, France, for further developing and exploiting the process.

The metal vulcanizes at a temperature a few degrees higher than that at which it melts, and vapours are evolved which, in the presence of air, rapidly oxidize and solidify in the form of a white powder, frequently known as *philosophers' wool*. There are two methods of obtaining the desired result, known as the *direct* and the *indirect processes*. The first method is practised chiefly in America, and the latter in France, the direct process being the simpler; other processes have been tried, but have not been a success.

Zinc oxide is a fine, brilliant, white powder, much lighter than white lead when ground—in oil—to a stiff paste, the form in which it is usually sold. It absorbs about 20 per cent of oil—a much larger quantity than is the case with white lead. If of good quality, it is not affected

by sulphur-laden atmosphere; therefore it retains its purity of colour for a long time. If it is of low quality, it contains a percentage of lead. Its opacity, or hiding power, is not good, but owing to the fineness of its particles, its covering power is excellent. All attempts to improve its opacity have failed. It makes an excellent paint, specially suitable for use as a finishing coat over white lead, and is also used extensively in the making of enamels.

Zinc oxide, if pure, is non-poisonous; its main defects are lack of density, and a failure to combine satisfactorily with oil. The film established with this material tends to become excessively hard, and to crack. There is also a lack of freedom in working under the brush. The material should be kept covered with oil after opening the package. On no account should it be covered with water. The best method with practically all such materials is to level the material and cover carefully with a piece of greaseproof or oil paper. Owing to zinc oxide's tendency to crack, driers should be used with care, oil driers being best.

LITHOPONE. This material consists of *zinc sulphide* in combination with *barium sulphate* (barytes, or *blanc fixe*).

The process of manufacture varies considerably; there are immense quantities produced in England, the United States, Belgium, Holland and Germany.

Lithopone is generally white, and its texture soft. Properly prepared, it has a greater opacity than any other white pigment, but it has the disadvantage of going off colour, which detracts from its value. When exposed to strong sunlight, it becomes grey, but improvements in manufacture have reduced this tendency. The higher the proportion of zinc sulphide, the greater the body and covering power.

Lithopone is used chiefly as an undercoating for inside work. It is unsuitable for outside work. Its chief advantage lies in its density, or obliterating power. It has fair covering power and generally dries without gloss, having a flattening effect. It makes an excellent flattening for application prior to enamelling, but if it is used for this purpose the binder should be gold size. When mixed with oil, Lithopone should not be allowed to come into contact with water, and brushes used in this material should be kept free from water also. It requires considerable experience before a satisfactory job can be made; this is on account of its rapidity in drying, which makes it difficult to apply.

MODERN BUILDING CONSTRUCTION

TITANIUM WHITE OR TITANIUM DIOXIDE. Titanium is found combined in three minerals, *rutile*, *brookite*, and *anatase*, in each case in a different crystalline form. It appears to occur most abundantly distributed in the minerals ilmenite, sphene, or titanite, and titaniferous iron ores. It is manufactured as a white pigment from the mineral *ilmenite*, which is a compound of iron oxide and titanium dioxide. Vast deposits of the mineral are found in Norway, though there are deposits in many other parts of the world. The English deposit, found chiefly in Cornwall, is unsuitable for use.

Briefly, the principal process of manufacture is as follows. Finely powdered ilmenite is mixed with concentrated sulphuric acid, and the mass heated. A violent reaction takes place under the coagulation of the mass, transforming the titanium and iron contents into titanium and iron sulphates. The coagulated mass is then dissolved in water, and freed from undecomposed minerals in a settling vat. The clear solution, containing the sulphates, is brought to a boiling temperature by the use of indirect steam, causing the *titanium* to precipitate *titanium hydrates*. The precipitates obtained are washed, to free them from iron, but they still contain absorbed sulphuric acid and basic sulphates of titanium in small quantities, which are, however, neutralized by adding barium carbonate. The neutralized precipitate is calcined to convert the *dioxide* into a *micro-crystalline state*.

In the finished material, which is a beautifully white pigment, there is a very small percentage of barium sulphate. By precipitating the titanium dioxide on a barium sulphate base, composite pigments are made. Titanium is a brilliant white in colour, and its texture is very fine. When ground into a stiff paste, it absorbs about 23 per cent of oil. The pigment is quite inert, that is, it does not assist or retard the oxidation of the oil, and it is not affected by heat, acid, or sulphur fumes. The pigment has very good body and covering power, and its opacity or obliterating power is nearly twice that of white lead. *It is absolutely non-poisonous.*

The paint film established by this pigment is rather soft, rendering it liable to pick up dust, etc., but this can be largely overcome by the addition of 10–15 per cent of zinc oxide, which hardens the film. Titanium is probably the most valuable addition to the long list of painters' materials that has been made for a

generation; and when its use and limits are really understood, it will no doubt largely displace certain other pigments.

ANTIMONY OXIDE is another new pigment, though it does not appear to have attracted quite so much interest and attention as titanium. The raw material used is *stibnite*, or *grey antimony*; alone or mixed with iron, the *stibnite*, as it occurs naturally, is roasted in the presence of air or oxygen. The fume or vapour created is antimony oxide, which is collected in a series of chambers, the finest particles being found in the chambers which are the greatest distance from the source of operation. If carefully prepared, antimony oxide is of a very pure white, and when ground into a stiff paste, requires about 10–12 per cent of oil. The paint film is soft and very similar to titanium, but it becomes yellow on exposure to sulphuretted hydrogen. Exposure to light and pure air restores it to its original colour. It does not change colour quite so quickly as white lead.

Antimony oxide has no action upon linseed oil, it being quite inert. It is slow drying, but this may be corrected if the material is used in conjunction with zinc oxide. Its opacity and covering power are very similar to titanium. It is poisonous.

Natural White Pigments. In the foregoing, the student will find sufficient information to assist him in making the best use of the white pigments that are manufactured. The use of the naturally occurring pigments is more a matter for the manufacturer than for the painter, but some points about a few of them may be of value.

These white pigments are regarded as colourless bodies, and are used chiefly because of their cheapness. In actual practice their use is primarily to give bulk and to maintain weight rather than to give opacity. Generally they have very little opacity when mixed with oil, but the reverse is the case when they are mixed with water.

The names of the principal, naturally occurring, white pigments are: *Barytes*; *Blanc Fixe*; *Whiting*, or *Paris White*; *Gypsum*, or *Terra Alba*; *China Clay*; *Strontian White*; *Satin White*; *Magnesite*; *Silicene*; *Asbestine*; and *Alumina*.

BARYTES, OR BARIUM SULPHATE, is the most important and most widely used. It occurs in a crystalline condition, and is known as *heavy spar*, or *cawk*. It is also prepared artificially. This material occurs in large quantities in

various parts of England, e.g. Derbyshire, Devonshire, Cornwall, Cumberland, and at various places in Wales and Ireland. It is generally white in colour, but when iron is present it is a pale yellow. It requires but little preparation, beyond separating from impurities, grinding very carefully, washing and grading. It is in the form of a heavy white powder, almost as heavy as white lead, and it is claimed to perform a distinct function in certain paints. The decorator, however, will find it necessary to doubt the utility of this material except in a limited number of cases. Its chief function is as an extender.

BLANC FIXE is, chemically, exactly the same as barytes, but varies physically. Barytes is crystalline, whereas Blanc Fixe is soft and spongy. It is made by precipitating solutions of barium salts by means of sulphuric acid.

WHITING, or PARIS WHITE, popularly known as *Gilders' whiting*, or *chalk*, needs but little description. After quarrying, it is put through a series of washings, levigated, and dried. Its chief use is in making distemper and, with linseed oil, putty. When ground in oil, it has no opacity.

GYPSUM, or TERRA ALBA, is found plentifully throughout this country. It is a brilliant white, and rather heavy. It has little body in oil. It is used as an adulterant or extender.

CHINA CLAY, found largely in England, France, and Germany, occurs almost ready for use, requiring only washing, etc. It is bulky and transparent when ground in oil. It is used to prevent settling out of pigments in paints made for dipping. It is also used extensively as a base upon which to strike or precipitate certain colouring materials. It plays an important part in the manufacture of ultramarine blue.

Coloured Pigments. The materials used by the painter and decorator for obtaining colour are many and varied; they are, as in the case of white pigments, natural and artificial. Generally, the coloured pigments produced by Nature are the most permanent as regards colour; but some can be, and are, produced chemically. This, however, is a matter principally of price, it being less expensive to produce the artificial variety because of the amount of preparation sometimes required to render the natural pigment fit for use. Generally, the natural pigments can be used safely when ground in either oil or water, but at all times it is most important to obtain pigments true to colour and well prepared. It is important, too, that all containers should be kept sealed, or their contents covered with oil

or water, to prevent, in the latter case, hardening or drying of the pigment, due to evaporation of the water, and in the former, oxidation of the grinding oil.

RED LEAD may be regarded as the most durable of the red pigments. It is an oxide of lead, and was known to the early Egyptians as *minium*; it is produced by roasting *liiharge*. Its chief use is for mixing with white lead for *priming*; this is the name given to the paint generally prepared for a first application on unpainted surfaces. When made into paint it is an excellent drier, assisting in the oxidation of the oil and producing an impervious film. It should be used thinly, and one application on woodwork is usually sufficient. *Several applications will most probably crack the film owing to its extreme hardness.* The pigment has excellent filling properties when applied on woodwork. Due to its great weight, the pigment settles out from the vehicle rapidly; priming needs constant stirring to keep the pigment in suspension. Manufacturers have produced a red lead paint that does not settle out quite so rapidly; it is called *non-setting red lead*. When exposed to sulphur-laden atmosphere the pigment turns brown. It is not suitable for the production of colour. It is generally sold in the form of a powder, and being poisonous, care should be used in handling it.

OCHRE is known by various names: yellow ochre, golden ochre, Italian ochre, spruce ochre, Oxford ochre; each kind is a different shade. They owe their colour to the presence of hydrated ferrous oxide. The pigment is safe in all mediums.

SIENNA, another earth pigment, is obtained chiefly from Italy. The colour of the pigment is similar to ochre, but it is more transparent. Its staining power is stronger than that of ochre, and therefore less is required. If not of good colour, but muddy, the sample should be rejected. It owes its colour to the large percentage of iron present. If the pigment is burnt its colour is changed from yellow to a low-toned red.

VENETIAN RED, INDIAN RED, AND RED OCHRE are earth pigments that also owe their colour to the presence of iron, the colour varying with the amount present, terra alba, or other suitable base, being mixed with it to produce standard shades and to regulate cost.

RAW TURKEY AND ENGLISH UMBER are useful brown earth pigments. Their composition is similar to ochres, the variation in colour being

MODERN BUILDING CONSTRUCTION

due to the higher percentage of *manganese*. When burnt, the colour becomes much warmer. It is a pigment much used in graining.

VANDYKE BROWN is manufactured from a brown earth that is rich in organic matter. It is also largely produced artificially, and is used, ground in water, for graining. *It is difficult to make vandyke brown dry satisfactorily when ground in oil.*

CHROME, or CHROMATE OF LEAD is an important pigment, *chemically produced*, ranging in colour from bright yellow to orange and red. It is a strong pigment, having most of the disadvantages of a lead pigment, i.e. it changes colour on exposure to sulphur-laden atmosphere, and is poisonous.

ZINC CHROME is a similar material to lead chrome, but it has not the disadvantages of lead. It retains its colour, and is used largely for making special pigments for *tinting distemper*, for which lead chrome is unsuitable. It is also used in conjunction with *Chinese blue* for making zinc greens. Unfortunately, the staining power of zinc chrome is not good. It is non-poisonous if of good quality.

ULTRAMARINE BLUE is an important and useful pigment. It occurs naturally as *lapis lazuli*, but practically all ultramarine is now made artificially. Individual manufacturers make a speciality of producing it. The process requires expensive plant and considerable experience; *china clay*, *sodium sulphate*, *soda carbonate*, *coal*, or *charcoal*, and *sulphur* are used in its production; the colour is beautiful and permanent. It is prepared dry, in powder form, and ground in oil or water. It is used extensively in distemper, and is unaffected by lime. As it contains sulphur, it should not be used in conjunction with lead pigments, or lead sulphide will be formed; it has a tendency to settle out in oil paints.

LIME BLUE is made by reducing ultramarine pigment with *terra alba*. It is used for staining distemper.

PRUSSIAN BLUE is probably the most extensively used blue pigment. It is also known as *Chinese blue* and *Berlin blue*, and is a chemical production. Berlin blue is also made by another process. Prussian blue is a remarkably strong stainer, though somewhat transparent. It is fairly stable when exposed to light and air, but when in contact with white lead, chrome,

or zinc oxide it is liable to lose some of its colour. It should not be used as a stainer in distemper.

CELESTIAL BLUE is Prussian blue reduced or extended.

COBALT BLUE, an *oxide of cobalt*, is a permanent greenish blue. Being too expensive for general use, it is often reduced, or adulterated with ultramarine blue.

BRUNSWICK GREEN is the most important green pigment, and is a combination of Prussian blue and chrome, considerably reduced with barytes. The quantity of barytes is regulated by the quality of the pigment required. Brunswick green is made in a wide range of shades, from a very bright colour to almost black. Its covering power is good, and its durability, when mixed with a suitable vehicle, is excellent. If, however, it is of poor quality, or is not properly protected by varnish, it loses colour and becomes a dirty grey.

The trade has not much use for pure Brunswick green, hence the use of a reducing agent. It is usually sold in three shades, pale, middle, and deep.

ZINC GREEN is composed of zinc chrome and Chinese blue. It is frequently sold in its pure state, though there are many uses for it in the cheaper grades (i.e. reduced with barytes), as it provides a range of clean, bright shades, and is much more permanent than similar pigments made from lead chromes. Its density is not so great as Brunswick green, but the price is higher. It should not be used in distemper.

BLACK PIGMENTS. The principal black pigments are *ivory black*, *drop black*, *carbon black*, *lamp black*, and *vegetable black*. These are produced by burning different types of material such as gas, ivory, and bone, vegetable matter, and animal matter. They are, almost without exception, bad drying pigments, and require special consideration in this connection.

LAKE PIGMENTS. This is a range of pigments produced by fixing an organic dye on an inorganic base. They are *crimson lake*, *scarlet lake*, *purple lake*, *carmine lake*, *madder lake*, *rose pink*, *Dutch pink*, and *black lake*. Great progress has been made in recent years in the manufacture of these pigments, and lake colours are now produced having very good body and covering power. This is accomplished by the use of barytes and other bases.

Chapter III—PAINTING

THE means by which paint is applied are of considerable importance. Articles are sometimes *dipped*, the paint being suitably prepared; or *sprayed* by means of a specially designed apparatus which, in some cases, executes the work in a wonderfully efficient manner; or the *brush* is used. Application of paint by the brush is, of course, the most satisfactory method, and it is generally the most efficient, if the right kind of brush is used, although a great deal of painting is carried out by other methods.

BRUSHES

The brush suited for the efficient application of paint should be of the very best. It should be of pure bristle, specially selected for particular types of brushes. Generally, paint brushes are made with black, grey, or white hog hair, the last kind having been bleached. Just as each particular job requires that the paint shall be made suitable for it, so does the paint require to be applied with the types of brush that will give the finest result. The bristles are set in glue, resin, cement, or vulcanized rubber, and are fastened with string, tin, or copper binding. Care must be taken to keep new brushes in a place that is neither too hot nor yet too damp. Heat causes a shrinkage of the timber, and damp the reverse, which, if excessive, may, in the case of string bound tools, cause the binding to burst. New brushes need attention when in stock because of moths, and special precautions should be taken accordingly.

For all general purposes, hog hair brushes are used for applying oil paints, distemper, and washable water paints on large and small surfaces, but many and varied are the brushes required for individual types of work.

Brushes that have been used for painting should be put away, carefully removing first all superfluous paint from the bristles and handle. The brush should then be suspended in water. This is easily accomplished by boring a small hole in a suitable position through which a stiff wire may be passed, allowing the wire to rest on the edge of a trough (suitably designed), or paint kettle, in which sufficient water is kept to prevent the paint from drying in the brush. The brush itself should not be allowed to stand on

the bristle, nor should the water be so deep that the binding is submerged. Fig. 1 shows a suitable trough and the manner of suspending brushes in it.

Types of Brushes. The principal brushes used for the application of oil paint are shown in Figs. 2 to 4. Figs. 5 and 6 are jamb or dust brushes. Figs. 7 and 8 represent two types of varnishing brush.

The bristles are set in resin, vulcanized rubber, or special cement; the two last-named became necessary because of the highly solvent action of some of the turpentine substitutes. The use of the flat brush for the application of oil paint is a comparatively recent development. It was

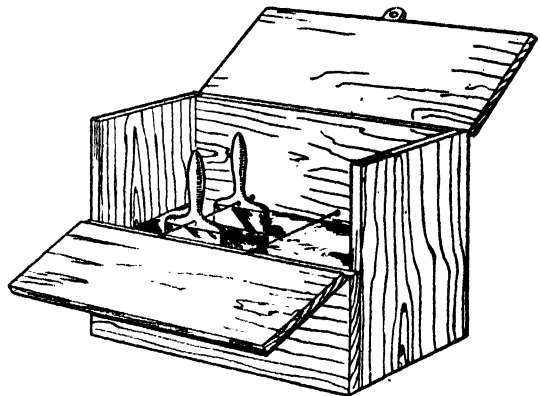

FIG. 1. TROUGH FOR PAINT BRUSHES

made primarily for varnish and not paint; but it finds favour because it is ready for immediate work, and also it seems easier in many operations to produce the desired result. It is not really a satisfactory tool for spreading paint. The flat brush is made in various widths, from 1 in. upwards, and various thicknesses. Black bristle appears to be the most serviceable in this type of brush.

POUND BRUSH. The pound, or ground, brush is the most efficient for the application of paint on large surfaces, and is made in various sizes, denoted by the weight of the bristle. Frequently the bristle is mixed, having a grey centre and white outside. The white bristle is often the stronger, being more carefully selected. Much fibre and whalebone are used in the brush trade,

MODERN BUILDING CONSTRUCTION

but it should be clearly understood that neither material is suitable for incorporation in paint brushes of good quality. The bristle is fixed with glue, cement, or rubber, and, as in the case of the sash tool, is too long for immediate use, and should be bridled. Before bridling, it is an advantage if a thin piece of wood (almost veneer thickness will do) is inserted in the core to the depth it is intended to bind the brush. This will do much to prevent the brush developing

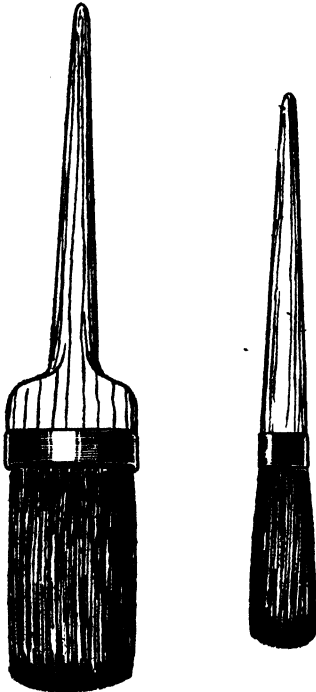

FIG. 2. POUND OR GROUND BRUSH AND SASH TOOL

a twist. Fig. 2 shows a pound brush before bridling, and Fig. 3 the same brush bridled.

SASH TOOL. The sash tool, Fig. 2, has its bristles set in either glue or cement, and is bound with string, tin, copper, or aluminium. It has a length of bristle that renders it unsuitable for immediate work. This is in order to allow for the application of the bridle, Fig. 3, which is usually of string, and has the effect of shortening the length of bristle. As the bristle wears down, the bridle can be shortened accordingly. The sash tool is used for purposes similar to the fitch, but in practice it is found that each has its own place in the trade.

FITCH. The fitch, Fig. 4, is a flat, or round, brush which is used for painting mouldings, sash

bars, etc., and many small surfaces. It is made in sizes and numbered accordingly, the largest being about $1\frac{1}{2}$ in. wide. A 1 in. or $1\frac{1}{4}$ in. flat brush is more satisfactory.

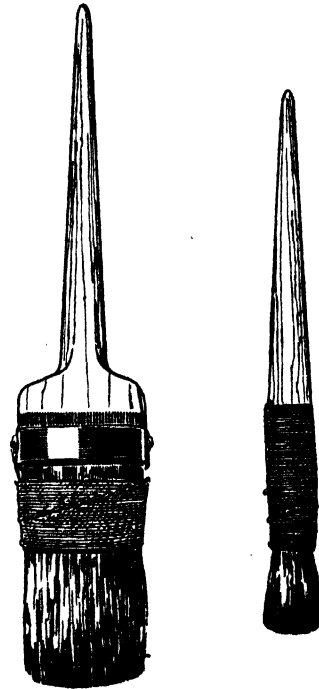

FIG. 3. BRIDLED POUND BRUSH AND SASH TOOL

Care of Brushes. If only on account of their cost, all brushes should be kept in proper condition and not allowed to become dirty, or "lousy," or the particles of paint in the stock will break up and work out into the new paint.

String bound brushes should be well soaked in water before use, in order to *expand the timber and tighten the binding*. The sash tool and ground brush will require a few days' work before the

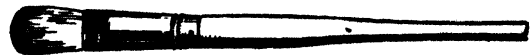

FIG. 4. A FITCH

best result can be obtained. It may be an advantage to "break them in" on some rough work first.

PRIMING COAT

Composition. *Priming* is the name given to denote the first coat of paint on a surface that has not been previously treated. For new wood-work it should consist of white lead ground in

PAINTING AND DECORATING

linseed oil, with sufficient red lead to make the paint a decided pink, the whole reduced with linseed oil in about three parts, and turpentine one part, and a little drier, about 1 oz. to 1 lb.

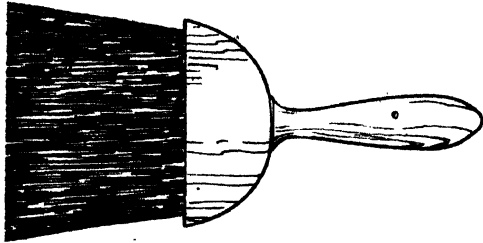

FIG. 5. A PITCH-SET JAMB BRUSH

The proportion, however, must be varied according to the type of timber, but this will be satisfactory for deal. With hardwoods, the oil will need to be very much reduced, also the red lead and driers, and the turpentine, or turpentine substitute, increased. If turpentine substitute

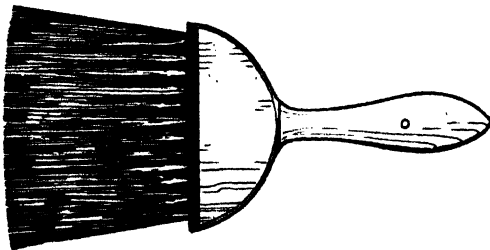

FIG. 6. RUBBER-SET JAMB BRUSH

is used, it should be of good quality, as specified by the British Standards Institution.

Preparation. The woodwork should have been well finished before the painter takes over, but if not, he should overhaul it himself. He may find it heavily scored across the grain. This is

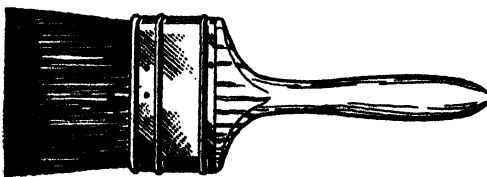

FIG. 7. FLAT VARNISHING BRUSH

due to a mistaken idea on the part of the woodworker as to the type of finish required by the painter, and it may be necessary to complete the process of rubbing down. Attention should be given to projections, as mitres, etc., and all nails should be well punched home.

The surface, after rubbing down, should be well dusted with the *dust brush*, technically called a *jamb brush*, Figs. 5 and 6.

KNOTTING. Loose knots should be removed and replaced with well-fitted timber. Projecting knots should be chiselled down below the

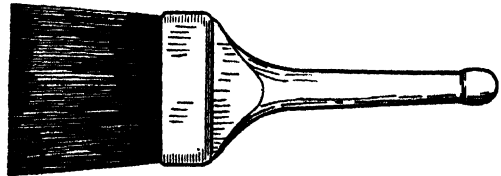

FIG. 8. OVAL VARNISHING BRUSH

normal surface, and all knots receive one coat of good patent knotting, which should be made from methylated spirit and shellac. This should be bought from a reliable manufacturer. To ensure that this preparation is in good condition it must be kept in a bottle properly corked, a hole being made in the cork in which a small sash tool, or fitch, has been tightly fitted. This is called a *knotting bottle*. If exposed, the spirit will evaporate, and the knotting will be thick

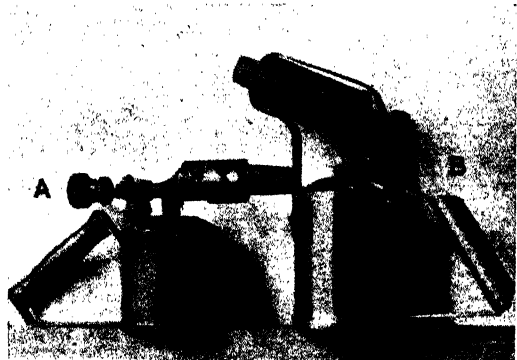

FIG. 9. BURNING-OFF LAMPS

A = For use with benzoline or petrol
B = For use with paraffin. Note the force pump

and unsuitable. If used, thickened knotting may cause defects to develop in the paint film later. The knotting should be applied thinly. Other methods are to cover knots with red lead and glue, red lead and gold size; a more expensive method is to cover them with metal leaf attached by thin *knotting*, or *Japan gold size* while tacky. If proper care is taken one application of *patent knotting* should be sufficient.

REMOVING OLD PAINT. If the woodwork has been previously painted and it is necessary to

MODERN BUILDING CONSTRUCTION

remove the old paint, the method of preparation is similar in intention; that is, first produce a surface as perfect as it is reasonably possible by removing the old paint, either by the use of the *burning-off lamp* (Fig. 9 A and B) and chisel knife, Fig. 10 or shavehook, Fig. 11, or by the application of a *solvent*.

Burning-off lamps are made in two types; that is, to burn *benzoline* or *petrol*, or *paraffin*,

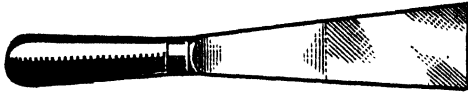

FIG. 10. CHISEL KNIFE

each type finding favour with different individuals. The main requirements, however, are that they should quickly develop heat and be not easily clogged, properly shielded against wind, and be as light in weight as possible. Care should be taken to light the lamp in a suitable place, to see that the stopper is screwed up properly; full instructions supplied by the makers should be carefully studied by the beginner.

If a solvent of a non-alkaline type is used, the surface may require to be washed with turpentine, or turpentine substitute, in order to remove any wax that may have been part of the ingredients of the solvent; if, however, an *alkaline*

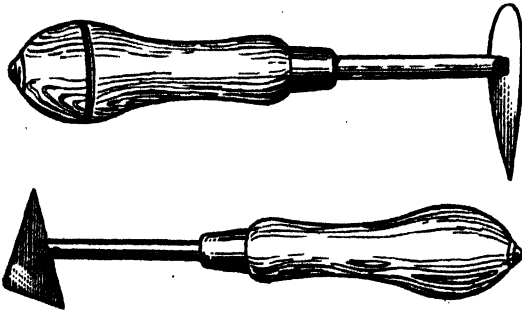

FIG. 11. SHAVEHOOKS

solvent has been used, as *lime*, *potash*, *pearlash*, or *soda*, then it will be necessary to wash the surface over with *dilute acetic acid*, or *vinegar*, to *neutralize* the *alkaline* material, and so avoid later trouble.

It has been the practice by many painters to rub down, with dry glasspaper of suitable grade, surfaces that have been stripped, while others use pumice stone, which is obtained from volcanic eruption and cut by the operative to suitable shapes for his work. It should be observed that,

usually, the *lighter in weight* a piece of pumice stone is, the more suitable it will be for the purpose.

The practice of rubbing down dry has stopped, however, it having been realized that the paint and other particles thrown off are a danger to health. Manufacturers have studied the question closely, and introduced *abrasive water-proof paper*, which may be used wet or dry; this tends to reduce the cost of rubbing down considerably, though there is, in the case of surfaces that have little paint upon them a tendency towards absorbing moisture, and not becoming properly dry before the priming is applied, unless time is allowed. The subject of treating surfaces previously painted will be dealt with more fully later.

Application. Priming should be applied thinly, and should be well brushed into the pores of the timber and all crevices. It should be

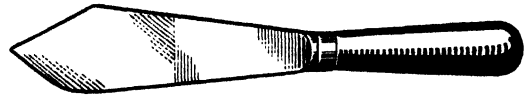

FIG. 12. PUTTY OR STOPPING KNIFE

applied with the same amount of skill and care as all other applications of paint, and not left, as is unfortunately frequently the practice of the builder, to any boy or labourer. Priming is the foundation of the later structure. When the priming is dry, and assuming the work has been fixed, the surface should be carefully rubbed down, care being taken to observe any regulations that may have been imposed in connection with this process. It should be carried out carefully in order that the shapes of mouldings, etc., be preserved.

STOPPING

All nail holes should be stopped with putty made from linseed oil and dry whiting, usually purchased ready prepared; the putty should be well pressed into the hole by means of the *putty*, or *stopping, knife* (Fig. 12), care being taken to leave the surface as smooth as possible. For all ordinary work little more need be done, but for a good job all indentations and irregularities of surface must be made good. This may be done by applying a filling by means of a *filling*, or *broad knife* (Fig. 13), which should have a very pliable blade. The filling material may be distemper, or preferably oil. Distemper filling is made of whiting and size, though some add a little plaster; this, however, makes it

more difficult to rub down, and increases the tendency of the material to crack. The filling may, if necessary, be applied to mouldings with a brush of suitable size, and much time may be saved by very careful application. There are many ready prepared distempers that are suitable. When dry, the surface can easily be rubbed down with ordinary glasspaper and, later, all dust removed by the application of a dust brush. The filling should then be coated with *glaze*, composed of equal parts of Japan gold size, or varnish and turpentine, or substitute of B.S.I. (British Standards Institution) Specification.

The glaze will change the composition of the filling, and make it similar in composition and as durable as linseed oil putty.

Oil, or lead, filling is made of white lead ground in linseed oil, mixed with Japan gold size and a little turpentine to a stiff paste. If the paste is too soft, it may be stiffened by the addition of a little dry whiting, or dry white lead, or slate powder may be substituted for white lead; but slate filling is best procured ready prepared from a reliable manufacturer. There are many excellent materials on the market suitable for use as fillings, and each individual will quickly find by a little experiment the one that best suits his purpose and class of work. It should be observed that it is practically useless to apply stopping or filling unless the surface has been *previously primed*, as the *binder* will be absorbed and the filling will have nothing to hold it together.

The filling process completed, the surface should be carefully rubbed down with waterproof abrasive paper kept flat by attaching it to a block of cork, wood, or rubber of suitable size and shape, the surface being slightly damped with a sponge of water and afterwards again sponged over to remove the material cut off by the abrasive paper, thus avoiding the creation of dust; this is a much more hygienic method than rubbing with ordinary abrasive paper, and quicker than using pumice stone.

FINISHING

The surface may now receive a coat of paint, which should not be too thick, and containing about equal parts of linseed oil and turpentine; the material should be well spread and not merely slopped on. Within reasonable limits, the more the paint is spread the better will be the degree of attachment and the longer its life. A series of thin coats of paint will always wear for a longer period than if the same volume of

material were used in fewer applications; further, the thinner the paint, provided always that it has sufficient body to suit its purpose, the more easy it will be to produce a better type of finish; the better the type of finish, other things being equal, the longer will be the life of the job.

Everything, therefore, depends upon sound craftsmanship, which can be possible only if a proper amount of time is allowed for the operative to do his work.

Subsequent applications of paint will depend entirely upon the type of finish: whether it is to be full or half gloss paint; *flattening*; a finish *without gloss*; or if it is to be *varnished* or *enamelled*; and how many coats of paint it is possible to allow for in preparation for the finish. These will be dealt with later.

Plaster Surfaces. FIRST COAT. Plaster surfaces should, when dry, first receive a thin coat of

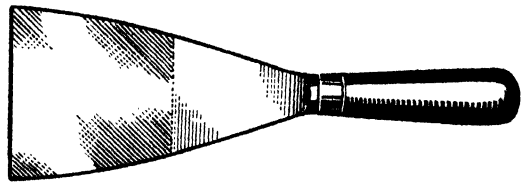

FIG. 13. FILLING OR BROAD KNIFE

paint in which there is a much greater proportion of oil than turpentine; three parts of oil and one of turpentine would be suitable, though many advocate an equal quantity of each.

The selection of the pigment is frequently settled in the specification, and may be *white lead*, *titanium*, or *timonox* (antimony oxide), or *zinc oxide*, to which may be added *red lead* sufficient to make a decided pink, or less if the finish is to be very light. The surface should not be rubbed down prior to application of the paint, as this may have a tendency to roughen the plaster, but care should be taken to remove any superfluous material, such as particles of plaster and mortar attached through the carelessness of other craftsmen and labourers. It will be found that the surface will absorb a considerable amount of material, therefore it should be thin and liberally applied. The absorption will be irregular, owing to the varying porosity of the surface due to the irregular pressure of the plasterer's tools. Well-finished surfaces may have a harder and smoother face. The paint will dry in about one day and be hard enough to work on again; it may then be lightly rubbed down, and any irregularities made good by filling and stopping,

MODERN BUILDING CONSTRUCTION

the filling material requiring to be glazed, or touched up, with paint of an oily character. See previous notes on filling.

SECOND COAT. The second coat should be much thicker (the painter would describe it as "rounder"); it should contain more oil if the first has been composed of equal parts of oil and turpentine. The quantity of dryers may also need to

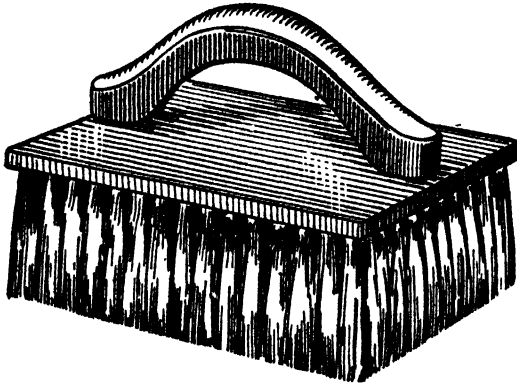

FIG. 14. STIPPLING BRUSH

be slightly increased, but it will vary according to the pigment it is decided to use, lead not requiring quite so much as zinc, titanium, tinnox, or mixtures of pigments. The paint should be well and evenly spread, and should not sink below the surface if the first coat has been properly prepared, though the gloss may not be absolutely uniform; the way of *laying off*, that is, the direction of the brushwork, will usually be *vertical* from ceiling downwards, and should be as fine as possible.

THIRD COAT. The third coat may have the proportion of the oil decreased, and the *fourth coat* be of three parts of oil and one part turpentine, giving a finish with a good gloss.

FLATTING. If, however, the walls are to be finished in flatting, or egg-shell gloss, the procedure will have to be so arranged that the material for application prior to the flatting is of an oily nature, three parts at least of oil and one part of turpentine; this proportion is required because flatting must be applied upon a surface that is of an adhesive nature. Flatting being composed of pigment and turpentine only, will not hold together, or attach itself to a surface that is hard and dry. *Flatting* should be thin, and ought never to be regarded as any other than a *decorative finish*. Many painters fail to apply it successfully, either because the surface is unsuitable, or because they try to make it

do the work of a coat of paint. If the final coat is to be a colour, or tint, the various coats of paint should be so tinted as to bring the last coat preceding the finish to nearly the same colour as the finish.

The scaffolding for men to work on during flatting should be so arranged that the necessary number can be engaged to carry the process through as quickly as possible; the material should be applied in a direct manner. Owing to its rapidity in drying there is not time, neither should any attempt be made to spread and cross the work, as is done when oil paint is applied. For an egg-shell gloss a little pale copal varnish may be added to the flatting used for the immediate undercoating.

STIPPLING. If a brush finish is not required the surface may be stippled, the *stippler* being applied rapidly at right angles to the wall surface with the object of removing all brush marks. Figs. 14 and 15 show two types of stippler.

When the work is complete, the apartment should be well-ventilated and the stippler properly washed out, care being taken to avoid wetting the backing of the stippler as little as possible, because it may cause the wood to warp, or twist and the bristles to become loose; the bristles should be well dried and separated, and the stippler hung up.

For an enamel finish, the various coats of paint will require to be so arranged that the material



FIG. 15. STIPPLING BRUSH WITH REVERSIBLE HANDLE

applied immediately prior to the enamel is flatting; a flatted ground will make it possible to get the maximum gloss from the enamel. Here, again, the scaffolding should be thoughtfully arranged, so that the work can begin at the right-hand top corner, the man at the top applying his material as far down as possible so that the one on the next stage of scaffolding can reach it; much can be done by proper co-operation to make the job a success.

The principles generally are the same whether the surface be a wall, ceiling, or a door.

Stone. The modern tendency appears to be toward using stone in building to a greater extent than ever. Some types of stone are exceedingly soft and may by absorbing moisture, serve as conductors of damp; this, of itself, has made it necessary to treat many buildings in order to make them proof against moisture. Manufacturers have produced quite a number of patent or special materials for application on stone. Their success is not so far very definite. Many of the so-called stone preservative materials are colourless, while some appear to change the colour of the stone, or may be of a definite colour as specified.

The use of these materials is, however, limited, and it is frequently necessary to apply paint, though many argue that stone should of itself be preserved and not require treatment.

PREPARATION. Prior to painting stone, it should be cleaned in order to remove all dirt, care being taken to remove any matter of a vegetable nature because of possible later developments. Usually, brushing with a stiff bass brush is sufficient, though it may be necessary to wash the more dirty parts. At all times it should be remembered that it is almost useless to apply paint on a surface that is either dirty or damp unless in the latter case the paint is of a special character.

After cleaning, the surface should be overhauled and defective parts made good; if the latter are large they may be repaired with stone, though in practice cement is frequently used (see later instruction for the treatment of cement).

PRIMING. If the surface is to be treated for the purpose of preservation, then the best material to use is a good lead paint. Oil should predominate. The first, or priming, coat should be made from white lead ground in oil; sufficient red lead to make it a decided pink should be added, the mixture broken up in oil and then reduced with American turpentine or substitute of recognized standard, the final proportion of oil and turpentine being about equal. The turpentine by reason of its acting as a thinner, will assist the paint to penetrate and so secure a firm grip on the surface; the red lead will act as a dryer, no other dryer being necessary, and will also give the film of paint a greater degree of durability. The oil will bind together the particles of pigment and keep the film elastic.

The priming paint should be well brushed in, remembering always that within certain limits

brushwork adds to the durability of the paint, and assists in securing a better degree of attachment to the surface.

REMEDYING DEFECTS. When the priming is dry, which will be after the second day, minor defects may be made good with either hard stopping or putty; but care should always be taken to preserve the texture of the surface, so that such repairs may be less visible. If putty is used, a slightly longer period must be allowed for it to harden than if hard stopping is used; this period might, however, be shortened by adding some white lead (or even red lead) to the putty. It may be an advantage to touch up these parts with a little of the priming paint, care however being taken not to go too far over the edges, or the patched up appearance might cause some difficulty in securing a uniform finish in the desired number of coats.

After a further period, to allow the paint used for touching up to dry, the surface is ready for further treatment. It will not be necessary to do much in the way of rubbing down except where the surface has been repaired; this may, however, require a slight rubbing with glass paper. Assuming that the work is external, it may be considered unnecessary to do this by the damp process, but it should be realized that it is generally less expensive to rub down by the damp process than otherwise if any high degree of finish is required. Further, in practice it is frequently considered unnecessary to do much rubbing down if the surface under treatment is any great distance from the floor; but here, again, the more care that is taken with all work, especially in the preparatory stages, the better will be the result, and usually the longer will be the life of the material.

SUBSEQUENT COATS. Upon the priming, paint should be applied containing about three parts oil and one part turpentine, white lead being the pigment, to which may be added such matter that will tint the white to a shade approaching the finishing colour; this will naturally be a stone colour, and the pigment to use will be an ochre and a little venetian red, or raw sienna alone will give a suitable colour, but the actual selections of coloured pigments will depend upon the tints required.

For some purposes, raw or burnt umber make excellent stone-like tints. Note that these pigments are all earth pigments and that their permanence of colour is reliable. Upon this oil coat should be applied the third coat, composed of similar pigments; but the liquids should be

MODERN BUILDING CONSTRUCTION

changed about as to proportions, that is, there parts of turpentine and one part of oil and a little drier. A slightly greater quantity of drier would be necessary in the preceding coat on account of the greater volume of oil to oxidize, but at all times the minimum amount possible to secure the result should be used; an excess of drier will impair the durability of the paint film. The consistency of the paint for the second coat should be "round" or thick enough to produce a comparatively even result as regards colour, but fluid enough to spread satisfactorily.

The hard, almost flat, glossless surface thus produced affords an excellent ground upon which to apply the finishing paint; care should be taken to tint the material to a suitable shade; many stone fronts that are painted are spoiled and lose much of their beauty by the selection of a tint that is unsuitable.

White lead changes its colour owing to the action of town atmosphere, or rather its chemical composition is changed, which renders it necessary to select a pigment that will not be affected. The safest white pigments are titanium white, timonox-dioxide (antimony white), or zinc oxide. It will be found that a mixture of either titanium and zinc or timonox and zinc will give best results. Zinc of itself dries too hard. The two first-named do not dry sufficiently hard and are inclined to chalk. The addition of zinc tends to prevent chalking. The proportion of about 15 per cent of zinc makes an excellent paint that absorbs a great quantity of oil and provides a finish of high gloss and considerable durability; it is worth noting that repainting will be found more economical if the finish has been on a formula of this kind.

Portland Cement. It has always been considered a difficult problem to treat surfaces finished in this material, and many are the recipes and formulae suggested as useful as a method of preparation. The difficulty lies in the fact that the alkaline constituents saponify the oil; the obvious remedy is to use an oil that does not act in this manner. There are a number of manufacturers who prepare paints that are really reliable for this purpose, and little or no trouble need be experienced, even with very new cement if the proper material is obtained and proper precautions taken in their use.

Generally, the safest way is to leave the cement surfaces untouched for a period sufficiently long to allow the atmosphere to neutralize the alkaline acids. A 50 per cent solution of zinc sulphate, or the application of certain kinds

of distemper, such as albastine, may give good results; but nothing is so certain as the use of a paint made with an oil that will not saponify.

Roman, Keene's, and Parian cements should be painted with sharp stuff, as soon as they are hard enough to allow the paint to be applied, which is not long after the trowelling process is completed. Sharp stuff is a lead paint in which the vehicle is practically all turpentine.

Stucco work, which is usually much softer than cement finishes, will absorb a greater quantity of oil in the priming, and generally does not present any serious difficulty that has not been explained already.

PAINTING METAL WORK

The treatment of metals brings with it problems that have a peculiarity of their own; there are metals used in building which should not require treatment for the purpose of preservation, while others will rapidly deteriorate unless treated almost immediately the metal-worker has ceased to work upon them.

Zinc, copper, and lead should not require treatment, but the decorator is frequently called upon to do something to change their natural appearance, chiefly when they occur as rainwater pipes, vent pipes, etc. Owing to the nature of the material, principally of lead and zinc, paint does not readily attach itself. The metal, being of a greasy nature, soft, and subject to fairly rapid expansion, presents a real difficulty.

It will be found an advantage to rub the surface over with a piece of glass paper of not too coarse a grade; this will scratch the surface and render it less smooth. Zinc might be treated with copper sulphate, which will also tend to render the surface more likely to allow the paint to grip. In each case the paint should be hard-drying and of an adhesive character. The addition of hard-drying varnish or gold size will be an advantage. The pigment should be crystalline.

CORROSION. Iron and steel behave erratically, and their resistance towards corrosive agencies varies considerably. Considerable experimental work has been carried out to try to determine the cause of corrosion, but there are so many different considerations involved that reliable results are difficult to obtain.

One thing only appears to be really definite, that when iron has once started to corrode it is extremely difficult to stay the process; and that if in the process of painting rust is sealed inside the paint, it does not of necessity prevent its further development.

Surfaces on which corrosion has already started should be thoroughly cleaned by being well-brushed with steel wire brushes and rubbed with a suitable abrasive paper, care being taken to remove every particle of rust and scale. It is most important that all crevices and joints receive special attention, because it is in these places where the rust is most likely to occur.

Materials. In selecting materials it should be remembered that owing to the very ready expansion and contraction of the metal, an elastic film must be aimed at. Dr. Newton Friend suggests, as the result of his experiments, that the best vehicle is linseed oil, with the addition of 0.1 to 0.3 of paraffin wax, the oil of itself having been found as the result of its continuous absorption of oxygen to be liable to crack; the wax arrests, or prevents, this tendency, rendering the resulting film more elastic and, therefore, more durable. The amount of wax should be regulated according to the drying time available. The greater the quantity of wax the slower the paint dries.

In regard to pigments, it is found that soft spongy pigments, absorbing a greater quantity of oil than the harder and more crystalline, should be employed; owing to the great absorption of oil oxidation is much retarded, the result being a more durable paint film.

The great point is to cover the surface as quickly as possible with a film of paint that is absolutely impervious to moisture; without moisture in some form iron will not rust.

Pigment. Careful grinding is most important; the finer a pigment is ground, within reasonable limits, the better will the maximum degree of intimacy between vehicle and pigment be secured; on the extent to which this is carried out will depend the future durability of the resulting mixture, if properly applied; further, the more soluble the pigment the better, the cause of rust being frequently attributed to galvanic action. Pigments that are only slightly soluble are considered to promote galvanic action, and so cause rust to develop.

COLOUR. The colour of the pigment is of considerable importance. Experiment seems to prove that the darker the pigment, the more durable will be the oil film, carbon black being a noteworthy example. The durability of this pigment is also due to the high degree of absorption of oil.

It is understood that the darker pigments absorb actinic rays from light, and prevent the disintegrative oxidation of the oil. Generally,

it is considered that chromes, zinc, and aluminium pigments are the best. Pigments should always be perfectly dry, moisture having a detrimental effect. Pigments that may absorb moisture should be well-dried before grinding. Only those pigments should be used that are permanent to light, air, and moisture; there should be the least possible action between the pigment and the oil.

Much experimental work has been carried out in the United States by H. A. Gardner at the Institute of Industrial Research, Washington. The reports are well worth studying. Gardner suggests that basic substances, used in sufficient concentration, prevent the corrosion of iron. Certain chromate pigments if they are used in large proportions are also effective, as basic lead chromate, normal lead chromate, and zinc chromate. So-called neutral or inert pigments produce, if well mixed with linseed oil, a very durable film, these pigments being brown, red, and black iron oxides, china clay, silica talc, and barium sulphate. Graphite, carbon black, and lampblack may be used as the constituents in the manufacture of paints for finishing coats on steel, but the metal should first be insulated by a paint made with a basic chromate pigment, mixed with linseed oil in liberal proportions, and turpentine only sufficient to make it reasonably easy to spread; these pigments if applied direct cause galvanic action, hence the need for insulation; they do, however, form very durable and weather-resisting paints.

A pigment much used is red oxide of iron, and this pigment has no equal for all general purposes if not too much extended.

GRAPHITE. Graphite is unaffected by acids, alkalis, heat, cold, and electricity, and if properly ground in a suitable medium provides a good paint for application over a priming coat; it is not desirable that it should be applied direct to the metal owing to galvanic action.

RED AND ORANGE LEAD. These pigments are bright in colour; they are oxides of lead, and therefore assist in the absorption of oxygen when used with linseed oil as a binder. Very little or no drier is required if the paint is applied in a fairly fluid state and well spread. Under such circumstances oxidation will take place rapidly. Care should be taken to keep the paint well stirred—on account of the great weight of the pigment it is liable to settle out rapidly and become solid in the bottom of the kettle. Non-setting red lead has been introduced in order to try to overcome this difficulty, and is very

MODERN BUILDING CONSTRUCTION

satisfactory. This material may be stored for quite a long period.

Boiled linseed oil is often substituted for raw linseed oil. As this contains some drier, it should be used with great care or the resultant film may not be as stable as is desired.

One coat is usually sufficient, though due regard should always be paid to the fact that two thin coats are more durable and satisfactory than one thick application.

ASPHALTUM. Asphaltum, or bitumastic, paints have come into prominence of recent years. They are obtained by reducing the material to a workable consistency by melting and thinning with a solvent, as coal-tar naphtha. The raw material is obtained chiefly from Trinidad, Cuba, and Mexico. If boiled oil is added to the pitch while hot, it can be thoroughly incorporated, rendering the materials more elastic and durable. True asphaltum resists the action of acid gases, alkalis, and fumes, and if properly prepared provides an excellent anti-corrosive paint.

Sterine Pitch is sometimes added in order to give elasticity.

There are quite a number of firms producing black paints specially prepared for use on iron and made from pitch that has been specially treated for individual or special purposes.

Ordinary coal tar is used, but does not give satisfactory results; ironwork upon which it has been applied has been found to have a continuous layer of rust under an almost continuous film of tar, this being probably due to certain acids in the tar.

Prior to the application of these cheap black paints the surface should be cleaned just as thoroughly as for any other material. A stiff wire brush proves most useful for this purpose, though these paints will dry on almost anything.

GALVANIZED IRON. Before paint is applied to galvanized iron it should be washed over with copper sulphide. The galvanizing material may be largely removed by washing with strong soda water, but care should be taken to wash off or neutralize any soda, especially from crevices.

Soil pipes, or vent pipes, and pipes that have to be put underground are often treated with black paints made from bitumen, Dr. Angus Smith's solution being frequently specified. This treatment of soil pipes, etc., provides a problem for the painter, because other paints will not dry upon them, and it is frequently necessary to treat them to bring them into line

with some definite scheme specified for the general treatment of ironwork on a building. Generally it will be found quite satisfactory if one or two coats of knotting are applied on the black; one coat should be sufficient if the whole of the surface is covered; this should be followed by thin paint of suitable colour. The pigment should be lead and a vehicle consisting of one part linseed oil and two parts turpentine or reliable substitute.

ALUMINIUM AND BRONZE PAINTS are made by reducing the metals to a fine powder, which is then mixed with a suitable vehicle as *amyl acetate*, a thick, colourless liquid having a smell like essence of pears, or a suitable pale varnish. Metallic paints are considered to be highly satisfactory for application on iron, but one would wish that more restraint were practised in their use as a finishing material; very garish and cheap effects are frequently created as the result of the almost indiscriminate use of them to railings, lamp posts, etc. Due regard should be paid to retaining the appearance of stability that one almost automatically associates with iron; therefore it appears hardly fitting to apply the imitative to something that could not, only at enormous cost, be produced in the genuine material. Metal powders vary enormously in quality; only the best should be bought.

Metals can be obtained in almost any shade, from silver to deep rich gold, and when applied should not be brought into contact with oil, it having an oxidizing action which would ruin the colour in quite a short period; the blackening of metallised surfaces is due largely to this action.

Excellent results have been obtained for hot-water pipes and radiators by mixing the bronze powder with terebine, though it may appear to be wrong in theory.

For application over metals special lacquers are produced, the object of which is the retention of true or original colour.

Aluminium is being more extensively used than ever, but due regard should be paid to utility and suitability. This metal lasts well if properly applied, and is not easily affected by the chemically-laden atmosphere of our towns; it resists sea air and water well. The metal is best mixed with a shellac varnish, cellulose nitrate or acetate varnish; a quick-drying pale varnish may also be used.

Cement washes have been found efficient as a protective coating; iron so treated has been free from rust after years of exposure.

Chapter IV—DISTEMPER

DISTEMPER is probably the oldest material used by the decorator, it having been used very early in the history of the world. Early man, immediately he developed a desire to have his habitation decorated, found that there were certain coloured earths and simple adhesive materials which, when mixed together, were easy to apply upon the walls of his crude dwelling. He did not, however, rest content with this, for he was not very long in discovering that he could trace out simple line decoration to make his home still more attractive. He used the pigments provided by Nature to decorate his house and his body. By mixing the pigment with certain greases, he made a fairly fast paint that would not easily be damaged or wash off, and so from this simple desire to enhance his beauty and adorn his home, man has developed the practice until it has become a craft demanding great skill to carry it to a successful finish.

Composition. A brief description of this useful material will no doubt assist in an easy understanding of its limitations. It is a paint composed principally of earth pigments held together by an adhesive, or sticky, material which is easily soluble in water, water being the thinner, and size or some similar material the binder, or adhesive unit. Its use is limited, due chiefly to the humidity of the atmosphere; therefore, in countries where the atmosphere is less humid, it may be used more extensively. It should not be applied on wood as a decorative treatment, but is often used as a filler, and afterwards glazed. It can be applied safely on plasters, brick, stone, and stucco, but not so successfully on smooth-faced cement work; in fact, it does not so easily attach itself to a perfectly smooth surface as it does to a slightly sand-like textured surface. It is very durable when applied under proper conditions and on proper surfaces, but lasts only a short time if conditions are unfavourable.

Distemper is almost an ideal material for ceilings and the upper parts of walls; the lower parts should be treated with a material that will stand friction better and not mark so easily. When considering the application of distemper, due regard should be given to the fact that it cannot be cleaned satisfactorily. If a distem-

pered surface has become damaged, the only thing to do is to renew the distemper.

By far the greater quantity of this material is used in white or very light tints on ceilings, as it is easily renewed and does not interfere with the porosity of the surface.

Pigments. The principal white pigment is *whiting*, sometimes called *Paris white*. It is a *carbonate of calcium*; the best quality is known as *Gilder's whiting*; this variety is cleaner and more free from undesirable matter, it having been more carefully washed and screened before casting into cakes, or balls. Whiting is found in great quantities in this country, more especially in Sussex. The crude material is first ground under *edge runner mills* to an exceedingly fine state; it is then run into tanks, in which the coarse material and heavy grit and sand settle out, the finer particles passing on to other tanks to settle out. It is then dug out and dried in the form of cakes, or balls. When properly prepared, it has great density, or obliterating power, but becomes almost transparent if mixed with oil.

The coloured pigments used are

Raw sienna	Burnt sienna
Raw umber	Burnt umber
French ochre	Italian ochre
Golden ochre	Spruce ochre
Dutch pink	Imperial yellow
Pulp chromes	Rose pink
Indian red	Ultramarine blue
Lime blue	Lime greens
Mineral greens	Lakes pulp
Pulp azure blue	Blue black
Venetian red	Vandyke

All the pigments used in distemper should be finely ground. They are usually received by the painter in the form of powder, but generally it would be much better if they were supplied in paste form, ground in water. Pigments in powder form are cheaper; this is often a deciding factor in regard to distemper, because it is generally specified on account of its comparatively low cost. If it were the custom to use pigments ground in water, the cost would be much higher; further, owing to manufacturers insisting on packing pigments ground in water in tins that easily rust, there is needless

MODERN BUILDING CONSTRUCTION

loss. To put up pigments ground in water in a rustless container seems to be considered impossible on account of cost, except in connection with the more expensive pigments. Pigments in powder form are frequently coarse, and cause considerable difficulty where a good job is required.

Preparation of the Material. The pigments will be found to mix readily with water, especially whiting, which should be broken into small pieces and covered with water and allowed to stand until it has become thoroughly saturated; the water should then be poured off and the pulp mixed well to a smooth paste. The coloured pigments should also be mixed to a stiff paste, then further reduced with water if necessary. In this form, the coloured pigment will mix readily with the whiting, and patterns should be tried out to test and compare the colour before adding the binding medium.

If pigment is mixed with distemper after the binder has been added it will form up into little balls, and not mix properly. After the desired tint is made, the binder may be added and the mixture strained.

THE BINDER. Generally *glue size*, in one form or another, is used as a binding medium. The requisite qualities of a suitable size are adhesiveness and the ability to form into a jelly. Glue and size are made by treating animal matter, such as bones, hoofs, horns, and skins; suitable vegetable matter has been used with considerable success. Size that will not form into a substantially strong jelly is useless. Boiling water should never be used when making size.

Scotch glue, when well-soaked in water, should make an excellent size. It absorbs about six times its own weight of water; this might be observed as a fair test; the better the glue, the greater quantity of water absorbed. Care should be taken in the selection of glue; acids and alkaline matter introduced in the process of manufacture may have a detrimental effect upon certain pigments, etc. Vinegar and alum are sometimes added to size to precipitate the adhesive matter and leave the size clear and pure. It is an advantage if size is strained before use. Under all circumstances distemper should be strained before it is applied to any surface; this will ensure that the gelatinous matter is uniformly mixed with the pigment particles that may have become attached together, which would result in streaks of pure pigment showing on the wall. Glue is frequently

powdered and sold in packets, and is known as *concentrated size*; usually it requires soaking, but the particles of glue, being small, absorb moisture more quickly than when the glue is in the form of a cake. After soaking, hot, not boiling, water should be added and the resultant allowed to cool and set to a fairly stiff jelly, which will be some evidence of its suitability for use in distemper. The quantity of water required is usually stated on the label.

Size should never be overheated, because this prevents it from jelling. Size in powder form should be stored in a dry place. Jelly size is prepared by manufacturers and is sold in tubs, called *firkins*; its strength is usually denoted as X, XX, and so on. The advantage is that it can be more easily prepared, only warm water being necessary. If the jelly is well broken up it will melt more readily.

Size is procurable in the following forms, the order indicating their suitability for use in distemper: Patent jelly X or XX, etc., cake gelatine, concentrated or powder size, and cake glue.

Jelly size is more dependable, being of uniform and tested strength. Size in solution should be of the same specific gravity as pure milk; this may be tested by using a lactometer, if necessary. Oil of cloves or peppermint essence is frequently added to size to make it keep, and to remove or overcome the objectionable, though characteristic, smell. Glycerine and sugar may be added to keep the distemper from drying so rapidly, but should not be necessary. Other binding materials used in distemper are beer, gum water, dilute seccotine, milk, starch, and honey water, but each has a special use outside the field of ordinary distemper work.

UNSUITABLE PIGMENTS. There are certain pigments that cannot be used in distemper because they are either definitely unsuitable to the medium, or do not mix well with other pigments, or are affected by alkaline matter.

The principal pigments that are unsuitable are—

White lead	Bitumen
Lead chromes	Napier yellow
Antwerp blue	Vegetable greens
Prussian blue	Vermilionette
Blown lake	Vegetable lake
Red lead	

Advantages and Disadvantages. The advantages of distemper are that it is the least expensive material that can be used for the decoration of

walls and ceilings; it has a beauty of colour remarkable for its purity if the right pigments are used, it being possible to make the most delicate tints; it is easily applied, providing the limits of the material are observed; it works freely on surfaces properly prepared; there is no difficulty in applying decoration upon a surface that has been properly distempered. Its use, as previously noted, should be limited to surfaces that are not too easily marked either by handling or by contact with people's clothes. It is quite possible to bind the pigments sufficiently that it will not rub off, though there is a limit to the strength of the binder: size that is too strong would tend to make the material too hard and liable to chip or peel off. The consistency of the size should be similar to that of ordinary table jelly when prepared. Distemper is used extensively by wallpaper manufacturers; many kinds of wallpaper have the surface treated with it. Much high-class decorative and pictorial work has been executed and stood the test of time remarkably well, where it has been possible to provide suitable conditions.

The chief objections to the use of distemper are founded on its liability to deteriorate easily in a humid or otherwise unsuitable atmosphere, moisture being readily absorbed by the material, causing it to appear darker in the patches so affected. When matching any definite shade of colour, it should be remembered that the material when wet is several shades darker than when dry, and that, owing to its high reflective power in good light, tints may appear altogether different from those on the shade card.

Proportions. There are many formulae of proportions of pigments and size, but these are generally unreliable, because proportions must of necessity vary according to the class and type of surface to be treated and the type of size to be used. The position of the work may render it necessary to use more size than would be necessary for another position, as walls are more liable to be touched than a ceiling, which may never be touched; further, some pigments are not so easily bound as others, but a little experience will teach quite a lot, and the intelligent beginner will quickly find that which suits his purpose best. Some advocate the introduction of a little alum when it is desired to make the material very fast: it is then not so easily marked by contact; while others view alum as an abomination. Six pounds of whiting, well-soaked and the surplus water poured off, to which is added 1 lb. of patent size, melted

and allowed to cool to a jelly, will make a distemper suitable for average work. The jelling of the size is important; if the size is not jellied, the distemper will be thin and its obliterating power less effective.

APPLICATION OF DISTEMPER

Preparation of Surface. The major portion of the work of the builder is new; therefore there is no need to consider at this stage surfaces that have been previously treated. A smooth surface is not so well-suited as one with what might be described as of a slightly sanded texture; the slight roughness gives a key for the material to grip. A smooth cement or highly finished plaster surface will not allow the best results to be obtained. Defects on the surface should be repaired with material as nearly similar to that of the existing structure as possible. The surface should be clean, free from grease, and any lumps of material removed that may have become attached in the usual routine of building operations.

Before applying the distemper, the surface should be *claircoled*, i.e. receive a coat of *preparation*; *Claircole*, or *prep*, is a material that should be applied to the surface mainly for the purpose of rendering the surface less absorbent, thus making the application of the distemper easier and allowing more freedom in working. If preparation, or claircole, is not applied, the liquid part of the distemper will be quickly absorbed into the surface, and make it difficult to work and obtain a satisfactory result.

Claircole consists of jelly size and whiting, the whiting proportion being small and regulated to a certain extent by the porosity and existing colour of the surface. If the surface is patchy in colour, the proper *balancing* of the ingredients in the claircole will do much towards making it uniform; about $\frac{1}{2}$ to $\frac{3}{4}$ of a pint of finishing distemper to 1 gal. of jelly size will be a suitable mixture for all ordinary purposes. If the surface is very porous, generally described as being *hot*, a little powdered alum dissolved in hot water may be added; this will make it possible to apply the distemper more easily. An excess of alum will make the claircole dry so hard that some difficulty may be experienced in washing it off when it requires to be renewed. In some districts, soft soap is also added to claircole; it gives a freedom in working that is helpful on a very dry or hot surface. Oil is also on occasions added with the soap, but should not be necessary; it certainly is not desirable,

MODERN BUILDING CONSTRUCTION

because of the risk of later work being affected; further, it is *foreign* to the nature of distemper work.

It is never a sound policy to try to save money by omitting to apply the preparatory coat of claircole. By its application a surface may be rendered uniform in absorbency, making it much more possible to obtain a uniform finish. Claircole dries quickly if the room is well-ventilated. The water will readily evaporate; the distemper may then be applied. Claircole should be applied freely.

Generally, it is unnecessary to rub down surfaces upon which distemper is to be applied; should it, however, be necessary, care should be taken or the surface may be roughened irregularly or in patches through breaking through the surface of the plaster.

Quite as much care should be taken in regard to the preparation of the material for distemper as for any other kind of work; it should be

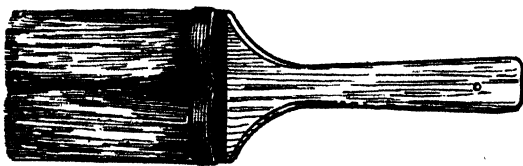

FIG. 16. COPPER-BOUND TWO-KNOT DISTEMPERING BRUSH

strained, and much may be said in favour of doing this after the material is in a jelly state; the strainer breaks up the gelatinous matter finely, and makes it more easy of application.

The scaffolding arrangements should be such that the work is made as accessible as possible. During the period of application, the operative has not time to attend to anything but the application of the material. For small ceilings two pairs of steps or trestles and two scaffold boards are all that is required, one board laid upon the top of the other. A scaffold of this kind is light and easy to move as each section, which is generally called "a shift," is completed.

Distemping New Surfaces. The material is applied with a broad flat brush which varies in pattern and width in different parts of the country. In London the brush used is either a narrow flat brush, or a two-knot, as Fig. 16, about 4 in. to 6 in. in width and varying in weight. A very light one contains 6 oz. of bristle. They are to be had in various widths and weights up to about 12 oz., but 8 oz. is a satisfactory weight. The bristles are hog hair,

and usually the brushes have grey or black bristles in the centre and white outside. The white bristles are frequently stronger and of better class. They are held in position by copper wire or a nailed flat copper band, but the

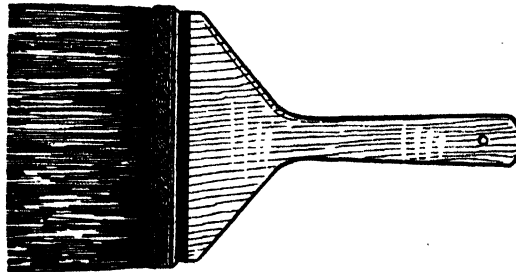

FIG. 17. LANCASHIRE PATTERN DISTEMPERING BRUSH

better kinds have a pressed copper band. New brushes should be well soaked prior to use, and all water removed before starting the work. This is most easily done by preparing the brushes on the previous night. It is necessary that all water is removed, or it will run down the handle. The water can be knocked out, or shaken out; brushes have been split by carelessly knocking out.

Brushes of Lancashire and Yorkshire pattern, Figs. 17 and 18, about 8 in. wide, are used in the north. They cover a larger area with each stroke.

The work should be started from the window side of the room by "cutting in," i.e. holding the

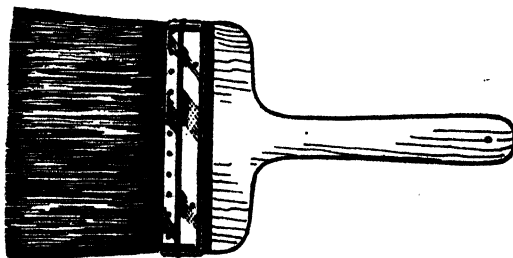

FIG. 18. YORKSHIRE PATTERN DISTEMPERING BRUSH

brush sideways after lightly charging it and drawing it carefully along the edge of the ceiling. A little practice will quickly give confidence and efficiency. This completed, the brush should be applied flat, continuing through the job a brush width each time. Distemper starts to dry immediately by the evaporation and absorption of the water, and on no account

should any attempt be made to go back over work already completed; there is no need to hurry unduly over the work, but it will be necessary to "keep moving."

Distemper should be put on freely, and no attempt made to brush it out. No *laying off*, as described in painting, is desired, or necessary; any attempt to do this may ruin the whole job. If possible, and skill will render it possible, the brushwork should incline from the part not treated, i.e. the wet edge of the material towards that part completed, but the brush should not be allowed to travel too far in this direction or material partly set, or dry, will be pulled up and the ceiling have what is known as a *scufted* appearance. It is generally considered to be quite impossible to touch up any part that is missed, so care should be taken to cover the whole of the surface freely; sufficient labour should be available to allow this to be easily possible, and, if necessary, additional labour to move scaffolding. If, however, it is necessary to touch up, a small area might be dealt with by steaming the part missed with steam from a kettle of hot water, or other suitable vessel. When the area is sufficiently wet, stipple distemper on gently, but confine operation to the centre of the patch of softened material, or a stain will appear when the patch is dry. With skill, care and experience, there is no need to cover floor and furniture, which should be protected with dust sheets, with distemper. Generally, the procedure is the same for ceiling and walls. When the work is complete, open doors and windows so that the distemper can dry out as quickly as possible; wash brushes out clean, and remove any spots that may possibly have been made.

Distemping Old Surfaces. Surfaces, either walls or ceilings, that have been previously treated with distemper must be well washed before any effort is made to apply distemper. The same reason operates, but in a different sense, in connection with renewal, as in touching up. If any attempt is made to apply new distemper on a surface already treated, the previous material will soften and pull up, leaving a patchy irregular finish. Old distemper can generally be removed without much difficulty if it is first soaked with clean water; warm water may at times help to soften the old material more quickly. Brushes should never be put into hot water, as it will destroy the spring of the bristle, making the brush soft and flabby. Distemper brushes should never be

allowed to become too dry; they should not be allowed to stand in water for indefinite periods when not in use, and for preference should be hung up. The brush used during the washing-off operation should not be dipped into the water above the top of the bristles, or the water will run down the handle and cause much inconvenience.

If the surface being dealt with is a ceiling, the scaffolding should be arranged as for distemping, the area easily reached being first well wetted with water; the distemper will quickly soften, and by holding the brush so that a scrubbing motion is possible, the wear being on the side of the brush, the material can be removed quickly. The brush gathering it up will need to be frequently rinsed in the water. Sponges are used extensively for washing after the surface has been well scrubbed, though they are not used in all parts of the country. An experienced person will have little difficulty in washing a ceiling and removing all the old material without needing to use a sponge very much. It is of the utmost importance that all the old material be either washed, or scraped off. If scraping is necessary, it is done with a *broad knife*.

If an excess of alum has been used in the old claircole, it will be almost impossible to clean off to the original plaster surface. If an excess of soap has been used, considerable difficulty will be experienced in keeping the water free from suds, but the addition of a little turpentine to the washing water will do much to prevent the soap making a lather.

Mouldings and enriched cornices will need special consideration; frequently the beauty of an elaborate enrichment is destroyed and lost through not being properly cleaned. Such work should be carefully washed, and, if necessary, a plasterer's spatula, or modelling tool, used to clean out the receding parts and the inner angles of mouldings. Suitable tools may be made from soft wood. Care must be taken in order that the enrichment is not damaged, and defective or missing parts should be repaired or replaced as necessary. It will be found an advantage to wet the enrichment a number of times before scrubbing, or the material will be washed off the high parts and lodge in the hollows.

When washing old work, it should be noted if the surface is absorbent, or uneven and defective, and a decision arrived at as to treatment. It is useless applying distemper on a

MODERN BUILDING CONSTRUCTION

surface that is not dry; therefore, any cause of dampness should be removed. If this cannot be done, the surface must be treated with a suitable preparation to prevent, as far as possible, damp

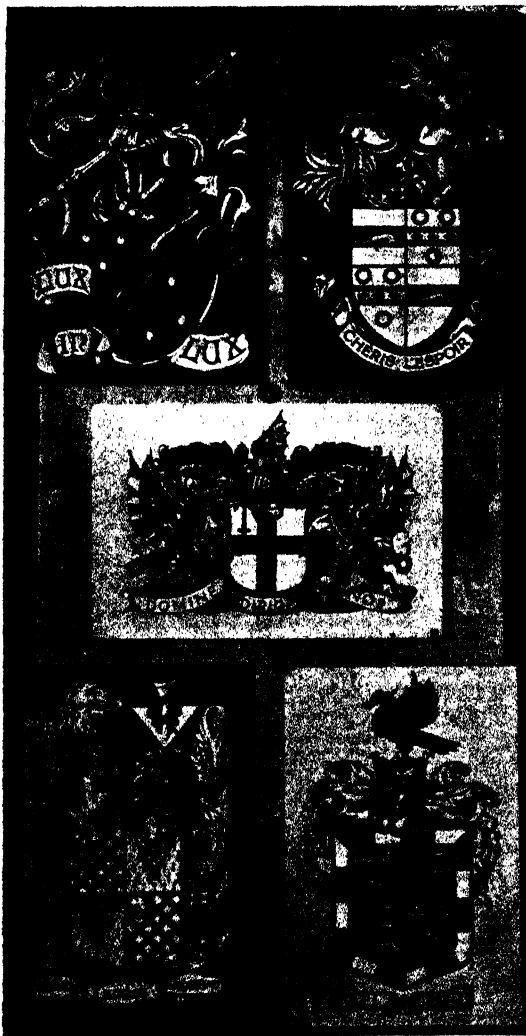

FIG. 19. SOME EXCELLENT EXAMPLES OF PAINTED HERALDIC WORK

Designed and executed by students at the School of Painting and Decorating, Northern Polytechnic, London

coming through, but generally if a surface is naturally damp it is unsuitable for distemping.

CRACKS IN PLASTER. All cracks should be raked or cut out. They should be cut back so that the crack is open wide enough to allow the repairing material to be properly pressed in. When cut back properly the crack will have a

V shape and be at least from $\frac{1}{4}$ in. to $\frac{1}{2}$ in. wide on the face side, and on the inside two or three times the width of the face of the crack. Before application of material to repair the defect, the crack should be made thoroughly wet with water. The repairing material should be plaster of Paris, Parian or Keene's cement; in regard to which material is selected, individual workers have individual preferences. For a small crack, the plaster or cement may be used neat. For a larger crack, it should be mixed with an equal quantity of clean sifted sand. The plaster or cement and sand should be mixed with water to a stiff paste and applied in small quantities, pressing it well into the crevice each time, and gradually bringing it to a smooth face. For a large defect it will be necessary to fill it in first roughly and allow it to set before finishing the face, leaving it with a texture as nearly like the old face as possible. It will be found that plaster of Paris sets very quickly; this is probably one of the reasons why the majority of operatives prefer cement, which certainly has many advantages.

Loose parts, such as are often found on ceilings, should be taken down, the laths examined and refixed, or new laths fixed if necessary, and the patch repaired; this is rightly the plasterer's work. But if the area is small and the remedy considered adequate, tough brown paper may be applied; it should be damped and then allowed to soak, and then be pasted with good flour paste on the opposite side to that on which the damping has been done. It will do much to strengthen a doubtful patch; it dries out tightly and is exceedingly strong.

Porous and Irregular Surfaces. If the surface is irregular in porosity, stained, and cracked, the least expensive remedy is to apply white lining paper over the whole of it; this will have the effect of creating a surface comparatively smooth and uniform in texture, and ready to receive the distemper, which need not be quite so thick as for a plastered surface. Further, there is a saving in that there will be no necessity to apply claircole; the surface will dry out beautifully uniform in texture and colour. Should the surface be stained, it is a safe inference that the stain will come through the distemper unless something is done to seal it. The quickest method, if the patch is dry, is to apply a coat of thin knotting of good quality. This will dry in a few minutes, but will leave the surface practically non-porous and non-absorbent, a condition

which is foreign to the intention of distemper work. The patch should have a thin coat of claircole, or well-bound distemper; the whole of the ceiling will require claircoling prior to distemping.

If the patch is damp, the application of a damp-resisting material may be helpful. There are many such materials on the market. *Brunswick black* is a good damp-resisting material, though there are some disadvantages in its use. Sulphate of zinc in water may be substituted for knotting, or the patch may be painted, but paint is not so satisfactory if the patch is damp. If paint is applied it should contain very little oil.

The principle to be followed is the same for all kinds of surfaces; its application may vary according to the individual requirements of the job or time available. Some recommend that very porous surfaces should be painted, but this is foreign to the objects of distemper work. The important factor is that the ability to absorb condensation is necessary to quite a considerable portion of all rooms, or the condensed moisture will collect and the walls will be frequently damp in humid weather, rendering houses unhealthy.

The application of a thin coat of paint may at times be absolutely unavoidable, and while impairing the absorption of the surface, it makes it possible to execute a seemingly good job under adverse conditions.

The application of a coat of water paint has been frequently recommended; but this is not sound practice, because if the surface is not very clean the water paint will almost certainly scale or peel off, creating a fresh problem to be tackled at another time. Large surfaces require special consideration. Everything necessary should be done in the preparatory work to make it possible for the right result to be obtained with the minimum of effort. One exception to the application of oil paint or water paint is in connection with enriched surfaces. If such surfaces are painted when new it is much easier to clean out the old distemper from recessed parts because the paint prevents water from being absorbed and allows the distemper to become more completely saturated and easier to remove, thus enabling the worker to preserve the ornamentation.

In places that are infected, disinfectant should be used in washing water and a little added to the material. Carbolic will generally be suitable and should be used more frequently. Washable distemper and water paint is not

washable in the sense that by washing it may be made to look like new work, but rather that it will not wash off and that it can be made reasonably clean and fresh by washing.

Decoration on Distempered Surfaces. The application of decoration on distempered surfaces involves various considerations, that of expense being not the least important. Owing to the liability of the material to become damaged if conditions are not favourable, and the fact that the material is generally used on account of its low cost, the use of another and more durable material is advisable if elaborate decoration is involved. On account of the nature of the material, the application of ornament by direct brush work must be limited to broadly treated flat ornament; fine work may be regarded as not characteristic of the material. Much elaboration can be done by the picking out or emphasizing of suitable parts of enriched surfaces and mouldings with tints and colours. Generally, the material will be best applied to such parts with a small brush, such as a pound brush, sash tool or fitch, the brush being selected according to the work to be done; surfaces to receive such selective treatment will not be covered in the general process of distemping, but left so that the tinted material may be applied direct on the claircole; this is on account of the undesirability of applying or attempting to apply one coat of distemper over another—an impossible task to accomplish satisfactorily. If at any time the result aimed at is not attained, the remedy is to wash off and start again. Time may be saved by considering carefully before applying tints and colours to any specific part of the work; over-elaboration is likely to be unsettling, and at any time is not in the best of taste.

As a general rule, the concave or receding parts of the work must be treated first with receding or deeper tints, and the advancing or projecting parts last, it being easier to cut in a straight edge in this way. If, in treating receding members, material goes over the edge, it should be wiped off carefully; the later colour will cover this and make it possible to get a clean finish.

When the pattern is of elaborately enriched work, as a centre piece, then the enrichment may be first treated; but in doing so, as little as possible of the coloured or tinted material should be allowed on the background which may be cut in afterwards; thin distemper may be better for the background and will cover

MODERN BUILDING CONSTRUCTION

well if the surface is properly prepared. The thin distemper may be applied more easily and satisfactorily with a softer brush; a camel-hair brush is made that is particularly adapted for such work; this brush may also be used on smaller mouldings and beads, because it deposits a more liberal supply of material than a brush made of hog hair, which is inclined to be harsh and scrubby.

Lines may be run with a *lining or angle fitch*; a thin bevelled edged lath being used as a guide. The lines should be first marked out by the use of a *chalk line*; a piece of thin twine, soft string or cotton will serve for this purpose. It should be well chalked with chalk of a suitable colour; whiting will do for a white line and a piece of burnt stick or charcoal for black. The line should be held firmly at both ends, the centre lifted away from the surface and then allowed to spring back smartly; it may be helpful if a loop is made in the chalk line at a suitable position. The line should be first cut in with the lining fitch, on each edge if it is too wide to complete with one stroke of the fitch; the space between should be filled in as the work proceeds by holding the lining fitch at a different angle.

STENCIL WORK can be applied on distempered surfaces, but generally lines are best run with a fitch; there are objections to mixing methods.

Lining and stencilling is more easily executed in thin material, which may be flat paint in which the minimum of binder is used. Japan gold size is the best binder, but only sufficient for the purpose should be used, or the line will be edged with a dark stain through the spreading of the vehicle. Ordinary distemper may be used with a non-gelatinous size or gum water as a binder; whatever medium is used the material should be thin. Water paint is unsuitable because it chips off if applied on distemper. Spirit colour or thin flat paint is better for stencilling on distemper, because the liquid part of the distemper is liable to make the stencil plate soft, and when dry it becomes brittle and liable to break easily. If the plate has had one or two coats of knotting, it will last for a considerable time. Japan gold size is regarded by many as the most suitable binder for both stencilling and lining on distemper. If distemper colour is used, the addition of glycerine or sugar will make it dry less quickly.

For high-class decorative work upon a distemper ground, the best medium to use for binding the pigments is egg well-beaten and mixed with vinegar or acetic acid, and thinned

with water; it is easy to apply and dries comparatively slowly. After a short period of exposure it becomes practically insoluble in water. Work executed in this medium is almost permanent.

MANUFACTURED DISTEMPER. There are many brands of distemper now manufactured and sold to the trade. They are usually in the form of a stiff paste or powder. Some have remarkably good obliterating power and great claims are made for them. They have advantages which are amply set forth in advertisement matter, though one must use some common-sense when reading the instructions for their application and the claims of what they are supposed to do.

Generally, the most efficient material is that which is prepared by the intelligent and skilled craftsman who knows what is needed for the particular result he desires to get.

WASHABLE DISTEMPERS AND WATER PAINTS

These are almost legion in number. The efficiency of some of these materials, which are generally marketed under special names, leaves nothing more to be desired, and fully justifies the claims made for them, while others are an abomination which find only a ready sale to the ignorant and uninitiated.

Ordinary distemper may be described as a material in which the vehicle is water, the binder being an adhesive and gelatinous material soluble in water which dries by evaporation of the water, producing a hard film.

Washable distemper, or water paint, is a material in which the binder is an emulsion of drying oil, with a solution of an adhesive material which becomes insoluble in water when dry. The oldest form of this material is, no doubt, that previously referred to as a mixture of egg, vinegar, and water; this material has been used for many generations for decorative and pictorial work, examples of which are to be found in many of our picture galleries. The cost, even when eggs are at the lowest price, is prohibitive for general work; therefore recourse has to be made to some other medium that will give as nearly as possible the same result.

Each manufacturer no doubt varies his formula according to his knowledge and experience, but generally the coloured pigments are limited by the same considerations that apply for ordinary distemper, excepting that the number of white bases becomes extended. In

the place of the albumen of the egg, *casein* is used, and is combined with substances to form an agglutinant compound, which, on exposure, becomes practically insoluble in water.

Casein is derived from milk, which consists of water, fat, casein, albumen, and sugar; fat and casein are regarded as the most important constituents. Casein is found suspended in a state of distension, and is easily separated by filtration. The decorator does not, however, require to have much theoretical knowledge of the origins of this valuable material, but is concerned with it only when it becomes available to him. Washable distemper and water paint are usually supplied ready prepared, in white and in a wide variety of pleasing tints, with definite instructions for their further preparation for use.

Applying Washable Distemper. The surface upon which it is proposed to apply washable water paint, or washable distemper, requires similar preparation to that for ordinary distemper, details varying according to instructions issued by the manufacturers. Some makes are complete in themselves and require only water to thin them, while others have to be thinned with material supplied, generally described as petrifying liquid. The surface should be absolutely clean; all other material than water paint should be thoroughly removed by washing with water and scrubbing with an old distemper brush, usually known as an *old stock brush*. New brushes are at times used for such work, but only for a few days; the reason for using such a brush is to wear it down a little or, as the operative describes it, to *break it in*.

The scrubbing is of the utmost importance. If old distemper has previously been applied, water paint is almost sure to peel off if applied over it. One of the valuable properties of a surface treated with these materials is that the porosity of the surface is scarcely interfered with, it being almost as absorbent as if untreated; but, should it be found impossible adequately to remove the old distemper, then the surface may receive a very thin coat of paint in which the proportion of the vehicle is three of turpentine to one of oil, or even a smaller amount of oil; this will penetrate and change considerably the condition of the material on the surface and make it less liable to chip. The thinner the paint, the less it will fill the pores of the surface, and thus some degree of absorption will be retained.

Old distemper that is too stubborn to wash off may frequently be removed by scraping with a broad knife, but should this be ineffectual and time permits, it may be removed by the application of stiff flour paste to which glue has been added. If the apartment can be kept dry and warm the paste will dry hard, contract, and pull off the old material. But modern conditions do not usually allow time for remedies of this kind; further, if the volume of old material is not great, the surface may be covered with white or tinted lining paper; but here again care is necessary, because the paste may contract and pull away the old distemper, which is usually thick at the top of a wall, and thus the paper will come away. Generally, it would seem that thin paint is the best cure, but on a papered surface one is almost certain to get a good even finish if due care is observed in applying the material.

Repairs to cracks and defective parts of the surface should be done as described in distemping; but if they are extensive it will be difficult to execute a satisfactory job. The material applied over the whole surface will dry a different colour on the new plaster or cement from that on the old. Even if the paint is applied only to the new parts it will cause a variation; therefore something must be done that will render the surface uniform in absorption and texture.

Composition and Formulae. Generally, it is not economical to try to prepare paints of this type; manufacturers with their plant and resources can produce a more satisfactory and reliable article than the operative painter, though there are times when it may be necessary to make a specially fast distemper or water paint at short notice.

Whiting soaked in distemper, to which alum and size have been added, and into which is put a mixture of soft soap and oil, will be found to be very difficult indeed to wash off, and it will weather outside for years.

Lime slaked in either pure or skimmed milk, but preferably pure, will resist the action of the weather for a long time; it is made more waterproof by the addition of hot soap and oil or tallow, but if an excess of tallow is used it will easily mark. Whiting and milk is a preparation that is fairly fast, and after a few days' exposure will not easily wash off, milk when dry being practically insoluble in water.

Glue or size does not, however, give any satisfactory result if mixed with lime, but if

MODERN BUILDING CONSTRUCTION

used is improved by the addition of some oil or fatty matter. In some of these formulae, it may not be quite so easy to make a pure white, the fatty matter making the whitening rather less opaque; in all cases the surface should be reasonably clean.

A good formula for a casein water paint is 20 lb. casein, 50 lb. whiting, and 30 lb. china clay and water.

A better one is 20 lb. casein, 14 gals. water, 17 lb. solvent, and $\frac{3}{4}$ lb. creosote B.P. The solvent should be composed of 1 gal. water,

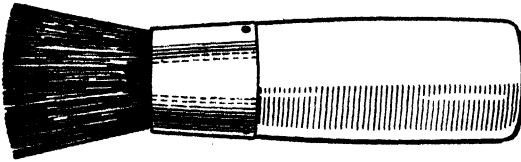

FIG. 20. STENCIL TOOL

4 lb. No. 880 ammonia, 3 lb. formalin (40 per cent formaldehyde), making 17 lb. of solution in all.

A still better formula is—

85 lb. white china clay, 15 lb. zinc oxide, 1 gal. linseed oil, 65 lb. solution, as per formula already referred to.

These formulae are for white, but tints and strong colours can be made by substituting the necessary amounts of well-prepared stainers (or pigments, as they are more properly named) for a proportionate amount of white base.

The materials made on these formulae may require further reduction with water or solution to meet the requirements of individual work.



FIG. 21. PALETTE KNIFE

The pigments should be well-pugged together before the liquids are added; on the job it will not be practicable to make up large quantities.

Generally, after about one week's exposure to the air, it will be found that these materials are washable. In all cases at least 24 hours is a desirable period which should elapse before a second coat is applied.

Stippling. Water paints should be applied freely, and generally there is no need to lay off carefully in any one direction, but the surface should be left with the material laid off fairly lightly, or it may be stippled.

A stippler, Figs. 14 and 15, is a brush composed of a flat piece of wood to one face of which

is affixed a handle, which may be straight and projecting over the side sufficiently to allow it to be held conveniently. The brush is used for removing brush marks from a surface treated with oil paint, glaze, water paint, and sundry other materials. It is applied at right angles to the wall, being brought down smartly and continuously over the whole of the surface under treatment, thus removing the marks left by the bristle of the brush, and leaving a granular or mottled-like texture. Stipplers are made in a variety of shapes and sizes.

For small work a *stencil tool*, Fig. 20, is substituted; this is a brush in which one or more knots or bunches of bristles are set in a handle. The bristles may be fixed by means of a metal ferrule, or in a larger stencil brush in a number of smaller knots.

Painted or stencilled decoration may be applied with safety, using as the means of expressing one's artistic ability the same material or flat paint. Interesting effects are easily obtained by coarse stippling with a bristle or rubber stippler. Excellent results have been obtained by using a piece of coarse material attached to a suitable surface, and used as a stippler, or by some motion that draws the material into forms that may be sometimes rather grotesque. Broken colour treatment is possible by colouring a surface suitably and then applying other colours over this ground, the material being applied by means of a coarse or fine sponge as the effect desired may demand or require; the result will be a single-coloured or multi-coloured surface, according to the number of colours or tints applied. This method is capable of much development, and quite ordinary rooms may at little extra cost become interesting. Further pattern work may be done by the manipulation in a suitable manner of combs similar to those used by the grainer, or pieces of rubber, or leather in which notches or teeth have been cut may be used.

Fig. 21 is a painter's palette knife.

PLASTIC PAINT

The material known as *Plastic Paint* is not really a paint in the strictest sense of the word. It is generally sold in powder form, and when ready for use, is a thick pasty material capable of considerable manipulation in skilful hands. It is a material for surface decoration and may be used to establish textures more or less definite in character and of comparatively low relief, or very high relief, as may be desired.

Plastic paint demands manipulative ability, but if the best results are to be obtained, a knowledge of form and design is essential, for all the work may be said to consist of drawing and modelling with a great variety of tools.

It should be noted that the texture of plastic paint tends to harbour dust, and some people think that such surface finishes are unhygienic and not in themselves justified.

Composition. There are definite requirements to be met if plastic paint is to be satisfactory. As a rule, the material is prepared and sold in powder form, and it must always be kept dry. The powder is converted to a stiff paste by the gradual addition of water, the mixture being well-beaten to eliminate all lumps, for an even and smooth batter is essential. The degree of fluidity is governed by the type of job to be carried out; a texture of low relief requires a thinner paste than one of high relief. There are materials with which the boldest relief can be obtained, while others have their limitations in this respect. Experiment with the various types of materials offered will disclose those suitable for particular types of work.

The material in paste form must be capable of easy application and manipulation. However thick or thin the paste may be when manipulated to form texture, it must be capable of remaining in position without slipping or sagging, and shrinkage must be very limited. Some types of material shrink very little. After application, the paint must set and dry hard in a reasonable time, although it is obvious that high relief effects will take longer to harden than low relief patterns.

The actual composition of plastic paint varies considerably, each manufacturer having individual formulae. Certain requirements must, however, be met, and a certain similarity in formula therefore prevails. The body of the material is generally China clay (kaolin), a finer type of potter's clay, and gypsum, i.e. plaster of paris. Casein, a constituent of milk, is used to bind together the particles of material; gum arabic provides adhesive or sticking properties, and mica serves to hold the material together. Finally, water is added to make the mixture of the various ingredients into a smooth paste of the desired consistency.

Craftsmen have experimented with washable water paint and distemper, adding plaster of paris and whiting and other materials according to fancy and experience, and some successful results have been obtained. Generally, however,

it is better to use a reliable type of material specially prepared for the purpose. These vary considerably in price, and the better types are naturally the more expensive. The only apparent advantage of home-made materials is that they are cheaper; they may, however, prove expensive if large jobs are carried out with them and defects develop which have to be rectified.

Tools. Some indication of the variety of tools which can be used is given in the following list: Hair and rubber stiplers; combs of steel, celluloid, wood, and leather; palette knives;

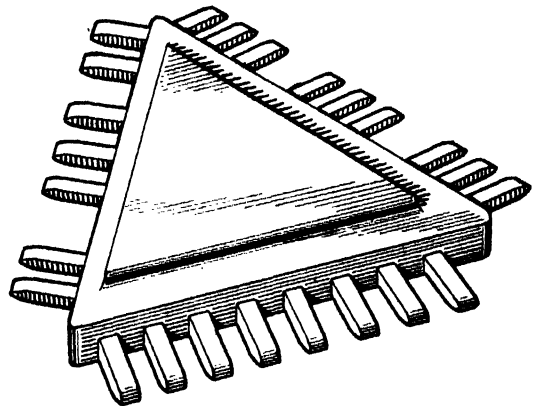

FIG. 22. COMB FOR PLASTIC PAINT

broad knives; putty knives; flat and surface-shaped blocks of wood, rubber and cloth-covered blocks, all of varying sizes; brushes of various kind and shapes; discs and various shapes of thin wood; shaped rubber-pointed or flat-ended sticks used singly or fastened fanwise; stencils; sheets of paper laid on and pulled off the wet surface, rag rolled or bundled roughly together in pieces; crumpled coarse paper. Fig. 22 shows a comb which will produce three variations of pattern in plastic paint.

Application. Surfaces should be clean, free from dirt, dust, and grease. They should not be unduly porous, otherwise the liquid content of the plastic paste will be absorbed, rendering it difficult to obtain proper attachment of the material, limiting the working or manipulative properties of it, and adversely affecting stability. Porous surfaces should receive one coat of paint, which should be thin enough to penetrate. A formula of three parts of oil to one of turpentine or good substitute, with lead as the pigment, will prove satisfactory. Sizing, as a means of stopping porosity, is not satisfactory and may result in scaling.

MODERN BUILDING CONSTRUCTION

As already stated, the degree of fluidity of the mixed material will vary according to whether high or low relief work is to be done. For high relief, the paste must be thick enough to give the desired texture. Application of the material may be made with a brush of suitable size and such as will suit the area to be covered; a small area demands a smaller brush than a brush for a large area. If the plastic paste is very thick it may not be so easy to apply with a large brush.

It is not advisable to start working or manipulating the material on the surface immediately

Another simple and effective texture capable of considerable variation is obtained by striking the surface with the flat bristles of a flexible flat brush, held flat. Combs and other simple tools may be made from wood, leather, celluloid, etc., each being shaped suitably to obtain the effect desired. Stencils may be used, cut in thick knotted paper, zinc or cardboard, the thickness of the material regulating the height of the relief. Shapes cut in various materials and in a variety of arrangements can be laid on the surface and removed when the process is complete. They will adhere easily, while the surrounding surface is being manipulated by sponge texture or fine or coarse stipple, for which a suitable rubber stippler is made. The surface can be finely or coarsely stippled and blocked out to give a stone-like effect. Rollers, which may be plain or figured, may be used for establishing interesting texture; in fact, there is no limit to the variety of work which can be done, for great scope is offered to those experienced in design and with some knowledge of modelling. It is essential to note, however, that the nature and character of the material should always be recognized, and the effects produced should be characteristic of that material. Undue liberties may produce merely a burlesque of work which can properly be done with this adaptable material.

Much can be written about establishing various textures, but the reading will not be so interesting as time spent in endeavour. Practice should begin on small surfaces and simple work is all that should be undertaken at the start. More complex patterns can then be undertaken, and when a greater understanding of the material has been obtained, experiments can be made with any tools that suggest themselves for easy use. In this way, interest will develop and good work result. Fig. 23 shows one way of patterning a surface in plastic paint.

When it has been decided that manipulation is complete, which must be before the area covered is set too hard, all surplus material attached to adjacent surfaces, such as edges of architraves, should be removed and left clean, as also should skirtings and floors. The area dealt with at each stage should not be larger than can be worked upon successfully before becoming too set. When complete, the plastic paint must be allowed to dry, after which it must be painted, the necessary number of coats being applied to establish a finish upon which scumbling and glazing may be carried out, if desired.

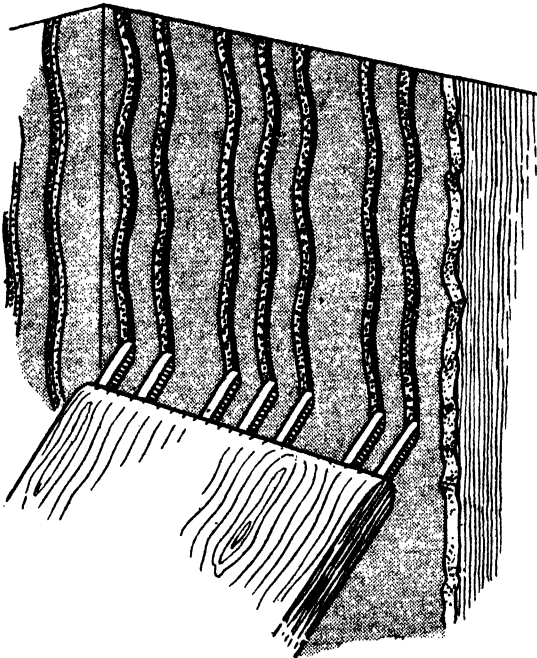

FIG. 27. METHOD OF COMBING PLASTIC PAINT

it is applied; some time should elapse, the length of which will vary according to what it is proposed to do with the material. The variety of textures that can be obtained are limited only by the resourcefulness of the manipulator. Similarly, the tools vary, and almost any tool that will give a particular texture may be used. For example, if the surface is dabbed evenly with a coarse sponge a granulated texture will be obtained; if combed with a fairly coarse comb a lined texture is established, while if the comb consists of teeth with intervening flat teeth of varying widths a texture of lines and flat spaces will be made. The combs must be used to scrape off material which, however, should not be allowed to drop on the floor.

Paperhanging

By CHARLES H. EATON, F.I.B.D., F.R.S.A.

Chapter I—EQUIPMENT AND PREPARATORY WORK

If a paperhanger is to be successful he must have a well-developed artistic appreciation. Art training is as necessary to him as it is to the craftsman who is engaged in the direct application of ornament with paint as the medium of expression. The manner in which some types of patterned paperhangings may be applied varies considerably, and success will be achieved only by those who have a well-trained artistic sense. The paperhanger must also have a knowledge of geometry in order to assist him in setting out and in solving problems of good display.

The practice of paperhanging varies little, whether the building be old or new, provided certain conditions are constant. The surfaces of ceilings and walls must be clean and in good condition. In new buildings, walls may be splashed with mortar, lime or other materials; this is to a certain extent inevitable, though it is often the result of carelessness and lack of interest on the part of workmen. All such surfaces should be examined and mortar or lime scraped off and appropriate treatment applied to those parts which vary from the normal; e.g. there may be stains to wash out, while, even although the building is new, there may be cracks in plaster finishes which should be repaired. Cracks appear during the drying out process and are sometimes caused through slight settlement of the building or local movement caused through shrinkages. The conditions of old walls should also be examined as in the case of new walls. Practice will vary only in detail according to the particular job.

STRIPPING

Walls. In paperhanging, each job and each kind of paper and pattern makes individual demands. It is bad practice, and also unhygienic, to allow one paper to be applied over another, sealing in as it does, the dirt of, perhaps, years. The old paper should therefore always be removed and the plaster surface well washed and repaired. As a hygienic precaution, disinfectant may be added to the washing water,

and although this is not often done in practice its advantages are obvious.

All old paper must, therefore, be removed. This should be done in such a way that the plaster surface is disturbed as little as possible; loose plaster must be taken down and replaced.

Generally, all the scaffolding required is trestles, or steps, and scaffold-boards. Steps and trestles must always be securely placed and, if open, should be opened to the full extent, the cords being examined from time to time for chafes, etc. Two boards are required, being placed one over the other, the upper board

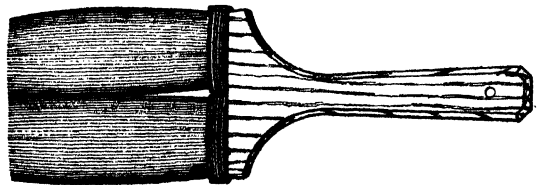

FIG. 1. STOCK BRUSH

acting as a liner to the lower, thus reducing the spring and contributing to safety. A too springy scaffold-board may result in movement of steps or trestles and cause an accident, especially on wet floors. The tools required for stripping are a stock or distemper brush (Fig. 1) for the application of water to the papered surfaces, and a scraper or broad knife (Figs. 2 and 3). The stripping knife (Fig. 2) should be a tool of good quality, for a cheap one may result in the plaster surface being needlessly damaged. In addition to the above, two buckets or pails for water will be required, together with bags in which to put the paper as it is removed with other debris. It should be a rule that at the end of a day's work pails should be emptied, otherwise damage to ceilings in rooms below may occur through leakages of water. For the same reason refuse should be removed because it may be sodden with water, and when stripping walls, care must be taken to ensure that water is not allowed to

MODERN BUILDING CONSTRUCTION

collect on floors. If necessary, floors must be protected.

It is an advantage if a room is free of all furniture, but if furniture must remain, the items should be put together—generally in the centre of the room—and covered with dust sheets. When arranging furniture, however, it must be remembered that the scaffold-board must clear it; it is therefore often impracticable to place one piece on another.

Wall-paper is attached to surfaces with paste, which is soluble in water, and it is therefore obvious that water must be applied to remove old paper. It is well to start work along one side of the room, the ceiling receiving first attention, whether it is papered or distempered. The scaffold-boards should be of such a length that

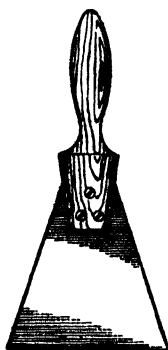

FIG. 2. SCRAPER

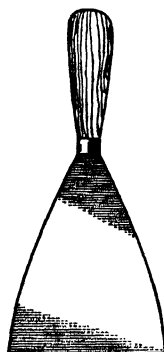

FIG. 3. BROAD KNIFE

it is easy to reach from each side wall. First of all, a "shift," that is, a strip across the room about 6 ft. to 8 ft. wide, is wetted by applying water as liberally as possible without splashing it about the room. The upper part of the wall is then wetted-in, the process being repeated several times. Unless the paper is sufficiently soaked to allow the paste to become thoroughly soft, more labour will be involved in the use of the stripping knife. This knife has a square-ended blade which must be kept sharp, and it is used by being pushed forward and under the paper. A 2½ in. or 3 in. knife is the most useful for this purpose. If a narrower one is used, time is wasted; a wider knife will involve more energy in pushing off the paper, unless this is thin.

VARNISHED PAPERS. Papers which have been varnished present something of a problem. The varnished paper may be scrubbed over with a wire brush which cuts through the varnish by scratching and exposes enough surface to allow water to penetrate. The more usual practice is

to apply a solvent to soften the varnish, which may then be scraped off. Such a solvent may consist of caustic soda. It is sometimes "bodied up" with lime, which has the effect of delaying the drying of the soda water, thus rendering unnecessary the repeated wetting of the surface. Potash and pearl ash are also used and are much stronger in action. They are dissolved in hot water, care being taken to avoid getting the mixture on the hands and clothing or on adjacent woodwork, where it will soften the paint. It will, of course, be difficult to keep skirtings completely free from contact with the solvent, but its action can be limited by repeatedly washing the skirting with clean water.

Some craftsmen prefer a different formula from the above, one in which stiff flour paste takes the place of lime, about 1 lb. or 2 lb. of soda being used to 1 gal. of stiff paste. It should be noted, however, that flour paste, if allowed to dry upon a painted surface will cause the paint to crack, so that adjacent woodwork must be protected. It may also be observed that when a strong alkaline material is used, it is liable to destroy the bristles of brushes. Fibre-filled brushes are not, however, affected to the same extent. The modern method employs a chemical solvent. These solvents are manufactured products, consisting of non-alkaline materials, some of which are bodied with wax to delay evaporation. The wax content has disadvantages, for it must be removed. There are some excellent proprietary materials available, and though they are more expensive than soda, potash or pearl ash, they are easier to control and their action is more certain. Investigation and trial will quickly lead to the discovery of the most suitable types. The solvents soften the varnish, which should then be scraped off and placed in containers, such as paint kettles, and not allowed to drop on the floor, where it will stick firmly. The paper should then be soaked, preferably with hot water. Excessively hot water, however, is liable to injure the bristles of brushes. When the paper is removed, all surfaces which have been in contact with soda, potash or pearl ash solutions must be washed down with dilute vinegar—about 50 : 50 solution—in order to neutralize the alkaline matter which may not have been completely washed away. If a chemical solvent in which wax is a constituent has come into contact with the surface, the wax may be removed by rubbing over with turpentine or turpentine substitute of good quality.

There are also paperhangings finished with materials which render them non-absorbent to water, e.g. those printed in oil paint; metallised papers, etc.; but the foregoing information

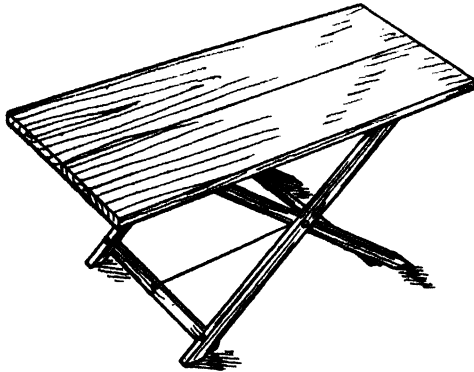

FIG. 4. PASTEBOARD SUPPORTED AT CENTRE BY TRESTLE

should provide a solution to the best method of removing them.

There is at least one good machine on the market for stripping wall-paper, i.e., Sandersons' Lightning Stripper, but the use of such a machine is obviously only justifiable on large or difficult jobs.

Ceilings. Sometimes plaster on a ceiling appears to be springy; this may be due to

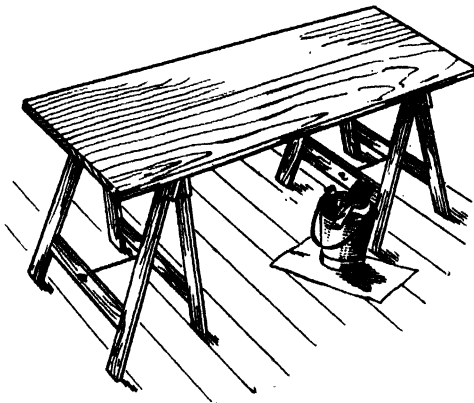

FIG. 5. PASTEBOARD SUPPORTED BY PAIR OF TRESTLES

extra wide spacing of the laths or to the "key" of the plaster failing to hold. In this case care must be taken to prevent pieces of the ceiling falling away. Parts of a ceiling affected in this way may be strengthened when stripping and washing is completed by pasting a sheet of

brown paper over them; the paper must first be wetted on one side. Allow it to soak, causing expansion, paste on the opposite side and apply, leaving the edges turned outwards for about 1 in. On drying, the paper shrinks and tightens up the patch. The edges can then be torn off, resulting in a feathered or chamfered edge, which, with the careful application of No. 1 glass-paper, will make the thickness of the brown paper patch invisible through the final patterned paper. Always the factor of safety must govern operations.

The wet paper, having been well soaked, is scraped off the ceiling first, then from the upper parts of the walls. Care must be taken to

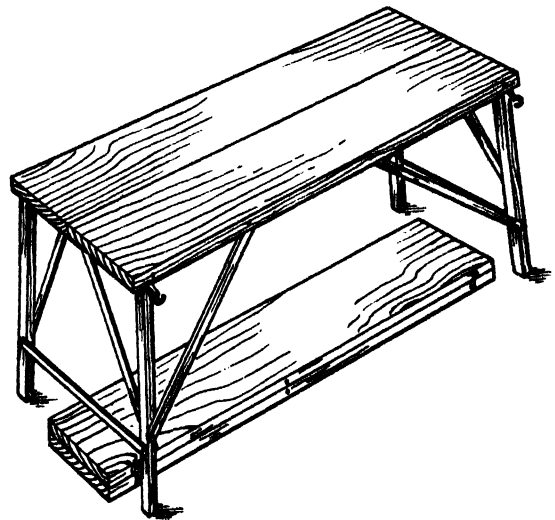

FIG. 6. FOLDING PASTEBOARD AND TRESTLE

ensure complete removal; some papers seem to come away from the walls, leaving in places some of the back of the paper. This may in part be due to incomplete penetration by the water, but in some instances there is a tendency for the front of the paper to leave the back which may be firmly attached to the wall. In this case, it must again be soaked and then removed. When scraping is completed, the plaster surface must be scrubbed with the stock brush and water to remove entirely all the old paste and size. Repairs may be effected as each "shift" is ready, and this will obviate unnecessary movement of scaffolding. If the stripped paper has not been "bagged" as each shift is completed, it should be cleared up before proceeding with the lower part of the walls, although if it is not very wet it may be preferable to brush it up to

MODERN BUILDING CONSTRUCTION

the skirting where it will absorb any water which runs down during the stripping and washing of the lower part of the walls.

Rubbing Down and Sizing. All surfaces, when stripped, washed, repaired, and dry, should

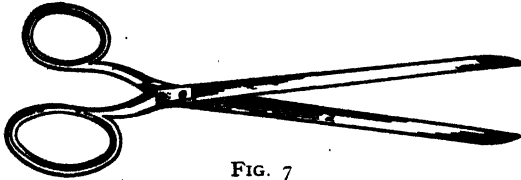

FIG. 7

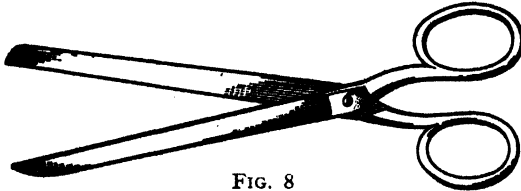

FIG. 8
PAPERHANGERS' SCISSORS

be rubbed down with glass-paper, size 1 or 1½. If the plaster is soft, as it sometimes is, care must be taken to avoid breaking the surface.

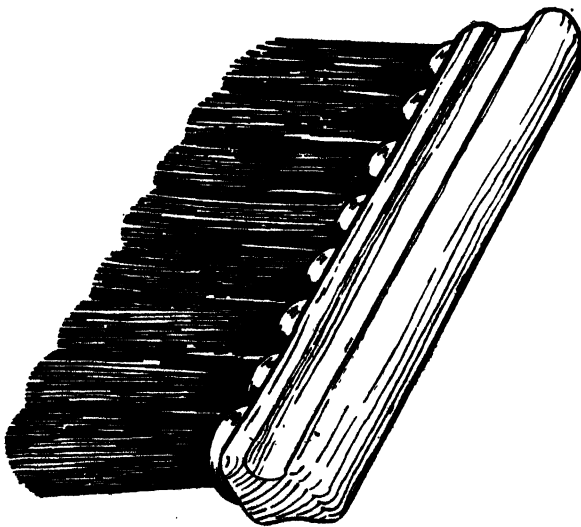

FIG. 9. PAPERHANGERS' BRUSH

The final stage of preparation is sizing, but before this is undertaken, all ledges, such as the tops of skirtings, etc., should be freed from dust which accumulates as a result of rubbing down. All surfaces upon which paper is to be applied

must be sized, the consistency of the size varying according to whether the surface is hard-faced or soft-faced, a stronger size being required on a soft-faced surface, but for all general purposes the strength may best be indicated as a loose

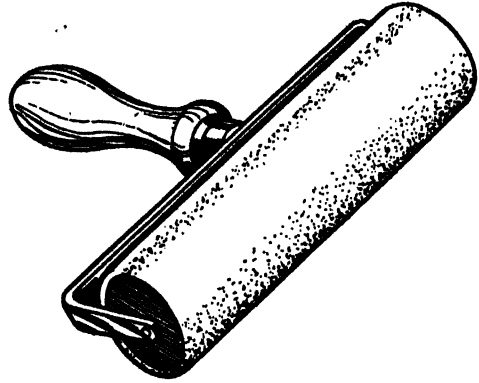

FIG. 10. FELT-COVERED ROLLER

jelly when cold. Size should not be allowed to come into contact with painted surfaces because it causes paint to crack. Woodwork must always be left clean.

Tools. Steps, scaffold-boards, and stripping knife and stock brush have already been

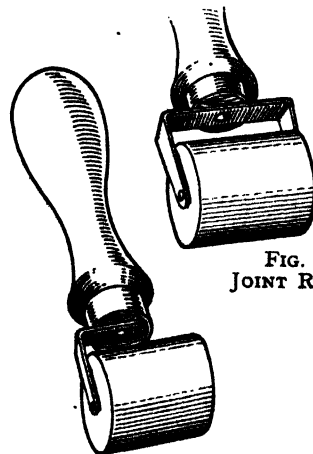

FIG. 11
JOINT ROLLER

FIG. 12. ANGLE ROLLER

mentioned in connection with stripping, but a chisel knife and small trowel will have various uses. An important piece of paperhanging equipment is the pasteboard and trestles. These vary in arrangement, but whichever type is used, it should be rigid and fairly light in weight. Some paperhangers prefer to use two loose boards, 6 ft. long and 12 in. wide, about ¾ in.

thick, Fig. 5, supported on a pair of trestles, which should have a stay to prevent them closing up during use as a result of the slight spring in the board. Others prefer to have the boards hinged together to fold face to face, while others prefer a jointed board with attached trestles, which can be folded underneath. Again, some prefer a thicker board with less spring. There are pasteboards with collapsible trestles so placed underneath that the centre one-third of the board is well supported as in Fig. 4. Another type has a simple type of trestle support near each end. There is yet another type which is so arranged that the trestles are attached to and fold up with the board in such a manner that a few rolls of paper

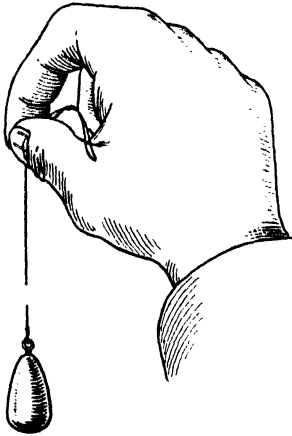

FIG. 13. PLUMB-BOB

can be packed inside (Fig. 6). Practice and experience will quickly lead the craftsman to select a type which meets his individual requirements.

Other tools are a 2 ft. rule, two pairs of scissors, one pair being double-pointed, Fig. 7, while the other pair, which will be slightly heavier, has a square end (Fig. 8), steel straight-edge, and strip of zinc. Trimming knives will of course be required, some paperhangers preferring a shoemaker's knife for trimming purposes, others favouring the lino-cutting knife. In addition, there are casing tools, and paperhanging brushes (Fig. 9). Brushes vary in type; for light papers, a two-row brush is satisfactory, while for heavier papers a five- or six-row brush is required. The length also varies; for some purposes an 8 in. brush is suitable, and for others 11 in. or 12 in. brushes may be more useful. A felt-covered roller, 7 in.

or 8 in. wide (Fig. 10), a joint roller (Fig. 11), an angle roller (Fig. 12) are also necessary, as are a plumb bob (Fig. 13), spirit level (Fig. 14) and chalk line. It is important that all tools should be of first-class quality and should always be kept scrupulously clean and fit for use. The scissors should be kept in sheaths in order to prevent damage, and knives require similar protection. An emery board and good-quality oil stone are useful additions to the kit. Scissors must be kept sharp by rubbing the blades forward and backward on an oil stone, holding the width of the blade at approximately right angles to the face of the stone (Fig. 15). The blade must then be lightly rubbed on the stone, its flat side being against the face of the stone (Fig. 16), thus removing the burr from the edge of the blade. Remember that pasted wall-paper demands really sharp scissors if a clean cut is to be made.

Pastes. Paste is an essential to paperhanging; it is the adhesive material with which wall-



FIG. 14. SPIRIT LEVEL

paper is attached to various types of surface. Although it can be bought ready prepared, it is better to prepare it as and when required. It is made from flour; plain flour, commonly known as "household," is the best for most purposes. Rye flour is favoured by many paperhangers for making paste for heavy material because it is more glutinous and has therefore better adhesive properties. Starch, sago and potato flour and dextrine, are also used. Flour for paste-making must be kept dry until required. Time spent in the careful mixing of paste is well worth while.

To $3\frac{1}{2}$ lb. of household flour must be added, gradually, nearly 1 qt. of cold water, the mixture being well-beaten to a smooth paste and allowed to stand for 10 to 15 minutes. Carelessness in the preparation of this batter will result in lumpy paste. To the batter should be added nearly 1 gal. of boiling water. It is better if the water is boiled in a saucepan rather than a kettle, because it is important that the water should be poured rapidly upon the batter, which must be well-stirred during the process. The effect of the boiling water will be to thicken the mixture and produce a really thick paste. About

MODERN BUILDING CONSTRUCTION

$\frac{1}{2}$ pt. of cold water must then be poured gently on the paste to prevent a skin forming, after which the paste should be put aside in a cool place until cold. It may then be thinned with cold water to whatever consistency is suitable for the job. The paste should not be thinned too much, otherwise its adhesive qualities may be lost.

Another method is to pour 1 gal. of boiling water direct upon the dry flour; this method is usually successful, but if the flour is even slightly damp, the paste will be lumpy and will require straining.

Furthermore, paste to which such an addition has been made is liable to cause the colour of some paper, especially pulps, to change and fade.

Paste should always be fresh. If stale, fermentation may have started, and although it may not be obvious, at a later stage spores may develop and considerable trouble caused. If paste has to be delivered to a job a considerable time before it can be used, a few drops of oil of cloves will prevent deterioration.

Dextrine. This is favoured by some paper-hangers for the purpose of making paste for

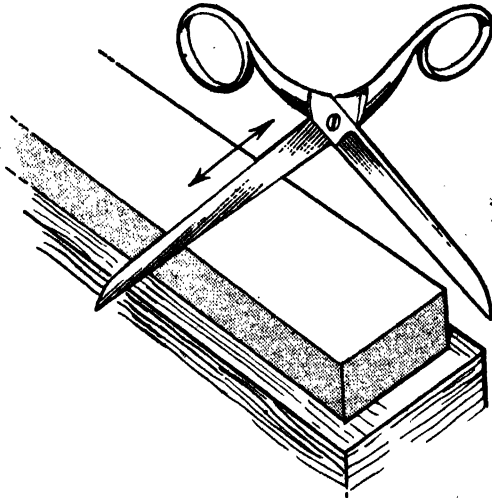

FIG. 15

METHOD OF SHARPENING SCISSORS

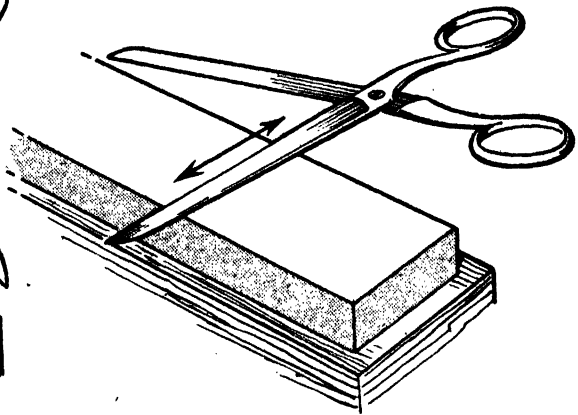

FIG. 16

PASTE FOR RELIEF MATERIALS. For relief materials, such as Anaglypta, Lincrusta and heavy papers, the adhesive properties of the paste must be improved. In this case, the paste is made from rye flour, if possible, and to the mixture glue is added. The glue must be first soaked, i.e. broken up and covered with water and allowed to stand for about 12 hr., during which time it will absorb water, soften and expand. It should then be melted, preferably in a glue pot, i.e. a double pot. About $\frac{1}{2}$ lb. of glue will be sufficient for the purpose. When the paste has been made, the glue should be added and well stirred into the mixture, and although this will appear to thin the paste, it will thicken up on cooling. It is also recommended that 4 oz. of turpentine should be added.

In some parts of the country, alum or soda is added to the paste, to give more grip to it, but this is not necessary if the paste is well made.

use in hanging relief materials because it has superior adhesive properties. Dextrine powder only requires to be mixed with the requisite quantity of cold water to make a thick paste.

Starch. Some wall-papers are surfaced with materials which are easily disfigured by paste, and in this case a paste made from starch is used. $\frac{1}{2}$ lb. starch is mixed with 1 pt. of water, and will give about 1 gal. of paste.

Proprietary Pastes. Manufacturers prepare a variety of material, generally in powder form, although the claims made for some of these brands are not always justified by results. Frequently these pastes lack "slide" and grip, but their main advantage is that they are easy to carry and prepare, usually requiring to be mixed with cold water only.

Paste, fully prepared, is also offered by manufacturers, but does not find favour with many paperhangers.

Chapter II—WALLPAPER

THE term "wallpaper" includes ceiling papers. There are so many types that only a brief reference can be made to them here.

Pulps constitute the largest kind, and also include the cheapest. They may be white, coloured or patterned. The colouring matter is incorporated in the paper during the pulp stage and the pattern is applied afterwards.

Another type is known as "Grounds," the colouring being a surface treatment only, applied to the finished paper by machine. Grounds may be finished plain, metal, or satin, and the effects are many and varied, as may be seen by a study of a representative pattern book.

Pattern is applied by hand, i.e. block, printing, or by machine, i.e. machine printing, and there is practically no limit to the variety of colour and pattern. Hand-printed papers make a great appeal, although the machine-printed variety supplies a great need.

The colouring material may be of the distemper type, i.e. size-bound, or oil. The variety known as "Sanitaries" constitutes the oldest type of oil-printed papers. They are smooth-faced and may be left as hung; or varnished. They are also supplied ready varnished, but the varnish is not so durable as that applied after hanging. "Sanitaries" require to be twice-sized before varnishing, but the varnish must be pale, otherwise the colour value may be altered. Oil-printed papers which are not included under the general heading of "Sanitaries" are made, and many are of very choice and pleasing pattern and colour and superior to that of the normal sanitary type.

There is a large variety of papers the surface finish of which is imitative of different materials, such as fabrics, silks, leather, skins, woods. There are also available, real silk, leather and woods, the last-named being veneers mounted on a paper backing.

The figuring of wall-papers by embossing represents another widely useful and interesting variety. The embossing may be of low or comparatively high relief in line and pattern.

Imitative marbles, tiles and mosaics of greatly improved variety provide a useful class of materials for specific purposes.

A combination of embossing and printing,

with a wide range of colour treatment, constitutes another interesting group. Still another group is "semi-plain," of special value for decorative work where a semi-plain surface is required as a background. This group is known as "Polychrome."

The type known as "Ingrain" has been popular for many years as backgrounds; the surface finish is of a slightly rough texture and colour is incorporated with the paper.

Another type with a raised pattern is known as "flocks," the pattern generally being rather formal in design, slightly raised, and surfaced with silk or wool which is attached with an adhesive material. Their tendency to attract dust is a disadvantage which probably accounts for their being little used to-day despite the pleasing effects that can be produced.

Materials like Anaglypta and Lincrusta are in a different class; there is a fairly wide variety of this kind of relief material, the heavier patterns being in squares and the lighter in continuous rolls.

The wall-paper industry is one in which patterns are almost continuously changing; as fashions change so also do the types of wall-paper change to suit the popular taste. At one period the patterns may be naturalistic, at another, strictly formal. Similarly, for a period a great deal of pattern and colour may be popular, succeeded by a swing over to semi-plain and plain papers. Designs based on the great decorative periods always appeal to those of developed taste.

Size of Rolls. Generally, English wall-papers are printed in continuous rolls which are officially 12 yd. long (they are actually 11½ yd.) and 22 in. wide. Some types, such as linings, are frequently 30 in. wide. The width of surface that is effective and covered by plain colour, or pattern in colour, or figured in one way or another, is 21 in., ½ in. being allowed on each edge for trimming. This affords protection to the edge of the pattern, for without the selvage the edge might become damaged. American, French, and other Continental imported wall-papers vary from the standard English sizes. American wall-papers are 18 in. or 28 in. wide and 8 yd. long and they are generally in rolls of double

MODERN BUILDING CONSTRUCTION

length, i.e., 16 yd., which results in less waste in cutting. French wall hangings are generally 18 in. wide and 9 yd. long, although French patterns are sometimes printed on rolls of paper of English length, i.e. 12 yd.

Borders and friezes are designed for general use and to harmonize with particular patterns of paper. They are printed in rolls 9 yd. long and vary in width according to pattern. Patterns over 10½ in. wide have one width to the

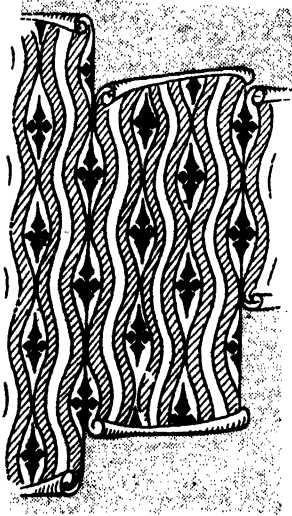

FIG. 17
STRAIGHT PATTERN PAPER



FIG. 18
DROP PATTERN

roll, over 7 in. wide, two widths, over 5 in. wide three widths, etc. The roll is generally 22 in. wide.

It will be clear that the number of lengths of paper obtainable from each roll for actual hanging will vary according to the height of the room. The number is influenced by the size of the pattern; if the pattern is small, the repeat will be more frequent and if large, less frequent, a large pattern tending to increase waste. The effective width of the paper, say 21 in., English pattern, regulates the frequency of the repeat, the design being based on a unit divisible into 21 in., as 10½ in., 7 in., 5¼ in., with similar variations for American and French patterns.

ESTIMATING NUMBER OF ROLLS REQUIRED. It is not usually practicable merely to take the overall measurements of the wall surfaces and deduct from them the total area of openings,

etc. In some rooms, the 7 sq. yd. of an English wall hanging may have almost a complete value, while in others it may be possible to use only 5 sq. yd. effectively. For example, a room 9 ft. high makes it impossible to use more than three lengths from one roll, though theoretically the roll is 36 ft. long. Neither is it possible to obtain more than three lengths if the height is 8 ft. 6 in. unless the pattern is small. Each length of 9 ft. or 8 ft. 6 in. must be cut with such an addition that it can be handled effectively. This requires at least 1 in., preferably 3 in. or 4 in., extra at the top and bottom, but it is not often that the pattern works in to repeat exactly at this length. If the height is 8 ft. then it may be possible to obtain four lengths from each piece.

It will be noted that the first example of 9 ft. for the height of the wall leaves theoretically a length of 9 ft. to spare, but as, in practice, the length of the roll is 11½ yd., this will not be so. These short lengths can conveniently be used under and over windows and over doors, so they are not as a rule wasted.

Estimating the number of rolls of paper required for ceiling or walls of any room is not easy unless a drawing, or the actual room, is seen. The expert craftsman, as a result of wide experience, can often judge by sight the quantity of paper required in the average room, but this cannot be relied upon entirely owing to the fact, already noted, that the scale of the pattern may result in considerable unexpected waste. It is better to go round the walls and measure the number of lengths; this, with the height of the room, will give a reliable result, due allowance being made for the use of short ends. Note that it is not a workmanlike job to use two short ends to make an extra length.

When cutting lengths of paper, consideration must be given to pattern and, as far as practicable, the cut at the top should be at such a part in the pattern that the least amount of mutilation takes place. The same consideration should be given to the bottom.

POSITION OF FIRST LENGTH. Another point of importance is the selection of the part of the room where the first length shall be hung. As far as practicable the paper-hanger should work away from the light, as this results in joints being less visible, although frequently pattern governs the choice of starting place. Generally, the start will have to be made over the mantel-piece and in the centre, so that working right and left towards the door, the pattern will be exactly the same at the external angles of the

chimney breast. Even where there is no chimney breast, it is well to work from the centre so that the pattern is identical at the sides of the mantelpiece. The nature of the pattern will influence the decision as to whether the joint is to be in the centre or whether the first piece of paper is placed in the centre. If the pattern is a straight pattern, i.e. repeating horizontally on the same line, then the joint can be in the centre, but if the pattern is a drop pattern, i.e. the repeat is not immediately opposite on each edge, then it may be that the first length of paper will have to be placed in the centre, i.e. its edge will be $10\frac{1}{2}$ in. from the centre. Careful consideration of the way in which the pattern repeats is necessary; Figs. 17 and 18 indicate a straight and a drop pattern.

Ceilings present individual difficulties, and each job must be considered separately. Generally, however, it is advisable to start from the centre of the ceiling when the pattern is of a definite or bold character. The centre of the ceiling must be found, but this is easily done by dividing the length of opposite walls equally and striking a line across; the centre of this line will give the centre of the ceiling, which must be clearly indicated. The application of the paper is dealt with later, as also is the snapping or striking of lines.

TRIMMING

English papers are generally printed on paper 22 in. wide, the patterned surface being 21 in. wide, which leaves $\frac{1}{2}$ in. on either edge as selvage; this provides protection to the end of the rolls of paper from the time of production until the paper is applied. This selvage has to be trimmed off. Some manufacturers make papers which have the edges so treated that the selvages can be easily removed from the rolls by tapping them sharply on the edge of the paste bench, although such papers are not always entirely successful. The selvage may be removed by trimming with scissors or using a trimming knife and straight-edge, which is a bevelled lath of wood or steel. Removal can also be carried out by means of one of the various devices specially manufactured for the purpose and known as "trimming wheels," or by means of a trimming machine. The commoner kinds of paper may be trimmed by machine, but few paperhangers care to adopt this method when good quality papers are being used, preferring one of the hand-trimming methods.

Scissors or trimming wheels may be used for

all light weight, or even middle weight, papers, but heavy material is better trimmed by straight-edge and knife. Whichever method is adopted, the trimming should always be carefully done.

One edge must always be trimmed close to the edge of the pattern or, in plain papers, at least to the line indicated, although some paperhangers prefer to trim plain papers beyond the line indicated, i.e. further from the edge. This is a matter of choice and experience.

When common papers are being hung some paperhangers trim only one edge, while others trim one edge close and on the other leave about $\frac{1}{8}$ in. of the selvage. Both these methods involve a lapped joint, which may perhaps be justified on rough walls and with inexpensive paper, although no really good craftsman likes to see a lapped joint. In all good paperhanging the edges are butted, i.e. the edge of one length of paper is hung close to the other (Fig. 19). If the lapped joint is adopted, some of the rolls of paper will have to be trimmed close on one edge



FIG. 19. BUTT AND LAPPED JOINTS

and others close on the opposite edge, because if the correct procedure is followed, the first piece will either be centred over the mantelpiece or hung by the window, proceeding each way towards the door. In this way the joints are less obvious. Even with butt jointing the same procedure must be adopted.

Some paperhangers prefer to cut the wall-paper into suitable lengths, and paste and then trim them. This is known as "wet trimming." The majority of craftsmen, however, prefer "dry trimming." It should be noted that all good craftsmen must be well skilled in scissor trimming, even though they may later prefer to use one of the other methods described.

Scissor Trimming. For scissor trimming the paperhanger sits, and whatever the seat may be, it is better if it is not too high. His legs should be stretched straight in front of him, the heels resting on the floor with feet practically together (Fig. 20). The roll of wall-paper should rest on the instep, the upturned feet keeping it in the correct position, the end of the paper being gently drawn forward to the knees. The scissors, in the right hand, are held just below the outer side of the knee and coincident with the edge of the paper. Trimming may proceed rather slowly when the paper is first being rolled

MODERN BUILDING CONSTRUCTION

up with the left hand, but after the first few yards have been trimmed and rolled, progress should be more rapid. It will be seen that trimming and re-rolling proceed together, and some practice is required before proficiency in this operation is attained. Some paperhangers prefer to rest a pasteboard on their knees and allow the wall-paper to roll on it, while others prefer to work on the pasteboard on the trestles, allowing the roll of paper to lie on the floor where, however, it may pick up dirt if no protecting sheet has been laid down.

Wet trimming is done on the pasteboard after the paper is pasted and folded, and may present some difficulty when long lengths are involved. For light and medium weight papers the scissors are used, but for heavier varieties the knife and

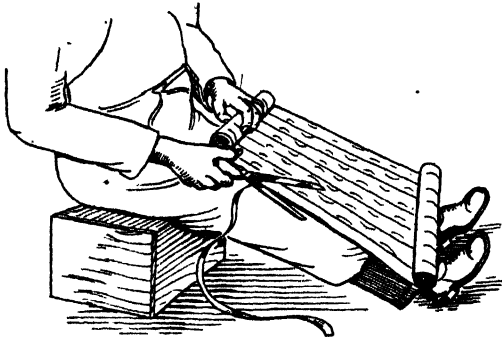

FIG. 20. TRIMMING WALLPAPER WITH SCISSORS

straight-edge are better. Care must be taken to avoid squeezing out the paste, which has a great affinity for the front or pattern side of the paper.

Straight-edge Trimming. Trimming with knife and straight-edge is always done on the pasteboard, which must be rigid. Whichever type of knife is used, it must be kept sharp either by rubbing it on an emery board, i.e. a piece of wood to which a piece of emery paper has been glued, or by means of a fine carborundum stick. An oil stone may be used, but anything oily should be kept well away from wall hangings. Some craftsmen prefer to stick the emery paper to the underside of the straight-edge, as this will prevent the straight-edge from slipping, but it is liable to collect dirt and damage the paper or scratch delicate surfaces.

If wet trimming is being carried out, the paper must be accurately folded, after pasting, and before trimming. If the dry trimming method with straight-edge is being followed, the paper is rolled as it is trimmed. Some craftsmen

use a hardwood straight-edge, while others prefer a steel straight-edge as the extra weight

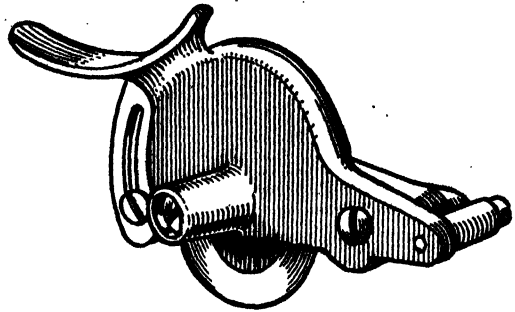

FIG. 21

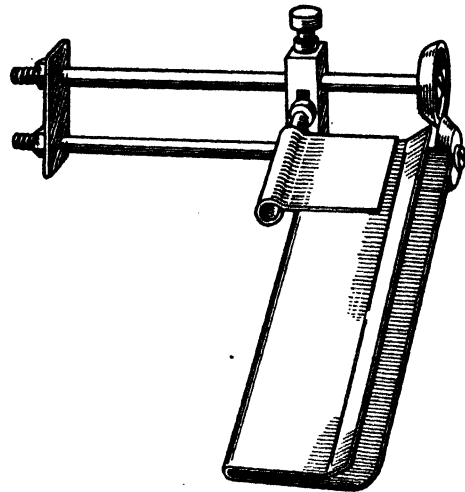

FIG. 22

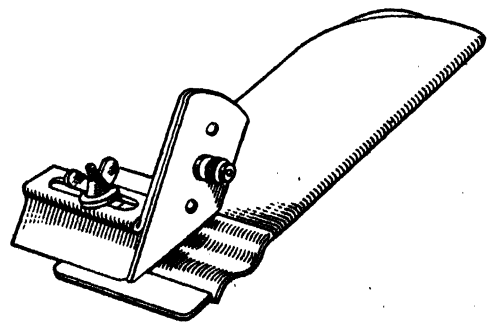

FIG. 23
WHEEL TRIMMERS

does much towards helping to keep position, although its smooth surface tends to allow it to move easily on smooth surfaces. The straight-edge must be taken care of; the cutting edge is important and should be bevelled.

For bench trimming with the straight-edge, the front edge of the bench must have fixed to it a strip of zinc, 3 ft. to 4 ft. long, and about 3 in. wide. This must be well fitted; if the edge of the zinc is not fixed down tightly it may damage the paper. The paper to be trimmed is placed in its proper position on the bench, i.e. with the selvage edge on the zinc strip. The straight-edge, which is to act as a cutting guide, is then placed along the edge of the pattern and held in position by the fingers and thumb of the left hand. The knife is held firmly in the right hand at a slope of rather more than 30° and is drawn firmly towards the body and along the straight-edge. The first cut having been made, the paper is moved along the bench to a new position and the trimmed portion is rolled up, care being taken that the trimmed edge does not become damaged. If it has to rest on the floor at the end of the trimming bench or paste-board, a clean dust sheet or piece of paper should be placed on the floor so that the wall-paper does not become soiled.

For heavy papers, the knife may need to be held in a more vertical position in order to exert more power. If the blade of the knife is not kept square in its width with the bench, the cut may be a slight distance from the edge of the straight-edge, and will thus not be in the correct position in relation to the edge of the paper. Knife trimming has obvious advantages, especially when good-quality papers are being used; with butt-jointing it is essential. It is also the better method to adopt for most relief materials, especially of the heavy type.

Wheel Trimming. Those craftsmen who wish to practise trimming with one of the patent wheel-trimmers, of which there are various-types acting on the same general principle, should study the manufacturer's instructions. Wheel-trimmers usually have a guide which slips on to the edge of the paper and which can be regulated so that the cutting wheel may be suitably placed. As the wheel is moved along the edge of the paper, the guide must be kept in the correct position, otherwise the cut may leave some of the selvage on the piece or take off some of the pattern. The tool, when not in use, should be placed in its case. It must be kept clean, and oiled if necessary, but no oil should be allowed to come in contact with the paper. Figs. 21, 22, 23 illustrate three types of wheel-trimmer. Figs. 21A and 22A show two types of trimmer in use.

Machine Trimming. The machine is generally mounted upon a box about 8 in. wide, 24 in. long, and 4 ft. high, into which the trimmings fall as they come off the roll of paper. The roll is carried on a horizontal rod and fed into the machine. Beyond the rod is a rest, at the ends of which are two cutting wheels so arranged that

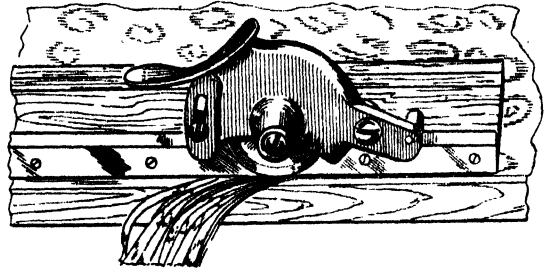

FIG. 21A

one slightly overlaps the other, the overlapping sides being flat. The wheels are made to revolve by means of a handle, this action cutting off the selvage and moving the paper forward, a simultaneous operation. The end of the roll is held between a split wooden rod situated beyond the wheels, the rod turning round as the wheels

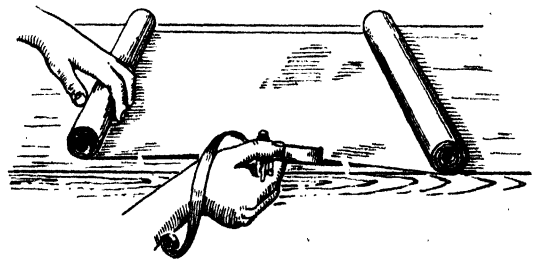

FIG. 22A

revolve and rolling up the paper as trimming proceeds. The paper must be held fairly taut and not allowed to sag unduly as it passes from the unfolding roll to be rolled up after cutting, otherwise the cut may not be true. The wheels can be set so that they trim both edges close to the pattern, or trim one edge close and leave a little on the other, or trim one edge only.

While paperhangers may not dislike machine trimming of inexpensive paper, they prefer other methods for the better qualities. The machine must be kept in good working order or it may get out of register, resulting in faulty trimming.

Chapter III—PASTING AND HANGING

GENERALLY, the pasteboard and trestles should be placed near the light, although if they are too near a window, there may be days when the sun may dry the paste on the paper. The paste pail is usually placed under the bench and well to the right. Pasting is done from the side of the pasteboard furthest from the light, so that the paper to be pasted is between the operator and the light. A half-worn stock brush is suit-

Plain and semi-plain papers, Ingrains, etc., present problems which experience will solve. Because of a slight lack of uniformity of colour, some require to have each length reversed, so that the edges of the two adjacent lengths are off the same side of the roll of paper.

Pattern must be studied. Straight patterns, i.e. those in which the halves of the pattern on each edge are opposite (Fig. 17) do not present much difficulty in cutting up, but waste may be unavoidable with a large pattern. With a drop pattern, i.e. one in which the pattern on the opposite edge is not parallel (Fig. 18), waste may seem unavoidable, but if two lengths are cut together and properly matched, the wastage will generally be reduced. This involves cutting from two rolls of paper at the same time.

Lengths of paper are cut 3 in. or 4 in. longer than the actual distance

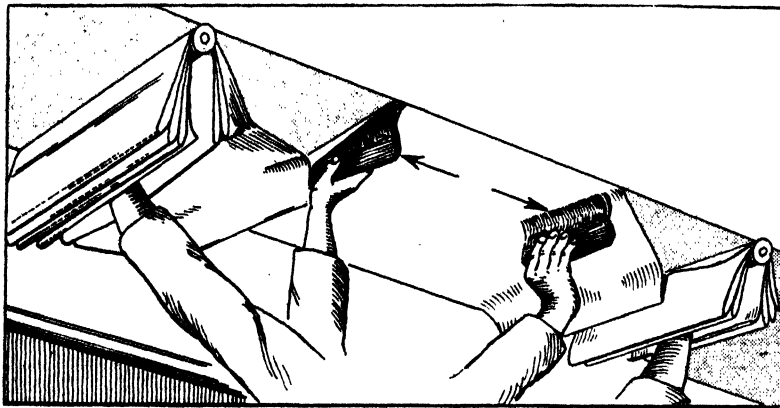

FIG. 24. HANGING CEILING PAPER: TWO PAPERHANGERS

able for the application of the paste. It is a good practice to put the paste pail on a piece of paper so that any paste which may fall from the brush when resting across the pail between operations, may be prevented from soiling the floor. The brush should not be allowed to stand in the paste. When pasting, it is well to avoid charging the brush too fully otherwise the paste may drop about the floor. The procedure adopted for pasting varies according to the choice of the craftsman; some paste along the front half of the paper first and finish along the back half, while others paste the back half and then push the various lengths on the bench further over the back edge, drawing the partly pasted length forward to the front in order to paste the front part. The object of moving the paper back is to prevent paste from getting under the edge.

Lining papers are the easiest to handle; they do not require trimming and are always butt jointed.

to be covered, i.e. wall to wall on a ceiling. The number of lengths to be cut varies; for a ceiling of average size, taking eight or nine lengths, all may be cut on the bench at the same time, but for walls it may be well to cut sufficient, say, to cover from window to door, further lengths being cut afterwards. Short lengths for positions under and over windows and over doors are cut as required.

A newly unrolled length of paper may not lie flat, but the curl can be taken out of it by back rolling it—round another roll. The lengths of paper as cut from the roll are face or pattern side up and have to be turned over to be pasted.

Ceilings. The method of folding paper after pasting varies as between ceilings and walls, but in detail only. If the ceiling has been centred, and there are two paperhangers, the folding for the first length will be as indicated in Fig. 24, but if one man is engaged on the job, the folding will be as in Fig. 25, but he will first have to measure his pattern and mark his paper

so that he will know exactly where his pattern abuts with the wall. It should be noted that although Fig. 24 shows a plain paper, actually this method would not be adopted unless the paper were patterned. Two men would start at the centre and work outwards in opposite directions, but one man has to start at one end and work towards the other. The folded and pasted paper may be held more conveniently on a roll of paper (Fig. 25).

If the pattern is not very definite it may not be necessary to centre the room and a start can be made from the window, but in any case a line should be struck as it is never possible to rely upon the junction of wall and ceiling being absolutely straight. The position of the line should normally be $20\frac{7}{8}$ in. from the wall, but if the wall and ceiling line is not straight, allowance must be made and the distance varied accordingly. If more than $\frac{1}{4}$ in. has to be allowed, the extra amount must be trimmed off in position, first indicating the angle by drawing the point of the scissors along it, or by using a pencil, but if the latter is used the line should not be visible when the job is completed.

The pasted and folded paper is held in position on a roll of paper and the free hand used to place it exactly where it is required. Being pasted, it will slide slightly with gentle pressure, and so adjustment of position is easy. The hanging brush, which will be ready in the apron pocket, may then be brought into use to brush out the paper as now attached to the ceiling, thus the first 18 in. or 2 ft. of paper is squarely placed along the line which has been struck. Note that all paperhangers require an apron with a large pocket in which to place scissors, brush, rule, etc.

The short surplus of 2 in. or 3 in. will attach itself to the wall if there is no cornice. If there is a cornice, then the surplus will hang down. The next fold may then be let out (Fig. 25), the paperhanger being careful to see that the edge follows the line and that the brush is used as from the part already attached, and forward and

outwards towards the unfolded paper. There must be no creases, and it should be noted that too much pressure one way may push the paper over the line, while too much pressure the other way will push it away from the line.

Proceed fold by fold until the opposite wall is reached, quickly examine and brush down edges, then cut off the ends neatly in the angle of ceiling and wall. If more than about $\frac{1}{4}$ in. is allowed to fold on to the wall it is liable to pull away through shrinkage.

The procedure is similar for following lengths, but it is essential that the pattern should match

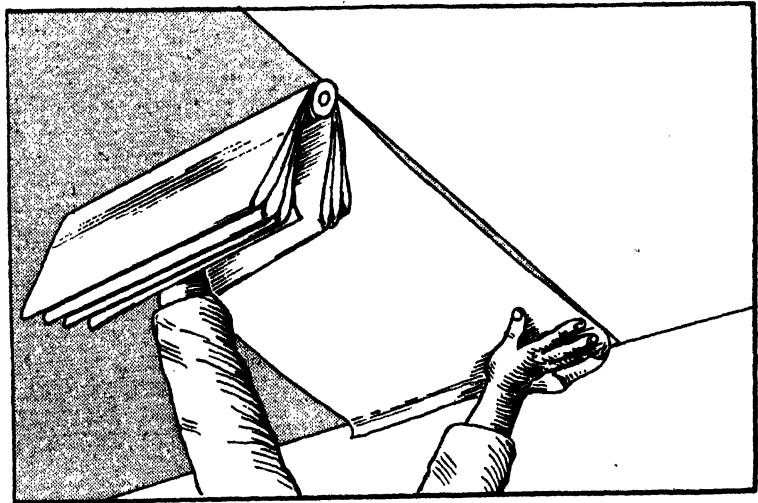

FIG. 25. HANGING CEILING PAPER: ONE PAPERHANGER

exactly, that there are no creases, and that all edges are down. Joint rollers (Fig. 11) are used in good-class work. Frequently, however, it is desirable to hold a piece of wall-paper up on the joint and roll on this, as the roller applied direct may cause the joints to develop a slight shine. In addition, rollers must be used carefully, otherwise paste will be squeezed out on to the face of the paper and leave a stain.

When the work has proceeded to the last length, the distance from the edge of the last piece to the angle will be less than 21 in. The folding of the paper will be slightly altered, so that the distance can be marked on the pasted and folded length of paper on the bench. The rule is laid the required distance from the front or matching edge of the paper, and with the fingers acting as a guide, the point of the scissors or, if suitable, a pencil, is used to mark the distance as the rule is drawn along the full

MODERN BUILDING CONSTRUCTION

length of the paper as folded. The width cut may allow for some selvage, say 1 in., if the wall cannot be relied upon for straightness; this selvage or surplus is trimmed off in position, again remembering that any lap on the wall of more than $\frac{1}{8}$ in. will cause creases to develop as the paper shrinks in drying.

Walls. For walls, when it has been decided where to start—from a window or over the fireplace—a vertical line must be struck in the

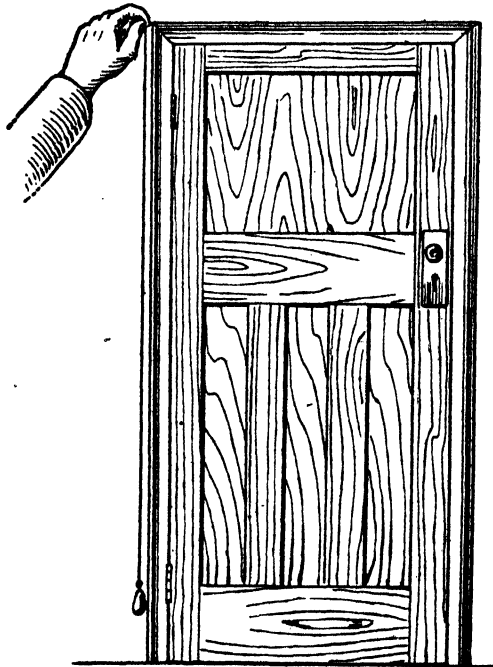

FIG. 26. OBTAINING AN UPRIGHT LINE

proper position, i.e. the centre of the chimney breast or $10\frac{1}{2}$ in. from the centre, according to the way the pattern balances at the angles, for each angle must match, and if a start is made from the window, the uprightness of architrave or framing must be checked and due allowance made if it is out of the vertical. A plumb bob and line is used for obtaining the upright line desired. Fig. 26.

The lengths of paper are matched and cut, allowing, as already indicated, from 3 in. to 4 in. at each end over the length. Care must be taken to see that the top of the pattern, where the cut is to be made is in an appropriate part of the pattern. Similarly, if careful attention is given to the pattern at the lower end, a good result will be obtained.

The number of lengths to be cut varies, of course, according to the starting position. For example, if a start is made over the mantel there will probably be three or four short lengths. These can be pasted and hung, after which lengths may be cut for, say, chimney breast to window or door. As experience is gained, it will be possible to decide more easily how many lengths to have on the pasteboard to begin with.

FOLDING. The folding of paper for hanging on walls is different from that for ceilings, but the difference is one of detail and not of principle. Paste the length of paper on the board, fold the top over half the length of the board, draw this along so that more paper is brought forward on the board for pasting, keeping it to the front edge of the board. If necessary, the part already folded can be double-folded. The bottom is folded in the opposite direction, the fold being quite short, say 8 in.

To hang, unfold the first length from the top, but do not let it unfold quickly or it may tear right across. Hold the top of the paper in both hands, the hands being on the edge. Place one edge on the line, thus releasing one hand. Put the edge of the paper carefully in position with the pattern correctly placed at the top and on the line and brush down the edge. Then brush outwards and downwards, draw the end of the scissors along the top between the angle of wall and ceiling or moulding, then trim off the surplus neatly. Fold the trimmed waste, pasted sides together, and do not throw it on the floor. It may be put on the top of the steps or some other safe place, but should never be dropped on the floor, where it may cause an accident. Brush the paper down to the skirting, watching the line, trim off the bottom surplus, and brush down edges. The next piece will then be hung, taking care that a good match is made and avoiding overlapping the pattern of one edge with the other. Always sponge paste off skirtings, mouldings, etc.; it causes paint to crack.

Where the condition of the walls is suitable, butt jointing is the best method to employ. Roll the edge if required with a joint roller, Fig. 11, although for inexpensive papers this will not always be necessary. Proceed to the angle; at both internal and external angles, the length of paper must be cut the required width. This is done after pasting, and the distance taken for an external angle is such that it will turn round it. If more than 1 in. is allowed, creases may develop because the line of the angle may not be true throughout its length.

For internal angles, the distance of the cut must be such that the wall surface is covered into the angle. This may be out of true, so that allowance will have to be made, which may be $\frac{1}{4}$ in. or even more, but if more than $\frac{1}{4}$ in. folds round the angle on to the next length of wall, the surplus must be cut off. The distance for the remainder of the length of paper must be measured and a line struck. When hung, that piece must be plumbed, for it must be upright. Sometimes, the fact that the angles are not upright causes a piece of pattern to be cut away, thus making exact matching impossible. In such circumstances, the job must be done as well as possible. If the lengths are not plumbed at each angle, the pattern at the top will run down or up according to the way the length is out of the vertical.

Borders, Friezes, etc. Borders are in various widths. Generally, lengths are cut off, pasted, and folded, then the borders are cut at the proper widths. As a rule there is some feature such as a moulding against which the edge of the border is to contact. If, however, there is no such feature, then lines must be struck. If panelling is involved, lines must be struck in appropriate positions, and if no individual ornamental feature is provided for the angles, an appropriate mitre must be made. The pattern must be studied and every effort made to secure that at least the angles pair.

Make sure that the border is placed in the correct position, because any movement on the ground on which it is applied may leave a mark.

Friezes are generally perforated round the pattern, if of the "cut-out" type. The appropriate lengths are cut and pasted, the surplus being removed after pasting. If there is no perforation, then the pattern must be cut out by hand. This should not be done with scissors, but with a stencil knife, the cutting being carried out on glass in the same way as for stencil cutting.

The pattern must be properly balanced by centring (i.e. over the mantelpiece) and, as far as practicable, each wall should be centred, assuming that there will be a break at the angles by stopping the frieze a short distance from the angle. If, however, it is to be continuous, it may not be possible to give individual consideration to each wall.

Spot ornaments, ornamental features of individual character, crowns, sprigs, and other similar features require individual consideration, and as experience is gained the craftsman will have solved so many problems that these will

present little difficulty. It is pointed out, however, that due consideration must be given to pictures, ornaments, furniture, etc., when deciding where to place individual ornamental features.

Relief Materials. The hanging of relief materials should not be undertaken until considerable experience has been gained with other types, and even then it will be found that the technique is different in many ways. Relief materials are mainly of two types—low and high. Low relief materials are generally made up in rolls of the same width as ordinary wall-paper and may be sold by the yard or by the piece of normal length. They may be solid or hollow backed; in the former, the pattern is solid and the back is therefore flat, while in the latter the pattern is embossed and hollow. The weight of these materials varies considerably according to the height of the relief, which may range from a slight emboss to 2 in.

The surfaces upon which embossed materials are to be hung should be sized and covered with a good-quality white lining paper, which should be well and carefully applied.

The trimming is of course done close to the pattern and must be a clean job. A sharp knife is therefore essential. Generally, it is better to trim prior to cutting up and pasting. The paste must be stiff, as already indicated on page 682; Dextrine paste may be used. Thin paste would be absorbed by the material and soften it, and as the material is liable to stretch when soft, some of the pattern would be lost. Careful spreading of the thick paste is important—it must be uniform, and a palette knife or broad knife is often helpful for this purpose. The lengths are cut as for wall and ceiling papers, rather longer than required, and lines snapped in proper position to indicate where the material is to be placed. Centres, etc., must be clearly indicated.

When pasted, the lighter types can be folded like wall-paper, but care is essential at the bends to ensure that the pattern is not distorted. The pasted relief material is rather heavy, and it is more than one man can do alone to put up lengths other than comparatively short ones. Short folds are better than long ones. When handling, avoid using an uneven pressure, otherwise the material will stretch and the pattern will be lost in places.

The paperhanging brush must be used with a dabbing and not a brushing motion in order to prevent the emboss being affected by stretching.

MODERN BUILDING CONSTRUCTION

When the subsequent lengths are hung, the time between pasting and hanging each length should be as nearly as possible the same, otherwise the lengths may stretch unequally and result in matching difficulties.

Solid reliefs, low in pattern, are treated in a similar manner. The paste needs to be rather stiffer and evenness of spreading is important. It is often necessary, after pasting, to lay the material aside to soak. Solid reliefs can be treated in this way, as they are not so liable to stretch as hollow-backed material. Sometimes it is an advantage to sponge over the side to be pasted with warm water and allow it to soak. This makes the material softer and more easily workable.

HIGH RELIEF MATERIALS. These are hollow-backed, the height of the relief varying considerably. The material should be handled carefully so that the relief is not damaged. The sheets of relief have the trimming lines clearly indicated. Trimming is best done with knife and straight-edge. Prior to starting any necessary setting out or striking of lines must be carried out.

The paste must be stiff flour paste or Dextrine, as already indicated. Several applications of paste may be necessary and time allowed for the material to soak so that the flat parts which are to make contact with the surface are pliable. The material must not be stretched unduly. When the relief material is in position, the background should be well pressed to the surface.

Dabbing with the paperhanging brush will assist, but it will not be enough. Pressure should be applied carefully with the fingers or thumb over the flat surfaces, working carefully round the pattern. Joints must receive special attention and, where practicable, a small joint roller may be used, but its use requires skill to avoid damaging the pattern. As a rule, thumb pressure will do all that is required.

It is not advisable to hang hollow materials in positions where they may be exposed to pressure, e.g. on the lower parts of walls. If this is necessary, however, the hollows must be filled in with a plastic material before pasting. A mixture of glue paste, with sawdust and plaster of paris, is suitable for this, but there are a number of plastic materials now available which are quite efficient.

Some days will be required to allow the paste to become completely dry, after which the surface may be treated, e.g., by painting. Ordinary distemper should never be applied.

Relief materials give great scope for decorative finishes, and the background can be picked out in tints if required. There are many varieties of patterns available, and manufacturers of relief material are always ready to give assistance and advice as to schemes for individual designs and layouts. If the craftsman has little experience he should start with low relief on small areas and work up progressively to more exacting types.

Glazing

By CHARLES H. EATON, F.I.B.D., F.R.S.A.

THE principal ingredients of glass are silica (white sand), lime (lime stone), soda (soda ash), arsenic, and charcoal; these materials, when melted together under intense heat, fuse and form a homogeneous fluid mass.

Until comparatively recent years all glass was made by hand, i.e. blown and manipulated by the glass-blower; but now machinery has been produced which carries out the work on a large scale in much the same way as that employed by the glass-blower.

The difference between *sheet* and *plate* glass is that the latter is cast and rolled, and the former blown.

To appreciate fully the skill of the glass-blower one needs to see him at his work, but an outline of the process may be of assistance. The operator gathers a quantity of molten glass on a blowpipe, or *gather*; by repeated blowing and heating, this globular mass is blown by the mouth into a hollow cylindrical shape, the operator, or gatherer, swinging the gather and its "bubble" in a long pit in the floor while he is blowing. After cooling, the cylinder is split; it is then placed in a kiln where it "unrolls" and is flattened out by a skilled workman.

Machine-made Glass. This is produced in practically the same manner, though the cylinders are considerably larger, about 40 ft. long, than it is possible to produce by mouth blowing.

All blown, or "drawn," sheet glass has surface defects which prevent it from being used on first-class work. It is quite impossible to get a perfectly flat surface, there being always a slight concavity with unevenness which causes distortion; "swirls" and air bubbles cannot be eliminated entirely.

The limitation of the process makes it impossible to produce sheet glass in larger sizes than about 7 ft. by 4 ft. Generally, English sheet glass is made in the following weights: 15 oz., 21 oz., 26 oz., and 32 oz. per square foot.

The use of 15 oz. glass is limited to small squares, or panes. Care should always be taken to use glass of a weight that errs on the side of safety; thin glass is liable to break with only

slight vibration or uneven pressure and may, in falling cause injury to some person.

Plate Glass. The manufacture and use of plate glass has grown considerably of recent years. Much may be said for its more general adoption; it is free from blemish, is of even thickness, and beautiful in itself; sheet glass by its variation of thickness is liable to give one a distorted picture, whereas plate glass always gives exact and true vision; further, colour is unaffected or affected to the minimum, but if seen through sheet glass colour is liable to vary considerably.

A vast plant is necessary for the production of *polished plate glass*. It involves the mining of silica, the quarrying of limestone, the manufacture of soda ash, and the treatment of fireclay for crucible making.

Crucibles. The making of fireclay crucibles for melting glass constitutes one of the heaviest expenses in the industry; the time involved in making them may vary from a few months to a year; when complete, its life is only about one month. Each pot holds about one ton of molten glass, and must withstand the 3000° F. of the furnace.

Melting. After heating to the required temperature the pot is filled with ground soda, lime, silica, and broken glass and placed in the furnace; as the material settles and sinks down, more is put in until the charge is sufficiently large.

The temperature is maintained for about 16 hours; the mixture changes from a sticky mass full of bubbles to a liquid almost as thin as water. When all the bubbles have risen to the top the "founder" in charge of the furnace reduces the heat, and for a period of several hours the liquid glass is allowed to cool. Impurities are then skimmed off, and by means of an overhead crane the pot is removed and the material poured on to the casting table.

This is a large, flat, iron bed with a steel roller covering its full width; gauges or metal flanges attached to the edge of the table adjust the thickness of the glass plate that is to be made.

MODERN BUILDING CONSTRUCTION

Casting is the most spectacular part of the process. The fiery, sticky mass is poured on to the table where it is rolled into a plate, the cooling glass changing in colour from red to clear green. Although its surface is rough, opaque, and unpromising, within the surfaces it is crystal clear.

Annealing, or Cooling. The plate of glass is soon strong and solid enough to be moved and passed through a series of brick ovens, or cooling chambers. These chambers lead to a long tunnel, called a *lehr*, through which there is a steady drop in temperature. The glass is propelled slowly along by travelling bars which, after carrying it forward, return down the *lehr* for further plates.

The process of cooling is a very delicate one, as a too sudden exposure to cold air may break the plate of glass, and whereas by the older processes three or four days were involved in the cooling process, only as many hours are now required.

When cool, men receive the glass at the end of the *lehr*, take off the rough edges, and cut the sheet to suitable sizes. The cutting is done with a *diamond*, and, on account of the expense involved if a plate is broken, requires to be done by skilled men.

Grinding. By means of an overhead crane the glass is then removed to the grinding table. The method of lifting the glass is interesting; a large frame fitted with eight or ten rubber suckers descends and attaches itself by suction. A vacuum chamber provides the suction, and the large plates of glass are moved easily and safely. The glass is placed on the grinding table with many other plates of all sizes until the table is completely covered. A thin coat of plaster of Paris is washed over the table immediately prior to the laying on of the plates. Men mount the table upon each plate, and by executing a kind of rhythmic dance they stamp the glass into the plaster. The glass-covered table is then taken to the grinding machine where in contact with each other, both the table and the two large steel-studded discs, or "runners," of the grinding machine revolve in opposite directions. Considerable pressure is exerted, and in a short time all rough irregularities are removed. As table and runners revolve, sharp sand and water is poured on the glass; the coarseness of the sand is gradually reduced, and when the last grains have been washed off fine emery powder is brought into use. Both sides of the glass are treated to this process.

Polishing. The table is then taken to the polishing machine, which is similar to the grinding machine in operation. As before, the table is lifted hydraulically above the underground motors, and the two great discs lowered on to the glass.

In the place of the steel grinders, however, are a number of circular, felt-covered plates, which revolve as the table turns round. Rouge and water are fed on to the glass, which soon attains a brilliant and permanent polish. The process of grinding and polishing both sides of the glass takes from three to four hours, and when the glass plates leave the polishing machine they have assumed the well-finished appearance of plate glass as seen in everyday use.

The glass is then removed to an inspection room, where, in specially lighted cabinets, it undergoes a very strict examination. Flaws are here easily apparent and are clearly marked. No faults are allowed to pass; if defective, the glass is cut into smaller sheets to eliminate the defective parts.

Polished plate glass is by this process manufactured in varying thicknesses from $\frac{1}{8}$ in. for windows to 2 in. for ship portlights and similar purposes. Specially fine pieces are selected for mirrors. For this purpose very careful examination of the glass is made because the silvering process of mirror-making accentuates the slightest defect.

Polished plate is only one of the many kinds of glass produced by the casting and rolling process. Cathedral and other types of patterned glass are made in the same way, the pattern being impressed by rollers while the glass is still in a semi-molten state.

There are many advantages in the use of plate glass wherever possible, clearness of vision being perhaps the most obvious; but lack of distortion of the view is characteristic. Rooms glazed with plate retain heat much more readily than those glazed with sheet glass.

Plate glass is approximately four times stronger than ordinary sheet glass; the tensile strength is fully demonstrated when large areas are used for skylights and have to bear the weight of heavy snow. When reinforced with wire, its enormous strength is such that the cost of building may be appreciably reduced; there is no risk should the wired plate be broken, the particles being held securely together.

Varieties of Glass. The principal types of glass used are—

Fluted. In which the surface consists of

regular flutes or curves, segments of circles, generally all of the same width, and giving the surface a reeded effect.

Cathedral. In which the surface is figured as though it had been hammered.

Prismatic. A rolled glass, consisting of prisms running parallel in such a way that light received is reflected according to the angle of the prism. Another variety has the surface covered with angular prismatic shapes, irregularly spaced.

Reeded Glass. This is similar to fluted glass. Broad and narrow varieties are available.

Cross Reeded Glass. This is a type produced as a result of the reeding running both ways across the glass, resulting in square shapes of high reflective properties.

Chevron Reeded. The figuring in this glass is reeding which is arranged in a regular triangular pattern.

Maximum Glass. The surface consists of regularly spaced prismatic forms running parallel. It has very high reflective properties. The opposite side is fluted in the opposite direction from the prismatic forms.

Generally, these types of glass are figured on one side only. There are, however, varieties in which both sides are figured in order to increase reflection. It is obviously necessary that all types of glass must be kept clean if they are to serve their purpose.

There is a wide variety to select from and the student is urged to study catalogues and then familiarize himself with the actual glass so that he may become acquainted with their possibilities.

Armourplate Glass. Armourplate and toughened glass is plate or sheet glass which has been heated in a specially constructed electric furnace, from which it is withdrawn and the surfaces exposed to cold air, the core retaining its heat and cooling slowly. The process gives the glass great strength. Armourplate does not break if damaged; it disintegrates into numberless small pieces. Its resistance to a load or wind pressure is about seven times that of plate glass of similar thickness. Its thickness is rather less than $\frac{1}{16}$ th of an inch.

Armourplate has all the qualities of polished plate glass, i.e. it is clear and brilliant and never becomes discoloured. It is a proprietary material. Each piece is complete in itself and bears the name branded in it.

This glass is used for a variety of purposes where greater security is needed; it can be used unframed in shop windows, thus eliminat-

ing inconvenient glazing bars. Its advantages for windows such as jewellers' and furriers', where valuable goods are exposed to view, are obvious. Other uses are as shelves, table tops, machine guards, road signs, portholes, furnace inspection doors, fire screens, etc. It is made in black, clear and tinted, rolled, cathedral, and a variety of other forms.

Armourplate cannot be cut after the hardening process is completed as the edges are annealed. Holes also must be drilled before hardening and these are limited as to size, i.e. they must not be more than $\frac{1}{4}$ in. They must be well away from the edge, which is the weakest part of the sheet, the centre being much stronger.

Several types of toughened glass are obtainable, but Armourplate is made only by Messrs. Pilkington Bros., Ltd., St. Helens, Lancs.

Cutting Glass. The tool generally used for cutting glass is a *diamond*, which should be appropriately set in a steel holder to which is affixed a suitable handle; this is generally considered to be the only acceptable tool for the efficient cutting of glass. Diamond glass cutters are of various qualities, according to the type and thickness of glass to be cut, so the size and quality of the stone will need to vary. Thus, a diamond of the quality that will efficiently cut sheet glass would be useless for quarter plate; and one that will efficiently cut quarter plate would cut sheet glass right through quite easily. The cash value of the diamond to cut quarter plate would, of necessity, be much higher than for the one of lower quality.

The diamond is held in an almost vertical position between the first and second finger of the right hand, and when once so used the position must always be maintained; changes of angle will probably render it necessary to have the stone reset.

Wheel glass cutters have been brought into more prominent use of late; they consist of a tiny wheel of specially hardened steel suitably mounted. For trade use they are becoming more popular and reliable in their cutting value, due to improvements in the selection of steel.

For cutting shapes there is a cutter, operating from a central point, called a "circular glass cutter." It consists of a hollow rubber disc which creates a suction when pressure is applied, and an arm to which the cutter is attached, the cutter moving round the disc at the required distance. Another type is mounted on a special table and functions in a similar manner.

MODERN BUILDING CONSTRUCTION

There are other special types of cutters, but further reference is unnecessary because circular and shaped pieces are usually ordered to pattern.

Tools. The tools required by the glazier for all ordinary purposes are few. Large plates of glass are most frequently put in by men from the merchants or manufacturers, who do nothing else, and are therefore very highly skilled in handling plates of glass which to the novice may appear to be almost unmanageable.

The tools are diamond or wheel capable of cutting the various kinds of glass. The diamond should be used by only one person; if more than one person uses it, the "cut" will be destroyed. Hammer and hacking knife are required for the removal of old putty when reglazing. A wood chisel is often found useful, so also is a

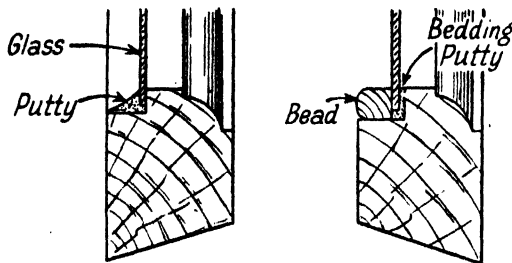

FIG. 1. SHOWING METHOD OF FIXING WINDOW GLASS

pair of glazier's pliers. T-square and a straight-edge and a 2 ft. rule complete the essentials.

The glass-cutting table may be a plain, flat-topped table, but it is an advantage if it is squared and lettered in inches, etc.

Fixing Glass. As a preliminary to glazing a new window, whether it be iron or wood, the *rabbit* (or rebate) must be properly painted (see priming woodwork). This is more especially the case with wood, in order to prevent the absorption of oil from the putty, thus robbing it of the material that binds the particles together. Further, it is necessary to paint in order to secure a proper degree of attachment of this putty with which the glass is held in place. Putty should be made of whiting and linseed oil, but manufacturers frequently use other oils which often are not satisfactory. The rabbit is that part of the sash which forms a seat or place to hold the glass. After the paint is dry, the bedding putty is applied; this serves as a bed upon which the glass may be pressed evenly when placed in position. The glass may then be secured by the use of glazier points or small

pins; the points are small, triangular pieces of zinc of various sizes, one point of which is driven securely into the wood after the glass is placed in position, and has been carefully pressed down to an even bed; facing putty may then be applied. The putty should be soft but not sticky; a little practice will enable one to roll the putty between the thumb and first finger and at the same time place the right amount in position. The putty may then be levelled to the right angle of about 45° with the face of the glass. See Fig. 1.

Putty, when hard, should be adequately protected with at least three coats of paint.

If a sash is to be reglazed, then all old glass must be removed carefully, and the putty, both bedding and face putty, chipped out with a hacking knife. It is most important that this be done carefully and that the woodwork is not damaged. Special care is required to clean out the groove at the top of lower hung sashes.

Shop Fronts. Generally, the large plates of glass prove to be something of a problem to those who are experienced in handling only small pieces of sheet glass; the difficulty arises mainly through inexperience and lack of confidence. An accident may result in serious injury, and it is now more than ever the practice to depute the manufacturers or merchants to fix them; they usually keep a staff of well-skilled men who, as the result of handling these large plates, become so experienced that they very rarely have an accident. Further, owing to the system of insurance of plate glass, the work is very frequently placed direct into the hands of firms who make a speciality of this work, or the company themselves maintain a department. Strictly, there is but little to fear; all that is required is careful and thorough preparation of the frame to receive the glass, and a definite and concerted plan of procedure; to do the job oneself may be false economy.

LEAD GLAZING AND STAINED GLASS

Lead Glazing and stained glass work do not ordinarily come in the work of the builder in these days; the work is generally put out to specialist firms.

The glass used is frequently ordinary 21 oz. glass, suitably tinted by a special process, but frequently $\frac{1}{8}$ in. and $\frac{3}{16}$ in. polished plate is used; it is far better to use these better types of glass, as they are free of distortion. Compared with the whole cost of the building, the extra charge for plate where lead or stained glass

windows are to be used is but little. The design of the window and arrangement of the leads is all-important. In old stained glass work, it is a common thing to find the lead running right across an important piece of the design, distorting the shape; the aim was to obtain glass

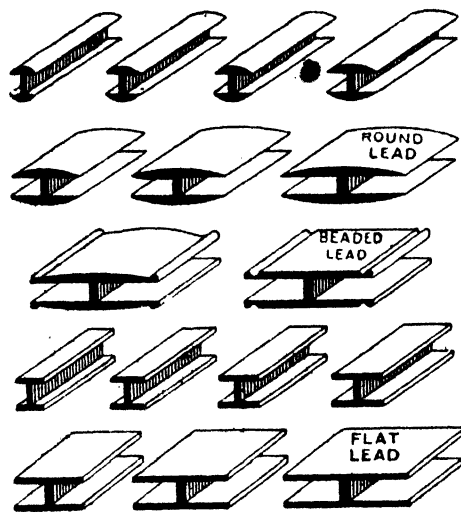

FIG. 2. TYPES OF LEAD CAMES

of a shape easy to cut. More attention is now paid to the arrangements of the leads, or *cames*, to make them part of the design. The leads may be all lead, or steel cored to give strength.

For exterior work, lead cames are $\frac{1}{2}$ in. and $\frac{3}{8}$ in. Beaded leads are mostly in keeping with architectural requirements, but for interior work a narrower came can be used. Until recent years the cames were recognized only as a medium for keeping the glass in position, and designs were obtained by painting or staining the glass, but now so much progress has been made in the production of beautifully coloured glass that it is often unnecessary to paint or stain it. By careful selection it is possible to assemble the units and produce designs of considerable beauty, originality, and boldness. Nearly all the work of present-day stained glass artists is obtained by designs where the leads play the part of outline only.

Stained Glass. The subject of painted or stained glass. It is so wide and complex that it is impossible here to do more than make brief references. The stained glass artist does not always prefer modern glass to that produced by the older and less exact processes despite the fact that modern glass is at least as brilliant and varied as the old and is practically free

from such imperfections as *striæ*, air bubbles, and other defects. It is, indeed, because of its perfection that modern glass is less adaptable to artistic use.

Perfect glass does not deflect light; external objects are seen through it clearly when used for stained glass. This removal of defects robs stained glass of much of the beauty which is its chief characteristic. The older and less perfect glass scattered and broke up the light, which it refracted and deflected in a way that made windows appear as brilliant, self-luminous objects. Modern glass makers are now producing special glass, which contains many of the old defects, rolled and muffled glass being chiefly used. As a result, material is becoming available which may be considered to be as suitable as that which was used in ancient work. The range of colour is practically unlimited.

The procedure of the stained glass artist is first to prepare a scheme showing colour and composition on a small scale. Next, a full-sized carton in monochrome or charcoal is made, all details being carefully drawn, and the cames and iron bars for strengthening the window shown. A tracing on cloth is then prepared showing the lines the leads are to follow; this is called the "cut-line," on which the selected pieces of glass are laid, and cut to shape. Finally, a tracing of the detail from the carton is prepared and painted with brown enamel; the

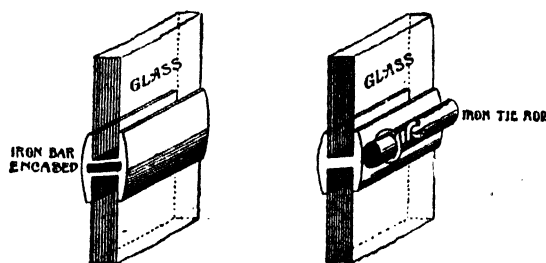

FIG. 3

pieces of glass are now fired and fixed into the leads. Fusible glass, mixed with opaque manganese or ferric oxide and tar oil, is used for making the brown enamel which is used for all outline shading and detail. This enamel may be removed as required before firing by means of a quill or shaped stick, so as to show details of form.

PROPRIETARY GLAZING SYSTEMS

Glazing bars, as a general rule, are made of iron, and the glass held in position without

MODERN BUILDING CONSTRUCTION

the use of putty, rendering repair work fairly simple; usually all that is required when replacing broken glass is the removal of a few screws, and a cover cap or simple lead flashing which may be easily bent back and replaced.

Metal Glazing Bars. These have the advantage of rendering it possible to support long sheets of glass, their strength and lightness being a great asset; the smallness of the sections used renders it possible to admit the

Roof Glazing. In roof work, as skylights, etc., it is impossible to provide normally for the support of the glass between the bars, therefore they must not be spaced too far apart. The distance is regulated considerably by the type and size of glass it is proposed to use. Rolled or muffled plate can safely be used in fairly long lengths, and the strength of the glass admits of a wider spacing of the bars. Wired glass, which of itself is very strong indeed and, if broken, is

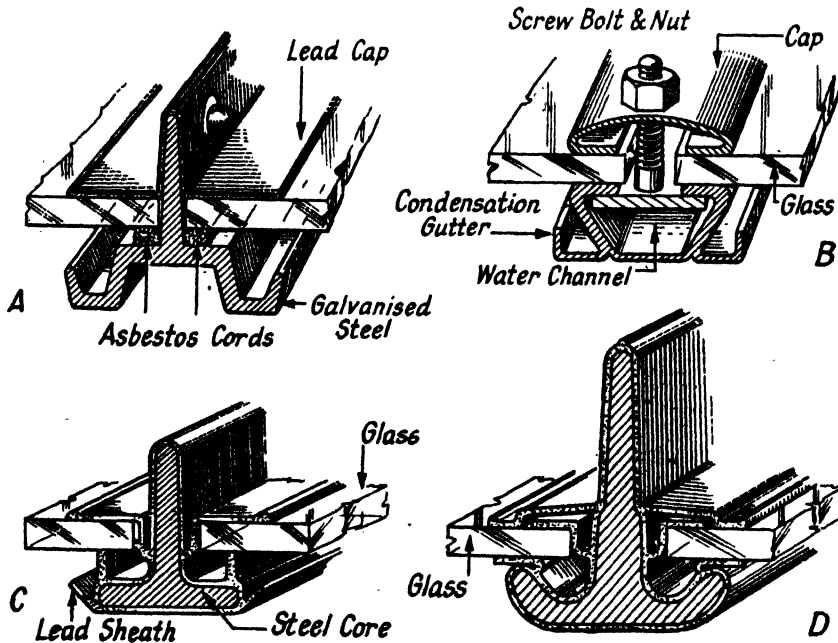

FIG. 4. FOUR TYPES OF GLAZING BAR

A. Lead-capped "Reform" Bar No. 42 (Messrs. Haywards, Ltd.). B. "Invincible" Bar for bearings up to 4 ft., made of copper or zinc (Messrs. Wm. Edgcombe Rendle & Co., Ltd.). C. Steel-cored, lead-sheathed Bar (The Pennycook Patent Glazing & Engineering Co., Ltd.). D. "Eclipse" glazing-bar with bituminous and tallow-forming insulation against electro-chemical action, and ensuring close adhesion of the lead sheath (Messrs. Mellowe & Co., Ltd.).

maximum amount of light. Generally, the bar is of a T section with, in some systems, a slight variation or shaping in order to gain additional strength; the sections are used with either the T upwards or inverted, according to the method of covering or fixing the glass externally. In some systems the glass is held by putty and clips to prevent slipping, and in others copper, lead, or zinc is used as a cover, and the glass merely bedded on a suitable material; asbestos or similar materials are frequently used, and channels are provided to carry away condensed moisture. Fig. 4 illustrates four types of glazing bar.

not so liable to cause injury, can be recommended.

If sheet glass is used it must be in comparative short lengths, the square of glass at the bottom of the light being bedded solid and laid first; this should have one or two 1 in. or 1½ in. metal clips at the bottom to prevent it from slipping. The next square may be bedded and laid in position. This also should have a metal clip at the bottom to prevent slipping of the glass; or two small pins may be used, but these are not always satisfactory. The advantage of the clip is that the small space created between the two squares of glass allows for the passage of condensation, but the disadvantage of the

system is the accumulation of dirt between the two squares of glass at the overlap, which should be about 1 in., and is necessary for proper weathering. Usually, the glass is not more than 18 in. long if sheet glass is used, but the length depends considerably upon the weight of glass per square foot.

PAVEMENT LIGHTS

In narrow streets, especially where buildings are high, it is not always easy to secure daylight in sub-basement and basement premises. If, however, expert consideration is given to the problem, a great deal can be done to secure reasonably good lighting. Similarly, there are many parts within buildings where it may ordinarily be difficult to admit daylight, yet it may be possible with proper advice to secure effective admission of daylight.

The pavement light provides a solution to many of these problems. There are many types of pavement light; the efficiency of some, when installed, may approach the maximum, but they are liable to develop defects. Small fractures quickly show, being the result of disintegration, efflorescence develops, impairing the transmission of light and quickly reducing the efficiency of the lighting unit, besides becoming unsightly and possibly dangerous.

Pavement lights, if they are to be satisfactory, must withstand vibration, shock, heat and cold, and the resulting variation of expansion and contraction, and the effects of impure air in industrial areas.

A defective pavement light, in addition to being ineffective, may expose pedestrians to unnecessary risk, leading to injury and possibly becoming the basis of an expensive action, the object of which would be to secure compensation for injury received as a result of negligence.

The vertical light from the sky has been computed as ten times as effective as light through ordinary windows. Pavements, because they are horizontal, are ideal for receiving and transmitting daylight, if the surface consists of suitable material (see Fig. 5). The requirement is not limited to pavements, for there are many positions where pavement lights may be used, possibly far from crowded thoroughfares. The most suitable material for use in pavement lights is glass. Though heavy glass, such as rough cast, has been used, and ordinary lenses are to be seen everywhere, they do not constitute the best means of effectively using daylight in difficult positions. The light is too local and

deflection is unsatisfactory; something more is needed. A great deal of research has been carried out by specialists in an effort to ascertain what type of glass is most suitable and capable of meeting all the various demands, and the best form of lens for various positions and purposes. Types of lenses have been produced which appear greatly to increase the amount of light available far beyond what is ordinarily expected. The old-fashioned bar gratings and iron frames, glazed with rough-cast glass or wedge-shaped lenses, have been displaced and their retention is no longer justified when more effective methods are available.

Frames. The design of framework suitable to the many positions in which pavement lights may be used has also received attention, and as

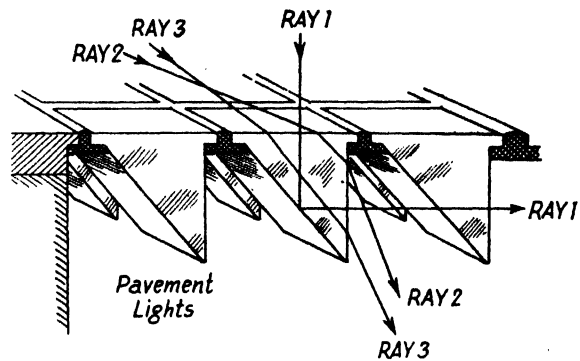

FIG. 5

may be expected, the materials from which the frames are made has been greatly improved. Being of the finest material and craftsmanship, they indicate a great advance in the understanding of constructional detail.

The arrangement of the special lenses is most important if maximum efficiency is to be secured. It is also important, when it is proposed to use a manufactured product, that the manufacturer should be supplied with the fullest information, so that he can give correct advice as to the type of lens and frame best suited to any given position. Price should not be the first consideration in this matter; efficiency must be the controlling factor.

Frames in which lenses are fitted vary considerably. Each square, circle, or rectangular shape, is rebated and the lens set with special mastic jointing composition. If the frames are not rustless they need frequent painting when placed in certain positions. Metal is vigorously

MODERN BUILDING CONSTRUCTION

attacked by impurities in the air; galvanized frames do not always resist the attack of such impurities for a long time, but iron-framed lights need not be used where the air is of such a nature that the metal will be quickly attacked. The problem of rust and maintenance has received a great deal of attention. Facilities are available for repair and maintenance, and it is obviously better to entrust certain types of work to those who have special facilities. It has long been realized that there are situations where it is most undesirable that iron frames should be used, a notable example being public lavatories, where lights heavily encrusted with rust may be seen. The difficulty has been overcome by the concrete pavement light.

The cast-in-situ pavement light has inherent

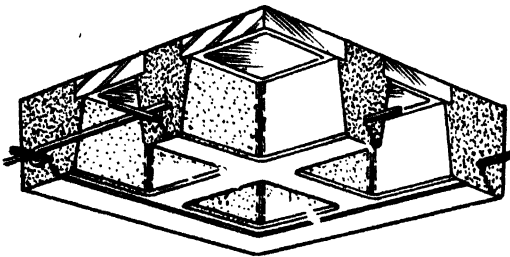

FIG. 6. "CRETE-O-LUX" PRE-CAST FERRO-CONCRETE PAVEMENT LIGHT

disadvantages arising out of the difficulty of effectively curing and hardening the concrete, and the obstruction to other operations arising out of the use of forms and centering which must remain in position during the setting process. They have now been displaced by the ferro-concrete pavement light, which is purpose made, even if for only one light or a series to cover a large area. By the introduction of the ferro-concrete light, delay is overcome, obstruction being reduced to the minimum. They are specially made to fit each position, and being pre-cast, they can be cured and hardened prior to fixing, and special provision can be made where it is anticipated that the light may have to carry more than the normal load.

It has already been noted that the manufacture of pavement lights is a highly specialized job. Messrs. Hayward have done much work in connection with improvements in materials and design of such lights, and two features are worthy of special attention, the first being the special lens made from Hayward's "W" Glass, which is the outcome of many years' experiment. "W" Glass lenses are slightly higher in price

than other makes, but the superior service fully justifies this. The other feature, which gives especially good service, is the "Crete-o-Lux" light, a pre-cast ferro-concrete light, which gives guaranteed service. See Fig. 6.

Repairs. It is important that all pavement lights, especially for public use, should be kept in a good state of repair. Manufacturers supply and service lights of their own manufacture, but there are times when it may not be possible to call on them. In this case, broken lenses should be chipped out with a sharp chisel, all old bedding material removed, and the new lenses set in the mastic jointing composition provided for the purpose. With this, it is possible to make a perfect, watertight joint. Portland cement is not really suitable, as it is liable to crack and allow water to percolate. Those who undertake the repainting of iron-framed lights should study carefully the section in this book dealing with painting and repainting of ironwork, realizing as a first necessity that all rust must be removed and that lead paint as a finishing material is liable to be adversely affected by impure air.

DAYLIGHT REFLECTORS

Windows, being normally vertical, are frequently so situated that it is only possible to get a view of the sky from a position within a few feet of them. This illustrates the impossibility of getting direct daylight into a room for more than a few feet. As streets are frequently narrow and land valuable, buildings are often erected to the limit of height allowed by building regulations, the result being that daylight does not penetrate direct to lower floor windows. Normally, the materials used in the construction of a building have no reflective properties, though there is no reason why a building should not be faced with glass that has high reflective properties, or even stainless steel. The glass need not be black, as in the case of at least one notable example; it might with advantage be coloured. This indicates a field not yet properly explored, but there is no reason why daylight should not be made available even though the building is denied the right of a clear view of the sky and is facing a grey stone elevation which absorbs more light than it reflects.

Daylight reflectors are a solution to the problem. The light received by the surface of a daylight reflector placed at the correct angle and in the right position, is at least ten times stronger than that received by the surface of a

vertically placed window. The glass used for this purpose is not flat, but fluted, the fluting being rather narrow in order to provide a greater area of reflection. The patent silvering process ensures that the glass has really high reflective properties, the efficiency of which depends not only on the quality of the silvering but also upon the glass itself. A glass made of indifferent material, even though fluted, would absorb and not reflect light to the same degree as a glass of suitable quality. These mirror-like fluted reflectors are capable of receiving and reflecting light across a wide area, and may convert a room from perpetual gloom and depression into a bright, cheerful apartment. The reflector must be mounted in a frame which is well backed; it must be strong and well fixed, because it has to withstand the buffeting of the wind. The frame must be watertight, for water must not be allowed to percolate into the back of the frame. The frames must be well constructed and not liable to warp or twist, otherwise the glass, which is not usually very thick, will break. If necessary, the surface must be protected by a wire-mesh. The iron fitting must be well secured and kept in good condition, as also must the chain supports which are sometimes necessary. The glass must always be kept clean.

The limit of the reflective surface is fixed only by the size of the window opening. Generally, however, reflectors are fitted outside the upper parts of windows, so that the area of surface through which light is reflected is approximately equal to that of the top half of the window. It is obvious that a reflector in this position lights the upper part of the room, and it may be desired that the light shall be more evenly diffused, in which case the fitment may be placed in a lower position. Fig. 7 illustrates the principle of the daylight reflector.

The use of reflectors is not limited to external parts of buildings. There are positions within buildings where they may be hung, e.g. to receive light through staircase gratings or below skylights, in which case the reflected light may be directed along an otherwise badly lighted corridor.

The considered use of reflectors may result in a great saving of artificial light and consequent reduction in the very regular charges. Further, as it is much more healthy and less fatiguing to

work in daylight, the value of reflectors is obvious.

It is always necessary to ensure that the correct position and angle of the fitment is obtained. The angle in one position may be 45° , in another 60° , but whatever the angle, it should be such that the maximum use is made of the daylight available.

RIBBED AND PRISMATIC REFLECTOR GLASS

There are many ways of increasing the light available in apartments where it is difficult to secure direct daylight.

All are familiar with the apartment which is

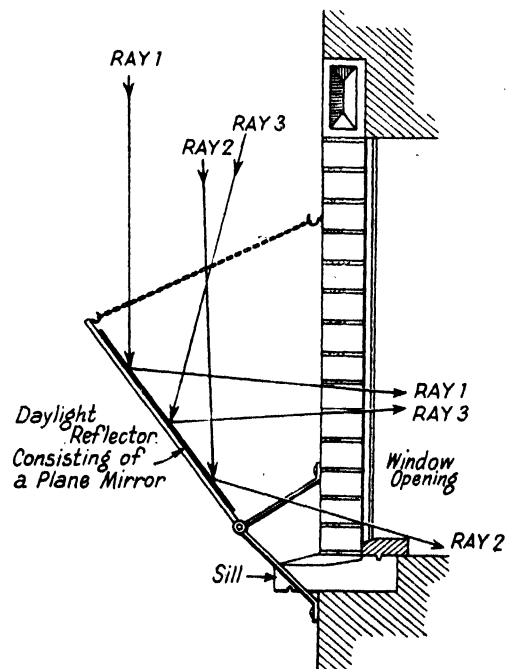

FIG. 7

gloomy and in which the outlook is not inspiring and the view frequently obscured by the use of frosted or figured glass or of glazier's window decoration covered with ornament, often of bad design.

Where lighting is deficient and the view not inspiring, windows may well be fitted with one of these ornamental figured or fluted types of glass. The glazing problem is in no way very different from that of any other glazing job.

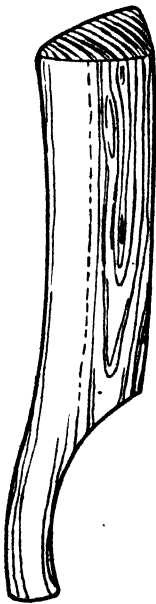

FIG. 1. DRESSER

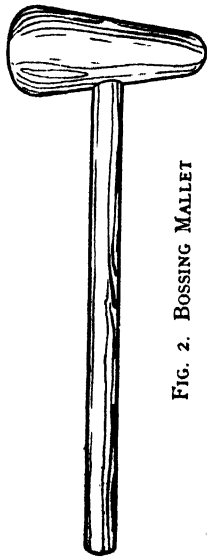

FIG. 2. BOSSING MALLET



FIG. 3. BENDING STICK



FIG. 4. BOSSING STICK



FIG. 5. STRAIGHT CHASE WEDGES

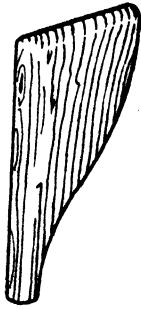

FIG. 6. SIDE BENT CHASE WEDGE



FIG. 7. DRIP PLATE



A

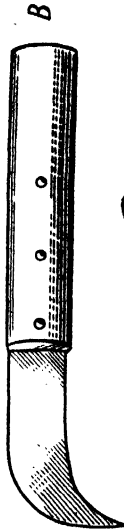

B



C

FIG. 8. PLUMBER'S KNIVES



FIG. 9.

MANDRILS



FIG. 10.

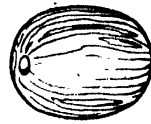

FIG. 11. BOBBIN

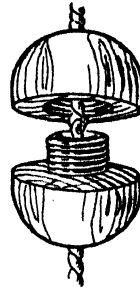

FIG. 12. BRASS FOLLOWER OR BOBBIN DRIVER

Plumbing

By PERCY MANSER, R.P., A.R.S.I., *Honours Silver Medallist*

Revised by A. C. MARTIN, M.R.S.I.

Chapter I—TOOLS

Introduction. During the past few years, the class of work entrusted to the plumber and domestic engineer has undergone a considerable change; the ever increasing use of hard metals, the new types of fittings, and more up-to-date methods of application have brought about this change, and the modern craftsman, in addition to being a worker in lead, must be skilled in the use of other metals.

The Final Examination in plumbers' work of the City and Guilds of London Institute now includes—in addition to tests in joint wiping, lead burning, lead-pipe bending and sheet-lead bossing—such tests as the bending and welding of iron pipe, the bending of copper tube, and the working of sheet copper for roof covering.

From the foregoing remarks it is clear that a much more varied kit of tools is required in order to carry out plumbing work at the present time; the original kit, however, is still required, and has not changed. A few illustrations and descriptions of some of the tools will be useful.

DRESSERS (Fig. 1). These vary in size and shape and can be obtained in various types of wood, the two chief kinds being hornbeam and boxwood; the former is used for the general work and the latter for finishing. The chief points to be observed in the selection of a dresser are: It should have smooth sides and face, free from sharp edges, and the handle should be well pitched to allow room for the knuckles of the user.

MALLETS are made in various sizes, and usually of *lignum-vitae* or boxwood. A *bossing mallet* (Fig. 2) should be perfectly smooth, the nose rounded, the face nearly flat, and the edges nicely rounded. The handle can be of ash or Malacca cane and should be well fitted, glued, and wedged to the head. It is used for lead bossing, the face or side being used as required to suit the particular job in hand.

BENDING DRESSERS are made of boxwood. They are broad and slightly rounded on the face, both in width and length (Fig. 3), and are chiefly used for driving the lead when making

bends in large diameter pipes. A great number of plumbers prefer a rounded hornbeam dresser for this work, as less marks are produced than with the harder boxwood bending dresser.

BOSSING STICKS. A bossing stick (Fig. 4) is similar in shape to a bending dresser, but narrower and more rounded. It is used for working various forms of sheet leadwork. It should be perfectly smooth, and so shaped that it is well balanced in order to enable the *bossing* to be executed with ease. It is made of boxwood.

CHASE WEDGES. These are usually made of boxwood and to all sizes and shapes; some are known as *side-bent* and others as *front-bent* wedges, whilst driving wedges are generally quite straight. The larger type of chase wedge is fitted with an iron ferrule, as also is the driving wedge, to enable them to withstand the blows of the hammer. The smaller wedges are plain, and should be struck with a mallet. Figs. 5 and 6 show two forms of chase wedge. The plain wedge should have a blunt edge, and is used for chasing back the angles of leadwork, while the driving wedge has a square edge and is used for driving back the angles of overcloaks from the edge of the lead when a drift or drip plate is used.

DRIFT, OR DRIP, PLATE. This is a small rectangular plate of steel (Fig. 7), and is used in the working back of overcloaks in lead roof coverings. *Lead will not slide on lead*, therefore this plate is placed between the undercloak lead and the overcloak, to enable the latter to be worked back into position by means of the chase wedge.

KNIVES. Plumbers' knives are of three kinds—

The *clasp knife*, Fig. 8 (a).

The *draw knife*, Fig. 8 (b).

The *chipping knife*, Fig. 8 (c).

The first-named is a pocket knife with a stout single blade, rivet-linged to a sheath handle. The draw knife (or sheet knife) consists of a steel blade with a sharp point firmly riveted to a wooden handle about 6 in. long; it is chiefly used for cutting up the lead from the sheet.



FIG. 13. BENDING BOLT OR PIN



FIG. 18. STEP TURNER

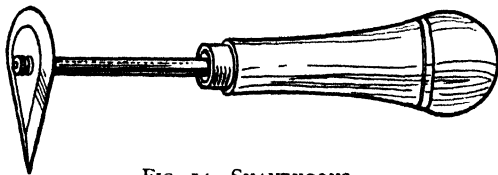
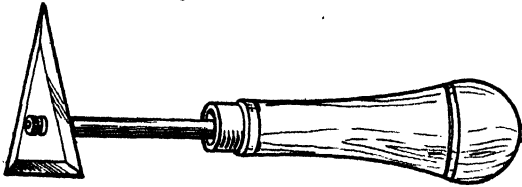
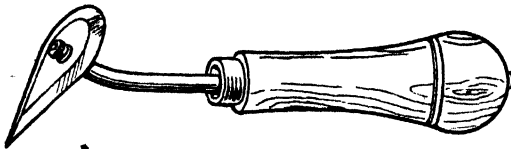

FIG. 14. SHAVEHOOKS

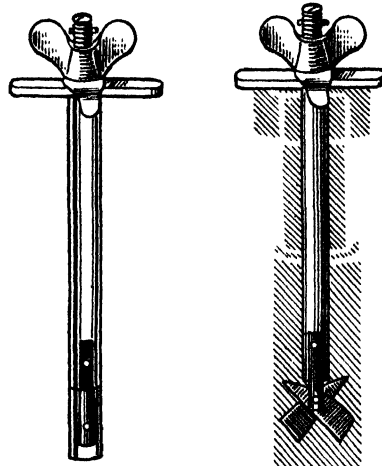

FIG. 19. THE "BURLOC" FIXING TOOL

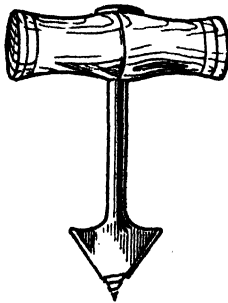

FIG. 15. PIPE OPENER

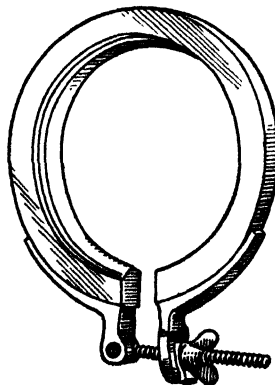

FIG. 16. PIPE CAULKING CLAMP OR CLIP

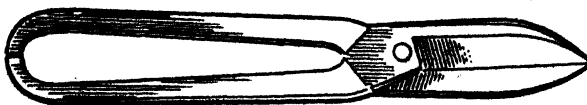

FIG. 17. SNIPS

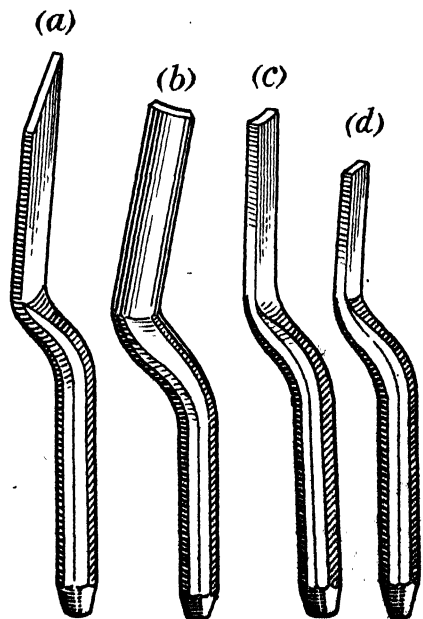

FIG. 20. CAST STEEL PIPE CAULKING TOOLS

The chipping knife is a much stouter tool, fitted with two strips of leather riveted through the steel to form a handle, its use being chiefly for trimming or chipping thicker parts of the

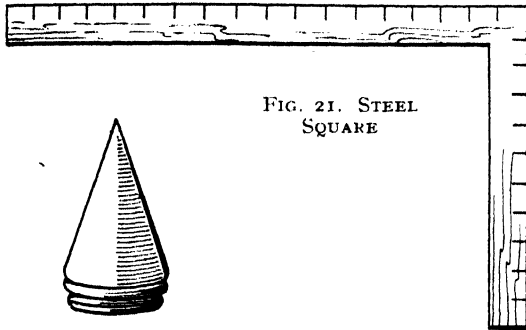

FIG. 21. STEEL SQUARE

FIG. 22. TURNPIN

lead, and where a hammer is required to drive the blade through the substance, also for hacking out old putty when glazing.

MANDRILS. These are made in a variety of lengths and diameters and are of two kinds, parallel and expanding. They are obtainable in boxwood, lignum vitae, and beech. The parallel type is used for passing through lengths of lead pipe to remove indentations, thus leaving the pipe true and cylindrical in readiness for preparation previous to fixing. The expanding type is used for forming the socket portion of an expansion joint. Figs. 9 and 10 show each type.

BOBBINS. A bobbin (Fig. 11) is a smooth boxwood or lignum-vitae tool, semi-oval in shape, with a hole running through the length; they are made in all standard pipe diameters and used for trueing up bends in lead pipes. Followers made of beech and of a similar shape, are used to drive the bobbin round a bend; or a bobbin weight (Fig. 12) is used, a cord passing through the bobbin and fixed in the weight by means of a knot. The plumber and his mate each operate an end of the cord, which should be kept tight to prevent the weight jumping about and so damaging the pipe.

BENDING BOLT (Fig. 13) is a steel bolt tapered at one end; they are made in various lengths from 9 in. to 24 in., and $\frac{1}{8}$ in. to $\frac{3}{4}$ in. in diameter. When a branch joint is required, the bolt is used to open the lead pipe that is to receive the branch; a small hole is first made with a pipe opener, and the hole is then enlarged as

required by means of the bolt and the hammer. They are also used for working out the throats of bends in small lead pipes.

SHAVEHOOKS (Fig. 14). These can be obtained in a variety of shapes: heart, three-square, spoon, and what is known as a gauge-hook. They are made of steel, sharpened at the edges, and riveted to a steel stem about $\frac{1}{16}$ in. or $\frac{3}{8}$ in. in diameter, fitted with a wood handle, through which the stem passes and is firmly riveted over a steel washer at the end. They are used for shaving the ends of pipes, and the surfaces of leadwork in preparation for soldering.

PIPE OPENER. This is a steel tool (Fig. 15) constructed on the principle of a gimlet or what is sometimes called a "ladder bit." It is used for piercing the wall of a lead pipe to admit entry of the bent bolt when a branch joint is being prepared.

CAULKING CLAMP. Now that cast-iron pipes are so extensively used, the use of clay for collars when running joints in molten lead is rather a lengthy task, and a set of collars or clamps is not only a time-saving factor but a much cleaner operation. Fig. 16 shows one form of



FIG. 23. PIPE BENDING SPRINGS

clamp. Another type is in the form of a tough asbestos rope upon which slides a metal clip; this can be adjusted to suit various sizes of pipe.

SNIPS (Fig. 17), also known as shears, are made in various sizes with straight or bent cutting jaws, and are used for cutting sheet lead, copper,

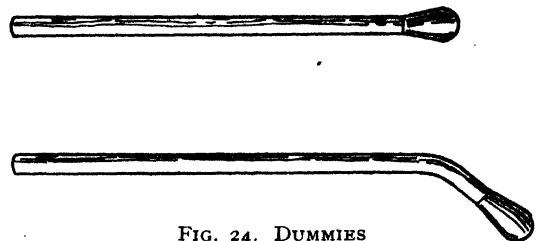

FIG. 24. DUMMIES

zinc, tin, iron, etc. They should be kept in good condition and well sharpened, as a blunt pair of snips is very trying to one's temper, as well as making a ragged cut.

STEP TURNER (Fig. 18). This is a useful tool that can be made by the plumber himself. It

MODERN BUILDING CONSTRUCTION

is used for turning the leadwork of step flashings, that is, that portion which enters the joint of the brickwork.

FIXING TOOL (Fig. 19). This is a useful form of tool and an ideal fixing for brass unions when

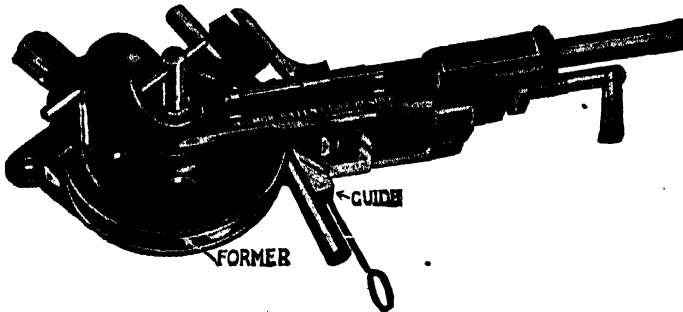

FIG. 25 (a). THE HILMOR TUBE BENDING MACHINE

wiping them to lead pipe. It obviates the use of wood splints or the grooving of the brasswork and the consequent closing of the lead into the groove.

The cap is held securely by the spring clamp *A*, whilst the lever *B*, expanded, is gripping the inside wall of the pipe, thus ensuring security whilst wiping the joint; the lever *B* is operated by the wing nut at the top.

YARNING AND CAULKING TOOLS. These may be obtained in a great variety of shapes, and in Fig. 20 is shown at (a) a picking out tool, (b) double cranked tool for left- or right-hand position, (c) curved tool, and (d) a flat tool. It is necessary to possess a number of these tools in order to caulk joints which occur in most difficult positions. It is sometimes necessary to make a special tool to overcome a difficult job.

STEEL SQUARE. A square (Fig. 21) is a necessary tool in the plumber's kit. It is usually 18 in. by 12 in., with figured dimensions. A bevel is also required.

TAMPIN, OR TURNPIN. This tool is cone-shaped and made of boxwood (Fig. 22), its chief use being to open the ends of pipes when preparing a joint. They are made in several sizes.

BENDING SPRINGS. These tools are used for making simple bends such as occur in fall pipes to water closets and in short pieces of waste and overflow pipe. Fig. 23 shows two springs: (a) is constructed of square section steel strip

and used for lead pipe; (b) is for use with copper pipe.

Only slow swept or "easy" bends should be attempted with springs. For bending lead pipes $1\frac{1}{4}$ in. to 2 in., boxwood bobbins (Fig. 11) are used threaded on flexible steel cables. Instead of threading the cable through the bent pipe and snatching the bobbins through the bend, the modern method is to drive the bobbins through the bend, and then snatch them back by means of the cable. This is a much less laborious process than trueing the bend by snatching the bobbins through.

DUMMIES (Fig. 24). These are made in various lengths and consist of a bulbous head of metal fitted to a handle, which may be of steel or Malacca cane. They are usually made by the plumber himself, and are either perfectly straight or with a bent handle. They are used to work out the buckle that appears when making a bend in large pipes for soil and ventilation work. Loose dummy heads, with a screw

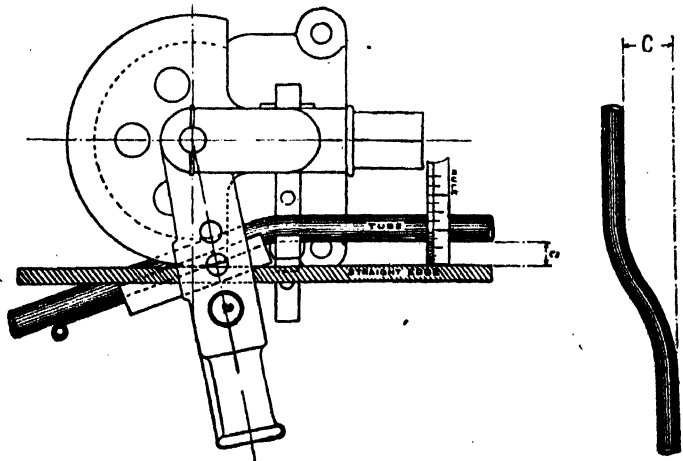

FIG. 25 (b)

boss, are also made to fit a $\frac{1}{2}$ in. barrel, thus enabling the plumber to fit various lengths of barrel and make a short or long dummy as required.

BENDING MACHINE (Fig. 25) (a) and (b). This is one of several machines for bending light-gauge copper tube. The diagram at (b) shows how the dimensions for an offset may be obtained.

Chapter II—MATERIALS

THE materials used in modern plumbing work include lead, copper, zinc, tin, iron, marble, pottery, and a number of alloys and cements.

Before proceeding with the description and source of these materials, it is essential to refer to the *physical properties* of various substances which render them suitable for different purposes.

Physical Properties of Metals. All metals possess properties peculiar to themselves; briefly outlined, they are *tenacity, malleability, lustre, ductility, conductivity, fusibility, and volatility.*

TENACITY in a metal enables it to resist being torn asunder. The tensile strength of a metal is usually given as the breaking strain in tons per square inch. The following list gives the relative tenacities in tons per square inch of those metals of most interest to plumbers—

Steel	30	Zinc	2
Wrought Iron.	22	Tin	1½
Copper	18	Lead	1

It would be seen from the list that steel would support 30 times as much as lead, and so on for the other metals.

A simple practical illustration of tenacity is shown by the fixing of lead or iron or copper pipes; whilst the fixings for lead must be only a short distance apart, those for iron and copper may be kept at greater distances, owing to the higher tensile strength of these two metals.

MALLEABILITY refers to the property a metal possesses which enables it to be hammered or rolled into sheets without fracture. The following metals are given in order of their malleability: gold, silver, copper, tin, lead, zinc, and iron.

LUSTRE is the power of reflecting light. Most of the commoner metals very soon tarnish when exposed, owing to their affinity for oxygen. Tin is an exception; we speak of tin as possessing a very brilliant lustre, and it is not affected when exposed to the atmosphere. Large quantities of iron plate are coated with tin and used in the manufacture of domestic utensils. Copper plates are also coated with tin, and used for lining sinks and making domestic utensils and reflectors.

DUCTILITY in a metal enables it to be drawn

into a fine wire without fracture. In their order of ductility the commoner metals are iron, copper, zinc, tin, and lead.

CONDUCTIVITY is the transmission of heat or electricity. All metals are conductors of heat and electricity, and placed in their order are as follows—

Conduction of Heat	Conduction of Electricity
Copper	Copper
Zinc	Zinc
Iron	Iron
Tin	Tin
Lead	Lead

FUSIBILITY is the reduction of matter to a fused or molten condition. The fusing or melting points of the common metals are—

Tin	442° F.
Lead	621° F.
Zinc	786° F.
Copper	1,985° F.
Cast iron	2,785° F.
Wrought iron	4,000° F. (above)

VOLATILITY enables a metal to be volatilized, i.e. converted into vapour. For instance, zinc coating on galvanized iron is destroyed when the iron is strongly heated.

SPECIFIC GRAVITY. In order to compare the relative densities of materials, water has been chosen as a standard of comparison and is taken as unity. The term *specific gravity*, or *relative density*, means the weight of a given mass when compared with the weight of an equal mass of water. For example—

1 cub. ft. of lead weighs 710 lb.
1 " " water " 62.5 lb.

Therefore $\frac{710}{62.5} = 11.36$, which is the specific gravity of lead.

LEAD

PROPERTIES. Chemical symbol Pb, from the Latin *plumbum*. Melting point 621° F., 327° C. Specific gravity 11.36.

Lead is found in Cornwall, Derbyshire, Cumberland, also U.S.A. and Spain. It is bluish grey in colour, soft, and malleable. When quite

MODERN BUILDING CONSTRUCTION

new it has a bright lustre, but soon tarnishes when exposed to the air, owing to the action of acid vapours and oxygen in the air. It is low

carbonate of lead composed of lead, carbon, and oxygen ($PbCO_3$).

MANUFACTURE. The first process is the extraction of the lead from the ore; this is carried out by means of a reverberatory furnace (Fig. 26). The ore is sorted over and placed in the furnace, where it is roasted in a very fierce heat on the hearth, after which it is run off into pigs from the tap hole. These pigs vary in weight from 1 cwt. to 2 cwt.; and from these pigs are obtained the sheet lead and pipe with which we are more familiar.

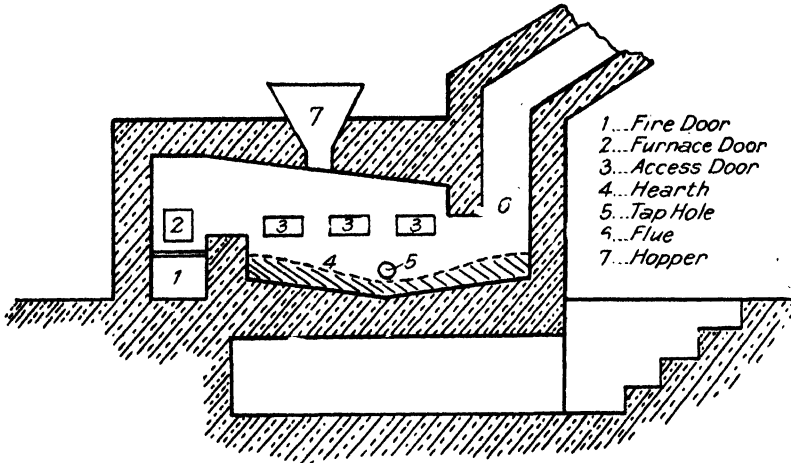

FIG. 26. REVERBERATORY FURNACE

in tenacity and would be of little use where great strains or stresses were required. The rate of expansion and contraction is high, and examples of this may be seen on lead-covered roofs, where the changes of temperature, due to the heat of

contained in a casting frame (Fig. 27). The surplus metal is removed by means of a tool called a strike; this is a specially shaped piece of wood, and so adjusted as to leave the cast sheet the desired thickness. The tail end of the

Sheet Lead. This may be either cast or milled.

Cast Sheet Lead is obtained by pouring the molten lead on to a prepared bed of sand

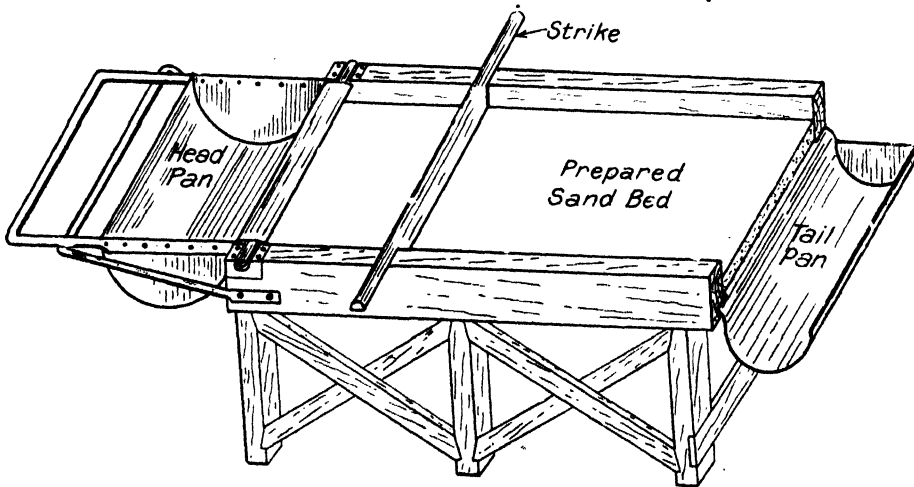

FIG. 27. CASTING FRAME

the sun and the cold of the night, has caused buckles to appear, which eventually form a rib and finally a crack.

ORES. The chief ores of lead are *galena*, the blue lead ore; *sulphide of lead*, a combination of lead and sulphur (PbS); and *Cerussite*, a

sheet is then trimmed off, after which the sheet is removed and rolled up. Low relief ornament may be produced by suitable impressions in the sand bed.

Milled Sheet Lead is obtained by means of a milling machine. The process is as follows:

A cake, or plate, of lead about 7 ft. by 8 ft. and 5 in. to 6 in. thick is first cast. This cast cake is then placed by a crane on to the milling machine. This consists of two powerful steel rollers in the centre of a long table; on either side of these rollers are a series of auxiliary steel and wood rollers to assist in the movement of the lead. The cake, or cast, is placed between the main rollers; the machinery is set in motion, and the lead is made to pass backwards and forwards between the rollers. Power is applied to the latter, which roll or mill the lead down to the required substance. The milling machine is on the principle of a huge mangle. If very thin lead is required, two or more sheets are milled together.

Lead Pipe. The early method of making lead pipes consisted of folding sheet lead round a mandril, and forming a seam with fine solder by means of a copper bit, and much praise could be given for the skilful manner in which some of these seams were made. The pipe used at the present time is, however, made in a hydraulic press, and is known as *solid-drawn lead pipe*; so also are the lead traps used by the plumber. Properly speaking, the term *drawn* is not quite correct, as the pipe is forced through the machine. The lead press is cylindrical in form, and fitted with a steel core and die and a powerful piston. The core is of the same diameter as the internal bore of the pipe to be made, and the die equal to the external diameter. The lead is run into the cylinder, the upper portion of which is heated to keep the lead in a semi-molten state. Pressure is applied to the lower portion of press, and the piston forces the lead up between the core and die, from whence it issues in the form of a pipe. It is then cut off in lengths or wound round wooden drums to form coils.

Red Lead. This substance is obtained by heating lead in a current of air, when it combines with oxygen and forms lead monoxide, or *litharge* (Pb.O), which has a yellow colour. If this litharge is further heated in air, it absorbs more oxygen and is converted into *red lead*.

White Lead is *lead carbonate*, a chemical compound of lead, oxygen, and carbon. The *Stack process* of conversion is a good one, though slow in operation. It consists of placing thin sheets of lead in layers over earthenware jars; the jars are filled with acetic acid and the whole covered with spent tan. Heat is thus produced and causes the acid to attack the lead, converting it into carbonate of lead. After a period of three

to four months, the lead is removed and passed through a machine, which separates, by a water process, the carbonate from the metallic lead. After further treatment in water, the carbonate is mixed with linseed oil to form the white lead paste. The metallic lead left over is re-melted and cast into sheets ready for replacing in the conversion stack.

COPPER

PROPERTIES. Chemical symbol Cu. from *cuprum*. Melting point 1,085° C., 1,985° F. Specific gravity 8.9.

The chief ores of copper are *cuprite*, a red oxide of copper, and *copper pyrites*, a yellow ore. They are found in Cornwall, Devonshire, United States of America, and Australia.

Copper possesses a fine red colour; it is a tough metal and rather hard. It tarnishes when exposed to the air, and is a good conductor of heat and electricity. It is a very ductile and malleable metal and can be drawn into very fine wire; also beaten into very thin sheets and worked into all manner of shapes. It may be softened by heating to red heat and then cooling. By beating, bending, etc., it becomes work-hardened, and in intricate or prolonged work it may require annealing to restore its soft malleable properties.

MANUFACTURE. The first process is the extraction of the copper from the ore; this is crushed and washed to free it of as much earth as possible, and in charges of about 30-40 cwt. is roasted in a reverberatory furnace on a bed of sand. When fusion has taken place, the metal is run out from the tap hole of the furnace into *pigs*, after which it is again melted and refined. After the refining and purifying process is complete, the metal is again run out into ingots ready for conversion into various forms.

Copper forms one of the chief materials used by the plumber. Copper tubes are now largely used for hot and cold water services and waste pipes in place of iron and lead. It also forms the greatest proportion in the composition of alloys for valves and other fittings. Copper nails, tacks, screws and clips are used for fixing sheet lead, copper-work and patent roof glazing. In the form of sheets it is largely used as a roof covering. The resistance of copper to the chemical action of moist air gives it a great advantage over iron for many purposes. Copper is an important ingredient in various alloys used in plumbing. (See "Alloys.")

MODERN BUILDING CONSTRUCTION

ZINC

PROPERTIES. Chemical symbol Zn. Melting point 786° F., 419° C. Specific gravity 7.2.

Chief ores of zinc: *Blende*, a zinc sulphide; *calamine*, a zinc carbonate. These are found in Gloucestershire, Cumberland, and in Belgium and Spain.

Zinc is a hard metal, bluish white in colour, crystalline in structure, and very malleable when heated to 260° F., but at ordinary temperature it is brittle. If heated to above 390° F. it is again brittle and can be crumbled. It will also burn, giving a bright bluish-white flame. Zinc is not affected by ordinary dry air, but soon tarnishes when exposed to a moist atmosphere, and becomes coated with an oxide of zinc, which acts as a protective coating and prevents further action. It is largely used for roof coverings and for coating cisterns, pipes, and various fittings used by the plumber in the form of *galvanized iron*.

MANUFACTURE. The ore is treated somewhat differently to that of lead and copper, the metal being obtained by distillation: The ore is heated in a current of air, then mixed with crushed coke, and again heated in large crucibles till the metal volatilizes at red heat. The vapour given off is collected in a series of condensers, from whence it is cleared out. After cleansing it is cast into ingots and is termed *spelter*.

TIN

PROPERTIES. Chemical symbol Sn, from *stannum*. Melting point 442° F., 231° C. Specific gravity 7.3.

The chief ore is *tinstone*, tin and oxygen, SnO₂. It is found chiefly in Cornwall; also found in Australia and Mexico.

Tin is a soft metal, yellowish white in colour, low in tenacity, but very ductile and malleable. It possesses a bright metallic lustre, and does not tarnish when exposed to dry or moist air. Pure tin when bent emits a cracking sound. It forms an important constituent of a number of alloys and is also used for coating iron plates, which are commonly known as *tin plates*; it is a poor conductor of heat and electricity.

Tin-lined pipe comprises a pipe of tin contained in an outer pipe of lead, and is manufactured in a similar manner to lead piping.

MANUFACTURE. The ores are first carefully sorted, crushed, and washed. The ore is then placed into a reverberatory furnace and mixed with finely-crushed charcoal and lime; after heating, the molten metal is run out into ingots.

Sometimes the metal is again melted down to further purify it before being placed ready for dispatch for commercial purposes.

IRON

Cast Iron is obtained by smelting the ore in blast furnaces and running the metal into moulds termed *pigs*. There are three kinds of cast iron—white, grey, and mottled.

Cast iron is crystalline in structure and is hard and brittle; it soon corrodes in moist air, ferric oxide (rust) being formed. It is more resistant, however, than mild steel or wrought iron; hence its use for water mains, drains, etc.

CAST-IRON PIPES. These may be cast in horizontal or vertical moulds. The vertical method is now chiefly used as it gives greater density to the socket portion, which is at the bottom of the mould.

SPUN PIPES. The Stanton Ironworks Co., Ltd., have for some time past manufactured cast-iron pipes by a new process. This process is carried out in a centrifugal pipe-casting machine and dispenses with sand moulds and loam cores. The pipe is formed in an accurately machined cylindrical steel mould which is revolved on its own axis by an impulse water turbine inside a water-cooled casing. The casing, with its revolving mould, is caused to traverse backwards and forwards on its bed plate by means of a hydraulic cylinder beneath the casing. Through the annular space between the cylinder and the casing, the cooling water is circulated, being kept at a constant temperature and pressure. A tilting ladle and a cantilever trough supply the metal to the revolving mould. The bed plate of the machine slopes slightly away from the tilting ladle so as to give the metal, during casting, the requisite fall and ensure uniform thickness of metal in the pipe. The only core used is that which is necessary to form the inside of the socket.

Wrought Iron is obtained from cast iron by a series of processes, chiefly by melting in a *puddling* furnace. The object of this is to remove the carbon and impurities which cause the cast iron to be brittle. The bars obtained from the puddling process are then passed between rollers of various shapes. Plates are obtained by passing the heated bars between straight rollers.

WROUGHT-IRON TUBES. There are three weights of wrought-iron tubing in general use, e.g. gas, water, and steam. They are made from special strip, rolled from bars of puddled pig

iron: the strip is folded around a core, the edges being welded together by a butt or lap welded seam.

EARTHENWARE

Earthenware Pipes are made from clay found in Dorsetshire and Devonshire, while fireclay comes chiefly from the Midlands.

The method of manufacture is by a machine consisting of a mould, hopper, and ram. The clay is placed in the hopper, at the bottom of which is the mould; the ram descends and completely fills the mould with clay, the socket or collar of the pipe being at the bottom and secured to the upper part of the mould by clips. The clips are then released and the pipe is forced out through the bottom, where it is cut off by a wire to the desired length. It is then trimmed, and the grooves on the socket and spigot are formed. The articles are next dried and then fired in a kiln, and whilst in the kiln are glazed by the volatilization of salt.

ALLOYS

An *alloy* is a mixture of two or more metals and is obtained by fusing these metals together. A proper alloy is an intimate mixture but not a chemical compound. Although metals can be made to combine, they can again be separated. When melted down and mixed together, if they are allowed to stand, the metals will separate owing to their different specific gravities, the heavier metal sinking to the bottom of the pot and the lighter rising to the top. It is for this reason that the plumber should always stir the solder well before taking out a ladleful to wipe a joint. In Tables I, II, and III are given the chief alloys that are of interest to plumbers.

On referring to the list it will be seen that *gun metal* is composed of copper and tin.

TABLE I
ALLOYS

Alloy	Copper	Zinc	Tin	Lead	Iron	Nickel
Brass, Ordinary	2	1				
.. Turning	3	1				
Pot Metal	2½			1		
Bronze Cocks	88	10	2			
Gun Metal	90½		9½			
Bell Metal	4		1			
Muntz Metal	3	2		100		
Gedge's Metal	60	38.2			1.8	
Babbitt's Metal	4	9	96			
White Brass	3		90			
German Silver	8	3.5				3
Pewter			4	1		

TABLE II
SOFT SOLDERS

Tin	Lead	Bis-muth	Melting Point, F.	Solder
1	2		441°	Plumbers
2	1		340°	Tinmen and zinc-workers (copper bit)
1	1		320°	Blow-pipe
1	1	2	203°	Pewterers
1	1	1	254°	Very fine

TABLE III
HARD SOLDERS

Copper	Zinc	Silver	Brass-wire	Solder
2	1			Spelter (hardest)
3	2			.. (hard)
1	1			.. (soft)
2	2	¼		.. (fine)
1		3		Silver (hard)
		2	1	.. (soft)

This metal is used for making valves, cocks and fittings for use in water and steam-fitting works. Copper alone would be too soft to stand the wear and tear of continual use, but by alloying the copper with tin we get a much harder substance more suitable for the purpose. By alloying two parts copper and one part zinc, we get brass of a second quality, whilst the better quality is a mixture of three parts copper and one part zinc.

Ternary Alloys. Two alloys of lead have been introduced by the British Non-Ferrous Metals Research Association. They are known as B.N.F. lead alloys and are formed in one case by adding to the lead ¼ per cent of cadmium and ½ per cent of antimony, and in the other case by adding ¼ per cent of cadmium and 1½ per cent of tin. These alloys have a much greater resistance to vibration than pure lead and are approximately one-third stronger than ordinary lead in other respects. Their use for water pipes above ground inside the building has been approved in weights 30 per cent lighter than ordinary lead pipes. From tests made, the resistance to frost is the same as that of thicker lead pipe of equal strength which they replace. The alloys lend themselves perfectly to bending and soldering and tend to give a brighter surface. Tellurium lead is another recent alloy. In addition to its improved qualities over ordinary lead pipe, it becomes actually stronger under strain, similar in effect to the way copper behaves in the soft annealed state.

MODERN BUILDING CONSTRUCTION

SOLDERS

The *soft solders* are those used by the plumber for jointing lead pipes, tinning brasswork preparatory to wiping to lead pipe, making fine solder seams with the copper bit, etc. The zinc worker and tinsmith use copper-bit solder for making their seams and joints.

The pewterer, owing to the low melting point of pewter, uses a solder with a very low melting point, the heat being applied by means of a small blow-pipe.

The hard solders are used for brazing copper, brass, and iron tubes and fittings. They require

in a handful of powdered sulphur; a thick crust will form on the surface of the solder, and this crust should be carefully removed, if possible, in one piece. This is termed *burning out the solder*, the sulphur cleansing it and bringing the poisonous substance to the surface. Care should be taken when cleansing a pot of solder to have an open flue to the fireplace, as sulphur fumes are given off in the form of sulphur dioxide. To clean out any traces of sulphur, add a small piece of tallow and resin, stir up, and ignite the vapour.

Tinman's and Zinc-worker's Solder is cast into

TABLE IV
LOW-TIN SOLDER

Argent Grade	Composition			Freezing Temperatures				Corresponding B.S. Grade
	Tin %	Silver %	Antimony %	° C. Solidus	° C. Liquidus	° F. Solidus	° F. Liquidus	
Argent Q 380	38	1.22	1.70	180	227	356	441	B
Argent T 300	30	0.63	---	178	251	352	484	G
Argent Q 330	33	0.90	1.70	180	238	356	460	M
Argent Q 180	18	0.39	0.89	180	271	356	520	D

a very much higher temperature to melt them: a brazing lamp, oxy-acetylene blowpipe or gas blowpipe with foot bellows is necessary. The coppersmith solders or brazes the dovetail joint used in making sheet-copper articles with hard solder, the copper requiring to be brought to a bright red heat during the process. The apparatus generally used is known as a *brazing hearth*.

Plumbers' Solder. This is an alloy of lead and tin in the proportion of two parts lead and one part tin. It is usually cast into bars of eight, and weighs approximately 56 lb. per cast.

The characteristics of good plumbers' solder are briefly: The ends of the bars should have a bright appearance; there should be several white spots about the size of peas. It should work somewhat like butter, so that fat edges do not work up on the joint or tears form on the underside of a horizontal joint. When solder contains an excess of tin it will be found to stick to the cloth. The best method of testing solder is to wipe a joint and note how it works.

It often happens that a pot of plumbers' solder becomes *poisoned*. This may be due to the presence of zinc which renders the solder useless. It can be remedied by heating the solder in the usual way over a fire and stirring

sticks, each weighing approximately $\frac{1}{2}$ lb. If a stick is held close to the ear and bent, a slight cracking should be heard, indicating the presence of a fair proportion of tin in the solder. Modern stick solders for use with the blow-lamp contain a small percentage of antimony to reduce the amount of tin required. While this reduces appreciably the amount of tin needed, the balance of antimony must bear a definite ratio to the whole, hence it is not suitable as a pot solder in which the proportions vary day by day.

Low-tin Solder. Urgent need for economy in the use of tin brought on to the market a number of solders of various alloys found by experiment. One recommended fine solder, known as T.M.5, for general work with blow-lamp or copper bit, consists of 91 per cent lead, 5 per cent tin, and 4 per cent antimony. Its melting point, however, is high (about 540° F.) and it is not so easy to use as ordinary rich tin-lead alloys. Tables IV-VI are issued by the British Standards Institution with a view to encouraging economy in tin.

The essential composition of these B.S. solders and their melting points are given in Table IV, but normal solders with a lower tin content should be used wherever possible; and with a view to establishing economy in the use of

tin alloy solders for ordinary wiped solder joints, etc., these further recommendations have been made by the British Standards Institution:

The extended use of welding, lead-burning, and brazing in place of soldering; the adoption of alternative methods, such as the cup and cone joint for plumbing; reduction in size of wiped solder joints; the use of substitute solders with little or no tin in hard metal

In addition to the above list, there are several good fluxes in paste, liquid, and powder form; among these may be quoted Fluxite, Baker's Fluid, and the various welding and brazing fluxes supplied by the British Oxygen Co.

Plumber's Soil, or Smudge. This is a mixture of lampblack and glue size mixed to a stiff paste. There are also other good forms on the market; one is a powder that simply needs mixing with

TABLE V
ANALYSES OF B.S. SOFT SOLDERS

B.S. Grade	Use for which the Solder is Primarily Intended	Tin per cent		Antimony per cent		Lead	Impurities			
		Max.	Min.	Min.	Max.		Alu- minium, Zinc, or Cad- mium	Iron	Arsenic	Total
								per cent	per cent	per cent
C	Tinsmiths', coppersmiths' fine work, general work.	40.0	39.0	2.0	2.40	The remainder	0	0.02	0.05	0.25
D	Lead cable, wiped joints, plumbers' wiped joints .	30.0	29.0	1.0	1.70		0	0.02	0.05	0.25
G	General electrical purposes, tinned electrical joints. Zinc and galvanized iron-work	42.0	41.0	—	0.40		0	0.02	0.05	0.25
M	Special tinsmiths' fine work and hand soldering	45.0	44.0	2.3	2.7		0	0.02	0.05	0.25
N	Dipping solder, for radiator manufacture, etc.	18.5	18.0	0.75	1.0		0	0.02	0.03	0.25

soldering; and the use of lower tin content solders where tin-lead alloys are necessary. (See Table V.)

FLUXES

A flux is a substance used to prevent the oxidation of metals to be soldered, and also to assist in the flowing of molten metals and the adhesion of the solder to the metal. Without the aid of a flux, oxidation, or *tarnishing*, would occur; the result would be a faulty joint or seam, as the case may be.

Chloride of zinc (more commonly known as *killed spirits*) is obtained by dissolving zinc in hydrochloric acid, the hydrogen being given off and leaving chloride of zinc. This may be used as a flux for soldering brass, copper, and iron, but should not be used for tinning brass or copper unions and fittings previous to wiping joints, owing to the presence of the zinc (see note on poisoned solder).

Table VI gives a list of the fluxes in general use.

TABLE VI
FLUXES

Material	Flux
Lead with Fine Solder	Resin and Tallow
Lead with Coarse Solder	Tallow
Tin and Zinc	Chloride of Zinc
Brass and Copper with Soft Solder	Resin
Brass and Copper with Hard Solder	Borax
Pewter	Gallipoli Oil
Aluminium	Stearic Acid

water, and another is in the form of a block similar to blacklead, and only requires a wet brush to moisten it. The work to be soiled is first cleaned by cardwire, then well rubbed with chalk to assist in *killing* the grease. The soil is applied by means of a brush; to dry the soil quickly slight heat may be used.

Chapter III—PIPE JOINTS

LEAD PIPES

THERE are several methods of joining lead pipes by means of fine and coarse solder.

Wiped Joint. Fig. 28 shows a *plumber's wiped joint*. The method of preparation is to rasp the ends of the pipes square; one end is opened out by means of a turnpin, and the other end is

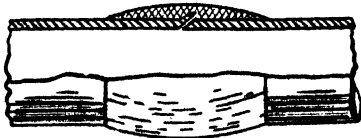

FIG. 28. WIPED JOINT

slightly tapered with the rasp to fit well into the opened end. The pipes are then "soiled" with lamp-black to prevent the solder from sticking for a distance of about 6 in., and when dry are marked with the joint gauge. The ends are shaved perfectly clean with a shavehook and rubbed over with tallow (or "touch"), as a flux, after which the pipes are entered and firmly

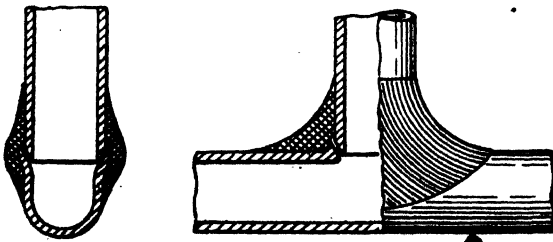

FIG. 29. BRANCH JOINT

quicker at this point; unless this is done an ugly thick edge is the result.

For an upright joint a lead collar is used. The solder is splashed on to the joint, and the collar—which is fixed just beneath—catches the solder; this is continued until sufficient solder is splashed on. By means of the splash-stick the hot solder is picked up from the collar, and this, together with that on the joint, enables the plumber roughly to mould the joint and wipe it smooth, as with the underhand joint. The chief points to remember are: a good heat, clear the edges, and quickness in wiping; these points apply to all wiped joints.

Branch Joint, Fig. 29, shows a branch joint. It is prepared by piercing a hole in the main pipe which is opened out, by means of a bent bolt and hammer, to form a lip around the opening as shown.

The branch pipe should now be rasped square and tapered down slightly to form a good fit into the main pipe, but it must not project inside. The pipes are now "soiled," the shape of

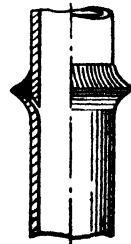

FIG. 30. TAFT OR FLANGE JOINT

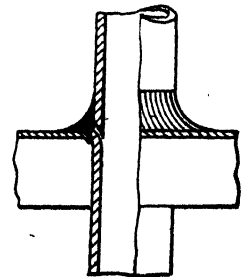

FIG. 31. BLOCK JOINT

fixed with steel fixing points and tie-cords ready for wiping. In the case of an underhand joint, the solder is poured on to the pipe from a ladle, the wiping cloth being held beneath the pipe to catch the metal and work it round the whole of the joint until a proper wiping "heat" is obtained. By a few quick movements the joint is roughly moulded into shape, and finally wiped to a smooth surface with the cloth. It is necessary to clear the edges of the joint first, as the solder or metal cools much

the joint on main pipe being marked out by means of scribing gauge and compasses. The branch, or entry, pipe is marked with the joint gauge. The pipes are then shaved and smeared with "touch" and firmly fixed. The method of wiping is similar in all respects to an upright joint, except that a collar is used only if the branch joint is to be wiped in an upright position. For a horizontal branch a small platform can generally be fixed up to catch the surplus solder; of course, when wiping on the

bench, this is unnecessary, as the bench itself acts as a platform.

Flange Joint, Fig. 30, sometimes called a *taft joint*, is about the simplest type of joint. One end is opened out by means of a short thick

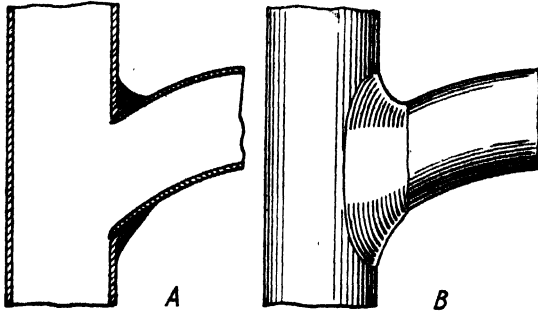

FIG. 32. UPRIGHT JOINT CONNECTING BRANCH WASTE PIPE

turnpin and shaved clean inside. The entry pipe or male end is shaved clean; a little tallow and resin are used as a flux, and fine solder is melted in by means of a blow-pipe or lamp. Another method is to use only tallow and coarse (wiping) solder, and finish the joint by wiping round with a very narrow cloth, leaving what is termed a *finger-wipe*.

Block Joint, Fig. 31, is another example of an upright joint; it is used where pipes are fixed in a chase inside a building. Stout wood blocks, with holes the size of the pipe cut in them, are built in the wall on either side of the chase; the pipes are prepared, and then passed through the block far enough to form the joint. A lead collar is passed over the top end of the first length, which is then opened; the next length is then placed in position, and the whole wiped as shown in the drawing. It not only makes a most reliable joint, but a good fixing. Where lead pipes pass through lead flats a joint of this description is used, the leadwork of the flat forming the collar piece.

Fig 32 (A) shows the method of connecting a branch waste pipe to a vertical waste pipe, the end of the branch pipe being bent slightly in the direction of the flow. Fig. 32 (B) shows a view of the finished joint.

Amalgaline Joint (Fig. 33). This joint was introduced some years ago and was used to a limited extent, but recently attempts have been made to revive it. The joint is made by means of closely-fitting male and female joints cut in the ends of abutting pipes. This involves the use of a pair of metal cutters, one for the

male and the other for the female connection. The cutters are mounted on spindles of the same diameter as the bore of the pipe. To make the joint, a prefluxed solder foil is wrapped round the male cone, the two pipes held tightly together, and heat applied with a blow-lamp. The solder foil should be rolled from solder of B.S. Grade M.

For lead to lead joints, the Amalgaline joint is economical both of solder and lead, but it is not so suitable for thin-walled pipes such as are used for soil pipes.

Expansion Joint. Where hot water is used, and the waste pipes are of lead, it is necessary to fit them with expansion joints, Fig. 34, more especially if the pipe is of any great length, owing to the expansion and contraction caused by the varying temperatures to which the pipe is subjected.

The joint is prepared by forming a socket on the end of a length of pipe by means of an expanding mandril; this operation expands the pipe, for a length of 6 in., large enough to receive the spigot end of the next length and two rubber

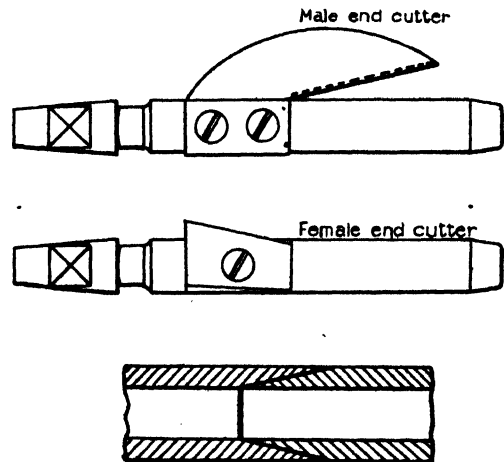

FIG. 33. AMALGALINE JOINT

or asbestos rings. A pair of astragals and cast-lead tacks are then soldered to the socket for fixing the pipe to the wall, the astragals giving the socket a finished appearance; the spigot end is slightly opened. A lead capping piece is placed on the top of the joint to prevent dirt, etc., from getting in.

BRASS-TO-LEAD JOINTS

Blown Joint, Fig. 35, is chiefly used in gas-fitting when jointing brass unions to lead or

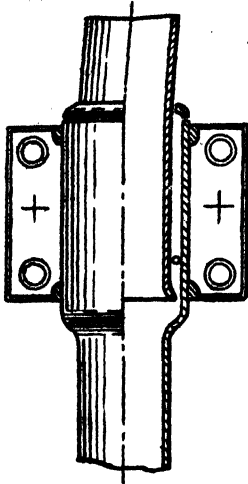

FIG. 34. EXPANSION JOINT

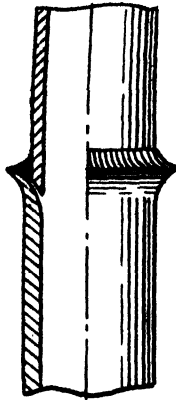

FIG. 35. BLOWN JOINT

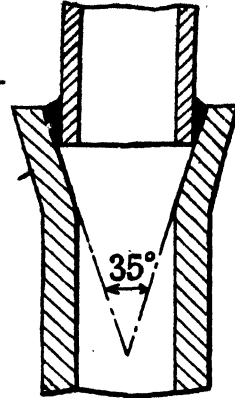
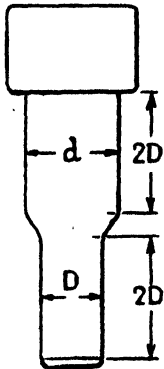
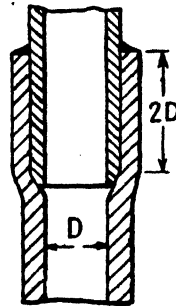

FIG. 36. CUP AND CONE, OR FINGER WIPE JOINT



(a) Mandrel



(b) Lead Pipe to Brass Fitting

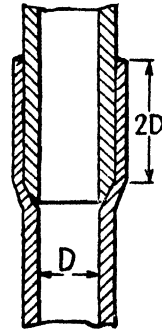

(c) Joint in Thin-walled Pipe

FIG. 37. SPIGOT AND SOCKET JOINT

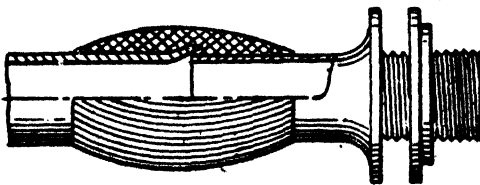

FIG. 38. CISTERN CONNECTION WITH SINGLE-NUT BOILER SCREW

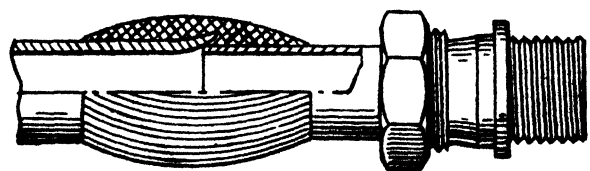

FIG. 39. LEAD-TO-IRON UNION JOINT

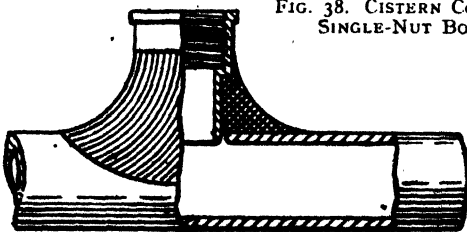

FIG. 40. BRANCH JOINT FOR TAP CONNECTION

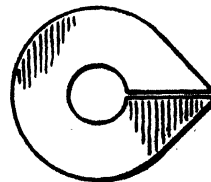

FIG. 41. LEAD COLLAR

compo pipe. The preparation is the same as for the flange joint, and the solder is melted in by means of a blowpipe flame. Fine solder is used for this joint.

Cup and Cone, or Finger Wipe Joint. For a joint to brass union, the lead pipe end is opened as shown in Fig. 36, and the tinned brass fitting

tin, they have proved of practical value and show that economies in normal practice are still possible for some purposes. Nevertheless, the wiped solder joint is still the most suitable for pressure work.

Cistern Connection. Fig. 38 shows a single-nut boiler screw wiped to a lead pipe, for making

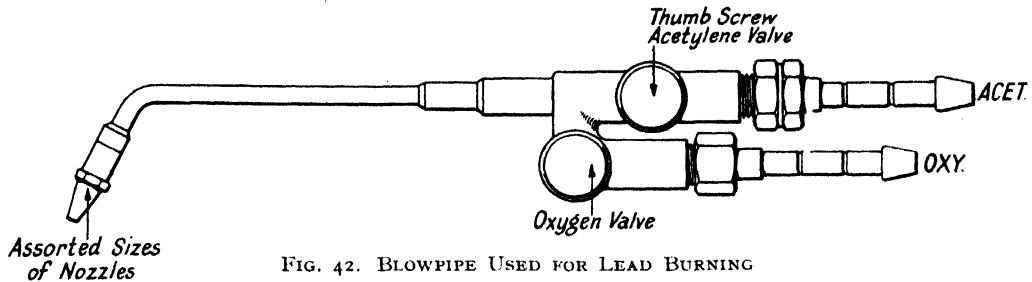

FIG. 42. BLOWPIPE USED FOR LEAD BURNING

entered. Coarse solder is then wiped flush, as shown, similar to the taft or flange joint, but using less solder. Widely used in the gas industry, this joint takes up only a small proportion of the solder required for a wiped joint.

Spigot and Socket Joint (Fig. 37). This joint is even more economical in the use of solder than is the cup and cone joint, and it is rather stronger. The end of one pipe is opened out to form a socket by means of a mandrel having two cylindrical portions of suitable diameters (Fig. 37). The end of the other pipe, which should be bevelled or tapered, is then inserted in the socket so that it fits snugly in the bore

the connection to a cistern. Boiler screws can be obtained with either single or double nuts and with threads of different lengths suitable for iron, fireclay, or slate cisterns. The advantage of the double nut is that it can be tightened up from inside or outside the cistern, and will allow of a little adjustment.

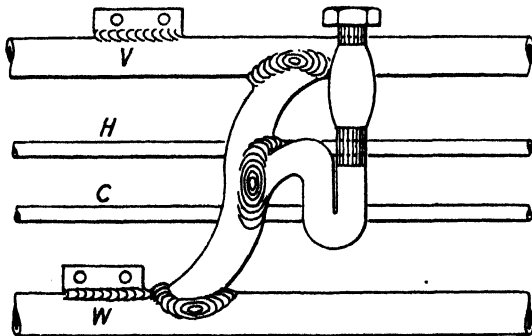

FIG. 43. LEAD BURNING IN SANITARY WORK

and on the shoulder. Placing the joint in an almost vertical position, solder is then run in by means of a blowpipe flame. When used for lead to lead joints, an additional length of pipe is required for the overlap.

Although the low-tin content solders were intended as an expedient to meet a shortage of

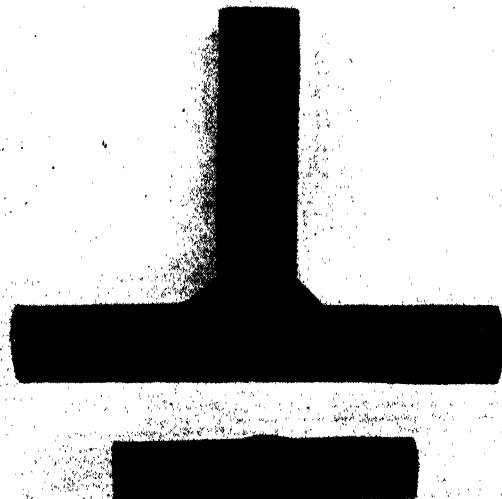

FIG. 44. LEAD-BURNT JOINTS ON LEAD PIPES

Lead-to-iron Pipe Connection. This joint, Fig. 39, is formed by a brass union, consisting of a cap and lining and a nipple piece screwed for iron. The lining is wiped to the lead pipe, the brass or bronze nipple is screwed into the socket of the iron pipe, and both connected up by means of the cap and lining. This union is

MODERN BUILDING CONSTRUCTION

sometimes termed a *lead-to-iron union*, or a *nipple union*.

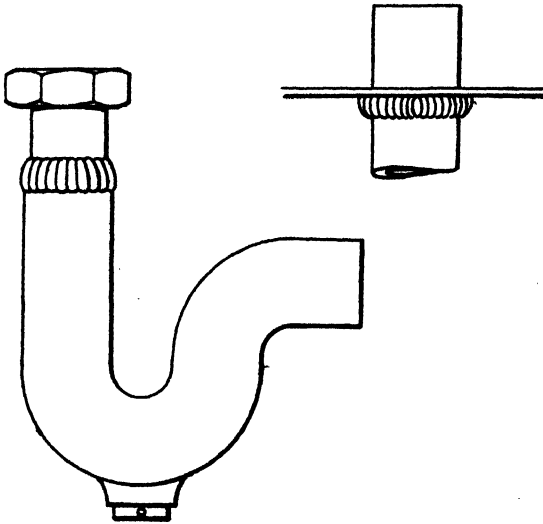

FIG. 45. LEAD-BURNT JOINTS ON LEAD PIPES

Tap Connection. Fig. 40 shows the joint required for fixing a tap to lead pipe, and consists of a brass screw boss wiped to the lead by a branch joint. The pipe is opened as described for a branch joint; the brass boss is "tinned"

and fitted to the pipe, and joined by a wiped solder joint. The *stop end* may be formed in a number of ways; one method is to rasp the end of the pipe tapering, then boss over square, and finish with a wiped convex end of solder, as shown at the right. The interior of the boss is screw-threaded to receive the tap.

BRASSWORK. The preparation of brasswork ready for soldering to lead pipes needs care and attention. The brasswork to be wiped is first filed quite clean and then "soiled" to the length required. A flux of resin or fluxite is then placed on the filed portion, and with a copper bit and fine solder a coating or film of "tinning," i.e. solder, is formed on the brass, which is then securely fixed to the lead pipe ready for wiping; this "tinning" causes adhesion of the solder and thus makes a sound joint. Killed spirits of salts should never be used for tinning brasswork, as, being a chloride of zinc, it would not improve the wiping solder owing to the presence of zinc.

Fig. 41 shows a collar used for catching the solder when wiping upright joints. It is cut out of a piece of sheet-lead, well "soiled" to prevent the solder adhering by tinning, opened out at A, and placed round the pipe in the form of a shallow cup or basin. It is the usual procedure



FIG. 46. OXY-ACETYLENE OUTFIT FOR LEAD BURNING IN USE ON SHEET LEAD

to have several collars of different sizes on the job.

Lead-burnt Joints. This form of joint has hitherto been used only in chemical plumbing, but, with the portable lead-burning equipment now available, the burning or fusing of lead pipe is often applied to domestic plumbing. Such joints are made on the bench where the work can be turned about for convenience. Stick lead is used in place of solder.

The process of lead-burning is to some extent taking the place of soldering in ordinary plumbing. It consists of uniting the edges of piping or sheet lead by means of an intensely hot and concentrated needle-like flame. It is, in effect, welding, and a gas-flame similar to that

necessary position for easy burning. (See also "Chemical Works Plumbing," Chapter XIII.)

IRON PIPES

Iron pipes are joined by means of screw threads and sockets, flanges, welding or by caulking, according to the size and kind of pipe and the nature of the job.

Wrought-iron and Mild Steel Pipe. The method chiefly used at the present time for wrought-iron and mild steel pipes is the *screwed thread and socket joint*. The pipe can be obtained in lengths varying from 1 ft. to 20 ft. Each length is supplied with a socket, and is threaded both ends to the standard gauge. In carrying out screwed iron-pipe work, a great number of

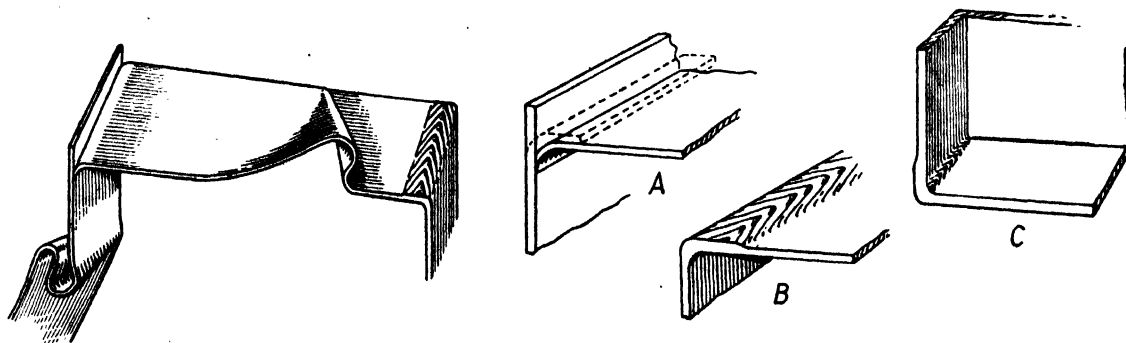

FIG. 47. ORDINARY CORNERS IN SHEET LEAD WORK

used in welding hard metals is used. The flames suitable for lead-burning are: aero-hydrogen, oxy-coal gas, and oxy-acetylene. Oxy-coal gas is employed to a large extent in factories and schools of plumbing, etc., where a coal gas supply exists. The easiest to control in any position is the oxy-acetylene flame.

Fig. 42 shows the type of blowpipe used; it is very light and only about 7 or 8 in. long. Fig. 43 shows one trap of a range connected to the waste and ventilation pipe as under a range of wash-bowls. A wiped joint is shown for connection to the brass union, but even this could be lead-burnt. Figs. 44 and 45 show practice joints on lead pipes.

Fig. 46 shows the apparatus and method of application for sheet lead. Fig. 47 shows ordinary corners in sheet lead work. Inset drawing A shows the preparation. The shaved up-standing edge is used as a feed, and welded down to give the appearance of sketch B. The inner edge can be knitted down with the flame as shown in C. The large drawing shows how a lead bay can be bent up to get the

threads must be cut owing to the many different lengths that are necessary; to carry this out efficiently a good set of *stocks and dies* is required, or, better still a *thread-screwing machine*. Although the latter is an expensive item, its cost will be fully recovered if large quantities of threads are required; and this is generally the case on a job of any size.

The pipe may be cut with a hack saw or a wheel pipe cutter. The latter usually leaves a burr, which must be removed from the interior with a reamer and from the exterior with a file. This filing operation also leaves a clean surface for the dies, which are now run up the pipe the required distance; the cutting edges of the dies being protected by a liberal application of a suitable lubricant. The threads on the pipe and inside the socket or other fitting are then smeared with a jointing compound, after which they are screwed together by hand and finally tightened by means of a Stillson wrench or chain tongs. The use of hemp as a packing medium for screwed joints has been discontinued where British Standard Taper threads are used in

MODERN BUILDING CONSTRUCTION

conjunction with taper threaded fittings; the use of these taper threads ensures a metal-to-metal joint throughout the whole length of the engage-

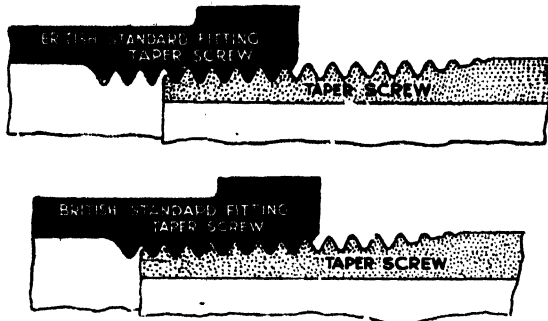

Crane, Ltd.

FIG. 48. BRITISH STANDARD TAPER THREADED FITTINGS

Top. Taper threaded pipe. All threads engaged in a metal to metal joint when only hand tight
Bottom. Taper threaded pipe, wrench tight

ment of the threads. The chief thing to be observed is to clean the threads before applying the jointing compound, as small pieces of metal

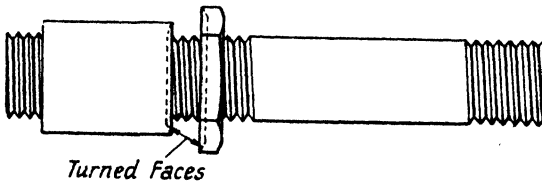

FIG. 49. CONNECTOR

or grit set up friction which may cause damage to the threads, and probably an unsound joint. With these taper threads, very little tightening with the wrench is required to make the joint sound (Fig. 48). Where parallel threads are used it is necessary still to use hemp together with a jointing compound.

Where there are two fixed units, as between boiler and hot store vessel the last joint made on the pipe between the two needs a special form of coupling.

Fig. 49 shows what is termed a *connector*; it consists of a running thread and socket with a back-nut and a thread on the tail end to screw into a socket or other fitting; a connector is necessary where two free ends of pipe are required to be joined up. A glance at the illustration will show how this is done; the pipe

to be connected has the thread butted against the running thread of the connector. Solution and hemp is applied; the socket is run on and

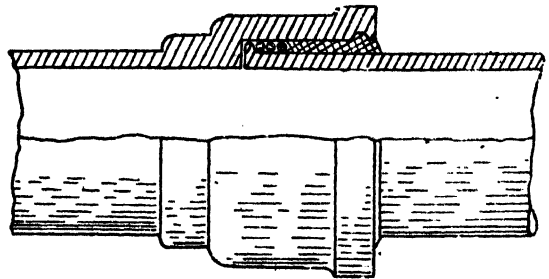

FIG. 51. CAULKED LEAD JOINT

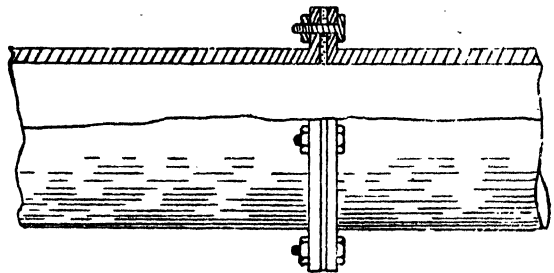

FIG. 52. FLANGE JOINT

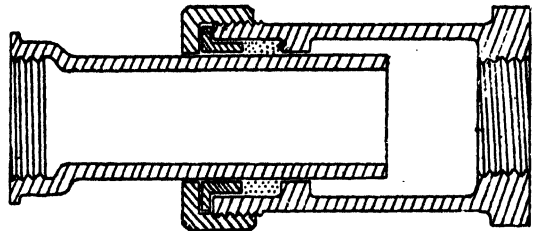

FIG. 53. EXPANSION JOINT FOR SCREWED TUBE

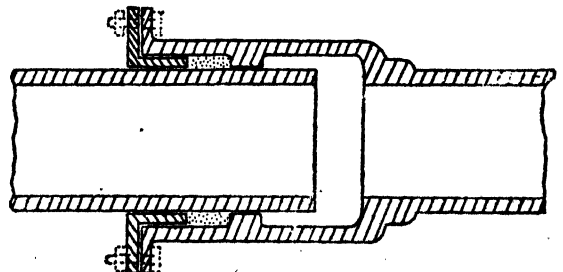

FIG. 54. EXPANSION JOINT FOR CAST-IRON PIPE

screwed home tight; a *grummet* of hemp, smeared with solution, is placed between the back edge of socket and back-nut, and the latter is then screwed home tight, thus making a sound joint with the grummet as a packing



(Crane, Ltd.)

FIG. 50

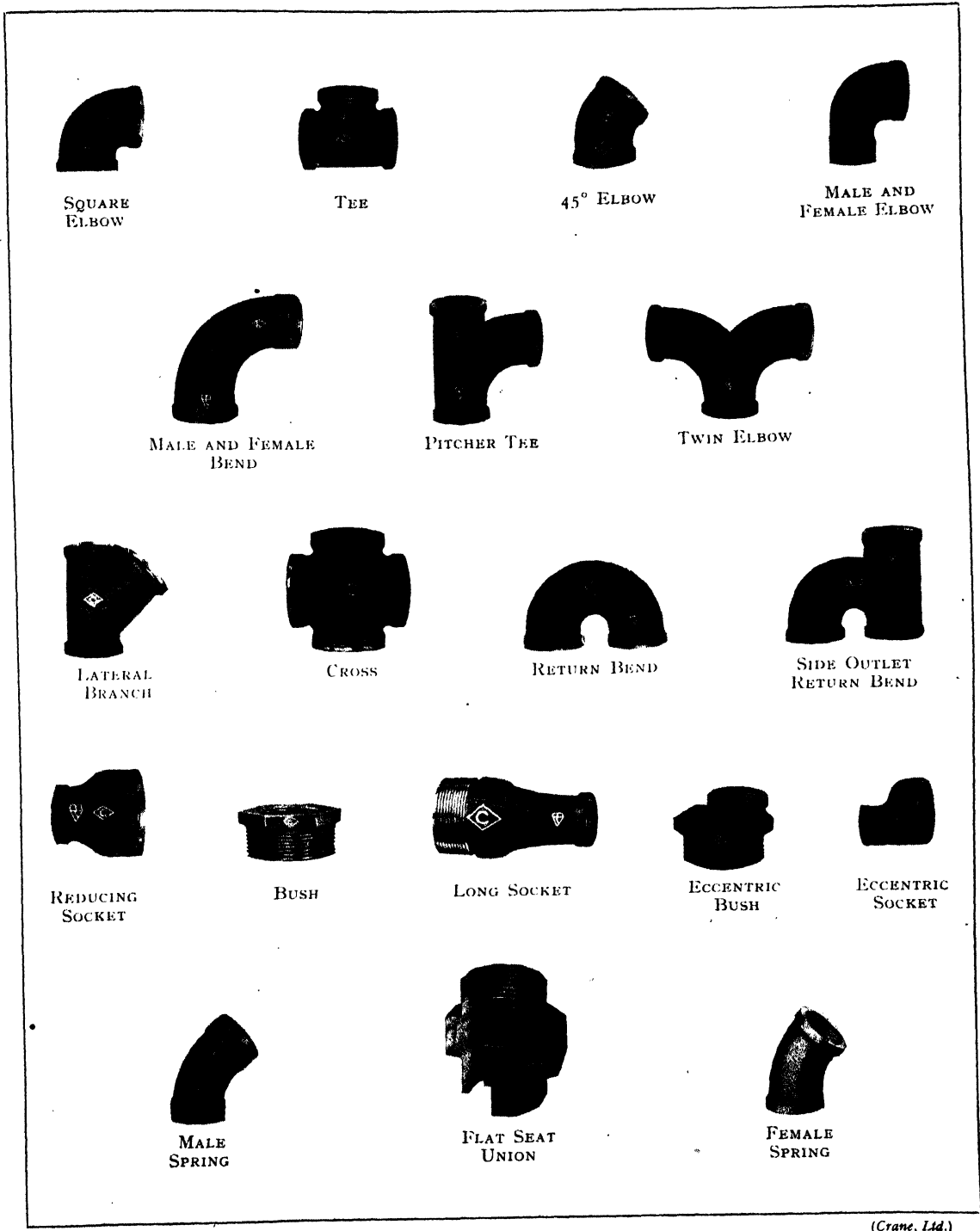

(Crane, Ltd.)

FIG. 55. MALLEABLE IRON FITTINGS FOR USE WITH MILD STEEL AND WROUGHT IRON PIPING

MODERN BUILDING CONSTRUCTION

medium. It will be noticed that the tail end of the socket and face of the back-nut are turned to enable the packing of hemp to be held in position. In place of connectors, malleable iron or gunmetal unions with metal-to-metal seatings are now often used (Fig. 50).

Cast-iron Pipe. Fig. 51 shows a section of a lead-caulked joint; it is used chiefly for water and gas mains, also cast-iron drain pipes. A few strands of *gasket* (or *yarn*, as it is sometimes called) is first caulked well into the socket; molten lead or lead wool is then used as the jointing medium. For molten lead joints on horizontal pipes a band of clay is first placed around the edge of the collar, with a lipped opening on the upper side for pouring in the lead; a more up-to-date method is to use an asbestos collar to retain the lead as it is poured

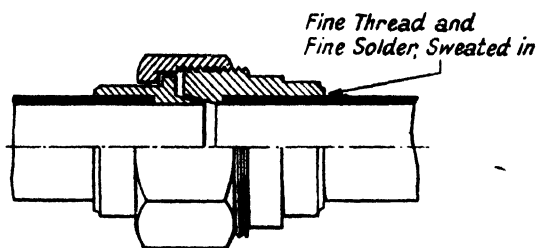

FIG. 56. SCREW COUPLING FOR BRASS OR COPPER PIPE

in. The band is now removed and the lead well caulked into the socket with caulking chisels (Fig. 20), the surplus being neatly trimmed with a sharp chisel.

Cast-iron hot-water pipes for low pressure work, such as warming for horticultural purposes, are sometimes jointed by caulking in gasket and red and white lead; this is a very good jointing medium, providing that due regard has been given to expansion and contraction.

Fig. 52 shows a simple type of *flange joint*, the packing being either of rubber, asbestos, or corrugated metal rings.

Figs. 53 and 54 show two types of *expansion joint*.

Fittings. The fittings used with screwed iron tubing are of two kinds, wrought and malleable iron. The latter are now extensively used. They are neat and smooth in appearance and are designed to meet every modern requirement; they possess many advantages over the wrought fitting. Fig. 55 shows various types.

Welded Joints. The welding of pipes by the oxy-acetylene or electric process is now applied to many installations. One example is in a

panel-heating system: the coils are of $\frac{1}{2}$ -in. pipe with welded joints, and in many instances, the branch pipes to the various coils are welded into the main risers at each floor. It should be pointed out that the piping is severely tested for leaks before being covered up. Welded joints are also used for brass and copper pipes. See "Welding and Pipe-Bending" (Chap. IV).

BRASS AND COPPER PIPES

These pipes may be joined by screw threads, welding, soft soldering, brazing, and union or coupling joints. In the case of copper pipe, compression joints are now extensively used. The type of joint depends upon the substance of the pipe and the nature of the job. If screwed thread and socket joints are required, the pipe must be of a stout character, though the threads are much finer than those for iron pipe. Welded joints in light gauge copper tubing may be made in a variety of ways, such as butt joints, bell joints, and sleeve joints; special fluxes and feed rods are easily obtainable for this purpose.

The coupling joint (Fig. 56) consists of a cap and lining and a nipple or bush piece; the lining and bush piece are either soft soldered or brazed to the ends of the pipes and the joint completed by screwing the cap on to the nipple. These couplings are now usually made with metal-to-metal seatings, a grummet not being required.

Fig. 57 shows a very good type of compression joint known as the "Kongrip"; special fittings are obtainable for making these joints. The union, or bush, pieces are slipped over the pipe; the ends of the latter are filed square and opened by means of a tapering steel mandril; the nipple is then placed into the opened ends and the cap screwed on and tightened up. The operation is very simple, and another distinct advantage is that each fitting is a connector in itself. Fig. 58 (A) shows an *elbow*, or *bend*; (B) a *connector to iron*; (C) a *steel mandril* for expanding the ends of the pipe.

Fig. 59 is a sketch of the "Instantor" compression joint and Fig. 60 the "Kontite" compression joint. Fig. 61 is a light form of compression joint designed to reduce cost and suitable for waste pipes, etc., in light gauge copper. Fig. 62 shows another form made for pipes 3 in. to 6 in.

Owing to the rather high cost of these fittings in the large diameters, other means of jointing can be adopted for positions where the pipe need not be taken down for clearing, etc.

Capillary Solder Joints. It has been proved

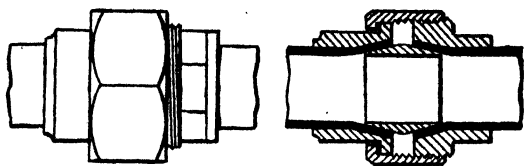

FIG. 57. COMPRESSION JOINT, COPPER PIPE WORK

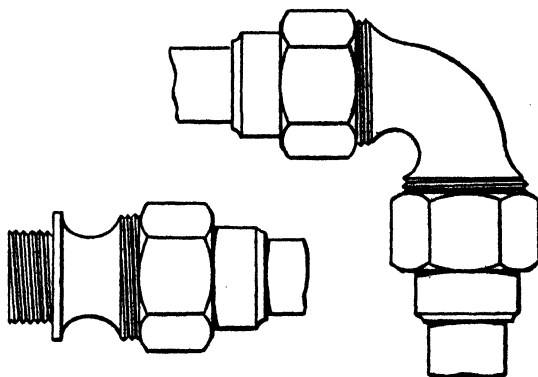

FIG. 58. (A) ELBOW; (B) CONNECTION TO IRON; (C) STEEL MANDRIL

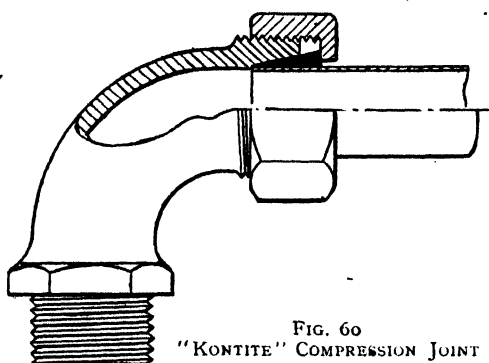

FIG. 60
"KONTITE" COMPRESSION JOINT

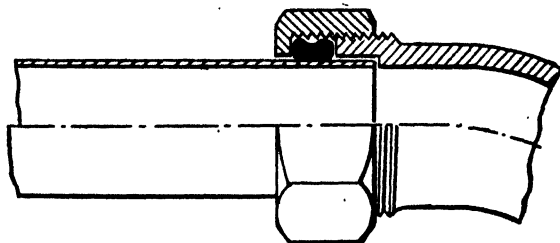

FIG. 59. "INSTANTOR" COMPRESSION JOINT

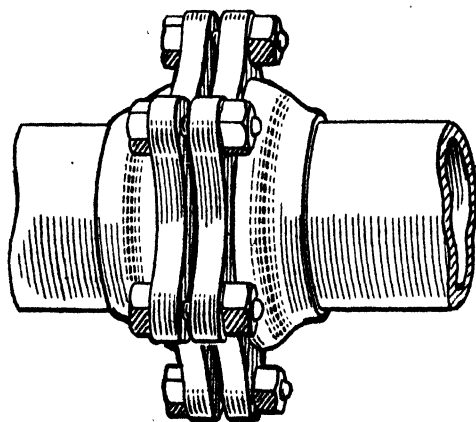

FIG. 62. "SECUREX" PATTERN COMPRESSION JOINT FOR 3 IN. TO 6 IN. PIPES

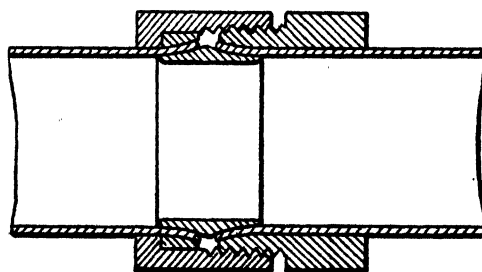

FIG. 61. LIGHT TYPE OF COMPRESSION JOINT

MODERN BUILDING CONSTRUCTION

that if the correct spacing or tolerance between the copper pipe walls and the inner walls of the fitting is given, fine solder will seep up, no matter in what position the joint is made, to completely fill the space between and so form a sound, strong joint. That they can be perfectly sound has been proved by the hydraulic pressure test and by torsion or mechanical pull. In each case the wall of the pipe yielded, but the joints remained sound. On the other hand, cases of failure have occurred in practice. The causes of failure have usually been found to be derived from the following mistakes: (1) Joints not properly cleaned, or cleaned with emery cloth. The least trace of emery on the

nique if he wishes to be a good all-round man. The manipulative process can easily be mastered, and satisfactory work carried out. The beginner, however, should attend classes, because it is easy to form bad habits and produce unsound work if the correct technique is not closely followed in the early stages. While reading a good technical work on the subject is helpful, and indeed important, the correct manipulation of blowpipe and filler rod can be gained only by practice at the bench. For light gauge copper pipes, bronze welding is the most satisfactory for work in situation.

Bronze Welding. A very useful joint for light gauge copper tube is made with oxy-acetylene

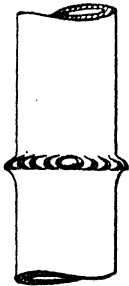

FIG. 63A

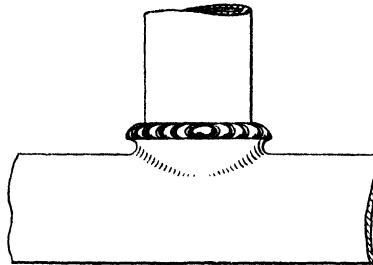

FIG. 63C

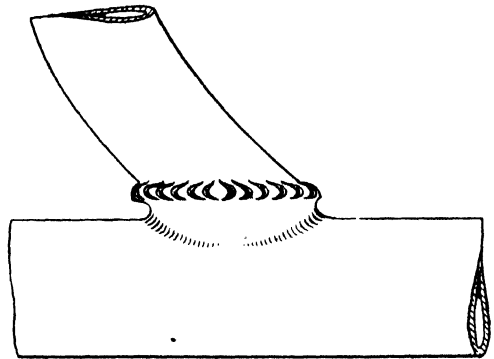

FIG. 63B

WELDED JOINTS IN COPPER TUBE

walls will prevent capillarity. Steel wool should be used. (2) The gauge of pipe and fittings used have been dissimilar. For instance, if 19 gauge pipe and 18 gauge fittings are used, the space between will be too wide for the solder to creep in by capillary attraction. Where the conditions have been reversed, i.e. 18 gauge tube and 19 gauge fittings, the pipe ends have had to be filed to get them in the sockets. Hand filing is not sufficiently accurate.

There are several forms on the market in which solder is applied at the edge after cleaning and fluxing. Another make has the solder already in an annular sinking within the fitting. A blow-lamp flame is applied and should be withdrawn when solder appears on the outer edge.

WELDING

Owing to the gradual changes, and the addition of hard metals in modern plumbing, every plumber should be practised in welding tech-

nique. It has recently been used with success on hot and cold water pipes and in sanitary work in copper. It consists of fusing spot by spot a rod of brass or bronze in the prepared joint. Fig. 63A shows the appearance of a straight or running joint, Fig. 63B a branch joint for sanitary work, and Fig. 63C another branch joint as used in small diameter pipes.

Fig. 64 shows an operator executing bronze welds on copper ventilating pipes *in situ* for internal plumbing, the pipes being carried in a duct built round them. An assembly of bronze welded joints, with compression joints at suitable points for dissembling them when necessary, is a sound proposition in building work.

BRANCH JOINTS. For small diameter tubes, a hole is drilled in the main pipe and enlarged by means of a bent bolt. To open easily and form a socket above the crown of the main, all blows on the bent bolt should be struck in an upward direction. For large diameters, the size of the branch is marked on the main pipe

and two holes drilled about $\frac{3}{8}$ in. inside the marks. The copper is softened with the blow-pipe flame, and a slit made between the holes with an old draw-knife struck by a hammer. The bent bolt is then entered and the hole enlarged, a piece of iron barrel being used to enlarge the hole still further. See Fig. 65 for method employed. When properly effected,

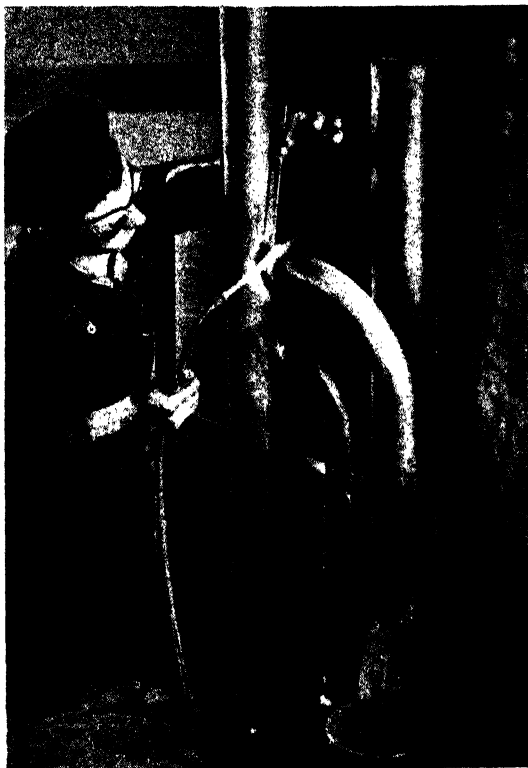

FIG. 64. EXECUTING BRONZE WELDS

the copper edge is raised, as shown in the photograph, to form a socket to receive the branch. The edge is then spread out slightly to receive the bronze welding rod. The secret of bronze welding is to use a slightly oxidizing flame and, after getting a start, add the next bead on the liquid bath of the preceding spot, running it forward with the flame. If the filler rod is melted only an eighth of an inch too forward, an oxide "cess" is formed between the two spots, and it will be found difficult to form a union. A suitable flux should be used.

JOINTS FOR IRON PIPES. For wrought iron and mild steel pipes, a filler rod of mild steel is

used. A flux is not necessary; but a carefully adjusted flame is essential. The size of the blowpipe tip must be in proper proportion to the thickness of the metal and to the mass of metal to be welded. To get penetration to the inner surface of the pipe walls, bevelling of the abutting edges is necessary in order that a vee gap is obtained. This vee is then filled with the filler rod, the operator making sure that both edges of the pipes are wetted (molten) simultaneously with the melting of the filler rod.

For a fixed pipe it is best to begin underneath and gradually work upwards to the top, working first one side up and then the other. The



FIG. 65. FORMING A SOCKET FOR A BRANCH JOINT

welded metal should be left slightly higher than the pipe surface to ensure strength of the joint. Care must be taken not to burn the welding metal. Beginners generally try to melt the rod on to the work as in soldering. This is entirely wrong because in trying to fuse it in, it burns and oxidizes the filler rod iron. The proper technique is to produce the molten bath on the pipe ends and melt the filler rod in it. The correct part of the flame must also be studied. The neutral zone only should come in contact with the iron. This zone is $\frac{1}{8}$ in. to $\frac{1}{4}$ in. from the end of the white luminous cone of the flame.

Chapter IV—PIPE BENDING

Lead Pipes. Thick lead service pipes need practically no tool work to form them. They are made by leverage of the arms on the pipe, the left hand clamping the pipe at the point on which the bend is formed. By a firm grip on the sides of the pipe, spreading of the walls of the pipe is checked.

Waste and ventilating pipes are relatively thin, and require a special technique. A full-size drawing of the required bend on the bench, or a spare piece of sheet metal, is an advantage. The walls of the pipe contained in the bend are

pipe full of tool marks. The experienced man makes these bends easily with a minimum amount of tool work.

For bends of large diameter lead pipe, a different technique is necessary. The lead pipe is heated on the section of the proposed bend and then lifted until a shallow kink is formed in the throat; a lead-loaded dummy is then entered and the kink knocked upwards until the true circular section is obtained. Surplus lead from the throat is dressed round to the back of the bend, thus completing one "throw."

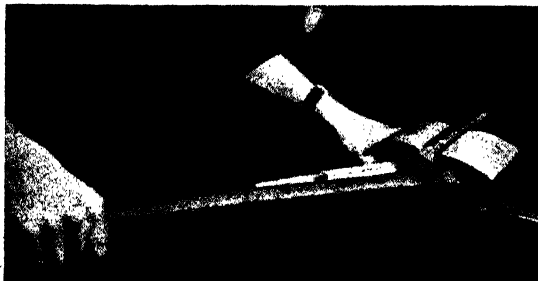

FIG. 66. HAND-BENDING SMALL DIAMETER PIPING

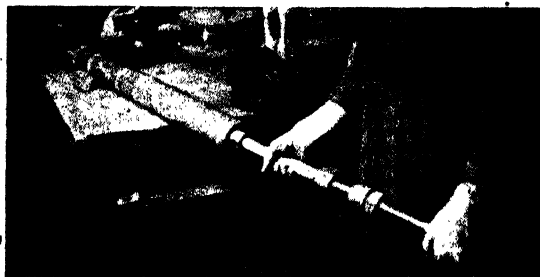

FIG. 67. ENTERING THE COMPRESSOR

dressed slightly elliptical, and the bend started by holding the pipe down with a pad on the thin edge of the ellipse, and lifting the free end of the pipe upwards. This is known as a "throw." When the bend tends to kink in the throat, the lifting is stopped and boxwood bobbins on a steel cable are driven round the bend to lift out the kink. The bobbins are then snatched back. The pipe should not be dressed with the bobbins in the bend. If the bobbins are stubborn, the cable is hitched round a heavy hammer-head, by means of which the bobbins are easily withdrawn. The pipe is heated with a soft flame and another throw given, but this time with the hand slightly away from the point of the last throw, to form an "easy" swept bend. The operation of driving the bobbins through the bend and snatching them back is repeated until the required angle is obtained. Beginners are usually inclined to rely too much on tool work to make these bends, and as a result the work is made difficult, the back of the bend unduly stretched, and the

The process is continued until the desired angle is obtained.

A square bend in a 4 in. pipe requires four or five throws to complete. A bobbin is snatched through with a back weight attached, or alternatively, driven through the bend and then snatched back with the cable. The throat is gently dressed with a boxwood bending-stick and, if a high finish is required, the bend is thrashed with a strip of sheet lead to take out tool marks.

Copper Pipes. The thinner the walls of a pipe, the more difficult it is to make bends in it successfully. One difficulty has, however, been largely overcome by modern methods. Fig. 25 *A* and *B* shows a machine for bending light gauge copper tubes without loading. Such a machine will bend tubes up to 1½ in. diameter, but to avoid undue compression in the throat of pipes 1 in. to 4 in., they should be loaded so that they will bend like a solid rod. The loadings are removed after the bend is made. The loadings used are lead, pitch, resin, sharp sand, etc.

For bending large diameter tubes from 2 in. upwards, a geared machine is necessary, and unless there is a large amount of such work, the heavy initial cost of the machine does not warrant the outlay. There is also another type known as a draw-bar machine which is very successful but very expensive. This machine draws a steel mandrel through the bend as it is formed so that a very true full bore bend is produced.

Hand-bending. Bends in light gauge copper tube can be successfully made with little trouble if the proper technique is followed. Small diameter pipes up to $1\frac{1}{4}$ in. are sometimes loaded with lead and then bent. The object of the loading is to prevent the tube from collapsing. Fig. 66 shows the method, which is as follows:

The loaded tube is placed between two lead clamps in the jaws of a vice. A series of chalk lines is placed along the section of pipe contained in the bend (see Fig. 66). The sharp edges of the lead clamp are rasped off to prevent ridges occurring in the throat. An iron sling having a cushion of leather on the throat side is then placed over one of the chalk lines. An iron lever is placed in the sling with a piece of deal quartering between the bar and the tube, close up to the sling. The lever is then pulled, as shown, until the required sweep is obtained. The sling is then moved to the next chalk mark and the process repeated. Four to five throws are required for a right-angle bend. A templet cut to the required sweep of the throat should be to hand for testing during the process of bending. A wire templet will serve, but a piece of sheet-iron with a corner cut off at the required sweep is more satisfactory than wire, which may inadvertently be altered. It should have been stated that pipes to be bent with loadings other than sand, should first be annealed (softened) by bringing the section to be bent up to red heat and quenching it with clean water. The pipe should be heated before pouring the loading in. The pouring of lead should be continuous to avoid "cold-shuts" occurring in the loading. The lead has to be melted out when the bend is completed.

The process for resin or pitch loading is the

same, but two hours must be allowed for solidification. Great care must be taken in melting out the loading. The flame must be applied at the ends first and gradually worked along the pipe, otherwise a serious explosion can occur. All-copper plumbing is becoming more popular, so the method of bending large diameter pipes is explained in detail.

Sand-loading. The most convenient loading for plumbing work is sharp silver sand, and with it very successful bends can be quickly made. The bends are made at *red heat*. The success depends upon the solidity of the sand, and great pains must be taken to make the sand solid between the two wooden plugs in the ends of the pipe.

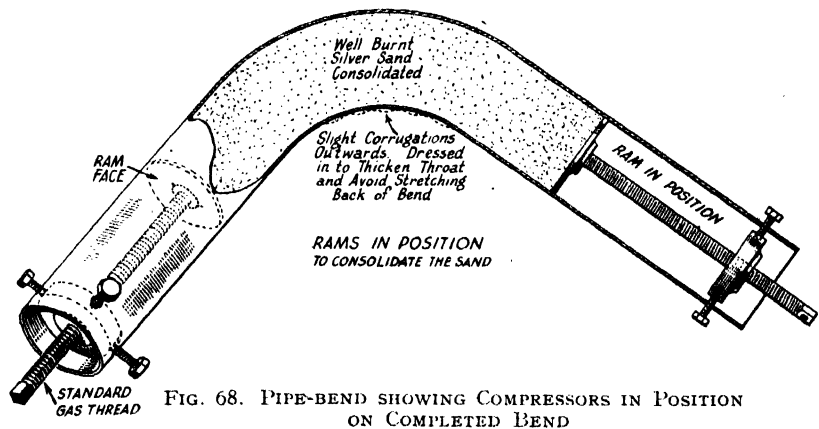

The best way of getting the sand solid is to hold the pipe upright and tap the tube on the outside for from ten to fifteen minutes with a piece of deal quartering. As the sand solidifies, the plugs should be driven further in. The bend is then formed by holding the pipe in the jaws of a vice and pulling the pipe round. The bend should be made in a series of throws, bringing the heat up to red, and gradually drawing the flame along the section to be bent until the required sweep and degree of angle is obtained. It is an advantage to over-bend the angle a few degrees and then pull the pipe back to the correct position. The throat of the bend should be made red hot to do this. The pulling back has the effect of pulling out any tendency to kinking in the throat, and to draw in the sides of the bend which may have spread slightly.

In bending large diameter copper pipes with the aid of mechanical compressors, large lead clamps to embrace the pipe in the jaws of the

MODERN BUILDING, CONSTRUCTION

vice, are an advantage. The procedure is as follows:

Distinctly mark the length of pipe contained in the bend and fix one compressor in the end of the pipe and adjust the position of the ram so that it is a few inches away from the first throw. See Fig. 67, which shows the compressor



FIG. 69. FILLING THE PIPE WITH SAND

being entered. The tube has to be drilled, as shown in Fig. 68, so that the $\frac{3}{8}$ in. pins can be fixed to secure the boss through which the ram works. Fig. 69 shows the pipe being filled with sand, an improvised funnel being used and the sand being partly consolidated by tapping the sides with a piece of wood. The other compressor is then entered, the pipe placed in the vice, and the compressors tightened up dead tight. If a flame is passed along the pipe and the pipe tapped still more, the compressors can be tightened up still farther owing to the expansion of the copper walls. The sand being now almost stone hard,

bending can begin. Heat up a point in the throat farthest from the free end of the pipe, and when red, get an assistant to pull slowly on the end to make a throw to the required radius. The bend may slightly pucker in the throat, but if the sand has been kept solid, the puckers will be outwards and they can be thickened in by using an old bending stick. Fig. 70 shows the second throw of the bend being pulled. If the back of the bend is overheated, it is likely to break across.

The process is continued until the required bend is obtained. As there is a tendency for the sand to become loose, because the back of

the bend stretches more than the copper in the throat of the bend compresses; the steel compressors should be tightened up on completion of each throw, this being the main advantage of the compressors. Compressors known as the "Eupce" can be obtained with ram plates to fit from $1\frac{1}{2}$ in. to 6 in. diameter tube. Offsets or any form of bend can be obtained with the aid of these machines.

Wrought Iron and Mild Steel Pipes. These can be bent cold by machine, but hand-bending is also practised. Tubes $\frac{1}{2}$ in. to $1\frac{1}{2}$ in. are brought to red heat and lightly gripped in the



FIG. 70. PULLING THE SECOND THROW

jaws of a firmly-fixed vice. With an assistant holding one end of the pipe, the plumber lifts the other end to form a throw. The jaws of the vice prevent the side walls of the pipe spreading. The bend or bends, as with an offset, are made in this manner, bringing the pipe up to red heat for each throw. For sharp bends or easy bends in large diameter pipe, the pipe should be sand loaded, using well-burnt silver sand for preference. The pipe may be pulled in any convenient anchor for the pipe: for instance, stout pins in a metal-covered bench. If the sides of a bend show signs of spreading, they are placed in the jaws of a vice and gently pinched up.

Chapter V—WATER SUPPLY

A GOOD and sufficient supply of water is of great importance to the well-being of a community and may be said to occupy first place among the many conveniences of modern life. The lack of a good water supply has in many instances in the past been responsible for disease epidemics and other forms of ill-health. The availability of a good supply of water should be one of the first considerations in selecting building sites of any description.

Water is a chemical compound, two atoms of hydrogen combining with one of oxygen; it is formed when hydrogen, or a combustible substance containing hydrogen, is burned in oxygen or atmospheric air. The symbol for water, that is, the formula signifying its chemical composition, is written H_2O .

The available sources may be classified as follows—

1. Streams and rivers.
2. Lakes and ponds.
3. Rainwater collected directly from roofs.
4. Shallow wells.
5. Deep wells.
6. Springs.

The source of natural waters is from the rainfall. The sun's rays cause evaporation of water from the moist surface of the land, the sea, and rivers, which rises in the form of invisible vapour and, forming clouds, descends in the form of rain; under changes of temperature it may be in the form of dew, mist, snow, hail or sleet. The greater part of this water flows over the surface of the land or sinks through the earth until an impermeable stratum is reached, where it is arrested and flows along this stratum, and either issues in the form of springs or finds its way into a water-course or the sea. In other cases, where the strata are of a different formation, underground lakes are formed, from which we obtain some of our water supplies by sinking wells and tapping the water-bearing stratum. A great deal depends upon the nature of the ground on which the rain falls, as to the amount which percolates into the earth. For instance, if on clay very little water will pass into the earth, whilst it will pass freely through a gravel or

sandy formation. From this it will be readily understood that a clay soil is impermeable, whilst a sandy or gravel soil is permeable, or in other words, these two soils are non-porous and porous respectively. Rain-water in its natural state is soft, and if collected well away from any contaminating influences, is usually pure and wholesome; in proximity to manufacturing towns, however, many impurities are picked up, in its descent from the clouds. These impurities are the products of coal combustion, etc., and sulphurous and ammoniacal impurities are thus added to the rain, rendering it impure.

Hard and Soft Waters. In passing from the clouds and through the earth rain absorbs *carbonic acid gas*; this gas is a solvent of nearly all the rocks, and in the passage of the water over the rocky formations, salts of lime and magnesia are dissolved out and absorbed or held in solution, thereby rendering the water either *temporarily* or *permanently hard*. If, in the form of *carbonates*, the water will be temporarily hard, but if in the form of *sulphates*, then permanent hardness will result. This hardness is determined by the action of the water on soap, or in other words, on its soap-destroying properties. Water containing up to 6° or 8° of hardness, is spoken of as *soft*, whilst water containing hardness above this percentage, is known as *hard* water.

One grain of lime per gallon of water constitutes 1° of hardness.

The characteristics of a wholesome water are as follows: It should be clear, bright, and sparkling, free from odour, tasteless, soft to touch, and should dissolve soap readily.

Waters obtained from the chalk formation are clear and sparkling, and although usually hard, form a good supply. But waters from the limestone and magnesium limestone formations, sometimes containing the fixed salts, are not as a rule so good as those from the chalk. Hard water is very wasteful; this can be proved by the amount of soap that is required before a lather can be obtained.

Water Softening. Temporary hardness may be removed by boiling or by the "Clark" process; the latter consists of adding to the water a given quantity of lime in the form of milk of

MODERN BUILDING CONSTRUCTION

lime: the bicarbonates of calcium and magnesium (which cause the hardness) being transformed into less soluble carbonates. The softening of water on a large scale is usually confined to the reduction of temporary hardness. Permanent hardness is reduced by the use of various reagents such as sodium carbonate, caustic soda, or barium compounds. The treatment of water for industrial purposes depends upon the particular industry.

A water may contain both temporary and permanent hardness. Water is required to be softened: (1) Where the hardness is appreciable and not satisfactory for domestic and potable purposes. (2) For preparation of patent foods, essences, etc. (3) For use in hot-water supply apparatus. (4) For use in steam boilers. (5) For use in dye and bleaching works. (6) For laundries.

CHEMICAL BASE EXCHANGE SYSTEM. This method has become popular in recent years and consists of filtering the hard water through zeolite mineral matter. Recently, synthetic zeolites have been manufactured and it is claimed that they have better softening properties than the earth's natural ones. The original term for the process was the Permutit system. Greensand, or zeolite, contains alumina sodium and lime, and has the property of softening water for a time; but it becomes exhausted after a period of usage. Calcium and magnesium are retained in the zeolite, which can be regenerated by passing a solution of sodium chloride (common salt) through it. It is important, after regeneration, that the first water should be run off to get rid of all traces of the brine.

The domestic form is about 8 in. in diameter, four to seven feet in height, according to make, and is capable of softening 300 to 400 gallons per working day until regeneration is needed. This is effected by operating taps to cause a flow of brine through it. The advantages of this system are: (1) It is compact and occupies little floor space. (2) As it is a pressure appliance, it may stand on any floor; the basement if required. (3) It reduces both permanent and temporary hardness, down to zero if required. (4) There is no sludge to deal with, as in the "Clark" or Porter-Clark processes, but, on the other hand, it requires salt as a regenerating medium as against added lime in the "Clark" process.

It is more efficient in its early stages, but gradually wanes in power, so that hard water

may inadvertently be passed where the demand is elastic. In such premises it is advisable to order oversize plant. Some plants are fitted with a meter to indicate the gallons passed.

Green staining of sanitary fittings under the taps may occur if all traces of brine are not removed. (The usual test for detecting the presence of brine is by taste.)

ETHERIUM SYSTEM. This system is insufficiently well known to prove conclusively that it is effective. It consists of hanging special cylinders known as *activators* at staggered intervals in the cold storage tank. These activate the water so that the mineral matter is thrown down as a friable or loose powder. The makers also claim that it breaks down lime encrustations from boilers and circulating pipes of old installations. The tank must not be fixed near a wet wall because, it is stated, a short-circuit will occur. The inlet and outlet of the storage tank must be at opposite ends, to give the activators time for the water to be energized, and to ensure that the water comes in contact with them. The activators need changing when they become exhausted.

Action of Water on Metals. Hard water has practically no action on the commoner metals, while soft water has a solvent action on most of them; for this reason, great care must be taken that pipes and cisterns, for storage and distribution, shall be of such material that will withstand the action of soft water. Lead is readily attacked by soft water; particles are dissolved out and taken up in solution, rendering the water unfit for domestic purposes, and may cause lead poisoning or paralysis. This action on lead is known as the *plumbo solvent action*, that is, the lead dissolving action. Lead pipes used for the distribution of hard waters become coated with a film, or thin crust, which acts as a protection against further action. Iron and zinc are also attacked by soft waters, which gradually destroy the metal.

Pure tin is not affected by either hard or soft waters.

For the hard waters, pipes may be of lead, ternary lead, tellurium lead, copper, cast or wrought iron; cisterns may be of slate, galvanized wrought iron, cast iron, or wood lined with copper or lead; whilst on the cheaper kinds of work, wood cisterns lined with sheet zinc are sometimes used. Vitrified stoneware and fireclay cisterns are very good, but the chief objection is their great weight.

For the soft waters, the following materials are suitable: lead-encased tin pipe, the Walker health pipe both in lead and iron; tin-lined iron and copper pipes, glass-lined and porcelain enamelled iron pipes; and pipes protected by the Bower-Barff process or Dr. Angus Smith's solution. Cisterns may be of fireclay, stoneware, slate jointed with the angles protected by cement fillets, and iron cisterns coated with patent cement.

Lead-encased tin pipes consist of a pipe of pure tin inside an outer pipe of lead; the pipe of tin is forced through the die together with the pipe of lead in one operation.

The use of *copper pipe* for water services has increased considerably. Many advantages are claimed for this material over iron and lead.

Copper is dissolved by water less than either iron or lead, and waters not acid in reaction may be used with copper with complete safety. Waters that are acid, if treated for acidity, are quite safe to use with copper.

Fig. 71 shows sectional sketches of tin-lined pipes.

Glass-lined and porcelain enamelled iron pipes are very good, though expensive; the chief objection is the ease with which the lining becomes damaged, and the consequent difficulty in cutting lengths without damage to the lining, and exposing the metal to the action of the water.

The *Bower-Barff process* of treating pipes consists of raising the pipes to a very high temperature, and exposing them to a current of superheated steam; this forms a protective coating of black oxide, which is proof against the rusting action of the water.

Dr. Angus Smith's method of coating pipes is carried out by immersing them in a hot mass composed of bitumen, resin, and coal tar at a temperature of about 400° F.; they remain in this liquid until the pipes reach the temperature of the coating mixture, after which they are withdrawn and allowed to drain and harden.

TOWN SUPPLIES

The quantity of water allowed per head per day varies in different parts of the country. The following table gives the total consumption per head in a few towns. In some of these cases, the figures include water for industrial and municipal purposes whilst in others, the figures indicate a fair amount of waste by leakage and other losses.

TABLE VII

Town	Gallons per Head per Day
Faversham R.D.C.	8
Birmingham	26
London	37
Dublin	41
Edinburgh	52
Paisley	82
New York, U.S.A.	110

Water is required for cooking, drinking, personal cleanliness, washing clothes, utensils, cleansing of houses, sanitary fittings, drains, and sewers; also the watering and cleansing of streets.

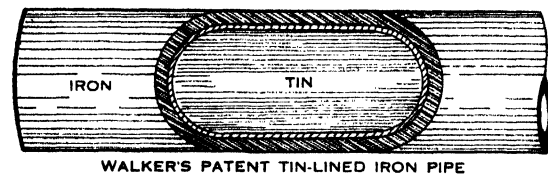
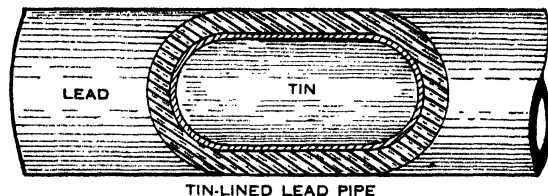

FIG. 71. TYPES OF TIN-LINED PIPE

Purification.¹ The removal of harmful bacteria is of primary importance, and there are three ways in which this is done: by storage, filtration, and chlorination. Storage may be "active" where the water is maintained in circulation at a definite rate, or passive where the water is kept still. During storage, chemical action goes on which is not favourable to the multiplication of harmful bacteria. There are many different kinds of bacteria, or microbes, and while a few are responsible for infectious and contagious diseases, most are harmless and many are known to be useful. The two microbes most likely to convey disease in water are those producing cholera and typhoid. A single day's storage in a reservoir diminishes the number of microbes in river water by 40 per cent. From 1904 to

¹ Reproduced by the courtesy of H. E. Stilgoe, Esq., M.Inst.C.E., Chief Engineer, Metropolitan Water Board.

MODERN BUILDING CONSTRUCTION

1916 the Metropolitan Water Board stored all raw river water for approximately 30 days before feeding it to the filters. In 1916 they began to chlorinate the Thames water at Staines; by this means a great saving was effected, as no pumping was required to the storage reservoirs. In modern practice, chlorination is usually

grows in and on the surface layer of sand. This film retains microbes, upon the action of which the purification of the filtrate largely depends. The period of economical operation varies with the condition of the raw water and may be only about a week, but when the raw water is in good condition will extend for much longer

periods and up to about 18 weeks; when the filtering head has increased to about 4 ft., the filter is put out of operation and the "surface film" removed and the surface of the sand raked over and smoothed. It takes about two days for the film to grow on clear sand, and during this period no water is passed through the bed. The disadvantage of these filters is that they are necessarily slow. With a sand filter having an area of an acre, and with a varying head of water becoming greater as the surface film increases, about 1½ to 2 million gallons of water pass over per 24 hours. Mechanical filters are often used; they are quicker in action and the cost of upkeep is less than that of sand filters.

Distribution. The present-day method of distribution from the reservoirs is by means of cast-iron mains passing under our roads, the communication between the main and the consumer's storage cistern being effected by a brass ferrule, which is

tapped and screwed into the cast-iron main, the ferrule union being wiped on to the lead service pipe. Where the larger type of building is to be supplied from the water for fire service, or where building connections of more than 1½ in. are required, connection made to the company's main is by a cast-iron branch to which a cast-iron service pipe is connected. The service pipe is continued below ground to the interior of the premises, whence it rises to the storage tank or tanks and is termed the *rising main*; an efficient stop-valve must be provided to control the supply pipe.

The water companies' mains are fitted at

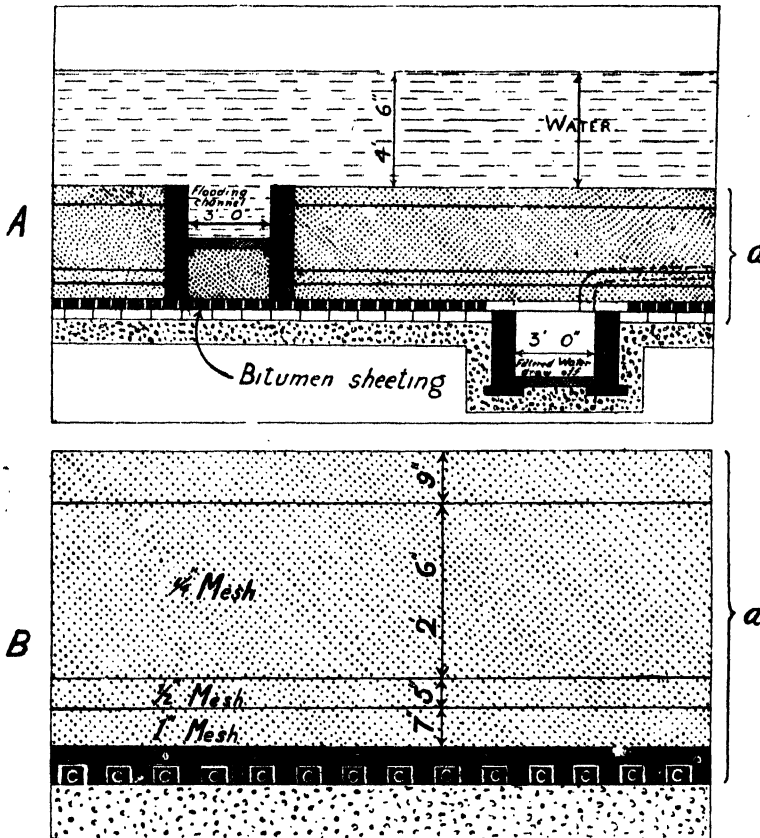

FIG. 72. M.W.B. FILTER AT HAMPTON

applied to the water after final filtration. Gaseous chlorine is now used and many water-works use the Paterson Chloronome for chlorination, manufactured by the Paterson Engineering Co., London. Chlorination apparatus of the Candy Filter Co., and Wallace and Tiernan Co., has also been used. Storage does not remove the whole of the harmful microbes. Filtration through sand follows storage, and in this process any suspended solids are held back, as well as most of the bacilli which have not been destroyed during storage. Fig. 72 shows sections of a sand filter of the M.W.B. at Hampton; the efficiency of the filter depends on the gelatinous film which

various points with valves and emptying plugs, to control and drain out the pipes when new connections or repairs are required to be carried out.

SMALL DIAMETER CONNECTION TO MAIN. The *drilling and tapping* of the cast-iron mains is

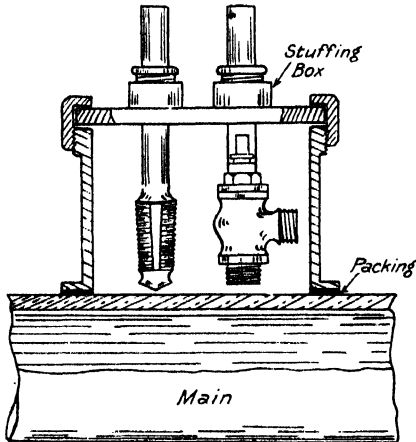

FIG. 73. APPARATUS FOR TAPPING MAIN UNDER PRESSURE

usually done by the ordinary ratchet drill and tap, which necessitates the main being shut down. There is an apparatus (Fig. 73) that enables the main to be drilled and tapped and the ferrule screwed in with the water still in the main at full pressure. The operation is quite simple and very little water is wasted.

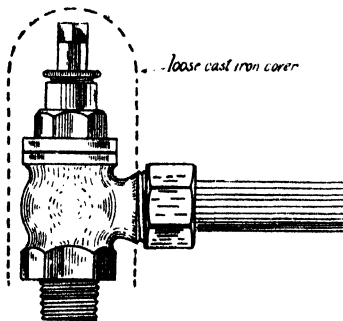

FIG. 74. SCREW FERRULE

The apparatus consists of a small saddle-shaped iron body, the top of which is constructed so as to enable the plate which holds the drill and tap and the screw ferrule to revolve; the hole is drilled and tapped by a combined tool, which is then withdrawn. The top plate is given a half-turn to bring the ferrule immediately over the tapping, when the ferrule is screwed down. The chain grip, holding the apparatus to the

pipe, is then released, and the operation is complete.

Fig. 74 shows a screw ferrule with stop-cock and union. In some cases, an *iron key* is fitted to the square shank of the spindle,

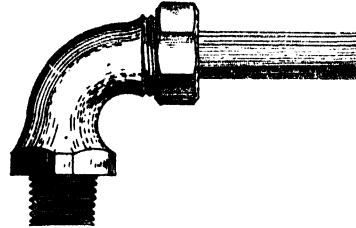

FIG. 75. BENT PLAIN FERRULE

and of a length to allow it to reach to within an inch or two of the pavement level; in others, an iron dome covers the body, as shown by dotted lines, and the whole is buried beneath the roadway.

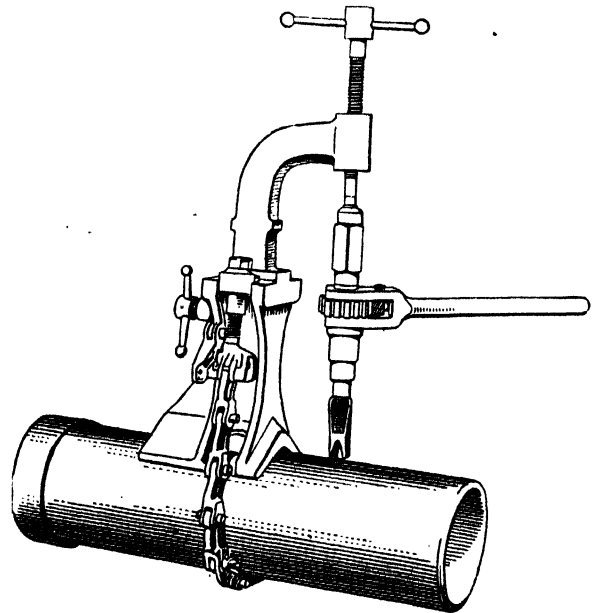

FIG. 76. DRILL STAND

There are also plain ferrules used for connecting lead service pipes to cast-iron mains. Fig. 75 shows a plain ferrule without stop-cock; these are also supplied with screw threads to receive screwed wrought-iron tube connections for main service pipes.

Fig. 76 shows a drill stand used for drilling and tapping a cast-iron main when the water is shut down.

MODERN BUILDING CONSTRUCTION

MAIN STOP-COCK. Fig. 77 shows the method of arranging the main stop-cock and draw-off taps suitable for basements. A branch pipe should be taken out on the main side of the stop-cock and fitted with a draw-off tap and control stop-cock, thus enabling water to be

iron or painted tablets fixed on the wall showing their purpose. In a large number of town houses, it is sometimes convenient to fix the house draw-off tap over a sink and thus fulfil two purposes, that of a drinking water supply, and also a means of draining out the rising main.

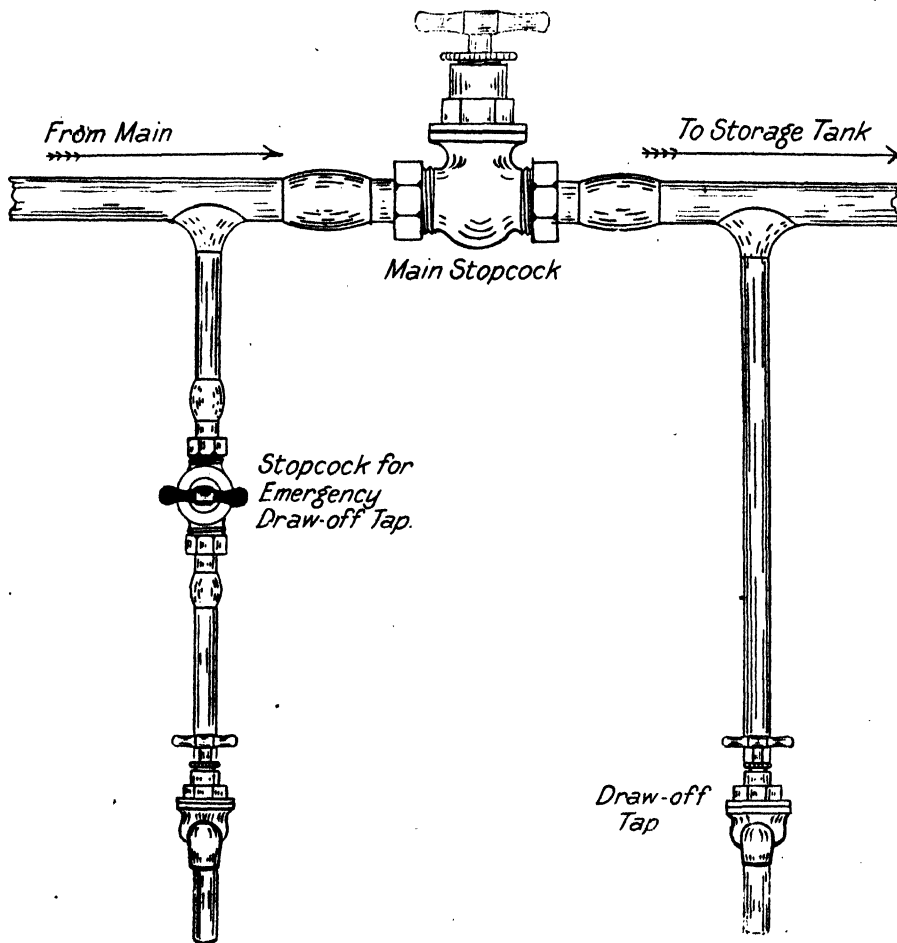

FIG. 77. ARRANGEMENT OF MAIN STOP-COCK AND DRAW-OFF TAPS

drawn in the event of house supply being shut down for any length of time. The draw-off tap, on the house side of the main stop-cock, enables the whole of the rising main to be emptied when the main stop-cock is shut down; this is essential, especially in times of frost, and is also a necessary item when repairs are required to the rising main.

The stop-cock and draw-off taps should be placed in a prominent and accessible position immediately inside the premises, and enamelled

Storage. The storage of water for domestic purposes is a matter that calls for strict attention. In large numbers of houses, it seems to be the general rule that any place will suffice for the fixing of a storage cistern; and one has only to visit a few houses, both in town and country, to find cisterns in all sorts of out-of-way positions, uncovered and exposed to filth of every description, fixed beneath floors where the open joints of the boards allow dust and floor washings to pass freely through, fixed in roofs beneath

the slates, and without proper coverings, and in a host of other positions of a most unwholesome character.

It is not always possible to construct a proper cistern room, but if the following idea is carried out, the stored water would be kept free from contamination. A storage cistern should be fixed in a light, airy and accessible position, away from the direct action of the sun's rays; the overflow should terminate well away from any soil pipe or waste pipe terminal; and the cistern should be fitted with a close-fitting dustproof cover.

When cisterns are fixed inside the building, safes should be provided beneath them and fitted with waste pipes discharging into the open, to act as *warning pipes* in case of a leakage.

In larger establishments, and where the best possible results must be obtained, proper cistern rooms are constructed. A small radiator on the heating system will prevent trouble from frost effects.

Contamination. Generally speaking, the supply from public water companies is pure and wholesome, and it is a rare occurrence for a town supply to become contaminated, though it is quite possible by the admission of foul matter to the storage reservoir, or by the entry of such matter to the mains when these are opened up for repairs.

Where the intermittent system of supply is in operation, contamination may take place by the in-suction of foul water when the mains are shut down.

The ways of contamination after the water leaves the company's mains are many and varied, but with the great advance of sanitation and the introduction of modern sanitary fittings, the risk of contamination of water has been greatly reduced; there is still, however, much to be said against the manner in which our house supplies are open to contaminating influences, and for the need of better supervision in the fitting-up of services, cisterns, and tanks.

In remote districts, where the supply is obtained from wells of a shallow character, the risk of contamination is greater than in towns with a public supply, or in districts supplied from deep wells. Shallow-well water is classed as dangerous, and this is quite feasible, as percolation of fouled surface and subsoil water into a shallow well is an easy matter; leaky drains and cesspools are also another source of well contamination. Even though drains may be a considerable distance from the well, the

rise and fall of the ground water will sooner or later be the means of this form of pollution finding an entry to the well.

Streams from which supplies are sometimes drawn may be polluted by the entry of sewage and waste matters, and by the admission of fouled storm or flood water.

PRECAUTIONS AGAINST CONTAMINATION. The overflow pipes from storage cisterns should discharge into the open air, and be fitted with a hinged copper flap or be cross-wired to prevent small birds from entering them. Overflow pipes should not be connected to any *rain-water pipe, soil or waste pipe, drain or gutter*.

Water is an absorbent of gases, and this fact should be borne in mind when deciding on the position of a storage cistern.

Supplies to W.C.'s, urinals, slop and other closets should not be taken direct from storage cisterns, but an intermediate tank or syphonic flushing tank should intervene.

It is often necessary in the smaller type of house to place the storage cistern in the roof just beneath the slates; and when this is done, the underside of the rafters should be closely boarded to prevent the passage of dirt and dust to the cistern through the laps of the slates or tiles; in addition provision should be made for light and ventilation. In country districts where the communication pipe between the company's main and the house requires to pass beneath the ground for a considerable distance, care should be taken to keep the course of the trench well away from contaminating influences, more especially where cesspools are provided for the reception of drainage, as it is often found that contamination is due to the passage of mains through polluted subsoils.

Frost Burst. Water, like other liquids, expands when the temperature is raised and contracts when its temperature is lowered, but at certain temperatures water possesses a peculiar nature. The *maximum density* of water is reached at 39° F., or 4° C.; by this is meant that at this temperature the water is at its most dense point, the molecules or atoms of its composition being more closely packed, as it were, at 39° than at any other temperatures.

If we heat a quantity of water from 39° to 212° F., it will expand about one-twenty-fourth of its volume; conversely, in cooling down through this range of temperature, it will contract until 39° is reached. Now, if further cooling takes place, the peculiar nature of water is that it will *expand*; the expansion in cooling

MODERN BUILDING CONSTRUCTION

from 39° to 32° F. is about one-ninth of its volume, and the water is converted to a solid in the form of ice. This expansion is the cause of fractures that occur when pipes burst.

If a length of lead service pipe that has been exposed to frost is examined, it will often be noticed that in several places, if a fracture has not occurred, the pipe will show swellings (Fig. 78). These are due to the lead, being of a soft nature, yielding to the sudden expansion that takes place when the water is converted to ice; if these swellings were cut, the substance of the pipe would be found very thin, and on a second frost taking place a fracture would probably occur. A burst in lead pipe is usually small and accompanied by a large swelling, thus showing that the pipe had undergone a considerable amount of stretching before fracture had taken place.



FIG. 78. SHOWING SWELLING IN LEAD PIPE CAUSED BY EXPANSION OF WATER DURING FROST

PREVENTION. It is essential that provision should be made for protecting all service pipes, storage cisterns, and fittings from being attacked by frost, not only those pipes and fittings that are much exposed, but also other services. The first item that should be provided for is the installation of sufficient stopcocks and draw-off taps to permit of shutting down and emptying all service pipes.

Cisterns, pipes, and fittings in exposed positions should be protected by proper coverings of good non-conducting material. Several kinds of material are used for this purpose, and among them the following are often used: *hair felt*, plain or with a canvas backing, *slag wool*, *asbestos*, *sawdust*, and *fine wood chips*.

When cisterns are to be encased, it is the best plan to construct hollow wooden casings to receive the packing medium. If this method is adopted, the cistern can be easily exposed when repairs are necessary. The practice of encasing a cistern and filling the cavity between the casing and the cistern with loose sawdust or asbestos is not a good one, as very often some of the packing finds its way into the water. For pipes, one of the best materials to use is the canvas-backed felt, made in narrow strips, thus enabling it to be easily placed around the pipe.

Where there is a choice of route for pipes, the warmest positions and inner walls should be used to carry the pipe runs.

METROPOLITAN WATER BOARD

Every communication pipe (supply pipe from town main carrying water to the building) shall be of lead, ternary alloy or cast-iron and shall have a bore of not less than half an inch.

Cast-iron mains are usually 2 in. upwards in diameter.

Material for Pipes other than Communication Pipes. Every supply pipe and pipe external to a building and through an external wall thereof shall be of lead or cast-iron provided, however, that a supply or distributing pipe if not in contact with the ground, below the surface of a solid flooring supported by the ground (unless in an accessible channel) may be of copper, brass, wrought iron, steel or a corrosion-resisting alloy.

To prevent trouble (or reduce it to a minimum) from rust in tap water, wrought iron and mild steel pipes should be galvanized. Cast-iron pipes, though less liable to corrosion than wrought iron, are coated internally and externally with a black bituminous solution such as Dr. Angus Smith's.

Connections to Mains. For lead or ternary alloy lead pipes from $\frac{1}{2}$ in. to 1 in. bore, the connection shall be by means of a screw-down ferrule. For pipes $1\frac{1}{4}$ in. to 2 in. bore the connection shall be by means of a union and stop-valve attached to a branch pipe to be inserted in the line of the Board's main.

For cast-iron communication pipes of 2 in. bore and upwards the connection shall be by means of a branch pipe to be inserted in the line of the Board's main with a sluice valve fixed as close as practicable to the branch.

The foregoing, from the plumber's point of view, means that pipes $\frac{1}{2}$ in. to 1 in. may be entered into the top of the Board's main by drilling it at the top, tapping (threading) the hole, and screwing in the approved brass fitting. On the other hand, supply pipes greater than 1 in. must have a junction-piece entered into the main pipe and the fittings mentioned jointed to the junction. Such work is usually done by the Company's employees.

It is seldom, for ordinary buildings, that a pipe greater than 1 in. is required, because the storage tanks form a reserve supply against such time when the water may be cut off to effect repairs.

Supply pipes 2 in. upwards may be required on the pressure side (i.e. between town main and storage vessel) for large factories, etc., and any building which requires fire extinguishing equipment. In the latter case 4 in. is the recognised minimum diameter to supply 2 in. fire hydrants.

Definition of a Lead Pipe, M.W.B. 1934.

Lead and tin not less than 99/84.

Ternary Lead

- No. 1. Antimony not less than .4% or more than .6%.
 Cadmium not less than .2% or more than .3%.
 Lead the remainder.
- No. 2. Tin not less than 1.25% or more than 1.75%.
 Cadmium not less than 20% or more than 30%.
 Lead the remainder.

Ternary lead and other alloy pipes are not allowed in these weights buried underground but must conform to the weights required for lead pipes in such positions. The weights have been given (and as published) in the yard unit. In many districts the five yard unit is used,

TABLE VIII
 STRENGTH OF PIPES. WEIGHT IN POUNDS PER YARD
 (Metropolitan Water Board)

Bore of Pipe	$\frac{3}{8}$	$\frac{1}{2}$	$\frac{3}{4}$	1	1 $\frac{1}{4}$	1 $\frac{1}{2}$	2	2 $\frac{1}{2}$	3
For ternary lead alloy pipes—									
For pressures not exceeding 250 ft. head of water	3 $\frac{1}{2}$	5	7 $\frac{1}{2}$	11	14	18	25 $\frac{1}{2}$	40	57
For pressures 250 ft. up to 400 ft. head of water	4	6	10	14	19	23 $\frac{1}{2}$	32	—	—
Distributing pipes of lead for—									
Cold water	4	5	8	11	14	18	24	38	54
Hot water	4 $\frac{1}{2}$	6	9	12 $\frac{1}{2}$	16	20	28	44	63
Ternary lead—									
Hot or cold water	3	4	6	8 $\frac{1}{2}$	11	13 $\frac{1}{2}$	19	29 $\frac{1}{2}$	42

TABLE IX
 LEAD PIPES. SUPPLY AND DISTRIBUTING
 (Ministry of Health Regulations)

Internal diameter in inches	$\frac{3}{8}$	$\frac{1}{2}$	$\frac{3}{4}$	1	1 $\frac{1}{4}$	1 $\frac{1}{2}$	2			
For pressures not exceeding 110 ft. head of water, i.e. 48 lb. per sq. in.	4.5	6	9	12.5	16	20	28	lb. per yard		
For pressures exceeding 110 ft. head but not exceeding 250 ft., i.e. 108 lb. per sq. in. approx.	5	7	11	16	21	27	38	—	—	—
For pressures exceeding 400 ft., i.e. 173 lb. per sq. in. approx.	6	9	15	21	28	35	48	—	—	—
Flush and warning pipes (overflow pipes)	—	3	5	7	9	12	16	—	—	—
Soil-waste and waste ventilating pipes (see local by-laws for own district)	1 $\frac{1}{4}$ " 7	1 $\frac{1}{2}$ " 9	2" 12	2 $\frac{1}{2}$ " 14.4	3" 17.1	3 $\frac{1}{2}$ " 20	4" 22.8	4 $\frac{1}{2}$ " 29.1	5" 41	6" 57 lbs.
Gas and condensation	$\frac{3}{8}$	$\frac{1}{2}$ 3	$\frac{3}{4}$ 3.5	$\frac{1}{2}$ 5	1 7	1 $\frac{1}{4}$ 9	1 $\frac{1}{2}$ 12	2 16	lb. per yard	

No pipe to be fixed within 18 in. of eaves.
 Stop valves to be fixed on all outlets from storage cisterns, as near to cisterns as practicable.

All jumper valves shall be free to rotate and on all hot-water valves and stop-valves on distributing pipes, the valves shall be secured so as to lift with the spindle.

These details are shown in Figs. 87 and 90, page 744.

thus $\frac{1}{2}$ in. 7's in the foregoing table would be $\frac{1}{2}$ in. 35's; $\frac{3}{4}$ in. 11's would become $\frac{3}{4}$ in. 55's, and so on.

Compo pipes for gas are supplied in diameters from $\frac{1}{4}$ in. usually measured externally. Such pipes are made from lead hards and externally tinned during manufacture.

MODERN BUILDING CONSTRUCTION

Brass and Copper tubes are of two kinds: brazed-seam tubing and solid-drawn seamless tubing, the latter being much stronger and better for general use, especially where a lot of bending is required. The seamed tube is made by folding the flat metal round a core and then brazing the abutting edges.

The solid-drawn tubing is made by first casting a "billet" of the metal which is then pierced through its length: this billet is then forced through a special machine from whence it issues in the form of a tube. Before leaving the works, the tube is generally annealed so that bends may be easily made with the aid of a bending machine, without which it is necessary to "load" the pipe, i.e. fill it with lead, pitch, sand, or resin to prevent buckling during the bending operation.

TABLE X
STANDARD GAUGES FOR LIGHT COPPER TUBES

Bore of Tube in Inches	Pressures in Pounds per Square Inch					
	Pressures up to 50 lb.		Pressures over 50 lb. up to 125 lb.		Pressures over 125 lb. up to 200 lb.	
	Thick-ness S.W.G.	Lb. per Foot	Thick-ness S.W.G.	Lb. per Foot	Thick-ness S.W.G.	Lb. per Foot
$\frac{1}{8}$	19	0.08	19	0.08	17	0.12
$\frac{1}{4}$	18	0.17	17	0.21	16	0.24
$\frac{3}{8}$	18	0.25	17	0.29	16	0.34
$\frac{1}{2}$	18	0.32	17	0.38	15	0.50
$\frac{5}{8}$	18	0.39	17	0.46	14	0.68
$\frac{3}{4}$	18	0.46	16	0.63	14	0.80
$\frac{7}{8}$	18	0.54	16	0.73	14	0.92
1	17	0.71	15	0.93	13	1.21
$1\frac{1}{8}$	17	0.88	15	1.15	12	1.70
$1\frac{1}{4}$	17	1.05	15	1.37	12	2.02
$1\frac{3}{8}$	16	1.40	15	1.59	12	2.33
2	16	1.60	15	1.80	12	2.65
$2\frac{1}{8}$	16	1.98	14	2.50	10	4.07
3	15	2.68	13	3.44	9	5.48
4	13	4.55	11	5.78	7	8.89

In some districts a lighter gauge is allowed for distributing pipes and also for warming and flush pipes, etc., thus—

$\frac{1}{8}$ in.	.	.	19 gauge
$\frac{1}{4}$ in.	.	.	19 "
1 in.	.	.	19 "
$1\frac{1}{8}$ in.	.	.	18 "
$1\frac{1}{4}$ in.	.	.	18 "
2 in.	.	.	17 "

The stout walled pipe is, however, better for bending and general purposes, whether to be bent by hand or by machine. None of these pipes is allowed underground.

TABLE XI
WROUGHT-IRON PIPE

Nominal Bore in Inches	Approx. Outside Diam. in Inches	S.W.G.	Weight in Lb. per Foot
$\frac{1}{8}$	$1\frac{1}{2}$	13	0.300
$\frac{1}{4}$	$1\frac{3}{4}$	13	0.425
$\frac{3}{8}$	$1\frac{7}{8}$	12	0.640
$\frac{1}{2}$	$2\frac{1}{8}$	11	0.900
$\frac{5}{8}$	$2\frac{3}{8}$	10	1.270
1	$2\frac{7}{8}$	9	1.780
$1\frac{1}{8}$	$3\frac{1}{8}$	8	2.600
$1\frac{1}{4}$	$3\frac{3}{8}$	7	3.250
$1\frac{3}{8}$	$3\frac{7}{8}$	7	3.800
2	$4\frac{1}{8}$	6	4.500
$2\frac{1}{8}$	$4\frac{3}{8}$	6	4.980
$2\frac{1}{4}$	5	6	5.775
$2\frac{3}{8}$	$5\frac{1}{8}$	6	6.325
3	$5\frac{3}{8}$	6	6.850
$3\frac{1}{8}$	6	6	7.750
4	$6\frac{3}{8}$	6	8.700

The modern concrete building is more conducive to sound transmission than old brick buildings with soft bricks and plaster facings. Some thought should be given to means of softening the transmission of noises; they can be most irritating, for example, in a flat situated close to the storage tank supplying a block of flats. The tank should be entirely covered in with boarding and insulated, preferably with slag-wool, which is a mineral product that will not rot or harbour vermin. If a Portsmouth type of ball-valve is used, it can be fitted with a silencing pipe. This pipe allows the water to enter the tank below the surface, thus subduing the splashing noise as it fills.

Hard metal pipes such as copper and iron are more likely to transmit noise than lead, and when used on domestic, office buildings, hospitals, etc., the noise of water rushing through them can be reduced if they are fitted with insulating sleeves where they pass through floors and walls. For w.c. apartments a quiet type of flushing cistern with the ball-valve fitted with a silencing pipe should be chosen. Boarded floors on joists should be insulated with slag-wool. In high-pressure systems, water-hammer, chattering and singing, etc., may be prevented by using slow-closing valves on the draw-offs. An equilibrium type of ball-valve may be necessary on the feed to the cold water storage tank.

Chapter VI—CISTERNS

THE first thing to be considered is the position and size of the cisterns and services necessary to give an adequate supply to all fittings.

These two items are usually determined when the plans are drawn up and are marked upon the drawings in the same manner as the remainder of the plumber's work. The amount of storage and sizes of pipes that will be required depend upon the type of building and what it is to be used for, whether residential, office, factory, hospital, or workshops, and, in the case of factories or workshops, the nature of the work to be carried on therein.

In most of our towns the supply is on what is known as the *constant system*, while in some parts the *intermittent system* is still in operation. With the former, the mains and communication pipes are always charged, and water may be drawn at all hours. Under the intermittent system, the mains are shut down at intervals during the day and night; therefore provision must be made for adequate storage where this system is in operation. It is often considered sufficient if a small amount of storage is provided where the constant supply system is in operation; this may be quite suitable for the smaller class of premises, but for buildings of a large type, a small storage is a great mistake and often leads to inconvenience, especially if the mains happen to be shut down for repairs during the time when large quantities of water are being drawn, and this is not infrequent.

The usual method of calculation for household storage is based on a daily minimum consumption per head of 25 gals. and provision for two days' storage; so that for a household of ten persons, we get $25 \times 10 \times 2 = 500$ gals. storage. The sizes of the supply pipes required for the various purposes must be determined when the number and kind of fittings that are to be supplied are known.

Slate Cisterns are composed of smooth-faced slabs grooved to receive the jointing medium. The sides of the cistern run beyond the ends far enough to allow a bolt and nut to pass through and so hold the sides and ends together. The material for jointing should be painters' putty. These are not general and are used only for water of pronounced acidity, and for pickling tanks.

Lead-lined Cisterns are formed by building up an outer casing of wood $1\frac{1}{2}$ in. to 2 in. thick (according to size of cistern) with grooved-and-tongued joints and dovetailed angles. This casing is lined with sheet lead; the angles may be joined by lead burnt or wiped soldered seams. The weight of lead per foot super should be 6 or 7 lb. for a medium cistern; for a larger type 10 lb. bottom and 8 lb. sides should be used. Lead-lined cisterns are little used at the present time for storage of water for domestic purposes.

Galvanized Iron Cisterns are made up from plates of sheet iron of various thickness, the usual gauges being $\frac{3}{16}$ in. and $\frac{1}{4}$ in. plate; they are held together by $\frac{3}{8}$ in. rivets fixed at $1\frac{1}{2}$ in. centres. With open top cisterns $1\frac{1}{2}$ in. angle iron is used around the top inside edge to stiffen and strengthen the free edge of the plate; this angle iron is fixed by $\frac{3}{8}$ in. rivets at 4 in. centres.

After the cisterns are riveted up, they are immersed in a bath of molten zinc, which effectually coats the plates, rivets, seams, etc.; this process is called *galvanizing*.

The larger cisterns are provided with stay rods to strengthen them and prevent undue strain upon the riveted seams when they are filled with water.

Galvanized iron tanks and cisterns for very cheap work are also made up of much lighter gauge iron, the seams being welted in place of rivets.

There is also a very good cistern made by Messrs. Fredk. Braby & Co. The seams are welded by electricity, after which the cisterns are heavily galvanized; with this type of cistern the rivets are dispensed with. They have been approved by many leading authorities and are excellent cisterns for general use.

Cast-iron Cisterns are built up in sections, each section being cast with a machined flanged edge drilled to receive bolts and nuts; the joints are made with bituminous cement or millboard soaked in waterproofing compounds; the flanges may be arranged to fit internally or externally.

This type of cistern is used for very large storage purposes.

MODERN BUILDING CONSTRUCTION

Mild Steel Tanks. These are much favoured in some industries and are used in factories, in horticultural work, and for oil tanks. They consist of pressed steel panels bolted together with bituminous putty at the joints as with cast-iron tanks. The panels are pressed with cross webs on each to form stiffeners. The standard sizes of panels are 3 ft., 4 ft., and 1 metre square. For building up very large tanks they can be obtained with lugs on the panels on which anchor rods or stiffening rods can be bolted to prevent bulging of the tank sides when subjected to water pressure. To resist

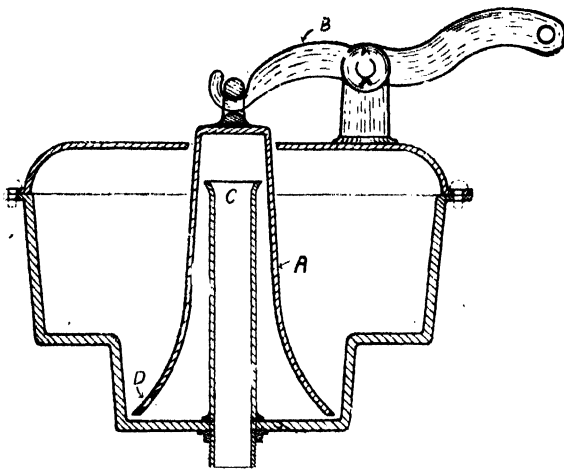

FIG. 79. SECTION THROUGH SHELL AND SYPHON OF VALVELESS FLUSHING CISTERN

corrosion, the panels are dipped in hot asphaltum by the manufacturers.

Fireclay and enamelled porcelain cisterns are moulded, fired, and glazed in the potteries similar to other goods of this type. They are used chiefly for the storage of water for culinary purposes and are of capacities from 50 to 100 gals. It is possible to obtain these cisterns moulded with a flushing rim for cleansing purposes. The bottom should be made with a slope to a centre outlet and fitted with a cleansing plug and standard.

Flushing Cisterns. These are of two kinds: (1) the *syphonic action* flushing cistern, which is operated by hand; and (2) the *automatic syphon* flushing cistern, which, as its name implies, works automatically. The first named, which are also known as *water-waste preventing* cisterns are obtainable in 2 and 3 gal. capacities and in a large variety of patterns. The outer

shell or casing may be of cast iron or fireclay, and the working parts may consist of brass, copper, or cast iron. Most of the flushing cisterns used at the present time are what are known as *valveless* syphon flushing cisterns, which means that the syphonage is started by other means than the raising of a loose valve or seating.

Figs. 79 and 80 illustrate clearly the difference between a valveless cistern and one fitted with a loose valve.

Fig. 79 shows a section through the shell or outer casing and the syphon of a valveless

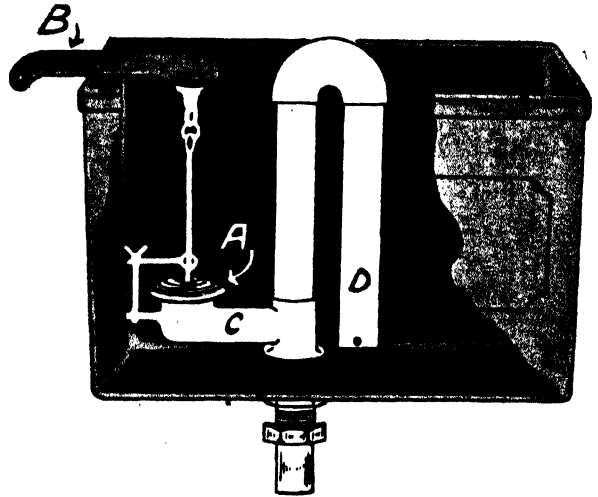

FIG. 80. SYPHON FLUSHING CISTERN WITH LOOSE VALVE

syphonic flushing cistern; for clearness, the ball valve and overflow are not shown. The syphonage is set up by the *cast-iron bell A* being raised by the *lever B*; on being released the bell falls back, and in doing so forces sufficient water over the *syphon standard C* to displace the air and create a partial vacuum in the flush pipe, which forms the long leg of the syphon; the contents of the cistern are then emptied by syphonage. The bell usually has a small hole drilled at *D* to admit air to the syphon to prevent the noise that is caused when the last of the water passes the base of the bell; the term applied to the function of this air-hole is *breaking the syphonage*.

Fig. 80 shows a view of the interior of another type of syphonic flushing cistern, made by Messrs. John Bolding & Sons, and, as in Fig. 79, the fittings are left out for clearness. This cistern is fitted with a brass syphon and seating,

and a drop valve known as a "Grant's" valve. The syphonage is set up by raising the valve *A* by the lever *B*, thus admitting water to the long leg of the syphon direct through the branch *C* and creating a partial vacuum. The valve drops back again on to its seating, and the contents of the cistern are syphoned out through *D*.

It will be seen that if the valve rubber becomes worn or perished a waste of water is bound to occur; to prevent this waste, cisterns

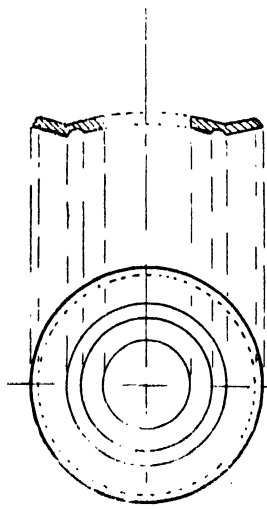

FIG. 81
PLAN AND SECTION OF A
GRANT'S VALVE RUBBER

of a valveless type are insisted upon by most water companies.

In the valveless cistern the water necessary to start the syphonage must be *lifted*, or *thrown*, over the leg of the syphon, and various methods are adopted in the different cisterns on the market to fulfil this operation.

Fig. 81 shows plan and section of a Grant's valve rubber.

Fig. 82 shows a view of the interior of another type of valveless flushing cistern made by Messrs. John Bold-
ing & Sons. The minor details are omitted for

clearness and the drawing is only intended to show the principle by which the syphonage is set up. The *plunger*, enclosed in a small cylinder *B*, when raised by the lever *C*, lifts and throws sufficient water over the bend of the syphon to displace the air (that is, to create a partial vacuum) in the *long leg D*, and thus start syphonic action. The contents of the cistern are then syphoned out through the cylinder. The syphonage is *broken* by means of a small snift valve fitted to the crown of the syphon bend, and operated by a rocker arm and stem which is connected to a submerged copper float. This prevents the objectionable sucking noise which occurs at the end of the flush of many flushing systems. As the water passes beneath the bottom of the float, its weight causes it to drop and open the valve, thus admitting air to the syphon; as the tank fills, the float rises and again closes the valve. This cistern is silent in operation and an excellent type to use. The shell is of

cast iron and the working parts of brass and copper.

AUTOMATIC FLUSHING CISTERNS. These are made on two principles, one working with a small drip supply and the other with a reverse-action ball valve. They are obtainable in all sizes from a capacity of 1 gal. upwards, and are made in galvanized sheet iron, cast iron—either painted, enamelled, or galvanized; also in enamelled fireclay. For ranges of urinals and

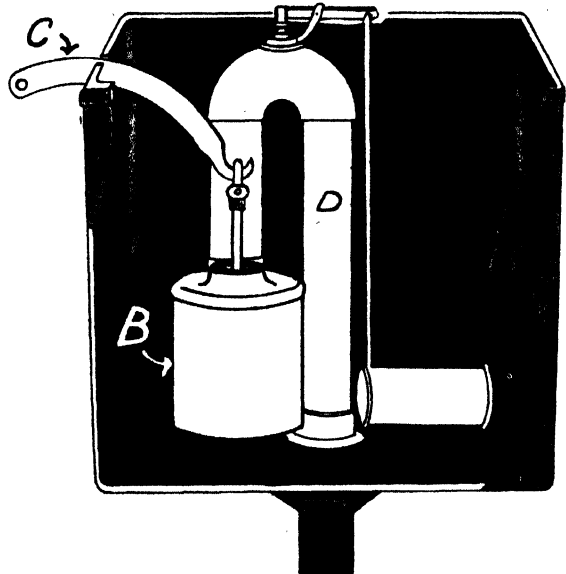

FIG. 82. VALVELESS SYPHON FLUSHING CISTERN

such works as underground conveniences, they can be made up to any shape and size to suit the job. They are fixed in various positions; a few of the uses to which they are put are: flushing sewers, drains, urinals, trough closets, etc. The pattern that works with a reverse-action ball valve is usually fitted with a *round pipe syphon*, whilst that with the drip supply has what is known as an *annular syphon*. Fig. 83 shows one of the latter type. The action of the tank is as follows. The base of the tube *A* dips into the water contained in the *trapping box B*; the tube is covered with a dome *C*, and as the water rises in the tank it compresses the air in the tube. The pressure continues until the water reaches the top of the tube, where, by the special construction of this top, the water overflows and falls down the centre of the tube, carrying air with it; this eventually creates a *partial vacuum*, which is overcome by the atmosphere acting on the surface of the water

MODERN BUILDING CONSTRUCTION

in the tank. The contents are then syphoned out with considerable force.

Fig. 84 shows a section through a special type of union supplied by the Metropolitan Water Board for use with automatic tanks

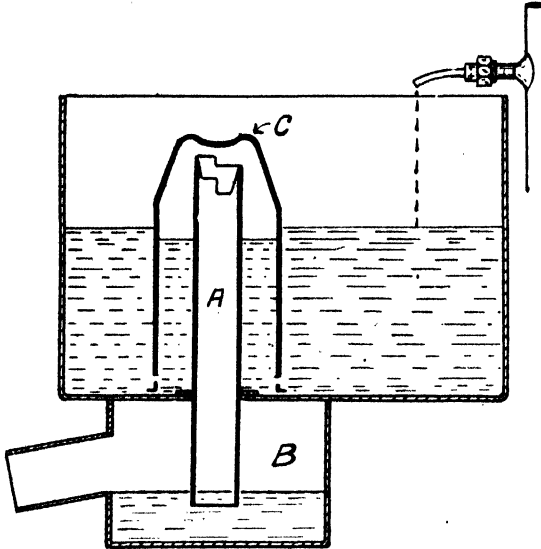

FIG. 83. ROGER FIELD AUTOMATIC FLUSHING TANK WITH DISC DRIP SUPPLY

with a *drip supply*. The outlet half of the union contains a *solid disc* through which a very fine hole is drilled by the M.W.B.; the size of the hole varies according to the rate at which the tank is required to discharge. The union is sealed after fixing so that no unauthorized person shall tamper with it. A *stopcock* must

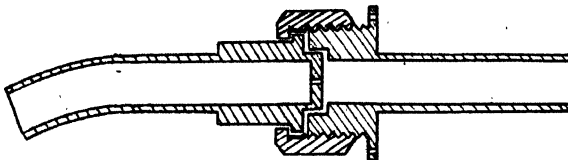

FIG. 84. DISC UNION FOR DRIP SUPPLY

always be provided close at hand to control this disc, so that the Water Board's officials can inspect it from time to time.

RAPID FLUSHING SYSTEMS. Many flushing cisterns, particularly the bell type, will not give a second flush for some minutes after the preceding one. This is unsatisfactory in factories and buildings where fittings are used only within limited times by numbers of persons. There are many ingenious devices on the market

to produce a quick second flush. Fig. 85 illustrates one method. It consists of one long trough-cistern supplying the whole range of flushing units. The flushing units are fixed in the trough and give full flushes every few seconds. A small air pipe breaks the siphonage after the required amount of water has passed out of the trough. Another advantage of the trough system is that only one ball-valve and service connection, and only one overflow are required for the whole range.

Another form is known as *gravity feed*. In this, a large tank adjacent to the range provides a supply pipe entering the bottom of the flushing cisterns. The cisterns thus fill up quickly

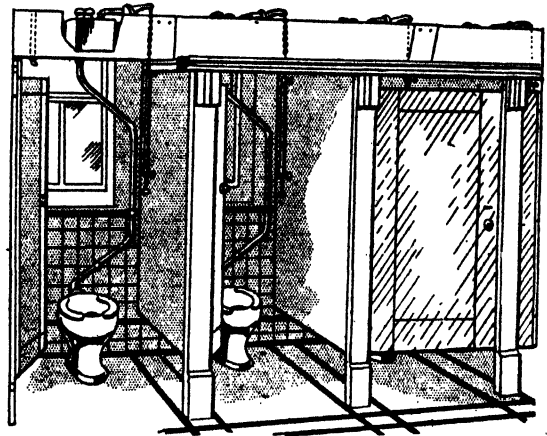

FIG. 85. RANGE OF FLUSHING UNITS

to the height of the water in the gravity feed tank instead of delaying until the usual ball-valve has time to operate. Small mushroom valves on the inlets to the cisterns prevent one cistern robbing another of its flush.

An ingenious invention for individual cisterns is shown in Fig. 86, designed to give a quickly following flush. It is known as the *Filkwik*. It is made of cast-iron and can be placed inside an ordinary flushing cistern under the float of the ball-valve. An elbow is provided to fix on the stem to suit the position of the ball, as shown. It works as follows.

When the cistern is flushed it also empties the *Filkwik* receptacle by self-siphonage (see siphon, on left). The cistern immediately begins to fill, the ball-valve remaining open full bore because the ball float cannot rise in the empty receptacle. When the water rises to the crown of the siphon on left, however, the water floats in to lift the ball and shut the water off. This

height, because it is the flushing level in the cistern, makes an immediate full second flush.

The by-laws fix the filling time for flushes at a maximum of two minutes (M.W.B. 1934). In high-class work, one-and-a-quarter minutes is pre-

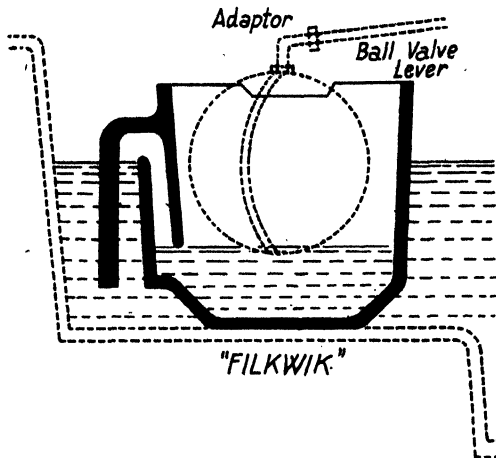

FIG. 86. "FILKWIK" FLUSHING SYSTEM

ferred, and in special installations (sports grounds, etc.), special types have to be adopted to fill in less than half-a-minute. Although two gallons is the usual flush limit under most authorities, hospitals and other institutions provided with water meters may use three-gallon flushing cisterns.

Underground Tanks. In isolated country districts where the rainfall is depended upon to supplement the water supply, underground storage tanks or reservoirs are usually constructed for the storage of rain-water collected from roofs and, in some cases, special gathering grounds or plots. These tanks are constructed in various ways, of which the following are good methods—

1. Hard stock brickwork rendered inside with Portland cement and sand trowelled smooth.
2. Reinforced concrete rendered as above.
3. Blue Staffordshire bricks built in cement mortar.

The exteriors should be backed by at least 9 in. of clay puddle, and the roofs built over and fitted with one or more manhole covers for access purposes. The rain-water is conveyed from the tank to a primary filter, after which it can be pumped into

storage tanks above ground and again filtered before use.

Covered reservoirs should be ventilated with dwarf pipes provided with conical covers, or a wire cage, to keep out birds and vermin. Fig. 86A shows a simple scheme for collecting and filtering surface water where the fall of the land permits. The main collecting tank must be large enough to hold sufficient water for the needs of the establishment. The rain-water separator indicated is a device which allows the first dirty flush from roofs, etc., to run to waste, then automatically tilts to allow the cleaner water that follows to run to the storage tank. By operating the valves, water is passed through the sand and gravel filter to the small clean-water tank from which it is raised by means of a pump. The filter is made in two sections so that one half can be cleansed or rested as occasion demands, but both sections can be put into use if required.

While the wholly downward type of filter is to be preferred, the more compact down and upward percolation type reduces the cost of sinking the main storage reservoir below the bottom of the filter. This type is shown in Fig. 66 of the "Drainage and Sanitation" section of this work. The up and down form remains

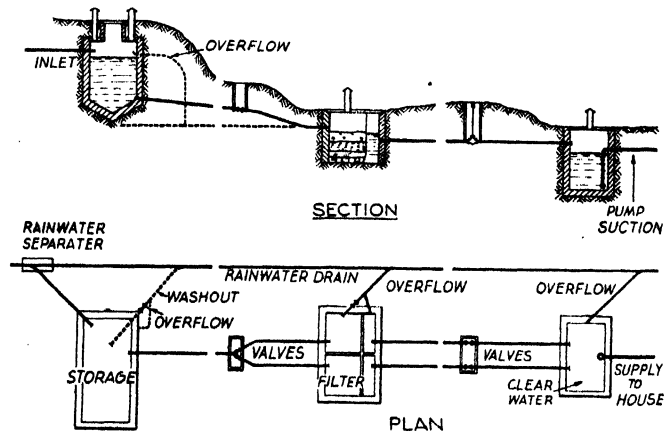

FIG. 86A

waterlogged between rainfalls, so that the filtering media do not get oxidized and air-flushed unless a fine weeping-hole is provided. A sinking in the main tank allows the pump to empty the tank completely. The settling tank or catch-pit on the inlet allows heavy silt, etc., to sink, and thus prevents the filtering media becoming sludged up quickly.

Chapter VII—WATER FITTINGS

ALL water fittings should be of the best quality brass, gun-metal, or nickel alloy.

Stopcocks. Fig. 87 shows a double-union high-pressure screw-down stopcock as used at the present time. Fig. 88 is similar, but has plain ends tinned for wiping to lead pipe; this pattern is very little used now, having been replaced by the double-union stopcock.

Fig. 89 shows a single-union screw-down stop valve, with flanged and screwed tail piece and

valve, or *bib tap*, and is what is generally called a *fixed jumper*, or *valve*; this may seem odd, as the valve is quite free to revolve on the small grub screw which engages the slot in the stem. The object of it is to prevent scrubbing

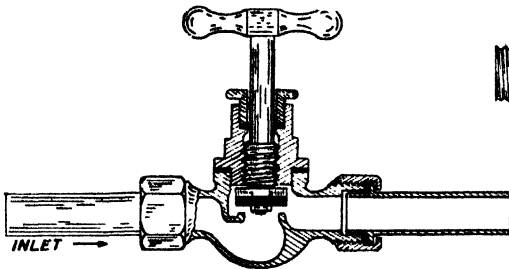

FIG. 87. DOUBLE-UNION HIGH-PRESSURE SCREW-DOWN STOP VALVE

back nut connecting same through the side of a storage cistern; the wiped joint to the service pipe is also shown. These three stop valves are fitted with fixed *jumpers* or *valves*.

It is very important that the valves shown

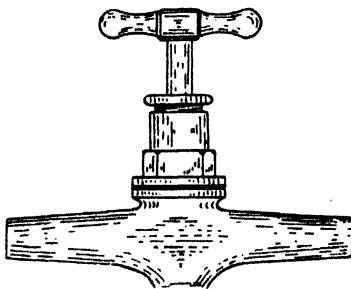

FIG. 88. HIGH-PRESSURE SCREW-DOWN STOP VALVE WITH PLAIN ENDS

in Figs. 87, 88, and 89 are fixed in the pipe-line, or from the tank, in the correct direction of flow. If fixed the wrong way, they do not operate properly. A study of the section in Fig. 87 will make this clear.

Fig. 90 shows a sectional detail of the *jumper* and part of the spindle of a *screw-down stop*

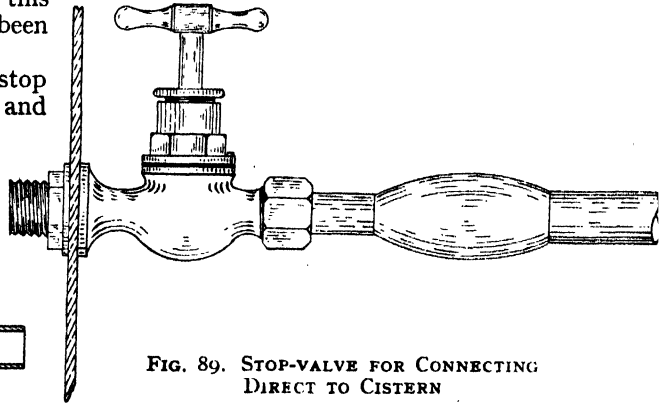

FIG. 89. STOP-VALVE FOR CONNECTING DIRECT TO CISTERN

and undue wear on the washer when screwed down.

Fig. 91 shows a section through a *capped jumper*, or *valve*; this type is chiefly used for seatings of a soft nature, of which rubber forms a part and which are used in valves of a

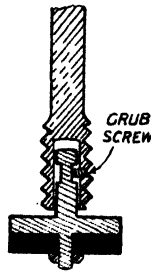

FIG. 90. SECTION OF PART OF SPINDLE AND VALVE OF SCREW-DOWN TAP

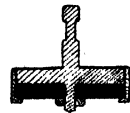

FIG. 91. CAPPED JUMPER

type known as $\frac{1}{4}$ and $\frac{1}{2}$ turn lever valves as used for baths and lavatory basins.

Fig. 92 shows a full-way stop, or *gate valve*, screwed for iron barrel; its operation is similar in all respects to a *sluice*, and when open has a clear way equal to the bore of the pipe. The plan of the valve shows the guides

cast on the sides of the body, which keep the gate in position as it opens or closes. This type of valve is used chiefly for hot-water work where full-bore fittings are essential. They

This type is also used chiefly for hot water work.

Taps. Fig. 94 shows a section through a plug tap. This is one of the earlier forms of

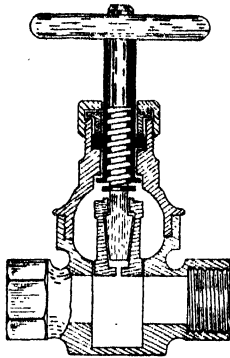

FIG. 92. FULL-WAY STOP VALVE

are also used for cold water supply when full-way valves are specified.

Fig. 93 shows a gland stopcock screwed for iron barrel; it consists of a heavy cast gun-metal body into which is fitted a solid taper plug through which is cut a water way, or

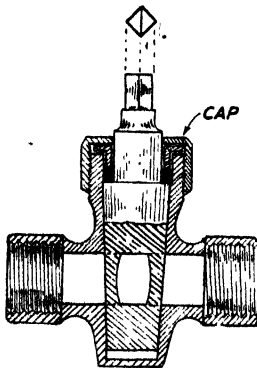

FIG. 93. GLAND STOPCOCK

port; the plug is operated by a loose key which opens or closes the water way by a quarter turn; the head of the plug is grooved in the direction of the port. The upper portion of the body is made to receive packing, which is held in position by the gland and screw cap.

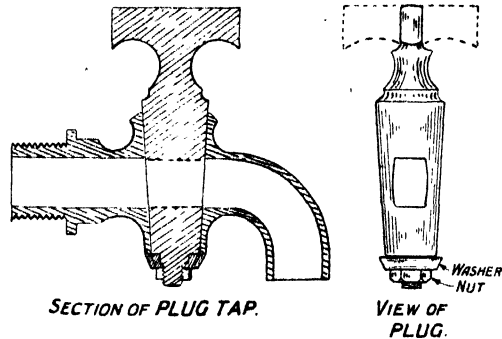

FIG. 94. PLUG TAP

tap used for general domestic water supply; but owing to it being a *quick closing* fitting, it often set up a chattering, known as *waier hammer*, by the sudden arrest of the flow of water. The principle is similar to the gland stopcock described in Fig. 93. They are also obtainable with a square head and loose key, and in this form are used at the present time as emptying cocks for boilers.

Fig. 95 shows a section through an ordinary high-pressure screw-down bib tap. This is

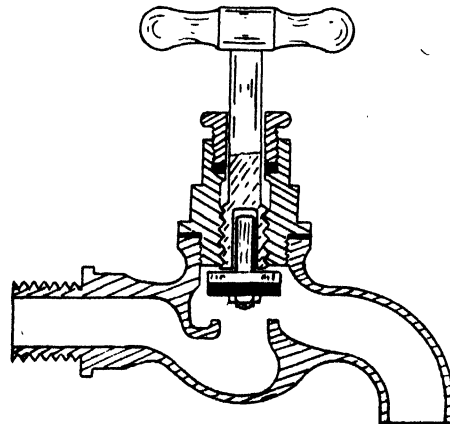

FIG. 95. HIGH-PRESSURE SCREW-DOWN BIB TAP

similar in all respects to Figs. 87 and 88 in construction and working parts. It is in general use, and in most parts is insisted upon by the water companies.

Fig. 96 shows a capstan-head screw-down pillar valve as used for baths and lavatory

MODERN BUILDING CONSTRUCTION

basins. The connection to this fitting is made by a cap and lining and wiped joint. A similar valve to this can also be obtained with $\frac{1}{4}$ -turn

Fig. 97 is a section through the back skirting of a washing-up sink and shows the type of tap and fitting used for this purpose.

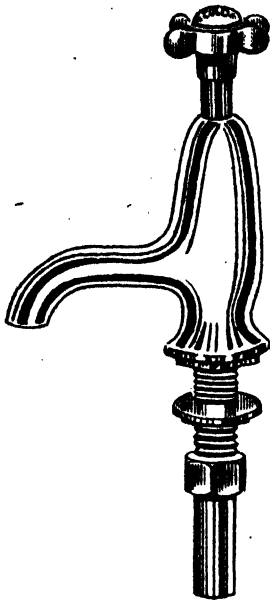

FIG. 96. CAPSTAN HEAD SCREW-DOWN PILLAR VALVE

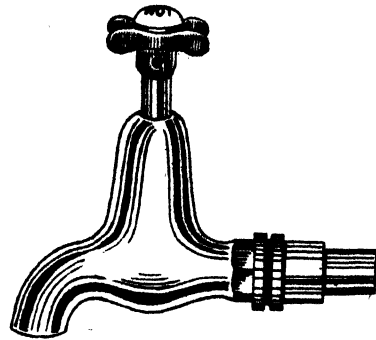

FIG. 98. BIB TAP WITH SHIELD BODY COVER

Fig. 98 shows another form of bib tap now largely used, which has a shield, or covering, over the upper portion of the body, thus masking the irregular surface and rendering the fitting easy to clean.

Fig. 99 shows a chromium-plated globe pattern valve now very much used.

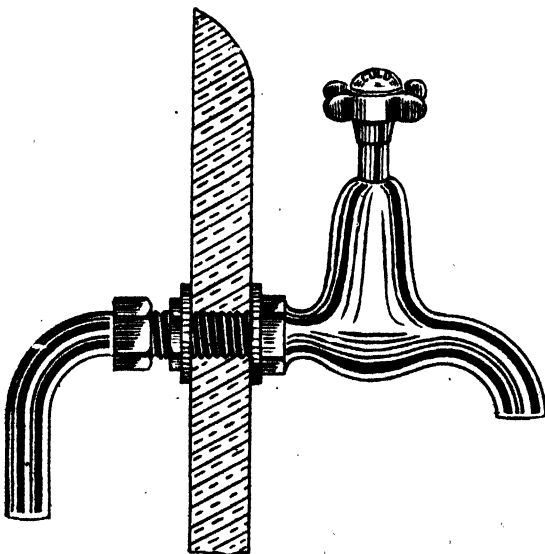

FIG. 97. SECTION THROUGH BACK SKIRTING OF WASHING-UP SINK

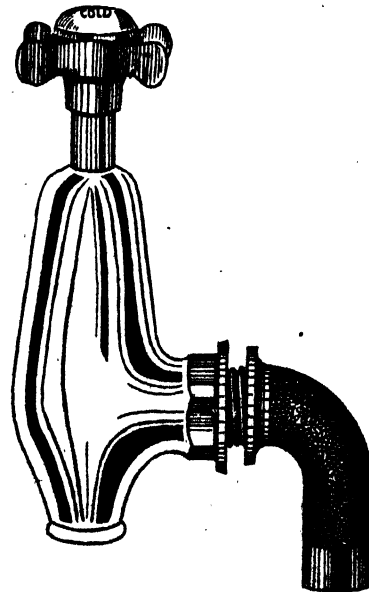

FIG. 99. GLOBE VALVE

lever handles, the interior being fitted with a very steep-pitched thread which allows the valve to rise from its seating on a slight movement of the lever.

In addition to these fittings, a very large number of baths and basins are now fitted with valves and waste apparatus that are coated with porcelain enamel; they give the complete fitting a very clean appearance and

do not require the same amount of cleansing as those of brass or nickel plate. The one disadvantage is the liability to chip the coating. If repairs are required to be carried out to these taps, the portion covering the body is usually made so as to be easily removable.

SPRING TAPS. To reduce waste of water in connection with fittings used by the public, e.g. railway stations, schools, a spring pattern type of valve operated with a press button is employed. These taps discharge only when the button is pressed. They are usually of pillar tap design, and when ordering, the non-concussive type must be specified, otherwise

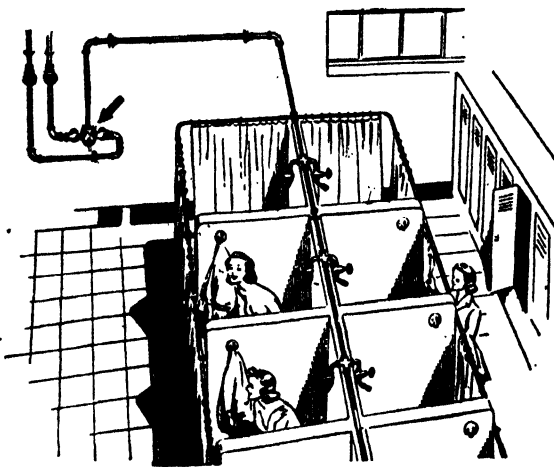

FIG. 100. MIXING VALVE SERVING BATH SHOWERS

nuisance will occur from water-hammer. The non-concussive type, when properly adjusted by the grub-screw provided, runs for a few moments after the press button has been released.

Mixing Valves. These valves are designed to be operated by one handle, and discharge water at any required temperature below boiling point to tepid and cold. They are essential for shower baths. There is an internal grub-screw which can be adjusted to prevent risk of scalding. Used for the supply to baths, they reduce the amount of steam escaping in the room, a disadvantage associated with the ordinary separate hot and cold supply taps. One type on the market operates direct from the steam pipe.

Mixing valves are expensive, but a more general demand for this useful fitting will no doubt reduce the cost.

Fig. 100 shows a mixing valve fixed on pipe

lines to control and regulate the supply and temperature of a number of bath showers in cubicles. The mixing valve is regulated and set by an attendant in such cases. Each shower needs then only one control valve. Fig. 101 is a sectional view of an industrial type of thermostatic control valve.

Ball-valves. Every high pressure ball tap shall close against a test pressure of 200 lb. per sq. in.; every low pressure ball tap against a test pressure of 10 lb. per sq. in. All ball-valves to be marked having letters H-P; L-P; or F-W

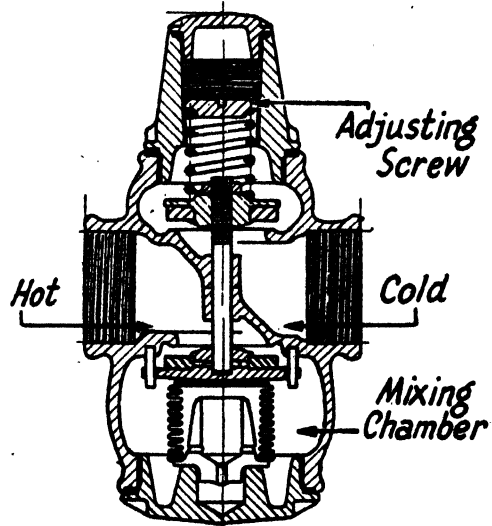

FIG. 101. SECTION THROUGH MIXING VALVE SERVING BATH SHOWERS

cast or stamped on the body of the fitting (M.W.B.).

The type of ball-valve should be chosen according to the pressure it has to resist. If, for example, a H-P type is fixed on a low pressure position the supply tank will be slow in filling. If, on the other hand, a L-P type is fixed on a high pressure position, water-hammer will probably occur.

Ball valves are often referred to as *ball cocks*; there is, however, a distinct difference between the two fittings.

A *ball cock* is in the form of an horizontal plug cock, to the square head of which is fitted the arm carrying the ball, and by one eighth of turn opens and closes the water-way, or port, in the plug, the port being cut at right angles through the plug. This fitting was the forerunner of the ball valve and is not in general use at the present time.

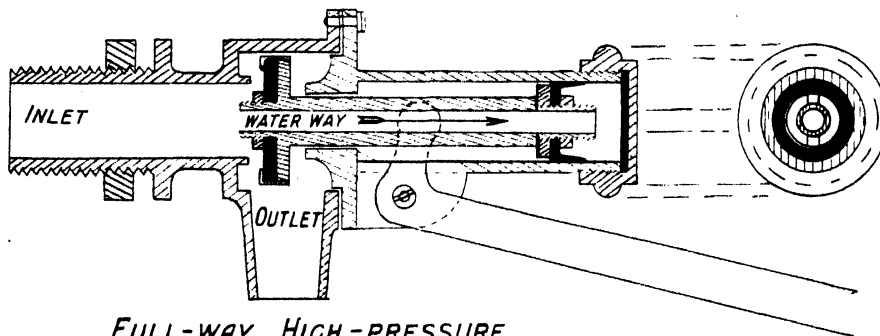
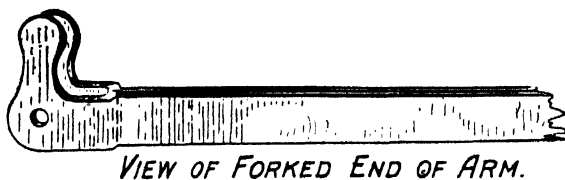
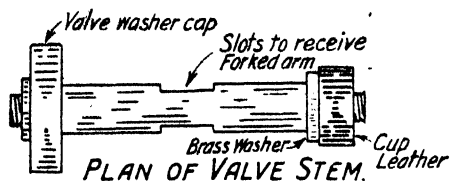

FULL-WAY HIGH-PRESSURE
EQUILIBRIUM BALL VALVE.

FIG. 102

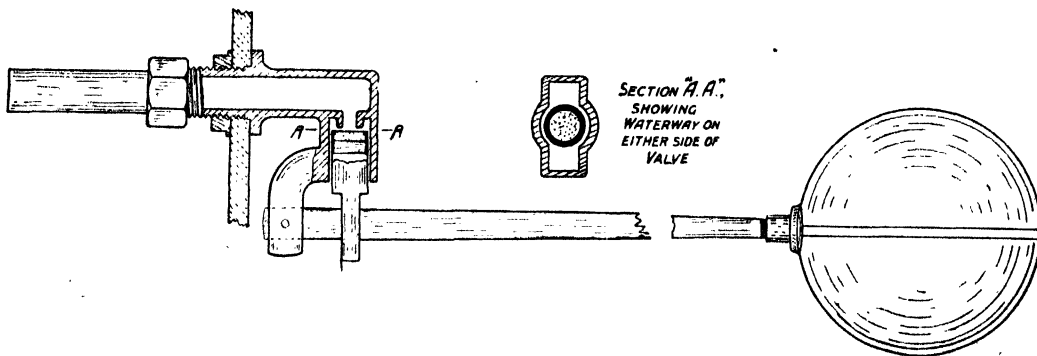

CROYDON BALL VALVE

FIG. 103

CONNECTION OF BALL TO ARM

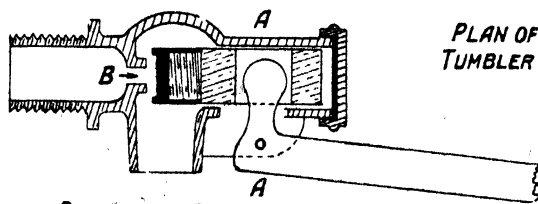
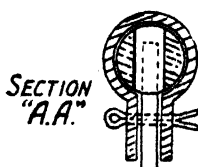

PORTSMOUTH PATTERN BALL VALVE
HIGH PRESSURE.

FIG. 104

A *ball valve*, on the other hand, is fitted with a loose *valve, tumbler, or diaphragm*, operated by the arm of the floating ball.

Fig. 102 shows the equilibrium (or full-way high-pressure) ball valve, so called because there is an equal pressure of water on both sides of the valve; that is, *there is the same force tending to close the valve as there is to open it*, the water passing through the hollow spindle of the valve and acting back on the cup leather. This valve is usually fitted with a silence pipe and is a very good type to use.

Fig. 103 shows the Croydon ball valve, chiefly a high-pressure fitting and very extensively used. The great objection to this valve is the noise set up by the incoming water being split up as it issues from the valve on each side of the tumbler; *note section of valve on A-A*. This valve may also be obtained to suit low pressure, the water way being enlarged as required.

Fig. 104 shows the Portsmouth ball valve, high pressure type. This is also a very good fitting to use and, like the equilibrium type, can be fitted with a silence pipe; this is a distinct advantage these two fittings possess over the Croydon pattern. The Portsmouth valve can also be obtained to suit low pressures; the chief difference between the high- and low-pressure type is the size of the orifice, or water way, at *B*. A silence pipe is carried down to discharge below the water surface in the tank, and so subdues the noise when filling. It should have a fine hole drilled near the top, to prevent its acting as a siphon.

ARRANGEMENT OF FITTINGS

The provision of suitable stopcocks is an important matter in controlling water supply, but unfortunately neglected in a great number of buildings. It often happens that the omission of a stopcock means the wasting of large quantities of water to enable a minor repair or alteration to be carried out, whereas the initial cost of installing a stopcock would be very small.

Stopcocks should be provided on all down service pipes immediately beneath the cistern; and where a number of fittings are supplied on different floors, a stopcock should be fixed on each branch service pipe. All stopcocks should be labelled to indicate the fittings they control. In buildings of any great height, a stopcock should be provided on the top floor near the storage cistern to control the ball valve.

ARRANGEMENT OF PIPES. Fig. 105 is a diagram showing the arrangement of service pipes in a non-basement house. The connection to the company's main is made as described in a previous chapter, but the main stopcock and a draw-off tap are placed in a small pit inside the garden wall or fence; this pit should be large enough to allow of reasonable easy access to the fittings from the ground surface, and not simply fixed up with a small drain pipe as is often the case; the pit should be fitted with a hinged iron cover at ground level. The main is then continued beneath the path, entering the house at the side, and passes up through the pantry, where stopcock No. 1 is placed; a draw-off tap is provided over the pantry sink for a drinking water supply, and also to act as an emptying tap when the main is shut down.

Stopcocks should be provided as shown and explained on the diagram, and in addition combined stop and ball valves, Fig. 106, should be provided to the W.C. flushing cisterns. It should be pointed out, however, that while Fig. 105 provides for a suitable number of stopcocks, that where expense is not considered and work is to be of the best possible type, then each fitting should be provided with a separate stopcock; this is often done and, strictly speaking, is the correct method, as it enables any fitting to be disconnected or repairs to be carried out without interfering with the remainder of the fittings in the house.

In arranging the run of pipes, it is desirable to group them together as far as possible, and preferably on an internal wall, where they are less liable to be attacked by frost. Several methods are adopted for the passage of supply pipes through a building, but some of these methods are not to be recommended, as they lead to extensive damage to property when a small defect occurs. Unfortunately, the chief object appears to be to hide up and bury anything in the nature of a service or soil pipe; this is quite a good idea from an artistic view point, but if pipes are to be concealed, then proper provision should be made for this purpose in the form of recesses large enough to allow of proper fixings to the back and sides of recess and to give ready access to the pipes for inspection and repairs. It is not always consistent or convenient to fix pipes on the wall face, but when possible without undue disfigurement it should be done. Where pipes are to be enclosed within a casing, due regard should be given to the construction

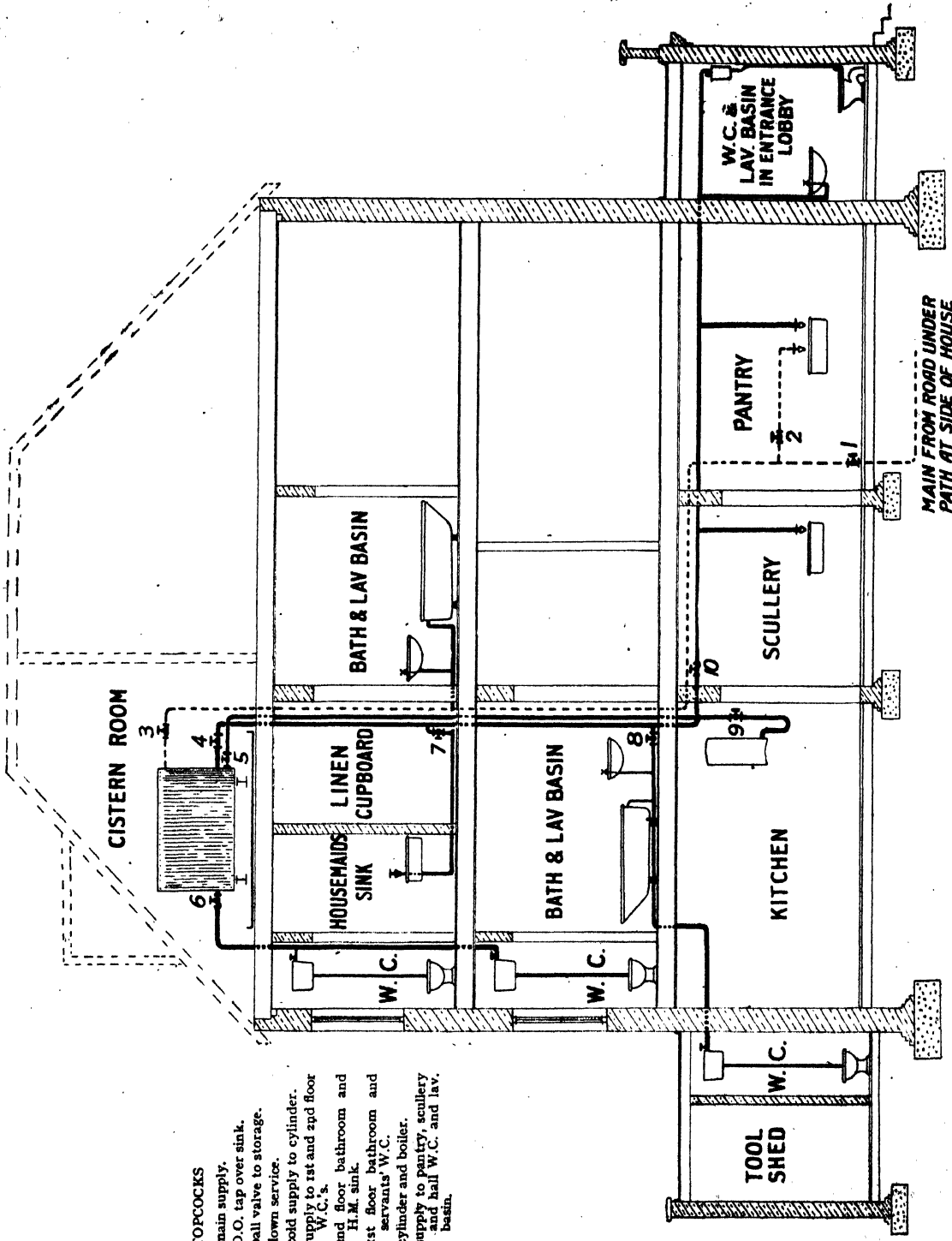

STOPCOCKS

- No. 1 controls main supply.
- " 2 " D.O. tap over sink.
- " 3 " ball valve to storage.
- " 4 " down service.
- " 5 " cold supply to cylinder.
- " 6 " supply to 1st and 2nd floor W.C.'s.
- " 7 " and floor bathroom and H.M. sink.
- " 8 " 1st floor bathroom and servants' W.C.
- " 9 " cylinder and boiler.
- " 10 " supply to pantry, scullery and hall W.C. and lav. basin.

FIG. 105. ARRANGEMENT OF PIPES FOR A SUBURBAN HOUSE

of this casing to enable it to be easily removed and refixed without damage to the building.

In the larger type of building, provision is usually made for the main runs of pipe to be grouped together and fixed in a specially constructed duct or shaft which is accessible from floor to floor.

Fig. 107 shows a method of fitting up a storage cistern in a building, together with the

the cistern, after which the plug can be refixed. It will be noticed that the cleansing plug terminates just below the water level; this is to prevent unauthorized persons from detecting its presence and tampering with it. The ends of overflow and safe waste pipes should be fitted with hinged copper flaps.

Fig. 108 shows the method of fixing a pair of bib taps over a sink when the supply pipes are of iron; this is often done when the cold

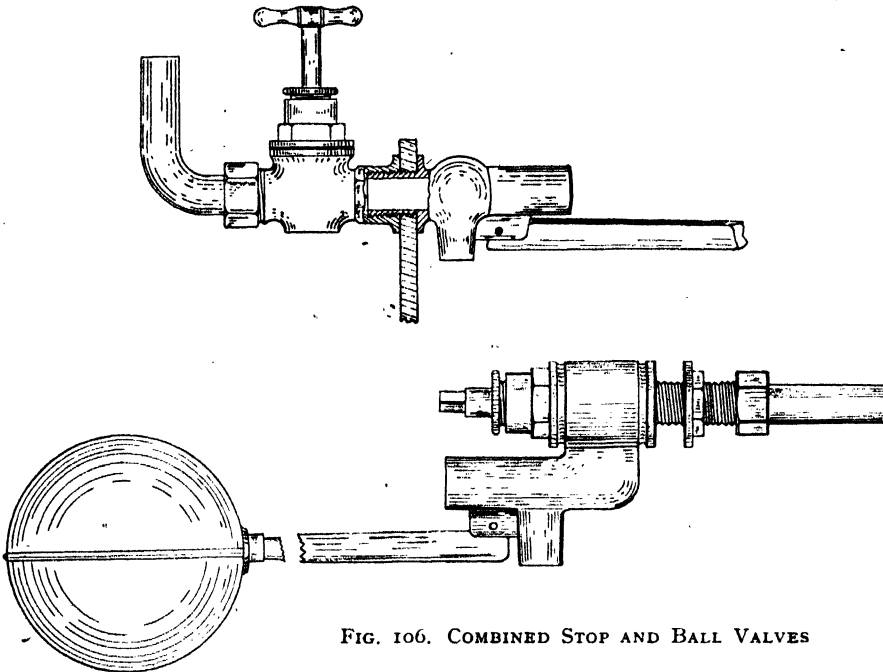

FIG. 106. COMBINED STOP AND BALL VALVES

general arrangement of the pipes; for sake of clearness, one down service only is shown. A cleansing plug and waste pipe should be provided for use when the cistern requires cleaning out; this waste should discharge into a *rain-water head*, and should be carried down separately to discharge over a properly trapped gully. This "waste" is required when a cistern has to be cleaned; without it, the whole of the water, together with the dirt that accumulates, must be drawn off through the service pipes and fittings, which is most objectionable; whereas with this waste pipe the water, together with the washings of the cistern, can be carried away straight to the drain. The supply can afterwards be allowed to run to waste for a few moments to thoroughly wash out the bottom of

supply is of lead, a short length of iron being inserted and connected to the lead with a plumber's union. This method is very neat and makes a firm fixing independent of the wall above the sink.

Regulations. The various water companies issue regulations covering the districts they supply. The following are the chief regulations of the Metropolitan Water Board for London and will give a general idea of the requirements.

Weight of Lead Pipes. No lead pipe shall hereafter be laid or fixed in or about any premises for the conveyance of or in connection with the water supplied by the Company (except when and as otherwise authorized by these Regulations, or by the Company), unless the same shall be of equal thickness throughout,

MODERN BUILDING CONSTRUCTION

and of at least the weight following, that is to say for pressures not exceeding 250 ft. head of water—

Internal Diameter of Pipe in Inches	Weight of Pipe in lb. per linear Yard
$\frac{1}{4}$ -inch diameter	5 lb. per linear yard
$\frac{3}{8}$ " "	7 " "
$\frac{1}{2}$ " "	11 " "
1 " "	16 " "
$1\frac{1}{4}$ " "	21 " "

Interior Pipes. Every pipe hereafter laid or fixed in the interior of any dwelling-house for the conveyance of, or in connection with, the water of the Company, must, unless with the consent of the Company, if in contact with the ground, be of lead, but may otherwise be of lead, ternary lead, copper, or wrought iron, at the option of the consumer.

Connection to be by Ferrule or Stopcock. The connection of every "communication-pipe" with any pipe of the Company shall hereafter be made by means

of a sound and suitable brass screwed ferrule or stopcock with union, and such ferrule or stopcock shall be so made as to have a clear area of waterway equal to that of a $\frac{1}{4}$ -in. pipe. The connection of every "communication-pipe" with the pipes of the Company shall be made by the Company's workmen, and the Company shall be paid in advance the reasonable costs and charges of and incident to the making of such connection.

Material and Joints of External Pipes. Every "communication-pipe" and every pipe external to the house and through the external walls thereof hereafter respectively laid or fixed, in connection with the water of the Company, shall be of lead, and every joint thereof shall be of the kind called a "plumbing" or "wiped" joint.

No Pipe to be Laid Through Drains, etc. No pipe shall be used for the conveyance of, or in connection with, water supplied by the Company, which is laid or fixed through, in, or into any drain, ashpit, sink, or manure-hole, or through, in, or into any place where the water conveyed through such pipe may be liable to become fouled, except where such drain, ashpit, sink or manure-hole, or other such place, shall be in

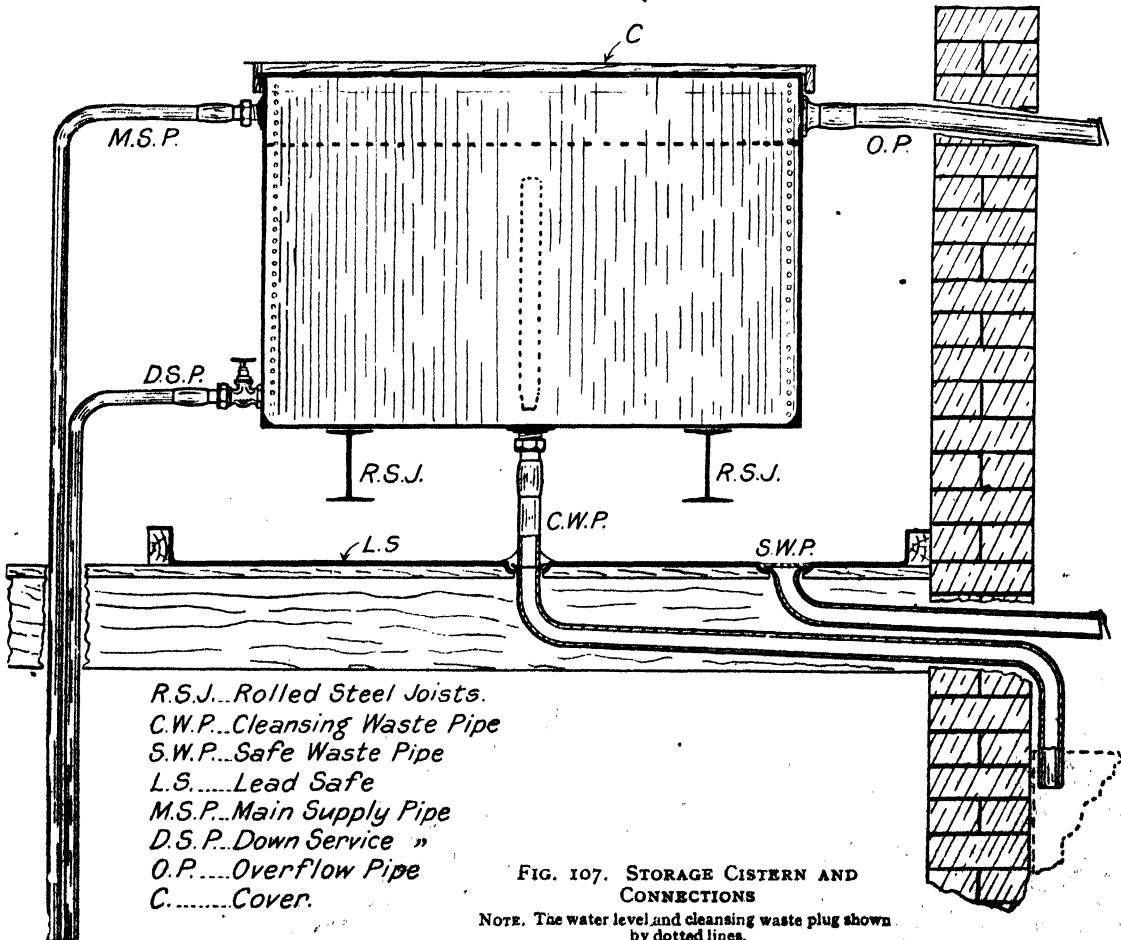

the unavoidable course of such pipe, and then in every such case such pipe shall be passed through an exterior cast-iron pipe or jacket of sufficient length and strength, and of such construction as to afford due protection to the water-pipe.

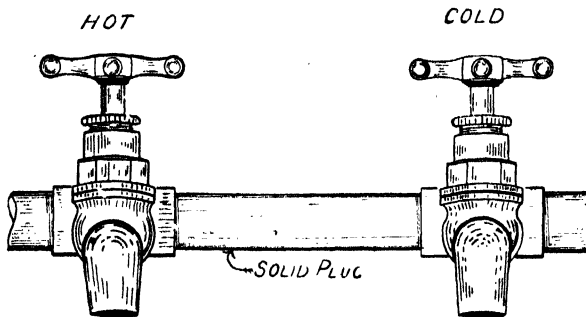

FIG. 108. METHOD OF FIXING A PAIR OF VALVES ON SCREWED-BARREL SUPPLY

Depth of Pipes Under Ground. Every pipe hereafter laid for the conveyance of, or in connection with, water supplied by the Company, shall, when laid in open ground, be laid at least 2 ft. 6 in. below the surface, and shall in every exposed situation be properly protected against the effects of frost.

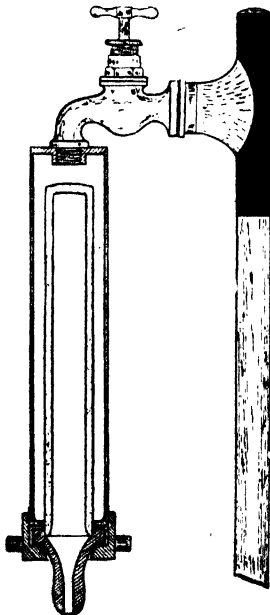

FIG. 109. THE PASTEUR CHAMBERLAND FILTER

No Connection with Rain-water Receptacle. No pipe for the conveyance of, or in connection with water supplied by the Company, shall communicate with any cistern, butt, or other receptacle used or intended to be used for rain-water.

Stop-valve. Every "communication-pipe" for the conveyance of water to be supplied by the Com-

pany into any premises shall have at or near its point of entrance into such premises, and if desired by the consumer within such premises, a sound and suitable stop-valve of the screw-down kind, with an area of waterway not less than that of a 1/2-in. pipe, and not greater than that of the "communication-pipe," the size of the valve within these limits being at the option of the consumer.

If placed in the ground such "stop-valve" shall be protected by a proper cover and "guard-box."

Arrangement of Warning-pipes. Every "warning-pipe" shall be placed in such a situation as will admit of the discharge of the water from such "warning pipe" being readily ascertained by the officers of the

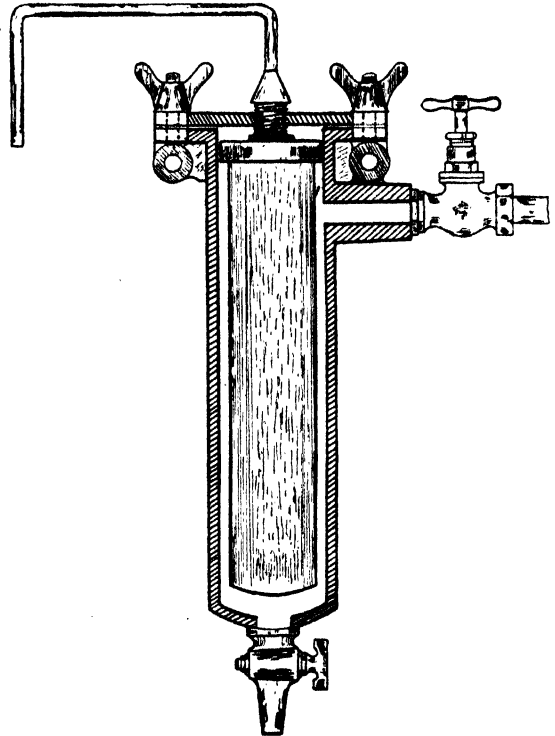

FIG. 110. THE BERKEFELD FILTER

Company. And the position of such "warning-pipe" shall not be changed without previous notice to and approval by the Company.

Water-closet Apparatus. Every water-closet cistern or water-closet service-box hereafter fitted or fixed in which water supplied by the Company is to be used, shall have an efficient waste-preventing apparatus, so constructed as not to be capable of discharging more than 2 gals. of water at each flush.

Weight of Lead Pipes Having Open Ends. All lead "warning-pipes" and other lead pipes of which the ends are open so that such pipes cannot remain charged with water, may be of the following minimum weights, that is to say—

1/2-inch (internal diameter)	. . .	3 lb. per yard.
3/4 " "	. . .	5 " "
1 " "	. . .	7 " "

MODERN BUILDING CONSTRUCTION

Proportional Pipe-sizing. The discharging powers of pipes is as the square root of the fifth power of their diameters. This is an easy formula for computing quickly the approximate

and one $\frac{3}{4}$ in. tap need a full discharge when all are open at the same time. Find a pipe which will give this supply. The factor for $\frac{1}{2}$ in. is $\cdot 18$ and for $\frac{3}{4}$ in. $\cdot 49$.

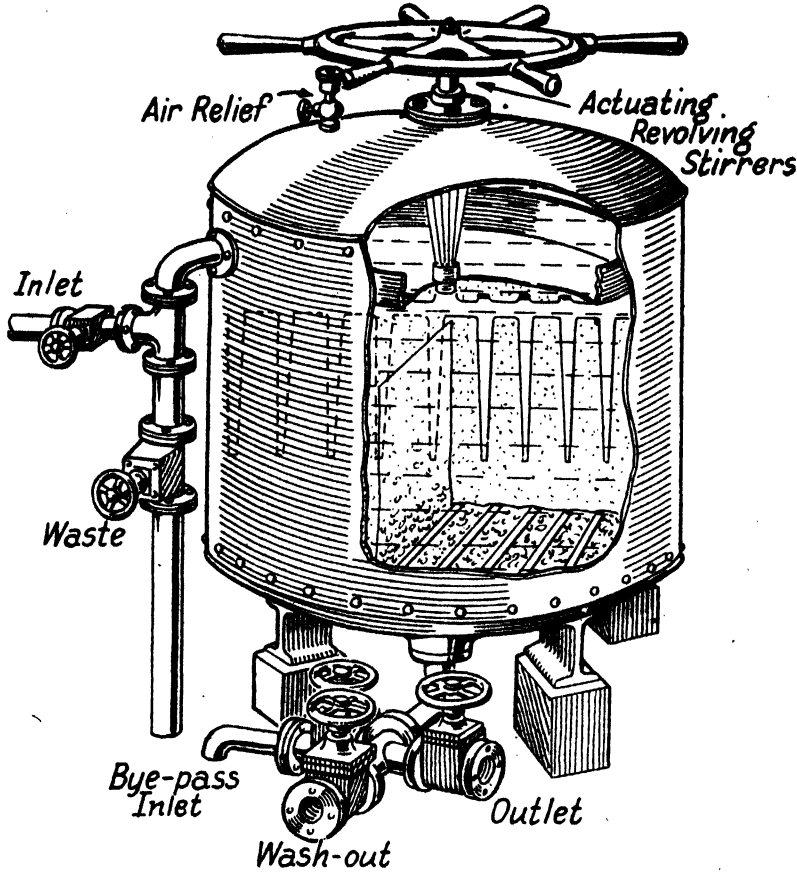

FIG. III. PATERSON'S PRESSURE FILTER

proportional diameter of a required pipe to supply a number of branches. The following table has been compiled from it—

Pipe Bore	Factor	Pipe Bore	Factor
$\frac{1}{4}$ in.	0.03	in.	5.5
$\frac{3}{8}$ in.	0.09	2	
$\frac{1}{2}$ in.	0.18	3	15
$\frac{3}{4}$ in.	0.49	3½	26
1 in.	1.00	4	32
1½ in.	1.75	5	56
2 in.	2.75	6	88

To use the table, assume that two $\frac{1}{2}$ in. taps

$$\text{Then } 2 \times \cdot 18 = \cdot 36$$

$$1 \times \cdot 49 = \cdot 49$$

$$\text{The sum} = \cdot 85$$

The nearest factor above $\cdot 85$ in. in the table is 1, therefore, a one-inch pipe is indicated. When dealing with numbers of fittings in a range, or in a busy building, it can be assumed that half the number will be open at the same time, or, alternatively, if all are open, half the full delivery will be sufficient at each tap. Thus, for a range of 12 wash-basins, each provided with $\frac{1}{2}$ in. taps, the diameter of pipe to give full delivery to 6 taps will be $6 \times \cdot 18 = 1.08$. Just above a 1-in. pipe.

TABLE XII

TABLE FOR DETERMINING DISCHARGE OF WATER IN GALLONS PER MINUTE, ACCORDING TO THE FORMULA OF THOS. BOX (COMPILED BY W. E. FRETWELL, M.I.MECH.E., ETC.)

Value of Length over Head $\frac{L}{H}$	Diameter of Pipe									
	½ in.	¾ in.	1 in.	1¼ in.	1½ in.	2 in.	2½ in.	3 in.	3½ in.	4 in.
0.2	10.68	29.4	60.5	105.7	166.2	341.4	596.7	938.8	1377.0	1923.0
0.4	7.54	20.8	42.8	74.8	117.6	241.4	422.0	664.0	974.0	1360.0
0.6	6.1	16.8	34.9	60.9	95.9	197.0	344.2	591.6	795.0	1109.0
0.8	5.32	14.7	30.25	52.8	83.1	170.8	298.3	470.0	689.0	961.0
1.0	4.77	13.1	27.0	47.0	74.0	152.7	268.0	420.0	616.0	860.0
1.2	4.35	12.0	24.6	43.2	68.0	139.4	243.0	384.0	564.0	790.0
1.4	4.03	11.1	22.8	40.0	63.0	129.0	225.0	355.0	520.0	730.0
1.6	3.77	10.4	21.38	37.4	58.8	120.7	211.0	332.0	487.0	680.0
1.8	3.55	9.8	20.16	35.2	55.5	113.9	198.0	313.0	460.0	643.0
2.0	3.37	9.3	19.1	33.4	52.6	108.0	188.6	296.0	436.0	610.0
2.5	3.02	8.3	17.1	29.8	47.0	96.6	168.6	256.0	391.0	546.0
3.0	2.75	7.6	15.6	27.2	43.0	88.1	154.0	243.0	357.0	499.0
4.0	2.38	6.6	13.5	23.6	37.0	76.3	134.0	210.0	310.0	432.0
5.0	2.14	5.9	12.0	21.2	33.0	68.3	118.0	188.0	276.0	385.0
6.0	1.95	5.4	11.0	19.3	31.0	62.3	108.0	173.0	252.0	350.0
7.0	1.8	5.0	10.2	17.8	28.0	57.7	101.0	159.0	233.0	326.0
8.0	1.69	4.6	9.5	16.7	26.4	54.0	94.0	148.0	218.0	304.0
9.0	1.59	4.4	9.0	15.7	25.0	51.0	89.0	140.0	205.0	288.0
10.0	1.51	4.16	8.5	15.0	23.5	48.0	84.0	133.0	195.0	270.0
11.0	1.43	4.0	8.15	14.2	22.4	46.0	81.0	126.0	186.0	260.0
12.0	1.38	3.96	8.0	13.62	21.5	44.1	77.0	122.0	178.0	249.0
13.0	1.34	3.65	7.5	13.1	20.6	42.0	74.0	116.0	170.0	240.0
14.0	1.27	3.5	7.2	12.6	20.0	40.6	71.0	113.0	165.0	230.0
15.0	1.23	3.4	7.0	12.2	19.2	39.4	69.0	109.0	160.0	223.0
16.0	1.2	3.3	6.7	11.8	18.6	38.0	66.0	105.0	155.0	216.0
17.0	1.16	3.18	6.6	11.4	18.0	37.0	64.6	102.0	150.0	210.0
18.0	1.12	3.1	6.37	11.1	17.6	36.0	63.0	99.0	145.0	203.0
19.0	1.1	3.05	6.2	10.75	17.1	35.0	61.2	96.0	141.0	198.0
20.0	1.07	2.95	6.05	10.5	16.7	34.1	59.7	94.0	138.0	194.0
22.0	1.02	2.8	5.75	10.05	15.9	32.5	57.0	89.5	133.0	184.0
24.0	0.975	2.7	5.5	9.65	15.5	31.0	54.0	86.5	126.0	175.0
26.0	0.947	2.58	5.3	9.26	14.6	29.7	52.3	82.0	120.0	170.0
28.0	0.9	2.5	5.1	8.9	14.0	28.8	50.5	79.5	116.0	163.0
30.0	0.87	2.4	4.95	8.6	13.6	27.8	48.8	77.0	113.0	158.0
32.0	0.84	2.32	4.76	8.3	13.2	27.0	47.4	74.3	109.0	154.0
34.0	0.82	2.24	4.63	8.06	12.7	26.2	46.0	72.0	106.0	147.0
36.0	0.79	2.18	4.5	7.84	12.3	25.5	45.6	70.0	103.0	143.0
38.0	0.775	2.12	4.37	7.63	12.0	24.8	43.5	68.0	100.0	140.0
40.0	0.75	2.08	4.25	7.5	11.75	24.0	42.0	66.5	97.5	135.0
45.0	0.712	1.96	4.03	7.05	11.12	22.76	39.8	62.6	92.0	128.0
50.0	0.675	1.86	3.82	6.68	10.5	21.6	37.7	59.5	87.5	121.0
55.0	0.635	1.77	3.64	6.34	9.98	20.6	36.2	56.6	83.0	116.0
60.0	0.612	1.7	3.5	6.1	9.6	19.7	34.5	54.5	80.0	111.0
70.0	0.57	1.56	3.25	5.63	8.85	18.2	32.0	50.0	73.6	102.0
80.0	0.53	1.47	3.025	5.25	8.35	17.0	29.8	47.0	69.0	97.0
90.0	0.505	1.38	2.84	4.95	7.8	16.2	28.2	44.2	65.0	91.0
100.0	0.477	1.31	2.7	4.7	7.4	15.2	26.8	42.0	61.6	86.0
125.0	0.427	1.17	2.41	4.2	6.6	13.6	24.0	37.5	55.0	77.0
150.0	0.348	1.07	2.2	3.83	6.05	12.5	21.8	34.2	50.3	70.0
200.0	0.337	0.93	1.91	3.34	5.26	10.75	18.86	29.6	43.6	61.0
250.0	0.302	0.83	1.71	2.98	4.7	9.64	16.86	25.6	39.1	54.6
300.0	0.276	0.76	1.56	2.72	4.3	8.82	15.4	24.3	35.7	50.0
350.0	0.255	0.7	1.44	2.5	3.95	8.16	14.3	22.4	33.0	46.0
400.0	0.238	0.66	1.35	2.36	3.7	7.6	13.4	21.0	31.0	43.2
450.0	0.226	0.62	1.27	2.22	3.5	7.2	12.6	19.8	29.0	40.5
500.0	0.214	0.59	1.2	2.12	3.3	6.8	11.8	18.8	27.6	38.5
550.0	0.207	0.558	1.15	2.0	3.16	6.5	11.4	17.8	26.2	36.6
600.0	0.195	0.54	1.1	1.93	3.1	6.2	10.8	17.3	25.2	35.0
700.0	0.18	0.5	1.02	1.78	2.8	5.76	10.1	15.9	23.3	32.6
800.0	0.1687	0.456	0.95	1.67	2.64	5.4	9.4	14.8	21.8	30.4
900.0	0.159	0.44	0.90	1.57	2.5	5.1	8.9	14.0	20.5	28.8
1000.0	0.151	0.416	0.85	1.5	2.35	4.8	8.4	13.3	19.5	27.0

Resistance of fittings to be taken into consideration in length value.

MODERN BUILDING CONSTRUCTION

For low pressure a $1\frac{1}{4}$ in. pipe should be selected. For high pressure service 1 in. would be sufficient.

For more exact determination, a table compiled by W. E. Fretwell, M.I.Mech.E., can be used. In this, the figures in the body of the table give gallons discharged per minute. L = length of pipe and H = head of water in feet.

To take an example, using Table XII. Find the diameter of a pipe which will discharge 33 gals. per minute if the pipe is 210 ft. long and the head of water above the discharging point

is 120 ft. Then $\frac{L}{H} = \frac{210}{120} = 1.75$. The nearest factor, column 1 in the table, is 1.8. Run the eye along this line, where it will be found that the nearest figure to 33 is 35.2 under $1\frac{1}{4}$ in. pipe. A $1\frac{1}{4}$ in. pipe, therefore, should be chosen because, under the given conditions, a 1 in. pipe would discharge only 20.16 gals. per minute.

To find the discharge from a known diameter, under the same conditions as the above: $\frac{L}{H} = 1.8$, and a $1\frac{1}{4}$ in. pipe. Look down the $1\frac{1}{4}$ in. column and along the line opposite 1.8. It will be seen that the $1\frac{1}{4}$ in. pipe will discharge 35.2 gals. per minute. It must be remembered, however, that bends, elbows, tees, stop-valves, etc., offer resistance to free flow. In practice, each type of fitting is given a resistance factor which is expressed in terms of the equivalent length of pipe of the same diameter and offering the same resistance to the flow of water. That is, a few feet of pipe is added to the length of piping, the amount varying according to the type of fitting and the diameter.

The following table from "Copper Pipe Lines for Buildings" is offered as a guide to the amounts of water required in gallons per minute to give a reasonably brisk service.

TABLE XIII
TAPS FULL OPEN

Fitting	Gallons per minute at each tap
Baths—Domestic	6 to 10
Factories, Institutes	8 " 12
Shower	5 " 8
Wash basins—Domestic	3 " 5
Factories, etc.	4 " 6
Sinks	3 " 5
W.C.s.	2 " 4
Bidets	$1\frac{1}{4}$ " 2

Minimum quantities by another authority (Rayner) are—

	Gallons per minute at each tap*
Baths	5
Showers	5 to 6
Sinks	3
W.C.s, Urinals	1
Wash basins	1

DOMESTIC FILTERS

Wherever the purity of water is under suspicion when dealing with water supplies, an item that must not be overlooked is the provision of a suitable filter for drinking water. The chief object in filtering water is to hold back impurities and micro-organisms, and a good filter should be capable of effectually holding back such impurities, etc. Filters are composed of various materials, and may consist of *manganous carbon*, *spongy iron*, *silicated carbon*, *animal* or *vegetable charcoal*.

Filters are of two kinds, high and low pressure; the latter is in reality simply a container through which the water slowly passes by downward filtration. The high-pressure filter is the type mostly used at the present time and is so-called because a *head* or *pressure* of water is required to work them, otherwise the rate of flow of filtered water would be very slow and little more than a dribble. Two of the best types of domestic filters in use at the present time are the "Pasteur Chamberland," Fig. 109, and the "Berkefeld," Fig. 110.

The Pasteur Chamberland filter tube is made of fine porcelain, and the Berkefeld tube is of infusorial clay. It is essential that these filters be kept clean; the *candle*, or filter tube, is easily removed for this purpose.

Other forms of filter mentioned must have the filtering medium periodically changed or sterilized.

For dealing with large volumes of water, pressure filters can be obtained in the form of large steel cylinders. One such is shown in Fig. 111. The filtering media consists of graduated layers of quartz and sand. To cleanse it, the flow is reversed, and the capstan at the top rotated to stir up the sludge which is flushed out through the waste pipe provided, the valves being operated to suit the circumstances. Rapid filters may work at rates up to 200 gal. per sq. ft. per hour, depending, however, on the nature of the raw water. A usual rate for complete filtration is from 80 to 100 gal. per hour, per sq. ft., per hour.

Chapter VIII—PIPE FIXINGS

THE fixing of iron and lead pipes may be carried out by various devices, the chief being pipe hooks, pipe clips or saddles, soldered back tacks and face tacks, iron holderbats, school

being set up between the iron hook and the lead pipe. They are not a suitable fixing for iron pipes.

Clips, Saddles (Fig. 113). These may be obtained in a variety of patterns and may consist of tinned iron and steel, malleable iron, galvanized iron, cast lead, polished brass, and wrought iron. They form a very good fixing, and if properly fixed with brass or gun-metal screws are easily removed.

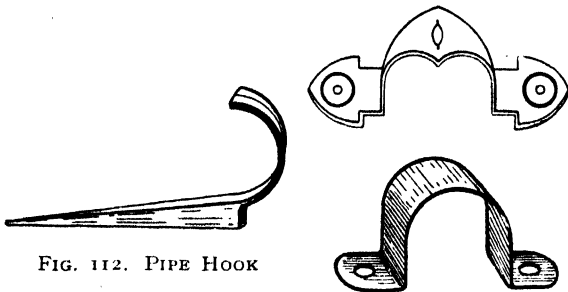

FIG. 112. PIPE HOOK

FIG. 113. SADDLES, OR CLIPS

board clips, cradles, joist clips or lugs, and astragals and tacks.

Pipe Hooks (Fig. 112). These are used chiefly on the cheaper class of work ; they form

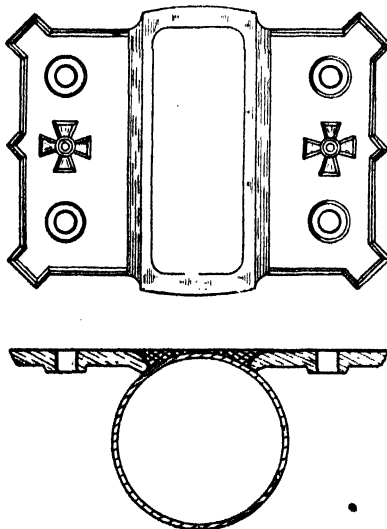

FIG. 114. DOUBLE-CAST BACK TACKS

a very good fixing and a fairly neat job. When these hooks are used for lead pipe, a strip of stout sheet lead should be placed between the hook and the pipe, to prevent the hook from cutting into the pipe and to prevent action

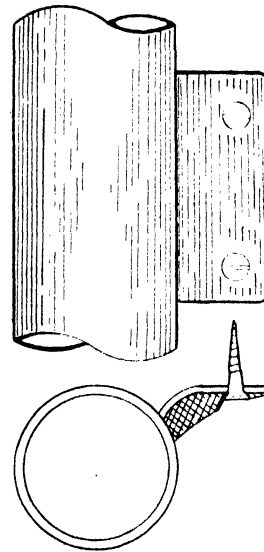

FIG. 115. FACE TACK

Back Tacks are usually of cast lead and often ornamental, but tacks cut out of very stout sheet lead are sometimes used. They are soldered to the back of the pipe singly or in pairs and form an excellent fixing and a very neat and workmanlike job. Fig. 114 shows a pair of cast tacks and the method of soldering to lead pipe.

Face Tacks are also a good form of fixing for lead pipes and give the work a finished appearance. This tack is formed by a piece of stout sheet lead being soldered to the pipe, the solder forming the face of the tack. Stout brass or gun-metal screws pass through the substance of the solder and lead, giving a firm fixing. Fig. 115 shows a view and section of a face tack.

MODERN BUILDING CONSTRUCTION

Holderbats (Fig. 116) are used for fixing iron pipes of all descriptions and form the best kind of fixing for these pipes; they are obtainable in almost any size and vary somewhat in the manner they are secured around the pipe.

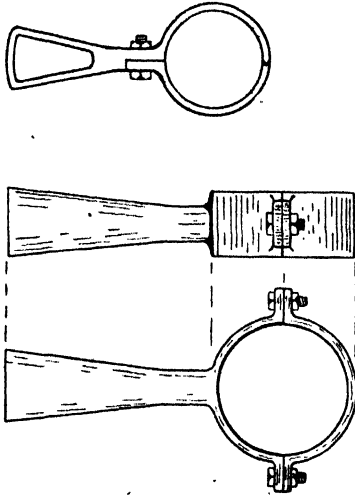

FIG. 116. HOLDERBATS

The best makes are fitted with gun-metal set-screws or bolts and nuts, while the cheaper kinds have iron screws or nuts. The latter rust after a time and become set and very difficult to remove, which often means a new fitting, owing to the breaking of the screw in

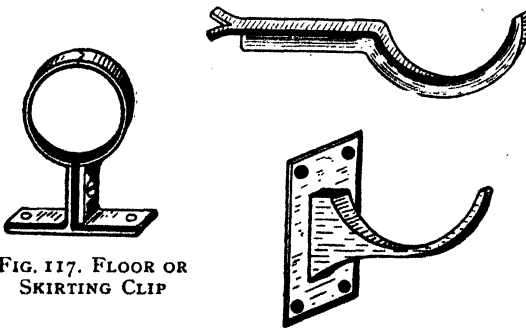

FIG. 117. FLOOR OR SKIRTING CLIP

FIG. 118. CRADLES

attempts to remove it. The above types are secured by plugging or building into the wall and cementing in. Clearance from the wall is usually allowed so that pipe wrenches, etc., can be conveniently used on the pipe.

Fig. 117 shows what is often referred to as a *school board clip*, also known as a *floor bracket*

and "*skirting*" clip. They are similar to the holderbat as a means of holding the pipe, but are made with a flange or back plate for screwing into woodwork. They form an excellent method of fixing brass, iron or copper pipes.

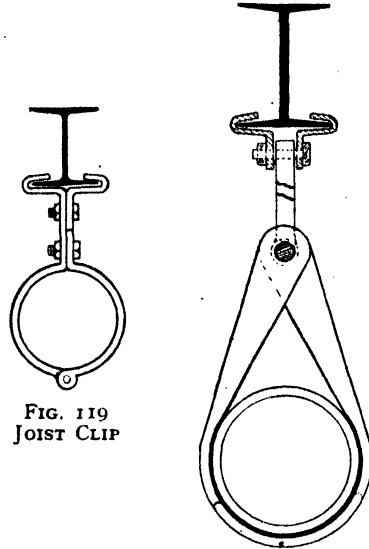

FIG. 119
JOIST CLIP

FIG. 120. CALLIPER CLIP

Cradles are chiefly used for the larger forms of pipe, such as those used in large steam-heating and hot-water work, water mains, and cast-iron drain pipes when suspended above ground. Fig. 118 shows two forms of cradle.

Joist Clips (Fig. 119) are often referred to as *girder clips*. Where pipes pass across ceilings constructed of steel joists, clips of this type are used and clamped to the flange of the joists. They can be obtained in various forms, and

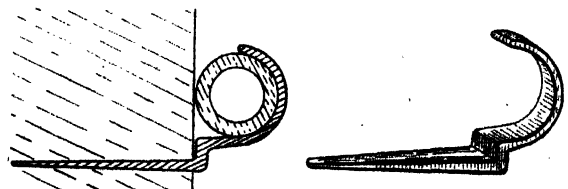

FIG. 121. IMPROVED PIPE HOOK

very often they can be made on the job, especially if only a few are required.

Fig. 120 shows another type of pipe fixing known as a *calliper clip*. These clips are used for carrying cast-iron drain pipes or water mains when passing through buildings and must be suspended from ceilings. They can

be made to fit on to a steel joist, as shown ; or fitted with a screw thread, nut, and washer plate for fixing to floors constructed of wood ; or they may be split in the form of an anchor bolt for building into concrete.

Fig. 121 shows a section and view of an improved form of pipe hook. It is simple in construction, being forged from a flat strip of metal, thus giving a broader surface for the pipe to rest on. The shoulder is also much broader than in the old type thus allowing ample room for a driving punch to be used quite easily when fixing the hooks. The portion which fits the pipe is somewhat shorter than that in the old pipe hook, and, whilst

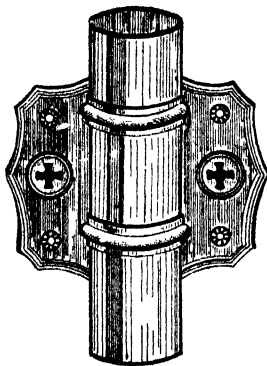

FIG. 122. ASTRAGALS AND TACKS

giving a firm fixing for the pipe, enables the improved hook to be removed without injuring the pipe in any way.

Fig. 122 shows a pair of cast-lead tacks with astragals. Cast-lead sockets with astragals similar to that shown can also be obtained. This form of fixing is extensively used at the present time and it gives the work a finished appearance.

Fixing Pipes. When fixing lead pipes by any of the foregoing methods, the chief object is to provide for the fixings at close intervals, more especially on horizontal runs of pipe ; this prevents the unsightly appearance of sagging pipes that is often noticed when fixings are placed too far apart. It is a good plan to provide wood

fillets to support lead pipe where long horizontal runs occur.

For the small sizes of iron pipe, the best type of fixing is the holderbat, shown at top of illustration (Fig. 116), as it not only supports the pipe but allows for expansion and contraction, whereas if hooks (Fig. 112) are used, the expansion of the pipes cause them to work loose.

Another point that must not be overlooked is the provision of sleeves where iron pipes pass through walls ; these may be of cast-iron or

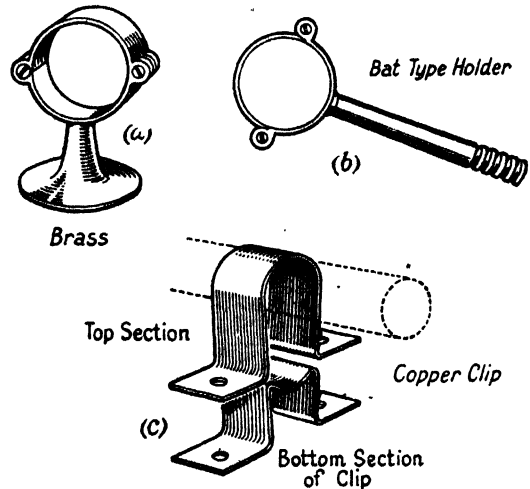

FIG. 123. CLIPS FOR LIGHT GAUGE COPPER PIPE

wrought-iron pipe, but should be large enough to allow the supply pipe to pass easily. The object of the sleeves is to allow for expansion and contraction of the pipes and prevent damage to the wall face, which often occurs when pipes are built in.

Where lead pipes pass through walls, a wrapping of felt should be placed around the pipe as a protection against the action of mortar and cement. A good substitute for felt is a few thicknesses of stout brown paper.

Special clips are used for light gauge copper pipe. They are made in two pieces as shown in Fig. 123. This gives clearance for the usual large form of compression joint, and convenient room to use the spanners for tightening up.

Chapter IX—HOT-WATER FITTING

IN all buildings where hot water is required for heating or domestic purposes, one of the main features is the provision of an apparatus that will give satisfactory results with the minimum consumption of fuel. In order to meet the increasing demand for central heating and a con-

stant supply of hot water, various types of apparatus suitable for small or large systems are now available.

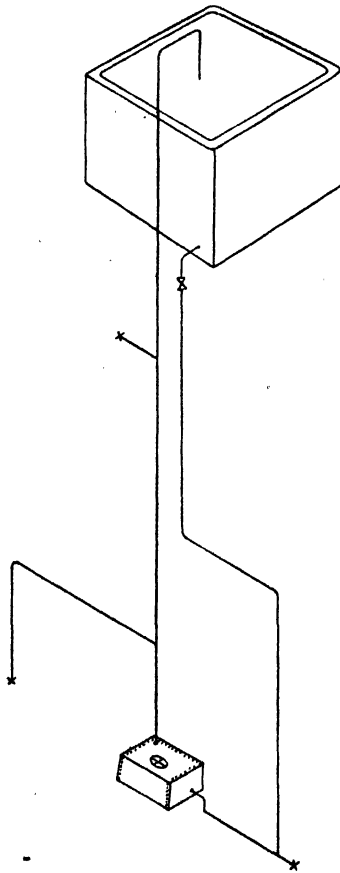

FIG. 124. EARLY FORM OF H.W. APPARATUS

stant supply of hot water, various types of apparatus suitable for small or large systems are now available.

DOMESTIC SUPPLY

An early type of apparatus is shown in Fig. 124. The boiler, which had a capacity of about 6 gal. was of wrought iron with riveted seams;

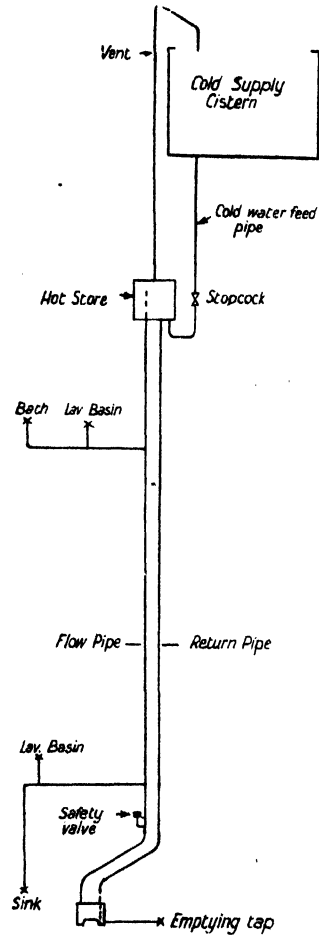

FIG. 125. TANK SYSTEM

$1\frac{1}{4}$ in. diameter iron; the branch pipes supplying a bath at first floor level and a sink in the basement were of $\frac{3}{4}$ in. diameter iron. The cold feed pipe of 1-in. lead was connected to an iron pipe passing from the boiler through the side of the chimney breast, where an emptying tap was also fixed.

Following on this form of apparatus and many

other types too numerous to mention, a system of storage was introduced whereby the water, after being heated in the boiler, could be stored until sufficient was obtained for use. There are at the present time three systems in common

Tank System. Fig. 125 shows one of the older forms of apparatus not so much used at

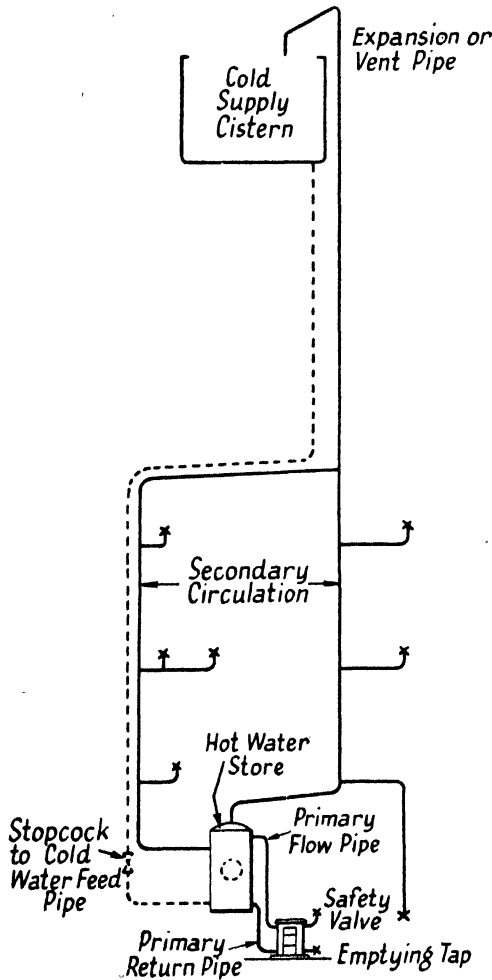

FIG. 126. CYLINDER SYSTEM
With secondary circulation

use: (1) The tank system; (2) The cylinder system; (3) The cylinder-tank, or combined, system. Each of these has been extensively used in small and large premises and, where sufficient thought has been given to the general arrangement, good results have been obtained. In modern storage installations, various methods and devices are adopted to obtain the best possible results, but the principle in practically every case is based upon one or another of the three systems mentioned.

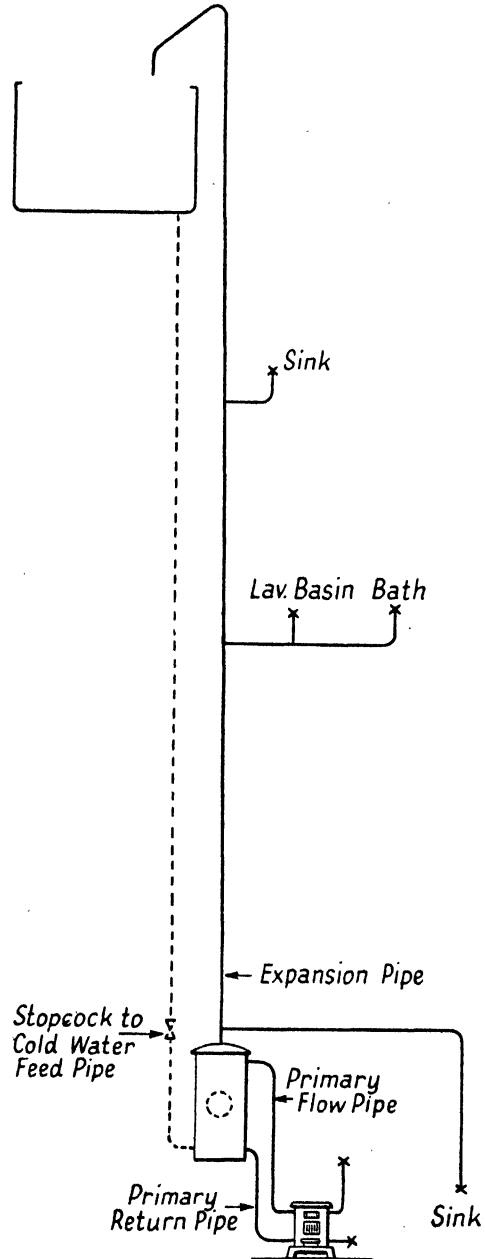

FIG. 127. CYLINDER SYSTEM
Single expansion pipe

the present time. The draw-off taps are taken from the flow pipe below the hot store tank; this ensures a good flow of water at the taps,

MODERN BUILDING CONSTRUCTION

but should the cold supply fail, the hot tank is liable to be emptied before the failure becomes known; this may occur when a large fire is burning, which for safety should be drawn. There is also considerable loss of heat from the long lengths of primary circulating pipes entailed.

tion is necessary for good working and to avoid drawing a lot of dead cold water before hot water is obtained. The draw-off taps are taken from the flow pipe above the hot storage vessel; this is an advantage over the tank system. If the cold supply fails, the cylinder will remain full after the taps have ceased to yield water, thus allowing ample time for an inspection of the apparatus without the necessity of drawing the fire. A cylinder full of water would require a large amount of heat to evaporate in the form

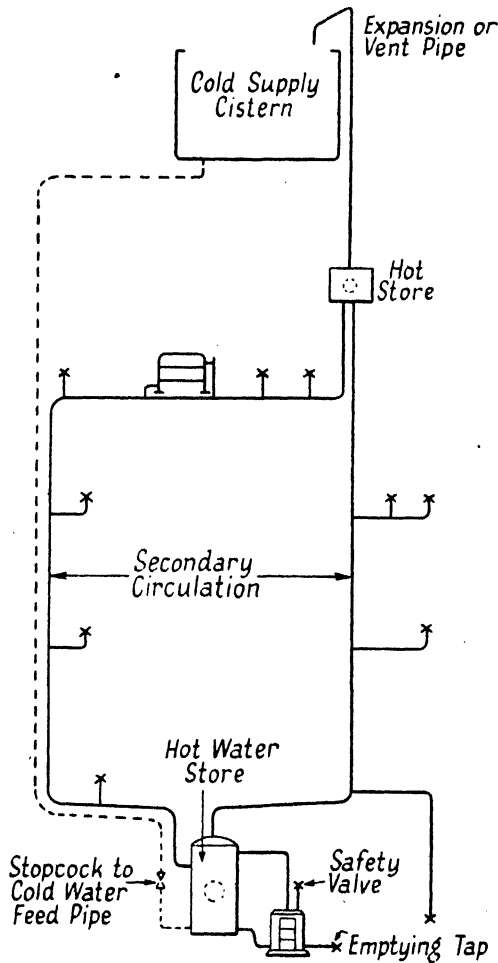

FIG. 128. CYLINDER-TANK SYSTEM

Cylinder System (Fig. 126). This system is now used in preference to the tank system. The hot storage vessel is fixed as close to the boiler as possible, thus giving a short primary circulation. Where only two or three draw-off taps are required and these are within a short distance of the apparatus, a single expansion pipe only need be fitted as in Fig. 127; but where there is a considerable distance for the supply pipes to reach a fitting, then a secondary circula-

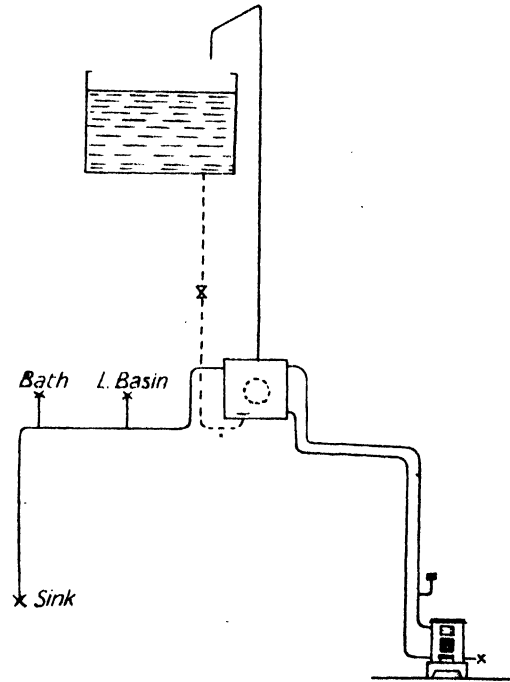

FIG. 129. SMALL HOUSE SUPPLY

of steam; at the same time, precautions should be taken to allow the apparatus to cool down. For the efficient working of this system, it is necessary to fit a fairly large cold feed pipe because the fittings on the upper floors rely on the hot water being pushed up, as it were, by the volume of cold water entering the cylinder; if a small bore pipe is used, the higher fittings more often than not fail to yield water or, at the most, a dribble when taps on a lower floor are open.

A secondary circulation is also needed where towel rails or coils for airing linen are required. Dead legs (single pipe-lines) as they are called, must not exceed 25 ft. (M.O.H.), 16 ft. (M.W.B.), except in cases of multipoint gas heaters when

lengths exceeding the limit may be used provided they are well-lagged.

Cylinder-tank System. Fig. 128. This is similar to Fig. 126, but has additional storage in the form of a tank or tanks fitted in the upper part of the building. It is a system very much in use, and for the higher type of building is most suitable to install, as it provides an overhead storage of hot water from which the fittings on the upper floors may be supplied.

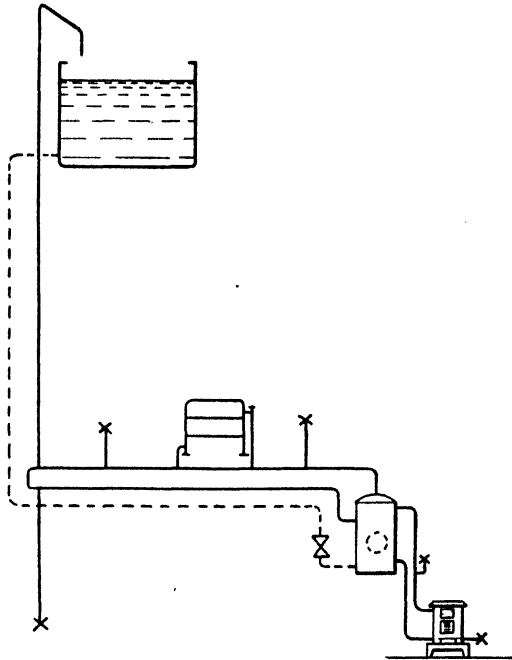

FIG. 130. CYLINDER SYSTEM WITH SMALL RADIATOR

To compare the merits of the three systems—

TANK SYSTEM

Advantage. A good outflow of water at all fittings.

Disadvantages. Long runs of circulating pipe between the boiler and hot storage vessel. Liability to empty the apparatus should the cold supply fail.

CYLINDER SYSTEM

Advantages. The whole of the heated water collects in hot store if the connections are correctly made, i.e. from the top or near the top of the hot store, thus ensuring withdrawal of hot water at taps.

The apparatus cannot be emptied through the draw-off taps.

Where stopcocks are not provided to each fitting, repairs to fittings on the secondary circulation can be carried out without emptying the whole apparatus.

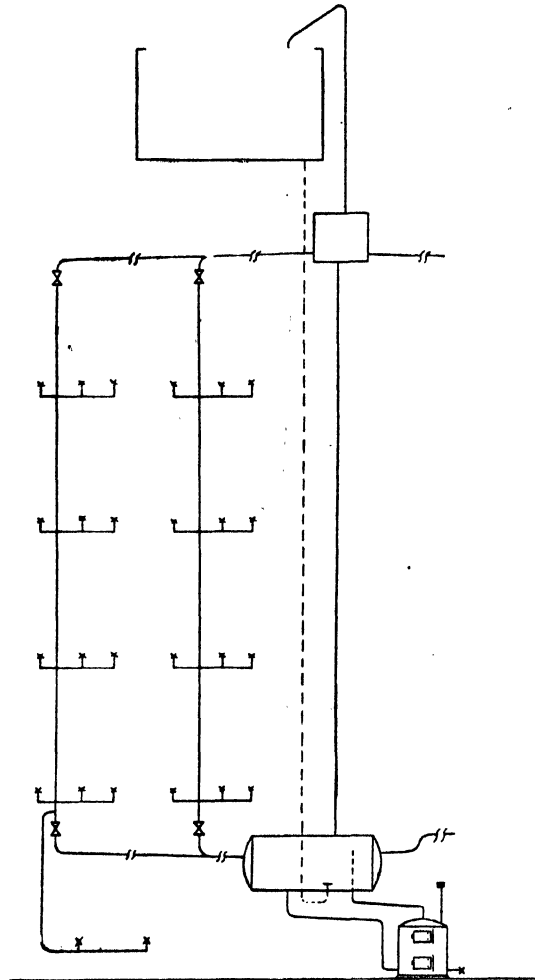

FIG. 131. RECONSTRUCTED SYSTEM

Disadvantage. Liability of poor outflow at fittings in the upper part of the building, unless the feed pipe is large and all supply pipes kept large in diameter.

CYLINDER-TANK SYSTEM

This system possesses the advantages of both the former systems. It is used only for distant and highly placed bathrooms to ensure a direct head to the adversely placed fittings.

MODERN BUILDING CONSTRUCTION

Fig. 129 illustrates a system suitable for the small type of house where a supply of hot water is required for a bath, lavatory basin, and sink. The tank, fitted on the cylinder principle, may be fixed at first-floor level within an enclosure which forms an airing cupboard. The supply

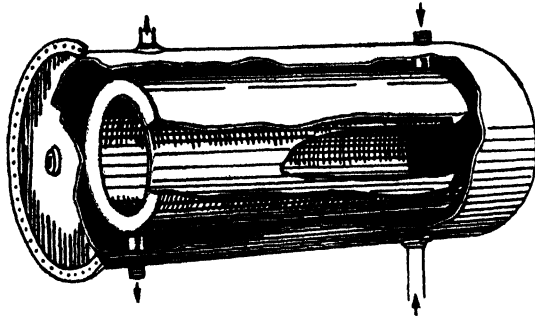

FIG. 132. IDEAL INDIRECT CYLINDER
Water to Water (National Radiator Co.)

to the fittings is taken from the tank near the top; this is to avoid spasmodic issues of water at the taps which often occurs when the supply is taken from the expansion pipe just above the tank. The boiler for this system may be of an independent type as shown, or a block or arch flue boiler fitted behind an open fireplace. To obtain really good results, the small independent type is to be preferred.

Fig. 130 illustrates a cylinder system as an alternative for the small type of house where it is required to heat a towel rail in addition to the other fittings; a return pipe being taken back to the cylinder and completing a secondary circulation.

The demand for a constant supply of hot water has increased considerably since the introduction of lavatory basins in the bedrooms of private houses and hotels. To meet this demand, many installations have been partially or wholly reconstructed. Fig. 131 is a diagram illustrating part of a reconstructed system on the cylinder-tank principle for supplying a number of baths and lavatory basins. Stopcocks were not fitted to each group of fittings, but the four dropping pipes were fitted with stopcocks at the upper and lower ends so that the section fed by each pipe could be isolated for repairs without interference with the boiler or cylinder.

Where very large quantities of hot water are required, the apparatus must be of a more powerful nature. It is a good plan where a large installation is necessary, to fit the boilers and storage vessels in duplicate and arrange

them so that one or both may be in use. This method is often adopted in large institutions to avoid shutting down the entire apparatus for cleaning operations or repairs.

Indirect System. In this system the water is heated by either water or steam in what is termed an "indirect heater," or "calorifier"; Figs. 132 and 133. This consists of a storage vessel in which there is a coil, radiator, cylinder, or tubes through which the heating medium passes without coming in direct contact with the water to be heated. The source of heat may be water from a heating circulation or steam where such is available. It is a process of heat transmission from the water or steam in the inner vessel to the water contained in the outer vessel. The heated water is conveyed to the various fittings by circulating pipes in the same manner as in a direct system.

Where a combined central heating and hot-water supply system is required on a small installation such as for domestic premises, an indirect heater can be used with advantage. The circuit for the central heating is a separate unit from the hot-water supply; hence there is no discoloration of the water drawn at the taps

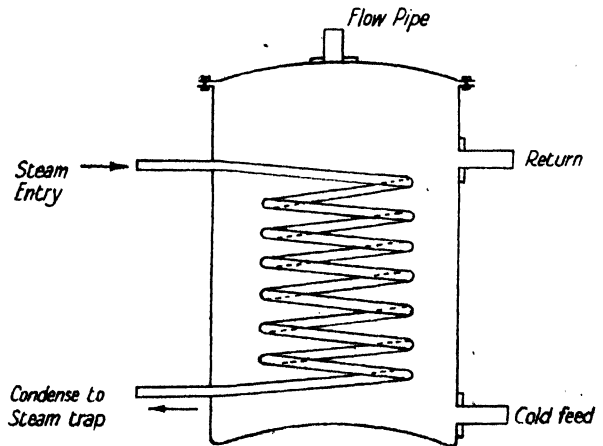

FIG. 133. STEAM CALORIFIER

due to it having passed through radiators and heating pipes. There is no risk of "furring up" of pipes or boiler, as once the heating section is charged, little or no fresh water is introduced into the boiler to deposit solid matter. For this reason indirect heaters are most useful in districts where the water has solids in suspension. With ordinary direct-heating boilers, these solids are deposited in the form of a hard substance resembling chalk in some cases, and in others a

brown scale or a sandy-like substance, according to the nature of the water. This deposit must be removed from time to time from the boiler, as a coating of scale greatly impairs the heating capacity and also damages the boiler plate by excessive heat. Alternatively, waters of this character should be treated before being passed into boilers and thus avoid constant "furring up" and consequent cleaning.

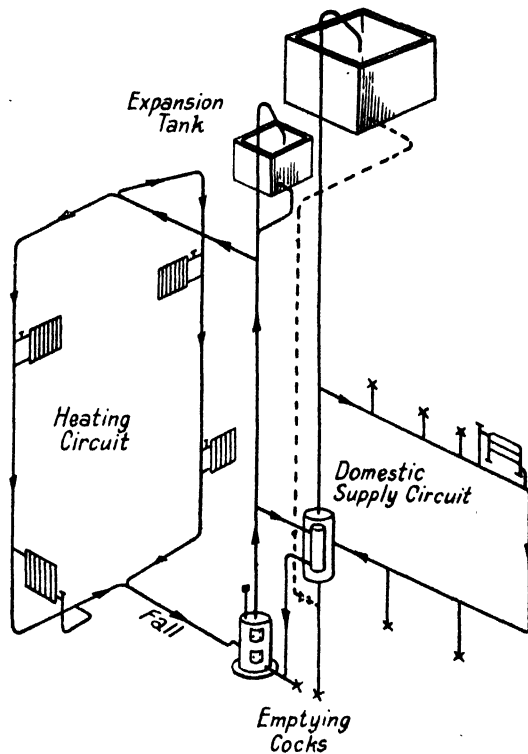

FIG. 134. COMBINED SYSTEM
Heating and Domestic Supply

Fig. 134 shows diagrammatically a combined central heating and hot-water supply system. The boiler is fixed at ground-floor level; therefore the heating circuit is on what is termed the *drop system*, the return pipe to the boiler passing just below floor level. The runs of pipe in a horizontal direction are given a slight fall in the direction of the arrows. The supply to the fittings is on a secondary circulation, returning to the cylinder about one-third of the way down. Emptying cocks should be provided where shown.

Indirect heating by steam is the best method where large quantities of hot water are required,

and, where steam boilers are installed for various purposes, as in many of our large institutions, calorifiers are invariably used for heating water for domestic use or for central heating.

Boilers. The manufacture of boilers has reached such a high standard of efficiency that one has a very wide choice and it is difficult to decide which type is the best to use for any particular installation. It should, perhaps, be mentioned that range boilers are not so much in evidence at the present time, their place being taken by the small independent boiler or one of the various forms of gas water heaters now obtainable.

The power of boilers is based upon the transmission rate of B.Th.Units per square foot of boiler heating surface per hour; this is termed the *rating* and varies with different makes. This rating is a guide in the selection of a boiler for any specified duty, or one may be

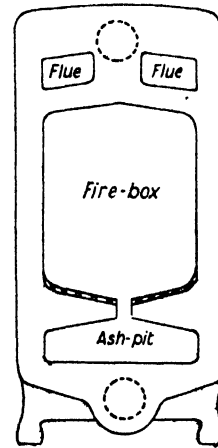

Crane, Ltd.

FIG. 135. SMALL SECTIONAL BOILER WITH
LOW RETURN CONNECTION

guided by the results obtained from experience with different types which have been fixed and put to the test under actual working conditions. These ratings are usually given with boilers for hot-water supply in both total transmission in B.Th.U. and the quantity of water in gallons which the boiler is capable of heating per hour through a given range of temperature when under the same conditions. This range is usually from 50 to 150° F., i.e. an increase in temperature of 100°. It is a simple matter to determine the total number of B.Th.U. required to heat a given quantity of water through a given range of temperature.

MODERN BUILDING CONSTRUCTION

EXAMPLE. It is required to heat 32 gal. of water per hour from a temperature of 50° F. to a temperature of 150° F. How many heat units are necessary?

1 B.Th.U. will raise 1 lb. of water 1° F.
 100 " " " 100 lb. " 1° F.
 1 gal. of water weighs 10 lb.

It is necessary to convert the gallons to lb. of water.
 Then—

Total B.Th.U. required
 = Gallons × 10 × temperature rise
 $32 \times 10 \times 100 = 32,000$ B.Th.U.

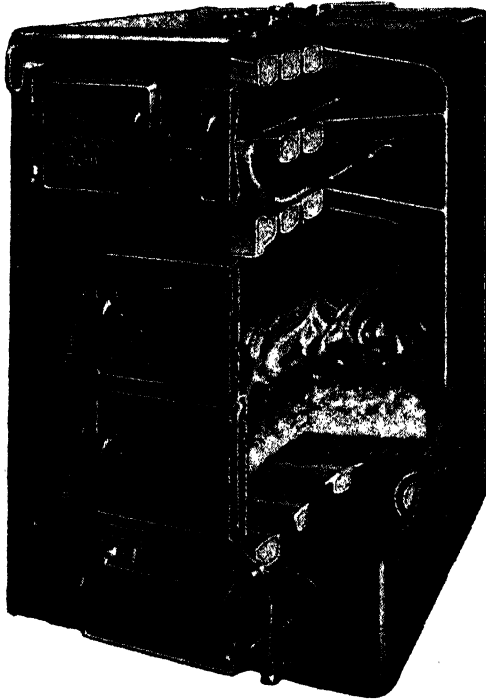

(Crane, Ltd.)

FIG. 136. THE WHITEHALL SECTIONAL BOILER

Conversely,

What quantity of water in gallons per hour will a boiler rated at 32,000 B.Th.U., raise from a temperature of 50° to a temperature of 150° F.?

Gallons

$$= \frac{\text{Total transmission in B.Th.U. per hour}}{\text{Temperature rise} \div \text{Weight in lb. of 1 gal. of water}}$$

$$32000 \div 10 = 32 \text{ gal.}$$

HEATING SURFACE. The *total* heating surface of a boiler is that area which receives heat by contact with the fire and from the hot gases leaving it. *Direct* heating surface is that area exposed to the actual fire. *Indirect* heating surface is that area exposed to the hot gases as they pass from the fire.

Assuming the transmission rate of a boiler

to be 10,000 B.Th.U. per sq. ft. per hr., the heating surface necessary to heat the quantity of water referred to in the above example will require to be: $32,000 \div 10,000 = 3\frac{1}{2}$ sq. ft.

Boilers of the small independent type are produced in many designs. They are made either wholly of cast iron, or the boiler shell itself of wrought iron with cast-iron fittings and doors. Small sectional boilers suitable for central heating or combined systems are also manufactured and finished in a variety of designs to suit any position.

Fig. 135 is a diagram illustrating a section through a boiler of this type which has water-cooled firebars and a waterway beneath the

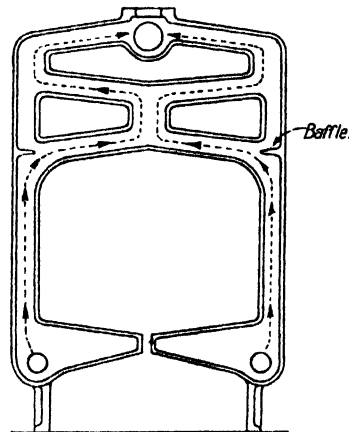

(Crane, Ltd.)

FIG. 137. SECTIONAL BOILER WITH CONTROLLED WATER TRAVEL

ashpit. It is made with an extra low return tapping to enable radiators to be fixed at the same level as the boiler, and is obtainable in various capacities from 29,000 to 75,000 B.Th.U. per hr. Fig. 136 is a pictorial view of a sectional boiler with part cut away to show the construction of the flues and waterways. This boiler is also fitted with water-cooled grates and may be fitted for oil burning or mechanical stoker firing as well as coke. Fig. 137 is a section showing a new feature of the previous boiler in the form of baffles which direct the water over the crown of the combustion chamber, the object being to give longer travel. Fig. 138 is a section through a wrought welded independent boiler with waterway beneath ashpit.

Gas-heated Systems. Gas water heaters may be divided broadly into three types as follows: (1) *Instantaneous heaters* of the single and multipoint type and referred to as *geysers* and

distributing geysers; (2) *Storage water heaters* of the low and high gas consumption types—the first is frequently referred to as the *accumulator* or *thermal storage* type; (3) *Circulators*.

These cover a very wide range, and from them can be chosen a water heater which will efficiently perform any desired duty from that of heating the smallest to the largest quantity of water at a cost proportional to requirements. Among the many advantages claimed for gas as a water heating agent are: cleanliness; ease of control both of appliance and water temperature; absence of space for fuel storage; low

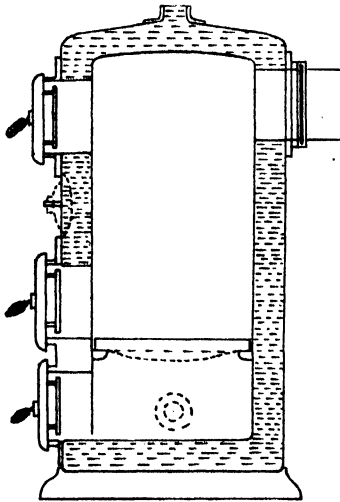

FIG. 138. WROUGHT INDEPENDENT BOILER
Waterway beneath ashpit

maintenance cost of fuel and appliance; saving of labour and the fact that appliances can be chosen to work independently of, as an auxiliary to, or in conjunction with, an existing hot-water supply system and solid fuel boiler.

Distributing geysers differ from the ordinary type as they are supplied with water under pressure and are capable of delivering hot water to fittings on upper floors; upon opening a water tap on any part of the service, the gas supply valve on the geyser is automatically opened so that full consumption of gas takes place only whilst water is being drawn; when sufficient hot water is obtained, the closing of the tap again shuts down the gas supply to the small by-pass consumption.

Storage water heaters are obtainable in various capacities; they are automatic in operation and may be fitted independently for domestic supply or as an alternative to an existing system, as

shown in Fig. 139, in which the boiler may be either a range or other solid fuel pattern; the cold feed pipe is extended as shown by dotted lines and connected to the heater. A special valve is provided having two outlets, of which one is always closed. Low consumption thermal

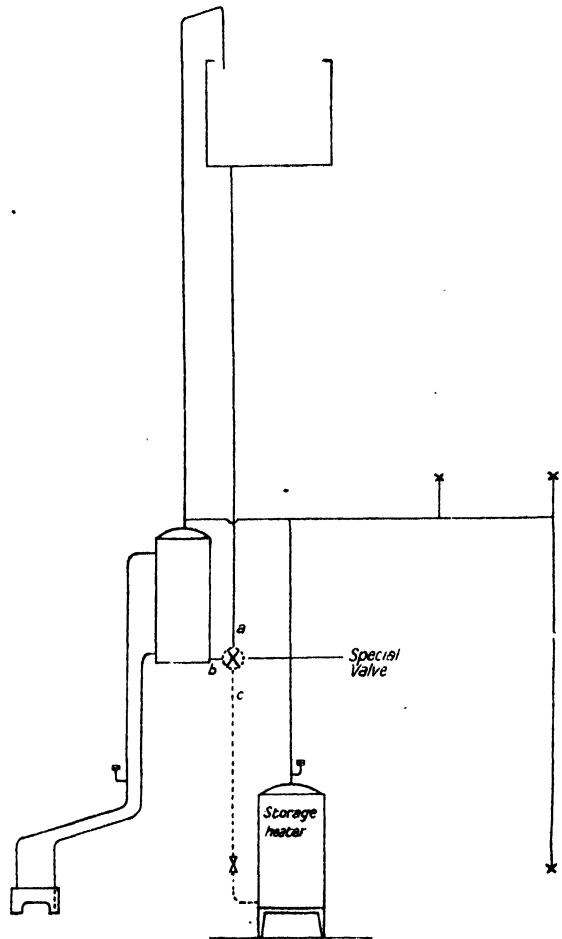

FIG. 139. STORAGE HEATER FITTED TO EXISTING SYSTEM

storage systems are not very elastic and should be adopted only in cases where the demand is intermittent with long periods of rest between demands for hot water. When the range boiler is in operation the outlet *B* of the valve is open and outlet *C* is closed; when the gas heater is required, the valve is given a quarter turn, which opens *C* and closes *B*, thus admitting cold feed water to the heater. A separate stop-valve must be provided near to the

MODERN BUILDING CONSTRUCTION

heater as shown. A safety valve must also be fitted.

Fig. 140 shows alternative methods of connecting a gas circulator to an existing system.

boiler and does not enter the storage vessel; when this happens, the *thermostat* on the heater operates and closes the gas supply before any store of hot water is obtained. The method

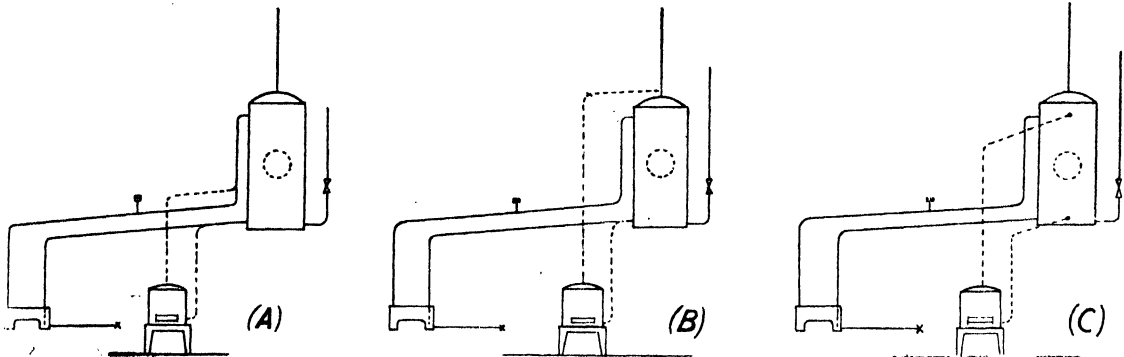

FIG. 140. ALTERNATIVE METHODS OF CONNECTING GAS CIRCULATOR TO EXISTING SYSTEM

- A. Connected to primary flow and return with pitcher tees
- B. Flow connected to expansion pipe and return to primary return
- C. Flow and return connected direct to cylinder

The same principle is adopted as that for connecting an ordinary independent boiler as an auxiliary to the range boiler. The method shown

shown at *B* is much better, but where it is convenient, the best plan is to connect direct to the cylinder as shown at *C*. If the system is on the tank principle, the flow and return pipes from the heater should be carried well up and as close to the tank as possible before connection is made; this should be done with pitcher tees to avoid any possibility of inter-circulation.

An important point to remember when fitting gas heaters is the lagging of all pipes which convey heated water; it is estimated that every foot of unlagged 1-in. pipe represents an unnecessary cost for gas of $\frac{1}{4}$ d. per week. The cost of lagging the pipes would soon be recovered by the saving in fuel.

In addition to the small gas-heated appliances that are in use, many hot-water installations of a very large character are now entirely heated by gas. Gas-fired central heating units are also used.

Where gas is used, a useful introduction to economize gas consumption can be arranged as shown in Fig. 141. When the full capacity of storage for baths in a family house, for example, is required, the valve *A* is opened. When only house-cleaning water is required, the valve *A* is closed. The water between the bottom of the cylinder and *C* remains cold and stagnant, the volume between point *C* and *b*, the crown of the cylinder, circulating between the boiler and cylinder. In the positions of the two branch returns a full hot store of 30 gals. becomes 15

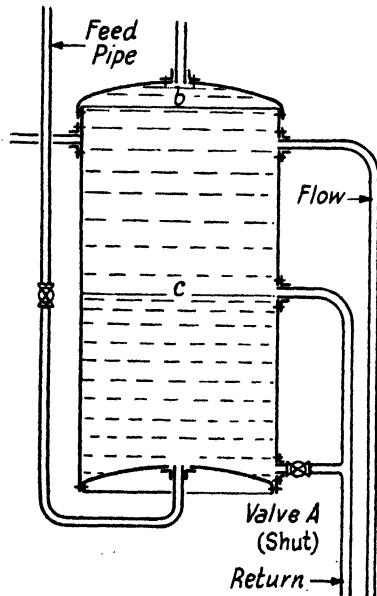

FIG. 141. HOT WATER STORAGE TANK (GAS OPERATED)

at *A* is often carried out, but there is a liability of the phenomenon known as *intercirculation* being set up, which means that the heated water circulates between the gas heater and the range

when the valve *A* is closed. The return connection on line *C* can be higher up if required to give, for example, 30 gals. and only 10 gals. at off peak load times. As water is a bad heat-conductor, there is practically no loss of heat between the low strata of cold and the hot zone above.

For safety and for further economical reasons, it is important that all gas-heated installations should have—

(1) A flue operating correctly.

(2) Secondary circulations reduced to a minimum where necessary. A night valve should be fixed within easy reach on the secondary return to prevent the water in the store circulating and cooling during the night when hot water is not required.

(3) Hot store, boiler, and circulation pipes should be insulated to prevent undue losses.

(4) The gas supply should be automatically controlled by a thermostatic valve.

(5) Where the burner is of bunsen type, very careful regulation of the flame must be made to ensure that the maximum amount of air and the minimum amount of gas is used in the admixture to the flame. One cub. ft. of gas contains 500 B.Th.U. and will raise 5 lb. of water 100° F. As the efficiency of gas boilers is about 75 per cent, the 5 lb. becomes 3.75 lb. A gas boiler consuming, say, 60 cub. ft. of gas per hour will raise 22.5 gals. 100° F. per hour.

Electrically Heated Apparatus. Owing to the cost of electricity in many districts, special care is needed to conserve the heat in domestic fitments. Where electricity is issued at a cheap rate (some companies issue electric power at very cheap rates at off-peak load times) it forms a most convenient means of providing hot water for domestic use. Insulated hot store and immersion heaters which only require connecting to the pipe lines can be supplied

together with the necessary wiring up. As an alternative, immersion heater units can be fitted to an existing hot store to act as boosters, or to be used independently in the summer when boiler fires are not convenient or desired.

Fig. 142 shows an immersion heater fitted to a hot store tank of an existing apparatus. Two or more units can be fitted according to the capacity of the store, and the hourly demand

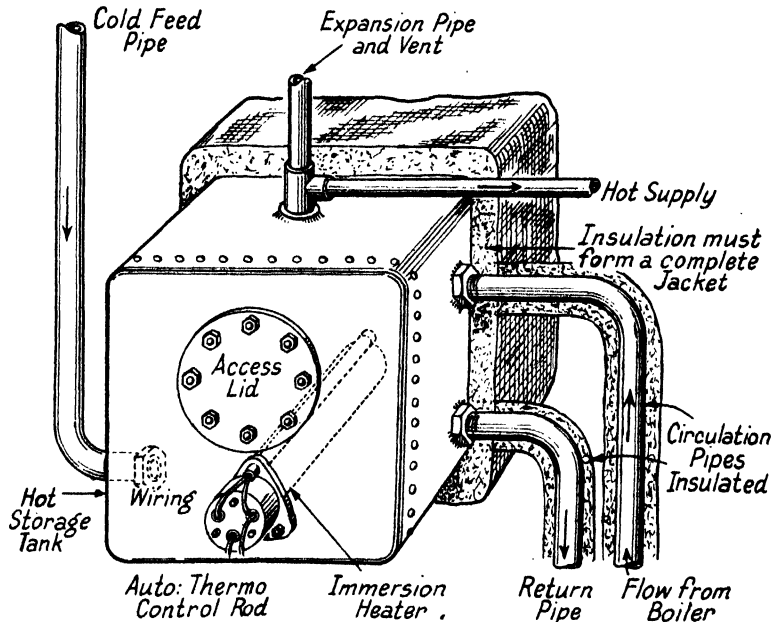

FIG. 142. IMMERSION HEATER IN HOT STORE TANK

for hot water. If a storage vessel is large, and the demand for hot water limited, the immersion heater should be fixed higher up. Only the water surrounding and above the immersion heater is heated, the water below remaining stagnant. One kilowatt hour = 1 Board of Trade Unit = 3,410 B.Th.U. Therefore, one B.O.T. Unit will raise 3.41 lb. of water 100° F., or 10 units 34 lb., or 3.4 gals. of water, without allowing for any loss by radiation, etc.

It is claimed for the Belling immersion heater that one unit will boil 2 gals. of water in 30 minutes, with a loading of 2,000 watts. Water at from 120° to 140° F. is sufficient for dish-washing purposes. Bath temperature is from 100° to 110° F.

Chapter X—WATER PRESSURE

THE tremendous pressure exerted by a column of water often presents to the plumbing student problems which are difficult for him to realize ; a few simple calculations will show how this pressure is brought about.

Pascal's Law states : *Pressure exerted anywhere upon a mass of water is transmitted undiminished in all directions and acts with the same force on all equal surfaces and in a direction at right angles to those surfaces.*

From this principle, it will be seen why a cylinder is used for the storage of hot water when fixed under a great head ; owing to its shape it will withstand a much greater internal pressure than a square or rectangular tank. If the latter were used, it would be necessary to provide stay rods to strengthen it. The tendency is for the tank to assume a spherical or cylindrical shape due to the pressure being transmitted equally in all directions. A cylinder constructed of plate $\frac{1}{4}$ in. in thickness will withstand a normal pressure of 25 lb. per sq. in., whilst a tank made of the same material will withstand only a pressure of $4\frac{1}{2}$ to 5 lb. per sq. in.

There are instances where cylinders and tanks have been fixed under greater heads than those mentioned, but the figures given are for safe working.

If a tank fixed under too great a head of water is examined, the sides will be found to have bulged, due to the pressure of 0.434 lb. per sq. in. on the tank for every foot in height of the cold-supply pipe above the normal 10 ft. head.

A tank that is required to withstand high pressure should be constructed of $\frac{1}{10}$ in. or $\frac{1}{8}$ in. plate and fitted with cross stay rods riveted to the sides.

USEFUL DATA RELATING TO WATER

- 1 cu. ft. of water weighs $62\frac{1}{2}$ lb., or 1,000 oz.
- 1 cu. ft. of water equals $6\frac{1}{8}$ gals.
- 1 cu. in. of water weighs 0.0361 lb.
- 1 gal. of water weighs 10 lb.

Head or pressure of column of } = 0.434 lb. per sq.
 water for each foot in height } in. of surface

If the weight of a cubic foot of water is divided by 144, the result will be 0.434 lb., and this is the

weight of a column of water 1 sq. in. in area and 1 ft. in height.

Head of water in ft. $\times 0.434$ = lb. pressure per sq. in.
 " " $\times 62.5$ = lb. pressure per sq. ft.

The head is the vertical distance between the surface of the water in supply cistern to the point of issue or valve seating, as the case may be.

In calculating the head on enclosed cylinders, tanks or boilers, the head is measured from the centre of the enclosed vessel to the surface of water in supply cistern.

Pressure is due to vertical height alone.

Head of water gives pressure.

Pressure of water gives velocity.

Diameter of pipe or cylinder in inches squared and multiplied by 0.034 = gallons per foot run.

Diameter of pipe or cylinder in inches squared and multiplied by 0.34 = weight of water in lb. per ft. run.

Freezing point of water = 32° F. = 0° C.

Maximum density of water = 39° F. = 4° C.

Boiling point of water = 212° F. = 100° C.

Water is said to be incompressible. The compressibility being equal to about $\frac{1}{24,000,000}$ part of its volume.

When heated from 39° to 212° F., water expands about one-twentyfourth of its volume. In cooling down through this range of temperature to 39° , it contracts ; but if further cooling takes place it expands, and at 32° becomes a solid in the form of ice. In cooling from 39° to 32° F., it expands one-ninth of its volume.

CONSTANTS

3.1416 = relation, or ratio, of diameter to circumference

0.7854, or $\frac{3.1416}{4}$ = relation of circle to square

0.5236, or $\frac{3.1416}{6}$ = relation of cube to sphere

0.034 gals. of water is contained in 1 ft. of 1 in. pipe
 0.34 lb. " " " " 1 in. "

Contents in gallons of rectangular cisterns

= length \times breadth \times depth $\times 6.25$

Contents in gallons of cylinders

= area of base \times height $\times 6.25$

Contents in gallons of spherical-shaped vessel

= diameter cubed $\times 0.5236 \times 6.25$

Relative capacities of pipes are as the squares of their diameters. To find the diameter of one pipe equal in cross-sectional area to several smaller pipes, apply the following rule—

RULE. *Square each diameter separately and extract the square root of their sum.*

EXAMPLE. What will be the size of pipe required to equal three 4 in. pipes in area?

SOLUTION. $4^2 = 16$; $16 \times 3 = 48$; $\sqrt{48} = 6.9$, or say a 7 in. pipe. *Ans.*

See page 755 for relative discharging power of pipes.

Pressure Due to Head of Water. By dividing the weight of a cubic foot of water by 144, we find the weight of a column of water 1 ft. in height and 1 sq. in. in area to be 0.434 lb.

RULE. To find the pressure per square inch of a given head of water, multiply the head in feet by 0.434.

Fig. 143 is a diagram illustrating the increase of pressure inside a closed vessel that would be caused by fixing the tank 2 ft. below the normal head of 10 ft. Assuming the tank to be 2 ft. \times 2 ft. \times 2 ft., the pressure under the 10 ft. head would be 10×62.5 multiplied by superficial area of tank.

	Sq. ft.
Area of tank; Perimeter \times height	$= 8 \times 2 = 16$
Top	$= 2 \times 2 = 4$
Bottom	$= 2 \times 2 = 4$
	<hr/>
Total area	$= 24$

$24 \times 10 \times 62.5 = 15,000$ lb. total internal pressure.

The pressure under the increased head of 2 ft. would be $12 \times 62.5 \times 24 = 18,000$ lb., an increase of 3,000 lb. total pressure inside the tank.

The pressure per square inch in each case would be—

Under the 10 ft. head, $10 \times 0.434 = 4.340$ lb.

Under the 12 ft. head, $12 \times 0.434 = 5.208$ lb.

The extra head of 2 ft. would thus give an increase of 0.868 lb. on every square inch of the tank.

EXAMPLE. Find the pressure at the base of a pipe due to a head of 20 ft.

SOLUTION. $20 \times 0.434 = 8.68$ lb. pressure per sq. in. *Ans.*

To find the head or height due to a given pressure, apply the following rule—

RULE. Multiply the pressure by 2.31.

Thus, if pressure is 8.68 lb. per sq. in., we get $8.68 \times 2.31 = 20.0508$ ft. head. Compare the last example.

EXAMPLE 1. Required to find the total pressure inside a hot-water tank 2 ft. \times 2 ft. \times 1 ft. 6 in. deep, fixed under a mean head of 10 ft.

SOLUTION. Head in feet $\times 62.5 =$ lb. pressure per sq. ft., therefore pressure per sq. ft. multiplied by superficial area of tank in sq. ft. = total pressure inside tank.

Therefore, $10 \times 62.5 = 625.0$ lb. pressure per sq. ft. Area of tank in sq. ft.—

Sides of tank $= 8 \times 1.5 = 12$ sq. ft.
 Top " " $= 2 \times 2 = 4$ " "
 Bottom " " $= 2 \times 2 = 4$ " "

Total super area of tank $= 20$ sq. ft.

Then, $20 \times 625 = 12,500$ lb. total pressure inside tank. *Ans.*

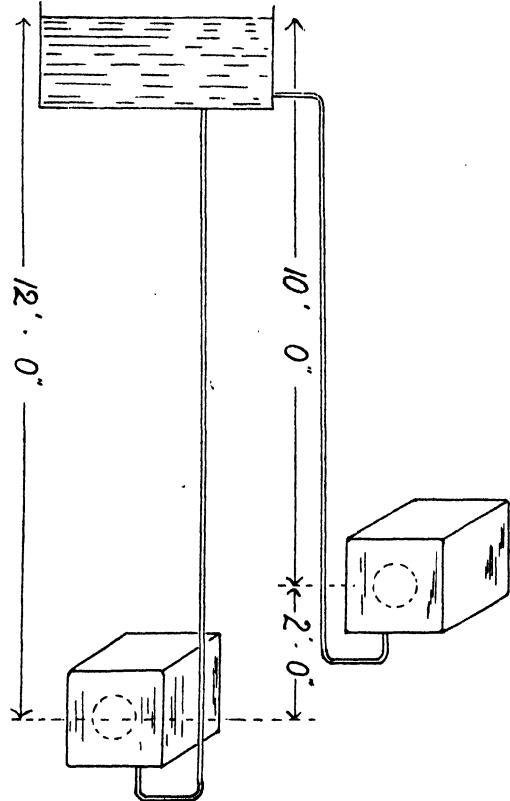

FIG. 143. ILLUSTRATING WATER PRESSURE INCREASE

Weight of Water in Vessel. The pounds pressure inside a closed vessel must not be confused with the weight of the contained water. To find the weight of water the tank in question would hold, the volume, or cubic capacity, must be found.

Volume of tank $=$ Length \times Width \times Depth. Then, volume in cubic feet $\times 6.25 =$ gallons in tank, and volume in cubic feet $\times 62.5 =$ pounds of water in tank.

Volume of tank in last example $= 2 \times 2 \times 1.5 = 6$ cu. ft. $\times 62.5 = 375$ lb. weight of water in tank when full, or $6 \times 6.25 = 37.5$ gals.

MODERN BUILDING CONSTRUCTION

EXAMPLE 2. What would be the total pressure tending to force the manlid off a hot water tank; diameter of manlid, 9 in.; head of water, 15 ft.?

SOLUTION. The pressure on the manlid will be the area of manlid in sq. in. \times lb. pressure per sq. in.
 Area of circle = diameter squared \times 0.7854.
 Then, $9^2 = 81$ and $81 \times 0.7854 = 63.62$ sq. in.

Curved surface = $1.5 \times 3.1416 \times 3 = 14.137$ sq. ft.
 Top = $1.5^2 \times 0.7854 = 1.767$ „
 Bottom = $1.5^2 \times 0.7854 = 1.767$ „

Total superficial area = 17.671 sq. ft.
 Total internal pressure = $45 \times 62.5 \times 17.67$
 = 49,700 lb. *Ans.*

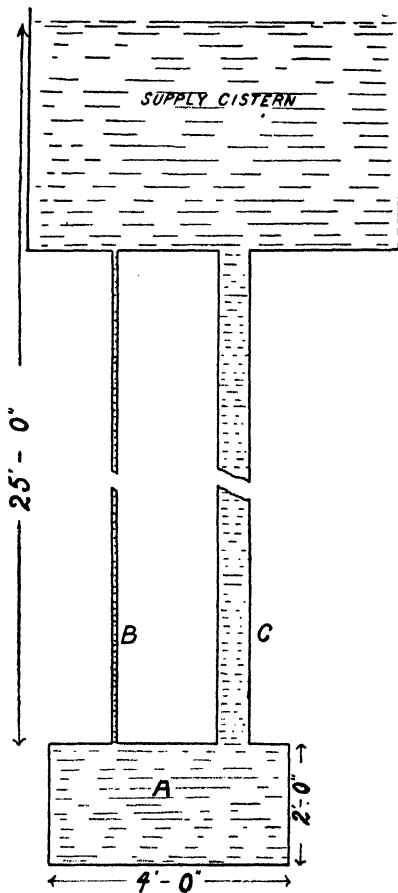

FIG. 144. ILLUSTRATING WATER PRESSURE

Head = 15 ft.; then $15 \times .434 = 6.51$ lb. pressure per sq. in.; and $6.51 \times 63.62 = 414.15$ lb. pressure tending to force cover. *Ans.*

EXAMPLE 3. Find the contents in gallons of a cylinder 1 ft. 6 in. in diameter and 3 ft. in height; also the total internal pressure under a head of 45 ft.
 Volume of cylinder = area of base \times height.
 Superficial area (or surface) = circumference of base \times height, plus area of both ends.
 Circumference of circle = diameter \times 3.1416.
 Volume = $1.5^2 \times .7854 \times 3 = 5.3$ cu. ft.; and $5.3 \times 6.25 = 33.13$ gals. the cylinder would hold. *Ans.*

In calculating pressure problems, the size of the supply pipe makes no difference. Fig. 144 is a diagram illustrating this principle. Let *A* represent a closed vessel being supplied by two pipes, *B* and *C*, of different diameters under the same head. The pressure per square inch in each case will be the same, and the total pressure inside the vessel will be the same; but if we require the total pressure exerted over the area of the base of each pipe, this will be in proportion to the areas of their diameters. Therefore, if pipe *B* is 1 in. and pipe *C* is 6 in., then, as *B* is to *C*, 1^2 is to $6^2 = 1$ to 36. The total pressure at the base of pipe *C* will be 36 times as great as the total pressure at the base of pipe *B*. The actual pressures are obtained as follows—

Area of pipe *B* = $1^2 \times .7854 = .7854$ sq. in.
 Area of pipe *C* = $6^2 \times .7854 = 28.27$ sq. in.

and, $\frac{28.27}{.7854} = 36$

Head of water = 25 ft., then $25 \times 0.434 = 10.85$ lb. pressure per sq. in. exerted by both *B* and *C*.

Area of *B* = .7854 sq. in., then $10.85 \times 0.7854 = 8.52$ lb. total pressure at base of *B*.

Area of *C* = 28.27 sq. in.; then $10.85 \times 28.27 = 306.77$ lb. total pressure at base of *C*.

To find the total pressure inside the vessel, we must add 1 ft. to the head as the vessel is 2 ft. in depth. Therefore, total pressure = $26 \times 62.5 \times$ area of vessel in square feet. Size of vessel 4 ft. \times 3 ft. \times 2 ft. deep.

Perimeter of vessel = 14 ft. \times depth 2 ft. = 28 sq. ft.
 Top " " = 4 ft. \times 3 ft. = 12 „
 Bottom " " = 4 ft. \times 3 ft. = 12 „

Total area of vessel = 52 sq. ft.

$\therefore 26 \times 62.5 \times 52 = 84,500$ lb. total pressure inside vessel.

Closed vessels which will have to resist considerable pressure due to head are made cylindrical in shape the better to resist distortion and leakage from the internal pressure. The ends are domed for the same reason.

Chapter XI—WELLS AND PUMPS

WELLS

IN many parts of the country, water supplies are obtained by sinking wells and tapping the water bearing formation. Wells are usually classed as "shallow" or "deep," and are excavations made to below the level of the water table of the formation to be tapped, the water filling the excavation up to the level of the water table and becoming available for use.

SHALLOW WELLS are those sunk in the permeable upper stratum and obtain their supply from surface and subsoil water. They are comparatively cheap to construct, and as the water level is not far below the surface, the water can be easily raised without elaborate apparatus. The quality of the water from a shallow well depends upon the nature of the soil, the proximity of houses, farmyards, cesspools, drains, etc., the construction of the well, and the direction of the flow of underground water. They are more liable to pollution than are deep wells, and this pollution is most likely to arise where the surface area is bare, such as in farmyards or from underground sources, such as leaky drains and cesspools; subsoil water may also be contaminated by manuring of cultivated land.

DEEP WELLS are those that are sunk and pass through an impervious stratum and tap a water bearing stratum. They are a much safer source of supply, and water from deep wells is usually of a wholesome character and very palatable provided the well is properly constructed.

Pollution of deep wells rarely occurs, but it is quite possible by the passage of organic matter from the surface or subsoil, either along fissures or down the sides of the well itself, when proper care has not been exercised in their construction.

Deep wells are sometimes referred to as *artesian wells*; this, however, is not quite correct. An artesian well is one that is sunk to a very great depth and taps a pervious strata that may be fed from a source away up in the hills, and by this means the water rises and sometimes issues as a cascade from the mouth of the tube which is used to form the well. Properly speaking, artesian wells are bored and form what are known as *artesian bored tube wells*. These wells have been known for a great

number of years, and were first sunk in the French province of Artois.

Where there is an abundant supply of water to be obtained from an underground reservoir, it is often a great advantage to sink a well. It is for this reason that many sinkings are made to the water in the London basin for supplying

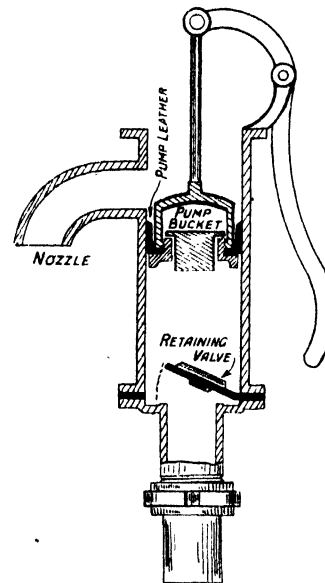

FIG. 145. JACK PUMP

the various new buildings. These sinkings are now usually made in the form of borings.

In London, a Water Board "stand by" supply is entailed, however, to meet the need should the natural supply not be available. Such wells, though giving a prolific supply at first, have sometimes failed to keep up to their early promise owing to other tube wells being driven in the near vicinity.

ABYSSINIAN TUBE WELLS. Where water exists within 25 to 28 ft. of the surface, this form of well is convenient and cheap to construct. It is formed by driving into the ground a tube in several lengths which are screwed together as the work proceeds, the lower tube being fitted with a sharply-pointed end and perforated for a short distance. The tubes are driven in for

MODERN BUILDING CONSTRUCTION

a distance of 20 to 25 ft., and when water is reached, a pump is fixed to the upper tube for raising the water. These wells are suitable only for water-bearing strata of loose ground such as gravel or coarse sand; fine sand and clay are apt to choke the perforations. The method is not recommended for permanent supply owing to infiltration of sand causing the valves to leak.

PUMPS

The ordinary common *jack pump*, Fig. 145, is used for raising water from a shallow well,

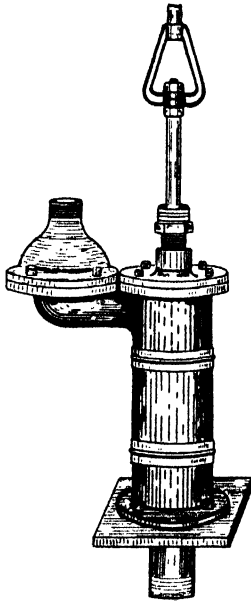

FIG. 146. LIFT PUMP

that is, where the water level in the well is not more than about 25 ft. from the ground level where the pump is fixed.

If the well is deeper, or the water level is liable to variation, the pump shown in Fig. 146 should be used and fixed in the well about 10 to 15 ft. from the water line; this type is known as a *lift and force pump*, and may consist of single, double, or treble-barrels, according to the quantity of water required. They are sometimes worked by hand, but it is now usual to carry out the pumping by means of machinery and if gas or electric power is not available, a small petrol or oil engine is often installed; in other places, natural forces are brought into operation by means of a small windmill, which is a very effective means of raising water by pumping.

When fixing pumps of this type, it is necessary to provide an *air vessel* on the delivery pipe close to the pump. The object of this is to produce an even or continuous movement of the water in the delivery pipe, or rising main.

ACTION OF PUMP. The action of a pump is governed by the pressure of the atmosphere: *the limit to which an ordinary Jack pump will raise water is equal to the height of a column of water the atmosphere is capable of supporting.* Theoretically, this is approximately 33 ft., but in practice the distance the pump should

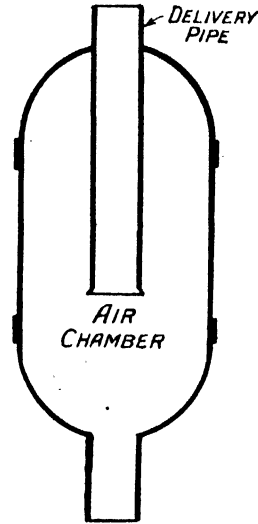

FIG. 147. AIR VESSEL

be fixed from the water level should not exceed 25 ft.

The atmospheric pressure at mean sea-level is 14.7 lb. per sq. in., usually referred to as 15 lb. per sq. in. This pressure will support a column of mercury 29½ in. in height and is usually stated as 30 in. of mercury. The specific gravity of mercury is 13.56; therefore $13.56 \times 2\frac{1}{2}$ ft. = 33.8 ft., the height of the column of water the atmosphere will support.

The action of the vessel is simple: on the upward stroke, water is forced into the delivery pipe and also into the air vessel, compressing the air in the upper portion; on the downward stroke, the air expands and forces the water out into the delivery pipe. This operation is repeated on each stroke of the pump. To put it another way, an air vessel acts as a *cushion*, or *buffer*, for the column of water passing up the delivery pipe.

Fig. 147 shows an ordinary type of air vessel ; they are made of iron, copper or brass.

Air Lift Pump. When water is to be raised from a deep well or borehole, an air lift pump (Fig. 148) is often used. Two concentric pipes are lowered into the borehole to a convenient point below the water level, the outer tube being about 10 ft. longer than the inner tube. A compressor is fixed at ground level, and the compressed air is passed into the annular space between the two pipes, the result being that a mixture of air and water is forced up the inner pipe to the point of delivery. In some cases the inner pipe carries the air, the water being forced up the annular space. The depth *S* from water level to the point of application of air is termed

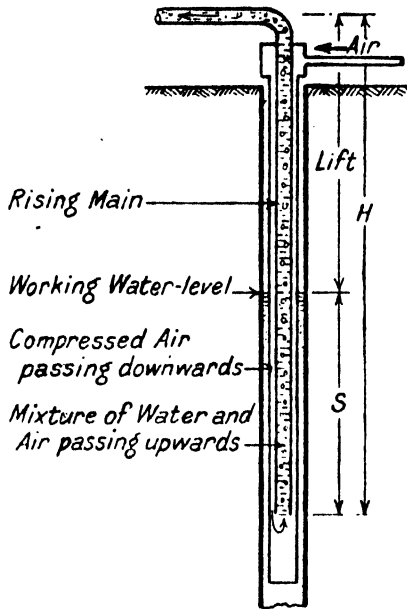

FIG. 148. AIR LIFT PUMP

the submergence; the hydrostatic pressure due to this depth or head being the driving force. The percentage submergence varies according to the lift.

Hydraulic Ram. Fig. 149 shows an hydraulic ram for raising water by the momentum of water flowing through the machine. The drive pipe is carried to a stream or lake. When water flows down, it escapes at the hanging dash valve which, when the velocity reaches a certain point, is dashed up on its seating point, the recoil of water escapes into the air vessel and from there, owing to the closing of the delivery valve, it is pressed up the delivery pipe. At the recoil,

the dash valve falls open again, the cycle being repeated as long as water flows down the drive pipe. By impulse the water is raised to a height

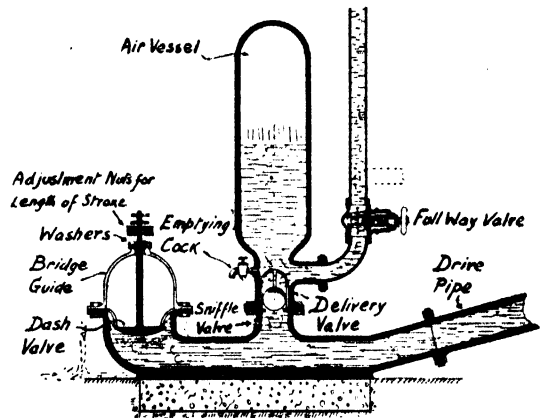

FIG. 149

much greater than that at the source of supply. The requirements are a suitable water supply

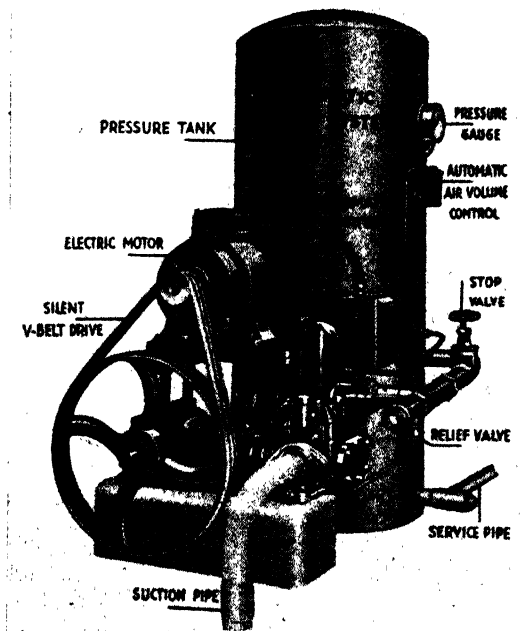

FIG. 149A. ELECTRICALLY DRIVEN PUMP AND STORAGE TANK

and a good fall on the drive pipe. To obtain the necessary power, the drive pipe must be long. The general minimum for obtaining good results is a drive pipe 50 ft. long working on a

MODERN BUILDING CONSTRUCTION

2 ft. head or fall. The tail water must be free to escape by natural gravitation. In the case of a stream, it can be led back to rejoin at a lower point.

Automatic Water System. Fig. 149A shows an electrically-driven pump combined with storage at pressure. The water is pumped into the attached cylinder, the trapped air at the top giving a pressure sufficient to raise the water to the highest part of the building to be supplied. When a predetermined pressure is obtained, the pump automatically cuts out. When a draw-off tap on the piped system is opened, as the pressure drops the electric circuit is re-established and the pump automatically comes into action again. A small plunger pumps in air to sustain the pressure. Petrol and paraffin-driven engines can be obtained but cannot be automatically operated as described.

PUMP CALCULATIONS

Water Discharged. The amount of water raised per stroke is equal to the contents of the pump barrel, or the amount of water that passes through the piston or bucket valve at each downward stroke of the piston.

RULE. *The diameter of the barrel in inches squared, multiplied by 0.034, multiplied by the length of the stroke in feet, multiplied by the number of strokes per minute = gallons discharged per minute.*

Written as a simple formula, this rule is—

$$G = D^2 \times 0.034 \times L \times S$$

where G = gallons per minute ;

D = diameter of pump barrel in inches ;

0.034 = gallons in 1 ft. of 1 in. pipe ;

L = length of stroke in feet ;

S = number of strokes per minute.

Another rule is as follows: *The cross-sectional area of the pump barrel in feet, multiplied by the length of the stroke in feet, multiplied by the number of strokes per minute, multiplied by 6.25 = gallons per minute.* This rule, however, is a lengthy one, and the first rule mentioned is more simple and easy to calculate.

EXAMPLE. How many gallons of water would be raised per minute by a 3 in. pump with a 9 in. stroke working at 25 strokes per minute.

SOLUTION. Using the first rule, we get
 $G = 3^2 \times 0.034 \times 0.75 \times 25 = 5.73$ Ans.

From this it will be seen that 5.73 gals. per minute would be raised. Theoretically, this is correct, but in practice a certain amount would be lost by slip of water at the clack valves as they recover their seating, and an allowance must be made for this loss in determining the working efficiency of the pump. A fair allowance for loss is 10 to 15 per cent, according to the condition of the pump.

Resistance. To find the power to be overcome in raising water by pumping, apply the following rule.

RULE. *Diameter of pump barrel in inches squared multiplied by 0.34 = pounds to be overcome for each foot raised.*

EXAMPLE. What is the resistance to be overcome in raising water by a 3-in. pump to a height of 20 ft. above the water level in the well.

SOLUTION. $3 \times 3 \times 0.34 \times 20 = 61.2$ lb.

This is also the amount of pull on the pump handle.

The power to be overcome is equal to a column of water, equal in area to the pump barrel and of a height equal to the vertical distance between the surface of the water in the well and the discharging end of the delivery pipe.

Allowance has to be made for friction and balance of power (over net resistance) to perform the work. This, for deep wells, is not less than 33½ per cent, the resistance to the stroke. If the power available is limited, geared pumps may be used, or alternatively, a smaller pump. A 2 in. pump requires one-quarter the power of a 4 in. pump, but of course, it will take four times as long to pump an equivalent volume of water.

Horse-power. The following formula can be used for calculating the horse-power required to work a pump—

Multiply gallons to be raised per minute by 10 (1 gal. weighs 10 lb.). This gives the weight of water to be raised in pounds per minute. Multiply this result by the total head in feet to obtain the number of foot-pounds of work to be done. (One horse-power equals 33,000 lb.) Divide this then, by 33,000, which reduces it to horse-power. This must be doubled to give balance of power to do useful work.

EXAMPLE. What must be the horse-power of an engine which will raise 15 gals. of water per minute against a total head of 220 ft. ?

$$\text{H.P.} = \frac{\begin{array}{c} \text{gals.} \quad \text{lb.} \quad \text{head in ft.} \\ 15 \times 10 \times 220 \times 2 \end{array}}{33,000} = \frac{66}{33} = 2$$

Chapter XII—ROOF WORK

Metals Used in Roof Work. The metals chiefly used for roof coverings are lead, copper, and zinc, whilst for buildings of a temporary character galvanized corrugated iron sheets are often used. During the past few years, the use of metal roof coverings has been discontinued in many instances in favour of various compositions—patent sheetings, asbestos, and asphalt. Sheet copper is now extensively used, and plumbers are adapting themselves to the methods of laying this metal, but the material of most interest to the plumber is lead, and though its use as a roof covering has been discontinued to a large extent, there is still an amount of lead used for this purpose, as some of our recent buildings show. The chief objection to lead is no doubt its initial cost; the question of its weight is also another reason; but lead will compare very favourably with some of the composition roof coverings which must be laid to a thickness of $\frac{3}{4}$ in. to be effective.

From the point of view of durability, lead is well to the front, as most of our very old buildings, where lead has been the covering, will prove.

Provided that lead of a proper substance is used, and that it is skilfully laid, there is no doubt about the soundness of the job and its ability to stand the test of time, compared with any other roof covering.

The process of casting and milling sheet lead has been referred to in a previous chapter. Cast sheet lead was extensively used until the introduction of milled sheet lead. There are, however, many old buildings about the country that were originally covered with cast sheets, and which have been recently partly renewed and repaired with sheets cast on the job.

It is claimed that cast lead will expand and contract more freely owing to the atoms, or particles, of its structure being in a more natural position than they are in milled lead, as during the milling process these atoms are forced into unnatural positions. For this reason, cast lead is considered better than milled lead for roof work. On the other hand, milled lead is easier to work or "boss" into shape; it is of more even thickness and more easily adapted to intricate and difficult positions; and where extensive "boss-

ing" is required for ornamental and delicate work, milled lead is the best to use. Cast-lead sheets are liable to vary in thickness and are much rougher, although the latter is often considered to add to the appearance of work in exposed positions, such as turrets and domes.

Method of Laying. To obtain the best results, the following points should be observed—

1. The sheets should be laid of a size that will allow them freedom to expand and contract without causing a fracture.

2. The fixings for the sheets should be of a type that will allow reasonable movement for expansion and contraction, and yet keep the lead in position.

3. The sheets should be of a size that will allow the plumber to handle and fix them in position with sufficient ease to avoid "distressing" the lead.

4. *Gutters* to be not less than 1 ft. in width in narrowest part, and not to exceed 9 ft. in length.

5. *Drips* to be not less than $2\frac{1}{4}$ in. in depth, the undercloak to be well chased into capillary grooves.

6. *Flats.* The bays not to exceed 9 ft. in length and 2 ft. 8 in. between the rolls, the lead to be well fitted under the latter, which should be undercut to afford a good fixing.

7. All lead should turn up against walls 6 in., lie up the roof 10 in. from sole of gutter or flat, 6 in. to lie under slates from the springing or tilting fillet.

8. *Step and Cover Flashings* to lie 6 in. on slates, stand up against wall 6 in., with a $2\frac{1}{2}$ in. water (or weather) line, and 1 in. step into joints of brickwork.

9. *Hanging Stepped Flashings* to be not less than 6 in. in width.

10. *Slating* to walls to be made good by soakers and stepped flashings.

11. All flashings and aprons to be secured to brickwork by oak or cast-lead wedges.

12. *Dormer Cheeks* and similar surfaces to be secured by secret tacks soldered to back of sheets, where practicable, and firmly fixed by wood blocks and screws.

13. All free edges of lead to be secured by lead or sheet copper bale tacks, or tingles, fixed 2 ft. to 2 ft. 6 in. apart.

MODERN BUILDING CONSTRUCTION

14. *Lead Coverings* to stonework to be secured by lead dots or dowels properly cut into stonework.

15. *Flashings* to stonework to be burnt in.

Regarding the foregoing items, the manner in which the roof is constructed will, to a large extent, govern the sizes of the sheets of lead to

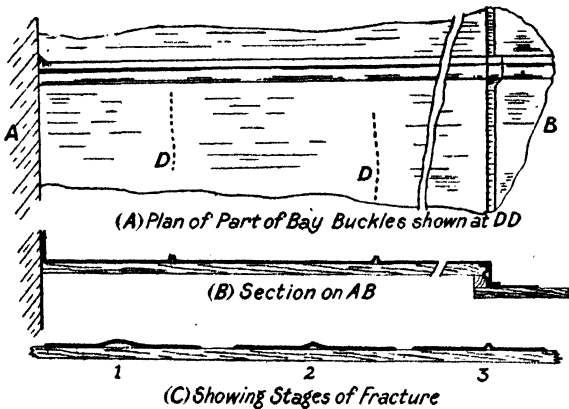

FIG. 150. FRACTURE OF LEAD BY EXPANSION AND CONTRACTION

be laid; the extra cost of forming drips and furring-up entailed, etc., and the extra labour incurred in laying the lead in small pieces are the chief drawbacks to the adoption of a lead-covered roof. The lengths of gutters and bays will, of course, vary slightly according to the nature of the roof, but it is not advisable to lay these in longer lengths than 9 ft.; and if it can be arranged, a length of 8 ft. is to be preferred. The width of gutters, given as 1 ft. in narrowest part, should only be varied in the case of a long tapering gutter, when a width of 9 in. could be allowed at the lower end or start of the gutter; this is often done to prevent too great a width at the top end and to avoid using a roll in the centre of the gutter between two pitched roofs.

TABLE IX
WEIGHTS OF LEAD

Job	Weight per Square Foot
Gutters and flats	6 or 7
Ridging	6
Dormer tops	6
Dormer cheeks	5 or 6
Flashings	5
Soakers	4

Expansion of Leadwork. The expansion and contraction of the leadwork on roofs is a matter of great importance, and due regard should be given to this when planning the arrangement and fixing of the work. Most leadwork is exposed to the heat of the sun during some portion of the year, and to extreme cold during the winter.

The linear expansion of lead is .000015 for each degree Fahrenheit; therefore, if we assume a variation of temperature of 80°, the amount of expansion on a 10 ft. length of lead will be $10 \times 80 \times .000015 = .012$ ft.

This may appear too slight to cause any serious trouble, but, unless the lead has perfect freedom to expand and contract, in course of time this expansion, and the efforts of the lead in contracting to regain its former position, will have a serious effect.

Another influence which affects the lead during expansion and contraction is the friction between the roof boards and the lead, especially if they happen to be rough. Many lead flats and gutters will, on inspection, bear evidence of the results of expansion in the form of buckles, and it will be noticed that they are invariably due to the expansion through the length of the gutter or flat. These will crack in time from the constant movement.

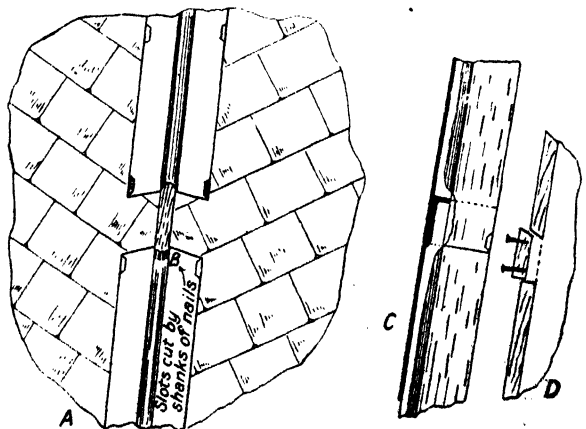

FIG. 151. LEAD CREEPING ON HIP AND METHOD OF PREVENTION

Fig. 150 shows the various stages that take place in the formation of the splits that are to be found in lead flats and gutters where the lead is fixed in lengths above the approved amount.

Lead coverings to steep-pitched roofs often creep from position, due to a large extent to

expansion and contraction, but the weight of the lead and the manner in which it is fixed is also responsible for this creeping, and when nails are used along the top edge to support the lead, they will often be found to have cut through the substance of the lead, which then slides from position. Fig. 151, *A*, shows how steep-pitched hip coverings often creep or slide

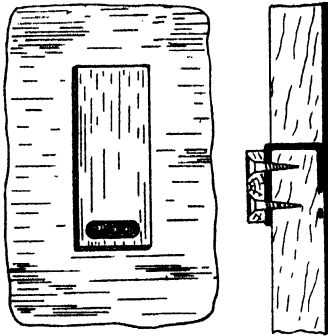

FIG. 152. SECRET TACK

from position when nails have been used to fix the top end, the shanks of the nails having cut through the lead, leaving slots as shown at *B*. The section at *C*, Fig. 151, shows a good method of fixing the hip coverings, the top end of each length being bossed over the roll in a similar manner to a roll end on a flat, the next length of wood roll being fixed over the bossed end; to do this, the wood roll must be cut to the length of the hip coverings, less the amount for the lap and bossed end. Should the wood roll be fixed before the plumber can arrange for this method, a very good alternative is to cut out a short piece of the crown of the roll, which can easily be refixed after the top end has been bossed into position and nailed as shown at *D*, Fig. 151.

CAPILLARY GROOVES should be provided in all laps and passings on a lead-covered roof; the undercloak lead should be well chased into these grooves. The object of the groove is to break the passage of water that takes place (by *capillary attraction*) between the undercloak and overcloak lead. This action can be clearly seen if two pieces of glass are held together with the lower ends in water, when the water will rise between the two sheets of glass much higher than the level of the water in which they are placed.

Woodwork. One of the chief points is the preparation of the woodwork that is to be covered with lead; unfortunately, this is a point

that is often neglected, with the idea that as the wood is to be covered it does not matter. This is a great mistake, and does not assist the plumber to turn out a really efficient job. The roof boards should be laid, as far as possible, in the direction of the flow of water; they should be of stout material, and well supported by means of bearers at close intervals to prevent *springing*. All external angles should be rounded and sharp arrises avoided. Where laps or drips occur, housings should be cut to receive the undercloak, to avoid obstruction when the overcloak is laid; gaps between boards and open joints should be avoided. Much depends on the woodwork as to how a lead-covered roof will appear when finished.

FIXINGS

NAILS, for fixing leadwork, should be of copper; the practice of using iron nails should be condemned, as iron and lead in the presence of moisture sets up a destructive action, and the iron is gradually destroyed.

BALE TACKS. These are often spoken of as *tingles*, and may be of sheet lead or copper. They are usually about 2 in. wide, and of a length suitable for the particular job in hand. They are used for securing the free edges of lead to ridgings, aprons, and flashings.

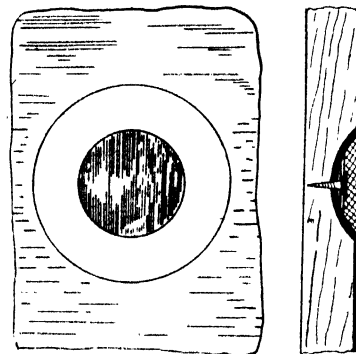

FIG. 153. SOLDERED DOT

SECRET TACKS. These are pieces of sheet lead, or copper, cut out and soldered to the back of the sheet; and passing through a cut in the woodwork are secured on the inside by means of a wooden block and screws. Fig. 152 shows a section and elevation of a secret tack and method of fixing; the object of this tack is to give a fixing and allow for freedom of movement during expansion and contraction.

SOLDERED DOTS. These are formed by

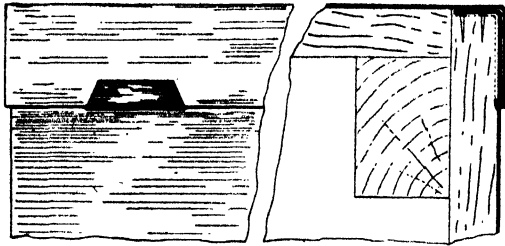

FIG. 154. WELTED TACK

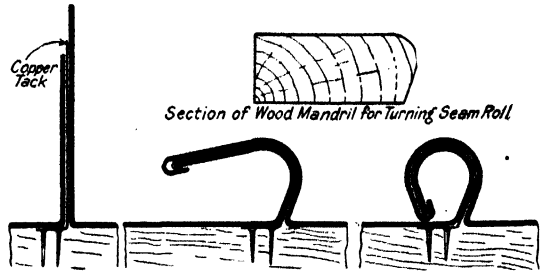

FIG. 158. SEAM ROLL

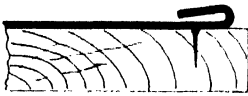

FIG. 155. SINGLE WELT

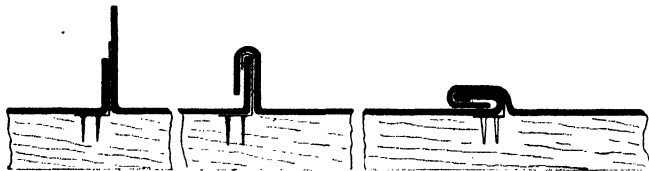

FIG. 156. DOUBLE FLAT WELT

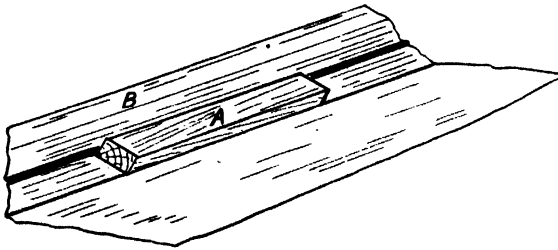

FIG. 161. METHOD OF WORKING LEAD TO SPRINGING

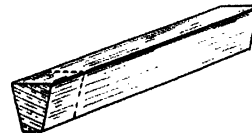

FIG. 160. CAST LEAD STRIP FOR WEDGES

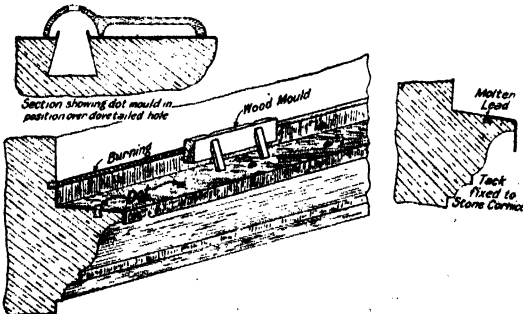

FIG. 159. METHOD OF COVERING, AND FIXING LEAD TO STONE CORNICE

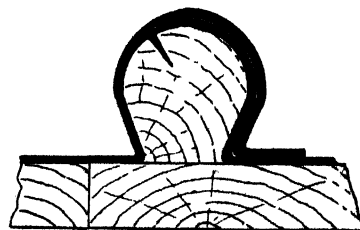

FIG. 157. SECTION OF SOLID ROLL

sinkings in the woodwork into which the lead is dressed. A copper screw and washer is then used, the head of which is tinned; the sinking is now prepared and soldered flush with the leadwork. The objection to this form of fixing is that it holds the lead too rigid, and does not allow for any movement. It will often be found that a crack has occurred at the edge of the soldered dot, and very often the expansion and contraction of the lead has withdrawn the screw from the woodwork, with the result that the lead has moved bodily from position and exposed the roof boarding. Fig. 153 shows a section and elevation of a soldered dot.

WELTED TACKS. These are similar to a bale tack in size, but are welted to the free edge of the lead on dormer cheeks, etc.

A nib is left on the edge of the lead opposite the tack when trimming; the end of the tack is then folded over on to the nib, which is now again folded over on to the sheet, and finishes in alignment with the free edge. Fig. 154 shows the elevation and section of a welted tack.

WELTS. These may be either single or double welts. A *single welt* is used sometimes for turning and covering nailing, and also on the edge of secret gutters. A *double welt* is formed when joining two sheets of lead together, such as is used on stone cornices, and in positions where a roll is not used. Fig. 155 shows a single welt and Fig. 156 the method of forming a double welt.

ROLLS. These are of two kinds, and are used when two sheets or bays are to be joined.

That most commonly used is the *solid wood roll*, and this should be made well undercut as shown in Fig. 157.

The other type of roll used is what is known as a *hollow, or seam, roll*. This is formed by folding the undercloak and overcloak to fit into each other, the fixing being formed by sheet copper tacks, or tingles, fixed about 2 ft. apart, and folded with the leadwork similar to a flat welt. Fig. 158 shows a seam roll and method of turning.

DOTS, OR DOWELS. A lead dot, or dowel, is the method employed to fix lead coverings to stonework. A dovetailed hole is cut by the mason in the stonework, and molten lead is poured into the hole; the head of the dot, which is hemispherical in shape, is formed by a dot mould. Fig. 159 shows a section and view of a lead dot on a stone cornice and a dot mould.

BURNING-IN FLASHINGS. This is the term ap-

plied to the method of fixing flashings and similar coverings to the groove, or *raglet*, in stonework. It consists of pouring molten lead into the groove, by means of a wooden mould, after which the exposed face of the lead is slightly caulked with a narrow caulking tool, and left cross-hatched. Fig. 159 shows a sketch of the mould and method employed.

WEDGES. Where flashings and apron pieces are to be secured to brick walls, wedges of oak or cast lead should be used to hold the lead in position; the wedges should be driven well into the groove, or joint, of the brickwork, so that the pointing of the joints will cover them. A good method is to cast a stick of lead, as shown by Fig. 160, and cut off the wedges as they are required.

TILTING FILLETS, OR *springing pieces* as they are sometimes called, are battens, triangular in section, 2 in. to 3 in. in width and $\frac{3}{4}$ in. or 1 in. in thickness. The object of this fillet is to give a *tilt* to the eaves course of slates, so that the next course will bed firmly at the lower edge. Fig. 161 shows how the leadwork should be worked back into the neck of the springing, the plumber and his mate kneeling on the quartering placed as shown at *A*, and, by raising and lowering the lay-up lead at *B*, assist the lead to fit the necking; a mallet and a blunt edge dresser is then used to finish the work.

Alternatively, a tack is left on the turn-down when trimming off. This tack is then turned back on to a pre-fixed copper tingle which is out of sight and is also a better protection against the lead being lifted during a gale.

ROOF DETAILS

The leadwork for roofs is dealt with partly in "Roof Coverings," but various details of a practical nature are explained in this chapter.

Soakers. When a roof slope abuts at right angles against a brick wall, soakers are used to make good to the wall. These should be cut from sheet lead or copper and turn up against the wall 3 in. and lie on the slate to approximately half the width; the length is equal to the gauge of the slate plus the lap and 1 in. for nailing.

TO FIND THE LENGTH OF SOAKER REQUIRED. Deduct the lap from the length of the slate, divide by 2, and add 4 in.

EXAMPLES.

Countess Slates, 20 in. \times 10 in., laid with 3 in. lap.

$$(20 \text{ in.} - 3 \text{ in.}) \div 2 = 8\frac{1}{2} \text{ in.};$$

$$8\frac{1}{2} \text{ in.} + 4 \text{ in.} = 12\frac{1}{2} \text{ in. length of soaker.}$$

MODERN BUILDING CONSTRUCTION

Duchess Slates, 24 in. × 12 in., laid with 3 in. lap.
 $(24 \text{ in.} - 3 \text{ in.}) \div 2 = 10\frac{1}{2} \text{ in.}$;
 $10\frac{1}{2} \text{ in.} + 4 \text{ in.} = 14\frac{1}{2} \text{ in.}$ length of soaker.

Ladies' Slates, 16 in. × 8 in., laid with 3 in. lap.
 $(16 \text{ in.} - 3 \text{ in.}) \div 2 = 6\frac{1}{2} \text{ in.}$;
 $6\frac{1}{2} \text{ in.} + 4 \text{ in.} = 10\frac{1}{2} \text{ in.}$ length of soaker.

Breaks. It often happens that the sides of a flat, or gutter, are broken by a projection in the

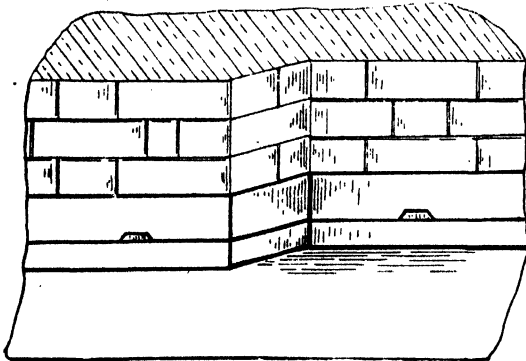

FIG. 162. SINGLE BREAK

form of a pier or chimney stack, and when this occurs it is necessary to form what is termed a *break*, consisting of an internal and external corner.

Fig. 162 shows a *single break*, a type that is often met with; and Fig. 163 shows a *double break* formed around the base of a small pier. In many instances, where the latter type of break occurs, it is sometimes possible to arrange

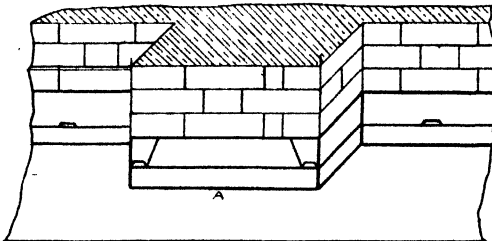

FIG. 163. DOUBLE BREAK

the leadwork so that a roll can be placed in the centre of the pier, at *A*, and so form a pair of single breaks. These two forms of break are most commonly met with, though there are several others which occur in covering various roofs.

Lead Slates. Where pipes must, of necessity, pass through a slated or tiled roof; the method employed to make a watertight job is by using what is known as a *lead slate*. These may be

"bossed" up from a piece of sheet lead, or may be formed by soldering or burning a short stump of lead pipe to a piece of sheet lead.

Fig. 164 shows view and sections of these two forms of lead slate. In the case of a bossed lead slate the lead is first roughly formed to the shape of a half-opened umbrella; it is then worked in to form a considerable lump in the centre to form the pipe; it will be necessary during the working of the lead to flatten out the base to get rid of the ribs that are formed.

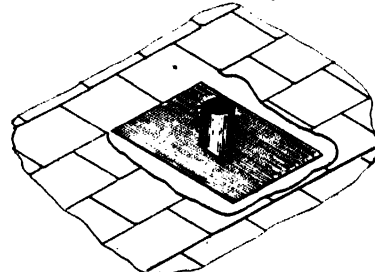
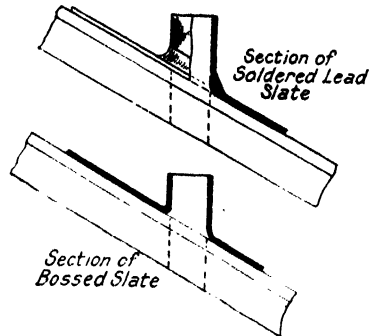

View of Lead Slate

FIG. 164. LEAD SLATES

Care must be taken when working the lead into the shape of the pipe, as there is a tendency for it to drag and work thin, and unless plenty of lead is driven in during the first stages of the operation, difficulty will be found when forming the bottom angle. When the bossing has been completed, the top can be pierced by a pipe opener, and worked back in the same manner as a branch joint is opened with a hammer and bolt; the pipe can then be dressed up on a mandril.

Drips. A lap in a gutter or flat is formed by a *drip*, and should be not less than $2\frac{1}{2}$ in. deep, and if possible 3 in. deep. It is often considered sufficient if 1 in. or $1\frac{1}{2}$ in. is allowed to form the drip; this is a great mistake, for one has only to

lift up the overcloak and examine the woodwork at the edge of the drip, on any roof where these shallow drips are found, to see the damage that is caused by capillary attraction. This will be sufficient proof that deep drips are necessary to make a sound and watertight job. Fig. 165 is a section through a drip in a gutter, and shows the capillary grooves in the drip. In very exposed positions, a vertical groove is an extra precaution against effects of a driving rain as shown in the lap, or passing, in Fig. 165.

Roof Cesspools. The lower ends of gutters are made to discharge the water collected in various ways; (1) by means of the gutter being carried straight through the wall in the form of

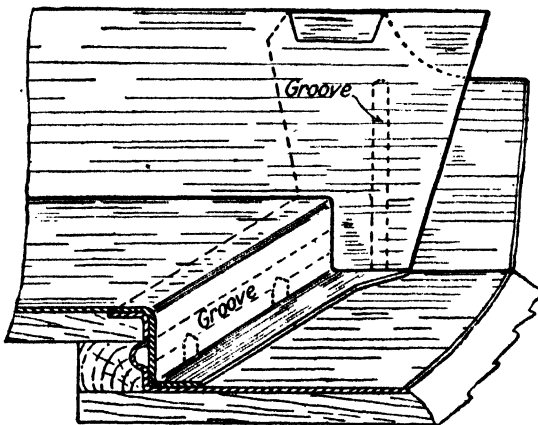

FIG. 165. SECTION THROUGH DRIP, SHOWING CAPILLARY GROOVE

a chute to discharge into a rain-water head; (2) by soldering a socket pipe into the gutter; (3) by forming what is known as a *cesspool* at the lowest end, and fitting the socket pipe to this. The cesspool should be not less than 18 in. in length and 12 in. in width; the depth should be not less than 6 in.

Fig. 166 shows the setting out of the leadwork for a cesspool suitable for a tapering parapet gutter. The shaded portions being cut out, the lead is ready for soiling and shaving in preparation for soldering. The two dotted lines in the 10 in. margin represent the *springing*. Where the double dotted lines occur, the point of the shavehook should be dug well in to score the lead, so that the $\frac{1}{4}$ in. piece that is left on can be turned sharply to stiffen the angle whilst it is being soldered up. After the necessary preparations are completed, the lead is folded up on the dotted lines as shown, the angles set

in, and the $\frac{1}{4}$ in. nibs turned; after which the cesspool is fixed up in a suitable position for soldering.

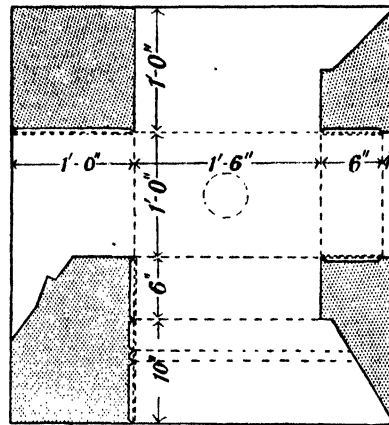

FIG. 166. SETTING OUT LEAD FOR CESSPOOL

Fig. 167 shows sections of cesspool and pipe. In this case the lead pipe has two bends in the form of an offset, but it often happens for want of room that a pipe, as shown at Fig. 168, must be used. The joint to the cesspool in this form is what is termed a *bird's-mouth joint*. It is very

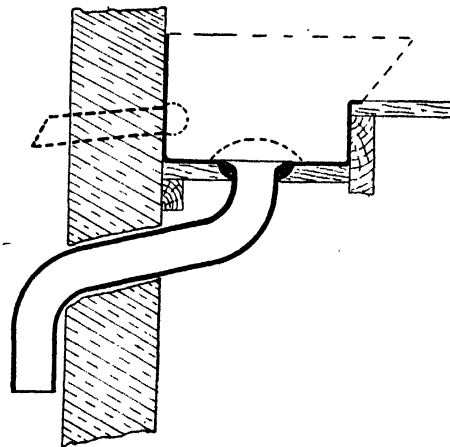

FIG. 167. SECTION OF CESSPOOL AND SOCKET PIPE

often used and claimed, quite correctly, to be an advantage over the type shown at Fig. 167, as there is only one bend, and therefore less liability to become choked.

Cesspool Overflow Pipe. This is an item that is very seldom provided unless the job is of a first-class character, although it is quite as

MODERN BUILDING CONSTRUCTION

necessary as an overflow to a cistern. Where a roof is in the vicinity of trees, it often happens that a few leaves will block completely the outlet to a cesspool, and in the absence of an overflow pipe the result during a storm is

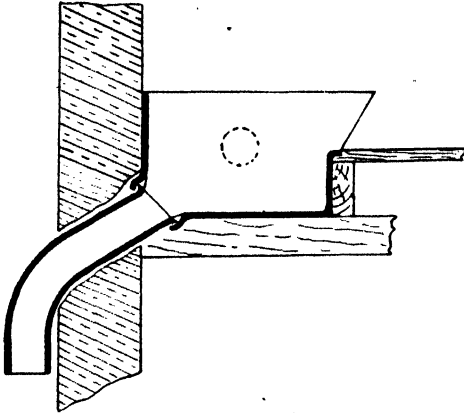

FIG. 168. SECTION OF CESSPOOL WITH BIRD'S-MOUTH OUTLET

obvious, and considerable damage is done to the premises before the trouble is known. The provision of an overflow pipe would give warning and prevent damage and inconvenience. The dotted lines in Figs. 168 and 169, show the

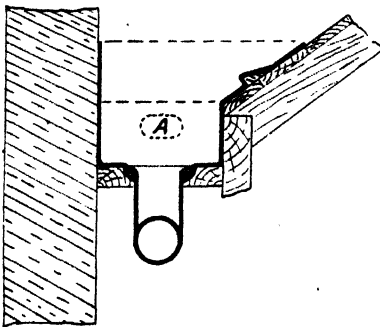

FIG. 169. TRANSVERSE SECTION OF CESSPOOL

position of the overflow pipe. It is a good plan to flatten the pipe slightly as shown at A, Fig. 169.

Ornamental Cast Lead. Ornamental cast sheet lead is obtained by making suitable impressions in the sand bed. Molten lead is poured down the sand frame and struck off to the required thickness with the wooden strike. Plaster models may be used to form the ornament.

Ornamental cast lead is sometimes used for making-up rain-water heads and fall-pipes. Fig. 169A shows a simple form produced by

Messrs. Stoner & Saunders, leadworkers. The ornamental sheets when cast are cut to size and folded, the edges being joined by lead-burnt seams. Larger heads of elaborate design are heavy, and to prevent "creep" the heads are carried on dowels built in the wall. Pieces of lead pipe are burnt or soldered across inside the head a few inches below the top, the dowels passing into these to give additional support to the nails on the side ears.

Procedure on the Building. 1. The plumber should see that the slater or tiler is provided with sufficient lead soakers of correct size so that one can be inserted to each course of slates, at the junction of chimney or wall with the roof slope, as the slates are laid. If this is not done, the soakers will have to be slid into position afterwards, with considerable

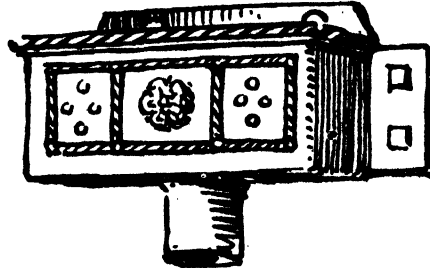

FIG. 169A

risk of breaking the slates when levering up to get the soakers in.

2. Make up back gutters of chimneys and skylights, if any. Lay them in but do not nail them.

3. Make up cesspool and fit outlet-pipe, i.e. always start weathering at the lowest point.

4. Lay gutters, starting from the cesspool.

5. Cover flat, if any. It is a good plan to chop the mortar joints out before laying the lead, making sure to sweep all grit away. Some plumbers chop out for the flashings for chimneys, etc. "Step" and "cover" as soon as the slater has fixed his battens. This is a good plan because the battens make a convenient ladder, and risk of breaking slates is reduced.

6. Chimneys are weathered in the following manner: (a) lay back gutters. (b) fix front aprons; (c) fix side step flashings; (d) boss gutter ends down on to top of flashings; (e) fix cap flashing at the back of the chimneys.

When arranging the work on flats, carpenters should leave the rolls loose so that the plumber can pull them up, lay a bay of lead, and then fix the timber roll up to it.

Chapter XIII—CHEMICAL WORKS PLUMBING

IN chemical laboratories, glass vessels and tubes are used because they are convenient and because they are acid-resisting. In factories producing chemicals on a large scale, however, glass is naturally unsuitable and lead is used instead. Solder would be attacked by the acids, so lead-burning is the method employed for making joints which, on sheet lead linings, are *butt*, *lap*, and *upright*. Fig. 170 shows a group of these joints. Sketch *A* is of a flat butt seam.

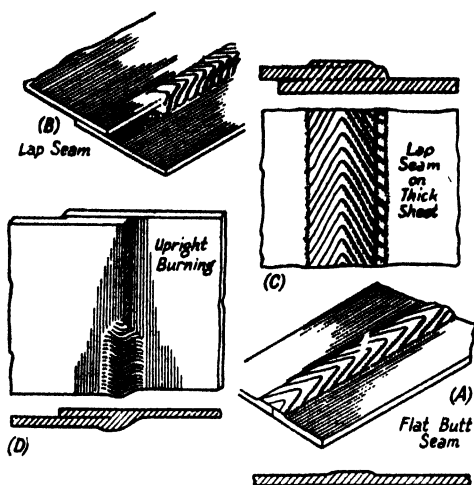

FIG. 170. LEAD-BURNING: BUTT, LAP AND UPRIGHT SEAMS

The seam is made with the flame, using a stick of lead for the feed, fusing it down spot by spot, gradually and progressively, so that a thumb-nail or, with a faster flame, a herring-bone wave, or ripple is produced, as shown, along the face of the seam. Sketch *B* shows a flat lap seam. In this the underside of the overlapping piece is shaved as well as the top faces. Using a feed rod of lead, the seam is then burnt along. For sheet thicker than 5 lb. it is necessary to build up by going along the seam several times, as indicated in sketch *C*. The most difficult seam is that shown in sketch *D*, where the edges of sheet-lead have to be burned in an upright position. The edge of the overlap is used because a feed rod cannot. The work is shaved clean, including the underside of the overlapping edge. Starting at the bottom, the

edge is burnt down on to the back sheet. Then, bead by bead, the seam is formed, working upwards, each lower bead forming a shelf for the next bead fused on above. It needs considerable practice to make this form of seam, but most technical schools now provide facilities and equipment for lead-burning practice.

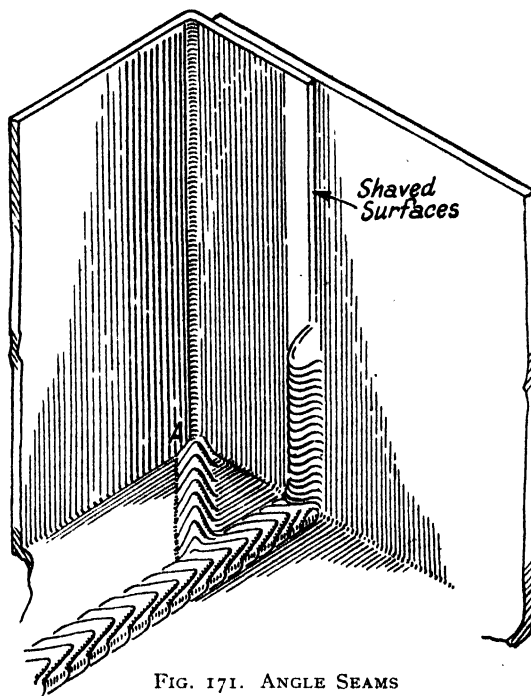

FIG. 171. ANGLE SEAMS

Angle seams in a fixed position are difficult, and in setting out a lining for a tank, the operator usually cuts the lead so that the seams are a few inches from the angles, as shown in Fig. 171. The point marked at *A* is difficult to negotiate and needs practice to avoid thinning the wall at the junction, or even burning a hole in it. Angle burning can easily be accomplished if the work can be turned into a convenient position, as shown in Fig. 172. Using the feed rod freely, by a deft touch a soft oxy-acetylene flame can be made to lick up the sides to form a strong joint. If a hard or rigid flame is used, too much pressure at the regulators will thin down the lead walls at the junction

MODERN BUILDING CONSTRUCTION

of the feed lead. This is shown in the right-hand drawing.

Heavy plate lead is often used in chemical works, and needs special application to produce

indicating full penetration and strong convex surface of the seam face.

Making and Supporting Large Diameter Lead Fume Pipes. Pipes greater than 6 in. diameter

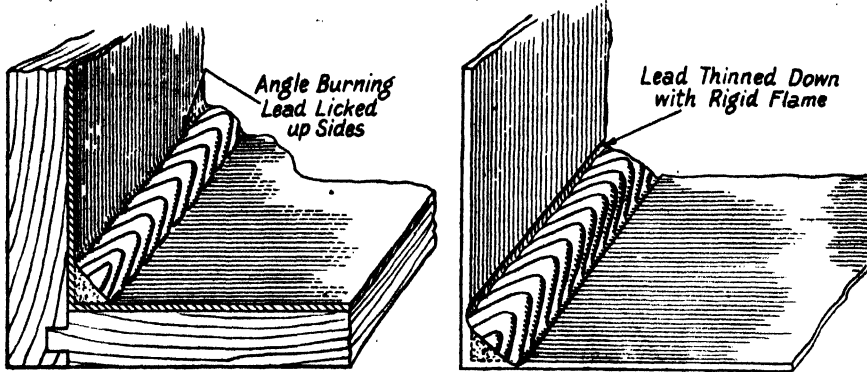

FIG. 172. EFFECTS OF USING SOFT AND RIGID FLAME IN LEAD BURNING

strong and acid-proof joints. Fig. 173 shows the steps required. First prepare the edges to be joined as shown in sketch A. The seam is then burnt along as shown in B, making sure of penetration to the underside and using a fast flame and a full feed from the rod. The seam is then traversed several times with the flame and the rod as at C, and, finally, with a full feed, to float above the surface of the sheet as at D to form a strong joint.

For burning a seam in an upright position on plate lead, a mould is required. The procedure

have to be made up from stout sheet lead. Fig. 175 shows how this is done. The lead is cut wide enough to form the perimeter or circumference of the pipe. This is bent round a mandrel, and a seam burnt along the meeting edges. A strip of iron can be used with advantage, as shown, to ensure thorough penetration. Bends are bossed in halves on wooden cradles and horses,

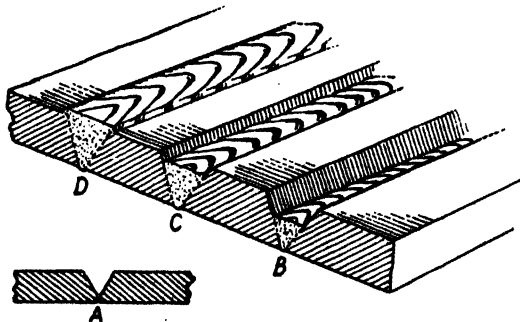

FIG. 173. MAKING AN ACID-PROOF JOINT

is indicated in Fig. 174. Starting at the bottom, an assistant holds the mould in position and gradually taps it upwards as the plumber forms the seam with blow-pipe and lead rod. The blow-pipe is usually held in the right hand and the feed rod in the left, unless the operator is left-handed. A section of the joint is shown

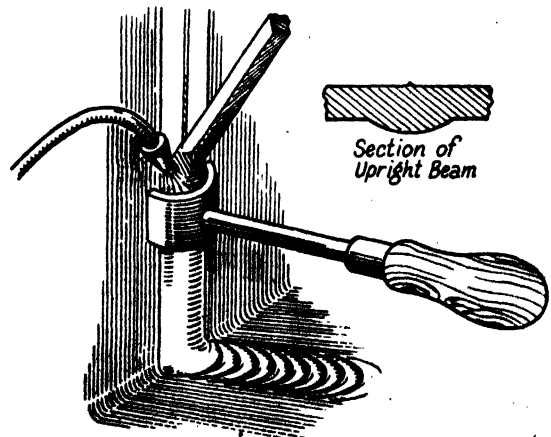

FIG. 174. UPRIGHT SEAM ON PLATE LEAD

and the two halves burnt together. Owing to the heavy weight and softness of lead, special means have to be employed to support it. Fig. 176 shows a special sling with timber laths arranged to distribute the support and so avoid collapse of the walls of the pipe.

Fig. 177 shows the means employed to support

large acid fume pipes in a vertical position. Special iron bands are lead-coated and then burnt on to the walls of the pipe, as shown. Where joints are required, the lead edge of

antimony, known as "Regulus Metal," is used. This can be burnt on to lead pipes using a stick of regulus metal as a feed rod. Fig. 178 shows

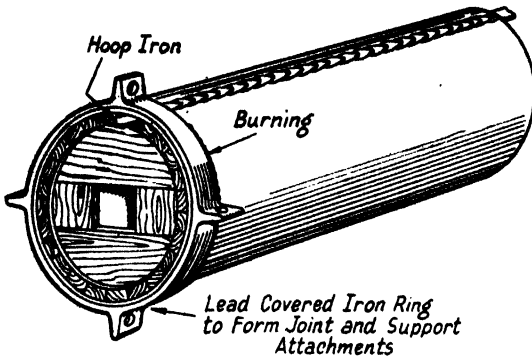

FIG. 175. SHEET LEAD LARGE DIAMETER PIPE WITH JOINT AND SUPPORT ATTACHMENTS

the pipe is flanged on to the top of the iron ring. The top pipe with shaven and bevelled end is then lowered on to it and the joint burnt round, forming a lead-burnt flange joint.

For work in chemical factories, a special pure

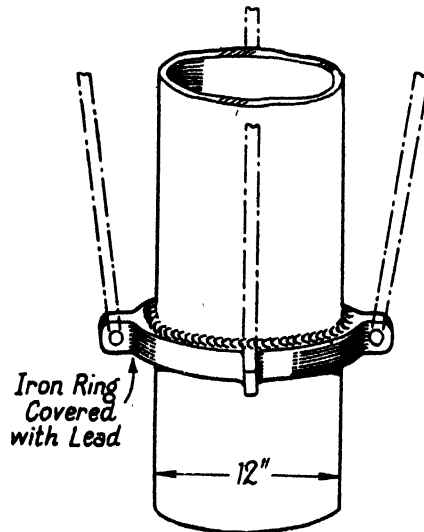

FIG. 177. METHOD OF SUPPORTING ACID FUME PIPES VERTICALLY

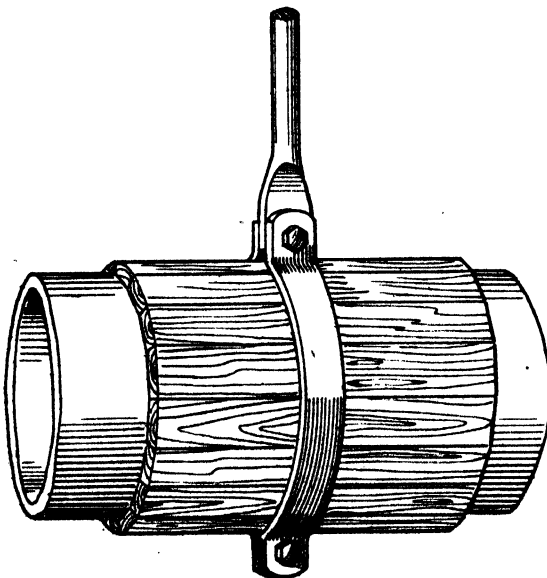

FIG. 176. SPECIAL SLING FOR SUPPORTING LARGE ACID FUME PIPES

lead is necessary. It is known as *chemical lead*, and is manufactured from virgin lead from the mines. Valves of brass, etc., cannot be used as they are not acid-proof. An alloy of lead and

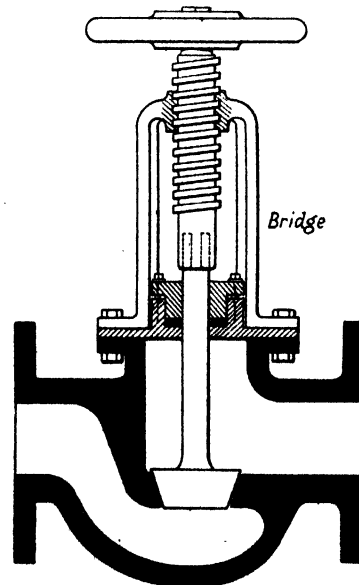

FIG. 178. ACID-PROOF STOP-VALVE IN REGULUS METAL

a large diameter stop-valve. All parts in contact with acid are made of this alloy. The flanges shown are bolted together with an acid-proof cement between the flange faces.

Chapter XIV—PREFABRICATION

PREFABRICATION in plumber's work is not new, and many plumbers are expert in making up work in the shop for fixing on the site. Fig. 179 shows waste pipes, ventilation pipes, and cold water service pipes made up ready for fixing under ranges of wash-bowls. Similar work is prepared in light gauge copper pipes and brazed or silver solder joints. Where, say, six houses are to be built, the plumber fitting the hot water

As can be seen, the arrangement is on what is known as the "one-pipe" system (see section on "Drainage and Sanitation") all fittings discharging to one main vertical waste. The top ends of this waste pipe and that of the branch vent running alongside are fitted with couplings for easy connection to the section serving the floor above. As can be realised, this lower section will vary from the sections serving the



FIG. 179. WASTE, VENTILATION, AND COLD WATER SERVICE PIPES MADE UP READY FOR FIXING

service when cutting lengths of pipe and making bends for one house, makes up at the same time six of each length, etc., to the single pattern. This is a great time-saving if the buildings are exactly alike. In making compound bends, care must be taken to see that three left-hand and three right-hand bends are made. When the cold service is in light gauge copper, the same procedure is followed. If it is proposed to build in the near future further houses of the same design, an extra set of pipes is made, and these are used as templets for the next set of buildings.

Fig. 180 shows the waste pipe arrangements for one floor of a block of flats. The pipes are in light gauge copper with bronze welded joints.

intermediate floors, because the branch vent, to save running it through the roof as a separate vent, enters the main stack in the topmost section above the height of the fittings. The hot and cold service is made up in the same manner, and the whole of the work hidden behind the mask.

The vertical pipes are carried in a duct or trunk in the internal corner. Everything is thus rendered proof against the effects of frost, circulation pipes of the heating section being carried within the duct. In smaller schemes, as for bungalows and two storey buildings, the same duct can carry or house an asbestos flue pipe from the boiler. Removable panels can be arranged to give access to the plumbing spaces.

Overflows are carried through the external wall. The foot of the stack is fitted with a connection suitable for fitting to the stoneware drain bend, or to a cast-iron drain bend. The flushing cisterns may also be fixed within the duct.

For small properties of standard construction, all the pipes are clipped on to the ironwork of

pipng, and to avoid, as far as possible, the need for trap and branch ventilation. For the same reason, the sink waste pipe on the ground floor is not branched into the stack, but taken to a gully trap. This class of work can, of course, be made up on the job by a skilled plumber almost as easily as in the workshop, and would by that means allow for more variation in planning.

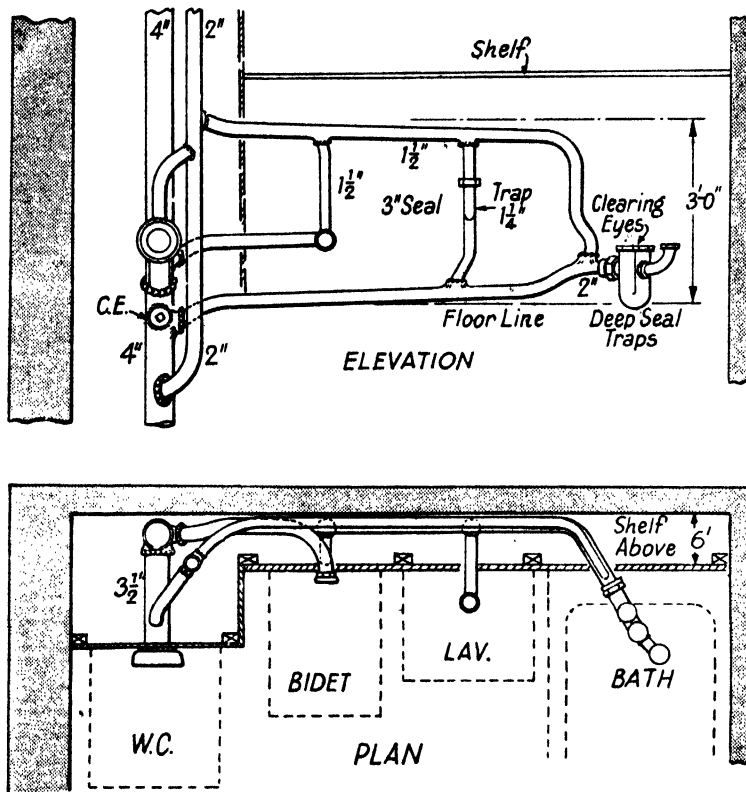

FIG. 180. WASTE PIPE ARRANGEMENTS FOR ONE FLOOR OF A BLOCK OF FLATS

a frame constructed of angle iron and strip welded together to form a self-supporting trunk. Each trunk is single-storey height and may be obtained to bolt together or to stand on the floor. The first floor has, of course, to be framed to give clearance for the pipes and flue. The top section of trunking is surmounted with the cold feed tank, and within the same section, the hot water storage tank and the flushing cistern to the W.C. is housed.

The position of the fittings is planned to back on to the duct to give a minimum amount of

Fig. 181 is the final illustration in this subject. It is proposed to produce this in self-contained trunks at the factory. The ends of the pipes are fitted with couplings so that sections simply need the use of spanners to render them water-tight.

For the cheaper sets, it is proposed to use mild-steel pipes. This will lead to trouble from rust in the draw-off water unless the pipes are galvanized or coated with a protective solution. An all-copper job would be more satisfactory, and the sections lighter to handle.

MODERN BUILDING CONSTRUCTION

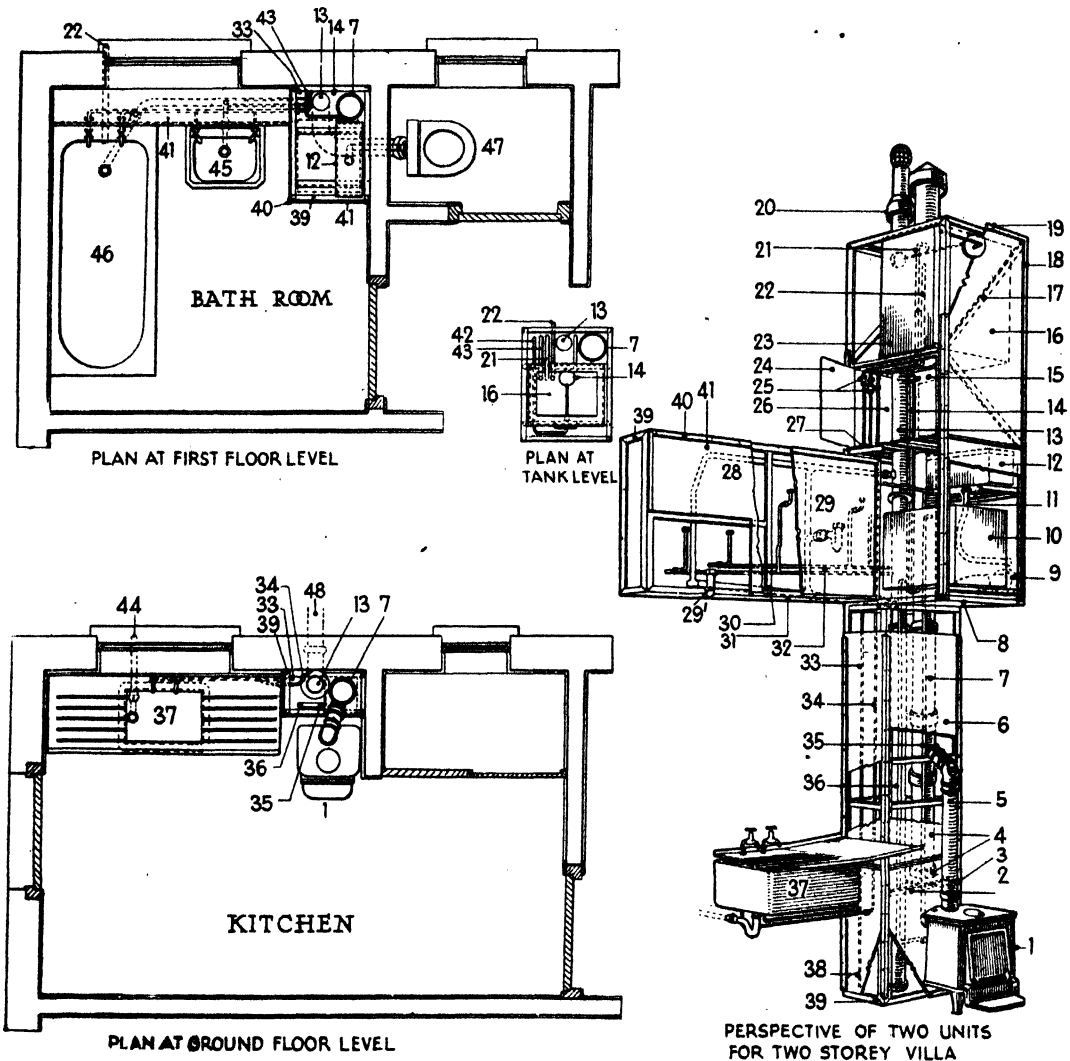

- | | | |
|--------------------------------------|-----------------------------------|------------------------------|
| 1. Solid fuel boiler | 17. Brace | 33. Rising main |
| 2. Bearer | 18. Cover strip | 34. Hot supply |
| 3. Soot access | 19. Slotted top cover strip | 35. Primary flow |
| 4. Asbestos lining | 20. Weathering cowl | 36. Primary return |
| 5. Cast-iron flue | 21. Expansion pipe | 37. Sink |
| 6. Removable wallboard lining | 22. Overflow | 38. Connect with SC. to main |
| 7. Flue | 23. Felt pad to underside of tank | 39. Angle iron frame |
| 8. Internal angle iron flanged joint | 24. Door | 40. Cover strip |
| 9. W.C. connector | 25. Control valves | 41. Panel lining |
| 10. H.W. tank | 26. Airing cupboard | 42. Rising main |
| 11. Flush pipe | 27. Slatted shelf | 43. Cold supply |
| 12. W.W.P. | 28. Anti pipe | 44. Connection to gully |
| 13. Soil and vent pipe | 29. Deep seal traps | 45. Lavatory basin |
| 14. Cold feed | 30. Support for basin bracket | 46. Bath |
| 15. Asbestos flue | 31. Waste pipe | 47. Water closet |
| 16. Cold water storage tank | 32. Hot and cold services | 48. Connection to main |

FIG. 181. THE DENHAM PLUMBING AND HEATING SYSTEM UNIT
(Designed by S. J. Gravely and S. C. Warren)

Gas-Fitting

By R. J. ROGERS

Chief Superintendent, Fittings Department, City of Birmingham Gas Department

Revised and with Additions by R. A. WOODROOK

Chapter I—GAS MANUFACTURE

Manufacture. Fig. 1 illustrates diagrammatically the process of gas manufacture. The crushed coal is hoisted by means of a conveyor into an automatic hopper from which it is released into a *vertical retort* from which air is excluded. This retort is heated externally and the gas in the coal is driven off, while the coke is continuously ejected at the base.

Gas is also made in *horizontal retorts* of  pattern.

In this case banks of retorts are built in fire-brick settings. These retorts are obviously not continuous like the vertical, and the time of distillation varies from 8 to 12 hours or so according to the quality of the coal carbonized, and of the gas required.

The gas given off is drawn through *cooling towers* where a proportion of the tarry matter is condensed, then through *scrubbers and washers* which remove the sulphur and ammonia compounds.

The remaining sulphuretted hydrogen is separated from the gas by passing over hydrated oxide of iron in the *purifiers*, after which the gas is measured by the *station meters* and passes forward to the *gasholder*. It is the by-products removed in cleansing the gas which form the basis of all aniline dyes and coal tar products.

Composition of Gas. Coal gas obtained from this process of distillation is a mixture made up of various chemical compounds and elements, the proportions of which vary according to the particular coal used and temperature of carbonization.

The approximate composition of straight coal gas made from a Newcastle coal is as follows—

Hydrogen	48·49	} Combustibles and Illuminants.
Marsh gas	35·90	
Light yielding hydro- carbons	3·83	} Inert gases.
Carbon monoxide	6·61	
Carbon dioxide	0·12	
Oxygen	nil	
Nitrogen	5·05	
	<u>100·00</u>	

Gas undertakings are to-day required to supply gas of a definite declared *calorific*, or *heating*, value. In order to do this economically, it is often the practice to add to the straight coal gas a proportion of *water gas* or *carburetted water gas*. These proportions are varied according to the type of coal used and method of carbonization, the aim being to obtain a town's gas of unaltering thermal value and one which requires a known admixture of air for complete combustion. The composition of this town's gas varies according to the *declared value* adopted by the gas undertaking.

The following may be taken as a typical example—

Hydrogen	46·0
Marsh gas	23·0
Light yielding hydrocarbons	2·4
Carbon monoxide	12·6
Carbon dioxide	4
Oxygen	1·1
Nitrogen	10·9
	<u>100·0</u>

It is gas of approximately the above composition which is supplied by the great majority of gas undertakings in Great Britain, and which will be dealt with in this section.

Some gas undertakings have adopted a calorific value of 400 B.Th.U. per cub. ft., whilst others supply gas as high as 560 B.Th.U. per cub. ft.

The majority of gas undertakings in the United Kingdom have, however, adopted a calorific standard between 450 and 500 B.Th.U. per cub. ft.

DISTRIBUTION OF GAS

Distribution Pipes. The problem of distributing the gas from the works to the consumer presented great difficulties to the pioneers, and various materials were used by them to construct conduits for the gas. The chief recognized

MODERN BUILDING CONSTRUCTION

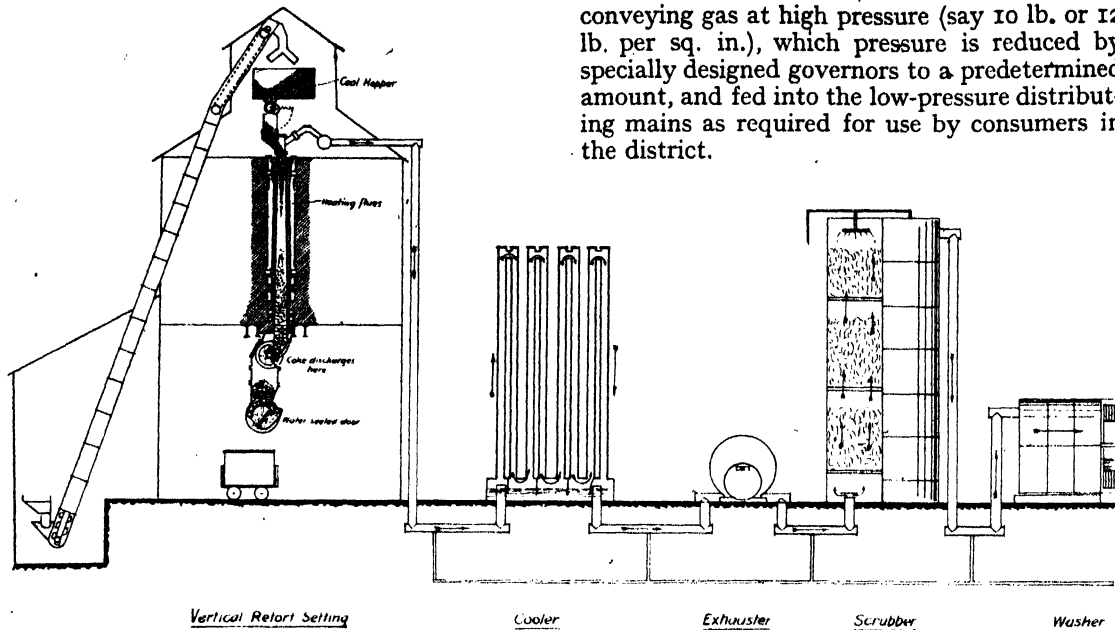

conveying gas at high pressure (say 10 lb. or 12 lb. per sq. in.), which pressure is reduced by specially designed governors to a predetermined amount, and fed into the low-pressure distributing mains as required for use by consumers in the district.

materials used to-day for the manufacture of gas mains are—

1. Cast iron.
2. Steel.
3. Wrought iron.

Of these, cast iron and steel are mainly used for the larger underground mains, while wrought-iron pipes are used for services, internal piping, and in some cases for underground mains conveying gas at high pressures.

In deciding upon the size of gas pipes it should be remembered that the volume of gas which will pass through any main is proportional to the *square* of the pipe diameter, while any roughness of the inner surface, sharp elbows, or tee pieces restrict the carrying capacity of the main. Fig. 2 is a graph giving the discharge of gas through pipes with a loss of pressure of 1-in. head of water.

The pressure at which gas is generally distributed is only slightly above atmospheric pressure, the difference being usually equal to 3 in. or 4 in. of water column.

Gas being lighter than air (specific gravity .4 to .5), pressures tend to be higher at the more elevated parts of the district.

To obtain equal pressure throughout the district it is therefore often necessary to install district control governors.

A supply of gas is sometimes given to out-lying districts by means of special supply mains

FIG. 1. DIAGRAM SHOWING PROCESS

“Since the first world war the sale of gas in bulk has been greatly extended. Coke oven gas especially has a very high calorific content, and was in certain cases almost a waste product until sold to neighbouring towns for dilution with coal gas of their own make. The distribution of this “waste” gas over considerable distances in one or two well-known cases has enabled the local use of gas to be developed and maintained without recourse to the expensive method of building new, or replacing old gasworks, in the retail sale area.

Gas Service. The pipe conveying gas from the street main to consumer’s premises is known as the “service.” This service pipe should be of wrought iron (for all sizes below 3 in. diameter). It should, whenever possible, be taken off the top of the main by a bend or m. & f elbow. It must be laid with a definite fall, preferably back to the main.

The tube used should be of steam-quality wrought iron, either specially wrapped or laid in wood troughing into which hot bitumen is poured. A connector (sometimes called a *long screw and back nut*), should be left near the

main to render possible the disconnection of the pipe.

A *main cock* and key must be fixed on the service immediately ahead of the meter inlet lead. The *gas meter* should be fixed as near as possible to the front line of the building. This minimizes the possibility of uncontrolled gas escapes and makes for safety in case of fire. On no account should a service pipe be laid under a hollow wooden floor to kitchen or back cellar; if so laid a small

escape may pass unnoticed until gas has accumulated under the building in a sufficient quantity to become dangerous.

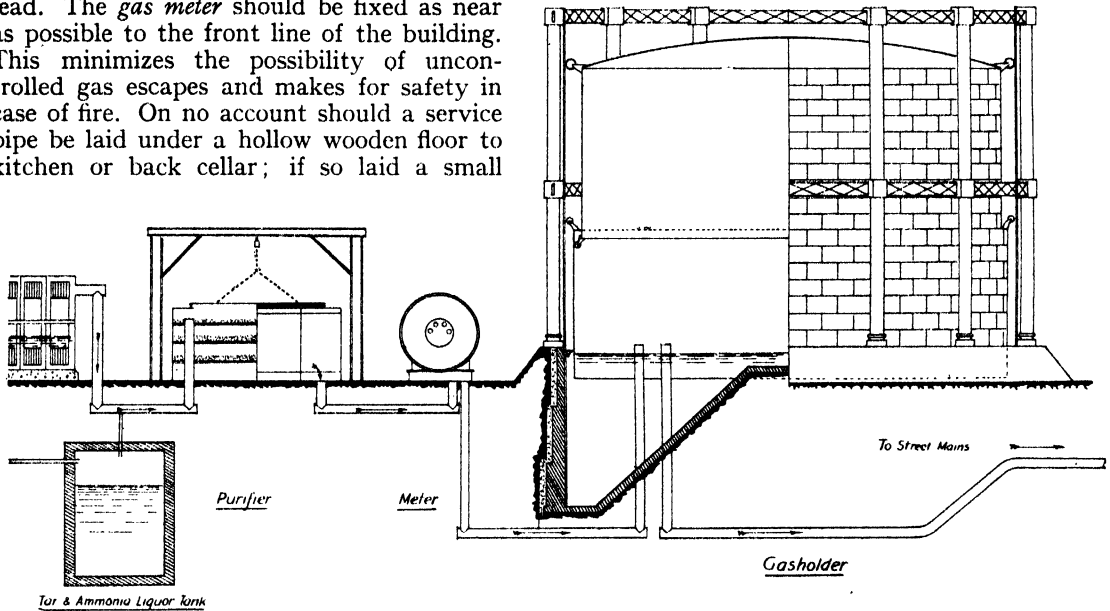

OF GAS MANUFACTURE

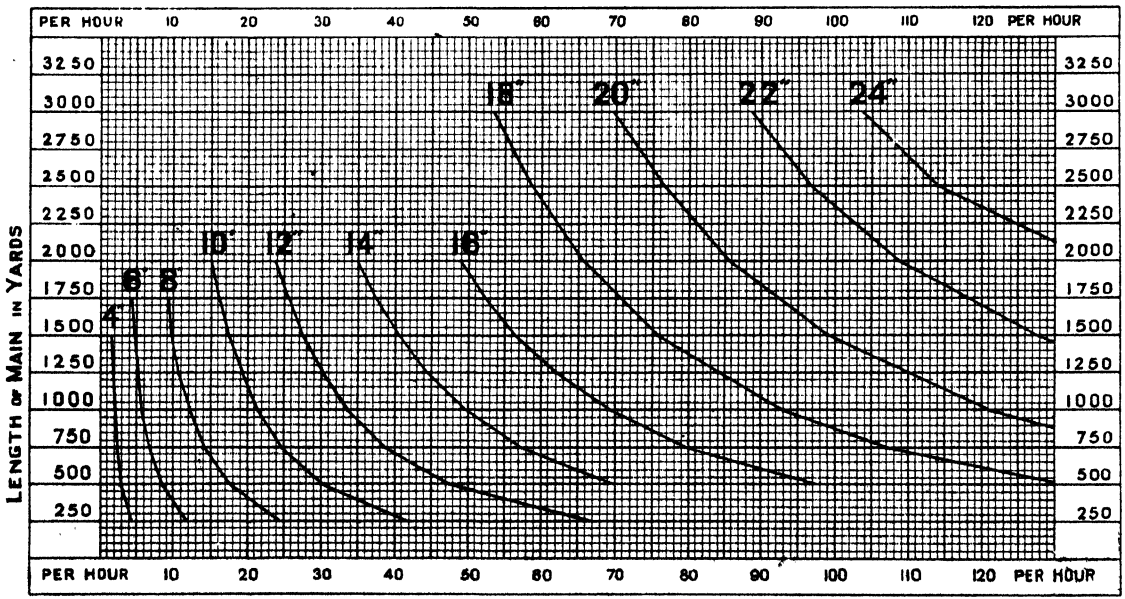

FIG. 2. GRAPHS SHOWING APPROXIMATE AMOUNT OF GAS WHICH WILL PASS THROUGH VARIOUS LENGTHS OF CERTAIN SIZES OF MAINS WITH A LOSS OF PRESSURE OF 1 IN. WATER COLUMN

Chapter II—PIPING OF BUILDINGS

THE pipes chiefly used on internal fitting work are *wrought iron* or *compo*. Copper or brass pipe is sometimes used for connecting up gas fires or other apparatus to the internal supply pipe.

Wrought-iron Pipes. Those used for internal supplies are usually of gas quality. For services

They are cheaper than wrought iron, and if of good quality are quite satisfactory.

Jointing of Iron Pipes. Iron pipes and fittings are threaded with a special Whitworth thread known as *gas thread*. The size of iron pipes is designated by the diameter of the bore. Pipes of less than $\frac{1}{4}$ in. bore should not be used for the conveyance of gas in houses. Pipes are jointed together by sockets, the thread having first been smeared with a mixture of red or white lead and boiled oil of the consistency of thick paint. Graphite and several of the proprietary jointing materials on the market are quite satisfactory, but ordinary paint should not be used for jointing.

Tools for Iron Pipes. The following are the tools most commonly used—

Stocks and dies, or screwing machine, for threading pipe.

Three-wheeled cutters, or hacksaw.

Portable vice.

Tongs, footprints, or pliers.

Small tools, such as saw, chisel, gouge, augur, drills, etc.

Composition Pipe. Compo pipe is made of an alloy of lead and tin. The admixture of tin allows a thinner pipe wall to be used than would be the case with pure lead. It tends to make the pipe more rigid and less porous. Compo pipe can be very easily bent, and therefore obviates the use of various fittings. It is largely used for making the bend connections to meters of the smaller sizes. It presents a smooth surface to the flow of gas, and is not subject to corrosion.

The chief disadvantage of using compo pipe for gas supplies is its tendency to sag, and so allow the accumulation of moisture from condensation. Also, nails are apt to be driven into it, and mice and rats have a habit of nibbling through it. If it is used, copper or brass fittings must be soldered to it to enable pendants or brackets to be attached. Straight and tee joints are made by tan-pinning out, chamfering off the pipe, and soldering with best tinmen's solder, composed of 60 per cent tin and 40 per cent lead.

Remember that the designated size of compo and lead pipe is the external diameter, not the bore, as is the case with iron gas supply pipes.

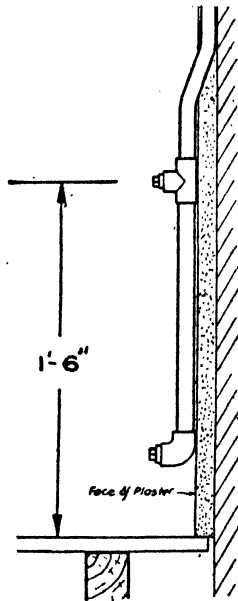

FIG. 3. RISING MAIN FROM METER POSITION

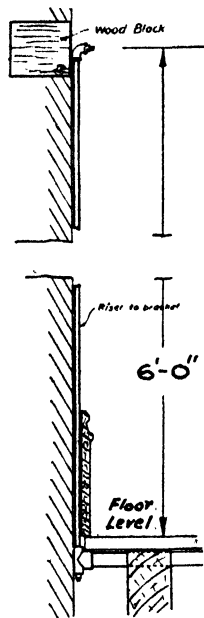

FIG. 4. BRACKET SUPPLY

underground best steam quality pipe should be used.

A very large amount of steel gas pipe is sold, and is often used under the impression that it is wrought iron. Steel tubing is cheaper than wrought iron, but does not resist corrosion so well, and it is best to specify that only wrought-iron pipe, or, as it is sometimes termed, *wrought-iron barrel*, manufactured from *puddled iron strip*, be used.

Fittings. The commonest wrought-iron fittings are sockets, diminishers, elbows, tees, crosses, bends, plugs, caps, nipples (preferably space or barrel nipples), long screws, and back nuts or connectors.

Malleable cast-iron fittings are largely used.

The Fitting of Iron Pipes. The following general rules should be observed when fitting up premises with iron gas supply pipes—

1. Pipes must be laid with a definite fall towards a syphon in which condensed moisture may collect. This syphon should be left in an accessible position near the meter, a sett being made on the rising main (Fig. 3), and a tee left about 18 in. from the floor for connection to meter. If it is impossible to lay all pipes with a fall to this main syphon, another must be left in an accessible position.

2. Keep pipes well away from all electric cables.

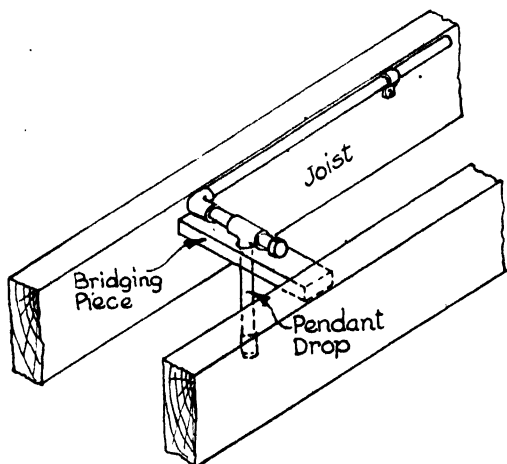

FIG. 5. BRIDGING PIECE FOR PENDANT

3. Do not notch joists more than 3 ft. away from supporting walls, and do not cut out any more of the joist than is necessary to accommodate the pipe.

4. Do not lay pipes in the plaster of ceilings.

5. Leave a plugged tee, not an elbow, on the bottom of all risers to brackets. Properly plug the wall with a wood block on to which the pattress block is to be screwed (Fig. 4).

6. Pendant drops should project 1½ in. below the under-surface of the joist to allow for plastering. As a pendant position usually comes between the joists, a wooden bridging piece must be provided to take the weight of the fitting, and keep the drop in a vertical position (Fig. 5).

7. Long screws and back nuts should be left in convenient positions for disconnecting purposes.

Sizes of Pipes. In deciding on the sizes of pipes, allowance should be made for possible extensions. The tendency is frequently to lay pipes too small for requirements.

The following general rules should be borne in mind—

1. A ¼ in. pipe is sufficient for one bracket light; to supply two brackets a ⅜ in. pipe should be run.

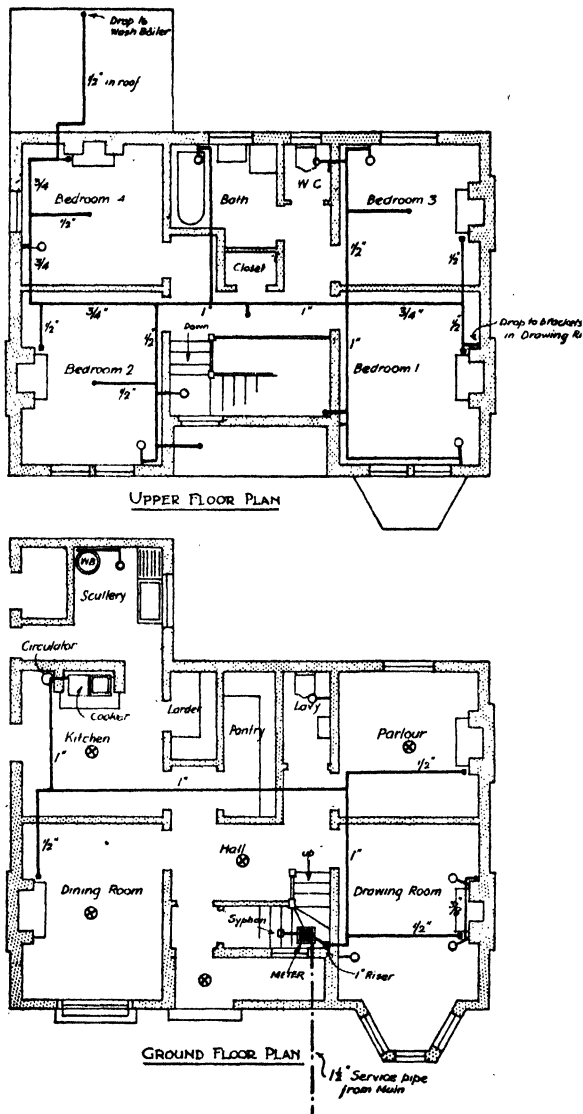

FIG. 6. LAYOUT OF PIPES IN VILLA

2. Never lay a pipe of less than ½ in. diameter under floor boards.

3. Not less than ½ in. supply should be laid to every gas fire or wash boiler.

4. A ¾ in. pipe will supply a cooker or two gas fires.

MODERN BUILDING CONSTRUCTION

5. No rising main from meter should be less than $\frac{3}{4}$ in.

6. A geyser supply should preferably be run direct from the meter outlet and in $\frac{3}{4}$ in. throughout.

7. A $2\frac{1}{2}$ gal. per minute hot-water Multi-point type heater requires a 1 in. pipe, and a 2 gal. type a $\frac{3}{4}$ in. pipe.

Typical Plans. The application of the foregoing general rules will be seen in the fitting up of the residence, the ground floor and upper floor plans of which are shown in Fig. 6.

The position for the meter is usually arranged by the architect or builder with the gas undertaking concerned. The apparatus required and the positions for lights, etc., are matters for the architect or his client, and this information must be obtained before starting on the work. The first things to decide on are the runs and sizes of pipes, bearing in mind the rules already given. In the example given, in addition to the usual lighting points, provision has to be made for gas fires in each of four

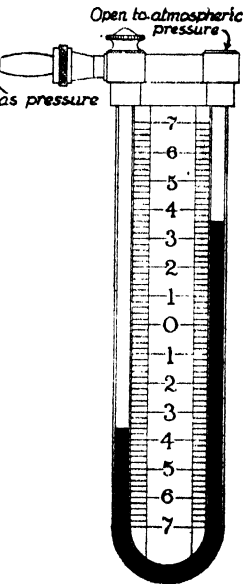

FIG. 7. PRESSURE GAUGE

bedrooms and three rooms downstairs, also a cooking stove, hot-water circulator, and a wash boiler or sink heater.

In this case we should recommend that two main pipes be run from the meter, each of 1 in. diameter, the first clipped to the underside of the joists carrying the ground floor, to supply the cooker and circulator in the kitchen and the gas fires on the ground floor; the second 1 in. main rising to the chamber floor level and running along and across the top of the joists, these being notched where necessary. This pipe will supply the lighting points and the gas fires in the bedrooms. It will be noted that the size of pipe is diminished as the various points are taken off, but that no horizontal pipe is less than $\frac{1}{2}$ in. diameter.

In the more modern flat the Multi-point type water heater now enjoys a great vogue. The

large $2\frac{1}{2}$ gal. size would require a 1 in. pipe run directly from the meter, preferably independent of any other supply, though the cooker alone might be taken off it, but not any gas fires. These heaters must not be fixed in any premises without informing the gas company, as they require a high capacity meter.

The wash boiler is more conveniently taken off the chamber floor system of pipes, and the scullery bracket off the supply to the wash boiler. The pipes should be given a slight fall back to the main riser in every case, and a length of pipe (syphon) left under the hollow floor near the meter to collect any condensation from the pipes. Arrangements should be made for the carpenter to leave a section of board screwed down over the syphon and also over the gas fire points, pendant drops, etc.

The whole of the pipes should be painted some days before being fitted, and touched up afterwards as required.

Testing of Installation. Where alterations or extensions have been made in a house already fitted for gas, the system where completed is tested by a gasfitter's U-shaped pressure gauge (Fig. 7).

When, however, gas is not available—as is often the case with new installations—the following method will be found satisfactory. An ordinary pressure gauge containing mercury instead of water is fixed in a convenient position (say, the bracket point in the scullery). The attachment shown in Fig. 8, which consists of a bush piece with an ordinary cycle tube valve soldered in it, is then fixed at a point some distance away (say, on the tee left for the meter). These connections should be carefully made and care taken to see that the gauge is sound. All other positions are then properly plugged or capped.

By means of a cycle pump the pressure of air in the pipes is slowly raised until the difference of level of the mercury in the two arms of the gauge is about 4 in. The pressure in the pipes will then be roughly 2 lb. per sq. in. The gauge is now watched. If there is no alteration in the level of the mercury after five minutes, the installation may be passed as sound. If there is a leakage the pressure will fall.

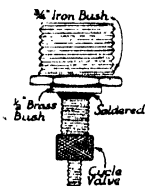

FIG. 8
FITTING FOR
ATTACHMENT
OF CYCLE
PUMP

Chapter III—METHODS OF MEASURING GAS

Gas Meter. For safety and convenience it is desirable that the meter should be fixed in a light, accessible and well-ventilated position.

For accuracy of registration it is essential that it should be fitted perfectly level and in a position which is not subjected to extremes of heat or cold. Trouble and inconvenience may be avoided if a position for the meter is arranged when the house is planned.

The gas meter, though a much maligned machine, is one of the most accurate measuring instruments in general use to-day. Its accuracy is vouched for, not only by the meter makers and by the gas undertaking, but by Statutory Gas Inspectors working under the jurisdiction of a panel of Justices of the Peace appointed by the local authority. By law the maximum of error of a meter must come within the limits of 3% slow—that is, against the gas undertaking, and 2% fast—that is, against the consumer.

The *wet meter* is the oldest type, and in suitable positions, such as cellars or basements, it has much to recommend it.

This meter depends for its registration on the revolution of a drum divided by oblique vanes into three or four chambers which consecutively fill with gas over a water seal and then discharge to the meter outlet.

The *dry meter* is a much commoner type to-day. This is made of tinned plate and is divided horizontally into a shallow upper compartment and a larger measuring chamber below.

This measuring chamber is again completely divided by a central vertical plate. To each side of this vertical plate are attached bellows of Persian sheep skin, prepared and tanned to a specification. By suitable slide valves and ports gas is fed alternately inside and outside both these bellows, thus giving four discharge chambers to outlet, the inflation and deflation of the leather diaphragm ensuring a steady flow of gas to the outlet. By means of flag wires, tangent and train of wheels each motion of the diaphragm is recorded on the index of the meter.

Fig. 9 shows the internal construction of a dry meter. From the inlet of the meter the gas enters, through the orifice H, the triangular chamber C, a portion of which has been cut away to show the valves V_1 and V_2 . The

bottom portion of the meter is divided into halves by the vertical partition P. In each half is a cylindrical chamber, A_1 and A_2 , the end of which is formed by a disc K attached to the rim of the cylinder by a flexible leather diaphragm D. The meter is actuated by the pressure of the gas. The function of the valve (which resembles the slide valve of a steam engine) is to admit gas alternately to the inside and outside chambers, both being used for measuring purposes. Whilst the inside chamber is filling, the valve allows the gas displaced from the outer chamber by the movement of the disc K, to pass to the outlet of the meter, and in the same way allows the gas from the outer chamber to pass to the outlet whilst the inside chamber is filling. It is necessary to have the chambers and valves in duplicate so that the action of the meter shall give a continuous supply of gas at the outlet.

As shown, the valve V_2 is admitting gas to the outer chamber M_2 , and is allowing gas from the inner chamber A_2 to pass to the outlet. This is shown more clearly in the enlarged section through the valve.

The registration is accomplished through the tangent arms T_1 and T_2 , which are moved to and fro by the rods R_1 and R_2 . These rods are rotated first one way and then the other by the in-and-out movement of the discs K. By means of the links L_1 and L_2 , the pendulum motion of the tangent arms is converted into a rotary motion in one direction at the worm wheel W, and this by means of a pinion and shaft is made to actuate a train of spur wheels and pinions, attached to which are the index fingers. Motion is given to the valves by connecting rods working on cranks on the worm wheel shaft.

The *prepayment*, or *slot*, *meter* is exactly the same in construction as the ordinary meter, except that suitable mechanism, actuated by the engaging of the coin in the necessary cog, enables a gas valve to be opened, which valve is gradually closed again as the gas is consumed.

It should be remembered that the gas registered on the index of the prepayment meter is not affected by any inaccuracy or breakdown of the automatic mechanism.

Sizes of Meters. The size of meters from

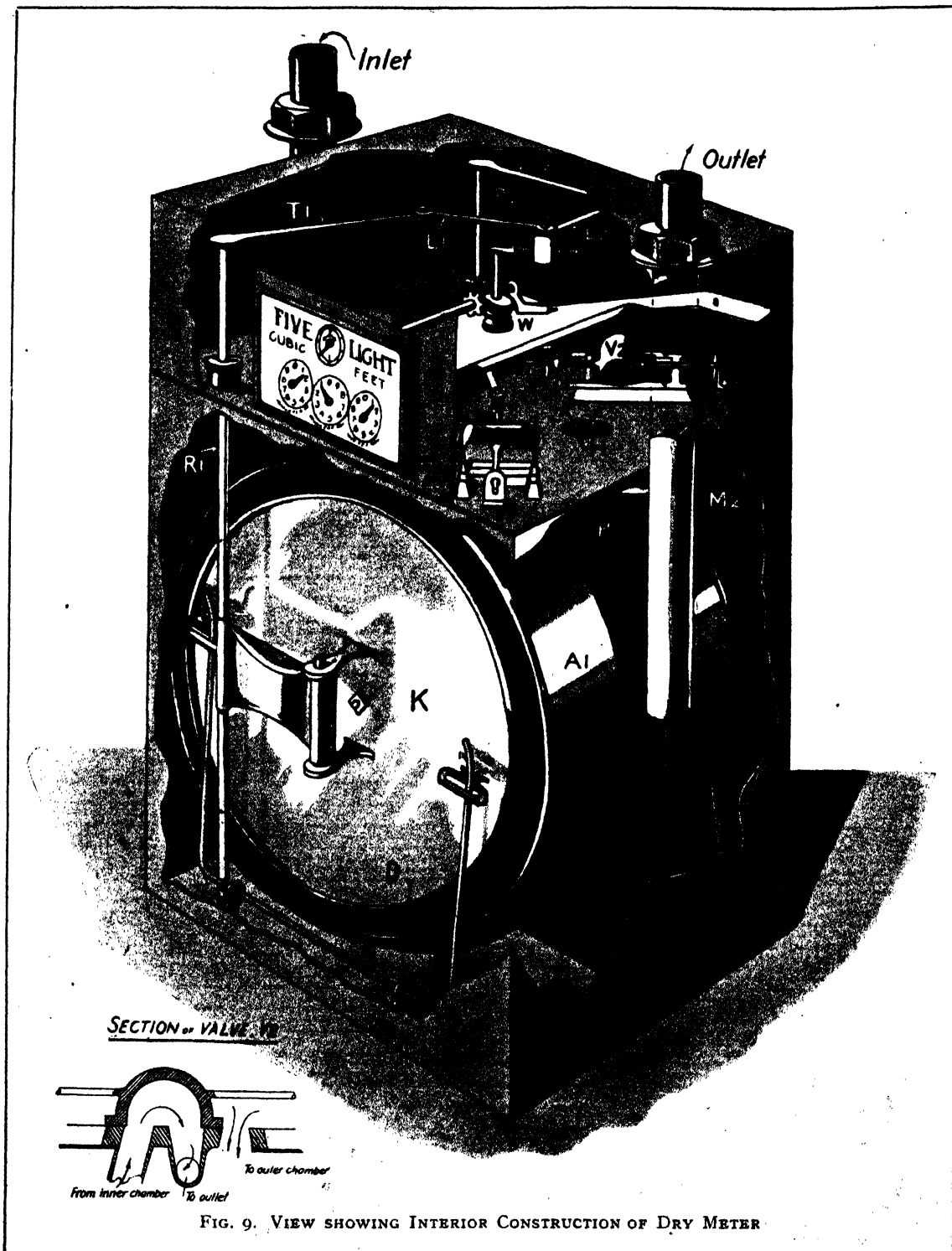

their inception up to a few years ago was designated in "lights." Each "light" represented a nominal capacity of six cubic feet of gas per hour, so that a 5-light meter had a normal capacity of 30 cubic feet per hour. This nomenclature is a relic of the days when gas was used almost entirely for the flat flame or bat's-wing burner, the approximate hourly consumption of which was 6 cubic feet.

In recent years a series of *standard* size meters has been adopted by the gas industry, and Table I gives the capacity of both *light size* and *standard size* of meters.

TABLE I
SIZES OF GAS METERS

Standard size	Size in lights	Capacity in cu. ft. per hr.	Size of service In.
1	5	30	$\frac{3}{4}$
2	-	40	$\frac{3}{4}$
3	10	60	1
4	20	120	$1\frac{1}{4}$
-	30	180	$1\frac{1}{2}$
5	-	210	$1\frac{1}{2}$
-	50	300	$1\frac{1}{2}$
-	60	360	2
6	-	420	2

The resale of gas through slot check meters for controlling fires in hotels and boarding houses has developed small high capacity meters of varying types with their inlets and outlets in positions other than those shown in the meter illustrated.

On no account should a slot check meter be fitted to a pipe controlled by a main slot meter. Unless the supply company is informed when additional appliances are fitted, a breakdown or failure of the meter to deliver the necessary quantity of gas for the efficient operation of the appliances will result.

System of Charging for Gas. Although we have spoken of gas being measured in cubic feet, it is now charged in many districts at a price per *Therm*. The reason for this is plain. Not only does the consumption of gas in cookers, gas fires, etc., depend upon its heating value, but, as will be seen in a later chapter, the illumination received from an incandescent mantle is also dependent on flame temperature derived from the heat in the gas.

As the consumer of gas requires to purchase *heat*, the basis of charging for gas supplied has been arranged on the calorific, or heating, quality, in place of charging on the volumetric measurement, which does not take into account the heating quality of the gas.

Under the Gas Regulation Act, 1920, all gas undertakings are required to declare the calorific value of the gas they undertake to supply, and the local authority will test and certify that the gas, as supplied, is up to the declared standard. The consumer then pays for the heat content or *therms* in the gas he uses.

The unit of heat measurement is known as the *British Thermal Unit*. This is the amount of heat required to raise the temperature of one pound of water 1° Fahrenheit.

The calorific value of a gas is the number of these heat units in one cubic foot of the gas.

The therm is equal to 100,000 of these *British Thermal Units*. Thus, if gas has a

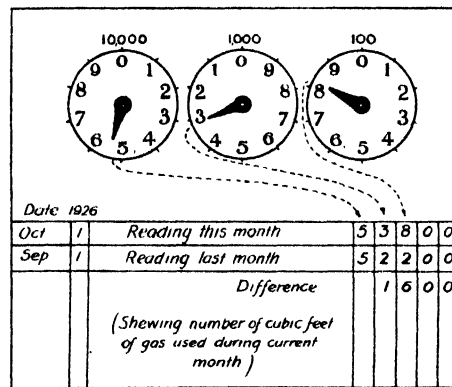

FIG. 10. HOW TO READ THE GAS METER

calorific value of 500 *British Thermal Units* per cubic foot, one therm would be contained in---

$$\frac{100,000}{500} = 200 \text{ cubic feet.}$$

Or if its calorific value were 475, then $\frac{100,000}{475}$, i.e. 210.5, cubic feet of the gas would equal one therm.

To Read a Gas Meter (see Fig. 10). Write down the figures next behind the pointers, beginning at the left-hand dial, and then add two ciphers. Whenever the hand lies between two numbers the lesser number is read. It will be noted that whereas the two outside pointers rotate in a clockwise direction, the order of the figures on the middle dial is reversed and the pointer rotates anti-clockwise.

From the number obtained in accordance with these instructions deduct the previous reading of the meter. The difference between the two represents the quantity of gas consumed in the interval.

Chapter IV—GAS AS AN ILLUMINANT

GREAT progress has been made in recent years in the design of gas lighting fittings, and there is now no difficulty in obtaining pendants and brackets to harmonize with any scheme of decoration or period of architecture.

The Bunsen Flame. Successful results from gas as an illuminant are most readily obtained if one possesses an elementary knowledge of the theory of the Bunsen flame. Gas requires for its complete combustion an admixture of four or five times its own volume of air. With the old flat-flame burner, the gas, issuing through a narrow, spreading aperture, obtained the oxygen it needed at the point of combustion, and a large area of luminous flame was obtained. The bunsen burner, however, utilizes the injecting effect of the gas issuing from a small nipple to draw in air from ports spaced radially alongside the nipple. The mixture of gas and in-drawn air then passes through a suitable tube, or *mixing chamber*, and is ignited at a nozzle, where it burns with a non-luminous flame.

Primary and Secondary Air. When gas is distributed at ordinary pressure, the force at the nipple is insufficient to draw in all the air required for combustion, and at the same time to keep the velocity of the mixture sufficiently high to prevent the mixture *lighting back*. In practice, we find that about two volumes of air per volume of gas are drawn in around the injector. This is known as *primary* air.

The remaining two volumes of air per volume of gas required to complete the combustion are obtained from the air surrounding the actual flame. This is known as *secondary* air.

High-pressure Gas. The object of high-pressure gas, or the use of air blast, is to increase the velocity of the mixture, so that the whole of the air required for complete combustion is supplied as primary air, thus ensuring a very homogeneous mixture of air and gas and a higher flame temperature combined with a smaller flame area. It is, of course, obvious that no increase of pressure, or arrangement of air supply, can alter the total amount of heat given out when a definite quantity of gas is completely burned, but it is possible to secure a more complete mixture of gas and air, and so reduce the flame area and increase the flame temperature.

The Gas Mantle. The usefulness of this increased flame temperature is apparent when we consider the physical properties of the gas mantle.

The mantle consists of a fabric which is dipped in a solution of the salts of the rare earths, cerium and thorium. These have the property of becoming very highly incandescent when raised to a high temperature; also, having reached incandescence, a very slight further rise in temperature results in a very large increase in the illumination given out from the combustion of a stated quantity of gas. Some idea of the extent to which illumination is dependent upon temperature can be gauged by the fact that an increase of 400° C. will treble the power of the illumination given out by the mantle. A special daylight mantle for colour matching purposes is also available.

Measurement of Illumination. Some standard is required for calculating intensity of illumination. The unit usually adopted is the "foot candle." A foot candle is the intensity of illumination obtaining at a distance of 1 ft. from a "standard candle." The standard candle, as defined in the Metropolitan Gas Act of 1860, was a sperm candle, six to the pound, and which consumed 120 grains of spermaceti per hour. In practice this standard candle was not found to be very satisfactory, and Mr. A. G. Vernon Harcourt, one of the Gas Referees, devised a specially constructed lamp known as "Harcourt's Pentane Lamp," burning the volatile spirit pentane, and emitting from a definite area at the base of the flame a light equal to ten standard candles.

The intensity of illumination naturally decreases as we get farther and farther from the source of light. It is found that this decrease varies with the square of the distance from the light source.

This principle is embodied in the *Law of Inverse Squares*, which states: "The illumination falling upon two equal surfaces at different distances from a light source is inversely proportional to the square of the distances of the surfaces from the source." That is to say, if the intensity of illumination at a point 1 ft. from the light source were 1 ft. candle, then at

2 ft. away it would be $\frac{1}{4}$ ft. candle, or at 3 ft. away it would be $\frac{1}{8}$ ft. candle.

Intrinsic Brilliancy. If the intrinsic brilliancy of a light exceeds a certain figure, the human eye cannot look at it without distress or injury. Intrinsic brilliancy may be defined as the candle-power emitted per square inch of effective illuminating surface. The maximum permissible brilliancy may be taken as the brightness of the light from the open sky in June or July, and this is usually equal to about 4.35 candles per square inch. The intrinsic brilliancy of artificial light sources is often much higher than this, as the following list shows—

INTRINSIC BRILLIANCY OF SOURCES OF LIGHT

	Candles per Square Inch.
Ordinary Candle	2.5
Paraffin Lamp Flame	4-9
Gas Mantle, Low Pressure, Upright	23
Gas Mantle, Low Pressure, Inverted	50
Gas Mantle, High Pressure	300
Tungsten Vacuum Electric Lamp	1,000
Tungsten Gas-filled Electric Lamp	5,250

It will be seen, therefore, that most forms of artificial illuminants, and especially all types of electric lamps, in order to avoid injury to the eyesight, should be placed well out of the line of vision, or the light diffused by means of globes or shades.

Reflection. It must be remembered that adequate illumination is not entirely dependent on the quantity of light given out by the light source, but is very largely influenced by the position of that illuminant and the manner in which it is shaded, also by the colour of the wall-paper or surrounding decorations. The power of reflection of various substances varies greatly, as may be seen from the following figures—

- White blotting paper reflects about 82 per cent of the light falling upon it.
- Deal wood reflects about 40 per cent of the light falling upon it.
- Yellow wall paper reflects about 40 per cent of the light falling upon it.
- Dark brown paper reflects about 13 per cent of the light falling upon it.

The position of lighting points requires careful consideration. It should be remembered that a central pendant position gives a better distribution of light than brackets. Where brackets are used for inverted burners the positions should be at least 6 ft. from the floor. Kitchen or scullery lights should be placed so as to give a good light into the oven and on to the sink.

Bedroom lights should be placed where they will not throw shadows on the blind. A pendant position over the dressing table is very useful.

Amount of Light Required for Different Purposes. What one considers a good or bad light depends very largely upon the purpose for which the room is to be used. Table II gives the average intensity of illumination in foot candles required for different purposes and situations.

TABLE II
AMOUNTS OF LIGHT REQUIRED

Situation	Illumination Required in Foot Candles
Art Gallery—Walls	5.0
Swimming Baths	2.0
Billiard Room (General)	1.0
Billiard Table	15.0
Church	3.0
Desk	4.0
Drawing Office	8.0
Factory (General Illumination Only, where Additional Special Lighting of Machine or Bench is Provided)	1.5
Local Bench Illumination	4.0
Complete (no Local Illumination)	4.0
Garage	2.0
Hospital—	
Corridors	0.5
Wards (with no Local Illumination Supplied)	1.5
Wards (with Local Illumination Supplied)	0.5
Operating Table	12.0
Laundry—Ironing Table	4.0
Library—Reading Room (with no Local Illumination)	4.0
Office (General)	4.0
Railway Carriage	2.0
Reading (Ordinary Print)	4.0
Reading (Fine Print)	6.0
Residences—	
Porch	0.5
Hall	1.0
Drawing Room	1.5
Sitting Room	1.5
Dining Room (General)	0.5
Dining Room (Local on Table)	4.0
Kitchen	2.0
Bedroom (General)	1.0
Dressing Table	4.0
School (Classroom)	3.0
Shop Window—Light Goods	8.0
Medium Goods	16.0
Dark Goods	20.0
Shops (Interior)—	
Light Goods	5.0
Dark Goods	10.0
Station (Railway)	2.0
Studio	4.0

Consumption of Burners. With regard to the consumption of gas for lighting purposes, there

MODERN BUILDING CONSTRUCTION

are three different sizes of inverted incandescent mantles in general use—*bijou*, *medium*, and *ordinary*. When properly adjusted, the maximum hourly consumption of these should not exceed—

Bijou . . . 2.5 cu. ft. per hour.
 Medium . . . 3.5 cu. ft. per hour.
 Ordinary . . . 4.5 cu. ft. per hour.

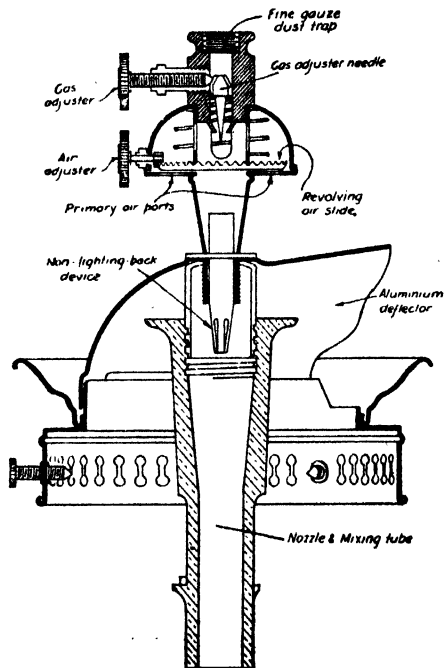

FIG. 11. SECTION THROUGH INVERTED BURNER

The Inverted Burner. Fig. 11 shows a section through an inverted burner, and is self-explanatory. The purpose of the gas and air adjusters is to ensure as perfect a mixture of gas and air as possible at the nozzle, always remembering that the larger the proportion of primary air that can be drawn in at the air ports, the hotter will be the flame and the greater the illumination from the mantle.

The use of burners with fixed gas and air nipples has been developed with outstanding success by the South Metropolitan Gas Company for use in particular on their own area. By a trinity of conditions made possible by close supervision—constant specific gravity and pressure, as well as the declared calorific value—the Metro burner, as it is called, is adaptable also to uses other than lighting. Slight adjustments due to pressure may be made by means of the tap. This Metro lighting burner has only

five main parts; a bayonet socket for the bracket or pendant, an ejector of brass fitted with dust cap, a mixing tube, corona, and nozzle. The whole burner may be taken down in a moment by a half-turn of the hand. There are no screws to manipulate even for fitting a globe, which has three lugs to correspond with slots on the underside of the corona.

Multiple Superheated Burner. This desire for a higher flame temperature has led to the adoption of the *cluster burner*. In this type a metal chamber is arranged above the burner nozzles. The products of combustion passing around this

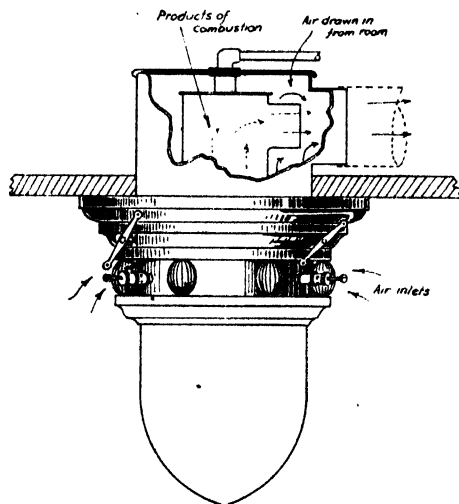

FIG. 12. VENTILATING LAMP

chamber heat the gas and air mixture before ignition. The burner nozzles are *bijou* size, and are screwed directly into the preheater. This type of burner gives a greater candle-power per cubic foot of gas than does the single mantle burner, and the life of the smaller mantle is longer than that of the larger type.

Another type of superheated burner is that in which the mixing tube is vertical with the gas and air inlets at the bottom, and the superheater at the top. This is available with the ordinary *bijou* mantle for standard and table lamps, and with larger units for office and factory lighting.

Ventilation. One of the advantages of gas as an illuminant is the assistance it renders in the ventilation of an apartment. The products of combustion, carbon-dioxide and water vapour, being at a high temperature, rise immediately to ceiling level, and owing to their high specific heat are not readily cooled. The air fouled by

the breathing of persons in the room, which would otherwise fall again to breathing level, is thus kept near the ceiling until disposed of through the usual channels of ventilation, and the air of the room is kept in gentle movement.

In order to take advantage more fully of the ventilating effect of gas burners, special lamps, Fig. 12, have been designed in which the products of combustion and the foul air from the ceiling level are removed through a duct into a brick chimney, or shaft, or into the outside air. By this means the number of air changes per

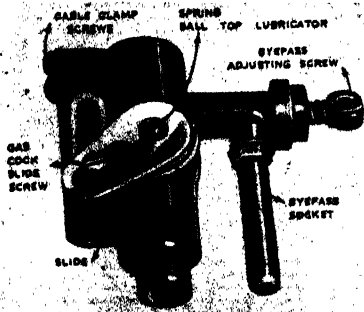

FIG. 13. GAS COCK (BY-PASS TYPE)

hour can be increased, and the ventilation of the room is effected from near the ceiling level; any possibility of the vitiated air dropping to the breathing level is thus avoided.

Globes. Much of the prejudice attributed to gas lighting by the fragile nature of globes has been counteracted by the production of heat-resisting glassware and the Vitreosil globe.

Switches. The retention of gas for lighting against competition has been considerably assisted by improvements made in the various forms of switch control. The pneumatic switch controlled through a tiny air tube is still popular, and given suitable maintenance affords a satisfactory service. The need for a continuously lighted by-pass has, however, been dispensed with by the cable-operated Newbridge lighter in which the ignition is by catalyst. A 3-volt battery inside a bakelite box fitted contiguously with the control lever provides the necessary current, and lasts under normal usage about six or eight months.

Closure of the electric circuit is part of the switching operation and preheats the filament in which catalytic action takes place when the gas comes into contact. Releasing the hand from the switch control automatically breaks the electric circuit.

A special gas cock is provided, and is ingeniously fitted with an oil well, so that dismantling of the cock is unnecessary for re-lubrication, which would under ordinary conditions require frequent attention owing to the heat to which the cock is subject. The oil used, however, has a very high resistancy to heat and does not gum.

Fig. 13 shows the gas cock, and Fig. 14 the tumbler hand control. See also Fig. 17.

Portable Units. The use of gas for domestic

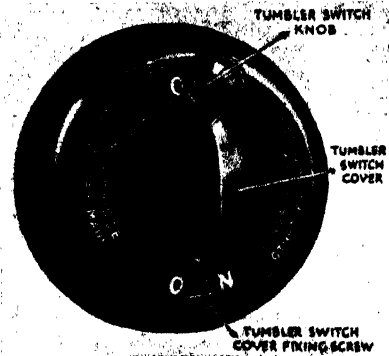

FIG. 14. TUMBLER HAND CONTROL

lighting need not be confined to brackets or pendants. By means of the plug-in tap and flexible tube, a convenient portable source of light is available in the use of table lamps or standard lamps. These are of particular value in the modern lounge where the family gather after meals, now that rooms are no longer allocated to specific uses such as sewing, etc.

The light can be moved about at will subject only to a reasonable length of tubing, say 9 ft. limit; but there is no reason why a plug-in connection should not be fitted to each side of the apartment.

By-passes. Apart from the convenience of the by-pass to small home lighting units, the principal use of this device is in connection with distance control, of which the Sugg is an outstanding example. This enables lamps to be lighted either in continuous line or disposed at intervals, each series with its own control, as is so often the need on railway platforms and in concert halls.

Briefly, the system operates by using the ordinary pressure of gas within the supply pipe. Opening of the control allows the gas to inflate a leather diaphragm fitted to the lamp and to lift the valve, the full gas supply thus reaching the mantle where it is ignited by the by-pass.

Chapter V—GAS FOR HEATING AND COOKING

SCIENCE has proved that what foreigners have been pleased to term one of our prejudices has in reality everything to recommend it. We refer to the British preference for radiant heat from open fires, and to our general dislike to the convected heat produced by what are wrongly termed radiators. The natural humidity of our atmosphere, the extreme variability of our

ants, the motive force of the ascending hot products is used to draw air from the room up the chimney, through a ventilating space alongside the flue proper.

The modern gas fire also exerts a beneficial effect on general health through the emission of short-wave infra-red rays which penetrate the skin without discomfort.

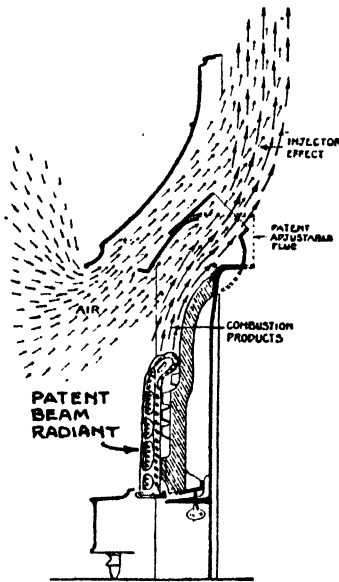

FIG. 15. INJECTOR VENTILATOR FIRE

climate, both militate against the exclusive use of central heating in private houses.

The improvement in the general standard of living and the increasing difficulty in obtaining domestic help, have led to a widespread demand for houses in which manual labour is reduced to a minimum. Architects and builders of to-day have to build for the future, and the future will demand smokeless, labour-saving, adjustable forms of heat. The modern gas fire meets this demand. Ample flue outlet is provided, not only to carry away all products of combustion, but also to ensure the necessary air change in the room.

Fig. 15 shows a section through a modern upright fuel type of fire. In addition to a flue opening extending the whole width of the radi-

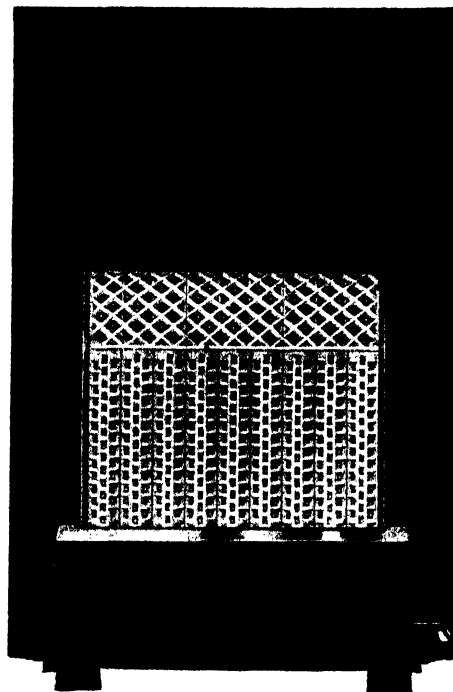

FIG. 16. HIGH BEAM GAS-FIRE

Types of Fires. Gas heaters in general may be classified into five main groups—

- (a) Independent units and inset fires.
- (b) Panel fires.
- (c) Portable fires.
- (d) Radiators.
- (e) Overhead panels.

The term "independent fire" is self-explanatory. Some modern fires are fitted with a self-lighting device. This is quite unobtrusive as will be seen by the illustration of a High Beam

fire (Fig. 16). Fires not so fitted when made can be lighted by the Newbridge lighter which is shown in Fig. 17.

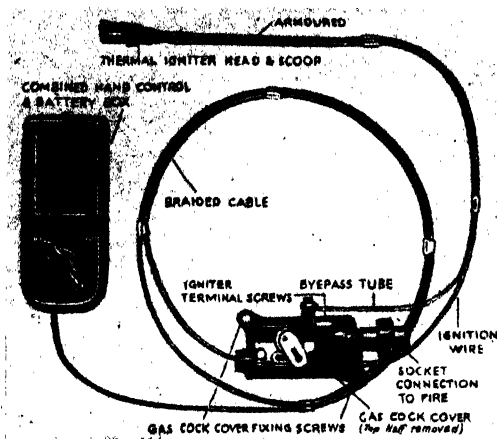

FIG. 17. THE NEWBRIDGE LIGHTER

(a) The gas mantle register is of interest to builders because it has been specially developed for housing schemes. These registers can be obtained in a variety of styles and finishes, and save the need of building up a special mantel shelf. They can, of course, be flued into either an ordinary brick flue or a special gas fire flue. Fig. 18 is a fine example of inset fire, set in mantel

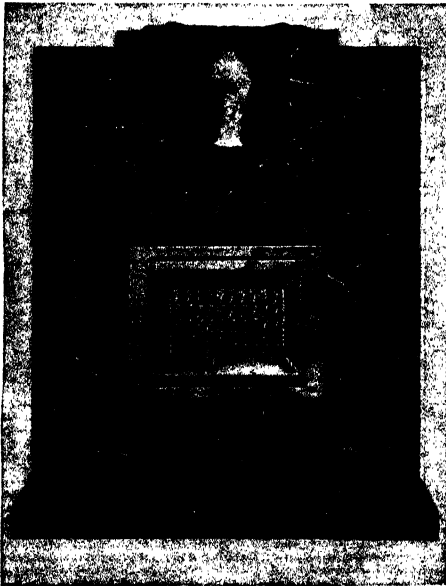

FIG. 18. MERIBLE INSET FIRE SET IN MANTEL SURROUND

surround for good-class estate work. The inset fire consists of a back brick with radiants fitted within a frame, to fix into the existing coal grate after removal of the front bars, or into a



FIG. 19. CINDERELLA FIRE

modern arched interior. It is not always necessary to remove the bottom fret of the old grate. A good example of this type of fire is shown in the Cinderella, Fig. 19.

(b) Panel fires are usually provided with plaque surrounds which are obtainable in a variety of finishes. They are generally fitted

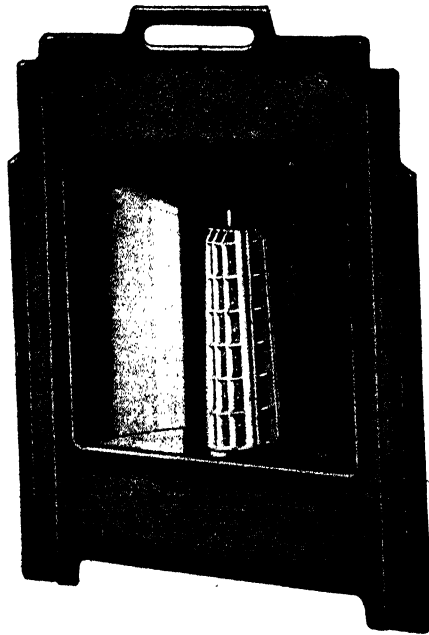

FIG. 20. PARAVEX PORTABLE HEATER

MODERN BUILDING CONSTRUCTION

above floor level, built directly into and flush with the chimney breast, or can be set directly into a wall without a breast, in conjunction with Nautilus Economy Gas Fire Flues, of which more later. Panel fires are particularly suitable for housing schemes, where it is desirable

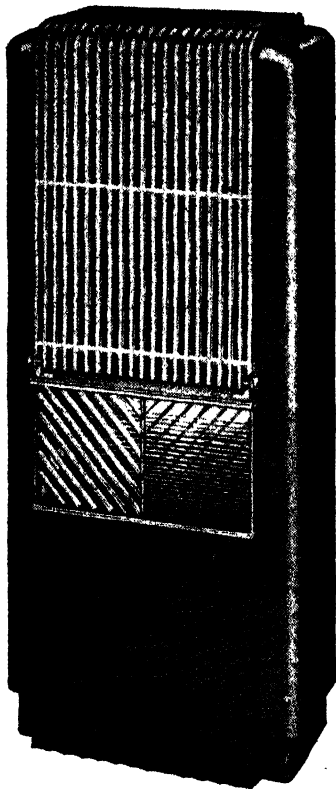

FIG. 21. LUMA GAS HEATER

to follow some special pattern of design or colour. (c) Portable fires have come into prominence in recent years to meet the demand for intermittent heating in rooms used only occasionally, for rooms without the usual chimney flue, and to avoid the need for a permanently-fitted gas fire. Some discretion is needed in their use, and it has been laid down as a general rule that no portable fire should be used where the consumption of gas would exceed 1 cu. ft. per hour per 100 cu. ft. of free air-space in a well-ventilated but chimney-less room. A good example of portable fire is the Paravex, illustrated in Fig. 20. Others are the Portcullis, Mainscreen, and Kernscreen, all of which are adaptable as fire-screens when not in use in their normal capacities. Smaller forms of portables with horizontal heating bars instead of the usual upright radiants are represented by the, Nocturne, Thermette, Zonette, etc., while the smallest of all is the simple bowl fire with single circular radiant, like the Sunglo and Raybol.

(d) The term "radiators" usually include the various types of heaters with cast-iron columns for warming halls, schools, passagés, offices, etc. These are ably served by a variety of designs, some with luminous and some with bunsen

burners. Later developments are of more pleasing appearance such as the Luma, shown in Fig. 21, or the Beacon or Ubic. Space heating, however, is so often the central heating problem, that the choice of individual radiators for smaller jobs can perhaps better be left to the individual user. The builder need not fear to put a gas point for heating into a private garage, as there are several types of safety garage radiators which have been passed by the leading insurance companies. The other method of garage heating, suitable also for greenhouse or conservatory, is the gas-heated small-circulating boiler using hot water pipes as the heating medium.

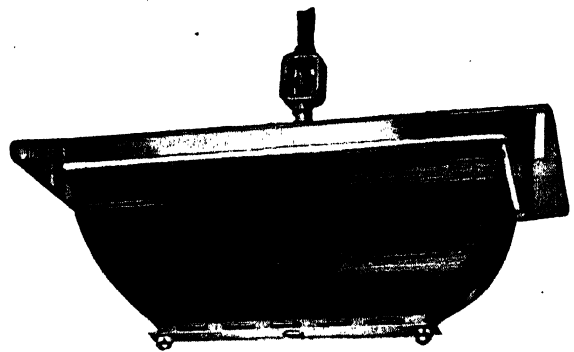

FIG. 22. PORTCULLIS WEDGE TYPE SUSPENSION HEATER

(e) For modern problems where even distribution of heat is impossible owing to the disposition of furnishings, machinery, stock, etc., an easy solution is assured by the use of overhead radiant heaters. These are available either for suspension or wall fixing, and are of various designs. There is also a garage model in this type of heater which has been passed by the Home Office and the London County Council, etc. A Portcullis wedge-type suspension heater is illustrated in Fig. 22.

Flues. It is essential that every gas fire shall be provided with a separate and efficient flue. As, however, the waste products from a gas fire are less in volume than those from a coal fire, a chimney of smaller area will suffice to take away the products of combustion and give the necessary air change in the room. Such flues, measuring 9 in. by 4½ in., can be incorporated in a building while under construction.

In building gas fire flues, the successive courses of brickwork should be set as closely together as possible, and the joints should be neatly pointed with cement or adamant. This prevents

to a large extent, the products of combustion attacking the mortar joints, and prevents sand and mortar from falling on or behind the fire. With a coal fire this rubbish would be swept away day by day with the ashes, but with a gas fire it accumulates until specially removed.

A better type of flue for use with gas fires is the Nautilus Economy Flue, which not only provides an ideal shaft for carrying away the

Fixing of Fires. Gas fires are usually provided with a cock by the makers, but when fixed another full-way union cock should be fitted to the supply. This will enable the supply to the fire to be disconnected and the fire removed at any time, without affecting the supply of gas to other apparatus. If a gas fire cock with loose key is used, it is quite easy to hide the supply to the fire under the kerb and tiled hearths, so long as this is done before the hearth is laid.

In fact, all gas fire taps should be of the safety variety, either with hinged twig, or separate loose key, so that they cannot be turned on accidentally. Some of the popularity of the

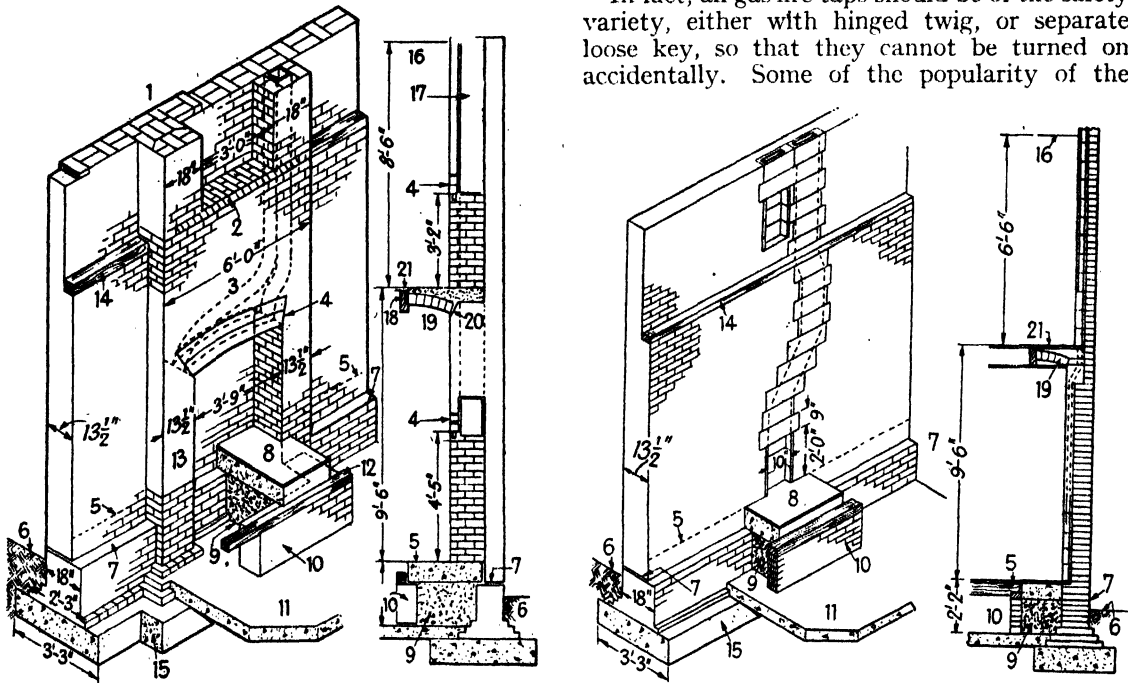

CONSTRUCTION OF BRICK FLUES AND FIREPLACES

FIG. 23.

NAUTILUS FLUES IN FIREPLACES SPECIALLY CONSTRUCTED FOR GAS FIRES

- | | | |
|--------------------------------|------------------------------------|--|
| 1. External wall. | 8. Cement floated concrete hearth. | 15. Foundation concrete. |
| 2. Skew back for trimmer arch. | 9. Hard core. | 16. Ceiling level. |
| 3. Chimney breast. | 10. Fender wall. | 17. 9 in. by 9 in. cored and pargetted flue. |
| 4. Two-ring rough brick arch. | 11. Surface concrete. | 18. Trimmer. |
| 5. Ground floor level. | 12. Wall plate. | 19. Brick trimmer arch. |
| 6. Ground level. | 13. Jamb. | 20. Skew plate. |
| 7. Damp-proof course. | 14. Wall plate. | 21. First floor level. |

products of combustion, but may be used as an ordinary means of ventilating an otherwise flueless apartment where no form of artificial heating is in use. Nautilus flues save considerable cost in brickwork, as they dispense with the usual chimney breast. The accompanying drawings (Fig. 23) show an ordinary brick breast, and a gas fire-place using these flues. Nautilus blocks are made in single units, or can be built up suitably in sets to satisfy chimney requirements of blocks of flats.

portable appliances is due to the very efficient plug-in taps now available. This innovation was introduced about 1930, and enables a small heater, ring, or lamp to be fitted as easily as an electric light lamp. The plug which is fitted to the reverse end of a length of flexible tubing, is inserted into the cock and given a half turn which opens the gas way; reversal turning off the supply again. One or two varieties are fitted with a twig tap as well for extra safety.

In fixing the inset type of fire, precautions

MODERN BUILDING CONSTRUCTION

should be taken to prevent mortar and sand falling down the chimney on to the fire. Such dirt will either fall through the fuel into the burners or drop out on to the hearth. Fig. 24 shows one way in which this can be avoided by fixing sheet iron baffles up the chimney.

Size of Fire Required. The following data, reproduced by courtesy of Radiation, Ltd., gives the approximate number of radiants required for heating rooms of different sizes—

Length of Room in Feet.	Width of Room in Feet.																											
	7	8	9	10	11	12	13	14	15	16	17	18	19	20	7	8	9	10	11	12	13	14	15	16	17	18	19	20
7	6	6	6	6	6	6	6	6	6	6	7	7	7	7	6	6	6	6	6	6	6	6	7	7	7	7	7	
8	6	6	6	6	6	6	6	6	6	6	7	7	7	7	6	6	6	6	6	6	6	6	7	7	7	7	7	
9	6	6	6	6	6	6	6	7	7	7	7	7	9	9	9	9	9	9	9	9	9	9	9	9	9	9	9	
10	6	6	6	6	6	7	7	7	7	9	9	9	9	9	9	9	9	9	9	9	9	9	9	9	9	9	9	
11	6	6	6	6	7	7	7	7	9	9	9	9	9	9	9	9	9	9	9	9	9	9	9	9	9	9	9	
12	6	6	6	7	7	7	9	9	9	9	9	9	10	10	10	10	10	10	10	10	10	10	10	10	10	10	10	
13	6	6	7	7	7	9	9	9	9	9	9	10	10	12	12	12	12	12	12	12	12	12	12	12	12	12	12	
14	6	6	7	7	9	9	9	9	9	9	9	10	10	12	12	12	12	12	12	12	12	12	12	12	12	12	12	
15	6	7	7	9	9	9	9	9	9	10	10	12	12	12	12	12	12	12	12	12	12	12	12	12	12	12	12	
16	6	7	7	9	9	9	9	10	10	12	12	12	12	12	12	12	12	12	12	12	12	12	12	12	12	12	12	
17	7	7	9	9	9	9	10	10	12	12	12	12	12	15	15	15	15	15	15	15	15	15	15	15	15	15	15	
18	7	7	9	9	9	10	10	12	12	12	12	12	15	15	15	15	15	15	15	15	15	15	15	15	15	15	15	
19	7	9	9	9	9	10	10	12	12	12	12	15	15	15	15	15	15	15	15	15	15	15	15	15	15	15	15	
20	7	9	9	9	10	10	12	12	12	12	15	15	15	15	15	15	15	15	15	15	15	15	15	15	15	15	15	
21	7	9	9	9	10	12	12	12	12	15	15	15	15	15	15	15	15	15	15	15	15	15	15	15	15	15	15	
22	9	9	9	10	10	12	12	12	15	15	15	15	15	15	15	15	15	15	15	15	15	15	15	15	15	15	15	
23	9	9	9	10	12	12	12	15	15	15	15	15	15	15	15	15	15	15	15	15	15	15	15	15	15	15	15	
24	9	9	10	10	12	12	12	15	15	15	15	15	15	15	15	15	15	15	15	15	15	15	15	15	15	15	15	
25	9	9	10	12	12	12	15	15	15	15	15	15	15	15	15	15	15	15	15	15	15	15	15	15	15	15	15	
26	9	9	10	12	12	12	15	15	15	15	15	15	15	15	15	15	15	15	15	15	15	15	15	15	15	15	15	
27	9	10	10	12	12	15	15	15	15	15	15	15	15	15	15	15	15	15	15	15	15	15	15	15	15	15	15	

IMPORTANT NOTE. The above figures refer to number of radiants and not to the width of fire in inches

These, of course, apply to average rooms. Where rooms have a cold aspect, or a large window in the north or north-east side, a fire larger than the normal will be required. A *duplex* tap, available with most large type fires, enables the whole fire to be used for heating up, and warmth is then maintained by the use of the fewer radiants.

COOKING

Very great advances in gas cooker construction have been made in recent years. In addition to its widespread use in hotels, restaurants, and institutions, it is in almost universal use in all suburban homes to-day, and proper provision should be made for it when the kitchen is planned. Numberless cookers are fixed without oven flues, and in fact work better without any direct connection to a flue, but it must be remembered that only about 30 per cent of the gas used by the average housewife is consumed by the oven burners, the top plate burners being in much more frequent use.

The correct way to fix a cooker, therefore, is under a hood or a canopy, which has a direct connection into a flue. This will carry away all smell of the actual cooking, all products of combustion, and will also keep the kitchen cool and well ventilated. If a gas-heated wash boiler is fixed, its flue can also discharge under this hood; but whatever are the cooking arrangements in the kitchen, provision should be made for general ventilation into a

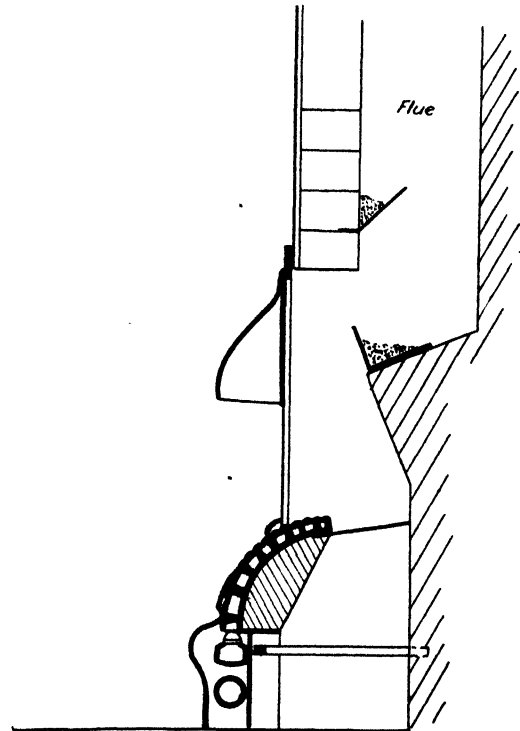

FIG. 24. CHIMNEY BAFFLES

flue with a good up-draught, and this entry into the flue should be made as near as possible to the ceiling level. Flues from cooker ovens should not be run through the wall directly to the open air, as in windy weather it is likely that gusts of air, passing down the flue, will prevent the escape of combustion products and cause smothering of the oven burners.

Where space can be spared—a length of 4 ft. 6 in. is required—the one-level type of cooker should be installed. In this the oven and hot plate are side by side, and it is not necessary to stoop down to the oven or to reach up to the hot plate.

Recent Developments. The increased use of enamelled iron, and the production of plain

castings free from grooves, or decoration, in which grease might lodge, have made the modern gas cooker much easier to clean. This is, of course, an improvement from the point of view of hygiene. Several other alterations have been made to ensure that the utmost possible proportion of the heat from the gas is usefully employed.

In many cases, the flue outlet from the oven has been transferred from the top of the oven to the bottom. There is no doubt that this ensures a very even heat throughout the whole of the oven space, and it is claimed that the device enables the heat of the oven to be maintained with a greatly reduced gas consumption, because the products of combustion do not pass out at the flue outlet at so high a temperature as was formerly the case.

Thermostatic control of oven temperature has also been quite successfully achieved. The thermostat is incorporated in the oven construction and is provided with a graduated dial, the adjustment of which to any particular setting assures that the oven will not rise above the predetermined temperature. The thermostat is set according to the nature of the food to be cooked, and may then be relied upon to maintain an unvarying temperature in the oven without further attention.

These alterations in oven construction have been accompanied with improvement in cooker hotplates. As previously mentioned, in the average household the major portion of the cooking is done, not in the oven, but on the various hotplate burners. Manufacturers have, therefore, given a very great deal of attention to this part of the cooker, and the modern hotplate may be relied upon to give an overall increase in efficiency of 12 to 15 per cent over the older types. This has been attained (*a*) by altering the construction of the bars and cornice of the hotplate, and (*b*) by improvement in the burners themselves.

The old pattern bars consisted of straight rods of cast iron or wrought iron across the cooker, and a very considerable loss of heat occurred through the flames playing on these, which heat was conducted along the bars away from where it was required. Also, in some cases, the burners were placed too near the outer cornice of the hotplate; and not only was efficiency reduced owing to the heating up of the cornice, but also the products of combustion did not get freely away from the burner, and the hottest Bunsen flame was, therefore, not properly developed.

With the new type, the bars are cut away and so arranged that the various jets of flame pass directly to the bottom of the vessel to be heated, without impinging on the metal of the bars, thus ensuring the utmost heating efficiency and

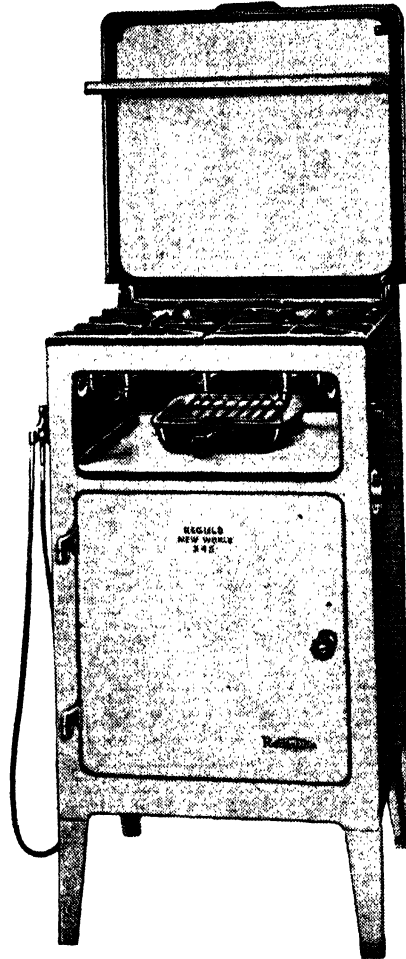

FIG. 25. NEW WORLD GAS COOKER WITH HOTPLATE

obviating the possibility of any breakage of the flame cones.

The proper and regular development of the individual flames in the burner is obtained by the even drilling of the burner at a particular angle. Where drilled burners are not employed, a special cone-spreading burner gives concentration of heat.

A modern design of gas cooker with hotplate is shown in Fig. 25.

Chapter VI—GAS FOR HEATING WATER

APPLIANCES for supplying hot water by gas may be divided into two main groups—

1. Instantaneous heaters.
2. Storage heaters.

Instantaneous Heaters. These are of the single-point type for sink or bath, and the multi-point for supplying two or three points such as sink, basin, and bath.

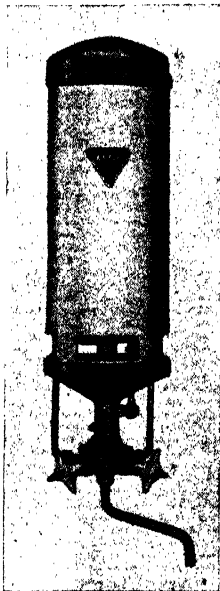

FIG. 26. "ASCOT"
SINK HEATER

The small sink heater is fitted over basin or sink, and provides a useful supply of hot water for culinary or washing-up purposes, or for supplementing the ubiquitous kettle. For positions away from the normal domestic water supplies, such as outhouse or workshop, it is ideal. The range of temperature is up to about 160° F., which is hot enough for most domestic requirements.

A typical and well-known example of sink heater is the Ascot R12/4, which is illustrated in Fig. 26. A model similar in appearance is also available for the delivery

of boiling water, which is ready within three-quarters of a minute at the rate of flow of three to three and a half pints per minute. This boiling water appliance is for household use only, and is intended for water supplies the hardness of which is not more than 13° Clark. It may also be used as an ordinary sink heater, and both types can be fitted in place of the ordinary tap, thus saving space. Neither of these models requires a flue when fitted in a well-ventilated apartment and used only intermittently.

The instantaneous heater serving two or more taps is popularly known as the multi-point, and in ordinary domestic service is connected to the three taps mostly in use, viz. sink, basin, and bath. It will in suitable circumstances supply

one or two bedroom basins as well, and can also be coupled up to and used on an ordinary hot-water system, as will be shown later.

A special sized Ascot heater, the R12/5 is provided for sink and very small bath, or two or three sinks, where in either case the receptacles are adjacent to one another, or in the case of the bath, immediately overhead.

A common tendency in some quarters is to fit the smallest appliance obtainable irrespective of its suitability either in general performance or for the particular job. This is entirely wrong, in fact reprehensible, and is bound eventually to discredit gas in particular. There is no possible excuse nowadays for fitting inefficient or wrong appliances, for apart from adequate published technical information, the gas industry has its own organizations for assisting would-be users, and gas undertakings in general are only too happy to co-operate with both builders and architects in the selection of suitable apparatus for either new buildings or conversions.

Thus, in no instance should be R12/5 be fixed to supply a normal sized bath. Its capacity is limited to 1 and 1½ gal. of water per minute raised 50° and 40° respectively, whereas the normal bath requires at least 2 gal. delivered per minute if the water is not to be cold by the time a sufficient quantity has been run off. This R12/5 model is especially suited to the small self-contained flatlet with a combined kitchenette and bathroom with sit-up bath.

A single-point machine for bath only is also made by Ascot, in which the spout can be swivelled over the basin when this is fitted directly alongside the bath.

All these appliances are fitted with a safety device, which shuts off the main gas supply if for any reason the pilot jet is extinguished.

The efficiency of most gas-heated hot-water appliances in use is very largely dependent on their being properly fixed, and in this the flue outlet plays an important part. Those already mentioned have the baffle incorporated as a part of the machine. The principal function of the baffle is to divert downdraught away from the interior of the heater. If this is not done, this downdraught would probably seriously interfere with the process of combustion. This

baffle completes the primary flue. The function of the secondary flue is to discharge the products of combustion into the open air. Some considerations of this problem are given in the next section on Geysers.

The following notes to builders are extracted from *Notes Relating to the Physics and Chemistry of Heating Water by Gas-fired Appliances*, published by Ascot Gas Water Heaters, Ltd.

It has been brought to our notice that our customers are not always conversant with the special principles involved in the fitting of Ascot appliances in blocks of flats. In addition to normal requirements, the following considerations apply to multi-point gas-water heaters—

1. (a) *Water Supply.* The best method is to run independent water supplies to each heater from a tank. A common tank may be used to supply each vertical block, providing that it is of sufficient capacity.

(b) If it is not possible to run separate down services, a single-down service should be run from the tank to the top floor in $1\frac{1}{4}$ in. pipe, with 1 in. branches to the heater. From the top floor to the remaining floors in 1 in. pipe, with $\frac{3}{4}$ in. branches to the heaters.

(c) A common rising main should in no circumstances be used, but if a sufficient head of water is not available on the top floor, the heater on that floor may be supplied from a $\frac{3}{4}$ in. separate main supply, the other heaters being supplied from a tank. (Subject to the requirements of the local water authority.)

2. *Flue Installation.* Each vertical block of heaters should be connected to separate flue of the correct size, which should be constructed either of (a) brick, or (b) asbestos cement (rectangular sections are usually more convenient if built-in flues are used). The sizes for such flues may be obtained from the Technical Department of Ascot Gas Water Heaters, Ltd., if the following details are available—

(a) Type of heater.

(b) The vertical height of each main flue.

(c) The material in which the flue is to be constructed.

NOTE. "Nautilus" flue blocks are not recommended for use with gas-water heaters.

Geysers. For single-point operation the machine known by the public as the geyser is still popular and available in many makes. For the domestic bath the closed type is the best; in this the water does not come into contact with the products of combustion. Two types are listed, the Locking-gear and the Automatic-valve. The former is usually supplied when the water supply is from a tank, while the latter is necessary if the cold supply is directly from the main. In the locking gear the water tap crosses the gas tap at or near right angles, preventing the gas tap from being opened until water is running through the geyser. Correct placing of these taps is ensured by a milled edge on the water control by means of which wear can be taken up. See Fig. 27. In the automatic-valve

type the gas supply is controlled by the pressure of water, so that if for any reason the latter fails, the gas supply is shut down to by-pass level.

As the bath geyser uses gas at a relatively high rate a flue is essential, and as incorrect fixing of a flue may seriously affect the efficient working of the appliance, a few notes on flues will not be inappropriate.

1. See that all secondary flue, i.e. between baffle and atmosphere, is not smaller than the baffle outlet.

2. Keep as much flue pipe inside the building as possible.

3. Use imperishable material, such as compressed asbestos.

4. Finish with a terminal even if inside a loft space.

5. Carry outside flue at least 18 in. above the guttering, but if terminating on the outside wall is the only alternative, use a ventilator-type cowl.

6. On no account use an open cowl in which birds can build. Suitable terminals for all purposes are available.

7. Provision can be made for brick flues to be included in the design of a new building when it is known that gas water heaters are to be installed.

8. When gas heaters are fued into existing brick chimneys care should be taken not to insert the flue spigot too far, lest interference be caused to the passage of the products of combustion.

9. Do not use a flue into which *any* other products of combustion are carried.

Connecting Multi-point to Hot-water System.

As already indicated, a multi-point heater can be connected to an ordinary domestic hot-water system with the usual flow and return pipes. Its use in this connection should be as an alternative to the solid fuel, and not merely to supplement it. Connections should be made as in Fig. 28, which shows the system heated only by the solid fuel boiler, and then with the gas heater added. A water control valve is fitted at a suitable point to isolate one appliance when the other system is being used.

Storage Heaters. Storage heaters are of two

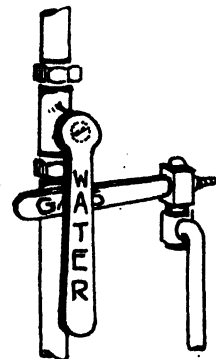

FIG. 27. HOT WATER GEYSER LOCKING-GEAR

MODERN BUILDING CONSTRUCTION

types. Those connected directly to a system of hot water circulating pipes, and those supplying a single point. The former may be used either separately or in conjunction with a coal- or coke-heated boiler.

The apparatus is connected directly to the hot-water storage by the flow and return pipes. These should, if possible, be independent of any

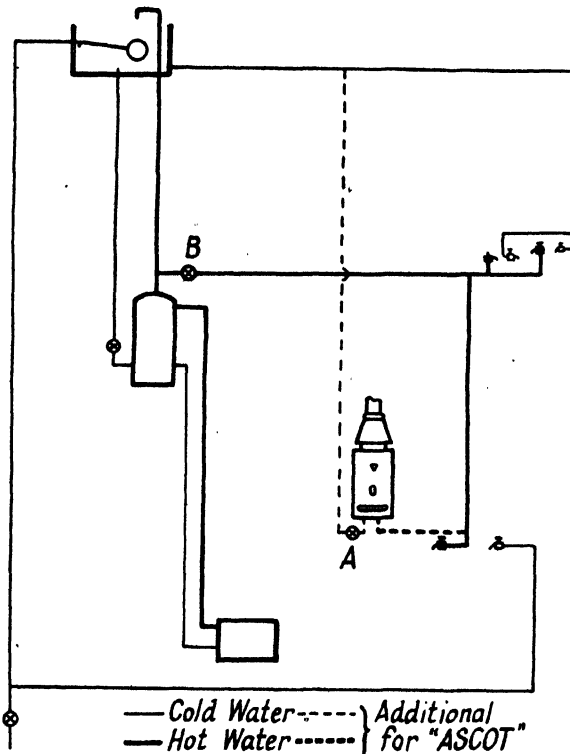

FIG. 28. DIAGRAM SHOWING INSTALLATION OF MULTI-POINT GAS WATER HEATER AS AN ALTERNATIVE TO A BOILER SYSTEM

flow and return pipes between the hot-water tank and the coal or coke boiler, although, if necessary, connection may be made into these with Y-shaped tees. The object of independent circulation pipes is to avoid all possibility of inter-circulation between the solid fuel-heated and the gas-heated boiler.

The circulator is constructed either of cast iron or copper, and the best pattern for any particular district depends very largely on the degree of hardness, or corrosive action, of the local water supply.

These boilers must, of course, be fitted with a flue pipe, and as they are usually fixed in place of, or alongside, a solid fuel boiler, the flue may

be conveniently run into a chimney. To prevent the possibility of either sudden puffs of down-draught or excessive pull affecting the burner flames, it is best to provide some break in the flue; and this may be very neatly done by the use of the "Bentee" fitting (Fig. 29).

These circulators, of which the Potterton "Empire" and Radiation "B.T.U." are typical examples, will provide ample supplies of very hot water for bathing or washing-down purposes. Cases, however, arise where it is desirable to have at hand small quantities of heated water available at all times, or at particular times during the day. Example, a hairdressing saloon with two or three basins in use at the same time. Each basin requires a limited quantity of hot water which can be cheaply and conveniently provided by the combined cylinder-circulator type of gas water heater. Of these the Sunhot and Equator are typical examples. By suitable lagging the water stored is kept hot by a relatively small quantity of gas. All these heaters are fitted with thermostatic control, which shuts down the main supply of gas when the water reaches a predetermined temperature.

The single-point storage heater, also thermostatically controlled, is made in sizes ranging from two to about twenty gallons, and takes correspondingly more time to provide hot water, the smallest delivering it in rather less than an hour. It is automatically fed by cold water after hot is drawn off. Ascots make a special storage heater of one and a half gallons for hairdressing establishments, and provide this heater with a three-way cock, twin hoses, and shampoo roses for use with two basins.

Gas Wash Boiler. No mention of water heating by gas would be complete unless reference

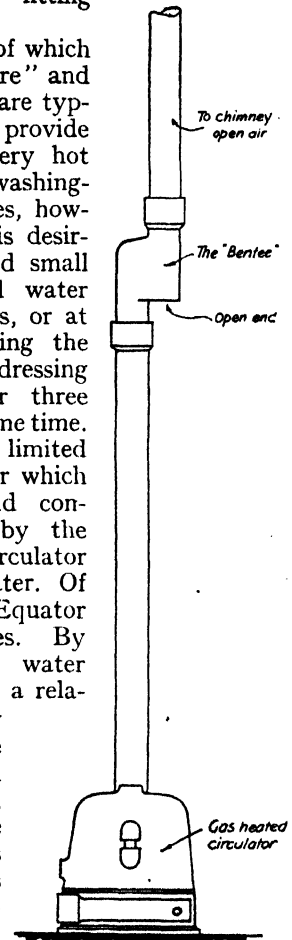

FIG. 29. THE "BENTEE"

were made to the gas-heated wash boiler. There is probably no field where the advantages of gaseous over solid fuel are so patent. The copper is not an apparatus which is in regular daily use, and so the difference in fuel cost is extremely small. It is chiefly used for laundry purposes, and any contact between wet clothes and smuts, ashes or stoking, is most objectionable, while the adjustability of the heat of the gas-heated copper is also a great advantage.

Where a $\frac{3}{4}$ in. gas supply pipe has been run to the cooker, as advised in a previous lesson, it is a simple matter to tee off a $\frac{1}{2}$ in. supply to the wash boiler. One point should be borne in mind—a flue from the apparatus is essential.

All good types of boilers are made so that one flue outlet takes away both the steam and the products of combustion. The flue can be led away under a hood, as with a cooker, or to an existing chimney. If neither of these methods is possible, a flue pipe, arranged as in Fig. 30, will usually be found quite satisfactory.

It has been found that the mixture of steam and hot products of combustion has a corrosive effect on metal flues, and it is best to use asbestos cement or earthenware flue pipe.

It should be remembered that the fatigue of washing is very considerably reduced if the work is carried out in a pure atmosphere. Much of the weariness resulting from the old-fashioned washing day can be traced to working in a hot, steam-laden atmosphere.

The advent of the gas-heated washing machine calls for rather more space; it is recommended, therefore, that architects might give some attention to this point.

Gas-heated Apparatus for Warming Buildings.

In large towns and cities where space is valuable and rents high, the provision of a boiler house and fuel store is often a matter of great difficulty. It must also be remembered that disposal of ashes is not at all easy, and in many places the work of loading these up, as well as the delivery of new fuel, often has to be carried out in the early morning, so that labour costs frequently work out higher than would at first seem likely. In such cases a town's gas has proved an ideal fuel. Central heating is so much farther developed in America than in this country that it is only natural that greater progress has been

made there with the newer type of fuel, and gas-heated boilers for supplying hot water to radiators throughout the building are in common use. The use of the gas-heated boiler is rapidly becoming recognized in this country, and many very successful plants are now being installed.

For this purpose, a battery of two or more gas-heated circulators, or a boiler of the Rex

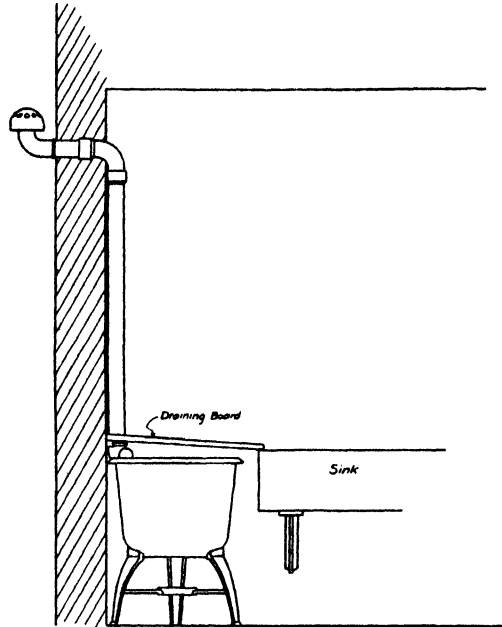

FIG. 30. FLUE FROM WASH BOILER

type, will prove most convenient for private dwellings and suites of offices. Where there is no resident caretaker, the boiler may be lighted up by means of a special clock control before the hour the premises are opened. The ease by which temperature can be controlled with gaseous fuel adds greatly to the general comfort of the offices, and results in economy in heating.

General Use of Gas. So many and varied are the uses for which gas-heated hot-water appliances are now available that the builder should in all cases satisfy himself that nothing has been left undone to cater for the job he has in hand by this most versatile commodity. It is even used for heating up the water in public bath and slipper-bath installations.

Electrical Fitting

By F. CHARLES RAPHAEL, M.I.E.E., M.Cons.E., F.I.E.S.

Chapter I—UNITS AND LAYOUTS

Introductory. Electrical fitting is specialists' work, both as regards specification and execution. For new buildings it may fall to the province of the architect and builder, but the practice is growing of employing a consulting electrical engineer to draw up the specification, let the contract, and see the work through. Similarly, the contract for the work may be let to the builder, who in turn may employ his own wireman or arrange a sub-contract with an electrical contractor. In any case, however, it is highly desirable that the architect and builder should have more than a superficial knowledge of the principles of electrical work and the manner in which it is carried out in practice.

Buildings may, of course, be in towns and urban districts in which electrical supply is available, or they may be at some considerable distance from electric lighting mains, involving the necessity of the erection of plant to generate the electric current required. The general principles and practice upon which the wiring of the building are based are the same in both cases. The wire and cable employed is insulated to prevent leakage of current, and in house installations its quality is decided chiefly by the question of durability. For a cable which, in addition to enjoying a good life, has to withstand a certain amount of handling and bending about in erection, it is not possible to go below a certain thickness of insulation, and consequently the standard sizes are the same for all pressures up to the usual supply pressures of the electric lighting mains for electric light distribution.

It is true that when we get to accessories, such as switches, lamp holders, plugs, and fuses, a lower degree of protection would be adequate for the lower pressures than the higher ones; but, as the material required for lighting installations connected to public supply mains represents the bulk of that which is manufactured, and only a comparatively small proportion is used for installations supplied by low-pressure private plants, it is not worth while having a

separate set of standards for the latter, and it is only in the case of a few particular pieces of apparatus and accessories that cheaper material can be used.

UNITS

Pressure. The first of these terms is electrical *pressure*, sometimes called *voltage*, or *difference of potential*. The volt is the unit of electrical pressure, and, if the installation is connected to the public lighting mains, there is a certain definite *declared pressure* for which all the apparatus must be suitable. The standard voltages for lighting from the public supply mains in this country vary in different districts; a standard of 230 volts has been adopted for the most part, but other voltages are still in use to a certain extent, the commonest being 200, 220, 240, and 250. Higher voltages are used for motors above a certain size. On private electric lighting plants, however, pressures as low as 25 volts are used for very small installations, and, for larger ones, 50 volts or 100 volts and upwards. It is of the utmost importance to quote the voltage when ordering electric lamps or other apparatus. A lamp intended to burn at 230 volts will give a poor light at 200 volts, while if put on a 240 or 250 volt supply would give more than its normal light and would burn out after a comparatively short life. Similarly, an electric fire employed at a lower pressure than that for which it is designed will give insufficient heat, while if it is supplied at a higher pressure the heating elements will burn out very quickly, as they will be run at a higher temperature than they should be.

Current. The unit of electric *current* is the *ampere*. If a number of volts is supplied to any piece of apparatus, a certain number of amperes will flow through it, and the maximum number of amperes required for the whole building is obtained by adding together the number of amperes required by every piece of apparatus that is in use simultaneously.

Power. The foregoing two terms are comparatively simple, but now we get to a little more complication, namely, the conception of electric *power*. It is obvious that if a machine is driven by an electric motor, a certain amount of electric power must be required to drive it. Just in the same way, electric power is required to light a lamp or heat an electric fire, this amount depending on the amount of light or heat produced. Electric power is measured in *watts*, and this term represents the product of the volts and amperes; that is, if you know the pressure and know the number of amperes the apparatus or group of apparatus will take, you multiply these two numbers together to get the number of watts of power taken. To put this in symbols, if V is the number of volts, A the number of amperes, and W the number of watts, then

$$W = V \times A$$

This may be put in another way, namely,

$$A = \frac{W}{V}$$

In other words, if you know the watts required and divide this by the pressure in volts, the result gives you the current required in amperes.

This rule can be taken to apply generally to electric lighting by most of the ordinary filament lamps, electric fires, cookers, irons and other sundry accessories used in houses. In works wiring, when motor circuits have to be considered, it does not always apply, as will be seen later.

Electric lamps are nowadays rated according to their wattage. There are 15-watt lamps, 25-watt lamps, 40-watt lamps, 60-watt lamps, 75-watt lamps, 100-watt lamps, and so on. The current taken by a 60-watt lamp at 230 volts pressure will, therefore, be 60 divided by 230, namely, 26 ampere (just over a quarter of an ampere). If there are a hundred 60-watt lamps in the building, the total current required when all the lamps are on will thus be 26 amperes, and the service cable supplying the building must, therefore, be strong enough to carry this current.

THE KILOWATT. There is another unit of power, namely, the *kilowatt*, the usual abbreviation for which is kW. This is 1,000 watts. This unit comes in very usefully for larger pieces of apparatus. A very common size of ordinary domestic electric fire is 2 kW., that is to say, 2,000 watts. If the voltage is 230, every such electric fire will require 8.7 amperes. If the

voltage is 200, you must divide 2,000 by 200 instead of by 230, and the current required by the fire will then be greater, namely, 10 amperes.

HORSE-POWER. The size of motors, on the other hand, is usually given in h.p., namely, the actual power which they will develop, which is somewhat less than the power that has to be put into them. The ratio between the power put in and the power given out is known as the *efficiency* of the motor. If, for instance, a motor has 90 per cent efficiency, this means that 10 per cent of the electric power put into it is used up in the heat developed by the windings, friction of the bearings, etc., and the balance of 90 per cent only is available for running the machine which the motor drives. To ascertain the watts required by a motor, one must multiply by the number 746, as 746 watts are equivalent to a h.p., and then one must make allowance for the efficiency of the machine. Suppose, for instance, a 5 h.p. motor is required for a mortar-mixing machine used in building operations, and that, when working at full load, the efficiency of this motor is 85 per cent. The actual watts to be put into the motor at full load will be

$$\frac{5 \times 746 \times 100}{85}$$

that is, about 4,400 or 4.4 kW. The division by 85, and multiplication by 100, makes allowance for the efficiency of the motor being only 85 per cent.

Voltage of Supply. *A.C. Single-phase and 3-phase.* The voltage of the supply has already been mentioned. In the majority of districts there is an *alternating current* (a.c.) supply at this voltage. For lamps and the various domestic appliances, this supply is what is known as *single-phase* a.c., but for motors of 5 h.p. and upwards it is found more economical to furnish a *3-phase* supply, when three cables will be led to each motor and the corresponding voltage between any two cables (called the *voltage between phases*) will be 400. The service cable brought into the building will then have four copper conductors, the fourth being known as the *neutral*, and the voltage between each *phase conductor* and the neutral (for lighting and small appliances) will be 230. On systems for 240 volts lighting pressure, the voltage between phases will be 415 instead of 400; and for 200 volts lighting pressure the voltage on the *3-phase* cable between phase wires will be 346.

In a factory, for instance, in which the

MODERN BUILDING CONSTRUCTION

supply is given at 400/230 volts, motors would be ordered for 400 volts 3-phase and connected to the three phase wires, while the lamps would be connected between a phase-wire and the neutral at 230 volts.

To calculate the current required by a 3-phase motor, the following formula is used—

$$\text{Current (amperes)} = \frac{\text{Kilowatts} \times 577}{\text{Voltage between phases} \times \text{Power Factor}}$$

The power factor is a property inherent in the motor and also dependent on the proportion of full-load it is carrying. In practice, an average figure may be taken as .85 for the full-load power factor if these particulars are not available.

In calculating the current required by a single-phase motor, the watts as given by the formula on p. 815 would be used, and the total would be divided by the voltage to be applied to the motor and by the power factor.

D.C. Motors. With these no correction for power factor is necessary, and the current is obtained by dividing the watts (as given by the formula on p. 815) by the voltage.

LIGHTING LAY-OUTS

Positions of Lights. We now turn to the most important matter of all in the electric lighting of a building, namely, the position of the lamps and switches. It is a remarkable fact that one of the most difficult things with which an electrical engineer has to contend is to obtain precise instructions as to where the lamps are to go. Most clients cannot bring themselves to come to a decision as to this on the plans for the position of the lights must depend to a large extent on the position of the furniture. Yet, in new buildings electric light wiring should be buried in the walls or between the floors and ceilings, for the sake of appearance. Some cutting away for them can usually be saved if the tubes for the wires are put in before the walls, partition, and floors are completed. In any case, the tubes must be in place before plastering.

Thus, the position of the lights and switches should be marked out on the plan at as early a stage as possible, and the man primarily responsible for the installation, be he a consulting electrical engineer, the architect, builder, or electrical contractor, should do this. It is his affair to see that the lighting is good, and he must therefore be capable of setting out the

correct positions of the lamps, and indicating the sizes of these and the character of the most suitable fittings. Needless to say, the client will have a say in the matter, but the selection of the positions and fittings should not be left entirely to him, as is only too frequently done.

The light in the hall should be placed in front of and not over the centre of the staircase, and the illumination of the hall and stairs should be less than that of the rooms, or the latter will appear dull in contrast.

The dining-room should have a light over the centre of the table. In a large dining-room, a bracket or a pair of brackets may be required in addition over the sideboard or carving table. If a dining-room is to be used as the regular "living room," wall sockets should be provided on the skirting board, to enable floor standards to be plugged in near the armchairs for reading.

In drawing-rooms, good central lighting from fittings hung from the ceilings is usually the best, but no hard and fast rule can be given. Brackets are decorative, but there are few rooms in which good illumination can be afforded by brackets alone.

The proper place for the light in a bedroom is over the dressing table, half-way between the mirror and the person using it. If a second light is required, it should be over the head of the bed.

Writing tables are best lighted by pendant lights, a foot or two to the left of the centre of the table.

In bathrooms, well-glass fittings should be used, fixed on the ceiling, and the switch should be outside the door, not in the room itself.

The main light in the kitchen should be as close to the front of the cooking range as possible, not in the centre of the room behind the cook. A bracket or tube pendant, ending in a well-glass fitting, may be provided over the sink in the scullery.

Size of Lamps. The size to give to the lamps is a matter of experience, and depends very much on whether the decoration and furniture of a room is light or dark. From the light-reflecting point of view, purple, red, and brown wallpapers can always be considered dark, as must also green and blue, unless they are pale. White, cream, yellow, and the lighter greys give the best reflection. As a rough guide, an allowance of one watt per square foot of floor area gives a good light in a brightly decorated room.

If the colours in the room are dark, or the light from the lamps obscured with coloured shades or absorbent glass fittings, twice this allowance may be necessary. Another thing to remember is that the lighter the decoration of the room, the fewer is the number of lighting points that are required irrespective of the total wattage. Light colours are a cheerful form of economy.

Other Electrical Appliances. Wall sockets and plugs (now termed socket-outlet points) should be provided not only for use with occa-

drawing room or lounge the socket-outlets for points for lighting are controlled by switches at the door, and there is a separate socket for the wireless set. A bracket light with reflector at first floor level lights the garden and is controlled by a switch near the french window in the lounge.

Notwithstanding the small size of the scullery, room was found for an electrical refrigerator, served by a socket-outlet in the corner, and an electric cooker. The 2-way switches for the

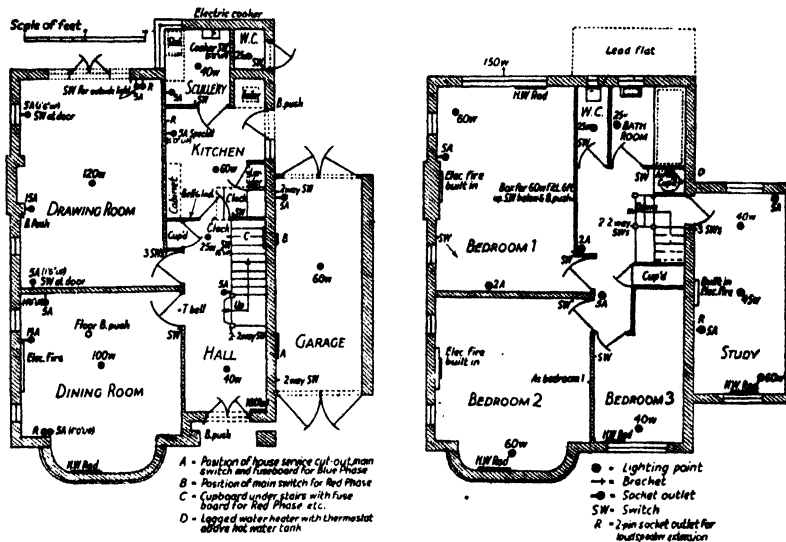

FIG. 1. LAYOUT IN A DETACHED HOUSE

sional portable lamps in the living rooms, but also for other appliances, such as electric fires, kettles, irons, vacuum cleaner, refrigerator, etc. In modern building construction there should be at least one such socket-outlet point in every room, in the larger rooms 2, 3 or even more may be required. Especially in small houses, however, the practice is growing of using built-in electric fires. The electric cooker should be controlled by a suitable cooker control unit, not by an ordinary socket-outlet.

A TYPICAL LAYOUT

(Fig. 1) shows the lay-out in a fairly small modern private house, in which there is central heating with auxiliary electric heating. The lighting lay-out is more or less on the lines already indicated. The two socket outlets in the dining room are for a reading lamp and electric plate warmer respectively. In the

hall and landing lighting are recessed in the newel posts; the 2-amp. socket on the landing is for a bronze fitting on a pedestal controlled by the stair switches, and the 2-amp. socket in the large bedroom is for a reflector lamp over the wardrobe, controlled by a wall switch.

Other Buildings. Details of the electrical layout in other buildings varies considerably, and lighting by means of fluorescent lamps may involve special arrangements. Schools should have four lights in each classroom of average size together with at least one socket-outlet in each. Retail shops constitute a special problem, and a high degree of lighting is particularly necessary if there is insufficient daylight; window-lighting should be by top lights with reflectors out of view of the window gazers. In office buildings and flats, the stairs and corridors must be lighted from an independent circuit.

Chapter II—METHODS OF WIRING

Wiring in Steel Conduit. By far the greater part of electric wiring in buildings is drawn into steel conduit. Whenever possible this conduit is erected out of sight, between the ceiling and the floor above, and behind the plastering of the walls. On the top floor, if there is a loft space the conduit is laid there; if, however, there is a cement or asphalted flat above the



FIG. 2. NORMAL BEND

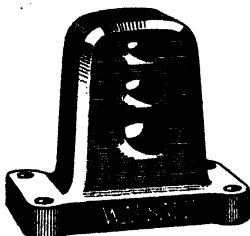

FIG. 3. CONDUIT BENDER

top floor, the conduit together with the necessary outlet boxes is laid on the shuttering before the cement is poured. The same process is frequently followed on other floors in ferro-concrete buildings; but with wood-joint floors the conduit for the points in the room below is fixed on the joists themselves, and when crossing joists these are nicked just sufficiently to keep the tubing and couplings clear of the floor boards above. In walls the small thicknesses of the plaster now used frequently make it necessary to cut away a shallow chase in the brick or partition material behind to ensure that the conduits and couplers are well-covered. In post-war construction, however, it is probable that prefabricated building material will be largely used for new construction on mass-produced lines, and that channels may be left for the reception of the wiring, particularly for the down-drop to the switch at the side of the door architrave.

Screwed Conduit. In the best practice, heavy-gauge screwed conduit is used. The conduit is a steel tube, *enamelled inside and out*, the function of the enamel being not to afford an electrically insulating coating, but to protect the conduit itself from rust and corrosion. It is essential, therefore, that the material be properly handled, both in packing

and on the job itself. Gas-piping is no longer used for electrical work; the gauges of electrical conduit are different and the threads are different. The sizes go by external, not by internal, diameter as in the case of gas-piping, and the thickness of metal is less. The conduit usually specified is heavy-gauge welded, that is to say, it has a longitudinal welded seam. Solid-drawn conduit, being more expensive, is now seldom employed except for specially high-class work.

The smallest size of electrical conduit is $\frac{1}{2}$ in., which in the case of heavy-gauge conduit has an internal diameter of $\cdot388$ in. This, however, will only take two cables of the smallest size employed for house wiring. It will be seen in a subsequent chapter that the usual method of wiring in conduit involves the running of three cables to the majority of the lighting points and switches, so in practice wiring firms prefer to employ $\frac{3}{8}$ in. conduit as the minimum standard size. The next size of conduit is $\frac{3}{4}$ in., and the sizes increase by $\frac{1}{4}$ in. up to $1\frac{1}{2}$ in., and then in $\frac{1}{2}$ in. steps to $2\frac{1}{2}$ in. As an alternative to the enamelled conduit, galvanized conduit is sometimes employed. Experience shows that there is no advantage in employing this for sunk



FIG. 4. SCREWED COUPLER

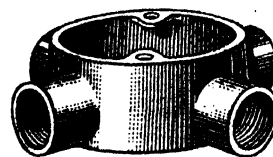

FIG. 5. FOUR-WAY BOX

work, but for exposed work in damp places it may be preferred.

In all cases the tubing is made in lengths of from 10 ft. to 15 ft. If longer lengths of straight run are required, screwed couplers, as shown in Fig. 4, are used. The thread employed for conduit is finer than for gas, but is standardized. British Standards Institution standard (B.S.I.) thread should always be specified, so that standard conduit stocks and dies may be employed. Conduit is delivered threaded both ends, and when lengths have to be shortened,

they may easily be cut with a hack-saw and, after being filed smooth, threaded with a die.

Bends must be "easy," for in all cases the conduit has to be erected first, and the cables drawn into it after the walls and ceilings are finished. Fig. 2 shows the shape of a manufactured normal bend into which conduit is screwed; the radius is about $2\frac{1}{2}$ times the diameter of the conduit. In practice, however, it is more usual to bend the conduit itself on

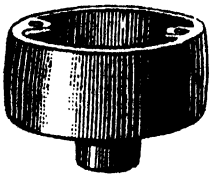

FIG. 6. BACK ENTRY
TERMINAL BOX

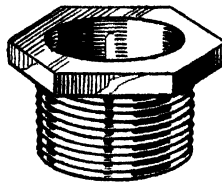

FIG. 7. SMOOTH-BORE
HEXAGON BUSH

the job, and the bends should not be sharper than this; the larger the radius of the bend, the easier will be the "draw" of the cable. The simplest bending machine is a piece of 3 in. \times 3 in. timber with a hole drilled in it, through which the conduit is passed, but for neater and quicker work a bender shown in Fig. 3 is utilized. This is of cast-iron and has separate shaped holes for three sizes of conduit. Where extremely accurate or repetition work is required, more elaborate bending machines are available.

CONDUIT BOXES. Boxes must be used behind every switch and fitting, and are also employed as draw-boxes on long runs or if there are several turns. Generally speaking, there should not be more than two bends between boxes, but a third is admissible if it is not in the same plane as the other two. On the other hand, two bends may be awkward to draw through if they are close together in the middle of a long run.

Fig. 5 shows one type of box which may be employed for bends and as a draw-in box. The one shown is 4-way, but in addition there are standard 3-way (tee), 2-way through, 2-way right angle, and also single-way, or terminal boxes, all of similar design. For back entry behind fittings, a box such as that shown in Fig. 6 may be employed. There is another type of box, different from that illustrated, which has clearance holes instead of screwed sockets to take the conduit; a coupler (Fig. 4) is then screwed on the end of the conduit and brought close up against the hole in the box, through which a threaded male hexagon bush (Fig. 7)

is passed and tightened up to bring the socket-end tight against the box. Such boxes are usually employed if two or more conduits have to enter from the back.

Where sunk switches and socket-outlets (wall sockets and plugs) are to go, a different pattern of box is usually employed (see Chapter IV). On sunk work, boxes must be recessed into the wall so that the edge will come just behind the finished surface. If the box is to be used only as a draw-box without any fitting or accessory over it, an overlapping cover is used as in Fig. 8.

The screwed joint, whether between two lengths of conduit and a coupler, or between a conduit and a box or fitting, must be dry without oil or red lead, for electrical as well as mechanical continuity is essential, and red lead, or an oily surface, presents a resistance to the passage of an electric current. When it is essential, however, to have the joints absolutely water-tight, red-lead and tow joints screwed up very tight have been successfully used; but if this method is employed, it is necessary to make a test for electrical continuity with an instrument made for the purpose, before the conduit is covered up.

SURFACE WORK. Heavy-gauge screwed conduit is also used for the best quality surface work. For this a silver-grey finish is obtainable in place of the black-enamel finish; it takes paint more easily, but is more liable to rust

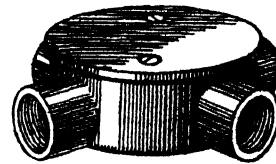

FIG. 8. CIRCULAR DRAW-BOX WITH OVERLAPPING
COVER FOR SUNK WORK

inside. In painting black-enamelled conduit it is advisable to treat the surface with knotting before applying the first coat of paint.

GRIP FITTINGS. To save the cost of screwed conduit, and also to enable a lighter gauge to be employed, some firms use *grip* fittings instead of screwed fittings. There are many varieties of these grip fittings, none of which, however, can be regarded as absolutely water-tight, although they are frequently used on competitive sunk work. One of the numerous forms is shown in Fig. 9. The lighter gauge conduit, most frequently employed with grip fittings, is

MODERN BUILDING CONSTRUCTION

known as *close joint* conduit. It has a longitudinal seam, the edges of which butt closely together but are not brazed, or welded. In early practice, this type of conduit was much employed with couplings and other fittings simply slipped over it without any grip contact. This is no longer permissible under the wiring regulations enforced by the authorities, and is, in point of fact, bad practice and dangerous; for it is absolutely essential, as a precaution against shock and fire, that the conduit throughout its length, including all bends and fittings, must be electrically continuous. In employing the grip fittings of the lug pattern, the ends of the conduit must, therefore, be scraped clean of enamel where they are gripped by the fitting.

FIXING CONDUIT. Conduit is fixed in much the same way as other pipes, by means of *clips*, *crampets*, or *saddles*. In ordering these, however, they should be specified for the size of *electrical*

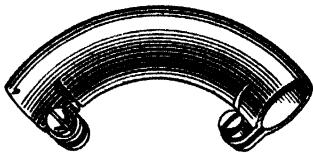

FIG. 9. NORMAL BEND WITH LUG PATTERN GRIP

conduit required, as those for gas and water piping will not fit. Clips of the pattern requiring only one screw fixing to the wall save labour. When surface work is carried out in hospitals, schools, and other public buildings, it is quite usual to specify a clearance between the conduit and the finished surface of the walls. *Spacing saddles* must then be employed.

Cable. Before describing other systems of wiring, a brief description of the cable employed for conduit work will be useful. The smallest size of cable allowable is that containing a single wire, .044 in. diameter. The cable has this wire as a centre, and over this a layer of insulation. Over this is a continuous braiding impregnated in wax—usually red, or black. The wire itself is of copper, which, if the insulator is vulcanized rubber, has been tinned to resist the action of any sulphur that may exude from the rubber in the vulcanizing process. Larger cables have a conductor formed of 3, 7, 19, or 37, etc., wires twisted together into a strand, as a wire of large diameter is not sufficiently flexible to permit its being easily drawn into conduit.

Table I gives the size and carrying capacity of some of the more usual sizes of conductors.

TABLE I
CABLE SIZES AND CURRENT-CARRYING CAPACITIES

No. and Dia. of Wires (in.)	Nominal Sectional Area of Conductors (sq. in.)	Maximum Carrying Capacity (amperes)	
		Normal Rating	War-emergency Rating
1/.044	.0015	5	5
3/.029	.002	5	10
3/.036	.003	10	15
7/.029	.005	15	20
7/.036	.007	20	35
7/.044	.010	38	45
7/.052	.0145	45	54
7/.064	.0225	56	67
19/.044	.030	65	78
19/.052	.040	78	93
19/.064	.060	102	122

The current ratings in the table apply to vulcanized rubber insulation and to such other insulations as P.V.C. (a plastic preparation of polyvinyl chloride) which may be used as substitutes. The ratings given also assume that not more than four cables up to 7/.029 in. or two cables of larger size are carried in the same conduit. If more are carried, the ratings have to be decreased and wiring tables should be consulted. Table II below gives the wiring capacity of steel conduits of various sizes.

TABLE II
WIRING CAPACITY OF STEEL CONDUITS

Size of Cable	Conduit for 2 Cables		Conduit for 3 Cables		Conduit for 4 Cables		Conduit for 5 Cables		Conduit for 6 Cables	
	S.	B.	S.	B.	S.	B.	S.	B.	S.	B.
1/.044 in.	in.	in.	in.	in.	in.	in.	in.	in.	in.	in.
3/.029 in.	in.	in.	in.	in.	in.	in.	in.	in.	in.	in.
3/.036 in.	in.	in.	in.	in.	in.	in.	in.	in.	in.	in.
7/.029 in.	in.	in.	in.	in.	in.	in.	in.	in.	in.	in.
7/.036 in.	in.	in.	in.	in.	in.	in.	in.	in.	in.	in.
7/.044 in.	in.	in.	in.	in.	in.	in.	in.	in.	in.	in.
7/.052 in.	in.	in.	in.	in.	in.	in.	in.	in.	in.	in.
7/.064 in.	in.	in.	in.	in.	in.	in.	in.	in.	in.	in.
19/.044 in.	in.	in.	in.	in.	in.	in.	in.	in.	in.	in.
19/.052 in.	in.	in.	in.	in.	in.	in.	in.	in.	in.	in.
19/.064 in.	in.	in.	in.	in.	in.	in.	in.	in.	in.	in.
19/.085 in.	in.	in.	in.	in.	in.	in.	in.	in.	in.	in.
37/.072 in.	in.	in.	in.	in.	in.	in.	in.	in.	in.	in.

The columns S relate only to straight runs in which the distance between draw-in boxes does not exceed 14 ft. If there are bends or longer runs, the sizes in the columns B must be selected.

The method of calculating the current which has to be carried by the cable has been explained in Chapter I. It must be mentioned, however, that for long runs of cable, it is often necessary

to employ a larger size of wire than that indicated by the current-carrying capacity table, to prevent an undue drop of pressure when the maximum current is being employed. The method of calculating the drop of pressure will be explained in a later chapter.

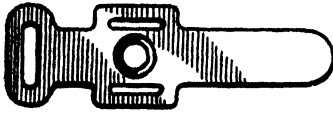

FIG. 10. BUCKLE FIXING CLIPS

Lead-covered Cable. Wiring, by means of lead-covered cable, has become a favourite method for competitive work; and although not being so well protected from mechanical damage as conduit wiring, it will nevertheless make a good sound job if properly carried out. Its main disadvantage is that it is so easy and simple that it is too frequently entrusted to inexperienced hands.

The cable employed is insulated with vulcanized rubber, or P.V.C., and covered with a

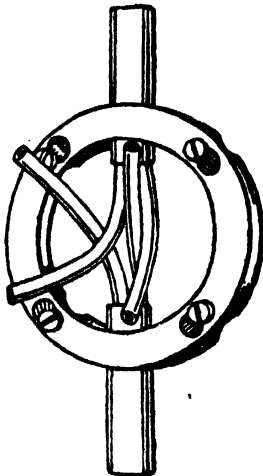

FIG. 11. UNIVERSAL BONDING CLAMP

close sheathing of lead alloyed with a small proportion of tin or other metal, to stiffen it slightly and to overcome sagging between supports. It may be fastened on the surface of walls by means of saddles, or special clips—the latter being made so that only one line of fixings is necessary. Fig. 10 shows one form of these clips. In running the cable, it may follow the angle between the wall and the ceiling, or be fixed above the picture rail, and the downward drop to the switches can be brought

close up to the architrave of the door, so as to be unobtrusive. There is also no objection to laying the horizontal parts of the runs under wooden floors, either between the joists, or, where it crosses them, threaded through small holes, or laid in notches cut in the joists of sufficient depth to ensure that the floor boards do not bear on them. It may often be "fished" down in lath and plaster partitions, and if buried in new work can be laid under the plaster, provided that the plaster employed is

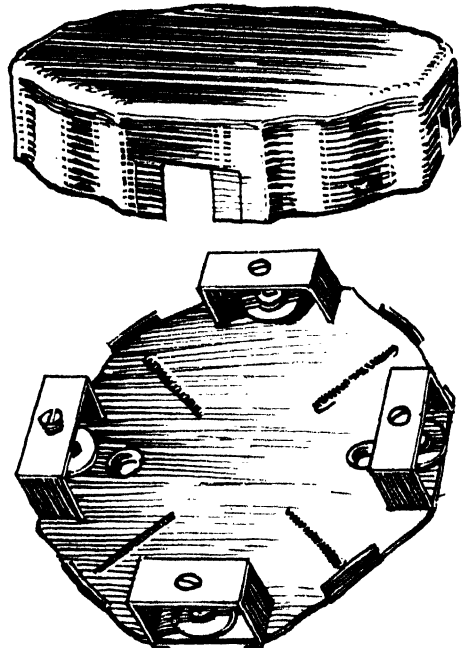

FIG. 12. C.R. PATTERN JUNCTION BOX

not one of those varieties which act chemically on lead. The chief risk is danger of the cable being pierced by nails, when pictures and fixtures are subsequently put up. Lead-covered cable may be bent round a fairly short radius without damage, but, of course, a sharp right angle bend will damage the sheathing. A safe guide, in determining the sharpness of bends and turns, is that the sheathing must not be crinkled on the inner side of the bend. The cable must not be hammered to straighten it, or to get it in position, but light tapping with a hammer, or mallet, with a block of wood intervening between it and the cable will not damage it. Kinks are to be carefully avoided, as the cable suffers damage when they are straightened out.

MODERN BUILDING CONSTRUCTION

With lead-covered work, as with conduit, *bonding* and *earthing* are essential, that is to say, there must be complete metallic connection of the lead sheathing right through, and the end of the sheathing must be connected to earth (a water-main, or an earth-plate, *not* a gas pipe) at its lower end. Therefore, at every fitting, or accessory, or junction box, or fuseboard, to



FIG. 13. DETAIL OF SINGLE- AND DOUBLE-BONDING CLAMPS

which more than one cable enters, devices are provided to make a good firm contact between the lead sheaths of the cables.

Although wood blocks are being used less and less on conduit work, they form a convenient method of mounting switches and fuses in lead-covering wiring. Fig. 11 is a bonding clamp to go behind a wood block; the cables are clamped between the two tinned brass rings. Fig. 12 illustrates a junction box for lead-covered wiring, and Fig. 13 shows the details of its bonding clamp. "Twin flat" cable is used mostly, the two insulated conductors being under the same lead sheath; and, as an alternative to bonding the lead sheath itself and to facilitate earth continuity at accessories and fittings, some prefer a similar cable containing an additional uninsulated wire in it for earthing.

Earth Clips. For earthing the conduit or cable sheathing at its lower end, special earth clips are employed. One of these is clipped round the water pipe (which must first be cleaned) and the other round the end of the conduit or cable sheathing; the two clips are connected together with copper wire or cable, at least half the sectional area of the largest electric cable on the job, and in any case not smaller than 7/029 in. This wire must be protected from corrosion. Somewhat similar clips are employed for connecting the sheathing of the lead-covered cables together at distribution boards if wooden fuseboards are used.

T.R.S. Wiring. "T.R.S." cable, that is cable covered with a sheathing of tough rubber (formerly known as C.T.S. cab-tyre-sheathing), is particularly useful in places where there would otherwise be a danger of attack by acid, or fumes, or other chemical action. It is possible that P.V.C. sheathed cable will take its place in future practice.

Impregnated Paper Insulation. Lead-covered cable is employed for street mains and services, and also finds application for main runs in large buildings. The insulation of these cables is impregnated paper instead of india-rubber. In the manufacturing process, the conductors, after being covered with a sufficient thickness of paper, have a protecting tube of lead pressed over them to make them watertight, and are usually armoured with steel tape or galvanized steel wires as a further mechanical protection. For such cables, the current-carrying capacities are greater than for rubber-insulated cables in the larger sizes (7/036 in. and upwards), but the smaller sizes offer no advantage over the rubber cables because the ends have to be specially protected. Considerable economy can result, however, by their use between the main distribution board and sub-fuseboards in large buildings wired in accordance with Fig. 25, Chapter III, and the cables are more durable than V.I.R. cables in conduit. End boxes filled with compound are used to prevent moisture being absorbed into the cable ends.

Recent Developments. Serious shortage of india-rubber during the war intensified research in the manufacture of substitutes. One of these, a preparation of polyvinyl chloride (P.V.C.), has been used for cables by Government departments and in wiring buildings. Its insulation is sufficiently high, it will withstand the action of moisture, oil, and acid better than india-rubber, and it is believed that it will last longer. It is not so flexible, however, and becomes soft at very high temperatures. If, therefore, sharp bends are left in it where it is subject to heat, where led into a lampholder for instance, the insulation may "creep" and leave the conductor bare. If installed with care, however, it makes a very satisfactory job.

In temporary houses, V.I.R. cable is being used without the protection of conduit or lead covering. The cable is laid in recesses provided in the prefabricated building, and is frequently supplied cut off to the exact lengths required and sometimes actually already connected up to the lampholders and switches.

Yet another development is the "extended bus-bar system" for factories in which the ultimate position of the machines is uncertain or liable to change. A similar method is being applied for the plug points in domestic premises, a ring circuit being carried round each room and socket-outlets with "line tap" terminals connected up to it (see pp. 823 and 832).

Chapter III—CIRCUITS

HAVING decided upon the positions which the lighting points and switches are to occupy, and having selected the method of wiring to be adopted, the next thing to do is to arrange the electrical circuits.

In this connection, electric lighting is to be considered on an entirely different basis from gas lighting. In piping for gas, a pipe is run up from the meter, and branches, or tapings, are taken off from various points to the gas burners required. A similar method was originally adopted for electric lighting, two cables being taken up from the meter and other cables tapped off to the various lighting points, one of the wires to the lamp being interrupted at some point of its route for the insertion of a switch. This method was known as the *Tree system*. The branching cables were soldered on to the main cables, and at each branch, that is, wherever the sectional area of the conductor was reduced, a *fuse* was inserted which would melt if excessive current passed through the branch owing to damage or any other cause. This Tree system, with soldered T-joints and fuses dotted all over the place, is now quite obsolete and is no longer permitted. There is a risk of danger from joints the insulation of which has deteriorated owing to age; the fuses are not sufficient protection against damage at the joints themselves; and the use of a number of fuses placed indiscriminately in the building, instead of being collected together at one or two definite places is, to say the least, inconvenient and unsightly.

Latterly, however, it has been made permissible in particular cases to tap off from a larger conductor through a fuse, but this must be done with mechanical connectors placed in easily accessible boxes or, in the case of plug and socket connections (socket outlets) for small appliances, through fuses in the plug tops.

Electrical Resistance. Before going farther the object of the fuse may be explained. If a cable carries too large a current, the conductor will heat and damage the installation, or it may even melt. In the first chapter an explanation was given of the use of the units volt and ampere, for pressure and current, respectively, and it was explained how the current can be

calculated from the known wattage. We have now to speak of another term, namely, electrical resistance, the unit of which is the *Ohm*.

Every conductor possesses a definite resistance, depending on the material of which it is made, proportional to the length of the conductor, and inversely proportional to the sectional area. Thus copper wire, or cable,

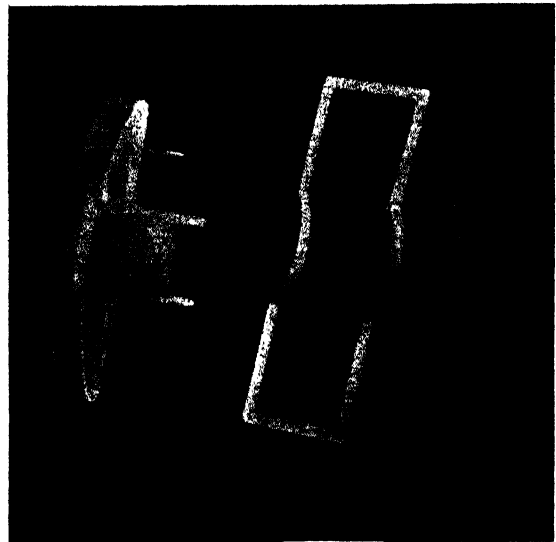

(Wm. White and Co.)

FIG. 14. FUSE CARRIER AND BASE

5 yd. long will have five times the resistance of a wire of the same size 1 yd. long, and if we look up in Table III (page 829) the number of ohms resistance per 1,000 yd. of a cable of given size, we have merely to divide by 1,000 to obtain its resistance per yard. Again, if we have two cables of the same length, but one of them twice the sectional area of the other, say, for instance, one .003 sq. in. and the other .0015 sq. in., the cable of larger sectional area will have half the electrical resistance of the smaller cable.

To give an actual example, the 1/044 in. cable referred to on page 820, Chapter II, which has a sectional area of .0015 sq. in., has a resistance of approximately 16 ohms per 1,000 yd.; and the 3/036 in. cable, which has a sectional area of .003 sq. in., has a resistance of about

MODERN BUILDING CONSTRUCTION

8 ohms per 1,000 yd. The intermediate size, 3/029 in., with its sectional area of .002 sq. in., has one-and-a-half times the resistance of the 3/036 in. cable, as the ratio of the sectional areas is 2 to 3, and its resistance is therefore about 12 ohms per 1,000 yd.

Fuses. The filament of an electric lamp possesses a very high electrical resistance, and consequently very small current passes through it; it only requires .26 of an ampere to light a 60 watt lamp with a supply voltage of 230. On the other hand, if the lamp were removed and

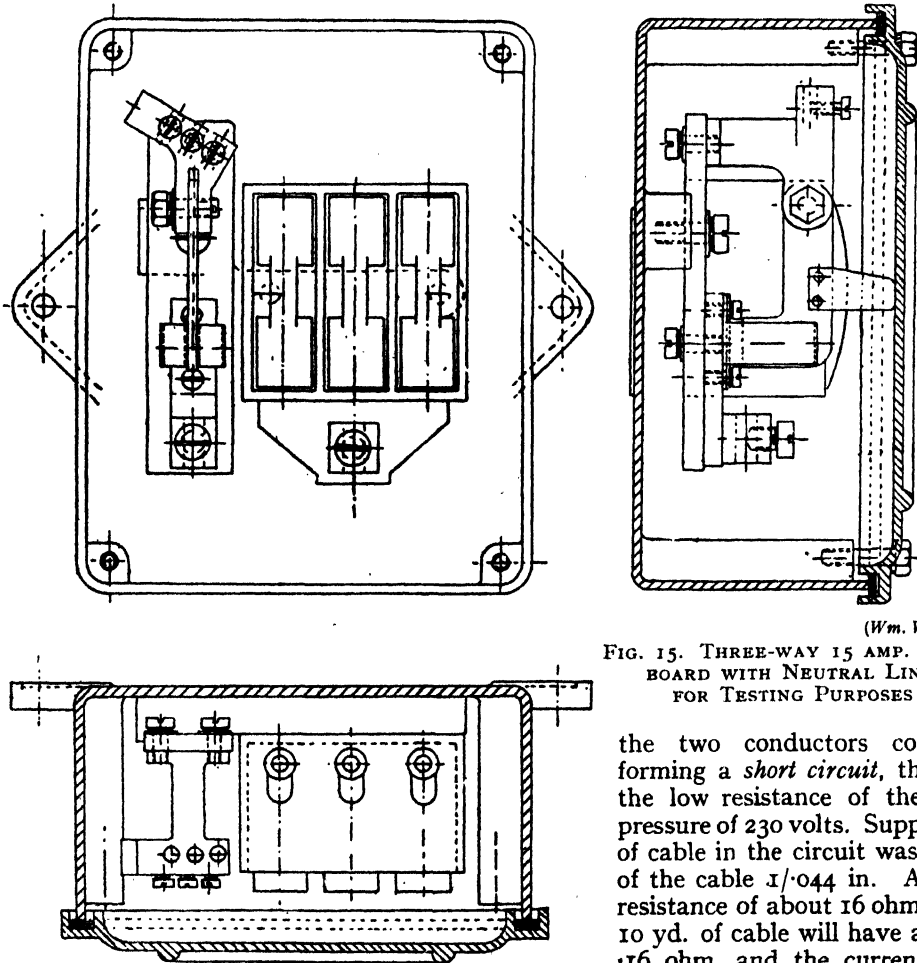

(Wm. White & Co.)

FIG. 15. THREE-WAY 15 AMP. FUSE-BOARD WITH NEUTRAL LINK FOR TESTING PURPOSES

As will be expected, there is a definite relation between the electrical pressure, the resistance of the conductor, and the current passing through it. This relation, which is very simple, is known as *Ohm's Law*. The current forced through the conductor is given by dividing the pressure by the resistance of the conductor. Thus if V be the pressure in volts, and R the resistance of the conductor, then

$$C = \frac{V}{R}$$

the two conductors connected together, forming a *short circuit*, there would only be the low resistance of the cable across the pressure of 230 volts. Suppose the total length of cable in the circuit was 10 yd. and the size of the cable 1/044 in. As 1/044 in. has a resistance of about 16 ohms per 1,000 yd., the 10 yd. of cable will have a resistance of only .16 ohm, and the current that would pass on the short circuit being made would be 230 volts divided by .16 ohm, that is, 1,437 amperes. The maximum safe carrying capacity of a cable of this size is only 6 amperes, and it would melt with a bang and a flash. Such a short circuit might occur accidentally, instead of intentionally for the purposes of the experiment described above (which my readers are recommended *not* to perform for obvious reasons), and consequently some form of protection to the cable is necessary which will prevent too large a current passing through it.

This protection is given in the form of a *fuse wire*, which is a thin wire of tin, lead, lead-tin alloy, silver or tinned copper, which will melt before the current carried by the cable exceeds a really dangerous limit. In practice the size of the fuse wire is selected so that it melts at 1.4 to 1.7 times the normal carrying capacity of

One of the many types of these fuses is shown in Fig. 14, and Fig. 15 is an illustration of a three-way *fuseboard*, in which three such fuses are placed in one box with a "neutral" busbar for connection to the other pole of the circuit. Such a fuseboard is sometimes called a *distribution board*.

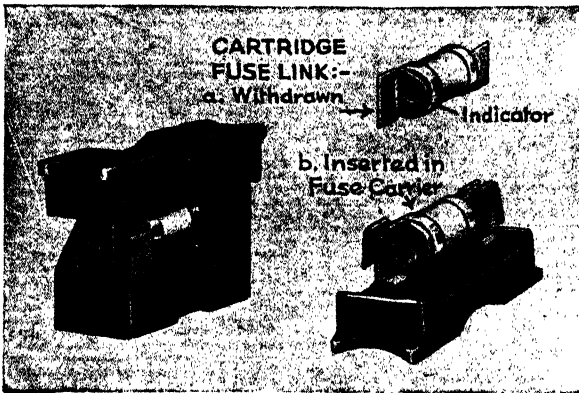

FIG. 16. ENGLISH ELECTRIC CARTRIDGE FUSE

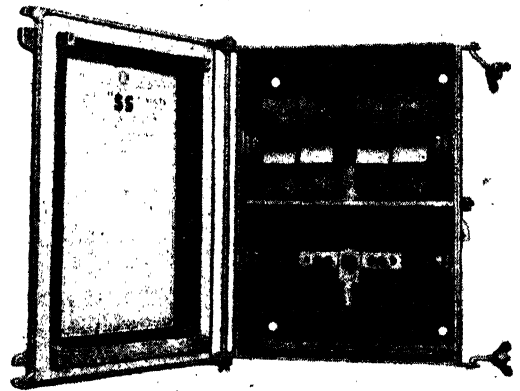

FIG. 16A. ENGLISH ELECTRIC 4-POLE S.P. FUSEBOARD WITH NEUTRAL BUS-BAR

the smallest cable, or "flex," on the circuit which it protects, but no fuse wire smaller than that with a nominal carrying capacity of 3 amperes need be employed.

The following sizes conform with this rule—

Current-carrying Capacity of Smallest Cable (amperes)	Gauge and Material of Fuse Wire
1 to 3	23 S.W.G. tin-lead alloy*
4 to 5	21 S.W.G. tin-lead alloy
6 to 8½	30 S.W.G. tinned copper
8½ to 10	29 S.W.G. tinned copper
10 to 15	25 S.W.G. tinned copper
15 to 17	24 S.W.G. tinned copper
17 to 20	23 S.W.G. tinned copper

* 63 per cent tin, 87 per cent lead.

The fuse wire is held in a porcelain carrier which fits into contact clips. The term "fuse" usually implies the complete combination of the fuse wire, carrier, and the base with its contact clips; and the arrangement is so designed that no spluttering of metal outside the fuse carrier occurs when the fuse wire melts, and that there is no danger of one's fingers making contact with the clips when the carrier is taken out for replacement of the fuse wire.

Another type of fuse which is growing in popularity is a "cartridge" fuse (Fig. 16) in which the fuse wire is contained in a cylindrical cardboard case in which it is surrounded by a fine powder. In these the whole cartridge has to be replaced when renewing the fuse, and not merely the wire inside. It is in these fuses that

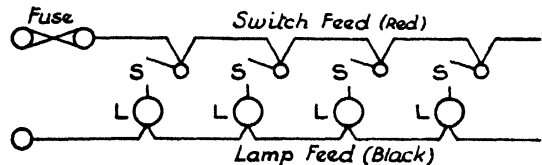

FIG. 17. LOOPING-OUT

silver wire is frequently employed to prevent oxidation so as to prolong its life.

Looping-out. Fig. 17 shows how the lamps are connected up to the fuse, by the method of "looping-out" which is now invariably employed. In the figure, four lamps with their switches are shown; and, in practice, this method may be continued up to ten lamps, although it is usual to stop at eight to allow provision for future additions. It will be noticed that the switches are all connected to one wire, called the *switch-feed*, or sometimes the *red wire*, as a red-braided cable should always be employed

MODERN BUILDING CONSTRUCTION

to distinguish it from the *lamp-feed*, which should have a black braiding. Fig. 18 shows the arrangement in detail, as it is done in the case of a pendant lamp from a ceiling rose. The red cable, i.e. the one to which the switches are connected, must be the one taken from the fuse. Fig. 19 is an alternative arrangement.

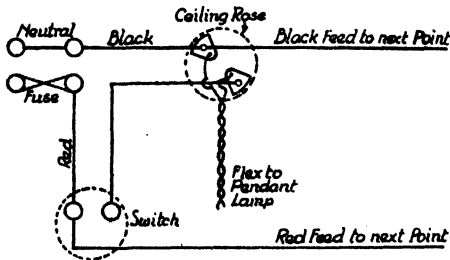

FIG. 18. LOOPING-OUT FROM SWITCH AND CEILING ROSE

sometimes preferred, employing a *three-plate* ceiling rose, and thus requiring only two wires, instead of three, to be brought out to the switch.

This method, or that shown in Fig. 20, is the one usually adopted with twin lead-covered wiring. In the latter arrangement, a junction box is employed similar to those described in a previous chapter, and this is usually preferred for surface work, as only one twin cable need be brought to each lamp and switch.

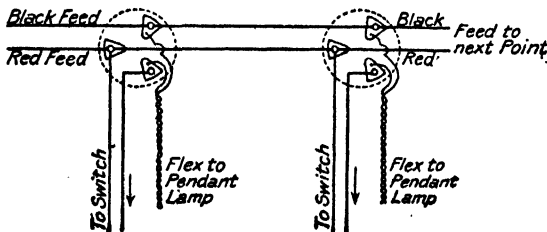

FIG. 19. LOOPING OUT FROM THREE-PLATE CEILING ROSE

One type of connector employed in such a box is illustrated in Fig. 21, which is full size. It is a porcelain block which is sometimes rectangular in shape, with a loose barrel-type D-section brass connector inside it. An alternative pattern is shrouded in moulded insulating material.

Circuits and Sub-circuits. When an installation consists of no more than eight or ten lamps, we now know what to do. The circuit is

arranged as in the diagrams given, and this has to be connected to the supply. The supply authority provides and fixes what is known

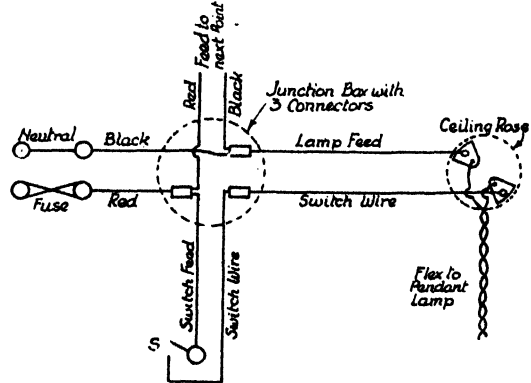

FIG. 20. LOOPING-OUT WITH JUNCTION BOX AND TWIN WIRING

as a "house service cut-out" or sealed fuse which consists of a fuse to which the switch-feed terminal is connected and a copper link (detachable for testing purposes) for the lamp feed or "neutral" side. A meter is included in the connection. The circuit is, however, not connected directly to the house service cut-out and meter, as the consumer's contractor has to fit a double-pole main switch with a fuse on the side to which the switch-feed (red wire) is connected. This connection is shown diagrammatically in Fig. 22 in which, however, the meter connection is omitted to simplify the diagram. It will be seen that one pole is marked "earthed side" and the other "live side."

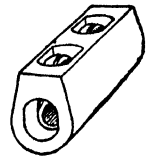

FIG. 21. PORCELAIN CONNECTOR

The "earthed" side is connected to the lamp-

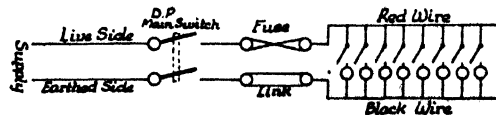

FIG. 22. CIRCUIT OF EIGHT LAMPS WITH MAIN SWITCH AND FUSE

feed, and is the pole of the supply that is connected to an earthplate at the supply station. It must not, however, be earthed on the consumer's premises.

When the installation is larger than eight or ten lamps a distribution board is employed, and separate circuits of not more than eight or

ten lamps each are taken from it as shown in Fig. 23.

For larger installations, it is often economical to employ sub-boards connected as shown in

Figs. 26 and 27 illustrate two patterns of main switch and fuse for the position shown for these in the various diagrams. Fig. 28 has a D.P. switch with a replaceable wire fuse in a

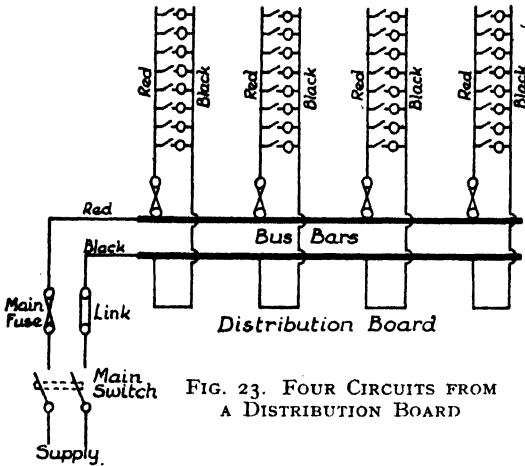

FIG. 23. FOUR CIRCUITS FROM A DISTRIBUTION BOARD

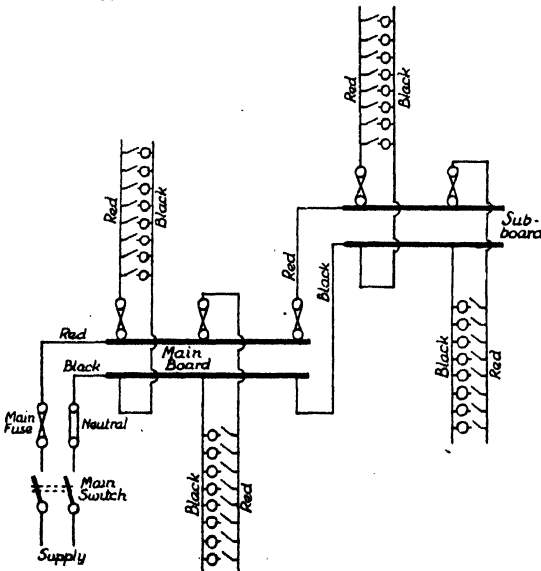

FIG. 24. SUB-BOARD FED FROM A PAIR OF FUSES ON MAIN BOARD

Fig. 24, as the extra cost of the sub-board may be less than bringing each circuit back to the main board. This method may be extended further by connecting another distribution board as "sub" to the sub-board, through a fuse on the latter, and so on from floor to floor in a large building. Another arrangement, preferable for very large installations, is shown in Fig. 25.

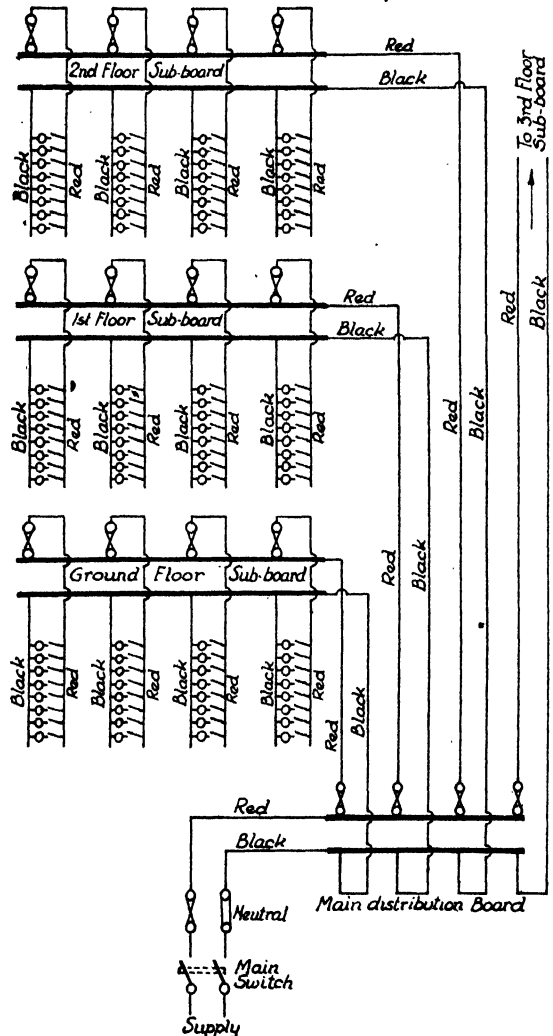

FIG. 25. DISTRIBUTION BOARD WITH SUB-BOARDS ON EVERY FLOOR

porcelain carrier for the live main, and a solid link for the neutral, and in Fig. 29, known as a fuse-switch, the fuse and neutral link are themselves carried on the movable arm of the switch.

For still larger installations and those in which there are three-phase motors, a "three-phase four-wire" supply is usually provided (see Chapter I, p. 815). The main switch is then triple-pole

MODERN BUILDING CONSTRUCTION

with an additional neutral link. The fuseboards supplying the lighting are connected between one phase-wire and neutral, a different phase wire being used in each section of the building if the lighting load is so large that it has to be balanced, the three-phase motors being connected to a triple-pole fuseboard. Alternatively, the latter may be fed with four cables, the fourth, which may be of smaller size than

on a staircase or a long corridor, or in a small bedroom where one lamp only is employed, which it should be possible to switch on or off either near the door or from the bed, *two-way* switches with three terminals are employed. Fig. 28 gives the connections for new work, and Fig. 29 an alternative method to use when ordinary switching has to be converted to two-way.

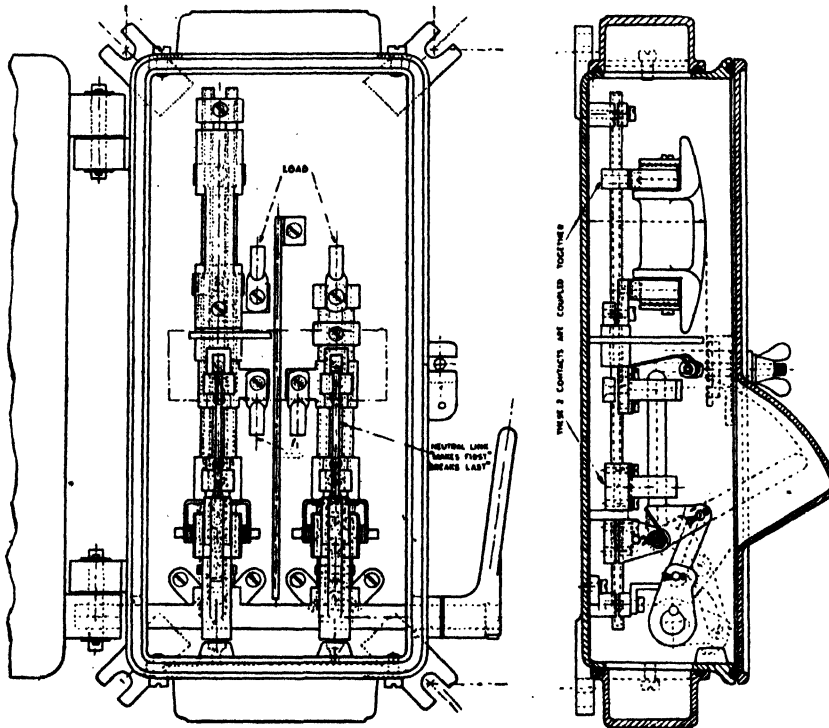

FIG. 26. WILLIAM WHITE 30-AMP. D.P. SWITCH WITH S.P. FUSE AND NEUTRAL LINK

the other three, being taken to a neutral bus-bar on the fuseboard; lighting and heating circuits, and the single-phase motors (if any) are then connected between a fuse on one of the phases and the neutral bus-bars.

The main switches and the fuseboards illustrated in this chapter are on the assumption that there is a normal A.C. supply. When the supply is D.C., "double-pole" fuseboards have to be employed, the "black" conductor also being connected through a fuse; nevertheless, all the simple-pole switches for the lamps, etc., must be on the "red" conductor.

Two-way Switching. When it is desired to control a lamp from two points, as for instance

giving an example. Suppose a private installation, with its generating plant 50 yd. from the house, requires altogether 30 amperes of current, and that the voltage is 50 volts. A 7/044 in. cable will be large enough to carry this current according to Table III, and its resistance is about 2.3 ohms per 1,000 yd. One hundred yards of cable (allowing for the pair of cables) will, therefore, have a resistance of .23 ohm. Multiplying this by 30 amperes in accordance with the formula, we get a voltage drop of 6.9, or 14 per cent of the lamp voltage. In practice, a drop of less than 2 volts should be contemplated in such a case. This would mean a maximum resistance of .067 ohm for the

Drop of Pressure. We now come to the important question of calculating the size of the cable to allow for drop of pressure. It is not difficult to understand that, in every circuit carrying electric current, there is a fall of pressure which is proportional to the current, and it is also proportional to the resistance of the conductor. Ohm's Law has already been stated and is $C = V/R$, where C is the current, V the voltage, and R the resistance. The equation may be written $V = CR$, from which it is seen that, to calculate the voltage drop, we have merely to multiply the number of amperes of current by the resistance in ohms of the conductor in question.

The calculation can be made quite clear by

ELECTRICAL FITTING

cables; that is, a cable having a resistance of .67 ohm per 1,000 yd. Referring to Table III it will thus be seen that 19/052 in. cable must be selected; the actual drop on which will be $.061 \times 30 = 1.8$ volts at full load.

It is thus seen that, in a large building, par-

would actually be permissible (and with 100-volt supply only 3 volts, and with 50-volt lamp pressure only 2 volts).

On motor circuits, a larger voltage drop can be permitted in some circumstances, but should in no case exceed 7.5 per cent of the supply voltage.

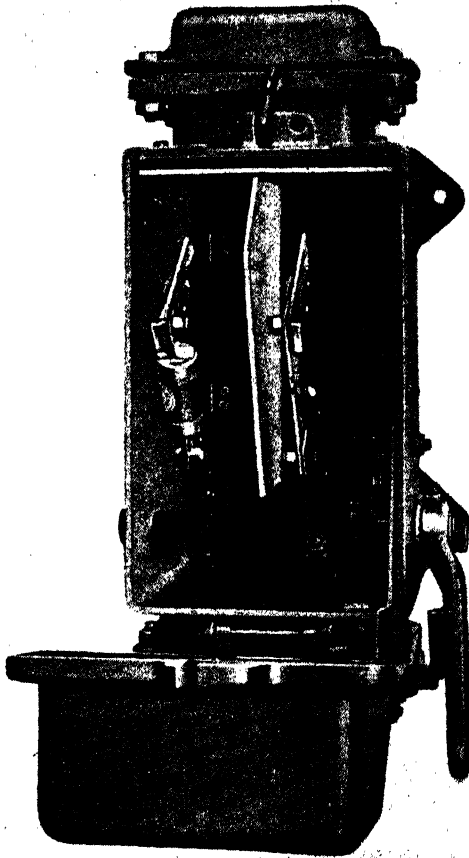

FIG. 27. ENGLISH ELECTRIC D.P. FUSE SWITCH WITH NEUTRAL LINK

ticularly if the distances between the distribution boards is great, it is not sufficient merely to base the size of the cables on the table of current-carrying capacities, but the drop of pressure must be worked out to see that it is not excessive.

The maximum drop of pressure allowed between the main switch and the farthest lamp in accordance with the regulations of the Institution of Electrical Engineers, is 1 volt plus 2 per cent of the pressure at the consumer's terminals when all the lamps are on. With a 230-volt supply, therefore, a drop of 5.6 volts

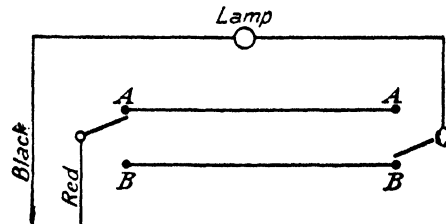

FIG. 28. TWO-WAY SWITCHING

In the case of single-phase motors, the drop is not simply $C \times R$, but is $\frac{C \cdot R}{\text{power factor}}$ which gives a somewhat higher value.

TABLE III. PROPERTIES OF CABLES

No. of Wires and Diameter of Wires (in.)	Nominal Sectional Area of Conductor (sq. in.)	Resistance per 1,000 yd. (ohms)	Maximum Carrying Capacity (amperes)	Approximate Total Length in Circuit (lead and return) for 1 volt Drop with Maximum Permissible Current as in Column 4
1/.044	.0015	15.79	5	36
3/.029	.0020	12.36	5	47
3/.036	.0030	8.02	10	35
7/.029	.0045	5.28	15	34
7/.036	.0070	3.43	29	27
7/.044	.0100	2.29	38	32
7/.052	.0145	1.64	45	37
7/.064	.0225	1.08	56	45
19/.044	.0300	0.85	65	49
19/.052	.0400	0.61	78	57
19/.064	.0600	0.40	102	65

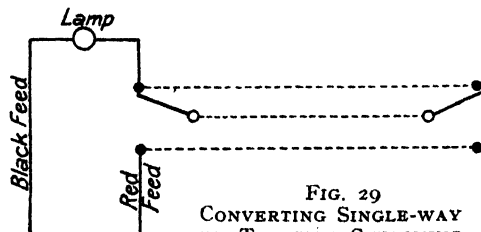

FIG. 29
CONVERTING SINGLE-WAY TO TWO-WAY SWITCHING

For three-phase motors, the voltage drop in each phase (both conductors) is the current calculated from the formula on p. 816 multiplied by the resistance of one conductor and by 1.73.

Chapter IV—ACCESSORIES, FITTINGS, AND DOMESTIC APPLIANCES

Lampholders and Lamps. The *bayonet socket*, or *B.C.* (bottom contact), lampholder is universally employed in this country, except for lamps of 200 watts and over. There are broadly three types: the *cord-grip* holder for pendants, the holder *threaded* at the end to screw on to a fitting which is made with $\frac{3}{8}$ in., $\frac{1}{2}$ in., or $\frac{5}{8}$ in. thread, and the *batten*, or *flange*, holder, which has a flange enabling it to be screwed to a conduit box wooden block on the ceiling. The holder has a threaded ring called the *shade-carrier ring* for clamping the shade on to it.

In its usual form it takes only 80 watts, is 5 ft. in length, and gives light almost equivalent to a 150-watt filament lamp but more usefully distributed. It is mounted in a special fitting, which embodies a choke-coil and condenser, and requires a special starting switch. Smaller sizes are being introduced.

Switches and Blocks. The ordinary surface pattern tumbler switch needs no illustration. The standard size, whether for single lamps or groups of lamps, is 5-ampere. Although a 60-watt 230-volt lamp requires only about a quarter

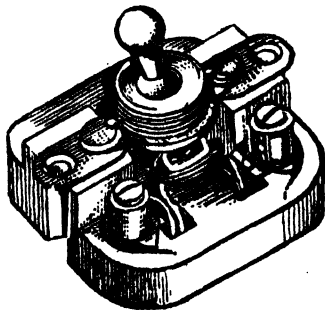

FIG. 30. FLUSH SWITCH WITH TOP-SCREW TERMINAL

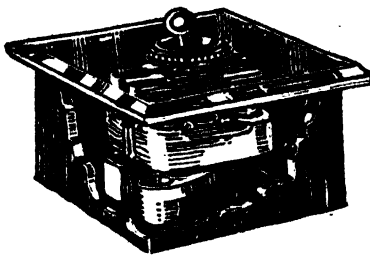

FIG. 31. FIXED GRID BOX WITH 5-AMP. SWITCH

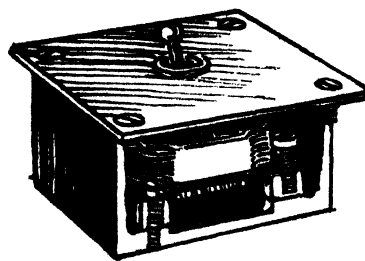

FIG. 32. SKELETON PATTERN ADJUSTABLE GRID BOX

If a lamp is within 8 ft. of the floor or within easy reach of a person in contact with earthed metal, there would be danger of shock from the cap of a defective lamp when replacing it. Such lamps, unless they are in earthed metal holders, must have their caps protected by bakelite skirts.

For 200 watts, E.S. (Edison screw) holders are used; and for 300 and 500 watts, G.E.S. (Goliath Edison screw).

Shade Galleries. Some patterns of lamp shades are made with wide openings at the top which cannot be clamped under the shade carrier ring of the lampholder. For these, *galleries* must be used. The standard sizes of galleries are $2\frac{1}{2}$ in. and $3\frac{1}{2}$ in.

Fluorescent Lamps. During recent years a very economical tubular lamp, in which the light is given by fluorescent vapour has been introduced for works lighting, and this type is now available for large rooms and retail stores.

of an ampere, and a 15-watt lamp considerably less than one-tenth, the standard 5-ampere size is almost always employed, as there is no gain in reducing the size of the contact surfaces.

To conform with Regulations all switches on conduit wiring, whether the conduit be sunk or surface, must be mounted in or on metal boxes. On such work, therefore, very little is gained by fitting a surface pattern switch. Fig. 30 is a flush switch on a porcelain base. On screwed sunk work a cast-iron box (Fig. 31) is recessed into the wall. It has clearance holes to which the conduit is fixed by means of a coupler and screwed bush as explained in Chapter II, p. 819, and the switch is screwed down on to the grid, leaving plenty of wiring space in which the slack of the wire is taken up. The box has to be fixed so that the lip will come just below the finished surface of the plaster, and the overlapping cover, which may

be of metal or bakelite, is held down by a neck ring on the switch or by corner screws.

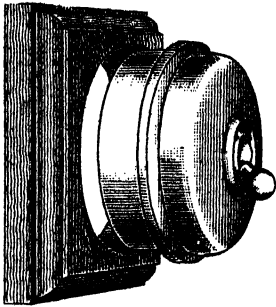

FIG. 33. SEMI-RECESSED SWITCH AND BLOCK

brought forward if the box is too far back in the plaster.

For grip conduit a shallower form of box with a grip fitting is obtainable, and shallow boxes in which the switch screws right down to the bottom of the box can be employed for screwed surface work.

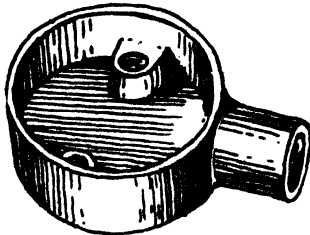

FIG. 34. IRON BOX FOR SEMI-RECESSED SWITCH

An alternative, both for surface and shallow sunk work, is the semi-recessed switch (Fig. 33) which can be used with a sufficiently deep block or hard wood box for lead covered and T.R.S. wiring, or with a shallow iron box (Fig. 34) on conduit work.

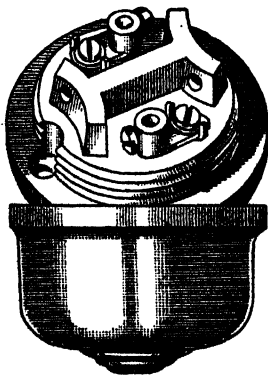

FIG. 35. CEILING ROSE

Ceiling Roses. The old-fashioned porcelain ceiling rose for pendants (Fig. 35) still survives; the flex passes through the hole in the cover and then each conductor is brought separately through the two holes in the bridge piece and connected under the screws and washers on the terminal plates. Similar 3-plate ceiling roses are frequently fitted for lead covered wiring see Fig. 19, page 826). A more up-to-date construction is the bakelite ceiling rose

(Fig. 36) which is much easier to wire, and which can be screwed on to a standard conduit box, the lip of which is flush with the ceiling.

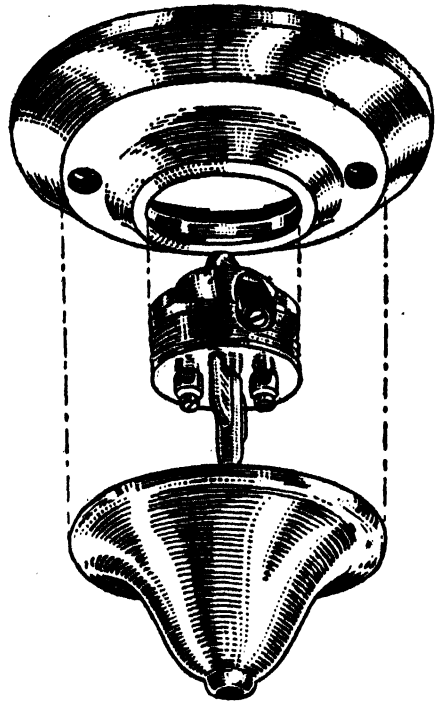

FIG. 36. G.E.C. BAKELITE CEILING ROSE

Ceiling Plates. As a substitute for a ceiling rose a metal cord-grip ceiling plate (Fig. 37) gives a neater finish. It screws similarly directly on to a standard conduit box, and the connections between the solid wires and the flex are

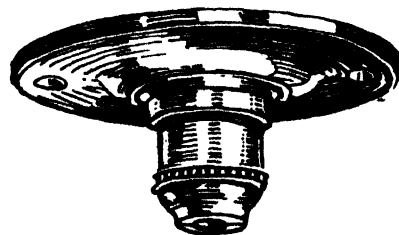

FIG. 37. CEILING PLATE

made with porcelain or bakelite connectors in the box.

Lighting Fittings. Whether of the industrial or artistic type, fittings on sunk work should have back-plates sufficiently large to overlap the standard conduit box, and with fixing holes at 2 in. centres, except in the case of very heavy

MODERN BUILDING CONSTRUCTION

fittings for which the large 4-screw conduit box is suitable. A back-plate, drilled to fit on this and with the necessary overlap, should be ordered. Industrial fittings, however, are frequently supplied without the down tubes,

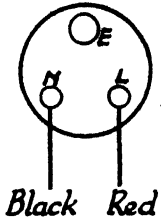

FIG. 38.
THREE-PIN
SOCKET OUTLET
CONNECTIONS

but with a socket to take conduit thread (or sometimes gas thread) into which the wireman has to fit the down tube. For the top flange of this, to screw on to the conduit box, it is best to use a "ball socket" cover as this ensures an automatically vertical position for the down tube, and saves subsequent adjustment if the thread is not cut absolutely true.

Socket Outlets and Plugs for Portable Lamps and Appliances. These are now standardized by the British Standards Institution, and except for very special circumstances, no other socket outlets should be used. The 3-pin type should be installed, the third pin and socket being larger than the two "live" pins. This third socket has to be connected to earth, either

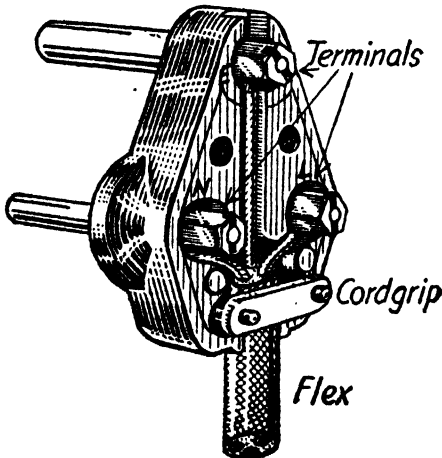

FIG. 39. M.K. STANDARD 3-PIN PLUG TOP WITH COVER REMOVED TO SHOW TERMINALS

through the conduit or, in the case of lead-covered and T.R.S. wiring, to the lead sheathing or the earth continuity conductor in the cable. The corresponding pin of the plug is connected by a third conductor in the flex to the metal case of the appliance. The connection to the three socket tubes must be in the correct order as shown in the diagram (Fig. 38), seen facing the wall; that is to say the order must be neutral (black wire), earth, and live wire (red)

in a clockwise direction. The plug top, one pattern of which is shown full size in Fig. 39 must be similarly connected. In new flexes the colours will be red for live terminal, black for neutral and green for earth-wire, but if appliances are supplied with flex already fitted, they should first be tested out to see which is the earth wire because in previous practice the colours have been different.

Socket outlets may be switch-controlled, but this is only compulsory on D.C.

Socket outlets should preferably be in iron boxes, as in the case of switches, but surface patterns are permissible.

Before wiring for electric fires and other domestic appliances, the system of metering and charging should first be ascertained. If electric heat and power are charged for at a different rate from lighting, and there are separate meters, two entirely separate sets of circuit are required, each with its own main switch, main fuses, and distribution boards. If, however, there is only one charge per unit—for instance, a fixed charge of so much per quarter, plus so much per unit, no matter for what purpose the electricity is employed—the heating and power may be run on circuits from the same distribution boards as the lighting.

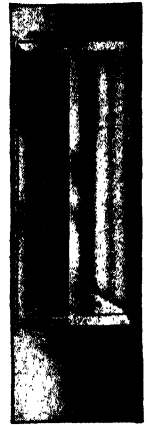

FIG. 40
2 KW. VERTICAL
REFLECTOR PANEL
HEATER FOR RECESSED MOUNTING
(About $\frac{1}{2}$ size)

The standard ratings of socket outlets have hitherto been 2-amp., 5-amp., and 15-amp., but a well-designed 5-amp. socket and plug, made strictly to the B.S. specification, will carry the 8.7-amp. taken by a 230 volt 2 Kw. fire, and a movement is on foot to "up-rate" it officially to 13 amperes. In accordance with pre-war practice, a maximum of three 5-amp. sockets constitute one sub-circuit, and every 15-amp. socket should be on a circuit by itself. Under war-emergency conditions, some additional latitude is allowed with the use of local fuses; and it is possible that, instead of wiring up the sockets in small domestic houses in a number of circuits, it will eventually be allowable, as a permanent measure, to use a "ring main" of 7.029 in. or 7.036 in. cable to which all the socket outlets will be connected with local fuses either in or adjacent to the socket

outlet box; 2-amp. sockets may be connected in with the lighting points, the maximum number on a sub-circuit being 8 or 10.

Flexibles. It is false economy to employ anything but the best insulated "flex." For pendants twin-twisted flex may be employed, but for portable apparatus the flex should be circular braided, that is to say, the two conductors separately insulated but under one braiding. This is less liable to kink.

The standard sizes and ratings of flex up to 20 amperes are given in Table IV. If a comparatively heavy shade has also to be suspended from the flex, a larger size should be employed to take the weight, but, of course, heavy fittings should always be separately suspended by chains or steel wires.

TABLE IV
SIZES AND RATINGS OF FLEX

No. and Diameter of Strands and S.W.G.	Nominal Sectional Area	Current-carrying Capacity
	(sq. in.)	(amperes)
14/0076 in. or 6/012 in.	0006	2
23/0076 in. or 9/012 in.	0010	3.0
40/0076 in. or 16/012 in.	0017	5.0
70/0076 in. or 28/012 in.	0030	10
110/0076 in. or 40/012 in.	0048	15

Electric Fires. It is unnecessary to illustrate the ordinary portable electric fire. Fixed or built-in fires are growing in favour; they are, made with the elements horizontal or vertical and Fig. 40 shows one form of the latter. These heaters for building-in are contained in a shallow box which has to be recessed into the wall or surround, and the exact dimensions of the recess required should be obtained in advance from the makers. The one illustrated requires a recess to be cut out, or left 16½ in. high by 4½ in. wide which is overlapped by the front of the heater, but it has to be cut so that its horizontal centre-line is ¾ in. above the horizontal centre of the front panel. The depth of the box in this model is very slight, exceeding only by ¼ in. the thickness of the standard slate surround usually employed, but some patterns have to be recessed deeper so that the cutting away of the plaster may not then be sufficient.

Electric Cookers. These are usually let on hire by the supply authority, in which case they are wired on a separate circuit direct from the supply intake board. If, however, the cooker is the consumer's own property, it should be

wired from a 30-amp. way on the main switch-board. Wiring should be in screwed conduit and be terminated in a cooker switch unit



FIG. 41. "HOT-POINT" 8-KW. COOKER

conveniently near the cooker; this contains a main switch, an indicator to show whether it is ON or OFF, and a 3-pin socket outlet for an electric kettle controlled by a separate switch on the unit. Cookers take a load of from 4 to



FIG. 42. "TORRIBAR" BOILING PLATE

8 Kw. according to their equipment. That illustrated in Fig. 41 is fitted with two 2-Kw. boiling plates, a 1900-watt grill, and a 2100-watt oven with 3 heats. Fig. 42 shows the top of a boiling plate, the coils of which are embedded in magnesium oxide in a stainless steel tube. Fuses for each separate part of the equipment are contained in the removable panel below the switches on the right-hand side. In some models the boiling plates are circular.

Chapter V—BELL AND TELEPHONE WORK

The Electric Bell. Fig. 43 shows an ordinary electric bell of more or less standard construction. A wooden base *A* carries a light iron casting having a projection *C* which is drilled and tapped to take a pillar that holds the gong of the bell. Two iron cores of an electro-magnet *E* are screwed into the casting, and there is also a lug with a circular hole in it; and a screw, passing through a correspond-

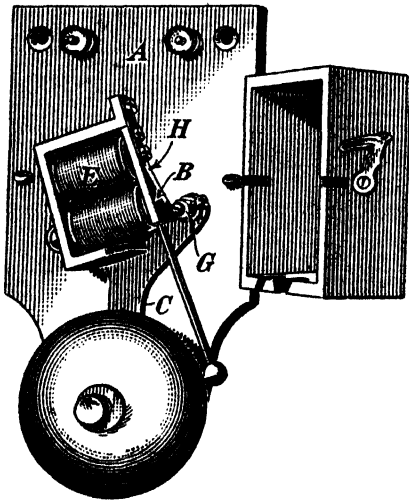

FIG. 43. TREMBLING BELL

ing hole in the wooden base and through a bushed hole in the casting, holds the contact pillar *G*. A flat spring *H* carries an armature *B* of soft iron, and in its normal position touches the point of the screw fixed in the contact pillar. The point of the screw and the corresponding spot of the armature are covered with a speck of special metal that will not be oxidized by the spark which occurs when the bell rings. The electrical connections are shown diagrammatically in Fig. 44. On the circuit being made by depressing the contact push, current passes from the battery to the contact pillar, and thence through the armature spring to one end of the electro-magnet coil, the other end of which is connected to the second terminal of the bell so that the circuit is then completed. The electro-magnet becomes magnetized and attracts the armature, causing the hammer to

strike the gong of the bell. This breaks the circuit, the electro-magnet loses its magnetism, and the hammer returns to its original position. By doing this the circuit is made again, and the armature is again attracted, so that the hammer is constantly travelling against the gong and back again so long as the push remains depressed.

The only adjustments needed from time to time in the bell are to clean the metal contact between the point of the screw and the armature spring, and to adjust the contact screw in the pillar if this has worked loose. The latter, however, should not occur as there is a locking screw, but adjustment is sometimes necessary

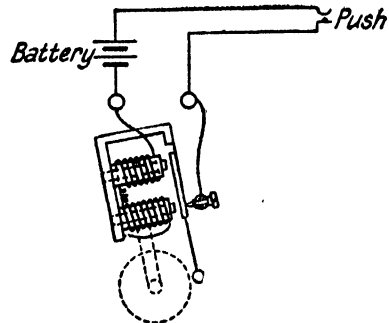

FIG. 44. SIMPLE BELL CIRCUIT

when the bell is originally installed, to find the best position for the screw, as it regulates the distance of the armature from the poles of the magnet and the travel of the hammer.

To clean the contact, a piece of ordinary paper (*not* emery cloth) should be passed backwards and forwards between the contact screw and the spring.

Iron or stamped steel bases and covers are now largely used instead of wooden ones, and on A.C. work a "bell transformer" replaces the battery. If, however, a transformer is to be employed, this should be mentioned when ordering the bell, as the cores of the electromagnet are then laminated.

Bell Pushes. Pushes for rooms usually consist simply of two flat metal springs on a wooden base or at the end of a "pear shaped" handle, with a screw-on cover through which the press

button passes. For outside use, including front-door pushes, a weatherproof construction is necessary, and care should be taken that the

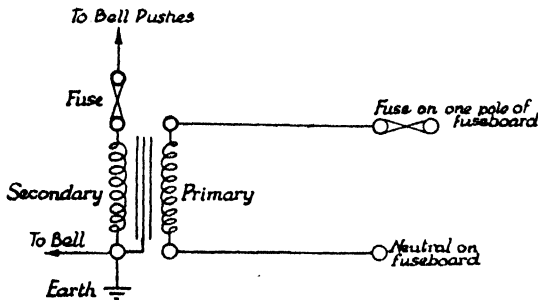

FIG. 45. CONNECTIONS OF SIMPLE BELL TRANSFORMER

wires are well covered with waterproof insulating protection right up to the terminals as they are liable to corrode away there if they become damp.

Transformers. These should preferably be iron-clad built for conduit entry. A fuse has

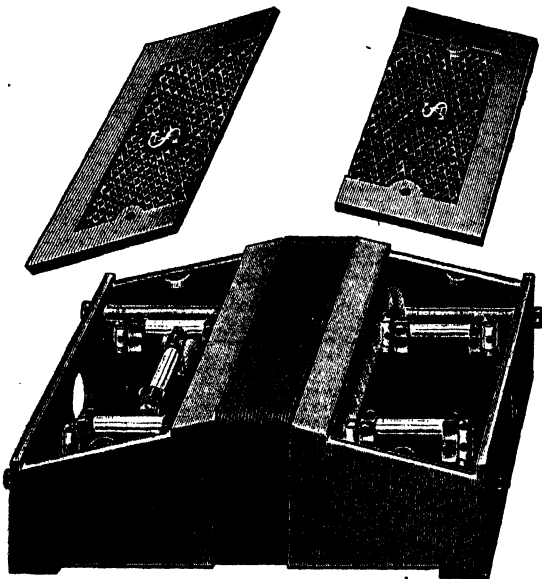

FIG. 46. LARGE BELL TRANSFORMER
(Julius Sax)

to be included on the secondary side. The primary side may be wired up with two cables from a separate way on the fuseboard or looped out with two wires from the red and neutral on any conveniently near sub-circuit. Fig. 45 shows diagrammatically the connection of the

simplest pattern. The two terminals of the secondary winding are connected to the bell circuit through a fuse and take the place of the battery shown in Fig. 44 and the later diagrams, but one of the secondary terminals is connected to the iron core of the transformer, and this terminal should be earthed. The fuse connected in circuit with the other terminal protects the transformer from overload if there is a short-circuit in the wiring to the bell. The secondary is wound to give a voltage of 4 to 8 volts. On larger installations with large bells, or long circuits between the pushes and the bell, a higher voltage may be required and the secondary may be wound for a maximum voltage of 24 with tapings at 8 and 16 volts, connected so that the fuse on the un-earthed side of the secondary is in circuit whatever the

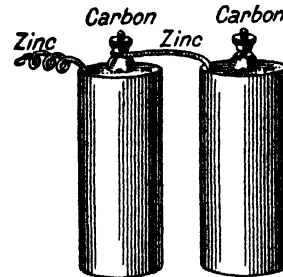

FIG. 47. TWO DRY CELLS IN SERIES

voltage used. Fig. 46 shows a well-made pattern of ironclad transformer suitable for such installations. It has fuses both on the primary and secondary side, but the primary fuses merely give protection additional to that already given by the sub-circuit fuse and are necessary only when there is considerable other load on the sub-circuit.

The Battery. If a battery is used, two No. 2 cells (Fig. 47) are sufficient for a small house installation, but for larger installations 3 or more cells of larger size may be employed. The larger the cell, the longer its life before replacement is required.

Indicators. In all bell systems in which the bell is to be rung from two or more rooms, an indicator board is essential to show whence the call has come. This consists of a number of *indicator movements* in a glass fronted box, the disc of each movement showing through an unpainted window in the glass. There are three types of indicator movement: the *pendulum* type (Fig. 48), in which a disc is deflected by the action of an electromagnet and then

MODERN BUILDING CONSTRUCTION

oscillates backwards and forwards for about a minute by the action of gravity; the *hand-replacement* indicator (Fig. 49), in which the disc is allowed to drop in front of the window when the current passes and remains in the

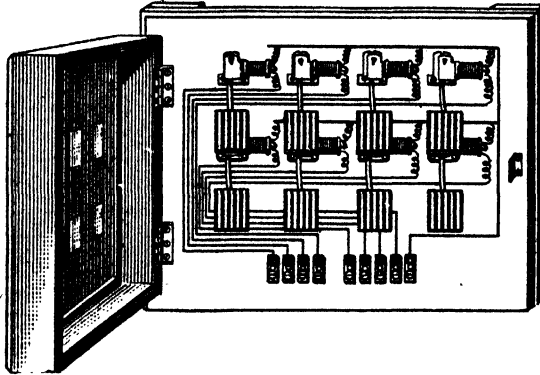

FIG. 48. PENDULUM INDICATOR (8-WAY)

dropped position until replaced by pushing in a rod at the side of the indicator board; and the *electrical* replacement type, used chiefly on very large indicator boards in hotels, etc., and in which the replacement of the disc is done by a second coil worked on an independent circuit closed by a push in any convenient position.

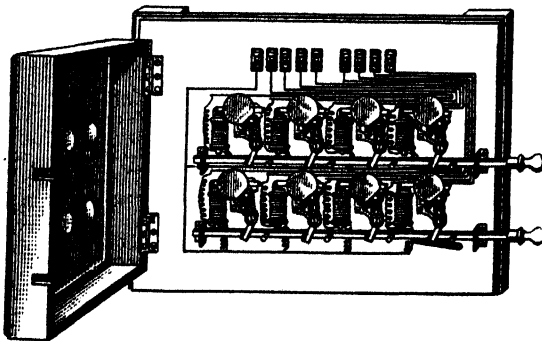

FIG. 49. HAND-REPLACEMENT INDICATOR (8-WAY)

Connections. If an indicator is employed, the arrangement is as Fig. 50, the diagram showing four pushes ringing the same bell through separate indicator movements. If two pushes are required in the same room, the second one is connected as shown in the dotted line. Unless all the rooms of a house are fitted for bells, it is desirable to have one or two spare ways on the indicator board which can be employed later if required; this is particularly advisable in public buildings, as the purposes for which the

rooms are allocated are usually subject to change.

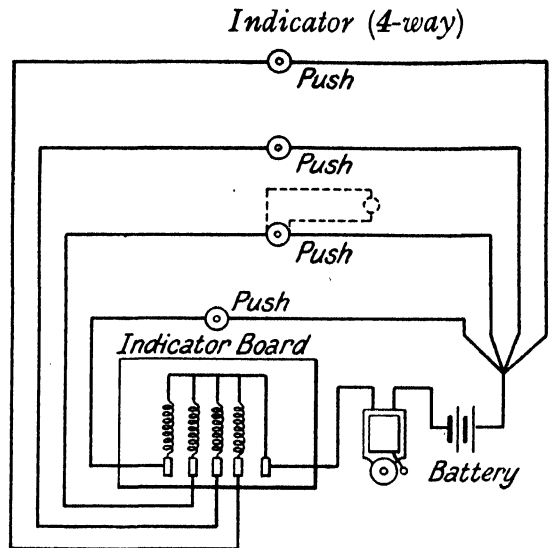

FIG. 50. BELL AND INDICATOR CONNECTIONS

In private houses it is sometimes desired that there should be a separate bell for the front door, having a different tone to that for the rooms; it is not then absolutely necessary to have an indicator for this bell, and it can be

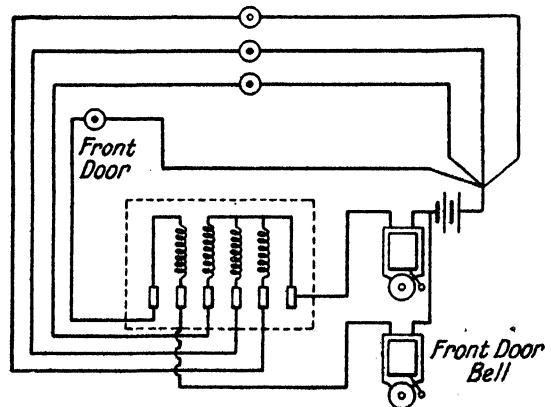

FIG. 51. BELL CONNECTIONS WITH SEPARATE BELL AND INDICATOR FOR FRONT DOOR

wired as an entirely independent circuit as Fig. 44, but run from the same battery as that for the bell and indicator system. On the other hand, if an indicator is desired on this circuit, one movement must be disconnected from the common bell terminal on the indicator

board, and the wiring then takes the form of Fig. 51.

An extension bell is sometimes necessary. This should be connected *in parallel* with the main bell as shown in Fig. 52, and a switch may be inserted in the circuit as shown if the extension is sometimes required to be silent. When

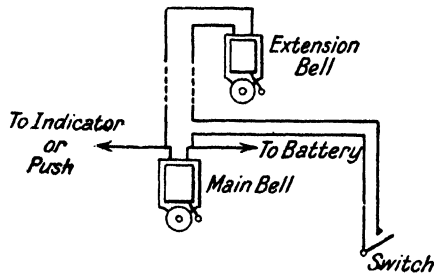

FIG. 52. EXTENSION BELL

an extension bell is required, *both* bells should be of the *high resistance type*, that is, having a resistance of about 15 ohms, to obtain the best results, as, unless the resistance of the bells is high, a difference in the length, and, consequently, the resistance of the wiring to the two bells will result in inequality of ringing.

Sometimes a *continuous ringing* bell is desired, for instance, as a night bell, which goes on ringing after the push has been released until it is

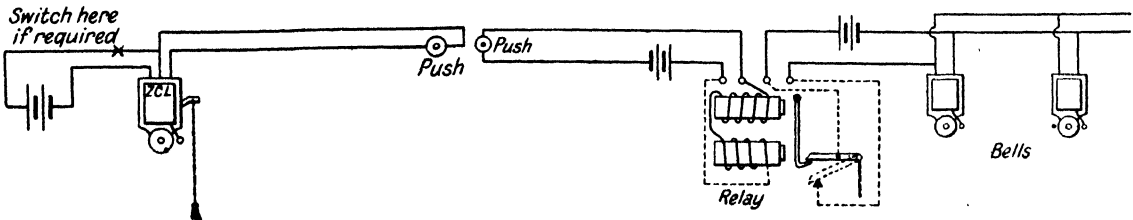

FIG. 53. CONTINUOUS RINGING BELL

stopped. For this purpose a special bell is usually employed, in which a lever drops on the first movement of the armature and short-circuits the line to the push. A cord from the side of the bell is pulled to replace this lever and stop the ringing. This bell has three terminals, and the connections are as Fig. 53, but it should be pointed out that the arrangement of the three terminals differ in various makes of bell. In the diagram the actual bell terminals are *Z* and *L*, and the extra terminal which is connected to the carbon of the battery is marked *C*; this lettering is usually followed, although the position of the terminals may vary, *A*

switch may be inserted in the wire between *C* and the carbon of the battery, to disconnect the continuous ringing attachment when not required.

Another method of effecting continuous ringing is by means of a *continuous ringing relay*, and this is used when more than one bell has to be rung continuously and the means of stopping the bells is to be at one point only as, for instance, on some fire-alarm installations. The relay has four terminals; the method of connection is given in Fig. 54.

Bell Wiring. The usual wire employed on cheap and competitive work is No. 20 S.W.G. tinned copper wire covered with a thin layer of pure india-rubber and two layers of paraffined cotton. This answers its purpose for surface work if care is taken not to damage the light insulation when hammering in the staples, and it is preferable that "Blake" staples should be used, or similar ones with a cushion of vulcanized fibre, to prevent the staple from coming into contact with the wire. For concealed work, however, a better class of wire should be employed.

For buried work, ordinary electric light conduit—screwed for best quality work, and close joint for competitive work—may be used and insulated cables (similar to those used for electric light) drawn in. The wires need not be so

FIG. 54. RELAY CONNECTIONS

large as those for electric lighting circuits, and 20 S.W.G. is sufficient. This is in every way preferable to the old practice of placing cotton-covered wires in zinc tubes.

For surface work, twin lead-covered cable is also preferable to the ordinary I.R.D.C.C. (India Rubber Double Cotton Covered) wire previously mentioned. Except on very long circuits, the wire need not be larger than No. 22 S.W.G. or what is known as 10 lb. per mile copper, which is slightly smaller. The conductor is enamelled and covered with two layers of cotton, and the two conductors are enclosed in a solid-drawn lead sheath. This twin lead-

MODERN BUILDING CONSTRUCTION

covered wire may also be used for sunk work drawn into conduit to protect it.

If reference is made to Fig. 50, it will be seen that a common return can be employed from all the bell pushes back to the battery or transformer, and, in consequence, in a large building there is no need to bring back a separate wire from each push on the common side. Where pushes are near together the common wire may be looped from one push to the next; and, in other cases, simple distribution boards may be used on each floor, and the wires radiated from them, one from a common bar, and the other from separate terminal plates or tabs. This method also facilitates tracing out faults on bell systems, for any wire can then be disconnected at the board, and a test made both ways.

In new work, pushes are usually fixed to blocks which are let into the walls, and made good by plastering, so that the back of the push comes flush with the wall. If this is done, the end of the conduit should be brought right into the block, and there should not be a gap between it and the back of the block. An alternative method is to end the conduit just projecting beyond the surface of the wall, and to mount the push on a thin surface block.

The *rosettes* employed for connecting pear push flexes to the wiring should be fixed in a similar way to bell pushes.

Telephones. House telephones may be divided into three classes—

1. Those employed on ordinary bell circuits, usually with single-way ringing so that any room may communicate with the servants' quarters;
2. Ordinary telephones between two rooms;
3. Intercommunication telephones and automatic dialling systems.

Most telephone instruments are made with a *switch hook* upon which the receiver or combined transmitter and receiver is hung, and this performs the function of connecting the bell to the line when the telephone is on the hook and connecting the telephone instruments to the

line when the instrument is taken off the hook. In addition, some telephones of the combined type are provided with a handle key to close the local circuit of the battery and microphone, while in others this is also done by a connection on the switch-hook. There are so many different arrangements of telephones that diagrams of the circuits will not be given here; they may always be obtained from the makers from whom the instruments are purchased.

The same remarks as to the wiring for this class of house telephones apply as in the case of bell circuits.

Intercommunication telephones make much greater demands as to wiring. As it has to be possible for a connection to be made from any one instrument to any of the others, it means that the number of wires brought to every instrument must be equal to the number of instruments in the building, plus from two to four wires according to the system used for the common connection and the battery connections. For surface work, the wire usually employed is a multiple cable made up of separate wires each coated with enamel and double cotton covered, the whole being enclosed in a single or double braiding. The wires for the battery connections are of slightly heavier gauge than the others. For external work and buried work, a similar cable is employed but lead covered, and, in fact, this is to be recommended for surface work, also as better protection is afforded to the conductors. The circuits may be looped out from one instrument to the next at the instrument terminals, or they may be branched at distribution boards which are made for the purpose.

House and office telephone systems in which connection is made between two stations by means of an exchange switchboard and automatic dialling systems come outside the category of building work. Nevertheless, it is advisable that, in new buildings, the wiring should be sunk, and arrangements should be made for the necessary conduit to be erected in the walls before they are finished.

Chapter VI—WIREMAN'S TOOLS

To a very large extent good and efficient wiring is dependent on the use of good and efficient tools, and the wireman has to provide the greater part of these himself and to keep them in good order. Every wireman should possess the following—

LIST A

Screwdriver, 12 in.— $\frac{7}{8}$ in. blade
 Screwdriver, 8 in.— $\frac{5}{8}$ in. blade
 Screwdriver, 4½ in.— $\frac{3}{8}$ in. blade
 Screwdriver, Long Thin type
 Bradawl—Large
 Bradawl—Small
 Pliers
 Side Cutters
 Knife
 Rule—2 ft. Steel and Wood
 Hacksaw Frame—adjustable
 Hammer, ½ lb. Flat Pane
 Hammer, 1½ lb. Ball Pane
 Hammer (Tack Hammer)
 Carpenter's Brace (Ratchet)
 Bits, $\frac{3}{8}$ in. to 1½ in. and Countersink
 Tenon Saw
 Square
 Pad Saw
 Wood Chisels, ¼ in. to ½ in.
 Chisel, Floor Lifting
 Spanner, Small Adjustable
 Footprints, 9 in.
 Footprints, 7 in.
 Spirit Level, 9 in.
 Pencil
 Centre Punch
 Long Chalk Line
 Plumb Bob
 Blow Lamp Pricker

The full kit is rather heavy, but need not be taken to every job. The best plan is to pack it in two boxes, one to include what is likely to be required on jobbing or small domestic work, and the remainder in a second box. For the small "fiddling" jobs, e.g. connecting up accessories, that always arise, the wireman will usually add some light tools of his own selection such as a still smaller screwdriver (say $\frac{1}{8}$ in. blade), a

light pair of pliers and, for use in connection with some accessories and appliances, a split screwdriver.

If heavier work of a semi-engineering character is to be carried out, some or all of the following list may be added—

LIST B

Cold Chisels
 Assortment of Drills and Taps
 Soldering Irons
 Tinsmiths' Snips
 Tank Cutter
 Tap Wrench
 Scriber
 Large and Small Wheel Brace
 Additional Wood Bits
 Smoothing Plane
 Small Plane
 Additional Wood Chisels
 Large Crescent Spanner
 Stillson Wrench, 14 in.
 Brass Punch
 Hide Mallet
 Large Cable Knife
 Jointers' Tools
 Set Spanners
 Box Spanners

Screws and nuts and hacksaw blades are provided by the employer, who also furnishes the following when they are necessary—

Footprint Vice
 Stocks and Dies (Small Pattern with
 1 in.— $\frac{3}{4}$ in.— $\frac{1}{2}$ in. Dies)
 Knox Cutter, 1 in.— $\frac{3}{4}$ in.— $\frac{1}{2}$ in.
 Steel Tape
 Round File
 Flat File
 Spare Rawl Bits
 Rawl Tools

Set spanners and box spanners have been included in List B, but even on lighter work a selection to fit the most prevalent size of nuts will not only save time, but will also save spoiling the corners of the nuts.

Builder's Office and Routine

By R. F. GALBRAITH, B.Sc.

Revised by J. H. BENNETTS, A.I.O.B

Chapter I—THE BUILDER'S OFFICE

SITUATION. The situation of the office of a builder is of considerable importance. It must be in close touch with both workshops and stores; it must be near the centre of the circle of operations, and it should be accessible to architects and other clients.

If the office and workshops are in a big city the office will be convenient and accessible, but the rent and rates on the premises will be heavy. It is difficult to obtain a satisfactory builder's yard near the centre of a large city.

The alternative, the office and works situated in outlying districts, has the advantage of cheap rent and rates, combined with a convenient and ample yard, but the works are removed from the sphere of work, and transport charges are increased.

A city office with works in an outer district lacks the close co-operation between office and workshop which is essential.

In choosing a site, the advantages must be set against the disadvantages and a decision made on the merits of the case.

SIZE. The size and arrangement of a builder's office will naturally depend on the size and importance of the concern, but the following departments or divisions must be accommodated—

Directors and management.

Surveyors and estimators.

Buyers (often the same staff as the estimators).

Accountant and cashier.

General clerical and typists.

No general rules can be laid down for the planning or arrangement of the office. Most building businesses grow gradually and the offices are enlarged as required, but it is most essential that the offices, wherever situated, should be well lighted and as quiet as possible, in order to obtain the maximum efficiency from the staff.

EQUIPMENT. The equipment of the office need not be elaborate, but should be carefully

arranged. The essential requirements are suitable desks, files for letters and other papers, telephone, typewriters, and ample storage space. The ideal desk for general work is a flat table, 2 ft. 8 in. high with pedestals of drawers between each worker. Plan drawers should never be fixed under a desk to be used for writing, but should be fixed as a separate fitting. It is impossible to work properly in front of plan drawers, and it is not convenient to obtain plans from a set of drawers when someone is working in front. A low desk should be supplied for the typewriter and independent desks for the manager and other important officials.

Filing Equipment. Undoubtedly, the best form of file is a vertical filing cabinet. This is convenient to use, and papers housed in separate folders carrying the firm's name on the tab can be obtained from it easily. The initial cost is fairly high, but this will speedily be saved. Next to a filing cabinet, the book form of file is best. Holes are punched through the papers to be filed and the papers threaded on to metal pins and fastened in with a clip.

Separate letter baskets should be provided for Letters Received, Letters for Dispatch, Invoices, Requisitions, or Orders.

To save delay, letters and requisitions related to the offices controlling work are distributed to that authority on receipt, preferably after being copied. Correspondence from architects, clients, etc., are usually copied to insure the originals being retained in the General Office files. Copies are distributed to the works or foremen to keep them in touch with matters affecting work in progress.

Mechanical Equipment. Typewriters are essential to a builder's office, as well as telephones with the necessary extensions. A duplicator is useful, especially for dealing with inquiries, bills of quantities and specifications, etc. A fireproof safe should be installed for the custody of financial books, contracts and other important documents.

BUILDER'S OFFICE AND ROUTINE

Drawing Office. The drawing office should preferably face north and be very well lighted. Ample storage room should be provided for plans and drawings. A flat desk, about 3 ft. high, is convenient for drawing boards, which should be slightly tilted. If an electric copying machine is provided, it should be housed in a separate room, and not in the general drawing office.

OFFICE STAFF AND DUTIES

The following departments or sections must be staffed—

Management, to deal with all questions of organization and routine and to supervise the whole of the work of the business.

General Office. Correspondence, interviews, and general clearing house for all inquiries.

Surveyors and Estimators, to undertake the preparation of estimates and to adjust variations that occur during the course of a contract.

Buying, to undertake all purchases made.

Accountant and Cashier, to keep the various financial books of the company and make the necessary payment, including workmen's wage income tax monies.

Management. The management is usually undertaken by a board of directors and a secretary in the case of a limited company, or by the owners or partners, or else by a manager in the case of an unlimited company.

In addition to the ordinary duties of management, the correspondence of the firm, the arrangement of finance, the co-operation with architects and supervisors of the various contracts and jobs, special duties are imposed by law on the secretary or owner of a business.

Form "E" must be filed with the Registrar at Somerset House thirty days after the annual general meeting of a limited company. Particulars of the share capital issued, debentures and loans, are required, as well as the names and addresses of the director of the company and all shareholders. A fee of 5s. must be paid on each form.

Income Tax. A return to the local Inspector of Taxes of all salaries paid out by the firm within 14 days of any employee starting to earn, as well as a return of all employees who earn £2 per week or over, must be made.

A return of the profits earned by the business must be made annually on the appropriate form. This is usually prepared by the auditor after preparing the balance sheet.

In connection with the assessment of profit for income tax, certain questions will be raised by H.M. Inspector of Taxes. The basis of valuation of stock, amounts included for repairs and materials, and similar questions, will have to be certified. The answers to these questions are usually best made after consultation with the auditor.

Census of Production. Periodically a census of production is taken by the Board of Trade.

TIME SHEET OF ----- J.S. LTD		WEEK ENDING ----- AT -----		TRADE -----	
SAT	STARTING TIME	Job			
MON					
TUES.					
WED	FINISHING TIME				
THURS.	Job number				
FRIDAY					
TOTAL HOURS					

ACTUAL TIME SPENT

DESCRIPTION OF WORK

FIG. 1. TIME SHEET

Various details as to output and production have to be answered.

General Office Duties. The following duties and items of routine are undertaken by the general office staff.

TIME-KEEPING. Time-keeping at works. A check must be kept of the actual hours worked by each workman; the time spent on each "job" or "operation" must be separated, usually by means of time sheets. The number of hours worked is entered every day in a time book; and at the end of the week, after checking

MODERN BUILDING CONSTRUCTION

against the time sheets, the total number of hours worked by each man can be arrived at and the total gross wages obtained. A deduction must be made from the gross wages for income tax, unemployment and health insurance.

TIME SHEETS. Each workman employed on jobbing or day work must fill in a time sheet, Fig. 1, at the end of each week, showing the actual time worked on each job and in what manner he was employed.

FILING LETTERS, ETC. All letters, invoices, accounts, delivery tickets, etc., should be filed after they have been answered, or the necessary details entered through the various "books" of the builder. This duty should be performed

goods and any shortages, breakages, or damage reported immediately.

INVOICES. Invoices, showing the quantity, quality, price, and total cost of goods supplied, or work done, are received by the builder a few days after the goods have been delivered. The total cost of the goods is entered in the purchase journal by the ledger clerk, and the invoices are checked against the delivery ticket, to see that the goods charged for have been delivered. The price should be checked by the order issued by the buying departments and the working out of the cost checked. Any error should immediately be dealt with, and the invoice returned for correction. Invoices for goods supplied or work

		LABOURERS	MACHINISTS	MECHANICS	PAINTERS	TOTAL WAGES	MATERIALS	SUNDRIES	INSURANCE	ESTABLISHMENT CHARGES	MACHINE & PLANT CHARGES	TRANSPORT CHARGES	TOTAL
27/4/46	Factory, London	1 5 3	3 10 7						2 4				
6/5/46	6 Days Tank		5 6 3	3 10 -					5 -				
13/5/46	Swing Bridge		1 7 3	8 5 4					7 -				
20/5/46				8 5 4					7 -				
27/5/46				1 6 5					1 6				
3/6/46					6 7 6	39 3 11	28 5 6	10 3		9 15 11			79 8 5

FIG. 2. PRIME COST JOURNAL

regularly and promptly, in order that a particular paper required may be found in the correct file when required.

DELIVERY TICKETS. All plant and material delivered to a job from the yard should be accompanied by a *delivery ticket*, stating quantity, size, and description of the goods. It is usual to send the ticket in duplicate form, one copy being retained on the job and returned at the end of the week to the office, and the other copy is signed and returned to the carman.

Materials delivered by merchants are also accompanied by a *delivery note*, and it is only by means of these delivery notes that invoices can be properly checked. Delivery notes should be filed under "jobs," in preference to alphabetical filing.

ADVICE NOTES. Goods dispatched by train are usually "advised" by post, giving details of quantity and the nature, station consigned to, and whether carriage paid or carriage forward. The details should be checked on receipt of

done by the builder should be prepared and dispatched by the cashier as soon as possible after the job is complete. The surveyors should supply the necessary details, or supervise the preparation of these invoices, from actual measurements, delivery tickets, or prime cost journals.

PRIME COST. The expression "prime cost" means the actual cost of producing a particular article or piece of work. The prime cost of excavation, concreting, stone, brickwork, joinery or other trade work should include cost of materials, wages, ironmongery, and establishment charges, to cover cost of rent, rates, water, power, and supervision. Establishment charges are usually added in the form of a percentage of the labour costs. The percentage varies according to the nature of the work undertaken, and the agreed terms accepted at the placing of the work.

Probably the best way to ascertain the "prime cost" of joinery is to allocate each

MODERN BUILDING CONSTRUCTION

entered. The above are the main duties to be undertaken by the general office staff, but there are numerous other small items that must be carried out in addition to the typing of correspondence and other work. Insurance cards of workmen have to be stamped, list of workmen with names and addresses prepared, unemployment returns to answer, income tax deductions and queries to negotiate between the Income Tax Surveyor and the workmen, workmen's compensation, etc.

Surveyors and Estimators. The duty of the surveyor and estimator consists of the preparation of estimates, the adjustment of variations, the preparation of valuations for payments and accounts, and the final adjustment of the contract price.

ESTIMATES. When an estimate is required, bills of quantities should be sent to the builder in order to place all firms tendering on the same basis. The habit of sending drawings and specifications of work required to several builders and obliging them to expend money on preparing bills of quantities should be discouraged by refusing to tender for such work, unless the value is, say, less than £1,000, and only one or two firms have been invited to tender.

On the receipt of a set of bills of quantities, inquiries should be sent out for materials required and for work that is usually sub-let, such as structural steelwork, granolithic work, etc. The specifications clause detailed in the preambles of each bill should accompany each inquiry where they affect the quality of articles required, and an exact copy of the specifications and schedule should be sent when prices are required for sub-let work. The bills of quantities are then priced and the value of each item worked out and totalled. Each extension and cost should be checked; special care should be taken to see that a total which is transferred to a summary is not also carried forward to next page.

VARIATIONS. Variations of work that are a departure from the specified items of work on building work, contract, or schedule of prices jobs, whether additions or omissions, are usually measured and costs adjusted by the builder's surveyors in conjunction with the surveyors appointed by the building owner or architect. Where the contract provides "that no alterations or additions shall be made without a written order from the architect," application for such altered instructions to be confirmed in writing from the architect is a very necessary procedure.

DAY WORK. Small jobs, such as alterations and maintenance jobbing, repairs and certain items on large contracts, are done on a "day-work" basis. That is to say, the actual cost of labour and materials is charged with the addition of an agreed percentage to cover cost of tools, supervisors, profit, etc.; the percentage will vary from 15 to 30 per cent, according to the nature of the work.

Day work on a large contract should only be adopted when the work is of a very difficult nature, and where it would be impossible to arrive at a fair price without having the actual cost available. Generally, it pays better to "measure" a job and price the items than to execute it "day work."

Usually the time spent on day work is entered on a special sheet and vouched for by the owner, architect, or his representative. See forms, Figs. I and II.

VALUATIONS FOR PAYMENTS ON ACCOUNT. On a large job, payments are usually required on account from time to time. A valuation, or statement, of the value of work executed is usually prepared by the surveyor, often in conjunction with the owner's or architect's acting surveyor. The prices of the bill of quantities being used as the basis of value, and the amount executed should be noted on the side. Extra work can be valued approximately, but no payments on account affect the final settlement of monies paid for the executed work.

Works Superintendent. An additional sectional officer, the Works Superintendent, is linked with the managerial department of a builder's business when the directors of such are more concerned with the financial side of large contracts than with practical supervision. He is responsible for seeing that hand and power plant comply with the Factory Acts, local and district by-laws and similar administrative matters. He undertakes duties that link up Head Office and Works sections with the several general job foremen employed in control on building sites and contracts.

A busy city area may call for night service in labour and materials; railway, chemical and electrical building construction introduce dangerous trades and special workmen's compensation insurance negotiations; all such items reveal abnormal conditions which cannot be estimated on the basis of labour and material executed under ordinary conditions, and call for the practical knowledge of applied building that the works superintendent must have.

Chapter II—BUYING

THE buying department of a builder's business is one of the most important departments. A mistake in buying, even if due to a misunderstanding, may have very serious results. The following points must be considered in every purchase: Price, together with quality, delivery dates, terms of payments, and methods of delivery. Loading and off-loading charges are saved by direct delivery to the building site where this is possible.

Every order should be in duplicate on a special order form (if the order is made by telephone it should be confirmed in writing). The order, Fig. 4, should set out the quantity, quality, price, how and when delivered, and terms of payment.

Certain materials, such as timber, cement, steel, sand, ballast, should be delivered direct to the building site whenever possible.

TIMBER

Softwoods are invariably sold "per standard" of 165 ft. cube for all sizes of deals, battens, and boards down to 1 in. x 4 in. Flooring, matching, and other prepared sections are sold "per square" of 100 ft. superficial; strips, i.e. sections 1 in. x 3 in. and less, are sold per 100 ft. run.

Hardwoods are sold "per foot superficial as 1 in. thick," or "per foot cube" when the thickness is 1 in. or over, and "per foot superficial" when less than 1 in. thick. For example, 2½ in. teak planks sold at "2s. 6d. per foot super as 1 in." cost 6s. 3d. per sq. ft., or 30s. per foot cube; whilst ½ in. teak boards at 1s. 6d. "per foot super" cost 36s. per foot cube. Logs are usually sold "per foot cube," caliper measure.

The Purchase of Timber may be divided into four classes—

- (a) Timber purchased before it is imported, i.e. a "bill of lading."
 - (b) Timber purchased for stock as and when a suitable parcel is available.
 - (c) Timber purchased for a particular purpose; for example, timber for housing work, joinery, or timber for a particular contract for delivery direct to the building site.
 - (d) Hardwoods.
- (a) **Timber Bought Before Importation.** In

this case, great care must be exercised in making the deal. The quantity to be purchased and the quality (i.e. first, second, third unsorted, and fourth) must be examined. The port of shipment and price asked must be compared with

ORDER

No. 95 Telephone No.
CITY 2121

J. SMITH & Co. LTD.
BUILDERS
CITY ROAD E.C.

To ----- 1914-

Please Deliver to -----

Signed for the firm -----

FIG. 4

current quotations for "landed goods." It is usually cheaper to buy "goods to arrive," but a drop in the price of landed goods can easily occur between the signing of the contract, say in December, and the arrival of the shipment, perhaps in May. However, if the builder is buying for a special purpose, he knows what price he can afford to pay and so can eliminate any possibility of actual loss.

Having decided to make a forward purchase, a contract is signed between the builder and the importer or agent.

MODERN BUILDING CONSTRUCTION

Definite lengths cannot be guaranteed, but they vary between 12 ft. and 25 ft. (Ends, i.e. 5 ft./11 ft. lengths, are usually imported separately.) The price quoted will be either "c.i.f.," "ex ship" or "delivered" to a specific place.

If the price is c.i.f. (which means cost, insurance, and freight), the buyer must take delivery from the ship and pay for the unloading and removal of the timber.

An *ex ship* price means the cost of unloading

SALE NOTE		NORFOLK HOUSE TOWER ST LONDON. E. C. 4.
Goods AT		
STATION W/M MILLWALL E.	SURREY DOCKS YARD	SMEDS
SOLD TO		
M. _____		
per _____		
Ex. S.S. _____		
from _____		
	<i>Rent free till</i>	
Terms _____	A. B. COX & SON	

FIG. 5

is paid for by the seller, but the buyer must provide a barge to receive and remove the timber.

The contract will detail the terms of payment, which may be as follows—

In a c.i.f. contract the cost of freightage is paid "net cash in 30 days," and the balance of purchase price either "cash in 30 days less 2½ per cent," or by a bill of exchange at four months. In an *ex ship* contract, the purchase price is paid for either "cash" or by a "bill of exchange."

(b) **Timber Purchased for Stock.** Although bargains can occasionally be obtained, it is frequently necessary to make a definite purchase of timber from landed goods for stock and other general purposes. The usual procedure is to consult two or three merchants, either by tele-

phone or by reference to their monthly stock list, and obtain particulars of various parcels of timber that are *apparently* suitable. The parcels should then be inspected in the docks or at the wharf where they are stowed. This inspection is absolutely essential, because brands of timber that were recognized as standard some years ago, are not absolutely dependable now, and one shipment from a particular port will vary from the rest. While inspecting the timber, a note should be made of the "number of hearts," or centres of logs, in the pile; whether the wood is strong, i.e. coarse grained with large knots; how the timber is piled; and whether in the open or under cover. A few boards on top of the pile should be turned over and examined.

When a purchase of timber is made, the timber merchant sends the buyer a *sale note* (see Fig. 5).

The sale note is a contract and specifies the quantity of timber sold, quality, price, and how delivered. Any error in the sale note should be rectified immediately.

When the timber is sold "in docks," a *dock order* is issued to the buyer, showing the mark of the timber, number of pieces of each length, and place of storage.

Usually, the storage of timber is paid for by the seller for 14 days after the date of the sale note. After that date rent must be paid for by the buyer.

Timber purchased in this way is usually sold with 2½ per cent discount for cash at 30 days after date of sale note, or else for a four months' bill.

(c) **Timber for a Specific Purpose.** The chief point to be considered in this case is the question of "lengths." It is important that there shall be as little waste as possible, and to obtain every length required it is worth while to pay a little more or even split the order into two or three parts, and obtain some lengths from one merchant and the remainder from another; the extra cost of repiling is usually charged when timber is purchased in the docks, and the piles have been disturbed to obtain the length required.

(d) **Hardwood.** The purchase of hardwood is an extremely difficult task. Experience, together with a good knowledge of the characterization and uses of hardwood, are invaluable. The wastage in hardwood can be anything up to 50 per cent, so every effort should be made to obtain lengths and widths to suit the job in hand. If unsawn logs are purchased, great care

should be taken in converting to planks. The heart should be cut into a thick plank 3 in. or 4 in. thick suitable for frames or sills. The widest parts of the log next to the heart should be cut into panels and the remainder into suitable thicknesses for door framing, counter tops, etc. (see Fig. 6). Unsawn logs must be well seasoned before use.

STEEL

Steel bars, joists, etc., can either be purchased from "stock" or else procured direct from the rolling mills. Steel from stock is usually about 30s. per ton dearer than steel from the works, and the range of stock lengths is somewhat limited.

In dealing with a contract for steel from the mills, several points should be observed. The total quantity required, the rate of delivery, and the period over which delivery is to be made must be clearly stated. Any extra charges for lengths or small sizes should be clearly set out. The common term, "to approved specifications," should not be accepted without a definite written arrangement as to what constitutes "an approved specification." It is often better to clearly detail the exact requirements.

The testing of steel sometimes causes trouble unless the matter is settled before the signing of the contract. Most steel is supplied in accordance with the British standard specifications for steel. These specifications provide that test pieces shall be tested by an inspector appointed by the buyers. Many steelworkers like to insist that all tests shall be made at the works and some mills charge extra if Lloyd's (the surveyors to Lloyd's Registry) carry out the test.

CEMENT

It is usually advantageous to enter into a contract with a firm of cement manufacturers to supply the whole of the cement required during a year, at rates ruling at date of dispatch. This ensures the supply in the event of a shortage of cement occurring. At the same time, the purchaser has the right to "cover" the cement required for a particular job at a firm or settled price.

If cement is purchased from casual sources, arrangements must be made to ensure that the cement shall pass the specified tests, usually those laid down by the "British Standard Specification for Portland Cement."

When ordering cement, sufficient time must

elapse between delivery and use for the necessary tests to be carried out; usually ten days is sufficient for this. On a large job this means that ten days' supplies must be in hand, which is often very inconvenient. To avoid storing cement on a job, some engineers specify that a bin of cement shall be tested and reserved solely for one job, and all cement required shall be delivered from this bin as required. Care should be taken to have a second bin tested before the first is emptied. Sacks are charged at 1s. 9d. each and a credit of 1s. 6d. is granted on return in good condition. Special care is needed to ensure all sacks are returned promptly. Paper bags are now largely used.

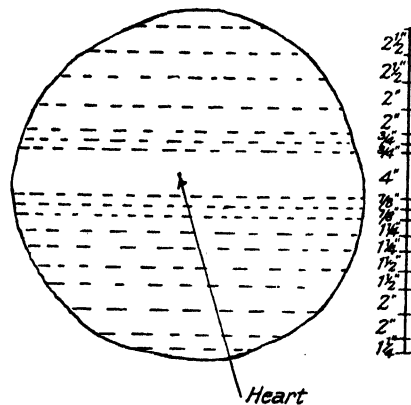

FIG. 6

SAND, BALLAST, ETC.

The technical points in connection with the purchase of sand and ballast are as follows—

(a) A cubic yard of "Thames" or pit ballast contains, when screened, about $\frac{3}{4}$ yd. cube of stone and $\frac{1}{4}$ yd. cub. of sand. Most specifications require the sand and aggregate to be mixed separately; but a cheap concrete is obtained by using ballast as dredged.

(b) A cubic yard of wet screened ballast or sand contains less solid matter than a cubic yard of the same ballast when dry. (Some ballasts will "shrink" 15 per cent in drying.)

(c) A ton of wet ballast or sand contains less solid matter than a ton of the same ballast when dry, and when purchasing by the ton it is futile to pay for water.

(d) A large ballast contains a greater proportion of solid matter than a small ballast.

(e) Clean ballast or sand is essential for good concrete.

(f) Broken brick or stone when screened from

MODERN BUILDING CONSTRUCTION

dust has a larger proportion of voids than a ballast of similar size.

In making a purchase of materials for concrete, the rate of delivery should be definitely arranged so that the daily supply of both sand and ballast shall be adequate for the work in hand. A large stock of sand and ballast on a job is wasteful, as it entails extra handling.

BRICKS

Common bricks, such as *Flettons* or *ordinary stocks*, can readily be purchased from one of the numerous manufacturers. A contract should be signed with the brick company, specifying the approximate total requirements, rate of delivery, and price. In the London area, it is usually advantageous to have the bricks delivered to the site by the brick company, rather than to have them consigned to the nearest railway station, and then carted. An extra charge, usually 1s. per 1,000, is made when bricks are loaded into skips ready to be hoisted off by crane. This is amply compensated for by the convenience of unloading, when crane power is available on building site.

Facing bricks and *glazed bricks* require more consideration in purchasing. The quality, colour, and quantity available are important. Delivery by rail often causes many breakages, which are the builder's risk, and whenever possible glazed bricks and specials should be delivered by road transport. Often a cheap rate goods station can be found, which will reduce the number of "shunts" that the truck is subjected to, and therefore reduce the breakages.

Purpose made bricks, such as *arch bricks* or *special quoins*, should be ordered as early as possible to avoid delay when required.

SUNDRY MATERIALS

LEAD. The price of lead is subject to violent fluctuations, but as lead is usually not required till a contract is well in hand, ample time is available to purchase when the market is favourable. A contract to supply during a period of three months can usually be arranged.

NAILS, SCREWS, GLUE, ETC. These should always be purchased in fairly large quantities, as small quantities invariably cost more.

LINSEED OIL improves with keeping, if care is taken not to disturb the bulk.

TURPENTINE should be purchased in steel barrels, and care taken to see that the tap is properly fitted with a shellac joint.

IRONMONGERY should only be purchased

after considering samples, as several qualities of each article are available.

SUB-CONTRACTS

Part of the duties of the surveyor's department is the arrangement of *sub-contracts* for various trades not usually undertaken by the general building contractor.

In each case an inquiry should be sent to several suitable sub-contractors. The inquiry should be an exact copy of the part of the "bills of quantities" concerned, with the necessary references to the specification, as well as any other special conditions that may be attached to the particular section of the works, such as scaffolding, hoisting of materials, etc. The inquiry should ask the time required for completion, as well as the time required for commencement of delivery. This is very important in the case of structural steelwork and stonework, because so many other trades are dependent on the rate of progress of these two trades.

Each quotation received should have total prices compared on their merits.

If a formal contract is not signed, a written order to the sub-contractor must be issued, embodying the main points of a formal contract, viz.—

1. Schedule of prices.
2. Terms of payment (usually 80 per cent or 90 per cent of the value of work completed in monthly payments).
3. Period of retention of balance (usually three months).
4. The work to be executed to the satisfaction of the architect (or building owner).

If the sub-contractor has been selected by the architect or building owner, the following additional clauses should be added to the contract or order—

1. That you insure against all third party risks, such as accidents caused to any person or persons or to property by employees of the sub-contractor, or by reason of any defects in the ways, works, machinery or plant of the sub-contractors whilst on or about the works and claims under the "Workmen's Compensation" Acts, produce receipt for premium when called on and indemnify us against all claims.
2. Our liability for payment to you is limited to such amounts as we ourselves have actually received from the employers in respect of work under this order by virtue of certificates of the architect from time to time.
3. All other terms and conditions of the principal contract applicable to this order are incorporated herein.

These conditions are recommended by the London Master Builders' Association.

Chapter III—ACCOUNTANT AND CASHIER

THE accountant and cashier will be responsible for making all necessary entries in the cash book, ledgers, and journals.

Payments of Accounts. Every month, or at convenient intervals when money is available, a list of all accounts due should be prepared by the cashier. Special note should be made of any accounts that are overdue, and of any discrepancies in the invoices that have not been agreed. This list is then scrutinized by the manager, or director in charge of the finance, who will decide what accounts to pay; probably accounts which have not been agreed would be held over pending settlement.

Cheques are now issued and forwarded. A cheque slip (see Fig. 7, which shows the slip about two-thirds size) is of great convenience, and should always be used.

The cashier is responsible that properly signed and stamped receipts are received in due course for all moneys sent, unless a receipt form is printed in the cheque itself, in which case the bank will not make payment until the receipt is signed, and stamped if required.

Payment of Wages is one of the most important items of routine in the cashier's department. In the building trade, the pay week ending varies, but wages are usually paid out at 12 noon on Saturday. A wage sheet (see Fig. 8, the actual size of the wage sheet being foolscap), showing the trade and name of every man employed on the jobs, together with total hours worked each day and total for the week, rate of pay, and deductions for insurance, is filled in by the timekeeper of each job, and forwarded to the builder's office on Friday evening. On Saturday morning these wage sheets must be checked, the exact number of £1 notes, 10s. notes, silver, and copper required abstracted, the money obtained from the bank, and made up ready for each separate job. A pay clerk is sent from the office to the job, and it is his duty to pay each man individually. If a man is absent and desires another man to draw his money, he should send a note to that effect by the man drawing the money, who must sign a receipt for the same. Any money not paid out on Saturday should be returned to the office, and obtained from there by the owner on returning to work.

Petty Cash. Sundry payments, both on the jobs and at the office, are made from *petty cash*. The cashier is in charge of this money, at the office, and is responsible for checking the payments made on a job, by means of receipted

J. SMITH & CO.
Builders and Contractors
123 CITY ROAD, LONDON, E.C.
 Phone—Rodney 2962

.....194...

TO.....

.....

Dear Sir,

We enclose herewith cheque value £.....

in payment of.....account

.....

.....

.....

Your receipt will oblige.
Yours truly,
J. SMITH & CO.

FIG. 7

bills returned each week. It is convenient to have the back of the wage sheets ruled with two sets of cash columns, one for receipts and the other for expenditure. This statement should be filled in by the timekeeper or foreman.

In a builder's business, money is usually received at irregular intervals in more or less large sums. Owing to the variation in terms of payment on various jobs, it is sometimes a matter of some difficulty to arrange for an even

Chapter IV—CONTRACTS

CONTRACTING terms vary. A builder may contract to execute building work on the basis of—

- (a) Fixed lump sum contract.
- (b) Cost plus percentage.
- (c) Measured as executed and paid for on an agreed schedule of prices.
- (d) Day work basis.

Sub-contracts are common to most building schemes, and may be negotiated between the builder and a sub-contracting firm undertaking work outside the builder's trade range, or negotiated through the client's architect as specialists work.

For negotiation procedure between the builder and a merchant, agent, or manufacturer for the supply of materials, see "Buying."

General Contract. The following are the chief points incorporated into a general contract between a building owner and the builder—

1. The general scope of the work, together with the agreed contract price.
2. The time within which the builder undertakes to complete the work, and the "agreed and liquidated damages" payable for delay. The wording of this clause is most important. Delay may, and often does, occur through causes absolutely outside the control of the builder. The laws of England are framed to be just to both parties of a contract, which means that any penalty for a time limit contract, if valid, should carry clauses covering a bonus for anticipated completion.

3. Conditions under which the time limit mentioned above should be *extended* include—

An allowance for wet and inclement weather, including frost, strikes, lockouts and trade disputes, additional work, shortage of labour and materials, and alterations in design other than minor ones.

4. *Terms of Payment.* It is customary in the building trade for builders to receive 80 per cent to 90 per cent of the value of the work completed, either at stated intervals or when a certain minimum amount of work has been done. The remaining 20 per cent or 10 per cent, as the case may be, is called the *retention money*, and is retained by the employer until the work is finally completed and with an agreed interval.

For example, a contract might stipulate that 20 per cent of the value of the work would be paid monthly, while in another case 90 per cent of the value would be paid with a minimum advance of £1,500. Sometimes, when expressly provided, the value of unused materials lying on the site are included in the value of work executed for purposes of payment.

The retention money is often held till the end of the maintenance period.

The terms of payment are of great importance to a builder, and if very stringent terms are involved, an allowance to cover interest and use of capital should be included in the tender, or else the contract refused.

5. *Maintenance Period.* A contract usually provides that the builder shall make good any defects that occur during a stated period (three to twelve months), called the *maintenance period*, due to faulty materials or defective workmanship. Of course, faulty design is not the responsibility of the builder.

6. *Arbitration.* An arbitrator should be appointed under the contract to settle all disputes occurring, in accordance with the Arbitration Act, 1894, excepting those specially mentioned to be settled by the architect.

Subsidiary Points in Contract. The following minor points should be included either in the main contract, or in the conditions of contract—

Fire Insurance. Whether building is to be insured, or whether the building owners will not cover the fire risks, if a builder undertakes to erect a given building, he accepts that responsibility, and in his own interest covers by insurance against fire, storm or flood or any other reasonable risk to which the building is subjected during progress, including the plant values.

The architect should specifically mention *alterations or additions*, the extent to which additions and omissions shall be allowed, and the basis of pricing these variations. The value of day-work rates, and any other details connected with the variation, should be set out in this clause.

The Architect's Power. Usually, the architect has conditional authority in judging the quality of materials and workmanship, also the manner in which the work shall be executed.

MODERN BUILDING CONSTRUCTION

Subletting. Usually, permission to sublet work is required from the architect. Consistently, conditions as to customary rates of wages and specification conditions are imposed on the sub-contractor.

Wages Variations. A clause covering variations in the rates of wages should be included.

Default of the Builder. The right of the building owner in the event of bankruptcy, or other default of the builder, should be set out in detail. Usually, the right to determine the contract, after due notice, and to enter into new

foreman to take charge of the work on the building site. If a suitable foreman is available from another job, naturally he would be engaged, otherwise an advertisement is necessary and applicants interviewed. The qualifications of a good general foreman are numerous. A thorough knowledge of all the trades and operations that are contained in a finished building, together with a good knowledge of various materials used, are essential. Tactful handling of men and leadership are invaluable. Accuracy, energy, honesty, and sobriety are imperative. A good general foreman means the success of the job, whilst a bad or mediocre foreman means loss and trouble.

ORDERING MATERIALS. The general foreman should order all plant and materials required, in writing, on an *order form*. See Fig. 9, which shows a form torn from the order book; the illustration is reduced, the actual size of the form being about 10 in. by 8 in.; the back side is blank. Full details of the materials required should always be sent. An order for "nails" is vague, but an order for "5 cwt. 4 in. cut nails" is definite.

Details of materials that have to be purchased are first submitted to the controlling officer for his scrutiny before being passed to the buying department. Plant or materials that are in stock at the builder's yard would be collected by the yard men or storekeeper, ready for delivery to the job, the supervisor making the necessary arrangements for transportation.

Plant and small tools are often available on other jobs, and the co-operation of other supervisors is necessary to ensure economy in the use of plant.

The chief factor to ensure the successful handling of materials is ample notice of requirements, and the avoidance of urgent telephone messages for materials that could have been delivered a day or so earlier if a little forethought and arrangement had been observed.

Often special drawings must be made before ordering certain materials such as stone sills, copings, wrought-iron work, cast-iron work, etc. These special drawings should be made by, or under, the direction of the supervisor.

All materials and plant received on the job should be entered in a special book kept for the purpose by the timekeeper or general foreman. Plant should be kept separate from the material actually used in the finished structure. Items such as sand, ballast, bricks, cement, etc., which are used in large quantities, should be recorded

ORDER FORM	
J. SMITH & CO. 123 CITY ROAD, LONDON, E.C. Date.....	CONTRACT
Particulars of Goods Required	For Office Use only
	Date.....

FIG. 9

contracts to complete the work, is granted to the building owner, in addition to any remedy against the builder for breach of contract.

SUPERVISION

When a contract is obtained by a builder, control of everything connected with same should be definitely allocated to one man—a director of the company, the manager, or one of the surveyors who, subject to consultations with the other directors or managers of the company, should have oversight and negotiation authority over all matters connected with the specific building work.

General Foreman. One of the first things the officer controlling does is appoint a *general*

BUILDER'S OFFICE AND ROUTINE

in tabular form under suitable headings, in order that the total quantity delivered at any date may be easily ascertained.

J. SMITH & CO.		Week ending.....194.....	
PROGRESS REPORT			
Men Working		CONTRACT.....	
Tradesmen	Labourers	STATE OF WORK	
		EXCAVATORS and CONCRETORS	
		BRICKLAYERS	
		SLATERS and MASONS	
		PLUMBERS	
		PLASTERERS	
		CARPENTERS and JOINERS	
		PAINTERS and GLAZIERS	
		SMITH and STEEL ERECTORs	
		SCAFFOLDERS	
		GENERAL LABOURERS	
		MESS ROOM BOY	LOST TIME Days B/F Present Week
		Total Number of Men	Total
			Daywork, Hours B/F Present Week
			Total
		Total Wages as per Sheet £ : :	
		Signature..... <i>Foreman</i>	

FIG. 10 REPORT FORM

WEEKLY REPORTS. The general foreman should make a weekly report on the state of the contract and on the progress made. A suit-

able report form is shown in Fig. 10, the actual size of the form being foolscap; the back of the form is headed as shown in Fig. 10 (a). It will be noticed on the front of the form that a section is provided for each separate trade; the numbers of tradesmen and attendant labourers are noted on the left-hand side. The total number of men engaged is filled in at the bottom, together with allowance for wet time, the time spent on daywork, and the total wages.

On the back of the report any special items, such as special instructions received from the architect, important alterations, etc., should be referred to.

MATTERS CAUSING DELAY	
Architect's Comments or Instructions and Variations	
CALLERS	DAILY WEATHER CONDITIONS
	Mon.
	Tue.
	Wed.
	Thu.
	Fri.

FIG. 10 (a) BACK OF REPORT FORM

In order to make the report of real value, details of the work completed should be given; for example, it is not sufficient to say that the "bricklayers are engaged on bricklaying," but that the "north wall is 4 ft. above the second floor level, and all other walls are 3 ft. above that level." Details of the foregoing nature enable the progress of the job to be determined.

Visiting Jobs. The officer in control should pay frequent visits to the building site and keep in touch with the progress and needs of the work. He should discuss with the foreman the numerous points and difficulties that arise in the course of the erection of a building. He should ascertain what materials already ordered have not been delivered, and generally satisfy himself that the work is well served with efficient labour and materials.

Control should never interfere with men engaged on the work. If anything is wrong he should tell the foreman, and let him put it

MODERN BUILDING CONSTRUCTION

right. The men then know whom to look to for orders.

Sub-contracts. The buying department will often place the order, or contract, for certain works soon after the commencement of a job, and arrangements must be made a little before the actual work is ready, in order that the sub-contractor may get his materials forward and arrange for men. The control officer should keep in close touch with the sub-contractors.

An important item of routine is the measurement of the work executed by the sub-con-

important. For example, suppose an old wall has to be underpinned, details of the length, breadth, and depth of digging, the amount of concrete used, the thickness of the brickwork and length of same, and the amount of timbering used, should all be noted; or, again, if a wall has to be partly pulled down, all necessary records of the amount of work disturbed should be made, and if necessary the total time spent in the alterations.

DAY WORK. Where a price for extra work cannot be easily arrived at, for example the

J. SMITH & CO.														
123 CITY ROAD, LONDON, E.C.														
ACCOUNT OF DAY WORK AND MATERIALS USED										Day Sheet No.....				
Week ending.....										day of.....				
CONTRACT.....										194.....				
NAME	TRADE	S.	M.	Tu.	W.	Th.	F.	Total Hours	Description of Work on which they were Employed			Materials Delivered		
<div style="text-align: right; margin-right: 50px;"><i>Clerk of Works</i></div>														

FIG. 11. EXAMPLE OF DAYWORK SHEET

tractor. In order to have some indication of the moneys due to him, arrangements should be made to commence this measurement as soon as possible. For example, if the plastering is sublet, as soon as one floor is complete the measurement could be commenced.

This measurement, and the checking of the final account and agreeing prices, is an important duty, usually undertaken by the joint surveyors.

Variations. Very few jobs are completed without some form of variation, addition, or omission. The general foreman should keep full particulars of all variations. The date ordered, and including, possibly, the dates the work was started and completed, should be recorded, together with all measurements that cannot readily be obtained when the building is complete. A sketch of the work carried out is

cost of pulling down a wall and rebuilding, or altering the size of a door opening, the total net cost of labour and material, plus an agreed percentage for establishment charges and profit, is charged. This method of charging is called "day work." It is customary to enter the hours worked by each man and the material used on a day-work sheet (see Fig. 11, which is about half actual size), and present these sheets weekly to the clerk of works or architect, for his approval and signature.

Day work should only be used when the work is so difficult that a fair price cannot be agreed.

It is often advantageous to keep a record of the time taken to complete a certain job, in order to arrive at the fair basis of price for that job.

DRAWINGS. A record of all drawings received

BUILDER'S OFFICE AND ROUTINE

should be kept at the office. The date, the number of copies received, drawing numbers, descriptions, and the dispatch of same should be recorded. If any drawing is cancelled, or superseded, a note to that effect should be made against the records.

THE BUILDER'S YARD

In connection with the office, a store-yard and workshop must be considered. Fig. 12 shows a typical layout of a builder's yard and shops.

The yard should be as large as possible, with a separate entrance and exit in order to facilitate loading and unloading of plant and materials.

Plant, that is, scaffold poles, boards, putlogs, running planks, etc., should be stored in a separate part of the yard, poles being stored in a vertical position, if possible, the butts being raised from the ground.

Machinery, such as concrete mixers, crushers, hoists, crabs, wagons, etc., should be stored under cover, whilst electric motors, tackles, ropes, and small mechanical tools should be stored in a *dry* lock-up shed.

All plant should be examined and overhauled on arrival from a job.

Defective poles should be cut down, rotten putlogs and boards put on a firewood heap. Hemp or wire scaffold lashings should be coiled. All machinery should be cleaned and repaired when received, so that no delay occurs when again required for use.

All plant should be under the care of a yard man or storekeeper, with the necessary fitters and labourers under him to ensure prompt repairs and quick loading and unloading.

Timber for joinery should be stacked in sizes under cover, and should be easily accessible from the joinery works.

A suitable store should be provided for nails, screws, and other small hardware, as well as for oils, painters' sundries, and other goods kept in stock.

Steel rods should be under cover, if possible, and should be kept "in sizes."

Joiners' Shop. The joiners' shop and sawmills will be under the control of a "shop foreman." It is his duty to obtain particulars of all joinery required, prepare "rods" or details of the work, make out cutting list, and supervise the machinists in preparing the work and the joiners in assembling.

A careful check on materials used should be kept, especially on hardwood. Before cutting a plank of hardwood, it should be marked out

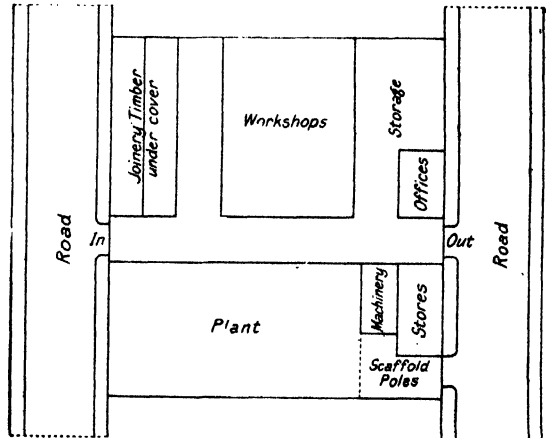

FIG. 12. TYPICAL LAYOUT OF A BUILDER'S YARD

in chalk to avoid waste, and to ensure that any "grain," or "figuring," may be used in the most advantageous part of the work.

In order to ensure accuracy, all dimensions should be checked, whenever possible, on the site, either by the general foreman of the job, or, if necessary, by the shop foreman.

One important duty to be carried out by the shop foreman is the annual practical stock-taking of all joiners' materials.

Control officers who have administrative and oversight charge of building jobs, should keep in close touch with the shop foreman and give him approximate forward dates when the finished framings on order will be required.

Book-keeping, Accounting, and Costing

By ROBT. G. LEGGE

Author of "Builders' Accounts and Costs" (Pitman)

Chapter I—WHAT IS BOOK-KEEPING?

BOOK-KEEPING means much more than merely keeping books or records. It means (1) keeping records of business transactions *accurately*, and (2) in such a manner that these records will give the utmost possible financial information to us, at short notice, concerning our business.

The only method that can achieve these two objects is *double entry book-keeping*. This method is based on recognizing that an internal check is essential, and that this can only be secured by viewing every transaction from two sides, and the recording of these two sides in our book-keeping.

Every transaction necessitates a transfer of value. If I receive cash, my cash is increased and my indebtedness to some person or firm is thereby reduced. If I supply goods, my stock is reduced and the person or firm who receives the goods from me becomes my debtor.

This principle is most clearly shown in the most important of books of account, namely, the *ledger*. In the ledger we keep *accounts*, each of which has two sides, and an entry is made on one side or another of an account, according to whether or no the result is to increase or reduce its value. Every transaction must appear on the debit side of one account and on the credit side of its opposite. This is something like the use of scales, when we never put a weight on one side without always putting an equal weight on the other. Thus the scales will always balance. This is what happens in the ledger.

LEDGER ACCOUNTS

There are two kinds of ledger accounts—personal and impersonal.

PERSONAL ACCOUNTS. Personal accounts are those that show transactions with another person or firm. Reference to personal accounts will show whether our business is indebted to the

person or firm, or whether that person or firm is indebted to our business.

The entering or writing up of transactions into the ledger is referred to as *posting*, or *the posting up*, of the ledger.

The rule for posting the ledger in the case of personal accounts is to debit the receiver and to credit the giver of value, no matter whether the value be in the form of money or things. Thus, if I sell goods or send money to a firm of the name of B. Cragge, this transaction will duly appear in the ledger as shown in Fig. 1.

This is entered on the debit (*Dr.*) side because B. Cragge has received from me value to the amount named. The double entry will be completed by another entry in the cash book (which as we will see later, is really a cash account), as shown in Fig. 2.

Inversely, if goods had been purchased from B. Cragge or money received from him, his account would have been credited. When posting to the ledger, each entry must be considered from the standpoint of the name of the account appearing as its heading.

IMPERSONAL ACCOUNTS. There are two kinds of impersonal accounts—real and nominal.

Real accounts are those that deal with assets. *Assets* are any form of property or anything of worth or value that can be turned into money (including, of course, cash itself), such as stock, plant, and machinery. The rule for posting the ledger in regard to assets is to debit increase of value and credit decrease of value.

Nominal accounts are those that deal with the losses and gains of the business. Examples: wages, salaries, rent, interest, and discount. The rule for posting nominal accounts in the ledger is to debit the account for expenditure, and to credit the account for earnings or income.

BOOK-KEEPING, ACCOUNTING, AND COSTING

For the benefit of those readers who are not familiar with the ruling of a ledger, we give a specimen ruling in Fig. 3.

Examples of transactions as they will appear in the ledger accounts—

EXAMPLE 1. 1946, Jan. 1. Bought timber from B. Cragge, £130.

Method. A "Materials," "Stock" or "Purchases" account will be debited (because this account receives value), Fig. 4 (a); and an account for B. Cragge will be credited (as value comes from him), Fig. 4 (b).

EXAMPLE 2. 1946, Jan. 2. Sold timber to C. Doe, £50.

Dr.		LEDGER B. CRAGGE				Cr.
1946 Jan. 31	To Cash	£	260	s.	-	d.

FIG. 1. ENTRY IN LEDGER

Dr.		CASH BOOK				Cr.
1946 Jan. 31	By B. Cragge	£	260	s.	-	d.

FIG. 2. ENTRY IN CASH BOOK

Dr. (Debit side)		LEDGER NAME OF ACCOUNT				(Credit side) Cr.	
Date	Particulars of Entry	Ref. to Source of Entry	Amount	Date	Particulars of Entry	Ref. to Source of Entry	Amount
Year Mth. Day	To		£ s. d.	Year Mth. Day	By		£ s. d.

FIG. 3. RULING OF LEDGER

Dr.		LEDGER PURCHASES ACCOUNT				Cr.		
Jan. 1	To B. Cragge	P.D.B.	I	£	130	s.	-	d.

Note. P.D.B. here means Purchases Day Book whence item is taken.

FIG. 4 (a). DEBIT ENTRY IN LEDGER FOR EXAMPLE 1

Dr.		LEDGER B. CRAGGE				Cr.		
1946 Jan. 1	By Purchases A/c	P.D.B.	I	£	130	s.	-	d.

FIG. 4 (b). CREDIT ENTRY IN LEDGER FOR EXAMPLE 1

Dr.		LEDGER C. DOE						
1946 Jan. 2	To Sales	S.D.B.	I	£	50	s.	-	d.

FIG. 5 (a). DEBIT FOR EXAMPLE 2

MODERN BUILDING CONSTRUCTION

Method. C. Doe receives value, therefore his account in the ledger will be debited, Fig. 5 (a). The double entry is completed by crediting a sales account, Fig. 5 (b).

EXAMPLE 3. 1946, Jan. 3. Paid cash to B. Cragge in settlement of his account.

Method. Cash is given, so cash book (which is the cash account) is credited, Fig. 6 (a); and B. Cragge receives, therefore his personal account in the ledger is debited, Fig. 6 (b).

EXAMPLE 4. Jan. 4. Bought machinery from D. East, £75.

LEDGER SALES ACCOUNT

						Cr.	
1946	Jan. 2	By C. Doe	S.D.B.	£	s.	d.	
			1	50	-	-	

FIG. 5 (b). CREDIT FOR EXAMPLE 2

CASH BOOK

						Cr.	
1946	Jan. 3	By B. Cragge	L. 1	£	s.	d.	
				130	-	-	

FIG. 6 (a). CASH CREDITED FOR EXAMPLE 3

LEDGER

B. CRAGGE

Dr.						Cr.	
1946	Jan. 3	To Cash	C.B.	£	s.	d.	1946
			1	130	-	-	Jan. 1
							By Purchases A/c
							P.D.B.
							1
							130
							-
							-

(C.B. = Cash Book.)

FIG. 6 (b). LEDGER DEBITED FOR EXAMPLE 3

LEDGER

MACHINERY ACCOUNT

Dr.									
1946	Jan. 4	To D. East	P. & M.	£	s.	d.			
			1	75	-	-	<i>Note.</i> P. & M. refers to a Plant and Machinery Record, which will contain details of this purchase		

FIG. 7 (a). DEBITED LEDGER FOR EXAMPLE 4

LEDGER

D. EAST

						Cr.	
1946	Jan. 4	By Machinery A/c	P. & M.	£	s.	d.	
			1	75	-	-	

FIG. 7 (b). CREDITED LEDGER FOR EXAMPLE 4

CASH BOOK

						Cr.	
1946	Jan. 5	By Machinery A/c	Cheque Book	£	s.	d.	
			1	100	-	-	

FIG. 8. CASH BOOK CREDITED FOR EXAMPLE 5

BOOK-KEEPING, ACCOUNTING, AND COSTING

Method. As the value of our machinery has increased, the "machinery account" in the ledger will be debited, Fig. 7 (a); and as D. East supplied value, his account in the ledger will be credited, Fig. 7 (b).

EXAMPLE 5. Jan. 5. Purchased machinery for cash, £100.

Method. The machinery account will be debited in the same manner as the previous item. In this instance, however, the cash book will be credited as in Fig. 8.

CASH AND CREDIT TRANSACTIONS

From the above it will be seen that cash transactions must be dealt with differently from credit transactions. A credit transaction means that the goods were not paid for at the time of purchase or sale, but that the cash side of the transaction was completed at a later date. A difference in book-keeping treatment is essential, because a credit transaction means that until the item is paid for, a record of the liability must remain in the books of account. Thus, in every case of a credit transaction, our own business becomes either a debtor or a creditor to some other person or firm. In other words, a credit transaction will necessitate that a personal account must be opened in the ledger.

Cash transactions are always entered directly into the cash book.

Credit transactions are always first entered in some detail book.

DETAIL BOOKS. Detail books for credit transactions are variously known as "detail," "subsidiary" or "books of prime" or "first entry."

The purpose of these detail books is to avoid the ledger accounts being encumbered with a mass of detail. When we refer to a ledger account we must be able to tell quickly whether the debit or credit total is the larger. If we first had to plough through a mass of detail before we could see the state of an account, it would take considerable time before we could obtain the desired information.

It will be seen from the rulings that have been given, that the cash columns in all books are preceded by a narrow margin for reference to the source of the item. In the ledger this margin would refer us to the cash book or to the detail book, giving the page where more detailed information may be found.

The ledger may be described as that most important of all our books, wherein by means of debit and credit statements, termed "accounts," we may ascertain at short notice

any information required concerning our business.

DETAIL BOOKS

The Journal. It helps to the understanding of double entry to acquire the habit of journalizing. This necessitates the thinking out of the two accounts that will be affected by each transaction, and by constant practice the student will be able to decide this without special mental effort.

The journal is the book of first entry used for particulars of those opening entries, closing entries, special transactions, and adjusting entries that have no claim to be entered in any of the other detail books.

If the reader were to become a book-keeper to a building firm where the accounting had not been done in a satisfactory manner, the first thing for him to do would be to set out the financial position of the business. This would mean compiling a list of its assets and liabilities and these will be shown in the journal.

Or, in beginning an examination exercise, the opening position of the business must be first journalized. The assets and liabilities in this journal entry should agree in their totals.

EXAMPLE. We are asked to open the books of A. Baxter, builder, and on 1st January, 1946, we find the position to be as follows—

Cash at Bank	£
Cash in Hand	542
Plant, Tools, etc.	50
Stock	1440
B. Cole owes	600
C. Drake owes	40
Due to—	180
D. Ensor	312
E. Fry	140

This position will be shown in the journal as shown in Fig. 9.

In reference to the following, it is to be noted that the word *sundries* in book-keeping means several entries, or more than one item.

B. Cole and C. Drake are debtors.

D. Ensor and E. Fry are creditors.

The amount of the capital is found by deducting the total amount of the liabilities from that of the assets. Capital is thus the excess of the assets of a business over its liabilities.

The form—

To	Dr.
at the head of the above entry is the usual mode of setting out a journal entry.	

MODERN BUILDING CONSTRUCTION

JOURNAL

1946			£	s.	d.	£	s.	d.
Jan. 1	Sundries	<i>Dr.</i>						
	To Sundries—							
	Cash at Bank		542	—	—			
	Cash in Hand		50	—	—			
	Plant, Tools, etc.		1440	—	—			
	Stock		600	—	—			
	B. Cole		40	—	—			
	C. Drake		180	—	—			
	D. Ensor					312	—	—
	E. Fry					140	—	—
	Capital					2400	—	—
	Being Assets, Liabilities, and Capital at this date		£2852	—	—	£2852	—	—

FIG. 9

PURCHASES DAY BOOK

1946			£	s.	d.	£	s.	d.
Jan. 8	B. Cragge—							
	1 square 7 in. × 1 in. 1st Yeo Matching		2	—	—			
	500 ft. 3 in. × 2 in. Yeo		4	—	—			
	200 ft. 5 in. × ½ in. White		2	—	—	8	—	—
„ 9	C Doe—							
	10,000 Flettons		20	—	—			
	8 tons Cement		40	—	—	60	—	—
	Purchases <i>Dr.</i>					£68	—	—

FIG. 10

SALES DAY BOOK

1946			£	s.	d.	£	s.	d.
Feb. 1	E. Faro—							
	Sundry Repairs to Cottage					13	—	—
„ 3	F. Gibb—							
	1 yd. Sand			10	—			
	1 yd. Lime			10	—			
	Cartage			5	—	1	5	—
	Sales A/c <i>Cr.</i>					£14	5	—

FIG. 11

Date	Name of Firm (from whom or to whom returned)	Amount (of each Item)			Amount (Total of Consignment)		
		£	s.	d.	£	s.	d.
	Details of Goods	£	s.	d.	£	s.	d.

FIG. 12. RULING FOR RETURNS BOOKS

BOOK-KEEPING, ACCOUNTING, AND COSTING

The items, where the amounts are shown in the debit column, are the names of the accounts to be opened and debited in the ledger. The exceptions are "cash at bank" and "cash in hand," which will appear on the debit side of the cash book.

Inversely, the items where the amounts are shown in the credit column are the names of accounts that must be credited.

Also, at the foot of each journal entry, there must be written a "narration," i.e. a brief explanation of the meaning or purpose of the entry, e.g. "Being . . . date" in the foregoing illustration (Fig. 9).

Purchases and Sales on Credit. Particulars of purchases and sales on credit and particulars of returns inwards and outwards will need to be kept. A book for each of these four classes of transactions will be required. The simplest form of ruling for these will be as shown in Fig. 10.

It will be seen from Fig. 10 that there is first stated the date and name of the supplier; then the details of materials; the amount of each item in the first cash column; total amount of each invoice is carried out into the second cash column.

Daily, or at short periods, the second column will be totalled, and this will show the amount to be debited to the purchases or materials account in the ledger. The total amount of purchases from each firm will be credited to the personal account of such firm in the ledger.

The double entry of the above illustration will thus be effected as follows—

	£	
<i>Debit.</i>	Purchases A/c with . . .	68
<i>Credit.</i>	B. Cragge's A/c with . . .	8
	,, C. Doe's A/c with . . .	60

Sales Day Book. The ruling, Fig. 11, and setting out of entries in this book will be similar to that of the purchases day book. The difference will arise in practice, i.e. in posting from the day book to the ledger accounts.

From the purchases day book the purchases

account in the ledger is debited, and the personal account of the supplier is credited; when posting from the sales day book, a reverse procedure must be followed, that is, the personal account of the receiver of value will be debited, and the sales account credited. For example, from the entries given in the above illustration, E. Faro's personal account in the ledger will be debited—

To Sales A/c £13 - -

F. Gibb's personal account in the ledger will be debited—

To Sales A/c £1 5 -

Sales account will be credited—

By Sundries £14 5 -

Returns Inwards Book. In the event of goods being sent out either in excess of the quantity required, or should they be defective or unsatisfactory to the customer in any way, they will probably be returned by him. Any such "returns" must be entered in a "returns inwards" book.

Returns Outwards Book. On the other hand, we may not be satisfied with the goods that we get from our suppliers, and will return them. These will be entered in detail in a "returns outwards" book.

RULINGS FOR RETURNS BOOKS. A simple journal ruling (two cash columns on right of each sheet), similar to that used for the journal and the purchases and sales books, can be used for the returns books.

The particulars to be provided for in this ruling will be as shown in Fig. 12.

POSTING OF THESE "RETURNS" TO THE LEDGER ACCOUNTS—

Returns Inwards. A "returns inwards" account will be opened and debited; the personal accounts of those firms, who return the goods, will be credited.

Returns Outwards. The personal accounts of those to whom goods are returned will be debited; "returns outwards" account will be credited.

Chapter II—THE CASH BOOK

In Chapter I it was explained that one of the first things in book-keeping is to distinguish between cash and credit transactions, and that the one kind must be dealt with differently from the other. All cash transactions, i.e. those paid for at the time, must be directly entered in the cash book.

The Three-columned Cash Book. The student must learn the use of the three-columned

cash book, the ruling of which is shown in Fig. 13.

Supposing that Mr. E. Fagg owes us £100 and pays this on 1st February, 1946, by cheque, after deducting a cash discount of £5 which was agreed. This will be entered in the cash book as shown in Fig. 14.

It will be noted that when the actual payment is reduced on account of a cash discount being

Dr.						CASH						CONTRA						Cr.					
Date	Particulars	Ref. Col.	Dis-counts Allowed			Cash Receipts			Bank Receipts			Date	Particulars	Ref. Col.	Dis-counts Received			Cash Pay-ments			Bank Pay-ments		
			£	s.	d.	£	s.	d.	£	s.	d.				£	s.	d.	£	s.	d.	£	s.	d.

FIG. 13. RULING OF THREE-COLUMNED CASH BOOK

Dr. (or Debit side)												CASH BOOK											
Date	Particulars	Ref. Col.	Dis-counts Allowed			Cash Receipts			Bank Receipts			Date	Particulars	Ref. Col.	Dis-counts Received			Cash Pay-ments			Bank Pay-ments		
			£	s.	d.	£	s.	d.	£	s.	d.				£	s.	d.	£	s.	d.	£	s.	d.
1946 Feb. 1	To E. Fagg .		£	5	-	£	-	-	£	95	-												

FIG. 14. ENTRY IN CASH BOOK

LEDGER
E. FAGG

Date	Particulars	Ref. Col.	Dis-counts Allowed			Cash Receipts			Bank Receipts			Date	Particulars	Ref. Col.	Dis-counts Received			Cash Pay-ments			Bank Pay-ments		
			£	s.	d.	£	s.	d.	£	s.	d.				£	s.	d.	£	s.	d.	£	s.	d.
1946 Feb. 1	By Discount		£	5	-																		
	„ Bank					£	95	-															

FIG. 15. CREDIT ENTRY IN LEDGER

BOOK-KEEPING, ACCOUNTING, AND COSTING

CASH BOOK				Cr.
			Cash or Bank Column	
	1946 Feb. 2	By A. Blank	£ 50	s. d. - -

FIG. 16

Dr.	CASH BOOK			
				Cash or Bank Column
	1946 Feb. 2	To A. Blank	£ 50	s. d. - -

FIG. 17

Dr.	CASH BOOK			
				Cash Column
	1946 Feb. 3	To Sales	£ 40	s. d. - -

FIG. 18

CASH BOOK				Cr.
			Cash Column	
	1946 Feb. 4	By Purchases	£ 40	s. d. - -

FIG. 19

CASH BOOK				Cr.
			Cash or Bank Column	
	1946 Feb. 5	By Plant and Machinery A/c	£ 100	s. d. - -

FIG. 20

CASH BOOK				Cr.
			Cash or Bank Column	
	1946 Feb. 6	By Wages A/c	£ 60	s. d. - -

FIG. 21

MODERN BUILDING CONSTRUCTION

allowed, both the discount and the amount received or paid are entered on the same line, but in their respective columns.

In the foregoing example, if the amount had been paid by cash instead of by cheque, the amount received would have been entered in the cash column instead of in the bank column.

The amount received was an amount owing to us by E. Fagg. The double entry will be effected by a posting on the contra (in this instance the credit) side of E. Fagg's account in the ledger, as shown in Fig. 15.

It is important to understand that the cash book is really two ledger accounts—"cash" and "bank"—which are bound up separately in the form of the cash book, as this is much more convenient. Consequently, an entry in the cash book will only need to be posted to one account in the ledger to complete the double entry. If the item is on the debit side of the cash book, it will be posted to the credit side of the corresponding ledger account. Conversely, if the item first appears on the credit side of the cash book, it will be posted to the debit side of the ledger account. Thus the cash book is both a book of first entry and two ledger accounts.

To further illustrate the method of entering up the cash book, we will give the following examples.

If value has been received from an outside firm and this is now paid, the entry in the cash book will be as in Fig. 16.

If, on the other hand, value had been sent to an outside firm and payment for same therefore due, the entry will appear on the debit side of the cash book, Fig. 17.

Amounts received for cash sales will need no personal account in the ledger, and therefore no personal reference in the cash book. Such transactions will be periodically summarized (this is best done daily) and entered in the cash book, as in Fig. 18.

Contrariwise, payments for cash purchases will be entered on the credit side of the cash book, Fig. 19.

When plant, machinery or other assets are purchased by cash, an entry will be made on the credit side of the cash book, as in Fig. 20.

Cash expenses, such as wages, salaries, rent, rates or taxes will be entered as shown in Fig. 21.

PETTY CASH BOOK

Petty Cash. It is advisable to pass all receipts and payments of money through a bank, but it is impossible to conduct a business without retaining some amount of cash in the office for petty disbursements. For example, odd items of postage, fares, and such-like will have to be paid immediately the indebtedness is incurred, or the amounts may even have to be advanced beforehand. This will necessitate that no payment must be made except the recipient of the cash gives a voucher or receipt, and these will be duly filed by the petty cash clerk.

When starting a petty cash system in an office, the first thing is to decide on a balancing period. This, for example, may be weekly, that is, Monday to Saturday inclusive—the petty cash book will thus be ruled off and balanced at the close of each week, and a fresh start made the first thing each Monday morning. Next, the utmost amount likely to be spent on petty expenses in the course of any weekly period must be decided upon. Assume that £10 will cover all likely demands in any one week. A cheque will be drawn for this amount, and on the credit side of the cash book an entry will be made, as shown in Fig. 22.

A clerk will be deputed to be responsible for the keeping of this petty cash, and he will be provided with a petty cash book ruled in tabular form, that is, with a number of analytical columns on the credit side, and each leaf will be divided into debit and credit sides.

On the debit side will be entered—

A. Date of cheque drawn for petty cash purposes;

B. Cash book reference;

C. Amount of cheque (see Fig. 23).

On the credit side, Fig. 24, will be entered—

A. Date of payment;

B. Voucher number;

C. Brief explanation of item of expenditure;

D. Ledger reference;

E. Total amount of item;

F, etc. Extension of E into appropriate columns (each column is for a heading or class of expenditure, such as Postage, Stationery, Travelling Expenses, Carriage, etc.).

It will be seen from the foregoing that the credit side of our petty cash book shows disbursements totalling £2 1s. 4d. If on the following Monday morning a cheque is drawn for this amount, the petty cash clerk will be able to start the next week afresh with £10.

BOOK-KEEPING, ACCOUNTING, AND COSTING

This procedure will be renewed at the close of each week. The effect of this will be that any time the total value of cash, plus vouchers held by the petty cash clerk, will be £10. The petty cash account for the week will be balanced and ruled off as shown in Fig. 25.

CASH BOOK

	1946 Jan. 4	By Petty Cash A/c	P.C. 1	Ba £ 10	n m s. -	k n d. -
--	----------------	-------------------	-----------	---------------	-------------------	-------------------

FIG. 22

Dr. PETTY CASH BOOK : DEBIT SIDE

A	B	C					
1946 Jan. 4	C.B. 1	£ 10	s. -	d. -			

FIG. 23

PETTY CASH BOOK : CREDIT SIDE

A	B	C	D	E	F Postage	Station- ery	Travel- ling Expenses	Carriage	Sun- dries
1946 Jan. 4	1	Stamps . . .		£ s. d. 13 - -	£ s. d. 13 - -	£ s. d. 14 4 -	£ s. d. 12 - -	£ s. d.	£ s. d.
" 5	2	Writing Paper . . .		14 4 -		14 4 -			
" 7	3	Fares . . .		12 - -			12 - -		
" 9	4	Gratuity . . .		2 - -					2 - -

FIG. 24

Dr. PETTY CASH BOOK Cr.

Date	Cash Book Ref.	Amount	Date	Voucher No.	Details	Ref.	Total	Postage	Station- ery	Travel- ling Expenses	Carriage	Sun- dries
1946 Jan. 4	1	£ 10 - -	1946 Jan. 4	1	Stamps . . .		£ s. d. 13 - -	£ s. d. 13 - -	£ s. d.	£ s. d.	£ s. d.	£ s. d.
" 11	2	2 1 4	" 5	2	Writing Paper . . .		14 4 -		14 4 -			
			" 7	3	Fares . . .		12 - -			12 - -		
			" 9	4	Gratuity . . .		2 - -					2 - -
					Balance . . .	c/d	2 1 4	13 - -	14 4 -	12 - -		2 - -
							£ 12 1 4					
Jan. 11	b/d	10 - -										

FIG. 25

Chapter III—A PRACTICAL SUMMARY

The Meaning of "Capital." Let us assume that a man named "A. Black" decided to begin business as a builder on 1st January, 1946. He has a private account at "The Provincial Bank, Ltd.," which shows a balance to his credit of £1,500. For the purpose of starting this business, he saw the bank manager and arranged to open a separate account for the business. Therefore there was transferred to "A. Black's" business account the sum of £1,000. Thus, £1,000 has left his private account and has been transferred to his business account.

The student must grasp the important fact that the business is just as liable to A. Black for this amount as if it had been invested by an outside person. This £1,000 invested in the business is its capital. Capital has been usefully defined as "spare cash," that is, that portion of a person's wealth which can be used in order to create more wealth. For book-keeping purposes, capital can be better understood as the amount by which the assets of a business exceed its liabilities. The business owes the amount of its capital to its proprietor or owner.

Liabilities and Assets. The precise meaning of *liabilities* can be remembered by the use of the simple word "owe," and *assets* by the use of the small word "own."

Liabilities are what a business owes.

Assets are what a business owns.

The assets of a business must be equal to its liabilities. Assets should not be valued at inflated figures.

Provided the liabilities of a business are equalled by the amount of its assets (reasonably valued), the business is said to be "solvent," that is, sound, or able to meet its obligations.

In opening the books of A. Black we must commence by showing—

- A. The amount of the capital of his business ;
- B. How the capital is made up.

Items A and B are shown by means of an entry in a book called *The Journal*.

WORKED EXAMPLE

ITEM 1.

Fig. 26 is a journal entry showing the opening position of business.

Of course, this money will not be left at the

bank. The student will realize that this would make business impossible. Before any work can begin, suitable premises and equipment must be purchased and contracts must be secured.

ITEM 2.

A. Black is able to get a small office and yard at a rental of £10 per month payable in advance. The first payment for this rent is made by cheque on 2nd January (1946).

This transaction will necessitate another entry, as Fig. 27, in the Journal.

The next stage will be to furnish the office ; to fit up a small stores and general workshop ; to buy plant ; and to engage a man to act as clerk, storekeeper, etc. These arrangements will involve records such as the following—

ITEMS 3 TO 6.	£
Jan. 4. Cheque paid for office furniture and stores fixtures	50
.. 5. Cheque paid for plant	70
.. 6. Cheque paid for machinery for workshop	100
.. 7. Man engaged as clerk-storekeeper at a salary of £3 per week.	

These items will show in the cash book as in Fig. 28.

From these entries in the cash book, ledger accounts will be posted as in Fig. 29.

ITEMS 7 TO 9.	£
Jan. 8. Timber for stock purchased on credit from B. Cragge	130
.. 9. Bricks, lime, cement, etc., purchased on credit from C. Doe	210
.. 11. Ironmongery and sundries purchased on credit from D. East	80

These three items must, firstly, be entered in a materials inwards book, Fig. 30, and will from thence be posted to the debit of a "Materials Account" in the ledger, Fig. 31, and to the credit of the personal accounts of the suppliers.

With the above transactions before us and before proceeding further, we can take note how the capital has been changed up to this point.

When A. Black commenced business on 1st January, the business owed him £1,000, which was the amount of the capital of the business, and there was £1,000 in the bank to

BOOK-KEEPING, ACCOUNTING, AND COSTING

JOURNAL

1946 Jan. 1	Bank To Capital A/c Being Asset and Liability at commencement of Business.	Dr.	£ 1000	s. -	d. -	£ 1000	s. -	d. -	

FIG. 26

JOURNAL

1946 Jan. 2	Rent A/c To Bank Cheque paid for Rent for month of January.	Dr.	£ 10	s. -	d. -	£ 10	s. -	d. -	

FIG. 27

A. BLACK'S CASH BOOK

Dr.		Cash						Contra						Cr.	
1946 Jan. 1	To Capital	£	s.	d.	£	s.	d.	1946 Jan. 2	By Rent	£	s.	d.	£	s.	d.
								Jan. 4	" Office Furni- ture				10		
					1000			Jan. 5	" Plant				50		
								Jan. 6	" Machinery				70		
													100		

FIG. 28

A. BLACK'S LEDGER

CAPITAL ACCOUNT

1946 Jan. 1	By Bank	C.B.	£	s.	d.	1	1000	-	-

RENT ACCOUNT

1946 Jan. 2	To Bank	C.B.	£	s.	d.	1	100 - -

OFFICE AND STORES FURNITURE ACCOUNT

1946 Jan. 4	To Bank	C.B.	£	s.	d.	1	50 - -

PLANT AND MACHINERY ACCOUNT

1946 Jan. 5	To Bank	C.B.	£	s.	d.	1	70 - -
" 6	" Bank	1	100				- -

FIG. 29

MODERN BUILDING CONSTRUCTION

PURCHASES DAY BOOK OR MATERIALS INWARDS BOOK

		£	s.	d.	£	s.	d.
1946							
Jan. 8	B. Cragge: Timber				130	-	-
" 9	C. Doe: Bricks, Lime, Cement, etc.				210	-	-
" 11	D. East: Ironmongery and Sundries				80	-	-
					<u>£420</u>	-	-

FIG. 30

LEDGER

MATERIALS ACCOUNT

<i>Dr.</i>		M.I.B.	£	s.	d.			
1946								
Jan. 11	To Sundries	1	420	-	-			
B. CRAGGE <i>Cr.</i>								
						M.I.B.	£	s. d.
						1	130	- -
C. DOE <i>Cr.</i>								
						M.I.B.	£	s. d.
						1	210	- -
D. EAST								
						M.I.B.	£	s. d.
						1	80	- -

FIG. 31

BALANCE SHEET OF A. BLACK (BUILDER) AS ON 1ST JANUARY, 1946

<i>Liabilities</i>		<i>Assets</i>	
Capital	£1000	Cash at Bank	£1000

BALANCE SHEET OF A. BLACK (BUILDER) AS ON 12TH JANUARY, 1946

<i>Liabilities</i>		£	s.	d.	<i>Assets</i>		£	s.	d.
Capital		1000	-	-	Cash at Bank		780	-	-
Creditors—					Plant and Machinery		170	-	-
B. Cragge	£130				Furniture and Fixtures		50	-	-
C. Doe	210				Stock of—				
D. East	80				Timber	£130			
		<u>420</u>	-	-	Bricks	210			
					Ironmongery	80			
						<u>420</u>	-	-	
		<u>£1420</u>	-	-		<u>£1420</u>	-	-	

FIG. 32

BOOK-KEEPING, ACCOUNTING, AND COSTING

cover this. Thus at that time a balance sheet up to 11th January, will be as in Fig. 32 at the close of that date.

The student is advised to note carefully the position of each transaction as it appears in the revised balance sheet.

It will be seen that "Cash at Bank" has been reduced by £220. This amount has been paid out for plant, machinery, furniture, and fixtures; also stock has been purchased to the value of £420.

As this latter item is composed of credit purchases (i.e. not paid for at time of purchase), we have to show on the liabilities side three creditors, and on the assets side the amount of purchases now appears as "Stock."

We will now proceed with the conduct of our business in periodic sections, which we will show the working of as we go along.

ITEM 10.

Jan. 12. Contract No. 1 secured and signed for erection of house for E. Fagg . £1000

As far as our books are concerned, this is a memorandum only. Nothing need be done at this stage except a heading made in the ledger, as in Fig. 33, in preparation for the contract account.

ITEM 11.

Jan. 13. Plant carted to site of Contract No. 1 and cartage paid by cheque . . . £1

If this were a general expense it would be journalized and debited to a nominal ("Cartage") account in the ledger, to which it would be posted from the cash book. As, however, it is an expense specifically incurred in respect to contract No. 1, it will be advisable to debit contract No. 1 account in the ledger with this amount. We shall, therefore, have two entries (debit and credit) as in Fig. 34 (a) and (b).

ITEM 12.

Jan. 14. Materials carted to Contract No. 1 from stock £200

This amount will be debited to the contract or job account. A "materials" account will be credited with the issue, as Fig. 35 (a) and (b).

(Note. This posting will be made from a "materials" or "stores issued book," which will be explained later.)

ITEM 13.

Cartage on previous item paid by cheque £1

See Fig. 36 (a) and (b).

ITEM 14.

Jan. 15. B. Cragge's account paid by cheque less cash discount of 5 per cent.

Reference back will show that there has been one transaction with B. Cragge, viz.—

Jan. 8. Timber for stock purchased on credit . £130

To clear this, we must first make an entry on the credit side of the cash book, showing (a) the allowance of cash discount of £6 10s., and (b) the net payment of £123 10s. The latter amount will show in the bank column, as it was paid by cheque (see Fig. 37).

Prior to this payment, B. Cragge's ledger account was as in Fig. 38.

From the cash book the payment of £123 10s. and the allowance of cash discount £6 10s., will be debited to B. Cragge's account (as by this payment B. Cragge receives value), and this will balance his account as in Fig. 39.

ITEM 15.

Jan. 16. Purchased bricks, sand, and cement from C. Doe for stock £300

This will be entered in the purchases day book, and from thence will be debited to materials account and credited to C. Doe's account in the ledger (see Fig. 40 (a), (b) and (c)).

ITEM 16.

Jan. 16. Cheque signed for office expenses . £10

This will need an entry on the credit side of the cash book, as shown in Fig. 41.

A tabular petty cash book will be prepared, and this £10 will be debited therein, Fig. 42.

ITEM 17.

Jan. 16. Clerk-storekeeper paid one week's salary by cash.

This item may be dealt with in one of two ways—

1. It may be entered on the credit side of the cash book.

Then from there the item will be posted to the debit of a salaries account in the ledger (see Fig. 43 (a) and (b)).

2. Or, alternatively, this item may be entered on the credit side of the petty cash book and carried out to a column headed "Ledger A/cs," and marked alongside this entry "Salaries A/c," Fig. 44.

ITEM 18.

Jan. 16. Wages cheque drawn for No. 1 contract £110

MODERN BUILDING CONSTRUCTION

LEDGER

Dr.		CONTRACT NO. 1 ACCOUNT (HOUSE FOR E. FAGG, £1000)						Cr.		
		£	s.	d.				£	s.	d.
FIG 33										

LEDGER

Dr.		CONTRACT NO. 1 ACCOUNT						Cr.		
		£	s.	d.				£	s.	d.
1946 Jan. 13	To Bank or To Cartage	C.B. 1	1	-	-					

FIG. 34 (a)

CASH BOOK

		CONTRACT NO. 1 ACCOUNT						Cr.		
		£	s.	d.	£	s.	d.	£	s.	d.
1946 Jan. 13	By Contract No. 1 A/c (Cartage)	L 1						1	-	-

FIG. 34 (b)

LEDGER

Dr.		CONTRACT NO. 1 ACCOUNT						Cr.		
		£	s.	d.				£	s.	d.
1946 Jan. 14	To Materials A/c	M.I.B. 1	200	-	-					

FIG. 35 (a)

MATERIALS ACCOUNT

		CONTRACT NO. 1 ACCOUNT						Cr.		
		£	s.	d.	£	s.	d.	£	s.	d.
1946 Jan. 14	By Contract No. 1 A/c	M.I.B. 1	200	-	-					

FIG. 35 (b)

LEDGER

Dr.		CONTRACT NO. 1 ACCOUNT						Cr.		
		£	s.	d.				£	s.	d.
1946 Jan. 14	To Bank or To Cartage	C.B. 1	1	-	-					

FIG. 36 (a)

CASH BOOK

		CONTRACT NO. 1 ACCOUNT						Cr.		
		£	s.	d.	£	s.	d.	£	s.	d.
1946 Jan. 14	By Cartage (Contract No. 1)	L 1						1	-	-

FIG. 36 (b)

BOOK-KEEPING, ACCOUNTING, AND COSTING

CASH BOOK

Cr.

	1946 Jan. 15	By B. Cragge	L	£	6	s.	10	d.	-	£	s.	d.	£	s.	d.
													123	10	-

FIG. 37

LEDGER

Dr.

B. CRAGGE

Cr.

			£	s.	d.	1946 Jan. 8	By Materials A/c						M.I.B. 1	£	s.	d.
														130		-

FIG. 38

LEDGER

Dr.

B. CRAGGE

Cr.

1946 Jan. 15	To Discount		£	s.	d.	1946 Jan. 8	By Materials A/c						M.I.B. 1	£	s.	d.
		C.B.												130		-
,, 15	„ Bank	C.B.														-
			£130											£130		-

FIG. 39

PURCHASES DAY BOOK

1946 Jan. 16	C. Doe : Bricks, Sand, and Cement	£	s.	d.	£	s.	d.
					300		-

FIG. 40 (a)

LEDGER

Dr.

MATERIALS ACCOUNT

Cr.

1946 Jan. 16	To C. Doe	P.D.B. 1	£	s.	d.												
						300											

FIG. 40 (b)

C. DOE

Cr.

		1946 Jan. 16	By Materials A/c	P.D.B. 1	£	s.	d.
					300		-

FIG. 40 (c)

CASH BOOK

																	Bank Column
		1946 Jan. 16	By Petty Cash	P.C.B. 1	£	s.	d.										
					10		-										

FIG. 41

MODERN BUILDING CONSTRUCTION

Dr.											PETTY CASH BOOK											Cr.		
Date	Ref.	Amount			Date	Voucher No.	Details	Ref.	Total			Postage			Stationery			Traveling Expenses			Sundries			
1946		£	s.	d.				£	s.	d.	£	s.	d.	£	s.	d.	£	s.	d.	£	s.	d.		
Jan. 16	C.B.	10	-	-																				

FIG. 42

CASH BOOK											Cr.									
											Cash Column									
								1946										£	s.	d.
								Jan. 16	By Salaries A/c			L						3	-	-

FIG. 43 (a)

Dr.											LEDGER											SALARIES ACCOUNT										
1946	Jan. 16	To Cash				C.B.	£	s.	d.																							
							3	-	-																							

FIG. 43 (b)

PETTY CASH BOOK																																										
Date	Ref.	Amount			Date	Voucher No.	Details	Ref.	Total			Postage			Stationery			Traveling Expenses			Ledger Accounts																					
1946		£	s.	d.				£	s.	d.	£	s.	d.	£	s.	d.	£	s.	d.	£	s.	d.																				
Jan. 16					1946	1	Salary	S.B.	3	-	-																															

FIG. 44

CASH BOOK											Cr.												
								1946										£	s.	d.			
								Jan. 16	By No. 1 Contract (Wages)			L									110	-	-

FIG. 45 (a)

Dr.											LEDGER											No. 1 CONTRACT ACCOUNT										
1946	Jan. 16	To Wages				C.B.	£	s.	d.																							
							110	-	-																							

FIG. 45 (b)

BOOK-KEEPING, ACCOUNTING, AND COSTING

This will need an entry on the credit side of the cash book, and from there the item will be posted to the debit side of No. 1 contract account in the ledger (see Fig. 45 (a) and (b)).

This must be treated as a memorandum or note, and nothing more need be done at this stage than to prepare the heading for the contract account in the ledger (see Fig. 46).

ITEM 19.
Jan. 18. Contract No. 2 secured and signed for erection of stables for Mr. F. Gibb . £800

ITEM 20.
Jan. 17 Purchased sanitary goods from Doulton & Co., Ltd., for stock £275

LEDGER

Dr.	No. 2 CONTRACT ACCOUNT (MR. F. GIBB)						Cr.			
			£	s.	d.			£	s.	d.

FIG. 46

CASH BOOK

							Bank Column		
							£	s.	d.
		1946					£	s.	d.
		Jan. 19			By No. 2 Contract (Cartage)	L	1	-	-

FIG. 47 (a)

LEDGER

Dr.	No. 2 CONTRACT ACCOUNT					
			£	s.	d.	
1946			1	-	-	
Jan. 19	To Cartage	C.B.				

FIG. 47 (b)

PURCHASES DAY BOOK

		Total			Stock			Contracts		
		£	s.	d.	£	s.	d.	£	s.	d.
1946								£	s.	d.
Jan. 20	B. Cragge: Sundry Materials	130	-	-				130	-	-
								(Contract		
								2)		

FIG. 48

LEDGER

Dr.	No. 2 CONTRACT ACCOUNT					
			£	s.	d.	
1946			130	-	-	
Jan. 20	To B. Cragge	P.D.B.				

FIG. 49 (a)

B. CRAGGE

							Cr.		
							£	s.	d.
		1946					£	s.	d.
		Jan. 20			By No. 2 Contract A/c .	P.D.B.	130	-	-

FIG. 49 (b)

MODERN BUILDING CONSTRUCTION

This will be entered in the purchases day book, and from thence to the debit of materials account in the ledger—

To Doulton & Co., Ltd. . . . £275
and to the credit of Doulton & Co.'s account—
By Materials A/c £275

ITEM 21.

Jan. 19. Plant carted to site of No. 2 contract :
cartage paid by cash £1

This will be entered on credit side of cash book, and from there it will be posted to the debit side of the contract account in the ledger (see Fig. 47 (a) and (b)).

ITEM 22.

Jan. 20. Materials purchased on credit from
B. Cragge and delivered direct to
No. 2 contract £130

This transaction will pass through a purchases day book, which will be ruled with an extra column for purchases for contracts (see Fig. 48).

(Note. The word "sundry," or "sundries," in book-keeping means "more than one item.")

As these materials were delivered direct to No. 2 contract, this item will be debited to the account for this contract; and as it is a credit transaction, it will be credited to the account of "B. Cragge" (see Fig. 49 (a) and (b)).

ITEM 23.

Jan. 21. Materials carted to No. 1 contract *ex*
stock £240

This will be, firstly, entered into a materials outwards book, and from there will be posted to the debit of No. 1 contract account, and to the credit of materials account in the ledger; see Fig. 50 (a), (b), and (c).

(Note. These postings are in accordance with the rule—

Contract receives value, therefore debit contract account;

Materials or stock give value, therefore credit materials account.)

ITEM 24.

Jan. 22 Contract No. 3 secured and signed
—for erection of a bungalow for
G. Haddon £1100

As there is no transfer of value, this must be treated as a memorandum only. All that is necessary at this stage is the preparation of a sheet, or folio, in the ledger for the contract account (see Fig. 51).

ITEM 25.

Jan. 23. Clerk-storekeeper paid one week's wages by cash.

This will require a credit entry in the cash

book (cash column), and wages account in the ledger must be debited. This has already been illustrated in the case of a similar item on 16th January.

ITEM 26.

Jan. 23. Cheque drawn for wages paid on contracts—
No. 1 £260
No. 2 £170

Credit bank column of cash book, and post to the debit side of the respective contract accounts in the ledger (see Fig. 52 (a) and (b)).

ITEM 27.

Jan. 25. Materials delivered from stock to contracts—
No. 1 £40
No. 2 £260

This will need an entry in the "materials issued book," and from there the item will be entered to the debit of the respective contract accounts, and to the credit of the materials account in the ledger.

ITEM 28.

Jan. 25. Drew cheque for office cash . . . £10

Credit cash book bank column, "By Petty Cash A/c," and debit the petty cash book "To Bank."

ITEM 29.

Jan. 25. Cartage paid by cash to be charged
equally between contracts Nos. 1 and 2 £2

Credit petty cash book and extend to the analytical column headed "Carriage"; note amounts to be charged to each contract either at foot or at side. Then debit the respective contract accounts in the ledger, £1 to each described as "To Cartage."

ITEM 30.

Jan. 26. No 1 contract completed, surveyed, and
architect's fees paid by cheque . . £10

Credit the bank column of the cash book and debit No. 1 contract account in the ledger (see Fig. 53 (a) and (b)).

ITEM 31.

Jan. 27. Certificate received for the whole amount of
No. 1 contract.

When the certificate is received the amount becomes due to the contractor. Therefore a journal entry, Fig. 54 (a), will be made debiting the personal account of the contractee (the person or firm for whom the work is done), and crediting the contract account. This will be posted to the two accounts in the ledger (see Fig. 54 (b) and (c)).

ITEM 32.

Jan. 27. Purchased material from Messrs. Sands
& Co., for No. 3 contract, and
delivered to job direct £85

MODERN BUILDING CONSTRUCTION

CASH BOOK

Cr.

				Bank Column		
	1946 Jan. 26	By No. 1 Contract (Architect's Fees)	—	£ 10	s. —	d. —

FIG. 53 (a)

LEDGER

Dr.

NO. 1 CONTRACT ACCOUNT

1946 Jan. 26	To Architect's Fees	C.B.	£ 10	s. —	d. —
-----------------	-------------------------------	------	---------	---------	---------

FIG. 53 (b)

JOURNAL

1946 Jan. 27	E. Fagg To No. 1 Contract A/c Architect's Certificate received.	<i>Dr.</i>	L	£ 1000	s. —	d. —	£ 1000	s. —	d. —
-----------------	---	------------	---	-----------	---------	---------	-----------	---------	---------

FIG. 54 (a)

LEDGER

Dr.

E. FAGG

1946 Jan. 27	To No. 1 Contract A/c	✓	£ 1000	s. —	d. —
-----------------	---------------------------------	---	-----------	---------	---------

FIG. 54 (b)

NO. 1 CONTRACT ACCOUNT

Cr.

	1946 Jan. 27	By E. Fagg	✓	£ 1000	s. —	d. —
--	-----------------	----------------------	---	-----------	---------	---------

FIG. 54 (c)

PURCHASES DAY BOOK (ELABORATED FORM 1)

Date	Item or Voucher No.	Supplier	Details of Materials	Led. Ref.	Total	Purchases for Stock	Purchases for Jobs				
							Amount	Job No.			
1946 Jan. 27	1	Sands & Co.	Sundry Materials	L	£ 85	s. —	d. —	£ 85	s. —	d. —	C. 3

FIG. 55 (a)

This will be entered in purchases day book in such manner, Fig. 55 (a), as to show that it is a purchase expressly for a job.

From the purchases day book, No. 3 contract account will be debited and the account for Messrs. Sands & Co. will be credited, as in Fig. 55 (b) and (c).

ITEM 33.

Jan. 28. Plant carted to site of No. 3 contract ;
cartage paid by cheque £1

This will necessitate a debit to No. 3 contract account in the ledger, which will be described "To Cartage," and a credit in the cash book (bank column) "By No. 3 Contract (Cartage)"; or to place this procedure in correct order, the item will be firstly entered in the cash book, and from thence to the contra account in the ledger.

ITEM 34.

Jan. 29. Materials delivered to No. 3 contract
ex stock £180

This will be firstly entered in the materials outwards book, and from there will be posted to two ledger accounts—

To debit of "No. 3 Contract" described as "To Materials."

To credit of "Materials A/c" described as "By No. 3 Contract A/c."

ITEM 35.

Cartage on previous item paid by cash £2

Enter in cash book on credit side, "By No. 3 Contract," as Fig. 56, or this may be dealt with in the petty cash book, and post to the ledger, from there to the debit of No. 3 contract account "To Cartage."

ITEM 36.

Jan. 29. No. 2 contract completed and surveyed, and certificate received for the whole amount.

A journal entry, Fig. 57 (a), must be made debiting the personal account of the contractee, F. Gibb, and crediting No. 2 contract account. These two accounts in the ledger will be posted from the journal entry, as in Fig. 57 (b) and (c).

ITEM 37.

Jan. 29. Architect's fee paid by cheque to No. 2 contract £8

This will firstly necessitate a credit entry in the cash book (Fig. 58 (a)), and No. 2 contract account in the ledger will be debited as Fig. 53 (b).

ITEM 38.

Jan. 29. Local council's demand received in connection with No. 1 contract £30

This will firstly necessitate a journal entry (Fig. 59 (a)), from which two postings will be made in the ledger: one debiting, Fig. 59 (b), and the other crediting, Fig. 59 (c).

ITEM 39.

Jan. 29. Local council's demand received in connection with No. 2 contract £20

This will be dealt with in similar fashion to the previous example, except that in this case the contract to be debited will be No. 2.

ITEM 40.

Jan. 30. Bill at three months received for the whole amount of No. 2 contract.

(Note. The word "bill" is often mistakenly used to denote an invoice. A "bill" here means a *bill of exchange*, i.e. a written order addressed by one person to another requiring the person to whom it is addressed to pay a specified sum on a future date for value received.)

As a bill of exchange is only turned into money at some future date, a journal entry must be made and ledger accounts posted for this, as shown in Fig. 60. Debit "Bills Receivable A/c" and credit the personal account of the contractee with the value of the bill. This shows that F. Gibb has paid the amount due from him on completion of the work.

A reference back to the illustrations under Item 35 will show that the above postings have the effect of closing F. Gibb's account.

ITEM 41.

Jan. 30. Wages paid in respect of No. 2 contract £120

Bank column of cash book will be credited as Fig. 61 (a), and No. 2 contract account in the ledger will be debited as Fig. 61 (b).

ITEM 42.

Jan. 30. Wages paid in respect to No. 3 contract £310

This will be dealt with similarly to the previous item.

ITEM 43.

Jan. 30. Cheque received in payment of certificate for No. 1 contract £1000

This will require a credit entry in the cash book (bank column), "By E. Fagg," and a debit entry to E. Fagg's personal account in the ledger, "To Bank." This will have the effect of closing E. Fagg's account in the ledger.

ITEM 44.

Jan. 30. Certificate received for £550 on account of No. 3 contract.

MODERN BUILDING CONSTRUCTION

LEDGER

Dr. No. 3 CONTRACT ACCOUNT

1946 Jan. 27	To Sands & Co	P.D.B.	£	s.	d.			
			85	-	-			

FIG. 55 (b)

SANDS & Co.

Cr.

			1946 Jan. 27	By No. 3 Contract A/c	P.D.B.	£	s.	d.
						85	-	-

FIG. 55 (c)

CASH BOOK

Cr.

								Cash Column
				By No. 3 Contract (Cartage)		£	s.	d.
						2	-	-

FIG. 56

JOURNAL

1946 Jan. 29	F. Gibb To No. 2 Contract A/c Certificate received on Completion of Work to Architect's Approval.	Dr.	L	£	s.	d.	£	s.	d.
			L	800	-	-	800	-	-

FIG. 57 (a)

LEDGER

Dr. F. GIBB'S ACCOUNT

1946 Jan. 29	To No. 2 Contract A/c	✓	£	s.	d.			
			800	-	-			

FIG. 57 (b)

No. 2 CONTRACT ACCOUNT

Cr.

			1946 Jan. 29	By F. Gibb	✓	£	s.	d.
						800	-	-

FIG. 57 (c)

CASH BOOK

Cr.

								Bank Column
				By No. 2 Contract (Architect's Fee)		£	s.	d.

FIG. 58 (a)

	To Architect's Fee	C.B.	£	s.	d.			
--	------------------------------	------	---	----	----	--	--	--

FIG. 58 (b)

BOOK-KEEPING, ACCOUNTING, AND COSTING

JOURNAL

1946		Dr.	L	£	s.	d.	£	s.	d.
Jan. 29	No. 1 Contract A/c To X Council Fees due.	L	L	30	-	-	30	-	-

FIG. 59 (a)

Dr.

NO. 1 CONTRACT ACCOUNT

1946		£	s.	d.		
Jan. 29	To X Council	30	-	-		

FIG. 59 (b)

X COUNCIL

Cr.

1946		£	s.	d.		
Jan. 29	By No. 1 Contract A/c	30	-	-	✓	

FIG. 59 (c)

JOURNAL

1946		Dr.	L	£	s.	d.	£	s.	d.
Jan. 30	Bills Receivable A/c To F. Gibb Bill received at Three Months.	L	L	800	-	-	800	-	-

FIG. 60 (a)

LEDGER

Dr.

BILLS RECEIVABLE ACCOUNT

1946		£	s.	d.		
Jan. 30	To F. Gibb	800	-	-	✓	

FIG. 60 (b)

F. GIBB

Cr.

1946		£	s.	d.		
Jan. 30	By Bills Receivable A/c	800	-	-	✓	

FIG. 60 (c)

CASH BOOK

Cr.

1946		£	s.	d.		
	By No. 2 Contract (Wages)	120	-	-	L	

FIG. 61 (a)

Dr.

NO. 2 CONTRACT ACCOUNT

1946		£	s.	d.		
	To Wages	120	-	-	C.B.	

FIG. 61 (b)

MODERN BUILDING CONSTRUCTION

Dr.

CASH BOOK

		Discount			Bank		
		£	s.	d.	£	s.	d.
1946 Jan. 31	To Bill Receivable (Gibb)	L.	10	-	790	-	-

FIG. 62 (a)

LEDGER

BILLS RECEIVABLE ACCOUNT

Cr.

		1946 Jan. 31	By Bank	C.B.	£	s.	d.
					800	-	-

FIG. 62 (b)

CASH BOOK

Cr.

		Dis- counts			Cash			Bank		
		£	s.	d.	£	s.	d.	£	s.	d.
1946 Jan. 31	By C. Doe	L.	25	10				484	10	-
" "	" D. East	"	4	-				76	-	-
" "	" Doulton & Co.	"	13	15				261	5	-
" "	" B. Cragge	"	6	10				123	10	-
" "	" Sands & Co.	"	4	5				80	15	-
" "	" X Council	"	2	10				47	10	-

FIG. 63

JOURNAL

		£			s.			d.		
		£	s.	d.	£	s.	d.	£	s.	d.
1946 Jan. 31	Sundries									
	To Plant A/c				7	-	-			
	No. 1 Contract A/c	3	-	-						
	No. 2 Contract A/c	2	10	-						
	No. 3 Contract A/c	1	10	-						
	Being Depreciations of Plant charged to Contracts on Basis of 10 per cent of Value	£7	-	-	£7	-	-			

FIG. 64 (a)

LEDGER

Dr.

NO. 1 CONTRACT ACCOUNT

		£	s.	d.
1946 Jan. 31	To Plant	3	-	-

PLANT ACCOUNT

Cr.

		1946 Jan. 31	By No. 1 Contract A/c	£	s.	d.
				3	-	-

FIG. 64 (b)

BOOK-KEEPING, ACCOUNTING, AND COSTING

This will be dealt with similarly to Item 35 in respect to No. 2 contract, i.e. a journal entry debiting personal account of contractee and crediting contract account, and from this the respective ledger accounts will be posted.

ITEM 45.

Jan. 31. Cheque received in payment of certificate *re* No. 3 contract £550

This will be dealt with similarly to Item 42, which was in respect to No. 1 contract.

ITEM 46.

Jan. 31. Discounted Gibb's acceptance (*re* No. 2 contract) for £790.

Reference back to Item 39 will show that the term "acceptance" is another name for "bill of exchange," which in this instance was for the amount of £800. To "discount the bill" means that instead of waiting until it "matured" (or its full period had expired), the holder took it to his banker, who was prepared to accept the bill as security for an advance of its face value, less the banker's commission of £10. This will be entered on the debit side of the cash book, as Fig. 62 (a), and from there will be posted, in one sum, to the credit side of bills receivable account in the ledger, Fig. 62 (b).

ITEM 47.

Jan. 31. All outstanding accounts settled by cheque less a cash discount of 5 per cent in each case.

This will involve the credit entries, Fig. 63, in the cash book.

This will also include a further payment in respect of clerk's salary due—£3—which will be dealt with as before.

ITEM 48.

Jan. 31. Plant charged to contracts on basis of 10 per cent of value of plant used.

This requires a journal entry, Fig. 64 (a), debiting the contract accounts as follows—

No. 1 with £3.
No. 2 with £2 10s.
No. 3 with £1 10s.

and crediting plant account with £7.

From this entry the four ledger accounts will be posted as in Fig. 64 (b).

(Accounts for Nos. 2 and 3 contracts will be posted similarly to No. 1 contract account.)

The Trial Balance. The ledger accounts must now be gone through, and those accounts that have debit or credit balances must be set out in the form of a trial balance. If the student has compiled or posted his ledger from the foregoing transactions, he will find that the balances are as in Fig. 65.

It will be seen that the total debits agree with the total credit balances. This is as it should be, and is a check on the ledger work, showing (unless a debit and credit entry has been mistakenly reversed) that the book-keeping has been accurate up to this point.

TRIAL BALANCE

	Ledger Folio	Debits			Credits		
		£	s.	d.	£	s.	d.
Cash in Hand	C.B. 1	6	—	—			
Cash at Bank	C.B. 1	902	—	—			
Office Furniture, etc., A/c	L. 2	50	—	—			
Plant A/c	L. 3	63	—	—			
Machinery A/c	L. 4	100	—	—			
Salaries A/c	L. 5	9	—	—			
Rent A/c	L. 6	10	—	—			
Materials (or Stock) A/c	L. 7	205	—	—			
Contract No. 3 A/c	L. 11	29	10	—			
Contract No. 1 A/c	L. 9				104	—	—
Contract No. 2 A/c	L. 10				217	10	—
Discounts A/c	L. 8				53	—	—
Capital A/c	L. 1				1000	—	—
		£ 1374	10	—	£ 1374	10	—

FIG. 65

Chapter IV—THE FINAL ACCOUNTS

THE trial balance, in addition to being a check on the accuracy of the ledger posting work, also provides the data from which the final accounts can be prepared, and the amount of profit made over the period ascertained.

THE TRADING ACCOUNT

This account is intended to show us the profit made on buying and selling (i.e. "trading") before overhead expenses are charged against the profit. The profit made on trading is termed "gross profit." The items that we must take out of our trial balance, in order to build up this account, are materials and contracts accounts. These must be arranged as follows—

Debit Side	Credit Side
Value of stock purchased less value of issues during period. Losses on contracts.	Profits on contracts. Value of stock at close of trading period.

We will now set out our figures in this way Fig. 66, page 884, and thus see what gross profit has been made.

In the foregoing it will be observed that each item is a balance taken from the contract accounts and the materials account.

Each contract account is really a manufacturing account, so that our trading account in this example is really a summary of our various works undertakings. In regard to the item *work in progress*, this is the value of unfinished work, which in our example is taken at cost.

The value of closing stock on credit side is arrived at by adding 10 per cent to the value of the stock remaining after all issues had been credited to materials account. The value of closing stock is usually ascertained as a result of stock-taking.

The principles underlying the preparation of a trading account are as follows.

It will comprise all actual trading during the

period, that is, the handling and selling of saleable goods, and will be compiled from the trial balance (except closing stock, which will be based on valuation at stock-taking). Marshallled in debit and credit array this account will be as under—

Debit Side	Credit Side
<ol style="list-style-type: none"> 1. Value of stock at commencement of trading period. 2. Purchases of saleable materials (less returns outwards), or cost of goods manufactured during trading period. 3. All wages and expenses incurred in handling the goods to the time they are sold. 	<ol style="list-style-type: none"> 1. Value of sales. 2. Value of work in progress. 3. Value of closing stock.

MANUFACTURING ACCOUNTS

A building business may include various works at headquarters, such as a joinery factory. In this case, a manufacturing account, in addition to a trading account, must be prepared. The figures for both accounts will be taken from the

Debit Side	Credit Side
<ol style="list-style-type: none"> 1. Value of stock of raw materials (ironmongery, timber, etc.), at commencement of trading period. 2. Value of work in progress or partly manufactured articles at commencement of trading period. 3. Total Purchases of materials (less returns inwards) for stock, to be used on manufactures. 4. Factory wages. 5. Other items of purely factory expenditure. 	<ol style="list-style-type: none"> 1. Value of manufactures completed and transferred to warehouse for sale. 2. Value of closing stock of work in progress. 3. Value of closing stock of unused material remaining in stores.

BOOK-KEEPING, ACCOUNTING, AND COSTING

trial balance, and will be set out as shown on page 882.

Note. Value of item 1 on credit side of the above account is ascertained by deducting total of 2 and 3 on credit side from total of all items on debit side. The student is advised carefully to study this account.

Following on from a manufacturing account, prepared as above, the trading account would be compiled as follows—

Debit Side	Credit Side
<ol style="list-style-type: none"> 1. Value of stock of completely manufactured goods at commencement of trading period. 2. Bring down item 1 from credit side of Manufacturing A/c, viz., cost of goods manufactured during the trading period. 3. All wages and expenses incurred in handling the completed work from the time it leaves the factory to the time it is sold. 	<ol style="list-style-type: none"> 1. Value of sales. 2. Value of closing stock of completed and saleable manufactures.

This illustration shows the detailed principles that should guide the student in the preparation of these accounts.

PROFIT AND LOSS ACCOUNT

If the reader will turn back to the trial balance and the trading account of our worked exercise, his next step will be to compile a profit and loss account, Fig. 67. Our gross profit or profit on trading was £342, but this is not actual profit, as we have yet to set against this the overhead or non-productive expenses. From the trial balance we can see that these are as follows: Salaries and rent are debits, and discount is a credit.

We see from this that after reducing the profit on trading by the total amount of overhead charges (£19), and crediting the amount gained by discounts (£53), we have made over the trading period an actual net profit of £376.

In a business where there is one proprietor only, this amount will be transferred to the capital account, so that the original capital of

the business will be increased by the amount of net profit made.

THE BALANCE SHEET

The final stage in the working out of our exercise is to prepare the balance sheet, showing the state of the business at the close of the trading period. The data for this will be the items in the trial balance that have not been dealt with in the trading and profit and loss accounts; the amount of net profit as shown by the profit and loss account; and the values of the work in progress and stock of materials at the close of the period.

The balance sheet is not prepared in the same form as an account. It is rather a statement showing on the left side the liabilities of the business, and on the right side the assets of the business. Let us set these out (Fig. 68) from the particulars in our trial balance, etc.

The balance sheet shows the position of A. Black's business at the close of his trading period, with the net result that his capital has increased by nearly 40 per cent. This capital is covered by a number of sound assets.

DEPRECIATION. Assets such as office furniture and machinery will, of course, "depreciate," or lose value, and for this reason it is usual, after the trial balance has been agreed, to pass an entry through the journal, debiting profit and loss account and crediting office furniture (and other) account with the amount of the depreciation. The rate of depreciation is usually based on original cost divided by estimated life in years, equal proportion for year to be charged against profit.

DRAWINGS. Should the proprietor take money out of the business for his personal use, this will be passed through the journal, and a "drawings account" debited. The capital account will be credited to complete the double entry. Drawings are *not* debited to profit and loss account.

ANALYTICAL BOOK-KEEPING

In modern book-keeping, analysis necessarily holds a prominent place. Analysis may be effected either concurrently with the ordinary book-keeping work, or by means of separate records. Analysis in the ordinary books of account is known as "tabular book-keeping," or the term "columnar" instead of "tabular"

MODERN BUILDING CONSTRUCTION

Dr.				TRADING ACCOUNT				Cr.			
1946		£ s. d.		1946		£ s. d.					
Jan. 31	To Stock	205	-	Jan. 31	By Contract No. 1	104	-				
" "	" Contract No. 3	29	10	" "	" Contract No. 2	217	10				
" "	" Gross Profit	342	-	" "	" Work in Progress	29	10				
				" "	" Stock at Close	225	10				
		<u>£576</u>	<u>10</u>			<u>£576</u>	<u>10</u>				

FIG. 66

Dr.				PROFIT AND LOSS ACCOUNT				Cr.			
1946		£ s. d.		1946		£ s. d.					
Jan. 31	To Salaries	9	-	Jan. 31	By Gross Profit b/d from Trading A/c	342	-				
" "	" Rent	10	-	" "	" Discounts	53	-				
" "	" Net Profit	376	-			<u>£395</u>	<u>-</u>				
		<u>£395</u>	<u>-</u>			<u>£395</u>	<u>-</u>				

FIG. 67

BALANCE SHEET OF A. BLACK, BUILDER, AS ON 31ST JANUARY, 1946

Liabilities							
Jan. 1		£		Jan. 31		£	
Jan. 1	Capital	£1000	-	Jan. 31	Cash in Hand	6	-
" 31	Add Net Profit	376	-		Cash at Bank	902	-
		<u>£1376</u>	<u>-</u>		Office Furniture	50	-
					Plant	63	-
					Machinery	100	-
					Stock	225	10
					Work in Progress	29	10
		<u>£1376</u>	<u>-</u>			<u>£1376</u>	<u>-</u>

FIG. 68

RULING FOR PURCHASES DAY BOOK (TABULAR FORM)

In-voice	Date	Supplier	Particulars of Materials	Led. Ref.	Total		Plant and Tools		For Store		For Contracts		Contract No.
					£	s. d.	£	s. d.	£	s. d.	£	s. d.	
1	1946 Sept. 1	A. Jones.	1/30 Rd. Ladder 1 cwt. Nails Door Furniture Butts and Screws		£	s. d.	£	s. d.	£	s. d.	£	s. d.	
					6	3 8	3	-	1	8 -	19	8	101
											16	-	102

FIG. 69

BOOK-KEEPING, ACCOUNTING, AND COSTING

may be used. The student will be familiar with the method of cross totals, for example—

1	2	3	4	10
2	3	4	5	14
3	4	5	6	18
4	5	6	7	22
10	14	18	22	64

This illustration has been made purposely simple. The fact that the sum of the vertical and the sum of the horizontal totals both equal 64 is a check on the accuracy of both sets of additions.

Similarly, tabular book-keeping means that a total amount for each item or transaction is given in the records, but followed by a series of analytical columns in which the value of the entry is dissected under suitable headings. The agreement of the sums of the vertical and horizontal totals (as above illustration) proves the arithmetical accuracy of each page or folio.

As a more practical illustration, let us decide to keep our purchases day book by this method. We decide to analyse all purchases under three divisions—

1. Plant and Tools (capital expenditure).
2. Materials for Store.
3. Materials for direct delivery to Contracts.

A suggested ruling for this will be as in Fig. 69. These columns can, of course, be added to as required.

A separate purchases book may be preferred for plant and tools with analytical columns for—

1. Plant and Tools (capital).
2. Plant and Tools (repairs and renewals).
3. Plant and Tools (consumable).

Analytical columns may be required to denote—

- (a) Different branches of a business.
- (b) Different departments.
- (c) Different contracts.
- (d) Different trades on the same contract.

Where the business is of very huge proportions, it is found that separate books for the several sections of analysis are required. For example, in the costing of a large contract, the execution of which may extend over a long period, one ledger may be needed for this contract alone. The subdivisions of cost may be the respective trades, so that the ledger will be divided up so as to allow so many folios for each trade.

Where a business is organized into departments, and invoices are issued to responsible departments for certification, invoices should always go through the hands of a responsible department, or clerk, and issued out to the department that is required to certify the invoice. The invoice will then be passed through the purchase books.

Estimating

By HENRY A. MACKMIN, F.S.I., M.I.STRUCT.E., M.R.SAN.I.

Author of "Builders' Estimates and Data"; Formerly Lecturer on Analysis of Pricing at The College of Estate Management, London, and Head of the Building Department, Croydon Polytechnic

Chapter I—METHODS OF ESTIMATING: CUBING

THE preparation of builders' estimates is a task that needs considerable experience, and no matter what position one may occupy in regard to the construction of buildings, sooner or later the question of cost will arise. The client may stipulate the cost of the work must not exceed a certain amount, or as soon as the drawings are ready he will require to know the approximate cost. The architect will prepare a rough outline of the cost himself, or perhaps he may consult a quantity surveyor. In the provinces, it sometimes happens that the architect prepares his own quantities, but in London and other large towns independent quantity surveyors do the work.

Frequently the architect bases his approximate estimate upon what are known as "cube" prices; whilst the quantity surveyor is more likely to prepare "rough quantities" and price the items upon actual data obtained from other work, similar in character.

The latter method is more reliable than the former; in fact, "cube" prices if used by the inexperienced can be very dangerous as well as misleading. When proper measurements are taken and a careful bill of quantities prepared, the preparation of prices is not so difficult a matter for the builder, or his estimating surveyor, as when drawings and specification only are supplied; for in this latter event the person preparing the estimate will find it necessary to take out the quantities as well as prepare the prices. Many building firms of repute now refuse to tender unless bills of quantities are supplied, except of course for small jobs, repairs, or decorating work; but when it does become necessary for the builder to take out quantities the latter do not contain anything like the amount of detail as given in a surveyor's bill of quantities, but are in the form of "rough" quantities as mentioned earlier.

It may happen that the client himself consults

a builder and asks him to prepare his own specification and estimate, in which case it also becomes necessary to prepare "rough" quantities. This name does not accurately describe the work; "grouped" quantities would be a better term. Often the client consults more than one builder, which means that several men are occupied upon similar tasks, but only one of them will be repaid. This is one of the difficult problems in the building trade, and the custom is probably due to so many persons offering to supply "estimates free," a description one so often finds upon billheads, and even displayed in advertisements.

The amount of time expended in the preparation of estimates for work which he does not obtain is a serious matter to many a builder. It is to be hoped that in the near future some remedy may be found, for it is not fair to expect one section of the community to work for nothing.

From the previous remarks it will be seen that there are three practical methods of estimating: "cube" prices, "rough" quantities, and detailed pricing of accurate bills of quantities. It is intended here to explain each method, but most attention will be paid to the last-named process and the analyses of prices. There is one other form of pricing, which, however, can hardly be considered a method, but which is used by certain individuals, particularly with regard to painting and decorating work. It simply consists of guessing at the price. The individual concerned may claim that his past experience enables him to form his idea of price without taking any measurements; but it has been found that the more experienced a man becomes, the less he relies upon anything in the nature of gambling with prices and measurements. With "spot items," i.e. work that has to be valued on the site, it is necessary to a certain extent to compile the prices without taking

measurements, but even these figures can be obtained by estimating the number of hours required for the task.

To prepare a reliable estimate there is only one sound method, and that is to prepare a proper bill of quantities, and to price each item in a careful manner, using prices prepared upon a detailed analysis of each separate item.

Tenders. These can be of two kinds, that is *lump sum tenders* and *priced schedules*. For lump sum tenders it is usual for bills of quantities to be prepared, and these are forwarded to builders for them to price. After pricing each item in the bill, the builder forwards the total only as his tender; and later, if his price is accepted, he forwards a complete priced bill. The priced bill becomes the basis for any variations that occur during the progress of the job; any extras or omissions are priced at the prices contained in the detailed bill of quantities.

Another form of tendering is for the architect to forward the builder a schedule of typical items that are likely to occur on the particular job, but without giving any quantities. The builder prices each item, and later on as the work proceeds it is measured up and priced at the rates quoted. Government departments and municipal authorities sometimes prepare a priced schedule of all items likely to occur in a building; and this document is forwarded to contractors, who quote a percentage to be added to, or deducted from, the prices given in the schedule. It is obvious that the great disadvantage of priced schedules is the difficulty of knowing in advance the size of the job, and the impossibility of finding if the job is profitable or otherwise until the work is measured up. Tendering by giving lump sums is preferable, and priced schedules should be used only when time does not permit the preparation of bills of quantities.

Variations in Estimates. To the uninitiated the great disparity that occurs between the highest and lowest tenders, as shown in the lists published in the technical press, is remarkable, but even experienced practitioners are occasionally surprised. Two of the principal reasons for this remarkable difference are keen competition and incompetent estimating. An eminent builder recently wrote the following words: "I think at the present time if every builder's surveyor were to price each item of a bill of quantities based upon what the work would actually cost, he would not get a single job."

It often happens that the experienced

builder's surveyor will discover some pitfall or circumstance connected with the job that might add considerably to the cost, but which could easily escape the notice of competitors not so experienced; and in such cases he may sometimes price the items at rates lower than they should be, so that his tender may not appear extraordinary when compared with others. There are many other reasons for variations in pricing, but the most annoying one is incompetent estimating. Architects and surveyors are often surprised that such men can retain their posts, but the builder himself knows how very difficult it is to obtain a first class estimating

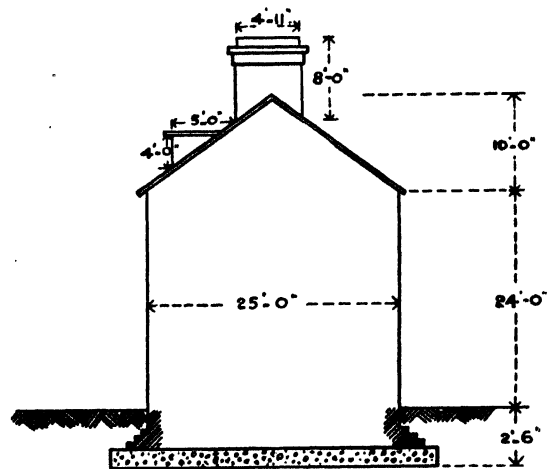

FIG. 1

surveyor, and will often put up with indifferent men until he can find someone more experienced. Many young men imagine that bills of quantities can be priced by simply copying prices from a standard list and then adding or deducting a percentage; it is the intention here to try to explain how dangerous this is.

Cubic Contents of a Building. Before we attempt to explain cube prices and examples it is necessary to mention there are different methods of finding the "cube." Fig. 1 will explain the method recommended.

The sketch illustrates a small building with one chimney stack and two dormers. To obtain the cubical contents for the purposes of an approximate estimate, the length is multiplied by the breadth, and then by the "height," the latter being taken from a point half-way between ground level and the bottom of foundations to a point half-way up the height of the roof.

MODERN BUILDING CONSTRUCTION

Afterwards the cubical contents of the dormers and chimney stack are added.

In the foregoing sketch it is assumed that the structure is 32 ft. in length, the chimney stack is 1 ft. 6 in. wide, and the two dormers are each 3 ft. 6 in. wide. The "height" is found as follows: Half of 10 ft. is 5 ft., half of 2 ft. 6 in. is 1 ft. 3 in., and these figures added to the height of 24 ft. (from ground level to eaves) give 30 ft. 3 in. The height of the chimney stack is taken from the position where it first emerges from the roof. As one side of a dormer is a triangle, take the dimensions of the dormers above the roof and take *half* of their cubical contents.

The dimensions are as follows—

ft. in.	ft. in.	ft. in.
25 0	4 11	2 $\frac{1}{2}$ /5 0
32 0	1 6	3 6
30 3	8 0	4 0

There are other methods of finding the "cube," but the student must note that whatever method he adopts, he must strictly adhere to it, and compile his prices accordingly.

CUBE PRICES

The method of obtaining the "cube" has been explained, but a few words are necessary to warn the beginner not to place too great reliance upon prices obtained by such methods. If a building costs a certain amount, and from this amount the price per foot cube is obtained it is a fair assumption that a similar building in the same neighbourhood will cost about the same amount per foot cube. In making calculations for cube prices, it is usual to omit drainage, lighting, paths, and fences, as these can vary so much. In making an approximate estimate on a cube basis, the surveyor usually prices the cubical contents at a price he considers suitable, and adds the extras we have mentioned. As a general rule, the builder is in a better position to obtain cube prices which will be more reliable than those prepared by a surveyor or architect, for the builder will be dealing with actual costs, while the prices prepared by others will be based upon tenders. It is a good plan, when pricing a job where quantities are not supplied, to cube the structure afterwards, price it at a suitable rate, and compare the result obtained by the more detailed work. This will serve as a rough check for the accuracy of the "taking off" and the pricing. Cube prices should be used for no other purpose than

obtaining a rough approximate estimate, and for this purpose the following prices are given for comparative purposes; they are *not* submitted as actual costs, and are based upon March, 1939, prices.

PRICES PER FOOT CUBE

Cottages, from 8d.
Bungalows, from 10d.
Small houses, from 1s.
Town houses, from 2s.
Village halls, from 1s. 9d.
Churches, from 2s. 6d.
Flats, from 1s. 4d.
Flats (high-class), from 2s.

The above indicates the kind of list that a surveyor may prepare, but against each cost he would give a brief description of the materials used and the class of work, as well as data regarding rates of wages and the situation of the job.

ROUGH QUANTITIES

For the purpose of obtaining an approximate estimate, a far better method of finding the price is to prepare *rough quantities*. This is a system often used by estimating surveyors when the architect supplies plans and specifications only, and there is insufficient time to "take off" the quantities in a proper way. It needs a considerable amount of experience; and for actual tendering it should be used as seldom as possible by the beginner, as it is liable to make him careless and may prevent him from learning to "take off" quantities in the proper manner. The system consists of grouping many items together, and omitting the various labours and fine detail of the quantity surveyor; afterwards the items are priced at rates which include all the labours and other items grouped in the particular dimension. The following is a list of the principal items as grouped together in "rough quantities."

TRADES, ETC. GROUPED ITEMS

ITEMS	HOW MEASURED
Excavator.	
Clear the site; provide site concrete and hard core (all in one item).	} Per yard super.
Trench excavation, carting away, returning and ramming; also foundation concrete.	
Drainlayer.	
Excavation, concrete, pipes, bends, accessories, gullies, and filling in trenches.	} Per foot run.
(Manholes, enumerated complete.)	

Bricklayer.

Brickwork measured over-all to include all labours—cuttings, arches, facings, pointing and all sundry items, also the plastering (internal and external). } Per rod super (or per yard super) reduced.

Partitions. (Brick, slab, or stud.)

To include all materials used in construction and the plastering both sides. } Per yard super.

Carpenter and Joiner.

Floors, to include all plates, joists, flooring, and skirting. } Per square super.

Ceilings, to include joists, plastering and cornices } Per yard super.

Roofs, to include all timbers, boardings, slates or tiles, flashings, lead-work, gutters, and rain water pipes. } Per square super. (Flat roofs to include all coverings.)

Plumber.

Sanitary fittings, to include traps, hot and cold branches, W.C. flush pipes, and all fixing and making good in all trades. } Per number.

Water supply pipes, soil and waste pipes, including all accessories. } Per foot run.

The various fittings and fitments are then enumerated, viz.—

Doors.

To include door, frame, linings, ironmongery, lintel, architraves, etc., and allowing for deductions from brickwork and plastering complete. } Per number.

Windows and Casements.

As for doors, and including glass. Per number.

Stoves.

To include stove, setting, hearth, flue, pot, chimney piece, and allowing for deductions from brickwork and plastering. } Per number.

Staircases.

To include treads and risers, hand-rail, balusters, newels, strings, and all labours. } Per tread.

Landings extra, including skirtings, etc. } Per number.

The following items are frequently priced per point: Hot-water supply, gasfitting, electric lighting, and bells.

It will be noticed that several trades are grouped in the same item, and that very many items which usually appear in a bill of quantities are omitted entirely. It is obvious that very little time is required for the "taking off"; in fact, when the builder is given insufficient time to prepare an estimate (if no quantities are supplied), it is the only method he can adopt. It is also more reliable for the architect or sur-

veyor to prepare his approximate estimates in a similar manner, for he can obtain data for pricing by taking typical items of a similar job, having a detailed bill of quantities which has been priced by a builder.

BILLS OF QUANTITIES

For the purpose of giving instruction regarding correct methods of the preparation of estimates, we will assume that the reader is in the position of an assistant to an estimating surveyor, and we will describe the work of pricing a bill of quantities from the time it first reaches the builder to the submission of the tender. The estimating surveyor will first read the *preliminaries* and the *preambles*, and make notes of items requiring further detail.

The beginner should note that there is a separate bill for each trade, and one other bill termed *Preliminaries* which contains items that cannot be allocated to any particular trade and the general conditions. The *Preambles* are descriptions at the commencement of each trade describing the work, the materials, and methods of preparation, also any details necessary to the estimating surveyor for the preparation of prices.

From a perusal of the bill it will be found that several special kinds of materials are specified; therefore it will be necessary to communicate with the different manufacturers and obtain quotations; this is usually the junior's first job. It will also be necessary to obtain quotations for essential materials, such as bricks, sand, ballast, cement, lime, and timber—delivered to the site if possible. If necessary, prices must be obtained for haulage and carting, and the exact distance of the nearest railway station ascertained. It may also be necessary to obtain the local rate of wages and lodging facilities. This information must be tabulated, so that the estimating surveyor has as much data as possible available for detailed prices.

It is most essential for the estimating surveyor to have a sound knowledge of the "Standard Method of Measurement," especially with regard to those trades which a general contractor frequently sub-lets, such as the "Plasterer," "Plumber," and "Painter." Sub-contractors in these trades sometimes claim as measured "extras," items that are not given in the "Standard Method of Measurement," so that should the General Contractor's Surveyor agree such items with the Sub-Contractor, he will find the Quantity Surveyor will not allow them.

Chapter II—BRICKLAYER

BEFORE preparing an estimate it may be necessary to visit the site, but it is difficult to make any hard and fast rule regarding this. With a detailed bill of quantities, plans, and specification, it may not be necessary to visit the site at all, but in most cases it is advisable, especially if the work is in a district new to the surveyor. Sometimes it is necessary to inspect the site before preparing prices, but as a general rule it is possible to price a considerable portion of the bill first, in which case the visit can be deferred until the surveyor has made a list of items for which he will require local information.

ORDER OF PRICING THE TRADES. It is not usual to price the bills in the same order as tabulated by the quantity surveyor, and in some cases it is not possible to price the preliminary bill until all the others are complete, and others may require a visit to the site. As a general rule, it is a good plan to prepare the prices for the principal constructional trade first, which is either the bricklayer, or (with a stone building) the mason. Therefore, we will begin with the bricklayer. It is not possible in a work of this nature to give detailed prices of every item that can possibly occur in any particular trade; such a task would require several books, but it is proposed to analyse the most typical items, so that the student will learn to prepare prices for himself upon a scientific basis.

In the detailed examples of typical items which follow the rates of wages are taken as 1s. 9d. per hour for craftsmen and 1s. 3½d. per hour for labourers; these being current London rates in March, 1939. This date is taken for the reason that it was adopted by the War Damage Commission in assessing property values. For practice it is suggested that the student compiles prices for himself, using the rates current in his own district and local prices of materials. If the data thus acquired are kept upon separate cards, any item can be revised from time to time as prices vary.

Mortar. Before we can price items in the bricklayer's bill it is necessary to calculate the prices of mortar. Brickwork may be in lime mortar or in cement mortar, and the usual proportions are one part of lime or cement to

three parts of sand. Sand is sold (usually) by the yard cube. Portland cement is sold by the ton, which contains eleven sacks. Lime is sold by the ton and sometimes by the yard; it varies in different districts, but we will assume two yards cube to the ton. The prices vary in different districts, and cartage is a big factor, but for our purpose we will assume cement at £2 3s. 4d. per ton, and lime at £1 17s. 6d. per ton delivered, including unloading costs. It is now usual for cement to be supplied in paper bags (20 bags equal 1 ton). Portland cement at £2 3s. 4d. per ton amounts to £2 7s. per yard cube, as one yard cube equals 21·7 cwt.

In the calculations which follow, the proportions taken will be based upon a "mix" of one part (by measure) of Portland cement to three parts (by measure) of sand.

It is convenient to find first, the cost of a yard cube of mortar. This can be found quite easily by taking the materials in the proportions specified, adding a percentage for the reduction in bulk after mixing, and then finding the resultant price for one yard cube.

In the detailed cost for cement mortar (1 to 3) which follows, it will be noticed that one yard cube of Portland cement and three yards cube of sand are taken, making a total of four yards cube. To find the price, therefore, of one yard cube, the result is divided by 4 after the percentage for reduction in bulk has been added. If the proportions used were 1 to 2, then the total must be divided by 3; if the proportions were 1 to 1, then the total must be divided by 2.

<i>Detailed Costs: Cement Mortar (1 to 3)—</i>		£	s.	d.
1 yd. cube of Portland cement at				
£2 3s. 4d. per ton		2	7	—
3 yd. cube of sand at 7s. 9d.		1	3	3
		3	10	3
Add for reduction in bulk 33½%		1	3	5
		4	13	8
Total for 4 yd.		4	13	8
Take one-fourth		1	3	5
Labour mixing 12 hrs. at 1s. 3½d.		15	9	
		1	19	2
Price per yard cube		£1	19	2

<i>Lime Mortar (1 to 3)—</i>	£ s. d.
1 yd. cube of Greystone lime at 37s. 6d.	1 17 6
3 yd. cube of sand at 7s. 9d.	1 3 3
	<hr/>
Add 33½% for decrease in bulk	3 0 9
	1 0 3
	<hr/>
Total for 4 yd.	4 1 0
	<hr/>
Take one-fourth	1 0 3
Labour mixing 8 hrs. at 1s. 3½d.	10 6
	<hr/>
Price per yard cube.	<u>£1 10 9</u>

Mortar mixed in other proportions can be calculated in a similar manner to the two preceding examples.

The question of reduction in bulk of materials after mixing will be dealt with in a later lesson, viz. Chapter V (Concrete), but for those wishing to work out other proportions the percentages to be added for reduction in bulk are given below, viz.—

Mortar 1 to 3	33½%
„ 1 to 2	25%
„ 1 to 1	20%

Bricks. The standard size of a brick (known as the R.I.B.A. standard) for the South of England is 9¼ in. in length, including joints, measured from centre to centre, and in height four courses, including joints, should measure 1 ft. Owing to differences in the sizes of bricks, an amendment was made in the year 1919 to apply to the North of England. The difference is in height only, and four courses should measure 13 in.

In the Midlands seven courses are often taken to equal 2 ft.

Unit of Measurement. The unit adopted for the pricing of brickwork varies in different parts of the country, and requires careful consideration. In London and the south all brickwork is reduced to a standard rod of 272 ft. super of 1½ bricks in thickness; and any walls less or greater in thickness have to be “reduced” to this standard. In the Midlands and the North of England the work is reduced to a standard of 1 yd. super, but one brick in thickness. In certain Government schedules and upon some engineering works the brickwork is billed per yard cube or per foot cube. These different units have a considerable bearing upon the calculations for materials required.

Materials Required (per Rod reduced). Space does not permit the inclusion of the mathematical calculations necessary to find the number of bricks and the quantity of mortar required. It is not a very difficult task for the

student to work out the quantities himself, but for the purpose of preparing examples it will be assumed that one rod super of reduced brickwork will require 4,400 bricks and 2½ cub. yd. of mortar. The actual number of bricks per rod is really 4,290, but an allowance for waste must be made, and in the above number 2½ per cent has been taken for this. The allowance of waste varies considerably and depends upon the nature of the brick. Flettons and other hard bricks cause little waste, and an allowance of 1 per cent should be sufficient. For London stocks 2 per cent is suggested, and for local common bricks 5 per cent will not be too much.

Materials Required (per Yard reduced). With northern bricks and working to the 1919 standard, 90½ bricks are required, if 2½ per cent is allowed for waste; and, for mortar, 1⅓ ft. cube should be allowed.

Scaffold. The use and waste of scaffolds is a serious item, especially as this kind of plant requires constant renewal. In addition, there is the cost of erecting and taking down to allow for, as well as the cartage. This item does not appear to have received the attention it deserves, for many estimating surveyors simply deal with the cost on a percentage basis. From careful data acquired with several jobs, the writer is of opinion that the use and waste, and the labour erecting and striking is worth about 32s. per rod reduced, and per yard reduced, 9d.

Labour. We now come to the most vital as well as the most difficult factor. The quantities and prices of materials can be analysed and calculated, but the cost of the labour is affected by very many things: all men cannot work at the same speed; the state of the weather affects the progress of the work; the nature of the job; and the class of bricks used—all contribute to make the task of the estimating surveyor a difficult one.

The following calculations will be based upon the assumption that one bricklayer and one labourer will lay 65 bricks per hour, but the student must remember that this must be varied according to circumstances. In some parts of the country, and on some kinds of work, it is often possible for one labourer to assist more than one bricklayer; this will affect the cost considerably. If the work is pierced by many openings additional time must be allowed, as their formation delays the work. If the work is to be executed during the winter months longer time must be allowed, owing to the weather. If the job is some distance away from

MODERN BUILDING CONSTRUCTION

a town, and lodgings are difficult to obtain, additional time must be assumed, because the most skilful bricklayers can always obtain work near their own homes. This factor also applies to other trades, especially that of the plasterer. From the above remarks, the student will at once appreciate the difficulties of the estimating surveyor, and he will also see how it is necessary to know the conditions of each job as well as each neighbourhood.

Water. For wetting the bricks and preparing the mortar, water is required, but the cost is not allowed for in the following prices, as great variation occurs in different districts. In some places water can be obtained free; elsewhere a charge is made by the water authority, as a percentage upon the whole job (often 7s. 6d. per £100 of work); or it is sometimes sold per gallon. Local inquiries are necessary, but the following quantities may assist the beginner—

Per rod reduced, about 300 gals.
Per yard reduced, about 6½ gals.

Cartage. In the following items it is assumed that the prices of the materials include delivery, but if it becomes necessary to obtain prices for cartage or haulage, the quotations given will usually be weights; therefore the following must be allowed—

Bricks, per thousand 3-3½ tons
Sand per yard 1½ tons
Cement, 11 sacks or 20 bags 1 ton
Stone lime per yard about ½ ton
Mortar, per yard about 1½ tons

DETAILED EXAMPLES

Brickwork in Lime Mortar (1 to 3), Southern Practice—

	£	s.	d.
4,400 bricks at £4 15s. per 1,000 delivered	20	18	—
2½ cub. yd. lime mortar at £1 10s. 9d.	3	5	4½
Scaffold: use, waste and labour, say 32s.	1	12	—
Bricklayer and labourer, 68 hrs. at 3s. 0½d.	10	8	3
	36	3	7½
Profit and Establishment, 12½%	4	10	5½
Price per Rod super reduced	£40	14	0½

Brickwork in Cement Mortar (1 to 3), Southern Practice—

	£	s.	d.
4,400 bricks at £4 15s. per 1,000 delivered	20	18	—
2½ cub. yd. cement mortar at £1 19s. 2d.	4	3	2½
Scaffold (as before), 32s.	1	12	—
Bricklayer and labourer, 70 hrs. at 3s. 0½d.	10	14	4½
	37	7	7½
Profit and Establishment, 12½%	4	13	5½
Price per rod super reduced	£42	1	0½

Brickwork in Cement Mortar (1 to 3) in Cavity Walls, in Two Half-brick Thicknesses and 2½ in. Cavity—

	£	s.	d.
Cost of brickwork, two-thirds the amount of previous item	28	0	8½
Extra labour in forming cavity. Bricklayer and labourer, 7½ hrs. at 3s. 0½d.	1	2	11½
Wall ties (galvanized), ½ cwt. at 20s.	10	—	—
	29	13	8½
Profit and Establishment, 12½%	3	14	2½
	£33	7	10½

As this item is usually priced per foot super it is necessary to divide by 272, which gives the price of 2s. 5½d. per foot super.

Brickwork in Cement Mortar (1 to 3) in Half-brick Walls—

	£	s.	d.
Cost of brickwork, one-third of the cost of 1½ brick wall	14	—	4½
Extra labour in forming fair faces both sides. Bricklayer and labourer, 7 hrs. at 3s. 0½d.	1	1	5½
	15	1	9½
Profit and Establishment, 12½%	1	17	8½
	£16	19	6½

This item is priced per foot super; so if the above cost is divided by 272, the amount per foot super will be (say) 1s. 3d. If the work is in the formation of sleeper walls or other work which will not require scaffolding, the cost of this must be deducted.

Brickwork in Lime Mortar (1 to 3), Northern Practice—

	£	s.	d.
90½ bricks at £4 15s. per 1,000 delivered	8	7	—
11½ cub. ft. of lime mortar at 20s. 9d. per yard cube	—	10	—
Scaffold (as described earlier), 9d.	—	9	—
Bricklayer and labourer, 1½ hrs. at 3s. 0½d.	4	7½	—
	14	9½	—
Profit and Establishment, 12½%	1	10½	—
Price per yard super Reduced	16	7½	—

Brickwork in Cement Mortar (1 to 3), Northern Practice—

	£	s.	d.
90½ bricks at £4 15s. per 1,000 delivered	8	7	—
11½ cub. ft. of cement mortar at 39s. 2d. per yard cube	1	7½	—
Scaffold (as described earlier), 9d.	—	9	—
Bricklayer and labourer as last item, but plus 10%	5	0½	—
	16	—	—
Profit and Establishment, 12½%	2	—	—
	18	—	—

Arches. The formation of arches is priced separately from the other brickwork, as "extra only" over the cost of ordinary brickwork. This means that the item is priced as an addition to the cost of building the wall in the ordinary way, and if a superior brick is used it is necessary to find out the cost over and above the price of the ordinary brick used. Rough relieving arches are numbered, but gauged arches, axed arches, and segmental arches are priced per foot super "extra only." In the quantity surveying articles in this work, it will be noted that the measurement of the latter class of arches is taken to every exposed face, and this fact must be kept in mind in preparing prices.

ROUGH RELIEVING ARCH. For a typical opening to a span of 3 ft. allow for extra time, bricklayer and labourer, $1\frac{1}{2}$ hours, and for ten extra bricks.

GAUGED FLAT ARCH. For an opening similar to the above, and assuming that the arch is $4\frac{1}{2}$ in. in the wall, about 25 special facing bricks will be required and 12 ordinary bricks will be displaced. Allow for extra time for bricklayer and labourer $1\frac{1}{4}$ hours per foot super, and for jointing material about 4d. per foot super.

AXED ARCHES AND SEGMENTAL ARCHES. These can be worked out in a similar manner to the above.

ITEMS PRICED PER FOOT OR PER YARD SUPER

DAMP-PROOF COURSE (SLATE). Allow for labour one-tenth of an hour and two slates, and for cement (about) 3d. per foot super.

BREEZE SLAB WALLS. To the cost of the slabs, which is usually 2s. to 3s. per yard super, allow for labour one hour, and for mortar $\frac{1}{4}$ ft. cube per yard super.

BRICK PAVING. Allow per yard super 34 bricks; 1 ft. cube of mortar; and for labour, one hour.

ITEMS PRICED PER FOOT RUN

BRICK ON EDGE COPINGS. Allow for bricks; extra mortar (say) 1d.; and for labour, 6 ft. per hour.

CUTTINGS. For fair cuttings allow about 3 ft. per hour, and for rough cuttings 6 ft. per hour.

NUMBERED ITEMS

BED AND POINT FRAMES. Allow for labour 1-2 hours each, according to the size; and for mortar $\frac{1}{4}$ -1 ft. cube for each frame.

CORE AND PARGE FLUES. Allow 10 ft. per hour, and material about 2d. per foot.

SETTING STOVES AND KITCHENERS. Allow for labour 4-8 hours; for bricks 10-40, in accordance with the size of stove; and for mortar 2-9 ft. cube.

Facings. Facing bricks are priced "extra only" over the cost of ordinary bricks (every exposed face being measured). If ordinary bricks cost £4 15s. per 1,000, and the special facing bricks £12 5s. per 1,000, obviously the extra cost is £8 per 1,000.

DETAILED EXAMPLE

"Extra Only" over Ordinary Brickwork for Picked Red Facing Bricks. Prime Cost £11 per 1,000 (delivered), including Pointing in Cement with Struck Weathered Joint—

	s.	d.
8 facing bricks at £8 "E.O." per 1,000	1	3½
Extra cement mortar		½
Bricklayer and labourer, extra time 5 mins. at 3s. 10½d. per hour		3
	1	6½
Profit and Establishment, 12½%		2½
	1	8½

GLAZED BRICKWORK. This work is measured "extra only" in a similar manner to the ordinary facings, and the price can be compiled as detailed in the last item. There are, however, extra items per foot run for plain angles and for bull-nosed angles; but as the manufacturers will quote for these special bricks separately it is a simple matter to compile the price.

CAVITY WALLS. These walls can be priced from the data acquired for walls $4\frac{1}{2}$ in. thick; 9 in. thick, and so on. If the wall has two half-brick skins, the price previously obtained for half-brick walls can be doubled, to which can be added the cost of one minute per foot super for a bricklayer and labourer in forming the cavity. To the above, the cost of the wall-ties must be added, and as the prices per cwt. can be obtained from a builders' merchants' list (or the standard price list) it is only necessary to remember that 240 ordinary wall-ties weigh one cwt. The outer skin, if in facings, will, of course, require to be especially pointed, and the cost of this must be added in the manner shown in the detailed example given previously, plus an allowance of 50 per cent.

If the wall has one half-brick skin and one full brick skin, the cost of the 9 in. skin per foot super can be found from the previous datum per rod super (or per yard super).

Chapter III—PAVIOR; MASON; SLATER AND TILER

PAVIOR

MANY kinds of pavings are now supplied and laid by Specialist Sub-contractors, but the General Contractor is frequently called upon to price brick and tile paving, also granolithic floors. The present price of granite chips in London is £1 12s. per ton which equals 3s. 4d. yard cube. Paving bricks as assumed at £5 per 1,000.

DETAILED EXAMPLES

	£	s.	d.
<i>Granolithic Paving 1 in. thick—</i>			
5 yd. cube granite chippings at 40s.	10	—	—
2 yd. cube Portland cement (see Chapter II) at 47s.	4	14	—
	14	14	—
Add for reduction in bulk 50%	7	7	—
	22	1	—
Take one-seventh	3	7	—
Labour mixing and laying, 5 hrs. at 1s. 9d.		8	9
Price per yard cube	3	15	9
Take one thirty-sixth	2	1½	
Add for Labour floating 1½ hrs. at 1s. 9d.	2	7½	
Profit and Establishment, 12½%	4	8½	7½
Price per yard super	5	4	

A thickness of 1 in. is one thirty-sixth of one yard cube, hence the division by 36.

	£	s.	d.
<i>Hard Red Brick Paving 2 in. thick Laid Flat; Jointed and Pointed in Cement Mortar—</i>			
34 paviors at £5 per 1,000	3	6	
½ ft. cube cement mortar (1 to 3) at 1s. 9d.		10½	
Bricklayer and labourer, ¼ hr. at 3s. 0½d.	2	3½	
Profit and Establishment, 12½%	6	8	10
Price per yard super	7	6	

The actual number of bricks required is 32 per yard super but two bricks have been added for waste.

MASON

The pricing of a complete stone building is somewhat difficult to those accustomed to brick structures, but stone dressings are less difficult.

Many firms sublet the work, and upon receipt of a bill of quantities the bill for the stonework is forwarded to a mason, who prices it. For convenience, stone walls can be described as either *rubble* or *ashlar* work. The former term indicates rough walls of untrimmed or roughly trimmed stone, whilst the latter term indicates walls built of stone worked to a finely dressed face. The erection of rubble walls is usually carried out by men accustomed to this class of work, and they are termed "wallers."

Waller. It is practically impossible to give accurate data for this trade, as the conditions and prices in each district, and for each kind of stone, vary considerably. In accordance with the "Standard Method of Measurement," walls 18 in. and under in thickness are priced per yard super, but any walls above this thickness are priced per yard cube.

DETAILED EXAMPLE

	£	s.	d.
<i>Coursed Rubble Wall in Lime Mortar, 12 in. Thick—</i>			
1 yd. cube of local rubble, at 18s. per load of 1½ yd.	12	—	
½ yd. cube of lime mortar (as before) at £1 10s. 9d. per yard cube		3	10
Waller and labourer, 4 hrs. at 3s. 0½d.	12	3	
Profit and Establishment, 12½%	1	8	1
	3	6	
	£1	11	7

For uncoursed rubble walls, a waller and labourer will require about two hours each, and one-fifth of a yard cube of mortar should be allowed owing to the greater number of voids. In many districts rubble walls are built dry, with the exception of the coping course.

Ashlar Work. At the present time it is not usual for buildings to be erected entirely of stone; but frequently the structure consists of steel or of reinforced concrete, or perhaps may be constructed of brick, and is afterwards encased with stone. Ashlar work requires great care, and the mason fixing the stone usually receives 1d. more per hour than the ordinary rate. A very substantial scaffold is required, and this adds to the cost. The bill of quantities will describe the stone in detail and give the superficial area, stating the

average depth of stone in the wall. The price for the work has to include all labours, but dressings and special stones are taken out in detail (see later). The measurement of all kinds of stone (except York stone) is similar; it is, therefore, proposed to take Portland stone and Bath stone as typical examples, as other building stones would be worked out in a similar manner.

COST OF STONE. At the time of writing, Bath stone is quoted at 3s. and Portland stone at 4s. 9d. per foot cube in trucks at London railway stations.

COST OF FINISHED BLOCKS. To the cost of the stone, it is necessary to add the cost of carting, unloading, stacking, converting into useful sizes, sawing to shape, and delivering to the job. The cost of the finished blocks will, therefore, depend upon the transport facilities and modern machinery possessed by the contracting firm. In these circumstances, it is impossible to give rules for finding the charges, as they can be found only by careful costing methods; but for the purpose of these articles we will assume an average price of 16s. 6d. per foot cube for Portland stone, and 12s. per foot cube for Bath stone, to include waste and all labours.

DETAILED EXAMPLE

Portland Stone in Ashlar Work, Average Depth in Wall 7 in., Bedded and Jointed in Special Lime and Stone Dust Mortar (as described previously)—

	<i>s. d.</i>
Cost of stone and labours, seven-twelfths of a foot cube at 16s. 6d.	9 7½
Use and waste of scaffold, per foot super	2½
Hoisting, labourer 10 mins. at 1s. 3½d. per hour	2½
Mortar, one-twelfth of a foot cube at 34s. per yard cube (or 1s. 3d. per foot cube)	1½
Fixing, mason and labourer, ¼ hr. at 3s. 0½d. per hour	9½
	10 11½
Profit and Establishment, 12½%	1 4½
	12 3½

Several items in the detailed cost will require some explanation. The mortar used is composed of equal parts of lime and stone dust, and actual calculations should be made as described in an earlier chapter; but with lime at £1 17s. 6d. per ton, the cost of a yard cube of mason's mortar will work out at about £1 14s. per yard cube. One foot cube of stone will require about one-sixth of a foot cube of mortar, and a fair allowance for the scaffold will be 2½d. per foot super of stone. The hoisting of the stone into position is a speculative item, as the height may

not be known and so much depends upon the plant available, but with ordinary work a fair allowance per foot cube would be one-third of an hour of a labourer's time. The bedding and fixing is worth half an hour of a mason and labourer's time per foot cube.

Stone Dressings. Dressings and similar items are now given as "stone and all labours" in a bill of quantities, and the student is referred to the chapters on *Quantity Surveying* in this work for methods of measurement.

WASTE. The sizes given are the sizes of the smallest blocks out of which the finished block can be cut; but the estimating surveyor finds it necessary to make a further allowance for waste, and an addition of 5 per cent is suggested.

LABOURS ON STONE. For accurate estimating, a series of costs, calculated over a considerable period, is necessary so as to obtain average prices. From such data a list, as shown in Table I, can be prepared for different classes of stone, and these labour costs must be added to the cost of the stone.

TABLE I
LABOURS IN HOURS, PER FOOT SUPER

	Portland Stone	Bath Stone
Labour to Back	0·25	0·09
Beds and Joints	0·50	0·17
Sunk Ditto	0·75	0·25
Plain Face	1·50	0·50
Sunk Face	2·00	0·75
Moulded Work	4·00	1·50

The data given for Portland stone will serve for similar hard stones, and that given for Bath stone may be taken as indicating the less expensive stones. Derbyshire stone will probably cost 20 per cent more to work than Portland, and York stone about 15 per cent more than Portland. It often happens that certain labours, especially narrow widths, are given per foot run, and in such cases the prices can be found from the table, using proportionate methods. If the labour is prefixed by the word "circular," it is usual to double the allowance; and if described as "circular circular," then it will be necessary to treble the figure.

York Stone. York stone is sold by the foot super and is used principally for sills, thresholds, copings, cover stones, templates, and similar items. In a bill of quantities, sills and copings are given per foot run, and templates are numbered. The labour preparing York stone

MODERN BUILDING CONSTRUCTION

sills and copings will be found to cost about 3s. 6d. per foot super, but naturally this price will vary in different districts.

COST OF YORK STONE. The cost of the stone at present is 2s. 6d. per foot super for 3 in. thicknesses, and 3s. 6d. per foot super for 4 in. stone delivered in trucks in London.

COST OF YORK STONE ITEMS. Working on the prices given previously, the following items will work out as under—

	s.	d.
Stone Sills out of 12 in. by 4 in.	7	—
Stone Sills out of 9 in. by 3 in.	4	6
Copings out of 15 in. by 4 in.	8	9
Copings out of 13 in. by 3 in.	6	6

Other items of worked York stone can be calculated by similar proportionate methods.

COVER STONES AND TEMPLATES. For these items it will be sufficient to take the net cost of the stone and add 15 per cent.

STEPS AND LANDINGS. It is necessary for the estimating surveyor to take out rough quantities for himself and price the labours—all as described in the previous typical example.

SLATER AND TILER

The measurements in these trades are similar, although in various parts of the country different methods exist, but in this article we will follow the "Standard Method of Measurement." By this method, the net area of the roof is taken and various extras for cuttings and waste are added per foot run. The builder frequently sublets the work in these trades, as the specialist contractors can usually obtain better terms by purchasing in bulk at the quarry. In these circumstances it is considered unnecessary to give many examples.

SLATER

It is necessary to bear in mind the difference between the terms *gauge* and *lap*. With slating work, it is usual to specify the "lap," and for the purpose of finding the spacing for the battens and the number of soakers (if required) it is necessary to find the "gauge." If the slates are nailed near the head, take the length of the slate, subtract the "lap" plus 1 in. (this is for the portion near the head), and divide by 2. If the slates are nailed near the middle, simply deduct the lap from the length of the slate and divide by 2.

Slates are sometimes sold by weight at the quarry, but per 1,000 by merchants. The number of the slates required per square of 100 ft. super, naturally varies in accordance with

the size of the slate, the lap, and whether nailed at the head or the middle. As a lap of 3 in. is most usual, Table II gives the number of slates for this lap only, for it is a simple matter for the student to work out others for himself from the data given previously.

DETAILED EXAMPLE

Best Bangor Slating 20 in. by 10 in., Laid to 3 in. Lap and Nailed near Head with Two Composition Slate Nails—

	£	s.	d.
180 slates at £25 per 1,000 delivered	4	10	—
Waste, add 5%	4	6	—
Nails, 2½ lb. at 3½d.	—	—	9½
Slater and labourer, 2 hrs. at 3s. 10½d.	6	1½	—
	5	1	5½
Profit and Establishment, 12½%	—	12	8
Cost per square	£5	14	1½

Extras. The merchants will quote for special slate ridges and hips, but for cuttings it is usual to take the price per square as a basis and work on the following—

Eaves	Length	× by	12 in.
Verge	" "	× "	6 in.
Verge (slate and a half)	" "	× "	12 in.
Top Edge	" "	× "	6 in.
Square Abutments	" "	× "	6 in.
Valleys and Hips	" "	× "	6 in. (each side)

These details will give the rates per foot run at which the items should be priced.

TABLE II
NUMBERS OF SLATES PER SQUARE AND WEIGHTS PER 1000

Sizes of Slates	Number Required per Square		Approximate Weight per 1000
	Nailed near Head	At Middle	
18 in. by 10 in.	206	192	27½
20 in. by 10 in.	180	170	30
22 in. by 12 in.	136	127	43
24 in. by 12 in.	120	115	47

TILER

Tiles are sold per thousand, and the "gauge" is usually specified. The usual size of a tile is 10½ in. by 6½ in., and a square laid to a gauge of 4 in. will require 555 tiles; whilst a square laid

to a gauge of $3\frac{1}{2}$ in. will require 634 tiles. An allowance must be made for waste, and usually 5 per cent should be sufficient; but if the tiles are very brittle this allowance must be increased. Very frequently the battens are included in the item, but these are more suitably included in the "carpenter" bill.

DETAILED EXAMPLE

Plain Broseley Tiling Laid to 4 in. Gauge Fixed every Fourth Course with Two Galvanized Pegs to each Tile—

	£	s.	d.
555 tiles at £4 10s. per 1,000 delivered.	2	9	11
Waste, allow 5%	2	6	
8 lb. of tile pegs at 3d. per lb.	2	—	—
Tiler and labourer, 3 hrs. at 3s. 0 $\frac{1}{2}$ d.	9	2 $\frac{1}{2}$	
	3	3	7 $\frac{1}{2}$
Profit and Establishment, 12 $\frac{1}{2}$ %	7	11 $\frac{1}{2}$	
Cost per square	£3	11	6 $\frac{1}{2}$

EXTRAS. Special quotations can be obtained for special shaped valley tiles, and for hips and ridges, but for cuttings and waste allowances can be made as described for slater, viz.—

Eaves	Length	× by	8 in.
Verge	"	× "	6 in.
Verge (tile and a half)	"	× "	12 in.
Top Edge	"	× "	6 in.
Square Abutments	"	× "	6 in.
Valleys and Hips	"	× "	6 in. (each side)

CONTINENTAL INTERLOCKING TILES. The measurement for these tiles is similar to the measurement of ordinary tiling. *Marseilles tiles* are usually laid to a gauge of $13\frac{1}{2}$ in., and *Courtrai tiles* to a gauge of $9\frac{3}{8}$ in. The former take 127 tiles and the latter 207 tiles to cover a square of 100 ft. super. The labour is about the same as with English tiles.

ENGLISH INTERLOCKING TILES. These are much superior to continental tiles, which, prior to 1939, they were gradually displacing. As with continental tiles, they have a single lap and the usual type is known as "double-roman." The size of each tile is $16\frac{1}{2}$ in. × 14 in. and they are laid to a gauge of $13\frac{1}{2}$ in. One square of tiling requires 85 tiles, but an allowance of 5 per cent should be made for waste. Allow for tiler and labourer laying, $2\frac{1}{2}$ hours.

CORRUGATED IRON SHEETING. This material can be obtained in sheets of various lengths and in different gauges. The lengths vary from 5 ft. to 10 ft., but the widths are such that when laid with a horizontal lap of one corrugation, the net measured width is 2 ft. It is usual to allow for a lap of 12 in. per sheet in the

sloping length. The gauges vary from No. 26 to No. 18, but the commonest gauge in use is No. 22, and the commonest length in use is 8 ft. The sheets are sold by weight, and one sheet 8 ft. long of No. 22 gauge weighs $27\frac{1}{2}$ lbs. The gauge and actual thickness of the sheet can be found in the merchants' catalogues and in most books of tables. The sheets are fixed with galvanized bolts, nuts and washers; galvanized hook bolts and nuts; and curved washers. Each sheet requires five ordinary bolts, nuts, and washers, five hooked bolts, nuts, and washers, and five curved washers (allowing for waste). Allow for fixing ordinary sheets, fixer and labourer $\frac{1}{4}$ hour per sheet for No. 22 gauge and for heavier sheets add in proportion.

In estimating for this class of roofing it is very necessary to inspect the drawings to ascertain if the waste in cutting (either at the eaves or at the verge) is likely to be excessive; it can be 10 per cent and even more. Special ridge and hip coverings, also verges and valleys can be obtained.

ASBESTOS-CEMENT ROOFING. *Sheets.* Corrugated asbestos-cement sheeting is now in great demand for industrial buildings and in many cases is more suitable than corrugated iron sheeting. The sheets can be obtained in various thicknesses, the sizes corresponding to those of corrugated iron. The sheets are fixed in a similar manner to the corrugated iron sheets and the time taken is about the same; it is usual, however, to use sheets somewhat longer in length than the iron sheets where it is found possible, therefore, for heavy sheets an addition of 50 per cent is necessary. The special fittings and coverings can be obtained in asbestos-cement as described for iron sheeting, also gutters and rain water pipes with their respective fittings.

Diagonal "Tiling." This material has been used extensively for bungalows and "semi-temporary" buildings. The "tiles" are $15\frac{3}{4}$ in. × $15\frac{3}{4}$ in. and are laid to a lap of 3 in. One square of tiling takes ninety-three tiles, one hundred and eighty-six nails weighing $1\frac{3}{4}$ lbs. (allowing for waste) and ninety-three copper disk rivets (sold per 1000). Allow $1\frac{1}{2}$ hours for one mechanic and one labourer for fixing.

"Imitation" Slating. The "slates" in common use are 24 in × 12 in. but other sizes can be obtained and the lap is usually 3 in. Each slate requires two nails and one copper disk rivet, and the time taken for fixing is about the same as for the "tiling."

Chapter IV—CARPENTER AND JOINER

BEGINNERS frequently experience difficulty in separating the work of the carpenter from that of the joiner, and in many cases it is difficult to draw a hard and fast line. It is often stated that the joiner's work is in connection with timber that requires the use of a plane, while carpentry work is unwrought; but this is not strictly correct, for occasionally the plane is used upon carpenter's work, such as exposed faces of roof timbers. Actually the carpenter erects the carcass of the structure, i.e. plates, joists, roof timbers, and rough boardings, while the joiner prepares the finishings, such as floors, skirtings, doors, windows, cupboards, and all fittings. It is usual to have separate bills prepared for the carpenter and for the joiner, but occasionally these trades are included in one bill.

Timber. Before prices for carpentry or joinery work can be compiled, it is necessary to find the cost of the timber delivered to the site or to the contractor's works. The principal timber used in construction is described as *fir*, and is imported from the northern ports of Europe and from America. The unit in common use is the "Leningrad" standard of 165 ft. cube, although other standards are used occasionally by certain timber merchants. If the builder is in a substantial way of business, and can purchase timber at the docks in bulk, he can quote much lower prices than competitors who are not so fortunate. To the price of the timber as purchased, it is necessary to add the cost of cartage, unloading, stacking, and converting to useful sizes; it is also necessary to make some allowance for waste. As the unit for pricing purposes is the foot cube, it is not difficult to divide the price per standard by 165, to find the price per foot cube; therefore it is desirable to add the various costs to the price per standard before finding a basic price per foot cube.

Prices. The prices of timber naturally vary from time to time, and at the time of writing the price per standard varies from £22 to £26, in accordance with the quality and the scantlings; but when delivered, sawn, and roughly converted to suitable sizes the price at present will average about 3s. to 4s. 6d. per foot cube, and these figures will be used for the purpose of preparing

many examples herein. For actual pricing, costs must be worked out locally; and in adding for cartage, it must be remembered that the weight of timber is computed at the rate of 50 cub. ft. to the ton.

Temporary Work. A considerable amount of work carried out by the carpenter consists of temporary work for other trades, and this usually consists of centering, shoring, and shuttering. Planking and strutting is usually included in the bill for "excavator." All temporary work is difficult to price, for the units used in a bill are not the most convenient for the estimating surveyor.

CENTRES FOR ARCHES. This item is usually given per foot super, and the quantity is the superficial area of the portion of the arch supported by the centre. The student is therefore advised to copy an example from a good textbook on building construction, or, better still, measure up and sketch a centre actually in use and "take off" the quantities of the material. The timber can then be priced at current rates, and for the labour it will be found that a centre for a segmental arch will take about two hours of a carpenter's time, for every foot of span. After use the centre has some value as old material, and this value can be deducted, say, 25 per cent. The student will find that in typical cases the cost of a centre for one arch will work out at 4s. per foot super, but if it can be used for several occasions, the price can be reduced accordingly.

SHORING. This is a speculative item and the costs for an actual shore are necessary to arrive at a price. Textbook data have little value here, and the student is strongly advised to measure up an actual shore and take off the quantities carefully, as suggested for centres. For labour it is suggested that one hour per foot cube for labourer's time, and one-tenth of one hour per foot cube for carpenter's and bricklayer's time will give average prices. If the timber is credited at half cost, the price of a typical shore will amount to 9s. per foot cube.

SHUTTERING. In reinforced concrete work, this is a very important item and difficult to price. It is impossible to give data applicable for all cases, for actual costs are necessary. The

measurement given is the net area of the concrete supported by the shuttering, and the price per foot super must include all supporting timbers. Obviously, the number of occasions upon which it is possible to use the timbering is the important factor, but at present the price varies from 6d. to 9d. per foot super.

Permanent Work. Timber for permanent work can usually be classed either as "framed" or simply "fixed." Timbers requiring joints are known as "framed" even if the joint is a simple one; but timbers which are only placed in position, such as plates and lintels, require no allowance for carpenter's time, except for roughly sawing to the requisite sizes. The following are typical items.

"FIR IN PLATES AND LINTELS." To the price of the timber delivered to the job, say 3s. per foot cube, allow for carpenter one-sixth of an hour, and labourer one-twelfth of an hour per foot cube; this, at London rates and plus 12½ per cent for profit, etc., amounts to 3s. 9d. per foot cube.

"FIR IN GROUND FLOOR JOISTS." This item can be priced in a similar manner to the last item, with equal allowances, and the cost will be the same, viz., 3s. 9d. per foot cube.

"FIR FRAMED IN UPPER FLOORS." The timber itself will be more expensive, at the present time about 4s. 3d. per foot cube, and there will be a certain amount of waste, for which 5 per cent will be a fair allowance. A labourer's time must be allowed for carrying the timber to the room and the carpenter's time must allow for forming any tusk tenons required. It is suggested for carpenter twenty minutes and for labourer seven minutes per foot cube, but with heavy timbers allow ten minutes for labourer.

DETAILED EXAMPLE

Fir joists, 9 in. by 2 in., per 1 ft. cube	s. d.
Waste, 5%	4 3
Carpenter, 20 mins. at 1s. 9d. per hour	2½
Labourer, 7 mins. at 1s. 3½d. per hour	7
	1½
	5 2½
Profit and Establishment, 12½%	7½
Price per foot cube	<u>5 10</u>

"FIR FRAMED IN RAFTERS AND COLLARS." The rafters and similar timbers will cost about 3s. 9d. per foot cube, but the purlins and heavy timbers may cost as much as 4s. 6d. It is suggested for carpenter's time one hour, and for labourer's time twelve minutes per foot cube be

allowed. An allowance must be made for waste as in the last item, and for nails allow ¼ lb. per foot cube.

DETAILED EXAMPLE

Fir rafters, collars, purlins, etc., per 1 ft. cube	s. d.
Waste, 5 per cent	3 9
Carpenter, 1 hour at 1s. 9d.	2½
Labourer, 12 minutes at 1s. 3½d. per hour	1 9
Nails, one-fifth of 1 lb. at 3d.	3
	½
	5 11½
Profit and Establishment, 12½ per cent	9
Price per foot cube	<u>6 8½</u>

The purlins would, of course, be given separately.

"FIR FRAMED IN STUD PARTITIONS." The timbers may be 4 in. by 3 in. and 4 in. by 2 in., and will not cost more than 3s. 6d. per foot cube. Allow one hour per foot cube for carpenter, and ½ lb. of nails, and for waste as in previous examples.

DETAILED EXAMPLE

Fir in sills, uprights, head, etc., 1 ft. cube	s. d.
Waste, 5 per cent	3 6
Two-fifths of 1 lb. nails at 3d.	2½
Carpenter, 1 hour at 1s. 9d.	1½
	9
	5 6½
Profit and Establishment, 12½ per cent	8½
Price per foot cube	<u>6 2½</u>

"NOGGING PIECES." These are billed separately, and the item is worth about 3d. to 4½d. per foot run.

"FIR FRAMED IN ROOF TRUSS." This item is not so frequent as in former years owing to modern methods of construction. With timber at £33 per standard, the price per foot cube is 4s. Add for waste as before, and allow for carpenter's time 2½ hours per foot cube.

DETAILED EXAMPLE

Fir in tie-beam, principals, post, and struts per 1 ft. cube	s. d.
Waste, 5 per cent	4 -
Carpenter, 2½ hours at 1s. 9d.	2½
	4 1
	8 3½
Profit and Establishment, 12½ per cent	1 -½
Price per foot cube	<u>9 3½</u>

The ironmongery for the above item will be billed separately in the "Smith and Founder." Hoisting is a separate item. It is suggested that for labourer's time twenty minutes per foot cube

MODERN BUILDING CONSTRUCTION

be allowed for a height of 30 ft., and that other heights be priced in proportion.

"ROUGH BOARDING" (as laid to roofs, etc.). This material is sold by the square of 100 ft. super, and 1 in. boarding at present is worth about 18s. per square. For waste it is necessary to allow 10 per cent, and about 4 lb. of nails per square are required.

DETAILED EXAMPLE

	£	s.	d.
One square 1 in. rough boarding	18	—	—
Waste, 10%	1	10	—
Carpenter, 4½ hrs. at 1s. 9d.	7	5	—
Labourer, 1½ hrs. at 1s. 3½d.	1	11½	—
Nails, 4 lb. at 3d. per lb.	1	—	—
	<hr/>		
	1	10	2½
Profit and Establishment, 12½%	3	9½	—
	<hr/>		
Price per square super	£1	14	—

If the work in the last item is specified to be traversed for metal coverings, an allowance of two hours more should be made for carpenter's time.

If the boarding is in gutters and is to include bearers, the above price should be doubled; and as the item is priced per foot super, the amount of £1 14s. must be divided by 100, which gives the price per foot super of 4d.

JOINER

This bill is the longest in a bill of quantities, and usually takes up a considerable amount of space. As regards pricing, probably greater variation occurs with this bill than with any other, for, unless the builder is in possession of very accurate shop costs, the pricing is speculative. The bill should be priced by a person who is acquainted with the particular joinery shop, for it is impossible for anyone else to know the prices at which the builder can execute the work. The governing factor is the amount of modern machinery available, but very important points are: the purchasing capacity of the firm and its financial standing, transport facilities, and workshop management. There is no doubt that in this particular trade the large firms have a great advantage over smaller establishments. Apart from the advantage of modern machinery and organization, the accurate and detailed cost accounts of shop joinery, as prepared by the larger building firms, provide most useful data for the estimating surveyor, and enable him to quote prices that can be relied upon. The writer has had many opportunities of examining builders' books and accounts, and in very many

instances he has noticed that a builder has not the slightest idea what his joinery items cost; frequently he only knows whether a job has been profitable or otherwise. With accurate joinery costs, the pricing of this bill is not always easy, and without shop costs the pricing is exceedingly difficult; but to attempt to carry out work at cut rates, prepared without reference to the actual costs compiled in the particular shop, is to invite disaster. In the detailed costs which follow the prices are average ones, and for large jobs no doubt considerable reductions could be made.

Prices of Timber. The prices for joinery timber vary considerably. For the moment we will consider ordinary deal timber. To the price per standard of 165 ft. cube (see "Carpenter"), which at present is about £28, it is necessary to add cost of cartage, unloading, converting to useful sizes, etc., all as explained for carpentry work; but, in addition, in this trade, it also becomes necessary to add for planing by machinery, and preparing the material ready for framing up into the finished article. It is obvious that this will vary with every firm, but for the purpose of finding a basic price for these articles, we will assume that the total of all charges brings the cost of the prepared timber up to £41 5s. per standard, which is equal to 5s. per foot cube.

PRICE PER FOOT SUPER. In order to compile joinery costs, it is necessary to find a short method of ascertaining the price per foot super when the price per foot cube is known (or the price per standard). Many persons use timber calculators for this purpose, but with a little practice the young estimator can soon find the cost of timber per foot super for any thickness by the following method. When the price per foot cube is known, call the shillings as pence, and the parts of shillings as parts of pence; the result is the price per foot super in pence for timber 1 in. thick. Other thicknesses can then be found by proportionate methods. For example, if the price per foot cube is 5s., then the price per foot super "as inch" is 5d.; and for timber 2 in. thick, it is twice this amount, or 10d.; and for timber ½ in. in thickness, half the former amount, or 2½d. For timber 1½ in. in thickness the price will be one and a half times 5d., i.e. 7½d., and so on. The operation is so simple that it can be performed mentally.

PRICE PER FOOT RUN. Having found the price per foot super "as inch," it is equally

simple to find the price of timber per foot run, for any size, by similar methods. If the price of 1 ft. super 1 in. thick is 5d., then the price of 1 ft. run of timber half this width, i.e. 6 in., is 2½d., or, in other words, with timber at 5s. per foot cube, 6 in. by 1 in. costs 2½d. per foot run. On the same basis, the student will see that 1 ft. run of 3 in. by 2 in. costs 2½d.; 1 ft. run of 2 in. by 1½ in. costs 1½d.; and so on. All sizes of timber can be calculated mentally by similar proportionate methods.

Unframed Material. This term will be applied to material purchased practically ready for use, and fixed upon the job. It consists chiefly of floorings, skirtings, and mouldings; and the analyses of costs can be built up in much the same way as carpentry costs; in fact, the work is frequently carried out by carpenters.

FLOOR BOARDS. Flooring is sold and billed by the square of 100 ft. super, but timber merchants frequently allow the builder 105 ft. The time taken to lay a square of flooring, including the cleaning off at completion, varies a little with the thickness of the boards; and the following periods are suggested: 1 in. boards, 4 hours; 1½ in. boards, 4½ hours; and for 1¾ in. boards, 4¾ hours. In addition to the craftsman's time, an allowance must be made for a labourer assisting and taking the boards to the room, say a quarter of an hour per square. For waste it is necessary to allow about 15 per cent, and about 6 lb. of nails per square are required. If the boards are to be in narrow widths, about 25 per cent should be added to the labour and the nails.

DETAILED EXAMPLE

1½ in. Deal Square Flooring in Batten Widths, including Splayed Heading Joints—

	£	s.	d.
One square of flooring at 29s.	1	9	—
Waste, 15%		4	4½
Carpenter, 4½ hrs. at 1s. 9d.		7	10½
Labourer, ½ hr. at 1s. 3½d.			4
Nails, 6 lb. at 3d.		1	6
		2	3
Profit and Establishment, 12½%		5	4½
Price per square super	£2	8	5½

SKIRTINGS. The material is sold per 100 ft. run but allowance must be made for waste. For labour fixing 7 in. and 9 in. skirtings, a carpenter will take ten minutes per foot, and for skirtings deeper than 9 in., extra time will be allowed in proportion to the depth. For labourer's time assisting, add 25 per cent to the car-

penter's time, and for nails allow 1 lb. per 100 ft. for skirting and 2 lb. per 100 ft. for grounds.

DETAILED EXAMPLE

9 in. by 1 in. Wrought Deal Torus Moulded Skirting, including all Grounds and Backings—

	£	s.	d.
100 ft. run of skirting at 32s.		1	12
100 ft. run of 3 in. rough grounds at 2d.		16	8
100 ft. run of rough fillet at ½d.		4	2
Waste on above, 10%		5	3
34 rough backing pieces at 2d.		5	8
Carpenter, 16½ hours at 1s. 9d.	1	9	2
Labourer, 4 hours at 1s. 3½d.		5	3
		4	18
Profit and establishment, 12½%		12	3½
	£5	10	5½

Dividing the total in the last example by 100 gives the price per foot run as 1s. 1½d.

Misres on the above are worth about the value of 1 ft. of skirting.

MOULDINGS. Mouldings are also purchased per 100 ft. run as explained in the last example, and the following data are suggested. For 2 in. mouldings allow for carpenter fixing, 12 ft. per hour; for 3 in. mouldings, 10 ft. per hour; 6 in. mouldings, 8 ft. per hour; and for others in proportion. For waste, an allowance of 5 per cent should be sufficient. If plugs are specified, these are worth about ½d. each, and 25 per cent should be added to the carpenter's time for extra labour.

BOARDINGS. Machine-prepared boardings and match-boardings are sold and billed per square, as explained for rough boardings in "Carpenter." Boards 1 in. thick will take about four hours of carpenter's time and 4 lb. of nails; other thicknesses in proportion.

DETAILED EXAMPLE

	£	s.	d.
1 square of ¾ in. prepared matching at 20s.	1	—	—
Waste on ditto, 20%		4	—
5½ lb. nails at 3d.		1	4½
Carpenter, fixing 4½ hrs. at 1s. 9d.		7	10½
Labourer, assisting 2½ hrs. at 1s. 3½d.		2	11
		1	16
Profit and Establishment, 12½%		4	6
Price per square	£2	—	8

Framed Joinery. We now come to the most difficult task of the estimator. The preparation of pricing data necessitates taking out "rough quantities," for the units by which the various manufactured articles are billed (usually feet

MODERN BUILDING CONSTRUCTION

super) are not always convenient for the calculation of prices. For the various sundries, such as small wedges, glue, and glasspaper, it is convenient to add a small percentage, say, 2½ per cent.

DOORS. The prices for the preparation and the hanging of doors depend upon the superficial area and the thickness of the door, and it

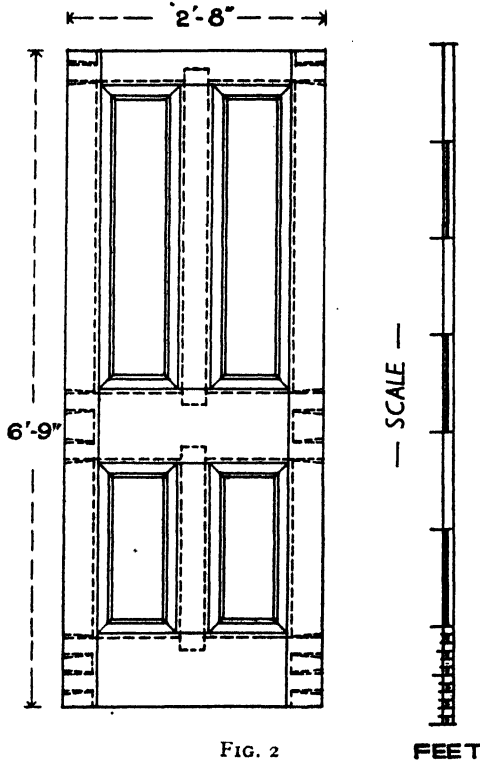

FIG. 2

must be remembered that when hanging a large door the craftsman will require the assistance of a labourer.

Making Doors. The following table gives the approximate time which should be allowed for making doors only. The hanging is dealt with separately on the job.

Description of Door	1½ in.	1½ in.	2 in.
Ledged and braced	2½ hr.	3 hr.	4 hr.
Framed and braced	5½	5½	6
Square, two panel	6½	6½	6½
Square, four panel	7	7	7½

For six-panel doors add 1½ hours. For bolec-

tion moulded doors add 2 hours per side. For diminished styles and glazing bars add 4 hours.

Hanging Doors. For cleaning off and hanging doors on the job allow 1 hour for a carpenter for common doors and for heavier doors allow two hours for a carpenter and one hour for a labourer assisting.

Rough Quantities for a Typical Door. A typical four-panel door is shown in Fig. 2, and the "rough quantities" taken out by the estimating surveyor would appear as follows—

2/2 ft. 9 in.	run of 9 in. by 2 in.
2 ft. 9 in.	" 4 in. by 2 in.
2/6 ft. 9 in.	" 4 in. by 2 in.
3 ft. 3 in.	" 4 in. by 2 in.
2 ft. 2 in.	" 4 in. by 2 in.
2/3 ft. 1 in.	} super of ½ in. panel boarding.
10 in.	
2/1 ft. 11 in.	} " " "
10 in.	
2/4/3 ft. 0 in.	panel moulding.
2/4/1 ft. 9 in.	" "
2/8/0 ft. 10 in.	" "

In the above it will be noticed that allowance has been made for tenons.

DETAILED EXAMPLE

2 in. Deal Four-panel Door with Planted Mouldings both Sides—

	£	s.	d.
5 ft. 6 in. run of 9 in. by 2 in. prepared timber at 7½d. per foot run	3	5	½
21 ft. 8 in. run of 4 in. by 2 in. prepared timber at 3½d. per foot run	5	10	½
8 ft. 8 in. super of ½ in. prepared boarding at 2½d. per foot run	1	10	
52 ft. 4 in. run of panel moulding at 1d. per foot run	4	4	½
	15	5	½
Waste on above timber, say 10%	1	6	½
	17	0	½
Joiner and Carpenter, 10 hrs. at 3s. 0½d.	1	10	7
Labourer assisting, 1 hr. at 1s. 3½d.	1	3	½
	2	8	11
Sundries, 2½% on total cost	1	2	½
	2	10	2
Add for Profit and Establishment, 12½%	6	3	½
	£2	16	5

This gives the price for the door, but if the sketch (Fig. 2) is carefully scaled and the superficial area ascertained, it will be found that the door contains 18 ft. super (being 2 ft. 8 in. by 6 ft. 9 in.); dividing the above price by 18, will give the price per foot super of 3s. 1½d.

SOLID DOOR FRAMES. These are billed per foot run and are not difficult to price. The price of the timber (prepared) can be ascertained as described earlier, and for the labour putting together, it is suggested that for ordinary frames about one hour be allowed for each 10 ft. run of material.

LININGS. If in narrow widths, these are billed per foot run, whilst wider ones are billed per foot super (see the Chapters on "Quantities"). The price of the material can be ascertained as described earlier, and for joiner's time allow about two hours per foot super.

CASEMENTS AND FRAMES. The casements are billed per foot super, and the frames separately at per foot run. The prices of the latter can be calculated as described for door frames. For the casement it is necessary to take out rough quantities for a typical case, and to price the timber as described for the example of the door. For labour making allow about half an hour per foot super.

DOUBLE-HUNG SASHES AND FRAMES. These are exceedingly difficult, for the price per foot super has to include not only the whole of the timber (except window boards and linings to jambs and soffits), but the cost of the sash lines, weights, and axle pulleys is included in the same price.

It is impossible to give data suitable for every case, but the typical example will probably explain itself. We will assume a deal-cased frame with double-hung sashes, as shown in the sketches, Fig. 3.

The overall dimensions of the frame may be taken as 2 ft. 9 in. by 5 ft. 6 in., i.e. a superficial area of 15 ft. 1½ in., which is near enough to call 15 sq. ft. It should be noted that the sash fastener and sash lifts are *not* included.

ROUGH QUANTITIES FOR DEAL-CASED FRAME AND DOUBLE-HUNG SASHES

3 ft.	0 in.	run of 4 in.	by 2 in.	} Sashes.
2½ ft.	6 in.	..	2 in. by 2 in.	
2½ ft.	0 in.	..	2 in. by 1½ in.	
2½ ft.	5 in.	..	2 in. by 2 in.	
3 ft.	0 in.	..	2 in. by 2 in.	
2 ft.	6 in.	..	2 in. by 2 in.	
2 ft.	5 in.	..	2 in. by 2 in.	
3 ft.	0 in.	..	6 in. by 4 in. oak sill.	
3 ft.	2 in.	..	5 in. by 1½ in. } Pulley styles	
2½ ft.	3 in.	..	5 in. by 1½ in. } and head.	
2½ ft.	5 in.	..	5 in. by ½ in. } Outside	
3 ft.	8 in.	..	5 in. by ½ in. } and inside	
14 ft.	6 in.	..	4½ in. by ½ in. } linings.	
2¼ ft.	10 in.	..	1 in. by ½ in. bead.	
3 ft.	0 in.	..	1 in. by ½ in. bead.	
2½ ft.	6 in.	..	1½ in. by ½ in. parting slip.	

DETAILED EXAMPLE

Deal-cased Frame and Double-hung Sashes (as Sketches). Timber at 5s. per Foot Cube (Prepared), and Oak at 10s. per Foot Cube—

	£	s.	d.
12 ft. 8 in. run of 1 in. by ½ in. bead at ½ d. per foot run			6½
10 ft. run of 1½ in. by ½ in. bead at ½ d. per foot run			2½
6 ft. run of 2 in. by 1½ in. bead at 1½ d. per foot run			7½
17 ft. 9 in. run of 2 in. by 2 in. bead at 1½ d. per foot run	2	7	
3 ft. run of 4 in. by 2 in. bead at 3½ d. per foot run			9½
14 ft. 6 in. run of 4½ in. by ½ in. bead at 1 d. per foot run	1	2½	
14 ft. 6 in. run of 5 in. by ½ in. bead at ½ d. per foot run			11
13 ft. 8 in. run of 5 in. by 1½ in. bead at 3 d. per foot run	3	5	
11 ft. run of 6 in. by ½ in. bead at ½ d. per foot run			8½
3 ft. run of 6½ in. by 4 in. oak at 1s. 9d. per foot run	5	3	
	16	3	
Add for waste, 10%	1	7½	
	17	10½	
4 axle pulleys at 1s.	4	—	
4 sash weights at 1s. 3d.	5	—	
7 yd. of sash line at 3d.	1	9	
Joiner making and carpenter fixing, 12 hours at 1s. 9d.	1	1	—
Labourer assisting, 1 hour at 1s. 3½ d.	1	3½	
Sundries, 2½% on timber			5
	2	11	4½
Add for Profit and Establishment, 12½%			6 5
	£2	17	9½

Dividing the above total by 15 gives the price per foot super of 3s. 10½ d.

STAIRCASES. In the opinion of the writer, these are the most difficult of all items to price. The superficial dimensions given in a bill of quantities for the treads and risers do not include the whole of the timber used in making the treads and risers. The handrail, balusters, and strings are given separately, and are not difficult to price, for the material can be assessed as described for skirtings. Carriages and blocks are not given separately. The student is strongly recommended to measure all the material in an actual staircase (the one in his own home will answer the purpose), and then price the quantities in a similar manner to our typical examples. Afterwards, he can measure up and take out the quantities by the usual method employed by the quantity surveyor, and adjust his price accordingly. The following data are submitted

MODERN BUILDING CONSTRUCTION

as a rough guide. For staircases 3 ft. in width allow 2½ hours per tread ; for those 6 ft. in width allow 3 hours per tread ; and others in proportion. The typical example will show the methods employed.

DETAILED EXAMPLE

For this purpose we will assume a staircase of fourteen treads and risers 2 ft. 6 in. wide, of a total superficial area of 50 ft.

Deal Staircase of 1½ in. Treads and 1 in. Risers, including 6 in. by 3 in. Rough Fir Carriages, etc., Complete—

	£	s.	d.
34 ft. run of 12 in. by 1½ in., at 7½d.	1	1	3
40 ft. run of 7½ in. by 1 in., at 3½d.	12	6	
15 ft. run of 6 in. by 3 in. (rough fir), at 4½d.	5	7½	
17 ft. run of 7 in. by 1½ in. rough brackets, at 2½d.	3	2½	
40 ft. run of bed moulding, at 10s. per 100 ft.	4	-	
28 rough fir blocks, at ¼d.		7	
Waste on timber, 15%		7	½
Nails and sundries, 3% on £2 7s. 2d.	1	4½	
Joiner making and fixing, at 2½ hours per tread ; 35 hours at 1s. 9d.	3	1	3
	5	16	10½

Add for Profit and Establishment, 12½%

£6 11 5½

Dividing the above by 50, gives the price per foot super of 2s. 7½d.

HARDWOODS. The prices of hardwoods vary from time to time, but at present the cost, inclusive of carting, unloading, converting, and finishing ready for framing, will work out as follows: teak, 20s. ; oak, 22s. ; and mahogany, 34s. per foot cube. For labour costs, the student may use the data given for deal, and multiply by the following figures : oak, 2 ; mahogany, 2½ ; and for teak, 3.

IRONMONGERY AND BRASSWORK. The prices can be found in the various catalogues. Fixing must be calculated for each article, but many builders allow a percentage on the prices to cover this, frequently 10 per cent. This method, however, is unsatisfactory.

Some quantity surveyors give a provisional sum for the whole of the ironmongery and brasswork to be supplied and delivered, and then describe the fixing of each item separately. This prevents erratic pricing and necessitates the estimating surveyor affixing a separate price against each item.

The following data are given in respect to fixing to deal (or similar soft woods) but for hardwoods the multipliers given in the previous

descriptions for hardwoods can be used (i.e. oak two, mahogany two and a half, teak three).

Fixing Only, Ironmongery and Brasswork to Softwoods.

Barrel bolts . . . 10 mins.	Cupboard lock . . . 30 mins.
Casement stay and pin . . . 15 "	Cross garnets per pair . . . 30 "
Sash fastener . . . 15 "	Rim lock . . . 1 hr.
Cockspur fastener . . . 15 "	Letterplate and forming opening . . . 1½ hrs.
Ordinary butts per pair . . . 20 "	Mortice lock and furniture (per set) . . . 3 "
Flush bolt (each) . . . 20 "	
Monkey tail bolt . . . 20 "	

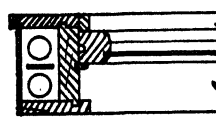

PLAN

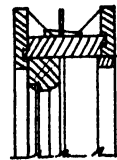

SECTION AT HEAD

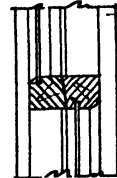

SECTION AT MEETING RAILS



SECTION AT SILL

FIG. 3

READY MADE ARTICLES AND MATERIALS SUPPLIED DIRECT TO THE JOB. Doors. There are several makers who supply factory-made doors and the prices can be obtained from their catalogues, but it must be remembered that the cost of "cleaning off" and hanging must be added as for shop-made doors.

Mouldings. Stock dado mouldings and picture rails are sold per 100 ft. lineal, and before fixing require "cleaning off." For a moulding 2 in. wide, 1½ hours should be allowed for a joiner to "clean off" for every 100 ft.; and for a moulding 3 in. wide, 2½ hours should be allowed.

Chapter V—EXCAVATOR; CONCRETE; SPECIALIST TRADES

HAVING priced the "bricklayer" (or "mason") and the "carpenter" bills, the trained surveyor will have a fair idea of the probable size of the job. He will then price the "joiner" (or, on the other hand, this particular bill may be priced by an expert in this subject); after which a visit to the site may become necessary. It might be possible, especially with a good bill of quantities, to price the whole of the items without visiting the site, but it is usually advisable to inspect the soil. As a rule, it will be found that the remaining bills, other than those described in the previous articles, require quotations from specialist firms, or for proprietary articles, and a junior should be able to obtain and tabulate these.

Visiting the Site. The following points should be noted on the spot: nature of the ground, and whether waterlogged; whether the sub-soil is rock or difficult to excavate; whether trial holes are necessary; if access is easy or difficult; whether a "draw in" is possible, or if it is necessary for all excavated and other materials to be moved across public ways; whether basketing is necessary; whether any buildings or old foundations exist; whether ground is level or sloping; whether the excavated material is likely to prove of value. It will also be necessary to make certain local inquiries, such as carting facilities; names of local merchants, sub-contractors, and haulage contractors. It sometimes becomes necessary in certain districts to inquire if lodgings are available for specialist craftsmen, who will come from another district, for often there is considerable difficulty. In rural districts it may be necessary for the contractor to provide temporary accommodation, and it may happen that the difficulty is so acute that the builder will be well advised to decline to tender. In some districts it may be desirable to make inquiries as to sanitary regulations and by-laws, and to ascertain such information as depth of sewer, water regulations, and fees demandable by local authorities. As a rule, the visit to the site and local inquiries necessitate a hard day's work, if the job is far from the contractor's headquarters. After visiting the site and making his local

inquiries, the estimating surveyor is then in possession of sufficient data to complete the whole of the remaining bills.

EXCAVATOR

The items in these trades are not difficult to price, if the data for materials are available, for once the cost of bulk items is calculated, the remaining items can be found by proportionate methods. With regard to excavation items, it will be necessary to make an addition for such matters as extra depths, basketing, distance of shoot, and other factors which affect the price.

Excavation. Apart from the question of the local rate of wages, the most important matter is the cost of cartage, for this has a great bearing upon the price of the item. The cost naturally depends upon the distance of the nearest shoot, and for keen prices it is obvious that local knowledge is necessary. This item alone should convince the novice that it is impossible to correctly price a bill of quantities from stock data.

DETAILED EXAMPLES

Excavate for Basements not Exceeding 5 ft. Deep and Throw Out— s. d.

Excavator (loose ground), 1 hr. at 1s. 4½d.	1	4½
Profit and Establishment, 12½%	1	4½
		2
Price per yard cube	1	6½

Excavate in Trenches not Exceeding 5 ft. Deep and Throw Out— s. d.

Excavator (loose ground), 1½ hrs. at 1s. 4½d.	1	9
Profit and Establishment, 12½%	1	9
		2½
Price per yard cube	1	11½

Wheel and Deposit Excavated Material a Distance of 50 yd.— s. d.

Labourer, filling barrows and wheeling 1 hr. at 1s. 3½d.	1	3½
Profit and Establishment, 12½%		2
Price per yard cube	1	5½

MODERN BUILDING CONSTRUCTION

Fill Excavated Material into Carts and Cart Away to Shoot—

	<i>s. d.</i>
Labourers (2), one-third of 1 hr. at 2s. 7½d.	10½
Cartage (assumed quotation), 6s. per load .	6 —
	6 10½
Profit and Establishment, 12½%	10½
	<hr/> 7 8½

The student must bear in mind that 1 yd. cube of earth before excavation becomes 1¼ yd. cube when excavated. The use of electrically driven plant, lifts, chutes, and concrete mixers can effect great saving with large jobs, but the question of labour-saving machinery cannot be analysed without accurate costing data. We must, therefore, assume that all the work in the detailed examples given is done without the aid of machinery. It should be noted that an excavator usually receives 1d. per hour more than the labourer.

EXTRA DEPTHS. For extra depths below 5 ft. staging becomes necessary, and the work is usually arranged so that one man throws up the earth excavated by two others. The cost of the staging can be worked out as described for planking and strutting, and it usually amounts to about 3s. to 5s. per foot cube of excavation. The extra labour must be added at the rate of 50 per cent for 10 ft. depths, 75 per cent for 15 ft. depths, and so on.

RETURN, FILL, AND RAM. This item is priced separately and five hours per yard cube for labourer should be allowed.

CONCRETE

The cost of lime or cement must be calculated before the price of a cubic yard of concrete can be worked out. The trade "bushel" was once a familiar unit for pricing, but estimating is now carried out in a more scientific manner, and far more accurate prices can be obtained by using cubic quantities for lime and cement.

PORTLAND CEMENT. One ton of Portland cement at present costs £2 3s. 4d. inclusive of carting, unloading, and paper sacks. As one cubic yard of cement weighs 21.7 cwt., the price per foot cube is 1s. 9d. In this calculation it was assumed that the unloading took two labourers half an hour each. The cement manufacturers make a charge of 1s. 6d. each if jute sacks are supplied, but these are credited in full if returned in good condition. No charge is now made for paper bags.

LIAS LIME. At the time of writing the cost of one ton of lias lime is £2 1s. inclusive of cart-

ing, unloading and use of sacks. One ton contains about 39 cubic feet, and this works out at 1s. 0½d. per foot cube. In this calculation the cost of unloading was assumed to be the same as for Portland cement, and for the use of sacks, 11 to the ton are taken.

REDUCTION IN BULK. The apparent reduction in bulk which takes place after the dry materials are mixed and combined with water is due to voids in the large aggregate being filled during mixing, with the smaller aggregate (sand) and the cement. The extent to which allowance must be made depends therefore upon the percentage of voids in the aggregate and whether the materials are graded or not. Unsifted ballast contains too much sand, but in a mixture of one to four (not 1:2:4) little reduction in bulk occurs. With carefully graded materials the final reduction has been found to be somewhere between one quarter and one-third of the total volume of materials before mixing.

In preparing detailed costs, therefore, it will be found convenient to calculate the quantities of the materials in the proportions given in the Specification, using the yard (or foot) cube as the unit for material, and then to add a percentage for the apparent reduction in bulk. The result can then be divided by the total number of yards cube of materials used so as to obtain the price of one yard cube.

Waterproofed Concrete. It is frequently necessary to add a waterproofing powder to concrete. The various proportions necessary can be obtained from the merchants who supply the material, but it will be found that, compared to the weight of the cement required for the particular "mix," the amount of waterproofing powder required is not more than 5 per cent by weight. Concrete for waterlogged soil and in the proportions of 4:2:1 will require 10½ lb. of waterproofer to the yard cube of concrete. This is equal to 2 per cent of the weight of the Portland cement. This proportion is adequate if a graded aggregate is used. In preparing a detailed analysis, it is necessary to remember that 2 per cent by weight of the cement is almost 5 per cent by bulk, because the powder weighs half as much as an equal bulk of cement.

In a "mix" of 4:2:1 the addition of waterproofing powder will increase the bulk of the materials by 5 per cent of the bulk of the cement or ½th of one yard cube. The actual cubic proportions therefore are 4 parts of ballast;

2 parts of sand; 1 part of Portland cement, and $\frac{1}{20}$ th part of waterproofer.
The powder costs about 1s. per lb.

DETAILED EXAMPLES

Portland Cement Concrete (1 to 6) in Foundations—

27 ft. cube (1 yd.) Portland cement as described, at 1s. 9d. per ft. cube	£	s.	d.
2 yd. cube of coarse sand at 7s. 9d. per yard cube		15	6
4 yd. cube of broken stone at 6s. per yd. cube	1	4	—
	4	6	9
Add for decrease in bulk 33 $\frac{1}{3}$ %	1	8	11
Total for 7 yd. cube	£5	15	8
Take one-seventh		16	6 $\frac{1}{2}$
Labour, mixing and laying 4 hrs. at 1s. 3 $\frac{1}{2}$ d.		5	3
	1	1	9 $\frac{1}{2}$
Profit and Establishment, 12 $\frac{1}{2}$ %		2	8 $\frac{1}{2}$
	£1	4	6

Lias Lime Concrete (1 to 6) in Foundations—

27 ft. cube (1 yd.) lias lime at 1s. 0 $\frac{1}{2}$ d. per ft.	£	s.	d.
2 yd. cube ungraded sand at 7s. 9d. per yd. cube		15	6
4 yd. cube broken rubble at 6s. per yd. cube	1	4	—
	3	8	2 $\frac{1}{2}$
Add for decrease in bulk, 33 $\frac{1}{3}$ %	1	2	8 $\frac{1}{2}$
Total for 7 yd. cube	£4	10	11
Take one-seventh		12	11 $\frac{1}{2}$
Labour, mixing and laying, 4 hrs. at 1s. 3 $\frac{1}{2}$ d.		5	3
		18	2 $\frac{1}{2}$
Profit and Establishment, 12 $\frac{1}{2}$ %		2	3 $\frac{1}{2}$
	£1	—	6

Portland Cement Concrete as Before, but Spread and Levelled over Site, 6 in. Thick, with Spade Finish—

Concrete, one-sixth of 1 yd. cube at	s.	d.
	11	$\frac{1}{2}$
Add extra labour spreading, levelling and finishing, $\frac{1}{4}$ hr. at 1s. 3 $\frac{1}{2}$ d.	11	$\frac{1}{2}$
Profit and Establishment, 12 $\frac{1}{2}$ %	1	$\frac{1}{2}$
Price per yard super	1	1 $\frac{1}{2}$

SPECIALIST TRADES

Drainlayer. This is a simple trade to price, as the cost of many of the items can be worked out from data obtained from previous examples. The trenches and the concrete are billed per foot run, but as the depth is stated the costs

can be found by proportionate methods. Planking and strutting must be included in the price for digging.

STONEWARE PIPES. Quotations should be obtained for the pipes, but at present these work out at 7 $\frac{1}{2}$ d. per foot run for 4 in., and 10d. per foot run for 6 in. pipes. For the labour jointing 4 in. and 6 in. pipes allow $\frac{1}{4}$ hour per joint for bricklayer and labourer. For cement for jointing, allow $\frac{1}{2}$ gal. for 4 in., and $\frac{3}{4}$ gal. for 6 in. diameter pipes. A joint is required every 2 ft. in length.

IRON PIPES. The pipes and the jointing material being of metal, the prices fluctuate considerably, and quotations must always be obtained. At present the pipes cost 2s. 6d. per foot for 4 in. diameter and 3s. 8d. per foot for 6 in. diameter. For the metal joints, allow 4 $\frac{1}{2}$ lb. for 4 in. pipes and 10 $\frac{1}{2}$ lb. for 6 in. pipes, and allow for a joint every 9 ft.

INSPECTION CHAMBERS. The brickwork, concrete, and rendering prices can be obtained from the data compiled for the different trades, but owing to the confined nature of the work, it is usual to add from 20 to 30 per cent in accordance with the depth of the chambers. The prices for channel pipes can be found from the maker's lists, and for joints add labour and cement as described for pipes. The cost of the iron covers and frames can be found from the catalogues, and for labour, bedding, and fixing allow for bricklayer and labourer $\frac{1}{4}$ hour.

Temporary Timber Work. For ordinary "excavator" items, it is usual for the timber work to be given separately; but for drainage work it is often included in the item. It is very difficult to calculate prices, for frequently the material can be used many times.

DETAILED EXAMPLE

<i>Planking and Strutting—</i>	£	s.	d.
One square of 1 $\frac{1}{2}$ in. boarding at 26s.	1	6	—
Walling boards and struts, add 50%		13	—
Total cost	£1	19	—
Assuming the above timber can be used upon five occasions: take one-fifth		7	10
Carpenter, 2 hrs. at 1s. 9d.		3	6
Labourers, 6 hrs. at 1s. 3 $\frac{1}{2}$ d.		7	10 $\frac{1}{2}$
		19	2 $\frac{1}{2}$
Waste and nails, add 10%		1	11 $\frac{1}{2}$
Profit and Establishment, 12 $\frac{1}{2}$ %	1	1	2
		2	8
Cost per square (of 100 ft.) super	£1	3	10

MODERN BUILDING CONSTRUCTION

From the above it is a simple matter to find the cost per foot super, and to utilize the information for pricing, planking, and strutting to trenches per foot run when the depth is stated.

Pulling Down. In large towns this work is frequently placed in the hands of specialist contractors, who give lump sum prices for the work; but frequently, especially in alteration jobs, the builder may be called upon to price items of demolition. Many men of experience can quickly assess the value of such work, but the young estimator will find it necessary to take out rough quantities and to price the items separately. As a very rough guide, it will be found that the labour pulling down amounts to a little less than half of the time the work takes to erect, for constructional trades, but the work is carried out by labourers and not by craftsmen. The labour removing the work of the finishing trades is about one-fifth of the time expended in fixing the material.

Constructional Steelwork. This work usually is placed in the hands of special contractors, who fabricate and erect the material. It may happen that the builder is called upon to erect certain items of steelwork, such as detached stanchions and girders. Whenever possible, the builder should consult specialists, but the price of the material can always be obtained from the manufacturers, although it varies from time to time. For the cost of labour erecting some knowledge of the sizes of the members is necessary, but an average allowance is one to three hours per cwt.

WROUGHT IRON. The articles of wrought iron used in a building are not many, and consist principally of straps, rails, chimney bars, and similar items. The work is usually billed by weight, and quotations must be obtained for the material. For labour a fair allowance would be fifteen hours of smith's time per cwt. of metal.

CAST IRON. This formerly was the principal metal in this bill that the estimating surveyor was called upon to price, and it included gutters and rain-water pipes. These items are now included in "Plumber."

IRON AND STEEL. The prices of metal vary so frequently that it is not advisable to give detailed examples herein; prices should always be ascertained before tendering.

Hot Water Fitter. This is another specialist

trade; in fact, the work is now described as engineering work. The builder, however, is often required to price small domestic hot-water systems, but he frequently sub-lets the work. The pipes used are known as "barrel" or "tubes," and the prices can be obtained from the "Standard Tube List," a copy of which can be obtained from the manufacturers. The list is subject to a large discount, which varies in accordance with the fluctuations of the market. To the prices of the tubes, allow for fixing as follows: for $1\frac{1}{4}$ in. and $1\frac{1}{2}$ in. pipes $\frac{1}{4}$ hour per foot for fitter and mate; for pipes of smaller diameter, allow ten minutes per foot.

Gas-Fitter. The work is billed in a similar manner to the work of the hot-water fitter, and prices for material can be found from the "Standard Tube List." For fixing, add for fitter and mate eight minutes per foot for pipes 1 in. in diameter and under, and for $1\frac{1}{4}$ in. and $1\frac{1}{2}$ in. pipes allow twelve minutes per foot.

Electrician. The general contractor is not asked to price this work, it being an engineering trade, and in consequence not governed by the trade union rules for the building industry. The general contractor, however, is frequently called upon to price items for attendance—cutting away—and making good. This item is usually given per "point," and a "point" is assumed to be one position for lighting, or heating, including one position for a switch and may necessitate the bricklayer cutting a chase in the brickwork. It is a most speculative item, but a common allowance is 1 hour bricklayer, $\frac{1}{2}$ hour carpenter (plugging wall) and $1\frac{1}{2}$ hours plasterer and labourer (making good).

Heating Engineer. The general contractor frequently has to price the attendances upon this trade, but a proper bill of quantities would give the exact number of items. Where bills of quantities are not supplied, perhaps the number of radiators only may be given. Each 4 foot length of radiator requires a stay "cut and pinned" and each radiator requires two brackets "cut and pinned." Each radiator will require two holes in the floor. For the radiator stay allow $\frac{1}{2}$ hour each for bricklayer and plasterer. For each bracket, $\frac{1}{4}$ hour each, and for each hole in the floor $\frac{1}{2}$ hour for carpenter. If chases in wall are required it will be necessary to measure the lengths and allow for bricklayer and labourer 10 minutes per foot run.

Chapter VI—PLUMBER

THIS, for the estimating surveyor, is another difficult trade; also, it is one of the few trades in which the price of the material used is far more important than the rate of wages paid. Frequently, in a bill of quantities, the work is divided into two parts, external work and internal work, but a more convenient division is to devote separate sections to lead-laying, water supply, and sanitary engineering. It is impossible to price items in this trade without a good knowledge of quantity surveying, but it is equally impossible to take out the quantities without a very sound knowledge of building construction and sanitary engineering. The prices for the materials fluctuate in a remarkable manner, and, being expensive, it is important that quotations, or the current market rates, are obtained before prices are compiled.

LEAD-LAYING

FLATS. In covering ordinary flats with lead, a plumber and mate should be able to lay from 4 ft. to 5 ft. super per hour, including dressing over the rolls. It makes very little difference to the amount of time expended if the weight of the material varies; and, as the work is billed

DETAILED EXAMPLES

Lead and Labour in Flats (assuming 7 lb. lead)—

	£	s.	d.
1 cwt. of sheet lead, at 25s. per cwt.	1	5	—
Waste, say 2½%			7½
Plumber and mate at 4 ft. super per hr. = 4 hrs. at 3s. 0½d.		12	3
	1	17	10½
Establishment and Profit, 12½%		4	8½
Price per cwt.	£2	2	7½

Lead and Labour in Gutters (assuming 7 lb. lead)—

	£	s.	d.
1 cwt. of sheet lead at 25s. per cwt.	1	5	—
Waste, say 2½%			7½
Plumber and mate, at 3½ ft. super per hr. = 4½ hrs. at 3s. 0½d.		13	9½
	1	19	5
Establishment and Profit, 12½%		4	11
Price per cwt.	£2	4	4

by weight, it is obvious that data for this unit are difficult to compile. Lead is usually described by its weight per foot super, i.e. 5 lb., 6 lb., and 7 lb. For the typical examples given we have assumed that 7 lb. lead is used, as would occur with first-class work. For ordinary lead gutters, about 3½ to 4 hours per foot super should be allowed for plumber and mate, and for cesspool outlets 2 hours each. For work requiring solder (as in cesspools) add 2½ per cent to the price of the lead.

FLASHINGS. For ordinary flashings allow for lead as in the foregoing items, adding 2½ per cent for waste. Tacks are usually allowed in the measurement by the quantity surveyor, so nothing need be added for these. For the labour, it is suggested that 25 per cent be added to the previous data.

STEPPED FLASHINGS. Allow for material as for ordinary flashings, but for labour add 25 per cent to the time suggested for flats.

WATER SUPPLY

In compiling prices for fixing lead pipes, allowance must be made in the price for joints; and, as regards pipes of less diameter than 1½ in., an allowance for bends must be included in addition. The regulations as to weights of pipes vary for different districts, and inquiries must be made locally regarding the regulations enforced by the water authority. The Metropolitan Water Board regulations can be taken as typical, being 2 lb. per foot run for ½ in. pipe, 3 lb. per foot run for ¾ in. pipe, and 4 lb. per foot run for 1 in. pipe. At the time of writing, lead pipe costs 18s. 8d per cwt., which is equal to 2d. per lb., but this price fluctuates in accordance with the market conditions. It is necessary to allow about 2½ per cent for waste.

FIXING LEAD PIPES. It is suggested that, for plumber and mate, the following periods should be allowed, which are inclusive of forming bends and joints—

½ in. pipe	= 7½ minutes per foot.
¾ in. pipe	= 8 minutes per foot.
1 in. pipe	= 11 minutes per foot.

For solder allow ½ oz. per foot for ½ in. pipe, ¾ oz. per foot for ¾ in. pipe, and 1 oz. per foot

MODERN BUILDING CONSTRUCTION

for 1 in. pipe. If pipe clips are required, add $2\frac{1}{2}$ per cent to the price of the pipe.

DETAILED EXAMPLE

$\frac{3}{4}$ in. Lead Pipe and Fixing to Walls, including Clips—

	s.	d.
1 ft. of lead pipe, i.e. 3 lb. at 2d.	6	
Waste, $2\frac{1}{2}$ %	$\frac{1}{4}$	
Solder, $\frac{1}{4}$ oz. at 1s. 1d. per lb.	$\frac{1}{4}$	
Plumber and mate, 8 min., at 3s. 0 $\frac{1}{2}$ d. per hour	5	
Pipe clips, $2\frac{1}{2}$ %	$\frac{1}{4}$	

Profit and Establishment, 12 $\frac{1}{2}$ %

Price per foot run

11 $\frac{3}{4}$
1 $\frac{1}{2}$
<hr/> 1 1 $\frac{1}{4}$

LEAD WASTE PIPES. The weights usually specified are 4 lb. per foot run for $1\frac{1}{4}$ in. pipe, $4\frac{1}{2}$ lb. per foot for $1\frac{1}{2}$ in. pipe, and 6 lb. per foot for 2 in. pipe. For joints the following periods are suggested for labour and solder—

RUNNING JOINTS

- $1\frac{1}{4}$ in. pipe—7 $\frac{1}{2}$ minutes per foot and 2 oz. solder.
- $1\frac{1}{2}$ in. pipe—8 minutes per foot and 2 oz. solder.
- 2 in. pipe—8 $\frac{1}{2}$ minutes per foot and $2\frac{1}{2}$ oz. solder.

BRANCH JOINTS

- $1\frac{1}{4}$ in. pipe—10 minutes per foot and 2 oz. solder.
- $1\frac{1}{2}$ in. pipe—10 $\frac{1}{2}$ minutes per foot and 2 oz. solder.
- 2 in. pipe—11 minutes per foot and $2\frac{1}{2}$ oz. solder.

DETAILED EXAMPLE

$1\frac{1}{2}$ in. Lead Pipe and Fixing as Waste Pipe—

	s.	d.
1 ft. run of pipe, i.e. $4\frac{1}{2}$ lb. at 2 $\frac{1}{2}$ d. (i.e. 25s. 8d. per cwt.)	1	0
Waste, $2\frac{1}{2}$ %	$\frac{1}{4}$	
Solder, 2 oz. at 1s. 1d. per lb.	1 $\frac{1}{4}$	
Plumber and mate, 10 $\frac{1}{2}$ min. at 3s. 0 $\frac{1}{2}$ d. per hour	6 $\frac{1}{4}$	

Profit and Establishment, 12 $\frac{1}{2}$ %

Price per foot run

1 8 $\frac{1}{4}$
2 $\frac{1}{4}$
<hr/> 1 11

LEAD SOIL PIPES. Lead soil pipes are usually $3\frac{1}{2}$ in. or 4 in. in diameter, and the usual weights are $6\frac{1}{2}$ lb. per foot for the former, and $7\frac{1}{2}$ lb. per foot for the latter. For fixing, allow for plumber and mate 17 minutes per foot run, including forming the joints. For waste allow $2\frac{1}{2}$ per cent; for lead tacks 5 per cent; for solder allow $\frac{1}{4}$ lb. per foot run; and lampblack $\frac{1}{4}$ oz. per foot.

LEAD ANTI-SIPHONAGE PIPES. These costs can be compiled in a similar manner to the lead waste pipes, detailed earlier, as the weights are usually given in a bill of quantities.

DETAILED EXAMPLE

4 in. Lead Soil Pipe and Fixing to Wall with Cast Lead Tacks—

	s.	d.
1 ft. of lead pipe, i.e. $7\frac{1}{2}$ lb. at 3 $\frac{1}{2}$ d. (i.e. 30s. per cwt.)	2	0 $\frac{1}{2}$
Waste, $2\frac{1}{2}$ %	$\frac{1}{4}$	
Solder, $\frac{1}{4}$ lb. at 1s. 1d.	3 $\frac{1}{4}$	
Lampblack, $\frac{1}{4}$ oz. at 1s. per lb.	$\frac{1}{4}$	
Tacks, add 5%	1 $\frac{1}{2}$	
Plumber and mate, 17 min., at 3s. 0 $\frac{1}{2}$ d. per hr.	10 $\frac{1}{2}$	

Profit and Establishment, 12 $\frac{1}{2}$ %

Price per foot run

3 4 $\frac{1}{2}$
5
<hr/> 3 9 $\frac{1}{2}$

IRON SOIL AND WASTE PIPES. The prices for the material can be found from the manufacturers' lists, and it is not difficult to compile prices. The following data are submitted: for fixing, inclusive of caulked lead joints, allow for plumber and mate 15 minutes per foot run, and for 2 in. pipes six minutes per foot. For lead (for caulked joints) allow 5 oz. per foot for the former, and $1\frac{1}{4}$ oz. per foot for the latter.

SANITARY FITTINGS

It is impossible in this work to give data for fixing sanitary fittings; in fact, it is extremely difficult to compile a price even if the design is available. If the bill of quantities simply gives the prime cost of the apparatus, it is usual for the builder to add a percentage to cover fixing; this percentage varies from 10 per cent to 20 per cent.

LEAD TRAPS. These are required for sinks and lavatory basins, and prices can be obtained from the merchants' price lists. For fixing, allow for plumber and mate three-quarters of an hour, and for solder 4 lb.; this allows for two joints.

CAST IRON GUTTERS AND RAIN-WATER PIPES

The prices of material can be found in the published price lists, but the cost of fixing must be added. For 4 in. and 5 in. cast-iron gutters, allow sixteen hours for plumber and mate per 100 ft.; and for 3 in. and 4 in. rain-water pipe allow seventeen hours per 100 ft.

JOBGING WORK, OR WORK WITHOUT QUANTITIES

When bills of quantities are supplied, the various items of plumbing work are enumerated by the quantity surveyor, and although the pricing of a plumber's bill is always difficult, it is even more difficult when no "quantities"

are supplied, as with jobbing work, or repairs and additions to existing property. In compiling his rough quantities, the estimating surveyor must include for many things that at first are not apparent, and as the various items of material are so expensive, the writer gives herewith a summary of a few items that are often omitted from estimates.

When pricing stopcocks, two joints are necessary, one each side of the cock. If the lead service pipe is to be fixed against walls, pipe clips and small lead tacks are required. In jointing lead pipes, such as soil pipes and anti-siphonage pipes to different materials, brasswork must be included. In jointing a glazed fireclay w.c. pan to a lead soil pipe, a brass thimble is required, and in jointing a lead soil pipe to a glazed stoneware drain pipe, a brass ferrule becomes necessary, and as brass thimbles and ferrules cost about 10s. each, exclusive of the jointing, this matter is important. In jointing lead pipes to a galvanized iron cistern, allowance must be made for the drilling and tapping of the cistern, and for brass boiler screws.

In taking pipes through walls, a bricklayer will be required to form the hole and to make good, and this labour in connection with a w.c. pan, especially in additions or repairs to old work, can be very expensive, as a large hole is necessary. For a w.c. cistern, an overflow pipe is needed, necessitating a hole through the wall; the services of a carpenter are required to fix the back-board for the cistern, the brackets, and the w.c. seat.

Where branches are taken from main services, wiped soldered branch joints become necessary. The waste pipes from baths, sinks, and lavatories may require "puff" pipes to comply with local sanitary regulations, and these will necessitate a soldered branch joint, and a hole through the wall; also, owing to recent regulations, it will be found that in many districts the "puff" pipes will have to be continued up the walls to a point above eaves level, so as to conform with regulations for anti-siphonage pipes. Stoneware and fireclay sinks will need a brass union for the lead waste, also a washer and plug. Sinks and lavatory basins will require a trap, but with baths a trap is usually included in the maker's charge.

Many of the items mentioned are to be found in a carefully prepared bill of quantities, but occasionally such items as attendance of carpenter and bricklayer are included in a clause in the preliminary bill. "Allow for attendance

of all trades in all trades," and in these circumstances great care must be used. When adding a percentage to the provisional amounts for sanitary apparatus, do not forget to allow for the unpacking, and the carriage and return of empty packing cases.

If the work is in connection with an existing building, careful inquiries must be made to ascertain if a scaffold is necessary, for in some cases the erection and striking of a scaffold can cost more than the value of the actual plumber's work.

The above are the principal items to be remembered. But there are many others, and the student will now appreciate the necessity of a thorough knowledge of plumbing work before an attempt is made to price this bill; it is a task for an expert.

ZINCWORKER

ROOFING. This work is usually carried out by specialist contractors, and quotations should be obtained from them. As a rough guide for the purpose of preparing approximate estimates, it will be found that, the price of zinc being £30 per ton, the cost of labour and materials per foot super of roof will work out at about 7½d., assuming wages at 1s. 9d. per hour.

GUTTERS AND RAIN-WATER PIPES. As the price of the material fluctuates, quotations should be obtained from time to time, but to the material the cost of labour must be added, and this can be based upon the data give in *Plumber* for iron rain-water goods.

COPPERSMITH

ROOFING. The conditions are similar to zinc roofing. With sheet copper at £94 per ton, the price per foot super for roofing will work out at about 1s. 7d., assuming the wages rate is 1s. 9d. per hour.

TUBE WORK. Work in copper tubing for hot-water services is becoming more common than formerly, owing to the fact that the price of copper now compares favourably with other metals. The joints are usually formed with gun-metal or brass screwed fittings, and the cost of these can be found in the merchant's catalogues. For approximate estimates the following data can be used; the prices include the cost of fittings—

With copper tubing at 1s. per lb. and the price of labour as before, the prices per foot run will be, for 1 in. pipe, 9d.; for ¾ in. pipe, 7½d.; and for ½ in. pipe, 5½d.

Chapter VII—PLASTERER

IN compiling or obtaining prices for plastering work, the estimator has to use great discretion, for conditions in this particular trade vary more than in other trades, and prices compiled in one district often vary to a remarkable extent when compared with those compiled in another part of the country. The weather has a great effect upon the time taken, and allowance must be made in the prices if the work is to be executed in damp and foggy weather, even for internal work. As it is impossible to foretell the weather, it is obvious that the task of the estimating surveyor is one of much difficulty. It often happens that owing to the action of the weather, non-arrival of material, or delay caused by other trades, work in connection with large surfaces is executed after the ordinary working hours, in order that the particular piece of work can be finished in one operation; in consequence, overtime money must be paid.

Unlike the work of other trades, a complete job, such as a wall flank, must be completed in one day, and it is not an easy task to gauge accurately the work in such a way that the plasterers finish exactly to time. If the task for the day falls a little short of the working day, the men will probably work the same number of hours, but if overtime becomes necessary, extra money must be paid. A building contract does not take into consideration these aspects, consequently the builder runs a considerable risk of losing on plasterer's work.

Sub-contractors. Owing to the many difficulties mentioned, the general contractor will frequently sublet the plastering work, and one of the early tasks allotted to the junior estimating surveyor is that of measuring the work executed by the sub-contractor. Measurements and customs of plasterers vary, and as this subject is a frequent cause of difference between builders and their sub-contractors, a few words regarding measurements may not be out of place. In preparing a bill of quantities, the quantity surveyor will follow (or should follow) the Standard Method of Measurement, and the estimating surveyor, in compiling his price, will naturally price the items as shown in the bill. If the sub-contractor charges "extras," which

are not allowed by the quantity surveyor, the builder is out of pocket. A proper schedule should be agreed before the work is started and, in order that the schedule may conform to the Standard Method of Measurement, the plasterer should be asked to agree to the following items.

THICKNESS OF COATS. It is now definitely decided (in the Standard Method) that the thickness of two-coat work shall be taken as not exceeding five-eighths of an inch, and for three-coat work as not exceeding seven-eighths of an inch. Two-coat work, in patent plastering materials, is taken as half an inch thick. The question of thickness of coats is very important, for the plastering sub-contractor may claim "dubbing out" over surfaces, for which the builder may not get paid. In the detailed examples which follow, no percentage has been added for waste, but allowance for waste is included in the extra thicknesses of coats.

NARROW WIDTHS. Another frequent cause for disagreement is the want of a proper understanding as to what constitutes a "narrow width," for this work is priced at a higher rate than the general plastering. It is definitely stated in "The Standard Method of Measurement," that work 6 in. in width, and less, must be measured per foot run; and that work above 6 in. and not exceeding 12 in. in width must be billed per foot super. This does *not* apply to returns of chimney breasts and strips occurring in plain work where openings occur (such as between windows and similar work). No other work can be described as "narrow widths."

DEDUCTIONS. No deductions from the general surface should be made for work 4 ft. super and less in area, and no deductions should be made for pipe casings less than 12 in. wide.

SMALL QUANTITIES. This work is also priced at a higher rate than the general surfaces. Work of a less area than 1 yd. super, detached from other work, is described as "in small quantities."

EXTERIOR WORK

The prices are only approximate, for one day of inclement weather can undo the work of two

days; also, scaffolding must be included in the price. The writer suggests that an allowance be made as described in the lesson on "Brick-layer," but it is obvious certain jobs require more scaffolding than others; yet frequently the estimating surveyor has no data regarding the height of the work.

Exterior work is usually in Portland cement, but frequently rough casting (or pebble-dash) is executed in lime mortar. Roman cement is not used to a great extent, except in repairs to existing work of similar material. The cost of ordinary Portland cement has been analysed in Chapter II, so no further explanation is necessary, the analysis of cement and sand have also been dealt with in Chapter II.

DETAILED EXAMPLE

Render and Set in Portland Cement and Sand (1 to 3)
 $\frac{3}{8}$ in. Thick—

9 yd. super of material $\frac{3}{8}$ in. thick (see Chapter II), £1 19s. 2d. per yd. cube at 9 $\frac{1}{2}$ d.	£ s. d. 7 3 $\frac{1}{2}$
Plasterer and Labourer, 5 hrs. at 3s. 0 $\frac{1}{2}$ d.	15 4
Total for 9 yd. super	<u>1 2 7$\frac{1}{2}$</u>
Take one-ninth	2 6 $\frac{1}{2}$
Profit and Establishment, 12 $\frac{1}{2}$ %	3 $\frac{1}{2}$
Price per yard super	<u>2 10$\frac{1}{2}$</u>

In the above example the thickness of material has been taken as $\frac{3}{8}$ in. so as to allow for waste.

Roman Cement. Work in Roman cement is worth about double the price of work in ordinary Portland cement.

SCAFFOLDING. All the work in connection with the last items may require a scaffold, and, although this is a speculative item, by working upon the data given previously for "Brick-layer," it will be found that the cost works out at about 1s. 2d. per yard extra.

Preparation of Data. The following items show the detailed costs of the mixed material for Plasterer's "Putty," "Coarse Stuff," and "Fine Stuff" per yard cube. If a superficial area of one yard and 1 in. in thickness is required then the cost of the material for this area would be one thirty-sixth of the price per yard cube, i.e. yard super for "Coarse stuff." A similar area $\frac{1}{2}$ in. thick would, of course, be half the price of the area 1 in. thick. Other thicknesses can be obtained by similar proportionate methods.

"Coarse Stuff" (1 to 3)	£ s. d.
1 yd. cube of slaked lime at 9s. 7d.	9 7
3 yd. cube washed sand at 8s. 3d.	1 4 9
	<u>1 14 4</u>
Add for decrease in bulk 33 $\frac{1}{3}$ %	11 5
Total for 4 yd.	<u>£2 5 9</u>
Take one-quarter	11 5 $\frac{1}{2}$
Add for cow-hair, 9 lb. at 5d.	3 9
Preparation, two labourers 2 hrs. at 2s. 7 $\frac{1}{2}$ d. per hr.	5 3
Cost per yd. cube	<u>£1 - 5$\frac{1}{2}$</u>

Plasterer's "Putty"

11 ft. cube of unslaked lime at 11d. per ft. cube	s. d. 10 1
Two labourers "running" the material, 3 hrs. at 2s. 7 $\frac{1}{2}$ d. per hr.	7 10 $\frac{1}{2}$
Cost per yard cube	<u>17 11$\frac{1}{2}$</u>

In the above example it has been assumed that the material decreased in bulk by 150 per cent.

"Fine Stuff" (1 to 2)	£ s. d.
1 yd. cube plasterer's putty at	17 11 $\frac{1}{2}$
2 yd. cube fine washed sand at 8s. 3d.	16 6
	<u>1 14 5$\frac{1}{2}$</u>
Add for decrease in bulk, 33 $\frac{1}{3}$ %	11 5 $\frac{1}{2}$
Total for 3 yd.	<u>2 5 11$\frac{1}{2}$</u>
Take one-third	15 3 $\frac{1}{2}$
Preparation, two labourers 3 hrs. at 2s. 7 $\frac{1}{2}$ d. per hr.	7 10 $\frac{1}{2}$
Price per yard cube	<u>£1 3 2$\frac{1}{2}$</u>

SIRAPITE. "Coarse" Sirapite delivered including handling and use of sacks costs £3 14s. per ton, and "Finish" Sirapite costs £4 2s. per ton. If these figures are divided by 35 it will be found that this works out at 2s. 0 $\frac{1}{2}$ d. and 2s. 4 $\frac{1}{2}$ d. respectively per foot cube.

Detailed Cost of Material for First Coat (1 to 3) on Walls—

27 ft. cube "coarse" Sirapite (= 1 yd. cube) at 2s. 0 $\frac{1}{2}$ d. per ft. cube	£ s. d. 2 15 1 $\frac{1}{2}$
2 yd. cube of washed sand at 8s. 3d. per yd. cube	1 4 9
	<u>3 19 10$\frac{1}{2}$</u>
Add 33 $\frac{1}{3}$ % for reduction in bulk	1 6 7 $\frac{1}{2}$
Total for 4 yd. cube	<u>£5 6 6</u>
Take one-fourth	1 6 7 $\frac{1}{2}$
Labour preparing 12 hrs. at 1s. 3 $\frac{1}{2}$ d.	15 9
Cost of yard cube	<u>£2 2 4$\frac{1}{2}$</u>

(or 1s. 2d. per yd. super 1 in. thick)

MODERN BUILDING CONSTRUCTION

Detailed Cost of Material for First Coat (1 to 1) on Wood Laths—

27 ft. cube "coarse" Sirapite (i.e. 1 yd. cube) at 2s. 0½d. per ft. cube	£2 15 1½
1 yd. cube of washed sand at 8s. 3d.	8 3
	<hr/>
Add 20% for reduction in bulk	3 3 4½
	12 8
	<hr/>
Total for 2 yd. cube	3 16 0½
	<hr/>
Take one-half	1 18 0½
Add for cow-hair, 9 lb. at 5d.	3 9
Labour preparing 12 hrs. at 1s. 3½d.	15 9
	<hr/>
Cost of yard cube	£2 17 6½

(or 1s. 7½d. per yard super 1 in. thick)

Detailed Cost of Material for Finishing Coat in Neat Sirapite—

27 ft. cube (or 1 yd. cube) of "finish" Sirapite at 2s. 4½d. per ft. cube	£3 3 6½
Add for decrease in bulk, 17½%	11 1½
	<hr/>
Cost per yard cube	£3 14 8½

(or 2s. 1d. per yard super 1 in. thick)

This material is mixed while the work is proceeding, so nothing has been added for labour as it is included in the detailed example.

In the above examples it will be noticed that the percentage added for reduction in bulk alters with the proportions of the "mix."

INTERIOR WORK

The action of the weather can affect interior work, even though such work is not exposed to the weather; moisture in the atmosphere and fog probably cause the most trouble, but frost is disastrous. Interior work frequently requires scaffolding, especially for lofty ceilings, and it is very difficult to calculate reliable data for this class of work. If the plastering is a separate contract, and the builder is called upon to include for the sub-contractor's scaffolding, the matter is more difficult; but the beginner should note that it is usual for the general contractor to provide scaffolding for rooms under 11 ft. in height, and for the sub-contractor to provide his own scaffold for lofty rooms. There is no definite rule, and arrangements should be made before any work is commenced. If the general contractor is to provide scaffolding, he should be informed in the bill of quantities of the approximate areas and the heights. A fair allowance for scaffolding, for ordinary ceiling work, would be about 9d. per yard super, and for internal walls (for which trestles would be sufficient) about 3d. per yard super.

Two-coat work is described as "render and set," and three-coat work as "render, float, and set," and if on laths as "lath, plaster, float, and set." Many people prefer to base calculations upon surfaces of 100 yd. super, but the writer prefers to take much smaller areas; in fact, an area of about 9 yd. super is as much as one can keep under observation, and represents approximately a wall flank.

Rendering, Floating, and Setting. The first and second coats consist of "coarse stuff," and the third coat of "fine stuff." The best method for preparing costs is to calculate the costs per yard cube for the material mixed, and then to work out later the costs of using such material for work of different thicknesses. In the data which follow, it is assumed that one labourer assists one plasterer, but in practice it is frequently possible for one labourer to attend upon two plasterers, especially if the material arrives on the job ready for use.

Lathing. In large towns this work frequently is sublet to a lathing contractor, and costs at present about 1s. per yard super. One "bundle" of laths, which costs from 2s. 6d. to 3s., will cover about 4 yd. super, and will require ½ lb. of nails. A man should cover about 6 yd. super per hour.

DETAILED EXAMPLES

Render Float and Set Walls (½ in. Thickness)—

9 yd. super "coarse stuff" ½ in. thick at 3½d.	£ 2 7½
9 yd. super ditto ¾ in. thick at 2½d.	1 10½
9 yd. super "fine stuff" ½ in. thick at 1d.	9
	<hr/>
Plasterer and labourer, 5 hrs. at 3s. 0½d.	5 3
	15 4
	<hr/>
Total for 9 yd.	£1 - 7
	<hr/>
Take one-ninth	2 3½
Profit and Establishment, 12½%	3½
	<hr/>
Price per yard super	2 7

Lath, Plaster, Float, and Set Partitions, ¾ in. Thick—

9 yd. super of lathing as quoted at 1s.	£ 9 -
9 yd. super "coarse stuff," ¾ in. thick at 4½d.	3 4½
9 yd. super ditto ½ in. thick at 1d.	9
9 yd. super "fine stuff" ¾ in. thick at 1d.	9
Plasterer and labourer, 5 hrs. at 3s. 0½d.	15 3½
	<hr/>
Total for 9 yd.	£1 9 2½
	<hr/>
Take one-ninth	3 3
Profit and Establishment, 12½%	5
	<hr/>
Price per yard super	3 8

Lath, Plaster, Float, and Set Ceilings ($\frac{1}{2}$ in. thick)—

	s. d.
Labour and material as last item	3 6 $\frac{1}{2}$
Add 10%	4 $\frac{1}{2}$
	<hr/>
Price per yard super	3 10 $\frac{1}{2}$

EXPANDED METAL. If the lathing in the last item is to be upon expanded metal, add 30 per cent to the price.

Cornices. It is almost impossible to prepare reliable data for cornices without a design, as the price depends upon this, although in a bill of quantities cornices are generally billed per foot super or, in certain cases, per foot run. When given per foot super, it means that the quantity surveyor has measured the length by the girth, and girth has the same meaning here as described in "Mason."

Many practical estimating surveyors work out a datum giving a price per foot run per inch in girth, and at the time of writing a contractor quoted the writer 1 $\frac{1}{4}$ d. per foot run per inch, which for a cornice of 9 in. girth amounts to about 1s.

Sirapite. This is a proprietary material which is very popular, owing to the speed at which the work can be carried out; and for the benefit of those unacquainted with this plaster, the following details, taken from the manufacturer's book of instructions, are appended—

First Coat on Walls. One measure of "coarse Sirapite" to two or three of good clean sand.

First Coat on Laths. One measure of "coarse Sirapite" to one of good clean sand. Hair strengthens the work and should be added.

Finishing Coat. Neat "finish Sirapite" mixed in a pail and applied when the first coat is dry.

Although the above instructions are taken from the manufacturer's own pamphlet, it should be noted that many practical plasterers have found by experience that different proportions can give satisfactory results and, if "Sirapite" is used upon a backing of Portland cement, the result is excellent. It will be noticed that only two coats are necessary.

One ton of Sirapite contains 35.07 cub. ft.

DETAILED EXAMPLES

Render and Set in "Sirapite" and Sand $\frac{1}{2}$ in. thick (1 to 3)—

9 yd. super "coarse" Sirapite $\frac{1}{2}$ in. thick at 7d.	s. d. 5 3
9 yd. super "finish" Sirapite $\frac{1}{2}$ in. thick at 3 $\frac{1}{2}$ d.	2 5 $\frac{1}{2}$
Plasterer and labourer, 3 hrs. at 3s. 0 $\frac{1}{2}$ d.	9 2 $\frac{1}{2}$
	<hr/>
Total cost of 9 yd. super	16 10 $\frac{1}{2}$

Take one-ninth	s. d. 1 10 $\frac{1}{2}$
Profit and Establishment, 12 $\frac{1}{2}$ %	2 $\frac{1}{2}$
	<hr/>
Price per yard super	2 1 $\frac{1}{2}$

Lath, Plaster, Float, and Set Partitions in "Sirapite" on Ceilings ($\frac{3}{4}$ in. thick)—

9 yd. super of lathing (as before described) at 1s.	£ s. d. 9 -
9 yd. super "coarse" Sirapite $\frac{1}{2}$ in. thick at 1s.	9 -
9 yd. super ditto $\frac{1}{2}$ in. thick at 2 $\frac{1}{4}$ d.	1 8 $\frac{1}{2}$
9 yd. super "finish" $\frac{1}{2}$ in. thick at 3d.	2 3
Plasterer and labourer, 5 hrs. at 3s. 0 $\frac{1}{2}$ d.	15 3 $\frac{1}{2}$

Total for 9 yd. super 1 17 3

Take one-ninth	4 2
Profit and Establishment, 12 $\frac{1}{2}$ %	6 $\frac{1}{2}$
	<hr/>

Price per yard super 4 8 $\frac{1}{2}$

The above calculations do not include for any scaffolding.

The student is again warned *not* to use any of the prices given, nor those given in the trade papers; the cost of each particular job must be worked out in detail and, from the explanations given, the reader will appreciate the difficulty of the task. So uncertain are the conditions, and so many extraordinary factors enter into the calculations, that the writer would have preferred to omit this trade entirely; but he trusts the few examples given will warn the reader of his difficulties, and assist him to calculate data for himself. In the detailed examples given the labour rates used are those given for ordinary craftsmen and labourers, but in point of fact plasterers are able to obtain more than this as they are allowed "expenses" in addition which vary from 1s. to 3s. per day.

In the detailed examples given it will be noted that in all cases the price was based upon one plasterer and one labourer working together, but in actual practice, it is found that in most cases, one labourer can easily attend upon two plasterers, and this affects the cost.

In bills of quantities, it is usual for the work to be given in two sections, viz. "External work" and "Internal work." As regards analysis, this is of little importance, but with regard to the scaffolding required, the matter is of extreme importance. In many cases it might be possible for the plasterers' work to be carried out from the bricklayers' scaffold which might be left in position, but with internal work, especially with large rooms, a very elaborate scaffold might be necessary. Careful inquiries should be made before tendering.

Chapter VIII—PAINTER, PAPERHANGER, AND GLAZIER:
COMPLETING THE ESTIMATE

PAINTER

If the surfaces to be painted are new, this is not a difficult bill to price; but if the work is old or high-class decorative effects are desired, the task is more difficult. In this trade a great deal depends upon the quality of the finished work; one man may take half an hour to apply two coats of paint to a given area; another man may require one hour for the same task; but the finish produced by the second man may be worth more than double the value of the work produced by the first man. It is unfortunate that the number of coats specified in a bill of quantities does not give a true indication of the class of work required, and in consequence the estimating surveyor is often at a loss to assess the amount of labour involved. If the surfaces are very old, the cost of preparation, rubbing down, and perhaps burning-off, may amount to a considerable sum; in fact, a thorough wash is often found to be worth the cost of a coat of paint. The principal material used in the preparation of paint for outside work is white lead, and though many experiments have been made no substitute has yet been found to give the same results. For inside work, zinc white is often used with excellent results; and as legislation in course of time will limit the use of white lead, it is necessary to consider the prices of substitutes.

Exterior Work. Surfaces exposed to the weather, which are usually painted, require repainting every three or four years, and the principal difficulty in compiling prices is the cost of scaffolding. Many estimators add a percentage, which varies from 12½ to 25 per cent, but if the use of hanging cradles becomes necessary, the cost of the hire of such plant will cost more than the actual painting work. It is impossible to give a datum per yard super for the cost of scaffolding for painting work, and quotations should be obtained for each job. The pricing of exterior paintwork is speculative, and the weather is the governing factor, for a shower of rain can cause considerable damage, which the builder must put right at his own expense; also the action of the sun may cause

so much blistering that the work may require rubbing down and painting again.

Materials. The principal paint bases are white lead and zinc (i.e. zinc oxide), but these materials are mixed with linseed oil (or, for external work, boiled linseed oil), turpentine, and some form of driers. To the above mixture a pigment is sometimes added, but this will make little difference to the cost of the paint, as the addition of the pigment usually displaces other material. Exception must be made, however, to expensive pigments, such as vermilion, ultramarine, and similar colours. The prices of all paint materials fluctuate frequently, therefore the current market rates must be studied.

In addition to the application of paint, enamel, and varnishes, and the decorative treatment of painted surfaces generally, the painter's bill also contains items for work in the following materials: lime-white, distemper, tar, solignum, and stains. Owing to the difficulty of calculating data per yard super, the following examples have been calculated upon superficial areas of 100 yd.

DETAILED EXAMPLES

<i>Three Coats of Paint on Ironwork—</i>		£	s.	d.
¾ lb. of red lead at 4d. lb.				3
67 lb. of white lead at 5½d. per lb.	1	9	3½	
2 gal. of linseed oil at 3s. od. per gal.		6	—	
1½ gal. of boiled linseed oil, at 3s. 2d. per gal.		3	11½	
¾ gal. of turpentine (turps) at 3s. 4d. per gal.		2	6	
Painter, 50 hrs. at 1s. 8d.	4	3	4	
		6	5	4½
Add for depreciation of brushes, 5%		6	3½	
		6	11	7½
Profit and Establishment, 12½%		16	5½	
Total cost	£	7	8	1

Dividing the above by 100 gives the price per yard super of 1s. 5½d.

Three Coats on 4 in. by 3 in. C.I. Gutters (Inside and Outside). One linear foot of gutter is equal to 1 ft. 6 in. super of painted surface; therefore, if the above price of 1s. 4d. is divided

by six (1 ft. 6 in. being one-sixth of a yard super), the price per foot run will be obtained ; this amounts to 2½d.

Three Coats on 3 in. Rain-water Pipe. One linear foot of 3 in. pipe is equal to one-ninth of a yard super ; therefore if the price is divided by nine, the price per foot run is easily obtained for this and similar items.

DETAILED EXAMPLES

Knot, Prime, Stop, and Paint Woodwork, Three Coats—

	£	s.	d.
1 pint of knotting at 2s.		2	—
1 pint of gold size at 4s.		4	—
4 lb. of dry white lead at 4½d.		1	6
¼ lb. pumice at 8d.			2
1 lb. of red lead at 4d.			4
100 lb. of white lead at 5½d.	2	3	9
4½ gal. of linseed oil at 3s.		13	6
9½ pints of turpentine at 3s. 4d.	1	10	10
1½ lb. of patent driers at 8d.			2
Painter, 82 hrs. at 1s. 8d.	6	16	8
	<hr/>		
Add for depreciation of brushes, 5%	11	13	11
		<hr/>	8½
Profit and Establishment, 12½%	12	5	7½
		<hr/>	8½
Total Cost	<u>£13</u>	<u>16</u>	<u>4</u>

Dividing the above by 100 gives the price per yard super of 2s. 9½d.

Rub Down, Prepare, and Paint Woodwork, Three Coats (Zinc Oxide)—

	£	s.	d.
1 lb. of pumice at 8d.			8
1 quire of waterproof sandpaper at 2s. 6d.		2	6
30 lb. of zinc oxide at 9d. per lb.	1	2	6
1½ gal. of linseed oil at 3s.		4	6
1½ gal. of turpentine at 3s. 4d.		3	9
1½ lb. of special zinc driers at 10d.		1	3
Painter, 70 hrs. at 1s. 8d.	5	16	8
	<hr/>		
Add for depreciation of brushes, 5%	7	11	10
		<hr/>	7
Profit and Establishment, 12½%	7	19	5
		<hr/>	11
Total Cost	<u>£8</u>	<u>19</u>	<u>4</u>

Dividing the above total by 100 gives the price per yard super of 1s. 9½d.

Data for Labour. The foregoing are typical examples of the methods used to build up prices, and the student should practise further examples for himself. The following data are submitted for surfaces of 100 yards super.

First coat in lead paint, 20 hours ; second and third coats, 15 hours. Zinc paint will not take so long to apply, and a deduction of 25 per

cent from the above is suggested. The preparation of old surfaces is worth anything up to about 30 hours. For the application of varnish and enamel, 15 hours should be sufficient. Ordinary distemper requires about 11 hours per coat, and washable distempers 17 hours per coat.

DETAILED EXAMPLE

Clearcole and Distemper Ceiling, One Coat (100 yd. super)—

	£	s.	d.
12 lb. of whiting at 1½d.		1	3
Pigment (ochre or blue), ½ lb. at 4d.			2
Size, 2 firkins at 3s. 6d. per firkin		7	—
Painter, 18 hrs. at 1s. 8d.	1	10	—
	<hr/>		
Add for depreciation of brushes, 5%		1	18
		<hr/>	5
Profit and Establishment, 12½%	2	—	4
		<hr/>	11
Total Cost	<u>£2</u>	<u>5</u>	<u>4½</u>

Dividing the above by 100 gives the price per yard super of 5½d.

PAPERHANGER

Paper. Paperhangings for walls and ceilings are billed per "piece," which is 9 yd. long and 21 in. wide if of English manufacture. French papers are 8 yd. long and 18 in. wide, but foreign papers of other dimensions are used occasionally.

Frequently the actual paperhanging work is carried out by piece workers, who submit a schedule of rates for different classes of paper, but occasionally builders employ paperhangers who are paid by the hour. A man should trim and hang a "piece" of ordinary wallpaper or lining paper in one hour, but superior papers require extra time. As a rule, the price of the paper gives an indication of the quality of the material, and the better the quality the longer time it takes to hang. For papers up to 2s. per piece, allow one hour. For papers above 2s. and up to 6s., allow 1¼ hours ; and above 6s., allow 1½ to two hours.

Preparation. The wall surface usually requires a coat of size, but old walls require stripping and a considerable amount of preparation. If the plastering is defective, the cracks must be cut out and stopped in Keene's cement, and the repaired portions will require a coat of white knotting. The cost of preparation is billed per "piece," and this is not a convenient unit for the estimating surveyor ; but as an average surface requires about one-third hour of a painter's time, if we assume 6 yd. to the piece,

MODERN BUILDING CONSTRUCTION

we obtain two hours for the value of preparing a wall surface for one piece of paper.

DETAILED EXAMPLE

<i>Strip, Prepare, and Paper Walls with Paper, at per Piece—</i>	<i>s. d.</i>
Keene's cement, one-fifth gallon at 5d.	1
White knotting, one-twentieth pint at 3s.	1 3/4
Size, one-twentieth firkin at 3s. 6d.	2
Paper, 1 piece at 3s. 6d., less discount	2 7 1/2
Flour, 1/2 lb. at 3d.	1 1/2
Painter, 2 hrs. at 1s. 8d.	3 4
Paperhanger, 1 1/2 hrs. at 1s. 9d.	2 7 1/2
	9 1 1/2
Add for depreciation of brushes, etc., 5%	5 1/2
	9 6 3/4
Profit and Establishment, 12 1/2%	1 2 1/2
	10 9

GLAZIER

The prices of the different kinds of glass can be found from the merchants' lists without difficulty, and for the labour little explanation is necessary. Small squares require about one-quarter hour per foot super, and larger squares will require about one-third of an hour. Plate glass will require an addition of 50 per cent to the above time, except for very large squares, which will take double the time required for ordinary sheet glass. For putty, an allowance of one-twelfth of a pound per foot super of glass should be made.

COMPLETING THE ESTIMATE

Preliminary Bills. Having priced all the trade bills, the estimating surveyor will price the preliminary bill. Many of the items detailed require no price at all, but care must be taken so that no provisional sums are omitted from the pricing columns. It should be noted that the preliminary bill usually contains an item for "contingencies," and it is not usual to add anything for profit to this item.

NOTICES AND FEES. Local conditions must be studied and, if necessary, inquiries should be made. In London, statutory fees are due to the district surveyors, and these charges can be found in the London Building Act, or *Laxton's Price Book*.

FOREMAN'S AND CLERK OF WORKS' OFFICES. As a rule, no charge is made in the bill for the offices themselves, as such structures are usually part of the builder's plant, but an allowance must be made for the attendance of a labourer,

for oil, and for fuel. This depends entirely upon the period of the contract and the season of the year. A fair allowance would be 12 hours per week for a labourer, 1/4 cwt. of coal and coke, and 1 gal. of oil per week.

SANITARY CONVENIENCES. It is not usual to make a charge for the structure, but the attendance of a labourer is necessary occasionally, and six hours per week is suggested.

INSURANCES. The rate for fire insurance is usually 2s. 6d. per £100 of contract. For National Health and Unemployment Insurances it is usual to add a percentage at the end of the bill, say 1 1/4 per cent of the amount of the contract. Employers' liability and third party insurances are usually covered by a general policy, and the premiums are included in the builder's overhead charges.

WATER. In London, it is usual to allow 7s. per £100 of contract, which is the charge made by the Metropolitan Water Board, but, naturally, in some districts it is possible to obtain water without charge.

The Summary. The pricing of the various bills being complete, the extensions are made and checked, and finally the total of each bill is brought into the summary. To these totals the charges for insurances and for water are added, also the quantity surveyor's charges and the cost of lithography. Many builders deduct a percentage from the total of the summary before bringing the price into the form of tender. But if this is done, it should be borne in mind that the total contains many provisional sums, and should a lump sum be deducted from the final total, in the form of a percentage, a deduction has therefore been made from such provisional amounts, and the builder commences with an initial loss in respect of such items. If a percentage is deducted, the provisional sums should be excluded.

Variations. The task of preparing variation accounts is part of the work of an estimating surveyor, though it is often carried out by the quantity surveyor, so a few words thereon may not be amiss. The account should be compiled in quantity form, so that the prices for extras and omissions may be the same as those given in the bill of quantities for the job. It is good practice to measure everything that can possibly be measured, and for this purpose the "Standard Method of Measurement" should be followed. (This document is published jointly by the Chartered Surveyors' Institution and the National Federation of Building Trades Employers.)

If it is impossible for the work to be measured and day work vouchers are permitted, little difficulty occurs if the vouchers have been certified. It must be remembered that the question as to whether the work can be measured or otherwise is at the discretion of the architect, that is, if the usual R.I.B.A. form of contract has been signed. If, during the execution of the work, the builder considers the particular task cannot be measured, he should obtain the approval of the architect before carrying out the work, and see that time sheets are submitted each week for approval of the architect or his clerk of works. Neglect of this is a frequent cause of disagreement with the quantity surveyor at the settlement of the accounts.

Certain individuals, especially those with limited experience, rely upon "sharp practice" to enable them to obtain "extras" which actually have never been carried out. This procedure is strongly condemned by first-class building firms, but unfortunately there are others not so conscientious. However, the modern builder's estimating surveyor is better educated than his predecessors, and in consequence "sharp practice" is not common. In his dealing with a building firm of repute the quantity surveyor finds that the builder (or his surveyor) is actuated by the same motive—the preparation of an account which is accurate and just to all parties to the contract—and in such circumstances work is a pleasure. With firms who act otherwise, the quantity surveyor may discover

that a considerable amount of his time (or of his assistant's time) is occupied in preventing work being measured that is actually included in the contract, or in refuting extravagant claims, and in consequence he will endeavour to avoid future dealings with such persons. If the individuals measuring have a sound knowledge of building construction and quantity surveying, and if the builder himself obtains variation orders from the architect for all extras and omissions, there is no reason for any disagreement.

Conclusion. In a work of this scope, it is impossible to attempt to analyse the cost of every item that can occur in a bill of quantities; in fact, such a task would require many volumes; but typical items have been taken, so that students may be encouraged to compile prices for themselves. Once the method is thoroughly understood, the student should have no difficulty in adapting the system to any job, provided he has a sound knowledge of building construction and quantity surveying. In a review of a book written by the present writer, it was stated: "There is perhaps no profession which requires so detailed a knowledge of other people's business as that of the builder's estimating surveyor." This would appear to be a contradiction of the old proverb, "A little learning is a dangerous thing," but it is very true. So long as a student is aware of his limitations, he will come to little harm, for in this profession it is very important to acquire a "little learning" of many trades, and to know our own work thoroughly.

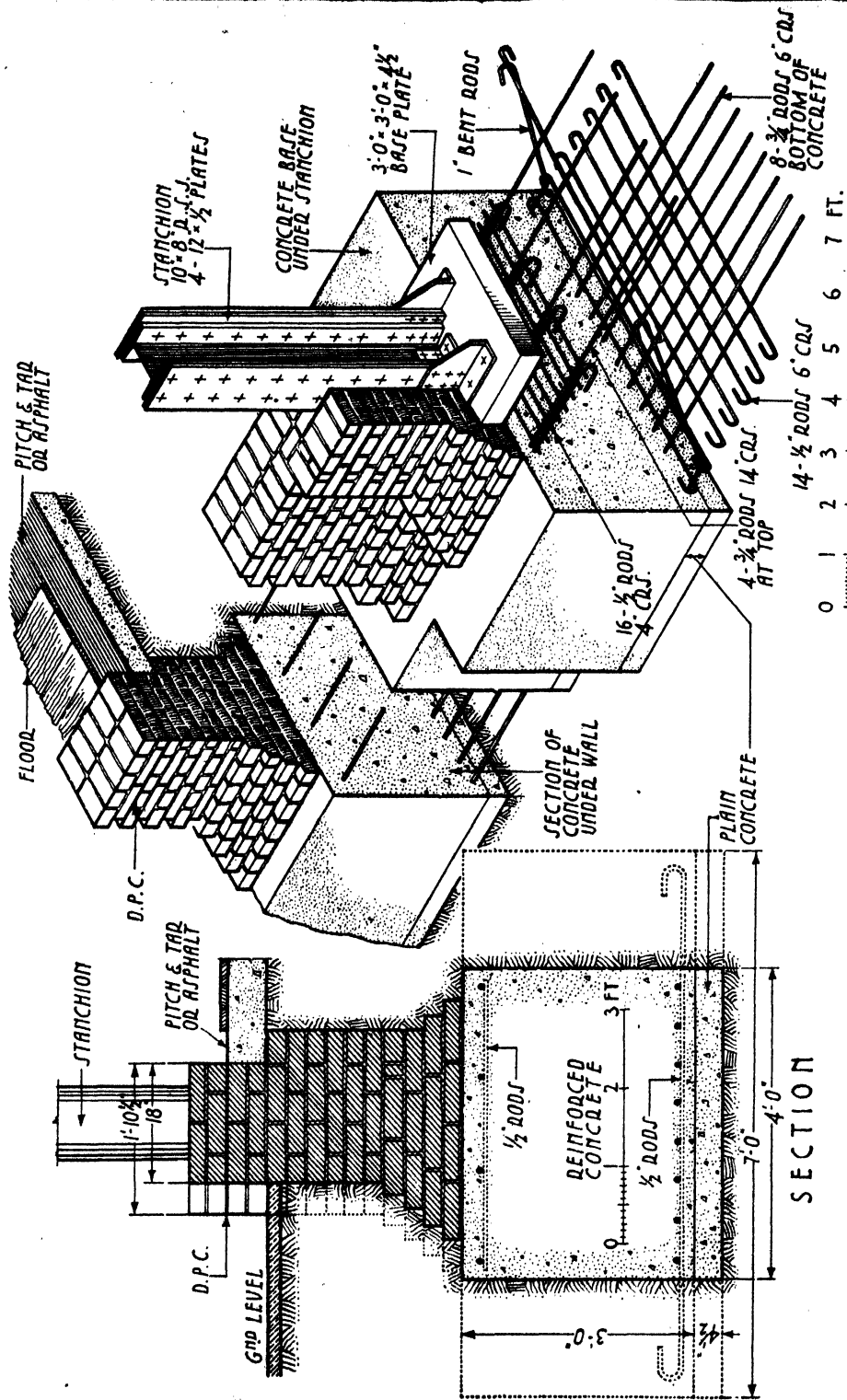

REINFORCED CONCRETE FOUNDATIONS FOR STANCHION AND BRICK WALL

Preliminary Operations

By R. V. BOUGHTON, A.I.STRUCT.E.

Chapter I—PRELIMINARY PROCEDURES TO BUILDING

BUILDING procedures began to alter after the end of the Great War in 1918, and by 1939 many changes had been made for the betterment of building. There were still left, however, many loopholes for the designing and constructing of buildings in accordance with the old codes of practice, a few of which were good and many that were not. The World War has shown the need for greater changes in town and country planning, in the planning of buildings, and particularly houses, in methods of construction and the use of traditional and modern materials, and for the national essentials of economy.

These great changes make it necessary for all connected with and interested in building to realize that preliminary procedures to building do in many instances vary considerably from those which ruled before 1939. Not only have architects, surveyors, quantity surveyors, structural engineers, technicians, and other professional persons to master these changes; but, as well, builders, their administrative and operative staffs, and the operatives also must be masters of the changes. The officials of various Authorities should by no means be left out of the groups, as they, like many others, are charged with the duty of ensuring that building, as a whole, shall conform with all codes which are framed to ensure betterment in the national interests.

Prior to the World War there were not so many restrictions in building as there are now. In the past it was possible to choose and buy a plot of land which was on a site zoned for housing, have "plans" prepared for the Local Authority, comply with rules governing the density of houses to the acre and with building by-laws, which were not so good as they are now, and let a builder build the house for a pre-arranged sum of money. With slight variations to the above procedure the speculative or jerry builder would lay out estates and build houses with few restrictions on architectural design and construction. Now, conditions and procedures are to be different in that, though they will not hinder proper freedom in the

siting, design and construction of buildings, they will prevent the abuse of common rights.

Town and Country Planning. Before any site is bought or any building is contemplated, it is essential to find out how the Town and Country Planning Acts will affect the site and the proposed building, or any existing building which it is intended to alter or do other work on. Information as to the operation of the Acts can be obtained from the Local Authorities, who will be found most helpful. Much trouble should be taken to obtain the fullest information, which should be carefully studied. It should be borne in mind that the chief objects of the Town and Country Planning Acts is to ensure, within practical limits, the best layout of streets, sites, and buildings of a residential, shopping and industrial character to suit most, if not all, of the various interests connected with towns and other areas which are or will be built up. These objects, it will be realized, represent great and responsible duties to be performed by the Authorities, and, while for the common good, the operation of the Acts may affect adversely the interests of some persons.

If an architect or other professional adviser is employed he will either know or obtain the information regarding town and country planning.

The Building By-laws. A study of the building by-laws is the next procedure; there may be something in them that will influence the purchase of the site and the general design and construction of a proposed building.

Most Local Authorities in England and outside the London area have building by-laws based on the Model By-laws of the Ministry of Health and are obtained, usually for 1s., from the offices of the Local Authority of the district in which the building is to be erected.

Buildings in London are controlled by the L.C.C. by-laws. It is a good plan to obtain particulars from the District Surveyor of all by-laws which affect the project under consideration and to buy them from the publishers

MODERN BUILDING CONSTRUCTION

named in the by-laws. A complete set of the by-laws can be obtained from P. S. King & Staples, Ltd., publishers, 14 Great Smith Street, London, S.W.1.

Building by-laws were revised and altered during the few years before 1939, and many of the revisions and alterations are so different from those which architects, builders, and others were accustomed to for so many years, that it is necessary to study them with the utmost care. The revisions and alterations are generally a marked improvement on many of the old by-laws which were framed to suit traditional methods of construction and materials. During the period in which the new by-laws were framed, and the years of the World War, great strides were made in connection with new methods of construction and materials, and there is little doubt that the by-laws will be altered to permit buildings to be designed and constructed in accordance with what modern science, research, and experience have proved is to the advantage and betterment of building.

Because some by-laws are not quite up-to-date this does not necessarily imply that buildings cannot be designed in accordance with modern methods. Local and other Authorities have powers to waive certain by-laws and permit buildings to be designed and erected in accordance with approved modern principles and details, including of course what is known as prefabricated work. The by-laws should be examined to find out what drawings must be submitted to the Local Authorities.

Architects and other Professional Advisers. The procedure of employing an architect and/or other professional advisers requires explanation. There should seldom be any doubt about obtaining professional advice. It is usually essential, because a competent architect or other adviser designs, specifies the work, supervises it, and arranges all the financial phases of the building work to enable the building employer to pay proper amounts, and, what is of extreme importance, advises and negotiates most, if not all, of the many preliminary procedures to building.

A considerable proportion of the bad, or poor and monotonous planning and aesthetic treatment of the elevations of houses is due to building employers—and under this definition must be included speculative and jerry builders—not employing competent architects, and paying their reasonable fees for services.

Architects are trained to plan properly, and to give, where necessary, artistic character to

the elevations and interiors of buildings, be masters of constructional work, and to supervise work to ensure its being carried out in accordance with the terms of the agreement between the building employer and builder. Except for very small works, an architect should be employed to guard the interests of the building employer, and to ensure equity between all the parties in the Contract Agreement, and the general public in the case of housing estates.

Quantity surveyors are employed on building works where it is advisable or necessary to provide many builders tendering for a contract with detailed and accurate quantities of, perhaps, many thousands of items. Manifestly, it is wrong to expect each of, say, six or more building contractors who are tendering for a job to undertake the onerous and expensive duties of preparing quantities when one qualified quantity surveyor can prepare bills of quantities which are uniform for all the contractors.

The quantity surveyor's duties include measuring and valuing work for interim payments, adjustment of variations, settlement of final accounts and much other important and useful work.

Structural engineers and building technicians connected with general building, are becoming of increasing importance owing to the great strides which have been made in the scientific, structural and technical phases of building work. Building work is much more complex nowadays than it was up to a few years after the Great War. Structural steelwork, reinforced concrete, plain concrete, timber construction, proprietary methods of construction and materials, prefabrication and general essentials and economics of construction have made it necessary for specialized training of men who are capable of dealing with structural designing and its many calculations and costs as affecting economics. Many modern architects are giving much more attention to these important aspects of building works than did architects in the past. Many structural engineers and building technicians are on the staffs of specialist contractors, and some are employed by architects either as staff members or consultants.

On works of importance and value one of the preliminary procedures to building is to ensure that structural and technical works should be undertaken by those specially trained in this class of work.

Legal advisers, such as solicitors, have to play their role in connection with the buying

of land, properties, and often with building finances.

Builders. The builder is, of course, one of the most important parties in any building undertaking, and an essential preliminary procedure is to choose a limited number of the right kind of well-trained and reputable builders to tender for the work. If this is done it will probably be found that the tendering is reasonably uniform, and if the builders have been chosen with care the lowest tender may be accepted with the assurance that the contract will be carried out faithfully. Even the best of builders and their estimating staffs, however, make mistakes sometimes, and if it is found that one tenderer is much below the others, it is unwise to accept his tender without advising him to check his estimates, but not, of course, giving him any information as to the amount he is below his competitors. Nothing gives more trouble to the parties to a building contract than for the builder to find out eventually that he has made such a serious error in his estimating as to cause financial loss.

Finance. The financial matters connected with building works must, of course, be settled as a preliminary procedure. Sites and/or property if not already belonging to the building employer have to be paid for at some time according to the financial arrangements which are agreed. The builder will probably require interim payments as the work proceeds (unless the value of the work is small) and a final payment within a specified time of completion of his work. The building employer may have the necessary funds immediately available or at short call. On the other hand he may have to negotiate finance through his bank, a building society, or other source. In whatever way the work is to be financed it is essential that all definite financial arrangements should be made before any contract or agreement is signed by the parties. The professional advisers, such as the architect and the solicitors, should be consulted in the case of any difficulties which may arise in connection with finance. Very often the times of interim payments to a builder and to specialist or sub-contractors can be so arranged by an architect as to coincide with the revenue of the building employer.

Forms of Agreement. It is generally recognized that the Form of Agreement and Schedule of Conditions for Building Contracts of the Royal Institute of British Architects is equitable to the parties to a building contract. There are

forms of contract which specialist and sub-contractors prefer to be used, and there are also various forms of contract used by the Ministries, Government and Local Authorities. An essential preliminary procedure is to ensure that the terms and conditions of any forms are understood and mastered and that the *blank* spaces are filled in only after very careful consideration by the building employer, architect, builder and any other parties.

GENERAL PRELIMINARIES

Preliminary operations in all building undertakings, whether small or large, require very careful attention by the architect who designs and specifies the various works, and much forethought and organization by the builder who executes the work. The architect has to design and compute to ensure that the foundations and general preliminary works of a structure will be safe and correct, and yet economical. The builder has, in addition to carrying out the work in accordance with the architect's designs and instructions, to give attention to many matters which are not always of great import to the architect but essential where work has to be properly done and a profit obtained.

For the purposes of these chapters it has been deemed advisable to treat the preliminary operations in approximately the same order as a *builder* should conduct them, and to deal conjunctively with matters of design, computations, and other subjects which are usually within an architect's province.

Drawings, etc. The builder's first essential is a complete set of all the general drawings, comprising plans, elevations, sections, and a sufficiency of details to enable the work to be correctly set out and the ordering of all those materials and manufactured articles required at the beginning of a contract. A complete specification is also necessary. Architects usually supply two copies of drawings and specifications, one each for the builder's office and the job. Two copies are usually insufficient for the proper prosecution of a contract, as from its beginning to almost its completion the builder has to send out with his inquiries for various materials, joinery, sub-contracts, etc., copies of drawings, details and specifications. Therefore, it is necessary to endeavour to obtain from the architect, say, six blue prints of the general drawings, for which a small charge may be made, or the loan of original tracings to allow prints being taken; copies of details may be similarly obtained.

MODERN BUILDING CONSTRUCTION

It is often difficult to obtain more than two copies of the specification, so about six copies should be made if possible. There are modern processes of reproduction which make it unnecessary to have specifications typed and checked.

The possession of the above will be invaluable throughout the contract; for instance, prices will be required for joinery, probably labour prices for brickwork, plumbing, plastering, electrical work, and many other trades and materials, and all that need be done is to submit inquiries to four or five firms with prints and extractions from the copies of specification of the appropriate trades, annotated or adjusted as required, and stipulating that the drawings and specification must be returned with the quotation.

If bills of quantities have been prepared, a copy should be given to the foreman and a copy kept in the builder's office to facilitate ordering materials and checking the progress of the works. Some builders do not deem it advisable to let a foreman have a fully priced set of bills of quantities which may indicate the computed profit and general financial considerations of the contract, and consequently only supply an unpriced copy. A foreman, however, should know the costs that he has to work to or "beat," and it is a good course to supply him with a set with net costs of labour and materials, but without additions for overhead, establishment charges, profit, etc.

These may be in the form of a schedule of prices not extended or cast up. If all items have oncost and profit percentage added to them then the percentage may be deducted, which is a rather long process. The method of pricing each item net cost of materials and labour, and adding on-cost and profits percentages on the speculative and P.C. items at summary is recommended.

Access to Site. A perusal of the drawings will enable the best position for access to site and storage space for materials to be gauged. Wherever possible, access to site for carts or lorries should be as central as conditions will permit and to allow for shortest "roads," to prevent not only the cost of making a "road" but "churning up" of ground in wet weather. Materials, particularly bricks, should be deposited either in a central position or in a number of positions nearest to the work, to save excessive handling costs. At the same time materials must not be placed where they will hinder the progress of other trades.

The Foreman's Office should be "sectional" to allow for easy assembling and dismantling at various sites, 6 to 7 ft. high at eaves, from 7 ft. × 6 ft. to 12 ft. × 8 ft. on plan depending on the size of the contract, and constructed with boarded floor on joists, timber-framed walls covered externally with match or weather boarding, and timber-framed roof, weather boarded or felted; it should be fitted with door, window, pay hatch, letter box, bench, drawer, stool, and stove; also shelves for storage of small valuable materials such as ironmongery, plumbers' fittings, etc. It should be erected in a position which will allow a view over the whole of the building operations.

A telephone should be installed on jobs of importance to facilitate prompt decisions being made between the builder and foreman on the points that arise almost daily, and to allow the foreman to communicate quickly with merchants about delivery of materials and to save time and correspondence.

Hoardings. The necessity of a hoarding, which is a rather costly item, depends on the locality of the works, the degree of protection that is required, and whether a watchman is employed or not. In a quiet, good class neighbourhood a hoarding may not be essential, particularly if there is an existing hedge or fence, or a cheap form of fencing can be erected. If the site abuts on a busy thoroughfare, or it is necessary to protect an existing building which is being altered, a proper close boarded hoarding will have to be erected.

There are several types of hoarding; some are formed with stock sections kept by builders and fixed to a timber framework; others of old doors, shutters, etc., secured to a similar framework. The most common type is that formed with rough 4 in. × 3 in. or 4 in. × 4 in. posts at about 6 ft. centres, with three rails of 4 in. × 2 in. or 4 in. × 3 in., and covered with 1 in. rough boarding. The posts may be let into the ground where there is no pavement to disturb, or a better way is to place a sole or sill piece to which the posts are spiked or dogged. The posts must be suitably strutted or stayed to ground, building, or scaffolding. The hoarding should project at least 4 ft. beyond the building line and have an access door fitted with lock, etc., to allow for materials and men passing through. Where a hoarding abuts on, or is constructed over, a public footway the doors must open inwards to prevent obstruction on the footway or injury to pedestrians; most local authorities'

PRELIMINARY OPERATIONS

by-laws demand this. Fig. 1 shows a typical hoarding.

Water for building works is an important preliminary, and application should be made to the water company immediately a job is begun. If the work is in connection with an existing building, the water would be already in the building, and when the water company has been notified a connection may soon be made. In

The size of sheds will depend upon the magnitude and class of contract, and as they are costly they should be made in sections to allow for removal from one job to another. The storage sheds should be large enough to prevent shortage at any time.

They should be constructed with strong, dry, boarded floors, and have timber-framed walls and a roof covered with suitable material,

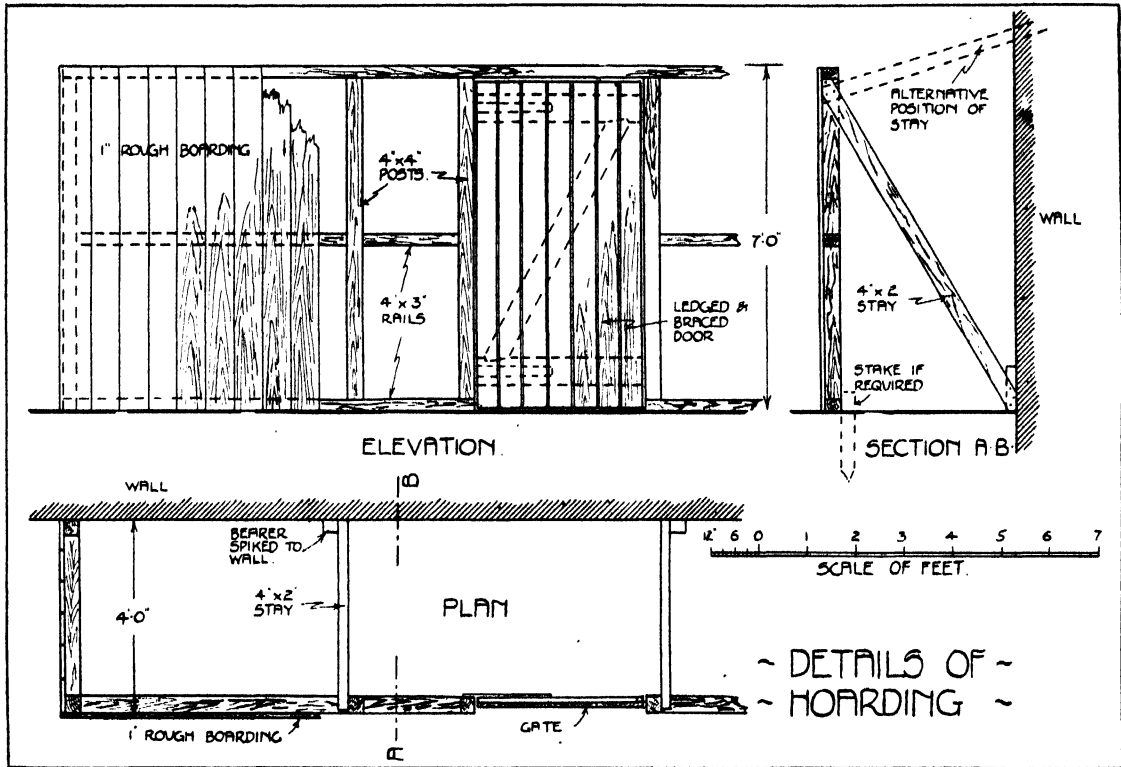

FIG. 1

the case of a new building, it will probably take a few days to install the supply. As the building supply will eventually be the permanent supply, it is necessary to instruct the water company to lay their pipe in the correct position for the future rising main. Provide necessary water tanks, pipes, hose, taps, roses, etc., for the works.

Sheds for Storage of Materials and Mess-room. Weather-proof sheds must be erected, unless there are suitable erections on the site, for the storage of cement, lime, and general perishable materials, and also a mess-room for the men.

such as weather-boarding, boarding and felt, or corrugated iron, and be fitted with doors with locks, etc. They should be situated to give easy access for delivery of materials and for withdrawal to the works, near to mixing stages or platforms. If the building operations are likely to continue for a considerable time, a rough brick fireplace should be built in the mess-room.

Insurances must be effected, before work is started, against fire, employers' liability, including third-party risks, and any special risks.

Chapter II--PLANT

THE term *plant* comprises all those things temporarily required for mixing the various materials, hoisting, stagings, scaffolding, and to allow of the craftsmen's access to the various parts of the building during its erection. When it is considered that the "use and waste and

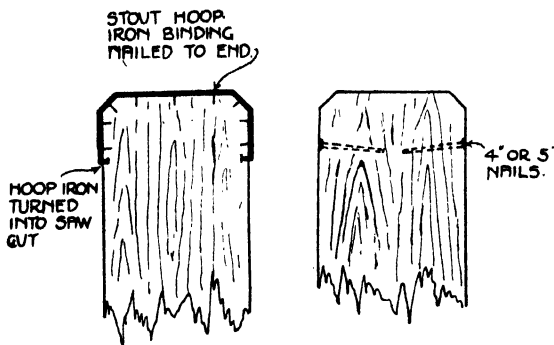

FIG. 2

FIG. 3

transport" of plant necessitates an expenditure of 1 per cent to 2 per cent of the cost of a building, it may be realized that care must be exercised in its requisitioning, use, and maintenance. The following is a brief description of some of the ordinary "plant" items.

SCAFFOLD POLES used for the *standards*, *ledgers*, and *braces* of scaffolding vary in length from 12 to 33 ft.; they must be straight, free from defects, barked, not too slender, tapering from the butt to top, with the latter about 2 in. diameter for poles about 15 ft. long, 2½ in. for 22 ft. long, and 3 in. for longer lengths. Scaffold poles should be from young larch or spruce trees.

SCAFFOLD BOARDS used for the platforms of scaffolding should be as long as possible, up to about 13 or 14 ft., 9 in. wide, and not less than the usual thickness of 1½ in.; they should be northern pine or spruce, or other tough, strong elastic timber, free from any defects that might cause snapping under suddenly applied loads, which often occur on scaffolds. The ends should be bound with hoop iron to prevent splitting or fraying, or protected by the economical method of cutting off the corners and spiking with 4 in. nails. Figs. 2 and 3 show these methods.

PUTLOGS are short lengths of timber, about 6 ft. long, and 3 in. × 3 in., 4 in. × 3 in., or 4 in. × 4 in. scantling, of the same timber as scaffold boards, or of birch.

SCAFFOLD CORDS should be of best tarred hemp, cut and whipped into 16 ft. lengths, not less than ½ in. and preferably ⅝ in. diameter (1½ in. circumference).

SCAFFOLD LASHES are of flexible galvanized steel wire and are preferable to cords, as they do not stretch. They are obtainable in 12, 15 and 18 ft. lengths.

LADDERS are purchased in lengths of rung units of 8 in. (sometimes 8½ in. or 9 in.), from 14 to 100 rungs (or more). There should be sufficient short ladders to give access to the lowermost and intermediate stages of scaffolding, and also others capable of reaching the highest parts of the building. They should have sides of Norwegian spars, oak rungs, and iron tie rods.

GAUGING BOXES for proportioning the materials for concrete, etc., are bottomless, and have four sides only; they are square on plan and of area and depth to hold any required quantity

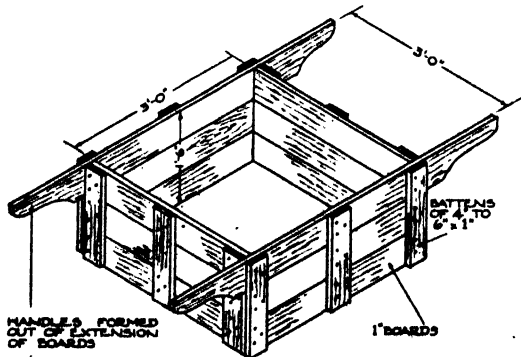

FIG. 4. GAUGE BOX (BOTTOMLESS), HALF-YARD CUBE CAPACITY

of material. Fig. 4 depicts a gauge box to hold ½ cub. yard of materials.

Boxes of various sizes are made or kept as plant stock by builders. The following are useful sizes—

For ballast sand, etc.—

- 1 cub. yd.: 4 ft. 6 in. long × 3 ft. wide × 2 ft. deep.
- ½ cub. yd.: 3 ft. long × 3 ft. wide × 1 ft. deep.

PRELIMINARY OPERATIONS

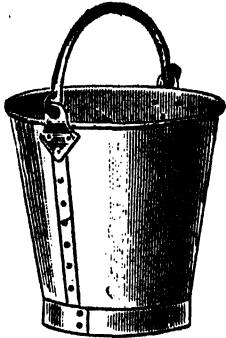

FIG. 5. BUILDER'S PAIL



FIG. 6. SHOVEL

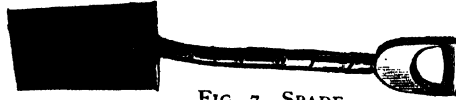

FIG. 7. SPADE

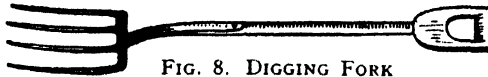

FIG. 8. DIGGING FORK



FIG. 9. BASE OF EARTH RAMMER

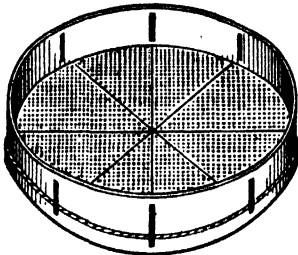

FIG. 10. SAND WASHING SIEVE

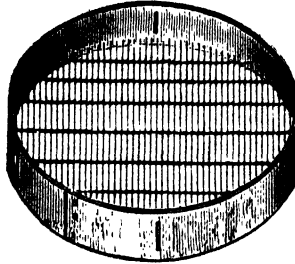

FIG. 11. GRAVEL SIEVE

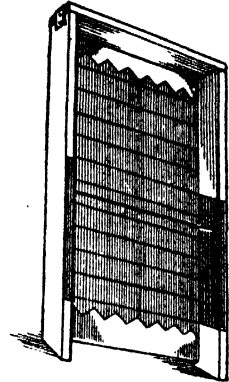

FIG. 12. SCREEN

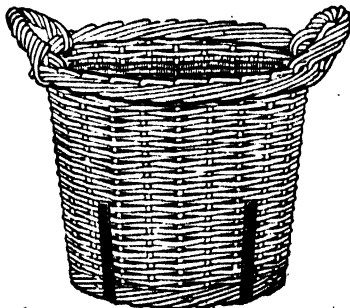

FIG. 13. BUILDER'S RUBBISH BASKET



FIG. 14. BASKET SLING

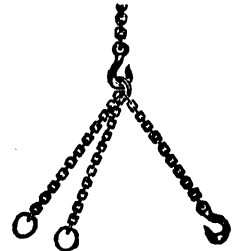

FIG. 15. BARROW SLING



FIG. 17
SINGLE PULLEY
BLOCK

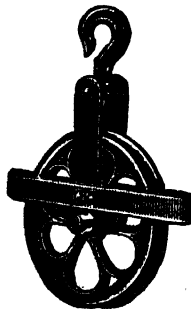

FIG. 16. GIN BLOCK OR
RUBBISH WHEEL



FIG. 18
DOUBLE PULLEY
BLOCK

MODERN BUILDING CONSTRUCTION

For cement—

- 1 cub. ft.: 1 ft. × 1 ft. × 1 ft.
 1½ " " : 1 ft. 3 in. × 1 ft. 3 in. × 11½ in.
 2 " " : 1 ft. 3 in. × 1 ft. 3 in. × 1 ft. 3½ in.
 2½ " " : 1 ft. 6 in. × 1 ft. 6 in. × 1 ft. 3½ in.

BUILDERS' PAILS should be strong and riveted, and 12 in. to 13 in. deep, as Fig. 5.

SHOVELS AND SPADES. A type of shovel, as used for shovelling materials, is shown by Fig. 6, and a spade, as used for digging, by Fig. 7.

A DIGGING FORK is shown by Fig. 8, and has four or five square prongs and riveted eye handle.

EARTH RAMMERS are as Fig. 9, and have wide cast-iron bases, stout ash handles, about 5 ft. long, and weigh about 11 lb.

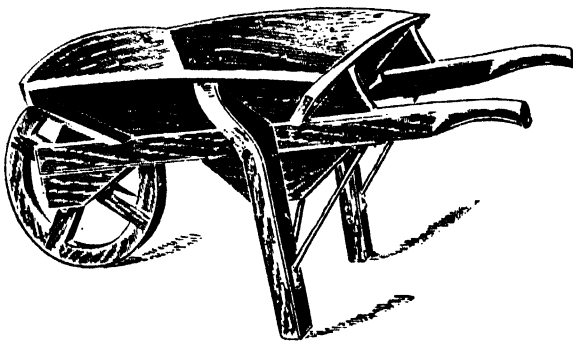

FIG. 19. NAVY BARROW WITH WOODEN WHEEL

end to engage the handles of basket. Fig. 14 illustrates.

BARROW SLINGS have three lengths of chain connected to a ring at top; two of the chains have eyes at end to fit over handles of barrow, and the other chain has a hook to grip the barrow wheel. Fig. 15 illustrates.

GIN BLOCKS, OR RUBBISH WHEELS, as shown by Fig. 16, are used for hoisting light loads, and have stout metal frames and about 10 in. diameter wheels; the top hook is for securing to scaffolding, etc. Strong manilla fall ropes, 1½ in. to 3 in. circumference, are used for hoisting.

PULLEY BLOCKS, as Figs. 17 and 18, which show single and double blocks, are used for hoisting heavy loads, such as girders, etc., and

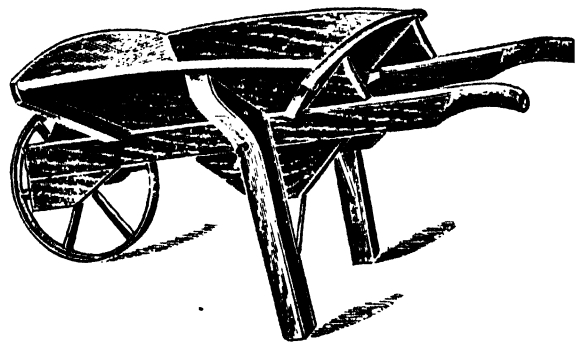

FIG. 20. NAVY BARROW WITH IRON WHEEL

A SAND-WASHING SIEVE is shown by Fig. 10. These sieves are obtainable with four to sixteen holes to the inch. The rims are usually of oak and the bottoms of iron or copper wire. The sizes are about 20 in. diameter, 5 in. deep inside and 7 in. deep outside.

GRAVEL SIEVES are as Fig. 11. They are 20 in., 22 in., or 24 in. in diameter, with wires set to various gauges, from ½ in. to 1 in., and sometimes more, with oak rims about 3½ in. deep. The mesh is straight, as illustrated, or square.

A SCREEN is shown by Fig. 12, and these are obtainable in sizes 5 ft. × 2 ft. 6 in., 5 ft. 6 in. × 2 ft. 9 in., and 6 ft. × 3 ft., with straight mesh varying from ⅜ in. to ½ in.

BUILDERS' RUBBISH BASKETS are as shown by Fig. 13, and are made of stout cane with iron binding at bottom and of half-bushel capacity.

BASKET SLINGS have two lengths of chain connected to a ring at top and a hook at each

are made to take ¾ in. or 1 in. diameter ropes. The action and use of pulley blocks will be described in a later chapter.

NAVY BARROWS are made in a variety of forms, Fig. 19 and 20 depicting barrows with wood and iron wheels, respectively. A good barrow should have ash frame, legs, and wheel runners, and elm body; ½ in. cross-frame bolt; steel strengthening stays; either hardwood wheel, with 1½ in. iron tyre, or stout cast-iron wheel ¾ in. diameter or tread; and have a capacity of two bushels. Figs. 21 and 22 show two types of modern steel barrows, the former having a steel tubular frame and pneumatic tyred wheel (or with a C.S. wheel if preferred), and the latter with strapped legs with C.S. wheel (or pneumatic tyres if preferred).

MISCELLANEOUS REQUIREMENTS include water tank, pipe, hose, a few squares of rough boarding for bankers, etc., and a few hundred linear feet of 3 in. × 2 in. and 4 in. × 2 in. fir for general purposes.

PRELIMINARY OPERATIONS

The plant described represents the general things required for preliminary operations; the requirements for various trades such as brick-laying, masonry, carpentry, painting, etc., are in the nature of tools and implements, and cannot be dealt with here.

Records of Plant should be very carefully kept so that (a) its quantity and condition may be

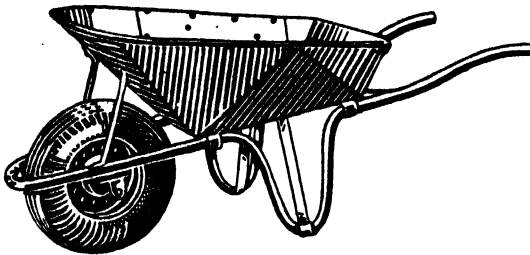

FIG. 21. STEEL BARROW WITH TUBULAR FRAME AND PNEUMATIC TYRED WHEEL

checked and stock taken periodically; (b) its movements from job to job, etc., may be recorded; and (c) the proper proportion of depreciation and cost of upkeep allocated to each job. Builders adopt various methods of allocating the cost of plant to each job, all of which have their advantages and disadvantages.

A good method is to debit the job with the amount allowed in the estimate for use and waste of plant, and to credit a plant on-cost

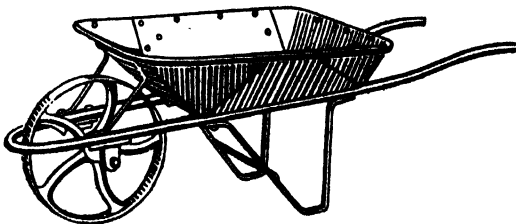

FIG. 22. STEEL BARROW WITH STRAPPED LEGS AND CAST STEEL WHEEL

account. At specified intervals, say six months or yearly, a valuation of plant is then taken, and if the "depreciation" is greater than the amount of the plant on-cost account, the jobs must be debited with the difference *pro rata* to the original estimate, or *vice versa*.

The term "depreciation" must include the loss of value due to wear and tear, and in addition the cost of plant upkeep, which latter item is one very often overlooked in the general method of debiting the job with the original cost of the plant, and crediting it with the

reduced value when returned. It also serves to act as a check on the foremen if they know that the greater the cost of upkeep the greater will be the debit to their job.

SCAFFOLDING

Scaffolds are rigid erections that are temporarily built up and lashed together, and have platforms for the purpose of enabling materials to be hoisted to, and work to be done at, various heights of a building.

Trestle Scaffolds are of a more portable nature, formed with boards spanning between and supported by trestles.

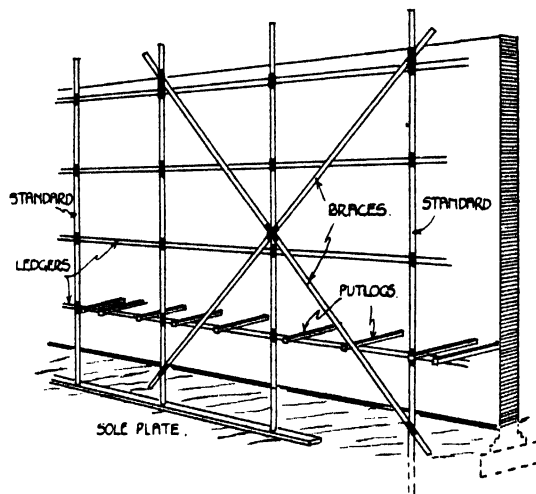

FIG. 23. SKETCH OF BRICKLAYERS' SCAFFOLD

There are two general types of scaffolds: Bricklayers' Scaffold, which is partly supported by a brick wall; and a Masons', or Independent, Scaffold, which derives no support from the wall.

Fig. 23 illustrates a typical bricklayers' scaffold, such as would be used for an ordinary two-story house, and Fig. 24 one for a higher building, the various members and considerations being explained below.

Standards are the vertical members, which are usually placed 8 ft. to 10 ft. apart on straight runs of walls and at lesser distances where short returns or other conditions demand. The distance apart is usually gauged by experience coupled with common sense; but there are a few rules. For example, where the scaffold is required for normal loads, and stout poles are available for standards and ledgers (the latter have to act as beams), then the distance between

MODERN BUILDING CONSTRUCTION

standards may be, say, 10 ft.; if slender poles are used, then the distance must be decreased. Also, if the loads are to be heavy the distance should be lessened, and if very heavy, two poles may have to be lashed together. Where one pole will not reach to the required height, two or more may be joined together.

The bottom of standards must rest on a firm foundation, such as will be obtained by embedding them in firm ground, or letting them

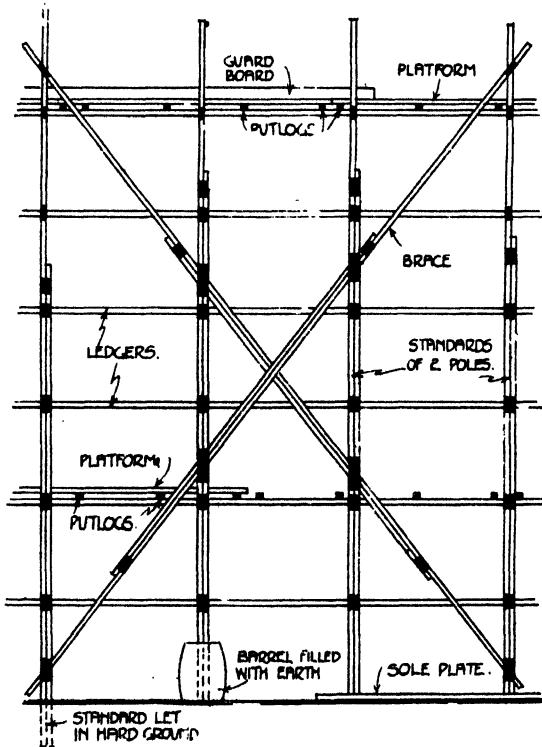

FIG. 24. BRICKLAYERS' SCAFFOLD FOR HIGH BUILDING

rest and be fixed to a timber sole plate; other methods are fixing them in barrels filled with well-rammed earth, or letting them rest on flags or other stones. The framework of scaffolding is usually placed about 4 ft. from the wall.

Ledgers are the longitudinal horizontal members usually formed of stout scaffold poles well lashed on the building side of standards at 5 ft. vertical centres, which is the maximum stage heights of the platforms from which a man can work effectively. As these members act as beams, it is essential that they be stout enough to carry the loads of platforms (materials and men), and if stout poles are not available, then

the standards should be placed closer together to reduce the span, or sometimes two poles may be used in conjunction.

Putlogs are the short transverse horizontal members which are supported at one end by the ledgers and the other end by the brick wall, a header being left out temporarily to form a bearing. Putlogs are usually 3 in. by 3 in. upwards and about 5 ft. long; and as these act as beams supporting the scaffold boards, the distance apart that they should be placed is governed by their scantling, the thickness of boards used, and the loads to be carried. Under normal loading with $1\frac{1}{2}$ in. thick boards, putlogs are placed not more than 4 ft. apart. Where 2 in. boards and stronger putlogs are used, the

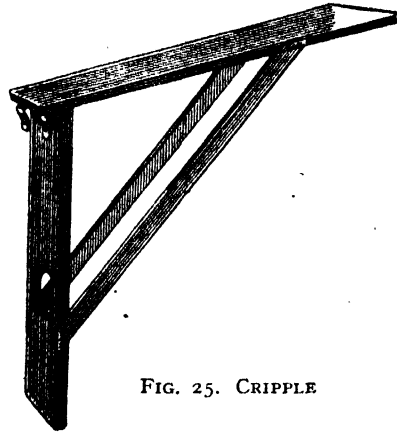

FIG. 25. CRIPPLE

distance may be increased to 5 ft. Their distance apart is also regulated by the length of boards used, which are obtainable from 10 ft. to 13 ft. long. Two putlogs placed not more than 12 in. apart must be used when the boards butt join.

SCAFFOLD BOARDS form the platform or stages and rest usually loose on the putlogs. The usual width of a platform is 3 ft. 9 in., comprised of five 9 in. by $1\frac{1}{2}$ in. or 2 in. boards.

GUARD BOARDS are those fixed vertically along the outside edge of the platform to form a curb to prevent materials falling over.

BRACES are generally used to stiffen high scaffolding, and consist of poles lashed on the outside of the standards, as shown by Figs. 23 and 24.

Masons', or Independent, Scaffolds are formed of two frames of standards, ledgers, and braces, one being placed in a similar position as a bricklayers' scaffold, and the other as close to

PRELIMINARY OPERATIONS

the wall as working conditions will allow, but not supported by it owing to the impracticability of leaving out putlog holes in masonry. Owing to the heavy loads of blocks of stone and stresses induced in hoisting same by tackle, a masons' scaffold must be of stronger construction than a bricklayers' scaffold, which can usually be attained by placing the standards fairly close together. Transverse staying is necessary, and is usually done by tying in the scaffold through the window openings.

Scaffolds on both sides of walls are usually required for brick walls more than 9 in. thick and for all masonry walls, but sometimes the internal scaffolding may be substituted by—

Trestle Scaffolding, formed with strong timber trestles (which rest on any firm foundation or floor) on which scaffold boards are placed. Trestles are usually 5 ft. high, which is the

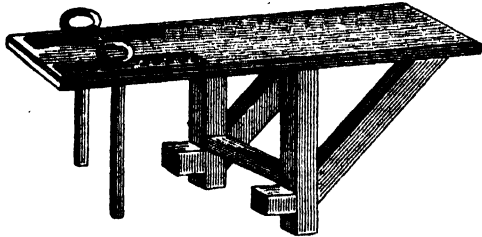

FIG. 26. PAINTER'S WINDOW MACHINE -

ordinary stage height, and any additional stage may be formed by placing a fresh set of trestle boards on the subjacent set.

Scaffolds and devices to provide access to existing structures are as follows.

A **CRIPPLE** is shown by Fig. 25. The hooks engage over a rung of a ladder and the vertical back member bears against several rungs. Another type of cripple has a wrought-iron framework, the top of which clips over a rung and the bottom round the stiles or sides of the ladder, and an adjustable sliding quadrant which permits the platform to be adjusted to any reasonable level.

A **PAINTER'S WINDOW MACHINE** as depicted by Fig. 26 is used by fixing over a window sill and adjusting the handled dogs to assure a firm grip.

STEEL WALL BRACKETS are shown by Fig. 27, their action being that the inclined member causes a thrust on the wall; the top horizontal member, being in tension as well as being subjected to bending, needs very secure fixing by means of the grapples in the wall to prevent it

being dragged out. Such scaffolds should not be used in defective brickwork, and only where light loads have to be supported.

A **SWINGING CRADLE** is swung from any well-tailed and weighted cantilever from roof or window, its height being regulated by the ropes over the pulley blocks.

STEEL SCAFFOLDING

Steel scaffolding is one of the modern advances in building, and it is a welcome contribution

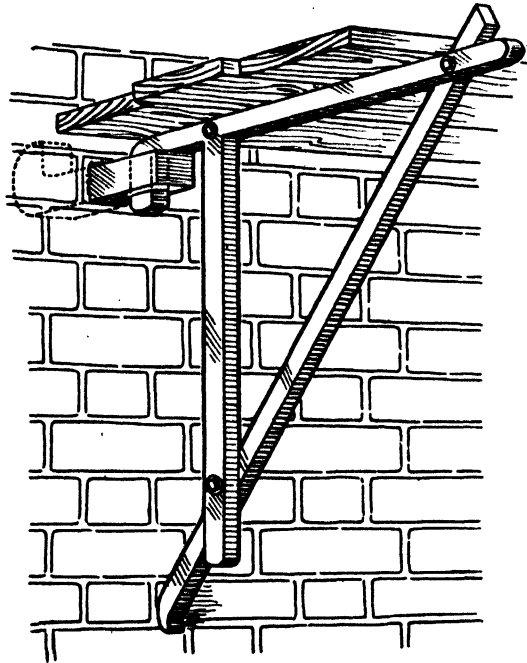

FIG. 27. STEEL WALL BRACKET

towards overcoming many of the difficulties which exist in construction, repair, and maintenance. The original inventor was Daniel Palmer-Jones in 1918. This method of scaffolding is universal in its application; it can be used for the building of a low wall or to give access to a ceiling, and it is equally suitable to attain great heights such as to towers or to the inside of domes. The fact that it is now so extensively used on large buildings and works, and is rapidly gaining favour with builders of small structures, proves that steel scaffolding has exceptional advantages over the timber systems in the matter of rapidity of erection and striking, with the consequent saving in labour costs.

The initial cost of the various components of

MODERN BUILDING CONSTRUCTION

steel scaffolding is greater than that of the ordinary timber equipment, but when credit is given for the advantages that steel has over timber in respect to long life, lesser storage space, ease of transportation, safety, and the difficulty of wasting it by careless cutting, it will be found that steel scaffolding is the most economical.

Steel scaffolding consists of much the same members as ordinary timber scaffolds, the chief variation being that patent couplers are used instead of scaffold cords or steel lashes, and other differences that will be understood by the description of the various parts. Single scaffolds in which the putlogs are supported by the walls, also independent masons' scaffolds, are erected similarly in principle to timber scaffolds, there being, however, several differences in detail

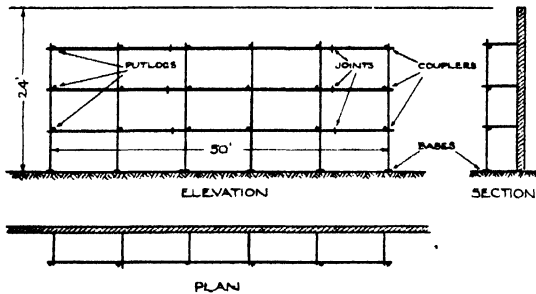

FIG. 28. GENERAL LAYOUT OF STEEL SCAFFOLDING

which will be explained later. Fig. 28 shows a general layout of steel scaffolding to scaffold an area of 1,200 sup. ft. The standards are placed at 10 ft. centres, ledgers 6 ft., to provide platforms at 6 ft. high stages. The width of platforms is about 4 ft. or as required to suit the work, putlogs being supplied in lengths of 4 ft. 6 in., 5 ft., and 5 ft. 6 in.

The main framework members, such as the standards and ledgers, etc., consist of steel tubes, $1\frac{1}{2}$ in. internal diameter or nearly 2 in. external diameter. Ordinary standard steam tubing is much used for ordinary class steel scaffolding, this tubing being butt-welded 5 I.W.G., and of steel of breaking tensile strength of about 24 tons per in. An objection to butt-welded tube when used for scaffolding is that it is apt to split at the welds owing to the stresses induced in the tube. For best quality work, solid drawn tubes, 7 I.W.G., of 30 to 35 tons tensile steel are used. The thinner metal with its higher tensile strength makes it equal to, or even stronger than the butt welded 5-gauge

tube; makes it of less weight, and there is no danger of the tubes splitting. It is much more costly than ordinary butt-welded tube. The couplers and other members are generally forgings or possibly malleable castings.

Standards. These upright members, which act as stanchions, are of steel tubes, and require

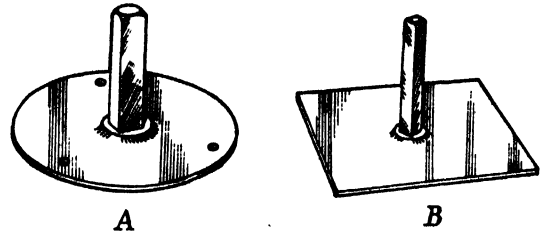

FIG. 29. STANDARD BASE PLATES

care in their disposition so as to ensure that the loads on the scaffolding are safely carried. The same principle of course should apply to ordinary timber scaffolds, but they are not always given the same care as the manufacturers of steel scaffolding recommend should be given in the erection of their speciality. It is manifest that the height of a building or structure, and the nature of the loading on a scaffold, cause a considerable variation in the stresses that are induced in the standards; and, as a general rule, despite the fact that the scientific arrangement of scaffolding dictates that it should be partly supported by the building, there are more stresses in standards at lower levels or stages than in the upper stages. This fact makes it necessary

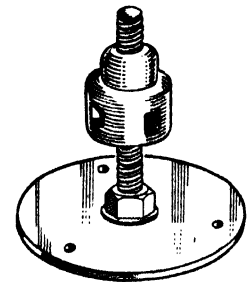

FIG. 30
ADJUSTABLE BASE

to comply with the following rules, which are subject to variation in cases of any special conditions of loading on the scaffolding.

(a) Standards for ordinary buildings up to about 40 ft. high should not be spaced at more than 10 ft. apart.

(b) Ditto—40 to 50 ft. high, 7 to 8 ft. apart.

(c) Ditto—greater heights, 5 to 6 ft. apart.

(d) Standards for heavy masons' work, irrespective of height of building should not be spaced more than 6 ft. apart, and preferably 5 ft.

(e) The above rules are applicable to single and independent scaffolds, but in both types the important rule should be adhered to that

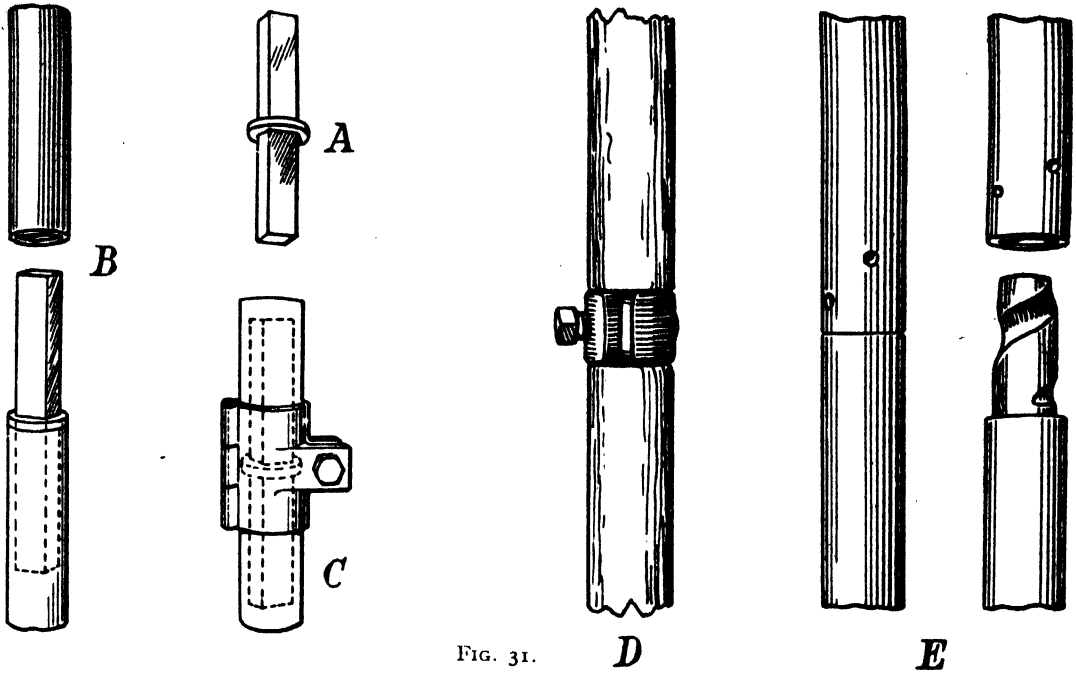

FIG. 31.

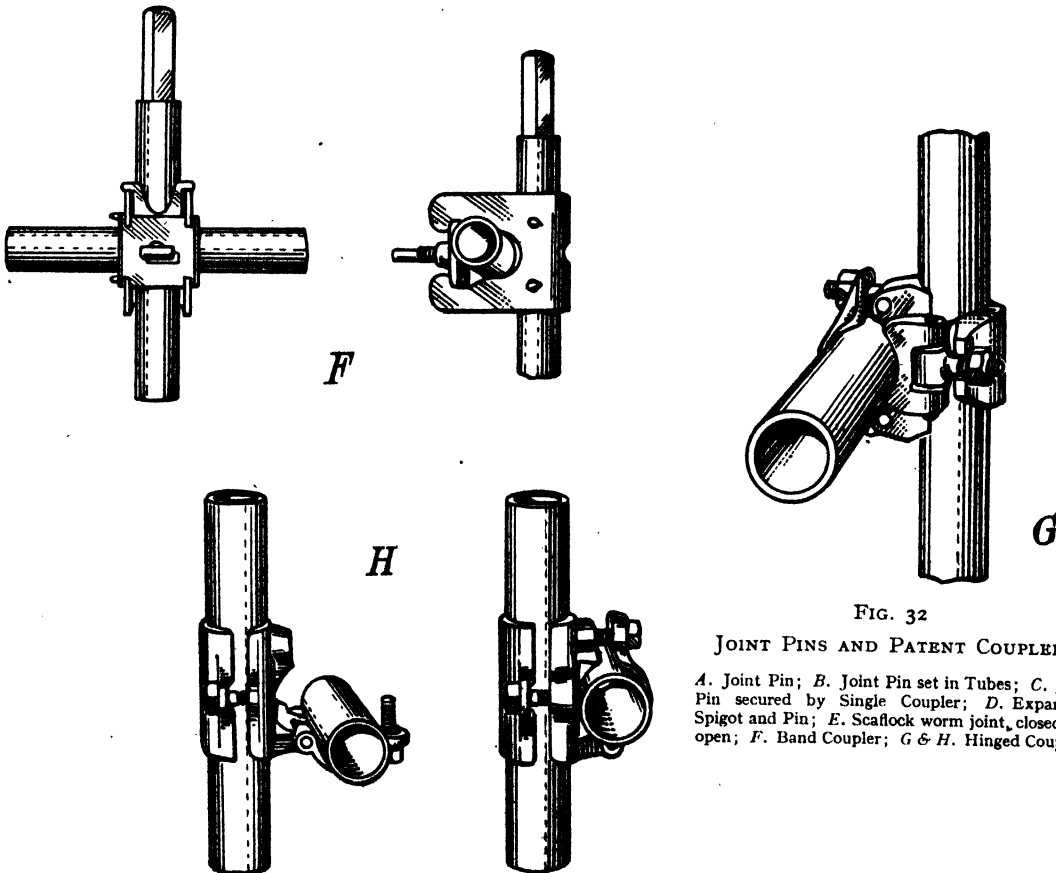

FIG. 32

JOINT PINS AND PATENT COUPLERS

A. Joint Pin; B. Joint Pin set in Tubes; C. Joint Pin secured by Single Coupler; D. Expanding Spigot and Pin; E. Scaffold worm joint, closed and open; F. Band Coupler; G & H. Hinged Couplers.

MODERN BUILDING CONSTRUCTION

the scaffolding should be supported by the walls of the building at frequent intervals, this being done by struts from the standards to any suitable bearing on the walls.

BASES OF STANDARDS are shown by Fig. 29, the tubular standards fitting over the strong pin in the base plate. If the foundation for the base is firm, the plate may rest directly on it; if not very firm, or there are pavement lights

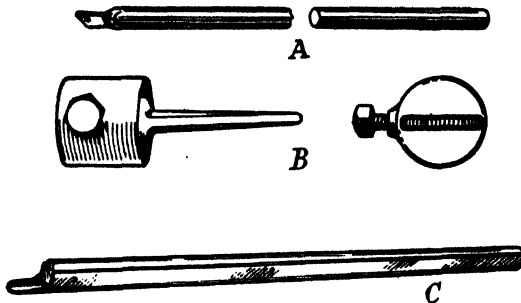

FIG. 33. PUTLOGS

A. Tubular putlog with forged end for fixing to wall; B. Putlog end for fixing to end of tubular putlog to provide wall bearing; C. Putlog of steel channel with hardwood filling.

or manholes to be spanned, then the base plates may be fixed to timber sole plates. Fig. 30 indicates an adjustable base which is very useful for certain positions where heights have to be adjusted.

JOINTS IN STANDARDS. The standards are usually supplied in 10 to 12 ft. lengths, and the methods of joining them are self-explained by Fig. 31 which shows joint pins. It is advisable to so arrange joints in standards that they are not all at the same level but break joint on alternate standards. The joints between standards and ledgers, etc., are explained later.

Ledgers. These are the horizontal members placed at usual stage heights that act as girders, and support the putlogs; they are securely connected to the standards by various types of patent couplers depicted by Fig. 32. These couplers are exceptionally strong, ensure rigidity and right angles at the joints, and allow adjustability. The tubes for ledgers are usually supplied in various lengths up to 18 ft.

JOINTS IN LEDGERS should be made as near to the standard as possible, and jointed similarly to standards with joint pins. If the load is heavy the horizontal joints may be reinforced with a coupler.

Putlogs are of various kinds as shown by Fig. 33. The tubular type where the ends are supported by ledgers are connected thereto with

the same type of coupler as used for connecting standards and ledgers. Where putlogs are to be supported by walls, they have special ends, as shown, to fit into joints in the wall, and while security is given they have the advantage of reducing the cost of making good the putlog holes. For ordinary timber scaffold boards, putlogs should not be placed apart more than 3 ft. 6 in., but where boards abut, if lapping is not desirable, two putlogs should be set 1 ft. 6 in. apart so that the adjacent planks overlap these putlogs about 9 in. each. Putlogs are supplied in 4 ft. 6 in., 5 ft., and 6 ft. lengths. It will be noted by the illustrations that tubular putlogs are made in one part with forged ends for building into the joints of brickwork, etc.; that there are detachable putlog ends for fixing to the ends of standard tubing, and also putlogs formed of steel channel with end shaped for building into joints, and with a hardwood filling fixed into the channel upon which the scaffold boards rest; they are not so likely to slip as when they are supported by tubes.

BRACING. It is advisable that large and high scaffolds, and particularly those to long front-ages be braced on the outer face by means of tubes placed diagonally. The braces are very easily fixed, preferably to the ends of the

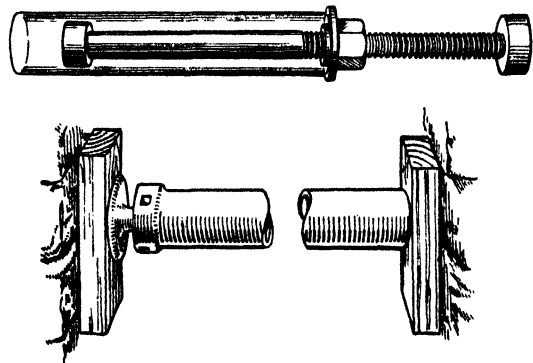

FIG. 34. TWO TYPES OF REVEAL PIN AND SCREW

putlogs, by means of the standard couplers which allow adjustment to any angle.

Supporting Scaffolds. Where the ends of putlogs in single scaffolds occur by window, door, or any other openings in walls, they may be supported by tubular members fixed vertically between the head and sill of an opening, or between the floor and ceiling at the inside of the building. Alternatively a horizontal tube, termed a "bridle," is slung from the putlogs on either side of the opening to which the

PRELIMINARY OPERATIONS

intermediate putlogs are attached. Fig. 34 illustrates what are termed *reveal pins*, or *screws*, and they may be used vertically as shores or punchions, or horizontally as struts between reveals or jambs of openings, with wood pads inserted between the ends of the reveal pins and the abutments. Ends of putlogs may be secured to the vertical shores by standard couplers. Another use to which reveal pins are put is to assist tying-in a scaffold to the building; by their being fixed tightly in openings,

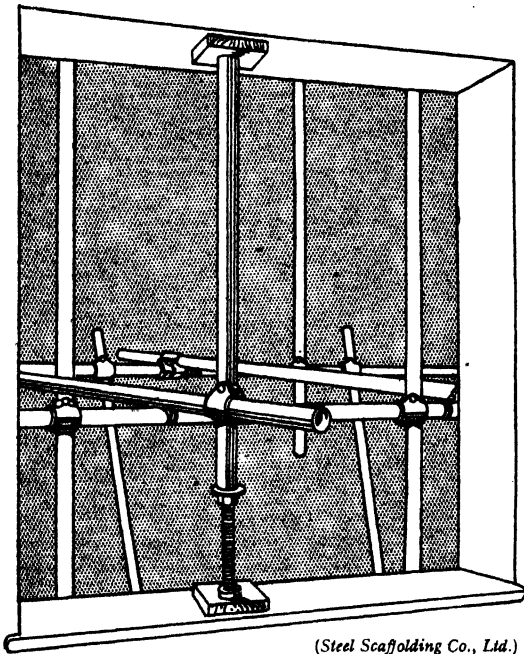

FIG. 35. REVEAL PIN IN USE IN AN OPENING

(Steel Scaffolding Co., Ltd.)

and putlogs being secured to them, a certain amount of rigidity is ensured. If these reveal horizontals are to take weight they must be supported by a puncheon from the sill.

As explained, as much as possible of the weight of and on a scaffold must be transmitted to the building by means of struts to a bearing on the building. The struts, which are inclined members, should be fixed with a coupler at one end to the outer standards (not to the inner standards of an independent scaffold) and the lower end on a firm bearing on the building, and secured in position. Another important matter is to tie in the scaffolding to the building; the putlogs that enter walls partly effect this, but in addition the tying-in should include secure fixing to reveal pins in openings as Fig.

35, or preferably through window, etc., openings secured to a firm member on the inner face of the wall.

Scaffold Boards. Ordinary timber scaffold boards may be used with tubular scaffolding. One of the scaffolding firms advocate a steel board which they state allows putlogs to be spaced at a greater distance apart than is essential for timber boards. Fig. 36 shows a method of fixing the boards, whether of wood or steel, to the tubular putlogs by means of guard board clips.

Guard Boards, which are necessary to prevent materials falling off a scaffold, are fixed vertically to the outer edge of the working platforms, and secured to the standards. The guard

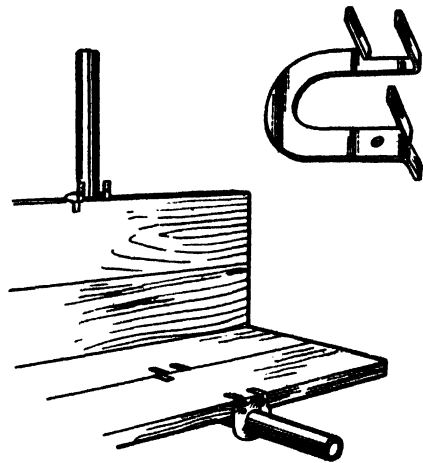

FIG. 36. GUARD BOARD CLIPS WITH SCAFFOLD AND GUARD BOARDS, AND ENLARGED VIEW OF CLIP

board clip effects this fixing as indicated by Fig. 36. *Guard fans* may be easily constructed by means of inclined tubes fixed with couplers to the ordinary members of the scaffolding, and the fan boards being fixed in the same way as the guard or platform boards.

It is necessary to ensure that all couplers and connections are tight, and if scaffolds are left up for extended periods they should be periodically examined. Standards must be fixed plumb, and then it is simple to ensure that ledgers are level horizontally. Avoid projecting ends that would be liable to injure pedestrians. Keep the tubes, couplers, and other parts in good condition.

Steel scaffolding is extensively used for many purposes other than ordinary scaffolding, such as permanent or semi-permanent erections such as storage racks; covered and

MODERN BUILDING CONSTRUCTION

uncovered grand stands, temporary shelters, searchlight towers, foot-bridges, and so on almost indefinitely.

GANTRIES

Timber gantries may be generally defined as erections to permit (a) in the case of gantries to support travellers or cranes, the manipulation of heavy weights and materials to various parts of a site; and (b) in the case of elevated platform gantries, a base for working and reception of heavy materials in a position that would avoid interfering with space at a lower level. The

useful in connection with the design and construction of one to suit any particular condition.

All local authorities have regulations, some rather strict, that govern the design and erection of gantries over a public footway, and the first preliminary is to apply to the authorities for permission to erect, and to ascertain their regulations.

DESIGN. The exigencies of the site and building operations greatly control the design of an elevated platform gantry. Primarily it is prudent to realize that these erections are rather

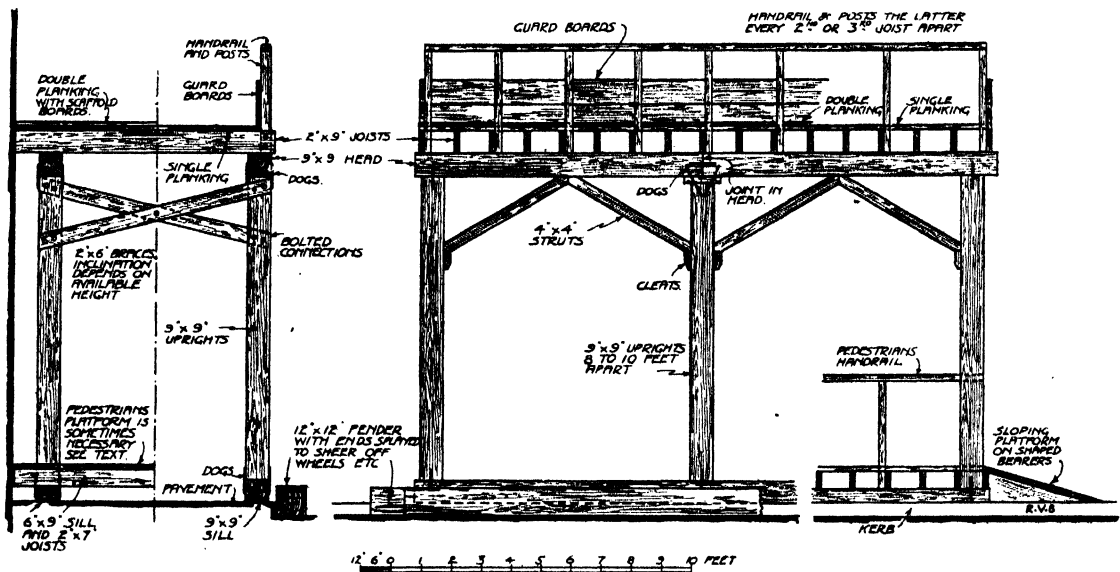

FIG. 37. BUILDER'S GANTRY

types of gantries as (a) do not greatly interest builders, as they are usually erected when required for building operations by specialists.

The elevated platform gantry is commonly used and erected by builders; one position where they are essential being on a site of an existing building which has but little space for the reception or storage of materials, and which building abuts to a pavement. The gantry in such a case permits a reasonably speedy unloading of materials from the road by means of simple hoisting apparatus, and the storage of a certain amount of materials; the foreman's office can be erected on it; and it also acts as a base for certain working operations and the erection of superimposed scaffolding.

Fig. 37 shows a typical elevated platform gantry, and the following information will be

costly, so their length and height should be sufficient to allow only for the economical operation of the work. The height is often regulated by that required to permit the safe passage of pedestrians. It will be noticed by Fig. 37 that a pedestrian platform is sometimes necessary, such necessity arising where work has to be done under the pavement, i.e. vaults or drains, etc.

The gantry is constructed with a framework of baulk timbers consisting of sills, uprights, and heads, the framework being braced transversely between the uprights, and strutted longitudinally between such members with small scantling timbers. The baulk timbers are usually dogged together, and the braces bolted with large diameter bolts, say 1 in., and the struts properly framed and well spiked. The framework forms the foundation for the platforms,

PRELIMINARY OPERATIONS

joists, planking, guard boards and rails, ordinary methods of construction being adopted in their fixing. To prevent dust and water falling on to pedestrians, the high level platform should be double-planked as shown (most local authorities insist on this, or some protection to pedestrians) or, alternatively, corrugated iron or other material may be fixed under the platform as

carried, or any special conditions exist, the sizes of all members should be carefully calculated, using the formula given in connection with the chapter on "Shoring," and allowing an ample superimposed load on the platform, and a fairly low factor of safety of say 4 or even 3.

Steel. Steel permits great loads to be supported by the use of comparatively light framed

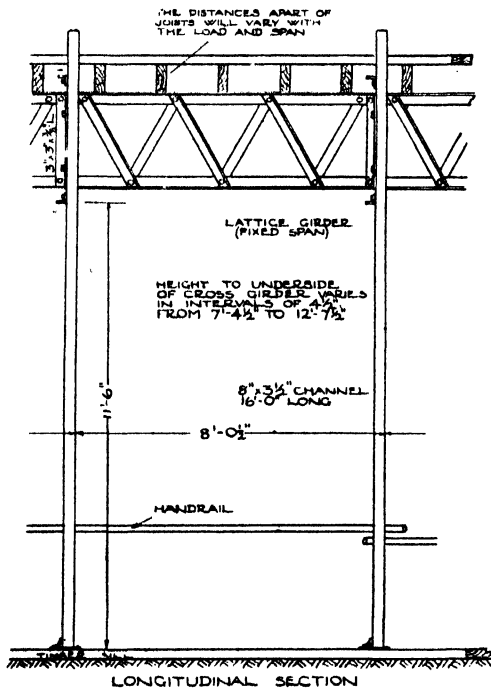
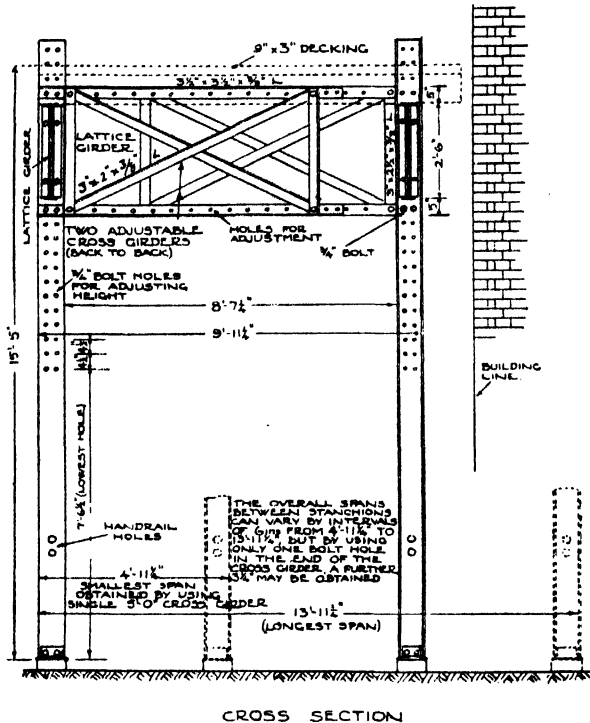

FIG. 38

CONSTRUCTIONAL DETAILS OF PATENT ADJUSTABLE STEEL GANTRY



CROSS SECTION

FIG. 39

a dust- and water-proof roof. The inner uprights are usually kept a reasonable distance from the wall to permit easy working.

To protect the gantry from damage, and possibly serious damage or collapse, by vehicles colliding with it, it is essential (if the gantry extends to the kerb of a pavement or near to it) that a heavy balk fender with splayed ends be fixed at the base of the uprights.

CALCULATIONS. Gantries usually have to perform heavy duties, and be subject to rather rough usage; therefore it is essential that they be strongly constructed of sound materials. The sizes shown by Fig. 37 may be considered a sample for ordinary purposes and for the design shown. Where very heavy loads have to be

and braced steelwork members which are designed properly. Further, the ease with which they can be adjusted to various heights, widths, and projection is an advantage which allows the use of the gantry for considerable variations in site conditions. These types of gantry have a long life and can be used many times before replacements are necessary.

Figs. 38 and 39 show the constructional details of the "S.G.B." (Scaffolding (Great Britain), Ltd.) patent adjustable steel gantry. A study of the general principles and details will prove that it is of practical design and is capable of being used for the many variations which have been described.

Chapter III—SHORING AND UNDERPINNING

A STRUCTURE to be temporarily supported, for any of the reasons explained below, is done by means of shoring of various types, the particular type depending upon the nature or exigency of the case. Where alterations are to be made to an existing building, or a new building is to be erected adjoining and perhaps with foundations at a lower level than the existing foundations, it is necessary to inspect and make adequate provision to prevent subsidence or even overturning of existing work.

The most common objects of shoring are—

(a) To temporarily support walls that have developed such defects as to make them dangerous, as subsidency, inward or outward bulging, and leaning, and to prevent further development of defects ;

(b) To temporarily support floors and roofs, etc., that are, under ordinary conditions, properly supported by such defective walls ;

(c) To prevent subsidence and failure of sound walls by the removal of subjacent supports, such as may be caused during the construction of a basement next or near to a building without a basement ;

(d) To temporarily support a structure, or structures, which had an intermediate structure by which collateral support was given, e.g. one building of a terrace being removed might endanger the adjoining structure and necessitate shoring to prevent collapse ;

(e) To support a floor during the demolition of its supporting wall or partition and the insertion of a bressummer or girder ;

(f) To temporarily support the superstructure, comprising walls, floors, and roof, during the removal of a wall under them to form a large opening or for a shop front ;

(g) To allow for the formation of small openings in walls.

The stresses and thrusts caused by defects in buildings, and by the various members of the shoring used to counteract them, are very difficult to compute, except in the case of dead shores ; the forces involved are vertical, inclined, and horizontal, and induce tension, compression, and transverse stresses both in the shored work and the shores. It is, therefore, best and even safest to adopt designs and to use

sizes of timber formula, etc., as will be given by tables later, which have been based on judgment and experience, than risk any errors that may be made in abstruse calculations.

Types of shoring include (1) *raking*, (2) *horizontal* or *flying*, and (3) *dead* or *vertical shoring*.

Raking Shores, sometimes called *inclined shores*, are constructed in a variety of ways, depending upon the thrusts to be borne, the height of the building, and the space available for the "spread" of the shores. Fig. 40 shows the simplest type, known as a *single raking shore* ; Fig. 41, a *double raking shore* ; Fig. 42, a *treble raking shore*. There may be four or more rakers in a system. Fig. 43 depicts a system of raking shores for use where there is ample room for spreading, and this method permits the use of less and shorter timbers.

In all types, except in some cases where *single shores* are required to support a "point" or concentrated load, a wall plate of 9 in. × 2 in. or 9 in. × 3 in. deal is fixed against and spiked to the wall with wall hooks, and receives and is afterwards further secured by the needles and rakers. The wall plate should extend 3 ft. above and below the top and lowest rakers, respectively, and be in one length if possible ; if jointing is needed the joint should be as Fig. 44. The base of the rakers must be supported on a *sole piece*, usually of 11 in. × 3 in. deal, bedded in an inclined position in the ground and set slightly *acute*, say 85°, with the outer or top raker. The rakers should be levered up with a crowbar, operated in a notch in the foot of each raker, and securely "dogged" and cleated to the sole piece, as shown by Fig. 45. Wedges must not be used, as knocking them into position would be liable to shake the work. If the ground is soft, the area of the sole piece must be increased by forming a platform of timber, so that the pressure may be distributed over a sufficient area.

The top end of the rakers have to support the wall, and must be connected to the wall plate which transmits the support provided by the rakers over the wall. This is done by means of *needles* of 4 in. × 3 in., preferably of oak or other hardwood and shaped as shown by Fig. 46, which extend through the wall plate and at

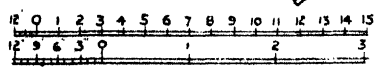
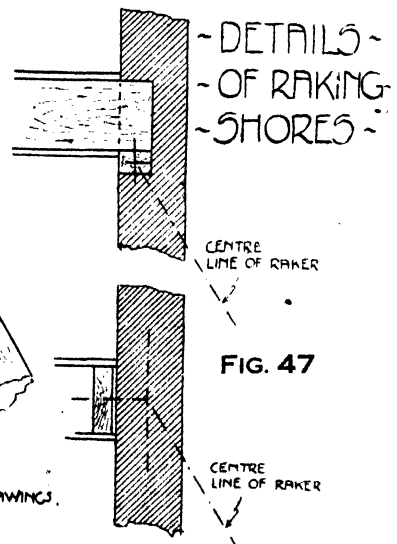
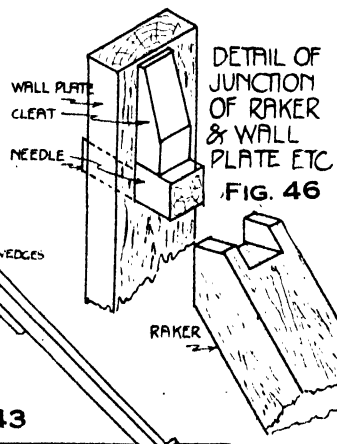
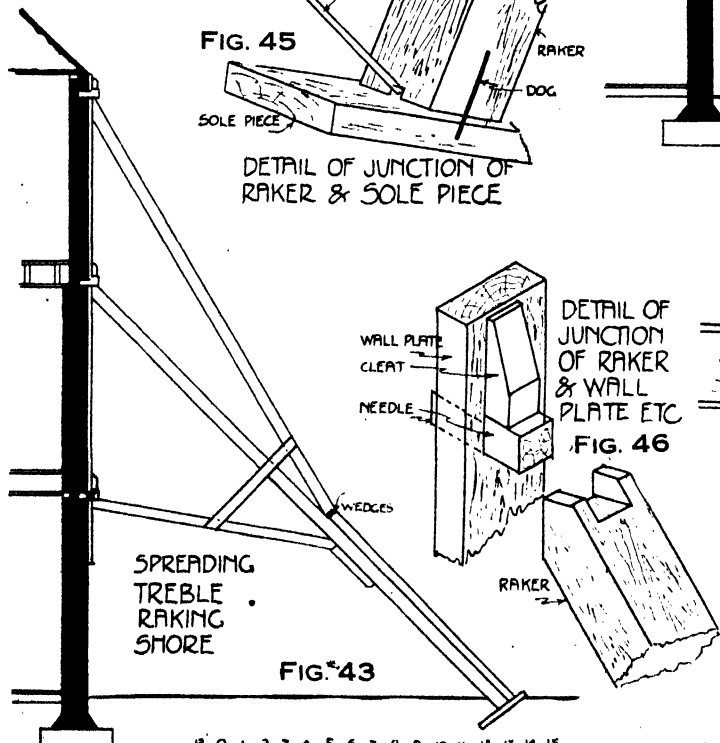
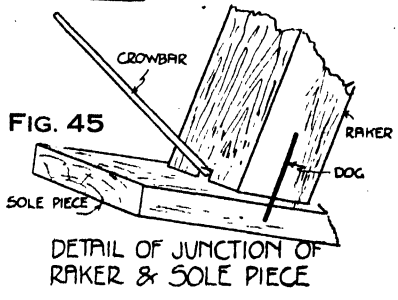
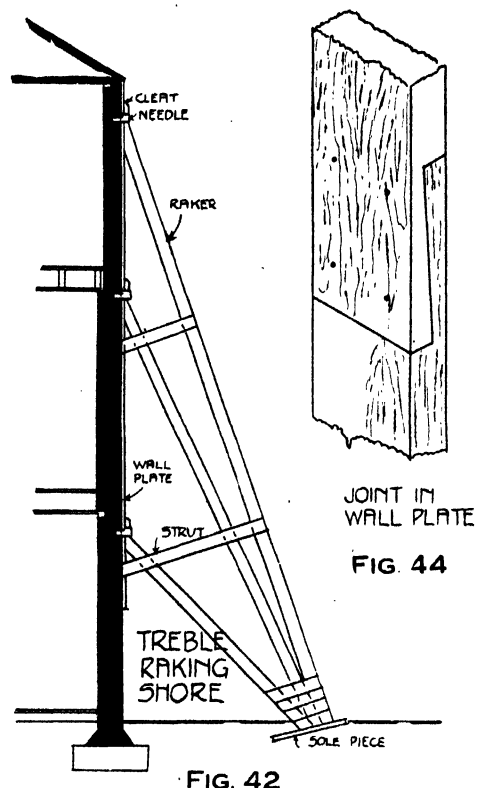
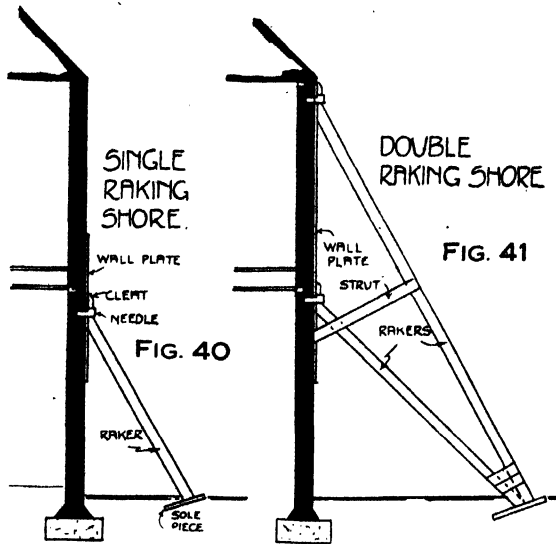

MODERN BUILDING CONSTRUCTION

least $4\frac{1}{2}$ in. into the brick or stone wall. The needles should be cleated to the wall plate as shown. The heads of the rakers must be notched and fitted to the needles and wall plate, as indicated. The rakers and wall plate should be strutted together at frequent intervals with 9 in. \times 1 in. boards well spiked to the members; and where there is more than one raker, the feet should be well bound together with stout hoop-iron or two or three boards spiked to the struts.

The internal angle between the outer or top raker and the horizontal, or ground, should be

run parallel to the shored wall, the best position is given by making the centre lines of rakers, wall and floor meet at a point. Fig. 47 illustrates these arrangements.

As a general rule, the shores should extend to the eaves of the roof.

Lateral or side supporting may be necessary to raking shores, to prevent side buckling; but, as a general rule, the rakers should be of sufficient size to prevent lateral bending. It is manifest that the struts considerably stiffen the rakers in one direction but not sideways, and

DETAILS OF JOINTS IN RAKERS.

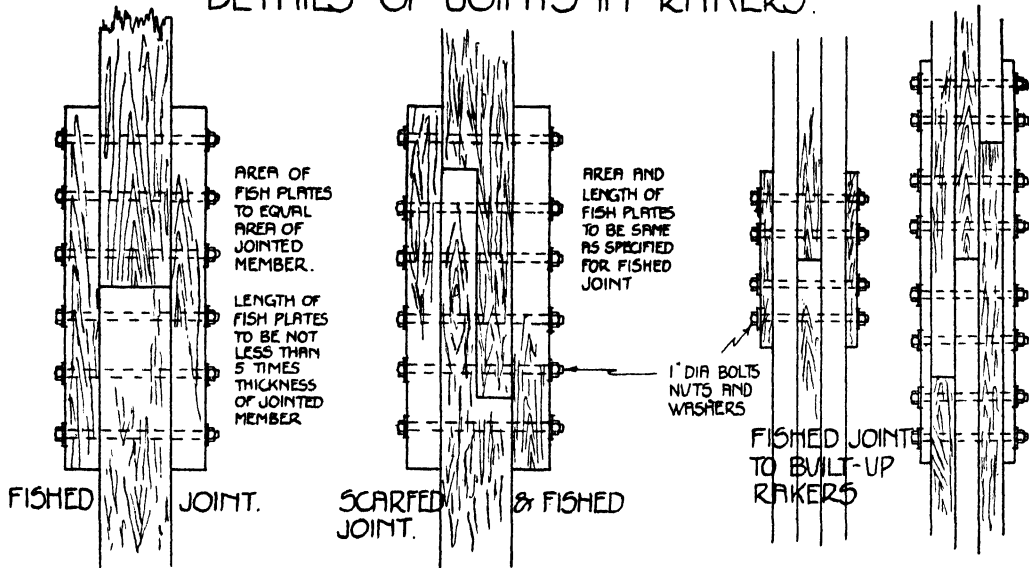

FIG. 48

FIG. 49

60°- to 75°, the former being the usual for practical purposes.

The sets of shores should be normally placed 10 ft. apart, centre to centre, but this distance will vary where there are windows or other openings, which will necessitate the shores being placed against piers.

The position of the top ends of rakers should be at those points where there is an *internal resistance* to a tendency for a wall, under the *external pressure* of the rakers, to bulge inwards, and the best position is at about floor or roof levels. The actual position, where the ends of floor joists are supported by the shored wall, is given by arranging the raker so that a line drawn through its centre, and continued, would meet the centre of the wall plate or the centre of the bearings of the floor joists. If the joists

it is therefore, advisable to brace the sets of shores together with light scantlings or stiff boards. Owing to this lateral weakness the writer advocates the use of rectangular timbers instead of square, such as 9 in. \times 6 in. or 11 in. \times 6 in. instead of 7 in. \times 7 in. or 8 in. \times 8 in., as it is then possible to arrange the timbers scientifically with the lesser dimensions in the direction where the "strut-length" is shorter, and the greater dimensions where the "strut-length" is greater.

SCANTLINGS FOR RAKING SHORES. Table I gives the sizes of members of raking shores under various conditions. The scantlings given are for new or sound second-hand timber; if the timber is old, and only in fair condition, then use scantlings shown for height of wall 5 ft. higher than the actual; i.e. if wall is 30 ft. high,

PRELIMINARY OPERATIONS

TABLE I
SCANTLINGS FOR RAKING SHORES OF FIR OR EQUAL STRENGTH TIMBER

Height of Wall in Feet	Number of Rakers	Distance Apart of Rakers in Feet Sectional Area of Rakers in Inches					Angle of Outer Raker with Horizontal
		8 Feet	10 Feet	12 Feet	14 Feet	16 Feet	
15	1	16	16	20	24	28	60 to 75
		16	18	22	26	30	55
		17	20	24	29	33	50
20	1 or 2	18	20	24	27	30	60 to 75
		20	22	26	30	34	55
		22	24	29	33	37	50
25	2	25	30	35	40	45	60 to 75
		27	33	38	44	50	55
		30	36	42	48	54	50
30	3	33	40	46	52	58	60 to 75
		36	44	50	57	64	55
		40	48	55	62	69	50
35	3	42	50	58	64	70	60 to 75
		46	55	63	70	77	55
		50	60	70	77	84	50
40	3 or 4	53	64	75	86	97	60 to 75
		58	70	82	94	102	55
		63	77	90	102	114	50
45	4	60	72	84	96	108	60 to 75
		65	78	92	105	118	55
		72	86	100	115	130	50
50	4 or 5	66	80	94	108	122	60 to 75
		72	87	103	118	135	55
		79	96	113	130	147	50

Wall plates : 9 in. × 2 in. up to 30 ft. high, and 9 in. × 3 in. where over.

Struts : 9 in. × 1 in. or 1½ in.

Sole piece : 11 in. × 3 in.

Needles : 4 in. × 3 in. or 4 in. × 4 in.

NOTES. If timber is only in fair condition, then use rakers of sizes specified for rakers 5 ft. higher than actual. If rectangular rakers are used, the greater dimensions should be in the direction *parallel* to wall; this ensures the maximum lateral stiffness to the shores and prevents them buckling sideways. In the other direction they are stiffened in their length by the struts or braces. This does not, of course, apply to single shores, which have no struts or braces and which should be of square scantling.

MODERN BUILDING CONSTRUCTION

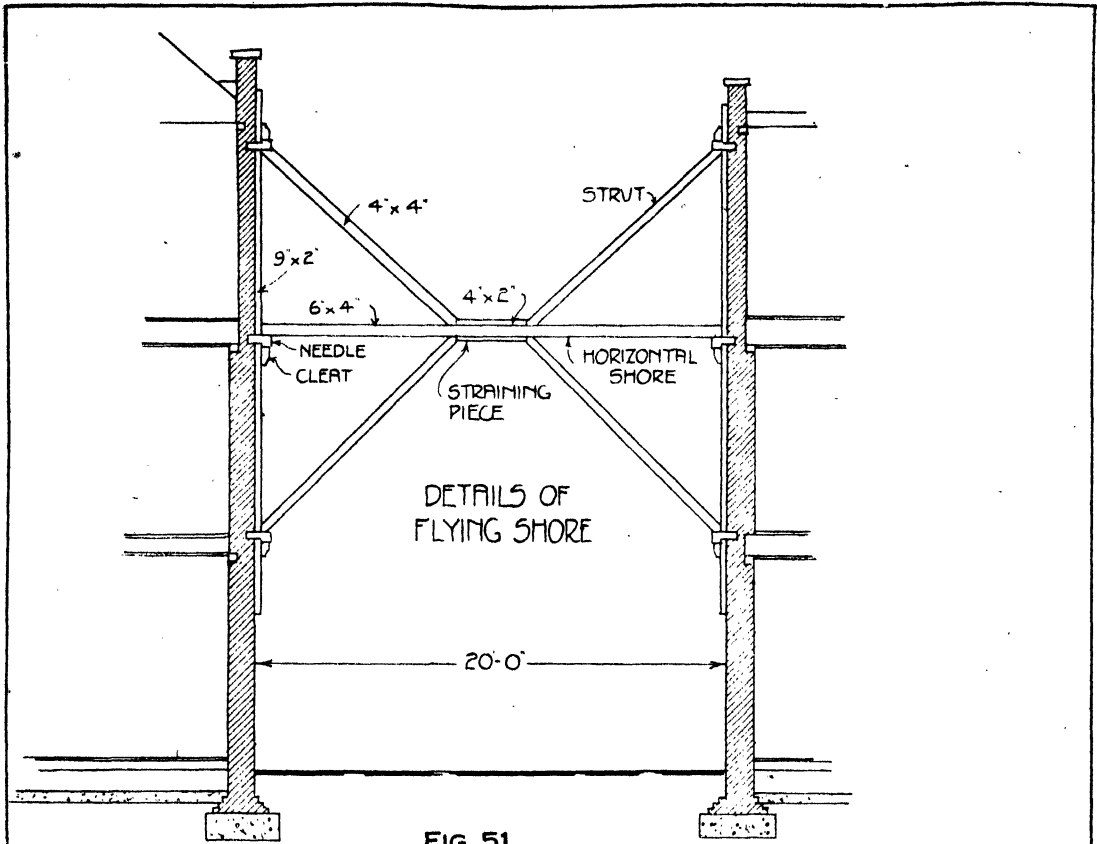

FIG. 51

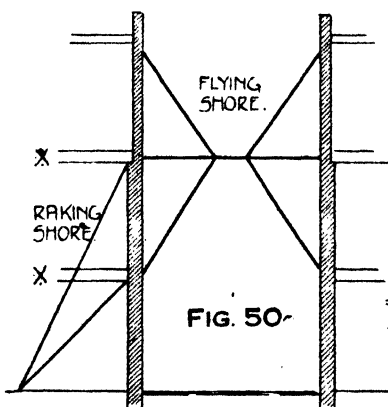

FIG. 50

DIAGRAM SHOWING RAKING SHORE TO GIVE SUPPORT TO WALL WHERE FLOORS X ARE TO BE REMOVED

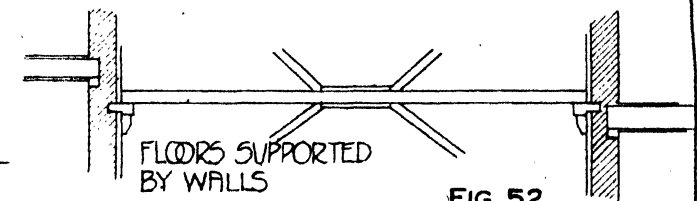

FIG. 52

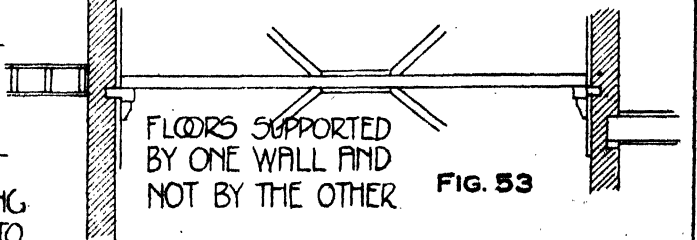

FIG. 53

then use scantlings for 35 ft.-high wall. Any special circumstances may necessitate an increase in sizes of members.

Table II shows the best *rectangular* sections to use compared with *square* sections.

JOINTS IN RAKERS. "Balk timbers" can be obtained in longer lengths than "planks," and where "balks" are used they should be in one length if possible, otherwise very strong fished or scarfed and fished joints must be used, as shown by Fig. 48. Rakers composed of "planks" lend themselves to economical jointing by well lapping the joints by the adjacent member and simply "fishing," as shown by Fig. 49.

Horizontal, or Flying, Shores are used to provide temporary support to two walls during the removal of an intervening structure, or the condition may be that one defective wall has to be supported by another wall that is in a good state. Also, in some cases, the internal walls and floors of one building may have to be removed without pulling down the external wall (which is bonded to the internal walls and carries the floors) which, unless laterally supported, would have a tendency to overturn. To maintain equilibrium, such a wall needs shoring from both sides, as it is manifest that any pressure exerted on one side would tend to overturn it to the other side. If there is a building near to the wall in question,

separated by, say, an alley, the best way to shore the wall would be by a flying shore on one side and raking or flying shores on the inside. Such a condition is illustrated by Fig. 50.

Fig. 51 shows a simple flying shore. The wall plates, needles, cleats, and position of struts in relation to floors and roof should be in

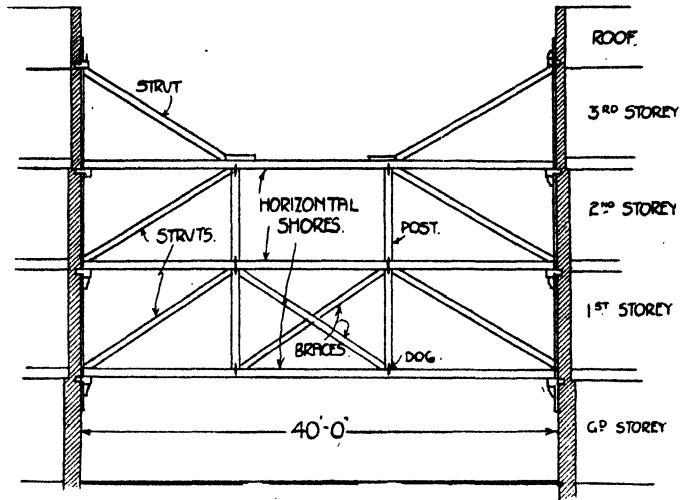

FIG. 54. COMPOUND FLYING SHORE

conformity with the rules for raking shores. Where the floors of both buildings are at the same level, there is no difficulty in placing the horizontal shore on the centre line of each floor; but where the floor levels vary 1 ft. or 2 ft., the best position to place this shore is a matter that requires a little consideration. Where the floor joists run parallel to *both* walls or where both walls support the joists, the horizontal shore should be placed between the two floor levels as shown by Fig. 52. If the difference in level is small, there is no harm in placing this shore a little out of horizontal if desired. The raking struts can be regulated to varying levels, as their angle of inclination is of no great import. In the case where the joists run parallel to one wall and into the other, as the latter condition provides a greater strength to the wall than the former, then if the floors are at different levels, the best course is to place the shore centrally with the floor which has its joists running parallel to the wall, and as near as possible to the other floor, as shown by Fig. 53.

The shores must be erected during or before demolition of a building commences, and removed when the new work is of a sufficient height to make shoring unnecessary.

TABLE II

SQUARE AND RECTANGULAR SCANTLINGS FOR RAKERS

Square	Solid Rectangular	" Built-up " Rectangular
Inches	Inches	Inches
4 × 4	4½ × 3½	
4½ × 4½	5 × 4	
5 × 5	6 × 4 or 7 × 4	
6 × 6	7 × 5	2/7 × 2½
7 × 7	8 × 6	2/8 × 3
7½ × 7½	9 × 6	2/9 × 3
8 × 8	9 × 7 or 11 × 6	9 × 3 and 9 × 4 or 2/11 × 3
8½ × 8½	9 × 8 or 11 × 7	2/9 × 4 or 11 × 3 and 11 × 4
9 × 9	11 × 8	2/11 × 4
10 × 10	11 × 9	3/11 × 3
11 × 11	13 × 9	
12 × 12	14 × 10	

MODERN BUILDING CONSTRUCTION

The horizontal shore is placed between the two wall plates; and if there is a space between one end of shore and wall plate, a pair of folding wedges must be inserted and lightly driven up.

Straining pieces, 2 in. thick and of same width as struts, must be spiked to the shore to form an abutment for struts.

The struts should be fixed at about an angle of 45°, and cut tightly in between straining pieces and needles; they are further tightened by driving in folding wedges between struts and straining pieces on upper side, which will cause the horizontal shore to deflect slightly and so stiffen the lower struts and the whole framing. The horizontal shore is strengthened by the struts, which also support the walls.

A compound flying shore is depicted by Fig. 54 and is useful where high walls have to be supported. The details are very similar to a simple flying shore, the vertical struts being dogged to the horizontal shores.

A combination of simple and compound flying shores may be used where walls are very high.

SCANTLINGS FOR FLYING SHORES. Table III gives sizes of the various members for different spans, but special conditions may require greater scantlings.

TABLE III
SCANTLINGS FOR FLYING SHORES

Span in Feet	Horizontal Shore	Struts	Straining Piece	Wall Plate
	Inches	Inches	Inches	Inches
Up to 20	6 × 4	4 × 4	4 × 2	9 × 2
" 25	6 × 6	4 × 4	4 × 2	9 × 2
" 30	9 × 6	6 × 4	4 × 2	11 × 3
" 35	9 × 9	6 × 6	6 × 2	11 × 3

Dead, or Vertical, Shoring is used temporarily to support walls, floors, roofs, etc., superimposed on work that has to be removed for such reasons as forming openings in walls, taking down defective lower parts of walls and rebuilding them, removing walls that are not required and permanently supporting the work over, removing ground story walls to permit the insertion of shop fronts, and for various other reasons. This type of shoring is generally a combination of beams and posts that have to support loads that are calculated, and such members must be of sizes that may be computed by formula, as explained. Alternatively, empirical formulae

which are described later may be used; these formulae reduce calculations to a minimum.

To explain fully the correct methods of shoring, the writer will carry the student through simple examples, and, finally, a rather complicated case of shoring will be considered.

In all types of dead shoring the first essential, unless the empirical formulae are used, is to calculate the loads to be supported, and to compute them in a practical manner, allowing a reasonable margin for safety, and giving proper consideration to the fact that the building may or may not be inhabited or used for storage, etc., during the execution of the structural work.

Table IV shows the practical dead and superimposed loads of and on various parts of buildings that should be allowed in calculating dead shoring. *The loads shown must not be considered as suitable for use in the actual design of floors, roofs, etc., as more detailed loads are then necessary.*

Loads of Brickwork on Beams. For purposes of calculating shoring, it is advisable to allow that the whole of the brickwork over an opening has to be supported, and not to consider the "triangular area," explained below, except perhaps for openings not more than 10 ft. wide where the work is in good condition.

In calculating a beam to *permanently* support a brick wall, it is not usual to allow that the whole weight of brickwork over the beam will have to be supported by it, as, subject to certain conditions, a proportion of the load is transmitted, owing to the bond of the brickwork, to the walls or abutments at the side of the beam. In a case as shown by Fig. 55 it is manifest that practically the whole of the brickwork must be carried by the beam, but if there were abutments, as shown by Fig. 56, the load to be supported by the beam may be taken as equal to the area enclosed by the triangle marked *B*. If there are perforations in the wall, such as windows, as shown by Fig. 57, the load area would be as marked *C*.

The conditions under which such reduced areas of brick walls may be calculated are important and are—

1. That the breadth of each abutment is not less than half span of opening;
2. That the brickwork is thoroughly bonded together;
3. That great rigidity is not essential.

CALCULATION OF BEAMS. After the loads have been calculated—examples will be given later—and the design of the shoring settled, the

PRELIMINARY OPERATIONS

TABLE IV
LOADS ON STRUCTURES FOR PURPOSES OF CALCULATING DEAD SHORING
 See footnotes regarding important reductions

Part of Structure	Load in Cwt. per Super Foot		
	Dead Load	Super-imposed Load	Total Load
Roofs, pitched, of timber construction, including rafters, etc., boarding or battens, slating or tiling, and wind, measured on slope of roof	0·25	0·10	0·35
Roofs, pitched, with roof trusses, purlins, and lightweight roofings, such as asbestos, cement, etc.	0·15	0·10	0·25
Roofs, flat, of timber construction, including joists, firrings, boarding, asphalt or other flat roofing, ceiling covering and superimposed loads	0·25	0·25	0·50
Roofs, flat, of reinforced concrete, etc., 4 in. thick with beams, screeding to falls, asphalt or other flat roofing, ceiling covering, and superimposed loads	0·75	0·25	1·00
Roofs, flat, as last, but reinforced concrete 6 in. thick	1·00	0·25	1·25
CEILINGS, of timber construction, to ordinary type of house roof, including ceiling joists, ceiling covering, etc.	0·10	—	0·10
FLOORS of timber construction, including flooring boards, etc., and ceiling covering for following types of buildings with superimposed loads as specified—			
(a) Residential floors, flats, hotel buildings, hospital rooms and wards, corridors, etc. (40 lb. F.S.)	0·20	0·36	0·57
(b) Offices, above entrance floor (80 lb. F.S.)	0·25	0·72	0·97
(c) Offices on and below entrance floor, churches, schools, reading rooms, art galleries, and similar buildings (90 lb. F.S.)	0·25	0·80	1·05
(d) Workshops, factories and garages for motor vehicles not exceeding 2½ tons net weight (150 lb. F.S.)	0·28	1·34	1·62
(e) Warehouses, book stores, stationery stores, etc. (200 lb. F.S.)	0·30	1·78	2·08
FLOORS of reinforced concrete or similar construction about 4 in. thick, including beams, etc., flooring and ceiling coverings for types of buildings with superimposed loads as (a) to (e) as last items—			
(a)	0·70	0·36	1·06
(b)	0·75	0·72	1·47
(c)	0·80	0·80	1·60
(d)	0·85	1·34	2·19
(e)	0·90	1·78	2·68
FLOORS, as last items, but about 6 in. thick—			
(a)	0·95	0·36	1·31
(b)	1·00	0·72	1·72
(c)	1·05	0·80	1·85
(d)	1·10	1·34	2·44
(e)	1·15	1·78	2·93
WALLS, of brickwork, measured overall of ordinary size openings (which will allow approximately for plastering, etc.)--			
9 in. thick	0·80	—	0·80
13½ in. thick	1·20	—	1·20
18 in. thick	1·60	—	1·60
	Per cub. ft.		
Concrete, plain	1·25	—	—
Concrete, reinforced	1·33	—	—

Where floors are not used during shoring operations for the purpose for which they were constructed, then the *superimposed loads* specified in this table may be reduced to one-half, the balance being generally sufficient to allow for builders' material, plant, men, etc., which may be superimposed on the floors.

The loads specified are to be used in the design of shoring only, and not for structural designing, which necessitates more accurate computations.

MODERN BUILDING CONSTRUCTION

student must then be able to compute the sizes of beams and shores or posts. Calculations for determining the strengths of all types of structures are given fully in the section on "Structural Engineering," to which the reader is referred, but to make this chapter complete in itself, simple and suitable calculations for shoring are here given. For the purpose of shoring, the simplest formulae for beams may be used; these are—

Beams simply supported at each end.

$$(1) W = \frac{Cb d^2}{L}$$

$$(2) b d^2 = \frac{WL}{C_1}$$

where W = total safe load in cwt.

b = breadth of beam in inches.

d = depth of beam in inches.

L = span in feet.

C = constant for Formula (1) as Schedule of constants.

C_1 = constant for Formula (2) as Schedule of constants.

SCHEDULE OF CONSTANTS

Timber	Uniformly distributed load or Two equal concentrated loads at quarter points from bearings		One concentrated load at centre of span		One concentrated load at third point from a bearing		Two equal concentrated loads at third points from bearings or Three equal concentrated loads at quarter points	
	C	C ₁	C	C ₁	C	C ₁	C	C ₁
Non-graded ordinary redwood with f. 800 lb. as L.C.C. by-laws	0.8	1.25	0.4	2.5	0.45	2.22	0.6	1.67
Douglas fir, etc., with f. 1,200 lb. as L.C.C. by-laws	1.2	0.84	0.6	1.68	0.67	1.48	0.9	1.11

Deflection. It is of vital importance that needles and heads to dead shoring should not deflect excessively, and not more than 1/360th of span. Safe rules to avoid excessive deflection are—

Make the *depth* of needles not less than 1 in. for each foot span. The *depth* of heads and beams should not be less than 1/4 in. per foot of span where the loads are not very great, and up to 1 in. per foot of span if the loads are very great. (See the Empirical Formulae.)

Calculation of Dead Shores. These are calculated as "posts," with ends considered as free

to rotate. Table V is practical and simple to use.

TABLE V
MAXIMUM PRESSURE IN CWT. PER SQUARE INCH ON DEAD SHORES

Slenderness Ratio, i.e. Length Divided by Least Cross-section	Non-graded Ordinary Redwood	Douglas Fir and Timbers of Similar Strength
Not exceeding 10	7.15	8.93
Exceeding—		
10 and not exceeding 12	7.00	8.80
12 " " 14	6.90	8.65
14 " " 16	6.73	8.50
16 " " 18	6.47	8.20
18 " " 20	6.15	7.80
20 " " 22	5.66	7.31
22 " " 24	5.05	6.65
24 " " 26	4.32	5.80
26 " " 28	3.75	5.35
28 " " 30	3.26	4.32

Note. It is advisable that the slenderness ratio of dead shores shall not exceed 24.

SIMPLE DEAD SHORING. Fig. 58 represents part plan and section of a one-story building, in which it is required to form an opening 12 ft. wide, as shown by Fig. 59. The design of shoring should be as Fig. 60. Each needle will have to support practically only the wall; the small amount of roof load may be neglected, as it cantilevers over the bearer supporting it. The load will be the length from centre of one "bay" to centre of next, which is equal to distance apart of needles \times by height of wall \times by weight of wall = $4 \times 5 \times 0.75$ cwt. = 15 cwt. The span of needles from centre to centre of dead shores = say, 6 ft. For practical purposes, the load should be considered as concentrated in centre of each needle—it is actually a little away from centre—and the calculation is as follows for redwood—

$$b d^2 = C_1 W L$$

$$b d^2 = 2.5 \times 15 \times 6 = 225.$$

Try 6 in. \times 6 in. needle; $6 \times 6^2 = 216$ which is near enough to suit 225.

The next process is to calculate the load on dead shores. As the wall is not supported in the centre of needles, it is obvious that the outer and inner shores do not have the same load to carry, the inner having more than the outer owing to the wall being nearer to the former; also, the inner shore has to support the roof in addition. The loading of wall on needle is shown by Fig. 61, and by simple mathematics

PRELIMINARY OPERATIONS

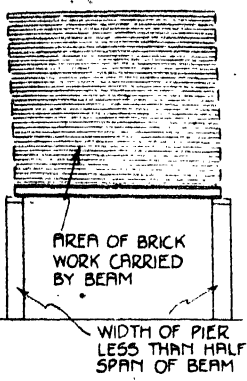

FIG. 55

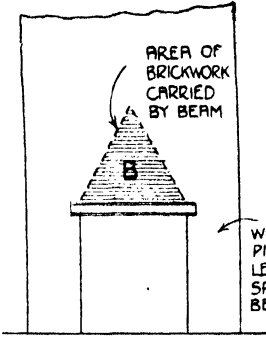

FIG. 56

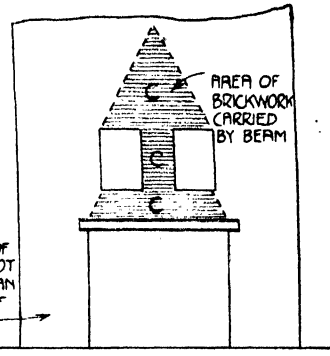
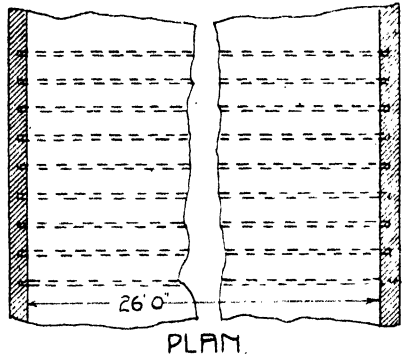
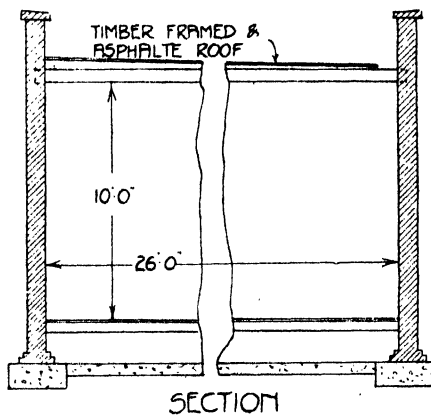

FIG. 57



PLAN

FIG. 58



SECTION

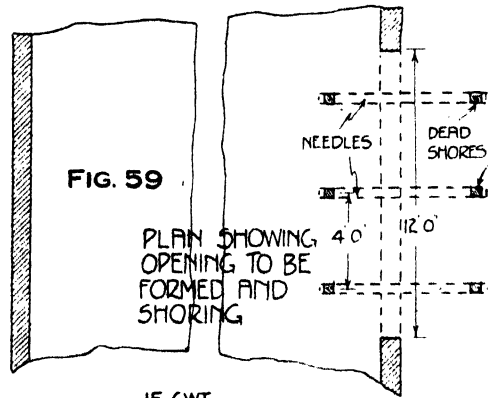

FIG. 59

PLAN SHOWING OPENING TO BE FORMED AND SHORING

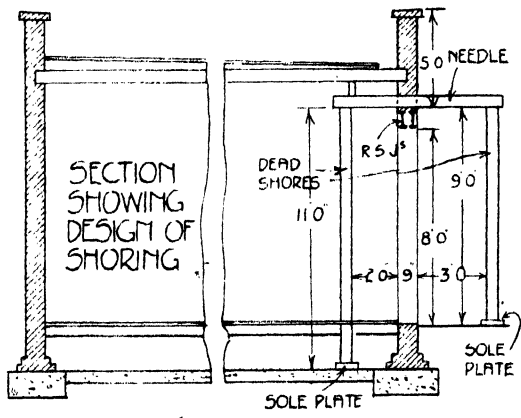

FIG. 60

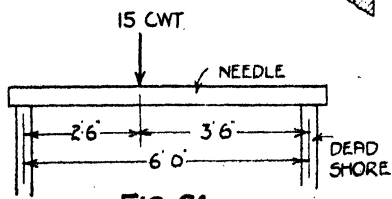

FIG. 61

MODERN BUILDING CONSTRUCTION

the load on outer shore will be $15 \text{ cwt.} \times \frac{2.5}{6.0} = 6\frac{1}{4} \text{ cwt.}$ That on inner shore will be $15 - 6\frac{1}{4} = 8\frac{3}{4} \text{ cwt.}$ The flat roof will give a load on inner shore equal to half width of building \times distance apart of shores \times weight, as Table IV, $= 13 \times 4 \times 0.50 \text{ cwt.} = 26 \text{ cwt.}$ Therefore the outer shore will have to support only $6\frac{1}{4} \text{ cwt.}$ (as above) and the inner $8\frac{3}{4} + 26 = 34\frac{3}{4} \text{ cwt.}$ The length of the inner and outer shores are respectively 11 ft. and 9 ft. long, and the timber to be used is redwood.

First calculate with the aid of Table V the size of the *outer shore* which is 9 ft. long and has to carry a load of only $6\frac{1}{4} \text{ cwt.}$

As stated in Table V, it is advisable, as a general rule, not to let the slenderness-ratio exceed 24, but in this case, as the load is small and there will be ample over-strength in the shore with a higher slenderness-ratio, this general rule may be waived to a little extent.

Try 4 in. \times 4 in. shore: Slenderness-ratio $= \frac{19.8}{.75} = 27$. The maximum pressure for this ratio is 3.75 cwt. per square inch, which multiplied by 16 = 60 cwt., which is much more than is required to meet the load of $6\frac{1}{4} \text{ cwt.}$ It may be mentioned that a 3 in. \times 3 in. shore would theoretically carry the load: the slenderness-ratio would be very high, viz. $\frac{19.8}{.56} = 36$, and the maximum pressure would be 2.28 cwt. per square inch. Therefore, $9 \times 2.28 = 20.52 \text{ cwt.}$ It is advisable to use the 4 in. \times 4 in. shores.

The *inner shores* should next be calculated. The length of each shore is 11 ft., viz. 132 in., and the load is $34\frac{3}{4} \text{ cwt.}$ Try 5 in. \times 5 in. The slenderness-ratio $= \frac{19.8}{.62} = 32$. The maximum stress is 4.32 cwt. per square inch, which multiplied by 25 = 118 cwt., which is more than ample to meet the load of $34\frac{3}{4} \text{ cwt.}$

Although $4\frac{1}{2}$ in. \times $4\frac{1}{2}$ in. shores would have a slenderness-ratio of 30, they are worthwhile considering. The maximum pressure is 3.26 cwt. per square inch; so $3.26 \times 4\frac{1}{2} \times 4\frac{1}{2} = 66 \text{ cwt.}$

The beam supporting the roof should be calculated as before explained.

After the shoring is in position the wall may be removed, the jambs quoined up, the girders inserted, brickwork pinned in between top of girder and underside of existing wall, and then, after a lapse of two or three days to allow the new work to set, the shoring may be removed and floor and ceiling made good.

ADVANCED DEAD SHORING. Figs. 62 and 63 depict plan and section of a two-story building, having a $4\frac{1}{2}$ in. brick division wall extending

through both stories. It is desired to remove such wall on ground story, and to insert a girder to support the wall over and the first floor joists, which are now carried by the wall. Fig. 64 shows the section of the system of shoring that is considered better than the method shown by Fig. 64, as the $4\frac{1}{2}$ in. wall on first floor, being partly carried by the joists, allows the needles being placed at a greater distance apart than if the wall was not so borne.

It will be noted that Fig. 63, and enlarged detail *A*, show the steel girder placed in position below the timber joists, which will avoid the necessity of cutting and fitting the ends of them to the girder, and also prevents interfering with the bearing of the $4\frac{1}{2}$ in. partition wall. Sometimes a condition may be imposed on the builder, which will require the girder to be placed in the thickness of a floor—a rather difficult and costly matter,—and Fig. 64 and enlarged detail *B* show this condition. As the joists must be cut and fitted to the girder, the partition wall will lose its support until the girder is fixed, and consequently needles must be inserted at only short distances apart to carry the wall. A difficulty arises in getting the girders into position between the ends of joists, and this is best overcome by using two girders, the first one being quite easily fixed, as shown at *B*, and sufficient space being arranged between it and the end of the joist shown to allow, with a little manipulation, the hoisting and fixing of the second girder.

It may at first be deemed practicable to shore only the floors and allow the wall, with its superimposed roof load, to be borne by the floor joists; but such a method would not be in conformity with good principles of shoring, because (1) the dead shores must be placed at such a distance away from the centre line of wall as will allow room for working the girder into position; (2) there must be sufficient room to cut and fit the joists to the girder; and (3) a great strain would be imposed on the joists that would cantilever over the heads of shoring.

The distribution of the loads to the shoring will be as follows. The roof and first story ceiling will be transmitted through the shores in the first story to the shores in the ground story, and also partly through the wall; the weight of the wall in the first story will be equally distributed, partly through the floor joists, and partly through the needles to the shores in the ground story; the first floor will be borne by the heads fixed to the shores,

DETAILS OF SHORING

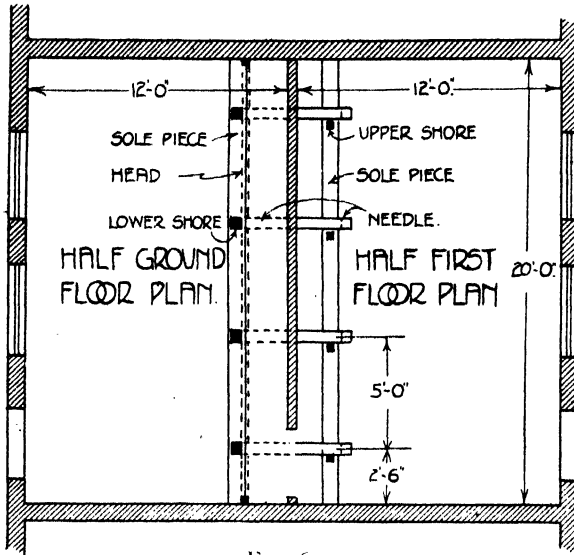
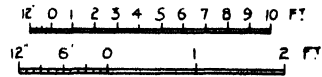
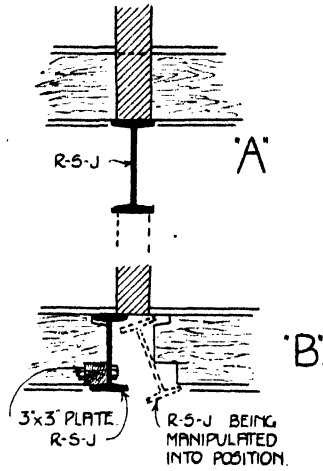
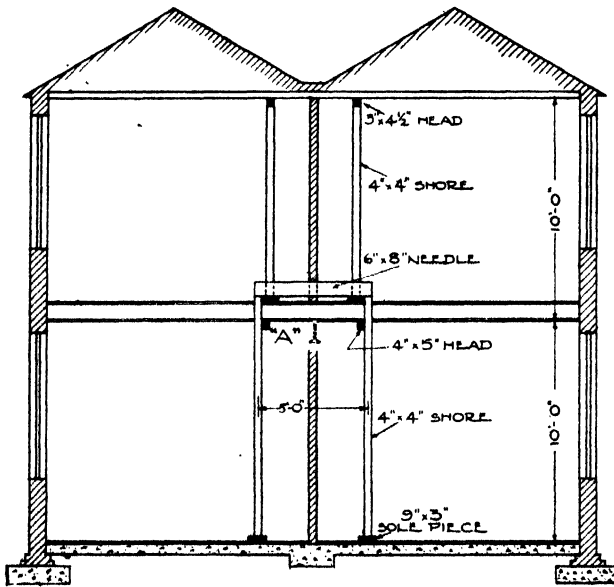

FIG 62



SCALES



SECTION

FIG. 63

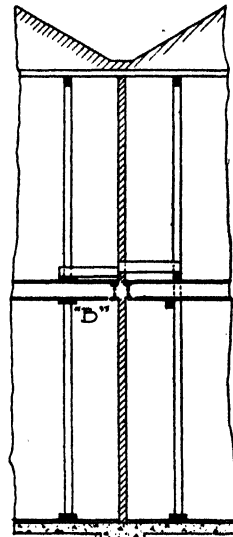

ALTERNATIVE METHODS OF SHORING

FIG. 64

MODERN BUILDING CONSTRUCTION

and consequently transmitted to the dead shores.

Calculations for Timbers. Calculate the loads, commencing from the roof and working downwards, and allow for one bay of shoring 5 ft. wide, as shown by plan, Fig. 62. Allow that half * of roof load is carried by the external walls, one-quarter by the centre wall, and one-eighth by each of shores.

Weight of 5 ft. bay of roof = total sloping lengths \times width of bay = 28 ft. \times 5 ft. = 140 super. ft. \div 2 * = 70 super. ft. \times 0.35 cwt. (as Table) for slated or tiled roof = 24.5 cwt.

The centre wall will take 12.25 cwt., and each shore 6.12 cwt.

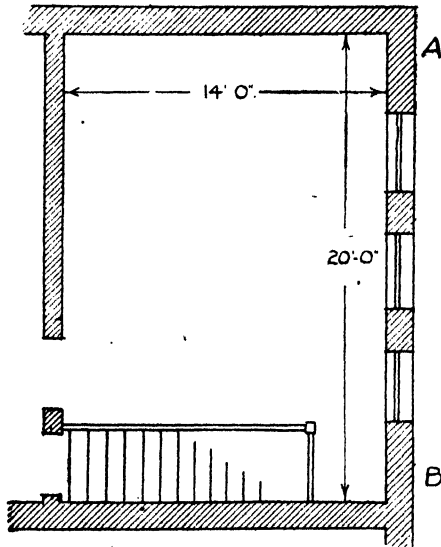

FIG. 65. PLAN OF BUILDING

Weight of ceiling on each shore = 6 ft. \times 5 ft. \times 0.1 cwt. (as Table IV) = 3 cwt.

Weight of 4½ in. wall (measured overall of doorway) = 5 ft. \times 10 ft. \times 0.375 cwt. = 18.75 cwt.

Weight of floor, timber framed, used for domestic purposes, on each shore, = 6 ft. \times 5 ft. \times 0.57 cwt. = 17.1 cwt.

The loads on the various members will be as follows—

Heads Over Upper Shores, 9.12 cwt., uniformly distributed.

Upper Shores, 9.12 cwt.

Needles = weight of wall, and roof = 31 cwt., concentrated at centre.

Heads Under First Floor = floor only, and not including load of upper shores, which should be fixed over lower shores = 17.1 cwt., uniformly distributed.

Each Lower Shore = load from one upper shore plus half load of wall and roof plus load of floor = 9.12 + 4½ + 17.1 = say, 42 cwt.

Calculations of Redwood Scantlings by formula as before explained—

Heads Over Upper Shores. $bd^2 = C_1 WL$. $bd^2 = 1.25 \times 9.12 \times 5 = 57$. Try a head 3 in. wide \times 4½ in. deep. $3 \times 4\frac{1}{2}^2 = 61$, which indicates a suitable size.

Heads Under First Floor. $bd^2 = 1.25 \times 17.1 \times 5 = 107$. Try 4 in. \times 5 in. deep. $4 \times 5^2 = 100$, which indicates a size a little too small but which may be accepted.

Needles. The load is 31 cwt. concentrated at centre of span. $bd^2 = 2.5 \times 31 \times 5 = 387$. Try 6 in. \times 8 in. deep. $6 \times 8^2 = 384$, which is suitable.

Upper Shores are, say, 9 ft. long and have to carry 9.12 cwt. 4 in. \times 4 in. is the minimum size which should be used.

Lower Shores are 10 ft. long and carry 42 cwt. Although 4½ in. \times 4½ in. shores will more nearly comply with the rule that the slenderness-ratio should not exceed 24, it may be considered advisable to allow a ratio of 30 in this instance. Therefore, try 4 in. \times 4 in. shores. Slenderness-ratio = $\frac{10}{\frac{4}{12}} = 30$, and maximum

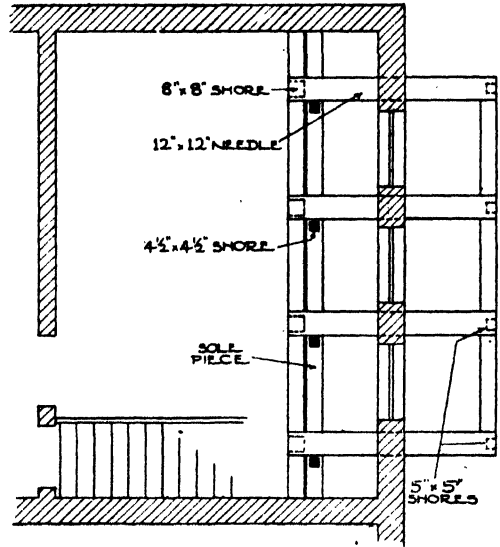

FIG. 67. PLAN SHOWING SHORING

pressure per square inch is 3.26 cwt., which multiplied by 16 = say, 52 cwt., which is ample to meet the load of 42 cwt.

DETAILS OF CONSTRUCTION. The upper heads should be secured to the ceiling joists by well spiking the upper shores to heads, and sole pieces also by well spiking; the needles must be "dogged" to lower shores, and the lower heads bolted to shores, with cleats under. The sole piece under lower shores should be 9 in. by 3 in. In some cases the upper shores might be dispensed with, and the whole of the roof and ceiling loads considered as borne by the wall; but generally this is contrary to the rule which dictates that walls should be relieved of as much weight as possible, as by so doing the needles may be placed at a maximum distance apart consistent with the greatest width that a brick wall will "hold itself together" without support. This distance is about 4 ft. and 6 ft. for

DETAILS OF SHORING

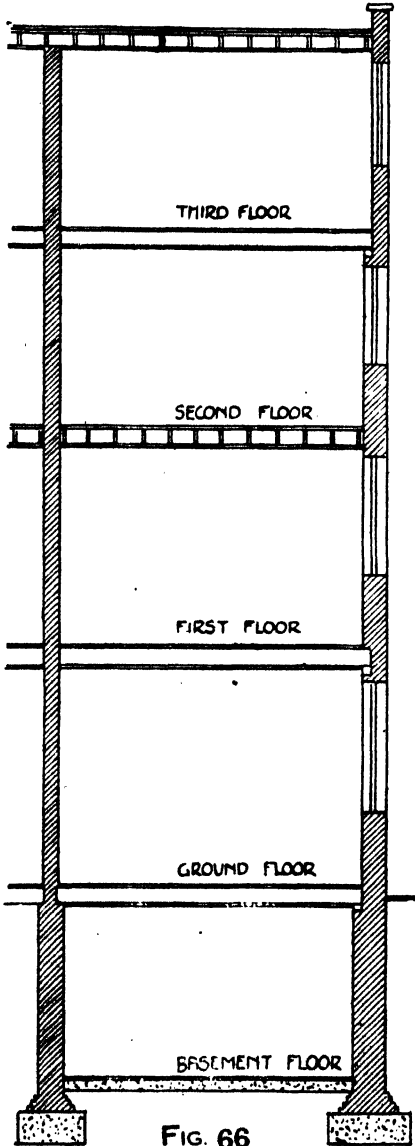

FIG. 66

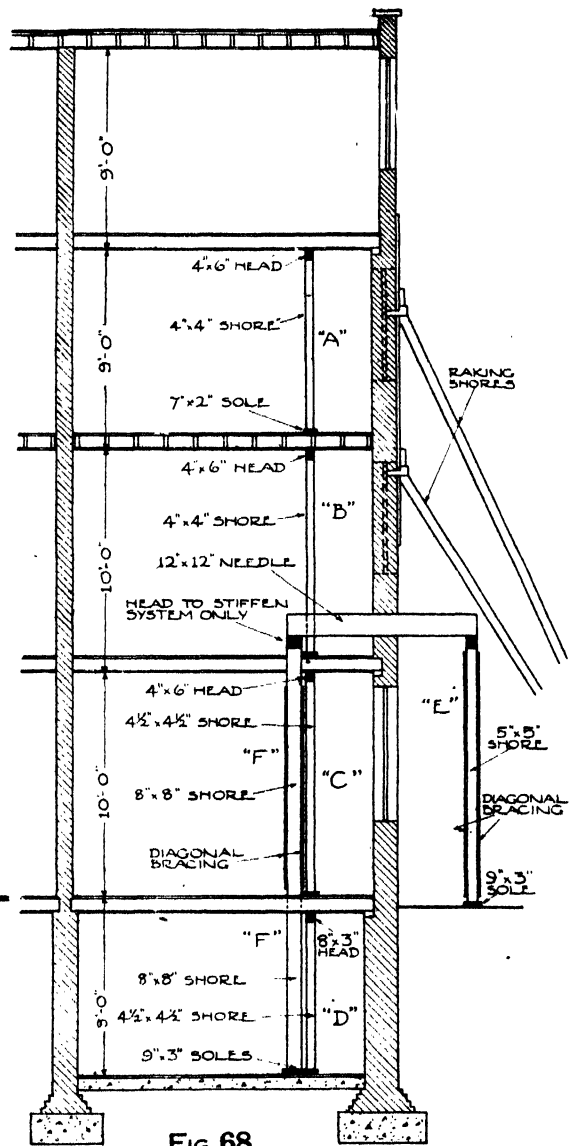

FIG. 68

SCALE: 1" = 3'-0"

MODERN BUILDING CONSTRUCTION

work built, respectively, in lime and cement mortar, provided that the work is in good condition and properly bonded.

COMPLICATED DEAD SHORING. This example fully explains the principles and calculations of dead shoring as necessary for the common procedure of removing the ground floor front wall of a building, to allow for the insertion of a shop-front. Figs. 65 and 67 show the plan and section of an existing building, and it is required to remove the whole wall from *A* to *B* in ground story. Fig. 66 shows plan, and Fig. 68 sectional elevation of the completed shoring. The wall to be temporarily supported must first be relieved of the weight of floors that bear on it; it will be noticed that the second floor and roof have the joists supported by the party walls, and therefore do not exert any appreciable pressure on the wall in question. To give such relief, light dead shores, placed 5 ft. apart, must be inserted where shown.

In this class of shoring it is advisable to assure general stability by means of raking shores as shown. As the main loads are taken by the dead shoring, the raking shores need only be set against the floor next above the needles and to the top floor, and not the first floor and roof. For practical purposes, the raking shores should be of scantlings as before given, though theoretically they could be of lighter sizes. The main wall must be carried by needles and dead shores as shown, placed, say, 5 ft. apart.

Calculations. The loads on the various members will be as follows—

Heads to Floors. Floor area and load supported = 5 ft. × 7 ft. × 0.57 cwt. = 19.95 or, say, 20 cwt. uniformly distributed.

Shore A. Third floor load as head = 20 cwt.

Shore B. Third floor load only (and not second floor load, as joists are supported by party walls) = 20 cwt.

Shore C. Third floor load plus similar load of first floor = 20 × 2 = 40 cwt.

Shore D. Load from *C* only (and not from ground floor, which is supported by wall to remain) = 40 cwt.

Needle—

Third story wall and parapet = 5 ft.	
× 12 ft. × 0.8 cwt.	= 48 cwt.
Second and first story walls = 5 ft.	
× 17 ft. × 1.2 cwt.	= 102 ..
	150 ..

This load is concentrated at centre of needle.

Shores E and F will each support half load on needle = $\frac{150}{2} = 75$ cwt.

Calculate scantlings of redwood as follows—

Heads. $bd^2 = 1.25 \times 20 \times 5 = 125$. A 4 in. × 6 in. deep head will be suitable because $4 \times 6^2 = 144$. So will 8 in. × 4 in. deep placed flatways to ceiling as

$8 \times 4^3 = 128$. It will be noted that 8 in. × 4 in. contains more timber than the 4 in. × 6 in.

Shores A and B. The load is 20 cwt. and length is 8 ft. or 96 in. As explained previously, it is inadvisable to use a shore with a greater slenderness-ratio than 24, so in this case use 4 in. × 4 in.

Shores C. Load = 40 cwt.; length = 10 ft. or 120 in.

Try $4\frac{1}{2}$ in. × $4\frac{1}{2}$ in. $\frac{120}{4\frac{1}{2}} =$ say, slenderness-ratio for which the permissible stress is 3.75 cwt. per square inch. Therefore $4\frac{1}{2} \times 4\frac{1}{2} \times 3.75 =$ say, 76 cwt., which is ample to meet 40 cwt. If it is deemed advisable to reduce the slenderness-ratio to 24, then use 5 in. × 5 in.

Shores D carry the same load as *C* but are shorter, and theoretically a lighter shore than *C* would be suitable, but for practical purposes do not reduce the size.

Needles. Load concentrated at centre = 150 cwt. and length is 7 ft. $bd^2 = 2.5 \times 150 \times 7 = 2625$, which indicates that a very heavy needle is necessary. This raises an interesting and important subject. Redwood needles would require to be 14 in. × 14 in. because $14 \times 14^2 = 2744$.

Now try using the stronger Douglas fir or a timber having an extreme fibre stress in bending of about 1,200 lb. per square inch, using the appropriate formula

$$bd^2 = 1.68 \times 150 \times 7 = 1764$$

This reduced figure will allow the use of 12 in. × 12 in. because $12 \times 12^2 = 1728$, which is near enough to 1764. Alternatively, steel needles could be used. From tabular information given in Steelwork Handbooks, 150 cwt. or $7\frac{1}{2}$ tons load concentrated at centre of span of needle is equivalent to 15 tons uniformly distributed, and it will be found that 8 in. × 6 in. × 35 lb. B.S.B. will be suitable.

Shore E. Load = 75 cwt. and length = 12 ft. Try 6 in. × 6 in. $\frac{144}{6} = 24$ slenderness-ratio. Permissible stress = 5.05 cwt. per square inch. $6 \times 6 \times 5.05 = 182$ cwt., which is very excessive to meet 75 cwt. Although 5 in. × 5 in. gives a slenderness ratio of $\frac{144}{5} = 29$, they might be used.

Shore F. Load = 75 cwt., and length, say, 20 ft. or 240 in. From the above information and the tables either 8 in. × 8 in. or 9 in. × 9 in. shores may be used, the former having a rather high slenderness-ratio, viz. 30.

TABLE VI
EMPIRICAL FORMULAE FOR ASCERTAINING SIZES
OF MEMBERS OF DEAD SHORING
(See Important Footnotes)

Timber Needles. Basis. Where supporting only a roof and a little brickwork over, such as in a 1-story building, the needles being 5 ft. long and 4 ft. apart, use 5 in. deep × 4 in. wide needles.

For every extra foot in length add 1 in. to depth of needle; this rather sharp increase is to avoid excessive deflection. For every extra foot apart add 1 in. to width of needle. In the case of buildings of more than 1 story, calculate as above, and then add 1 in. to depth of needle for every extra story. This apparently small increase is due to the fact that a considerable proportion of the load in upper stories is spread over those parts of the building not affected by the shoring.

Steel Needles. Use the nearest stock size B.S.B. in depth, equal to or over (but not under) two-thirds the depth of a timber needle that would be required to do the duty, and half to two-thirds the width of such timber needle.

Dead Shores for Main Wall Shoring. Multiply the distance apart in feet of the shores by 6 for a 1-story building, 9 for 2 stories, 12 for 3 stories, 15 for 4 stories, and 18 for 5-story buildings. The result will give the sectional area in inches of the shores, which should be square, or as nearly as possible so. The height of a shore should not exceed about 24 times its least dimension.

Heads for Main Wall Shoring. Where they support needles which are not directly over shores, make their depth equal to $\frac{3}{4}$ in. for every clear foot of span, plus an extra $\frac{1}{4}$ in. for every story in the building (including the ground story). Where they do not so support needles and are used merely to provide stiffness to a set of shores, then make their depth equal to $\frac{1}{2}$ in. for every foot of span. The width in all cases to be not less than the thickness of the shore on which they are fixed.

Light Shores to Floors and Roofs, and Thin Internal Partitions. Multiply distance apart in feet by 3 for single-story buildings (in this case a roof only would be supported), 5 for 2 stories, 7 for 3 stories, 9 for 4 stories, and 11 for 5-story buildings. The result will give the sectional area in inches of shore which should be square or about so, and not exceed in height about 24 times its least dimension.

Light Heads to Floors and Roofs Only. To be not less than width of shore, and in depth equal to $\frac{1}{2}$ in. for every foot of span plus an inch.

Needles for Light Shores to Floors, Roofs, and Thin Internal Partitions. Conform to the general rules for needles. Although the weight of brickwork may be less than for external walls, internal partitions often carry considerable floor loads due to floors being on both sides of the partitions.

Sole Plates on Firm Ground. To be continuous and 3 in. thick and about $1\frac{1}{2}$ times width of shores. This usually means using 9 in. \times 3 in. or 11 in. \times 3 in. When on soft ground, to be specially calculated.

Notes

The above rules are applicable for the following conditions—

1. That the timber used is sound redwood or timber of not less than equal strength.
2. That the shoring is in connection with moderate sized alteration work where there are no very considerable loads to be borne. Special work and very heavy loads necessitate proper calculations being made, and not the use of the above empirical formulae.
3. That the buildings to be shored are the ordinary class, such as houses, shops, offices, flats, light stores, and generally buildings having a superload on floors not exceeding 90 lb. per super foot. For buildings having a super load on floors up to about 150 lb. super foot, the formulae may be used subject to the condition that the calculated depth of all needles and heads and the sectional area of all shores be increased by 25 per cent.
4. Where dead shores extend through more than one story, it is not necessary to use the same sized shore in all stories. The heaviest shore would be in the lowermost story and they would be reduced in each upper story, in accordance with the above rules. The same rule applies to needles.

FOUNDATIONS FOR SHORES

It is of extreme importance that shores rest on firm foundations, and that the loads be distributed thereto

by means of wide sole plates; any subsidence would seriously endanger the whole work. If there is any soft ground, proper platforms of concrete, or a grillage of timber planks should be formed.

Safe rules are as follows—

Raking Shores. These are designed as "long columns," and generally the loads transmitted to sole plates are less than dead shores. Allow that each square inch of section of one or more rakers that rest on sole plates transmits $\frac{1}{4}$ ton to the plate. Therefore, if there are two 6 in. \times 6 in. rakers the sectional area equals 72 in., which, multiplied by $\frac{1}{4}$ ton, equals 9 tons.

Dead Shores. Allow $\frac{1}{4}$ ton per inch of section, therefore one 6 in. \times 6 in. shore has a sectional area of 36 in., which, multiplied by $\frac{1}{4}$ ton, equals 9 tons.

Next decide what the earth or other foundation will safely support. If, as an instance, it will support 2 tons super foot, the sole plate will have to be $4\frac{1}{2}$ super ft. to take 9 tons. A matter of weakness in timber sole plates is that shores exert a pressure at right angles to the fibres in them, timber being very weak when subjected to such stresses. Ordinary redwood will fail by indentation (which will cause a shore to sink) with a load of about $\frac{1}{4}$ ton per square inch. With raking shores exerting a pressure of $\frac{1}{4}$ ton square inch, there is a factor of safety of only 4, which, although not very good, may be permitted. With dead shores with $\frac{1}{4}$ ton square inch the factor is only 2, which is far too low. There are three ways of overcoming this difficulty: by using (1) Douglas fir sole plates, which are twice as strong as redwood, or oak which is three times as strong; (2) by increasing the size of bases of dead shores, by housing in cleats; and (3) by using concrete soles.

It should be manifest that the above considerations are of extreme importance, as any weakness at such a vital point as a foundation has the probable effect of reducing the strength of the whole system of shoring to that of the weakened foundation.

DIMENSIONS OF LENGHTENING JOINTS IN DEAD AND RAKING SHORES

Lapped or Fish Joint for Built-up Shores. Make each lap equal to 4 times maximum overall dimensions of shore, and use 4 bolts to each lap, staggered, and with pitch about equal to maximum dimension of shore.

Fished Joint. Length of fish plates to be 6 times maximum dimension of shore (3 times on each side of joint). Use 3 bolts each side of joint, staggered, and with pitch about equal to maximum dimension of shore. Thickness of fish plates to be one-third of such maximum dimension.

Scarfed and Fished Joint. Length of scarf to be 4 times maximum dimension of shore, and length of fish plates 6 times such dimension. Use 6 bolts, as last described. Fish plates to be same thickness as for fished joint.

Bolts. Diameter not to be less than $\frac{3}{4}$ in., and otherwise $\frac{1}{2}$ in. diameter for every 3 in. or part thereof of maximum dimension of shore.

Maximum Dimension refers to the dimensions of cross-section and not length.

GENERAL PRINCIPLES OF DEAD SHORING

Where the lower part of any wall has to be removed, it is advisable to relieve the upper part of the wall of any floor, roof, or other loads

MODERN BUILDING CONSTRUCTION

supported by it; this is done usually by means of light dead shores carried from roof to floor, and from floor to floor until a firm foundation is obtained, each shore being as near as possible in vertical alignment.

Positions of Needles. The position of the needles to support temporarily the wall over that to be removed must be at such a height as to allow sufficient room to insert the girder, or other beam, to be permanently employed to carry the wall over, and also to permit of properly pinning up between the girder, or beam, and the underside of the old work.

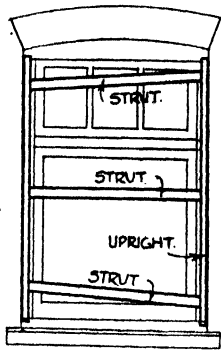

STRUTTING TO
WINDOW OPENING
1 2 3 FT
SCALE

FIG. 69

position of needles, as it is manifest that it would be useless to place a needle under the centre of a window opening and, therefore, needles in perforated walls must be placed under piers.

Fixing Shores. Where long shores under needles are necessary, and it would be difficult to place them in position in one length, they may be formed in two or more lengths by inserting stout heads, or transomes, at each joint, but it is essential to place the shores over each other.

It is sometimes advisable to support shoring laterally by means of light diagonal bracing fixed between, and to, the various shores.

The needles must be forced tightly up to the brick or other work, and to do this oak folding wedges should be inserted between the top of one of the pairs of shores and the underside of needle, and driven in by a number of reasonably light taps, and not with a few violeht knocks that might shake the work.

All shores, heads, and needles must be securely dogged together.

Before any brickwork or other work is removed, all window and other openings in the wall above that to be demolished should be strutted by means of deal vertical members, placed against each reveal or jamb, and properly strutted, as shown by Fig. 69. If there are arches, they should have heads, or centres, made to fit tightly to the soffits.

When the whole of the shoring has been constructed, it should be thoroughly inspected, and any necessary adjustments made, before any demolition is commenced.

Shoring should not be erected until everything is in readiness for the new work; steelwork should be on the site, or its delivery assured immediately it is required. Foundations for stanchions, brick piers in basement, etc., should be completed, if possible, before shoring is erected, so as to strengthen the work.

Careful consideration must be given as to whether a wall should be demolished in sections, or all at one time; the nature of the work, length of wall, and state of building all regulate this operation. As a rule, it is advisable to remove as little as possible of old work until as much as practicable of the new is constructed, and in the example shown by Fig. 70 it would be better to remove a sufficient width of wall at *one* end to enable the new brick pier to be built, or stanchion placed in position, then to repeat the operation at the other end, and finally the centre work demolished to allow the girder to be inserted. If, however, the building is in excellent condition and the wall to be removed is not very long, it may be removed at one time. Another instance of sectional removal is provided by assuming that a stanchion, or column, is required in the centre of the shop-front, shown by Fig. 71, and that the girders are jointed over the stanchion. Under these circumstances about half of the wall, from one end to the centre, could be removed first and the stanchion and girder fixed, and afterwards the other part demolished. All brickwork, masonry, etc.; in new work, piers, pinning up, etc., and concrete must be executed in good cement mortar. No shoring should be struck until the new work has properly set and taken its bearings, usually two or three days for light work and about a week for heavy constructional work being sufficient to allow for this. The order of striking shoring, as shown by Figs. 67 and 68, should be, firstly, needles and their shores, then

PRELIMINARY OPERATIONS

window struttings, internal struttings to floors and ceilings, and, lastly, the raking shores. It is advisable to strike these members without haste, and preferably with a little delay between each of the items stated.

Shoring and the Law. Shores erected over the public footpath are subject to licence by, and regulations of, local authorities, and in some districts to payment of fees, depending on the

commenced and completed before another length, or section, is started, by which means the superstructure is held up by the adjacent work retained during the demolition of the old, and the rebuilding of the new work.

The length of each "short length" depends upon the condition of the work, and sometimes by the incidence of any concentrated, or extraordinary, loads on the wall. Brickwork in cement mortar, in good condition, will support itself over an opening 6 ft. wide, which is the greatest length that should be allowed when executing underpinning; brickwork in lime mortar, or work in only fair condition, will

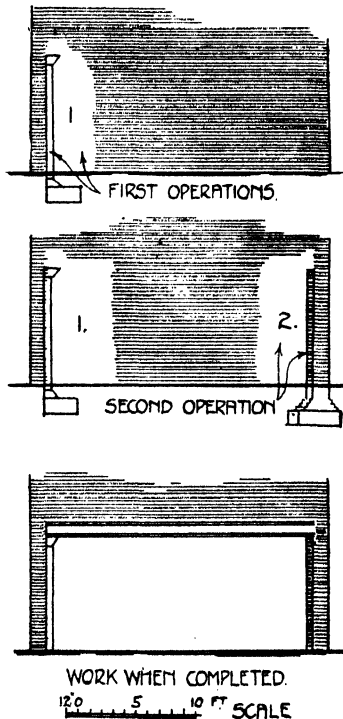

FIG. 70. METHOD OF REMOVING WALL

duration of the shores. As these vary in different districts, the builder should make application to the local authority for particulars.

UNDERPINNING

Underpinning may generally be considered as any new work, such as concrete, brickwork, masonry, etc., constructed adjacent to existing work for the purpose of replacing defective work, strengthening old work, or lowering the foundations of a wall to provide additional height to a story. It is by no means difficult work, but is governed by a few rules that it is important to observe.

Principles. Underpinning is usually executed in "short lengths," that is, one short length is

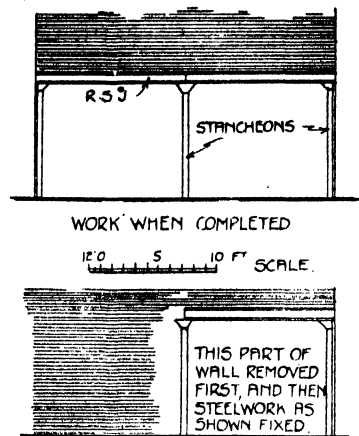

FIG. 71. REMOVING WALL WHEN CENTRE STANCHION IS USED

carry over 4 ft. Therefore it may be considered that "short lengths" vary from 4 ft. to 6 ft., and for practical purposes should be from 3 ft. to 5 ft.

All work in underpinning should be done in cement mortar.

New work must be very carefully and solidly pinned up to the underside of the old work, stout slates being used where thick mortar joints would otherwise be necessary.

In the case of underpinning a long wall, it is best to start operations at the centre of wall, then to work sideways, from the centre, alternatively from side to side, until the corners are reached.

If the work to be underpinned is not in good condition, raking shores should be placed at the external angles of the wall to be underpinned; also dead shores may be necessary to relieve the wall of any concentrated loads.

MODERN BUILDING CONSTRUCTION

EXAMPLE I. An existing flank wall of a house showed signs of subsidence, and an inspection of the foundations gave evidence that the

footings have to be removed, and in breaking, or hacking, them off there is a tendency to shake and bring down the superimposed work.

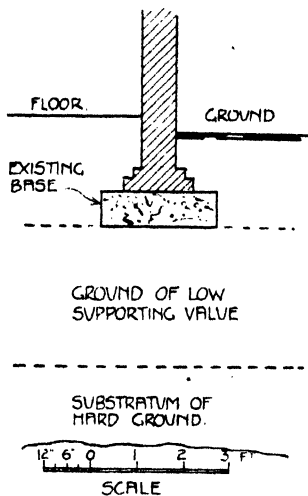

FIG. 72. SECTION OF WALL TO BE UNDERPINNED

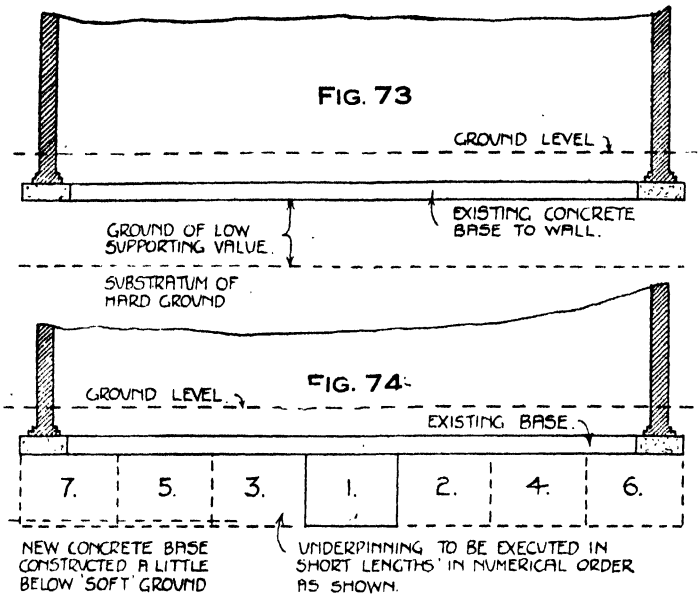

FIG. 73. ELEVATION OF WALL
FIG. 74. METHOD OF UNDERPINNING

concrete foundations, although good, were resting on ground of a low supporting value; a trial pit proved that there was a substratum of hard ground 3 ft. below the underside of the existing concrete, as shown by Fig. 72. It was decided to extend the concrete foundation to the hard ground, and the work was done as follows: Fig. 73 shows an elevation of the existing wall, and Fig. 74 the underpinning with new concrete to the centre "short length," with the other sections in numerical order of their construction. The work was executed from the outside of the building, and the new and old concrete was of the same width.

EXAMPLE 2. A basement story is only 6 ft. high and it is desired to make it 8 ft. 6 in. high, by lowering its floor and walls. Fig. 75 depicts the existing conditions, and Fig. 76 the work when altered, one only of the walls being shown to illustrate the operations. The floor must be taken up, the ground excavated in, say, 4 ft. lengths. No greater length should be done in this case, as the old concrete foundations and

The new concrete foundations, footings, and wall, etc., are then constructed. The question of "damp" proofing the wall must also be considered and will depend upon requirements.

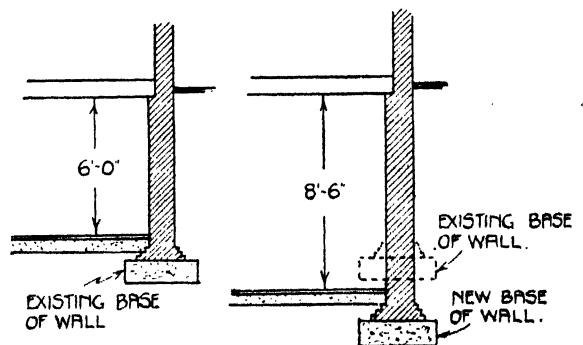

FIG. 75. WALL BEFORE UNDERPINNING
FIG. 76. WALL AFTER ALTERATION

Chapter IV—FOUNDATIONS

GROUNDWORK, as its name denotes, is work in or about the ground or foundation, and is a very important preliminary to all building undertakings. The order of consideration is (1) the architect's, or designer's, duty to ascertain the nature and bearing capacity of the ground upon which the bases are to be imposed; (2) to design the concrete or other bases correctly; (3) the builder's responsibility for correct setting out in accordance with the general drawings and with proper widths and depths; and (4) temporarily maintaining the sides of excavations with timbering until the bases are built.

Trial pits should be dug at a number of points on the site, and a careful note made of the nature, levels, thicknesses, and inclinations of the strata; also, whether there is any water, or springs, and if so at what level, and any necessary particulars must be taken for consideration of its diversion. Information should be obtained of any made-up ground, its depth, and the nature of ground underlying it.

Characteristics of Good Foundations are—

- (a) The ground should be practically incompressible, or if this is unobtainable, then,
- (b) Slightly but equally yielding over its whole area.
- (c) Not subject to atmospheric or other influences that may alter its nature, or powers to resist the loads to be placed upon it.
- (d) The strata should be level, so that the pressure from walls, etc., will be perpendicular to it.

Bases of Walls. These should be so designed and proportioned as to exert, as far as practicable, a uniform pressure on the ground, so as to avoid any settlement; or, alternatively, that any one part of a structure will not settle more than another. The bases should also be at such a depth below surface as to assure them being free from atmospheric or other influences. Grounds such as chalk, gravel, and sand, or a combination of these, and generally all grounds, except clay, may be considered to be unaffected by atmospheric influences at a depth of 3 ft. below surface. In the case of clay, which is liable to fissures and the consequent percolation of water to a certain depth underground, the minimum depth should be 4 ft.

Confusion often arises in the indiscriminate use of the terms *foundations* and *bases*. Sometimes work such as brickwork, stonework, and concrete bases which are below the ground are called foundations. It is much better to use terminology which defines more accurately the differences between the various structural parts. The foundation of any structure is its primary support, which in the majority of instances is the ordinary ground; if that is weak, then as a general rule anything which is supported by it is liable to be weakened. It is not much use to design carefully the concrete bases of a wall, or a stanchion, nor indeed many parts of the superstructure of a building, if the ground—that is the foundation—is liable to be weak; the whole of the superstructure may then be only as strong as the ground which primarily has to support the total loads. Therefore, it is best to use definitions as follows—

The foundation of a structure is that which primarily supports the loads of all work which is superimposed on it, viz. the ground.

The base of a structure is that which is immediately supported by the foundation, such as a *concrete base*, to a wall, pier or stanchion. The base may be a concrete raft, or a pile, but in both these cases they are supported in some way or other by the foundation.

GROUNDINGS

Soft and Compressible. ORDINARY EARTH AND SOFT CLAY come under this heading; and as their bearing capacities are low, it is essential to provide a sufficient spread, or area of base, to walls, etc., so as to distribute the loads over an area of ground that will safely resist them.

MADE-UP GROUND must be well consolidated before being built upon; if not of great depth and overlying a natural hard ground, the bases of the building should be extended to the natural ground.

LOAMY SOILS, which are chiefly composed of clay and sand, with the latter predominating, may be safely built upon, provided proper bases are constructed.

CLAY LOAMS are similar to the last, but with the clay predominating.

SOFT CHALK requires to be kept as dry as

MODERN BUILDING CONSTRUCTION

possible, as water considerably increases its softness.

LOOSE SAND may only be termed soft, or yielding, if it is not laterally confined; but if it is properly contained and free from water scouring, it is practically incompressible, and so makes an excellent foundation.

SLAKE, MUD, PEAT, TURF, BOG, QUICKSAND, MORASS, MARSHES, ETC., are very unsuitable to build upon, and require special treatment for building operations.

Hard and Slightly Compressible. **SOLID AND ORDINARY CLAY** is a good ground to build upon, provided that it is sound, kept fairly dry, and protected from atmospheric influences as before explained.

LONDON BLUE CLAY is similar to the clay last described, but has a greater supporting capacity.

HARD CHALK. The degree of hardness in chalk varies considerably, from equal almost to rock to a very soft clay, and generally its hardness is reduced by water, which should be prevented from gaining access to chalk which will then make a good foundation.

CONFINED SAND makes an excellent foundation, and is practically incompressible.

COMPACT GRAVEL, composed of various small stones with a small proportion of sand, well bound together and prevented from lateral movement, is practically incompressible, and makes one of the best foundations; it is unaffected by atmospheric conditions.

SANDY GRAVEL is similar to above but with a greater proportion of sand; it forms an excellent foundation, but owing to the sand it is a little more liable to spread laterally.

CLAYEY, OR LOAMY, GRAVEL is not so good as the gravels before described, and its quality depends upon the proportion of clay in it.

Incompressible. **ROCK** makes a very secure foundation but is sometimes found to have defective parts, or fissures, which should be cut out and filled in with concrete before building is commenced. Where rock exists under a part only of a site for a building, the softer ground should be made as firm as the rock, or otherwise unequal settlements may occur unless such precautions are taken.

VERY HARD CHALK is similar to rock but is liable to be rendered soft by water.

Composite. Grounds often vary in their characteristics; the area, or strata, may be composed of various classes of grounds, such as are described below.

PARTLY HARD AND PARTLY SOFT GROUND. An

area of, say, partly rock and partly soft chalk, to illustrate an extreme, or ground partly gravel and partly soft clay, to show a moderate variation, all of which do not give the same resistance, requires careful treatment of the ground and design of the bases of structures to assure against unequal settlement.

If the softer grounds are in small patches, they may be either bridged or arched over between the harder grounds, or they may be excavated and filled in with a material that will provide as firm foundation as the harder ground.

If the softer ground is extensive, short piles driven in close together would consolidate the ground.

Wherever possible, structures to be supported by a softer ground should be commenced and carried up to a reasonable height, so as to allow for as much settlement as possible before the parts on the harder ground are commenced. In some cases, it is advisable to keep the structure erected on the harder ground separate from that built on the softer.

SHALLOW SOFT STRATUM OVERLYING HARD GROUND. This condition is not difficult to deal with, as the bases of walls may be economically extended through the soft to the hard ground, or piers of any suitable material so extended and the superstructure carried by them.

FAIRLY SOFT BUT SOUND GROUND OF AN INDEFINITE DEPTH may be treated as suitable to build upon, provided that the bases of structures are so designed as to distribute the loads over an area of ground that will safely resist the pressures.

VERY SOFT GROUND OF AN INDEFINITE DEPTH should be considered as dangerous to build upon without special treatment by piling, or other methods, which will be explained later.

HARD GROUND OVERLYING A SOFT SUBSTRATUM. The method of treating this class of foundation depends chiefly upon the thickness of the hard ground, and the supporting capacity of the soft ground.

If the "hard" is of considerable thickness, it may be built upon without making much allowance for the soft ground, as the loads would be transmitted, in an inclined outward direction, through the hard ground to a large area of the soft ground.

Where the "hard" is fairly shallow and the "soft" is of low supporting value yet sound, it may generally be considered safe to design the bases of structures suitable for the soft ground and ignore the hard.

PRELIMINARY OPERATIONS

TABLE VII
APPROXIMATE SAFE RESISTANCES OF GROUNDS
OR FOUNDATIONS

Description of Ground	Maximum Safe Load in Tons per Super Foot
Ordinary earth or soft clay	1
Made-up ground well consolidated	2
Loamy soils (sand predominating)	3
Clay loams (clay predominating)	4
Soft chalk, dry	1
Loose sand	1
Solid and ordinary clay	2
Confined sand	2
Clayey or loamy gravel	2
Sandy gravel	3
London blue clay	4
Hard chalk	4
Compact gravel	4
Very hard chalk	5
Rock	8

If the substratum is very soft and liable to water scour influences that may cause it to ooze from under the hard ground, then particular care must be taken to prevent such influences, or building must not be attempted.

Matters that must be considered relative to the nature and bearing capacities of grounds are as follows—

CARTING AWAY SURPLUS EXCAVATED MATERIAL. The nature of the ground will often regulate the width and depth of the bases to be built upon it, and consequently it devolves on a designer to bear in mind that carting away of excavated material is generally a costly item, and that sometimes it is possible to construct a base which in itself is more costly than one of ordinary type, but in saving the cost of carting away causes an ultimate saving.

FILLING-IN. In connection with carting away should be considered the question of the proportion of excavated material that may be utilized in filling-in and ramming about foundations. Heavy or bulky foundations and thick brick bases displace a great amount of earth, and often entail a greater amount of carting away or depositing on site than, for instance, a slender reinforced-concrete foundation.

BALLAST, ETC., DUG FROM SITE needs but little comment—its value usually well repays for digging.

COSTS OF DIGGING VARIOUS EARTHS vary considerably according to their nature; therefore this cost must be considered in conjunction with cost of carting away and the design of bases, etc.

FILLING UNDER SURFACE CONCRETE, FLOORS, ETC., is an item that also demands attention; if the excavated ground is suitable for filling and a good quantity is required, the amount of trench digging for bases is of little importance, as filling that has to be bought generally costs more than the labour necessary in digging and the possible separation of hard from soft excavated material.

Bearing Capacity. Table VII gives the safe bearing capacities of various grounds, and may be used when the nature of the ground is known.

If the nature of the ground is doubtful, it will be necessary to ascertain by tests what it will safely support, a simple method being to drop a heavy iron weight—such as an earth rammer, with handle attached, which will assist the weight to strike flatly against the earth—from a certain height of say 20 ft., and to measure the

depth that the flat part embeds in the ground, and then to calculate the safe resistance of the ground by the following formula

$$R = \frac{144Wh}{dfa}$$

where R = safe resistance in pounds per super foot

W = weight in pounds

h = height dropped in inches

d = depth embedded in ground in inches

f = factor of safety

a = area of flat part of weight that strikes ground in inches.

EXAMPLE. An earth rammer with flat part of base having an area of 20 in. and weighing 14 lb., drops 20 ft. and embeds itself 1 in. in the ground; find what is the safe load that may be imposed on the ground with a factor of safety of 8.

SOLUTION.

$$R = \frac{144 \times 14 \times 240}{1 \times 8 \times 20} = 3,024 \text{ lb. per super ft.}$$

The test should be made at a number of places, and the average embedments taken, as the ground may vary.

Natural Characteristics. The natural characteristics that are likely to lessen the stability of, or endanger, a structure, and that require treatment to improve them, are: (a) inequality of resistance, (b) the possibility of sliding, (c) a tendency to lateral escape, (d) withdrawal of water from a stratum, and (e) atmospheric action.

INEQUALITY OF RESISTANCE IN GROUNDS. Fig.

MODERN BUILDING CONSTRUCTION

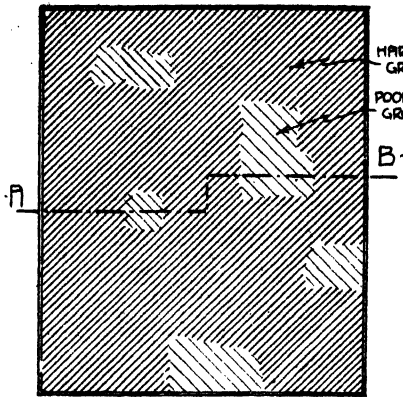

PLAN.
FIG. 77

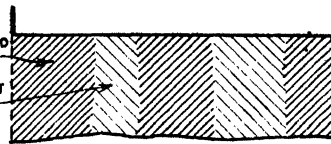

SECTION A-B

FIG. 78

HARD GOOD GROUND & POOR SOFT GROUND SHOWN SHADED DARK & LIGHT RESPECTIVELY

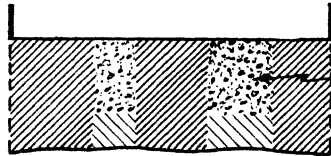

FIG. 79

FILLING OF HARD MATERIAL SUCH AS BALLAST, GRAVEL, HARDCORE ETC

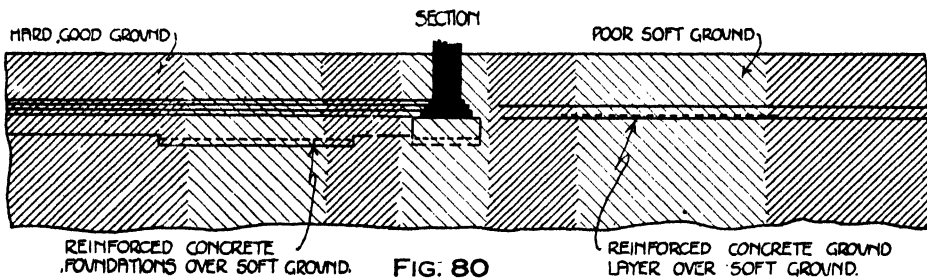
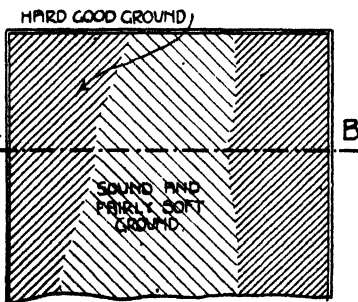

FIG. 80



PLAN
FIG. 81

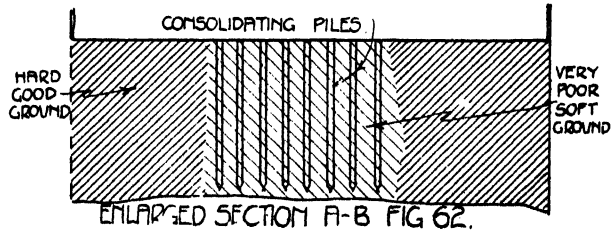
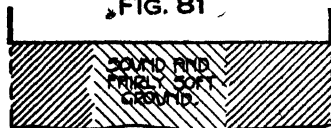

FIG. 83

ENLARGED SECTION A-B FIG. 62.



SECTION A-B

FIG. 82

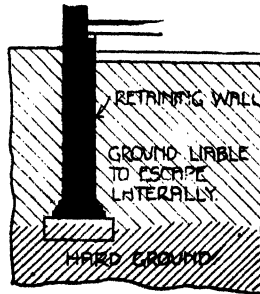

FIG. 84

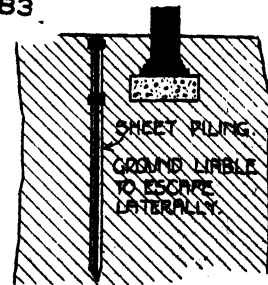

FIG. 85

PRELIMINARY OPERATIONS

77 shows a plan and Fig. 78 a section of a site which has hard good ground, as shaded darkly, with patches of poor soft ground, as shaded lightly. Fig. 79 depicts a section showing a method of excavating the soft patches and filling in, to a good depth, with hard material such as ballast, gravel, or hardcore, which should be well consolidated. The filling, although resting on a soft substratum, is of such sufficient depth that the loads placed on the surface will be distributed through the earth to a large area of the soft ground. The filling could be of a very "weak" concrete, say 1 to 12, but if this method is adopted, there is a chance of the hard ground being of less resistance than the concrete, and unequal settlements occurring.

A very good way to obviate digging and filling is to increase the depth of, or reinforce, the concrete foundations of all walls that are built over the soft ground, and also to similarly treat surface concrete. Fig. 80 illustrates the principles explained. The reinforced concrete should be properly calculated as beams and slabs as explained in another section.

Figs. 81 and 82 show a site which has areas of hard and large areas of sound and fairly soft ground, and this may be economically dealt with by exceptional care being taken to properly proportion the sizes of concrete foundations to safely carry the loads well within the safe resistances of the two classes of ground. For instance, if the hard and soft grounds will safely resist, respectively, 2 tons and 1 ton per super foot, and a wall exerts a pressure of 4 tons per linear foot (of its length), the width of concrete should be not less than 2 ft., where on the hard ground, and 4 ft. in the case of the soft ground, so that safe pressures will not be exceeded.

In a case similar to that last described, but where the soft ground is of a very poor nature, its resistance may be considerably increased, and probably made equal to the hard ground, by consolidating it with piles driven in close enough together to give the required resistance, as shown by Fig. 83.

Another example is where soft areas overlie hard ground which is at a moderate depth below the surface. The best way to treat this is to excavate down to the "hard" and fill in with hard material, concrete, or sand if it will be laterally confined by the hard ground.

TENDENCY TO SLIDE. These tendencies are due usually to the strata being sloping, declining towards the bottom of a hill, and any superimposed loads causing the strata to detach and

slip. A proper retaining wall is the best thing to overcome this condition, although piles driven well through the various strata are sometimes adopted as a means to bind the strata together, and transmit the loads of the structure to levels that are beyond the range of sliding tendencies.

TENDENCY TO LATERAL ESCAPE. Grounds that escape laterally when subjected to external pressure are running sand, wet soft clay, peat, etc. These require to be confined before they are subjected to loads. If there is a strata of such ground near surface level, which overlies sound ground, the external walls of a building may be taken through the soft ground to the lower sound stratum, and form in themselves retaining walls that will prevent lateral escape of the contained ground, due to pressure of floors and walls within the building, as shown by Fig. 84.

If the soft ground is of considerable depth, the site should be sheet piled to prevent lateral escape, as shown by Fig. 85, details of such piling being given in a later chapter.

WITHDRAWAL OF WATER FROM A STRATUM. When this happens after a structure has been erected it is liable to cause serious consequences, and it is necessary to make foundations below the level of any adjacent outlet for water. A common instance is where a stratum of wet sand is over impervious clay. While the sand is wet its bulk is maintained; but should water be drained away, the sand will reduce in bulk and subside, with a possibility of a similar effect to any structure erected upon it.

ATMOSPHERIC ACTION. Rain-water and the atmosphere by heat and frost affect most grounds, except hard rock and gravel, which are not appreciably affected. Water may reduce chalk to a muddy consistency, make clay soft, and reduce some soils to mud. At different seasons and temperatures ground will contract and expand, clay being particularly susceptible to dampness, dryness, and changes in temperature. To avoid deleterious effects, the underside of the bases of structures should be at such a level underground where the atmosphere does not act to much extent, or where water will not saturate the ground. Rock may be built upon at practically any level; gravel is not subject to damage if built upon at 2 ft. to 2 ft. 6 in. below surface; other grounds, except clay, may be considered suitable to construct on at 3 ft. below surface. Clay has a tendency to develop fissures on the surface, and these fissures may extend a foot or more underground, which allows water to percolate rapidly to the lower strata;

MODERN BUILDING CONSTRUCTION

consequently, bases should be at least 4 ft. underground.

BASES OF STRUCTURE

Modern By-laws. During recent years the building by-laws have been revised to a considerable extent, and it is therefore essential that they should be studied with the utmost care. Many of the old by-laws were based on rules which do not conform with modern research and knowledge, and they often erred well on the side of safety and were consequently uneconomical. The new by-laws, while being rather exacting, do ensure a reasonable compliance with codes governing structural essentials and economics.

The L.C.C. by-laws which govern foundations and bases of buildings in London, and the Model by-laws controlling them outside London, differ in many respects. They are given below.

The L.C.C. By-laws

The pressure upon earth to support any part of a building shall be calculated if so required by the district surveyor; and the intensity of such pressure shall not exceed that allowed by the district surveyor.

The following loads are given only as a general guide to the safe bearing capacity of various subsoils—

	Load on ground Tons per square foot
Alluvial soil, made ground, very wet sand	$\frac{1}{2}$
Soft clay, wet or loose sand	1
Ordinary fairly dry clay, fairly dry fine sand, sandy clay	2
Firm dry clay	3
Compact sand or gravel, London blue or similar hard compact clay	4

(Note. The loads given in Table VII agree with those given above.)

Unless supported on a beam every wall or pier or the footings thereof (if any) shall rest on concrete, and such concrete shall extend horizontally beyond each of the side and end faces of the wall or pier to a distance not less than the thickness of the wall or pier at the underside of the course immediately above the footings, or, if there be no footings, the thickness of such wall or pier where it rests upon the concrete.

Provided that the distance to which such concrete shall extend horizontally beyond each of the side and end faces of the wall or pier may be less than that hereinbefore in this by-law specified if the district surveyor is satisfied that the standard of stability in each part of the building will not thereby be rendered inferior to that required otherwise by these by-laws.

Provided also that where an external wall is built against another external wall or against a party wall, the district surveyor may allow such concrete on the side of the first mentioned external wall next to the other external wall or next to the party wall to be omitted.

The angle of dispersion through such plain concrete

shall be taken as not less than 45 degrees with the horizontal.

The Model By-laws

The foundations of every building shall be—

(1) so constructed as to sustain the combined dead load of the building and the superimposed load and to transmit those loads to the subsoil in such a manner that the pressure on the subsoil shall not cause such settlement of the building or any part of the building as may impair its stability; and

(2) taken down to such a depth or so constructed as to render the building immune from damage from movements due to seasonal variations in the content of moisture in the ground.

Every structural wall (including a pier forming part of the wall) shall rest upon—

(a) solid undisturbed rock; or

(b) a layer of cement concrete of sufficient width and thickness; or

(c) proper footings of sufficient width built directly on suitable ground; or

(d) proper footings built on a layer of cement concrete of sufficient width and thickness; or

(e) proper footings built on a layer of lime concrete of sufficient width and thickness; or

(f) a sufficient raft of cement concrete properly constructed and where necessary suitably reinforced; or

(g) a layer of cement concrete of sufficient width and thickness on suitable piles driven to a proper depth; or

(h) a bressummer of sufficient strength; or

(i) some other not less sufficient substructure as a foundation.

In the case of a domestic building the walls of which are constructed otherwise than with framework, the requirements of sub-paragraphs (b), (c) and (d) of paragraph (1) of this by-law shall, where the wall is not more than fifty feet high and the bearing capacity of the ground under its foundation is not inferior to that of firm clay or coarse sand, be deemed to be satisfied if—

(a) (i) the width of the bottom of the foundation (except where an adjoining wall or pier interferes) is not less than twelve inches or not less than twice the thickness of the wall in the lowest story, whichever is the greater; and (ii) where there is a pier forming part of the wall, the foundation is carried round the pier on all sides so as to project at least to the same extent as it projects beyond the wall; and

(b) the foundation is situated centrally under the wall or pier (except where an adjoining wall or pier interferes); and

(c) the height from the bottom of the foundation to the base of the wall or pier is not less than nine inches or not less than one and one-third times the projection of the foundation from the base, whichever is the greater; and

(d) where there are footings of brickwork, the footings—

(i) are built in cement mortar; and

(ii) are either in regular offsets from the face of the wall or pier or in one offset; and

(iii) where they are built directly upon the ground, and the wall is more than nine inches thick,

PRELIMINARY OPERATIONS

have a further course of brickwork at the bottom of the footings; and

(e) where there are footings built upon cement concrete, the thickness of the concrete is not less than one and one-third times the projection of the concrete from the footings.

EXAMPLES. Fig. 86 depicts a concrete base to a one-brick thick wall which accords with the L.C.C. by-laws, and Fig. 87 a similar base in agreement with the Model by-laws. Fig. 88 is a composite illustration showing half each of a base to an 11 in. thick cavity wall designed in accordance with the L.C.C. and Model by-laws.

Concrete. The bases of walls, piers, and stanchions are usually superimposed upon beds of

(say 1 ft. 5 in. by 1 ft. 5 in.). As the concrete will safely support 12 tons per super foot, the area of York stone must be $\frac{40 \text{ tons}}{12} = 3\frac{1}{3}$ sup. ft.,

which is given by a base about 1 ft. 10 in. by 1 ft. 10 in. The ground's capacity = 2 tons super ft., and therefore the area of concrete is $\frac{40 \text{ tons}}{2} = 20$ super ft., which requires a base

about 4 ft. 6 in. by 4 ft. 6 in. The above calculations ignore the weights of stone and concrete which should theoretically be allowed. There is a growing tendency to support bases of stanchions direct on concrete, as will be explained later.

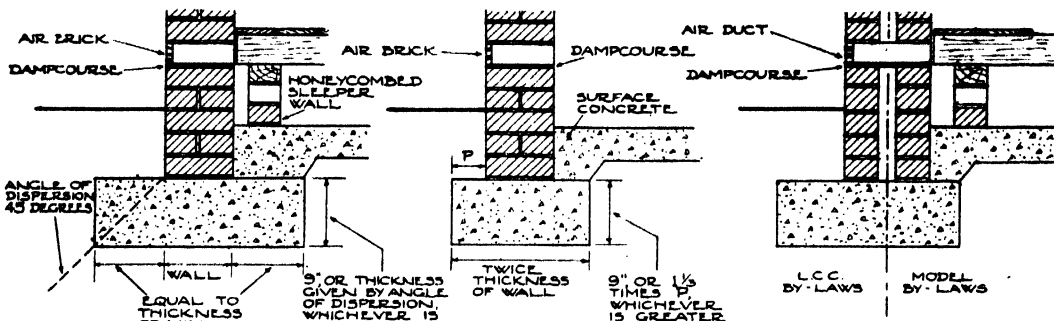

FIG. 86
CONCRETE BASE TO ACCORD
WITH L.C.C. BY-LAWS

FIG. 87
CONCRETE BASE TO DOMESTIC
BUILDING TO ACCORD WITH
MODEL BY-LAWS

FIG. 88
CONCRETE BASE TO CAVITY
WALL TO COMPLY WITH L.C.C.
AND MODEL BY-LAWS

concrete of sufficient area to distribute safely the loads over the foundation or ground, and of sufficient depth to prevent fracture. The reason why concrete is commonly used is that it is one of the cheapest and strongest materials for such purposes; other materials, such as York stone, would be as effectual as concrete, but the cost would be prohibitive.

To explain the importance of the correct design of bases, and the use of various materials to transmit loads through each other to the ground, the best instance is that of a steel stanchion supported primarily by a York stone pad, secondly by concrete, and finally by the ground. It is manifest that any weakness in one of these materials, or the ground, will have the effect of reducing the strength of the others, and cause waste of money. Fig. 89 shows the case. The load on stanchion = 40 tons, and as hard York stone will safely support 20 tons per super foot, the steel base must = 2 super ft.

Concrete Bases to Brick Walls. In the past it was customary to use footings to brick walls; but during recent years building scientific research has proven that footings are needless in the majority of ordinary building structures, and particularly housing work. This is due to the fact that the area of the base of a brick wall—without of course any footings—is sufficiently great to ensure a sufficient area of it being spread over modernly composed concrete without the latter being over stressed. The concrete must, however, be of sufficient width or size to transmit the loads to the foundation, and it must be of a depth to prevent it fracturing under the stresses which are induced by the downward force and the upward reaction of the foundation. Building by-laws now allow the omission of footings subject to rules governing the sizes of concrete bases which support walls. The most common type of concrete base is that required to a brick wall with or without footings,

MODERN BUILDING CONSTRUCTION

and it should be of sufficient *width* to distribute the loads of wall, floors, roof, and other loads supported by the wall, over an area of ground that will safely support it; it should also be of sufficient *depth*, or *thickness*, to prevent it fracturing by stresses induced by bending or shearing. The depth may be calculated as will be explained a little later, or it may be designed by empirical formula or rules, or constructed in accordance with building laws.

Fig. 90 shows a base of a 9 in. wall formed in accordance with the old by-laws, the footings being constructed to comply with the rule that there shall be a course of footings for every half-brick thickness of wall, and that the offsets shall be quarter-brick, and the width of the lowermost course equal to twice the thickness of base of wall. Under the new by-laws, if footings are used, the width of the concrete base need only be the same as shown by Figs. 86 and 87, or as specified by the new by-laws.

For ordinary two-story houses, or other light buildings, the rules given by the by-laws, and bases as Figs. 86 and 87, provide ample strength if they bear on foundations—the ground—of reasonably good supporting value such as not less than 1 ton per foot super. It will, however, readily be understood that they cannot, in all cases, allow for a correctly designed base, they do not make provision for width in relation to bearing value of ground and for depth to combat fracture. Examples allowing for different bearing values of ground will be informative and interesting.

Fig. 91 depicts a plan and section of an ordinary house, and the approximate loads on the front wall will be—

	<i>Cwt.</i>
Roof 5 ft. × 1 ft. × 0.5 cwt. =	2.50
First floor ceiling. 7 ft. × 1 ft. × 0.1 cwt. =	0.70
First floor 7 ft. × 1 ft. × 0.82 cwt. =	5.74
Wall 21 ft. × 1 ft. × 0.75 cwt. =	15.75
Per linear foot =	24.69

Or, say, 1.25 tons.

This load indicates that houses do not exert great pressures on foundations, and allowing for the above load per linear foot, a ground capable of carrying 1 ton per super foot would require concrete 1 ft. 3 in. wide, and ground capable of $\frac{1}{2}$ ton per super foot would necessitate concrete 2 ft. 6 in. wide.

Another example is that of a factory wall as illustrated by Fig. 87, the loads per linear foot of wall being—

Concrete roof—	<i>Cwt.</i>
6 ft. 6 in. × 1 ft. × 1.33 cwt. =	8.645
2nd floor of fir joists and boarding—	
6 ft. × 1 ft. × 2.33 cwt. =	13.980
1st floor of fir joists and boarding—	
6 ft. × 1 ft. × 2.33 cwt. =	13.980
9 in. wall 12 ft. × 1 ft. × 0.75 cwt. =	9.000
13½ in. wall 22 ft. × 1 ft. × 1.12 cwt. =	24.640
	70.245

Or, say, $3\frac{1}{2}$ tons per linear foot of wall.

If the concrete base were as Fig. 92, the ground would have to support $\frac{3\frac{1}{2} \text{ tons}}{3 \text{ ft.}} = 1.16$

tons per super foot, which most grounds will safely do. If the ground is only capable of safely carrying $\frac{3}{4}$ tons per super foot, then the width of concrete should be $\frac{3\frac{1}{2} \text{ tons}}{\frac{3}{4} \text{ ton}} = 4 \text{ ft. } 8 \text{ in.}$, as

shown by Fig. 93, which is interesting as it complies with the old by-laws, but not the new ones, which prohibit the use of concrete only 9 in. thick in the case shown. The thickness would have to comply with the L.C.C. rule regarding the 45 degree angle of dispersion as Fig. 86, or the Model by-laws as Fig. 87.

Calculation of Depth. The depth of concrete bases requires very careful attention. Take Fig. 94 as the example. The concrete under the footings may be considered as subject to compression stresses only, and that any ordinary depth will be suitable, but the edges on each side projecting beyond the footings must be considered as cantilevers with distributed loads equal to the pressure exerted by them on the earth, or in other words, the amount of resistance exerted by the earth to maintain equilibrium. For the purpose of calculation, the concrete must be considered to have a tensile value of 50 lb. per sq. in.—although in reinforced concrete work the tensile value of concrete is ignored—and also a compression value of 500 lb. per sq. in., these values being for a good 1 to 6 cement concrete.

Bending moment (B.M.) must equal moment of resistance (M.R.), and the formula to ascertain

$$\text{depth is } \frac{wl^2}{2} = \frac{fb d^2}{6},$$

$$\text{and therefore } d^2 = \frac{6 wl^2}{2 fb},$$

$$\text{and } d = \sqrt{\frac{6 wl^2}{2 fb}},$$

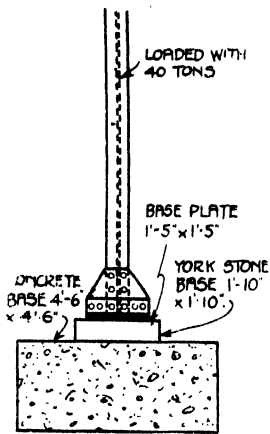

FIG. 89

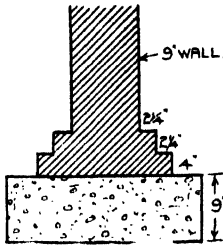

FIG. 90

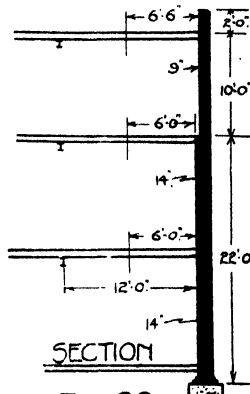
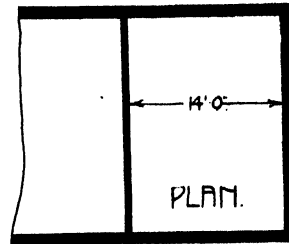

FIG. 92

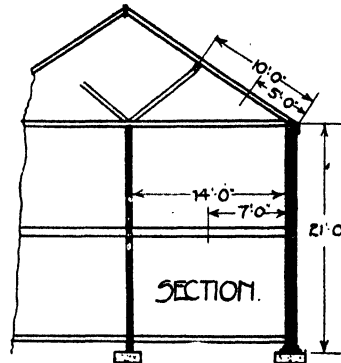

FIG. 91

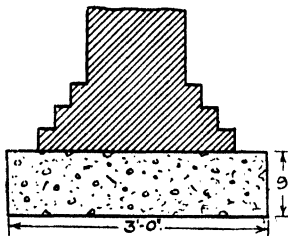

FIG. 93

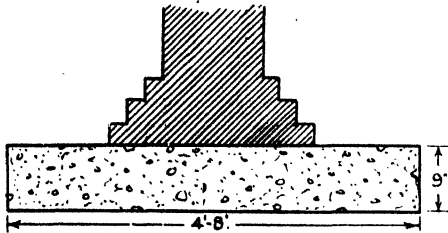

FIG. 94

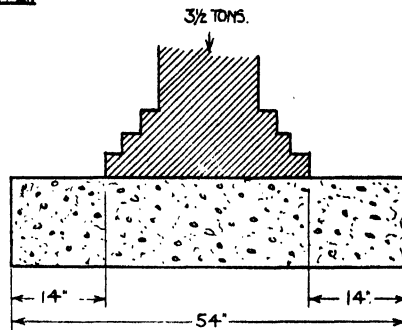

FIG. 95

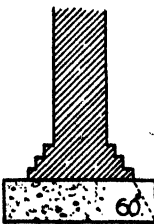

FIG. 96

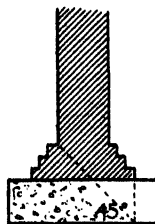

FIG. 97

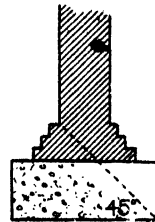

FIG. 98

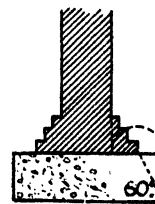

FIG. 99

MODERN BUILDING CONSTRUCTION

where w = load in pounds per inch of span;
 l = length in inches;
 f = safe tensile strength of concrete
 = 50 lb.;
 b = breadth in inches;
 d = depth in inches.

In the example the total width of concrete is 54 in. and the pressure is $3\frac{1}{2}$ tons, so that the load in pounds per inch of span

$$= \frac{3\frac{1}{2} \times 2240}{54} = 145 \text{ lb.},$$

which will be the value of w .

$$d = \sqrt{\frac{6 \times 145 \times 14^2}{2 \times 50 \times 12}} = \text{nearly } 12 \text{ in.}$$

It will be found that by cancellation of the constants that the above formula may be

$$\text{reduced to } d = \sqrt{\frac{wl^2}{200}}$$

for, of course, a constant breadth of 12 in.

Rules for Ascertaining Depth. Many methods have been devised to give the depth of concrete bases, and a few methods are shown by Figs. 95, 96, 97, and 98, which are self-explanatory and which vary considerably in their merits. Fig. 91 shows a common method that is economical and suitable for most cases in practice; it provides a depth that would resist fracture under a ground pressure of 3 tons per super foot, as given by the writer's method explained later. Fig. 97 gives a depth much greater than ever required in ordinary circumstances. Fig. 96 is a reasonable modification of the method shown by Fig. 97. Fig. 98 is a modification of Fig. 95, and makes the width of concrete relative to the width of footings, instead of making the width of concrete proportional to the load and bearing capacity of the ground. Any of the methods shown by Figs. 95 to 98 should be checked up with by-law requirements before being used.

The writer's method for determining the depth of concrete bases to walls, etc., is shown by Fig. 99, and makes rational allowances for the width of concrete required to distribute the load safely over the ground, and the bearing capacities of various grounds; it is suitable for good 1 to 6 cement concrete. If concrete is gauged 1 to 8, the depth should be increased by 20 per cent. The depth of the concrete is given by the intersection of the vertical edge of concrete with the inclined line coinciding with the bearing capacity, or resistance, of the ground. The width of concrete is, of course, calculated to

suit the bearing capacity of the ground, but should the width, for practical purposes, be greater than required, then the inclined line suitable to the pressure on the ground may be taken.

Concrete Bases to Stanchions and Columns should conform, as to area and depth, to the principles explained for bases to walls. Fig. 100 illustrates a typical base to a steel stanchion, which has to transmit a load of 32 tons over ground capable of safely supporting 2 tons per super foot. The area of concrete must be $\frac{32}{2} = 16$ super ft., and assuming that it is to be square, a concrete base 4 ft. by 4 ft. will be

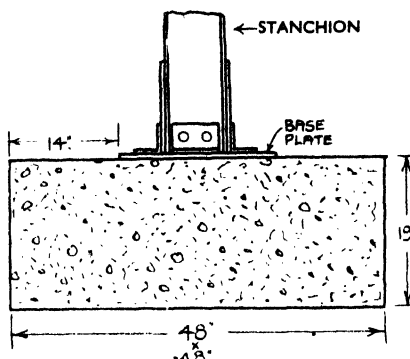

FIG. 100. SQUARE BASE TO STEEL STANCHION

satisfactory. The depth of concrete by calculation will be $d = \sqrt{\frac{wl^2}{200}}$, which is the reduced formula previously explained. As the base is 4 ft. long, w in this case will be $\frac{32}{4} = 8$ tons; therefore $\frac{8 \text{ tons} \times 2240}{48 \text{ in.}} = 373 \text{ lb.}$

$$\text{and } d = \sqrt{\frac{373 \times 14^2}{200}} = 19 \text{ in.},$$

which is also given by the writer's depth method as Fig. 101.

Another example will explain the calculations for a rectangular concrete base for a stanchion. It is not always convenient to make a base square on plan; a wall or the boundary of a site may prevent extending a base in a certain direction. Fig. 102 depicts a stanchion, loaded with 33 tons, to be supported on ground capable of exerting a safe resistance of $1\frac{1}{2}$ tons per super foot, and the base is not to exceed 4 ft. one way. The area of base must be $\frac{33}{1\frac{1}{2}} = 22$

PRELIMINARY OPERATIONS

super ft. As 4 ft. must be one dimension of the base, the other will be $\frac{22}{4} = 5$ ft. 6 in.; therefore the base should be 4 ft. by 5 ft. 6 in. In

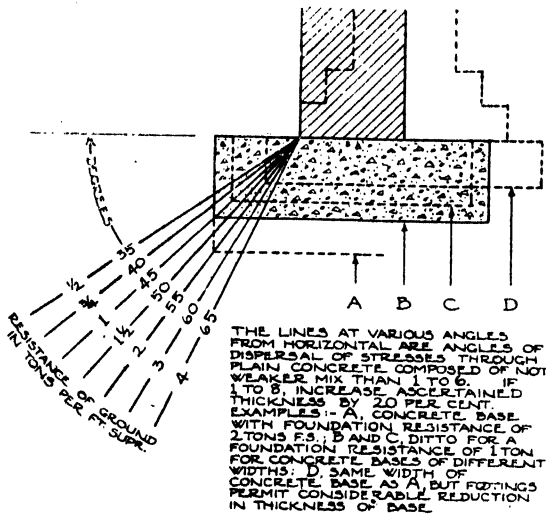

FIG. 101. METHOD OF DETERMINING THICKNESS OF CONCRETE BASES
(R. V. Boughton's Method)

calculating the depth required, it is important to note that the maximum projection of concrete beyond base of stanchion is taken; that is, in this instance, the projection in the line of the 5 ft. 6 in. dimension. The load per 1 ft.

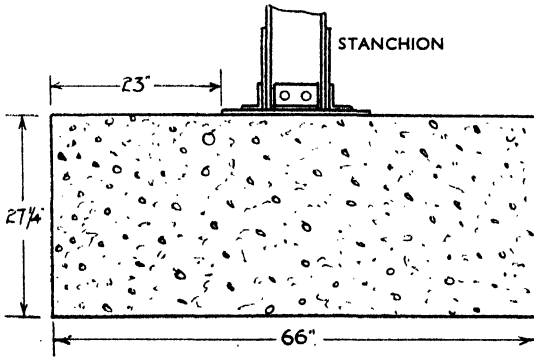

FIG. 102. RECTANGULAR BASE TO STANCHION

length of concrete will be $\frac{33}{4} = 8\frac{1}{4}$ tons; and therefore $w = \frac{8\frac{1}{4} \times 2,240}{66 \text{ in.}} = 280$ lb.

$$d = \sqrt{\frac{280 \times 23^2}{200}} = 27\frac{1}{4} \text{ in. about.}$$

A similar depth is also given by the writer's depth method.

Reduction of Total Loads on Foundations. The London County Council's by-laws makes allowance for the fact that buildings, of more than two stories in height and except those floors which are scheduled for an applied loading exceeding 100 lb. per super foot, cannot in practice transmit to the foundations, at any one time, the total amount of superimposed loads

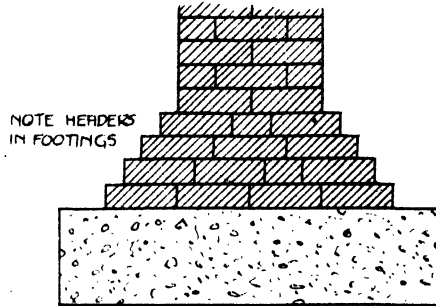

FIG. 103. TYPICAL FOOTINGS AND CONCRETE TO BRICK WALL

calculated for all floors and roofs—the incidence of live and concentrated loads which are allowed in the equivalent superimposed loads are reduced to static loads at the bearings of beams, and any live or concentrated load in one part of a building is apt to be distributed over a greater portion of the building in its transit to the foundations.

The regulation allows reductions as shown by Table VIII.

TABLE VIII

REDUCTION OF TOTAL LOADS ON FOUNDATIONS, ETC., DUE TO PERMISSIBLE REDUCTIONS OF SCHEDULED SUPERIMPOSED LOADS ON ROOFS AND FLOORS ALLOWED FOR PURPOSES OF CALCULATING FOUNDATIONS IN ACCORDANCE WITH L.C.C. BY-LAWS

N.B. This table is not applicable for floors which are scheduled for an applied (superimposed) load exceeding 100 lb. per super foot.

Position of superimposed load	Percentage of each superimposed load that may be allowed in calculating foundations, stanchions, etc.
Roof	100
Topmost story	100
Next story below topmost story	90
Next story below	80
Next story below	70
Next story below	60
Each succeeding story	50

MODERN BUILDING CONSTRUCTION

It is important to note that the dead (or actual) loads must be calculated in full.

Bases of Brick Walls. FOOTINGS. For the purpose of distributing the loads of, and on, a wall over a greater area of concrete or ground, the base of the wall is made wider by means of footings formed by offsets, as shown by Fig. 103. Footings are no longer enforced by the building by-laws.

The generally accepted rules are that the bottom course of footings shall be double the width of the base of wall, and that the offsets shall be one-quarter brick, which causes there to be one course of footings for every half-brick thickness of wall.

The brickwork bond for footings should be, as far as practicable, header bond, and where stretchers are necessary they should, if possible, be placed in the centre of walls.

Whether the general work above ground is to be Flemish or English bond, all work (excepting footings) below ground should be in English bond, which is stronger than Flemish bond.

Bricks in foundations should be hard and well burnt, without much regard being paid to shape, and should be built in cement mortar. Figs. 104, 105, and 106 illustrate sections and plans of bases of 1, $1\frac{1}{2}$, and 2 bricks thick walls. Fig. 107 is an elevation of the base of a wall showing header bond in footings, English bond between top of footings and ground level, and Flemish bond above ground.

Ends of walls should preferably have projecting footings and concrete as shown by Fig. 108, and not "cut off square" as shown by Fig. 109.

DETACHED PIERS. These are properly constructed when they have footings similar to walls, with the lower course equal to double the width of the least dimension of the pier, as shown by Fig. 110. The footings must extend beyond all sides of the pier. Sometimes there are circumstances that require a greater spread of footings, which may be provided by constructing a greater number of offsets.

ATTACHED PIERS. Piers constructed to carry special loads, such as would occur when the end of a girder rests on a wall, or when built to stiffen a wall, should have footings and concrete calculated for the combined thickness of wall and pier, and the footings and concrete should be returned at sides. Fig. 111 shows a 14 in. by $4\frac{1}{2}$ in. pier attached to a 9 in. thick wall with proper footings and concrete.

Piers constructed for ornamental purposes only or where required to support light loads,

may be built off the main wall footings as depicted by Fig. 112.

RECESSED WALLS. These may be built with footings and concrete designed for each thickness of wall, as shown by Fig. 113.

Stepped Foundations. To obviate too much "buried work" in sloping sites, it is often necessary to "bench" or "step" bases of structures so as to form, as near as possible, a uniform depth of work below surface. As an instance, Fig. 114 depicts a site which is not level, with bases carried down without "steps." Fig. 115 shows "stepping," which saves a considerable amount of work; and generally it is in conformity with good principles of construction to do this, provided that the ground is satisfactory at the various levels. At the points where the "steps" occur, the concrete of the lower step should extend well under the concrete of the step immediately above, as shown at *A*, Fig. 115, and should not be formed as shown at *B*. As a rule, this extension should equal the depth of concrete.

STONE WALLS. These should generally be in agreement with the principles governing the construction of brick bases, but adapted to suit the different material. Figs. 116 and 117 illustrate section and elevation of the base of a stone wall built in uncoursed random rubble. If possible, the footings should be of "through stones," i.e. those that extend in one piece from face to face of wall; if not, then the stones must "tail" as far as possible into the wall.

STANCHIONS, ETC. There are three common methods of designing and constructing the bases for stanchions and columns—

(a) Fig. 118 shows a stanchion base plate resting on a York stone pad, to which it is connected with rag bolts, the stone being supported by concrete which, in its turn, is supported by the ground. The method of calculating the area and depth of concrete has been fully explained before, and it is only necessary to state that the area of base plate of stanchion must be proportioned to the safe bearing capacity of hard York stone, which must not exceed 20 tons super ft., and that the stone must be of sufficient area to exert not more than 12 tons super ft. on the concrete. York stone pads should not be less than 6 in. thick, and also not less in thickness than the maximum projection beyond the edge of base plate, as shown by Fig. 119. A York stone pad forms a true bearing for the base, and the object of the rag bolts is to prevent lateral movement and to "tail down" the base.

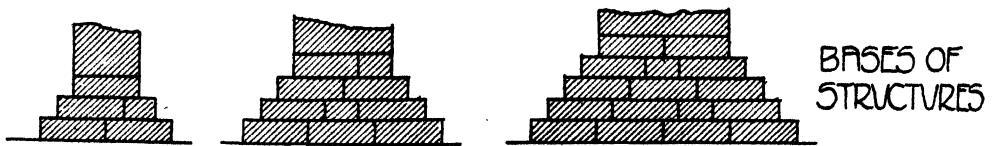

BASES OF STRUCTURES

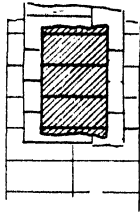

FOOTING TO 1 B. WALL.

FIG. 104

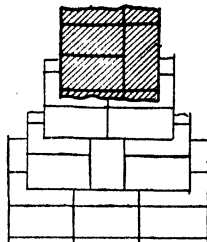

FOOTINGS TO 1 1/2 B. WALL.

FIG. 105

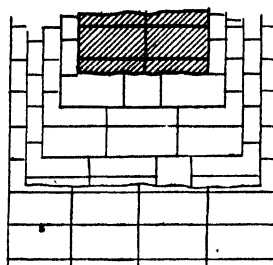

FOOTINGS TO 2 B. WALL.

FIG. 106

RULE:-FOOTINGS SHOULD HAVE AS MANY HEADERS AS POSSIBLE.

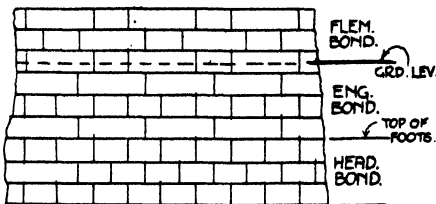

ELEVATION OF WALL SHOWING VARIOUS BONDS.

FIG. 107

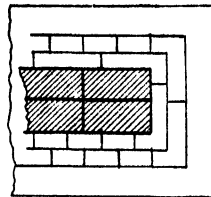

CORRECT WAY OF FORMING FOOTINGS AT END OF WALL.

FIG. 108

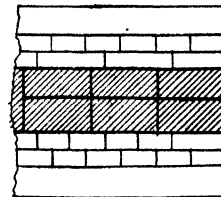

INCORRECT WAY OF FORMING END.

FIG. 109

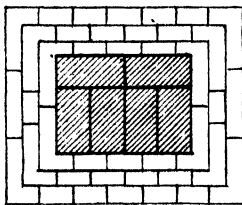

FOOTINGS TO BRICK PIER.

FIG. 110

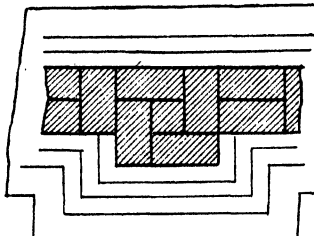

FOOTINGS TO ATTACHED PIER TO CARRY LOADS.

FIG. 111

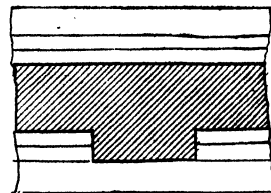

FOOTINGS TO ATTACHED PIER USED FOR DECORATIVE PURPOSES.

FIG. 112

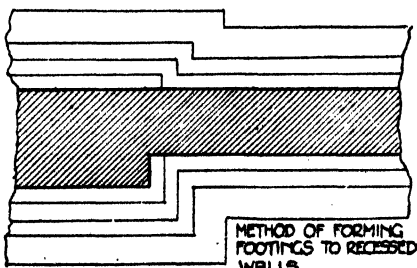

METHOD OF FORMING FOOTINGS TO RECESSED WALLS.

FIG. 113

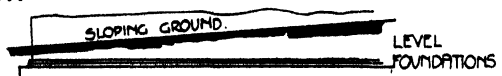

FIG. 114

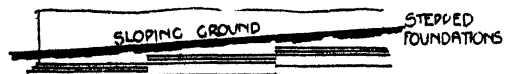

FIG. 115

MODERN BUILDING CONSTRUCTION

(b) Fig. 120 shows the same stanchion as Fig. 113 supported directly by the concrete, the steel base plate being proportionately increased in area to allow for a pressure of not exceeding 12 tons super ft. on concrete, instead of 20 tons on stone. This type of base is more economical than the last described type, and is much used in modern construction. The underside of steel

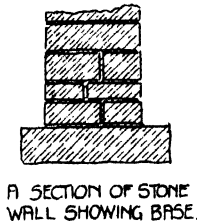

FIG. 116

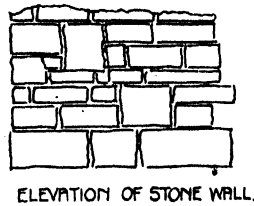

FIG. 117

base should be wedged with steel wedges, and properly grouted with cement. The holding-down bolts secure the base to the concrete, and if long, help to prevent any tendency to overturning owing to the great weight of the concrete.

(c) Fig. 121 depicts another method which is also now much used, as the base of the stanchion is held firmly in position by the surrounding concrete, which makes the use of holding-down

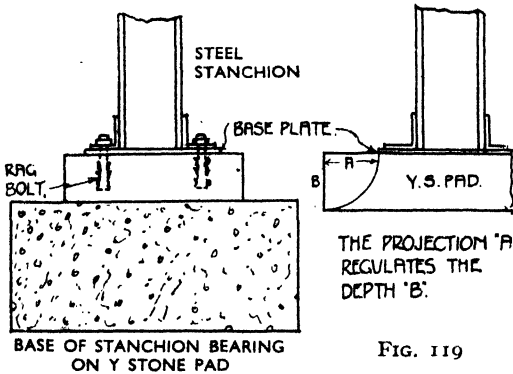

FIG. 118

FIG. 119

bolts unnecessary, and also the base is protected from corrosion by the concrete.

PILE FOUNDATIONS

Ordinary bearing piles may broadly be defined as huge plugs driven into ground and maintained in position, and made capable of supporting loads by the pressure and friction of the earth against the sides of the piles and the resistance at the point of the pile against

penetration; the load they are capable of sustaining depends on the nature of the ground in which they are driven, the length of the pile, and other considerations which will be explained.

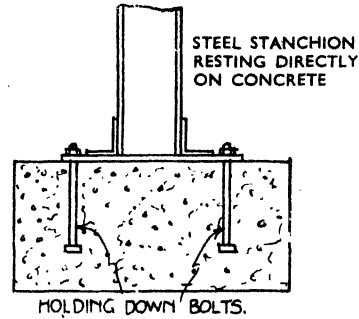

FIG. 120

A simple experiment to illustrate the general principles of piling may be made by taking a piece of stick with a pointed end, and driving it into fairly hard ground with a mallet, or other similar article, with light, even taps, and noticing the decreasing distance that each tap drives the "pile" into the ground; the lesser the distance driven with a tap of equal force indicates the greater amount of resistance of the ground.

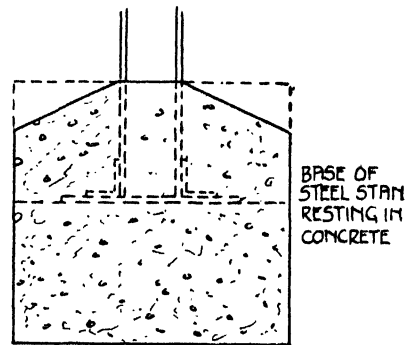

FIG. 121

Types of piles are as follows—

Bearing piles, which are driven into ground to form piers upon which a superstructure may be built, the ground in which they are driven being of such poor supporting value that it could not be built upon without the aid of piles.

Consolidating, or short, piles, which are driven into soft ground for the purpose of compressing the ground together, and thereby increasing its supporting value to enable it to be built upon.

PRELIMINARY OPERATIONS

Sheet piles are those which are driven close together into ground that is liable to lateral escape for the purpose of containing it.

Materials for piles include red pine, beech, larch, elm, oak, greenheart, teak, reinforced concrete, and cast iron, and below is given the chief characteristics of these materials.

Red pine (soft wood), weighing about 35 lb. per cub. ft., requires to be kept dry to be durable, and as piles are usually in positions liable to dampness, it should only be used in temporary piling works. It is, of course, a cheap wood.

Beech (hard wood) weighs 43 lb. to 53 lb. per cub. ft., is durable if kept quite dry or wholly

for piles, but is not so strong and durable as its English cousin. There are many other varieties of oak; and if it is proposed to use any of them, their very varying characteristics should be ascertained from any standard treatise on timbers. Oak is a rather expensive timber.

Greenheart (hard wood), 58 lb. to 72 lb. per cub. ft., is expensive, but is probably the best wood for piling in earth or under water. It is heavy, very hard, and very strong, with a great resistance to crushing, and is the least liable of the timbers described herein to the attacks of worms.

Teak (hard wood), 41 lb. to 52 lb. per cub. ft., is also expensive and is almost as good as greenheart for piling; it is stronger and stiffer than English oak and resists insects.

Reinforced concrete is gradually superseding timber for piling, owing to it being practically indestructible and of great strength. Its drawbacks are its brittleness when subjected to shocks (modern pile drivers practically eliminate this trouble), its weight compared with timber, and the care required in driving, all of which considerations will be dealt with later.

Iron piles are sometimes used and will be explained later.

Bearing Piles of timber vary from 9 in. to 18 in. square, depending on their length, which, as a common rule, should not exceed 20 times the least dimension. They should be of whole timber, straight grained, with bark or rough projections removed, free from large knots, and used with butt end downwards. The bottom ends must be pointed, preferably with wrought-iron shoes as Fig. 122, or as in Fig. 123, which has the point of cast iron and the straps of wrought iron, to prevent the points being broken or crushed when being driven against hard substances.

The point of the shoe must be axial to the pile, otherwise it will be apt to deviate from the vertical during driving.

The head of pile should have a wrought-iron hoop or ring, placed not more than $1\frac{1}{2}$ in. or less than $\frac{3}{4}$ in. from top, as shown by Fig. 124, to prevent it splitting during driving.

The number and disposition of piles depend on the loads to be supported, their position on site, and the resistance of the driven piles, all of which have to be carefully designed and calculated.

Bearing piles must be driven until the shoes are embedded in a hard stratum, or until the pressure or friction of the ground on their sides

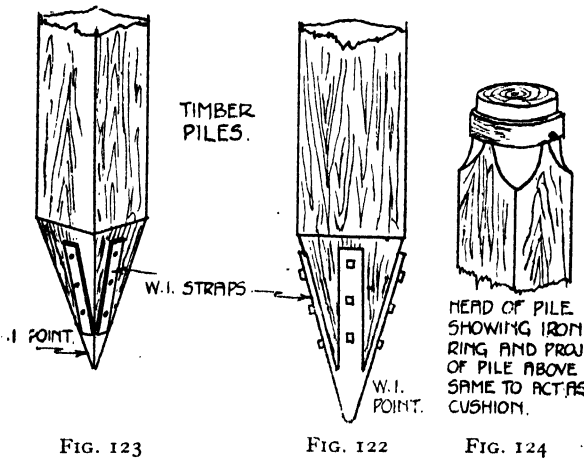

FIG. 123

FIG. 122

FIG. 124

submerged in water, but if used in positions liable to alternate wet and dry it soon decays. Dampness is its greatest enemy and causes it to rot quickly; it is also very liable to attack by worms.

Larch (soft wood) weighs 32 lb. to 38 lb. per cub. ft. and is sometimes used for piles; it is similar in its characteristics to red pine, excepting that it is tougher.

Elm, common English (hard wood), weighs 34 lb. to 37 lb. per cub. ft., is very fibrous, dense, and tough, offers great resistance to crushing, is durable if kept constantly wet or dry, but will decay when subject to alternation of wet and dry; it is liable to attack by worms.

Oak, English (hard wood), 49 lb. to 61 lb. per cub. ft., is strong, hard, and tough, is durable in damp earth or when submerged in water, and is, like most timbers, subject to the depredations of worms. It is capable of withstanding great crushing loads. American oak is suitable

MODERN BUILDING CONSTRUCTION

is sufficient to prevent further penetration under a load a little less than the failing load for which they are calculated. A sufficient resistance is considered by engineers to be obtained when the last blow does not sink the pile more than $\frac{1}{4}$ in. There is another test which appears to be sound—

W = weight of ram ; H = fall of ram ; and
 D = set of pile with *last blow*.

Then—

Either $W = 8$ cwt., $H = 5$ ft., $D = \frac{1}{4}$ in. in 30 blows
 Or $W = 15$ cwt., $H = 15$ ft., $D = \frac{1}{4}$ in. in 10 blows
 Or $W = 8$ cwt., $H = 30$ ft., $D = \frac{1}{8}$ in. in 10 blows

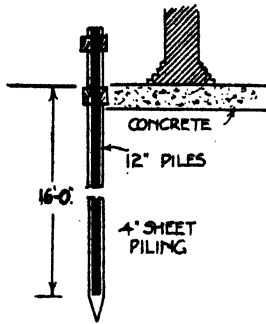

SECTION.

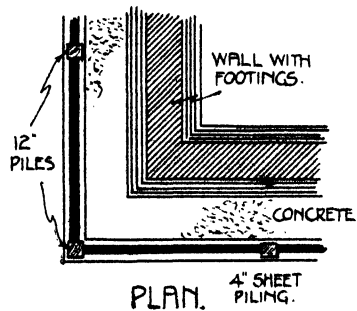

FIG. 125

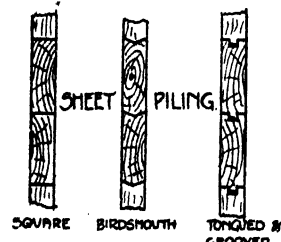

FIG. 126 FIG. 127 FIG. 128

It must be noted that D is the set of the *last* blow of the total number shown, and not the set caused by 10 or 30 blows.

There are several formulae for estimating the load that a bearing pile will support, the simplest one that gives a very fair result is that of Major Saunders, U.S.A.—

$$L = \frac{Wh}{8d}$$

where L = safe load in cwt. ;
 W = weight of ram in cwt. ;
 h = height that ram falls in inches ;
 d = distance driven by last blow in inches.

This formula allows a factor of safety of 8.

Pile drivers and engines will be explained later, but it will be advisable now to consider the *ram* of the driver, i.e. the weight that in falling a certain distance drives the pile into the ground. It is considered in practice that a light ram with a long fall is best for clay soils, and a heavy ram with a short fall for sand and sandy soils, and a great number of light blows is preferable to a small number of heavy blows, especially in sand.

The weight of the ram varies from 5 cwt. to 40 cwt., and is generally 10 cwt. to 20 cwt. for ordinary work, but the weight is regulated by various rules and formulae, as follows—

(a) A rough rule is that the ram should be not less than or more than $1\frac{1}{2}$ times the weight of the pile.

(b) Diameter or least dimension of pile in inches minus 5 multiplied by 3 = weight of ram in cwt.

(c) Length of pile in feet multiplied by sectional area in inches divided by 4 = weight of ram in lb.

Test these formulae by taking a 12 in. by 12 in. oak pile, 20 ft. long, weighing 56 lb. per cub. ft.—

By (a) 20×56 lb. = 1120 lb. = 10 cwt. ram (or $1\frac{1}{2}$ times = 15 cwt.)
 (b) $(12 \text{ in.} - 5) \times 3 = 21$ cwt.
 (c) $\frac{20 \times 144}{4} = 720$ lb. = about $6\frac{1}{2}$ cwt.

Formula (a) may be considered the best to use, allowing for ram equal in weight to pile for long falls, and $1\frac{1}{2}$ times weight of pile for short falls.

The fall of ram varies from 5 ft., which is the usual distance, to 10 ft., but as stated before the fall depends on the nature of the ground and the weight of the ram. A light ram with a long fall has a tendency to shiver the pile.

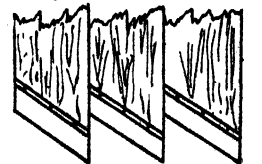

FIG. 129

Consolidating, or Short, Piles are usually from 6 ft. to 12 ft. long, more slender than bearing piles, and are driven into the ground to so compress and consolidate it as to make it capable of being built upon in conjunction with the

piles. They are usually placed as close together as possible, but far enough apart to avoid the tendency of one pile, while it is being driven, causing the adjacent ones to rise. Usually, 2 ft. 6 in. centres will be suitable.

Sheet Piles are used to enclose areas of foundations which are liable to escape laterally, and so cause subsidence, or in some cases to protect a site from water.

Fig. 125 shows a typical case of sheet piling. Guide piles, similar to bearing piles, are driven at 6 ft. to 10 ft. apart, with 2 ft. or 3 ft. left projecting above ground, to allow for the fixing of the walings, which are formed of two pairs of 9 in. by 4 in. to 6 in., the 4 in. thickness being suitable when the guide piles are about 6 ft. apart, and the greater thickness being used as the distance apart of guide piles is increased.

One set of walings is fixed near the head of guide piles, and the other as near ground as possible. The distance apart of walings in each set must be fully equal to the thickness of the sheet piles which are driven between them.

The sheet piling is usually composed of 9 in. by 3 in. to 11 in. by 6 in. timbers, the thickness depending on their depth and the load of earth to be retained. The writer considers that the size of guide piles should not be less than one-sixteenth of their length in ground, and that the sheet piling should be one-third thickness of guide piles where guides are 6 ft. apart, and increasing up to one-half thickness in the case where the guides are from 6 ft. to 10 ft. apart, but in no case less than 3 in. thick.

As an instance, a depth of 16 ft. has to be sheet piled, with guide piles 6 ft. apart; the guide piles would be one-sixteenth of 16 ft. = 12 in. square, and the sheet piling one-third of 12 in. = 4 in. thick, as shown by Fig. 125.

Figs. 126, 127, and 128 depict, respectively, square, bird's-mouthed, and grooved-and-tongued edges to sheet piling. The square edged may be used for short piles, but when long piles are used it is necessary to provide additional strength, and to guide the pile that is being driven into the adjacent one, by making the members lock into each other, for which purpose bird's-mouthing is favoured. The shoes of the sheet piles are shaped as shown by Fig. 129, so that during their penetration into the ground they are "wedged" towards the neighbouring pile. The shoes are shod as shown to protect them during driving. The guide piles must have a sinking or groove to correspond with the tongue or projection on the sheet piles.

Reinforced Concrete Bearing and Sheet Piles are now extensively used and are gradually superseding timber owing to them being practically indestructible by dampness or insects. At first consideration, the great compressible strength of concrete compared with timber may be deemed of great import; but further consideration will show that as a pile chiefly depends for its strength on the pressure or friction of the earth in which it is driven, and not so much on the actual compressible value of the concrete, a reinforced concrete pile may be no more effective in supporting a load than a timber one; as a

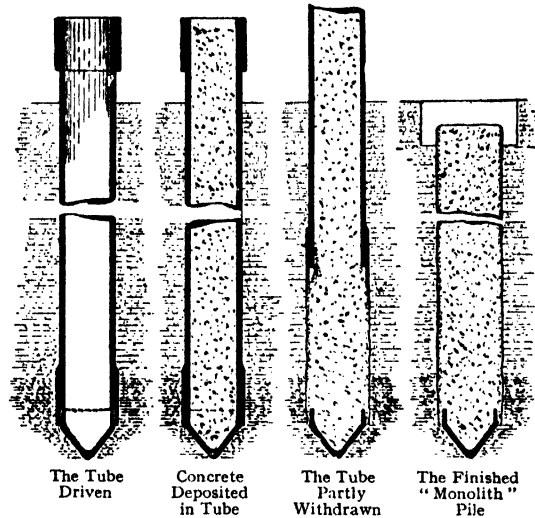

FIG. 138. THE "MONOLITH" PILE AS CARRIED OUT BY CONCRETE PILING, LTD.

matter of fact, a 12 in. \times 12 in. timber pile, although much weaker as an actual *strut* than a concrete pile of considerably less sectional area, might be considerably stronger as a pile owing to the greater area of sides upon which the ground acts.

The design and calculations for reinforced concrete piles are rather complicated, but generally follow the rules for pillars, regard being paid to the fact that the steel reinforcement is chiefly to resist fracture caused by the blows of the ram. When reinforced concrete piles are used they should be obtained from a specialist firm.

Figs. 130, 131, 132, 133, and 134 illustrate respectively the Hennebique, Considère, and Coignet piles (all of which have cast-iron pile shoes) and B.R.C. square and octagonal piles.

The head should have a cast-iron helmet

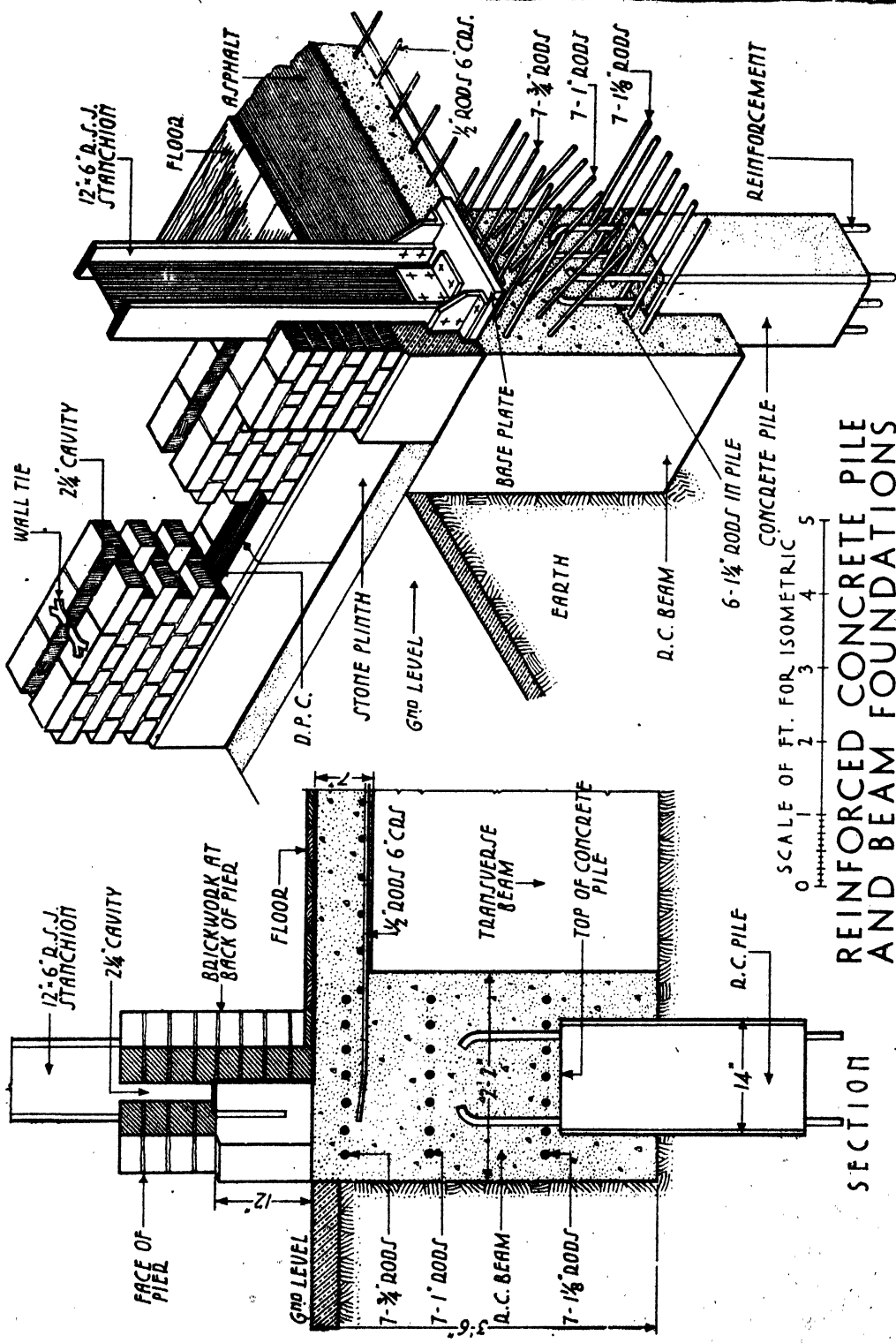

REINFORCED CONCRETE PILE AND BEAM FOUNDATIONS

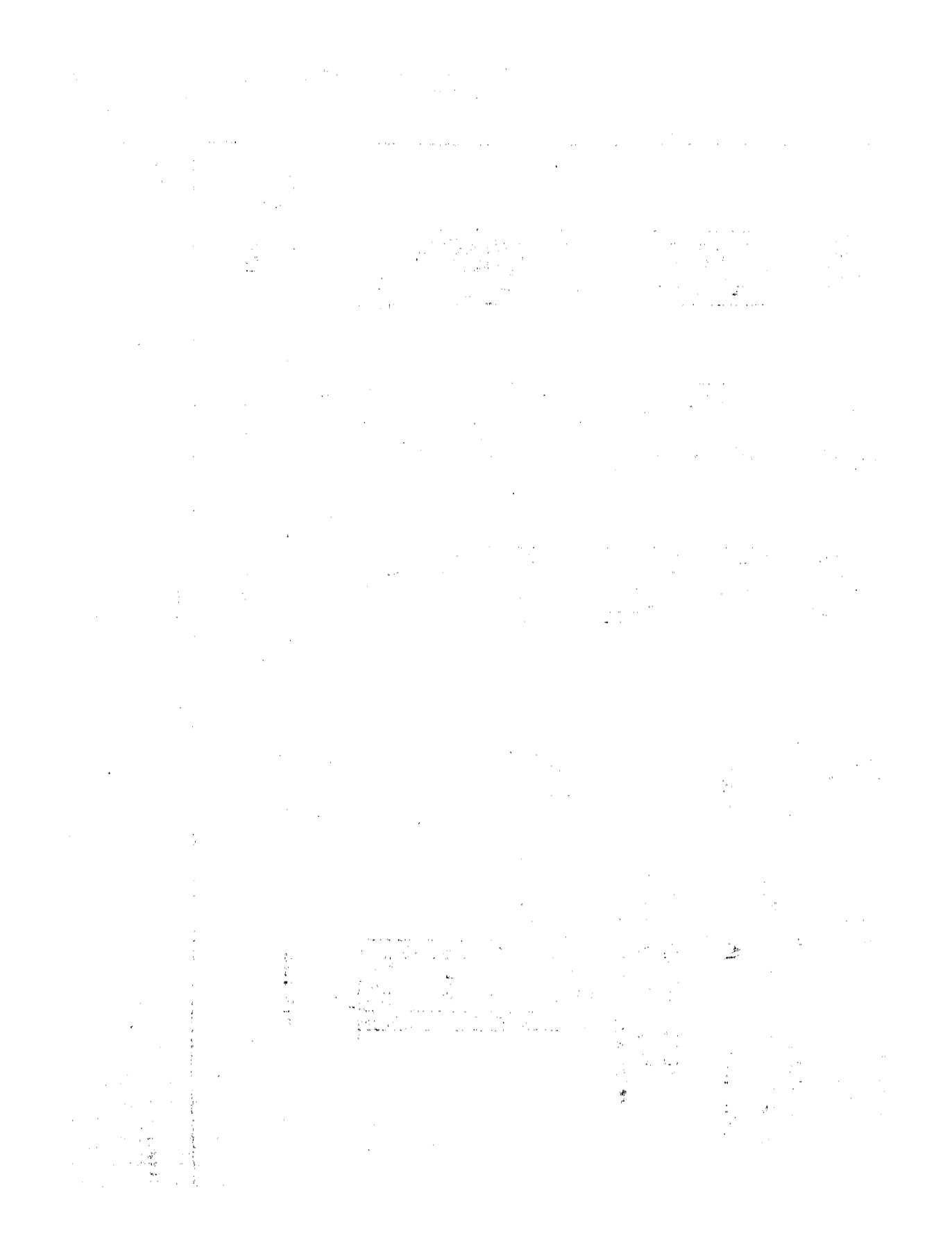

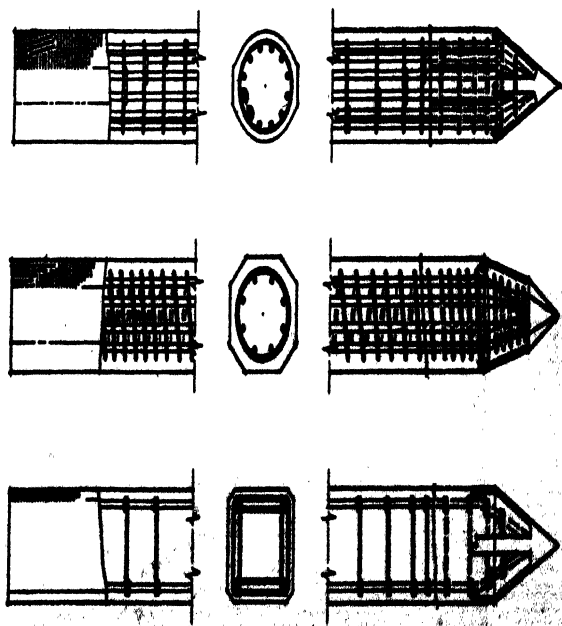

HEMISPHERICAL CONOIDAL SQUARE PILE. HEMISPHERICAL CONOIDAL ROUND PILE. CORNET SQUARE PILE.

FIG. 130

FIG. 131

FIG. 132

IRON HELMET TO PROTECT PILE WHILST BEING DRIVEN.

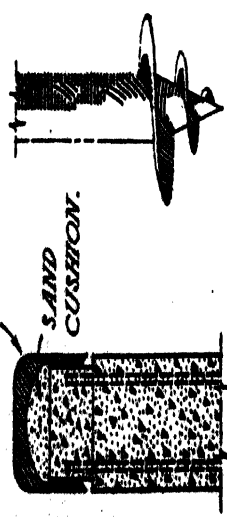

SCREW PILE.

FIG. 137

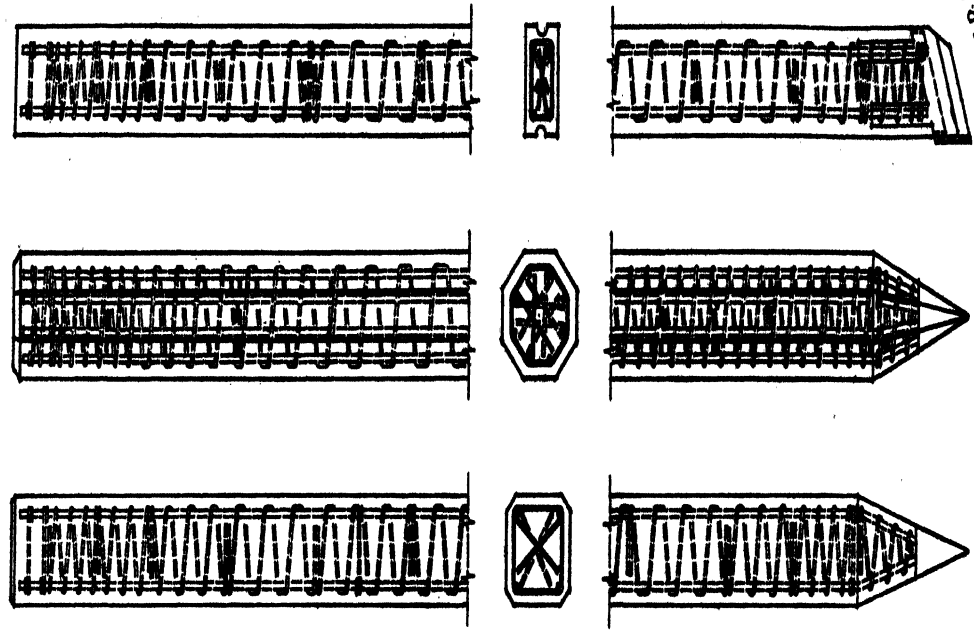

STANDARD R.R.C. PILES.

SQUARE PILE. OCTAGONAL PILE. SHEET PILE.

FIG. 133

FIG. 134

FIG. 136

PRELIMINARY OPERATIONS

PILE DRIVERS AND DRIVING

with sand cushions, as shown by Fig. 135, to protect piles during driving. Instead, a wooden "dolly" may be placed at the top of the pile, upon which the ram acts.

Fig. 136 shows a B.R.C. sheet pile. *Screw piles* are those of which the pile itself is of timber, or a cylinder of cast or wrought iron, fitted with a screw at bottom, as shown by Fig. 137, which penetrates into the ground upon

The general principle of all pile drivers is that a heavy block of iron, called the *ram*, is raised to a certain height on a frame and then released so as to allow it to fall on the head of the pile.

The simplest type of pile driver is the *ringing engine*, which consists of an upright pole or leader, supported by side braces, and steadied by guy ropes. The ram is kept in position and

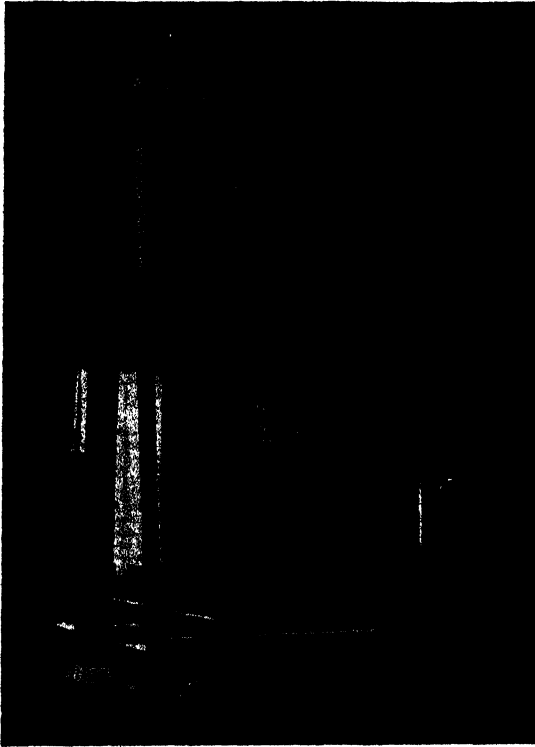

FIG. 139. DRIVER FOR PILES OF MODERATE LENGTH

being rotated by means of long radiating levers at the top end, actuated by animal or other power, or with capstan by hand power, or with the assistance of a crab winch.

Cast-in-place Piles are constructed on the general principle of driving a hollow metal cylinder into the ground by a pile driver or hammer, withdrawing the cylinder a few feet either immediately before or after concrete is poured into the cylinder, and continuing such method until the top is reached. Fig. 138 shows the various stages in the construction of monolithic concrete piles as carried out by Concrete Piling Ltd., Victoria Street, S.W.1.



FIG. 140. LARGE PILE DRIVER

guided by straps fitted to its sides and made to fit round the leader. The ram is operated by a number of men, who each work one of the tails of the rope, thus hoisting the ram 3 or 4 ft., letting it go, and then taking advantage of the rebound of the ram to raise it again.

Fig. 139 shows one of Messrs. Henry Sykes Ltd. types of drivers, suitable for piles of moderate length, and these consist of a sturdy framework on which the ram works vertically up and down. The ram is connected to, and raised by, a device called a *monkey*, which consists of a counter-weighted lever which has a hook in the centre. This hook engages the ram,

MODERN BUILDING CONSTRUCTION

which, when at the required height, is released by pulling the rope as shown. The monkey is attached to the hoisting rope, which is operated by a windlass or crab worked by men, horses, or steam power.

Fig. 140 is a photograph of a large pile driver for timber piles as made and used by Messrs. Henry Sykes, Ltd., Southwark Street, S.E.1.

The drivers for concrete piles are usually fitted with a two-ton ram, which is hoisted by a steam winch, and driven at speeds from 30 to 40 blows a minute. The driving should be by uniform and steady blows, with a short drop, as otherwise the head of the pile may be damaged by splintering or cracking. The piles must be carefully handled, hoisted, placed in position, and plumbed up before driving commences. When a cast-iron helmet is used, a strong cushion of sawdust in sackcloth should be packed inside the helmet to relieve the pile-

head from the ram's impact, thereby preventing damage being done to the pile. As an alternative to the helmet, an elm block or dolly about 3 ft. long is placed on the pile-head.

In driving piles care must be taken that (a) the points of the piles are in a true line of the axis and that the sides are equally bevelled; (b) the length of the pile is measured before driving to ensure that the correct specified length is used, and also that subsequently driven piles may be of modified length if necessary; (c) the amount of drive of the last few blows be measured by ruling a line across the head of the pile with a levelled straight-edge, and chalking on the side frame before and after the blow; (d) sound materials are used so as to avoid a pile breaking; (e) when a pile meets some immovable obstacle after it has been driven to a considerable depth, it is better to leave the pile in position, and cut off the top.



WORKING DRAWINGS OF GATEKEEPERS LODGE

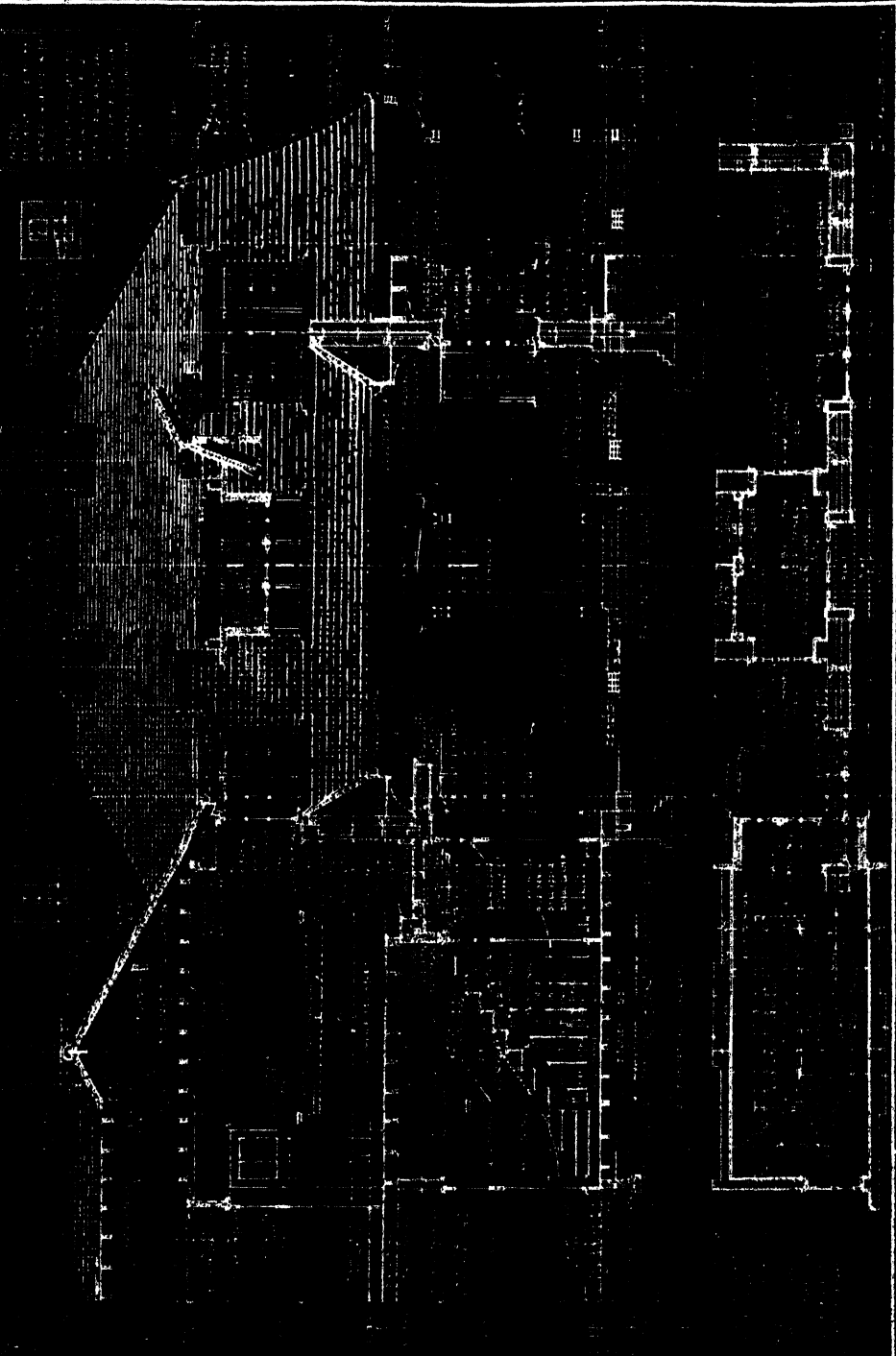

(Drawn by a Student, Northern Polytechnic, London)

BLUE-PRINT WORKING DRAWING

Reduced from Imperial Size

(T. 8462)

Superintendence

By P. J. LUXTON, *Member of the Incorporated Clerks of Works Association*

Chapter I—PERSONNEL

THE BUILDING OWNER'S REPRESENTATIVES. The building owner is represented by the *architect*, *his assistants*, and the *clerk of works*, who, for all practical purposes, may be regarded as the architect's assistant on the job. In addition, the building owner, who is generally termed the *employer* in contract documents, may be represented by various *consulting engineers*—structural, heating and ventilating, electrical—and even mechanical, where there are a lot of lifts or machinery. These act separately, in that they are employed as experts responsible for their particular section of the work, but all are either under or in consultation with the architect.

Whatever their work may be, it has to fit in with the general plan and scheme of the building which he has designed. It is usually on large jobs only—public buildings, extensive commercial premises, places of entertainment or big factories—that the consultant is required. On small buildings the building owner will probably be represented by the architect only, although assistants that the latter employs may be deputed to visit works in progress, if they are sufficiently experienced to be of use in that direction.

THE CONTRACTORS' REPRESENTATIVES. The representative of the contractor is almost invariably his foreman: a *general foreman* if the job is large enough to require one whose whole time is devoted to supervision, and a *working foreman* on smaller works where the organization side does not require so much attention, or where the builder assists with the supervision. In this case the foreman, who is a craftsman, works at his trade.

The general foreman has practically full control of the job, as far as the contractor's work is concerned, and usually receives his instructions from a manager, or the estimator who has priced the bills of quantities; but these do not interfere, except in important matters, when the general foreman is a competent man who has the confidence of his firm. Whether the contractor or contractors—in the case of a firm with a

board of directors—take any active part in the actual erection of the work, and frequently visit the job, depends upon its size, and the extent of the firm's general business. The largest firms leave that sort of thing to their managers: the contractor lower down in the financial scale cannot afford highly paid assistants, and keeps in close touch with all phases of his work.

The general foreman has deputies who see to the various trades, navvies, bricklayers, carpenters, plumbers, painters, and so on, who are described either as *deputy-foremen*, *gangers*, or by the rather objectionable term *leading hands*. When the job is going ahead, and many are employed, these supervisors have enough to do in keeping their part of the machine running smoothly. At other times, as when their branch of the work is only beginning or nearing its conclusion, they work as operatives.

SUB-CONTRACTORS. One other type of supervisor, who acts indirectly under the general foreman, is the sub-contractor's leading man. Except on large jobs, he works at his trade. Typical examples are asphalters, steel erectors, floor layers of various kinds, slaters, tilers, erectors of special types of constructional floors, heating and ventilating engineers, electricians, marble fixers, and lift erectors. At intervals an outdoor manager, or similar representative of the sub-contractor doing the work, visits the job and gives any necessary instructions to his men; but for all practical purposes they have, while on the works under his control, to carry out the orders of the general foreman with regard to general procedure.

Thus there is a great variety of method, varying from that on the largest of jobs, where the contractors may be represented by a manager or agent, a general foreman, and his numerous satellites, and the owner by a chief and assistant clerks of works down to that carried out by the small speculative or jobbing builder, where the supervision is almost nil, and nothing but good luck produces a satisfactory financial result. This general description applies, of course, to

MODERN BUILDING CONSTRUCTION

the type of building work which is most frequently met with, where a contractor undertakes to perform specific services for either a lump sum of money, for prices set forth in a schedule, or for the actual cost of the work plus a percentage for overhead charges and profit.

DIRECT LABOUR. All building work, however, is not done on this basis. Some large commercial firms, with works departments, buy their own materials and plant and engage their own labour; whatever may be required, either the erection of new premises or the maintenance of existing, is done under the superintendence of their own staff, probably a manager and various kinds of foremen. Some municipal authorities adopt this method, and, to a certain extent, it is also resorted to on large estates, and such establishments as cathedrals and hospitals. On both the estates and the establishments the superintendent is usually the clerk of works; and he has a staff of supervisors, clerks, etc., varying in number according to the extent of the area covered, and the amount of money spent.

The two typical superintendents are the clerk of works and the general foreman. Whatever applies to them with regard to methods of supervision on large works, applies in a lesser degree to their prototypes on works of lesser importance. In the explanations supplied in this Section, they will be the principal persons dealt with, and as much relating to the purely technical side applies to both types, this part will be incorporated in the description of the clerk of works' functions.

Duties of Building Superintendents. These can be divided into three groups: *technical*, *financial*, and *social*. The first applies to the materials and processes peculiar to the erection and equipment of buildings, and with it is closely interlocked the financial—the cost of the materials and processes. For instance, the cost of making and fixing a stone ball on a brick pillar will depend upon the judgment shown in selecting a suitable stone, and the method and craft of the mason doing the work.

The third group, the relationship of one individual to another, is largely independent of the other two. Any remarks on this subject have a general application, and no special significance for any particular superintendent; it will therefore be dealt with at this stage.

Now, it is true that in any occupation social harmony and co-operation are important matters, whether it be a printing office, football club, boot factory, or drapery store. But on

constructional works, and building works in particular, which contain more detail than does, say, harbour construction or bridge building, there are factors which do not apply elsewhere.

The number and variety of persons concerned exceed those engaged in any purely manufacturing process in a factory. They range from the building owner, architect, and contractor, down to the mess-room lad, and include a variety of highly skilled craftsmen, whose accomplishments are the result of many years training. In many factories a process can be learnt in seven days. A skilled plumber has to spend that number of years at his trade, before he reaches a good standard of proficiency. Then there are always a number of unskilled men who are of all types. They are engaged without reference to character, and before the war could leave, or be discharged, at an hour's notice. They have not undergone the disciplinary training involved in acquiring a skilled craft, and sometimes they can be very unpleasant.

In addition to the principal persons, the owner or owners, the architect and the contractor, there are surveyors, persons who will be using the building and like to get a hearing at intervals, makers of different materials, the officials of public authorities concerned with Building Acts, By-laws and Regulations, representatives of sub-contractors, and even reporters and the police.

In the middle of all these, receiving instructions, hearing complaints, and supplying information, are the building superintendents. They have to adjust their dispositions to deal with all kinds of weather, personal risk, matters giving rise to controversy, trade disputes, cramped surroundings, often much dirt and discomfort, avoidable and unavoidable delay, and the exactions of their superiors. No two large buildings are alike; on each new one fresh problems arise, and when the work is finished the superintendents may have to find fresh employment. Holidays have to be taken when circumstances permit, and sometimes they do not permit for several years.

It is impossible to define lines of conduct applicable to these differing circumstances. The superintendents have their personal idiosyncrasies which are inherent. There are times when two men of different character constantly in contact, as the clerk of works and foreman are, cannot get on at all.

The clerk of works should appreciate the fact that the builder has undertaken to do the work because he hopes to make a profit, and that

losses are experienced as well as profits. The foreman, in his turn, should realize that a contract is an obligation to perform defined services, and that the duty of the clerk of works is to see that this is done.

The clerk of works should not interfere with the general conduct of the work, as long as the stipulations of the contract are being observed. He should deal direct with the foreman, or, in minor matters, with the deputies, when the general foreman does not object to that being done. He should not give instructions to workmen, or hinder their operations. He can, however, often make useful suggestions with regard to procedure which will not be resented; on the other hand, they will often be cordially welcomed.

It is not, as a rule, wise for the clerk of works to recommend that any particular person be employed unless he is very sure of his man; the foreman may be inclined to suspect that this is being done in order to obtain information. But he has the right to object to the employment of a man whom he regards as being unsuitable, such as an incompetent mechanic. Under the terms of the contract this should be done by the architect, but usually the authority of a clerk of works is recognized in such matters.

With regard to the attitude of the foreman to those employed under him, there is usually something wrong if an atmosphere of general dissatisfaction prevails on a job. It is his business to see that the men know what they have to do, can perform their work in reasonable safety, are not compelled to lose time where such loss can fairly be prevented, and are supplied with proper accommodation for meals, safe storage for tools, and clean sanitary conveniences. When it is necessary to point out mistakes, this should be done without giving offence.

THE CLERK OF WORKS

The clerk of works who supervises the erection of new buildings is the one most frequently met with, and the circumstances connected with his appointment will be explained first. Almost invariably he is employed to act under the instructions of an architect or engineer, usually the former, except in the case of local authority work, where he may be under the control of the chief technical officer, variously described as the city or borough engineer, or surveyor.

It is important that he should remember that all his instructions come from his technical chief, and not from his employer. When he is employed under a local authority, there

may be a tendency on the part of members of the authority to interfere with the conduct of his work, and to act on the assumption that they have a right to give instructions. The clerk of works should courteously inform them, when such circumstances arise, that he will bring the matter to the notice of the architect, or, if the point raised is clearly covered by the contract, he can explain the position. It is very easy indeed for a layman to jump at entirely wrong conclusions when building work is in an unfinished condition.

The clerk of works is at the disposal of an architect on jobs where constant supervision is required. This is not part of the architect's duties, and obviously, in the case of a man with a large practice, is impossible. The *Conditions of Engagement*, under which a member of the Royal Institute of British Architects is employed, includes the following paragraph—

That in all cases in which constant superintendence is required, a clerk of works shall be employed for this purpose. He shall be nominated and approved by the architect, and appointed and paid by the client. He shall be under the architect's direction and control.

METHOD OF ENGAGEMENT. When the whole of the preparatory work has been completed, the contract signed or nearing that stage, and the client has decided to engage a clerk of works, the architect sets out to find his man. He may advertise in the technical journals, inquire of other architects or surveyors, or what is frequently done, apply to the secretary of a society such as the Incorporated Clerks of Works Association. On the other hand, he may have a waiting list, or the addresses of men previously engaged, whose services he would like again to obtain. The probability is that there will be several applications, even hundreds, for well advertised jobs, and a choice has to be made.

What guides this choice? Many things: age, length of experience in superintending works both as clerk of works and foreman, the nature of the experience—whether on similar works to the one contemplated—trade (if any), quality and source of references, technical qualifications such as examination certificates, salary required, and inferences drawn from the phrasing and writing of the application. When the batch of applications has been reduced to a few by applying these tests, interviews are requested, and a choice is finally made.

The architect himself may make the choice, and obtain his client's approval, but in public authority work it is done by a committee,

MODERN BUILDING CONSTRUCTION

perhaps a few men allotted the task because of their special knowledge, perhaps the whole council. An applicant must be prepared to face a roomful of councillors, but not many will ask him any questions which matter, probably the architect and the chairman only. The final selection is made by voting, and that is where the dumb councillors come in. The impression left by the appearance and answers of the candidates decides their votes.

Qualifications. There are some fundamental qualifications. The applicant will have little chance of success if his age is under thirty at least. Unless he is a very exceptional man, or can exert private influence, it will be assumed that his experience is too short to qualify him for a post of authority. He should be proficient at a skilled building craft. Most clerks of works have been either carpenters, bricklayers or masons, usually carpenters. The plumber will have to find scope for his ability in other directions. There may have been instances where a plasterer or painter has filled the position—on purely decorating work the latter may have been employed—but they have been very few. Carpenters are preferred because they are accustomed to setting out. Their training has taught them to be careful and exact, and as a rule their general education is higher than that of the other craftsmen mentioned.

The applicant will usually be expected to present evidence of experience as a foreman, or in a similar supervising capacity. The son of a builder who has assisted in the management of his father's business is a case in point. As the clerk of works will have to be of equal status on the works to the foreman, this factor of previous superintendence is regarded as important. The exception would be small jobs in country districts.

TECHNICAL TRAINING. Young men should be able to prove that they have spent a considerable time in studying building construction, and some of the sciences connected therewith, such as geometry. This means the production of certificates from recognized external institutions, such as the Institute of Builders, the Incorporated Clerks of Works Association, or various public education bodies. The subjects which should be studied are building construction, and the trades—carpentry and joinery, brickwork, masonry, plumbing, etc.—and sanitary science, geometry, mechanics, elementary chemistry and physics as applied to building construction, and builders' quantities. Where possible,

classes should be attended; personal contact with a good teacher who will explain the many difficulties that arise is preferable. Failing an opportunity for attending a technical institute, the would-be superintendent should take some recognized course of instruction by correspondence. But even then he should endeavour to pass one or more of the examinations mentioned; the Incorporated Clerks of Works Association holds one annually for clerks of works, usually in September. It is divided into Parts I and II, preliminary and final, with an oral examination to each.

GENERAL EDUCATION. A fair general education is necessary, so that the clerk of works can meet other people on a level. He should write a legible hand, be able to explain his meaning clearly, and be acquainted with the general economic and other conditions underlying building work. His duties will carry him into all sorts of places, where he will have to grasp the principles on which the use of the completed building is based, such as hospitals, schools, factories, and public buildings. The buildings will be designed to meet the requirements of the occupiers; they will not be intelligible to the superintendent unless these requirements are understood.

One other point deserves mention. The applicant for a post must look like a superintendent, and his general character must bear the fullest investigation.

Where these qualifications exist, practical experience, including as a supervisor, technical knowledge gained by study in addition to that acquired by experience, a fair general education implying adaptability, and a good address and character, their possessor can consider that he has a fair chance of success in applying for the position of clerk of works.

FORM OF APPLICATION. He will, in making the application, state his age, occupation, experience, and general qualifications. These should be expressed concisely—the people who wade through the applications are busy men.

An important point is that of salary; this may be stated in the advertisement, or the applicant may have to say what he requires. Generally speaking, it is from eight guineas upwards. On any important job it will be higher than that; it usually bears some relationship to the wages of skilled operatives, an uncertain datum line now. The applicant will be taken at his own valuation—if he asks for pay below the

average he will be regarded as a superintendent below the average.

Typed copies of references should be sent with the application, the originals being retained until required.

An appointment being obtained, the applicant receives a formal notice to that effect which he acknowledges—he may have to sign a short agreement—and on a specified date he takes up his duties. Before dealing with these duties, the other types of clerks of works will be mentioned in so far as their job differs from the man who is employed on new buildings.

The Estate Clerk of Works superintends building works, and to that extent his duties do not vary from those of the other types. But he has to know a lot about farm buildings, their construction and equipment, the special points to be observed in connection with stables, cowsheds, piggeries, barns, silos, stores for grain, roots, and other foods, and buildings containing farm machinery. There are problems connected with drainage and water supply that do not arise on new buildings in towns, and the use of local materials is also an important factor.

He will probably have to know something about forestry, the upkeep of paths, by-roads, hedges, gates and fences. Maintenance work on structures as widely different as the mansion and the cottage will be his business, and he may have to collect rents, superintend a fire brigade, organize functions, and even play a church organ. Much of the work done under him will be by direct labour, and as far as possible such materials as timber, stone, sand, ballast, and perhaps slate will be obtained on the estate.

He is provided with a house, and is often a person of importance in his district. He does a considerable amount of designing of farm buildings and cottages, and generally is a combination of architect, builder and superintendent. Posts of this kind are fewer now than they were a few years ago, because of the breaking up of large estates, farms having been sold to their occupiers or an investor. The estate clerk of works is usually responsible to the estate agent, as far as the non-technical side of his work is concerned, or to his employer direct.

Vacancies are infrequent. They may be advertised in a paper like *The Field*, filled privately, or through the Society of Estate Clerks of Works. Sometimes, on a large estate, an assistant succeeds to the vacancy. Salary would depend on a number of considerations, extent of estate,

size of house occupied, supply of fuel and farm produce, and other things.

The general qualifications are those already mentioned for the new building clerk of works, plus a knowledge of agricultural and similar matters. Books dealing with farm buildings are obtainable, and the Board of Agriculture and Fisheries supplies pamphlets gratis which contain much valuable information. As the estate clerk of works buys materials and pays wages, he has to have a knowledge of business methods which would be somewhat akin to those adopted in a small builder's office. On an extensive estate he is supplied with a clerk, who has to be a fair draughtsman.

The Establishment Clerk of Works is in a position which is a cross between the man on new buildings and the man on the estates. The word "Establishment" is used as meaning places like hospitals, asylums, poor law institutions, ecclesiastical and public buildings, not directly concerned with agriculture. On military buildings a particular type of superintendent known as a military foreman of works is employed, whose status and duties will be explained later.

The duties on establishments include the occasional supervision of new structures, but more particularly the maintenance of extensive existing buildings. This clerk of works employs direct labour, buys materials, and takes his instructions from an architect, and probably an engineer. He is concerned with the renewal of damaged or worn parts, with internal alterations—which may be frequent—with periodical re-painting and cleaning, the keeping in wholesome condition of drains and sanitary fittings, the inspection of hydrants and fire extinguishing appliances, renewal of lighting defects, and the upkeep of heating and similar apparatus. Often he makes fittings and appliances which cannot be conveniently obtained from outside sources. On cathedrals and similar buildings the clerk of works usually is a man who has been a stonemason; on other kinds of establishments the carpenter is most frequently met with.

The qualifications do not vary from those already detailed. The pay will depend upon several circumstances, such as the use of a residence, the right to a superannuation allowance or pension, meals on the premises, and other things. Generally speaking, the establishment clerk of works is as well off as the man on a new building, but like the one on estates, he has the advantage of holding a position which is

MODERN BUILDING CONSTRUCTION

permanent and not lost when a building is completed. Much tact and patience is necessary, one difficulty sometimes being the number of persons in authority connected with the establishment. The number of such posts is not large, consequently vacancies are infrequent. They are usually filled privately.

Public authorities employ a clerk of works whose position is somewhat similar, although usually he does not employ direct labour. He is found, for instance, in the service of county education committees, where he acts under the committee's architect on works connected with the upkeep of, and addition to, school buildings and premises. In addition to inspections of structures, drainage, etc., he measures up and checks accounts for final approval, makes surveys for proposed alterations or additions, interviews people to obtain a report on their views, and prepares drawings of existing and proposed work. Being able to drive a car is an advantage in a large county where a lot of travelling is necessary.

City and Town Councils owning a considerable amount of property sometimes have a clerk of works, and this man may have to include in his duties the inspection of public conveniences, highways and paths. Public authority positions are usually filled through advertising. On civil government buildings the establishment clerk of works is usually an officer of the Ministry of Works. He has probably been promoted from a subordinate position, after passing examinations, and the permanent man is entitled to a pension, if he lives long enough. In addition, the Ministry of Works has a temporary staff. The London County Council also has permanent and temporary staffs. Particulars of the requirements and conditions of appointment under both the Ministry of Works and the L.C.C. can be obtained on application to these authorities.

FOREMEN

The office of clerk of works, as has been explained, varies considerably in its character. That of the foreman is different; his employer is nearly always the builder or contractor.

General qualifications are obviously very similar to those of a clerk of works. But there is this distinction between the two occupations. Most building operations require a foreman; for the larger ones only is the cost of employing

a clerk of works entertained. So the number of openings for a foreman are greatly in excess of those for a clerk of works. The majority are for the working foreman, and an ambitious building operative will, if he watches his opportunity, find one of these without a great deal of difficulty. He must be a responsible person, energetic in looking after his employer's interest, competent at a skilled craft, and able to get other men to work under him.

But it is not so easy to get an appointment as a general foreman. Most men in this position are on the wrong side of the forties, and have not been given the responsible post they hold until they have had considerable experience, and shown capacity above the average. The cost of the buildings on which they are employed will probably be not less than £5,000, and may be at any figure between that and £1,000,000. Jobs costing £100,000 are not by any means uncommon, and the contractor has much at stake in undertaking to do work involving such a sum. The possibility of loss is usually present. Consequently his chief man on the works, the general foreman, is not selected at random.

The general foreman usually has a more regular job than the clerk of works, in that if satisfactory to his employers, he moves from one job to another; few architects have a practice sufficiently large to enable them to retain the services of a clerk of works for a long period. In comparing the remuneration of the two, the advantage probably lies with the general foreman. There would not be much difference in salary, but the latter often receives a bonus if his management produces a profitable result. The clerk of works receives his salary only; occasionally his employers may give him a present on parting, but he has nothing whatever to do with profits.

An appointment as general foreman is obtained by promotion, by private recommendation, by direct application to contractors, by advertising in trade journals, and through the various builders' foremen's associations. Of these there are three in London, and some in Bristol, Birmingham, and other large cities. The position of working foreman is usually filled by promotion, or by direct application to contractors. Deputy foremen, who superintend particular trades under a general foreman, are usually appointed by him, and not by the contractor.

Chapter II—OFFICE EQUIPMENT AND METHODS

Duties of Clerk of Works. The general practice governing the circumstances, qualifications, and appointment of both types of building superintendent have been explained. There will now follow a description of the duties of a clerk of works on taking up an appointment.

A typical specification clause referring to his duties is the following—

The clerk of works shall be considered to act solely as an inspector and under the architect, and the contractor shall afford him every facility for examining the works and materials.

This, it will be seen, does not give him direct authority to demand that any particular operation shall be performed or not performed, or materials used or not used. Theoretically his duty is to see that the intentions of the drawings, specifications, and other documents forming part of the contract are observed, and if they are not to report to that effect to the architect, whose decision is final.

In actual practice, unless there is something radically wrong with the parties concerned, the position is otherwise. The clerk of works is treated as the architect's representative on the works, in that any reasonable demand on his part, respecting the interpretation of the contract, is regarded as being the demand of the architect. The contractor's representative can easily judge whether an appeal to the architect direct over the head of the clerk of works, when the latter states his attitude, would produce an alteration. If the demand is a fair one, it obviously would not, hence the custom of acknowledging the clerk of works' authority. There are many small points which the architect settles by direct instructions when visiting the job. Here the clerk of works conveys the instructions to the contractors, perhaps a written explanation, perhaps a drawing, and such instructions are accepted as being from the architects.

The clerk of works has no authority to incur extra expenditure, and should carefully refrain from doing this unless the circumstances are exceptional. When a failure takes place, such as a settlement, and immediate action is required, it is up to the clerk of works to undertake the responsibility for instructions. Perhaps a job

has to be finished quickly; an unexpected point arises involving expenditure, which, if referred to the architect, means loss of valuable time. This, again, is a case where the clerk of works must assume a position which lies outside his authority. Such occurrences, however, are exceptional; on all ordinary occasions he should not incur extra expenditure without the implied or direct instructions of his superiors, which the latter afterwards confirm.

The Office. Another clause in a specification refers to the clerk of works' office, etc. It is usually on the following lines, although there does not appear to be any recognized standard—

The contractor shall erect and keep in repair a proper office for the use of the clerk of works. It is to be fitted up by the contractor, with a desk with large drawers for drawings, and small drawers for papers, etc., and with locks and keys; also with a large table and chairs, drawing board, T-square, etc., and other necessary conveniences for keeping and preparing drawings and for writing. The contractor is to provide a stove and light, and necessary attendance.

Sometimes the size of the office is stated—such as 80 ft. super, and the contractor may be required to provide stationery. On the other hand, this clause may be a bare reference to a suitable office and attendance.

These two clauses, one defining his status, and one the equipment to which he is entitled, define the position of the clerk of works under the contract. Before paying his first visit to the job, he will probably be supplied with a set of $\frac{1}{8}$ in. scale drawings, any $\frac{1}{4}$ in. scale or full-size details that may be available at the time, and a copy of the specification. He may also receive an unpriced set of bills of quantities, weekly report forms, and be given instructions to purchase stationery, etc., as required. He usually has his own 5-ft. rule, a steel tape, and some drawing instruments, and it is desirable that he should have his own dumpy level. As little can be done beyond a general survey of the site, and a first inspection of the drawings, etc., without some stationery, it is advisable to obtain this without delay.

STATIONERY, ETC. A diary will be required; a ruled foolscap book is better than an ordinary printed foolscap diary for this purpose. Entries vary in length, and increase as the building rises.

MODERN BUILDING CONSTRUCTION

A squared-paper notebook for sketches, costing about 6s. 6d., an ordinary notebook with stiff covers, opening lengthways, at 3s., a surveyor's dimension book at about 4s. 6d., some plain and ruled foolscap, detail paper for drawing (supplied by drawing office materials firms at about 3d. per yard), thin typewriting paper for rough notes, drawing pins, rubber, pencils, and similar minor accessories will nearly complete his outfit. Receipted bills should be obtained with these purchases, as the clerk of works will be refunded for his outlay by the employer.

For letter writing, a duplicate book, quarto size, with numbered pages, and the name of the job across the top, and "Clerks of Works' Office" and address in the right-hand top corner, is as good a plan as any. Copies are kept together, and if indexed can be found without difficulty. A fountain pen with a hard nib will leave a clear impression on the duplicate sheet. Some memo paper, with a similar printed head-line, is also useful for correspondence not requiring copies, such as acknowledgments.

Correspondence received is best kept in files; a double sheet of foolscap answers the purpose. On the outside the name of the sender is written—architect, contractor, surveyor, the names of sub-contractors, etc. Miscellaneous notes, calculations, etc., should be collected and made easily accessible in the same way. If the list of architect's drawings received is scheduled—number of drawing, subject, and scale—and the schedule is pinned to the wall, it is readily available for reference when a particular drawing is required. As far as possible, of course, these drawings should be kept in their right order; on them the date of receipt should be pencilled.

DIARY. It has been mentioned that a convenient form of diary is a foolscap book. This should have a pencilled line drawn down the left-hand side, far enough from the edge to allow room for the date and a description of the paragraphs. The number of items to be recorded will depend on the size of the job and the requirements of the architects. The diary is a record of progress, and all events and particulars connected therewith should be inserted. In the event of an arbitration or controversy, it forms part of the evidence, and great care must be taken to explain clearly and in detail any matter that is likely to be of importance. It is constantly needed throughout the job for information as to past events, and forms the basis of the weekly reports. The following extract from a mythical diary illustrates the method—

<i>June 21st</i>	Weather. Showery. 2 hours lost.
<i>Men</i>	30 labrs., 19 bklyrs., 12 carp., 4 plbrs., 4 plbrs.' mates, 6 plas., 4 scaff., 2 Mortise, Tenon & Co., 4 Bibcock & Son.
<i>Visitors</i>	Architect: Mr. Gaskin: Mr. Pinn (Mortise, Tenon & Co.)
<i>Drgs recd.</i>	Nos. 81, 82. From Bibcock & Son. Nos. 123/5, and 6.
<i>Materials</i>	6 yd. sand; steel windows for basement; 3,000 red facings; 4 y.c. chalk lime; 2 tons P. cement.
<i>Work</i>	North Wing. Gd. Rendering ceiling, Room 2; setting walls, Corridors and Lobby; hanging sashes, Rooms 4-9. 1st. Laying floors, Bed. R. 6; fixing grates and building m.p. Sitting R. External. Pointing W. wall. East Wing. 2nd. Raising bkwk. :— S. and W. external walls; centering for 3rd floor over annexe. Drains. Excavating for connection to sewer.
<i>Architect's instns.— Ironmongery</i>	Locks to be separately suited for each wing. Front door key to pass West Gate. Basement on master only. Messrs. Box Staples' representative to visit site and obtain particulars.
<i>Hearth tiles.</i>	Hearth tiles to be rejected on account of colour. Makers to send further sample for approval.
<i>Roof light</i>	Roof light opening in East Wing Annexe flat to be increased in size to 6 ft. 6 in. x 7 ft. 3 in. Contractors have been informed.
<i>Panelling</i>	Mr. Pinn took dimensions of Entrance Hall panelling. He stated that his tender did not provide for painting back; architect instructed that this must be done. Delivery promised on 18th July.

Usually, it is not worth while to mention in detail the work of electricians, heating engineers, or plumbers, when pipe running is being done. A lot of ground can be covered in a day, and the description would have to include the names of all sorts of rooms, corridors, etc. It will be sufficient if occasional mention is made of these activities, such as the completion of a floor or section. On an ordinary contract it is not often necessary to give exact details of quantities of materials received. The only reason for mentioning the subject at all is that the record shows whether proper progress is being made. If the contract is not completed within the agreed period, the question of enforcing the penalty clause may arise. The record in the diary of materials received would show whether any delay arose on account of belated delivery on the part of the contractor or the sub-contractors.

BARLEY PARKS HYDRO

Clerk of Works Report for Week ending.....June 23rd, 19—..... No. 29.

NO. OF MEN EMPLOYED	Mon.	Tues.	Wed.	Thurs.	Fri.	Sat.	DRAWINGS RECEIVED
Labourers	27	30	29	30	30	30	Nos. 81, 82, 87
Scaffolders	4	4	4	4	4	3	
Bricklayers	20	20	19	19	19	19	
Masons	2	2	—	—	—	—	From Bibcock & Son Nos. 123/5-6
Tilers							
Carpenters	12	12	12	12	14	14	
Joiners							
Plasterers	6	6	6	6	6	6	
Plumbers	4	4	4	4	4	4	
„ Mates	4	4	4	4	4	4	
Painters and Glaziers							
Watchman	1	1	1	1	1	1	
SUB-CONTRACTORS							DRAWINGS REQUIRED
Mortise, Tenon & Co.	—	—	2	2	2	—	Details of dormer to Lavy., E.Wg.
Bibcock & Son	4	4	4	4	4	2	
Black Asphalt Co.	3	3	—	—	—	—	
				2 hours lost			
WEATHER	←←	Fine	→→	Showery	←← Fine →→		
VISITORS	Architect	Mr. T. Smith		Architect Mr. Gaskin		Sir E. Knight	

MATERIALS DELIVERED.

18 y.c. sand ; 5,000 red facings ; 6 tons P. cement ; 18 y.c. ballast ; 4 y.c. chalk lime ; 2 y.c. grey lime ; drain pipes ; steel windows for Baset. ; 2 baths ; 6 squares 1 in. T. and G. flooring.

STATE OF WORKS.

MAIN BLOCK. N. Wing. BASET. Plastering ceilings completed.

GD. Plastering: completed in Rooms, 1, 3, 4, and Lavy. ; part do. in Corridors and Lobby ; Rooms 2 and 5 rendered ; Kitchen floor screeded. Sashes hung on N. and E. sides.

1ST. Laying wood floors completed except in Store Room ; sash hanging completed ; wall tiling commenced in Lavy. and w.c.'s ; m.p. fixed in Sitting R. and Library ; balusters fixed, 1st to 2nd floors.

2ND. Fixing locks in progress.

EXTERNAL. Pointing completed except plinth ; all R.W.P. fixed.

East Wing. GD. As Report 28.

1ST. Breeze partitions fixed in Bed R. 4-10 ; stair concrete, 1st to 2nd floor completed.

2ND. Bkwk. above floor level:— N. external wall, 9 ft. ; W. and S. do., 7 ft. 3 in. ; E. do., 6 ft. ; Annexe, to ceiling level ; centering for Annexe 3rd floor fixed.

GARAGE. Excavation about half completed.

DRAINS. Excavation for connection from interceptor M.H. to sewer in progress.

Signature.....J. VANCE, C. of W.....

MODERN BUILDING CONSTRUCTION

The diary can be written up either on the evening of the day recorded or the next morning. The latter is usually the more convenient time, and the entries are made from rough notes. The foreman would supply information about men employed and materials received; the clerk of works would check these particulars occasionally.

WEEKLY REPORT. The weekly report sheets may be provided by the architect, or the clerk of works may be requested to obtain them himself. The items include men employed in each trade, and by sub-contractors, drawings received and required, names of principal visitors, weather, progress of works, and, perhaps, queries. The queries may be either entered on the report sheet or stated in a letter; a third way is to place them on the left-hand half of a sheet of foolscap, the replies being written on the right. The architect will state which method he prefers.

A typical report sheet is given on page 985.

FILLING IN A REPORT SHEET. Everything is tabulated except the progress of works. As the essential requirement is to arrange the description of this progress so that, while being as brief as possible, it is lucid, a definite method is necessary. The obvious grouping is in blocks or sections, floors, roofs, and external work. Walls will be located by the points of the compass, or the names of adjacent rooms, and the interior work by the names or numbers of rooms, etc., given on the plans. When the building is rising, it is convenient to speak of constructional floor work as being "over dining hall" or wherever it may be. Drains will be located by inspection chamber numbers—"from R.W. gully to M.H. 6"; staircases by their position—"Main," "Left," "East," and so on. The name of the wing or block can be made prominent by printing it, and the description of the floor—whether ground, first, second, etc.—by underlining. Examples are "NORTH WARD BLOCK. Gd.," or "WEST BLOCK Front wing, 2nd."

Methods like these enable the architect to grasp readily the description of works in progress, and save a lot of irritation.

It is not necessary to give each week a full description of the condition of the job. The report sheets must be regarded as a series which have to be read as a whole. Each sheet will record progress during the current week; if nothing has been done on a floor or section, the entry will be "As Report No. . . ." If the statement is made that the rafters are fixed on

a roof, a parapet wall built, or chimney pots fixed, it is obvious that all walling lower down has been completed constructionally.

The most readily understood arrangement is to write on a small scale plan the conditions of different parts; a scale of $\frac{1}{16}$ in. to the foot is large enough. The use of coloured pencils is of assistance, all the walls at a particular level being coloured one tint, and those at other stages, other tints. Floors and roofs can be hatched in. Some kind of description would have to be provided; the advantage of the different colours is that the eye takes in the situation more easily.

Usually, the clerk of works has no time to prepare these plans, which need be line diagrams only, except at infrequent intervals. The written record has to be relied upon. Sometimes, however, on large jobs, prints are supplied by the architect which the clerk of works deals with in the manner that has been explained above; but, of course, many particulars relating to finishings cannot be conveyed except in writing.

QUERIES must be clearly stated; the best plan is to draft them first, and illustrate where necessary by intelligible sketches or drawings. When the inquiry relates to a piece of work in a particular position, a clause in the specification, or a matter which has already been the subject of correspondence, clear references should be given. In the first case, a sketch or drawing is nearly always required; drawing is the language of construction. If the architect frequently visits the job, queries can be collected on a sheet of foolscap, and probably be settled in the clerk of works' office. On country jobs his visits are fewer, and many things of comparatively minor importance have to be dealt with through the post.

REFERENCE BOOKS containing information on sizes, weights, simple formulae, regulations, etc., are a necessary part of office equipment. These include such items as Molesworth's or Hurst's Pocket Books, the handbooks issued by constructional steel contractors, and catalogues of ironmongery, sanitary fittings, paint, glass and other items usually obtainable from large firms of manufacturers or merchants. In addition, a copy of the by-laws or other regulations of the public authority for the area in which the job is situated should be obtained and, if they are not incorporated in the contract, regulations dealing with welfare. It may also be useful to have a copy of any agreement between employers and operatives on wages and site conditions which apply to the job.

Chapter III—SETTING-OUT

Profiles. Under the terms of the contract it is the builder's business to do the setting-out, and he is responsible for the accuracy of this operation. The duty of the clerk of works is to check carefully. Profiles will be fixed in the ground if there is clear space; if not, the positions will be marked on adjacent walls, on the timbers where there is a basement excavation, or recorded by other convenient methods. The width of the wall, the footings, and the foundation concrete should be shown separately.

Too much care cannot be taken in doing this, and it is worth while to give the profile or other surface a coat of white distemper, on which, when dry, the marks will be readily seen. The profiles must be fixed clear of the excavations, rough preliminary measurements being taken to ensure this. The cross-pieces should be level and firm; a 6 in. by 1½ in. board, 12 in. longer than the width of the trench, on 4 in. by 2 in. stakes driven firmly into the ground, makes a suitable profile. These must be fixed at all external angles and in line with the principal cross-walls.

Other interior walls can be set out separately without the use of profiles. Lines are stretched between the profiles; the position of the secondary walls is measured from them and located by driving iron pins into the ground (½ in. round bar, 2 ft. long, will do). Lines are stretched between the pins, and the navvy cuts the outline of the trench to them; the pins are then withdrawn. This will not be exact enough for the wall proper. In building, the walls which have profiles will be raised first to a height of about one course above the footings; the position of the secondary cross-walls will be marked on this brickwork and squared from it.

The clerk of works must insist on proper setting-out methods. When the contractors are a large firm, with an experienced foreman, there will be no difficulty in this respect; but sometimes a firm undertakes a contract larger than it has been accustomed to, and the setting-out methods may be very crude. Scratches on the ground, roughly measured, and angles fixed by a long-used and inaccurate building square, or even fixed by the eye, may be resorted to. A

little tact and advice in such circumstances will usually produce a scrapping of this "system."

CHECKING SETTING-OUT. In checking, the clerk of works will use his plan and lightly tick off the dimensions as they are disposed of. He will check all principal angles by the 3-4-5 method, using his steel tape for the purpose. Multiples of these figures should be used, say, 18-24-30 ft.; the two former are measured from the intersection of the profile lines, one in each direction, giving two sides of a right-angled triangle, the hypotenuse of which should measure 30 ft. This check should be made at not less than two angles. There will be, at least, one unalterable line, probably the frontage, which will remain fixed whatever adjustments have to be made with the others.

In the event of an angle being other than a right angle, it will be checked as described above, but the length of the sides will be obtained by setting it out on the drawing board, with the base 12 in. long, measuring the other sides, and multiplying each by 20, or another convenient figure. Small breaks or cross-walls will be checked by using a building square.

The clerk of works must ascertain that this article is correct; a square, like a wide levelling board, or straight-edge, adopts all sorts of strange shapes, when it is left exposed to sun and rain. Such tools should always be painted at least two coats. The square is checked by placing it on a floor with one edge against a straight surface, such as a wall or plank. The position of the other edge, the one which should complete the right angle, is marked on the floor. The square is then revolved so that the edge against the plank points in a direction opposite to that of its first position, and the projecting edge is again marked. If the two marks coincide the square is true; if not, half the amount of the variation must be planed off the projecting arm.

Errors. Any discrepancies discovered in checking the setting-out must, of course, be put right before digging commences. Sometimes the foreman and the clerk of works do the setting-out together; this is the most convenient method, although the contractor is not thereby absolved from being responsible for errors. There is

MODERN BUILDING CONSTRUCTION

nothing disturbing, however, about this condition; it is unlikely that both men will overlook an error of magnitude. Where no clerk of works is employed, the architect should either check the setting-out himself, or send a responsible representative to do so. On town jobs where a site is surrounded by property belonging to different owners, the position of the enclosing walls of the new building, projection of footings, etc., will be decided after consultation and agreement with the surveyors representing the different parties concerned. Here the clerk of works will receive definite instructions respecting each enclosing wall, which he will follow to the letter.

Levels. The lines of the setting-out being fixed, there remains the question of depths of trenches and other excavations. The datum from which all these will be obtained will probably be the *ground floor level*, decided either arbitrarily, or in reference to an ordnance datum, a fixed point such as a pavement, or, in the case of extensions, existing floor levels. On open sites, the floor level should be recorded on the building area itself by means of stout pegs driven into the ground and concreted, and cut off to the exact level required. There should be several of these on a large site. In addition, the floor level should be recorded by a mark that cannot be easily removed, such as a chisel mark, saw cut, or paint on an adjacent fixture, if there is one, like a wall or tree. Chisel marks on surrounding buildings, or a built-in point, like a blue brick or tile, may be used to mark a floor or other datum line for an enclosed site.

The depths of excavations—basements or trenches—will be found on the drawings. The simplest check, when the excavation is supposed to be at the required depth—apart from the question of sound or unsound bottoms—is to level with a levelling board from the nearest datum peg or mark, and measure downwards. This is done at each end of a straight run, and intermediate points are checked with boning rods. The tops of the pegs at the *foundation concrete level* should be the basis of the check, the depth of the concrete being measured afterwards. The clerk of works should see that the pegs are firm; on a ballast bottom it is usually necessary to start the hole with a crowbar.

CHECKING LEVELS. A dumpy level is the best means for checking levels. It will be used by taking a reading when the staff rests on a datum point, adding the required depth, and reading again with the staff resting on the pegs in the excavation. In the event of depths shown on the drawing being dimensioned in relation to a *ground level* point, and not a floor line, this point should be carefully obtained before the ground is disturbed and transferred to a fixture, like a wall, tree or fence, as has previously been described. The ground floor level, however, provides the best datum, as foundation walls and concrete are usually dimensioned in even parts of a foot and easily calculated.

Before the site is disturbed, the clerk of works should take levels at points that will give a fair average of the general *surface contour*, and record these on the plan, as being above or below floor level. If any remeasurement of quantities is necessary, the depth of soil removed is easily ascertained from these particulars.

OLD PIPES, ETC. A site may contain old drains and pipes of various kinds, and old wall foundations. The line of the pipes will be traceable if they appear in several trenches, and the clerk of works should record these and the old walls on a tracing of the ground floor plan. He should also make sure that all pipes are out of action; if old water and gas pipes, they should be broken off outside the building, and the end stopped in with concrete, as a precaution against any possible connection to live pipes which may have been overlooked. It is usually specified that old soil drains are to be rooted out; where they are shallow this should be done, and the site made firm with hard filling. But where these drains are deep, say 5 ft. and over, it is better to fill the exposed ends with concrete.

If land drain pipes are discovered, it is usually possible to judge whether they are alive. Badly laid land drains soon become useless through subsidence and get choked with soil. If they appear to be in this condition, any severance made during excavations can be ignored; but if they are active, it will be necessary to let the open end drain into a soakaway pit some distance from the building, or connect to the part of the system which is not cut, if it can be discovered, or empty into a ditch.

Chapter IV—FOUNDATIONS

Planking and Strutting. It is the duty of the contractor to do all necessary strutting and timbering in trenches and excavations. In a comparatively shallow trench in ordinary firm soil, this will be a simple arrangement of open poling boards, walings, and struts; in an enclosed site, with one or more basements, it can be sufficiently elaborate to require planning and exact setting-out. Between these two extremes range a wide variety of methods, depending on depth, the nature of the soil, and the area of the excavation. Even where the excavation is not deep, it can be very troublesome in "rotten" ground, such as where the excavation has to be cut through dumped soil and refuse containing the foundations of old walls, drains, etc. Short, close, poling boards are necessary in such cases; the sides of the excavation will probably crumble in places, whatever is done.

A water-logged soil, of course, requires close sheeting; and a pump will have to be used, with the end of the suction hose in a sump-pit. A frequent discovery is a water-bearing strata of ballast several feet below firm soil, requiring open polings in the upper part, and close sheeting below. The clerk of works is responsible for efficient timbering only to the extent that it is his business to draw attention to danger points. These may lead to injuries to the workmen, damage partly completed work, or necessitate filling, which is scarcely ever so firm, unless it be done with solid concrete, as the original soil—the exception being the made-up ground previously mentioned. Where there is a deliberate neglect of proper precautions, and his protests lead to no improvement, the clerk of works should report to his architect. Such cases, however, are not common; they usually arise where the contract price is too low, and risks are taken, with the hope of eliminating the probable financial loss.

Inspection of Foundation Bottom. Before the concrete is laid, the suitability of the trench bottom must be investigated. In London this has to be approved by the district surveyors, who are appointed under the London Building Act. In most provincial towns the inspection of foundations is included among the duties of the building inspector. In rural districts it may be no one's duty, there being no public authority

officer competent to pass an opinion on the subject. The clerk of works will satisfy himself that the bottom is sufficiently firm for its work, before asking either the architect or a public officer to inspect and approve. He cannot test in any real sense of the word. The best plan is to drive in, by hand, the point of a crowbar. If there is resistance, and the point penetrates a few inches only, the bottom is good; if the bar can be pushed downwards into the soil for a foot and more, it is bad. Between these two there are grades which must be left to the judgment of the various people concerned.

Inquiries made in the district, if there are existing buildings anywhere near to the site, will probably elicit useful information. Ballast is nearly always safe (the existence of "pot holes" being an exception); so is blue clay; so is yellow and boulder clay, if the foundations are deep enough. Anything in the nature of a peaty soil is suspect; sand is all right if it is compact and there is no probability of future deeper excavations being made near at hand. If the strata is bad all over the site and does not improve within a reasonable depth, engineering operations, involving piers and beams, may be required—it is not the business of the clerk of works to design these. If it is bad in patches, the defective soil is removed, and additional concrete inserted, the variation from the original depth being measured and recorded; the extra depth must not, on any account, be filled in with hard core or ballast.

Up to this stage no permanent constructional work has been described. This will now be dealt with by following the subdivisions that are usually adopted in specifications—concretor, bricklayer, drainlayer, slater, tiler, carpenter, and so on, and not by tracing the erection of the building from the foundations to the last coat of paint. Details of work connected with these and similar trades are given in other sections of this work. Here the points dealt with are those which require the particular attention of the building superintendent, especially the clerk of works.

FOUNDATION CONCRETE

Aggregate. Before excavations are completed and ready for concreting, a sample of the ballast

MODERN BUILDING CONSTRUCTION

or aggregate that the contractor proposes to use should be obtained. A sample load is desirable; material of this kind cannot be judged from a small quantity in a packet. Ballast for mass concrete in trenches is in question, not carefully graded shingle and sand for reinforced work. It is usually described as being approved, clean, passing a 1½ in. or 2 in. ring, with sufficient sand to fill the interstices, and by other phrases of a like kind. In London, Thames ballast is usually supplied; and if the proportions of the different sizes of stones and sand make together a compact mass, it is good enough for all ordinary purposes.

The clerk of works will find his greatest difficulty in deciding whether a particular pit ballast is suitable—generally one obtained in the district. The question is whether it makes a satisfactory concrete, and not whether it exactly conforms to a theoretical standard. If the stones are coated with fine sand, clay or loam, it does not. On the other hand, if these are clean so that the cement can directly coat them, and a small amount, about 5 to 8 per cent of fine material is scattered through the mass, the concrete, properly mixed, will be quite sound and get very hard. It is the case that a ballast can be suitable when dry in summer, but not so in winter, when the fine material sticks to the stones and is added to by loam, which washes into the gravel pit from the soil overhead.

The clerk of works should have a lump of concrete of the specified proportions and containing the proposed aggregate made, and break it when it is a week old. His experience will tell him whether it is sound. If it approaches the border line he should, if possible, consult his architect; it is unfair to put the contractor to the expense of transporting ballast a long distance if an approved quality is available nearer to the site. But there is no need to consult the architect if, when the ballast is shaken up in water in a bottle, there is an appreciable layer of sediment on the top when the water clears, or when the stones have a coating of fine material on them. It should be rejected without any parley.

The use of broken brick may be permitted by the specification. This should be hard, and free from plaster of Paris and other materials having a gypsum base. Most broken stone is suitable unless it is soft limestone; sufficient sand and fine ballast to make a dense mass must be added, if stone is broken by hand and is on the large side.

Cement. The inspection and testing of the Portland cement used for the foundation concrete is not the important matter that it once was—the manufacture having been standardized to an extent which reduces the possibility of producing an unsound cement to a minimum. For foundation concrete, it will probably be sufficient if the clerk of works makes an occasional pat on a piece of glass, and observes its setting properties and freedom from cracks. These pats should be made at intervals when a batch is delivered, and have the name of the cement and date marked on them. Ordinary observation of the concrete will soon reveal whether there is anything wrong with the cement.

In the case of cement used for reinforced concrete work, which will be dealt with later, it may have to be sent to an analyst for approval, or the clerk of works may be supplied with testing apparatus. But that is a different matter. Mass concrete in foundations only on firm soil, where no reinforcement is needed, is being considered here.

Mixing. Mechanical mixers are now part of the equipment of all except the smallest builders, and will almost certainly be used, but there may be some of the "twice wet and twice dry" hand mixing. In mixing by hand, the distribution of the cement throughout the aggregate should be nearly complete after the dry mixing, before the water is added. The clerk of works must see that it is thoroughly done; the foreman will probably be willing to have a long-pronged rake, or a pick, pulled through the heap before mixing commences; this is a valuable procedure. The two operations required for the wet mixing do not include the shovelling of the concrete into a wheel-barrow; "turned twice wet" means turned twice on a platform, or hard clean surface, such as paving.

The amount of water added depends on the wishes of the architect or engineer—if any are expressed—on the temperature and humidity of the atmosphere, and on the nature of the trench or place which is to receive the concrete. The best consistency, under ordinary circumstances, is a "mushy" one, when a handful, pressed tight, coheres and does not crumble or flow. If the soil is very dry, the concrete should be wetter than this condition, and, in addition, water should be thrown over the surface before depositing. If the weather is wet and cold, the concrete should not have more water than is absolutely necessary. It is difficult to control the water

supply to a fine margin if hand mixing is performed—the human factor is too variable. When the mixing is done in a machine, there is no difficulty; the water supply can be regulated easily.

With hand mixing, the clerk of works must see that a can having an undamaged rose outlet is used, that the concrete is transferred to its resting place without delay, and not dumped from a height, that the mixing platform is kept clean, and that dirt, straw, and rubbish does not get mixed up with the ballast. He must insist on the use of proper gauge boxes, measure and check their sizes, see that the cement box has a bottom, and that its capacity is not reduced by caking. When a machine is used, the hopper provides the gauge box for the aggregate; its capacity is usually supplied by the makers. The cement is measured in a box and added when the hopper is only part full. The cement does not get blown away when the hopper is emptied if this is done.

PROPORTIONS. Sometimes the foreman wishes to adjust his gauging, so that he can use a bag of cement at a time—when the mixing is by hand. There is no objection to this being done if the right proportions are adhered to; the cement should be part shovelled out and distributed—so that it is not dispersed in a cloud in all directions—and the remainder emptied from the bag. Portland cement is usually supplied in paper sacks containing 1 cwt or $1\frac{1}{16}$ cub. ft. in volume. A whole sackful must be used at a time, not parts from two sacks.

When laying finishes for the day part-way along a trench, the end should be left rough and inclined. If side trenches are at a higher level than the main trenches which they intersect, as in the case of a cross wall meeting an external wall, the greater depth should be extended into the cross-trench for the length of about one foot, thus providing a stooling under the higher concrete and a connection of the two sections.

The rapid-setting cements will not often be used for foundation concrete on account of their extra cost. Where they are used, the instructions of the makers must be closely followed. An important point in connection with *ciment*

fondu is that it must not be mixed with Portland cement, and the latter must be thoroughly removed from any platform on which *ciment fondu* is used.

Protection Against Weather. Frosty weather often presents a problem, particularly early frosts with the mercury near the freezing point up to 10 or 11 a.m. In the case of reinforced concrete, when ordinary Portland cement is used, no risks must be run, whatever the delay may be; 39° F. is usually the lowest temperature permitted. For concrete in trenches, 36° F. is safe if there is no frost in the aggregate—as there might be after a frosty night—and the water is taken direct from the pipe supply, and not from an icy tank. When a cold wind is blowing, the surface of the concrete in trenches or elsewhere should be protected, as it also should be at night when a frost appears probable. During hot weather protection should be afforded to prevent evaporation of the water before complete hydration of the cement has occurred. Sacks, tarpaulins, or boards are used for this purpose. In the case of external surface concrete, under pavings, etc., protection must also be afforded at extremes of temperature, but if it can be avoided—if completion is not an urgent necessity—surface concrete should not be laid when frost threatens. It is not sheltered as is trench concrete.

The clerk of works will constantly be up against this factor of completion to time, and will have to use a lot of discretion with regard to concreting, and many other works requiring the use of water—bricklaying, plastering, cement floor laying, rendering, and similar processes. He must not agree to work being carried on under conditions which will result in a defective job; on the other hand, he must not, where completion in a stipulated period is important, do anything to cause avoidable delay. By protecting both materials—covering sand and ballast, for instance, when frost is probable—and completed work, and generally exercising foresight, many of the difficulties due to adverse weather conditions can be avoided. Cement, lime, and plasters will, in any case, be stored in a weather-proof shelter; that is always essential.

Chapter V—CONCRETE

SURFACE CONCRETE

THE precautions to be observed in supervising the use of mass concrete in foundations apply to plain surface concrete, which is usually laid on a bed of hard core. The levels and depths of both hard core and concrete must be checked, and if wooden pegs are used to fix the levels they must be removed before the concrete sets. Dry rot has occurred more than once, because pegs left in the ground have become affected by fungus, and conveyed the infection to floor and other timbers. It is not enough to drive them below the surface of the concrete and cover over; they must be taken out before the concretor leaves his job. A better method is to use iron pegs; short pieces of gas or water pipe are usually available and these can be left in the ground.

Pipe Channels. Before surface concrete is laid, provision should be made for the passage of any pipes—water, gas, hydrants, heating, drains, etc.—that may have to pass under the floor. The clerk of works should ascertain the runs of the pipes, in some cases from subcontractors, in others from the architect, or from his own devices approved by the architect. A sketch plan should be made giving the necessary information, positions being dimensioned from suitable points, and depths indicated; the arrangement is shown more clearly if coloured pencils are used to distinguish each type of pipe. Concrete or brick channels may have to be provided, and are always preferable; provision for the insertion of small water pipes, such as main supplies to cisterns, can be made by burying drain pipes from the point where the water pipe enters the building to where it rises through the floor. Where large ducts are formed for receiving pipes, it will be necessary to arrange channels, etc., in floors for branch runs. Breaking up set concrete is an expensive job which causes delay, and the clerk of works must see that it is avoided as far as is possible.

Where comparatively narrow channels for pipe runs, up to say 12 in. wide, are formed with concrete, which is cheaper than brick and quite satisfactory, and the channels are sealed afterwards, and not covered with detachable boxes, a good method is to leave rebates, 3 in. or 4 in.

thick, in the surface concrete on each side; place asbestos-cement sheeting, cut to width, in them as a permanent centering, and cover with strong concrete, thus completing the floor. This, of course, is not done until pipe laying is completed, and it is desirable, if possible, to provide some arrangement whereby the pipes can be withdrawn at the end of the channel in the event of leakages, etc., occurring.

Lintels. Concrete lintels are preferable to wood lintels. They are reinforced either with rods, angles or small R.S.J.'s, which will probably be described in the specification. A rough rule for ordinary openings, such as windows, up to, say, 4 ft. wide, with no special weight over, is one $\frac{1}{2}$ in. rod to each $4\frac{1}{2}$ in. thickness of brickwork in 9 in. deep lintels, made with clean ballast, or coke breeze concrete, and proportioned 6 : 1. The ends of the rods should be hooked to about a 2 in. diameter curve and extend about 3 in.

The lintels are often pre-cast between 9 in. scaffold boards placed on edge on a board platform, and spaced the thickness of the lintel apart. The length is fixed by putting bricks without frogs, or pieces of wood, a distance apart equal to the span plus 1 ft. 6 in. (two 9 in. bearings). A series of lintels can be cast at one operation by this method. The clerk of works must see that $1\frac{1}{2}$ in. of concrete is placed in the bottom of the trough formed by the scaffold boards, and the rods, with the hooks upwards and vertical, pressed into it. The top of the lintel must be marked *top* by scoring the concrete while it is green, so that no mistake is made in placing it the right way up when fixing. The date should also be scratched on the top.

The boards are lime-whitened, and the clamps which bind them together are removed in about two days. The vertical boards should be gently lifted out as soon as this can be done safely; a little experimenting will be the guide. It saves a lot of laborious hacking afterwards if the side of the lintel that has to be plastered is scored while it is green with the point of an ordinary iron dog. The bottom of the lintel, of course, cannot be touched until fairly hard—at the end of six days under normal circumstances.

MINOR CONCRETE ITEMS. There are many small pieces of construction that can be cast in concrete on an ordinary building, instead of being built with brick or stone. Coal chutes, gully dishings, thresholds, templates under light loads, window sills, copings on walls, piers, and vent stacks, etc., come within this category. The clerk of works should be watching points like these, which may not be particularly described in the specification; his suggestion, if practicable, will not be resented by the architect. Concrete is a jointless material and if, for instance, a gully dishing and channel can be formed with it and given a clean, even face at one operation, the method is an improvement on using brick and facing with cement render.

REINFORCED CONCRETE

Reinforced concrete requires as much supervision as any item on a building. Failure is a serious matter. Each part of the design has its own particular function; if wrong materials are used, or right materials are wrongly placed, there is trouble. Except in small matters, such as the lintels previously mentioned, flats of small area, or parts where the stress is small, and even a light reinforcement such as metal lathing gives ample strength, the clerk of works should not attempt to design reinforcement. In the event of failure, the architect or engineer will be involved, and held responsible.

The supervisor of reinforced concrete work must study and become familiar with the general principles underlying a combination of steel and concrete. The arrangement of the steel will not be intelligible unless this is done. Shear, tension, compression, neutral axis, lever arm, and other terms used in connection with designing, should have a real meaning to him and not be dismissed as "theory."

Reinforced concrete work may be used in conjunction with structural steel, as in steel-framed buildings—the most frequent method for town blocks of offices, public buildings—or on a brick building, where rolled steel joists transfer the loads to walls; or it may be used for all purposes, foundations, walls, piers, stanchions, floors, and roof. Factories are often of the last type. In addition, it may be used as a grillage for foundations on any type of job. The clerk of works is not likely to be employed on any buildings, except small dwelling houses, where reinforced concrete is not used in one way or another.

Both the design and the execution of the work

may be done by a firm of specialists, or the execution may be done by the general contractors to an engineer's designs and specification. In each case the clerk of works will be supplied with particulars.

Cement. Testing cement, and blocks of concrete made with it, is usually done by professional analysts. In the case of cement, samples are taken from several bags and forwarded in a suitable metal container, together with the name of maker and works, name of merchant if obtained from one, and date of delivery. Obviously this must be done before concrete-making begins. For large contracts, one or more silos of cement may be allocated for the sole use of the job, and tests made of samples taken from the silo direct, not from bags on the site. In such cases, delivery bags are usually marked with the number of the silo. Sample blocks, 6 in. × 6 in. × 6 in. made with concrete taken direct from a batch during concreting operations, may be required for a crushing test. The method of making these is described in the Concrete Code of Practice, and must be followed. The clerk of works should either make them himself or be present when they are made, and see that the date is scratched on the top of the block while it is green. Steel moulds for these cubes can be hired from cement firms if not otherwise obtainable; three should be enough. The main contractors, or sub-contractors, if the concreting is the subject of a separate contract, will dispatch the blocks to the testing laboratory. If the size and importance of the job justifies it, crushing tests are made weekly. A note should be made of the position in which the batch from which the samples have been taken has been placed.

Sometimes clerks of works have been instructed to do the testing, and provided with apparatus. The Le Chatelier test for expansion can easily be done, but tension tests on briquettes require some practice. The expert gets reliable results, because he knows how to get a good mixture with the minimum amount of water allowed, and how to press the paste into the briquette mould. Different pressures in this respect give widely varying results, and there have been cases where the amateur tester has obtained a low figure, and complained of inferior material to the makers. The latter have been able to prove that the method of conducting the test has been wrong and not the cement. Apart from the question of expertness in testing, and the undesirability of a situation like this

MODERN BUILDING CONSTRUCTION

arising, the clerk of works will have quite enough to do in supervising construction; he cannot be in the laboratory and on the job at the same time.

Aggregate. The coarse aggregate and sand will be approved before the work commences. Samples should be kept and each delivered load inspected. It must be clean, and the sand must not contain more than 4 per cent in volume of very fine materials, loam or clay. This is tested by shaking up the sand in water in a measuring glass, the fine matter settling on the top; if it is dark in colour, organic matter is present, and the sand must be rejected. A common test is to rub some damp sand between the hands. No stain is left if the material is clean. Grading must be watched; the larger stuff may not be evenly distributed through the dumped heap. The supervisor will find that after some instructions and persistence, he can get intelligent labourers to do what is required in this respect.

Gauge boxes must be checked, and the cement box kept clean. Water must be clean, and if for hand mixing, poured from a can with a rose. The mixed concrete should be used within about twenty minutes, and any left in the banker during the dinner hour must be discarded. Where a machine mixer is used, the drum should make at least twelve revolutions. It is unlikely that there will be any difficulty about this; the concrete will not, on most jobs, be removed quickly enough to cause any lack of proper mixing in the machine. The clerk of works must see that the drum is cleaned out every night.

Centering. Before the concrete is placed in position the supervisor must inspect the forms and prove that they are to correct dimensions, level, and upright. Where floors are carried by R.S.J.'s, the centering will probably be hung with bolts; elsewhere it will be supported from below by struts, or on stirrups resting on walls. It must be inspected for strength, and care must be taken to see that folding wedges are used under the struts, that they are on a firm bottom (a sole plate if no concrete is laid), and if an upper floor is supported on one below, that the latter is either properly set or supported in turn.

The supervisor must see that beam centering is so secured in its width that it will not bulge, and that a slight camber is provided. This may or may not be specified; $\frac{1}{8}$ part of the span is a customary allowance. If the concrete has to be left with a fair face, the boards should be either well wetted, or treated with soft soap,

limewash, etc.; this prevents lumps of the concrete breaking away, or pieces of framework remaining behind. Beam centering must be arranged so that sides can be removed in two or three days; that in soffits will remain in position longer, the period depending on the load, time of year, and other factors.

Laying. If possible, the laying of any particular slab should be completed in one day, but often where there are continuous slabs spanning from beam to beam, this is not possible. The specification will indicate where the joints are to be made—usually in the centre of the span. Where new work is joined to old, the supervisor must see that the latter is swept clean, hacked, and given a coat of grout, or a thin coat of cement and sand mortar, before the new concrete is applied. It is essential that all centering is swept clean before use, and care must be taken to ensure that the exposed ends of columns are not sprinkled with shavings, etc., before new concrete is put in. The reinforcement makes this difficult sometimes, but column boxes should have sacks placed over them until they are filled.

The clerk of works may be required to take samples of steel for testing; he will keep a record as for cement. He must see that the steel is to the size specified; that bending is done to the proper shape; that stirrups, column reinforcement, etc., are wired with not less than 16 S.W.G. wire; that rods are in their right positions both with regard to depth and to plan position, and that they are free from scale, dirt, and other loose protuberances. Reinforced concrete is a comparatively modern constructional material; its use is now standardized to a large extent, but different engineers have their different ideas, and the supervisor will usually find that these are clearly defined in the specification, particularly with regard to the disposition of steelwork.

The details given respecting the protection of mass concrete, under varying weather conditions, apply equally to reinforced concrete. It must be covered against frost and cold winds, and kept wet until properly set during hot weather. On floor areas wet sacks afford the best protection, a hose-pipe being used at intervals to balance evaporation.

Where there is a restricted space into which concrete has to be put, such as the soffit of R.S.J. casings, cement and sand grout, about 2 : 1, should be poured in, and the ordinary concrete added. Generally speaking, in beams it is best to use a wet concrete at the bottom around the steel, and drier concrete above.

Chapter VI—BRICKWORK

BRICKS

Common Bricks. The kinds of bricks to be used will be specified, and steps must be taken to obtain approved samples at an early date. Grooved Flettons for plastered walls are an advantage—they cost about 2s. per 1,000 more than the ungrooved—and, if specified, the clerk of works must see that they are used where necessary, and that a sufficient supply is kept on the job. Their inclusion cannot be called for if not specified—unless, of course, they are regarded as an “extra.” If ungrooved Flettons are used, the joints must be raked out on plastered walls; this should be done roughly with a point which will leave serrated edges.

In some parts of the country common bricks from local brickyards are available. They should be hard and free from cracks, except ordinary fine fire cracks. Efflorescence causes trouble sometimes in that, if it is pronounced, the expansion of the crystals of the efflorescence pushes the plaster off, or, passing through the plaster, injures the decorations. Local inquiries will probably produce evidence on this point when the use of an unknown brick is in question, or a test can be made by completely saturating the brick and then drying it. This, however, is not a conclusive method; efflorescence may be due to the effect of moisture on the bricks *and* the mortar.

Facing Bricks. Facing bricks are of many kinds. Some are very hard—such as the Leicester red—and others are made of a sandy clay, which produces a brittle but quite serviceable brick. The latter type are often very absorbent before they have been built in the wall and become “weathered”; as the edges are rather friable, care has to be taken to protect exposed parts during erection. Some bricks of this type have a tendency to peel in the face after exposure. If laminations parallel with the face are visible, the bricks must be rejected, as they also should be if lighter in colour than the approved sample; a pink tint nearly always means a soft, under-burnt brick.

The type of facing brick to be used is nearly always selected by the architect. If, however, the clerk of works has to pass an opinion on the

suitability of a sample which he has not met before, he should, if possible, inspect walls containing it which have been erected for several years, in addition to examining particular samples for size, hardness, porosity, cohesion, freedom from cracks, soundness when struck with an iron chisel, etc.

A method that has been adopted to test whether facing bricks will be affected by changes of temperature and frost is as follows. Boil one or more bricks in a 20 per cent solution of Glauber's salts for half an hour, then stand them in the open air, not exposed to rain, for twenty-four hours. Examine them, at the end of this period, to see whether they have split through the frost-like action of the crystals. If not, they are again boiled in the solution and exposed, and the process repeated as often as may be desired. If Glauber's salts cannot be readily obtained, a saturated solution of common salt may be used—as much as can be dissolved—but this test is not so severe. The action of the crystals is very similar to that of frost, and the effect of immersion in the hot solution and cooling afterwards, shows the brick's resistance to changes of temperature. It is advisable to apply the test to known and unknown bricks, and compare the results.

Stock Bricks. The term “stock bricks” is variously used, but, generally speaking, it applies to those in which ashes have been incorporated with the clay. The yellow London stock is probably the best known member of this family. It is a very deceptive brick in that although it has excellent qualities—weathers well, has good compressive strength, does not deteriorate when buried, has high fire-resisting qualities, and gives a good key to plaster—it looks unserviceable. There are several grades: *seconds* and *thirds* are suitable for inside walling, and *firsts*, which are the best shaped, for facings. The architect will decide whether well-formed stocks, with a “heather flare,” are to appear on the face of the wall.

An average sample should be obtained; it is advisable to use the word “average” in asking for samples of any material where the product is variable in shape or appearance. A particular consignment can always be rejected, but this

MODERN BUILDING CONSTRUCTION

means delay, which can be avoided if the supplying firm is informed that adherence to an average quality, as represented by a sample, is required.

Most brindle or multi-colour bricks are of the stock variety. The colours are usually shades of reds, browns, and purples, the variation being due to local methods of firing. These bricks, also, are graded; firsts are those which are hardest and of the best shape, and perhaps of a particular tint. Where multi-colour bricks are used, the clerk of works must see that bricklayers do not attempt pattern making; if, for instance, there is a small proportion of dark headers, these must be distributed in such a way that, while any part of the surface has its share, they do not define diagonal, horizontal, or vertical lines up the wall.

Some brickfields which have a comparatively small output produce excellent multi-coloured bricks. They are made in the summer only, and the preliminary drying is done in the open air. In such cases it is essential that steps be taken at the outset to ensure that delivery can be given as required, and the building superintendents must regard vigilance on this point as important. On a large job the consumption may be equal to nearly the whole output of the brickyard. The brickmaker has undertaken to supply what is required at an agreed price, but if, during the summer, when he has a big stock ready for transport, a higher price is offered for part, he is apt to forget that they are not for disposal. The consequence is that the job is delayed because the supply of facing bricks is exhausted, and no more can be made until the brickmaker can place his raw clay bricks in the drying racks without risk of their being spoiled by frost. Although the bricks are multi-colour, it is probably impossible to replace them by multi-colour bricks from another yard, because of a difference in texture, which is particularly noticeable in a finished wall.

Glazed Bricks. Glazed bricks should be free from fire cracks, and possess a glaze which does not shell off when tapped lightly with a metal tool in the middle or at the ends. Excellent glazed bricks, made with fireclay, can be obtained from reputable firms. There is usually a certain amount of damage caused during rail transit, edges becoming chipped when trucks are shunted. Some of these can be used for closers, or where a cropped brick has to be inserted, but an allowance for waste through damage is always advisable when ordering. It is scarcely neces-

sary to add that glazed bricks with chipped faces must not be used.

The grading of good quality glazed bricks is a question of tint and constant shape. If salt-glazed brown bricks of even colour are required, they grade as firsts and cost more, because of the extra labour involved in selection. With other kinds the colour is more constant, although there are variations of shade in whites, that are usually more apparent when seen in a wall than when handled separately, which require close attention.

Miscellaneous Bricks. *Hard bricks*, such as Blue Staffords, Southwaters, and the white Marland bricks, do not call for any special comment. They are usually sound and uniform in shape. *Narrow bricks*, about 2 in. thick, have become popular for facings where they can be afforded. They are usually sound and well shaped, although there may be a slight camber in the length. If they are used for facings only, with a backing of ordinary 3 in. bricks, the through bonding will be at intervals, according to the thickness. If the work is all in cement mortar, metal ties, wire mesh, or hoop-iron can be used to advantage for bonding front to back. Where an old building has been demolished, the specification may permit the use of whole *old bricks* for interior work. Obviously these must be sound and have the mortar cleaned off; an important point is that bricks with soot on them should not be used.

Red rubber bricks for arches, aprons, and other gauged work are usually the well-known "T.L.B.'s," from Bracknell in Berkshire. They are larger than ordinary bricks, to allow for cutting and rubbing, and very suitable for their particular purpose. As they are friable, it is necessary to protect edges until the scaffolding is removed. The *yellow malms* seen in gauged arches in many old buildings were of fine texture, and could be cut to a true shape, but they were made to ordinary brick size, and it will be found that the arch stretchers are not much over 8 in. in length.

An important point in connection with the selection of bricks, where more than one kind are used in a wall, is to see that there is no appreciable difference in their respective sizes, nor variations in the length of any one kind, and that the length is proportionate to the width, so that large perpends (vertical joints) are not required. Variations in length are a nuisance, particularly in facings where openings have been spaced on the assumption that the length of a

brick plus joint is 9 in. If part of the batch is longer than this the whole have to be sorted out, the longer bricks cropped, or the openings respaced; neither of these alternatives is desirable.

MORTAR

Mortar can be made in a variety of ways. For engineering work it is always sand and cement gauged 2, 3, or 4 and 1. This makes a strong job, and if the bricks have a good key and the work is grouted, a wall so constructed is practically monolithic. Lias lime and sand, 3 : 1, is a good mortar for ordinary purposes, and there are various other kinds of lime, which when used by builders familiar with their characteristics, are quite satisfactory. Roman cement, often employed before Portland cement became readily available, made an excellent mortar; now it appears to have almost gone out of use, though it is occasionally introduced in stucco repairs.

A lime and Portland cement mortar makes a good job. The lime and sand, gauged 3 or 4 : 1, are mixed in the usual way and allowed to stand for not more than seven days. Portland cement and sand, gauged 2 : 1, is mixed when required, and one part of this is added to three parts of the lime mortar. The lime used here is of the feebly hydraulic kind, which slakes quickly, and not lias or similar rapid-setting lime. The introduction of the cement makes an otherwise rather weak mortar into a hard one, and the method is useful in districts where the kind of lime here mentioned is the most readily and cheaply obtained.

Where lime, other than ground lime, is specified and proportions are given, the measurement of lime is in the lump before slaking, and the clerk of works must see that it is not too big—pieces about as big as a man's fist are a fair average. Pre-hydrated lime, sold in powder form as cement is, and of various kinds, has been manufactured on an ever-increasing scale during recent years. For mortar, it can be used without any preliminary slaking or tempering, and it has many advantages over lump lime.

Mortar Aggregate. The aggregate in mortar is usually sand, although crushed clinker, furnace ashes, or crushed brick and similar hard materials may be used on occasion. The sand for Portland cement mortar should not contain more than 5 per cent of fine material, and be quite free from organic substances. That for

lime mortar can contain up to 7½ per cent of fine material, additional to quite clean sand, without suffering any diminution of strength. Tests conducted several years ago by the late Mr. W. J. Dibdin, who was chief chemist to the London County Council, showed that clean clay added to a mixture of 5 Leighton Buzzard sand and 1 grey lime, actually gave an increase in strength up to 10 per cent. The clerk of works must see that all kinds of dirty rubbish and sweepings do not get mixed up with the sand, but there is no harm in allowing the use as aggregate of sifted mortar droppings, unless they have become mixed with earth, etc.

Mortar mixing by hand must be done thoroughly. Portland cement and sand must be first mixed dry, as with concrete, and must only be used as required, and not left overnight and knocked up again the next morning. Lime mortar must be well "larried," so that the lime is thoroughly distributed. Lime is a variable substance, and must be used with discretion; if it is not thoroughly slaked it will blow—particles will slake and consequently expand, bursting off pointing or plastering, after work is completed—and if it becomes clotted and inert, it is practically useless.

DAMP-PROOF COURSES

For a damp course the best material is asphalt, although the familiar slates laid in cement finds favour with many architects. Slates have the advantage of being easily laid as required by the bricklayer; where asphalt is used, a sufficient length of wall has to be raised to d.p.c. level at one time to justify the asphalt sub-contractors sending a layer and his potman on to the job.

Asphalt. Often the laying of an asphalt d.p.c. has to be done in sections; when that is so, care must be taken to leave some of the laid asphalt projecting, either part way along a straight wall or at the intersection of cross walls, so that a watertight joint can be made when laying commences again. For vertical asphalt, as on the outside of a basement wall, joints should be raked out, and if the vertical asphalt has to be carried over footings, it is best to render these so that a plain splayed surface is provided, instead of a series of steps. Where vertical asphalt meets horizontal, at the foot of a wall underground, the latter must project beyond the vertical, so that an asphalt fillet can be formed. The clerk of works must see that the specified thickness is provided, which may be

MODERN BUILDING CONSTRUCTION

either $\frac{1}{2}$ in., $\frac{3}{4}$ in., or $1\frac{1}{8}$ in.—one, two, or three coats respectively. He must also watch junctions, and see that these are properly formed, and that the damp course above ground level is kept back about $\frac{1}{2}$ in. from the face of the brickwork to allow for pointing. Screeds are not used in laying vertical asphalt below ground; a good layer has no difficulty in getting the right thickness.

Asphalting is always done by specialist firms, and they are usually required to guarantee their work for a period—two or three years. Asphalt should not have a tarry smell, and should be free from burnt pieces; the clerk of works should know enough about the subject to be able to recognize good from inferior. If he has real cause for suspicion, it is advisable to get the opinion of an expert; the probability is that the laying will give more cause for complaint than the material. The employment of a good class firm is essential if these difficulties are to be avoided.

Slates in Cement. The slates used in a damp course must ring clearly when struck with a chisel, be free from an earthy smell when damp, and not be less than $\frac{3}{16}$ in. thick. They must, of course, be free from cracks, and laid so that the joints of the upper course are in the centre of the slates below it. The edge must be kept back from the face for pointing, and in calculating the height of a wall with a slates-in-cement damp course, in relation to the foundation concrete, it must not be forgotten that the d.p.c. is about $1\frac{1}{4}$ in. thick. The cement mortar used will be 1 : 1 or 2 : 1, and the sand must not be coarse. The clerk of works must see that the slates are firmly bedded. Where the walling above is in lime mortar, and the specification says that the damp course is to be two courses of slates laid in cement mortar, the clerk of works can require that the mortar on which the slates are laid is in cement, but the builder is quite in order in using lime mortar over the slates—that is, two cement joints can be claimed, not three.

There are several good damp courses—and some inferior ones—made in sheets. Broadly speaking, quality varies with cost. They must be well bedded, laid with lap joints fixed with a mastic solution, and kept back $\frac{3}{4}$ in. from the face of the work. If it is necessary to provide a d.p.c. in an old house built without one, brickwork can be cut out, at the required level, not less than two courses deep, and Blue Stafford bricks, well grouted in cement, built in

and pinned. This is an expensive process which is not often employed.

BUILDING BRICKWORK

Bond. The type of bond to be used will be specified, usually either Flemish or English. The latter is the best and simplest method, but rather monotonous in appearance, and Flemish is more usually adopted. On inside plastered walls either bond will do. Cracks in walls are nearly always due to unequal settlement of the foundations, and a wall has to be very badly built to fail because of defective bonding. For all practical purposes there is no difference between the two types in respect of strength, and even garden-wall bond—three courses of stretchers to one of headers—makes a sound job if the bricks are properly laid in good mortar. The specification usually mentions bats—half bricks—in some way; they are either not to be used, or only where required to ensure proper bond. The latter proviso applies in the case of a brick-and-half wall in Flemish bond; bats in the centre of the thickness are unavoidable. Some bricks snap rather easily during transport, or when stacked high on the site. The clerk of works must use his discretion with regard to the inclusion of these in the wall. In cement mortar work, occasional false headers—two bats instead of one whole brick—can do no harm; they can also be cut for closers or used where the bonding makes the use of cropped bricks necessary.

If the work has to be grouted, the clerk of works must see that the gauge pot is used. "Flushing up" is usually regarded as meaning working the mortar well into the cross joints with a trowel, but not necessarily using water at the same time as with grouting. He must also see that the cross joints are "buttered" to practically their full length; bricklayers have a habit of buttering the outer end only. Wall faces, openings, etc., must be upright. The face must be particularly watched at scaffold levels; a brick wall is made of many pieces, laid in a semi-fluid mixture, and it is liable to get out of level. The best plan is to use a story rod with the joints and floor level set out on it. At particular stages, at ground floor level for instance, headers are laid which project beyond the inside face of the wall near the angles, and at intermediate stages, about $1\frac{1}{2}$ in. If care is taken to get them level, and the story rod is placed on them at intervals, any departure from accuracy as the wall rises is easily detected.

Bricks must be well wetted during hot

weather, and the top of built work must be protected by boards, felt, tarpaulins or any other suitable covering during frost or heavy rains. The clerk of works must see that, as far as possible, defacement through scaffold splashings is avoided, and that arrises, etc., are protected. Where pointing has to be done after the wall is built, joints must be raked out $\frac{1}{2}$ in. deep as the work proceeds; this is a point which is not always attended to unless closely supervised. In cavity-wall work, battens must be placed in the cavity, resting on the last row of ties laid or suspended by string, and drawn up, cleaned off, and replaced as the work proceeds; if wrapped with hay bands, there is less risk of mortar droppings passing the edges. At the bottom of the cavity provision must be made for clearing out collected droppings when the work is completed.

FROST. The lowest temperature at which bricklaying should be proceeded with may be stated in degrees Fahrenheit, but there are other methods. "When mortar clings to or coagulates on the steel blade of the trowel, and hangs like beads and knots on the line, and the surface of the mortar on the mortar board becomes like thin pie crust, then it is time to pack up and go home." By using hot lime, which has previously been dry slaked, work can be proceeded with safely during temporary frosts—in the early morning, for instance. The bricks and sand must be dry and free from frost, and the previous day's work must have been protected. Mortar is not exposed as concrete is; when spread it is protected by the bricks. And while, on the one hand, work must not be done under conditions which will produce defects; on the other hand, it is unwise to insist upon the cessation of work—and consequent lost time to operatives and delay of the job—on occasions when the adoption of such precautions as those mentioned above removes the element of risk.

Arches. The clerk of works should inspect the setting out of gauged or fair-axed arches before cutting is commenced, and if any unusual feature presents itself, he should draw the arch to a large scale on his drawing board. He will then be able to give the necessary instructions, without hesitation, when the bricklayers are ready to commence on the work. He must see that rubber arch bricks are grooved in the centre of their bed and grouted with neat cement, and that they have a continuous lime putty joint, and do not require stopping in. They must, of

course, be truly cut, with a key brick in the centre, and a parallel joint at the skew backs, which will be in the walling mortar. The lower bricks in the skew-back voussoirs, and at the centre, should be stretchers.

Where gauged brickwork is to be carved, it should be set in shellac; if the joints are to be visible, add lime putty, dry lime powder (air slaked), white lead in oil, or white lead powder. The cutting must be done very accurately, with joints of parallel thickness throughout, so that no voids are exposed when the work is undercut by the carver.

Axed arches must be truly cut and have joints not exceeding $\frac{1}{4}$ in. thick, and be set in cement; a strong job is obtained if an open space is left in the centre of the cross joint, into which grout is poured. In the case of a gauged arch, the clerk of works can require that a groove be provided for grouting, but not usually where the arches are fair axed. As a matter of fact, if the cross joints are properly made, these arches are quite sound; the grouting is an advantage where the soffit is level, except for the usual camber of $\frac{1}{16}$ in. to each foot of span—the so-called "flat" arches.

Flues. If flues have to turn at awkward angles on their way from the fireplace to the top of the chimney stack, their route should be drawn to, say, an inch scale, and the position and amount of "gather-over" be dimensioned. It is best to express the latter in relation to courses; for example, gather-over $1\frac{1}{2}$ in. in each course to a height of eight courses. This applies to unavoidable change of direction; in any case it is advisable to make an easy break in the straight run of the flue at some point, usually near the inlet. If the flue is gathered over so that on looking up it daylight cannot be seen at the top, the bend is sufficient to act as a draught check, and to prevent rain reaching the fire.

All flues must be "cored" at completion by having a folded sack drawn through them, or by some other method, and if the height is appreciable, coring holes should be provided and bricked up when it is certain that the completed flue is not blocked in any way. At the bends it is an advantage to put a thin layer of sand on the lower inclined face, so that mortar or parging droppings do not stick. Care must be taken to avoid the blocking of flues with short pieces of timber, bricks, or any of the other materials which are usually lying about on floors and scaffolds during the course of construction.

MODERN BUILDING CONSTRUCTION

It is advisable temporarily to cover the open end of a partly completed flue. The clerk of works must see that putlog holes in stacks are properly made good, and that the outer faces of breasts and stacks are rendered where they pass through a wood floor or roof.

Pointing. Pointing is done in a variety of ways, according to the nature of the bricks and the taste of the architect. When it is done after erection, the work must be thoroughly cleaned down, and it may be necessary to use a weak solution of hydrochloric or muriatic acid to remove stains. Damaged bricks must be cut out and replaced, and care must be taken to avoid varying tints of the pointing mortar; enough sand of a particular shade should be ordered and reserved for pointing, and the same thing applies to cement. Both sand and cement vary appreciably in colour.

Terra-cotta. Terra-cotta is usually laid by bricklayers. The clerk of works must see that this material is ordered at an early stage, and that full particulars are available. He will often have some difficulty in deciding whether a particular piece should be rejected on account of bad shape, and no rule can be given, except that if the departure from perfection is so obvious that it would catch the eye of the most unobservant person, there is no alternative to rejection. Terra-cotta is a baked material, and exactness of outline must not be expected. The glaze must be quite sound, and must not be cut to remove inequalities at joints. There should be no pinholes; these can be detected by wiping red ink over the face of the glaze, and then removing it. If there are pinholes, the ink will enter them and become visible when the non-porous part has been cleaned. Terra-cotta blocks are filled with a weak concrete; six of small stone ballast, three of broken brick, and one of Portland cement is a suitable mixture, as is a 9 to 1 coke breeze concrete.

Holes for Pipes. Holes for pipes—soil, waste, cold, hot, and rain-water, drains, etc.—should be provided as far as possible as the work proceeds. Cutting through thick walls is an expensive business, and cutting through any wall does not improve it. Often the runs of pipes are not decided during the early stages of the work, and holes in such cases have to be cut, but it is usually possible to provide for w.c. branches, overflows, and drain pipes. Even if the opening left is not in the exact position required, there is an advantage in forming it; to extend is easier than to pierce.

DRAINS

Gradients. The drain plan will show the positions of the main runs, branches, and sewer connection, and may or may not give the depths. The datum levels will be those of the interceptor manhole and the branch farthest from it. The depth of the former can be found by calculating the run of the drain, allowing a fall of 1 ft. in 40 ft. for 4 in. drains, and 1 ft. in 60 ft. for 6 in. drains, and adding the depth to invert of the highest branch. If, for instance, the total run is 250 ft., 160 ft. of which is 4 in. and the remainder 6 in. drain, the depth of the interceptor manhole is 1 ft. 6 in. (depth at highest point) + 4 ft. + 1 ft. 6 in. = 7 ft. to invert, if the site is quite level. Inequalities of the surface would have to be allowed for by adding or deducting, according to the contour. The falls may be different to those mentioned above, on account of peculiarities of the site; 1 ft. in 40 ft. and 1 ft. in 60 ft. is a general practice, but there is nothing hard and fast about these gradients, except that usually they are a minimum.

If the clerk of works has to give the levels, he will find it a good method, on open ground, to have pegs firmly driven into the ground at salient points, manholes, etc., and take readings on these with his dumpy level. By setting up levels thus taken on the drawing board, in sections, he can set out the run of the drain, working back from the interceptor, the depth of which is already known, and supply the depth of the excavation at any point where pegs have been provided. If the navvies excavate exactly to these depths, intermediate points can be obtained with boning rods. As the invert of the pipe is the datum, its thickness and that of the concrete under must be allowed for in finding depth of excavation.

When the gradient and depths at important points are given on the plan the builder may do the levelling, and the clerk of works check only, but the method described has the advantage of simplifying both the foreman's task and the checking. The drawing is useful when a complete plan of the drainage is made on completion. Manholes should be numbered for reference in some convenient way, and it is best to measure up drainage work as it proceeds, giving position, length, description of pipes, thickness of concrete, etc., depth to invert below the surface, and fittings, such as bends, junctions, and gullies.

Pipes. Drain pipes are of three kinds—"tested," "trade best," and "seconds."

The first-named are marked "tested"; and "seconds," which should be used for surface water only, have a black band painted on them; the others are usually unmarked. Seconds are either incompletely glazed, untrue in shape, or both. The kind to be used will be specified. The use of tested pipes cannot be insisted upon unless they are specially mentioned—as they usually are on good jobs. Cast-iron pipes, with lead or cement joints, should be used where drains pass under walls and floors.

Laying. Soil drain pipes should have at least 4 in. of concrete (gauged 6 : 1) under them, projecting 6 in. on each side, and be benched up at the sides to the level of the top of the pipes after testing. Bricks should be laid flat in the concrete under the collar positions, and removed before it sets, so that the bottom of the pipe rests on the concrete throughout its length, and there is sufficient room under the collar to enable the joint to be made, and to feel it, for leaks. The testing water in the pipes should remain until the benching has been done; it keeps them rigid, and shows whether any defect has developed during the benching process.

The clerk of works must see that the benching concrete is not thrown into the trench carelessly; either a board should be laid on the pipes, and the concrete carefully shot down the side of the trench and then spread, or it should be lowered in buckets. Further, he must see that it is shovelled under the belly on the pipe, so that the latter has a continuous bearing. In filling in, also, care must be taken to avoid damage; the soil should be dropped down by the sides, and the first foot of depth spread by a man in the trench. As the filling rises it must be rammed, and, in hot weather, soaked with a hose.

Testing. Drain testing is done by a representative of the local authority, usually the sanitary inspector or the building inspector. For straight runs between manholes it will probably be necessary to fix a temporary bend, and one straight length at the high end, the joint being made watertight with clay, and the pipes kept rigid with struts. The clerk of works or foreman should see that the testing is done, and the joints and pipes proved to be sound, before the inspector is asked to be present. If no leaks appear after the water has remained in the pipes for an hour, it can be safely assumed that the drain is sound. Before testing, the clerk of works should make sure that there are

no projecting pieces of cement inside the pipes; he may be able to look direct down them, or have to use a mirror and light, or run a steel ball through. He should also put his arm down the bend at the foot of soil pipes, if the latter are not fixed, and feel the joint.

Manholes. Manholes must always be built in cement mortar, and soil manholes must be cement rendered. Whether both soil and surface water runs into the same sewer depends on the system of mains in the district. In London, where the main drainage reaches the Thames and sea via immense sewage disposal plants, they do; where the soil passes through filter beds, the surface water main system is separate, and consequently branches from buildings are separate.

Hard non-porous bricks are necessary for manholes; the cement mortar should be proportioned not more than 3 : 1, and the cement render 2 : 1. The clerk of works must see that the necessary depth is obtained, and a firm bottom reached; that the brickwork is grouted; that a key is provided for the render coat; that galvanized step irons are built in not more than 1 ft. 6 in. apart, where the depth exceeds 3 ft. 6 in.; that a fall is given to the main channel; that the size is reduced near the top to take the manhole cover by gathering over the brickwork, or some other suitable means; and that the brickwork is rendered on the outside, or covered with fine concrete where gathering-over leaves ledges through which water can soak downwards into the wall.

Main and branch channels are either white or salt-glazed. Many varieties are made, and particulars of angles can be obtained from catalogues; care must be taken to specify the correct "hand" when ordering channels. For soil branches the channels should be three-quarter section; where drains from more than one direction meet in a manhole, they should have flush invert, that is, the main channel should have junction channels into which the branch channels enter direct. Channels should not be cut, if this can possibly be avoided; no harm is done if drain pipes project into the manhole a few inches, as long as the free use of cleaning rods is not interfered with.

Soil manholes must stand a water test, and the whole of the soil system, drains, manholes, soil and vent pipes and branches, and sanitary fittings, should be smoke tested on completion. The local authority's representative will do this.

Chapter VII—MASONRY: SLATING AND TILING

MASONRY is a subject with many ramifications. A building may be built almost entirely of stone, as a church; faced with it only, as a steel-framed block in an important thoroughfare; or merely contain some stone dressings, sills, cornice, and perhaps a portico, the features of many private houses and small public buildings. In some districts stone is the cheapest walling material available, and is used for every type of permanent structure; on the edge of Dartmoor, for instance, the smallest farm buildings, and even field boundary walls, are built with granite.

There are many varieties of stone, each with their particular characteristics, and the building superintendent cannot expect to have an intimate acquaintance with all. But they have many features in common, and a knowledge of Portland stone as a representative limestone, and York or Forest of Dean stone as representative sandstones, will go a long way towards forming a judgment of the properties of unknown varieties. As is the case with facing bricks, the best plan in making a decision respecting the adoption of a particular kind of stone is to examine buildings containing it which have been in existence for several years. These should be, obviously, in the district where the new building is to be erected.

The stone to be used is nearly always specified, and the jointing, in the case of ashlar work, etc., may or may not be shown on the elevations. If not, drawings will be prepared by the people supplying the stone, usually sub-contractors, and the clerk of works will check these and note any alterations that may be necessary. He will keep a copy, on which the stones will be numbered, and it is useful to record on this copy the date of fixing as the work proceeds.

Bed. Stonework should lie on its natural bed except in the case of cornices, when it may be edge bedded—be set with the plane of bedding vertical, and at right angles to the face of the wall. In such cases, however, the top of the cornice must be protected by lead, asphalt, or other material, to prevent penetration by rain. The natural bed can easily be detected in some stones, such as Box Ground, Ham Hill, and some York sandstones, but not in others. It may show up when the stone is wetted and scrubbed,

or it may be detected by observing the position of fossils, shells, or flakes of mica. Most of these lie parallel with the bed. When the natural bed cannot be located with any certainty at all, as is the case with some pieces of Portland stone, it may be assumed that the stone can be used in the manner that is most convenient, without reference to bed. A magnifying glass is of great assistance to the inspector of masonry.

Defects in Stones. Many stones contain shells, both large and small; because of the frequency of these, some stones are practically useless for face work. Whether the presence of small pits, due to the breaking away of shell, in what is otherwise a hard sound stone should cause its rejection, or whether these should be filled with hard stopping, is a matter in which the clerk of works must use his discretion, unless his architect's instructions on the point are positive. The position of the block in question, whether near the ground in a prominent place or high up, must influence his decision.

If blocks of Portland stone contain voids, they will emit a dull, hollow sound when struck with an iron chisel; a perfect block rings clear. Stone should be free from "quarry sap" before fixing, although it is often worked on the banker while in this condition, there being less labour required before drying has taken place. When once it has been worked the face should not be interfered with, other than being washed and scrubbed. Some stones contain veins more or less at right angles to the natural bed, the result of fissures which opened at some period during their formation and afterwards became filled. If these are fine and hard, and not an eyesore, they do not usually constitute a weakness, but if they are measurable and contain fine sand, or other weak filling, the stone should be rejected. Some sandstones have small sand pockets, and these should not appear on the face nor be filled with stopping.

York Stone. The term is not specific, that is, there are many York stones with quite different characteristics, but all are sandstones, which are thus described quite correctly. The colour varies from white to brown, and some are blue, and very much like Forest of Dean stone. In some the planes of bedding are very prominent

—worn York stone slabs, with their laminated structure showing very clearly, are a familiar sight on pavements—in others they are invisible. There are also degrees of size of the particles; some are coarse, others very fine, the latter being a characteristic of thin slabs. Most York stone weathers well; when used for steps and landings the texture should be compact and the planes of bedding fine and far apart.

Jointing. Of the several methods of jointing stonework—slate dowels and dovetail cramps, pebble dowels, copper cramps, and joggle joints in cement—each have their advantages and drawbacks, and have to be used according to circumstances. Dowels require careful fixing so that they either exactly fit, or that the mortar used fills the space around the dowel but does not, because of excess, prevent a close joint being made. Iron cramps must not be used. When a window contains mullions, and the sill is in more than one piece, the joint should be in the centre of the opening and not under the mullions. Sills should be bedded at each end, and only pointed in the centre.

The clerk of works must check all mouldings, sinkings, grooves, drips, etc., and see that they conform to the drawings; carefully examine the entasis of columns, and require that a profile be made and approved before the blocks are worked; see that the bed joints are true and not hollowed out, and that all work is properly protected during erection.

Artificial Stone. "Artificial" stone is cheaper than most natural stones of similar efficiency, but the subtle quality of texture is different and less pleasing to the eye. The chief difficulty experienced by makers is the avoidance of "crazing"—fine lines which, while not being serious defects, look like cracks, particularly when the face is wet. Much has been done to eliminate this drawback, and the clerk of works should reject artificial stone on which the crazing is noticeable when the stone is dry. On the face of steps and landings, the use of carborundum provides a hard-wearing surface; built-in ends of spandril steps must be square.

Discoloration by Cement. Cement used in mortar or grouting on Portland stone and other limestones has the effect of discolouring the face. This is not a permanent disfigurement, but its avoidance is desirable; the stone facing of steel-framed buildings is thin—usually $4\frac{1}{2}$ in. and 9 in. deep alternatively in ashlar work—and cement has to be used to make a sound job and, in London, to conform to the Building

Acts. Several methods have been adopted to attempt to obviate this nuisance, including painting the joints and back with special solutions, or coating them with lime putty. As there is usually a brick backing to the stonework, also in cement mortar, stain due to contact of the two materials can sometimes be avoided by forming a narrow cavity, and keeping it free from droppings. Where concrete floors or lintels come against Portland stone, the latter can be insulated by fixing slates vertically between it and the concrete, or the stone can be coated with lime putty on the back. This must be applied as a plaster, about $\frac{1}{2}$ in. thick, and not merely brushed on as a limewash. A suitable jointing mortar for Portland stone is composed of five parts of stone dust, two of stone lime, and one of Portland cement.

SLATING

Slates vary much as stone does. The Welsh varieties, Bangor, Portmadoc, Carnarvon, Preeceley, etc., and the rather thicker and more attractive slates from Westmorland and Delabole, in Cornwall, are the best known. There are other Welsh varieties, sundry kinds used near their source of origin only, and some imported slates.

A good slate should ring clearly when sharply struck, be free from soft places and pyrites—light patches—and be practically non-absorbent. When immersed it should not absorb more than 2 per cent of water by weight. There are several kinds of nails: galvanized iron, zinc (which contains a small percentage of tin), zinc and copper ("composition"), and copper. The usual sizes are $1\frac{1}{2}$ in., $1\frac{3}{4}$ in., and 2 in., the latter being used for heavier slates like Westmorland. On steep slopes, such as the lower part of a Mansard roof, it is advisable to use three nails when the slates exceed 18 in. in width; under all ordinary circumstances two are sufficient. The kind of nails to be used should be distinctly specified and a sample be supplied.

The clerk of works must obtain at an early stage an average sample of medium size, say 18 in. long, of the slates to be used. Westmorland slates, for instance, vary considerably, and there is a lot of waste at the quarries; slate without any blemish whatever would not be an average sample. If the slates are to be laid in random courses he must see that they are properly sorted, and that each slate has its specified lap; the largest are laid at the bottom of the slope. One drawback to using very large

MODERN BUILDING CONSTRUCTION

slates in random work is the possible difficulty of obtaining a similar size and quality for renewals. If, with regular sized slates, there is a difference of thickness, they should be sorted into three groups, the thickest being laid at the bottom of the slope, and the thinnest at the top.

At verges, slate-and-a-half size must be used for alternate courses, and this size will also be required for hips and valleys. If the hips are mitred—and not covered with a ridge tile—the clerk of works must see that the cutting is carefully done, and that soakers equal to lap plus gauge are inserted in every course. A small tilt should be given at verges, and also against stacks, parapet walls, etc., by putting a $\frac{1}{4}$ in. lath under the battens at these points. At verges an “undercloak”—two courses of slates bedded flush and breaking joint immediately under, and projecting the same as the roof slating—should be provided; it should be bedded and pointed.

The spacing of battens must be checked. Counter-battening is an advantage in that it permits ventilation and the escape of any water that may find its way through the slates. The clerk of works must see that a tilting fillet is fixed at all eaves, gutters, valleys, etc., and that a double course is laid at the eaves; $\frac{3}{4}$ in. thicker than the battens usually provides sufficient tilt.

Roofing felt is made in several thicknesses; a good quality sarking felt should be dense in texture and not tarry. It is sometimes laid from top to bottom of the slope but usually across; if it is laid across, thinner battens must be used over the lap. Vertical slates, fixed on walls, gables, etc., should not be large; 13 in. by 7 in. or 14 in. by 7 in. are suitable sizes. Larger slates put more weight on the nails and make slipping probable.

TILING

Roofing tiles may be precisely specified or a term like “approved hand-made sand-faced tiles” may be used. This means a selection from samples which will vary, apart from quality, in colour and texture; as a tile roof is a prominent decorative feature, the architect will probably have very decided ideas as to what

he requires. Plain tiles should be free from cracks, including fire cracks (ice, forming in a crack, easily splits a tile), camber in their length, be free from twist, hard baked, holed for nails, and contain nibs having a proper seating. They can be obtained without nibs for tile creasing on brick walls, if required.

Tiles are usually nailed every third or fourth course with 2 in. nails. Piecework is a common practice among tiling and slating sub-contractors and the tiler may have to supply the nails. The clerk of works must see that the quantity of nailing specified is done; he can easily do so by trying to push the tiles upwards in the courses which should be nailed. The lap will depend on the pitch of the roof; $2\frac{1}{2}$ in. or 3 in. is customary; the former is sufficient for a 45° pitch.

Most of the points mentioned in connection with slating apply to tiling: tilt, double eaves course, undercloak, tile-and-half or double-tile at verges, hips and valleys, accuracy of gauge, counter-battening, etc. The last-named item cannot be demanded unless specified or paid for as an extra. Bonnet-shaped hip tiles must course with the tiling and be true pitch; the lower end is bedded and joints slightly recessed, and the top end nailed or screwed. Top courses of tiles on either side of the ridge are often bedded in cement; the batten should be so spaced that the top tile has a proper fixing, but does not have a margin that differs appreciably from that of the rest of the roof. Ridge tiles should be bedded solid at each end and pointed; sometimes the centre portion is left open—not pointed underneath—in order to provide ventilation. The exposed end of three-quarter section ridge tiles should be filled in with a piece of plain tile neatly cut to the right shape and bedded.

Pan tiles are not often used on important buildings; they are rather clumsy, and leaks are frequent unless the laying is well done. Counter-battening is always desirable on boarded roofs, and the cavities under hip and ridge tiles should be filled in with pieces of plain tile bedded in cement. In open roofs—sheds and similar buildings—pan tiles are usually “torched” at the upper end in lime and hair mortar.

Chapter VIII—CARPENTRY AND JOINERY

CARPENTRY and joinery work differs from most of the trades previously mentioned—concreting, brickwork, drain laying, and masonry—in that, excepting in some of the constructional parts, defective items can easily be replaced or repaired. To renew a piece of bad walling is an expensive, difficult, and prolonged job; to renew a winding, shrunk, or badly hung door is merely a question of time; the general structure is not interfered with. It also differs in respect of the materials used; the variations of structure and properties of timber are infinite; that is not the case, except in a minor degree, with regard to materials that have been manufactured by burning, baking or smelting.

TIMBER

The familiar specification that the timber is to be free from large knots, shakes, and sap, has to be regarded as representing an ideal and not available material, except in small quantities. It, however, undoubtedly confers the right to reject any piece which does not reach such a standard. There is a growing tendency to discard this formula and specify more scientifically, which is to the advantage of the contractor in that he knows what is really required, and to the clerk of works in that he is not given the difficult task of translating the ideal into the practical.

For joiners' work, Archangel deals are a good standard. Firsts have a few small knots, infrequent sap, a few small shakes and centres. In seconds and thirds these "defects" increase proportionately, fourths have some waney edge, and fifths are poor timber. Some sapwood is inevitable, but it should present a bright surface when planed; blue sap should not be present, although it is doubtful whether this point should be insisted upon in cases where quite good timber has unavoidably been exposed to rain, and the small proportion of white sapwood that it contains has become blue. Grain should be practically straight and wandering heart nil. The straighter the grain the less risk there is of winding.

Timber for carpentry should be clean and bright, free from waney edge, large shakes, large, loose, or dead knots, and with a small

proportion of sap only. For both classes of work, carpentry and joinery, it should be seasoned; but as this term means that the percentage of contained moisture should be approximately similar to the percentage in the atmosphere, it is obvious that seasoned joinery in a warm room must be dryer than seasoned carpentry in a roof, otherwise it will shrink. Generally speaking, 15 per cent of moisture in joinery timber, and 18 per cent in carpentry, is a workable standard. The clerk of works has to use his judgment on these points; exact definitions are of very little use. Timber containing a lot of sap, decay, bad knots or shakes should be rejected; at the other end is the perfect material of the specification; and in between are qualities that may be placed in four grades or four hundred.

SEASONING. His judgment must also guide him with regard to seasoning; he can test a piece of wood by drying it until practically all the water has been evaporated, and then weigh it. The result obtained is, obviously, the weight of the wood substance only; a piece of undried wood of similar size will weigh more, and the difference is due to the presence of water, which can be expressed as a percentage on the lines indicated above. This method is adopted in kiln drying. The test is of value when joinery work can be transferred to a practically dry building; under most circumstances variations of humidity in the atmosphere of buildings in the course of erection are such that moisture is absorbed and repelled by timber at intervals, inevitably producing expansion and contraction. Approximate stability is ultimately reached when joinery is painted or otherwise coated, and when the floors and roofs of occupied premises are exposed to only slight changes of humidity.

Hard Woods. Hard woods do not present the same difficulties. For instance, oak containing sapwood should be rejected. The expensive imported hard woods, such as mahogany, teak, walrus, and the recently introduced Indian timbers like laurel wood and gurjun, contain little or no sap. The defects to look for in these are shakes, insufficient seasoning, decay, large knots, and the substitution of kinds inferior to those specified. There are many kinds of both

MODERN BUILDING CONSTRUCTION

mahogany and oak, which can only be distinguished from each other by comparison with specimens, or by an expert who is continually handling them.

The clerk of works must see that all timber brought to the job for future use, if approved, is properly stacked and protected from rain. During erection, particularly in winter, timber used in constructional work, like rafters, is bound to get wet after fixing, but as the edge only is directly exposed no serious harm can be done. Roof boarding should be covered with felt as soon as laid, or protected by tarpaulins. Floor boards should not be laid until plastering is completed, otherwise there is a risk of ceilings being cracked during laying. Plates and all other timber built in, including ends of joists, purlins, etc., should be coated with creosote or a similar preservative, which must be allowed to dry before bedding is done. If this is not specified, the clerk of works will be well advised to raise the point; the extra cost is trifling.

All joinery fixed before plastering, building breeze partitions, or similar work is done, must be fully protected against damage, as must window and door sills, staircases, etc. The clerk of works must see that deal, which has to be stained and varnished, is not splashed with plaster, which produces permanent discoloration that cannot be disguised. He must also see that such work is not glass-papered across the grain.

Plywood. During the last twenty years the manufacture of plywood, laminated board and wallboard has been so increased that for one purpose or another they appear in most kinds of building. For concrete which has to be finished with a smooth face, Columbian Pine plywood about $\frac{3}{4}$ in. thick has been made in Canada and U.S.A.: its surface has been so treated that the ply does not peel on coming into contact with wet concrete. After being used several times there is, however, some movement of the grain which leaves faint marks on the concrete surface. Another way of using manufactured boards for centering smooth-faced concrete ceilings and walls, is to have open spaced batten centering, with boards, say, 3 in. apart, and lay masonite or similar hard wallboard on it. Adhesives have been produced which are so tenacious and durable that air-screws are made from piled plywood; a material which will stand up to this test is obviously suitable for use in buildings, and the plywood panel in framing or on flush doors is entirely replacing solid wood for such purposes. Sur-

facing, with knife-cut veneers from selected figured logs, is an economical way of using such logs and a means of getting an effective decorative treatment of joinery without abrupt changes of grain pattern. It is with the method of framing the core of flush doors that care has to be taken, particularly in the selection of wood that is seasoned and straight grained. Generally the skeleton type of framing is used, with provision for lock fixing. But there are other methods, including the solid core which has piled boards laid in reversed directions and glued. As there is no direct means of ascertaining on the site whether flush doors have suitable cores, except the unsatisfactory one of waiting to see whether or not the doors warp, it is advisable that the clerk of works pays one or more visits to the joinery works.

The manufactured sheets which are collectively known as wallboards, vary in quality, kind, and price. Their appearance usually tells its own tale, and no specific comments are called for except that the softer kinds must be kept dry, and fixing battens and fillets must be spaced to suit the stock sizes of the sheets, usually at 1 ft. 4 in. centres.

WORKMANSHIP

In carpentry there are points covered by by-laws, e.g. the distance of woodwork from flues, and the provision of trimming joists or rafters 1 in. thicker than the ordinary joists or rafters, which have to be observed, whether specified or not. Joints require attention; they must fit and not be the happy-go-lucky sort. A tusk tenon is no better than a single tenon if badly made; properly formed, it is the most scientific joint known to the craft. Hip, valley, and rafter seatings, scarfings, birds'-mouths, halvings of plates, purlins, ridges, and the shoulders of the various kinds of tenon joints, are points to which the clerk of works must pay attention. The elaborate joints connected with open timber roofs are rarely used now, except in churches, and occasionally the hall of a public building. The spacing of rafters and joists will probably be defined in the specification, usually not more than 12 in. apart. If the area covered does not, in its length, equal a multiple of the specified spacing, the odd dimension should not be divided among all the spacings, but left to take care of itself at the end. Otherwise it will be necessary to cut all the laths.

Some specifications require that joinery shall be delivered on the site unprimed, and the clerk

of works must see that this stipulation is observed, although bad defects cannot be hidden by a coat of priming. When it is on the site, however, and approved, he should get the priming done as soon as possible, to prevent avoidable absorption of moisture. He should see whether any hidden woodwork has to be painted, such as the back of sash frames and panelling, bottom of sills, etc. Builders like to use "smudge" for this work—oil paint from the bottom of cans, etc., mixed together with the necessary oil and tinted with lampblack.

Principal methods of joinery fixing will be specified, and may include iron straps with split ends for solid door and window frames, screws sunk and pelleted, cups and screws for sash and glazing beads, dowels, slot screws, and ordinary brass or iron screws and nails. Where no special provision is made, the latter only can be called for as necessary, in conjunction with breeze bricks or hardwood fixing slips or plugs. The clerk of works must see that all joinery is accurately made to details and properly framed and finished; that double tenons are provided for lock rails and in wide framing; that skirtings, fascias, and similar vertical work is tongued and grooved at the internal angles; that mouldings intersect and have the mitres painted in exposed external work; that doors and sashes and their frames do not wind; that bottom rails of sashes fit sills; and that all water bars, etc., are provided, and bedded in white lead. It is necessary that he should consider joinery details in connection with the ironmongery specified, and see that enough width or depth is allowed. Sufficient width of stile in casement doors, to allow for the insertion of an upright mortise lock, is a case in point.

Flooring requires close attention; defects are prominent, whether shrinkage, sap, inferior workmanship, shakes, bad knots, or untrue alignment. The clerk of works must see that tongues are not damaged; that boards are properly cramped up and not folded, edges not split or bruised, hardwood mitre borders to hearths, etc., properly fitted and glued, provision made for screwed-down traps; and that after cleaning off, the boards are protected by sawdust or other means against defacement, which includes splashing by decorators. The kind of wood to be used, and the method of fixing, is always specified and does not require comment.

The treatment of dry rot does not come within the scope of a description of new building work, but the clerk of works must bear in mind

that it is an insidious disease, which is both difficult and expensive to exterminate. In addition to ensuring as far as is possible that sound timber is used, he must see that shavings, chips, and odd pieces are not left under floors or in covered recesses; that men are prevented from committing a nuisance in the building; that air bricks are inserted wherever necessary; and that water cannot obtain access through roof or other defects.

FITTING AND FASTENINGS

Ironmongery must be equal in quality to approved samples. There is an almost infinite variety of such items as locks; sash, casement, and fanlight fasteners; floor, overhead, and helical springs for doors; and door furniture. The clerk of works should obtain the catalogues of good firms; these are particularly useful when an unusual fitting is required. If locks are to be suited, he must see that the order is placed at least three months before the locks are to be fixed (the period depending on the quantity required) and that, if specified, the keys have the name or number of the room stamped on them. Solid instead of bow handles are an advantage here. He must ascertain that bronze fittings are solid and not bronzed only; scratching the back with the point of a knife reveals this. Screws should be of the same metal as the fitting: japanned, sheradized, brass, bronze, aluminium or nickelled, as the case may be, and long enough to grip the fitting securely.

Floor springs must work smoothly, and the check and top pivot be easily adjustable by set-screws. Shallow boxes can be obtained for solid floors but, if possible, one of not less than 2 in. depth should be used; in goods springs all parts are easily renewable. Locks must be neatly fitted, close the door tightly, and have furniture which works easily and does not rattle. The hand of a lock is the hand of the shutting stile when viewed from the outside.

It is advisable for the clerk of works during the progress of a job to occasionally visit the joiners' shop, both to examine work during the preparation stages, and to see that satisfactory progress is being made. Whether he should visit timber yards to inspect stacks is a doubtful point; it is the timber on the job that he is concerned with. If he does make such inspections, it should be clearly understood that general approval of a brand or parcel does not necessarily mean final approval of every stick in that brand or parcel.

Chapter IX—SMITH AND FOUNDER; PLUMBING; PLASTERING; PAINTING AND DECORATING

SMITH AND FOUNDER

Constructional Steelwork. The principal item in the smith and founder section of a specification is the constructional steelwork. It is sure to appear in some form; at the most, the framework of the whole structure, walls, floors and roof; at the least, a few lengths of rolled steel joists, or some light trusses. On some private jobs, and most of those of large public authorities, the steelwork is designed by a consulting engineer; the clerk of works will be provided with a complete specification and set of details, and will check all parts of the delivered work. But it is not unusual for the designing, in the engineering sense of the word, to be done by the sub-contractors who carry out the work. They are responsible for the safety of the structure, although drawings are approved by the architect, and the arrangement must fit in with the general design of the building. In this case drawings are provided to the general contractors and the clerk of works, but there is not, as a rule, a detailed specification, although such matters as rate of delivery, painting, etc., will be mentioned.

A handbook giving particulars of standard sections should be obtained; the sizes of members can easily be checked by referring to the appropriate tables. The clerk of works must see that all parts have true bearings, and are to correct length; that struts, tees, etc., are straight, and bolts to the correct sizes in holes having not more than $\frac{1}{16}$ in. clearance, with the heads firmly tightened up; that rivet heads fit, and are countersunk where bearing on other steelwork or templates; and that damage is not done to the structure by erectors. Lengths, heights, etc., should be checked on the job by a representative of the steelwork contractors before the work is fabricated, particularly where the site is bounded by existing buildings of irregular shape.

The clerk of works must see that on all steelwork rust has been cleaned off prior to the application of the coat or coats; if this has not been done—and projecting patches scratched with a knife will show whether rust is painted

over—a blowlamp and wire brush must be used, and the painting be redone. Although steel surrounded by concrete does not rust, the application of cement grout with a brush on steel is not a satisfactory job, particularly in hot weather; it either powders or flakes off.

Iron and steelwork in railings, grills, and similar framed articles does not call for any particular supervision. Dimensions and details must be as drawn or described, joints fit, the parts be straight or to true curves, finished off in a workmanlike manner, and painted before erection.

Rain-water Gutters and Pipes. Rain-water gutters and pipes must be to required size and weight. The joints of gutters must be jointed with red lead and bolted, and twice painted before fixing; brackets must be strong, not less than $1\frac{1}{2}$ in. by $\frac{1}{2}$ in., and have at least three $1\frac{1}{2}$ in. No. 10 screws, where fixed to the feet of rafters, each 6 ft. length being supported in the centre and at the ends. Square and ogee gutters are screwed at the back to a fascia usually; the heads of the screws must be bedded in red lead and painted soon after fixing. Half-round gutters rest on brackets; there are several patterns, and the chief point, apart from strength, is provision of a clip arrangement of some kind to prevent rotation when repairs are being done. As, during repairs, a man's life may depend on the security of the rain-water gutter, this question of fixing must be regarded as very important.

Gutters should have as much fall as can be provided without presenting an unsightly appearance; cast-iron gutters are rarely quite straight, and a fall is necessary to balance inequalities. Rain-water and all other iron pipes should be fixed at least 1 in. clear of the wall at the sockets, so that the back can be painted. This can be done by fixing thick lead distance pieces, using pipes with cranked lugs, or holderbats. Pipe nails must be at least 4 in. long, fixed to hardwood plugs, and be galvanized, or painted soon after fixing.

Soil Pipes. Iron soil pipes must have a clear bore free from projections, with bends, junctions, etc., to the correct angle, and containing

packed cleaning caps fixed with gunmetal screws. A soil pipe is on the market which has a rifled socket that gives a better joint than the straight bore socket. Lead wool is better than hemp for caulking sockets, and the clerk of works must see that the run lead fills the cavity, and is neatly weathered off at the top. Where soil pipes pass through cornices, etc., the position must be definitely fixed beforehand; in fact, this should be done in any case; there is no need to "see how it works out." The building superintendent should make it his business to know in advance, as far as is possible, how things will "work out." That is his job.

He must see that soil pipes which pass through a roof, and have no immediate support from a stack or wall, are stayed in a suitable manner from the roof slope or a dormer. The stays should be not less than 2 in. by $\frac{1}{4}$ in., and be bolted to the pipe; if they are slight, the support given may be sufficient, but rust is a destructive agency, and a wide margin of safety is necessary. The clerk of works has to regard this factor of rust as of paramount importance in connection with all exposed iron and steel articles, and see that a protective coat is applied as soon as possible after these materials are on the job, whether they have been previously painted or not.

Metal Windows. Metal windows must be to correct sizes, provided with necessary fixing lugs, etc., work easily, and have suitable fittings. There will not be much the matter with them if a firm of repute is engaged; polished fittings or other parts should be protected by oiling or wrappings during the progress of the work. The section of the bottom rail of metal window frames must be taken into consideration when designing stone sills.

Central Heating. Central heating and hot-water supplies are nearly always executed, except on small jobs, by specialist firms. The clerk of works will be more concerned with the position of pipes, etc., than with their connections and sizes. Defects, like leaks and stoppages, immediately reveal themselves when the system is put into operation, and its efficiency is easily tested. A specified temperature, usually 60° F. when the outside temperature is zero, is required from a central heating system, and is checked with thermometers; for the domestic supply, the obvious requirement is that hot water must be rapidly supplied at taps.

The clerk of works must see that all chases, ducts, and channels in walls and floors are

formed during the progress of the constructional work, and that afterwards no cutting away is done that will injure or deface the structure. There are nearly always some snags in the pipe runs shown on plans, and the fitter in charge should be instructed to chalk their positions on the walls before proceeding with the work. Pipes should pass through "sleeves" in walls and floors; the simplest type is a piece of plain barrel filed off neatly at the ends, kept flush with the plaster on walls, and given a projection of about $\frac{3}{4}$ in. on floors, so that water does not get into the space between the pipe and the inside of the sleeve when floors are washed. In the case of terrazzo and similar decorative floors, the exposed end of the sleeve is usually covered by an ornamental bronze cap which neatly fits the pipe.

Care must be taken that pipe runs do not obstruct the working of fanlights, and that, as far as is possible, they do not cross an opening at all. The fact that the pipes must have a rise or fall frequently prevents this. Holderbats are much better than pipe clips for fixing, and pipes should be kept at least 1 in. clear of the finished wall and ceiling surfaces. Discoloration of the surfaces immediately above or behind hot-water pipes appears to be unavoidable; it is caused by the charring of tiny particles of dust which are always present in the atmosphere. Behind radiators the disfigurement can be reduced by painting the surface a dark colour, separated by a painted band from the decoration of the rest of the wall. The clerk of works must note the provision, if any, of covers to pipe trenches in ground or basement floors, and see that these are flush with the general floor surface, and easily detachable.

Pipes for cold water are usually in lead; when in iron the points to be observed are similar to those mentioned. All pipes containing water in exposed places must be protected from frost by a wrapping of hair felt, secured with copper wire. This is nearly always necessary in tank chambers or roofs.

Gas-fitting does not call for any particular comment, except that dips must be avoided, or provision made for draining them and the system must be leak-proof.

PLUMBING

In the supervision of plumber's work, method requires more attention than materials, in that lead is practically constant in quality, and the only point of importance requiring attention is

MODERN BUILDING CONSTRUCTION

the weight used. This will be specified, and can be checked either by weighing a small piece, say 6 in. by 6 in., or measuring with a gauge or calipers; an experienced man only needs to feel and bend the sheet. Lead pipe can be tested in the same way; water companies usually have definite requirements as to the size of lead pipe, and these are expressed as weight per yard run.

The following table is helpful for ascertaining the weight of sheet lead—

Weight in lb. per sq. foot	3	4	5	6	7	8
Approx. thickness in inches	$\frac{3}{16}$	$\frac{1}{4}$	$\frac{5}{16}$	$\frac{3}{8}$	$\frac{7}{16}$	$\frac{1}{2}$
Approx. S.W.G. No.	18	16	14	12	11	11

External Leadwork. The usual weights of sheet lead used in ordinary building work are 4 lb., 5 lb., 6 lb., and 7 lb. The lightest is sufficient for soakers and minor items, like condensation gutters to roof lights. For flashings, aprons, dormer cheeks, hip coverings, etc., 5 lb. is suitable; and 6 lb. at least is necessary for flats, valleys, gutters, and any other place where there is likely to be some traffic, or where water can be retained. Lead on flats should not be more than 3 ft. 6 in. wide, including turn-up over rolls, and 10 ft. in length; drips should not be less than 2 in. deep, and the fall not less than $1\frac{1}{2}$ in. in 10 ft. Where exposed copper nailing is specified, as on dormer cornices, the term "close copper nailing" can be taken as meaning not more than 1 in. apart—and not less than $\frac{3}{4}$ in.—and "copper nailing" as meaning more than 1 in.; how much more, depends on the position of the lead.

The particulars respecting falls, etc., of flats apply also to gutters. These should be wide enough at the narrowest end to allow room for a man's foot, not less than 9 in. if possible. The allowance for turn-up is usually 6 in. against walls, and 9 in. under tiles or slates, measured from the sole of the gutter; laps should not be less than 5 in. Flashings should be about 8 in. wide, be let into the brickwork not less than $\frac{3}{4}$ in., and secured with lead wedges, and finish about 2 in. above the sole of the gutter or flat. The latter distance is flexible; it depends on the relative positions of the brickwork joint and the gutter. Lead tingles of not less than 6 lb. lead must be used for flashings, aprons, and similar pieces having a free edge. On the best work copper tingles are used. In grooves formed in stone or terra-cotta, lead flashings should be burnt in, not pointed.

On lead-covered slopes there is a tendency to

movement downwards, and the top edge of the sheet requires more secure fixing than by nailing only. One good plan is to turn the top edge down and sandwich it between the edges of two of the roof boards. Plumbers hold differing opinions as to whether the over-cloak of a roll should stop at the bottom of the roll or extend an inch on to the flat and be dressed down. There is probably nothing in it if the free end of the over-cloak is placed opposite to the direction of prevailing winds and rain.

Soakers should be at least 6 in. wide—3 in. on tile and 3 in. turn-up is sufficient for practical purposes—and of a length equal to lap plus gauge plus 1 in. Lead dots will be necessary for fixing flat vertical surfaces, such as dormer cheeks; it is best to fix with two screws placed skew-ways. Secret gutters are easily choked, causing leaks and damage, and not a form of roof drainage that can be recommended.

Lead Soil Pipes. Lead soil pipes must be fixed with strong cast-lead tacks at not more than 4 ft. 6 in. intervals; the joints must be carefully made and shapely, and bends, etc., properly worked and free from kinks. Brass inspection caps must be wiped on at all junctions, and brass ferrules provided where the pipe enters the drain and where branches enter w.c. or other pans. Lead sleeves (6 lb.) are required at roof perforations, the upper part extending under the slates or tiles far enough to make a watertight joint—the exact distance obviously depends on several factors; the principle is to regard it as a lead slate.

Internal Plumbing. The arrangement of internal plumbing work is principally governed by the types of sanitary fittings used—w.c. pans, waste preventers, sinks, lavatory basins, housemaids' closets, baths, urinal stalls, and so on. Pipes have to be run to these points in the most convenient manner; they must not be in the way of other pipes or fittings, and be fixed close against walls—not being self-supporting as iron pipes are—with tacks or clips, back boards being provided where necessary.

Of sanitary fittings there are many types, and different qualities of each type. The firm supplying the goods will probably be named in the specification, and the clerk of works must see that a choice is made, and at least one of each type of the approved articles delivered on the job, soon after the internal plumbing commences. If this is done, the various pipes—supplies to taps, wastes, overflows, w.c. branches, anti-syphons, and others—can be taken to their

correct positions, or near enough to permit final fixing without the alteration of runs.

Waste preventers should be fixed at a height of from 7 ft. to 7 ft. 6 in. from the floor to the bottom, sinks should be 3 ft. high, and lavatory basin 2 ft. 9 in.—conditions may compel small variations of these dimensions. The clerk of works must see that traps—lead, iron, or brass—have cleaning caps which are accessible (bath traps are most troublesome in this respect); that w.c. pans are securely fixed to the floor; that overflows project sufficiently to prevent damage to walls when in action (about 8 in.); that cantilevers are firmly pinned and give a fall to sinks; and that stop-cocks are provided in convenient positions wherever required. One stop-cock should be adjoining each waste preventer, so that ball valve repairs can easily be made, and one to each lavatory basin, sink, and bath, or range of either of these. High-pressure ball valves are necessary on main supplies, and where the head of water from a cistern exceeds about 20 ft.; for a less head, low-pressure valves should be supplied. The relative positions of hot and cold taps should be constant throughout the building; usually, the former is left-hand.

Care must be taken to prevent damage to the glaze of fittings; they should not be fixed until all constructional work has been done, and be covered while the painter is operating. Puff pipes must be provided to the traps of lavatory basins and similar fittings if the anti-siphon type of trap is not used; when taken through an external wall, not into a vertical vent pipe, a brass grating must be wiped on the end. The provision of all necessary anti-siphon pipes also requires attention. Pipes in ground must have not less than 2 ft. soil cover, to avoid the action of frost.

PLASTERING

Plastering is a coating applied on rough surfaces, or to lathwork, either wood or metal, stretched across voids. It must be sufficiently tenacious and compact to remain in position, have a straight and even surface without depressions or ridges, and be free from cracks and loose pieces. This general description applies to all plasters, but in detail there is a considerable difference between the many kinds used.

Keene's cement on a Portland cement backing is very hard, and can be finished to a polished surface; lime plaster is nothing like so hard or smooth. Materials with a gypsum

base—Keene's, parian, sirapite, plaster of Paris, and other plasters which are sold under fanciful names—set rapidly and expand during the process. Lime putty sets slowly and does not expand at all. The former materials produce a practically non-absorbent surface; the latter is porous and absorbs atmospheric moisture which, on the gypsum plasters, condenses.

Lime plaster is the cheapest, and, if well done, and not subjected to abrasion or blows, is quite satisfactory; the gypsum plasters are more expensive, if the same number of coats are laid, but can be finished more quickly, an important factor on most large commercial and public buildings.

The kind of plaster required will be specified, including proportions of sand, matrix, hair, and type of lathing. The sand must be clean, and coarse for undercoats and fine for finishing coat. The lime must be fresh; grey stone lime—feebly hydraulic—is best for rendering and floating, and chalk lime for setting. Lime must be run at least a month prior to use or "knocked-up" with sand for undercoats, and allowed to stand for that period. The tiniest particles of unslaked lime will blow, burst off the plaster face, and spoil the appearance of the finished work, sometimes several months after application.

Hair must be long, clean, and well beaten to convert lumps into loose strands before incorporation in the coarse stuff; the mixing must be done by hand, not in a mortar mill, which cuts up the hair. Hair is usually specified as being used in the proportion of 1 lb. to 3 cub. ft. of coarse stuff. In actual practice hair is rarely added by measure; the clerk of works has to use his judgment as to whether enough has been used. He can easily ascertain this by picking up a trowelful of coarse stuff and letting some overhang the edge; it will not drop off, except in small particles, if there is sufficient hair.

In fact, most proportioning in plastering is done by guessing, and an experienced plasterer's labourer is never far out. He may use some rough measurement, such as barrows of sand and pails of putty, but this is obviously a different matter to the accurate measurement of concrete ingredients in boxes. The same principle applies to patent plasters; these vary in their rate of setting, and have to be gauged accordingly; if he is getting the right result, the clerk of works should leave such matters as these to the plasterer.

As lime plaster hardens by the absorption of

MODERN BUILDING CONSTRUCTION

carbon-dioxide from the atmosphere, it is advisable that the undercoat should be nearly dry before the setting coat is applied. Cracks, due to shrinkage, in the undercoat, do not show through if this precaution is observed, and the "key" is not destroyed. It is a point that the clerk of works must watch, because the tendency is to apply successive coats as quickly as possible, so that scaffolding can be released. The addition of some Portland cement to the coarse stuff expedites this process. A hard and non-porous finishing coat should not be used on an ungauged lime undercoat. Dry brickwork, soffits of patent block floors, etc., must be well wetted before plastering commences, and each undercoat must be scratched to provide a key for the following one; $\frac{3}{4}$ in. is thick enough for any plaster, unless rough surfaces have to be "dubbed out."

Laths should be "lath-and-half" in thickness; not less than $\frac{3}{8}$ in. apart on ceilings, and a little less on partitions. All fixed grounds must be provided with a key, and be in position and tested before plastering commences. The back of any piece of joinery meeting plaster in the same plane, such as a trap-door lining, or the "Austral" type of window frame used in hospitals, must be grooved to receive the plaster. Laths must be clean, free from sap and knots, and straight grained; they should break joint in bays of about 3 ft.

Fibrous plaster should be fixed with a space of not less than $\frac{3}{8}$ in. between the joints; the stopping should be lime and hair mortar, gauged with coarse plaster and containing plenty of hair; it must be packed in the joint so that it passes over the top of the slabs, forming a key after the manner of lathwork. Galvanized nails or screws must be used, and these must be driven home just sufficiently to fix the slab and prevent movement.

Metal lathing is best fixed with galvanized staples; it must not bulge, and there should be a short lap at joints. Portland cement render, with a very small proportion of lime mortar added to make it work more easily, must be used on metal lathing, not a gypsum plaster of any kind.

PAINTING AND DECORATING

Proprietary brands of paints, enamels and distempers cover a wide range of uses for internal and external work on wood, plaster, brick and metals of every kind, including cement floors, and on heated surfaces. Paint making and matching by hand on the site is

not often required, and the skilled painter who could do it so well is becoming scarce. Mentioning in the specification the particular kinds of paint to be used, or the names of suppliers, is a frequent practice, although the finishing tints may, or may not, be taken from a standard tint card.

Usually the paints are supplied ready for use and do not require thinning; in such cases it is necessary to see that turps or turps substitutes are not added. Variations of tints for the different coats is advisable so that they can be identified as first coat, second coat, and so on. There may be no intention whatever to miss coats, but it is easy to do this if the items to be painted are scattered and completion has to be speeded up.

Preparation of surfaces is as important as the application of the coats, particularly when repainting is being done. Here the best plan is to require that a batch of windows or doors be thoroughly cleaned before any paint is applied, and then to inspect them as a whole. When joinery is delivered it may or may not have been primed; in any case it should be primed and given its first coat soon after arrival on the site. All new buildings are damp and the unprotected wood will absorb some moisture which it will give up later on, and in so doing it will shrink. The preliminary coats will not be a complete protection, but they will do something to reduce ultimate shrinkage. During the finishing stages, when enamels, gloss paints, or varnishes have to be applied, it is necessary that the rooms and passages be thoroughly cleaned first, with all dust and rubbish entirely removed, and if possible that the temperature be not below 55–60° F.

On steelwork, the enemy is rust. When steel items arrive on the site they should be cleaned, and given one coat of paint. This should be insisted on. Tubing for water and heating surfaces should be given a priming coat soon after fixing, unless it is to be covered. If the clerk of works thinks of paint as a protection first and a decoration afterwards, he will be seeing it in the right perspective.

On plaster, the principal points to watch are that it is as dry as possible before distemper or paint is applied, particularly the latter, and that all making good has been done. It is almost impossible to disguise plaster patches that have been made on a surface after the finishing coat. To let the patches dry and do the whole surface again is the only satisfactory method.

Drainage and Sanitation

By HENRY C. ADAMS, M.INST.C.E., F.R.SAN.I., ETC.

Chapter I—CONSERVANCY SYSTEMS

PRIVY middens were in use up to the last quarter of the nineteenth century, and are still to be found in all their foulness in many country places. No attempt at disinfection or deodorization was made in those days, simply because the people knew no better, and although numerous Public Health Acts were passed, it was not until they were consolidated in the 1875 Act that any real progress was made.

The term *conservancy* is applied to any system where the foul faecal matter is retained on the premises for a more or less lengthy period. They are sometimes described as *Interception* systems. Even when constructed and maintained in the most hygienic manner these systems are quite unsuitable for use in towns. In the country, conservancy systems may be quite satisfactory if the conditions are suitable, as would be the case if every cottage stood detached on its own plot of ground; but in many circumstances the cottages are huddled together and the systems are allowed to degenerate until they become a real menace to health. The alternative to a conservancy system is the *water-carriage system*, in which water flowing through drains is used to remove the foul matter from the premises immediately it is produced. The success of this latter system depends upon the sufficiency of the water supply, and this, in general, does not obtain unless there is a proper piped public supply laid on to each house. A good supply of water is not only necessary to keep the drain in proper order, but to continue the transport of the foul matter through the public sewers. If the supply of water is deficient a water carriage system may become quite as unsatisfactory as a neglected conservancy system.

The foul matter derived from an inhabited house comprises certain liquid wastes, consisting of water polluted by its contact with grease, soap and other impurities resulting from personal washing and bathing, house cleansing, and laundry washing, together with the waste water from culinary processes; dry, or semi-dry

vegetable refuse; urine and faeces. Conservancy systems are intended to deal only with the faecal matter, although a certain amount of urine must also of necessity be included. The remaining liquid waste should be distributed over the garden ground attached to the residence so that it drains away into the subsoil. The vegetable matter should be dumped on to a refuse heap where, in the course of from one to two years, it will completely rot and may then be used to manure the garden.

Middens. A midden is a pit or a hole in the ground formed for the reception of faecal matter. In its earliest form it consisted of a hole dug in the ground, and having a board, with an opening in it, supported over the hole for a seat. An improvement upon this occurred when it became customary to put a brickwork floor and walls to the pit, and to erect a small building over it to screen the user and protect him from the weather. The two principal objections to this system were the large volume of foul decomposing matter exposed to the air, and the invariable admission of water into the pit. The pits were large, so that the excreta were retained for very long periods until in the greater portion the process of putrefaction was complete.

Putrefaction, or decomposition, is the term employed to denote the decay or dissolution of organic matter brought about by the action of living organisms, or bacteria, present in the excreta or other organic matter. It is accompanied by the emission of foul gases, including ammonia and its compounds, which have a pungent odour, and sulphuretted hydrogen, which has a putrid smell. The foul gases are subsequently purified by the oxygen in the air, thus reducing the amount of oxygen normally present, and impairing the vitality of those breathing the polluted atmosphere. When the excrement is exposed for long periods in the open air it attracts dung-feeding and dung-breeding insects, including beetles, privy-bugs, and flies which spread zymotic diseases, that is, those diseases similar to small pox, supposed to

MODERN BUILDING CONSTRUCTION

be produced by germs entering the system and acting like a ferment. The admixture of water, urine, or dampness of any sort to excrement, causes it to give off a foetid odour; but so long as it is kept dry, by adding sufficient soil or other matter to absorb moisture, little nuisance will occur.

Privy Middens. A privy midden is a building with a fixed receptacle for faecal matter. Frequently the receptacle is also used for ashes, when it may be known as an ash-pit-privy; its construction is shown in Fig. 1. Ashes may always, with advantage, be put into a receptacle primarily intended for faecal matter, but faecal

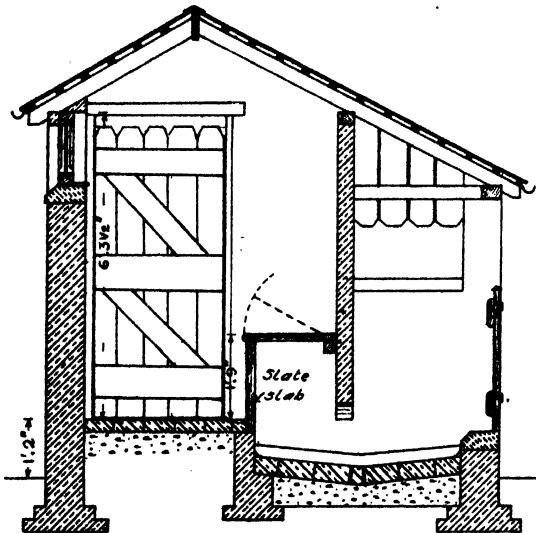

FIG. 1. PRIVY AND ASHPIT

matter should never be put into a receptacle provided for ashes. If used for faecal matter only, the receptacle must not exceed 8 cub. ft. in capacity, say, 3 ft. \times 2 ft. \times 16 in. deep, but if also used for ashes the capacity can be enlarged to 10 or 12 cub. ft. In the latter case, too, there may be openings through which the ashes may be thrown, but for faecal matter only it is desirable that the pit should be enclosed, except for such openings as may be required for ventilation. If uncovered faecal matter is exposed freely to the air it attracts flies, which walk over it in feeding, and then, with the filth adhering to their legs, probably fly to the nearest pantry and walk over the food destined for human consumption.

The emptying of privy middens is generally a difficulty unless a cart can be brought up alongside. The material is spadeable and can be

transported in a wheelbarrow. An iron barrow is desirable in order to avoid liquid drippings soiling the ground. If there is no way from the back to the front without going through the house, a privy midden should not be used, but if one does exist under such conditions the contents should be buried in the garden and covered over with at least 12 in. of soil. The emptying should take place at intervals not exceeding three months, and when the contents are removed the interior should be sprinkled over with chloride of lime.

Where privy middens are sanctioned by by-laws, it is generally provided that the buildings shall not be within 6 ft. of the dwelling house.

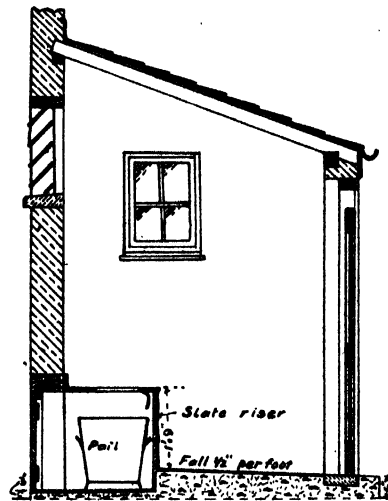

FIG. 2. PAIL CLOSET

This is very close and they should be at least 20 ft. away. The floor of the pit should be constructed of non-absorbent material, not less than 3 in. above the ground. The floor and the walls to a height of 4 ft. 6 in. should be rendered in cement mortar or covered with asphalt, unless they are formed in blue brickwork in cement. Every precaution against leakage should be taken, but, as an additional safeguard, the building should be located so that it is at least 40 ft. away from any well, spring, or stream used to supply water for human consumption. Under no circumstances should any drain be made in the pit, nor any connection to external drains. Not only would the drains most probably become blocked, but their presence would encourage the throwing of slops into the privy, with consequent nuisance. A drain would also prevent the early detection of wetness

or dampness which must not be allowed to exist, and is the reason why the floor is kept above the ground.

Pail Closets. Pail closets are technically privies with movable receptacles. They are in every way preferable to privy middens, but they are not suitable for use in towns. The London County Council by-laws permit pail closets, but

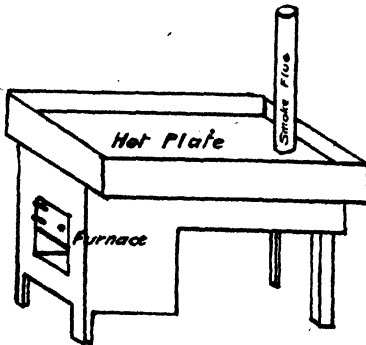

FIG. 3. DRYING HEARTH FOR EARTH

the restrictions surrounding them make construction almost impossible. For instance, the building must not be within 20 ft. of a dwelling house, nor within 100 ft. of any water supply. It must be located so as to be easy of access and such that the filth can be removed from the premises without being carried through any dwelling house or other building.

The general arrangement of a pail closet to comply with the usual by-laws is shown in

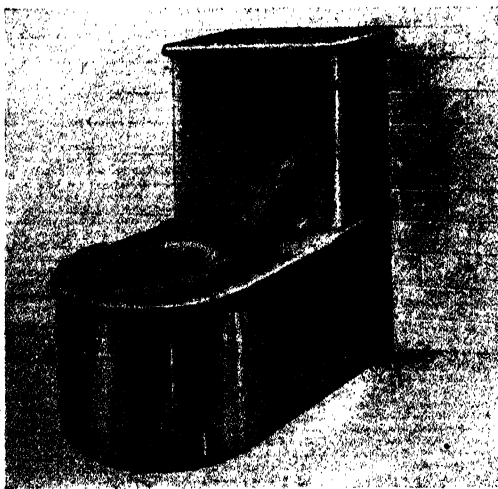
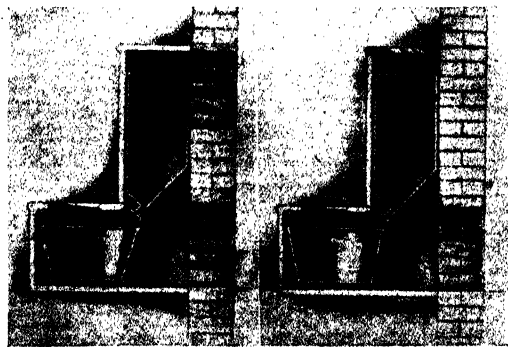

FIG. 4. PEDESTAL PAIL CLOSET

Fig. 2. Sufficient openings should be provided for ventilation as near to the top as possible, and communicating with the open air. The floor should be not less than 6 in. above the ground, and should have a fall towards the door of $\frac{1}{4}$ in. per ft. The portion under the seat should be sunk 3 in. lower, leaving it 3 in. above the external ground. The floors and walls should be of flagging, slate, or good brickwork at least 9 in. thick, rendered in good cement or asphalted so as to be non-absorbent. The riser at the front of the seat is preferably formed with a 2-in. slate slab. There should be a door at the back or side of the pail chamber for the removal of the receptacle and the cleansing of the space. If this is impracticable, the seat may be hinged so that the pail can be lifted out.

The capacity of the pail must not exceed 2 cub. ft., or say, 16 in. diameter and 18 in. deep. This limitation is to prevent misuse and to ensure frequent emptying. Pails should be emptied at least once a week, but every three days is preferable. Guides should be provided to fix the position of the pail under the seat so that the excreta shall fall into the receptacle and not foul the floor or sides of the space. The best pails to use are of galvanized iron or mild steel. They should be oval in shape and formed higher at the front end than at the back.

A local authority may undertake the emptying of the pails, otherwise the occupier is responsible. They are generally emptied at night, a man going round with a "night-soil" cart and tipping the contents of the pails into it. Where the authority undertakes the work, an arrangement that is most satisfactory comprises the use of pails having air-tight lids, which are taken, with their contents, to a central depot for emptying and cleaning; a fresh pail is left in



MODERN BUILDING CONSTRUCTION

the meantime at each house in exchange for the pail removed.

Earth Closets. Any midden or pail closet in which earth is applied to the excreta as a deodorant, becomes an earth closet. As, however, the applications of the earth might be discontinued at any time, most by-laws require

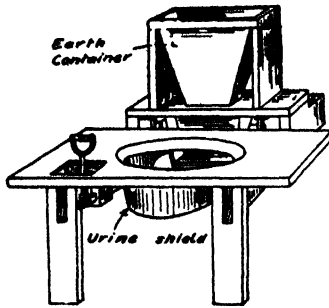

FIG. 5. MOULE'S EARTH CLOSET

that the earth shall be applied by mechanical means. It is essential that the material used should be earth, and a loamy soil is best. Such substances as chalk, gravel and sand, are useless as they are sterile and contain no bacteria. Ashes are useful in so far as they keep the excreta dry, but otherwise they have no effect.

Dry earth applied to excreta produces the change known as humification, namely the con-

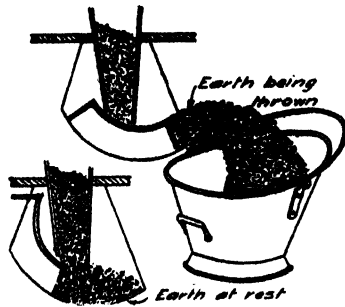

FIG. 6. METHOD OF APPLYING EARTH

version into humus or soil. A complete combination takes place between the substances in a period of about three months, and is brought about by the bacteria which exist in the excreta. There is an entire absence of smell during the process, and the earth may be used over and over again. It is requisite that the mixture be neither too dry nor too wet while it is maturing; a moisture content of about 33 per cent gives the best results. Before re-use, the earth must be made perfectly dry. This is best done

by storing it during the summer months under cover, but freely exposed to the air. Failing this it may be dried on a *drying hearth* consisting of an iron tray with a furnace underneath, as shown in Fig. 3.

Generally, only movable receptacles for the excreta are permitted, and their capacity should be limited to 2 cub. ft. The capacity of fixed receptacles does not, in general, exceed 12 cub. ft., although the Birmingham by-laws allow 40 cub. ft. In every case the excreta receptacles must be of non-absorbent material and so placed that no rain or other moisture reaches the excreta. The dry earth container should be



FIG. 7. JENNINGS'S EARTH CLOSET

easily accessible and of ample capacity to permit about 1½ pints of earth being applied each time the closet is used.

A pedestal pail closet made by Messrs. Oates & Green, Halifax, is shown in Fig. 4. It is made in one piece of brown salt-glazed fire-clay, of heavy design to guard against breakage, and is fitted with hardwood "Fixton" pads. The pail is removable through a door in the wall at the back. This makes a very neat and clean arrangement, which can be used anywhere where a pail closet is suitable, but it is particularly adapted to use in schools and factories, where strength and stability are essential.

The earth may be applied by hand with the use of a shovel, and in such case it is easily distributed over the whole of the deposited excreta. It is, however, preferable to eliminate the human element and adopt mechanical means. Fig. 5 shows Moule's Earth Closet, in which the

earth is shaken over the filth by a hinged spreader connected with the handle. An alternative method, which is more certain in its results, of applying the earth is shown in Fig. 6.

Bradley's patent automatic earth closet, made by George Jennings, Ltd., in which the spreader is actuated by the movement of the seat, is shown in Fig. 7. The weight of the user depresses the seat and a certain quantity of earth falls on to the spreader; then when the seat rises, the spreader throws the earth over the excreta. A rise of 1 in. of the seat is

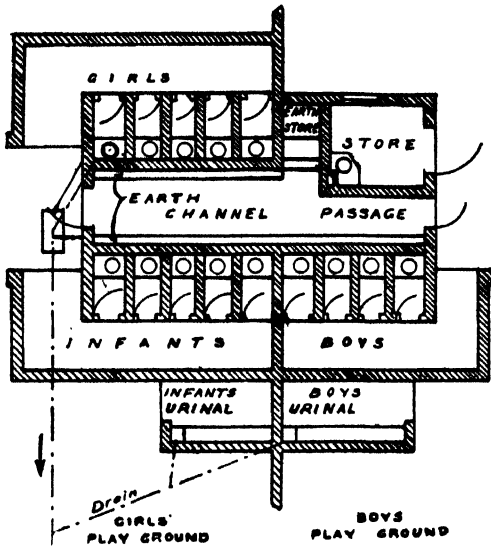

FIG. 8. EARTH CLOSETS FOR SCHOOLS

sufficient to operate the mechanism, which is very simple and not likely to get out of order.

A range of closets suitable for an elementary mixed school in the country is shown in Fig. 8. The closets are back to back, with a passage way between for the removal of the excreta. In this case the earth would be applied by hand, as automatic arrangements very quickly get out of order in schools, factories, and such-like places. Fig. 9 shows a section through the girls' closets which are fitted with a half-pipe channel for the reception of urine, in order that as little as possible may be mixed with the excreta. Fig. 10 is a section through the boys' closets.

Cesspools, frequently called *dumb-wells*, may be classed as conservancy appliances because the sewage is retained on the premises, but a water carriage system is required in conjunction with the cesspool to convey to it the

sewage from the house. Cesspools are usually circular in form and 4 ft. or more in diameter. They should be built and maintained in a water-tight condition in order to prevent pollution of the subsoil and underground water, particularly if the latter is used for water supply. Underground water is always flowing in some definite direction, and pollution may be carried considerable distances. Any well for domestic use should be placed on the upstream side of a cesspool and as far as possible from it; a distance of 100 ft. to 200 ft. is by no means excessive.

A design for a cesspool is shown in Fig. 11. The brickwork is surrounded by 6 in. or 9 in. of clay puddle to prevent leakage. Clay puddle is prepared from tough tenacious clay which must

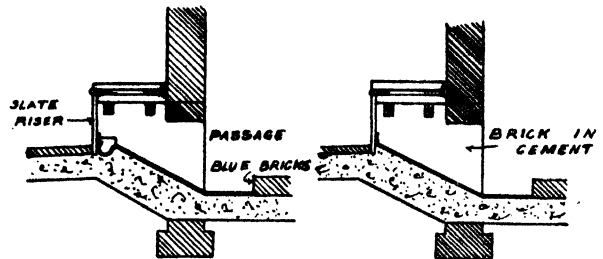

FIG. 9. SECTION THROUGH GIRLS' CLOSET

FIG. 10. SECTION THROUGH BOYS' CLOSET

be entirely free from sand or loam. The clay should be weathered and tempered, cut up and trampled on, until it is entirely homogeneous. To test the clay, a ball, some 3 in. diameter, should be made and put into a pail of water. If at the end of twenty-four hours the ball is intact, the clay is suitable for use, but if there is any sand or other extraneous matter in the clay, the ball will fall to pieces. The brickwork should be of hard bricks laid in cement mortar, or if of soft bricks it should be rendered in cement. The ground is excavated sufficiently large to receive the puddle outside the brickwork; then, after a few courses of bricks have been laid, the puddle should be laid in the annular space and tamped solid, care being taken not to disturb the brickwork. Then a few more courses of bricks are laid and more puddle inserted in a similar manner, and so on, until the top is reached.

The cesspool illustrated in Fig. 11 is covered over with a dome which is somewhat expensive to construct. An alternative method of covering, by corbelling over the brickwork and finishing with a stone slab, is shown in Figs. 12 and 13. Provision should be made in the top, not only

MODERN BUILDING CONSTRUCTION

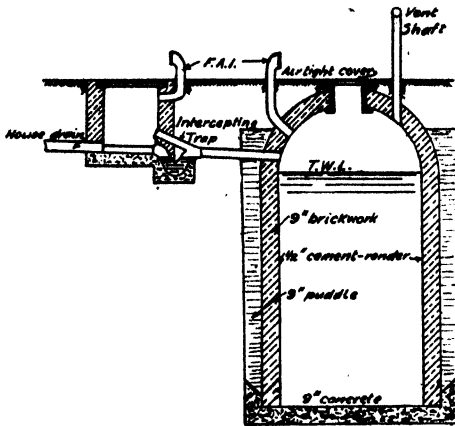

FIG. 11. CESSPOOL AND DRAIN CONNECTIONS

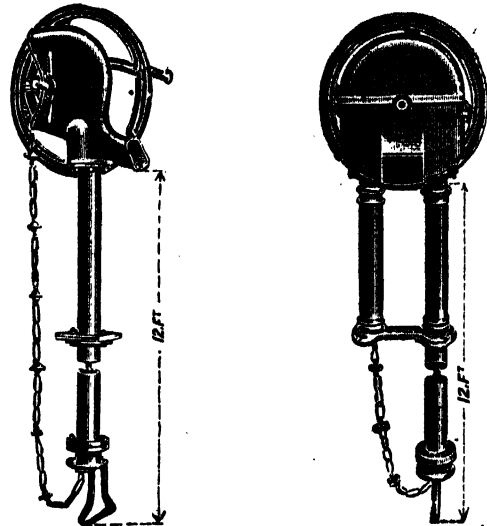

FIG. 14. CHAIN PUMP

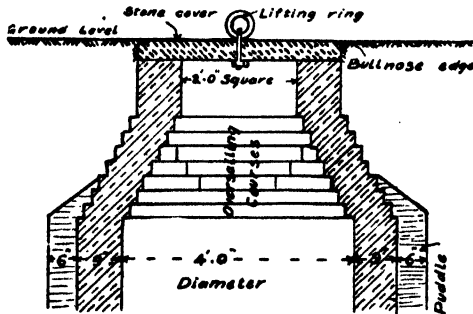

FIG. 12. SECTION THROUGH TOP OF CESSPOOL

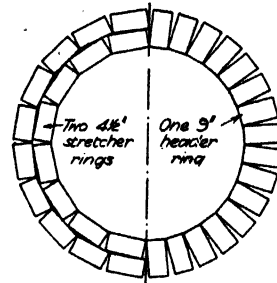

FIG. 15. ALTERNATIVE METHODS OF LAYING BRICKS IN CESSPOOLS

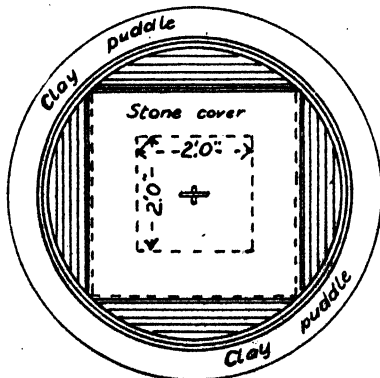

FIG. 13. PLAN OF CESSPOOL



FIG. 16. WELL BRICK

for access, but for building in a ventilating pipe, and it is further advantageous to have, as a permanent fixture, a chain pump as shown in Fig. 14, for emptying the cesspool. If circumstances permit, the liquid from the cesspool can be pumped out at frequent intervals and distributed over the adjoining garden ground, and thus avoid the nuisance and trouble of emptying and depositing the whole of the contents at one time.

If a considerable area of land is available, an overflow pipe can be built into the cesspool so that the surplus liquid can be irrigated over the land, or the overflow pipe can be connected to a system of underground open-jointed pipes laid a foot or so below the surface, and the sewage disposed of by sub-irrigation. Neither of these

the drain. The cesspool is also provided with a fresh air inlet, because a single vent shaft would permit only the expulsion or admission of air as the level of the liquid rose and fell in the cesspool, whereas for ventilation it is necessary to have an inlet as well as an outlet. The inlet should be at, or near, ground level, while the outlet shaft should be carried up as high as convenient, but not less than 6 ft. The shaft should be fastened to a wall or other rigid structure, and not to a tree because its swaying in the wind would break the pipe or its joints.

It should be noted that owing to the action of the bacteria in the sewage on the organic matter, the latter is disintegrated and a great portion of the solid matters go into solution, so



FIG. 17. VACUUM CESSPOOL EMPTYING APPARATUS

arrangements should be permitted if there is any water supply near by, and, except in the special circumstances mentioned, no overflow should be attached to a cesspool.

The bricks are frequently laid in one 9-in. header ring, but this is objectionable because it gives such wide joints at the back. A preferable way is in two 4½-in. rings. The relative thickness of the joints obtained can be seen from Fig. 15. Square bricks are used for the sake of economy, but in good work specially made curved bricks, known as *well bricks*, shown in Fig. 16, should be used. These can be laid with very thin joints, and a cesspool which will be more permanently watertight will be obtained.

The house drain should be disconnected from the cesspool by an intercepting trap, built into a chamber to allow of access; the sewage passing through the chamber in an open channel. The chamber should be provided with a fresh air inlet, marked *F.A.I.* in Fig. 11, to ventilate

that when a cesspool is emptied very little solid matter is found. When the contents are being removed, a special iron slop cart is required, so that the foul matter shall not drip on to the road during its conveyance to the dumping ground. To minimize the nuisance inseparable from the emptying of a cesspool, some deodorizing substance should be employed. The most modern method of emptying cesspools is to employ a vacuum tank, as shown in Fig. 17, which represents an apparatus made by The Karrier Motors, Ltd., Huddersfield. The tank is a cylindrical one, mounted on wheels, and sealed. When about to be used the air is exhausted from the tank, creating a partial vacuum, and a hose pipe from the tank is let down into the cesspool. Upon opening a valve on the pipe, the contents of the cesspool are sucked up into the tank, so that the cesspool is emptied without any of its contents being exposed to the air.

Chapter II—WATER-CARRIAGE SYSTEMS

Principles of Design. The essential principle of the water-carriage system is the introduction of a sufficient quantity of water into the drains which, in flowing through them, will carry with it all the foul matters from the premises. The water is used as the transporting agent, and to enable it to flow the drains must be laid with a falling gradient from every point at which the sewage is admitted down to the junction with the main sewer. It is not merely necessary for the water to flow, but it must flow with a velocity which will carry the foul matter along. Experiments and observation have shown that flowing water will transport material as follows. A velocity of 0.25 ft. per second will move semi-fluid mud; 1 ft. per second will move sand and gravel the size of beans; 2.2 ft. per second will move 1 in. rounded shingle; and 3.25 ft. per second will move angular shingle the size of a hen's egg. A greater velocity is required to pick up and transport any matter deposited on the bottom of the pipes than is necessary to carry it along when once it is on the move.

The ideal at which to aim is rapid and complete removal of the foul matter. Fresh sewage is comparatively harmless, but after a short time putrefaction, that is, the decomposition of the organic matter, sets in, and this is accompanied by the emission of foul-smelling gases. Sewage consists of the waste-water from the house containing grease, soap, and foul matter from the washing and cleansing of the house, the body and clothes, together with urine and faeces. The impurities are partly in suspension in the water and partly in solution; the proportion of solid matter in suspension is very small, amounting only to about 40 parts per 100,000, or one-twenty-fifth of 1 per cent. Of these solid matters some float, some are carried along in the body of the liquid, while others tend to sink to the bottom. This is due to the varying specific gravity of the matter. *Specific gravity* is the ratio of the weight of any substance to the weight of an equal volume of water. Thus, as substances with a smaller specific gravity than water are lighter than water, they float; those of the same specific gravity remain promiscuously in the body of the water; those of greater specific gravity tend to sink. The trans-

porting power of water varies with the sixth power; that is, if the velocity is doubled, the transporting power is increased 2^6 , or 64 times. It is, therefore, apparent that a very small variation in velocity is of considerable importance. The velocity must at all times be sufficient to prevent the heaviest matter in the drains from settling to the bottom.

VELOCITY OF FLOW. When a volume of liquid is flowing through a conduit it does not move forward as a homogeneous mass, but the velocity

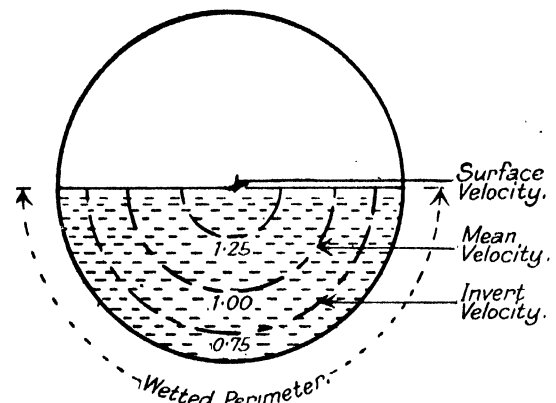

FIG. 18. DIAGRAM SHOWING VARIABLE VELOCITY OF FLOWING LIQUID

varies in different parts of the cross section, so that the particles are continually changing their position relative to each other. This variable velocity is shown in Fig. 18. The surface velocity in the centre is 25 per cent greater than the mean, while at the sides and bottom the velocity is reduced by friction between the flowing water and the conduit to about 25 per cent less than the mean. In order, therefore, to give a "self-cleansing" velocity at the bottom of the pipe, arrangements must be made for a mean, or average, velocity one-third greater.

The mean velocity depends upon the slope or gradient of the drain. The particles of a liquid move very freely among themselves, and the surface of a liquid at rest is always horizontal, consequently liquid in an inclined pipe slides down in an endeavour to take up a horizontal position at the lowest level, and the steeper the

pipe the more readily the particles of water slide over each other and the quicker the velocity. A simple formula to find the mean velocity of flow in a pipe is—

$$V = 4\frac{1}{2}\sqrt{fs} \text{ (Eytelwein)}$$

when V = mean or average velocity in feet per second, f = fall in inches per yard, s = hydraulic mean depth in inches.

The *hydraulic mean depth* is the ratio of the cross-sectional area of the flowing water divided by the length of that portion of the perimeter of the pipe which is in contact with the liquid, or briefly—

$$\frac{\text{Area}}{\text{Wetted perimeter.}}$$

In the case of a pipe flowing full, the hydraulic mean depth (generally written H.M.D.) will be—

$$\frac{\text{Area}}{\text{Circumference}} = \frac{\pi r^2}{2\pi r} = \frac{r}{2} = \frac{d}{4}$$

where r = radius, d = diameter, and π = ratio of circumference to radius of a circle = 3.1416 or $\frac{22}{7}$.

For a pipe flowing half-full it will be found that the H.M.D. is also $\frac{\text{diameter}}{4}$. It therefore

follows that the average velocity of flow is the same whether the pipe is full or half-full, but it varies for any other depth of flow. If the average velocity of a pipe flowing full or half-full is taken as unity or 1, the average velocity at one-fourth full will be 0.75, at one-sixth full it will be 0.5, and at four-fifths full it will be 1.15, which is the maximum obtainable. Calculations are made on the basis of the drain flowing full or half-full, but allowances must be made when the quantity of liquid is insufficient to fill the pipe to this extent, as is invariably the case with house drains. The discharge is given by multiplying the cross-sectional area of the flowing liquid by its mean velocity.

SIZE OF HOUSE DRAINS. The usual size for house drains is 4 in. diameter, but where a number of houses are drained through a single pipe, or in the case of institutions, then a 6 in. pipe is generally used, and is ample for the purpose.

FALL OF DRAINS. House drains are generally laid with a fall, or gradient, of 1 in 40 for 4 in. pipes, and 1 in 60 for 6 in. pipes, which gives velocities when full or half-full of 3.75 and 4 ft. per second respectively. This apparently excessive velocity is required because of the extreme fluctuations in the flow through the pipes. It is

undesirable to lay pipes more steeply than will give an average velocity (when half-full) of 8 ft. to 10 ft. per second, as in such case there is a risk of the liquid draining away, and leaving unbroken solid matter behind in the pipes. Also, running water has the power to erode and wear away the hardest materials; this power varies with the square of the velocity, or double the velocity gives four times the eroding power. The wearing out of the house drain by the flowing water is, however, more an academical than a practical possibility.

It should be noted that there are a large number of formulae giving the velocity of flow in pipes, and that they all give slightly different results. The explanation is that each formula is based on a limited number of experiments under similarly limited conditions, and is not necessarily correct under other conditions.

Systems of Drainage. There are two systems of drainage, the *separate system*, where two entirely separate sets of drains are laid to a single property, one of which carries the rain-water and the other the sewage; and the *combined system*, in which one drain only is laid to carry off everything which comes from the premises. The determination of the system to adopt depends, in towns, upon the system employed for the public sewers. In many instances of town sewerage a compromise is effected. A "storm water sewer" is laid to collect and convey the rain falling on the streets and the front roofs and gardens of houses, and the "foul water sewer" receives the sewage from the houses and the rain which falls on the back roofs and yards; this is known as the *partially separated system*. In such case the houses would be drained on the "combined system." So far as the house owner is concerned, a separate system practically doubles the cost of the drainage. It also has the disadvantage that during dry weather the mud left behind in the storm water drain decomposes, and gives off foul gas, which may escape into the air.

When there are no public sewers, and the sewage has to be disposed of by the owner within the boundaries of his own property, it is desirable that the flow of rain-water to the outfall, or purification plant, should be reduced as much as possible, and it may be practicable in many cases to discharge the greater part of the rainfall on to the garden without it entering the drains at all. When providing for rainfall in single house drains, allowance should be made

MODERN BUILDING CONSTRUCTION

for a fall at the rate of $1\frac{1}{2}$ in. to 2 in. per hour over the area occupied by the house, out-buildings, and paved yards. This rate would not probably continue for more than a few minutes at a time, but the drains should be large enough to carry the maximum quantity they may receive.

The quantity of sewage derived from a single house varies with the character and occupation of the residents, but the figures in Table I give an approximately correct average flow.

TABLE I
QUANTITIES OF WATER (ALSO FOR SEWAGE) FOR
DOMESTIC PURPOSES

	Gal. per Head per Day
Cooking	0.7
Drinking	0.3
<hr/>	
Total for Dietetic Purposes	1.0
House Cleansing	3.0
Clothes Washing	3.0
Personal Ablutions	3.0
<hr/>	
If Water Closets are installed, add	10.0
If Baths are installed, add	5.0
<hr/>	
Total for Domestic Use	20.0

Pipes. The essential points in laying drains are that the pipes should form absolutely straight lines, and that the interior should form a perfectly true cylinder from end to end. Care in laying is, of course, necessary, but the foregoing conditions cannot be obtained unless "best" pipes are used. "Seconds" pipes, usually found with a black band painted round them, are comparatively cheap and are useful for some purposes, but they are not suitable for house drains.

The pipes should be best *stoneware* socketed pipes to the British standard specification, in lengths of 2 ft. The sockets should be conical with a slope of $\frac{1}{8}$ in., thus making the diameter $\frac{1}{8}$ in. greater at the top, or mouth, than at the bottom. The interior of the sockets should be grooved $\frac{1}{8}$ in. deep, and the length on the spigot equal to one and a half times the depth of the socket should be similarly grooved. These grooved portions of the pipe should be unglazed in order that the jointing material may adhere. The bodies of the pipes are glazed by the fumes of volatilized common salt, and are said to be *salt glazed*. As the pipes are

stacked in the kiln for glazing vertically, with the spigot of one pipe in the socket of the one below it, the fumes do not easily reach the interior of the socket and the end of the spigot, and thus the unglazed condition of those parts is obtained, except in the pipes in the top and bottom rows. These latter pipes should be sorted out and be put with the "seconds" pipes. The pipes, generally, should be thoroughly vitrified, salt glazed, straight in bore, true in cross-section, correct in thickness and other dimensions, smooth inside, and free from fire cracks and all other defects.

The thickness of the barrel and socket of the pipes should be $\frac{1}{2}$ in. for 4 in. pipes and $\frac{3}{8}$ in. for 6 in. pipes. The depth of the socket should be 2 in. for 4 in. pipes and $2\frac{1}{4}$ in. for 6 in. pipes, while the maximum space at the back of the socket for the jointing material should be $\frac{3}{8}$ in. for 4 in. pipes and $\frac{7}{16}$ in. for 6 in. pipes. The permissible variation in the thickness of the pipes is $\frac{1}{16}$ in., while the diameter in any direction, and in any part of the pipe, should not vary from a true circle by more than $\frac{1}{8}$ in. for 4 in. pipes, and $\frac{3}{16}$ in. for 6 in. pipes. In the straightness of the barrel there should not be a greater deviation than $\frac{3}{16}$ in. "Tested" pipes are subjected to an internal hydraulic pressure of 20 lb. per sq. in. maintained for five seconds.

The density of the material forming the pipe, and its water-tightness, are tested by an absorption test. A piece of stoneware varying from 8 in. to 20 in. super is broken from the pipe and dried at a temperature of 150° C. It is weighed and is then immersed in water, which is raised to boiling and allowed to boil for one hour. The test piece is then removed, allowed to cool, wiped, and reweighed. The increase of weight should not exceed 5 per cent. It should be noted that there are many first-class manufacturers turning out pipes better in every respect than the requirements of the foregoing specification.

Earthenware pipes are made from ordinary clays such as are used for common bricks, tiles, and field drains. They are weak and porous, and if glazed the glazing soon wears off. They are not suitable for house drain pipes. Pipes made north of Derby are made of fireclay or non-vitreous material, which is sometimes described as earthenware, but fireclay pipes would be a better definition. Midland and south country pipes are made from stoneware and are stronger and more compact in texture than the northern pipes. The British Standard Committee get

over the difficulty of nomenclature by specifying "ware" pipes, and any pipe complying with the specification requirements would be acceptable.

Jointing of Pipes. The joints of ordinary socketed pipes should be made first by caulking in two or three strands of tarred gaskin, and then tightly pressing in cement mortar to fill up

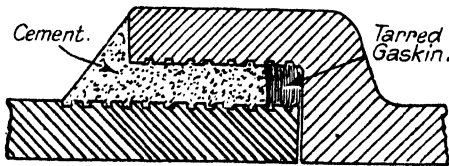

FIG. 19. ORDINARY CEMENT JOINT

the remainder of the socket. The outside of the joint should be finished with a neat fillet of cement mortar extending all round the pipe, as shown in Fig. 19. The cement mortar should be a strong mixture. Neat cement is undesirable, as it is liable to crack in setting and thus lead to leakage. A mixture of one or two parts of cement to one of sand will form a good sound joint.

PATENT JOINTS. If the ground is very wet it is almost impossible to form cement joints. They may look all right in the upper portion, but when water reaches the underside the unset cement will disintegrate and fall off, leaving a space through which the sewage may flow out or the subsoil water may enter. In such cases *patent jointed pipes* should be used. There are

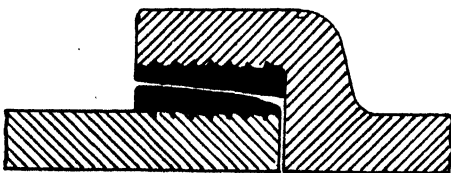

FIG. 20. ORIGINAL STANFORD JOINT

many types of these joints which have been evolved from the original *Stanford joint*, made by Messrs. Doulton & Co., shown in Fig. 20. The lining of the joint is formed of black bituminous material, run into a mould to give it the required shape. These rings are covered with plastic jointing composition, which completely seals up the joint when the pipes are forced together. Another advantage of such joints is that the adjoining pipes are truly concentric, and there is no possibility of any

ledge inside the pipe which would form an obstruction to the flow of the sewage.

A more reliable, and also more expensive, joint is *Hassall's double-lined joint*, shown in Fig. 21. When the pipes are put together with the bituminous rings in contact, an annular space is left around the pipe, which is filled by cement grout run through two holes in the crown of the socket. The cement forms a solid joint and it is impossible for the pipes to be separated. The inner bituminous rings in this joint are of the same wedge shape as the "Stanford" joint, but instead of being close fitting, these rings, as well as the parallel outer rings at the mouth of the socket, are cast so as to allow a slight clearance space between them, which is filled up with a cushion of plastic cement to receive, embed, and render harmless any grit which may be in the way. It also fills up any flaw in the castings, besides making a

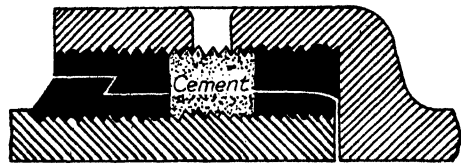

FIG. 21. HASSALL'S DOUBLE-LINED JOINT

temporary water-tight joint while the Portland cement is setting. In making the joint, the plastic cement should be laid on the lining in the socket to a depth of about $\frac{1}{8}$ in., and also in the recess in the outer collar on the spigot, so that when the pipes are brought together the cement will be compressed and close the spaces, leaving only the annular ring for the cement. Before pouring in the liquid cement, a light cane should be inserted in one of the upper holes, and worked round the annular space to prove it is free from obstruction. The cement should then be poured in through one of the holes, the cane still being worked about, until the cement rises to the top of the pipe at the other hole, when the cane should be withdrawn. If a tundish or funnel is not used for pouring in the cement, a small clay dam should be formed round the hole to guide the cement into it. As the grout is poured into the annular space the heavy particles of cement will sink to the bottom, causing the greater part of the water to separate and rise to the surface; so that, to ensure a solid cement joint all round the socket, a further quantity of grout should be run into the joint about a quarter of an hour after the first pouring. It is

MODERN BUILDING CONSTRUCTION

desirable to lay a good number of pipes, and then to run all the joints together afterwards so that one mixing of grout will suffice.

A pipe of another type is shown in Fig. 22. This is *Doulton's level-invert pipe*, and is devised, as its name implies, to ensure the pipes being laid so that the inverts of adjoining pipes are truly in line. The spigot of one pipe, when laid

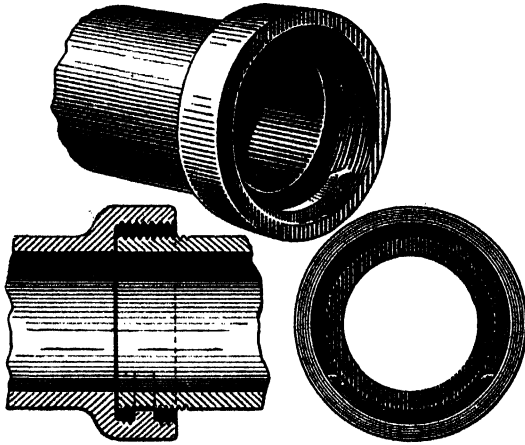

FIG. 22. DOULTON'S LEVEL-INVERT PIPE

on the projecting ridge in the socket of the next pipe, is in the correct position for jointing. The pipes can be laid quicker than those with ordinary sockets, but there is some difficulty in making a sound joint with gaskin all round the pipe, and if the gaskin is omitted there is a risk of cement being forced into the pipe.

When a change is made in the diameter of the drain the two sizes of pipes should be connected by a properly formed *taper pipe*. For general use the long taper (Fig. 25) is the most suitable. In using a short taper, it is preferable to lay it with the drop in the invert, as shown in Fig. 24, rather than to have the enlargement in the upper part as in Fig. 23.

Excavation and Timbering. House drains are necessarily laid in close proximity to the buildings which they serve, and at depths near to, if not below, the level of the foundations of the walls. Foundations of heavy and important buildings are designed so as to impose a load on the ground not greater than it is assumed to be capable of bearing. The bearing capacity of a soil is estimated on the assumption that it cannot spread laterally, but will hold up to its work. When, however, a drain trench is dug adjacent to a building, particularly if it is parallel to the wall, the lateral support of the footings is taken away

and precautions must be taken to prevent the settlement of the building. First of all, the building should be shored, or strutted, then the drain trench should be excavated only in short lengths, and such lengths should be firmly timbered. Every two yards or so a solid concrete block or wall should be built across the trench from the bottom to just above the footings, to buttress the building.

If the ground is dry there is generally not much danger of damage occurring, but in wet ground arrangements will be made to pump the water out during construction, and there will be a continuous flow of water into the trench to feed the pump. If the soil is sandy, or of fine texture, as it will probably be, the flowing water will carry with it particles of soil which come from beneath the foundations, which will thereby be undermined. The length of time during which pumping takes place should be curtailed as much as possible, and in the interests of the stability of the building, the drainage work should be carried on night and day until complete.

Running Sand. Running sand is probably the greatest bugbear of the excavator. It is not a case of the sand having any specially diabolical features, but the condition is brought about by a combination of circumstances, which are in themselves separately innocuous. The digging of a trench, through sandy soil, may proceed without any difficulty until a certain depth is

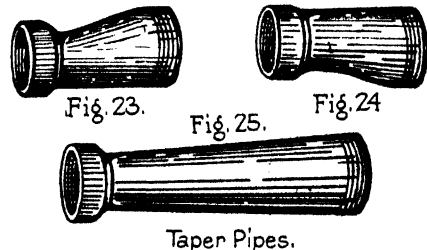

FIGS. 23-25. TAPER PIPES

reached, when the sand becomes soft and unstable. This condition is always associated with the presence of water. The sand will not bear any weight, and as fast as a shovelful is removed some more sand appears and takes its place, so that although digging may proceed the trench does not get any deeper; in fact, it may get shallower.

This condition arises when the trench bottom is below the level of the subsoil water, and the

water flows into the trench upwards from the bottom; or, possibly, where an impermeable stratum is penetrated and sand is discovered beneath containing water under pressure—that is, under artesian conditions. The rising water carries with it grains of sand, and keeps them in a state of flotation, the finer and lighter the sand particles, or the stronger the flow of water, the more the solidity of the sand is reduced. If the water were allowed to rise in the trench, and come to rest at its normal level, it would be found that the sand had settled down and the trench had a firm bottom beneath the water;

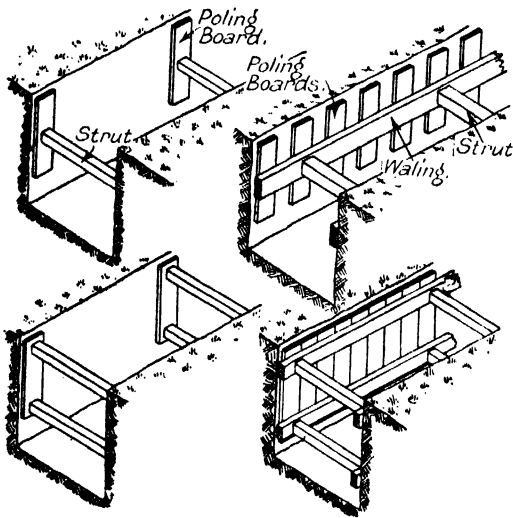

FIGS. 26-29. TIMBERING FOR DRAIN TRENCHES

but, of course, the pipes could not be laid in such circumstances. There is only one way of dealing effectively with running sand, and that is to lower the level of the subsoil water in the locality to below the floor of the trench.

Trenches for the construction of drains should be made at least 2 ft. wide, to give room for a man to plant his feet on either side of the pipe without disturbing it, and to give plenty of elbow room for the pipes to be jointed. It is useless to expect good work unless the men can work under comfortable and convenient conditions. In throwing out the excavated material, the surface soil or paving should be deposited in a separate heap to the subsoil. It should be thrown so that there is a clear space along the edge of the trench for a man to walk.

Drain trenches are usually shallow, and are open for so short a time that it is frequently

unnecessary to support the sides by timbering. It is, however, bad policy to run any risk, because the contractor is responsible for any harm that may befall the workmen; and if the side of a trench collapses a great width of ground falls in, which is not only expensive to remove but the subsequent construction is made difficult. Also, if the pipes happen to have been laid, they are usually pushed out of position and the joints broken, so that a new drain has to be laid.

The style and amount of timbering required in the trench depends upon the depth of the drain and the nature of the soil. Even if the ground is naturally firm and stable some timbering should be put in, because the weight of the excavated material heaped up at the side of the trench, and the traffic of the men up and down, tend to cause the sides to fall. The least possible amount of timbering is shown in Fig. 26. The *poling boards* of elm, 1½ in. thick, 9 in. wide, and 2 ft. to 3 ft. long, are held in position by square or round fir struts about 4 in. thick. In deeper trenches, long poling boards, each pair held up by two struts, and possibly placed closer together, should be used, as shown in Fig. 27. When the ground is looser, the poling boards must be placed closer together, and it would then be impracticable to use struts to each pair of boards as before, because they would cause so much obstruction in the trench that it would be difficult to lay the pipes. The boards are, therefore, held back against the earth by a *waling*, that is, a fir plank 9 in. by 3 in. and possibly 12 ft. or 14 ft. long, as shown in Fig. 28. The walings are held in position by struts across the trench, generally one strut at each end, the walings on each side of the trench being laid in pairs with joints opposite to each other. In very loose ground the poling boards must form a solid shield against the side of the trench, as shown in Fig. 29, and in such case, as the timber has to withstand a great load, two rows of walings should be provided to each setting of poling boards.

Laying Drains. In setting out the work, pegs are driven over the centre line of the drain, one being at each change of direction. Then on either side of the centre pegs iron pegs are driven in at half the width of the trench away. A cord stretched from one of these iron pegs to the next one, along the line, enables the edge of the trench to be marked out ready for excavating. To enable the drain to be laid accurately to the pre-determined levels, *sight rails* are

MODERN BUILDING CONSTRUCTION

fixed up, as shown in Figs. 30 and 31. Having settled upon a convenient height for the boning rod (Fig. 32), the sight rails are fixed this height above the proposed invert of the drain

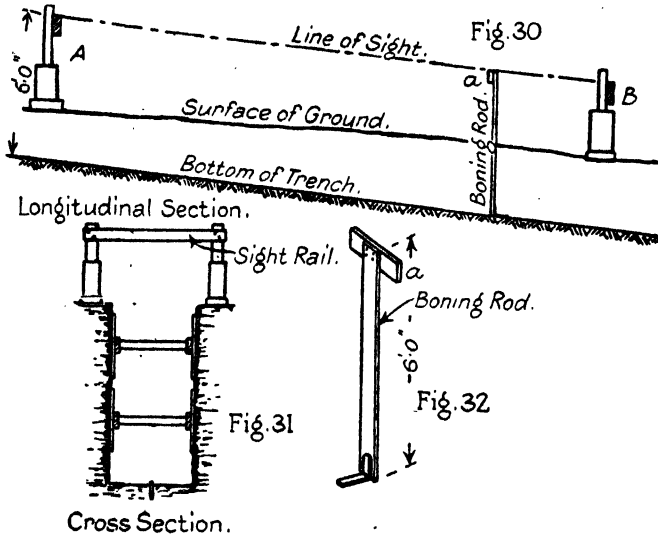

FIGS. 30-32. SIGHT RAILS AND BONING ROD

at the respective positions. The *invert* is the lowest point at the bottom of the interior of the pipe.

A line of sight from one rail to the next will be parallel to the drain, and at a distance above it equal to the height of the boning rod. The sight rails are secured to uprights either sunk into the ground, or set in drain pipes placed on the ground and filled with earth. For small drainage work, where the trench is unlikely to remain open for more than a day or so, a less elaborate form of sight rail may be used, but it is essential it should be rigid.

In using the *boning rod*, one man holds it in the trench between the sight rails, while another man stands behind one of the rails and, looking over the top, signals to the other to raise or lower the rod until the cross-piece on it and the two sight rails are all in the same straight line. If no concrete is to be put under the drain, the trench should be excavated to the depth given by the boning rod, and then, just before the pipes are laid, a small quantity of earth should be removed from under the line of pipes to give a solid bed for them, as shown in Fig. 33. The

bottom should be recessed for the sockets, so that only the barrel of the pipe is in contact with the ground. If the ground is excavated to the full depth at first, the trampling of the men will break up the ground, so that a firm bed is not obtainable for the pipes. In clay soils a concrete bed to the drain is essential; its thickness should be 6 in. A temporary cross-piece can be fastened to the boning rod to give the level for the bottom of the concrete.

To enable the pipes to be laid accurately, an angle bracket is fixed to the bottom of the boning rod, and this is placed in the invert at the mouth of each pipe as it is laid. If the pipe is too high some more earth should be removed from the bed, and if it is too low it should be packed with pieces of slate. Under no circumstances should a low pipe be packed with earth, as it is certain to yield when the trench is filled in and the weight comes upon it, with the result that the alignment of the pipes is destroyed. In filling the trench,

small material should be put in first and packed in solidly by hand at the side of, and under the haunches of, the pipes. The filling material should then be carefully placed and gently

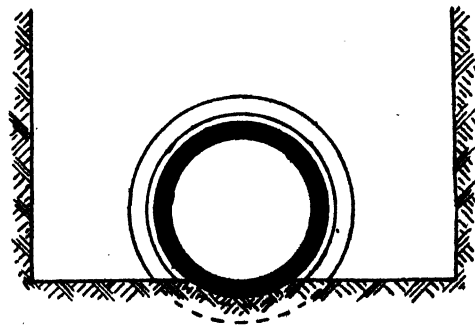

FIG. 33. BEDDING PIPES ON SOLID GROUND

consolidated by spading and treading, until there is a cover of about 6 in. over the pipes; the remainder of the material can then be filled in and rammed. Throwing large clods of earth and stones into the trench is very likely to break the pipe joints, by reason of the jarring which occurs.

Chapter III—TRAPS, CHAMBERS, AND GULLIES

TRAPS

THE admission of sewer and drain air into a house is a certain cause of illness, and every precaution must be taken to prevent its access. The passage of foul air is barred by the placing of traps in suitable positions. *Traps* are made by forming a depression in the pipe so that it will retain water and then arranging a tongue, or projection, from the upper part of the pipe, and dipping a short distance below the surface of the liquid. Waste matter can readily escape by passing through the trap under the tongue, but the passage of air above the surface of the liquid is barred.

less than $1\frac{1}{2}$ in., nor more than $3\frac{1}{2}$ in. The passageway through this trap should be slightly restricted in size, so that the velocity is increased; this is obtained by making it oval in shape instead of circular. A drop in level from the invert of the incoming pipe to the water level is advantageous, as it induces the solid matter to pass more readily through the trap. Intercepting traps must be set horizontally on the base provided, otherwise the water seal may be lost.

Investigations show that the air in drains is as bad as, if not worse than, the air in the sewers. This is not invariably the case, but

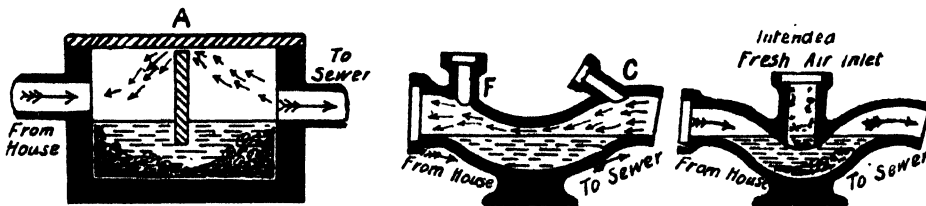

FIG. 34. OLD FORMS OF TRAPS

Some old forms of traps are shown in Fig. 34 with a view to indicating what to avoid. They fail in two essentials; they do not prevent the passage of foul air, and they retain accumulations of decomposing solid matter, that is, they are not self-cleansing. Traps vary in form according to the situation in which they are to be used.

Intercepting Traps are used to disconnect house drains from the sewers. They are generally placed at the boundary of the property, the idea being to put them as far from the building and as near to the sewer as practicable. Two good forms are shown in Fig. 35; they are suitable for building into the wall at the outgoing end of an intercepting chamber. The inspection branches at the top of the trap are provided to enable the length of drain between the trap and the sewer to be rodded in case of obstruction, but normally the branches are closed by stoppers fixed in with plastic composition, so as to be easily removed in case of necessity. The depth of the seal should not be

depends upon the condition of the sewers. In modern, well-ventilated systems, where the sewers are properly proportioned and are laid with self-cleansing gradients, there should be no accumulations of foul air, and intercepting traps on the drains may be omitted. On the other hand, many old systems of sewers are found with decomposing matter lying in the bottom and other defects. In such cases the air will be worse than in the drains, and intercepting traps should be employed.

Many objections to intercepting traps have been made. They may be inoperative owing to improper design and fixing. Water flowing rapidly through the trap may reduce the water level and destroy the seal. A dish cloth, or rag, may siphon the water out of the trap by capillary attraction. Traps form an obstruction to the flow of sewage, and are objectionable by reason of the quantity of foul liquid which is retained in them. It is also found that when a house drain becomes blocked, the stoppage generally arises in the intercepting trap. More frequently

MODERN BUILDING CONSTRUCTION

than not, however, the stoppage is due to improper use of the drains and the careless discharge of scrubbing brushes, cloths, etc.

CHAMBERS

Intercepting Chambers. A chamber, as shown in Fig. 36, is generally built in conjunction with the intercepting trap to provide means of access to the trap and to the drain. The size of the chamber depends, to some extent, upon the depth of the drain. If it is necessary for a man to enter the chamber to reach the drain, the chamber should be about 3 ft. long and 2 ft. wide. The sewage passes through the chamber in an open channel, which may be formed with channel pipes or in concrete, and the trap is fixed at the outlet end. The chamber may be built in brickwork, or concrete. The interior surface should be smooth and impervious, and if brickwork is adopted the face should be rendered in cement mortar (two parts sand to one part cement). The *benching* should be similarly coated, and should have a fall of 6 in. per foot towards the channel. The chamber should be covered with an airtight cast-iron cover, as Fig. 37. The groove in the frame can be filled with Russian tallow, plastic composition, or even water. The projection on the lid fits into this groove and forms a trap, which prevents the emission of foul air.

Junctions. Every connection of a branch drain must be made by a special junction pipe. The branch should make an angle of 60° with the pipe, so that the entering sewage will not obstruct the flow in the main pipe. Square, or 90°, junctions should never be used, as the opposing streams of sewage would lead to solid matter being deposited in the pipe instead of flowing away, and eventually stoppage might result. It is undesirable to have branches on each side of the pipe opposite each other, as in Fig. 38, even though they may be curved on the plan. A slight alteration should be made in

the lines of the branches, so that they may enter the main drain as shown in Fig. 39.

It is sometimes desirable to insert junction pipes in a drain, with a view to the branch being used at a later date. In such cases the mouth of the branch should be sealed by a junction cap, as illustrated in Fig. 40. This is Doulton's

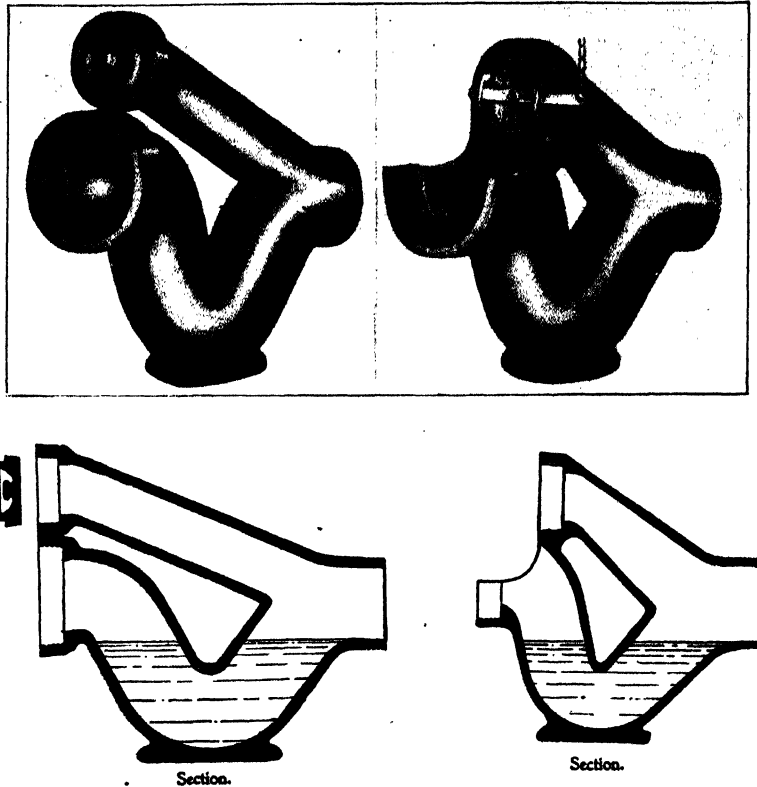

FIG. 35. INTERCEPTING TRAPS

“Closure” junction cap, and it affords a means of effectually closing the socket of a junction branch until it is required for use. The cap fits over the outside of the socket, and is secured with an ordinary cement joint. During manufacture a partial division of the material is made at the point marked *A*, leaving sufficient thickness to preserve strength. The outer disc can be readily detached by a chisel, leaving the interior of the socket ready to take the branch pipe. Since the cap is a separate piece of ware, the disc is detached without risk of damage to the pipe.

Another fitting with a similar object is Jennings' “Joinder.” In this case the cap is

attached to the junction eye in manufacture, but is separated for use in a similar manner.

Access to Drains. At one or more points in the course of a drain, provision should be made for access to the interior in case of necessity, without breaking the pipes. Where inspection

It is desirable, if additional expense permissible, to construct *inspection chambers* at all bends and junctions on the main drain. When a chamber is built, as many branch drains as possible should be laid to discharge into it. The branch drains should be laid in straight lines to the inner

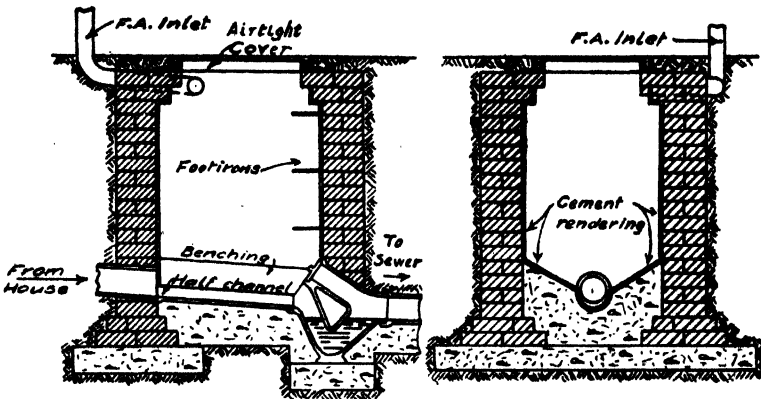

FIG. 36. INTERCEPTING CHAMBER

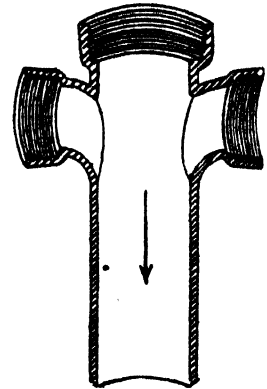

FIG. 38. DOUBLE JUNCTION PIPE

chambers are not used, special *access pipes*, as shown in Fig. 41, are inserted. Two types are illustrated. The first has a loose cap which is fitted into a socket, and jointed so that it can be easily removed. A good method of joining is to bed the cap on a thin layer of clay, and then cover the joint on the outside with a fillet

face of the chamber walls, and then should be brought round with sharp curves to discharge in the direction of the main flow, as shown in Fig. 42. The channels in this case are formed

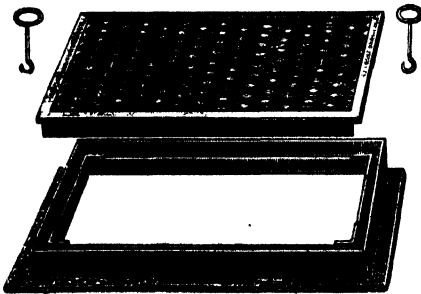

FIG. 37. INSPECTION CHAMBER COVER

of lime mortar, which will not set hard underground. Cement mortar should never be used, as its removal is impossible without breaking the pipe.

In the other illustration, the cap is held down by a screw passing through a bridge, which spans it and is held in position by clips turned in under the socket.

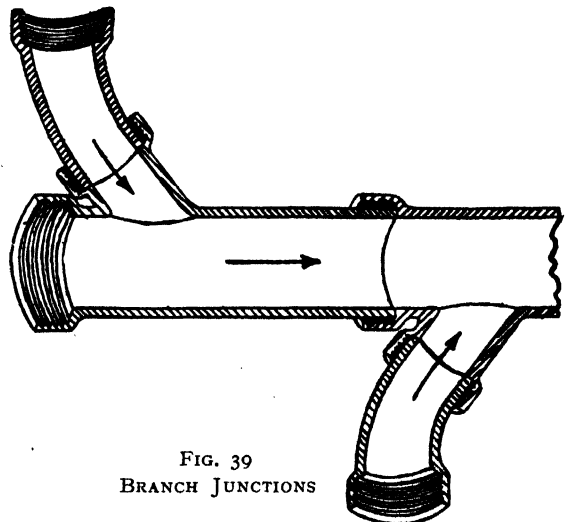

FIG. 39
BRANCH JUNCTIONS

with half-pipes glazed and socketed, as shown in detail in Fig. 43. These are useful when the fall in the branch drains is small, and there is no margin for a further drop at the chamber. Frequently the branch inlet bends are made in

MODERN BUILDING CONSTRUCTION

one piece, as shown in Fig. 44, and in such case they are set so that the underside of the blocks rest on the top of the half-pipe channel, and the sewage drops into the channel, although it still

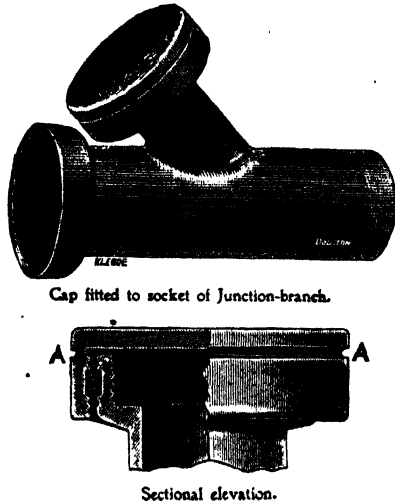

FIG. 40. DOULTON'S "CLOSURE" JUNCTION-CAP

has a velocity in the direction of the main flow. This particular block is one of Doulton's "Square-face" branch bends. The internal shape is such as to prevent fouling, or splashing, and to turn the flow of the sewage in the most efficient manner in the direction of the channel.

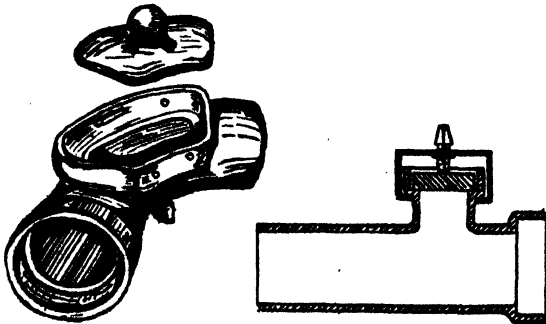

FIG. 41. ACCESS PIPES

The flat base, rebated at the front to fit upon the channel, ensures correct fitting. Each bend has a glazed rectangular front which forms, when the bend is in position, a 3 in. extension to the depth of the main channel, which can be continued either side by adjoining bends, or by glazed tiles, 3 in. high. They are carefully

moulded, and the formation of the bends provides for the easy insertion of a testing stopper. The difficulty is to obtain branches at the precise angle required. They are stocked suitable for a number of different angles and possibly one or other may be made to fit, but if it is necessary to have a block specially made, some delay is inevitable. The half-pipe channel junctions are all made at one angle, and the

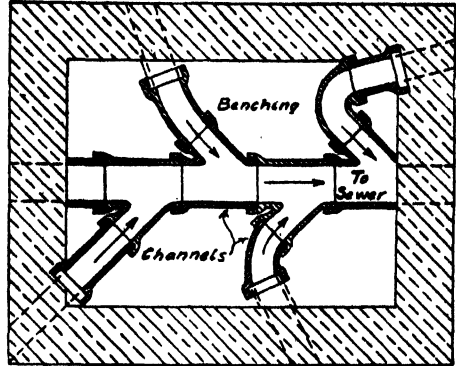

FIG. 42. INVERT OF JUNCTION CHAMBER

manoeuvring to fit the incoming pipe has to be done in the bend.

Fig. 45 shows, in section, a complete intercepting and junction chamber with Doulton's fittings. The cap on the rodding eye of the intercepting trap can be removed by pulling

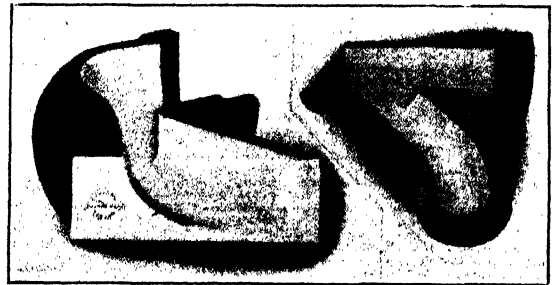

FIG. 43. HALF-PIPE CHANNEL JUNCTION

FIG. 44. DOULTON'S "SQUARE-FACE" BRANCH BEND

the chain, which releases the catch, and the door either drops or can be pulled out. This is an advantage, because if a blockage occurs in the trap, the chamber will gradually fill up with sewage, and there would otherwise be some difficulty in getting at the cap to open it. The invert channel, in one piece, facilitates laying

and saves joints. The drain chute, at the upper end of the chamber, enables rods to enter the pipe easily when they are worked from the

great care, otherwise the sewer pipe will split, and would have to be entirely removed and be replaced by a new one. In inserting a pipe in the main sewer, whether it be a junction pipe or not, half of the socket on the pipe to be inserted is cut away, as is also half the socket on the sewer pipe. The pipe to be inserted is then lowered into position, and rotated through an angle of 180°, so that the cut portion of the socket comes on top. The joints, and the missing pieces of the socket, are then made good with cement mortar.

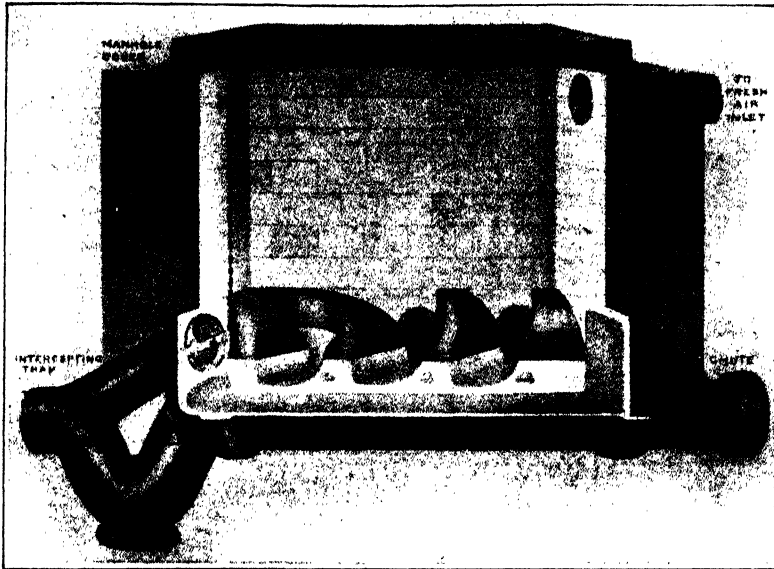

FIG. 45. INTERCEPTING AND JUNCTION CHAMBER WITH DOULTON'S FITTINGS

surface of the ground. This illustration also shows how the branch blocks, shown in Fig. 44, are fixed.

In default of special channel pipes and branches, the invert can be formed in cement concrete, faced with cement rendering, or with "granolithic," the latter consisting of one part cement, two parts sand, and two parts granite chippings. The lower part of the channels should be formed in a perfect semicircle, and the sides above it brought up vertically and a distance apart equal to the diameter of the pipe. All curves must be regularly and evenly formed. The total depth of the channel should not be less than the full diameter of the pipe.

Connection to Sewer. If a junction pipe has been left in a sewer in a suitable position, the connection of the house drain is a simple matter, but if not, then the sewer has to be cut. The best method is to cut a circular hole in the required position, and insert an oblique saddle junction piece, as shown in Fig. 46. The joint between the saddle and the sewer pipe should be made with cement mortar, but it is difficult to make watertight owing to the glazing on the pipe. The cutting of the hole must be done with

great care, otherwise the sewer pipe will split, and would have to be entirely removed and be replaced by a new one. In inserting a pipe in the main sewer, whether it be a junction pipe or not, half of the socket on the pipe to be inserted is cut away, as is also half the socket on the sewer pipe. The pipe to be inserted is then lowered into position, and rotated through an angle of 180°, so that the cut portion of the socket comes on top. The joints, and the missing pieces of the socket, are then made good with cement mortar.

GULLIES

Excepting only the discharges from water closets, bidets, and slop sinks, all liquid wastes enter the drains through gullies unless the "one-

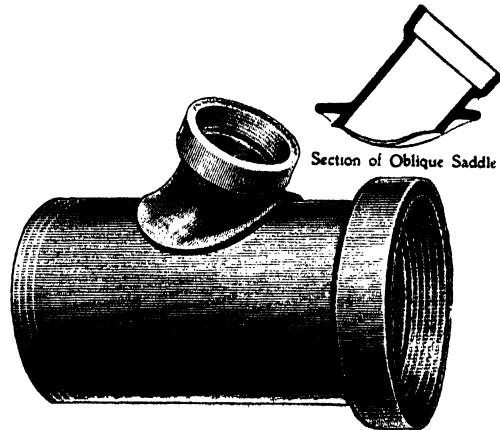

Saddle Junction-Piece fitted to main sewer
FIG. 46. DOULTON'S OBLIQUE SADDLE JUNCTION-PIECE

foul air shall pass into the house. They are usually made of salt-glazed stoneware, although in special situations it is preferable to have cast-iron gullies.

MODERN BUILDING CONSTRUCTION

A standard square stoneware gully with cast-iron grating is shown in Fig. 47. The gullies are trapped by a water seal, about 2½ in. deep, similar to the intercepting traps. The gully illustrated has a P outlet, which is the most usual one; but, if required, they can be obtained with Q outlets, that is, outlets looking down-

wards at an angle of 45°, or S outlets which terminate looking vertically downwards.

pipe in this position than it would be if the pipe discharged over the top of the grating. The branch drains between the gullies and the main drain are difficult of access. An ordinary drain rod cannot be passed through a gully, and even if there is a chamber at the junction with the main drain, the bends adjoining the gully

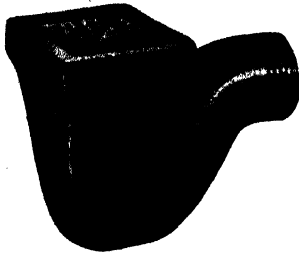

FIG. 47. STANDARD SQUARE STONWARE GULLY

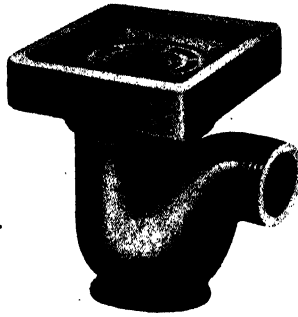

FIG. 48. ROUND GULLY WITH LOOSE TOP

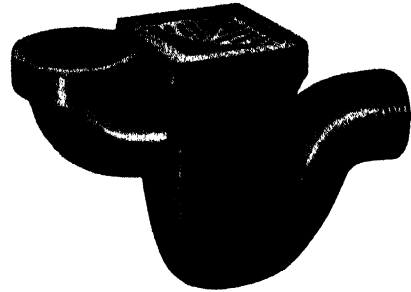

FIG. 49. BACK-INLET GULLY WITH VERTICAL EYE (Doulton)

Gullies should be set on a bed of concrete about 4 in. thick, and should also be haunched up with concrete to prevent them rocking on their bases. A gully of the type shown in Fig. 47 would be set with one of its sides against, or parallel to, the wall of the house, hence the outlet can lead only in two directions, parallel to the wall or at right angles to it. This may lead to difficulties in making the connection with the branch drain, and possibly several bends must be inserted to reach the right direction. In some places, therefore, it is desirable to employ a circular gully with a loose top, as shown in Fig. 48. The dish containing the grating can always be set with one side parallel to the wall, and the gully can be twisted so that its outlet will point in any required direction.

will probably bar the progress of the rods. To obviate this disadvantage, access or inspection gullies are used, as shown in Figs. 51 and 52; in the former the eye is inside the gully and the cap, or plug, is secured with tallow, or plastic composition; while in the latter the eye is on the outlet pipe with the socket and the plug

The gratings over the gullies are to prevent any large and improper articles entering the drains, but a certain amount of small debris collects on them and is unsightly. As a remedy for this, back inlet gullies as shown in Figs. 49 and 50 are used. With these fittings the liquid is introduced into the gully below the grating but above the surface of the water in the trap, so that disconnection is still effected. It is sometimes objected that foul gas may be given off from the surface of the water in the trap, and will be more readily drawn up the waste

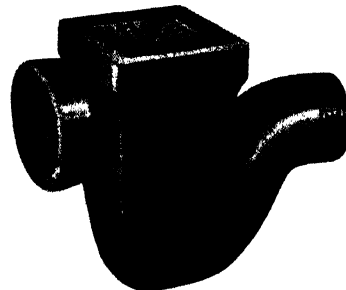

FIG. 50. BACK-INLET GULLY WITH HORIZONTAL EYE (Doulton)

fitted with a screw, formed with bitumen composition, so that the plug can be screwed into position.

Many by-laws stipulate that bath and sink wastes should discharge into a channel leading to a gully, and not over the gully itself, as an additional precaution against foul air from the gully passing up the waste pipe. A fitting designed to meet this provision, made by Doulton's, is shown in Fig. 53. The gully itself

can be turned to discharge in any direction. Syke's *disconnecting slipper* for the same purpose is shown in Fig. 54. In this case, separate eyes

debris discharged from the sink. When the tray is lifted out it brings with it the grease off the surface. This should be done each day. The solid cakes of grease may be returned to the drains, as they will pass off safely in that condition, provided that care is taken that hot water is not being discharged at the same time.

In Hellyer's grease trap the tray rests in the bottom of the trap, so that the small debris passes direct into the drains without being arrested on the tray. This is, perhaps, an advantage as it is not likely to cause any trouble in the drain or sewer, and the matter is quickly and finally disposed of so far as the householder is concerned.

Petrol Traps. The discharge of petrol into the drains, or the washings of garage and other floors upon which petrol has been spilt, is extremely dangerous. The petrol floats on the top of

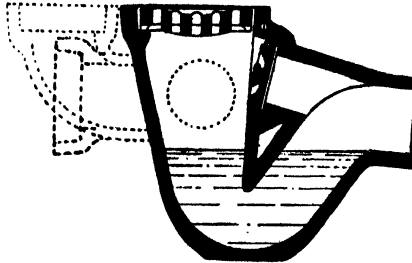
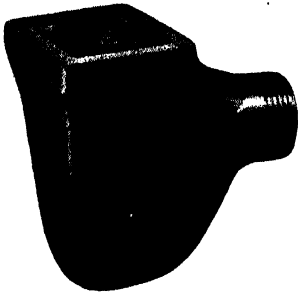

FIG. 51

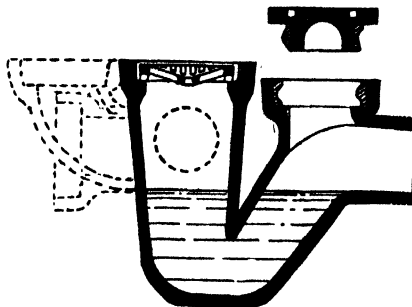
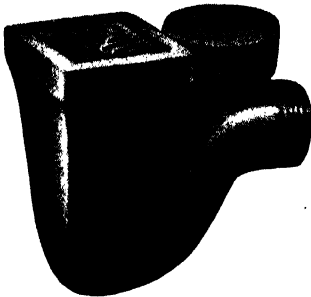

FIG. 52

FIGS. 51 AND 52. ACCESS GULLIES

are provided for the several waste pipes, and the liquid is introduced underneath the grating.

Grease Traps. In large establishments, considerable trouble is apt to be caused by grease entering the drains with the waste water. When grease is in solution in hot water, or in an emulsified condition, it will readily pass through any grating, and it is impossible to prevent its entrance while in that state. As it cools in the drains it coagulates and forms lumps, which may adhere to the pipes and eventually lead to a stoppage. Doulton's "Metropole" grease interceptor is shown in Fig. 55. The trap contains a large volume of water, which is generally in a cool condition, and immediately chills the grease-conveying water as it enters. The grease congeals and rises to the surface, where it remains, while the water, now freed from grease, flows out into the drains. The two essentials of a grease interceptor are a large volume and a surface area, where the grease can collect without disturbance. The perforated tray (through which all the water has to pass before leaving the trap) collects much of the

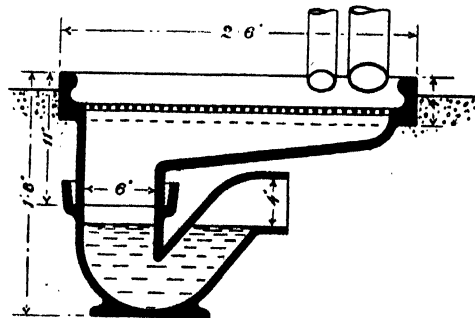
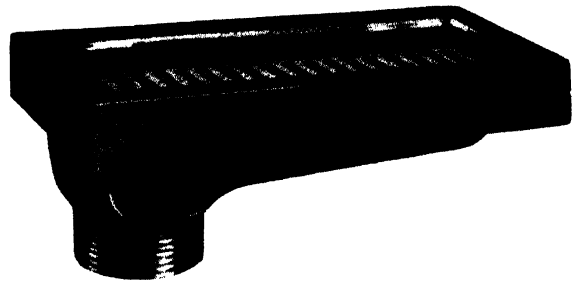

FIG. 53. DOULTON'S DISCONNECTING SLIPPER

MODERN BUILDING CONSTRUCTION

the sewage in the sewers, and gives off inflammable gas, which is apt to become ignited by the lights of the sewer men. A design for a petrol intercepting trap is shown in Fig. 56. It consists of a series of chambers, through which the liquid has to flow before it can reach the sewer. In the first chamber the drainage enters at the surface and the

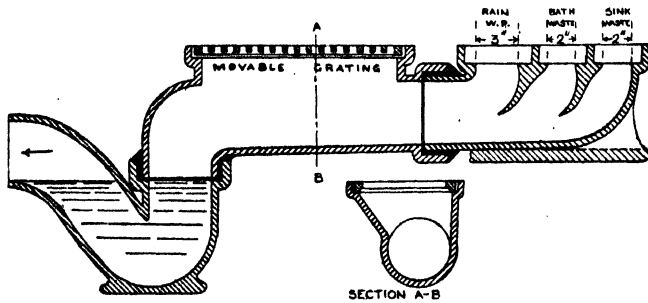

FIG. 54. SYKE'S DISCONNECTING SLIPPER

greater portion of the petrol will remain at the surface, but a certain amount is certain to remain mixed up with the water. The outlet to the second chamber is taken off at a point about two-thirds the depth of the first chamber, as it is found that the liquid is in the cleanest condition there. The same is repeated for the subsequent chambers, so that all the petrol is removed by the time the outlet is reached. It is important to ventilate the chambers, and to arrange that the vent pipe terminates in such a position that there is no chance of the vapour becoming ignited. The covers should, of course, be airtight.

Stable Drainage. The drainage of stables presents special points because of the large amount of solid matter, consisting of straws, etc., which is carried off with the liquid. The floor should be formed of impervious material in a homogeneous layer without any joints, but grooves imitat-

ing joints should be formed in the surface to afford a foothold for the horses. Special surface channels may be formed to carry off the liquid, but they should be very shallow and should not have vertical sides. They should be laid with sufficient fall to enable the liquid to drain away, say, not flatter than 1 in. in 10 ft. The shape should be that of a wide shallow V. Instead of

the open channels first described, stables are sometimes equipped with sunk channels, covered with gratings, as shown in Fig. 57. The advantage of these is that the liquid passes out of sight and flows away, while the straw and other solid matter is retained on the grating, and can easily be swept up. If the stable is not large, the channels can lead to a pipe passing through the wall, and discharging over a gully outside; but in an extensive stable, they should be constructed to fall to a number of selected points where drain pots, as

shown in Fig. 58, should be fixed. Pipes from these drain pots would be laid to discharge outside the building. In this way there are no gullies or traps inside the building, which is an important matter, because the urine is of an exceptionally foul character, and its retention in the traps would seriously pollute the atmosphere.

Stable Gullies. A special type of gully should be employed in connection with stable drainage, one that will intercept the straw and solid matter. Fig. 59 shows Broad's stable gully.

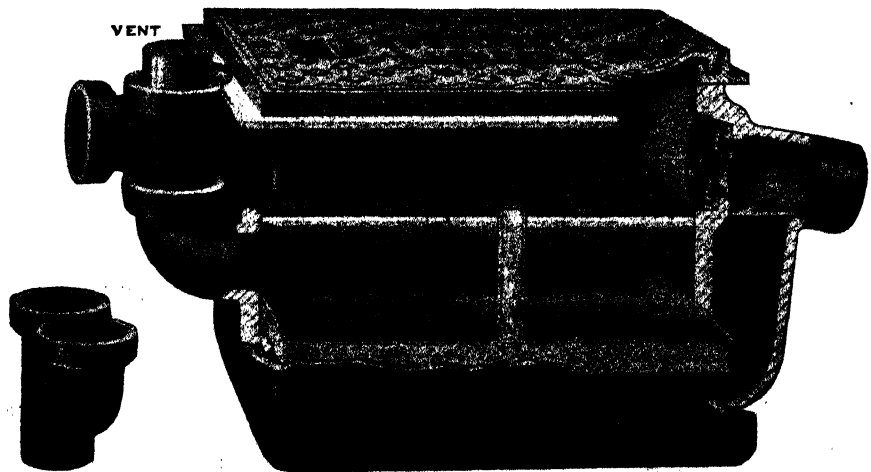

FIG. 55. DOULTON'S "METROPOLE" GREASE INTERCEPTOR

DRAINAGE AND SANITATION

In this case a movable, perforated, iron receptacle, or basket, is fixed inside the gully in such a manner that nothing can leave the gully without first passing through the receptacle. The

Moore's stable gully, which is shown in Fig. 61, is intended to be fixed at the end of a channel, the entrance to the gully and the trap being guarded by gratings. It is improbable that

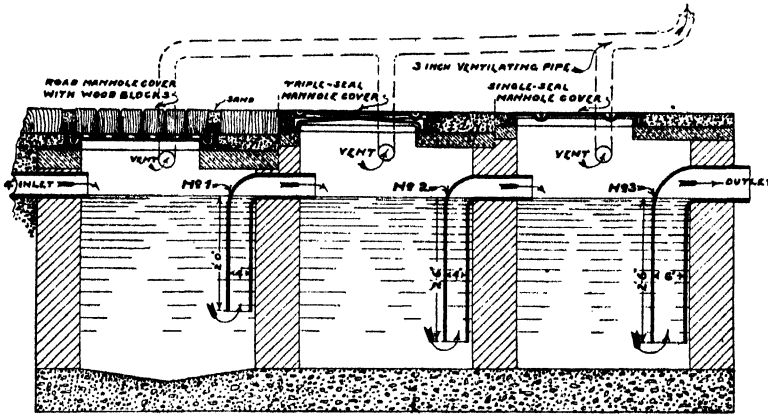

FIG. 56. PETROL INTERCEPTING TRAP



FIG. 57. COVERED STABLE CHANNEL

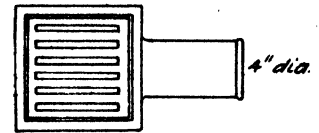

FIG. 58. STABLE DRAIN POT

solid matter is easily separated from the liquid, and there is no difficulty in lifting the basket out and emptying it.

Sankey's deep intercepting gully is shown in Fig. 60. This is somewhat similar, except that

much solid matter would enter this gully, but if any succeeded there is another grating in front of the outlet, which would prevent its escape. The gully is easily cleaned.

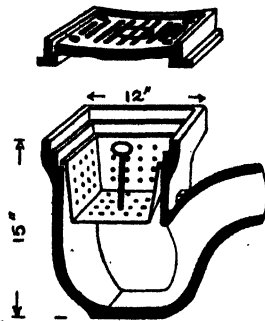

FIG. 59. BROAD'S STABLE GULLY

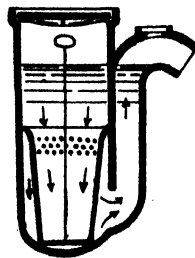

FIG. 60. SANKEY'S DEEP INTERCEPTING GULLY

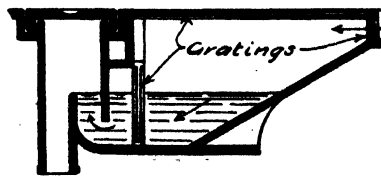

FIG. 61. MOORE'S STABLE GULLY

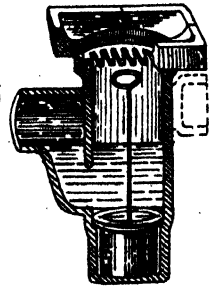

FIG. 62. YARD GULLY

the basket stands on the bottom of the gully. The gully is made specially deep, because when the basket is removed a large volume of liquid is withdrawn at the same time, and this would result in the gully becoming untrapped if it were not for the deep seal. The gully should be recharged with water when the basket is replaced.

The gully illustrated in Fig. 62 is a *yard gully*, especially adapted for collecting mud and grit, rather than the lighter matter for which stable gullies are used. This gully is certain to be untrapped when the pot is removed, and it should, therefore, be instantly recharged with water.

Chapter IV—RAIN-WATER UTILIZATION

Collection. Rain-water from roofs runs first into horizontal gutters of cast-iron, wood, lead, or zinc. Zinc gutters are very apt to be damaged and knocked out of shape by rough usage, particularly by the pressure of ladders placed against them. A misshapen gutter does not permit the water to pass off properly, but causes it to overflow and run down the walls of the building, leading to dampness and deterioration of the internal decorations. Iron gutters should be regularly painted, otherwise they will rust and decay. The supports should be painted at the same time, to preserve them, because if they fail the gutter will fall. Small gutters are usually "half-round," or semi-



FIG. 63. CAST-IRON PAVEMENT GUTTER

circular, in shape; larger ones are moulded ogee shape.

The down pipes are similarly made of zinc, or cast-iron, but the latter are preferable. The upper part of the pipe should have a socket to fit on to a nozzle in the underside of the gutter, while the lower end should terminate in a shoe discharging over a gully. Rain-water pipes are never connected direct into a drain carrying sewage; but sometimes a "separate" system of drainage is adopted, in which two sets of drains are installed, one for carrying sewage and the other rain-water, and in such cases rain-water pipes may be connected directly to the rain-water drain. This is not altogether a desirable arrangement, as a considerable amount of organic mud is carried into the drain with the rain-water, and some of it remains adhering to the pipes, or is deposited in the bottom. The decay of this may give rise to nuisance, and the gases will rise up the vertical pipes and be set free in the gutter just under the eaves of the roof, from which point they may easily be drawn into the house. A gully acts as a small catchpit and arrests at least a portion of the mud. Sometimes a trapless gully is used. This has a recess

for collecting mud, but there is no projecting tongue to form a seal, and there is free communication between the outlet drain and the open air. Small zinc down pipes, 1 in. or $1\frac{1}{4}$ in. diameter, are used to take the rain-water from small areas, such as bay windows, but generally cast-iron pipes of 2 in., 3 in., or 4 in. diameter are used. The pipes are cast of specially light weight and are very thin; they are formed with spigot and socket joints. The joints should be made with yarn and red lead, but frequently the pipes are left unjointed. Square or rectangular pipes are often used, as they have a better architectural effect. Their disadvantage is that they have corners which collect dirt, and their interiors are not so well cleaned by the rain as is the case with a properly proportioned circular pipe.

Where houses abut on the footpath, it is usual to carry the rain-water across the path in a cast-iron pavement gutter, as shown in Fig. 63. The internal diameter is $3\frac{1}{2}$ in., and the width across the chequered surface 4 in. A special inlet shoe is made for the upper end, and a cleaning groove is provided throughout the length of the gutter.

Storage. In many rural districts the supply of water is so precarious that it is necessary to conserve the rain-water for domestic use. The rain-water is collected from the roof surfaces, but it is not in a pure condition. The rain in falling washes the air, and brings down with it the dust and impurities therein. It further carries from the roof bird droppings, dust, and other accumulations, and finally runs over the decaying organic mud in the gutters. After a certain amount of rain has fallen the air and the roof are washed clean, and the later rain flows off the roof in a much purer condition than that at the beginning of the rainfall. Then, in this country, there is a superabundance of rain during the winter months and often a scarcity during the summer, consequently storage is necessary. If rain-water containing organic impurities is stored, decomposition occurs, and the water is not only unfit to drink, but becomes too offensive for general household use.

It will be apparent that two things are

necessary before a satisfactory supply of rain-water can be obtained for use. First, the separation of the impure rain which falls at the beginning of the shower from that which falls later, and, secondly, the provision of a storage tank of sufficient capacity to enable the ample rains of winter and spring to be retained, to give

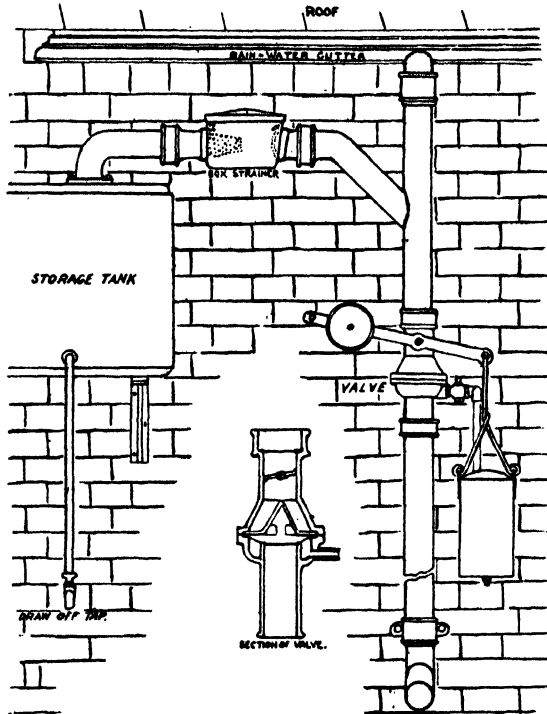
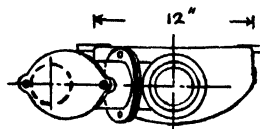
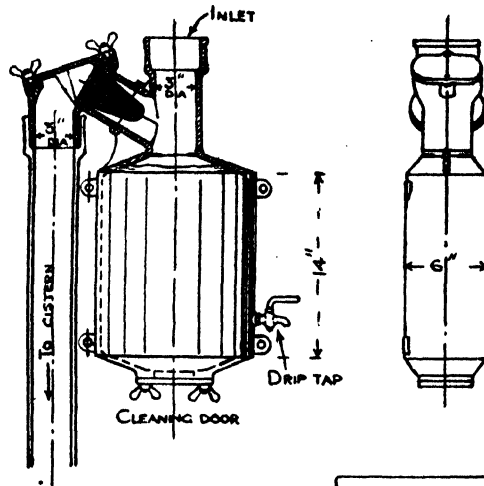

FIG. 64. INCE'S APPARATUS FOR SEPARATING AND COLLECTING CLEAN RAIN-WATER

an effective daily supply during the summer. It should be noted that a comparatively large roof area is necessary to yield a reliable supply.

Separators. Ince's patent apparatus, for separating and collecting clean rain-water from roofs, is shown in Fig. 64. This is made by Ham Baker & Co., and was designed by an engineer located in a tropical climate, where water is exceedingly scarce, to enable the clean and fresh rain-water to be stored, while care has been taken to keep mosquitoes out of the apparatus, and also to prevent them using it for breeding purposes. The growth and development of mosquitoes, and other poisonous water-breeding insects in many parts of the country during recent years, makes the latter feature of the apparatus an important one. It

will be seen from the illustration that the rain-water falling into the down pipe passes through the valve chamber to the outlet at the ground line in sufficient quantities to wash thoroughly the roof first and to drive out any dirt, or mosquitoes, that may be there. A portion of the rain-water, however, is intercepted at the valve box, and is diverted through a strainer into a container on the right. This causes the container to fall, and the butterfly valve on the axis of the lever to close the connection pipe to the outlet. The water then heads up in the down pipe, and passes up to the left through the strainer box into the storage tank. It will be observed that the box is provided with a fine gauze strainer, to prevent mosquitoes being washed through into the storage tank. This



HAYWARD-TYLER & CO.

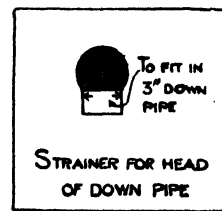

FIG. 65. GALVANIZED-IRON RAIN-WATER INTERCEPTOR FOR DOWN PIPE

box is also provided with a cover for scouring and cleaning, as well as a flap valve to prevent the mosquitoes getting in. The container is provided with a small outlet pipe and a regulating cock. When the supply of rain-water stops, this box empties itself, and the butterfly valve is again opened pending next rainfall, but as long as it rains the valve is closed to divert all clean rain-water into the storage tank. Any

MODERN BUILDING CONSTRUCTION

number of storage tanks can be filled in this way.

A different type of separator is shown in Fig. 65. This is made by Hayward-Tyler & Co., and consists of a container into which the rain runs direct from the roof. The heavier impurities in the water settle to the bottom, and when the tank is full the surplus passes through a conical gauze screen at the top, and enters the pipe leading to the storage cistern. The screen keeps back the floating matter. There is a drip tap at the bottom of the container, which gradually empties it when the rain has ceased to fall, and leaves the apparatus ready for the next shower.

Filters. Neither of these appliances will remove the organic matter in solution in the

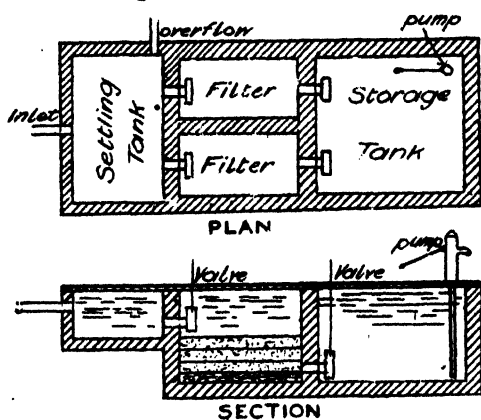

FIG. 66. RAIN-WATER FILTER AND TANK

water, nor can it be relied upon to remove the whole of the finer solid particles, although probably the water will be rendered sufficiently pure for storage and use. A more elaborate arrangement is shown in Fig. 66, which illustrates a rain-water filter and storage tank. The rain-water first enters a settling tank, where the heavier particles are deposited; it then flows on to one or other of two sand filters, through which it sinks, and finally enters the storage tank. The filtering material consists of a layer of sand from 6 in. to 9 in. thick on the surface. The sand is supported on graded gravel, clinker, or other material. The gauge, or size, of the material in each layer should be such that the material immediately above it will not pass through. The bottom layer of all should be fairly large, say 3 in. or 4 in. gauge. The filters

are in duplicate, so that one can be cleaned out without putting the whole arrangement out of commission. The filter simply acts mechanically as a strainer, and there is probably very little bacterial action after it is first put into use. A coating, or film, will form on top of the sand, and should be removed periodically when it gets sufficiently thick to retard the passage of the water. After several years' use, it will be necessary to remove the whole of the filtering material, and either wash and replace it, or provide new material to take its place.

RATE OF RAINFALL. There are two aspects of the rainfall to which attention must be given, namely, the rate of fall and the quantity in any given period. The rate of fall governs the sizes of the gutters, down pipes, and drains, because they must severally be large enough to carry off the rain as it falls, no matter how fast that may be, while the total fall governs the size of the storage tank. The intensity of rainfall varies within very wide limits, and depends upon the length of the period over which it is averaged. For instance, during a period of five minutes, rain may fall with an intensity at the rate of 2 in. per hour; but if a longer period is taken, say, 15 minutes, the average intensity during that period might be at the rate of $1\frac{1}{2}$ in. per hour. All gutters, etc., should certainly be capable of carrying off a rainfall at the rate of 2 in. per hour.

QUANTITY OF RAIN-WATER. A large country mansion might occupy an area of 100 ft. by 80 ft. and would, therefore, receive rainfall on an area of 8,000 sq. ft., because the area is measured as on the plan and not on the slope of the roof. At the rate of 2 in. per hour the rain falling on this would be

$$8000 \times \frac{2}{12 \times 60} = 22.22 \text{ cub. ft.} \\ = 139 \text{ gals. per minute.}$$

A common rule for the size of down pipes is to provide 1 sq. in. of cross-section for each 100 sq. ft. of roof area. This rule would indicate a 1 in. diameter pipe to be sufficient for $78\frac{1}{2}$ sq. ft., but a somewhat larger pipe should certainly be put in for such an area. The rule would also give a 2 in. diameter pipe for about 300 sq. ft., and a 4 in. pipe for, say, 1,250 sq. ft. The mansion previously referred to would, therefore, require seven 4 in. down pipes, or, say, eight, four on each side, placed about 25 ft. apart.

Chapter V—DRAINS

VENTILATION

THE ventilation of drains is effected by making such arrangements that a continuous stream of fresh air shall flow through them, and penetrate into every corner. This fresh air will dilute the drain air, and render it less harmful should it escape at any point where it might enter the house, or where people may breathe it. The oxygen in the air introduced into the drain also facilitates the decomposition of any organic matter retained in the pipes. The flow of air through the drains is brought about by natural means, and is due to the fact that when air is heated it expands, so that any given volume of it is lighter than a similar volume of cold air. Thus, if there were two equal columns, one of warm air and one of cold, the weight of the latter would be greater, and would exert a greater pressure on the base. If air exists in any confined place at different temperatures, the heavy cold air will always occupy the lowest position, and will push out the warmer and lighter air.

Movement of Air in Drains. The diagram, Fig. 67, will demonstrate the movement of air which takes place in a drain. It represents a U-tube with open ends. The pressure of the atmosphere at the level *A* will be the same on the open end of each branch. The pressure in the tube at *B* will be the atmospheric pressure at *A*, plus the weight of the atmospheric air in the tube *AB*. The pressure in the tube at *C* will be the atmospheric pressure plus the weight of the air in the tube *AC*. If, now, heat is applied so as to warm the air in the tube *AC*, such air will expand and some will escape, so that the weight of air in *AC* will be less than in *AB*. Thus the pressure at *B* will be greater than at *C*, and the air in the bend *BC* is forced out and up the tube *CA*. The effect would be

the same if the tube *BA* were removed, because the pressure at *B* would remain unaltered. The air in a drain is usually warmer, and therefore lighter, than the ordinary atmospheric air; consequently, the natural tendency is for the atmospheric air to sink into the drain, and to drive out the drain air.

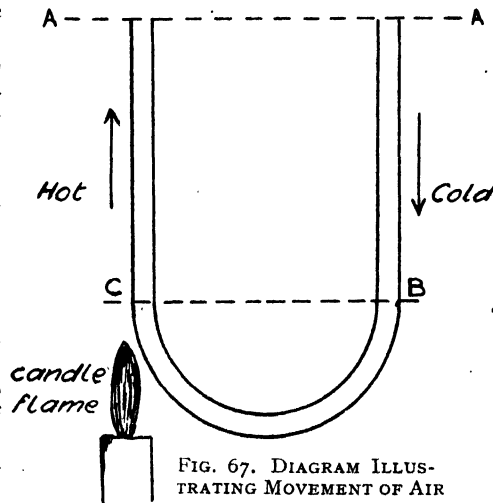

FIG. 67. DIAGRAM ILLUSTRATING MOVEMENT OF AIR

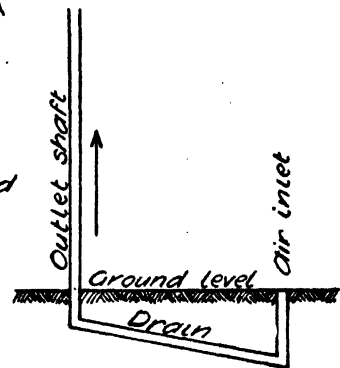

FIG. 68. AIR MOVEMENT IN DRAIN

Fig. 68 shows the application to a drain. An outlet and an inlet are both necessary. Usually the inlet is at ground level, or thereabouts, and the outlet is through a shaft terminating high up in the air. In practice, circumstances arise which interfere with the regular working of the ventilating system. The sun shining on the up-cast vent pipe will accelerate the ventilation, while a cold wind blowing against it will have the opposite effect. The air in the drain is not always warmer or lighter than the atmosphere. Sometimes the flow of air is reversed so that it enters at the top of the outlet pipe, and escapes at the inlet pipe; it is, therefore, essential that the inlet, equally with the outlet, should be located so that any occasional escape of foul air should not detrimentally affect people in the locality. The air inlet is usually at the front of the house, at a point on the drain nearest to the sewer, and the outlet at the far extremity of the drain at the back of the building; but

MODERN BUILDING CONSTRUCTION

provided it is equally convenient, the opposite arrangement would be satisfactory.

Air Inlets. When an intercepting chamber exists, a 4 in. stoneware pipe is built into the top of the wall, just below the cover, and extended to a convenient point above the

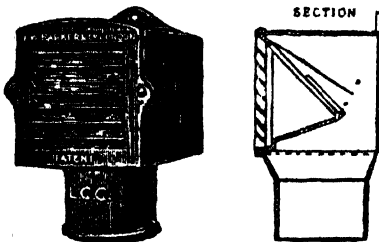

FIG. 69. FRESH-AIR INLET

ground, where it terminates with a fresh air inlet head, as shown in Fig. 69. The valve consists of a hinged flap of mica, which is shown

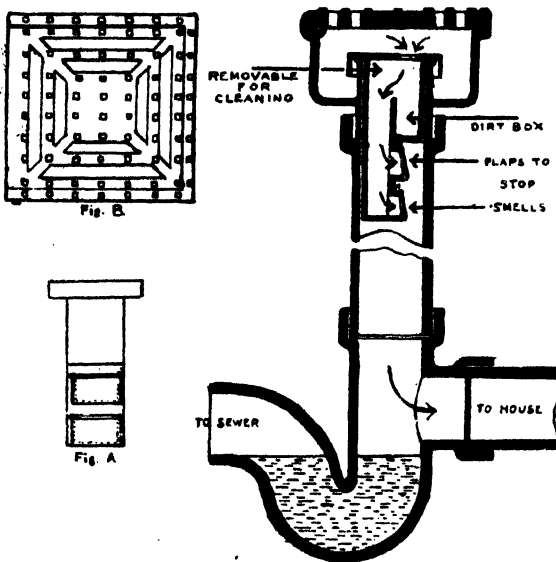

FIG. 70. BEAUMONT'S AIR-INLET VALVE

partly raised from its seating. It is protected by a louvred front to the cast-iron box which contains it. Very little excess in pressure of the outside air over the inside air is required to open the valve, as the mica is very thin and light; and on the air ceasing to flow, or a back draught occurring, the valve falls back on its seating, and thus as long as it is in working order no air can escape from the drains. The mica

flaps do not, however, have a very long life; the hinges are apt to get out of order, and the mica may be damaged by sticks, or other improper objects, forced through the louvres. These inlets are often fixed at a height of 1 ft. or 2 ft. above the ground, but if a convenient

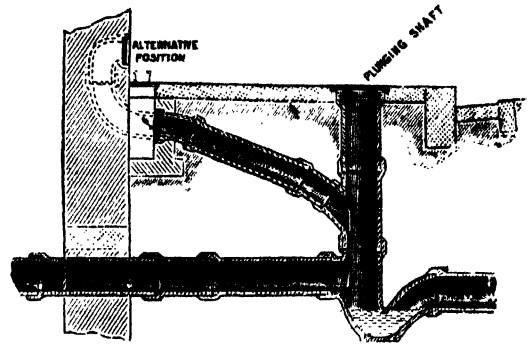

FIG. 71. AIR-INLET CONNECTION TO TRAP

wall exists it is better they should terminate at a height of about 6 ft.

Pavement Inlets. Where there is no intercepting chamber, the air inlet is connected directly to the trap, as shown in Fig. 70, which illustrates Beaumont's air-inlet valve, made by Ham Baker & Co. The cover, which is fixed level with the surface of the ground, has a number of openings which permit the air to enter. The portion of the box under these openings is formed as a dirt box to collect any foreign matter falling through, but the open end of the ventilating pipe leading to the drain is located under the solid portion of the cover. Beaumont's valve is shown in position. The flaps of the valves are made of aluminium in this case, and effectually prevent any back draught. Fig. A shows an elevation of the valve, and Fig. B shows a plan of the air-inlet cover. An alternative design of inlet, for use where it is not convenient to have a grating immediately over the trap, is shown in Fig. 71. A solid cover is placed over the shaft from the trap, and can be removed when access to the trap is required. The air inlet can be sunk in the pavement at the back, or can be inserted in the wall just above. An inlet valve with a mica flap can be inserted in the mouth of the pipe, as shown.

Ventilating Shafts. Ventilating shafts should be of cast-iron, and not less than 4 in. diameter. The vertical soil pipe from a water-closet generally provides sufficient ventilation for the drain,

and there is no objection to its use for such purpose, provided it is in a suitable position. The upper end should stand well above any adjoining roof, and should be so placed as regards windows, chimneys, and eaves that the escaping air will not enter the house. It is difficult to say what distance is necessary to ensure safety in this respect. It depends upon the exposure and the direction of the prevailing wind. A distance of 20 ft. would generally be thought ample, but cases have arisen in practice where this is not sufficient. The pipes should be

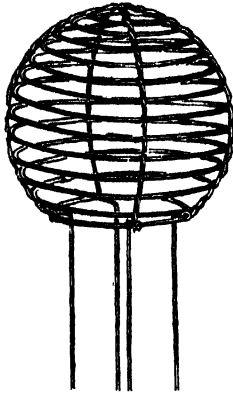

FIG. 72. WIRE CAGE FOR TOP OF VENTILATING SHAFT

jointed with yarn and molten lead run into the sockets, and properly caulked. The top should be protected with a wire cage, or screen, as shown in Fig. 72. A pipe used solely for ventilation purposes will rust badly inside, and the flakes falling down might collect in the bend at the bottom, where the vertical pipe joins the horizontal drain, and render the shaft inoperative. To prevent this, a rust pocket should be formed at the bottom, with a removable vessel to collect the particles.

CLEANSING

Flushing should be unnecessary in a properly designed and constructed system of drainage. In order that drains should be self-cleansing, it is requisite that the liquid flowing through them should have a certain minimum velocity. The velocity is dependent upon the gradient of the drain, and the volume of the liquid considered in relation to the diameter of the pipes. Flushing, therefore, only becomes necessary when the drain is laid at too flat a gradient, or when the pipe is too large for the volume of liquid it has

to convey. It has been shown that the velocity of flow in a drain of a given gradient depends upon the depth of the liquid in it, and that the maximum velocity obtainable with such a gradient occurs when the pipe is half full. The object to be aimed at in flushing is, therefore, to add such additional quantity of liquid that the pipe will be filled to at least half its depth while the liquid is flowing through it. Some advantage can be gained by discharging the liquid into the drains by means of an automatic siphon, or a tipper which gives it an initial

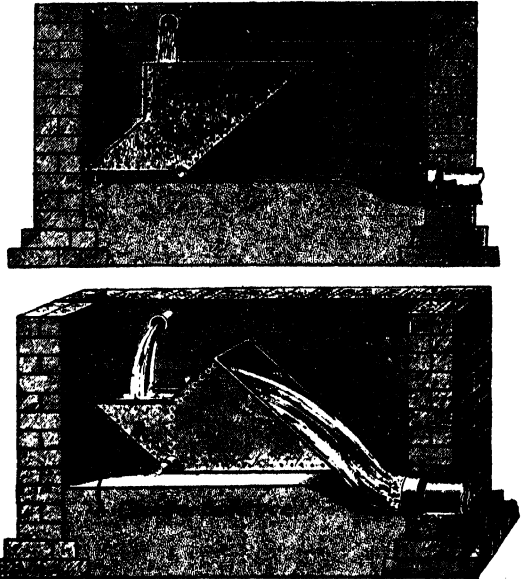

FIG. 73. TIPPER FOR FLUSHING DRAINS

velocity, but the effect of this will not extend very far down the drain and the liquid will soon travel at the normal velocity due to the gradient.

It is very desirable that only clean water should be used for flushing, because flushing involves the collection and the holding up of the liquid pending its sudden discharge in bulk into the drain. The holding up of foul liquid is contrary to sanitary principles, and the walls and floors of the chamber in which such liquid is collected will become coated with a layer of filth. Fig. 73 shows a galvanized iron tipper for flushing drains. The tipper is made with two compartments, the main one to hold the flushing water, and the smaller one at the back to receive water while the tipper is discharging. It thus acts as a counterbalance and restores the tipper to its original

MODERN BUILDING CONSTRUCTION

position when the flush has taken place. If dirty water is used for flushing, the interior of the chamber becomes very foul from the splashing of the liquid. The bottom of the chamber should be constructed so that the full force of the flush is directed into the mouth of the drain.

Automatic Flushing Siphon. Miller's automatic flushing siphon is illustrated in Fig. 74. At the commencement of operations the deep seal in the outlet leg of the siphon stands full of water, at the same level on each side of the bend. The upstanding leg, the dome of the siphon, and the flushing chamber will be full of air at atmospheric pressure. When the water, which is then run into the chamber rises to the lip of the dome it imprisons the air therein, and as the water rises farther in the chamber this air is compressed. The pressure of the air depresses the level of the water in the leg on one side of the bend, and causes the displaced water to trickle out of the open-ended outlet on the other side. The water rises in the dome, but not to the same extent as in the chamber, and at all times the difference in level between the water in the dome and in the chamber, marked X, is

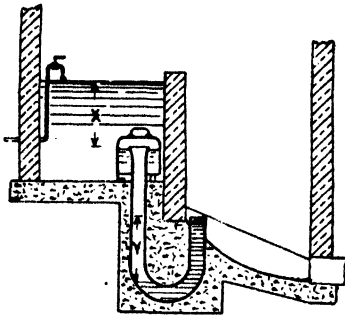

FIG. 74. MILLER'S AUTOMATIC FLUSHING SIPHON

the same as the difference between the level of the water on the two sides of the bend, marked Y. That is, the pressure of the imprisoned air is sufficient to support a column of water of height X or Y. If, now, further water is run into the chamber, the water in the long leg of the siphon is depressed to such a point that the air escapes around the bend with a rush that carries away some of the water in the short leg. This at once destroys the equilibrium, and the water from the chamber enters the dome and passes through the siphon in a continuous stream. It will be seen that the principle of the action of this siphon is the sudden release of a volume

of air under pressure, permitting the water to rush in and fill the siphon. There are other siphons in which discharge is produced in a different manner. In these a column of air at atmospheric pressure is confined between two

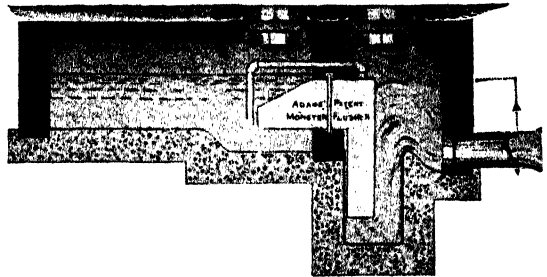

FIG. 75. ADAMS' HYDRAULICS LOW-DRAUGHT SIPHON

traps filled with water. Drops of water falling through the air column carry out particles of air through the lower trap, so that a partial vacuum is formed, and the pressure of air is reduced to such an extent below atmospheric pressure that the outside air forces the water to enter with a rush and fill the siphon.

Low-draught Siphons. The normal depth of water in a flushing chamber is about 30 in., but when, owing to the levels of the drain, such a

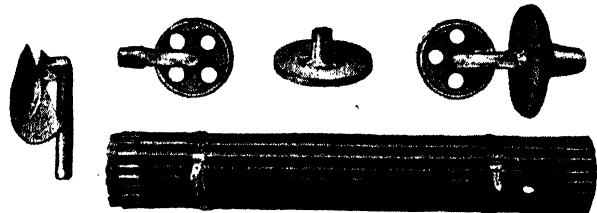

FIG. 76. DRAIN CLEANING TOOLS *Doulton*

depth is not obtainable, a special low-draught siphon is used. Adams' Hydraulics low-draught siphon is shown in Fig. 75. This will work with a depth of water of 9 in. or less. In all siphons it is necessary that the outlet should be perfectly free, because if it is restricted in any way, as, for instance, by an elbow bend being fixed upon it, the rush of water is checked, and instead of flowing away it falls back, and the action of the siphon is stopped. The capacity of the tank should depend upon the size, length, and gradient of the drain to be flushed. The smallest capacity to be of any use is about 20 gals. For a 4 in. drain, with a gradient of 1 in 100, the

capacity should be about 60 gals.; and for a 6 in. drain, with a gradient of 1 in 120, a capacity of about 150 gals. It cannot be too frequently, or too forcibly, emphasized that a water-service tap left running is of no use whatever in keeping drains clean. The water should be discharged in bulk and as rapidly as possible.

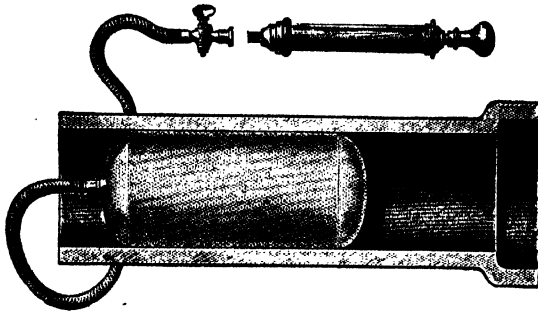

FIG. 77. CANVAS BAG PIPE STOPPER

Stoppages in Drains. Stoppages in drains are generally due to one or other of three causes, namely, bad design, physical failure, and the insertion of improper articles. Bad design covers absence of gradient and wrongly formed junctions. Physical failure includes breakage of

lengths from 2 ft. to 4 ft. These canes are flexible, and will pass round an ordinary easy bend. The screwed joints should be fitted with safety catches to avoid the possibility of rods becoming uncoupled in use, and a length being left in the drain. The various fittings are designed to cope with the different circumstances that may arise.

The brass *cleaning wheel* allows the rods to run easily over any projecting joint in the pipes, and if fitted with a whale-bone head the internal surface of the pipes will be swept at the same time. The india-rubber *plunger* acts as a piston, and brings considerable pressure to bear on the stoppage. The double *spiral screw* may be used to penetrate a mass of matter collected in the pipes and then to draw it out. The *drop-scraper* will remove sediment from the bottom of the pipes, its construction being such that it will pass over the obstruction when being pushed into the pipe, and will draw it out on the backward journey.

TESTING

The method to be employed in testing a drain depends upon whether the test is made during or at the completion of its construction, or

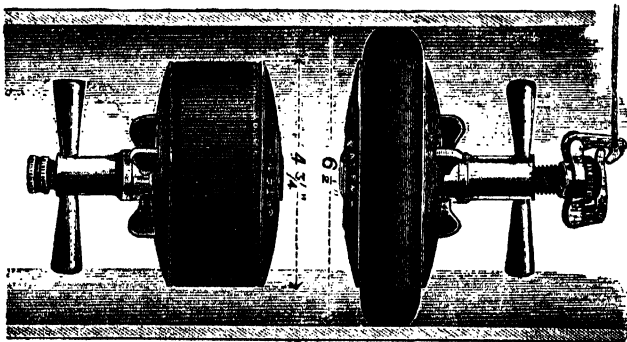

FIG. 78. EXPANDING PLUG FOR STOPPING DRAINS

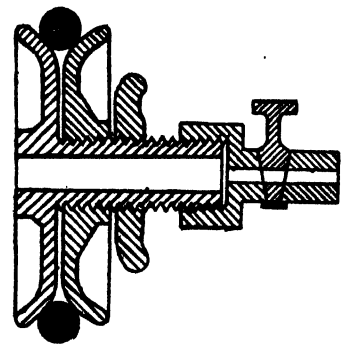

FIG. 79. SECTION OF EXPANDING PLUG

pipes due to uneven bedding, defective joints allowing liquid to escape while solid matter is left behind in the drains, the crushing of pipes due to excessive loading on the surface, etc. The introduction of floor cloths and scrubbing brushes frequently leads to drains being blocked.

Temporary stoppages caused by accumulations of soil, paper, etc., may be removed by the use of drain cleaning tools, a set of which is shown in Fig. 76. The rods are formed out of Sarawak bamboo, or red Malacca canes, in

whether the test is being applied to an old, completed, drainage system. New drains are most generally tested under hydraulic pressure.

The first step is to stop up the lower end of the drain by means of an *expanding bag* or a *stopper*. The bag, shown in Fig. 77, is made of canvas, specially treated to be airtight, and capable of withstanding an internal pressure of about 10 lb. per square inch; it is light and flexible, and will accommodate itself to any irregularities in the pipe. Fig. 78 shows an

MODERN BUILDING CONSTRUCTION

expanding plug that can be used in a similar situation. The plug is placed in position, and then the turning of the handle brings the outer plates closer together and squeezes the rubber

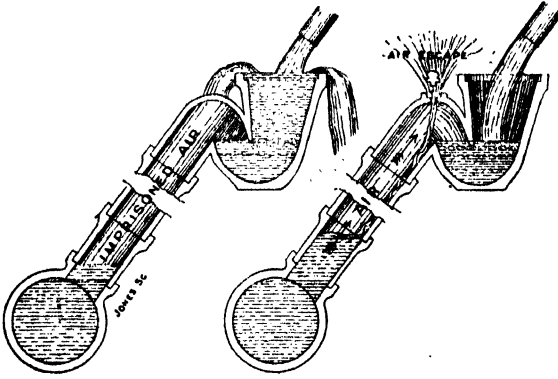

FIG. 80. KNOWLES' "VENTEST" GULLY

disc, which expands radially until it fills the area of the pipe. A hole is formed through the stopper and the spindle to permit the escape of the water when the test is completed, the flow being controlled by a cover and catch which can be released by pulling the cord. This enables the water to be let out of the drain without the operators getting wet. A sectional drawing of an expanding plug is shown in Fig. 79.

Water Test. The drain should next be filled with water through the gullies, but if they are not yet fixed a bend and upstanding pipe can be temporarily fixed at the upper end of the pipes. The pressure of the water in the pipes will vary according to the depth of the pipes below the surface of the standing water. As the drain is laid with a fall, the pressure at the lower end will be greater than at the upper end. A test pressure of about 2 ft. head of water is desirable, but care should be taken that the pressure at the lower end does not exceed 5 ft. or 6 ft., or the joints may be damaged.

Filling a drain through a gully, or when gullies are fixed, is unsatisfactory, and the test is unreliable because air becomes trapped between the rising water in the drain and the water in the gully, as shown in Fig. 80. The air will be compressed until its pressure is such as to support a column of water of height equal to the difference

between the outlet and the top of the gully—a matter of some 6 in. or 7 in.—and then no further water will pass into the drain. The overflowing water at the gully gives the impression that the drain is full of water up to the surface, but actually it will be under only a small pressure. The presence of an air vent on the drain side of the gully, as shown, enables the air to escape and the drain to be completely filled. This gully was patented, under the name "Ventest," by John Knowles & Co. A similar result can be obtained by the use of a gully with an inspection eye on the outlet, which is further advantageous in enabling the gully branch drain to be rodded should the necessity arise.

If the intercepting chamber has been constructed at the time of testing, the plug can be inserted in the mouth of the drain at that point, and the test proceeded with in the ordinary way. If it is desired to test the intercepting chamber, the various openings can be plugged as shown in Fig. 81. The inlet to the trap is stopped with one of Reekie's patent flange plugs, which is sealed by clay being pressed

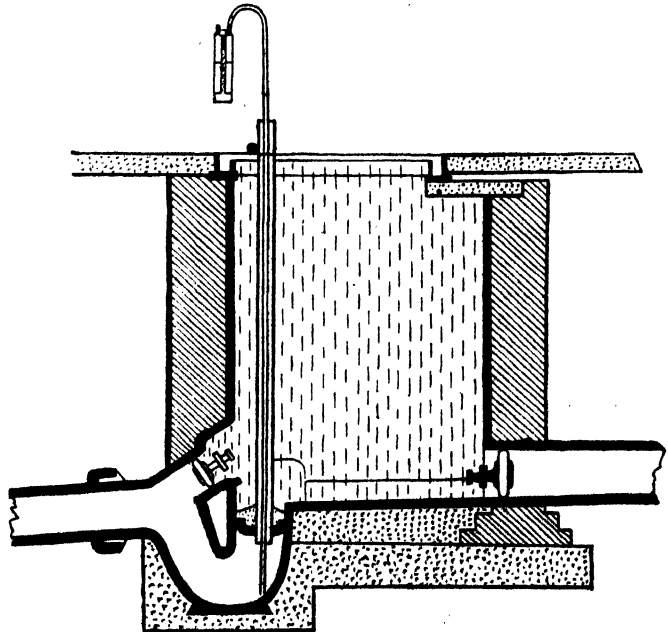

FIG. 81. TESTING AN INTERCEPTING CHAMBER

round the edge. The vertical pipe rising therefrom is connected to a pressure gauge. The water is emptied out of the trap before the plug is fixed, and the vertical pipe is pushed down to the

bottom of the trap, so that if any water leaks past the stopper it will accumulate in the trap, and in rising will compress the air in the tube and indicate its presence on the pressure gauge. There is, however, nothing to show whether

in the closet and gullies, therefore it is necessary to plug off only the end of the drain entering the intercepting chamber, the mouth of the pipe to the fresh air inlet and the top of the vent pipe, provision being made for pumping in air through one of the stoppers by means of a small hand pump.

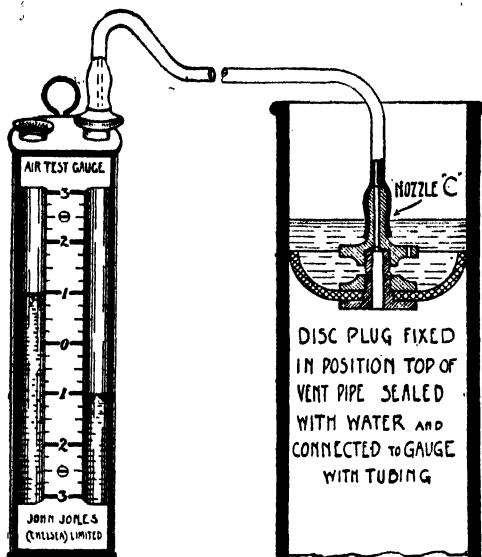

FIG. 82. "IDEAL" AIR-TEST GAUGE

The pressure is ascertained by means of an air-test gauge, as shown in Fig. 82, where it is attached to the top of a vent pipe. The gauge consists of a U-tube with water in the bottom. One limb of the gauge is open to atmosphere, and the other is connected to the interior of the drainage system and, therefore, subject to the test pressure. The effect of this pressure is to depress the water on one side of the gauge and cause it to rise on the atmospheric side. The difference in level between the water in the two limbs measures the pressure. In the illustration shown the air is under a pressure equivalent to 2 in. head of water. It is advisable to cover the plug in the vent pipe with water to prevent the leakage of air and, as far as possible, to treat other plugs in the same way. If, on pumping air into the drain, no pressure is shown on the gauge, the existence of an extensive leak in the system is indicated. On the other hand, if the required pressure is obtained and the gauge remains stationary for, say, three minutes, the system under test may be considered airtight. Should there be a gradual diminution of pressure, it is advisable to test the air-tightness of the plugs and connections to the gauge before concluding that the drain is faulty.

water is leaking past the other plugs into the drain.

Testing by Air Pressure. Old drainage systems are usually tested by air or smoke, as the water test is too stringent. Whereas with water the pressure varies according to the fall in the drain,

Smoke Test Apparatus. The "Eclipse" drain

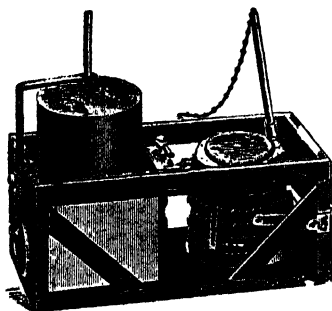

FIG. 83. "ECLIPSE" DRAIN TESTING APPARATUS



FIG. 84. SMOKE ROCKETS FOR DRAIN TESTING

the pressure of compressed air is uniform throughout the system. It is usually considered that a pressure equivalent to 2 in. head of water is sufficient to indicate any defect. Such a pressure will not "blow" the water seal

testing apparatus shown in Fig. 83 can also be used for compressing the air in a drain, and at the same time, or subsequently, introducing smoke into the pipes. The apparatus consists of a double-action bellows and a copper cylinder

MODERN BUILDING CONSTRUCTION

for use as a fire box, and is connected by a flexible hose to a nozzle passing through one of the plugs stopping up the end of the drain. The cylinder is contained in a square copper tank which, being filled with water, keeps the cylinder cool. A copper cover or float fits over the cylinder and, together with the water, forms an airtight joint, after the manner of a gasometer. In operation, as the pressure of air in the drain increases by the action of the bellows the float rises and will remain stationary if the drain is airtight. If the float sinks after the cessation of pumping, a leak is indicated, and its magnitude will be proportional to the rate at which the float sinks. Some smoke-producing material, such as carbolized smoke paper or oily cotton waste, is then placed in the cylinder and lighted. The bellows will pump the smoke into the drain and the position of the leak may be located. That is to say, the air is used to prove the presence of a leak, while the smoke is used to locate it. Care must be exercised not to raise the pressure to such an extent as to force the seals of the traps on the various fittings throughout the system.

Testing by Smoke Rocket. The ordinary smoke rocket consists of a black-coloured cylindrical tube about 10 in. long and $1\frac{1}{4}$ in. diameter. It is filled with material which, when fired, produces a dense and pungent smoke, and is fitted with a time fuse that gives a sufficient period to enable the rocket to be inserted in the drain, and the opening stopped up before the discharge takes place. It is important that one man should fire the rocket while another looks for leaks, because if the smoke is smelt at the time of discharge the sense of smell is dulled for some time afterwards, or at least it is difficult to detect any fresh source of smell. Patent smoke-test rockets can be obtained with fuses that are not extinguished by water. These may be lighted and passed through the water seal of a closet until the end projects above the water. A handle can be obtained for holding the rocket

while placing it in position. The rocket should be allowed to remain for about ten minutes while the operator searches for leaks. The smoke will travel very slowly through the drain owing to the absence of draught.

Kemp's drain tester which, with a smoke rocket, is shown in Fig. 84, is inserted through a gully or a water-closet. One end of the string is held when the tester is lowered into the water, and then a pail of water, hot preferred, is poured down to wash the tester into the drain. As soon as the tester is unwrapped, or the paper holding the cap on gives way, strong odour and smoke are discharged into the system. A *drain ferret* consists of a thin glass phial containing material which emits smoke and smell when it is broken, which occurs very easily as it falls into the drain.

Smell Tests. Certain chemicals and essences are sometimes used for testing drains by themselves instead of in company with smoke. One or two ounces of oil of peppermint discharged into the drains, and followed by a few cans of hot water, is very effective. If put through a water closet, the trap should be covered with wet cloths to prevent the smell escaping into the room. The person who inserts the oil must not be the one to search for the leak, as the slightest particle on the hand or clothes will distribute the scent wherever he goes. If the oil is put through a water closet, the operator should remain in that room until the others have completed their search for leaks. A small quantity of water poured down from time to time will distribute the smell. If the water closet connections are suspected of leakage, the peppermint should be inserted through the top of the soil pipe, or through a gully near to the foot thereof. Essences are useful for measuring the extent to which sewer gas escaping from the top of a vent pipe is likely to reach adjoining windows. In such cases, the oil could be introduced through the water closet and the top of the soil pipe should be left open.

Chapter VI—PLANNING DRAINAGE SYSTEMS

BEFORE attempting to arrange the lay-out of a drainage system, the local by-laws should be studied, in order that the design may comply with the provisions thereof. The by-laws should, indeed, be referred to before any sanitary details are determined. Owing to the varying age of the by-laws in force throughout the country, and other circumstances, considerable divergence is found in the provisions. By-laws are not worded in general in a very precise manner, the intention being to describe broadly the principles which shall be observed in the work, and to leave the interpretation in detail to the official responsible for seeing that the by-laws are adhered to. For instance, as a general principle, the drains should be laid on a firm, unyielding bed. The London County Council by-laws certainly specifically require that the drains shall be laid on a concrete bed, but there are other places where, owing to a similar treacherous clay subsoil, it is essential to provide a layer of concrete to give a firm foundation. On the other hand, with, say, a gravel subsoil, it would be absurd to dig the gravel out and put concrete in its place.

INSPECTION CHAMBERS. As a general principle, inspection chambers should be constructed at each change of direction of a drain, but such chambers are expensive and in many cases the cost would be prohibitive. Inspection chambers are used only when some trouble occurs in the working of the drainage system. A properly designed system, constructed under expert supervision, should never fail unless subject to gross misuse, consequently many inspection chambers are not opened after they are first constructed. In such cases the chambers represent so much money lying idle. There should be some means of access to the drains, and a chamber should always be constructed at the intercepting trap; then, if there are many branch drains, a considerable number of which can be brought together at one point without unduly long runs, an additional chamber might advantageously be constructed at that point.

Terrace Houses. An arrangement for the drainage of a terrace house, with sewer at

the back of the premises, is shown in Fig. 85. When the main sewer is constructed of masonry, a specially-shaped stoneware junction block, as shown, is built in to receive the house drain. In this case, one chamber is made to serve for the purpose of giving access to the intercepting trap and to the house drains. Each drain is laid in a straight line throughout its length. Ventilation is provided by means of a fresh-air inlet, connected to the chamber at one end, and the soil pipe at the other end carried up above the roof, and terminating with an open end. One gully is made to serve for the bath waste and a rain-water pipe, by allowing both those pipes

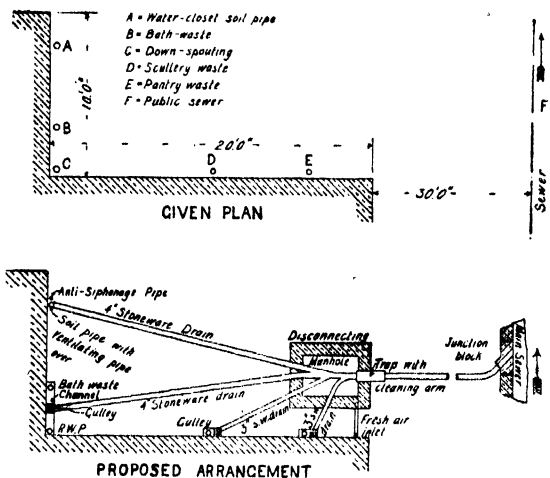

FIG. 85. DRAINAGE OF TERRACE HOUSE WITH SEWER AT BACK

to discharge over a channel leading to the common gully. In old by-laws it was frequently provided that sink and other wastes should discharge into a channel 18 in. long, leading to a gully. The idea was to prevent the possibility of any emanations from the gully passing up the pipe to the house. These channels invariably became very dirty, and it is now usual for the waste to discharge over the gully or into it by a back inlet.

Another terrace house is shown in Fig. 86, but in this case the sewer is in the front road and the drain passes under the

MODERN BUILDING CONSTRUCTION

house. It is usually provided in the by-laws that a drain shall not pass under any building except where any other mode of construction is impracticable. If it is so laid, then, if practicable, it must be laid in a direct line under the building, and means of access must be provided at each end of the portion under the building. In *urban* districts it is illegal to

drain to a width at least equal to the external diameter of the pipe, and, further, the concrete for the full width of the bed is required to be haunched up, so as to embed the pipe to the extent of not less than half its diameter.

In Fig. 86 two alternative arrangements of the ground floor water-closet are shown. The advantages of the suggested improvement are,

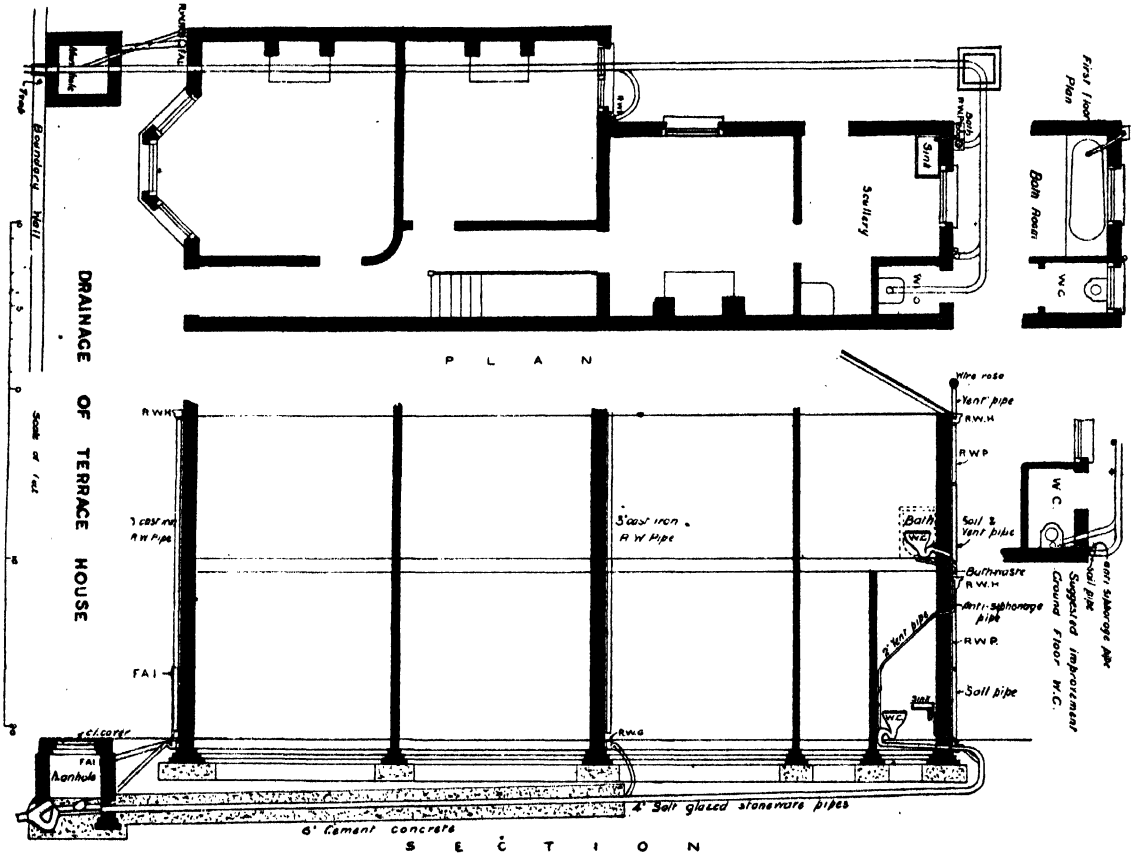

FIG. 86

build a house over an existing drain without permission from the local authority. If the drain under a building is formed with stoneware pipes, they should be completely embedded in, and covered with, good and solid concrete at least 6 in. thick all round. The by-laws of many provincial cities require such a drain to be surrounded with concrete, irrespective of the material of which it is formed; but in London, when iron pipes are used, they are required to be laid only on a bed of good concrete not less than 6 in. thick, extending on each side of the

first, that a side outlet from the closet trap is more convenient for connecting to the drains, and, secondly, the soil pipe from the upstairs w.c., being at the head of the drain, is in the best position for ventilation purposes. The hopper head for the reception of the bath waste is a fitting that is losing favour. Its object is to permit an air-break in the waste pipe, so that the unventilated length shall be as short as possible. The disadvantage, however, is that the inside surface of the hopper head becomes very foul, and this, with the down pipe, which

MODERN BUILDING CONSTRUCTION

the outlets. Owing to the exceptionally foul nature of the sewage from the stables, house drains are frequently disconnected from the

and there is no chance of unsealing the trap. The internal sanitary fittings are shown in Fig.

90. The water-supply pipe gives service to the sink and bath on its way up to the cistern, where it terminates with a ball valve. A pipe is taken off from the bottom of the cistern to supply the flushing tanks for the water-closets. The overflow and waste pipes from the sink and bath, respectively, come together in a common pipe, which is trapped as close to the fitting as possible. The arrangement of the soil pipe and the anti-siphonage pipe is clearly shown. Two alternative positions for the top of the soil pipe are shown. It may be necessary to take the pipe to the height shown in order to clear some adjacent window, and as the projecting end requires to be firmly stayed, it may be more convenient to take it up the slope of the roof, but it must not be forgotten that any bend in a ventilating pipe reduces its efficiency considerably. Relieving arches are turned over the drain where it passes through the walls.

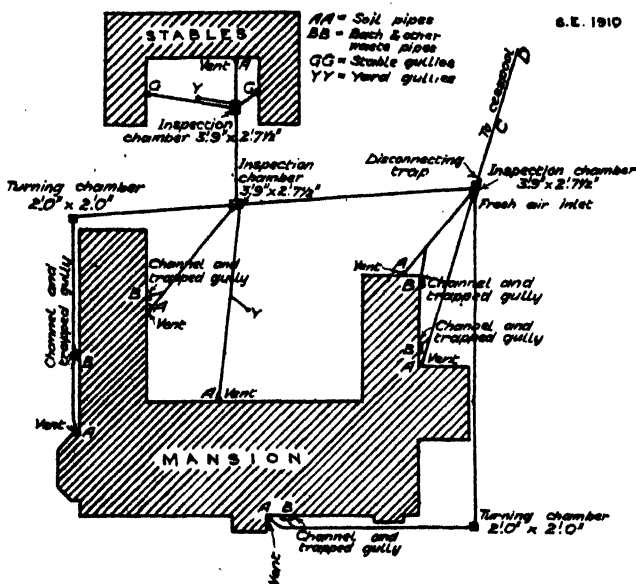

SYSTEM OF DRAINAGE
Fig. 89

stable drains by placing an intercepting trap on the former before the stable drains join.

External Sanitary Fittings.

The general arrangement of the external sanitary fittings is shown in Fig. 87. The anti-siphonage pipe is necessary because two water-closets discharge into the same soil pipe. In such a case, the sewage from the top closet falling down the pipe, past the mouth of the pipe from the lower closet, is liable to draw the air out of that pipe and create a partial vacuum, which might unseal the trap. The anti-siphonage pipe is connected to the outlet of the closet from the top closet, where it is connected to the soil pipe. Thus, if any air is drawn out of the lower pipe, its place is at once taken by air from the anti-siphonage pipe,

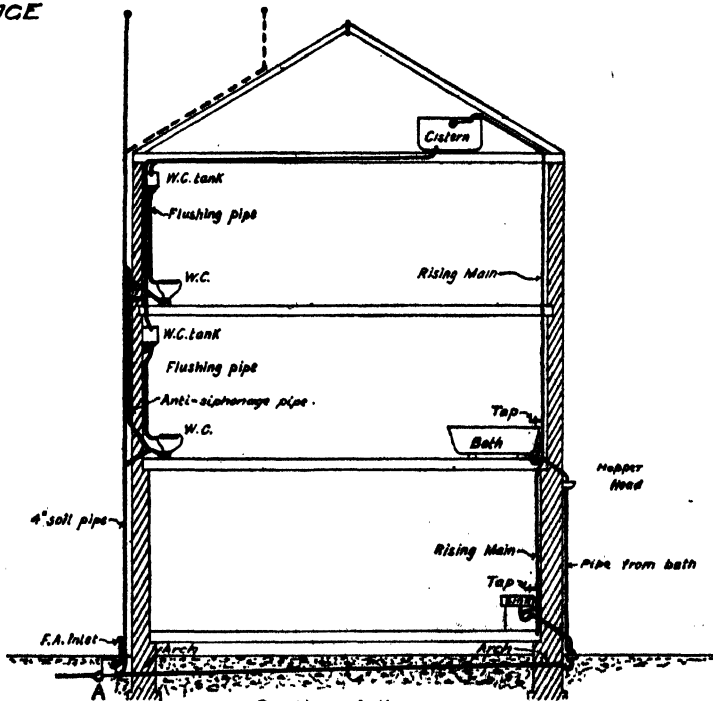

Section of House
showing sanitary fittings.

FIG. 90

DRAINAGE AND SANITATION

ONE-PIPE SYSTEM OF SANITATION

It is generally admitted that dangerous gases are generated from the slimy matter which adheres to the sides of the waste pipes from bath and lavatory fittings. Normally these gases are excluded from the room in which the fitting is situated by a trap on the outgo, but they are allowed to escape from the waste pipe where it

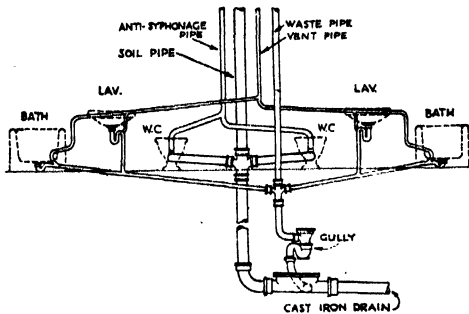

FIG. 91. ORDINARY DUAL-PIPE SYSTEM

discharges over a hopper head or gully. The gases naturally rise and may possibly be blown into the building through a window, thus defeating the object of the trap. It would seem, therefore, far better to discharge such waste into a "closed" pipe similar to the soil pipe, and so prevent the escape of the gases until they are conveyed to a place where they can be diffused and cause no harm. It would, however, be uneconomical and unnecessary to run two separate pipes up a building side by side to collect equally foul water and discharge them into the same drain; so the two pipes are combined, giving the basis of the "one-pipe" system.

General Arrangement. This single pipe takes the wastes of all the various fittings—water-closets, baths, lavatories, and sinks. A further pipe is necessary to ventilate the system and to prevent siphonage. Efficient and adequate ventilation is of paramount importance if the system is to work satisfactorily. All fittings, as far as practicable, should be grouped together, so that only short branches are needed to convey the wastes to the common down pipe. Long branch pipes frequently laid at flattish gradients are liable to rapid deterioration owing to the waste not running off quickly and cleanly and ventilation not being adequate.

The normal layout for a group of sanitary appliances drained by the dual pipe system

arranged by Messrs. Dent & Hellyer is shown in Fig. 91. This should be compared with Fig. 92, prepared by the same firm, which shows the same group of appliances drained by the one-pipe system. The simplification of the plumbing obtained by this system is obvious. The common soil pipe is carried up the building from the drain to a point well above the eaves, as in the

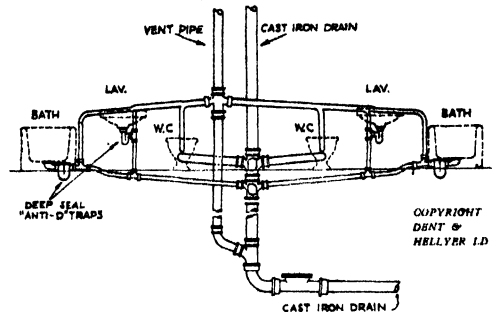
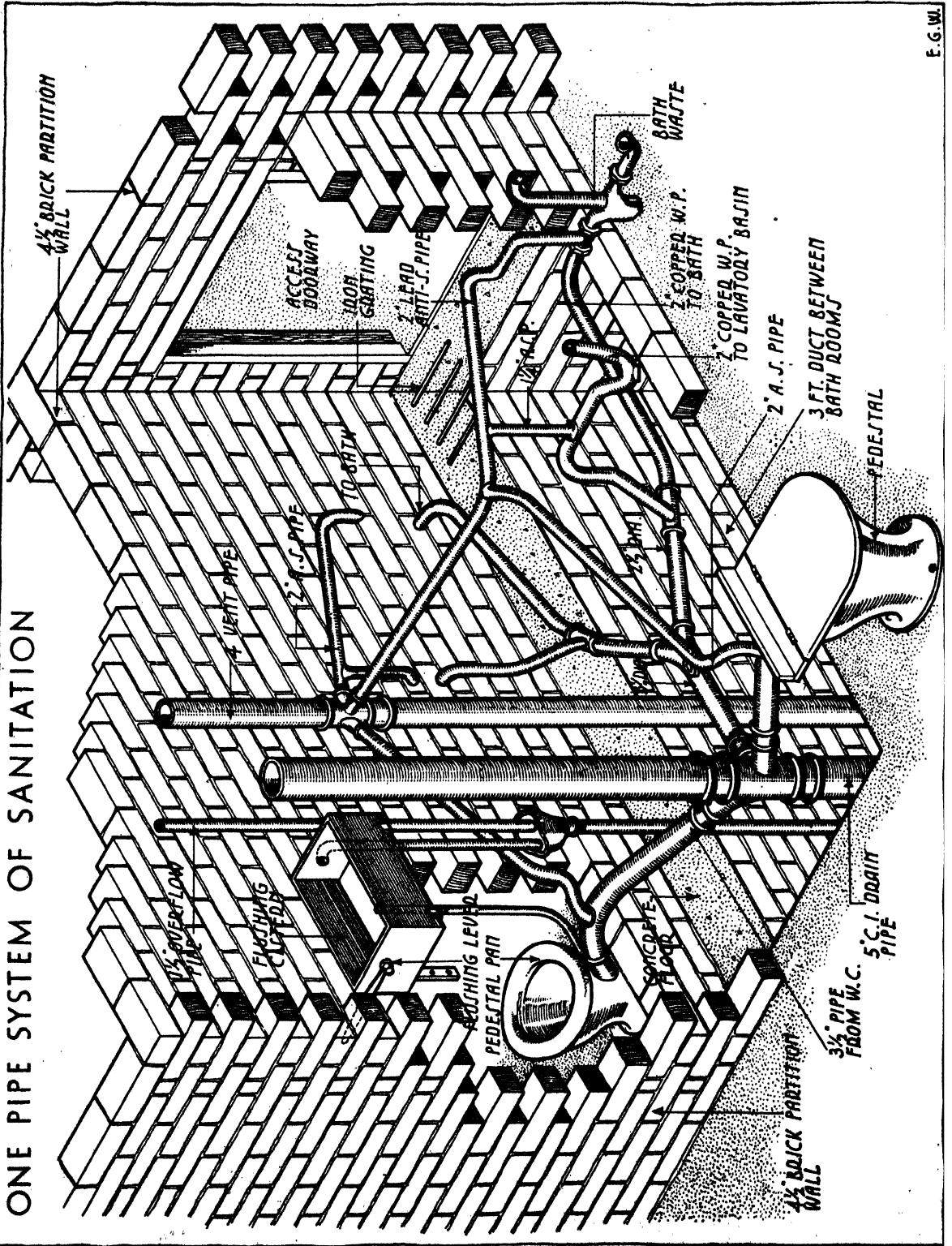

FIG. 92. ONE-PIPE SYSTEM

case of the dual pipe system at present in common use. To this pipe the various W.C., bath, and lavatory wastes are connected at each floor level through special curved junctions, which are provided with access boxes, for use in case of stoppage.

Each fitting is connected to its waste pipe through a special deep seal trap of modern, self-cleansing, anti-siphonage design, as shown in Fig. 93. The seal should be between 2 in. and 4 in. deep, excepting the W.C., where the flush is limited to the standard 2 gallons. In this case a seal of 1½ in. is the maximum which can be used if the flush is to be fully effective, but as the area of this seal is large, namely about 4 in. across, there is little danger of it being forced. The deep seal traps are necessary because the pressures formed in a one-pipe system are greater than in the dual system, consequently there is greater risk of the seal being forced, and, further, it is essential to avoid any possibility of the seal being lost by evaporation. To prevent siphonage a vent pipe is taken off near, but not at, the crown of the trap of each fitting on the outgo side and led to a common vent pipe running up the building by the side of the common soil pipe to which it is connected below the lowest fitting. The size of this common vent pipe is most important, and should be such that it can provide a quantity of air equal to that displaced by the wastes

ONE PIPE SYSTEM OF SANITATION



F. G. WIL

DRAINAGE AND SANITATION

of all the fittings likely to be in action at one time. It will thus be seen that it should be approximately the same size as the soil pipe.

All fittings and workmanship must be of the best quality and the connections both on the waste pipes and air vents must be made in such a manner that they will assist rather than impede the flow through them, and of course the whole system must be gastight. The best material for the main soil and vent pipes is cast iron coated with Dr. Angus Smith's solution or other preservative and jointed with caulked lead. The soil pipe should be suitably supported by a cast-iron "loco" type bend on a foot, all supported on concrete to obviate settlement. Branch wastes can be either of cast iron or of copper. Lead should be used only for branch vent pipes and perhaps for W.C. connections, as this material is liable to suffer injury from expansion and contraction due to hot bath and lavatory wastes.

Advantages. It is obvious that with a single vertical pipe taking all wastes the plumbing work is very much simplified. This simplification leads to increased efficiency. The single pipe has the advantage of being flushed more often, sometimes with quite hot water from lavatory basins, and is therefore kept in a cleaner condition. Ventilation is greatly assisted by the impulses of the increased amount of flushing, and so any drain air which escapes will be in a less concentrated form. From an architectural point of view, the one-pipe system is to be preferred as it requires fewer pipes and connections on the elevation of the building. A well-designed deep seal trap must be used in a one-pipe installation, as it is able to withstand siphonage and back pressure better than the standard short seal type. A deep trap will take longer to lose its seal by evaporation than a short one, and a deep seal will absorb and pass through less gas than a shallow one; also it must be remembered that there will be less gas to be absorbed in a one-pipe system.

The permeability of a water seal to gas is an important matter. Water tends to absorb and become impregnated with gas in contact with its surface, and this gas is given off, in a modified degree on the outer side of the water seal as in a W.C. trap. The time taken for gas to impregnate a water seal depends on the atmospheric conditions on both sides of the trap and may

vary from an hour to many days. The dangers arising from impregnation are nullified by providing pure air on the soil side of the trap which is obtained by thorough ventilation of the drains and bringing the moving air close to the water surface in the trap by anti-siphonage pipes.

On large installations, the one-pipe system will effect considerable saving in the length of pipe used, and the time taken over the job, and

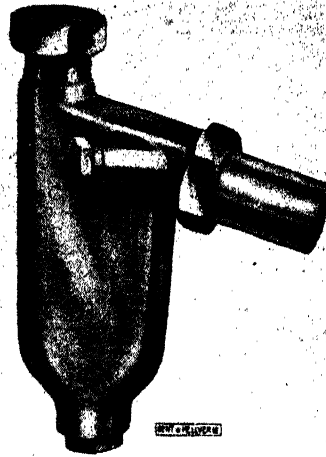

FIG. 93. DEEP-SEAL TRAP

hence will be cheaper to install. In big buildings and blocks of flats where it is sometimes necessary to have internal "plumbing" areas, these may be reduced in size, with a corresponding increase in the size of the adjacent rooms. In the dual pipe system channel gullies receive wastes from baths, and all kinds of liquids, many very unpleasant, from kitchen sinks. These wastes are allowed to run over a length of open channel and diffuse obnoxious smells into the air at ground level. Where a one-pipe system is installed channel gullies are automatically done away with, and the waste is taken direct into a drain. The discharge of hot water into the cast-iron soil pipe is said to cause the caulked lead in the joint to "creep" out owing to the slight expansion movement of the pipes. To obviate this, pipes with corrugated sockets should be used.

Chapter VII—INTERNAL FITTINGS

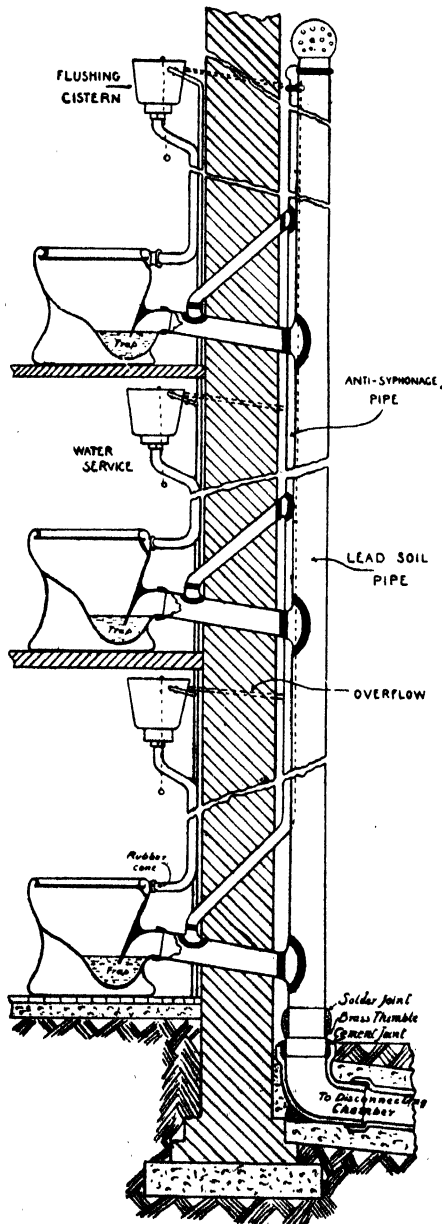

FIG. 94
VERTICAL RANGE OF WATER-CLOSETS

Water-closets. The most important of the internal sanitary fittings is the water-closet. It should be of such a height that the seat is $17\frac{1}{2}$ in. above the ground, and the front of the seat should be about 23 in. from the wall. It is preferable to have the pan and trap in one piece, and a pedestal type avoids casing the closet in, and thereby forming a receptacle for dirt. The pan should be provided with a flushing rim, so arranged that the whole of the pan is cleaned at one flush. This can be tested by covering the interior of the pan with lampblack, and observing whether it is all washed off at one operation.

The contents of the pan should also be swept away at one flush, but if this does not occur the fault is probably that the flush pipe is too small, or the cistern is not high enough. The pipe should be at least $1\frac{1}{4}$ in. diameter, and if practicable the bottom of the cistern should be not less than 5 ft. above the top of the pan.

A vertical range of closets is shown in Fig. 94, from which the various connections can be clearly seen. A *puff pipe* is fixed on the outgo of each trap and connected to the *anti-siphonage pipe*. The puff pipe should be at least 4 in. away from the top of the arm of the trap, as otherwise there is a risk of faecal matter being carried up with the flush and lodging in the mouth of the pipe, which would ultimately become stopped. In connecting the lead soil pipe to the stoneware drain, a brass thimble is soldered on to the lead pipe with a "wiped" joint to form a rigid end to the pipe, between which and the drain an ordinary cement joint may be made. Under no circumstances should any trap be put at the foot of the soil pipe.

Closest and Slop Sinks. A more detailed illustration of a *wash-down closet* is shown in Fig. 95.

The seal should not be less than $2\frac{1}{2}$ in. The after-flush chamber shown at the back of the pan is for the purpose of ensuring that the trap is sealed after the closet has been flushed, as sometimes, with a very powerful flush, there is a tendency for the momentum of the water to carry too great a volume forward over the edge of the trap, so that when the water comes to

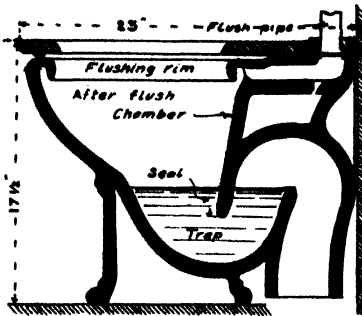

FIG. 95. DUCKETT'S WASH-DOWN "CLENCHER"

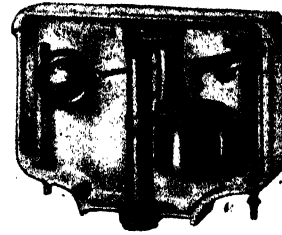

FIG. 98. CISTERN WITH VALVE FITTINGS



FIG. 96. COMBINED CISTERN AND WATER CLOSET

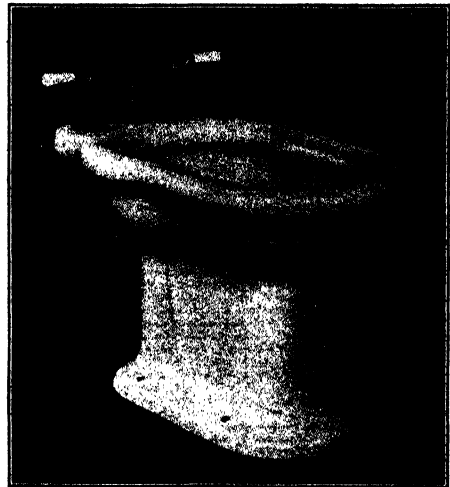

FIG. 99. A BIDET (Doulton)

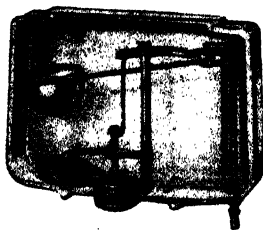

FIG. 97. CISTERN WITH VALVELESS FITTINGS

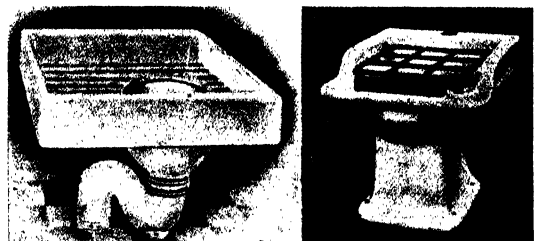

FIG. 100. SLOP SINKS

MODERN BUILDING CONSTRUCTION

rest in the bottom of the trap the lip is not submerged to a sufficient depth. While the flushing water is entering the pan, a portion of it runs into this chamber, and as the outlet is

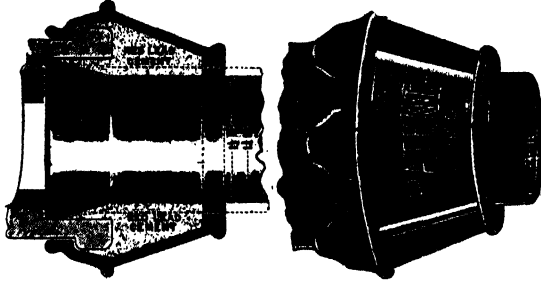

FIG. 101. CONE JOINT FOR W.C. FLUSH PIPE

restricted in size, it escapes slowly and runs into the pan after the flush has finished.

The *Unitas* toilet suite, Fig. 96, manufactured by Twyford's, Ltd., does away with the need of a flushpipe between the lavatory pan and cistern, and in consequence the noise of the rush of water through the flushpipe is eliminated. Flushing is practically inaudible outside the room. As the illustration shows, it is a neat, self-contained unit in which also the plumbing is simplified. The cistern is bolted to the top of the pedestal by four wing nuts, the only connections necessary being those to the inlet, outlet and overflow. Cisterns can be of the valveless, Fig. 97, or valve, Fig. 98, type,

according to the requirements of the local water authority. To obtain maximum quietness in operation, the cistern should be fed from a storage tank, not from main supply. If the supply must come from the main, a stop-tap to control the flow should be fitted, or a special silent ball-valve obtained from the makers.

A *bidet*, made by Doulton & Co. in their well-known "Queensware," is illustrated in Fig. 99. These useful appliances are now frequently fixed in the bathrooms of good class houses. The water supply is laid on direct to the basin. There are hot- and cold-water lever-handled control valves for a rising spray or for heating the rim. The outlet, which is trapped, should be connected to the soil pipe, or other-

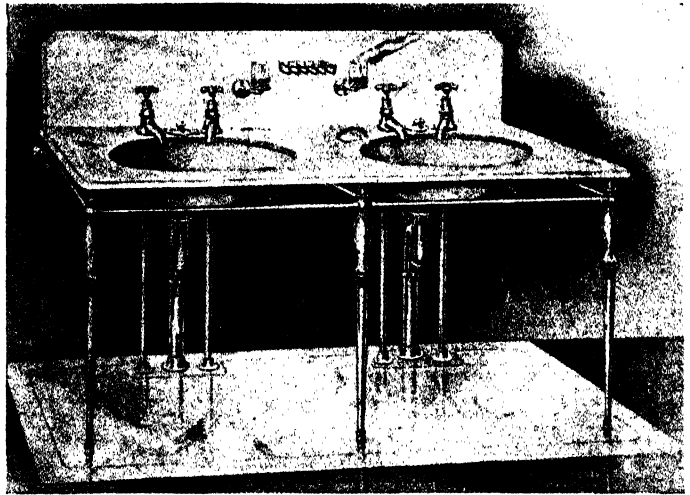

FIG. 103. LAVATORY RANGE FOR TWO PERSONS

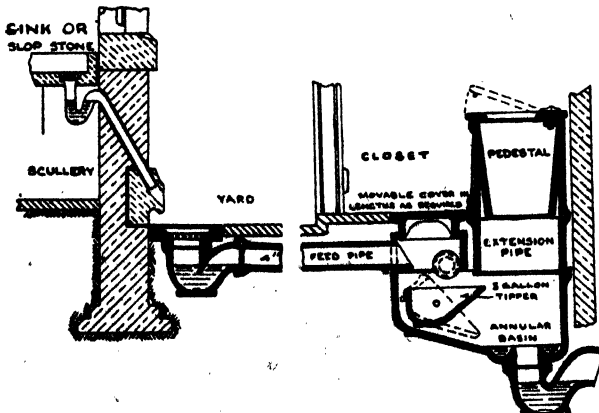

FIG. 102. DUCKETT'S SLOP-WATER CLOSET

wise be treated exactly the same as a water-closet.

Fig. 100 shows two *slop sinks*, or *housemaids' closets*. They should be used solely for the reception of bedroom slops. These fittings should also be connected exactly similar to water-closets. They should not be confused with sinks on the one hand, or with slop-water closets on the other.

A *cone joint*, made by George Jennings, Ltd., for securing the flush pipe to the pan of a closet in a watertight and substantial manner, is shown in Fig. 101. The lead cone is passed over the bead on the closet, and then the clips are bent down to form a grip and prevent the withdrawal of the fitting. The flush pipe passes full bore into the

inlet of the basin, thus preventing a check to the flow, and the arrangement dispenses with a solder joint between the flush pipe and the lead cone. In making the joint, the cone is passed over the end of the flush pipe, which is then opened out with a turn pin, to prevent any cement being forced into the pipe and to allow the water to flow more easily.

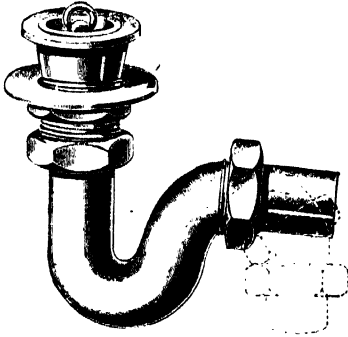

FIG. 104. OUTLET FROM LAVATORY BASIN

The interior of the cone is then filled with red lead and putty cement, and the cone is forced on to the inlet arm of the basin. Bending over the clips and trimming off the surplus cement finishes the fixing, and the joint is ready for use.

Slop-Water Closets. Slop-water closets are closets designed to be flushed with slops, or

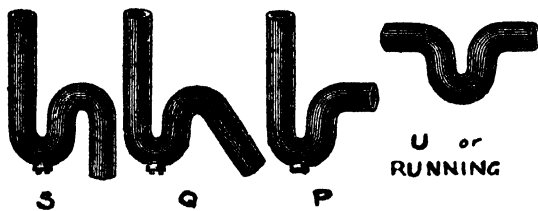

FIG. 105. LEAD TRAPS FOR SANITARY FITTINGS

waste water, instead of clean water. The object, of course, is to conserve the water supply, but it is generally considered that the disadvantages outweigh the advantages. These closets were first introduced at Burnley, Lancs, some forty years ago, and, although they had a certain vogue at first, they have fallen into disfavour.

Fig. 102 shows Duckett's slop-water closet; it was the pioneer of this class of closet, and is a good example of the type.

Lavatory Basins. A modern double lavatory range, such as might be fixed in a bedroom, is shown in Fig. 103. This is a marble range for

two persons; it is 5 ft. long with a 12 in. skirting at the back. The basins are of white porcelain, clipped to the slab. The standards and rail framing to support the top are made of polished brass, to match the valves, but all can be obtained chromium-plated, which is preferred by many people. A detail of the waste-pipe fitting is shown in Fig. 104. The outlet valve is passed through the hole in the basin, and then clamped in position by the lock nut and washer. The trap is subsequently attached. There should always be a trap on the waste pipe.

Several forms of traps are shown in Fig. 105, with the letters by which they are known. Means of access is provided by a screw cap at the bottom of the trap, and this cap is useful to remove any collection of fibrous matter and soap which may occur.

Sinks. Fig. 106 shows a modern scullery sink, It is 21 in. wide and 10 in. deep, and is made in lengths from 3 ft. to 4 ft. The sink is made in white porcelain-enamelled fireclay; the rim and

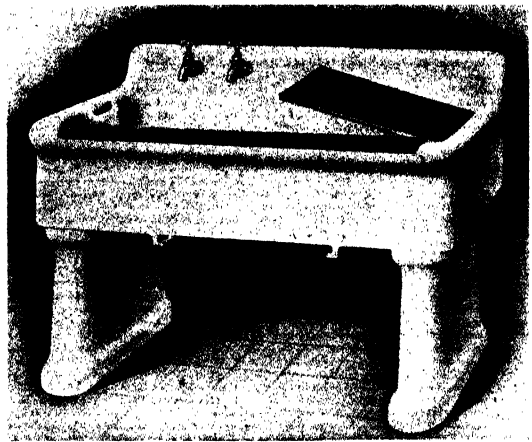

FIG. 106. SCULLERY SINK

drainer are made of teak. Slides are formed under the sink to receive the drainer when not in use. There is an open weir overflow, which can be easily kept clean by pushing a sink mop down the orifice. The taps are $\frac{3}{4}$ in. size in order that water may be obtained quickly. The waste is also large—2 in.—for rapid emptying.

Butlers' sinks are usually made entirely of teak, to minimize the risk of breakage of valuable glass and china. The taps are usually placed about 15 in. above the bottom of the sink, in order that water may be run direct into wine decanters when they are being washed.

MODERN BUILDING CONSTRUCTION

BATHS

A fixed bath is now considered an essential adjunct to every house. They are even being installed in many rural cottages where there is no piped water supply nor any system of sewerage. The difficulty of water supply is overcome by collecting the roof rain water in an elevated tank whence it is piped to a tap over a boiler placed adjacent to the bath; the hot water being ladled from the boiler to the bath. The disposal of the waste water is a more difficult matter as the volume is con-

cheaper ones painted inside and the better ones coated with white porcelain enamel. The surface finish of painted baths is affected by the hot water and they require repainting every few years. The porcelain enamel finish has a long life and is most satisfactory.

The baths may be parallel in width, or tapered; the latter requiring rather less water. The exterior may also be fully exposed or cased in with decorative panels.

The height of a bath is of importance, and for the convenience of elderly people, children

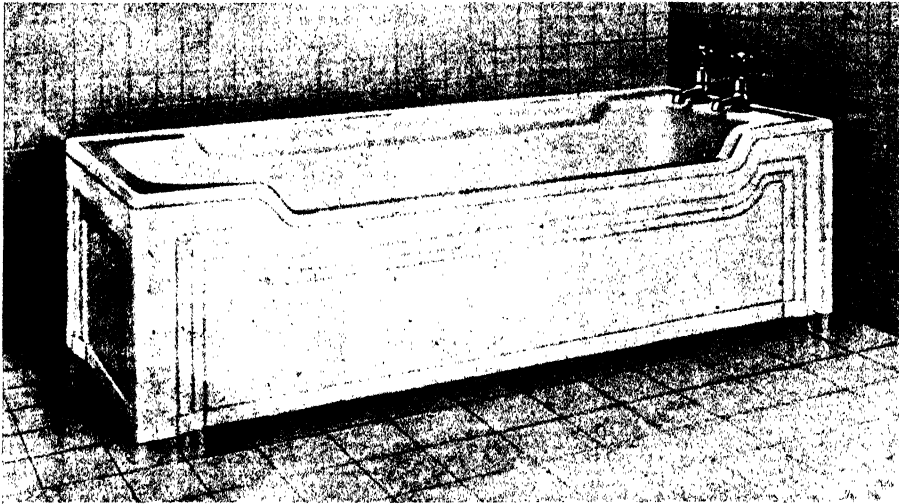

FIG. 107. PANELLED BATH OF WELL-BALANCED DESIGN

siderable, especially if there is a large family imbued with strong ideas of cleanliness. A cesspool becomes filled quickly, and the frequent emptying is expensive and a nuisance. A soak-away would probably be clogged with the soap and soon become ineffective. Connection to a convenient land or surface water drain only results in transferring the nuisance from one point to another. Modern sanitary equipment in a house demands public water supply and main drainage.

White glazed or enamelled fireclay baths are probably the best. They are strong and not easily damaged, and do not require renovating after a number of years service, but they are heavy and expensive. The manufacture of such large pieces of pottery is not easy and it is difficult to avoid blemishes. The baths are generally sold in three qualities, but the difference between them is solely one of appearance.

Baths are usually made of cast-iron, the

and invalids, it should be as low as practicable. The minimum inside depth necessary to avoid undue splashing is about 17 in. The bath is supported on four feet, and the height which these lift it off the floor depends upon how the waste outlet can be dealt with. If the outlet can be sunk below the floor the bath need be lifted only about 1½ in., making a total height of 18½ in., but if the outlet has to be above the floor then the total height will need to be about 23 in. If the bath is exposed, the outlet must be above the floor as the cutting away of the floor boards would form an unsightly hole which would collect dirt. With a panelled bath the outlet can be below the floor provided the floor joists are placed so that the waste pipe may be fixed between them.

The surge of water in a bath tends to cause splashing at the ends rather than at the sides. Messrs. Clark, Hunt & Co. supply a panelled bath which is only 17 in. above the floor along

the front but is raised at the ends to 20 in. or thereabouts, thus combining the luxury of a deep bath with the convenience and easy accessibility of a shallow one. The design is balanced by having a large soap shelf, formed at the back of the bath, of the same length and depth as the dip at the front (see Fig. 107).

The inside length of a bath may vary from 4 ft. to 6 ft., but they are usually 5 ft. or 5 ft. 6 in. long. The width is generally from 22 in. to 24 in. The overall outside dimensions depend upon the design of the bath, but they will

to any position of the bath, that is to say the bath may be in the middle of the room and panelled on the four sides; it may have a side or end against a wall, and panelled on three sides; it may be in a right-angle or left-angle corner and panelled on two sides; or in a recess and panelled on one side only. In every case a bath may be obtained with the arrangements for the fittings at whichever end may be the more convenient. Instead of being tied down to buying a bath that can be squeezed into the bathroom, it would be advantageous to select

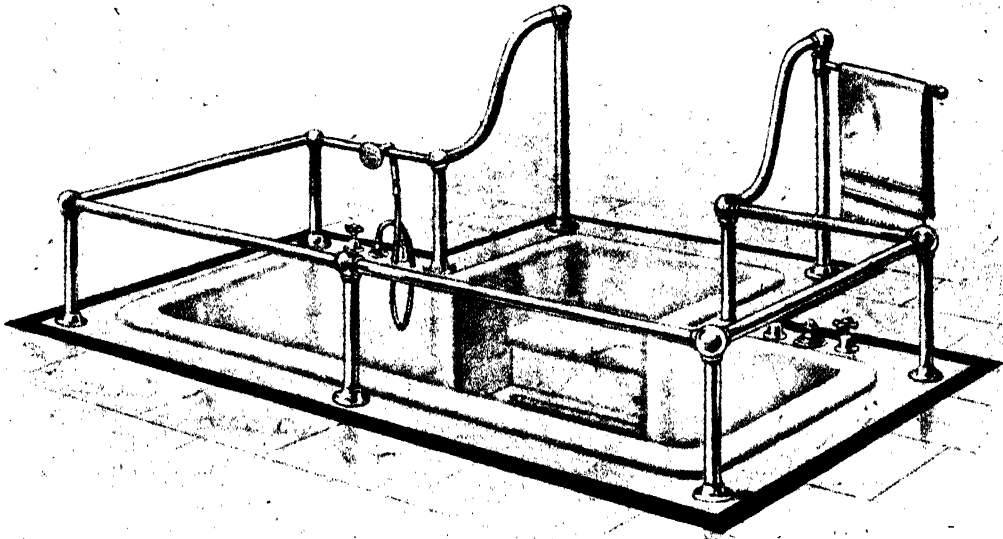

FIG. 108. SUNKEN BATH

generally be about 6 in. greater than the inside dimensions.

Tapered baths are not generally cased in; they are 22 in. or 23 in. wide at the shoulder and 5 in. or 6 in. narrower at the foot.

In connection with the larger sized baths, it should be noted that it is becoming the custom for water authorities to make an extra charge for water for baths of a greater capacity than 50 gals., measured up to the centre of the overflow. It would be convenient in this connection and also useful in indicating the roominess of a bath if the makers gave the capacity figures in their catalogues with the other descriptive matter.

Enclosed baths have slabs of marble fitted between the underside of the rim of the bath and the floor. The panelling can be adapted

the bath, and indeed all other sanitary fittings, and then build the room to accommodate them.

Reminiscent, on a small scale, of the ancient Roman baths is the sunken bath, where the rim is level with the floor. The bath is usually 21 in. deep inside and requires a depth of nearly 3 ft. from the floor of the bathroom to the ceiling of the room below. Access steps, with hand-railing, should be provided, together with a dwarf kerb railing round the edge. An example of this type of bath is John Bolding's "Lido" shown in Fig. 108.

Nursery baths, or baby baths, are about 42 in. \times 22 in. \times 6 in. deep overall, and are supported on a base so that the height is about 32 in. above the floor. The main part of the bath should be shallow to permit the child to lie comfortably, while one end should be deepened to form a

MODERN BUILDING CONSTRUCTION

bowl with a reserve of water for washing purposes. The bath may be fitted with the usual bath or lavatory basin fittings, but it is advantageous to have a blending or anti-scalding tap

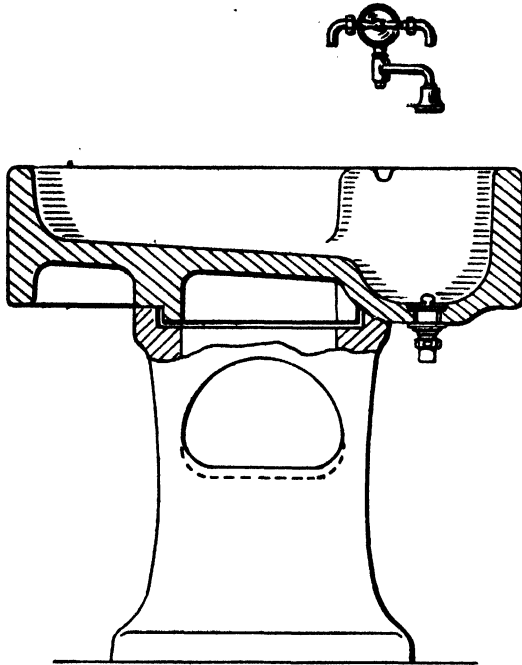

FIG. 109. SECTION OF BABY BATH
(Note recess in pedestal for sponge)

which will give cold, tepid, or hot water at will, and also a swivelled spray nozzle. The tap should be fitted with a thermometer, but it should be remembered that there is a slight time lag in the indication of the temperature of the water, particularly if it changes rapidly. Fig. 109 shows Twyford's, Ltd., "Adamant" baby bath. Baths for children's use can also be obtained of similar design to a normal bath with inside length from 2 ft. 6 in. to 4 ft. 6 in., and supported on iron standards to give the required height of about 30 in. above the floor.

Foot baths are usually of enamelled fireclay, placed on the floor and occupying a space of about 21 in. from back to front and 18 in. overall width. The depth is about 12 in. at the back and 9 in. in front. They are supplied with hot and cold water and the usual lavatory basin fittings.

For use in flats and modern houses where space is very limited, Messrs. Clark Hunt &

Co. supply a "Nusyt" bath, Fig. 110, shaped more or less like an enclosed chair. The bottom is stepped, part of it forming a seat and the remainder a well for the feet. The overall length is 3 ft. 6 in. and the width 26½ in.; the depth inside at the seat is 15½ in., and the depth at the well 24 in. It is said that this shape will provide an entirely adequate bath for a 6-ft. man. This bath is also supplied combined end to end with a lavatory basin, in which case the overall dimensions are 5 ft. × 26½ in. One set of swivel taps, with a mixing chamber, supplies water to both compartments. This is a convenient fitting and reduces the cost of plumbing. Lavatory basins are sometimes fixed over a bath, but if this is done, provision should be made for separate wastes so that the dirty water from the lavatory basin does not foul the bath.

The bathroom walls should be covered with tiles to a height of about 3 ft. 6 in. They need not necessarily be white, but may be selected to suit any approved general colour scheme. Practically all sanitary fittings can now be obtained in a variety of art shades, and the marble panels of enclosed baths are obtainable in many colours. The placing of a water closet in the same room as the bath may sometimes save a little space, but it interferes with the

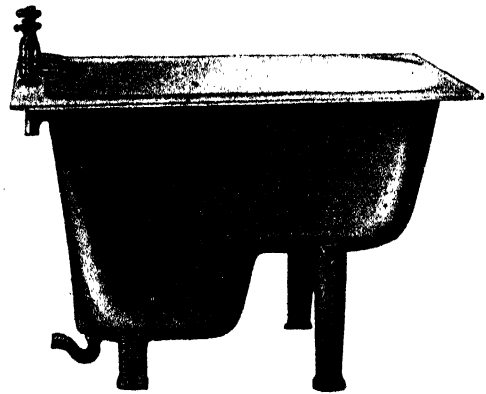

FIG. 110. BATH SUITABLE FOR LIMITED SPACE

free use of both fittings and is otherwise objectionable.

The bath supply taps should be not less than ¾ in. diameter; the overflow should have an area exceeding the combined area of the supply taps, and in any case not less than 1½ in. diameter; the waste outlet should be 1½ in. or 2 in. diameter. The taps should be of easy clean, pillar type, chromium or nickel plated. It is

possible to obtain taps clad in pottery which save labour as they only require wiping with a cloth, but there is a risk of breaking them. The waste pipe should be trapped to prevent the entry into the bathroom of noxious gases from the soap encrusted waste pipe. If the waste pipe is more than 2 ft. or so in length it should be provided with an anti-syphonage pipe to prevent unsealing the trap. This is particularly necessary if the waste pipe is carried to the ground without the insertion of a hopper head, or cistern head as it is sometimes called. Fig. 111 shows a pillar bath set.

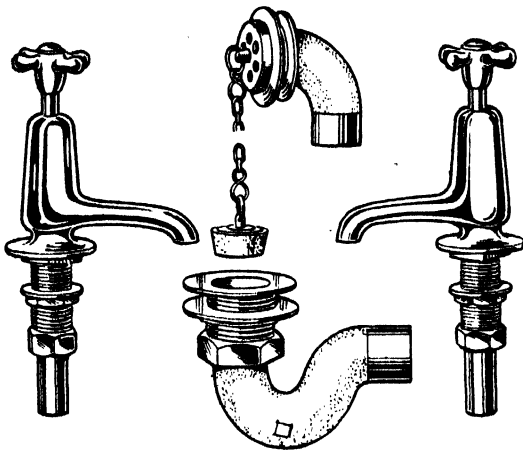

FIG. 111. PILLAR BATH SET

The arrangement of the overflow is a matter of importance. If it is by way of a rose high up in the bath, the connecting pipe should be joined to the waste pipe on the bath side of the trap. Secret wastes should never be used as they become fouled and are inaccessible for cleaning. The most satisfactory overflow on sanitary grounds is the pull-up combined waste and overflow which consists of an upstand pipe placed over the waste outlet. When this pipe is raised the waste water escapes through a grid in the bottom; when the pipe is seated the overflow water runs into the top of the pipe. The whole fitting can be pulled out when cleaning is required.

An overhead shower can be arranged in connection with a plunge bath if effective means are taken to prevent splashing. The screens usually consist of plate glass secured to a metal frame or a waterproof curtain suspended on a rail surrounding the shower. Unless the bath is a large one, with ample flat standing space,

it will be found that a detached shower bath is more comfortable to use. These may be arranged singly or in ranges. Fig. 112 shows a portion of a shower bath range made by John Bolding & Sons, Ltd. When in ranges, the partitions would be formed of marble or slate slabs and a movable curtain provided only across the front. The base should be recessed to prevent water spreading over the floor and also to form a foot bath. The base should be provided with a large size trapped outlet. An effective blending or mixing valve is a necessary adjunct to a shower bath. Separate hot and cold water connections are made to the valve and by means of a regu-



FIG. 112. PORTION OF A SHOWER BATH RANGE

lating handle the water may be delivered cold, tepid, or hot to any desired degree. For efficient working, however, it is necessary that the hot and cold water should be supplied under equal pressure, that is from cisterns at equal heights above the valve. If desired the shower cubicles can also be fitted with tubes on one wall to give a body spray. (For details of plumbing requirements see the section on "Plumbing.")

Chapter VIII—SEWAGE PURIFICATION

NOTWITHSTANDING that a domestic sewage purification plant can practically be bought ready made from a shop, the purification of sewage from a single private house or a small community is one of the most difficult problems of sanitary engineering. The excessive fluctuation in the rate of flow is one disturbing factor. During many periods in the day there will be no flow at all, while at other times the flow may reach a rate approaching 500 times the average flow.

The strength of the sewage, that is the amount of organic matter it contains, will vary within wide limits; at one time a bucket of highly polluted water may be emptied into the drains, while at another time a bathful of almost pure water may be discharged. Extreme variations in temperature are not conducive to facility of purification, and yet at one time a large volume of cold bath water may be sent down, and at another water which is almost boiling may be discharged.

Process of Purification. Sewage purification consists essentially of a process of decomposition, whereby the very complex compound is split up or resolved into its harmless elements. The process is akin to the natural one of decay or decomposition, which affects all organic matter, and is brought about by bacteria or micro-organisms which exist in the organic matter. If any dead body, animal or vegetable, is allowed to remain undisturbed, certain changes take place in it, brought about by organisms, and during these changes some of the matter is converted into gases of various kinds which escape into the air, and ultimately nothing is left but inert humus matter, similar to garden mould, which has no smell and is perfectly harmless. The appliances used in the purification of sewage are designed to assist and expedite these natural changes. There are two main groups of organisms, the *aerobic* ones, which require the presence of air, and the *anaerobic* ones, which thrive in the absence of air.

There are two stages in the purification of sewage. The first is designed to effect the removal of as large a quantity as possible of the solid matter in the sewage, to bring the

remainder to a finely divided condition, and generally to prepare the sewage for the second stage. In the second stage, the liquid, with such small solid matter as it contains, is treated in such a way that the organic matter is completely oxidized and nitrified, and a non-putrescible effluent is produced. The final stage is the important one, and is Nature's process.

The removal of the solid matter is brought about by allowing the sewage to flow slowly through tanks, during which the solids gradually settle down to the bottom. Time and distance of flow are important factors; the longer the tank, within reason, the better the precipitation, but the cross section must be such that the flow is slow. This indicates somewhat a large tank, but that involves the retention of the sewage for a lengthy time. Decomposition starts in the sewage within a few hours, and if the tank is large the decomposition reaches an advanced stage, when it becomes very offensive, and is not so easily treated in the final part of the process.

The modern practice is to get the sewage through the tank before it has time to become septic, and yet sufficiently slowly to secure the deposition of the greater part of the solid matter. Such a tank is known as a *sedimentation* tank.

Septic Tanks. Another type of tank is that known as the *septic* tank. The difference arises in the method of working the tank, and not, to any material extent, in the design. In a septic tank sedimentation takes place, but the deposited sludge is allowed to remain for long periods, and to become almost entirely decomposed. While this process is going on gases are formed, and these buoy up portions of the sludge which are floated up to the surface, carrying up at the same time myriads of bacteria. When the particles reach the surface, the gas is liberated and the heavier matter falls down again, while the lighter particles remain at the top and form a floating scum. Hence, in a septic tank, there is a scum at the top and sludge at the bottom, with the anaerobic bacteria being carried up and down in the central portion, through which flows the sewage passing through the tank. One

effect of the septic tank is to liquefy the solid matter, as salt and sugar go into solution in

a large country house when the "family" is away; and, again, if the tank is to be worked on a non-septic basis, the sludge must be frequently removed, which is not always convenient. The rate of flow through a tank depends upon the relationship between the size of the tank and the daily quantity of sewage to be treated. For instance, if the sewage flow is 300 gals. per day and the tank holds 900 gals., it will theoretically take three days for the incoming sewage to displace the whole contents of the tank, and therefore it may be said that it takes three days for any particular particle of sewage to pass through the tank.

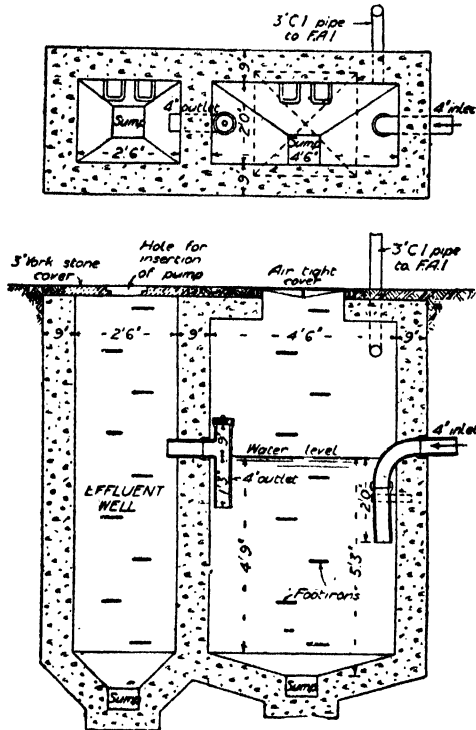

FIG. 113. SEPTIC TANK AND EFFLUENT WELL FOR A SMALL HOUSE

water, and consequently although large quantities of solid matter are continually being introduced into the tank, and but little flows out, the capacity is not reduced by such an accumulation as one would expect. A septic tank can be easily worked for twelve months without any of the sludge being removed, although it is not desirable to leave it so long. For domestic installations a septic tank is generally advisable, because it minimizes the difficulty of handling the sludge. In the case of a sedimentation tank, the sludge must be removed at intervals not exceeding a week if the tank is not to become septic.

Certain tanks are designed and sold as non-septic, but it should be noted that any tank can immediately become a septic tank if the sludge is allowed to remain in it in contact with the sewage, and more particularly if the rate of flow through it is reduced, such as occurs in

a "glorified cesspool," and such a tank is shown in Fig. 113. This illustration shows one of the difficulties that has to be dealt with. The sewage will not flow out of the tank at a higher level than that of the incoming drain, and the liquid has to be disposed of. In this case it is collected in a well from which the effluent can be pumped out and irrigated over garden ground, for which it is very suitable. It may be well to repeat that the tank is only a preparatory stage; the effluent of a septic tank is much more foul and offensive than the crude sewage, and further treatment is absolutely essential if the effluent is to be discharged into any ditch or water-course. The tank must be ventilated to pass off the gases, which besides being offensive are explosive.

Filtration. The second stage, where the aerobic bacteria have full sway, comprises a filter. This consists of a mass of clinker,

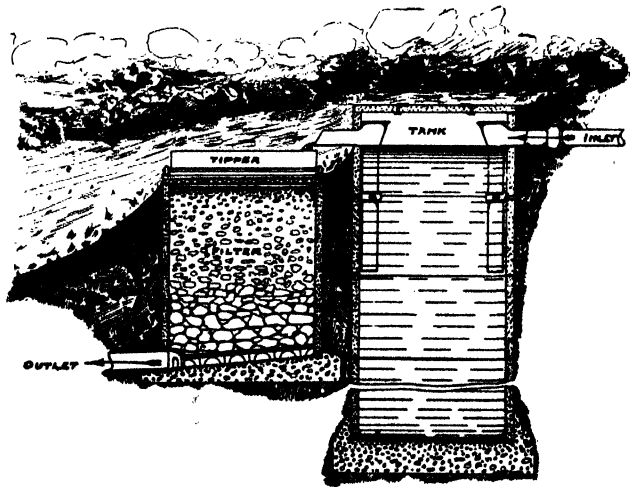

FIG. 114. SMALL SEPTIC TANK AND FILTER

MODERN BUILDING CONSTRUCTION

broken brick, or other similar material broken to a gauge of about $1\frac{1}{2}$ in. The sewage is applied to the top of the filter, and slowly trickles through in a thin film, and comes into intimate contact with the bacteria, which are lodged in the interstices of the material. When it flows out at the bottom all impurities are removed. If there is an excess amount of solid matter in suspension in the tank effluent, the filter will become clogged, which also occurs if the sewage is dumped down in one place instead of being spread evenly over the surface. If, however, the filter is worked properly it will assimilate a reasonable amount of solid matter, and will continue in operation for many years without

at very irregular rates. The filter is circular in shape, and the sewage is distributed over the top of it by means of a rotary water-wheel distributor. This appliance consists of a number of long horizontal troughs, into which the sewage is poured. When the weight of the accumulated sewage is sufficient, the wheel is caused to rotate and the sewage is dejected on to the filter, while the wheel moves forward so that the next discharge of sewage takes place over a different portion of the filter. This continues while the distributor travels round and round the bed. At the bottom of the filter under-drains are laid to facilitate the collection and discharge of the effluent. The final chamber is a humus pit.

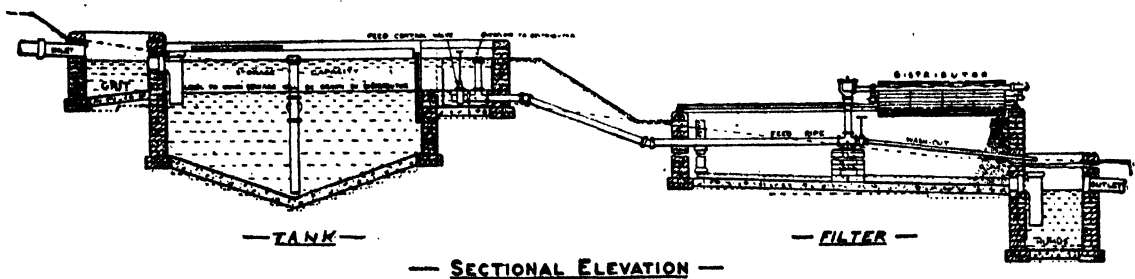

FIG. 115. SEWAGE PURIFICATION INSTALLATION FOR A LARGE INSTITUTION

clogging. Fig. 114 shows a septic tank and filter with a tipping-trough distributor which, when full, cants and discharges the sewage into small troughs covering the surface of the bed. The slope of the ground indicated in this illustration shows the ideal condition for a site for sewage purification works, as the effluent can be run out on to the surface of the ground at a lower level.

Fig. 115 shows an installation for a large institution. The sewage enters a grit tank where heavy mineral matters, such as sand, etc., are deposited. The material settles very quickly, and the tank must be designed of sufficient size to enable it to do so, but not so large that the organic matter in the sewage will settle. The outlet from the septic tank is controlled so that the flow to the filter shall be at a more or less regular rate throughout the day, provision being made to hold up the sewage, which is received

The effluent from the filter contains a certain amount of matter which is washed out from the filter, known as humus, which would be deposited and become unsightly, and possibly a nuisance if the effluent ran straight into a small ditch.

Sub-irrigation. Where the subsoil consists of light soil, sand, or gravel, domestic sewage can frequently be treated by sub-irrigation. It is essential to remove the solid matter by tank treatment first, and then the liquid is discharged by a tipper or a siphon into a network of underground agricultural pipes, laid with open joints, through which the sewage escapes into the adjacent soil. If the soil is light garden mould or similar material in which bacteria occur, certain organic purification will take place, but sand and gravel are sterile, and in such cases only a straining action would take place, and solid matters would accumulate.

Heating

Revised by J. R. KELL, A.M.I.MECH.E., M.I.H.V.E., M.INST.F., M.A.S.H.V.E.

Chapter I—HEAT AND TEMPERATURE

IN considering the fundamental principles which underlie all calculations in connection with heating and ventilation, it is essential that the various terms used should be absolutely clear and understood.

Heat is a form of energy, and as such can be transformed into other forms of energy. Heat is not a substance and cannot be isolated or exist by itself. Heat can, however, pass from

instance, heat will always flow from a body at a higher temperature to one at a lower temperature, irrespective of the quantity of heat contained by that body.

For convenience in comparing temperatures, many scales of temperature have been devised, the two most commonly used being that invented by Fahrenheit (used in England) and that invented by Celsius (used abroad and in all scientific work), called the Centigrade scale (see Fig. 1). In both cases, two fixed points were taken, the lower fixed point and the higher fixed point, and in both cases the higher fixed point chosen was the temperature at which water boiled. This higher fixed point was given the number 100° in the Centigrade scale and the number 212° in the Fahrenheit scale.

Quantity of Heat. The accepted unit of quantity of heat adopted in this country is that quantity of heat required to raise the temperature of 1 lb. of water through 1° F. (from 39° F. to 40° F.). This unit is called the *British Thermal Unit* (B.Th.U.).

The Continental unit of heat is the *calorie*, and represents the quantity of heat required to raise 1 gram of water through 1° C. The large caloric is the quantity of heat required to raise 1 kilogram of water through 1° C.

Specific Heat. The specific heat of a substance is the quantity of heat required to raise unit weight of that substance through unit difference of temperature. In the British scale this means 1 lb. through 1° F. Thus, in the case of water, as will be seen from the definition above, the specific heat is 1.0. Other materials, liquids, and gases have lower specific heats than 1, water being the highest. For specific heats and method of calculation see page 157 (Vol. I).

Mechanical Equivalent. It was stated earlier that heat, being a form of energy, could be transformed into other forms of energy. By experiment it has been found that if 778 ft.-lb. of mechanical work be converted into heat, 1 B.Th.U. will be generated. Similarly, when

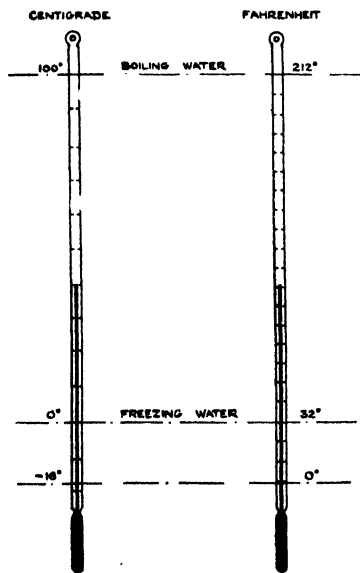

FIG. 1. COMPARATIVE THERMOMETER SCALES

one substance to another, whether solid, liquid, or gaseous, and it is chiefly with this transmission of heat, together with the initial generation of heat, that the heating engineer is concerned.

Temperature is not a measurement of quantity of heat, but is a quality possessed by every substance, and is in direct proportion to the "intensity" of heat contained by that body. Temperature may be defined as that condition of a body which determines the direction of heat transmission to or from the body. For

MODERN BUILDING CONSTRUCTION

electrical energy be converted to heat, the following relation holds good

$$1 \text{ watt} = 3.415 \text{ B.Th.U.s.}$$

Therefore one Board of Trade unit (= 1,000 watts, or one kilowatt maintained for 1 hour) is equivalent to 3,415 B.Th.U.s.

Transmission of Heat. There are three methods by which heat may be transmitted from one substance to another, or a combination of any of these may be responsible. They are *radiation, conduction, and convection.*

RADIATION. Radiant heat travels in straight lines from the warmer body, radiating in all directions until intercepted by some cooler body. It may well be compared to rays of light, obeying the same laws. Radiant heat passes through gases without affecting their temperature or being absorbed; for example, the heat of the sun is transmitted to the earth by means of radiation without directly heating the gases through which it passes. If solids, such as dust or drops of moisture, be present in the gases through which the heat is radiating, they will themselves absorb heat, rise in temperature, and it will appear that the gases have risen in temperature.

CONDUCTION. Conduction is the transmission of heat by direct contact from particle to particle of a substance, producing a temperature rise which gradually spreads throughout the whole substance. Thus, if a rod of iron be held with one end in a fire, the heat will gradually travel along the bar and eventually the whole bar will become hot. Various substances transmit heat by conduction at various rates, assuming other factors to be similar, and are said to have different coefficients of conduction or *conductivities.*

The conductivity of a material is expressed in B.Th.U.s per sq. ft., per ° F. difference of temperature per 1 in. thickness, per hour. Some conductivities of common materials are given in Table I.

TABLE I
CONDUCTIVITIES OF VARIOUS MATERIALS

B.Th.U./sq. ft./hr./1° F. difference/1 in. thickness	
Copper	2670
Iron, cast	480
Steel, mild	325
Limestone	10.6
Concrete	7.3
Glass	7.0
Building brick	5.0
Lime plaster	4.0
Timber	1.0
Water	4.0
Magnesia	0.4
Cork	0.3
Fibre board	0.38

Materials which are poor conductors are

known as insulators, and are used to conserve heat either as linings to buildings or as lagging to pipes, boilers, etc. The last three in the table are in this category.

CONVECTION. Convection is the transmission of heat by the movement or circulation of a fluid over a hot body. The cooler particles of the fluid become heated by direct contact with the hot body and, passing on, impart their heat to other cooler bodies, usually the other particles of the same fluid with which they come in contact. The air of a room, for instance, becomes heated by circulating over a radiator on the floor, the air in contact with the radiator becoming warmed up. Such air currents are called *convection currents.*

EXPANSION. Most materials expand on increase of temperature. The proportion of its original length which it increases for a unit rise of temperature is termed the coefficient of linear expansion. In British practice this means the increase in length for 1° F. (See Table IX, p. 154, for coefficients of linear expansion of common materials.)

Expansion must be allowed for in the layout and fixing of pipes used for conveying steam or hot water by allowing freedom for movement in order to avoid damage.

PROPERTIES OF WATER AND STEAM

When the water is heated from 32° F. (freezing point) to 212° F. (boiling point), 180 B.Th.U.s have to be added per pound. If heat continues to be supplied and the water is open to atmosphere the temperature will not rise but the water will boil, emitting steam. For each pound of water converted into steam 970.6 B.Th.U.s require to be added. Because this heat is not noticeable by rise of temperature it is termed *latent* or hidden, as distinct from the heat to raise the water to boiling point, termed *Sensible Heat.* The more complete description is the *Latent Heat of Evaporation.*

If, on the other hand, the water is in a vessel not open to atmosphere, as heat is added after 212° F. is reached, the steam generated will cause a rise of pressure in the steam and water. This has the effect of raising the boiling point, for example at 50 lb. per sq. in. above atmospheric the temperature will be 300° F. The sensible heat will obviously have risen and the latent heat will be slightly reduced, but the *Total Heat* (sensible plus latent heat) will be higher than at 212° F. For full information on this important subject, tables giving the

Properties of Saturated Steam should be consulted.

It should be noted that when steam is condensed back into water the latent heat is given up, and it is this characteristic of steam which makes it such a valuable heating medium, as roughly 1000 B.Th.U.s are conveyed for each pound weight.

Another similar but reversed phenomenon occurs when water at 32° F. is cooled. In this case ice is formed and heat has to be removed at the rate of 144 B.Th.U.s per pound for each pound of water at 32°, converted into ice at the same temperature. When the ice is melted this heat requires to be added. In either case the heat is latent and is termed the *Latent Heat of Fusion*.

TEMPERATURES IN BUILDINGS

Certain internal temperatures have become accepted as representing the required standard of comfort in this country, and are given in Table II. These internal temperatures are to be

TABLE II
STANDARD INTERNAL TEMPERATURES

Bedrooms	52-55° F.
Living rooms	65° F.
Churches	55-60° F.
Conservatories	60-70° F.
Factories (heavy)	55° F.
" (sedentary)	60-65° F.
Garages	42° F.
Gymnasium	50° F.
Hospital wards	60° F.
Operating theatres	70-80° F.
Museums	55° F.
Offices	60-65° F.
Restaurants	65° F.
Schoolrooms	55-60° F.
Theatres	60° F.

maintained under certain specified conditions, and an outside temperature of 32° F. is usually specified, as it is on only a few days in the year that lower temperatures are recorded for any length of time. It is obvious that to maintain an internal temperature of, say, 60° F. with an outside temperature of 0° F. would require more heat, than to maintain this internal temperature when the outside temperature had risen to, say, 32° F. In special cases, such certain types of factory, where it is essential to the process to maintain a certain temperature for 24 hours per day throughout the year, a lower external temperature may be specified as a safeguard against a possible stoppage of work through too

low a temperature occurring even for a short period.

Heat Losses. It is necessary to calculate the amount of heat to be supplied to any building in question, in order to maintain the required internal temperature.

It will at once be apparent that having once reached the required temperature, it is necessary to supply as much heat, and as much heat only, as escapes or is lost from the building.

There are two methods by which heat is lost—

(a) By transmission through the walls, windows, ceilings, floors, and doors.

(b) By being carried away in the form of warm air due to the air interchange of the room. This may be unintentional and may occur through the doors being frequently opened, or may be intentional and caused by the occupants desiring a supply of fresh air for ventilation purposes and leaving a window open.

In either case, cold fresh air will be introduced into the room to take the place of the escaped warm air, and this fresh air must in turn be warmed up to the temperature of the room.

The American practice is to calculate the amount of air leakage through crevices in the window frames and doors, but in this country, where the weather conditions are not so extreme, it has been found satisfactory to estimate the number of air changes occurring, according to the type, position, exposure, and use of the room.

HEAT LOSSES THROUGH MATERIALS. Many investigations have been carried out both in this country and abroad to determine the heat loss through various building substances, and average values are tabulated in Table III. (See page 1068.)

The coefficient is expressed in B.Th.U.s per hour per square foot of surface per degree difference in temperature between inside and outside air, and represents the average total heat loss due to a combination of conduction and convection.

WARM AIR EXTRACTED. The amount of warm air extracted from a building depends upon many factors, such as the construction of the building, whether the windows and doors are tight fitting, whether it is exposed to high winds, and so on. For all ordinary purposes in which no forced ventilation is used, the figures given in Table IV have been found satisfactory.

MODERN BUILDING CONSTRUCTION

TABLE III

HEAT LOSS COEFFICIENTS FOR VARIOUS BUILDING MATERIALS

B.Th.U.s per square foot surface per hour per 1° F. temperature difference

WALLS	Thickness of Walls				
	4½"	9"	13½"	18"	22½"
Brickwork—					
unplastered59	.39	.29	.23	.20
plastered53	.36	.27	.22	.19
with 2" cavity		11"	15½"	20"	
unvented plastered27	.22	.18	
		4"	6"	8"	
Concrete—					
unplastered75	.61	.52	
plastered65	.55	.47	
lined ½" fibre board26	.24	.23	
		12"	18"	24"	
Limestone, plastered					
inside50	.40	.33	
4 in. Hollow tile, plastered inside50	
4 in. Glass block wall, hollow44	
Corrugated iron				1.5	
" asbestos cement				1.4	
" iron or asbestos, lined ½ in. fibre board31	
DOORS		½ in. thick	1 in. thick		
		.40	.50		
WINDOWS					
Single				1.0	
Double50	
FLOORS (earth assumed at 50° F., room at 60°. The following coefficients are adjusted so that they may be multiplied by full temperature difference, e.g. 30° to 60° = 30°).					
Soil floor20	
Concrete, bare, or hard finish13	
" with wood blocks or boards10	
Boards on joists, cavity under32	
ROOFS AND CEILINGS					
		Thickness			
		4 in.	6 in.	8 in.	
Concrete, asphalt over, plastered under58	.50	.44	
Hollow tile, asphalt over, plastered under44	
Tile or slate, unlined				1.5	
" lined boards, with plaster ceiling under32	
Corrugated iron, unlined				1.8	
" asbestos cement, unlined				1.6	
" iron or asbestos, lined ½ in. fibre board35	
Roof light, single				1.1	
" with lay light under55	

TABLE IV

AIR INTERCHANGES PER HOUR

Bedrooms	1
Living rooms	1-1.5
Offices	1.5-2
Entrance halls, corridors	3
Lavatories	2
Assembly halls	1.5-3
School classrooms	3-4
Hospital wards	3
" operating theatres	4
Factories, shed type	1-1.5
" densely occupied	4-6
Store rooms, warehouses	½-1

Note. 1. Above assume natural ventilation only.
2. Heat required for airchange = 0.019 B.Th.U.s per cubic foot for one airchange per hour.

They indicate the number of times per hour that the total cubic contents of the room may be assumed to be changed per hour.

In special cases, such as schoolrooms, assembly halls, theatres, etc., it is necessary to base the air interchange on the ventilation requirements, and to ensure that this air interchange be maintained. This question is, however, dealt with more fully in considering ventilation.

HEAT GENERATED BY PEOPLE, MACHINERY, ETC. In cases where rooms become crowded, it is found that the temperature rises, owing to the heat developed and given off by the people present, and it is sometimes necessary to take account of this heat. The same applies to factories where heat is generated by the machinery, and Table V gives the average amount of heat developed in various cases.

TABLE V

HEAT GENERATED BY VARIOUS SOURCES

An adult resting	300 B.Th.U.s per hour
An adult working	500 B.Th.U.s per hour
Gas lights	500 B.Th.U.s per cub. ft. of gas consumed
Machinery	2,545 B.Th.U.s per hour per b.h.p. actually absorbed in that room
Electric light and power	3,415 B.Th.U.s per hour per kilowatt expended in the room

TYPICAL HEAT LOSS CALCULATION

The simplest way of setting out and tabulating the heat loss calculations is as follows. Referring to Fig. 2, plan of a room, it is required to maintain an internal temperature of 60° F. when 32° F. outside, allowing an air interchange of twice per hour. In this calculation, it will be seen that the heat loss due to air interchange for 1° F. (which is .019 B.Th.U. per cubic foot, as given in Table IV) is first obtained; then

the loss for 1° F. due to conduction through walls; the sum is then multiplied by the temperature difference, 28° F.; and, finally, the heat loss through the inner wall is added.

	Heat Loss per 1° F. Temp. Difference
CUBE— 16' × 12' × 12' = 4,334 cub. ft. × 2 changes × 0.09 coefficient	165
WINDOWS— 4' × 6' = 24 sq. ft. 2' × 3½' × 6' = 42 sq. ft. 66 sq. ft. × 1 (coeff.)	66
WALLS— (N.) 4' × 12' = 48 sq. ft. (E.) 12' × 12' = 144 sq. ft. (S.) 16' × 12' = 192 sq. ft. 384 sq. ft. Less windows = 66 sq. ft. 318 sq. ft. × 0.25 (coeff.)	80
FLOOR— 16' × 12' = 192 sq. ft. × 0.1 (coeff.)	19
Total Temperature difference (60 - 32)	330 28
	9,240
INNER WALL (N.)— 12' × 12' = 144 sq. ft. × 0.5 (coeff.) Temperature difference (60 - 50)	72 10
	720
TOTAL HEAT LOSS	9,960 B.Th.U.s per hr.

It will thus be seen that approximately 10,000 B.Th.U.s will have to be supplied to this room each hour, to maintain the required

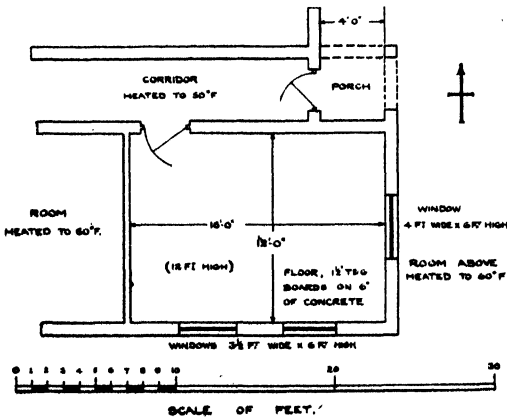

FIG. 2. PLAN OF ROOM

temperature under the conditions stated, regardless of the form in which the heat be supplied. It will be seen that this figure of 10,000

B.Th.U.s is only the heat loss of this room when the outside temperature is 32° F.

For instance, with an outside temperature of 50° F., it will only be necessary to supply—

$$330 \times (60 - 50) = 3,300$$

plus inside wall 720 = 4,020 B.Th.U.s per hour.

ALLOWANCE FOR EXPOSURE AND HEIGHT. Where a building is unusually exposed it is necessary to add an allowance to the heat losses so as to ensure the specified temperature being obtained.

Similarly, rooms facing N. or N.E. should have some addition as they will tend to be colder than rooms with other aspects.

The allowance usually made is 10 to 15 per cent of the total wall and window transmission.

In the case of high rooms an addition has to be made so that the temperature in the lower part of the room may be that required. Most types of heating system produce a higher temperature near the ceiling than near the floor, and though the average may be correct, the level at which it occurs may be above the 5 or 6 ft. of occupied space. The allowance for height is usually taken as follows—

13 to 17 ft.,	add 5%	to total B.Th.U.s required
17 to 22 ft.,	" 10%	" " "
23 to 27 ft.,	" 15%	" " "
27 to 32 ft.,	" 20%	" " "
32 to 37 ft.,	" 25%	" " "
over 37 ft.,	" 30%	" " "

INSULATION OF BUILDINGS. The cost of a heating system for any building, and the running cost of the installation when completed, is dependent on the heat losses. In order to effect maximum economy it is therefore necessary to reduce the heat losses to a minimum. This can best be done in the design of the building by using materials of low heat loss, e.g. brick in preference to concrete, or by insulation. There are many materials now available for insulation and fullest use should be made of them. A glance at Table III will show the great reduction in the coefficients brought about by lining, for example with fibre board. In the case of concrete the coefficient is reduced to about half, and in the case of corrugated iron to about one-fifth. The importance of insulation will thus be obvious.

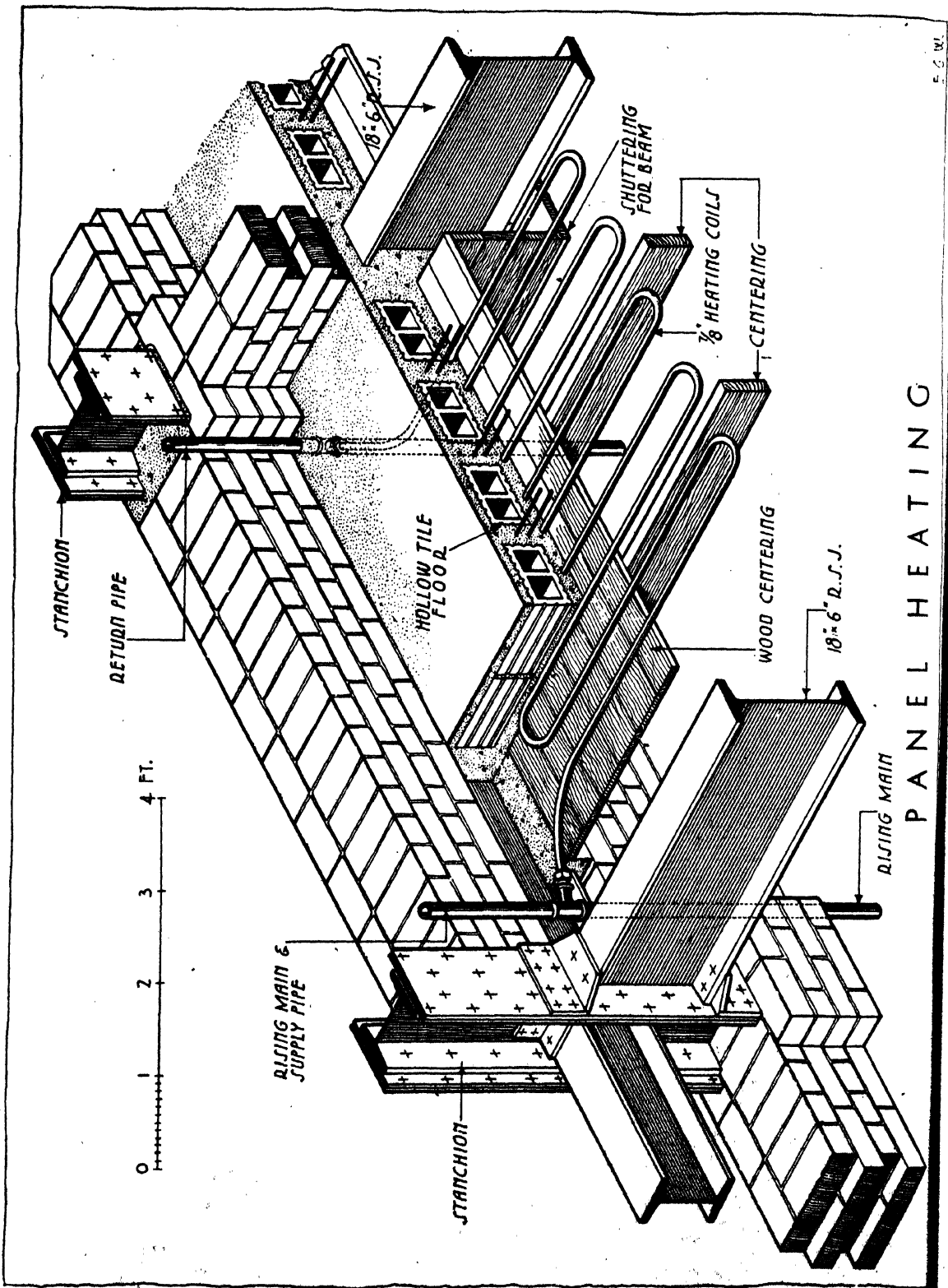

0
1
2
3
4 FT.

PANEL HEATING

Chapter II—DIFFERENT METHODS OF HEATING

VARIOUS methods of heating have been evolved and are in use at the present day, and a knowledge of the characteristics and relative costs is necessary in making a selection of the most suitable type for any particular building.

There are two main divisions of heating systems: *DIRECT* and *INDIRECT*.

Direct systems are those in which the fuel is consumed in the room to be heated.

Indirect systems are those in which the fuel is consumed outside the room, the heat being conveyed to the room by a medium such as steam or hot water.

There are many other forms of Direct Heating, such as gas and electric overhead radiant heaters, in which a metallic plate is heated to a high temperature so as to emit strong heat radiation; and gas and electric unit heaters in which air is delivered to the room by a fan and is warmed in its passage through the unit by heated elements. There are also low-temperature gas and electric radiant panels for fixing to walls, ceilings, etc., also electric tubular heaters for fixing near skirting level (see Fig. 3*b*). These systems are generally more expensive in first cost than those enumerated above.

DIRECT SYSTEMS

Direct systems are chiefly used for intermittent heating, or for heating isolated rooms. They may be summarized thus—

INDIRECT SYSTEMS

Indirect systems are chiefly used for the continuous heating of a number of rooms or large buildings from one central source, hence the name Central Heating. This does not

System	Advantages	Disadvantages	Efficiency
Open fires, burning coal or coke	Comfortable appearance in living rooms. Largely radiant heat, ventilation effect strong. Cheap in first cost.	Require flues. Coal and ashes to be carried about, causing dust and dirt. Heat localized. Unsatisfactory in large rooms.	About 25%
Slow combustion stoves, burning coke or anthracite	Steady warmth, partly radiant, but chiefly convected. Suitable for hutments and temporary buildings. Cheap to install.	Fumes sometimes given off. Coke and ashes to be carried about. Considerable labour involved for a large number.	About 50%
Gas fires	Easily lit, quick response, heat largely radiant, ventilation effect.	Small flue necessary. Intense radiation drying to skin.	About 50%
Gas convectors (see Fig. 3 <i>A</i>)	Useful for background warming and for halls, small shops, etc. No flue needed provided room is ventilated.	Fumes deleterious if installed in small rooms.	100%
Electric fires	Immediate response. Portable. Require no flue. No fumes. Heat chiefly radiant.	Ventilation not provided. Not suitable for large spaces.	100%
Electric convectors	Most suitable for heating large spaces where central system not possible. Automatic temperature control easily applied.	No disadvantages where this system is suitable. Installation cost comparable with central system.	100%

MODERN BUILDING CONSTRUCTION

necessarily imply that the heating source is strictly central, indeed it may be at a considerable distance from the building.

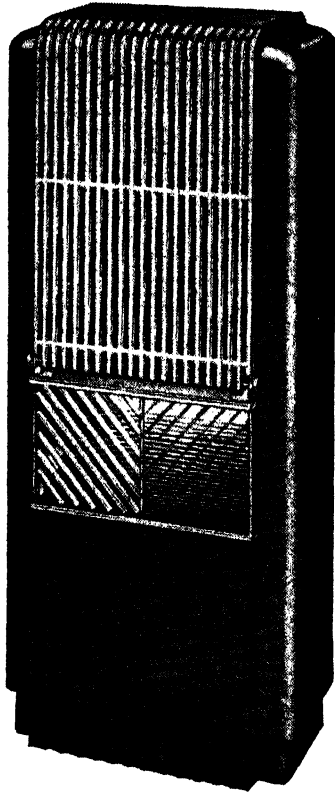

FIG. 3A. "LUMA" GAS CONVECTOR

This class of system finds its greatest application in large buildings of all types.

The advantages of the Indirect System are—

- (a) Fuel and ashes are kept outside the occupied spaces.
- (b) Individual flues are not required.
- (c) Cleanliness.
- (d) Equable temperature maintained in all parts, easily controlled automatically.

The disadvantages are—

- (a) Heat is lost from main piping where this is outside the occupied rooms. This loss can be minimized by proper insulation of the pipes.
- (b) Labour is required for stoking and removal of ashes. This applies only with solid fuel and can be greatly reduced with automatic firing.

The medium employed for the transmission of heat is either steam, hot water, or heated air.

Steam. In this system steam is generated in a boiler partly filled with water, and the steam is conveyed through pipes to radiators, unit heaters, etc., in the rooms to be heated. The steam is therein condensed into water which is preferably returned to the boiler through a system of return piping.

The advantages of steam are—low heat capacity, hence quick heating up and cooling

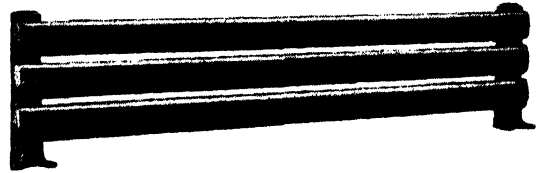

FIG. 3B. THREE-TIER "MAXHEAT" OVAL TUBULAR ELECTRIC HEATER

down; low cost due to high temperature of heating surfaces.

The disadvantages are the burning effect on dust particles in the air due to the excessively hot surfaces, and the lack of regulation. To overcome the latter the Vacuum System has been developed which permits of temperatures

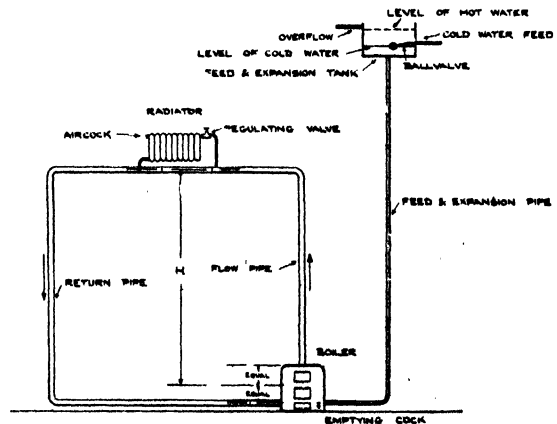

FIG. 4

in the radiators being maintained below the boiling point of water.

The lack of regulation referred to means wastage of heat in mild weather, hence higher fuel consumption and running cost than with a carefully controlled hot water system.

Hot Water. In this case the system, comprising boiler, pipes and radiators, is completely filled with water and is open to atmosphere by

connection to a tank at high level through which the water enters. A simple arrangement is shown in Fig. 4. When a fire is lit in the boiler the water circulates by thermo-syphon effect, or, in a large system, is circulated by pump. The heated water is conveyed through the flow pipes to the radiators or other heat emitting surface which become heated to the same temperature as the water. The water thereby becomes cooled and is returned to the boiler to be re-heated.

The flow water temperature is usually limited to about 180° F. and the return may be 20 to 40° lower. In mild weather lower temperatures are maintained; for instance, at 50° F. outside the flow temperature will generally be about 120° F.

The advantages of hot water are—complete flexibility of temperature to suit weather, hence maximum economy in fuel consumption; and relatively low temperature of heating surfaces giving a uniform and equable temperature in the heated spaces. It is these characteristics which make hot water the most suitable system for heating systems in this country. It is also simple to instal and maintain, but its success depends on correct design and proportioning.

Another system using hot water as the medium is the high pressure system using water under pressure above boiling point. This is extensively used for large factories but will not be referred to in detail here.

Heated Air. This medium is used in various forms. One is the "Pipeless Heater" type. In this a furnace in the basement is contained in a steel casing connected by ducting to the rooms to be heated. The warmed air circulates through the rooms and returns to the basement via a return duct. It is usually a cheap system to install but suffers from the disadvantage of the burning of dust particles common to all systems with high temperature surfaces. It is inapplicable to large buildings.

Efficiency of Steam and Hot Water Systems. The efficiency depends on efficiency of boilers and losses from mains. Boiler efficiencies depend on type, method of firing, and other factors, and vary between 50 and 75 per cent, for solid and liquid fuels. Gas fired boilers have an efficiency of about 80 per cent, and electrically heated boilers 100 per cent, less radiation losses, giving a net figure of 95 to 98 per cent. Losses from mains may be nil where all the pipes are inside the building or rooms heated,

or may be as much as 25 per cent in long exposed systems. They require to be calculated for each case.

CHOICE OF FUEL. The choice of fuel depends on cost, cleanliness and convenience. The fuels which need be considered are coal, coke, oil, gas, electricity. The cost of each can be estimated if the prices per ton or unit are known, also the heating value. If the efficiency of use is taken at 100 per cent, the costs per therm of 100,000 B.Th.U.s is as follows—

	Heating Value (B.Th.U.s)	Pence
Electricity at ½d. per unit	3,415	14·6
" " ¼d. per unit	3,415	7·3
Gas at 8d. per therm	100,000	8·0
Fuel oil at 100s. per ton	18,000 (per lb.)	3·0
Coal or coke at 60s. per ton	12,000 (per lb.)	2·7
" " " 40s. per ton	12,000 (per lb.)	1·8

The use of this table may be seen from an example: Taking a hot water system to give 500,000 B.Th.U.s per hour and an overall efficiency (boiler efficiency less mains losses) of 40 per cent.

$$\text{No. of therms per hour required} = \frac{500,000}{40} = 12,500$$

$$\text{The cost with coke firing at 60s. per ton will be } 2\cdot7\text{d.} \times 12\cdot5 = 33\cdot7\text{d. per hr.}$$

This may be compared with, say, electricity used in a direct system at 100 per cent efficiency at ½d. a unit.

$$14\cdot6 \times 5 \text{ therms per hr.} = 73\text{d.}$$

An allowance should be made in the case of electricity for accuracy of automatic control and absence of night banking losses, say, 25% = 18d. = 55d. per hr.

It will be seen that in this case electricity would be roughly 50 per cent more expensive.

The same comparison could be made for gas or other fuels.

Each case requires to be considered on its merits as it is dangerous to generalize.

The other considerations affecting choice of fuel already referred to are convenience and cleanliness. The highest in this regard are electricity and gas, next comes oil, and lowest come coal and coke. When any comparison is made due allowance should be made for cost of labour and value of space occupied by boiler house, fuel store, etc.

When all allowances are made it will generally be found that the solid fuels are still cheapest, but many cases occur where convenience and cleanliness outweigh monetary savings.

Chapter III—LAY-OUTS OF HOT-WATER SYSTEMS

As explained, hot water is by far the most commonly adopted heating medium in this country, and for this reason will be considered in further detail.

The lay-outs of systems in common use are as follows—

One-pipe Ring-main System. This is probably the earliest and most common lay-out, and is shown in Fig. 5. It consists of a large size main pipe running from the flow tapping of the boiler round the building, and back to the return tapping of the boiler. Connections are then taken from this ring main to each radiator. It will be obvious that the ring main has to be of sufficient size to carry the complete circulation of the system, and also that, as the water will be cooled off by the first radiators, those at the far end of the ring main will not have the same rate of emission of heat, as they will be fed with cooler water.

The circulation in the radiator branches is entirely independent of the circulation in the ring main, being due simply to the difference in height of the flow and return connections from the main pipe to the radiator. It may be emphasized that radiators having top flow connections give about 12 per cent greater emission per square foot of surface than those having bottom flow connections.

The one-pipe ring-main system, whilst perhaps being suitable for small private house work, or where a cheap job is required, is not suited for medium and large-sized schemes. For this class of work, either the two-pipe underfeed, or one- or two-pipe overhead drop systems, should be used.

The one-pipe system with pump circulation is, however, often suitable for long single storey buildings such as schools.

Two-pipe Underfeed System. In this system, a flow main and return main are taken from the boiler and, generally, run side by side right

round the building; flow and return connections to the radiators are then taken off the mains. This system has the advantage that the pipes can be made smaller in diameter, as connections are taken off; the return water from the radiators passes straight to the return main, and therefore does not have the cooling effect on the flow water which is the inherent disadvantage of the one-pipe ring-main system.

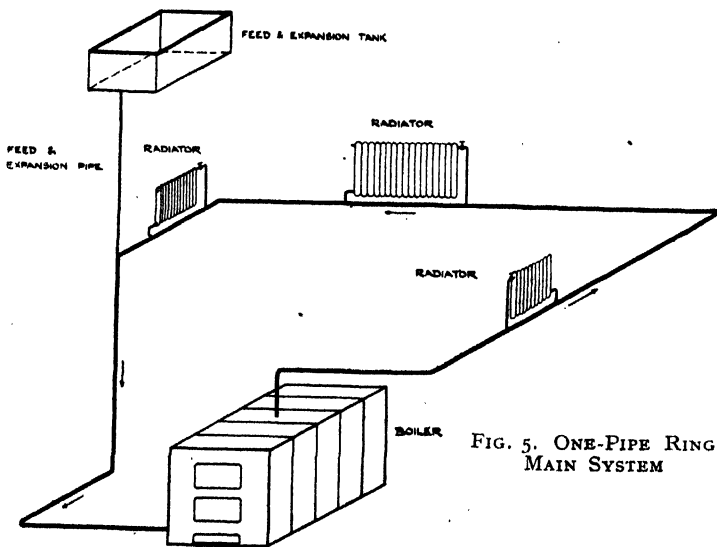

FIG. 5. ONE-PIPE RING MAIN SYSTEM

Fig. 6 shows a typical lay-out of a two-pipe underfeed system.

Overhead Drop Systems. This system, especially known as the *two-pipe overhead drop*, has found considerable favour of late years on account of its very positive action. A rising main is taken from the boiler flow connection direct to the top floor ceiling level, or roof space, of the building. This riser then splits, and is carried as a horizontal main wherever required; at the necessary points drop pipes are taken from the horizontal main (running at ceiling level or concealed in the roof space). These drop pipes, or return risers, then carry right down the building, feeding off radiators on their descent. They are then coupled into a single return main in

the basement or ground floor, which runs back to the boiler.

In the *one-pipe overhead drop system*, the return risers are of uniform diameter throughout, as the drop pipe is used both as a flow pipe to the radiators, and also as the return pipe from the radiators.

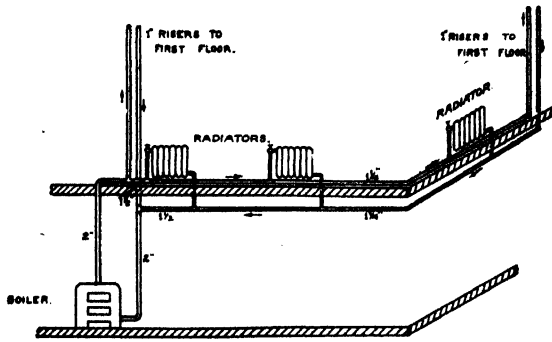

FIG. 6. TWO-PIPE UNDERFEED SYSTEM

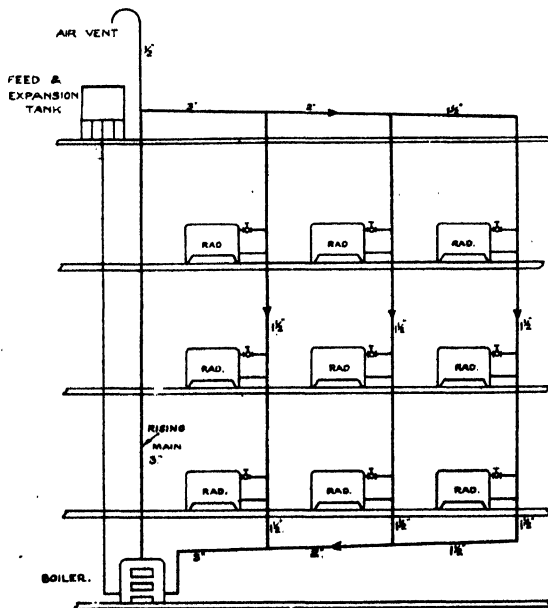

FIG. 7. ONE-PIPE OVERHEAD DROP SYSTEM

In the two-pipe overhead drop system, where the return riser leaves its horizontal supply, it is, of course, of full diameter to pass all the water required by its complement of radiators; after having served any one of these, however, its diameter is reduced, and the return water carried away by a separate pipe (see Figs. 7 and 7A).

The overhead drop systems are eminently adapted to the heating of large blocks of offices having several floors, and are especially convenient when the radiators can be located one underneath the other on the respective floors. The "two pipe" is well worth the additional cost of installation over the one-pipe drop

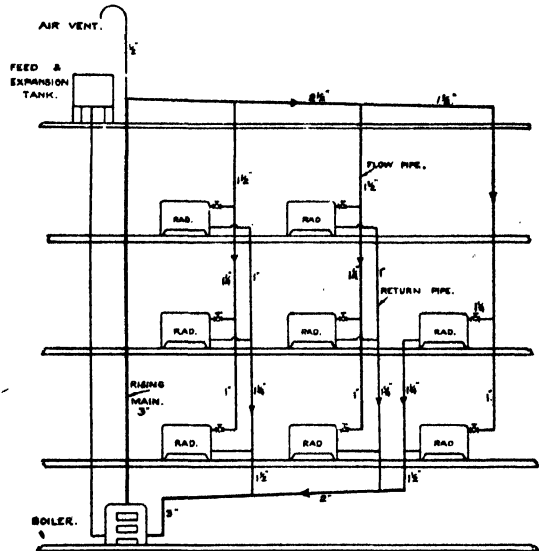

FIG. 7A. TWO-PIPE OVERHEAD DROP SYSTEM

system. The same remarks apply to drop systems as for the one-pipe ring main and two-pipe underfeed systems.

RELATIVE MERITS. The above four systems represent conventional designs of gravity circulating hot-water heating apparatus, but it is often advantageous to design a system which embodies two or more of the above principles, especially in buildings that present awkward features, and also where there is an objection to having pipes exposed in certain rooms or offices devoted to special purposes, such as drawing rooms in private houses, and board rooms in offices.

The following remarks may be taken as a guide for deciding what type of system to adopt: Generally, the overhead drop systems are more positive, and are easier to vent; in fact, if care is taken in connecting the radiator branches into the return risers, so that air may readily escape up the pipe into the overhead main, thence through the air pipe at the highest point, no air cocks are required on a drop system.

MODERN BUILDING CONSTRUCTION

Where top floor ceiling level or roof space is available, this should decide the adoption of

This means that heat can be raised quickly, and at the same time evenly distributed throughout the system. There is a tendency nowadays to fit pumps even to the smaller systems, and large installations are all so equipped. In the former, the pipes are often sized for gravity circulation and the pump is then of low head (3 to 5 ft.) so that it may be shut off at night, thus allowing the circulation to operate by gravity. In large systems the pump is generally installed in duplicate, of higher head (10 to 20 ft. or more) and gravity effect is ignored.

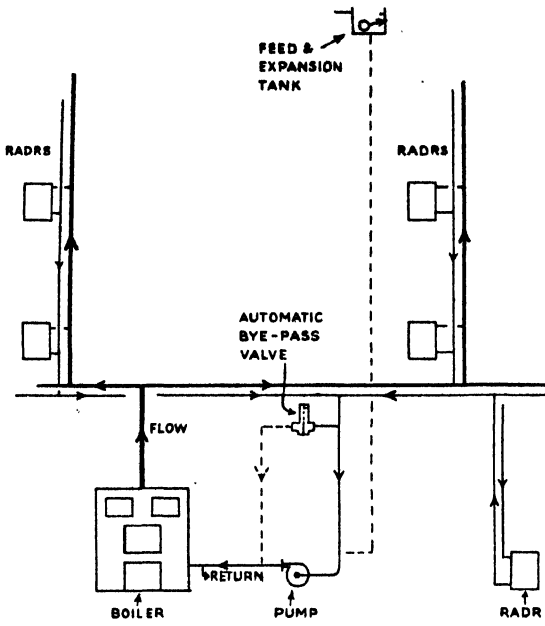

FIG. 8. PUMP CIRCULATION SHOWING PUMP IN RETURN

the overhead system. On the other hand, if overhead space is limited, and there is room at basement ceiling for flow and return mains, then the underfeed system is more suitable.

Accelerated Systems. There have been used in the past, various self-accelerating systems depending on the injection of steam or other device. These have now gone out of favour, largely due to the widespread availability of electric current which permits the use of an electrically-driven pump.

The pump creates a mechanical head to overcome the frictional resistance of the piping system, so that the pipes may be considerably reduced in size, thus reducing first cost and losses from mains. They may furthermore be run without restriction as to levels, dipping into trenches or serving radiators below the boiler in a way not possible with gravity circulation.

Circulation by pump is positive and independent of boiler temperature.

The pump is usually fixed in the return mains to the boiler, as in Fig. 8, but may be alternatively in the flow in certain cases. It is usual to fit an automatic bypass or non-return valve between suction and delivery to allow of gravity circulation when the pump is shut down, or on accidental current failure. There are, however, now available several types of fullway pumps which require no such bypass; one of this type is shown in Figs. 9 and 9A.

Pumps are best applied to the two-pipe type of system, but may equally be used with a single pipe as mentioned earlier. In the latter case it must be remembered that the pump

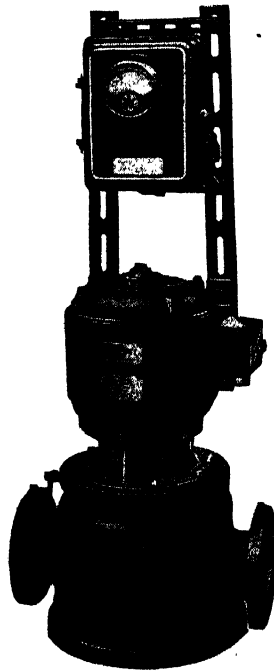

Rhodes, Bryden & Youatt.
FIG. 9. ELECTRICALLY-DRIVEN VERTICAL SPINDLE FULLWAY PUMP

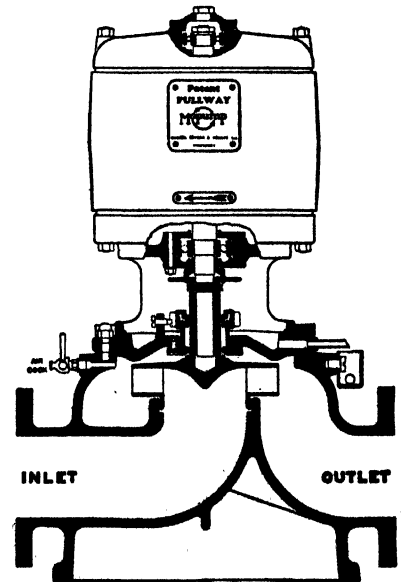

Rhodes, Bryden & Youatt.
FIG. 9A. SECTION THROUGH FULLWAY PUMP

does not assist the circulation through the radiators served off the pipe, and the connections thus require to be sized for gravity circulation.

Gravity Circulation. A gravity hot-water system may be represented diagrammatically by a U-tube, the two vertical branches being connected at the top as in Fig. 10.

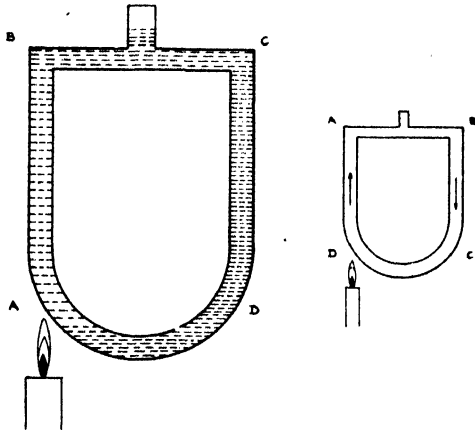

FIG. 10

Heat being applied under one branch of this U-tube will heat the water, which will expand, and the density of this column of water will be reduced. The column of hot water *AB* will thus weigh less than the column of cold water *CD*, and the state of equilibrium of the system will become upset. The column of cold water will thus force the hot water round until a state of equilibrium is maintained, when the cold water at *D* will come in contact with the supply of heat and get warmed up, while the hot water at *B* will cool down.

A circulation is thus maintained by the difference in weights of the two columns of water, and it will be obvious that this difference in weights will depend upon two factors, namely, the difference in temperatures of the two columns and the height of the two columns.

Table VI gives the weight of 1 cub. ft. of water at various temperatures.

FLOW-MAIN AND RETURN-MAIN TEMPERATURES. Standard practice is to adopt a flow temperature (that is, temperature of water leaving boiler) of about 180° F., and a return temperature of from 130° F. to 150° F. These figures have been adopted as the result of experience. In large systems, the flow temperature may be increased to 190° F., and a temperature difference of 50° F. may be used; but in very small systems, such as

a small boiler working, say, two radiators in a private house, where the stoking is done by the maid, and the boiler will probably not receive sufficient attention, it is safer to calculate on a

TABLE VI
WEIGHT OF 1 CUB. FT. OF WATER AT VARIOUS TEMPERATURES

Temp. ° F.	Weight lb.	Temp. ° F.	Weight lb.	Temp. ° F.	Weight lb.
40	62.425	136	61.462	175	60.673
45	62.422	137	61.444	176	60.652
50	62.409	138	61.426	177	60.630
55	62.394	139	61.407	178	60.606
60	62.372	140	61.388	179	60.583
65	62.344	141	61.370	180	60.560
70	62.313	142	61.351	181	60.545
75	62.275	143	61.331	182	60.511
80	62.232	144	61.312	183	60.487
85	62.182	145	61.291	184	60.464
90	62.133	146	61.274	185	60.441
95	62.084	147	61.254	186	60.416
100	62.031	148	61.237	187	60.393
110	61.890	149	61.218	188	60.370
111	61.874	150	61.201	189	60.347
112	61.860	151	61.180	190	60.324
113	61.844	152	61.159	191	60.300
114	61.829	153	61.138	192	60.276
115	61.813	154	61.118	193	60.251
116	61.798	155	61.097	194	60.228
117	61.781	156	61.077	195	60.203
118	61.766	157	61.057	196	60.180
119	61.750	158	61.038	197	60.154
120	61.734	159	61.081	198	60.130
121	61.717	160	60.998	199	60.105
122	61.701	161	60.978	200	60.081
123	61.685	162	60.955	201	60.055
124	61.670	163	60.935	202	60.030
125	61.655	164	60.914	203	60.003
126	61.639	165	60.893	204	59.978
127	61.622	166	60.871	205	59.950
128	61.605	167	60.850	206	59.925
129	61.588	168	60.827	207	59.900
130	61.571	169	60.805	208	59.873
131	61.552	170	60.783	209	59.847
132	61.535	171	60.762	210	59.820
133	61.517	172	60.741	211	59.792
134	61.499	173	60.720	212	59.769
135	61.481	174	60.698		

flow temperature of 150° F. or 160° F., and a return temperature of 120° F. or 130° F.

CIRCULATING PRESSURE. Assuming that a flow temperature of 180° F. and a return temperature of 140° F. be adopted, the weights of each cubic foot of water in the flow and return columns will be 60.560 lb. and 61.388 lb. respectively; the difference will represent the force tending to cause the circulation of water, namely, 0.828 lb.

MODERN BUILDING CONSTRUCTION

As this is not the most convenient form to use for circulating pressure, a unit of pressure of "inches of water column" has been adopted. This represents the "head," or pressure, of a column of water 1 in. high.

At the mean temperature of

$$\frac{180 + 140}{2} = 160^\circ \text{ F.},$$

a cubic foot of water weighs 60.998 lb. Imagine this as a cube with sides 1 ft. long. Then the pressure exerted by this water on the base will be 60.998 lb., and the pressure of a column of water only 1 in. high would be

$$\frac{60.998}{12} = 5.083 \text{ lb.}$$

Therefore a pressure of 0.828 lb., as before would be equivalent to $\frac{0.828}{5.083} = 0.163$ in. water column.

The circulating pressures of the most common flow and return temperatures used have been calculated in similar fashion, and are given in Table VII.

TABLE VII
CIRCULATING PRESSURES

Flow Temp. ° F.	Return Temp. ° F.	Temp. Difference ° F.	Circulating Pressure in Inches Water Column per Foot Head
175	145	30	0.121
180	140	40	0.163
185	135	50	0.204
190	130	60	0.245

As the circulating pressure is dependent on the height of the two columns of water, the total circulating pressure of the system is

$$C.P. = c.p. \times H$$

where *C.P.* = total circulating pressure of system in inches water column ;

c.p. = circulating pressure per foot head ;

H. = height in feet of column of water, or the head of the system.

For example, calculate the total circulating pressure of a heating system, as shown in Fig. 11, the flow temperature to be 175° and the temperature drop in the system 30° F., the height from the boiler to the top circulation being 10 ft.

From Table VII the *c.p.* is 0.121 in. The total circulating pressure is thus 0.121 in. $\times 10 = 1.21$ in. It should be observed that with a temperature drop of 30° F., each pound of water passing round the system will emit 30 B.Th.U.s. The quantity of water that this pressure will cause to flow will depend upon the resistance against flow of water due to

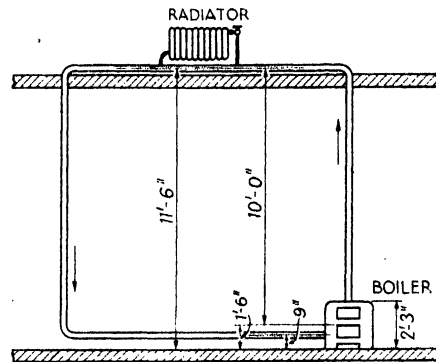

FIG. 11. DIAGRAM ILLUSTRATING CIRCULATING PRESSURE CALCULATION

the friction of the pipe and the various fittings through which the water must pass, so that the deciding factor becomes the circulating pressure per linear foot of pipe. Thus, by dividing the total circulating pressure by the total linear feet of pipe (travel), due allowance

being made for elbows, the factor $\frac{C.P.}{\text{travel}}$ may be determined.

In determining the "travel," the allowance to be made for tees, elbows, and bends may be taken as adding 3 ft. to the travel for every inch diameter of the fitting. This is approximately true for gravity circulation. Thus, for a 2 in. elbow, an allowance of 6 ft. of pipe should be made. Having ascertained the value of $\frac{C.P.}{T}$, the carrying capacity of various sized pipes may be obtained from Table VIII. These figures are given as pounds of water per hour.

If, therefore, in the previous example it is necessary to supply 18,000 B.Th.U.s per hour,

it will be necessary to pass $\frac{18000}{30} = 600$ lb. of

water, and assuming a total travel of 100 ft.,

then $\frac{C.P.}{T} = 0.121$ in., and a main flow and

MODERN BUILDING CONSTRUCTION

then average $H = \frac{P_1 h_1 + P_2 h_2 + P_3 h_3}{P_1 + P_2 + P_3} + \dots$

This process is repeated for each drop in turn, and that giving the lowest height is the index circulation. Heat emitted from horizontal flow and return mains may similarly be allowed for.

The *C.P.* for Index circuit is arrived at as for Fig. 12.

The *T* is measured for this circuit from the boiler and back, allowing for bends, etc. $\frac{C.P.}{T}$

is then found and Table VIII used for sizing. Each of the other drops is subsequently sized on the basis of its own

$\frac{C.P. - \text{resistance of flow \& return mains, boiler to branch}}{T \text{ for drop}}$

Pump Circulation. The temperature drop between flow and return in a pump circulation is usually taken at 30° F. for the two-pipe systems and 20° for the one-pipe system.

The quantity of water to be circulated by the pump in gallons per minute is

$$\frac{\text{Total B.Th.U.'s emitted by System}}{\text{Temperature drop (20 or 30°) } \times 10 \text{ (lb. per gal.)} \times 60 \text{ (mins. per hour)}}$$

The frictional head against which the pump must operate depends on the travel *T* and the resistance chosen per ft. run. Unduly high resistance means high pumping power, while very low resistance means large pipes. A normal average is about 0.1 in. per ft. In arriving at *T*, due allowance must be made for bends, tees, etc., but in this case, owing to the higher velocity, the loss per bend is greater than with gravity. Approximately five times the diameter in inches may be taken as the resistance of one bend in feet.

For example, if we take a system designed for 30° drop emitting 900,000 B.Th.U.'s per hour travel *T* of 1200 ft. including bends, and 0.1 in. resistance per ft., the pump duty will be

$$\text{Volume } \frac{900,000}{30 \times 10 \times 60} = 50 \text{ gals. per min.}$$

$$\text{Head } \frac{1200 \times 0.1}{12} = 8.33 \text{ ft.}$$

It is usual to add a margin to the volume to allow for short circuiting. No margin should be added to the head but losses in pump connections sometimes account for 12 in. or so of head. In this case a pump of 60 gals. per min. against 10 ft. head would probably be selected.

The pipe sizing is carried out as for the examples already given except that the gravity effect may generally be ignored. The B.Th.U.'s emitted from each radiator or circuit are then marked on the plans and added up back to the boiler, making due allowance for losses from mains (for which sizes must be assumed in advance). The first rough sizing may then be made using Table VIII and the resistance per foot selected for the pump head (e.g. 0.1 in.). The branches may be sized from the same table.

For accurate sizing the resistance of each length requires to be taken out separately, and the sizes adjusted to give a balanced resistance for each branch. Any lack of balance can in the completed installation be corrected by adjustment of the lock shield regulating valves, with which each radiator or circuit should be provided.

PIPE SIZING GENERALLY. The above examples are given as an indication of the processes involved in the sizing of the more simple types of system. There are many much more complicated lay-outs which require separate treatment and a fuller study than can be devoted to the subject here.

Chapter IV—HOT-WATER HEATING APPARATUS

BOILERS AND FITTINGS

Hot-water Heating Boilers. These are usually of the cast-iron or mild-steel sectional types, of which there are a number of excellent designs on the market.

Fig. 13 shows a typical cast-iron sectional

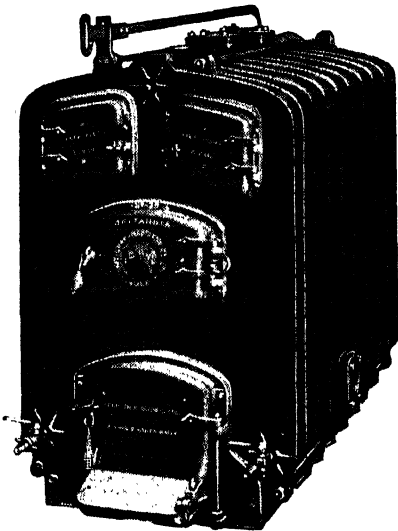

FIG. 13. SECTIONAL BOILER

boiler as supplied by a leading firm of heating apparatus manufacturers. The sections are coupled together by taper nipples and are pulled up by the four long bolts seen at the top and bottom. They are designed to give a large fire-box so as to burn for several hours on one charge of fuel.

Fig. 14 shows another type of sectional boiler with one side cut away.

Sectional boilers possess the great advantage that sections may be added should it be desired to extend the heating system; also, should any particular section be damaged, it is possible to replace one section without having to replace the whole boiler. Another advantage of the sectional boiler is that the sections can easily be carried through an ordinary door opening where it would be impossible to take a complete boiler.

Boilers of this pattern can be fitted with ordinary grate bars for burning coke, anthracite or other solid fuel by hand firing. Bituminous

coal is not suitable because it quickly soots up the heating surface, but it may be burned if an automatic stoker is fitted. This type of boiler is also suitable for oil firing. For gas firing, special types are available.

Boiler Mountings. The following mountings are usually supplied and fixed on a hot-water heating boiler. A *thermometer* for indicating the temperature of the water in the boiler is screwed into a mercury well, which in turn is screwed into a tapping (usually on the front section) on the boiler. This saves emptying the boiler in the event of breakage of the thermometer necessitating its replacement.

Altitude Gauge for indicating the head of water on the boiler; this is usually of the Bourdon type, provided with a flexible hollow brass tube of oval section connected by linkage to a pointer on a dial. The purpose of the gauge is to show whether or not the water level in the feed tank is being maintained.

Safety Valve. The object of this is to relieve pressure should the circulation be stopped, as, for instance, by freezing. It may be of dead-weight or spring-loaded type. There are various designs approved by insurance companies.

Open Vent Pipe. This is often provided to give an additional safeguard against excessive

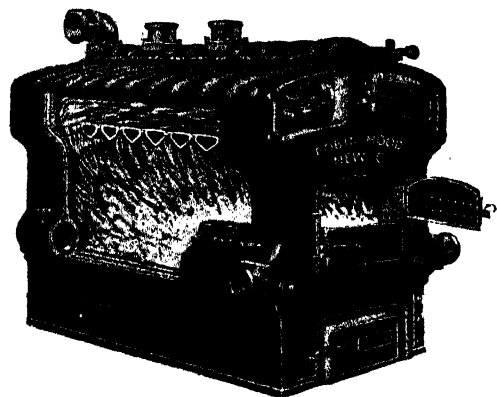

FIG. 14. SECTIONAL BOILER WITH SIDE REMOVED

pressure being generated in the boiler. It consists of an open pipe carried up above the level of the feed and expansion tank.

MODERN BUILDING CONSTRUCTION

Damper Regulator. This is a device to close or open the ashpit and/or check-draught doors on a boiler. It is thermostatically operated; that is, the expansion of a volatile fluid, enclosed in a corrugated brass bellows, provides the power to move dampers, through the intermediary of chains and levers. There are, in addition, more elaborate systems of electrical thermostatic control.

Stoking Tools are provided with each boiler. The set (mounted on a rack) comprises poker, slice bar, clinker rod, shovel, and wire flue brush.

Emptying Cock. This is usually fitted with hose union.

Insulated Steel Jackets are often supplied for sectional hot-water heating boilers. These comprise a galvanized sheet-steel casing, bolted round the boiler; on the inside of the casing is pegged some suitable non-conducting composition, such as slag wool or asbestos, to conserve the heat in the boiler and prevent large radiation losses from the heated surfaces. If such is not provided the boiler should be lagged with non-conducting composition.

Size of Boiler. The usual practice in determining the capacity of a heating boiler is to ascertain the total number of B.Th.U.s per hour to be emitted from the system of pipes, radiators, etc., including losses from all mains, add 25 per cent margin, and then take the nearest catalogue rating to this figure. If the mains are lagged, their loss may be taken at about 25 per cent of the bare pipe emission. In the case of an installation employing two boilers, good practice is to allow each boiler to be capable of dealing with two-thirds of the total load, which means that in mild weather only one boiler need be fired. In selecting a boiler, it is always better to choose a wide boiler of few sections, than a long, narrow boiler of perhaps 10 or 12 sections, so as to provide for possible future extensions; also, the wider boiler has the advantages of being more compact, and the fire is more easily stoked and cleaned.

Fuel Capacity. It is always advisable to check the fuel capacity of a boiler, and to estimate the length of time it will run on one fuel charge. This may readily be accomplished by taking the internal measurements of the boiler (always given in makers' catalogues); thus, length \times width \times height of grate to centre of fire door; this expressed in cubic feet and multiplied by 26 (the weight in lb. of 1 cub. ft. of dry gas coke) will give the total fuel charge.

The calorific value of 1 lb. of coke may be taken at approximately 12,000 B.Th.U.s. The

average sectional heating boiler has an efficiency of about 60 per cent.

EXAMPLE. Determine the length of time of burning of one charge of fuel in a boiler developing 625,000 B.Th.U.s. Internal measurements of boiler: length 5 ft., width 3 ft. 6 in., height of grate to centre of fire door 1 ft. There must, however, be sufficient fire left to rekindle the fresh charge of coal when the boiler is stoked, and for this it is usual to allow 15 per cent of the heat for rekindling purposes.

SOLUTION.

$$\frac{5 \times 3.5 \times 1 \times 26 \times 60 \times 12,000}{100}$$

$$= 3,320,000 \text{ available B.Th.U.s.}$$

$$\text{Less 15 per cent for rekindling} = 498,000 \text{ B.Th.U.s.}$$

$$\text{Available Heat} = 2,822,000 \text{ B.Th.U.s.}$$

$$\frac{2,822,000}{625,000} = 4\frac{1}{2} \text{ (approx.) hours. Ans.}$$

For night running, the boiler is usually banked and about one-third load is usually assumed.

Magazine Boilers. An important development of recent years is the Magazine or Gravity feed boiler. This type contains a large magazine or hopper into which the fuel is delivered, preferably from an overhead bunker. The fuel descends by gravity on to a sloping grate which is kept automatically fed. One charge of fuel may last 12-18 hours, thus this type of boiler requires much less attention than the normal hand-fired variety.

RADIATORS AND PIPE COILS

Types of Radiator. There are many different patterns of radiators and convectors available; a few of these are illustrated in Fig. 16. They may be obtained in various heights to suit their respective positions on the job. The window radiator is suitable for very low sills or for placing under seats.

Radiators of the normal types emit about 80 per cent of the heat by convection and 20 per cent by radiation. They are usually placed under windows which constitute the chief item of heat loss in the room. In this position the rising convection currents meet the cold air falling down the surface of the glass, whereas if placed on an inner wall the rising currents race straight up to the ceiling causing dirty marks up the walls. A shelf fitted above the radiator partially overcomes this objection, but not entirely.

Radiators are usually manufactured of cast-iron, are of sectional pattern assembled with screwed nipples, and possess heating surfaces

between $\frac{3}{4}$ and 8 sq. ft. per section, according to type and height.

Hot-water radiators are fitted with a small air release valve, screwed into the top of one of the end sections, to enable each radiator to be vented.

RADIATOR CONNECTIONS (Fig. 15). The flow and return connections may be at either the top or the bottom of the radiator, or they may be on opposite sides, or both on the one side, though the return connection must always be at the bottom of the radiator.

RADIATOR BRACKETS. These are for either

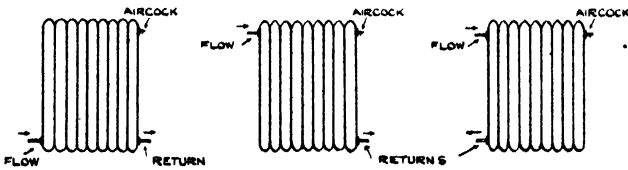

FIG. 15. RADIATOR CONNECTIONS

steadying the radiators or carrying them clear of floor, to allow the main to pass underneath and to provide room for sweeping. They are supplied by the radiator manufacturers in either cast or wrought iron, and are provided with a shank for building into the brickwork of the wall.

Radiant Systems. Heating surface may be disposed on the flat surface of walls and ceilings, in which case the heat is emitted largely as radiant heat. This tends to give a more uniform distribution of warmth and avoids the obstruction and appearance of radiators. Radiant systems also possess the advantage of reduced dirtying of decorations.

One form of this system is the cast-iron "Ray-rad" as illustrated in Fig. 16. The water is circulated at normal water temperature.

Another, but entirely different class, is that known as *Panel Heating*, shown on page 1070. Welded steel pipes for *ceiling heating* are embedded in the underside of the floor slab during construction, and are subsequently plastered with special plaster, so that the coils are completely invisible. Alternatively the pipes may be placed on wall surfaces or in the top surface of the floors for floor heating.

The ceiling position is the more common as the convection currents are then at a minimum, and the surfaces cannot be masked by furniture.

The water circulation is at a lower temperature than for normal radiation, usually about 100 to 135° F.

It should be noted that the Panel System is a highly specialized development, and it is unwise for the inexperienced to attempt to install it.

Sizing of Radiators, etc. The heat lost from the room must be replaced at the same rate if a steady temperature is to be maintained. The heating surface to be installed must therefore be capable of delivering the same quantity of heat as the heat losses calculated in the manner described earlier.

The emission from radiator, pipe, and other surfaces depends on the temperature difference between the air and the mean water temperature, and on the coefficient of transmission. For convenience Tables IX and X give transmissions direct in B.Th.U.s per sq. ft. of heating surface in the case of radiators and per ft. run for pipes for various temperature differences.

The heat loss is divided by the appropriate transmission figure, and the surface necessary so obtained. Sometimes a combination of pipes and radiators is used, in which case the heat emitted by the piping is first estimated, and the difference then has to be supplied by the radiators.

Transmissions from the Radiant systems involve more complicated considerations, and makers' data or one of the recent textbooks on heating should be consulted for such information.

EXAMPLE. A room has an hourly heat loss of 20,000 B.Th.U.s. Internal temperature required = 60° F., water flow 180°, return 140°. Neo-classic 4 column radiators are to be used. What heating surface is required?

SOLUTION.

$$\text{Mean water temperature} = \frac{180 + 140}{2} = 160^{\circ}$$

$$\text{air temperature} = 60^{\circ}$$

$$\text{Difference} = 100^{\circ}$$

4 column radiation emits (Table X) 170 B.Th.U.s per sq. ft.

$$\therefore \text{surface required} = \frac{20,000}{170} = 118 \text{ sq. ft.}$$

This is too large for one radiator; thus two radiators would be required each of 59 sq. ft., or three of 36 sq. ft.

Effects of Painting and Enclosing Radiators.

Bronze and aluminium paints reduce the heat emission of radiators and pipes by 10 to 15 per cent. Other paints of any colour have no appreciable effect on the emission.

Where a radiator is fixed in an enclosure its heat emission is reduced from 20 per cent to



(a) *Beeston School*

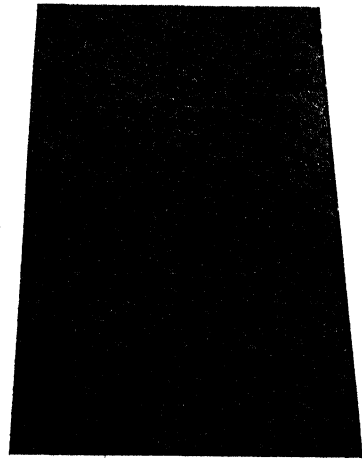

FRONT

(c) *Ideal Rayrad Wall*

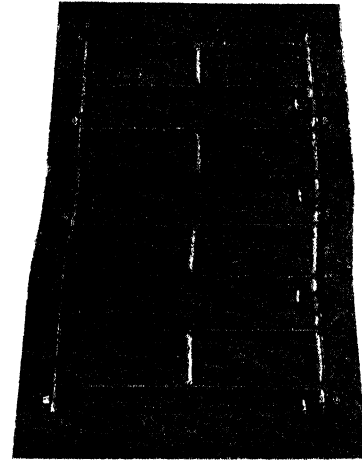

BACK

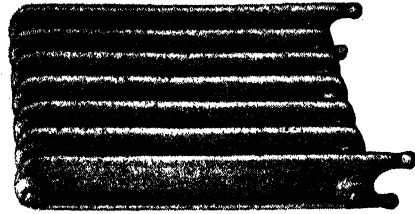

(b) *Ideal Neo-Hospital*

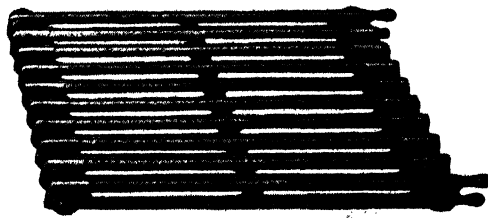

(f) *Ideal Neo-Classic*
2-Column

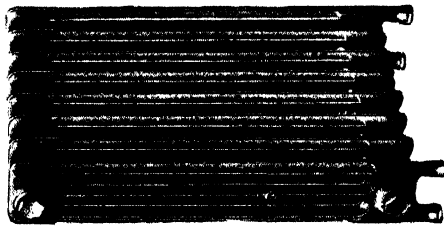

(g) *Beeston New Royal*
3-Column

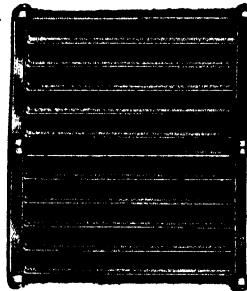

(d) *Beeston Royal Wall*

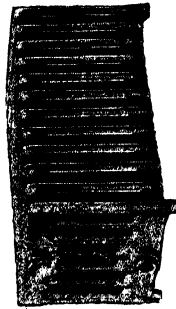

(e) *Beeston New Royal Window*



(h) *Crane*
4-Column

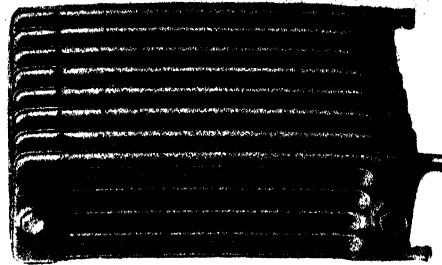

(i) *Beeston New Royal*
5-Column

FIG. 16 TYPES OF RADIATOR

30 per cent, depending on the design. The surface should therefore be increased accordingly.

When a fresh air inlet is provided behind a radiator its emission may be increased by as much as 20 per cent. A baffle plate should be provided in front to prevent the direct inblow of cold air.

TABLE IX
EMISSION FROM IRON PIPES IN B.Th.U.S PER
LINEAL FOOT PER HOUR

Nominal Size of Pipe in.	Sq. ft. Heating Surface per lin. ft.	Temperature Difference ° F. between Air and Mean Water		
		80	100	120
1/4	0.21	42	56	71
3/8	0.28	53	70	88
1/2	0.33	60	80	101
1 1/4	0.43	73	98	123
1 1/2	0.50	82	110	139
2	0.62	101	135	171
2 1/2	0.75	115	154	194
3	0.92	138	184	234
4	1.19	175	234	297
5	1.46	212	282	354
6	1.75	249	331	415

TABLE X
RADIATOR EMISSIONS IN B.Th.U.S PER SQ. FT.
PER HR.
(from makers' data)

Type	Temperature Difference in ° F. between Air and Mean Water		
	80°	100°	120°
Neo Classic, 2 col.	139	185	234
" " 4 col.	128	170	215
" " 6 col.	120	160	202
Hospital, 3 in.	139	185	234
" 5 1/2 in.	119	158	199
" 7 1/2 in.	113	150	189
Window	119	158	199
Wall	128	170	215
Pall Mall types	As above		
New Royal types	As above, but interpolate for 3 and 5 column types.		

PIPEWORK AND FITTINGS

Pipes usually employed by heating engineers are of wrought-iron or mild steel. Cast-iron

socket and spigot piping is used for greenhouse heating, and was at one time used for normal heating work in schools, etc., but its appearance is unsightly and it has gone out of favour. Cast-iron flanged piping is sometimes used for larger sized mains. Steel tube is made in three qualities, gas (painted black), water (blue), and steam (red). Water or steam qualities are normally used for heating work. Steam pipes are coupled together by screwed sockets, connectors, flanges, or unions.

Various fittings used in pipework, either made of wrought or malleable iron, are manufactured in immense variety, and the reader is advised to obtain a catalogue of these from the makers. Amongst the more usual fittings may be mentioned bends, elbows, offsets, or spring pieces, tees, flanges, connectors and backnuts, unions, sockets, reducers, plugs, caps, nipples, crosses, etc.

Good quality tube can be bent cold up to 3 in. in a bending machine or, for larger sizes, in a forge, to form double or cranked sets, and where numbers of pipes are required of similar dimensions, it is very much cheaper to bend the pipes, thus dispensing with fittings and diminishing the number of screwed joints. Of later years, oxy-acetylene welding has found much favour, and will, no doubt, be increasingly used. No fittings are then required. Bends are made on the pipe, tees, and reducers are made by welding.

Great care should be taken in the alignment of pipes; many jobs have failed on account of faulty levelling. All pipes should be graded to about 1/8 in. in 10 ft. rise or fall so as to vent into radiators or to the vent pipe. To support the pipework, there are a multitude of ready-made brackets and hangers on the market, but cheaper and more effective ones can be very often made up on the job.

PIPE COVERING. All pipes which are not being used for heating surface should be insulated with non-conducting covering composition, having an efficiency of at least 80 per cent. This will materially reduce the heat transmission from the pipes and thereby save fuel.

EXPANSION OF PIPES. The expansion of pipes when heated has been referred to. This expansion must be provided for, either by means of a sliding expansion joint or expansion bends. The latter is recommended, as sliding expansion joints, unless very carefully aligned, may set up stresses which are not properly taken up; the pipes may buckle and the expansion joints leak. Pipes should be free to move, and where

MODERN BUILDING CONSTRUCTION

passing through walls, floors, etc., should be enclosed in a sleeve leaving a slight gap all round.

Valves. Valves are provided at each radiator or pipe coil so that heat may be turned off or on as required. It is usual to fit two valves, one on flow and one on return, so that the radiator may be removed for decoration, etc., without emptying the whole system. The valve on the return is of lock shield type, i.e. without wheel.

In larger systems with numerous circuits and

volume on becoming heated to 210° F. from 40° F.; thus the tank should be so arranged that when the system is full of cold water, the level is so low that there is room for expansion of the water before the water level reaches the overflow pipe.

Water Content. Table XI gives the contents of pipes of various sizes, and the water contents of boilers and radiators, so that it is a simple matter to calculate the size of the feed and

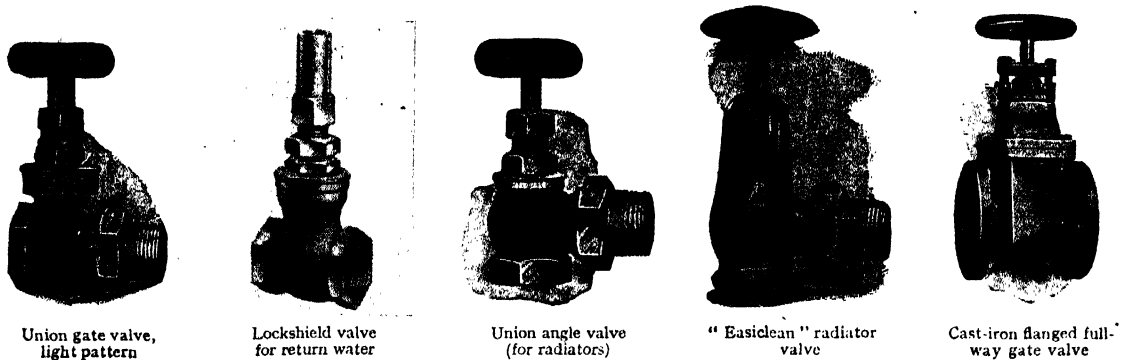

FIG. 17. RADIATOR VALVES

branches, valves are generally provided on flow and return of each main circulation, for regulation and isolation. Emptying cocks should also be provided at these points so that sections of the system may be emptied.

Where two or more boilers are provided, valves are necessary on the main flow and return of each, so that one boiler can be shut down for repairs leaving the other at work. Provision is then necessary by separate open vent or three-way safety cock device to ensure that the boiler shut down is still left open to atmosphere to guard against the fire being lit with the valves shut.

Valves are also necessary on pump suction and delivery connections except where a fullway type of pump is installed.

Valves for heating systems should be of the fullway type so as to leave a free way when open. The globe type valve is not suitable on account of the resistance and air pocket which it creates.

Fig. 17 illustrates various types of valves.

The duty of the feed and expansion tank is to regulate the supply of fresh water to the heating system, to compensate for any evaporation or leakage, and also to contain the expansion of water from the system, due to the water being heated.

It may be assumed that water in a low-pressure system expands one-twentieth of its

expansion tank. In practice, it is advisable to use a tank of standard size of liberal capacity.

The tank must always be placed above the

TABLE XI
WATER CONTENTS OF HEATING APPARATUS PIPES

Pipe diameter .	½"	¾"	1"	1¼"	2"	2½"	3"	4"	5"	6"
Gallons per 1 ft. length .	.0084	.019	.034	.076	.135	.212	.305	.542	.848	1.221

RADIATORS

Classic types, approximately 0.07 gals. per sq. ft. heating surface.

Hospital types, 0.2 gal. per sq. ft. heating surface.

BOILERS

Cast-iron sectional, approx. 1 gal. per 6000 B.Th.U.s. (For more accurate information on boilers and radiators consult makers' data.)

highest point of the heating system, in order that the highest radiators may be filled with water, and not air-lock the system.

Open Vents. With gravity circulation it is desirable to provide a vent pipe at the highest part of the system. This is shown on some of the diagrams given earlier. On pump circulations such pipes may discharge water, and it is more usual to provide an air bottle with air cock, or an automatic air vent.

Ventilation

By J. R. KELL, A.M.I.MECH.E., M.I.H.V.E., M.Inst.F.

Chapter I—PROPERTIES OF AIR

AIR consists of a mixture of 79 per cent nitrogen (N₂) and 21 per cent oxygen (O₂) by volume, with minute proportions of inert gases such as argon, neon, and a small admixture of carbon dioxide.

The specific heat of dry air (B.Th.U. necessary to raise the temperature of 1 lb. weight through 1° F.) is 0.24 at constant pressure.

Air, like all gases, expands considerably under the influence of heat at constant pressure, the increase in volume being proportional to the increase in the Absolute temperature. (Absolute zero on the Fahrenheit scale is -460°, e.g. 32° F. = 492° Abs. 60° F. = 520° Abs.)

TABLE I
PROPERTIES OF DRY AIR
(at normal pressure)

Temp. °F.	Vol. in cub. ft. of 1 lb. Dry Air	B.Th.U. to raise 1 cub. ft. through 1° F.	Cub. ft. raised 1° F. by 1 B.Th.U.
30	12.34	0.01957	51.10
35	12.47	0.01938	51.60
40	12.59	0.01919	52.11
45	12.72	0.01900	52.64
50	12.84	0.01881	53.17
55	12.97	0.01863	53.68
60	13.10	0.01846	54.18
65	13.22	0.01829	54.68
70	13.35	0.01812	55.19
75	13.48	0.01795	55.72
80	13.60	0.01779	56.21
85	13.73	0.01763	56.72
90	13.86	0.01747	57.25
95	13.98	0.01732	57.74
100	14.11	0.01716	58.28
110	14.36	0.01687	59.28
120	14.62	0.01659	60.28
130	14.88	0.01631	61.32
140	15.13	0.01605	62.31
150	15.39	0.01578	63.37
200	16.67	0.01462	68.41

For convenience Table I gives the volume occupied by 1 lb. of dry air over the range of temperatures used in practice, and the corresponding B.Th.U.s necessary to raise 1 cub. ft.

through 1° F., and cubic feet raised 1° F. by 1 B.Th.U. A useful approximation to remember is that 1 B.Th.U. will raise 55 cub. ft. of air 1° F. at temperatures around 60° to 70°.

Humidity. Atmospheric air always contains moisture in the form of water vapour. There is a definite fixed limit to the amount of water vapour which 1 cub. ft. of space can contain at any given temperature. When this limit is reached the air is said to be *saturated*.

The higher the temperature, the greater the weight of vapour required to reach saturation point.

Table II gives the weight of vapour present in 1 cub. ft. and 1 lb. of air saturated at various temperatures, in grains (1 lb. = 7,000 grains).

The *Relative Humidity* (R.H.) is the proportion of water vapour contained in 1 cub. ft. compared with the amount necessary to saturate the air at the same temperature, expressed as a percentage.* Saturated air has a relative humidity of 100 per cent and the temperature at which it is saturated is known as the *dew point*.

The dew point should not be confused with the *wet bulb temperature*. The reading of a wet bulb thermometer is the same as the dew point only at 100 per cent relative humidity, but at lower relative humidities the wet bulb temperature is always higher than the dew point by an amount depending on the percentage R.H. Thus the wet bulb temperature in conjunction with a psychrometric chart or table is a guide to the R.H. at any known dry bulb temperature.

EXAMPLE. What is the weight (in grains) of the water vapour present in 1 lb. of air at 60° F. and 70 per cent relative humidity?

From Table II at 60° F. 77.3 grains are necessary to saturate 1 lb. of air. For 70 per cent relative humidity the weight of water vapour will therefore be

$$77.3 \times \frac{70}{100} = 54.11 \text{ grains}$$

* The relationship is more correctly between the vapour pressures, but the statement is sufficiently near for normal use.

MODERN BUILDING CONSTRUCTION

Air being more dense than water vapour, the effect of increasing the relative humidity is to reduce the weight of 1 cub. ft. of the mixture. The last column of Table II gives the volume

TABLE II
PROPERTIES OF SATURATED AIR
(at normal pressure)

Temp. °F.	Weight of Saturated Vapour in Grains.		Volume 1 lb. Dry Air plus vapour to Saturate it cub. ft.
	per cub. ft.	per lb.	
30	1.943	24.11	12.41
35	2.380	29.88	12.55
40	2.868	36.41	12.70
45	3.442	44.21	12.85
50	4.113	53.47	13.0
55	4.895	64.43	13.16
60	5.804	77.3	13.33
65	6.855	92.6	13.50
70	8.069	110	13.69
75	9.46	131	13.88
80	11.06	155	14.09
85	12.89	184	14.31
90	14.96	217	14.55
95	17.32	256	14.80
100	19.98	301	15.08
110	26.38	415	15.73
120	30.18	569	16.52
130	44.49	780	17.53
140	56.91	1072	18.84
150	72.1	1485	20.60
200	208.0	16100	77.24

occupied by 1 lb. of air when saturated at various temperatures, and this may be compared with the corresponding volumes in Table I for dry air.

Increase of atmospheric pressure gives an increase in the weight of water vapour necessary to saturate a given volume of air, but the differences are unimportant over the normal range.

Necessity for Ventilation. A normal adult emits approximately 300 to 400 B.Th.U.s per hour of sensible heat, according to the activity, and in the respired breath and perspiration gives out approximately 1,000 grains of water vapour per hour, when at rest.

In addition, the action of breathing causes the inhaled oxygen to oxidize carbon from the blood so that the exhaled breath is charged with carbon dioxide (CO₂). Approximately 0.6 cub. ft. CO₂ are respired by a normal adult at rest per hour. The atmosphere generally contains about 4 parts CO₂ per 10,000.

If a number of individuals are placed in a

sealed room, the air will obviously rise in temperature, become more humid, and the CO₂ content will increase. Such a condition if allowed to continue above a certain limit would give rise to headaches, lassitude and eventual unconsciousness, whilst in time, of course, life could no longer exist. Thus ventilation is essential for existence, quite apart from comfort.

For comfort certain definite limits are found to be desirable. In winter, temperatures of 60 to 68° F. are suitable for persons at rest or doing light sedentary work, and in summer 65 to 75° F. The relative humidity to be aimed at is around 50 to 60 per cent.

The carbon dioxide content should not exceed 15 to 20 parts per 10,000, though greater concentrations are possible without harmful effects. Long before the concentration becomes serious to health, however, the air will have become too warm, humid and stuffy for comfort, so that the CO₂ content as a basis for ventilation calculation has long since ceased to be used.

Taking the sensible heat per person as 400 B.Th.U.s per hour it will be seen that this will raise (at 60° F.)

$$400 \times 54.18 = 21,672 \text{ cub. ft. air per hour through } 1^\circ \text{ F.}$$

Thus if a rise of 10° is permitted between inlet and outlet, the volume of air necessary for ventilation will be one-tenth of the above.

$$= 2,167 \text{ cub. ft. per hour per person.}$$

The increase in humidity taking 1,000 grains per person per hour with this volume of air will be

$$\frac{1000}{2,167} \text{ grains} = 0.46 \text{ grains}$$

If the air enters at 60°, 50 per cent relative humidity (see Table II) it contains 2.9 grains per cub. ft.

It will leave with 2.9 + 0.46 = 3.36 gr./cub.ft.

The leaving temperature will be at

$$60 + 10^\circ = 70^\circ \text{ F.}$$

The final condition of the air will then be found as follows—

At 70° and 100% R.H. (Table II) the air contains 8.07 gr./cub. ft.

Therefore 3.36 grains will give

$$\frac{3.36}{8.07} \times 100 = 42\% \text{ R.H. approx. (at } 70^\circ)$$

It will be noted that the relative humidity has fallen but the absolute humidity or actual weight of vapour present has increased. This is because at the higher temperature more water

vapour is required to cause saturation than at the lower temperature.

It is thus possible to arrive at the increase in temperature and water vapour with various volumes of ventilation per occupant as in Table III. This also gives the resulting CO₂ content with entering air containing 4 parts per 10,000.

TABLE III
EFFECT OF OCCUPANCY AT VARIOUS VENTILATION RATES

Cub. ft. air per Occupant per Hour	Temp. rise ° F. at 400 B.Th.U.s per occupant	Grains* Moisture added per cub. ft. air	Final Parts CO ₂ per 10,000
500	44.0	2.00	15
750	29.3	1.33	12
1,000	22.0	1.00	10
1,250	18.3	0.83	9
1,500	14.6	0.67	8
2,000	11.0	0.50	7
2,500	8.8	0.40	6.4
3,000	7.3	0.33	6.0
4,000	5.5	0.25	5.5
5,000	4.4	0.20	5.2

It will be seen that with only 500 cub. ft. per occupant the temperature would theoretically reach $60 + 44 = 104^{\circ}$ F., which is unduly high. At these high temperatures, however, the human body tends to get rid of more heat by evaporation (i.e. by perspiration) and less as sensible heat, until at 98° or thereabouts the whole heat loss is by evaporation. Indeed, at that temperature no heat transfer is possible as sensible heat, since the air is then at the same temperature as the blood. The result is, therefore, that some lower temperature would be reached than that given in Table III; instead of 104° it would become about 88° F.

✓ **Quantities of Air for Ventilation.** The method of determining the volume of air necessary to limit the temperature rise and moisture increase

* 1 lb. = 7000 grains.

applies in the case of theatres, cinemas, offices, and other crowded buildings occupied for lengthy periods.

The L.C.C. requires a minimum of 1,000 cub. ft. of fresh air per occupant per hour in places of public entertainment under its jurisdiction, and this has been followed by other authorities.

This should be regarded as a minimum and where money allows 1,500 or 2,000 cub. ft. per occupant are to be preferred.

A useful figure for many purposes is 30 cub. ft. per min. per occupant, which gives 1,800 cub. ft. per hour.

In many types of room and building it is not possible to base the ventilation on the volume per person and for these the air changes per hour are decided upon on an arbitrary basis.

As a guide to the usual accepted rates of ventilation, Table IV may be consulted.

TABLE IV
VENTILATION ON AIR CHANGE BASIS

Type of Room	Air Changes per hour
Offices above ground	4-6
Offices below ground	8-12
Workshops and factories	2-4
Workshops with unhealthy fumes	20-40
Laundries	20-30
Kitchens	20-30
Lavatories	12-15
Boiler houses and engine rooms	10-15
Laboratories	12
Hospitals operating rooms	10
Hospital treatment rooms	6
Restaurants	8-12
Smoking rooms	10-12
Stores, strong-rooms	1-2

EXAMPLE. It is desired to ventilate a basement office having a cubic content of 2,400 cub. ft. What volume of air is required per minute?

Taking 10 changes per hour the volume will be

$$\frac{2,400 \times 10}{60} = 400 \text{ cub. ft. per min.}$$

MODERN BUILDING CONSTRUCTION

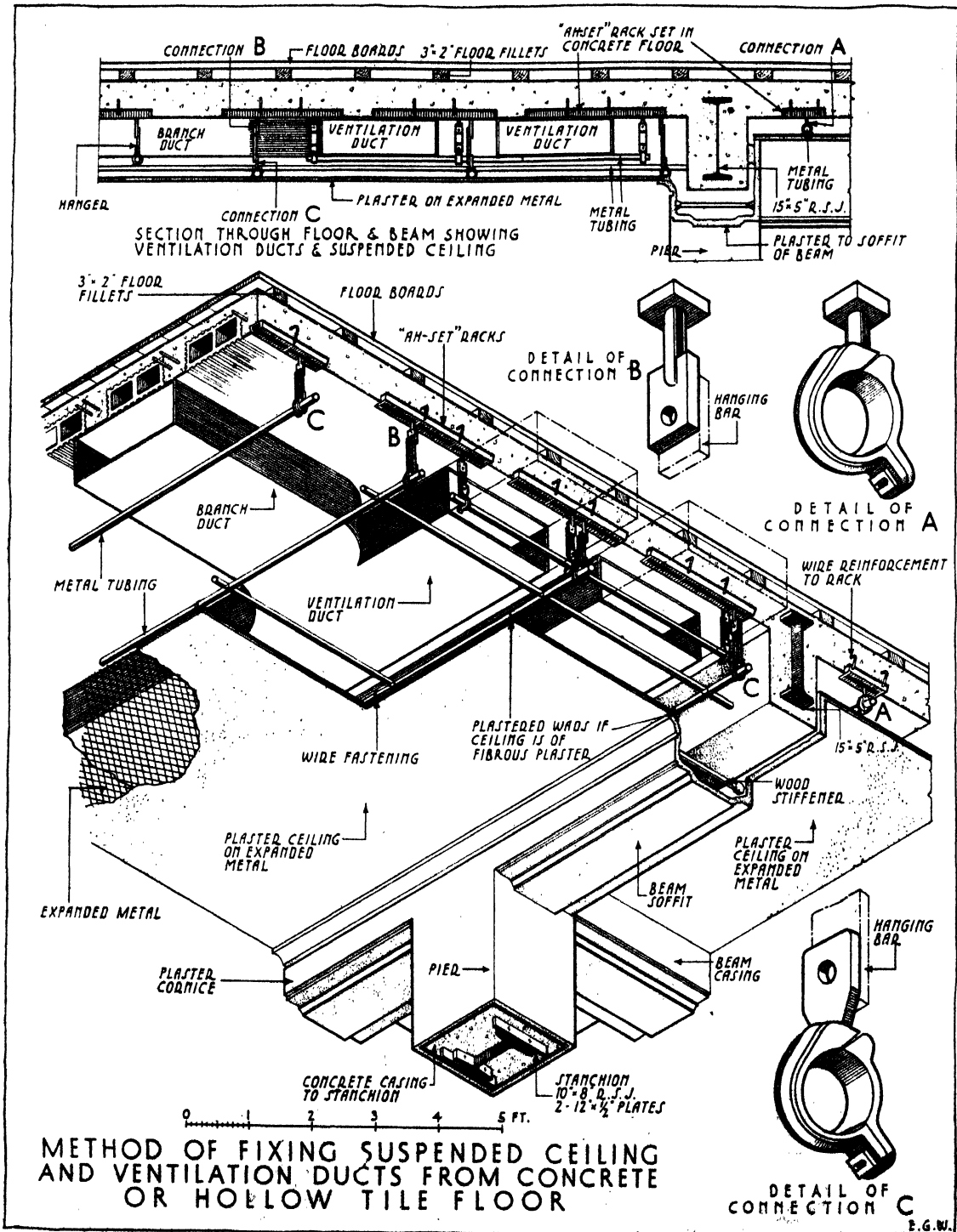

Chapter II—METHODS OF VENTILATION

THE methods of ventilation adopted in practice comprise—

- (a) Open windows and flues.
- (b) Natural ventilation by roof extractors.
- (c) Mechanical extract ventilation with natural inlet.
- (d) Mechanical inlet and extract.

Ventilation by Open Windows need not be discussed here. For a great many buildings it is entirely adequate, but with the increasing noise

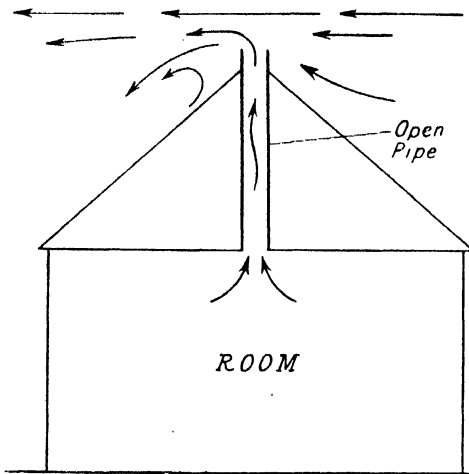

FIG. 1

and dirt of our cities many of the more important structures are providing mechanical means for introducing cleaned and washed ventilation air so enabling the windows to be kept closed.

For schools and hospitals a hopper type window is now much favoured. Opening at the top and at the bottom simultaneously.

Fireplace flues serve as means of ventilation in most domestic buildings and may account for anything between two and five changes of air per hour in the room, which is generally more than adequate for the small occupancy therein.

Roof Extractors depend for their operation on the action of the wind and on temperature difference between inside and outside.

Wind blowing over the end of an open pipe as in Fig. 1 causes a suction effect which draws air from the room below. An open pipe is not

practicable however and a great many designs of roof ventilators have been evolved to permit of this effect operating, and at the same time excluding rain, snow, etc.

One successful type is shown in Fig. 2.

The aspirating effect of any roof ventilator or flue due to temperature difference between inside and outside in still air may be calculated by estimating the difference in weights between the imaginary rising hot column inside and the

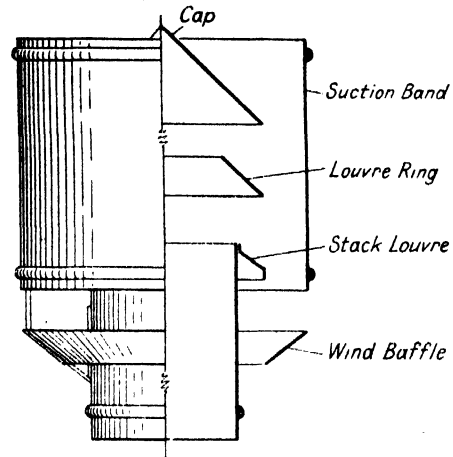

FIG. 2. ROBERTSON PATENT VENTILATION
(Part Sectional View)

imaginary external cold column for the height of building in question. From the difference of weight, the velocity due to gravity may be calculated. As the density of air is proportional to its absolute temperature it can be shown that the velocity v may be calculated from the formula

$$v = \sqrt{g \cdot h \cdot \frac{T_1 - T_0}{T_1}}$$

where g = acceleration due to gravity.

h = height of column (of room and flue).

T_1 = inside temp. (abs.).

T_0 = outside temp. (abs.).

This formula takes account of the fact that in a room with an inlet near the floor and an outlet in the roof, there is a neutral zone at atmospheric pressure half way up the height.

MODERN BUILDING CONSTRUCTION

The effective height is, therefore, half that in an ordinary flue where atmospheric pressure exists at the top.

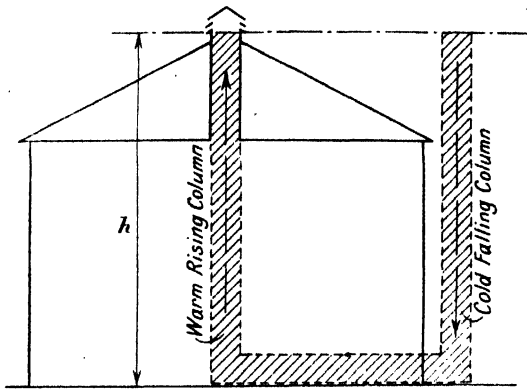

FIG. 3

Table V, calculated on this basis for an outside temperature of 40° F., gives the theoretical velocity in ft. per min. for various heights of column and inside temperature with no wind.

The practical velocity, due to resistance of turret, flue, outlet grille, etc., may be taken as 0.5 to 0.7 of the theoretical velocity.

TABLE V

Outdoor temp. 40° F.	Theoretical Velocity ft./min. for height of column ft.							
	5	10	15	20	30	40	50	100
Indoor Temp.								
° F.								
50	108	152	188	218	265	307	344	485
55	133	188	230	266	325	376	420	590
60	152	214	262	303	370	428	480	675
65	168	238	290	336	410	475	530	750
70	185	260	318	366	450	520	580	825
75	195	276	338	391	478	552	615	875
80	208	294	360	416	506	586	655	930
85	221	311	380	441	538	621	695	985
90	233	332	403	466	571	656	735	1050

EXAMPLE. A hall 30 ft. high having a cube of 20,000 cub. ft. is required to be ventilated at the rate of 6 changes per hour when inside at 65°, outside 40° F. What area of outlet in roof is required?

From Table V velocity = 410 ft./min. theoretical.

Practical velocity = $410 \times .6 = 246$ ft./min.

Volume required = $\frac{20,000 \times 6}{60} = 2,000$ cub. ft./min.

Area of outlet = $\frac{2,000}{246} = 8$ sq. ft. approx.

This would be provided by 3 turrets of approx. 22 in. diameter.

The increase in extraction effect due to wind depends largely on the type of extractors used and makers test data should be consulted.

Provision of means for air inlet is essential with this method of ventilation as with any other, and one common form is to leave openings around the walls behind the radiators.

Such systems are common in assembly halls, single storey workshops and factories, churches, etc., and are often quite sufficient.

It must be remembered that their operation tends to be spasmodic and unreliable, and on mild days with little difference of temperature and no wind they cease to function entirely though at such time they are perhaps most required.

Mechanical Extract with Natural Inlet. Mechanical extraction renders ventilation positive no matter whether any temperature difference or wind exists.

For this reason it is used in cases where a definite movement is required at all times, such

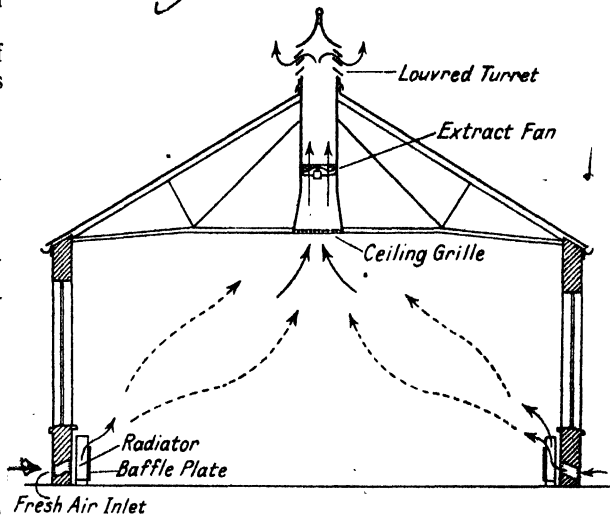

FIG. 4

as in lavatories, kitchens, laundries, factories with unhealthy fumes, and the cheaper type of cinema and theatre where the expense of a more elaborate system of inlet and extract ventilation cannot be afforded.

An extract system for a hall often takes the form shown in Fig. 4 in which a propellor fan draws air from the ceiling and discharges it through a turret on the roof. Another application is as Fig. 5 in which the fan is mounted direct in the wall with self-closing shutters which shut when the fan stops.

Extraction systems for lavatories, kitchens, and the like may make use of propellor fans in the walls or windows, but more often it is necessary to provide a system of ducts connected to a centrifugal cased fan as in Fig. 6.

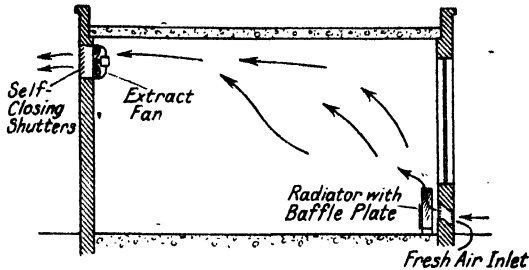

FIG. 5

The volume of air to be handled by the extract fan or fans in any system is arrived at simply by multiplying the appropriate number of air changes per hour by the cube of the room or rooms and dividing by 60 to arrive at the volume in cub. ft. per min. Makers' lists will help to determine the requisite size of fan.

There must be adequate area of fresh air inlet for this volume to pass at a speed through the inlet grating free area of not more than 300 ft. per min.

If radiators are placed in front of these inlets their surface must be such that they can warm the incoming volume from 30° or 32° to the temperature desired in the room such as 60° or 65°, as well as to offset the heat losses of the room as already referred to in the section on "Heating." Such radiators require to be provided with baffle plates on the front to prevent undue draughts.

Mechanical Inlet and Extract Ventilation. Complete mechanical inlet and extract ventilation permits of—

- (i) The incoming air being filtered to remove impurities, washed or humidified, and warmed.
- (ii) The distribution of the air to be such as is most suitable for the room, so as to avoid stagnant pockets.
- (iii) The rooms ventilated may be in basements, etc., not necessarily bounded by outside walls such as are needed for introducing air with extraction systems alone.

(iv) By maintaining a slight excess of inlet over extract all draughts through door and window cracks may be outward instead of inward.

The inlet system comprises fresh-air-intake, centrifugal cased fan, filter and/or washer, heater, and ductwork delivering the air to the room or rooms.

The extract system consists of a range of extract trunking connected to an extract fan of centrifugal type (or if there is little ductwork propeller type) delivering the exhausted air to atmosphere. Such a system, for example in a restaurant, would appear as in Fig. 7.

AIR DISTRIBUTION. The correct distribution of air in an inlet and extract system is of the greatest importance, but one of the most difficult if all parts of the room are to be adequately ventilated without draught.

There are three systems—

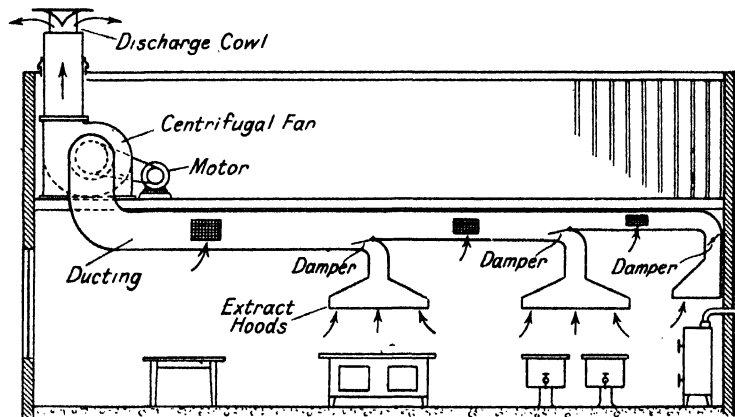

FIG. 6

(i) Upward as in Fig. 8. Here the air is introduced at low level and extracted from the ceiling. If the room is wide, it is often difficult to avoid a dead pocket in the centre without draughts at the sides near the inlets. For many cases it is the simplest system.

(ii) Downward as in Fig. 9. In this case air is delivered at the ceiling with some form of diffuser and is extracted at floor under the seats or near the floor at the sides.

Though not applicable to all cases this gives by far the most even distribution and is commonly adopted where a system of cooling of the air is included as the more dense air tends to fall and in doing so evenly over the whole area of the room does not give rise to

MODERN BUILDING CONSTRUCTION

draughts. This method is frequently adopted in the better class theatres and cinemas. There, owing to the heat of the occupants, the problem is generally one of cooling.

In small rooms or offices it is applied as in Fig. 10, the inlet and extract being on

the same side of the room. The air stream covers the whole volume as indicated.

(iii) Mixed upward and downward as in Fig. 11. This is favoured by some designers as combining the advantages of both systems, but the duct work is more complicated.

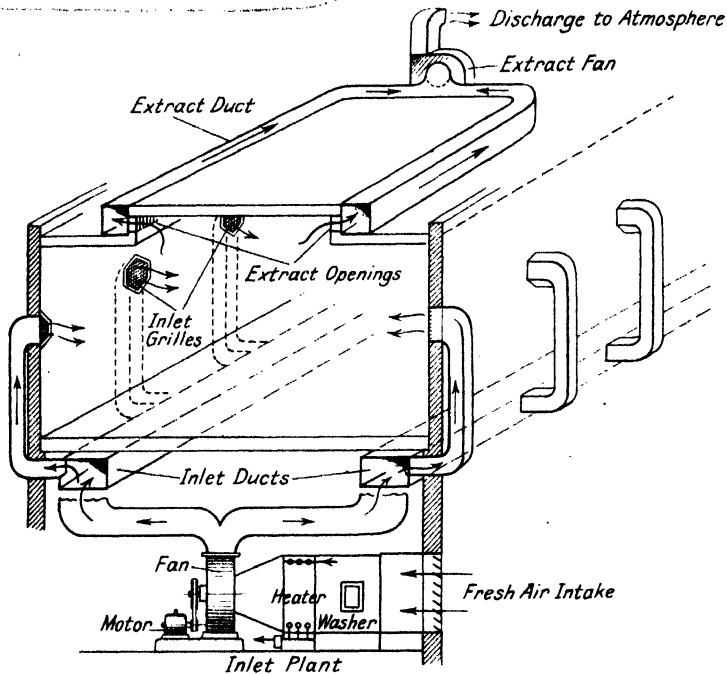

FIG. 7

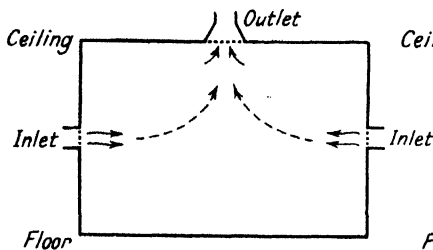

FIG. 8

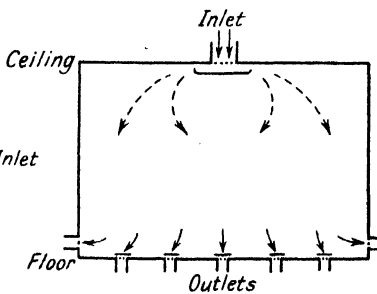

FIG. 9

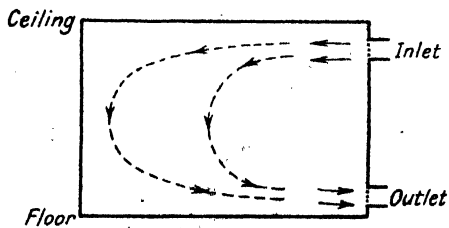

FIG. 10

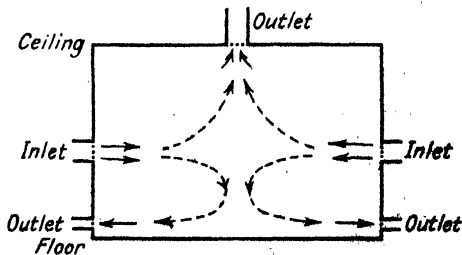

FIG. 11

Chapter III—FANS

Propeller Fans. These fans (Fig. 12) are most suitable for cases where they operate in "free air," i.e. mounted direct in a wall or roof turret. They may also be used for connection to duct-work provided the resistance is not more than

for commercial use 4,000 ft. per min. ; and where noise is unimportant 5,000 to 10,000 ft. per min.



(Messrs. M. W. Woods, Ltd.)

FIG. 12. PROPELLER FAN

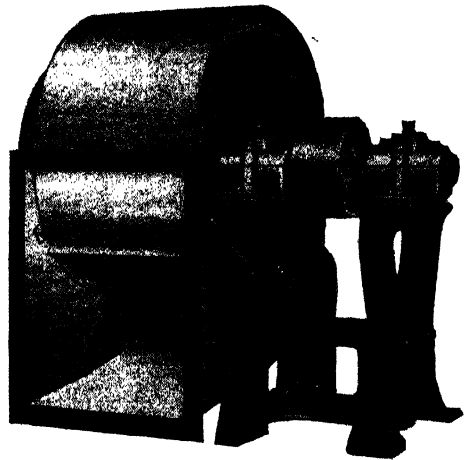

(Messrs. Matthews & Yates, Ltd.)

FIG. 13. CENTRIFUGAL FAN

air," i.e. mounted direct in a wall or roof turret. They may also be used for connection to duct-work provided the resistance is not more than

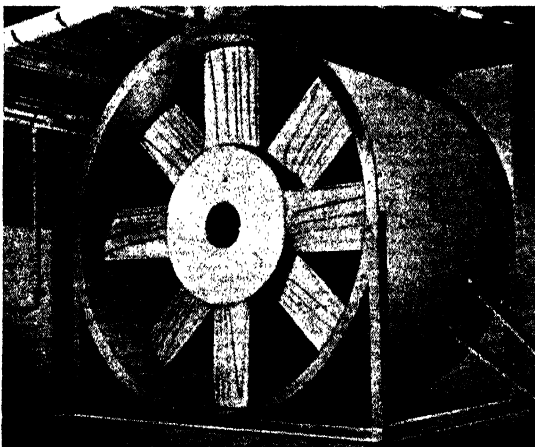

(Airscrew, Ltd.)

FIG. 12A. AXIAL FLOW FAN

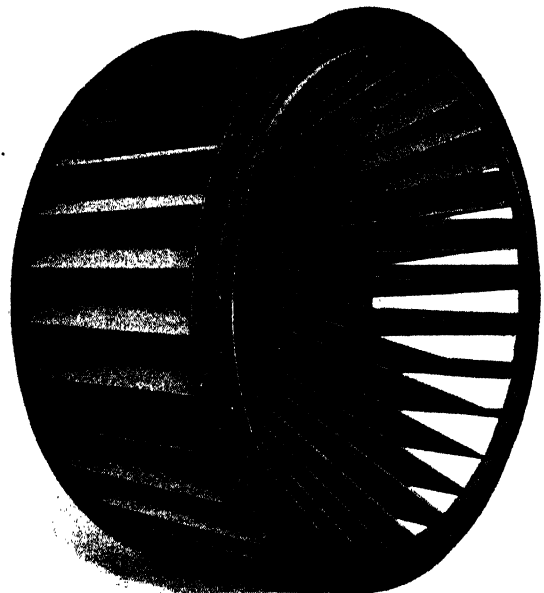

(Messrs. Keith Blackman, Ltd.)

FIG. 14. CENTRIFUGAL FAN RUNNER

·15 inches static water gauge. Above this the speed necessary is too great for silence.

For very quiet running the peripheral tip speed should be not more than 3,000 ft. per min.,

At the latter speed pressures up to 1½ in. water gauge may be produced.

MODERN BUILDING CONSTRUCTION

Sizes vary from 6 in. diameter to 60 in. and over, in steps generally of 1 or 2 in. Three typical sizes give the following duty for quiet running in free air—

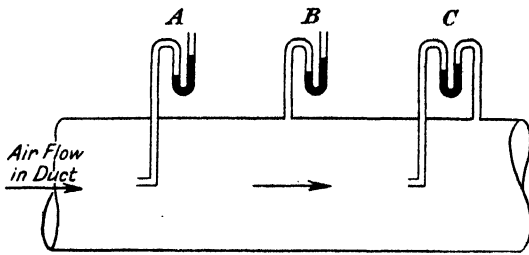

FIG. 15

Diam.	Speed	Cub. ft./min.	Watts consumed
9 in.	900 r.p.m.	350	30
24 "	540 "	4,300	170
60 "	270 "	34,000	1,550

It will be noted that relatively large volumes can be handled at low power, and the first cost is less than the cased type of fan. Larger fans are often more economical in current consumption than smaller fans for the same duty.

Where delivering to outside horizontally, a wind shield should be fitted a short distance from the face of the wall. Self-closing dampers are often fitted in addition to prevent back-draught.

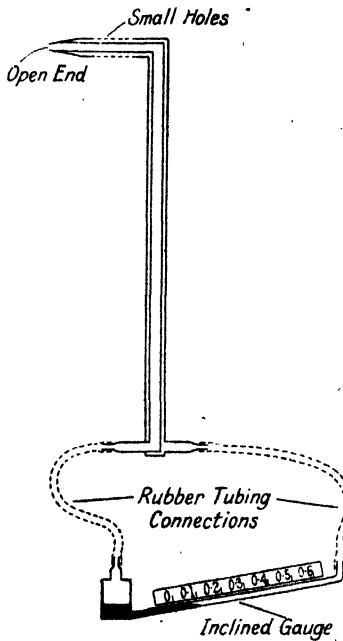

FIG. 16A. PITOT TUBE

Centrifugal Cased Fans. These fans (Fig. 13) are applicable to all cases, particularly where the resistance of heaters, filters, and extensive ranges of duct work have to be overcome.

The fan consists of a runner as in Fig. 14 having blades curved forward, radially, or backward according to the duty, mounted in a volute housing with an inlet on one side (single inlet) or both sides (double inlet). The forward curved blade type is the most common.

The impeller is either direct coupled to an electric motor, or driven by belt and pulley from a motor or prime mover. The V-belt drive is

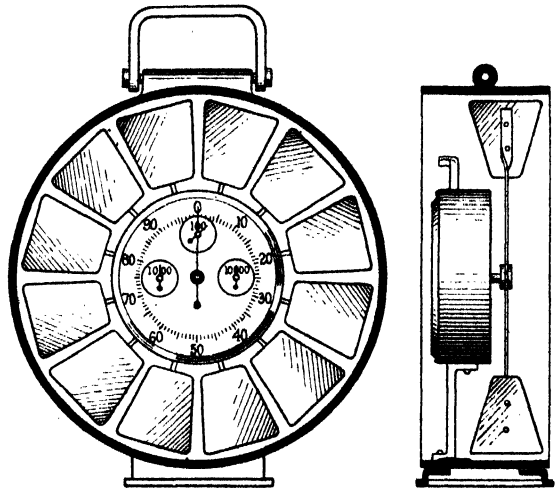

FIG. 16B. ANEMOMETER

now much used owing to its silence. With belt drive the motor may run at a higher speed than the fan, so leading to economy.

Single inlet centrifugal fans vary in duty from 1,000 cub. ft./min. to 100,000 cub. ft. per minute and over. Double inlet fans have double the capacity of single inlet.

The characteristics of centrifugal fans involve a consideration of speed, volume, water gauge (or pressure) horse-power, and efficiency.

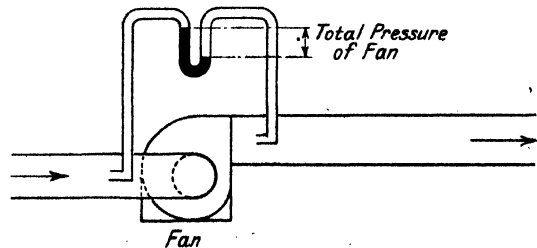

FIG. 17

When delivering into a system of ducts the volume varies directly as the speed of the fan is changed, the water gauge or pressure with the square of the speed, and the horse-power as the cube of the speed. The resistance and horse-power are also dependent on temperature.

Axial Flow Fans (Fig. 12A). This type is of recent development. The blades are of streamline form and are made of wood or aluminium. Their characteristics are such that they may be

used for all purposes for which propeller fans are used, and for overcoming resistance of duct-work. They can be made for silent running up

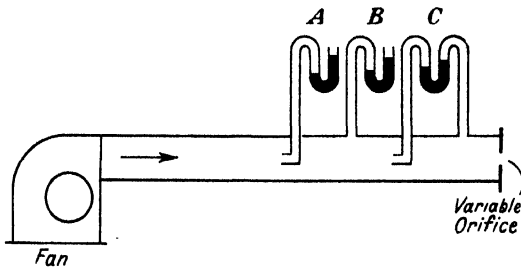

FIG. 18

to 1 in. water gauge or over, depending on size. They are often more convenient for fitting into confined spaces.

FLOW OF AIR IN DUCTS

Water Gauge. Considering Fig. 15, the starting of a flow of air in the duct causes the

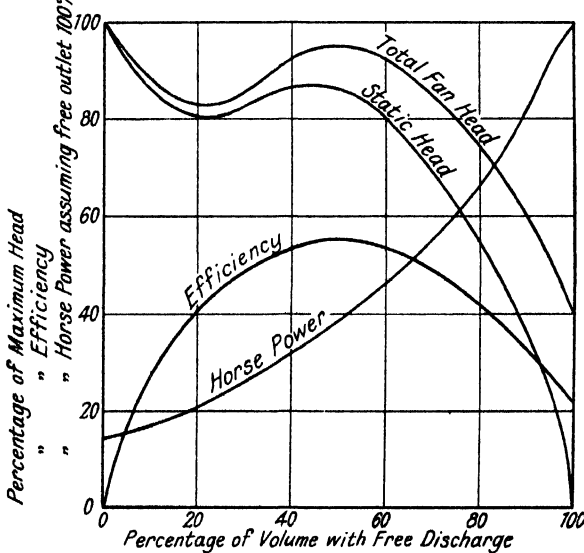
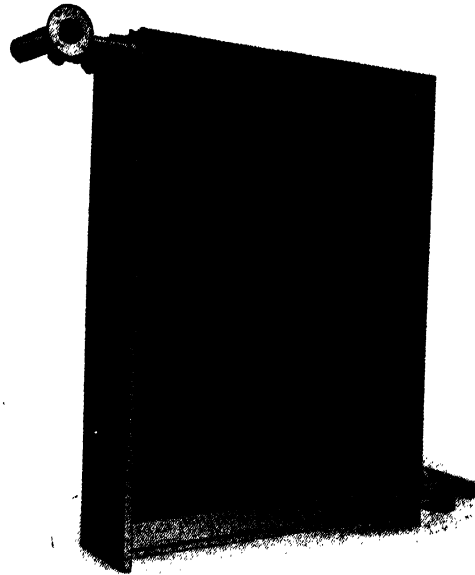

FIG. 19. CHARACTERISTIC CURVES OF FORWARD CURVED BLADED CENTRIFUGAL FAN

levels in the three U-tubes to change. If the amount of movement is measured, it will be found that A reads more than B, and that C is equal to the difference between A and B. The pressure recorded by the "facing" gauge at A is known as the *total head*, that recorded by the "side" gauge at B as the *static head*, and the difference as recorded by C as the *velocity or dynamic head*.

In a duct of uniform section with air flowing at constant velocity, the static head taken at successive points along the duct will be found to fall until at the outlet end it will be nearly zero. The static head is thus a measure of the friction or resistance of the duct. The velocity head will be constant to the end as the speed of the air has not changed (except for a negligible



(Victoria Tube Co.)

FIG. 20. WELDEX FINNED STEEL TUBE HEATER

increase of volume due to lowering of static pressure).

The velocity head is proportional to the velocity of the air squared. Fig. 34 gives the relationship between air velocities and water gauges.

The instrument for measuring water gauges is known as a "Pitot" tube and combines a facing and a side gauge in one instrument as Fig. 16A. It is most conveniently used with an inclined gauge, as shown, to give greater accuracy of reading. Above 800-1,000 ft. per min. this instrument is often used for measuring the velocities in ducts, but at lower air the pressures are too slight to be observed with accuracy, excepting with highly delicate apparatus.

An instrument which gives readings of velocities at all normal speeds operating with a vane wheel and counter mechanism is known as an anemometer, see Fig. 16B. It is held in the duct or in front of an inlet or outlet grille,

MODERN BUILDING CONSTRUCTION

and is timed over a minute by a stop watch. The velocity reading is multiplied by the area of the duct or grating so as to obtain the volume in cubic feet/min.

Another instrument for measuring air speeds direct without timing is the *Velometer*. This

Thus if the resistance of a system for which a fan has been installed is less than calculated the volume delivered will be greater and the motor will be overloaded. To overcome this an artificial resistance or damper must be installed or the speed reduced.

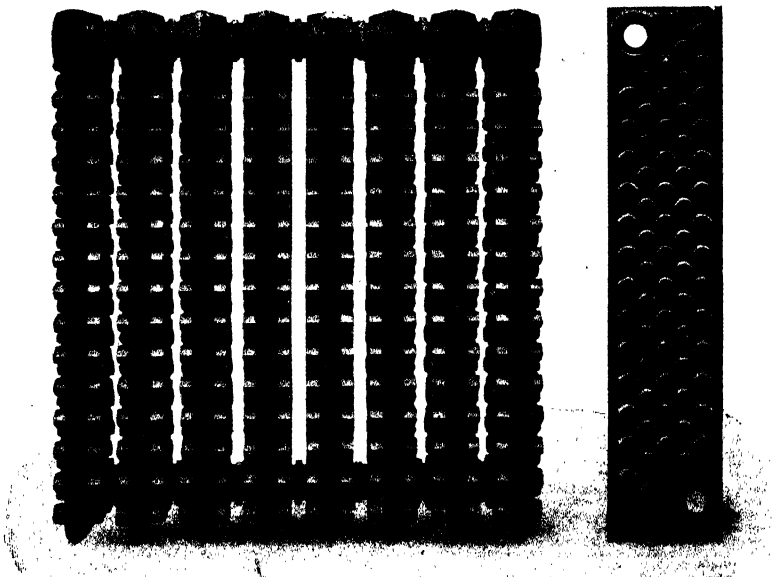

(Ideal Boilers and Radiators, Ltd.)

FIG. 21. "VENTO" CAST-IRON HEATER BATTERY

operates by means of a spring returned shutter and may be used with a number of adapters for various ranges of velocity.

Fan Characteristics. The water gauge produced by a fan is the difference between the total head on suction and delivery, and is obtained from the reading of two facing gauges as in Fig. 17.

Assume a fan to be connected to a length of duct with a variable orifice or resistance at the far end as in Fig. 18.

With the orifice shut, the static head *B* will be a maximum, and the velocity head *C* zero, *A* will then equal *B*. As the orifice is opened, the static head will fall and the velocity head will rise due to the air flow. Fig. 19 shows the characteristic curves for a forward curved bladed fan at constant speed when the volume is increased from zero to a maximum.

It will be noted that the total head falls towards the end, the efficiency rises to an optimum point and then falls, and the power taken rises without limit.

If the resistance is greater than that for which the fan is designed, the full volume will not be delivered and the power taken will be lower. To remedy this condition, the speed must be increased.

Characteristic curves are used in the selection of fans so as to determine that which best suits the conditions, one operating as near the peak of the efficiency curve as possible usually being selected. Fullest data are supplied by the various makers.

The characteristic curves of axial flow fans are rather different. The efficiency reaches a higher point (about 80 per cent), the pressure curves are smoother, and the horse-power curve rises to a maximum and then falls. This is called a self-limiting power characteristic and is important in cases where resistance is liable to vary. Backward curved centrifugal fans have a similar characteristic in this respect.

The total heads against which fans work in ventilating practice vary from $\frac{1}{8}$ in. for a

system with little duct work to 3 in. or over for extensive systems with filters, heaters, etc.

For silence, heads much over $1\frac{1}{2}$ in. are to be

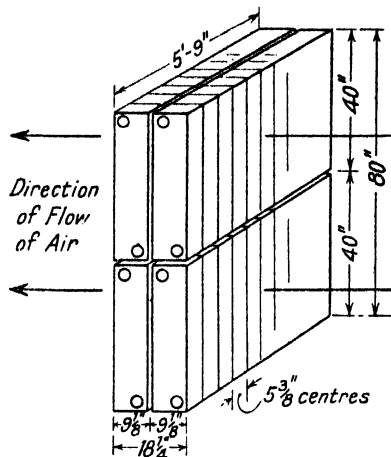

FIG. 22

avoided, and the fan outlet velocity should be limited to 1,300 to 1,500 ft. per min. if possible. When absence of noise is not essential, these conditions do not apply.

Heaters. The warming of the incoming air in winter is performed by a heater battery. The amount of heat required per hour is arrived at by multiplying the weight of air passing through hourly, by the specific heat, and temperature rise.

EXAMPLE. What is the quantity of heat in B.Th.U.s per hour required for a ventilation system delivering 20,000 cub. ft. per min. to a room at 60°, when outside air is at 30° F.?

At 60°, 1 lb. air occupies 13.1 cub. ft. (Table I).
The weight of air per hour

$$= \frac{20,000 \times 60}{13.1} = 91,500 \text{ lb.}$$

The temperature rise is 60-30 = 30° F. The specific heat of air = 0.24.

Thus quantity of heat per hour

$$= 91,500 \times .24 \times 30 \\ = 660,000 \text{ B.Th.U.s per hour}$$

(This assumes the air to be dry, the difference if humid is only slight.)

Heaters take the form of plain or gilled pipes of steel, brass or copper, and of cast-iron sections nipped together.

A Weldex steel gilled heater is shown in Fig. 20 and a Vento cast-iron heater in Fig. 21.

The face area of a heater is estimated for the volume passing at a speed of from 600 to 2,000 ft. per min. through the free area.

Thus in the above case for 20,000 cub. ft. per min. at a velocity of 1,200 ft. per min. a free area of 16.6 sq. ft. would be required. A Vento battery of 23 sections at 5 3/8 in. centres, 40 in. high would be suitable. The number of rows of tubes or "stacks" depends on the incoming temperature, temperature rise, and temperature of heating medium and whether steam or hot water.

For the above case with steam at 5 lb. pressure per sq. in. (gauge), temperature 227° F., reference to makers' list shows that two stacks would be necessary. Each stack is 9 1/8 in. deep.

The heater in question would then be 11 ft. 6 in. long by 40 in. high by 18 1/4 in. deep. To give a better shape the sections would be halved one row above the other, giving a length 5 ft. 9 in. and height 80 in., see Fig. 22.

The steam condensed per hour would be $\frac{\text{B.Th.U.s}}{\text{latent heat}} = \frac{66,000}{960} = 680 \text{ lb. per hr. approx.}$

The resistance to air flow through 2 stacks 5 3/8 in. centre, at 1,200 ft. per min. (again from makers' list) = 0.134 in. w.g.

The above exemplifies the method of calculation of a typical case. It is not possible to give

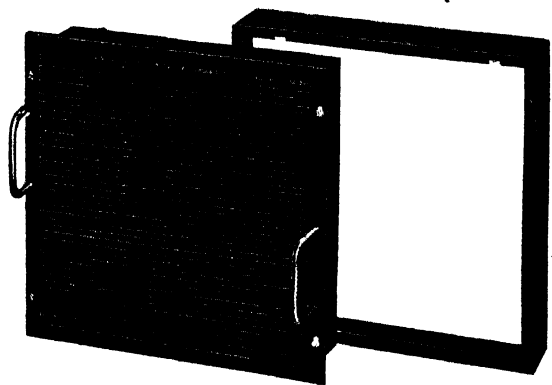

(Messrs. Ozonair, Ltd.)

FIG. 23. VENTEX FILTER CELL

here data for sizing tubular or finned heaters, but the method is the same for all. Ample data is published by manufacturers of the various types.

Filters. The filtering of the incoming air is

MODERN BUILDING CONSTRUCTION

accomplished by an air filter of which there are three main types.

- (a) Oil coated or viscous type.
- (b) Fabric type.
- (c) Throw away cell type.

An oil-coated hand-cleaned type is shown in Fig. 23. It is built up of cells of zig-zag plates

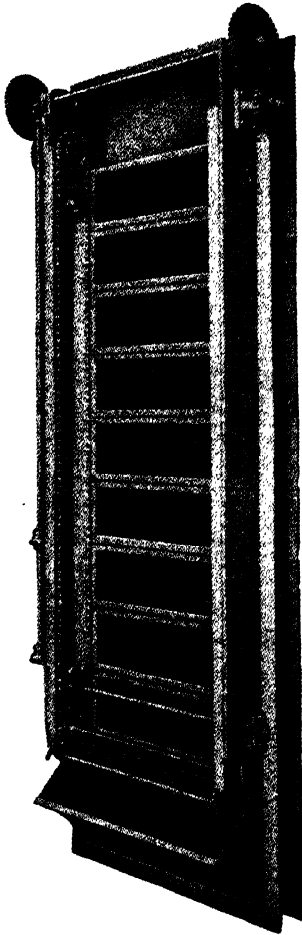

(Visco Engineering Co., Ltd.)
FIG. 24. SELF CLEANING OIL FILTER

about 18 in. square, each passing about 800 c.f.m., having a resistance of about 0.25 in. w.g. The cells are removed periodically, washed in hot caustic soda solution, dipped in fresh oil, allowed to drain and replaced.

The labour of this is considerable and self-cleaning types have been developed of which one is shown in Fig. 24. By turning a handle one cell is lowered into the oil-bath at the base each day and a clean one is lifted to the top,

all the remaining ones falling one step lower in the process.

The fabric filter consists of a flannelette material arranged on V-frames or in the form of bags, and through it the air passes at a speed of about 20 to 40 ft. per min. When dirty the fabric is thrown away and new material inserted, or is cleaned by vacuum cleaner.

When clean the resistance is about 0.15 in. w.g., and when due for changing about 0.3 in. w.g.

Fabric filters are more efficient as cleaning devices than oil coated, but the labour and cost of renewal is a disadvantage.

Throw-away filters consist of cardboard frames about 20 in. square into which is packed oil-coated glass silk, fibre, or other materials. The volume delivered per cell varies with the make, but with glass silk of the size stated it is 600 cub. ft. per min.

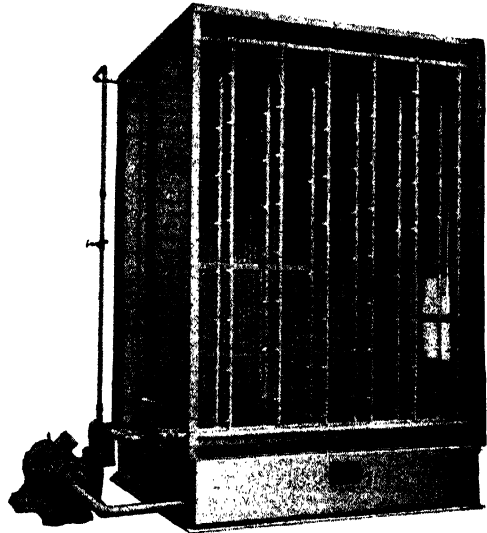

(Messrs. Mathews & Yates, Ltd.)

FIG. 25. AIR WASHER

Air Washers. An air washer performs the dual purpose of cleaning and humidifying the air, though it is not particularly efficient for cleaning when the air is charged with soot as water will not bring this down.

Fig. 25 shows a view of an air washer from the inlet side.

A series of sprays contained in an outer casing is fed with water by a pump from the tank in the base. The incoming air mingles with the fine mist from the sprays and due to evaporation is lowered in temperature and humidified.

The moisture laden air then impinges on the "scrubber plates" which consist of a series of zig-zag plates down which a stream of water is maintained. These bring down the solid matter entrained with the moisture.

Following this the air passes over eliminator plates where any free moisture is caught. The outer casing is often of galvanized steel, but

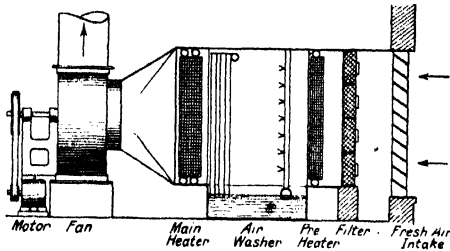

FIG. 26

concrete or brickwork may be used for greater permanence.

The pump is provided with a strainer to remove solid matter which might choke the sprays, and the tank at the base is kept filled by a ball valve.

The resistance to air flow of an air washer is generally about .15 in. w.g.

In order to humidify the air it is necessary to supply the heat of evaporation to the air before the washer in the form of a pre-heater, or to the water by means of a coil of pipes in the washer tank.

EXAMPLE. In the example on page 1099 assume the incoming air to be 100 per cent saturated and the air delivered to the room is to be maintained at 50 per cent relative humidity, what additional quantity of heat must be supplied for humidification?

Condition in room 60°, 50% R.H. (from Table II) grains/lb. air

$$= 77.3 \times \frac{50}{100} = 38.6$$

$$\text{Entering air } 30^\circ, 100\% \text{ R.H.} \quad \underline{24.1}$$

$$\text{Increase in vapour content per lb. air} \quad \underline{14.5 \text{ gr.}}$$

$$\text{Weight of air} = 91,500 \text{ lb./hr. (see previous example)}$$

$$\text{Weight of moisture} = \frac{91,500 \times 14.5}{7,000} \text{ lb./hr.} \\ = 190 \text{ lb./hr.}$$

The latent heat to evaporate 1 lb. water plus heat to raise its temperature 30° = approx. 1,000 B.Th.U.s. Additional heat/hr. to be supplied

$$= 190,000 \text{ B.Th.U.s per hr.}$$

The total heat to be supplied to the ventilating plant will thus be 660,000 + 190,000 = 850,000 B.Th.U./hr.

The preheater will require to be designed to warm the incoming air to a temperature slightly above the dew point corresponding to 60°, 50% R.H., in addition to supplying the heat for humidification. The balance will be supplied by the main heater. (It will be seen from Table II that the dew point or saturation temperature giving equal vapour content with the condition 60°, 50% R.H., 38.6 gr./lb. is between 40 and 45° F. By interpolation it is found to be 41.5° F.)

Complete Inlet Ventilating Unit. The complete equipment comprising filter, pre-heater, washer, main heater and fan would then appear as in Fig. 26 (draw through arrangement) or Fig. 27 (blow through arrangement). The resistance through this plant would then be somewhat as follows—

Filter	0.25 in w.g.
Pre-heater	0.10
Washer	0.15
Main Heater	0.13
	<hr/>
	0.63

To this must be added the resistance of the fresh air intake, fan connection, and the resistance of the ducts in order to obtain the static water gauge of the fan.

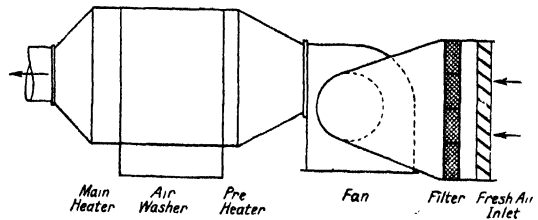

FIG. 27

Air Conditioning Plant. A complete air conditioning system is similar to the above with the addition of a refrigerating plant for cooling the washer water so that the air may be cooled and de-humidified in summer. The subject of air conditioning is a separate study in itself and the student is referred to the numerous textbooks on the subject.

Unit Ventilators and Air Conditioners. In order to afford means of ventilating or air-conditioning isolated offices, etc., where a central plant is not warranted, designers have produced cabinet units for standing in the rooms to be treated. These comprise in one casing, filter, fan, and heating coils, and, if required, cooling coils and humidifier. The fan is naturally extremely quiet running.

Chapter IV—DESIGN OF DUCTS

HAVING estimated the volume of air to be delivered to or extracted from the various rooms, or portions of the building, the arrangement of

(b) Pressure loss method. Velocity method is chiefly used for cases where absence of noise is essential. Velocities

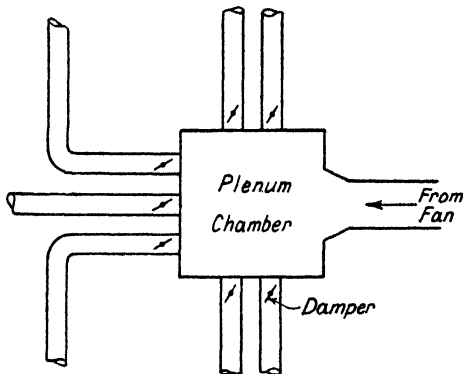

FIG. 28

ducts to connect these to the fans must be decided upon.

If there are a large number of rooms near the plant a "plenum" chamber may be arranged with a separate duct to each room as in Fig. 28.

If the rooms are in a line a main trunk with branch ducts may be used as in Fig. 29.

If the rooms are on several floors, main rising

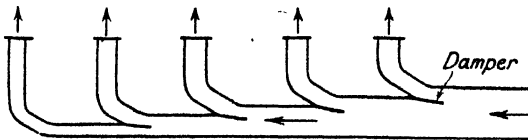

FIG. 29

shafts will be necessary up the building as in Fig. 30, horizontals being run out on each floor.

In the case of a theatre or cinema the arrangement is naturally determined by the plan, but it is usually possible to arrange for duct spaces in the early stages of the design above the ceiling, down the side walls in void spaces and under the floor if necessary. A system of this type would appear as in Fig. 31.

SIZING OF DUCTS

The sizes of ducts may be calculated on two methods—

(a) Velocity method.

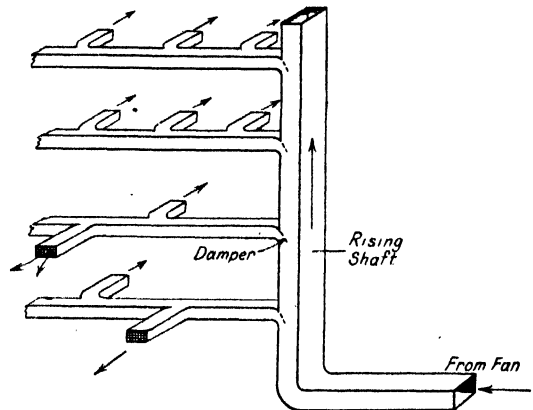

FIG. 30

are fixed first and the sizing of the ducts then becomes only a matter of arithmetic.

Table VI gives the velocities commonly used

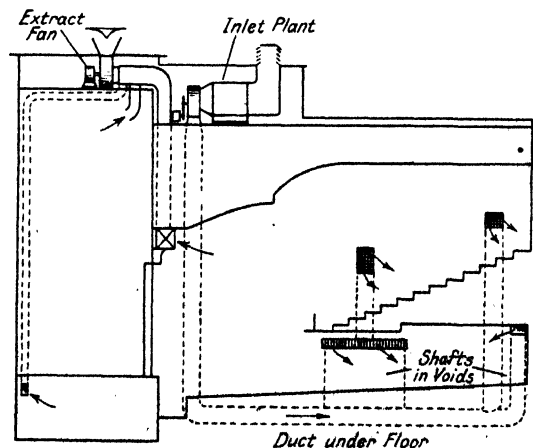

FIG. 31

in practice. There should be a steady lowering of the air speed away from the fan, and changes in velocity should be as gradual as possible.

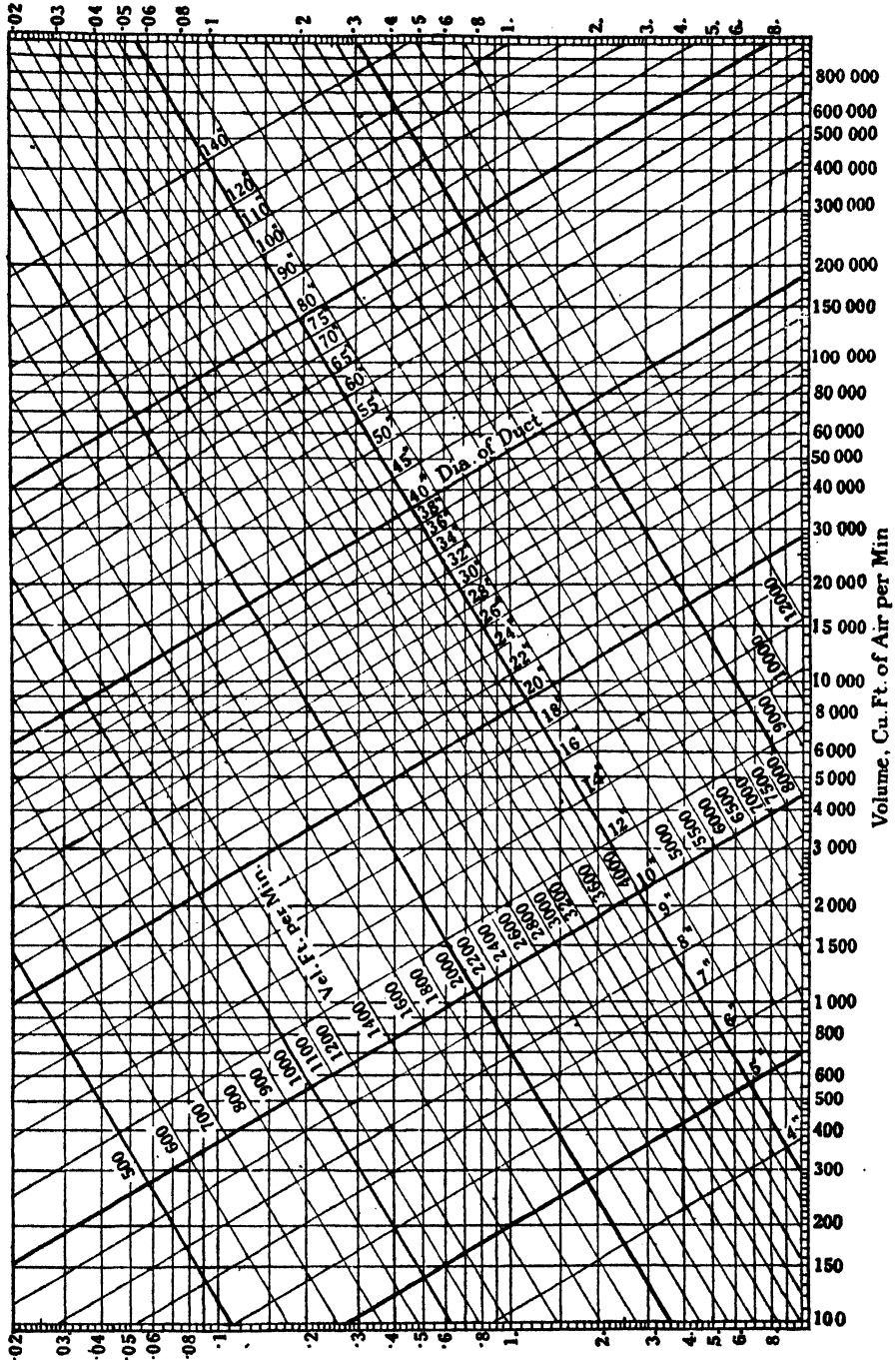

FIG. 33. DUCT FRICTION CHART

Resistance Ins. w.g. per 100 ft. run of duct (at 70° F. standard barometric pressure)

MODERN BUILDING CONSTRUCTION

TABLE VI
VELOCITIES IN DUCTS

	<i>ft. per min.</i>
<i>Inlet Plant—</i>	
Fresh air intake	800-1,000
Main ducts (large systems)	1,200-1,500
Main ducts (small systems)	1,000-1,200
Main branches and rising shafts	800-1,000
Smaller branches	600-800
Final connections to outlets	450-600
<i>Extract Plant—</i>	
Connections to gratings	500-700
Branch ducts	600-900
Main ducts	800-1,500
Fan delivery	1,000-1,500

EXAMPLE. In a multi storey office block the volumes to be delivered to the various rooms are given in Fig. 32. What size ducts would be suitable?

The volumes are added together back to the fan to obtain a grand total of 20,000 c.f.m. Each floor and each shaft being the same, we need consider only one in each case. The following schedule shows how the sizes of ducts would be arrived at.

Section	Volume c.f.m.	Velocity ft./min. selected from Table VI	Duct Area sq. ft.	Nearest Duct Size
				in.
Branch 1-2	250	500	0.5	12 × 6
2-3	500	600	0.83	12 × 10
3-4	750	650	1.16	12 × 14
4-5	1,000	700	1.42	12 × 18
Shaft 5-6	2,000	800	2.5	18 × 20
6-7	3,000	900	3.33	18 × 26
7-8	4,000	950	4.2	20 × 30
8-9	5,000	1,000	5.0	20 × 36
Main 9-10	10,000	1,100	9.1	36 × 36
10-11	15,000	1,200	12.5	36 × 48
11-12	20,000	1,300	15.4	36 × 60
F.A.I. 13	20,000	1,000	20.0	48 × 60

Having established the sizes, each branch must be fitted with a damper so as to permit of regulation when the system is put into operation.

The resistance of the ducts may now be calculated from the duct resistance chart, Fig. 33.

Pressure Loss Method. This method of sizing ducts is more applicable to manufacturing plants as some of the velocities may become too high for silence (i.e. over 1,000 to 1,500 ft. per min.).

The resistance or pressure loss for the ducts is fixed first, say, $\frac{1}{2}$ in., 1 in., or $1\frac{1}{2}$ in. w.g. according to the size and type of plant. The travel to the last outlet (including allowances for bends, tees, etc.) is measured from the drawings, and by division the available pressure loss per 100 ft. is arrived at in a manner similar to that

TABLE VII
RECTANGULAR DUCTS AND THEIR EQUIVALENT DIAMETERS

(to nearest inch)

Diameter Inches	Side Inches											
	4	6	8	10	12	14	16	18	20	22	24	
	Length of Duct Inches											
5	6	5										
6	8	6	4									
8	15	9	7									
10	24	15	11									
12	37	22	15	12								
14	54	30	22	17	14							
16		42	28	22	18	15						
18		54	38	28	23	20	17					
20			48	36	30	24	22	19				
22			60	44	36	30	26	23	20			
24				54	43	36	30	27	24	22		
26				64	52	42	36	31	28	26	24	
28					62	50	42	37	33	30	27	
30						58	48	44	38	34	31	
32						68	58	50	44	40	36	
34							66	56	50	45	40	
36								64	56	50	46	
38									64	58	52	
40										64	58	
42											64	
44												70

used in pipe sizing. A table of volumes delivered with this pressure loss per 100 ft. is then taken out and the sizes for the different sections read off direct.

It will be found that by this method the velocity is reduced as the ducts get less automatically and the method is quicker than the velocity method as the resistance does not have to be worked out afterwards.

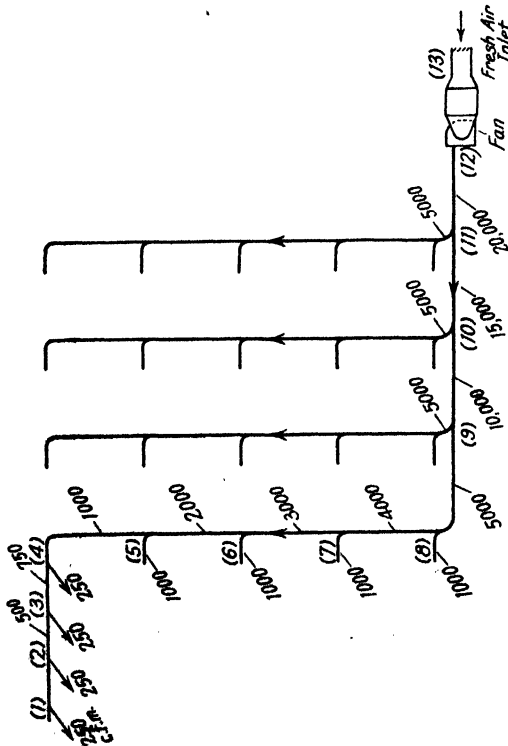

Fig. 32

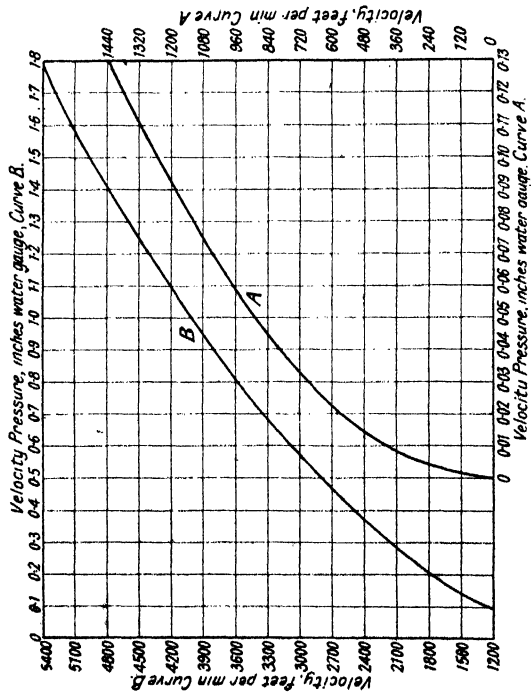

FIG. 34. CURVES SHOWING RELATIONSHIP BETWEEN VELOCITY OF AIR AND VELOCITY PRESSURE

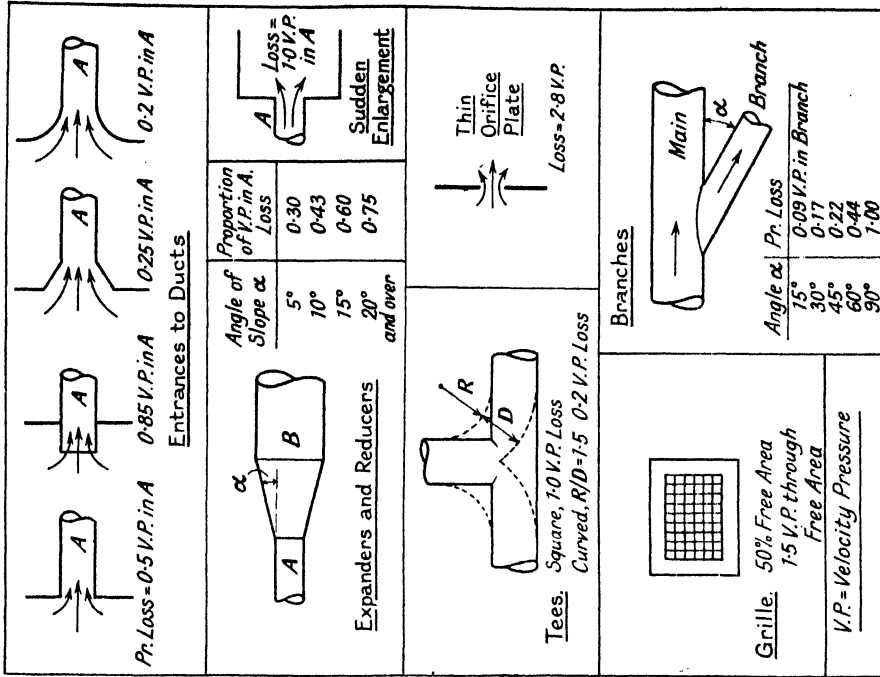

FIG. 35. RESISTANCES IN DUCT SYSTEMS

MODERN BUILDING CONSTRUCTION

Friction losses vary directly as the length of the duct, inversely in proportion to a function of the diameter, and directly as the square of the velocity. Fig. 33 gives a duct friction chart for circular metal ducts.

If the ducts are to be rectangular instead of circular it is necessary to determine the size of the former for equal friction. This may be done from Table VII. For builders work ducts an allowance of 50 per cent greater resistance per 100 ft. run should be made.

The allowance for bends may be taken as an equivalent feet run of duct according to the radius and diameter from Table VIII.

TABLE VIII
EQUIVALENT LENGTHS OF BENDS IN DUCTS

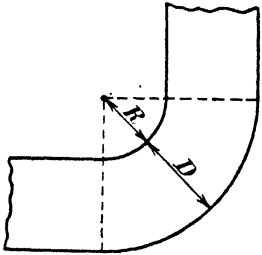

Ratio $\frac{R}{D}$	Equivalent Length of Straight Duct
5 and over	4 × diam. in feet
2 to 4	5 " "
1.5	6 " "
1.3	8 " "
1.0	10 " "
0.75	16 " "
0.5	30 " "
0.3	60 " "
0.25	70 " "
0 (Right angle bend)	100 " "

Resistances other than bends require to be dealt with afterwards and added to the total pressure loss at first assumed. These are estimated on the basis of loss of velocity head. The velocity at each resistance must first be ascer-

tained, and the velocity head can then be read from Fig. 34. The proportion of this head which is lost by various entrances to ducts, expanders, grilles, etc., is given in Fig. 35.

To the total pressure loss in the system so arrived at should be added the final velocity head discharging the air from the last grating.

EXAMPLE. In Fig. 36 for a factory calculate the sizes of ducts on the pressure loss method and the total from pressure, assuming $\frac{1}{4}$ in. w.g. to be taken by heater, filter, and fresh air intake.

Assume 1 in. w.g. to be absorbed in ducts.

Travel to last outlet from fan = 500 ft. + 1 bend.

say = 540 ft. total.

Pressure available per 100 ft. = $\frac{1.0}{5.4} = 0.184$ in. w.g.

A table may then be constructed and the sizes read direct from Fig. 33. The velocities should also be noted.

Section	Volume	Diam. from Fig. 33	Velocity from Fig. 33
1-2	20,000	40 in.	2,300
2-3	15,000	36 in.	2,100
3-4	10,000	32 in.	1,800
4-5	5,000	24 in.	1,600
5-6	4,000	22 in.	1,550
6-7	3,000	20 in.	1,400
7-8	2,000	17 in.	1,300
8-9	1,000	13 in.	1,100

The total pressure loss will be—

Heater, filter, F.A.I.	in. w.g.	0.75
Suction taper 15° slope. 1,500'/min. V.		
V.P. = 0.14 in. (Fig. 34)		
Loss = 0.6 V.P. (Fig. 35) =	0.084	
Ducts		1.00
Outlet grille. V. = 500'/min. V.P. = 0.15		
Loss = 1.5 V.P. 1.5 × 0.15	0.022	
Final velocity pressure	0.015	
Fan velocity pressure, 2,000'/min.		
V.P. = .26 allow 25% recovered in taper connection	0.20	
Total fan pressure	=	2.091

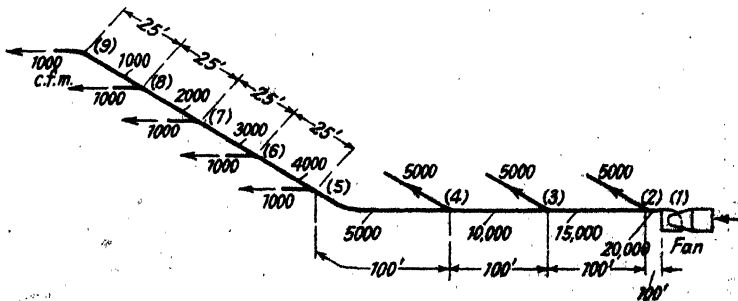

FIG. 36

Chapter V—COMBINED HEATING AND VENTILATION

Plenum System. This is a system commonly adopted for the heating of factories. It consists of a fan, hot water or steam-heated heater, and duct work arranged to deliver warm air to all parts of the factory. The temperature of the air delivered is well above the breathing tem-

perature. The plenum system is, however, a kind of ventilating system and may be used solely for

system in which the warming of the rooms is accomplished by means of radiators and the air introduced at or below breathing temperature.

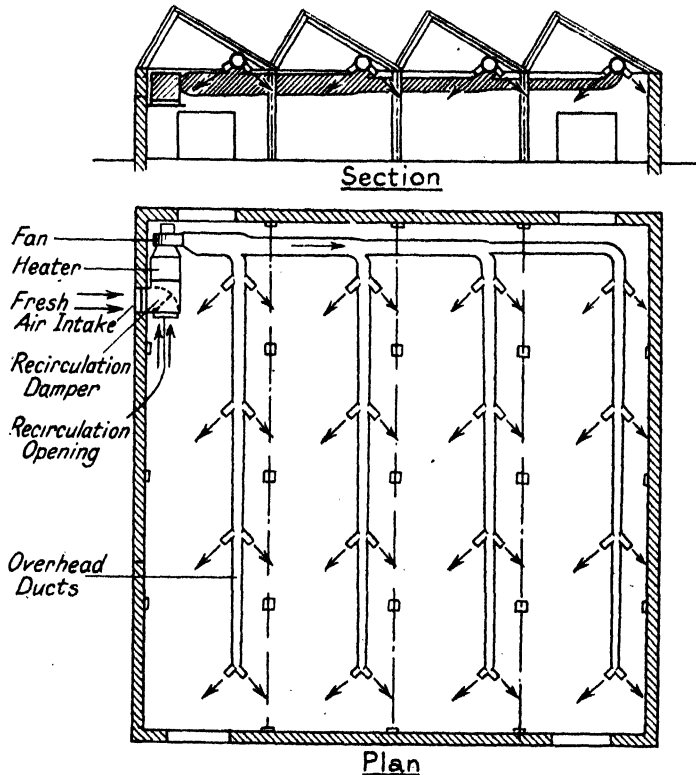

FIG. 37

perature so as to offset the cooling losses of the building.

There is usually no extract system, the aim being to maintain a slight "plenum" or pressure in the building and the air finds its escape under doors, and through cracks around window and roof glazing.

The system is cheap to install and does not require apparatus at floor level as the plant and ducts can all be fixed overhead as in Fig. 37.

It should not be confused with a ventilating

ventilation in summer when the fan can be set running without heat on, simply to cause a movement of air in the building.

A recirculating damper is often provided so that, instead of drawing in air from outside during very cold weather, air from the building is returned and re-heated. Without this provision the system is extravagant, as the whole of the air introduced is raised from, say, 30° to 120°, and is expelled from the building at 55° or 60°. The difference between 30° and

MODERN BUILDING CONSTRUCTION

60° is all wasted and represents in this case one-third of the total.

The volume of air to be introduced with the plenum system depends on the heat losses of the building, and on the temperature to which the air is warmed. The volume should not be less than the equivalent of four air changes per hour for good distribution and the incoming temperature should not exceed 130°.

EXAMPLE. A north-light factory has a heat loss of 2,000,000 B.Th.U.s per hour when inside at 55° and outside at 30° F. and has a cube of 400,000 cub. ft.

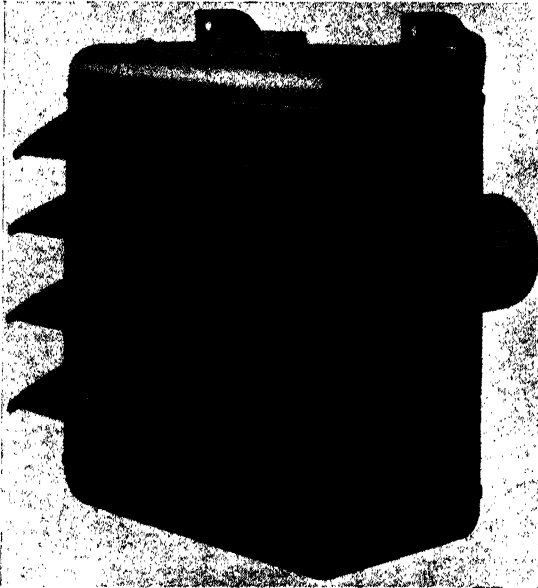

(Ideal Boilers and Radiators, Ltd.)

FIG. 38. UNIT HEATER

What volume of air is necessary if the inlet is at 130°, and what quantity of heat has to be supplied to the heater battery when 100 per cent fresh air is being introduced at 30° F.?

The weight of air will be given by the formula—
Weight of air per hour

$$\begin{aligned} & \text{B.Th.U./hr.} \\ & = \frac{\text{specific heat} \times \text{temp. drop let into outlet}}{2,000,000} \\ & = \frac{0.24 \times (130 - 55)}{2,000,000} \\ & = 111,000 \text{ lb. per hr.} \end{aligned}$$

Volume at 130° F. = 14.88 cub. ft./lb. (Table I)
Volume to be delivered by ducts to factory

$$\begin{aligned} & = \frac{111,000 \times 14.88}{60} \\ & = 27,400 \text{ cub. ft. per min.} \end{aligned}$$

(NOTE. If the blow through arrangement is used the fan will need to handle only

$$\frac{111,000 \times (\text{at } 30^\circ) 12.34}{60} = 23,000 \text{ cub. ft. per min.})$$

The heat to be supplied to the heater battery will be that necessary to raise the air from 30 to 130° = 100° rise.

$$111,000 \times 100 \times .24 = 2,650,000 \text{ B.Th.U.s per hour,}$$

(The above assumes all the ducts to be inside the factory to be warmed, so that any heat lost from them is usefully employed. If the ducts are external an addition must be made for duct losses.)

The volume of air introduced

$$= 111,000 \times 14.88 = 1,660,000 \text{ cub. ft. per hour.}$$

Thus the air changes are

$$\frac{1,660,000}{400,000} = 4.15 \text{ air changes per hour, which would be satisfactory.}$$

Direct Radiator System. Where a large number of separate rooms are to be heated and ventilated the plenum system is not so suitable as for large space heating. The difficulty arises owing to the differing heat losses and occupancy of the various rooms rendering the adjustment of dampers critical. For such cases a direct radiator system is to be preferred, designed to counteract the fabric losses only, with the ventilation catered for separately by a plant delivering air at room temperature.

Unit Heater-System. Another system in which air is used for the conveying of heat after the manner of a plenum system, but which requires no ducts, is the unit heater system.

A unit heater, one form of which is shown in Fig. 38, comprises a fan, motor, heater battery, and casing with louvres. The heater is supplied with steam or hot water heating the air to 120° or 130° or so. The fan draws air from the room and discharges it with sufficient velocity to make it carry 50 ft. or more. The units are fixed overhead and require to be appropriately placed in the space to be heated, having regard to surfaces of maximum exposure, length of discharge, height, etc. They give rapid heating up hence are particularly suited to factories with large doors and severe heat losses. They are very compact for their output, sizes ranging from 20,000 to 300,000 B.Th.U.s per hour. Larger sizes are available in the floor mounting type up to about 1,000,000 B.Th.U.s per hour.

These units may be run in summer without heat, to give air movement, or, if desired, may be arranged with fresh air inlet ducts to give ventilation.

With any unit heater system it is desirable to apply thermostatic control, the fan motor switching on and off according to temperature.

Prefabrication

By R. GREENHALGH, A.I.STRUCT.E.

THE word "prefabrication" is a misleading term. By derivation it means pre-made. But then a brick is pre-made, yet a brick house is not a prefabricated house. If, however, bricks were previously assembled into panels in a workshop and these panels then taken to the site and erected, this method would be an example of prefabrication.

Thus prefabrication means pre-assembly in a workshop, so that the building can be more quickly erected on the site. This pre-assembly in the workshop can be either partial or complete: that is, a complete house could be built in a workshop; or it could be built in two or more large parts; or the walls and floors could be made complete; or only parts of the walls, etc., could be pre-assembled. All these different methods—these different degrees of prefabrication—have been adopted, and will be briefly described before explaining in detail the methods most suitable to British practice.

Complete Houses. In America, complete houses have been prefabricated. They are made in a large workshop, complete with kitchen and plumbing fittings, and then conveyed on special trailers to the site already prepared to receive them, and where it is only necessary to connect the drain and other services. This method is, however, only applicable to small houses, and they are almost invariably small bungalows built of timber. It is not suitable for British conditions, for several reasons: our narrow roads, our comparative shortage of timber, our dislike of monotony and uniformity in design, and its general unsuitability to British ideas of housing.

Cubic Sections. Obviously instead of prefabricating the house complete in one unit, it

could be made in two or more sections, each containing one or more rooms, and then fixing these large units together on the site. Such houses have been built in fairly large numbers in America and are often called *demountable* houses because the houses can be readily taken

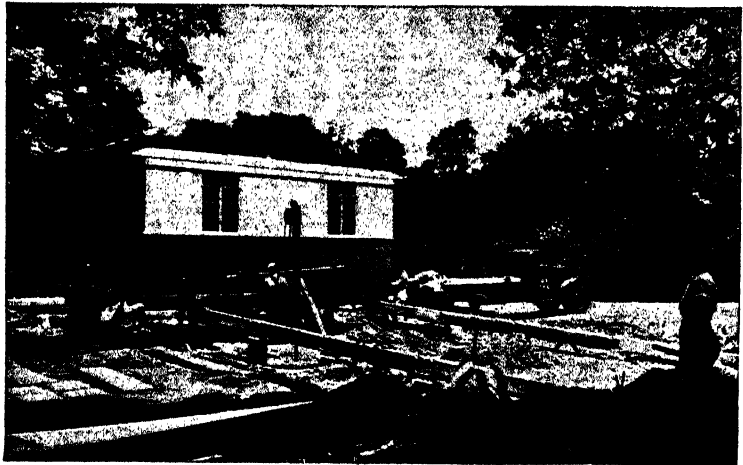

FIG. 1. DEMOUNTABLE HOUSE

apart, that is, demounted, and if desired erected on another site.

Fig. 1 shows part of such a demountable house for the Tennessee Valley Authority, U.S.A., being unloaded and placed in position on its foundations. These large cubic sections are built complete in the workshop and are on four small rollers, so that they can be rolled into position on the foundations. In this particular example the roof surfaces are pivoted at the eaves, so that the sections are less bulky for conveyance to the site, and the roof slopes are raised to position on the job.

Sectional Systems. By this is meant constructing the walls, floors, and roof slopes in large pieces, and fixing these large plane sections together on the site. As far as possible each wall is in one section to obviate vertical joints. Probably the best known of these

MODERN BUILDING CONSTRUCTION

methods is the Homasote, or Precision-Built, System devised by the Homasote Company, of America. A wall section is shown being prefabricated in Fig. 2. These walls consist of 4-in. by 2-in. studding to which are nailed and glued back and front the Homasote sheets. The sheets are of special wood-fibre board made in long lengths. In Fig. 2 the studs are shown

to their largeness they tend to lead to monotony in design. Consequently many systems of prefabrication have been evolved which employ small wall units, or "panels," as they are called. These panels are usually floor height (about 8 ft.) and 2 ft. to 4 ft. wide, and may be made of any suitable materials, but they are usually of timber, steel, or asbestos cement.

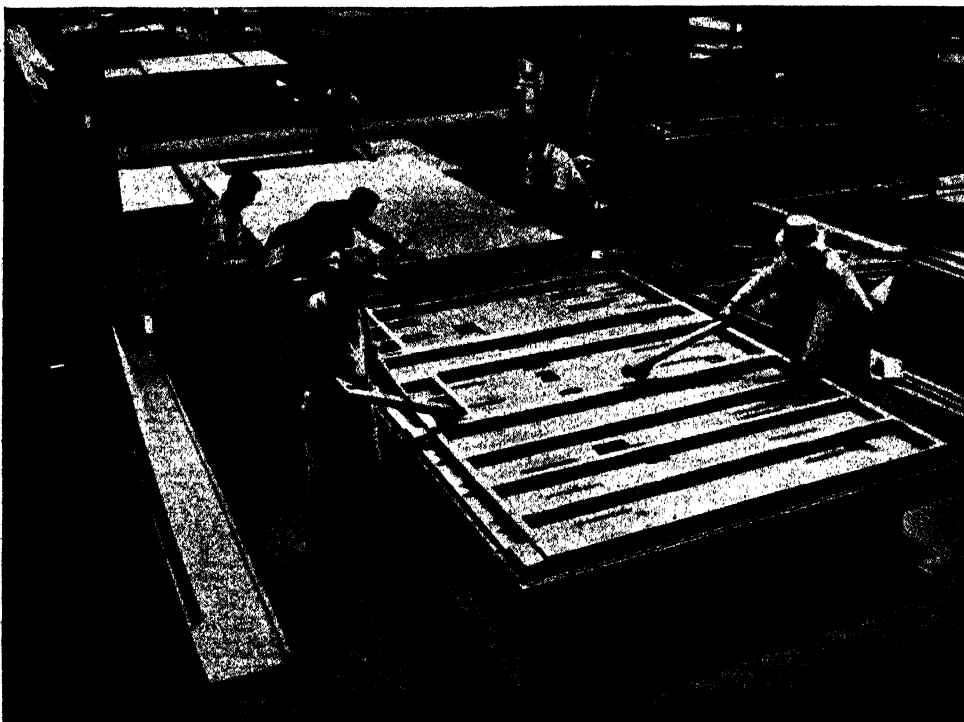

FIG. 2. PREFABRICATION OF HOMASOTE WALL SECTION
Glue "guns" are being used for gluing sheets to frame.

being glued by means of glue "guns." The electric wiring is fixed in position before the inside sheet is fixed. The external finish is either by spraying with a sand finish, or by a layer of weather-boarding over the Homasote, though sometimes a half brick skin is built, leaving a 2-in. cavity between brick and Homasote.

The sections are made of storey height, and for a two-storey house the construction is as shown in Fig. 3. Actually the construction is very similar to ordinary English timber house construction except that the sections are pre-built.

Panel Systems. In the sectional systems just described the units are large and therefore unwieldy and difficult to transport, and owing

Stressed-skin Construction. This is a special form of construction usually carried out on the panel system. See the diagrammatic section, Fig. 4. The walls (and also floors and roof) are built of "panels" consisting of sheets of plywood glued to a framework of battens or studs. With modern synthetic-resin glues the adhesion is so perfect that the sheets are rigidly attached to the studs between them. Thus, when a force, say wind pressure, acts on a panel, as shown by the arrow in Fig. 4, the two sheets of plywood resist the bending in the same manner that the flanges of a steel beam resist bending. The same can be said of the floors and the roof. The two "skins" thus not only form the surfaces of the panels, but also resist the stresses due to loads.

PREFABRICATION

The joints between the panels call for special mention. Between two adjacent vertical panels, the joint can be formed by a loose tongue, going half way into each end stud that abuts

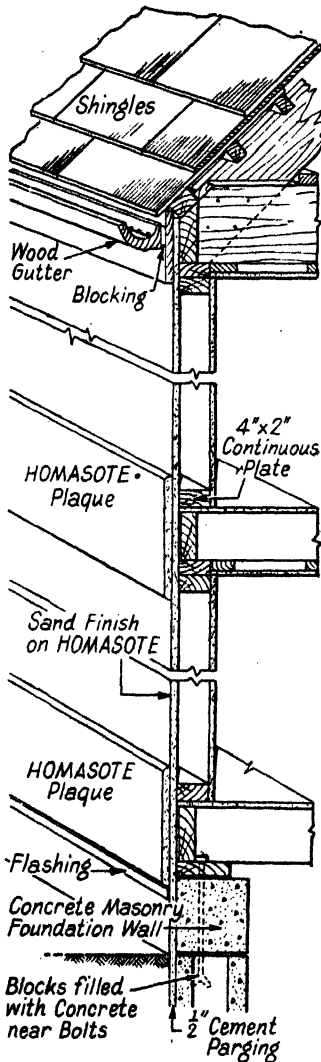

FIG. 3. VERTICAL SECTION SHOWING CONSTRUCTION OF TWO-STOREY HOUSE BY HOMASOTE SYSTEM

against another, and covered on the outside by a joint strip; sometimes the joints are made by mastic or glue. Joint strips can be dispensed with by keeping the studs back from the edges of the plywood, and fitting a loose stud, or spline, between the plywood skins at the joint, this spline being glued in position on the job.

The plywood may be left painted, but this is usually considered suitable only for temporary work, and the outside is often covered by weather-boarding or shingles.

Swedish Construction. Typical Swedish construction is shown in Fig. 5, though there are several variations of this method. The walls are of solid plank construction, and though wasteful of timber, the houses are warm in winter and cool in summer owing to the excellent insulating properties of the timber. Wood-fibre board may be nailed direct on the planking, but is not such a good method. The prefabricated sections, or panels, are large and heavy, and usually extend the full height of the house. Many hundreds of these houses have been built in Great Britain, chiefly Scotland, and some have been prefabri-

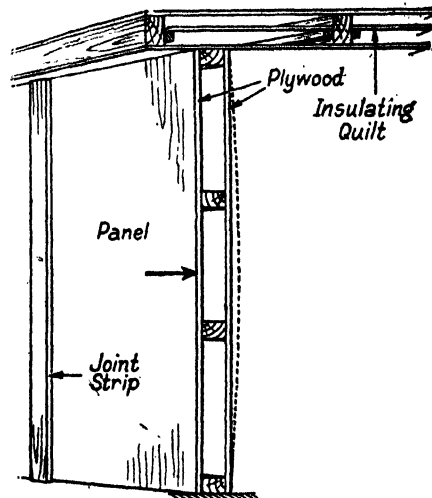

FIG. 4. DIAGRAMMATIC VERTICAL SECTION ILLUSTRATING PRINCIPLES OF STRESSED-SKIN CONSTRUCTION

cated in Sweden and shipped in section form to this country.

Asbestos-cement Panels. The two chief traditional building materials, brick and stone, are not very suitable for prefabricated systems, but other materials, in addition to timber, have been tried. One of the most promising of these is asbestos-cement sheets. These sheets can be obtained in various shapes, thicknesses, and finishes, and may be attached to a framework, as will be described later, but two well-known prefabricated systems employ two plain sheets of asbestos-cement with a "sandwich" of insulating material between them. The first of these was "Cemestos," introduced in America by the

MODERN BUILDING CONSTRUCTION

Celotex Company, in which the "sandwich" is wood-fibre wall board.

More recently the "Seco" system was introduced here and has been used in some thousands

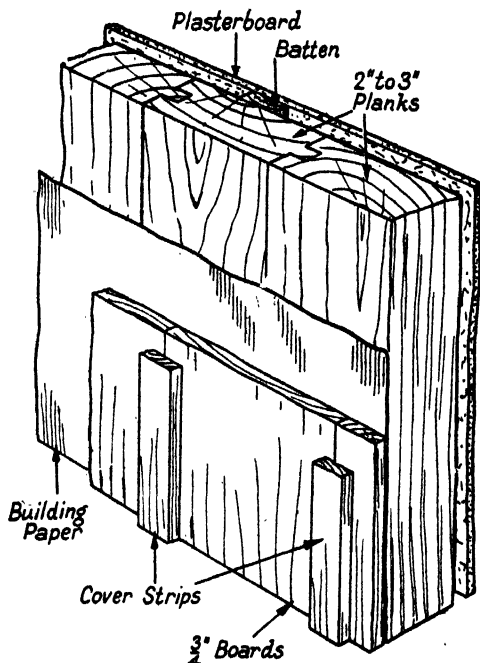

FIG. 5. TYPICAL SWEDISH HOUSE CONSTRUCTION WITH SOLID TIMBER WALLS

of wartime buildings. Houses have also been built on the "Seco" system. A section through the junction of the panels is shown in Fig. 6, and the general construction of the Seco house

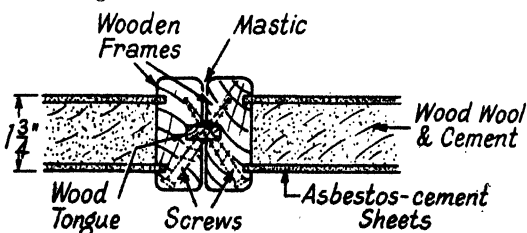

FIG. 6. CONSTRUCTION OF "SECO" PANELS SHOWING ONE METHOD OF FORMING JOINT BETWEEN THEM; AN ALTERNATIVE METHOD EMPLOYS COVER STRIPS OVER THE JOINTS

is shown in Fig. 7. The panels consist of two plain sheets of asbestos-cement with about 1½ in. of wood-wool and cement concrete between them. This composite slab has a wooden surround to protect its edges and to facilitate fixing the panels together; the asbestos-cement

sheets fit into grooves in the wood frame. The opposite edge of the wooden ribs also has a groove to receive the jointing tongue; in addition the two ribs are screwed together, and mastic is forced into the joint by means of a hand-pressure jointing gun.

The panels are load bearing, as shown in Fig. 7, where it will be seen that the centre-wall panels support half the weight of the house. This illustration also indicates the roof construction and the plywood lintels that tie the heads of the panels together.

Tarran System. (Figs. 8 and 9.) The wall panels are 1 ft. 4 in. wide and storey height. Each panel consists of two vertical plywood ribs 4 in. wide and ½ in. thick. Cast between these ribs is a "Lignocrete" slab composed of sawdust and cement, or alternatively of a water-resisting fine concrete; this slab is strengthened by horizontal ribs of the same material reinforced by steel wire. In fixing, the panels are screwed together, and then bitumen mastic is forced into the joint to make it weather-tight; the outside is then rendered in waterproof cement.

The floors are also of novel construction, and consist of prefabricated panels, or slabs, 4 ft. wide and spanning across the room. The long supports are steel channels, between which span small joists having plywood webs; timber "splines" form the flanges to which the plywood floor covering and ceiling finish are nailed.

Steel Panels. Between the two great wars several types of steel clad houses were built, and one of these, the "Telford" house, is illustrated in Fig. 10. It has structural steel panels of shallow "tray" section, No. 11 gauge. These are painted externally and internally as a protection against corrosion. The inside lining is of asbestos-cement sheets fixed to battens, and there is a centre membrane of sheet felt for insulation.

"Portal" (Churchill) Steel House. This is probably the most outstanding achievement in prefabrication and is due to the combined efforts of two architects, Mr. Mole and Mr. Kenyon, and the Building Research Station. It is called by the Ministry of Works "an emergency factory-made house" and is a total departure from traditional building methods; it is more akin to motor-car production or engineering technique. It is a temporary house, designed to last ten years. The walls are of pressed steel about ¼ in. thick; the steel panels have vertical

corrugations at intervals to strengthen them, and the edges have V-shaped pressed steel strips welded to them. In the joints are special mastic seatings, and the edges of the panels are pressed on to this mastic by driving steel wedges into slots cut in the horizontal steel flats to which the vertical sheets are fixed. The steel is bon-

on pressed steel rafters. Above the ceiling level is placed aluminium foil, as in the wall panels. An important feature of the house is the kitchen- and bathroom unit, comprising on one side the refrigerator, sink, and cooker; and on the other side the bath and wash basin.

Frame Systems. So far the prefabrication

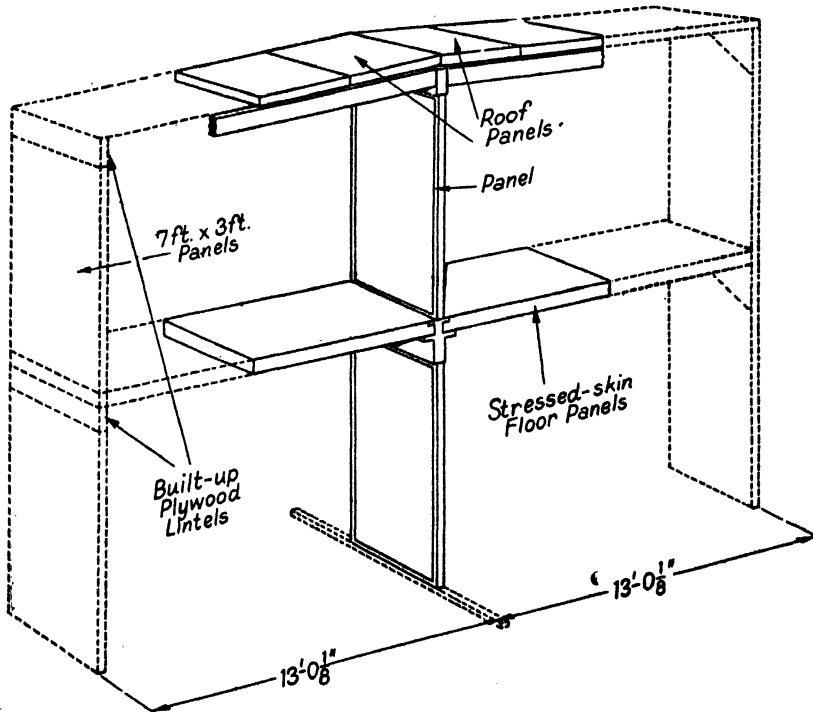

FIG. 7. ISOMETRIC SKETCH SHOWING THE GENERAL CONSTRUCTION OF THE SECO HOUSE AND HOW THE PANELS SUPPORT THE LOADS

derized (a kind of stove enamelling) and primed and painted; on the inner surface it is coated with flocculent anti-drum material.

The internal wall finish to the rooms is plywood or other wall board. Between the internal and external surfaces of the walls is fixed a sheet of aluminium foil on paper for heat insulation. See Fig. II, which shows the construction of the wall at one of the main joints. It should, however, be stated that in America several steel houses (for instance, the Scot-Built House) of a somewhat similar character to the "Portal" house were erected some years ago.

The floor joists are also made of pressed steel, bent to channel form, and on them are laid $\frac{3}{4}$ in. floor boards. The floor is brought to the site in sections. The roof has a small pitch of $6\frac{1}{2}$ degrees, and consists of pressed steel sheets

systems dealt with are composed of sections or panels that are not only self-supporting, but also load bearing. There is, however, a large class of prefabrication systems which have a frame, of steel or timber, to carry the external cladding and to support the roof and wall loads. Thus in one type, the "Coventry" house, the frame is of tubular steel (similar to tubular scaffolding), and the external wall cladding is tile-faced concrete slabs to the ground storey and asbestos-cement sheets to the upper storey. Other types of steel frames are made of channel or other rectangular sections.

A drawback to the steel frame is that bolts or various forms of clips have to be used to fix the external cladding. A laminated wood frame has therefore been devised, and this consists of posts and beams built up from narrow

MODERN BUILDING CONSTRUCTION

boards. Thus the posts can be made of three 4-in. by 1-in. boards, nailed and glued together with synthetic resin cement; short lengths of boards can be used so long as they break joint.

the main principles of its construction are shown in Fig. 12. It consists essentially of a steel frame, made up of units about 3 ft. wide and two storeys high, bolted together on the site.

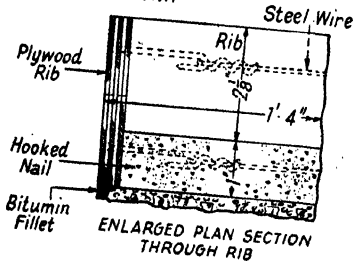
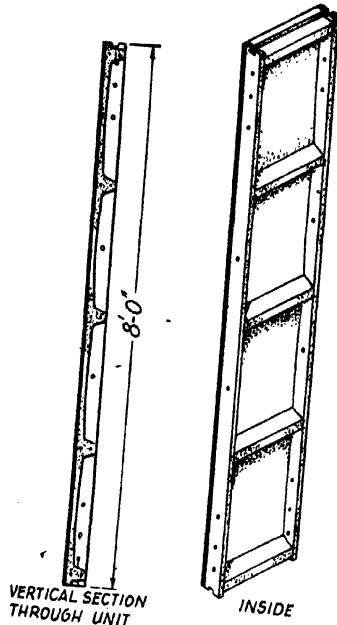

FIG. 8. DETAILS OF TARRAN WALL UNIT

This type of wooden frame also has the advantage that the defects in the boards are distributed and do not go through the entire section of the members, and that joints can be conveniently made by omitting parts of the laminations and forming tongues of the laminations on the connecting members.

Braithwaite System. The Telford house, already described, was constructed by Braithwaite & Co., Ltd., but a later house, of the steel-frame type, erected in 1944, is also the work of this firm. This later method is known as the Unit Frame Construction System, and

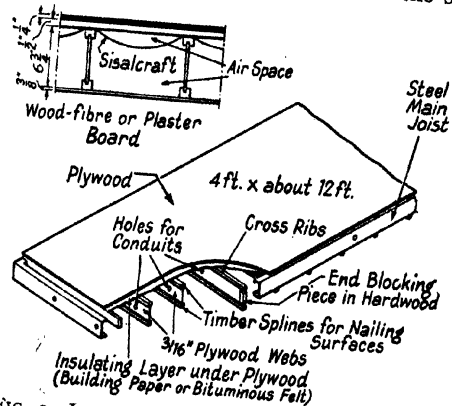

FIG. 9. ISOMETRIC SKETCH OF TARRAN FLOOR SLAB AND ENLARGED SECTION THROUGH PLYWOOD JOINT

The steel is only about $\frac{1}{8}$ in. thick and the vertical members are rolled to the section shown in the illustration. These vertical members of the units are fixed together by special joint clips

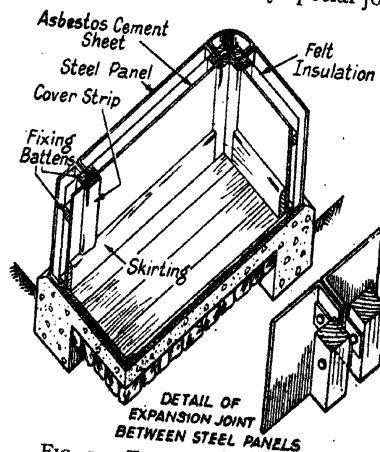

FIG. 10. THE TELFORD HOUSE
The external walls are of shallow "tray" sheet panels.

bolted to them, and these clips also secure the jointing strips which hold the external sheeting, or cladding, in position. Various kinds of cladding can be used, but the usual material is asbestos-cement sheets. These are thicker than usual and have a corrugated face, the corrugations running vertically and about 1 in. apart

from crest to crest. The jointing strips are made of zinc, and are wedge-shaped in section, so that when they are forced home, the wings snap on to the clips, which then hold the joint strips

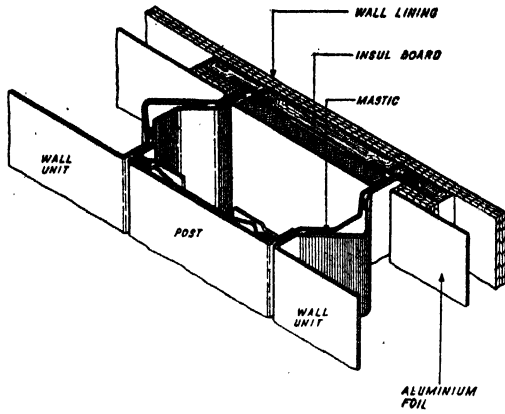

FIG. 11. WALL CONSTRUCTION OF CHURCHILL (PORTAL) SHEET HOUSE

tightly against the faces of the asbestos-cement sheets. The interior wall linings are fixed in a similar manner.

The floor consists of "squares," of about 3 ft. side, of batten-board fixed to wooden bearers,

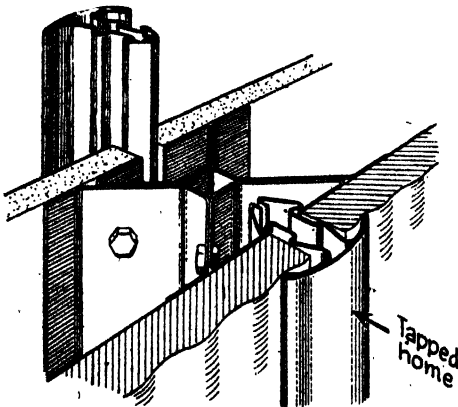

FIG. 12. BRAITHWAITE UNIT FRAME SYSTEM

and these squares are supported on thin steel beams of inverted channel section.

Concrete Houses. Concrete, like brick and stone, is so heavy that large panels made from concrete are not easy to transport and erect. Many systems have, however, been devised which employ concrete slabs and blocks. Usually piers are first erected, the piers being either pre-cast or cast *in situ*, and then the pre-cast blocks or slabs are fixed between them. Often the

blocks are of hollow construction, but sometimes they are made in the form of thin slabs and fixed so that there is a cavity between them. These thin slabs can therefore be made of a fair size without being unduly heavy, and thus a degree of prefabrication is achieved. But the smaller the block, the nearer the method approaches traditional brick or stone construction. With sawdust, shavings, or wood-wool concrete the slabs can be made larger without being too heavy to handle, but these types of concrete have not the same reliability as ordinary concrete because they expand and contract to a greater extent with atmospheric changes.

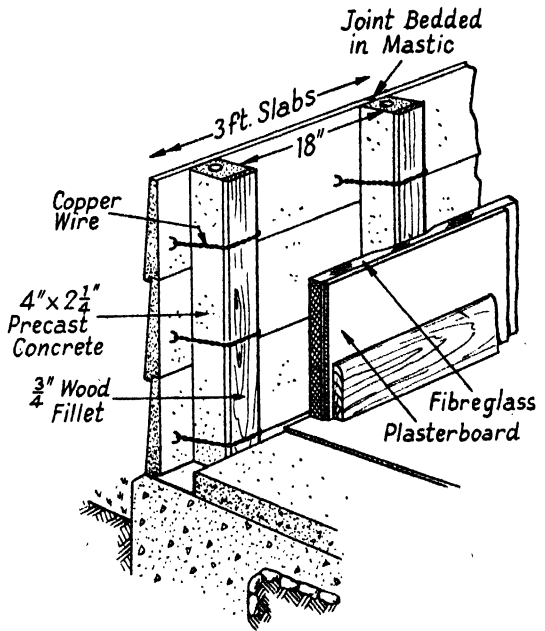

FIG. 13

A detail of the construction of the "Airey" concrete house is given in Fig. 13. On the foundation pre-cast reinforced-concrete posts, storey height and 4 in. by 2½ in. in section, are erected at 18 in. centres. To these posts are wired concrete slabs 3 ft. long, 9¼ in. deep, and about 1½ in. thick.

Temporary and Permanent Prefabrication. In Great Britain, prefabricated construction has been sharply divided into two classes: temporary and permanent. Thus we have two types of housing scheme: temporary houses and permanent houses. As all our temporary houses are prefabricated—the Seco, Arcon, and Aluminium houses, for example—it does not

MODERN BUILDING CONSTRUCTION

necessarily follow that all prefabricated houses are temporary. Thus, concrete prefabricated houses and also, for instance, the British Iron and Steel Federation steel house, are classed as permanent structures.

Actually there is too much rigidity in this sharp division between temporary and permanent. By "temporary" house, the Government mean a life of ten years, yet all the "temporary" houses mentioned above would last much longer than this period. Even timber

made to prefabricate the services and fittings as far as possible. The Tarran house, or rather bungalow, has a kitchen unit as illustrated in Fig. 14; this unit also has the bathroom fittings on the other side. These various fittings are all assembled into one unit in the workshop, and the unit is conveyed to the site and placed in position, where it is only necessary to connect it to the drainage, water, and other pipes.

In a house, the unit has, of course, to extend through the two storeys, or separate kitchen and bathroom units are pre-assembled. Units to hold the gas and electricity meters and connections are also prefabricated.

ADVANTAGES AND OBJECTIONS

Experts are divided in their opinions on prefabrication. For instance, some technicians say that prefabricated buildings are inferior to buildings built by the traditional methods, and that the cost is little, if any, lower; many trade union officials are afraid that it will throw skilled craftsmen out of work and lower the standard of craftsmanship; architects on the whole are apprehensive as they think it may lead to monotony of design.

There is certainly something in the last objection, for the larger the units the less flexibility there is in design; while the larger the units the greater the degree of prefabrication. Yet it might be argued that prefabrication in small house design could not do worse than the millions of houses built during the past hundred years. Possibly the solution might be to have a frame or a panel system to which could be attached small exterior covering units.

On the whole, prefabrication has made headway during the past few years. One reason is the huge amount of building required because of war damage and the cessation of civil building operations during the war, and the difficulty of meeting these huge demands with traditional methods alone. Some technicians believe that though prefabrication will be employed to cope with these demands, it will be only a temporary expedient and we shall return to traditional methods.

Probably most architects and builders are of the opinion that brick and stone are the best building materials for houses; they tend rather to improve in appearance with age than deteriorate. But these two materials are unsuitable for prefabrication methods: the units or panels would be too heavy.

Some hundreds of systems of prefabrication

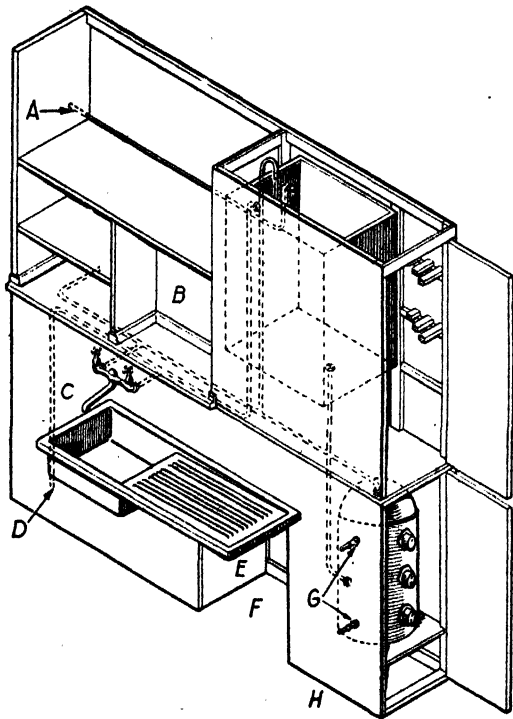

FIG. 14. TARRAN PLUMBING UNIT
For bungalows the other side of the unit contains the bathroom equipment.

houses, if properly constructed of good seasoned timber, can be classed as permanent, as is proved by timber houses still standing after hundreds of years. It is, however, the intention to scrap the temporary houses after ten years; and the design, sizing, and siting have been made on this assumption.

Plumbing Units. It is often assumed that the carcase of a house—that is walls, floor, roof, and partitions—represents nearly all the cost of a house, but actually the domestic services, fittings, and finishes account for more than half the cost. Many attempts have therefore been

have been devised, and many of them have been tried; with more or less success. So far, without exception, all the qualities considered, they do not seem to be as good as the traditional methods. But they certainly are quicker in erection. This does not mean that they are much cheaper than traditional construction, for two reasons. First, though less labour is used on the site more is necessary in the workshop; and secondly, the structural fabric only accounts for about one-third of the cost of the building. But the tendency is for the fitments and finishings also to be prefabricated and mass-produced, and for methods and machines to be perfected. Another argument that seems to be gaining ground, is that we do not need permanent houses, which become obsolete, and that houses with a medium life of fifty to one hundred years would be more sensible, and these medium life houses could be best produced by prefabrication methods.

Standardization. With the increasing use of machines, all kinds of building materials, both old and new, are being more and more mass-produced to standard sizes. For instance, there are over a hundred British Standard Specifications relating to building products. The main object of these specifications is to maintain a minimum standard of building, but it also follows that the standard sizes and qualities encourage mass production. But though we have a large degree of mass production by building material manufacturers, and a moderate degree of mass production in the builders' workshops, there is very little mass assembly on the building site. In fact, it is difficult to achieve

the latter, and what prefabrication seeks to do, is to pre-assemble the small units into larger units by the aid of machines in the workshops. Prefabrication has, in fact, also been called double-assembly, as much assembly as possible in the workshop and as little as possible on the site.

Dimensional Co-ordination. To facilitate the assembly of the small units into more complex units in the workshop, and to ensure that the different types of these units will fit together conveniently on the site, it is advisable that the units should be based on a common dimension. The American unit is generally 4 in., perhaps because American bricks are (nominally) 4 in. wide; the lengths and widths of doors, windows, etc., are therefore made to be multiples of this 4-in. unit. The unit is often called a "modular unit" or "module."

Obviously it would be best if a module, say 4 in., was adopted for all materials, so that whatever their nature they would fit conveniently together, but some prefabricationists favour the use of different modules for different buildings, according to the kinds of material employed, because different units suit different materials and processes of manufacture.

The adoption of a module is, on the face of it, certainly advisable, but is not so simple as it appears to be, owing to the allowances that have to be made for joints, and to the fact that actual sizes are often not the same as nominal sizes; a nominal 1-in. floor board is actually only $\frac{7}{8}$ in. thick. With a system of dimensional co-ordination it is therefore advisable to work from the centre lines of the small units.

Examinations and Professional Qualifications

By T. CORKHILL, M.I.STRUCT.E.

THE question of examinations is an important one to every keen student, as a certificate is evidence of his having completed some recognized course satisfactorily. Very often much time is lost through lack of knowledge of the procedure most useful for the individual's particular interests, and this article is intended to indicate the available opportunities. Those preparing for the more important professions are controlled by the schemes and courses of study prepared by those in authority. In fact, every profession has its own association to which those engaged in the profession may be admitted either by examination or by merit, and anyone interested should write to the secretary for the necessary information (see below). For some of the professions a University training is advisable, but so far Manchester is the only University that grants a degree in Building. Several of the important professional institutions are dealt with in other pages; hence this article is intended more for craftsmen and the rank and file of the building industry.

In the past it was usual for the part-time student to concentrate on one particular subject, but to-day everyone recognizes the necessity for a more liberal education, and courses are prepared that embrace several related subjects, in addition to the principal subject. The first step for anyone considering technical education is to enrol at a technical college, recognized by the Board of Education, where he will be advised as to the procedure necessary for his requirements.

NATIONAL BUILDING CERTIFICATES AND DIPLOMAS

These have been introduced to meet the demand for a uniform course of study suitable for those engaged in building. Before beginning this course, the student must have had preparation through a junior technical or secondary school, or by means of a special preparatory course at the technical college.

It is a big advantage for the boy to attend a junior building school on leaving the elementary school and before entering the building industry. If the course is satisfactory it will exempt the student from the first year of the National certificate course. There has been a big increase in the number of junior building schools the courses being arranged for two or three years, according to the requirements of the locality. A few technical schools provide a five year course, from the age of eleven years, giving a sound general education for three years and then specializing in building subjects for the last two years of the course.

The principal subject for the National certificate is Building Construction, with Building Science, Mathematics, and Geometry as auxiliary subjects, but the treatment of the related subjects varies considerably. In the third year of the course some colleges begin to specialize, and such subjects as Quantities, Structures, etc., are introduced.

The course covers a period of three winter sessions, with a minimum attendance of three evenings per week. Each year the school holds an examination, and if the student is successful and has given satisfaction in attendances, homework, and classwork, he proceeds to the next year's course. At the end of the third year the examination is controlled by the Institute of Builders (48 Bedford Square, W.C.1) in conjunction with the Board of Education. Assessors are appointed to approve the examination questions and the worked papers, and the student is awarded a certificate if he has given satisfaction and is at least 18 years of age.

The minimum requirements are 60 per cent attendance in each year, together with 40 per cent marks for homework, classwork, and examination. In the final examination, however, it is necessary to obtain a grand total of 50 per cent marks over the whole examination, with 40 per cent marks as the minimum for each subject. If the student finds it necessary

EXAMINATIONS AND PROFESSIONAL QUALIFICATIONS

to transfer to another college during the course his record is sent to the new college to avoid repetition.

Higher National Certificates. These courses are a continuation of the National certificate, but of a specialized character, and cover a period of two years. They are conducted on the same lines as for the previous certificates, and a successful student is considered as having a sound theoretical knowledge of both his own particular subject and Building generally. They can be obtained only through the technical colleges approved by the Board of Education.

Diplomas. Full-time day students have a similar programme for the National Diplomas and the Higher National Diplomas.

Most of the professional associations recognize the Higher National certificate and diploma as an exemption from parts of their own examinations, especially if the student has specialized in appropriate subjects. For instance, the Institution of Structural Engineers exempt from the Graduateship examination.

CITY AND GUILDS OF LONDON INSTITUTES

The craft student is particularly interested in these examinations, as a certificate is recognized as satisfactory proof that the recipient is an excellent craftsman and has a sound theoretical knowledge of his trade. The best procedure is for the student to obtain the National certificate, and then continue his studies with a view to the City and Guilds' examination instead of the Higher National certificate. He should have attained sufficient practical ability and knowledge to attempt the particular final examination, in which he is interested, after two years, which means an intensive course of study over a period of five years. The examination includes both theory and practice, and in some cases a preliminary model is necessary, the subject of which is selected by the candidate. Both intermediate and final examinations are held annually, usually in the college where the student is attending, or at some convenient centre. Advisory committees revise the conditions occasionally to meet modern requirements, and anyone interested should write to the Secretary (31 Brechin Place, South Kensington, S.W.7) for particulars; or any Technical College can supply the necessary information. A *Full Technological Certificate* is awarded to a student having appropriate qualifications in auxiliary subjects, such as the National certificate, which

qualifies the recipient to teach the particular subject. Medals and prizes are presented to the most successful candidates.

The City and Guilds' examinations suitable for Building students are: Brickwork, Masonry, Carpentry and Joinery, Plastering, Painting and Decorating, Plumbing and Sanitary Engineering, Structural Engineering, Heating and Ventilation, Builders' Quantities, and Welding.

Success in these final examinations usually allows for admission to the appropriate association, or exempts from part of the examination. A first-class pass in "Structural Engineering" gives exemption from the "Theory of Structures" paper in the Associate Membership examination of the Institution of Structural Engineers.

Handicraft. Many students are interested in this examination, which qualifies for teaching in elementary schools. The requirements are a good education, in addition to craftsmanship. The first examination enables one to obtain a position as an uncertificated handicraft teacher; after which he may sit for the final stage, which comprises Woodwork or Metalwork, Science Handicraft, Science, Mathematics, and Principles of Teaching.

REGIONAL EXAMINATIONS

The Technical colleges in the North-west, North-east, and Midlands are affiliated, and have central organizations that control the syllabuses and examinations held in the colleges. These bodies are the Union of Lancashire and Cheshire Institutes, the Northern Counties Union, and the Union of Educational Institutes respectively. Every kind of technological examination is conducted by these bodies through the local colleges, and the method of awarding certificates is similar to that for the National certificates, except that certificates are awarded for each year. In other parts of the country where these bodies do not operate, the individual Technical colleges often award their own certificates.

MISCELLANEOUS EXAMINATIONS AND QUALIFICATIONS

Institute of Builders (48 Bedford Square, W.C.1). In addition to the National Certificates and Diplomas, the Institute conducts examinations for Licentiate and Associate. Corporate membership requires nomination and election in addition. Election to Fellowship depends

MODERN BUILDING CONSTRUCTION

upon qualifications and approved experience as a master builder.

Worshipful Company of Carpenters (Carpenters' Hall, 28 Austin Friars, E.C.2.). Examinations in Sanitary Building Construction and in Carpentry and Joinery.

Incorporated British Institute of Certified Carpenters (Carpenter's Hall, by courtesy of the Worshipful Company). Associateship by examination or by City and Guilds' examination; Fellowship by means of Worshipful Company of Carpenters' examination.

Incorporated Institute of British Decorators (9 Little Trinity Lane, E.C.4). Examination for Associateship (Preliminary, Intermediate, and Final). Candidates may obtain exemption from the Preliminary and Intermediate stages by means of other approved examinations. Admission to Fellowship is by means of approved qualifications and experience.

Institute of Plumbers (81 Gower Street, W.C.1). Registration by examination or through the City and Guilds' examination.

Worshipful Company of Plasterers (22 Bedford Row, W.C.). Registration by means of City and Guilds' examination and approved experience, in conjunction with the joint Educational Board of the Plasterers' Association.

Association of Building Technicians (A.B.T.), 5 Ashley Place, S.W.1.

Royal Sanitary Institute (90 Buckingham Palace Road, S.W.). Examination for qualification as Sanitary Inspector to local authorities, membership of the Institute, etc.

Institution of Quantity Surveyors (5 Leicester Street, Wolverhampton). Examinations include Preliminary, Intermediate, Final, and direct membership as Associate or Fellow.

Institution of Sanitary Engineers (120 Victoria Street, S.W.1). Examination for Associate Membership and for Fellowship. Corporate membership through these examinations or by approved qualifications and experience.

Institution of Municipal and County Engineers (84 Eccleston Square, S.W.1). Examination for those engaged in Local Government service: (1) Testamur (a certificate of proficiency in Municipal Engineering and Surveying); (2) County and Highway Engineering; (3) Town Planning; (4) Diploma in Administration. Corporate membership is by means of (1) and (2), or other approved examinations, and election.

Institution of Heating and Ventilating Engineers (12 Russell Square, W.C.1). Examinations for Graduates and Associate Members. Associateship and membership by means of approved experience and qualifications.

Institution of Welding Engineers. 30 Red Lion Square, W.C.1.

Incorporated Association of Architects and Surveyors (75 Eaton Place, S.W.1). Examination for Associateship in the various sections. Election as Fellow or Associate through approved qualifications and experience.

Incorporated Clerk of Works Association (R.I.B.A.) (66 Portland Place, W.1.). Examinations for Preliminary and Final Certificate.

Builder's Foreman and Clerk of Works Association (9 Conduit Street, Regent Street, W.).

The professional associations, in most cases, enrol both students and Graduates, either by means of their own examinations or through approved qualifications. The senior examinations do not of themselves qualify for corporate membership; in addition, it is usually necessary to be nominated and elected.

