

**BIRLA CENTRAL LIBRARY**

PILANI (Rajasthan)

Class No:- 671

Book No:- S53A

Accession No:- 51101





## **MACHINING OF METAL**



*Machining  
of  
Metal*

ROBERT E. SMITH, *Ph.D.*

*Professor of Education  
Ohio State University*

McKNIGHT & McKNIGHT • BLOOMINGTON, ILLINOIS

671  
S 53 M

51101

c/bb 21 863=

**REVISED EDITION  
COPYRIGHT 1949**

BY McKNIGHT & McKNIGHT

*All rights reserved. No part of this book  
may be reproduced in any form without  
permission in writing from the publishers*

Lithographed in U S A

## INTRODUCTION

The working of metal in some form has engaged man's efforts thousands of years. Over long stretches of the period, the products achieved were those resulting from skill of hand and brain in the use of crude or at best simple tools. Reference to a lathe is found among the earliest of recorded writings. Such machines greatly extended man's productive capacity and enabled him to do things almost or entirely impossible previous to their invention. Nevertheless, they were very crude and ineffective when compared with the machines now used for machining metal.

The machining of metal received its greatest impetus with the development of the steam engine. When this device was perfected to the point where a steady, economical and reliable source of power was assured, the development of tools and machines to which power could be applied followed rapidly. Today the use of machinery in producing consumer goods has grown to such volume that some people fear that we have come to the point where we are controlled by the machinery created to serve us. Regardless of these pessimistic opinions and of the failures and shortcomings of this machine age, the fact remains that machines and machine products have made possible a standard of living unsurpassed in history.

Lack of a definite and lasting classification makes it difficult to determine the number of persons engaged in the machining of metal, such as screws, bolts, automobile engines and parts, airplane engines, locomotives and other products. In view of this situation no effort will be made to estimate the number of machinists, toolmakers, die sinkers or machine operators employed in this country. That the total number is large is seen in data taken from the 1940 census. These data show that in 9,107 establishments, 881,827 persons were employed in the manufacture of agricultural machinery, power transmitting machines, tools, boilers, pumps, compressors, engines of all sorts, machinery used in the production of food, oil, textiles and of machines used to produce other machines. These figures did not include persons engaged in the machining of metal in industries employing less than 10,000 people of which there were 39,541 with 1,076,890 employees. Some of these undoubtedly employed machinists, toolmakers or machine operators whose work was chiefly machining metal. These data indicate that approximately one person out of every forty gainfully employed in the United States is engaged part or full time in the machining of metal in some capacity.



## INTRODUCTION

Experiences gained in the school shop through work in the machining of metal are worthwhile because: (1) they help one to understand and appreciate how the machinist, the toolmaker and the machine operator serve society; (2) through these experiences one is able to discover ability and a liking for, or lack of ability and a dislike for, this sort of work as a possible vocation; (3) the skills and work habits acquired are applicable and usable in many industries and under many and varying conditions. One who becomes competent in the skillful operation of a machine has something he will never lose altogether. He may lose some of his refined techniques temporarily but these usually can be restored with a little practice. Furthermore, knowledge and ability to operate one kind of a machine often is a decided advantage in learning to operate a different type of machine. Good reputation achieved in the school shop is of advantage in securing employment after graduation.

## ACKNOWLEDGMENTS

Acknowledgment for illustrative material is appreciatively extended to the Atlas Press Company, Kalamazoo, Michigan, the Brown & Sharpe Manufacturing Company, Providence, Rhode Island, the Cincinnati Milling Machine Company, Cincinnati, Ohio, the Cincinnati Shaper Company, Cincinnati, Ohio, the Cleveland Twist Drill Company, Cleveland, Ohio, the South Bend Lathe Works, South Bend, Indiana, the L. S. Starrett Company, Athol, Massachusetts, The Norton Company, Worcester, Massachusetts, The DoAll Company, Des Plaines, Illinois; and the Racine Tool & Machine Company, Racine, Wisconsin.

# CONTENTS

## SECTION I. SAFETY

<i>Unit</i>	
1. Safety .....	9

## SECTION II. MEASUREMENTS AND MEASURING INSTRUMENTS

<i>Unit</i>	
2. Measuring Instruments .....	11
3. How to Use a Micrometer .....	14
4. How to Set and Use Calipers .....	15

## SECTION III. THE TOOL GRINDER AND ITS OPERATION

<i>Unit</i>	
5. The Grinder and Grinding Wheels .....	19

## SECTION IV. DRILLS AND DRILLING

<i>Unit</i>		<i>Unit</i>	
6. Twist Drills, Boring Tools and Reamers .....	21	10. How to Drill a Hole .....	29
7. The Drill Press .....	25	11. How to Bore a Hole With a Drill Press .....	33
8. Drilling Speeds, Feeds and Lubricants .....	26	12. How to Ream a Hole by Hand or With a Machine .....	34
9. How to Grind Metalworking Drills .....	27	13. How to Spot-Finish Metal With a Drill Press....	35

## SECTION V. THE LATHE AND ITS OPERATION

<i>Unit</i>		<i>Unit</i>	
14. The Metal Working Lathe .....	37	25. How to Knurl a Piece of Mild Steel .....	59
15. Cutting Speeds for Lathe Work and How to Calculate Them .....	40	26. Lathe Chucks and Faceplates .....	59
16. Grinding Lathe Cutter Bits .....	40	27. How to Mount and Remove Lathe Chucks .....	61
17. How to Grind and Whet Lathe and Shaper Cutters .....	43	28. How to Mount and True Up Work in a Four-Jaw Independent Chuck .....	63
18. How to Locate, Test, Drill and Countersink Centers Preparatory to Turning .....	44	29. How to Face and Turn Work Mounted in a Lathe Chuck .....	65
19. How to Set a Lathe Tool for Turning Metal .....	49	30. How to Machine Bore Circular Recesses in a Lathe .....	66
20. How to Mount Work Between Lathe Centers .....	51	31. How to Machine Work in a Lathe When Mounted on a Mandrel .....	68
21. How to Make Roughing and Finishing Cuts on a Lathe With the Stock Mounted Between Centers or in a Chuck .....	52	32. Calculating the Amount of Tailstock Set-Over for Turning Tapers .....	69
22. How to Face Work Mounted Between Centers....	55	33. How to Turn a Taper With a Metalworking Lathe .....	70
23. How to Use a Steady or Center Rest and Follower Rest on a Lathe .....	57	34. How to Cut Threads in a Lathe .....	72
24. How to File and Polish Work Revolving in a Lathe .....	58	35. Milling on the Lathe .....	78

## SECTION VI. THE SHAPER AND ITS OPERATION

<i>Unit</i>		<i>Unit</i>	
36. The Shaper .....	81	41. How to Square Rectangular Stock With a Shaper .....	91
37. Shaper Vises, Parallels, Hold Downs and Angle Plates .....	86	42. How to Make Vertical and Angular Cuts With a Shaper .....	92
38. Calculating the Cutting Speed of a Shaper .....	88	43. How to Cut Keyways and Other Stop Cuts on a Shaper .....	94
39. How to Adjust the Shaper for Stroke and Position .....	89	44. How to Plane Irregular Surfaces With a Shaper .....	94
40. How to Make Horizontal Cuts With a Shaper....	89		

## TABLE OF CONTENTS

## SECTION VII. THE MILLING MACHINE AND ITS OPERATION

<i>Unit</i>	<i>Unit</i>
44. The Milling Machine ..... 98	54. How to Mill a Keyway or Similar Groove .....125
45. Milling Machine Attachments .....102	55. The Dividing or Indexing Head and Its Operation .....129
46. Milling Cutters and Holders .....106	56. How to Mill Flutes or Grooves .....131
47. Calculating Cutting Speed on a Milling Machine and Determining Rate of Feed and Thickness of Chip .....110	57. Spur and Bevel Gears .....134
48. How to Grind and Whet Milling Cutters .....112	58. How to Mill Teeth on a Spur Gear .....137
49. How to Mill a Flat Face or Surface on Rectangular Stock .....114	59. How to Mill Teeth on a Bevel Gear .....140
50. How to Square Stock With a Milling Machine...117	60. Milling Helixes .....142
51. How to Face Stock .....119	61. Change Gears, Angles and Leads for Helical Milling .....144
52. How to Mill a Chamfer or Bevel on Rectangular Stock .....120	62. How to Mill a Helix on a Universal Milling Machine .....146
53. How to Mill a Square, a Hexagon, or Similar Shapes .....121	63. Milling a Helix With an End Mill .....150
	64. Milling a Helix With a Universal Spiral Attachment .....150

## SECTION VIII. THE POWER HACK SAW AND ITS OPERATION

<i>Unit</i>	<i>Unit</i>
65. The Power Hack Saw .....152	66. How to Cut Metal With a Power Hack Saw .....154

## SECTION IX. METAL CUTTING BAND SAWS AND THEIR OPERATION

<i>Unit</i>	<i>Unit</i>
67. Metal Cutting Band Saws .....156	71. How to Friction Cut Metal With a Band Saw.. 163
68. How to Cut Metal With a Horizontally Operated Cut-Off Band Saw .....159	72. How to Cut Refractory Materials With a Band Saw .....164
69. How to Saw Metal With a Band Saw .....160	73. How to File and Polish Work With a Band Saw .....165
70. How to Saw Internal Contours With a Band Saw .....162	

## SECTION X. SURFACE GRINDING MACHINES AND GRINDING

<i>Unit</i>	<i>Unit</i>
74. Grinding Machines .....167	84. How to Set-Up and Operate a Universal Grinding Machine for Exterior Taper Grinding ....196
75. Grinding Wheels and Selection .....177	85. How to Set-Up and Operate a Universal Grinding Machine for Straight Internal Grinding...198
76. How to Change and Balance a Grinding Wheel .....180	86. How to Set-Up and Operate a Universal Grinding Machine for Internal Taper Grinding .....199
77. How to True or Dress a Grinding Wheel on a Universal or a Plain Grinding Machine .....182	87. How to Set-Up and Operate a Plain Grinding Machine for Cylindrical Grinding .....200
78. How to Shape Grinding Wheels for Grinding Arcs or Angles .....184	88. How to Make Taper and Angular Cuts With a Plain Grinding Machine .....205
79. How to True or Dress a Wheel on a Surface Grinding Machine .....187	89. How to Support Work Using a Spring Type Back Rest .....207
80. How to Grind Centers .....188	90. How to Set-Up and Operate a Surface Grinding Machine .....208
81. How to Sharpen Cutters on a Universal Grinding Machine .....189	
82. Grinding Cutting Speeds and Feeds .....190	
83. How to Set-Up and Operate a Universal Grinding Machine for Cylindrical Grinding .....192	

## APPENDICES

Reference List .....213	Appendix .....218
Projects .....214	Index .....223

## SECTION I

### UNIT 1

## SAFETY

Safety applied to procedures in a school or industrial shop resolves into using common sense and good judgment. Modern machinery is equipped with guards and devices designed to protect the operator and make operation of equipment as safe as possible. However, statistics show that guards and other safety devices afford only 15 per cent protection. Thus 85 per cent of all accidents in school and industrial plants are due to a factor or factors that cannot be guarded against by mechanical devices. The principal factor accountable for preventable accidents is the human element. Strange as it may seem, the same percentage of accidents attributable to the human element applies not only to industrial plants, but to operation of automobiles, farming, homemaking and most other activities. Most accidents are a result of someone's thoughtlessness, carelessness or lack of consideration of the rights of others and may be avoided if one acquires the habit of *thinking before doing*.

If persons prone to accidents can be said to be habitually careless, thoughtless and reckless, the opposite usually may be said of persons whose records are reasonably clear; they may be classed as habitually careful, thoughtful, conservative and considerate.

Safety is principally a matter of striving earnestly to learn and follow safe practices and procedures at all times. It really is much more a matter of do's than don't's. Specific applications are:

1. Always apply *first aid treatment* to cuts or bruises, regardless of how slight. It is good practice to allow slight and moderate cuts to bleed for a minute or two before attempting to stop the flow of blood. Free bleeding will carry infectious particles out of the wound. Severe cuts or bruises should receive the immediate attention of a physician.
2. Always treat burns promptly, according to their degree of severity. A first degree burn is one in which the skin is merely reddened, a second degree burn is one in which the skin is blistered, and a third degree, one in which the flesh is seared or charred. Treat first degree burns by applying a paste made of baking soda and water, or by applying carbolated vaseline, or any good burn ointment. Second and third degree burns should receive the *immediate attention of a physician*.
3. Always wear appropriate dress when working around machinery. Keep your necktie tucked into your shirt and your sleeves rolled up or wear a garment with tight fitting sleeves.
4. Persons with long hair should always wear a cap when working around revolving machinery.
5. Avoid standing in your own light. One needs the best light possible to do accurate work and avoid injury.
6. The school shops or laboratories are places for purposeful activities, where the worker needs and has occasion to direct his undivided attention to the activity in which he is engaged. Do not divert his attention by play, needless conversation, shouting, whistling or boisterousness of any form.
7. Avoid grasping metal you suspect of being hot. If doubtful, test by touching the piece very lightly with the moistened tips of the fingers.
8. When grinding tools or materials, protect your eyes by using the shield provided; or if none is provided, wear goggles.

9. Always keep the tool rest close to the grinding wheel and the fingers from coming into contact with the revolving wheel. Do not hold short or small pieces against the wheel with the bare fingers.
  10. Carefully observe cautions as to safe practices when using machinery, given at appropriate places in the instruction units which follow as well as those given by your instructor.
  11. When it is *necessary to approach* someone operating a machine, do so in such manner as not to annoy or alarm him.
  12. When in the vicinity of a machine from which stock or parts are thrown occasionally, make it a practice to stand where you will be out of danger.
  13. Keep your fingers away from moving machinery or moving parts.
  14. Before starting a machine, be sure that all safety appliances with which it is equipped are in place and operating effectively.
  15. Make a practice of always stopping machines to make adjustments or when performing an operation where there is danger of the tool catching, for example, when using an inside caliper.
  16. Whenever you have occasion to remove guards, change the normal position of the machine, or remove parts to perform a specific operation, be sure that all are replaced properly before leaving the machine.
  17. When mounting stock in a machine be sure that it is fastened securely between centers, in the jaws of a chuck, or on a faceplate.
  18. Always remove the chuck key immediately after tightening the jaws on a lathe or drill press chuck.
  19. Always clamp the work to the drill press table before starting to drill it.
  20. When removing heavy chucks ask an associate to assist you. When the chuck has been removed place it in a rack or other suitable place in such position that it cannot roll or fall.
  21. Use a brush or a thin piece of wood to remove metal chips. *Do not use your bare hands.*
  22. *Always use a belt shifter to change flat belts.*
  23. When necessary to change V-belts *stop the machine*, then change the belt.
  24. Do not remove stock from the hack saw while the machine is in motion.
  25. Before starting to wipe revolving machinery or the work with waste, *be sure the machine or the work has come to a dead stop.*
  26. Place all waste material in proper receptacles.
  27. When closing electric switches always grasp the switch by the insulated handle and keep your hands away from the metal parts of the switch or the switch box itself.
  28. Before attempting to change fuses in individual starters be sure the main switch is open and the switch box then closed and locked.
  29. When you desire the assistance of a fellow student ask it in a gentlemanly manner. Be sure to explain the nature of the assistance wanted and any risks that may be involved, for example, handling hot metal.
  30. Practice being courteous, considerate and obliging at all times and under all circumstances.
  31. Practice lending a cheerful helping hand when requested or when you observe someone in need.
  32. Observe all rules of conduct regardless of whether made by your classmates or the school authorities. Generally, rules are for the effective, wholesome and safe operation of the institution in the best and most fruitful interest of all concerned.
  33. Under all conditions stop, look and *think* before you proceed in a dangerous or definitely unknown and unfamiliar situation.
- No person has ever achieved recognition as a careful, considerate, thoughtful, far-seeing workman who has not daily practiced these virtues.

## SECTION II

# MEASUREMENTS AND MEASURING INSTRUMENTS

## UNIT 2

### MEASURING INSTRUMENTS

The machinist uses many instruments for making the measurements necessary in the course of his work. Some of these measurements need not be made with greater accuracy than within limits of .01 of an inch. At other times measurements must be made accurately within thousandths of an inch. For making such measurements, micrometer calipers or gauges are used.

#### RULES

The steel rule, Fig. 1, is the instrument used by the machinist for making rough measurements. Steel rules may be had in lengths from 1 inch to 72 inches; commonly used lengths are 3 inches, 6 inches, 9 inches, and 12 inches. The better ones are made of spring steel, hardened and tempered, and may be graduated on one or both sides. Some rules are made with one side graduated in 16ths and 32nds and the other in 64ths and 100ths. Steel rules may also be had in flexible form, in rustproof or stainless steel.

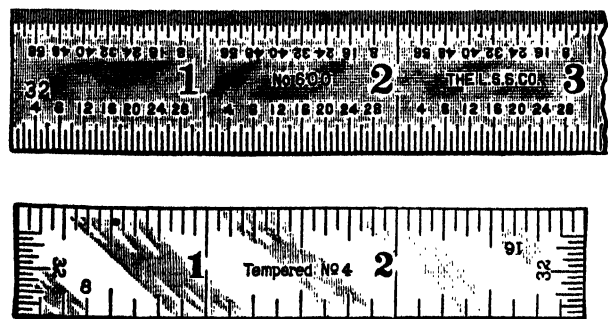

Courtesy, L. S. Starrett Co.  
FIG. 1. MACHINISTS' STEEL RULES

#### COMBINATION SETS

The combination square, protractor and center head, Fig. 2, is an instrument commonly used by the machinist for laying out work,

testing for squareness, measuring angles and finding the center of circular pieces.

#### DIVIDERS

These instruments are used chiefly for spacing, scribing circles and arcs and for laying out work. A, Fig. 3, has a solid nut, while B has a quick adjusting, automatic closing nut. Dividers may be had in sizes from 2 to 12 inches.

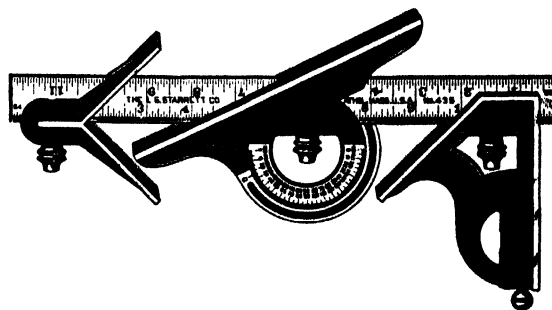

Courtesy, L. S. Starrett Co.  
FIG. 2. COMBINATION SQUARE

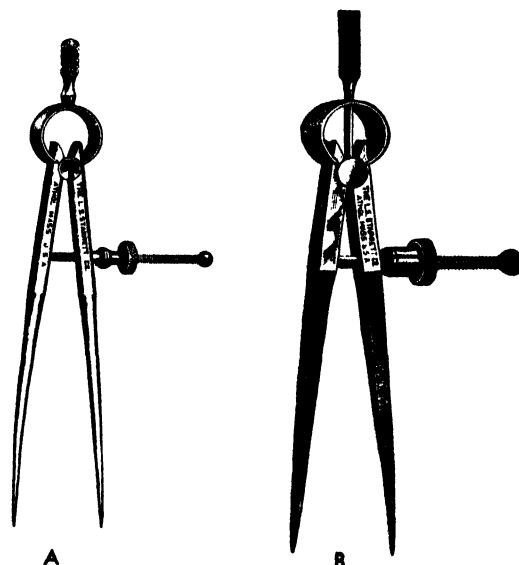

Courtesy, L. S. Starrett Co.  
FIG. 3. DIVIDERS

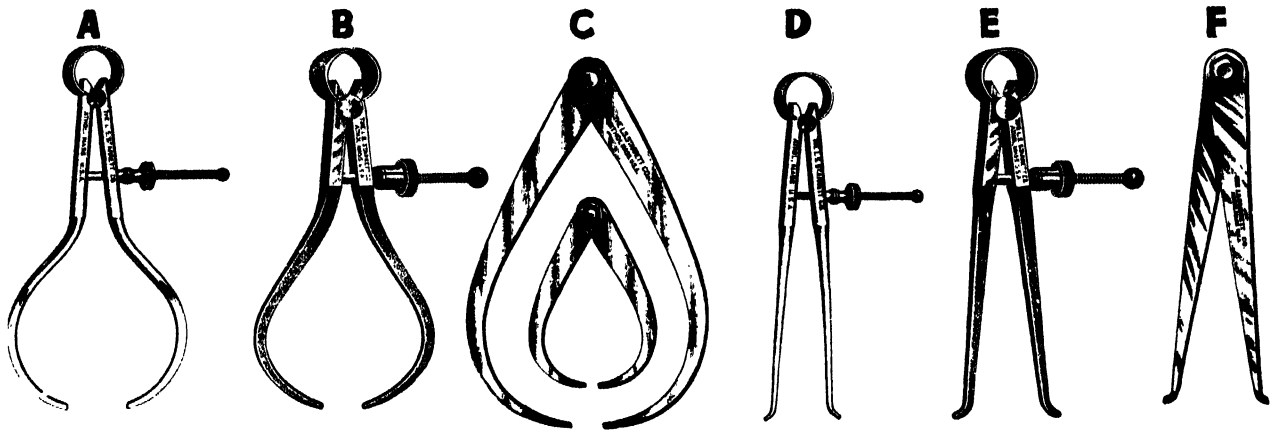

FIG. 4. CALIPERS

Courtesy, L. S. Starrett Co.

**CALIPERS**

These instruments are used chiefly for determining diameters. A, B and C, Fig. 4, are used for measuring outside diameters and D, E and F for inside diameters. C and F are called firm joint calipers, while A, B, D, and E are spring type, commonly called spring calipers. Calipers may be had in sizes from 3 to 10 inches or more.

**HERMAPHRODITE CALIPER**

This instrument, Fig. 5, is used by machinists for locating the center of circular objects and, under certain conditions, for determining inside and outside diameters. A, is the firm joint type, while B has a lock joint. It also is used for scribing lines parallel with a surface, A, Fig. 6, or for drawing lines at a desired distance from a curved surface, B, Fig. 6.

**CALIPER RULE**

The steel slide caliper rule, Fig. 7, is an instrument used for accurately measuring the

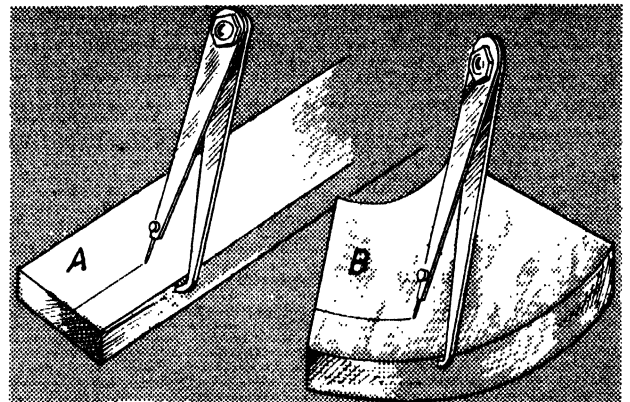

FIG. 6. SCRIBING LINES PARALLEL TO A SURFACE WITH HERMAPHRODITE CALIPER

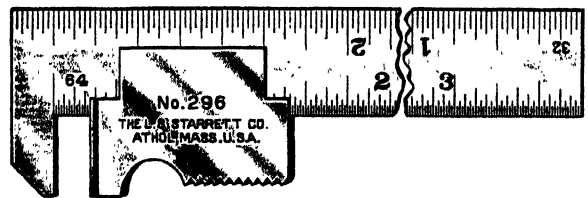

FIG. 7. CALIPER RULE

Courtesy, L. S. Starrett Co.

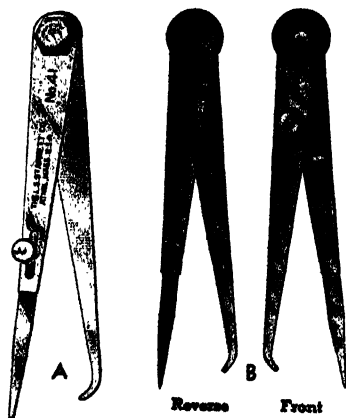

FIG. 5. HERMAPHRODITE CALIPERS

Courtesy, L. S. Starrett Co.

diameter of rods, tubing, and thicknesses of sheet metal and bars.

**CENTER GAUGE**

This instrument, Fig. 8, is used principally for grinding and setting thread cutting tools.

**DEPTH GAUGE**

This instrument, Fig. 9, is used to measure the depth of recesses accurately and quickly. The rod in A is forced downward by means of a spring and is locked in position by means of a clamping screw. B and C respectively have micrometer and vernier adjustments.

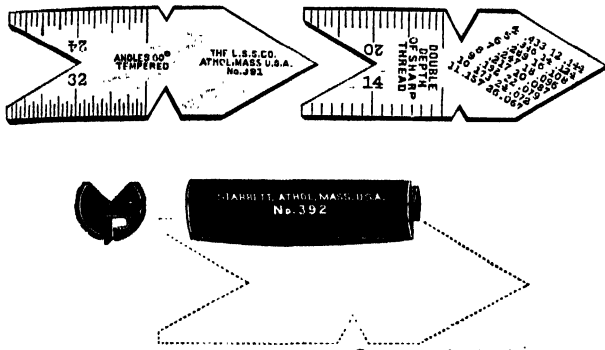

FIG. 8. CENTER GAUGES  
Courtesy, L. S. Starrett Co.

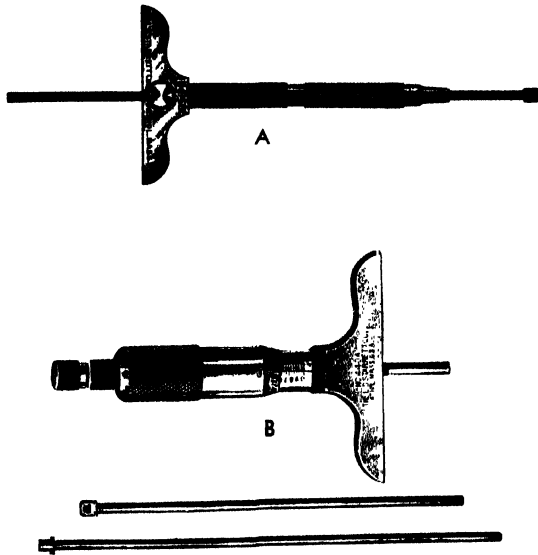

FIG. 9. DEPTH GAUGES  
Courtesy, L. S. Starrett Co.

**SURFACE GAUGE**

This instrument, Fig. 10, is used for a variety of purposes but chiefly for locating distances from a base and for locating points at a given height on opposite ends of an object lying on a flat surface. Another use is that of drawing a line at a given height on an irregularly shaped object, as, for example, a line on an irregularly shaped casting.

**SCREW PITCH GAUGE**

This instrument, Fig. 11, is used to determine the pitch of a thread or to compare the threads of different objects, as, for example, the thread on a bolt with that on a nut. The gauge has a number of notched blades. The notches on each blade are cut to match the

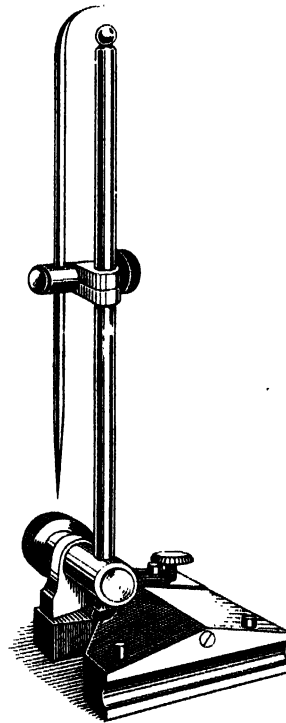

FIG. 10. SURFACE GAUGE

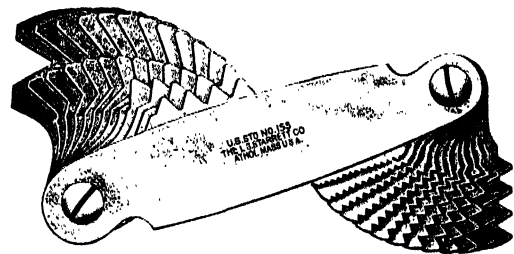

FIG. 11. SCREW PITCH GAUGE  
Courtesy, L. S. Starrett Co.

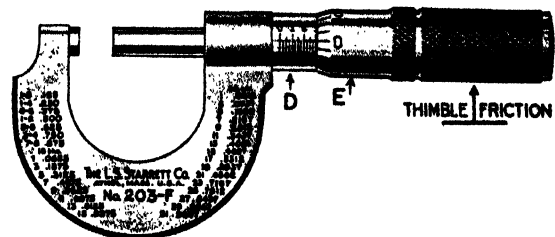

FIG. 12. MICROMETER CALIPER  
Courtesy, L. S. Starrett Co.



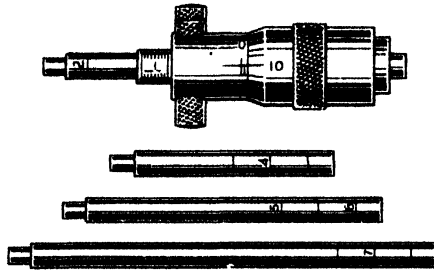
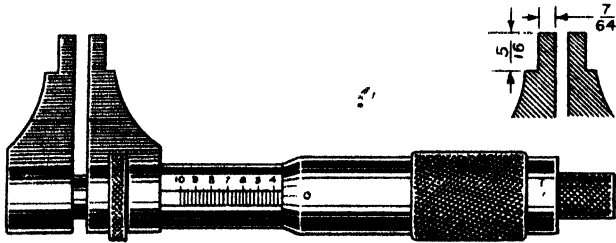

FIG. 13. MICROMETER CALIPER FOR MEASURING INTERNAL DIAMETERS AND RECESSES

pitch of a standard thread. Each blade is stamped with the pitch or number of threads per inch it represents.

**MICROMETER CALIPERS**

Micrometers are made in a number of shapes and sizes. These instruments are designed for making very close and accurate measurements. The one shown in Fig. 12 is designed for measuring outside diameters and thicknesses, while the one shown in Fig. 13 is designed for measuring internal diameters and recesses, and is usually called an inside caliper.

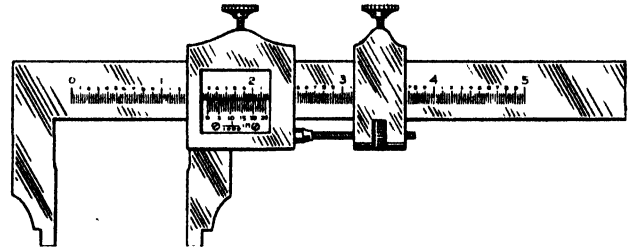

FIG. 14. VERNIER CALIPER

**VERNIER CALIPER**

This instrument, Fig. 14, is used for making accurate outside and inside measurements and for many other purposes.

**UNIT 3**

**HOW TO USE A MICROMETER**

The micrometer is a delicate instrument and easily damaged; therefore, it must not be forced over the work. Fig. 15 shows the various parts of a micrometer and the form of its construction.

The pitch of the screw threads on the inside of the spindle is one-fortieth of an inch; therefore, a complete revolution of the spindle moves it one-fortieth or twenty-five thousandths of an inch. Notice the fine graduations or divisions on the barrel, D, Fig. 16. There are forty of these in an inch. Also notice that every fourth division line is longer than the others and that these are numbered 0, 1, 2, 3, 4, etc. Each of these larger divisions represents 1/10 of an inch.

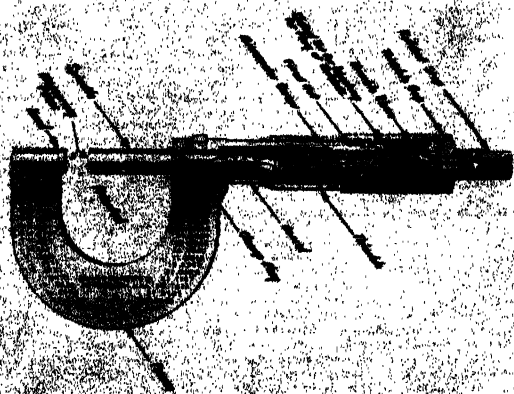

Courtesy, Brown & Sharpe Manufacturing Co.  
FIG. 15. PARTS OF A MICROMETER CALIPER

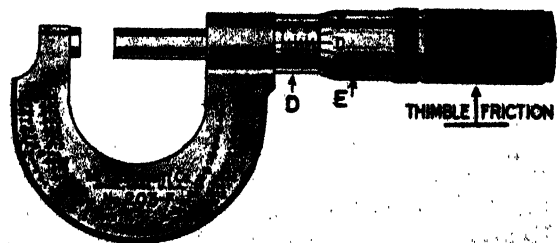

Courtesy, L. S. Starrett Co.  
FIG. 16. GRADUATIONS OF THE MICROMETER CALIPER

The beveled edge of the thimble E, Fig. 16, is marked in twenty-five divisions. Every fifth division line is longer and numbered 0, 5, 10, 15, etc. Rotating the *thimble* E through one of these divisions will move the spindle backward or forward, depending upon the direction in which the spindle is turned, one twenty-fifth of twenty-five thousandths, or one thousandth of an inch; rotating it five divisions will move the spindle five-thousandths of an inch.

#### PROCEDURE

**CAUTION:** When using a micrometer to measure work, the work must be stationary.

1. Hold the frame of the micrometer in the left hand, then revolve the *thimble*, E, Fig. 17, until the work just passes between the *anvil*, B, Fig. 17, and the tip of the *spindle*, C, Fig. 17.
2. Hold the micrometer perpendicular to the axis of the work and adjust the spindle until it lightly touches the surface.
3. With the "mike" in contact with the work, as in Fig. 17 or 18, read the number of vertical divisions on the barrel, D.

Removal of the micrometer before reading may cause the spindle to revolve slightly and thus cause an error in the final reading.

4. Multiply the number of visible divisions on the barrel, D, by twenty-five. Add to this product the number of divisions on the bevel of the thimble, from 0 to the line that is even with the horizontal line on the sleeve.

**EXAMPLE:** Fig. 17 shows 7 divisions visible on the barrel, D, and 3 divisions on the thimble, E, from 0 to the horizontal line on the barrel, D. Therefore, the distance between the anvil, B, and the tip of the spindle, C, is one

hundred seventy-eight thousandths of an inch. This figure is found by multiplying the number of visible divisions on the barrel, D, by 25 and adding the divisions on the thimble, E, from 0 to the division mark even with the horizontal line on D, in this case, 3. Thus:

$$7 \times .025 = .175 + .003 = .178.$$

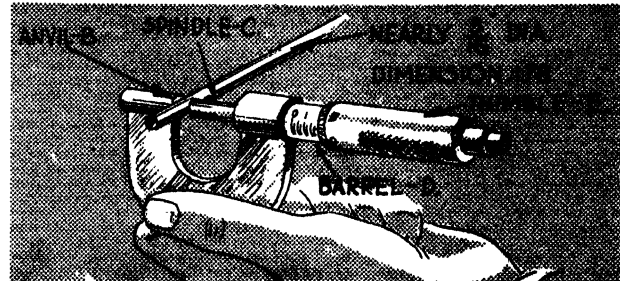

FIG. 17. USING THE MICROMETER CALIPER

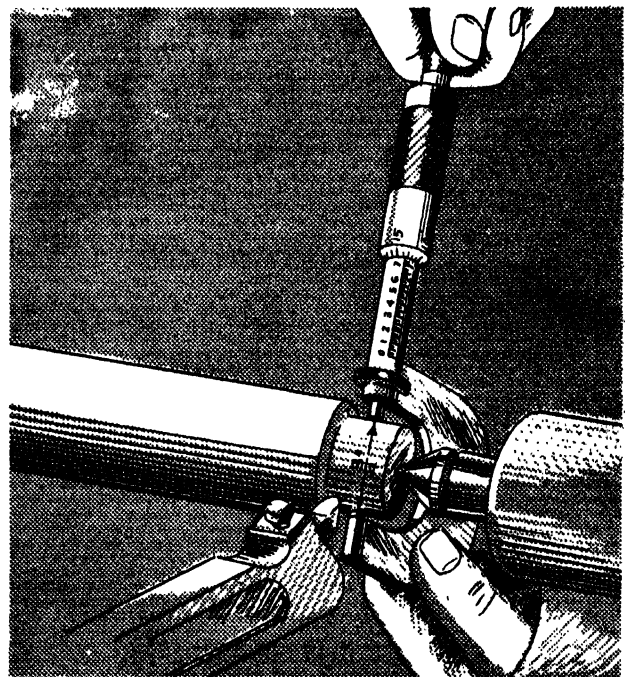

FIG. 18. USING THE MICROMETER ON WORK IN THE LATHE

## UNIT 4

### HOW TO SET AND USE CALIPERS

The calipers commonly used by workers in metal are the outside, inside and hermaphrodite. Outside calipers are used for measuring outside diameters and exterior surfaces. Inside

calipers are used for measuring inside diameters and the dimensions of recesses. Hermaphrodite calipers are used principally for locating centers on circular or approximately circular

stock. Both outside and inside calipers are made with a spring joint, a firm joint, or a lock joint. The latter has one loose leg and is commonly called a transfer caliper. The loose leg type, Fig. 19, is used for obtaining measurements of recesses which are wider at the bottom than at the top or for securing the measurement of a small object located so that it cannot be measured with an ordinary caliper. Usually calipers are set in one of two ways: first, by adjusting the caliper until the object to be measured will just pass between the extended legs, and second by setting the caliper to a particular dimension as described below.

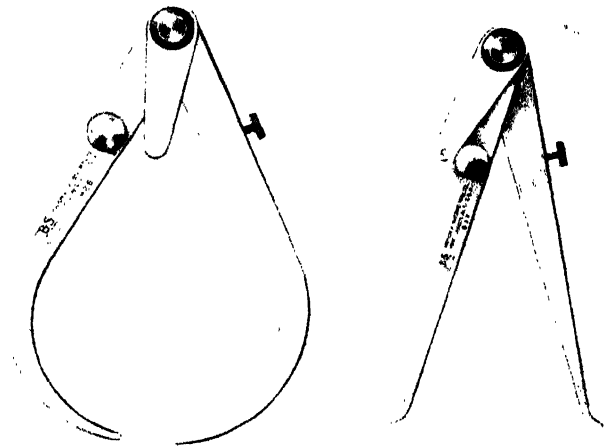

*Courtesy, Brown & Sharpe Manufacturing Co.*

FIG. 19. LOOSE LEG OR TRANSFER CALIPERS

#### PROCEDURE FOR SETTING THE SPRING JOINT TYPE

1. Grasp the rule in the right hand and the caliper in the left, as in Fig. 20.
2. Place the left leg of the caliper against the left end of the rule, then adjust the right leg by turning the thumbscrew with the right thumb and forefinger until the leg extends the distance desired, Fig. 20.
3. Test the setting carefully to see that it is correct. Make adjustment if necessary.

#### PROCEDURE FOR SETTING THE TIGHT JOINT TYPE

1. Set by closing or opening the legs with the fingers.
2. Make final adjustment.

Final adjustments are made by tapping an outer edge of the caliper lightly against a solid surface to decrease the distance

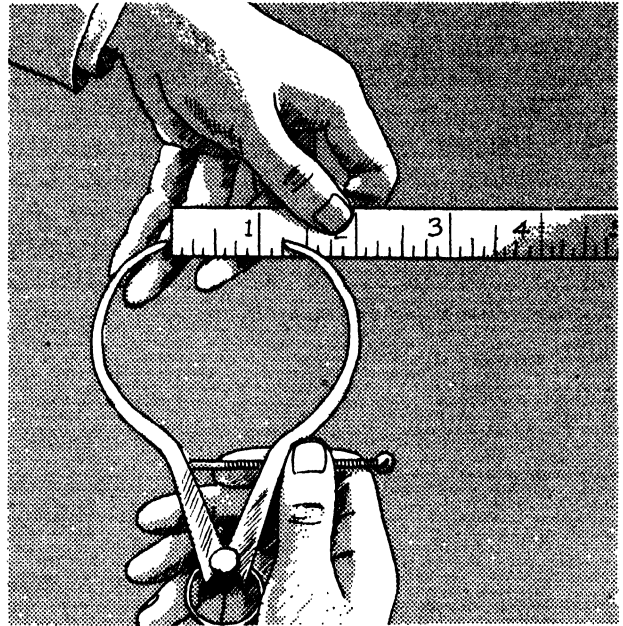

FIG. 20. SETTING THE OUTSIDE CALIPER

between the tips of the legs or by tapping the inside of one leg lightly to increase the distance between the tips.

3. Test and adjust in this manner until the proper setting is achieved.

#### PROCEDURE FOR USING THE OUTSIDE CALIPER

Accuracy in calipering can be achieved only by developing a keen sensitivity to touch. Always hold the caliper very lightly between the tips of the fingers. Continued practice will achieve dexterity.

**CAUTION:** The work to be calipered must be stationary.

1. Set the caliper.
2. With the work stationary, hold the caliper perpendicular to the axis and pass it over the work, Fig. 21.

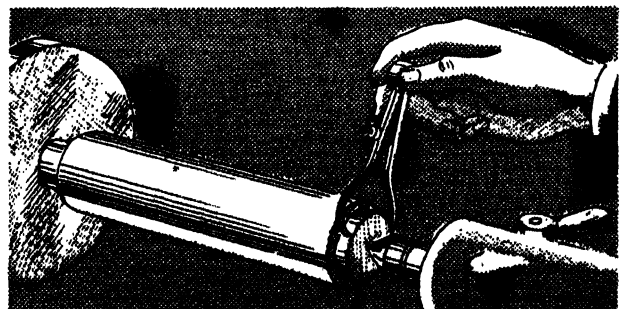

FIG. 21. USING THE OUTSIDE CALIPER

The piece has been reduced to the size desired when the caliper, of its own weight, just slips over the work. Do not force the caliper. A correct measurement cannot be thus obtained.

3. When turning work to size in the lathe, take a trial cut at the end of the stock, stop the machine and test with the caliper as in Fig. 21.
4. If the work is still too large, take another light cut, then test as before. Continue cutting and testing until the caliper will just slip over the work.

When calipering work machined in a shaper, milling machine, grinder or planer, proceed as in steps 3 and 4.

When the work is rotating about a center and the machine is equipped with a micrometer cross feed dial, measure the diameter of the work, then calculate the amount of material to be removed. Assuming the measurement is found to be  $1\frac{3}{8}$  inches and the desired dimension is  $1\frac{1}{4}$  inches, advance the micrometer cross feed  $\frac{1}{8}$  the existing difference of  $\frac{1}{8}$ , or  $\frac{1}{16}$  of an inch, then start the cut in the usual manner. When the cut has advanced a short distance, test with the caliper.

#### PROCEDURE FOR USING THE INSIDE CALIPER

**CAUTION:** Never use an inside caliper on work while it is revolving.

1. Stop the machine.
2. Place the caliper in the opening or recess to be measured as shown by the dotted line

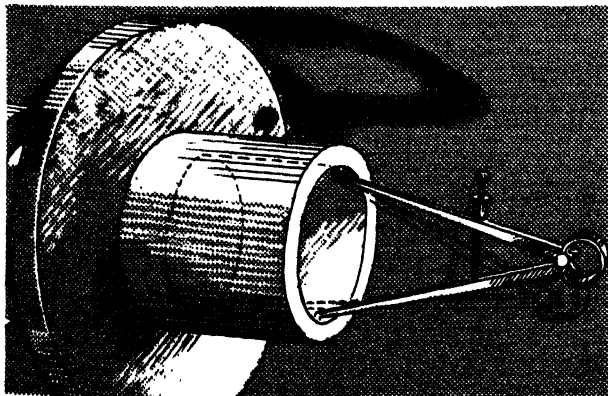

FIG. 22. USING THE INSIDE CALIPER

in Fig. 22, then raise the hand holding the caliper until it is in the position shown by the solid line in the illustration.

3. Adjust the caliper until the points of both legs touch the walls of the recess very lightly.
4. Remove the caliper and test the measurement with a rule as in Fig. 23.

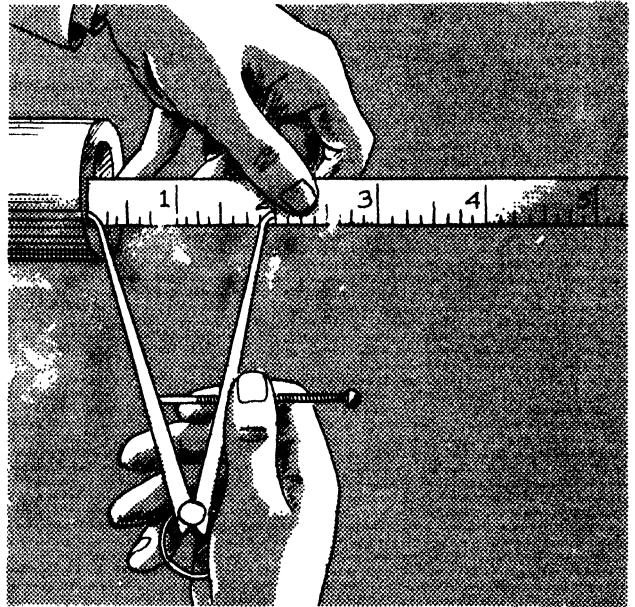

FIG. 23. SETTING THE INSIDE CALIPER

5. If the recess is not large enough, remove a little more stock at the entrance, then retest with the caliper.
6. Continue this procedure until the opening at the top of the recess is cut to the size required.

#### PROCEDURE FOR SETTING THE HERMAPHRODITE CALIPER

1. Spread the legs of the caliper to the position desired.

Test the setting by holding the tip of the bent leg against the end of a rule, the tip of the pointed leg on the face of the rule, and reading the distance between the terminals of the legs.

2. Make slight adjustments as in step 2 under "Setting the Outside Caliper, Firm Joint Type."

**PROCEDURE FOR LOCATING CENTERS WITH THE HERMAPHRODITE CALIPER**

1. Chalk both ends of the stock.
2. Set the caliper to approximately half the diameter of the stock, preferably slightly less than half.
3. Hold the caliper in a vertical position with the bent leg against the outside surface of the stock.
4. Holding it in this position, describe four short arcs as in Fig. 24.

When the caliper is set at exactly half the diameter of the stock, the arcs will have a form as at A, Fig. 24. When slightly less than half the diameter, they will have

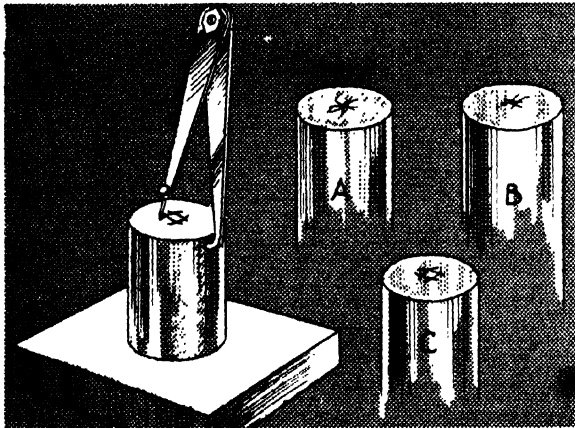

**FIG. 24. LOCATING THE CENTER WITH THE HERMAPHRODITE CALIPER**

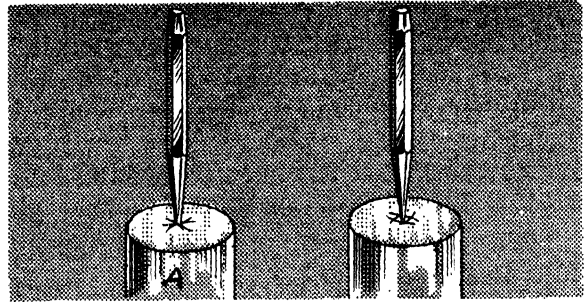

**FIG. 25. LOCATING THE CENTER**

a form as at B, Fig. 24. When slightly greater than half the diameter, the arcs will have a form as at C, Fig. 24.

5. Make a punch mark in the center of the area formed by the intersection of the arcs, or at the exact point of intersection, as would be the case at A, Fig. 25.
6. Check the accuracy of the location of the punch mark by placing the point of the straight leg of the hermaphrodite caliper in the punch mark, then rotating the caliper and observing if the point of the bent leg remains in contact with the work throughout the course of rotation.
7. If the punch mark is not located at the center of the work, draw the punch mark in the direction desired, then test as in step 6. See paragraph following step 10, Unit 10.

### SECTION III

## THE TOOL GRINDER AND ITS OPERATION

### UNIT 5

#### THE GRINDER AND GRINDING WHEELS

Grinders, either hand or power driven, are used for keeping cutting tools sharp and for shaping metals. Because of its greater cutting speed and its capacity for grinding harder metals, the grinding wheel of today has displaced the old-fashioned grindstone.

#### TYPES OF GRINDERS

Although there are many types of grinders, including pedestal grinders, bench grinders, drill grinders, cylindrical grinders, centerless grinders and others, only tool grinders will be considered here, Fig. 26. Tool grinders are divided into two distinct classes: (1) dry grinders and (2) wet grinders. The dry wheel usually has a coarse grain and is used for rough grinding. The coarse grain cuts the metal easily and prevents overheating. The wet grinder is used principally for grinding tools. Generally this type of wheel has a fine grain but, due to the fact that the fine grain does not cut the metal quickly, it is necessary to use water on the wheel to prevent the metal becoming overheated. Some power grinders are equipped with a pumping device, to keep a constant stream of water or other coolant playing on the wheel.

The grinding wheel is a simple tool to use but care must be taken in order to operate it effectively, efficiently and safely. When in operation, the tool rest should be adjusted as close to the wheel as possible in order to prevent the work becoming wedged between the rest and the wheel. After adjusting the rest, it is good practice to rotate the wheel by hand before turning on the power to determine if the wheel will clear the rest. If the tool rest is adjusted too close to an out-of-round wheel, the "high spot" may strike the rest.

If too much pressure is used when grinding, the tool or metal being ground will become overheated. The pressure or heat may cause the face of the wheel to wear away more rapidly at some points than others and thus become out of

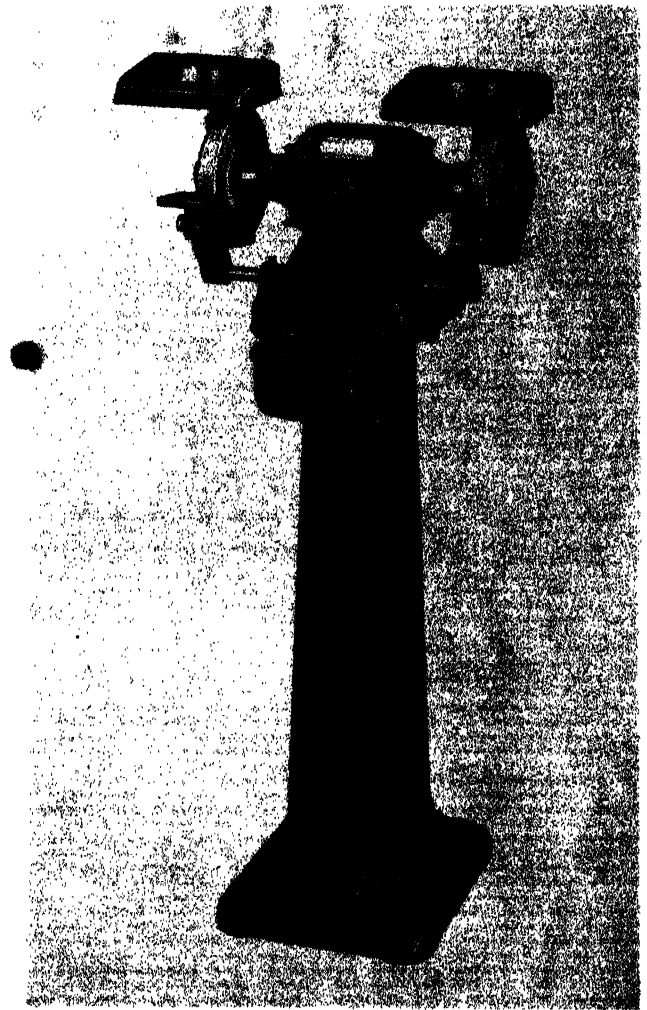

*Courtesy, Atlas Press Co.*

FIG. 26. TOOL GRINDER

round. In order to distribute the wear evenly on the face of the wheel, the work should be moved back and forth constantly.

The harder the stock being ground, the more quickly the grains become dull; thus, the harder the material, the softer should be the wheel. This is not true, however, of wheels used for grinding very soft metals such as brass, copper, or aluminum. In this case a medium soft wheel having coarse grains should be used. If the wheel becomes glazed, because the cutting particles have become dull, or because the pores between the cutting particles become clogged or loaded with the material being ground, or if it becomes out of round, it should be dressed and trued with a wheel dresser.

When operating the grinding wheel, always wear goggles to protect the eyes from flying bits of abrasive or pieces of metal. To avoid injury from flying particles, it is good practice, if possible, to stand to one side of the wheel instead of directly in front of it. If the hand or finger touches the wheel and becomes burned, it should be treated at once as infections easily result and are slow to heal.

#### GRINDING WHEELS

The composition of grinding wheels varies according to (1) the type of grinder they are to be used on, (2) the kind of material to be ground, and (3) the type of operation to be performed.

Grinding wheels are made from a mineral called bauxite. The ore is heated in an electric furnace until it fuses and is then allowed to cool slowly. In the cooking process it crystallizes and becomes very hard. It is then crushed (fractured) and particles with strong sharp edges result. The particles are then accurately graded according to their size. The grain or coarseness of a wheel is designated by numbers which indicate the number of meshes to the inch of the sieve through which the particles of abrasive pass, for example, 4, 6, 8 — 36 — 60, 77 — 100, 120, 150 — 240. These particles are mixed with a bonding substance which acts like a glue or cement. The mixture is then molded to the shape desired and allowed to dry partially, after which it is baked in a very hot oven for many hours, then allowed to cool

slowly. After the baking and cooling processes have been completed, the wheels are ready for use.

About 80% of modern grinding wheels are made with a vitrified bond compound of mineral and clay mixtures which fuse at a high temperature. For wheels larger than 30 inches, a bond consisting of silicate of soda and minerals is used. Very thin wheels are also made by this process. Because this mixture fuses to a hard cement-like material at a comparatively low temperature, it may be molded onto iron centers or backs.

Very thin wheels used for cutting off stock usually have a bonding substance composed of shellac and other organic materials which melt at low temperatures. This allows the dull particles to be torn easily from the bond and the new and sharp ones to attack the substance being cut.

Wheels used for high speed snagging and for severe cutting off operations generally are made with a bakelite bond or rubber bonds combining hardness with toughness.

For grinding aluminum, a wheel especially designed for that purpose should be used. The work should be held lightly against the wheel and advanced slowly.

#### GRADE AND GRAIN OF GRINDING WHEELS

Grinding wheels are graded according to kinds and size of grain. Classifications include coarse, medium, medium-fine and fine wheels. Hardness grades vary from "soft" to "hard" wheels. A soft wheel is one from which the abrasive grains dislodge easily; conversely, a wheel which holds its grains securely is termed a hard wheel. The grade and grain of grinding wheels are specified by numbers and letters. The number generally indicates the coarseness of grain and the letter, the degree of hardness.

#### SIZE OF GRINDING WHEELS

Grinding wheels may be obtained in a variety of shapes, such as disc, ring, cup and dish, and in many sizes.

When specifying the size of a grinding wheel, it is necessary to give the maker's name, the grade, shape, diameter, width of face, and the size of the arbor hole.

## SECTION IV

# DRILLS AND DRILLING

## UNIT 6

### TWIST DRILLS, BORING TOOLS AND REAMERS

Drills are used for piercing or cutting circular holes into or through material. There are many kinds of drills used for this purpose; however, twist drills of one kind or another are by far the most commonly used.

#### PARTS OF A DRILL

Generally speaking, a drill has three principal parts: the point, the body, and the shank, Fig. 27. The spiral grooves that wind around the body of the drill are called flutes. The purposes of the flutes are: (1) to provide a means whereby a suitable lip or cutting edge may be formed on the point of the bit; (2) to provide a means and a channel whereby the chip removed by the cutting lip may be carried to the surface; (3) to provide a means whereby a lubricant can easily be carried to the cutting edge. The narrow strip of metal, labeled "margin or land," Fig. 27, is formed by grinding away some of the metal along the body of the drill. The purpose of grinding away part of the body stock is to give the drill clearance.

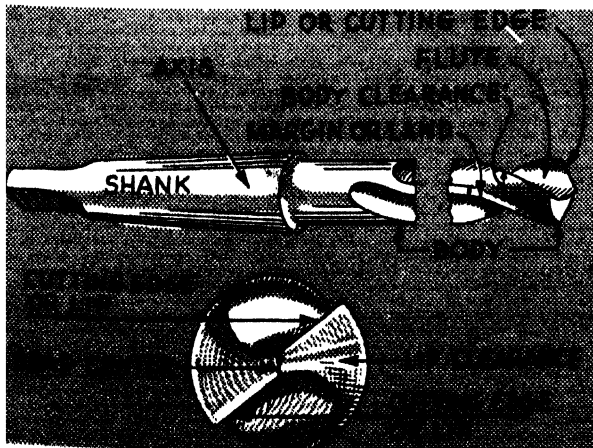
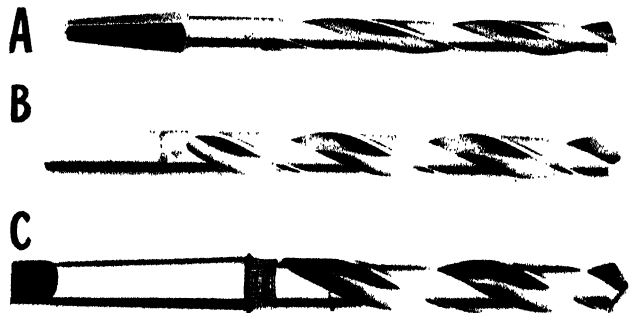

FIG. 27. PARTS OF A DRILL

The body of metal between the flutes forms what is called the "web." It is this part that gives rigidity and strength to the drill. As the web approaches the shank it tends to thicken. This is accomplished by cutting the flutes somewhat shallower but slightly wider. Widening the flutes permits free passage of the chips.

The shank, or that part of the drill which fits the spindle or chuck of the drill press or the jaws of a brace, varies in shape either according to size or purpose for which it was designed, Fig. 28. The bit with a square shank is intended for use with a bit brace; B is an ordinary straight shank and is found on drills up to  $\frac{1}{2}$ " diameter and intended for use with a chuck; C represents a taper shank drill. Taper shank drills have standard morse tapers and will fit the spindles of standard drill presses or auxiliary sleeves. The tang on shank C fits a slot in the spindle. This prevents the drill from slipping or turning in the spindle.



*Courtesy, Cleveland Twist Drill Co.*

FIG. 28. TYPES OF DRILL SHANKS

#### DRILL SIZES

Drill sizes are indicated in three ways: (1) by number; (2) by letter; (3) by fractional parts of an inch. Drill sizes by number are given in terms of wire gauge and range from No. 80, which has a diameter of .0135 of an



inch, to No. 1 with a diameter of .228 of an inch. Lettered sizes start with A and run to Z. An A drill has a diameter of .234 and Z a diameter of .413. Drill sizes given in fractional parts of an inch may be had as small as  $\frac{1}{64}$  of an inch in diameter to 3.5 or even larger on request. Drill sizes designated in fractions of an inch increase in size by  $\frac{1}{84}$  of an inch up to  $2\frac{3}{4}$  inches, after which stock drills increase by  $\frac{1}{32}$  or  $\frac{1}{16}$  of an inch. When desired, drills may be had in fractional parts of a millimeter.

### GRINDING DRILLS

Most of the difficulties encountered in drilling may be attributed to improper grinding. When grinding, three factors are important: (1) correct lip clearance, A, Fig. 29; (2) correct lip angle, B, Fig. 29; (3) correct location of the point with respect to the center of the drill, C, Fig. 29. Correct lip clearance is from  $12^\circ$  to  $15^\circ$ . This means that the heel of the lip should be ground away that much. Lip clearance permits the cutting edge of the lip to engage the work. Correct lip angle for ordinary metal is  $59^\circ$  with a line through the center of the drill, B, Fig. 29. To check the lip angle, use a drill grinding gauge. An angle of  $59^\circ$  is recommended because it has been found that drills ground at that angle cut more rapidly and with less exertion of power than when ground at any other angle. When grinding drills for drilling manganese steel, the lip angle should be  $75^\circ$ . This material is very hard and tough; consequently the shorter lip secured when ground at  $75^\circ$  takes less power to operate and

does not cause quite so great a strain on the drill. The point of a drill should have an angle of  $120^\circ$  to  $135^\circ$  and be centered exactly in line with the center of the drill, C, Fig. 29.

### USING DRILLS

To secure the best results a drill should be used at the correct speed and feed. The speed of a drill refers to the rate at which it travels at the circumference. This is called peripheral or outside speed and is given in terms of *feet* traveled per minute. The feed is the rate at which the drill advances into the work per revolution measured in fractions of an inch or millimeter. For correct speeds and feeds, see Unit 8.

When inserting a large drill, tap the point with a lead hammer or a mallet to seat it firmly in the socket. To remove a drill from drill spindle or sleeve, insert a drift, Fig. 30, in the slot just above the tang of the drill, with the rounded edge of the drift against the rounded end of the slot, then grasp the drill with one hand and tap the drift lightly with a hammer.



Courtesy, Cleveland Twist Drill Co.  
FIG. 30. DRILL DRIFT

### BORING TOOLS

When a drill of a particular dimension is not available or when a very straight, accurate hole is desired, a boring tool, Fig. 31, is sometimes used. In such cases a hole large enough to permit entry of the boring tool is drilled with a standard drill.

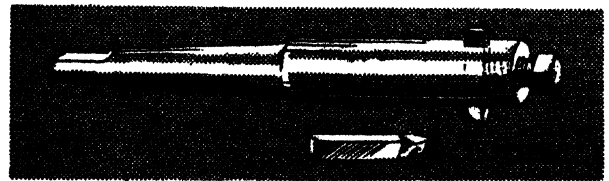
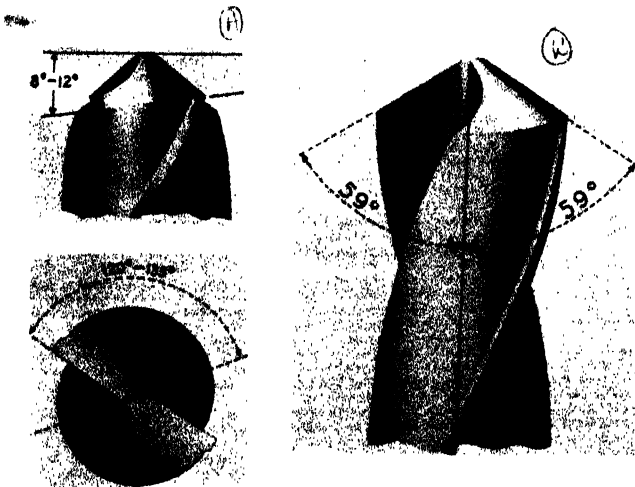

FIG. 31. BORING TOOL



FIG. 32. COUNTER-BORING TOOL



Courtesy, Cleveland Twist Drill Co.  
FIG. 29. CORRECT ANGLES FOR DRILLS

TABLE I  
CAUSES OF DRILL BREAKAGE, DAMAGE OR INACCURACY

<i>Symptoms</i>	<i>Probable Cause</i>	<i>Remedy</i>
Breaking of drill.	Spring or back lash in press or work. Too little lip clearance. Too low speed in proportion to the feed. Dull drill.	Test press and work for rigidity and alignment. Regrind properly. Increase speed or decrease feed. Sharpen drill.
Breaking down of outer corners of cutting edges.	Material being drilled has hard spots, scale or sand inclusions. Too much speed. Improper cutting compound. No lubricant at point of drill.	Reduce speed. Use proper cutting compound and correct application.
Breaking of drill when drilling brass or wood.	Chips clog up flutes.	Increase speed. Use drills designed for these materials.
Broken tang.	Imperfect fit of taper shank in the socket—due to nicks, dirt, burrs, or worn out socket.	Get a new socket or ream old one to prevent recurrence.
Chipping of margin.	Oversize jig bushing.	Use proper size bushing.
Chipping of lip or cutting edges.	Too much feed. Too much lip clearance.	Reduce feed. Regrind properly.
Chipping or checking of a high speed drill.	Heated and cooled too quickly while grinding or while drilling. Too much feed.	Warm slowly before using. Do not throw cold water on hot drill while grinding or drilling. Reduce feed.
Change in character of chips while drilling.	Change in condition of the drill such as chipping of cutting edge, dulling, etc.	Regrind drill properly.
Hole too large.	Unequal angle or length of the cutting edges, or both. Loose spindle.	Regrind properly. Test spindle for rigidity.
Only one lip cutting.	Unequal length or angle of cutting lips or both.	Regrind drill properly.
Splitting up center.	Too little lip clearance. Too much feed.	Regrind with proper lip clearance. Reduce feed.
Rough hole.	Dull or improperly ground drill. Lack of lubricant or wrong lubricant. Improper set-up. Too much feed.	Regrind properly. Lubricate or change lubricant. Reduce feed.

**COUNTER-BORING TOOL**

This tool, Fig. 32, is used to spot face for bolts and screws, to enlarge holes to receive the head of fillister head screws and for similar purposes. It has a pilot or guide on the point which frequently is interchangeable. Ordinarily, the pilot has a diameter about .002 of an inch smaller than that of the drilled hole. A counter-boring tool should be run at a lower speed than a drill of corresponding diameter. A lubricant should be used freely. Counter-boring tools may be had in many sizes.

**COUNTERSINKS**

A countersink, Fig. 33, is used to enlarge the end of a hole in conical form to receive the head of a screw. The inclusive angle of the

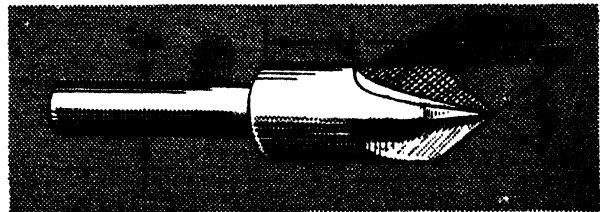
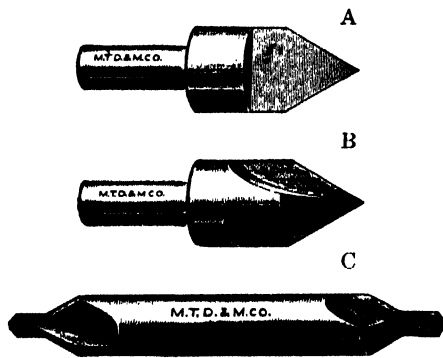

FIG. 33. ANGLES OF A COUNTERSINK



Courtesy, South Bend Lathe Works  
FIG. 34. TYPES OF COUNTERSINKS

point of this instrument is  $82^\circ$ . A and B, Fig. 34, illustrates two types of countersinks used for drilling center holes in stock which is to be turned while being held between centers. The inclusive angle at the point of these tools is  $60^\circ$ . The  $82^\circ$  countersink should never be used for countersinking centers, nor the  $60^\circ$  for countersinking for screw heads. The combination countersink and drill, C, Fig. 34, is used for drilling and countersinking centers in stock to be held between centers. This tool drills and countersinks at one operation. The combination drill and countersink may be had in several sizes.

#### REAMERS

A reamer is a device used to ream or enlarge a drilled hole to the exact dimension desired. Reamers are made in a variety of shapes and sizes, A, B, C, D and E, Fig. 35, and may be had in either carbon or high speed steel. Ordinary hand reamers increase in size by  $\frac{1}{64}$  of an inch from  $\frac{1}{8}$  to  $\frac{3}{8}$  of an inch, by  $\frac{1}{32}$  inch from  $\frac{3}{8}$  to 1 inch and by  $\frac{1}{16}$  of an inch from 1 to 2 inches. Reamers may be had with straight or spiral flutes, Fig. 35, and the flutes may have a right- or left-hand spiral, depending upon the material to be reamed and the finish required.

Reamers intended for use in a drill press have standard Morse taper shanks.

When made, reamers are ground as close to absolute accuracy as possible, and have a slight

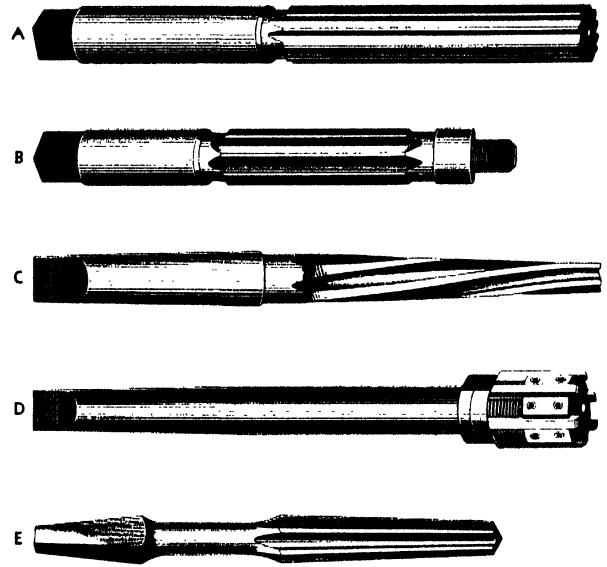

FIG. 35. TYPES OF REAMERS

taper at the lower end. This makes starting easier. When in use, a light cut should be taken, .002 to .005 of an inch, and the tool handled with care to avoid damage to the cutting edges. A tap wrench fitted to the square part of the shank is used to rotate the hand reamer, A and B, Fig. 35.

For rough work or when taking rather heavy cuts, an end cutting reamer, D, Fig. 35, should be used. When a very accurate hole is required, it is recommended that the hole be first machine or rough reamed to .002 of an inch under-size, then accurately hand reamed to the dimension required.

Reamers should always be rotated in a forward direction only, that is, in a direction which will cause the front of the teeth to engage in the work, usually clockwise. A reamer should never be turned backward regardless of whether the tool is being advanced or withdrawn. Turning the reamer backward will cause the chips to wedge between the wall of the hole and the cutting edges of the tool, which in turn will cause the cutting edges to chip off or become dull.

## UNIT 7

## THE DRILL PRESS

The drill press is one of the most important pieces of equipment found in a school or industrial shop. Its principal function is to turn drills and reamers used in drilling or boring round holes in various materials.

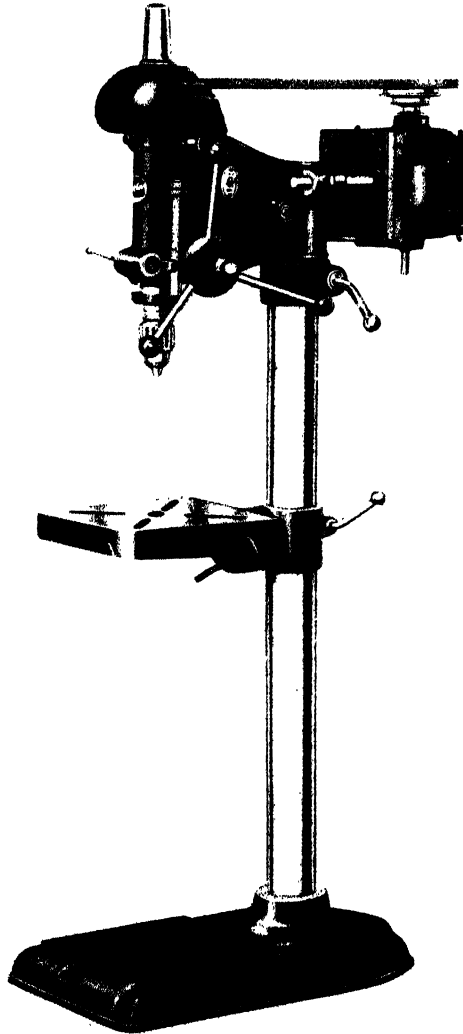

*Courtesy, Atlas Press Co.*

FIG. 36. DRILL PRESS

Variation in speed is accomplished by means of a cone pulley driven by a V or flat belt. The source of power on most modern presses is an individual motor mounted on the floor or at the rear of the column, Fig. 36. On the larger sizes of the more modern drill presses the spindle speed and rate of feed are varied by means of a series of gears. These are driven

by a single pulley, a silent chain, or by a direct drive from the motor.

**SIZE AND CAPACITY**

Usually, the size of a drill press is given in terms of the distance from the column to the point of the drill. A 16-inch drill press will drill a hole in the center of a circle 16 inches in diameter. The vertical capacity of the machine is determined by the distance from the table, in its lowest position, to the bottom of the jaws of the chuck when fully elevated, less the amount the drill projects. Another factor determining capacity is the distance of spindle travel. Still another factor is the size of drill the quill or chuck will accommodate. Drill presses are made in many sizes and for a number of special purposes. An example is the multiple spindle press used in the production of automobiles.

**PRINCIPAL PARTS**

The principal parts of a drill press are: base and column, spindle, motor and head, table, feed mechanism, quill and chuck.

**FEED AND SPEED**

All drill presses are equipped with a hand feed. In addition many are equipped with an automatic feed. The speed of drill presses varies from about 40 to 5,000 or more revolutions per minute. When in operation, the speed

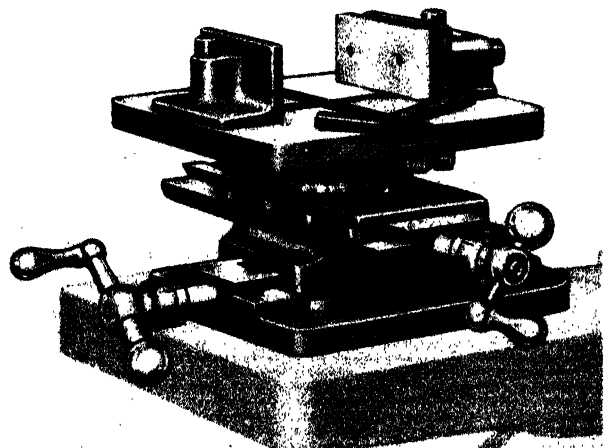

*Courtesy, Atlas Press Co.*

FIG. 37. COMPOUND REST AND VISE

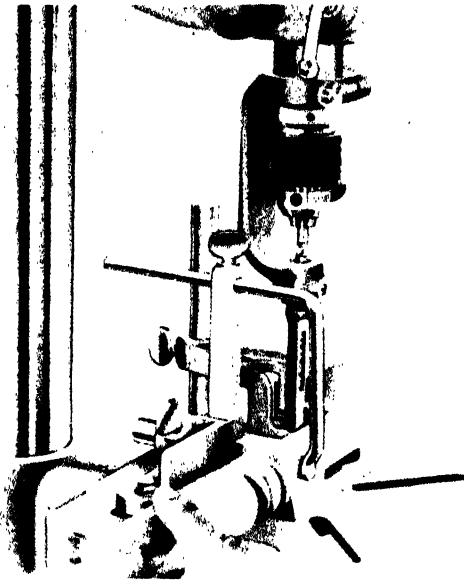

Courtesy, Atlas Press Co.  
FIG. 38-A. MORTISING ATTACHMENT

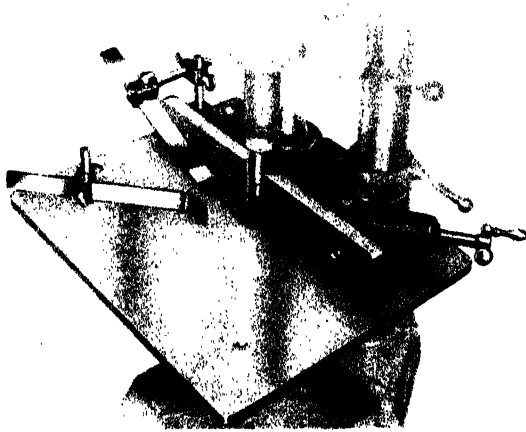

Courtesy, Atlas Press Co.  
FIG. 38-B. SHAPING ATTACHMENT

should be determined by the nature of the work and the size of drill used.

#### ATTACHMENTS

Special attachments, such as the compound rest and vise illustrated in Fig. 37, can be had for drill presses. A less complex device for holding work may also be had, Fig. 49. Other special features are: mortising attachments, Fig. 38A, shaping attachments, Fig. 38B, and tapping attachments, Fig. 38C.

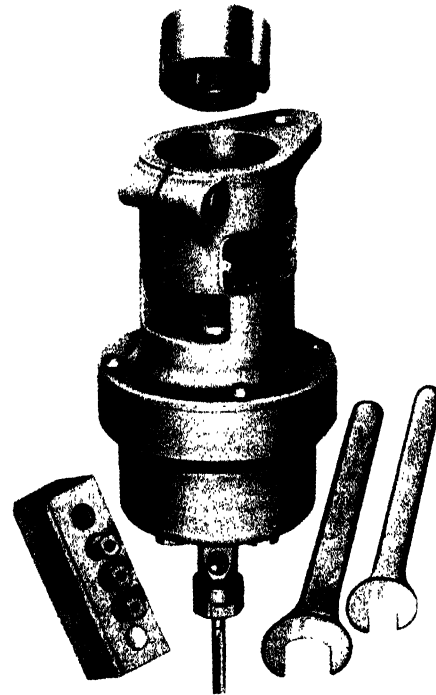

Courtesy, Atlas Press Co.  
FIG. 38-C. TAPPING ATTACHMENT

### UNIT 8

#### DRILLING SPEEDS, FEEDS AND LUBRICANTS

The speed at which metal should be drilled varies for different metals and with the size of the drill used. The following are general rules covering the cutting speed per minute with the more common metals and smaller sizes of carbon drills: Cast iron, 30 to 35 feet per minute; mild steel, 30 to 35 feet per minute; tool steel, 20 to 25 feet per minute; brass, 70 to 100 feet per minute. When high speed drills are used, these speeds may be doubled.

To determine the number of revolutions of the drill per minute necessary to give the cutting speed desired, divide one quarter of the diameter of the drill by the cutting speed desired.

For example, to drill mild steel, a  $\frac{1}{8}$  inch high speed drill should revolve at  $\frac{1}{8} \div 80 = 1280$  r.p.m. A carbon drill of the same size should revolve at about 40% of 1280 r.p.m. or 512 r.p.m.

TABLE II  
TABLE OF RECOMMENDED SPEEDS  
FOR HIGH-SPEED STEEL DRILLS

	Speed in F.P.M.
Mild Machinery Steel, .2 to .3 Carbon . . .	80-110
Steel, .4 to .5 Carbon . . . . .	70- 80
Tool Steel, 1.2 Carbon . . . . .	50- 60
Steel Forgings . . . . .	50- 60
Alloy Steel . . . . .	50- 70
Stainless Steel . . . . .	30- 40
Soft Cast Iron . . . . .	100-150
Hard Chilled Cast Iron . . . . .	70-100
Malleable Iron . . . . .	80- 90
Ordinary Brass and Bronze . . . . .	200-300
High Tensile Bronze . . . . .	70-150
Monel Metal . . . . .	40- 50
Slate, Marble and Stone . . . . .	15- 25
Aluminum and its alloys . . . . .	200-300
Magnesium and its alloys . . . . .	250-400
Bakelite and similar material . . . . .	100-150
Wood . . . . .	300-400

Carbon drills should be run at speeds of from 40% to 50% of those given above.

**FEEDS**

Feeds are governed by the size of the drill and the material to be drilled. The general rule when drilling mild steel is to use a feed of .001 to .002 inch per revolution for drills smaller than 1/8 inch; .002 to .004 inch for drills 1/8 to 1/4 inch; .004 to .007 inch for drills 1/4 to 1/2 inch; .007 to .015 inch for drills 1/2 inch to 1 inch; .015 to .025 inch for drills larger than 1 inch. Alloy and hard steels should be drilled at a lighter

feed than given, while cast iron, brass and aluminum usually may be drilled with a heavier feed.

Extreme speed or feed will cause drills to chip or break at the cutting edges or to split the web; similar damage may also be a result of improper grinding. Rapid wearing at the outer corners of the cutting edges is an indication of too much speed.

**LUBRICANTS**

To maintain the speeds and feeds recommended, it will be necessary to use a good cutting compound. The following are recommended in the order named:

Hard and refractory steel—Turpentine, kerosene, soluble oil.

Soft steel and wrought iron—Lard oil, soluble oil.

Malleable iron—Soluble oil.

Brass—Dry.

Aluminum and soft alloys—Kerosene, soluble oil.

Cast iron—Dry or with a jet of compressed air as a cooling medium.

*Do not use water to cool drills.*

**UNIT 9**

**HOW TO GRIND METALWORKING DRILLS**

Drills are used for producing round holes in metal. They are effective instruments for this purpose when properly sharpened. Three things are important when grinding a drill: proper *lip clearance*, *length* and *angle* of the *cutting lip* and *location* of the *point*.

*Lip clearance* is produced by grinding away the surface back of the cutting edge or lip, Fig. 39. If lip clearance were not given the drill, it would be impossible for it to enter the metal. Correct lip clearance for ordinary work is 12°, A, Fig. 29. Clearance greater than this weakens the cutting edge.

By experimentation and experience it has been found that the most effective lip angle for metal working drills is 59° with the axis, B, Fig. 29. The length of the lips must be equal, as must also the lip angle. Otherwise, one lip

will do more or all of the cutting and an over-size hole will be produced, Fig. 40. Furthermore, the point will be off center which may cause the drill to chip or break.

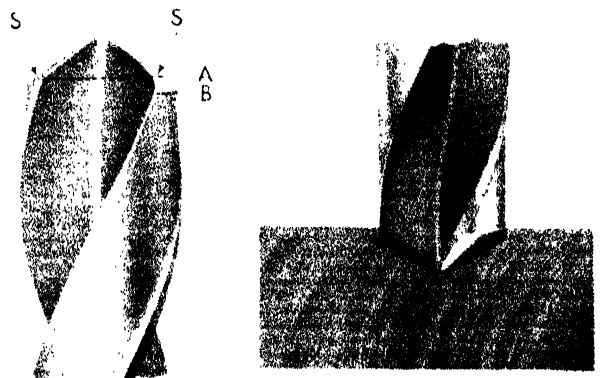

Courtesy, Cleveland Twist Drill Co.  
FIG. 39. LIP CLEARANCE OF PROPERLY GROUND DRILL.

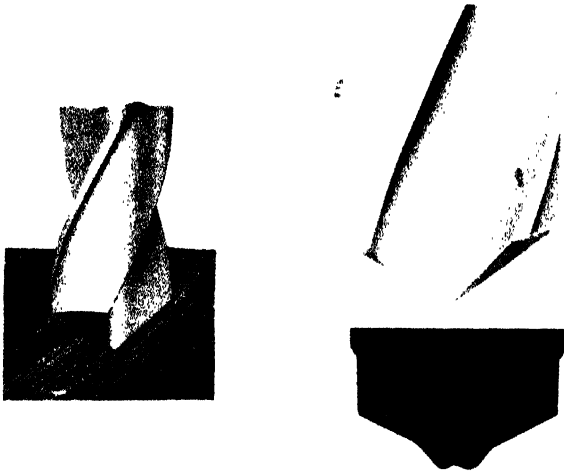

Courtesy, Cleveland Twist Drill Co.  
 FIG. 40. THE LENGTH OF THE LIPS AND THE LIP ANGLES MUST BE EQUAL

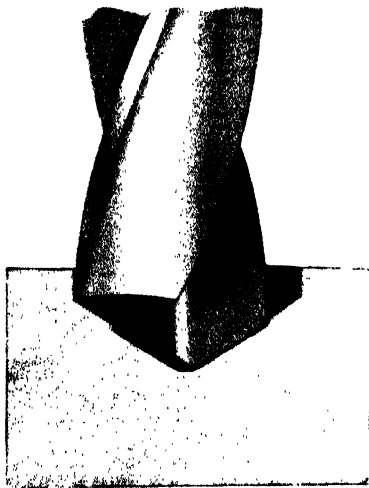

Courtesy, Cleveland Twist Drill Co.  
 FIG. 41. THE POINT OF THE DRILL MUST BE IN THE CENTER

To produce accurate work and to avoid undue strain on the spindle and bearings of the drill press, locate the point in the center of the drill. Fig. 41 shows the effect of the point being located off center, even though the lip angles are equal. To insure correct lip angles, test with a bit gauge.

Some grinders are equipped with a drill grinding attachment, Fig. 42. The V-block holder on this device centers the drill and holds it in place. A special lip stop and micrometer feed insures accurate grinding of both lips.

#### PROCEDURE

1. *Put on goggles.* This should be done even when the wheel is protected with a shield.

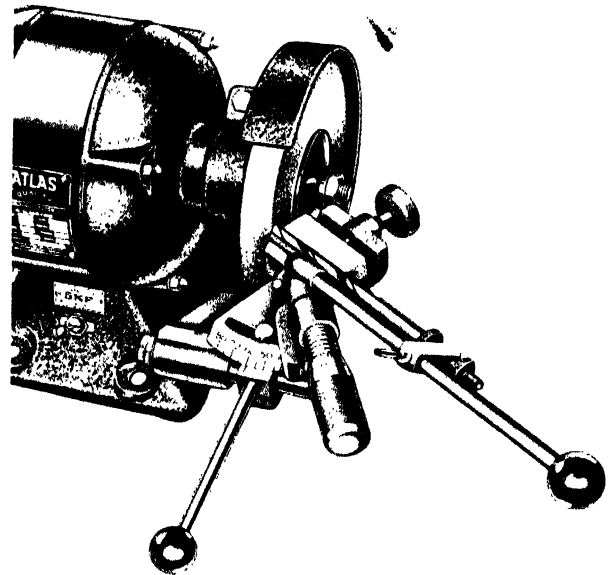

Courtesy, Atlas Press Co.  
 FIG. 42. DRILL GRINDING ATTACHMENT

2. Examine the grinding wheel to make sure the face is straight and true. If the face is not straight and true, dress it with a wheel dresser.
3. If a coolant is used, see that there is sufficient liquid in the reservoir, then start the machine.
4. Examine the angle at which the drill was last ground. Check with a gauge, if available.
5. Assuming the angle is correct, hold the cutting edge or lip of the drill parallel with the face of the wheel and perpendicular to the side, Fig. 43. Then bring the drill lightly into contact with the wheel and at the same time draw it slowly upward with a slight rotary motion or stroke. Repeat the operation until the cutting edge is sharp and the correct lip clearance is achieved. The rotary motion gives the bit enough clearance.

Be sure to hold the drill at the correct angle throughout the operation and hold it

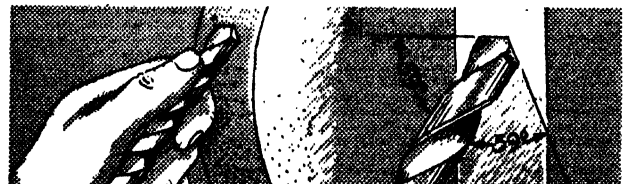

FIG. 43. GRINDING A DRILL

lightly against the face of the wheel. Otherwise, there is danger of drawing the temper by overheating, thus damaging the cutting qualities of the drill.

6. Give the drill a half turn and grind the other cutting edge in a similar manner. Be

sure to maintain the same angle on both edges.

7. Test the drill with a bit gauge. Be sure that both cutting edges are the same length and are ground at the correct angle. Make correction if necessary.

UNIT 10

HOW TO DRILL A HOLE

Holes may be drilled in most metals with an ordinary twist drill, providing it is correctly ground and a suitable lubricant is applied during the operation. Cast iron, brass, copper, lead or other soft metals require no lubricant when drilling. For mild steel use lard oil, machine oil, soluble oil, sulfurized oil, or an alkaline solution such as soda water.

**PROCEDURE FOR DRILLING WORK  
CLAMPED FLAT ON THE TABLE**

1. Locate the position of the hole with short light lines drawn at right angles, A, Fig. 44.
2. With a center punch, make a distinct impression at the intersection of the lines, B, Fig. 44.

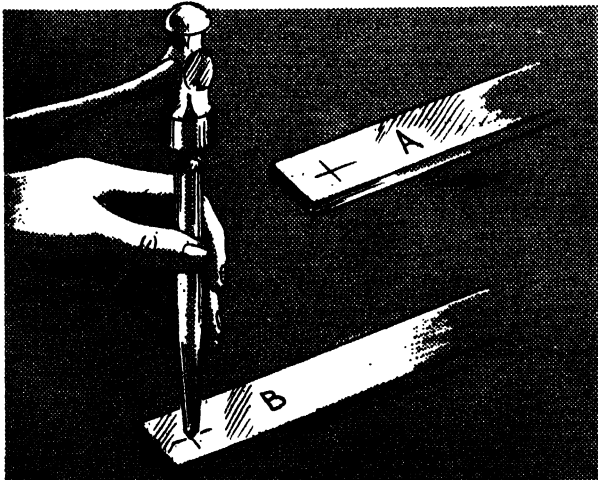

FIG. 44. CENTER PUNCHING

If extreme accuracy is desired, rub the surface of the piece with chalk, mark the center with a prick punch, then lay out the size of the hole with a pair of dividers, Fig. 45. Then with a prick punch, make

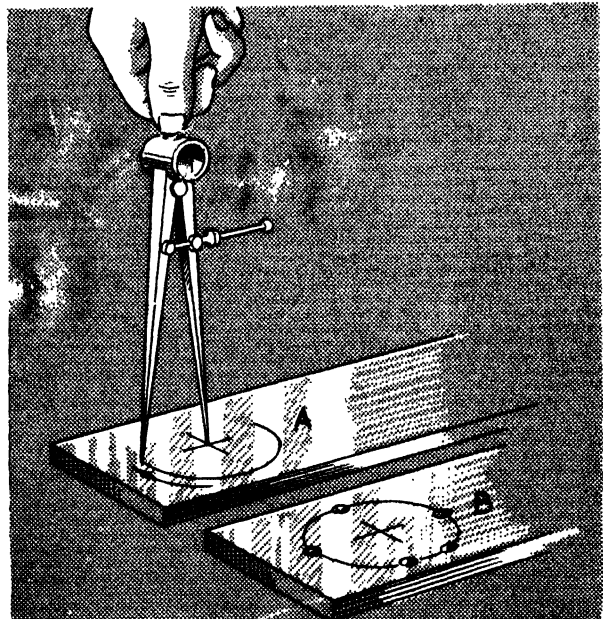

FIG. 45. SCRIBING THE CIRCUMFERENCE OF THE HOLE

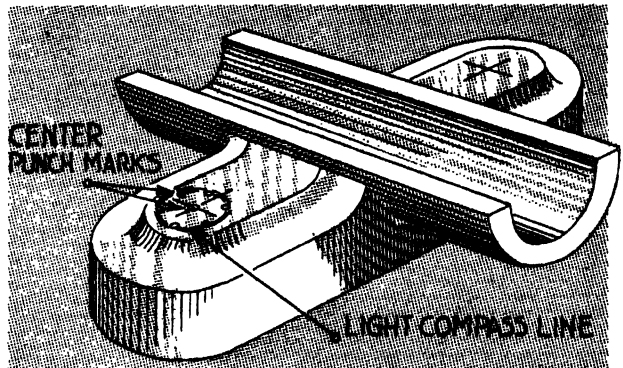

FIG. 46. SECOND CONCENTRIC CIRCLE SCRIBED AND PUNCHED

four or more marks along the circumference line as shown in B, Fig. 45. These marks will enable the operator to see if the hole is being drilled at the posi-



tion desired, even though the circumference line becomes erased. When a high degree of accuracy is required a concentric circle  $\frac{1}{32}$  to  $\frac{1}{16}$  of an inch larger in diameter is sometimes drawn and punch marked, Fig. 46. The second circle serves as a check if the drill should happen to lead off center and eliminate some of the punch marks on the first concentric circle.

3. Examine the impression to see if the center is located at the intersection of the lines and is large enough to receive the point of the drill.
4. Select a drill of the size desired, insert it in the spindle or chuck and fasten securely.
5. Determine the speed at which the drill should run to produce the best result (see Unit eight) then adjust the drive so as to produce the speed desired by changing the belt or speed differential.
6. Place the stock to be drilled on a block of wood on the drill press table. Round stock should be placed in a V-block, Fig. 47. Always make sure that the work is firmly supported so that there will be no spring when pressure is applied to the drill.

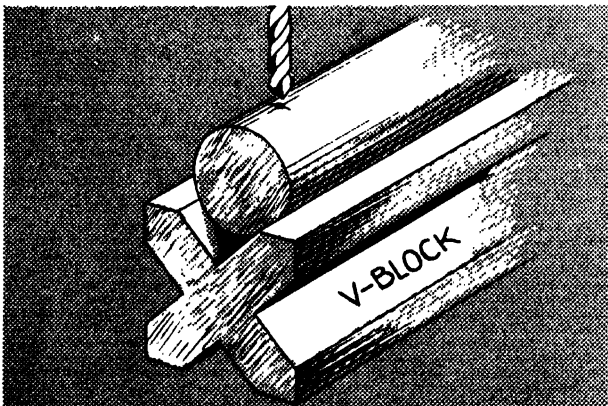

FIG. 47. ROUND STOCK SUPPORTED IN A V-BLOCK

7. Adjust the stock so that the punch mark is under the point of the drill.
8. Clamp or otherwise hold the work securely on the table, Fig. 48. A vise, such as shown in Fig. 49, is recommended, if available.
9. Start the machine, draw the drill down until the point is in contact with the work, then slowly advance the drill until a *distinct impression* has been made.

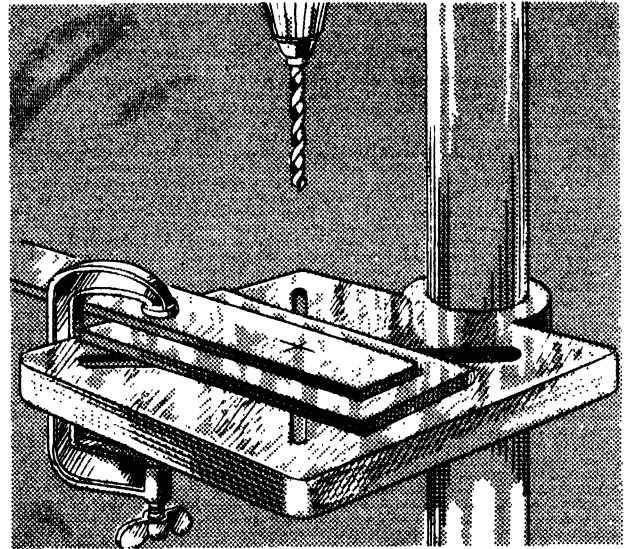

FIG. 48. C-CLAMP USED TO HOLD WORK

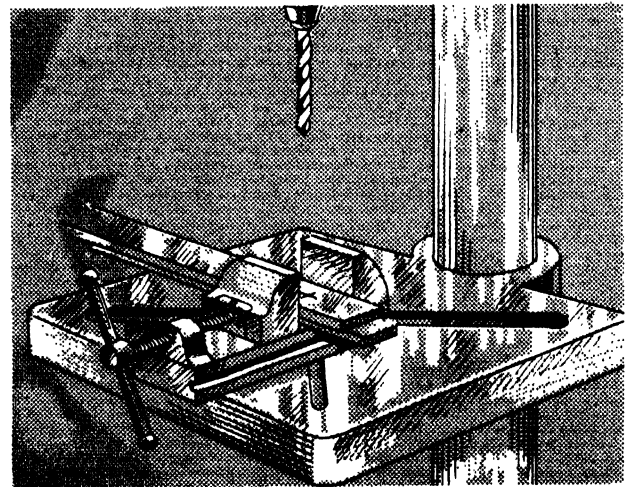

FIG. 49. VISE USED TO HOLD WORK

10. Raise the drill and examine the impression to be sure that the hole has been started at the position desired.

If the impression is not in the center, as in A, Fig. 50, make a prick punch mark on the side of the impression toward which the hole is to be drawn, B, Fig. 50. The punch mark should be made far enough from the center of the impression to draw the drill over the amount desired, Fig. 51.

If preferred or necessary, the center may be drawn over by cutting one or more small grooves in the waste stock on the side toward which the center is to be drawn, D, Fig. 50.

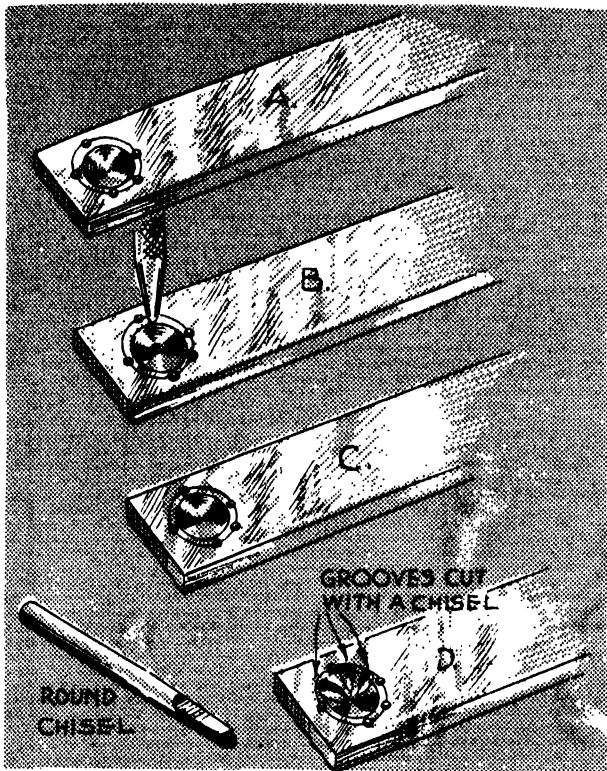

FIG. 50. MOVING THE CENTER OF A PARTIALLY DRILLED HOLE

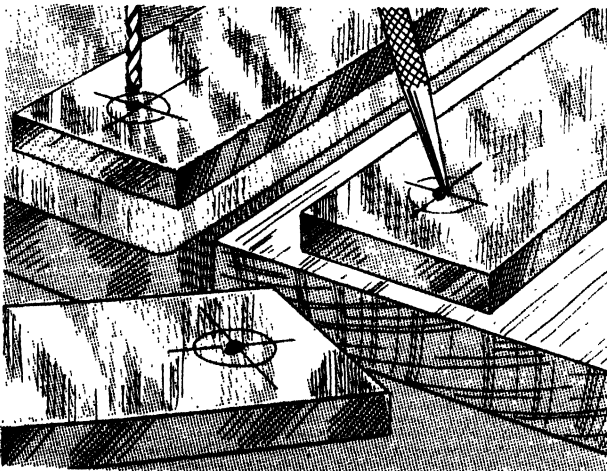

FIG. 51. CORRECTED CENTER PUNCH MARK

11. If a lubricant is needed, pour a few drops of oil, or other suitable lubricant, into the impression made by the drill.
12. Draw the drill down and feed it into the work slowly.

If the machine is equipped with a power feed, engage the automatic feed.

Fig. 52 shows how the chip should appear when mild steel is drilled with a correctly sharpened drill.

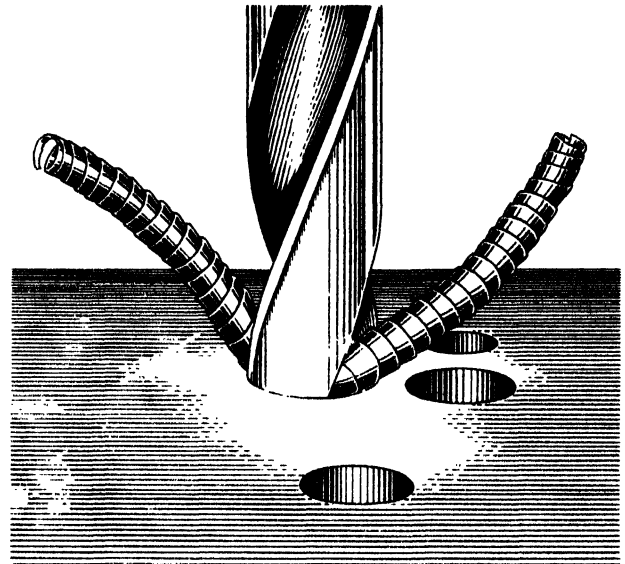

FIG. 52. DRILLING MILD STEEL

13. As the drill advances, pour a little more oil on the revolving drill about half an inch above the work.
14. When hand feeding and the point of the drill breaks through the metal, decrease the pressure on the feed mechanism, then continue to feed forward slowly until the hole is completed.

**CAUTION:** Be sure the stock is held securely throughout the operation, particularly when the point breaks through on the under side. If one fails to do this, the piece is likely to spin around with the drill and damage the drill or the work, or injure the operator.

When it is necessary to drill a hole to a certain depth, draw the drill down as far as it will go, then raise or lower the table until the top of the work is just even with the point of the drill, then raise the table an amount equal to the desired depth of the hole. When the machine is adjusted for depth, drill the hole in the usual manner. Some machines are equipped with a feed stop. In such cases one may control the depth of the hole by setting the stop at the position desired.

- When the operation is completed, stop the machine, remove the clamp, work and drill and return them to the place where they are kept when not in use.

#### PROCEDURE FOR DRILLING WORK CLAMPED IN A V-BLOCK

- With a center punch, mark the position on the stock at which the hole is to be drilled.
- Select a suitable sharp drill and insert it in the spindle or chuck.
- Place the stock in a V-block and adjust until the center of the punch mark is exactly under the point of the drill.

If necessary, test the accuracy of the setting by testing the center from both sides with a surface gauge as in Fig. 53, or by measuring with a rule and try square as indicated.

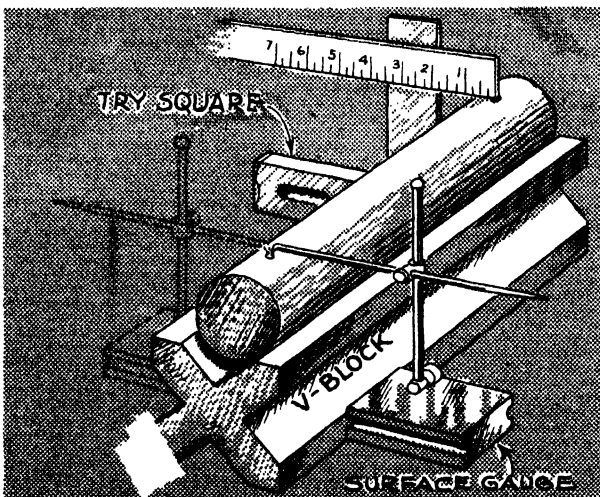

FIG. 53. CHECKING THE CENTER PUNCH MARK

- When the center has been located correctly under the point of the drill, clamp the piece in position on the table of the drill press with a strap clamp as in Fig. 54. Be sure the clamp is approximately parallel with the table.
- Adjust the machine for the correct speed and feed, Unit 8.
- Apply a suitable lubricant.
- Start the machine, then draw the drill down against the stock and continue feeding it forward until the hole is drilled the depth desired. Use the automatic feed if the machine is so equipped.

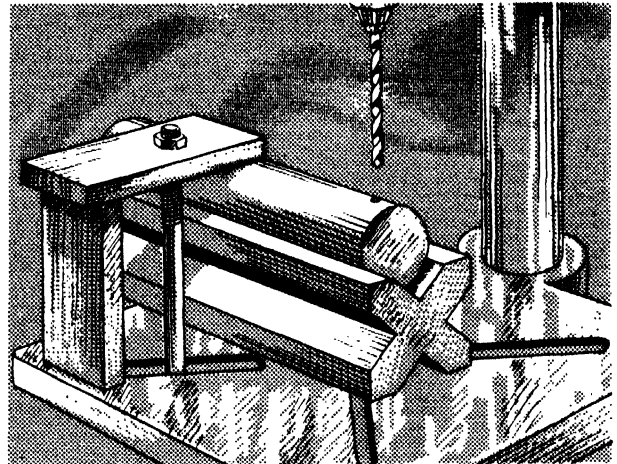

FIG. 54. WORK CLAMPED IN POSITION ON THE TABLE

- When the operation is completed, stop the machine, remove the clamp, stock and drill and return them to the place where kept when not in use.

#### PROCEDURE FOR DRILLING WORK HELD AGAINST AN ANGLE PLATE

- Accurately locate the point at which the hole is to be drilled and mark it distinctly with a center punch.
- Secure a sharp drill of the size desired and insert it securely in the spindle or chuck.
- Bolt an angle plate on the table of the drill press in such position that when the work to be drilled is clamped against it a hole may be drilled in the work at the position desired, Fig. 55.
- With a carriage clamp, fasten the work securely to the angle plate.

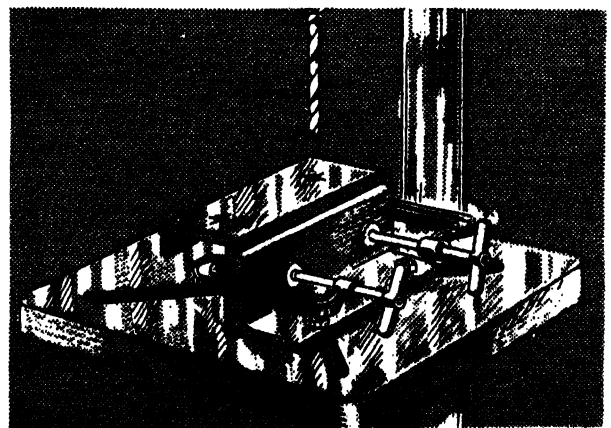

FIG. 55. WORK HELD AGAINST AN ANGLE PLATE

5. With the hand feed, advance the drill until the point is exactly over the center of the punch mark.
6. If necessary, adjust the table or the work until the point of the drill is centered over the punch mark.
7. If a lubricant is necessary, pour a few drops into the impression made by the punch.
8. Start the machine and draw the drill down against the work. Use the power feed if the machine is so equipped. Continue advancing the drill until the hole is drilled the depth desired.
9. When the operation is completed, stop the machine, remove the clamp, drill and work and return them to the place where kept when not in use.

#### PROCEDURE FOR DRILLING A LARGE HOLE

1. Prepare the stock in the usual manner and fasten it securely on the table of the drill press.
2. Select a drill of the size required, also a small drill having a diameter comparable

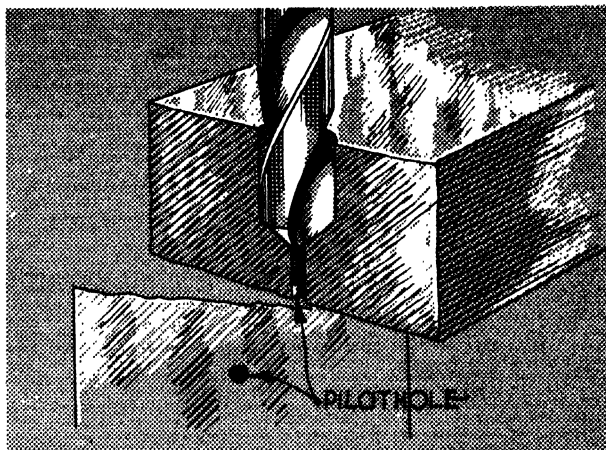

FIG. 56. DRILLING A LARGE HOLE

- to the thickness of the web of the large drill.
3. Insert the small drill in the spindle or chuck.
4. Start the machine and drill the hole (pilot hole), Fig. 56.
5. Remove the small drill and insert the large drill in the spindle.
6. Start the machine and drill the hole as in Fig. 56.

## UNIT 11

### HOW TO BORE A HOLE WITH A DRILL PRESS

When it is necessary to produce a very straight hole, it frequently is accomplished by first drilling an undersize hole, then finishing with a boring tool, see Fig. 57. Boring is also resorted to when a drill of the size desired is not available. For ordinary boring, the hole is drilled from  $\frac{1}{16}$  to  $\frac{1}{8}$  of an inch undersize.

#### PROCEDURE

1. Clamp the stock on the drill press and in the usual manner drill an undersize hole of the dimension desired.

**CAUTION:** Do not loosen the clamps or change the position of the stock on the table of the drill press except for correcting any error made in drilling.

2. Select a boring bar of suitable size and insert it in the spindle of the drill press. Tap the protruding end of the boring bar

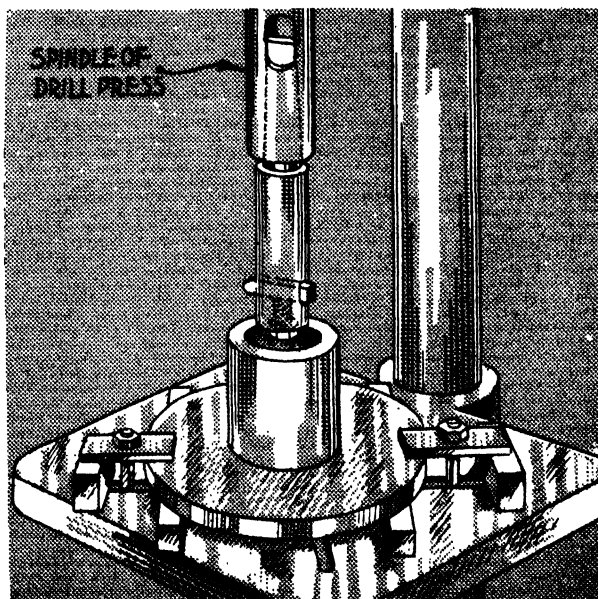

FIG. 57. USING A BORING TOOL IN A DRILL PRESS

with a lead hammer, thus seating it firmly in the socket or spindle.

3. Examine the cutter to make sure it is sharp. Grind it if necessary.
4. Adjust the cutter in the boring bar so that it will make a cut of the depth necessary to produce a hole of the size desired. Be sure the bit is fastened securely.
5. Set the machine at the speed recommended for drilling a hole of similar size.
6. Start the machine and feed the tool into the hole, Fig. 57.
7. When the tool has entered the stock to the point where a full cut is being made, stop

the machine and caliper or measure the diameter of the hole accurately.

8. If the hole is not being bored the diameter desired, make the necessary adjustment, then continue boring until the job is completed. If the machine is equipped with a power feed, its use is recommended.

**CAUTION:** When using a light boring tool be sure to take a light cut and feed.

9. When the operation is completed, remove the clamps, work and boring tool and return them to the place where kept when not in use.

## UNIT 12

### HOW TO REAM A HOLE BY HAND OR WITH A MACHINE

A reamer is used when it is necessary to produce a hole in metal which is both accurate and smooth. A hole may be machine reamed or hand reamed or both. A hand reamer is the more commonly used in school shops.

#### PROCEDURE

1. Drill a hole about .002 of an inch undersize for hand reaming. Allow from .002 to .005 of an inch when the work is to be both machine and hand reamed.
2. Grip the piece to be reamed in a vise.
3. Select a reamer and a tap wrench of the sizes desired.

**CAUTION:** Before using a reamer examine the cutting edges to make sure they are smooth. A burr on a cutting edge will ruin the work.

4. Fit the wrench on the end of the reamer.
5. Insert the point of the reamer in the hole, Fig. 58, then accurately align it with the axis of the hole and slowly turn it toward the right (clockwise). Continue advancing the reamer in this manner until the hole is reamed its full length.

Be sure to use a lubricant, preferably lard oil, when reaming steel.

When the hole has been drilled or bored in either a drill press or a lathe, the hole may be reamed with a hand reamer before the work is removed from the machine. If the work has been drilled or bored on

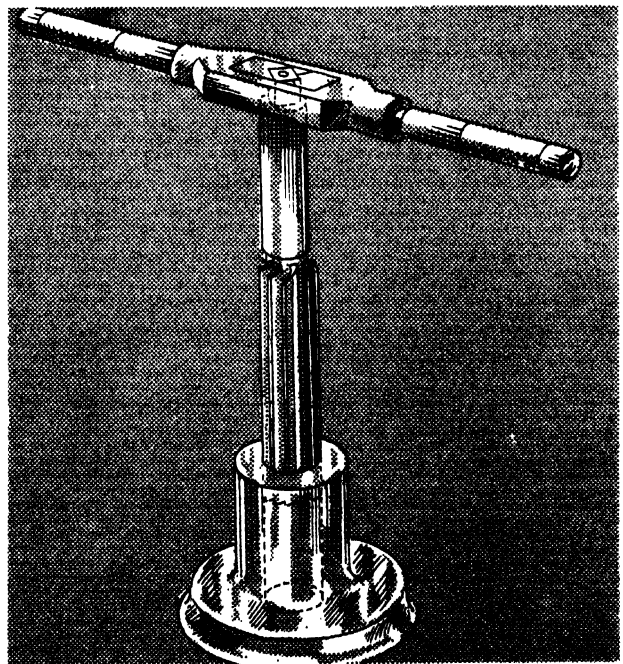

FIG. 58. STARTING A HAND REAMER

a drill press, remove the drill and insert a lathe center in the spindle. Fit the wrench on the shank of the reamer, then place the point of the reamer in the hole. Draw the center in the spindle down into the center-hole in the shank of the reamer, Fig. 59, then start turning the reamer with the wrench. Continue turning the reamer and advancing the center until the reamer has

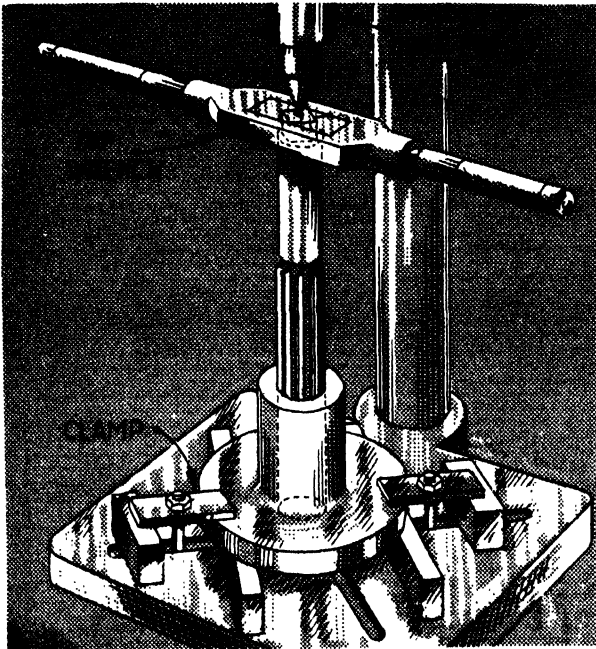

FIG. 59. USING THE DRILL PRESS SPINDLE TO KEEP THE REAMER ALIGNED

been advanced into the work far enough to insure a straight hole, an inch or so. If the work has been drilled or bored on

a lathe, place the reamer in the hole and draw the dead center against the center hole in the shank of the reamer. Turn the reamer with a tap wrench and at the same time advance it by advancing the dead center. Either of these methods will insure starting the reamer parallel with the axis of the hole. When using either of these methods be sure *not to crowd the reamer by advancing the center too rapidly.*

- When the hole has been reamed its full length, continue turning the reamer forward, to the left, and at the same time pull upward on the wrench. Continue thus until the reamer clears the hole. Never turn a reamer backward; doing so will damage the cutting edges and tear the work.

When work is to be machine reamed, the operation should always be performed before the work is removed from the machine. Machine reaming should be done at a slow or medium speed, preferably the former. Machine reaming may be done in a drill press or a lathe, using a taper shank reamer.

### UNIT 13

## HOW TO SPOT-FINISH METAL WITH A DRILL PRESS

Sometimes steel is given what is called a spot-finish. This process consists of making a series of small circular spots on the surface of the metal with a suitable device. The spots may be made so that they are merely adjacent, or with a certain amount of overlapping, usually the latter, A, Fig. 60.

#### PROCEDURE

- Machine or hand work the object to size.
- Polish the surfaces to be spot-finished with fine aluminum oxide or emery cloth and polishing oil. A heavy machine oil may be used for this purpose.
- Cut or make a short piece of dowel of the size needed to make the spots on the finished surface. Use a hard wood.

The chuck on most drill presses in school shops will not take a dowel larger in diameter than  $\frac{1}{4}$  inch. If a larger dowel is

needed, turn it with a shank that will fit the chuck on the drill press, B, Fig. 60.

- Mount the dowel securely in the chuck.

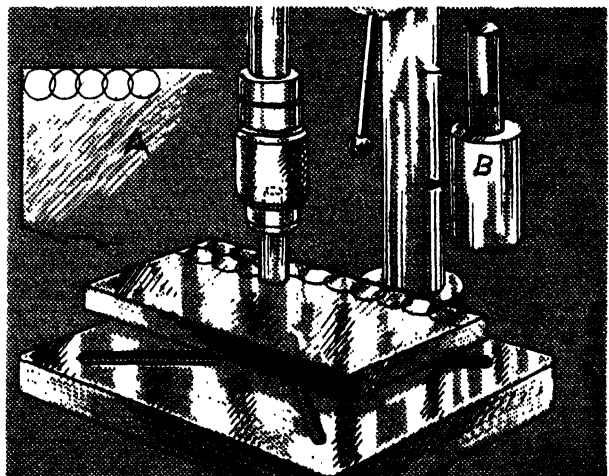

FIG. 60. SPOTFINISHING WITH A DRILL PRESS

5. Start the drill press, then square the end of the dowel by drawing it down against a sheet of abrasive cloth placed on the table of the press.
6. Prepare a pasty mixture of fine emery and lard oil. Coat the surface to be spot-finished with emery and oil.
7. Clamp a straightedge on the table of the drill press, in such a position that when the dowel is drawn down on the surface of the work, a spot will be made near one edge.

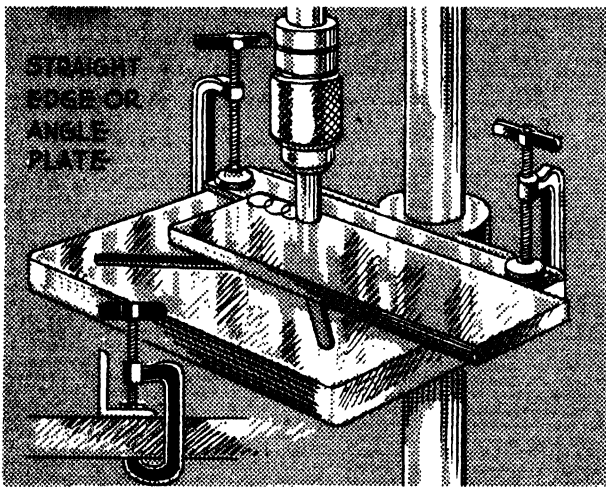

FIG. 61. BEGINNING THE SPOTFINISHING

8. Place the work against the straightedge and adjust it so that the first spot will be made at one corner, Fig. 61.
9. Bring the revolving dowel into contact with the surface of the work and hold it there for about 10 seconds, then raise the dowel and move the piece over the width of one spot, or, if overlapping, about  $\frac{2}{3}$  of this width.
10. Again bring the dowel into contact with the surface and make a second spot. Continue thus until the end of the work is reached.
11. Move the straightedge back the width of the spot, or, if overlapping,  $\frac{2}{3}$  of this width, then proceed as in steps 9 and 10.
12. Repeat the above steps until the whole surface is spot-finished.
13. Remove the dowel and straightedge, then thoroughly clean the drill press with an old rag or waste.
14. With clean waste or a soft cloth, remove remaining emery and oil from the finished surface of the object, then apply a coat of commercial antirust compound. Unless protected, steel rapidly oxidizes or rusts. The presence of moisture, even in small quantities, hastens oxidization.

## SECTION V

# THE LATHE AND ITS OPERATION

## UNIT 14

### THE METALWORKING LATHE

The lathe is thought to be one of the first machines invented by man. By whom or when the first lathe was built no one knows. One of the earliest known illustrations of a lathe is shown in Fig. 62. It is what is known as a tree lathe. This machine was intended for turning wood, and, as may be seen, consisted of two centers, a tool rest (the board in the rear) and a means of rotating the work. Several things in this crude machine are common in modern woodworking or metalworking lathes: centers, headstock, tailstock and legs.

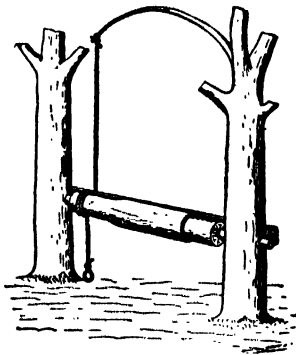

FIG. 62. PRIMITIVE LATHE

From the time of this first invention until 1797 when an Englishman, Henry Maudslay, designed and built the screw cutting engine lathe shown in Fig. 63 there doubtless were many improvements in lathe construction, but none which were strikingly outstanding or efficient. The outstanding feature of Maudslay's lathe is a lead screw geared to the spindle of the lathe. This invention made possible the advancement of the tool at a constant rate of speed and distance of travel.

In the older forms of the lathe, various means were used to rotate the work, the most common

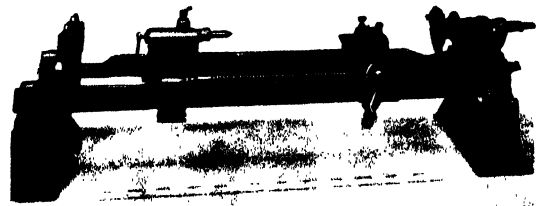

FIG. 63. LATHE OF 1797

of which were ropes, foot treadles, hand cranks and belts. The latter were used principally in connection with water, steam and electrically operated devices. The term *engine lathe* seems to have originated from the practice of driving lathes by means of a steam engine, which caused a line shaft to rotate, to which the lathe was connected by means of a belt.

#### MODERN LATHES

Modern lathes are highly efficient, accurate and complex devices, capable of doing a great quantity and variety of work. A well constructed engine lathe will, when properly operated, produce work accurate within .001 of an inch or even less. Fig. 64 gives an idea of the complexity of a modern lathe and shows many of the principal parts.

Motion is transmitted to modern lathes by means of individual motors. Sometimes the motor is direct mounted, while on other machines it is connected by means of a short belt, usually of the V type. Fig. 65 illustrates a type of lathe in which the motor is mounted under the head in the hollow leg. Fig. 66 shows a motor mounted at the rear of the lathe and power secured by plugging into a lamp socket.

The size or capacity of a lathe is given in terms of swing and length of bed. The swing refers to the diameter of work that can be rotated in the lathe. Thus a 16-inch lathe will



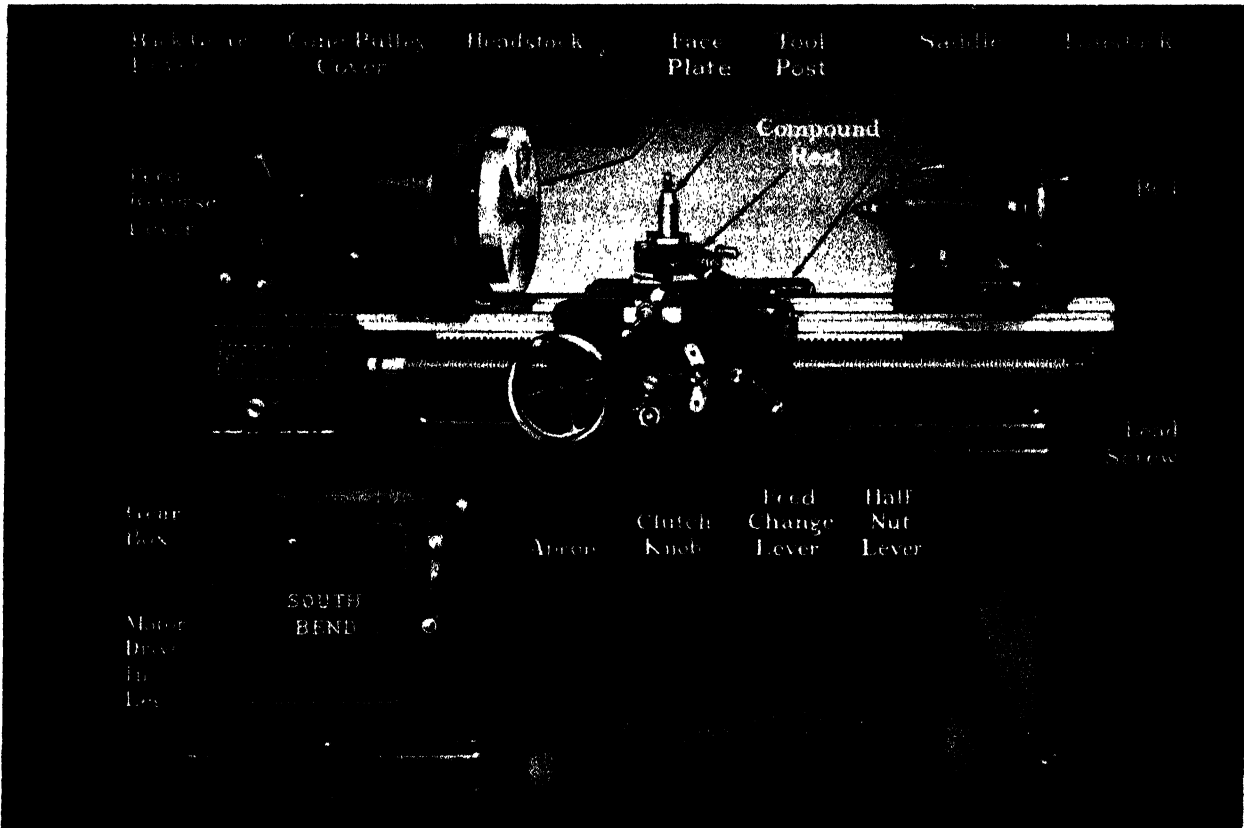
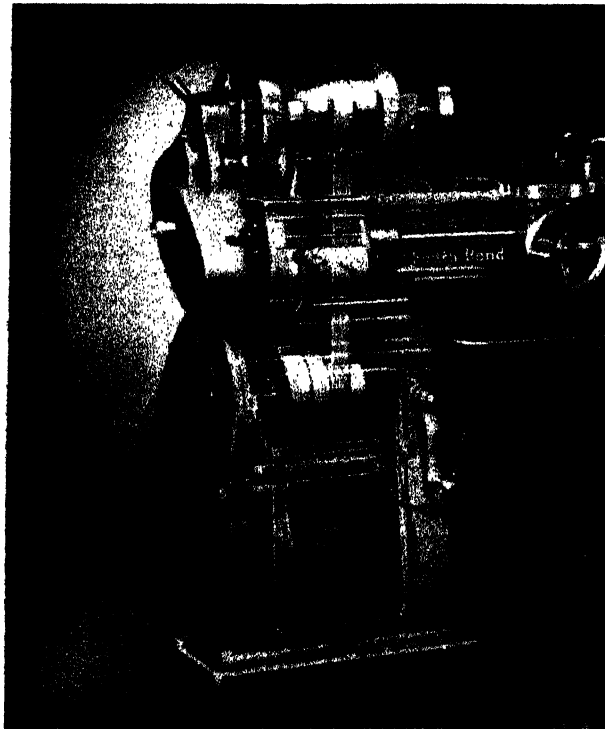
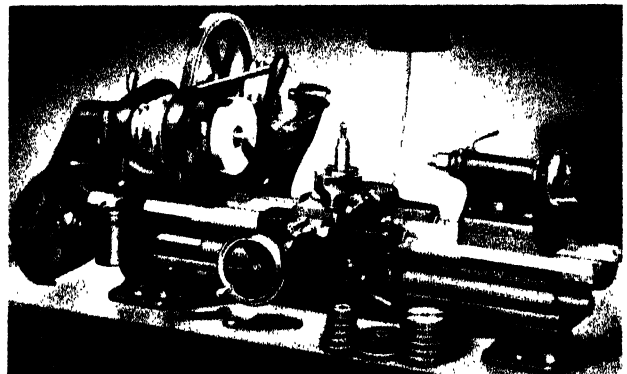

FIG. 64. MODERN LATHE

*Courtesy, South Bend Lathe Works*



*Courtesy, South Bend Lathe Works*  
 FIG. 65. BELT DRIVEN LATHE



*Courtesy, South Bend Lathe Works*  
 FIG. 66. BELT DRIVEN LATHE WITH MOTOR MOUNTED IN THE STAND

swing work as large as 16 inches in diameter. The length of a lathe should not be confused with the maximum distance between centers when the tailstock is moved to the rear end of the lathe bed. The maximum distance between centers, however, determines the length of stock that can be machined. Stock which is somewhat longer than can be machined between centers may be machined by holding the left-hand end

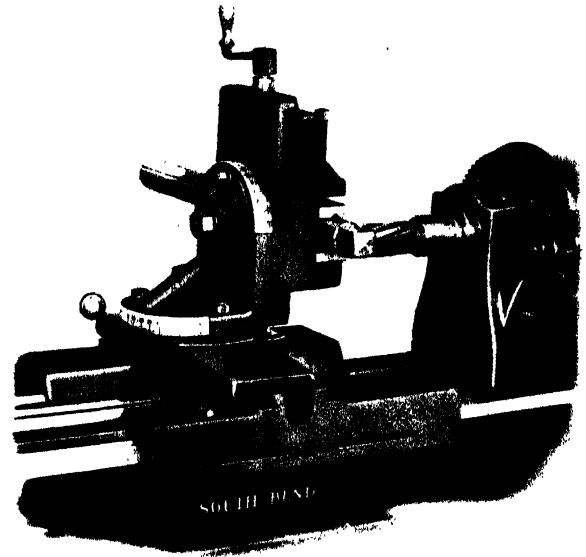
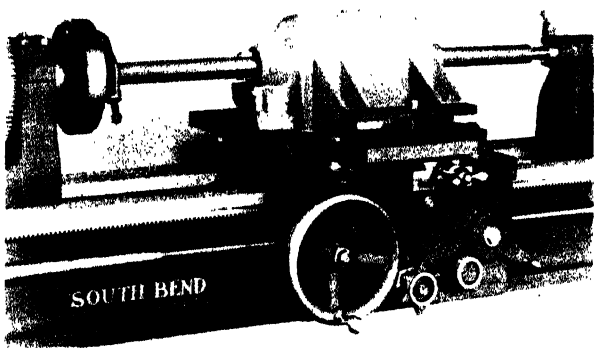

*Courtesy, South Bend Lathe Works*

FIG. 67. MILLING ATTACHMENT FOR A LATHE

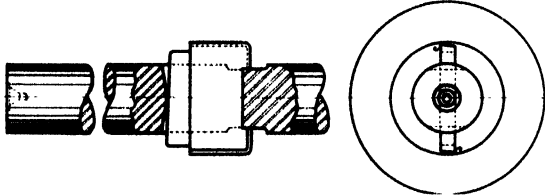
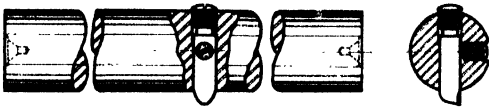
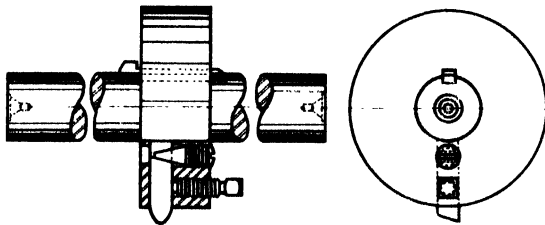

*Courtesy, South Bend Lathe Works*

FIG. 68. BORING ATTACHMENT FOR A LATHE

of the stock in a chuck and supporting the free end with a steady rest, or by using a clamp or a dog which can be fastened to the faceplate.

Lathes are made in a wide variety of types and sizes, from the small precision lathe found in watch repair shops to the immense machine used in manufacturing big guns.

**SPECIAL ATTACHMENTS**

In recent years manufacturers have produced attachments which can be employed on a lathe to perform functions or operations formerly done on a special machine. Figs. 67, 68 and 69 illustrate, respectively, a milling attachment, a boring attachment and a gear cutting attachment. Such devices greatly extend the variety of work that can be performed on a lathe.

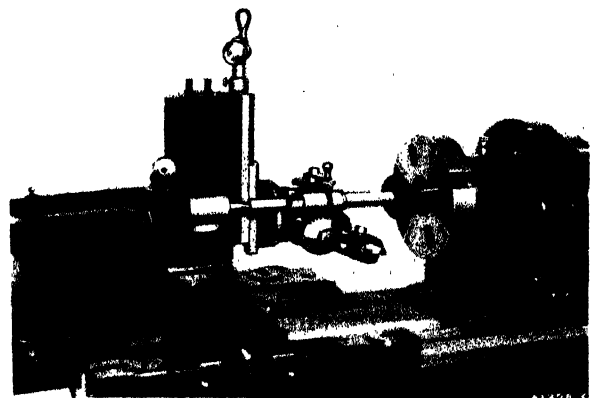
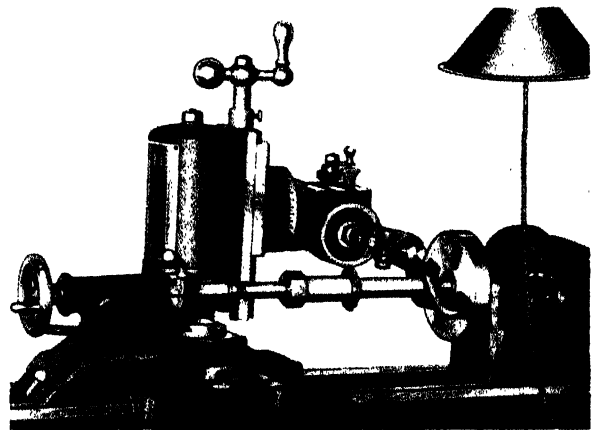

*Courtesy, South Bend Lathe Works*

FIG. 69. GEAR CUTTING ATTACHMENT FOR A LATHE

## UNIT 15

### CUTTING SPEEDS FOR LATHE WORK AND HOW TO CALCULATE THEM

Cutting speed refers to the rate per minute at which the tool removes the stock from the surface. F.P.M. indicates the Feet Per Minute periphery (surface) speed of the revolving work at the point of the tool; that is, the diameter of the work at the bottom of the cut. Conditions that affect cutting speed are kind of material, kind of tool used (e.g. carbon or high speed steel), rigidity of work, rigidity of machine, type of cut and kind of coolant employed.

The following speeds in feet per minute (F.P.M) are recommended when using high speed tool bits without coolant:

TABLE III  
RECOMMENDED CUTTING SPEEDS FOR HIGH SPEED  
TOOL BITS WITHOUT COOLANT

MATERIAL	TURNING & BORING		Cutting Screw Threads
	Heavy Cut	Finishing Cut	
Cast Iron .....	60	80	25
Machine Steel .....	90	100	35
Tool Steel, Annealed	50	75	20
Brass .....	150	200	50
Aluminum .....	200	300	50
Bronze .....	90	100	25

When using tungsten-carbide tipped tools, the cutting speed should be increased markedly — ordinarily, from three to four times the speed recommended for high speed tool bits.

To find the cutting speed, multiply the diameter of the work in inches by 3.1416. Multiply the product found by the number of revolutions per minute of the headstock spindle. Divide

this product by 12. This will give the cutting speed in feet per minute.

EXAMPLE: What is the cutting speed in feet per minute of a piece of cast iron  $1\frac{1}{2}$  inches in diameter revolving at 150.0 revolutions per minute?

$$\frac{1.5 \times 3.1416 \times 150}{12} = \text{Ft. per minute}$$

or

$$1.5 \times .2618 \times 150 = 58.9, \text{ approx. } 59 \text{ F.P.M.}$$

To find the number of revolutions per minute, the headstock spindle should make, to produce a cutting speed of a given rate, for example 90 feet per minute, multiply the cutting speed in feet per minute by 12, then divide the product found by the product of the diameter of the piece in inches multiplied by 3.1416.

EXAMPLE: How many revolutions per minute should a piece of mild steel  $1\frac{1}{4}$  inches in diameter make to produce a cutting speed of 90 feet per minute? Refer to table above to find recommended cutting speed.

$$\frac{90 \times 12}{1.25 \times 3.1416} = \frac{18}{.25 \times .2618} = 275 \text{ R.P.M. approx.}$$

or

$$\frac{90}{1.25 \times .2618} = \frac{90}{.32725} = 275 \text{ R.P.M. approx.}$$

## UNIT 16

### GRINDING LATHE CUTTER BITS

Lathe tool cutters are ground at various angles to give them keenness and strength. Grinding a tool so as to produce excessive side or front clearance will produce a keen but weak cutting edge. Such an edge breaks easily because the supporting metal has been ground away.

A tool is given side rake and back or top rake to increase its keenness and to facilitate free cutting. The angle of keenness, Fig. 70, varies from  $60^\circ$  to about  $87^\circ$  depending upon the kind of metal to be cut. Neither side nor back rake is required when brass or bronze is being turned.

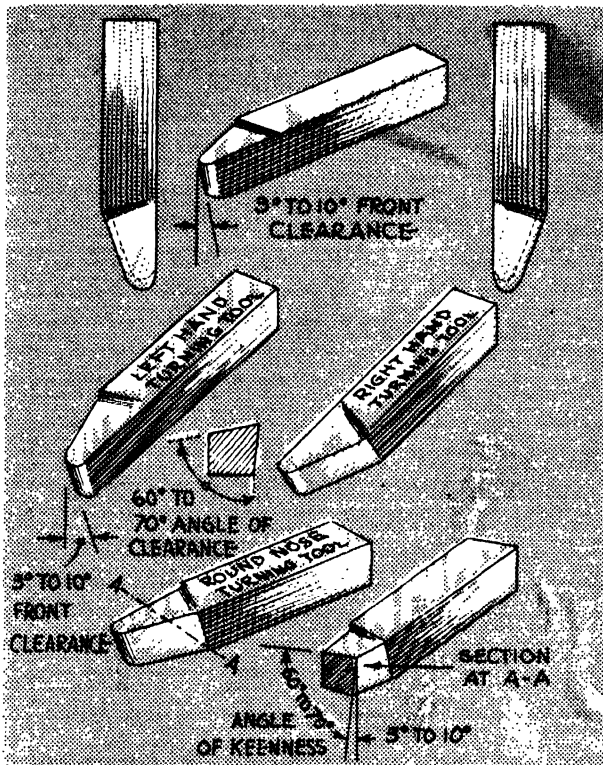

FIG. 70. TOOL ANGLES



Courtesy, South Bend Lathe Works  
FIG. 70-A. CUTTER BITS

The recommended angle of keenness for mild steel and soft brass is about  $60^\circ$  and for cast iron, hard steel and bronze  $85^\circ$  to  $87^\circ$ . For machining mild steel, the cutter should be given considerable back and side rake. For machining hard bronze, hard steel or cast iron, little side or back rake is necessary. Back rake may often be eliminated altogether.

For different metals, the amount of front clearance required, Fig. 71, varies from about  $3^\circ$  to  $15^\circ$ . For cutting mild steel, the bit should be given a front clearance of from  $12^\circ$  to  $15^\circ$  and a pronounced back and side rake, Fig. 72. If the bit is held in an Armstrong tool holder

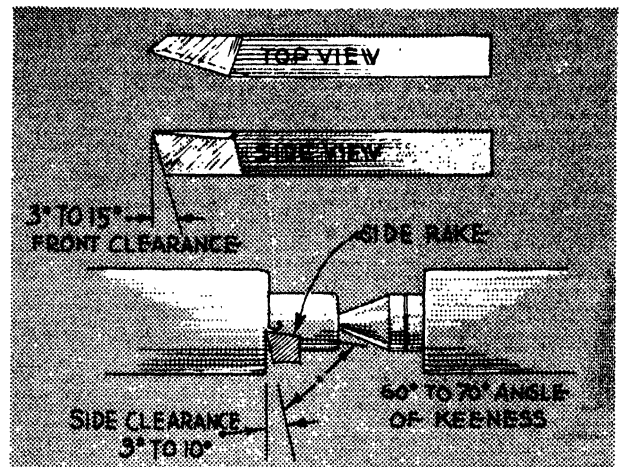

FIG. 71. CUTTING ANGLES VARY WITH THE METAL TO BE CUT

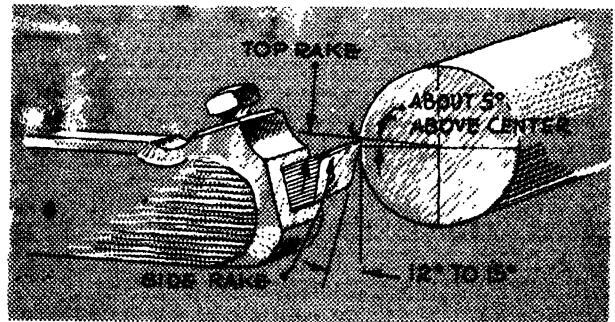

FIG. 72. CUTTING ANGLES FOR MILD STEEL

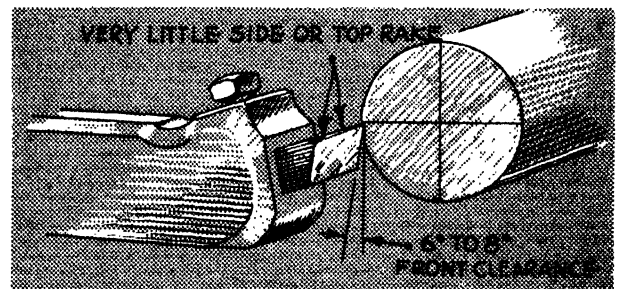

FIG. 73. CUTTING ANGLES FOR CARBON STEELS

only a very slight back rake, if any, need be ground on the bit because of the angle at which it is held. For cutting carbon steels, cast iron or other very hard metals, the bit should be given a front clearance of about  $6^\circ$  to  $8^\circ$  and very little top or side rake, Fig. 73. For cutting bronze or brass, the tool is given about  $12^\circ$  front clearance,  $6^\circ$  to  $8^\circ$  side clearance and no back or side rake. A parting tool is made with a little side clearance on each side. It is ground

with about  $3^\circ$  to  $5^\circ$  front clearance and no side rake. A very slight back rake is provided in the chip curve ground on the top of the bit, Fig. 74. This tool requires a special holder.

Threading tools are ground V-shaped with an inclusive angle of  $60^\circ$ . The bit is given from  $10^\circ$  to  $12^\circ$  front clearance and from  $8^\circ$  to  $10^\circ$  side clearance on each side, Fig. 75. The point of the bit is flattened about  $\frac{1}{8}$  of the *pitch* for National Coarse or National Fine threads.

Grinding high speed or carbon steel lathe bits presents no special problem other than to observe that the correct angles are produced for respective metals and that each ground face is as nearly a straight plane as possible, and never convex. Ordinarily, the nose of round-nose tools should be ground elliptical rather

than round. After grinding, whetting will produce a bit that will cut smoother and retain its edge longer.

#### TIP AND ALLOY BITS

In mass production and for machining very hard or abrasive materials tungsten carbide tipped or some form of alloy bits, Fig. 70A, increasingly are coming into common use. Cutter bits of this type will stand very high cutting speeds, generally two to three times that of high speed steel cutters and they do not lose their temper even when heated red hot. These bits are hard and somewhat brittle, so they should be ground with only sufficient front clearance to permit the tool to cut freely, also with somewhat less side and back rake than in the case of high speed steel bits. They should be ground on a soft or a special grinding wheel and whetted with a hard, fine whetstone. Tipped or alloy bits should be used only on machines which are rigidly constructed, and which can be operated at high speed.

#### TOOLS FOR MACHINING ALUMINUM

When machining aluminum it is advisable to use tools ground especially for the purpose. Tools for machining aluminum are ground with more top and side rake than tools for machining other metals, Fig. 75A. Increasing the side rake produces a shearing effect when making the cut. The total angle of the cutting edge should not be greater than about  $35^\circ$ . When setting the tool, the point should be placed far enough above the center of the work to provide a top rake of from  $45^\circ$  to  $52^\circ$ . Tools for machining aluminum should always be

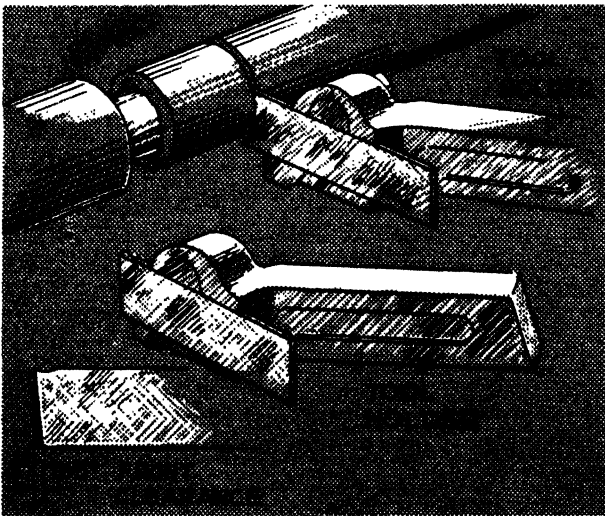

FIG. 74. PARTING TOOL HOLDER AND ANGLES

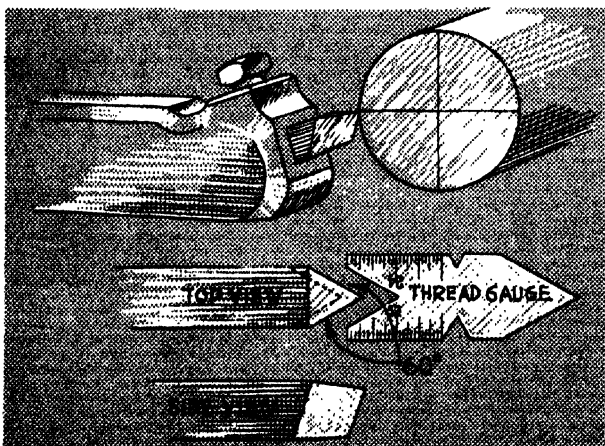
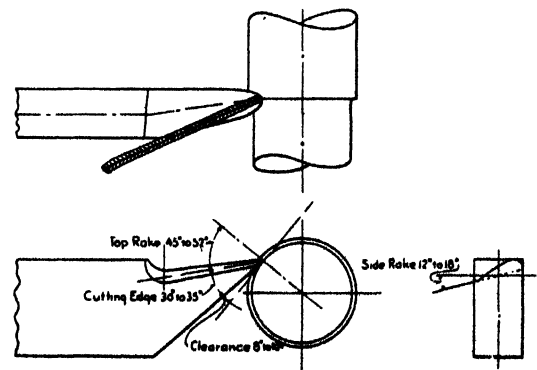

FIG. 75. CUTTING ANGLES FOR THREADING TOOLS



Courtesy, South Bend Lathe Works

FIG. 75-A. DESIRABLE SHAPE AND SETTING OF TOOL FOR MACHINING ALUMINUM

whetted to a *keen edge* and should be *smooth* and free of wheel scratches or wire edges, as aluminum sticks to rough surfaces.

Aluminum may be machined with ordinary high carbon tools, with high-speed tools, or with tools tipped with tungsten-carbide. The

latter hold their edges longer, do smoother work and give increased production.

Ordinarily, aluminum machines best at relatively high speeds, with fairly light cuts and frequent application of a coolant of equal parts of kerosene and lard oil.

## UNIT 17

### HOW TO GRIND AND WHET LATHE AND SHAPER CUTTERS

Good smooth work cannot be done on the lathe or shaper unless the cutters are sharp and are ground at the correct angle. The angle at which the respective cutters are ground generally is the same regardless of whether the cutter is a forged tool or a high speed steel bit. Carbide tipped and alloy bits are ground with a little less front and side clearance than that recommended for high speed steel bits.

A soft or medium soft grinding wheel is recommended for grinding cutting tools.

For grinding carbide-tipped bits, the apparatus and procedure shown in Fig. 76A is recommended.

#### PROCEDURE FOR GRINDING LATHE CUTTERS

1. Select a suitable wheel.
2. Examine the faces of the wheel for trueness and freedom from grooves.
3. If necessary, dress all of the surface to be used until all ridges or grooves have been removed and the wheel is running true, with the face of the wheel perpendicular to the sides.
4. Protect the eyes against flying particles of loosened abrasive by using a shield and goggles.

On some grinders a coolant is used. When this is the case, be sure there is sufficient in the container. Turn on the coolant and allow it to run on the face of the wheel for a minute before grinding.

5. Examine the angles at which the cutter was last ground and compare these with the suggestions offered in Unit 16. If the angles of front and side clearance and rake are not correct they should be corrected.
6. Assuming the front and side angles are correct, bring the heel of the cutter into

contact with the wheel, A, Fig. 76. Raise the rear of the tool until the face being ground rests its full length on the surface of the wheel, B, Fig. 76. Holding the cutter at this angle, slowly roll the tool from right to left across the face of the wheel, maintaining the same angle.

When grinding a flat surface, hold the cutter at the desired angle and move it back and forth in a path perpendicular to the side of the wheel.

When available, a grinder with an adjustable tool rest is recommended, Fig. 76A. Set the adjustable rest or table at the angle desired, the angle of clearance required, and clamp it in position. Place the

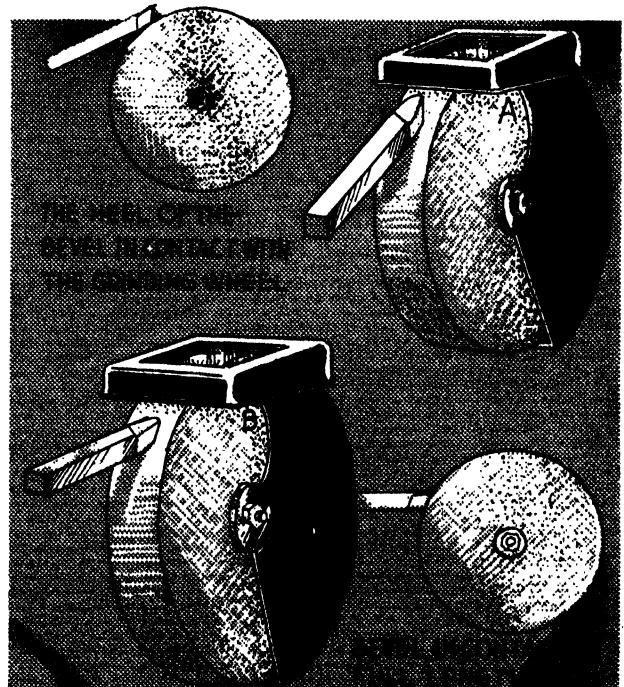

FIG. 76. GRINDING CUTTER BITS



Courtesy, The Norton Co.

FIG. 76-A. SHARPENING A CARBIDE-TIPPED TOOL ON A METAL BONDED DIAMOND WHEEL

cutter on the rest, then bring it against the face of the wheel and proceed as in steps 7 and 8.

7. Continue grinding until all parts of the cutting edge have been brought into contact with the wheel. Be sure to maintain the correct shape and angle.
8. Remove the tool from the grinder and carefully examine the *cutting edge*. If any bright spots are visible, again bring the part or parts of the cutter into contact with the grinding wheel, then continue grinding until all have been removed.
9. If necessary, grind the top of the cutter to give it the amount of rake recommended, Unit 16. Ordinarily, grinding on the top should be kept at a minimum.

#### PROCEDURE FOR WHETTING LATHE CUTTERS

1. Secure a medium soft slipstone and apply a little machine oil to one surface.

2. Hold the slipstone flat on the ground surface, Fig. 77, then move the slip up and down until the whole cutting edge has been whetted. Bear heavily on the downward stroke and very lightly on the return stroke.

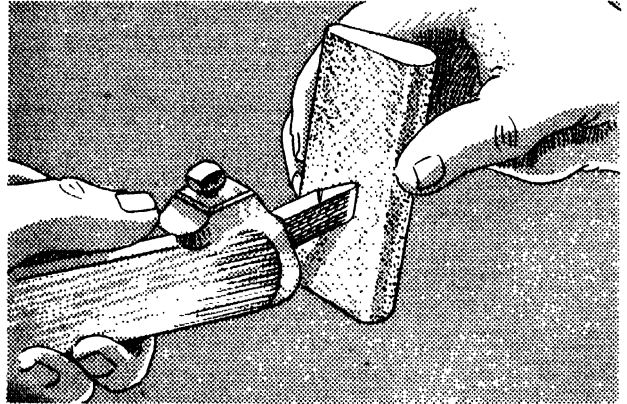

FIG. 77. WHETTING A LATHE CUTTER

#### PROCEDURE FOR GRINDING SHAPER CUTTERS

1. Proceed as under "Grinding Lathe Cutters," steps 1 to 4 inclusive.
2. Examine the angles of clearance at which the cutter was last ground and compare these with the recommendations made in Unit 16. Then make the necessary corrections.
3. Proceed as under "Grinding Lathe Cutters," steps 5 to 9 inclusive.

#### PROCEDURE FOR WHETTING SHAPER CUTTERS

1. Proceed as when whetting lathe cutters.

### UNIT 18

## HOW TO LOCATE, TEST, DRILL AND COUNTERSINK CENTERS PREPARATORY TO TURNING

The approximate center of round and irregular pieces of stock may be found in a number of ways. The most commonly used of these will be discussed in the following paragraphs.

#### PROCEDURE FOR FINDING THE CENTER WITH A CENTER SQUARE

1. Secure stock of the size desired.

2. Chalk the ends of the piece thoroughly.
3. Set the stock on its end on a bench or grip it in a vise.
4. Place the center square across one end of the piece as shown in A, Fig. 78, then carefully scribe a line across the chalked surface.

5. Give the square a third of a turn and scribe a second line.
6. Give the square another third turn and scribe a third line, B, Fig. 78.
7. Repeat steps 3, 4, 5 and 6 on the other end of the piece.
8. Place the point of a sharp center punch at the center of the intersection of the lines on one end of the stock.
9. Holding the center punch in a vertical position, strike it a light blow with a hammer.
10. Repeat steps 8 and 9 on the other end of the piece.
11. Examine the position of the punch marks. If each seems to be located in the center, increase their depth by punching them a little deeper.

If the punch marks are not in the center of the piece, correct them as in the paragraph following step 10, Unit 10.

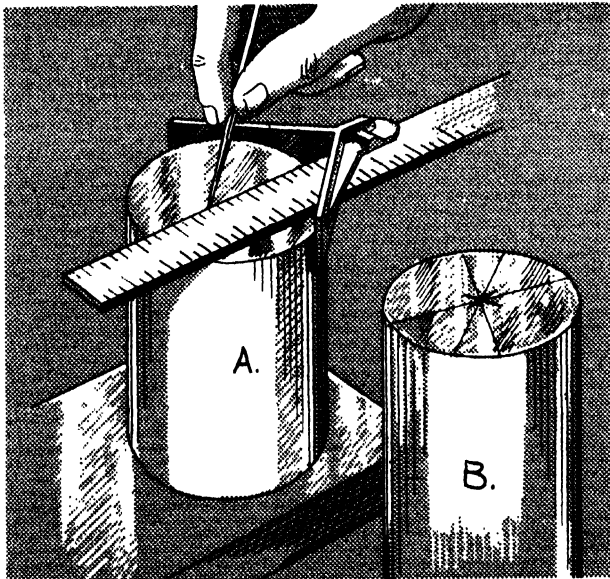

FIG. 78. FINDING THE CENTER WITH CENTER SQUARE

#### PROCEDURE FOR FINDING THE CENTER WITH DIVIDERS

1. Select and cut the stock to length.
2. Chalk both ends of the piece thoroughly.
3. Set a pair of dividers so that the distance between the points is slightly less than half the diameter of the piece.
4. Lay the work on a flat surface, preferably a metal surface plate, and hold it in position with the left hand.

5. Place one leg of the dividers on the plate at the position where the work lies, Fig. 79, then make a short arc on the chalked surface of the work.
6. Give the piece a quarter turn and repeat the operation.

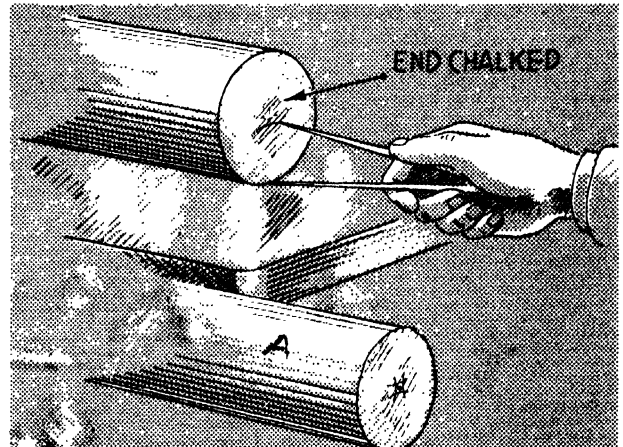

FIG. 79. FINDING THE CENTER WITH DIVIDERS

7. Continue this until the short arcs form a four sided figure, A, Fig. 79.
8. Place the point of a center punch at the center of the four sided figure, then with the punch held vertically, strike it a light blow with a hammer.
9. Find the center of the opposite end in a similar manner.
10. Examine the position of the punch mark at each end of the piece. If each seems to be located in the center of the four sided figure, punch them to the depth desired.

Location of center may be checked with a pair of dividers set to a distance equal to the radius of the diameter of the stock. Place the point of one leg in the punch mark, then rotate the point of the other leg around the circumference of the stock, observing how accurately the point follows the circumference.

If correction of position of punch marks is necessary, then proceed as in the paragraph following step 10, Unit 10.

#### PROCEDURE FOR FINDING THE CENTER WITH A HERMAPHRODITE CALIPER

1. Secure stock of the size desired.
2. Chalk the ends of the piece thoroughly.



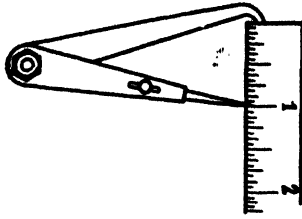

FIG. 80. SETTING THE HERMAPHRODITE CALIPER

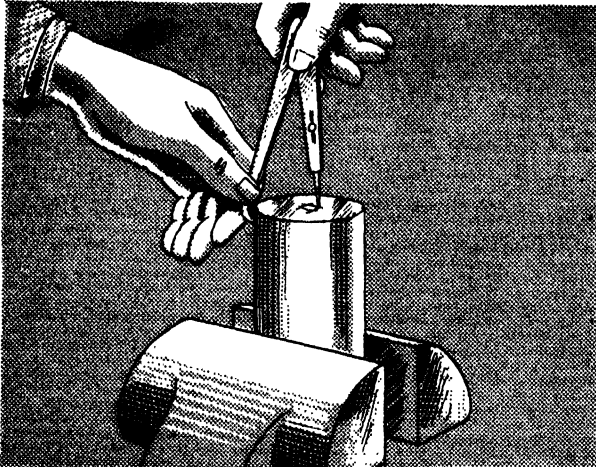

FIG. 81. FINDING THE CENTER WITH HERMAPHRODITE CALIPER

3. Set the stock on its end on a bench or grip it in a vise.
4. Set the hermaphrodite caliper so that the distance between the point of the bent leg and that of the straight leg, Fig. 80, is about  $\frac{1}{2}$  of an inch greater than half the diameter of the stock at the end where the center is to be located.
5. Place the bent leg against the side (circumference) of the stock *near the top edge*, hold it firmly in this position with the left hand, then with the straight leg of the divider draw a short arc on the chalked end of the stock, Fig. 81.
6. Move the bent leg of the caliper half of the distance around the circumference of the stock, draw a second short arc, then move the bent leg one-fourth of the distance and draw a third short arc. Continue thus until four short arcs have been drawn, Fig. 81.
7. Place the point of a sharp center punch at the center of the small enclosure made by the four arcs.

8. Holding the center punch in a vertical position, strike it a light blow.
9. With the hermaphrodite caliper, check the location of the center punch mark as described in the paragraph following step 10 under "Finding the Center with Dividers."

If the punch mark is not in the center of the piece, correct the position as described in the paragraph following step 10, Unit 10.

10. When the punch mark has been correctly located, increase its depth by punching a little deeper.
11. Locate the center at the other end of the piece, if necessary.

#### PROCEDURE FOR FINDING THE CENTER WITH A BELL CENTERING CUP

1. Select and cut stock to size. Be sure the ends are cut square with the axis of the stock.
2. With a file, remove any burrs or projections on the circumference of the stock at the end or ends to be centered.
3. Place the stock on its end on a flat solid surface, preferably a heavy surface plate.
4. Place the bell centering cup over the end of the work as in Fig. 82. Be sure the barrel of the cup is held in a plane *parallel* with the *axis of the work*.
5. Strike the center punch or plunger a sharp blow with a hammer, thus locating the center.
6. Locate the center at the other end in a similar manner, if necessary. When necessary to increase the depth of the punch marks, do so in the usual manner, using an ordinary center punch.

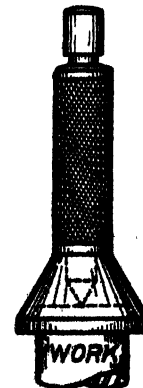

Courtesy, South Bend Lathes Works  
FIG. 82. BELL CENTERING CUP

### PROCEDURE FOR FINDING THE CENTER WITH A SURFACE GAUGE

1. Chalk the ends of the piece.
2. Mount the stock in a V-block or V-blocks on a surface plate, Fig. 83.
3. Set a surface gauge and draw a line near the approximate center of the piece, A, Fig. 83.
4. Move the surface gauge to the opposite end and draw a corresponding line on that end of the piece.
5. Turn the piece a quarter of a turn or as far as its shape will permit without raising either center, then draw a second line on each end.
6. Repeat steps 4 and 5 until a four sided figure has been described on each end, B, Fig. 83.
7. Place the point of a center punch in the center of the figure defined by the lines drawn in steps 3, 4, 5 and 6, then strike the punch a light blow with a hammer. Sink the punch mark to the depth desired with repeated blows.
8. Repeat the operation on the other end.

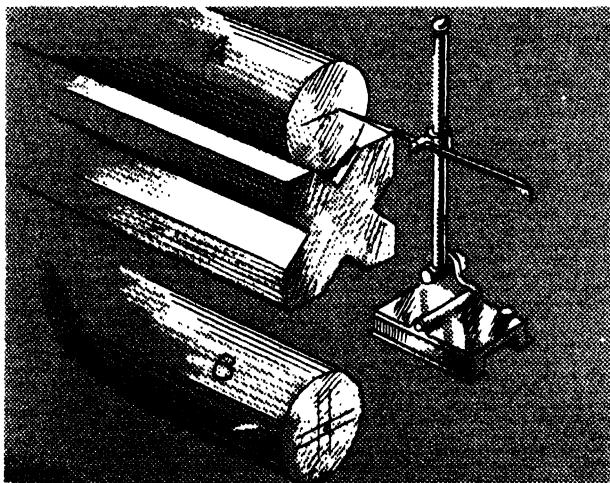
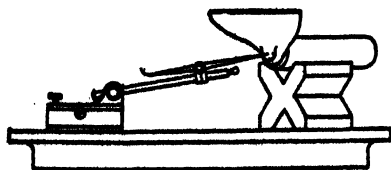

FIG. 83. FINDING THE CENTER WITH A SURFACE GAUGE



Courtesy, South Bend Lathe Works

FIG. 84. FINDING THE CENTER OF AN IRREGULAR SHAPE

Fig. 84 illustrates a method of finding the center on an irregular shape. Note the flat boss at the T end of the rest. This boss is placed there for convenience in centering the piece for turning.

### PROCEDURE FOR TESTING CENTERS

1. Place the work between the lathe centers, Fig. 85, then draw the tailstock center tight enough to support the work.
2. Hold a piece of chalk close to the work at one end, Fig. 85. The hand holding the chalk should be supported by resting the arm on the compound rest or other suitable support.
3. With the left hand, revolve the work and at the same time advance the chalk until it just touches the revolving piece. The chalk will make a mark on the high side, or the point farthest from the center.

This test may be made with the lathe running at slow speed.

4. Repeat the operation on the other end of the piece.

If the stock is accurately centered, the chalk will make a complete line around the piece. When the centers are not true, make necessary corrections as described in the paragraph following step 10, Unit 10.

There are two common methods of drilling and countersinking holes for centers. In one method, the drilling is done in a lathe; in the other, it is done on a drill press.

When drilling in the lathe, if the work is accurately centered and securely held in a chuck, and the drill held in the tailstock, it will not be necessary to locate the center in the work before starting to drill.



FIG. 85. TESTING CENTERS WITH CHALK

### PROCEDURE FOR DRILLING CENTERS ON THE DRILL PRESS

1. Secure stock of proper length. Be sure the ends are square with the side of the piece.
2. Locate the center of the work at each end of the stock and mark with a center punch. Test the location of centers as described under "Procedure for Testing Centers."

3. Insert a combination drill and countersink in the drill press chuck, Fig. 86.

For small or light work a No. 2 combination drill and countersink will answer the purpose. One of this size has a body diameter of about  $\frac{5}{16}$  of an inch.

4. Place the work in position on the drill press table and start the machine.

If available, a cup center accurately centered under the spindle of the drill should be used under the work. This will largely offset irregularities on the end of the work.

5. Draw the point of the drill into the impression made by the center punch, Fig. 86, and drill until the tapered part of the drill has entered about  $\frac{3}{4}$  of its full length. If drilling steel, keep the drill well lubricated.

A, Fig. 87, shows a correctly drilled and countersunk hole. Notice that the lathe center fits the tapered hole accurately with clearance at the point; B, Fig. 87, is not countersunk at the correct angle and C,

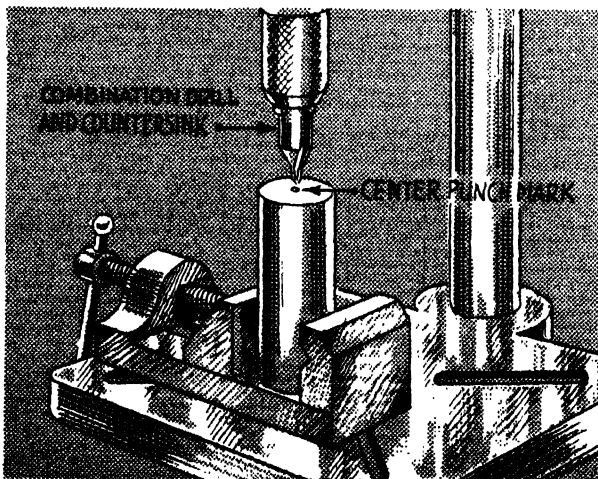
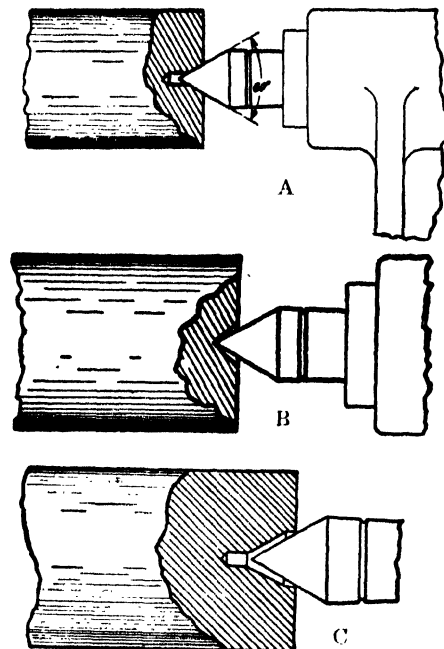

FIG. 86. DRILLING CENTERS WITH COMBINATION DRILL AND COUNTERSINK



Courtesy, South Bend Lathe Works

FIG. 87. POOR AND GOOD CENTER HOLES

Fig. 87, is drilled too deep to fit the center. A center drilled and countersunk as at either B or C, Fig. 87, will ruin the lathe center.

6. Drill the other end in a similar manner.

### PROCEDURE FOR DRILLING CENTERS ON THE LATHE

1. Secure stock of proper length.
2. Locate the center of the work at each end of the stock and mark with a center punch.
3. Remove the lathe center in the headstock.
4. Insert the shank of the drill chuck in the headstock spindle, Fig. 88.
5. Select a combination drill and countersink. A No. 2 or No. 3 will answer for light or medium work.

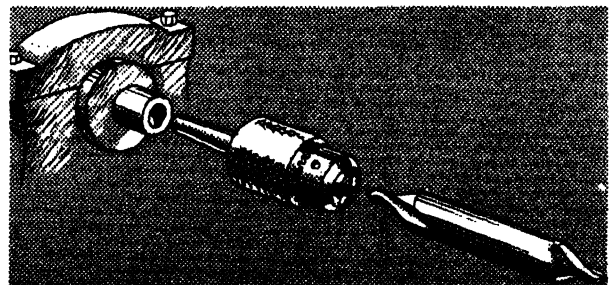

FIG. 88. INSERTING THE DRILL CHUCK IN THE HEADSTOCK SPINDLE

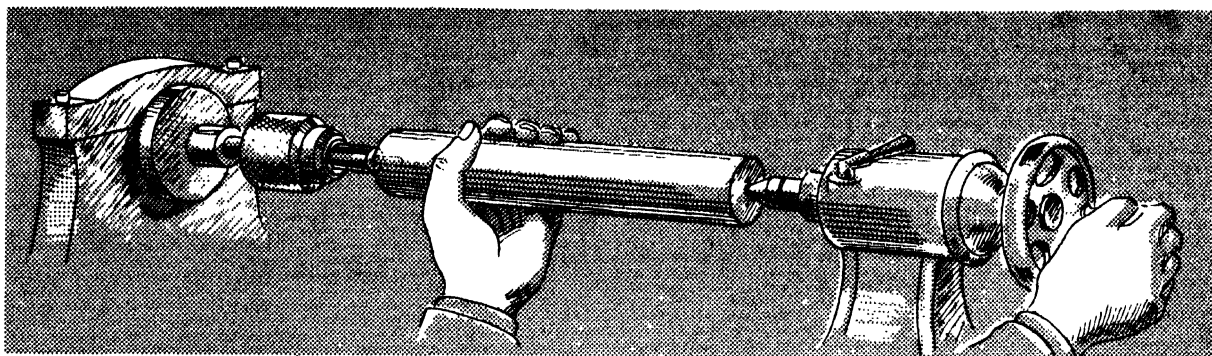

FIG. 89. DRILLING A CENTER HOLE ON THE LATHE

6. Insert the combination drill and countersink into the jaws of the drill chuck and fasten it securely with a chuck wrench.
7. Hold the center mark against the point of the drill, then draw the tailstock up to within  $\frac{1}{8}$  of an inch of the other end of the work.
8. Tighten the nut that holds the tailstock to the ways of the lathe.
9. Loosen the tailstock binding lever. This will allow the dead (tailstock) center to advance freely.
10. Place a little lubricant on the drill and then start the lathe on medium or slow speed.
11. Hold the work against the point of the dead center with the left hand, palm up, as in Fig. 89.
12. Feed the work forward slowly, by turning the hand wheel at the rear of the tailstock until the point of the drill enters the marked center.
13. Continue advancing the combination drill, slowly and carefully, until the tapered part has entered the work about  $\frac{3}{4}$  of the length of the taper.
14. When drilled to depth, draw the tailstock spindle and work back until the drill clears the hole, then stop the lathe.
15. Reverse the piece and drill the other end.

## UNIT 19

### HOW TO SET A LATHE TOOL FOR TURNING METAL

The height at which a lathe tool should be set depends upon the metal to be turned and to some extent upon the operation being performed. As a general rule the point of the tool should be set about  $5^\circ$  above the center, except when turning brass or copper, or when turning a taper, cutting a thread, boring, or cutting off stock. In all of these exceptions the point of the tool should be at exactly the same level as the axis of the work. When turning steel or cast iron of small diameter, the point of the tool should be set only very slightly above the axis of the work. For turning aluminum, a tool especially ground and sharpened for that purpose is recommended, with the point of the tool set considerably higher above the axis of the work than when turning steel. Regardless of

the operation to be performed or the kind of metal being turned, always make a practice of setting the cutter well back in the tool holder, and the holder itself so that it projects but slightly beyond the edge of the compound rest. Always make certain that the tool holder is fastened securely in the tool post and the cutter in the holder. A loose cutter or tool holder may cause an accident or damage the machine or the work.

#### PROCEDURE

1. Select a sharp tool of the shape and kind desired.

Select a roundnose tool for straight longitudinal cuts or facing cuts in face-plate turning, a right- or left-hand side

tool for sharp shoulders, a roundnose tool or a right- or left-hand turning tool for cutting shoulders with a fillet, a boring tool for boring recesses, a parting or cutting off tool for cutting narrow grooves or cutting off pieces of stock and a threading tool for cutting threads, Fig. 90. For turning cast iron, brass or aluminum, a roundnose tool is generally recommended; for steel, a roundnose or a left- or right-hand turning tool.

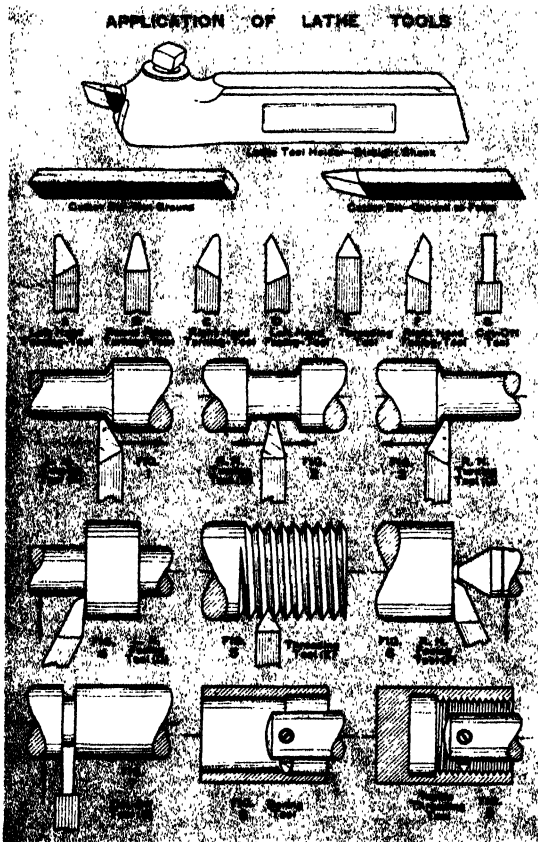

Courtesy, South Bend Lathe Works

FIG 90. CUTTER BITS AND THEIR APPLICATIONS



Courtesy, South Bend Lathe Works

FIG. 91. CUTTER BIT INSERTED INTO TOOL HOLDER

2. Insert the cutter in the tool holder, allowing it to project about one-half inch, as in Fig. 91, then tighten the setscrew that holds the cutter. Do not allow the cutter to

project more than the recommended amount, unless conditions *absolutely* necessitate.

3. Insert the tool holder in the tool post and adjust the point of the cutter to the height desired by sliding the wedge backward or forward in the tool post ring as occasion requires. See Fig. 92.

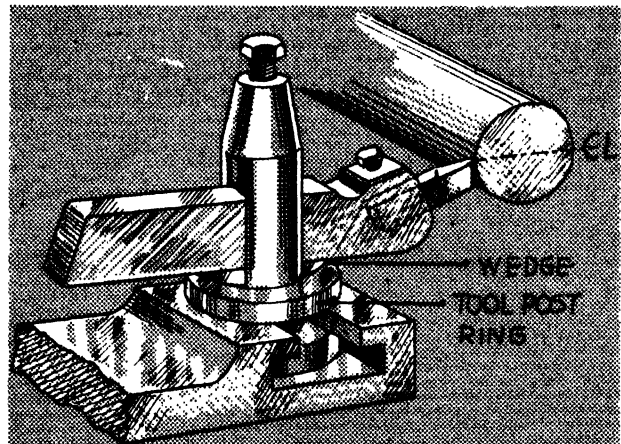

FIG. 92. ADJUSTING THE TOOL HOLDER IN THE TOOL POST

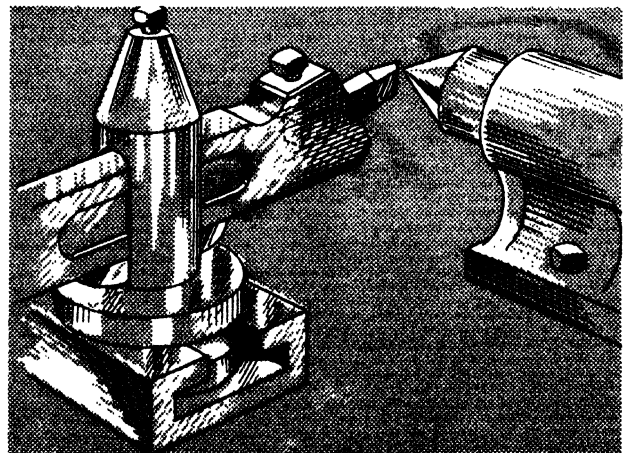

FIG. 93. TESTING THE HEIGHT OF THE TOOL

4. Clamp the tool holder in position by tightening the setscrew at the top of the tool post.  
5. Test the height of the tool by running in the cross slide until the point of the tool is as close as possible to the point of the dead center, Fig. 93.

## UNIT 20

## HOW TO MOUNT WORK BETWEEN LATHE CENTERS

Mounting work between centers is a very common method of holding work while it is being machined. To rotate the work, a faceplate having an open slot on one side is mounted on the spindle. A lathe dog with a bent tail is mounted on the stock and the tail engaged in the slot in the faceplate.

**PROCEDURE**

1. Remove the chuck if one is mounted on the lathe spindle.
2. Clean the threads on the lathe spindle with a piece of cloth or a small handful of waste, remove any remaining lint or threads, then apply a few drops of lubricating oil.
3. Test the points of the lathe centers for alignment, as in Fig. 94. Both points should be in the same horizontal and vertical planes.

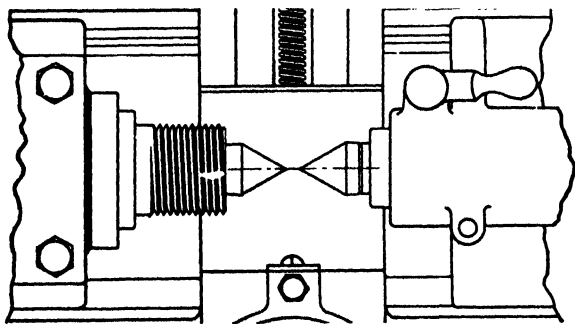

Courtesy, South Bend Lathe Works

FIG. 94. TESTING THE LATHE CENTERS FOR ALIGNMENT

4. Select a faceplate of suitable size. Clean the threads with a piece of cloth or waste and apply a few drops of lubricating oil.
5. Disengage the back gear, if any.
6. Hold the hub of the faceplate squarely against the nose of the spindle with the right hand, then rotate the cone pulley with the left, as in Fig. 95. Continue rotating the pulley until the faceplate comes *gently* against the shoulder of the spindle. If the spindle cannot be rotated, then rotate the faceplate by hand, clockwise.

**CAUTION:** Do not allow the hub of the faceplate to strike hard against the shoulder of the spindle, as this may make it very difficult to remove the faceplate.

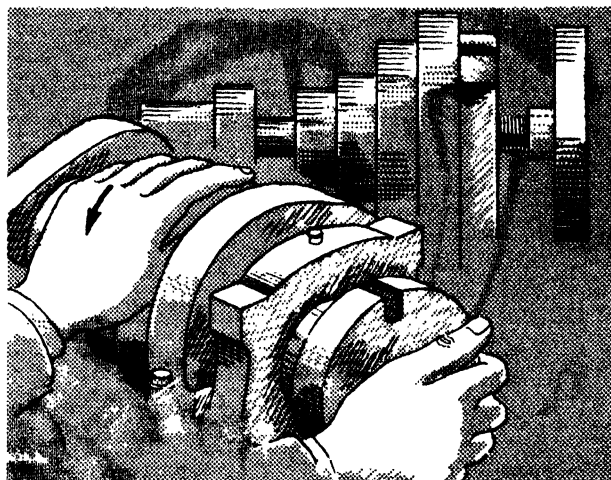

FIG. 95. MOUNTING THE FACEPLATE

7. Thoroughly clean the openings in the head and tailstock spindles with a piece of cloth or waste wrapped about a small stick. Remove any remaining lint or threads.

**CAUTION:** Never put your finger in the hole of the lathe spindle while it is revolving.

8. Wipe centers with a piece of cloth or waste.
9. Insert the soft center in the headstock spindle and the hardened one in the tailstock. The hardened center usually has a groove cut near the cone end, Fig. 94.
10. Fasten the lathe dog, Fig. 96, on one end of the work with the bent tail pointing outward.

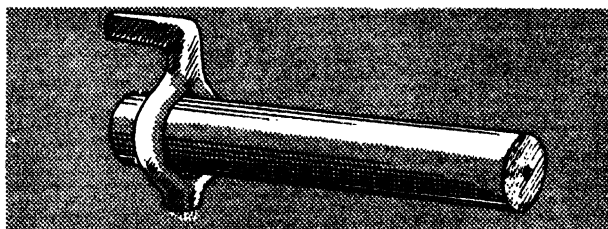

FIG. 96. LATHE DOG IN POSITION

If the work where the dog is attached is a finished surface, insert a small piece of sheet copper or brass between the end of the screw in the dog and the work; this will prevent marring.

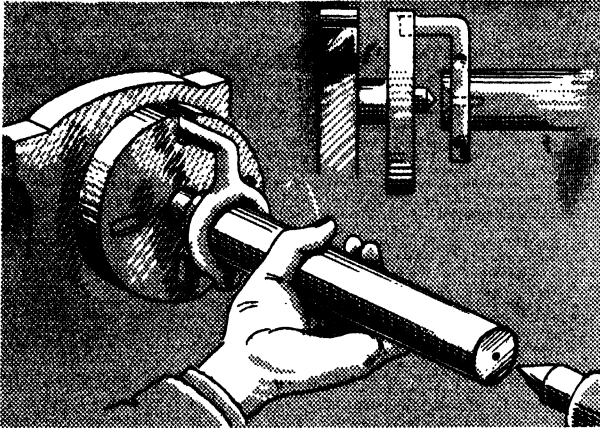

FIG. 97. ENGAGING THE LIVE CENTER

11. Place a little oil or white lead and oil in the center to be engaged by the dead (tailstock) center.
12. Engage the center hole in the work with the point of the live center (headstock center) with the tail of the lathe dog in the slot in the faceplate, Fig. 97. Hold the work in this position with the left hand.

**CAUTION:** Be sure the tail of the dog does not rest on the bottom of the slot in the faceplate, as that will prevent the center from entering the countersunk hole in the work correctly.

13. Grasp the tailstock with the right hand and move it forward until the point of the dead center enters the center hole in the stock.

14. Fasten the tailstock in position by tightening nut, A, Fig. 98.

**CAUTION:** Before clamping the tailstock in position, be sure there is sufficient room for the saddle and tool block to operate freely.

15. Advance the tailstock spindle by turning the handwheel at the rear of the tailstock clockwise, Fig. 98, until the point of the dead center enters the countersunk hole in the end of the work and all motion endwise is eliminated.

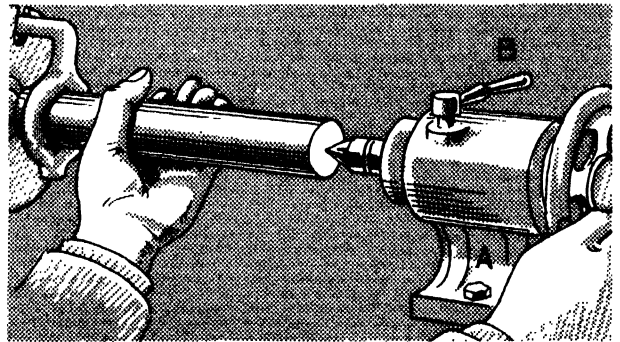

FIG. 98. ENGAGING THE DEAD CENTER

16. Turn the handwheel back very slightly, then move the tail of the dog back and forth and at the same time adjust the handwheel until only a slight resistance is felt, then tighten the tailstock binding lever, B, Fig. 98.

## UNIT 21

### HOW TO MAKE ROUGHING AND FINISHING CUTS ON A LATHE WITH THE STOCK MOUNTED BETWEEN CENTERS OR IN A CHUCK

A roughing cut, as the name indicates, is a cut taken to remove the rough stock on the surface. Usually it is a heavy cut, depending somewhat upon the amount of material to be removed and the capacity of the tool to stand the strain of removing a large amount of metal as quickly as possible. Naturally, this leaves the turned surface in a somewhat rough condition. In rough turning, the work should be machined to nearly the finished size in prepara-

tion for the finishing cut. Whenever possible, feed the cut toward the headstock, especially when turning between centers. Experienced workmen frequently finish the work to the size desired with a single cut.

When taking a rough cut on cast iron, cast steel or other metals that have a hard scale on the surface, be sure to set the tool deep enough to cut under the scale. Otherwise the hard scale will wear away the cutting edge.

Before mounting stock between centers, be sure the centers are in line. Test by moving the tailstock close to the headstock center, Fig. 94. This is a very rough check and must not be depended upon when accurate work is required.

A more accurate test may be made by turning a section at each end of the piece, then testing for accuracy with a micrometer, or a caliper. To make such a test, mount a piece of stock between centers and feed the tool in at A, Fig. 99, with the cross feed until the work has been reduced about  $\frac{1}{4}$  of an inch in diameter, then with the longitudinal feed advance the tool until a straight cut about  $\frac{1}{2}$  inch long has been made. Then stop the lathe and withdraw the dead center far enough to permit swinging the right-hand end of the stock far enough to the rear to permit the running of the carriage to the right until the tool clears the right-hand end of the stock. *When moving the carriage be sure that you do not change the position of the tool by moving the cross feed.*

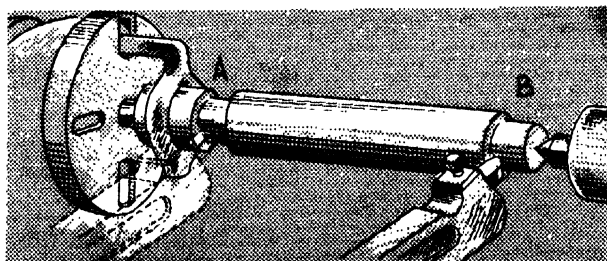

FIG. 99. TESTING THE ACCURACY OF LATHE CENTERS

Replace the stock on the dead center and adjust for tension. Then, without changing the cross feed, make a short longitudinal cut, as at B, Fig. 99. With a micrometer measure the turned sections at A and B. If the lathe centers are in line with each other there should be no difference in the diameter of the two sections. In most cases a difference of .002 of an inch or less may be disregarded.

If a difference in diameter greater than .003 of an inch is found, the centers should be brought into alignment by setting the tailstock over, in the direction desired, one-half the difference in diameter, for example, one-half of .003 or .0015 of an inch. For procedure in setting the tailstock over, see Unit 33.

After one has acquired skill in operating a lathe, he may use the automatic feeds when making long cuts. However, care must be taken that the safety device, Fig. 100, is set so as to prevent the tool from advancing too far.

#### PROCEDURE FOR STOCK MOUNTED BETWEEN CENTERS

1. Mount the work in the lathe. See Unit 20.
2. Select a sharp cutting tool of the size and shape desired.

For roughing cuts, select a tool strong enough to take a heavy cut. If the stock to be machined is cast iron or steel and the tool travels toward the headstock, the usual practice is to select a right-hand turning tool, Fig. 90. Use a left-hand tool if the

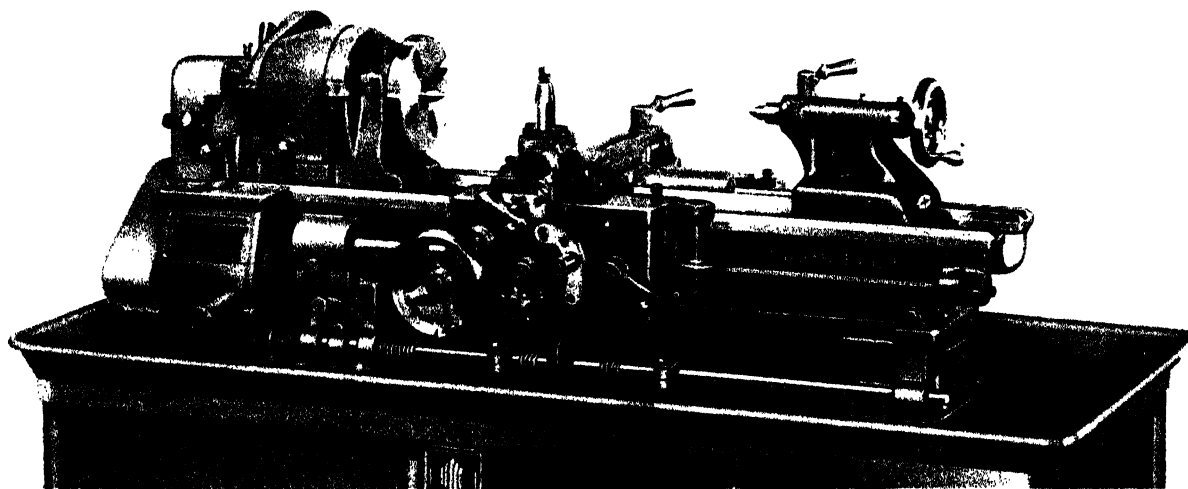

Courtesy, South Bend Lathe Works

FIG. 100. LATHE WITH DEVICE TO STOP AUTOMATIC FEED AT END OF CUT



tool travels toward the tailstock. For turning brass, select a roundnose tool.

3. Insert the tool in the holder with the point of the bit projecting about  $\frac{1}{2}$  inch, Fig. 91.
4. For turning steel or cast iron, set the tool holder in the tool post with the point raised about  $5^\circ$  above the center of the work, as in A, Fig. 101, and the nose of the holder projecting very slightly beyond the edge of the compound rest.
5. Swing the tool holder so that it is inclined about 4 or 5 degrees to the right or left depending upon the direction of travel. Swing to the right when the line of travel is toward the left, Fig. 101, then tighten the setscrew holding the holder in the tool post, also the setscrew holding the bit in the holder.

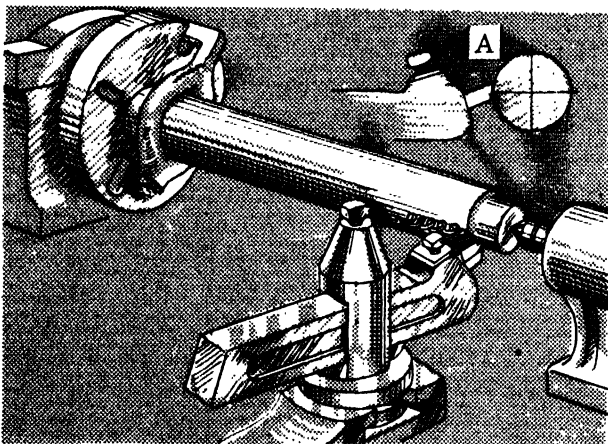

FIG. 101. CUTTING STEEL OR CAST IRON

This cannot be done when it is necessary to work close to the dog. In that case set the tool holder in the tool post so that any rotation of the tool holder, which will cause the tool to dig, will be prevented by reason of the tool holder being in contact with the sides of the slot in the tool post.

6. With the cross feed crank, draw the tool back until it clears the work, then start the lathe and carefully advance the tool until it is in a position to make a cut well below the scale on the surface of the work.
7. When the tool is in position to make the cut, advance it lengthwise of the work by turning the apron handwheel so as to advance the tool.

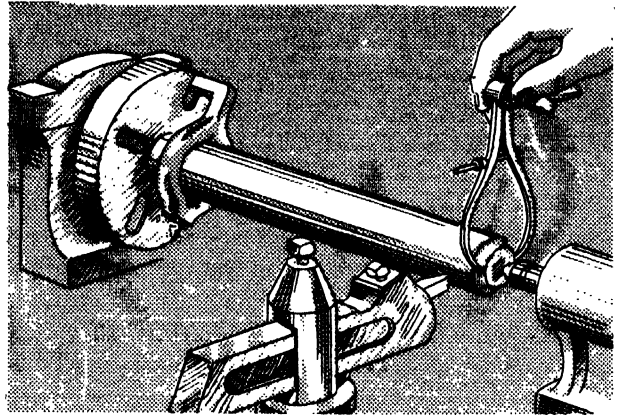

FIG. 102. TESTING THE PIECE WITH THE CALIPER

8. When about  $\frac{1}{8}$  inch of the piece has been machined, draw the tool back, then test the piece for size with a pair of calipers as in Fig. 102.
9. If the piece is under or over size, make the necessary adjustment. Be sure to allow about  $\frac{1}{32}$  of an inch for the finishing cut.
10. After making adjustments, proceed with the roughing cut, feeding the tool forward at the rate of about  $\frac{1}{64}$  of an inch per revolution. With experience, a heavier cut may be taken.
11. Continue until the tool is within about an inch of the dog, or, if the tool is set toward the right side of the compound rest, until the left side of the compound rest is within  $\frac{1}{2}$  inch of the dog, then stop the lathe and run the saddle back until the point of the tool is back beyond the turned end of the piece.
12. Remove the piece from between the centers, then remove the dog and place it on the turned end. Again mount the stock in the lathe and proceed as before.

#### PROCEDURE FOR FINISHING CUT

1. Adjust the tool for the finishing cut.
2. Machine a short section of the piece and test for size.
3. Make adjustments if necessary, then test again. When the stock is to be machined within very close tolerance limits, test the size of the work with a micrometer.
4. When the tool has been set so as to machine the piece to the dimension desired, proceed as when making a roughing cut.



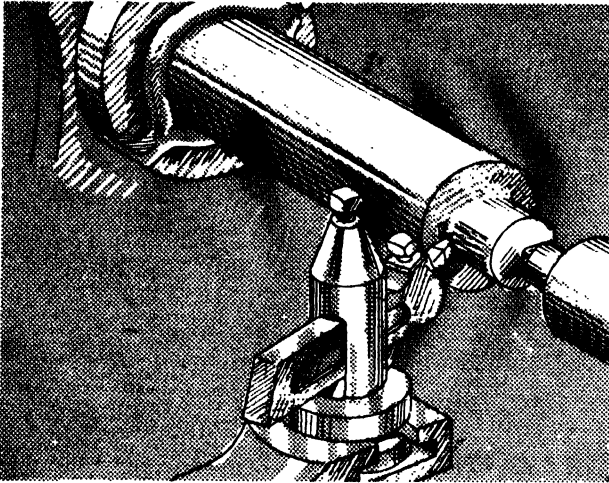

FIG. 105. FACING SHOULDERS WITH A FILLET

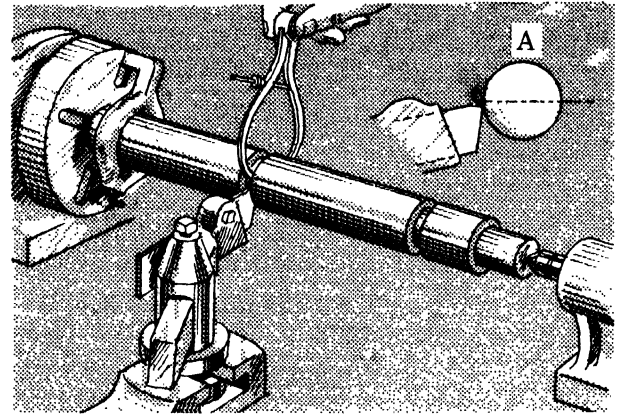
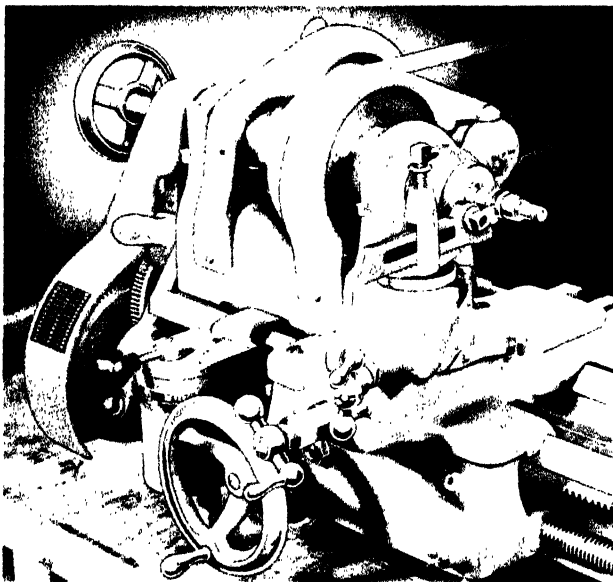

FIG. 107. TESTING THE DIAMETER WITH THE CALIPER



Courtesy, South Bend Lathe Works

FIG. 106. MAKING A CUT WITH THE PARTING TOOL

#### PROCEDURE FOR FACING SQUARE SHOULDERS

When a square shoulder is to be machined, the first cut often is made with a parting tool, Fig. 106. This provides clearance at the end of the part to be machined and permits of more rapid machining as one needs only to approach the end of the cut with care to avoid advancing the cut too far.

1. Select a suitable parting tool.
2. Securely mount the tool holder in the post with the point of the tool on the same level as the point of the dead center, A, Fig. 107.

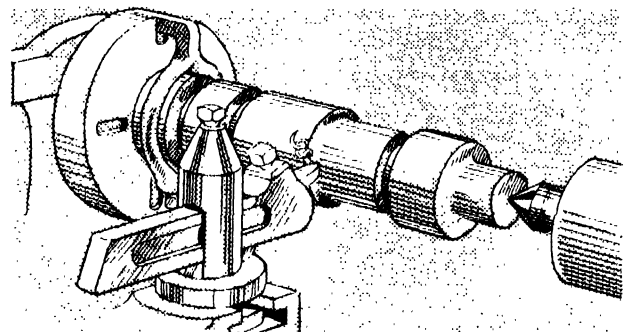

FIG. 108. REMOVING STOCK BETWEEN SQUARE SHOULDERS

3. With the apron handwheel advance the carriage and tool to the position where the shoulder is to be cut on the work.
4. Test the setting for accuracy by measuring with a rule.
5. Set the caliper for the desired diameter of stock at the shoulder.
6. Start the machine, then with the cross feed screw, advance the tool into the work, Fig. 107. Be sure to *make the cut in the waste stock*.
7. Hold the caliper lightly against the work in the cut, Fig. 107. When the caliper passes over the work, stop the cut immediately.
8. If necessary to give greater clearance at the shoulder, make a second cut as in steps 5 to 7 inclusive.
9. Remove remaining stock as when turning between centers. See Unit 21 and Fig. 108.

## UNIT 23

### HOW TO USE A STEADY OR CENTER REST AND FOLLOWER REST ON A LATHE

The steady rest (sometimes called a center rest), A, Fig. 109, is a device used to support long shafts or spindles of small diameter while they are being turned, bored or threaded. When in use, the rest is mounted on the lathe bed and held in position with a clamp. A follower rest, B, Fig. 109, is a supporting device which, when correctly attached to the saddle of the lathe and the supporting jaws adjusted to the work, follows along the finished face of the work and holds it steady against the cutting tool. When machining very long rods, shafts or spindles, it is sometimes necessary to use both a center and a follower rest in combination, Fig. 110.

#### PROCEDURE FOR MOUNTING THE STEADY REST

1. Mount the rest on the bed of the lathe and fasten it loosely.
2. Mount the work between centers. Do not draw the tail center too tightly, as there is danger of springing the work.
3. Adjust the center rest so as to support the work most advantageously. Usually this will be near the point where work is to be performed or near the center. Tighten the clamping bolt.
4. Adjust the jaws so that each one comes lightly into contact with the work, Fig. 111. The work should rotate quite freely.
5. Fasten the jaws securely, withdraw the

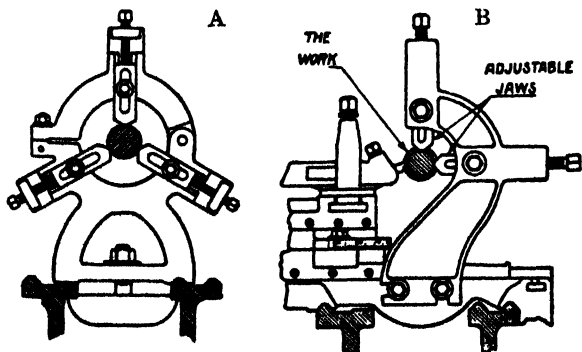

Courtesy, South Bend Lathe Works  
FIG. 109. STEADY REST AND FOLLOWER REST

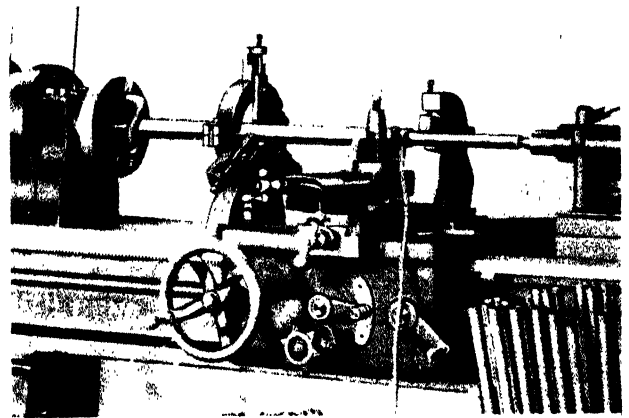

Courtesy, South Bend Lathe Works  
FIG. 110. USING BOTH STEADY REST AND FOLLOWER REST

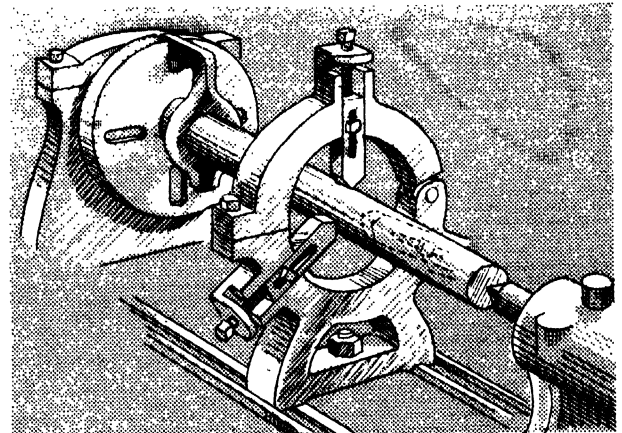
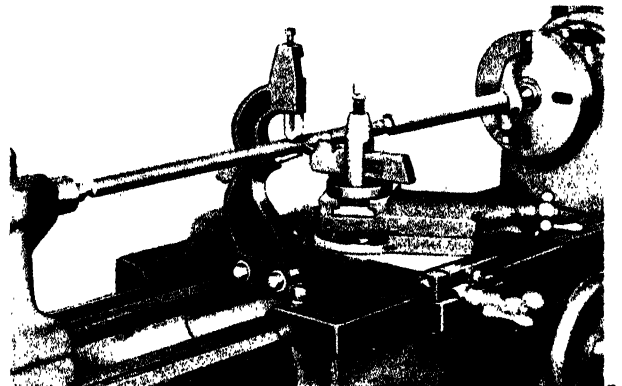

FIG. 111. ADJUSTING THE STEADY REST



Courtesy, South Bend Lathe Works  
FIG. 112. FOLLOWER REST IN POSITION

tailstock if necessary, then proceed to machine the work in the usual manner.

6. When the work is completed, remove the steady rest, clean the lathe and return equipment to the place where kept when not in use.

#### PROCEDURE FOR MOUNTING THE FOLLOWER REST

1. Attach the follower rest to the saddle of the lathe.
2. Mount the work between centers and turn a small portion of the work to size.

3. Adjust the jaws of the follower rest so that they bear directly against the rear of the turned part of the work just back of the cutting tool and on top of the work, Fig. 112.

4. Clamp the jaws in position, then proceed to machine the work in the usual manner.

5. When the work is completed, remove the follower rest, clean the lathe and return equipment to the place where kept when not in use.

### UNIT 24

## HOW TO FILE AND POLISH WORK REVOLVING IN A LATHE

Filing work while it is revolving in a lathe often is resorted to when only a very small amount of stock is to be removed.

#### PROCEDURE FOR FILING

1. Grasp the handle of the file in the left hand and the opposite end between the thumb and fingers of the right.
2. Place the file flat on the work near the left end of the part to be filed with the tip of the file pointed toward the right, as in Fig. 113.
3. Press lightly on the file and at the same time move it forward and to the right. At the end of the stroke release the pressure, raise the file from the work slightly and draw it back for the next stroke. Take long strokes and continue in this manner until the piece is filed smooth.

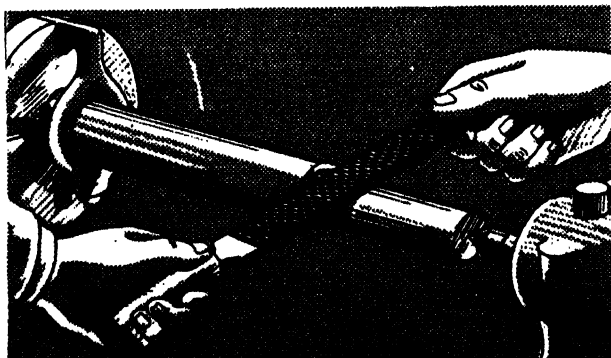

FIG. 113. FILING WORK REVOLVING IN A LATHE

#### PROCEDURE FOR POLISHING

1. Secure a strip of abrasive cloth, usually aluminum oxide or emery cloth. A strip about  $1\frac{1}{4}$  inches wide by 10 inches long will suffice.
2. Grasp the ends of the abrasive between the fingers, then place the cloth across the work and draw it across the rotating surface as when filing.
3. Greater force may be applied if the abrasive is mounted on a thin narrow stick and used as in Fig. 114.
4. To produce a finer finish and polish, use a finer grade of abrasive and for ferrous metals (iron or steel) apply a few drops of machine oil on the abrasive.

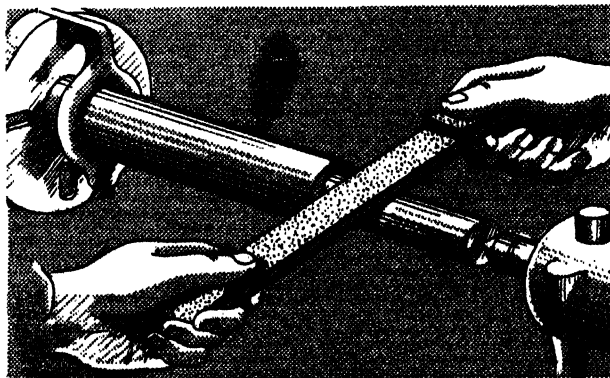
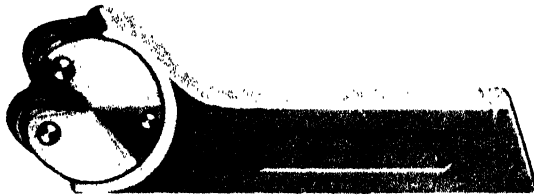

FIG. 114. POLISHING WORK REVOLVING IN A LATHE

## UNIT 25

## HOW TO KNURL A PIECE OF MILD STEEL

Certain machine parts, such as knobs, cylindrical handles, round nuts and collars, are knurled to improve their appearance and to provide a surface which can be gripped more effectively. Knurling tools are made with removable rollers, Fig. 115. Knurling tools with removable rollers may be used for producing a fine, medium or coarse knurl by merely inserting a roller that will produce a knurl of the degree of coarseness desired, for example medium, Fig. 116.



Courtesy, South Bend Lathe Works

FIG. 115. KNURLING TOOL WITH REMOVABLE ROLLERS

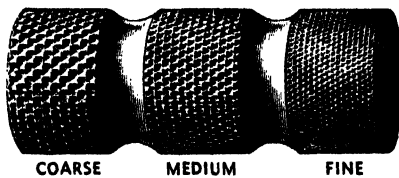

Courtesy, South Bend Lathe Works

FIG. 116. KNURL

## PROCEDURE

1. Finish turn the work to the dimension desired.
2. Select a knurling tool of the degree of coarseness desired.
3. Insert the knurling tool in the tool post with the front of the rollers flat against the side of the work and both rollers in contact with it.
4. Fasten the tool *firmly* in the tool post.

5. Throw in the back gears and start the lathe on the slowest speed.
6. With the apron handwheel, move the carriage over until the right side of the roller passes the right end of the piece about  $\frac{1}{8}$  of an inch.
7. With the hand cross feed, force the rollers about  $\frac{1}{16}$  of an inch into the work, and at the same time engage the longitudinal feed of the carriage and allow the knurling tool to travel across the face of the work, Fig. 117. Apply oil liberally throughout the operation.
8. When the left end of the knurling roller reaches the left end of the stock, stop the lathe.

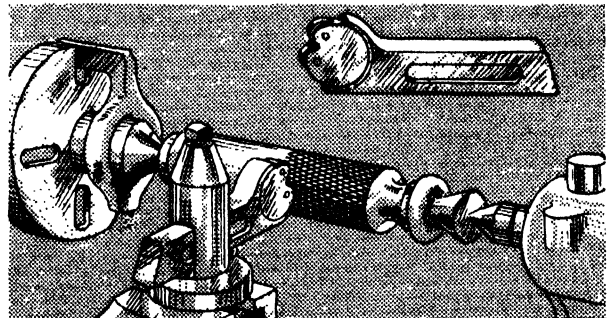

FIG. 117. USING THE KNURLING TOOL

9. Start the lathe *in reverse*, and at the same time advance the knurling tool about  $\frac{1}{8}$  of an inch. Immediately engage the longitudinal feed and allow the tool to feed toward the right until the right side of the tool is even with the right end of the work.
10. Repeat the operation until the knurling is the depth desired.

## UNIT 26

## LATHE CHUCKS AND FACEPLATES

Lathe chucks and faceplates are devices for mounting and holding work on a lathe while being machined. When work is mounted on a faceplate it usually is clamped with bolts and

metal straps. The plate is equipped with slotted holes to permit mounting work of varying size and shape. Figs. 118A and 118B show work mounted ready for machining.

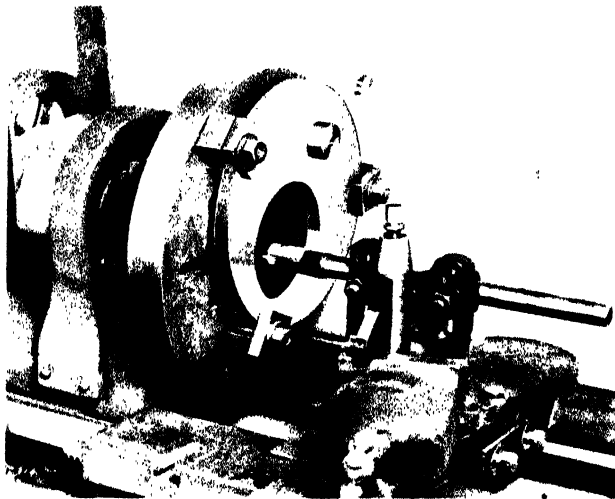

*Courtesy, South Bend Lathe Works*

FIG. 118-A. WORK MOUNTED ON A FACEPLATE WITH METAL STRAPS

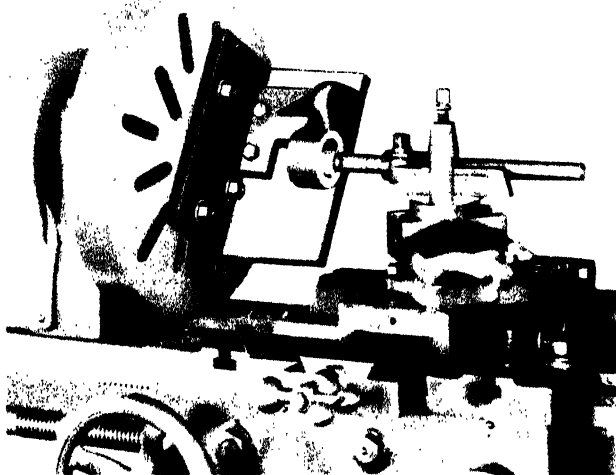

*Courtesy, South Bend Lathe Works*

FIG. 118-B. WORK BOLTED ON A FACEPLATE

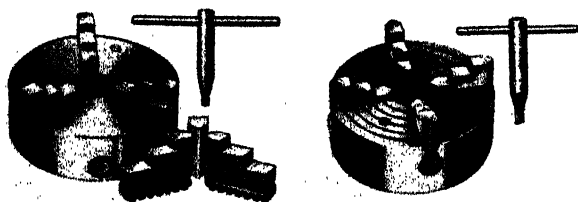

*Courtesy, South Bend Lathe Works*

FIG. 119. THREE-JAW UNIVERSAL AND FOUR-JAW INDEPENDENT CHUCKS

Chucks hold work by means of jaws which may be adjusted to accommodate work of varying size or shape. A, Fig. 119, shows a 4-jaw independent chuck. The jaws of this chuck move independently. This greatly increases the

versatility of the chuck, as it may be adjusted and used for holding work which is round, square, rectangular or irregular in shape. The jaws may be removed and reversed when occasion requires.

B, Fig. 119, is a 3-jaw universal geared scroll chuck. The jaws are reversible and operate as a unit. This greatly facilitates centering work. A 3-jaw chuck is intended primarily for holding round work.

#### COLLET CHUCK

This form of chuck is used chiefly in production and precision work. It is a device used primarily for holding small work and may be had in a number of sizes, designed for holding round, square or hexagon stock, Fig. 120. A

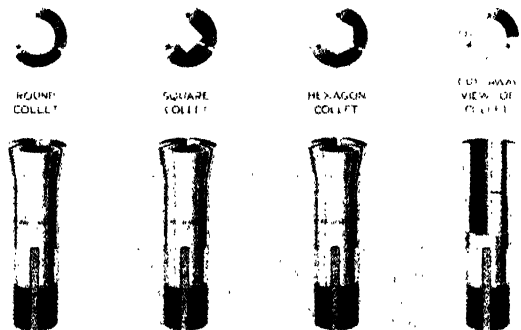
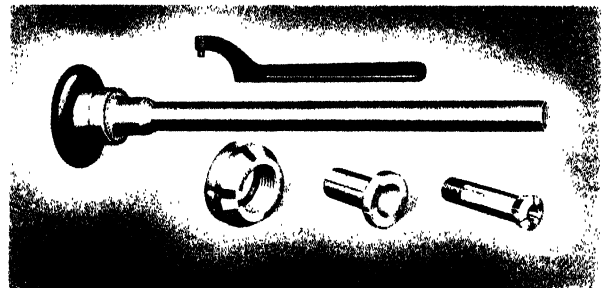

*Courtesy, South Bend Lathe Works*

FIG. 120. COLLET CHUCK AND COLLETS

spring collet chuck should be used only for the size of stock it is designed to hold, for example,  $\frac{3}{16}$  of an inch. Furthermore, to avoid danger of springing the chuck, it should not be used for holding stock which is more than .001 of an inch oversize or undersize. A collet chuck centers the stock more quickly and accurately than any other type. Fig. 121 shows an assembly of one form of draw-in collet chuck. The chuck is drawn tightly into the collet sleeve, inserted in

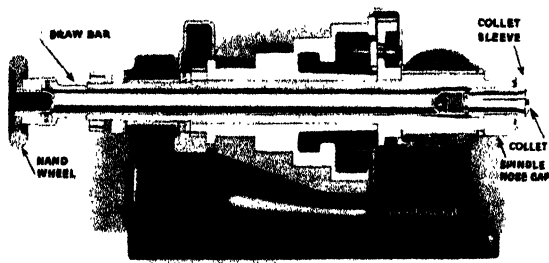

*Courtesy, South Bend Lathe Works*

FIG. 121. ASSEMBLY OF DRAW-IN COLLET CHUCK

the spindle by the turning of the handwheel at the rear end of the spindle toward the right and loosened by turning the wheel toward the left.

Centering stock in a collet chuck is merely a matter of placing the stock in the opening in the collet and drawing the collet into the collet sleeve so that the work is held securely.

#### SPINDLE CHUCK

This device, Fig. 122, resembles an ordinary drill chuck, except that it is designed to screw onto the nose of the lathe spindle. The movable jaws are tightened with a pinion key. A spindle chuck is used primarily for chucking small round work, which it does quickly and accurately within two or three thousandths of an inch.

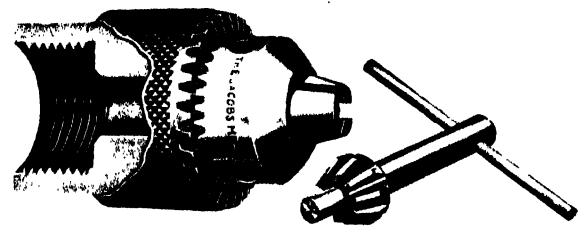

*Courtesy, South Bend Lathe Works*

FIG. 122. SPINDLE CHUCK

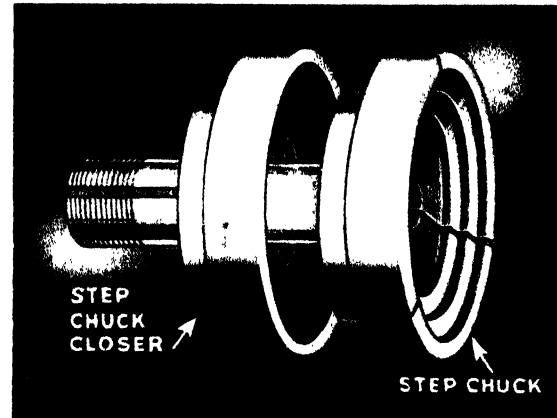

*Courtesy, South Bend Lathe Works*

FIG. 123. STEP CHUCK AND CLOSER

#### STEP CHUCK AND CLOSER

This piece of apparatus, Fig. 123, is designed for centering and holding small round discs. It operates on much the same principle as the draw-in collet chuck.

### UNIT 27

## HOW TO MOUNT AND REMOVE LATHE CHUCKS

When mounting or removing lathe chucks, take care to avoid damage to the threads in the chuck or those on the nose of the lathe spindle. To avoid injury to the operator, the instructions should be followed carefully.

#### PROCEDURE FOR MOUNTING CHUCK

1. Remove the live center by inserting a steel rod of appropriate size in the hollow spindle of the headstock. Grasp the projecting end of the center in the right hand and the rod in the left, then jar the center loose by gently striking the encased end with the rod.
2. Insert a small wad of clean waste in the
3. With the bent tang of a file sharpened to a point, clean the threads in the chuck. A special tool such as shown in Fig. 124 may be used for this purpose.
4. Wipe the threads with a piece of cloth or waste, remove any remaining lint or threads, then apply a few drops of oil to the threads.
5. In a similar manner clean the threads and shoulder of the spindle. Apply a few drops of oil.
6. Hold the chuck squarely against the nose of the spindle with the right hand and



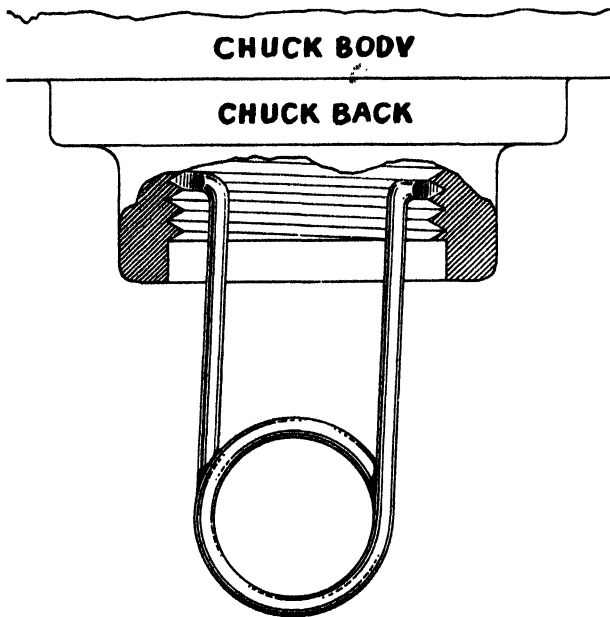

FIG. 124. CLEANING THREADS IN THE CHUCK

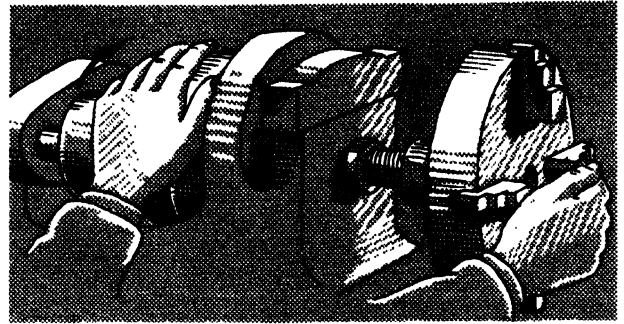

FIG. 126. STEADY SMALL CHUCKS WITH THE RIGHT HAND

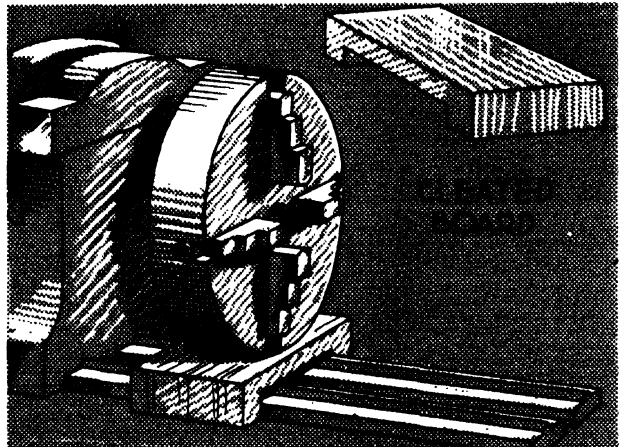

FIG. 127. WAYS OF THE LATHE PROTECTED WITH A CLEATED BOARD

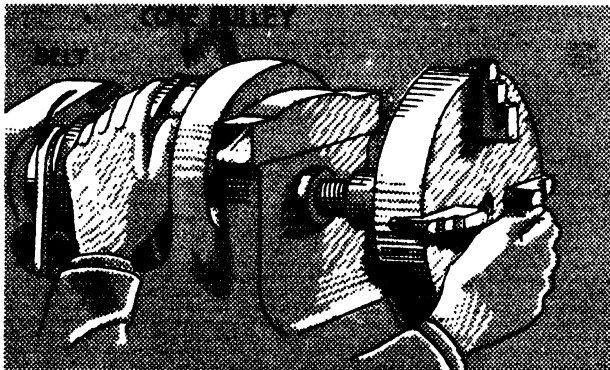

FIG. 125. MOUNTING THE LATHE CHUCK

arm, as in Fig. 125, then with the left, rotate the spindle forward. Continue in this manner until the hub of the faceplate rests *gently* against the shoulder of the spindle.

#### PROCEDURE FOR REMOVING CHUCK

A lathe chuck is a heavy piece of apparatus. Consequently, when removing or mounting it there is danger of injury to the operator, or of damage to the chuck or the ways of the lathe, unless care is exercised. The ways of the lathe may be protected by supporting the chuck with the right hand, as shown in Fig. 126. However, this is practicable only when the chuck is small.

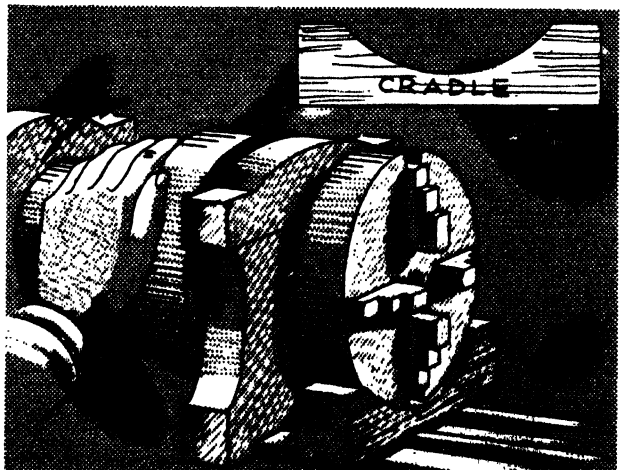

FIG. 128. LATHE CHUCK SUPPORTED WITH WOODEN CRADLE

Another means is a cleated board such as shown in Fig. 127. This device is hooked over the lathe bed under the chuck. Still another device is the wooden cradle shown in Fig. 128.

1. To remove the chuck, engage one jaw with a monkey wrench, as in Fig. 129, or place a strong bar between the jaws, then give the bar a sharp jerk.
2. Grasp the cone pulley or drive belt with the left hand. This will prevent the spindle from revolving. Then give the handle of the wrench a sharp jerk. This should loosen the chuck.
3. If the chuck cannot be thus loosened, place a block of wood under one jaw with one end resting on the rear of the lathe bed, as in Fig. 130, then throw in the back gears and give the spindle a quick backward turn.

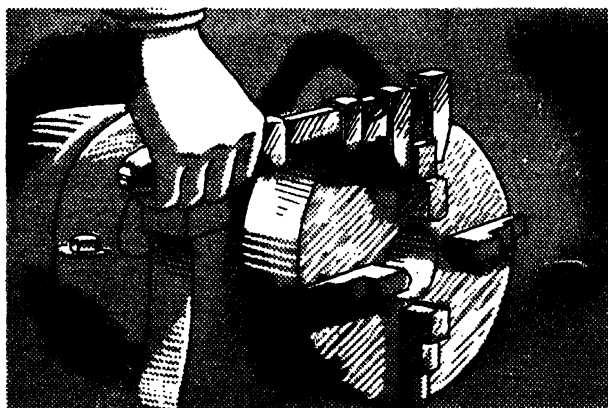

FIG. 129. LOOSENING CHUCK WITH A MONKEY WRENCH

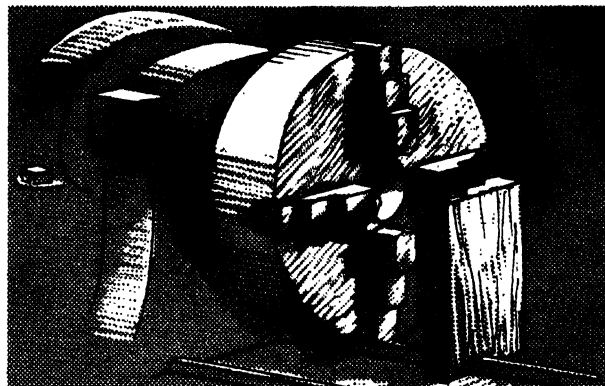

FIG. 130. LOOSENING LATHE CHUCK WITH A BLOCK OF WOOD

4. After loosening the chuck, grasp it with the right hand and arm, Fig. 126, then rotate the spindle backward with the left hand. As the chuck approaches the end of the thread on the spindle, press it against the nose of the spindle and hold it firmly to prevent falling.
5. If the chuck is too heavy to hold with one hand and arm, a wooden cradle such as shown in Fig. 128, may be used to support the chuck while dismantling it.
6. Carefully lift the chuck from the ways of the lathe and place it in the rack where it is kept when not in use, or some place where it cannot fall or roll about.

## UNIT 28

### HOW TO MOUNT AND TRUE UP WORK IN A FOUR JAW INDEPENDENT CHUCK

A chuck with independent jaws is often a convenience, for example, when chucking a piece of irregular shape, or when chucking a cylindrical piece in such position that a hole or a recess may be bored *off center*. Another feature of the independent jaw chuck is that the jaws may be taken out and reversed for certain types of work. This feature is not peculiar to independent jaw chucks as the same may be done, although it seldom is, with 3-jaw universal chucks.

#### PROCEDURE FOR MOUNTING STOCK

1. Adjust the jaws of the chuck to approximately the size of the work by withdraw-

ing or advancing the adjusting screw of each jaw with a chuck wrench, Fig. 131. Use the concentric circles on the face of the chuck for approximate centering of the jaws.

2. Place the work in the jaws of the chuck and fasten it by lightly tightening the adjusting screw of two opposite jaws, for example, jaws 1 and 3. Tighten these just enough to hold the work securely.
3. In a similar manner, tighten jaws 2 and 4. *Remove the chuck wrench.* Make a practice of doing this, otherwise you may forget it sometime and an accident may result.

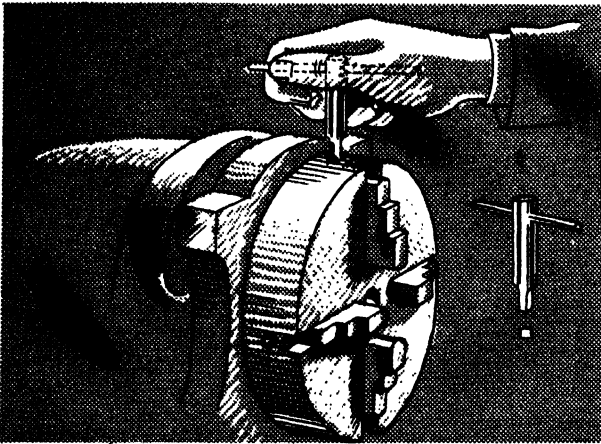

FIG. 131. ADJUSTING ONE JAW OF A FOUR-JAW INDEPENDENT CHUCK

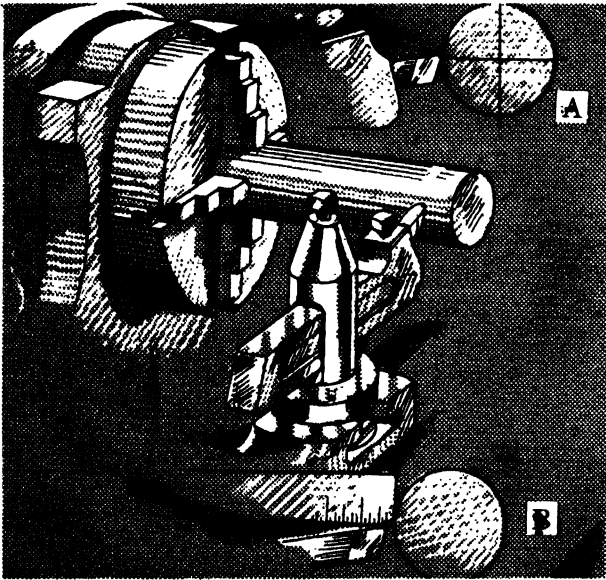

FIG. 132. TRUING WORK IN A FOUR-JAW INDEPENDENT CHUCK

4. Mount a suitable tool in the tool holder and set it at the correct height for the work to be machined.
5. Revolve the spindle slowly ~~by power or~~ by hand, then advance the tool until the point just touches the high side of the work, A, Fig. 132.
6. Give the work a half turn; then measure the distance from the point of the tool to the edge of the work, B, Fig. 132.
7. Loosen the pair of jaws on the *low* side of the work an amount equal to one-half the distance from the point of the tool to the edge of the work; sometimes it is necessary to loosen only one jaw.

8. Give the work a half turn and tighten the pair of jaws on the high side of the work.
9. Revolve the work as before and advance the tool until the point just touches the edge of the work. If the contact is continuous, the work is properly centered. If not centered, make adjustment as in steps 7 and 8, then test again.

#### PROCEDURE FOR CENTERING STOCK, CHALK METHOD

1. Mount stock as in preceding steps 1, 2 and 3.
2. Move the tool rest close to the work.
3. Revolve the work slowly by power or hand, then using the tool rest as a support for the arm, bring a piece of chalk lightly into contact with the revolving work, Figs. 133 and 134. The chalk will leave a mark on the high side only.
4. Stop the lathe, then locate the high spot (where the chalk has left a mark). Give

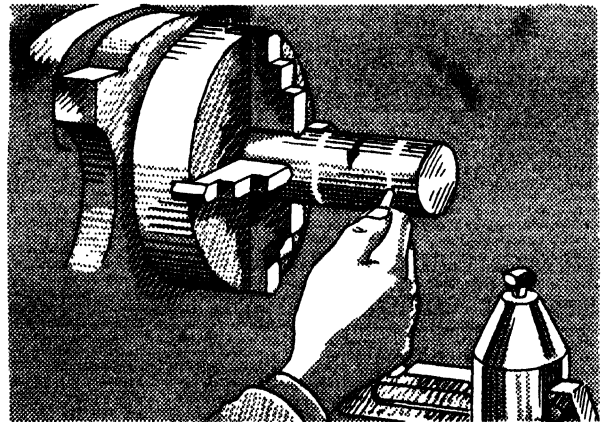

FIG. 133. USING CHALK TO TRUE UP WORK

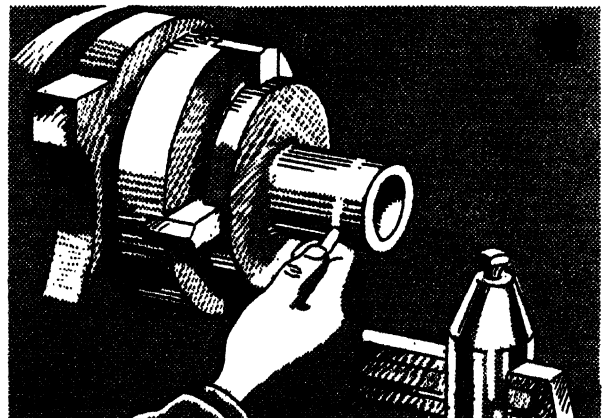

FIG. 134. CHALK MARK INDICATES THE HIGH SIDE

the work a half turn, then slightly loosen the adjusting screw on the side opposite the high spot. Give the work another half turn and tighten the adjusting screw, thus pushing the work toward the low side.

If the chalk mark extends as much as one-third the distance around the piece, it will be necessary to loosen two of the adjusting screws opposite the high spot, then tighten the other two screws. Adjust one pair of jaws at a time.

5. Revolve the spindle as before and again hold the chalk against the work. Make adjustments if necessary. Continue in this manner until the piece runs true. When the piece is running true, the chalk will make a line of uniform width completely around the work.
6. When the work is running true, firmly tighten the adjusting screw of each jaw, then proceed with the other machining operations.

## UNIT 29

### HOW TO FACE AND TURN WORK MOUNTED IN A LATHE CHUCK

Work may be mounted in a chuck and faced to a true plane or turned to a given diameter. Frequently the first step is to face or turn one side of the work to a true plane.

#### PROCEDURE FOR FACING STOCK

1. Mount the stock in a suitable chuck. See Unit 28.
2. Select a sharp right-hand facing tool.
3. Mount the tool in the holder and adjust the point or cutting edge of the bit so that it is the same height as the center about which the work rotates.
4. Incline the tool holder slightly toward the right of a line perpendicular to the face of the work, then fasten both it and the bit securely.
5. Start the lathe, then with the cross feed crank move the point of the bit toward the center of the work, Fig. 135.
6. With the apron handwheel, advance the tool so as to make a cut sufficiently deep to get below the scale.
7. With the cross feed crank, feed the tool steadily toward the left until the cut is completed.
8. Take other necessary cuts in a similar manner.
9. Finish with a light cut.

#### PROCEDURE FOR TURNING THE CIRCUMFERENCE

1. Mount the stock in a suitable chuck. See Unit 28.
2. Select and mount a sharp, roundnose tool in the tool holder.

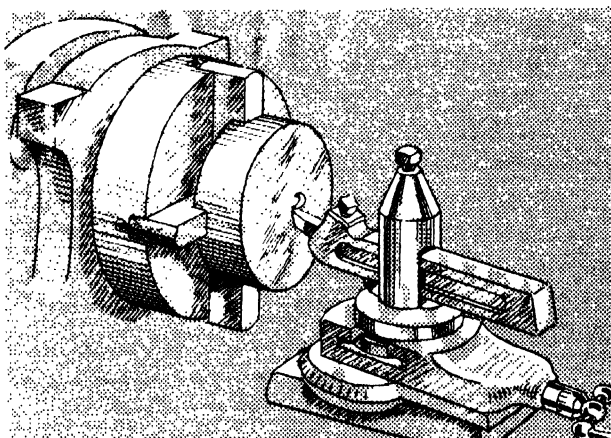

FIG. 135. FACING STOCK MOUNTED IN A CHUCK

3. Adjust the point of the tool to the height desired.
4. Incline the tool holder very slightly toward the right, then fasten both the holder and bit securely.
5. Start the lathe, then with the cross feed crank, advance the tool so as to take a cut of the depth desired, Fig. 136.
6. With the apron handwheel, advance the tool about  $\frac{1}{8}$  of an inch, then with a caliper or rule, test the work for size.
7. If necessary, make adjustments, then proceed to make the cut. Continue advancing the tool until the point of the tool is about  $\frac{3}{8}$  of an inch away from the jaw of the chuck.
8. Stop the lathe, then remove the work from the chuck by slightly releasing two of the jaws.

9. Turn the work around and rechuck it with the jaws of the chuck gripping the turned surface. Before starting to turn the unfinished part be sure the turned part of the work is centered accurately.
10. Turn the unturned part of the circumference as in steps 5, 6 and 7.
11. Set the tool to make a light finishing cut.
12. When the cut has advanced about  $\frac{1}{4}$  of an inch stop the machine and carefully test the work for size.
13. If necessary, make adjustments, then complete the cut in the usual manner.
14. Stop the cut when the point of the tool is about  $\frac{3}{8}$  of an inch away from the jaws of the chuck.
15. With the apron wheel, run the carriage back so that the tool clears the work. Do not change the position of the tool unless necessary to compensate for a slight variation in the diameter of the work (caused by rapid cooling) following a long cut.
16. Slightly loosen two of the adjusting screws and remove the work from the chuck.
17. Turn the work around and rechuck it on the finished surface. Be sure the finished surface is running true.

If there is danger of the jaws of the chuck damaging the finished surface, in-

sert a strip of copper or brass between the nose of each jaw and the work.

18. Start the cut on the unfinished part of the surface.
19. When the cut has advanced about  $\frac{1}{8}$  of an inch, test the work for size and make adjustment if necessary. This may necessitate adjusting the screws in the chuck in order to correct slight inaccuracy in rechucking.
20. Complete the cut in the usual manner.
21. When finished, remove the work from the chuck, then remove the chuck and return it to the place where it is kept when not in use.

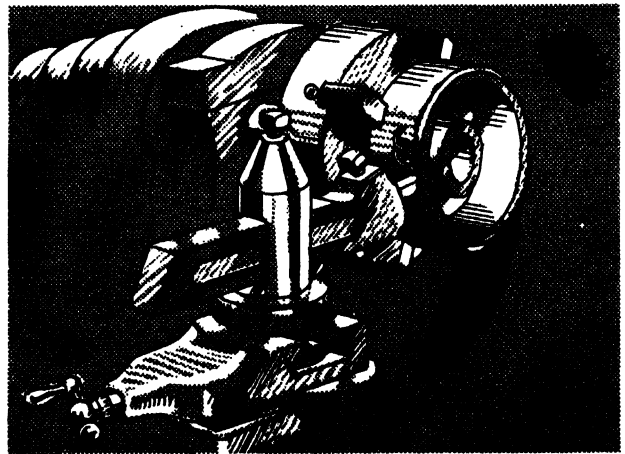

FIG. 136. TURNING CIRCUMFERENCE OF STOCK MOUNTED IN A CHUCK

### UNIT 30

## HOW TO MACHINE BORE CIRCULAR RECESSES IN A LATHE

The interior of a circular recess may be machined with a side tool or with a boring bar and bit, respectively, A and B, Fig. 137. When machining work of this nature, it usually is mounted on a faceplate or in a chuck.

#### PROCEDURE FOR MACHINING THE SIDE WALL

1. Mount the work on a faceplate, or in a chuck.
2. Select a suitable tool — a right-hand side tool or boring bar if the recess is open on both ends, a side tool if one end is closed.
3. Set the tool so that the point is level with the center line of the work, Fig. 138.
4. Make sure that both the tool and holder are fastened securely.
5. With the cross feed screw, advance the tool so as to make a cut of the depth desired, Fig. 138.
6. With the apron handwheel, advance the tool into the work about  $\frac{1}{4}$  of an inch.
7. Stop the machine and measure the diameter of the machined part of the recess with a rule or inside caliper, Fig. 139.

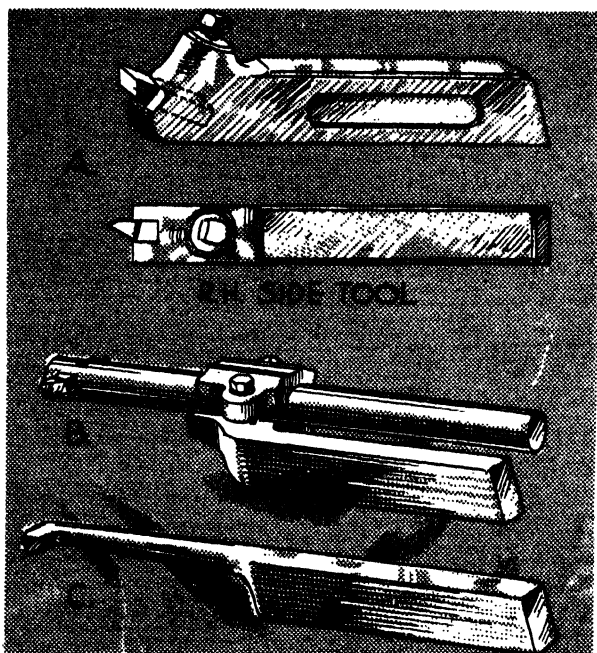

FIG. 137. TOOLS FOR BORING ON A LATHE

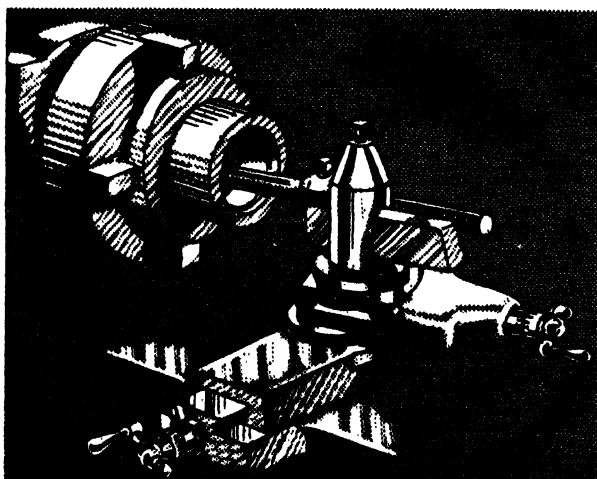

FIG. 138. BORING WITH A BORING BAR

8. Make adjustment if necessary, then complete the cut.

When machining a recess with a closed bottom, or a shoulder, be sure to stop the cut just as the point of the tool reaches the bottom or the shoulder.

9. If other cuts are necessary to enlarge the opening, proceed as in steps 6, 7 and 8.
10. Set the tool to make a light finishing cut.
11. Advance the tool into the work about  $\frac{1}{8}$  of an inch, then measure for size.



*Courtesy, South Bend Lathe Works*

FIG. 139. CHECKING THE DIAMETER OF THE RECESS

12. If necessary, adjust the depth of cut, then complete the cut.
13. When the work is finished, clean the lathe and return equipment to the place where it is kept when not in use.

#### PROCEDURE FOR

##### MACHINING THE BOTTOM

1. Set the point of a roundnose or a right-hand turning tool even with the center line of the work, with the longitudinal center line of the tool perpendicular to the face of the bottom of the recess.
2. Starting at about  $\frac{1}{2}$  inch to the left of the center of the work, feed the tool into the metal with the apron wheel.
3. When the tool has entered the metal the depth desired, feed it toward the right with the cross feed screw until the center is reached.
4. Reverse the direction of travel and feed toward the left inside wall.
5. When the cut almost reaches the side wall, stop the machine and set the tool holder at an angle sufficient to permit machining into the corner.

The roundnose tool will leave a small fillet in the corner; this may or may not be permissible. In the event a square corner is required, remove the roundnose tool and insert a right-hand corner or side tool.

6. Advance the corner tool with the apron wheel until the blunt angle just strikes the bottom, then with the cross feed screw,

- feed the tool slowly toward the left wall of the recess.
7. Stop the feed when the left side of the tool just touches the left wall of the recess.
  8. Finish both bottom and sides with light cuts, if necessary.
  9. Clean the lathe and return equipment to the place where it is kept when not in use.

### UNIT 31

## HOW TO MACHINE WORK IN A LATHE WHEN MOUNTED ON A MANDREL

Sometimes it is necessary to machine the exterior of cylindrical work accurately in relation to a hole that previously has been bored in the center of the piece. In such cases the work is often mounted on a mandrel, Fig. 140, and turned between centers. A mandrel is usually a cylindrical piece of hardened steel turned with



Courtesy, South Bend Lathe Works  
FIG. 140. MANDREL



Courtesy, South Bend Lathe Works  
FIG. 141. MANDREL WITH SLOTTED EXPANDING BUSHING

a slight taper. To meet an emergency, a mandrel may be turned from a piece of soft steel. Since a mandrel of given diameter has only limited application, an expanding bushing, Fig. 141, is often used. The illustration shows a mandrel equipped with a slotted bushing. The bushing is bored with a taper corresponding to the taper of the mandrel. A series of such bushings greatly extends the adaptability of a mandrel of a given size.

#### PROCEDURE

1. Secure or turn a mandrel of suitable size.
2. Apply a little oil to the surface of the mandrel and to the side walls of the hole. Distribute the oil evenly with the fingers.

Unless a lubricant is applied, there is danger of the mandrel freezing in the work, in which case it cannot be removed without damaging the work or the mandrel or both.

3. Insert the small end of the mandrel in the hole in the object and force it in tightly with a press or a lead hammer. The mandrel must be tight enough to prevent slipping while the work is being machined.
4. Mount the work between centers, apply oil on the dead center and turn in the usual manner. See Unit 21 and Fig. 142.

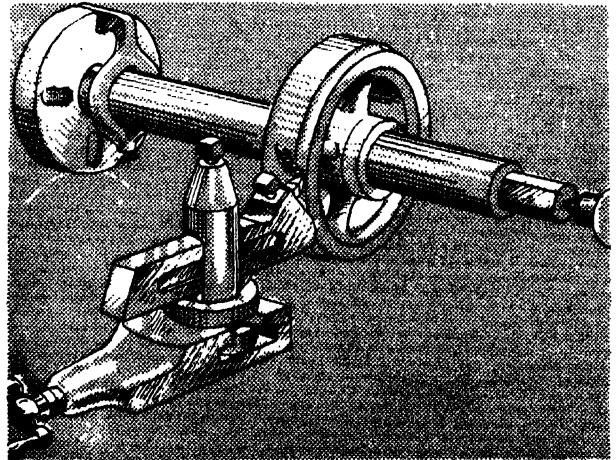

FIG. 142. TURNING WORK MOUNTED ON A MANDREL

5. To remove the mandrel, apply pressure to the small end with a press or by striking it with a lead hammer.
6. Clean the lathe and return other equipment to the place where kept when not in use.

UNIT 32

CALCULATING THE AMOUNT OF TAILSTOCK SET-OVER FOR TURNING TAPERS

WHEN THE WORK IS TO BE TAPERED ITS ENTIRE LENGTH

Subtract the diameter of the small end of the taper from the large end. Divide the difference by 2; the quotient will be the amount of set-over required.

EXAMPLE: Calculate the amount of tailstock set-over for turning a taper on a piece such as Fig. 143.

$$\begin{aligned} \text{Solution: } & \frac{1\frac{1}{2} - \frac{7}{8}}{2} \\ & = \frac{12/8 - 7/8}{2} = \frac{5}{8} \\ & \frac{5}{8} \div 2 = \frac{5}{16}'' \text{ amount of set-over required.} \end{aligned}$$

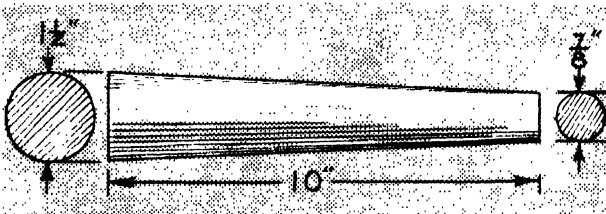

FIG. 143. PIECE TAPERED ITS ENTIRE LENGTH

WHEN THE TAPER PER FOOT IS GIVEN

Divide the *total length* of the stock or the distance between centers in *inches* by 12. Multiply the quotient by  $\frac{1}{2}$  of the amount of taper per foot given. The result will be the amount of set-over required.

EXAMPLE: Calculate the tailstock set-over for turning a taper of  $\frac{5}{8}$  of an inch per foot for a distance of 6 inches on a piece of shafting 16 inches long, Fig. 144.

$$\begin{aligned} \text{Solution: Total length} &= 16'' \\ \text{Amount of taper per foot} &= \frac{5}{8}'' \\ \frac{\text{Total length}}{12} &= 16/12 = 4/3 \\ \frac{\text{Given taper}}{2} &= \frac{5/8}{2} = \frac{5}{16} \\ 4/3 \times \frac{5}{16} &= \frac{20}{48} = 5/12 \text{ or } .417'' \\ &\text{amount of set-over required.} \end{aligned}$$

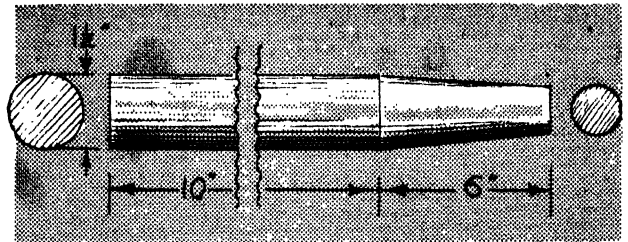

FIG. 144. PIECE TAPERED A PART OF ITS LENGTH

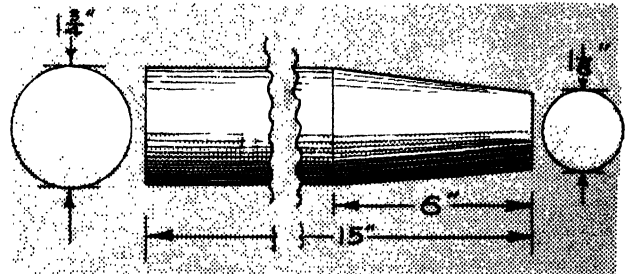

FIG. 145. PIECE TAPERED A PART OF ITS LENGTH

WHEN THE TAPER PER FOOT IS NOT GIVEN, BUT THE DRAWING SHOWS THE DIMENSIONS OF THE TAPERED SECTION

Divide the *total length* of the piece by the length of the portion to be tapered, Fig. 145. Multiply the quotient by one-half the difference between the large end of the taper and the small end.

EXAMPLE: Calculate the tailstock set-over for turning a taper for a distance of 6 inches on a piece of work 15 inches long. The large diameter of the taper is to be  $1\frac{3}{4}$  inches and the small end  $1\frac{1}{8}$  inches.

Solution:

$$\begin{aligned} (1) \quad & \frac{\text{Total length}}{\text{Length tapered part}} = \frac{15}{6} = \frac{5}{2} \\ (2) \quad & \frac{\text{Difference in diameters}}{2} = \frac{1\frac{3}{4} - 1\frac{1}{8}}{2} = \\ & \frac{14}{8} = \frac{9}{8} \\ & \frac{9}{8} \times \frac{5}{2} = \frac{45}{16} \\ (3) \quad & \frac{\text{Total length}}{\text{Length tapered part}} \times \frac{\text{Difference in dias.}}{2} = \\ & \frac{5 \times 5}{2 \times 16} = \frac{25}{32}'' \text{ amount of set-over required.} \end{aligned}$$



## UNIT 33

## HOW TO TURN A TAPER WITH A METALWORKING LATHE

There are several ways of turning tapers in a lathe. The most common ones are: setting the tailstock over the amount desired; by means of a taper attachment; or by setting the compound rest at the angle desired. The latter method is always used when very sharp, short tapers are cut and for boring tapered holes.

**PROCEDURE FOR CUTTING A TAPER BY SETTING THE TAILSTOCK OVER**

1. Find the center of the stock and prepare it for mounting between centers in the usual manner.
2. Turn stock to cylinder of size desired, then remove work from between centers.
3. Calculate the amount the tailstock should be set over.

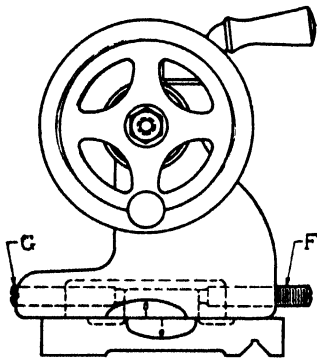

*Courtesy, South Bend Lathe Works*

FIG. 146. TAILSTOCK SET-OVER SCREWS

4. Loosen the clamping nut, also the tailstock set-over screw at the near side of the tailstock, for example, G, Fig. 146. This screw should be drawn out the distance required, for example,  $\frac{1}{4}$ ". Next screw in the tailstock set-over screw on the opposite side of the tailstock until the tailstock is set off center the distance desired by the witness mark on the base of the tailstock, for example,  $\frac{1}{4}$ ", Fig. 147. All lathes do not have witness marks on the base of the tailstock.

**CAUTION:** The set-over screws should always be drawn up snug, but not tight, to prevent a shift in position if the tailstock is moved.

5. Fasten the tailstock in position by tightening the clamping nut.

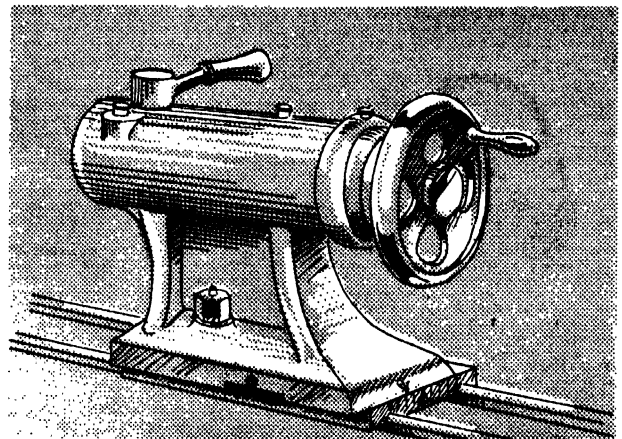
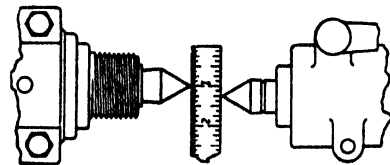

FIG. 147. TAILSTOCK SET OVER ONE-FOURTH INCH



*Courtesy, South Bend Lathe Works*

FIG. 148. CHECKING THE AMOUNT OF TAILSTOCK SET-OVER

The amount the tailstock has been set over may be tested by moving the tailstock close to the headstock, then with a rule measuring the difference in alignment of the points of the two centers, Fig. 148.

6. Mount the stock between centers. *Be sure to apply oil on the dead center.*
7. Select a tool of suitable size and shape, usually a right-hand turning tool. Mount the tool in the tool holder with the point of the tool *just even* with a line through the center of the work.
8. With the apron handwheel, draw the tool forward until it is in position to make a cut, then with the cross feed crank, advance the tool so that it will take a fairly heavy cut.
9. Start the lathe, then feed the tool toward the left in the usual manner, Fig. 149.
10. Continue advancing the tool with the handwheel until the cut runs out, then withdraw the tool and move the carriage back to the starting point. Take a second cut in a similar manner.

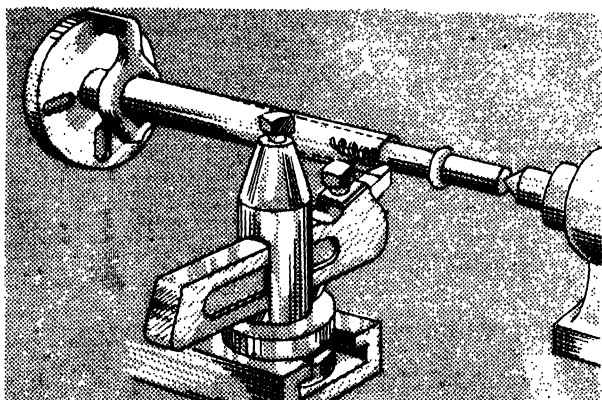

FIG. 149. CUTTING A TAPER WITH THE WORK MOUNTED BETWEEN CENTERS

11. Measure a unit of length on the taper, for example, one or two inches. At this point measure the large end of the taper, then measure the small end.
12. Calculate the amount of taper in the unit of length, then compare with the amount of taper required.
13. Make adjustment in taper if necessary.
14. With repeated cuts reduce the stock to approximately the size desired.
15. Set the caliper to the exact dimension, then with a light finishing cut reduce the piece to the size desired.
16. When the job has been completed, set the tailstock back in normal position.

Objections to this method of turning tapers are: (1) The center holes wear unevenly. (2) Calculation is necessary for each length of stock. (3) The procedure cannot be employed to bore tapered holes, except in some special cases.

#### PROCEDURE FOR CUTTING A TAPER BY SETTING THE COMPOUND REST AT THE DESIRED ANGLE

1. Mount the stock in the lathe, either between centers or in a chuck. Turn the piece to a cylinder of the size desired.
2. With a sharp scribe, lightly mark the terminus of the taper on the circumference of the work.
3. Mount a suitable tool in the tool holder, then set the point of the tool even with the center of the work.
4. Set the graduated compound rest at the angle desired, for example 60°, Fig. 150.

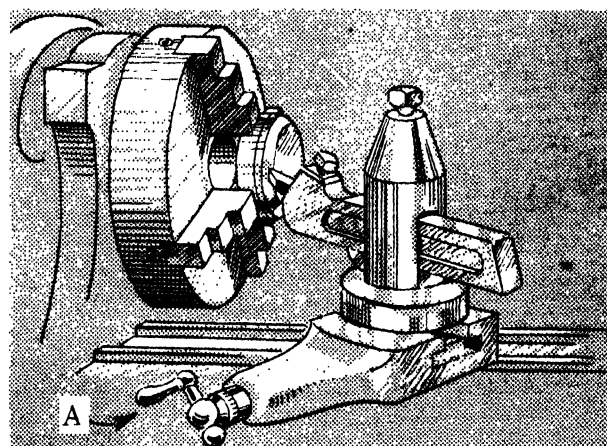

FIG. 150. CUTTING A TAPER BY SETTING THE COMPOUND REST

5. Advance the tool with the cross feed crank and apron handwheel until it is in a position to make a fairly heavy cut.
6. With the compound feed handle, A, Fig. 150, move the tool across the cut. At the end of the cut draw the tool back and adjust it with the apron handwheel and cross feed to make a second cut.
7. Make repeated cuts until the taper is cut the size desired, finishing with a light cut.

The advantages of this method of turning a taper are: (1) The centers are always in line. (2) Once the machine is set up, a taper of the same degree can be turned regardless of the length of the stock. (3) Given the degree of taper, no further calculation is necessary.

#### PROCEDURE FOR TURNING A TAPER WITH A TAPER ATTACHMENT

Fig. 151 shows a standard No. 5 Morse taper being cut on a lathe with a taper attachment. This device is standard equipment in commercial shops but not so frequently found in small school shops. Two forms of taper attachment are shown in Fig. 152. 152A is called a plain taper attachment and 152B, a telescopic attachment. When the latter is used it is not necessary to disconnect the cross feed screw as described in step 1.

1. Before engaging the taper attachment, it is necessary to disengage the cross feed screw, removing the screw that holds the cross feed control nut on the saddle.

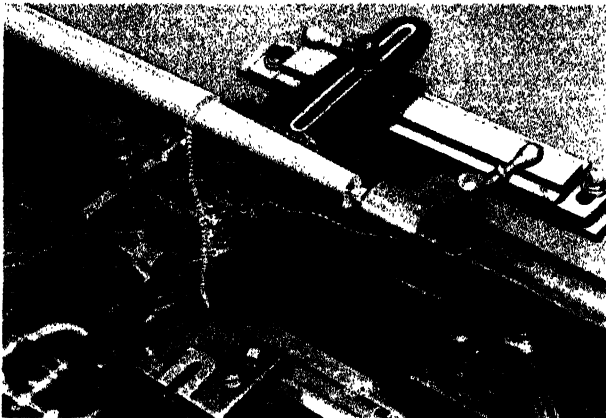

*Courtesy, South Bend Lathe Works*

FIG. 151. CUTTING A TAPER WITH A TAPER ATTACHMENT

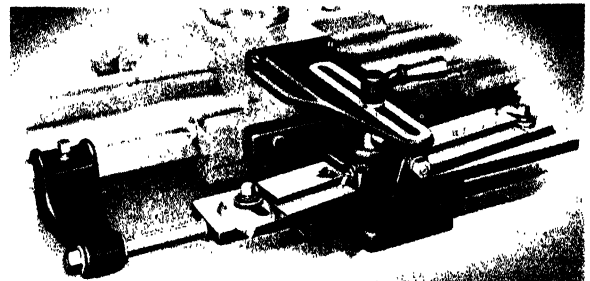

*Courtesy, South Bend Lathe Works*

FIG. 152-B. TELESCOPIC TAPER ATTACHMENT

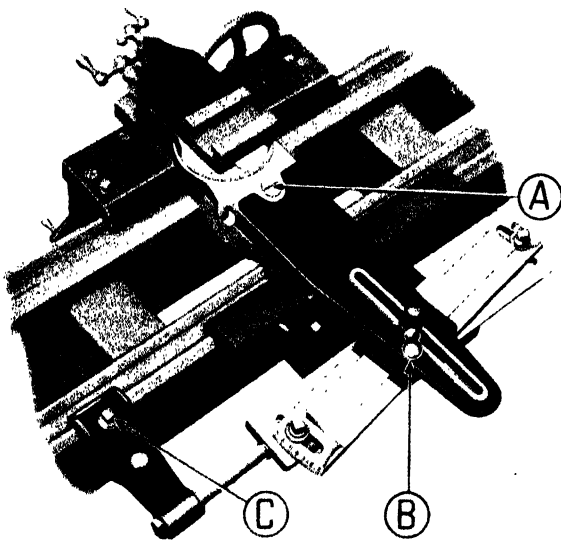

*Courtesy, South Bend Lathe Works*

FIG. 152-A. PLAIN TAPER ATTACHMENT

2. Attach the connecting slide arm A to the cross feed.
3. Engage the taper attachment on the ways

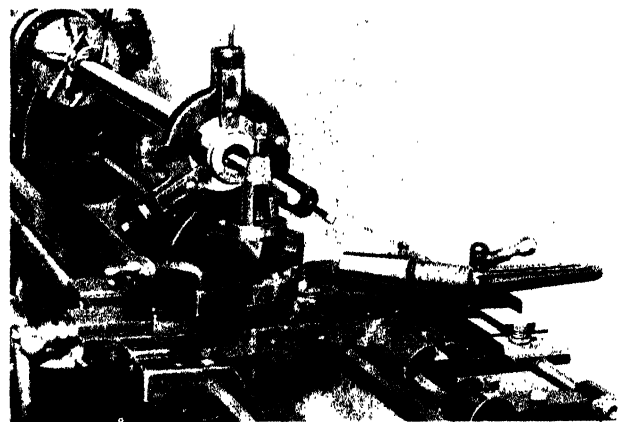

*Courtesy, South Bend Lathe Works*

FIG. 153. CUTTING AN INTERNAL TAPER

and fasten it with the setscrew, C, Fig. 152A.

4. Set the taper slide bar at the angle desired and clamp it in position with the setscrews.
5. Make the cut as in ordinary turning.

The advantages of this method of turning tapers are: (1) The centers are always in line. (2) A taper of a given amount may be cut independent of length. (3) This method can be used when tapering either external or internal surfaces, Figs. 151 and 153, respectively.

#### UNIT 34

### HOW TO CUT THREADS IN A LATHE

Cutting threads in a lathe is a common practice. The operation is performed by causing the lead screw to revolve at a desired ratio with the spindle of the lathe through a series of gears. The lead screw provides a positive and constant feed.

The system of gears on modern lathes is such that threads with a great variety of pitches may

be cut. The procedure to be followed in setting up the lathe to cut threads depends upon whether or not the lathe is of the standard change gear type or the quick change type. For the former, the problem is one of determining the gears to be used on the stud and lead screw respectively. This may be done by referring to the change gear chart found on the front of the

gear cover at the headstock end of a standard change gear lathe, Fig. 154. In the first column of the chart is found a list of common pitches of threads, Fig. 154C; in the second, a list of the stud gears available; in the third, a list of available screw gears. Supposing one should desire to set up the lathe for cutting 20 threads per inch: follow down the first column until the number 20 is found; then read the number directly opposite in the second column, which, on a South Bend lathe, is 16; finally, read the number in the third column, which is 40. When these two gears are mounted on the stud and lead screws respectively, Fig. 154, the lathe is set up for cutting 20 threads per inch.

**CAUTION:** The numbers found in the second and third columns of the gear chart are not the same on all makes of lathes. They vary with the pitch of the lead screw.

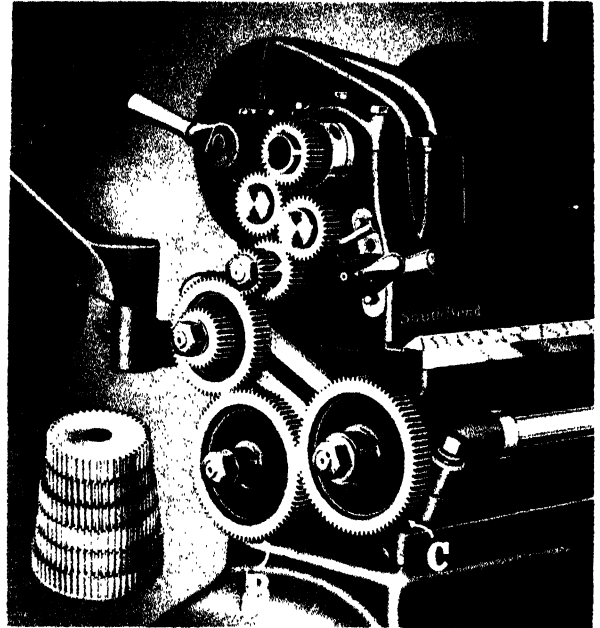

Courtesy, South Bend Lathe Works

FIG. 154-B. END VIEW OF STANDARD CHANGE GEAR LATHE

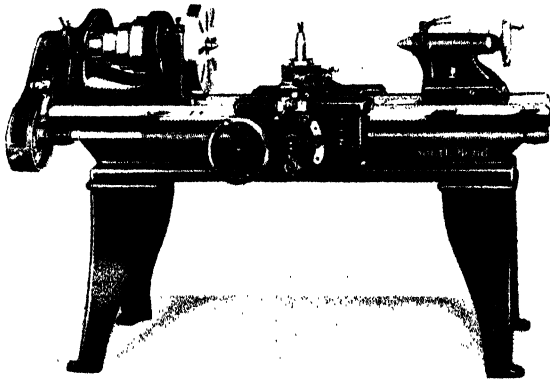

Courtesy, South Bend Lathe Works

FIG. 154-A. STANDARD CHANGE GEAR LATHE

If no change gear chart is found on the lathe, the gears required for cutting 24 threads per inch may be determined in the following manner: measure and count the number of threads per inch on the lead screw. Assuming this is found to be 8, then the ratio of the stud gear to the lead screw gear will be as 8 is to 24. This is because the ratio of the number of teeth in the change gears used will be the same as the ratio between the threads to be cut and the threads on the lead screw. No gear with 8 teeth is likely to be found in the available change gears; however, since any multiple of the above gears will serve the purpose, the problem may be solved by multiplying both numbers by the same number, for example, 2. When 8 and 24 respectively

CHART FOR THREADS AND FEEDS				
9-INCH WORKSHOP MODEL C LATHE				
THREADS PER INCH	STUD GEAR	LEAD GEAR	SCREW GEAR	FEEDS PER REV.
4	24	FIG. 1	48	
4 1/2	24	FIG. 1	54	
5	16	FIG. 1	40	
5 1/2	16	FIG. 1	44	
6	16	FIG. 1	48	
6 1/2	16	FIG. 1	52	
7	16	FIG. 1	56	
7 1/2	16	FIG. 1	60	
8	32	FIG. 2	32	
9	32	FIG. 2	36	
10	32	FIG. 2	40	
11	32	FIG. 2	44	
11 1/2	32	FIG. 2	46	
12	32	FIG. 2	48	
13	32	FIG. 2	52	
14	32	FIG. 2	56	
16	24	FIG. 2	48	
18	24	FIG. 2	54	
20	16	FIG. 2	40	
22 1/2	16	FIG. 2	44	
24	16	FIG. 2	48	
26	16	FIG. 2	52	
27	16	FIG. 2	54	
28	16	FIG. 2	56	
30	16	FIG. 2	60	
32	32	FIG. 3	32	
36	32	FIG. 3	36	
40	32	FIG. 3	40	
44	32	FIG. 3	44	
46	32	FIG. 3	46	
48	32	FIG. 3	48	
52	32	FIG. 3	52	
54	32	FIG. 3	54	
56	32	FIG. 3	56	
60	32	FIG. 3	60	
64	16	FIG. 3	32	.0156
72	16	FIG. 3	36	.0179
80	16	FIG. 3	40	.0215
88	16	FIG. 3	44	.0253
92	16	FIG. 3	46	.0290
96	16	FIG. 3	48	.0330
104	16	FIG. 3	52	.0396
112	16	FIG. 3	56	.0480
120	16	FIG. 3	60	.0570
160	48	FIG. 4	80	.0304
	40	FIG. 4	90	.0347
	32	FIG. 4	80	.0402
	24	FIG. 4	80	.0471
	16	FIG. 4	80	.0550

Courtesy, South Bend Lathe Works

FIG. 154-C. CHART FOR THREADS AND FEEDS

are multiplied by 2, the products found are 16 and 48. Gears with 16 and 48 teeth respectively are commonly found among change gears.

When threads are to be cut with a quick change gear lathe, the principle of the ratio between the speed of the spindle and the lead screw still holds. The problem of adjusting the machine is, however, much simpler because a quick change gear lathe is equipped with a gear box which enables the operator to produce various pitches of screw threads without resorting to the use of loose gears. With a quick change gear lathe, the pitch of the thread to be cut is controlled by the position of the sliding gear, the top lever and the tumbler lever. These are clearly shown in Fig. 155A. To set the machine, for example, a South Bend lathe, to cut 20 threads per inch, push in the sliding gear (A), turn the top lever (B) to the extreme right, and insert the tumbler lever (C) in the hole under the column in which the number 20 is found on the index chart, Fig. 155B.

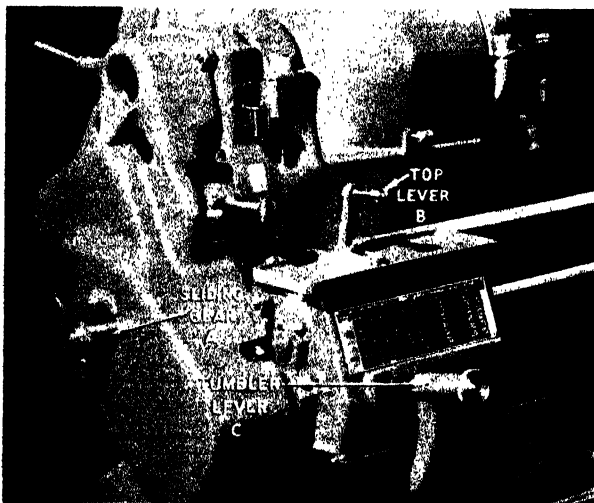

Courtesy, South Bend Lathe Works

FIG. 155-A. QUICK CHANGE GEAR MECHANISM

When threads are being cut in steel, a rough thread will result unless lard oil is applied freely throughout the operation. If lard oil is not available any good cutting oil will answer. Apply the oil with a small paint or shellac brush preceding each cut.

When it is necessary to remove the threading tool for sharpening or for other reasons before the thread has been cut to the depth desired, great care must be taken in resetting it to insure that it is following the original groove.

Courtesy, South Bend Lathe Works

FIG. 155-B. INDEX CHART FOR QUICK CHANGE GEAR LATHE

This may be done by setting the top part of the compound rest at a slight angle and making other adjustments with the cross feed screw. Another method is to loosen the dog and turn the work until the threading tool exactly fits the thread, then *retighten* the lathe dog.

To catch a thread when the tool has been moved, engage the split nut and carry the tool forward a few turns to take up backlash before fitting the tool to the thread groove.

#### UNIFICATION OF SCREW THREADS

On December 18, 1948 an agreement was reached on standardization of screw threads by representatives of Government and Industry Bodies of the United States, the United Kingdom and Canada. These representatives of the cooperating countries were charged with development of standards for screw threads. The following quotation presents the chief features of the agreement.

"The present unification agreement provides a 60° angle and a rounded root for screw threads. The crest of the external thread may be flat, as preferred in American practice, or rounded, as preferred by the British. The number of threads per inch for the various series of thread diameters has been unified, and the limiting dimensions, for three grades of fit have been agreed upon, thus, interchangeability of screw thread parts, based on the accord, now becomes feasible.

There is, however, a further degree of interchangeability attained by agreements on the numerical values for allowances and tolerances, thereby setting limits to the least and greatest amounts of looseness between mating parts. Such agreement provides for identity of sizes (or interchangeability of use) of screw thread gauges used in the different countries for controlling the limits of size of the threads. It also standardizes the grade or grades of fits between mating parts."<sup>1</sup>

<sup>1</sup> Technical Report 1215. National Bureau of Standards, U. S. Department of Commerce, Washington D. C.

The chief differences between the new standards and the American and National Coarse and National Fine threads are the rounded root, and optional rounded or flat crest. Maximum and minimum major and pitch diameters have been agreed upon, likewise maximum minor diameters for both external and internal threads.

A, Fig. 155C shows the old American form of thread and B and C show the standardized form. To produce a thread with a rounded bottom will require only rounding the point of the tool used for cutting the old form of thread. Further modification of the shape of the tool will be required to produce threads with rounded crests. For threads with small pitch the modification will be very slight.

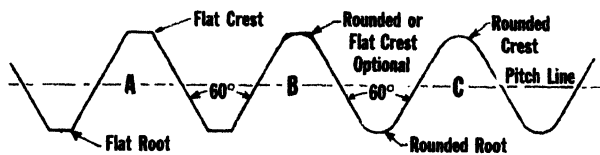

A Original American Form of Thread  
B and C New Standard Forms

FIG. 155-C. FORM OF STANDARD SCREW THREAD

#### PROCEDURE FOR A LATHE EQUIPPED WITH A THREADING DIAL

1. Determine the number of threads to be cut per inch.
2. Adjust the change gears to obtain the ratio desired.
3. Mount the work in the lathe. Be sure the dog is fastened securely, or if mounted in a chuck, be sure the jaws are drawn down tight.
4. Set the compound rest at  $29^\circ$ .

Setting the compound rest at less than  $30^\circ$  makes accurate adjustment of the threading tool easier, should it be necessary to remove the tool for grinding or other purposes before cutting of the thread has been completed. Another reason is that it makes possible the removal of most of the stock from one side of the thread only when this is necessary because of a rough or inaccurate surface. Furthermore, for better finish, the tool should drag slightly on the right-hand side of the thread.

5. Select a sharp, correctly ground threading tool, Fig. 156. The inclusive angle of the point of the tool should be  $60^\circ$ , with each cutting edge having the same degree of angularity.
6. Insert the tool in a holder with only the ground portions of the bit projecting beyond the nose of the holder.

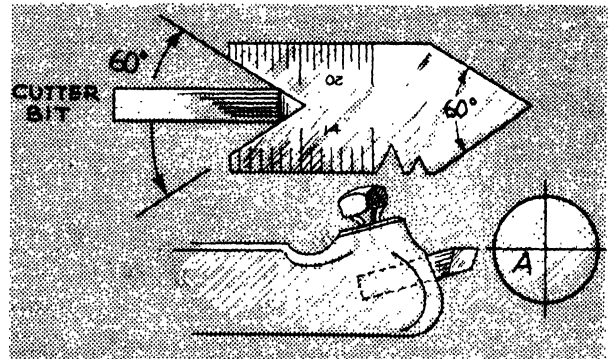

FIG. 156. TESTING A THREADING TOOL FOR CORRECT ANGLES

7. Set the point of the threading tool even with the center of the work. See A, Fig. 156.
8. Hold a thread gauge against the side of the work, then advance the threading tool and set it square with the work as in Fig. 157. Tighten the setscrew which holds the tool in the post and again test it for squareness with the work.
9. Test the height at which the point of the tool is set, Fig. 158.
10. When the threads end at some intermediate point on the surface of a straight cylinder, draw a line at the point desired with a piece of soapstone or a sharpened piece of chalk.
11. Advance the threading tool until the point just touches the work, then adjust the micrometer collar on the cross feed screw, Fig. 159, to zero.
12. Draw the tool back past the right end of the work, then advance the point of the tool about  $.002$  of an inch by turning the compound rest screw toward the right.

Adjustments of depth of cut may be made by advancing the cross feed or the compound rest. Experienced workmen of-

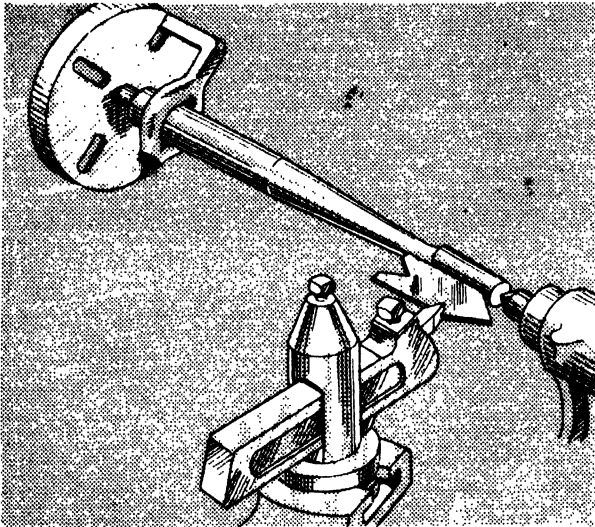

FIG. 157. SETTING THE THREADING TOOL SQUARE WITH THE WORK

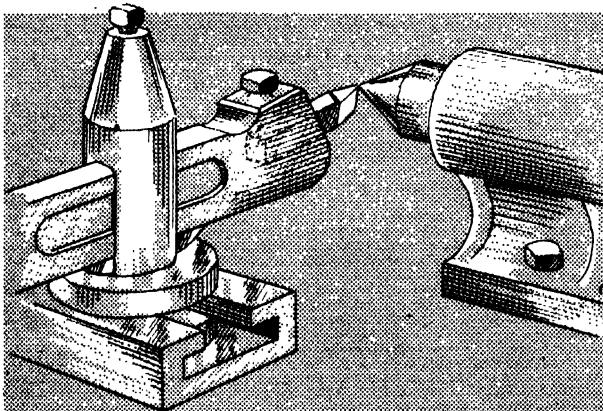

FIG. 158. TESTING THE HEIGHT OF THE THREADING TOOL

ten take cuts heavier than .002 of an inch.

13. Start the lathe, then engage the half-nut, Fig. 160, when line No. 1 on the dial indicator, Fig. 161, is just even with the line on the rim of the indicator.

The half-nut may be engaged on any line when cutting an even number of threads per inch. When cutting an odd number of threads, close the half-nut on a *numbered line only*.

**CAUTION:** When cutting threads in steel, keep the point of the tool well lubricated throughout the operation. Apply oil with a small brush, Fig. 161A.

14. When the threading tool reaches the terminus of the thread, quickly draw the tool

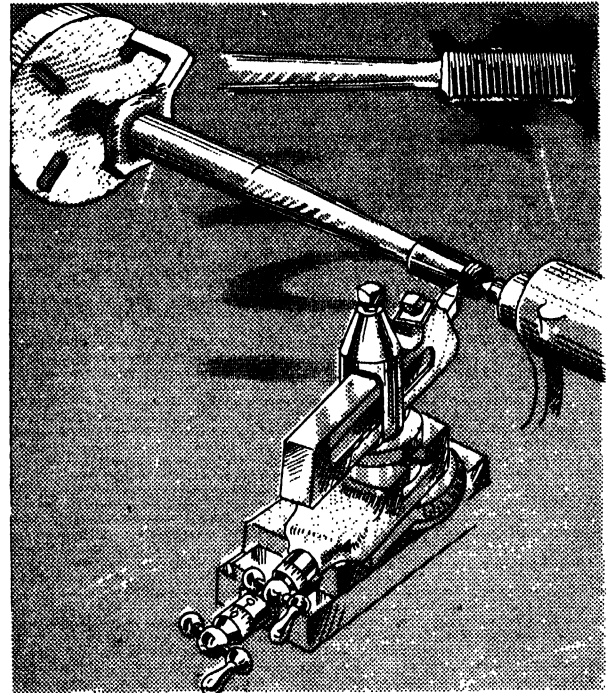
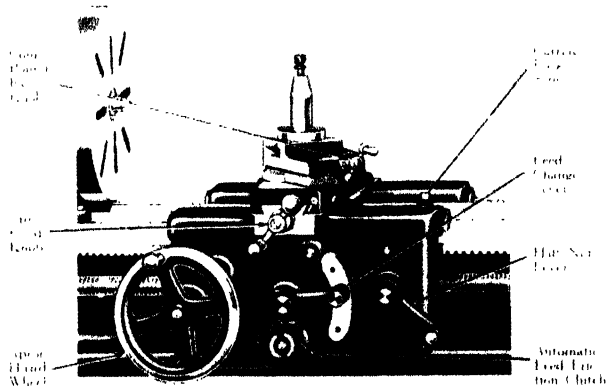

FIG. 159. CUTTING THREADS



Courtesy, South Bend Lathe Works  
FIG. 160. PARTS OF LATHE CARRIAGE AND APRON

away from the work by giving the cross feed screw one complete revolution toward the left, and at the same time *immediately disengage the half-nut*.

15. Draw the carriage back to the starting point with the apron handwheel, then advance the tool slightly by turning the compound rest screw toward the right, so as to advance the tool about .002 of an inch.
16. Turn the cross feed screw one complete revolution toward the right, then engage the half-nut when the indicator registers

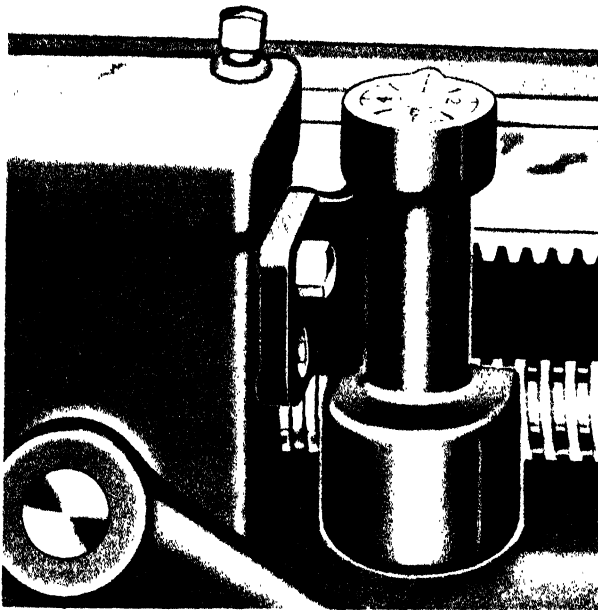

Courtesy, South Bend Lathe Works  
FIG. 161. THREADING DIAL INDICATOR

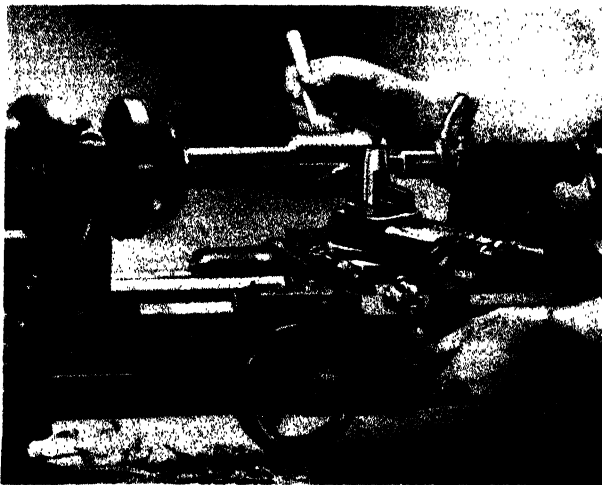

Courtesy, South Bend Lathe Works  
FIG. 161-A. APPLYING OIL WITH SMALL BRUSH

No. 1. Withdraw the tool at the terminus of the thread by giving the cross feed screw one complete revolution toward the left, and at the same time, immediately disengage the half-nut. A stop on the cross feed, Fig. 162, saves time.

17. Repeat these operations until the thread is cut to the depth desired.
18. Finish the open end of the threaded section by neatly chamfering the end with a right-hand turning or facing tool. This operation may be performed with the threading tool, providing care is exercised.

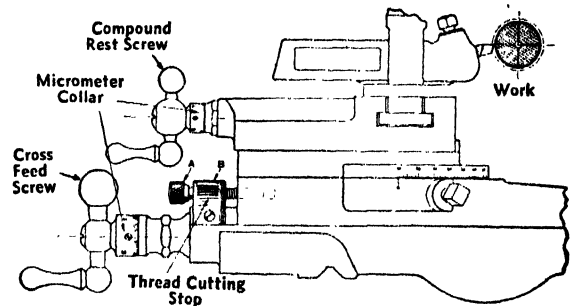

Courtesy, South Bend Lathe Works  
FIG. 162. THREAD CUTTING STOP ATTACHED TO DOVETAIL OF SADDLE

#### PROCEDURE FOR A LATHE NOT EQUIPPED WITH A THREADING DIAL

1. Proceed as with a lathe equipped with a threading dial, steps 1 to 3 inclusive.
2. Set the compound rest at  $29^{\circ}$ .
3. Proceed as with a lathe equipped with a threading dial, steps 5 to 11 inclusive.
4. Draw the tool back past the right end of the work, then advance the point of the tool about .002 of an inch by turning the compound rest screw to the right.
5. Engage the half-nut and clamp it firmly to the lead screw, then start the lathe. When the tool reaches the end of the threaded section, quickly withdraw the tool by turning the cross feed screw one complete revolution to the left, and at the same time throw the reversing lever, thus changing the direction of travel of the carriage.
6. When the point of the tool, on the backward travel, is just even with the end of the work, stop the lathe instantly. The point of the tool must be exactly opposite the bottom of the previous cut. With the tool in this position, advance it by turning the compound rest screw to the right about .002 of an inch.
7. Turn the cross feed screw one complete revolution to the right, then start the lathe. When the tool reaches the end of the threaded section, quickly turn the cross feed screw one complete revolution to the left and reverse the lathe.
8. Repeat steps 5 to 7 until the thread is cut to the depth desired.
9. Finish the open end of the threaded section by neatly chamfering the end with a right-hand turning or facing tool.



A left-hand thread is cut in the same manner except that the direction in which the feed screw rotates is reversed, thus causing the direction of travel of the tool to change. This may be done by adding or removing one idler gear in the change gear train. On most lathes this is accomplished by means of a lever at the left-hand end of the headstock which, by shifting adds or removes the idler gear. On some lathes change in the direction of rotation of the lead screw is accomplished by means of a lever on the apron.

#### PROCEDURE FOR CUTTING INTERNAL THREADS

For cutting threads on the inside of a hole a special threading tool, A, Fig. 163, or a boring bar fitted with a threading bit, B, Fig. 163, is required. The top of the point of the tool should be set at the same level as the axis (center) of the work.

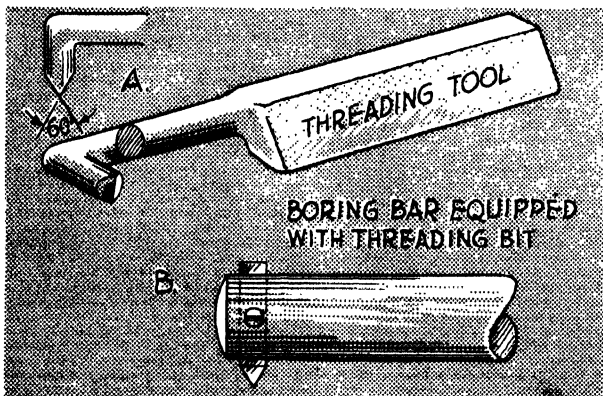

FIG. 163. TOOLS FOR CUTTING INTERNAL THREADS

1. Lay out and drill or bore a hole of the size required. Provide clearance at the bottom of the hole.
2. Select a correctly sharpened tool for cutting internal threads.
3. With a thread gauge, set the tool so that a line through the center of the cutting part of the tool is *perpendicular* to the wall of the hole, A or B, Fig. 164.
4. Clamp the bit in the holder securely and clamp the holder in the tool post.
5. With the apron handwheel advance the tool to within about  $\frac{1}{4}$  of an inch of the work, then with the cross feed screw, adjust the

tool until the point is even with the near wall of the hole.

6. With the compound rest feed screw, advance the tool about .002 of an inch.

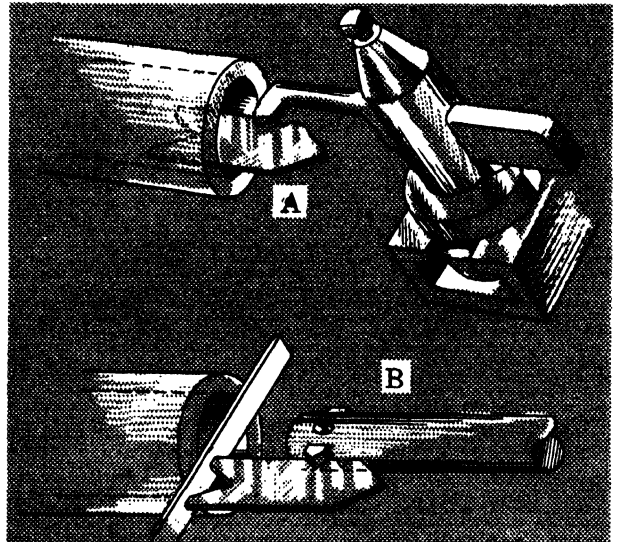

FIG. 164. SETTING THE BORING BAR FOR CUTTING INTERNAL THREADS

7. Start the lathe, then engage the half-nut when line No. 1 on the dial indicator is just even with the line on the rim of the indicator.

When cutting threads in steel be sure to keep the point of the tool well lubricated throughout the operation.

8. When the threading tool reaches the terminus of the thread, quickly draw the tool away from the work by giving the cross feed screw one complete revolution toward the *right*, and at the same time *immediately disengage* the half-nut.
9. Draw the carriage back to the starting point with the apron handwheel, then, with the compound rest screw, advance the tool about .002 of an inch.
10. Turn the cross feed screw one complete revolution to the left, then, when the indicator registers No. 1, engage the half-nut.
11. Again withdraw the tool at the terminus of the thread as in step 8.
12. Repeat these operations until the thread is out to the depth desired.

## UNIT 35

## MILLING ON A LATHE

milling operations, for example, cutting keyways, gears, slots and splines, facing and squaring stock.

The attachment shown in Fig. 165 is simply a device for holding the work in the position desired. It may be swiveled on its base horizontally and the slide swiveled in a vertical plane, Fig. 166. The cutter may be mounted on a taper

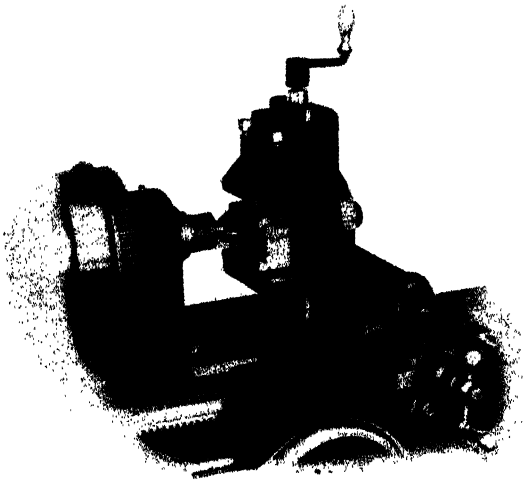

*Courtesy, South Bend Lathe Works*

FIG. 165. MILLING ATTACHMENT IN PLACE ON A LATHE

Many school shops and small machine shops are not equipped with a milling machine and in many cases do not have a volume of work which would justify the purchase of an expensive miller. To meet the needs of small school and commercial shops some manufacturers of lathes have designed and built milling attachments for their products. These attachments, when correctly mounted on the carriage of the lathe, enable the operator to perform many simple

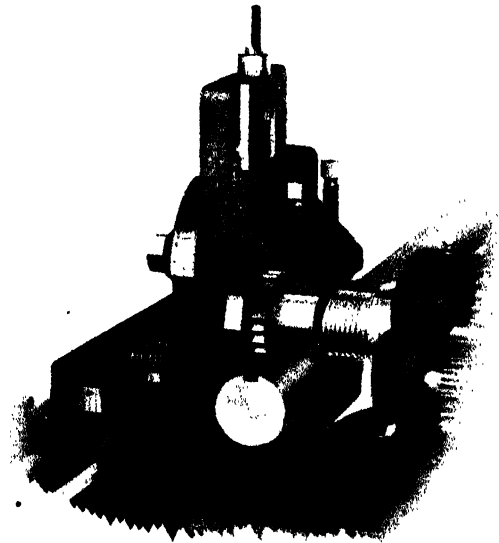

*Courtesy, South Bend Lathe Works*

FIG. 167-A. MILLING CUTTER MOUNTED ON A TAPER SHANK

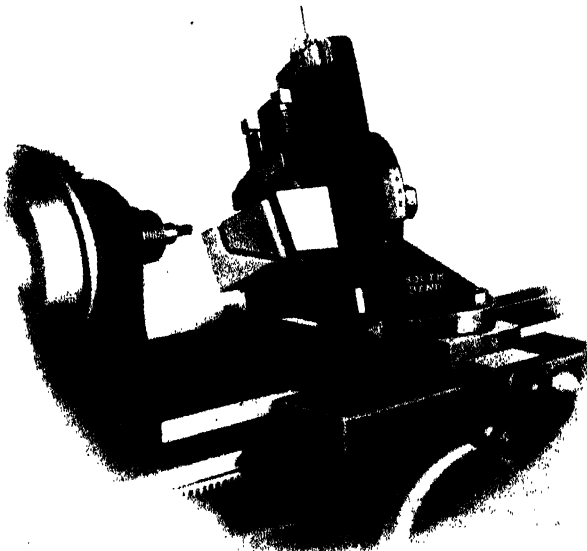

*Courtesy, South Bend Lathe Works*

FIG. 166. MILLING ATTACHMENT SWIVELED VERTICALLY

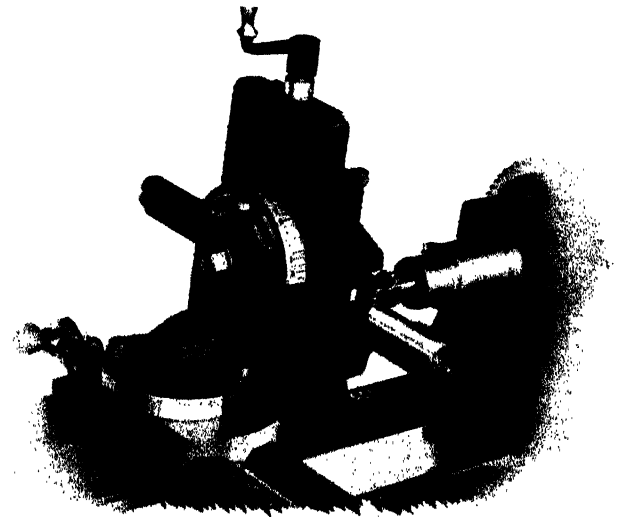

*Courtesy, South Bend Lathe Works*

FIG. 167-B. MILLING CUTTER MOUNTED IN A SPINDLE CHUCK

shank which fits the tapered hole in the lathe spindle, Fig. 167A, or if a cutter with a straight shank is used, it may be mounted in a collet, or in a spindle chuck, Fig. 167B. Cutters may also be mounted on an arbor held between centers, as in Figs. 168A and 168B. The work is brought into contact with the cutter by means of the handwheel on the carriage, the cross feed and the vertical adjusting screw at the top of the attachment. The cut is controlled by appropriate manipulation of the same adjusting devices.

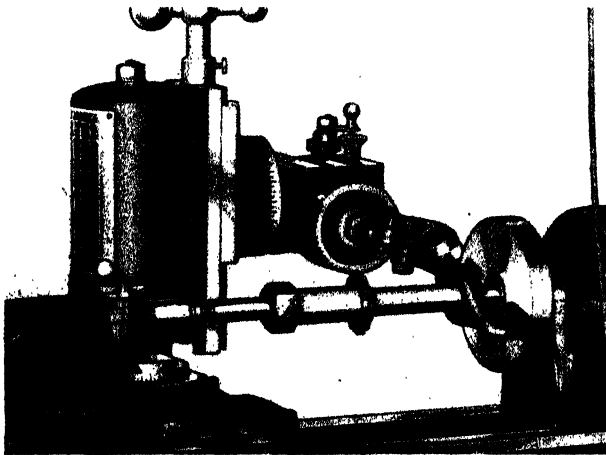

*Courtesy, South Bend Lathe Works*

FIG. 168-A. MILLING CUTTER MOUNTED ON AN ARBOR BETWEEN CENTERS

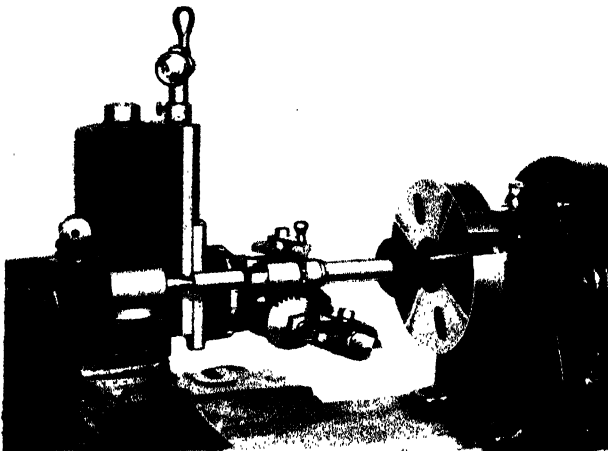

*Courtesy, South Bend Lathe Works*

FIG. 168-B. MILLING CUTTER MOUNTED ON AN ARBOR BETWEEN CENTERS

The attachments illustrated in Figs. 168A and 168B are designed for cutting teeth on spur and bevel gears, spirals and other forms of milling necessitating the use of a dividing head.

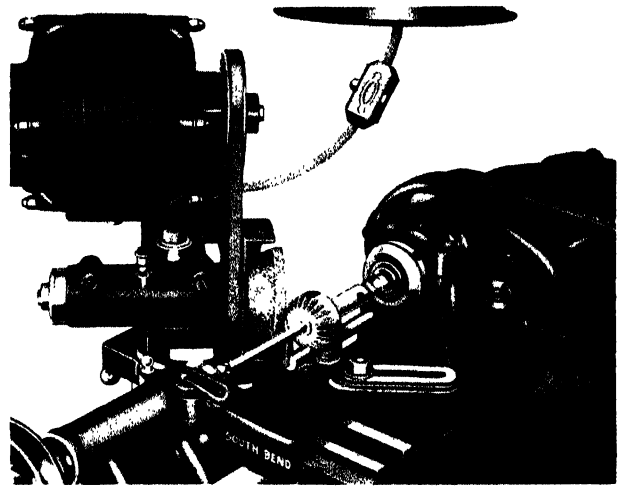

*Courtesy, South Bend Lathe Works*

FIG. 169-A. GRINDING A MILLING CUTTER ON A LATHE

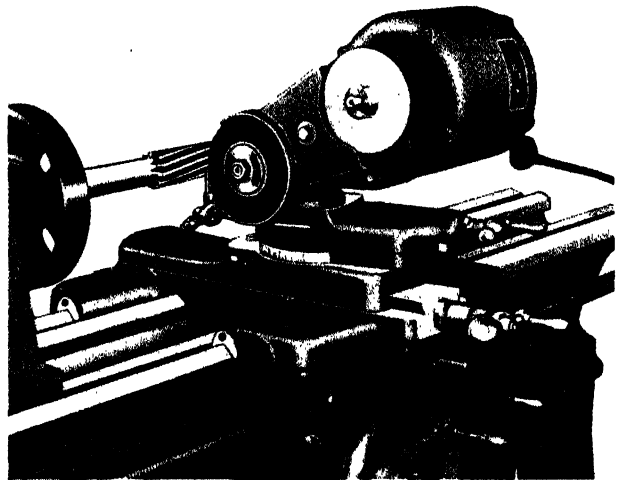

*Courtesy, South Bend Lathe Works*

FIG. 169-B. GRINDING A REAMER ON A LATHE

Accurate and efficient mill work requires sharp and correctly ground cutters. Figs. 169A and 169B illustrate a lathe attachment designed for grinding milling cutters, reamers, etc.

The procedures of setting up a lathe to perform a milling operation after the attachment has been mounted on the carriage are very similar to those described in setting up a standard milling machine; likewise, the manner of mounting the work in the vise or on an arbor, Units 50 to 53 inclusive. The rotation of the cutter should always be opposite the direction of feed. Thus, when the direction of feed is toward the rear of the lathe, the cutter should rotate clockwise.

SECTION VI

THE SHAPER AND ITS OPERATION

UNIT 36

THE SHAPER

The shaper is one of the most common and useful machines found in the machine shop. Primarily, a shaper is used to plane flat surfaces, although a skillful workman can manipulate it so as to plane curved surfaces, cut keyways, grooves and slots. The work is held stationary on an adjustable table while the tool moves forward on the cutting stroke, and returns quickly to the starting point. In the course of the return stroke the feed mechanism advances the table the amount desired for the next cut, usually not more than  $\frac{1}{16}$  of an inch.

The size of a shaper is determined by the maximum length of stroke it will take, for example, 14, 16, 20 inches, etc. Most modern shapers are operated by individual motors

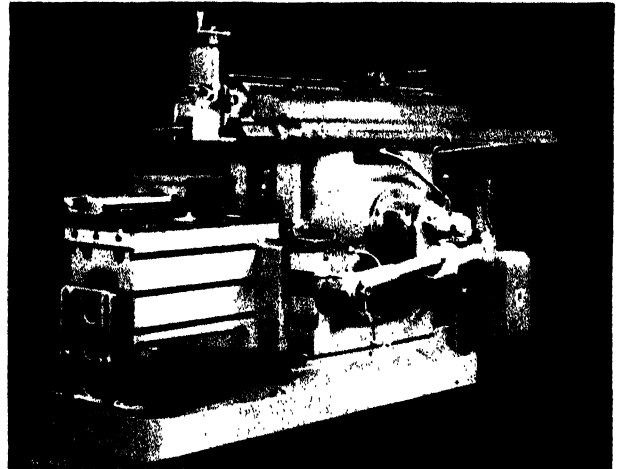

Courtesy, Cincinnati Shaper Co.

FIG. 170. SHAPER

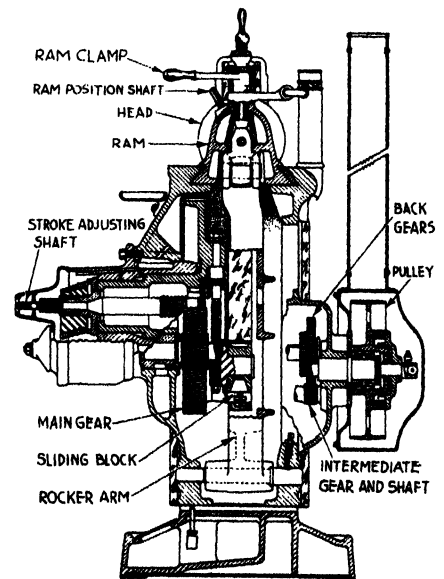
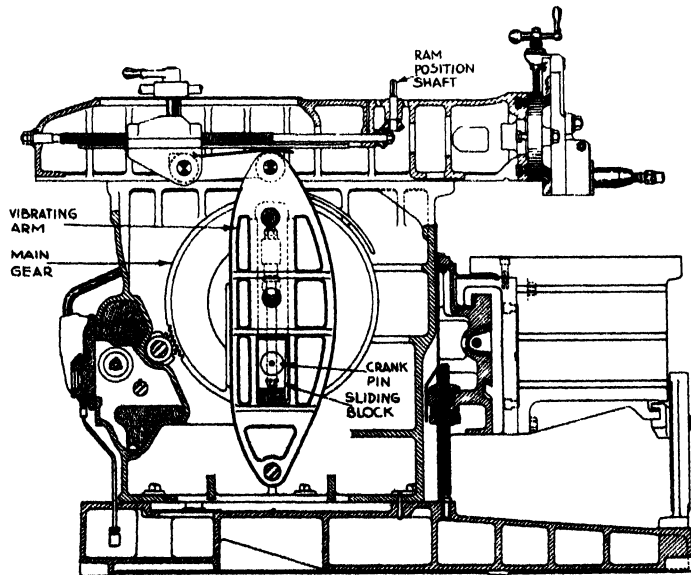

Courtesy, Cincinnati Shaper Co.

FIG. 171. SECTIONAL VIEW OF A SHAPER (FRONT)

FIG. 172. SECTIONAL VIEW OF A SHAPER (END)

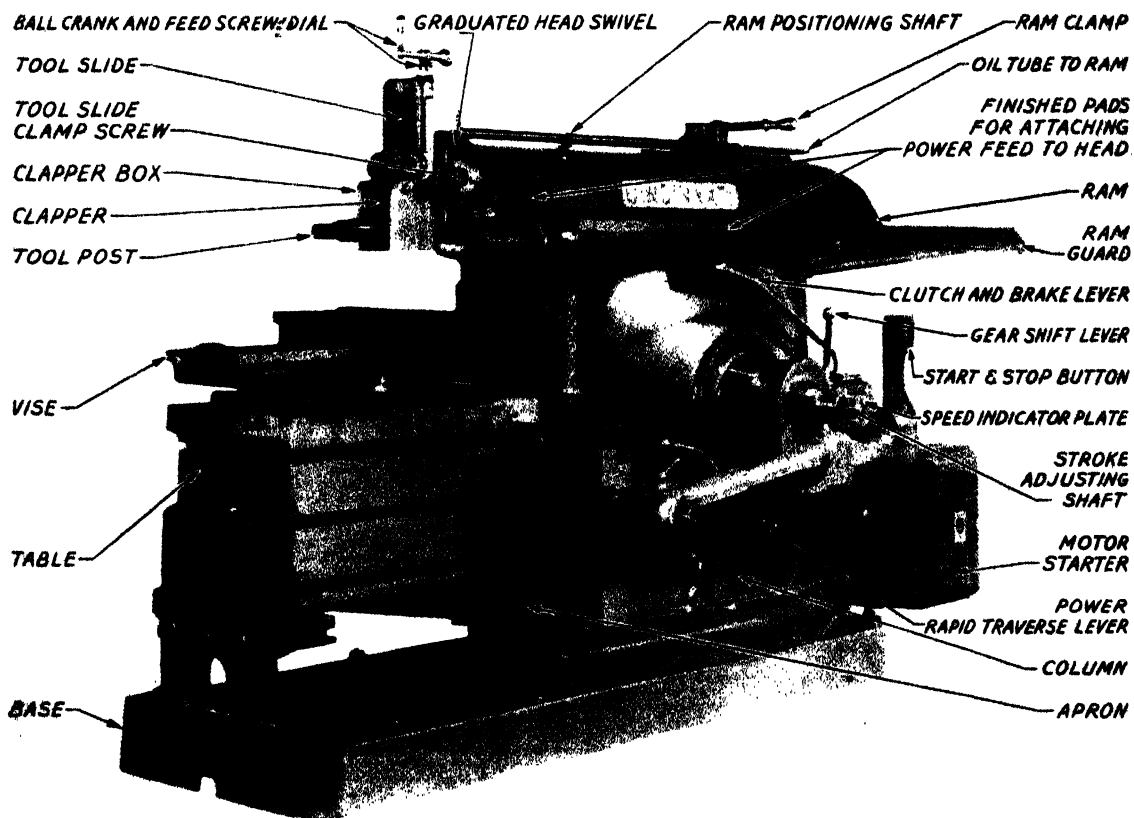

FIG. 173. PARTS OF A SHAPER (FRONT VIEW)

Courtesy, Cincinnati Shaper Co.

which activate the driving mechanism of the machine through belts, chains or gears.

#### PARTS OF A SHAPER

To the average person the shaper, Fig. 170, looks like a rather simple piece of machinery. However, study of the sectional views, Figs. 171 and 172, and an examination of the labeled parts in Figs. 173 and 174, show it to be a rather complex machine.

#### THE DRIVING MECHANISM

The ram which drives the head holding the tool is driven by a slotted rocker or vibrating arm which is connected to the main gear or driving wheel by a crankpin and a sliding block, Fig. 171. As the driving wheel revolves, the crankpin and the sliding block are carried through a circular path. This causes the vibrating arm to move forward as the block travels one portion of the path, and in the opposite di-

rection as it passes along the remaining portion. The crankpin which holds the sliding block is fastened to a second block which operates in a radial slide on the driving wheel. The position of this block is adjustable by means of a shaft and bevel gears. As the crankpin is drawn toward the center of the wheel, the distance the vibrating arm travels is shorter and consequently the distance (stroke) traveled by the ram. Acceleration on the return stroke is a result of the crankpin, which motivates the vibrating arm, having to travel a much shorter distance to bring the vibrating arm back to the point where the stroke starts than it travels in making the stroke — a ratio of approximately 2 to 3, Fig. 175.

#### SPEED

When set for any particular speed a shaper will make a constant number of strokes regard-

## THE SHAPER

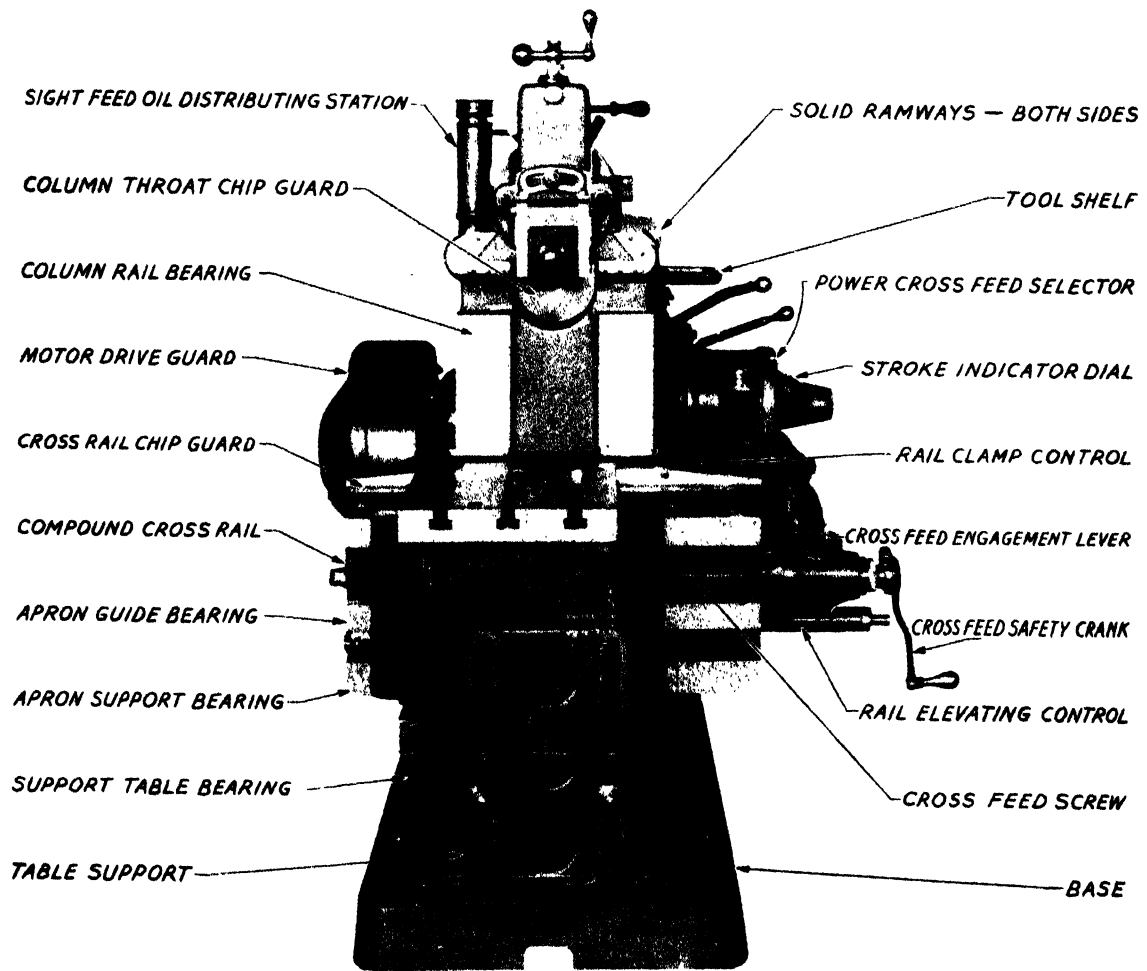

FIG. 174. PARTS OF A SHAPER (END VIEW)

Courtesy, Cincinnati Shaper Co.

less of the length of the stroke. To maintain a constant cutting speed (rate at which metal is removed) the shaper must make twice as many strokes when making a cut 3 inches long as when making one 6 inches long. In modern machines, increase or decrease of speed is accomplished through a system of speed change gears mounted in a box on the side of the machine, or on the inside of the column, Fig. 176. The gears are manipulated by levers conveniently placed near the position of the operator. An indicator or an index plate indicates which gears to engage in order to produce a given speed.

### FEED

The tool may be brought into contact with the work by moving the table along the cross

rail by means of a screw operated with a hand crank, by raising the table with a crank or by lowering the head on the end of the ram. In addition to hand feed, many modern shapers are provided with a horizontal automatic feed. This is accomplished on the older types of machines by means of a notched wheel and pawl, operated from the driving wheel by a connecting rod and an adjustable link or similar device. On modern types, change of feed is accomplished by a series of cams, for example, Fig. 177. The amount of feed is determined by the number of teeth (notches) the notched wheel advances on each *return stroke* of the shaper. The number of teeth advanced is determined by the position of the feed adjusting knob or hand-

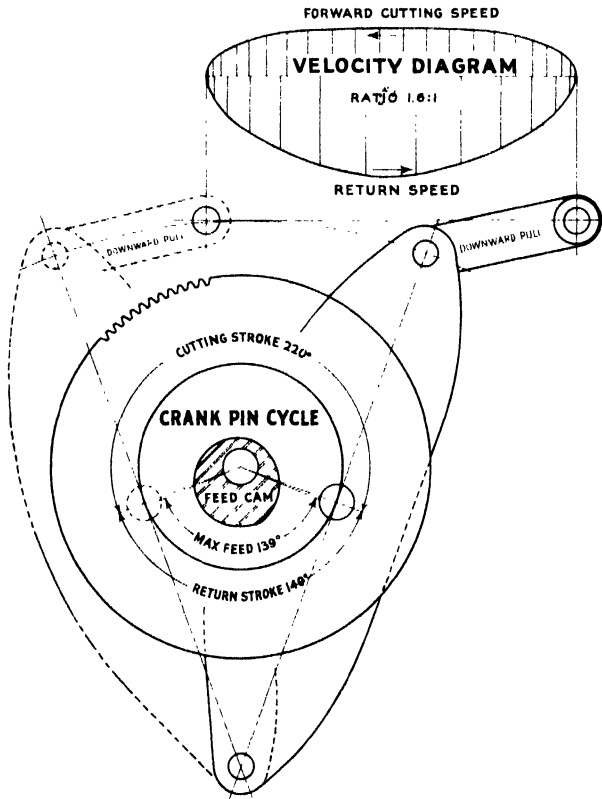

Courtesy, Cincinnati Shaper Co.

FIG. 175. DIAGRAM OF STROKE CYCLE OF 24" SHAPER

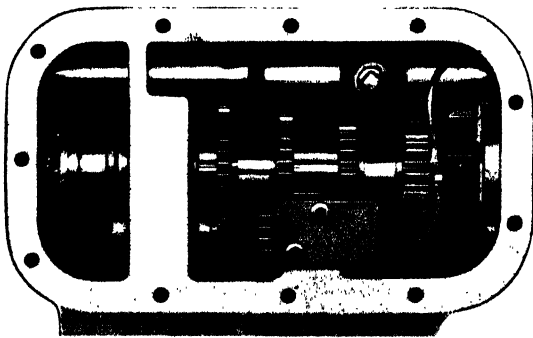

Courtesy, Cincinnati Shaper Co.

FIG. 176. SHAPER SPEED CHANGE GEARS

wheel in relation to the link connecting the rod and the feed rocking arm. The farther this handwheel is from the center the greater the amount of feed. On a cam actuated machine, change of feed is accomplished by adjusting the direct reading feed dial to the position desired, for example, a position which will give a feed of .06 of an inch. With this type, change of feed may be made while the machine is in operation.

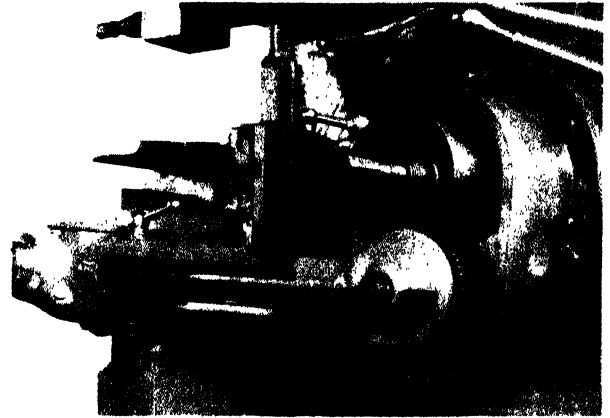

Courtesy, Cincinnati Shaper Co.

FIG. 177. TABLE FEED ACTUATING CAMS

**TABLE**

The table of a shaper consists of two parts: the table itself constitutes the front section and the apron or saddle constitutes the rear section, to which the table is bolted. The apron has a gib or hook-like projection which engages the cross rail located on the front of the column. In addition to being a support for the table the cross rail serves as a track along which the apron slides in a horizontal plane when activated by a feed screw. The cross rail carrying the apron and table may be raised or lowered by means of a vertical screw and bevel gears. Whenever *vertical adjustment* of the *cross rail* is made the clamping bolts holding it to the column should be loosened slightly and tightened again as soon as the adjustment has been made. The top of the work table is provided with T-slots. These are for convenience in clamping the work to the table or for attaching

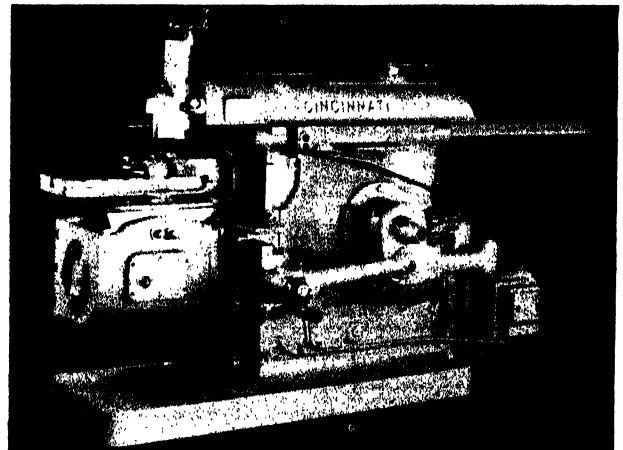

Courtesy, Cincinnati Shaper Co.

FIG. 178. UNIVERSAL SHAPER

devices such as vises and jigs. The sides of the table have similar T-slots. These serve the same purposes as those in the top but are much less frequently used. The vise, a common feature of all shapers, is mounted on a swivel base. This feature permits clamping the work with the jaws of the vise either parallel with, perpendicular to, or angular with the face of the column. What is known as a universal table may be had for some shapers. This table may be swiveled on the apron and may be tilted toward or away from the column. These adjustments are useful when making angular or bevel cuts. The universal type of shaper, Fig. 178, is equipped with the above form of table.

On some shapers the table is moved vertically or horizontally by power, either up or down, right or left. Machines so equipped are designated — Power Rapid Traverse. The advantages of this device are that the work can be brought into contact with the tool quickly and when the job is completed, the table can be moved quickly to one side so that the work clears the tool post and can be removed without hindrance.

#### HEAD

The tool head, Fig. 179, consisting of a head piece, a swivel base and apron, is designed for holding and adjusting the tool for depth of cut. The down feed screw has a collar graduated in thousandths of an inch. Thus very fine adjustment of cut can be made very simply. The swivel arrangement between the ram and the head makes it possible to make vertical or angular cuts. The tool is held in a tool post which is attached to the hinged tool block or clapper. During the cut, the tool block is forced back against the base of the clapper box and thus is solidly supported. On the return stroke the tool

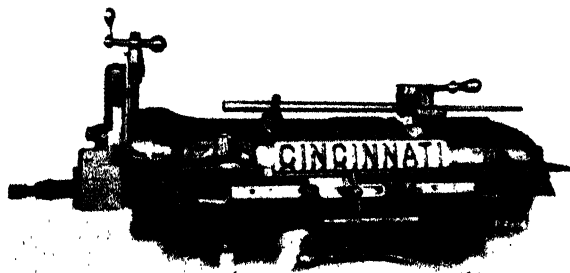

Courtesy, Cincinnati Shaper Co.  
FIG. 179. SHAPER TOOL HEAD

or clapper block swings free. This allows the tool to be drawn back across the work with only a slight rubbing effect and with consequent preservation of the cutting edge. By loosening the clamping bolt on the front of the apron, one may swing the apron to the right or left for the purpose of making angular cuts, Fig. 180, and for providing clearance at the point of the tool when making vertical or angular cuts. Some modern shapers are provided with both hand and power down feeds.

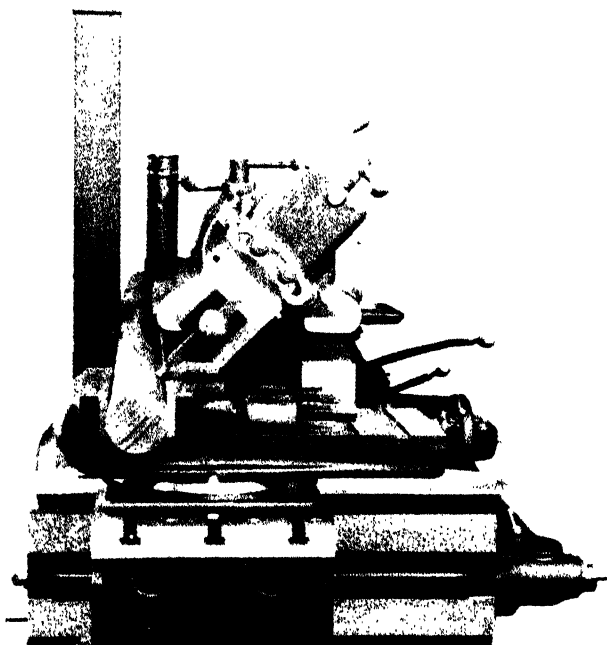

Courtesy, Cincinnati Shaper Co.  
FIG. 180. MAKING AN ANGULAR CUT WITH A SHAPER

#### SHAPER TOOLS

Shaper tools are of two kinds, forged and bits. The former is a heavy tool of which A, B and C, Fig. 181, are examples. Bits are short pieces of high-speed steel held in a tool holder, Fig. 182. High-speed bits are now more commonly used than forged tools. Shaper bits and tools are ground for making right- or left-hand cuts. The left-hand tool is the more commonly used because, the feed being from the left side of the work toward the right when viewed from the face of the column, the operator can observe the cut from the position he ordinarily takes when operating the machine.

#### CLEARANCE ANGLES

Shaper bits are ground with very little front or side clearance. A side clearance of about 2°



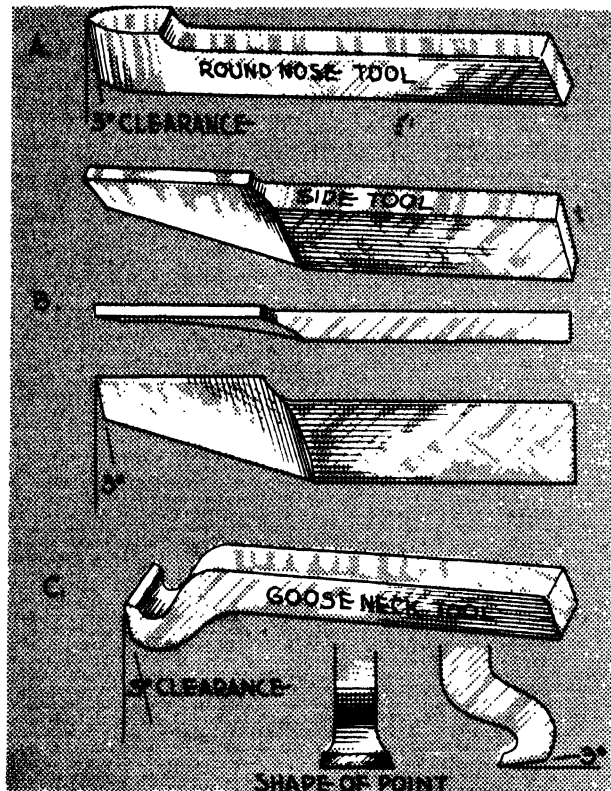

FIG. 181. FORGED SHAPER TOOLS

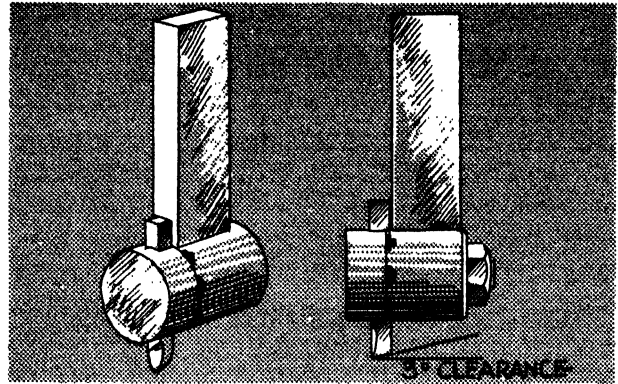

FIG. 182. SHAPER TOOL BITS

ordinarily is sufficient, as is a front clearance of about  $3^\circ$ . A shaper tool must be ground with the correct clearance as there is no provision in the tool post whereby the tool may be set to provide clearance or top rake as in a lathe.

#### RAKE

A shaper tool ordinarily is ground with a side rake of from  $8^\circ$  to  $10^\circ$  with no front rake, except certain finishing tools which are given a slight front rake to increase the keenness of the cutting edge.

## UNIT 37

### SHAPER VISES, PARALLELS, HOLD DOWNS AND ANGLE PLATES

Shaper vises generally consist of a fixed and a movable jaw which is operated by one or by two screws, A and B, Fig. 183. Ordinarily, these vises are mounted on a graduated swivel base. This arrangement permits the vise to be swung so that the face of the jaws may be parallel with, perpendicular to, or at an angle with the line of travel of the tool. The jaws of the shaper vise are made of soft steel, so care must be taken to avoid scarring or otherwise damaging them.

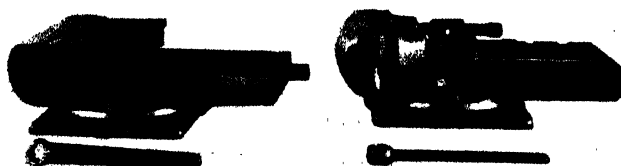

Courtesy, Cincinnati Shaper Co.

FIG. 183. SHAPER VISES

#### PARALLELS

To raise the work above the jaws of the vise and to provide a solid seat for it, parallels, A, Fig. 184, are used. Usually, these are strips of hardened steel which have been machined accurately to the size desired. Ordinarily these are made in pairs and in several sizes. For holding work at an angle, degree parallels are used, B, Fig. 184. These are similar to rectangular parallels except that one side has been machined at an angle of so many degrees with the base, for example,  $15^\circ$ .

#### HOLD DOWNS

Sometimes parallels, or combinations of parallels, of the size required to raise the work above the jaws of the vise are not available. This is particularly true when machining thin stock. Hold downs of the type shown in Fig.

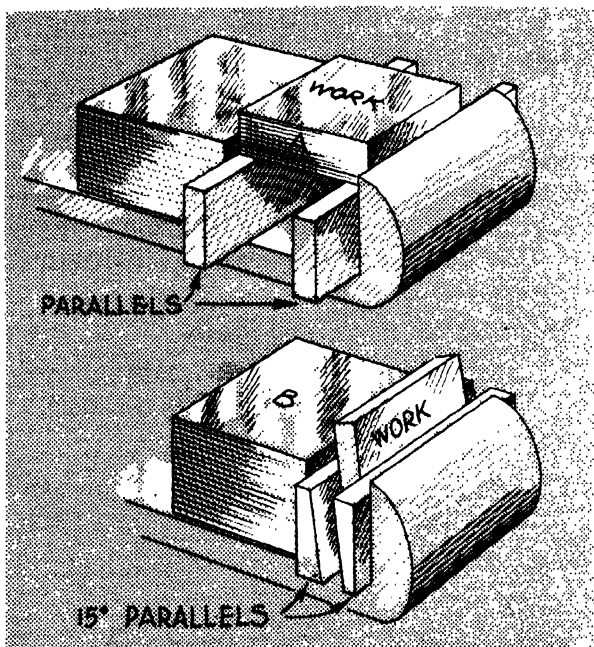

FIG. 184. USING PARALLELS

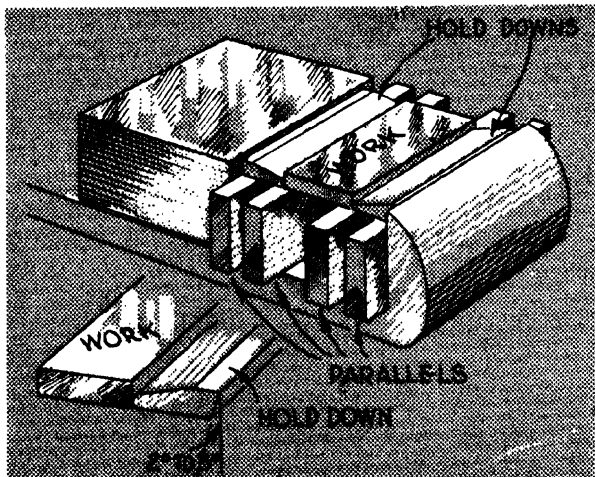

FIG. 185. USING HOLD DOWNS

185 frequently are used to grip the work and hold it in position while being machined. As may be observed in the illustration, these are wedge shape in cross section with the thin edge

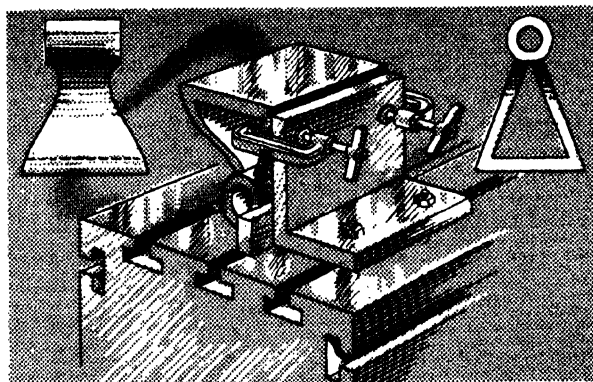

FIG. 186. USING ANGLE PLATES

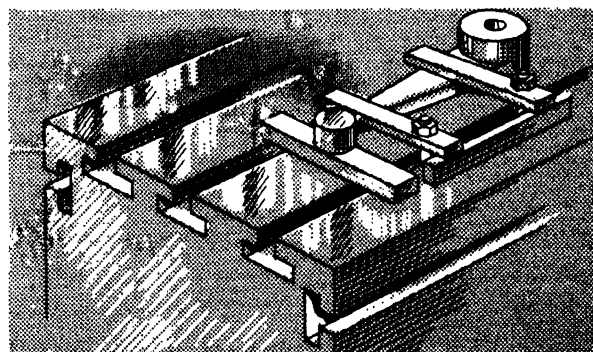

FIG. 187. USING STRAP CLAMPS

rounded and the thick one beveled 2 or 3 degrees. Beveling the back edge in the manner indicated causes the hold down to press downward at the thin edge when it is brought against the work. Thus the work is held sufficiently rigid to permit machining with light cuts.

#### ANGLE PLATES

Work that cannot be held in a vise may be machined by holding it in position clamped to an angle plate which is bolted to the table of the shaper, as in Fig. 186, or by clamping with strap clamps directly to the table, as in Fig. 187. When irregularly shaped pieces are clamped to the table, parallel bars are used to hold the work level.

## UNIT 38

## CALCULATING THE CUTTING SPEED OF A SHAPER

The rate or cutting speed at which metal may be removed with a shaper depends principally on: (1) the kind of material being cut; (2) the amount of material being removed at each cut; (3) the kind of material in the tool, as, for example, high-speed or carbon steel; (4) the rigidity of the machine. The following table gives the ordinary speeds employed when high-speed steel and carbon steel cutters are used.

TABLE IV  
CUTTING SPEEDS

*Tool — High-Speed Steel*

Cast Iron .....	60 to 70 ft. per min.
Machine Steel .....	80 to 100 ft. per min.
Tool Steel .....	50 to 60 ft. per min.
Brass .....	200 ft. per min.

*Tool — Carbon Steel*

Cast Iron .....	30 ft. per min.
Machine Steel .....	40 ft. per min.
Tool Steel .....	25 ft. per min.
Brass .....	100 ft. per min.

The speed at which a metalworking shaper removes metal cannot be calculated simply by multiplying the length of the stroke by the number of strokes per minute. Neither can it be found by dividing by two the time consumed in making the complete cycle of forward and return strokes, because, on most shapers, the cutting stroke takes approximately  $1\frac{1}{2}$  times as long as the return stroke. The ratio of time spent on the respective return and forward strokes is 1 to  $1\frac{1}{2}$ , or when each is multiplied by two, this ratio may be represented by the products 2 and 3 respectively. Thus  $\frac{3}{5}$  of each full minute of running time is spent in making cutting strokes and  $\frac{2}{5}$  in return strokes.

Cutting speed is always given in feet per minute. Hence, when the stroke is given in inches, the product found by multiplying the length of the stroke by the number of strokes per minute also must be converted to feet per minute. Dividing this product by twelve gives the travel of the cutting tool in feet. Since only

$\frac{3}{5}$  of the time is spent in making forward strokes, the cutting actually has been done in  $\frac{3}{5}$  of a minute. Therefore, the distance traveled in feet per minute must be divided by  $\frac{3}{5}$  to determine the rate at which the cutting tool moves across the work.

$$\begin{aligned} \text{When} \quad CS &= \text{Cutting speed} \\ N &= \text{Number of strokes} \\ L &= \text{Length of stroke in inches} \\ \frac{3}{5} &= \text{Portion of time spent} \\ &\quad \text{actually cutting} \\ 12 &= \text{Inches per foot} \\ \text{Then} \quad CS &= \frac{N \times L}{\frac{3}{5}} \\ \text{or} \quad CS &= \frac{N \times L}{7\frac{1}{5}} \quad (\text{or roughly, } 7) \end{aligned}$$

When using the shaper, the cutting speed desired and the length of the stroke will be known. Since it will be necessary to determine the number of strokes required to operate at the given cutting speed, the above formula for determining the cutting speed may be converted into the following form for determining the correct number of strokes to operate the shaper to produce a given cutting speed.

then

$$CS = \frac{N \times L}{7} \quad \text{or} \quad N = \frac{CS \times 7}{L}$$

EXAMPLE

A piece of machine steel 8 inches in length is to be machined with a high-speed tool.

The known factors are:

$$CS = 90 \text{ Feet per minute}$$

$$L = 8 \text{ inches}$$

Substituting the known values in the formula:

$$N = \frac{90 \times 7}{8} = \frac{630}{8} = 78.75$$

Setting the shaper to produce 80 strokes per minute will give a cutting speed within the allowable limits of operation.

## UNIT 39

## HOW TO ADJUST THE SHAPER FOR STROKE AND POSITION

The length of the stroke of the shaper is determined by the position of the crankpin and block in the slide in relation to the axis of the driving wheel. The farther the crankpin is away from the axis, the longer the stroke. The procedure for setting the stroke varies slightly for different makes of shapers.

**PROCEDURE FOR ADJUSTING THE STROKE**

1. Loosen the knob or device that locks the stroke setting shaft in position.

Some modern shapers do not have a locking device; on such machines the length of stroke once set is maintained automatically and can be changed only by revolving the shaft.

2. With the crank, turn the stroke setting shaft in the direction desired until the pointer on the ram registers on the index plate the length of stroke desired, for example, 4 inches, plus the amount required for overlap at the start and finish of the cut. The amount of overlap required will depend upon the number of strokes per minute, the time needed for the tool to drop into position, the depth of cut, kind of material, the rigidity of the machine, the tool and the work. In all cases, for efficient operation, overlap of stroke should be kept at a minimum.

**CAUTION:** The stroke should be at least  $\frac{1}{2}$  to  $\frac{3}{4}$  of an inch longer than the cut.

On machines equipped with an indicator dial adjacent to the stroke adjusting shaft, the shaft is revolved until the indicator registers the length of stroke desired.

3. When the machine has been adjusted for length of stroke, tighten the locking device, if any.

**PROCEDURE FOR ADJUSTING THE POSITION AT WHICH THE STROKE IS MADE**

1. Loosen the device that clamps the ram in position by turning the handle on the top of the rear part of the ram, Fig. 173.
2. With the clutch lever, engage the clutch lightly and advance the vibrating arm to its extreme forward position. The instant this position is reached, disengage the clutch.

Some machines are equipped with a handwheel on the driving shaft. This wheel is used to advance the arm to its extreme forward position.

3. With the crank, engage the projecting ram positioning shaft, at the rear of the head of the ram, Fig. 173. Then turn the shaft until the tool is in a position about  $\frac{1}{4}$  of an inch ahead of the work at the point where the cut ends.

## UNIT 40

## HOW TO MAKE HORIZONTAL CUTS WITH A SHAPER

The principal use made of a shaper is to plane flat, true surfaces. When machining work of this kind the work is held in the shaper vise, clamped to an angle plate, or if very large, clamped to the shaper table. The vise is mounted on a graduated swivel base. This permits revolving the work at various angles for convenience in machining. The table on some shapers is mounted on a swivel base and can be turned at various angles. When occasion requires, the table may be tilted at right angles to the axis

through a limited number of degrees.

Before placing work in a shaper vise or on the table, burrs on the edge or elsewhere on the work should be removed by carefully chipping or filing; likewise, burrs on the jaws of the vise or on the parallel bars used to align and support the work. All metal chips and dirt should be removed from the bottom of the vise and the surfaces of the work. Burrs on the work or equipment, or chips at the bottom of the vise or between the vise and parallel bars,

throw the work out of alignment and frequently are the causes of spoiled work.

**CAUTION:** Before starting the shaper be sure the head of the ram will clear the work at all points.

It is recommended that beginners inform themselves about the shaper before attempting to operate it by reading Unit 36.

#### PROCEDURE FOR ROUGHING CUT

1. Examine the work to make sure there are no burrs or bumps on the surface. If any are found, remove them by carefully chipping or filing.
2. Examine the jaws and bottom of the vise and remove any burrs, chips or other foreign matter found.
3. Select parallel bars of suitable width, thickness and length, Fig. 188. The use of two parallel bars is recommended whenever they can be employed. When conditions are such that two bars cannot be employed, use one if at all possible.
4. Open the vise to accommodate the work, then place the parallel bars on the bottom plate of the vise.
5. Place the work flat on the parallel bars in the center of the vise, Fig. 188. Locate the work centrally whenever possible so as to avoid unnecessary strain on the vise. To save cutting time, turn the work so that the longest stroke possible may be taken.

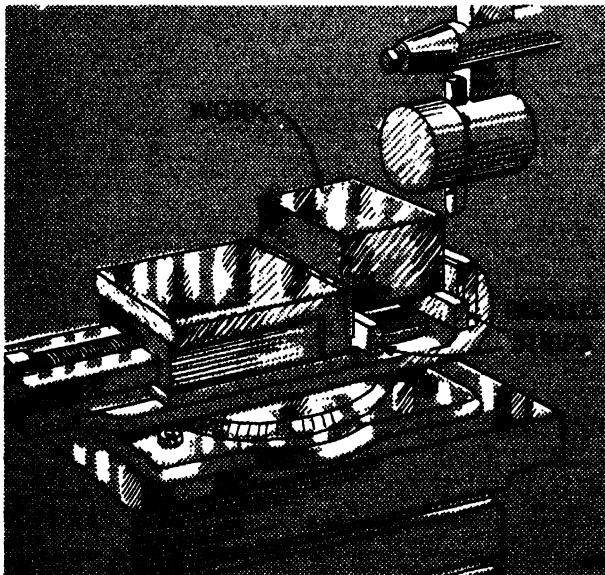

FIG. 188. WORK IN POSITION FOR SHAPING

6. With the hand crank, draw the vise just sufficiently tight to grip the work. To make certain that the work is resting evenly on the parallels, tap it lightly with a lead hammer, then tighten the vise screw until the work is held securely. Strips of thin paper under the corners of the stock will aid in determining when the stock is resting on the parallels. If one or more of the strips of paper is loose, the stock is not resting on the parallels at that point.

**CAUTION:** To avoid springing the work, do not draw the vise too tightly when clamping thin or very wide stock.

7. Select a suitable, correctly ground, sharp roughing tool, usually a roundnose, A, Fig. 189. B and C, Fig. 189, represent left- and right-hand roundnose tools.
8. Insert the tool in the holder or the tool post, placing it as close to the bottom of the tool block or clapper as the nature of the

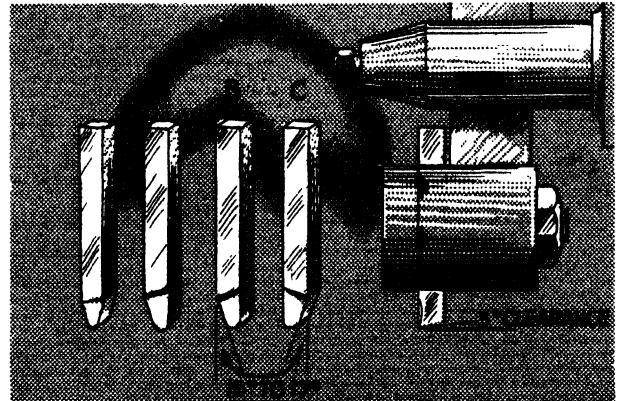

FIG. 189. CUTTING TOOLS



FIG. 190. TOOL IN POSITION FOR CUT

work to be performed will permit. Incline the tool slightly ( $2^{\circ}$  or  $3^{\circ}$ ) away from the work, Fig. 190, then clamp it securely. Inclining the tool will protect the cutting edge, because on the return stroke, the tool block swings up and carries the tool a short distance away from the work.

**CAUTION:** Be sure the tool block works freely and that it seats itself properly against the bottom of the clapper box.

9. Adjust the table until the part of the work to be machined is at the level of the point of the tool.
10. Determine the cutting speed desired, Unit 38, and adjust the machine accordingly.
11. Adjust the shaper for the length of stroke desired, Unit 39. The stroke should be about  $\frac{1}{2}$  to  $\frac{3}{4}$  of an inch longer than the work.
12. Next adjust the position of the ram. This is done by loosening the clamping lever at the rear of the ram, then moving the vibrating arm forward as far as possible. Place the hand crank on the ram positioning screw, near the head of the ram, and move the ram forward until the cutting tool is about  $\frac{1}{4}$  of an inch ahead of the front edge of the work. Then tighten the clamping lever at the rear of the ram.
13. Move the ram back to the end of the return stroke.
14. With the hand cross-feed screw, Fig. 174, move the table until the work is within  $\frac{1}{16}$  of an inch of the side of the cutting tool.
15. With the down feed crank on the head of the ram, lower the cutting tool until it is in a position to make a cut of the depth

desired. When cast iron is to be machined, set the tool to make a cut about  $\frac{1}{2}$  of an inch in depth. This will put the point of the tool well below the scale on the metal.

16. Check to make certain the tool is tight in the holder and the work secure in the vise. The automatic feed should not be engaged.
17. Engage the clutch lever, Fig. 173.
18. At the end of the first return stroke, feed the work toward the cutter by giving the feed crank one-fourth of a turn to the right. Start turning the crank as soon as the ram starts on the return stroke.
19. After two or three strokes have been completed, stop the machine and examine the work. Make adjustments if necessary.
20. Engage the automatic feed knob, or lever, Fig. 174, and start the machine. The automatic feed should operate at the end of the return stroke. If it is set to operate at the end of the forward stroke, the tool will drag on the return stroke, damaging the cutting edge.
21. When the surface has been planed, stop the machine and remove the cutting tool.

#### PROCEDURE FOR FINISHING CUT

1. Select a suitable finishing tool, usually one with a rather broad, slightly curved cutting edge. Be sure the tool is sharp.
2. Mount the tool in the tool post or holder.
3. With the down feed crank, adjust the machine to take a light cut, about .003 or .004 of an inch.
4. Proceed as above in steps 16 to 21 inclusive.
5. When the work has been completed, clean the machine and return the equipment to the place where it is kept when not in use.

### UNIT 41

#### HOW TO SQUARE RECTANGULAR STOCK WITH A SHAPER

Frequently it is necessary to machine stock on all surfaces. In many instances this may be done with horizontal cuts only. In other cases a combination of horizontal and vertical cuts will be found most advantageous.

#### PROCEDURE

1. Grip the stock in the shaper vise securely and plane one surface true. See Unit 40.

2. Place the planed surface of the stock against the solid jaw of the vise, then insert a round rod between the work and the movable jaw, Fig. 191.

A round rod is used to avoid change in the position of the stock caused by movement of the movable jaw or unevenness of pressure exerted against the work.

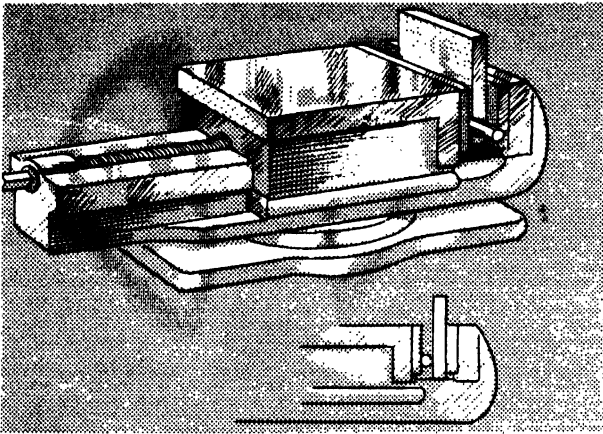

FIG. 191. ROUND ROD BETWEEN WORK AND MOVABLE JAW OF VISE

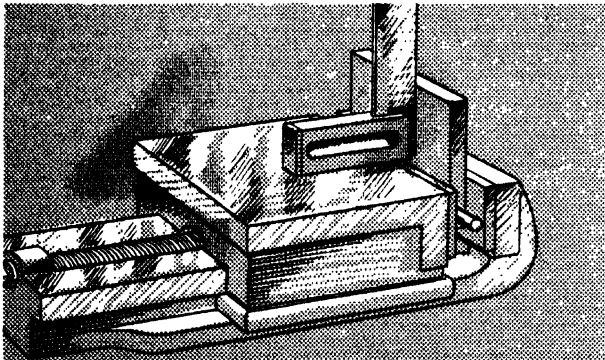

FIG. 192. TESTING VERTICAL PLANE OF WORK

3. Tighten the vise screw. Then, with a try square, test to see if the work is standing in a vertical plane, Fig. 192.
4. Machine the edge as in step 1.
5. Release the vise and turn the work around with the machined edge down and the

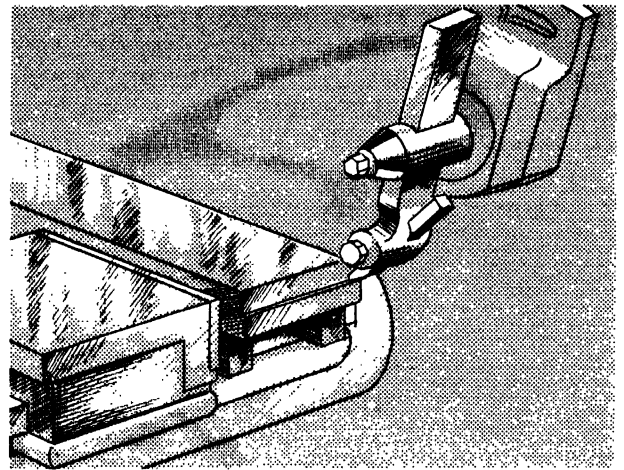

FIG. 193. MACHINING THE END OF A LONG PIECE

- planed surface against the solid jaw of the vise.
6. Proceed as when machining the first edge.
  7. Next place the work on parallel bars with the first machined face down, as in Fig. 193. Then proceed as in step 1.
  8. To machine the end, stand the stock vertically in the vise. Test with a square. Then proceed as when planing the edge, steps 2, 3 and 4.
  9. Plane the second end in a similar manner.

When the stock is quite wide or long it may not be practicable to machine it when it is standing vertically in the vise. In such cases adjust the vise and move the stock until one end projects a short distance beyond the jaws of the vise, Fig. 193. Then machine the end as when making vertical cuts. See Unit 42.

## UNIT 42

### HOW TO MAKE VERTICAL AND ANGULAR CUTS WITH A SHAPER

A vertical cut usually is made when cutting a groove, a tongue, a shoulder or a keyway, and, occasionally, when planing the end of wide stock. An angular cut is made when cutting dovetails or bevels on the edges or ends of work. When such cuts are being made, the down feed is used.

Angular cuts may be made by setting the *head* of the shaper at an angle corresponding to the angle to be produced on the work or by setting the work at an angle and then machining it in the usual manner. Commonly used devices for holding the work at a given angle are angle plates which have various degrees of

angularity and degree parallels. The latter are similar to ordinary parallels except that one face is machined at an angle.

Ordinarily, such operations as planing a true surface on at least one side and of squaring the ends and edges of stock, are performed before vertical or angular cuts are attempted.

#### PROCEDURE FOR MAKING VERTICAL CUTS

1. Lay out and mark the point or points where the cut is to be made in the stock.
2. Place the stock flat on parallels in the vise or on the shaper table, and clamp it securely. Before taking the final turn on the vise clamping screw, it is good practice to strike the work a light blow with a lead hammer.
3. With the down feed crank, draw the tool slide up as far as the nature of the work will permit. In this way the tool will have the optimum support from the ram throughout the operation and vibration will be reduced to a minimum.
4. Select a suitable, sharp tool. Grind it if necessary.

Usually a squaring tool, A, Fig. 194, or a cut off tool, B, Fig. 194, is used for cutting narrow grooves, shoulders, or keyways. When cutting a narrow groove, for example,  $\frac{1}{4}$  of an inch, it is good practice to select a tool which will make a cut of the width desired at one stroke. A side tool, C, Fig. 194, is sometimes used for cutting shoulders.

5. Insert the cutting tool in the holder and tighten the clamping screw.

When cutting narrow grooves, do not swivel the clapper box. On the other hand, when cutting wide grooves or shoulders

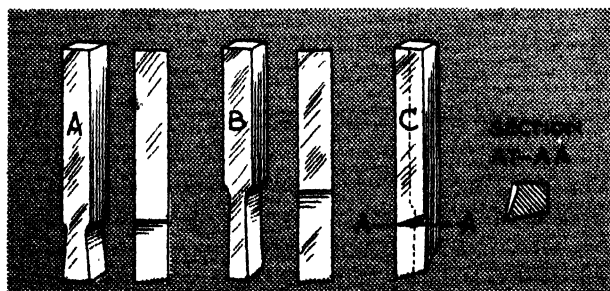

FIG. 194. SHAPER TOOLS

the clapper box should be swiveled through  $15^\circ$  to  $20^\circ$ , Fig. 195. This will give the tool clearance on the return stroke, as the tool block will then swing out and up.

When swiveling the clapper box, *always swing the top of the box away from the surface on which the cut is to be made.*

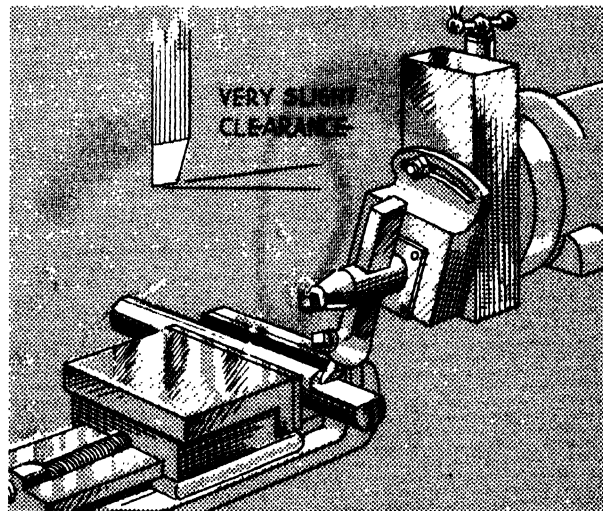

FIG. 195. CLAPPER BOX SWIVELLED TO CUT WIDE GROOVES

6. Adjust the table until the part of the work to be machined is at the level of the tool.
  7. Determine the length of stroke required.
  8. Adjust the stroke control so as to produce the length of stroke required. See Unit 39.
  9. Loosen the clamping lever at the rear of the ram, then with the hand crank engaged with the ram positioning screw, advance the ram until the cutting tool is about  $\frac{1}{4}$  of an inch beyond the cut.
  10. Lock the ram in this position by tightening the rear clamping lever.
  11. Move the ram back to the starting point of the cutting stroke.
  12. With the down feed crank, lower the tool slide until the point of the tool is about .002 of an inch below the work surface.
- CAUTION:** When machining cast iron be sure that the cut is sufficiently deep to penetrate about  $\frac{1}{8}$  of an inch below the scale.
13. With the feed crank, move the work table until the point on the work at which the cut is to be made is correctly aligned with the cutting tool.



14. Re-check the position of the work with respect to alignment with the tool, then make certain that the tool is fastened securely in the holder and that the clamping lever on the ram is tight.
15. Determine the correct cutting speed, then adjust the machine to produce the speed desired. See Unit 38.
16. Start the machine by engaging the driving mechanism.
17. At the end of the first return stroke, stop the machine and examine the cut for location. If the cut is not correctly located, make the necessary adjustments.
18. With the down feed crank, lower the head about .004 of an inch and again start the machine.
19. Repeat step 17 until two or three additional cuts have been made, then again stop the machine and check the position of the cut. Make adjustments if necessary.
20. When the machine has been set correctly, continue with the repeated cuts until the work has been machined to the depth desired.

After the machine has been correctly set, somewhat heavier cuts may be taken.

When cutting a groove where more than two series of cuts are necessary to produce a groove of the width desired, make the two outside cuts before attempting to remove the stock in the center.

21. When the cut is completed, clean the machine and return equipment to the place where it is kept when not in use.

#### PROCEDURE FOR MAKING ANGULAR CUTS

1. Proceed as in steps 1 and 2 under "Procedure for Making Vertical Cuts."

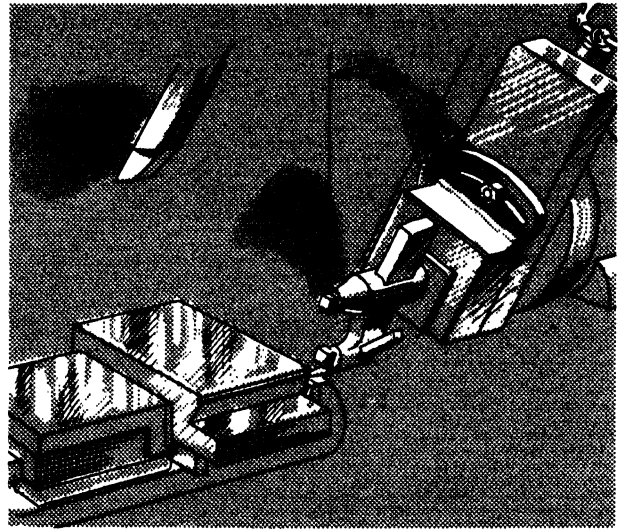

FIG. 196. CUTTING AN ANGLE WITH THE SHAPER HEAD SET AT AN ANGLE

2. With the down feed crank, draw the head up as far as the nature of the work will permit.
3. Loosen bolts holding the graduated swivel plate, then revolve the head through the number of degrees necessary to produce a machined surface having the degrees of angularity required, for example, 30°, Fig. 196.
4. When the head has been set at the angle desired, tighten the bolts holding the swivel plate.
5. *Swivel the top of the apron away from the surface on which the cut is to be made, through 15 to 20 degrees.*
6. Select a suitable, sharp tool. This may be an angle cutting tool or a side tool.
7. Insert the tool in the holder and tighten the clamping screw.
8. Proceed as in steps 6 to 21 inclusive, under "Procedure for Making Vertical Cuts."

### UNIT 43

#### HOW TO CUT KEYWAYS AND OTHER STOP CUTS ON A SHAPER

When cutting keyways, slots and recesses, it is often necessary to stop the cut somewhere in the metal. Under this condition the chips are not completely severed at the end of the stroke. With repeated cuts these pile up at the closed

end of the groove and eventually put such a strain on the tool that it breaks. In practice, piling up of the chips at the terminal end of the cut is overcome by drilling a hole at the closed end. When both ends are closed a hole is drilled

at each end of the groove. The hole at the end where the cut starts makes possible the entry of the cutting tool and a full cut throughout each stroke.

**PROCEDURE FOR CUTTING A KEYWAY WITH ONE CLOSED END**

1. Locate and mark the length of the keyway on the stock, Fig. 197.
2. At the closed end of the keyway drill a hole having the same diameter as the width of the keyway. The bottom of the hole should not be deeper than the depth of the keyway, *one-half the thickness of the key at the edge of the keyway.*
3. Place the work on a parallel bar in the shaper vise, with the marks up, Fig. 197. Then tighten the vise screw. Be sure the axis of the hole is aligned with the center of the cutter.

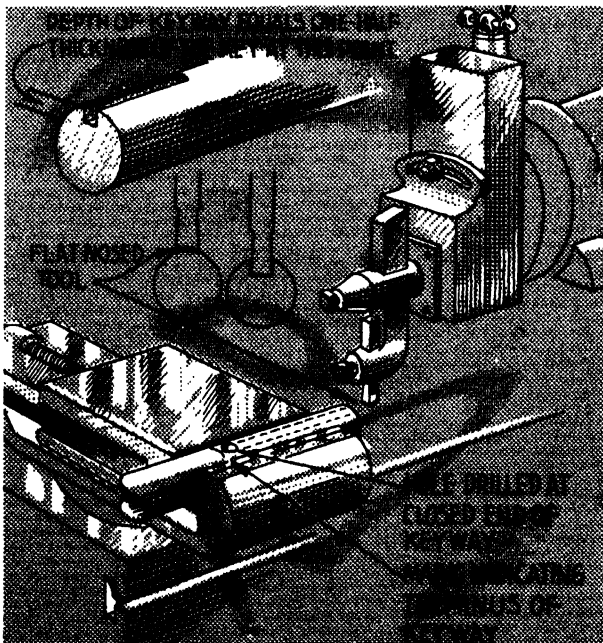

FIG. 197. CUTTING A KEYWAY WITH ONE CLOSED END

4. Proceed as in steps 3 to 21 inclusive, under "Procedure for Making Vertical Cuts," Unit 42.

**PROCEDURE FOR CUTTING A KEYWAY WITH BOTH ENDS CLOSED**

1. Locate and mark both ends of the keyway, A, Fig. 198.
2. With a drill having the same diameter as the width of the keyway, drill one or more

holes at each end of the keyway, B, Fig. 198. Be sure to drill in the waste stock and make each hole the same depth as the depth of the keyway.

3. Proceed as under "Procedure for Cutting a Keyway with One Closed End," except that the stroke must be set so as to begin and end at about the center of the drilled holes, Fig. 198.

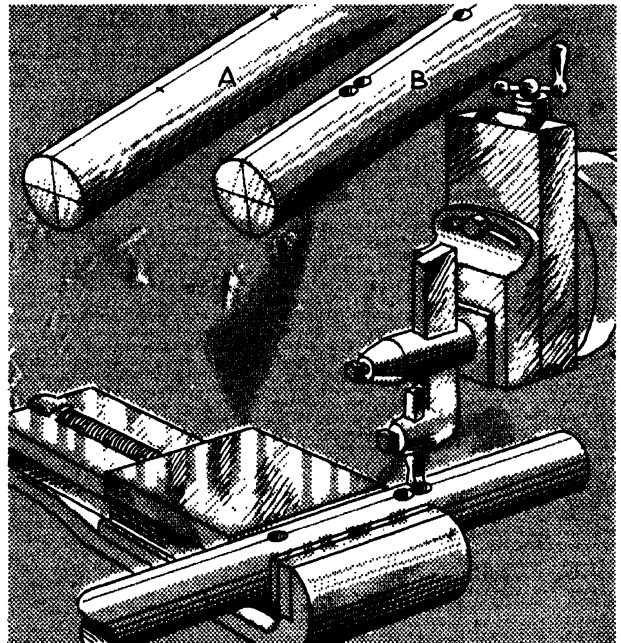

FIG. 198. CUTTING A KEYWAY WITH BOTH ENDS CLOSED

**PROCEDURE FOR CUTTING A KEYWAY IN THE HUB OF A WHEEL**

1. Locate and mark the position of the keyway on the face of the hub.
2. Grip the wheel in the shaper vise. Be sure the wheel is held vertically; test with a square.
3. Secure a suitable sharp tool. A tool similar to a boring bar often is used for this purpose, Fig. 199.
4. Insert tool in holder and fasten it securely. If the cut is made on the upper side, as illustrated in Fig. 199, vibration will be decreased. Regardless of whether the cut is made from above or below, a very light cut should be taken, not more than .002 of an inch.
5. Adjust the table until the center of the position at which the keyway is to be cut

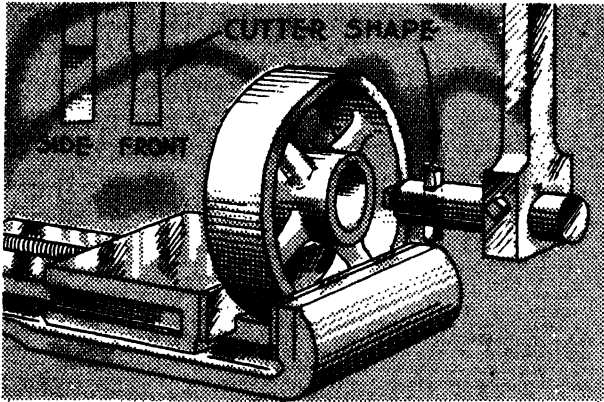

FIG. 199. CUTTING A KEYWAY IN A WHEEL HUB

is exactly aligned with the center of the cutting edge of the tool.

6. Proceed as when making vertical cuts, steps 6 to 21 inclusive, Unit 42.

#### PROCEDURE FOR MACHINING A PARTIALLY ENCLOSED RECESS

1. Lay out the shape of the recess on the face of the stock, A, Fig. 200.
2. Drill a hole about  $\frac{1}{4}$  of an inch in diameter in the enclosed corner, B, Fig. 200. The hole should not be deeper at its extreme than the depth of the recess.
3. Select a pair of parallel bars which are wide enough to hold the bottom of the recess above the jaws of the shaper vise.
4. Place the stock on the parallel bars in the vise in such a manner that a cut can be

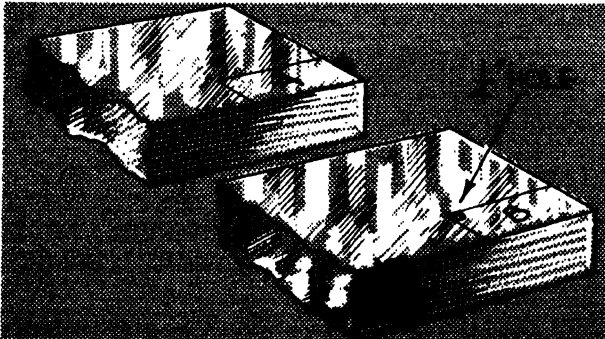

FIG. 200. LAYOUT OF A PARTIALLY ENCLOSED RECESS

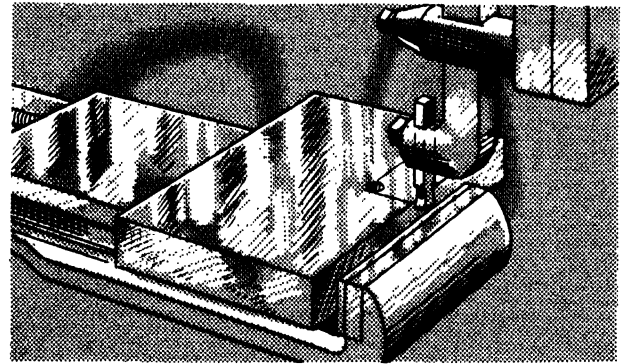

FIG. 201. CUTTING ONE END OF THE RECESS

taken across the closed end of the recess toward the drilled hole, Fig. 201.

5. Tighten the screw on the vise so as to hold the stock securely.
6. Select a sharp  $\frac{1}{4}$  inch cut off tool.
7. Proceed as under "Procedure for Making Vertical Cuts," steps 5 to 20 inclusive, Unit 42.
8. Turn the piece around in the vise, Fig. 202, and proceed as in step 7.

If much stock is to be removed, the roughing and finishing cut may be made as in steps 7 to 20, Unit 40.

9. Make the finishing cut as in steps 4 to 21 inclusive as under "Procedure for Making Vertical Cuts," Unit 42.

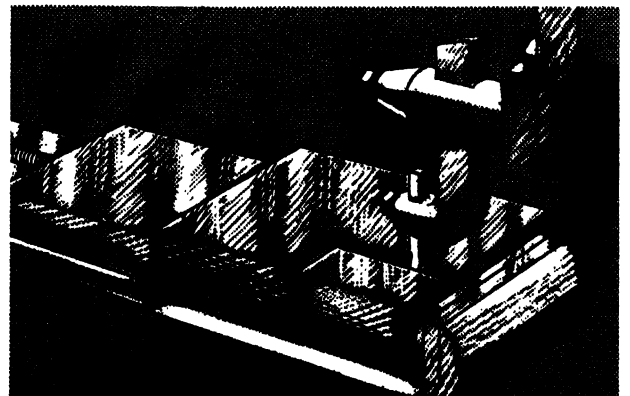

FIG. 202. CUTTING THE SIDE OF THE RECESS

### UNIT 44

#### HOW TO PLANE IRREGULAR SURFACES WITH A SHAPER

Ordinarily, machining irregular surfaces with a shaper is merely a matter of using, in

combination, the procedures used in making horizontal and vertical cuts.

1. Lay out the shape on the end of the work, A and B, Fig. 203, which when held in the vise, will first come into contact with the cutter.
2. Place the work on parallels (if practicable) in the vise and tighten the screw.

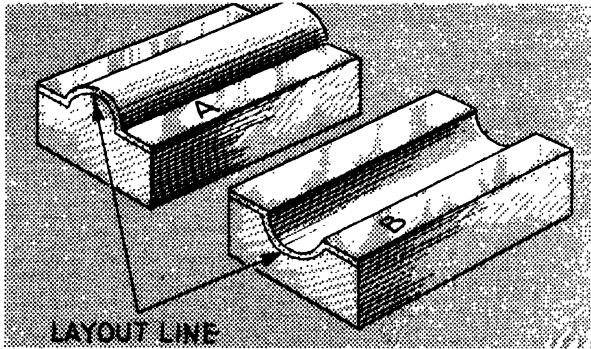

FIG. 203. LAYOUT OF IRREGULAR SURFACE FOR SHAPING

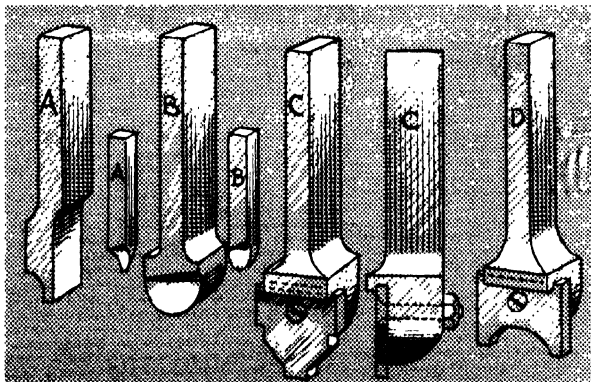

FIG. 204. SPECIAL FORMING TOOLS

3. Secure a suitable sharp tool, usually a roundnose; insert it in tool holder securely. Sometimes a special forming tool is used for machining irregular surfaces, for example, A, B, C, D, Fig. 204. When a forming tool is used, it usually is necessary to take a lighter cut than is the case when using a standard tool.

4. Adjust the tool to start the cut at the highest point on the surface to be machined.
5. Adjust the stroke and speed of the shaper in the usual manner.
6. Engage the table feed for a light cut.
7. Start the machine and on each return stroke advance the tool, with the down hand feed, sufficiently to take a cut of the depth desired, A, Fig. 205. Each roughing cut should follow the layout line closely.
8. When the entire surface has been rough cut, secure a finishing tool, if necessary, and mount it in the holder.

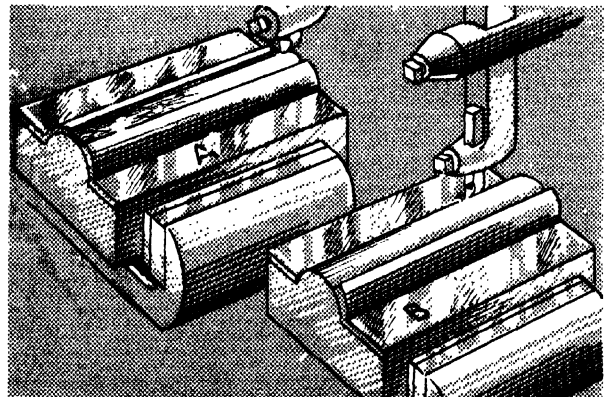

FIG. 205. CUTTING AN IRREGULAR SURFACE

9. Disengage the table feed if necessary. This will frequently be the case because of the necessity of taking more than one cut with the tool in the same vertical position.
10. Starting at the high point on the surface, take a light finishing cut, A, Fig. 205. If on the first stroke the tool does not cut quite to the layout, advance the down feed slightly and repeat the stroke.
11. With a combination of slight table and down feed adjustments continue machining the surface until it is completely machined to shape, B, Fig. 205.

## SECTION VII

# THE MILLING MACHINE AND ITS OPERATION

## UNIT 45

### THE MILLING MACHINE

A milling machine is a type of machine in which the work is fed against a rotating cutter, which is mounted on the revolving spindle of the machine. The spindle speed may be varied to accommodate cutters of various sizes, kinds and shapes and for cutting various kinds of metal. When desired, a number of cutters may be mounted on the spindle arbor for the purpose of machining several surfaces at the same time. All milling machines except certain small hand millers are provided with both hand and automatic longitudinal and transverse (cross) feeds. The table of most modern milling machines can be adjusted for height and some are equipped with an automatic vertical feed. Most standard machines are equipped with adjust-

able trip dogs which, when set at a particular position, automatically stop the feed at the end of the cut.

#### TYPES

There are many makes of milling machines on the market. Generally, these may be classified under two types: the vertical adjustable table type and the vertical adjustable spindle type. A further classification is: Plain, Fig. 206; Universal, Fig. 207; and Vertical, Fig. 208. Fig. 208A shows a vertical machine being used to mill a cam.

The plain type of milling machine is the one most commonly found in school shops and in most small commercial shops except where

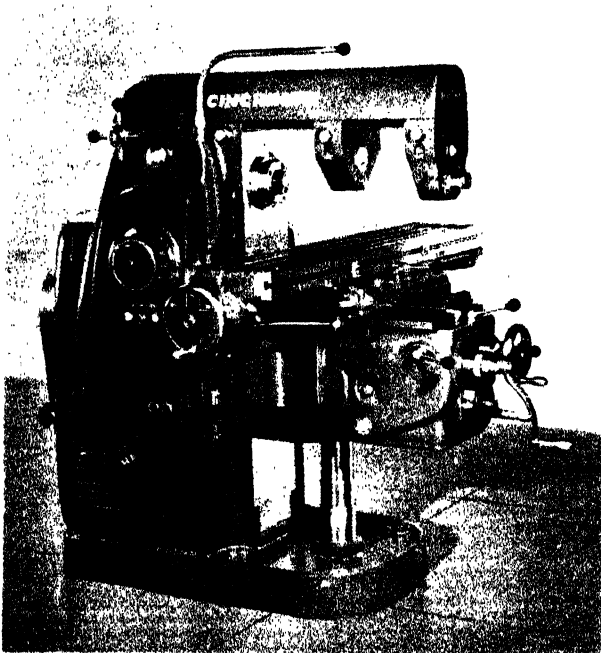

Courtesy, Cincinnati Milling Machine Co.  
FIG. 206. PLAIN MILLING MACHINE



Courtesy, Cincinnati Milling Machine Co.  
FIG. 207. UNIVERSAL MILLING MACHINE

some specialty is being produced, which involves some specialized operation which can be performed most advantageously on a particular type of machine, for example, the vertical spindle type, Fig. 209. Attachments, which are available and adaptable, greatly extend the range of work that can be done on a plain type of milling machine. These devices enable the experienced operator to perform on a plain milling machine many of the operations for which the universal vertical spindle milling machine is especially adapted.

The profiling machine is a special type of milling machine or, as illustrated in Fig. 210, a vertical milling machine with special attachments. Its special feature is the use of a template and tracer finger, by means of which the cutter may be guided so as to follow a particular outline or profile. The table, on which the template or master block is fastened, may be moved by power or by hand. By keeping the

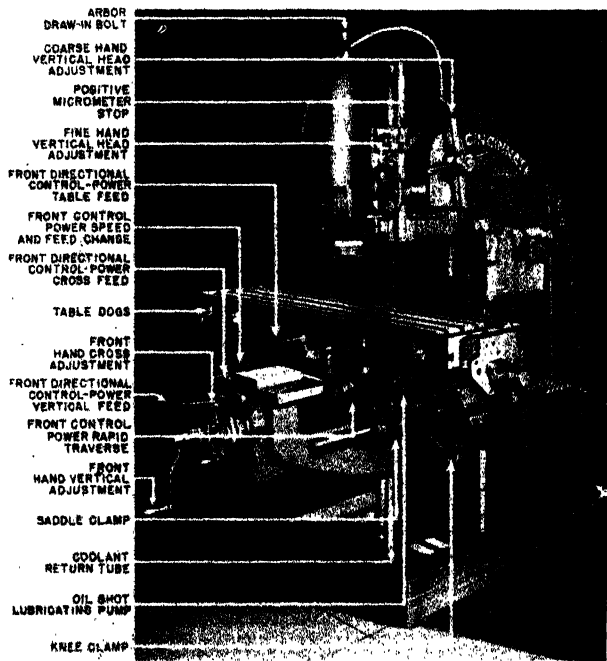

Courtesy, Cincinnati Milling Machine Co.  
 FIG. 208. VERTICAL MILLING MACHINE



Courtesy, Cincinnati Milling Machine Co.  
 FIG. 209. VERTICAL SPINDLE MILLING MACHINE

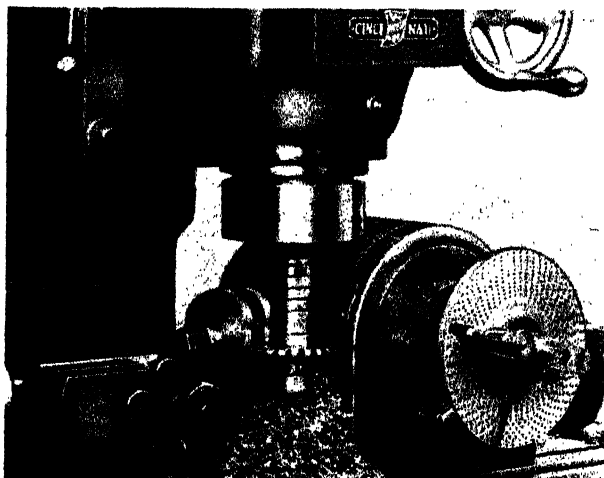

Courtesy, Cincinnati Milling Machine Co.  
 FIG. 208-A. MILLING A CAM

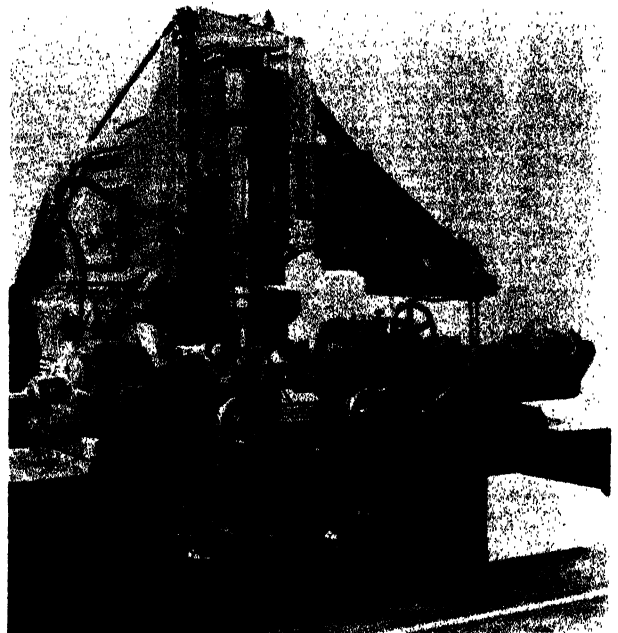

Courtesy, Cincinnati Milling Machine Co.  
 FIG. 210. VERTICAL MILLING MACHINE WITH PROFILING ATTACHMENT

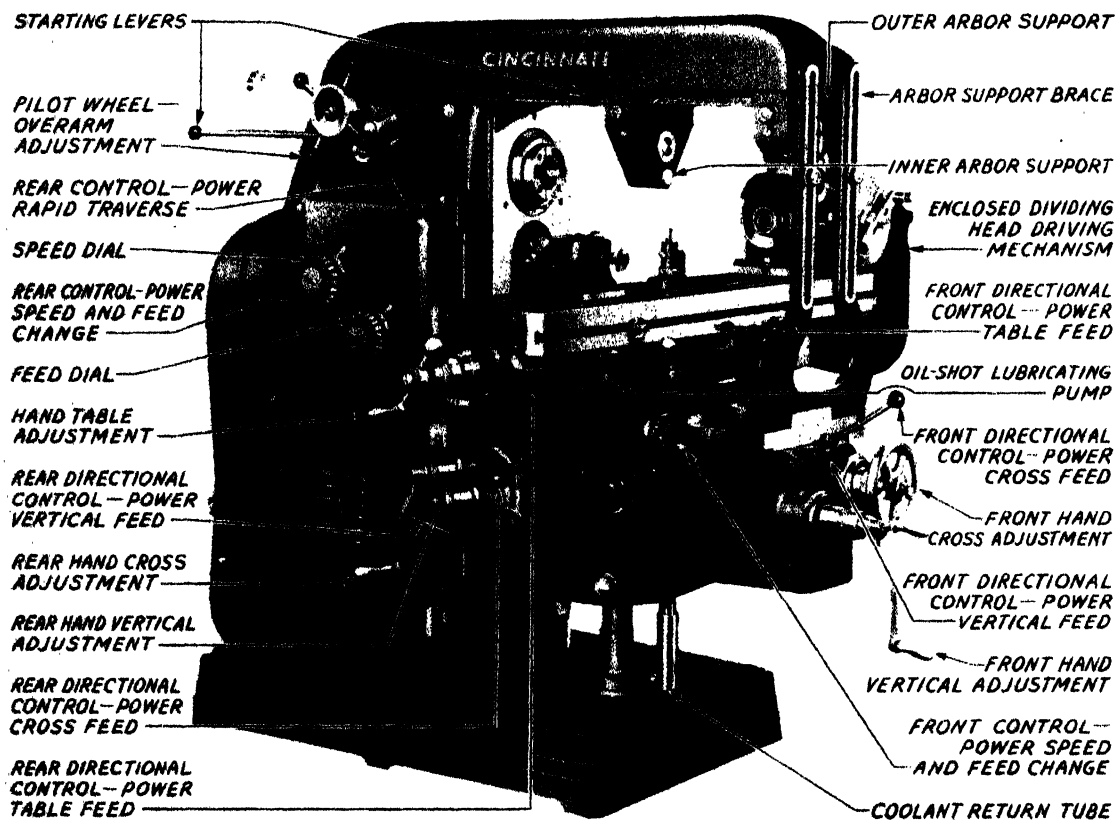

FIG. 211. PARTS OF A UNIVERSAL MILLING MACHINE

Courtesy, Cincinnati Milling Machine Co.

tracer finger constantly against the template or master, as shown at the right, Fig. 210, work corresponding to the profile of the template or master is produced.

#### PARTS

As can be seen from Fig. 211, the milling machine has many parts, the names and functions of which can be learned by observing the illustration and reading the accompanying descriptions.

#### SPEED

Most modern standard milling machines have constant speed drive. Change in cutting speed is accomplished through sets of gears mounted in what is commonly called a gear box. By operating the speed change levers at the front or side of the machine, Fig. 211, the position of the quick change gears may be altered (one set thrown out of gear and another set brought into operation) with a resulting change in the

speed at which the spindle rotates and a consequent change in cutting speed. Ordinarily, on modern standard machines, sixteen different speeds may be obtained by appropriately manipulating the speed change lever. Machines designed to operate at high speeds have an even wider range of speeds. On the newer types, speed and feed changes can be made from either the front or side of the machine. On the older type of milling machine, two series of four changes are provided through sliding gears and the back gears mounted in the gear case; also two series of four through sliding gears and the clutch.

#### FEED

Change in the rate of feed is accomplished through a series of change gears which are mounted in the feed-change gear box and operated by a lever at the front or side of the machine, Fig. 211. Change in the direction of

feed is accomplished by means of a reversing lever at the front of the machine.

Longitudinal, cross and vertical feeds are operated by levers at the front of the machine. These engage or disengage respective clutches with the driving mechanism.

Some milling machines are equipped with an automatic rapid power traverse. On machines so equipped the table moves forward rapidly until the cutter engages the work, then the feed motion slows down to the feed desired for a particular cutting speed. At the end of the cut the table moves back rapidly to the starting point, where the direction of travel is reversed and the table again moves rapidly forward. Machines equipped with rapid power traverse ordinarily can be adjusted to move rapidly toward or away from the work either to the right or left, up or down, toward or away from the column.

#### METHODS OF HOLDING WORK

There are many ways in which work may be held while it is being machined on the milling machine. The most common of these are by means of (1) a special jig which accurately locates the work in position for machining and at the same time holds it securely in position by means of clamping bolts, studs and screws, Fig. 212; (2) fastening the work securely to an angle plate with clamps or bolts; (3) a plain vise which is bolted to the table of the machine; (4) a universal vise, which may be revolved at any angle desired through a horizontal plane, or which, by means of a hinged knee, may be

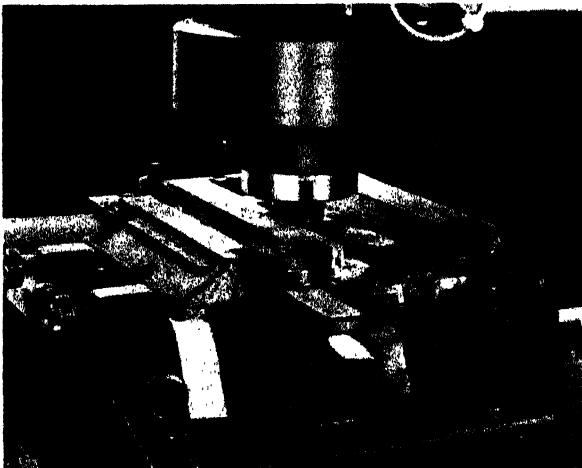

*Courtesy, Cincinnati Milling Machine Co.*  
FIG. 212. MILLING WORK HELD IN A SPECIAL JIG

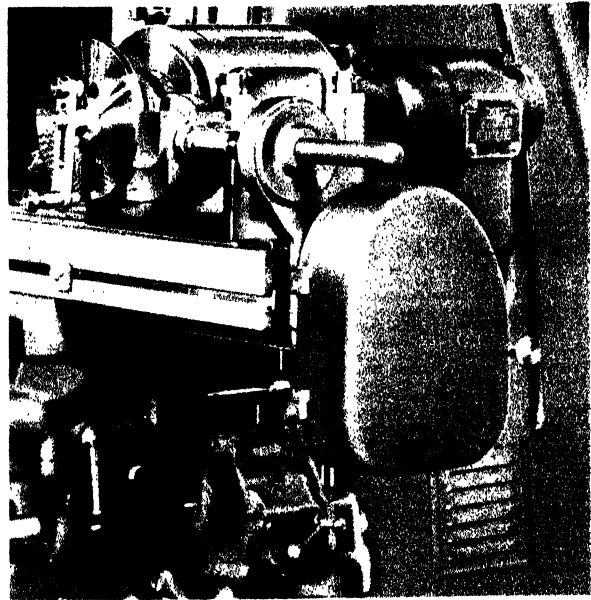

*Courtesy, Cincinnati Milling Machine Co.*  
FIG. 213. ENCLOSED DRIVING MECHANISM

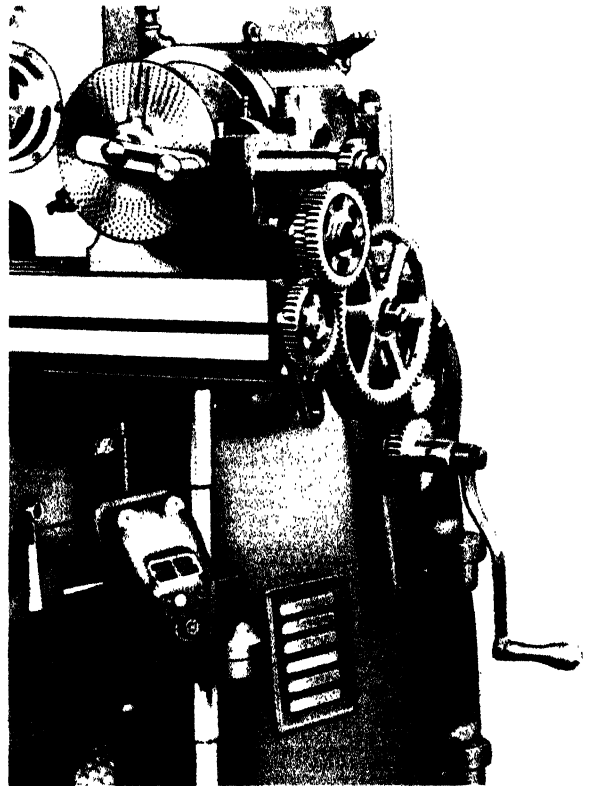

*Courtesy, Cincinnati Milling Machine Co.*  
FIG. 214. OPEN DRIVING MECHANISM

tilted and held stationary at any angle from the horizontal to the vertical; (5) supported between the centers of the dividing head; (6) the



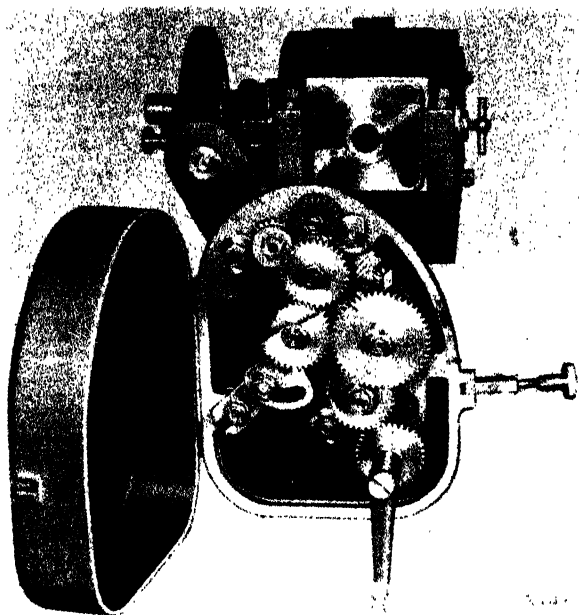

Courtesy, Cincinnati Milling Machine Co.  
FIG. 215. CHANGE GEARS

work held in a chuck which screws onto the spindle of the dividing head. Fig. 220 shows a chuck.

### SPIRAL MILLING

For milling spirals, a mechanism must be employed which will cause the stock on which the spiral is to be milled to rotate at a constant rate as the cut advances. Such a mechanism is an integral part of a universal milling machine. Two forms of driving mechanism which can be attached to a plain milling machine are shown in Figs. 213 and 214, enclosed and open types, respectively. Because of safety requirements, modern machines are being equipped with the enclosed type. Differences in speed of rotation are accomplished through interchanging the change gears at the rear end of the dividing head, Fig. 215.

A standard universal milling machine is equipped with a dividing head driving mechanism with a lead of  $2\frac{1}{2}$  to 100 inches. Lead refers to the distance the cutter travels in a longitudinal spiral along the face of the work in the course of one complete revolution of the work about its axis. Leads from  $\frac{1}{4}$  of an inch to 100 inches can be achieved by the introduction of special change gears or, as in some cases, an auxiliary reducing gear bracket.

## UNIT 46

### MILLING MACHINE ATTACHMENTS

In addition to the attachments which are furnished with a milling machine as standard equipment, many special devices are available, the use of which greatly extends the range of work that can be done conveniently and effectively on a plain, a universal or a vertical milling machine. Some attachments, for example, a universal vise, quick change adapters and a universal dividing head, make setting up of work a simple process, or, by use of adapters, enable the operator to change from one type of operation to another in a few seconds.

#### VICES

Three types of vises are available: plain, Fig. 216A; swivel, Fig. 216B; and universal, Fig. 216C. Plain vises may be bolted to the table of the milling machine in the position shown in the illustration, they may be turned so that the faces of the jaws are parallel with the face of the column, or they may be bolted with the jaws at some desired angle to the face of the column. Swivel vises generally resemble the plain type,

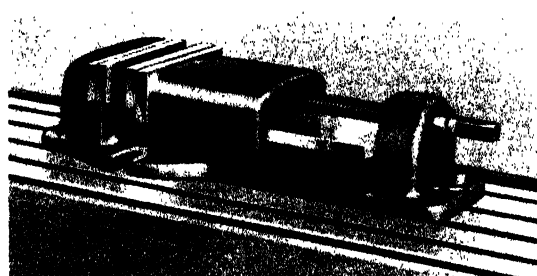

Courtesy, Cincinnati Milling Machine Co.  
FIG. 216-A. PLAIN VISE

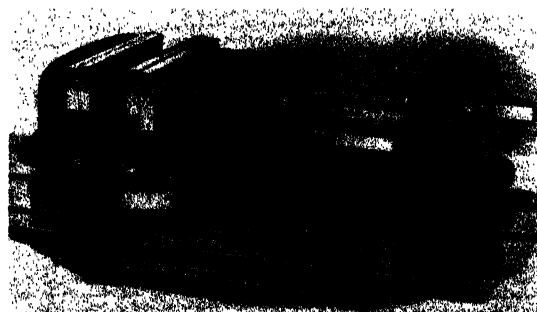

Courtesy, Cincinnati Milling Machine Co.  
FIG. 216-B. SWIVEL VISE

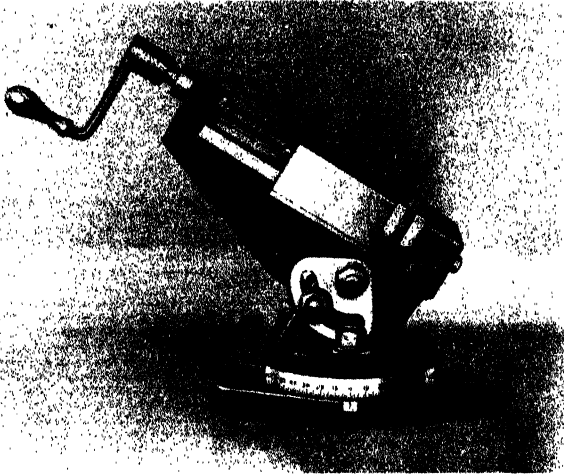

Courtesy, Cincinnati Milling Machine Co.  
FIG. 216-C. UNIVERSAL VISE

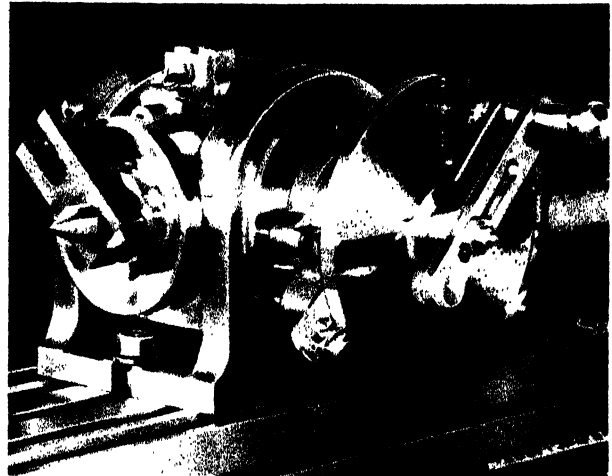

Courtesy, Cincinnati Milling Machine Co.  
FIG. 219. DIVIDING HEAD

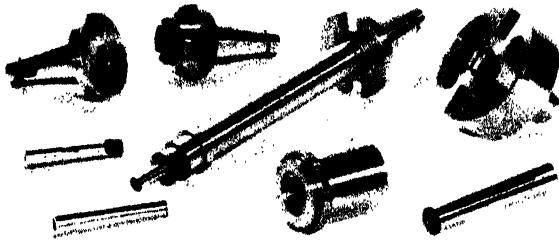

Courtesy, Cincinnati Milling Machine Co.  
FIG. 217. ARBORS, COLLETS AND ADAPTERS

that is to be machined at a double angle. They are mounted on swivel bases that can be moved through  $360^\circ$  in a horizontal plane. Vertically, they can be swiveled through  $90^\circ$ . Universal vises are particularly adapted for holding small work on which work is to be done at various points and at different angles.



Courtesy, Cincinnati Milling Machine Co.  
FIG. 218. CHANGING ADAPTER AND TOOL

but can be swung, on a graduated base, at any angle desired in a horizontal plane. Universal vises are particularly adapted for holding work

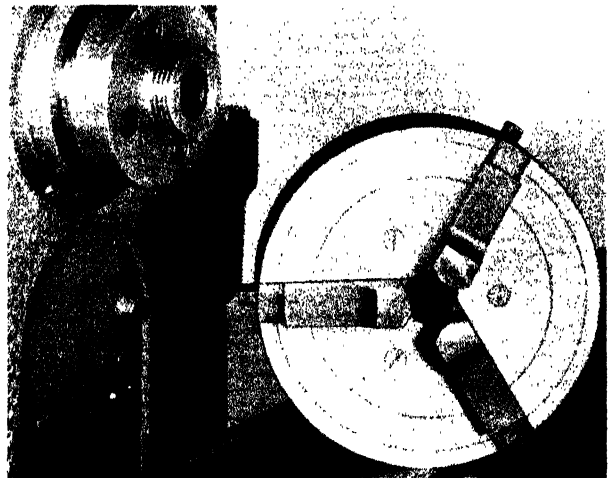

Courtesy, Cincinnati Milling Machine Co.  
FIG. 220. CHUCK

#### ARBORS, COLLETS AND ADAPTERS

These devices, Fig. 217, if carefully selected, enable the operator of the machine to use a wide range of sizes and shapes of standard and special cutters. Furthermore, they make it possible to change quickly from one type of operation to another without having to reset the work, Fig. 218.

**DIVIDING HEAD**

This device, Fig. 219, is frequently called an indexing head. It is designed principally for holding work between centers; however, a chuck, Fig. 220, which screws onto the nose of the head spindle, further extends its usefulness and adaptability.

**VERTICAL MILLING ATTACHMENT**

This attachment, Fig. 221, when mounted on the spindle of a plain or universal miller, enables the operator to perform work on one of

these machines that ordinarily requires the services of a vertical miller.

**HIGH SPEED ATTACHMENT**

This piece of apparatus, Fig. 222, is particularly advantageous for machining work where small cutters running at high speed can be used. The attachment illustrated can be used on a plain or universal miller. It is mounted on a

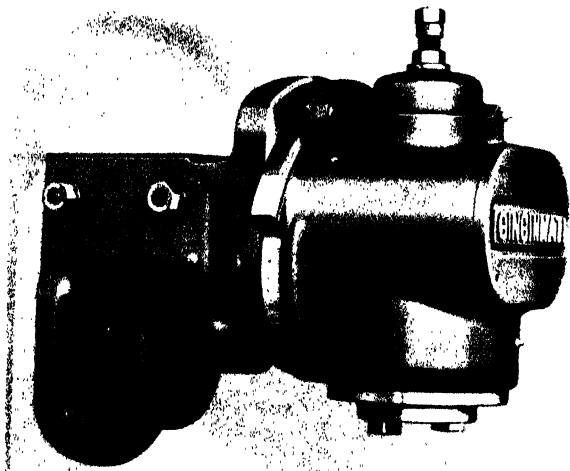

*Courtesy, Cincinnati Milling Machine Co.*  
**FIG. 221. VERTICAL MILLING ATTACHMENT**

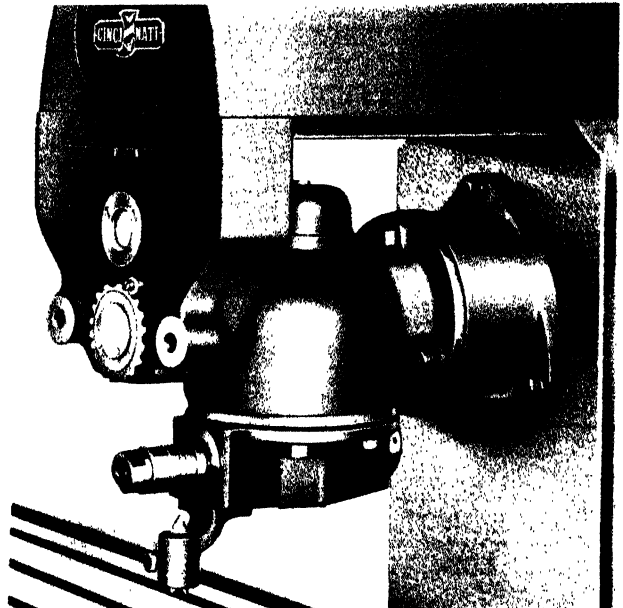

*Courtesy, Cincinnati Milling Machine Co.*  
**FIG. 223. UNIVERSAL SPIRAL ATTACHMENT**

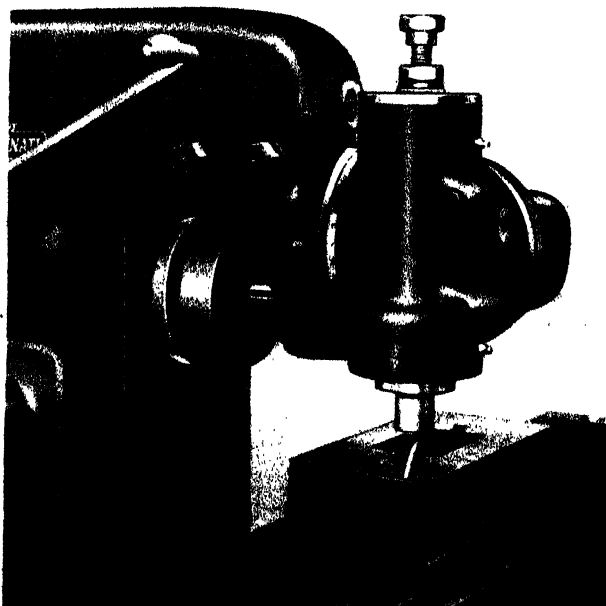

*Courtesy, Cincinnati Milling Machine Co.*  
**FIG. 222. HIGH SPEED ATTACHMENT**

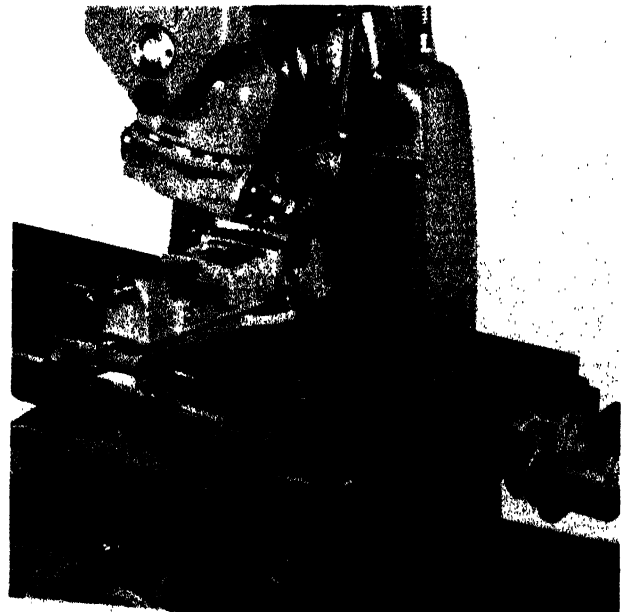

*Courtesy, Cincinnati Milling Machine Co.*  
**FIG. 223-A. USING A UNIVERSAL SPIRAL ATTACHMENT TO MILL RACK TEETH**



Courtesy, Cincinnati Milling Machine Co.  
FIG. 224. SLOTTING ATTACHMENT

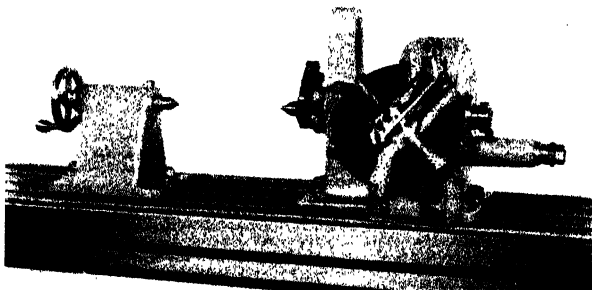

Courtesy, Cincinnati Milling Machine Co.  
FIG. 225. GEAR CUTTING ATTACHMENT

graduated swivel base which permits the cutter to be set at any angle desired in a plane parallel with the face of the column.

#### UNIVERSAL SPIRAL ATTACHMENT

This device, Fig. 223, is particularly useful when milling spirals, as the cutter can be set to mill in a horizontal, vertical or angular plane.

Fig. 223A shows a spiral milling attachment being used to mill teeth in a rack.

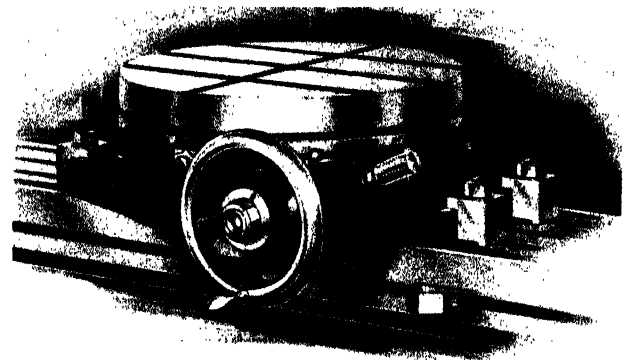

Courtesy, Cincinnati Milling Machine Co.  
FIG. 226. CIRCULAR MILLING ATTACHMENT, HAND FEED ONLY

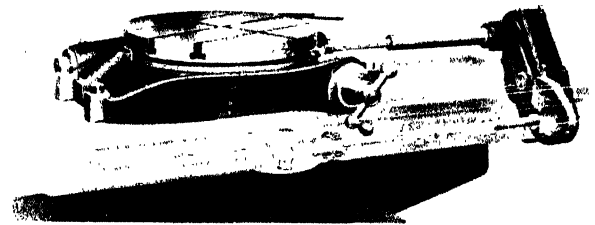

Courtesy, Cincinnati Milling Machine Co.  
FIG. 227. CIRCULAR MILLING ATTACHMENT WITH POWER FEED



Courtesy, Cincinnati Milling Machine Co.  
FIG. 227-A. CIRCULAR MILLING ATTACHMENT

#### SLOTTING ATTACHMENT

Although a special machine is designed for this operation, such a machine frequently is not available in school or small commercial shops; consequently the machinist must devise some other means of cutting slots. The attachment illustrated in Fig. 224, when mounted on the spindle of a milling machine, will perform many slotting operations efficiently. The tool slide can be swiveled at any angle through  $360^\circ$ , thus slotting can be done at any angle.

**GEAR CUTTING ATTACHMENT**

With this attachment, Fig. 225, teeth may be spaced quickly and accurately, and cut on spur and bevel gears. In combination with the universal spiral attachment, Fig. 223, teeth may be spaced and cut on helical gears and worm gears.

**CIRCULAR MILLING ATTACHMENT**

This piece of apparatus, Figs. 226 and 227, enables the operator to perform work on a plain milling machine which ordinarily requires the services of a miller with a rotary table. Fig. 227A shows a circular milling attachment equipped with an indexing unit.

**UNIT 47****MILLING CUTTERS AND HOLDERS**

Standard milling cutters are made in many shapes and sizes. A variety of cutters designed for specific purposes may also be had, as for example, a cutter for milling a particular kind of curve or combination of curves on the edges or some intermediate part of a piece of stock. However, a capable and resourceful operator, using a standard cutter, can perform economically and effectively many of the operations for which special cutters are designed. Cutters generally take their names from the operation which they perform. Those commonly recognized are: (1) plain milling cutters of various widths and diameters, used principally for milling plain flat surfaces; (2) angular milling cutters, designed for milling reamers, taps and cutters; (3) face millers, used for milling flat surfaces at right angles to the axis of the cutter; (4) forming cutters, used for the production of surface with some form of irregular outline. For milling aluminum, cutters especially designed for that purpose are recommended.

**TEETH**

Generally cutters are made with three types of teeth: saw, formed and inserted. The saw tooth is found on end mills, slitting cutters, and on small plain milling cutters. The front of the saw tooth type is parallel with a line drawn from the point of the tooth through the axis. The top of the tooth is given a slight clearance of 3 to 5 degrees.

The formed tooth cutter is used for cutting an irregular outline, for example, the teeth on gears. This type of cutter is machined to shape and the stock at the rear of the cutting edge backed off slightly to provide clearance. The cutter is then hardened and tempered, after

which it is sharpened by grinding the front, or face, of each tooth radially. A formed tooth cutter cannot be used to make undercuts, that is, to mill an arc of more than 180 degrees. Formed cutters are used frequently in combination with cutters designed for plain or angular milling.

The teeth of the inserted tooth type of cutter are made of high speed steel. They are inserted in a cast iron or mild steel blank which has been turned to size. This is a very economical type of cutter, first, because the body is made of an inexpensive material and second, because the teeth when they become worn are easily replaced. Some cutters of this type have heat treated alloy steel bodies. Cutters with such bodies are more expensive but they have a longer life period and retain greater accuracy.

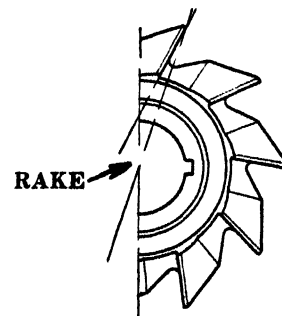

Courtesy, Cincinnati Milling Machine Co.

FIG. 228. MILLING CUTTER WITH RAKED TEETH

The teeth on some milling cutters are made with a rake, Fig. 228. When sharpening a raked tooth, care should be taken to maintain approximately the same amount of rake, except that the angle of rake should be very *slightly decreased* with subsequent grindings. This is done to avoid weakening the teeth at the base. Giving a tooth rake increases the angle of keenness,

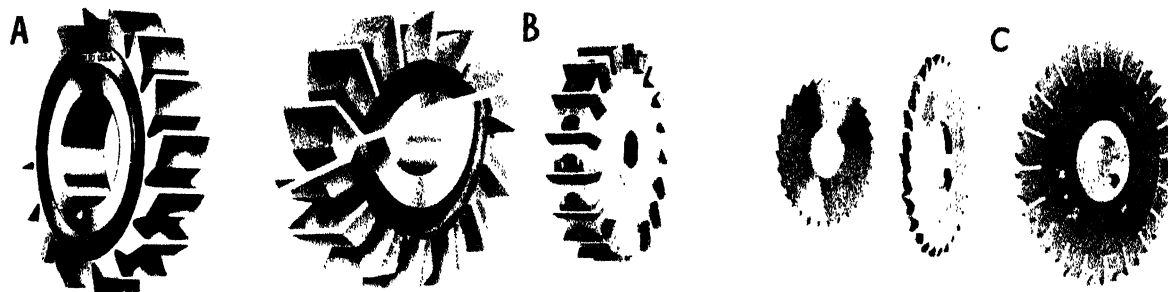

FIG. 229. MILLING CUTTERS

*Courtesy, Cincinnati Milling Machine Co.*

which is an advantage in performing certain operations and cutting certain metals and alloys.

**PLAIN MILLING CUTTERS**

This is the most common form of milling cutter, A, Fig. 229. It is cylindrical and has teeth cut or inserted in the periphery (front). When plain milling cutters are over  $\frac{1}{4}$  of an inch wide on the face, the teeth are cut on a spiral or inserted at an angle. The advantages of this are: (1) a shearing cut is produced; (2)

less power is required to operate when starting the cut; (3) the tendency to chatter is reduced; (4) a smoother finish is produced. The teeth of very wide cutters frequently are notched at intervals. This breaks up the chip and makes it possible to use a coarser feed.

**SIDE MILLING CUTTERS**

These cutters, B, Fig. 229, are similar to plain milling cutters except that the teeth have cutting edges on each side as well as on the periphery.

**SLITTING CUTTERS**

These are thin cutters, resembling an ordinary circular saw, C, Fig. 229. As the name implies, they are used for cutting off or slitting metal and sometimes for cutting very narrow grooves. Slitting cutters are hollow ground,

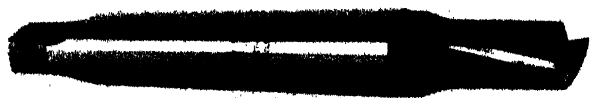
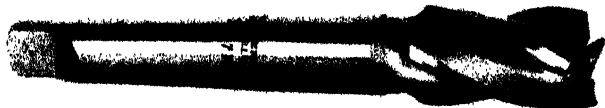

*Courtesy, Cincinnati Milling Machine Co.*  
FIG. 230-A. END MILLS

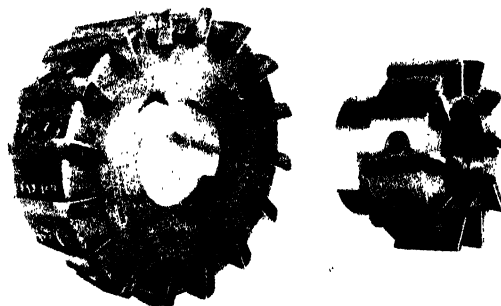

*Courtesy, Cincinnati Milling Machine Co.*  
FIG. 230-B. FACING CUTTER

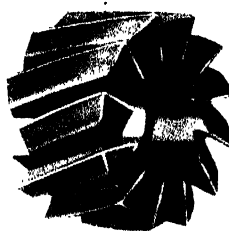

*Courtesy, Cincinnati Milling Machine Co.*  
FIG. 230-C. END SHELL MILL  
FIG. 230-D. T-SLOT CUTTER

made thinner toward the center, to provide clearance.

**4. END MILLS**

The most common form of end mill has a tapered shank which fits the tapered hole in the spindle, Fig. 230A. End mills have teeth both on the periphery and the end. They are made in many sizes and shapes. When end mills are over 2 inches in diameter they generally are made with standard removable shanks on which is milled a short tongue which engages the cutter and prevents it from revolving on the shank. End mills are used to perform a wide variety of work, for example, cutting shoulders, keyways, slots and for making certain facing cuts.

**5. FACING CUTTER**

This is a special form of end mill and is designed for mounting on the nose of the spindle, Fig. 230B. This form of tool, because of its proximity to the spindle bearing, is admirably suited for work requiring a high degree of accuracy. Fig. 230C is an end shell mill.

**6. T-SLOT CUTTER**

This is an end mill designed especially for cutting T-slots, Fig. 230D. To provide clearance, every other tooth on a T-slot cutter is machined off on alternate sides.

**7. KEY SEAT CUTTERS**

These cutters are especially designed for cutting keyways for Woodruff keys, A, Fig. 231. B, Fig. 231, is a keyway cutter designed for mounting on an arbor. Both types can be had in a number of standard sizes.

**8. FORMED CUTTERS**

These may be had in great variety, for example, with teeth ground at a single or double angle, convex or concave, Fig. 232. Formed cutters are used for cutting teeth on gears, reamers and taps and for shaping stock. Formed cutters for specific jobs can be had on

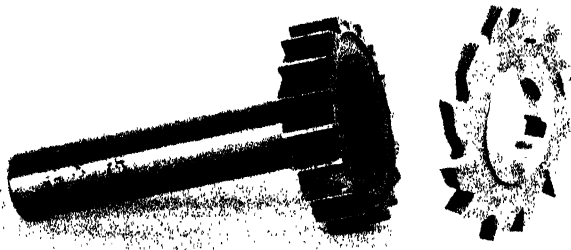
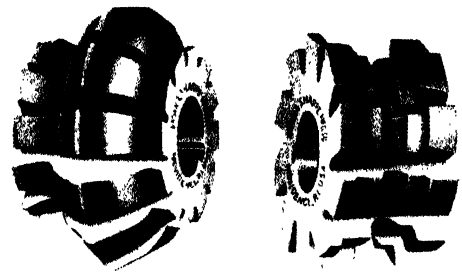

Courtesy, Cincinnati Milling Machine Co.  
FIG. 231. KEY SEAT CUTTERS

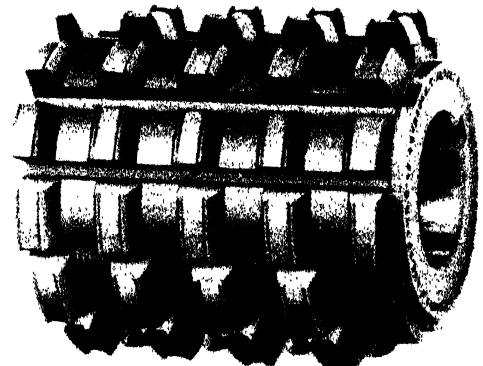

Courtesy, Cincinnati Milling Machine Co.  
FIG. 233. SPECIAL FORMED CUTTERS

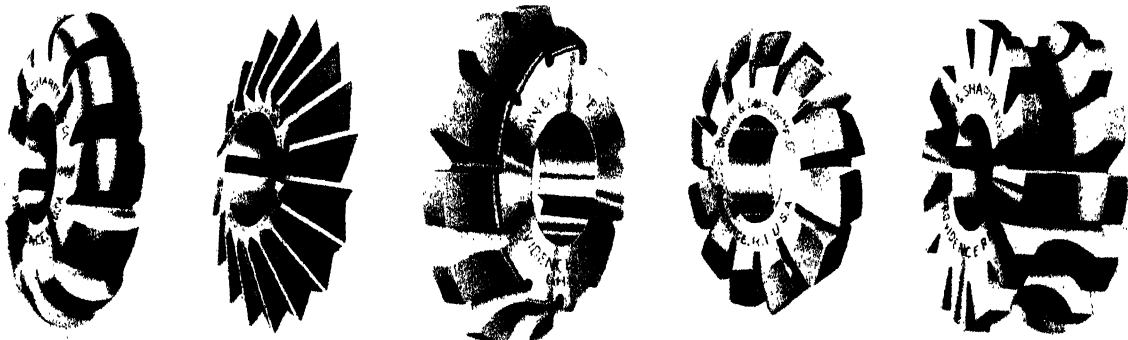
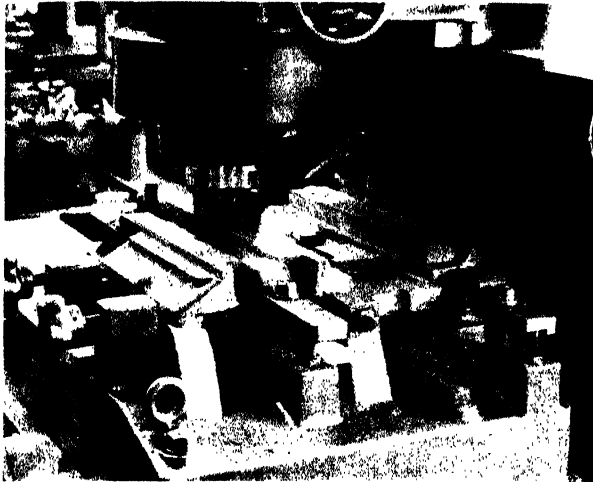
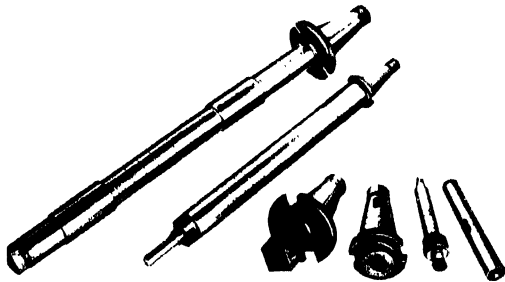

FIG. 232. STANDARD FORMED CUTTERS

Courtesy, Cincinnati Milling Machine Co.



Courtesy, Cincinnati Milling Machine Co.  
FIG. 234. CUTTER MOUNTED ON NOSE OF SPINDLE



Courtesy, Cincinnati Milling Machine Co.  
FIG. 235. MILLING ARBORS, COLLETS AND ADAPTERS

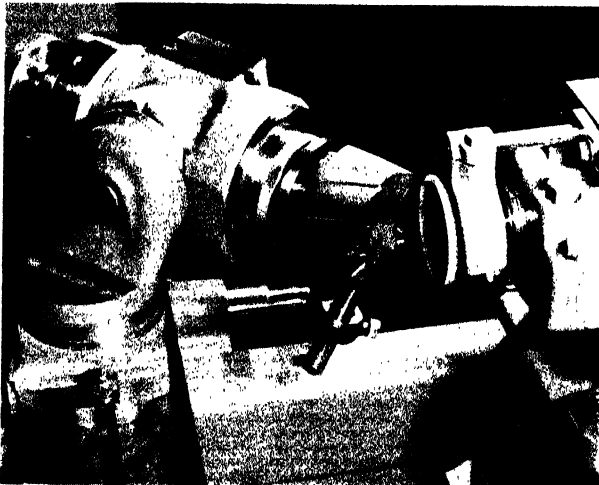

Courtesy, Cincinnati Milling Machine Co.  
FIG. 236. SHARPENING SAW TOOTH MILL

order from manufacturers of milling cutters. Fig. 233 shows some typical formed cutters.

#### MEANS OF HOLDING CUTTERS

Four means of holding milling cutters are generally employed: (1) by mounting them

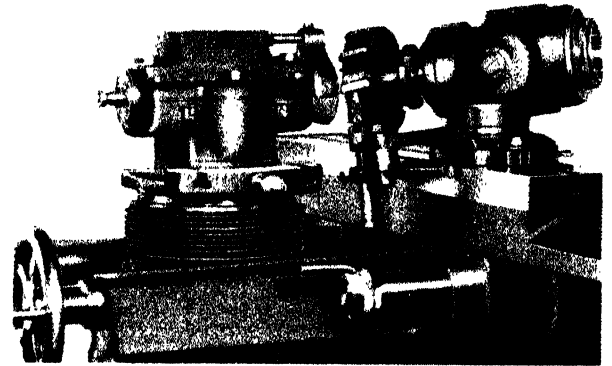

Courtesy, Cincinnati Milling Machine Co.  
FIG. 237. SHARPENING FACE OF TEETH OF SHELL END MILL

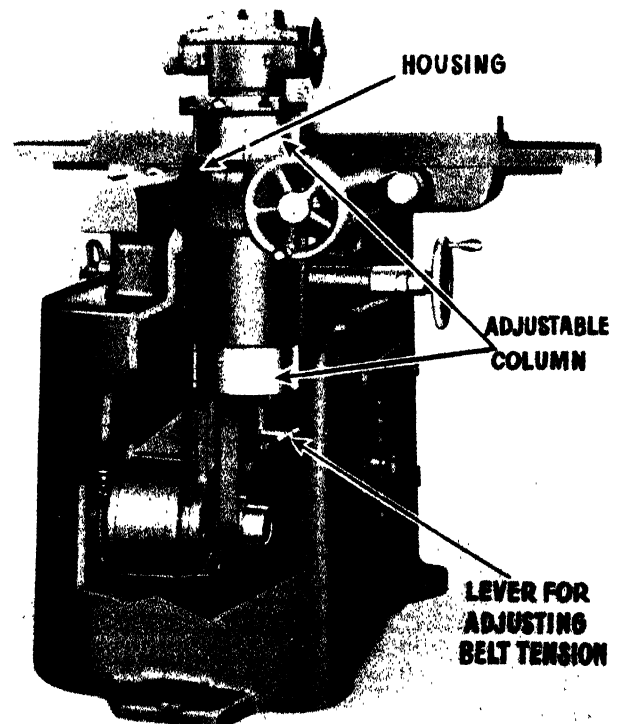

Courtesy, Cincinnati Milling Machine Co.  
FIG. 239. GRINDER FOR MILLING CUTTERS

on the nose of the spindle, Fig. 234; (2) by means of a shank inserted in the spindle hole; (3) by means of collets and adapters; (4) by mounting them on a milling arbor, Fig. 235.

#### SHARPENING CUTTERS

The teeth of milling cutters should be kept sharp for optimum (justifiable) production and wear. Cutters with saw or inserted teeth are sharpened by grinding away a little of the land on the periphery of the tooth at the rear of the cutting edge. (See Figs. 236, 237 and



238.) When performing this operation, take care to maintain the proper clearance. A clear-

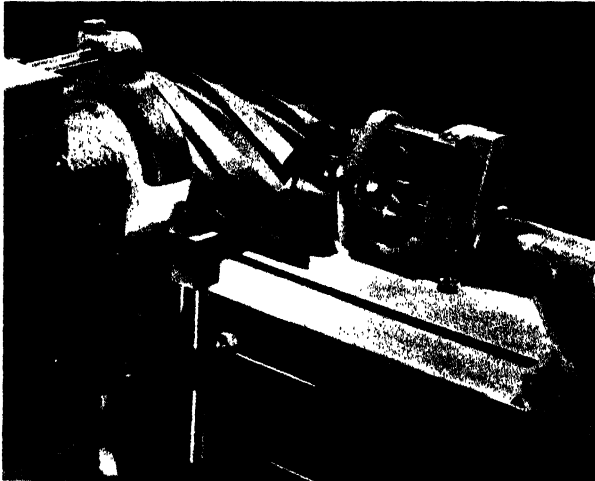

Courtesy, Cincinnati Milling Machine Co.

FIG. 238. SHARPENING SPIRAL MILL

ance of 6 to 7 degrees is recommended for cutters under 3 inches in diameter and of 5 degrees for those over 3 inches in diameter. End and side teeth are ground with less clearance, approximately 2 degrees. Formed teeth are sharpened by grinding the front of each tooth radially, Fig. 243. If the tooth is ground other than radially (parallel with a line from the point of the tooth through the axis of the cutter) the ground tooth will not be the proper shape.

A grinder designed for grinding milling cutters is recommended, Fig. 239. Inexperienced persons should not attempt to grind cutters without competent instruction and supervision. Milling cutters are expensive and may be very easily damaged by inaccurate and improper grinding.

#### UNIT 48

### CALCULATING CUTTING SPEED ON A MILLING MACHINE AND DETERMINING RATE OF FEED AND THICKNESS OF CHIP

The cutting speed of a milling cutter is the speed in feet per minute that a given tooth on the circumference of the cutter moves forward. To find the cutting speed in feet per minute it is necessary to know the circumference of the cutter and the number of revolutions it makes per minute. Thus it can be seen that the smaller the cutter the faster it must revolve in order to cut at a given rate per minute. However, the size of a milling cutter is never given in terms of its circumference but rather in terms of its diameter. Hence, to find the circumference, one must multiply the diameter of the cutter by  $\pi$  or 3.1416.

Research and experience have shown that, when a carbon steel tool is used, the most effective cutting speeds for the following metals are:

Annealed tool steel	20 to 30 feet per minute
Mild steel . . .	30 to 40 feet per minute
Cast iron . . .	40 to 60 feet per minute
Brass . . . . .	80 feet per minute

When a cutter with teeth made of high speed steel is used, the above rates may be at least

doubled. The cutting speeds given above, or double those speeds when using high speed cutters, are regarded as standard. The cutting speed in feet per minute being known for a particular metal, the problem then becomes one of determining how many revolutions per minute a cutter of a given size must revolve to produce the cutting speed desired. Assuming the problem to be the machining of a piece of annealed tool steel for which the standard cutting speed is 25 feet per minute, and that the diameter of the cutter is 4 inches, then,

$$\text{RPM} = \frac{\text{Cutting speed in feet} \times 12}{\pi \times \text{diameter of cutter in inches}}$$

$$\frac{\text{CS} \times 12}{3.1416 \times D} = \frac{\text{CS}}{.2618 \text{ approx.}}$$

The value .2618, or approximately .26, obtained by dividing 3.1416 by 12 is a constant by which the diameter of any cutter may be multiplied, thus simplifying the formula to

$$\text{RPM} = \frac{\text{CS}}{.26D}$$

Substituting the values given above,

$$\text{RPM} = \frac{25}{.26 \times 4} = \frac{25}{1.04} = 24.$$

Twenty-four, then, is the number of revolutions of a 4 inch cutter required to produce a cutting speed of 25 feet per minute. On modern milling machines the problem is simply one of adjusting the speed change lever or levers to the position nearest 24 on the speed index plate.

Always avoid excessive speed, as too much speed frequently causes the teeth of the cutter to become dull more quickly than would be the case if run at a lower speed.

#### RATE OF FEED

Feed is the amount that the work advances with each succeeding stroke of a given tooth on the cutter. The common practice is to speak of feed in terms of inches per revolution of the cutter. On most milling machines the correct feed for a given cutting speed is indicated on a plate attached to the machine near the speed and feed change levers.

Factors determining the rate of feed are the depth of cut, the width of cut, the diameter of the cutter, the number of teeth in the cutter, the speed at which the cutter revolves, the manner in which the cutter is held, the power of the machine, and the rigidity of the machine and of the work. Accuracy cannot be achieved if a heavy cut is taken on a machine lacking in rigidity or on work the nature of which makes it impracticable or in some instances virtually impossible to eliminate vibration.

When one has taken all of the above factors into account, the setting of the machine to feed at the rate desired is merely a matter of adjusting the feed change levers to the position desired as indicated on the feed index plate, for example, 1 inch per minute.

The normal rate of feed may be approximately doubled when a cutter having teeth of high speed steel is used, because the rate of cutting is doubled when cutters of this type are used.

Generally, at least two cuts will be required to finish work satisfactorily, a roughing cut and a finishing cut. In making these respective cuts the usual practice is to take a heavy roughing cut using as rapid feed as the cutter will

stand without overheating when a liberal amount of a suitable coolant is applied and without causing excessive vibration. The finishing cut is usually a light one, ordinarily about .005 of an inch, using a finer or slower feed.

#### DIRECTION OF FEED

Usually the work is fed in the opposite direction to the rotation of the cutter. The reasons for this are: (1) the tooth does not come into contact with the scale on the surface of the metal but rather breaks through from below; (2) the normal back lash in the feed screw is taken up in resisting the force of the cut, which prevents any tendency to gouge into the work. Cutting off stock and milling narrow deep slots are exceptions to this general practice.

#### THE CHIP

On a roughing cut the chip should be as heavy as the machine, cutter and work will stand without causing excessive vibration. A chip  $\frac{1}{4}$  of an inch thick is considered a very heavy chip. For the finishing cut a much lighter chip should be taken. *The feed should never be stopped before the cut is finished.* If the feed is stopped a slight groove will be milled into the surface of the work, Fig. 240; this can be removed only by taking another cut. The groove results from the fact that it is practically impossible to grind or mount a cutter on a milling machine so that it will run perfectly true. This means that some teeth on the cutter cut slightly deeper than others; this accounts for a groove being cut into the metal when the feed is stopped.

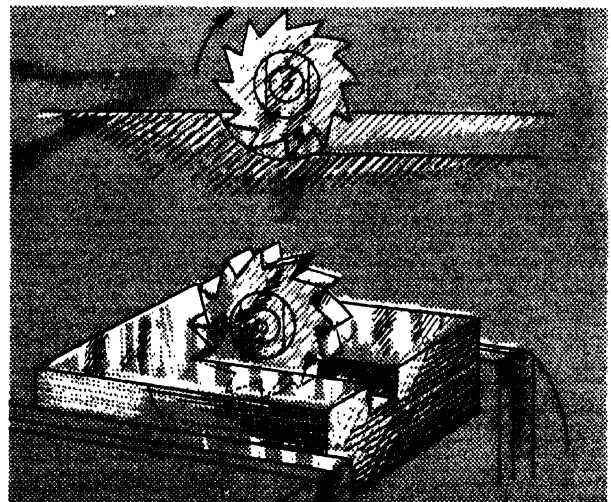

FIG. 240. FINISH THE CUT BEFORE STOPPING THE FEED

## UNIT 49

## HOW TO GRIND AND WHET MILLING CUTTERS

Saw tooth shaped milling cutters and plain milling cutters are sharpened by grinding away a little of the land back of the cutting edge on the periphery of the cutter. Formed milling cutters are sharpened by radially grinding the front of each tooth.

**PROCEDURE FOR GRINDING SAW TOOTH, PLAIN AND END MILLS**

1. Select a suitable grinding wheel and mount it securely on the arbor of the grinder.
2. Examine the wheel to make certain it is running true and that the face is straight and square with the side.
3. If necessary, secure a wheel dresser and true the wheel.
4. Protect the eyes against flying particles of the abrasive by using a shield or goggles.
5. Attach the tooth grinding rest to the frame of the grinder, A, Fig. 241. Set the top of the rest from  $\frac{3}{16}$  to  $\frac{1}{4}$  of an inch below the axis of the wheel, depending on the amount of clearance desired. For  $1^\circ$  or  $2^\circ$  set the rest about  $\frac{3}{16}$  of an inch below the axis and for  $5^\circ$  to  $6^\circ$  about  $\frac{1}{4}$  of an inch below.

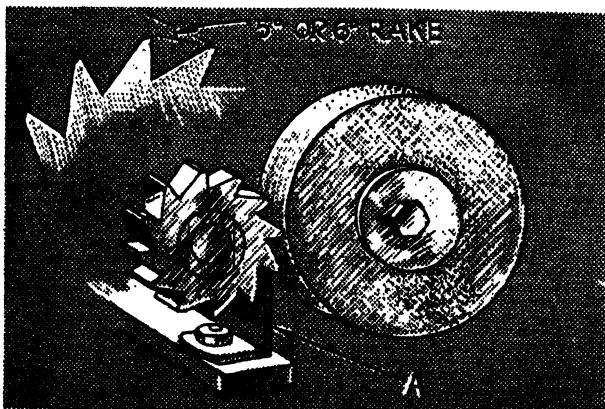
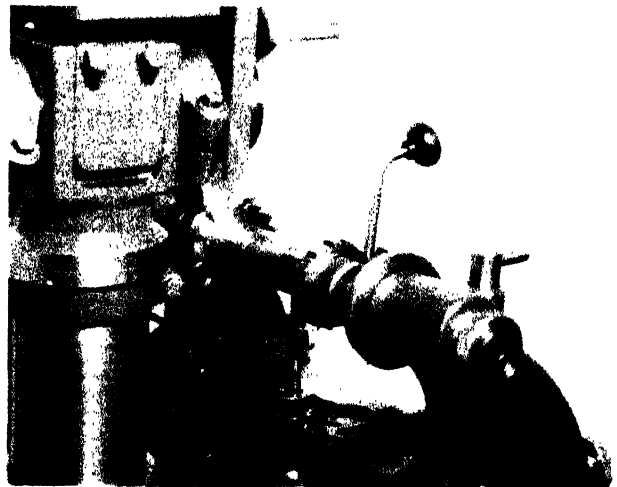

FIG. 241. TOOTH GRINDING REST IN POSITION

6. Carefully read the part of Unit 47 which deals with the sharpening of cutters.
7. Start the grinder, then place a tooth on the tooth rest, A, Fig. 241.
8. Raise the rear of the cutter and advance it until the land on the top of the tooth comes lightly into contact with the wheel

in such manner that the tooth will be ground with about  $5^\circ$  or  $6^\circ$  clearance. Do not change the position of the axis of the cutter with respect to the face of the grinding wheel until all teeth have been brought once into contact with the wheel, then, if further grinding is necessary, advance the cutter slightly toward the face of the wheel and continue grinding. If practicable, use a suitable coolant throughout the operation.

Greater uniformity and accuracy of tooth shape and clearance is achieved when the cutter can be mounted and ground on an arbor, as in Fig. 242.



*Courtesy, Cincinnati Milling Machine Co.*

FIG. 242. GRINDING A CUTTER MOUNTED ON AN ARBOR

**PROCEDURE FOR GRINDING MILLING CUTTERS WITH FORMED TEETH**

1. Select a suitable grinding wheel, usually a dish type.
2. Mount the wheel on the grinding arbor, Fig. 243. Be sure the wheel is running true and dress it if necessary.
3. Mount the cutter between the index centers.
4. Position the cutter with the front of the tooth parallel to the side of the wheel.
5. Adjust the dividing head for indexing the number of teeth on the cutter, Unit 56.
6. Start the machine and bring the wheel into contact with the tooth of the cutter.

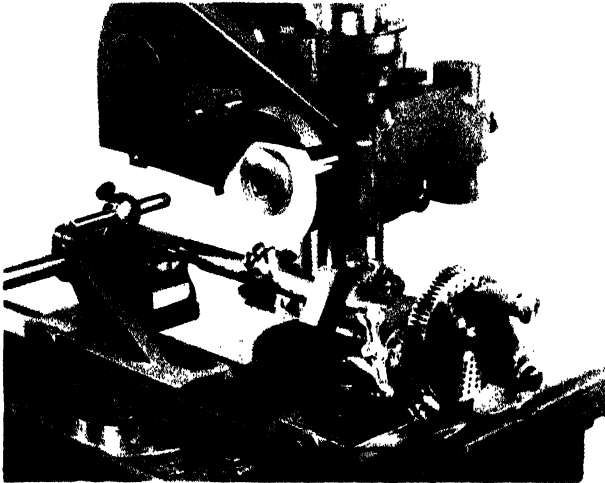

FIG. 243. GRINDING A CUTTER WITH FORMED TEETH

Continue grinding until there are no bright spots on the cutting edge.

7. Index for the next tooth and grind it.
8. Grind all teeth as in steps 6 and 7.
9. Remove the cutter and return equipment to the place where kept when not in use.

#### PROCEDURE FOR WHETTING MILLING MACHINE CUTTERS

1. Proceed as when whetting lathe cutters.

#### PROCEDURE FOR GRINDING SPIRAL MILL CUTTERS

Spiral mills should be mounted on an arbor held between centers. Otherwise, it is very difficult to achieve uniformity and accuracy of tooth shape and clearance.

1. Select a suitable grinding wheel and mount it securely on the arbor of the grinder.
2. Mount the cutter on a suitable arbor and place it between the centers of the grinder. Sometimes a grinding attachment which is mounted on a lathe is used for this type of tool grinding.
3. Advance the grinder or the work, as the case may be, until the mill is in position for grinding.

If the tailstock is equipped with a clearance setting dial, as in Fig. 244, adjust the dial for the degree of clearance desired; see graduations at the top of the dial.

4. Start the grinder and bring the mill into contact with the grinding wheel, with the cutting edge of the tooth slightly below the axis of the wheel.

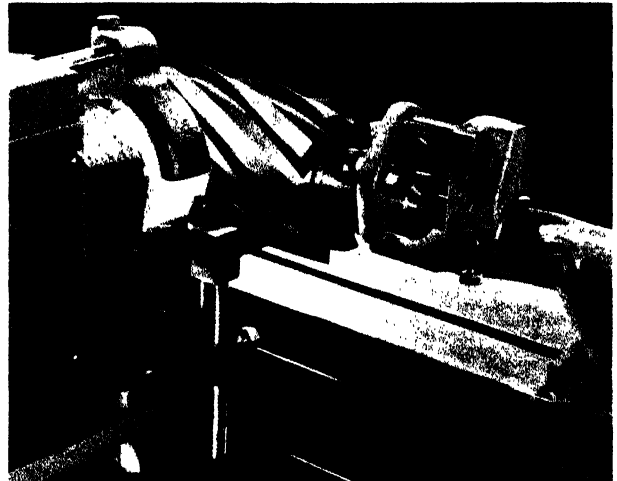

*Courtesy, Cincinnati Milling Machine Co.*

FIG. 244. TAILSTOCK EQUIPPED WITH A CLEARANCE SETTING DIAL

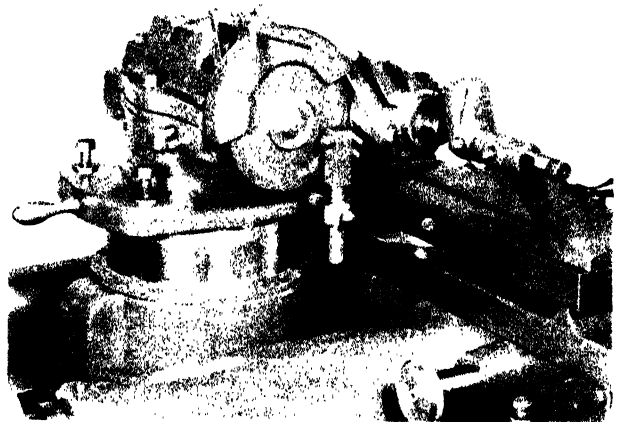

*Courtesy, Cincinnati Milling Machine Co.*

FIG. 245. GRINDING A SPIRAL MILL

5. Advance the mill slowly across the face of the wheel, Fig. 245, being sure to maintain the desired angle of clearance throughout the operation. Continue grinding until the wheel has passed across the length of the cutting edge. If practicable use a suitable coolant freely. Grind other teeth in a similar manner before advancing the cutter toward the wheel.
6. If necessary, adjust the machine for a second cut and proceed as in step 5. Continue until all teeth have been ground.

#### PROCEDURE FOR GRINDING CUTTERS WITH INSERTED TEETH

Milling cutters of this type may be ground as under Procedure, Grinding Saw Tooth, Plain

and End Mills; however, a more accurate job can be done with the grinder attachments illustrated in Figs. 246 and 247.

1. Select a suitable grinding wheel and mount it on the arbor of the grinder.
2. Examine the wheel to make certain that it is running true and that the face is straight and square with the side of the wheel.
3. Mount the cutter in or on the spindle of the headstock on the grinder, Fig. 246.
4. Move the headstock so that the work is in the correct position for grinding.
5. Tilt the headstock so that the tooth will be ground with the desired angle of clearance.

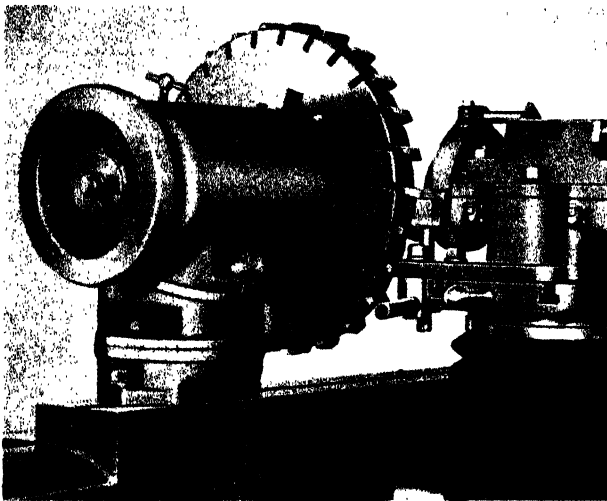

*Courtesy, Cincinnati Milling Machine Co.*

**FIG. 246. CUTTER MOUNTED ON GRINDER HEADSTOCK**

6. Start the machine and advance the mill against the grinding wheel. Continue grinding until the wheel has traveled completely across the cutting edge.
7. Grind remaining teeth in a similar manner, then if a second cut is necessary advance the cutter and proceed as in step 6. Continue as in steps 6 and 7 until a keen edge is produced on each tooth.

If the mill has teeth with more than one cutting edge, the side cutting edge may be ground as illustrated in Fig. 247. To perform this operation requires but a minor adjustment of the headstock.

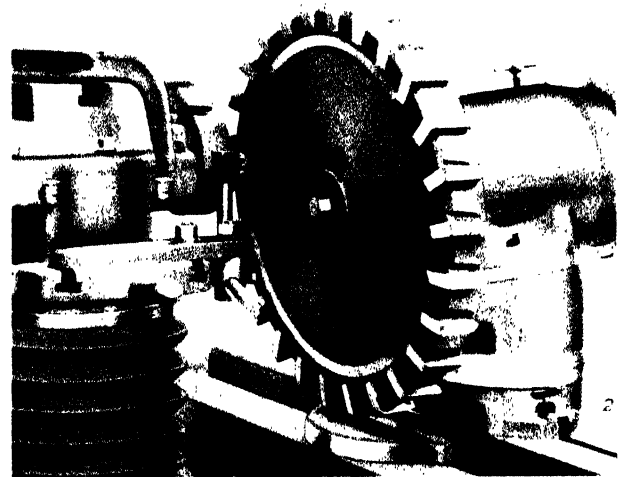

*Courtesy, Cincinnati Milling Machine Co.*

**FIG. 247. GRINDING THE SIDE CUTTING EDGE**

## UNIT 50

### HOW TO MILL A FLAT FACE OR SURFACE ON RECTANGULAR STOCK

Making a cut with a milling machine is a very simple matter after the machine has been properly set and the work accurately and securely fastened to the work table by means of a vise, clamping bolts or other suitable device. Skill in the operation of a milling machine is principally a matter of knowing how to adjust the machine to the correct cutting speed in feet per minute for the particular metal to be machined; how to determine the correct rate of feed per minute and set the machine accordingly; how to set up the work accurately, firmly

and securely on the table of the machine; how to select a suitable cutter; how to mount the cutter on the machine; and how to sharpen the cutter when necessary.

#### PROCEDURE FOR ROUGHING CUT

1. Secure the desired stock, Fig. 248, then with a file or grinder remove any burrs or other foreign projections.
2. Select a sharp cutter of suitable shape, diameter and width, preferably one not greater in diameter than necessary to make

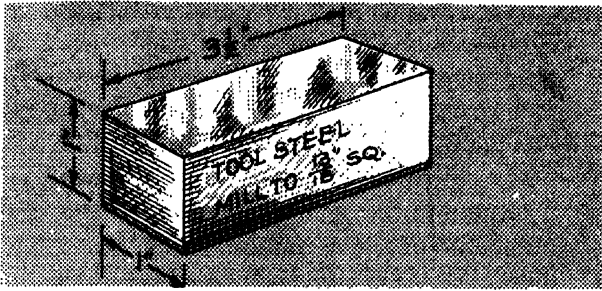
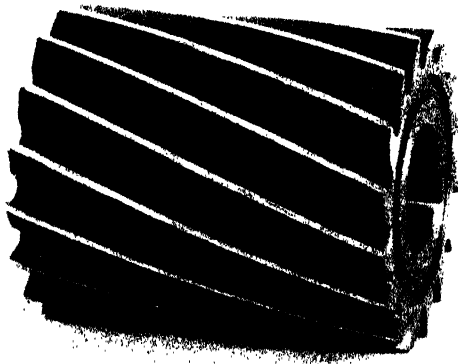

FIG. 248. LAYOUT FOR FLAT SURFACE MILLING



*Courtesy, Cincinnati Milling Machine Co.*

FIG. 249. CUTTER FOR MILLING A FLAT SURFACE

the cut and that will extend the width of the surface to be milled, Fig. 249. If the cutter is dull, ask your instructor to show you how to grind it. Never use a dull cutter because of danger of spoiling the work or permanently damaging the cutter.

3. Place a plain vise on the work table of the milling machine. Locate the vise near the rear of the table and as close to the column as the work and the necessary collars on the arbor will permit and still allow sufficient clearance, then partially tighten the bolts holding the vise on the table.

If necessary, slightly loosen the clamping screws on both the knee and saddle, but be sure to tighten them before starting the cut.

4. With a try square, align the stationary jaw of the vise with the machined face of the column, as in Fig. 250. Then tighten the clamping bolts.

A higher degree of accuracy may be achieved by placing a couple of test strips

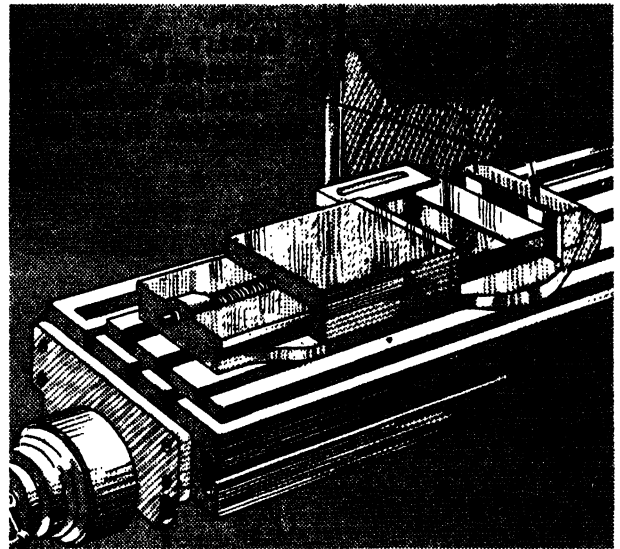

FIG. 250. VISE ALIGNED WITH MACHINED COLUMN

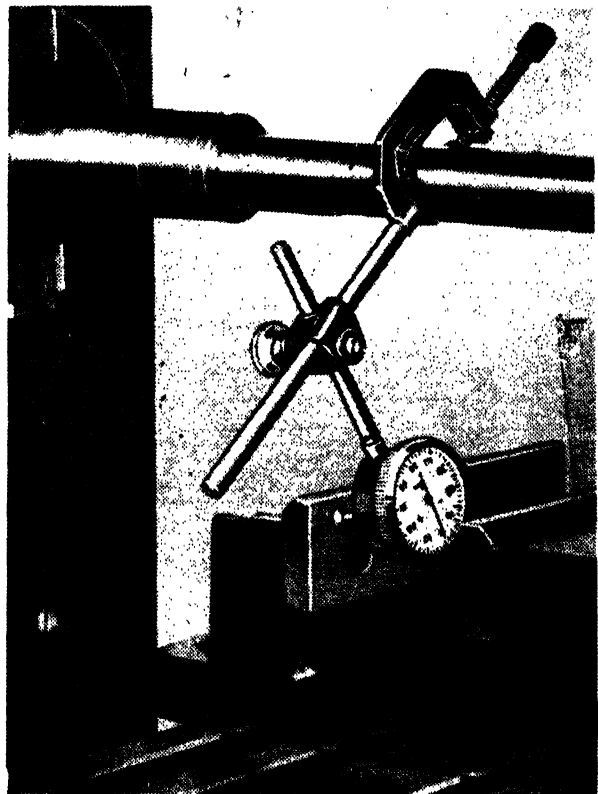

FIG. 251. TESTING SQUARENESS WITH DIAL INDICATOR

of tissue paper between the jaw of the vise and the blade of the square as shown in the illustration, and adjusting until both are held with equal firmness. When greater accuracy of setting is required, a dial indicator, Fig. 251, is used.

5. Select a pair of parallel bars of such width that the work when placed upon them will project above the jaws of the vise sufficiently to give at least  $\frac{1}{16}$  of an inch clearance when the cut is made.
6. With a whisk broom or duster, carefully remove all metal chips or dirt from the bottom and jaws of the vise and from the parallels.
7. Place the stock to be machined on the parallels, then with the crank, tighten the vise until it just grips the work. To seat the stock firmly on the parallels, strike it light blows near each end with a lead or copper hammer. Then draw the vise tight enough to hold the stock securely. If the stock is rough the jaws of the vise should be protected by placing pieces of heavy paper, copper or brass between the work and the jaws.

Long stock or large pieces may be clamped directly to the table of the miller with clamping straps and bolts, Fig. 252.

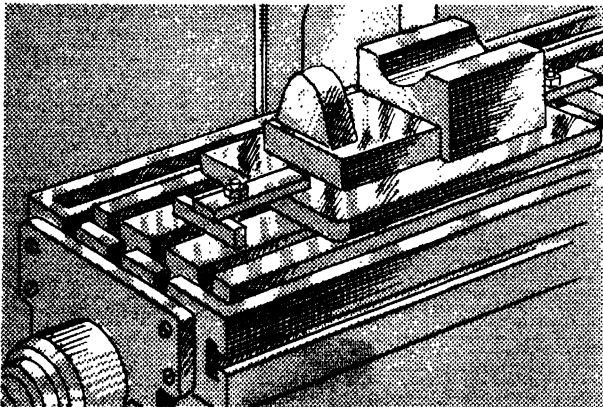

FIG. 252. STOCK FASTENED WITH CLAMPING STRAPS AND BOLTS

8. Select a suitable arbor and collars. When selecting an arbor choose one as short as the work and the necessary appurtenances will permit. A short arbor reduces vibration.
9. Carefully and thoroughly wipe the shank of the arbor with a piece of *clean dry waste*, then wrap a small wad of waste around the end of a bent scriber. Insert the waste in the shank hole of the spindle and give the scriber a few turns, thus removing chips or dirt from the recess.

10. Insert the arbor in the spindle and place one or more collars on the arbor, then the cutter, and finally, sufficient collars to fill the arbor just beyond the threaded part.

When placing the cutter be sure to turn it so that the cutting edges of the teeth are pointed in the same direction as the desired rotation of the spindle, Fig. 253.

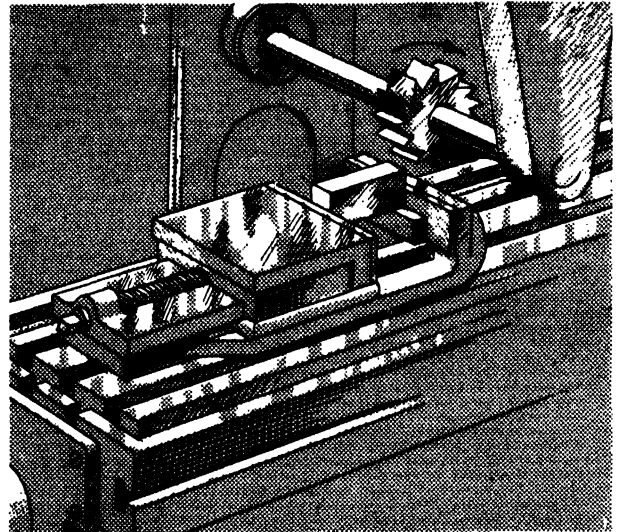

FIG. 253. CUTTING EDGES SHOULD POINT IN THE DIRECTION OF ROTATION

Milling machine spindles may rotate either clockwise or counterclockwise. Cutters should be placed on the arbor so that if the cutter slips on the arbor the arbor nut will be tightened. This means that the direction of rotation is determined by the kind of thread on the arbor, right or left hand. Some cutters and arbors are so made that the cutter can be keyed to the arbor. When this is the case the cutter may be rotated in either direction without danger of slipping.

11. Place the nut on the arbor and draw it tightly against the collar with the wrench.
12. Adjust the overarm and slide the arbor bearing over the end of the arbor, or insert the dead center into the arbor bearing and advance it until it fits into the center hole in the arbor, then fasten it in position.
13. Lock the overarm in position by tightening the clamping bolts, or with clamping lever if so equipped.

14. With the crank or wheel for making longitudinal adjustments, run the table back until the work is under the center of the cutter, Fig. 253.
15. With the vertical adjustment crank, raise the table until the work is about .01 of an inch away from the cutter.
16. With the longitudinal adjustment crank, draw the table back until it just clears the front of the cutter, then with the vertical adjustment, raise the table an amount equal to the desired depth of the cut plus .01 of an inch.

When there is much stock to be removed, it usually is necessary to take a rough and a finishing cut. When this is the case, the finishing cut should be much the lighter.

17. Determine the correct cutting speed for the metal to be machined, as for example, tool steel; see Unit 48.
18. By the speed index plate, set the speed control levers so as to produce the cutting speed desired.
19. Determine the correct feed for the work to be done. See Unit 48.

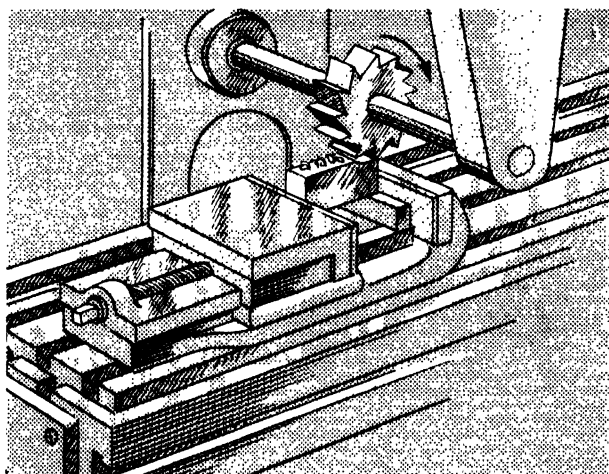

FIG. 254. MAKING THE ROUGHING CUT

20. Refer to the feed index plate, then set the feed control to produce the desired feed.
21. Start the machine; turn on the coolant, then, with the hand feed, advance the work until the cutter is just cutting its full depth, Fig. 254, then, if necessary, stop the machine, move the table until the work clears the cutter, and test the depth of the cut.

Note: Use a coolant freely with all milling operations.

22. Make adjustments if necessary, then again start the machine and *immediately engage* the longitudinal automatic feed.

**CAUTION:** Do not stop the feed while the cutter is revolving. To do so will cause an undercut or groove in the face of the work. This is because: (1) at least one tooth on every cutter, almost invariably, is longer than the others and as a result cuts deeper; (2) under normal cutting conditions the work, because of pressure exerted, has a tendency to spring away from the cutter slightly, when the feed is stopped the pressure is released, with the result that the teeth dig slightly deeper into the metal leaving a groove which can be removed only by taking another cut.

23. When the cut is completed, shut off the power and remove the work, unless a finishing cut is to be taken.

**CAUTION:** Always lower the table slightly or stop the machine before moving the work back under the revolving cutter.

24. When through using the machine, remove the cutter and arbor and clean them. Return parts to the place where they are kept when not in use, then with a brush remove all chips from the table and the machine.

#### PROCEDURE FOR FINISHING CUT

1. Set the machine in the usual manner for the depth of cut desired.
2. Proceed as in steps 21 to 24 inclusive.

### UNIT 51

## HOW TO SQUARE STOCK WITH A MILLING MACHINE

Sometimes it is necessary to machine a piece of rectangular stock to a specific thickness, width and length. The sequence of operations generally followed in performing this operation is given below. This may be varied, and often is, to meet particular conditions or occasions.

#### PROCEDURE FOR MACHINING ONE BROAD SURFACE

1. Prepare the stock and mount a *swivel vise*, if available, on the table of the miller, steps 1 to 7 inclusive, Unit 50.
2. Proceed as in steps 8 through 23, Unit 50.



#### PROCEDURE FOR MACHINING THE FIRST EDGE

1. Swing the vise through  $90^\circ$ , so that the jaws of the vise are parallel with the machined face of the column of the machine, Fig. 255. If necessary, test for alignment with parallel bars or other suitable means.
2. Lay a suitable parallel at the bottom of the vise, if needed, then place the machined surface against the stationary jaw, protecting it, if necessary, with pieces of heavy paper or sheets of copper or brass.

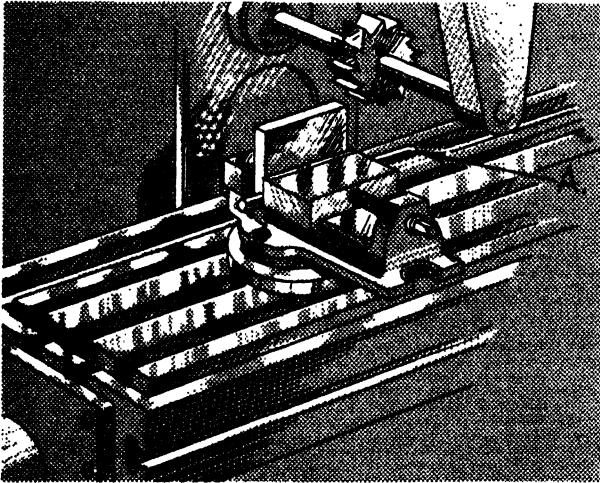

FIG. 255. STOCK IN POSITION FOR MACHINING THE EDGE

3. Hold a piece of rod between the movable jaw of the vise and the stock, A, Fig. 255, then with the hand crank, draw the movable jaw tightly against the rod. Be sure to place the rod about half way between the top of the parallel and the top of the jaw.
4. Proceed as in step 2, under Procedure, "Machining One of the Broad Surfaces."

#### PROCEDURE FOR MACHINING THE SECOND EDGE

1. Loosen the vise and turn the stock end for end, being sure that the machined edge lies flat on the bottom of the vise or the parallel.
2. Proceed as when machining the first edge.

#### PROCEDURE FOR MACHINING THE SECOND BROAD SURFACE

1. Revolve the swivel vise back through  $90^\circ$ . Make sure the jaw is perpendicular to the machined part of the column.

2. Proceed as under "Procedure, Machining One of the Broad Surfaces," steps 1 and 2, inclusive.

#### PROCEDURE FOR MACHINING THE FIRST END

1. Again swing the vise through  $90^\circ$ . Be sure the jaws are parallel with the face of the column.
2. Place one end of the stock on the bottom of the vise or on the parallel, then with a try square held against one edge test for perpendicularity, Fig. 256.

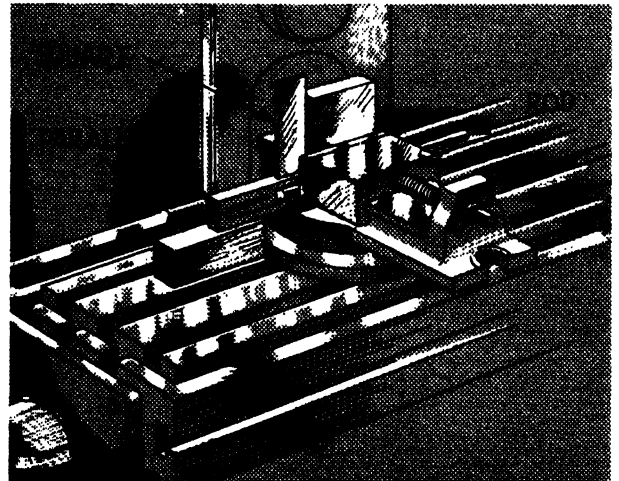

FIG. 256. CHECKING FOR SQUARENESS BEFORE MACHINING AN END

If the piece does not stand quite perpendicular, place shims of paper or metal under the low corner of the stock, then test again. Continue making adjustments until the machined edge is perpendicular to the bottom of the vise. This is important, otherwise the ends will not be at right angles to the sides.

3. Proceed as under "Procedure for Machining the First Edge," steps 3 and 4 inclusive.

#### PROCEDURE FOR MACHINING THE SECOND END

1. Turn the stock end for end and clamp it securely in the vise.
2. Proceed as when machining the first end.

## UNIT 52

## HOW TO FACE MILL STOCK

Face milling refers to the process of machining a surface at right angles to the axis of the cutter. One form of facing cutter is shown in Fig. 257. As can be seen, the teeth on this cutter have two cutting edges. The function of the cutting edges on the sides of the teeth is to take a very light finishing cut, leaving a smooth surface. The teeth must be kept sharp.

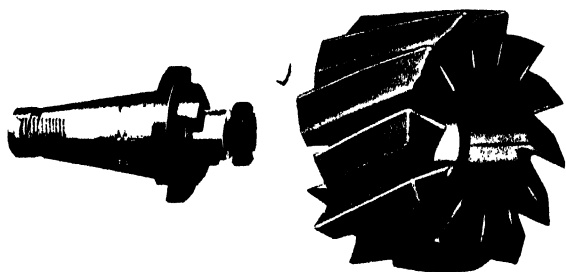

FIG. 257. FACING CUTTER

## PROCEDURE

1. Select a suitable facing cutter and mount it on the nose of the spindle of the milling machine. If a cutter with a taper shank is used, first select one of suitable shape and size. Next clean the tapered hole in the spindle and the shank of the cutter, then insert the shank in the hole. If the machine is equipped with a draw-in bolt, insert the bolt and draw the cutter into the recess.
2. Fasten an angle plate on the table of the miller, be sure the face of the plate is parallel with the machined face of the column. Test as in Fig. 258.

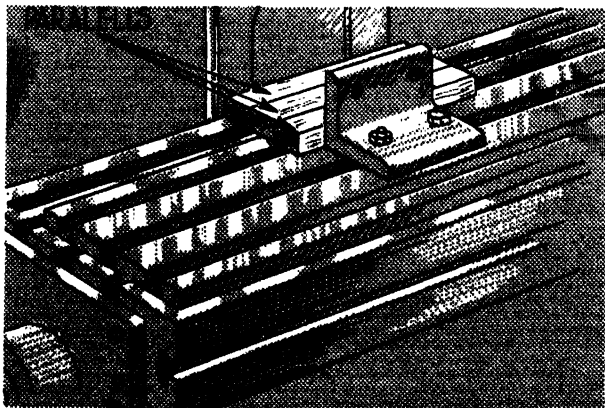

FIG. 258. CHECKING ALIGNMENT OF ANGLE PLATE

Frequently, a jig especially designed for holding the work in the position desired is used, in which case the fixture is clamped to the table of the milling machine and the work to the fixture.

3. With the longitudinal and hand cross feed, advance the work until the cutter is in position to make the cut.
4. With the vertical adjustment crank, raise the table until the cutter is in position for making a cut of the width desired.
5. Determine the correct cutting speed for the metal to be machined, as, for example, cast iron; see Unit 48.
6. By the speed index plate, set the speed control levers so as to produce the cutting speed desired.
7. Determine the correct feed. See Unit 48. Then by the feed index plate, set the feed control levers so as to produce the rate of feed desired.
8. With the spindle reverse mechanism, set the machine so that the direction of rotation will tend to press the work toward the face of the table.

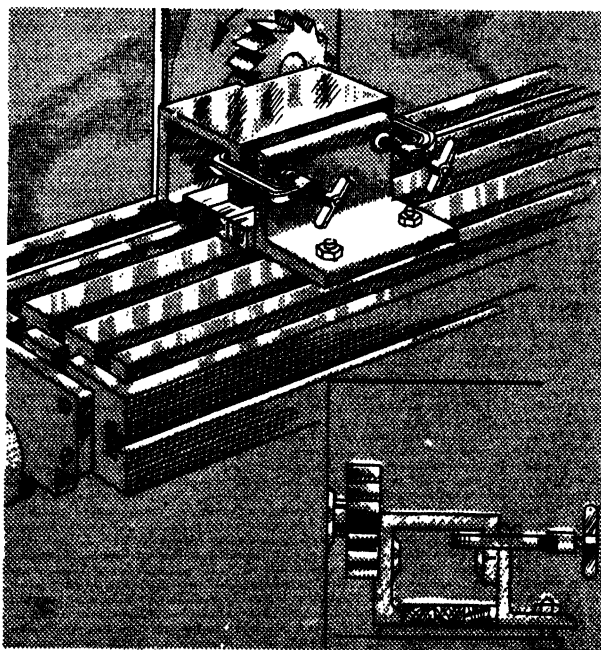

FIG. 259. MAKING THE FACING CUT

9. Start the machine and with the longitudinal hand feed, advance the work until the cutter is cutting the depth desired, Fig. 259, then, if necessary, stop the machine and test the width of the cut.
10. Make adjustments if necessary, then again start the machine and immediately engage the automatic longitudinal feed.
11. When the cut is completed, shut off the power and remove the work.

If a second cut is necessary, be sure to lower the table or stop the machine before running the work back for the second cut.

12. When through using the machine, remove the cutter and clean it thoroughly, then return the cutter and other fixtures to the place where kept when not in use. With a brush, remove all chips from table and other parts of machine.

### UNIT 53

## HOW TO MILL A CHAMFER OR BEVEL ON RECTANGULAR STOCK

Milling a chamfer or a bevel is merely a variation of straight milling such as discussed in Unit 50. Ordinarily, work that is to be chamfered or beveled will have been machined to size either by milling or planing. There are several ways of holding the work at the angle desired while it is being machined. Two commonly used procedures are: (1) clamping the stock in a universal vise; (2) holding the work in position with a setting strip, a form of jig.

### PROCEDURE WHEN USING A UNIVERSAL VISE

1. Fasten the vise on the table with the stationary jaw parallel with the face of the column.
2. Loosen the clamping bolt and raise the outside of the upper part of the vise until it registers the angle desired, as, for example,  $45^\circ$ , then tighten the clamping bolt.
3. Place the work in the vise, Fig. 260, being sure that one edge is resting flat on the bottom of the vise or on a parallel; protect the machined surface if necessary.
4. Tighten the vise, then check to see that the edge to be machined is parallel with the face of the column.
5. Select a suitable cutter and mount it on the machine in the usual manner.
6. Make the cut, following the usual procedure.
7. Machine other edges in a similar manner.

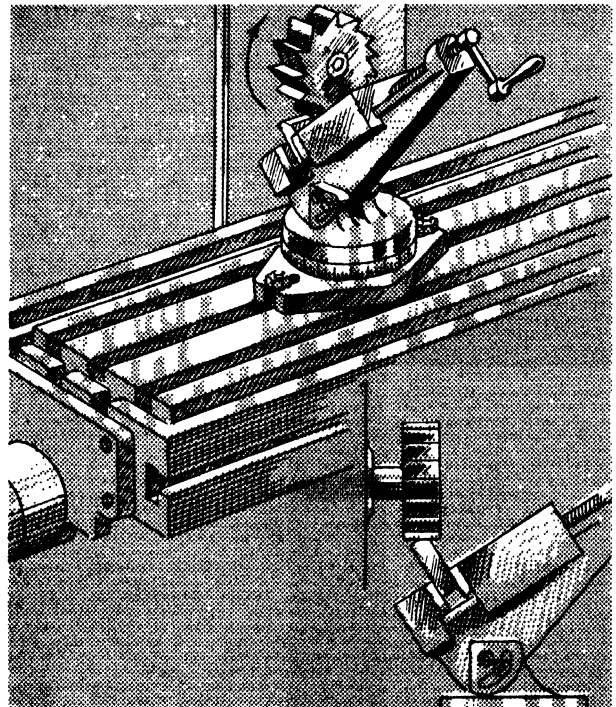

FIG. 260. MILLING A CHAMFER WITH WORK HELD IN A UNIVERSAL VISE

8. When the operation is completed, remove the work, clean the machine and return all appliances to the place where kept when not in use.

### PROCEDURE FOR USING A SETTING STRIP

1. Prepare a suitable setting strip or strips, Fig. 261. If only one or a small number of pieces are to be machined, the setting strips may be made of hard wood, although metal

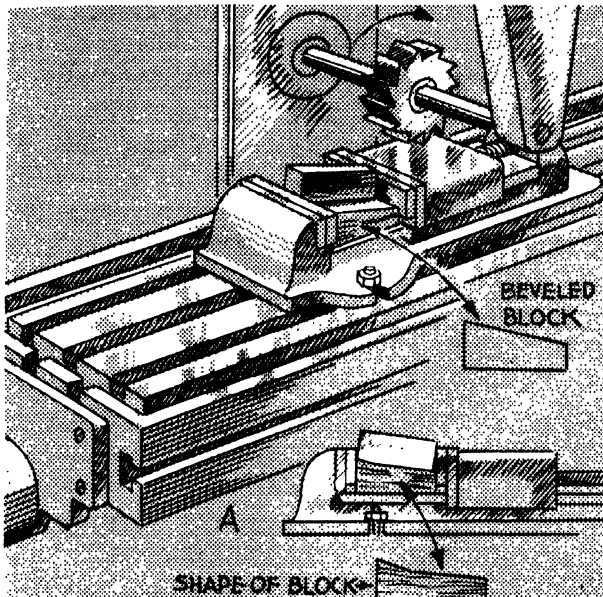

FIG. 261. MILLING A BEVEL WITH WORK HELD IN A PLAIN VISE

is recommended because it can be machined more accurately.

2. Clamp a plain vise on the table of the milling machine with the jaws either perpendicular or parallel to the face of the column.
3. Place the setting strips in the vise and lay the work upon them, being sure there are no chips between the strips and the work.
4. Align the edge to be machined parallel with the face of the column, then tighten the vise.
5. Make sure the work is seated solidly on the setting strips by tapping it lightly with a lead or copper hammer.
6. Proceed as in steps 5 to 8 inclusive, under Procedure When Using a Universal Vise.

If both sides of the piece are beveled, prepare a second setting strip, for example, A, Fig. 261; then proceed as in steps 3 to 6 inclusive.

#### UNIT 54

### HOW TO MILL A SQUARE, A HEXAGON, OR SIMILAR SHAPES

Milling a square or other flat surface on stock may be accomplished with the stock held between the centers of the dividing head or held vertically in the dividing head chuck. The latter is recommended when practicable.

#### PROCEDURE FOR CUTTING A SQUARE WITH AN END MILL

1. Place the dividing head on the table of the milling machine and fasten it in position as near the column as practicable.
2. Withdraw the stop pin in the index plate, if necessary, then disengage the worm by turning the knob or handle through a part of a revolution.
3. Remove the dividing head center and revolve the head spindle to a vertical position, Fig. 262.
4. Remove the nose guard and mount the chuck on the spindle.
5. Insert the cap that closes the end of the hole in the dividing head spindle. If a cap is not available, put a little waste in the hole.

The purpose of closing the hole is to prevent chips from falling through the hole

and becoming lodged between the swivel block and the base plate.

6. Secure a suitable, sharp end mill, A, Fig. 262. Clean the shank of the mill and the spindle hole thoroughly, then insert the shank firmly in the spindle hole. If equipped with a draw-in bolt, insert the bolt and tighten with a wrench.

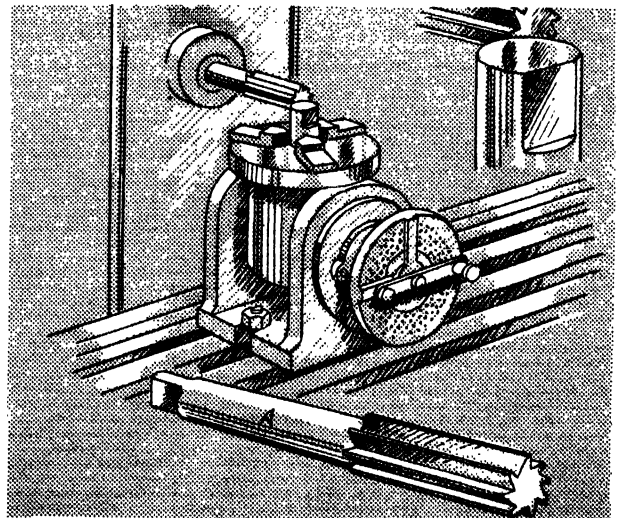

FIG. 262. MILLING A SQUARE WITH AN END MILL

7. Secure a piece of waste stock of approximately the same diameter or size as the work to be milled and insert between the jaws of the chuck. Draw the jaws tight with the key wrench.  
Assume that the stock has been turned to  $1\frac{1}{2}$  inches diameter and that a one inch square section is to be milled on one end. One inch subtracted from one and one-half inches leaves one-half inch of stock to be removed, or one-fourth from each side.
8. With the longitudinal feed, advance the table until the cutter almost touches the work, then with the vertical adjustment, raise the work so as to take a cut about  $\frac{1}{8}$  of an inch in depth.
9. With the cross feed, move the table until the stock is in such position that one-fourth inch of stock will be removed from one side of the work.
10. Start the machine and with the longitudinal feed, advance the cutter and make the cut. Use a cutting compound freely.
11. Stop the machine, then advance the table until the cutter clears the work.
12. Revolve the direct index plate, on the front of the spindle, through one-half turn,  $180^\circ$ , or half the number of equally spaced holes in any evenly spaced circle of holes, for example, 20 or 24. Lock the plate in position with the plunger pin located in the head.
13. Start the machine and advance the cutter.
14. When the cut is completed, stop the machine, then accurately measure the distance across the flats. If the work measures more than one inch across the flats, feed the table toward the column with the cross feed half the amount the stock is oversize, for example, half of  $\frac{1}{2}$  of an inch, and if undersize, half the amount away from the column.
15. When the machine has been set correctly, remove the piece of waste stock and mount the stock to be machined in the chuck, then raise the table so as to make a cut of the depth desired, providing the cutter is large enough to remove the stock at one cut.  
If the cutter is not large enough to remove the stock at one cut, then set it for

the first cut. After the first cut has been made, set the machine for the second cut and, if necessary, in turn for other cuts.

16. When the first flat has been completely machined, withdraw the plunger and revolve the index plate through one-fourth turn, then lock it in position with the plunger pin.
17. Machine the second flat in a manner similar to the first.
18. Continue as in steps 15 through 17 until all four sides have been machined.
19. When the operation is completed, remove the dividing head and cutter and clean them, then return all to the place where kept when not in use. With a brush, remove all chips from the table of the machine.

#### PROCEDURE FOR CUTTING A HEXAGON WITH AN END MILL

1. Proceed as in steps 1 to 7 inclusive.
2. Assume the stock has been turned to  $1\frac{3}{8}$ " diameter and that one end is to be milled in the form of a hexagon which measures one inch across the flats. One inch subtracted from one and three-eighths leaves three-eighths of an inch of stock to be removed, or three-sixteenths from each side.
3. With the cross feed, advance the table until the work is in such position that three-sixteenths inch of stock will be removed from one side.
4. Proceed as in steps 10 to 15 inclusive.
5. When the first flat has been completely machined, withdraw the plunger located in the dividing head, then revolve the direct index plate through one-sixth turn and lock it in position with the plunger pin.
6. Machine the second and subsequent flats in a manner similar to the first.
7. Proceed as in step 19.

#### PROCEDURE FOR CUTTING AN OCTAGON WITH AN END MILL

1. Proceed as under "Procedure, Cutting a Square with Stock Held Vertically in the Chuck," steps 1 to 7 inclusive.  
Assume the stock has been turned to  $1\frac{1}{4}$  inches diameter and that a one and one-fourth inch octagon is to be milled on one

end. One and one-fourth inches subtracted from one and one-half inches leaves one-fourth of an inch to be removed, or one-eighth inch from each side.

2. With the cross feed, move the table until the stock is in such position that one-eighth inch of stock will be removed from one side of the work.
3. Proceed as under "Procedure, Cutting a Square with Stock Held Vertically in a Chuck," steps 10 to 13 inclusive.
4. Stop the machine and accurately measure the distance across the flats. If the work measures more than one and one-fourth inches across the flats, feed the table toward the column with the cross feed half the amount the stock is oversize, for example  $\frac{1}{32}$  of an inch, and if undersize, half the amount away from the column.
5. When the machine has been set correctly, remove the waste stock and mount the stock to be machined in the chuck.
6. Start the machine, and raise the table so as to make a cut of the depth desired, then make the cut.
7. When the first flat has been completely machined, withdraw the plunger and revolve the direct index plate through one-eighth turn, then lock it in position.
8. Machine the second flat in a manner similar to the first.
9. Continue as in steps 7 and 8 until all eight sides have been machined.
10. When the operation is completed, remove all special attachments and clean both these and the table of the machine.

#### PROCEDURE FOR CUTTING A SQUARE WITH A PLAIN CUTTER

1. Proceed as under "Procedure, Cutting a Square, Using an End Mill," steps 1 to 5 inclusive.
2. Secure a sharp plain milling cutter of suitable size, also a cutter arbor and the necessary collars.
3. Wipe the arbor, collars, sides of the cutter, and the hole in the spindle with a piece of clean waste.
4. Insert the arbor and mount the cutter as close to the column as the work will per-

mit, Fig. 263, then insert such collars as necessary and draw them tight with the nut.

5. Slide the overarm bearing over the end of the arbor and clamp it in position, Fig. 263.

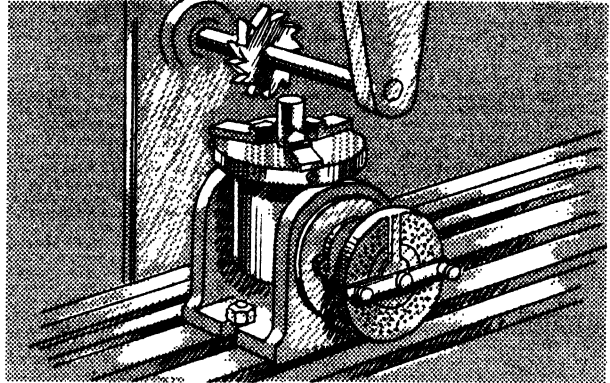

FIG. 263. MILLING A SQUARE WITH A PLAIN CUTTER

6. Proceed as under "Procedure, Cutting a Square Using an End Mill," steps 7 to 19 inclusive.

#### PROCEDURE FOR CUTTING A SQUARE WITH A STRADDLE MILL

1. Proceed as under "Procedure, Cutting a Square, Using an End Mill," steps 1 to 5 inclusive.
2. Secure two sharp plain milling cutters of suitable size, also an arbor and the necessary collars.
3. Insert the arbor and mount the first cutter as close to the column as the work will permit. Next select collars that will give the *desired width* between cutters, for example, one inch. Place these collars in position on

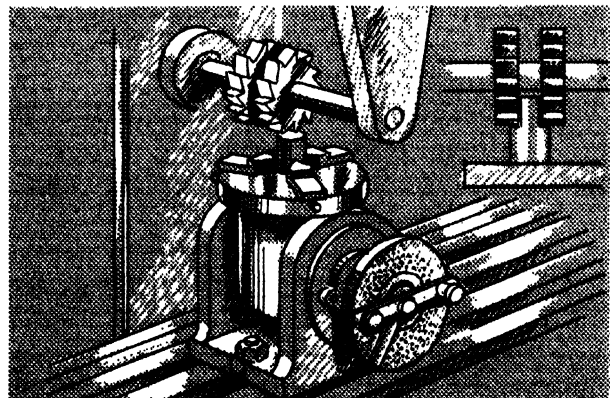
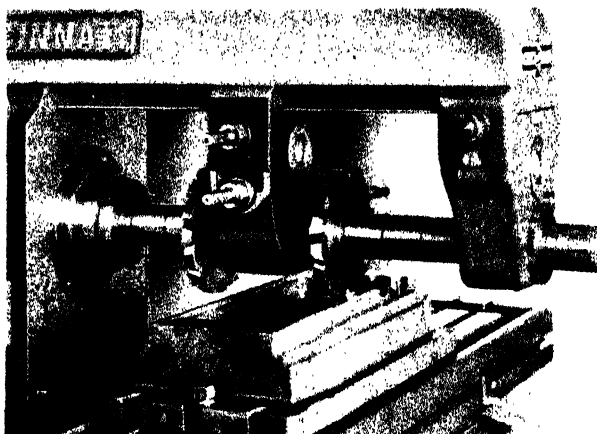

FIG. 264. MILLING A SQUARE WITH A STRADDLE MILL



Courtesy, Cincinnati Milling Machine Co.

FIG. 264-A. CAP-TYPE ARBOR SUPPORT USED IN STRADDLE MILLING

the arbor, then place the second cutter and other necessary collars and finally the clamping nut. Then draw the nut tight and adjust the overarm.

Fig. 264A illustrates a milling machine set for straddle milling. The cap type arbor support permits removal of the arbor without disturbing the position of the cutters. An arbor support practically eliminates vibration.

4. Center the cutter over the work and make a trial cut in the usual manner, Fig. 264. Then measure for size.

If the measurement is found to be incorrect, adjustment for size is made by inserting a wider or narrower collar between the cutters. Sometimes very thin discs of metal or even paper are used to achieve greater or less space between the cutters.

5. When the machine has been set correctly, mount the stock to be machined in the chuck, then raise the table so that a cut of the depth desired will be made.
6. Start the machine and make the cut, using a cutting compound freely.
7. Revolve the direct index plate one-half turn and make the second cut.
8. When the operation is completed, remove and clean the cutter, arbor and index head and return them to the place where kept when not in use. Then, with a brush, remove all chips from the table of the milling machine.

#### PROCEDURE FOR CUTTING A HEXAGON WITH A STRADDLE MILL

1. Proceed as under "Procedure, Cutting a Square Using a Straddle Mill," steps 1 to 6 inclusive.
2. Revolve the direct index plate one-sixth turn and make the second cut.
3. Revolve the index plate another one-sixth turn and make the third cut.
4. Proceed as under "Procedure, Cutting a Square Using a Straddle Mill," step 8.

#### PROCEDURE FOR CUTTING A SQUARE WITH STOCK HELD BETWEEN THE CENTERS OF THE DIVIDING HEAD

1. Place the dividing head and tailstock on the table of the milling machine, locating them as close to the column as practicable.
2. Adjust the tailstock and mount the work between the centers of the dividing head, Fig. 265.

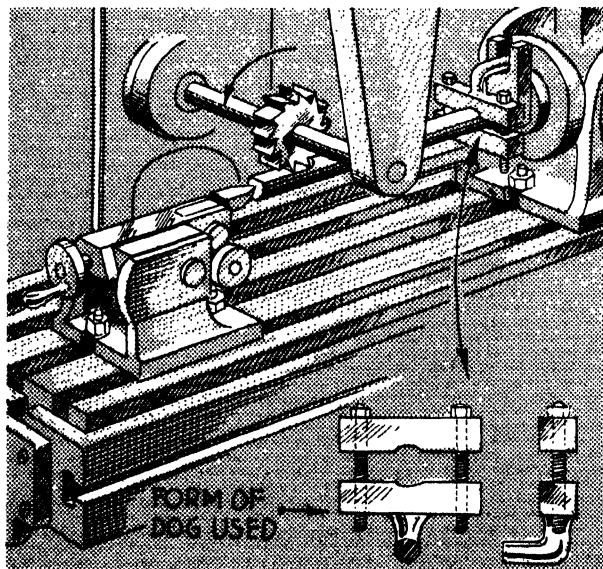

FIG. 265. CUTTING A SQUARE WITH STOCK HELD BETWEEN CENTERS

3. Select a suitable plain milling cutter or an end mill, as preferred.
4. Mount the cutter in the milling machine.
5. With the cross feed, adjust the table so that the axis of the work is under the center of the cutter, if the cut is to be made along the top of the work.

If an end mill is used, the cut may be made along the top or along the side. When the cut is made on the side, bring the axis

of the work and the cutter into the same horizontal plane, then with the cross feed, adjust for depth of cut.

6. Measure the stock, then carefully calculate the amount of stock to be removed from each side.
7. With the vertical adjustment, raise the table until the bottom of the cutter is just even with the work.
8. Start the machine, then with the vertical adjustment, raise the table until the cutter just touches the work, then move the table until the revolving cutter just clears the end of the work.
9. Set the vertical adjustment micrometer dial at zero, then raise the table an amount equal to the amount of stock to be removed, for example,  $\frac{3}{16}$  of an inch.
10. Feed the work toward the cutter and make the cut. Be sure to use a cutting compound freely.
11. At the end of the cut, stop the machine and move the work back until it clears the cutter.
12. Withdraw the plunger pin in the dividing head and revolve the direct index plate through one-half turn.
13. Again feed the work toward the cutter; at the end of the cut, stop the machine and move the work back.
14. With a pair of calipers or a micrometer, measure the distance across the flats.  
If the work is too large, raise the table half the amount the stock is oversize and take a second cut on both flat surfaces.
15. When the machine has been set correctly, turn the index plate one-fourth turn and machine the third side.

16. Index one-half turn and machine the fourth side.
17. When the operation is completed remove and clean the dividing head, the cutter and the arbor and return them to the place where they are usually kept. With a brush, remove all chips from the table of the machine.

**PROCEDURE FOR CUTTING A HEXAGON WITH STOCK HELD BETWEEN THE CENTERS OF THE DIVIDING HEAD**

1. Proceed as under "Procedure, Cutting a Square with Stock Held between the Centers of the Dividing Head," steps 1 to 14 inclusive.
2. When the machine has been set correctly, turn the direct index plate one-sixth turn, then make the cut in the usual manner.
3. Continue indexing by one-sixth turns and making the cuts until all six sides have been machined.
4. Remove all special attachments; clean them and the table of the machine.

**PROCEDURE FOR CUTTING AN OCTAGON WITH STOCK HELD BETWEEN THE CENTERS OF THE DIVIDING HEAD**

1. Proceed as under "Cutting a Square with the Stock Held between Centers," steps 1 to 14 inclusive.
2. When the machine has been set correctly, turn the direct index plate one-eighth turn, then make the cut in the usual manner. Use a cutting compound freely.
3. Continue indexing by one-eighth turns and making the cuts until all eight sides have been machined.
4. Remove all special attachments; clean them and the table of the machine.

**UNIT 55**

**HOW TO MILL A KEYWAY OR SIMILAR GROOVE**

A keyway or a similar groove may be cut with a plain milling cutter, with an end mill, with a cotter mill, or a special key cutter. There are several ways in which the stock may be held while the groove is being cut, the most common of which are: (1) in a V-block; (2) in a vise;

(3) between centers in the index head; (4) in the index head chuck.

**PROCEDURE FOR CENTERING THE CUTTER WITH STRAIGHT STOCK**

1. With the center head and square, scribe a line on the end of the stock, Fig. 266.



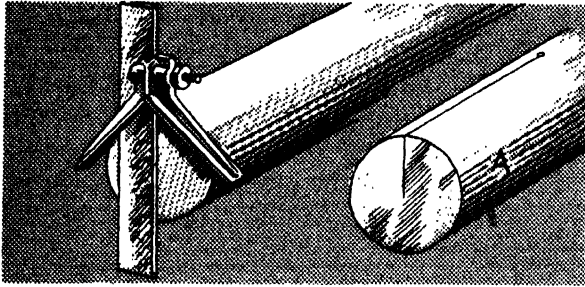

FIG. 266. SCRIBING A CENTER LINE ON THE END OF THE STOCK

2. Lay off the length of the groove on the stock accurately, then mark the terminus with a scribe, or very lightly with a prick punch, A, Fig. 266. This step is omitted when the groove extends entirely across the work.
3. Place the stock in a V-block with the scribed line perpendicular to the face of the V-block. Clamp the stock in position. Be sure the axis of the work is parallel with the face of the column of the machine.
4. Select and mount a suitable cutter on the milling machine.
5. With the cross feed, move the table until the scribed line on the end of the stock is exactly in the center of the cutter, Fig. 267. Test by measuring carefully with a rule.

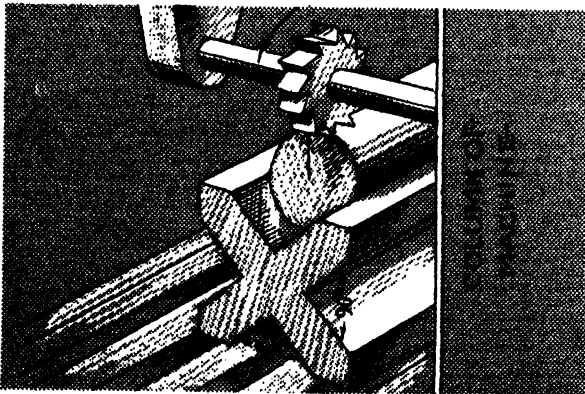

FIG. 267. STOCK IN POSITION FOR THE CUT

#### PROCEDURE FOR CENTERING THE CUTTER WITH SHOULDERED STOCK

1. Accurately lay off the length of the groove on the stock, then mark the terminus with a scribe, or very lightly with a prick

punch. This step is omitted when the groove extends the entire length of the work.

2. Place the stock in a V-block, or between centers in the dividing head. If mounted in a V-block, clamp the stock in position. Be sure the axis of the work is parallel with the face of the column.
3. Select and mount a suitable cutter on the spindle of the milling machine, for example a keyway cutter, Fig. 268.

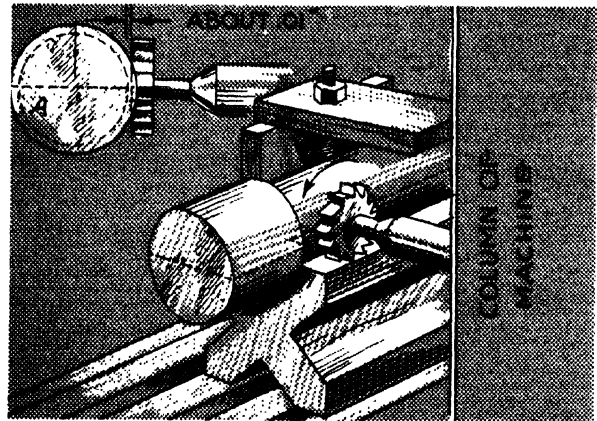

FIG. 268. KEYWAY CUTTER MOUNTED ON THE SPINDLE

4. With the vertical adjustment crank, raise the table until the axis of the work is even with the axis of the cutter, A, Fig. 268, but with the cutter not quite in contact with the work.
5. Start the machine, then carefully advance the work with the cross feed until it just barely touches the cutter. Test with a piece of tissue paper placed between the work and the side of the cutter. Stop advancing the work when the cutter starts to tear the paper.

**CAUTION:** Moisten one edge of the paper so that it will adhere to the surface of the work. Do not hold the tissue with the fingers.

6. Stop the machine, then lower the table until the top of the work is just even with the under side of the cutter.
7. With the cross feed, advance the work one-half the diameter of the work plus one-half the width of the cutter.

For example, assume the diameter of the stock is  $1\frac{1}{2}$  inches and the width of the

cutter is  $\frac{1}{4}$  of an inch, then  $\frac{9}{16}$  plus  $\frac{1}{8}$  of an inch =  $\frac{10}{8}$  of an inch, the distance to move the work toward the column.

8. Hold a square against the work, as in Fig. 269, then measure the distance from the edge of the square to the side of the cutter. In the example given above, the distance should be  $\frac{7}{16}$  of an inch, because  $\frac{9}{16} - \frac{1}{8} = \frac{7}{16}$  of an inch. Make the test from both sides of the stock.

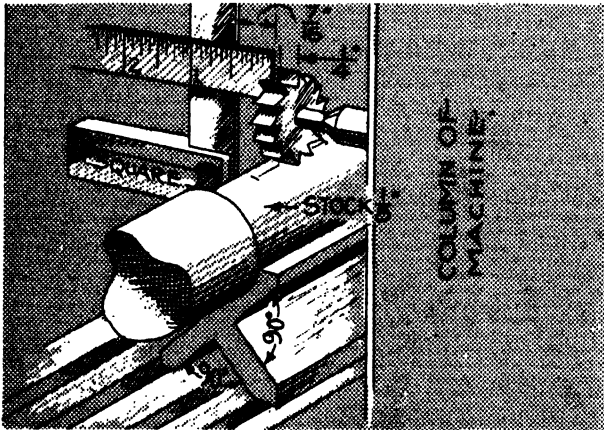

FIG. 269. CENTERING THE WORK UNDER THE CUTTER

9. If the center of the cutter is not located exactly over the center of the stock, make the necessary adjustment and again test as in step 8.

#### PROCEDURE FOR CUTTING A KEYWAY OR GROOVE WITH THE STOCK MOUNTED IN A V-BLOCK

1. Position and clamp the stock in place by either method described.
2. Move the table back so that the work just clears the cutter, Fig. 270.

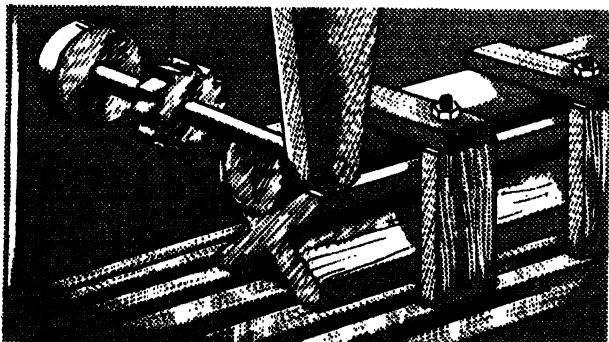

FIG. 270. MILLING A GROOVE WITH STOCK MOUNTED IN A V-BLOCK

3. Set the micrometer vertical adjustment at zero, then raise the table an amount equal to the desired depth of groove, for example,  $\frac{5}{32}$  of an inch. This measurement is taken at the edge of the groove; consequently, the table must be raised  $\frac{5}{32}$  of an inch plus the difference between the top edge of the groove and the top of the stock, in the example given, about .01 of an inch.
4. Make sure the setting is correct and the work correctly aligned and securely clamped. Then start the machine and feed the work toward the revolving cutter with the longitudinal feed.
5. When the cutter reaches the end of the groove, shut off the power and immediately lower the table.

If it becomes necessary to stop the feed before the end of the groove is reached, to change clamps or for any other reason, shut off the power at the same time the feed is stopped.

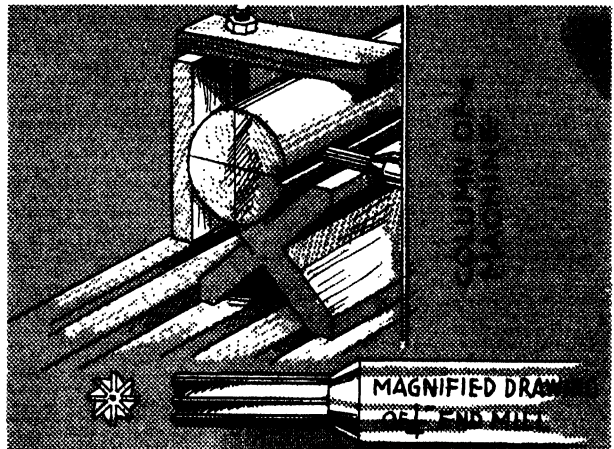

FIG. 271. USING AN END MILL TO CUT A GROOVE

If preferred and convenient, this operation may be performed with an end mill mounted in the spindle of the milling machine, Fig. 271. The work must be fastened to the table securely, or held in a vise.

A groove milled in the manner described above and terminated at some intermediate point in the stock may be finished with a twist drill and a chisel. Still another possibility is to mount an end mill in a drill press and mill out the remaining stock.

**PROCEDURE FOR CUTTING A KEYWAY OR GROOVE WITH THE STOCK HELD BETWEEN THE CENTERS OF THE DIVIDING HEAD**

1. Find the center of the stock. See Unit 18. In most cases this operation will have been performed in connection with other machine work performed on the stock.
2. Fasten the dividing head and the tailstock on the column side of the table of the milling machine.
3. Place the stock between the centers of the head and draw the tailstock tight.
4. Select a suitable cutter and mount it on a milling machine arbor.
5. Center the axis of the cutter over the axis of the work, Fig. 272, using one of the methods described under centering the cutter.

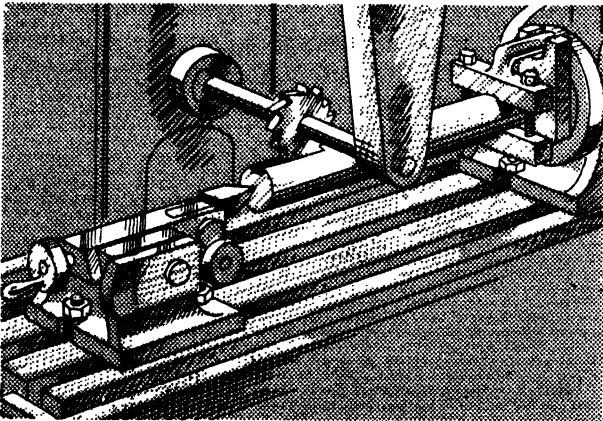

FIG. 272. MILLING A GROOVE WITH THE STOCK HELD BETWEEN CENTERS

6. Proceed as under "Procedure, Cutting a Keyway or Groove with the Stock Mounted in a V-Block," steps 2 to 5 inclusive.

If an end mill is used, bring the axis of the work and the axis of the mill into alignment. Then, with the cross feed, advance the work an amount equal to the depth of the groove.

7. When through cutting the groove, return all equipment to the place where kept when not in use and clean the machine.

**PROCEDURE FOR CUTTING KEYWAY FOR WOODRUFF KEY**

1. Mount the stock in a suitable manner on the table of the milling machine.
2. Lay off the longitudinal center of the key or keys, A, Fig. 273.
3. Select a key cutter of suitable diameter and width.
4. Mount the cutter in the machine.
5. Center the cutter over the axis of the work and midway of the longitudinal center of the key, Fig. 273. Then raise the table until the cutter barely touches the surface of the stock. See above procedures on centering the cutter.

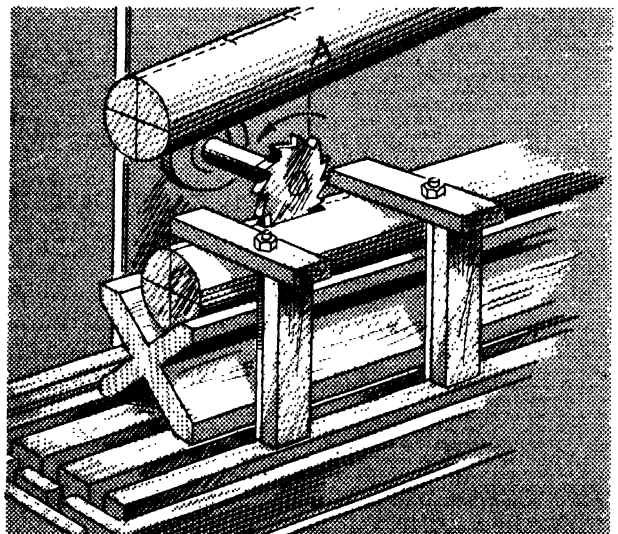

FIG. 273. CUTTING KEYWAY FOR A WOODRUFF KEY

6. Set the micrometer vertical adjustment at zero. Then start the machine and with the vertical adjustment, continue raising the table until the cutter is cutting at the depth desired, for example,  $\frac{7}{32}$  of an inch.
7. When the groove is cut to the depth desired, lower the table, then shut off the power.
8. Cut other grooves in a similar manner.
9. When the job is completed, return equipment to the place where kept when not in use and clean the machine.

## UNIT 56

## THE DIVIDING OR INDEXING HEAD AND ITS OPERATION

The dividing head may be thought of as an essential in the operation of a milling machine. In fact, without this piece of apparatus the utility of a milling machine is much restricted. The complete dividing head has two parts, the head and the tailstock, Fig. 274. The head is a

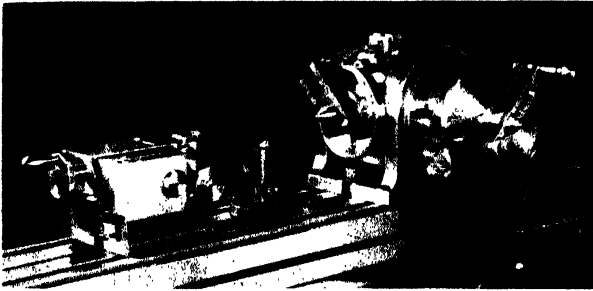

Courtesy, Cincinnati Milling Machine Co.

FIG. 274. DIVIDING HEAD

rather complex piece of apparatus consisting of a base plate, swivel block, spindle, worm and wormwheel, a direct and a standard indexing plate, side index plate and sector. The tailstock is a rather simple piece of machinery and is used for supporting the outer end of the stock being milled. The tailstock center can be moved longitudinally by means of a handwheel and by adjusting the block which holds it; the center may be moved vertically in either a horizontal or an inclined plane.

#### SIMPLE INDEXING

Simple indexing is achieved by means of a wormwheel attached to the spindle of the head and activated through a worm, keyed to the worm shaft to which a hand crank is attached. Since there are 40 teeth on the wormwheel, one complete turn of the crank, which will cause any one tooth on the worm to make a complete revolution, will cause the wormwheel to make 1/40 of a revolution. Thus 40 turns of the crank are required to cause the wormwheel to make a complete revolution, likewise the dividing head spindle, because the wormwheel is attached to the spindle. An example will make clear the operation of indexing. Assume that the problem is to cut a reamer with 10 equally spaced teeth. If 40 turns of the index crank are required to make one complete revolution of the

work, then 1/10 of 40 turns or 4 complete turns of the index crank after each cut will be required to space the teeth correctly on a 10 tooth reamer. It is good practice to make a habit of always turning the index crank to the right.

In the illustration given, a number was chosen by which 40 was divisible without leaving a remainder. If, instead of 10 teeth, we assume the problem is to cut a reamer with 14 teeth, then 1/14 of 40 turns, or 2 12/14 (2 6/7) turns of the crank will be required after each cut.

From the above examples it can be seen that the rule for calculating the number of turns of the index crank required to move the work through one division of any number of equally spaced divisions in a circle is as follows: When,

$N$  = the number of teeth on the wormwheel

$D$  = the number of divisions

$T$  = the number of turns

$$T = \frac{N}{D}$$

Solution:

$$T = \frac{40}{14} = 2 \frac{12}{14} \text{ or } 2 \frac{6}{7}$$

$$T = 2 \frac{6}{7} \text{ turns.}$$

So long as whole turns are involved, indexing is simply a matter of counting the turns. To divide a turn into sevenths and move the index handle through six of these sevenths would be difficult were it not for the fact that the index plate is provided with a series of circles of holes which are evenly spaced. See Fig. 274. Each circle contains a different number of holes, for example, 24, 25, 28, 30, 34, and so forth. The holes in the index plate are for the purpose of engaging a plunger in the handle of the index crank whenever the plunger comes exactly over a hole. In order that the plunger may be made to enter any particular row of holes, an adjustment is provided. If the clamping nut at the center is loosened, the crank may be moved toward or away from the

center of the plate. Thus the plunger in the handle of the crank may be adjusted to fit any row of holes.

Assuming the problem is to index for  $6/7$  of a turn, then taking the example of number of holes given above, it is observed that one of those rows — 28 — may be divided evenly by the denominator 7. Dividing 28 by 7 gives a quotient of 4. Thus in each seventh of a turn, the index crank must be moved four holes. To index them for  $2\ 6/7$  turns, the index crank must be moved 2 complete turns and through  $6/7$  or 24 of the 28 spaces in the circle having 28 holes. To avoid the problem of counting holes each time the crank is turned, not to mention the probability of making an error, the dividing head is provided with a sector; Fig. 275. This is a device fastened in front of the index plate.

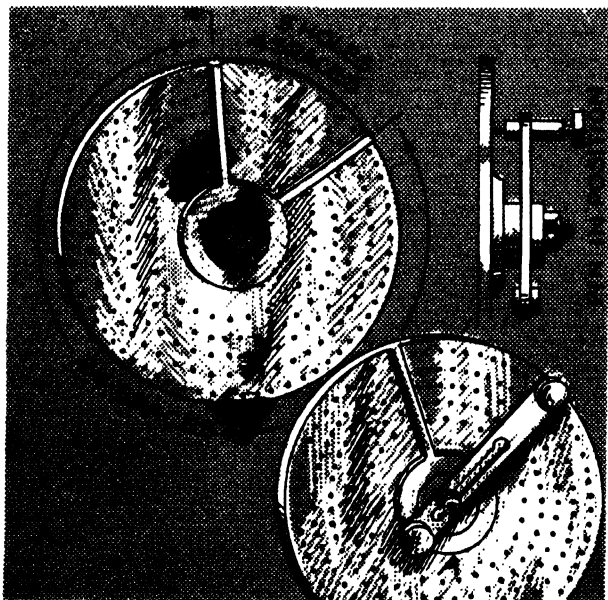

FIG. 275. SECTOR USED TO ENCLOSE  $6/7$  OF THE INDEX PLATE WITHIN OBTUSE ANGLE

It is composed of two radial arms which can be adjusted to any angle desired by loosening a clamping screw. To divide the index plate so that  $6/7$  of its area is included within the obtuse angle made by the arms of the sector, A, Fig. 275, one must move one arm of the sector against the plunger in the handle and then swing the other around until 24 of the 28 spaces are included in the obtuse angle. After moving the arms of the sector, always check for accuracy and then tighten the clamping

screw. When dividing space with a sector, it should be remembered that it is the spaces that count and not the holes. A good way to avoid making this mistake is to call the hole in which the pin is engaged zero, or count the spaces only. When revolving the index handle for a part of a revolution, release the pull on the plunger between the last two holes and let it slide across the space until it drops into the hole. After indexing, it is good practice immediately to move the sector for the next indexing.

Take another example and assume the problem is to cut 54 teeth on a spur gear.

$$\text{Solution: } T = \frac{N}{D} = \frac{40}{54} = \frac{20}{27} \text{ turns.}$$

This fraction tells us we must take 20 holes on the 27 circle, or 40 holes on the 54 circle.

The ordinary index plate also can be used for indexing by degrees. Since there are  $360^\circ$  in a circle, and since there are 40 teeth on the wormwheel, which must make one complete revolution as the work is revolved through  $360$  degrees, it follows that, for each turn of the crank a point on the circumference of the work will rotate through  $9^\circ$  or  $1/40$  of a circle ( $360^\circ \div 40 = 9^\circ$ ). If by moving the crank through one complete turn the work is revolved  $9^\circ$ , then, if the crank is moved through two spaces of an eighteen space circle, or six spaces of a fifty-four space circle, the work will be rotated  $1^\circ$  and if through one or three spaces respectively,  $\frac{1}{3}^\circ$ .

#### DIRECT INDEXING

Direct indexing is accomplished by disengaging the worm from the wormwheel. This permits a plate, which is attached to the spindle in the head, to revolve when a retaining plunger in the head is drawn back. This plate has a circle of equally spaced holes, usually 24 or some other number divisible by 4. To direct index, disengage the worm, then draw the plunger back and rotate the plate through the number of spaces desired, for example, 6 spaces or  $\frac{1}{4}$  turn, since  $6/24$  equals  $\frac{1}{4}$ .

For indexing when it is necessary to achieve very fine spacing or to divide a circle into a number of spaces not achievable with the standard index plate, a high number indexing attachment is available. This consists of a set

of plates with very fine spacing, Fig. 276. These plates are interchangeable with the standard index plate.

Fig. 276A illustrates a wide range dividing head. This head enables the operator to make a rapid selection of divisions, from 2 to 400,000,

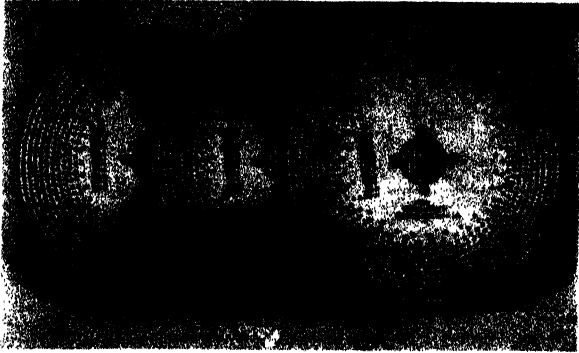

Courtesy, Cincinnati Milling Machine Co  
FIG. 276. SET OF HIGH NUMBER INDEXING PLATES

at any angle and at intervals of six seconds without the use of change gears or additional index plates.

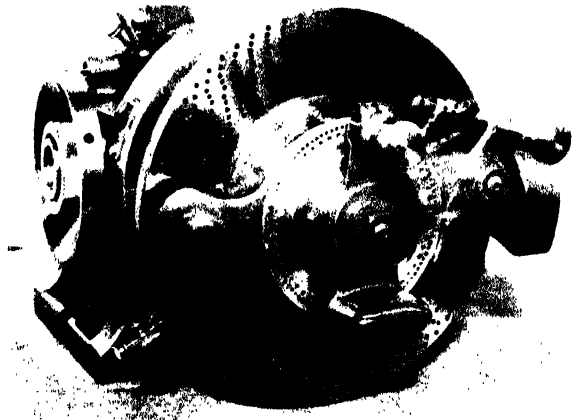

Courtesy, Cincinnati Milling Machine Co  
FIG. 276-A. WIDE RANGE DIVIDER

## UNIT 57

### HOW TO MILL FLUTES OR GROOVES

Fluting an object may be for the purpose of ornamentation, of increasing holding quality, for example, the handle of a screwdriver, or of providing a cutting edge and giving clearance to such tools as reamers, taps and milling cutters. Fluting may be done on a flat, a cylindrical, or a conical surface.

#### PROCEDURE FOR MILLING A FLUTE ON A FLAT SURFACE

1. Select suitable parallels and grip the stock in a vise, as in Fig. 277.
2. Select a sharp fluting mill of suitable size and shape and mount it on the arbor as close to the column of the machine as the nature of the work will permit.
3. Adjust the machine to make the cut, then proceed in the usual manner.

#### PROCEDURE FOR MILLING A FLUTE ON A CYLINDRICAL SURFACE

1. Center and turn the stock to the size and shape desired, A, Fig. 278.
2. Fasten the dividing head and tailstock on the column side of the table of the milling machine.

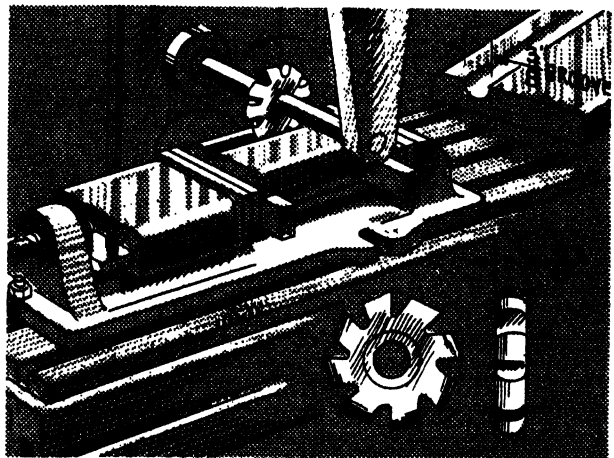

FIG. 277. MILLING A FLUTE WITH THE STOCK HELD IN A VISE

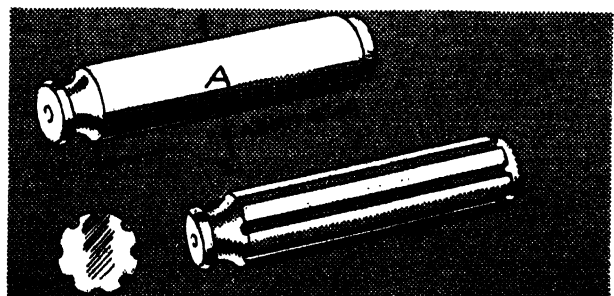

FIG. 278. FLUTED CYLINDER

3. Determine the number of flutes to be cut. If the number is small, direct indexing may be used, in which case the worm must be disengaged.

To cut a groove with one face radial it is necessary to off-set the work-piece laterally. To facilitate off-setting the work-piece draw a radial line on the tailstock end as in A, Fig. 302, Unit 63, then rotate the work until the radial line is aligned with the short face of the cutter, usually the  $12^\circ$  face. Test as shown in Fig. 305, Unit 63.

4. Determine the number of holes in the front index plate, then divide the number of holes by the number of flutes to be cut. Assuming eight flutes are to be cut and that there are twenty-four holes in the plate, twenty-four divided by eight equals three. This is the number of spaces to advance the index plate for cutting each flute.
5. Attach a suitable dog to the headstock end of the work-piece. See Fig. 280. Then place the stock between the centers of the head in such a manner that the direction of the cut will be away from the tailstock, then draw the tailstock center against the stock.
6. Select a sharp cutter of suitable size, shape, or type, a  $\frac{1}{4}$  inch convex cutter, Fig. 279, for fluting, or a double angle cutter, Fig. 281, for milling reamers, taps or helixes.
7. Mount the cutter on a suitable arbor as close to the column as the work will permit.
8. With the cross feed, move the table until the axis of the stock is exactly under the center of the cutter.
9. Raise the table until the bottom of the cutter just touches the top of the work. Test with a piece of tissue paper. Do not hold the paper with the fingers.
10. Move the table so that the end of the work just clears the cutter.
11. Set the micrometer vertical adjustment at zero, then raise the table an amount equal to the desired depth of cut, Fig. 279. If a smooth finish is desired, allow about  $\frac{1}{32}$  of an inch for a finishing cut.
12. Check carefully to see that the setting is correct, the work correctly aligned and securely fastened.

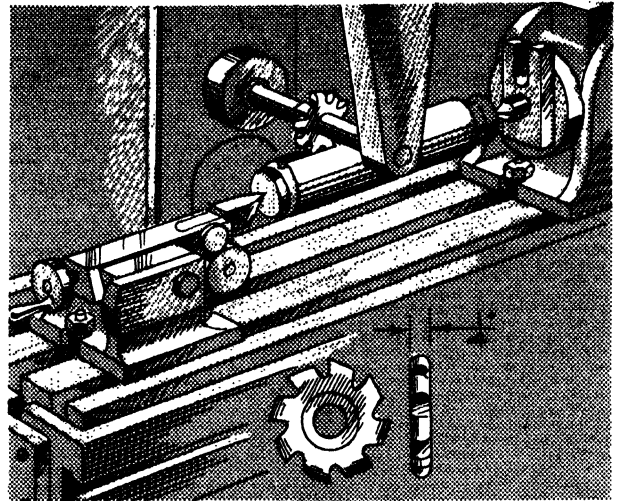

FIG. 279. MILLING A FLUTE WITH A  $\frac{1}{4}$  INCH CONVEX CUTTER

13. Start the machine and feed the work against the cutter, Fig. 279.
14. When the cutter reaches the end of the flute, shut off the power and immediately lower the table very slightly.
15. Move the table back to the starting position, then index for the next cut, for example, three spaces.
16. Raise the table the amount desired, as in step 11.
17. Start the machine and make the cut in the usual manner.
18. Continue as in steps 13 to 16 inclusive, until all flutes have been milled.
19. Set the machine for the finishing cut, then proceed in the usual manner.
20. When the job is completed, clean the machine thoroughly and return all special equipment to the place here kept when not in use.

#### PROCEDURE FOR MILLING A FLUTE ON A CONICAL SURFACE

Ordinarily, a flute or groove milled on a conical surface will be somewhat deeper and wider at the large end than at the small end. The land between the grooves will be narrower at the small end. This will mean that the small end will have to be raised an amount nearly equal to half the difference between the diameters of the large and small ends. The greater this difference, the larger will be the amount the small end will need to be raised above the hori-

zontal plane of the small end. As the difference in the horizontal plane levels of the two ends varies for stock having different tapers, it is recommended that variation in plane levels be determined by making a series of shallow trial cuts. When only a portion of the cylinder is tapered, the amount of set over required (set up in this case) may be calculated mathematically by using the formula given in Unit 32. However, calculation must be made by taking the bottom of the groove as a basis.

1. Make a full size layout of both ends of the fluted cone, if practicable. See Figs. 280 and 281.
2. Proceed as under "Procedure, Milling a Flute on a Cylindrical Surface," steps 1 to 8 inclusive.
3. Release the clamp on the vertical slide and raise the tailstock center an amount nearly equal to one-half the difference in diameter between the large and small ends of the stock, Fig. 280.

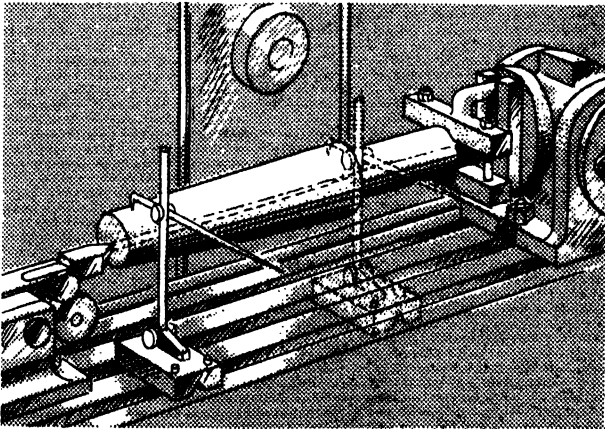

FIG. 280. SETTING UP TO MILL A FLUTE ON A CONICAL SURFACE

If the amount the tailstock center is to be raised has been calculated mathematically, then raise the center approximately that amount.

4. Tighten the vertical clamp, then with a surface gauge, test the difference in horizontal levels of the large and small ends, Fig. 280. Compare the differences found with the differences in the layout, or the amount found by calculation; make adjustments if necessary.

5. When the correct level at each end of the cone has been achieved, raise the table until the cutter just touches the top of the work at the small end, test with a piece of tissue paper, then move the table so that the cutter just clears the end of the work.
6. Set the micrometer vertical adjustment at zero, then raise the table sufficiently to make a cut of nearly the required depth. Make the cut in the usual manner, Fig. 281.

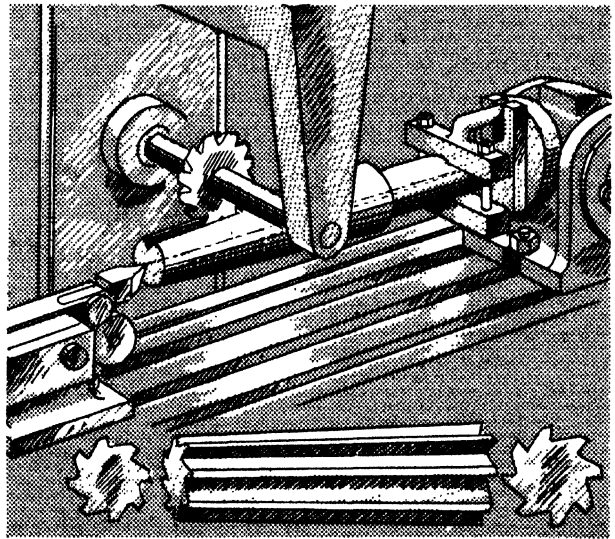

FIG. 281. MILLING A FLUTE ON A CONICAL SURFACE

7. Carefully compare the proportional difference in width of both ends of the machined groove with the widths of the respective layouts made in step 1.
8. If the difference seems to be relatively proportional, adjust the machine to make a cut which will remove about one-half the remaining stock, then test as before. If too much stock is being removed from either end of the groove, adjust the vertical slide in the tailstock so as to move the small end of the stock in a direction which will cause less stock to be removed from whichever end of the machined groove is too wide, then make a second light cut.
9. When the machine has been adjusted to cut a groove of the desired depth and width at each end, proceed as under "Procedure, Milling a Flute on a Cylindrical Surface," steps 12 to 20 inclusive.



## UNIT 58

## SPUR AND BEVEL GEARS

A gear is a wheel or roll upon the face of which teeth have been cut—the purpose of which is to give positive motion to a similar gear. If a plain revolving roll, for example, a pulley or roll with a flat face, is brought into contact with a similar object, motion will be transmitted to the second pulley, Fig. 282, providing the contact is strong enough to overcome the inertia (tendency to remain at rest) and residual friction (friction in bearings, etc.) of the second pulley. If, in addition to inertia and residual friction, a load is applied to the second pulley, then the first pulley will tend to slide along the surface of the second, either failing to cause the second pulley to revolve or revolving it at a greatly reduced speed with consequent loss of effectiveness. The teeth of a set of gears as they engage each other on their working faces (the part of the tooth above the pitch line, Fig. 283) transmit positive motion and each gear revolves at a constant rate. The gear connected with the source of power is called the driver and the one to which motion is transmitted, the driven. These terms have no relation to size. If it is desired that the shaft to which the driven gear is attached shall revolve at three times the speed of the drive shaft, then the driver must have three times the number of teeth of the driven gear, and conversely if the driven shaft is to revolve at only one-third the rate of the driver.

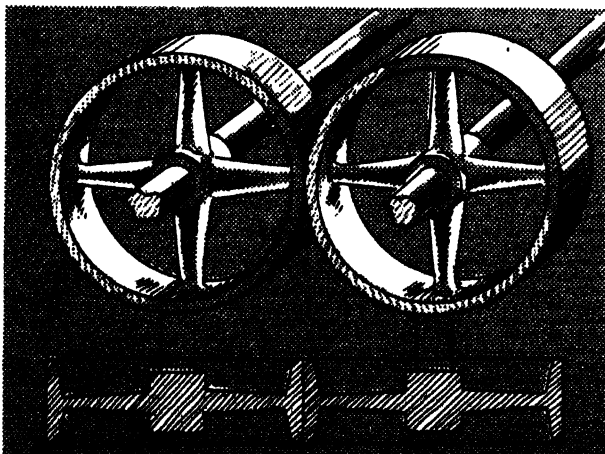

FIG. 282. PULLEYS OR WHEELS WOULD TRANSMIT MOTION INEFFICIENTLY

## SPUR GEARS

Gears on which the teeth run straight across the face and perpendicular to the sides are called spur gears. This is by far the most common form of gear.

In cutting gears on a milling machine, it is not necessary that the operator know how to lay out the teeth of a gear or that he even know the conventional shape of the teeth or the names of the different parts of a tooth. However, the operator who does know these things is likely to derive greater satisfaction in his work and to be a more intelligent and satisfactory employee.

Modern gears generally have involute teeth. This means that the shape of the tooth is generated or drawn with an involute curve; an involute curve may be drawn with a pencil inserted in the loop of a string wound about a cylinder and held taut as the string is unwound, Fig. 283. This form of tooth has been found to give the most satisfactory results in terms of quietness and smoothness of operation. The principal parts of a gear tooth are shown in Fig. 283.

The size of a gear is given in terms of its diameter at the pitch line, which is called

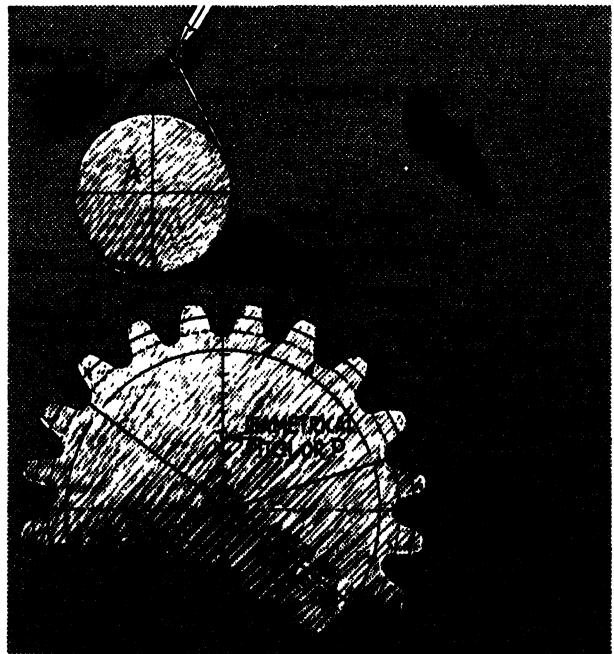

FIG. 283. PARTS OF A GEAR

the *pitch diameter*. This term should not be confused with diametral pitch, which refers to the number of teeth per inch of diameter. To say that a gear is 10 inches in diameter does not tell how many teeth it has. If, however, one says the same gear is a 10 pitch gear then we know it has 100 teeth and if a 20 pitch gear it has 200 teeth or 20 teeth per inch of diameter.

Whenever the word pitch alone is used, it is understood that the diametral pitch is referred to. Diametral pitch is represented in standard formula by the letter P and pitch diameter by the letter D' (D prime).

The outside diameter of a gear varies with the number of teeth. Thus, a 10 inch gear with 100 teeth would have a slightly larger outside diameter than one with 200 teeth. This is because the latter has less height of tooth above the pitch line than the 100 tooth gear. In formula, the outside diameter is represented by the letter D.

The distance on the pitch line from the center of one tooth to the center of the next is called the circular pitch and in formula is represented by the letter P' (P prime).

The part of the tooth above the pitch line is called the addendum and is known also as the working face of the tooth, Fig. 283. The part of the tooth below the pitch line, inclusive of clearance, is called the dedendum and is known also as the flank of the tooth, Fig. 283. The height of both addendum and dedendum on a particular gear varies proportionately with the number of teeth, for example, on a 10 inch gear with 100 teeth, a 10 pitch gear, the height of both addendum and dedendum would be slightly greater than on a gear of similar diameter with 200 teeth, a 20 pitch gear. Both addendum and dedendum are represented in formula by the letter s. Generally, the addendum and dedendum are equal to  $\frac{1}{P}$ . The thickness of the tooth is one-half the circular pitch, or in terms of diametral pitch,

$$\text{one-half of } \frac{3.1416}{P} = \frac{1}{2} \text{ of } \frac{3.1416}{P} = \frac{1.57}{P}$$

**EXAMPLE:** Given a gear 10 inches in diameter (at the pitch line) and having 100 teeth, calculate (1) the diametral pitch, (2) the circular

pitch, (3) the outside diameter of the gear, (4) the thickness of the tooth, (5) the working height of the tooth, (6) the clearance, and (7) the total height of the tooth.

- When: P = Diametral pitch  
 P' = Circular pitch  
 D = Outside diameter or addendum line  
 D' = Diameter of pitch circle  
 t = thickness of tooth  
 s = addendum  
 f = clearance  
 s + f = dedendum  
 D' = Working depth of tooth (addendum + dedendum)  
 N = Number of teeth in the gear

Solution:

1. The diametral pitch, P, equals the number of teeth, N, divided by the pitch diameter, D';

$$\text{then } P = \frac{N}{D'} = P = \frac{100}{10} = 10,$$

therefore, the diametral pitch or pitch = 10.

2. The circular pitch, P', equals the pitch diameter, D', divided by  $\frac{1}{3.1416}$  times the num-

$$\text{ber of teeth, } N = .3183N, \text{ hence } P' = \frac{D'}{.3183N} = \frac{10}{.3183 \times 100} = .314.$$

3. The outside diameter, D, equals the number of teeth, N, plus 2, divided by the quotient secured when the number of teeth, N, is divided by the pitch diameter, D',

$$D = \frac{N + 2}{\frac{N}{D'}} = \frac{100 + 2}{\frac{100}{10}} = \frac{102}{10} = 10.2,$$

therefore, the outside diameter = 10.2"

or

$$D = \frac{N + 2}{P} = \frac{102}{10} = 10.2''.$$

4. The thickness of the tooth, t, is equal to one-half the circular pitch, P'.

$$\text{When } P' = \frac{D'}{.3183N} = \frac{10}{.3183 \times 100} = .314$$

$t = \frac{P'}{2} = \frac{.314''}{2} = .157''$ , therefore, the thickness of the tooth equals .157'', or,

$$t = \frac{1}{2} \text{ of } \frac{3.1416}{P} = \frac{1.57}{P} = \frac{1.57}{10} = .157''$$

5. The working height of the tooth is equal to the addendum,  $s$ , plus the dedendum, both of which have the same value.

$$s = \frac{D - D'}{2} = \frac{10.2'' - 10''}{2} = .1'' \text{ height of addendum.}$$

Since addendum and dedendum have the same value, then total working height of the tooth =  $s + s = .1'' + .1'' = .2''$ , therefore, the working height =  $.2''$ .

6. Clearance,  $f$ , equals  $t$ , the thickness of the tooth,  $.157$ , divided by the diametral pitch,  $P$ .

$$f = \frac{t}{P} = \frac{.157''}{10} = .0157, \text{ therefore, the clearance} = .0157''.$$

7. The total height of the tooth equals the addendum,  $s$ , plus the dedendum,  $s$ , plus the clearance,  $f$ . Total height of tooth =  $s + s + f$  or  $2s + f$ . Then from 5 and 6 above  $2 \times .1'' + .0157'' = .2157$ , therefore, the total height equals  $.2157''$ .

Given the number of teeth and the diametral pitch, the pitch diameter,  $D'$ , may be found by dividing the number of teeth,  $N$ , by the diametral pitch,  $P$ .

$$D' = \frac{N}{P} = \frac{100}{10} = 10'', \text{ therefore, } D', \text{ the pitch diameter,} = 10''.$$

### BEVEL GEARS

If, instead of two flat rolls or pulleys in contact with each other, two conical or tapered

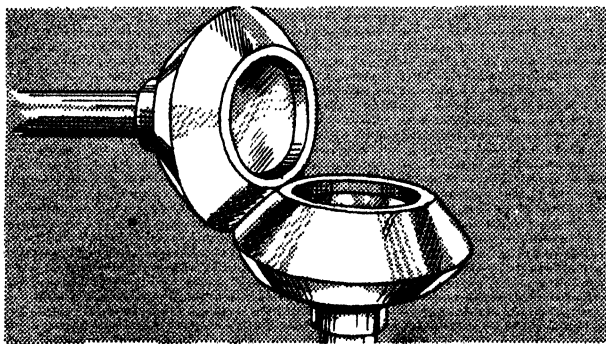

FIG. 284. THESE FLAT ROLLS WOULD TRANSMIT MOTION INEFFICIENTLY

rolls are brought into contact, as in Fig. 284, the driver will transmit motion to the driven. But when a load is applied there will again be slippage and consequent loss of effectiveness. Positive motion to the driven roll is accomplished by cutting teeth on each roll. A gear with a conical shape, such as shown in Fig. 285, is called a bevel gear. When it is desired to give positive motion to a shaft running at an angle to a second shaft, Fig. 285, a set of bevel gears is used; usually one gear, the pinion, is much smaller than the other. When both gears are the same size, they usually have a face angle of  $45^\circ$  and are called miter gears. A miter gear is merely a special form of bevel gear. Fig. 286 shows other forms of bevel gears. In A, the two shafts are in planes less than  $90^\circ$  apart, while in B, they are in planes more than  $90^\circ$  apart.

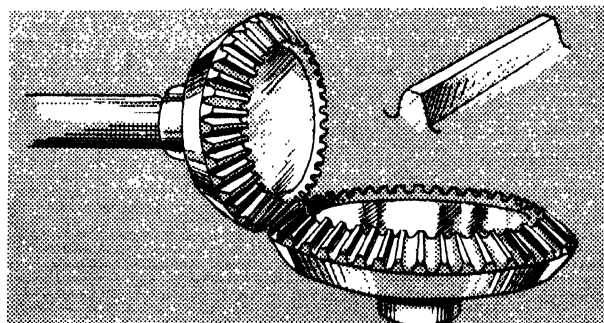

FIG. 285. BEVEL GEARS

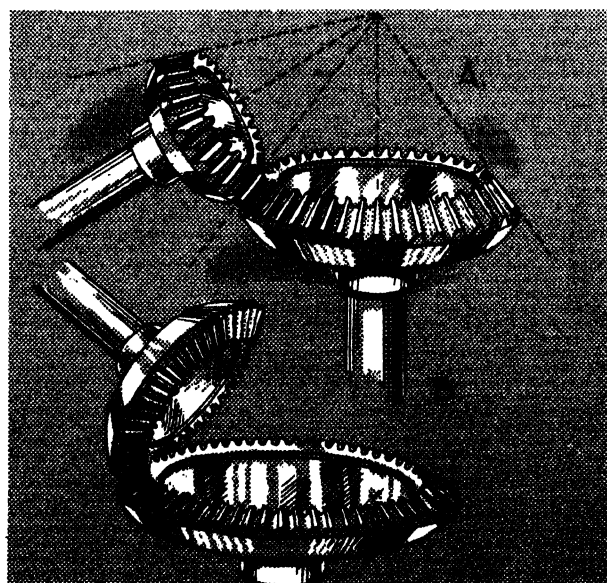

FIG. 286. OTHER FORMS OF BEVEL GEARS

The shape and size of the teeth on a bevel gear at the large end are the same as those in a spur gear, and the method of laying them off at the large end is practically the same. The first step in laying off a bevel gear is to determine the center angle, for example,  $30^\circ$ , A, Fig. 287, then the pitch diameter, the number of teeth, the diametral pitch and the width of the face. Assuming the gear is to have a 5 inch pitch diameter and 30 teeth, then the diametral pitch will be  $\frac{P}{N}$  or  $\frac{30}{5} = 6$  or a 6 P gear. Also assume

that the width of the face is is to be  $\frac{3}{10}$  of the hypotenuse of the center angle AOP, Fig. 287. Having made the necessary calculations, draw the angle AOB, Fig. 288, then draw line AB at

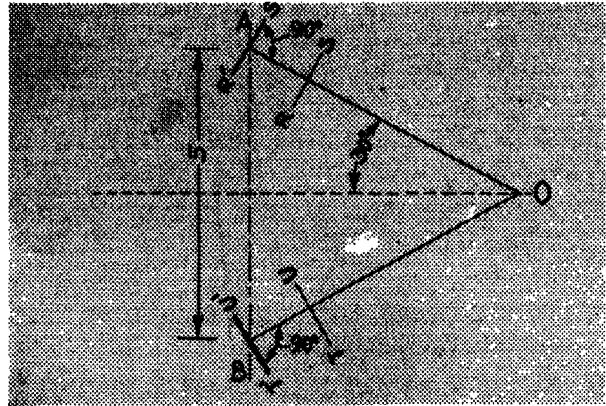

FIG. 288. PRELIMINARY LAYOUT OF A BEVEL GEAR

and T'U'. Using formula three above, calculate the outside diameter of the large end of the teeth and draw lines CO and DO, Fig. 287. Using formulas three and six above, calculate the dedendum of the tooth and the clearance required (the total height of the tooth below line AO), then draw lines EO and FO, Fig. 287. Next calculate the thickness of the tooth, using formula four above. To construct the tooth, extend line AB around the periphery of the wheel, then using the thickness of the tooth, set the dividers, and on the extension of line AB on the periphery, space off one or two teeth. Through the spacing marks on the peripheral line AB, draw involute curves, thus forming the sides of the teeth at the large end. As can be seen from Fig. 287, all lines converge toward the apex of the cone. This means that each tooth is thinner and shorter at the apex end than at the base end. A bevel gear cannot be cut very accurately on an ordinary milling machine using a standard gear cutter. In factories where much bevel gear cutting is done, a special gear-cutting machine is used.

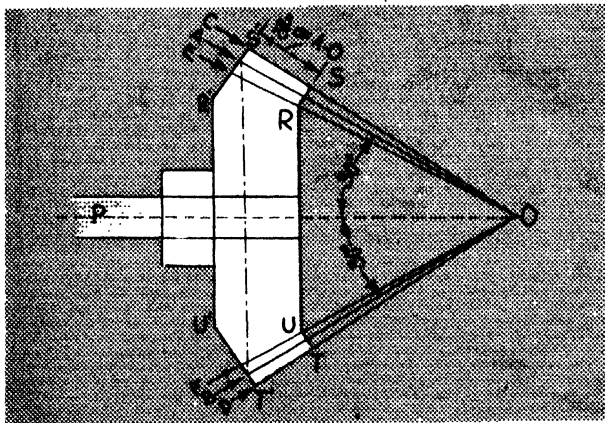

FIG. 287. LAYOUT OF A BEVEL GEAR

a point where it will be equal to the pitch diameter of 5 inches. Through points A and B respectively draw lines R'S' and T'U' perpendicular respectively to AO and BO. Next on lines AO and BO at a distance equal to  $\frac{3}{10}$  of AO draw lines RS and TU parallel to R'S'

UNIT 59

HOW TO MILL TEETH ON A SPUR GEAR

Gear cutting constitutes one of the many interesting kinds of work that can be accomplished on a milling machine and one that appeals very much to young workers. Before the invention of the dividing head it was the custom to cast the teeth on gears, or when they were cut, to space and lay out each tooth accurately.

The cutting process involved the laborious and careful hand setting of the machine for each tooth. The modern dividing head, cutters and other features of modern milling machines has made spur gear cutting a very simple operation once the machine has been properly set and adjusted.

**PROCEDURE**

1. Select a fairly short arbor of a diameter that will fill the hole in the hub of the gear blank.
2. Wipe the arbor clean with a handful of waste, then lightly oil the surface.
3. Force the arbor into the hole in the hub with an arbor press or by means of a lead hammer.
4. With the cross feed, run the table as close as practicable to the column.
5. Secure the dividing head and tailstock and place them on the table of the milling machine as close to the column as the nature of the work and the dividing head will permit. Be sure the index handle is toward the front of the table.
6. Adjust the position of the head and tailstock so that the edge of the gear blank nearest the dividing head, when it is mounted between the centers, will be slightly ahead of the cutter.
7. Fasten the dividing head securely in position. Then slide the tailstock forward until the centers just touch.
8. Examine the position of the points of the centers.

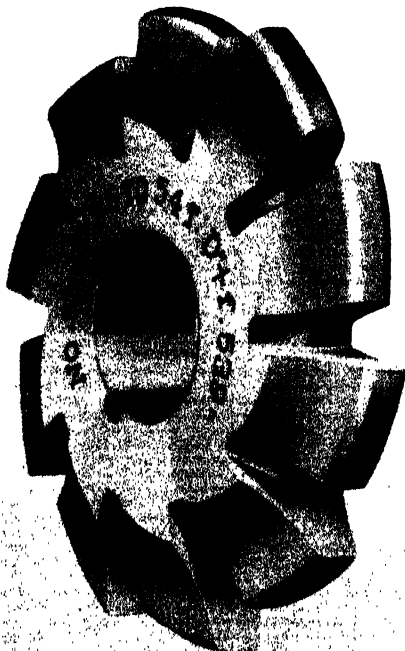

*Courtesy, Cincinnati Milling Machine Co.*

**FIG. 289. TEN PITCH GEAR CUTTER (NO. 5)**

are not in the same plane, adjust the tailstock center vertically until it is in the same plane as the point of the center in the head.

9. Move the tailstock back to the position desired and fasten it securely.
10. Secure a gear cutter of suitable size, for example, a 10 pitch gear cutter (No. 5), Fig. 289, also a cutter arbor, collars, and a dog.

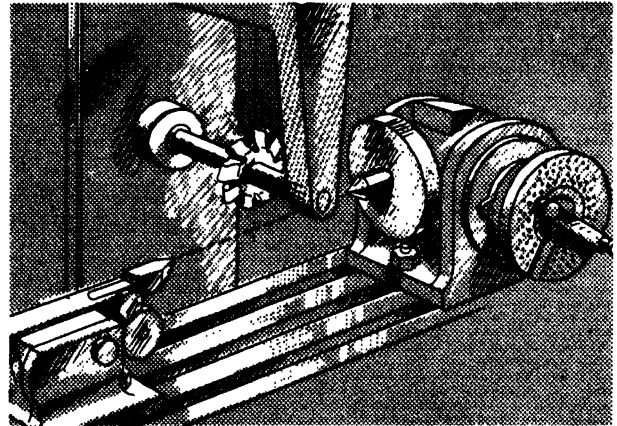

**FIG. 290. CUTTER IN POSITION OVER THE AXIS OF THE DIVIDING CENTER**

11. Wipe the shank of the cutting arbor clean and dry and insert it in the spindle of the milling machine. Then arrange the cutter on the arbor in such position that the center of the cutter is as nearly as possible over the axis (point) of the dividing center, Fig. 290.
12. Place the nut on the arbor and draw it tight against the collar with the wrench. Then adjust the overarm and slide the arbor bearing over the end of the arbor.
13. With the longitudinal feed, move the table back until the cutter is slightly to the left of the point of the center in the dividing head. Then with the vertical adjustment, raise the table until the point of the center is slightly above the level of the bottom edge of the cutter.
14. With the cross and longitudinal feeds, adjust the table until the center of the cutter is exactly over the point or axis of the center in the dividing head.

A more accurate setting may be achieved by mounting a trial blank between the centers of the dividing head. Make a trial cut, then turn the piece end for end and cut from the opposite direction. If the cutter is removing stock from the top of one side of the original cut and from the bottom of the other, the cutter is not centrally located, in which case the work should be moved *laterally away from the side* of the cut on which stock was being removed at the *top* of the original cut.

15. When the cutter has been accurately centered, lower the table and mount the work between the centers of the dividing head, Fig. 291. The large end of the arbor should be toward the headstock.

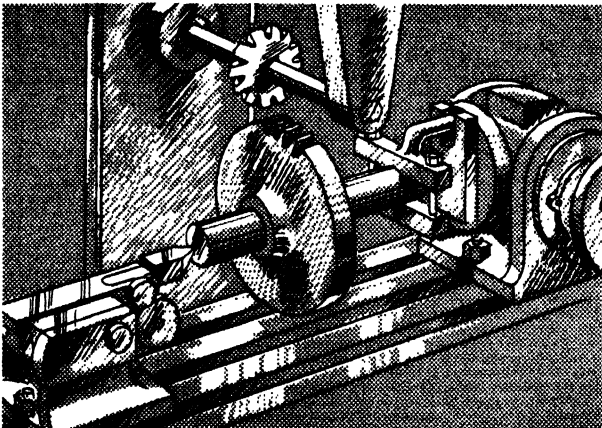

FIG. 291. CUTTING THE SPUR GEAR

16. Insert the tail of the dog in the carrier slot and clamp lightly.
17. Assuming that the gear to be cut has 100 teeth and that one turn of the index handle advances the worm which turns the dividing head spindle  $1/40$  of a turn, then the number of turns of the crank divided by the number of teeth to be cut will give the number of turns of the index handle required to advance the work for the next cut,  $40 \div 100 = .4$  of a turn.
18. Adjust the index pin to any circle of holes which is divisible by 10, then loosen the binding screw and set the sector arms to include 4 tenths of the number of spaces, for example, 4 tenths of 30, which equals 12. Remember it is the number of spaces

that count and that within the total space encompassed by the sector arms there will be one more hole than spaces. When adjusting the sector, be sure the index handle and the sector move freely. See Unit 56.

19. Move the index handle toward the *right* until the pin enters the last hole in the index plate, encompassed between the sector arms, then immediately advance the sector until the left arm touches the pin. Make a practice of always advancing the sector immediately after indexing, and of moving the index handle toward the right.
20. Start the machine, then run the work under the cutter and raise the table until the cutter just touches the work. Test with a piece of tissue paper placed between the work and the cutter.
21. Move the table back until the near edge is just to the rear of the front of the cutter.
22. Set the micrometer dial for vertical adjustment at zero, then raise the table to within about  $\frac{1}{32}$  of an inch of the depth of the finished cut, in this case about .190 on the dial. The total depth of tooth space of a 10 pitch gear is .216. See Unit 58, Solution 7.
23. Engage the automatic longitudinal feed and make the cut. *Be sure to use a cutting compound or lubricant freely.*
24. At the end of the cut, disengage the feed, lower the table and draw it back to the starting position for the next cut.
25. Index 4 tenths of a turn for the next cut then raise the table to the desired level and proceed as in steps 23 and 24.
26. When all teeth have been rough cut, set the machine to make the finishing cut and proceed as in steps 22 to 25 inclusive.

**CAUTION:** Before starting the finishing cut, be sure the cutter is sharp and do not stop the cut at some intermediate point, or run the table back without first stopping the machine.

27. When the job is finished, remove the work, cutter, and dividing head and return them to the place where kept when not in use. Then, with a brush, clean the machine.

## UNIT 60

## HOW TO MILL TEETH ON A BEVEL GEAR

Teeth cannot be cut accurately on a bevel gear with an ordinary bevel gear cutter on a standard milling machine. In large establishments where many gears are cut, a special gear cutting machine is used for this purpose. Small concerns do not have sufficient volume of business to warrant purchasing a special machine; consequently persons working in such establishments are at times confronted with the problem of cutting teeth on a bevel gear.

When choosing a bevel gear cutter, remember it is made thin enough to pass between the teeth at the small end and is shaped to cut the teeth of a spur gear having a *rolling pitch* of the same magnitude as the bevel gear in question, Fig. 292. A spur gear with a 10 inch rolling pitch surface may have many more teeth than a bevel gear of the same rolling pitch surface. However, it is the rolling pitch and not the number of teeth that determines the size of cutter to be used. The same cutter should not be used for cutting both the gear and pinion except when cutting miter gears. Each member of a pair of miter gears has the same number of teeth; this is not the case with a bevel gear and pinion.

A table giving the size of cutter to use for cutting gears and pinions with varying numbers of teeth can be found in a Brown and Sharpe catalog.

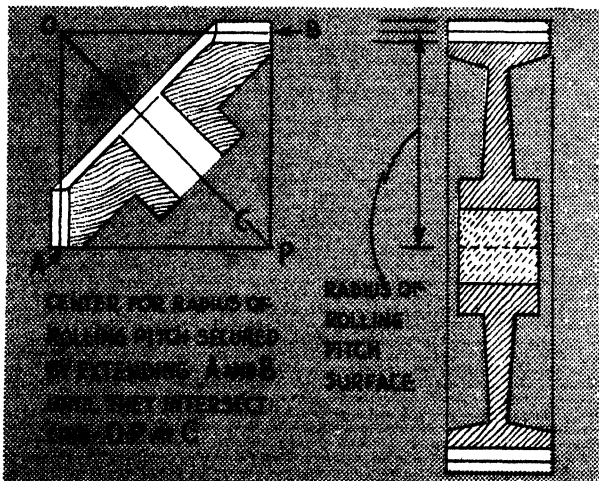

FIG. 292. DETERMINING THE ROLLING PITCH OF A BEVEL GEAR

## PROCEDURE

1. Select a suitable gear blank and machine it accurately according to the dimensions given.
2. Secure a dividing head and a dividing chuck. Fasten the head on the table of the milling machine and mount the chuck on the dividing head spindle.
3. Set the dividing head at the cutting angle as given on the drawing, Fig. 293.
4. Select a bevel-gear cutter of a size suitable for cutting teeth of the size specified, for example, 10 P.
5. Secure a spindle arbor and collars of suitable size. Be sure all chips are removed from the arbor and collars.
6. Mount the cutter on the arbor as near the nose of the spindle as practicable and in such manner that the cut will be made away from the dividing head. Position the overarm and arbor bearing and fasten securely.

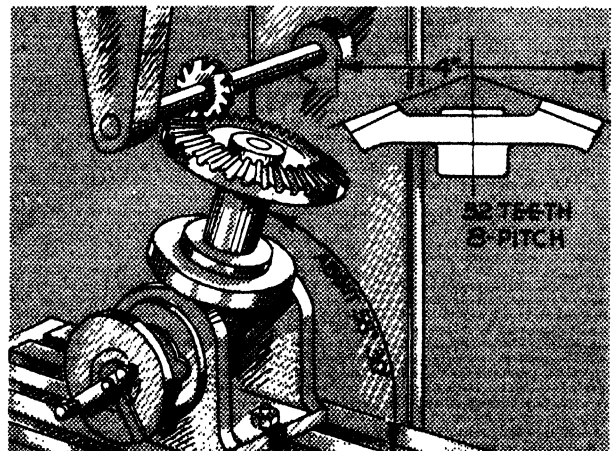

FIG. 293. CUTTING A BEVEL GEAR

7. Mount the gear blank in the chuck, being sure it is seated accurately, Fig. 293.
8. Adjust the table until the center of the point of the cutter appears to be in line with the axis of the gear blank, Fig. 293.
9. Start the machine, then raise and advance the table until the cutter just touches the surface of the gear blank.

10. Set the micrometer dial for vertical adjustment at zero, then raise the table the depth of cut, for example, .216 of an inch.
11. Make the cut in the usual manner, using a cutting compound freely and observing the usual precautions against drawing a revolving cutter over the work.
12. Index for the next tooth and make the cut.
13. Accurately caliper the thickness of the tooth at the large end. Use a gear tooth vernier caliper, Fig. 294. Assuming the large end is found to measure .194", then from this measurement subtract the finished thickness of the tooth, for example, .157", and divide the remainder by 2,

$$\frac{.194 - .157}{2} = \frac{.037}{2} = .0185''.$$

This figure represents the amount of stock to be trimmed from each side of the large end, A, Fig. 295.

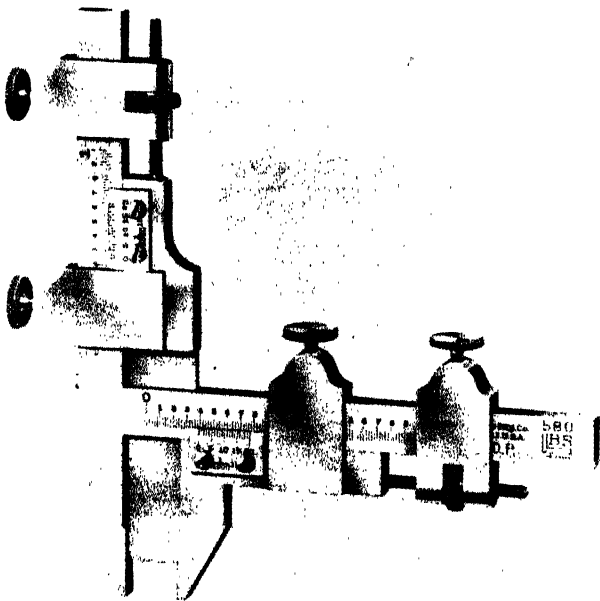

Courtesy, Brown & Sharpe Manufacturing Co.

FIG. 294. GEAR TOOTH VERNIER CALIPER

14. In a similar manner, calculate the amount to be trimmed from the small end. Ordinarily, only a very small amount, if any, will need to be trimmed from the small end.
15. Paint the cut surfaces of the tooth with a wash coat of shellac mixed with a little yellow ochre, or with a solution of blue vitriol.

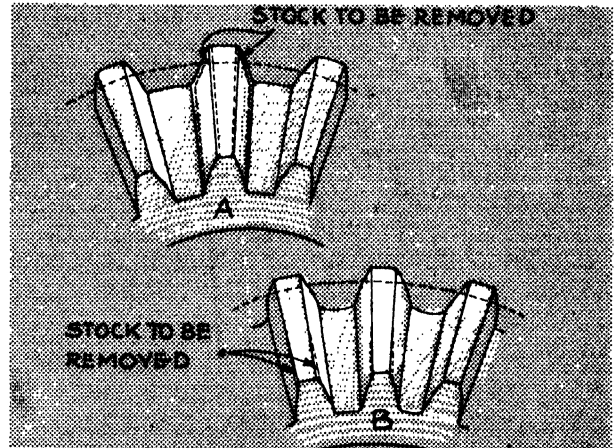

FIG. 295. LAYOUT OF STOCK TO BE REMOVED ON FINISHING CUT

Since only a very small amount has to be trimmed from the small end, the correct setting of the machine cannot be achieved by merely moving the index pin a hole or two to the right, as that would tend to move the small end of the gear proportionately with the large end and result in too much stock being removed from the small end. The amount of set over and the amount of roll for trimming teeth of various sizes will be found in the handbook of the particular machine being used, or in similar publications.

16. Loosen the clamping screws and offset the table of the milling machine about one-eighth of the thickness of the tooth at the large end, for example, about .02 of an inch, then clamp the table securely. Be sure to adjust for back lash.
17. Withdraw the index pin and, with the side index plate, rotate the blank until the edge of the cutter is in position to take a cut of the amount desired, for example, .0185".  
If the pin does not fit in a hole when the blank has been revolved to the position desired, loosen the index plate lock and move the plate until one of the holes comes under the pin.
18. Start the machine and carefully trim the side of the tooth. This should remove all of the shellac except at the extreme of the small end.
19. Again measure the ends of the tooth. If the tooth is still too thick at either end,



offset the blank (as in step 16) in the direction desired and take another light cut.

**CAUTION:** In making this second adjustment the amount of offset will be the difference between the required thickness of the tooth plus one-half the difference found when the tooth was first measured, for example,  $.157 + .0185" = .1755$  of an inch, and the magnitude of the last measurement, for example,  $.1805$  of an inch. Then  $.1805" - .1755" = .005$  of an inch, the amount to be removed.

20. Set the sector for the number of holes through which the index handle is to be moved, then index for the next tooth.
21. Start the machine and proceed in the usual manner, observing the usual precautions. Continue thus until all the teeth have been cut on one side.
22. Offset the table in the opposite direction an amount corresponding with the offset

for the first cut. Be sure to adjust for backlash.

23. Rotate the index handle the same number of holes as before but in the opposite direction.
24. Start the machine and trim the second side of the first tooth.
25. Carefully measure the finished tooth at both ends. Make adjustments, if necessary, and again trim the tooth.
26. When the first tooth has been cut to the size required, proceed to trim the second side of the remaining teeth.

Because the cutter does not have the proper curvature for cutting the top part of the small end of the tooth, it will be necessary to remove a little stock with a file.

27. File the top of the teeth until the desired curvature is achieved, B, Fig. 295.

## UNIT 61

### MILLING HELIXES

Helixes, or spirals, usually are milled on a universal miller, which, as standard equipment, is provided with a dividing head driving mechanism of either the enclosed or open type, as illustrated in Figs. 213 and 214.

A helix is a line, or more generally a groove, which advances longitudinally on a cylindrical or conical shaped object at a constant rate as the object is rotated about its axis. A helix may be either right handed or left handed. To determine the right or left handedness of a helix, hold the object in a horizontal plane before the eyes. If the helix leads or travels upward toward the left, it is a right-hand helix and if downward, toward the left it is a left-hand helix. The distance the helix travels longitudinally in inches while the object makes one complete revolution about its axis is called the lead.

The cylinder in Fig. 296 is twelve inches in length and shows that the helix has traveled twice around the cylinder in traversing its complete length. Thus, the helix has a lead of 6 inches. If the same cylinder were only 3 inches long, as indicated at A, the helix would still have a six inch lead, because the illustration

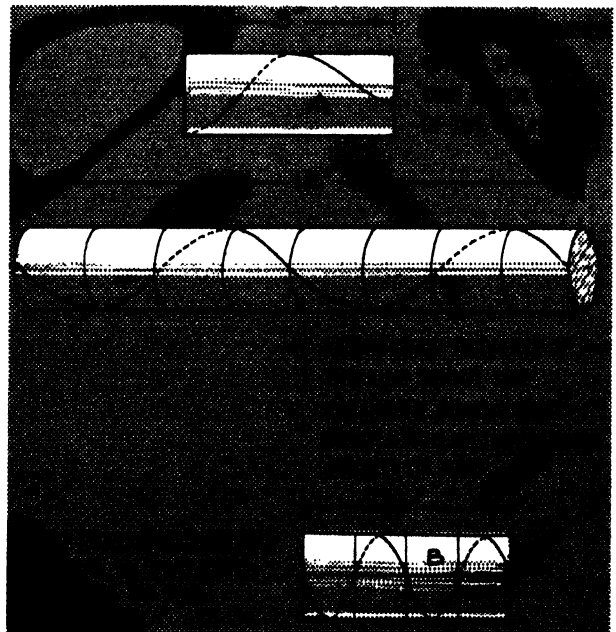

FIG. 296. RIGHT-HAND HELIX WITH A SIX-INCH LEAD

shows that the helix has traveled only half way around the cylinder in one complete revolution of the cylinder. On the other hand, if in two revolutions of a cylinder 3 inches long, the helix

had traveled twice around the cylinder, as in B, then the helix would have a lead of  $1\frac{1}{2}$  inches. Thus, the lead equals the distance in inches traveled by the helix, divided by the number of revolutions made while the helix is traveling the length of the cylinder. For example, if a cylinder 15 inches long makes  $2\frac{1}{2}$  revolutions while the helix is traversing its length, then 15 inches divided by  $2\frac{1}{2}$  turns equals 6, and the helix has a lead of 6 inches.

Variations in the rate at which the helix advances are achieved by variations in the size of gears used in the driving mechanism. These are called change gears. Ordinarily there are 12 gears in a set of change gears. In a compound train of four gears two are driving gears and two are driven. To achieve a given lead, one must select gears having a ratio that will cause the work to rotate at a given speed while advancing toward the cutter a given distance.

Change in the direction of rotation of the stock is accomplished by introducing an idler gear into the train of gears. The sole function of the idler is to change the direction of rotation. Introducing an idler in no way affects the gear ratio. After the helical mechanism has been adjusted, indexing for subsequent helices is done in the usual manner.

With universal milling machines and with dividing head driving mechanisms, comes a set of instructions entitled "Table of Change Gears, Angles and Leads." These instructions tell what gears to use and the position in which they are to be placed in the driving mechanism in order to produce a given lead in inches for each revolution of the stock. In the event of the loss of the instructions or of the need of computing a gear ratio not given, a mathematical formula is given in Unit 62.

When milling a helix, the work must be set at an angle to the axis of the cutter swiveling the table of the machine, except when using an end mill, C, Fig. 297. Even when the work is set at an angle, a helix with straight sides cannot be milled true and smooth with a circular cutter having parallel sides, for example, the cutter illustrated in A, Fig. 297. This is because a circular mill with straight sides cannot fit in a curved groove without striking and thus tearing the sides of the groove as it revolves, thus making the groove wider at the top than

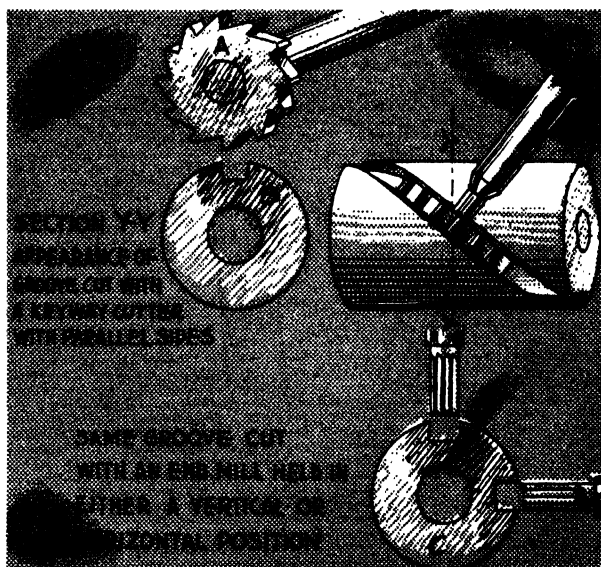

FIG. 297. HELICES CUT WITH KEYWAY CUTTER AND END MILL

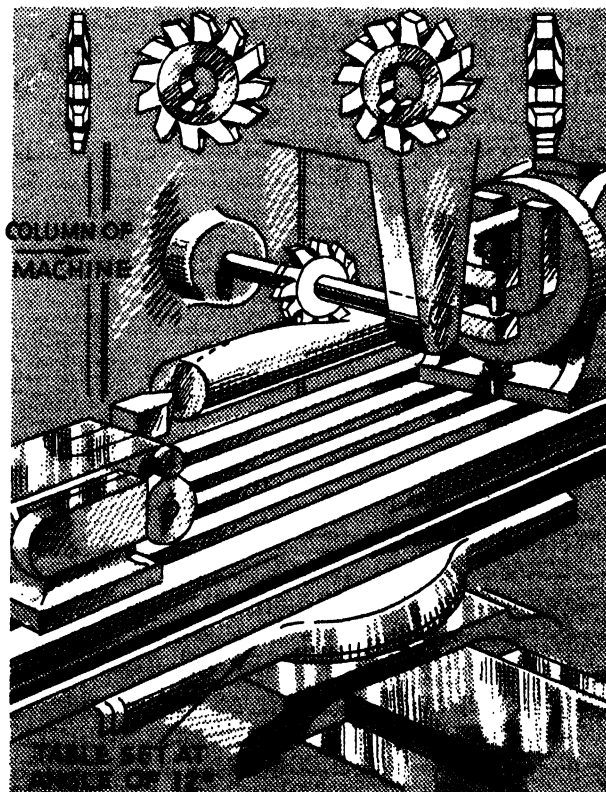

FIG. 298. HELIX BEING CUT WITH CUTTER HAVING FORMED TEETH

the dimension given, B, Fig. 297. On the other hand, a formed circular cutter on which the sides of the teeth tend to converge toward the point, can be used to mill a helix having sides

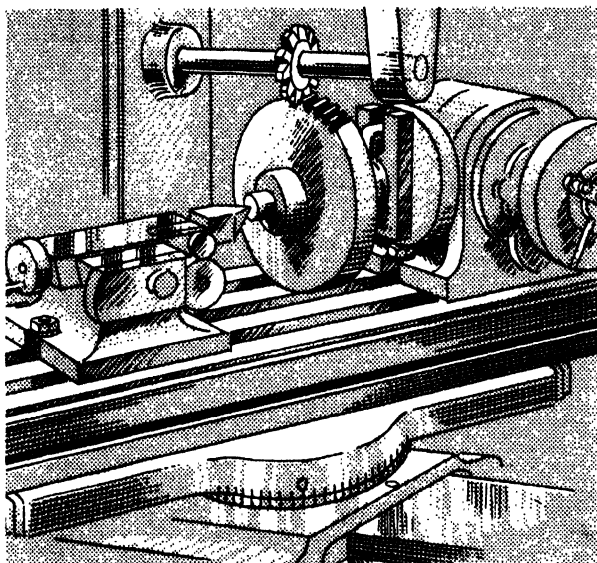
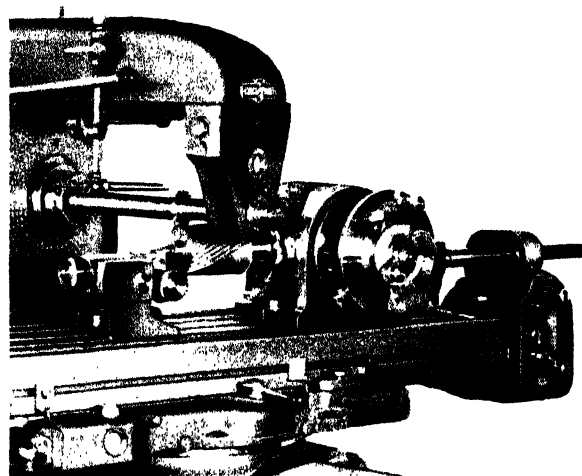

FIG. 299. CUTTING A LEFT-HAND HELIX

which conform to the slope of the teeth, for example, Fig. 298. This is because the sides of the teeth are only in full contact with the sides of the groove at the moment a given tooth is removing the metal at the bottom of the groove. After passing this point the sides of the tooth swing clear of the finished part of the groove.

The method of computing the angle at which the table should be swiveled for different helix leads is explained in Unit 62.



*Courtesy, Cincinnati Milling Machine Co.*

FIG. 299-A. CUTTING A RATHER STEEP LEFT-HAND HELIX

When cutting a right-hand helix, the table should be swiveled toward the right from the zero line on the saddle through the desired number of degrees, see Fig. 298. For cutting a left-hand spiral, the table is swiveled toward the left from the zero line as in Fig. 299. Fig. 299A illustrates the table swiveled to the left for cutting a rather steep helix.

Because of the impracticability or in some cases impossibility of swiveling the table for a steep helix, the use of a universal spiral milling attachment, Fig. 223, is recommended.

## UNIT 62

### CHANGE GEARS, ANGLES AND LEADS FOR HELICAL MILLING

When milling a helix one must employ some means of causing the work to rotate at a constant rate as the cutter advances. This is accomplished by gears with a definite ratio mounted in the dividing head driving mechanism. Furthermore, with rare exceptions, the work or the cutter must be set at an angle.

In the absence of instructions giving the gears to be used in the dividing head driving mechanism to produce a given rotation of the stock as the cutter advances, the workman can determine the gears to use by the application of a simple formula. Before he can do this he must know the pitch of the longitudinal feed screw on the milling machine. Usually the threads on this screw have a one-fourth inch

pitch. Thus, in 40 turns of the feed screw, the table will advance 10 inches. If a single pair of gears, one mounted on the feed screw and the other on the driving head worm, is used and each has the same number of teeth, for example 80, a one to one ratio will exist and the work will make one complete revolution about its axis while the table has advanced 10 inches. Such a helix would have a 10-inch lead. The same ratio would exist if four gears of the same size were used, two driving and two driven, for example, four gears each having 40 teeth. The same condition would prevail if the driving gears have a different diameter from that of the driven gears but if each driving gear has the same number of teeth

and likewise for the driven gears, that is, 32 and 40 respectively, for each gear in each pair.

Gear Formula:

$$\frac{\text{Lead of Machine}}{\text{Lead of Spiral}} = \frac{\text{Driving Gears}}{\text{Driven Gears}}$$

Since,

Lead of machine equals 10 inches

Lead of helix equals 15 inches (given)

Then,

$$\frac{\text{Lead of Machine}}{\text{Lead of Helix}} = \frac{10}{15} = \frac{\text{Driving Gears}}{\text{Driven Gears}}$$

Therefore, the fraction  $10/15 =$  the ratio of  $\frac{\text{Driving Gears}}{\text{Driven Gears}}$  necessary to produce a helix with a 15 inch lead, if a simple train of two gears is used. However, no such gears are available and a simple train of gears is seldom used, because a compound train of four gears makes it possible to obtain a much greater range of ratios than can be achieved using a simple train of two gears.

The ratio for each gear when four are used is obtained by splitting the fraction derived when the lead of the machine is taken as the numerator and the lead of the helix is taken as the denominator, in this case 10 and 15 inches respectively, into two fractions. Thus,  $\frac{10}{15} = \frac{5 \times 2}{3 \times 5}$  But gears with five, two and three teeth are not available. To overcome this difficulty both the numerator and denominator of each fraction are multiplied by a number that will give a numerator and a denominator which corresponds to the number of teeth on two of the available change gears, for example, gears with 40 and 32 teeth. Multiplying both members of a fraction by the same number does not change the value of the fraction.

Then,

$$\frac{10}{15} = \frac{5 \times 2}{3 \times 5} \quad \text{Multiplying both the numer-}$$

ator and denominator of  $\frac{5}{3}$  by 8 and  $\frac{2}{5}$  by 16,

$$\text{one gets } \frac{5 \times 8}{3 \times 8} = \frac{40}{24} \quad \text{and} \quad \frac{2 \times 16}{5 \times 16} = \frac{32}{80}$$

$$\text{Thus } \frac{40}{24} \quad \text{and} \quad \frac{32}{80} \quad \frac{\text{Driving Gears}}{\text{Driven Gears}}$$

This series of gears when arranged as follows will produce a helix with a 15 inch lead:

80 tooth gear on worm (driven gear)

40 tooth gear first gear on stud (driving gear)

32 tooth gear second gear on stud (driven gear)

24 tooth gear on feed screw (driving gear)

For a helix with an 18 inch lead, the ratio would be as follows:

$$\frac{\text{Lead of machine}}{\text{Lead of helix}} = \frac{10}{18} = \frac{\text{driving gears}}{\text{driven gears}} = \frac{10}{18} =$$

$$\frac{2 \times 5}{3 \times 6} \quad \text{Then multiplying } \frac{2}{3} \text{ by 16 and } \frac{5}{6} \text{ by 8}$$

$$\text{one gets } \frac{32}{48} \quad \text{and} \quad \frac{40}{48} \quad \text{Thus } \frac{32}{48} \quad \text{and} \quad \frac{40}{48}$$

$$= \frac{\text{driving gears}}{\text{driven gears}}$$

When making a set-up for cutting a left-hand helix, an idler gear must be introduced into the train of gears. This in no respect affects the gear ratio, but merely changes the direction of rotation of the stock. Usually, the idler gear is mounted on an adjustable idler bracket. On some machines an idler is used when cutting a right-hand rather than a left-hand helix.

#### THE ANGLE OF THE HELIX

The angle of the helix determines the angle at which the table of a universal milling machine should be swiveled when milling a helix with a cutter having parallel sides, except an end mill.

Swiveling the table at an angle is not feasible when milling very long or steep helixes, for example, helixes with a 6 inch lead. In such cases the use of a universal attachment or the use of an end mill is recommended.

Two methods of determining the angle of a helix, graphical and mathematical, are discussed here.

#### GRAPHICAL METHOD

The angle of the helix may be determined graphically by laying out a right triangle using the circumference of the object or stock as a

base and the lead of the helix as the altitude, for example, a cylinder  $1\frac{1}{2}$  inches in diameter and a lead of 24 inches.

Hence, when base =  $1\frac{1}{2} \times 3.1416 = 5.499$  or approximately  $5\frac{1}{2}$  inches and altitude = 24 inches, then the angle of helix equals Angle A, Fig. 300.

Determine the number of degrees in Angle A, by measuring it with a protractor. This is found to be approximately  $12^{\circ}54'$  or  $12-9/10^{\circ}$ . The line marked "hypotenuse" in Fig. 300 represents the line of the helix as it would traverse the cylinder if the triangle were cut out and wrapped around the cylinder.

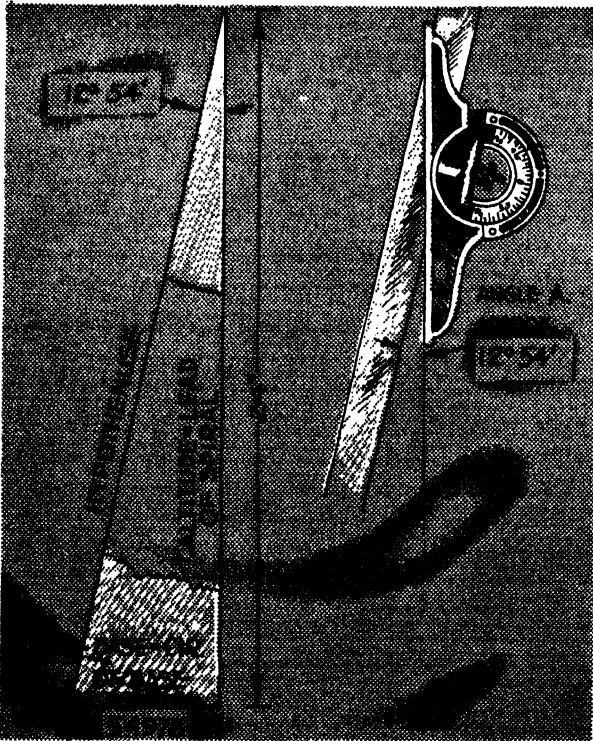

FIG. 300. GRAPHICAL METHOD OF FINDING THE ANGLE OF THE HELIX

#### MATHEMATICAL METHOD

The angle of a helix may be found by dividing the circumference of the stock by the lead.

Therefore,

$$\frac{\text{Circumference of stock}}{\text{Lead of helix}} = \text{tangent of the helix angle.}$$

Given the diameter of stock and the lead, for example,  $1\frac{1}{2}$  inches diameter and 24 inch lead,

Then,

$$\frac{1\frac{1}{2} \times 3.1416}{24} = \frac{5.498}{24} = .2291 \text{ tangent of angle.}$$

Examination of a table of trigonometric functions reveals that .2291 is approximately the tangent of an angle measuring  $12^{\circ}54'$ .

When given the diameter of the work-piece and the angle of the helix the lead may be determined by dividing the circumference of the work-piece by the tangent of the angle. For tangent of an angle see a table of trigonometric functions.

EXAMPLE: Find the lead of the helix of a work-piece  $2\frac{1}{2}$  inches in diameter, having a helix angle of  $15^{\circ}$ . From a table of trigonometric functions it is found that the tangent of an angle of  $15^{\circ}$  is .2679.

Solution.

$$\text{Lead} = \frac{\text{Circumference of Work}}{\text{Tangent of Angle}}$$

$$L = \frac{2.25 \times 3.1416}{.2679} = \frac{7.0686}{.2679} = 26.3852$$

Lead = 26.385 inches — roughly  $26\frac{1}{2}$  inches, which is sufficiently close.

Note: When calculating the helix angle of a helical gear, the pitch diameter is taken as the base.

#### UNIT 63

### HOW TO MILL A HELIX ON A UNIVERSAL MILLING MACHINE

A helix or spiral may be milled with an end mill, C, Fig. 297, with a double angle cutter, Fig. 232, with a convex cutter, Fig. 232, or with a formed cutter. If any but an end mill is used on a universal miller the table must be swiveled to correspond with the angle of the helix unless a universal spiral attachment is used.

The procedure which follows is for milling a right-hand helical (spiral) cutter on a milling machine on which the headstock of the dividing head is mounted on the right-hand end of the table. For a machine on which the headstock is mounted on the left-hand end the procedure is reversed. Compare C with D, Fig. 308.

**PROCEDURE FOR MILLING A HELIX  
USING A DOUBLE ANGLE CUTTER**

**EXAMPLE:** Machine a cutter  $2\frac{1}{4}$  inches in diameter, having 15 teeth with radial faces,  $\frac{1}{32}$  inch land, helix angle  $12^\circ$ . Use a double angle cutter  $48^\circ$ - $12^\circ$ .

1. Prepare and turn the stock to size.
2. Determine the number of grooves or teeth to be cut. The number of teeth and the width of the land will determine the amount of offset, see A, Fig. 304.
3. Determine the lead.

$$\text{Lead} = \frac{\text{Circumference of work-piece}}{\text{Tangent of angle}}$$

(See Unit 62.)

Tangent of an angle of  $12^\circ = .2126$  or  $.213$

Applying data gives

$$\text{Lead} = \frac{2.25 \times 3.1416}{.213} = 33.15, \text{ or roughly}$$

33 inches, which is sufficiently close.

4. Mount the dividing head and tailstock on the table of the milling machine, see Fig. 301.
5. Determine the change gears necessary to produce a helix with the lead desired.

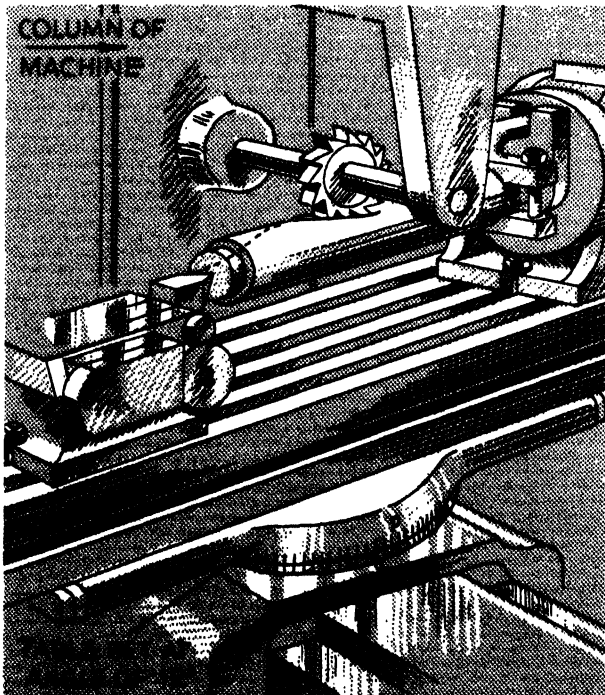

**FIG. 301. MILLING A RIGHT-HAND HELIX**

Mount the gears on the respective shafts and studs on the dividing head, see Unit 62.

6. Operate the longitudinal hand feed to determine that the dividing head mechanism operates freely.
7. Adjust the sector on the dividing head to include the desired number of spaces between the arms, then withdraw the stop-pin.

**EXAMPLE:** Assume that the problem is to mill 15 teeth on a helical cutter.

**Solution:** This means that the work-piece must be rotated through  $24^\circ$  for each tooth,  $360^\circ \div 15 = 24^\circ$ . Since the revolution of the dividing head rotates the work-piece through  $9^\circ$ , then  $24^\circ \div 9^\circ = 2\frac{2}{3}$  turns of the index crank for each tooth space; or since  $360^\circ \div 9^\circ = 40$ , then  $40 \div 15 = 2\frac{2}{3}$  turns of the index crank, or 2 full turns of the crank and  $\frac{2}{3}$  of any circle of holes divisible by 3, for example, 16 spaces on a 24 circle, or 32 spaces on a 48 circle, or 26 spaces on a 39 circle. See Unit 56.

8. Secure a suitable mandrel, arbor, cutter, dog, and surface gauge.
9. Apply a little oil to the surface of the mandrel and press it firmly into the work-piece.
10. Place the dog on the large end of the mandrel, then place the piece between the centers of the dividing head.
11. Loosen the swivel clamping bolts, then temporarily swivel the table to the angle desired, for example  $12^\circ$ . Feed the table crosswise until it clears the face of the column by  $\frac{1}{2}$  to  $\frac{3}{4}$  of an inch.

**Note:** For a right-hand helix move the zero line on the swivel plate to the right of the zero line on the saddle, Fig. 301. For a left-hand helix move the zero line on the swivel plate to the left of the zero line on the saddle, Fig. 299.

12. Apply a little copper sulphate, blue vitriol, to the tailstock end of the work-piece.
13. Set the point of the surface gauge at the exact height of the axis of the dividing head center.
14. Scribe a radial line on the coated end of the work-piece as illustrated in A, Fig. 302.

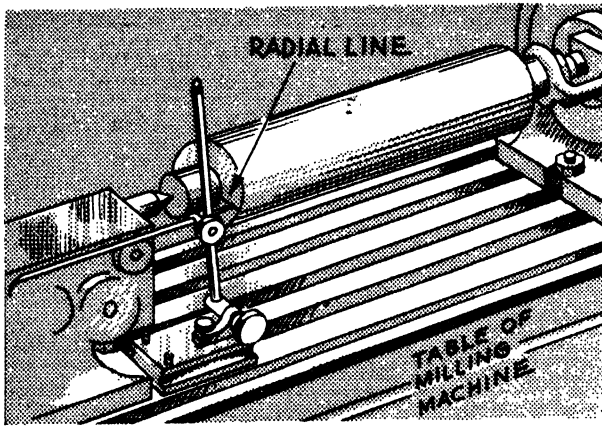

FIG. 302. SCRIBING A RADIAL LINE ON THE TAILSTOCK END OF THE WORK-PIECE

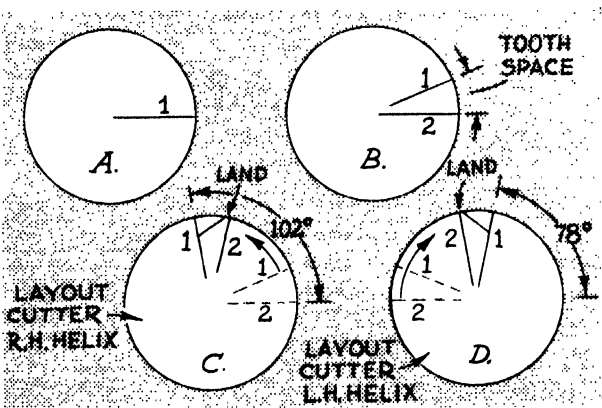

FIG. 303. LAYOUT FOR RIGHT-HAND AND LEFT-HAND HELICES

15. Index the work for one tooth space and draw a second radial line, see B, Fig. 303. Then index the work back one tooth space so that the first radial line will be in its original position, A, Fig. 303.
16. Wipe the arbor and insert it in the spindle, then draw it tight.
17. Mount the cutter on the arbor as nearly over the axis of the work as possible, position the overarm and bearing, then draw the clamping nut tight. In this position the axis of the cutter and the pivot center of the table should be approximately in the same vertical plane.
18. Move the table longitudinally until the end of the work-piece at which the cut is to start is under the center of the cutting arbor.
19. Swivel the table back to its normal position, zero on the graduated base. Adjust

the table laterally until the axis of the work-piece, at the work end, is exactly under the vertical axis of the cutter.

20. Index the work-piece counterclockwise through  $102^\circ$  from the horizontal,  $9\frac{1}{2}$  turns of the index crank, see A and B, Fig. 304.

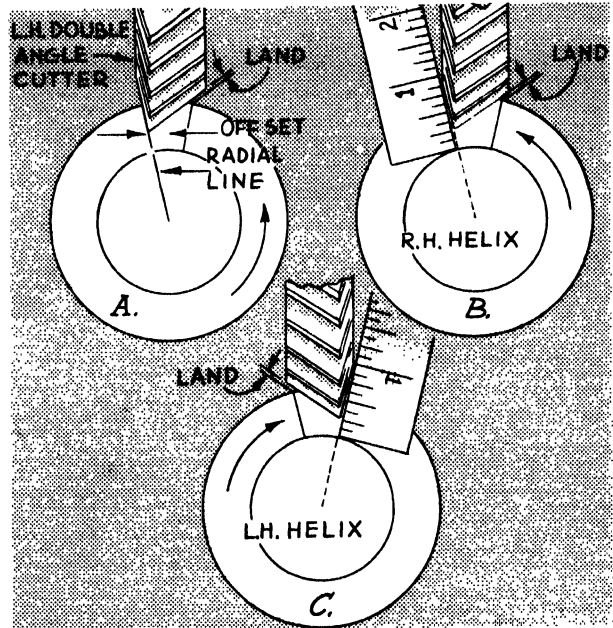

FIG. 304. WORK-PIECE IN POSITION FOR CUT

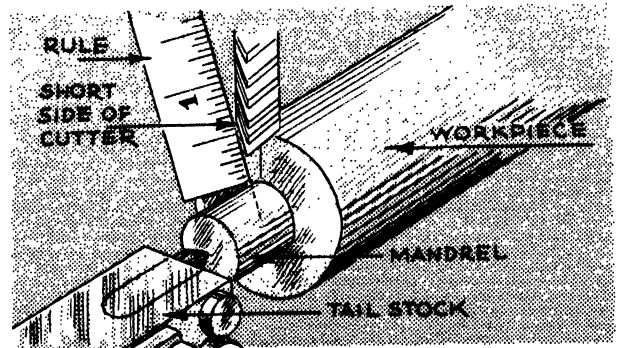

FIG. 305. CHECKING THE POSITION OF THE WORK-PIECE

21. Raise the table until the work just touches the cutter, then adjust the table transversely until the  $12^\circ$  side of the cutter is aligned with the radial line (in the same plane) on the end of the work-piece. Test by holding a rule against the  $12^\circ$  side of the cutter as in Fig. 305. This relationship will be changed when the table is raised to make the cut. To compensate for the change of relationship the table must be

adjusted in a manner that will again align the  $12^\circ$  side of the cutter with the radial line. When correctly positioned the side of the cutter with the acute angle should split the radial line.

C, Fig. 304, shows the work rotated through 78 degrees clockwise and the short side of the cutter aligned with the radial line. Rotated clockwise the work is in the position for milling a left-hand helix.

22. Swivel the table to the angle desired and tighten the clamping bolts.
23. Determine the depth of the groove.
24. Set the graduated collar on the vertical feed at zero.
25. Set the graduated collar on the cross feed at zero. This is done to facilitate making slight lateral (crosswise) adjustments, if and when necessary. Be sure to adjust for back lash, if any.
26. Start the machine, then engage the reverse traverse. When the cutter has cleared the work-piece disengage the power feed and raise the table an amount equal to the depth of the helix groove, less about  $\frac{1}{16}$  of an inch.
27. Engage the power feed, then when the cutter enters the work and is cutting its full depth stop the machine. Examine the cut to make certain that the  $12^\circ$  side of the cutter is within .01 of an inch of splitting the radial line on the end of the work-piece.  
If the cutter is not within about .01 of an inch of splitting the radial line, lower the table, reverse the feed and move the table back until the work just clears the cutter, then make the necessary adjustment by moving the table laterally in the direction desired. Be sure to adjust for back lash.
28. If adjustment was found necessary and has been made, again start the machine

and continue the cut until the cutter is cutting its full depth, then stop the table feed and examine the cut. If further adjustment is necessary, lower the table, reverse the direction of travel, then make the necessary adjustment.

29. When the cutter has been positioned correctly, advance the table until the cutter is cutting full depth, then reverse the table travel and index for one tooth space.
30. Proceed until the cutter is cutting its full depth. Then stop the machine and examine the width of the land (the flat spot at the end of the tooth), see A, Fig. 304. If the land is too narrow the table must be lowered an amount sufficient to increase the land the amount desired. If the land is too wide the table must be raised sufficiently to increase the depth of cut the required amount.  
**CAUTION:** In either event the table must be adjusted laterally to re-align the radial line with the  $12^\circ$  side of the cutter.
31. When the cutter has been properly aligned and set to depth, start the machine and make the cut, as in Fig. 301. Use a coolant freely.  
After the cutter has been set for depth of cut it is good practice to set the graduated collar on the vertical feed at zero. This will facilitate resetting for subsequent cuts.
32. At the end of the cut, lower the table, then reverse the feed and allow the cutter to travel back to the starting point.
33. Index for the next groove, then raise the table and proceed as in steps 31-32.
34. Proceed as in steps 32-33 until all grooves have been rough cut.
35. When all first cuts have been made, adjust the vertical feed for the finishing cut, if one is necessary, then proceed as in steps 31 to 34 inclusive.



## UNIT 64

**MILLING A HELIX WITH AN END MILL**

A helix having straight sides may be milled with an end mill, using either a plain or a universal milling machine, as it is unnecessary to swivel the table.

**PROCEDURE**

1. Turn the work-piece to size.
2. Determine the number of grooves to be milled.
3. Determine the change gears necessary to produce a helix having a lead of the magnitude specified.
4. Mount the dividing head on the table of the milling machine. Mount the gears on the respective shafts and studs of the dividing head mechanism, see Unit 62.
5. Mount the stock between the centers of the dividing head, parallel with the face of the column.
6. Secure a suitable end mill, insert it in the spindle and fasten it securely.
7. Adjust the sector arms on the side index plate to include the desired number of spaces, then withdraw the stop-pin. If spacing can be accomplished by direct indexing this step may be omitted.
8. Move the table longitudinally until the forward part of the cutter is aligned approximately with the end of the work where the helix starts.
9. With the vertical feed, raise the table until the axis of the work and the axis of the cutter are in the same horizontal plane, C, Fig. 297.
10. Set the graduated collar on the vertical feed at zero. This is done to facilitate making adjustments, if and when necessary.
11. With the cross feed, move the table until the end of the cutter just touches the side of the work, then set the graduated collar at zero.
12. Check to make sure that the horizontal axis of the work and that of the cutter are in the same horizontal plane.
13. With the longitudinal feed move the work forward until the cutter clears the end of the work, then with the cross feed, move the work toward the column of the machine an amount equal to the depth of the groove.
14. After setting for depth of groove it is good practice to reset the graduated collar at zero. This will facilitate setting the depth of cut for cutting subsequent grooves and eliminate a possible source of error.
15. Start the machine and engage the longitudinal feed. Use a coolant freely.
16. At the end of the cut draw the table away from the column sufficient for the work to clear the cutter, then reverse the feed and allow the cutter to travel back to the starting point.
17. Index for the next groove, if any.
18. Move the table toward the column until the graduated collar on the cross feed registers zero, then engage the table travel and proceed as in steps 15 to 17 inclusive.
19. Continue as in steps 15 to 18 inclusive until all helixes have been cut.

## UNIT 65

**MILLING A HELIX WITH A UNIVERSAL SPIRAL ATTACHMENT**

With a universal milling attachment an operator can mill a helix on a plain milling machine. This device is particularly well adapted for milling helixes which have a steep lead angle.

**PROCEDURE**

1. Turn the work-pieces to size.
2. Determine the number of grooves to be cut.
3. Determine the helix angle, see Unit 62.
4. Determine the change gears necessary to produce a helix having a lead of the magnitude specified.
5. Mount the dividing head on the table of the machine. Mount the gears on the

respective shafts and studs, see Unit 62.

6. Mount a spiral attachment on the nose of the spindle of the miller. (See Fig. 223.)
7. Attach a suitable dog, then mount the work between the centers of the dividing head.
8. If necessary, draw a radial line on one end of the work-piece. (See A, Fig. 303.)
9. Secure a suitable cutter and mount it in the spiral attachment. Be sure to fasten it securely.
10. Swivel the spiral attachment to the angle desired and fasten it securely in position.
11. Adjust the sector on the dividing head to include the required number of spaces between the arms, then withdraw the stop-pin.
12. With the cross and longitudinal hand feeds position the work for the first cut. Be sure the end of the work is positioned correctly. Test with a rule as in Fig. 305.
13. With the vertical feed raise the table until the cutter comes into contact with the work and test with a piece of tissue paper placed between the work and the cutter, then set the graduated collar at zero.
14. Start the machine in reverse and allow it to travel back until the cutter clears the work-piece, then raise the table sufficiently to make a cut of the depth required.  
Some operators reset the graduated collar at zero after the table has been raised. This practice facilitates setting the machine for depth of cut for subsequent grooves.
15. Reverse the direction of table travel, then when the cutter has advanced far enough to cut its full depth stop the machine and examine the cut.
16. If it is necessary to change the position of the work with respect to the cutter, reverse the direction of table travel, appropriately adjust the table, then start the machine and complete the cut. Use a coolant freely.
17. At the end of the cut lower the table until the cutter clears the work, then reverse the direction of travel and allow the cutter to travel back to the starting point.
18. Index for the next helical cut.
19. Raise the table an amount equal to the amount it was lowered in step 17, engage the longitudinal feed and proceed as in steps 17 and 18.
20. Continue as in steps 17 to 19 until all helixes have been cut.

## SECTION VIII

# THE POWER HACK SAW AND ITS OPERATION

## UNIT 66

### THE POWER HACK SAW

Power hack saws are used primarily for cutting to length metal of various kinds, sizes and shapes. Some machines are equipped with a vise that can be swiveled through 45°. With such machines stock can be cut square or at any angle within the capacity of the machine and vise.

#### TYPES OF POWER HACK SAWS

In general there are two types of power hack saws, wet and dry cutting machines. Both operate on the principle of a reciprocating stroke. On the cutting stroke the saw engages the metal, and as it progresses each tooth removes a small chip. At the end of the stroke the saw blade is raised slightly and moves back to a point where the direction of stroke is reversed, then it again moves forward and another cut is made. The wet cut type of machine runs at higher speeds, has a larger motor, a cabinet base which houses a coolant reservoir, and a pump which circulates the coolant. A dry cutting machine is illustrated in Fig. 306. Its rated capacity is 6 x 6 inches. Actually it will take

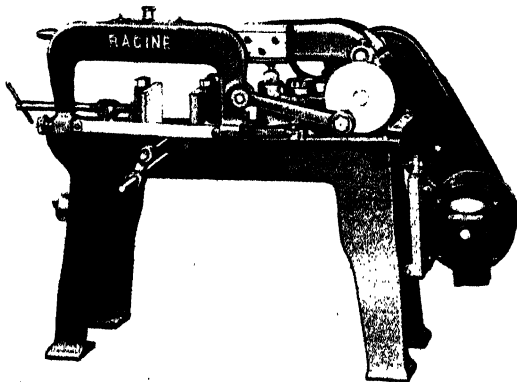

Courtesy, Racine Tool & Machine Co.  
FIG. 306. DRY CUTTING POWER HACK SAW

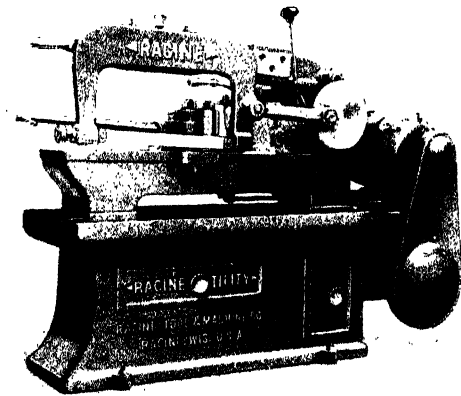

UW 34  
Courtesy, Racine Tool & Machine Co.  
FIG. 307. WET CUTTING POWER HACK SAW

stock a little larger than 6 inches square or 6 inches in diameter. Fig. 307 represents a Wet Cut machine. It has the same capacity as the Dry Cut machine. Both are classified as utility machines, which means that either will cut a variety of metals ranging from soft aluminum through hard alloys in the form of tubing, bars, or shapes.

#### FEED AND CUTTING SPEED

Both of the machines just described are equipped with oil hydraulic feed. This provides accurate feed and pressure control throughout the cut regardless of the type of material. When the cut has been completed a knockout disengages the clutch which activates the saw and the saw frame automatically rises to its highest inactive position. The Dry Cut machine has two cutting speeds, 70 and 100 strokes per minute. The Wet Cut machine is available with two or three cutting speeds. The two-speed type has 100 and 140 strokes per minute. The three-speed type operates at the rate of 140 strokes

for cutting mild and cold rolled steel, 90 strokes for tool steel and cast iron, and 60 for high speed steel, stainless steel and hard alloys. On machines equipped with a three speed transmission, changes in cutting speed are made by moving the change speed lever to the position recommended on the feed speed chart. Feed on these machines is controlled automatically, and likewise the downward pressure on the saw blade during the cutting stroke. At the end of the stroke the blade is automatically raised to clear the work and is carried back to the starting point of the cutting stroke. This prevents unnecessary wear on the back of the teeth, which would greatly shorten the life of the blade.

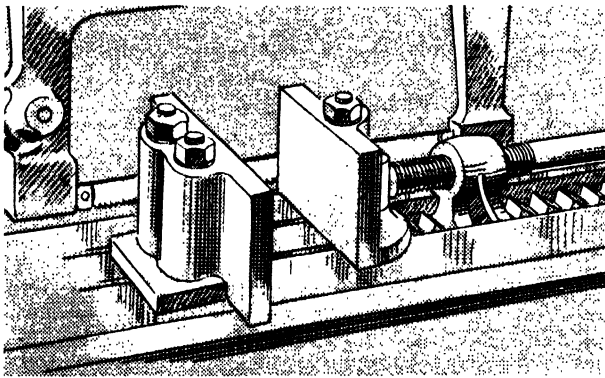

FIG. 308. POSITIONING THE VISE ON THE POWER HACK SAW TABLE

#### VICES

On the utility type of machine, the vises are of the swivel type and have a rated capacity of 4 inches. The movable jaw can be positioned quickly by means of a toothed (serrated) rack, Fig. 308, which is part of the table plate. Notice that in Fig. 307 the movable jaw of the vise has been advanced along the toothed rack until it is close to the fixed jaw, thus requiring little advance of the clamping screw to close the jaws completely. The machines illustrated in Figs. 306 and 307 have adjustable stops which when set to a particular dimension enable the operator to cut a number of pieces identical in length without having to measure each piece. In Fig. 306 the stop is plainly visible on the near side.

#### SAW BLADES

The blades recommended for the saws shown in Figs. 306 and 307 are 14 inches in length, 1½ inches wide and have 4 or 6 teeth per inch.

Blades with more teeth per inch can be used when necessary; for example, when cutting thin walled tubing. The blades are held in position against the aligning surfaces of the blade holder with socket head screws and tensioned by means of hardened bolts.

#### DRIVE

Both Wet and Dry Cut Utility Saws can be purchased with either belt drive or direct motor drive. The Dry Cut type of machine requires a motor with a capacity of one-half horse power, while the Wet Cut type requires three-fourths horse power to operate it satisfactorily.

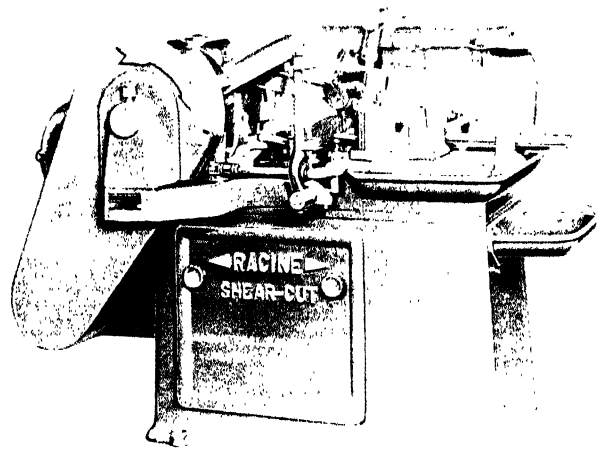

*Courtesy, Racine Tool & Machine Co.*

FIG. 309. SHEAR CUT POWER HACK SAW

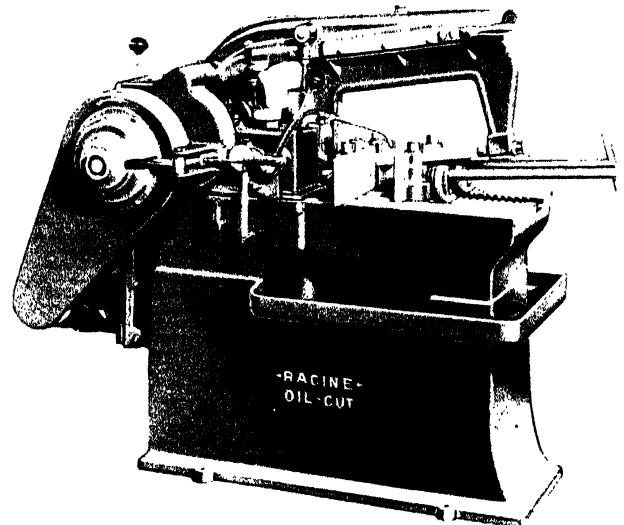

*Courtesy, Racine Tool & Machine Co.*

FIG. 310. HIGH SPEED POWER HACK SAW

Fig. 309 illustrates a saw which makes a shearing cut on each stroke. This machine has positive, progressive screw feed. As the saw is progressively advanced throughout the cut each tooth as it comes in contact with the work removes a long, thin, curled chip. The machine is made with a capacity as high as 8 or 9 inches.

Fig. 310 is a high speed saw which has a single lever control of feed, clutch, rapid traverse and neutral operating positions. It can be used to cut a great variety of metals. It is a high production machine.

Fig. 311 is another heavy-duty hydraulic saw. The machine illustrated has been loaded

with long bars from which pieces of a certain length are in the process of being cut. With this type of machine the stock to be cut is loaded on a carriage which, at the completion of a cut, automatically moves forward the distance required. Hydraulic pressure automatically operates the vise jaws, gauges the material, raises and lowers the saw blade. Once the machine has been set up for cutting stock to a given length it will operate automatically without the attention of an operator, until all stock loaded on the carriage has been cut. This machine is available with a swivel base for cutting angles, and a capacity as high as 20 x 20 inches.

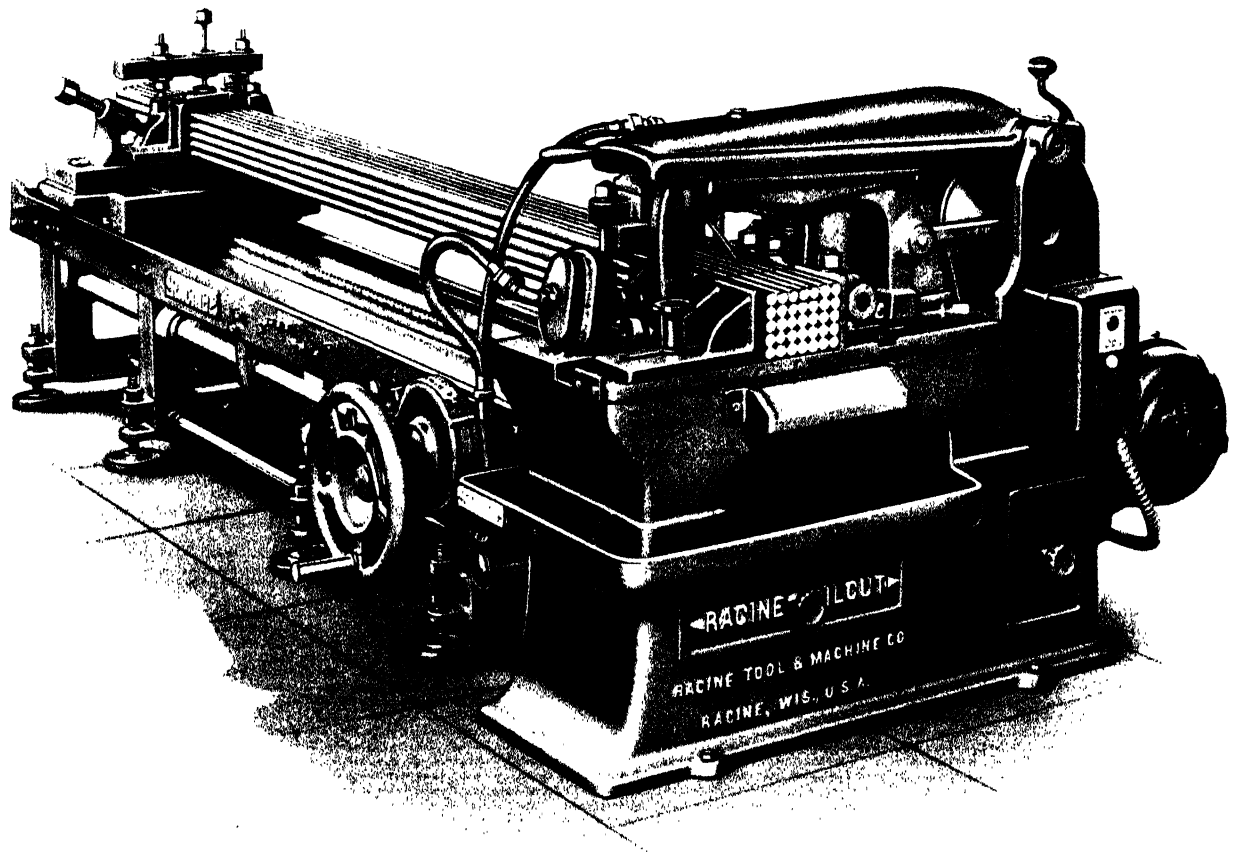

FIG. 311. HEAVY DUTY HYDRAULIC SAW

*Courtesy, Racine Tool & Machine Co.*

## UNIT 67

### HOW TO CUT METAL WITH A POWER HACK SAW

Power metal cutting saws cut most effectively when the recommended cutting speed is used for a particular material. For information

concerning cutting speeds, see Unit 66. Most of the metal cut in a school shop is of the soft variety and can be cut at high speed, 140

strokes per minute. When it is necessary to cut high speed steel, hard alloys, or cast iron the machine should be adjusted to run at either 60 or 90 strokes per minute.

Only when cutting thin walled material such as tubing or hard metal will it be necessary or advisable to use a saw with more than 4 or 6 teeth per inch.

#### PROCEDURE FOR SQUARE CUTTING

1. If necessary, adjust the machine for the speed recommended for the material to be cut.

If the machine is of the transmission type adjust the speed change lever to the position desired: high, medium, low. If belt driven, shift the belts in a manner that will produce the speed desired.

If a change of blade appears necessary consult the instructor.

2. Secure the stock to be cut.
3. Measure and mark the point on the stock where the cut is to be made, or set the stop so that the distance from the outside of the saw to the stop will be equal to the length of stock required.

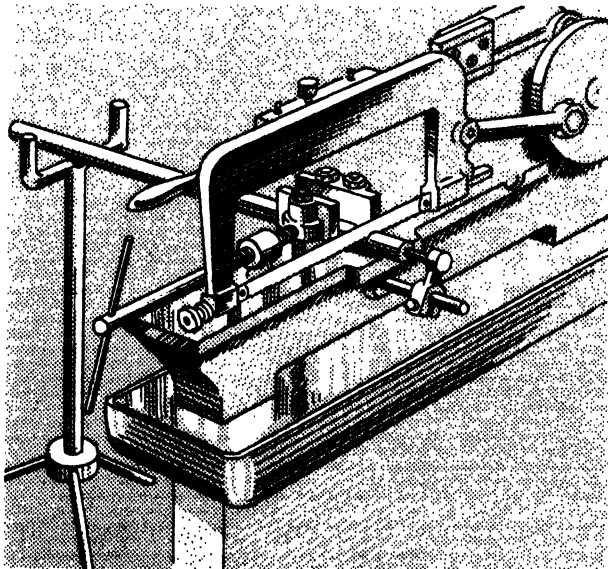

FIG. 312. USING A SUPPORT TO CUT LONG STOCK

4. Place the stock between the jaws of the vise in position to make the cut; the end against the stop if one is used. If the stock is long use a support as indicated in Fig. 312.
5. When the stock has been correctly positioned draw the movable jaw of the vise against the stock with the clamping screw.
6. When the work-piece has been fastened securely start the machine, open the coolant valve and direct the flow of coolant into the saw cut.
7. At the end of the cut shut off the power. This step is unnecessary if the machine is equipped with an automatic knockout.
8. Measure the cut piece to determine if it is the correct length. If not make the necessary adjustment of the stop.
9. Loosen the vise and adjust the stock for the next cut, if any, then proceed as in steps 6 and 7.

#### PROCEDURE FOR ANGULAR CUTTING

1. Loosen the clamping bolts on the vise jaws, then adjust the jaws to the angle desired, for example, 45 degrees, see Fig. 313.
2. Tighten the clamping bolts, then proceed as when making a square cut.

**CAUTION:** If a stop is used be sure to set it in a position that will produce a piece of material of the length required.

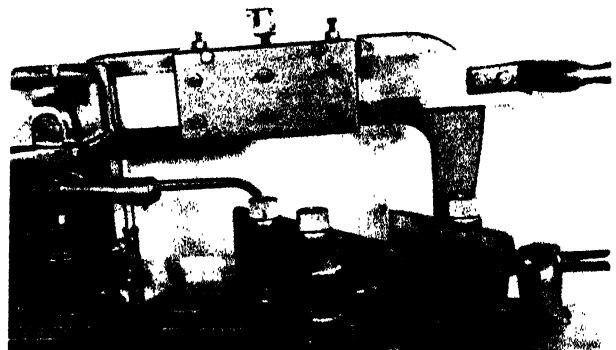

Courtesy, Racine Tool & Machine Co.  
FIG. 313. VISE IN POSITION TO MAKE A CUT AT A 45° ANGLE

## SECTION IX

# METAL CUTTING BAND SAWS AND THEIR OPERATION

## UNIT 68

### METAL CUTTING BAND SAWS

Cutting soft metals with a band saw has been practiced for many years, usually with band saws designed primarily for cutting wood. In some instances a blade designed for cutting metal was used, but frequently standard wood cutting blades were used. Neither was effective in terms of modern production requirements.

In recent years band saws especially designed for cutting metals have been developed. Two general types are available, one in which the blades travel in a horizontal plane or in a plane slightly inclined from the horizontal, as in Fig. 314. On the other type the blades travel in the traditional manner, approaching the work in

a vertical plane. On both types the saw blades travel around saw-carrier wheels which have a heavy layer of hard rubber cemented to the wheel surface to protect the saw teeth.

#### HORIZONTALLY OPERATED CUT-OFF BAND SAWS

The saw illustrated in Fig. 314 can be adjusted to cut stock square or at an angle. Its maximum capacity is 8 inches for round stock and 8 by 16 inches for flat stock. Within its capacity it can be used to cut a variety of irregular shapes. The feed is hydraulically controlled; consequently so long as the hydraulic system is working properly, the danger of too rapid feeding is eliminated. Other features are an adjustable vise, an adjustable stock stop and a means of varying the cutting speed. A means of applying a cutting oil is available in the form of a drip applicator. This attachment can be mounted directly on the machine and the lubricant directed at the saw teeth.

Saw blades for this machine are made of high quality carbon steel with permanently hardened teeth and a flexible back. The latter resists fatigue and facilitates continual bending.

#### CONVENTIONAL METAL CUTTING BAND SAWS

This type of saw is made in a number of sizes ranging in work capacity from 8 to 24 inches in thickness and 16 to 60 inches in throat-capacity. They may also be had with either fixed or variable speeds. The fixed speeds usually may be adjusted in increments of 1000 feet per minute of saw travel. The variable speed feature permits easy adaptation to various operating conditions and the peculiar characteristics of a wide range of materials.



*Courtesy, The DoAll Co.*

FIG. 314. HORIZONTALLY OPERATED CUT-OFF  
BAND SAW

Variable speed machines are equipped with a job selector, see Fig. 315. This is a circular chart that gives recommended saw travel and other data pertinent when cutting a large number of commonly used materials. Reference to the chart is a ready means of quickly determining correct cutting speed for a particular material or an operating condition, such as hardness and thickness of the material. Many of these machines are equipped with a "Speed-master" unit by means of which a desired speed can be obtained by merely turning a hand crank, located at the left side of the machine. A gear shift, also located at the left side of the machine, provides easy shifting of the gears so as to produce either high or low speeds.

Some saws are equipped with a tachometer or speed indicator, see Fig. 315. This instrument gives the speed the blade is traveling in feet per minute.

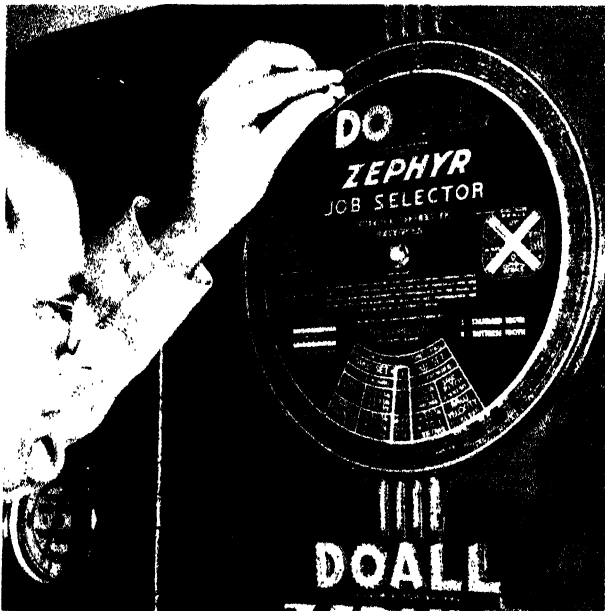

*Courtesy, The DoAll Co.*

FIG. 315. JOB SELECTOR CHART FOR A VARIABLE SPEED VERTICAL BAND SAW

The table on most of these machines can be tilted 45° to the right and 10° to the left, front and rear. A few machines can only be tilted 45° to the right and 5° to the left.

Some machines are equipped with power feed. This mechanism is shown in Fig. 316. A power feed control handwheel, located at the front of the machine, regulates the pull on the

work. When occasion requires, pressure applied to the power feed pedal instantly releases all pressure on the work. The feed mechanism is

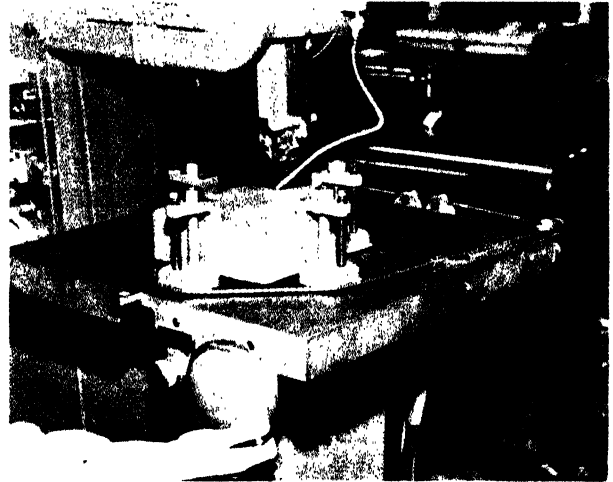

*Courtesy, The DoAll Co.*

FIG. 316. BAND SAW EQUIPPED WITH A POWER FEED

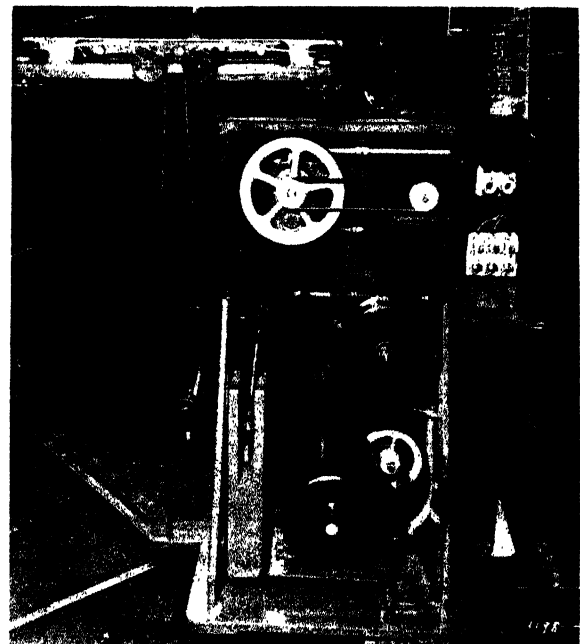

*Courtesy, The DoAll Co.*

FIG. 317. POWER FEED MECHANISM

at the rear of the machine and is illustrated in Fig. 317.

Metal cutting band saws of the conventional type are used both for cutting off stock and for contour machining — internal and external. When used for internal sawing, as in Fig. 323, the saw blade must be cut, threaded through a pilot hole drilled in the material, then butt



welded. To perform this operation a butt-welding and annealing unit can be had. Such a unit is shown in Fig. 318. This unit is combined with a flash grinder and saw-thickness gage built in the machine, or it may be had as a separate unit. Thus the blade is welded, annealed, reduced to uniform thickness and ready for service with a minimum of effort and interruption of production.

Many metal cutting band saws, particularly those which run at high speed, are equipped with automatic safety brakes. Such brakes are automatically set and the driving power cut off should the blade happen to break. On some machines the blades are fully guarded except at the point of work.

#### SAW BLADES

Blades for sawing metal have hardened teeth and a flexible back. The latter feature resists fatigue and facilitates continuous bending.



*Courtesy, The DoAll Co.*

FIG. 318. BUTT-WELDING AND ANNEALING UNIT

Some hard-tooth saw blades need no resharpening. Blades can be had in various widths, lengths, and pitches (teeth per inch). Commonly available pitches are 6, 8, 10, 14, and 18. Common widths are  $\frac{1}{4}$ ,  $\frac{3}{8}$ ,  $\frac{1}{2}$ ,  $\frac{5}{8}$ ,  $\frac{3}{4}$ , and 1 inch. The length of saw blade required for a particular machine is determined by the construction of the machine and its blade capacity. The life of a saw blade is determined in no small degree

by the manner in which the operator uses it. Improper speed, feed, or tension will shorten the life of a blade; consequently, it is the responsibility of an operator to see that the saw is properly tensioned, and that he uses the correct speed and feed for the work being done.

#### FILING AND POLISHING

Both of these operations can be performed effectively on metal cutting band saws. These are accomplished by means of endless filing and polishing bands. Excellent work can be done with filing bands and in much shorter time than by hand filing. The same applies to polishing bands. File bands can be had in various styles and cuts: flats, half-round and oval. Common sizes are  $\frac{1}{4}$  to  $\frac{1}{2}$  inch in width. The length is determined by the blade capacity of the machine.

#### APPLICATIONS

Metal cutting band saws can be used to cut or shape a great variety of materials and products, including practically all metals, pipe, punches, dies, plastics, and woods. Even such refractory materials as glass, tile, marble, granite, china, porcelain and silicon carbide products can be cut successfully by means of a diamond-tooth band saw blade. This is a comparatively new development in saw blades. The blade is constructed of high fatigue resistant steel with hundreds of small rods ( $\frac{1}{16}$  x  $\frac{3}{8}$  of an inch) consisting of natural diamond particles bonded with a patented tungsten alloy, electronically brazed to the steel band. The tungsten-alloy matrix wears away very slowly, and such blades have a long life. A cutting compound or lubricant should always be used with a diamond-tooth blade.

#### FRICTION SAWING

This is a recent development in metal cutting. It is much faster than conventional methods of cutting and will cut metal that can be machined in other ways only with great difficulty, if at all. Cutting is accomplished by momentary contact between the material and a rapidly moving saw-blade, which produces sufficient friction to heat the metal immediately ahead of the saw to its softening point. This process will not work satisfactorily with metals which melt at low temperatures: aluminum, brass, bronze, copper and others which soften and become

sticky in the low melting range. Another advantage of this method of cutting is the small amount of heat penetration into the side walls of the cut. Thus, the characteristics of the material are preserved. By this method of cutting only a very small burr is produced. This can be removed quickly by means of a band filing machine. This method is adapted to both straight and contour cutting, even contours involving radii as short as  $\frac{5}{8}$  of an inch, using a  $\frac{1}{4}$  inch saw. Only saw blades recommended for friction sawing should be used. The blade need not be sharp, as a dull blade increases friction, thus producing higher heat and higher cutting speed. Armor plate as thick as  $\frac{1}{2}$  inch can be friction cut successfully. Thicker material can be cut

by using a rocking technique. This procedure is accomplished by raising the rear end of the material. Thus, the top edge of the material is presented to the saw. When the saw starts to cut, the rear is lowered to the table, then raised and lowered alternately throughout the cut.

Friction cutting employs speeds ranging from 3000 to 15000 feet per minute, depending upon the composition and thickness of the material. As with other methods of sawing, thickness and composition of material governs the cutting rate.

The job selector chart which follows gives recommended saw velocity and saw pitch according to thickness and the kind of material for friction cutting.

TABLE V  
JOB SELECTOR CHART FOR FRICTION CUTTING\*

STEELS — S. A. E.	SAW VELOCITY			SAW PITCH		
	Thickness $\frac{1}{8}$ " - $\frac{3}{8}$ "	Thickness $\frac{1}{8}$ " - $\frac{1}{4}$ "	Thickness $\frac{1}{4}$ " - $\frac{1}{2}$ "	Thickness $\frac{1}{16}$ " - $\frac{1}{8}$ "	Thickness $\frac{1}{8}$ " - $\frac{1}{4}$ "	Thickness $\frac{1}{4}$ " - $\frac{1}{2}$ "
Carbon Steel #1010-#1095	3,000	5,000	12,000	18	14	10
Manganese Steel #T1330-#1350	3,000	5,000	12,000	18	14	10
Free Machining #X1112-#X1340	3,000	5,000	12,000	18	14	10
Nickel Steels #2015-#2515	3,000	6,000	13,000	18	14	10
Nickel Chromium #3115-#3415	3,000	6,000	13,000	18	14	10
Molybdenum Steel #4023-#4820	3,000	6,000	13,000	18	14	10
Chromium Steels #5120-#5150	3,000	6,000	12,000	18	14	10
Chromium Steels #51210-#52100	5,000	10,000	14,000	18	14	10
Chromium Vanadium #6115-#6195	5,000	12,000	15,000	18	14	10
Tungsten Steel #7260-#71360	5,000	12,000	15,000	18	14	10
N. E. Steels #8024-#8949	5,000	12,000	15,000	18	14	10
Silicon Manganese #9255-#9260	5,000	12,000	15,000	18	14	10
OTHER STEELS						
Armor Plate	3,000	9,000	13,000	18	14	10
Stainless Steel 18-8	3,000	9,000	14,000	18	14	10
Inconel	4,000	12,000	15,000	18	14	10
Cast Steel	3,000	9,000	12,000	18	14	10
CAST IRONS						
Gray Cast Iron	3,000	5,000	7,000	18	14	10
Malleable Cast Iron	3,000	5,000	7,000	18	14	10
Meehanite Castings	3,000	5,000	7,000	18	14	10

\* Courtesy, The DoALL Company.

UNIT 69

HOW TO CUT METAL

WITH A HORIZONTALLY OPERATED CUT-OFF BAND SAW

With a cut-off band saw stock may be cut square, or at any angle desired between zero and 45 degrees.

PROCEDURE FOR SQUARE CUTTING

1. Determine that the saw is set to make a square cut, make a trial cut and test with

a square. Make adjustments, if necessary.

2. Secure a piece of stock, then measure and mark the point at which the cut is to be made.
3. Place the stock or work-piece in the vise of the machine, then adjust it under the saw blade in a manner that will assure a cut at the point desired. Be sure that the work is so positioned that the cut will be made in the waste stock.
4. When the work-piece has been positioned correctly, clamp the work securely by means of the vise adjusting handwheel. If more than one piece is to be cut set the stop against the end of the piece.
5. Start the machine and make a very slight kerf, then stop the machine and measure the work-piece to determine that it is the length required. Make adjustment, if necessary.
6. Again start the machine, turn on the cutting lubricant and make the cut. Be sure the lubricant is directed against the teeth of the saw in the saw kerf.
7. Adjust the stock for the next cut, if any, then proceed in the usual manner.

#### PROCEDURE FOR ANGULAR CUTTING

1. Determine the angle at which to set the saw.
2. Release the clamping device and swing the saw frame to the required angle. See Fig. 319.
3. Secure a piece of stock and mark the point at which the cut is to be made.



*Courtesy, The DoAll Co.*

FIG. 319. CUTTING AT AN ANGLE WITH A HORIZONTALLY OPERATED BAND SAW

4. Place the piece of stock in the vise of the machine and position it so that the cut will be made where marked.
5. When the work has been positioned correctly clamp the work securely by means of the vise adjusting handwheel. If more than one piece is to be cut set the stop against the end of the piece.
6. Start the machine and make a very light saw kerf, then stop the machine and measure the work-piece to determine that it is the length required. Make adjustment, if necessary.
7. Again start the machine, turn on the cutting lubricant, then make the cut in the usual manner.

## UNIT 70

### HOW TO SAW METAL WITH A BAND SAW

Band saws are used for straight, angular, and contour cutting, both external and internal. Internal sawing is not included in this unit, as it involves an operation other than sawing.

#### PROCEDURE FOR CUTTING WITH THE TABLE IN THE HORIZONTAL POSITION

1. Secure the material to be cut.
2. Locate the position on the work at which the cut is to be made, then, if necessary, draw appropriate guide lines, or use appropriate machine guides, as in Fig. 320. The

attachment illustrated can be used for cutting off, ripping or mitering operations.

3. Determine kind and size of saw blade required to perform the operation; consult the job selector chart, see Fig. 315. If a change of saw is necessary, then make the change.
4. Determine the cutting speed required; consult the job selector chart.
5. Protect the eyes by wearing properly fitted goggles.

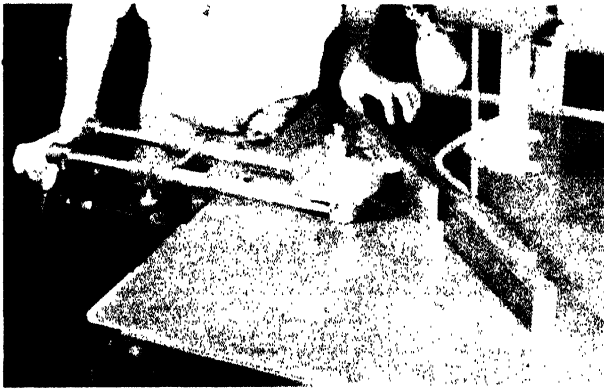

*Courtesy, The DoAll Co.*

FIG. 320. USING A GUIDE TO CUT STOCK AT AN ANGLE

**CAUTION:** When handling metals on which cutting produces a burr or when the metal has sharp edges it is good practice to protect the hands by wearing properly fitting leather gloves.

6. Lower the saw guide until it is within  $\frac{3}{8}$  to  $\frac{1}{2}$  inch of the thickest or highest part of the work surface, then clamp the guide in position.
7. Start the saw, then, when the machine is running at full speed, bring the material to be cut slowly into contact with the traveling blade. Advance the work by exerting a light but steady pressure. Do not crowd the saw; allow it time to remove the metal but keep the work advancing steadily. Power feed should be used for cutting heavy pieces when the machine is so equipped. See Fig. 316.

Round or irregular shaped pieces should be held in a vise, in a suitable guide, holding fixture, or jig. See Fig. 321.

The use of a cutting compound or lubricant is recommended when cutting steel. When a coolant is used it should be directed at the teeth of the saw at or slightly above where they contact the work-piece.

**CAUTION:** In placing the hands on the material be sure they are in a position that will not come in contact with the traveling saw blade.

8. At the end of the cut stop the machine and remove the work-piece. Remove the waste stock and clean the machine, unless other pieces are to be machined.

**CAUTION:** Use a piece of wood or other suitable material to remove short work-pieces or waste stock from the vicinity of the saw blade.

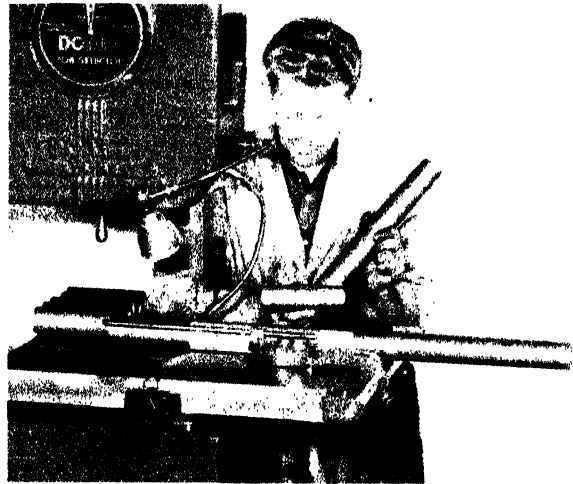

*Courtesy, The DoAll Co.*

FIG. 321. USING A CUT-OFF GUIDE

Use a brush to remove metal chips from the saw table. Never use the bare hands to perform either of these tasks.

#### PROCEDURE FOR CUTTING WITH THE TABLE AT AN ANGLE

1. Proceed as when making a straight cut, steps 1 to 4 inclusive.
2. Tilt the table to the angle desired and clamp it in position. When a heavy piece of material is being cut, a guide or fixture such as shown in Fig. 322 should be used.
3. Place the work on the saw table, and move it close to the saw blade. Then adjust the

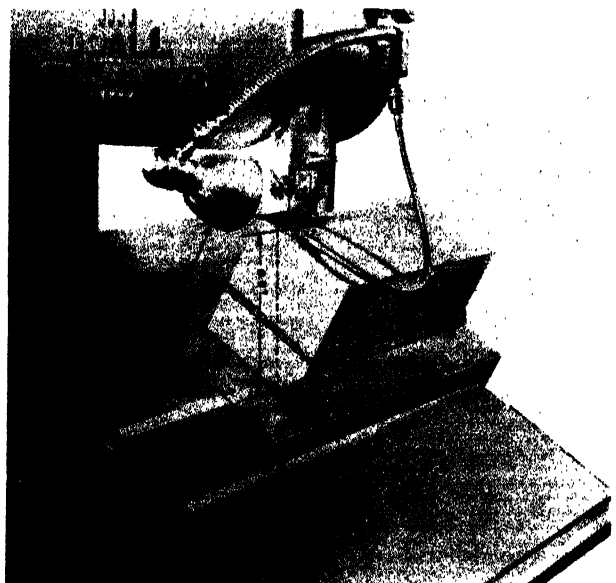

*Courtesy, The DoAll Co.*

FIG. 322. MAKING THE CUT WITH THE TABLE TILTED

saw guide, bringing it as close to the work surface as practicable.

4. Start the machine, move the work against the saw and make the cut in the usual manner.

Note: If a guide is used move the work-piece forward until the teeth of the saw just touch the foremost edge of the work, then examine the position of the work to make certain the cut will be made where desired.

#### PROCEDURE FOR CUTTING EXTERIOR CONTOURS

1. Secure the material to be cut.
2. Lay out the required shape on the surface of the work-piece. See Fig. 323.
3. Determine the size and kind of saw blade required to perform the operation; consult the job selector chart. When the shape involves sharp curves a narrow saw should be used.
4. Determine the cutting speed required; consult the job selector chart, see Fig. 315.
5. Protect the eyes by wearing properly fitted goggles. Use leather gloves when necessary.
6. Lower the saw guide to within  $\frac{3}{8}$  or  $\frac{1}{2}$  inch

of the thickest or highest part of the work; then clamp it in position.

7. Start the saw; then when the machine is running at full speed, bring the material to be cut slowly into contact with the traveling saw blade. Advance the work steadily and follow the outline. Do not crowd the saw. Power feed may be used to advantage when cutting contours which involve long sweeping curves. Round or irregularly shaped pieces should be held in a vise or jig, see Fig. 321.

When it is necessary to cut a very sharp curve it may be advisable temporarily to by-pass it; then, when the waste material has been removed from other parts of the work, return and make the cut in the usual manner.

Use of a cutting compound or lubricant is recommended when cutting steel.

8. At the end of the cut stop the machine, and remove the work-piece. Remove the waste stock by means of a piece of wood or other suitable material, then clean the machine, unless other pieces are to be machined. Use a brush to remove waste material or chips from the saw table, do not use the bare hands.

### UNIT 71

#### HOW TO SAW INTERNAL CONTOURS WITH A BAND SAW

Rectangular, circular, or irregular internal contours may be cut with a band saw.

##### PROCEDURE

1. Secure the material to be cut.
2. Lay out the required contour or outline on the surface of the work-piece, for example, Fig. 323.
3. Drill a pilot hole near one edge of the contour or outline. Be sure to make the hole large enough to permit free entry of the saw.

When the enclosure is rectangular a pilot hole should be drilled at each corner. A pilot hole drilled wherever a contour changes its direction sharply, involving an acute angle on a very short radius, will facilitate turning or reversing the direction of the cut.

4. Determine the size and kind of saw blade required to perform the operation; consult the job selector chart.
5. Cut the saw, then draw one end through the pilot hole in the work-piece, place the ends of the saw in the automatic butt welder and turn on the current. See Fig. 318. This will instantly weld the ends of the saw together.
6. Place the welded joint in the flash grinder, just beneath the automatic welder, and grind the joint smooth and even.

On machines not equipped with a welder the operation must be performed with a separate welder or brazed with a torch, the joint annealed and filed smooth.

7. Place the welded blade on the wheels of the machine and tension it correctly.



*Courtesy, The DoAll Co.*

FIG. 323. SAWING INTERNAL CONTOURS

8. Determine the cutting speed required; consult the job selector chart, see Fig. 315, Unit 68.
9. Adjust the speed control mechanism by revolving the speed control hand crank to the position desired.

On machines not equipped with a variable speed mechanism, change of speed is

achieved by changing the drive belt to the position desired on the step pulley. Shift to high or low speed is achieved by means of a gear shift on machines so equipped.

10. Protect the eyes by wearing properly fitted goggles. Use leather gloves when necessary.
11. Start the saw; then when the machine is running at full speed, bring the material to be cut slowly into contact with the traveling saw blade. Advance the work steadily and follow the outline. Do not crowd the saw.

When it is necessary to cut a very sharp curve it may be advisable to temporarily by-pass it; then return to make the cut in the usual manner. Use of a cutting compound or lubricant is recommended.

12. When the cut has been completed stop the machine, cut the saw blade and remove it.

Saw blades that have been cut to remove them from an enclosure often are set aside for use on a similar operation.

13. With a brush remove waste stock and metal chips from the saw table. Do not use the bare hands.
14. When the operation must be repeated on other work-pieces, proceed as instructed in steps 1 to 13 inclusive.

## UNIT 72

### HOW TO FRICTION CUT METAL WITH A BAND SAW

Straight or contour sawing can be done by means of the friction cutting process. In this process care must be taken that the recommended saws and cutting speeds are used, see job selector chart, Unit 68.

Most conventional methods of cutting metals employ a cutter with a keen edge. When cutting by friction a keen edge is not required; in fact, a dull edge is the more effective tool, because the dull instrument creates more friction and consequently more heat. See Fig. 324. This softens the metal immediately ahead of the blade and thus increases cutting efficiency.

#### PROCEDURE

1. Secure a work-piece.
2. Locate the position on work-piece at which the cut is to be made, then draw appropriate guide lines, or use appropriate machine guides.
3. Determine size and kind of saw required, consult job selector chart, Unit 68. Change the saw if necessary.
4. Determine cutting speed required; consult job selector chart.

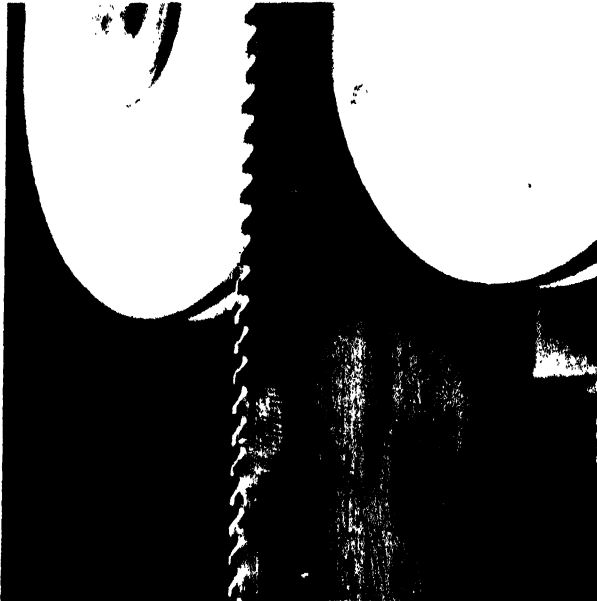

*Courtesy, The DoAll Co.*

FIG. 324. DULL EDGE FOR FRICTION CUTTING

5. Adjust the speed control mechanism by revolving the speed control hand crank to the position desired.
6. Protect the eyes, hands, and clothing by wearing properly fitted glasses, leather gloves, and appropriate coveralls.

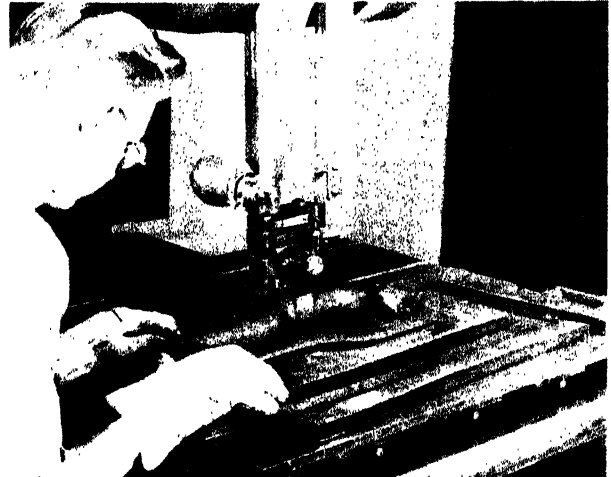

*Courtesy, The DoAll Co.*

FIG. 325. FRICTION SAWING

7. Start the machine; then when it has attained full speed bring the work gently into contact with the blade, as in Fig. 325. Advance the work steadily. Use the rocking technique, if necessary; that is, alternately slightly raise and lower the rear end of the work.
8. At the completion of the cut, stop the machine, remove the work and clean the work table.

### UNIT 73

#### HOW TO CUT REFRACTORY MATERIALS WITH A BAND SAW

A variety of refractory materials, glass, porcelain, china, marble, granite, and silicon carbides, can be cut with a diamond-tooth band saw.

##### PROCEDURE

1. Secure a piece of the material to be cut, for example, a piece of glass, Fig. 326.
2. Lay out the design on the work-piece or otherwise indicate where the cut is to be made.
3. Secure a diamond-tooth saw blade, Fig. 327, mount it on the saw and tension it properly.
4. Set the machine for a cutting speed of 2000 to 4000 feet per minute.
5. Protect the eyes by wearing properly fitted goggles.

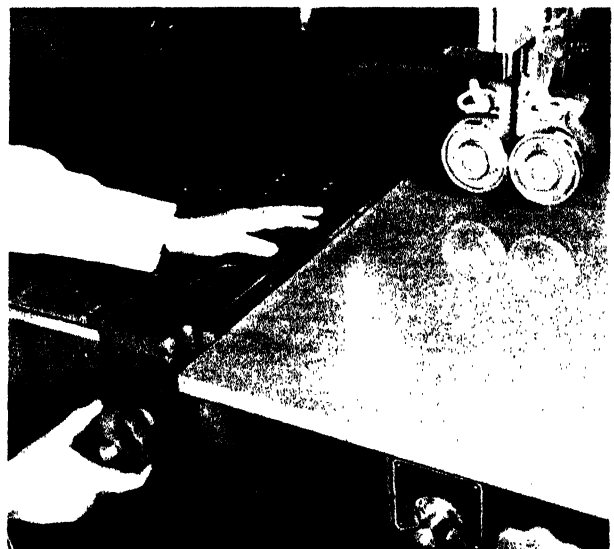

*Courtesy, The DoAll Co.*

FIG. 326. CUTTING GLASS WITH A DIAMOND TOOTH BLADE

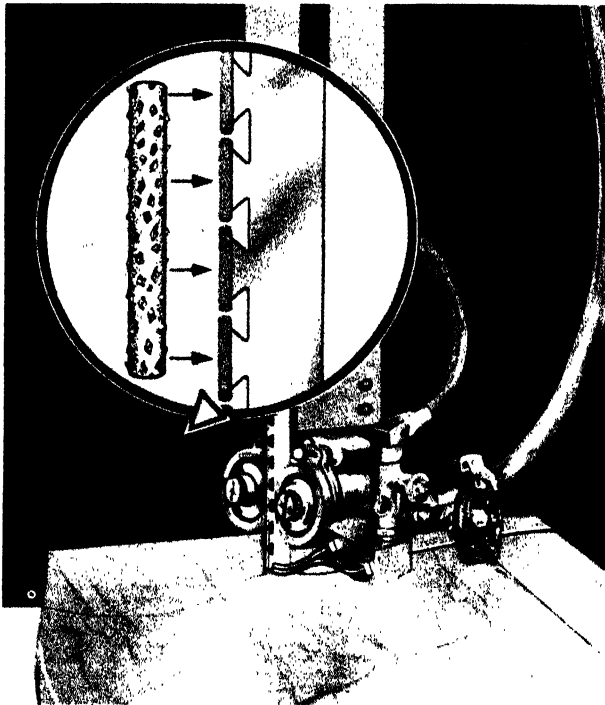

*Courtesy, The DoAll Co.*

FIG. 327. DIAMOND TOOTH BAND SAW BLADE

6. Start the machine, turn on the cutting compound or lubricant and direct it at the teeth of the blade where they contact the work-piece. A spray lubricator is recommended. Fig. 328 shows the spray tubes.

Note: When sawing circular pieces they should be held in a vise, a jig or by other suitable means. The same applies when sawing irregular shapes

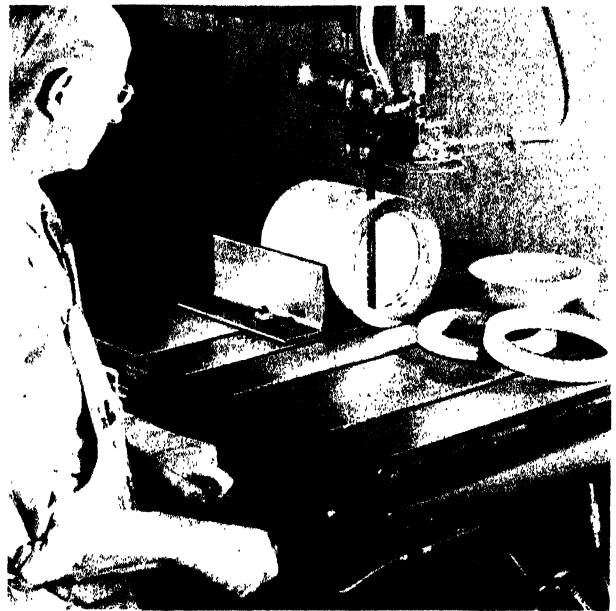

*Courtesy, The DoAll Co.*

FIG. 328. A SPRAY LUBRICANT IS RECOMMENDED FOR REFRACTORY MATERIAL

which do not seat themselves firmly on the saw table.

7. Bring the work-piece gently against the traveling blade and feed it steadily forward. (See Fig. 328.) Do not crowd the saw.
8. At the completion of the cut stop the machine, remove the work, then clean the machine.

## UNIT 74

### HOW TO FILE AND POLISH WORK WITH A BAND SAW

Endless filing and polishing bands are available for use with metal cutting band saws. When properly handled an endless file will do accurate work much more rapidly than can be done by hand. The same applies with respect to an endless polishing band. An endless file band is fitted with a special joint which permits its use for internal filing.

#### PROCEDURE FOR FILING EXTERIOR CONTOURS

1. Select a file band of appropriate grade and shape. Also select a suitable band guide.
2. Mount the guide on the guide post.
3. Mount the band on the wheels of the saw and tension it properly, usually about  $\frac{1}{4}$  turn of the handwheel after the band comes under tension.
4. Protect the eyes by wearing properly fitted goggles.
5. Start the machine and bring the work-piece gently against the traveling file band, Fig. 329. Move the work in a manner that will cause the file to remove the excess stock the entire length of the surface to be filed.



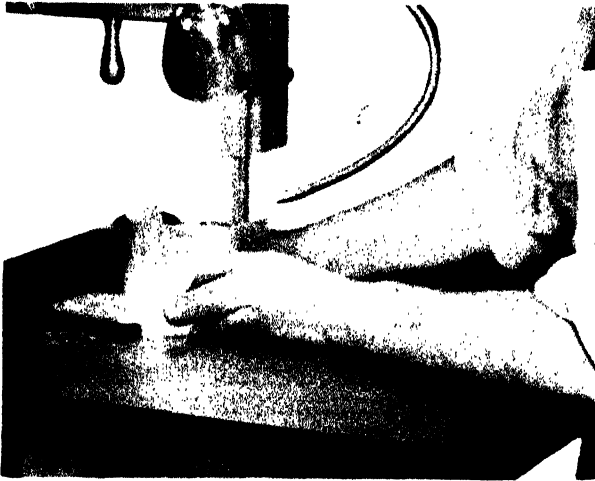

*Courtesy, The DoAll Co.*

FIG. 329. FILING ON THE BAND SAW

6. When filing has been completed remove the filing band and guide, then clean the machine.

#### PROCEDURE FOR FILING INTERNAL CONTOURS

1. Select a file band of appropriate grade and shape, and a suitable band guide.
2. Mount the saw guide on the guide post.
3. Uncouple the file band, Fig. 330, and insert one end through the opening in the work-piece, then couple the ends of the band and mount it on the wheels of the saw. Properly tension the band.
4. Proceed as in steps 4 through 6 inclusive, Procedure for Filing Exterior Contours. The procedure is illustrated in Fig. 329.

#### PROCEDURE FOR POLISHING

1. Select a suitable polishing band and guide.



*Courtesy, The DoAll Co.*

FIG. 330. UNCOUPLING THE FILE BAND

2. Mount the guide on the guide post and the band on the wheels of the saw.
3. Protect the eyes by wearing properly fitted goggles.
4. Start the machine, then bring the work-piece gently against the traveling band. Progressively move the work in a manner that will bring the polishing band into contact with all parts of the surface to be polished.
5. When the operation has been completed remove the polishing band and clean the machine.

## SECTION X

# SURFACE GRINDING MACHINES AND GRINDING

## UNIT 75

### GRINDING MACHINES

The grinding machine which formerly was a piece of toolroom equipment has become a production machine, developed to perform a wide variety of operations. The cutting tool used on grinding machines is an abrasive wheel. This tool differs from the ordinary machine cutting tool in that each particle of abrasive on the surface of the wheel is a cutter. Thus for each revolution of the wheel thousands of tiny chips of metal are removed from the workpiece. As the particles of the abrasive become worn and dull they are torn loose from the wheel, thus exposing new and sharp cutting particles to the work.

Like other metal working machines, grinding machines designed for specific purposes are available. The more common of these are: Plain or Cylindrical, Internal, Surface and Universal grinding machines. Some special types of grind-

ing machines are: Cutter and Reamer, Drill and Cylinder grinders.

Usually grinding machines are classified as to size by an arbitrary number given by the maker. Some, however, are classified in terms of their maximum capacity to accommodate work in terms of diameter and length.

#### THE PLAIN GRINDING MACHINE

This machine is shown in Fig. 331. It is designed for the outside grinding of cylindrical or tapered work. The principal parts of this

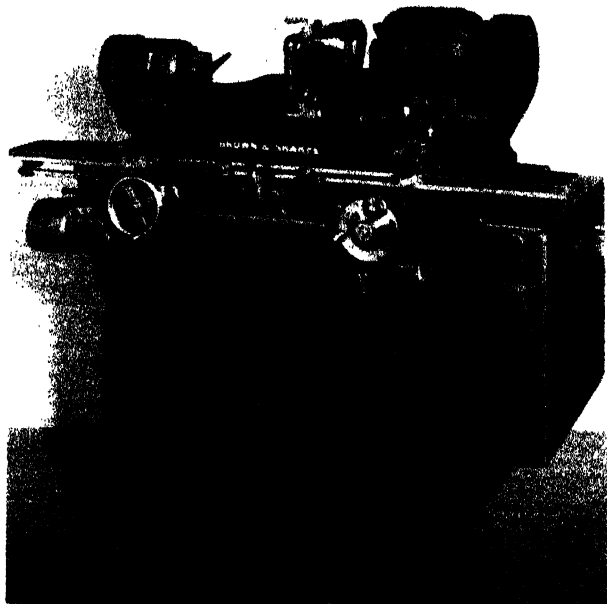

Courtesy, Brown & Sharpe Manufacturing Co.  
FIG. 331. PLAIN GRINDING MACHINE

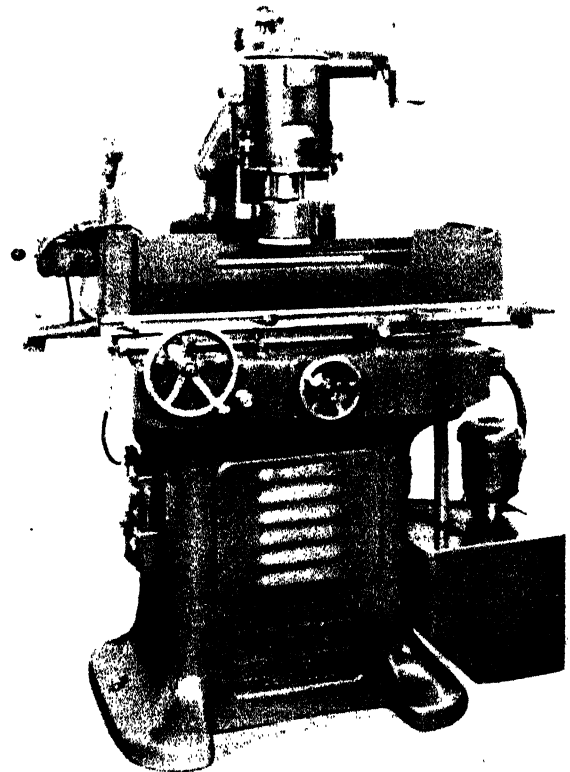

Courtesy, Brown & Sharpe Manufacturing Co.  
FIG. 333-A. SURFACE GRINDER WITH A VERTICAL SPINDLE

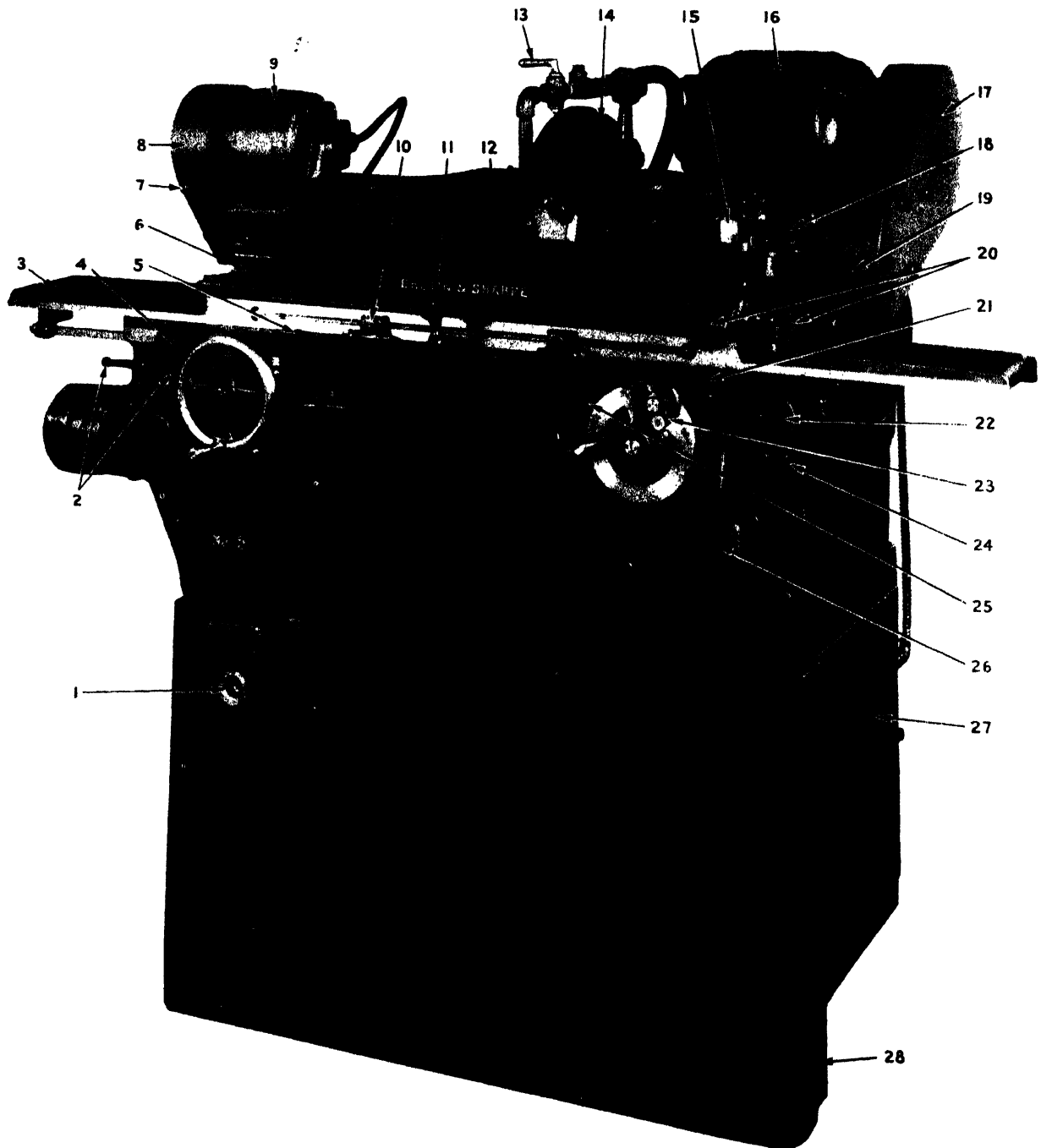

FIG. 332. PARTS OF THE PLAIN GRINDING MACHINE (FRONT VIEW) *Courtesy, Brown & Sharpe Manufacturing Co.*

machine are: a heavy bed which gives the machine stability; a wheel head mounted on a slide base; a headstock which is mounted on a table which can be swiveled through  $8^{\circ}$  to  $10^{\circ}$ ; a footstock or tailstock; a sliding table on which

the swivel table is mounted; longitudinal table feed mechanism; and cross feed mechanism. These and other parts are shown in Figs. 332 and 332A. Plain grinding machines can be equipped with special features such as Wheel

Slide Rapid Travel, Independent Automatic Cross Feed, and Wheel Spindle Reciprocating Mechanism.

### SURFACE GRINDING MACHINE

This is a machine designed for grinding flat surfaces and is made with a horizontal spindle,

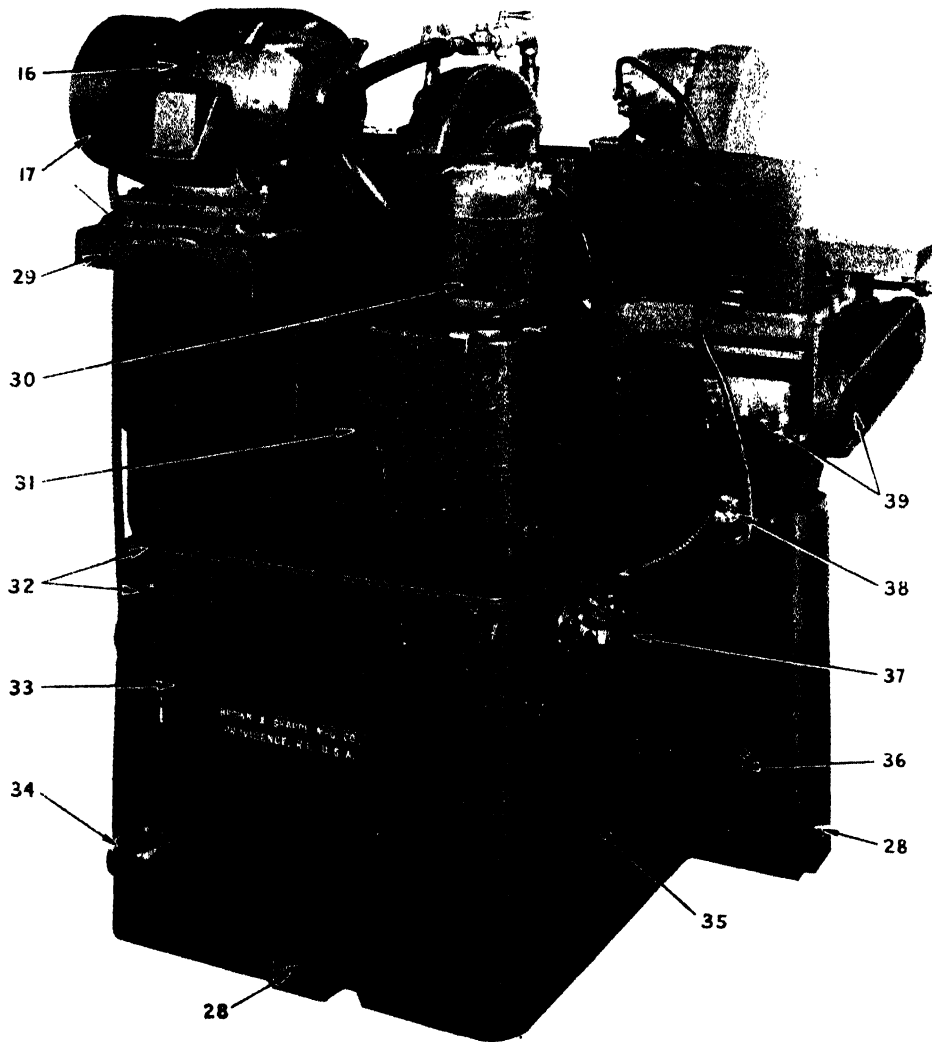

FIG. 332-A. PARTS OF THE PLAIN GRINDING MACHINE (REAR VIEW)

*Courtesy, Brown & Sharpe Manufacturing Co.*

- |   |  |
|---|--|
| 1 Sight indicator for automatic oiling system           | 21 Switch operating slide throwout lever                     |
| 2 Table speed selector levers                           | 22 Grind-True Switch   |
| 3 Sliding table   | 23 Index dial on cross feed handwheel                        |
| 4 Table handwheel                                       | 24 Machine start-stop push button switch                     |
| 5 Table start-stop lever                                | 25 Cross feed pawl lever                                     |
| 6 Swivel table  | 26 Mechanism for setting amount of automatic cross feed      |
| 7 Headstock brake lever                                 | 27 Electrical control compartment                            |
| 8 Headstock belt guard                                  | 28 Pocket for hoisting hook                                  |
| 9 Headstock motor                                       | 29 Wheel slide   |
| 10 Table reverse dog                                    | 30 Motor-driven centrifugal coolant pump                     |
| 11 Table reverse lever                                  | 31 Bed; includes coolant tank                                |
| 12 Work tray  | 32 Rim and sump for collecting possible coolant condensation |
| 13 Coolant valve  | 33 Base  |
| 14 Wheel guard and adjustable bracket                   | 34 Power inlet (terminal box)                                |
| 15 Spindle oil gauge                                    | 35 Tool compartment  |
| 16 Spindle motor  | 36 Drain plug for oil reservoir in base                      |
| 17 Spindle belt guard                                   | 37 Disconnect plugs for headstock and coolant pump motors    |
| 18 Footstock spindle clamp lever                        | 38 Oil gauge   |
| 19 Footstock operating lever                            | 39 Table driving motor and belt guard                        |
| 20 Swivel table adjusting knob, scale and clamp bracket |  |

Fig. 333, or a vertical spindle, Fig. 333A. The principal parts are a heavy bed, a wheel head, a sliding table which can be moved longitudinally or transversely by means of longitudinal and cross feed mechanisms.

#### INTERNAL GRINDING MACHINE

This machine is used for finishing round or tapered holes. It is a highly specialized machine and is rarely found in school or small commercial shops.

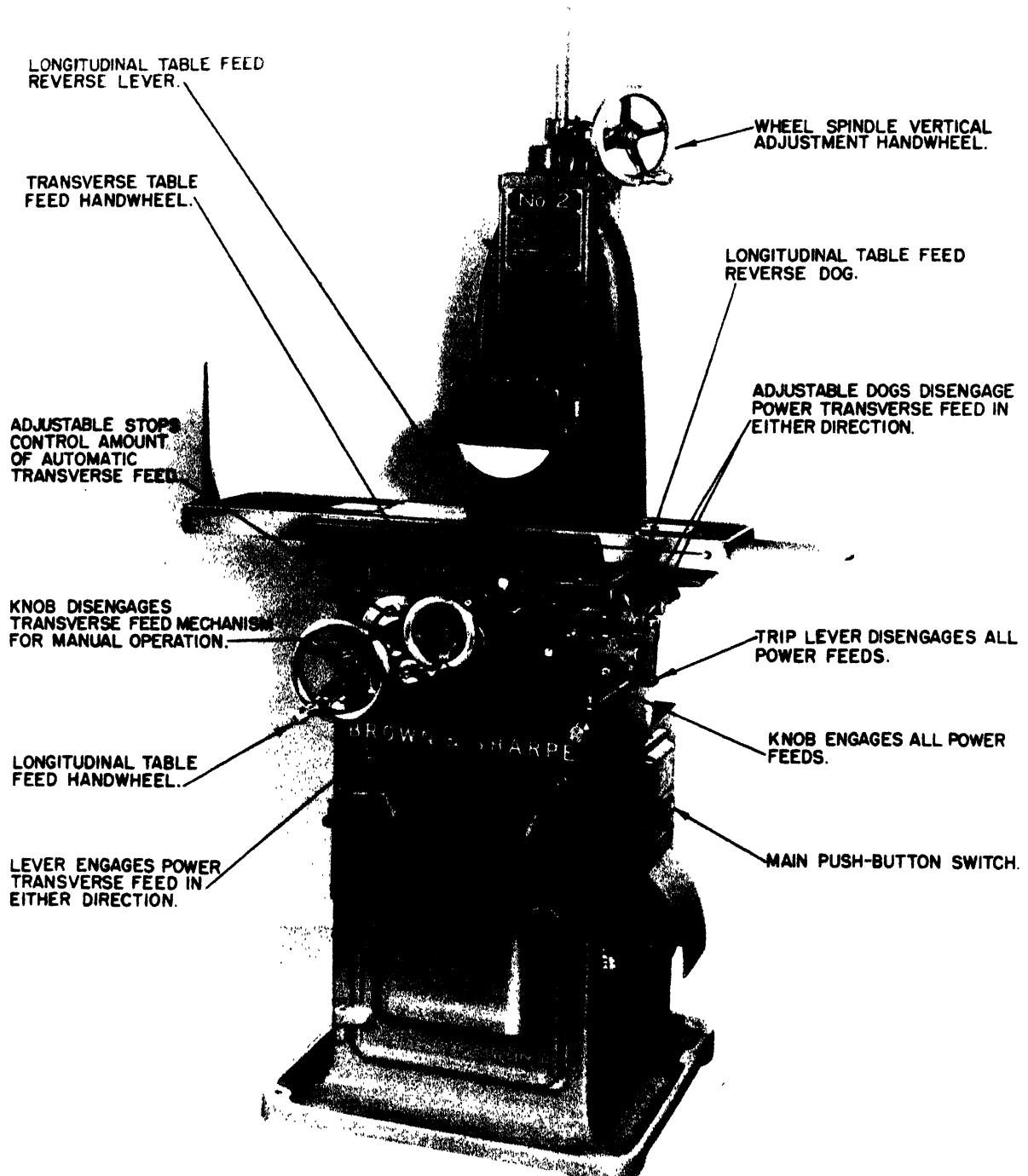

FIG. 333. SURFACE GRINDER WITH A HORIZONTAL SPINDLE

Courtesy, Brown & Sharpe Manufacturing Co.

**UNIVERSAL GRINDING MACHINE**

As the name implies this machine can be had equipped to perform a variety of grinding operations: external and internal cylindrical grinding, face grinding, reamer and cutter grinding. Universal grinding machines are made in sizes ranging in swing capacity from 10 to 14 inches or more, and in capacity between centers from 20 to 60 inches or more. Fig. 334 shows a Brown and Sharpe #2 Universal Grinder.

The wheel stand, Fig. 335, on universal grinding machines is adjustable along the wheel stand platen to which it is fastened by bolts in platen T-slots. The adjustment range is from  $3\frac{1}{2}$  to 19 inches from the axis of work, when held between centers. On the machine illustrated in Fig. 334, the work-piece is traversed while the wheel stand is stationary. On some machines the wheel is traversed while the table remains stationary. Fig. 334A illustrates the operating controls and principal parts of a universal grinding machine.

The platen, Fig. 335, which supports the wheel stand is bolted to the wheel stand slide. It can be swiveled to any angle desired by loosening the clamping bolts and set parallel with the slide matching guide lines on the platen and slide respectively.

The wheel stand slide bed, Fig. 335, provides the ways for the wheel stand slide. It can be swiveled to  $90^\circ$  either side of zero. A graduated scale is provided for angular setting.

Any tendency of the wheel stand slide to move toward the work-piece is resisted by a counterweight to compensate for back lash in the slide. The adjusting shaft is located at the rear of the slide, Fig. 335. Turning the shaft counterclockwise as far as it will go will exert pull away from the work-piece when external grinding, and turning the shaft clockwise as far as it will go exerts the pull away from the work-piece when internal grinding.

The grinding wheel may be mounted on the wheel spindle in three positions, between the bearings, as in Fig. 334, or on either end of the spindle, see Fig. 336. When the wheel is mounted on the right-hand end of the spindle special equipment is required.



*Courtesy, Brown & Sharpe Manufacturing Co.*

FIG. 336. MOUNTING A GRINDING WHEEL

**HEADSTOCK**

The headstock is clamped to the swivel table with two bolts and aligned by a lip on the base. It can be swiveled on its base through  $90^\circ$  either side of zero. The principal parts of the headstock are shown in Fig. 337. The headstock motor is started by turning the start-stop knob to the right and stopped by turning it to the left.

**FOOTSTOCK**

This unit, Fig. 338, is adjustable along the swivel table to which it is fastened with clamping bolts. It is aligned with the headstock by means of a lip on the front of the base. When

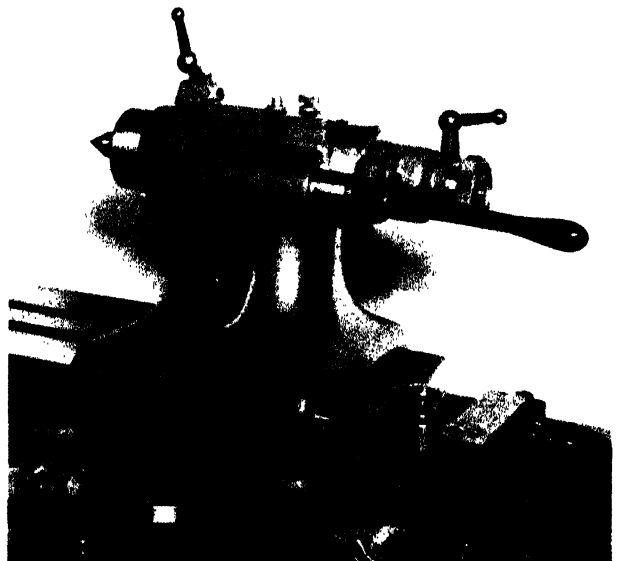

*Courtesy, Brown & Sharpe Manufacturing Co.*

FIG. 338. FOOTSTOCK OF THE UNIVERSAL GRINDER

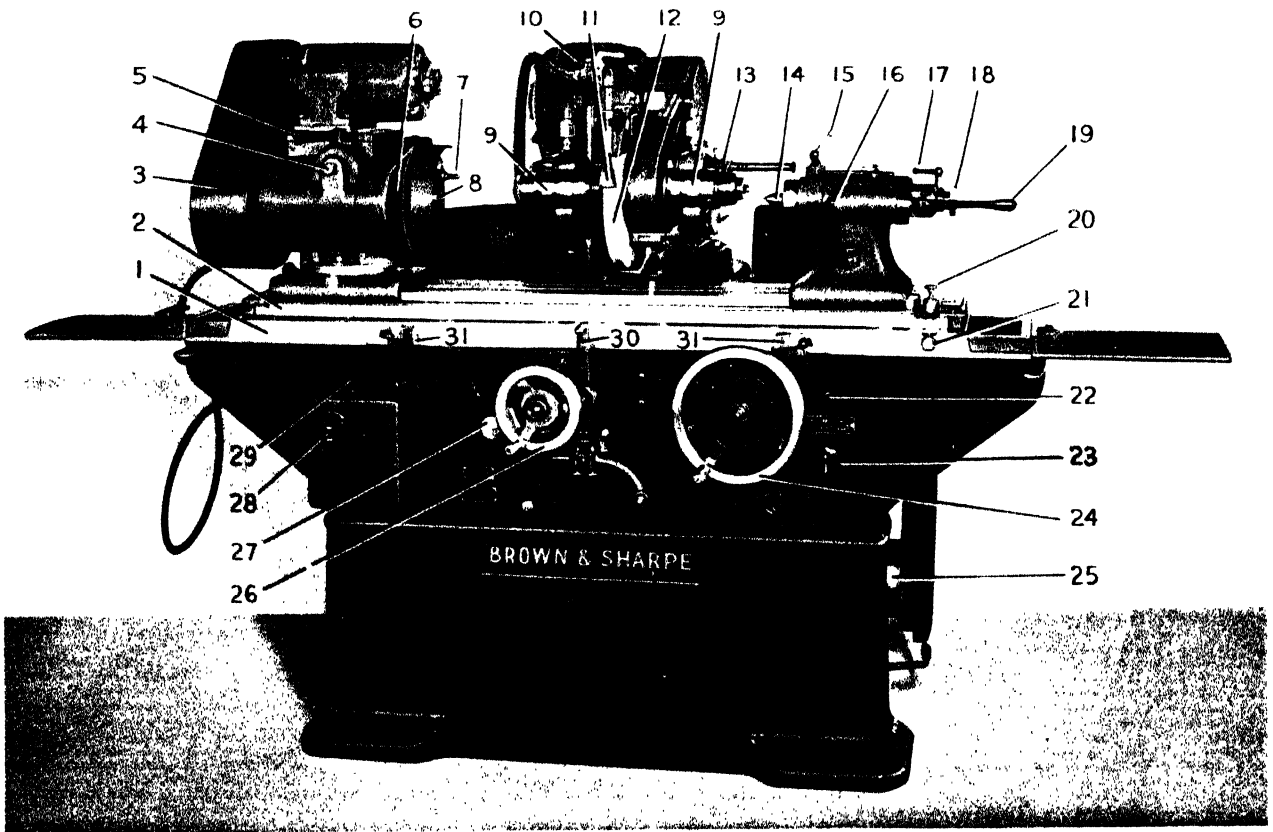

Courtesy, Brown & Sharpe Manufacturing Co.

FIG. 334 UNIVERSAL GRINDER (FRONT VIEW)

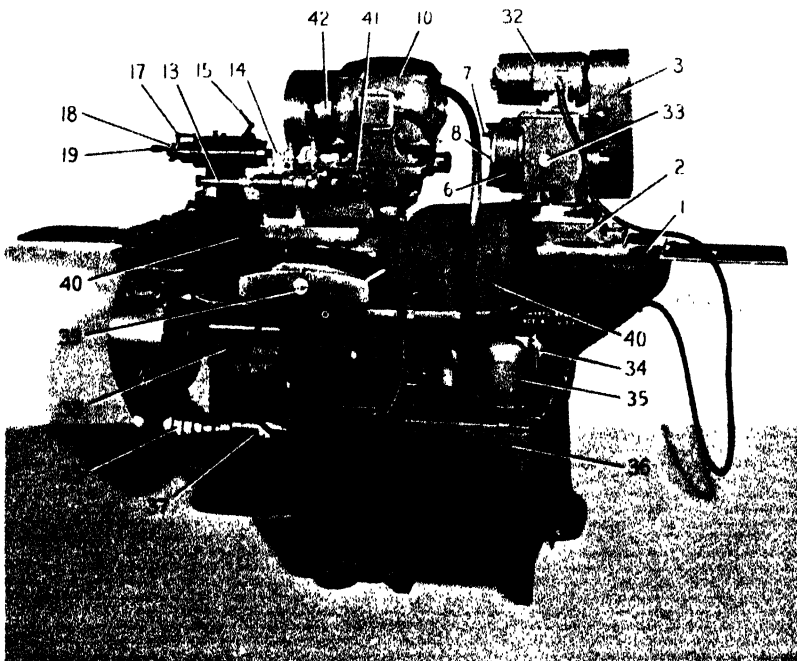

- 1 Sliding Table
- 2 Swivel Table
- 3 Spindle Drive Belt Guard
- 4 Tension Adjustment
- 5 Belt Tension Release Lever
- 6 Headstock Spindle Belt Guard
- 7 Work Driving Pin
- 8 Headstock Center
- 9 Wheel Spindle Bushing
- 10 Wheel Spindle Motor
- 11 Coolant Nozzle
- 12 Grinding Wheel
- 13 Internal Grinding Fixture
- 14 Footstock Center
- 15 Diamond Tool Holder Clamp
- 16 Spring Pressure Adjusting Nut
- 17 Footstock Spindle Clamp
- 18 Spindle Adjusting Knob
- 19 Footstock Operating Lever
- 20 Swivel Table Locking Pin
- 21 Swivel Table Adjusting Nut and Scale
- 22 Table Feed Engagement Lever
- 23 Table Motor Selector Switch Knob
- 24 Table Handwheel
- 25 Lower Table Feed Cone Pulley
- 26 Cross Feed Handwheel
- 27 4:1 Ratio Cross Feed Engagement Knob
- 28 Main Push-Button Switch
- 29 Headstock Start-Stop and Jog Control
- 30 Table Reverse Lever
- 31 Table Reverse Dog
- 32 Headstock Motor
- 33 Spindle Lock for Dead Center Grinding
- 34 Coolant Pump Disconnect Plug
- 35 Motor Driven Centrifugal Coolant Pump
- 36 Coolant Tank
- 37 Two-Speed Gearhead Table Motor
- 38 Table Reversing Mechanism
- 39 Counterweight Adjusting Screw
- 40 Pan Water Guard
- 41 Motor Plate Adjusting Screw Knob
- 42 Internal Grinding Fixture Driving Pulley

Courtesy, Brown & Sharpe Manufacturing Co

FIG. 334-A. UNIVERSAL GRINDER (REAR VIEW)

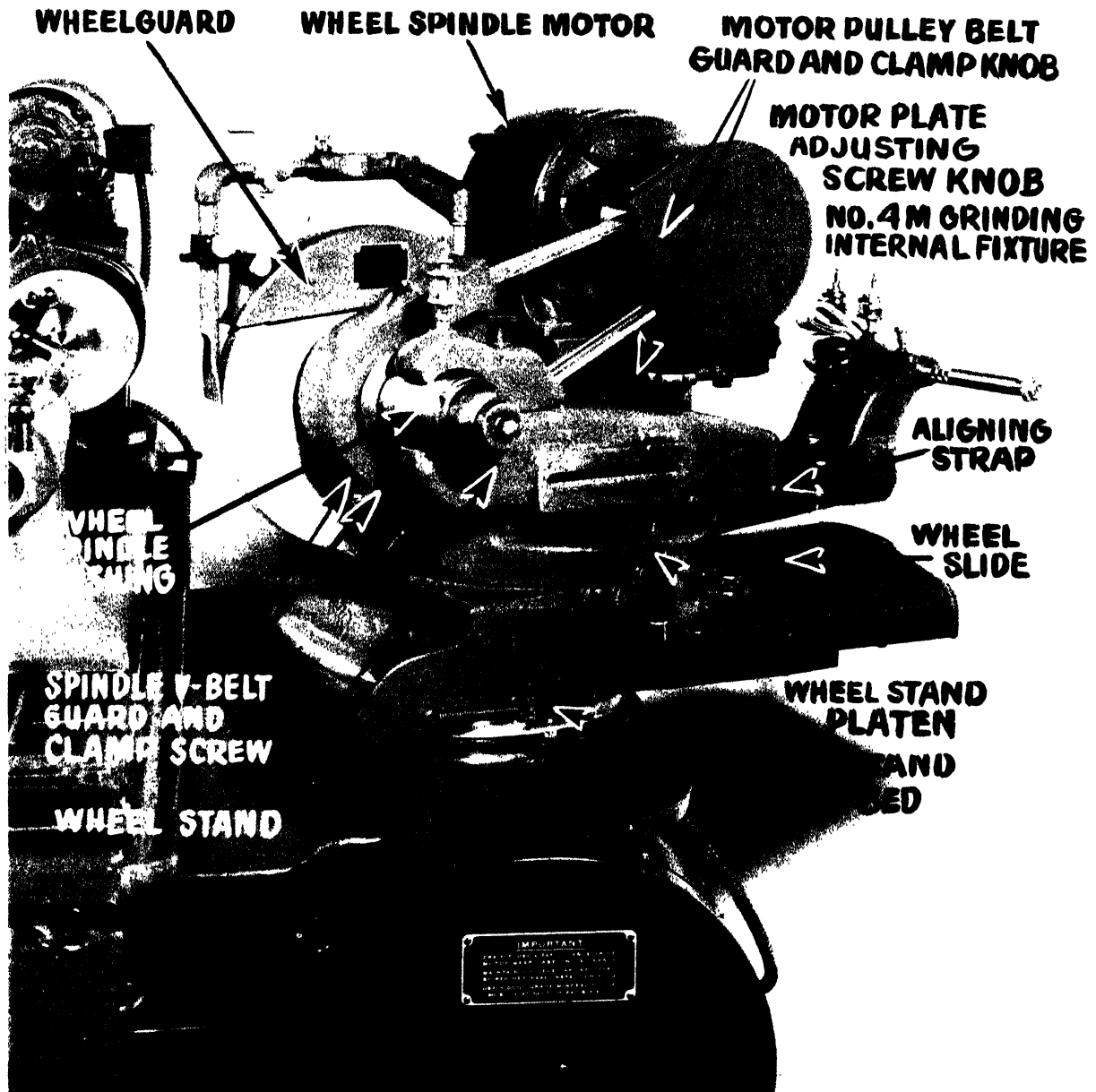

*Courtesy, Brown & Sharpe Manufacturing Co*

FIG. 335. WHEEL STAND, SHOWING PARTS

the footstock is brought into working position, a spring in the footstock holds the center firmly against the work-piece. The lever at the right is used to retract or withdraw the center when removing a work-piece or inserting a new piece.

The universal grinding machine has two tables, a sliding table on which is mounted a swivel table. The latter can be swiveled through  $7^{\circ}$  or  $8^{\circ}$  in either direction from zero. The

sliding table can be traversed manually or by power feed. Table reversing dogs, which can be positioned to suit the situation, control the table travel; and when power feed is used they automatically reverse the direction of table travel. The dogs may be operated by hand in conjunction with power table drive. Variation in the rate of table travel is accomplished by appropriately changing the position of the belt



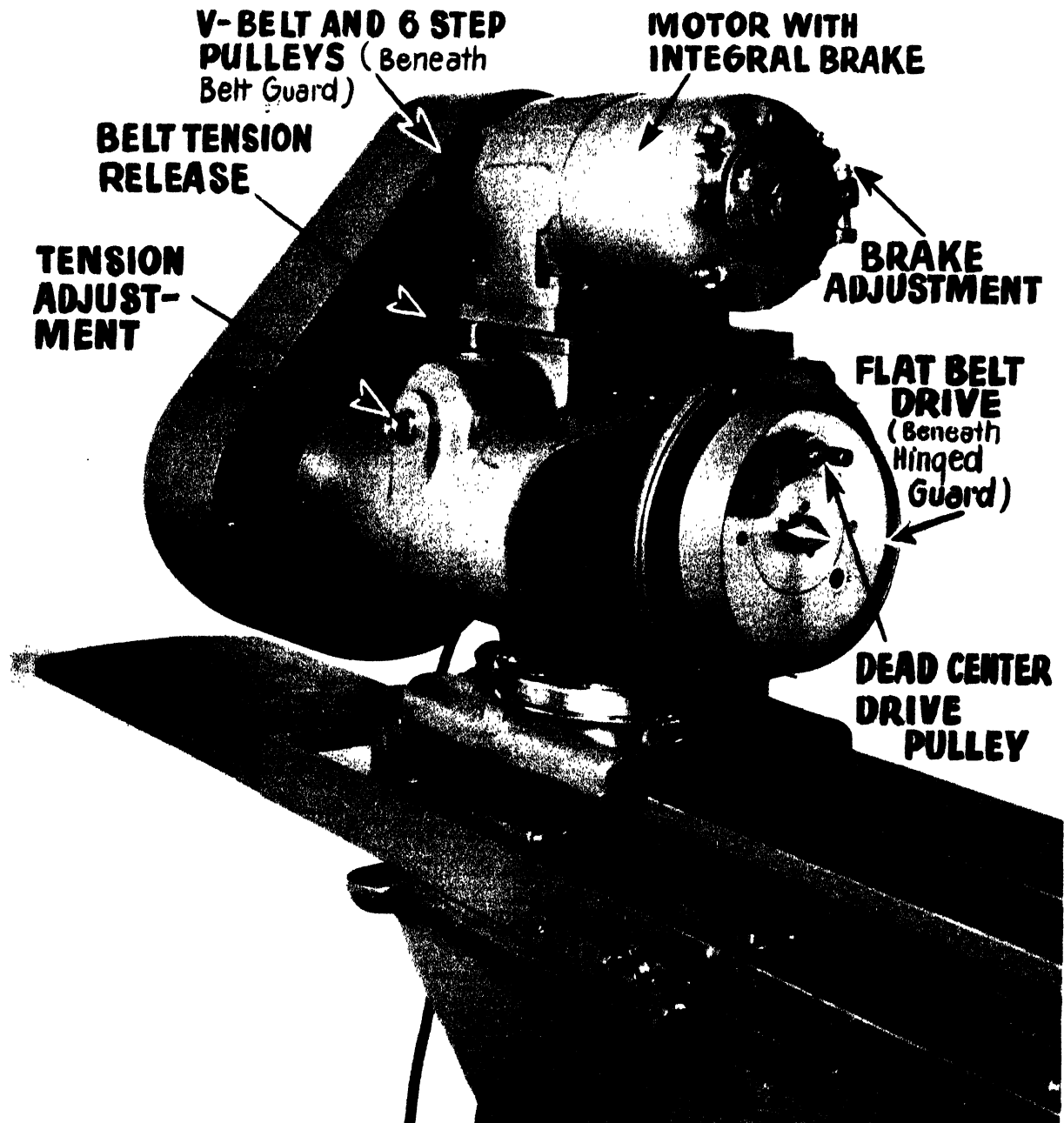

FIG. 337. PARTS OF THE HEADSTOCK

*Courtesy, Brown & Sharpe Manufacturing Co*

on the table feed cone pulleys at the footstock end of the machine, Fig. 339. For recommended feeds and speeds see Unit 83.

#### LIVE OR REVOLVING CENTER GRINDING

Live or revolving center grinding is accomplished by removing the dead center pulley and replacing it with an appropriate work driving unit, a face plate or a chuck. When setting-up for revolving center grinding the locking

plunger at the rear of the headstock must be withdrawn.

#### DEAD CENTER GRINDING

The machine is set-up for dead center grinding by placing a dead center pulley on the nose of the headstock spindle, releasing the tension on the V-belt by turning the belt tension release lever, Fig. 337, to the release position, then moving the V-belt to a step on the

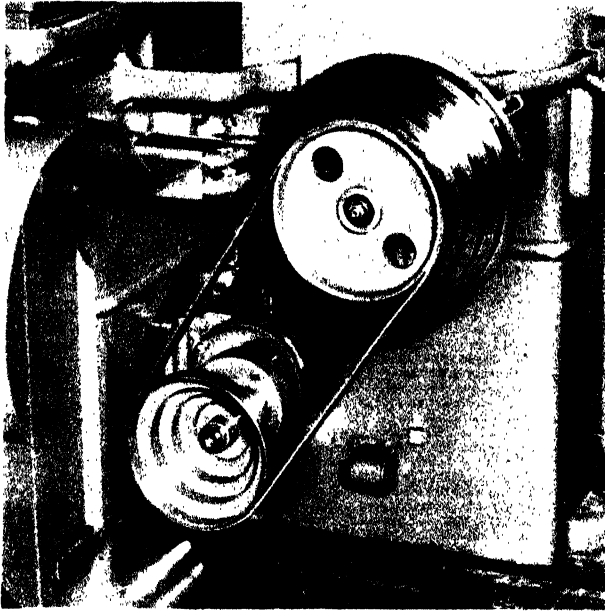

*Courtesy, Brown & Sharpe Manufacturing Co*

**FIG. 339. TABLE FEED CONE PULLEYS**

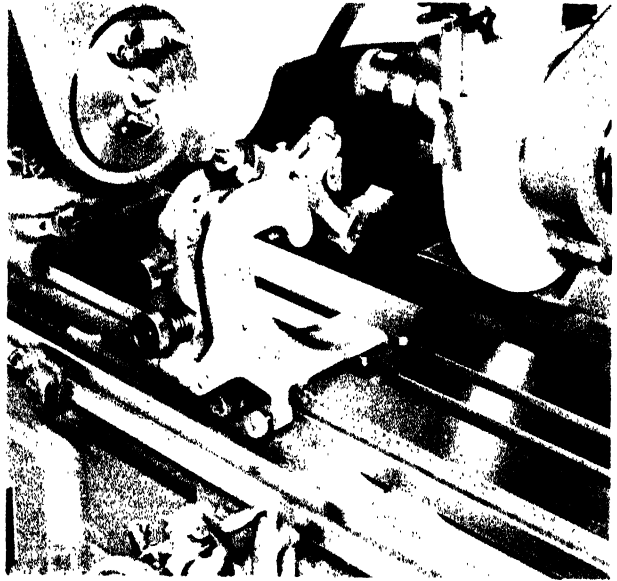

*Courtesy, Brown & Sharpe Manufacturing Co.*

**FIG. 341. BACK-REST OR WORK SUPPORT**

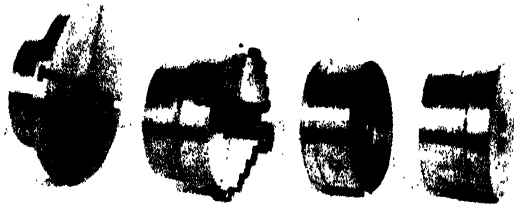

*Courtesy, Brown & Sharpe Manufacturing Co*

**FIG. 340. STANDARD WORK DRIVING UNITS**



*Courtesy, Brown & Sharpe Manufacturing Co*

**FIG. 340-A. ROTARY, PERMANENT-MAGNET TYPE CHUCK**



*Courtesy, Brown & Sharpe Manufacturing Co*

**FIG. 342. CENTER REST**

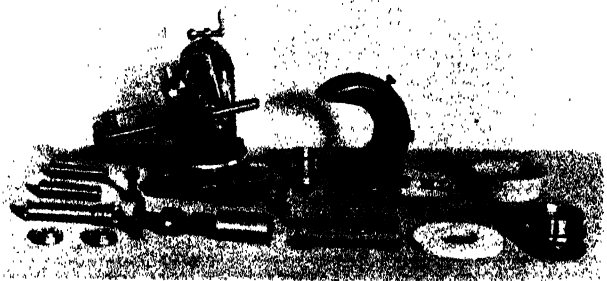

*Courtesy, Brown & Sharpe Manufacturing Co.*

**FIG. 343. UNIVERSAL HEAD AND EQUIPMENT**

cone pulley which will give the desired work speed. When the belt has been positioned correctly, move the belt tension release to the tension position. To hold the spindle and center stationary the locking plunger must be seated in the slot in the spindle.

Standard work driving units are illustrated in Fig. 340. A rotary, permanent-magnet type, chuck is shown in Fig. 340A. A back rest or work support is shown in Fig. 341 and a center rest in Fig. 342.

Fig. 343 is a universal head and equipment.

TABLE VI

## POSSIBLE GRINDING TROUBLES

<i>Symptom</i>	<i>Probable Cause</i>
Work Shows Chatter Finish.	Grinding wheel out of balance, or not clamped properly on the wheel sleeve. Grinding wheel dull, glazed or loaded. Poor choice of wheel for material being ground. Work not effectively supported, centers worn, or need lubrication. Not a sufficient number of back rests used, or back rests not properly adjusted. Too high a work speed, or rate of table travel. Cut too heavy, caused by excessive crossfeed. Unbalanced work-piece (for example, a crank shaft) running at a speed which is too high, or running away from the driving dog (too much momentum). A worn or defective driving belt, check headstock, spindle and table belts. Machine located on an insufficiently rigid floor, or a floor which transmits vibration to the machine.
Scratches on the Work.	Using a dirty coolant. Grinding wheel not trued properly. Truing diamond dull, cracked or broken, or not held rigidly in the holder or not clamped securely in the truing fixture, or the fixture not rigidly clamped in position, or footstock spindle not clamped. Too rapid table feed, or a too deep cut when truing or dressing the wheel. Wheel too coarse for the work.
Spiral Marks on the Work.	Point of truing diamond was too high. The wheel should be trued with the diamond point as near the heights of the work centers as possible.
Wheel Burning the Work.	Insufficient coolant used, or coolant not properly directed at the point of contact of the wheel and the work. Grinding wheel dull, glazed or loaded, needs dressing. Wheel too hard, or wheel speed too high, or work speed too low. Excessive cross feed.
Work Not Ground Parallel.	Swivel table not set accurately at zero. Swivel table pivot shoe may need adjusting. Headstock or footstock not seated properly on the table. Centers not seated properly in the spindle, or center points worn out of round. Center holes in work-piece dirty, or out of round, or do not fit the centers properly. Radial play in the footstock spindle. Spindle clamp not properly adjusted. Back rests needed, or if used, not properly adjusted.
Work Not Sizing Uniformly.	Wheel Slide Rapid Travel Arrangement motor brake needs adjusting. Cross feed screw thrust bearing needs adjusting.
Wheel Spindle Runs Too Hot or Stalls	Insufficient oil in spindle reservoir, or wrong kind of oil. Cross feed too heavy, beyond capacity of the machine. Spindle driving belts too tight.

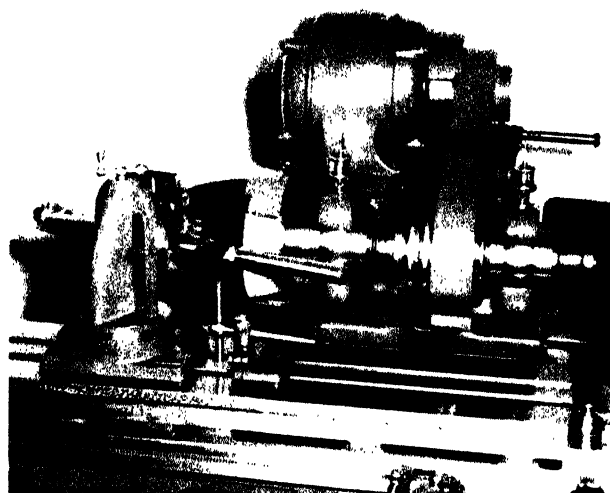

Courtesy, Brown & Sharpe Manufacturing Co.  
FIG. 344. USING THE UNIVERSAL HEAD

This is a supplementary piece of equipment which greatly facilitates holding many forms of cutters and other tools while being ground. A practical application is shown in Fig. 344.

#### CUTTER AND TOOL GRINDING MACHINE

This is a machine designed for grinding reamers, milling cutters, and taps, Fig. 345.

#### GENERAL PROCEDURE

1. Make all settings and adjustments as illustrated in Units 84, 85, 86, and 87.
2. Before starting the machine see that all driving belts have proper tension. A V-belt is properly tensioned when it can be depressed about one inch using only slight

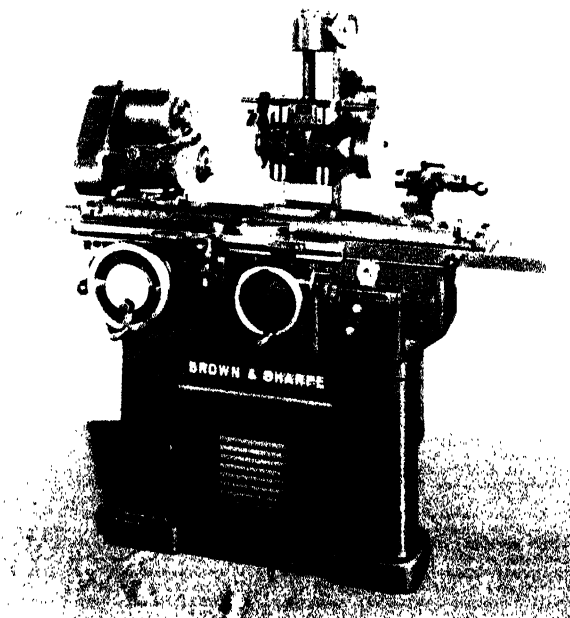

Courtesy, Brown & Sharpe Manufacturing Co.  
FIG. 345. CUTTER AND TOOL GRINDING MACHINE

- pressure. Excessive tension will cause belts to wear rapidly; it may damage the spindle.
3. Make certain that all guards are in working condition and in place. See that the machine is properly lubricated.
4. To produce accurate results a grinding machine should be run for about fifteen minutes before starting a grinding operation. This will bring the machine to running temperature and thus eliminate variations due to expansion of machine parts.

### UNIT 76

## GRINDING WHEELS AND SELECTION

Grinding wheels are made of a crushed abrasive or cutting grit held together by an appropriate substance called a bond. Between the abrasive and the bonding material are pores or air spaces. These provide clearance for the chips removed in the grinding process and minimize wheel loading.

#### ABRASIVES

An abrasive is a hard and tough substance, which when fractured has many sharp edges. The most common abrasives are aluminum oxide and silicon carbide. Aluminum oxide crystals, although not particularly hard, are tough

and are usually preferred for grinding materials of high tensile strength, such as alloy and high-speed steels. The abrasive is known by such trade names as Borolon, Aloxite, Alundum and others.

Silicon carbide crystals are very hard but quite brittle; consequently wheels composed of this material are used in grinding easily penetrated materials, such as copper, rubber and plastics; also hard materials of low tensile strength, cast iron and cast bronzes. Trade names for the material are: Electrodon, Carborundum, Crystolon and others.

**BONDING MATERIALS**

Commonly used bonding materials are: Certain clays, silicate of soda, shellac, rubber and resins. Vitrified clay bonded wheels are preferred for the general run of grinding because they are not affected by rapid changes in temperature and contact with water and oils. Wheels bonded with sodium silicate are known as silicate or semi-vitrified bonded wheels. This is a common type of wheel but not recommended generally for cylindrical grinding. Shellac, rubber, vulcanite and celluloid are used in the production of elastic bonded wheels. Shellac bonded wheels are common. This bond is used frequently in the manufacture of thin wheels. Elastic bonded wheels frequently are used for high quality finishing, for sharpening tools such as saws, and for cutting stock. This type of wheel is not recommended for heavy duty.

**RESIN BOND**

This form of bond is used in the manufacture of large, high speed wheels; also for heavy duty wheels.

**CLASSIFICATION OF GRINDING WHEELS**

Grinding wheels are classified according to size and shape, bond, grain and grade.

**SIZE AND SHAPE**

The size of a wheel is given in terms of its diameter in inches, diameter of spindle hole or opening at the center, and width of face. The more commonly used shapes are: cup, cylinder, disk, ring, saucer or dish. These are illustrated in Fig. 346. Fig. 347 illustrates some typical wheel faces.

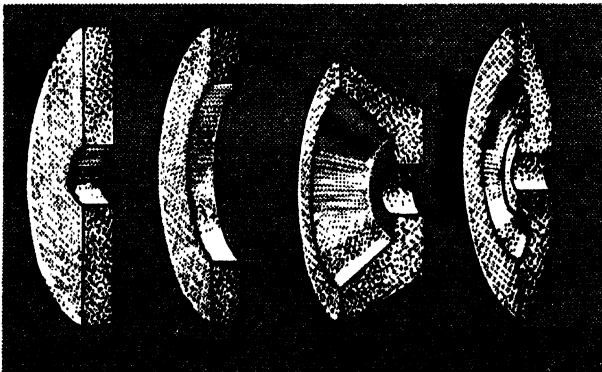

FIG. 346. GRINDING WHEEL SHAPES

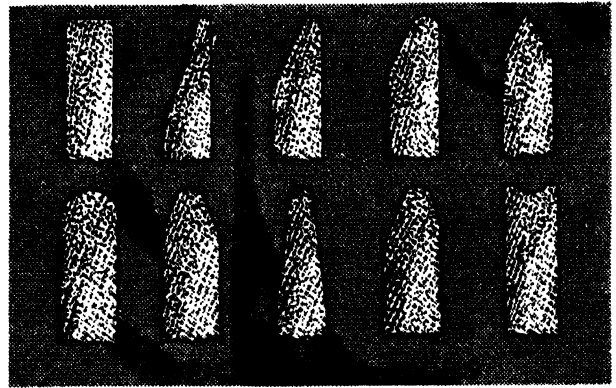

FIG. 347. TYPICAL WHEEL FACES

**BOND**

This refers to the kind of bonding material holding the abrasive.

**GRAIN**

This term refers to the size of the particles of abrasive used in the manufacture of the wheel. For example, an 80 grain wheel is one made of particles of abrasive that will just pass through an 80-mesh screen; that is, a screen having 80 openings per linear inch.

A combination wheel is one in which several sizes of abrasive have been used in its manufacture. Usually such wheels have special characteristics and are designed for a specific purpose.

**GRADE**

Wheels from which the grit or abrasive is readily torn are termed soft bond or soft grade. Conversely, wheels that steadfastly retain the abrasive over a considerable period of use are called hard bond or hard grade.

Hard grade wheels are used for grinding soft metals such as mild steel and soft grade wheels for grinding hard metals such as high carbon steel.

It should be remembered that the term hard as used with respect to grinding wheels has no relationship to the hardness of the abrasive, but rather to the ease or difficulty with which the worn particles of the abrasive are torn from the face of the wheel.

The grade of grinding wheels is designated in different ways by the various manufacturers. Most manufacturers use a letter system to indicate grade, some designate grade by a numerical system.

TABLE VII  
SELECTION OF GRINDING WHEELS\*  
EXTERNAL CYLINDRICAL GRINDING

<i>Suitable For</i>	<i>Wheel Material</i>	<i>Grain</i>	<i>Grade</i>
Good all-round wheels. Best adapted to soft steel.	Aluminox	2946	L
	Alundum	3836	L
	Aloxite	401	N
Hardened steel. Soft steel of small diam. Reamers, drills and general tool work. Hard steel, dry grinding. Cast iron and bronze.	Aluminox or Alundum	46	K
	Aluminox or Alundum	36	M <sup>1</sup>
	Aluminox or Alundum	80	K
	Aluminox or Alundum	100	I
	Crystolon	45	L
FACING SHOULDERS			
Ordinary work. Fine finish	Aluminox or Alundum	60	H or I
	Aluminox or Alundum	80	I <sup>1</sup>
SURFACE GRINDING			
Hardened steel.	Alundum or Aluminox	46	H
	Alundum or Aluminox	46	G <sup>2</sup>
	Alundum or Aluminox	60	F <sup>2</sup>
Hardened high speed steel or very thin pieces of hardened carbon steel.	Aloxite	367	U
	Alundum or Aluminox	46	G
Cast iron.	Carborundum or Crystolon	36	M
	Crystolon	36	J
DISK GRINDING			
Thick pieces, wet grinding. Thin pieces, wet grinding. High speed steel, dry grinding. Washers and similar pieces.	Aluminox or Alundum	30	K
	Aluminox or Alundum	30	J
	Aluminox or Alundum	60 or 80	H or I
	Aluminox or Alundum	60	I
INTERNAL CYLINDRICAL GRINDING			
Good all-round wheel. Roughing hardened steel. Finishing hardened steel. Ordinary finish without roughing.	Aluminox or Alundum	46	2 <sup>1</sup> I <sup>1</sup>
	Aluminox or Alundum	46	J or K
	Aluminox or Alundum	120	J or K
	Aluminox or Alundum	80 & 90	J or K
Roughing brass. Finishing brass. Automobile cylinders.	Crystolon	36	H or I
	Crystolon	80	H
	Crystolon	46	K
Automobile cylinders.	Carborundum	36	M to P
Automobile cylinders, roughing or fair finish.	Carbolite	36	H or I
Automobile cylinders, fine finish.	Carbolite	60	H
SHARPENING CARBON STEEL CUTTERS, DRY GRINDING			
Milling Cutters. Formed and Gear Cutters.	Aluminox or Alundum	46 or 60	I
	Aluminox or Alundum	46 or 60	I
SHARPENING HIGH SPEED STEEL CUTTERS, DRY GRINDING			
Milling Cutters. Formed and Gear Cutters.	Aluminox or Alundum	46 or 60	I
	Aluminox or Alundum	46 or 60	I
SHARPENING HIGH SPEED STEEL CUTTERS, WET GRINDING			
Milling and Gear Cutters.	Aluminox or Alundum	46	I
SHARPENING CARBON STEEL CUTTERS, WET GRINDING			
Formed Cutters.	Alundum	46	J
TUNGSTEN CARBIDE GRINDING			
Tool Grinding Roughing	Green Crystolon	60	I
	Green Grit Carborundum	80 or 100	S
Roughing Finishing	Diamond Grit	100	
	Diamond Grit	150	

\* Courtesy, Brown &amp; Sharpe Manufacturing Co.

<sup>1</sup> Elastic Wheel<sup>2</sup> Silicate Wheel

**SELECTION OF GRINDING WHEELS**

Factors to be considered when selecting a wheel are: the nature of the material, the surface of wheel and work, the amount of material

to be removed, and the accuracy and quality of finish.

Table VII will be helpful in selecting wheels for a variety of materials and conditions.

**UNIT 77****HOW TO CHANGE AND BALANCE A GRINDING WHEEL**

A grinding wheel should fit easily, yet snugly, on the wheel sleeve. A loosely fitting wheel cannot be centered accurately and consequently will be out of balance. Such a wheel should not be used unless the core is recast. Neither should a wheel be used that has to be forced on the sleeve. Forcing the wheel on the sleeve may crack it and thus make it unsafe for use. If the hole is only slightly too small it may be enlarged a trifle by means of a half-round file of appropriate size. Remove a little metal uniformly around the hole. If the wheel is lead bushed sufficient metal may be removed by scraping with a pocket knife.

On some machines the wheel is permanently mounted on a sleeve which, when change of wheel is made, is removed as a unit and a new unit of sleeve and wheel is installed. This practice saves time as the wheel need not be removed from the sleeve until a change is necessary because of wear or development of a flaw.

**PROCEDURE FOR REMOVING A WHEEL AND SLEEVE UNIT**

1. Secure an appropriate wheel sleeve puller and a pin wrench.
2. With the wrench supplied with the machine loosen the spindle nut, Fig. 348, by turning it clockwise. The nut has a left-hand thread.
3. Thread the outer member of the wheel sleeve puller into the sleeve, then tighten the cap screw, Fig. 349, against the end of the spindle, thus loosening the wheel sleeve from the spindle.

On the #5 Brown and Sharpe plain grinding machine a special T-handled wrench supplied with the machine has a threaded end intended for use as a wheel puller. To loosen the sleeve tap the handle of the wrench with a hammer.

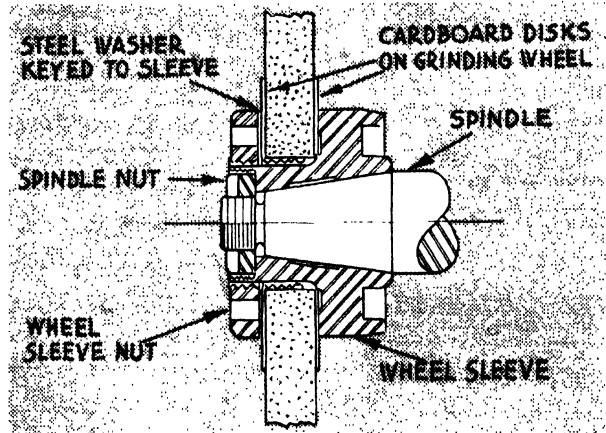
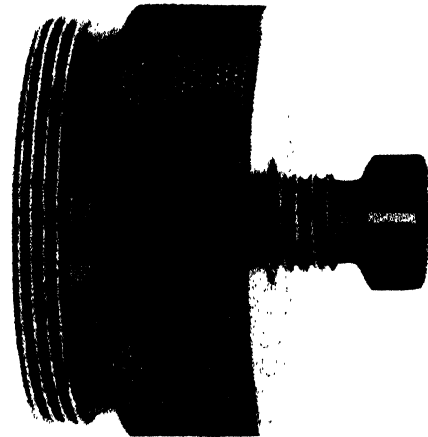

FIG. 348. CROSS SECTION OF WHEEL MOUNTED ON ARBOR



Courtesy, Brown & Sharpe Manufacturing Co.  
FIG. 349. CAP SCREW

**PROCEDURE FOR REMOVING THE WHEEL FROM THE SLEEVE**

1. With a pin wrench loosen the wheel sleeve nut, Fig. 348.
2. Support the wheel on parallels or blocks of wood, then with the fingers press the

sleeve of the wheel. If force is required use a rawhide or wooden mallet, tapping the sleeve very gently.

#### **PROCEDURE FOR MOUNTING A WHEEL AND SLEEVE UNIT**

1. Secure a wheel and sleeve unit suitable to the work to be performed.
2. See that the hole in the wheel and the end of the spindle are clean. If necessary wipe each with a clean cloth.
3. Slide the sleeve unit onto the spindle and seat it by hand, aligning the keyway with the key in the spindle.
4. Draw the sleeve tight on the spindle by means of the spindle nut and wrench. The clamping nut should be tightened just sufficient to hold the wheel securely in place. Too much pressure may crack the wheel.

#### **PROCEDURE FOR MOUNTING THE WHEEL ON THE SLEEVE**

1. Secure a wheel suitable to the work to be performed.
2. Insert a finger in the spindle hole of the wheel and suspend it in the air, then very lightly tap the edge of the wheel with a hammer or some hard substance. If the wheel is sound a clear ring will be heard. If no ring is heard the wheel is probably cracked and should not be used.
3. Insert a rubber, leather, or blotting paper washer between the wheel and each of the clamping flanges. Many makes of grinding wheels come with a heavy ring of blotting paper attached to each side of the wheel. Nevertheless it is good practice to use an additional ring or washer of rubber, leather, or blotting paper as a means of securing greater protection for the wheel.
4. Screw the outer flange or sleeve nut onto the wheel sleeve and tighten it with the wrench supplied for that purpose. Avoid exerting too much pressure.
5. Observe the condition of the spindle hole in the wheel and the end of the wheel spindle. They should be clean. If necessary wipe each clean with a cloth.
6. Slide the wheel sleeve onto the spindle and seat it by hand, aligning the keyway with the key in the spindle.

7. Draw the sleeve tight on the spindle by means of the spindle nut and wrench. The clamping nut should be tightened just sufficient to hold the wheel securely. Avoid too much pressure.

#### **PROCEDURE FOR BALANCING A GRINDING WHEEL**

To avoid excessive vibration it is essential that a grinding wheel be balanced. Because it is essential that grinding wheels run true most manufacturers balance their wheels before issuing them to the trade. Consequently wheels 10 inches or less in diameter rarely need further balancing. Larger wheels may need to be balanced because of wear and changes which may have developed within the wheel.

Balance may be achieved by: (1) Adding weight in the form of lead to the light side. This may be accomplished by removing small amounts of the wheel beneath the flanges, then filling the holes thus made with lead. (2) On some wheel units, balance is achieved by adjustment of segments attached to the inner sleeve flange, as in Fig. 350.

#### **PROCEDURE FOR BALANCING A GRINDING WHEEL BY ADDING LEAD**

1. Remove some of the abrasive material beneath the flanges on the light side of the wheel. Avoid removing too much material in one spot. It is better to make two or three small cavities than one large one. Cavities should be placed a short distance apart so as to distribute the added weight.
2. Fill the holes thus made with lead.
3. Remove excess lead so that the flanges will fit properly against the sides of the wheel.
4. Mount the wheel on a tapered mandrel, then place the mandrel on a support such as shown in Fig. 350. Locate the mandrel midway of the support.
5. Give the wheel a slight push and allow it to roll back and forth until it comes to rest, which it will do with the heavy portion of the wheel at the bottom.
6. Continue adding or removing weight until the wheel is in a balanced condition. This will be evident when the wheel rolls to a gentle stop with no evident tendency to roll backward, regardless of what portion of the wheel was at the bottom when it started to roll.



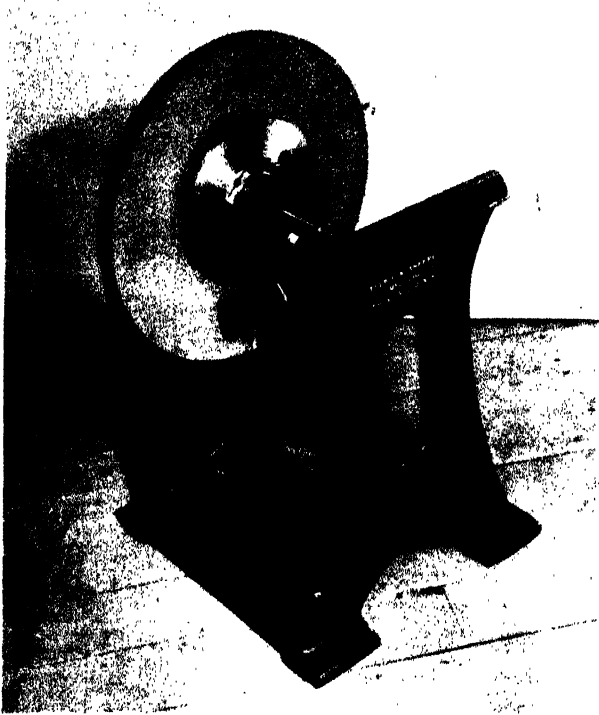

Courtesy, Brown & Sharpe Manufacturing Co.  
 FIG. 350. WHEEL BALANCED WITH SEGMENTS

#### PROCEDURE FOR BALANCING A GRINDING WHEEL WITH BALANCING SEGMENTS

1. Mount the wheel on a tapered mandrel, then place the mandrel on a support such as illustrated in Fig. 350. Locate the mandrel about midway of the support.
2. Give the wheel a very slight push and allow it to roll back and forth until it comes to rest, which it will do with the heavy portion of the wheel at the bottom.
3. Move the balancing segments in the direction of the light side of the wheel, then test as before.
4. Continue adjusting the balancing segments until the wheel is balanced. This will be evident when the wheel rolls to a gentle stop with no evident tendency to roll backward, regardless of what portion of the wheel was at the bottom when it started to roll.

#### UNIT 78

### HOW TO TRUE OR DRESS A GRINDING WHEEL ON A UNIVERSAL OR A PLAIN GRINDING MACHINE

Truing a grinding wheel refers to correcting eccentricity or an out of round condition by removing particles of the abrasive from the high part of the wheel by means of a diamond-tool; also to forming the wheel concentrically to a particular shape, for example, a wheel having a concave or a convex face. To be in good condition the wheel must be sharp and run true both on the periphery and on the sides.

#### PROCEDURE FOR TRUING A GRINDING WHEEL ON FOOTSTOCK TYPE FIXTURE

1. Secure and mount on the footstock, a footstock type of wheel truing fixture, as in Fig. 351.

If preferred a table type of wheel truing fixture, Fig. 352, may be clamped to the table of a plain grinding machine.

2. Position the grinding wheel so that it will clear the footstock as the table is traversed, (moved back and forth,) carrying the diamond-tool across the face of the wheel.

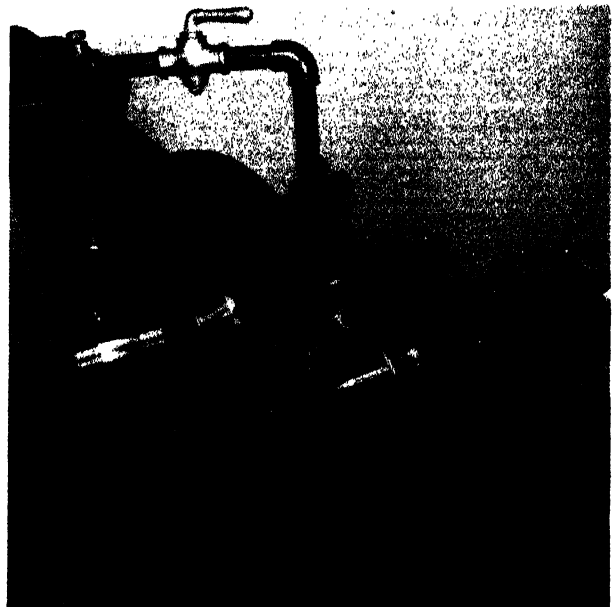

Courtesy, Brown & Sharpe Manufacturing Co.

FIG. 351. WHEEL-TRUING FIXTURE MOUNTED ON FOOTSTOCK



Courtesy, Brown & Sharpe Manufacturing Co.

FIG. 352. TABLE TYPE WHEEL-TRUING FIXTURE

3. Secure a diamond-tool and clamp it in the fixture as shown in Fig. 351, with the point of the diamond touching the center of the face of the wheel, which usually is the high part. The diamond-tool should contact the wheel very slightly below the axis of the wheel. This will prevent gouging and possible chattering. With the tool in position tighten the footstock clamp.

Note: Because a diamond wears through use, it is important that the tool always be positioned in a manner that will present a sharp edge to the face of the wheel. When the diamond has become cone-shaped, turn it in the holder so as to present it at a new angle to the wheel.

4. Position and adjust reversing dogs so that power table travel can be used. Be sure to provide for passing the truing tool a short distance beyond the edge of the wheel on each stroke.
5. Adjust the table travel for moderately rapid rate for the roughing cut.
6. Set the Grind-True Switch at True. This will assure a constant flow of coolant.
7. Push the start-stop button, then position the sliding table so that the diamond-tool is in contact with one edge of the wheel. Round the corner of the wheel slightly by manipulating the cross and longitudinal hand feeds.

**CAUTION:** Be sure the wheel guard is in position and fastened securely.

Rounding the corners of the wheel slightly prevents chipping the edges of the wheel when the tool is fed straight across the face of the wheel.

8. Round the other corner of the wheel in like manner.
 

If preferred the edges of the wheel may be slightly rounded with a hand-held diamond-tool or a Radius Wheel-Truing attachment such as illustrated in Fig. 353.
9. Start the table travel by pulling the start-stop lever forward.
10. Advance the wheel to take a cut of .0005 to .001 of an inch.
11. Continue passing the tool across the face of the wheel until the wheel is running true, then reduce the speed of table travel and take finishing cuts of .0005, then one or two of .0001 or .00025 of an inch.
12. When through truing or dressing a wheel remove the truing attachment, and thoroughly clean the machine to remove grit and other foreign matter. Return attachment and other tools to the place where they are kept when not in use.

#### PROCEDURE FOR DRESSING A WHEEL

A wheel is dressed to produce a sharp grinding surface. This is accomplished by removing the dull or loaded surface of the wheel with a diamond-tool, thus presenting new and sharp cutting particles of abrasive. Dressing is necessary whenever the wheel cuts very slowly or when the wheel is glazed or loaded. This indicates that it is dull. A wheel is said to be loaded when the spaces between the particles of the abrasive become filled with particles of metal, usually non-ferrous metals.

1. Proceed as in steps 1 to 12 inclusive under Procedure for Truing Face of Wheel.

#### PROCEDURE FOR TRUING THE RADIUS

Radius truing is the process of rounding the corners of the wheel for the purpose of grinding up to shoulders where a fillet is required. This operation is accomplished by means of a *radius wheel - truing attachment*, Fig. 353. This device provides a convenient means of shaping either the right-hand or left-hand corner of the grinding wheel within radius limits of zero and  $\frac{1}{2}$  inch.

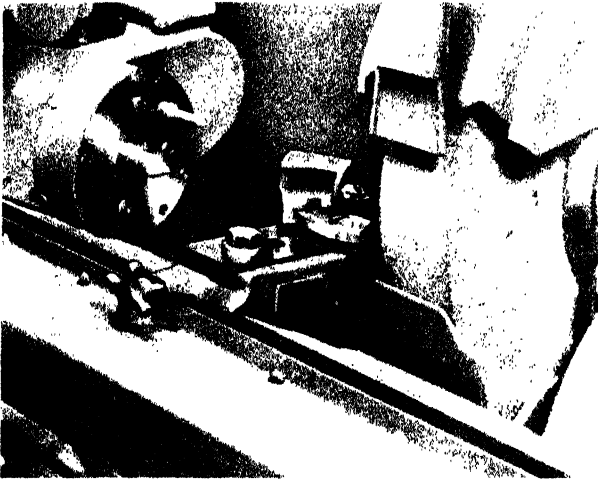

Courtesy, Brown & Sharpe Manufacturing Co.

FIG. 353. RADIUS WHEEL-TRUING ATTACHMENT

1. Secure, mount, and position a radius wheel-truing attachment on the swivel table, Fig. 353. Clamp the attachment in position with the knob at the front of the attachment.
2. With the cross feed bring the wheel to within a short distance of the radius attachment.
3. Determine the radial setting of the diamond-tool by subtracting the desired radius from the figures stamped on the back face of the tool holder. These figures show the exact radial distance from that surface to the center about which the diamond-tool is rotated.
4. Set the tool at the determined radial distance using a micrometer or gauge.
5. Swing the diamond-tool holder to its forward position (at right angles to the wheel spindle), then loosen the clamping bolt at the front of the traverse adjustment slide and move the attachment forward until the diamond touches the face of the wheel. Clamp the slide in position by tightening the nut on the clamping bolt.
6. Move the table sufficiently for the diamond-tool to clear the wheel, then swivel the holder until the tool is at right angles to the side of the wheel. With the table handwheel move the table forward until the diamond touches the wheel. The attachment is now correctly positioned to form the desired radius.
7. Withdraw the table slightly, so that when the diamond-tool holder is swiveled on the segment the tools will cut a small amount of material from the corner of the wheel. Swivel the holder back and forth around the segment, removing a small amount of the wheel at each pass. Keep the diamond advancing toward the wheel by moving the table of the machine a small amount after each stroke.
8. When the operation has been completed remove the attachment and thoroughly clean both it and the machine. Return the attachment and other tools to the place where they are kept when not in use.

## UNIT 79

### HOW TO SHAPE GRINDING WHEELS FOR GRINDING ARC OR ANGLES

In the manufacture of metals and other hard substances it is frequently necessary to grind one or more surfaces of a piece of work at an angle, a radial shape, or a combination of these. This is accomplished by appropriately shaping the face of the grinding wheel.

#### GENERAL PROCEDURE FOR RADIAL GRINDING

1. True the grinding wheel, see Unit 78. Be sure to protect the eyes with properly fitted goggles. Also be sure that the wheel guard is fastened securely in position.
2. Secure a *radius and angle wheel-truing attachment*, such as shown in Fig. 354. This attachment when appropriately adjusted, will form wheels so that they have accurate convex or concave faces as desired, up to 1 inch radius.
3. Position the fixture on the table of the machine, then tighten the clamping bolts.

#### PROCEDURE FOR FORMING A CONVEX FACE OR OUTLINE

1. Select a wheel appropriate to the work to be done and with the same face width as the radius to be formed. Mount the wheel on the spindle.
2. Proceed as in steps 1 to 3 in "Procedure for Truing the Radius."
3. Place a diamond-tool in the tool holder parallel with the slide, as in Fig. 354. The diamond-tool should contact the wheel slightly below the axis of the wheel. This will prevent gouging and/or possible chattering. Position the diamond-point by means of the setting gauge at the front of the tool holder. Clamp the tool in position.

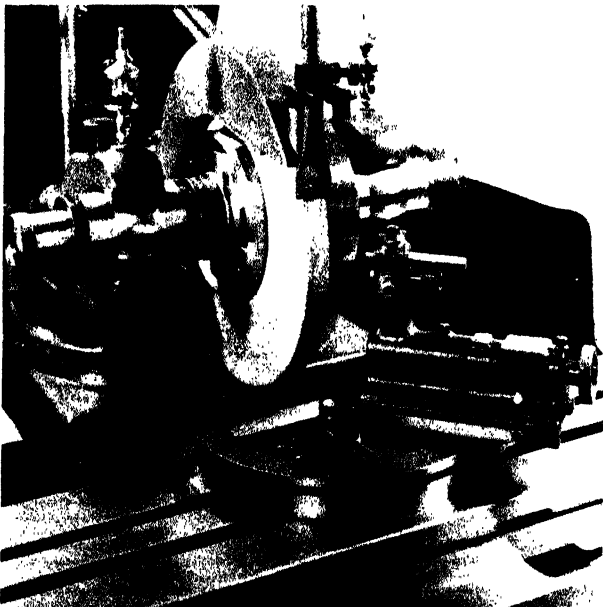

Courtesy, Brown & Sharpe Manufacturing Co.

FIG. 354. RADIUS AND ANGLE WHEEL-TRUING ATTACHMENT

4. Adjust the slide by means of the hand-wheel, withdrawing it to the right of center, by the scale on the slide, until the radius desired registers, for example,  $\frac{3}{4}$  of an inch. Then tighten the clamping screw at the back of the slide.
5. With the cross feed, position the fixture so that the axis of the diamond-tool is centered with respect to the center of the face of the wheel.
6. Start the machine, then with the longitudinal table feed advance the tool toward

the wheel. At the same time swivel the attachment on its base. Be careful to avoid a heavy first cut at the edges of the wheel.

7. Pass the tool across the face of the wheel two or more times by swiveling the fixture on its base, then with the longitudinal table feed advance the tool about .0005 of an inch and again take two or more strokes.
8. Continue with repeated strokes and table adjustments until the face of the wheel has the desired radius (shape), leaving about .0005 or .001 of an inch for finishing.

**CAUTION:** Do not advance the tool more than about .0005 of an inch at any single advancement.

9. Finish grinding with a series of light cuts, using a feed of about .00025 of an inch.
10. When the operation has been completed remove the attachment and thoroughly clean both it and the machine. Return the attachment and tools to the place where they are kept when not in use.

#### PROCEDURE FOR FORMING A CONCAVE FACE OR OUTLINE

1. Proceed as in steps 1 to 3, "General Procedure for Radial Grinding."
2. To form a concave face on the wheel, clamp the diamond-tool in the tool holder *parallel to the slide* as in Fig. 354. Position the diamond point by means of the setting gauge at the front of the tool holder. Clamp the tool in position.
3. Adjust the slide by means of the hand-wheel, advancing it to the left of center by the scale on the slide until the radius desired registers, for example,  $\frac{3}{8}$  of an inch. Then tighten the clamping screw at the back of the slide.
4. With the cross feed, position the fixture so that the axis of the diamond-tool is centered with respect to the center of the face of the wheel.
5. Start the machine, then with the table longitudinal feed bring the diamond-tool into contact with the face of the wheel.
6. Pass the tool across the face of the wheel by swiveling the attachment on its base. Take two or more strokes. Then by means of the table longitudinal feed advance the tool toward the wheel .0005 of an inch.

7. Continue with repeated strokes and table adjustments until the desired shape has been achieved except for a small amount of stock for finishing, about .0005 or .001 of an inch.

**CAUTION:** Do not advance the table more than about .0005 of an inch at any single advancement.

8. Finish grinding with a series of light cuts, using a feed of about .00025 of an inch.
9. When the operation has been completed, remove the attachment and thoroughly clean both it and the table of the machine. Return the attachment and tools to the place where they are kept when not in use.

#### PROCEDURE FOR FORMING AN ANGULAR FACE OR OUTLINE

1. Select a wheel of the size desired and suited to the work to be done.
2. Mount the wheel on the spindle, see Unit 77.
3. Secure a radius wheel-truing attachment, Fig. 354. Position and clamp the attachment on the table of the machine.
4. Loosen the clamping bolts and swivel the wheel stand and slide to the angle required, for example, 60°, as indicated by the graduations on the base. The slide must be set at right angles to the wheel stand.
5. Tighten the clamping screw, thus holding the slide at the required angle.
6. Place the diamond-tool in the holder at right angles to the slide.
7. With the table longitudinal and cross feeds adjust the position of the table until the edge of the diamond-tool comes into contact with the near edge of the wheel.
8. Start the machine, then with the cross feed handwheel move the tool back and forth across the wheel, taking a cut of about .0005 of an inch. Be sure the wheel guard is fastened securely in position.
9. After two or three strokes advance the tool by moving the table forward sufficient for another cut of about .0005 of an inch.
10. Continue as in steps 9 and 10 until the face of the wheel has the shape required. Fig. 355 illustrates a wheel shaped to grind a diameter and a slight shoulder.

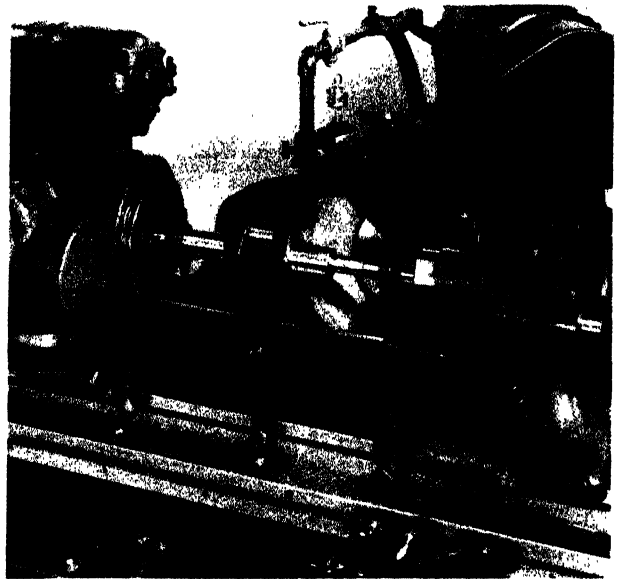

Courtesy, Brown & Sharpe Manufacturing Co.

FIG. 355. GRINDING A DIAMETER AND A SLIGHT SHOULDER

11. Finish truing with two or three light cuts.
12. When the operation is completed, remove the attachment and thoroughly clean it and the machine. Return the attachment and other tools to the place where they are kept when not in use.



Courtesy, Brown & Sharpe Manufacturing Co.

FIG. 356. TOOL MOUNTED AT RIGHT ANGLES TO THE SLIDE

**PROCEDURE FOR SHAPING GRINDING WHEELS ON A SURFACE GRINDER**

1. Secure a wheel suited to the work to be performed.
2. Mount the wheel on the spindle and true it in the usual manner.
3. Mount an angle wheel truing attachment on the table of the machine and clamp it in position.
4. Mount a diamond-tool in the tool holder at right angles to the slide, as in Fig. 356.
5. Loosen the clamping screw in the front of the base of the fixture, then swivel the slide to the angle required, for example, 60°, as indicated by the graduations on the base. Clamp the slide in position by tightening the screw.
6. With the vertical feed raise the table until the tool contacts the wheel slightly below the axis.
7. With longitudinal and cross feed hand-wheels position the tool to make the cut.
8. Start the machine, then with the hand-wheel at the rear of the attachment move the diamond-tool across the edge of the wheel taking a cut of about .0005 of an inch. Take two or three passes before advancing the tool.
9. With the longitudinal table feed advance the tool for a second cut; again take at least two passes.
10. Continue as in steps 7 and 8 until the wheel face has the desired shape, except for a light finishing cut.

**CAUTION:** Do not advance the tool more than about .0005 of an inch at any advancement.

11. Finish grinding with light cuts.
12. When the operation has been completed remove the attachment and return to the place where kept when not in use.

**UNIT 80****HOW TO TRUE, OR DRESS A WHEEL ON A SURFACE GRINDING MACHINE**

A grinding wheel should be trued each time it is put on the spindle, and dressed whenever it becomes dull, loaded or glazed.

**PROCEDURE FOR TRUING GRINDING WHEELS**

1. Protect the eyes by wearing properly fitted

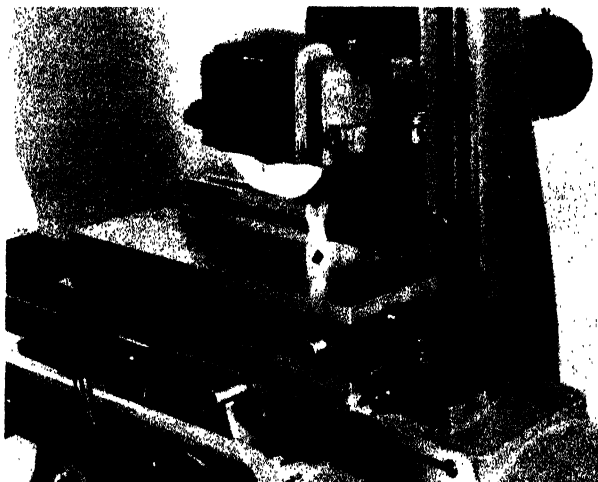

*Courtesy, Brown & Sharpe Manufacturing Co.*

**FIG. 357. GRINDING A V-SHAPED RECESS**

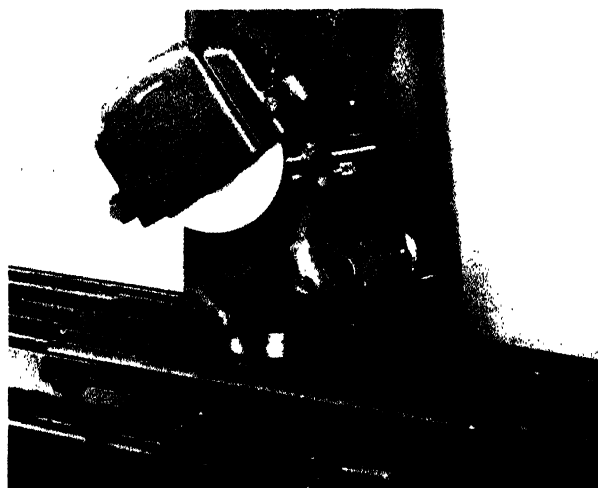

*Courtesy, Brown & Sharpe Manufacturing Co.*

**FIG. 358. SHAPING A CONVEX SURFACE ON A WHEEL**

Fig. 357 illustrates a wheel face formed for grinding a V-shaped recess.

Fig. 358 illustrates an angle and truing attachment positioned for grinding a convex surface on the face of the wheel.

goggles, and protect clothing by wearing suitable coveralls.

2. Mount the wheel on the spindle as instructed in Unit 77.
3. Secure a wheel truing fixture such as shown in Fig. 359.

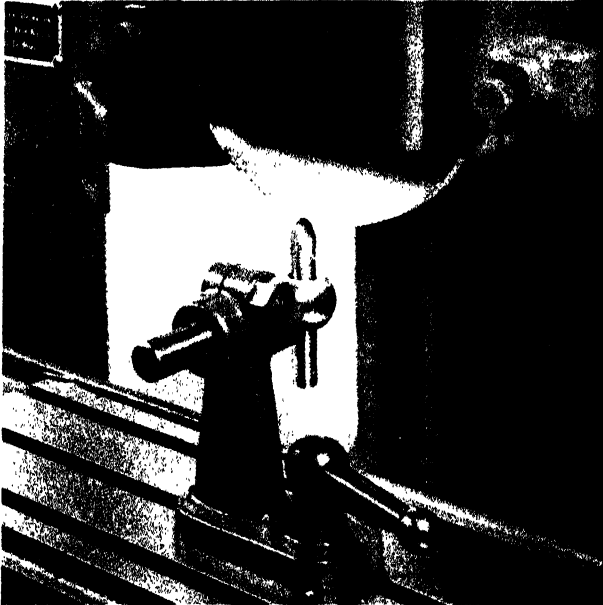

*Courtesy, Brown & Sharpe Manufacturing Co.*

FIG. 359. TRUING A WHEEL ON A SURFACE GRINDER

4. Position the fixture on the table of the machine so that the diamond-tool may be applied to the face of the wheel as illustrated in Fig. 359. In the illustration the contact point of the diamond-tool is slightly ahead of the vertical center of the wheel, and is inclined slightly in the direction of wheel travel. This will prevent gouging and tendency to chatter.
5. Clamp the fixture in position, then start the machine and with the vertical adjustment handwheel lower the grinding head until the wheel is lightly in contact with the diamond-tool.

**CAUTION:** Be sure the wheel guard is fastened securely in position.

6. With the cross feed move the table so that the diamond-tool clears the wheel, then lower the grinding head about .0005 of an inch.

To prevent chipping the edges of the wheel it is good practice to round the corners of the wheel slightly before truing the face. This can be done by bringing the diamond-tool into contact with the corner of the wheel, then by manipulating the cross and vertical feeds remove a small amount of material from each corner of the wheel.

7. Start the machine, then with the cross feed pass the diamond-tool across the face of the wheel two or more times. If a coolant is available use it freely.
8. At the end of the second or third stroke lower the head another .0005 of an inch and take another stroke.
9. Continue as in steps 6 and 7 until the wheel is running true.
10. On rare occasions it is necessary to true the sides of the wheel. To perform this operation position the fixture so that a cut may be taken on respective sides of the wheel. Then taking a light cut feed the grinding head downward. Continue with repeated cuts until the sides of the wheel are true.
11. When the truing operation is completed remove the truing fixture, then thoroughly clean both it and the machine.

#### PROCEDURE FOR DRESSING GRINDING WHEELS

1. Proceed as in steps 2 to 9 inclusive under truing.

### UNIT 81

#### HOW TO GRIND CENTERS

To produce accurate work when grinding work held between centers, the centers must themselves be as accurate as the operator can make them. Through constant use, centers which once were accurate lose this characteristic and must be reconditioned. This may be done by activating the live center on a machine equipped for this purpose. When such is the

condition the method of truing a center is similar to that of grinding an angle or taper as described in Units 85 and 89.

When activation of the headstock center cannot be accomplished, the operation of grinding a center can be performed readily by means of a special attachment such as illustrated in Fig. 360.

**PROCEDURE**

1. Secure a Center Grinding Attachment and place on the swivel table of the machine.
2. With a clean cloth wipe the body of the center and the hole in the attachment. Both must be clean.
3. Insert the center in the hole in the attachment. Be sure it is firmly seated.
4. Advance the grinding wheel to a forward position, then approximately position the grinding attachment and fasten it in position with the clamping bolt, as in Fig. 360.
5. Protect the eyes by wearing properly fitted goggles.
6. Set the Grind-True switch at True. This will give a constant flow of coolant.
7. Start the machine, advance the wheel against the work-piece (center) and at the same time rotate the center in the attachment by means of the handwheel at the rear of the attachment, Fig. 360.

**CAUTION:** Be sure the wheel guard is fastened securely in position.



*Courtesy, Brown & Sharpe Manufacturing Co.*

**FIG. 360. GRINDING A CENTER**

8. Continue grinding until the center is true and smooth.
9. When the operation is completed remove the center from the attachment, using a knockout rod, if necessary. Then remove the attachment and thoroughly clean both it and the machine. Return the attachment to the place where kept when not in use.

**UNIT 82**

### HOW TO SHARPEN CUTTERS ON A UNIVERSAL GRINDING MACHINE

Plain milling cutters with straight teeth can be ground on a universal grinding machine. Usually such work is mounted on a mandrel, as in Fig. 361. This operation can be performed on a plain cylindrical grinding machine.

**PROCEDURE**

1. Set the machine as for straight cylindrical grinding.
2. Protect the eyes with properly fitted goggles.
3. Mount the cutter on a suitable mandrel, and place it between the centers of the machine, using dead center grinding.

True the face of the wheel. Usually only a small amount of the face of the wheel comes in contact with the work, the remainder of the wheel face being dressed back a sufficient amount to prevent contact.

4. Fasten the tooth rest bracket on the swivel table and adjust the tooth rest. The rest

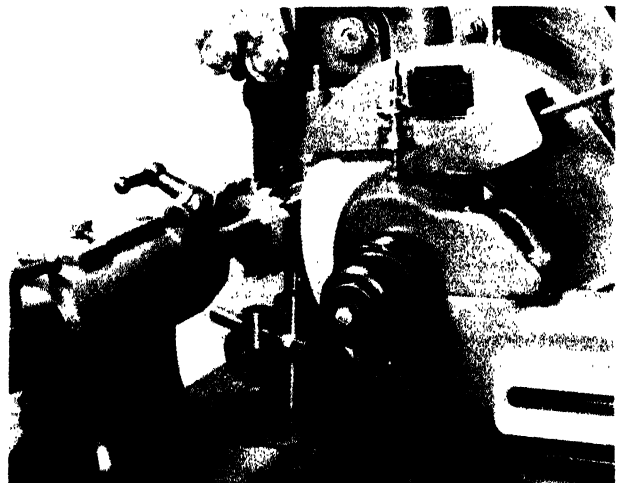

*Courtesy, Brown & Sharpe Manufacturing Co.*

**FIG. 361. GRINDING A CUTTER MOUNTED ON A MANDREL**



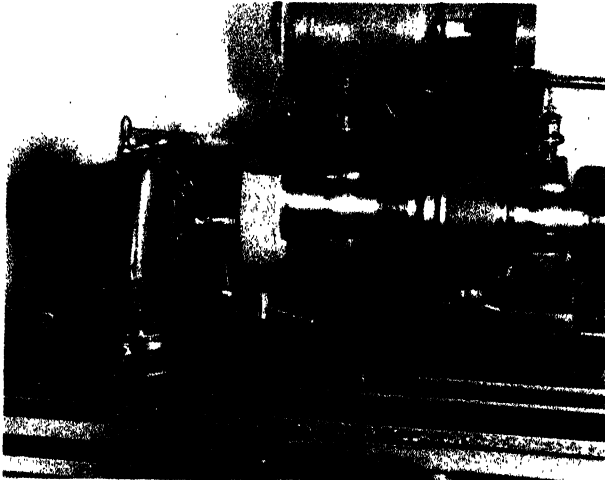

Courtesy, Brown & Sharpe Manufacturing Co.  
 FIG. 362. GRINDING AN END MILL, USING A  
 UNIVERSAL HEAD

must be set below the center of the wheel spindle sufficiently to grind clearance on the back of the tooth of from  $4^{\circ}$  to  $7^{\circ}$ , depending upon size.

5. Hold the first tooth to be sharpened down

on the tooth rack, then bring the wheel into contact with the cutter and move it back and forth across the face of the cutter until it is sharp. Use hand feed.

6. When the first tooth has been ground to a keen edge, set the stop lever of the cross feed mechanism against the stop pin and lock the lever.
7. Run the wheel back and turn the cutter counterclockwise until the next tooth comes up and rests upon the tooth rack.
8. Advance the wheel sufficient for a cut of not more than .002 of an inch, then with the table feed move the wheel back and forth across the tooth of the cutter. Continue with repeated advances and cuts until the wheel sparks out.

Note: When using the Universal Head, Fig. 362, the machine is set up in the same manner except that the wheel furnished with the head is mounted on the left end of the spindle. The headstock and footstock are not used.

## UNIT 83

### GRINDING CUTTING SPEEDS AND FEEDS

When setting up a grinding machine the matter of wheel speed, work speed and table travel must be given consideration.

#### WHEEL SPEED

The recommended surface speeds of grinding wheels range from 5500 to 6500 feet per minute. Speeds above 6500 are dangerous and should not be used. Speeds below 5500 feet per minute are used when a soft wheel action is desired. Surface wheel speed must not be confused with revolutions per minute. As the diameter of the wheel is decreased the revolutions of the wheel per minute may be increased. When the diameter of the wheel is increased the revolutions per minute should be decreased an amount sufficient to keep the surface speed below the maximum of 6500 feet per minute.

To determine the revolutions per minute (r.p.m.) necessary to produce a surface speed which will not exceed 6500 feet per minute one must first find the circumference of the wheel in feet, then divide the surface speed desired

by the circumference of the wheel. For example, the circumference of an eleven inch wheel in feet =

$$\frac{11 \times 3.1416}{12} = 2.88 \text{ feet}$$

Then

$$\begin{aligned} \text{r.p.m.} &= \frac{\text{Surface speed}}{\text{Circumference of wheel}} = \frac{6500}{2.88} \\ &= 2257 \text{ r.p.m.} \end{aligned}$$

The large pulley on a #5 Brown and Sharpe grinder will produce a spindle speed of 2077 revolutions per minute. With an eleven inch wheel this will produce a surface speed of 5828 feet per minute:

Surface speed = r.p.m. of spindle times the circumference of wheel in feet.

$$\begin{aligned} \text{EXAMPLE: Surface speed} &= 2077 \times 2.88 \\ &= 5828 \text{ feet per minute.} \end{aligned}$$

This speed is within the 5500 to 6500 limit recommended and assuming the appropriate type

of wheel has been selected should produce work of a high quality.

A higher surface speed may be achieved by using a larger wheel, for example, a 12-inch wheel.

EXAMPLE:  $\frac{12 \times 3.1416}{12} = 3.1416$  circumference of wheel

Surface speed = r.p.m. of spindle  $\times$  circumference of wheel

When r.p.m. = 2077, then

S.S. =  $2077 \times 3.14 = 6512$  feet per minute

This produces a speed in excess of that recommended as a maximum, and a lower r.p.m. should be used, for example, 1772 r.p.m.

Then,

Surface speed =  $1772 \times 3.14 = 5564$  feet per minute.

This is only a little above the minimum recommended, but is a safer operating speed.

#### WORK SURFACE SPEED

Recommended work speed for cylindrical grinding is from 50 to 100 feet per minute for most materials. Aluminum, brass and other soft material may be ground at the rate of 200 feet per minute. A work speed of from fifty to seventy feet per minute will produce good results. The slower the work-piece revolves the harder will be the wheel reaction; consequently the work speed should not be lower than the minimum or above the maximum recommended. Too much speed will not accomplish more work and is likely to cause excessive wear and possibly damage to the machine. For finishing cuts work speed usually is increased by about 33 percent. Changes in work speed are made by a four step pulley on the headstock of the grinder. Available headstock spindle speeds on a #5 Brown and Sharpe grinding machine are 202, 319, 505, 800 r.p.m.

EXAMPLE: Given the diameter of the work-piece, for example  $\frac{1}{2}$  of an inch, and a work speed of 70 feet per minute find the r.p.m. required.

To determine the r.p.m. of the headstock necessary to produce a given work surface speed, apply the following formula:

$$\text{r.p.m.} = \frac{\text{Work Speed in feet times 12}}{\text{Circumference of the Work}}$$

$$\text{Then r.p.m.} = \frac{\text{Work Speed} \times 12}{3.14 \times \text{Dia. of Work}}$$

$$\frac{70 \times 12}{3.1416 \times .75} = \frac{70}{.1950} = 354 \text{ r.p.m.}$$

Moving the belt to the 319 speed will produce a satisfactory work speed.

#### TABLE TRAVEL

Recommended rate of table travel for rough grinding is about  $\frac{2}{3}$  of the width of the grinding wheel per revolution of the work-piece. For finish grinding a rate of travel equal to approximately  $\frac{1}{3}$  or less of the width of the face of the wheel will produce good results. When a very smooth finish is desired the rate of travel may be as low as  $\frac{1}{4}$  of the width of the wheel.

To determine the rate of travel in inches multiply the desired work speed in revolutions per minute by the distance in inches the work-piece should travel per revolution.

EXAMPLE: Given a one inch wheel, a work speed of 319 r.p.m. and a table travel per revolution of  $\frac{2}{3}$  of the width of wheel, the rate of table travel in inches per minute equals:

Table travel = revolutions per minute  $\times$   $\frac{2}{3}$  width of wheel.

Table travel =  $319 \times .66 = 210$  inches per minute.

Table travel rates for the #5 Brown and Sharpe machine are 6, 11, 22, 39, 70 and 133 inches per minute, with a 60 cycle motor.

In the example given the highest rate of travel available would be used; and, if necessary, the r.p.m. would be reduced. Changes in longitudinal table travel are made by means of the table speed selector levers shown in Fig. 376. On the Brown and Sharpe machine, the rate of travel may be changed while the table is traveling.

#### DEPTH OF FEED

Assuming that a suitable wheel, correct wheel and work speeds, and proper table travel have been selected, then the depth of the cut is a matter of adapting the cutting load to the nature of the material and the power of the machine.

When making roughing cuts beginners tend to take a series of light cuts instead of a heavy cut which will remove a major part of the material at a single pass. Experienced operators usually take a heavy roughing cut. Ordinarily a roughing cut should be from .001 to .004 (thousandths) of an inch, finishing cuts are from .00025 to .0005 (ten thousandths) of an inch. The amount of stock left for grinding depends

upon the character of work and the nature of the material. On some materials or work-pieces as little as .005 of an inch might suffice, while on another piece as much as .04 should be left.

Through experience an operator can determine whether a cut is heavy or light by the volume of sparks that flow from the cut. A heavy volume indicates a heavy cut and conversely a light cut.

## UNIT 84

### HOW TO SET-UP AND OPERATE

#### A UNIVERSAL GRINDING MACHINE FOR CYLINDRICAL GRINDING

The procedure described in this unit is that of setting up a standard universal grinding machine to grind the exterior of cylindrical work. In general the procedure is applicable to standard makes of universal grinding machines.

**CAUTION:** To produce accurate work care and precision must be exercised in setting up a grinding machine. For the same reason the machine should be properly lubricated and warmed up before starting to grind.

When starting a universal grinding machine for the first time after it has been idle for several hours or days, press the start button, then almost immediately push the stop button. Repeat this three or four times so that the bearings of the spindle will be well lubricated before running the spindle at operating speed.

#### GENERAL PROCEDURE

1. Select a wheel suited to the work to be performed and mount it on the wheel spindle. (See Unit 77.) Be sure the wheel is sound. Support the wheel by inserting the forefinger in the spindle hole, then test by striking it a light blow on the edge with a hammer or some hard substance. A clear ring will indicate a sound wheel.

If the wheel is changed it will be necessary to true, and possibly balance, the new wheel before attempting to grind a work-piece. (See Unit 77.)

2. Determine desirable work surface speed. If necessary change the position of the headstock V-belt. A quarter turn of the

belt tension release lever, Fig. 337, will change the position of the intermediate shaft sufficient to slack the driving belts, thus facilitating change of work speeds, and of the work driving unit when necessary.

3. Determine desirable wheel surface speed. If necessary change the sheave on the spindle motor shaft.
4. Examine all driving belt tensions. A V-belt is properly tensioned when a light pressure will depress the belt slightly. Adjustment of the wheel spindle drive belt is made with the screw knob at the rear of the motor plate, Fig. 335, and the headstock drive by means of the belt tension lever, Fig. 337.
5. Determine the rate of table travel, if any. When the surface to be ground is the same width or is narrower than the width of the wheel no table travel is necessary. The same holds true when plunge or straight-in grinding a narrow recess.
6. Check to make sure that the swivel table is set at zero. If adjustment is necessary loosen the clamping bolts at each end of the table, then make the adjustment by means of the adjusting nut at the front of the machine. See Fig. 363. Verify the setting by a trial cut at each end of the work-piece.
7. Thoroughly clean the table and ways, then position the headstock and footstock to receive the work-piece. To avoid excessive

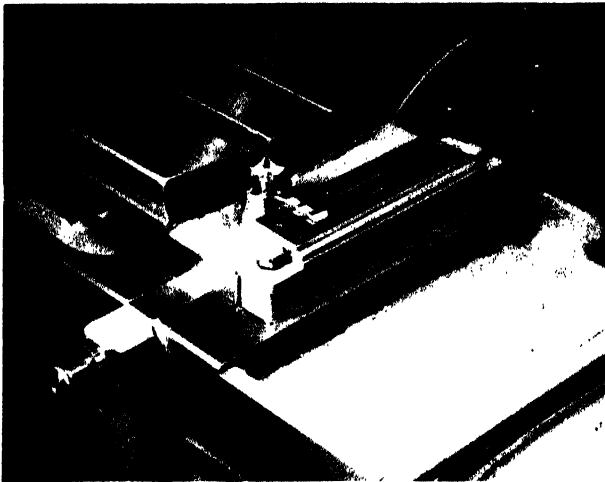

*Courtesy, Brown & Sharpe Manufacturing Co.*

FIG. 363. TABLE SWIVELED FOR A TAPER OF ONE INCH PER FOOT

wear at either end of the ways the head and footstocks should be an equal distance from the respective ends of the table. Align the headstock by means of the flange on the base, see Fig. 337.

8. Examine the centers of the grinding machine to determine that they are clean, smooth, and ground at the correct angle. Test with a center gauge. If the centers are not ground with an inclusive angle of  $60^\circ$  the angle should be corrected by regrinding, see Unit 81.
9. Before starting to grind attach table water guards and position the coolant piping and nozzle.

#### PROCEDURE FOR MOUNTING STOCK, ADJUSTING HEADSTOCK AND FOOTSTOCK

1. Secure a work-piece; make certain that the center holes are clean, of the correct shape and depth and well oiled.
2. Secure a suitable driving dog and place it on one end of the work-piece.
3. With the cross feed handwheel move the wheel slide back and forth to make sure that it is positioned on the platen so that the wheel will come far enough forward to grind the work, yet give sufficient clearance for inserting the work-piece between centers. If necessary to adjust the slide on the platen, loosen the clamping bolts, then make the adjustment and re-clamp.

4. For straight cylindrical grinding the wheel stand platen should be set parallel with the slide, at zero degrees by the scale on the base.
5. Adjust the counterweight pull for exterior grinding by turning the square end shaft counterclockwise as far as it will go. The shaft may be observed projecting from the rear of the wheel slide.
6. Arrange the headstock for dead center grinding by mounting the dead center pulley on the threaded nose of the spindle. Adjust and tension the flat belt, then tighten the release lever, see Fig. 337.

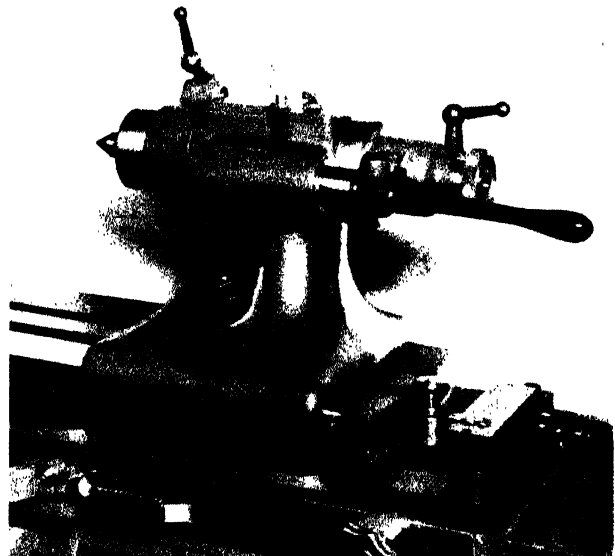

*Courtesy, Brown & Sharpe Manufacturing Co.*

FIG. 364. FOOTSTOCK OF THE UNIVERSAL GRINDER

7. Place the drive-end of the work-piece on the headstock center, then slide the footstock forward until it supports the other end of the work-piece. Draw the operating lever, Fig. 364, forward about a third of the way to withdraw the footstock center from the work-piece. Hold the operating lever in the above position by tightening the spindle clamp, Fig. 364. Now move the footstock forward until the center is seated in the center hole of the work-piece. Align the lip on the footstock with the edge of the swivel table and fasten the footstock in position by tightening the clamping bolt. Release the spindle clamp to permit the

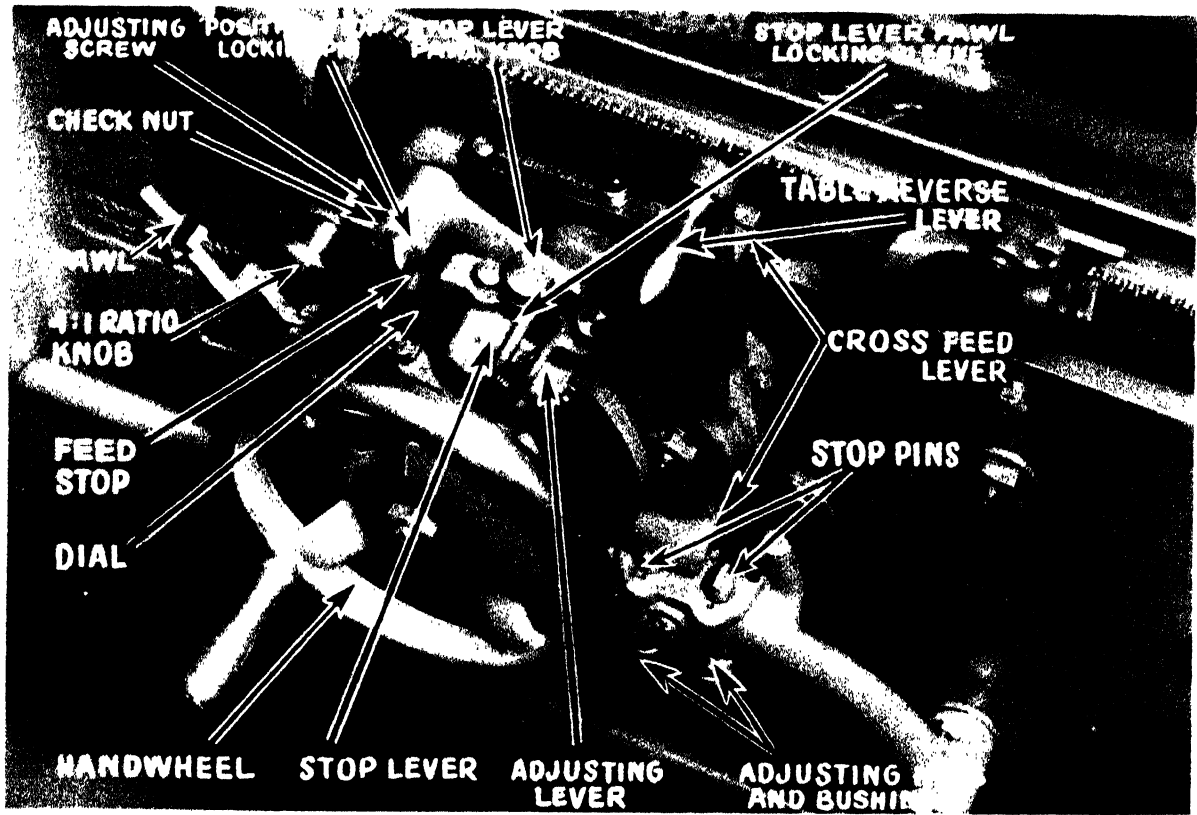

*Courtesy, Brown & Sharpe Manufacturing Co.*

FIG. 365. CROSS FEED AND TABLE REVERSE CONTROLS

spring at the rear of the spindle to push the center firmly against the work-piece.

**CAUTION:** Be sure the pressure of the spring is great enough to hold the center firmly against the work. Avoid excessive pressure.

8. With the cross feed handwheel, Fig. 365, advance the grinding wheel until it is within  $\frac{1}{4}$  inch of the work-piece.

#### PROCEDURE FOR SETTING TABLE TRAVEL

Table travel may be accomplished by hand or power feed. When power feed is employed stop dogs should be used. Stop dogs may be used with hand feed at the option of the operator.

1. To set the table reverse dogs first move the table to the left until the right-hand edge of the grinding wheel is  $\frac{1}{4}$  of its width to the right of the end of the work-piece, which usually is an open end.
2. Push the table reverse lever to the left as far as it will go.
3. Raise the pawl at the rear of the right hand dog, then move the dog along the rack until it comes against the table re-

verse lever, Fig. 366, then engage the pawl with the rack.

4. With the handwheel move the table to the right until the wheel is located at the position where the cut is to stop; for example, within  $\frac{3}{4}$  of an inch of the driving dog, or against a shoulder. Set the left stop dog.

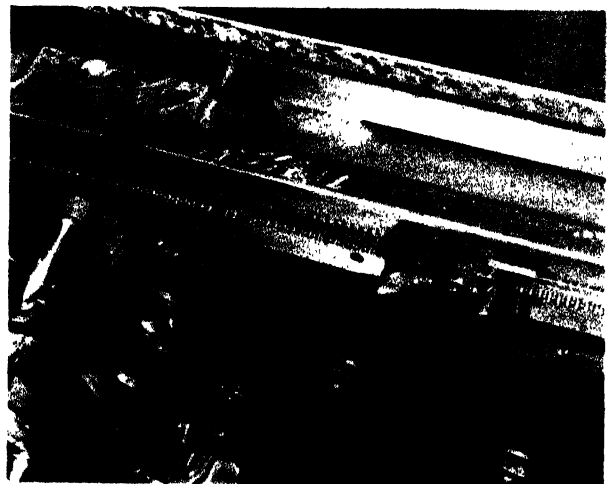

*Courtesy, Brown & Sharpe Manufacturing Co.*

FIG. 366. TABLE REVERSING LEVER AND DOG

### PROCEDURE FOR GRINDING WITH MANUAL CROSS FEED

1. To feed the wheel manually, release and disengage the pawl from the dial, Fig. 365, and slide the positive stop locking pin back into the bracket.
2. Start the machine, engage the table travel and advance the wheel against the work-piece, taking a moderate cut. Use a coolant freely.

**CAUTION:** Before starting to grind, the operator should protect his eyes by wearing properly fitted goggles.

3. When the work has sparked out, stop the machine when it reaches the footstock end. Then without withdrawing the wheel, accurately measure the diameter of the work and calculate how many .00025 (ten thousandths) of an inch the work is still to be reduced.

Assume that the work is still to be reduced by seven quarter thousandths,

$$7 \times .00025 = .00175 \text{ of an inch.}$$

4. Next slide the positive stop locking pin forward in its bracket, then lift the knob on the stop lever and move both the stop lever and the adjusting lever counterclockwise until they come into contact with the positive stop locking pin. (Consult Fig. 365.)
5. Pinch the stop lever and the adjusting lever together to within two quarter thousandths of the stock to be removed; for example five pinches, since seven quarter thousandths remain to be removed.  
Remember that each time the levers are pinched together they are moved clockwise one notch. Each notch the levers are moved clockwise will allow the wheel to advance sufficient to remove .00025 of material from the diameter of the work-piece.
6. Start the machine, advance the wheel with the cross feed handwheel and traverse the work past the wheel until it sparks out. Then stop the table traverse when the wheel reaches the footstock end of the work.
7. Run the wheel back from the work, and then accurately measure the work-piece to

determine the number of quarter thousandths of stock to be removed.

8. Pinch the stop and adjusting levers together the number of quarter thousandths of stock to be removed.
9. Start the machine, advance the wheel and continue grinding until the work sparks out. Then stop the machine and again measure the work. If more stock must be removed, adjust the cross feed as in step 8. If no adjustment of the levers is necessary, lock the levers in position.

Note: For plunge or straight-in grinding, the table is not traversed; however, the procedure for setting the cross feed is the same as just described.

On succeeding pieces slide the stop pin into its bracket, then feed the wheel by hand until the work is nearly reduced to size. Then slide the stop pin out and continue turning the handwheel counterclockwise until the stop lever comes against the stop pin.

Long pieces of work should be supported by means of one or more back rests, see Fig. 367.



*Courtesy, Brown & Sharpe Manufacturing Co.*

FIG. 367. USING BACK RESTS TO SUPPORT A LONG PIECE

### PROCEDURE FOR GRINDING WITH AUTOMATIC CROSS FEED

1. Mount a work-piece between centers as in steps 1 to 7, "Procedure for Mounting Stock."
2. Set the table travel as in steps 1 - 4 under "Procedure for Setting Table Travel."

3. Disengage the cross feed pawl, Fig. 365, then slide the positive stop locking pin back into its bracket.
4. Start the machine, engage the table traverse, then advance the grinding wheel by means of the cross feed handwheel.
 

**CAUTION:** Before starting to grind protect the eyes by wearing properly fitted goggles.
5. Stop the table travel when the wheel sparks out and has been returned to the footstock end of the piece.
6. Bring the pawl into contact with the dial, Fig. 365. Raise the knob on the stop lever, then move the stop and adjusting levers counterclockwise until the feed stop is under the pawl. The pawl must be raised to permit the feed stop to pass.
7. With the pawl resting on the feed stop, start the table, then pinch the stop lever and the adjusting lever together until the feed stop passes from under the pawl and the pawl drops and engages a notch in the dial at a reversal of the table, and then rides on the stop until the next reversal.
8. Stop the table travel with the wheel at the footstock end of the work-piece. Accurately measure the diameter of the work-piece and determine the number of quarter thousandths the work is yet to be reduced.
9. Pinch the stop and adjusting levers together once for each quarter thousandth the work is to be reduced in diameter.
10. With the stop lever at the desired setting, lock it in position by turning the knurled locking sleeve just below the latch until the sleeve is under the head of the screw at the left, Fig. 365. If preferred the feed stop may be positioned by lifting the knob on the stop lever, then setting the feed stop at the position desired by means of the scale on the side of the dial.
11. To control the movement of the pawl at each reversal of the table start the machine and table travel, adjust the projection of each of the stop pins, located just below the cross feed lever, Fig. 365. The amount of projection desired is achieved by means of the adjusting bushings and check nuts located at the lower ends of the stop pins. The left stop pin governs the feed when the wheel is at the left end of the work-piece and the right when the wheel is at the right end.
 

Note: On the machine illustrated, and on certain others each stop can be set so that the pawl will move the dial through any number of notches from one to sixteen at each reversal of the table. For each notch the dial is advanced the wheel will be brought forward sufficient to remove .00025 of an inch from the diameter of the work-piece. Furthermore, each stop can be set so that the pawl will engage the dial at alternate reversals. Engagement of the pawl may be at either end of the work.
12. Continue grinding until the cross feed ceases, then disengage the pawl and allow the table to traverse until the wheel is at the footstock end of the work-piece.
13. Measure the diameter of the finished work; then, if necessary, correct the setting of the feed stop and make another cut.
14. When grinding subsequent pieces mount the stock in the usual manner, then run the wheel in until it touches the work-piece and engage the pawl.
 

**CAUTION:** When grinding work that requires the wheel to come against a shoulder, the table dog which reverses the table travel at the shoulder should be checked for position when each new piece of work is mounted between centers. This precaution is necessary because of variations in the depth of center holes and the distance of the shoulder from the ends of the pieces.

## UNIT 85

### HOW TO SET-UP A UNIVERSAL GRINDING MACHINE FOR EXTERIOR TAPER GRINDING

The universal grinding machine may be set-up for grinding either slight or steep exterior tapers. Whenever practicable grind a taper with the wheel pressure toward the headstock.

#### PROCEDURE FOR GRINDING SLIGHT EXTERIOR TAPERS

Tapers up to 8 degrees usually are ground by swiveling the swivel table.

1. Swivel the table to the position required. Fasten the table by tightening the clamping bolts at each end. (See Fig. 363.)
2. Secure, change and true the grinding wheel, if necessary.
3. Secure a work-piece and mount it between centers.
4. Determine the work and spindle speeds required. Make the necessary adjustments.
5. Set table feed stop dogs in the usual manner, if used. (See Unit 84.)
6. Make sure that the pull of the counterweight is adjusted for external grinding.
7. Protect the eyes with properly fitted goggles.
8. Be sure the wheel guard is fastened securely in position.
9. Attach the table water guards, adjust coolant piping and nozzle, then turn on coolant.
10. Start the machine and grind in the usual manner. (See Unit 84.)
11. When grinding has been completed, clean and restore the machine to normal working condition.

1. Determine the angle of the taper, for example  $30^\circ$ .
2. Loosen the clamping bolts and set the slide at  $60^\circ$  ( $90^\circ - 30^\circ$ ). This will put the wheel in position to grind a  $30^\circ$  angle on the work surface. (See Fig. 368.) Next turn the platen so that the spindle is parallel with the slide; then clamp the slide and platen in position by tightening the bolts.
3. Secure a suitable wheel; change and dress it, if necessary.
4. Mount the work-piece in a chuck or other suitable holding device.
5. Adjust headstock for revolving spindle grinding.
6. Determine the work and wheel speeds required. Make necessary adjustments.
7. Make sure that the pull of the counterweight is adjusted for external grinding.
8. Protect the eyes with properly fitted goggles.
9. Be sure the wheel guard is fastened securely in position.
10. Attach the table water guards, adjust coolant piping and nozzle, then turn on coolant.
11. Start the machine, then with hand table feed bring the work into contact with the revolving wheel. Pass the wheel across the face of the work with the hand cross feed. If the face of the wheel is the same width, or wider, as the surface to be ground no movement of the cross feed is necessary.
12. At the end of the first cut advance the work slightly by moving the sliding table forward sufficiently for a cut of five or six quarter thousandths (.00025) of an inch depending upon the amount of stock to be removed.
13. Continue with repeated cuts until the work is reduced to size.
14. When the operation has been completed, clean and restore the machine to normal working condition.

**PROCEDURE FOR GRINDING STEEP OR SHARP EXTERIOR TAPERS**

Steep or sharp tapers are ground by swiveling the wheel head on its base to the required angle. In some cases it is preferable to swivel the headstock to the required angle.

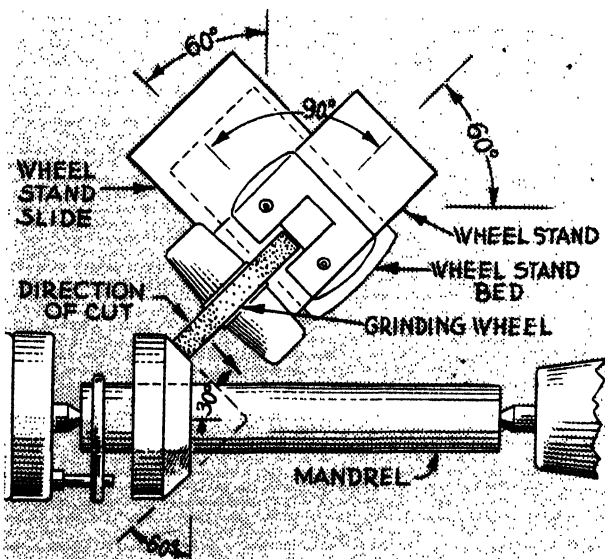

FIG. 368. GRINDING A STEEP TAPER



## UNIT 86

## HOW TO SET-UP AND OPERATE A UNIVERSAL GRINDING MACHINE FOR STRAIGHT INTERNAL GRINDING

The procedure described in this unit is that of setting up a standard universal grinding machine for internal grinding. With other machines the procedure may differ somewhat but the principles are essentially the same.

### PROCEDURE FOR GRINDING A STRAIGHT CYLINDER

1. Secure a work-piece and a suitable chuck.
2. Mount the chuck on the nose of the head-stock spindle.
3. Determine desirable work surface speed, and make necessary adjustments. See Unit 83.
4. Determine desirable wheel surface speed, and make necessary adjustments. See Unit 83.
5. Determine desirable rate of table travel, if any. Make adjustments accordingly. See Unit 83.
6. Bring the internal grinding fixture into position by loosening the clamping bolts of the wheel stand platen, then swinging the platen through 180° (half way around) and positioning it by the guide lines on the platen and slide. See Fig. 369.
7. Clamp the platen in position by tightening the clamping bolts.
8. Remove the V-belt guard and the belts from the sheaves on the wheel spindle motor.
9. Place the flat driving belt in position around the flat pulleys. The belt should be tight enough to give good traction, but should not be stretched. Tension on the belt is regulated by means of the knob and screw shown in Fig. 369. When making this adjustment it is first necessary to loosen the bolts which fasten the platen to the wheel stand.
10. Change the pull of the counterweight by turning the square-end shaft, at the rear of the slide, clockwise as far as it will go.
11. Be sure the swivel table and the head-stock are set at zero degrees.
12. Mount the work-piece in the chuck. Be sure it is centered accurately; if necessary, test by means of a dial indicator.
13. Adjust the machine for table travel, if desired. When used the table dogs should be so positioned that the wheel will pass

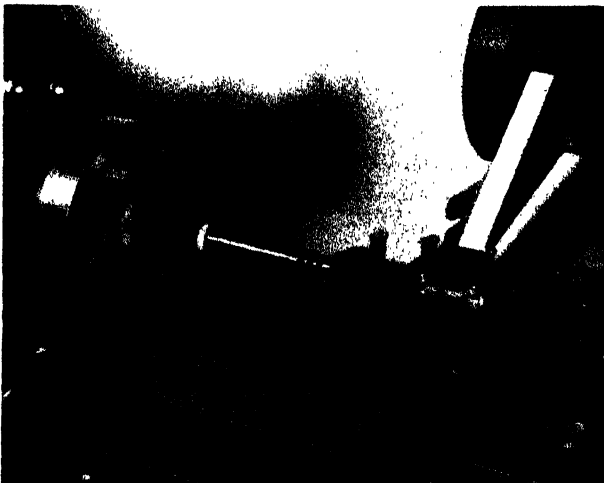

Courtesy, Brown & Sharpe Manufacturing Co.  
FIG. 369. INTERIOR GRINDING FIXTURE

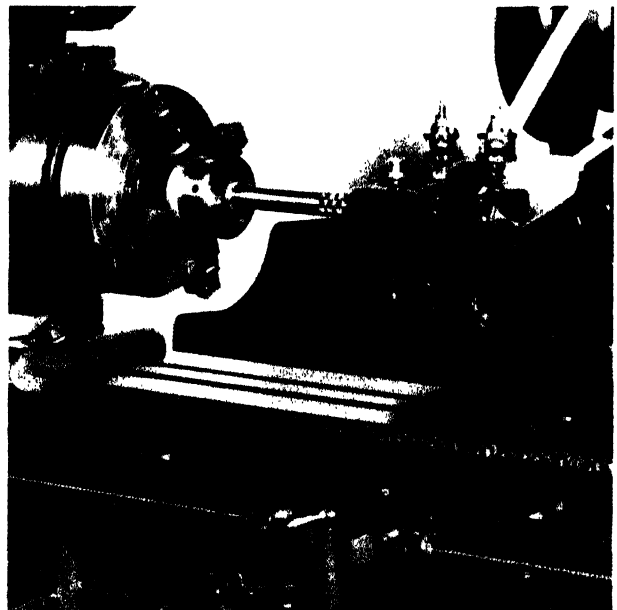

Courtesy, Brown & Sharpe Manufacturing Co.  
FIG. 370. GRINDING THE INTERIOR SURFACE OF A BEARING

only partly off the work at the beginning and end of the stroke.

**CAUTION:** If the work-piece has an internal shoulder or a closed end against which the wheel will come, the table stop dog at the shoulder or closed end must be so positioned that table travel will stop just as the wheel reaches the shoulder or the closed end.

14. Protect the eyes by wearing properly fitted goggles.
15. Start the machine, then run the wheel into the opening by hand, and at the same time advance the wheel against the rear of the hole with the hand cross feed, as in Fig. 370, taking a light cut. At the end of the cut, withdraw the wheel.

When using power table travel and grinding has been completed the wheel may be brought clear of the work by releasing the right hand stop dog.

16. Make repeated cuts in a similar manner.
17. When changing for subsequent work-pieces loosen only two adjacent chuck jaws, then remove the finished piece and insert a new piece.

**CAUTION:** When internal grinding long pieces the outer end should be supported by means of a center rest or other suitable device.

18. When through grinding clean and restore the machine to its normal condition. Return any special equipment to the place where it is kept when not in use.

## UNIT 87

### HOW TO SET-UP A UNIVERSAL GRINDING MACHINE FOR INTERNAL TAPER GRINDING

Either slight or steep internal tapers may be ground with a universal grinder.

#### PROCEDURE FOR GRINDING SLIGHT INTERNAL TAPERS

1. Make certain that the wheel stand is set at zero. Then swivel the wheel stand platen through 180° as in Fig. 369 and fasten it in position by tightening the clamping bolts.
2. Change the pull of the counterweight by turning the square-end shaft, at the rear of the slide, clockwise as far as it will go.
3. Determine the angle of taper required.
4. Remove the V-belt guard and the V-belts from the wheel spindle motor.
5. Place the flat driving belt in position and tension it with the knob and screw shown in Fig. 369.
6. Make certain that the headstock is set at zero degrees.
7. Mount the work-piece in a chuck or other suitable device. Be sure it is centered accurately. If necessary, test by means of a dial indicator.
8. Swivel the table through the required number of degrees, for example 5°, and clamp it in position.

9. Protect the eyes by wearing properly fitted goggles.
10. True and dress the grinding wheel, if necessary.
11. Set stop dogs, if desired.
12. Start the machine, then run the wheel into the opening by means of the hand table feed. At the same time bring the wheel lightly into contact with the work-piece by turning the cross feed handwheel clockwise. Advance the wheel into the opening by turning the table feed handwheel counterclockwise.
13. At the end of the cut bring the wheel back to the starting point. Then advance the wheel a small amount and take a second cut.
14. Continue with repeated cuts until the work is brought to size.
15. When the operation has been completed, restore the machine to its normal condition and clean the machine. Clean any special equipment and return it to the place where it is kept when not in use.

#### PROCEDURE FOR GRINDING STEEP INTERNAL TAPERS

1. Proceed as in steps 1 to 7.

2. Loosen the clamping bolts and set the slide at the required angle, for example  $15^\circ$ , then turn the platen so that the spindle is parallel with the slide. (See Fig. 368.) Secure the slide and platen by tightening the clamping bolts.
3. Protect the eyes with properly fitted goggles.
4. Start the machine, then run the wheel into the opening with the hand cross feed. At the same time advance the wheel against the face of the work-piece by moving the sliding table sufficiently to bring the wheel into contact with the work.
5. At the end of the cut bring the wheel back to the starting point; then advance the sliding table sufficiently to take a cut of about .002 of an inch.
6. Continue with repeated cuts until the work is brought to size.
7. When the operation has been completed, restore the machine to normal grinding position; then clean the machine. Clean any special equipment and return it to the place where it is kept when not in use.

### UNIT 88

## HOW TO SET-UP AND OPERATE

### A PLAIN GRINDING MACHINE FOR CYLINDRICAL GRINDING

The procedure described in this unit is that of setting up a standard plain cylindrical grinding machine to grind the exterior of cylindrical work. With different makes of machines the procedure may vary somewhat but the same principles will apply.

**CAUTION:** To produce accurate results the machine should be warmed up before starting to grind. Ordinarily a machine will reach optimum running temperature in about 15 minutes. If the spindle motor is started when the operator starts the process of setting up the machine as discussed in the following paragraphs, optimum running temperature will be achieved by the time he has completed the set-up.

Before starting to grind always determine that the machine is properly lubricated, that the supply of coolant is adequate for the work to be done, and that the coolant valve is set to deliver an adequate flow. Replenish the coolant whenever necessary.

When starting a grinding machine for the first time after it has been idle for several hours or days, press the start button, then almost immediately push the *stop* button. Repeat this three or four times so that the bearings of the spindle will be well lubricated before running the spindle at operating speed.

The diameter of the finished work should be checked occasionally to determine wheel wear. To compensate for wheel wear and to produce accurate work, the operator must appropriately

adjust the index dial on the cross feed as found necessary.

When operating a grinding machine the operator should always protect his eyes by wearing properly fitted goggles and his clothing with suitable coveralls,

#### PROCEDURE

1. Select a wheel suited to the work to be performed and mount it on the wheel spindle. (See Unit 77.) Be sure the wheel is sound. Support the wheel by inserting the forefinger in the spindle hole, then test it by striking it a light blow on the edge with a hammer or some hard substance. A clear ring will indicate a sound wheel. If the wheel is changed, it will be necessary to true, and possibly balance, the new wheel before attempting to grind a work-piece. (See Unit 77.)
2. Determine the work surface speed. (See Unit 83.) If necessary change the headstock V-belt.
3. Determine the wheel surface speed desired. If necessary change the motor pulley, or by other means change the ratio of motor and wheel spindle speed.
4. Determine the rate of table travel, if any. When the surface to be ground is the same width or is narrower than the width of the wheel no table travel is necessary;

likewise when plunge or straight-in grinding a narrow recess.

5. Check the setting of the swivel table. If adjustment is necessary, loosen the clamping bolts at each end of the table; then make the adjustment by means of the knob and scale shown in Fig. 371. This is an approximate setting which must be verified by a trial cut at each end of the work-piece.

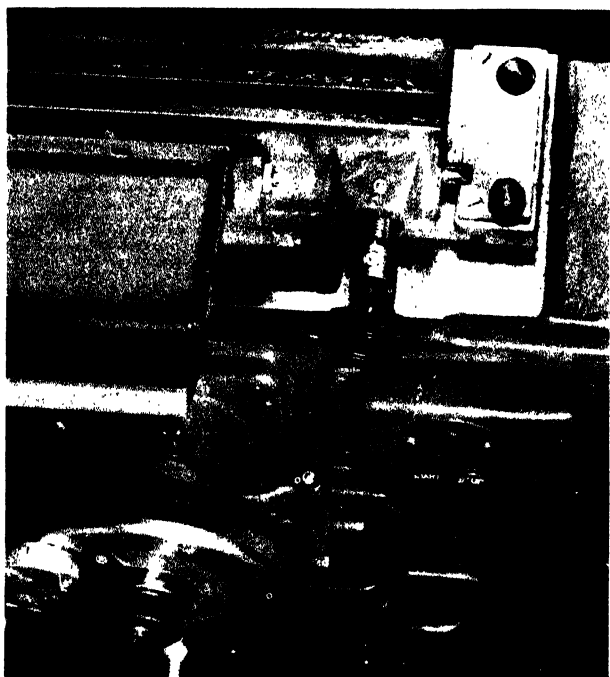

*Courtesy, Brown & Sharpe Manufacturing Co.*

FIG. 371. SWIVEL TABLE AND CONTROLS

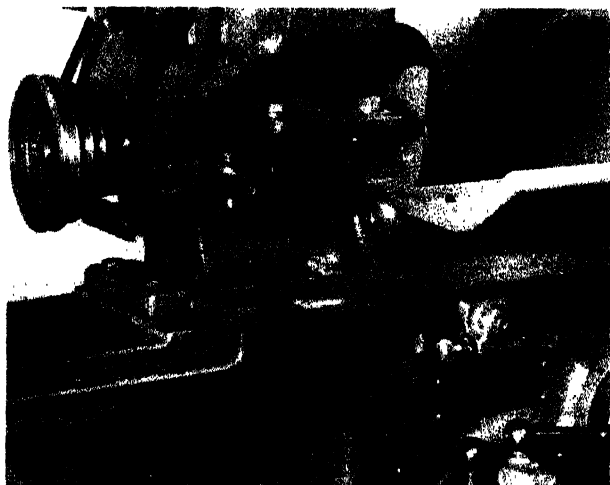

*Courtesy, Brown & Sharpe Manufacturing Co.*

FIG. 372. HEADSTOCK ALIGNED WITH FRONT LIP OF THE BASE

6. Thoroughly clean the table and ways, then position the headstock and footstock to receive the work-piece. To avoid excessive wear at either end of the ways the head and footstocks should be located an equal distance from the respective ends of the table. Align the headstock by means of the front lip of the base. (See Fig. 372.) Then fasten it in position by tightening the clamping bolts.
7. Be sure that the grinding wheel is set back far enough to permit putting a work-piece between centers. If the wheel is too far advanced, depress the switch operating slide by means of the throwout lever, Fig. 373, then move the wheel back the distance desired.

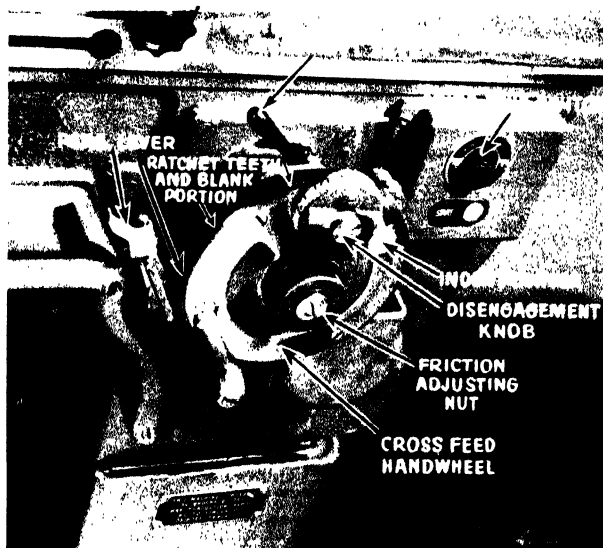

*Courtesy, Brown & Sharpe Manufacturing Co.*

FIG. 373. CROSS FEED HANDWHEEL CONTROLS

8. Examine the centers of the grinding machine to determine that they are clean, smooth, and ground at the correct angle; test with a center gauge. If the centers are not ground with an inclusive angle of  $60^\circ$  the angle should be corrected by regrinding. (See Unit 81.)
9. Secure a work-piece; make certain that the center holes are clean, of the correct shape and depth, and well oiled.
10. Secure a suitable driving dog and place it on one end of the work-piece.
11. Place the work-piece on the headstock center; then draw the footstock spindle oper-

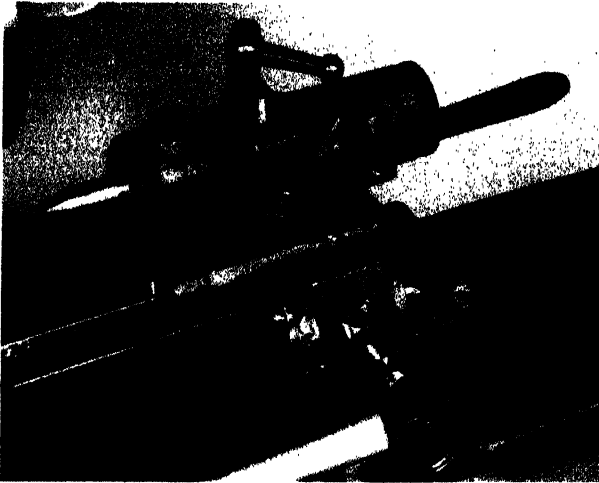

*Courtesy, Brown & Sharpe Manufacturing Co.*

FIG. 374. FOOTSTOCK, SHOWING OPERATING LEVERS

ating lever, Fig. 374, about a third of the way forward, to the left; then tighten the spindle clamp. Move the footstock forward until the footstock center is seated in the work-piece. Align the footstock with the front lip on its base; then clamp the footstock securely with the clamping bolt. Release the spindle clamp; this will permit the spring at the rear of the spindle to push the footstock center firmly against the work-piece.

If necessary to increase the spring pressure on the spindle, turn the spring pressure adjusting nut at the rear of the footstock clockwise. (See Fig. 374.) The pressure should be great enough to hold the center firmly in the work, but not great enough to cause the work to spring or prevent it from turning freely. After adjusting the spring pressure, tighten the spindle clamping lever to the position where free movement of the spindle is achieved. This adjustment should be made to take up slight looseness in the spindle bearing.

12. With the cross feed handwheel, Fig. 373, advance the grinding wheel until it is within  $\frac{1}{4}$  inch of the work-piece.
13. To set the table reverse dogs first move the table to the left until the right-hand edge of the grinding wheel is  $\frac{1}{4}$  of its width to the right of the end of the work-piece.
14. Turn the dog adjusting screws, Fig. 375, inward as far as they will go, then loosen the dog clamping bolts.

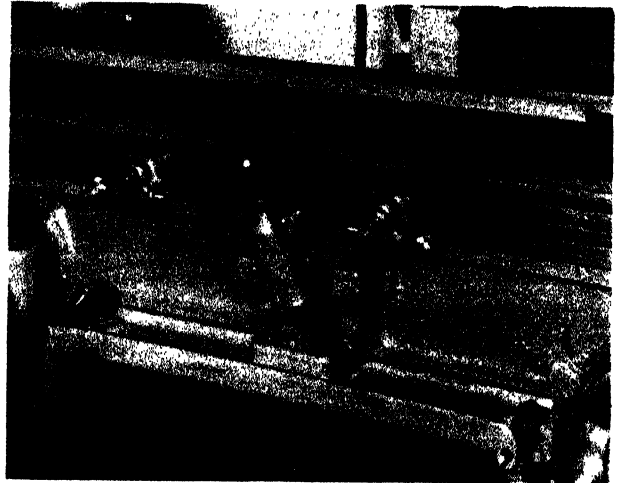

*Courtesy, Brown & Sharpe Manufacturing Co.*

FIG. 375. FRONT OF GRINDER, SHOWING TABLE REVERSING LEVER AND DOGS

15. Push the table reverse lever to the left until it strikes the left positive stop. (See Fig. 375.) Bring the right-hand dog into contact with the reversing lever; then with the handwheel move the table three or four inches to the right without changing the position of the dog in the T-slot. Tighten the dog clamping bolt.
16. With the hand feed move the table to the right until the left side of the grinding wheel is within a half inch or so of the driving dog.
17. Push the table reverse lever to the right until it strikes the right-hand positive stop; then proceed as when setting the right-hand dog.

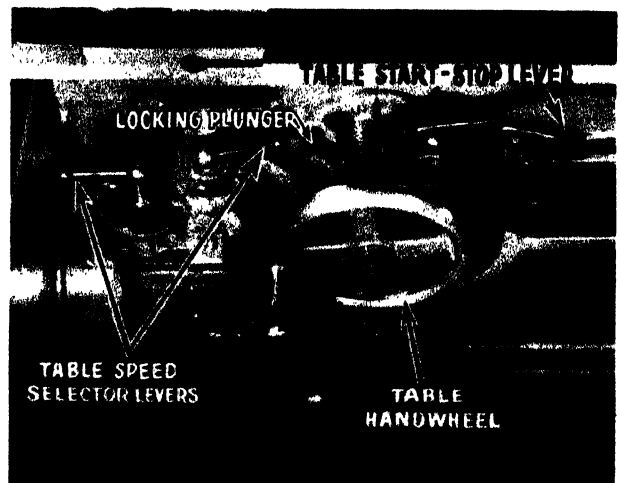

*Courtesy, Brown & Sharpe Manufacturing Co.*

FIG. 376. CONTROLS FOR LONGITUDINAL TABLE TRAVEL

18. Start the machine and engage the power table travel by pulling the start-stop lever forward, Fig. 376. Then back off the right-hand adjusting screw, Fig. 375, until the table reverses exactly at the position desired. Make a similar adjustment at the left-hand point of reversal, then tighten the check nuts on the dog adjusting screws.

Note: When grinding to the end of a piece, allow the end of the work-piece to run approximately half way across the face of the wheel before reversing.

19. With the cross feed handwheel return the grinding wheel to the starting or normal inactive position.

The grinding wheel may be brought into contact with the work-piece by advancing the wheel with the manual or hand-operated cross feed or by automatic cross feed.

#### PROCEDURE FOR MANUAL CROSS FEED

The correct amount of feed for a given piece of work depends upon the kind of material, the length and diameter of the work-piece, surface speed of the wheel and work, table speed, wheel characteristics, and finish requirements. Ordinarily for traverse (longitudinal) grinding a feed of .001 to .0015 of an inch will be found good starting feeds. For plunge-cut grinding .001 of an inch will be satisfactory. Experience and experimentation will suggest variations that may safely be made in both speeds and feeds.

1. With a work-piece mounted between centers and other adjustments completed as previously described, bring the grinding wheel forward until it just touches the work-piece.
2. Loosen the cross feed handwheel friction adjusting nut located at the center of the wheel, Fig. 373. This will permit the handwheel to be turned without turning the cross feed screw, and consequently without changing the position of the grinding wheel in relation to the work-piece.
3. Examine the position of the pins at the back of the handwheel. If either one is in contact with the switch operating slide, Fig. 377, turn the handwheel until both are in the same relative position with respect to the slide as shown in Fig. 377.

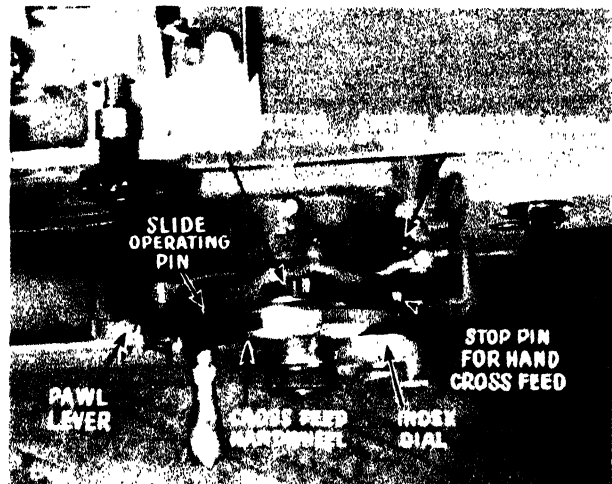

Courtesy, Brown & Sharpe Manufacturing Co.

FIG. 377. CROSS FEED HANDWHEEL AND CONTROL MECHANISMS (FROM ABOVE)

4. Pull out the index plunger, Fig. 373, then grasp the index dial and gently rotate it counterclockwise about its own center, until the permanently located stop pin behind the index dial is nearly in contact with the right-hand side of the switch operating slide, Fig. 377.

**CAUTION:** Do not hold the handwheel while rotating the dial.

5. Engage the index dial plunger, and throw the starting switch. Then turn the handwheel counterclockwise, bringing the stop pin against the switch operating slide, Fig. 377. Continue grinding until the work has sparked out the amount desired, then turn the handwheel clockwise, thus bringing the wheel back to the starting point. *Be sure the wheel guard is fastened securely in position.*

**CAUTION:** Whenever there is likelihood that contact of the grinding wheel with the work-piece will cause the piece to vibrate or spring away from the wheel the work should be stabilized by means of a back rest, similar to that shown in Fig. 378. For procedure in setting up and adjusting a back rest, see Unit 90.

6. With a micrometer or other suitable means carefully measure the diameter of the ground portion of the work and determine the amount it is to be reduced. Then turn the handwheel so as to bring the index dial near the top where it can easily be

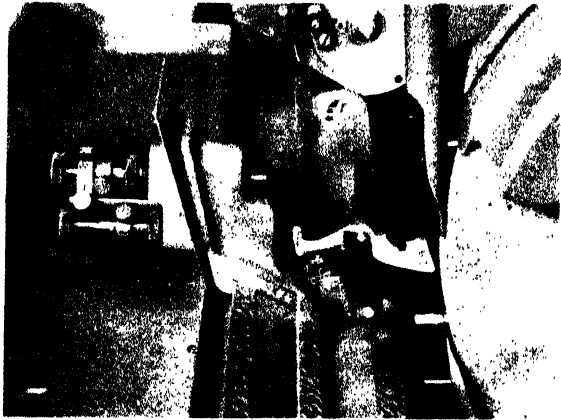

*Courtesy, Brown & Sharpe Manufacturing Co.*

FIG. 378. USING A BACK REST TO STEADY A SMALL PIECE

read. Now turn the dial clockwise so that the advance of the wheel will be stopped at the point desired, for example, when the wheel will have reduced the diameter of the work by .002 of an inch.

**CAUTION:** When making this adjustment remember that turning the dial through one of the graduations which appear on the rim of the dial will permit advancement of the wheel by .0001 of an inch. Moving the dial clockwise through one graduation will reduce the diameter of the work .0001 of an inch. A complete revolution of the dial clockwise will reduce the diameter of the work .004 of an inch.

To avoid the risk of grinding the work-piece too small, set the stopping point about two thousandths of an inch large.

7. Advance the wheel and further reduce the work. Again measure the diameter of the ground portion, then make final adjustment of the index dial. Check this setting, using a second work-piece and comparing the measurements of the ground surfaces. When the machine has been set up for rough grinding the work the left-hand pin at the back of the cross feed handwheel should be relocated, if necessary, so that only a relatively small movement of the handwheel will be necessary to bring the grinding wheel into contact with the work.
8. Place another work-piece between centers, then advance the wheel and engage the longitudinal table travel. When the work-piece has been reduced to size remove it from between centers; then move the

driving dog to the opposite end and again mount the work-piece between centers and complete grinding.

9. When all work-pieces have been rough ground, set the machine to make the finishing cut, usually between .00025 and .0005 of an inch at each reversal of table travel, then proceed to make the finishing cut or cuts in the usual manner.

#### PROCEDURE FOR USING AUTOMATIC CROSS FEED

1. Mount a work-piece between centers and complete other adjustments as previously described.
2. Set the Grind-True switch, Fig. 373, at Grind, with the switch operating slide in the raised position.
3. Determine the amount of cross feed desired at each reversal of the table, for example, .0015 of an inch.
4. Automatic cross feed is accomplished by means of an adjustable-radius crank mechanism such as illustrated in Fig. 379. To set the mechanism for a feed of .0015 of an inch, first disengage the pawl, Fig. 373, then loosen the wheel feed adjusting slide clamp, Fig. 379, move the slide to the set-

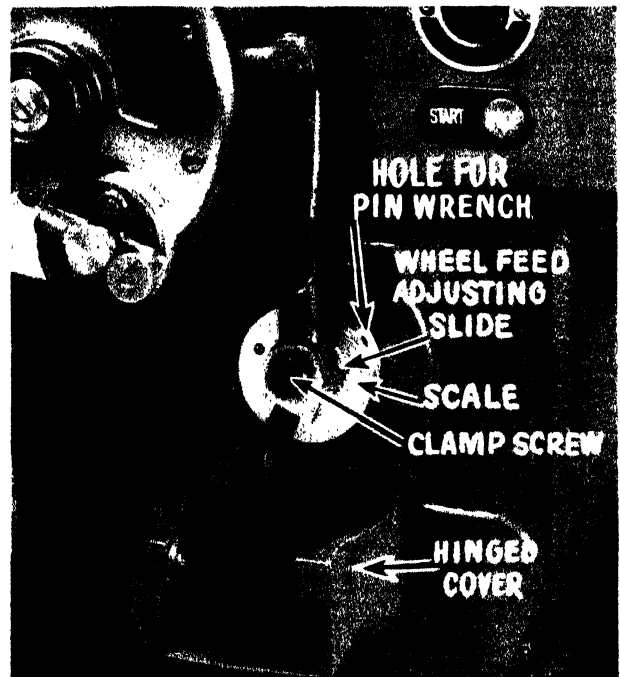

*Courtesy, Brown & Sharpe Manufacturing Co.*

FIG. 379. MECHANISM FOR ADJUSTING AUTOMATIC CROSS FEED

ting desired, for example .0015, and securely tighten the clamp screw.

Note: The scale on the Brown and Sharpe plain grinding machine, Fig. 379, shows the settings for feeds from .00025 to .0045 of an inch on the work diameter by quarter thousandths of an inch; the figures 1, 2, 3, and 4 indicate thousandths.

5. Next loosen the handwheel adjusting nut, Fig. 373, then with the index dial mechanism turn the handwheel so that when the pawl is engaged there will be six or seven ratchet teeth between the pawl and the non-toothed section on the rim of the wheel, Fig. 373.
6. Moderately tighten the friction adjusting nut, but do not force it; then start the table, engage the pawl and let the machine run until the cross feed has stopped. This will occur when the pawl strikes the smooth section of the handwheel.
7. As soon as the cross feed stops, disengage the pawl and stop the machine when the wheel reaches the footstock end of the work-piece. At the same time withdraw the grinding wheel to the starting position.
8. With a micrometer or other suitable means carefully measure the ground portions of the work and determine the amount the piece is to be reduced.
9. Advance the grinding wheel until it just touches the work, then, as in steps 4 and 5, turn the dial clockwise sufficient to advance the wheel the amount desired, for example .0005. Remember a revolution of one graduation on the dial will advance the wheel sufficiently to reduce the work .0001 of an inch.
10. Start the machine and let it run until the cross feed again stops; then again measure the work and make necessary adjustments.
11. After the first work-piece has been rough ground as far as the point of reversal stop the machine, change the driving dog to the finished end of the work, then finish rough grinding the piece.

When the machine has been set up for rough grinding the work, the left-hand pin at the back of the cross feed handwheel should be relocated, if necessary, so that only a relatively small movement of the handwheel will be necessary to bring the grinding wheel into contact with the work.

12. When all pieces have been rough ground, set the machine to make the finishing cut, usually between .00025 and .0005 of an inch at each reversal of the table, then proceed as when making a rough cut.

## UNIT 89

### HOW TO MAKE TAPER AND ANGULAR CUTS WITH A PLAIN GRINDING MACHINE

For the purpose of grinding tapered work, the swivel table on a plain grinding machine may be turned up to about eight or ten degrees in either direction from its normal position parallel with the sliding table. Steep tapers or angles are ground by swiveling the wheel head on the wheel stand bed of machines so equipped.

#### PROCEDURE FOR TAPERED CUTS

1. Determine the angle at which the table is to be swiveled and likewise the direction of swivel. Ordinarily the work will be mounted between centers with the small end toward the footstock.
2. Loosen the clamping bolts at both ends of

the swivel table. (See Fig. 380.) Then by means of the swivel-table adjusting knob, swivel the table until the indicator registers the desired amount of taper on the scale, for example  $\frac{5}{16}$  inch taper per foot. This method of setting frequently is slightly inaccurate and the setting must be corrected after a trial cut has been taken.

3. Tighten the clamping bolts, then set up the machine as for a normal grinding operation.
4. With the hand cross feed advance the wheel until it just touches the work-piece at the small end. Then without further advancing





*Courtesy, Brown & Sharpe Manufacturing Co.*

FIG. 380. TABLE SWIVELING CONTROLS AND SCALE OF TAPER

the wheel move the sliding table to the right and observe the relative positions of the wheel and work-piece. If a noticeable difference exists correct the angular setting of the swivel table by just barely loosening the clamping bolts; then make the correction by turning the adjusting knob in a direction which will correct the error. Turning the knob clockwise will increase the amount of taper. Tighten the clamping bolts.

5. Adjust the cross feed so that there will be sufficient excess stock remaining for a second cut.
  6. Start the machine and make the cut in the usual manner.
- CAUTION:** Be sure the wheel guard is fastened securely in position.
7. At the conclusion of the first cut test the angularity of the ground surface. The angularity of tapered work usually is tested by means of a cylindrical taper gauge.
  8. Make correction in the angular setting of the swivel table, if necessary, then grind

in the usual manner. Because of the angle or taper of the work-piece, the relation between the cross feed and the work is not constant unless the center holes are held in positive relation with the length of the work-piece. To assure accuracy of taper of a number of pieces it is recommended that two cuts be taken and the work tested after the first.

#### PROCEDURE FOR ANGULAR CUTS

In machine shop practice an angular cut is considered to be one having a greater taper than 10 degrees.

1. Mount the work-piece between centers, on a mandrel, or in a suitable chuck.
2. Loosen the clamping bolts on the wheel stand, then swivel the wheel stand slide bed to the angle required, for example 60°.
3. Set the wheel stand at right angles, 90°, to the movement of the slide, with the face of the wheel parallel with the surface to be ground, as in Fig. 368. Tighten the clamping bolts.
4. Start the machine, then by means of the cross feed position the grinding wheel for a roughing cut at the large end of the work-piece.
5. With the table traverse handwheel move the sliding table to the right sufficient to produce a roughing cut of the depth desired, usually .001 to .002 of an inch. To increase the depth of the cut move the traverse table a little farther to the right.
6. With the cross feed move the wheel across the face of the work-piece. Repeat as frequently as necessary to reduce the work to size, allowing sufficient material for a finishing cut.
7. With the cross feed move the wheel back to the starting point, then with the table traverse feed, position the work-piece for a light finishing cut. Make the cut in the usual manner.

## UNIT 90

## HOW TO SUPPORT WORK USING A SPRING TYPE BACK REST

Whenever work is slender and has a tendency to spring away from the grinding wheel it should be supported by means of a back rest or steady-rest. The rest shown in Fig. 341 will accommodate work up to 1 inch in diameter. Bronze shoes for the attachment are available for work from  $\frac{1}{8}$  to 1 inch in diameter, by sixteenths. The shoe of this device follows the work automatically, giving constant support and releasing its pressure when the work reaches the required size.

## PROCEDURE

1. Secure a back rest, mount it on the sliding table and clamp it in position with the clamping bolts.

When grinding long slender pieces support should be given every few inches. For example, a piece  $\frac{1}{2}$  inch in diameter should be supported every four or five inches of its length, measured from the machine centers.

2. Place a work-piece between centers.
3. Back off the shoe adjusting screws, until the shoe is clear of the work-piece.
4. Fit the shoe to the work-piece by hand and hold the shoe in that position while turning the adjusting screws until they just bear against the shoe. The upper screw acts upon the shoe through the lever shown in Fig. 381.
5. Start the machine, advance the wheel and take a light cut. As the wheel advances turn the shoe adjusting screws just enough

to keep the shoe in contact with the work-piece.

If more than one back rest is used, adjustment of the adjusting screws must be made on each rest.

6. With a micrometer measure the diameter of the work at two or more points. If variation of size is found, correct the variation by slightly advancing the lower shoe adjusting screw at the large end of the work; then grind as in step 5.
7. Again measure the work, and if variation in size is found, advance the shoe adjusting screw at the large end of the work. Continue making adjustments until the work-piece is of the same diameter throughout its length.
8. Take a finishing cut of the required depth. As the wheel progresses, advance the shoe adjusting screws sufficiently to keep the shoe in contact with the work-piece.
9. With the work-piece reduced to size and the shoe in contact with the finished piece, each sliding nut, Fig. 381, will be seated against its positive stop.
10. With the shoe in contact with the work, and the sliding nuts in position, tighten the clamping screws on both clamp collars.
11. Adjust the pressure on the shoe as necessary by means of the spring adjusting screws. The combined pressure of the two springs should be no greater than necessary to prevent chatter or springing of the work while it is being ground.
12. When a new work-piece is placed between centers the back rest springs will be compressed and the shoe or shoes, held against the work to support it.

The type of spring back rest illustrated may be used as a solid type merely by tightening the spring adjusting screws until the springs are fully compressed.

When used as a solid type back rest the shoe must be lowered to permit placing the work between centers. This is accomplished by with-

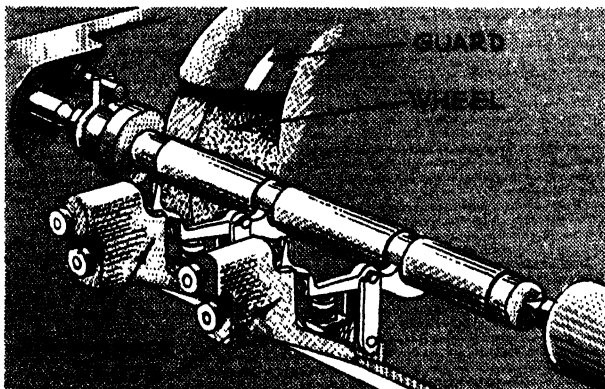

FIG. 381. SPRING-TYPE BACK RESTS IN POSITION

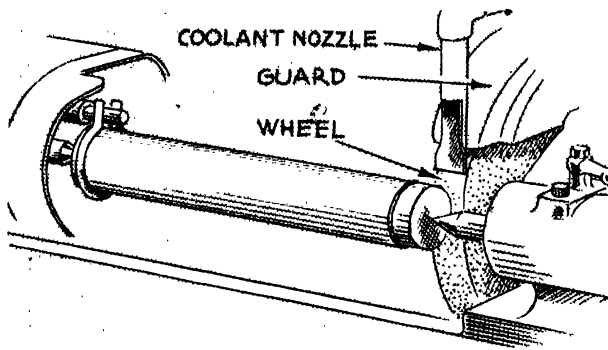

FIG. 382. SPOT GRINDING ONE END OF A WORK-PIECE

drawing the upper shoe adjusting screw. (See Fig. 381.) During the grinding operation the shoe is kept in contact with the work by advancing the upper adjusting screw as the work is reduced in diameter.

Some operators spot the work when using either a solid or compensating type of back rest: When this procedure is used short sections of the work-piece are ground straight in to within about .002 of an inch of the finished diameter. The procedure is illustrated in Fig. 382.

## UNIT 91

### HOW TO SET-UP AND OPERATE A SURFACE GRINDING MACHINE

The machine used as an example in this unit is a standard surface grinding machine. It can be operated manually or automatically by means of mechanical controls. With the addition of a wet grinding attachment it will operate as a wet grinder.

#### GENERAL PROCEDURE

1. Select a grinding wheel suited to the work to be performed, and mount it on the wheel spindle. (See Unit 76.) Be sure the wheel is sound. Test it by striking it a light blow with a hammer; a clear ring will indicate a sound wheel.

**CAUTION:** If the wheel is changed it will be necessary to true and balance the new wheel before attempting to grind a work-piece. (See Unit 77.) If the work-piece is to be form-ground it will be necessary to shape the wheel accordingly. (See Unit 79.) In dry grinding operations a means of protecting the operator and the machine from grit and dust should be employed. The recommended means is a central exhaust system, or an exhaust attachment such as illustrated in Fig. 383.

2. If available, connect the machine with the exhaust system, unless already connected.
3. Secure a work-piece or pieces, suitable clamps, vise, chuck or other means of holding the work.
4. Mount the work on the table of the machine:

A. *By Clamping:* Position, align and clamp the work-piece; for example, as in Fig. 384.

B. *By Using a Vise:* Position and mount the vise on the table, then support and grip the work as illustrated in Fig. 385. Make sure that the surface to be ground is in a horizontal plane by testing with an indicator or surface gage

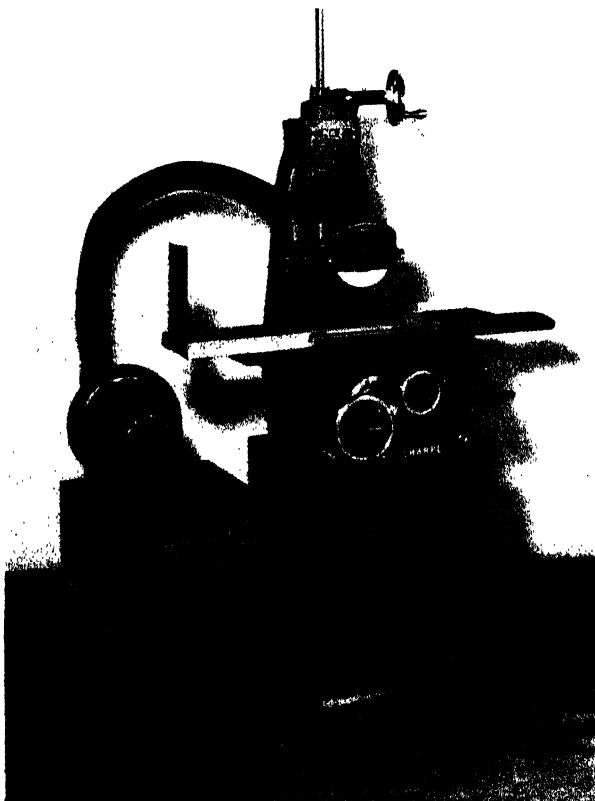

Courtesy, Brown & Sharpe Manufacturing Co.  
FIG. 383. GRINDER WITH EXHAUST SYSTEM

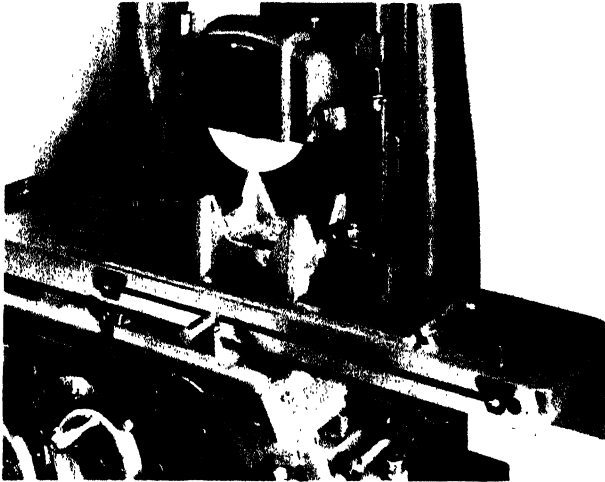

*Courtesy, Brown & Sharpe Manufacturing Co.*

FIG. 384. WORK-PIECE HELD IN POSITION WITH CLAMPS

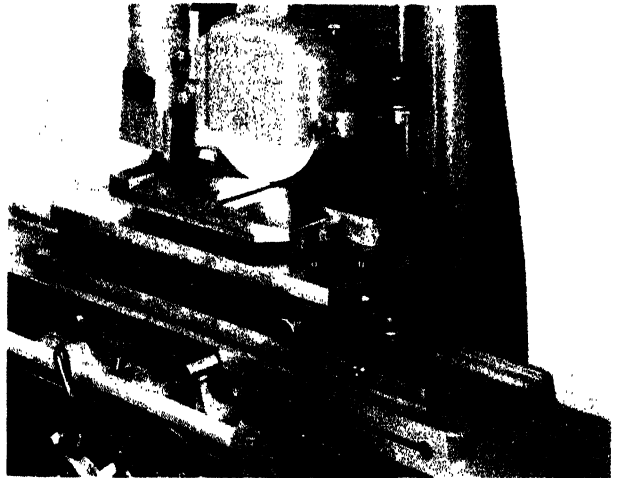

*Courtesy, Brown & Sharpe Manufacturing Co.*

FIG. 387. WORK-PIECE HELD ON A PERMANENT MAGNETIC CHUCK

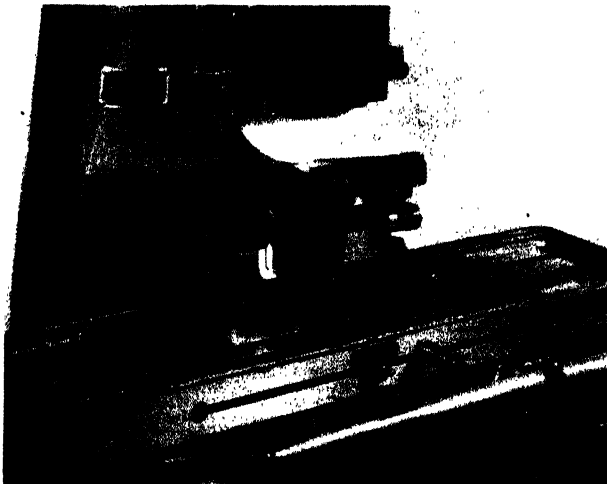

*Courtesy, Brown & Sharpe Manufacturing Co.*

FIG. 385. WORK-PIECE HELD IN A VISE

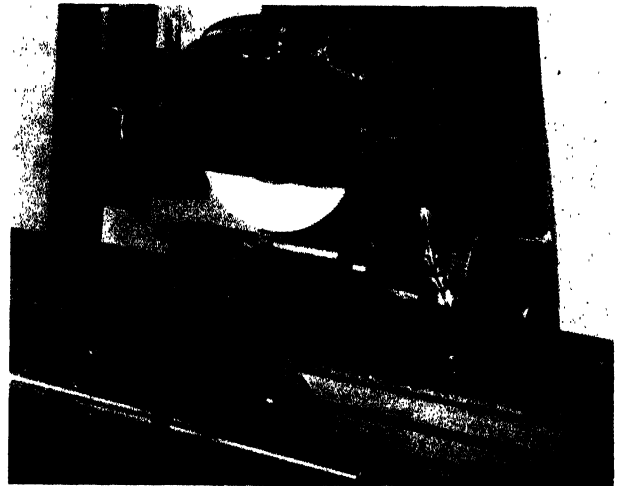

*Courtesy, Brown & Sharpe Manufacturing Co.*

FIG. 388. WORK-PIECE HELD BETWEEN INDEX CENTERS



*Courtesy, Brown & Sharpe Manufacturing Co.*

FIG. 386. WORK-PIECE HELD IN AN ADJUSTABLE SWIVEL VISE

- C. *By Using an Adjustable Swivel Vise:* Position the vise, then grip the work as illustrated in Fig. 386.
- D. *By Using a Permanent Magnetic Chuck:* Mount the chuck on the table and clamp it in position. Place the work-piece or pieces on the chuck, aligned in position with a parallel as illustrated in Fig. 387. With the work in position move the control lever 180° to the right. Use back or end-stops if the work-piece has only small contact with the chuck. Flat pieces of metal make good stops.
- E. *By Using Index Centers:* Mount the index head and footstock on the table

of the machine, aligning them by means of the tongues on their bases, then clamp in position. Place a driving dog on the work, then place it between centers and position it with respect to the grinding wheel, for example, as in Fig. 388.

5. Properly lubricate the machine before starting it. If the machine has been idle for some time, alternately press the start-stop push button in rapid succession three or four times before running the machine at operating speed.
6. Protect eyes by wearing properly fitted goggles. Clothing should be protected with suitable coveralls.

#### PROCEDURE FOR USING THE MANUAL FEED

1. Mount the work on the table of the machine in a suitable manner.
2. With the table handwheel move the work under the grinding wheel. Then lower the wheel by means of the vertical adjustment handwheel, Fig. 389, until it almost touches the work-piece.

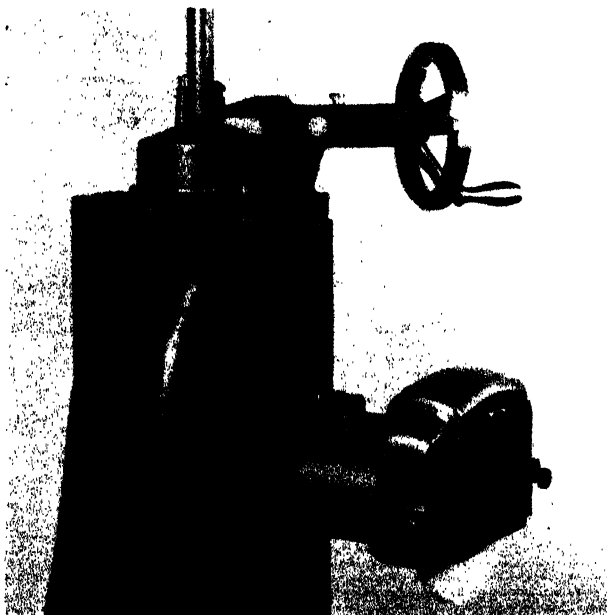

Courtesy, Brown & Sharpe Manufacturing Co  
FIG. 389. VERTICAL ADJUSTMENT HANDWHEEL

3. With the cross feed handwheel move the table outward until the far side of the wheel projects beyond the farthest edge of

the work-piece a distance equal to one-half the width of the face of the wheel.

4. Move the table to the right until the wheel clears the work by four or five inches.

On the machine illustrated the power feed mechanism should be disengaged whenever continuous manual operation is desired. This is accomplished with the knob in the center of the cross feed dial. Turn the knob clockwise until it is tight. The plunger of the dog-operated reversing lever, Fig. 390, should also be withdrawn to prevent the dogs coming into contact with the reversing lever.

5. Turn the vertical adjustment handwheel clockwise through sufficient graduations to produce a cut of .001 to .003 of an inch. Lock the grinding head in position by tightening the clamping screw, Fig. 389.

**CAUTION:** When dry grinding a flat surface considerable heat will be generated, particularly if a heavy feed is used. Overheating should be guarded against by using a light feed, and, where possible, a coolant.

6. Start the machine; then with the table handwheel advance the wheel steadily across the surface of the work. Move the wheel past the end of the work a sufficient distance to allow adjustment of the cross feed before reversing the table.

**CAUTION:** Be sure the wheel guard is fastened securely in position.

7. When the grinding wheel has cleared the end of the work-piece move the table inward by turning the cross feed handwheel clockwise one complete turn. This will give  $\frac{1}{4}$  inch feed. With experience a heavier feed may be taken.

**CAUTION:** Before moving the cross feed handwheel be sure the cross feed selector, Fig. 390, is in its central or neutral position.

8. Continue as in steps 6 and 7 until the entire surface has been rough ground.
9. When rough grinding has been completed, move the grinding wheel back to the starting point and lower the grinding head sufficiently to make the finishing cut, usually .001 of an inch or less.

### PROCEDURE FOR USING THE POWER FEED

1. Proceed as in steps 1 to 5 under General Procedure.
2. Mount the work on the table of the grinding machine in a suitable manner.
3. With the table handwheel, Fig. 390, move the work under the grinding wheel; then lower the wheel by means of the vertical adjustment handwheel, Fig. 389, until it barely touches the surface of the work-

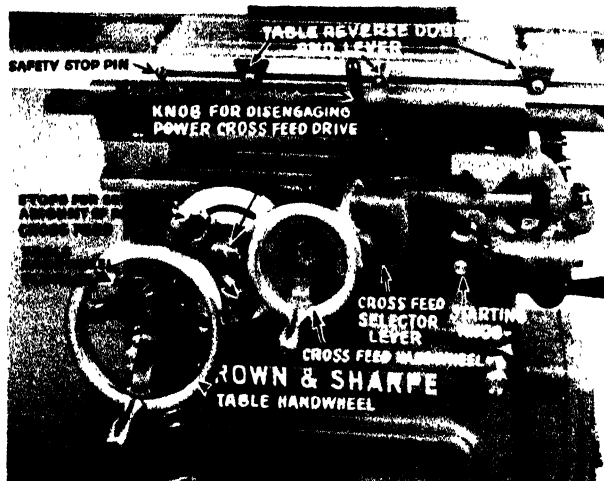

Courtesy, Brown & Sharpe Manufacturing Co.

FIG. 390. OPERATING CONTROLS OF A SURFACE GRINDING MACHINE

4. Move the table to the left until the work clears the wheel by five or six inches, more if found necessary.
5. Bring the left hand reversing dog against the left side of the reversing lever and fasten it in position by tightening the clamping bolt.
6. Move the table to the left until the grinding wheel clears the end of the work by five or six inches, more if found necessary.
7. Bring the right hand reversing dog against the right side of the reversing lever and clamp it in position.

**CAUTION:** When setting the table dogs for automatic reversing, be sure to allow sufficient over-travel of the work in both directions for completion of the cross feed action before the work comes back under the wheel.

By withdrawing the plunger in the top of the reversing lever and then lowering the lever, the table may be moved beyond the position of the reversing dogs without disturbing their location.

8. With the cross feed handwheel move the table outward until the far side of the grinding wheel projects beyond the farthest edge of the work-piece a distance equal to one half the width of the face of the wheel.

### PROCEDURE FOR ADJUSTING POWER CROSS FEED

1. Determine the desired direction of the cross feed, for example, inward or toward the rear of the machine.
2. Determine the amount of cross feed desired, for example, .05 of an inch.

On the machine illustrated, Brown and Sharpe #2, the amount of cross feed is controlled by two adjustable stops on the graduated dial. (See Fig. 390.) Figures on the dial indicate hundredths of an inch. The upper stop sets the feed at the right-hand end of the table travel and the lower stop at the left-hand end. Any amount of travel from .01 to .09 of an inch is available at each reversal of the table. If desired either stop can be set at zero, thus giving cross feed at one end of table travel only.

3. Adjust each stop on the dial to produce a feed of .05 of an inch.
4. Set the cross feed selector lever, Fig. 390, for inward feed by moving the lever to the left. For outward feed move the selector lever to the right. A neutral position of the lever disengages the cross feed.
5. Engage the power cross feed drive by turning the knurled knob in the center of the dial counterclockwise until it is loose.

The machine illustrated is equipped with trip dogs which can be positioned so that a cut may automatically be started or stopped at a particular point on the surface of the work-piece. (See Fig. 387.) After the cross feed of the table has been stopped by a trip dog the cross feed selector lever must be moved to change the direction of cross feed before again starting the table. Furthermore, the starting knob must be held in the engaged position until the trip dog has moved off the plunger sufficiently to permit the knob to remain engaged.

When using cross feed stop dogs, under no circumstances attempt to force the machine to grind beyond the maximum permitted in either direction by the dogs.

#### PROCEDURE FOR CUTTING

1. Turn the vertical adjustment handwheel through sufficient graduations to produce a cut of .002 to .003 of an inch. Lock the grinding head in position by the clamping screw, see Fig. 389.
2. With the work-piece in position and the longitudinal table travel and cross feeds properly adjusted, press the starting button and make the cut.
3. When the roughing cut is completed adjust the machine to take a finishing cut, about .0001 of an inch.

#### HIGH SPEED SURFACE GRINDING ATTACHMENTS

By means of a High Speed Surface Grinding Attachment that can be mounted in the ma-

chine spindle of some surface grinding machines, slots and semi-enclosed surfaces may be ground with wheels of appropriate size and shape. This attachment is illustrated in Fig. 391.

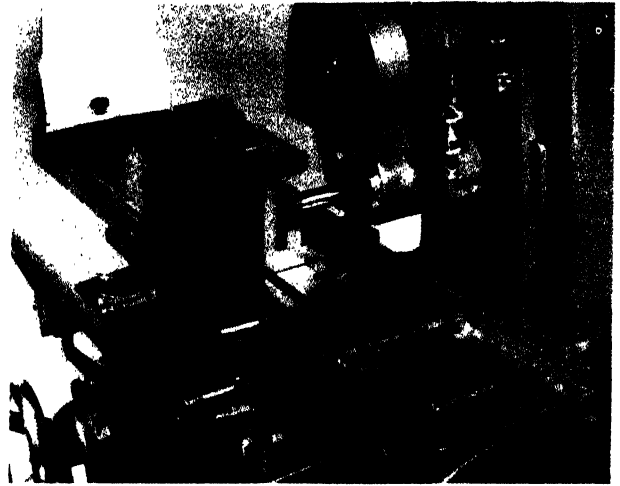

*Courtesy, Brown & Sharpe Manufacturing Co.*

FIG. 391. HIGH SPEED SURFACE GRINDING ATTACHMENT

## REFERENCE LIST

- Barritt, John W., *Machine Shop Operations*. Chicago, Illinois: American Technical Society, 1941. 876 pp.
- Boston, O. W., *Metal Processing*. New York, New York: John Wiley and Sons, Inc., 1941. 630 pp.
- Burghart, Henry D., *Machine Tool Operation*. New York, New York: McGraw-Hill Book Co., Part 1, 1941 (Third Edition), 401 pp. Part II, 1937 (Second Edition), 438 pp.
- Cole, Charles B., *Tool Making*. Chicago, Illinois: American Technical Society, 1940. 413 pp.
- Colvin, Fred H., *Starting a Small Machine Shop*. New York, New York: McGraw-Hill Book Co. Inc., 1948. 212 pp.
- Colvin, Fred H. and Stanley, Frank A., *American Machinists Handbook*. Eighth Edition. New York, New York: McGraw-Hill Book Co. Inc., 1945. 1546 pp.
- Colvin, Fred H., and Stanley, Frank A., *Running a Machine Shop*. New York, New York: McGraw-Hill Book Co. Inc., 1948. 521 pp.
- Cornetet, W. H., and Fox, Daniel F., *Applied Fundamentals of Machines*. Bloomington, Illinois: McKnight & McKnight, 1944. 323 pp.
- Cornetet, W. H., and Fox, Daniel F., *Methods of Measurement*. Bloomington, Illinois: McKnight & McKnight, 1942. 135 pp.
- Henry Ford Trade School, *Shop Theory*. New York, New York: McGraw-Hill Book Co., 1942. 267 pp.
- Handbook for Drillers*. Cleveland, Ohio: Cleveland Twist Drill Co., 44 pp.
- How to Run a Lathe*. South Bend, Indiana: South Bend Lathe Works, 128 pp.
- Ihne, Russell W. and Streeter, W. E., *Machine Trades Blueprint Reading*. Chicago, Illinois: American Technical Society, 1941. 169 pp.
- Johnson, Carl G., *Metallurgy*. Chicago, Illinois: American Technical Society, 1942. 418 pp.
- Kent, Robert T., *Mechanical Engineers' Handbook*. Eleventh Edition. New York, New York: John Wiley & Sons, Inc., 1948. Part II (Power), 1252 pp. Part III, (Design—Shop Practice), 1378 pp.
- Knight, Roy E., *Machine Shop Projects*. Bloomington, Illinois: McKnight and McKnight, 1943. 112 pp.
- Ludwig, Oswald A., *Metalwork Technology and Practice*. Bloomington, Illinois: McKnight & McKnight, 1947. 400 pp.
- Machining Aluminum*. Pittsburgh, Pennsylvania: Aluminum Company of America, 24 pp.
- Milling Machine Work*. Albany, New York: Delmar Publishers, Inc., 1947. 298 pp.
- Mollard, Wesley, *Essentials of Precision Inspection*. New York, New York: McGraw-Hill Book Co., Inc., 1944. 207 pp.
- Plumridge, Tom C., *Machine Tool Guide*. Chicago, Illinois: American Technical Society, 1945. 776 pp.
- Shaper Work*. Albany, New York: Delmar Publishers, Inc., 1947. 326 pp.
- Shuman, John T., *Machine Shop Work*. Chicago, Illinois: American Technical Society, 1942. 507 pp.
- Turner, William P. and Owen, H. F., *Machine Tool Work*. New York, New York: McGraw-Hill Book Co., Inc., 1945. 364 pp.
- Wagener, Albert M. and Arthur, H. R., *Machine Shop Theory and Practice*. New York, New York: D. Van Nostrand Co., Inc., 1941. 306 pp.
- Whipple, G. Graham, and Baudek, Anthony C., *Engine Lathe Operations*. Bloomington, Illinois: McKnight & McKnight, 1942. 160 pp.
- Winston, Stanley E., *Machine Design*. Chicago, Illinois: American Technical Society, 1942. 333 pp.



NAIL SET ~ TOOL STEEL, HARDEN AND TEMPER

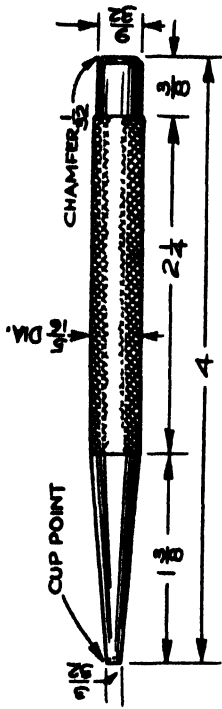

DRIVE PIN PUNCH ~ TOOL STEEL, HARDEN AND TEMPER

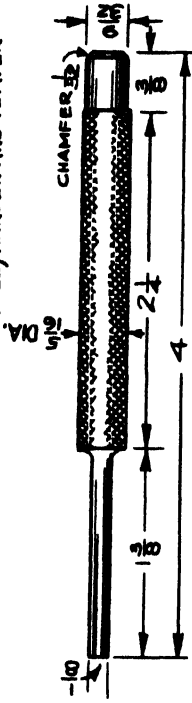

PRICK PUNCH ~ TOOL STEEL, HARDEN AND TEMPER

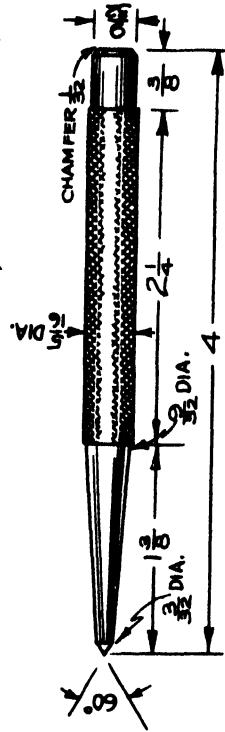

CENTER PUNCH ~ TOOL STEEL, HARDEN AND TEMPER

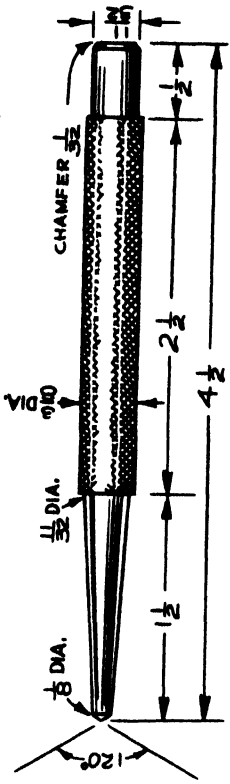

MILD STEEL CENTERING BELL

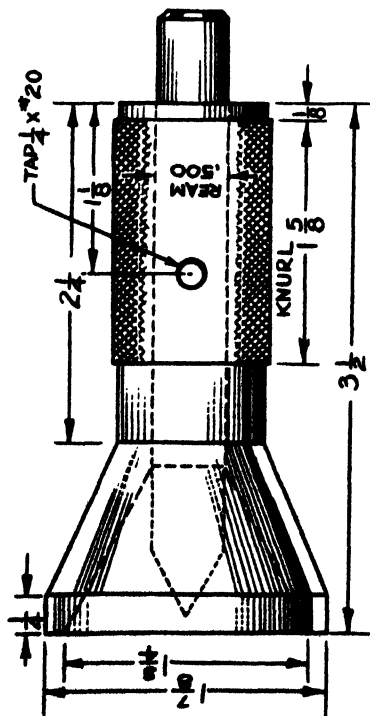

BELL PUNCH ~ TOOL STEEL  
HARDEN AND TEMPER

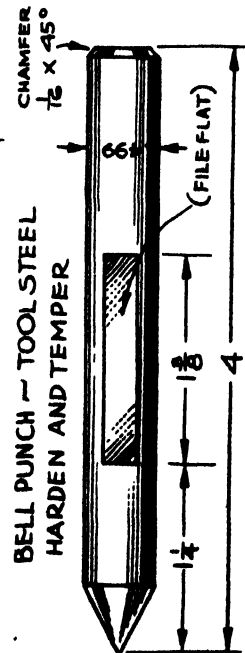

PLUMB BOB  
COLD ROLLED HEX. STEEL

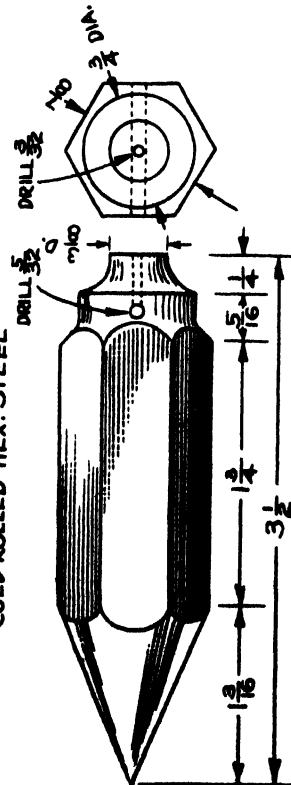





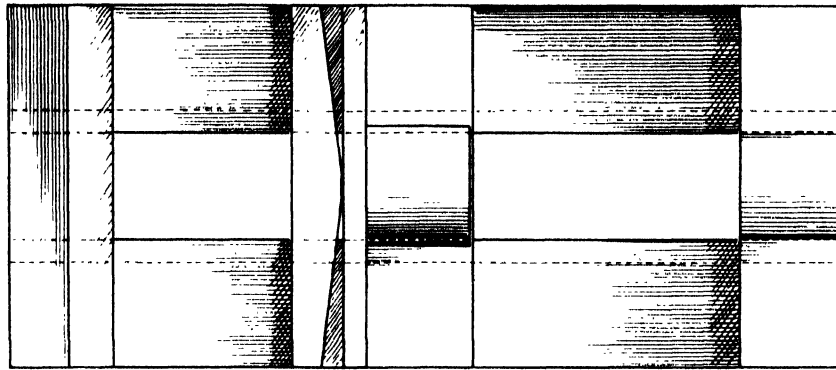

# DRILLING VISE

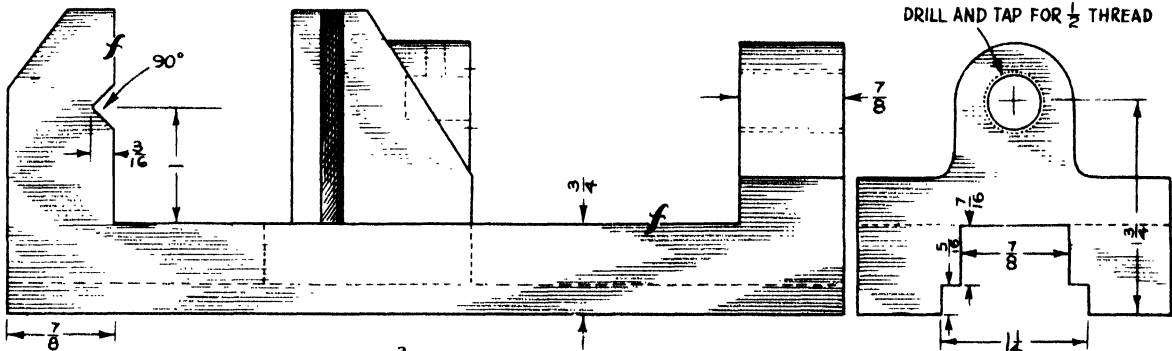
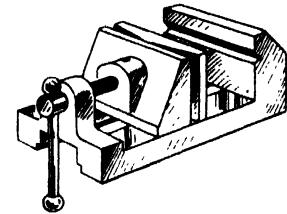

DRILL AND TAP FOR 1/2 THREAD

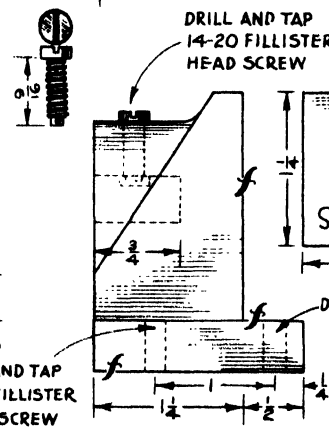
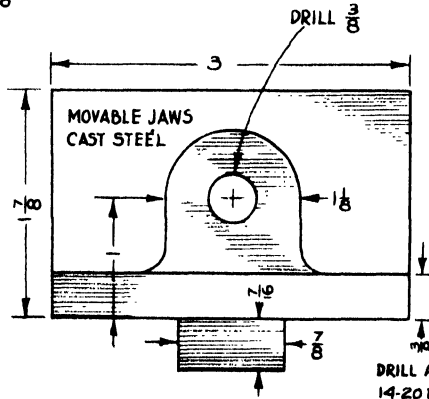

DRILL AND TAP 14-20 FILLISTER HEAD SCREW

COUNTER BORE FOR FILLISTER SCREW

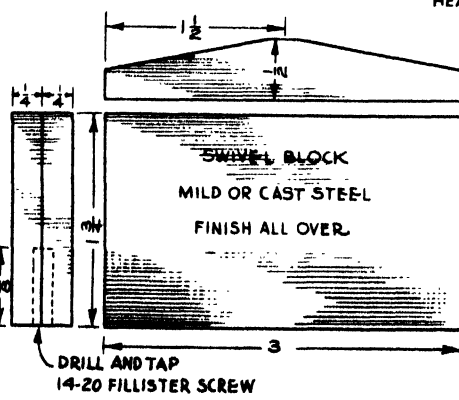

DRILL AND TAP 14-20 FILLISTER SCREW

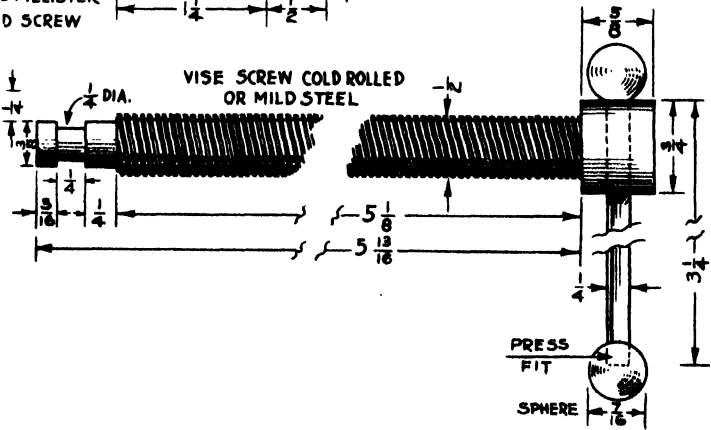

PRESS FIT

SPHERE

DECIMAL EQUIVALENTS OF PARTS OF AN INCH

$\frac{1}{84}$ equals .015625	$\frac{17}{84}$ equals .265625	$\frac{33}{84}$ equals .515625	$\frac{49}{84}$ equals .765625
$\frac{1}{32}$ " .03125	$\frac{39}{84}$ " .28125	$\frac{47}{84}$ " .53125	$\frac{55}{84}$ " .78125
$\frac{3}{84}$ " .046875	$\frac{43}{84}$ " .296875	$\frac{51}{84}$ " .546875	$\frac{59}{84}$ " .796875
$\frac{1}{16}$ " .0625	$\frac{47}{84}$ " .3125	$\frac{55}{84}$ " .5625	$\frac{63}{84}$ " .8125
$\frac{5}{84}$ " .078125	$\frac{51}{84}$ " .328125	$\frac{59}{84}$ " .578125	$\frac{67}{84}$ " .828125
$\frac{3}{32}$ " .09375	$\frac{55}{84}$ " .34375	$\frac{63}{84}$ " .59375	$\frac{71}{84}$ " .84375
$\frac{7}{84}$ " .109375	$\frac{59}{84}$ " .359375	$\frac{67}{84}$ " .609375	$\frac{75}{84}$ " .859375
$\frac{1}{8}$ " .125	$\frac{63}{84}$ " .375	$\frac{71}{84}$ " .625	$\frac{79}{84}$ " .875
$\frac{9}{84}$ " .140625	$\frac{67}{84}$ " .390625	$\frac{75}{84}$ " .640625	$\frac{83}{84}$ " .890625
$\frac{5}{32}$ " .15625	$\frac{71}{84}$ " .40625	$\frac{79}{84}$ " .65625	$\frac{87}{84}$ " .90625
$\frac{11}{84}$ " .171875	$\frac{75}{84}$ " .421875	$\frac{83}{84}$ " .671875	$\frac{91}{84}$ " .921875
$\frac{3}{16}$ " .1875	$\frac{79}{84}$ " .4375	$\frac{87}{84}$ " .6875	$\frac{95}{84}$ " .9375
$\frac{13}{84}$ " .203125	$\frac{83}{84}$ " .453125	$\frac{91}{84}$ " .703125	$\frac{99}{84}$ " .953125
$\frac{7}{32}$ " .21875	$\frac{87}{84}$ " .46875	$\frac{95}{84}$ " .71875	$\frac{103}{84}$ " .96875
$\frac{15}{84}$ " .234375	$\frac{91}{84}$ " .484375	$\frac{99}{84}$ " .734375	$\frac{107}{84}$ " .984375
$\frac{1}{4}$ " .25	$\frac{1}{2}$ " .5	$\frac{3}{4}$ " .75	1 " 1.

COMMONLY USED MEASURES AND FORMULAE

LINEAR MEASURE

12 inches (in.)	equals 1 foot..... ft.
3 feet	equals 1 yard..... yd.
$5\frac{1}{2}$ yards	equals 1 rod..... rd.

SQUARE MEASURE

144 square inches (sq. in.)	equals 1 square foot... sq. ft.
9 square feet	equals 1 square yard... sq. yd.
$30\frac{1}{2}$ square yards	equals 1 square rod.... sq. rd.

CUBIC MEASURE

1728 cubic inches (cu. in.)	equals 1 cubic foot. .... cu. ft.
27 cubic feet	equals 1 cubic yard..... cu. yd.

MEASURE OF ANGLES OR ARCS

60 seconds (")	equals 1 minute..... °
60 minutes (')	equals 1 degree..... °
90 degrees (°)	equals 1 right angle.... L
360 degrees	equals 1 circle..... cir.

LIQUID MEASURE

4 gills (gi.)	equals 1 pint..... pt.
2 pints	equals 1 quart..... qt.
4 quarts	equals 1 gallon..... gal.
$31\frac{1}{2}$ gallons	equals 1 barrel..... bbl.
2 barrels	equals 1 hoghead..... hhd.

DRY MEASURE

2 pints (pt.)	equals 1 quart..... qt.
8 quarts	equals 1 peck..... pk.
4 pecks	equals 1 bushel..... bu.

AVOIRDUPOIS WEIGHT

16 ounces (oz.)	equals 1 pound..... lb.
100 pounds	equals 1 hundredweight. cwt.
20 cwt. or 2000 pounds	equals 1 ton..... t.

MISCELLANEOUS MEASURES

12 articles	equals 1 dozen..... dos.
12 dozen	equals 1 gross..... gross
1 pint of water	equals 1.043125 pounds or approximately 1 pound.
1 cubic foot of water	weighs 62.425 pounds.

FORMULAE:

- The circumference of a circle is equal to  $\pi$  or 3.1416 times the diameter.  
cir. = 3.1416 x dia.
- The area of a circle is equal to  $\pi$  times the radius squared.  
 $a = 3.1416 \times r^2$
- The area of a rectangle or parallelogram is equal to length times the width.  
 $a = L \times W$
- The area of a trapezoid is equal to the sum of one half of the parallel sides times the height.  
 $A = \frac{a+b}{2} \times h$
- The area of a triangle is equal to the altitude times the base divided by 2.  
 $A = \frac{(ab)}{2}$  or  $A = \frac{1}{2}ab$

THE METRIC SYSTEM OF MEASUREMENT OF LENGTH

1 Millimeter (mm.) = . . . . . 0.03937079 inch, or about 1/25 inch  
 10 Millimeters = 1 Centimeter (cm.) = . . . . . 0.3937079 inch  
 10 Centimeters = 1 Decimeter (dm.) = . . . . . 3.937079 inch  
 10 Decimeters = 1 Meter (m.) = . . . . . 39.37079 inches, 3.2808992 feet, or 1.09361 yards  
 10 Meters = 1 Decameter (Dm.) = . . . . . 32.808992 feet  
 10 Decameters = 1 Hectometer (Hm.) = . . . . . 19.927817 rods  
 10 Hectometers = 1 Kilometer (Km.) = . . . . . 1093.61 yards, or 0.6213824 mile  
 10 Kilometers = 1 Myriameter (Mm.) = . . . . . 6.213824 miles  
 1 inch = 2.54 cm., 1 foot = 0.3048 m., 1 yard = 0.9144 m., 1 rod = 0.5029 Dm., 1 mile = 1.6093 Km.

DECIMAL AND MILLIMETER EQUIVALENTS OF FRACTIONAL PARTS OF AN INCH

Inches	Inches	mm	Inches	Inches	mm
$\frac{1}{16}$	.01563	.397	$\frac{1}{8}$	.51563	13.097
$\frac{1}{8}$	.03125	.794	$\frac{3}{8}$	.53125	13.494
$\frac{3}{16}$	.04688	1.191	$\frac{1}{2}$	.54688	13.890
$\frac{1}{4}$	.0625	1.587	$\frac{5}{8}$	.5625	14.287
$\frac{5}{16}$	.07813	1.984	$\frac{3}{4}$	.57813	14.684
$\frac{3}{8}$	.09375	2.381	$\frac{7}{8}$	.59375	15.081
$\frac{7}{16}$	.10938	2.778	$\frac{1}{2}$	.60938	15.478
$\frac{1}{2}$	.125	3.175	$\frac{5}{8}$	.625	15.875
$\frac{9}{16}$	.14063	3.572	$\frac{3}{4}$	.64063	16.272
$\frac{5}{8}$	.15625	3.969	$\frac{7}{8}$	.65625	16.669
$\frac{11}{16}$	.17188	4.366	$\frac{1}{2}$	.67188	17.065
$\frac{3}{4}$	.1875	4.762	$\frac{5}{8}$	.6875	17.462
$\frac{13}{16}$	.20313	5.159	$\frac{3}{4}$	.70313	17.859
$\frac{7}{8}$	.21875	5.556	$\frac{7}{8}$	.71875	18.256
$\frac{15}{16}$	.23438	5.953	$\frac{1}{2}$	.73438	18.653
$\frac{1}{4}$	.25	6.350	$\frac{3}{4}$	.75	19.050
$\frac{17}{16}$	.26563	6.747	$\frac{1}{2}$	.76563	19.447
$\frac{9}{8}$	.28125	7.144	$\frac{7}{8}$	.78125	19.844
$\frac{19}{16}$	.29688	7.541	$\frac{1}{2}$	.79688	20.240
$\frac{5}{4}$	.3125	7.937	$\frac{5}{8}$	.8125	20.637
$\frac{21}{16}$	.32813	8.334	$\frac{3}{4}$	.82813	21.034
$\frac{11}{8}$	.34375	8.731	$\frac{7}{8}$	.84375	21.431
$\frac{23}{16}$	.35938	9.128	$\frac{1}{2}$	.85938	21.828
$\frac{3}{2}$	.375	9.525	$\frac{5}{8}$	.875	22.225
$\frac{25}{16}$	.39063	9.922	$\frac{3}{4}$	.89063	22.622
$\frac{13}{8}$	.40625	10.319	$\frac{7}{8}$	.90625	23.019
$\frac{27}{16}$	.42188	10.716	$\frac{1}{2}$	.92188	23.415
$\frac{7}{4}$	.4375	11.113	$\frac{5}{8}$	.9375	23.812
$\frac{29}{16}$	.45313	11.509	$\frac{3}{4}$	.95313	24.209
$\frac{15}{8}$	.46875	11.906	$\frac{7}{8}$	.96875	24.606
$\frac{31}{16}$	.48438	12.303	$\frac{1}{2}$	.98438	25.003
$\frac{1}{2}$	.5	12.700	1	1.00000	25.400

DECIMAL INCH EQUIVALENTS OF MILLIMETERS AND FRACTIONAL PARTS OF MILLIMETERS

mm	Inches	mm	Inches	mm	Inches
1-100 =	.00039	43-100 =	.01693	85-100 =	.03346
2-100 =	.00079	44-100 =	.01732	86-100 =	.03386
3-100 =	.00118	45-100 =	.01772	87-100 =	.03425
4-100 =	.00157	46-100 =	.01811	88-100 =	.03465
5-100 =	.00197	47-100 =	.01850	89-100 =	.03504
6-100 =	.00236	48-100 =	.01890	90-100 =	.03543
7-100 =	.00276	49-100 =	.01929	91-100 =	.03583
8-100 =	.00315	50-100 =	.01969	92-100 =	.03622
9-100 =	.00354	51-100 =	.02008	93-100 =	.03661
10-100 =	.00394	52-100 =	.02047	94-100 =	.03701
11-100 =	.00433	53-100 =	.02087	95-100 =	.03740
12-100 =	.00472	54-100 =	.02126	96-100 =	.03780
13-100 =	.00512	55-100 =	.02165	97-100 =	.03819
14-100 =	.00551	56-100 =	.02205	98-100 =	.03858
15-100 =	.00591	57-100 =	.02244	99-100 =	.03898
16-100 =	.00630	58-100 =	.02283	1	.03937
17-100 =	.00669	59-100 =	.02323	2	.07874
18-100 =	.00709	60-100 =	.02362	3	.11811
19-100 =	.00748	61-100 =	.02402	4	.15748
20-100 =	.00787	62-100 =	.02441	5	.19685
21-100 =	.00827	63-100 =	.02480	6	.23622
22-100 =	.00866	64-100 =	.02520	7	.27559
23-100 =	.00906	65-100 =	.02559	8	.31496
24-100 =	.00945	66-100 =	.02598	9	.35433
25-100 =	.00984	67-100 =	.02638	10	.39370
26-100 =	.01024	68-100 =	.02677	11	.43307
27-100 =	.01063	69-100 =	.02717	12	.47244
28-100 =	.01102	70-100 =	.02756	13	.51181
29-100 =	.01142	71-100 =	.02795	14	.55118
30-100 =	.01181	72-100 =	.02835	15	.59055
31-100 =	.01220	73-100 =	.02874	16	.62992
32-100 =	.01260	74-100 =	.02913	17	.66929
33-100 =	.01299	75-100 =	.02953	18	.70866
34-100 =	.01339	76-100 =	.02992	19	.74803
35-100 =	.01378	77-100 =	.03032	20	.78740
36-100 =	.01417	78-100 =	.03071	21	.82677
37-100 =	.01457	79-100 =	.03110	22	.86614
38-100 =	.01496	80-100 =	.03150	23	.90551
39-100 =	.01535	81-100 =	.03189	24	.94488
40-100 =	.01575	82-100 =	.03228	25	.98425
41-100 =	.01614	83-100 =	.03268	26	1.02362
42-100 =	.01654	84-100 =	.03307		

AMERICAN NATIONAL COARSE THREADS

Size of Thread and Threads per Inch	Major Diameter D* Inches	Pitch Diameter E* Inches	Minor Diameter K* Inches	Commercial Tap Drill to Produce Approx. 75% Full Thread	Decimal Equivalent of Tap Drill Inches
1 x64	.0730	.0629	.0527	No. 53	.0595
2 x56	.0860	.0744	.0628	No. 50	.0700
3 x48	.0990	.0855	.0719	No. 47	.0785
4 x40	.1120	.0958	.0795	No. 43	.0890
5 x40	.1250	.1088	.0925	No. 38	.1015
6 x32	.1380	.1177	.0974	No. 36	.1065
8 x32	.1640	.1437	.1234	No. 29	.1360
10 x24	.1900	.1629	.1359	No. 25	.1495
12 x24	.2160	.1889	.1619	No. 16	.1770
1/4 x20	.2500	.2175	.1850	No. 7	.2010
5/16 x18	.3125	.2764	.2403	F	.2570
3/8 x16	.3750	.3344	.2938	7/8	.3125
7/16 x14	.4375	.3911	.3447	U	.3680
1/2 x13	.5000	.4500	.4001	1 1/4	.4219
5/8 x12	.5625	.5084	.4542	1 1/2	.4844
3/4 x11	.6250	.5660	.5069	1 3/4	.5312
7/8 x10	.7500	.6850	.6201	2	.6562
1 x 9	.8750	.8028	.7307	2 1/4	.7656
1 1/8 x 8	1.0000	.9188	.8376	2 3/4	.8750
1 1/4 x 7	1.1250	1.0322	.9394	3	.9844
1 1/2 x 7	1.2500	1.1572	1.0644	3 1/4	1.1094
1 3/4 x 6	1.3750	1.2667	1.1585	3 1/2	1.2187
1 7/8 x 6	1.5000	1.3917	1.2835	4	1.3281
2 x 5	1.7500	1.6201	1.4902	4 1/4	1.5469
2 1/4 x 4 1/2	2.0000	1.8557	1.7113	4 1/2	1.7812
2 1/2 x 4 1/2	2.2500	2.1057	1.9613	5	2.0312
2 3/4 x 4	2.5000	2.3376	2.1752	5 1/4	2.2500
2 7/8 x 4	2.7500	2.5876	2.4252	5 1/2	2.5000
3 x 4	3.0000	2.8376	2.6752	5 3/4	2.7500
3 1/4 x 4	3.2500	3.0876	2.9252	6	3.0000
3 1/2 x 4	3.5000	3.3376	3.1752	6 1/4	3.2500
3 3/4 x 4	3.7500	3.5876	3.4252	6 1/2	3.5000
4 x 4	4.0000	3.8376	3.6752	6 3/4	3.7500

AMERICAN NATIONAL FINE THREADS

Size of Thread and Threads per Inch	Major Diameter D* Inches	Pitch Diameter E* Inches	Minor Diameter K* Inches	Commercial Tap Drill to Produce Approx. 75% Full Thread	Decimal Equivalent of Tap Drill Inches
0 x80	.0600	.0519	.0438	5/8	.0469
1 x72	.0730	.0640	.0550	No. 53	.0595
2 x64	.0860	.0759	.0657	No. 50	.0700
3 x56	.0990	.0874	.0758	No. 45	.0820
4 x48	.1120	.0985	.0849	No. 42	.0935
5 x44	.1250	.1102	.0955	No. 37	.1040
6 x40	.1380	.1218	.1055	No. 33	.1130
8 x36	.1640	.1460	.1279	No. 29	.1360
10 x32	.1900	.1697	.1494	No. 21	.1590
12 x28	.2160	.1928	.1696	No. 14	.1820
1/4 x28	.2500	.2268	.2036	No. 3	.2130
5/16 x24	.3125	.2854	.2584	I	.2720
3/8 x24	.3750	.3479	.3209	Q	.3320
7/16 x20	.4375	.4050	.3725	1 1/4	.3906
1/2 x20	.5000	.4675	.4350	1 1/2	.4531
5/8 x18	.5625	.5264	.4903	1 3/4	.5156
3/4 x18	.6250	.5889	.5528	2	.5781
7/8 x16	.7500	.7094	.6688	2 1/4	.6875
1 x14	.8750	.8286	.7822	2 3/4	.8125
1 1/8 x12	1.0000	.9536	.9072	3	.9375
1 1/4 x12	1.1250	1.0709	1.0167	3 1/4	1.0469
1 1/2 x12	1.2500	1.1959	1.1417	3 1/2	1.1719
1 3/4 x12	1.3750	1.3209	1.2667	4	1.2969
1 7/8 x12	1.5000	1.4459	1.3917	4 1/4	1.4219

\* D=Outside diameter, E=Pitch diameter and K=Root diameter.

FOUR PLACE TRIGONOMETRIC FUNCTIONS

Table of trigonometric functions (Sines, Cosines, Tangents, Cotangents) for angles from 0° to 90°. The table is organized into columns for each function and rows for each angle, with sub-columns for Natural and Logarithmic values.



FOUR PLACE TRIGONOMETRIC FUNCTIONS (CONT'D)

Angles	Sines		Cosines		Tangents		Cotangents		Angles
	Nat. Log.	Log.	Nat. Log.	Log.	Nat. Log.	Log.	Nat. Log.	Log.	
34° 00'	.5592	0.7476	.8290	9.9186	.6745	9.8290	1.4825	0.1710	56° 00'
10	.5616	7494	.8274	9177	.6767	8317	1.4733	1683	50
20	.5640	7513	.8258	9169	.6830	8344	1.4641	1656	40
30	.5664	7531	.8241	9160	.6873	8371	1.4550	1629	30
40	.5688	7550	.8225	9151	.6916	8398	1.4460	1602	20
50	.5712	7568	.8208	9142	.6959	8425	1.4370	1575	10
35° 00'	.5736	9.7586	.8192	9.9134	.7002	9.8452	1.4281	0.1548	55° 00'
10	.5760	7604	.8175	9125	.7046	8479	1.4193	1521	50
20	.5783	7622	.8158	9116	.7089	8506	1.4106	1494	40
30	.5807	7640	.8141	9107	.7133	8533	1.4019	1467	30
40	.5831	7657	.8124	9098	.7177	8560	1.3934	1441	20
50	.5854	7675	.8107	9089	.7221	8588	1.3848	1414	10
36° 00'	.5878	9.7692	.8090	9.9080	.7265	9.8613	1.3764	0.1387	54° 00'
10	.5901	7710	.8073	9070	.7310	8639	1.3680	1361	50
20	.5925	7727	.8056	9061	.7355	8666	1.3597	1334	40
30	.5948	7744	.8039	9052	.7400	8692	1.3514	1308	30
40	.5972	7761	.8021	9042	.7445	8718	1.3432	1282	20
50	.5995	7778	.8004	9033	.7490	8745	1.3351	1255	10
37° 00'	.6018	9.7795	.7986	9.9023	.7536	9.8771	1.3270	0.1229	53° 00'
10	.6041	7811	.7969	9014	.7581	8797	1.3190	1203	50
20	.6065	7828	.7951	9004	.7627	8824	1.3111	1176	40
30	.6088	7844	.7934	8995	.7673	8850	1.3032	1150	30
40	.6111	7861	.7916	8985	.7720	8876	1.2954	1124	20
50	.6134	7877	.7898	8975	.7766	8902	1.2876	1098	10
38° 00'	.6157	9.7893	.7880	9.8953	.7813	9.8925	1.2799	0.1072	52° 00'
10	.6180	7910	.7863	8955	.7859	8954	1.2723	1046	50
20	.6202	7926	.7844	8945	.7907	8980	1.2647	1020	40
30	.6225	7941	.7826	8935	.7954	9006	1.2572	994	30
40	.6248	7957	.7808	8925	.8002	9032	1.2497	968	20
50	.6271	7973	.7790	8915	.8050	9058	1.2423	942	10
39° 00'	.6293	9.7989	.7771	9.8905	.8098	9.9084	1.2349	0.9216	51° 00'
10	.6316	8004	.7753	8905	.8146	9110	1.2276	896	50
20	.6338	8020	.7735	8894	.8195	9135	1.2203	869	40
30	.6361	8035	.7716	8884	.8243	9161	1.2131	843	30
40	.6383	8050	.7698	8874	.8292	9187	1.2059	817	20
50	.6406	8066	.7679	8863	.8342	9212	1.1988	792	10
Angles	Nat. Log.		Nat. Log.		Nat. Log.		Nat. Log.		Angles

Angles	Sines		Cosines		Tangents		Cotangents		Angles
	Nat. Log.	Log.	Nat. Log.	Log.	Nat. Log.	Log.	Nat. Log.	Log.	
40° 00'	.6428	9.8081	.7660	9.8843	.8301	9.9238	1.1918	0.0782	50° 00'
10	.6450	8096	.7642	8832	.8441	9264	1.1847	0.736	50
20	.6472	8111	.7623	8821	.8491	9289	1.1778	0.711	40
30	.6494	8125	.7604	8810	.8541	9315	1.1708	0.685	30
40	.6517	8140	.7585	8800	.8591	9341	1.1640	0.659	20
50	.6539	8155	.7566	8789	.8642	9366	1.1571	0.634	10
41° 00'	.6561	9.8169	.7547	9.8778	.8693	9.9392	1.1504	0.608	49° 00'
10	.6583	8184	.7528	8767	.8744	9417	1.1436	0.583	30
20	.6604	8198	.7509	8756	.8796	9443	1.1369	0.557	40
30	.6626	8213	.7490	8745	.8847	9468	1.1303	0.532	30
40	.6648	8227	.7470	8733	.8899	9494	1.1237	0.506	20
50	.6670	8241	.7451	8722	.8952	9519	1.1171	0.481	10
42° 00'	.6691	9.8255	.7431	9.8711	.9004	9.9544	1.1104	0.456	48° 00'
10	.6713	8269	.7412	8699	.9057	9570	1.1041	0.430	50
20	.6734	8283	.7392	8688	.9110	9595	1.0977	0.405	40
30	.6756	8297	.7373	8676	.9163	9621	1.0913	0.379	30
40	.6777	8311	.7353	8665	.9217	9646	1.0850	0.354	20
50	.6799	8324	.7333	8653	.9271	9671	1.0786	0.329	10
43° 00'	.6820	9.8336	.7314	9.8641	.9325	9.9697	1.0724	0.303	47° 00'
10	.6841	8351	.7294	8629	.9380	9722	1.0661	0.278	50
20	.6862	8365	.7274	8618	.9435	9747	1.0599	0.253	40
30	.6884	8378	.7254	8606	.9490	9772	1.0538	0.228	30
40	.6905	8391	.7234	8594	.9545	9798	1.0477	0.202	20
50	.6926	8405	.7214	8582	.9601	9823	1.0416	0.177	10
44° 00'	.6947	9.8418	.7193	9.8569	.9657	9.9848	1.0355	0.152	46° 00'
10	.6967	8431	.7173	8557	.9713	9874	1.0295	0.126	50
20	.6988	8444	.7153	8545	.9770	9899	1.0235	0.101	40
30	.7009	8457	.7133	8533	.9827	9924	1.0176	0.076	30
40	.7030	8469	.7112	8520	.9884	9949	1.0117	0.051	20
50	.7050	8482	.7092	8507	.9942	9975	1.0058	0.025	10
45° 00'	.7071	9.8495	.7071	9.8495	1.0000	0.0000	1.0000	0.0000	45° 00'
Angles	Nat. Log.		Nat. Log.		Nat. Log.		Nat. Log.		Angles

DECIMAL EQUIVALENTS OF THE NUMBER AND LETTER SIZES OF TWIST DRILLS

No.	Size in decimals	No.	Size in decimals	No.	Size in decimals	No.	Size in decimals
1	.2290	21	.1590	41	.0960	61	.0390
2	.2210	22	.1570	42	.0935	62	.0380
3	.2130	23	.1540	43	.0890	63	.0370
4	.2090	24	.1520	44	.0860	64	.0360
5	.2055	25	.1495	45	.0820	65	.0350
6	.2040	26	.1470	46	.0810	66	.0330
7	.2010	27	.1440	47	.0785	67	.0320
8	.1990	28	.1405	48	.0760	68	.0310
9	.1960	29	.1360	49	.0730	69	.02925
10	.1935	30	.1285	50	.0700	70	.0280
11	.1910	31	.1200	51	.0670	71	.0260
12	.1890	32	.1160	52	.0635	72	.0250
13	.1850	33	.1130	53	.0595	73	.0240
14	.1820	34	.1110	54	.0550	74	.0225
15	.1800	35	.1100	55	.0520	75	.0210
16	.1770	36	.1065	56	.0465	76	.0200
17	.1730	37	.1040	57	.0430	77	.0180
18	.1695	38	.1015	58	.0420	78	.0160
19	.1660	39	.0995	59	.0410	79	.0145
20	.1610	40	.0960	60	.0400	80	.0135

LETTER SIZES OF DRILLS

Letter	Size in decimals	Letter	Size in decimals
A $1\frac{1}{4}$	.234	N	.302
B	.238	O $\frac{1}{2}$	.316
C	.242	P $1\frac{1}{4}$	.323
D	.246	Q	.333
E $\frac{1}{2}$	.250	R $1\frac{1}{2}$	.339
F	.257	S	.348
G	.261	T $1\frac{1}{4}$	.358
H $1\frac{1}{4}$	.266	U	.368
I	.272	V $\frac{1}{2}$	.377
J	.277	W $1\frac{1}{4}$	.386
K $\frac{3}{4}$	.281	X	.397
L	.290	Y $1\frac{1}{2}$	.404
M $1\frac{1}{4}$	.295	Z	.413

# INDEX

- Abrasives, 177  
Accidents, human element, 9  
Adapters, for milling machine, 103  
Addendum, 135  
Alloy bits, 42  
Aluminum—machining, 42; oxide, 177  
Angles—for countersinks, 23; for drills, 22; for grinding, 205, 206; for helical milling, 144-146; of helix, 145; for lathe tools, 41; of shaper bits, 85, 86; shaping on grinding wheels, 184-187.  
Angular cutting, with band saw, 160, 162; with hack saw, 155; with shaper, 92-94  
Arbor, for milling machine, 103; support, 124  
Back rest, 175, 176; using, 204; using spring type, 207, 208  
Band saws and operation, 156-166; blades, 158; exterior contours, 162; filing, 165, 166; friction cutting, 158, 159, 163, 164; horizontally operated cut-off saw, 156, 159, 160; internal contours, 162, 163; internal sawing, 157, 158; operating vertical machine, 160-162; polishing, 165, 166; power feed, 157; cutting refractory material, 164, 165; variable speed, 157  
Bauxite, 20  
Bell centering cup, 46  
Bevel gears, 136, 137; cutter for, 140; cutting, 140-142; layout of, 137, 140, 141  
Bevel, milling a, 120, 121  
Blades, band saw, 156, 158; diamond-tooth band saw, 164, 165; hack saw, 153  
Bonding materials, 178  
Boring—on lathe, 66-68; tool, 22, 23; with drill press, 33, 34  
Boring attachment, for lathe, 39  
Burns, 9  
Caliper rule, 12  
Calipers, 12; setting, 15-18; types, 16; using, 15-18  
Carbide tipped tools, 40  
Carriage clamp, use in drilling, 32  
Center gauge, 12  
Center grinding attachment, 189  
Center holes (illus) 48  
Center punching, 29, 30  
Center square, 44  
Center rest, 175 (*See Also Steady Rest*)  
Centering stock, in four-jaw chuck, 64  
Centers—drilling, 48; grinding, 188, 189; locating, 44-49; testing, 47  
Chalk, use in truing work, 64  
Chamfer, milling a, 120, 121  
Change gears — chart, 72, 73, (quick) 74; determining, 72; for helical milling, 144-146  
Chip, in milling, 111  
Chucks, collet, 60, 61; four-jaw, 60; four-jaw, mounting work in, 63-65; grinders, 175; lathe, 59-61; magnetic, 209; mounting, 61, 62; removing, 62, 63; spindle, 61; step, 61; three-jaw, 60  
Circular milling attachment, 105, 106  
Circular pitch, 135  
Collet chucks, 60, 61  
Collets, for milling machine, 103  
Combination drill and countersink, 48  
Combination square, 11  
Compound rest, use in cutting a taper, 71  
Counter boring tool, 23  
Countersink, 23, 24  
Cutters, milling, 106-110; centering, 125, 126; end, 107, 108; facing, 107, 108; formed, 108; holding, 109; key seat, 108; plain, 107; sharpening, 103, 112-114, 189, 190; side, 107; slitting, 107; T-slot, 107, 108  
Cutting speed, of hack saw, 153; for lathe work (table), 40; for milling, 110, 111; for milling, (table) 110; shaper (table), 88  
Cutting tools—for lathe, 50; for shaper, 85, 90; specially formed, 97  
Cylindrical grinder, 167  
Cylindrical grinding, 200-205; on universal grinder, 192-196  
Diametral pitch, 135  
Dedendum, 135  
Depth gauge, 12  
Dial indicator, 115  
Diamond-tool, 183  
Dividers, 11; to find center, 45  
Dividing head, 104, 129-131, 209, 210; to cut groove, 128; to cut hexagon, 125; to cut octagon, 125; to cut square, 124, 125; to mill spur gears, 138; parts, 129; wide range, 131  
Double angle cutter, 147-149  
Dowel, to spot-finish, 35  
Dress, 9  
Drill breakage, causes (table) 23  
Drill drift, 22  
Drill press, 25, 26; boring with, 33, 34; for drilling centers, 48; for spot-finishing, 35, 36  
Drilling, 29-33; centers, 48; to depth, 31; feeds, 27; large holes, 33; lubricants, 27; speeds, 26, 27, (table) 27; speeds and feeds, 25, 26  
Drills, 21-24; grinding, 22, 27-29; parts of, 21; sizes, 21; using, 22  
End mill, 107, 108; to cut groove, 127; to cut helix, 143, 146, 150; to cut hexagon, 122; to cut octagon, 122, 123; sharpening, 112; to cut square, 121  
End shell mill, 107, 108  
Faceplates, lathe, 59-61; mounting, 51  
Facing cutters, 107, 108, 119  
Facing work—between centers, 55, 56; in lathe chuck, 65  
Feed direction—in grinding, 190-192; in milling, 111  
File band, coupling, 166  
Filing, on band saw, 158, 165, 166; on lathe, 58  
Fillet, 55, 56  
Fillister head screws, 23  
First aid, 9  
Flutes—of drill, 21; milling on a conical surface, 132, 133; milling on cylindrical surface, 131, 132; milling on flat surface, 131; of reamers, 24  
Follower rest, 57; mounting, 58  
Formed cutters, 108  
Friction cutting, 163, 164; job selector chart, 159; saw blade, 164; sawing, 158, 159  
Gear cutter, 138  
Gear cutting—bevel, 139-142; machine, 140; spur, 137-139  
Gear teeth, parts, 134, 135  
Gear tooth vernier caliper, 141  
Gear cutting attachment — for lathe, 39; for milling machine, 195, 106  
Gears, bevel, 136, 137, 139-142; spur, 134-139  
Grinders, tool, 19, 20; types, 19  
Grinding, 9; attachment for lathe, 80; drills, 22, 27-29; lathe cutters, 43, 44; lathe cutter bits, 40-43; milling cutters, 112-114; shaper cutter, 43, 44  
Grinding machines and operation, 167-212; angular cuts, 205, 206; attachments, 169; centers, 188, 189; cylindrical grinding, 192-196, 200-205; exterior tapers, 196, 197; feeds, 190-192; internal grinding, 198, 199; internal tapers, 199, 200; live center grinding, 174-176; operating surface grinder, 208-212; parts, 168, 171-176; sharpening milling cutters, 189, 190; speeds, 190-192; tapers, 205, 206; troubles (table) 176; types, 167; using back rest, 207, 208  
Grinding wheels, 20, 177-180; balancing 180-182; changing, 180-182; composition, 20; dressing, 182-184; dressing on surface grinder, 187, 188; selection (table) 179; shaping, 184-187; testing soundness, 192; truing, 182-184, 187, 188  
Grooves—milling, 125-128, 131-133; with one face radial, 132; cutting with shaper, 93  
Guards, for machines, 9  
Hack saws and operation, 152-155; blades, 153; cutting speed, 152, 153; drive, 153; feed, 152; heavy duty hydraulic, 154; high speed, 154; shear cut, 153, 154; types, 152; vises, 153  
Helixes—computations for milling, 144-146; cutting with end mill, 150; layout, 148; lead, 142; left-hand, 142; milling, 142-151; milling on universal milling machine, 146-149; milling with

- universal spiral attachment, 150, 151; right-hand, 142  
Hermaphrodite caliper, 12; to find center, 18, 45, 46; setting, 17; uses, 15, 16  
Hexagon, milling a, 122  
High speed attachment—for milling machines, 104; for surface grinders, 212
- Index head, 209, 210 (*See also dividing head*)  
Index plate—high number, 130, 131; use in cutting spur gears, 139  
Internal grinders, 167, 170  
Internal grinding, 198, 199  
Internal threads, cutting, 77  
Involute gear teeth, 134
- Jig, 101  
Job selector chart—for band saw, 157; for friction cutting, 159
- Keyway—cutters, 108; cutting, 125-128; cutting with shaper, 95; cutting for Woodruff key, 128  
Keyway cutter, to cut helix, 143  
Knurling—mild steel, 59; tool, 59
- Land, of drill, 21  
Lathes and operation, 37-80; automatic feed, 53; boring, 66-68; capacity, 37, 38; center rest, 57, 58; testing centers, 53; chucks, 61-63; cutting speeds, 40; for drilling centers, 48; facing work, 55, 56; filing, 58; finishing cuts, 54, 55; follower rest, 57, 58; facing work in chuck, 65; grinding cutter bits, 40-44; machining recesses, 66-68; machining work on mandrel, 68; for milling, 78-80; modern, 37, 38; mounting work between centers, 51, 52; parts of, 38; parts of carriage, 76; polishing, 58; primitive, 37; roughing cuts, 52-55; steady rest, 47; cutting threads, 72-78; setting for turning, 49, 50; tool uses, 49-50; turning tapers, 70-72; turning work in chuck, 65, 66  
Leads, for helical milling, 144-146  
Lip angles, of drill, 22, 27  
Lip clearance, of drills, 22, 27
- Mandrel, 68; in grinding, 189  
Maudslay, Henry, 37  
Margin, of drill, 21  
Measuring instruments, 11-18  
Micrometer calipers, 14; graduations, 14; parts, 14; reading, 15; using, 14, 15  
Milling attachment for lathe, 39, 78-80  
Milling cutters—grinding, 80; mounted on lathe attachment, 79  
Milling machines and operation, 98-151; attachments, 102-106; chamfer, 120, 121; to cut helixes, 146-149; cutters, 106-110; cutter holders, 106-110; for cutting bevel, 120, 121; cutting bevel gears, 140-142; cutting keyways and grooves, 125-128; cutting speed, calculating, 110, 111; dividing head, 129; driving mechanism, 101; face milling, 119, 120; feed, 100; flat surfaces, 114-117; flutes, 131-133; grooves, 131-133; for hexagon, 122; parts, 100; sharpening cutters, 109, 110, 112-114; spindle rotation, 116; speed, 100; spirals, 102; spur gears, 137-139; square, 121, 122; squaring stock, 117, 118; thickness of chip, 111; types, 98  
Miter gears, 137  
Morse taper, 71  
Mortising attachment for drill press, 26
- Octagon, milling, 122, 123
- Parallels, 87  
Pitch diameter, 135  
Platen, 171  
Planing irregular surfaces, 96, 97  
Polishing, on band saw, 158, 165, 166; on lathe, 58  
Profiling attachment for milling machine, 99
- Quick change gear chart, 74; mechanism, 74
- Radius and angle wheel-truing attachment, 184-186  
Radius wheel-truing attachment, 183, 184  
Rake, of lathe tools, 40; of milling cutters, 106  
Reamers, 24; grinding, 80  
Reaming, 34, 35  
Recesses, machining on lathe, 66-68  
Resin bond, 178  
Rolling pitch, 140  
Roughing cut, 52-55; cast metals, 52  
Rules, steel, 11
- Safety, 9, 10; in adjusting shaper, 89; in boring, 33, 34; in cleaning lathe spindle, 51; in cutting threads, 75; in dressing grinding wheel, 183; in drilling, 31; in grinding, 189; in milling, 117; in mounting faceplate, 51; in mounting work between centers, 52; in operating band saw, 161; in reaming, 34; in shaping operations, 90, 91; when setting tail-stock, 70  
Saw-tooth mills, sharpening, 112  
Screw pitch gauge, 75  
Sector, 130  
Setting strips, 120, 121  
Shank, of drill, 21  
Shapers and operation, 81-97; adjusting stroke, 89; angular cuts, 92-94; cutters, grinding, 43, 44; cutting speed, 88; driving mechanism, 82; feed, 83; feed change cams, 84; horizontal cuts, 89-91; for keyways, 94-96; parts, 82; planing irregular surfaces, 96, 97; sectional view, 81; for stop cuts, 94-96; speed, 83; speed change gears, 84; squaring stock, 91, 92; stroke cycle, 84; table, 84, 85; tool head, 85; tools, 85, 90; tools, special formed, 97; uses, 81; vertical cuts, 92-94; vises, 87  
Shaping attachment for drill press, 26  
Silicon carbide, 177  
Slitting cutters, 107  
Slotting attachment, 105  
Spindle chuck, 61  
Spiral mill, 107, 110; cutters, sharpening, 113  
Spiral milling, 102  
Spirals, (*see Helixes*)  
Spot-finishing, 35, 36  
Spot-grinding, 208  
Spring-type back rest, 205, 206  
Spur gears, 134-136; cutting, 137-139  
Squaring stock, with milling machine, 117, 118; with power hack saw, 155; with shaper, 91, 92  
Steady rest, 57, 175; mounting, 57  
Step chuck and closer, 61  
Straddle mill, to cut hexagon, 124; to mill square, 123, 124  
Stroke cycle of shaper, 84  
Surface gauge, 13; to locate center, 47  
Surface grinding attachment, high speed, 212  
Surface grinding machine, 167, 170, 208-212  
Surface milling, 114-117
- T-slot cutter, 107, 108  
Tang, of drill, 22  
Taper attachment, 70-72  
Tapers, grinding, 196, 197, 205, 206; grinding internal, 199, 200; turning 69-72  
Tapping attachment for drill press, 26  
Threading dial, 74, 75  
Threading tools, angles of, 42  
Threads, cutting internal, 77; cutting on lathe, 72-78; cutting lubricant, 74; gauge, 75  
Tooth rest bracket, 189  
Tungsten carbide tipped tools, 42; cutting speeds in lathe work, 40
- Universal grinders, 167-172, 192-200; for cylinders, 192-196; for exterior tapers, 196, 197; for internal tapers, 199, 200; for straight internal work, 198, 199  
Universal head, 175  
Universal milling machine, 98, 142; to cut helixes, 146-149  
Universal spiral attachment, 104, 105; to mill helix, 150, 151
- Vernier caliper, 14  
Vertical milling attachment, 104  
Vertical milling machine, 98  
Vise—hack saw, 153; plain, 102; shaper, 87; swivel, 102, 117, 118; universal 102, 103  
Vitrified clay bond, 178
- Web, of drill, 21  
Wheel and sleeve, removing, 180  
Wheel stand, 171; parts, 178  
Woodruff key, 128





