

**BIRLA CENTRAL LIBRARY**  
**PILANI (Rajasthan)**

Class No. 634-999

Book No W90 P

Accession No. 59566





PLYWOODS  
THEIR DEVELOPMENT, MANUFACTURE  
AND APPLICATION



A STUDY IN VENEERS

# PLYWOODS

*Their Development, Manufacture  
and Application*

*by*

ANDREW DICK WOOD

*and*

THOMAS GRAY LINN



W. & A. K. JOHNSTON, LIMITED  
EDINBURGH AND LONDON

1942

MADE AND PRINTED IN GREAT BRITAIN BY  
MORRISON AND GIBB LTD., EDINBURGH AND LONDON

## FOREWORD

ONE often hears people refer to the Plywood Trade, by which the speaker generally means the importing trade in this country, as a very youthful growth. It is often members of other sections of the Timber Trade who speak in this way, and compared with some other branches of the Timber Trade, as for instance the Imported Sawn Softwood, it is young. But it is not so young that it cannot even now be divided into at least two eras, which might be broadly defined as the "introducing" era, when the whole of a comparatively small trade was handled by a few firms, often on a somewhat speculative basis, and the "contract" era, when a growing number of importer firms bought goods on definite forward contracts for distribution from stock to a continually increasing number of merchants and users. These importers themselves became active propagandists for plywood and experts in its known uses as well as finding ever new uses for it. It is from the beginning of this latter era that plywood may be said really to have "arrived," although new developments were, and in fact still are, constantly taking place. If so, much can be said for the importing side of the industry, the manufacturing side is still older and, in fact, as readers will see, might lay claim to a very respectable antiquity.

It might be assumed from the above that Great Britain was somewhat slow to recognize the merits of this new product, but if this was so we have made up for lost time by having become such important users that there is practically no country manufacturing plywood which is not to-day vitally interested in the British market.

That considerable literature should have grown up round such an important industry was only to be expected, but I know of no book which deals with the subject in such a comprehensive manner as this volume, nor one which gives even the lay reader such a complete picture in simple language of what plywood is and does.

It was, therefore, with considerable pleasure that I received the request from my old friends, the authors, to write a Foreword to this book, the growth of which I have been privileged to watch. I have seen the meticulous care with which they have striven to verify their facts, whilst their researches into history, both ancient and of more recent times, have



been characterized by that thoroughness which those who know them would have expected.

The result is the present book, which may be described as a most valuable text-book for the Trade and which I think will prove of great interest not only to manufacturers, but also to agents and importers of plywood. To users of plywood and architects looking for the best medium for carrying out their designs and wishing to feel confidence in the materials they recommend to their clients the book should prove invaluable. Even members of the general public will find this no dry-as-dust treatise, as it has been written with a view, among other things, to interesting as wide a circle as possible, thus assisting in the development of the demand for wood in this, its latest, most scientific and most economical form.

G. L. WRIGHT.

ARTHUR STREET, LONDON, E.C.4.

*June 1941.*

## ACKNOWLEDGMENTS

**I**N the preparation of this volume we have received much valuable assistance from leading plywood manufacturers, makers of plywood machinery and from a number of important users of plywood.

This opportunity is taken to express our sincere thanks to all who have assisted. Special acknowledgment is made to the following: Mr. George L. Wright, twice Chairman of the Plywood Section, Timber Trade Federation of the United Kingdom, who not only contributed the Foreword but gave invaluable help in many other ways; Mr. J. Lyford-Pike, B.Sc., Forestry Department, University of Edinburgh, for his assistance during the early stages and in the preparation of Parts I. and II.; Mr. Eric G. M. Fletcher, LL.D., B.A.(London), who drafted the chapter on Disputes and Arbitration; Mr. Morton J. H. Cowie, A.R.I.B.A., A.R.I.A.S., whose line drawings have been largely used; Sir Eric Maclagan, C.B.E., for kindly allowing us to reproduce photographs of woodwork in the Victoria and Albert Museum; The Trade Commissioners of Australia, Canada and the Union of South Africa; The Statistical Department of the Board of Trade. Finally, our gratitude is expressed to those who supplied photographs and drawings; these have been acknowledged individually with the exception of the decorative veneered panels for which we are indebted to Messrs. Veneercraft Ltd.

# CONTENTS

	PAGE
FOREWORD . . . . .	v
ACKNOWLEDGMENTS . . . . .	vi
INTRODUCTION . . . . .	xv

## PART I

### DEVELOPMENT

CHAPTER

I. HISTORICAL . . . . .	1
II. DEFINITION OF VENEER AND PLYWOOD . . . . .	7
III. SOURCES OF SUPPLY . . . . .	12

## PART II

### PHYSICAL PROPERTIES OF WOOD AND PLYWOOD

I. (a) THE STRUCTURE OF WOOD . . . . .	17
(b) DEVELOPMENT OF FIGURE IN WOOD . . . . .	19
II. MOISTURE IN WOOD . . . . .	22
III. (a) CHIEF CHARACTERISTICS OF WOOD . . . . .	27
(b) CHARACTERISTICS OF PLYWOOD . . . . .	28
(c) HOW VARYING FIGURE IS DISCLOSED WHEN LOGS ARE CUT INTO VENEER . . . . .	30

## PART III

### THE MANUFACTURE OF MULTI-PLY

I. PREPARATION OF LOGS FOR CUTTING . . . . .	35
(a) Steaming Vats or Pits.	
(b) Preparing Logs for Rotary Cutting.	

CHAPTER	PAGE
II. THE CONVERSION OF WOOD INTO VENEER . . . . .	38
Sawing.	
Slicing.	
Rotary Cutting	
Half Round or Stay Log Cutting.	
III. TRIMMING TO WIDTH . . . . .	48
IV. PLYWOOD PRODUCTION PROCESSES . . . . .	52
V. DRYING VENEER . . . . .	55
VI. VENEER JOINTING AND REPAIRING . . . . .	63
(a) Veneer Jointers or Trimmers.	
(b) Jointing Veneers in the Width.	
(c) Jointing Veneers in the Length.	
(d) Repairing Veneer.	
VII. ASSEMBLING . . . . .	73
VIII. ADHESIVES AND THEIR APPLICATION . . . . .	76
Introduction.	
(a) Animal and Hide Glues.	
(b) Casein.	
(c) Soya Bean Glue.	
(d) Resin Adhesives.	
(e) Mechanical Glue-Spreaders.	
IX. PRESSES AND PRESSING . . . . .	93
Cold Presses.	
Hot Presses.	
Application of Heat and Pressure in Hot Press	
X. FINISHING OPERATIONS . . . . .	106
(a) Re-Drying.	
(b) Removal of Tapes.	
(c) Equalizing.	
(d) Final Processing.	
XI. MANUFACTURING DEFECTS . . . . .	113

P A R T I V

LAMINBOARDS, BLOCKBOARDS, COMPOSITE BOARDS  
AND SPECIALITIES

CHAPTER	PAGE
I. DEVELOPMENT . . . . .	117
II. MANUFACTURE OF LAMINBOARDS, BLOCKBOARDS AND LUMBER-CORE BOARDS . . . . .	119
(a) Preparation of Laminated Cores.	
(b) Preparation of Blockboard Cores.	
(c) Assembling Blockboards and Laminboards.	
(d) Manufacture of Batten-boards.	
(e) Manufacture of Strip-boards.	
III. MANUFACTURE OF COMPOSITE BOARDS AND SPECIALITIES . . . . .	127
(a) Shaped and Moulded Plywood.	
(b) Protection against Fire.	
(c) Composite Boards.	
(d) Metal-faced Plywood.	
(e) Improved and Compressed Wood.	

P A R T V

GRADING, TESTING, PACKING AND STORING

I. GRADING . . . . .	153
II. TESTING . . . . .	158
III. PACKING . . . . .	163
IV. STORING . . . . .	167
(a) Storing Plywood.	
(b) Storage of Veneers.	

P A R T VI

PLYWOOD-PRODUCING COUNTRIES OF THE WORLD 173

P A R T VII

(a) COMMERCIAL PLYWOODS . . . . .	243
(b) OTHER WOODS USED IN PLYWOOD MANUFACTURE . . . . .	275
(c) DECORATIVE VENEERS . . . . .	281

PART VIII

THE PLYWOOD TRADE IN THE UNITED KINGDOM

PAGE

CHAPTER			
I.	I.	(a) CONSTITUTION OF TRADE . . . . .	301
		(b) VARIOUS ASSOCIATIONS . . . . .	305
		(c) TRADE JOURNALS AND PERIODICALS . . . . .	309
	II.	CONTRACTS, CLAIMS, DISPUTES, ARBITRATION . . . . .	310
III.		(a) MARKETING PLYWOOD AND VENEERS . . . . .	317
		(b) SALESMEN AND SALESMANSHIP . . . . .	323
		(c) HANDLING OF SHIPPING DOCUMENTS AND PASSING OF CUSTOMS ENTRIES . . . . .	325
		(d) DRAWBACK ON PLYWOOD AND VENEERS SUPPLIED TO REGISTERED SHIPBUILDING YARDS . . . . .	327

PART IX

THE DEVELOPMENT OF WALL PANELLING . . . . .	331
---	-----

PART X

APPLICATION

I. VENEERING . . . . .	355
II. FURNITURE MANUFACTURE AND GENERAL WOODWORK . . . . .	363
III. SHIPBUILDING AND LIGHT CRAFT CONSTRUCTION . . . . .	385
IV. UTILITY SERVICES AND MOTORS . . . . .	401
V. BOXES, BARRELS, REELS, BASKETS, TRAYS . . . . .	411
VI. EXTERIOR WORK . . . . .	419
VII. TREATMENT AND DECORATION . . . . .	427
CONSTRUCTIONAL DETAILS . . . . .	430

APPENDIX

TERMS AND DEFINITIONS . . . . .	439
TECHNICAL DATA, WEIGHTS AND USEFUL TABLES . . . . .	445
INDEX . . . . .	463

# LIST OF PLATES

PLATE	PAGE
I. VENEERED COFFIN OF XIIIth DYNASTY . . . . .	2
II. PEDESTAL SECRÉTAIRE OF LOUIS XV. PERIOD . . . . .	4
III. VENEERED COMMODE. EARLY CURVED WORK . . . . .	6
IV. SPECIAL CABIN, R.M.S. <i>QUEEN MARY</i> . . . . .	15
V. MASUR BIRCH . . . . .	280
VI. CONFERENCE ROOM, ST. ANDREW'S HOUSE, EDINBURGH : <i>Architects,</i> Sir JOHN BURNET, TAIT & LORNE, F.F.R.I.B.A. . . . .	282
VII. WRITING ROOM, S.S. <i>TUSCANIA</i> , IN INDIAN LAUREL . . . . .	284
VIII. MAKORÉ BURR . . . . .	288
IX. BOARD-ROOM, IN QUEENSLAND MAPLE . . . . .	290
X. CABIN SMOKING-ROOM, R.M.S. <i>QUEEN MARY</i> . . . . .	292
XI. VESTIBULE TO OFFICE, IN FIGURED TEAK . . . . .	298
XII. EARLY SIXTEENTH-CENTURY PANELLING . . . . .	330
XIII. LATE SIXTEENTH-CENTURY OAK PANELLING . . . . .	332
XIV. THE "BROMLEY" ROOM, VICTORIA AND ALBERT MUSEUM . . . . .	334
XV. OAK PANELLING, ABOUT 1686-88 . . . . .	336
XVI. PANELLING IN WALNUT BURR IN ST. ANDREW'S HOUSE, EDIN- BURGH : <i>Architects,</i> Sir JOHN BURNET, TAIT & LORNE, F.F.R.I.B.A. . . . .	340
XVII. DINING-ROOM, IN HALF-QUARTERED FIGURED OAK . . . . .	342
XVIII. ENTRANCE LOUNGE, IN FIGURED OAK WITH METAL MOULDINGS . . . . .	346
XIX. CORNER TREATMENT IN FLAME BIRCH, NEW TOWN HALL, DAGEN- HAM : <i>Architect,</i> E. BERRY WEBBER, A.R.I.B.A. . . . .	350
XX. COUNCIL CHAMBER, IN FRENCH WALNUT : <i>Architect,</i> E. BERRY WEBBER, A.R.I.B.A. . . . .	352
XXI. CORRIDOR AND STAIRWAY, R.M.S. <i>QUEEN MARY</i> , IN SATINÉE AND ELM BURR . . . . .	386
XXII. CHILDREN'S PLAYGROUND, S.S. <i>ANDANIA</i> , IN SYCAMORE . . . . .	398
XXIII. CORRIDOR ON L. & N.E. RAILWAY'S "CORONATION" TRAIN . . . . .	400

# LIST OF ILLUSTRATIONS

FIG.	PAGE	FIG.	PAGE
1. Sections of plywoods . . . . .	10-11	33. Section through channel drier . . . . .	57
2. Methods of cutting veneer . . . . .	13	34. Breather drier . . . . .	58
3. Isometric drawings — plywood construction . . . . .	15	35. Cross-section of Coe drier . . . . .	60
4. Parts of tree . . . . .	16	36. Section of Proctor drier . . . . .	61
5. Radial direction . . . . .	17	37. Driers and guillotine . . . . .	62
6. Tangential direction . . . . .	17	38. Veneer trimmer . . . . .	64
7. Various parts of wood . . . . .	18	39. Tape-jointing face veneers . . . . .	65
8. A cylinder . . . . .	19	40. Types of pre-gummed tape . . . . .	66
9. Undulating arrangement of wood fibres in Sycamore . . . . .	20	41. Preparing large cross-grained outer plies . . . . .	68
10. How planks twist . . . . .	23	42. A modern tapeless splicer . . . . .	69
11. Section Douglas Fir log . . . . .	23	43. Jointing veneer in the length . . . . .	70
12. Direction of grain in rotary-cut veneer . . . . .	25	44. Modern edge-jointing equipment . . . . .	72
13. Graph . . . . .	26	45. Spreading adhesive and assembling veneers . . . . .	73
14. Demonstrating nail-holding properties of plywood . . . . .	29	46. Outdoor sign in Douglas Fir . . . . .	83
15. Track taken by knife during rotary cutting . . . . .	31	47. Resweld sign . . . . .	85
16. How figure is developed by slicing . . . . .	32	48. Gymnasium constructed of resin-bonded Oregon Pine . . . . .	89
17. Cutting a log into flitches . . . . .	33	49. Petrol-filling station built of plywood . . . . .	89
18. Oak cut to reveal varying figure . . . . .	33	50. Cold press . . . . .	95
19. How fiddleback figure is produced . . . . .	34	51. Old type hot press . . . . .	97
20. Drag saw . . . . .	37	52. Piston pumps . . . . .	98
21. Portable saw . . . . .	37	53. Column type hot press . . . . .	99
22. Veneer saw . . . . .	39	54. Large hot hydraulic press . . . . .	100
23. Vertical veneer slicer . . . . .	40	55. Pressing Finnish Birch plywood . . . . .	101
24. Horizontal veneer slicer . . . . .	40	56. Hot press and automatic loader . . . . .	102
25. Diagrammatic drawing, rotary cutting . . . . .	42	57. Equalizing Swedish Pine . . . . .	108
26. Rotary-cut Birch veneer . . . . .	44	58. Equalizing blockboards . . . . .	108
27. Rotary-cut Okoumé veneer . . . . .	44	59. Machine scraper . . . . .	111
28. Cutting checks . . . . .	45	59A. Knife stock or carrier . . . . .	111
29. Rotary cutting Finnish Birch . . . . .	46	60. Belt sander . . . . .	112
30. Cutting Swedish Pine . . . . .	46	61. Defects in inner plies . . . . .	113
31. Cutting to width . . . . .	49	62. A twisted plywood board . . . . .	114
32. Automatic clipper . . . . .	50	63. Building up core blocks . . . . .	119
		64. Preparing laminated core stock . . . . .	120
		65. Sawing blocks into laminated cores . . . . .	121

LIST OF ILLUSTRATIONS

xiii

FIG.		PAGE	FIG.		PAGE
66.	Sections of laminated cores . . . . .	121	96.	Storage rack for laminboards . . . . .	170
67.	Loading drying kiln . . . . .	122	97.	Storage truck for veneers . . . . .	171
68.	Section showing method of cutting blocks . . . . .	123	98.	Stressed angles in plywood . . . . .	172
69.	Snack bar panelled in plywood . . . . .	126	99.	Douglas Fir . . . . .	179
70.	Saloon bar in Masur Birch . . . . .	126	100.	Log pond, Tacoma . . . . .	179
71.	Curved forms in ratchet press . . . . .	128	101.	Trucks loaded with Douglas Fir logs . . . . .	180
72.	Sections of "Oceana" shaped plywood . . . . .	130	102.	Mounting flitch on veneer slicer . . . . .	185
73.	Section of shaped plywood . . . . .	131	103.	Felling a Birch tree in Latvia . . . . .	188
74.	Diagrammatic drawing of vacuum process . . . . .	132	104.	Sorting dried Birch veneer . . . . .	190
75.	Shaping and moulding press . . . . .	132	105.	Rotary cutting Douglas Fir . . . . .	194
76.	"Oceana" panel in Mahogany . . . . .	133	106.	Automatic clipper . . . . .	195
77.	Exterior, plywood framed buildings at San Francisco Exhibition . . . . .	137	107.	Loading hot press . . . . .	196
78.	Sections of composite boards . . . . .	140	108.	Birch forest . . . . .	202
79.	Counter at office faced with Micarta . . . . .	142	109.	Finnish Birch log-yard . . . . .	203
80.	Sections showing edge treatment of tops faced with resin laminated veneer sheet . . . . .	143	110.	Removing Birch logs from ponds by mechanical conveyer . . . . .	204
81.	Method of jointing laminated resin veneer sheet . . . . .	143	111.	Makoré curl . . . . .	286
82.	Hospital partitions in Plymax . . . . .	145	112.	Olivewood . . . . .	286
83.	Protecting exposed edges of metal-faced plywood . . . . .	148	113.	Sycamore "crotch" . . . . .	294
84.	Improved wood used in electrical work . . . . .	149	114.	Sycamore butt . . . . .	294
85.	Compressed wood . . . . .	150	115.	Staircase, s.s. <i>Stratheden</i> , in Betula . . . . .	300
86.	Bar of compressed wood . . . . .	150	116.	Bureau of plywood construction . . . . .	308
87.	Certificate of Inspection, Douglas Fir . . . . .	154	117.	Double writing-desk, for a bank . . . . .	316
88.	Birch and Gaboon plywood after shear tests . . . . .	160	118.	Writing-desk of modern design . . . . .	316
89.	Test piece prepared for shear testing . . . . .	161	119.	Coffee-table of plywood . . . . .	319
90.	Test piece prepared for tensile strength test . . . . .	162	120.	Showroom displaying veneered panels and flush doors . . . . .	320
91.	P.F.I. Warehouse, Tacoma, Wash., U.S.A. . . . .	164	121.	Marquetry picture . . . . .	322
92.	Electrical moisture content testing metre . . . . .	165	122.	Period panelling in Oak . . . . .	338
93.	Well-stacked piles of plywood . . . . .	166	123.	Panelling in Blackbean . . . . .	339
94.	Storage of blockboards . . . . .	166	124.	Detail of fixing plywood panelling . . . . .	343
95.	Gantry at plywood warehouse . . . . .	168	125.	Detail of shaped work . . . . .	344
			126.	Method of jointing laminboards . . . . .	344
			127.	Detail of simple panelling . . . . .	345
			128.	Metal mouldings . . . . .	347
			129.	Method of forming flush joints . . . . .	347
			130.	Panelling in private office, Australian Walnut . . . . .	348
			131.	"Side-matched" and "book-matched" figured Oak . . . . .	354
			132.	Four methods of matching decorative veneers . . . . .	356
			133.	Rotary-cut Indian Silver Greywood . . . . .	358



FIG.	PAGE	FIG.	PAGE
133A. Quarter-cut Indian Silver Grey-wood . . . . .	358	165. Railway freight-cars lined plywood . . . . .	402
134. Sideboard of Period design Mahogany curls . . . . .	360	166. Angle gusset of plywood . . . . .	404
135. Sideboard in Bubinga . . . . .	360	167. Mock-up of Boeing aircraft . . . . .	405
136. Modern wardrobes . . . . .	362	168. Tip-up lorries . . . . .	408
137. Bedside fitment and tallboy in English Walnut . . . . .	364	169. Plywood boxes and cases . . . . .	410
138. Bedside fitment in English Walnut Burr . . . . .	364	170. Tea-chests . . . . .	413
139. Carpet showrooms in English Elm . . . . .	366	171. Decorative cigarette box . . . . .	415
140. Window-sole with moulded plywood . . . . .	367	172. Potato barrel . . . . .	416
141. Fitments in Sycamore . . . . .	368	173. Caterers' boxes and trays . . . . .	417
142. Lounge at fitting-rooms in Ash Burr . . . . .	368	174. Sitting-boxes . . . . .	419
143. Section of double blockboard, edged with Oak . . . . .	371	175. Pre-fabricated buildings . . . . .	420
144. A simple plywood partition . . . . .	373	176. Exterior sheathing of office building . . . . .	421
145. Built-in kitchen cabinets . . . . .	374	177. Exterior flush doors . . . . .	422
146. Kitchen fitment of simple design . . . . .	375	178. Details of concrete shuttering . . . . .	424
147. Silk case and parcels fixture . . . . .	376	179. Erecting concrete shuttering . . . . .	425
148. Fitments in departmental store . . . . .	376	180. Reverse moulds . . . . .	426
149. Venesta plywood container . . . . .	378	181. Filing-cabinet of plywood . . . . .	427
150. Curved fronts of display shelves . . . . .	378	182. Corner treatment . . . . .	430
151. Stage scenery . . . . .	380	183. Corner treatment . . . . .	430
152. Stage scenery . . . . .	380	184. Corner treatment . . . . .	430
153. Sand-blasted Oregon Pine . . . . .	381	185. Construction of radio cabinet . . . . .	430
154. Plywood-built submarine . . . . .	382	186. Treatment of edges . . . . .	431
155. Plywood "sets" for film "Sabotage" . . . . .	382	187. Balustrades, fielded and raised panels . . . . .	432
156. Cabin in cross-channel steamer . . . . .	384	188. Details of joints . . . . .	433
157. Detail of veneered ship's side-lining . . . . .	388	189. Details of joints . . . . .	433
158. Details of bulkheading and ship's side-lining . . . . .	390	190. Details of joints . . . . .	433
159. Details of ceiling construction . . . . .	392	191. "Backing-out" at corner posts . . . . .	433
160. Navigating bridge of "Resweld" plywood . . . . .	393	192. Ledger rack of plywood . . . . .	433
161. Auxiliary cruiser built of "Resweld" . . . . .	395	193. Sections through tops . . . . .	434
162. Plywood frames and stiffeners in speed-boat . . . . .	396	194. Construction of curved corners . . . . .	435
163. Details of fixing . . . . .	397	195. Detail of panelling . . . . .	436
164. Railway container . . . . .	402	196. Braced frame door . . . . .	437
		197. Sliding doors . . . . .	437
		198. Ceiling treatment . . . . .	437
		199. Drawer front . . . . .	437
		200. Detail through mirror and notice board . . . . .	437
		201. Edge treatment, flush doors . . . . .	438
		202. Isometric drawing of RGC door . . . . .	438
		203. Detail of settee-end . . . . .	438

## INTRODUCTION

SINCE the early days of civilization man has endeavoured to make the most of Nature's abundant store of wood—surely one of the most important forms of vegetable matter. Wood as it was obtained from the newly felled tree set the user many problems, the first being to convert the hewn log into a suitable form for constructional work. The evolution of the adze and the saw overcame this difficulty, bringing planks and boards into general usage. Then it became evident that a second and more serious problem had to be faced, that of continual movement ; there was expansion as the cell walls absorbed moisture and contraction as the moisture was given off. This eventually led to the process of seasoning, and it was recognized that many kinds of wood, before they could be used with any degree of safety for fine work, had to be kept in the seasoning yard in the form of planks or boards for some considerable time, even, in the case of certain hardwoods, for several years. The thinner the planks the more easily and more quickly was the proper seasoning of the wood effected. From the thin board to the sawn veneer was but a short step which led, many years later, to the mechanically sliced veneer, and later still to the rotary-cut veneer which can be looked upon as the foundation-stone of the plywood industry.

Every hour of the day the man-in-the-street comes in contact with plywood ; in his house, in train, bus or motor-car, in hotel or restaurant, in his office or business. Plywood is now a commodity of importance to every wood-working trade and is also of such general interest that the desirability of a text-book is manifest.

Much of the matter in this volume has been collected and compiled over a number of years prior to the international troubles of 1939. It was difficult to decide whether to complete the work or delay publication until a later date owing to inevitable changes in European producing countries which might materially affect the future of the plywood industry. After careful consideration, the former course was adopted notwithstanding the fact that much of what has been written, more especially in Part VII., may soon pass into the realm of history.

The manufacturing processes vary in different countries, but we have described those of most general importance.

It is hoped that the matter which follows will be of help to those engaged in the distribution of plywood, to designers, and to all interested in this most useful commodity.

“To produce good plywood one must have good wood,  
good glue, good equipment and good technique.”

*From Veneers and Plywood*

# PART I

## DEVELOPMENT

### CHAPTER I

### HISTORICAL

AN examination of the present-day lumber-core board of Finnish manufacture or of the typical 5-ply board so largely used in America will reveal little more than a development of the veneered panel which has been made by furniture craftsmen throughout the ages. Such veneered panels can be traced back to the days of the Pharaohs. During the excavations in Egypt under the late Mr. Howard Carter, many articles of furniture of historical interest were brought to the light of day. Of particular interest, from the plywood enthusiast's point of view, is a bedstead discovered in the tomb of Iouya and Touya, the grandparents of the wife of Tutankhamen. The headpiece, which is clearly built on the plywood principle, is veneered with Laburnum wood and inlaid with gold and jewels. How the wood was sawn or cut, how the glue has managed to hold the face veneers to the solid core for some thirty-five centuries, must ever remain a wonder to the modern woodworker. Another interesting specimen, from a royal tomb of the Third Dynasty, is a sarcophagus the sides of which consist of six layers of wood securely glued together. The outer coffin illustrated (Plate I.) is an excellent example of veneered woodwork of the XIIth Dynasty.

In the Egyptian supplement to *The Times*, published in January 1937, dealing with the investigation by the late Mr. Quibell into the excavation at the Step Pyramid of Sakkara, it is stated that "traces of a quite modern employment of plywood, and also of wooden panelling, were revealed."

One could cite innumerable pieces of furniture of historical interest by world-famous English and continental craftsmen of the eighteenth century—in particular by Thomas Chippendale, Thomas Sheraton and Jean Henry Riesener—which give ample proof of the lasting properties of plywood-built veneered furniture.

Frederick Robinson, in his *English Furniture*, writes of Chippendale: "His frets were no mere pierced planks, but consisted of several thicknesses glued together in different ways of the grain, until the result was ornament capable of withstanding climatic changes and the effect of time to an extraordinary extent."

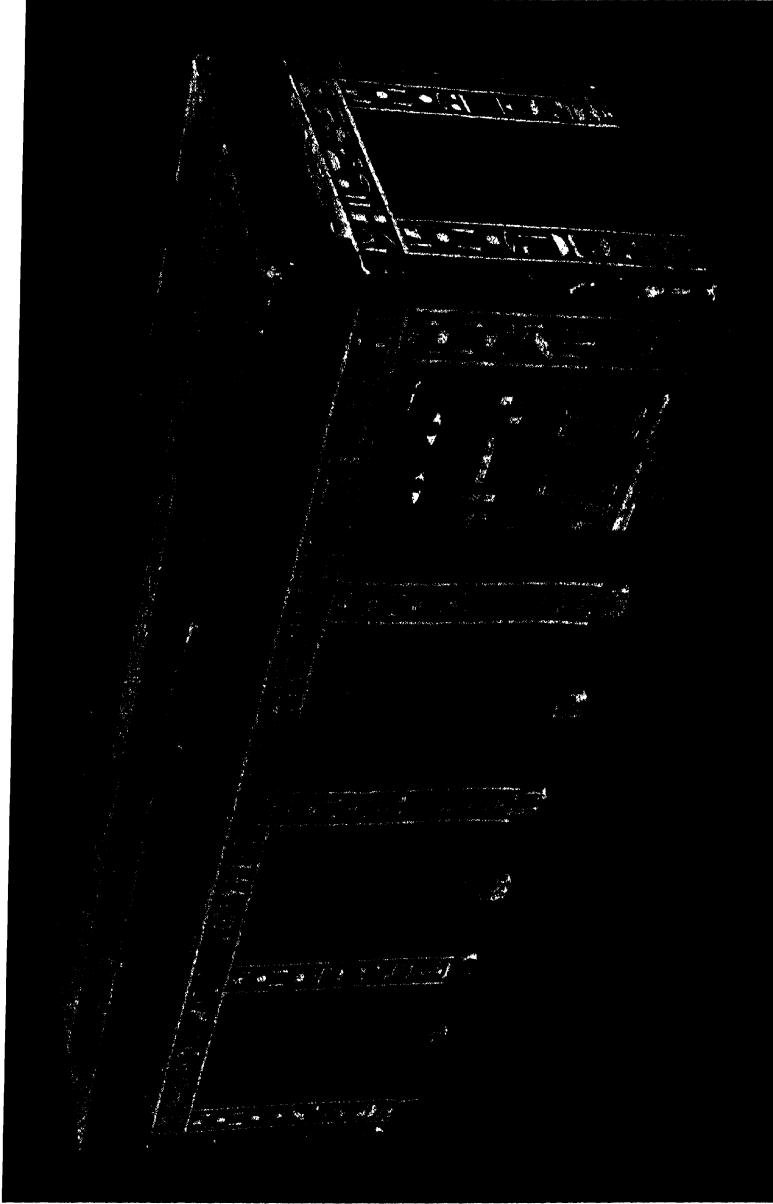

*By courtesy of Metropolitan Museum, New York.*

PLATE I.—OUTER COFFIN OF THE COUNT'S DAUGHTER NEPTHYS, FROM MEIR. XII DYNASTY  
(2000-1788 B.C.).

The coffin veneered with Cedar held in place by wooden pegs.

That renowned cabinet-maker, Riesener, spent nine or ten years in the building of his masterpiece, the "Cabinet of the King," for Louis XV. This magnificent and massive desk is veneered with the choicest of woods and was one of the famous exhibits to be seen in the Louvre, Paris.

A study of these ancient pieces will demonstrate that the natural defects of timber were fully recognized and there is little doubt that the lasting property of old-time furniture is a result (at least in part) of the application of the principle of cross-banding.

Towards the end of the eighteenth century T. Sheraton published a work called *The Cabinet-maker and Upholsterer's Drawing Book* in which he wrote, "and the panels are sometimes glued up in three thicknesses, the middle pieces being laid with the grain across, and the other two lengthwise of the panel to prevent its warping. The panels are, however, often put in solid stuff, without this kind of glueing." At a later date in describing an octagon library table he writes: "In the management of the doors of the niches it is advisable to glue them up in styles of hard and dry mahogany, one inch thick and two inches in width; and after being worked to their exact curve, to pin a slip of one inch thick mahogany lengthwise at top and bottom; the veneer being laid all over the ground and the work suitably cleaned off."

The craftsmen of the eighteenth and early nineteenth centuries put all their artistry and skill into the execution of each individual piece. In the building up of the cores of their panels every single piece of wood required careful selection before being sawn and jointed to its neighbours. Only when the cores satisfied the critical eye of the designer did he commence the even more intricate task of assembling the veneers of choice woods which he had decided to use for the faces of his work.

In this manner did the old masters build up their priceless pieces of furniture and in so doing they left behind them the idea of cross-banding for a future generation to improve upon and to produce eventually the typical twentieth-century commercial plywood.

Before proceeding to study the peculiar properties of plywood and veneer it may be interesting to consider the reasons which may have prompted the artisans in past centuries to choose veneer in preference to solid wood for the decoration of their masterpieces.

Pliny the Younger, for example, records that the wealthy Romans went to Greece and paid very high prices for great tables faced with veneers of rare Eastern and tropical woods. Why were these tables faced with veneer?

First and foremost the semi-precious character of many of the most beautiful woods must have had a restraining influence on those who would have used them in solid boards. To make the most of such valuable material it was cut into thin slices, and strength was given to

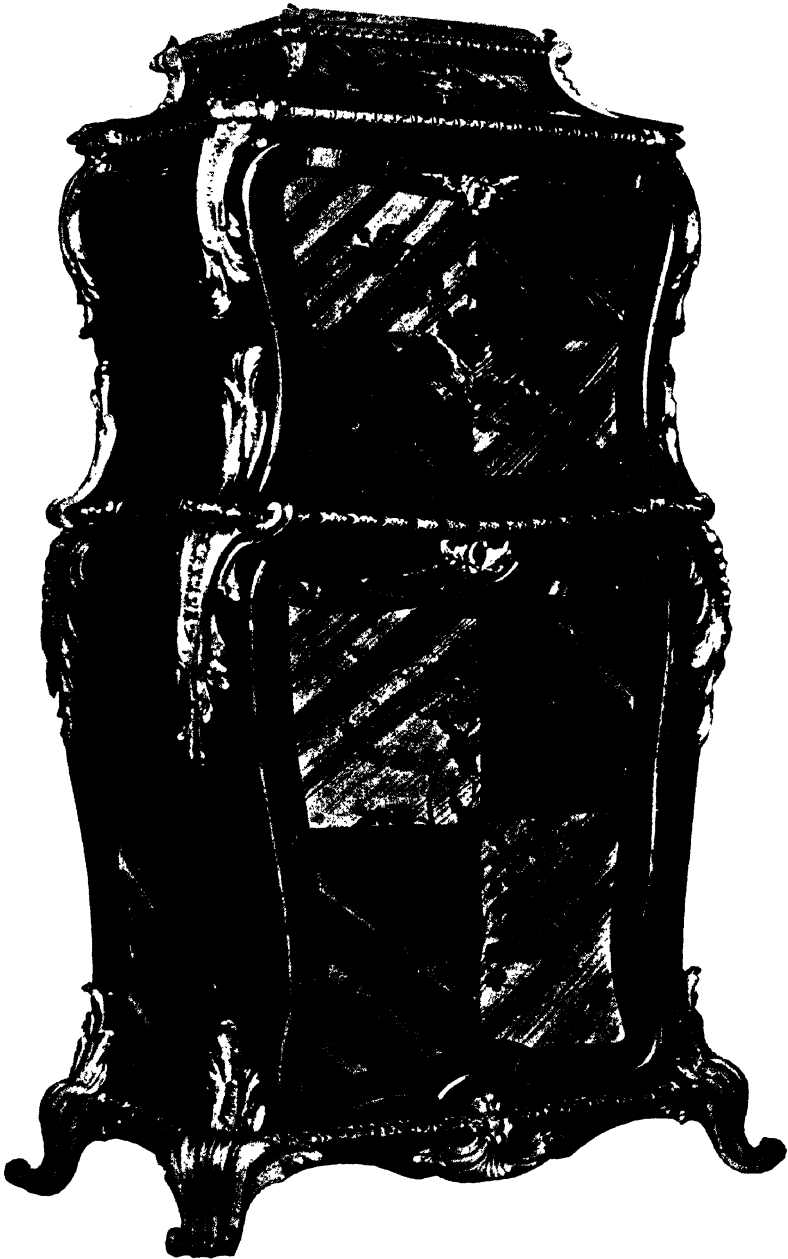

*Crown Copyright reserved.*

*[By permission of Victoria and Albert Museum.]*

**PLATE II.—PEDESTAL SECRÉTAIRE OF FRENCH WORKMANSHIP.  
(PERIOD OF LOUIS XV.)**

Tulipwood veneer has been used for the quartered panels, Olivewood for the delicate floral sprays and Padouk for the narrow banding surrounding the quartered panels. The interior is veneered with Kingwood.

these fragile slices by glueing them to a backing of unfigured but very good solid wood.

It was also apparent to these early craftsmen that many beautiful effects could be obtained by arranging woods of different colours with their grains running at varying angles to form geometric or symmetrical designs. Arrangements (such as those clearly seen in Plate II.) were only possible by virtue of the fact that woods were available in thin slices—the jointing together of thick boards would have presented insurmountable difficulties. These special arrangements of grain pattern led to what is nowadays known as “matching.” The impossibility of cutting two pieces of highly decorative wood of exactly similar appearance from different parts of the same log was apparent, but by sawing a board into two leaves and opening these up book-fashion a reasonably good match could be obtained. This led to the cutting of planks into very thin slices by a pit saw which made the most of the available wood.

In later years it was discovered that many beautiful effects were to be obtained by cutting across the irregular grain of a crotch or the distorted fibres of a burl. Such woods, if cut into boards, would distort, twist and crack to such an extent as to make them quite valueless as decorative material. In point of fact they can only be used in the form of veneer when supported by a rigid backing.

For generations the limitations of timber have been realized. For example, although it can generally be obtained in lengths to satisfy most requirements, it is restricted in width, while the difficulty in obtaining boards free from knots and of uniform grain and structure is known to all woodworkers.

Although the decorative value of veneer has been apparent from the earliest days of this civilization its merits in the commercial and utility sense were less generally appreciated until a much later date.

For many years the master cabinet-makers alone appear to have made use of the principle that strength was given to wood by glueing three pieces together, “the middle pieces being laid with the grain across.” During 1884 we find this same theory applied to the construction of chair seats. In this year a small factory was erected at Reval to manufacture seats for bentwood chairs from what must have been sawn or sliced Birch or Beech wood.

It was not until the invention of the rotary-cutter about 1890 that large sheets of veneer became available. It was then apparent that by using these veneers and applying to them this idea of cross-grained construction boards of exceptional size and strength could be built up. Some six years later plywood made primarily for tea-chests was evolved. The commercial 3-ply board followed shortly afterwards. It is wood



in the form of rotary-cut veneer which is used to produce present-day plywoods in such vast quantities.

During the early part of this century a number of factories commenced operations in various parts of Europe, some to meet the growing demand for 3-ply tea-chests and packing-cases, others to manufacture special boards for the cabinet-makers.

It is generally agreed that the Great War of 1914-1918 was, in the main, responsible for the very rapid advance made by aeronautical engineers from 1914 onwards. Aircraft factories required considerable quantities of thin plywood, and the development of the plywood industry kept pace with that of the aeroplane. Chemists throughout Europe and in America set about the task of evolving a waterproof glue, and it is questionable if plywood could have been the sound product it is to-day but for the intense research work crammed into these early days of the war.

In considering the matter which follows it will be helpful if readers will keep in mind the fact that there are two distinct types of veneer—the first used for purely decorative purposes and the second produced as one of the first steps in the plywood manufacturing process or used singly for other commercial purposes as will be described later in this volume.



*Crown Copyright reserved.*

*[By permission of Victoria and Albert Museum.*

PLATE III.

A beautiful Commode veneered with Harewood, inlaid with Satinwood, Tulip, Burr Walnut and Holly. An early example of curved work. About 1770-82.

## CHAPTER II

### DEFINITION OF VENEER AND PLYWOOD

**B**EFORE proceeding to a detailed description of the various processes employed in the modern veneer and plywood mills it may be advisable to establish the present-day definition of that much misunderstood word "veneer" and of the word "plywood." Other terms in common use in the plywood and veneer industries are defined in the Appendix on pages 439 to 444.

The words "veneer" and "veneered" even to-day give to many people an impression of some purely external show of good quality, leaving a consequent suspicion that any veneered work must be little more than an inferior substitute for solid wood. Until the advent of plywood the word "veneer" was used as often as not in reference to the rarer woods, as, for example, "a veneer of Burr Walnut," "veneered with Honduras Mahogany" and so forth.

Even as recent a publication as the 1931 Edition of *Chambers's Twentieth Century Dictionary* defines "veneer" as:—

"*v.t.*, to overlay or face with another and superior wood: to cover with a thin coating of any substance other than wood: to disguise with artificial attractiveness.—*n.*, a thin coating as of wood: false show or charm."

The idea of false show or charm has to some extent remained, but fortunately the newer meaning of the word is becoming more widely recognized. According to the *Shorter Oxford English Dictionary on Historical Principles*, reprinted in 1934 and edited by C. T. Onion, the word was first used as a verb in the year 1728, and is given as a later form of "finceer," from the German *Furni(e)ren*, French *fournir*—to furnish. The definitions are interesting, viz. :—

"1. *trans.*<sup>1</sup> To apply or fix as veneering: 2. To cover or face with veneer, 1742. *b. fig.*<sup>2</sup> To invest with a merely external or specious appearance of some commendable or attractive quality."  
2 *b.* "And onc the Master, as a rogue in grain veneer'd with sanctimonious theory.—TENNYSON."

To-day the word "veneer" has assumed a much wider significance and covers the thin sheets of wood which are obtained from any timber

<sup>1</sup> *trans.*—transitively.

<sup>2</sup> *fig.*—figuratively.

by one of the four methods of conversion employed by plywood manufacturers and veneer-cutters. The Second Edition of *Webster's New International Dictionary*, published in 1934, gives this modern conception of the word :—

“ 1. A thin sheet of a material : especially a thin layer of wood cut or sawed from a log ; specif. (a) a layer of a more valuable or beautiful material for overlaying an inferior one, esp. such a thin leaf of wood to be glued to a cheap wood ; (b) any one of the layers which are glued together to impart stiffness and strength to Plywood.”

The definition given by the British Standards Institution reads :—

“ Timber in the form of a thin layer of uniform thickness (produced by slicing, sawing or rotary cutting).”

The Forest Products Division of the U.S. Department of Commerce follow a similar line of thought in defining veneer as “ A thin layer of wood, usually a large sheet.”

An excellent description of the artistic veneer has been given by Mr. H. T. W. Bousfield in his booklet “ *R.M.S. Queen Mary : The Ship of Beautiful Woods.*” He writes : “ The term ‘ veneer ’ must not be misunderstood. A veneer is sometimes ignorantly imagined to describe a sham. In fact, a proper veneer is a thin layer of wood that must be either too delicate to be strong in bulk or, indeed, too rare and rich to be used at all, unless spread on some worthy substance (after all, one has to spread caviare on toast). A strong, tough wooden base of no artistic distinction is, therefore, covered by a thin layer of exquisite wood—as the pillars of the Temple of Solomon were overlaid with fine gold. If the beautiful woods you see on the *Queen Mary* were solid right through, half the forests of the world would have had to be devastated. . . .”

In the past veneer was used solely as a means of decoration, but if the modern conception of the word is kept in mind the stigma, which to the uninitiated is still attached to any veneered panel or piece of furniture, will soon disappear. As a knowledge of plywood manufacture and technique is gained it will be realized that well cut and matched veneer laid on a plywood base (Mr. Bousfield's “ worthy substance ”) is the most economical, as well as the most practical, method of producing large flat or curved surfaces of wood.

The origin of the word “ plywood ” is obscure, but at best it lacks any descriptive quality. It has been stated that the word originated in America, and this is probably correct as the earlier European description

of the first plywood boards was "three-ply," or as it was described in the classification list of the Mersey Docks and Harbour Board "Veneer Limed Boards." Laminated wood conveys to the mind of the woodworker a better idea of the common 3- or 5-ply board, while the French equivalent *contreplaqué* and the German *Sperrholz* have each the merit of being descriptive.

So far as we can trace, one of the earliest mentions of the word "plywood" in any standard dictionary appears in the Appendix of the 1931 Edition of *Chambers's Twentieth Century Dictionary*, as :—

"*n.*, a thin board made from three very thin layers of wood, the grain of the middle layer at right angles to the grain of the outer two, cemented together under pressure."

In the 1934 Edition of *Webster's Dictionary*, a more modern definition is given :—

"Wood made up of an odd number of veneer sheets glued together, the grains of the layers being (usually) at right angles to one another."

Mr. Onion, in the edition of the *Shorter Oxford English Dictionary* previously mentioned, gives the origin of the word as being "U.S. 1917 form of Ply (substantive 1 : 'layer or thickness') + wood."

"A compound wood made of three (five, etc.) thin layers glued or cemented together under pressure, and arranged so that the grain of one layer runs at right angles to the grain of any adjacent layer."

It will be noted that only *Webster's* of the three authorities quoted couples the term "veneer" with the construction of plywood.

In both Europe and America the word "plywood" is used by manufacturers and woodworkers alike to describe one of the several forms of board built up with rotary-cut or sliced-cut veneers of wood. These boards are generally classified into four main groups :—

- (1) Multiply construction in which an odd number of plies or veneers are glued together so that the grain of any one ply or veneer is at right angles to that of its neighbour or neighbours. In some cases multi-ply boards may consist of an even number of veneers, in which case the two centre plies are glued together with the grain of the wood running in the same direction.

- (2) Laminboard construction in which the core is built up with slats of veneer or thin wood not exceeding 7 mm. wide glued to each other and laid at right angles to the grain of the outer plies.
- (3) Blockboard construction in which the slats of veneer used in laminated boards are replaced by blocks of wood not exceeding 1 inch wide.
- (4) Battenboard construction is very similar to blockboard, but the core is formed of battens up to 3 inches wide in place of the 1-inch blocks. This is known as Lumber Core in America.

SECTIONS OF VARIOUS CONSTRUCTIONS



3 equal ply construction.

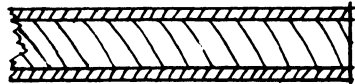

3-ply stout heart.

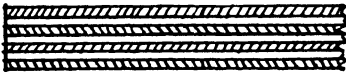

7-ply construction  
typical of Finnish Birch.

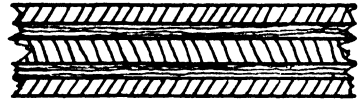

5-ply construction with thick outer plies  
for Bobbins.

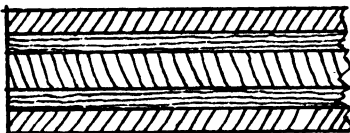

5-ply construction  
typical of Douglas Fir.

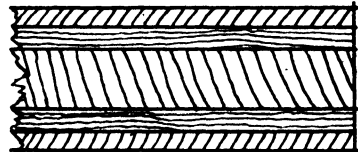

5-ply construction—stout heart.

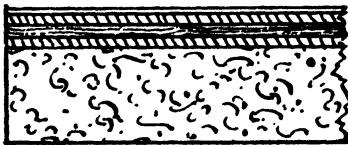

COMPOSITE BOARD.

$\frac{1}{4}$ -in. Insulating Board faced with 3-ply Birch veneered on face.

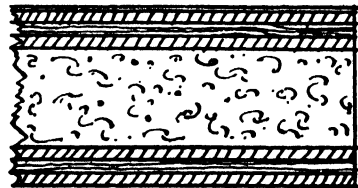

COMPOSITE BOARD.

$\frac{1}{4}$ -in. Insulating Board faced on both sides with 3-ply birch. Veneered on one side only.

FIG. 1.

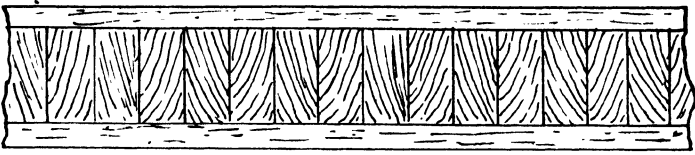

LAMINATED BOARD OR LAMINBOARD  
LAMINATIONS NOT EXCEEDING 7 M/M

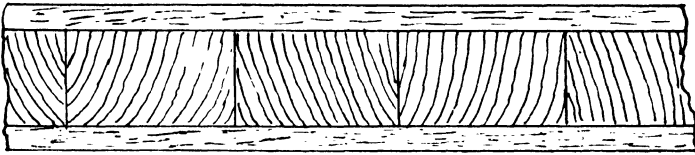

BLOCKBOARD  
BLOCKS NOT EXCEEDING 1 INCH WIDE

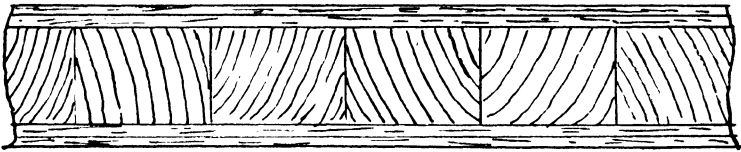

FINNISH TYPE OF BLOCKBOARD  
BLOCKS ABOUT  $\frac{5}{8}$  INCH WIDE

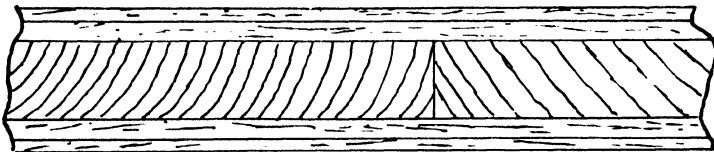

BATTENBOARD OR LUMBER-CORE BOARD  
CORES NOT EXCEEDING 3 INCHES WIDE

FIG. 1.

## CHAPTER III

### SOURCES OF SUPPLY

**E**FFICIENT and costly plant operated by highly trained personnel is necessary to produce good veneer.

Two distinct types of veneer are manufactured. The first from round logs cut on the rotary-cutter for the fabrication of plywood, cheese and cigar boxes, fruit baskets, barrels and match splints. The largest user of rotary-cut veneer is the plywood manufacturer.

The latter invariably cuts his own non-decorative veneers, and is concerned with the production of the largest possible quantity of sound veneer from any one log. Rotary-cutters are used in the plywood factory, as this is by far the quickest and most economical means of producing veneer from the round logs.

The woods in general use in European plywood mills are of the less expensive varieties, such as Alder, Ash, Beech, Birch, various Pines, Okoumé and several varieties of West African timbers. In North America the largest quantity of multi-plywood is manufactured from Douglas Fir.

The second type of veneer is cut from rarer woods received in the form of logs, roots, stumps, burls, burrs or crotches. The cutting of these valuable woods is an art demanding much care and thought as to the method of sawing in order that the best possible figure be revealed. Some may be sawn, some sliced, and some cut on the stay log or half-round cutter. The choice of method will depend upon the nature of the wood to be cut and the type of veneer desired. A few species, such as Maple, are cut into decorative veneer on the rotary-cutter.

These decorative veneers are sold to plywood manufacturers and to makers of furniture and architectural woodwork, to shipbuilders and other branches of the wood-working trade.

Several manufacturers produce plywoods faced on one or both sides with decorative woods, such as Oak, Walnut and Mahogany. Where the output is small the face veneers are purchased from veneer-cutters: where the output is large a slicer is generally installed to supply the face veneers for this part of the production.

Plywood mills, in common with the lumber and pulp industries, rely upon the forest for their raw material and are generally established in centres around which logs are available in good quantity and quality, or to which timber can be brought cheaply.

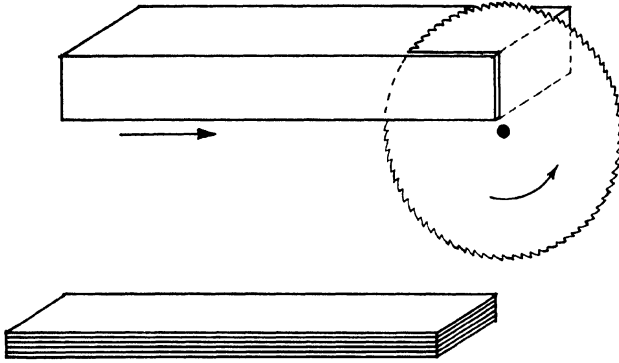

SAWING

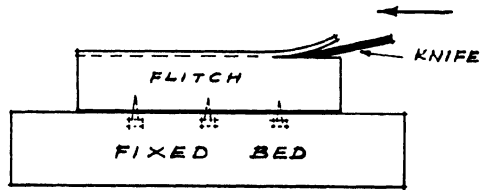
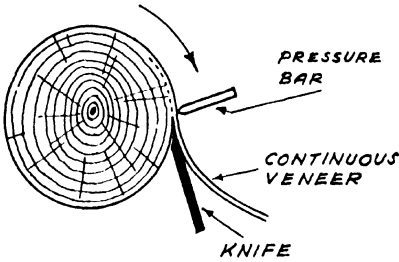

ROTARY CUTTING

HORIZONTAL SLICING

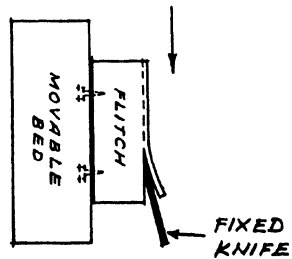
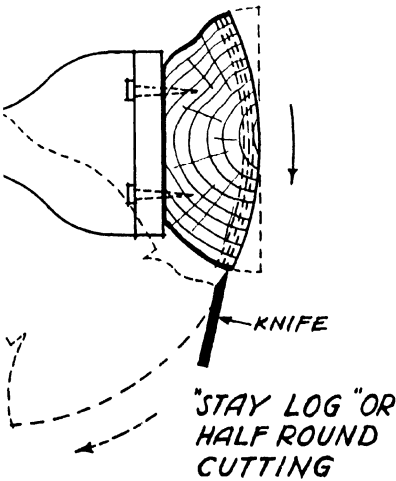

VERTICAL SLICING

[With acknowledgments to "The Veneer and Plywood Industry of Queensland."]

FIG. 2.—METHODS OF CUTTING VENEER.



The cost of carriage is an important item in the price of the logs at the mill and, as water is one of the most economical means of transporting timber, the ideal site for a plywood mill is on the bank of a river or lake having direct access to the source of the raw material. This makes it possible to float logs from the forest direct to the mill.

Good transport facilities should also be available to ensure the rapid distribution of the finished product and, as practically every plywood mill of importance in Europe relies upon the export trade to take up a considerable part of its production, good connexions with the main shipping ports are a most important consideration.

The Birch, from which most of the plywood consumed in Britain is made, grows in a broad belt extending from the Baltic into Central Russia. In this area will be found all Birch factories of importance. Finland, with its rocky soil and ample waterways, produces a silky-textured timber from which some of the finest Birch plywood is manufactured. Important Birch mills are also situated in Estonia, Latvia and the U.S.S.R.

Farther south, in the lower-lying and somewhat marshy lands, Alder grows at its best, and this wood feeds factories in Poland, White Russia and Lithuania. Beech is available in quantity in Roumania and Czechoslovakia, and in these countries much plywood is manufactured from this, their native tree. Norway and Sweden produce plywood from Pine and Spruce.

Douglas Fir (Oregon Pine) is manufactured into plywood in very large quantities on the western seaboard of the U.S.A. and Canada, while in the Mid-Western, Eastern and Southern states of America the veneer-cutting and plywood industries are also developed to a high state of efficiency. Japanese factories produce plywood from their domestic timbers, Oak and Sen, and also from Lauan, which is imported from the Philippines, and Serayah, an almost identical wood originating in British Borneo. There is a flourishing industry in Australia which has ample supplies of raw material to draw upon: the timbers chiefly used are Hoop Pine, Silky Oak and Queensland Walnut.

Okoumé (Gaboon Mahogany) is a most suitable wood for plywood manufacture; it has a mild, even grain, lends itself to easy cutting on the rotary-lathe and is obtained in logs of large girth and good length. It is shipped from the West Coast of Africa, and Gaboon plywood mills—which as a general rule produce several types of plywood—are found in many countries with direct or easy communications with the West African ports. The leading Gaboon plywood mills are situated in France, Germany, Holland, Switzerland,

Spain and Norway. Within recent years factories have commenced operations in England.

The chief types of plywood produced in European mills are :—

- (1) Multi-ply Boards of 3 or more plies.
- (2) Laminboards.
- (3) Blockboards.
- (4) Composite Boards, *e.g.* multi-ply, laminboards or blockboards faced with knife-cut veneers of rarer woods, or combined with metal, Asbestos insulating material and so forth.

The requirements of the British market in the first three constructions are, generally speaking, manufactured abroad. English factories, however, contribute a proportion and produce Gaboon plywood, laminboards and blockboards, Birch aircraft plywood and composite boards, in ever-increasing quantity and excellent quality.

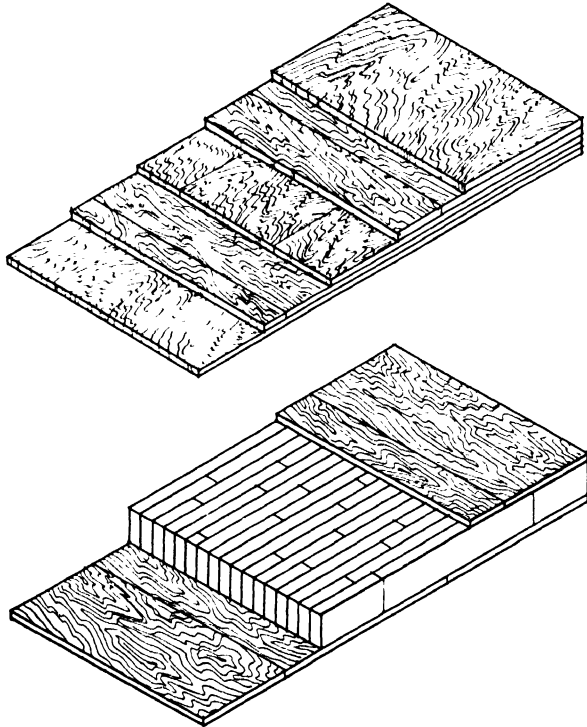

FIG. 3.

Isometric drawings showing construction of (*upper*) five-ply board ; (*lower*) laminboard.

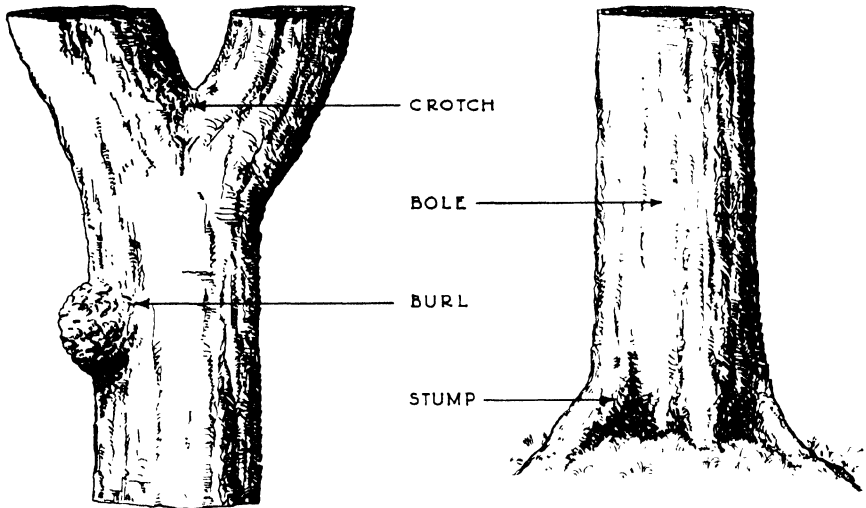

FIG. 4.

**PARTS OF THE TREE USED BY PLYWOOD MANUFACTURERS  
AND VENEER-CUTTERS.**

**BOLE.**—Straight and cylindrical Boles are valued by plywood manufacturers for rotary cutting, and are known as “peeler logs.” Boles may also be sawn or cut on the slicer, producing “flat-cut” or “quarter-cut” veneers.

**BURL.**—Burls are wart-like protuberances which appear on certain trees. They present contorted grain when cut on the slicer. Known also as Burrs.

**CROTCH.**—Formed by the junction of two large limbs or at the fork of the main trunk. Crotches are sawn or sliced and produce veneers of great beauty, generally known as Curls.

**STUMP.**—That part of the tree where the Bole enters the ground. Generally cut on the slicer or “stay log.”

## PART II

### PHYSICAL PROPERTIES OF WOOD AND PLYWOOD

#### CHAPTER 1

##### (a) THE STRUCTURE OF WOOD

**A** KNOWLEDGE of the structure and physical characteristics of wood is essential to a proper understanding of the general properties of plywood, so it is advisable to explain in as concise a form as possible the matters of chief interest.

Wood is not a homogeneous structure like steel or cement, but is composed of a very large number of elements such as fibres, vessels, rays, resin ducts, etc. These can be traced to run either axially or radially, and can be viewed with varying degrees of clearness on either transverse, radial or tangential surfaces.

(1) **AXIAL** : The great majority of the elements are arranged side by side, forming a structure which may be compared to a long bundle of fibres or straws tied and glued together. In hardwood the elements are usually thick walled, while in conifers the wood is chiefly composed of thin-walled tracheids ; these longitudinally placed elements give the chief mechanical strength to the structure.

(2) **RADIAL** : *i.e.* running at right angles to the axis. The radial elements are chiefly medullary rays which are composed of parenchyma cells. They are essential features of the anatomy of both softwoods and hardwoods and give much of the character to radially cut timber. In the case of the Oak they appear as large, hard glossy plates, while in the Beech they are much narrower.

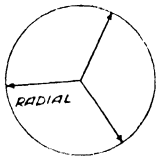

FIG. 5.

In conifers they are hardly visible to the naked eye, but give the beautiful silky appearance to freshly planed surfaces.<sup>1</sup>

(3) **TANGENTIAL** : *i.e.* direction at right angles to the radial ; although the annual rings of a tree are arranged tangentially, the fibres of which they are composed do not run in this direction.

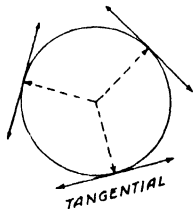

FIG. 6.

<sup>1</sup> It may be explained that if a log could be cut exactly along the medullary rays these would appear as straight plates. As the rays are never straight, either radially or axially, they appear in the form of flecks so typical of Beech or the "chamf" of Oak.

The growth of the tree is the result of the multiplication of tiny cells, each of which fulfils some distinct purpose. These cells lie immediately under the bark and constitute what is known as the cambium layer. Some form roots, others develop that intricate system of communication which conveys water and dissolved minerals from the roots to the tree. By energy derived from sunlight, atmospheric Carbon Dioxide is synthesized with water in the leaves. Oxygen is expired and the Carbon retained to form sugars which are distributed with the sap throughout the living tree and lead to the formation of cellulose and lignin in the form of new cells, which eventually add to the mass of roots, leaves, bark or timber.

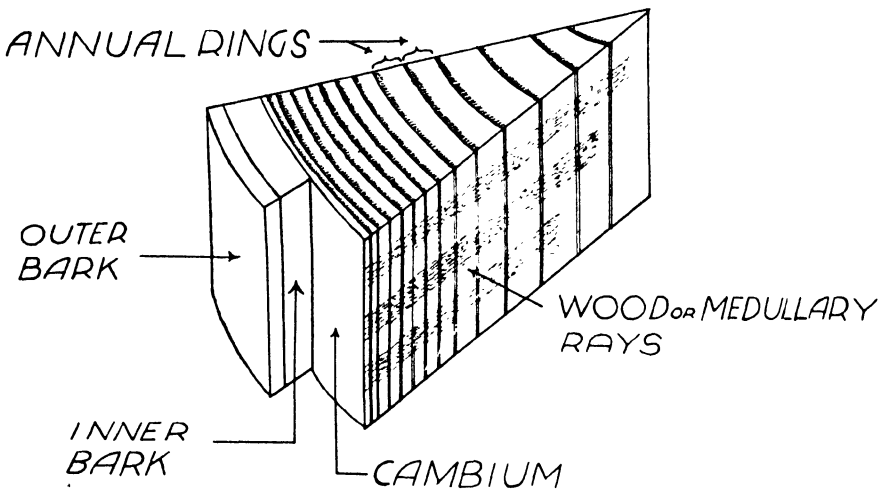

FIG. 7.

The girth of the tree is increased by the formation of successive layers of cellular tissue, one fresh zone being added to the outside of the tree every year. In the spring the cambium which lies immediately under the bark becomes active and, with sap rising in the tree and sugars descending from the leaves, new cells are added to the outer layer of the sapwood. The cells produced towards the end of the growing season in some species, *e.g.* the Pines, are flatter than those formed during the spring, the walls of the cells being therefore more closely packed together. Thus the springwood is more open in texture than the autumnwood which is more dense, and the contrast produces a visible circular zone known as the "annual ring." The annual rings visible in some other woods are formed in quite a different way; for example in the Oak, a *ring porous wood*, a layer of large pores formed in the

early spring is followed in the summer and autumn by an area of dense thick-walled elements. Owing to the presence of these circular rows of large pores the annual rings are again quite conspicuous.

In other species like the Birch and Sycamore, *diffuse porous woods*, the pores are scattered more or less throughout the whole seasonal growth. In consequence the annual rings of these species are indistinct.

It will be noted that visible rings are due to seasonal (annual) growth, consequently those trees which flourish in some tropical climates which have little or no seasonal changes grow uniformly and show no distinct annual rings.

### (a) CHIEF CHARACTERISTICS OF WOOD

The figuring of many woods (Walnut and Douglas Fir are excellent examples) is largely due to the development of these annual rings. If trees grew as perfect cylinders with perfectly straight trunks and with all rings of the same size each year the boles when cut into veneer would disclose a regular and uninteresting pattern, as demonstrated by Fig. 8. To the satisfaction of the lover of wood such conditions do not exist; the growth of trees is influenced by various factors; viz. their position in the forest, the quality of the soil, rainfall, exposure to severe winds and sun, general climatic conditions and so forth. The buffeting of storms and the constant swaying of the trees may result in twisted grain fibres. A blight may cause retarded growth during one season, which will be reflected in the wood as a narrow annual ring, while excessively wet or sunny weather during another season may result in more rapid wood formations producing a wider ring. The rings are usually larger on the warm sunny south side of the bole, a factor which still further deflects the bole from the true cylinder.

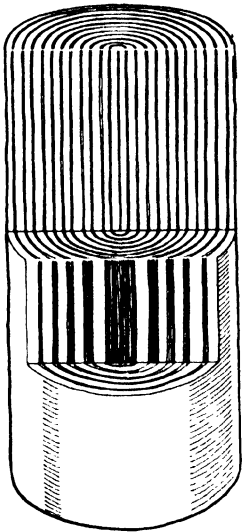

FIG. 8.

Thus, during the life of a tree, the formation of the annual rings varies to a marked degree and this irregularity of growth causes many diversions of vessels, interlocking of fibres, or irregular grouping of wood parenchyma, factors which all have their individual effect on strength, figure and stability. The annual rings are consequently not true circles.

The outer annual rings of the tree form a living area containing much

sap which is usually light coloured and is known as the sapwood. As the annual growth develops, a number of the innermost zones of the sapwood cease to function and become added to what is known as the heartwood, which is quite dead.

In certain species, of which French Walnut and Ebony are good examples, the deposition of chemical matter in the heartwood results in a marked distinction between the colour, weight and durability of

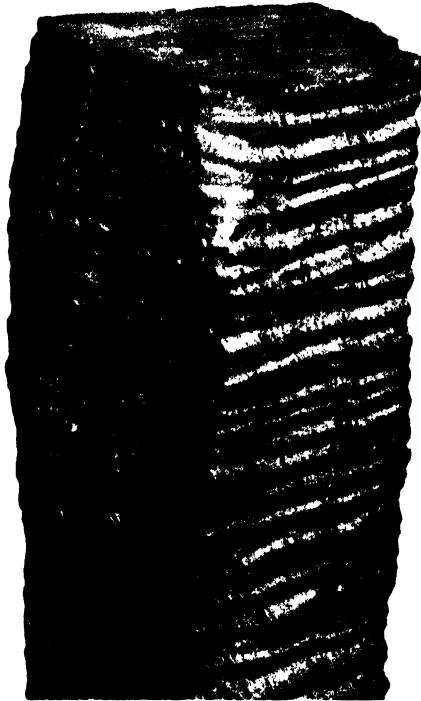

FIG. 9.

A piece of Sycamore split radially and tangentially to show the undulating arrangement of the wood fibres.

this part of the structure as compared with the living sapwood. It may be of interest to some readers to note that Black Ebony is merely the heartwood of the tree which is surrounded by a very much wider area of uncoloured sapwood which to the eye has all the appearance of Boxwood. In some trees the distinction between sapwood and heartwood is not visible for the reason that no colouring matter has been deposited in the latter. These variations in the composition and colour of annual

rings, heartwood and medullary rays all have their effect on the figuring of the timber.

The beauties of Queensland Walnut and a few other woods come from the sharp variations in the depth of colour of the annual rings.

Oak and Beech have already been mentioned as typical examples of woods having clearly defined medullary rays.

Undulating layers in the boles of Maple, Sycamore and Mahogany and the spiral growth of annual rings so prominent in Sapele Mahogany are other factors of importance in the development of figured wood.

The practice of pollarding or polling Walnut and Oak trees by cutting off the top branches is but one means of artificially stimulating irregular growth. Such woods, however, are of more concern to the veneer-cutter than to the plywood manufacturer.

The sections reproduced in Figs. 9, 11 and 15 were kindly lent by the Forestry Department, University of Edinburgh.



## CHAPTER II

### MOISTURE IN WOOD

WHEN a tree is felled it contains a large quantity of water both in the cell walls and within the cells themselves, and it is a well-known fact that before any freshly cut timber can be used for interior work it must be dried. One of the chief characteristics of wood of prime concern to every woodworker is that during this essential drying process it shrinks in volume. Unfortunately it does not do so uniformly as would a sheet of moist hide glue, but more unfortunate still the movement does not stop even when the wood is dry. This is due to the fact that it is hygroscopic, that is to say it is able to absorb or give up moisture according to the humidity of the surrounding atmosphere. For example, if a piece of very thin moist wood be placed in a dry room it will gradually lose both moisture and weight until, after several hours, it becomes stable. The moisture content is then in equilibrium with the humidity of the surrounding atmosphere. If the same piece is taken into a moist atmosphere, the process will be reversed.

The moisture of wood consists almost entirely of water although it may have minerals, sugars, tannins and other chemicals dissolved in it.

The water may exist in two distinct forms :—

- (a) in the form of “ free water ” which is contained within the tiny cavities of the cells ;
- (b) as “ imbibition,” or “ hygroscopic ” moisture which is actually absorbed by the walls of the cells, in a manner which has not yet been finally determined.

Under suitable atmospheric conditions the wood will “ dry out ” and at a definite stage in the drying process the cells will have parted with all their “ free moisture,” the cell walls retaining their full quota of “ hygroscopic ” moisture ; this point is known as the “ Fibre Saturation Point.” A lecturer in botany once explained this process to his students by using a simple analogy comparing the wood cells to the Indian chatty.<sup>1</sup> When the chatty is filled with water the bulk is contained

<sup>1</sup> The chatty is a porous earthenware vessel used in India for keeping water cool during the hot weather. This it does by the slow evaporation of surface moisture, which percolates through to the outer walls of the vessel. The analogy would have been complete had the vessel been made of hide glue or gelatine, in which event the walls of the vessel themselves would have expanded or contracted.

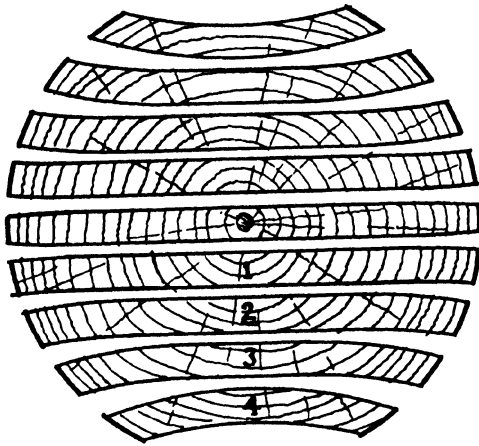

FIG. 10.

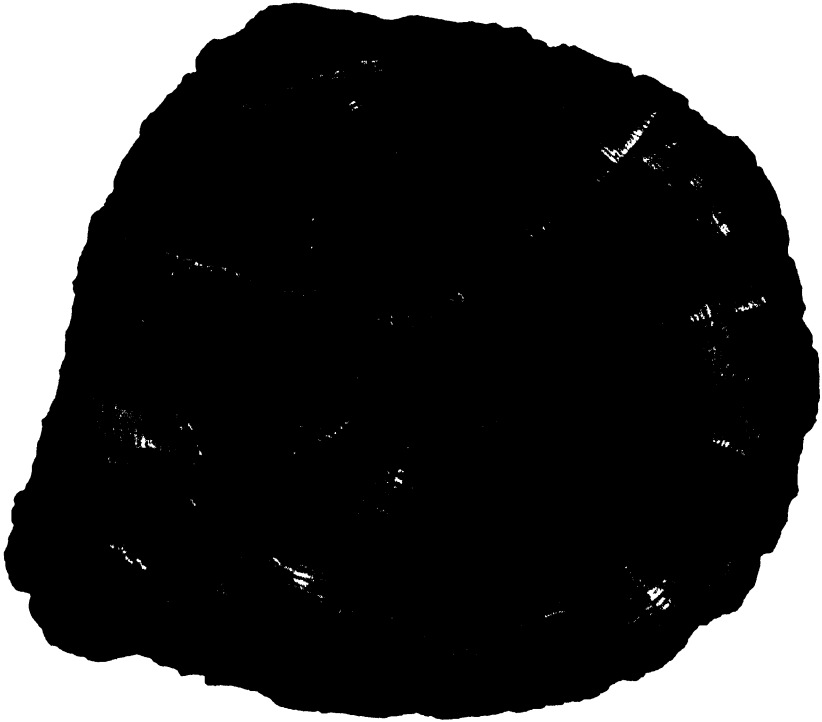

FIG. 11.

within the vessel itself, but a certain quantity is also absorbed by the sides and bottom. The bulk can be compared to the "free water" in the wood cells; that absorbed by the earthenware to the "hygroscopic" moisture. Water can be poured from the vessel without alteration to the quantity absorbed in its walls, but when empty the walls will gradually dry out; so it is with wood. The point at which the vessel becomes empty while the walls remain fully saturated is analogous to the "Fibre Saturation Point."

It is not known with any certainty how "hygroscopic" moisture is absorbed by the wood cells, and it is not of vital interest to us. It is important to note, however, that when timber is dried below fibre saturation point the cell walls alter their form as "hygroscopic" moisture is given up, the change being accompanied by a reduction in the volume of the cells and consequently of the wood.

This reduction of volume, commonly called shrinkage, shows a marked difference in the longitudinal, radial and tangential directions. When drying from green to air dry, wood shrinks about 0·1 per cent. of its original length, longitudinally; from 3 to 5 per cent. in the radial direction, along the medullary rays; and as much as 6 to 15 per cent. tangentially, around the annual rings. It will be apparent that for all practical purposes the axial shrinkage can be disregarded, but in a piece of timber—whether this be used for a table top or a beam—this radial and still greater tangential shrinkage is of the utmost importance and is the cause of many troubles experienced in timber seasoning and of the inevitable twisting and warping of wood.

Fig. 10 indicates how planks twist according to their position in the tree from which they have been sawn. It will be noticed that the centre board has shrunk more at both ends than in the centre, the reason being that the shrinkage at the centre is only 3 to 5 per cent. as compared to 6 to 15 per cent. at the outside of the log. The boards numbered 1, 2, 3 and 4 have all shrunk to a greater degree on their lower surfaces for the reason that these are more tangential than the surfaces cut nearer the heart.

The effect of shrinkage on a cross-section of a Douglas Fir tree is illustrated in Fig. 11. This happens to a greater or less degree in all species and is the reason why valuable Oak logs have to be cut into fitches before being shipped.

The timber merchant when seasoning timber endeavours to minimize this damage by stacking his freshly cut boards with pins between, and although boards so imprisoned may dry flat they are likely to twist immediately they get a chance to absorb or give up more moisture. This frequently happens when air-dry timber is used for outside window

frames or doors or for facings and furniture in a centrally heated building.

The various directions of the wood fibres of a piece of rotary-cut veneer in relation to their original position in the growing tree are demonstrated in Fig. 12. If we apply the loss of volume just described to any rotary-cut veneer we shall find that the greatest change will be in its width. For example, a piece of rotary-cut Gaboon veneer as it comes from the lathe clipped to 108 cm. wide will measure no more than 100 cm. when in a perfectly dry state. To a smaller degree the veneer will lose in thickness, whilst there will be practically no shrinkage in the length.<sup>1</sup> These facts are of great importance to the plywood manufacturer and are referred to in the following chapter.

Other properties of wood are also affected. As wood passes from fibre saturation point to a commercially dry condition, hardness and

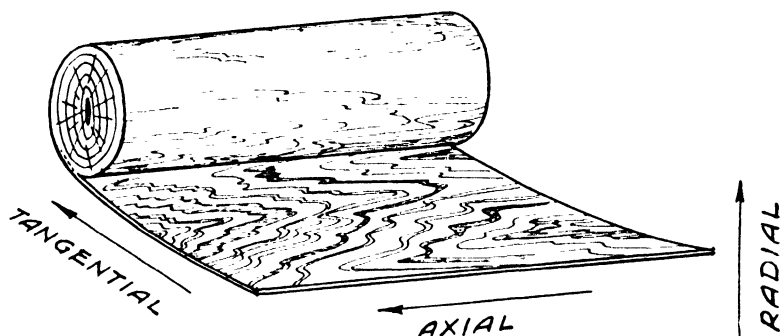

FIG. 12.

strength are notably increased—the gain in strength being as much as fourfold.

Dry wood is a bad conductor of electricity, the moisture in very wet wood is an excellent one. This variation in electrical resistance offers a means of determining moisture content, and several electrical devices for this purpose have been produced and are available.

The moisture content of timber is nowadays expressed as a percentage of the dry weight, and is easily determinable. To give a simple example: if a piece of wood weighing 20 ounces is dried in an oven at a temperature of 100° C. until the weight remains constant at 15 ounces, it will be obvious that it has lost 5 ounces of water. Its 15 ounces of dry wood had contained 5 ounces of water, viz. one-third of its dry weight =  $33\frac{1}{3}$  per cent.

<sup>1</sup> It should be noted that when reference is made to the length of a veneer or plywood panel the dimension along the grain of the wood is indicated.

The moisture content can be found by the following formula.

To ascertain the moisture content as a percentage of the dry weight :—

$$\frac{(MW - DW) \times 100}{DW} = MC \text{ per cent.}$$

MW = Moist weight. DW = Dry weight. MC = Moisture content.

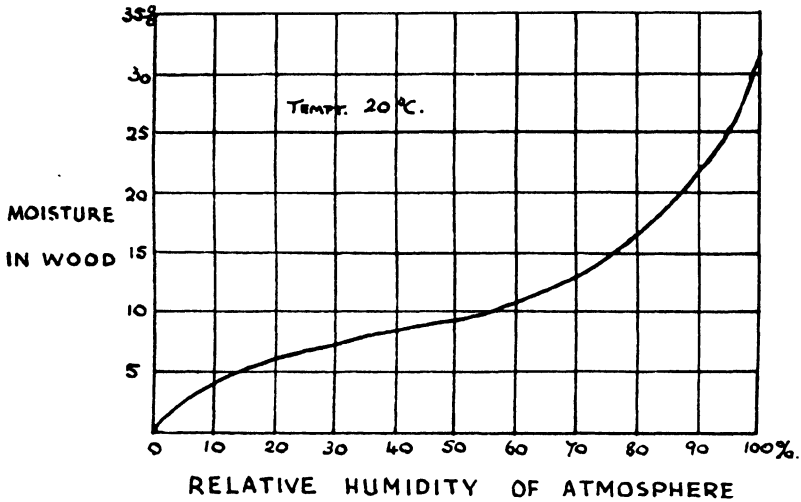

FIG. 13.

The humidity of the atmosphere, on the other hand, is expressed in percentage of humidity, *e.g.* where the air is fully saturated (as will be the case in heavy mist) the humidity is recorded as 100 per cent. ; when the air is dry, as 0 per cent. The moisture content of any piece of timber varies according to the humidity of the atmosphere, and the relationship of these two factors is shown on the above graph. Different species of wood show minor variations, but taking an average of the timbers in common use a relative atmospheric humidity of 40 per cent. is reflected in the wood by a moisture content of 8 per cent. ; of 100 per cent., by 32 per cent.

## CHAPTER III

### (a) CHIEF CHARACTERISTICS OF WOOD

IT is a well-known fact that timber possesses many remarkable properties which have made it the most desirable and popular medium used in the construction of furniture, fittings and general joinery work.

It is stronger for its weight than many other substitutes, is a bad conductor of heat and consequently is much more "friendly" to the touch, when used in articles of household or office furniture, than metals or synthetic materials. Its expansion under heat is infinitesimal. Wood is very strong under tension or compression, and were it a homogeneous structure there would have been to hand an ideal material combining lightness and strength. Unfortunately, owing to the manner in which the fibres are arranged axially, it is very easy to split it along the grain. The fibres cannot be split across the grain, nor do they part so easily in the tangential direction as they do in the radial, in fact to be parted in the tangential direction they must be cut. Furthermore, wood is less able to resist a shearing force applied axially than when a similar force is applied across the grain.

When a plank of wood is bent the wood fibres on one face (the concave side) are compressed and a tension corresponding to this strain is set up on the convex surface. As pressure is continued the deflexion of the plank is proportional to the load until a certain point is reached when the deflexion increases more rapidly than the load and fracture occurs, generally on the convex face. The tension and compression commence on either side of a point at the centre of the plank, increasing gradually to reach a maximum on opposite surfaces.

An interesting experiment can be made to prove this theory by gluing two hardwood veneers about 1.5 mm. thick to each side of a piece of pulp or fibre board. The result in the direction of the grain of the veneers will show a remarkable increase in the resistance to bending, approaching that of a solid board of equal thickness. If a thin sheet of 2-ply (the veneers at right angles to each other) instead of a single ply had been glued to either side of the fibre board this remarkable increase in strength would be shown no matter in which direction the wood was bent. This is a factor of great importance to remember when considering the structure of plywood.

The weaknesses of wood may be summed up thus :—

- (1) Liability to split axially.
- (2) Continual movement in size and shape with any change of humidity in the surrounding atmosphere.
- (3) Failure to resist shear.

By manufacturing wood into plywood these weaknesses are overcome.

### (b) CHARACTERISTICS OF PLYWOOD

The introduction of modern plywood as a commercial article has revolutionized the use of timber. Plywood has overcome the shortcomings of solid timber already mentioned by making full use, in a scientific manner, of its advantageous properties. By building wood up in laminations it gains greatly added strength both along and across its grain, a piece of well-made plywood being considerably stronger in all directions than the sum of the strength of the plies measured individually.

Furthermore, if it is to shrink or expand it must do so equally in both directions, and even this movement is restricted to the expansion or contraction of the longitudinal fibres of which it is composed and which as has already been stated is almost negligible.

In its most simple form—the 3-ply board—a veneer is glued to each side of a core, the grain of each outside ply being laid at right angles to that of the inner core. As balanced construction is absolutely essential to the building of all sound plywood, these two veneers must be of the same thickness and of the same species—otherwise unequal movement may result in twisting. If a stouter board is required, the thickness of the core can be increased or, as is more often the case, two additional outer veneers can be added to the mass, thus forming the typical 5-ply board. The grain of these additional veneers will run at right angles to their immediate neighbours. In a similar manner the number of plies can be increased to 7, 9, 11, 13 and so forth, until the desired thickness is obtained.

Let us now take three points mentioned above and consider these factors in relation to the symmetrical construction of a typical plywood board.

1. (a) The crossing of the grain of each adjacent veneer gives to plywood the greatest possible strength in both directions. As the number of plies are increased, the mass gains in strength until in a 7-ply board,  $\frac{7}{8}$  inch thick, the resistance to bending is practically equal in both directions of the grain.

(b) This cross-grained construction also obviously adds greatly to the resistance to splitting—a point of great value when we consider the placing of nails, screws or bolts close to the edge of the board, as is well demonstrated by Fig. 14.

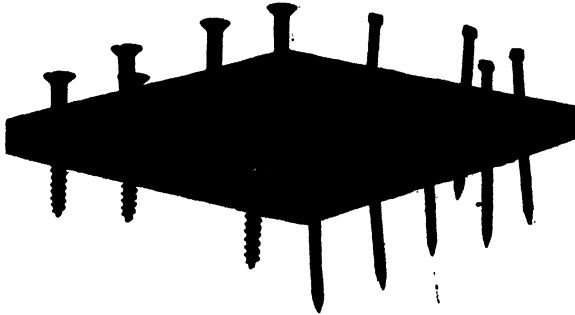

FIG. 14.

2. (a) We have explained how any rise in humidity causes expansion in veneer in a tangential direction, but has little practical effect along the grain. How do these factors concern us when the veneers are glued together into a 3-ply board? Left to itself the core would expand in width, but this movement is now restricted owing to the fact that it is firmly glued to the face veneers which in the axial direction are not affected by the change in humidity. The face plies are, therefore, subjected to a considerable tension. Conversely, normal movement in the tangential direction of the outer veneers is restricted by the axial grain of the central core which is thus subjected to tension while the outer plies are put under compression. To sum up, therefore, expansion or contraction in a 3-ply board is restricted by its cross-banded construction and the "working" of wood is greatly reduced, not exceeding the normal movement of wood in the axial direction, which is insignificant. In actual practice a 3-ply board, 60 inches wide, even when exposed to damp will not expand more than  $\frac{1}{16}$  inch.

These observations are all subject to the very important condition that the plywood should be well glued, as the glue line must be able to withstand the strains and stresses caused in the plywood board by any marked change in humidity.

(b) Plywood will "work" in its thickness, viz. in the radial direction of the wood if rotary cut, but this movement is small and, as the bulk of plywood is under 1 inch thick, for most practical purposes any movement can be disregarded. In the case of a  $\frac{1}{2}$  inch board, for



example, expansion or contraction will not exceed  $\frac{1}{100}$  inch in the thickness.

3. Provided the veneers have been securely glued together, the construction of plywood greatly increases the resistance to shear in a longitudinal direction. Good glue, in so far as it penetrates the wood, gives strength to each veneer and in a multi-ply board the effect of the glue has quite an appreciable influence on the resistance to shear and splitting. In the case of synthetic resins penetrating the veneer they act as a protection against decay, in addition to giving added strength to the structure.

### (c) HOW VARYING FIGURE IS DISCLOSED WHEN LOGS ARE CUT INTO VENEER

It is well known that the appearance of veneer produced from any particular wood will vary enormously according to the method of conversion, a rotary-cut veneer having a very different appearance from one produced by the saw or slicer. Although rotary cutting is the more economical method and yields much larger veneers than can be obtained by sawing or slicing, the decorative effect is seldom so effective. In certain species, however, the reverse is the case, as will be explained later.

A cross-section of a log is reproduced in Fig. 15; the course taken by the knife as the log makes one complete revolution in the rotary-cutter is traced. This track is nearly circular, being actually a spiral, and it may be likened to a coiled spring, the thickness of the spring being the thickness of the veneer. As logs are never exactly round and the annual rings are not true circles, the knife cuts in and out of, or across, the annual rings at many points and at a variety of angles. Thus a distinctive grain pattern is developed from some woods, particularly if they possess distinct annual rings. The width of the annual rings determines the fineness or wildness of the figure. In cutting through narrow rings a fine mild figure is obtained, while a wild figuring is shown when wide-ringed timber is cut. This wild grain is frequently obtained as the knife approaches the central part of the log. Typical examples of such woods are European Pine, Spruce, Douglas Fir and Californian Yellow Pine, which show little figuring when sawn into boards or cut into veneers on the slicer.

Some hardwoods also yield a more desirable figure when cut on the veneer-lathe than by any other method. Masur Birch and Bird's Eye Maple are typical examples of such woods. The well-known "Bird's Eye" figure is obtained when small irregularities prevalent in the annual rings of the Maple are exposed by cutting logs tangentially.

The cut made by the rotary-cutter is much more truly tangential than

any which can possibly be obtained by sawing or slicing. A saw or slicer cutting a round log through and through will produce veneers which become progressively wider the nearer the cut approaches the centre of the log. The first narrow veneers will be almost entirely tangential, but as the width of the veneer increases the proportion of

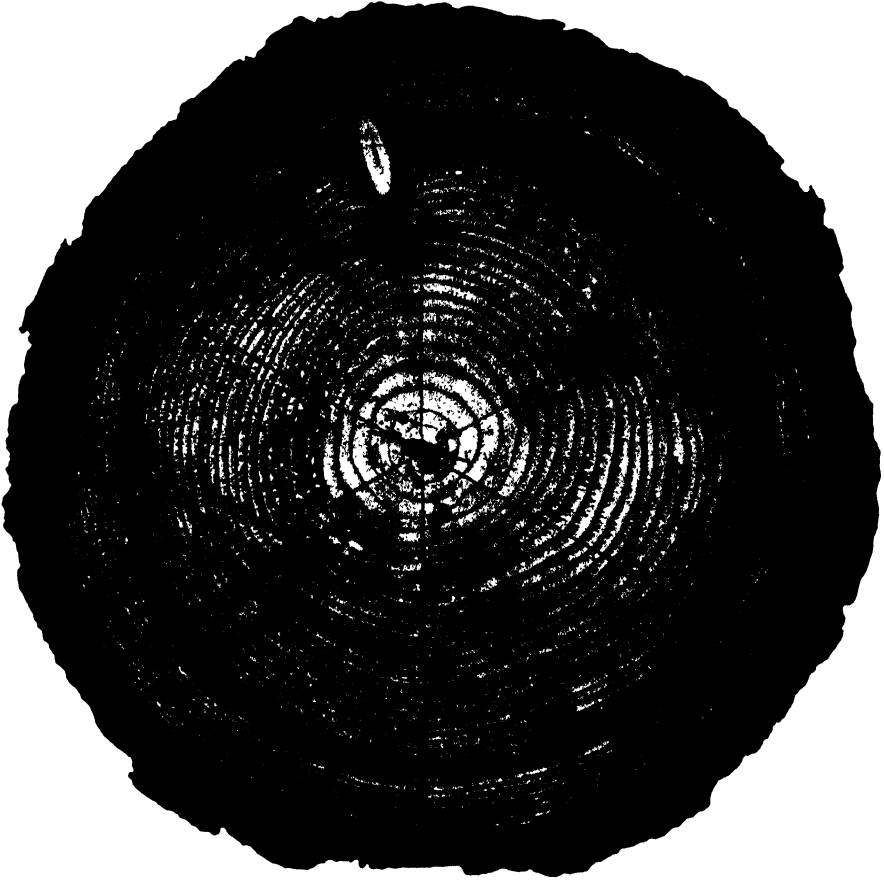

FIG. 15.

Cross-section of a small Douglas Fir log, showing the course taken by the knife during one revolution of the log in the lathe.

tangential wood will decrease, whilst the proportion of radial wood will increase, until, at the centre, the veneer is almost entirely radial. The change in the pattern of the veneer as cutting proceeded will be slight but progressive.

It should be noted that when a log is sliced into veneer, say,  $\frac{1}{8}$  inch thick, the first veneer is practically identical with the second; the

second with the third, and so on throughout the flitch. In thicker veneers the back side of the first veneer will be identical with the face of the second and so on.

The observation has been made that if trees grew as perfect cylinders with perfectly straight trunks the boles when cut into veneer would disclose a regular but uninteresting grain pattern. Fig. 16 amplifies this



FIG. 16.

point and demonstrates that if the cut were made to follow the course of the annual rings in an axial direction the figure would show as a series of approximately parallel lines. The path taken by the saw or veneer knife is straight and, as the longitudinal grain of the wood seldom is, it follows that the annual rings must be cut at a great many angles. This discloses an elliptical type of grain figuration, the rings running out of the veneer in the axial direction as is demonstrated by the plate already referred to and clearly visible in any sawn board.

It has already been explained that the medullary rays run in a radial direction and we find that many of the rarer beauties of wood are exposed when cut parallel to, or at an acute angle to, the medullary rays.

Such woods are generally cut on the slicer, the direction of the cut being determined in the band mill in which the logs are converted into flitches. The charge hand in this department can do much to make or mar the standard of veneer produced by the slicer both as regards quality of workmanship and in revealing the figure to best advantage. Should there be a doubt as to the best method of cutting, a 2" or 3" slab may be sawn off one end of the log. By splitting this radially and again at different angles to the radius and dressing the exposed surfaces, various types of figure will be disclosed from which the best angle of cut can be determined.

The smoothest cutting generally results from flitches which have been cut on the quarter and two methods commonly used for converting Oak logs in this manner are illustrated on the opposite page. To obtain fully quartered veneer the faces of the flitches should run parallel to the medullary rays, that is in a radial direction from the centre of the log. The most pronounced figure is exposed when the cut is made through and parallel to the rays, the figure becoming less and less pronounced as

the cut departs from the true radial path. Fig. 18 illustrates an Oak log cut in several directions. At A the cut is at right angles to the radial

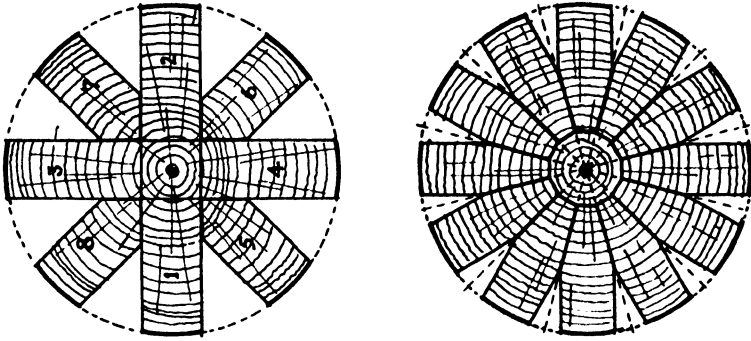
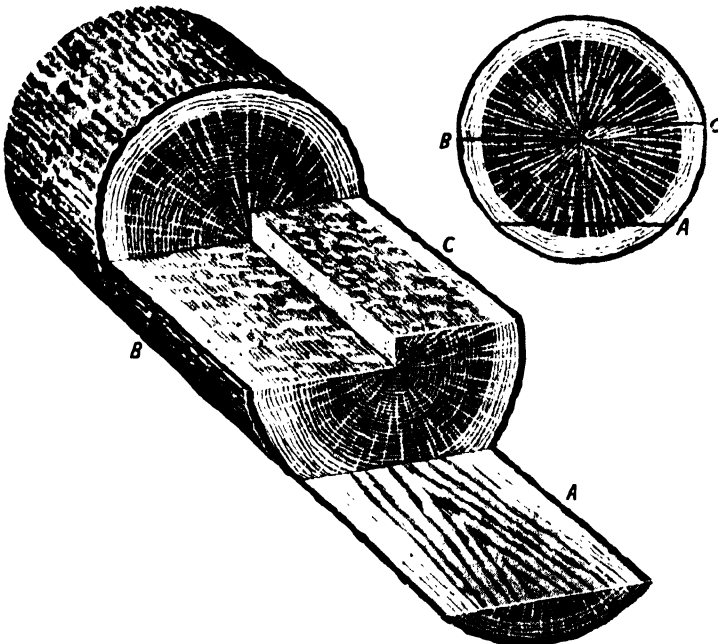

FIG. 17.

Two methods of converting a log into flitches.



*Reproduced by courtesy of the Editor of "Wool," and Mr. C. H. Hayward*

FIG. 18.

and the rays are only seen as thin lines ; veneers so cut are known as "Plain" Oak. A fully quartered surface is shown at B, while C illustrates a much smaller type of figure at the heart and a larger figure

c

at the circumference where the cut is more radial than at the centre. If the log were sliced through and through commencing at A a great variety of Plain Oak and half-figured (known as *faux quartier*) veneer would be cut before the fully quartered veneers at B were obtained.



FIG. 19.

Fig. 19 shows how the straight path taken by the knife across undulating fibres of certain Mahoganies, or, for example, the piece of Sycamore, illustrated on page 20, produces the fiddleback type of figuring.

## PART III

### THE MANUFACTURE OF MULTI-PLY

#### CHAPTER I

#### PREPARATION OF LOGS FOR CUTTING

##### (a) STEAMING VATS OR PITS

WITH many species of timber, before starting to cut them on the rotary-cutter or slicer, it is essential that the fibres of the wood be softened by steaming or by cooking in hot water. Where this is not properly done it is impossible to produce veneer without checking or fracturing the wood fibres, which defects lead to difficulties in the later stages of plywood manufacture. The woods which are generally cut cold are European Birch, Oregon Pine and European Pines. The other woods in common use by plywood manufacturers are steamed or cooked, viz. Alder, Beech, Gaboon and Oak, as are veneer logs in the round or in the form of stumps, crotches or burls. A few manufacturers of Douglas Fir plywood steam their logs before cutting, being of the opinion that by so doing the natural adhesives holding the wood fibres together are softened and that the resin in the timber is to some extent dissolved.

Considerable difference of opinion exists between manufacturers as to the better method to adopt to soften the wood fibres, but according to tests made by the Forest Products Laboratory, Madison, U.S.A., the shrinkage of veneers in drying shows little variation whether the logs have been steamed or cooked. The choice of treatment is one for the individual manufacturer.

In each case the operation is performed in large concrete-lined pits, which are generally placed between the log yard and the entrance to the mill. The vats are covered by well-fitting lids, which must be strong enough to withstand constant handling. Pipes are laid on through which the steam or boiling water is conveyed, while the waste water or condensed steam is carried off through a well-controlled drainage system.

The size of the pits must be such as to yield, during working hours, a continuous supply of properly cooked wood to the rotary-lathes, and it is important that efficient arrangements be made for the handling of the logs to and from the pits. A gantry covering the log yard and vat

is generally good practice, the logs being removed from the vats by travelling crane to a bogie which runs direct to cross-cut saws and thence to the rotary-cutters.

Cracking of logs in the vats may be a constant source of trouble if the temperature of the latter is too high when the logs are inserted. It is advisable to deposit the logs when the water is no more than moderately warm and gradually to increase the temperature.

Losses from splitting and cracking are reduced if the cutting of the logs into suitable lengths for the lathes is done after the cooking operation, and the pits should therefore be sufficiently large to take the longest logs likely to be delivered to the mill. Logs for the veneer mill are invariably cut into flitches before being steamed or cooked.

In order to secure consistent results vats should be built in two or more compartments thus making it possible to separate hard-textured wood from soft and long logs from short ones. As it is essential that the heat reaches the heart of the log it will be obvious that the time required to complete the process will vary according to size and to the density of the wood. Too much cooking is quite as bad as too little—in each case smooth cutting of the log is made difficult. The wood around the circumference of the log is generally too soft when taken from the vats, but cools off while the bark is being removed and during the journey of the log to cross-cut saw and lathe.

### (b) PREPARING LOGS FOR ROTARY CUTTING

On leaving the steaming vats, or, in the case of uncooked logs, as they enter the factory, the logs are cut into lengths to suit the day's production programme. One of the most useful tools for this type of work is the portable saw which, handled by two men and driven by compressed air or electric motor, can cross-cut the largest log in a few minutes. This saw can be carried to any part of the yard and saves much handling of heavy logs.

In the Douglas Fir industry logs are generally floated to a drag-saw and cut into suitable lengths before being removed from the ponds, as is demonstrated by Fig. 20.

The bark is removed by hand or by machine and the log trimmed, any surface irregularities or hard knots which might damage the knife being cut out.

Once the centre axis of the log has been marked the log is ready for cutting and passes to the lathes by overhead crane. It is swung into position and when centred in the lathe the holding bits on the main shaft are driven home.



*By courtesy of Pacific Forest Industries, Tacoma, Wash.*

FIG. 20.—THE DRAG-SAW AT WORK.



*[By courtesy of the Tyne Plywood Works Ltd.*

FIG. 21.—CUTTING OKOUMÉ LOGS INTO BLOCKS FOR ROTARY CUTTING BY AN ELECTRIC PORTABLE SAW.



## THE CONVERSION OF WOOD INTO VENEER

**H**ISTORY does not definitely record how ancient Egyptians cut the veneers of Sycamore, Ebony and other woods with which they decorated those interesting pieces of furniture referred to in Part I., but in scenes of the pyramid age which have come to light various primitive tools are depicted. For example, a study of the sculpture of Thebes which is referred to elsewhere indicates that a tool similar to the adze was used for shaping or for smoothing wood. The adze, incidentally, is still commonly used by the Egyptian woodworker. The axe appears to have been one of the early tools to be used by the Egyptians and it is of interest to note that this tool was the emblem of the office of the Royal Architect. A saw about 36 inches long, worked by both hands, was another of the Egyptian wood-working implements.

**Sawing.** Early forms of veneer were cut from logs by a pit-saw—one man standing on the top of the log, the other below the log in a pit, the procedure being very similar to native sawing as practised in certain parts of the East. It was impossible to cut thin veneers on this particular type of saw; the wood so cut was thicker than required and to-day would be more accurately described as very thin boards. This involved extravagance in valuable wood quite apart from the waste due to the heavy kerf made by the saw.

The first circular veneer saw to be used in England, which produced veneer about  $\frac{1}{8}$  inch thick, was erected in Battersea in 1805. Refinements were made from time to time culminating in segment saws, the largest of which had a diameter of 18 feet and cut veneers about 1 mm. thick. The cutting edge of these saws consisted of several segments of thin saw steel securely bolted to and stiffened by a heavy steel casting, the teeth being small and the "set" very fine.

By 1935 veneer-cutters in England had reached the conclusion that the day of the sawn veneer had passed and, with the improvement in veneer slicers, saws were discarded.

In a few American veneer mills woods which are very hard, or whose colour would be impaired by cooking, are occasionally cut on the segment saw; woods so cut include Satinwood, Black Ebony, Mahogany Curly and Quartered Oak.

The flitch to be cut, in its raw green state, is clamped to a travelling carriage which carries it against the saw, and after each cut the flitch is

advanced a fraction of an inch according to the thickness of veneer desired. It will readily be appreciated that sawing thin veneers must be a very wasteful process—in point of fact for every veneer produced an equal quantity of valuable timber is converted into sawdust.

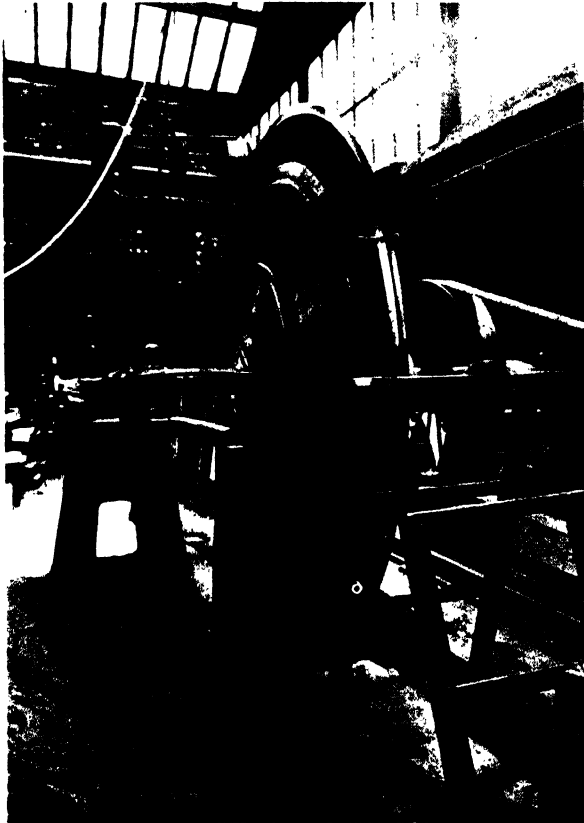

*By courtesy of Messrs. J. H. Ashton & Co. Ltd., Salford.*

FIG. 22.

This Veneer Saw, 10' 6" in diameter, was erected about 1860 and had been continuously worked for 60 years by one man before being discarded about 1934.

Sawing distorts the fibres of the wood less than either slicing or rotary cutting and enables veneer manufacturers to produce veneer free from "shell" or ruptured grain, defects which are liable to result when a Quartered Oak log with a large splash figure is cut on the slicer. Sawn Quartered Oak and all other sawn veneers are very expensive and are used only in the highest class of work. They are stronger

and less liable to show up defects than sliced veneers; they are reversible, making possible the use of either side without any risk



*By courtesy of Capital Veneer Co., Indiana, and Nicky Bros., Memphis.*

FIG. 23.—VERTICAL VENEER SLICER.

of cutting "checks" showing up after polishing. The veneers are retained in the order of their cutting, are dried and usually sold as complete "fitches."

**Slicing.** During the early nineteenth century small veneers were still cut by saw and hand plane; later a large mechanical plane was invented which was the forerunner of the modern veneer slicers, the

first of which made its appearance in France about 1830.

Two distinct types of veneer slicer are in use to-day and these are illustrated on this page. Each consists of a sturdy bed, to which the fitch is fixed by dogs; the powerful knife is carried on a rigid frame. The main difference between these two machines is that whereas in the American type or vertical slicer the knife is fixed and the bed movable, in the European or horizontal machine the bed is fixed and the knife is driven across the fitch in the manner of a



FIG. 24.—HORIZONTAL VENEER SLICER.

giant plane. The horizontal slicer illustrated is a massive machine which with great accuracy can cut logs as much as 4 metres long into thicknesses from 0.4 mm. to 6 mm. The knife is narrow, its thickness

increasing rapidly from the cutting edge, giving a rigid backing to the latter. It is secured to the box-like frame which moves diagonally across the bed of the machine—to which the flitch is fixed—the movement being controlled by accurately cut guides. As the knife is forced forward across the flitch the veneer is produced by a shear cut and emerges between the cutting edge of the knife and a pressure bar which runs immediately ahead of it.

At the end of each forward stroke the knife returns to its original position and in doing so it operates a ratchet which raises the flitch a fraction of an inch corresponding to the thickness of the veneer to be cut.

Veneer slicing machines are capable of fine adjustment and in the hands of a good operator even burls and crotches can be cut with accuracy and with tight-cut surfaces.

In some European countries Oak logs are frequently cut “across the heart.” This method of cutting admittedly saves much wood as compared with cutting logs on the quarter, but it does so at the expense of the quality of the veneer. The figure revealed by cutting veneers in this manner is similar to that produced by cutting a log into thin boards. As a general rule, however, while the first half of the log to be engaged by the knife may be well cut, immediately the knife passes the heart, some woods, more especially Oak, are liable to be “plucked” or torn, causing endless trouble in the finishing process.

The loss of wood in cutting a sound flitch on the slicer is restricted to that portion which is gripped by the dogs—a thickness of anything from  $\frac{3}{4}$  inch to  $1\frac{1}{8}$  inches.

As the veneers are taken off the machine they are numbered and piled in the order of cutting to make possible the proper matching of the stock when this has to be done later in the veneering shop. They are dried, reassembled and generally sold in complete flitches.

**Rotary Cutting.** To the plywood manufacturer the most important method of producing veneer is by rotary cutting, and probably 95 per cent. of his veneer is cut in this way.

The modern rotary-cutters are in effect massive lathes sufficiently well bedded to withstand any shock or vibration which might interfere with the smooth action of the log on the cutting knife. The log is mounted between two centres and is revolved against a knife running the whole length of the wood.

A gear from the main drive feeds the knife towards the centre of the log and is set according to the thickness of veneer required. The rate of feed is variable, and the veneer emerges between the cutting edge of the knife and an adjustable pressure or “nose

bar." The length is regulated by knives which are forced into the log ahead of the cutting knife.

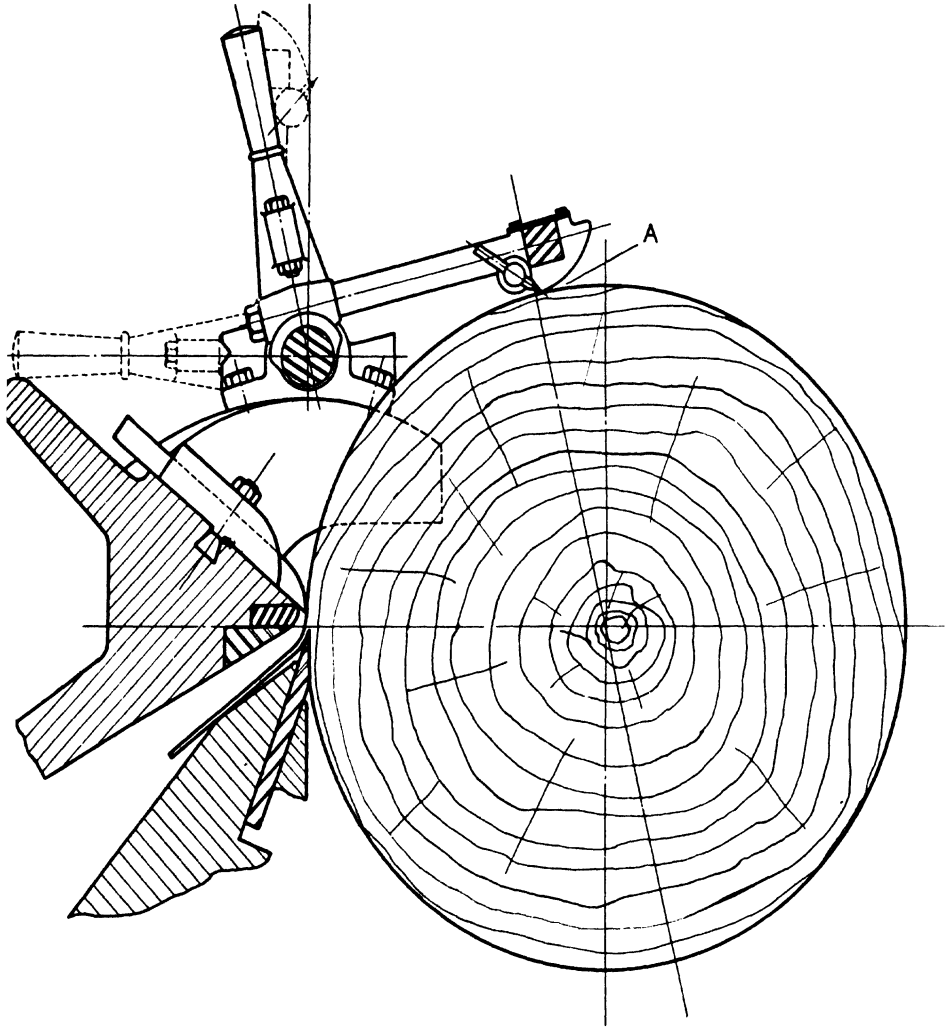

[By courtesy of Messrs. Coe Manufacturing Co.]

FIG. 25.

This diagrammatic drawing indicates the relative positions of knife and pressure bar. One of the spur knives (A), which cuts the veneer to exact length, is shown in position at the top of the block. A similar device, replacing the knife by a crayon, may be used to mark the tight-cut side of the veneer.

The method of cutting is clearly demonstrated by the various illustrations, while the relative position of pressure bar to the knife is shown in more detail above.

Logs for rotary cutting should be straight and sound and, for the most economical production, large in diameter, since the chucks supporting the logs must be of adequate diameter to avoid "chatter" or "whippage" of the log during the cutting process. When cutting a long log the pressure of the knife on the unsupported wood midway between the chucks may cause the log to "chatter" as the diameter is reduced. This renders good cutting impossible and should this happen the log must be removed from the lathe and reduced in length.

In every log a core remains after the rest of the log is converted into veneer and the diameter of this core varies with the original diameter and clearness of the log. There are special rotary-cutters available which are designed for converting small-diameter logs. These are fitted with relatively small chucks and the core coming from these lathes is considerably smaller than that which comes from the lathes in which large logs are cut. In some factories the cores from the larger lathes are reduced in length and are then re-cut on smaller lathes, producing veneers which are used for plywood core stock or for fruit basket and similar forms of package.

At first contact with the knife, the veneer is not whole, but once the log is trued up it comes away as a continuous sheet in much the same manner as paper is unwrapped from a roll. The best quality veneer is obtained early, but as the knife approaches the centre knots become more frequent and larger, each defect, of course, being repeated on the veneer with every complete turn of the log against the knife. From the manufacturers' point of view—and this view cannot be seriously challenged—the ideal way of cutting logs into veneer is to make the cut as thin as practicable for face veneers when working on good logs and thicker for cores when a knotty or otherwise defective log is in the lathe. The operator on the cutter must decide whether a log will produce veneer suitable for faces or cores. It will be recognized that the lathe charge hand must be highly skilled and intelligent as, in addition to this responsibility, unless he can produce veneer of even thickness and smooth cut, no amount of care in other departments will enable the factory to produce good plywood.

The modern rotary-cutter worked by a skilled operator is a remarkably efficient machine which will produce thick or thin veneer smoothly cut and regular in thickness. To produce such veneer, however, it is essential that the knives be kept sharp and properly ground and the pressure bar correctly positioned in relation to the cutting edge of the knife throughout its entire length.

The function of the pressure bar is to prevent splitting by exerting compression on the wood as it is fed towards the knife. The pressure

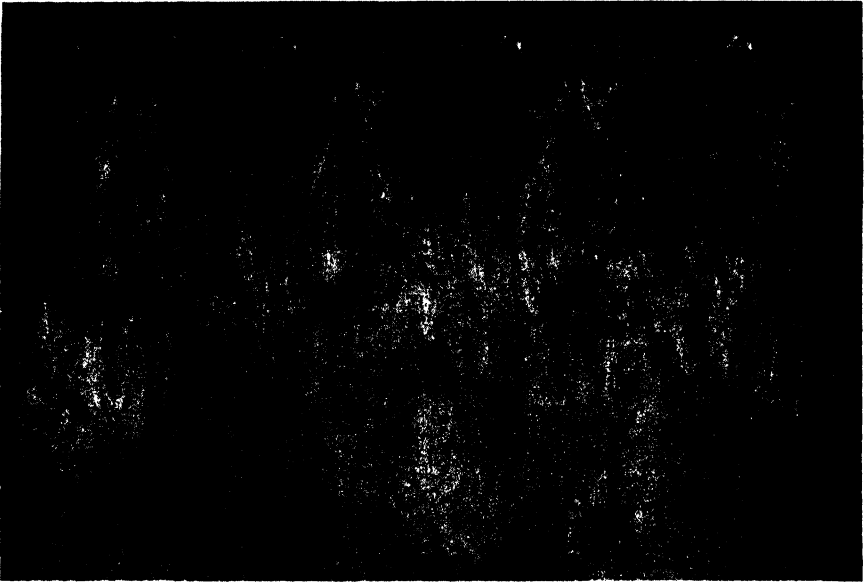

FIG. 26.—A PIECE OF ROTARY-CUT FINNISH BIRCH VENEER, 48" WIDE.

It should be observed that to obtain this sheet of veneer the log has made four complete revolutions against the knife. The gradual increase in the size of the knots will be noted.



[By courtesy of N.V. Houtindustrie, Picus.]

FIG. 27.—A CONTINUOUS RIBBON OF GABOON VENEER AS IT IS OBTAINED FROM A SOUND LOG.

should increase gradually and reach maximum when the actual cut is being made. The thinner the veneer to be cut the closer should the pressure bar be set to the knife.

The pitch of the knife, as determined by the angle which the bevel of the knife makes with a perpendicular line through its cutting edge, should be varied for logs of different diameters; it follows, therefore, that in order to make a smooth cut throughout the log the pitch of the knife should be adjusted as the diameter of the log decreases. In the latest types of Coe lathe the necessary adjustment is automatically controlled.

It is generally agreed that it is inadvisable to attempt a cut thicker than 5 mm., but "checking" as the knife "bites" into the wood is likely to render even this thickness unsuitable for other than core stock.

Thin veneer cut by a skilled worker should show little or no signs of cutting checks—such veneer is termed "tight-cut." With veneers 3 mm. thick and upwards cutting checks are practically unavoidable and care should always be taken to lay the veneers with the outer side exposed, so concealing the "loose-cut" surface. Veneer should always be laid as it comes from the log and for this reason it is advisable to mark the outer side as cutting proceeds. This enables workmen at all subsequent stages to recognize the "tight-cut" surface. Such a procedure is very essential in the manufacture of Gaboon plywood.

"Tight-cut" veneer can be produced more readily when excessive pressure is exerted on the pressure bar, but if this is done the veneer loses much of its flexibility. By careful adjustment of pressure bar to knife the highly skilled operator will be able to produce flexible veneer with a sound back. This is essential when the veneer is used for cores in 3-ply work: the core is the foundation of any panel, and unless flexible and sound veneer is used for this work it is impossible to produce flat and satisfactory plywood.

After being cut the veneer is flattened out and dried flat, so that the outside surface is under compression strain, the inner under tension.

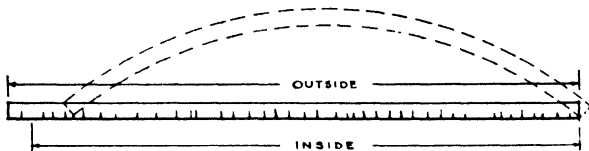

FIG. 28.

Cutting checks in thick veneer are forced open as the veneer is flattened out during drying, the inner surface being under tension.

The thicker the cut the more pronounced are these strains; this will be more readily appreciated if one keeps in mind the fact that the veneer





*By courtesy of Wilh. Schaumans Fanerfabrik A/B, Iyvaskylä.*

FIG. 29.—ROTARY CUTTING FINNISH BIRCH LOGS.

As the veneer comes from the log it is wrapped around a spindle. Veneer is being cut into widths by the guillotines on the left of the picture.



*[By courtesy of Ljusne : Woxna A/B.]*

FIG. 30.—CUTTING SWEDISH PINE LOGS.

Note length of the conveyor tables and guillotines for cutting veneer into widths.

when being cut was, so to speak, unwound from the log. It will always "try" to assume its original curve.

Veneer cut from properly cooked logs should be sufficiently flexible to lie flat on the conveyor tables or to be wound on a spindle without splitting or cracking.

The handling of veneer as it is produced by the rotary-cutters varies from factory to factory, but whatever the method adopted the desideratum is that the veneer reaches the subsequent stages in the manufacturing programme with the minimum amount of breakage.

In Finland and Poland, where the cut is generally between 1 and 2 mm. in thickness, the normal practice is to wind the veneer on a spindle as is clearly shown in Fig. 29. Certain Gaboon mills follow a similar practice notwithstanding the fact that this veneer may be 3 or 4 mm. thick. An alternative method is to run the veneer direct from the lathe to conveyor tables at the far end of which are placed the guillotines.

On the Pacific Coast of America, where Douglas Fir logs are cut at high speed, rapid handling of the veneer is essential. As it comes from the cutters it is led to conveyor tables along which it is carried on rubber belts. These conveyor tables may be 200 feet in length, and are built one above the other, five or six tables forming a unit at the far end of which are placed two clippers, one on the ground floor and the other immediately overhead. A gate serving all tables is placed a short distance from the lathe and leads the veneer to any table desired. A buzzer control is used by the guillotine operator, and when a signal is received by the lathe charge hand, the flow of veneer is altered to whichever table is indicated as being vacant. This method of handling veneer speeds up production and prevents damage.

Careless handling of veneer at this stage may result in a considerable loss through splitting.

**Half Round or Stay Log Cutting.** This is a modification of rotary cutting used by veneer manufacturers to produce thin high-grade veneer generally from Walnut stumps which have been cut through the heart.

The stay log device consists of a heavy bar which is secured to the ends of the spindles of the rotary-lathe. The log is fastened to this bar by screws and is swung around against the knife at radii which can be adjusted in order to expose the figuring desired. It is used mainly by veneer-cutters in the United States of America.

The device makes it possible to cut a flitch from the heart towards the circumference and enables the cutter to obtain some unusual and very pleasing types of grain figuring. Wider veneers are obtained by cutting in this manner than can be acquired on the veneer slicer.

## CHAPTER III

### TRIMMING TO WIDTH

**R**OTARY-CUT veneer may be trimmed into standard widths to suit the various press sizes, in which event it is graded after drying, or prior to drying the major defects may be cut out and the veneer clipped into standard or narrower widths with the object of obtaining the maximum quantity of sound veneer from the log. The method adopted by the management will depend upon the quality of the logs, the type and grades of plywood to be manufactured, and the requirements of the factory.

In Finland, Russia, the Baltic States and Poland, Birch and Alder veneer as it comes from the log is trimmed into standard widths. Serious defects in Oregon Pine veneer are cut out, the sound stock being trimmed into various standard sizes. Gaboon Mahogany veneer is generally clipped into a larger variety of widths, the defective wood being removed. In the case of both Oregon Pine and Gaboon Mahogany the charge hand on the clipper must be competent to decide quickly the best cuts to make in order to obtain the highest possible yield of sound veneer for outer plies. Serious defects which cannot be repaired, such as large dead knots, open splits and decayed wood, are unsuitable for either core stock or faces and must be cut out, but it is essential to economic production that the cut is made as close to the defect as is practicable in order that the quantity of veneer discarded, and so relegated to the furnace, be kept to an absolute minimum.

### VENEER CLIPPER OR GUILLOTINE

Many types of veneer clipper are in use in the various plywood-producing countries, some controlled by hand or foot, others partially automatically operated.

A typical guillotine or manual clipper consists of (1) a sturdy iron frame carrying at each end vertical knife guides; (2) a cutting table; (3) a shear plate; (4) a movable knife of sufficiently heavy section to render it free from any tendency to distort. The lateral movement of the knife is controlled by the guides, and it is vital to good workmanship that no play be allowed to develop at these points. This knife is counterbalanced by a weight which is raised by depressing a foot pedal, thereby releasing the knife which falls on to

the veneer with a shearing action. In certain machines the knife passes the shear plate or bar when the setting of knife to plate must be as close as possible. In other clippers a hardwood block is secured to the cutting table and the knife so adjusted that in falling it clears the bottom veneer without actually penetrating the hardwood block. If the setting is not carefully controlled, the block will very soon become damaged, as a



[By courtesy of Tyne Plywood Works Ltd.]

FIG. 31.

The operator in the background is winding Okoumé veneer on to a spindle as it comes from the rotary-cutter. In the foreground veneer is being cut into widths on a foot-operated clipper.

result of which veneer cannot be cut with the sharp square edges so essential to good workmanship.

### AUTOMATIC CLIPPERS

There are several types of automatic clipper in operation in European and American mills, many having been built or improved by the mills' own engineers. One such machine is illustrated on page 50.

The clipper is speedy in operation and is controlled by eight switch buttons which may be seen on the right-hand side of the machine

PLYWOODS  
AUTOMATIC CLIPPER

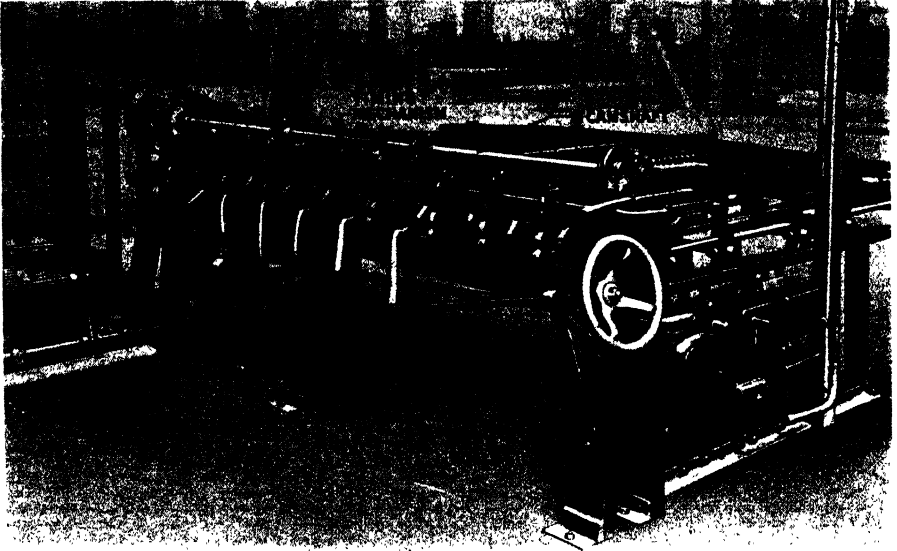

VIEW FEED END

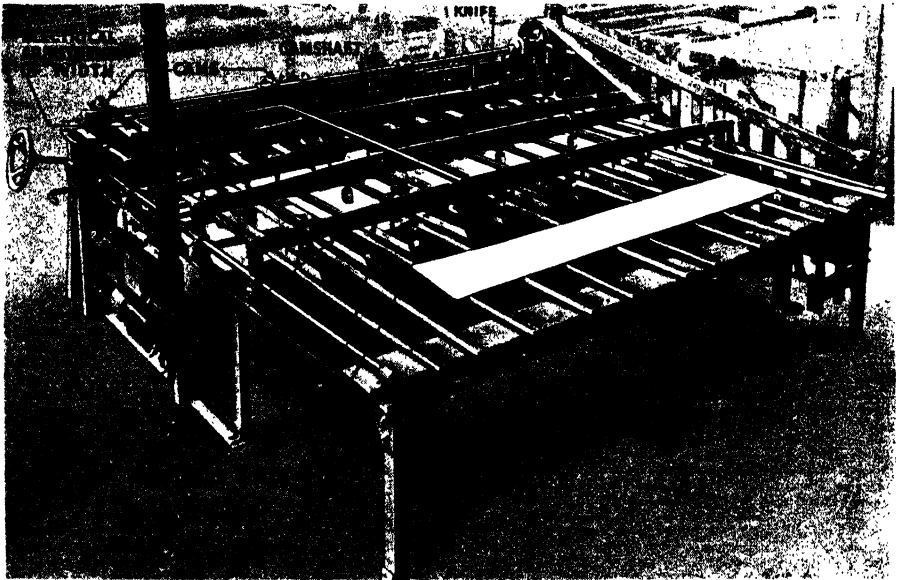

*[By courtesy of N.V. Houtindustrie, Picus.]*

VIEW DISCHARGE END

FIG. 32.

reproduced. Each button is connected in circuit with a contact which can be set at any desired distance from the knife up to a maximum of 5 feet. Any desired circuit is brought into operation by the depression of one of the control buttons and, as the veneer passing through the machine touches the contact, the circuit is closed. This immediately releases the knife and severs the veneer at the desired distance from the point of contact.

In the Picus factory veneer as it comes from the lathe is wound on spindles as described on page 47. From a loaded spindle the veneer is led beneath the feed rollers and is propelled through the clipper at any desired speed, the operator carefully watching the veneer as it passes before him. If clear veneer is being worked, there will be no need to alter the circuit, in which event the knife will drop each time the free end of veneer touches the contact. When a defective roll of veneer is in the machine the operator alters his setting so that defects are cut out and the veneer clipped into whichever set widths he decides will yield the maximum quantity of sound stock.

As each cut is made the sheet of veneer is taken up by rapidly revolving rollers which propel it forward to the discharge table, where it is selected and stacked on trucks ready for removal to the driers.

Several varieties of automatic and very speedy clippers are operated by the Oregon Pine plywood producers on the Pacific Coast.

The knives on such clippers are controlled by a series of push buttons set an inch or two apart on an endless chain which runs alongside the conveyor table at the same speed as the belt carrying the veneer. The charge hand with rule in hand carefully watches the veneer as it passes before him and pushes home a button opposite the spot on the veneer at which he wishes the cut to be made. As this button reaches the guillotine it operates a cam which controls the knife. A rapid stroke severs the veneer without even a momentary pause to its steady flow.

## CHAPTER IV

# PLYWOOD PRODUCTION PROCESSES

## DRY-CEMENTING AND WET-GLUEING

THERE are three forms of multi-ply board known to the plywood trade as (a) dry-glued, (b) semi-dry glued, (c) wet-glued. In referring to these processes the word "cemented" is commonly used in preference to "glued." The various manufactures may also be described by omitting the words "glued" or "cemented," e.g. "dry" Birch, "semi-dry" Birch or "wet" Birch. The wet-glued plywood produced in the U.S.S.R. is known as "ordinary" manufacture.

In these three types of plywood the difference lies in the treatment of the veneers before gluing and not upon the condition of the glue as might be, and often is, implied.

Plywoods manufactured on the dry-glued system are, without doubt, the most reliable, and in the modern factory represent an advanced stage of development from the original and somewhat cruder form of wet-glued board. In building up this improved type the veneers are invariably dried to a predetermined moisture content in the manner to be described before being assembled and pressed.

For high-class work, to be polished, stained or painted, no other than dry-cemented plywood should be specified or used, and buyers of plywood will be well advised to bear these various terms in mind when making comparisons between competitive stocks.

The manufacture of semi-dry and wet-glued plywoods is somewhat less costly than that of the dry-cemented stocks, and in consequence the two former types meet with a steady demand for purposes where cost is of prime consideration, e.g. for packing-cases, boxes, cheap covered-over work and so forth. A short review of the comparative costs of wet-glued and dry-cemented plywoods is included in the Polish section.

Semi-dry boards may be described as a "half-way house" between the "dry" and "wet" systems of manufacture. In effect they are little more than an improved form of wet-glued plywood and command similar prices to the best wet-glued stocks.

Wet-glued plywood is very similar to the material produced in the early days of the industry, and it is interesting to note that this particular type of plywood is still manufactured in that part of Europe in which

plywood was evolved, viz. Russia and the post-war (1914-1918) States of Poland and Latvia.

The quantity of wet-glued plywood produced in these countries is of sufficient importance to call for the following short description of the process of manufacture.

### THE WET-GLUED PROCESS OF MANUFACTURE

Veneers as they come from the rotary-cutters are trimmed into standard sizes generally such as will finish 60"×60", 60"×48" or 48"×60". Having been selected into stocks suitable for cores and faces but without previous drying they are taken to the glue spreaders.

Glues used in this process may be of Blood Albumin or Casein or more commonly a mixture of both in a solution of Hydrated Lime; the proportions of Albumin, Casein and Lime are varied according to requirements. It may be mentioned that at one time the formulæ for the preparation of glues were closely guarded secrets known only to a few "key" men of the industry who, in consequence, considered themselves to be of no mean importance.

The cores are glued and laid between face veneers in the usual way, assembled veneers in suitable batches being then removed to hydraulic steam-heated presses. These presses vary considerably in construction. In Poland the normal press has from ten to sixteen openings, each opening taking assembled veneers to yield from seven to ten boards 4 mm. in thickness. Once the press has been completely loaded, pressure is applied and the surface temperature of the platens raised to approximately 225° F. The temperature may be 10° higher or lower, according to the composition of the adhesive used. Pressure and heat must be maintained for from forty-five to fifty-five minutes, the actual period being determined by the charge hand according to the thickness of the boards and the number of assemblies in each opening. The application of heat expels moisture from the veneer, but normal shrinkage of the wood is prevented by the pressure applied to the mass by the platens of the press. The glue solidifies and once pressure is released the strains and stresses which are set up in the steaming-hot boards can well be imagined. The outer boards of each batch, having been in contact with or close to the heated plates of the press, are generally considered to be dry enough; the remainder of the batch are re-dried in what are known as drying presses. The latter are much lighter in construction than the gluing presses, each having six or seven steam-heated platens of similar build to the breather driers described on page 57. One pressed board is inserted into each opening, light pressure applied, and the press



kept closed until the desired moisture content in the boards has been attained. Here again the time required for re-drying depends upon the thickness and amount of moisture in the panels and is determined by the press operator.

The construction of wet-glued plywood of Polish manufacture was as often as not one veneer per millimetre of thickness, viz. 3 mm., three-ply ; 4 mm., four-ply ; 5 mm., five-ply ; 6 mm., six-ply ; 9 mm., nine-ply. Some mills built up 6 mm. boards by glueing two veneers each about 1 mm. thick to a pre-glued 4 mm. four-ply core. 9 mm. panels were frequently formed by glueing 4 mm. and 5 mm. boards together. Care was taken to retain the cross-grained construction, but in the case of boards with an even number of plies such as 4 mm. or 6 mm. the grain of the two centre veneers ran in the same direction.

Advancement in the general manufacturing technique of wet-glued plywood since 1935 has been very marked ; in addition, many mills improve the appearance of their boards by sanding one or both faces. Nevertheless, the limitations of wet-glued plywood are manifest.

The internal strains and stresses set up in the boards during re-drying are reflected in the face veneers in the form of countless tiny surface checks and splits caused by the bursting of the wood fibres. These surface checks vary in size with changes in the humidity of the atmosphere and as a result of this continual movement it is impracticable to obtain a satisfactory finish with paint, varnish or any of the other decorative media in common use. However, as we have already mentioned, wet-glued plywood is used for many purposes and meets with a considerable demand. In point of fact, during 1938 the demand exceeded the supply.

## CHAPTER V

### DRYING VENEER

THE drying of veneer for faces or cores, of battens for core stock, or the re-drying of panels after pressing, calls for an efficient drying system and competent supervision.

The more simple the design of the equipment and the more nearly automatic the control, the more satisfactory will be the results. The function of any drier is to reduce the moisture content of the stock to be dried to a predetermined percentage and when working on veneer to produce flat and pliable stock.

Driers are of many different types, the most simple being a kiln in which temperature and humidity, air circulation and ventilation are regulated and graduated throughout.

#### PROGRESSIVE KILNS OR CHANNEL DRIERS

Drying kilns in the plywood mill are most frequently of the progressive type, but the methods of applying heat and humidity vary considerably. The selection of a proper type of drier is a matter of prime importance.

Progressive kilns, channel driers or re-driers as they are frequently called, are built in the form of a tunnel at least 90 feet long in which both temperature and humidity can be controlled throughout the entire length. In larger factories producing blockboards as many as six or eight tunnels lying side by side may be required to cope with the production of the plant. In this event one kiln or more will be used exclusively for drying the raw material as it is brought from the seasoning yards, another set for re-drying the cores, and a third for the final conditioning of the plywood, blockboards or laminboards.

A cross-section of a typical channel drier is illustrated, and further information on this subject can be obtained from text-books devoted to the kiln drying of lumber. The question of air circulation is all-important and many different theories have been put into practice. The main essential is that conditioned air is brought into contact with the exposed surfaces of every board on the loaded trucks, failing which drying will be a matter of chance. Experience has proved that consistent results are obtained when the circulation of the air can be alternated at will from one side of the stack to the other. This movement is controlled by

electric blower fans of special design carefully positioned inside the kiln. The air is made to pass over, or through, a series of steam-heated pipes which lie above or below the kiln, according to the system in operation, and run throughout the entire length of the channel with the exception of a small portion at the loading end. The humidity is controlled by the introduction of steam through a series of jets or of fresh air, as may be required. Fresh air enters the kiln through ducts laid into the floor, through variously placed dampers or louvred ventilators fixed to the loading doors, whilst moist air is drawn off through a centrally placed chimney or through shafts built into and running up the outer walls. Both entrance and exit ducts are controlled by dampers.

The handling of the loaded trucks will be eased considerably if rails inside the kiln are laid on a very slight gradient running from the entrance towards the exit. At the loading end of the kiln the temperature is low and the humidity high, but as the truck proceeds through the channel it meets with a steadily rising temperature and a gradual reduction in the humidity until at the point of discharge the temperature is at its highest and humidity at its lowest.

The channel should be kept full of loaded trucks : as fresh trucks are pushed into the kiln a corresponding number are discharged. It will be obvious therefore that the rate of loading must be regulated by the speed of drying so that the capacity of the driers, to a considerable extent, determines the production of the mill. The moisture content of each batch should be checked immediately it is discharged from the kiln. Any attempt to speed up the passage through these channel driers can only result in disaster. A kiln set for drying lumber cores must never be used for re-drying plywood, or vice versa.

In the smaller plants other drying systems give good service and driers of the condenser or ventilated type are used. These are much slower in operation but are economical. They are useful in veneering plants for the re-drying of plywood, laminboards or blockboards. Both systems are based on the theory that hot air rises as cold damp air falls ; the principle can also be incorporated in the progressive type of drier. Heated air is introduced to the kiln below and between two loaded trucks ; as it rises it passes through the loads, striking the cooler walls down which it falls to find its way to the heated pipes and so the circulation continues. The humidity, temperature and volume of the air are kept under constant control.

In all channel driers recording instruments should be installed at several points and a record kept of the humidity and temperature inside the kiln while drying is in progress. The humidity is

measured by a hygrometer or may be estimated by means of wet and dry bulb thermometers. Humidity must be carefully controlled as, if the wood is allowed to dry too quickly, the surface wood cells will set and so retard proper drying in the centre of the boards. A relative humidity of 40 per cent. during the early stages in the drier will give satisfactory results.

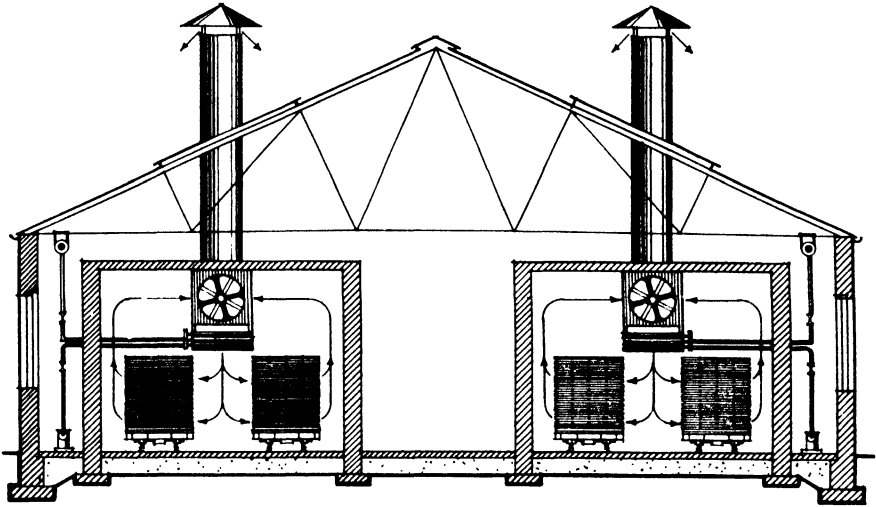

FIG. 33.—SECTION THROUGH A TYPICAL CHANNEL DRIER.

Section through a typical progressive kiln drier. Kilns of this type are commonly used in the production of blockboards for drying Pine or Spruce boards, also for re-drying prepared core-plates and finished blockboards. In larger factories many lines of kiln are necessary to keep the plant supplied with timber dried to the desired moisture content—generally between 4 and 6 per cent.

### PLATEN OR BREATHER DRIER

This type of drier is generally used for core stock over 2 mm. in thickness, or for re-drying veneer, and consists of a number of hollow steam-heated plates which move together and apart at regular intervals. Fig. 34 shows a typical breather drier consisting of twenty-two platens. This drier is in many respects similar to the steam-heated press, but the plates are so coupled that when one pair is closed the alternative surfaces of these two particular plates are free. The veneer is flattened with a slight even pressure when the platens close, and at the same time the moisture in the veneer is converted into steam which escapes as the platens open. Veneers can be quickly dried on the

breather drier down to 6 to 9 per cent. moisture content without any fear of case hardening or buckling.

There are several forms of platen driers combined with the progressive kiln type. In one of the German factories which had a reputation for large-sized Gaboon boards the drying of veneer for faces and cores was done by such a system. The veneer was rolled on to a spindle as it came from the lathe in the manner already described and the veneer from these rolls passed through a series of flat, hollow,

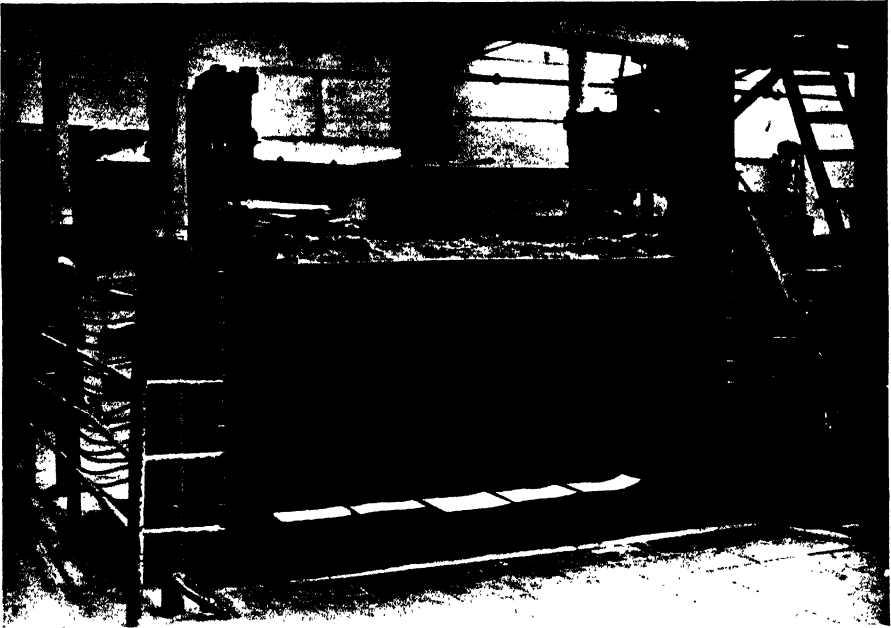

[By courtesy of N.V. Houtindustrie Picus, Eindhoven.]

FIG. 34.—BREATHER DRIER.

steam-heated platens which closed and opened at regular intervals. As the plates moved apart the veneer was carried forward a few inches, at the same time the steam formed from moisture in the veneer was drawn off. By the time the veneer reached the end of the last platen it was thoroughly dry and remarkably flat. It continued to move along an extended platform, at the extreme end of which was placed a guillotine which cut the veneer into widths, any defects being clipped out. Much thought had been put into the erection and operation of this particular drier, which was unique. It was considered by the management that veneer stock so dried was less liable to damage and that certain economies were effected.

## ROLLER OR CONVEYOR DRIERS

The modern veneer driers are improvements on the progressive kiln, the stock to be dried being propelled through the drier by a series of rollers, or carried on an endless belt or some similar contrivance. Many of these driers are over 100 feet in length and contain approximately 5000 yards of steam piping.

By the courtesy of the Coe Manufacturing Company of Painesville, Ohio, we reproduce on page 60 a cross-section of a typical 1938 installation. It will be seen that this drier is divided into four decks. The bottom rollers on each deck are driven by a chain and sprocket, and above each lies an idle roller. The veneer is held flat between these rollers and is thus propelled through the drying chamber. Laid across the drier at regular intervals is the system of steam piping, the heat from which is controllable and produces the requisite temperature. Between these pipes and the rollers lie a series of air nozzles which diffuse the air under the veneer as it passes.

The whole heating chamber is enclosed in a heavily insulated framework which prevents loss of heat by diffusion or radiation.

The temperature inside the drier is somewhat over the atmospheric boiling point so that as water is given up by the veneer it is promptly converted into superheated steam which mixed with air makes an excellent drying medium. This is kept in constant circulation by powerful fans and the veneer is subjected to additional heat from the coils and rolls by radiation, convection and conduction. The speed of travel through the drying chamber can be controlled by the charge hand as may be necessary according to the thickness of veneer, the amount of moisture to be removed, and the ultimate moisture content desired. On leaving the drier the veneer travels through a cooling chamber and is then removed by hand and stacked into size and thickness.

Fig. 36 shows an inside view of the Proctor drier—another popular machine. The method of propulsion of the older types consists of a number of endless belts superimposed one above the other and consisting of strong, straight wires. The bottom surface of the upper of the two belts moves in the same direction through the drier as the top surface of the lower and the sheets of veneer are carried firmly between these two surfaces. The latest type consists of six decks through which the veneer is carried on perforated metal containers, being held flat on these by a series of floating rollers spaced evenly throughout the length of the drying chamber.

Moist air inside any drier is essential to uniform drying as this keeps

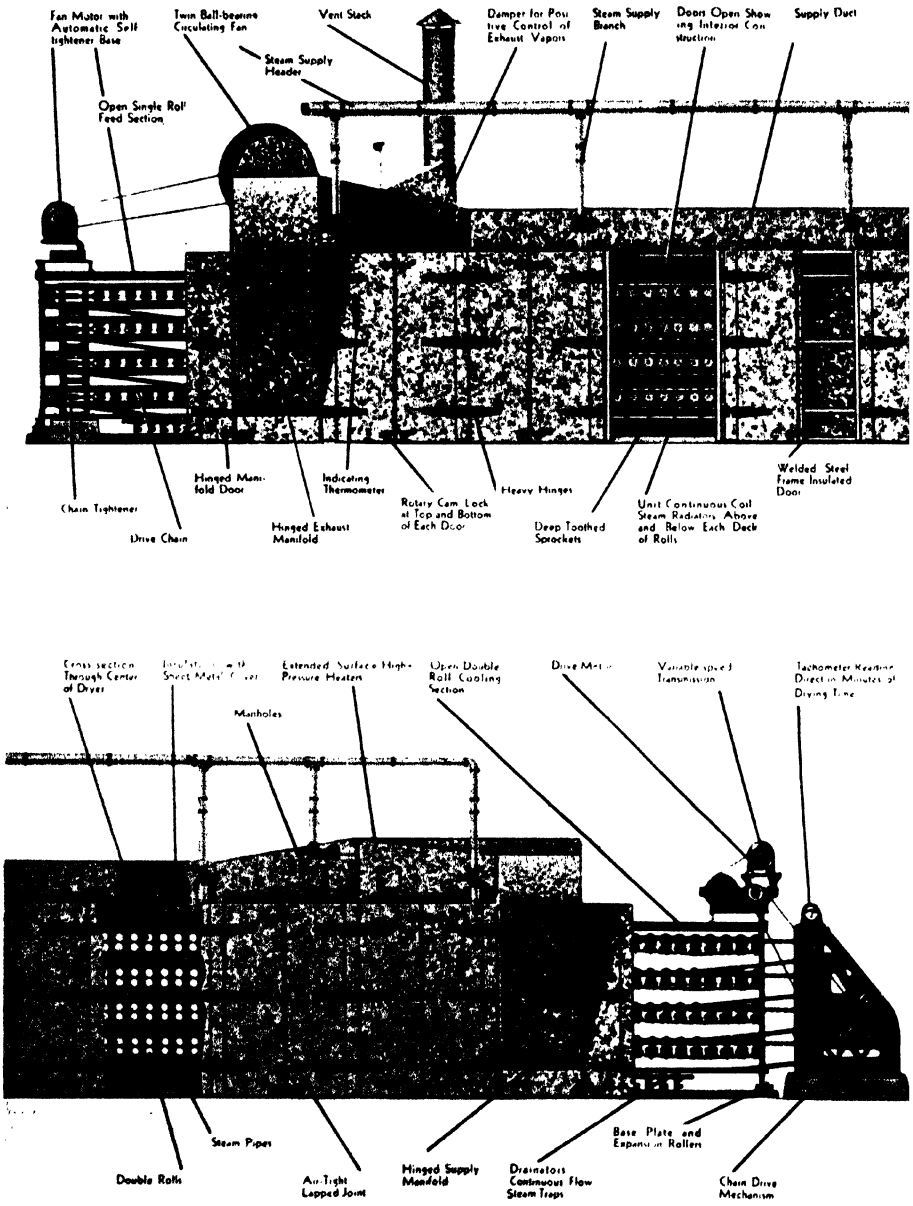

FIG. 35.—CROSS-SECTION OF A TYPICAL 1938 COE DRIER.

the surface pores of the wood open and allows the veneer to dry evenly. Rapid drying cannot give consistent results ; it generally means case-hardening through too close contact with overheated plates or rollers. This is a serious fault and causes endless trouble in subsequent operations. When veneer is properly dried the distribution of the moisture over the sheet should be equal, otherwise any change in atmospheric conditions will set up unequal strains and stresses in the veneer and result in buckled and brittle stock.

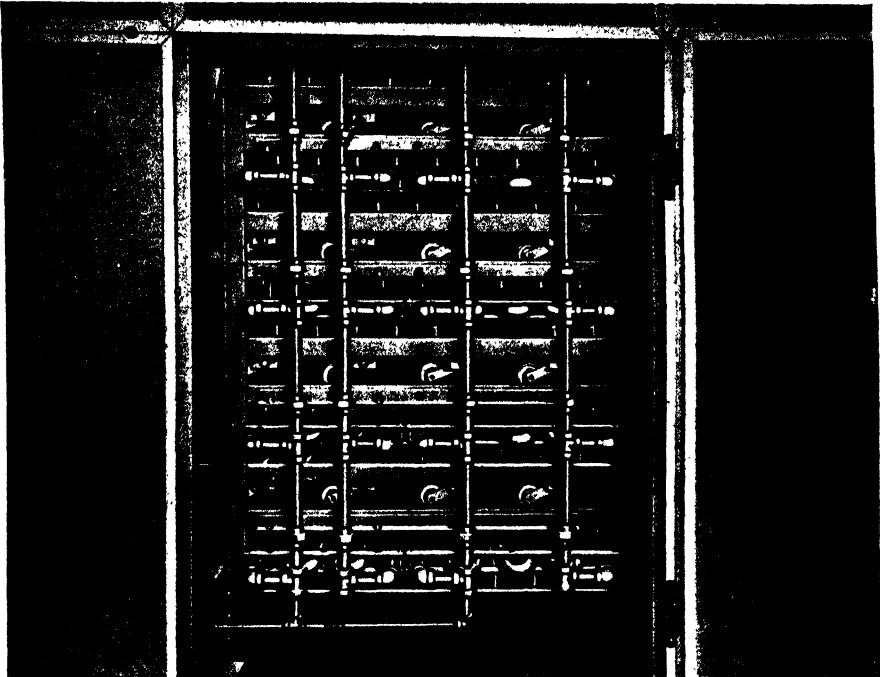

FIG. 36.—SECTION OF PROCTOR DRIER, SHOWING POSITION OF IDLE ROLLERS AND STEAM PIPING.

The loading and unloading of driers is performed by unskilled labour. In many of the European mills female labour is employed for this work.

In European mills veneer as it is discharged from the driers is loaded on trucks and removed to the veneer storage room. There it is sorted into face or core stock and stacked according to size, grade and thickness. Any sheets which can be improved by patching are laid aside and handled by specially trained workmen in the manner described on pages 70 to 72.



The production of Oregon Pine veneer is remarkably speedy. In many mills, with a view to reducing the risk of damage, out-feed conveyors receive the fragile dry veneer as it leaves the driers and carry it before a line of inspectors who select according to size and grade, each man removing from the belt only those veneers for which he is responsible. Veneer which is unsuitable for faces is taken straight to the core room where it is cut into suitable sizes.



[By courtesy of Ljusne: Wovne A/B]

FIG. 37.—MODERN MECHANICAL DRIERS, WITH GUILLOTINE IN FOREGROUND.

## CHAPTER VI

### VENEER JOINTING AND REPAIRING

**I**N the manufacture of large multi-ply panels, laminboards and block-boards, the outer plies are invariably formed by jointing together several narrow widths of sliced or rotary-cut veneer. As the finished boards may be painted, enamelled or used as a base for high-class veneered work it is imperative that all joints are perfectly made. Practically every veneered panel consists of two or more pieces of decorative veneer, the jointing together of which is a precision job demanding skill and great accuracy.

It is impossible to make good joints which will remain close unless the veneer to be joined together has been cut with perfectly straight edges free from all traces of splintering. This cutting is done on the veneer jointer—one of the most important machines in the plywood or veneering factory.

#### (a) VENEER JOINTERS OR TRIMMERS

Dried veneer is seldom flat, and it will be apparent that if the edges of veneer are buckled while being cut one cannot expect the joints to be close when the veneer is flattened in the press. Therefore when the cut is made the veneers should be held throughout their length by a pressure sufficient to reduce them to a true plane surface. When this is done the edges of the veneer will be in a similar position to the one assumed when being glued to the core in the hydraulic press.

Modern veneer trimmers are built in two main components: a substantial rigid bed with accurately machined top and a heavy carriage which travels on a track or guides machined into the solid bed. The carriage must be secured to the track in such a way that all lateral movement and vibration is prevented otherwise, the smooth cutting so vital to this work will not be accomplished. A pile of veneer, 1 inch or so thick, is clamped by sufficient force to press the veneers together until the edge of the mass exposed to the cutters has all the appearance of a solid block of wood. This stack of veneer is generally held against the bed, in which event the cutters are secured to the travelling carriage; in a few machines the positions are reversed.

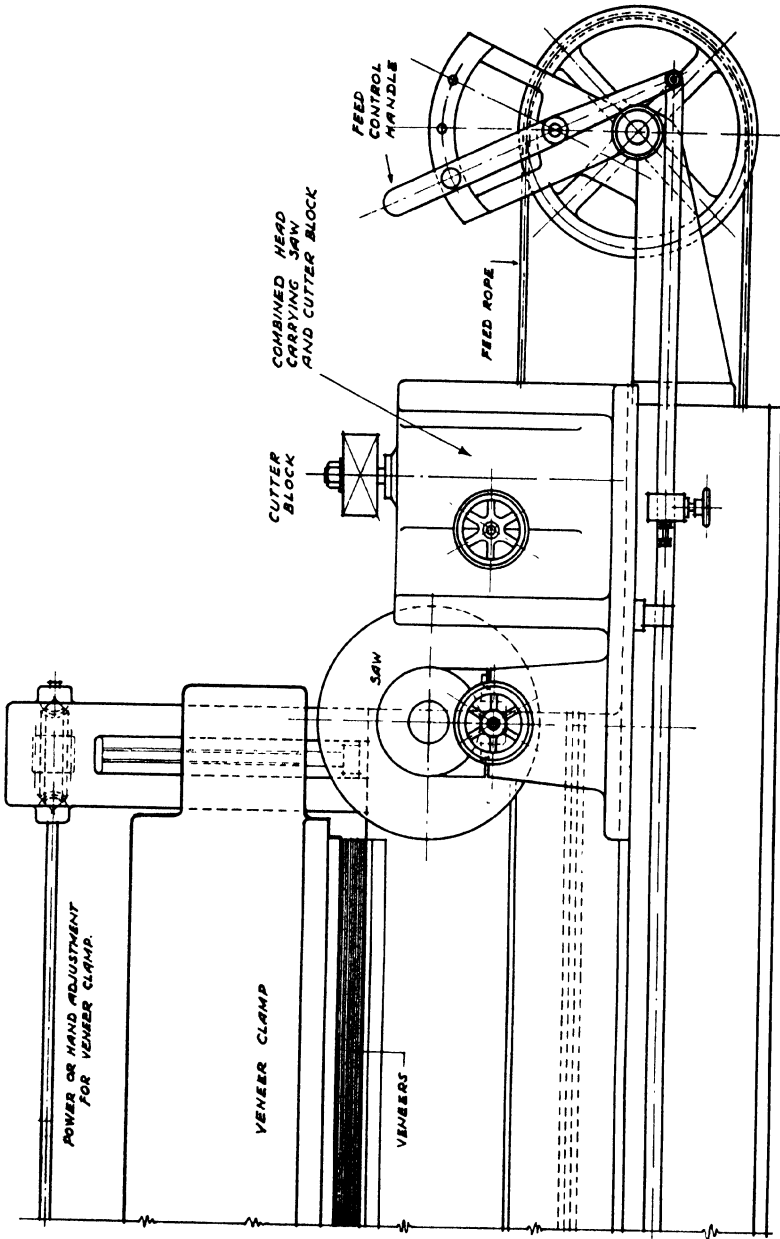

[By courtesy of Messrs. Thomas White & Sons Ltd., Paisley.]

FIG. 38.

Diagrammatic drawing, showing typical veneer trimmer with fixed bed and travelling saw and cutter-head working in tandem.

The cut may be made by saw or cutter-head, or both. In certain machines a first roughing cut is made by a finely set-saw and the second or finishing cut by spindle or cutter-head. Motorized eight-knife cutter-heads working in tandem are preferred by some manufacturers; in such cases both the rate of feed and the revolutions per minute of the cutter-heads must be controllable in order to meet the specific requirements of different timbers. A shearing cut reduces the risk of tearing or splintering.

The saw is used by some experts for jointing burl and crotch veneer, whereas the cutter-head is more commonly employed for plain or quartered stocks.

In the plywood mill, when working on veneer to be used for faces of blockboards or laminboards and, for all veneer to be spliced on the tapeless splicer, once the batch has passed the cutter-head the freshly cut edges are coated with a film of hide glue before the clamping bar is released. This makes it possible at a later stage to joint the veneers without the use of tape.

### (b) JOINTING VENEERS IN THE WIDTH

Once the veneer has been cut on the veneer jointer it is advisable to proceed with the next operation as quickly as possible to obviate the risk of any change in the moisture content taking place. Especially is this of importance when working on veneer with irregular grain.

#### TAPING MACHINES

A typical taper is illustrated in Fig. 39. The two leaves of veneer to be joined together are fed to leading rollers which are set in such a manner that they force and hold the edges of the veneer together. A

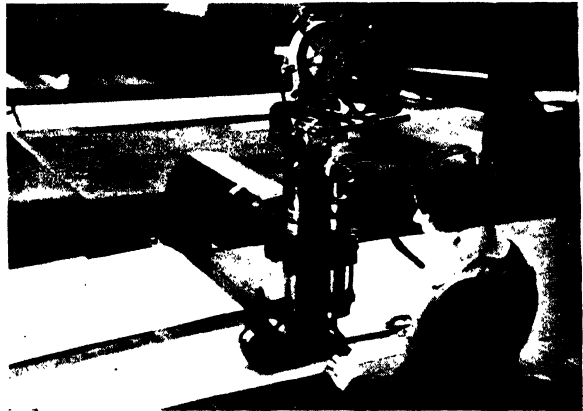
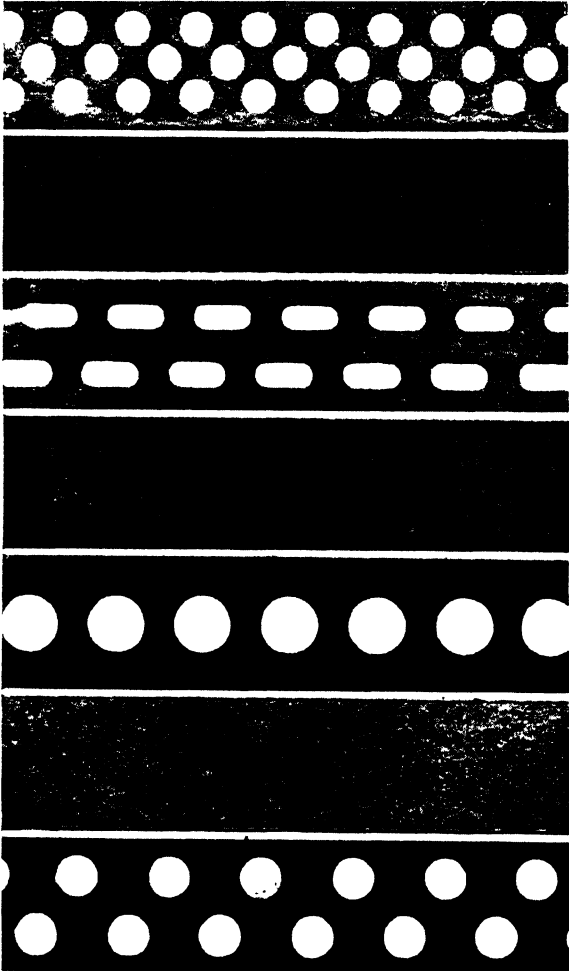

FIG. 39.—TAPE-JOINTING FACE VENEERS.

roll of pre-gummed tape is positioned above the machine as shown in the illustration, and as it is led towards the veneer it passes over a roller

which moistens the glue. The tape is then automatically laid over the joint and pressed against the veneers by an electrically heated roller which partially sets and dries the glue. Taping is generally done by female



1. Perforated tape which permits adhesive to reach maximum surface of veneers both along and at each side of the joint.

2. Cloth tape generally used for protecting samples.

3. Perforated tape permitting adhesive to reach areas on both sides of joint.

4. Heavy - weight paper tape.

5. Tape permitting adhesive to reach veneer along the joint.

6. Light-weight paper tape.

7. As 3.

FIG. 40.—VARIOUS TYPES OF PRE-GUMMED TAPE.

labour—two girls being employed on each machine. The first feeds the veneers into the rollers ; the second breaks the tape as each joint is made and carefully inspects the workmanship. If this is defective the tape should be removed before the glue has time to take its final set.

In the manufacture of Oak and other veneered plywoods many joints will be required before the requisite width is obtained. In such cases the off-bearer passes the taped veneer back to the charge hand who adds a further leaf of veneer and the process is repeated as often as may be required. Where wide panels are constantly being manufactured it is advisable to extend the table of the taper with a plywood board to form an area sufficient to support the entire sheet of veneer when completed. It is possible to slide veneers to and fro on such a plywood table without risk of damage.

Tape is generally made from kraft paper in different widths and thicknesses. Some manufacturers prefer to use a perforated tape. The ideal tape is one which is easily removable and various types of glue have been devised in an endeavour to obtain one which will set for a few hours only, thereafter quickly losing its adhesive properties when heat or moisture is applied. The solution to taping problems has not yet been found.

Perforated tapes are frequently used for cross-bandings, in which event they should be laid between core and cross-banding and not between the latter and the face veneer. Troubles follow in the wake of the practice of laying veneers with the tape down, *i.e.* between face veneer and cross-banding. The tapes should always be laid to the outer side of the face veneer and removed after pressing. Some manufacturers edge-glue the veneer after taping by folding back the joints, using the tape as a hinge and passing the two edges of veneer against a horizontal or vertical glue roller. The veneers are flattened, any surplus glue being removed, and then laid on a concave cradle taped side down until perfectly dry. This forces the glued edges together and will prevent glue oozing through the joint when the plywood is being assembled and pressed.

#### TAPELESS JOINTER FOR CROSS-GRAINED OUTER PLYS

A typical machine is illustrated in Fig. 41. Veneers already coated with hide glue in the manner described on page 65 are used. They are fed into the jointer by a series of rollers which are controlled by a foot-operated pedal. In front of these rollers is a trough containing a long pad saturated with formaldehyde. The glued edge of veneer is laid on this and then pressed against a veneer already engaged by the roller. As each veneer is fed into the machine it is held firmly against its leader, and between each forward motion the glued edges

are pressed by a heated platen which re-sets the glue. The jointing process continues until the requisite length is formed when an

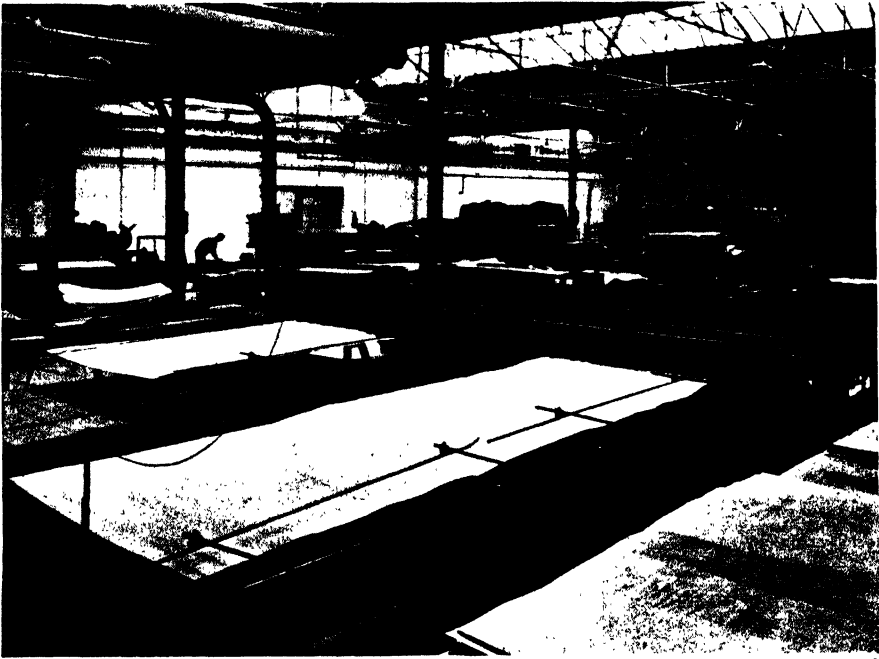

[By courtesy of Tyne Plywood Works Ltd.]

FIG. 41.

electrically controlled stop works a guillotine which cuts the veneer to the exact length required.

#### TAPELESS SPLICERS

Tapeless splicers are becoming more commonly used. One of the newer types which can joint veneer from 0.5 mm. to 5 mm. thick is illustrated on page 69. The feed-roller bearings are arranged in pairs, being secured to the top-head. The two pieces of veneer are fed by hand into the leading rollers and thereafter are automatically controlled until discharged from the machine. The edges are first pressed against moistening rollers and then held in close contact while the veneers pass between heated platen and rollers which finally set the glue.

Excellent results are obtained on the newer types of tapeless jointers, provided the veneer has been carefully cut and is of uniform thickness.

It is impracticable to joint veneers of uneven thickness on these machines, nor should this be attempted. The tapeless splicer is a very

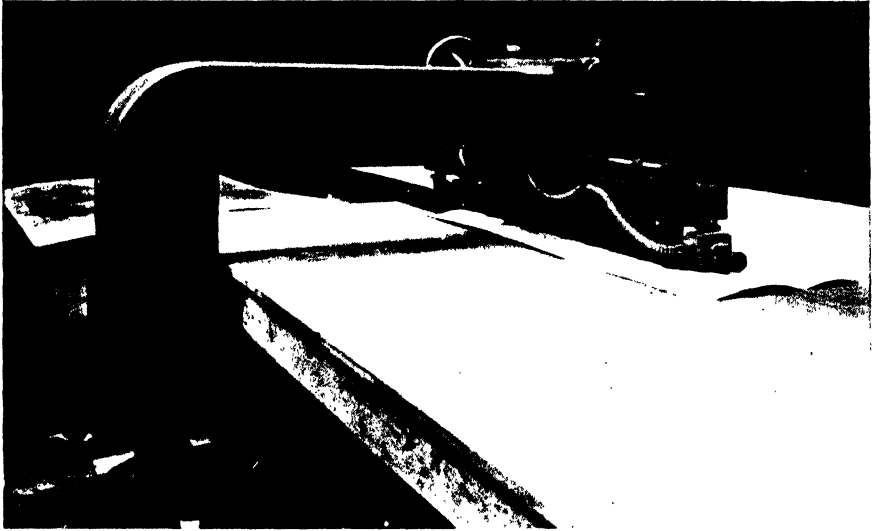

[By courtesy of Messrs. Veneercraft Ltd.]

FIG. 42.—A MODERN TAPELESS SPLICER.

Note the extended plywood table built to facilitate handling of veneer.

useful tool for jointing together veneers for inner plies, and when used for this purpose saves many rejects on account of overlaps and gaps.

### (c) JOINTING VENEERS IN THE LENGTH

In the preparation of veneer for the cores of laminated boards and for the inner plies of large cross-grained multi-ply panels, it is necessary to join together two or more pieces of veneer to obtain the lengths required—these will be slightly larger than the width of the finished board.

The method most generally adopted is the scarf joint, the scarf being made on a specially set-saw, sander or cutter-head. The angle of the cut must be consistent and as the wastage of wood is in direct proportion to the acuteness of the angle of the scarf, the setting of the machine should be such as will produce a gluing surface no longer than is necessary to yield a joint which will permit of handling without fracture. The stagger through the thickness of veneer should not be less than 12 inches to meet the requirements of B.S.S. 4 V 3.<sup>1</sup>

Quick-setting glue is used, and special machines are available for assembling and pressing these scarf joints. This work is frequently done

<sup>1</sup> British Standard Specification.



by female labour and smooth joints are obtained by what is a simple and inexpensive process. Much waste may be avoided by jointing veneers in the length. For example, the Picus organization at Eindhoven, Holland, ran a large cigar-box business in conjunction with their plywood plant and this accounted for the fact that they accumulated quantities of veneer in short lengths. These were joined together by a clever machine which was perfected by their own engineers. Square dovetails were cut by specially set cutter-heads, and the male and female parts engaged as the veneer passed through the machine. A saw operated by a patent device cross-cut the veneer to the desired lengths.

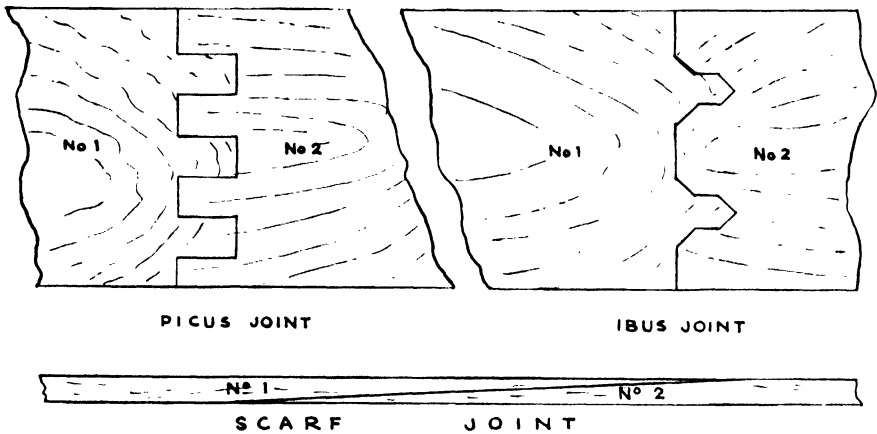

FIG. 43.

The manufacturers of the Ibus laminboard used a similar method in the building up of their core stock. The illustration shows the three methods of jointing which have been mentioned.

#### (d) REPAIRING VENEER

Veneers which have split badly during the drying process are generally re-cut into two or more pieces of narrower veneer on a foot-operated guillotine, and thereafter jointed in the usual way.

#### PLUGGING OR PATCHING

The appearance of the lower grades of Birch and dry-cemented Alder plywood has been greatly improved during recent years by excising the larger and unsound knots and filling the resultant spaces

with plugs of sound veneer of similar colour and texture to that of the surrounding wood. The Oregon Pine manufacturers adopt a similar device, but as labour on the American continent is so much more highly paid than in the Baltic States, Poland and Finland the number of patches inserted into any sheet of Oregon veneer very rarely exceeds four, whereas some sheets of European Birch plywood may have as many as twenty-five on each face. One would imagine that it would be cheaper to discard such veneer, but as the work is performed by girl labour the actual cost of removing the knots and inserting the plugs is very small. It will be recognized that the extent to which a defective or knotty veneer can be economically improved by plugging depends entirely upon the scale of wage paid to the operators and on the use for which the plywood is intended. With highly paid labour the point at which it is cheaper to use veneer for core stock than to attempt to repair it is very quickly reached.

In Finland and the Baltic States the removal of knots and defects is generally done by die or hand punch. These are of various sizes and shapes, generally round, oval or diamond. The round punches are easily made from steel tubing, one end being cut to an inside bevel by a tapered reamer, the steel being afterwards hardened and tempered.

The veneer is held over a round block placed on its edge so that when the die is tapped against the end grain of the wood of the block a clean cut is obtained. It is vital that chipping be avoided. The girls performing this work soon become expert and cover a sheet of 60" x 60" veneer very rapidly. This is passed to another operator, who just as rapidly inserts the plugs.

A stock of patches to fit the different sizes of dies, selected into various shades of colour and grain, should be at hand so that the operator can select the patch most suited to the colour of the veneer being repaired.

In some mills the edge of the plug is glued before insertion: in others the patches are held in place by gummed tape, sufficient glue being forced between the edge of the plug and the veneer during the pressing to seal the edges and ensure a lasting joint.

The manufacturers of Oregon Pine find it advisable to cut the plugs in the shape of a gunboat with pointed ends. This makes the patch much less conspicuous than when round or oval, the longitudinal hard and soft grain being given a better opportunity of blending into the surrounding veneer. The defects are generally cut out by a small router or by barrel saws, the cut being made on the bevel. The plugs are similarly cut, and when these are glued and tapped or pressed into place a very close fit is obtained. The workmen become very expert in

selecting patches which will harmonize with the surrounding veneer, and are highly paid. During the year 1938 "patchers" on the Pacific Coast of America earned up to \$1.00 per hour while in Finland the average wage paid to girls doing similar work was Finnish marks 5 per hour! The American costs at pre-war rates of exchange were, therefore, approximately nine times higher than the Finnish. Machines are now available which not only cut out the defects but also insert the patches.



*By courtesy of Messrs. H. Morris & Co. Ltd.*

FIG. 44.—A WELL-LAID-OUT ROOM FOR EDGE-JOINTING VENEERS.

When the patched veneers are pressed, the plugs are firmly held to the adjacent core or cross-banding. All plugged boards must be sanded—on no account should they be scraped—and a perfectly flat surface results, suitable for painted or for veneered work.

It is generally inadvisable to stain patched boards as an excess quantity of stain is apt to be soaked into the joint where the edge of the plug meets the surrounding wood, and this tends to show up the patch in a conspicuous manner.

## CHAPTER VII

### ASSEMBLING

At the beginning of each shift the Production Manager issues his orders to the storage department which is responsible for keeping the assembly crews supplied with the requisite face and core veneers to enable them to produce the thickness, size and quality required.

A load of veneer for outer plies is conveyed on a lifting truck or trolley to the glue-spreader and placed within easy reach of the "layer



*By courtesy of Lync Plywood Works Ltd.*

FIG. 45.—SPREADING THE ADHESIVE AND ASSEMBLING THE VENEERS.

up" who stands on the discharge side of the machine. A similar load of core stock is available at the loading side. The method of "laying up" for hot pressing varies in certain details from stocks to be pressed cold.

### HOT PRESSING

An empty platform truck is positioned as indicated in Fig. 45, and a supply of metal or wooden cauls is made available nearby. The

“layer up” places a caul on the truck and on this a sheet of veneer, face side down. The core-stock veneer is then passed through the spreader and an even layer of glue applied to both sides. It is accepted by the “layer up” as it emerges from the rollers and carefully laid upon the face veneer with the grain running at right angles to that of the face. Cores may be in single sheets of similar size to the outer plies or in several narrow pieces to make up the same area. In the latter event the greatest care must be taken to ensure that the pieces are carefully butted together and that one veneer is not allowed to “overlap” the other. Gaps between the pieces must also be avoided. Any glue removed from the veneer or displaced during handling must be carefully re-spread by hand.

A second outer ply is laid over the glued core with grain running parallel to that of the first face veneer. Two cauls are placed over the assembled veneers and the process repeated until as many assemblies have been made as will fill the openings of the hot press. Five and seven plies are assembled thus :—

5-PLY BOARDS				7-PLY BOARDS			
Caul				Caul			
Face veneer . . . .		l.g.		Face veneer . . . .		l.g.	
Glued cross-banding . . . .		c.g.		Glued cross-banding . . . .		c.g.	
Core . . . . .		l.g.		Veneer . . . . .		l.g.	
Glued cross-banding . . . .		c.g.		Glued core . . . . .		c.g.	
Face veneer . . . . .		l.g.		Veneer . . . . .		l.g.	
Caul				Glued cross-banding . . . .		c.g.	
				Face veneer . . . . .		l.g.	
				Caul			

l.g. = Length-grained  
c.g. = Cross-grained

When working on thin 3-ply boards two panels are frequently “laid up” between each caul and in this case the assembly will be :—

Caul			
Face veneer . . . . .		l.g.	
Glued core . . . . .		c.g.	
Face veneer . . . . .		l.g.	
Face veneer . . . . .		l.g.	
Glued core . . . . .		c.g.	
Face veneer . . . . .		l.g.	
Caul			

Immediately batches are ready they are removed to the presses. The greatest care must be taken to avoid delays which invariably result in a weakening of the glue joint.

## COLD PRESSING

The method of assembling is similar to that just described, but metal cauls are not used. The glued veneers are built up on a heavy wooden caul or retaining board generally  $2\frac{1}{2}$  to 3 inches thick. Two or three thinner cauls of  $\frac{3}{4}$  or  $\frac{7}{8}$  inch plywood are placed at intervals between the assemblies which are laid one atop the other until the mass is about 36 inches high. A second retaining board is added before the pile is transferred to the hydraulic press.

## CAULS

Retaining boards should be  $2\frac{1}{2}$  to 3 inches thick and are generally formed by gluing together three or more boards of thick plywood. These must be flat. Retaining boards are used only in the cold pressing operation.

Oregon Pine plywood,  $\frac{1}{2}$  inch or  $\frac{3}{4}$  inch thick, makes an excellent caul for cold pressing and is largely used for this purpose.

Cauls for hot pressing are generally of sixteen-gauge zinc or aluminium, the latter metal being preferred on account of its lighter weight. Metal cauls must be of even thickness and be handled with care as any surface dents will reflect themselves in every panel which comes in contact with the caul in the press.

For making very thin aircraft plywood, plywood cauls are frequently used. 4-mm. Alder plywood serves well, provided boards are selected which are free from core gaps or overlaps.

Plywood cauls used in the hot press have the decided advantage of being light in weight and, as they take up heat from the lower platen before transmitting this to the glued assembly, the worry of getting the press closed quickly is greatly reduced. Plywood cauls should be kept well waxed with a mixture of beeswax and tallow in equal parts, or paraffin wax and kerosene melted and applied hot. By so doing the deposit of glue during pressing will cause less trouble than if cauls are left unwaxed.

Fibre-board cauls are also used, but these are apt to twist and do not last as long as plywood or metal ones. Cauls and retaining boards must be kept smooth and clean, and all glue deposit must be scraped off before re-use.

## CHAPTER VIII

# ADHESIVES AND THEIR APPLICATION

## INTRODUCTION

“The glueing of Plywood is an art requiring meticulous care and precision to ensure a satisfactory product.”—*U.S. Dept. of Commerce Bureau of Standards.*

THE strength or weakness of any plywood depends upon the bond holding the various plies together, and an understanding of this process is essential to dealers and users alike.

We have all at some time or another glued two pieces of wood together, but how many have ever paused to consider the mechanics of adhesion which play such a vital part in the manufacture of plywood.

All matter, whether solid or liquid, is built up of innumerable molecules held together through an inherent power of mutual attraction. This molecular force is known as cohesion. Naturally the stronger the power of attraction the greater the resultant cohesion, and herein lies a fact of paramount importance, for upon cohesion depends the strength of any body.

The term *adhesion* is generally used to describe the same force operating between separate bodies in such intimate contact that molecular attraction, which can act only over the minutest distance, becomes effective.

Two further facts must be noted :—

- (1) As explained in Part II., Chapter II., wood shows a great affinity for moisture. Advantage is therefore taken of this knowledge by applying, in most cases, adhesives in a fluid or viscous state.
- (2) The cohesion of liquids is smaller than that of solids. Hence it is obvious that as a liquid glue begins to dry so the increased molecular attraction results in greater cohesion, until the maximum strength is attained when the adhesive solidifies.

Applying the foregoing principles to the bonding of plywood it is reasonable to assume that the cohesion of a good glue or other adhesive,

when set, should be equal to, or preferably greater than, the cohesion of wood. In everyday language, the solid glue should have greater mechanical strength than the wood itself.

Let us return now to a consideration of our two pieces of wood.

To obtain a sound joint the glue in a suitably fluid state is spread evenly over the wood. The two surfaces are laid together and pressure applied in order to obtain the necessary close contact which will allow molecular attraction to play its part.

What happens now is that the glue is forced into the hollow spaces between the fibres of the wood. The glue does not penetrate the cell walls but merely enters the exposed openings of all cavities, at the same time retaining its own continuity. It should now gel—*i.e.* become semi-solid—and subsequently harden into a solid mass anchored firmly to the wood fibres.

In addition to the force of molecular attraction, a certain keying effect is obtained. From the description given it may be possible to visualize a layer of solidified glue from which appear on both surfaces countless tiny tentacles which have penetrated and twisted themselves around the wood fibres.

Good glue is stronger than the material supplied by the growing tree to bind the wood fibres together, and consequently when the glue has effectively penetrated the texture of the wood the entire wood structure is strengthened.

## GLUES AND CEMENTS

In the manufacture of plywood and the affixing of decorative veneers to plywood boards, the adhesive used may be in the form of a true glue or a cement. The former sets when the excess moisture is eliminated through pressure, or, in some cases, through heat. The active chemical composition does not change, the process of setting being merely mechanical. In consequence, a true glue will always be able to re-absorb moisture and thus can never be termed waterproof.

A cement, on the other hand, during the process of setting undergoes a definite physico-chemical change which cannot be reversed. It is in the cement group, therefore, that we must look for waterproof adhesives.

There are many well-known substances which, when dissolved or melted and applied to wood, will on drying or cooling act as adhesives. Of such substances the ones of chief interest to us are the so-called animal glues, vegetable glues, casein, blood albumin and the resins of the urea and phenolic groups. In the plywood trade, the words glue and cement have come to be applied to any of the known adhesives. For example, reference is frequently made to a resin film glue, whereas



in the strict use of the word no synthetic resin should ever be classified as a glue.

For a detailed description of the manufacture of the older types of adhesive the reader is referred to one of the many excellent textbooks on the subject. We shall merely attempt to describe matters which are of interest to users and buyers of plywood.

#### (a) ANIMAL AND HIDE GLUES

These have been used for gluing wood for many centuries. The best grades possess strong adhesive properties and are very dependable. Their chemical composition is complex.

The glue manufacturer draws his raw material from the slaughter-houses in the form of hides and skins (which are not up to the standard demanded by the tanneries), bones, ears, snouts and other trimmings. On arrival these are washed and subsequently undergo a somewhat lengthy treatment with lime in open pits. The subsequent manufacturing process is a very difficult one which does not really concern us. Users are recommended to purchase only a high-grade hide or skin glue from a well-established manufacturer.

*Preparation.*—The consistency of hide glue may be varied according to the density of the wood to be glued and to the type of work on hand, but too concentrated a form must be avoided at all times. Once the desired mixture has been decided the quantities of both glue and cold clean water should be carefully measured and placed in a sterile vessel. In practice it will be found that one part of glue will absorb two or at most three parts of water. It is essential that the glue be completely covered by the water and after two or three hours it should be quite soft: for convenience, many woodworkers allow the broken glue to remain soaking overnight. It is ready for melting when uniformly soft. This is done in double water-jacketed glue-pots, care being taken to prevent the temperature of the glue rising above 150° F. until completely melted, when the heat must be reduced and the temperature kept below 140° F. At higher temperatures the glue commences to lose strength and decompose rapidly. Steam or gas-heated pots are frequently used as they enable the heat to be carefully and easily controlled; on no account should the heating be done over an open flame. The glue should be frequently stirred while melting, and during the course of the day further supplies of soaked glue can be added to the pots, care being taken to allow the supply to run out as closing time approaches. Hide glue should be prepared daily and at the end of each working day all surplus glue should be discarded and the vessels used

both for soaking and heating, carefully cleaned with boiling water in readiness for the following day. Glue left over in the pots is a common source of trouble.

*Application.*—Owing to the necessity of keeping hide glue at the normal working temperature of something under 140° F., a special type of heated trough mechanical spreader is required. Hide glues are frequently applied by hand. Veneer to be laid should be dried to 8 to 12 per cent. moisture content, and for easy working kept moderately warm. Should the glue be allowed to chill before the application of pressure the bond will not be reliable—heated cauls are generally used as a safeguard against this risk of chilling.

A pressure of 150 lb. per square inch is ample and should be retained by clamps for at least five hours. When used in the hot press the platens of the press are heated and, once pressure has been applied, cold water is passed through the platens to assist the glue to “set.” After removal from the press the boards should be allowed to lie overnight before any attempt is made to dimension or sand the glued panels.

Scotch hide glues do not stain fragile veneers but are liable to penetrate some of the light-coloured woods such as Avodiré, Sycamore and Maple. They are neither heat nor water resisting and their chief function in the factory is for laying fancy veneers to plywood cores, for jointing the edges of face veneers or core stock and for applying hardwood strips to the edges of panels or flush doors.

The necessity for scrupulous cleanliness in the glue room cannot be overstressed. As a general rule in wood-working factories insufficient attention is paid to this point, and hide glue is treated as a useful but “dirty” glue. When any disagreeable smell is noticed, the glue must be treated as suspect; a thorough cleansing of both glue brushes and pots should be undertaken at once.

### (b) CASEIN

The curd of milk was used by the Egyptians in the days of the Pharaohs for gluing papyrus, for fixing pigments, and for affixing ivory, metals and precious stones to wood. Casein glues of great efficiency are still produced from this same substance, such glues being largely used in the manufacture of plywood, in veneer shops, in cabinet-making and general joinery work.

It may be of interest to record the fact that the first patent for a waterproof casein cement was granted to Mr. Christian Luther, of Reval, in the year 1892.

Casein exists in milk in a state of suspension as a colloid; when milk

sours it separates in the form of the well-known curd. The fat content in the higher grades of casein must not exceed 1 per cent., and for this reason skim milk is invariably used in the production of commercial casein. The coagulation is done in large vats and generally is accelerated by the addition of rennet, weak lactic, sulphuric or hydrochloric acid. After precipitation the curd is carefully washed, pressed, dried and ground to one of several defined grades of fineness. Commercial casein is exported to all the plywood-producing countries from the Argentine. It is also manufactured in France, Holland, New Zealand and elsewhere.

Casein is delivered to the plywood factory as a fine dry powder, white or pale cream in colour ; it should be sweet-smelling, and for easy mixing should pass through a 50-mesh sieve.

There are many types of casein cement on the market which are made by mixing different grades of casein with lime, sodium silicate, borax and other chemicals to the patent and often secret formulæ of the various manufacturers.

The choice of casein mixture will depend upon the species of wood to be glued, the method of application and of applying pressure, the time of setting and degree of water resistance required.

Many woodworkers now find it unnecessary to prepare their own casein cement and prefer to purchase one of the reliable proprietary brands on the market. These can be purchased ready mixed and in fresh condition in quantities as may be required from 1-lb. tins to 1-cwt. drums. The preparation of these casein mixtures is a simple matter. The quantities of powder and water should be carefully measured, and the directions of the manufacturers carefully carried out.

The chief advantages offered by casein mixtures are :—

- (a) they can be prepared and used at room temperature,
- (b) they can be applied by hand or by mechanical spreader,
- (c) they are resistant to heat and cold,
- (d) they can be used without the necessity of heated cauls,
- (e) they can be prepared for both hot and cold pressing.

On the other hand, being alkaline, casein cements give a dark glue line to certain woods and are apt to cause staining in woods rich in tannic acid, such as Oak and Mahogany. It is possible, however, to prepare a type of casein which reduces the danger of staining, but it is a well-known fact that by reducing the elements which cause staining the water resistance of the glue is invariably diminished.

When working with thin veneers a quick-setting glue with reduced alkali content should be used and both pressure and time of pressing reduced to a minimum.

It is advisable to use a mechanical mixer when preparing all types of casein glue.

*Spreading and Pressing.*—Casein glues may be applied by mechanical spreader or by hand, using a brush. It is recommended that operators handling glued-up veneers or panels should be supplied with strong rubber gloves as the alkali in the glue will cause irritation and damage to the skin of the hands.

The amount of glue required to effect a satisfactory bond must be gauged by practical experience. Too heavy a spread should be avoided as this is wasteful, will cause excessive staining, and make re-drying more difficult: too thin a spread, on the other hand, will result in starved joints and blisters. The happy medium is what is required.

During pressing, the excess glue should be squeezed to the edges of the panels and appear as a series of fairly small beads; if a continuous line of glue is formed, the spread is too heavy: if no glue shows up at the edges, it can be assumed that too light a spread has been applied.

It is essential that glued-up panels be placed under pressure within fifteen minutes after the application of glue, otherwise blisters and starved joints are certain to result.

The force of pressure and length of application will vary considerably depending upon the type of work, moisture content and condition of the veneer, consistency of the glue, weight of spread and other factors.

When working with thin Oak, Mahogany or Walnut, burrs or curls—veneers which are liable to stain—pressure should rarely exceed 75 lb. per square inch, and the time of pressing be restricted to two hours. In order to lessen the risk of staining, it is advisable to use a thicker glue mixture and apply more lightly than usual.

Special casein cements are available for use on the hot press, and the manufacturers of these adhesives issue full instructions for use with their various mixtures. These can be made up to meet special requirements.

In several plywood-manufacturing countries, producing Birch and Alder plywoods, casein is used in conjunction with blood albumin in hot presses and yields a highly satisfactory bond.

### (c) SOYA BEAN GLUE

The Manchurian soya bean has given to the world a very varied assortment of products, including an interesting glue of the casein type

which is used in very large quantities by the manufacturers of Douglas Fir plywood.

In the year 1937 it was estimated that at least a billion square feet of plywood had been manufactured in the Pacific Coast plywood plants with this adhesive.

Soya bean glue has been used in preference to casein mixtures by the majority of Douglas Fir plywood producers since 1923.

*Manufacture.*—Once the valuable oil has been extracted from the bean, the residue undergoes a patented refining process, various chemicals being added. It is delivered to the plywood mills in the form of a whitish powder and is prepared for use by mixing with water and additional reagents as directed by the manufacturers' specification supplied with the powder. All plants employ experienced men to mix the adhesive, and variations of the formula are worked out to meet the degree of water resistance required and other specific conditions.

*Application.*—Soya bean glues give an alkaline reaction and in consequence are liable to stain fancy veneers. The glue is mixed cold and applied by a double roll spreader in the normal way. Care is required in assembling Douglas Fir plywood, because if gaps are allowed to occur in laying the core stock, a superfluity of glue may gather at the gap when, under certain conditions of humidity and if the adhesive is over alkaline, staining may result and show up on the face veneer in the form of a bluish or dirty brown band.

Pressure of between 125 and 150 lb. per square inch should be applied in a cold hydraulic press as soon as possible after gluing. The assembly time must not exceed twenty-five minutes and the pressed batch should remain in the clamps for at least eight hours. Soya bean glue gives a reddish colour to the glue line.

#### (d) RESIN ADHESIVES

The preparation of synthetic resins for use as wood adhesives is intricate work demanding the supervision of a skilled chemical engineer, and it is not the intention in this review to enter too deeply into what is a complex chemical process. However, it is necessary that the functions of artificial resins as bonding agents be properly understood.

The leading producers of resin adhesives supply detailed working instructions with their products, and many employ chemical engineers whose task it is to demonstrate the performance and adaptability of their adhesives on equipment belonging to prospective clients. The latter are strongly recommended to take full advantage of such services.

Synthetic resins demand greater accuracy in application and treat-

ment than any of the other adhesives in general use, but they do offer distinct advantages, the chief of which is all-important—a more reliable waterproof and fungus-proof bond. This development has opened up wonderful new fields to the plywood manufacturers.

In addition to the advantages just mentioned, resin-bonded plywoods are strongest at the point where commercial plywoods are weakest—the glue line—and they do give to the engineer and designer what is to all intents



*By courtesy of B.C. Plywoods Ltd.*

FIG. 46.

Resin-bonded Douglas Fir plywood is largely used for outdoor signs. It holds paint well and is not easily damaged by missiles.

and purposes a new material which may be expected to render service within the physical limitations of the wood of which it is composed.

The suggestion that phenol-formaldehyde resin could be used as wood adhesive was made in America about 1912 by Dr. Baekeland who gave his name to the moulded products known as bakelite which were bonded with artificial resins of the phenolic group. Some experimental work followed and in 1918 a thin sheet of paper impregnated with a phenolic resin made its appearance. It was not until twelve years later, however, that a resin film was produced in Germany in a form

suitable for commercial application in plywood mills. When first marketed this film was expensive and as a result was used only in high-quality productions of waterproof plywood for aircraft, boat-building, etc. It was followed by preparations of phenolic resins in other forms, e.g. as an emulsion in water, a varnish soluble in acetone or alcohol and as a dry powder; later various types of urea resins and vinyl esters were introduced to a receptive market.

As the demand increased, manufacturing costs were reduced and, immediately prior to the war in 1939, resin adhesives were commonly used in plywood and veneering plants both in Europe and America.

Plywoods produced with synthetic resins naturally command higher prices than do stocks cemented with casein or blood albumin and casein mixtures but the increase demanded immediately prior to the war was very reasonable; in the case of Gaboon Mahogany, for example, it was limited to between 5 and 10 per cent. The extra charge was based on the superficial area of glue line in each board.

PREPARATION OF SYNTHETIC RESINS.—Phenols and their homologues (e.g. cresols), also primary amines, urea and casein yield resin formations in reaction with various types of methylene condensation products such as formaldehyde. Such resins may vary considerably according to the relative quantities of raw materials used and to the general conditions governing their preparation. Phenol (carbolic acid) and formaldehyde are commonly used to produce, by chemical synthesis, what are known as the “phenolic” or “phenol-aldehyde” resins. The reaction takes place in three distinct stages, the second and third being of principal concern to users of resins as wood adhesives. While in the second, frequently termed the “reactive” or “resitol” stage, phenolic resins are insoluble in water, but may be dissolved in solvents such as alcohol or acetone; certain forms of urea resin on the other hand are soluble in water when in a similar stage of condensation. Both are thermo-plastic and thermo-hardening, that is to say they become plastic when heat is applied and then “set” to a hard, inert mass as polymerization takes place under continued heat action.

This final change to what is known as the “resite” stage is commonly called the “cure” or “hardening” of resin. It takes place in the hot press, and the quicker this final conversion can be completed the more satisfactory will be the resin as a wood adhesive.

In its final state phenol-aldehyde resin is infusible and insoluble except in concentrated alkalis. Urea resin is insoluble in water under 100° F. but, as a general rule, at higher temperatures a certain solvent effect is apparent which increases as the temperature rises.

In the preparation of resin adhesives the reaction is arrested when

in the "resitol" stage and the resins produced by the condensation process are refined and made into suitable forms (as, for example, films, varnishes or fine powders) to be used by the plywood and veneering plants. The actual manufacturing processes are invariably patented, and it is advisable that the manufacturers' instructions be followed carefully.

**PREPARATION OF RESIN FILMS.**—There are several types of resin film available, one of which has continued to retain its pride of place for a number of years.

Thin sheets of tissue paper or other paper of a porous nature are impregnated with a phenol-aldehyde resin frequently in varnish form.



FIG. 47.

Many of these signs have been exposed to the weather for four years and are still in perfect condition.

The paper may be dipped into the varnish or the latter sprayed or painted on to the carrier. The solvent is then evaporated off, leaving a thin even coating of solid resin in the "reactive" stage on the paper, thus giving the description "film" to the product. The greatest care must be taken to prevent any film from passing inspection which has any spots not completely impregnated.

Synthetic resins cannot be employed in film form in such an advanced reactive stage as varnishes, and as a rule they require a certain amount of moisture in addition to heat to effect plasticization. This moisture is supplied by the veneers during the pressing operation.

Resin films require modern hydraulic presses on which the necessary heat and pressure can be raised rapidly and accurately. They do offer



certain advantages and several manufacturers prefer this type of resin adhesive to any other. They are not inexpensive.

By using a good brand of resin film the plywood or veneer panel manufacturer can be certain that every square inch of veneer in an assembly receives an equal quantity of resin and that the moisture content of the mass prior to pressing has not been changed as invariably is the case when using "wet" adhesives.

The operation consists of cutting the resin film to requisite size, placing it between the veneers to be bonded and inserting the assemblies between the platens of the hot press where they are subjected to a specific pressure of about 300 lb. per square inch and a temperature of at least 266° F. The pressure is varied to suit the density of the veneers to be bonded, the guiding principle being the softer the wood, the lighter the pressure. The pressing time may be shortened and the water resistance of the glue slightly increased by pressing at higher temperatures. The harmful action of excessive heat on certain woods such as Walnut should be kept in mind when the use of high temperatures is contemplated.

As a rule, boards bonded with the well-known "Tego" resin film do not require any special treatment after pressing. The hot boards should be piled, using distance pieces in the manner described for re-drying hot pressed plywood and allowed to stand in the drying-room until equilibrium is reached. Used in an intelligent manner, resin films yield joints which are chemically inert, insoluble in water and impervious to attack by bacteria or fungi.

**RESIN IN VARNISH FORM.**—Phenol-aldehyde resin dissolved in denatured alcohol or acetone in the form of a varnish may conveniently be applied to veneer on a mechanical glue-spreader adapted for the purpose, or by spraying, brushing or dipping.

Resin adhesives in this form yield highly satisfactory results.

The early difficulties which were experienced in spreading resin varnishes have been overcome and specially designed automatic spreaders are now available which apply a thin even coating of resin to all but badly buckled veneers.

Phenolic resin in an advanced reactive state is stable at normal factory temperature, but by adding a catalyst or accelerator to a stable alcohol-soluble resin before spreading the hardening is assisted and both curing temperature and curing time can be reduced within certain limits. This is a matter of major importance which brings alcohol-soluble phenolic resins into the forefront of plywood adhesives. The setting time can be speeded up to such an extent that the output of the press is limited by the rapidity with which assemblies can be built up.

Alcohol-soluble phenolic resins are available in the form of a fine

powder, a thick syrup of stated resin content or a varnish prepared for factory use. Catalysts when required are supplied with the resin in separate vessels.

A typical example of this group of resins is marketed under the trade name of "Catabond." This liquid phenolic resin adhesive is delivered ready for use. It may be applied as received or mixed with varying amounts of wood or rye flour in order to stretch it. The percentage of both filler and catalyst may be varied within certain limits to suit the porosity of the veneer to be glued and the spread required.

Particular care must be taken to prevent any undue rise of temperature in the glue-spreading room, otherwise evaporation of the alcohol will be rapid. The resin will then thicken and become difficult to spread.

One of the best features of alcohol-soluble resin adhesives is that the moisture content of the dried veneers is altered only slightly by the application of the varnish. The moisture content of the veneer after spreading should be between the limits of 7 to 12 per cent. An interesting table showing the shear strength of alcohol-soluble resin bonded plywood is reproduced by the courtesy of Messrs. Catalin Ltd. :—

Moisture Content.	Platen Temp.	Net bonding time in minutes.					Test sample.
		2	4	6	8	10	
		Shear Strength lbs. per square inch.					
7 to 9 <sup>o</sup>	300 <sup>o</sup> F.	195	310	370	415	420	1
"	"	250	350	390	425	430	2
"	"	250	370	395	430	440	3
"	"	260	400	470	430	450	4
"	"	295	420	470	450	485	5
	Average	250	370	419	430	445	

Veneer constructions used for above shear tests is 3-ply  $\frac{3}{16}$  inch Birch suggested by Forest Products Laboratory at Madison, Wisconsin, accepted and used in the specification for aircraft of the U.S. Army and Navy. Shear tests were made in a Riehle machine on wet samples after thirty minutes' boiling. Test specimens were picked at random and laminated under a specific pressure of 250 lb. per square inch.

From this it will be noted that the length of bonding time has a marked effect on the shear strength of the resultant plywood.

When laying Avodiré or other fragile face veneers liable to stain the bonding process may be varied by allowing the solvent in the varnish

to evaporate off, once it has been applied to the core. The resin will become tacky to the touch and when in this condition the face veneers can be laid.

The bond obtained is completely waterproof and will resist attacks by termites, mould and bacteria.

Alcohol-soluble phenolic resins are also suitable for application to the faces of plywood boards—a process described elsewhere.

RESINS IN EMULSION AND COLLOIDAL SOLUTION.—A considerable number of patented adhesives may be included in this group in the form of aqueous emulsions of water-insoluble heat-hardening synthetic resins and water-soluble alkaline resins. Considerable quantities of these types of adhesives are used both in plywood mills and veneering plants.

The resins may be supplied as a finely ground powder or as an aqueous dispersion in colloidal form. They may be extended by a filler such as rye flour and invariably the curing is assisted by a catalyst or hardener.

The introduction of moisture into veneers before pressing must be more carefully controlled when working with resin adhesives than with casein, but provided care is taken in this respect, excellent results can be obtained with resins in colloidal solution or emulsion.

One of the original adhesives in this group known as “Kaurit” was developed in Germany and since its inception has been so largely used in the plywood industry for shipbuilding and railway work that a description of its particular function is necessary.

During recent years, “Kaurit” has been manufactured in England and it is now marketed under the trade name of “Beetle” Cement W. This is a resin of the urea-formaldehyde type supplied in liquid form. It must be used in conjunction with liquid or powder hardeners, a large range of which is available to suit different requirements. A special powder-hardener was developed by British chemists which gives to the adhesive the added property of withstanding boiling water; joints so made comply with British Standards specification 5V3.

When thoroughly mixed, a very thin layer of resin is applied to the core stock on a rubber roller or finely engraved steel roll automatic spreader. The resin is cured in the usual hydraulic press at a temperature of 195° to 212° F. and a pressure of 30 lb. per square inch or more, depending upon the density of the wood. Full strength Beetle Cement gives a waterproof bond of equal strength to the average phenolic film.

Both in plywood plants and veneering factories, when a waterproof bond is not essential, considerable savings can be effected by extending

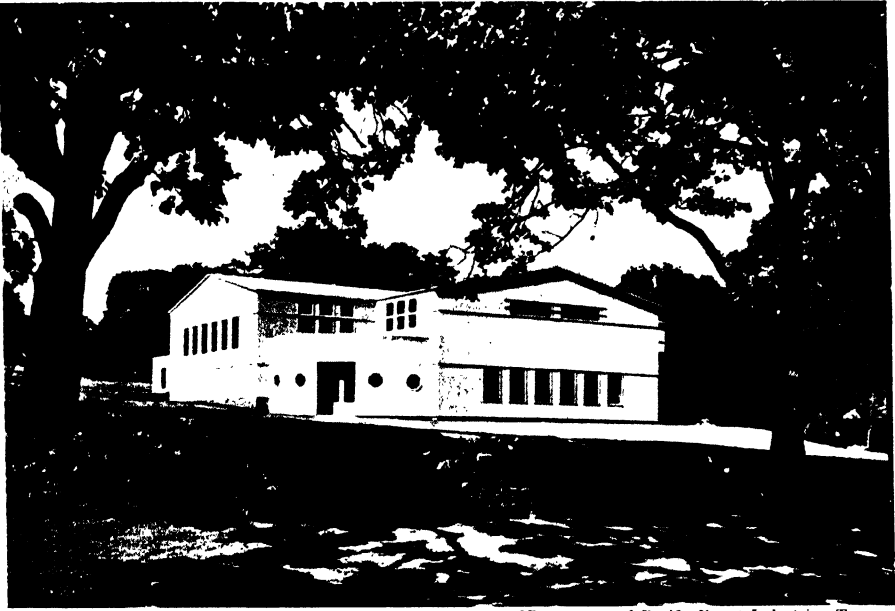

*[By courtesy of Pacific Forest Industries, Tacoma.]*

FIG. 48.—GYMNASIUM AND AUDITORIUM AT WHITE SALMON, WASH., U.S.A.  
The beams, sheathing, exterior walls, roof and interior panelling are all constructed with Oregon Pine resin-bonded plywood.



*[By courtesy of Pacific Forest Industries, Tacoma.]*

FIG. 49.—A PETROL-FILLING STATION CONSTRUCTED WITH OREGON PINE  
RESIN-BONDED PLYWOOD.

the cement with rye flour. This acts as a filler when working with porous woods and enables the glue to be more easily spread.

The glue joint resulting from the extended cement is almost as strong as that obtained with full strength "Beetle," and its water resistance is still superior to that of a good casein. The maximum strength is reached after forty-eight hours.

A development of some importance in this field was the discovery that an adhesive possessing certain novel characteristics could be produced by the reaction of urea and formaldehyde in the presence of zinc chloride. The method of manufacture is patented, the product being marketed in the form of a white powder under the trade name of "Lauxite."

An interesting point in connexion with this resin adhesive is that the zinc salts (which are commonly used in fire retardant processes) give some protection to the bonded veneers by introducing a film of fire-resistant material between the wood plies. The bond is infusible and insoluble in all known solvents but it does not withstand prolonged boiling. It is proof against fungus and mould.

Coniferous woods present different problems to the glue technician from those arising with hardwoods, and much experimental work has been done on the Pacific Coast of America in an effort to produce reliable waterproof adhesives for the Douglas Fir plywood industry.

One excellent adhesive for this purpose is prepared by reaction of metacresylic-acid and formaldehyde in the presence of caustic soda. The condensation product is soluble in water when in a certain state of alkalinity and is applied to veneers of low moisture content by mechanical glue-spreaders.

The resin is cured in large hydraulic presses at temperatures about 320° to 340° F., the pressure used when manufacturing Douglas Fir plywood being about 175 lb. per square inch.

A feature of this production is the so-called "tempering" process which the panels undergo after pressing. They are stacked in the usual manner on kiln trucks and subjected to an atmosphere of high relative humidity in special drying-rooms in which the temperature may be varied between 150° to 210° F. The comparatively high temperature tends to soften the wood fibres, and by so doing the stresses set up during pressing are relieved. The panels are subjected to this special kiln treatment until the moisture content is raised to the desired level, generally between 6 and 12 per cent.

The bond produced by this patented process is absolutely insoluble in water and is proof against fungus, mould and bacteria.

**RESIN GLUES FOR COLD PRESSING.**—Numerous adhesives with a phenolic or urea resin base which can be used with satisfactory results

in the cold press have been developed recently. Cold resin glues are not consumed to any large extent in European plywood mills, but their use is becoming more general in furniture manufacturing and also for veneering, door-making, general joinery work and aircraft construction.

As a general rule, the factory practice is to apply the hardener to one of the surfaces to be glued and the cement to the other.

It is reasonable to expect further and important advances to be made in the field of resin adhesives suitable for cold pressing.

Users and prospective users of resin adhesives are advised to experiment thoroughly on their own plants with the various types available before deciding which form best suits their individual operation. Then by a system of trial and error they should determine the conditions of moisture content of veneers, thickness of glue spread, pressure, temperature and time of applying pressure, under which their own production is best served.

Authorities agree that most consistent results are obtained with resin film and varnishes if the moisture content of the veneers is kept within the limit of 7 and 10 per cent. at the time of spreading. The other conditions mentioned are variable and demand most careful consideration.

The object will be to select an adhesive which will react quickly to heat and pressure yielding the strongest possible bond in the shortest possible time with the least loss through compression of the wood.

Buyers of resin-bonded plywoods should keep in mind the difference between full strength and extended resin adhesives. The former only should be used for exterior work and naturally enough command the higher price.

### (c) MECHANICAL GLUE-SPREADERS

The economical consumption of glue in the plywood factory is of great importance as this constitutes one of the major items in the cost of production.

With the increased use of expensive resin adhesives the necessity for preventing waste becomes of still greater importance.

Considerable improvements in the design of mechanical spreaders have been made during recent years and precision machines are available at reasonable cost. These have been developed to lay an even spread of adhesive to one or both sides of a veneer, and when it is remembered that many veneers are anything but flat the difficulties of the engineers will be appreciated. Plywood-making machinery is a specialized business, and those firms who have spent much time and labour in the development of machines for the industry are worthy of every support.

The rolls are made of steel, must be uniform in diameter and suffi-

ciently rigid to prevent any deflexion if small pieces of veneer are entered at one side or the other. Steel rolls are engraved in a variety of ways ; the corrugations may run longitudinally or spirally and must be evenly cut. For resin glues the steel core is frequently covered with rubber corrugated in similar manner to the steel rollers. The advice of the glue manufacturer on the most effective type of corrugation to spread his adhesive may be worth taking.

The rolls revolve in troughs containing the adhesive kept to a proper consistency. In the case of hide glues they must be kept to a temperature of approximately 140° F. which calls for an efficient electrical heating unit capable of fine adjustment.

The thickness of the spread is controlled by doctor rolls which run at a surface speed a shade slower than that of the glue rolls and so provide a wiping action. A point of importance in considering mechanical spreaders is that the adjustment device controlling the glue spread must be simple and accurate in operation.

It is of vital importance that every glue-spreader be kept clean and the corrugations kept free from chips or hardened lumps of glue.

On the modern machine the upper trough is refilled by a mechanical pump ; on some of the older types this operation is done by hand.

## CHAPTER IX

### PRESSES AND PRESSING

THAT pressure is required to make a sound glue joint is no modern discovery ; it is a fact which has been known to woodworkers throughout the ages. In the days of the Pharaohs heated stones and bags of heated sand were the means employed to give the necessary pressure.

In much more recent times the furniture craftsmen of the eighteenth and nineteenth centuries used a form of veneer "hammer" to get rid of excess glue and so obtain close contact between the two surfaces to be joined together. Later still, various types of hand clamps and screws were employed which led to the invention of hand presses. The mechanical and hydraulic presses followed.

The original method of manufacturing plywood on a hot-plate press was described in a patent granted to Christian Luther in 1896. Some four years earlier he had taken out a patent for a waterproof cement, and it was about this period that he installed in his Reval factory a steam-heated hydraulic press on which the first 3-ply boards were made.

It is of interest to note that the plates used in this press were ribbed to enable the steam to escape as heat was applied to the wet veneers. It soon became apparent that ribbing was quite unnecessary ; then smooth platens were substituted for the ribbed ones.

Mr. Henry Rutherford, the present Managing Director of Venesta Ltd., advised us that the earliest boards produced by the Luther mill were embossed by the ribbing of the plates, but that these interesting boards, which he himself had seen in Reval, were destroyed by fire some years ago.

Many improvements in design have since been made—the present-day hot-plate press being a precision-built machine of great value.

In the dry-glueing process of manufacture by which the vast bulk of plywood is produced the actual bond may be made by a cold or a hot press.

Cold pressing is the method adopted by the majority of manufacturers of Pine plywoods and is the normal system operated in British Columbia and on the Pacific N.W. Coast of America. Cold presses are largely used in many of the plywood and furniture manufacturing plants throughout the United States of America, by plywood manufacturers in Australia and Japan, and by European producers in the preparation of cores for blockboards and laminboards.



Adhesives used in cold pressing are applied in a fluid state and, as a general rule, take considerably longer to set than do those which require heat to effect the bond. Cold-pressed plywood must be carefully re-dried once the adhesive has set.

The cold press has many uses and is by far the more economical way of applying pressure if the plant is expected to produce a large variety of sizes and constructions. It demands less highly skilled labour than is essential for hot pressing, the risk of error being relatively smaller.

Plywood produced on the cold press is quite as reliable as that bonded in the hot press, notwithstanding the fact that several authorities argue that hot-pressed panels are more easily sanded and are flatter. Hot pressing is the general practice in European mills manufacturing Alder, Beech, Birch and Gaboon into multi-ply. In the production of laminboard and blockboards hot presses are used to cement the outer plies to the cores.

Since 1936 hot-plate presses have been installed in several Pacific Coast plants producing Douglas Fir plywood for exterior use. They are also becoming increasingly popular with plywood and furniture manufacturers in other parts of the United States of America, mainly due to the excellent results which have been obtained with synthetic resin adhesives. It would appear that glue technicians and chemists, catering to this larger field, are devoting more and more attention to the improvement of hot-plate adhesives.

The original cost of a hot press is considerably higher than that of a cold one of comparable dimensions. They are more expensive to operate, but do speed up production and simplify the re-drying of the finished plywood.

With hot presses, specially designed to yield the requisite output in the chief sizes it is desired to produce, expenditure on heat and power can be restricted to a minimum.

In the plywood mill both hot and cold presses are operated by hydraulic power. Many veneering plants and furniture manufacturers have laid down hydraulic presses, the most modern of which yield a very large output.

### COLD PRESSES

Hand presses are still used in small veneering shops, whilst clamps are useful for edge veneering, repair work and other minor cabinet-making jobs. Moreover, the hand-operated press is still found handy in veneering plants for odd jobs and for curved work. As a matter of interest, one such press which has given good service for many years is illustrated in Fig. 71. This press consists of three sections which can

be used separately or as one unit. Each section consists of a heavy plywood plate firmly bolted to a series of light I-beams which are held at right angles to a heavier I-section by sturdy coach springs. These help to distribute the pressure evenly over the whole area of the press. Pressure is applied by a ratchet screw. The bed of the press is mounted on bearings and can be pulled out from the upper plates to simplify loading.

Fig. 50 illustrates a simple hydraulic cold press used in the manufacture of Oregon Pine plywood. Another type of cold press built

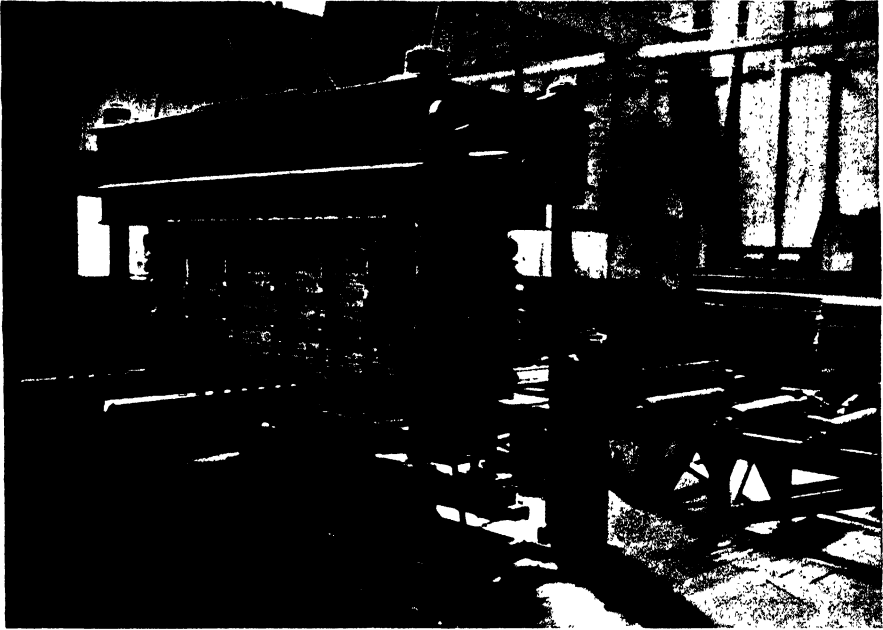

FIG. 50.—COLD PRESS, WITH CLAMPED BATCH OF BOARDS READY FOR REMOVAL TO DRYING ROOM

specially for the production of cores for blockboards and laminboards is shown in Fig. 64. The heavy-pressure heads may be of iron and cast in one piece or built up from structural steel I-beams as shown in the illustration. The lower side of the head and the top side of the lower platen must be ground or otherwise machined to yield perfectly level surfaces.

The pressure head is supported by, and securely fixed to, four steel columns—known as “strain” or “tie” rods—which rise from the base of the press. These serve as guides to a movable lower platen actuated

by two or more rams or pistons. The hydraulic power is derived from rotary or piston pumps working on a thin oil or more generally soluble oil and water. The capacity of the pumps should be sufficient to apply a pressure of at least 250 lb. per square inch of platen surface.

A gauge indicates the pressure being applied to the rams by the pumps.

The loading and unloading of the press is greatly simplified by a series of conveyor rollers which are shown in the illustration. The glued-up mass of veneers, held between heavy cauls, is positioned in the centre of the press on these rollers and I-section beams are carefully laid above and below the pile in the manner shown. Pressure is applied by setting the pumps in action, and when the correct gauge reading is recorded retaining clamps are adjusted. These clamps should be slipped over the I-beams (securing a lower beam to another directly above it) and gradually tightened while pressure is being raised.

The final tightening must be rapidly and evenly done while pressure is held at the desired level. Valves and packing of pistons must be kept in good condition, otherwise pressure may fall before all clamps are adjusted with serious consequences.

When the veneers have been pressed the press is opened and the clamped batch of veneers removed to the drying-room where it remains until the glue has properly set. In the plywood factory the batches are generally left to lie overnight, the clamps being removed in the morning when the boards are re-dried.

## HOT PRESSES

The hot-plate presses first used in Russia were crude affairs in comparison with the presses of to-day, but they served their purpose in that they supplied sufficient heat and pressure to coagulate and set the blood albumin and casein adhesives. The presses were small, hydraulically operated, heated by steam, and varied in size from 48" × 36" to 54" × 48" or 60" × 40". The pressing-room in these early plants was anything but a pleasant place. The glues were "messy" and the atmosphere during working hours appeared to consist of a mixture of steam-laden air and nasty smells. Blood albumin was not suitable for laying decorative veneers, and a development of importance was the installation of a large press by a well-known wood-working concern in Altenessen. This press (illustrated by Fig. 51) was designed for the manufacture of large veneered boards with block cores, and was installed about 1912.

The platens of the press were heated by steam. Hide glues were

used to prevent staining of the decorative face veneers, and after the necessary pressure had been applied, cold water was passed through the platens to reduce the temperature sufficiently to complete the bond. The output was very limited.

The development of the hot press proceeded more rapidly after the Great War. As new glues were evolved greater precision was called for, but the press manufacturers met each and every demand made upon them by the glue technicians.

Casein mixtures required only heat and pressure to effect the bond and, as the use of these glues became more general, press manufacturers were able to discard the cooling systems and concentrate on the more



FIG. 51.

This press with fourteen "daylights" and platens measuring 75" x 56" was the prototype of the large presses now used in the manufacture of blockboards.

rapid heating of the platens. This was an advance of major importance and the production from hot-plate presses was speeded up enormously. About 1930 another notable stage was reached when a satisfactory resin adhesive was introduced. Resin glues demanded greater accuracy, not only in regard to the temperature and pressures developed in the press, but also in the production of veneers of even thickness. Manufacturers of both hot presses and rotary-cutters rose to the occasion and produced machines which could be worked within the fine limits specified by the technical staffs of the leading plywood producers and glue manufacturers.

The illustrations show several types of hot-plate presses used in the production of high-class veneered work and plywood. Many of these

are massive machines ; the largest in the United Kingdom can produce boards with a surface area of 100 square feet, the platens measuring  $200'' \times 72''$ .

The orthodox press consists of a heavy structural head supported by four or more columns and a press table actuated by several rams of large diameter. When the press is open the plates are supported at regularly spaced intervals between the head and press table. The spaces between the open platens are known as "daylights." Closure is applied by raising the press table which lifts each platen in turn, the movement of



FIG. 52.—PISTON PUMPS.

The smaller pump is used to close the press ; the larger one builds up, and maintains, the requisite pressure.

both platens and table being controlled by rigid column guides. The columns must be of sufficient strength to prevent any deflexion of the platens and to absorb all diagonal stresses. A deflexion of  $\frac{1}{100}$  of an inch when full pressure is applied over the entire platen area will cause trouble with some forms of adhesive.

In this connexion it should be observed that only one or at the most two assemblies are placed in each "daylight" or opening and that any deflexion in the press must be taken up by a small thickness of wood. If serious deflexion occurs uneven pressure will be applied to certain areas which may result in faulty gluing or in the crushing of the wood

fibres in particular spots. This is in contradistinction to the cold press in which any deflexion of the head is distributed over a thickness of 30" to 36" of assembled veneers.

The columns may be placed at the corners, sides or ends according to the design of the press and the method of loading. Side-loading offers several advantages to the plywood manufacturer whereas end-loading is very frequently preferred where production is confined to blockboards and laminboards.

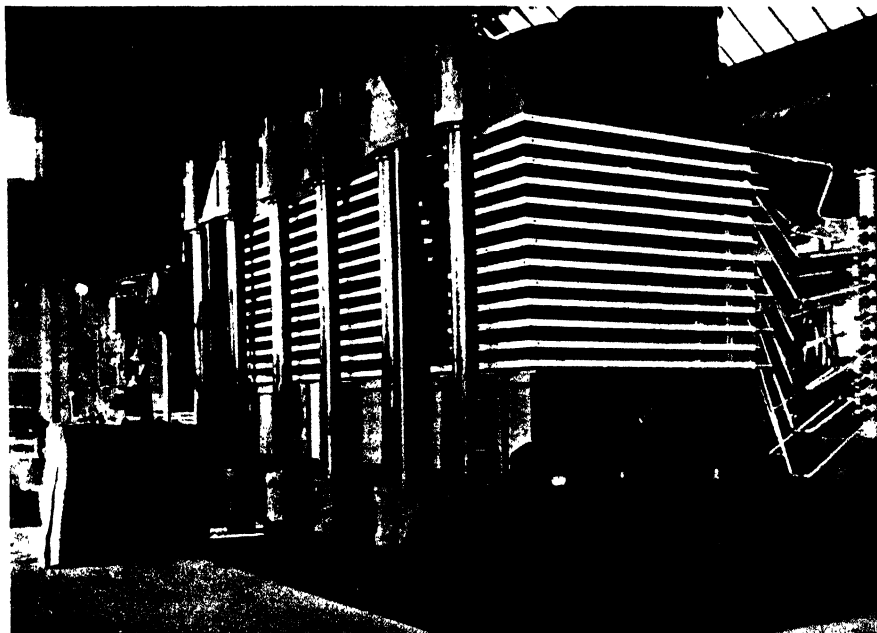

*By courtesy of Interwood Ltd., London.*

FIG. 53.—COLUMN TYPE OF PRESS BUILT FOR END-LOADING. TWELVE OPENINGS.

The floor of the factory will be built up to the level of the base of the controls on the left of the illustration.

Both press table and top must be of rigid design with accurately machined surfaces. The platens,  $1\frac{1}{2}$  to 2 inches thick, may be made of armour-plated steel or an alloy of high compressible strength and of high heat conductivity. They must be carefully machined to ensure even pressure over their entire area. Each platen is accurately drilled to form a network of evenly spaced channels. The greater the amount of channelling available for the passage of steam the more even will be the heating of the platens. The ends of all the channels not connected with the main steam or hot-water supply are closed by steel screw plugs which

can be removed for cleaning purposes. The connexions between main steam supply and platens, seen in the illustrations, are of flexible piping or metal tubing with knuckle-joints to allow for movement during opening and closing of the press.

The design of a modern hydraulic press demands most highly skilled technical knowledge, one of the most complex problems being the method of compensating expansion of metal parts when high temperatures are applied.

Heat is supplied to the platens by steam under high boiler pressure.

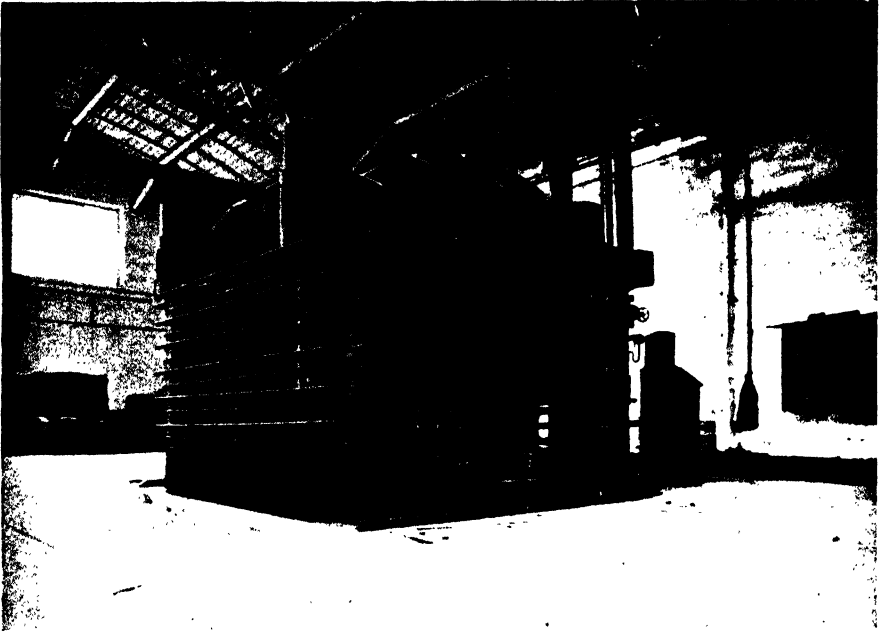

FIG. 54.—A LARGE HOT PRESS CAPABLE OF PRODUCING BOARDS 137"×89".

With boiler pressure of 100 lb. per square inch or, say, 75 lb. at the hot press, it should be practical to secure plate temperatures of 320 to 325° F.

Pressure is developed by rotary or piston pumps, the former being frequently used for closing the press and the latter for applying and maintaining the higher pressures. The pumps should be of ample capacity to supply a sufficient volume of liquid to the rams. Several press manufacturers prefer rotary pumps, as these build up the required pressure smoothly without the pulsations common to other types. Fig. 54 illustrates a German press which has produced vast quantities of high-class resin bonded Gaboon plywood. In this press the cylinder

on the top head carries a sufficient volume of water completely to fill the pressure cylinder. The water passes to the pressure cylinder by gravity and, aided by a rotary pump, raises the press table and closes the press. At this point an inlet valve opens, automatically actuating high-pressure pumps which supply the final pressure.

As a general rule, pumps operate on a mixture of water and water-soluble emulsion which overcomes the packing troubles frequently experienced when worked on oil. Modern presses are fitted with



FIG. 55.—HOT PRESSES BEING LOADED WITH GLUED-UP VENEERS OF FINNISH BIRCH.

pyrometers which record the temperature of the platens and with automatic devices for maintaining constant pressure during operations.

The number of "daylights" or openings in a hot press will be decided by the general output of the factory and by the type of adhesive used. For example, if plywood is cemented with casein the press may have twelve or more openings, as there will be an ample margin of safety between the time required to load the press fully and the setting time of the adhesive. On the other hand, when rapid thermo-setting resins are used trouble is certain to result if an attempt is made to load more than four or five openings before closing the press. The total



output of the press need not be affected, as it will be possible to obtain a greater number of pressings per shift with quick-setting adhesives than with slow-reaction glues.

In modern pressing equipment a mechanical loader is included. This consists of a framework, at both loading and discharge ends of the press, which carries a series of platforms lying level with the platens of the press when in open position. The platforms at the loading side are filled with veneers glued in the usual manner and assembled between metal cauls. The press is opened and is reloaded by a mechanical

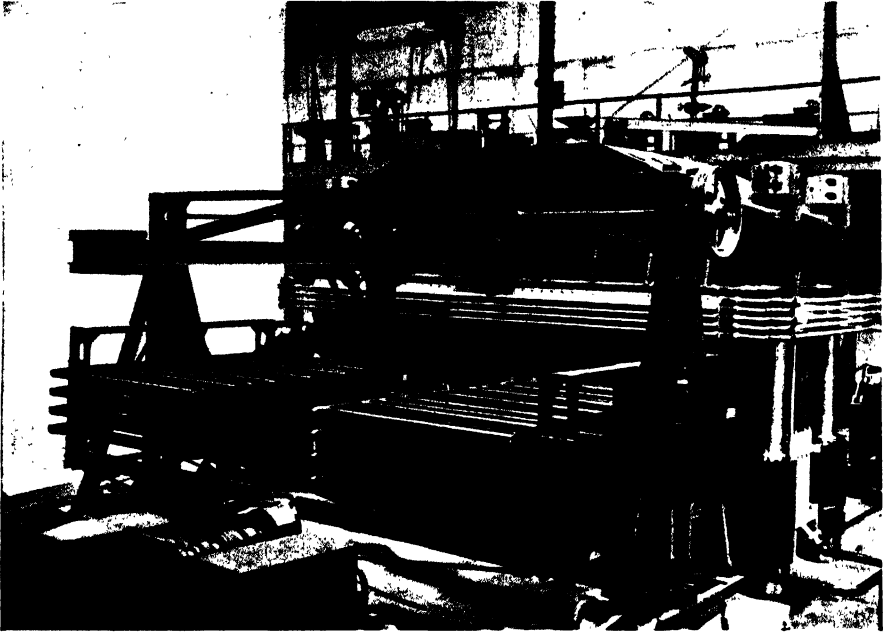

FIG. 56.—A MODERN HOT-PLATE PRESS WITH 4 "DAYLIGHTS" SHOWING LOADING MECHANISM.

device which pushes the assemblies into the press openings. As they are forced home the pressed boards are ejected on to the platforms at the discharge side of the loader.

By this means each assembly is in contact with the hot plates of the press for exactly the same time in contrast to a hand-loaded press in which the first assembly to be entered may be subjected to heat from the platens for a minute or so longer than the final ones, the difference in time naturally depending upon the skill of the workmen and the number of "daylights" to be filled. The lower assemblies are in contact with heat for a longer period and subjected to the pressure of the upper

platens to a degree which also varies according to the number of platens to be raised by the press table before final pressure can be applied. These variables do not lead to the manufacture of a standard product ; however, in order to compensate, in some measure, for the added heat and pressure applied to the lower assemblies the press should be loaded from the top "daylight" downward.

Various trade papers have reported interesting experiments in the application of high-frequency electrical currents to generate the heat required to effect the cure of synthetic resins in place of the usual hot-press methods. During 1938 the chief of the Australia Division of Forest Products, Mr. I. H. Boas, first made the suggestion that the requisite heat might be derived from such a source and experiments both in Australia and America have proved the soundness of this idea.

Recently in America encouraging results have been obtained in this field of research and if the idea can be applied economically present methods of hot-pressing may be radically altered in future years. According to *The Timberman*, of Portland, U.S.A. :—

"The equivalent of hot-pressed plywood can be produced by the application of high-frequency currents in the ordinary cold press. By the introduction of ionizing elements in the adhesive, the high-frequency currents develop high temperatures at the glue line which act the same as heat applied by hot plates. The wood is also heated evenly throughout its entire structure, both on the inside and on the surface, although it does not reach the temperature attained at the glue line. The ratio runs about 300 to 240 degrees F. respectively between glue and wood.

"In preparing the charge in the press, one terminal or plate, the size of the charge, is placed on the bottom and another at the top, the current passing through the entire mass from top to bottom. For even greater effectiveness a third electric plate may be inserted in the middle of the charge.

"The speed of the high-frequency method of plywood manufacture is said to be remarkably fast. For example, a 22-ply lamination can be produced in four minutes, according to the engineers."

## APPLICATION OF HEAT AND PRESSURE IN HOT PRESS

When resin adhesives in solvent form were first introduced skin troubles were frequently experienced by the press operatives. When the cause was discovered to be exposure to fumes given off during pressing, hoods were fitted over the press heads and the fumes drawn off through a flue by suction. With many of the modern types of resin

adhesive such a safeguard is not now essential, but it is advisable to take this precaution.

In all hot pressing three rules should be kept in mind :—

1. The quicker the setting-time the greater the accuracy required.
2. Heat applied and time of heating should be kept to a minimum.
3. Never attempt to speed up production by using excessive heat or pressure.

The cardinal point to remember when considering pressing problems is that under certain circumstances overpressing may be quite as detrimental to the average glue joint as underpressing. It may result in the crushing of the wood fibres or, as is the case with casein, blood albumin and animal glues, excessive pressure tends to squeeze the glue out towards the edges of the panels and into the wood fibres, leaving starved spots in the centre. All danger of starved joints is avoided by using resin film and is reduced considerably with resins in varnish and other forms, but even with these adhesives the pressure will have served its primary purpose once the two surfaces to be glued together have been brought into close contact.

With the modern equipment which is now available there is no excuse for irregular or uneven cutting of veneer and, as it is only poorly cut stock which demands excessive pressure, trouble of this nature should be rectified in the cutting.

In the plywood mill the cost of production must be carefully watched and as this is influenced to a considerable extent by the output of the hot press the speed of this operation must be accelerated wherever possible.

When working with resin adhesives comparatively high pressures may be usefully employed in order to aid the transference of heat throughout the assembly, thus speeding up the cure of the resin and boosting up the output of the press. However, care is required to prevent any gain made in this direction being offset by a loss in thickness of the panels caused by the undue compression of the wood. The amount of pressure which any veneer can withstand depends upon the density of the wood and it is obvious that the density will be increased by compression in the press. This process is carried several stages further in the manufacture of what is known as "improved wood." The higher the moisture content at the time pressure is applied the more easily wood is compressed and, as a high moisture content also retards the speed of heat transference, it will be apparent that the lower the moisture content of the veneers at the moment of pressing the better will be the results. This must not be reduced too far, however,

otherwise the effect on resin film joints, to give an example, would be disastrous. Care is required in deciding the pressure to be used on blockboards made up with woods of different density, *e.g.* when veneers are laid on boards with Pine block cores and Gaboon outer plies the pressure should be based on the compressibility of the least dense wood, which in this case is the Pine.

The question of the temperature of the platens is a vital one in resin bonding. It is true that the higher the temperature the faster will the heat be transferred to the centre of the assembly and in consequence the quicker will the cure of the resin be accomplished, but many woods react unfavourably to high temperatures. It is fortunate, therefore, that the curing of phenolic and urea resins is regulated by both degree and duration of heating and, in cases where high temperatures must be avoided, the same strength of bond can be obtained by extending the pressing time and reducing the working temperature. Excessive or prolonged heat will not yield high-quality plywood. It is also well to bear in mind that the plasticity of wood increases at temperatures around the boiling-point of water so that undue compression may very easily result when high temperatures are applied. The heat at all times must be under strict control and it is advisable to use a pyrometer, which will indicate the temperature of the surface of the platen, rather than attempt to calculate this from a reading on a thermometer which is as often as not inserted into the side of the platen. It is surface heat that counts.

The total thickness of the panel to be pressed and the distance of the glue line farthest from the platens are factors which will decide the time of pressing required.

The thickness of the core has also a direct influence on this question owing to the fact that as soon as the heat reaches the innermost glue line it is absorbed by the core until such time as the temperature of the entire mass is in equilibrium. It will be obvious that it must take longer to bond a  $\frac{3}{4}$ -inch 5-ply panel than another 5-ply panel of only half the thickness of wood.

In pressing boards with thick cores, the moisture content of the latter assumes added importance. Should the moisture content of the core be greater than 12 per cent., the time taken to raise the temperature of the mass sufficiently to effect a cure of the resin will be quite unprofitable with a resin of the phenolic type. The heat input will be absorbed in effecting the vaporization of the water in the core stock, and until this is completed there will be no appreciable rise in the temperature of the mass. It will generally be found advisable to build up thick panels in two operations.

## CHAPTER X

### FINISHING OPERATIONS

#### (a) RE-DRYING

**P**LYWOOD, whether manufactured on the hot or cold press, must be re-dried and the process is a very vital one. Panels are stacked on a truck with a perfectly level platform and distance pieces of well-seasoned wood,  $\frac{3}{4}'' \times \frac{3}{4}''$  or  $1'' \times 1''$ , are inserted at regular intervals between the panels. It is essential that these distance pieces or "skids" are laid one directly above the other. The topmost board is loaded with a heavy iron beam and the truck passed through the channel re-drier which reduces the moisture content of the mass to the desired percentage.

During the glueing operation a considerable quantity of moisture may be added to the veneers: it is estimated that in the manufacture of Gaboon 7-plywood with normal casein mixture approximately  $2\frac{1}{2}$  kilogrammes of water is added to each square metre of plywood the dry weight of which is  $12\frac{1}{2}$  kilogrammes. Thus to the original dry weight 20 per cent. of water is added. In the hot press about half of this water will be expelled leaving the balance to be extracted in the re-drier. When the cold press is used, however, only a small quantity of moist glue is forced out through the edges, therefore practically the whole of the added water must be eliminated by re-drying.

Should this re-drying process be rushed the panels will come from the kiln in a warped or twisted condition which no subsequent treatment will rectify. On the other hand, if the re-drying is incomplete the latent moisture may commence a fungoid growth known as "manufacture damp" which is apt to spread with disastrous results.

After pressing veneers with certain types of resin binders, the plywood may be over-dry in which case moisture must be reintroduced by subjecting the boards to what is known as a tempering process performed in a drying kiln the humidity of which is accurately controlled. One such process is referred to on page 90. Alternatively the panels may be sprayed with, or plunged into, water and afterwards stacked in a tight pile. After a few hours the boards should be re-stacked in the usual way and allowed to stand until the moisture content is uniform throughout.

#### (b) REMOVAL OF TAPES

When tape has been used in the jointing of veneer its removal after pressing frequently causes difficulty. In some plants the sander or

scraper is used for this work but these machines can only turn out a satisfactory job if the panels to be worked are perfectly dry; should tapes be moist the sticky glue will quickly clog up the sander or scraper resulting in frequent stoppages and faulty work.

Better results are obtained when the tape is removed by hand before attempting to finish the panels on the sander. Tapes are most easily removed immediately the boards are discharged from the press. More often than not moisture is required to soften the glue and, in order to avoid the risk of joints opening (which can only be repaired with difficulty), great care must be taken if veneers have been laid with animal or any other non-waterproof glue; there is little danger of trouble resulting when the panels are resin bonded or cemented with a waterproof adhesive. A hand scraper is frequently used to hasten the removal of damped tape; this should have a broad flat blade and be handled with great care to obviate any gouging of the veneer along the joints. Should wood be torn and a depression thereby made, no amount of sanding in the finishing operation will repair the damage. Once tapes have been removed the panels must be thoroughly dried before sanding or scraping.

### (c) EQUALIZING

Once the plywood has been properly re-dried it is trimmed to dimensions and squared up on double cut-off saws with automatic or chain feed. A great variety of machines is available.

In the production of multi-plywood in sizes which can be easily handled, the sheets are generally cut into lengths on one set of parallel saws and to widths on a second set. The off-bearer of the first saw feeds the second one as is illustrated in Fig. 57. This appears to be a most economical method and a very large output can be obtained from two such machines. It is essential that the saws be accurately set as little or no tolerance is allowable when cut sizes are in production. The feed to the saw requires fine adjustment to ensure that the second cut is exactly at right angles to the first one.

A heavier machine is necessary for the production of laminboards, blockboards or large multi-ply boards which are not easily handled. One typical machine is illustrated in Fig. 58. This machine carries two sets of parallel saws, the one set running at right angles to the other. The heavy boards are placed on a movable bench and one of the saws seen supported by the frame on the left of the machine, revolving clockwise, is drawn across the board to make the first cut. The board is then pushed through the framework, the two lower saws cutting to the width required. The final cut is made across the board by the second of the two



FIG. 57.—SWEDISH PINE PLYWOOD BEING SAWN TO LENGTH (foreground) AND WIDTH (right foreground).



FIG. 58.

upper saws, which revolves in an anti-clockwise direction, as the carriage moves across the framework to its original position.

#### (d) FINAL PROCESSING

From the equalizing saws the plywood sheets are passed for final processing to the sanders or scrapers on which any surface imperfections are removed and a smooth even finish given to the boards.

The scraper, which gives a "planed" appearance to the wood, is in general use in plywood factories working on Gaboon, Alder, Beech and Birch whereas the drum sander is used exclusively in Douglas Fir plants and for all woods in grades which permit of "plugging" as is described on pages 70 to 72. Laminboards and blockboards with cross-grained outer plies must be sanded as must also all boards whose width exceeds that of the scraper—this as a general rule is 64 inches. In factories producing veneered boards both drum and belt sanders are used in addition to scrapers.

**DRUM SANDERS.**—The sanding machines found in plywood and veneering plants are similar in every respect to those used by other sections of the wood-working trades. They may consist of two, three or more drums of the roll-feed or endless bed-feed types.

Triple-drum sanders with rubber-studded chain bed feed are most efficient tools and yield the large output so vital to every plywood manufacturer.

Each sander must be fitted with an efficient dust extractor serving all drums otherwise the machine will rapidly clog up with a rapid fall-off in the quality of the finished job. The larger modern sanders are massive machines which run at all speeds without any trace of vibration. The sander drums are positioned above the table and are given a lateral and reciprocating movement in addition to the rotary action. The thickness control can be adjusted with great accuracy. Each roller is covered with felt which acts as a cushion between roller and abrasive paper; the latter is spirally wound over the periphery of the roller and must be carefully adjusted. The first roll carries the roughest paper, the second a finer one and the last a finishing grade. Care must be taken in selecting the grades of paper: very rough papers should be avoided as these tend to scratch the surface of certain woods severely, making it practically impossible to remove the marks without cutting through the outer plies.

The rolls must be kept in good condition as it is false economy to retain a paper which has lost its abrasive properties. If a worn paper is used on the last drum a gloss surface will result which gives endless trouble in any finishing process.



The felt on the sanding rollers is apt to thicken in spots and should be examined and trued up as may be necessary when papers are renewed.

The reputation of the factory, to a large extent, depends upon the skill of the sander charge hand; a careless workman or a defective machine can destroy the best efforts of the most efficient plywood or veneering plant.

The moisture content of the plywood should not exceed 8 per cent., otherwise best results will not be obtained.

When sanding on the endless rubber-bed machines the boards should be fed squarely to the rollers, one board following the other as closely as possible. This reduces the risk of rounding the leading edge as it is engaged by the rollers. In the roll-feed machines boards should be entered at a slight angle to obviate similar trouble. Only one side is sanded at a time. The off-bearer is responsible for a rapid inspection of the workmanship and returns the boards to the charge hand, over the top of the machine, to be sanded on the second face. The back side should be sanded first. By doing so a level surface is obtained which ensures accurate and good surfacing of the face veneer: the risk of sanding off corners on the face side is thereby greatly reduced. This is of particular importance when working on veneered stock.

It is generally mistaken policy to pass a veneered surface through a triple drum sander more than once. As a general rule the thickness of the veneer will not exceed 0.8 mm. and this does not allow any margin for over-sanding. Any low spots can be touched up on the belt sander as a subsequent operation. Re-sanding is only permissible if the first cut is merely intended to remove or partially remove tape in which event little of the face veneer will have been touched by the rollers and the second run will do the actual sanding. When working with the heavier face veneers of laminated or blockboard stocks, the surfaces of which are often irregular, two runs may be required before a level surface is produced. It should always be borne in mind that a better surface will be obtained by making two light cuts than one heavy one. When the excessive pressure required to make a heavy cut is applied, a rippling "washboard" effect generally results from the sandpaper cutting more deeply into the softer parts of the wood.

The sander is used in some plants as a surfacer before veneering; this is not always satisfactory especially with plywood under  $\frac{3}{8}$  inch thick as, should the edges be rounded off, trouble will be experienced during pressing. If the panels must be levelled off, better results will be obtained by using a carefully set scraper.

**SCRAPER.**—The machine scraper is largely used in plywood mills and gives a finish to the boards very similar to that obtained by the woodworker when cleaning off solid wood with a hand scraper.

The plywood is carried by a series of feed rollers against a fixed knife, of special grade of steel, the keen edge of which has been turned to a specified degree. This edge projects a fraction of an inch above the surface of the knife stock which, when in position, is secured to the bed of the machine.



FIG. 59.—MACHINE SCRAPER.

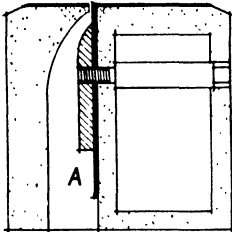

FIG. 59A.—KNIFE STOCK OR CARRIER.

The knife stock or carrier is built in two sections as illustrated in Fig. 59A and the shavings pass from the machine through the opening at A. This knife stock can be drawn out through the side of the machine to allow for the rapid changing of the knife.

A continuous shaving is removed from the surface of the plywood as it passes through the scraper; the thickness is uniform and may be adjusted to meet requirements.

The removal of this shaving from straight-grained woods leaves a highly polished surface that is absolutely true and even.

Difficulty is occasionally experienced in finishing swirl-grained Gaboon in the scraper but any odd patches of irregular surface can be touched up on the belt sander. Boards which have been well scraped are generally preferred for veneering upon and for high-class enamel work as the pores of the wood are clear of sander-dust and surfaces are entirely free from the "washboard" effect already referred to; there are also no rounded-off or cut-away edges.

The scraper should not be expected to do the work of a thicknesser and must not be used if panels have been "plugged" or "patched."

The scraping knife may be replaced by a toothing knife which is useful for surfacing plywood prior to laying a decorative veneer. The teeth of this knife may be fine or coarse, as desired.

**BELT SANDER.**—This is a very useful machine for fine veneer work and is frequently used on curved surfaces. A modern belt sander is illustrated in Fig. 60. The table is movable and the belt of abrasive paper is pressed against the veneered surface by a flexible pad controlled by the lever shown in the illustration. The pad is kept moving to and fro on the running belt and a forward or backward movement given to the table at the same time.

The belt sander is commonly employed for removing odd pieces of tape which have escaped during sanding in the trip<sup>le</sup> drum machines or for touching up low spots. A careful workman will produce panels ready for polishing, cellulosing or enamelling.

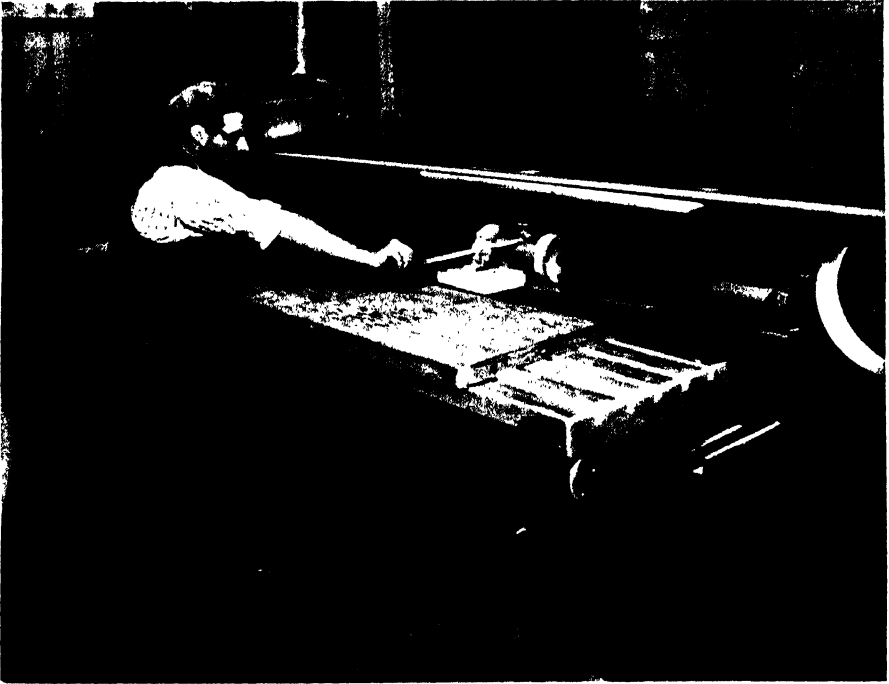

*[By courtesy of the Editor of "Wood."]*

FIG. 60.—BELT SANDER.

CHAPTER XI  
MANUFACTURING DEFECTS

THE following are the chief manufacturing defects which must be taken into account in the grading of plywood :—

1. *Overlaps and gaps in the inner plies* can be serious when the overlap or gap occurs in the core of a 3-ply board or in the cross-banding of a multi-ply panel. The defects are caused when glued veneers are allowed to “over-ride” one another (overlap) or are not closely butted together when the assembly is made up (gap). Gaps in 3-ply

DEFECTS IN INNER PLYS

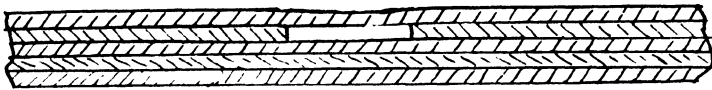

GAP



OVERLAP

FIG. 61.

wood cause a weakening of the structure ; they are less dangerous in multi - ply when not immediately under the outer veneer. Any overlap or gap in the ply adjacent to the face veneer generally reflects itself as a ridge or depression when the plywood is polished or enamelled ; boards with such defects should not be used for veneering upon.

Veneers used in cores and cross-bandings of best quality plywoods, more especially those bonded with synthetic resins, are commonly jointed on the tapeless splicer, thereby removing all trouble from both overlaps and gaps throughout the production.

2. *Blisters, faulty glueing.*—As a result of faulty glueing or pressing or other mischance an occasional board of plywood may be produced

containing spots where the adhesive has not set. These generally show up during the sanding process and only on rare occasions do faulty boards pass the inspectors in well-regulated factories. Blisters can be discovered by tapping the boards with a hard instrument.

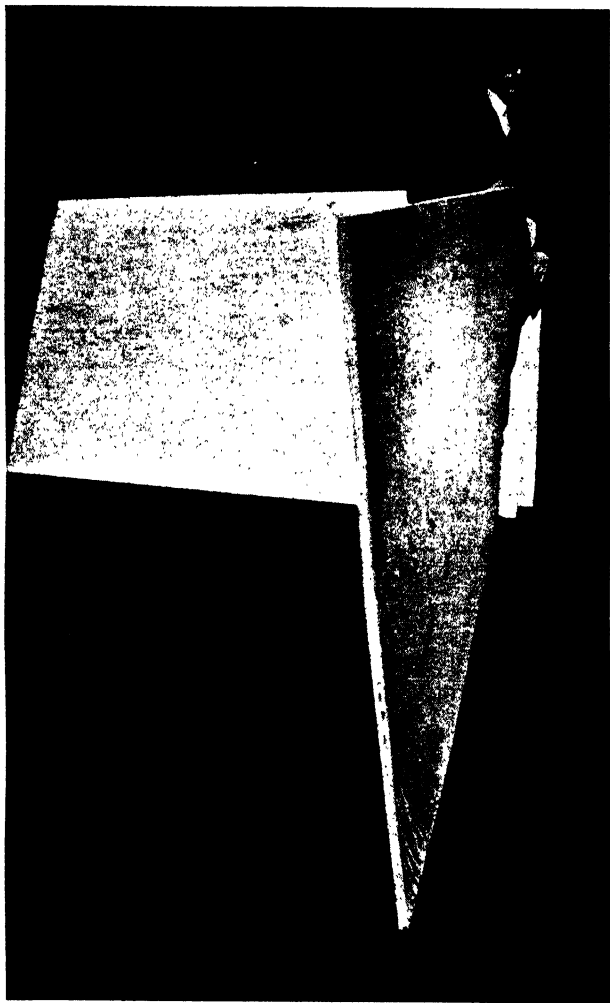

FIG. 62.—ONE RESULT OF FAULTY DRYING: A BADLY TWISTED BOARD.

3. *Hollows and low spots* result from outfallen knots or wide gaps in the ply immediately underlying the face veneer. They render the plywood unsuitable for veneered or polished work.

4. *Pressmarks* may be caused by using dirty cauls or by pieces of

hardened glue or scrap veneer becoming lodged between caul and face veneer during assembly. Marks so caused may be quite deep and are not removed by sanding or scraping.

5. *Glue stains and glue percolation.*—Staining can generally be traced to an over-alkaline mixture or to a lack of cleanliness in the gluing-room. Where an excess of alkali is present the glue is liable to cause staining in Oak, Okoumé, Douglas Fir and several other woods. Iron salts and ammonia are also dangerous and, under certain conditions, may produce dark brown stains on Oak.

Occasionally Douglas Fir plywood is disfigured by narrow, irregular bands of blue or red-brown colour. Careful examination will invariably reveal a joint in the veneer immediately below the defect. During manufacture an excess of glue is liable to gather at such points and, if the boards have not been properly re-dried, the excess of moisture draws the alkali used in the normal glue mixture to the surface and causes the stain. Such marks are intensified into dark lines when varnish or stain is applied.

Dark-coloured hide glues are liable to penetrate and stain some of the most attractive of the light-coloured veneers such as Avodiré and Maple. If these glues are used for edge-jointing light-coloured woods the joints will show up as thin dark lines which are most unsightly.

Should the face veneer have patches of open grain and the adhesive be too thin the latter may penetrate through to the outer surface giving a "muddy" appearance to the board which no amount of sanding will remove.

6. *Splits and cracks.*—Serious splits are generally cut out in the trimming operation, but cracks or shakes along the grain-fibres in the body of a sheet of veneer or splits at the ends, all of which may result from irregular drying, cannot be entirely eliminated.

Carelessness in handling the fragile dried veneer may cause numerous small end splits. If during the pressing operation the edges of the veneer at the fracture re-make close contact only a hair-line will be seen to the trained eye; in this event the defect is not detrimental for veneered, painted or enamelled work and is known as a "closed split."

More often than not, however, the veneer "springs" along the fracture, being widest at the edge of the veneer and gradually diminishing in width till it finally disappears towards the centre; it thus exposes a long triangle of the core stock. This is known as an "open split," which must be cut out or repaired before the plywood can be used for painted, enamelled, stained or veneered work.

7. *Open joints* should not be found in any well-made stock. The defect may show up when polish is applied as a hair-line, but can gener-

ally be filled during the polishing process without harm to the resultant surface.

8. *Rough and irregular cutting.*—When a log is allowed to “ chatter ” in the rotary-lathe during cutting the resultant veneer cannot possibly be smooth, on the contrary the surface may be quite irregular, being generally worst in the neighbourhood of twisted grain or hard knots. These cutting marks may be so deep that no amount of sanding will yield a smooth surface. If thick face veneers are laid with the loose-cut surface uppermost, as occasionally happens in block- and laminboards, the cutting checks so exposed constitute serious defects.

9. *Twisting* is commonly caused by careless re-drying of the plywood after pressing or may result from unbalanced construction. In plywood up to 5 mm. thick a certain amount of waviness across the grain is not uncommon and for many purposes is not detrimental, but any twisting in thick plywood may be a serious matter and render the boards unsuitable for many purposes.

10. *Scraping and sanding defects.*—Scraper marks having a close “ washboard ” effect on the face of a panel is a common result if the plywood is not subjected to adequate pressure during the scraping operation or if the knife is badly set. They are difficult to remove and may prove to be very troublesome, more especially in the case of veneered panels. Irregular or curly grain around knots is difficult to scrape and frequently results in patches of torn grain. The sander can also cause a “ washboard ” effect, but a more common trouble, called “ snake ” marks, results from the oscillation of a sander drum carrying a badly fitted paper. Other sanding faults are “ rounding off ” at the edge and high spots in the core causing the sander to cut through the face veneer.

11. *Manufacture damp.*—Unless the re-drying of wet-glued plywood or plywood made on the cold press by the dry-cemented process is properly done, latent moisture in the core may set up a fungoid growth which under favourable conditions will spread rapidly and completely destroy the glue line. This trouble is known to the trade as “ manufacture damp.” It may be recognized in its early stages by the appearance on the surface of the panels of a minute pink or yellowish dust-like fungus.

The moisture content will be high and the boards generally feel “ damp ” to the touch. This trouble has been known to occur in plywood made by the dry-cementing process on the hot presses.

Fortunately, with the development in manufacturing methods, this defect is no longer a common one, and under the Form of Contract in general use by the Plywood Section of the Timber Trade Federation of the U.K. buyers have the right to reject, should this defect make its appearance within a stipulated period.

## PART IV

### LAMINBOARDS, BLOCKBOARDS, COMPOSITE BOARDS AND SPECIALITIES

#### CHAPTER I

#### DEVELOPMENT

LAMINBOARDS, blockboards and lumber-core boards are marketed in a great variety of constructions, the most important of which will be described. They are in a field apart from the multi-plywoods notwithstanding the fact that all types are frequently produced in the same factory.

The batten or lumber core board is not manufactured in, nor imported into, the United Kingdom in any quantity. It is produced on a very large scale in America where it is used as a base for high-class veneered work ; smaller lots are also made in Finland.

The construction is similar to that of the veneered panels prepared by the artisans of the eighteenth and nineteenth centuries and used in the building of their furniture. Whereas Sheraton and his compatriots used Mahogany or Oak for this purpose, the cabinetmakers of Germany built up their cores from strips of well-seasoned Black Poplar 2 to 3 inches wide to which they glued a cross-banding of some close-grained wood. The decorative veneers were laid to these carefully prepared foundations, the merits of which have been amply demonstrated by the examples of furniture which have been left to us.

The commercially produced *Tischlerplatten* (cabinetmaker's board) was, with the approach of industrialization, but a step in the natural sequence of events. One concern in Böhlen, Thüringerwald, Germany, claims to have been manufacturing a type of veneered board for the trade since 1858. During the early part of this century, boards of this nature were made with a core of pine or fir with American whitewood cross-banding. The construction was somewhat peculiar and not too sound, but a market was developed and other mills commenced to make *Tischlerplatten* in large sizes with outside layers of Poplar, Gaboon, Birch and Alder. Small quantities of these boards were shipped to England during 1910.



Kiln-dried pine or fir core stock was not nearly so reliable as the carefully seasoned Black Poplar or Mahogany of the cabinet-maker, and in an attempt to make a more reliable board the width of the battens was reduced. This led to the introduction of what is now known as the blockboard. These boards, as originally conceived by one, Richard Kümmell by name, had cores of blocks about 1 inch wide with outer plies of Gaboon and were first commercially produced in the Deutsche Holzplattenfabrik at Rehfelde, near Berlin, in the year 1910. The drying of the blocks for core stock frequently caused difficulty and the result of a haphazard experiment led, by accident more than design, to the idea of building cores from thinner, rotary-cut veneer. The original board of this improved type was produced in Bavaria with a Pine core and was quickly followed by what came to be known to British buyers as the *Ibus Laminated Board*.<sup>1</sup> The latter, manufactured with a core of strips 3.3 mm. in width and outer veneers of similar thickness, both of Gaboon, was introduced in 1921 and met with considerable success. It was copied by several continental manufacturers. In 1925 another concern marketed the *Bisco Laminated Board* which differed from its Ibus prototype in that the laminated core was of Memel Pine and the outer plies of Alder. Since then the production of laminboards and blockboards has grown apace and many new ideas have been put to the test. Improvements in the methods of drying and jointing have resulted in a considerable advance in the reliability and uniformity of these boards but little or no radical change has been made from the construction as originally marketed. Of this group the most reliable board is that built up with a core of laminations not exceeding 5 mm. in width of sliced or rotary-cut veneer laid between thick outer plies of Gaboon or some other mild-textured wood.

<sup>1</sup> As so much confusion has arisen due to the American and British conceptions of the word "laminated" it may be recorded that the term "laminated board" in England came into use as a result of a description of the *Ibus Board* which was given to British buyers by the first seller of this product, Mr. O. L. Trier. He described the board as having a core of "narrow Gaboon laminations" and the term "laminated board" was thereafter applied to distinguish the board from the less reliable blockboard. In recent years the word laminboard has been used to describe this particular construction.

## CHAPTER II

# MANUFACTURE OF LAMINBOARDS, BLOCK-BOARDS AND LUMBER-CORE BOARDS

### (a) PREPARATION OF LAMINATED CORES

IT is a common belief that odds and ends of veneer are quite good enough for the cores of laminboards. In point of fact nothing is further from the truth. Reliable stock can only be produced from good quality timber free from broken knots, irregular or twisted grain, and other serious wood or manufacturing defects. Veneers for cores may be sliced or rotary cut. The actual thickness will be decided by the raw material which is available and may vary from the 1.5 mm. Birch or Alder used by some Finnish and Latvian mills to the maximum of 7 mm. which is the standard selected by one of the English producers working on Gaboon logs. It is bad practice to use different thicknesses

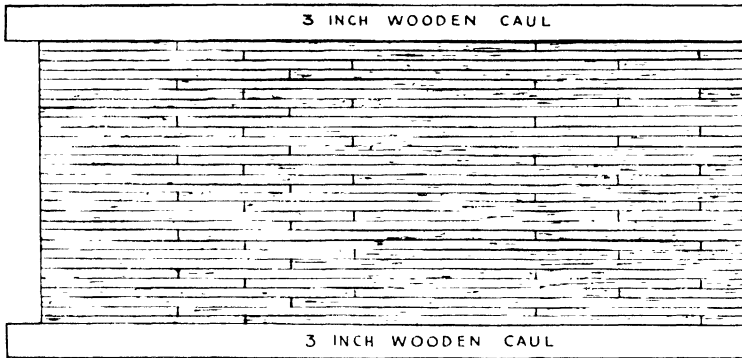
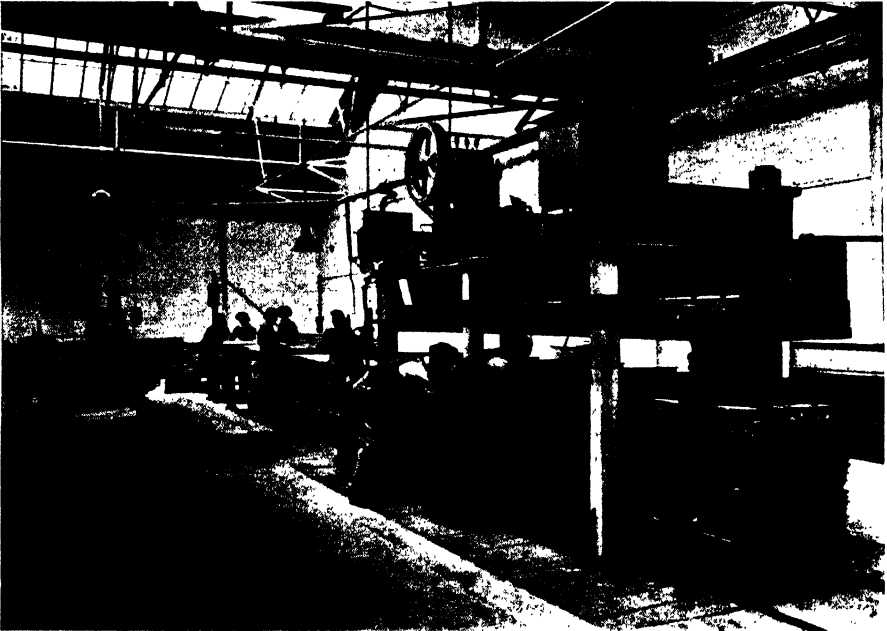

FIG. 63.—METHOD OF BUILDING UP BLOCKS.

Laminated core stock is prepared in a similar manner.

or different woods in any one core plate. All veneers must be accurately dried to the moisture content specified, a factor which is variable between the limits of 7 to 10 per cent. according to existing atmospheric conditions and the density of the wood. Serious defects must be cut out in the usual way when the veneer is trimmed into standard widths. Once the stock has been suitably prepared it is, of course, in random lengths and is assembled in an L-shaped framework—slightly longer than the board to be manufactured—the lengths being made up of two or more pieces in a similar manner to that depicted by Fig. 63. Particular

care should be taken to stagger the joints in building the block which, when assembled to a height of about 36 inches, goes to the glue-spreader through which each alternate layer is passed. The block is then re-formed on a heavy wooden caul. Veneers must be accurately laid to obviate the risk of gaps being left where ends are butted together. This is a matter of such importance that several different methods of jointing have been introduced in order to build up long lengths of veneer free



*[By courtesy of Tyne Plywood Works Ltd.]*

FIG. 64.—GLUEING AND PRESSING GABOON VENEERS IN THE PREPARATION OF CORES FOR LAMINBOARDS.

from voids. (Methods of jointing are described on pages 69 and 70.) In some mills veneers prepared to give the total length required are glued without previous assembly.

Once the entire block has been glued and re-assembled, a second caul is placed on the topmost veneer and the mass subjected to pressure in a cold hydraulic press. Pressure is taken up by retaining clamps in the usual manner and the block removed to the drying store there to remain until the glue has properly set.

The next stage in the process is demonstrated by Figs. 65 and 68. Cutting the blocks into slabs of various thicknesses may be done on a



FIG. 65.—SAWING BLOCKS INTO LAMINATED CORES.

The block is fixed to the bed of the saw with the layers of veneers at right angles to the saw cut.

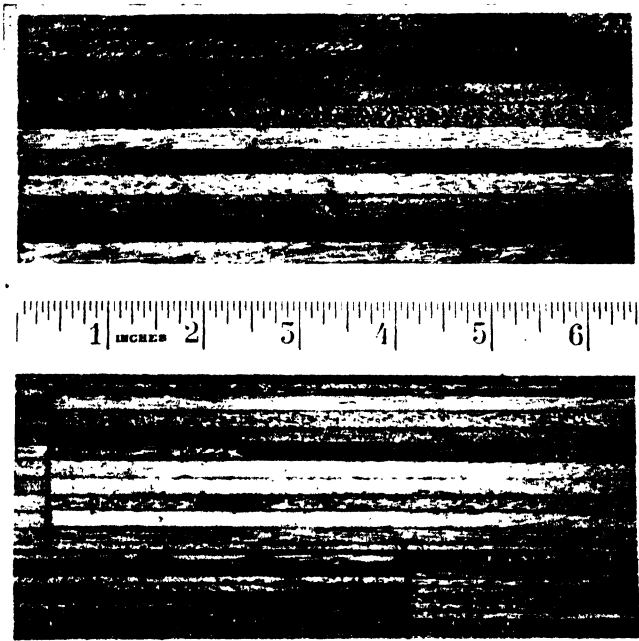

FIG. 66.

Note the two thicknesses of veneer and the butt joints on the poorly constructed core.

frame saw, or a horizontal or a vertical band resaw, according to the custom of the manufacturer. The cutting must be accurate, due allowance being made in the thickness for loss during re-drying and dressing both sides on the surfacer or planing machine.

The width of the core stock is made up by glueing two or more slabs edge to edge. These completed cores are stacked on a flat platform-truck between evenly spaced distance pieces and passed through the drying kiln until moisture content is constant throughout the pile.

On leaving the drier cores are dressed to exact thickness required, and any defects, open spaces or torn grain removed and made good either by the insertion of a plug cut from sound core stock or by a good mastic.<sup>1</sup> Fig. 66 illustrates very clearly the difference between a well-made core and one of bad construction.

Cores are then ready to be built up into boards by being glued, assembled between stout outer plies, and pressed in the usual manner.

### (b) PREPARATION OF BLOCKBOARD CORES

Centres for blockboards are built up in much the same way as for laminboards, veneers being used for the latter and boards of Central



FIG. 67.—LOADING DRYING KILN.

European Pine or Fir of mild growth,  $\frac{1}{2}$  to  $\frac{3}{8}$  inch thick, 10 inches and up wide, for the former. East Prussian or Memel Pine was a favourite wood for this purpose. Reliable boards can only be produced from well-seasoned wood, and experience has shown that most consistent results are obtained when the lumber is air-

seasoned for some time before being finally conditioned in the drying kiln.

The lay-out of seasoning yards, sheds and drying kilns in a large factory producing high-grade blockboards covers an extensive area. A network of narrow gauge rails connecting the yards and sheds with the kilns makes it practicable to load the timber direct from railway

<sup>1</sup> Great care must be given to the dressing of all core stock as uneven cutting or poor workmanship will cause serious trouble to the ultimate user of the board.

wagons to trucks which carry their loads through the various stages and deliver them, thoroughly seasoned and kiln-dried, at the crosscut saws. Kiln trucks are constructed of steel members to form a flat platform which will support the boards throughout their entire length. The wheels should be mounted on roller or ball bearings.

The stacking of timber on the trucks is important. Distance pieces of well-seasoned  $\frac{3}{4}$  or 1 inch squares should be evenly spaced between each layer of boards and laid in a true vertical line throughout the pile. While the wood remains in the open yard the top of the pile should be covered by old plywood sheets. The duration of the seasoning process varies considerably according to the original condition of the wood and the weather, but, when thoroughly air-dry, the moisture content will approximate 20 per cent. The drying is then completed in the kiln or

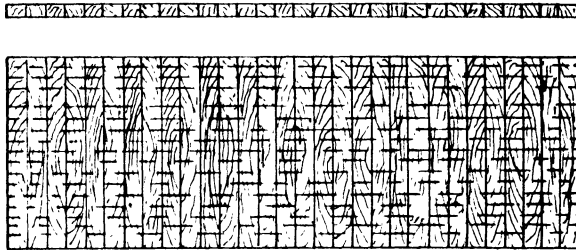

FIG. 68.—METHOD OF CUTTING BLOCKS INTO CORES FOR BLOCKBOARDS.

The broken lines indicate saw cuts. Note how boards have been glued heart side to heart side.

channel-drier in which temperature and humidity are regulated to reduce the moisture content of the wood to the desired percentage, generally between 4 and 6 per cent. On removal from the kilns the boards are squared up on the crosscut saw, any large knots or serious wood defects being cut out. Pieces are then assembled to build up the lengths required, all joints being staggered throughout the pile as shown in Fig. 63. The boards are glued, re-assembled on a heavy caul, all joints butted closely, pressed and sawn in the same manner as in the production of laminated cores already described. While building up the pile, boards should be laid in pairs, heart side to heart side, as the natural tendency of the wood is to warp away from the heart. By gluing up in this manner all subsequent movement of the wood fibres as moisture is absorbed or expelled is distributed to the least disadvantage.

The re-drying of block cores prior to surfacing is a matter of supreme importance. Should any part of the core be drier than the other when

finally surfaced, it is inevitable that, once the moisture content becomes equalized, that part which was over-dry will swell more than the rest, and an irregular surface result. The block cores prior to planing are generally dried to a moisture content of between 6 and 8 per cent., but much depends upon the percentage of water contained in the glue mixture. After planing, all defects are made good before the inner cores and outer plies are assembled.

In an effort to lessen the risk of subsequent movement in block cores, various experiments have been made by cutting grooves at regular intervals along, or at an angle to, the grain of the blocks. By so doing it was thought that any swelling of the wood fibres would be taken up by these saw cuts. Although the idea may be sound theoretically, its application in practice presented difficulties and no decided progress in this direction has been made in European productions.

### (c) ASSEMBLING BLOCKBOARDS AND LAMINBOARDS

The core stock is delivered to the loading side of the spreader and the large outer plies to the other side. The outer plies for cross-grained laminated boards are built up as is explained on page 67.

An aluminium or zinc caul is laid on a platform-truck immediately opposite the spreader and one outer ply, with loose-cut side upwards, positioned on this caul. A built-up core is passed through the spreader, supported as it emerges on a hardwood pole held by two operators, and laid upon the outer ply. A second face veneer is added with loose-cut surface down, then two cauls and another assembly, and so on until a load to fill the press has been made ready thus :—

Aluminium caul.  
 4 mm. outer ply.  
 Glued laminated or block core.  
 4 mm. outer ply.  
 Aluminium caul.  
 Aluminium caul.  
 4 mm. outer ply.  
 Glued laminated or block core.  
 4 mm. outer ply.  
 Aluminium caul.  
 4 mm. outer ply, etc.

The press is loaded from top opening downward, the assemblies being fed into each opening with the aid of supporting guides.

After bonding in hot hydraulic presses at temperatures and pressures which vary according to the adhesives used, the pressed boards must

be finally re-dried to a moisture content of approximately 12 per cent. before being dimensioned and sanded.

#### (d) MANUFACTURE OF BATTENBOARDS

Batten or lumber cores are formed of well-seasoned strips of Birch, Chestnut or other close-grained wood not exceeding 3 inches in width. The strips are glued edge to edge on a revolving clamp carrier, and, after being carefully re-dried, are planed on both faces to the required thickness. Core stock must be perfectly flat; if twisted to even a slight degree it will be absolutely impossible to produce straight boards. The core is glued between double outer plies of Birch or other hard wood. In the United States of America cores are made from Poplar, Gum or Chestnut, cross-bandings of Poplar, Gum, Maple or other veneer, to which are laid the faces and backs of decorative veneers.

#### (e) MANUFACTURE OF STRIP-BOARDS

Whitewood boards in random lengths dried by the method just described are dressed on both faces to specified thicknesses, which may vary from  $\frac{1}{2}$  to  $\frac{3}{8}$  inch according to the custom of the mill. From the surfacer the boards pass directly to an accurately set multiple saw which cuts them into narrow widths representing the exact thickness of the core stock desired. Provided saws are properly set and sharp the sawn surfaces will be perfectly smooth and quite as level as the planed faces.

The cut blocks are assembled on a table, lengths being made up by butt-jointing two or more pieces, care again being taken to stagger these joints; the blocks being laid with one of their sawn edges to the table. Once the full length and width has been built up the blocks are secured by several lengths of string. Cores at this stage are fragile and demand careful handling. The upper and lower surfaces are glued, laid between outer plies, and pressed in the usual way. When the blocks are laid on one of the outside veneers the string is generally removed, and any pieces which have become deranged are replaced by hand before the second outer ply is laid. Several manufacturers prepare these strip cores in two or more sections, each 18 or 24 inches wide, to overcome the difficulty of handling. A few mills endeavour to make closer and firmer joints in the length by dovetailing the pieces together end to end. It should be noted that whereas these strips are glued to the outer plies they are not glued to one another. A certain amount of glue does penetrate between the strips during gluing and pressing, but the amount is small and, as a result, strip-boards have not the same mechanical strength across the grain of the outer plies as have laminboards or blockboards. The process of manufacture varies in the different countries.





[By courtesy of Messrs. D. Burkle & Sons Ltd.

FIG. 69.—SNACK BAR AT OLYMPIA. MESSRS. J. LYONS & CO. LTD.  
Wall panels and shaped panelling around bars are plywood built.



[By courtesy of Messrs. Veneercraft Ltd.

FIG. 70.—SALOON BAR. "CHESHIRE CHEESE," NEAR CREWE.

The bar front is of  $\frac{3}{4}$ " laminboard which was sufficiently flexible to bend round the solid framing. The bar fitting and the two quick returns on either side of the bottle shelves are  $\frac{1}{2}$ " multi-ply, while the wall panels are  $\frac{1}{2}$ " Gaboon laminboard. The decorative veneer is Mazur Birch banded with Zebrano.

## CHAPTER III

# MANUFACTURE OF COMPOSITE BOARDS AND SPECIALITIES

### (a) SHAPED AND MOULDED PLYWOOD

By bonding thin veneers with synthetic resin adhesives into pre-formed shapes, waterproof plywood of amazing strength and durability is obtained. The grain of the veneers can be so arranged as will give to the plywood the maximum resistance to strain and stresses applied in any given direction. The possibilities in this field offer perhaps the greatest scope to the plywood technician working in co-operation with the research chemist.

For decorative work plywood can be moulded to practically any shape, provided the manufacturer is given some latitude in respect of thickness and construction. Obviously, it would be absurd to expect any but "freak woods" to be bent lengthwise to a small radius or to an acute angle, but quite remarkable results are frequently obtained by skilled workers on modern equipment.

The pressing of the plywood may be effected in one of three ways :—

- (1) on a ratchet or hydraulic press, using specially shaped male and female forms or moulds ;
- (2) by what is known as the vacuum process in which one form only is required ;
- (3) on specially constructed shaping and moulding presses.

(1) Shaped forms may be of wood or metal and must be most carefully prepared to yield the exact contour desired. In consequence, they are expensive and are seldom used, except in the manufacture of shapes which are in frequent demand or for work in which the prime cost of the forms can be absorbed into the contract price of the panelling.

Forms to yield many simple curves and segments of circles are generally held as part of the stock-in-trade of high-class panel manufacturers and, when suitable moulds are available, the cost of shaped sections is not unduly high.

The forms are built up in two parts, three typical moulds being illustrated in Fig. 71. As these are used in conjunction with hydraulic or hand veneering-presses they must be sufficiently strong to withstand

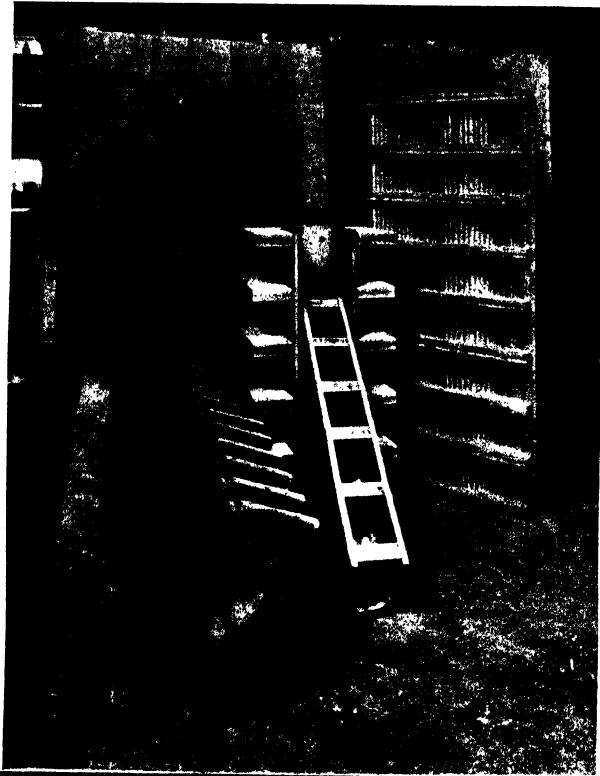

*[By courtesy of Messrs. Veneercraft Ltd.]*

FIG. 71.

*Upper : MALE AND FEMALE CURVED FORMS.*

*Lower : GLUED VENEERS ASSEMBLED IN CURVED FORMS UNDER PRESSURE IN THE RATCHET PRESS.*

the maximum pressure likely to be applied when in the press. The forms illustrated consist of a number of solid members connected by a series of hardwood laths of equal thickness which run the entire length of, and make a bearing surface for, the thin metal or plywood with which they are covered. The solid members, both male and female, are shaped on bandsaw or spindle to carefully designed templates, in the preparation of which due allowance must be made for the thickness of the assemblies, cauls and laths. Unless the pressure is distributed evenly over the surface area of both male and female forms good work cannot be expected. In place of thin zinc cauls, linoleum or another flexible material is frequently used.

Metal forms are only used when their cost is warranted by important repetition work, as for example the mass production of shaped panels for radio cabinets. The glued veneers are assembled on the female form, felt or paper being laid between the outer veneers and the cauls, and the whole carefully secured while the male mould is positioned. The pressure is applied in the manner illustrated on page 128. An interesting type of shaped plywood made in France was marketed under the trade name of "Oceana" panels and a few examples are illustrated. It should be observed that the moulded design is actually impressed into the wood itself. Metal forms are used to obtain the sharp clear-cut lines and it will be obvious that the manufacture calls for a high degree of skill to prevent fracture of the veneer during the moulding process.

(2) A less expensive method of making curved panels is in a rubber bag, by what is known as the vacuum veneering process. The principle is to subject prepared and pre-glued veneers to atmospheric pressure which may vary, according to weather and locality, from 25 to 29 inches of mercury. This is quite sufficient to lay any type of veneer to a prepared and shaped base, or to mould three or more plies into shaped plywood panels, always provided that the proper selection of veneer and glue has been made.

The equipment consists of a rubber bag, the walls of which are about one-eighth of an inch thick, sealed by a quick-acting device, which clamps the two opposite walls tightly together near the open end; a vacuum pump, provided with gauge, and worked by an electric motor; a baseboard, bored to allow free passage of air, which lies, inside the bag, resting on the lower wall; a carrier, which after being entered at the open end of the bag slides the work into position upon the baseboard.

The available pressure depends on the existent atmospheric (barometric) pressure and the degree of vacuum obtained by the pump. If both are expressed in inches of mercury and, for practical purposes,

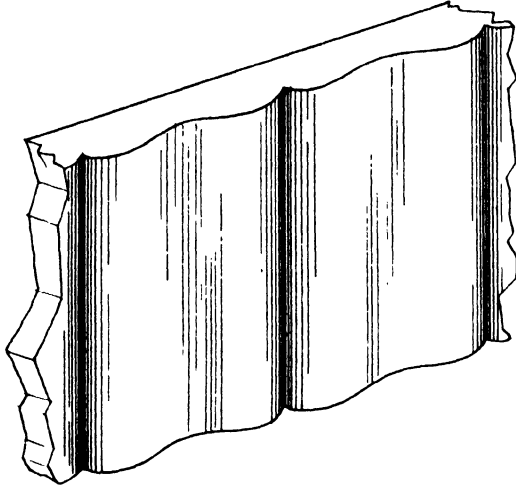

Isometric drawing of "Oceana" panel illustrated on page 133.

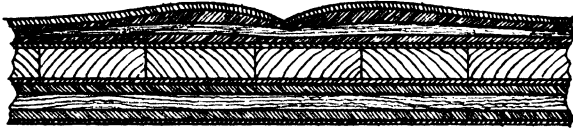

Section showing construction of above.

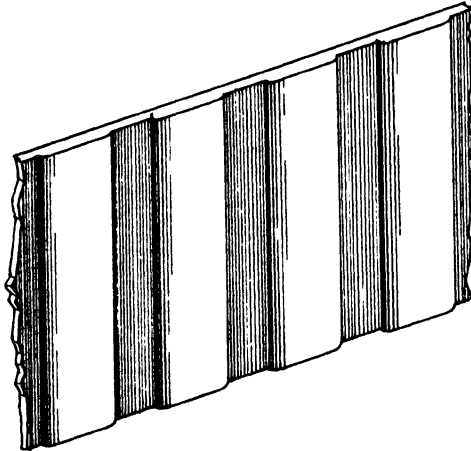

Isometric drawing of moulded "Oceana" panel.



Section showing construction of above.

FIG. 72.

the round value of 14 lb. per square inch taken for a barometric height of 28 inches of mercury (say  $\frac{1}{2}$  lb. pressure per square inch for each inch of height of barometer), with the barometer at 29 inches and the vacuum gauge reading  $2\frac{1}{2}$  inches, *i.e.*  $26\frac{1}{2}$  inches of mercury of positive pressure, the pressure per square inch is  $13\frac{1}{4}$  lb.

Some jobs, as for example the building up of plywood to a fixed radius, require special forms on which the work is assembled. One form only is necessary for each shape, and as these can be built up in a lattice formation over solid shaped ends they are relatively inexpensive. They need not be of such sturdy build as the male and female forms used in the veneer press.

The construction of 3- or multi-ply panels must be carefully considered. Fig. 73 illustrates the arrangement of veneers in a section

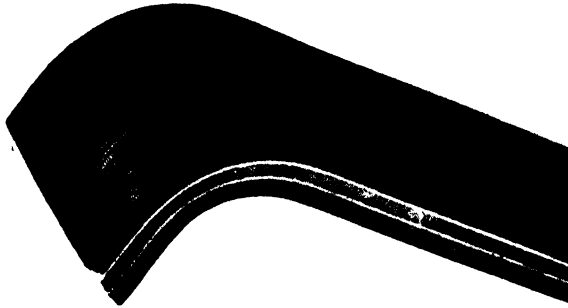

FIG. 73.

$\frac{3}{4}$  inch thick with face veneer of American Black Walnut bent to an outside radius of 3 inches. The thickness is made up of a core and two veneers of  $\frac{5}{32}$  inch Poplar bent across the grain, and four veneers of  $\frac{1}{16}$  inch Poplar, two lying immediately below the outside veneers of  $\frac{5}{32}$  inch Walnut, all being bent in the direction of the grain.

The core stock is glued up in the usual way and the veneers assembled on a shaped form, being held in position by a few tacks or sprigs. The assembly is placed on the carrier and slid into the centre of the bag which is then sealed and the pump set in action. As the air is exhausted from the bag the upper wall gradually conforms to the contour of the mould. The latter should be positioned inside the bag in such a way that the pressure of the rubber wall comes first on the centre of the work, spreading gradually towards the edges. The operator must smooth out the rubber as the vacuum forms to make certain that the entire surface to be glued is subjected to an even pressure, preventing

the formation of air-bubbles in the glue. For straightforward veneered work on to solid wood or plywood cores some operators find it expedient

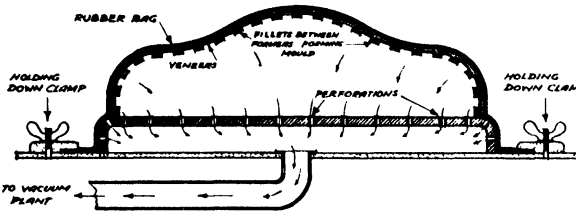

FIG. 74.

This drawing, which is purely diagrammatic, indicates the relative positions of formers, veneers and rubber bag once the air from the latter has been exhausted.

to use cauls of heated cork-linoleum between the veneer to be laid and the rubber wall of the bag.

A quick-setting glue with good adhesive properties at the pressure available is essential.

In the construction of small cabinets with rounded corners the two gables and top may be veneered in one operation, sufficient plywood being left unglued

at the corners to enable these to be moulded to shape around prepared solid corner-pieces which are inserted as illustrated in Fig. 185. The rounded corners may be pressed in the vacuum bag, but if both square and rounded packing pieces have been accurately cut, external pressure should not be necessary.

(3) Special moulding and shaping processes are in the course

of evolution, and it is from experiments in this direction that one may reasonably anticipate developments of considerable interest and value.

The most simple of these processes is a European invention and consists of a vacuum bag in which the prepared work is moulded to the contour of the form under atmospheric pressure in the manner just described. When the vacuum is complete the whole is passed into a drum in which it is subjected to additional pressure and heat derived

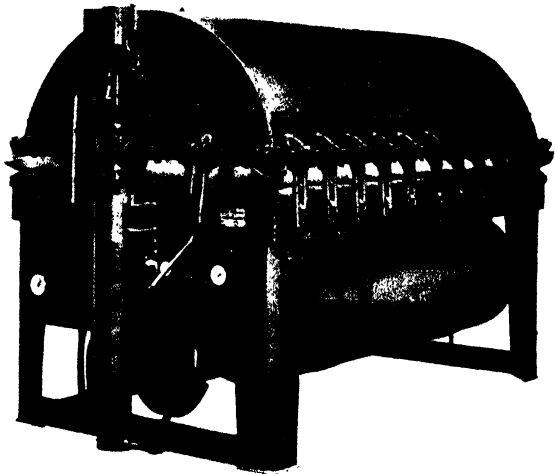

(By courtesy of Interwood Ltd., London.)

FIG. 75.—SHAPING AND MOULDING PRESS.

from compressed air and steam. Both pressure and temperature are sufficient to "cure" thermoplastic resin adhesives, thus enabling the manufacturer to produce moulded plywood with a waterproof bond

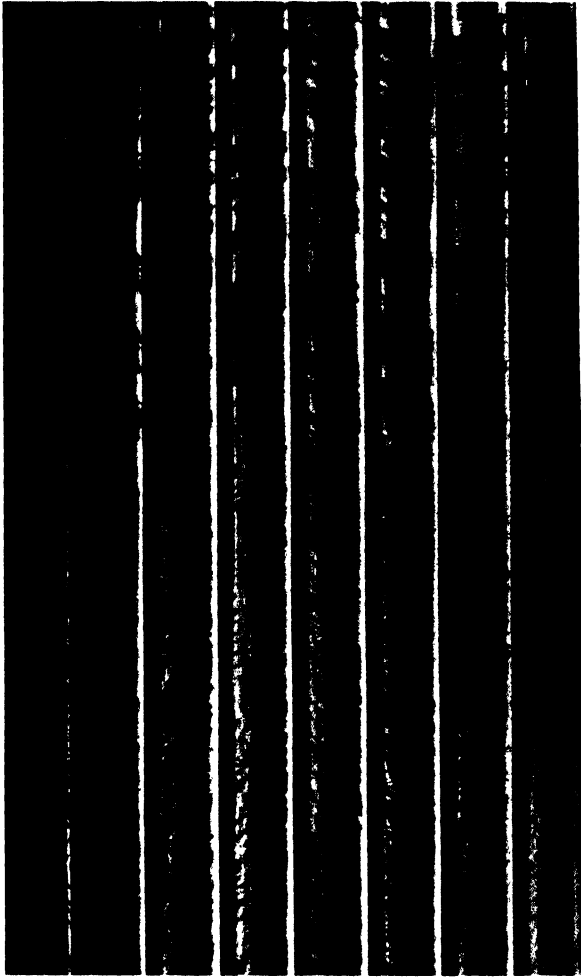

FIG. 76.—"OCEANA" PANEL IN MAHOGANY.

of equal strength and durability to that obtained on the hot hydraulic press. This steaming process incidentally causes the wood fibres to become much more plastic as a result of which they are less liable to fracture when bent along the grain. The moulds or forms must be of somewhat stronger build than those used with the vacuum bag. For



repetition work metal moulds may be cast, but, due to the inevitable expansion and contraction of the metal, wooden forms are generally preferred.

In America considerable headway has been made in the production of moulded plywood, more especially as applied to the manufacture of aircraft, small speedboats and other light craft. The results so far have been most encouraging and two patented processes have already proved their worth. These are similar to the European system just described but the tanks are larger and of much heavier build.

Veneers to which resin adhesive has been applied are laid on or around a metal or wooden mould and inserted in a rubber bag from which the air is gradually exhausted in much the same way as has already been described. This bag is then placed in a tank—not unlike those used in the fireproofing process—and subjected to steam-pressure until the hardening of the resin has been completed. By using well-designed male moulds it is possible to cast large sections of aircraft complete with ribs and stringers securely fixed to the plywood skin, so forming units of great strength which are of the utmost value to the aeronautical engineer. The possibilities offered by these processes are immense. During April 1941 the announcement was made that an aeroplane with fuselage and wings of moulded plywood had been accepted by the Air Department of the United States of America.

Special presses and forms are used in the manufacture of many plywood-built articles, from grand-piano rims to tennis racquets.

### (b) PROTECTION AGAINST FIRE

Plywood subjected to a fireproofing process or built up in combination with Asbestos or a fire-resisting composition is required by certain industries.

Shipbuilders demand such material for statutory fireproof and fire-resisting bulkheads in passenger vessels, for bulkheads and furniture on naval craft, for E.L. Trunking and several other purposes. Civic authorities in various parts of the country will not permit plywood or wallboards to be used in exhibition halls unless they have been rendered fire-resisting, while theatrical and film producers are governed by similar regulations and must use fire-resisting materials for scenic effects, studio sets and so forth.

Strictly speaking, it is wrong to refer to any plywood as being "fire-proof." Wood is organic, and all organic substances, no matter how treated, ultimately carbonize when subjected to high temperature for any length of time. However, plywood can be made non-inflammable

and by virtue of this the term "fireproofed" plywood is frequently used in the timber and associated trades.

During the past decade there have been several disastrous fires on important passenger vessels—to mention four: *The Queen of Bermuda* at Belfast, the German *Europa* at Bremen, the French *L'Atlantique* and the American *Morrow Castle*.

The question of how similar occurrences could be prevented or controlled before reaching serious proportions gave the authorities concerned in this problem cause for serious thought. Investigation into the cause of fires aboard ship led to the framing of certain regulations by the Board of Trade and similar state departments in America and elsewhere.

British shipowners acknowledged the fact that the most vulnerable materials on board passenger vessels are to be found among the furnishings and passengers' personal belongings. Curtains, for example, are a frequent source of danger. They appear to have an unhappy knack of collecting cigarette-ends thrown overboard by careless passengers and blown into staterooms through open port-holes. It was obvious that unless such inflammable material could also be protected, the number of fires would not be lessened merely by fireproofing the plywood bulkheads, linings and ceilings. By so doing the most that could be hoped for was that the bulkheads would localize the fire or at least prevent its rapid spread.

The better-known passenger vessels recently commissioned are protected by sprinkler installations, by specially constructed plywood used for fireproof bulkheads, and by the liberal use of fire-resistant paints.

After the Belfast fire Mr. Lyford-Pike, Senior Lecturer in Forest Utilization, University of Edinburgh, conducted a series of experiments to test the action of flame on plywood as compared with that of solid wood of similar species and moisture content. The result of these tests was as anticipated, namely, that plywood in the early stages after the application of flame did not ignite so readily as the solid wood. Once the flame had penetrated the first glue stratum, the outer veneer tended to fall off and the fallen pieces added to the general conflagration, but the various layers of cement appeared to restrict the progress of the flame from veneer to veneer. Inflammable gases were slowly evolved from the solid wood when a temperature of 300° F. was reached, the rate of discharge being accelerated as the heat became more intense until at about 700° F. the gases burst into flame. Carbon formed at this stage was gradually consumed by glowing. Gases given off the solid wood were in considerably greater volume than from the plywood. It was concluded that the glue layers and cross-banding retarded, to a considerable extent, the evolution of inflammable gases. Laminated boards restricted

the spread of flame more effectively than multi-ply ; the edge grain of the laminations, which were exposed once the outer ply had been destroyed, charred but did not ignite, except under intense and continued heat. The solid wood was finally destroyed more rapidly than was the plywood.

Certain adhesives, more especially those of the phenol-formaldehyde type, are non-inflammable and restrict flame penetration to a marked degree. This fact has been demonstrated in the fire which broke out in the International Exhibition on Treasure Island, San Francisco, and in other serious outbreaks where fire authorities have acknowledged that resin-bonded plywood has restricted the spread of flame while other materials have burned fiercely.

In England two well-known establishments, one at Crayford, the other at Market Bosworth, subject large quantities of plywood to fireproofing processes, both of which are recognized by the Admiralty and other Government departments. Plywood fireproofed by either process can be painted, polished and worked in much the same manner as the untreated boards. Commercial stocks do not deteriorate during processing provided they have been manufactured with a resin or waterproof casein adhesive.

Elsewhere in the United Kingdom various firms operate a fireproofing process for timber and plywood with an *anti-pyrene* mixture manufactured by Imperial Chemical Industries. The methods of fireproofing timber and plywood in common use in England are highly efficient.

To fireproof timber or plywood successfully it is necessary to remove the sap and wood gums from the cells of the wood before any effort is made to inject the anti-pyrene salts. This is done in a large steel cylinder—of heavier build than the usual creosoting tank—built to withstand pressure up to 250 lb. per square inch. The wood is subjected to a steaming process, after which sap and wood gums in solution are drawn off in the accumulated water. Vacuum pumps are then applied. While still excluding all air from the cylinder the anti-pyrene solution is introduced and forced into the wood cells and fibres under pressure. The plywood is then dried in the air and subjected to a special drying process in kilns which leaves the anti-pyrene salts in the fibres of the wood in the form of minute crystals.

When dealing with 5- or 7-ply resin-bonded plywood a difficult problem presents itself, as unless the salts can be made to penetrate the layers of resin, which are impervious to moisture, and fill the wood cells in proximity to the bond, the veneers in the centre of the panel cannot be evenly treated.

In an endeavour to overcome this problem and to produce fire-

resistant plywood at an economic price, certain manufacturers have experimented with the impregnation of veneer before it is built up into plywood, and considerable success has been achieved in this direction.

Salts can be injected into thin veneer by pressure alone, but care



*By courtesy of Pacific Forest Industries, Tacoma, U.S.A.*

FIG. 77.—INTERNATIONAL EXHIBITION OF 1940 ON TREASURE ISLAND, SAN FRANCISCO.

This illustration depicts three buildings in course of erection—the Island Club (left background), Manila Inn (centre), and Theatre and Television Centre (right foreground). The battens above the canopy of the Theatre have been positioned ready to take the plywood. For the exteriors of all three buildings resin-bonded Oregon Pine plywood was used.

During August 1940 a serious fire broke out in the California Building and it is on record that after burning through 1" diagonal wooden sheathing on the inside face of the wall-studs the fire was actually checked by the 1/4" resin-bonded Oregon Pine plywood exterior panels. The fire was confined to a single building and, in the opinion of both Exhibition authorities and insurance inspectors, if the roof had also been of plywood construction, the fire could probably have been subdued within the room in which it started. The heat had little effect on the resin bond and the rate of charring was greatly reduced owing to the absence of all tendency to ply separation.

should be taken to ensure that a sufficient quantity of the anti-pyrene solution is forced into the wood, as a low absorption of even the most efficient salts will not suffice.

Plywood itself is not a ready conductor of heat and may be rendered fire-resisting by salts which react to heat in divers ways :—

1. The evolution of the water of crystallization may damp the firing of gases sufficiently to restrict the spread of flame.

2. The salts may emit gases which do not support combustion. These mix with the inflammable gases given off by the wood and yield a non-inflammable mixture. Arsenates and arsenites possess this property to a high degree, but cannot be used as the gases discharged are noxious.

3. Heat may create a physical change by fusing the salts to a protective glaze which prevents oxygen from reaching the surface of the plywood. "Oxylene" treated wood possesses this property: according to one report the "crystals expand and form a glassy coating which excludes the oxygen of the air."

Reliable mixtures contain salts which, when subjected to heat, will produce at least two of these reactions.

The selection of suitable salts is further restricted by the following conditions :—

1. They must not be hygroscopic, otherwise in damp weather they will tend to absorb moisture from the atmosphere: water may collect on the surface of the plywood to a considerable extent.

2. They must be non-volatile and chemically stable when exposed to varying atmospheric conditions over lengthy periods.

3. They must not react unfavourably on the glues or cements used in the manufacture of the plywood or in any subsequent processing.

4. They must not be corrosive to metal.

5. They must not be efflorescent.

Authorities appear to agree that Mono- and Di-Ammonium Phosphate are used in many of the fire-retardant formulæ in combination with other substances, such as Phosphoric Acid, Ammonium Bromide and Chloride, Zinc Chloride, Magnesium Chloride or Borate, Borax and Boric Acid. While some of these chemicals used alone would ultimately cause metals to corrode, this disadvantage can be overcome by adding other salts to the mixture.

It will be obvious that the greater the concentration of anti-pyrene solution injected into the wood, the greater will be the margin of safety, but this must not be pushed too far, otherwise the wood will become brittle, making the handling of veneers a difficult matter.

*Surface Application.*—Plywood can be protected against flame penetration by various paints and chemicals applied by spray-gun or brush. Several patented or registered fire-resisting paints give very satisfactory service even when exposed to high temperatures over prolonged periods and are largely used in the shipbuilding industry. Most of these paints have the property of intumescence, that is, when

heat is applied they swell up and form a thick blister-like skin which cuts off all oxygen from the surface of the wood and so prevents the spread of flame.

When, as frequently happens, non-inflammable plywood is specified for exhibition stalls and so forth, temporary protection is all that is required. In such cases two or three coats of "waterglass" Sodium Silicate will give excellent results. This tends to lose its fire-retardant properties, but further applications may be given as necessary. Solutions containing Phosphoric Acid and Ammonium Phosphate are used in a similar manner, and proprietary mixtures are available. The plywood can be dipped into a suitable solution or the latter applied by hand. Ammonium Phosphates and Sodium Silicate have also the property of intumescence. It should be remembered that the salts used in all anti-pyrene formulæ are soluble in water and, in order to retain the effectiveness of a surface application, treated boards should be protected by non-inflammable paints or a lime wash. Fireproofed surfaces must be carefully protected if exposed to the weather, otherwise the soluble salts may be partially removed by rain-water.

### (c) COMPOSITE BOARDS

Highly efficient non-inflammable plywood can be produced by combining Asbestos or another non-combustible material with wood veneers. The protective material selected, in addition to being fire-resistant, must have a high insulation value against heat. It should also be light in weight.

Metal coverings are not suitable as invariably they are good conductors of heat and expand when exposed to high temperatures—the transmitted heat causing charring which results in the ultimate decomposition of the bond between metal and plywood. Asbestos itself is light in weight, its insulating value is excellent, but it neither holds paint nor glue well. It has little mechanical strength, and if used as the core of a composite board is liable to break down if subjected to such movement as must be expected during the "working" of a ship in heavy seas. When the composite boards are to be secured to a framework not liable to any movement, Asbestos fibre sheets can safely be used. These should be saturated with weak glue-size and dried before the board is built up. This treatment adds slightly to the strength of the Asbestos and helps to make a better bond between the latter and the wood veneer. The Asbestos should be treated as a ply and be laid with the fibres running at right angles to the grain of the two adjacent veneers.

Asbestos cement has the disadvantage of being heavy and is apt to crack and explode under intense heat.

Asbestos paper or cloth skilfully applied will give satisfactory results, but the various compositions similar to those known as Asbestos wood are probably the most efficient for this type of work.

Unless the insulating properties of the non-combustible material cemented to the face of the plywood are good, heat will pass through the protective layer. If this heat becomes intense the plywood will begin to char and pockets of steam and inflammable gases, evolved from the wood, will gather between the protective layer and the plywood. Such a condition can only result in the breakdown of the entire structure. This is overcome by using material of high insulating value which will prevent

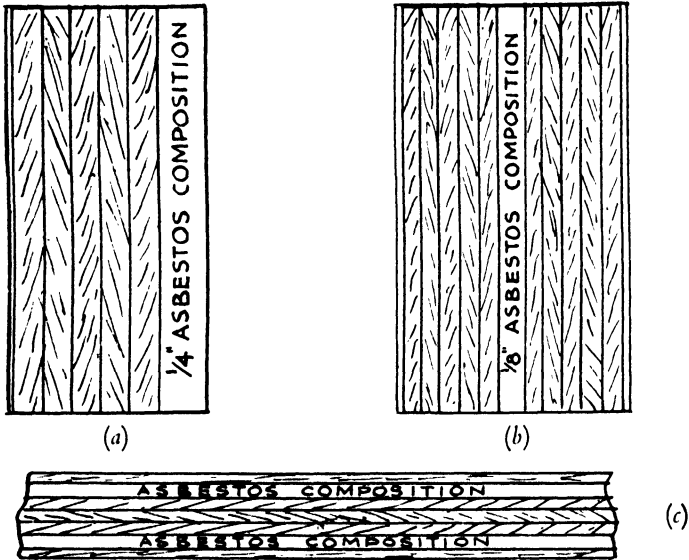

FIG. 78.—COMPOSITE BOARDS.

the temperature of the wood from rising to the point at which the gases ignite, or alternatively by using an Asbestos covering thin enough to allow the water vapour and gases to escape. Good results have been obtained with Asbestos paper as thin as 0.2 to 0.3 mm. Exposed to a moderate (but not intense) fire it was found that the underlying plywood was slowly carbonized but that there was no flame-penetration.

Experience has also shown that by using a good bonding agent highly satisfactory results are obtained by laying the Asbestos composition immediately below the face veneer (Fig. 78 (c)). The latter carbonizes, but, so long as it remains fixed to the Asbestos, acts as a non-conductor. The Asbestos itself prevents any flame-spread.

Fig. 78 (a) and (b) show sections of composite boards used for statutory

fireproof and fire-resisting bulkheads on the *Queen Mary*, *Mauritania* and *Queen Elizabeth*.

Composite boards should be glued up in a cold press, using one of the proprietary casein or cold resin adhesives.

Protection against flame-spread may also be obtained by covering the outer plies with a phenolic resin in film, varnish or powder form and pressing between polished steel plates. A highly glazed, hard surface is obtained.

Composite boards incorporating one of the standard insulating boards in any desired thickness will be found useful in the building of partitions, temporary telephone booths in exhibitions and so forth.

Flexible panels can be constructed by combining canvas and wood veneers. Decorative veneers backed with canvas are useful at times, but a 3-ply board with canvas impregnated with a plastic between the wood veneers makes it a much more reliable product. Of similar construction is an American product which incorporates a decorative veneer, metal of thin gauge and canvas.

Compressed cork cemented between two sheets of metal-faced or ordinary plywood is used on a considerable scale in the construction of cold-storage rooms and refrigerators ; also for ice and meat containers or vans, both for road and rail transport.

Gas-proof plywood, occasionally used in laboratories and works, can be prepared by laying a sheet of tin-foil between two of the plies before pressing.

Various types of composite board incorporating sheet lead or rubberized lead are used in X-ray work. The lead, 3 mm. or thicker according to specification, is frequently sandwiched between two sheets of plywood. Doors may be constructed in a similar manner, using blockboards or laminboards in place of multi-ply. The lead should be carried to the extreme edge of the door.

Plywood may be covered with Bakelite, Traffolite, Mfcarta, Formica or any of the urea or phenolic resin laminated veneer sheets. These yield excellent hard surfaces which are reasonably scratch-proof and can be made blister-proof during manufacture by inserting a thin sheet of metal-foil immediately below the decorative surface. The phenolic resins are darker in colour and are considered to stand harder wear than the urea type which is available in a good range of attractive pastel shades.

These veneer sheets have become very popular for counter, bar and table tops ; they are largely used for tops of furniture in passenger vessels, for lining bathroom walls and for other positions where a decorative and hard-wearing surface is required.

The manufacturers generally recommend or supply a suitable



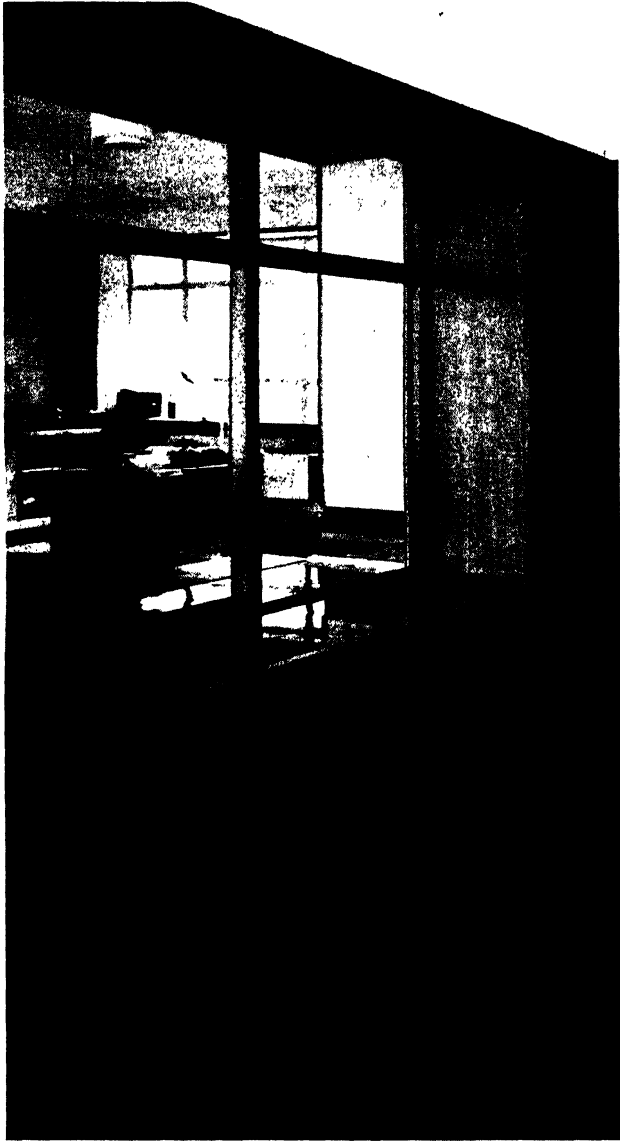

FIG. 79.

1" Blockboard veneered with Micarta is used for this counter to the general office of Messrs. L. Keizer & Co. Ltd., Leith. The edges are covered with strips of solid Teak. The wall panels are  $\frac{1}{4}$ " plywood faced with figured Teak.

adhesive for laying their material to plywood, but in the absence of such particulars a good casein mixture will serve well.

It is essential that well-made plywood, blockboards or laminboards at least  $\frac{5}{8}$ " thick be used for the base. Thinner sheets are liable to curl owing to the "pull" of the laminated sheet, but this may be counteracted to a limited extent by laying a cheap wood veneer on the reverse side. For table tops which will be secured to a rigid framework  $\frac{7}{8}$ " or 1" thick blockboard or laminboard should be used.

The sheets can be cut with a close-set, fine-cut saw, and in order to compensate for any "skidding" it is advisable to cut the panels on the full side. The reverse side of the material should be sanded or sand-

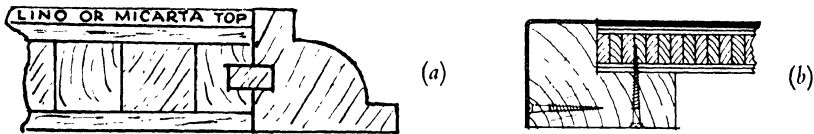

The edges of plywood tops faced with lino, resin laminated veneer sheet or other material may be covered with a solid wood moulding glued and tongued to the plywood.

Staybright steel angle screwed to solid edge into which the  $\frac{7}{8}$ " laminboard faced with resin laminated veneer sheet is recessed and secured by screws.

FIG. 80.

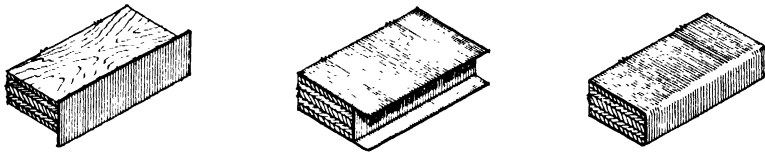

The resin laminated veneer sheet is glued to the edge of the plywood and then flushed off.

Top and bottom sheets are then glued into position.

These are flushed off by hand-plane or spindle and edges rounded and smoothed with sand-paper.

FIG. 81.

blasted until the surface resin has been removed and then carefully cleaned with a rag soaked in petrol, benzol or benzine.

A thin even coat of adhesive must be applied to the plywood and the laminated sheet then carefully positioned. It is advisable to cover the top surface with a piece of smooth paper to prevent the sheet from sticking to the platens of the press. Pressure should not exceed 100 lb. per square inch as higher pressures are liable to cause "starved" joints.

The treatment of edges should be carefully considered and various suggestions are illustrated. When the edges of a bar top have to be covered with the laminated sheet they should be treated first, and when the cement has thoroughly set the resin sheet can be trimmed off flush with hand-plane or spindle. The topmost covering is then cemented into position and neatly trimmed off in the manner shown.

*(d)* METAL-FACED PLYWOOD

By cementing very thin sheets of metal to both sides of a piece of plywood we obtain a product having unique properties which, in a measure, bridges that wide gap between metal and wood.

On page 27 the observation was made that by glueing two hardwood veneers to a piece of fibre board having in itself little strength a considerable increase in the resistance to bending is obtained. A similar theory may be applied to the laying of thin sheets of metal to a plywood core. For instance, if two thin sheets of galvanized steel be cemented to a piece of  $\frac{3}{16}$ " plywood—neither plywood nor steel having in themselves much rigidity—the gain in the resistance against bending will be very marked. To obtain the same measure of rigidity a steel section would require to be at least four times as heavy.

If the metal be cemented only to one side of the plywood the gain in rigidity will not be so great, but nevertheless the resistance to compression and tension offered by the metal will be reflected in a considerable increase to the stiffness of the panel.

The problem of fixing metal to wood, however, is not an easy one to solve and it will generally pay to leave this to one of the mills which specialize in the manufacture of this type of plywood. The metal itself must be specially rolled at the rolling mills to a fine gauge of even thickness, and contracts for such material are only of interest to the makers when the quantities ordered make it worth while to set up the machines for a special run.

The metal must be absolutely free from oil or grease, and as a general rule it is necessary to "key" the metal to assist the adhesive to grip. This may be done by means of an acid wash which will pit the sheet, or by toothing the metal with abrasive belts. In either case the work demands great care; if acid is used it must be carefully washed off before the cementing operation.

The actual bond is made with special cements which have been evolved by the makers of metal-faced plywood. The difficulties experienced in glueing wood to metal will be apparent to every woodworker. It is well known that heat causes metal to expand to a varying degree whereas cold has quite the opposite effect: neither heat nor cold has much effect on the plywood base, therefore a shearing strain is set up between the two substances with every movement of the metal. Obviously an adhesive that is hard and brittle will be useless. A further difficulty must be faced in that no known adhesive can be made to permeate metal as glue does wood. In view of the above a cold setting adhesive is preferable to a heat-reactive one.

To be satisfactory, cements should contain little or no solvent or should harden by chemical reaction as do certain forms of synthetic resin in the presence of a catalyst. Casein and latex can be successfully blended to yield a bond having some elasticity which will take up much of the difference in the contraction and expansion of the metal and the plywood.

The cement used by the leading manufacturers of metal-faced plywood is waterproof in that it will not disintegrate under influence

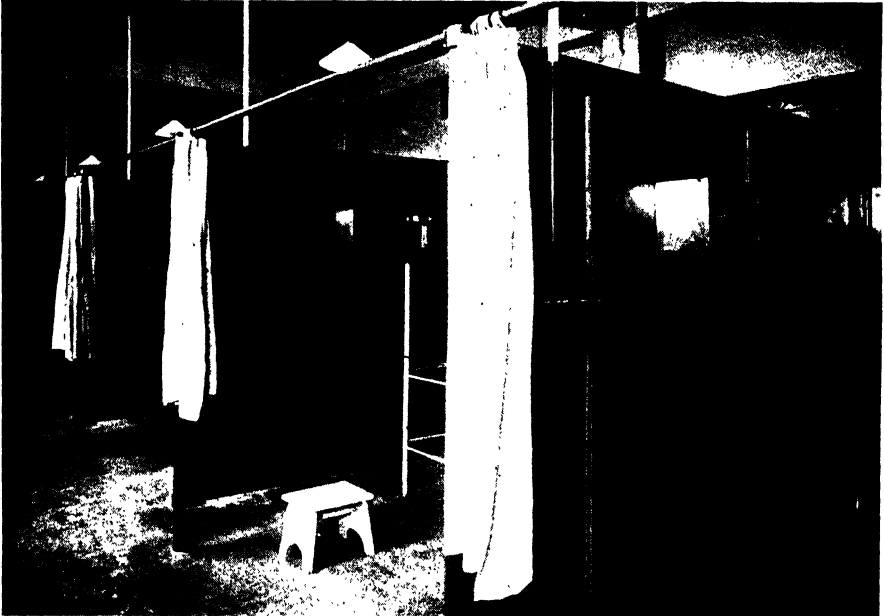

[By courtesy of Messrs. Venesta Ltd.]

FIG. 82.

Three-sixteenth inch Plymax with galvanized steel on both sides recessed into a wooden framework. The high-gloss paint finish is easily cleaned and disinfected.

of moisture, but nevertheless it is essential to good performance that as much moisture as possible be excluded from the bond. If this is not done, damp may cause corrosion of the inner metal surface, may produce a chemical change in the adhesive and, sooner or later, must cause a breakdown at the joint.

Any of the brands of metal-faced plywood which are accepted by the Admiralty are certain to give long service, on the other hand cheaply made boards will prove to have a relatively short life.

The plywood itself must be of sound construction and bonded with

a waterproof cement. It may be faced with any of the following metals on one or both sides :—

Galvanized steel.	Monel metal.
Stainless steel.	Copper.
Aluminium.	Bronze (Gilding metal).

Any combination of these metals may be incorporated in building double-sided boards, galvanized steel being frequently used for the backs of panels faced with one of the more expensive metals such as monel metal, bronze or copper.

#### PROPERTIES OF METAL-FACED PLYWOOD

The chief advantages which are offered by metal-faced plywood may be summed up thus :—

1. It offers the maximum resistance to buckling and bending of any constructional material per unit of weight.
2. It enables metal surfaces to be exposed without any danger of the metal "sweating." Its thermal conductivity is low (about  $1/2000$  that of  $\cdot 22$  gauge steel), the thin sheet of metal rapidly gaining equilibrium with every change in the temperature of the surrounding atmosphere, while the plywood core acts as an insulating pad between the two layers of metal.
3. It is "dead," like wood, and does not ring when the metal face is struck with a hard object.
4. It is not easily damaged by a surface blow (unless a sharp object is used), the metal resisting penetration. The plywood absorbs the energy of a blow and distributes it over the entire area, instead of buckling or breaking as a thin sheet of metal would do. The principle is much the same as led to the use of snow-shoes in Arctic countries, the impact of each step being spread over the whole area covered by the snow-shoe which, therefore, does not break through the surface of the snow.
5. Although it is not claimed to be fireproof it prevents spread of flame. Under intense heat the metal will get red-hot and destroy the adhesive, then, as the plywood chars, gases given off will make the metal covering bulge. If the heat is continued the structure will eventually break down.
6. It is hygienic and can be easily kept clean.
7. It is proof against rats, mice and vermin of all kinds.

Double-sided material is generally the more satisfactory, provided the edges are sealed in such a manner as will prevent penetration of damp. Plywood, faced on both sides with metal, will not alter shape unless force is applied and, provided the thickness in relation to the size of the panel is adequate, it will stand unsupported, and will remain flat enough for all practical purposes. Plywood faced with metal on one side only, due to the fact that the exposed plywood face will absorb or expel moisture with changes in the atmosphere whereas the metal face will not, is unlikely to remain flat unless supported against a framework. The framework must be strong enough to resist the "pull" of the metal-faced panel.

Metal-faced plywood is usefully employed for a great variety of purposes and many of these are mentioned in Part X. The following notes on individual types of metal-faced plywoods may be helpful:—

*Galvanized Steel.*—This is one of the most useful forms and is the least expensive. It should not be used as flooring or subjected to constant wear, otherwise the galvanizing will be destroyed and the steel will eventually rust. After being in use for a year or so, if exposed to moisture, the surface should be carefully painted.

*Aluminium.*—Aluminium as a metal must be carefully used and naturally similar conditions apply to aluminium-faced plywood. Many forms of anodized aluminium are most attractive, but while they can be very decorative they must be used with intelligence. A special cement is required to effect the bond between aluminium and plywood.

It must be observed that aluminium deteriorates very rapidly in the presence of alkalis, and for this reason it must not be used for the outside of vans or other vehicles which may be exposed to sea-spray or in any other position in which the metal may come into contact with alkalis as, for instance, in laundries or in bathrooms.

Aluminium-faced plywood is very light and gives one of the best surfaces obtainable for high-gloss enamel work.

*Monel Metal.*—This is most useful for bars, shopfitting and showroom shelving. It is a nickel alloy which, under normal conditions, will neither corrode nor rust. In the form of metal-faced plywood it is delivered with a dull matt surface which will take on a mirror polish if desired. It can easily be kept in good condition by cleaning with a damp cloth.

*Copper and Bronze.*—Plywood faced with either of these metals is delivered with the ordinary dull surfaces as supplied by the rolling mills, but the surface may be polished, or coloured to any desired shade by chemical means. The finished surface should thereafter be protected by a lacquer or good beeswax polish.

**BENDING.**—By screwing to a rigid framework single-sided metal-

faced plywood may be bent to a minor curve, provided the metal is on the outside of the curve. More acute curves can be obtained by passing the material through bending rollers in much the same way as is adopted with sheet metal.

Compound curves can be made by using special presses which are only available to the manufacturer of metal-faced plywood who should be consulted if work of this nature is in contemplation.

With metal on the inside of the curve, one-sided aluminium-faced plywood can be made to bend to a radius of not less than five feet without special appliances.

METHODS OF WORKING

Metal-faced plywood can be cut with ordinary wood-working or metal-cutting saws having little or no set. Hacksaws or jigsaws may also be used.

It can be nailed, screwed, punched, drilled or otherwise manipulated with the ordinary tools of a joiner.

METHODS OF PROTECTING EXPOSED EDGES OF METAL-FACED PLYWOOD

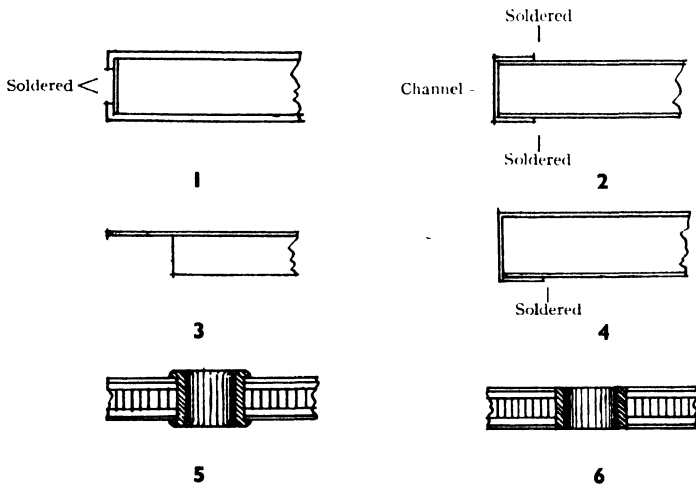

FIG. 83.

1. Venesta patent. This is the most satisfactory method of sealing the edges of double-sided Plymax and offers a perfectly flush surface on each side of the panel.

2. A light galvanized channel made from about 30 gauge steel is soldered to the metal faces in the manner shown.

3 and 4. Method used when one flush surface is required such as for shelves or table tops. May be used for single or double-sided stocks.

5 and 6. When it is advisable to protect the edges of small circular holes this can be done by bushing. The bush may take the form of a short length of tube expanded or curled over at the ends (Fig. 5) or it may be soldered in position (Fig. 6).

(e) IMPROVED AND COMPRESSED WOOD

The manufacture of compressed and improved wood has become highly specialized and should be conducted under the supervision of a competent chemical engineer. For many years experiments were made by plywood manufacturers in this field, and much time and labour was expended before satisfactory results were obtained.

The difference between improved and compressed wood lies in the treatment of veneers before pressing. In improved wood each veneer

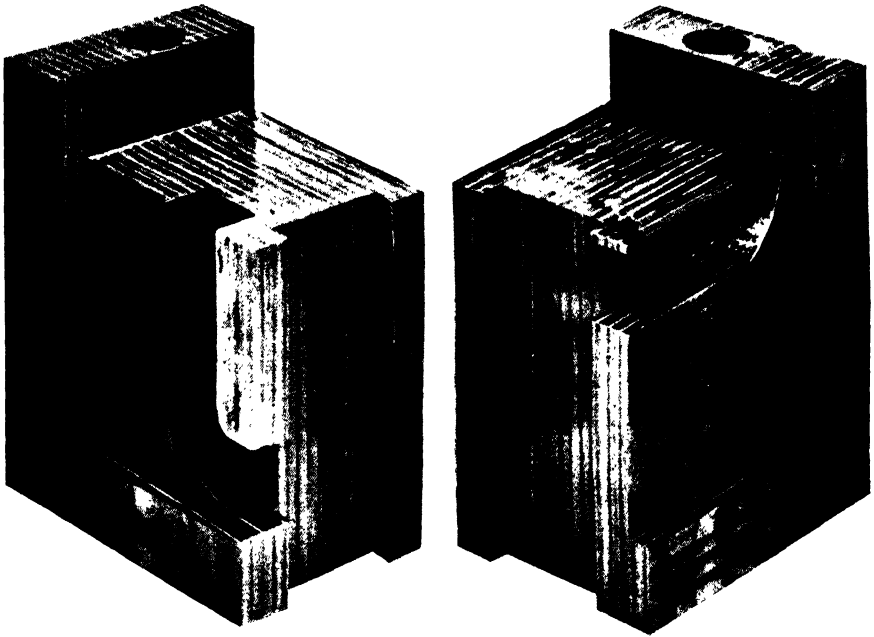

[By courtesy of the Editor of "Wood."]

FIG. 84.

These end-winding supports for a short circuit test generator have been fabricated from improved wood.

is impregnated with an alcohol-soluble phenolic or cresylic resin, dried and then assembled; in the manufacture of compressed wood a film of phenolic resin is laid between the veneers forming an assembly, or each alternate veneer is coated with resin in the usual way. The thickness of the veneers used varies within wide limits as does the number of veneers in any one assembly. The density of the finished product will depend upon the pressure applied to the mass in the press; in the production of improved wood a pressure of 1500 tons is not uncommon,



while in order to obtain the requisite impregnation in compressed wood it may be necessary to increase the pressure to 2500 or even 3000 lb.

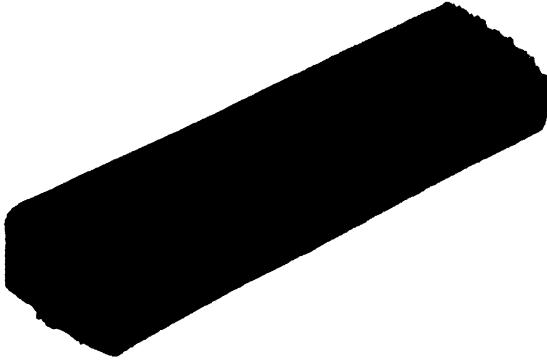

FIG. 85.

A piece of compressed wood  $1\frac{1}{4}$ " thick showing the "flayed" end where pressure has not had uniform effect. This piece consists of 66 pieces of Birch veneer each 0.5 mm. thick, bonded with phenolic resin film.

per square inch. The physical properties of the product will vary according to the arrangement of the grain fibres of the veneers: these may be laid with the grain of each alternate veneer crossed as in plywood

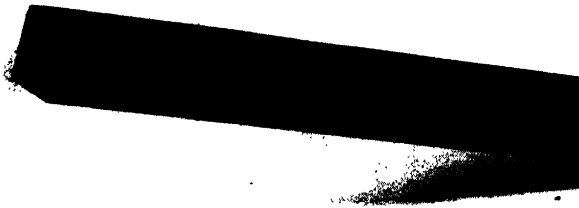

FIG. 86.

A bar of compressed wood  $\frac{3}{4}$ " thick consisting of 60 Poplar veneers each 0.5 mm. thick running lengthwise, with 14 veneers each 1 mm. thick running crosswise, bonded with phenolic resin and compressed to  $\frac{3}{4}$ " thick.

construction, or the grains of all veneers may run in the same direction or be alternated at different angles to give the maximum resistance to the forces likely to be applied during use.

At present the most important outlet for compressed and improved wood is in aircraft construction, but possible uses cover a wide field,

and a bright future should be the reward of those who have spent so much time and money in experimental work.

One of the early uses was for the roots of air-screw blades, but in recent years both types have been employed on quite an extensive scale for constructional parts of aircraft demanding high tensile, impact or shearing strength.

Improved wood is usefully employed in the electrical industry, more particularly for lift rods for high-tension oil circuit-breakers, switch handles, busbar barriers, transformer parts, and in fact for all work in which high mechanical and high dielectric strength are required.

One of the early outlets for compressed wood made in France was to the electric railways for fish-plates. In the engineering industry improved wood is used for gear wheels, pulleys, bearing plates and bushes for highly stressed bearings. The textile mills find shuttles and bobbins made from compressed wood give better service than those turned from dog-wood, persimmon or any other hard wood. It also comes in useful for floors of elevator cars, giving great strength with minimum weight.

As a general rule compressed wood is stronger in tensile strength than improved wood ; in the former, tensile strengths go up to 63,000 lb. per square inch for a specific gravity of 1.35. Under compression, improved wood shows the better results, running up to 25,000 lb. per square inch, as against 22,000 lb. per square inch for compressed wood.

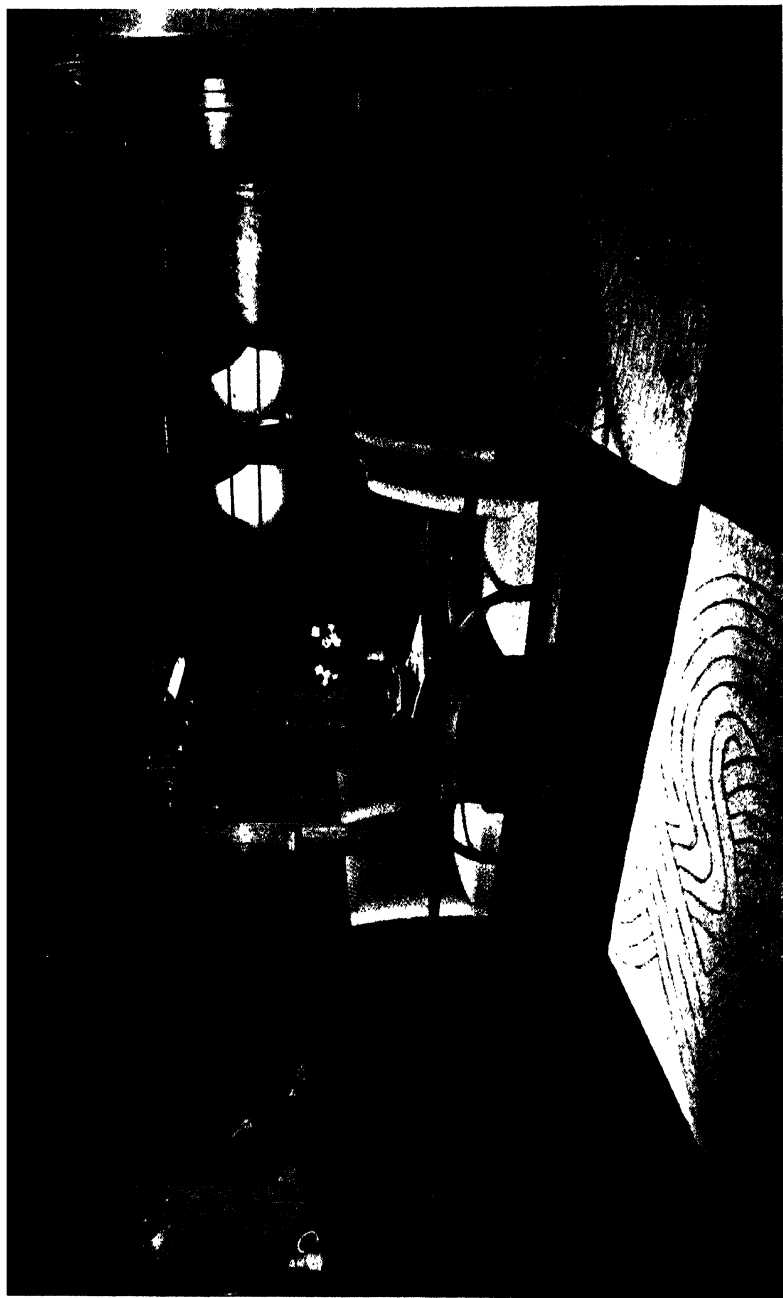

PLATE IV.

Special Cabin, R.M.S. *Queen Mary*. Executed by Messrs. Trollope & Sons (Decorators) Ltd. The panelling is of  $\frac{3}{4}$ " Gaboon multi-ply veneered with Burr Ash. The furniture is veneered Betula. In the Marquetry picture the following veneers are incorporated: Hungarian Ash, English, American and Italian Walnut, Camphorwood, Laburnum, Boxwood, Sandalwood, Satin  (three shades), Prima Vera, Holly (three shades), Sycamore (three shades), Bird's Eye Maple (blue), Orangewood, Ebony Black, Ebony Macassar, Kingwood, Olivewood, Almondwood, West Indian Satinwood, Coralwood, Red Saunders, Tulipwood.

# PART V

## GRADING, TESTING, PACKING AND STORING

### CHAPTER I

### GRADING

ONE of the most difficult tasks which all buyers of plywood must attempt to understand is the vexed question of grading, more especially as applied to Alder and Birch plywoods.

About 1934 a committee was appointed by the plywood section of the Timber Trade Federation to co-operate with other authorities and the British Standards Institution in an attempt to draw up a specification covering the grading of various plywoods. In February 1935 a specification was issued by this Institution covering the grading of plywood veneered with Oak, Mahogany, Walnut, Teak and other ornamental woods. Some progress was made in the more difficult task of defining suitable grading for imported Birch, but co-operation from several producers was not forthcoming and, as it was realized that without the willing concurrence of the leading manufacturers any specification would be worthless, the attempt was given up. This was a short-sighted policy on the part of a few important producers of that period who feared that, by agreeing to a standard specification to which all mills could work, their own goodwill in the United Kingdom might be weakened.

It would be folly to attempt to deal with this subject on a broad basis as it will be recognized that the grading of plywood must vary with the character of the raw material, the equipment available and the standard of workmanship. The question is further complicated when the same plywoods are exported from more than one producing country.

The manufacturers who have most successfully tackled this subject are those working on logs which yield a large percentage of high-grade veneer such as Douglas Fir and Gaboon, and a few other groups who have had the foresight to co-operate in a national organization.

An outstanding example of the latter is the Douglas Fir plywood industry operating in the states of Oregon and Washington, the whole of whose export sales are conducted by an association known as the Pacific Forest Industries.

This is a unique organization acting as an export sales agency to all member mills and having its own warehouses through which all the plywood for export must pass. The plywood, on arrival at these

central warehouses, is examined and graded by inspectors acting under the direct supervision of the Douglas Fir Plywood Association Inspection Bureau. These inspectors act quite independently of the mills and issue a certificate with each shipment in the form illustrated below. The grading rules which are given in full on page 255 are quite straightforward.

P. 100

**DOUGLAS FIR PLYWOOD ASSOCIATION**  
**INSPECTION BUREAU**  
TACOMA MILLWORKS  
**TACOMA, WASH. U. S. A.**

**Inspector** Ray C. Demler regularly approved  
Inspector licensed by the Douglas Fir Plywood Association and of the time acting in that capacity,  
do hereby certify that I have personally verified and inspected the parcel enumerated below,  
and have found the same to be in good order and condition, up to grade specified and containing  
the quantity as given in the body of this certificate.

**DOUGLAS FIR PLYWOOD**

390 Pcs. 3/8" Net 3-Ply S2S "A" Grade	-	10,440 Sq. Ft.
26 Bbls. of 15 pcs. each		
1518 Pcs. 7/8" Net 7-Ply S2S "A" Grade	-	39,175 "
253 Bbls. of 6 pcs. each		
<b>Total 279 Bundles</b>		<b>48,615 Sq. Ft.</b>

**Marks:** **E L C O**  
**SHIPBUILDING**  
**GLASGOW**  
**2151-31**  
**MADE IN USA**  
**Nos. 1-279, Incl.**

**Total Weight - 112,075#**

*Ray C. Demler*  
Inspector

Subscribed and declared to before me, the undersigned, a Notary Public in and for the State of  
Washington residing at Tacoma  
by the above named party, I personally known to me as the  
person signing the above certificate.

Date Dec 26 1939

*[Signature]*  
Notary Public

*[Signature]*

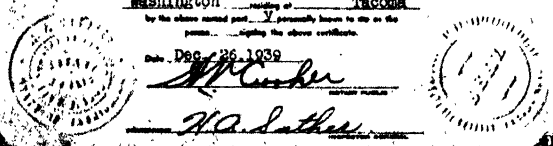

Fig. 87.

This is an ideal arrangement which has proved to be of the greatest value to the member mills and to importers in all foreign markets. The grading has been standardized to a degree which would have been impossible had the mills bracked their stocks independently, and a considerable measure of price stability has resulted.

The grading rules should be taken as a guide only. In practice the average is somewhat higher than the minimum classification as laid

down in the official rules. So much so that buyers have come to expect a somewhat higher standard.

The Canadian manufacturers of Douglas Fir follow similar grading rules.

It should be kept in mind that the high quality of peeler logs used by the industry makes Douglas Fir a comparatively simple plywood to grade.

Okoumé—Gaboon Mahogany—is another species of wood which, being reasonably free from defects, yields a high percentage of veneer of good quality. As a general rule serious wood defects are cut out during the trimming operation, and the grading of the plywood in consequence becomes a question of the good jointing or otherwise of the outer veneers, and the seriousness of any manufacturing faults.

The grading given on page 265 was originally established by the I.D.S.<sup>1</sup> in agreement with a few of the leading British importers and covered eventually most continental productions. It should be observed that the small tight knots known by the French as “*épinés*” are not considered to be defects. British-made Gaboon is graded on similar lines.

The Norwegian Gaboon production was bracked into two qualities, the higher one being unjointed and practically free from defects on both faces, whereas the lower one known as *Ilnd A* admitted well-made machine joints and minor defects on both sides.

The grading of all Swedish Pine plywood was based on the grading rules agreed and issued by the Association of Swedish Plywood Manufacturers to which the Norwegian mill also subscribed. Grading of Pine plywood manufactured in Latvia was done on very similar lines.

The most difficult plywoods to grade are Alder and Birch, not so much from any large variation in the quality of the veneer obtained from the average log, although this is great enough, but mainly on account of the lack of co-operation between manufacturers in the various producing countries.

That satisfactory grading rules could be drawn up is proved by the fact that Russian Birch is well graded into four qualities. The Venesta organization, with mills in Finland, Estonia and Latvia, evolved a successful scheme covering the entire production of their mills in these three countries.

The Finnish producers could well follow this lead, and we may express the hope that when once again the Finns are able to ship their plywood to Britain they will do so in a restricted number of standard grades.

In the early days of the Finnish industry mills had an opportunity of using selected logs for plywood manufacture and a fair percentage of boards of high quality was obtained. As the industry developed, competition for the best logs became more intense until by 1938 the average diameter of the logs used by the mills had dropped to 10 inches.

<sup>1</sup> Refer to page 216.

The percentage of veneer in the higher qualities diminished as the quality of the logs fell, but it is obvious that, at all times, it is the nature of the log supply which controls the quality of the veneer. This fact has been the cause of trouble on more than one occasion for the reason that buyers had no definite grading rules to guide them and had come to expect a better grade than the average standard.

Fixed price lists have been issued for Finland from time to time, but these serve little purpose unless they are accompanied by clearly defined grading rules to which all leading mills subscribe. For example, on one historic occasion after a price list had been agreed to, covering three higher qualities called "A," "A-B" and "B," one manufacturer decided to include all three grades in his "B" quality. The ruse succeeded for a short time only and it proved to be a very short-sighted policy, as other producers followed his lead. Ever since that time "B" quality has been the highest grade shipped from Finland.

The Latvian industry under Government supervision drew up a list of grading rules which was intended to cover the production of Latvia. This was a complex document which would have resulted in an innumerable number of grades.

Some serious effort should be made by importers and shippers to reach agreement on the subject of grading and to restrict the number of commercial grades of Birch to five or at most six. After all is said and done, any further selection which may be necessary to satisfy any small but particular need can surely be made by the importer or merchant.

It should be remembered that importers have to carry in stock all qualities and thicknesses, and the difficulty in holding a representative stock can well be imagined. In one price list, compiled by the authors for February to March 1939, no fewer than eighty-four different items of thickness and quality in Birch plywood were included, several of the categories consisting of ten different sizes.

Wet-glued Alder stocks, shipped during 1938 and 1939, were even more confusing than Birch, not that the grading is more difficult, but on account of the fact that many shippers coined special descriptions for various grades. Thus what was once known as *IV* quality became "BBB," "BBB/BBBB," "BBBB," "SK" or "C." It was all very unnecessary and confusing, and one wonders if a measure of confusion were not intended to conceal the fundamental issue. There is no need for more than a few clear-cut classifications of cheap wet-glued stocks and three or at the most four grades should suffice. A few of the better producers in Poland managed to restrict their grading of dry-glued stocks to three grades, and we have endeavoured to reconcile the various descriptions in Part VII.

The question of the grading of cut sizes is a problem in itself, and when logs must be cut to produce special orders the manufacturers would be justified in demanding appropriate prices for unsorted grades.

In the case of Douglas Fir, orders for large quantities of cut sizes are frequently placed in "B" quality with the certain knowledge that the logs will yield a considerable percentage of higher grade veneer. The producers therefore receive a lower average price for specially manufactured contracts than the figure they would have obtained had the same logs been cut up and graded into standard stock. This is a difficult problem, but is one which has tended to lower the average price of Douglas Fir plywood shipped to the United Kingdom. With a little intelligent co-operation between buyers and sellers a satisfactory solution could be worked out. The Tyneside mill refused to accept orders for cut sizes in B/B quality only. Buyers of cut sizes wishing to purchase the lower grades had to accept qualities "as falling" from the logs. Only up to 30 per cent. of "B/B" quantity was permitted, the balance being delivered in "A/B" at the "A/B" quality price. This is a sensible condition which makes it possible for the manufacturer to obtain a fair price for his production.

If the grading rules covering various plywoods were more commonly known this might lead to the ordering of the higher grade to make certain of obtaining the proper stock rather than, as so often happens in an effort to save a few pounds, ordering the lower grade and "hoping for the best."

A small saving in price appeared to suit the speculative element in the plywood trade in exchange for a slight lowering in quality, and this has been responsible to a great extent for the gradual drop in the grades of many types of plywood shipped to Britain over the last decade. The shippers have had to face a steady demand for cheaper and cheaper stocks. When the average quality had been forced to its lowest limit a start was made in the thickness and this was gradually reduced until the danger-point was reached. More especially in the furniture trade was this true—a trade which consumes a vast amount of plywood. The people responsible were the salesmen of the speculative element referred to above whose sole idea was to obtain orders without giving the slightest thought to the difficulties of the producers. In an organized trade such people serve no useful purpose.

The solution of grading problems appears to be practical politics only when some system of co-operation between producers exists. It is the old story, "United we stand, divided we fall," and plywood manufacturers throughout Europe might well follow the lead of the Pacific Forest Industries, the I.D.S. in Germany or the Association which has functioned so well in Sweden.



## TESTING

**MOISTURE CONTENT.**—Electrical machines are now available which will record the moisture content of veneers and plywood with sufficient accuracy to meet most requirements. One such machine is illustrated. Alternatively the moisture content may be determined in the manner described on page 25 by drying a small piece of plywood or veneer of known weight at a temperature of 95°–105° C. until the weight no longer decreases.

The moisture content of Commercial plywood should not be lower than 7 per cent. nor greater than 14 per cent.

**TOLERANCE IN THICKNESS.**—The permissible allowances vary to a considerable extent. The thickness of any panel should be measured at least two inches away from the edge.

*Douglas Fir.*—U.S. Commercial Standard Specification CS 45E–36 allows a tolerance of  $\frac{1}{32}$  (0·0312) inch over or under the specified thickness on unsanded panels and  $\frac{1}{84}$  (0·0156) inch on sanded panels.

*Birch.*—According to one of the leading Finnish manufacturers the thickness of unsanded plywood is variable between the following limits :—

mm.			mm.		
2·80	3	3·20	9·80	10	10·20
3·80	4	4·20	11·80	12	12·20
4·30	4½	4·70	12·30	12½	12·70
4·75	5	5·20	14·60	15	15·40
5·80	6	6·35	17·50	18	18·30
8·80	9	9·20	21·60	22	22·40

*Latvian Birch, Alder, Pine, Fir or Oak.*—Under the standard classification of Boards drawn up by the Economic Rationalization Institute (Riga, 24th May 1939) the maximum permissible tolerances were :—

	Before Sanding.	After Sanding or Scraping.		Before Sanding.	After Sanding or Scraping.
3 mm.	+0·35 mm. –0·20	+0·15 mm. –0·40	8 mm.	+0·65 mm. –0·35	+0·45 mm. –0·55
4 mm.	+0·40 mm. –0·20	+0·20 mm. –0·40	9 mm.	+0·70 mm. –0·35	+0·50 mm. –0·55
4½ mm.	+0·43 mm. –0·20	+0·25 mm. –0·40	10 mm.	+0·80 mm. –0·40	+0·60 mm. –0·60
5 mm.	+0·50 mm. –0·25	+0·30 mm. –0·45	12 mm.	+0·90 mm. –0·45	+0·70 mm. –0·65
6 mm.	+0·55 mm. –0·30	+0·35 mm. –0·50	15 mm.	+1·00 mm. –0·50	+0·80 mm. –0·70

It will be observed that the over-thickness allowance is very generous and, if such wide fluctuation in thickness were permitted throughout any particular delivery, considerable inconvenience might result.

The British manufacturers work to much closer tolerances, and the following may be accepted as being reasonable :—

$\frac{1}{8}$ " and under . . . . .	± 10 per cent.
Over $\frac{1}{8}$ " up to $\frac{1}{2}$ " . . . . .	± 5 per cent.
Over $\frac{1}{2}$ " . . . . .	± 2½ per cent.

*Gaboon.*—A tolerance of ± 5 per cent. is permitted for all thicknesses.

TOLERANCE IN LENGTH AND WIDTH

*Douglas Fir.*—Under Commercial Standard CS 45E-36 a tolerance of  $\frac{1}{32}$  (0·0312) inch over or under the specified length and/or width shall be allowed, but all panels shall be squared within  $\frac{1}{8}$  (0·125) inch.

*Continental Plywoods.*—A difference of plus or minus 3 mm. in length and/or width is generally permitted in stock sizes from the 60" press.

STRENGTH OF GLUE-JOINTS

SHEAR TESTS

The testing of the glue-joint is generally done on a machine specially designed to carry out tensile tests in accordance with Government specifications. The Avery type is commonly used in Britain, the Riehle on the Continent and in America. Pieces of plywood taken from the batch to be tested are carefully marked and cut to the pattern illustrated on page 161. The two ends of one piece are gripped by the lugs of the machine and pulled apart, the glue-joint and the centre veneer taking the strain as the load is applied at whatever constant time-rate may be prescribed. A careful record is kept of the strain in lbs. or in Kilograms at which fracture occurs, and the nature of the fracture, viz. failure of wood, failure of glue, or partial failure of both glue and wood-fibres.

Wood is much less brittle when moist, so tests are frequently made in the dry state and also after 3 hours' boiling when the fibres of the veneers are in their toughest condition, enabling the maximum strain to be applied to the bond.

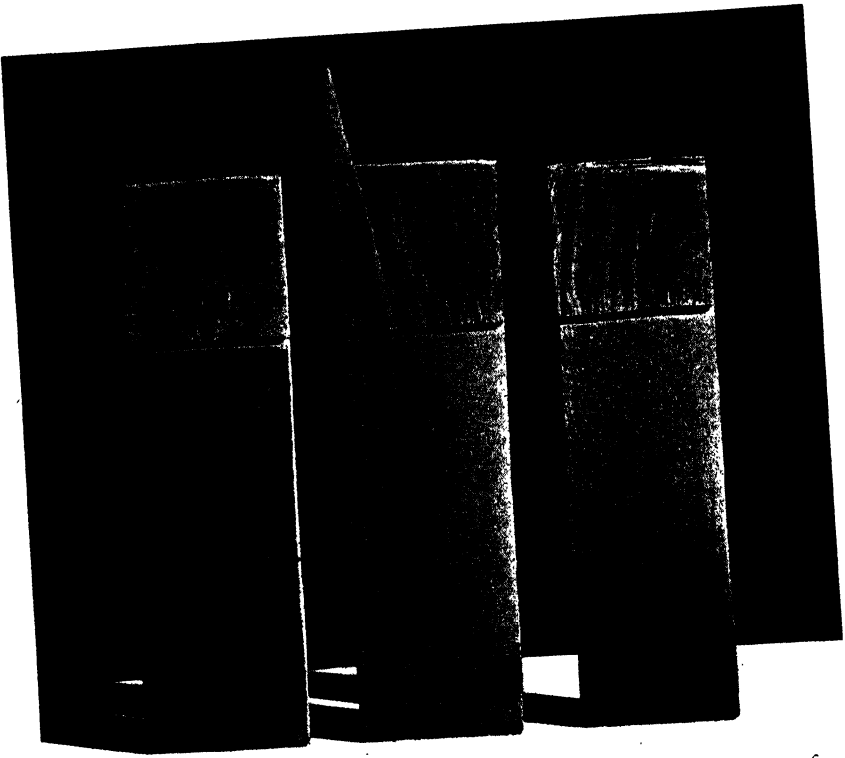

(a)—Three Samples of  $\frac{1}{8}$ " Birch Plywood after Shear Test, showing Partial Failures of Wood and Glue.

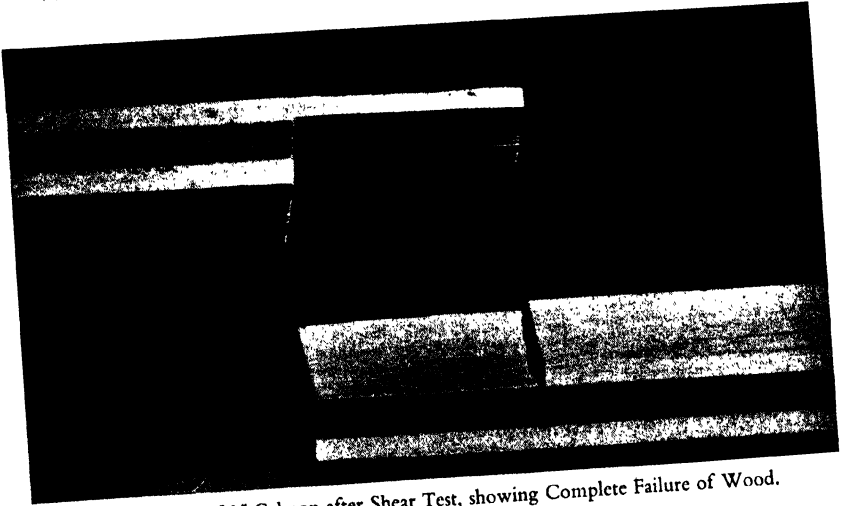

(b)—Sample of  $\frac{1}{4}$ " Gaboon after Shear Test, showing Complete Failure of Wood.

Under the Latvian standard classification already mentioned the shear value of the glue-line must not be less than—

Dry.	80%	of tested pieces . . . . .	17 Kg./sq. cm.
„	20%	„ „ . . . . .	14 Kg./sq. cm.
Moist.	All pieces . . . . .		8 Kg./sq. cm.

(after being soaked for 24 hours at average room temperature).

RESISTANCE TO WATER

Plywood is commonly boiled (while completely submerged) in water for three hours, then plunged into cold water and, after cooling in the water, the glue-line is tested by forcing the veneers apart with a knife. Waterproof plywood must not show any signs of blistering or

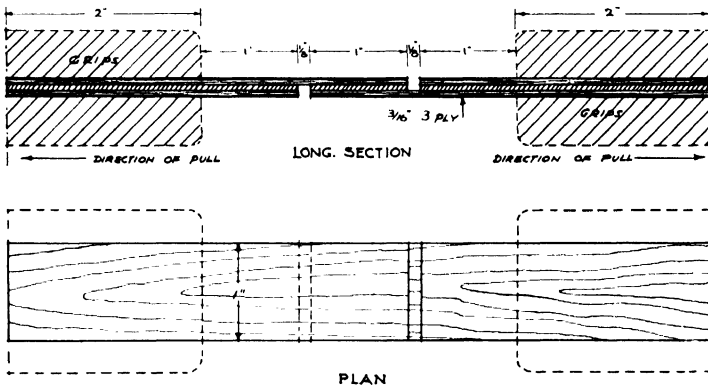

FIG. 89.

ply-separation, and it should not be possible to effect a clean separation between any two veneers. Fractured surfaces of well-made plywood should show a similar appearance to those illustrated on page 160.

METHOD OF DETERMINING TENSILE STRENGTH<sup>1</sup>

Two test pieces, of the dimensions shown in Fig. 90, shall be cut from each selected board in such a manner that—

- (i) The length of one of the test pieces is parallel to the grain direction of the face veneers. If the board contains end-grain joints, the test piece shall be prepared so that one of the joints is centrally disposed in a direction at right angles to the length of the test piece. Each test piece shall be as free as possible from wood defects.

<sup>1</sup> Extracted from British Standard Specification, 5 V. 3.

(ii) The length of the other test piece is at right angles to the grain direction of the face veneers. If the board contains edge joins, the test piece shall be prepared so that one of the joins is centrally disposed in a direction at right angles to the length of the test piece.

(iii) The central ply must be in the centre of the reduced section.

Each test piece shall be pulled in an approved testing machine, the stress in the test piece being increased uniformly at a rate of from 4000 to 8000 lb. per square inch per minute. The load shall be applied axially.

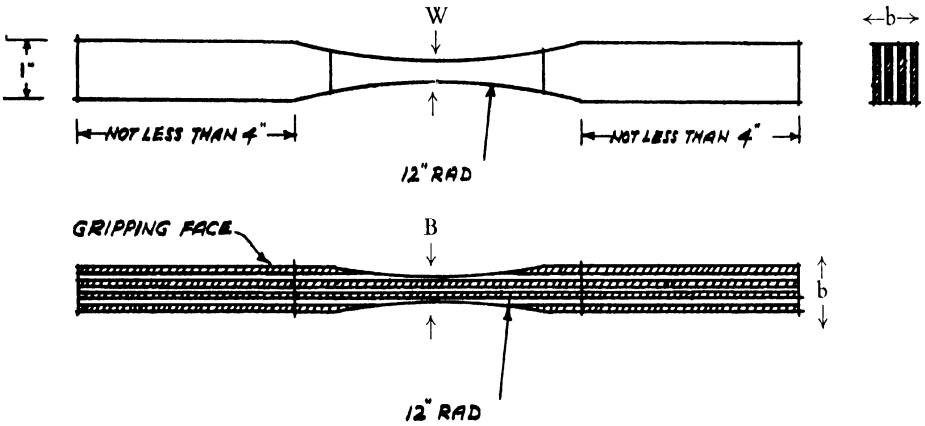

FIG. 90.

Cross sectional dimensions of test length :—

$$W = \frac{I}{8t} \text{ (Maximum = 1 in. Minimum = } \frac{3}{8} \text{ in.)}$$

$$B = t \text{ or } \frac{3}{8} \text{ in., whichever is the smaller.}$$

Thickness of test piece :—

$$b = 1 \text{ in. or } t, \text{ whichever is the smaller.}$$

$$t = \text{thickness of original material.}$$

## CHAPTER III

### PACKING

PLYWOOD boards being flat are easily packed and it is only on rare occasions that complaints are made on the score of careless bundling.

Until about 1925 much of the plywood from U.S.S.R., Poland and Latvia was shipped in roped bundles, but during more recent years rope has given place to iron or steel hoop of various widths and thicknesses. Plywood so packed forms tight, compact masses and, provided the bundles do not contain too many boards, is easily handled.

All packages must be securely bound together as they may be subjected to much ill-usage during transit from mill to ship, from ship to importer's warehouse, from importer's warehouse to inland merchant or consumer. Any one package may have to stand up to four or five journeys which means that it will be handled on eight or ten different occasions.

The weight should be restricted to  $3\frac{1}{2}$  or 4 cwt. as although importers have facilities to handle the heavier packages smaller merchants and consumers have not, and considerable inconvenience is caused when excessively heavy bales are delivered. Heavy bundles are more liable to damage during transit. A few dealers whose imports were handled through the Port of London Authority have at times, from purely selfish motives, been guilty of encouraging shippers to pack an excessive number of boards in each crate. For example, one Finnish Birch mill actually included forty boards, each  $60'' \times 60'' \times 6$  mm. in each package. The gross weight was approximately 7 cwt. and it will be realized that man-handling such bales was a thankless task. Complaints were made both by stevedores and receivers of the plywood.

The highest grades should be protected on both faces and all four edges and, as might be expected, the quality of the protection varies in direct ratio to the value of the plywood. Cheapest grades such as W.G. Finnish Birch, BBBB or C quality Polish or Latvian Alder are seldom protected on the faces although two or all four edges are commonly covered with pieces of  $\frac{1}{2}$  or  $\frac{3}{8}$  inch timber or rejected plywood.

Cores from the rotary-lathes, logs with defective hearts or which have split during rotary cutting, are sawn up into suitable sizes and used for protecting the edges of the bundled plywood. Scrap veneer, woven latticework fashion, makes a satisfactory covering for faces and is largely used. To prevent hoop iron from cutting into and damaging the edges

of the plywood, pieces of cardboard, kraft paper or veneer should be inserted between iron and plywood, when battens are not used.



[By courtesy of Pacific Forest Industries, Tacoma.

FIG. 91.—ONE OF THE P.F.I. WAREHOUSES, SHOWING OREGON PINE PLYWOOD PACKED READY FOR SHIPMENT.

The contents of each package must be clearly marked on two surfaces and the following information given in lettering which can be easily read :—

- Number of pieces.
- Size.
- Thickness.
- Quality.
- Shipper's or importer's trade mark.
- Shipping marks and instructions.<sup>1</sup>

On no account whatever should more than one quality, size or thickness be packed in the same bundle. Experience has proved that the most convenient place for stamping shipping marks, etc., is on the battens covering the two shorter edges. The different methods of packing commonly used by various manufacturers are mentioned in Part VII.

<sup>1</sup> It is advisable that packages should be stencilled "Use no hooks."

The British manufacturers of Gaboon seldom require to pack their plywood which is generally delivered in loose sheets direct to buyers' premises by motor or other conveyance.

Laminboards and blockboards are in themselves very heavy and, being valuable, demand careful and strong crating. As a general rule the two long edges are protected by  $\frac{3}{4}$  or 1 inch strips of solid wood, the faces with rejected plywood boards and the whole bound together with strong

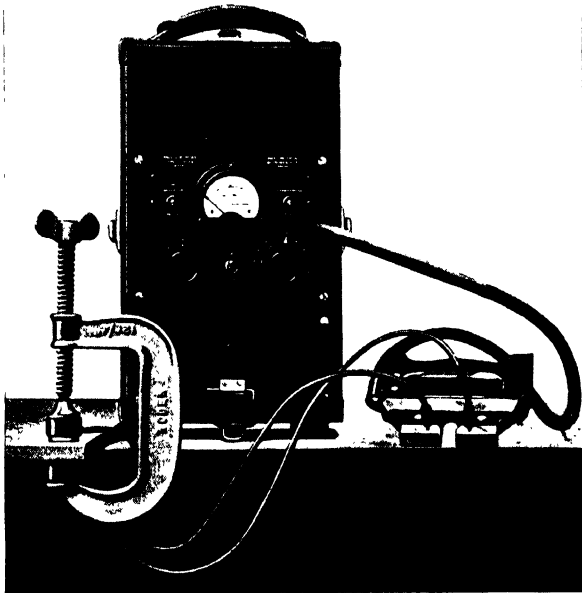

*[By courtesy of Messrs. Marconi-Ekco Instruments Ltd.]*

FIG. 92.—A HANDY ELECTRICAL INSTRUMENT FOR DETERMINING MOISTURE CONTENT IN WOOD.

straps of steel hoop. Occasionally the short edges are also covered. Oregon Pine plywood is beautifully packed in strong fibre cartons by a special machine designed by the Pacific Forest Industries. The Canadian Douglas Fir is shipped in strong kraft paper which, while not giving the same protection as fibre, makes a package which is easily handled. Stronger material could be used with advantage for protecting the thicker and heavier boards which, if dented on the exposed surface, are difficult to repair. Japanese plywood, in higher grades, was packed in wooden crates, an expensive but exceedingly serviceable method.





FIG. 93.—WELL-STACKED PILES OF PLYWOOD SHEETS IN VARIOUS THICKNESSES AND SIZES.



FIG. 94.—STORAGE OF BLOCKBOARDS AND LAMINBOARDS IN A PLYWOOD FACTORY.

## CHAPTER IV

### STORING

#### (a) STORING PLYWOOD

ALL types of plywood, but more especially laminboards and blockboards, demand careful handling and storage.

Much too often one finds well-made plywood exposed to injurious conditions or subjected to bad treatment. It is frequently stored in open sheds in which during foggy or similar weather conditions humidity is high. As a result the moisture content of laminboards or blockboards is completely "upset," causing needless trouble to the ultimate consumer.

The plywood store must be dry and airy and, wherever possible, temperature and humidity should be controlled, as rapid changes are most harmful to all plywoods. Following the recent legislation governing working conditions in all factories, several efficient heaters and humidifiers were placed on the market at reasonable prices. Such equipment is invaluable to the plywood merchant who appreciates the worth of his stock and who is desirous of rendering the best possible service to his clients. The larger user will also find these instruments a worth-while investment which will save many a disappointment in the production of high-class veneered work.

The outer walls and roof of the building may be constructed of any of the usual media so long as special care is taken to prevent all condensation and ensure reasonably good insulation throughout the interior. The floor of the store must be soundly constructed; wood, cement or one of the proprietary jointless floorings will answer equally well, precaution having been taken to avoid all risk of damp-penetration from the sub-soil. Constant dumping of heavy crates or bales with sharp edges quickly causes serious damage to poorly laid floors. Upper floors must be laid over strong joists and supports as the load per square foot will be heavy even when piles are no more than breast high. This factor demands special care when it is intended to make use of an old building for the storage of plywood. The maximum load to be carried should be carefully estimated (the tables of relative weights on page 445 should be helpful) and an architect or surveyor consulted to make certain that the existing joists will carry the load. Frequently it will be found necessary to strengthen the flooring by a few steel joists supported by brick piers

or steel stanchions. The shock-load caused during the unloading of high piles is another factor which must be kept in mind. In this connexion a cork-filled sack will be found useful for absorbing the initial shock and breaking the fall.

Some sort of overhead gantry or a mono-rail conveyor system will be found a great boon in the larger warehouse. Where height

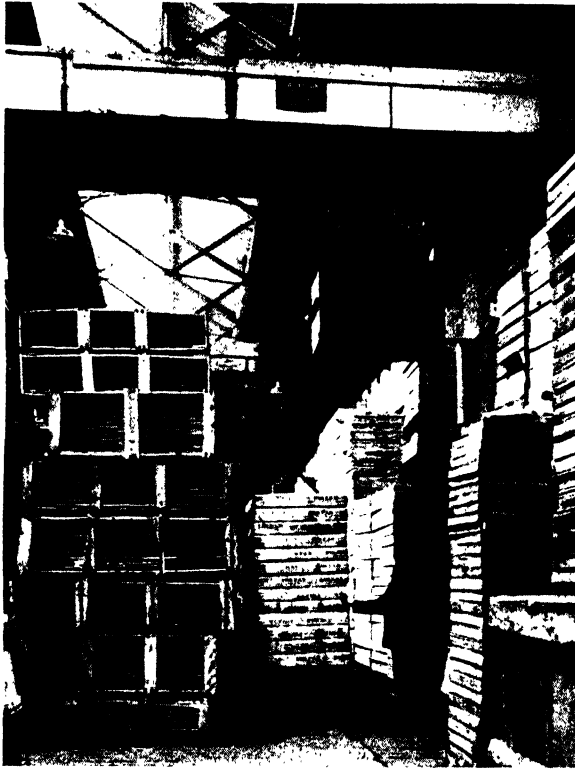

FIG. 95.—A USEFUL GANTRY COVERING THE MAIN WAREHOUSE OF MESSRS. L. KEIZER & CO. LTD., ST. ANNE STREET, LIVERPOOL.

permits, an overhead crane covering the whole length and width of the main building is of inestimable value. In smaller areas a mono-rail system should suffice and will save much needless handling and trucking.

The ideal way of storing plywood is on the flat, but it will seldom be practicable to keep to this ideal when it comes to laying out a warehouse to accommodate the large variety of sizes, qualities and thicknesses which a merchant is expected to carry in stock.

The majority of imported plywood reaches the British market in well-made crates or fibre cartons and, so long as these packages are intact, the boards will come to little harm when allowed to stand on one of the shorter edges provided they are stored with care against a flat support and kept upright.

Boards to be veneered or used without any framework for small doors and such like must be stored on the flat. It is well to keep this fact in mind, otherwise the plywood will probably be delivered to the consumer with a cast or twist which may cause serious trouble.

When storing on the flat whether in original crates or loose sheets, plywood must never be laid on the bare flooring. Battens (2" × 1" white or redwood is useful stock) should be evenly spaced at about 20" centres to carry the stacks. A rough frame should be constructed which will give support to all four edges of the plywood sheet or package, the centre being filled in with similar timber at 18" to 20" centres. Once in position the framework must be carefully levelled off and made perfectly rigid before the first sheet or bundle is placed in its position. It is a simple matter to run up semi-permanent framing to carry the various sizes in most regular demand.

These frames serve a double purpose—they allow a constant current of air to pass below the pile and also obviate all risk of damp being drawn up from the floor.

Packages stowed on edge should also be kept about 1 inch from the floor by lengths of timber. The battens which come off crates of Baltic plywoods will come in useful for this purpose.

A large percentage of the plywood consumed in the London area is stored at various docks in the majority of which bundles are stowed on edge. In private warehouses where a similar practice is followed it will pay to erect a "lean-to" against the wall to support the edges and centre of the rearmost bundle. If this is not done it is unlikely that the package will be evenly supported by the wall and, as it must carry the full weight of the row, it runs a grave risk of being badly twisted in the process. A useful device of this sort served for several years to support large packages of Oregon Pine Shipbuilding Panels with satisfactory results. Any loose boards can be kept clean and in good condition if they are placed between two of the unopened packages in the row.

Although it is permissible to store well-crated plywood on edge, once packages have been opened the loose boards should be stored in the manner just mentioned or on the flat. When this is not done and plywood is allowed to stand about in loose sheets, undesirable stresses are set up, resulting in crooked, twisted or buckled panels. This perhaps is not a matter of any great consequence where low-grade plywood is concerned,

but the better qualities—veneered panels and more expensive stocks—do call for more reasonable treatment, and for such material special racks should be provided. These can be simply and inexpensively erected around the walls in odd parts of the warehouse covering the whole area from floor to ceiling, and will soon pay a maiden dividend to any merchant. The exposed side and the bottom of each compartment should be covered with  $\frac{1}{4}$ " plywood which will add to the strength of the structure and keep the contents clean. The front can be closed by a dust-sheet when expensive veneered boards call for special protection. Up to fifty panels of  $\frac{1}{4}$ " stock can be housed in a section 15" deep, woods, qualities and thicknesses being mixed where necessary. It is inadvisable to mix sizes. A covering board for each compartment should be provided: plywood, wood-pulp or fibre board from Oregon Pine cartons will serve well, keeping dust and light from the surface of the stock.

Each section should be numbered and a careful record of the location of all contents retained in a special rack stock book. It is a sound idea to keep two or three sections specially for off-cuts if much cutting to size is done on the premises.

Laminboards and blockboards must be carefully handled, and a drawing showing a specially constructed frame is reproduced below. The steel framework was specially designed to carry a varied stock of boards in sizes up to 84"  $\times$  200" in good condition. Where floor space is limited, racks built on this design will give excellent service. The great importance of the proper storage of laminboards and blockboards is by no means appreciated by the average plywood merchant or, for that matter, user. These frames can be constructed either for side- or end-loading.

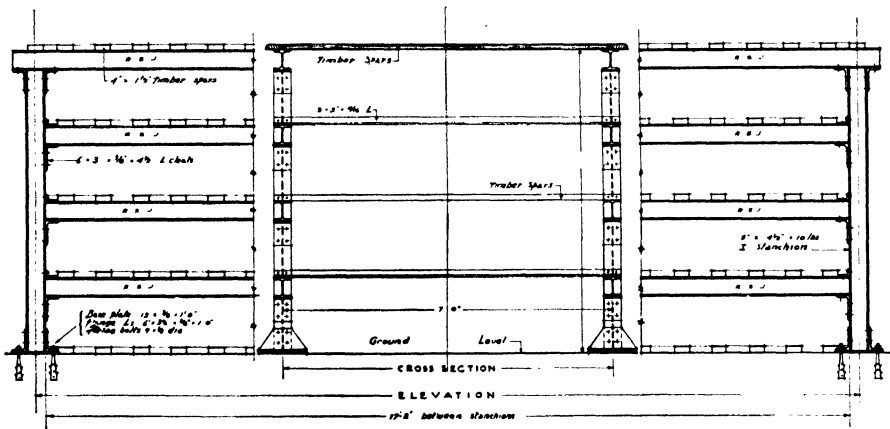

FIG. 96.—STEEL STORAGE RACK FOR SIDE-LOADING AT WAREHOUSE OF MESSRS. L. KEIZER & CO. LTD., GLASGOW.

## (b) STORAGE OF VENEERS

Decorative veneers whether sawn, sliced or rotary cut are frequently expensive and invariably fragile; in consequence they both deserve and demand careful treatment. Storage space should be of generous proportions, dry, well ventilated but free from draughts; a cool, artificially lighted room below ground-level can be made to serve as an excellent veneer store. Much too often one finds veneers stored in workshops immediately below a light roof or exposed, during certain periods of the day, to the direct rays of the sun. In such places wide fluctuations in humidity and temperature cannot be avoided and both are detrimental to choice veneers.

As a general rule, decorative veneers purchased from a reliable source will be delivered in good condition, with sheets numbered and arranged in the order of cutting. Some users prefer to retain veneers until they are required in the packing-cases supplied by the cutters, but this procedure, while saving a certain amount of handling, has its risks as water damage cannot always be detected from the outside appearance of the crates. It is generally advisable to check quality, quantity and condition of the contents on delivery and to lay the bundles in proper sequence on storage racks provided for this purpose. An ample supply of racks or shelves must be available in order that the various thicknesses, qualities and woods may be stored separately.

A number-tag showing contents, size and wood should be affixed to each bundle and similar details recorded in the stock record-book. By so doing, time lost in turning over bundles will be saved and breakages avoided.

The importance of keeping veneers in the order of cutting until

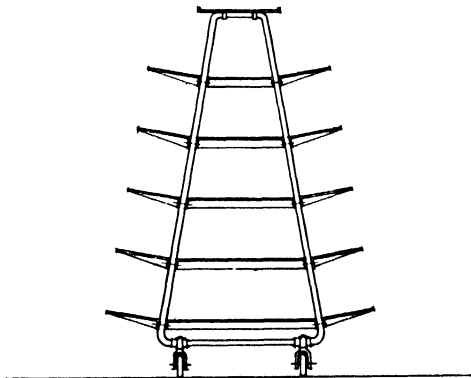

FIG. 97.—END VIEW OF STORAGE TRUCK FOR VENEERS.

such time as they are delivered into the hands of the matcher cannot be overstressed. Veneers which have been numbered as they were cut can easily be replaced in their proper sequence should they become deranged during drying or trimming, but it should be remembered that in the veneer shop, once a bundle has been crosscut, one of the two pieces falling from the saw will be unnumbered. If two oblique lines (running thus,  $\setminus /$ ) be drawn down one or more edges of the bundle towards the unnumbered end there should be little difficulty in finding the proper position of any misplaced pieces.

In a few mass-production furniture factories and veneering plants, veneers are stored on movable trucks consisting of four or more flat platforms fixed to each side of inverted V-shaped frameworks such as that illustrated in Fig. 97. These trucks can be wheeled from the store direct to re-drier or veneer jointer, as may be required, and save a considerable amount of handling.

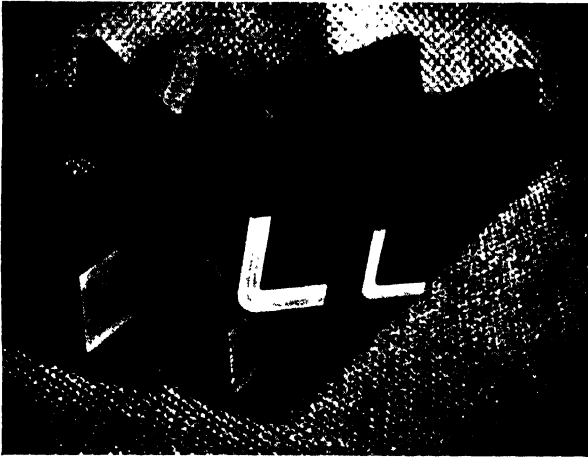

FIG. 98

Stressed angles built of plywood have the merit of offering all the maximum strength with a minimum of weight. They can be prepared in a large variety of sizes and are of particular interest to the aircraft industry.

## PART VI

### THE PLYWOOD-PRODUCING COUNTRIES OF THE WORLD

#### THE CONTINENT OF AFRICA

THE plywood industry on the continent of Africa is not of great importance notwithstanding the fact that much of the raw material used by plywood manufacturers in England, France, Germany and Holland was shipped from the West Coast of Africa. The reason for this seeming anomaly is the humid climate and lack of trained labour in those parts richest in timber. Just prior to the war a few promising efforts were made to establish veneer-cutting plants in French Gabon and it is probable that by making use of modern equipment the peculiar climatic difficulties will be overcome. It has already been demonstrated that, under the guidance of experienced charge hands, native labour can be trained to operate plant such as that used in the West African Gold Mines which calls for quite as much intelligence as does the working of plywood-making machinery.

A Spanish company which operated a large concession in Spanish Guinea went one stage further than the French concerns we have just mentioned by erecting a complete plywood plant at the port of Bonito. During the planning of this factory special precautions were taken to circumvent the severe climatic conditions which prevail in an area lying only a few degrees north of the Equator. Here again this experiment had not been given a chance to prove itself before the outbreak of war upset all normal trading.

The idea of this Spanish company was to make the most of short lengths and unfigured wood, which were not readily saleable in export markets, by converting them into plywood. The scheme was sound economically as, in addition to having valuable reserves of raw material within easy reach of the factory, labour was cheap in comparison with that of European values.

Until plywood factories are established on the West Coast of Africa where suitable raw material is abundant it is unlikely that the continent of Africa can become a plywood producer of any consequence.



One other small mill in Alexandria, Egypt, operated on imported logs which were cut into veneer and match-splints, and it is understood that limited quantities of plywood were also made.

Egypt, Tunisia and Morocco imported fair quantities of plywood from Poland, France and other European countries.

## UNION OF SOUTH AFRICA

**I**N the Union of South Africa two concerns manufactured plywood from imported logs of Okoumé, Douglas Fir and Lauan. These mills also supplied much of the decorative plywoods used in the Union : commercial grades of plywood were imported from Japan, Europe and America until this trade was upset by the war in 1939. No plywood was exported from the Union.

The mills in the Union manufactured a wide variety of plywoods, including laminboards and blockboards, veneered laminboards for the furniture trade, veneered flush-doors for the building trade, and practically any special type of multi-ply wood used by wood-working trades. In addition to the woods already mentioned and the usual range of decorative veneers, the following South African timbers were also used on a limited scale : Stinkwood, Kejaat, Wit Els, Red Els, Yellowwood and Ironwood.

These two mills distributed their manufactures either direct to the larger furniture manufacturers and other large consumers, including Railway Administration and Government Departments, or through established timber merchants who, in turn, supplied the various trades and smaller consumers.

Overseas suppliers of plywood to the Union were usually represented by agents or brokers who sold to, or booked business with, merchant distributors or, in some cases, actual users.

Various unsuccessful attempts had been made by the manufacturers to convert some of South Africa's indigenous and exotic hardwoods into plywood, more especially the *Eucalyptus saligna* which is available in good quantity. It was found that the logs split very readily and, to quote from a report published in the *Official Journal of the Department of Commerce and Industries*, "the veneers came off the rotary-cutter in bits and pieces, brittle, and badly cracked."

The manufacturers therefore were content to use logs of Okoumé and other imported woods (which cut easily on the veneer-lathe)

until supplies of these were cut off by war conditions. Shipments of softwoods, in normal times, had been imported in large quantities from Baltic countries and when these also stopped consumers in South Africa began to realize that other sources of supply had to be found without loss of time.

Towards the end of 1940 the Forest Products Institute in Pretoria commenced experiments with *Eucalyptus saligna* and other species in an effort to produce plywood which would meet the pressing demand for boxes for fruit and other commodities. By varying the methods of steaming and cooking logs "good quality veneer as compared with previous results has been obtained. The experimental drying and gluing of the veneers into plywood has been equally promising."

It is hoped that these experiments by the Forest Products Institute will be equally successful when applied to commercial production.

During the fiscal year 1938 the duties leviable on plywood imported into the Union of South Africa were :—

Alder and Birch plywoods . . . 30 per cent. *ad valorem*.  
 Other plywoods . . . . . 4s. per cubic foot or 25 per cent. *ad valorem*, whichever is the greater.

The following table which has been kindly supplied by the Trade Commissioner, South Africa House, London, gives the imports of plywood into the Union of South Africa during the years 1936 to 1939 :—

Origin.	1936.		1937.		1938.		1939.	
	Cub. Ft.	Value.	Cub. Ft.	Value.	Cub. Ft.	Value.	Cub. Ft.	Value.
		£		£		£		£
United Kingdom	3,567	4,209	4,066	5,391	2,417	3,353	2,355	2,166
Canada . . .	362	202	21,920	8,352	13,003	4,763	24,078	9,387
Finland . . .	7,857	2,782	7,821	2,915	17,009	5,557	27,044	8,774
Latvia . . .	7,850	2,610	9,055	4,125	25,080	7,713	19,481	4,816
Poland . . .	60,087	15,136	73,244	21,197	71,329	22,567	39,385	11,028
Japan . . .	87,870	32,282	108,675	47,310	47,230	19,921	61,499	18,432
U.S.A. . . .	83,932	31,416	64,518	24,076	32,815	11,902	51,336	18,680
Totals . . .	363,139	130,560	413,826	163,914	288,581	108,901	280,972	101,329

Only principal countries of origin specified. Other suppliers were Australia, Hungary, Lithuania, Russia, China, etc.

## UNITED STATES OF AMERICA

WHEN the average "plywood man" in Britain reads of American-made plywood he immediately thinks of "Oregon Pine" which for so many years has been shipped from the North-West Pacific Coast to European markets. The development of this trade is described later.

It was estimated that in 1939 some eighty-six factories were engaged in the production of plywood in America. The value of the plywood manufactured during that year was reported as being \$38,878,932, in addition to which plywood to the value of some \$12,000,000 was produced as a subsidiary product by concerns not wholly engaged in plywood manufacture. This total was subdivided into :—

Utility plywood for constructional work, boxes, etc.—

Made from Douglas Fir . . . . .	\$26,379,198
Made from other woods . . . . .	7,942,464

Decorative plywood for cabinet trade, etc. . . . .	14,953,232
--	------------

These figures are quoted to give some idea of the valuable quantities of plywood made from woods other than Douglas Fir. The value of plywood produced and "consumed in further manufacture in one and the same establishment" has not been included.

A type of plywood very similar to that produced by European cabinet-makers during the nineteenth and twentieth century has been used in America since 1870, and much of the decorative plywood produced for furniture-making in that country is of the construction known as lumber-core stock.

Since 1914 larger quantities of veneer-core boards (the American description for European three- or multi-ply) have been made and, with the advent of resin adhesives, this type of production has shown a steady increase. American manufacturers were quick to grasp the possibilities in resin-bonded waterproof plywoods and many hot-plate presses were laid down. They are fortunate in having the active assistance of the Forest Products Division of the United States Department of Commerce, and the industry has derived considerable benefit from the research work which has been conducted at the United States Forest Products Laboratory, Madison, Wisconsin. Those responsible for the activities of this laboratory during the past decade deserve much credit for the encouragement and assistance they have given to the plywood industry not only in America but in other parts of the world. The machinery

manufacturers also moved with the times and, in conjunction with plywood technicians and chemical engineers, devised new machines and improved old ones, making possible the rapid development of resin adhesives. This close co-operation has been of great value to the industry with the result that American-built plywood machines are to be found in plywood plants the world over.

The industry is well catered for by the trade press and supports the only monthly journal entirely devoted to its subject, *Veneers and Plywood*. Well-written articles appear in many other journals in connexion with the lumber, engineering, furniture and other trades interested in plywood manufacture. One plywood machinery and glue manufacturing concern in Seattle, Washington, for several years past has issued a monthly publication to the trade which serves a useful function, helpful technical articles, on occasion, being lightened by flashes of humour which make easy and instructive reading.

Some of the best literature devoted to the subject of plywood has come from America, a publication under the title of *Faces and Figures*, which was reprinted by the Veneer Association, Chicago, in 1935, deserves special mention.

The standard constructions of American plywoods other than Douglas Fir are :—

	Faces and Back before sanding.	Core.	Cross- banding.
$\frac{1}{8}$ 3-ply Rotary Veneer Core .	$\frac{1}{16}$ to $\frac{1}{8}$ "	$\frac{1}{2}$ "	—
$\frac{3}{8}$ " " " " " .	$\frac{1}{8}$ "	$\frac{1}{8}$ "	—
$\frac{1}{2}$ " " " " " .	$\frac{1}{4}$ "	$\frac{3}{8}$ "	—
$\frac{1}{4}$ " " " " " .	$\frac{1}{8}$ "	$\frac{1}{4}$ "	—
$\frac{3}{8}$ 5-ply Rotary Veneer Core .	$\frac{1}{16}$ "	$\frac{1}{8}$ "	$\frac{1}{8}$ "
$\frac{1}{2}$ " " " " " .	$\frac{1}{8}$ "	$\frac{3}{8}$ "	$\frac{1}{2}$ "
$\frac{3}{8}$ " " " " " .	$\frac{1}{16}$ "	$\frac{1}{4}$ "	$\frac{3}{8}$ "
$\frac{1}{2}$ " " " " " .	$\frac{1}{8}$ "	$\frac{3}{8}$ "	$\frac{1}{2}$ "
$\frac{1}{4}$ 5-ply Lumber Core .	$\frac{1}{16}$ "	$\frac{1}{4}$ "	$\frac{1}{4}$ "
$\frac{3}{8}$ " " " " " .	$\frac{1}{8}$ "	$\frac{3}{8}$ "	$\frac{1}{2}$ "

These constructions are subject to some variation, especially in regard to the thickness of the face and back veneers. When  $\frac{1}{16}$ " veneer is used, the cores are generally cut full thickness.

The manufacture of both "rotary veneer core" (multi-ply) and lumber-core plywoods has already been described. Cold presses are still largely used by American manufacturers, but these are slowly being replaced by the newer types of hot presses, making possible the use of resin adhesives.

American-made decorative plywood is of excellent quality but is expensive in comparison with the stocks normally used by British users. The plywood of most interest to buyers in the United Kingdom is Douglas Fir, commonly known as "Oregon Pine."

## PACIFIC COAST OF AMERICA

AN industry flourishes on the Pacific Coast of America which, during the year 1941, had a potential output of 2 billion square feet of plywood based on  $\frac{3}{8}$ " rough thickness.

It is recorded that the first plywood mill was established at St. Johns in the State of Oregon in the year 1905. This and other plants established in the early days of the industry manufactured panels for the door industry, and in most instances they formed departments of, or were associated with, door-manufacturing plants. The industry grew steadily and during 1919 the first shipments of Oregon Pine plywood were made to the United Kingdom. This plywood, which was of excellent manufacture and was obtainable in large sizes, quickly grew in popularity, and an important export business was built up.

The raw material used in the many plants on the North-West Pacific Coast is almost exclusively Douglas Fir—*Pseudotsuga taxifolia*—still commonly called Oregon Pine. The tree is an individual species, *i.e.* botanically, it is neither a pine nor a fir. The United States Forest Service adopted Douglas Fir as the official designation of this important wood, but plywood manufactured from it on the Pacific N.W. Coast of America is sold abroad as Oregon Pine. According to a booklet issued in 1937 by the Forest Products Division of the United States Department of Commerce, "The name (Douglas Fir) immortalized the work of the famous Scottish explorer and naturalist, David Douglas, who as field representative for the Royal Horticultural Society visited the Columbia River district in Oregon and Washington in 1827 and returned with seeds and numerous plantings. Douglas Fir is a conifer or softwood, in many respects resembling pine, and is superior to true firs in strength, durability, usefulness and all other properties."

In the States of Oregon and Washington vast areas of territory are covered by dense evergreen forests which, from many points of vantage, stretch as far as the eye can see. These coniferous forests represent the largest body of high-quality softwood timber in the world.

Favourable silvicultural conditions in this part of America produce perfectly proportioned trees which grow to heights of 200-300 feet.

The lower part of the bole is generally free from branches, some specimens having a breast diameter of 10 to 12 feet. The majority of the plywood manufacturers employ their own log buyers who select the choicest logs as they are cut in the forest. These logs, known as "peelers," comprise less than 5 per cent. of the total production of Douglas Fir logs, must have a minimum diameter of 25 inches at the small end, and be free from limb-knots and other defects. The good log-buyer has a wonderful knack of selecting the timber he desires, containing a maximum of clear soft heartwood of uniform ring-growth.

From the forests the "peeler" logs, in lengths up to 40 feet, are conveyed by water, rail or road to the plywood mills, there to lie in the log ponds until they are required.



FIG. 100.—SELECTING DOUGLAS FIR LOGS.

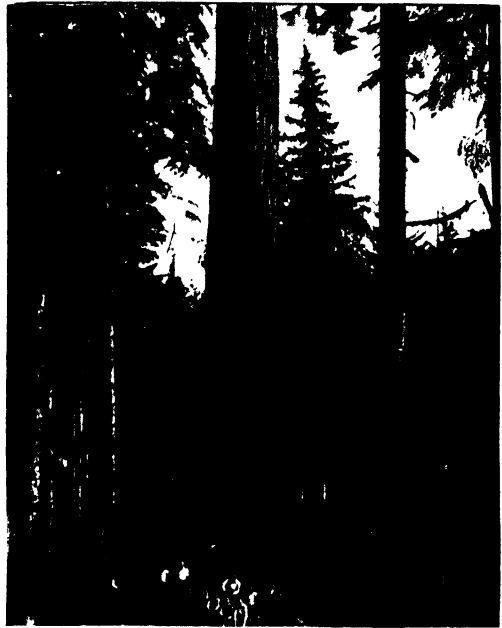

FIG. 99.—A DOUGLAS FIR, 425 YEARS OLD. 300 ft. high. 127 ft. to first limb. Diameter, 10 ft. 10 in.

The average diameter is between 5 and 6 feet.

The supply of prime-quality peeler logs has from time to time caused some anxiety in the minds of those who have the welfare of the industry at heart, and during 1939 a Bill was laid before Congress which had as its object the prohibition of the

export of these "peeler" logs. At one period much choice material

was shipped abroad to countries, such as Japan, where it was made into plywood by cheap labour. The "Peeler Bill" will be re-introduced in the 1941 Congress.

The grain of old-growth Douglas Fir is very fine and showing from 15 to 30 annular rings to the inch, makes beautiful plywood. It is old-growth Douglas Fir which yields the pleasing small figured veneer which is so desirable for panelling work. The quicker grown timber with wide annular rings gives, when cut on the rotary-lathe, a wild figure which is not nearly so attractive. The timber is of soft texture but is

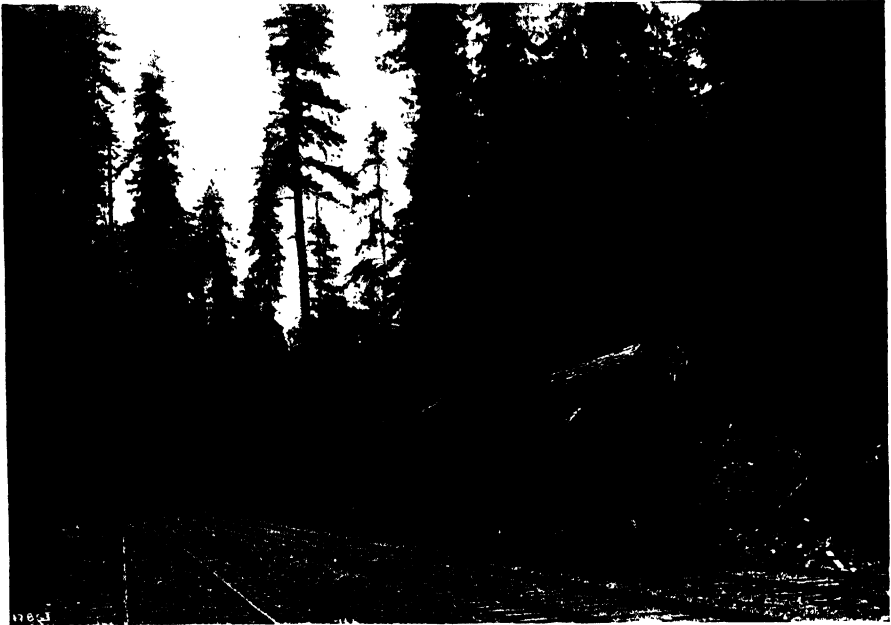

FIG. 101.—HUGE DOUGLAS FIR VENEER LOGS *EN ROUTE* TO THE FACTORY.

one of the most durable and most useful softwoods in the world. The sapwood is of a light yellow colour while the heartwood ranges from dark yellow to light brown.

In the plywood mill selected logs are floated to a drag-saw on which they are cut into lengths to meet the day's production—commonly 7 or 8 feet. They are then removed from the water by overhead cranes, and carried direct to a barking-lathe, and thence into the mill proper. The general practice is to cut the logs cold.

Many plywood plants have been laid out with the object to obtain the maximum output with the minimum amount of labour which, on the

Pacific Coast is very highly paid. A few of the plants are excellent examples of what is commonly known as "straight-line" production, the various manufacturing processes proceeding in a steady sequence from the cutting of the log to the sanding of the plywood.

By a system of belt-conveyors much handling of veneer is avoided and this practice might well be followed in other countries. From the lathe the veneer is carried direct to the automatic cutters in the manner described on page 47, pitch-pockets and other defects being cut out. The sound veneer is selected into widths and conveyed to progressive driers which are loaded by hand. The dried veneer leaves the drier on a conveyor-belt and is thrown automatically on to another belt running at right angles to the first one. It is carried before a number of inspectors who select it into grades and sizes. From the rotary cutter to this point in the manufacture the veneer is handled but thrice. An elaborate system of conveyor-belts below floor-level serves the various machines and removes all waste material direct to the "hogs" in which it is broken up into pieces suitable for the furnace.

The veneer as it comes from the log yields a large proportion of clear stock, but as the cut approaches the centre the wood becomes very knotty and the core is discarded when it reaches a diameter of between 12 and 15 inches. So far no satisfactory use has been discovered for this material other than cutting it into 4 inch by 2 inch battens.

The presses used throughout the industry until 1936 were exclusively of the "cold" type. In that year, however, two large hot presses were erected. For many years it was thought impracticable to manufacture Douglas Fir plywood on the hot press, but the introduction of resin adhesives revolutionized the industry. During 1940 some eleven hot-plate presses were in operation.

Cold-pressed Oregon Pine is largely glued with adhesives of the Soya Bean type, and panels so produced have given satisfaction both to domestic and foreign buyers over the last twenty years.

The general manufacture is excellent, the average stock being remarkably flat and, as a general rule, exceptionally well sanded on six or eight drum machines.

One of the minor difficulties of plant executives is to find means of disposing of sander-dust. One plant visited on the Pacific Coast had a monthly production of 3 million feet of plywood and, as the sanders remove  $\frac{1}{2}$ " from each side, this plant accumulated the equivalent of approximately 18,750 board feet in the form of sander-dust each month. This same executive reckoned that from each 1000 board feet of Douglas Fir log they could produce 2500 square feet of  $\frac{3}{8}$ " plywood.

At one period during the development of the industry, raw material



was plentiful and cheap, and little attention was paid to waste. The waste of timber, in comparison with European practice, was very high, but the manufacturers argued that as labour was expensive and raw material cheap, the latter could not bear the expense of much work being expended upon it. However, times have changed, and every effort is now made to get the most possible out of the raw material available to the plants. The patching and jointing of veneer and the repairing of the finished boards has reached a fine art. Patching of veneers before gluing is described on page 71.

The repairing of boards showing pressing faults or split veneer is done by highly skilled workmen who earn anything up to \$1 per hour, equal to £8 for a 40-hour week. These men use a series of metal punches which remove a piece of the face veneer which is replaced with a plug of sound veneer of similar grain to the surrounding wood. Splits are replaced by cutting to the depth of the veneer with a high-speed handsaw which makes an even groove into which is inserted a strip of veneer which completely fills the cut.

One mill in Oregon, working on Western (or Californian) Yellow Pine, has an annual capacity of 18 million square feet of  $\frac{3}{8}$  inch thickness. In California there are two mills, working on similar wood, with the combined capacity of from 45-50 million square feet of  $\frac{3}{8}$  inch thickness per annum.

In addition to Douglas Fir, a few of the mills produce plywood manufactured from Californian Redwood, Western Yellow Pine, West Coast Hemlock and Cottonwood. Some plywood is also faced with various Philippine hardwoods, but the quantity so produced is relatively small.

Many of the Douglas Fir producers have their own chemical laboratories in which tests are carefully made on each batch of glue as it is made up, while samples are taken at random during the day's working and tested to make certain that the adhesive and moisture content of the finished plywood is as it should be.

The industry is organized on most modern lines, all manufacturers being members of the Douglas Fir Plywood Association, with headquarters in Tacoma, Washington. This is a "non-profit association of all United States manufacturers of Douglas Fir plywood, founded to sponsor a continuing programme of research, to promote the use of this material in construction and industry, and to help users to employ it to the best advantage."

The Association serves a most valuable function and has equipped a research laboratory with the latest scientific testing apparatus. The trained staff of this laboratory are continually working for the good of the industry as a whole, and the results of their labour are available to all members of the Association.

The United States Forest Products Laboratory, in co-operation with the University of Wisconsin, has also rendered valuable service to the Douglas Fir plywood industry.

During the past few years the industry has concentrated on the development of waterproof adhesives. The West Coast coniferous woods present entirely different glue problems from the hardwoods used by the plywood industry in other parts of America. The greatest forward strides have undoubtedly been made by the industry in this field and for some years past the manufacturers have been able to unconditionally guarantee their plywood against ply-separation.

The products of the various mills are distributed through a wide network of builders, merchants and lumber dealers. The majority of the plywood mills run their own stock houses in the larger distributing centres in which a varied stock is continually on hand.

The authors had the privilege of introducing hot-pressed Oregon Pine plywood to the British market and developed this business under the trade name "Resweld Firply," which became known as a reliable and absolutely waterproof product largely employed for outdoor work.

About 10 per cent. of the total production is generally available for export, but the quantity varies considerably, depending as it does both on the state of the home market and the most important foreign ones. The export markets are catered for by a co-operative organization which is owned and operated by the manufacturers of Douglas Fir plywood in the United States of America. This organization, known as the Pacific Forest Industries (P.F.I.), was developed by Mr. Axel H. Oxholm, who himself has an intimate knowledge of practically all the principal markets of the world. The export business is conducted in accordance "with the accepted distributive methods established by the trade in each foreign country."

The P.F.I. have established their own export warehouse in the Port of Tacoma, to which all plywood for export is despatched by member mills. In this warehouse each shipment is checked for quality and the plywood is packed into excellent fibre cartons on automatic machines which were themselves invented by the P.F.I. The inspectors act independently of the mills and issue a sworn certificate, in the form reproduced on page 154, with each shipment. These certificates give a guarantee to foreign buyers that each shipment is of standard quality and correct quantity. Many mills now brand their trade name and grade of panel on the end or ends of each panel. This is more consistently done in the case of resin-bonded panels, which must be so stamped before they can be used in certain government work in America.

It should be observed that the P.F.I. sell their plywood in all foreign markets as Oregon Pine. Their trade mark is "Firply."

Figs. 99, 100 and 101 are reproduced by courtesy of the Pacific Forest Industries, Tacoma.

## AUSTRALIA

THE plywood industry in Australia is growing in importance, and valuable quantities of well-made plywood have reached the United Kingdom since the closure of the Baltic ports to British trade. These stocks must prove a worthy advertisement for Australian plywoods.

The first plywood venture in the Commonwealth was during the early days of the last war when a small plant in South Brisbane produced a quantity of  $\frac{3}{8}$ " three-ply panels from Hoop Pine logs. This concern prospered. A few others laid down plywood-manufacturing plants, until by 1931 the productive capacity was sufficient to cater for the total requirements of the Commonwealth. The healthier state of the industry enabled the Government to assist the manufacturers still further to increase their production by applying an *ad valorem* duty of 65 per cent. on imported plywood. During the early days of the industry prices were high—for example, during 1920  $\frac{3}{8}$ " Pine was sold at 37s. 6d. per 100 square feet—but as competition developed prices gradually fell to reach the low level of 11s. 6d. to 12s. 6d. per 100 square feet in 1933. Until 1931 the imports of plywood in comparison with the total consumption of the Commonwealth had been considerable. Douglas Fir from America, Birch from Finland and the Baltic States, Alder from Poland, and Oak from Japan constituted the bulk of the plywood imports.

The following figures, extracted from the *Australian Overseas Trade Bulletin*, illustrate the considerable decline in the quantity of plywood imported into the Commonwealth since the fiscal year 1929–1930 :—

<i>Fiscal Year.</i>	<i>Plywood Square Feet.</i>
1925–1926	8,796,795
1929–1930	10,637,730
1930–1931	1,300,000
1938–1939	2,890,388

It is interesting to note that whereas the average value of imported plywood per 100 square feet was 29s. 2d. in the year 1929–1930, it had fallen to 16s. 10d. in 1930–1931, and to 13s. 11d. in 1931–1932.

According to the *Australian Manufacturers' Directory*, 25 factories were in operation during the year 1939. These were located in the following States :—

- Queensland—12 plywood mills, 1 veneer mill.
- New South Wales—10 plywood mills, 6 veneer mills.
- Victoria—3 plywood mills, 2 veneer mills.

The total production of plywood on a  $1\frac{3}{8}$ " basis rose from approximately 50,000,000 super feet in 1933 to 115,000,000 super feet in 1936. Since that year a further marked increase in production has taken place.

Australian plywood manufacturers follow the procedure of the Pacific Coast American Mills, viz. the dry-cementing process using casein or soya bean adhesives on cold presses. We understand that quite recently one or two plants have modernized their equipment and have installed hot-plate presses.



*[By courtesy of Cairns Timber Co. Ltd.]*

FIG. 102.—MOUNTING FLITCH ON VENEER SLICER.

The mills in the State of Queensland have supplied the bulk of the plywood exported to the United Kingdom, the reason being that this State has the most abundant supply of suitable native timber. During the fiscal year 1938-1939 Queensland manufactured 63 per cent. of the total Australian production. The Queensland Forest Service deserves much credit for the efforts it has made, by co-operating with plywood manufacturers, to ascertain how native woods can best be used in the production of plywood.

The more important Queensland timbers are described in Part VII. Those used by the plywood mills include: Hoop Pine, Buny Pine,

North Queensland Kauri Pine, Silky Oak, Queensland Walnut, Queensland Satinay and Silver Ash.

Hoop Pine and various scrub species, such as Coachwood (*Ceratopetalum Apetalum*), are amongst the most important woods used by the New South Wales mills in addition to which Douglas Fir peeler-logs are imported from the Pacific North-West Coast of America. Various timbers from New Britain, the Solomon Islands and New Guinea have been used and are likely to play an important part in future years.

Logging is generally done during winter months, the logs being carted to the mills by wagon or motor lorry during spring, when the roads are in a fit state to carry heavy loads.

The total export of plywood from Australia during the fiscal years of 1937-1938 and 1938-1939 was no more than £39,258 and £44,254 respectively. Since then the exports to the United Kingdom alone must have reached substantial figures; these included Kauri Pine, Hoop Pine, Ash and various Oaks. It was reported in the *Australian Timber Journal*, published in August 1940, that all the veneer and plywood mills in North Queensland were extremely busy at that time, mainly as a result of large orders received from overseas markets. The progress made by the industry is illustrated by figures published by the Cairns Harbour Board. Shipments passing through this port, which handles shipments to other Australian ports in addition to the export business, were valued at £146,915 in 1938, and £195,971 in 1939, while the 1940 figures were expected to exceed £250,000.

During 1932 the Queensland Pine Plywood Export Association was formed and exercised a useful function in ensuring that a uniform product was shipped against all export contracts.

The British Preferential rates shown on opposite page are subject to "Exchange adjustment," *i.e.* a deduction of either one-quarter of the duty or one-eighth of the value of the goods for duty purposes, whichever is less.

During pre-war years Australian plywoods could not compete with the cheap European stocks in the British market, notwithstanding the preferential tariff, and until 1939 practically only decorative plywoods such as Silky Oak, Queensland Walnut and Maple met with much demand, though small lots of Hoop Pine were imported to meet certain government specifications calling for Empire plywoods.

The duties leviable on plywood imported into the Commonwealth of Australia were as follows:—

Plywood (including Plywood veneered with any Material).	British Preferential Tariff.	General Tariff.
1. Not exceeding $\frac{3}{8}$ " thickness. Per 100 square feet	5/-	7/-
Or <i>ad valorem</i> (whichever rate returns the higher duty).	50%	65%
2. Exceeding $\frac{3}{8}$ " thickness but not exceeding $\frac{7}{8}$ " thickness. Per 100 square feet.	5/-	7/-
With an additional duty for each sixteenth of an inch in thickness in excess of $\frac{3}{8}$ ".		
Per 100 square feet.	1/6	2/-
Or as an alternative to the cumulative fixed rates provided above <i>ad valorem</i> (whichever rate returns the higher duty).	50%	65%
3. Not elsewhere included. <i>Ad valorem</i>	50%	65%

### NEW ZEALAND

THE plywood industry in New Zealand is not of any great importance. The *per capita* consumption of plywood in the Dominion is not high, but very large quantities of Kauri and other species of pine are cut into veneers and used for butter-boxes. There are at present three plants cutting veneer and manufacturing plywood, and it is reported that orders for new equipment have been placed recently. The imports of veneer and plywood during recent years do not appear to justify any great expansion in the manufacturing field. Total imports into the Dominion have been :—

1925, £35,661.	1935, £35,371.	1937, £89,697.
1930, £40,998.	1936, £61,923.	1938, £70,119.

New Zealand possesses the finest stands of Kauri Pine in the world, which makes an excellent plywood, but it is questionable if the Dominion has sufficient supplies of raw material to enable the industry to produce plywood in sufficient quantity to cater for the domestic demand and leave any surplus for export.

Veneers and plywood are admissible into New Zealand under a General Tariff chargeable at the rate of 45 per cent. *ad valorem*. If produced in the British Empire, duty is payable at the rate of 20 per cent. *ad valorem*. The dutiable value is the current domestic value in the country of export increased by 10 per cent.

## THE BALTIC STATES OF ESTONIA, LATVIA AND LITHUANIA

THE evolution of the plywood board has already been reviewed very briefly in Part I., but it may be recorded here that the first sheets of plywood to be produced on anything approaching a



[By courtesy of V.E.F., Riga.]

FIG. 103.—FELLING A BIRCH TREE IN LATVIA.

commercial scale were made in the Luther factory at Reval about the year 1896.

### ESTONIA

During 1884 Christian Luther commenced experiments in an effort to produce a strong and light chair seat from three pieces of veneer, and, being quickly successful, a small factory was erected in Reval in which the fabrication of plywood seats began in March 1885. Very shortly afterwards complete bentwood chairs were also made. This development resulted in the opening of a furniture factory which manufactured a variety of wooden articles some of which were clearly "plywood-built," and were being manufactured by 1892. When the first plywood sheets were actually produced in steam-heated presses is not clearly

established. It was probably in 1895, but in 1896 rectangular pieces of 3-ply suitable for tea-chests were imported into London by Mr. E. H. Archer, the founder of Venesta Ltd. Plywood, in sheet form, followed shortly thereafter, the better qualities of board being sold as plywood, those with slightly more defects for chests.

The factory at Reval grew in size to become one of the most important sources of Birch plywood in Europe. It was associated with the Venesta group of mills, which accounts for the fact that early forms of plywood were commonly referred to as "Venesta" board. This factory produced plywood for export exclusively for the distributing company, and sold its products through the various departments of Venesta Ltd. in the United Kingdom, Germany, Belgium, Holland and elsewhere. The main products were multi-ply produced in a wide range of thicknesses and sizes. Large quantities of tea and rubber chests were manufactured, in addition to barrel parts, which were assembled and distributed by the Venesta organization.

#### LATVIA

Two plywood manufacturers were firmly established in Riga before the Great War of 1914-1918. The names of these early producers live to-day in the memories of the pioneers of the plywood trade:—

A/G, F. W. Nather.

Plywood Factory, Julius Potempa Ltd.

The Nather concern owned two mills, the original factory being one of the first to be erected in Riga. The Potempa mill was originally built in 1907, was destroyed during the Great War, and rebuilt in 1924. Potempa "J. Crown P." Birch and Alder plywoods were well known to buyers of plywood in the United Kingdom in pre-war days. To the regret of many, both of these concerns went out of business some years ago.

The Daugava and two other rivers flow into Riga Bay and, with their tributaries, serve a vast hinterland, including large areas in U.S.S.R., Poland and Lithuania, all rich in timber. These waterways carry the Birch and Alder logs from the forests to plywood mills which are mainly established in the vicinity of Riga. A certain quantity of Birch is imported to supplement the Latvian logs, part of the imported wood being floated down the river Daugava from Polish forests. As Birch logs sink when left in water for lengthy periods, they are generally made up into rafts with logs of Polish Pine.

In 1936 fifteen factories were producing plywood in Latvia, a few of the largest mills being equipped with modern plant capable of producing high-grade dry-cemented stocks. An old mill, reorganized by the State Electrotechnical Works, came into production during 1936. The majority



of these factories were owned by Lettish or Jewish interests, but British, Swedish and German capital also helped to develop the industry. In the year 1935 the plywood mills in Latvia employed approximately 2500 workers and consumed a total quantity of 170,000 cubic metres of Birch, Alder and Pine logs.

A considerable quantity of the plywood shipped from Riga was of the cheaper wet and semi-dry glued varieties. Such plywood is suitable for cheap covered-over work, packing and so forth, but is twisted to a less or greater degree, depending upon the thickness and general manufacture of the boards.



[By courtesy of V.E.F., Riga.]

FIG. 104.—SORTING DRIED BIRCH VENEER.

A few of the more recently built mills were beginning to produce Birch plywood comparable to the Finnish stocks when the troubles of 1938 upset normal production. Some excellent laminboards and blockboards were also manufactured, and one or two plants had gained reputations second to none for Birch aircraft plywood, the manufacture of which demands such close attention to detail. The Latvian *Economic Review*, published in April 1936, reveals the interesting fact that during 1935 the output of aero-Birch plywood from five mills averaged 3000 lats per ton, whereas the average for commercial stocks was no more than 218 lats per ton.

As with many things emanating from Riga, the best stocks are very good and the worst are bad enough to be left alone. The reputation of Latvian plywood manufacturers suffered from the casual dealings of a few of the less responsible producers and exporters whose ideas of grading were influenced by the prices obtainable. This spirit permeated various sections of the timber trade to such an extent that in 1936 efforts were made by the Latvian Government "to place the Latvian Timber Trade upon a sound basis."

In the early days of the Latvian State little attention was given to re-afforestation, and the cutting of the best Birch forests in the north-east of the country was allowed to continue with ever-increasing tempo to meet the rising demands of the plywood factories. There could only be one end to such an uneconomic system, and the blow fell in 1935 when Birch and Alder logs were in very short supply. Attempts were then commenced to resuscitate the Birch forests by scientific methods of afforestation, cutting being restricted and larger purchases made from neighbouring states to keep the plywood industry moving.

A strong nationalistic movement developed during 1937 and difficulties were placed in the way of mills in foreign ownership, more especially in regard to supplies of raw material. Later a grouping of mills was ordered by Government decree and three trading companies were formed. The first comprised mills under Lettish ownership, the second, those owned by Jews, the third represented foreign interests.

Latvian Alder has frequently a pinkish colour which detracts from its appearance, but nevertheless the best dry-glued stocks commanded prices on a par with the average Polish dry-glued stocks. As a general rule, Latvian dry-glued Alder contains a considerable number of brownish specks or streaks which are objected to by some users. The colour variation in Alder plywood depends to a considerable extent on the method of handling and storing logs before and during processing. Alder logs became scarce, and during 1935 the output of Alder plywood was less than 20 per cent. of the entire production.

Latvian Birch is generally darker than the Finnish variety and may be likened more to the Russian wood. It seldom has the lustre of the Finnish Birch.

## LITHUANIA

Two of the best-equipped mills in northern Europe were to be found in Memel. These were built by private enterprise and for some years were under the able management of A. Bisdom & Zoon.

A few years ago, when the nationalistic movement in Lithuania gained in strength, the controlling interest in this large industrial organization

changed to Lithuanian ownership, the position becoming more involved by the loss of Memel itself in March 1939.

The Luisenhof mill is perhaps the better known, as it was in this factory that the well-known "Cuba," three-equal-ply, Alder was manufactured. This was one of the first really reliable dry-glued Alder plywoods and, more especially in the higher grades, was most attractive stock. Like all good things it was expensive, but it was an excellent advertisement for plywood and did much to enlarge the uses of plywood for better-class work. From this mill also came the "Bisco" board—with Alder outer plies and a core of narrow Pine laminations; "Vencor," a flexible Alder plywood, 0.8 mm. thick; and, in "Walderyply," the first effort was made to produce large plywood sheets in competition with fibre and pulp wallboards.

The second mill at Schmeltz was in operation during the World War but was dismantled when Lithuania reached independence. It was re-equipped and re-opened during 1928 for the large-scale production of blockboards, using Alder for the outer plies and Pine for the cores. Boards of a high standard were produced.

The mills at Memel are well laid out with modern equipment and, in addition to the ample supplies of high-grade Lithuanian Alder and of the famous "Memel" Pine, received logs from the U.S.S.R., floated to Memel on the River Niemen which, incidentally, serves one other plywood mill at Wilno.

Although the Lithuanian forests have suffered severely at the hands of the country's masters from time to time, the timber resources are considerable. The State owned some 82.8 per cent. of the total forest area in 1939. These forests were administered by the Ministry of Agriculture, which controlled the cutting and developed, to a high degree, the work of afforestation. The average age of the species available in the Lithuanian forests is Fir, 54 years; Pine, 48 years; Black Alder, 43 years. The largest forest areas are traversed by the Niemen River. The famous forests of Punia hold some Fir trees from 110 to 120 years old, which attain a height of as many feet. Some Pines, if not quite so tall (they grow to about 110 feet), are even older, the estimated age being between 120 and 140 years.

Lithuanian Alder and Birch are of good colour, the Alder logs yielding a fair percentage of veneers in long lengths: 72", 84" and 96". In order to make best use of clean veneer for faces the outer plies were invariably jointed.

The processing of the logs left nothing to be desired, and all stocks shipped from the Memel mills were classified with the best Alder plywoods available.

PLYWOOD-PRODUCING COUNTRIES 193

Under normal conditions the mills at Memel, on account of their geographical situation, should continue to be of importance to all plywood-importing countries.

**LATVIA**

	1925.				1930.			
	Metric Tons.	Thousand Lats.	£ @ 25·07.	Average Price per Metric Ton.	Metric Tons.	Thousand Lats.	£ @ 25·21.	Average Price per Metric Ton.
Plywood & Veneers : Total Exports . . . . .	5,477	2,421	£ 96,569	£ 17·632	28,661	12,390	£ 491,471	£ 17·148
Of which to—								
United Kingdom (including Eire) . . . . .	4,183	1,849	73,753	17·632	15,200	6,396	253,709	16·691
Union of South Africa . . . . .	(a)	(a)	..	..	..	..	..	..
Australia . . . . .	(a)	(a)	..	..	..	..	..	..
Germany . . . . .	398	188	..	18·842	6,714	3,144	..	18·575
Argentina . . . . .	(a)	(a)	..	..	799	356	..	17·674
United States of America . . . . .	(a)	(a)	..	..	..	..	..	..
British India . . . . .					} 921	} 328	} ..	} 14·127
Ceylon . . . . .								
British Malaya . . . . .	(b)	(b)	..	..	227	77	..	13·455
Netherlands East Indies . . . . .					1,031	363	..	14·214

	1935.				1938.			
	Metric Tons.	Thousand Lats.	£ @ 15·13.	Average Price per Metric Ton.	Metric Tons.	Thousand Lats.	£ @ 25·22.	Average Price per Metric Ton.
Plywood & Veneers : Total Exports . . . . .	44,001	9,647	£ 637,607	£ 14·491	52,879	20,266	£ 803,568	£ 15·196
Of which to—								
United Kingdom (including Eire) . . . . .	16,524	3,420	226,040	13·680	18,217	6,745	267,446	14·681
Union of South Africa . . . . .	226	49	..	14·330	456	181	..	15·739
Australia . . . . .	..	..	..	..	..	..	..	..
Germany . . . . .	10,092	2,835	..	18·567	17,040	6,878	..	16·005
Argentina . . . . .	4,730	862	..	12·045	2,017	928	..	18·243
United States of America . . . . .	302	62	..	13·569	40	13	..	12·887
British India . . . . .	1,363	186	..	9·019	3,509	1,085	..	12·260
Ceylon . . . . .	617	84	..	8·998	535	166	..	12·303
British Malaya . . . . .	960	122	..	8·399	1,195	397	..	13·173
Netherlands East Indies . . . . .	110	16	..	14·545	1,244	425	..	13·546

(a) Not separately specified.

(b) Not available from records at present in the Statistical Department, Board of Trade.

## CANADA

AN important plywood industry functions on the West Coast of the Dominion, in addition to which several mills operate on a more limited scale in Quebec Province. It may seem paradoxical that the bulk of the plywood shipped to the United Kingdom from Canada should be produced in mills on the Western seaboard, but until the outbreak of war in 1939 the manufacturers in Eastern Canada showed

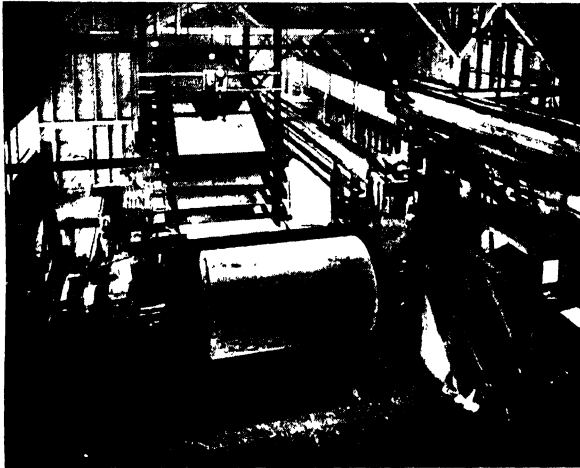

FIG. 105.—ROTARY CUTTING.  
Note Five-decked Conveyor Table.

little interest in export business, nor were they equipped to cater for this trade.

The first plywood mill in British Columbia was erected during 1912 by a lumber and door-manufacturing company to supply panels to the door-making plant. It has continued to function ever since and, from time to time, has exported limited quantities of plywood in door-panel and stock sizes.

During the year 1935 one of the largest Canadian operators in lumber commenced the erection of a factory for the production of Douglas Fir plywood on similar lines to the mills in the States of Oregon and Washington. This plant found ready markets for its products both in Canada and abroad; the original output on a  $\frac{3}{8}$ " thick basis of 12 million super feet was raised to 45 million feet by the end of 1938, a figure which was further increased during the following year. The

present equipment of this important factory consists of 3 lathes, 6 driers, 2 hot presses, 1 cold press and 6 sanders, all housed under one roof which covers a floor area of 165,000 square feet.

Until 1939 practically the entire output was produced on cold presses, but during that year manufacturing methods were radically altered by the installation of new plant and about 75 per cent. of the production is now bonded on hot-plate presses.

The maximum size of sheet produced by hot pressing is 110"×66", and by cold pressing 120"×60".

During 1940 a start was made on the manufacture of thin plywood



FIG. 106.—AUTOMATIC CLIPPER CUTTING VENEER TO WIDTH.

and veneers from Canadian Western White Birch grown in British Columbia to meet the demand from aircraft factories in Canada and other parts of the Empire. Veneers are cut from  $\frac{1}{16}$ " in thickness upwards.

A second plant with a potential annual output of 30 million feet of resin-bonded Douglas Fir plywood is in course of erection at Port Alberni, within reach of one of the few stands of old-growth Douglas Fir still uncut in British Columbia. This plant will produce a maximum size of 130"×66".

The demand for resin-bonded plywood in Canada has been most encouraging, and the material has opened a wide field to plywood manufacturers, more especially for the outside sheathing of factory and farm buildings.

In addition to the three mills already mentioned, two smaller concerns in British Columbia manufacture both veneers and plywood.

The more important of these mills cuts cottonwood logs obtained in the mountain country, and produces excellent plywood on hot-plate presses in sizes up to 84"×48".

Douglas Fir is undoubtedly the most important wood used by Canadian plywood manufacturers, but smaller quantities of a few other species are cut.

Western Hemlock is available in considerable quantity, and has not such a pronounced grain as Douglas Fir when peeled on the rotary-cutter. It would probably be used in larger quantities were it not for the fact that it takes twice as long to dry as the Fir. The dryers generally act as a "bottle neck" in the manufacturing process, so that the

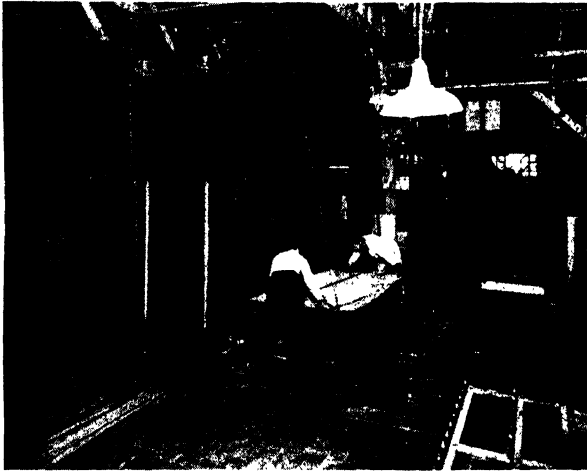

FIG. 107.—LOADING THE HOT PRESS.

production of Western Hemlock plywood reduces the output of the plant to a marked degree.

Western Red Cedar is another wood which makes an excellent plywood but is used on a limited scale. It is difficult to cut. Old trees are frequently soft or hollow in the core, making it necessary to select logs with sound hearts without which the chucks of the lathe cannot obtain the firm "bite" so essential to rotary cutting. This wood demands the supervision of an expert charge-hand on the lathe, as it is apt to tear during cutting.

Western White Pine, *Pinus Monticola*, makes one of the most attractive plywoods and is used on quite an extensive scale in Western Canada. The grain is pleasing and somewhat less pronounced than Douglas Fir.

In the province of Quebec five or more companies cut veneers and

manufacture plywood from Birch, Basswood, Ash and Elm. Until 1940 most of this plywood was produced on cold presses with vegetable glues and was used for box shooks. It met with little or no demand from the United Kingdom and only a small business was transacted. Recently efforts have been made to bring the manufacturing processes up to date, and at least one new plant has been laid down for the manufacture of Birch veneers and plywood. The high wages and heavy freight rate made it impossible for Eastern Canadian mills to compete with the Birch plywoods produced in Finland, U.S.S.R. and the Baltic States. Apart from Douglas Fir, Canada is rich in timbers suitable for the manufacture of plywood and it may well be that the Dominion will retain an important place as a post-war supplier of plywood.

The prices of Canadian Douglas Fir plywood, C.I.F., U.K. ports, generally ran from 7½ per cent. to 10 per cent. higher than American stocks which resulted in the ex-quay prices being approximately the same, *ad valorem* duty, at the rate of 10 per cent., being chargeable on American stocks while the Canadian product was admitted free of duty under Imperial Preference.

VENEERS AND PLYWOOD EXPORTED FROM CANADA

(Values stated in Canadian Dollars for Fiscal years ending 31st March in the years stated.)

To	1935.	1936.	1937.	1938.	1939.
	\$	\$	\$	\$	\$
United Kingdom . . .	80,158	196,404	703,323	1,038,289	870,032
Africa, Br. South . . .	—	915	13,810	17,560	37,460
Australia . . . . .	374	5	5,063	1,020	11,592
New Zealand . . . . .	413	2,909	13,654	27,289	48,020
Belgium . . . . .	—	—	1,584	22,188	49,891
Netherlands . . . . .	—	20	40,062	86,343	93,546
Dutch West Indies . . .	—	—	363	3,453	7,709
Denmark . . . . .	—	—	565	6,761	4,459
Portuguese Africa . . .	—	—	14,422	15,033	8,358
United States of America	4,377	8,283	27,608	25,408	10,745
Other Countries . . . .	1,136	3,850	3,472	21,450	15,685
<b>Total Exports . . . .</b>	<b>\$86,458</b>	<b>212,386</b>	<b>823,926</b>	<b>1,264,794</b>	<b>1,157,497</b>

Figs. 105, 106 and 107 are reproduced by courtesy of Messrs. B.C. Plywoods Ltd., Vancouver, B.C.



## THE DANUBIAN STATES

### ROUMANIA

THE forests in the mountainous regions of this kingdom covered an area of approximately 17,000,000 acres and yielded abundant supplies of high-grade Beech, Spruce and Lime. Oak, Walnut, Alder and other woods were available in smaller quantities. Based on this valuable raw material a plywood industry of some importance was developed.

The first mill was erected during the 'twenties of the present century and constituted part of an important wood-working organization. Until the partition of Roumania four factories were in active production, but one of the two most important, with an annual export production available for the United Kingdom of upwards of 2400 cubic metres, functioned in the Province of Bucovina, which was ceded to the U.S.S.R. in 1940.

All four mills were equipped with modern machinery laid out for the economical production of dry-cemented plywood on hot-plate presses. A wide range of adhesives, including "Tego" Film and other synthetic resins, was used.

Multi-ply was produced from Beech, Lime, Cherry, Maple and Alder, and considerable quantities were veneered with Oak or Walnut, while blockboards, in quite important quantities, were manufactured in sizes up to 72" x 144" with Spruce cores and outer plies of Lime or Beech. Special productions included Beech aircraft boards and plywood for bobbin-heads constructed with outer plies of 3 mm. Beech.

Until 1935 the bulk of the plywood produced in Roumania was used on the domestic market, although a fair export trade was done with neighbouring States and with the Middle East.

It may be definitely stated that it was the demand for plywood in flush-door sizes that finally established Roumanian plywood on the British market. Before the year 1936 small lots of Beech plywood had been shipped to the U.K. from time to time, but these were not received with much favour on account of a marked tendency to twist and the poor adhesion of the plies. Sample shipments of Roumanian-made Beech plywood in suitable sizes were made when the demand for Alder and Birch flush-door stocks was greater than the supply. This new source of supply was doubly welcome as the stocks shipped proved to be of excellent manufacture and the prices competitive.

Having once gained a footing on the British market, other stocks, such as the special construction for bobbin-heads, Lime- and Beech-faced blockboards, and multi-ply Beech in stock sizes, were introduced, and an export business of appreciable value to the Roumanian producers was built up.

### BULGARIA

A few plywood mills operated in Bulgaria, but all were small and no export trade worthy of note has been traced. Wet-glued Beech was produced for local consumption. A number of manufacturers and shippers of Walnut veneer carried on a small export trade.

### JUGOSLAVIA

Two mills of some importance operated in this kingdom, one of which has shipped limited quantities of plywood to the United Kingdom since 1927. During 1937 considerable quantities of flush-door panels in Beech were shipped which, on the whole, were favourably received. Small quantities of blockboards were also produced. Jugoslavia was better known as an exporter of Oak veneer, the fine texture and general quality of "Slavonian" Oak being appreciated by woodworkers throughout the world. The standard set by the Yugoslav veneer-cutters was high, in consequence of which Slavonian Oak veneer was in good demand, and a valuable export trade was done with Britain and other consuming countries.

### AUSTRIA

The plywood industry in Austria was run on very similar lines to that of Germany. Blockboards with outer plies of Gaboon and cores of Spruce, also multi-ply Beech, Alder and Gaboon were the principal products. The quality was excellent and, as prices for multi-ply on the domestic market were high, no effort was made to compete in foreign markets, although a certain trade was done from time to time in blockboards.

The importation of Austrian-made plywoods into Britain was insignificant until 1932. During 1933 the persecution of Jews in Nazi Germany, under the so-called "Aryan paragraph," was in full flood, when, by way of retaliation, Jewish traders in the United Kingdom banned German-made goods. As a result of this move Austrian

producers derived some small benefit, for a limited period, until other considerations intervened.

The industry is not of any importance to plywood-importing countries.

### CZECHO-SLOVAKIA

A few mills operating in Czecho-Slovakia manufactured blockboards of excellent quality. Local supplies of whitewood were used for cores, and Okoumé was imported for the outer plies. The industry catered for the domestic demand and only insignificant quantities were exported to the U.K. During 1937 and 1938, however, the mills derived some benefit from business which, in more normal times, would have been placed with German manufacturers. During the former year a total of 103,175 cubic feet of plywood, mainly blockboards, was imported by British traders.

### HUNGARY

One old-established mill, with an export surplus of some 1200 cubic metres per annum and manufacturing a wide variety of plywoods on both wet and dry processes, constituted, with a few smaller concerns, the plywood industry in Hungary.

The chief products were blockboard faced with Lime, Gaboon or Poplar ; dry-cemented multi-ply in Beech, Obечи, Lime and Alder ; built-up panels faced with Oak, Walnut, Saple and Makoré ; special bobbin-head plywood in Beech ; resin-bonded plywood and wet-glued Beech. A considerable trade in well-cut veneers was done.

Much of the plywood produced in Hungary was consumed locally or in the surrounding States, and only small quantities have ever been exported to the United Kingdom.

## FINLAND

THE Finnish plywood industry came into being in June 1912 when a plywood factory was erected by Wilh. Schaumans Fanerfabrik Aktiebolag at Jyväskylä. In a brochure, published to mark the twentieth anniversary of this company, the interesting fact is recorded that, prior to 1912, "the main economic use of Birch woods was to cut them up for firewood or have them sawn into boards. The prices paid for them, however, were very low and, as forestry experts regarded the Birch as destructive to other species of timber, it had to give room as a rule to Spruce and Pine which industry could use." In 1927 the plywood mills alone utilized approximately 400,000 cubic metres of Birch logs, the consumption rising to practically double this quantity during 1938. The importance of the plywood industry to the national economy of Finland is apparent.

The growth of the Finnish industry was slow until 1921, when only four separate factories were working. Five years later the number had increased to ten with four more in contemplation. By 1938 eighteen plants were actively engaged in the manufacture of plywood, but, following the re-drawing of Finland's eastern frontier with the U.S.S.R., four mills with a total output of 44,000 cubic metres were transferred to Russian ownership.

Professor Marti Levon, in a report to the Finnish Forest Products Research Institute, declared that "only about 30 per cent. or less of the total quantity of Birch is suitable for the plywood industry and from this selected raw material the factories only obtain about 30 per cent. of finished goods."

According to the same authority two species of Birch are found in Finland, *Betula verrucosa* and *Betula odorata*, both being used by the plywood manufacturer.

Birch trees are felled when still in leaf during August and September, the branches being removed and the logs bucked and piled in the late autumn. The practice of felling the trees when still in leaf increases the floating capacity of the Birch wood. Normal winter weather enables the forester to convey his logs on horse-drawn or motor-driven sleighs to the banks of waterways where they remain until the thaw sets in, when the logs are carried down-stream on the spring floods. On arrival at certain assembly points, they are made up into rafts and then towed to their destination.

Birch logs, when "piled" under water, will keep fresh for several

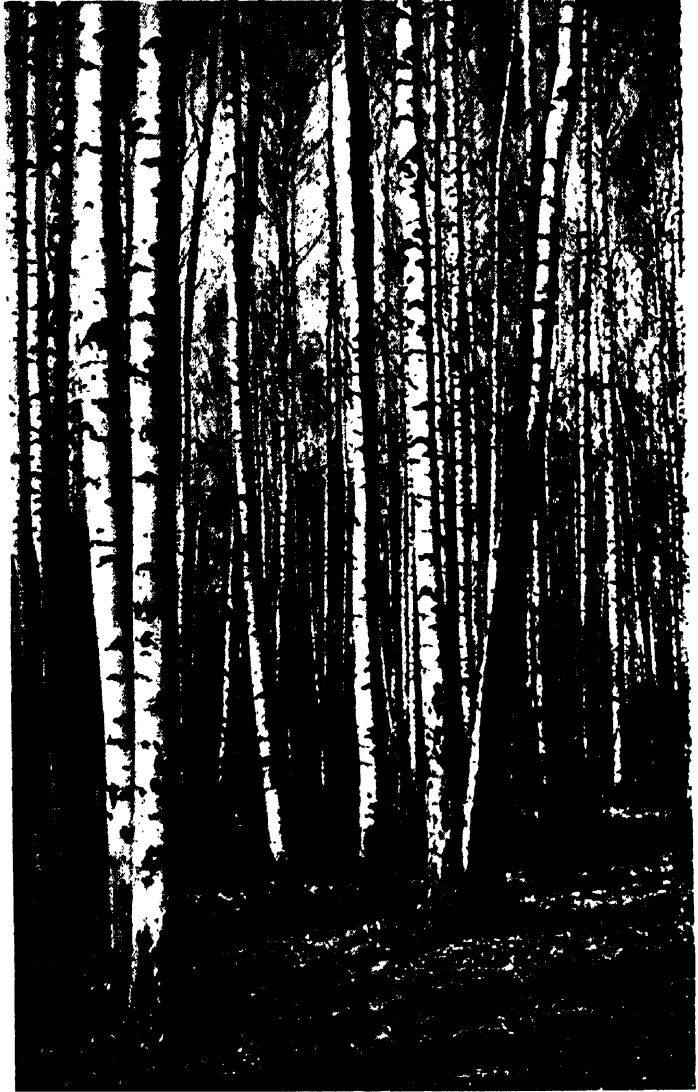

*(By courtesy of Editor of "Wood.")*

FIG. 108.—A YOUNG BIRCH FOREST.

years. Contrary to common supposition, discoloration is not caused by over-exposure to water, but results from the action of bacteria and fungi which develop rapidly if logs are allowed to dry-out in the open during spring and summer. These bacteria and injurious fungi cannot live so long as the moisture content of the log is kept high.

At the plywood mills the logs are removed from the water, carried by mechanical bridge-conveyor into the factory, cut into lengths suitable for the peelers, and subsequently subjected to the dry manufacturing process.

Finnish Birch, when rotary cut, is of a pleasing colour, the tones



*By courtesy of Itä-Suomen Kutomo OY., Savonlinna.*

FIG. 109.—FINNISH BIRCH LOGS IN LOG-YARD.

varying from white, through straw, to a beautiful golden shade which is enhanced by the silky texture of the wood. It is fairly hard, is not easily bruised, and when made into plywood, is as suitable for veneering upon as it is for making tea and rubber chests. In the early days of the trade it was known as White Birch.

The Finnish plywood industry held a high reputation in the markets of the world, not only for the quality of its products, but also for the upright and conscientious manner in which contracts were fulfilled and the happy relationship which existed between workmen and management.

Although individual mills in other Baltic States produced Birch ply-

wood of equal quality to the average Finnish stocks, the latter was acknowledged by the trade to be the best European Birch plywood available for commercial purposes. In consequence, during years of normal trading, Finnish Birch commanded a higher price than average Russian, Latvian or Polish productions.

At one time Finnish mills confined their production to boards

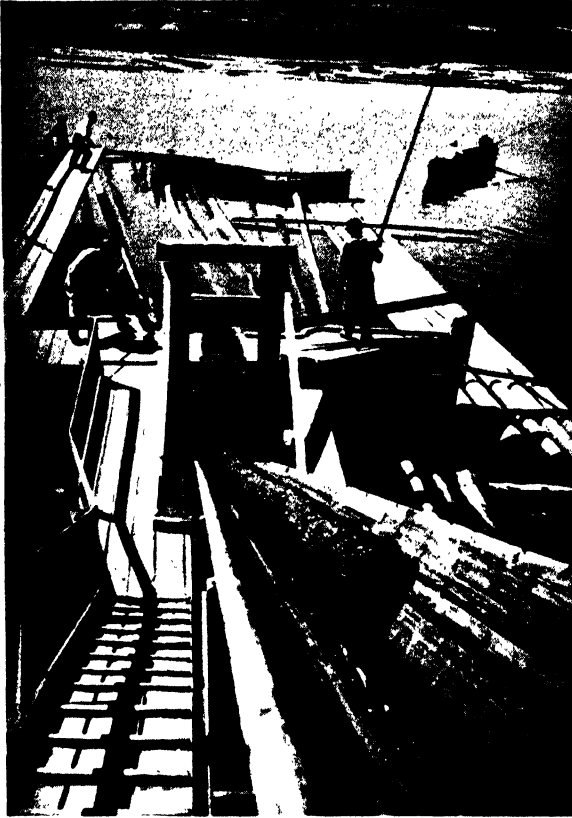

FIG. 110.—REMOVING BIRCH LOGS FROM PONDS TO FACTORY BY MECHANICAL CONVEYOR.

which “fell” from standard-sized presses, 48" × 38", 50" × 50", 48" × 48", 42" × 42"—one of the drawbacks to the Finnish specification being the considerable number of “as falling” sizes which were shipped.

The waste factor is of enormous importance to the manufacturer, and every effort was made to devise ways and means of utilizing defective and narrow veneer. This led to the practice of “patching” or “plugging,” the low labour-cost making this a profitable operation. In addition, jointing machines were installed by many manufacturers and, by these means, considerable quantities of

narrow and low-grade veneer were rendered serviceable for outer plies.

At a later date what was considered to be a wonderful step forward was made when 60" presses were introduced and, following the increased use of jointed veneers, larger presses were installed at a still later date.

Another business which formed an important part of the total production of the Finnish mills was the manufacture of sizes suitable for tea and rubber chests and other sizes to meet special requirements for

trunks, trouser-presses, perambulators, the motor trade and so forth. This enabled the mills to make good use of a considerable quantity of small-sized logs which they were obliged to accept from each season's felling.

A serious situation had to be faced when, as one result of the world depression, the demand for tea and rubber chests dropped considerably. Reference to page 455 will show that the number of rubber chests imported from Finland into British Malaya fell from 1,538,410 in 1930 to 794,900 in 1935. The various mills had no option but to endeavour to obtain orders for small sizes from other trades and a large-scale selling of "cut sizes" resulted in 1935. This proved to be a double-edged weapon, as might have been anticipated. It was perfectly obvious that the furniture manufacturer who could purchase his bed-ends, drawer-bottoms, wardrobe and chest gables, doors and tops cut to exact sizes, would anticipate his requirements and order his special needs rather than suffer waste and expend labour in cutting up stock-sized sheets. This is what happened, and the mills soon found themselves overloaded with orders for special sizes and starved of contracts for stock boards without which no mill could be economically run. To add a Gilbertian touch to the tragedy, many of the smaller cut sizes were actually sold below the price for standard-sized sheets of similar quality and thickness. Efforts were subsequently made to restrict the sale of cut sizes within certain definite limits, and to a percentage of the quantity contracted for in standard-sized sheets.

The problem which faced the Finnish manufacturers was to strike an even balance between veneers obtained from available log supplies which were suitable for faces, and those which could only be used for core stock. The solution was eventually found by restricting the percentage of thin boards supplied both in stock and cut sizes. For example, a typical selling specification of 1938 was 25 per cent. in 4 mm. to 6 mm., and 75 per cent. in 8mm. or thicker. The Finnish suppliers had an excellent reputation for thick boards and very large quantities were consumed by the furniture trade, the sanded surfaces being second to none for veneering upon. It can reasonably be said that the development of mass-produced furniture in England saved the Finnish Birch plywood industry from a difficult situation.

Until about 1930 Finnish Birch was graded into A/B, B, B/BB and BB qualities, but, as time went on, the supplies of standard-sized veneer which could be classed as A or B quality became increasingly scarce. Considerable quantities of clear veneer in narrow widths, however, had been accumulated by various mills, and these were jointed together and built up into boards described as AJ or BJ. These grades were sold at



discounts off the prices for unjointed boards, but, even so, buyers in Britain, for a long time, were reluctant to accept Birch plywood with jointed faces. The objections were very often quite illogical as many who refused to use jointed Birch boards accepted without demur veneered Oak and Mahogany panels which were invariably jointed. Much the same may be said about "plugging," as even the finest Walnut and other burrs must be prepared before laying by removing all imperfections and filling the holes so made with pieces of sound veneer. The prejudice against jointed and plugged boards, nevertheless, was difficult to destroy, but eventually, about 1934, plugs and joints were admitted in all BB Finnish stocks. About this time a lower unplugged grade described as WG (which was guaranteed to be well glued only) was introduced in an effort to compete with BB quality Russian Birch. The average specification offered by Messrs. Ahlstrom O/Y., Warkaus, may be quoted as being typical of 1938-1939 :—

15	per cent.	B and/or B/BB.
65	„	BB.
20	„	BB/WG and/or WG.

The logs available to the Finnish producers are of smaller diameter than average Russian stocks, and this one factor is responsible for the marked difference in the sizes of the plywood sheets which were available from these countries. The Finnish mills working on logs down to a diameter of 8", and an average of between 10" and 11", found it impossible to cut more than 50 per cent. of their veneers over 50" long, and, as a natural consequence, both lathes and presses had been laid down to make the best possible use of available raw material. The usual percentage of sizes is :—

40/50	per cent.	from 50" × 50" press.
50/60	„	„ 60" × 60" and 60" × 50" presses.

In an endeavour to supply larger sheets one mill introduced a method of scarf-jointing the outer veneers in their length, which enabled them to produce boards in the following large variety of sizes :—

36"/40"/50"/60"/72" × 72"/84"/96"/120"/144"/180".

Such surfaces are quite suitable for painted or veneered work. Any deterioration in strength may be disregarded.

The Finnish mills developed an excellent type of blockboard constructed with a Pine core in strips varying from 12½ mm. to 22 mm. wide between double outer plies of Birch, each cut about 1.5 mm. thick. This type of board was evolved in the Eklöf factory at Borgå about 1932, and was quickly taken up by many of the other mills. Finland, with ample

supplies of both Pine and Birch, was in a very favoured position to produce boards of this construction, as, in addition to the wealth of raw material, the preparation of core stock and jointing of the outer veneers could be done by female labour which is both abundant and cheap. The outer plies used for these blockboards were equivalent to BJ/BB, one side being practically free from defects and jointed, while the reverse side was both jointed and patched. This made a good surface for mass-production veneered work for furniture parts, etc. In addition to boards in standard sizes, panels specially manufactured for wardrobe doors, gables and other purposes were also available. The production was confined to thicknesses of 12½ mm. and up. Boards consisting of a core of narrow Birch laminations between double outer plies of Birch were also manufactured, but their heavy weight was against them and the quantity produced was not important.

Various attempts have been made from time to time, without success, to bring the Finnish plywood mills into one selling organization on the lines of the strong Finska Pappersbruksforeningen or the Finska Cellulosaforeningen which handled the entire output of the paper and cellulose mills respectively. All mills were members of the Central Association of Finnish Woodworking Industries (Finska Träförädlingsindustriernas Centralförbund) which dealt with domestic affairs. They also formed one sales group to handle the tea and rubber chest business. Except for this, so many conflicting interests existed that close co-operation in regard to export sales of plywood was not practicable. Later the "Association of Finnish Plywood Industry" was formed.

A few factories had departments producing various articles from or of plywood, such as chair seats and backs, hat-boxes, botany-boxes, trays, mirrors and furniture. Birch veneer was stamped into ice-cream spoons and tongue-depressors used by the medical profession, while Aspen veneer was cut into match-splints.

Some of the plywood mills developed into, or formed part of, vast industrial organizations. For example, the Kaukas concern at Willmanstrand consisted of a saw-mill, a large plywood mill, a spool factory, sulphate and sulphite pulp mills, a small experimental artificial silk plant (on which their own cellulose was tested) and the requisite engineering shops. Schaumans, of Jyväskylä, owned farms which were administered for the benefit of their workers.

The Finnish manufacturers marketed their output through selling agents in the various importing countries, and the practice was to dispose of the output in large or small sales, the unit frequently being 100 cubic metres. Plywood mills in Finland are well known to the leading British plywood importers, all of whom have the happiest recollections of days spent in Finland with their hospitable hosts.

## FINLAND

	1925.				1930.			
	Metric Tons.	Thousand Marks.	£ (@) 191·86.	Average Price per Metric Ton.	Metric Tons.	Thousand Marks.	£ @ 193·20.	Average Price per Metric Ton.
Plywood & Veneers :			£	£			£	£
Total Exports . . .	43,900	127,656	665,360	15·156	82,199	239,343	1,238,835	15·071
Of which to—								
United Kingdom (including Eire) . . .	31,350	89,657	467,304	14·906	45,535	132,964	688,219	15·114
Union of South Africa . . .	(a)	(a)	..	..	33	110	..	17·253
Australia . . . . .	(a)	(a)	..	..	(a)	(a)	..	..
Germany . . . . .	2,711	7,763	..	14·925	5,359	15,745	..	15·207
Argentina . . . . .	1,028	4,491	..	22·770	2,563	7,848	..	15·849
United States of America . . . . .	(a)	(a)	..	..	58	208	..	18·562
British India . . . . .								
Ceylon . . . . .	4,222	12,201	..	15·062	13,155	36,446	..	14·340
British Malaya . . . . .								
Netherlands East Indies . . . . .	1,119	2,776	..	12·930	2,200	5,838	..	13·735

	1935.				1938.			
	Metric Tons.	Thousand Marks.	£ (a) 227·00.	Average Price per Metric Ton.	Metric Tons.	Thousand Marks.	£ (a) 227·00.	Average Price per Metric Ton.
Plywood & Veneers :			£	£			£	£
Total Exports . . .	127,338	327,657	1,443,422	11·335	155,354	425,874	1,876,096	12·076
Of which to—								
United Kingdom (including Eire) . . .	88,524	228,156	1,005,092	11·354	104,045	280,427	1,253,361	11·873
Union of South Africa . . .	80	208	..	11·454	441	1,358	..	13·565
Australia . . . . .	38	103	..	11·941	28	137	..	21·554
Germany . . . . .	8,735	24,916	..	12·566	18,331	55,552	..	13·350
Argentina . . . . .	1,987	5,309	..	11·770	4,560	12,485	..	12·061
United States of America . . . . .	(a)	(a)	..	..	258	706	..	12·055
British India . . . . .	5,645	13,013	..	10·155	4,348	11,835	..	11·991
Ceylon . . . . .	1,611	3,818	..	10·440	936	2,294	..	10·803
British Malaya . . . . .	809	1,769	..	9·633	889	2,347	..	11·630
Netherlands East Indies . . . . .	1,424	3,226	..	9·980	1,306	3,508	..	11·833

Based on official trade statistics.

(a) Not available from returns and, if any, probably comparatively negligible.

## FRANCE

THE French plywood industry has been encouraged to make full use of, and in fact has been built up on, the large and valuable supplies of timber which are available in their West African Colonial Empire. A variety of woods were in common use, but by far the most important was Okoumé, so commonly known as Gaboon or Gaboon Mahogany.

The industry was established towards the beginning of the present century, the first French Gaboon plywood being exported to the United Kingdom early in 1916 from a mill in Lisieux. It is interesting to recall the fact that this particular concern originally produced cheese-boxes from rotary-cut Poplar veneer, and that the manufacture of plywood was developed as, and for many years continued to be, a subsidiary undertaking.

The leading plywood mills have been built in districts of France, having good transport facilities with the main centres of the colonial wood trade, Le Havre and Rouen, or in other ports to which logs may be shipped direct from Libreville or Port Gentil.

During the early 'twenties of this century five important mills were in full production, and the home trade, protected as it was from foreign competition by high import duties, was in a healthy condition, the demand for reconstruction work following the war being considerable. About this period the factory already mentioned, and one other at Nantes, manufactured considerable quantities of thick waterproof plywood, the outer plies of which were unjointed and finished approximately 3 mm. thick after sanding or scraping. The general construction and appearance of these boards was excellent, and they did much to establish the reputation of plywood as a sound material for bulkheading and other constructional work in the shipbuilding industry of the United Kingdom. An export business of some value was gradually built up.

The increasing importance of the industry attracted fresh capital. Several new mills were built, and once these came into production fierce competition developed between the new interests and the established producers who endeavoured to retain the goodwill of their old customers at home and abroad. A falling-off both in quality and price was the inevitable result.

At the same time the quality of the logs showed a continual and definite decline, much of the best wood being shipped by the concessionaires, not to their compatriots in France, but to other countries where higher prices were obtainable. One large plywood manufacturing

concern worked its own concession in West Africa, but this was an exception to the general custom of the trade.

The French plywood manufacturers have themselves to thank for many of the difficulties they have had to surmount, and they have failed conspicuously to benefit from the advantages they should have had over their competitors in other countries in respect of raw material. Competition in the home market was generally intense and, although various trade associations have functioned from time to time, few producers have prospered to any marked degree. On the contrary, more than one well-established mill had to shut down or changed hands.

French plywood was made by the dry-cementing process on hot-plate presses. A few cold presses were operated; the Lisieux mill, for example, produced all their thick panels on the cold press, re-pressing them on the hot press as a subsequent operation—an effective, if somewhat expensive, method. Various adhesives, generally of the casein type, were used; synthetic resins were also employed by a few mills for specialized work.

The output of the mills consisted very largely of multi-ply in all thicknesses, smaller quantities of blockboards and laminboards being produced by some manufacturers for the home market. Two concerns specialized in thick multi-ply and high-class veneered panels for the railways and shipyards of France, while Asbestos composite boards, metal-faced and aircraft plywoods, were manufactured by a select few of the more important producers.

In addition to Okoumé, the following West African woods have also been used for the manufacture of plywood, some of which are described briefly in Part VII. :—

Acajous d'Afrique (Acajou	Bossé.	Irokó.
de Grand Bassam and	Fraké-limbo.	Makoré-Douka.
Acajou Krala).	Noyer du Gabon.	Olon.
Avodiré.	Noyer d'Afrique.	Sapelli.

Some excellent plywood was made from rotary-cut Sapelli of the Cameroons variety—a wood having a much higher density than Okoumé. One important mill at Rochefort S/Mer introduced a novel form of moulded plywood which was marketed as “Occana” panelling and is described elsewhere.

Since the world depression only two out of the dozen more important French mills could be relied upon to produce plywood in thicknesses from 9 mm. to 25 mm., of uniform grade and degree of flatness, comparable with the average German stocks shipped to the United Kingdom. As we have explained on page 217, exports from

Germany were subsidized by the Nazi Government—a factor which enabled manufacturers in that country to buy a better grade of log than their French competitors who were facing a period of low prices and intense competition on their domestic market. In addition to the deterioration in the quality of the logs, labour troubles, currency troubles and the lack of co-operation on the part of the workers contributed to explain the drop in the value of the plywood exported to the United Kingdom.

Exports to the United Kingdom reached their peak in 1929 when just over 11 million square feet of plywood were shipped, but by 1932 the export business had faded into insignificance, and continued at a very low ebb during the years immediately thereafter. Some of the lost trade went to Spanish mills, but to a large extent Gaboon plywood was replaced by Japanese-made Lauan which was sold at very low prices.

During 1937 both home and export trade commenced to show some signs of betterment, and with a larger home market for which to cater various mills found it profitable to expand their productions by accepting orders for an export grade which could be worked in with the diversity of orders to be manufactured for the home market. This enabled a limited percentage of the output to be sold abroad at the low prices which were necessary to compete with Japanese-made Lauan. French Gaboon plywood up to 6 mm. thick was used mainly in the British furniture trade for carcass work, drawer-bottoms and so forth. Certain mills produced and shipped to Britain special grades of Gaboon plywood known as A/B or B quality, boards which offered excellent value, one side being generally free from wood defects, with minor defects on the reverse. Much of this plywood was unjointed.

In normal times quite a valuable export trade was conducted with South America, and also with Algeria, Tunisia and the other French colonies and mandated territories.

The French plywood mills distributed their products in the home market through stock houses or depots located in the main consuming centres. The Rochefort mill, for example, had twenty-seven depots throughout France. Business was done with timber merchants and with the larger consuming industries such as the railways and shipyards.

As is mentioned elsewhere, Okoumé is an excellent wood from which to manufacture plywood, as it cuts easily on the veneer lathe and yields a large percentage of clear veneer of good size. A considerable quantity of low-grade stock falls during the course of manufacture, which, in free-trade countries, is somewhat difficult to market against the competition of cleaner and cheaper Birch and Alder plywoods. However, the taxes on plywood of foreign manufacture imported into

France were very high, and created what was virtually a monopoly in favour of the French manufacturers. In consequence, little or no Birch or Alder plywood was imported and the producers were thus able to sell their lower grades of Gaboon to consuming trades, more particularly the joiners, cabinet-makers and packing-case makers.

The effect of substantial import duties will best be illustrated by stating a typical case.

During the fiscal year of 1938 the duty leviable on plywood imported into France was 105.40 francs per 100 kilogrammes, this being the approximate weight of 360 square feet of 4 mm. Birch plywood. A reasonably good grade of Birch could be purchased from Finland at 50 francs per 100 square feet c.i.f. French ports, against which Okoumé manufacturers offered a board of similar thickness and comparatively free from defects at 60 to 65 francs per 100 square feet f.o.r. factory. Thus, whereas on a duty-free basis the French producers would have experienced difficulty in meeting this competition, by virtue of the tariff of 29.27 francs per 100 square feet the landed cost of the imported Birch exceeded that of the home-manufactured Okoumé by approximately 20 per cent.

It should be observed that, under this method of assessing the duty payable, expensive plywoods, such as aircraft Birch, did not benefit to the same extent as lower-priced material. In point of fact, the competition offered by foreign-made Birch plywood manufactured to Air Ministry Specification was particularly severe at times.

A French concern with connexions in West Africa shipped a few rotary-cutters, complete with guillotines and drying equipment, from Le Havre to the forest regions with a view to cutting the logs at their source and so saving much expense in ocean freight. This and other ventures of a similar nature had not been given time to prove themselves before normal trading was interrupted by the war. It is likely that plywood plants will one day be established in West Africa once the problem of drying veneer and manufacturing plywood in a humid climate has been solved. The experience of the veneer-cutters of Paris, which was one of the leading centres of this trade, should be of great value in the solution of this problem.

FRANCE

	1925.				1930.			
	Metric Tons.	Thousand Francs.	£ @	Average Price per Metric Ton.	Metric Tons.	Thousand Francs.	£ @ 123·88.	Average Price per Metric Ton.
Plywood & Veneers :			£	£			£	£
Total Exports . . .			..	..	6,521	45,128	364,288	55·864
Of which to—								
United Kingdom (excluding Eire)			..	..	1,474		..	..
Union of S. Africa	(b)	(b)	..	..	(a)		..	..
Australia . . .			..	..	(a)	Not published	..	..
Germany . . .			..	..	749		..	..
Argentina . . .			..	..	159		..	..
United States of America . . .			..	..	(a)		..	..

	1935.				1938.			
	Metric Tons.	Thousand Francs.	£ @ 74·27.	Average Price per Metric Ton.	Metric Tons.	Thousand Francs.	£ @ 170·59.	Average Price per Metric Ton.
Plywood & Veneers :			£	£			£	£
Total Exports . . .	4,141	18,432	248,176	59·931	7,764	59,441	348,444	44·879
Of which to—								
United Kingdom (excluding Eire)	996	Not published	..	..	2,097		..	..
Union of S. Africa	(a)		..	..	(a)		..	..
Australia . . .	(a)		..	..	(a)	Not published	..	..
Germany . . .	53		..	..	115		..	..
Argentina . . .	111		..	..	695		..	..
United States of America . . .	(a)	..	..	(a)	..		..	

(a) Not separately specified.

(b) Not available from records at present in the Statistical Department, Board of Trade.



## GERMANY

THE capacity of the plywood mills in Germany was very large ; as a consuming country she was in the first rank and, in normal times, large quantities of Birch and Alder plywoods were imported to supplement the home production.

Germany has played an important part, not only in the development of the plywood industry, but also in the advancement in the design and manufacture of plywood-making machinery. As is explained in another chapter, her technicians were instrumental in placing upon the market boards of the block and laminated types, and introduced the first synthetic resin adhesives for commercial application.

The actual year during which the plywood industry came into being in Germany must remain a matter for conjecture, but it would appear that, as was the case in America, the first plywood boards were evolved from various veneered furniture-making processes. We do know that at least three concerns manufacturing plywood at the outbreak of the war in 1939 were established during the nineteenth century, and two of these claim to have been making veneered panels for furniture for over fifty years.

The need for a reliable foundation on which decorative but fragile veneer could be laid led to much experimental work, which culminated in the introduction of the blockboard about 1910. Until 1914 the bulk of the plywood produced in Germany was in what would now be called battenboard or blockboard construction. Small quantities of multiplywood of excellent quality were manufactured for specialized work, but it was not until the war years of 1914-1918 that this form of plywood became popular, or that any great forward stride was made in manufacturing technique. Over this period, established mills concentrated upon the production of waterproof plywood for aircraft and, as happened in other manufacturing countries, much valuable experience was gained. One concern at Mannheim, which built the S.L. type of airship, constructed the girders and entire framework of specially designed plywood-built sections, a type of construction which proved to have remarkable strength. This concern, in later years, turned its attention to the manufacture of plywood of high quality.

Immediately after the war, import duties on all manufactured goods coming into Germany were sharply raised—a fact which, coupled with the intense industrial activity witnessed during the inflationary years of 1919-1923, enabled the plywood mills to expand and prosper.

Whosoever suffered, many of the plywood concerns appeared to thrive in these days of inflation.

The raw material chiefly used during and immediately after the war was Pine, Poplar, Beech, Alder and Birch. Once commercial trading was re-established with France, however, Okoumé logs were again shipped from West Africa to Hamburg, and in subsequent years this timber became the backbone of an industry which developed rapidly.

The plywood produced was of excellent quality; indeed for many years German Gaboon and Oak plywoods were looked upon as being the acme of perfection. One or two mills specialized in the manufacture of thick multi-ply boards which were largely used in the shipbuilding industry for cabin partitions, linings and ceilings. Boards for this purpose called for most careful manufacture: they had to be perfectly flat, free from voids in the inner plies, have thick outer faces (preferably free from joints) and be cemented with a thoroughly waterproof adhesive. When the British shipbuilding yards were busy, a valuable trade was done in sizes up to 120" × 84", the chief thicknesses being  $\frac{3}{8}$ ",  $\frac{1}{2}$ ",  $\frac{3}{4}$ ",  $\frac{7}{8}$ " and 1". Large cross-grained jointed panels from the 60" × 177" presses found favour for ceilings, and were also used largely as base-boards for high-class veneered work.

The development of the blockboard had gone on apace, and large quantities were used by German industry in the years following the war. Much of this stock was veneered on one or both sides with Oak, Sapele Mahogany, Teak or American Black Walnut and presented quite a new medium to architects and designers; the maximum size of these veneered boards was 132" × 59".

The drying problem was not solved, however, until about 1925, and many a beautiful veneered surface in these early years was marred by a ribbed pattern formed by the Pine strips of the core showing through both cross-banding of 4 mm. Gaboon and decorative veneer. This may seem incredible, but for several years the authors' faith in blockboards remained at a very low ebb following the close inspection in an Essen hotel of a large and beautifully veneered Walnut screen, which was ruined in the manner just described.

Improvements in drying and in the construction of the core stock to a great extent overcame the trouble of excessive core movement, and a large export trade in blockboards was built up. Some of the earliest blockboards to be shipped were of Gaboon throughout, but the trade developed on the construction which came to be associated with German mills, viz. Pine core with Gaboon outer veneers. Boards with Poplar or Alder outer plies and Pine cores were also manufactured chiefly for domestic consumption.

The so-called laminated board (subsequently to be known as lamin-board) was introduced in 1921, and the superiority of this new construction over the blockboard was soon manifest. The "Ibus" laminated board, the first of this type to be exported to the United Kingdom, was built with outer plies, which stood 3.3 mm. thick before sanding, and a core of narrow laminations of roughly the same width. Gaboon Mahogany was used for both core and outer veneers. Many manufacturers thought this an excellent opportunity for using scrap veneer, cuttings from multi-plywoods, etc., and as a result boards of inferior quality were marketed until it came to be recognized that no form of plywood was quite so bad as an inferior laminboard. At a later date, laminboards were sold with Pine cores and Gaboon outer plies, and these were very successful.

In post-war years (1919-1920) at least two of the German manufacturers interested in the export trade established trading companies in Holland in order to circumvent Treaty restrictions and also Reparations. These concerns built up an export business of some importance with the United Kingdom and other countries. The export trade with Great Britain increased rapidly to reach its peak in 1929 when, in point of actual value, Germany was Great Britain's third most important supplier.

One or two plants specialized in the manufacture of table-tops and furniture parts and, commencing in 1932, export orders were accepted by practically all German mills for blockboards cut to buyers' exact sizes. These were largely bought by furniture manufacturers in Britain, and elsewhere, for gables and doors of wardrobes and chests. At one time blockboards could be purchased veneered on one or both sides with decorative veneer, the Pine core being concealed by lipping the edges with strips of solid wood to match the face veneer. Plywood so made was looked upon as "furniture parts" by H.M. Customs, and the high rate of duty imposed soon stopped this particular trade.

The troubles of the German industry commenced in 1931-1932 when internal trade was in distress. Imports of plywood into Germany fell from £563,000 in 1930 to £373,000 in 1931, and these figures reflect the poor state of general trade. Business showed signs of some revival towards the end of 1932, but this was more than offset by currency difficulties which reduced the available supplies of Gaboon logs. The Government intervened to protect the industry by raising tariffs on imported plywoods, and a general control was instituted over the home trade. The trade, both domestic and export, was supervised by Interessengemeinschaft Deutscher Sperrholzfabriken, an association which

came to be known as the I.D.S. The internal difficulties were not helped by the divorce of the pound from the Gold Standard, nor by the competition which developed from the Finnish type of blockboard and the thicker boards of Russian Birch, which were sold at very low prices. It is interesting to note that the German Government thought the plywood industry of sufficient importance to assist it to retain its export trade by making good through the I.D.S. the loss of exchange. By 1934 the import of raw materials was put under State control, and no mill was allowed to purchase Gaboon logs until it could produce contracts for specified quantities of plywood with foreign buyers. Many were the schemes thought out at this time by the German exporters to overcome the restrictions placed on trading by their Government. A further blow to the plywood manufacturers fell when a virtual embargo on German-made plywood was enforced by Jewish traders in other countries, following the persecutions of their race by the Nazi regime.

In 1939 the German industry consisted of some sixteen large mills which were interested in the export trade, and a great many more which manufactured solely for the home market. One of the leading producers had a capital of approximately £500,000, owning four important plywood mills with a vast selling organization throughout Germany. The larger manufacturers in Germany sell their products through timber dealers scattered throughout the length and breadth of the country. Under the I.D.S. Regulations any timber merchant who agreed to retain a minimum stock of 15 cubic metres was acknowledged to be a "dealer."

The plywood industry of Germany was in a unique position, as although the country is rich in certain woods, it has no large available supplies of wood suitable for plywood manufacture. The industry depended upon imported Gaboon logs to keep it alive—other timbers were also used at odd times, and even Douglas Fir logs were imported from America in the search for alternative supplies. The high tariff on imported plywoods ensured an economical price level for the manufacture on the home market, and the cream of the Gaboon production was shipped to the United Kingdom and sold at such prices as it would fetch in competition with other producing countries. The export trade was therefore largely subsidized by home market sales and, at a later date, under the Nazi administration, by direct financial aid.

It would appear that the German plywood industry, in so far as the British market is concerned, has already fulfilled its purpose, and is unlikely to regain the important place it once held. The German blockboard and laminboard, at one time so largely used for mass-produced furniture, has been replaced by the Finnish type of blockboard, while British-made boards will meet home requirements for specialized work ;

Gaboon shipbuilding boards have to a large extent been replaced by Oregon Pine or by British-made Gaboon boards; Oak and veneered panels have long since given way to Polish- and British-made stocks.

During the fiscal year 1938 the duty leviable on plywood imported into Germany was R.M. 20 per 100 kilos which, at the rate of exchange then current, and taking 4 mm. B/BB quality Finnish Birch as an example, was equivalent to 9s. 2d. per 100 square feet, or just over 100 per cent.

## GERMANY

	1925.				1930.			
	Metric Tons.	Thousand Reichs-marks.	£ (a)	Average Price per Metric Ton.	Metric Tons.	Thousand Reichs-marks.	£ (a) 20:38.	Average Price per Metric Ton.
Plywood & Veneers :			£	£			£	£
Total Exports . . .			..	..	9,686	8,262	405,397	41·854
Of which to—								
United Kingdom (including Eire)			..	..	3,316	2,732	134,053	40·426
Union of S. Africa	(b)	(b)	..	..	33	32	..	47·581
Australia . . .			..	..	41	44	..	52·658
Argentina . . .			..	..	1,046	850	..	39·873
United States of America . . .			..	..	61	57	..	45·850

	1935.				1938.			
	Metric Tons.	Thousand Reichs-marks.	£ (a) 12:19.	Average Price per Metric Ton.	Metric Tons.	Thousand Reichs-marks.	£ (a) 12:18.	Average Price per Metric Ton.
Plywood & Veneers :			£	£			£	£
Total Exports . . .	9,159	4,625	379,409	41·425	4,119	2,209	181,363	44·031
Of which to—								
United Kingdom (including Eire)	5,986	2,833	232,404	38·824	2,409	1,179	96,798	40·182
Union of South Africa	56	29	..	42·482	(a)	(a)	..	..
Australia . . .	(a)	(a)	..	..	(a)	(a)	..	..
Argentina . . .	170	81	..	39·087	79	35	..	36·374
United States of America . . .	(a)	(a)	..	..	(a)	(a)	..	..

(a) Not separately specified.

(b) Not available from records at present in the Statistical Department, Board of Trade.

## HOLLAND AND BELGIUM

THE plywood trade in the Low Countries, *i.e.* Holland and Belgium, was conducted on very similar lines, and a considerable amount of inter-trading appeared to be done. Several Dutch concerns had offices in Belgium and vice versa.

Birch, Alder and other plywoods were imported from Finland, the Baltic States, Poland and U.S.S.R. in important quantities, while during normal times Holland and Belgium were large buyers of Douglas Fir plywood.

There were five mills of some importance in Holland and two in Belgium which produced plywoods from Poplar, Gaboon, Oak and a variety of decorative veneers. In addition, the special requirements of the railways, shipyards and the aircraft industry were manufactured locally. The value of the exports to the United Kingdom and elsewhere varied very considerably, but the combined export to Britain seldom exceeded £100,000 in any one year.

The most important mill, situated at Eindhoven, obtained its raw material, in the form of Gaboon logs, from Rotterdam by canal barge. It was well equipped with modern machinery and produced much plywood of excellent quality.

The history of the development of this concern is of considerable interest. The business commenced as a small factory, making cigar-boxes and printing labels and bands. It was conducted on very similar lines to another business operated at Hanau by a relative of the Dutch proprietor.

Cedar was used for the best boxes, Gaboon being introduced at a later date to produce a cheaper variety. Originally logs were sawn or sliced, but in order to speed up production rotary-cutters were installed with satisfactory results. The manufacture of plywood from this rotary-cut veneer commenced quite as an ancillary venture, but developed rapidly during the war years of 1914-1918 when it will be remembered Holland was neutral. The company prospered under the able guidance of Mr. Bruning, the founder of the firm, and the plywood factory was extended to cater for the increased demand both from Britain and continental countries. At this period, supplies of Gaboon logs were cut off and the domestic woods, Eipen (Elm) and Peppel (Poplar), were used on a considerable scale. After 1918 the factory was further extended, and the plywood side of the business became predominant. The Eindhoven "Picus" mill was one of the first to manu-

facture laminated boards and large cross-grained multi-ply (known as shipbuilding) panels with veneers jointed in their length. This technique eliminated all risk of gaps in the inner core and made the best possible use of short lengths of veneer. The method of jointing is described and illustrated on page 70.

A considerable number of hot-plate presses were operated, and a wide variety of adhesives, some of which were evolved in the "Picus" laboratory, including synthetic resins, were used.

In addition to this important manufacturing business a large distributing organization was set up to handle imported plywoods along with the "Picus" products. The production covered multi-ply and laminated boards in sizes up to 60"×177"; Gaboon plywood in standard sizes up to 120"×60"; a wide range of veneered panels, mainly figured Teak, Sapele Mahogany and Oak; composite panels faced with Asbestos or metal; aircraft plywood, and flush doors. Such a varied production, carefully planned to work in with the cigar-box output, enabled this concern to prosper where other attempts in free-trade countries to combine plywood manufacturing with a plywood-importing business had failed. During recent years, however, the output of the plywood plant had decreased greatly as the consumption of Dutch-made Gaboon plywood gave way to cheaper Birch and Alder, Douglas Fir and Swedish Pine plywoods, as well as Gaboon from other countries which, as a result of exchange depreciation, cheaper labour or other reasons, could produce more economically. The excellence of the "Picus" manufacture did much to popularize Gaboon plywood in Britain.

The production of the four other mills which operated in Holland was confined to veneered boards, blockboards and laminboards. Little of the output was exported to the United Kingdom.

The largest factory in Belgium was part of a very important furniture-manufacturing organization with headquarters at Courtrai. This plant was originally conceived to supply the requirements of the parent company, which exported furniture to many parts of the world. It was entirely re-modelled about 1937 when much additional modern machinery was installed. The output, as might be expected, consisted largely of veneered plywood in special sizes for furniture manufacturers; blockboards and laminboards were manufactured from Gaboon; standard sizes in decorative woods were other important items of production.

A considerable quantity of locally grown Poplar was used for the core stock of veneered boards which could be faced with practically any type of veneer desired.

One other small mill in Belgium worked in conjunction with an important Polish factory, both being controlled by a financial house in

Antwerp. The output of the concern was confined to boards manufactured from Gaboon and other African woods faced with a variety of decorative veneers.

In Holland the more important plywood importers and agents for foreign manufacturers were members of an organization known as the "IMPAG Institute"; a similar association in Belgium was known as "G.I.A.C.O." Both Dutch and Belgian organizations were successful in bringing about fair competitive conditions in their respective countries by eliminating the commission-splitting evil and other abuses. Group-buying of certain foreign stocks was occasionally practised.

During 1938 the import duty on plywood imported into Holland was 6 per cent. *ad valorem*, with an additional duty of 1 per cent. *ad valorem*, and a special import duty of 4 per cent. of the duty-paid value. The difficulties which the Dutch manufacturer had to face when imported stocks were forced on the market can be well imagined.

## ITALY

ALTHOUGH Italy can boast of upwards of a dozen plywood mills, no serious effort was made to compete in foreign markets. Several of the mills were well equipped with modern plant on which multi-ply, laminboards and blockboards of average-to-good quality were produced. Poplar was commonly used for cores and occasionally for faces, whilst Gaboon and Douglas Fir logs were imported to supplement supplies of European woods.

Boards with Poplar cores faced with Walnut, Sapele, Oak, Maple and a large variety of decorative wood were featured by the largest mill in Milan. This concern also manufactured Aircraft plywood and other specialities.

An attempt to develop trade between Italy and Britain in plywood was made in 1937 when plywood to the value of £21,000 was imported. The attempt was shortlived, and is not likely to be repeated. Some business in veneers was done.



## JAPAN

THE Japanese plywood industry had a modest beginning about 1908, when a small mill was erected in Nagoya. Slow progress was made until 1914 when a rapid forward movement commenced following the outbreak of war in Europe. Many new mills were built in Nagoya and, subsequently, in other centres such as Tokyo, Yokohama, Osaka, Shidzuoka, Otara and elsewhere. By 1927 the total production was estimated at 66 million square feet.

The first Japanese plywood to be imported into the United Kingdom was manufactured from veneers sawn from quartered flitches of the famous Hokkaido Oak. The outer plies (about  $\frac{1}{8}$  inch thick) were well matched and, as the plywood was exceedingly well made, it met with a ready demand, being used for high-class work.

As time went on, prime Oak logs proved to be much too valuable to be converted into veneers by the wasteful sawing process and, about 1930, sliced-cut veneers became the standard for all figured Oak stocks.

During 1931 when, following the embargo placed on the export of gold, the yen exchange slumped badly, an added stimulus was given to the export trade, and shipments to the United Kingdom and other countries rose rapidly. At the same time the output of the mills showed a corresponding jump.

By 1932 something like 120 factories (many of them admittedly small and working in conjunction with larger concerns in typical Japanese fashion) were in operation and an excellent export trade was done to the United Kingdom, Australia, South Africa and elsewhere, chiefly in well-manufactured panels of sliced figured Oak, rotary-cut Oak, Sen and Lauan.

Important quantities of Basswood and Birch plywood, in sizes suitable for tea and rubber chests, were shipped to British India, Dutch East Indies and the Federated Malay States.

Taking advantage of the slump in exchange values, and selling at very low prices in terms of sterling, Japanese exporters captured a considerable volume of the tea and rubber chest business from the Finnish, Estonian and Latvian mills which in past years had catered for this valuable business. The quantities of plywood shipped in the form of rubber chests during 1934-1935 must have constituted a valuable proportion of the total Japanese export. Incidentally this comparatively new competition added greatly to the difficulties which beset the Finnish manufacturers about this period.

A shortage of suitable Oak logs commenced to be felt about 1934, and in an attempt to keep up production other woods were substituted for the Oak which for many years had been so popular. Lauan logs imported from the Philippine Islands and the domestic timbers known as Sen and Tamo, in addition to Shina (Basswood), were used extensively. The competition for supplies of raw material may be gauged from the fact that one plywood mill alone claimed to have produced, during 1938, a total of 126 million square feet. The quantities of Oak declined considerably, being confined to rotary-cut and sliced-cut stocks of a quality which compared unfavourably with the original Japanese plywood.

Many of the smaller manufacturers offered their plywood through exporters who knew little or nothing about the trade and, from subsequent actions, appeared to care less. Stocks were offered at very low prices as these agency houses competed for any available business. The climax to this farce was reached when some manufacturers, who, at an earlier date, in their efforts to produce a still cheaper board had reduced their thickness from  $1\frac{3}{8}$  inch to 4 mm., went a stage further and marketed a panel which was quite unique in its thickness of  $3\frac{1}{2}$  mm.—surely a worthy monument to the supreme folly of the producers of this period and to the speculative buyers in London who encouraged such a procedure!

During 1936 British buyers of Japanese plywood discovered to their cost that low prices and poor manufacture march hand in hand; cheaper types of glue were used which caused further disappointment and resulted in claims being made against shippers, many of which were dishonoured.

As a natural consequence, the reputation of the Japanese industry as a whole suffered severely from the misdeeds of a few unprincipled exporters. It should be recorded that several of the better-known manufacturers refused to take part in this mad scramble for export business at prices which were obviously entirely uneconomic. The established producers, in an effort to bring some order out of chaos, formed the Japanese Plywood Exporters Association. This consisted of twenty members, and effected some control over export prices. Nagoya remained the centre of the industry, and in this district alone thirty-six mills, selling through members of the Exporters Association, were allotted numbers by which their plywood could be identified in the event of complaints being made by the buyers.

Some of the larger mills produced a large variety of plywoods for local consumption during the years from 1935 onwards, several concentrating on supplies for the war services, in particular for the aircraft industry. Many of these plants operated hot presses, but the bulk

of the production continued to be manufactured on the dry-cementing process, using cold hydraulic presses. Many adhesives were used, mainly of the vegetable or Soya Bean types.

When trading with Japan reached a virtual standstill in 1939, Japanese plywood was seldom used in Britain other than for cheap cabinet work, drawer-bottoms, blind-panels and so forth.

It is difficult to forecast the future of the plywood industry in Asia, but it is unlikely that Japan will again become such an important exporter to the United Kingdom.

## JAPAN

	1930.		1935.	1938.	1930.		1935.		1938.	
	100 Kins.	Tons.	1,000 sq. ft.	1,000 sq. ft.	1,000 Yen.	£ (a) 9·877	1,000 Yen.	£ (a) 17·143.	1,000 Yen.	£ (a) 17·143.
Plywood & Veneers :										
Total Exports . . .	28,343	1,673·8	64,028	99,494	565	57,203·6	4,397	256,490	6,064	353,730
Of which to—								(8/-)		(7/1)
United Kingdom (including Eire)	11,650	687·9	23,344	22,548	234	23,691·4	2,149	125,357	1,757	102,491
Union of South Africa	1,145	67·6	2,827	3,706	17	1,721·2	266	15,516·5	244	14,233
Australia . . .	4,843	285·9	1,928	2,177	121	12,250·7	162	9,449·9	220	12,833
Germany . . .	(a)	..	..	323	(a)	..	..	..	23	1,341·7
Argentina . . .	781	46·1	863	1,945	21	2,126·2	74	4,316·6	172	10,033·3
British India . . .	358	21·1	999	6,527	14	1,417·4	62	3,616·6	301	17,558·2
Burma . . .			(a)	73	{ (a)	.. }	(a)	..	..	..
Ceylon . . .	(a)	..	86	5	{ (a)	.. }	12	700	..	..
British Malaya . . .			(a)	..			(a)	..	..	..
Straits Settlements . . .	2,776	164	31	4	24	2,430	4	233·3	..	..
Netherlands East Indies . . .	1,017	60	278	996	27	2,734	21	1,225	103	6,008

(a) Not separately specified.

Figures in brackets show approximate price in shillings and pence per 100 superficial feet.

A few mills operate in other parts of the East, in India, Ceylon, Malaya and China. Those in the first three countries are chiefly interested in the production of plywood for tea and rubber chests. Excellent plywood has been produced in Manchuria, and it is probable that some part of the vast timber resources of that country will be used by plywood manufacturers in future years.

## POLAND

THE marsh-lands of Eastern Poland and White Russia, through which the River Pripet and its many tributaries flow to join the Dnieper, are famed for their forests. To the foreigner perhaps the best-known districts are between Minsk and Pinsk, across which countryside the Polish-Russian frontier was drawn by the Peace Treaties of 1919 and 1920. These forests supply the raw material used by many plywood mills both in Poland and the U.S.S.R. The climate and soil combine to produce some of the finest Alder trees in Europe. These grow to a good size and yield a wood of mild grain which is admirably suited for cutting on the rotary-lathe. In other parts of the State valuable forests yield Birch, Oak, Ash, Pine and Fir.

The canals and rivers of Poland, more especially the rivers Niemen and Welejka, serve as important waterways on which logs are conveyed to the plywood factories. The best-equipped mills are generally to be found within easy access of, or having good communication with, the forest regions.

Until 1932 the output of the mills was practically confined to 3 mm. and 4 mm. Alder plywood manufactured by the wet-glued process; small quantities of thicker boards and some Birch plywood were also made. This plywood met a considerable demand from the United Kingdom, Channel Islands, Holland, Belgium, Switzerland, Argentina, Palestine, Egypt, British India and a number of less important markets. A varying proportion of the total output was consumed locally.

During 1932 the Polish plywood industry was faced with a situation of extraordinary difficulty when its chief competitor (the U.S.S.R.), for reasons of its own, decided to force the sale of Birch and Alder plywoods on world-markets at prices which had no possible bearing on the actual cost of production. For example, the prices ruling during March 1933 for Lesbel Alder against which Polish stocks had to compete were:—

	A/B	B	BB	C
3 mm. . . . .	3/10	3/6	3/1	2/8
4 mm. . . . .	5/-	4/7	4/1	3/6
5 mm. . . . .	6/1	5/8	5/-	4/2
6 mm. . . . .	7/2	6/8	6/-	5/-

per 100 square feet, c.i.f. London or Hull.

These prices were subject to a discount of  $5\frac{1}{2}$  per cent. for quantities of 5000 cubic metres, and it seems inconceivable that the sellers could have

had much left over to be placed against cost of manufacture and raw material, once the rail charges from the mills in White Russia to Leningrad, the ocean freight from Leningrad to London, and the insurance had been paid. This must have been one of the most insane periods in the history of the plywood trade and, as a natural consequence, the value of the exports from Poland to the United Kingdom fell precipitously from 13,000 tons, value 10 million zloté, in 1929, to 4055 tons, value 1,270,000 zloté, in 1933, representing a reduction in the average value per ton of practically 60 per cent. The breakdown of the Gold Standard during 1932 rendered trading with the United Kingdom all the more difficult.

Privately owned mills which catered for the export trade were unable to compete in foreign markets and the position became so serious that eventually the Government stepped in. The Board of the Polish State Forests found it impossible to obtain a reasonable market for their logs and, under the exceptionally difficult conditions which faced the industry, a step was taken which was quite unprecedented. Two plants were purchased and agreements were entered into with the owners of several other plywood mills under which the Board of the Polish State Forests agreed to supply the raw material required by the factories and took the responsibility of marketing the finished products. The owners, on the other hand, operated the plants and were paid a rental for the use of the machinery. In point of fact, however, the Board of Polish State Forests very soon discovered that, in marketing the finished plywood, they came into direct competition with those manufacturers who had been financially strong enough to retain their independent operations.

The scheme was not a great success and many factories found a temporary solution by closing down. A few of the more far-seeing individuals decided that their only salvation lay in making a quality-article from the excellent raw material at their disposal and commenced to re-organize their factories for the production of dry-cemented and an improved type of wet-glued plywood.

This proved to be a very wise move ; the output of well-made dry-cemented Alder increased rapidly, in addition to which considerable quantities of Birch, Oak, Ash and Pine were produced. Plywoods demanding specialized knowledge, such as aircraft Birch and metal-faced stocks, also laminboards and blockboards, tea-chests and other cut sizes, were also manufactured.

During 1934 sanity began to return to the trade and prices showed some improvement. The local consumption rose to approximately 55,000 tons during the year, while the export demand also increased considerably. As a result, many of the mills which had closed down re-

opened and the special arrangements which the Board of the Polish State Forests had made with certain mills were not renewed. About this time the demand for sizes suitable for flush doors became of some importance, and those mills which had laid down larger presses and had modernized their equipment derived considerable benefit from this particular trade. There were periods when the demand actually exceeded the supply, and a valuable business was done until the troubles of 1939 came upon Poland and the world. In this year twenty-six factories were operated under private ownership in addition to the two mills owned by the Board of the Polish State Forests. The production of the latter was commonly referred to as Polish Ministry plywood.

The rise in the average value per cubic foot of the plywood exported from Poland since 1933 was encouraging, and it is doubtful if the industry could possibly have survived had not the more prominent manufacturers taken the bold step of bringing their plants up to date when business was at a low ebb.

It will be apparent to any who study the subject how much more profitable it must be to manufacture dry-cemented plywood rather than low-priced wet-glued stocks. Certain costs are constant to both processes; for example, cost of raw material, transport to mill, cutting into veneer, gluing operation, assembling, equalizing, sanding, packing, rail and ocean freights, and, for all practical purposes, insurance. The costs which *may* be increased are: drying veneer, pressing, re-drying plywood. The outturn of dry-cemented plywood per cubic metre of log was less favourable than that obtained by the wet-glued process, but it is questionable if the difference is worthy of consideration now that jointed boards are accepted in BB quality; this fact is a strong argument in favour of the dry-cementing process.

Taking the last published selling prices of the Ministry stocks as a guide and keeping in mind the fact that large sizes were made solely by the dry-cementing process, the average increase in the latter over wet-glued Alder was  $33\frac{1}{3}$  per cent. Comparing prices for 60" press boards only, the increase for average Polish stocks varied from 15 to 20 per cent. The higher-priced article carries a benefit to the exporting country in real wages in addition to the increased currency gathered in exchange for the manufactured article. An interesting comparison can be made by analysing the prices of Alder-faced plywood imported into the United Kingdom during 1938. The average price of Polish stocks was  $6/3$  per cubic foot against the Russian  $4/1\frac{1}{2}$  per cubic foot. The average price paid for all Polish plywood imported into the United Kingdom during 1938 was  $6/11$  as against  $5/5$  in 1933. The Russian averages for the same years being  $5/0\frac{1}{2}$  and  $3/4$ .

It is likely that the leading Polish plywood mills will continue to function and, once peace returns, Polish plywood must regain an important place in the consuming countries of the world.

## POLAND

	1925.				1930.			
	Metric Tons.	Thousand Zlote.	£ (a) 27·85.	Average Price per Metric Ton.	Metric Tons.	Thousand Zlote.	£ (a) 43·36	Average Price per Metric Ton.
Plywood & Veneers : Total Exports . . .	9,790	8,195	£ 294,254	£ 30·057	29,169	21,358	£ 492,574	£ 16·887
Of which to—								
United Kingdom (including Eire)			..	..	7,942	5,767	133,003	16·747
Union of S. Africa			..	..	(a)	(a)	..	..
Australia . . .			..	..	(a)	(a)	..	..
Germany . . .			..	..	2,342	1,703	..	16·770
Argentina . . .			..	..	940	662	..	16·242
United States of America . . .	(b)	(b)	..	..	349	233	..	15·397
British India . . .			..	..			..	..
British Malaya . . .			..	..			..	..
Netherlands East Indies . . .			..	..	(a)	(a)	..	..

	1935.				1938.			
	Metric Tons.	Thousand Zlote.	£ (a) 25·99.	Average Price per Metric Ton.	Metric Tons.	Thousand Zlote.	£ (a) 25·93.	Average Price per Metric Ton.
Plywood & Veneers : Total Exports . . .	54,840	21,267	£ 818,276	£ 14·921	54,206	23,826	£ 918,859	£ 16·951
Of which to—								
United Kingdom (including Eire)	16,231	6,595	253,751	15·634	9,944	4,542	175,164	17·615
Union of South Africa	690	268	..	14,944	1,032	503	..	18·797
Australia . . .	(a)	(a)	..	..	(a)	(a)	..	..
Germany . . .	237	142	..	23·053	3,079	1,561	..	19·552
Argentina . . .	5,789	2,235	..	14·855	8,455	3,567	..	16·270
United States of America . . .	(a)	(a)	..	..	27	12	..	17·140
British India . . .	3,969	1,301	..	12·612	3,650	1,296	..	13·662
British Malaya . . .	(a)	(a)	..	..	321	113	..	13·576
Netherlands East Indies . . .	526	166	..	12·143	1,647	549	..	12·855

(a) Not separately specified.

(b) Not available from records at present in the Statistical Department, Board of Trade.

## SCANDINAVIA

SCANDINAVIA is famed for her forests of Pine and Spruce, and it is but natural that the plywood industries of Norway and Sweden should have been conceived to make full use of the available supplies of these domestic woods. Norway had one important mill; Sweden at least six; while Denmark had two small plants catering mainly for the local demand: the Swedish and Norwegian industries had a virtual monopoly in their home markets.

### NORWAY

One of the earliest plywood mills to be built in Scandinavia was erected at Kristiansand on an ideal site, having its own deep-water quay alongside which vessels of considerable size could berth. This enabled the mill to supplement the available supplies of Norwegian Pine with Gaboon Mahogany logs which were imported direct from the West Coast of Africa. The first Pine plywoods to be used in England were shipped from this mill, and for many years quite an important business was conducted with the United Kingdom, both in Norwegian Pine and Gaboon Mahogany plywoods.

The original mill was destroyed by fire in 1928 and was rebuilt immediately thereafter—the present well-equipped factory being the result of careful planning at that time. One of the best-known stocks which originated in the Kristiansand factory was sold as IIndA U.L.V. Gaboon. This plywood was manufactured on the dry-cemented process and consisted of outer plies of Gaboon Mahogany practically free from defects, but admitting joints on both sides, and a core of Norwegian Pine.

Special mention of this stock is made as it was the means of introducing jointed face veneers in commercial plywoods to many consumers in the United Kingdom and in some measure paved the way for the jointed Finnish Birch stocks which made their appearance at a much later date. The fact that the jointed Gaboon boards had given good service over so many years was an argument used in favour of accepting the jointed grades of Finnish Birch.

Pine logs were manufactured into a variety of sizes and grades, and in 1933 work was started on the production of blockboards manufactured with Gaboon outer plies and core of Pine blocks about  $\frac{3}{4}$ " wide.

The demand for plywood from all parts of Norway absorbed a large portion of the total production of the Kristiansand mill.



Visitors to the mill cannot fail to have noticed the sensible method of utilizing the saw- and sander-dust, which was compressed into briquettes and used as fuel.

## NORWAY

	1925.				1930.			
	Metric Tons.	Thousand Kroner.	£ @	Average Price per Metric Ton.	Metric Tons.	Thousand Kroner.	£ @ 18·17.	Average Price per Metric Ton.
Plywood & Veneers :			£	£			£	£
Total Exports . . . . .			..	..	2,459	1,246	68,575	27·887
Of which to—								
United Kingdom (excluding Eire) . . . . .			..	..	379	248	13,649	36·018
Union of S. Africa . . . . .	(b)	(b)	..	..	(a)	(a)	..	..
Australia . . . . .			..	..	(a)	(a)	..	..
Germany . . . . .			..	..	1,519	733	..	26·558
Argentina . . . . .			..	..	84	46	..	30·139
United States of America . . . . .			..	..	(a)	(a)	..	..

	1935.				1938.			
	Metric Tons.	Thousand Kroner.	£ @ 19·90.	Average Price per Metric Ton.	Metric Tons.	Thousand Kroner.	£ @ 19·90.	Average Price per Metric Ton.
Plywood & Veneers :			£	£			£	£
Total Exports . . . . .	1,807	933	46,884	25·946	796	400	20,101	25·252
Of which to—								
United Kingdom (excluding Eire) . . . . .	851	547	27,487	32·300	91	62	3,115	34·237
Union of South Africa . . . . .	(a)	(a)	..	..	46	25	..	27·310
Australia . . . . .	(a)	(a)	..	..	(a)	(a)	..	..
Germany . . . . .	161	73	..	22·785	246	116	..	23·696
Argentina . . . . .	(a)	(a)	..	..	(a)	(a)	..	..
United States of America . . . . .	(a)	(a)	..	..	(a)	(a)	..	..

(a) Not separately specified.

(b) Not available from records at present in the Statistical Department, Board of Trade.

## SWEDEN

In point of capacity, the Swedish industry was the most important in Scandinavia, the total production for the year 1937 being given by the Swedish Board of Trade at a little over 20,000 tons or 33,000 cubic metres. Of this quantity some 8373 tons were exported, practically one-half being shipped to the United Kingdom and Eire.

There were five important mills which interested themselves in the export trade—all were well equipped and produced plywood which was flat and carefully manufactured by the dry-cemented process. Some mills used the cold-pressing system, others installed hot presses; there was little to choose between the hot-pressed and cold-pressed boards once they had been sanded.

The Swedish plywood mills were found in areas around which ample supplies of raw material were available, the mill at Ljusne, one of the largest in Sweden, being a typical example. It was built at the mouth of the River Ljusne, down which was floated some of the finest Spruce and Fir in the north of Sweden. In addition to the plywood mill, this concern controlled a large sawmill, planing mill and a wallboard factory which consumed much raw material which otherwise would have gone to waste. The Kristinehamn mill, also, was in a choice situation on the shores of Lake Vänern, the largest lake in Sweden. High-grade Pine logs were floated from the very centre of Sweden, on river and lake, to this plywood mill, while the finished product was shipped direct from Kristinehamn to British ports via the Göta Canal.

The woods used by Swedish mills were mainly Pine and Spruce, but small quantities of Birch plywood were also manufactured. Swedish Birch, however, is not of a particularly good colour and was used chiefly in the domestic market. Blockboards, with core of Pine blocks and outer plies of Birch or Pine, were also produced at the Hernösand plant, which was one of the most important in the country.

It is interesting to note that it was not until 1935 that the first hot press was installed by a Swedish plywood producer, but since then more attention has been paid to this, the more modern method of pressing. It was generally considered that the amount of resin in the Pine made hot pressing a dangerous procedure until new glues were evolved and a special technique developed.

An established Association of the leading mills controlled domestic affairs and export prices—the agreement, in so far as export prices were concerned, extended to the Norwegian mill and, although this originated in the nature of a “gentleman’s agreement,” the conditions were faith-

fully fulfilled by all parties. One factory commenced operations outside the Association in 1936, but did not find it profitable to play a lone hand and joined the fold in 1938. In the domestic market the Swedish Association engaged in a considerable amount of trade extension work and issued a number of useful handbooks on the uses of plywood.

This agreement might well be followed in other producing countries as was well proved during the periods of tumbling prices in other plywood markets. The fixed price basis gave foreign buyers a measure of security, and several contracts for Swedish Pine were made with British buyers when business in other plywoods was at a virtual standstill.

## SWEDEN

	1925.				1930.			
	Metric Tons.	Thousand Kroner.	£ @	Average Price per Metric Ton.	Metric Tons.	Thousand Kroner.	£ @ 18.11.	Average Price per Metric Ton.
Plywood & Veneers : Total Exports . . .			£	£	5,141	1,876	£ 103,589	£ 20.150
Of which to—								
United Kingdom (excluding Eire)			..	..	1,149	387	21,369	18.598
Union of S. Africa	(b)	(b)	..	..	(a)	(a)	..	..
Australia . . .			..	..	(a)	(a)	..	..
Germany . . .			..	..	2,590	1,000	..	21.320
Argentina . . .			..	..	(a)	(a)	..	..
United States of America . . .			..	..	(a)	(a)	..	..

	1935.				1938.			
	Metric Tons.	Thousand Kroner.	£ @ 19.40.	Average Price per Metric Ton.	Metric Tons.	Thousand Kroner.	£ @ 19.40.	Average Price per Metric Ton.
Plywood & Veneers : Total Exports . . .	6,809	2,361	£ 121,701	£ 17.874	7,822	2,681	£ 138,196	£ 17.668
Of which to—								
United Kingdom (including Eire) . . .	4,207	1,441	74,278	17.656	3,564	1,198	61,753	17.327
Union of South Africa	15	5	..	17.182	68	24	..	18.193
Australia . . .	(a)	(a)	..	..	(a)	(a)	..	..
Germany . . .	722	256	..	18.277	771	285	..	19.054
Argentina . . .	(a)	(a)	..	..	(a)	(a)	..	..
United States of America . . .	(a)	(a)	..	..	(a)	(a)	..	..

(a) Not separately specified.

(b) Not available from records at present in the Statistical Department, Board of Trade.

## DENMARK

Denmark is a low-lying country which has no abundance of woods to call its own, but boasts of a highly prosperous agricultural community which creates quite a brisk demand for plywood. In a "plywood sense" Denmark is in a very similar position to Great Britain—the import is considerable and the *per capita* consumption quite high.

There were two mills in Denmark which produced plywood suitable for the local markets, being mainly concerned in the manufacture of veneered boards, laminboards and blockboards. In the manufacture of the latter, imported Gaboon was used for the outer plies and Spruce or Pine for the cores. From time to time small quantities were exported, but no effort was made to compete with low-priced stocks, and Denmark was not looked upon as a plywood producer of any importance.

## UNION OF SOVIET SOCIALIST REPUBLICS

THERE are few individuals actively engaged in the plywood trade in Britain who have any intimate knowledge of the interior of the Russian plywood mills, the collective output of which is thought to be the largest in Europe. Of the total production in 1935 it was estimated that approximately one-third was exported and, if this figure is even reasonably accurate, the domestic consumption during that year must have been in the region of 400,000 cubic metres.

It has not been possible to obtain any official statistics covering production during recent years, but as no plywood was imported the industry had to cater for the entire domestic demand, which called for special constructions for aircraft, etc., in addition to the usual forms of multiplywoods and blockboards.

The principal exports were dry- and wet-glued Birch, wet-glued Alder, Ash and veneered Oak. Smaller parcels of various other types of plywood have found their way to the British market from time to time, one of the most interesting being built-up Oak from the old Skidelsky mill in Eastern Siberia—a factory which supplied some of the best plywood to the United Kingdom in pre-war (1914–1918) days and doubtless will supply more in future years. Pine plywood and some experimental blockboards have also been shipped.

Wet-glued Alder plywood, so well known to British and continental buyers as Lesbel Alder, was manufactured in mills situated in the Ukraine and White Russia. The forests in the Volhynia district and on the marshes between Minsk and Pinsk lie partly in Polish but mainly in Russian territory, therefore the high grade of Alder-wood grown in these districts and which, as we have already mentioned, was used by Polish mills, was also available in even larger quantities to the industry of the U.S.S.R.

Alder plywood was manufactured solely by the wet-glued process until 1937, when the Russians decided to bring their method of production into line with modern practice. Small quantities of dry-cemented stock made their appearance in the United Kingdom just prior to the outbreak of hostilities in Europe.

The earliest Birch mills were to be found in the Leningrad area and those parts of the U.S.S.R. which adjoin the Baltic States. The newer plywood mills, however, have been erected towards the East (in the Volga district) in accordance with the declared policy of the U.S.S.R. to build up all industries in areas away from the Russian-German frontier.

In Perm Province and in the triangle formed by the Volga and Kama rivers are to be found some of the finest Birch forests in Europe, and it is these areas which feed the modern plywood plants which have been built to take full advantage of this wealth of raw material. One important mill was at Kazan. According to the *Russian Economic Journal* the logs from the Volga and Kama regions are of large diameter, averaging about 18 inches, and a number of logs have been produced with a diameter of over 24 inches. The average diameter of the logs available in the forests of the Leningrad area, which have been extensively cut, is no greater than 12 to 14 inches.

The first plywood to reach the United Kingdom from the U.S.S.R. arrived in London late in 1921 and was sold during 1922. These early shipments consisted of a mixed specification to a total of 7000 cubic metres of wet-glued Birch and Alder which the post-revolution Government had accumulated in various mills and shipped abroad to be sold for what they would fetch. Other consignment parcels followed at various times until 1925, when the selling policy was changed and contracts for forward delivery were made. About this period experiments in dry-cementing were commenced, sample parcels of this improved product being shipped during 1927-1928. The first large shipments followed a year or eighteen months later. During 1930, for the first time, thicker boards from 9 mm. upwards were included in the Russian specifications.

The policy of the Trust responsible for the sale of plywood appeared to be to export as much as could be manufactured in excess of actual domestic requirements in exchange for sterling. As a consequence, it was occasionally found that specifications were not at all suitable for the British market—a circumstance which accounted for the fact that prices of Russian veneered Oak plywood, to state an example, were out of all relationship to the value of similar stocks shipped from mills which catered specially for this market by manufacturing the sizes and thicknesses which were in demand. In fact, for some time it seemed that their price-policy was governed by considerations which had no relation to the market value of the article concerned, although probably in the background there was also the desire to establish a footing in foreign markets for the increasing volume of products which were the result of the intense drive to industrialize the country.

During the years 1930 and 1931 the entire export of plywood from the U.S.S.R. to the United Kingdom was contracted for by a British company which had little previous experience of this trade and which distributed the plywood through various trade channels. The policy of confining the output to one concern was not an unqualified success and

by the end of 1931 this company found itself in possession of considerable quantities of unsold stock. Subsequently when London agents, acting on behalf of the Russians, endeavoured to make contracts with importers for delivery during 1932 they discovered that landed stocks were ample to meet the demand and as a result the quantity disposed of was small and very much less than the sellers had expected. Thereafter as stocks were produced in the U.S.S.R. they were shipped, on consignment only, to accumulate in the London Docks. Immediately this move became known, prices for landed Russian plywood fell precipitously to reach their lowest level early in 1933.

The extraordinarily low prices which prevailed at this period served one good purpose, in that many industries were tempted to switch over to this material from solid wood or strawboard and in doing so discovered for themselves the advantages to be gained from using plywood. Later, when prices rose, many of these converts continued to pay the higher prices rather than revert to the material they had used prior to plywood. Later in 1933 an embargo was placed on all Russian goods by the British Government, and as surplus stocks went into consumption prices gradually rose to more reasonable levels.

A more rational selling policy was evolved during the following year when the quantity exported to the United Kingdom amounted to 55,000 cubic metres of Birch and 15,000 cubic metres of Alder, an effort being made to obtain higher prices. Business began to improve, the peak, on a purely quantitative basis, being reached in 1935, when the exports to Britain rose to 108,000 cubic metres of stock sizes and 12,000 cubic metres of tea-chests, while some 90,000 cubic metres were shipped to various other countries. Later, when the demand for tea and rubber chests fell away, attention was diverted to small cut sizes in lower grades used for tin-plate packing and general box-making. Important quantities of veneered Oak plywood were shipped about this time. The total value of plywood imported into the United Kingdom from the U.S.S.R. topped the million pound mark during 1935 and again in 1937.

During 1933 a start was made to re-organize the Russian plywood industry, several new mills being built in the Volga region. Some five years later the process was practically completed by the removal of much of the plant from the older mills in the Leningrad area to the mills which had been erected in the East. While this phase of the plan was in progress the quantity of plywood available for export was greatly reduced and exports ceased entirely in 1939.

Shipment was normally made from Leningrad and, when this port was closed, from Odessa and Murmansk. It is likely that in future years

a considerable proportion of the Russian Birch plywood produced in the mills in the Volga region will be shipped via Odessa.

The following figures culled from various price lists tell their own story of the ups and downs of the Russian plywood industry :—

PRICES PER 100 SQ. FT., C.I.F. LONDON

YEAR.	DRY-CEMENTED.				WET-GLUED.	
	3 mm. BB	4 mm. BB	6 mm. B	9 mm. BB	3 mm. BB	4 mm. BB
1925	nil	nil	nil	nil	6/3	8/1
1931	4/6	5/4	10/1	11/5	3/9	4/10
1933	4/-	4/8	8/4	10/-	3/4	4/4
1934	4/2	5/-	8/10	10/8	3/4	4/4
1937	5/10	6/5	13/1	13/6	5/5	6/1
1938	6/2	6/9	13/9	14/2	5/9	6/4

Russian Birch logs yield veneer which is less knotty, but frequently is of a darker colour than the Finnish variety—the “lustre” and the “brightness” of the latter are lacking. The larger girth of the logs, however, made it possible for the Russian mills to produce a more attractive specification of sizes and qualities than was available from Finland, but the Russian plywood mills manufacturing dry-cemented Birch never managed to reach the uniformly high standard of the leading Finnish producers. As a general rule, no attempt was made to repair wood defects in face veneers, and little patching was done until 1937.

The bulk of the Russian Birch plywood exported to the United Kingdom consisted of BB grade—most useful boards for general purposes, as usually they could be cut up to give at least one side free from serious defects. The output of the mills was almost wholly confined to boards falling from the 60"×60" and 60"×48" presses. Small quantities were available from time to time in larger sizes up to 96"×60". The last selling specification to be issued during 1938 was :—

Proportion of quantities : Dry, 50% ; Wet, 50%.

B quality : 60"×60", 64% ; 60"×48", 36%.

BB quality : 60"×60", 53% ; 60"×48", 47%.

Proportion of quantities : Dry : 15% B ; 76% BB ; 9% C.

Wet : 10% B ; 70% BB ; 20% C.



The construction of dry-glued Birch was sound; the boards were sanded or scraped on one or both sides according to quality and thickness.

Russian Alder plywood was shipped in a variety of sizes measured on the metric scale. This was one of the best wet-glued Alder stocks available and met with a ready demand.

Russian Birch and Alder plywoods constituted an important item in the imports into the United Kingdom and doubtless in the future will again take a prominent part in filling the requirements of this market.

## U.S.S.R.

	1925.				1930.			
	Metric Tons.	Thousand Roubles.	£ @ 9·25.	Average Price per Metric Ton.	Metric Tons.	Thousand Roubles.	£ @ 9·449.	Average Price per Metric Ton.
Plywood & Veneers :			£	£			£	£
Total Exports . . .	8,920	1,428	154,378	17·307	53,557	7,583	802,519	14·984
Of which to—								
United Kingdom (including Eire) . .	3,015	491	53,081	17·606	16,730	2,331	246,693	14·745
Union of South Africa . .	..	..	..	..	17	2	..	12·451
Australia . . . . .	..	..	..	..	226	48	..	22·477
Germany . . . . .	263	51	..	20·964	6,548	941	..	15·209
Argentina . . . . .	..	..	..	..	3,435	494	..	15·220
United States of America . . . . .	1	0·2	..	21·622	550	89	..	17·125

	1935.				1937 (d).			
	Metric Tons.	Thousand Roubles.	£ @ 5·655.	Average Price per Metric Ton.	Cubic Metres.	Thousand Roubles.	£ @ —	Average Price per Metric Ton.
Plywood & Veneers :			£	£			£	£
Total Exports . . .	126,921	7,161	1,266,313	9·977	148,195			
Of which to—								
United Kingdom (including Eire) . .	83,343	4,589	811,494	9·737	103,656	} (b)	..	..
Union of South Africa . . . . .	527	34	..	11·409	531		..	..
Australia . . . . .	..	..	..	..	..		..	..
Germany . . . . .	8,988	580	..	11·411	..		..	..
Argentina . . . . .	3,140	(b)	..	..	3,500		..	..
United States of America . . . . .	..	..	..	..	..		..	..

(b) Not available from records at present in the Statistical Department, Board of Trade.

(d) 1937 in case of Soviet Union, 1938 figures not available.

(e) Equivalent to approx. 111,146 metric tons.

## SPAIN

THE industry in Spain was conducted on very similar lines to that of France. Okoumé logs imported from Spanish Guinea and French West Africa were converted into plywood by the dry-cemented process on both hot and cold presses. The quality produced by the half-dozen best-equipped mills was similar to that of the French productions described on page 266.

The output of the mills was sufficient to supply the entire domestic demand and varying quantities were exported. Only small shipments have been made to the United Kingdom, the average for the four years 1932-1936 being no more than £21,700 per annum.

## SWITZERLAND

AT least six small mills operated in Switzerland at the commencement of hostilities in September 1939, working on imported logs of Okoumé, Limba, other West African woods and Douglas Fir. The *per capita* consumption of plywood was high, but the Swiss mills produced three- and multi-ply laminboards and blockboards from the woods already mentioned in sufficient quantity to meet the domestic demand. The quality was good and a small export trade was done. At one time a fair quantity of Oregon Pine plywood, which was very popular, was imported, but subsequent legislation put an end to this trade and, in its stead, plywood producers purchased Douglas Fir peeler-logs from the North-West Pacific Coast of America and manufactured the plywood themselves.

During recent years the industry was protected by very high import duties which made it practically impossible for any country to export plywood to Switzerland; furthermore, an enactment made it compulsory for an importer to prove that he had purchased a given quantity of Swiss-made plywood before a licence could be granted for the importation of any plywood whatsoever.

The internal trade was well controlled under an agreement whereby the manufacturers fixed selling prices to the users but did not trade with them direct; a sliding scale of discounts or rebates (which varied according to turnover) was granted to the distributors, who carried stocks and handled the entire consumer trade. The scheme appeared to function very smoothly.

## UNITED KINGDOM

IT is unfortunate that present conditions do not permit us to give a complete survey of the plywood industry in Great Britain, nor are we able to illustrate certain processes which are of considerable interest. However, the exigencies of the Service Departments must be observed.

The potential output of plant capable of manufacturing plywood in Great Britain is considerable and constitutes a valuable national asset. During the period of twenty years from 1918 at least five plywood mills operated in Great Britain; few of these plants found it profitable to convert logs into veneer, but this was done on a limited scale. They produced excellent plywood to meet the requirements of Government departments, railways and other public undertakings, also composite boards, such as metal-faced plywood, in sufficient volume to supply a demand from domestic and export markets. These mills also produced veneered plywood equal to the best stocks manufactured in America, Germany and other countries. No attempt, however, was made to compete with the imported mass-produced commercial plywoods.

The output of these mills was supplemented by that of a considerable number of wood-working concerns which had laid down hydraulic presses and ancillary plant for the production of veneered panels which were sold to plywood merchants or direct to furniture manufacturers. Others, including many high-class furniture and joinery manufacturers, produced veneered panels which were used in the manufacture of their own products. Several of these concerns owned plant on which plywood of excellent quality could be produced. They were in fact plywood factories in miniature, without the equipment necessary for the actual cutting of logs into veneer.

During the year 1938 efforts were made to produce Okoumé plywood on mass-production lines, in competition with continental manufacturers, by a new factory on Tyneside. This plant was originally laid out for the mass production of large-sized blockboards, laminboards and cross-grained multi-ply panels from Okoumé—with a smaller output of multi-ply length-grained panels in sizes up to 84" × 60". It was unfortunate that work should commence just when the demand for Gaboon blockboards had fallen considerably, having been superseded by the cheaper Finnish type of blockboard, while Alder-faced laminboards with cores of Pine to a large extent replaced the "Gaboon throughout" boards which had held the field for high-class work for so many years. At a later date various additions to the plant were

made and a wider range of multi-ply produced. Canadian Birch logs were imported and small quantities of well-made Birch plywood were marketed just before the outbreak of war.

A second factory, erected on the Thames, commenced production in 1939 working on Okoumé, Limba, various other African woods and Birch. This mill was equipped with modern machinery and produces plywood of a high standard of quality.

In addition to these plywood producing and veneering plants several concerns installed machinery for the manufacture of "improved" and "compressed" wood. Great headway has been made by pioneers in this interesting development which is closely linked with the aircraft industry.

During the years preceding the European war of 1939 Great Britain was the most important buyer of plywoods in the world, and all-producing countries endeavoured to sell their exportable stocks to this market.

Consumers in Britain were in the fortunate position of being able to purchase their supplies of plywood at prices below those prevailing in the majority of Western European countries. Not infrequently prices were actually lower than those in the countries of manufacture.

The importance of the British market to those countries producing Birch and Alder plywoods was obvious from the keen competition which existed between the U.S.S.R., Finland, Baltic States and Poland; supplies of all but the cheapest stocks were generally abundant, and prices kept to reasonable levels. The shipbuilders were in a very favourable position as their requirements in thick multi-ply boards were of particular interest to plywood manufacturers in Germany, Canada and the Pacific Coast of America. For many years the cream of the German production in Gaboon multi-ply found its way into British shipyards at prices which, due mainly to an export subsidy paid by the Government of the Reich, were at least 20 per cent. cheaper than those payable by German consumers. Other factors helped to create this seemingly anomalous situation. The desire to keep mills operating at full production and the Canadian competition accounted for the fact that, for several years, prices c.i.f. London for Douglas Fir plywood were considerably cheaper than those payable in the States of Oregon and Washington, *ex mill*.

These are all factors which, while being of considerable help to consumers in Britain, did not encourage the home manufacturers.

At one time the disposal of low-grade Gaboon plywood and the prejudice against jointed faces created what appeared to be insurmountable difficulties to anyone contemplating the manufacture of plywood in Britain, but as jointed panels are now freely accepted a better yield

from logs of average quality can be obtained. However, the British consumer has still to be persuaded to pay a reasonable price for, or even to use, Gaboon plywood of low grade.

Until 1st March 1932 plywood was admitted into the United Kingdom free of duty. Thereafter, under the Import Duties Act of 1932 a duty at the rate of 10 per cent. *ad valorem* was leviable, except in the case of plywoods consigned direct to a registered shipyard, or imported from the Empire under Imperial Preference, in which event they were exempt. Furthermore, drawbacks of duties previously paid were allowed on delivery of plywoods into registered shipyards.

This general tariff was, for all practical purposes, valueless to the British plywood manufacturer, and various applications were made to the Import Duties Advisory Committee in the hope that this body would recommend additional duties to the Treasury. At the outbreak of the war the duty remained at 10 per cent. *ad valorem*, but it would have been increased on Gaboon plywood had not the war intervened and made this unnecessary. An interesting fact, and one frequently overlooked, is that the importation of Okoumé-faced plywoods of all descriptions constitutes a very small percentage of the whole. For example, during the fiscal year 1938—on a measurement basis, Gaboon plywoods amounted to approximately 4 per cent. against at least 78 per cent. in Birch and Alder-faced stocks; calculated on a sterling basis, c.i.f. U.K. ports, the corresponding figures were approximately 8 per cent. and 71 per cent.

It would be unwise to attempt to forecast what the future has in store for plywood manufacturers and importers in the United Kingdom, so much depending upon the future fiscal policies of this and other governments.

That a plywood industry is of great importance to the United Kingdom has been amply proved by the present war, and the ultimate solution must lie in keeping a sound balance between plywoods which can be economically produced at the source of the raw material and those of a more refined nature which can best be produced from imported logs in this country. Both the manufacturer of plywoods and the consuming public deserve, and must receive, consideration.

## PART VII

---

### FOREWORD

IN compiling the descriptions of the various woods and veneers included in Part VII., the following authoritative publications have been consulted :—

*A Dictionary of Wood.* By E. H. B. Boulton.

*Timbers of the World.* By Alexander L. Howard.

*The Timbers of Commerce.* By Herbert Stone.

*A Handbook of Empire Timbers.* Edited by H. A. Cox, and published by the Department of Scientific and Industrial Research.

*The Veneer and Plywood Industry of Queensland.* Issued by the Sub-Department of Forestry, Brisbane.

*Nigerian Timber.* Published in connexion with exhibit at Empire Exhibition, Scotland, 1938.

*Bois Coloniaux.* Published by Le Comité National des Bois Coloniaux, Paris.

# KEY TO PRICE SCALE AND AVAILABILITY COLUMNS

## Price Scale

THE following letters indicate the average retail prices for  $\frac{1}{4}$ " thickness in normal stock sizes which prevailed in September 1939, and show, approximately, the differences in value of various grades and types of plywood :—

- WW . . . . . Approximate prices do not exceed 17/6 per 100 square feet.
- XX . . . . . Approximate prices exceed 17/6 but do not exceed 30/- per 100 square feet.
- YY . . . . . Approximate prices exceed 30/- but do not exceed 40/- per 100 square feet.
- ZZ . . . . . Approximate prices exceed 40/- per 100 square feet.

### *Availability from Landed Stocks*

- SS . . . . . Small supplies generally available in a restricted range of sizes ; or boards may require to be specially manufactured.
- LS . . . . . Limited quantities generally available in fair assortment of sizes.
- AS . . . . . Plentiful supplies available in all standard sizes.

NOTE.—We have endeavoured to class the qualities into four groups which are indicated by the Roman numerals in the left-hand columns

# Alder

## DRY-CEMENTED

### Species of Timber used.

ALNUS GLUTINOSA.

### Principal Centres of Manufacture.

POLAND : Białystok, Bydgoszcz, Łódź, Lwów, Mikaszewice, Mosty.	LATVIA : Riga. LITHUANIA : Memel.
---	--------------------------------------

U.S.S.R.

**Description.**—Wood is white when cut, turning to reddish-white on exposure. It is soft and light, with smooth, fine grain. Generally shows some brown flecks which detract from its appearance for stained work. Glued with casein on hot-plate presses. Boards are generally scraped, except when plugged, in which case they are sanded. Boards from Memel, also from best Polish and Riga mills, were very flat. Peeling excellent. Takes stain and paint exceedingly well.

### Thicknesses and Construction.

3 mm., 4 mm., 5 mm. . . 3-ply.  
 6 mm. and 8 mm. . . . Usually 5-ply.  
 9 mm. up to 25 mm. . . 5- or multi-ply.

Only small quantities of 3 mm. were available.

### Sizes.

Mainly from 60/61" × 60/61" press.  
 60/61" × 48/49" press or reverse.  
 Small quantities, 72/90" × 60/61" press or reverse.  
 72/96" × 48/49" press or reverse.  
 Also in flush-door sizes, viz. about 6' 8" long by 28", 30" and 32" wide.

**Packing.**—Well packed with protective battens on four edges, and bound with hoop iron. Higher grades protected by inferior boards or lattice-work veneers.

Boards per bundle.—Lengths up to 60" : 4 mm., 30 ; 5 mm., 25 ; 6 mm., 20 ; 9 mm., 13.  
 Lengths over 60" : 4 mm., 25 ; 5 mm., 20 ; 6 mm., 16.

QUALITIES.	PRICE SCALE.	AVAILABILITY.	DESCRIPTION AND USES.	
I. Prime.	XX	LS	Classed B by Polish Ministry. Unjointed and practically free from defects both sides. Used for work in which panels will be seen on both sides.	
II. First.	XX	AS	Classed B/BB by Polish Ministry. Face side practically free from all defects and unjointed. Reverse side admitting minor blemishes, occasional small knots and joints. Suitable for better-class joinery work when panels are required reasonably sound on both sides.	
III. Second.	WW	AS	Classed BB by Polish Ministry. Admitting minor defects on both sides, may be jointed on one or both sides, in which event boards should be packed separately and marked accordingly. Suitable for general joinery work. Occasionally "plugged" on one or both sides.	
	B/BBB.	WW	LS	An intermediate grade. Face side practically free from defects. Reverse side plugged and/or jointed, permitting all defects not interfering with strength of the board. A useful board where only one side will be seen. Manufactured in large sizes as a "flush-door" grade.
	BB/BBB.	WW	AS	Permitting large tight knots, occasional splits, plugs and/or joints on both sides. One face better than the other, the reverse side admitting more serious defects. Uses : packing and covered-over work.
IV. BBB.	WW	AS	Admitting all defects. Uses : packing and covered-over work in which open knots are not detrimental. Warranted well glued only.	



# Alder

## WET- AND "SEMI-DRY"-GLUED

<b>Species of Timber used.</b>	<b>Principal Centres of Manufacture.</b>
ALNUS GLUTINOSA.	LATVIA : Riga.      POLAND : Białystok, Grodno, Łódź, Lwów, U.S.S.R.                      Nowy Dwór, Pinsk, Szczuczyn.

**Description.**—Wet-glued Alder is invariably darker in colour and somewhat less flat than the dry-cemented stocks. Face-veneers have tiny checks so should not be used for high-class work. Glued with blood-albumen and casein on steam-heated presses, as described on page 53. Boards over 5 mm. thick are liable to twist. Grading varies very considerably. Lower grades are generally unsanded. "Semi-dry" stocks produced in Riga.

<b>Thicknesses and Construction.</b>	<b>Sizes.</b>
Mainly— 3 mm. and 4 mm. . . . . 3-ply. 5 mm. and 6 mm. . . . . 5-ply. 9 mm. and 12 mm. . . . . 5- or 7-ply.	Mainly from 60/61" × 60/61" press ; 60/61" × 48/49" press or reverse. Large number of smaller sizes down to 48" × 48". Occasionally sizes such as 80" × 49", 79" × 48", 73" × 49", 72" × 60", 72" × 48".

**Packing.**—In roped or hooped packages with or without edge or face protection. Contents of bundle marked on face or ends. Number of boards may vary according to practice of individual mills.

QUALITIES.	PRICE SCALE.	AVAILABILITY.	DESCRIPTION AND USES.
I.      B.	XX	LS	Supplied in very small quantities from U.S.S.R. (wet) and Latvia (semi-dry). Free from wood defects on both sides.
II.     B/BB.	WW	AS	B/BB, generally the highest grade shipped from Poland and similar to the BB Russian Alder. Cuts up to give panels with one clear side, and largely used in cabinet-making, motor trade, etc. Useful stock for general purposes.
III.    BB/C or BBB/SK.	WW	AS	Generally unsanded. Largely used for packing-cases, covered-over work, cheap cabinet work.
IV.    BBBB or C or SK.	WW	AS	Admitting all defects, but must be well glued. Used on a considerable scale for covered-over work, packing, potato barrels and other purposes where knots not detrimental. Large cracked knots admitted. C quality Russian Alder regarded as equal to Latvian BB/C.
NOTE.—Latvian semi-dry Birch and Polish wet-glued Birch were graded and used in similar fashion to Alder described above.			

# Ash

## EUROPEAN

**Species of Timber used.**  
FRAXINUS EXCELSIOR.

**Principal Centres of Manufacture.**  
POLAND : Mikaszewicze. U.S.S.R.  
BELGIUM

**Description.**—Heartwood is whitish-brown to brown, occasionally tinged with pink. Sapwood is yellowish to greyish white. Grain open but not extremely coarse. Areas of porous springwood show as an attractive and distinctive figure in rotary-cut veneers. Bends well. Scraped or sanded both sides. Stains, polishes and varnishes well.

**Thicknesses and Construction.**

4 mm., 5 mm., 6 mm. . . 3- or 5-ply.

**Sizes.**

Mainly 79" × 48", 72" × 48", 61" × 48", 60" × 60".  
Limited quantities 84" × 48".  
Also supplied in flush-door sizes and a limited number of cut sizes.

**Packing.**—Top and bottom edges protected by battens. Bound with hoop-iron bands. Contents marked on end battens.

Boards per bundle.—4 mm., about 25 ; 5 mm., 20 ; 6 mm., 16.

QUALITIES.	PRICE SCALE.	AVAILABILITY.	DESCRIPTION AND USES.
			European Ash plywood is not always available, and, during recent years, only small quantities have been imported from U.S.S.R.
First.	XX	LS	Polish Grade. Face side free from defects, veneer being selected for light colour. Reverse side permitting joints and small defects.
Second.	XX	LS	Polish Grade. Admitting small defects and joints on both sides. Veneers not selected for colour.

# Ash

## JAPANESE AND SIBERIAN

(Known as TAMO and SEN ; also SIBERIAN ASH)

### Species of Timber used.

TAMO : FRAXINUS MANDSCHURICA.  
 SEN : ACANTHOPANAX RICINIFOLIUM.

### Principal Centres of Manufacture.

Tamo and Sen, JAPAN.                      Siberian Ash,  
 MANCHURIA.                                      U.S.S.R.

**Description.**—TAMO : Generally lighter in weight and of a darker brown colour than European Ash. Quite a strong wood. Rotary cut from logs up to 36 inches in diameter or more. Manufactured by dry-cemented process on cold presses. Vegetable glues used. Open pores of springwood show up as distinctive figure when rotary cut.

SEN : Commonly known as White "Ash" but is a totally different wood. Has much of the appearance of Ash, but is not nearly so strong. Is much lighter in colour than the Tamo.

All boards are sanded or scraped both sides.

### Thicknesses and Construction.

Mainly 4 mm. and  $\frac{3}{16}$ " . . . . . 3-ply.  
 Occasionally  $\frac{1}{4}$ " . . . . . 5-ply.

### Sizes.

72" x 30", 72" x 36", 72" x 48".  
 Occasionally larger sizes up to 96" x 48" are available.

**Packing.**—Varied.

QUALITIES.	PRICE SCALE.	AVAILABILITY.	DESCRIPTION AND USES.
	XX	LS	<i>Tamo and Sen.</i> —Shipped as first quality, free from defects on face side. First quality sub-divided into : (a) unjointed on face side ; (b) face side admitting up to 3 joints. Reverse side permitting joints and/or minor defects. Almost exclusively used in cabinet-making for drawer-bottoms, backs, dust-boards, kitchen cabinets, etc.
	XX	LS	<i>Manchurian and Siberian Ash.</i> —When available, this plywood meets with a ready demand. Well manufactured in lengths up to 72" in various widths, generally 24", 30" and 36". Qualities A, A/B and B, occasionally other grades, included in special consignments. Thicknesses : 4 mm., 5 mm. and 6 mm.

# Beech

**Species of Timber used.**  
FAGUS SYLVATICA.

**Principal Centres of Manufacture.**  
ROUMANIA, HUNGARY, JUGOSLAVIA, CZECHO-SLOVAKIA.

**Description.**—The colour varies from pale brown to reddish-brown and darkens if the wood is steamed. Frequently sold as steamed (Red) or unsteamed (White). The fine silky grain is generally straight with attractive "silver grain" flecks. Boards should be protected against moisture, otherwise the wood is liable to "work." Manufactured by dry process on hot presses. Various adhesives, including "Tego" Film, can be used for sizes up to 78" × 48". Sanded or scraped both sides. Takes stain and polish well.

**Thicknesses and Construction.**

4 mm., 5 mm., 6 mm. . . . . 3-ply.  
8 mm., 9 mm., 12 mm. . . . . 5-ply.  
15 mm., 18 mm. . . . . 7-ply.  
Poplar or Alder cores are frequently used.

**Sizes.**

English sizes up to 96" × 48", generally 87", 84", 78" and 72" long by 36" and 48" wide; occasionally 57" widths are available.  
Cut sizes, including flush-door sizes, supplied.

**Packing.**—Shipped in crates bound with hoop iron with edges protected. Faces, in higher grades, generally well protected.

QUALITIES.	PRICE SCALE.	AVAILABILITY.	DESCRIPTION AND USES.
A/BB.	XX	SS	Face side free from defects and unjointed, reverse side admitting defects and joints. Largely used for flush doors to be stained.
B/BB.	XX	LS	Face side admitting occasional inlays (plugs) or knot repairs and an occasional sound knot or a little inbark, brown-heart stain and other discoloration, closed splits, but generally clean. Unjointed. Reverse side admitting defects and joints. Largely used for flush doors.
BJ/BB.	XX	LS	As above, but admitting joints on face side. Used for flush doors to be painted.
BB/BBB.	XX	LS	Best face clean except for very small sound knots, heart discoloration and well-made joints. Veneers being 25 cm. wide or wider, except possibly at the edge of the panels. Joints and all defects admitted on reverse. Best face sanded or scraped.
Bobbin Manufacture.	—	—	Specially manufactured for bobbins in thicknesses from 6 mm. to 35 mm.; in sizes from 16½" to 33" long by 10" to 20" wide or reverse. Outer plies are 3 mm. thick, unjointed and unsanded. Cores usually 2 mm. to 3 mm. thick. Also made in sizes up to 125 cm. by 125 cm. = 49" × 49"; outer plies jointed.

## Canadian Birch

**Species of Timber used.**  
BETULA LUTEA.

**Principal Centres of Manufacture.**  
QUEBEC, and Maritime Provinces of Canada. ENGLAND.

**Description.**—Logs, 2 to 3 feet in diameter. Sapwood is of a light yellow colour; heartwood, distinctive reddish-brown. Wood is of uniform texture and takes an exceedingly good finish on the scraper or sander. Having exceedingly high mechanical properties, plywood made from Canadian Birch is largely used in the aircraft industry. Some logs produce curly grained veneer on the rotary-lathe. Polishes highly. Takes stain, paint or enamel well.

**Thicknesses and Construction.**

**Commercial thicknesses:**  
 $\frac{3}{8}$ ",  $\frac{3}{4}$ ",  $1\frac{1}{8}$ " . . . 3-ply.  
 $\frac{1}{2}$ ",  $\frac{3}{4}$ " . . . 4- or 5-ply.  
 $\frac{3}{4}$ ",  $1\frac{1}{8}$ " . . . 5-ply.  
 Various other thicknesses to A.I.D. specification.

**Sizes.**

Canadian manufacture: Commercial stocks—sizes up to 86" × 50", but generally smaller, 72" × 36", 84" × 30", 84" × 36".  
 English manufacture: Mainly 48", 60" and 72" × 36", 48" and 60"; and other special sizes.  
 Occasionally 84" × 36", 48" and 60"; 96" × 36", 48" and 60".

**Packing.**—In hooped crates.

QUALITIES.		PRICE SCALE.	AVAILABILITY.	DESCRIPTION AND USES.
				<p>The marked difference between the colour of the sapwood and that of the heartwood is reflected in a considerable variation in the colour of the rotary-cut veneer, especially in region where sapwood and heartwood meet. A considerable amount of sound veneer of variable colour is used for the backs for first quality plywood.</p> <p>The following grades were agreed to by an English mill manufacturing commercial grades from Canadian Birch logs:—</p>
I.	A.	YY	SS	Face: Colour uniform, unjointed, no defects. Back: Colour variable, unjointed, no defects.
I.	B.	XX	SS	Face: Colour variable, no joints, no defects. Back: Colour variable, one or two balanced joints, no outfallen or loose knots, 4" closed splits allowed.
II.		XX	SS	Face: Colour variable, three joints (not necessarily balanced), sound, no outfallen or loose knots, 4" closed splits allowed. Back: Colour variable, joints, splits and open knots admitted.

# European Birch

(a) FINNISH

Shipped from Helsingfors, Wiborg, Kotka, Hango or Åbo.

## Species of Timber used.

BETULA ODORATA.  
BETULA VERRUCOSA.

## Principal Centres of Manufacture.

Borgå, Heinola, Joensuu, Jyväskylä, Kuopio, Lahti, Lojo, Nyslott, Säynätsalo, Suolahti, Tavarkhus, Warkaus, Willmanstrand.

**Description.**—Pleasing colour, varying from white through straw to a beautiful golden shade. Silky texture. Fairly hard and is not easily bruised. Logs are small, the average diameter being about 10 inches. Plywood is well manufactured by dry-cemented process, with flat surfaces making an excellent base for veneered work. Hot presses are operated, and casein-blood albumen, casein or various resin adhesives are used. All boards sanded or scraped. Unplugged boards take stain and polish well. Holds glue, paints and enamels well.

## Thicknesses and Construction.

3 mm., 4 mm., 4½ mm. . . . . 3-ply.  
5 mm. . . . . 4-ply.  
6 mm. and 8 mm. . . . . 5-ply.  
9 mm. and up. . . . . multi-ply.

Thickness is generally stated before scraping or sanding.

## Sizes.

As falling from standard presses : 50" × 50", 60" × 50", 60" × 60", 72" × 50", 84" × 50".  
Boards over 60" in length are not readily obtainable in qualities better than BB. Boards from 72" × 50" and 84" × 50" presses are generally cross-grained in BB or BB/WG grade. The larger sizes up to 72" × 180" described on page 206 are also available.  
Cut sizes for all trades and for various forms of packing-cases are supplied within certain limits.

**Packing.**—Well packed in bales bound with hoop iron generally protected on all four edges with battens and on faces with lattice-work veneers.

Boards per bundle.—50" lengths : 4 mm., 40 ; 5 mm., 35 ; 6 mm., 30 ; 9 mm., 20 ; 12 mm., 15.  
60" lengths : 4 mm., 30 ; 5 mm., 30 ; 6 mm., 20 ; 9 mm., 15 ; 12 mm., 12.

QUALITIES.		PRICE SCALE.	AVAILABILITY.	DESCRIPTION AND USES.
	A.	YY	SS	Very occasionally shipped. May be looked upon as a "selected" grade. Practically free from all defects on both sides. Machine-scraped both sides. Used for panelling, visible both sides.
I.	B.	XX	LS	Generally the highest grade shipped. One side free from defects, the reverse side admitting a few knots up to 5 mm. in diameter. Unimportant natural timber defects permitted. Largely used for panelling seen on both sides and for high-class joinery work to be stained or polished.
II.	B/BB.	XX	AS	Face side practically free from defects, admitting occasional small black or white knots : reverse side admitting plugs and/or well-made machine joints. Brown streaks and discoloration permitted. Surface must be sound. Sanded two sides. This grade largely used when one clean side is required in general joinery work and cabinet-making.
III.	BB.	WW	AS	Unsound knots removed and replaced by plugs of sound veneer. Well-made machine joints admitted, both sides lightly sanded. Boards present sound surfaces and a reasonably clean appearance. Largely used for veneering upon and for painted or enamelled work. Meets a constant demand from cabinet-making trade, motor industry, etc.
IV.	WG.	WW	AS	Admits open defects in any number. Only guaranteed to be well glued.  Various other grades supplied, such as B/WG : BB/WG being a combination of two grades. Jointed panels are generally indicated as BJ/BB or BJ/BJ = jointed one, and jointed both sides, respectively.

# European Birch

## (b) RUSSIAN—U.S.S.R.

Wet and dry manufactures  
Shipped from Leningrad, Odessa and Murmansk.

### Species of Timber used.

BETULA ALBA.

### Principal Centres of Manufacture.

Borders of U.S.S.R. and Baltic States. Perm Province and district about Kazan at junction of Kama and Volga rivers.

**Description**—Colour, straw to pale brown, some wood being darker than others. Dry-cemented stocks produced on hot presses with casein comprise bulk of the production which is well made, flat and, on the whole, well scraped or sanded. Lacks the consistent good finish of the Finnish stocks. Wet-glued manufacture is reasonably good and meets with a ready demand. Special cut sizes supplied, but deliveries were more irregular than from Finland.

### Thicknesses and Construction.

**Dry**—  
3 mm. . . . . 3 equal ply.  
All other thicknesses, outer plies are cut 1.5 mm. thick.  
4 mm. . . . . 3-ply.  
5 mm. and 6 mm. . . . 3- or 5-ply.  
9 mm. to 25 mm. . . . multi-ply.  
**Wet**—  
3 mm. and 4 mm. . . . 3-ply.  
5 mm. and 6 mm. . . . 5-ply.

### Sizes.

60" × 60", 58" × 58", 56" × 56", 60" × 48", 48" × 60" and smaller sizes.  
Small lots of 72" × 60" boards in dry-glued are occasionally shipped.  
**Sanding**—  
Dry-cemented, 5 mm. and up, sanded 2 sides.  
A/B and B qualities, 3 mm. and 4 mm. sanded 1 side.  
BB quality, all thicknesses, sanded 1 side.  
Wet-glued boards unsanded.

**Packing**—Bales bound with hoop iron protected on 2 or 4 edges. A/B and B qualities protected on faces with rejected plywood or lattice-work veneers.  
Boards per bundle.—60" × 60": 3 mm., 25; 4 mm., 20; 5 mm., 15; 6 mm., 12; 9 mm., 8; 12 mm., 6; 18 mm., 4. 60" × 48": 3 mm., 30; 4 mm., 25; 5 mm., 20; 6 mm., 15; 9 mm., 10; 15 mm., 6.

QUALITIES.	PRICE SCALE.	AVAILABILITY.	DESCRIPTION AND USES.
I. A/B.	XX	SS	Highest grade shipped in dry manufacture only. Practically free from defects. Only a small quantity available and, during recent years, has been practically eliminated.
II. B.	Dry XX Wet WW	AS	Not more than 15 per cent. of the total production available in this grade. One side practically free from defects, occasional minor defects admitted on the reverse side, also occasional rough patches and discoloration. In good demand for general joinery work in both wet and dry manufactures.
III. BB.	WW	AS	Comprising at least 75 per cent. of the production of both wet and dry manufactures. An excellent grade for general purposes. Occasional open defects or plugged knots admitted on both sides. Small patches of rough peeling and occasional splits permissible. One side is better than the other. This grade can generally be cut up to yield panels clear on at least one side. Largely used by all industrial concerns, more especially the motor and furniture trades. BB dry manufacture in all thicknesses makes a satisfactory base for commercial veneered work.
IV. C.	WW	LS	Unsorted and unsanded in both wet and dry manufactures. In demand chiefly for packing-cases.

# European Birch

## (c) BALTIC STATES AND POLAND

Shipped from Ports mentioned. Polish stocks are shipped from Danzig or Gdynia.

### Species of Timber used.

BETULA ALBA.

### Principal Centres of Manufacture.

LATVIA : Riga, Kuldiga, Liepaja. ESTONIA : Tallinn.  
POLAND : Bialystok, Mikaszewicz, Mosty.

**Description.**—Colour varies considerably from a very light brown to a much darker variety. Some of the dry-cemented stocks from Reval and Riga are excellent productions. Manufactured on hot presses ; casein, blood albumen and synthetic resin being used. Polish stocks are more knotty and therefore less valuable than best Latvian productions. Boards are sanded or scraped on both sides. The semi-dry and wet-cemented stocks from both Latvia and Poland are somewhat darker in colour and less flat than the best dry-cemented manufactures.

### Thicknesses and Construction.

3 mm., 4 mm., 5 mm. . . 3-ply.  
6 mm. . . . . 4- or 5-ply.  
9 mm. and up. . . . multi-ply.

Outer plies are cut about  
1.5 mm. thick.

### Sizes.

Mainly from 60/61" × 60/61", 60" × 48" and 48" × 48" presses. Very small quantities of larger boards up to 84" × 60" can be obtained on occasions.

Only small quantities are available in 3 mm. or in grades higher than BB.  
Cut sizes are supplied by a few mills.

**Packing.**—Well packed in bales bound with hoop iron, protected on all 4 edges with battens and on faces with lattice-work veneers.

Boards per bundle.—60" lengths: 3 mm., 40; 4 mm., 30; 5 mm., 25; 6 mm., 20; 9 mm., 15; 12 mm., 10; 15 mm., 8; 18 mm., 7.

QUALITIES.		PRICE SCALE.	AVAILABILITY.	DESCRIPTION AND USES.
		ZZ	SS	Aircraft, Birch specially manufactured to specifications issued by various foreign Air Ministries.
I.	B.	XX	LS	Available in small quantities only. Generally the highest grade shipped. Both sides free from serious defects. Face side frequently free from all defects, a few small knots and other minor wood defects may be expected on the reverse. Largely used for high-class joinery and shopfitting for work seen on both sides.
II.	B/BB.	XX	AS	A few unimportant wood defects permitted on face side: the reverse may contain joints and/or plugs, discoloration, and other wood or manufacturing defects not detrimental to the board as a whole. Used as a general purpose board or for panelling seen on one side only.
III.	BB.	WW	AS	Large white knots permitted. As a general rule, all unsound knots are removed and replaced by plugs of sound veneer. Frequent joints, slight glue penetration and other manufacturing defects permitted. Useful for cutting up for practically all industrial purposes and for painted work.
IV.	WG.	WW	AS	Guaranteed only well glued. Large open knots and splits admitted on both sides. Rejects from BB grade included. Used for covered-up work.



## Western Red Cedar

**Species of Timber used.**  
THUYA PLICATA.

**Principal Centres of Manufacture.**  
BRITISH COLUMBIA and States of WASHINGTON and OREGON,  
U.S.A.

**Description.**—The largest of the Cedars native to North America. Logs vary from 3 feet to 8 feet in diameter. Has very thin sapwood of light yellow tinge: the heartwood varies considerably in colour from a pinkish-red to a deep warm brown. Generally straight-grained. Takes an excellent smooth satin finish which stains and paints well.

**Thicknesses and Construction.**

$\frac{3}{8}$ "	$\frac{1}{2}$ "	$\frac{3}{4}$ "	.	.	.	3-ply.
$\frac{1}{2}$ "	$\frac{3}{4}$ "	1"	.	.	.	5-ply.
$\frac{3}{4}$ "	1"	1 $\frac{1}{4}$ "	.	.	.	7-ply.

**Sizes.**

Lengths: 60", 72" 84" and 96". Widths: 12", 24", 30",  
36", 48" and 60".  
Special sizes can occasionally be supplied.

**Packing.**—As for Douglas Fir.

QUALITIES.		PRICE SCALE.	AVAILABILITY.	DESCRIPTION AND USES.
				This is a very useful plywood with grain much less pronounced than Douglas Fir. It should become more popular. Many logs cannot be cut on the rotary-lathe on account of soft or defective heart, which will not hold the chucks. Used mainly for panelling and general joinery work.
I.	AA.	ZZ	—	The following grading rules were in force during the year 1939:— One face shall be a single piece, reverse face may be one or more pieces well matched for colour and grain, but not more than three pieces in 48" widths. Faces must be smoothly cut veneer 100 per cent. heartwood, free of all open defects, but will permit well-matched inconspicuous small patches.
II.	A.	ZZ	SS	One face may be of two pieces well matched for colours and grain, the reverse face of not more than three pieces reasonably matched for colour and grain. Both faces must be free of open defects, but will permit shims and neatly made patches.
IIa.	A/C.	YY	—	One face to be equal to face of "A" grade, reverse face may contain one or more pieces and open defects that will not seriously affect the strength for serviceability of the panel.
III.	B.	YY	SS	Each face may be of one or more pieces reasonably matched for colour and grain—free of open defects, but will permit any number neatly repaired defects.
IV.	B/C.	YY	—	One face to be equal to face of "B" grade, reverse face to be same as poorest face of "A/C" grade.

# GRADING RULES

## DOUGLAS FIR PLYWOOD

### Commercial Standard Export Grades

*(As approved by the United States National Bureau of Standards)*

OREGON PINE PLYWOOD shall be graded according to both sides of the piece into the following standard grades. The grade descriptions set forth the minimum requirements, and therefore the majority of panels in any shipment will exceed the specification given.

**AA GRADE :** Each face shall be of a single piece of smoothly cut veneer of 100 per cent. heartwood that is free from knots, splits, checks, pitch-pockets and other open defects. The faces shall be a yellow or pinkish colour without stain. Shims that occur only at the ends of panels and inconspicuous, well-matched small patches not to exceed  $\frac{3}{8}$ " wide by  $2\frac{1}{2}$ " long shall be admitted. This grade is required for uses where a light stain or natural finish is desired.

**A GRADE :** One face shall be equal to the description for AA Grade, while the opposite face shall be sound and of one piece.

**B GRADE :** This grade must present a sound surface on both sides, but may show any amount of discoloration. Joints on one side permissible. All unsound defects must be neatly repaired, and the entire face must present a surface suitable for painting. Unsound defects not permitted in faces.

**AA/BB GRADE :** One face shall be equal to the description for AA Grade, whilst the opposite face shall admit solid or open defects in number and size which will not seriously affect the strength or serviceability of the panel for purposes where but one face is exposed.

## RESIN BONDED HOT-PLATE PRODUCTION

**GOOD 2 SIDES :** Each face shall be of a single piece of smoothly cut veneer of 100 per cent. heartwood that is free from knots, splits, checks, pitch-pockets and other open defects. The faces shall be a yellow or pinkish colour without stain. Shims that occur only at the ends of panels and inconspicuous, well-matched small patches not to exceed  $\frac{3}{8}$ " wide by  $2\frac{1}{2}$ " long shall be admitted. This grade is required for uses where a light stain or natural finish is desired.

**GOOD 1 SIDE :** One face shall be equal to that described under Good 2 Sides grade, while the opposite face shall be sound, but may be made up of two or more pieces well joined. All unsound defects will be neatly repaired.

**SOUND 2 SIDES :** Will have sound faces made of one or more pieces with all defects neatly repaired and present a smooth surface suitable for painting. Cores and cross-banding will be of specially selected material suitable for industrial use.

**SOUND 1 SIDE :** The face side will have a sound face made of one or more pieces with all defects neatly repaired and present a smooth surface suitable for painting. Cores and cross-banding will be of specially selected material suitable for industrial use. The back may contain excess discoloration, small knot-holes, pitch pockets or other defects in number and size that will not affect the strength of the panel.

# Oregon Pine or Douglas Fir

(I)

UNITED STATES OF AMERICA

<b>Species of Timber used.</b> PSEUDOTSUGA TAXIFOLIA.	<b>Principal Centres of Manufacture.</b> States of OREGON and WASHINGTON : Aberdeen (Wash.), McCleary (Wash.), Seattle (Wash.), Everett (Wash.), Olympia (Wash.), Tacoma (Wash.), Hoquiam (Wash.), Portland (Oregon), Vancouver (Wash.).
--	--

**Description.**—Commonly called Oregon Pine. Colour, light reddish-yellow to reddish-brown. Most useful plywood : manufactured on cold presses. Veneer cut from old growth peeler logs has very attractive small figure : from quick grown timber rather a wild figure, which is not so suitable for panelling. Largely used for shipbuilding and all commercial work. Grain is apt to show through paintwork unless surfaces have been specially treated to counteract this danger. Stains, varnishes and polishes quite well.

<b>Thicknesses and Construction.</b> $\frac{3}{16}$ " $\frac{1}{4}$ " $\frac{5}{16}$ " . . . . . 3-ply. $\frac{3}{8}$ " $\frac{1}{2}$ " $\frac{3}{4}$ " . . . . . 5-ply. $\frac{7}{8}$ " 1" . . . . . 7-ply. $1\frac{1}{8}$ " up . . . . . multi-ply. $\frac{3}{8}$ " and $\frac{1}{2}$ " occasionally made in 3- or 5-ply.	<b>Sizes.</b> Lengths : 60", 66", 72", 84", 90", 96", 108", 120". Widths : 24", 30", 36", 42", 48", 60", 72", 84". Special orders can be fulfilled in lengths up to 192", and in widths up to 96". A minimum quantity of 50 panels in each size must be ordered. Delivery of special sizes generally takes about four months.
---	--

**Packing.**—Very carefully packed in stout fibre cartons on special bundling machine, contents adjusted to make bundles suitable for handling.  
Following are standard for 96"×48" boards :  $\frac{3}{8}$ ", 25 pieces ;  $\frac{1}{2}$ ", 20 pieces ;  $\frac{3}{4}$ ", 15 pieces ;  $\frac{1}{2}$ ", 11 pieces ;  $\frac{3}{8}$ ", 9 pieces ;  $\frac{3}{4}$ ", 7 pieces ;  $\frac{7}{8}$ ", 6 pieces ; 1", 5 pieces ;  $1\frac{1}{4}$ ", 4 pieces.

QUALITIES.	PRICE SCALE.	AVAILABILITY.	DESCRIPTION AND USES.
			Refer to grading rules on page 255.
I. AA.	XX	—	Very seldom available. A specially selected grade.
I. A.	XX	AS	One face without defect. Reverse side unjointed, any defects being repaired (plugged). This is generally the highest grade available in U.K., and is largely used for general joinery work and for bulkheading and lining in shipbuilding industry. Door panels and other special sizes manufactured to requirements.
II. AA/BB.	XX	LS	A grade introduced for flush doors, yielding one perfect side with defects on the reverse side. Largely used for panelling work seen on one side only.
II.a B.	XX	AS	This grade constitutes the bulk of the production. Both faces are sound. Boards may be jointed on both sides, but frequently one side is unjointed. Used for painted or enamelled work and for cutting up into small sizes when the majority of pieces will be free from plugs. This may be considered to be a valuable general-purpose board.
III. B/BB.	XX	LS	Face side sound, may be jointed, admitting well-made patches. The reverse side may contain open defects. A useful board when one sound side is required. Only available in sizes up to 96"×48". Known as Wallboard Grade.
Industrial.	XX	—	Only available against special orders, when panels can be made up for automobile and special industries. Panels are generally unsanded.

# Oregon Pine or Douglas Fir

(2)

UNITED STATES OF AMERICA  
RESIN BONDED HOT-PLATE PRODUCTION

**Species of Timber used.**  
PSEUDOTSUGA TAXIFOLIA.

**Principal Centres of Manufacture.**  
NORTH-WEST PACIFIC COAST OF AMERICA.

**Description.**—See Oregon Pine (1).

**Thicknesses and Construction.**

$\frac{3}{8}$ " ,  $\frac{1}{2}$ " ,  $\frac{5}{8}$ " . . . . . 3-ply.  
 $\frac{3}{4}$ " ,  $\frac{7}{8}$ " ,  $1\frac{1}{8}$ " . . . . . 3- or 5-ply.  
 $1\frac{1}{4}$ " ,  $1\frac{3}{8}$ " ,  $1\frac{1}{2}$ " . . . . . 5-ply.  
 $1\frac{3}{4}$ " ,  $1\frac{7}{8}$ " ,  $1\frac{3}{4}$ " . . . . . 7- or 9-ply.

**Sizes.**

Mainly 96" × 48" ; also 72", 84" long by 24", 36", 48" wide. Special sizes can be supplied in the following ranges : widths up to 84" ; lengths up to 144". Maximum of 144" × 84". Larger panels may be produced by scarf jointing.

**Packing.**—Well packed in fibre-cartons.

Boards per bundle.—24" to 48" wide × 60" to 96" long :  $\frac{3}{8}$ " , 25 ;  $\frac{1}{2}$ " , 20 ;  $\frac{5}{8}$ " , 18 ;  $\frac{3}{4}$ " , 15 ;  $\frac{7}{8}$ " , 11 ;  $\frac{1}{4}$ " , 9 ;  $\frac{1}{2}$ " , 7 ;  $\frac{3}{4}$ " , 6 ; 1" , 5 ;  $1\frac{1}{8}$ " , 4.

QUALITIES.	PRICE SCALE.	AVAILABILITY.	DESCRIPTION AND USES.
G.2.S.	ZZ	SS	Good 2 Sides : Each face is free from defects and unjointed. Sanded both sides. Used where panels will be decorated on both sides with a light stain, or when a natural finish is desired.
G.1.S.	ZZ	SS	Good 1 Side : One face as above, reverse is sound, but may be jointed. Specified when one side only is required with natural finish.
S.2.S.	YY	AS	Sound 2 Sides : Both sides are sound, all defects being neatly patched. May be jointed, but frequently is not in sizes up to 96" × 48". Largely used for concrete shuttering, all external work which is painted, signs and out-buildings. This is the most popular grade for general out-door work.
S.1.S.	YY	SS	Sound 1 Side : Face as for S.2.S. Reverse side contains more defects, e.g. small knot-holes which will not affect the strength of the panel. Used for work which will be painted and seen on one side only. Lining of trailers, caravans, etc.

# Douglas Fir

## CANADIAN

**Species of Timber used.**  
PSEUDOTSUGA TAXIFOLIA.

**Principal Centres of Manufacture.**  
VANCOUVER, BRITISH COLUMBIA.

**Description.**—Commonly known as Columbian or B.C. Pine, but these names are rapidly being discontinued. Best forests are on Vancouver Island and the adjacent mainland. Logs generally run from 3 to 6 feet in diameter, and “peeler” logs are imported from States of Oregon and Washington. A profound difference between spring and summer wood gives rotary-cut veneer a distinctive grain pattern. Made by dry-cementing process on both cold and hot presses. Casein, Soya Bean and Resin adhesives are all used. Refer to page 194 for further details.

**Thicknesses and Construction.**

1 1/2"	1 1/4"	1 1/2"	3-ply.
1 3/4"	1 3/8"	1 3/4"	5-ply.
2"	1 7/8"	2"	7- or 9-ply.

**Sizes.**  
Cold press: 60", 72", 84", 90", 96", 120" long by 24", 30", 36", 48", 60" wide.  
Hot press: up to 120" x 66".  
Cut sizes can be supplied.

**Packing.**—Packed in light kraft-paper packages, without further protection. Average weight, 2½ to 3 cwt. Contents adjusted according to size to make bundles suitable for handling.  
Boards per bundle.—1 1/8", 20; 1 1/4", 10/15; 3/8", 10/15; 1/2", 10; 3/4", 5/7.

QUALITIES.	PRICE SCALE.	AVAILABILITY.	DESCRIPTION AND USES.	
			The plywood is in all respects very similar to the American product.	
			The following were the grading rules in operation from 2nd January 1940 for cold-press stock:—	
AA.	XX	SS	Good 2 Sides. Each face shall be of a single piece of smoothly cut veneer of 100 per cent. heartwood, free from knots, splits, checks, pitch-pockets and other open defects. The faces shall be a yellow or pinkish colour without stain. Shims that occur only at the ends of panels and inconspicuous, well-matched small patches not to exceed 3/8" wide by 2 1/2" long shall be admitted. This grade is recommended for uses where a light stain or natural finish is desired.	
I.	A.	XX	AS	Good 1 Side. One face shall be equal to that described under "AA—Good 2 Sides"—while the opposite face shall be equal to the "B—Sound 2 Sides" grade described below.
II.	B.	XX	AS	Sound 2 Sides. Each face shall be of one or more pieces of firm, smoothly cut veneer. When of more than one piece, it shall be well jointed and reasonably matched for grain and colour at the joints. It shall be free from knots, splits, checks, pitch-pockets and other open defects. Streaks, discolorations, sapwood, shims and neatly made patches shall be admitted. This grade shall present a smooth surface suitable for painting.
III.	B/BB.	XX	LS	Sound 1 Side. One face to be equal to the description for "B—Sound 2 Sides." The reverse face shall admit solid or open defects in number and size which will not seriously affect the strength or serviceability of the panel for purposes where only one face is exposed. This grade is only supplied in stock sizes, i.e. 12" to 48" widths; 60", 72", 84" and 96" lengths.

# Lauan—Red

Also known as

SERAYAH

**Species of Timber used.**  
SHOREA (various species).

**Principal Centres of Manufacture.**  
JAPAN.

**Description.**—Logs are shipped from Philippine Islands and British North Borneo. Colour varies from a dull yellowish-brown to a brown-red or brown. Is apt to split when cut into veneer unless very carefully handled. The plywood is not particularly strong and is used only for work of a secondary nature. Takes stain quite well. Shipped as "Red" or "Pink" Lauan, the Red being preferred.

**Thicknesses and Construction.**  
3 mm., 3½ mm., 4 mm., 5 mm., and 6 mm.

**Sizes.**  
72" × 36", 72" × 48". Sanded on both sides.  
84" × 36", 84" × 48" available in smaller quantities.

**Packing.**—Packed in crates with battens on edges and iron hoop. First-quality protected on faces. Boards per bundle.—72" × 48" : 4 mm., 25 ; 6 mm., 20. 72" × 36" : 4 mm., 30 ; 6 mm., 25.

QUALITIES.		PRICE SCALE.	AVAILABILITY.	DESCRIPTION AND USES.
	First.	XX	LS	Face side free from defects, admitting up to 3 joints in boards 48" wide. 36" width generally unjointed. Reverse side admitting occasional defects, patches and joints.  Used largely in furniture industry for drawer-bottoms and backs. To a considerable extent replaced Gaboon for cheap work on account of low prices in the larger sizes. Occasionally available with unjointed face.
	Second.	WW	LS	Defects admitted on both sides. One side generally obtained free from serious defects. Permitting loose cutting, faulty sanding or scraping and occasional gaps or overlaps in core.

# Limba or Limbo

Known as

## FRAKÉ-LIMBO

### Species of Timber used.

TERMINALIA SUPERBA.

### Principal Centres of Manufacture.

ENGLAND, BELGIUM, FRANCE, GERMANY, SWITZERLAND and practically all centres producing Gaboon plywood.

**Description.**—Logs are imported chiefly from Mayombe in the Middle Congo, the diameter varying from 0.60 to 1.20 metres. Density varies considerably from 0.450 to 0.600. Is sold under two categories: (a) Dark Limba or Black Fraké-Limbo, which has a heart of dark wood extending to about two-thirds of the diameter; (b) Light Limba or White Fraké-Limbo, which is devoid of, or has only a very small, black heart. Dark Limba is similar in colour to American Black Walnut. Light Limba is yellowish-white, resembling Hungarian Oak. All boards are scraped or sanded both sides. Both woods can be stained, waxed or polished very successfully.

### Thicknesses and Construction.

4 mm., 5 mm., 6 mm. . . 3- or 5-ply.  
8 mm. to 16 mm. . . . 5- or 7-ply.  
19 mm. to 22 mm. . . . 7- or 9-ply.  
25 mm. to 30 mm. . . . 9-ply.

### Sizes.

Rotary-cut veneers: 72" and 84" long by 36", 48" and 60" wide.  
Sliced and quarter-cut veneers: 72", 84", 96" and 108" long by 36", 48" and 60" wide.

**Packing.**—Carefully packed in bales bound with hoop iron. Plywood protected on all 4 edges and both faces.

Boards per bundle.—4 mm., 30; 5 mm., 25; 6 mm., 16/20; 9 mm., 10/15; 12 mm., 6/12.

QUALITIES.	PRICE SCALE.	AVAILABILITY.	DESCRIPTION AND USES.
			As the centre of the log is often very soft such logs cannot be rotary cut, but are sliced.
		Rotary cut	<p><i>Rotary-cut Light Limba.</i>—Available in limited quantities and gives an attractive clean surface which takes an excellent polish or makes an exceedingly good base for high-class enamel work in passenger vessels.</p> <p><i>Sliced cut and fully Quartered cut.</i>—Generally sold as fully quartered or half-figured one or both sides. Fully quartered panels generally have a very attractive figure in yellowish tones. The reverse side is frequently streaky Limba. The half-figured is less striking, but makes a very attractive plywood.</p>
A/A.	YY	LS	Both sides free from defects, but may have few joints on each face. Core is frequently Gaboon or Poplar.
A.	YY	LS	Face side free from defects, but admitting a few joints. Reverse side small defects, streaky wood, discoloration and joints.
Second.	YY	LS	Both sides admitting small splits at ends, occasional repaired joints, sound knots, small black spots and faulty matching in colour.
			<p><i>Dark Limba</i> is generally marketed as one side Dark Limba without defects, with streaky Limba reverse. This plywood is frequently used in conjunction with Walnut in cabinet-making and high-class joinery work. It does not meet with such a ready sale as Light Limba stocks.</p> <p>All categories are used in shopfitting, panelling, general joinery work, cabinet-making and shipbuilding.</p>

# Oak

## AUSTRALIAN SILKY

(Commonly known as LACEWOOD in America)

**Species of Timber used.**  
CARDWELLIA SUBLIMIS.

**Principal Centres of Manufacture.**  
NORTH QUEENSLAND, AUSTRALIA.  
Veneered boards made in U.K. and elsewhere.

**Description.**—Light brown colour with occasional pinkish tinge. Cut from logs up to 10 feet in girth. Veneers cut from quartered flitches show large number of medullary rays. Veneer is well cut and free from checks. Manufactured by dry process on cold presses. Moisture-resistant casein glues are used. Sanded both sides, face side generally finished on belt sander. Stains and polishes well. Does not fume.

**Thicknesses and Construction.**

1 1/8"	3-ply, outer plies 3/16" core 3/16"
1 1/4"	3-ply " " 1/8" " 1/8"
1 3/8"	5-ply " " 1/8" " 1/8"
1 1/2"	7-ply " " 1/8" "

**Sizes.**  
Mainly 72" x 36", 72" x 48", 84" x 36", 84" x 48".  
Queensland shippers will also manufacture special sizes.  
Can also be manufactured in U.K. to special sizes by veneering on Birch or Gaboon plywood.

**Packing.**—Packed in very light crates bound by hoop iron. Heavy cardboard protects edges of plywood from hoop.

QUALITIES.	PRICE SCALE.	AVAIL-ABILITY.	DESCRIPTION AND USES.
First A.	ZZ	SS	<p>The figuring can be varied by the angle of cutting with regard to its large medullary rays. The most striking "silver grain" is seen on quarter-sliced veneers. Rotary-cut veneer has lace-like appearance from the mottling produced by cutting through the ends of the rays.</p> <p>Sold in various grades:— Full Figured, Sliced Cut, Red Silky Oak, one or both sides. Medium Figured, Sliced Cut, Red Silky Oak, one or both sides.</p> <p>Face side jointed and free from defects. Veneers well matched for figure and colour. Reverse side may be Rotary-cut Red Silky Oak or Queensland Pine.</p>
Second B.	ZZ	SS	<p>Face side admitting occasional defects. Veneers not so well matched.</p> <p>Silky Oak is used on a considerable scale for shopfitting and makes very handsome showcases. Also for wall panelling in houses, offices, banks and public buildings. In furniture trade for dining-room furniture.</p> <p>Must be carefully finished, otherwise much of the beauty may be lost. Judicious staining is recommended to bring up the natural figuring to the best effect.</p>



*Oak*  
EUROPEAN  
VENEERED STOCKS

**Species of Timber used.**  
QUERCUS (various species).

**Principal Centres of Manufacture.**  
UNITED KINGDOM, HOLLAND, LATVIA, FINLAND, POLAND,  
HUNGARY.

**Description.**—Large quantities of Polish, Slavonian and American-cut Oak veneers are imported and glued to Birch, Alder, Gaboon or other plywood on one or both sides. The resultant boards are sold as "Veneered" Oak. Very large quantities of Veneered Oak are sold annually both in standard sizes and in special sizes for the furniture trade, Finnish or Russian BB Birch being the favourite plywoods for base stock.

**Thicknesses and Construction.**

Can be made in any thickness.

**Sizes.**

Commonly 60" × 60", 60" × 48", 72" × 36", 72" × 48", and in special sizes. Laminboards and blockboards are commonly veneered in matched Oak veneers to special designs for higher-priced work.

**Packing.**—In crates bound with hoop iron and protected on edges.

QUALITIES.		PRICE SCALE.	AVAILABILITY.	DESCRIPTION AND USES.
	Prime.	YY	LS	Veneers must be well matched for figure and colour. Must be free from discoloration. Joints and sanding faultless. Should be sanded on belt sander for high-class work.
	First.	YY	AS	May show some discoloration, dark streaks, faulty matching, slightly uneven surfaces, faulty sanding and jointing.

# Oak

## EUROPEAN

### BUILT-UP PLYWOOD

**Species of Timber used.**  
**QUERCUS PEDUNCULATA.**  
**QUERCUS SESSILIFLORA.**

**Principal Centres of Manufacture.**  
**POLAND.**      **BELGIUM.**      **FINLAND.**      **HUNGARY.**  
**GERMANY.**    **HOLLAND.**      **LATVIA.**      **FRANCE.**

**Description.**—Built-up Oak is distinct from Veneered Oak in that the panels are properly balanced during manufacture, the Oak veneer acting as a "ply," and not merely a veneer superimposed during subsequent treatment. Oak veneers are generally sliced 0.8 mm. thick, rotary-cut veneers 1.2 mm. Much of the Oak veneer used by plywood mills in Poland and elsewhere is cut from Volhynian Oak, which is of excellent colour. Many countries import Oak in form of veneer, or as sawn butts, to produce their individual types of plywood. Scraped or sanded both sides.

**Thicknesses and Construction.**

4 mm. . . . . 3-ply.  
 5 mm. and 6 mm. . . . 5-ply.  
 8 mm. and up. . . . . multi-ply.

**Sizes.**

60", 66", 72", 84" long by 36" and 48" wide.  
 96" lengths are occasionally available.  
 Cut sizes can be supplied.  
 Cores, and backs of one-sided Oak, are generally of Birch, Alder, Poplar or Gaboon.

**Packing.**—Well protected on faces and edges, in hoop iron bundles. Average weight about 3 cwt. per package.

Boards per bundle.—4 mm., 20/30; 5 mm., 16/26; 6 mm., 14/20; 9 mm., 8/14; 12½ mm., 6/12; 15 mm., 4/8; 18 mm., 4/6.

QUALITIES.	PRICE SCALE.	AVAILABILITY.	DESCRIPTION AND USES.
	Category	Category	Oak stocks are generally shipped in 2 or 3 qualities in the following categories:— (a) Figured Oak both sides. (b) Figured Oak one side; Plain Sliced Oak reverse. (c) Figured Oak one side; Rotary-cut Oak reverse. (d) Figured Oak one side. (e) Plain Sliced Oak both sides. (f) Plain Sliced Oak one side. (g) Rotary-cut Oak both sides. (h) Rotary-cut Oak one side.
Prime.	ZZ	LS	Free from any defects, clean perfect joints, faultless sanding, well-matched veneers free from discoloration. Only small quantities of prime quality stocks available in figured Oak.
First.	ZZ	AS	Perfect joints and sanding, but admitting narrow dark streaks inherent in the wood and occasional minor defects. Veneers well matched.
1 Star.	YY	SS	Free from manufacturing defects, but admitting discoloration and other wood defects and faulty matching. Used for Jacobean and dark-stained work.
Japanese grading.	XX	LS	Introduced by Polish mills to compete with cheap Japanese stocks. Rotary-cut veneers, the outer plies being 1 mm. thick after scraping. Face side admitting minor defects and up to 3 joints in 36" boards, and 4 joints in 48" boards. 4 mm., 1½", and 1", 3- or 5-ply. Sizes, 72" × 36", 72" × 48", and cut sizes for furniture trade.

# Oak

## JAPANESE

**Species of Timber used.**  
**QUERCUS GROSSESERRATA.**

**Principal Centres of Manufacture.**  
 JAPAN : Tokyo, Yokohama, Otaru, Osaka, Shidzuoka.

**Description.**—Sold as “Rotary-cut” and “Quartered” Oak plywood. Manufactured by dry process with vegetable glues. Stains and fumes well. Sanded or machine-scraped both sides.

**Thicknesses and Construction.**  
 4 mm.,  $\frac{3}{8}$ " ,  $\frac{1}{2}$ " . . . . . 3-ply.  
 $\frac{3}{4}$ " ,  $\frac{1}{2}$ " . . . . . 5-ply.

**Sizes.**  
 48" × 36", 54" × 36", 60" × 36", 72" × 36", 72" × 48".  
 Small quantities, 84" × 36".  
 Also flush-door sizes in 4 mm. only.

**Packing.**—Well packed in wooden crates with protective paper.

QUALITIES.	PRICE SCALE.	AVAIL-ABILITY.	DESCRIPTION AND USES.
First or A.A.	YY	AS	Figured Oak on face side. Second-quality Plain Oak on reverse. Face side free from defects. Suitable for one-sided work only.
	XX	LS	Rotary-cut Oak on face side admitting up to 3 joints, free from all defects. Reverse admitting minor defects and/or joints. Used largely for gables in furniture, general cabinet-making and cheap panelling.
Second or A.	XX	AS	Figured Oak on face side admitting minor defects. Second quality Oak on reverse.
	XX	LS	Rotary-cut Oak on face side, jointed, admitting minor defects.

# Okoumé

## GABOON MAHOAGANY

(i)

**Species of Timber used.**  
AUCOUMEA KLAINEANA.

**Principal Centres of Manufacture.**  
ENGLAND, GERMANY, HOLLAND, SWITZERLAND. There are several manufacturing centres in each country.

**Description.**—Colour, pale red-brown. Light in weight, but strong. Barked logs are shipped from Port Gentil or Libreville, French West Africa, from 3 to 5 metres long by 0.60 to 1.20 metres in diameter. Plywood is available in large sizes and in a great variety of thicknesses. Manufactured by the dry-cementing process on hot presses, using casein or various synthetic resin adhesives, mainly "Kaurit" and "Tego." Straight grain takes glue well. All boards are machine-scraped or sanded both sides. Is difficult to stain, but polishes quite well. Is an excellent base for high-class veneer or enamel work.

**Thicknesses and Construction.**

3 mm. to 6 mm. . . . . 3-ply.  
8 mm. to 16 mm. . . . . 5-ply.  
19 mm. to 22 mm. . . . . 7-ply.  
25 mm. to 30 mm. . . . . 9-ply.

Outer plies are generally cut 1.6 mm. thick; thicker veneers about 2.6 mm. can be cut if required, at an additional price.

**Sizes.**

60", 72", 84", 96", 120" long by 36", 48", 60", 72" and 84" wide, or reverse.  
Maximum sizes: about 120" x 86½", in all thicknesses from 4 mm. up to 32 mm.  
Cross-grained multi-ply boards commonly referred to as "shipbuilding panels": 60" x 177" to 72" x 200" by 10 mm. thick and up to 32 mm.  
Cut sizes can be supplied in certain qualities, the minimum quantity generally being 50 pieces in any one size.

**Packing.**—Foreign material is generally well packed in crates protected on faces and all four edges. Number of boards per crate varies according to size. English-made boards are generally delivered unpacked. The exact number of boards required can generally be purchased.

QUALITIES.		PRICE SCALE.	AVAILABILITY.	DESCRIPTION AND USES.
	A/A.	YY	SS	Unjointed and free from defects both sides. This grade is difficult to obtain in large quantities. Is used for work which is seen on both sides and in which joints are an objection.
	A/B.	YY	AS	Face side free from defects and unjointed up to 60" wide. Over 60" up to 86½" widths permit joints. The B side allows joints and/or small defects in all sizes. Looked upon as the highest grade available in commercial quantities. Is largely used in the shipbuilding industry, shopfitting and high-class furniture manufacture for two-sided work.
	A/BB.	YY	LS	The A face as described for A/B quality. BB side allows joints and/or large defects in all sizes. Used mainly for work which is seen on one side only. Wall panelling, etc.
	B/B.	YY	AS	Small defects and/or joints allowed both sides. This grade makes an excellent base for high-class veneered work for shipbuilding, and is also used where large flat surfaces are required which will be decorated by paint or enamel.
<p>Large cross-grained multi-ply boards are generally shipped in a grade which permits well-made machine joints on both sides. One side is generally free from all defects; and only minor sound defects, such as discoloration or small tight knots, are permitted on the reverse side. Boards are sanded across the grain. Used mainly for veneering upon, and for positions demanding large surfaces which will be painted, such as ceilings in ships.</p>				

# Okoumé

## GABOON MAHOGANY

(2)

**Species of Timber used.**  
AUCOUMEA KLAINIANA.

**Principal Centres of Manufacture.**  
FRANCE : Clichy (Seine), Le Havre, Nantes, Lisieux, Rochefort.  
NORWAY : Kristiansand.  
SPAIN : Valencia, Barcelona, Bilbao, San Sebastian.

**Description.**—Refer to Okoumé (1), and to page 209. French and Spanish Gaboon plywood is generally shipped in thicknesses up to 9 mm. and is less expensive than the manufactures classed under group (1). The plywood is manufactured by the dry-cementing process on hot and/or cold presses. Casein is the adhesive generally used. Norwegian Gaboon (refer to page 229) has generally a core of Pine. All boards machine-scraped or sanded.

**Thicknesses and Construction.**  
3 mm., 4 mm., 5 mm., 6 mm. 3-ply.  
9 mm., 12 mm., 12½ mm. . . 5-ply.  
Occasionally—  
15 mm. to 25 mm. . . multi-ply.

**Sizes.**  
General stock sizes, 60", 72", 84", 96" long by 36", 48", 60" wide.  
Large percentage of French plywood was shipped in 36" and 48" widths in 3 mm. and 4 mm. thicknesses.  
Maximum size, 120" × 60".

**Packing.**—Quite well packed in crates protected on 4 edges with wood strips covering whole or part, and, on both faces, with a lattice-work of scrap veneer.  
Boards per bundle.—4 mm., 35 ; 5 mm., 30 ; 6 mm., 25 ; 9 mm., 15 to 20.

QUALITIES.		PRICE SCALE.	AVAILABILITY.	DESCRIPTION AND USES.
I.	A.	YY	SS	Face side free from defects and joints. Reverse side permitting occasional épine (sound, pin-knot) and/or joints.
II.	B.	XX	AS	Sold by some mills as first quality. Both sides permitting small defects and joints, with rather more defects on one side than the other. Frequently unjointed on both sides. Mainly used for blind panels, drawer-bottoms and carcass work in furniture making.
III.	BB.	XX	SS	Both sides permitting wood and manufacturing defects. This grade only available at odd times in very small quantities.
	B/BB. Flush-door grade.	XX	LS	Face side without defects. Reverse side admitting defects which are not in themselves detrimental to the strength of the board. Introduced when demand for flush-door stock was considerable.  A few French manufacturers produce thicker boards, from ½" up to 1", similar to the plywood described on page 265.  <i>Large defects.</i> —Tight knots over 3 cm. in diameter, worm holes, broken veneers, large open splits and imperfect joints, outfallen knots.  <i>Small defects.</i> —Variation in colour, tight or repaired knots up to 3 cm. in diameter, small heart rough surfaces, glue stains, "nearly closed" splits up to 2 mm. wide and 15 cm. long. Few small worm holes as well as occasional whirls and imperfect joints.

## Kauri Pine

Included in some Shipments of

### QUEENSLAND PINE

**Species of Timber used.**  
AGATHIS PALMERSTONI.  
AGATHIS AUSTRALIS.

**Principal Centres of Manufacture.**  
NEW ZEALAND and NORTH QUEENSLAND.  
Queensland production only is exported to the U.K.

**Description.**—Very strong and durable wood of even texture and straight grain. Sapwood is pale in colour. Heartwood varies from pale brownish-yellow to light brown or brownish-red. Provides the best veneer log in Australia for shape and size. No clearly defined annual rings. Figured logs are sometimes found. Logs up to 18 feet in girth. Manufactured by dry process on cold presses. Casein glues used. Takes excellent finish. Stains and polishes well. Sanded or machine-scraped both sides.

**Thicknesses and Construction.**  
 $\frac{3}{8}$ " ,  $\frac{1}{4}$ " ,  $\frac{1}{2}$ " . . . 3-ply, outer plies  
about  $\frac{1}{16}$ " thick.  
 $\frac{3}{4}$ " . . . . . 5-ply.

**Sizes.**  
72" × 36", 72" × 48", 84" × 36", 84" × 48".  
Sizes up to 96" × 48" are occasionally available.

**Packing.**—Packed in very light crates bound by hoop iron; average weight about 118 lb.  
 $\frac{3}{4}$ " boards packed 14 pieces per crate;  $\frac{1}{2}$ " , 12/14 pieces per crate, according to size.

QUALITIES.	PRICE SCALE.	AVAIL- ABILITY.	DESCRIPTION AND USES.
First A.	YY	SS	Unfortunately Kauri Pine plywood is not available in any quantity. It makes an excellent plywood which could be used in considerable quantities were it to become better known.
Second B.	YY	SS	Face side free from defects. Minor defects on reverse. Unjointed both sides. Minor defects both sides. Occasional splits admitted on reverse side. May be jointed.

# Pine

## HOOP OR QUEENSLAND PINE

**Species of Timber used.**  
ARAUCARIA CUNNINGHAMII.

**Principal Centres of Manufacture.**  
QUEENSLAND.

**Description.**—Close even-textured wood which takes an exceedingly smooth finish. Colour, ivory to creamy-brown. Available in logs up to about 10 feet in girth. Manufactured by dry process on cold press. Moisture-resistant casein adhesive is used. This plywood can be stained to any tone, and makes an excellent surface for painting. Sanded or machine-scraped both sides.

**Thicknesses and Construction.**  
 $\frac{3}{8}$ " ,  $\frac{1}{2}$ " ,  $\frac{3}{4}$ " . . . 3-ply, outer plies  
 about  $\frac{1}{16}$ " thick.  
 $\frac{7}{8}$ " . . . . . 3- or 5-ply.

**Sizes.**  
 $72" \times 36"$ ,  $72" \times 48"$ ,  $84" \times 36"$ ,  $84" \times 48"$ .  
 Sizes up to  $96" \times 48"$  are occasionally available.

**Packing.**—Packed in very light crates bound by hoop iron; average weight about 118 lb.  
 $\frac{3}{8}$ " boards packed 12/14 in each crate according to size.

QUALITIES.		PRICE SCALE.	AVAIL-ABILITY.	DESCRIPTION AND USES.
	First A.	YY	SS	<p>Queensland Pine veneer is largely used as core stock for all other plywoods manufactured in Queensland, and for butter-boxes in Australia and New Zealand.</p> <p>Face side free from defects. Minor defects on reverse. Unjointed both sides.</p> <p>Is a very useful plywood for internal panelling and general joinery work. Could also be used in furniture trade for drawer-bottoms and backs in better quality suites.</p>
	Second B.	YY	SS	<p>Minor defects both sides. Occasional splits admitted on reverse.</p>

# Pine

NORWEGIAN      SWEDISH  
LATVIAN          POLISH

**Species of Timber used.**

PINUS SYLVESTRIS.  
PICEA EXCELSA.

**Principal Centres of Manufacture.**

SWEDEN : Ljusne, Hernosand, Sparreholm, Kristinehamn, Skattkärr.  
NORWAY : Kristiansand.  
LATVIA : Riga.  
POLAND : Mikaszewicze, Bialystok.

**Description.**—Redwood (Pine) is more commonly used by the plywood manufacturer. The colour varies from the pale reddish-brown heartwood to the lighter yellowish-brown sapwood. Whitewood (Spruce) is yellowish-white in colour. Manufactured by dry-cementing process on both hot and cold presses. Boards are flat and well finished, but are generally somewhat "sticky" to the touch. Lower grades are very knotty. Higher grades stain, paint and varnish quite well

**Thicknesses and Construction.**

4 mm., 5 mm. . . . 3-ply.  
6 mm. . . . . 4-ply.  
9 mm. and up. . . 5- or multi-ply.  
Outer plies are generally cut about 1.5 mm. thick.

**Sizes.**

Chiefly 48/50" × 48/50"; 60" × 60"; 60" × 48", 36", 30" and 24"; 72" × 48/50", 36" and 24"; 80" × 48", 40", 36" and 24".  
Occasionally 84" × 48/50", 36" and 24"; 72", 78", 80" and 84" × 60".  
Cut sizes can be supplied by special arrangement.

**Packing.**—Generally protected on all four edges and on faces with veneer lattice-work.

Boards per bundle.—4 mm., 30; 5 mm., 25; 6 mm., 20; 9 mm., 15; 12½ mm., 10; 18 mm., 7.  
Contents vary slightly according to surface area of boards.

QUALITIES.		PRICE SCALE.	AVAILABILITY.	DESCRIPTION AND USES.
	A.	XX	SS	The following grades were usually shipped to the U.K. from Sweden. Norwegian, Polish and Riga shippers worked to similar grading:— Face and reverse : A few pearl-knots or other small defects ; scraped and sanded.
I.	A/B.	XX	SS	Face : A few pearl-knots or other small defects ; scraped and sanded. Reverse : Some sound knots and some other defects ; scraped and sanded.
	A/BB.	XX	SS	Face : A few pearl-knots or other small defects ; scraped and sanded. Reverse : several sound and repaired knots and some other defects, occasional perfect joints ; scraped.
II.	B.	XX	AS	Face and reverse : Some sound knots, small repaired knots and some other defects ; scraped and sanded. One side may permit occasional perfect joints.
III.	B/BB.	WW	AS	Face : Some sound knots and some other defects ; scraped and sanded. Reverse : several sound and repaired knots and some other defects, occasional perfect joints ; scraped.
IV.	BB.	WW	AS	Face and reverse : Several sound and repaired knots and some other defects ; scraped and sanded. Both sides may permit occasional perfect joints.



# Walnut

## QUEENSLAND

(Known as ORIENTAL WOOD in U.S.A.)

**Species of Timber used.**

ENDIANDRA PALMERSTONI.

**Principal Centres of Manufacture.**

NORTH QUEENSLAND.  
Veneered boards are manufactured in the U.K. and elsewhere.

**Description.**—A very handsome wood when quarter cut. A striped Walnut figuring results from the decided variation in the depth of colour in the annual rings. It has a greenish-yellow tinge with a great variety of colour shades varying from pale chocolate-brown to salmon-red with black streaks. The large logs yield veneers from the slices which are long and of good width. Plain logs produce a striped figure; figured logs yield veneers with mottled, fiddle-back and ripple figuring. Commercial Queensland Walnut plywood, made in Australia, is described here.

**Thicknesses and Construction.**

Commercial stocks :  $\frac{3}{8}$ " ,  $\frac{1}{2}$ " . . . 3-ply.  
 $\frac{5}{8}$ " ,  $\frac{3}{4}$ " . . . 3- or 5-ply.  
 $\frac{7}{8}$ " ,  $\frac{1}{1}$ " . . . 5- or 7-ply.

**Sizes.**

72" x 36", 84" x 36", 72" x 48", 84" x 48", 96" x 36".  
Can also be manufactured in U.K. to special sizes by veneering on Birch or Gaboon.

**Packing.**—Carefully packed to avoid damage to faces and edges.

QUALITIES.	PRICE SCALE.	AVAILABILITY.	DESCRIPTION AND USES.
	ZZ	SS	Rotary cut.—Is somewhat difficult to cut and is hard on cutting-knives as the timber has a high silica content. This makes quite an attractive board which can be usefully employed in shopfitting, etc. Permitting 4 joints in 36" widths and 5 joints in 48" widths. Veneers well matched for colour and grain.
	ZZ	SS	No. 1 and No. 2 Ribbon Grain Sliced-cut Walnut, one or both sides.—An attractive striped figure which can be used for panelling and shopfitting in medium-priced jobs.
	ZZ	SS	Medium Figured Sliced Cut, one or both sides.
	ZZ	SS	Full Figured Sliced Cut, one or both sides.—Produces a most attractive board with a great variety of figuring. Highly recommended for dado panelling and high-class shopfitting, ship panelling, etc.
			All veneers take a good finish and polish. Face veneers are finished on belt sander. Backs of single-sided boards may be Rotary-cut Walnut, Rotary-cut Coachwood or Rotary-cut Queensland Pine.

## LAMINBOARDS AND BLOCKBOARDS

LAMINBOARDS and blockboards are largely used in the construction of furniture and for high-class panelling. The former are the more expensive but should always be used for veneered work in preference to blockboards. The general construction has already been described in Part IV.

5-ply boards are produced by laying veneers of Alder or Gaboon, cut about 1·6 mm. thick, to each side of a laminboard or blockboard. The grain of these additional veneers runs in the same direction as the core; they may be jointed or unjointed according to width and are generally machine-scraped.

The veneers used for faces of cross-grained laminboards admit slight discoloration but, otherwise, must be free from wood or manufacturing defects; joints are permitted both sides. All boards are sanded across the grain to a smooth surface. Resin adhesives may be used for laying the outer plies to the core.

Special requirements in both 3-ply and 5-ply construction can generally be manufactured within the limits of the maximum sizes given in the following tables, provided a minimum quantity of at least 50 panels in any one size is ordered. Some continental mills fix the minimum quantity at 100 square metres (1076·44 square feet). Smaller orders should be cut from stock-sized boards.

## Laminboards

GROUP.	CONSTRUCTION.		THICKNESS.	MAXIMUM SIZES.		MANUFACTURING COUNTRIES.
	OUTER PLYS.	CORE.		CROSS-GRAINED 3-PLY.	LENGTH-GRAINED 5-PLY.	
A.	Rotary-cut Okoumé. About 3.7 mm. thick for $\frac{3}{8}$ " to 2" boards. About 2.7 mm. thick for $\frac{1}{4}$ " and $\frac{5}{8}$ " boards.	Rotary-cut Okoumé. Laminations from 3 mm. to 7 mm. wide.	$\frac{1}{2}$ " to 2" Also small lots of $\frac{3}{8}$ ".	72" × 200"	120" × 72"	England, Germany and Holland.
B.	Rotary-cut Okoumé or Limba. May be sliced. Thicknesses as above.	Rotary-cut Pine or Spruce. Laminations 5 mm. to 6 mm. wide.	As above, A.	72" × 193"	120" × 72"	Germany, Holland and Switzerland.
C.	Rotary-cut Alder. About 4 mm. thick for $\frac{3}{8}$ " to 2" boards. About 2.7 mm. thick for $\frac{1}{2}$ " and $\frac{5}{8}$ " boards.	Rotary-cut Alder. Laminations 4 mm. to 6 mm. wide.	As above, A.	86" × 183"	120" × 84"	Memel, Lithuania.
D.	Rotary-cut Alder. As above, C.	Rotary-cut Pine or Spruce. Laminations 4 mm. to 6 mm. wide.	As above, A.	86" × 183"	120" × 84"	Memel, Lithuania.
E.	Rotary-cut Alder. About 2.7 mm. thick for $\frac{1}{4}$ " and $\frac{5}{8}$ " boards. About 3.6 mm. for $\frac{3}{4}$ " and upwards. For boards over 1" thick, may be 2.3 mm. thick laid double.	Rotary-cut Alder. Laminations 4 mm. to 6 mm. wide.	$\frac{3}{8}$ " to 1 $\frac{3}{8}$ "	66" × 199"	—	Poland.

Groups C, D, E, F and N. The outer veneers may be graded into two qualities.

Laminboards—continued

GROUP.	CONSTRUCTION.		THICKNESS.	MAXIMUM SIZES.		MANUFACTURING COUNTRIES.
	OUTER PLYS.	CORE.		CROSS-GRAINED 3-PLY.	LENGTH-GRAINED 5-PLY.	
F.	Rotary-cut Alder. As E.	Rotary-cut Pine or Spruce. Laminations 4 mm. to 6 mm. wide.	$\frac{3}{8}$ " to $1\frac{1}{8}$ "	66" × 199"	—	Poland.
G.	Rotary-cut Beech. About 3 mm. thick.	Rotary-cut Fir. Laminations 5 mm. to 6 mm. wide.	$\frac{3}{8}$ " to $1\frac{1}{2}$ "	60" × 180"	—	Czecho-Slovakia.
H.	Rotary-cut Alder. About 3 mm. thick, or about 1.2 mm. thick, laid double (5-ply).	Rotary-cut Birch, Alder, Pine or Spruce. Laminations about 4 mm. wide.	1.2 mm. to 2.5 mm.	60" × 120"	—	Latvia and Poland.
I.	Rotary-cut Birch. About 1.2 mm. thick, laid double (5-ply).	Rotary-cut Birch. Laminations from 1.2 mm. to 2 mm. wide.	1.2 mm to 2.5 mm.	60" × 196"	—	Latvia and Finland.
<i>Blockboards</i> <sup>1</sup>						
J.	Rotary-cut Okoumé. About 3.7 mm. thick for $\frac{3}{8}$ " to 2" boards. About 2.7 mm. thick for $\frac{3}{4}$ " and $\frac{7}{8}$ " boards.	Okoumé Blocks. About 2.5 mm. wide, glued edge to edge.	$\frac{3}{8}$ " to 2"	72" × 192"	120" × 72"	England.

<sup>1</sup> When core blocks are not glued edge to edge the product is known as a strip-board.

Blockboards—continued

GROUP.	CONSTRUCTION.		THICKNESS.	MAXIMUM SIZES.		MANUFACTURING COUNTRIES.
	OUTER PLYS.	CORE.		CROSS-GRAINED 3-PLY.	LENGTH-GRAINED 5-PLY.	
K.	Rotary-cut Okoumé or Limba. As J.	Blocks of Pine or Spruce. About 22 mm. wide, glued edge to edge.	13 mm. $\frac{3}{8}$ " to 50 mm. 2"	72" × 200" 86 $\frac{1}{2}$ " × 185"	120" × 72"	England, Germany, Holland, Switzer- land, Czech o- Slovakia, Austria.
L.	Rotary-cut Lime. About 3.5 mm. thick.	Blocks of Pine. About 22 mm. wide, as K.	18 mm. to 38 mm.	72" × 144" 66" × 160"	—	Hungary, Roumania.
M.	Rotary-cut Beech.	Blocks of Spruce. About 22 mm. wide.	12 mm. to 35 mm.	66" × 180"	—	Czecho-Slovakia, Hun- gary, Roumania.
N.	Rotary-cut Alder. As C or E.	Blocks of Pine. About $\frac{3}{8}$ " wide, glued edge to edge.	$\frac{3}{8}$ " to 2"	86" × 183"	120" × 84"	Memel (Lithuania), Poland.
O.	Rotary-cut Poplar. About 3.5 mm. thick.	Blocks of Pine. About 22 mm. wide, glued edge to edge.	$\frac{3}{8}$ " to 1"	66" × 180"	—	Holland, Austria, Czecho-Slovakia.
P.	Rotary-cut Birch. Cut about 1.2 mm. thick, laid double, making 5-ply. Quality equal to Bj/BB or BBj/BBj.	Blocks of Pine. About $\frac{3}{8}$ " wide, may be glued or unglued.	12 $\frac{1}{2}$ mm. to 40 mm.	66" × 196"	—	Finland, Latvia.

NOTE.—Boards over 1 $\frac{3}{8}$ " to 2" thick in groups C, D and N are recommended in a construction known as "centre-ply" which consists of a double laminated core separated by a central veneer of Alder and covered by outer plies of Alder, making 5-ply in all.

## OTHER WOODS USED IN PLYWOOD MANUFACTURE

### *Cottonwood*

POPULUS SPP., mainly *P. deltoides*

Alternative Trade Name.	Chief Sources of Supply of Timber.	Average Diameter of Logs.
EASTERN COTTONWOOD.	Widely distributed throughout EASTERN U.S.A. and CANADA.	24" to 30".

**Description.**—Grey-white in colour. Smooth even texture. Cuts readily on the rotary-lathe. Cottonwood plywood is very largely used in Canada and U.S.A. for boxes. Veneers are frequently used as core stock or cross-banding in America. Is seldom seen in Europe.

### *Poplar*

POPULUS CANESCENS

Alternative Trade Name.	Chief Sources of Supply of Timber.	Average Diameter of Logs.
GREY POPLAR.	EUROPE: BELGIUM and HOLLAND.	20" to 24".

**Description.**—Sapwood is generally creamy in colour, the heartwood being greyish-brown, frequently showing darker brown streaks. The grain is open but fine. Fibres are tough. Cuts well on the rotary-lathe without steaming, and is an excellent wood for cores and backs of veneered boards and for outer plies of laminated boards. Is used on a considerable scale in Dutch and Belgian productions. Takes glue very well. Must be carefully worked on the scraper to prevent "woolly" grain.

*Populus Euphratica.*—Is reported from India as being a useful wood for plywood manufacture.

### *Canadian Poplar*

POPULUS TREMULOIDES

Alternative Trade Name.	Chief Sources of Supply of Timber.	Average Diameter of Logs.
CANADIAN ASPEN.	Widely distributed across CANADA, generally associated with Birch.	15" to 20".

**Description.**—Dingy white in colour. A soft-grained wood which cuts well on the rotary-lathe, and glues well. Is apt to be "woolly" unless scraped with care. Plywood is mainly used for packing purposes and boxes. Veneer used for match-splints.

### *Lime*

TILIA CORDATA

Alternative Trade Name.	Chief Sources of Supply of Timber.	Average Diameter of Logs.
—	EUROPE: ROUMANIA.	24" to 30".

**Description.**—White to creamy-white in colour. Wood is straight-grained and cuts very well on both rotary-lathe and slicer. Fine even texture, makes excellent surface for outer plies of laminboards, blockboards or plywood. Glues, stains, paints well. Unfortunately Lime plywood is seldom available in commercial quantities to buyers in U.K.

## *Western Hemlock*

### TSUGA HETEROPHYLLA

Alternative Trade Names.	Chief Sources of Supply of Timber.	Average Diameter of Logs.
B.C. HEMLOCK. ALASKA PINE. GREY FIR.	WEST COAST OF AMERICA, from ALASKA to OREGON.	Generally 3' to 4', occasionally up to 6'.

**Description.**—A very useful non-resinous soft wood which might be used in much larger quantities in the plywood mills of Canada and America. Neutral colour with pinkish or reddish-brown tinge. It is of fine texture and has a distinctive grain pattern not so pronounced as Douglas Fir. Takes glue well and finishes well on scraper or sander. This is an attractive wood when rotary cut and, as large supplies of logs are available, it is possible that the wood will be more readily available in the form of plywood in future. Hemlock takes twice as long to dry as Douglas Fir and, for this reason, has not been extensively used.

## *Western Yellow Pine (Pinus Ponderosa)*

## *Western White Pine (Pinus Monticola)*

Alternative Trade Names.	Chief Sources of Supply of Timber.	Average Diameter of Logs.
CALIFORNIAN YELLOW PINE. CALIFORNIAN WHITE PINE.	From MEXICO northwards into B.C., CANADA.	4' 0" to 6' 0".

**Description.**—These pines grow in the mountain forests along the western parts of America and Canada, frequently being associated with the Sugar Pine (*Pinus Lambertiana*) in California. The physical characteristics vary according to locality and altitude. The wood is straight-grained, of even texture and cuts well on the rotary-cutter: the springwood is a cream colour, the summerwood slightly darker, but the difference is very slight. Plywoods made from these Pines are of excellent appearance; they sand to a smooth surface without raised grain and yield a soft uniform texture. They stain, paint or enamel well. This wood is used extensively in Western Canada for the outer plies of plywood, the core generally being of some less expensive wood.

## *Basswood*

### TILIA GLABRA

Alternative Trade Name.	Chief Sources of Supply of Timber.	Average Diameter of Logs.
SHINA (in Japan).	CANADA: From ATLANTIC COAST to MANITOBA. Northern half of MISSISSIPPI BASIN.	Generally 15" to 30", occasionally up to 42".

**Description.**—A species of Lime which is easily cut when cold on the rotary-lathe. Sapwood is creamy-white, heartwood very light brown. Holds glue well. Fine texture and takes good finish. Is not a durable wood. Is used in America for cores and cross-banding. Excellent veneer for bent plywood cores. Canadian and Japanese Basswood plywood is usefully employed for packing-cases.

*Abura*  
MITRAGYNE STIPULOSA

Alternative Trade  
Names.

BAHIA (Fr.)  
SUBAHA.

Chief Sources of Supply of  
Timber.

IVORY COAST, NIGERIA, CAMEROONS,  
GABON.

Average Diameter of  
Logs.

**Description.**—The colour is light brown with a pinkish tinge, grain is close and texture very uniform. It cuts well on the rotary-cutter or slicer and takes an excellent finish. The wood resists corrosion by acids and, Abura plywood, if bonded with synthetic resin, might well be usefully employed in electrical work. It has not been used to any extent in plywood manufacture, but has distinct possibilities.

*Iroko*  
CHLOROPHORA EXCELSA

Alternative Trade  
Names.

AFRICAN TEAK.  
KAMBALA.  
OROKO.

Chief Sources of Supply of  
Timber.

CAMEROONS, IVORY COAST and throughout  
WEST COAST OF AFRICA.

Average Diameter of  
Logs.

30" to 42"

**Description.**—This is a very useful timber which should not be classified as a Teak. The wood is yellowish when cut, rapidly darkening to various shades of golden brown which have been compared to Chestnut or old Oak. It is moderately hard and cuts well on the slicer. Iroko is not much seen in the form of plywood, but has occasionally been used to face Gaboon. Hard and soft layers of grain frequently cause difficulties in the finishing operations. Iroko is recognized by the London County Council as fire resistant, so, if bonded with synthetic resin, a useful plywood might be produced.

*Makoré—Douka*  
MIMUSOPS SPP.

Alternative Trade  
Name.

BAKU.

Chief Sources of Supply of  
Timber.

IVORY COAST (Makoré). CAMEROONS and  
GABON (Douka).

Average Diameter of  
Logs.

About 36" to 42".

**Description.**—Makoré is generally the finer wood and is described on page 289. Douka is lighter in colour, with close grain, which cuts well on the rotary-cutter. Unfigured logs have occasionally been manufactured into plywood in France, and boards faced with this wood have been favourably received. Boards faced with Douka offer a firmer surface than those made with Okoumé outer plies.

*Opepe*  
SARCOCEPHALUS DIDERRICHII

Alternative Trade  
Name.

—

Chief Sources of Supply of  
Timber.

IVORY COAST, LIBERIA, GOLD COAST,  
NIGERIA.

Average Diameter of  
Logs.

3' 0" to 4' 0".

**Description.**—Uniform golden yellow to orange-brown colour. Available in large quantities. The wood glues fairly well and takes quite a good finish on the scraper. When well filled it stains and polishes quite well. Has not so far been used in any large quantities in the manufacture of plywood.



## Obechi

### TRIPLOCHITON SCLEROXYLON

Alternative Trade Names.	Chief Sources of Supply of Timber.	Average Diameter of Logs.
AFRICAN WHITEWOOD. ABACHI. AYOUS (Fr.) ARERE. SAMBA (Fr.)	GOLD COAST, NIGERIA, IVORY COAST, CAMEROONS.	3' 0" to 5' 0".

**Description.**—Obechi is a white to pale yellow wood of firm texture but with more or less open grain. It is very liable to become blue-stained and does not appear to possess much resistance against decay. Rotary-cut veneers have no distinctive figure, but occasional figured logs are found which when quarter cut show a striped figuration. There appears to be a doubt as to whether the Ayous of French Cameroons is the same wood as the Obechi of Nigeria, but most authorities consulted agree that this is so. Certain French mills, following a series of troubles with plywood made from Ayous, discontinued using this wood. We understand that other plywood manufacturers in England using the Nigerian Obechi for faces of Gaboon boards have had good results. According to *Empire Timbers*, seasoned Obechi is liable to infestation by Powder-Post beetles; this appeared to be the cause of the French troubles. Resin adhesives, properly applied, might act as a deterrent. The wood is very soft and can be marked by a finger-nail.

## Olon

### FAGARA SPP.

Alternative Trade Name.	Chief Sources of Supply of Timber.	Average Diameter of Logs.
—	CAMEROONS, GABON.	—

**Description.**—This is a yellowish-white wood, at times almost lemon colour. It lacks distinctive grain, but cuts well on the rotary-lathe, and takes an excellent finish. Some Olon plywood imported from France, which was otherwise most interesting, was disfigured by ring shakes, but it has not been possible to ascertain whether or not these shakes are common to this particular timber. Olon has been given as an alternate name to Avodiré but, according to Le Comité National des Bois Coloniaux, the two woods are distinct species.

## Pearwood

### GUAREA CEDRATA

### GUAREA THOMPSONII

Alternative Trade Names.	Chief Sources of Supply of Timber.	Average Diameter of Logs.
BOSSÉ (Fr.). OBOBO. NIGERIAN PEARWOOD.	NIGERIA, IVORY COAST.	3' 0" to 4' 0".

**Description.**—A comparatively dense wood. When cut the sapwood is creamy-white or pale pink, according to species, the heartwood not unlike a pale Mahogany, both darkening on exposure to light to a brownish-red shade. The grain is fine. Wood cuts well on the rotary-lathe and takes an exceedingly good finish on the scraper. This wood has been usefully employed to face multi-ply shipbuilding boards built up with Okoumé inner plies, giving a much harder surface to the panels than is obtained with Gaboon. This is a very useful wood.

*Coachwood*  
CERATOPETALUM APETALUM

Alternative Trade Name.	Chief Sources of Supply of Timber.	Average Diameter of Logs.
—	COASTAL REGION OF NEW SOUTH WALES, QUEENSLAND.	Up to 2½ feet.

**Description.**—Colour is pinkish-brown. The texture is very smooth and not unlike that of Kauri Pine. It is straight-grained and cuts well on the rotary-lathe. This wood is used on a considerable scale by plywood mills in New South Wales with good results. Supplies are limited.

*Silver Ash*  
FLINDERSIA PUBESCENS AND F. SCHOTTIANA

Alternative Trade Names.	Chief Sources of Supply of Timber.	Average Diameter of Logs.
BUMPY ASH. CUDGERIA.	QUEENSLAND, NEW SOUTH WALES.	—

**Description.**—Of pleasing greyish-white colour this wood is easily cut on the rotary-cutter, and makes a high-grade plywood for general joinery work. It is used on a considerable scale by the Brisbane manufacturers. The wood is somewhat open in the grain, but takes an excellent finish. Plywood made from this wood has been commented upon very favourably.

*Queensland Satinay*  
SYNCARPIA HILLII

Alternative Trade Name.	Chief Sources of Supply of Timber.	Average Diameter of Logs.
—	FRASER ISLAND, QUEENSLAND.	24" to 30".

**Description.**—The name Queensland Satinay was given to this wood by the Queensland Forest Service. It grows rapidly, and is generally cut on the slicer. Satinay is a close textured wood of bright pink colour which makes one of the strongest Queensland plywoods. It frequently shows attractive grain figuration. This wood is highly fire resistant.

*Red Tulip Oak*  
TARRIETIA ARGYRODENDRON

Alternative Trade Name.	Chief Sources of Supply of Timber.	Average Diameter of Logs.
RED CROWSFOOT ELM.	NEW SOUTH WALES, QUEENSLAND.	3' 0".

**Description.**—This is an attractive wood, in various shades of reddish-brown, with smooth, fine grain. The logs cut well on the veneer-lathe and produce plywood of considerable strength. The wood itself has high electrical insulating properties. In the form of plywood it is largely used for decorative purposes.



PLATE V.—MASUR BIRCH. ROTARY CUT.

This illustration shows to perfection the depth of beauty that can be attained by using cold adhesives for laying pale woods.

## DECORATIVE VENEERS

### *Birch. Canadian Yellow*

#### BETULA LUTEA

Alternative Trade Names.	Chief Sources of Supply of Timber.	Price Group.
YELLOW BIRCH. QUEBEC BIRCH. Figured veneers known as BETULA, CANADIAN SILKWOOD, FLAME BIRCH.	NEWFOUNDLAND, and in Provinces of QUEBEC and ONTARIO, CANADA, North-Eastern Parts of U.S.A.	Betula . 2 to 6. Flame . 4 to 6.

Thicknesses.	Sizes.
Usually $\frac{1}{16}$ ". Thicker gauges are not advised. Rotary cut.	5' to 9' long : 12" to 40" wide.

**Waste in making up Panels.**—Waste should not exceed 15 per cent. provided suitable lengths are available.

**Description.**—Fine even-textured wood which cuts into veneer well on rotary-lathe. The sapwood yields creamy-white veneers, the heartwood brownish-red. Frequently heartwood and sapwood are mingled in one piece of rotary-cut veneer.

Plain Birch veneer is a tough, excellent wood, largely used in plywood manufactured to A.I.D. (Aeronautical Inspection Department) specification. The veneer, when highly figured, showing a curly wavy grain, is of great beauty. The name *Betula* is applied to ordinary figured Birch. The more highly figured veneer is frequently sold as Canadian Silkwood. It is very rare. Pinky coloured Birch is sometimes called Flame Birch.

**Working Notes.**—Birch veneer glues well. Takes excellent finish on belt sander or scraper. High and lasting polish can be obtained.

### *Masur Birch*

Alternative Trade Name.	Chief Sources of Supply of Timber.	Price Group.
CURLY BIRCH.	SWEDEN and FINLAND.	Varies considerably from 4 to 12.

Thicknesses.	Sizes.
Generally $\frac{1}{16}$ ". Rotary cut.	Veneers seldom exceed 42" long, but being rotary-cut wide widths are available.

**Waste in making up Panels.**—Waste is frequently very heavy, much depending upon the design of the panelling.

**Description.**—The illustration will give a better idea of this attractive veneer than any description in words. The dark markings—known as pith-flecks—result from the growth of pith-like cells in channels, burrowed into the cambium of Birch trees during growth, by the larvæ of an insect known as *Agromyza carbonaria*. The shape of these pith-flecks is never alike; in fact, the variation in figure is so great that it is difficult to obtain a sufficient quantity of any one type to complete the decoration of even quite a small area.

**Working Notes.**—Masur Birch veneer is difficult to lay and should be worked into small panels. It is inadvisable to attempt to end-joint the veneers.

PANELLING IN GOVERNMENT OFFICE

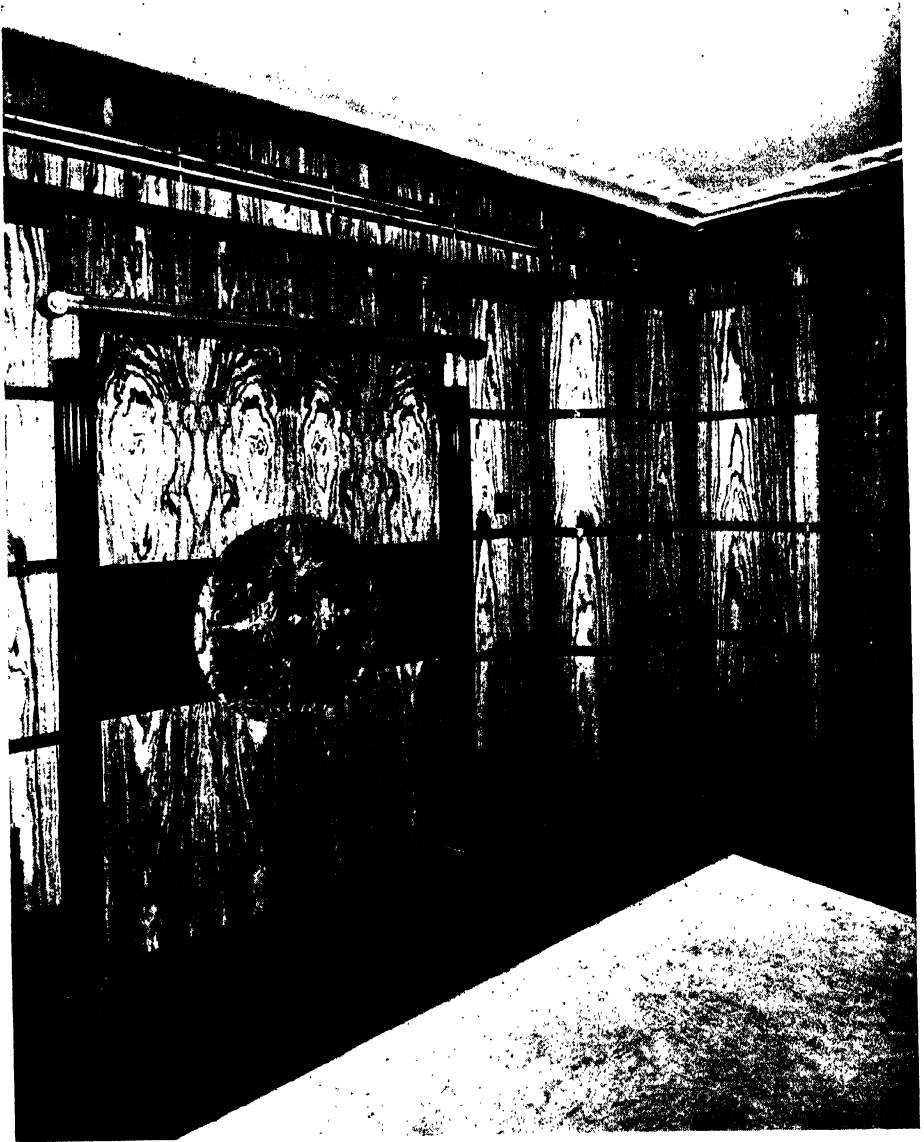

[By courtesy of Messrs. Veneercraft Ltd.

PLATE VI.—ONE OF THE CONFERENCE ROOMS, ST. ANDREW'S HOUSE, EDINBURGH.

The walls are of Indian Silver Greywood, banded with Indian Laurel, laid upon  $\frac{3}{4}$ " Multi-ply Gaboon. The doors, of the special construction illustrated in Fig. 202, are also veneered with Indian Silver Greywood and Indian Laurel. The inlaid circle is of Walnut Burr. The sub-floor, seen in the illustration, is  $\frac{3}{4}$ " Resweld Oregon Pine.

## *Black Bean*

### CASTANOSPERMUM AUSTRALE

Alternative Trade Name.	Chief Sources of Supply of Timber.	Price Group.
BEAN TREE.	SOUTH QUEENSLAND and Northern Part of NEW SOUTH WALES.	Knife Cut . . . 4 to 10. Sawn . . . . . 12.
<b>Thicknesses.</b>		<b>Sizes.</b>
About $\frac{1}{32}$ " to $\frac{1}{16}$ ". Thicker veneers are difficult to slice and should be sawn.		Irregular shape of tree makes return of veneer small. From 4' 6" to 8' long by 6" to 12" wide.

**Waste in making up Panels.**—Averages from 15 to 20 per cent.

**Description.**—One of Australia's most beautiful woods. Of attractive brown colour, in a variety of shades, generally showing a number of greyish-brown or black streaks. Frequently mottled. A very hard wood. Supplies are not large.

**Working Notes.**—Is difficult to work, and is occasionally ruined during cutting. When veneers have been well cut there should be no risk of surface "cracking." Sawn veneers, when available, should be used in preference to sliced. It is difficult to glue on account of "oily" surface and should be worked with care. Cleans well on belt sander or scraper and takes a brilliant finish. It is frequently difficult to purchase suitable solid timber to use with Black Bean veneer as the wood is difficult to season.

## *Indian Silver Greywood*

### TERMINALIA BIALATA

Alternative Trade Name.	Chief Sources of Supply of Timber.	Price Group.
WHITE CHUGLAM.	ANDAMAN ISLANDS.	Knife Cut . . . 4 to 12.
<b>Thicknesses.</b>		<b>Sizes.</b>
Generally $\frac{1}{8}$ ". Sliced; occasionally rotary cut.		Available in long lengths, 6' and up; 8" to 20" wide.

**Waste in making up Panels.**—Should not exceed 20 per cent.

**Description.**—Some logs are of a uniform straw colour throughout, others have a smoky-grey to yellowish-brown heartwood with irregular dark markings which give a distinctive figure to the wood. The light-coloured wood is known as White Chuglam, the dark as Silver Greywood. Wavy grain produces the choicest veneer. Colour is distinctive.

**Working Notes.**—Chuglam is seldom used as a veneer. Quarter cutting is recommended for Silver Greywood. Wood is dense and cuts into veneers well. Glues easily. Cleans up easily on scraper or belt sander. Takes a beautiful polish.



*[By courtesy of Messrs. Waring & Gillow Ltd., Lancaster.]*

PLATE VII.—WRITING ROOM, S.S. "TUSCANIA."

The highly decorative fielded panels in Indian Laurel are worked on a base of Gaboon Multi-ply.

## *Indian Laurel*

### TERMINALIA TOMENTOSA

Alternative Trade Name.	Chief Sources of Supply of Timber.	Price Group.
LAURELWOOD.	Figured logs mainly from BURMA and SOUTH INDIA. Plain logs, NORTH INDIA.	Unselected . 2 to 4. Finely Figured 7 ,, 8.
<b>Thicknesses.</b>	<b>Sizes.</b>	
Generally cut $\frac{1}{2}$ " Sliced.	4' to 8' long: quarter cut, up to 12" wide; cut across crown, 18" to 24".	

**Waste in making up Panels.**—Probably between 20 and 33½ per cent., according to type of veneer selected.

**Description.**—Variable brown colour with occasional wavy streaks of a darker shade, which produce very attractive figure. Logs vary considerably in both colour and figure. A "ripple" figure disclosed when logs are quarter cut adds beauty to the veneers. A dense and hard wood. Cheaper veneers, cut "across the crown," are not recommended.

**Working Notes.**—Care is required to obtain sufficient veneer from one log to complete work in contemplation, as matching from another log will present difficulties. Veneer must be glued with care. Should be finished on the belt sander. A fair amount of filling is necessary. The lustrous surface of the veneer is best retained by wax-polishing.

## *Avodiré*

### TURRÆANTHUS AFRICANA

Alternative Trade Name.	Chief Sources of Supply of Timber.	Price Group.
—	IVORY COAST, GOLD COAST, ANGOLA.	Plain . . . . . 1 to 2. Slightly Mottled 2 ,, 3. Fully Mottled . 3 ,, 5.
<b>Thicknesses.</b>	<b>Sizes.</b>	
$\frac{1}{4}$ ", $\frac{3}{8}$ ", $\frac{1}{2}$ ". Sliced.	Up to 10' long; quarter cut, 6" to 16" wide.	

**Waste in making up Panels.**—Veneer is generally supplied with parallel edges, so waste should not exceed 20 per cent.

**Description.**—White or pale yellow when freshly cut, turning to a darker shade, at times to a bright golden-yellow which is most decorative. The medullary rays are strongly developed and regular, and when cut radially highly figured veneers are occasionally obtained which have a "moiré" surface, not unlike Satinwood. Fine grain.

**Working Notes.**—Veneers showing blue discoloration must be avoided. Darker patches in highly figured veneer are liable to crack, consequently the very large figure should be used carefully. Glues well, but a white glue should be used. Finishes well on belt sander or scraper. Polishes well.



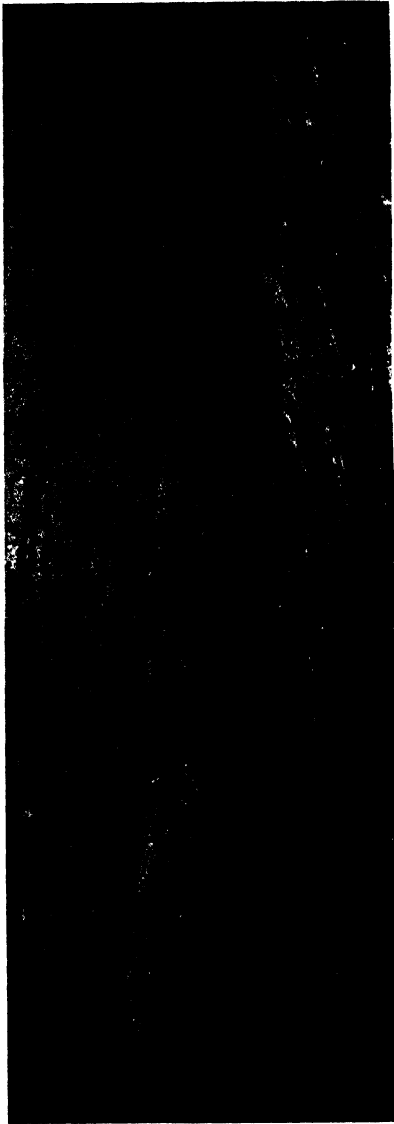

FIG. 111.

A beautiful Makoré curl which is over 7' high. The beauty in this veneer has been retained by laying with a cold adhesive.



FIG. 112.

A twelve-piece horizontally matched panel in Olivewood.

## Mahogany. African

KHAYA SPP., mainly *K. ivorensis*.

Alternative Trade Names.	Chief Sources of Supply of Timber.	Price Group.
LAGOS or BENIN or AXIM or SECONDI or GRAND BASSAM MAHOGANY. DUALA.	NIGERIA, GOLD COAST, IVORY COAST, FR. CAMEROONS.	Varies considerably. Figured . . . 2 to 4. Highly Figured 3 ,, 9. Curls . . . 9 ,, 12.
<b>Thicknesses.</b>	<b>Sizes.</b>	
$\frac{1}{2}$ " , $\frac{3}{8}$ " , $\frac{1}{2}$ " ; $\frac{1}{2}$ " is generally selected for high-class work.	Up to 10' long ; quarter cut, 10" to 18" wide ; across tree, up to 30" wide.	

**Waste in making up Panels.**—Should not exceed 20 per cent. Curls may show wastage of 60 to 75 per cent.

**Description.**—Pink when freshly cut, turning to reddish-brown or a deep mahogany shade on exposure. Rotary cut gives an excellent surface—somewhat harder than Gaboon—which takes enamel or cellulose finish to perfection. Figured logs are quarter cut on slicer, which gives a ribbon stripe not so pronounced as Sapele. The varieties of figuring may be classified as Fiddle Mottle, Broken Mottle, Block Mottle, Broken Stripe. African Mahogany is liable to show "crossbreaks" or "thundershakes" which may show up in rotary-cut veneer as a series of irregular fractures across the grain and are serious defects. Mahogany curls are dangerous, and frequently crack after polishing. Sawn curl veneers should be used.

**Working Notes.**—Glues well and generally finishes well on sander or scraper. Quarter-cut veneers occasionally yield "woolly" surface and require care. Polishes well, but in some species the figure is liable to fade out after polishing. Surface is occasionally spoilt by high french-polishing.

## Mahogany. Honduras (also Cuban)

SWIETENIA MACROPHYLLA

Alternative Trade Name.	Chief Sources of Supply of Timber.	Price Group.
CENTRAL AMERICAN MAHOGANY.	CENTRAL AMERICA.	Figured, $\frac{1}{8}$ " . . . 1 to 4. Figured, $\frac{3}{8}$ " . . . 3 ,, 9. Sawn Cuban . . . 8 ,, 12.
<b>Thicknesses.</b>	<b>Sizes.</b>	
$\frac{1}{2}$ " , $\frac{1}{4}$ " , $\frac{3}{8}$ " ; $\frac{1}{2}$ " is generally selected for high-class work.	6' to 10' long ; quarter cut, 10" to 18" wide ; across the tree, up to 30" wide.	

**Waste in making up Panels.**—Should not exceed 20 per cent. Curls may show wastage of 60 to 75 per cent.

**Description.**—The colour varies from yellowish-brown to a rich golden brown. Somewhat harder than African variety. Veneers are generally sliced from quarter-cut flitches, but occasionally are cut across the crown of the log when not highly figured. Quarter-cut wood offers a wide variety of beautiful figuring, the most attractive being "Beeswing," Fiddle Mottle and Broken Roe. Mahogany "curl" and "crotch" veneers are also available.

**Working Notes.**—Glues well. Takes excellent finish off sharp scraper or belt sander. Generally takes a better polish than African Mahogany veneers.

**Cuban or Spanish.**—The best and most expensive of all Mahoganies, which is occasionally sawn into veneer. On exposure darkens to a deep rich red. Wood is very hard. Much veneer is beautifully figured. Colour improves with age, provided veneers are not stained or thickly french-polished. Waste may be slightly more than with Honduras.

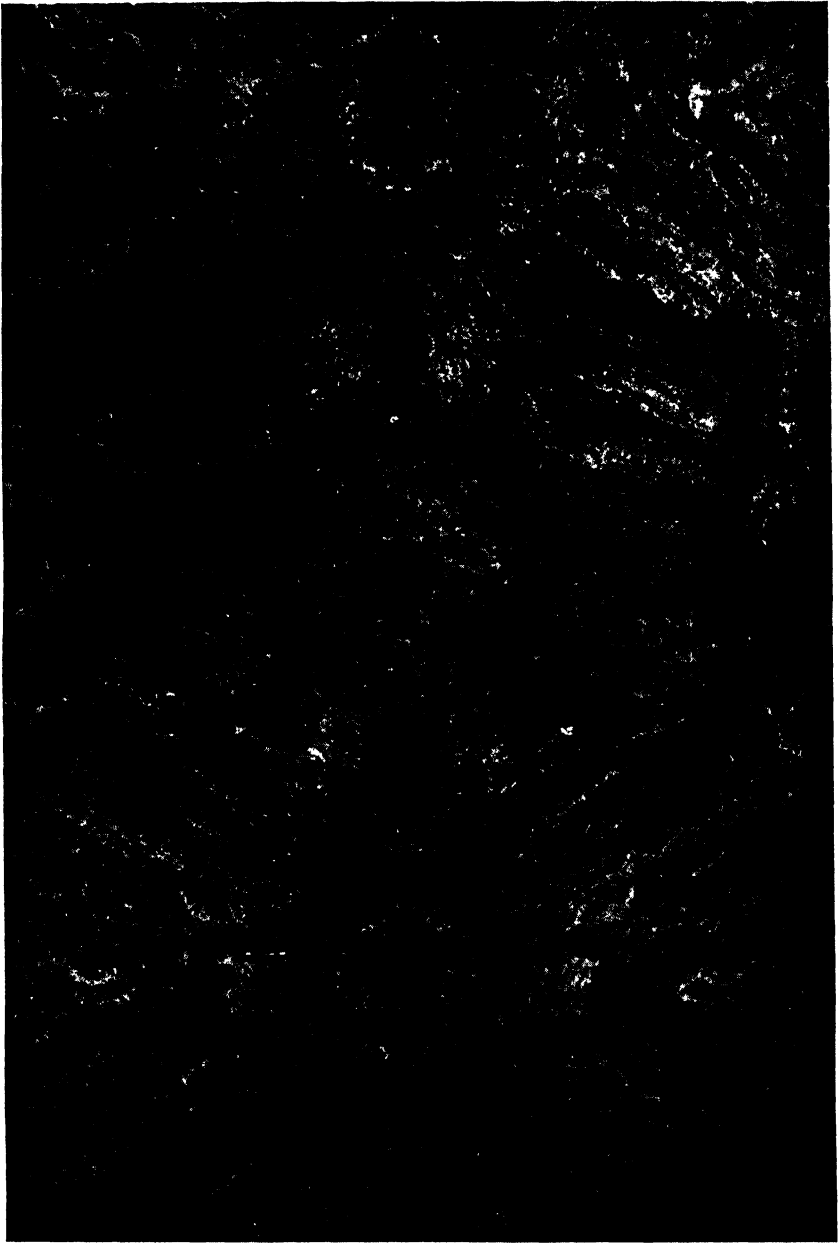

PLATE VIII.—MAKORÉ BURR LAID IN EIGHT PIECES.

## *Makoré*

### MIMUSOPS HECKELII

Alternative Trade Names.	Chief Sources of Supply of Timber.	Price Group.
CHERRY MAHOGANY. BAKU.	NIGERIA, IVORY COAST, GOLD COAST, LIBERIA, SIERRA LEONE.	1 to 3. Specially choice veneers, 5 to 11.
<b>Thicknesses.</b>	<b>Sizes.</b>	
Generally cut $\frac{3}{16}$ ". Sliced.	Up to 10' long : 18" and up wide.	

**Waste in making up Panels.**—Should rarely exceed 15 per cent.

**Description.**—Colour is variable between pale reddish-brown and warm red. It is frequently highly figured, showing "mottle" or "block" figure when quarter cut. Choice veneers may be streaked with irregular dark veins which add to the beauty of the wood.

Makoré is a moderately hard wood with a very fine grain, and is considered to be one of the most attractive of the African timbers.

**Working Notes.**—Veneer glues well. Takes a good finish on belt sander, and polishes well. There is a tendency for the figure to "fade out" after polishing in a similar way to some types of African Mahogany.

(See also Makoré—Douka, page 277.)

## *Sapele*

### ENTANDOPHRAGMA CYLINDRICUM

Alternative Trade Names.	Chief Sources of Supply of Timber.	Price Group.
SAPELE MAHOGANY. SCENTED MAHOGANY. ABOUDIKRO (Fr.) Blistered figure called POMMELÉ.	WEST AFRICA : FROM IVORY COAST to CAMEROONS. Nigerian wood generally yields choicest veneers.	Striped . . . 1 to 3. Pommelé . . . 3 ,, 6. Highly Figured, $\frac{3}{8}$ " . . . 8 ,, 12.
<b>Thicknesses.</b>	<b>Sizes.</b>	
Mostly $\frac{3}{16}$ ". Special thicknesses can be cut. Highly figured, generally $\frac{1}{8}$ ".	6' to 10' long. Quarter cut, 10" to 20" wide.	

**Waste in making up Panels.**—About 25 per cent.

**Description.**—Pink when freshly cut, turning to choice reddish-brown mahogany colour. This is a hard wood which is occasionally cut on the rotary-lathe by some French plywood manufacturers, but much more frequently is quarter cut on the slicer, which produces the well-known "ribbon stripe" or "roey" figure. When the stripe is broken by a mottle, or the wood shows any of the other typical mahogany types of figuring, Sapele can be very attractive. Value is enhanced when stripes are straight and close together. The blister figure known as Pommelé is the rarest variety of Sapele and makes up into beautiful panels.

**Working Notes.**—Glues well. The light and dark bands of alternating grain require careful sanding. Must be stained carefully. Polishes very well.



PLATE IX.

Board-Room of the National Society of Operative Printers and Assistants, London, panelled in figured Queensland Maple.

## Queensland Maple

FLINDERSIABR AYLEYANA  
FLINDERSIA PIMENTELIANA

Alternative Trade Name.	Chief Sources of Supply of Timber.	Price Group.
MAPLE SILKWOOD.	NORTH QUEENSLAND.	Knife Cut . . . 2 to 6. Butts . . . 6 ,, 9.
<b>Thicknesses.</b>		<b>Sizes.</b>
$\frac{1}{2}$ " and $\frac{3}{8}$ ".		Up to 96" long and 18" wide. Butts : Up to 48" long by 12" to 18" wide.

**Waste in making up Panels.**—20 per cent. or more depending upon design and size of panels.

**Description.**—This is a very beautiful wood with the lustre of satin. It has a pleasing flesh-pink colour, and veneers cut from butts and crotches "produce a riot of colour which is indescribably lovely." "The broken ribbon and ripple figuring found in butt veneers are particularly beautiful, having the appearance of shot silk."

**Working Notes.**—The choicest veneer comes from butts which must be carefully cut, but attractive veneer is also obtained by cutting Maple logs on the quarter. The wood is very hard and cleans up well on the belt sander. It takes a fine polish and responds well to ammonia fuming, turning to attractive grey tones which enhance the natural figuring.

## Maple

ACER SACCHARUM

Alternative Trade Names.	Chief Sources of Supply of Timber.	Price Group.
BIRD'S EYE MAPLE. BLISTERED MAPLE. PATAPSCO. QUILTED MAPLE.	Eastern Parts of CANADA and U.S.A.	Bird's Eye . . . 4 to 6. Blistered } . . . 6 ,, 12. Patapasco }
<b>Thicknesses.</b>		<b>Sizes.</b>
$\frac{1}{2}$ " and $\frac{1}{4}$ ".		4' to 8' long by 12" to 30" wide. Rotary Cut.

**Waste in making up Panels.**—If suitable lengths can be obtained, waste should not exceed 20 per cent.

**Description.**—*PatapSCO* : A beautiful white and silky hardwood, occasionally showing curly figure, mottle and a kind of blister figure. Described as Bird's Eye Maple with the "eye" replaced by a "blister." Irregular curly grain. The Blistered or Quilted Maple must be regarded as being in the nature of a freak figure, so uncommon is it. Supplies are irregular. Lengths generally up to 7 feet only.

**Bird's Eye Maple.**—The peculiar markings of "Bird's Eye" are well known and are described on page 32. The whiter and more silky the background showing up the Bird's Eye markings, the more valuable is the veneer.

**Working Notes.**—Glues well. Finishes exceedingly well on belt sander. Takes excellent polish. Quilted or Blistered Maple is liable to glue penetration, so stout veneers and a white glue should be used.

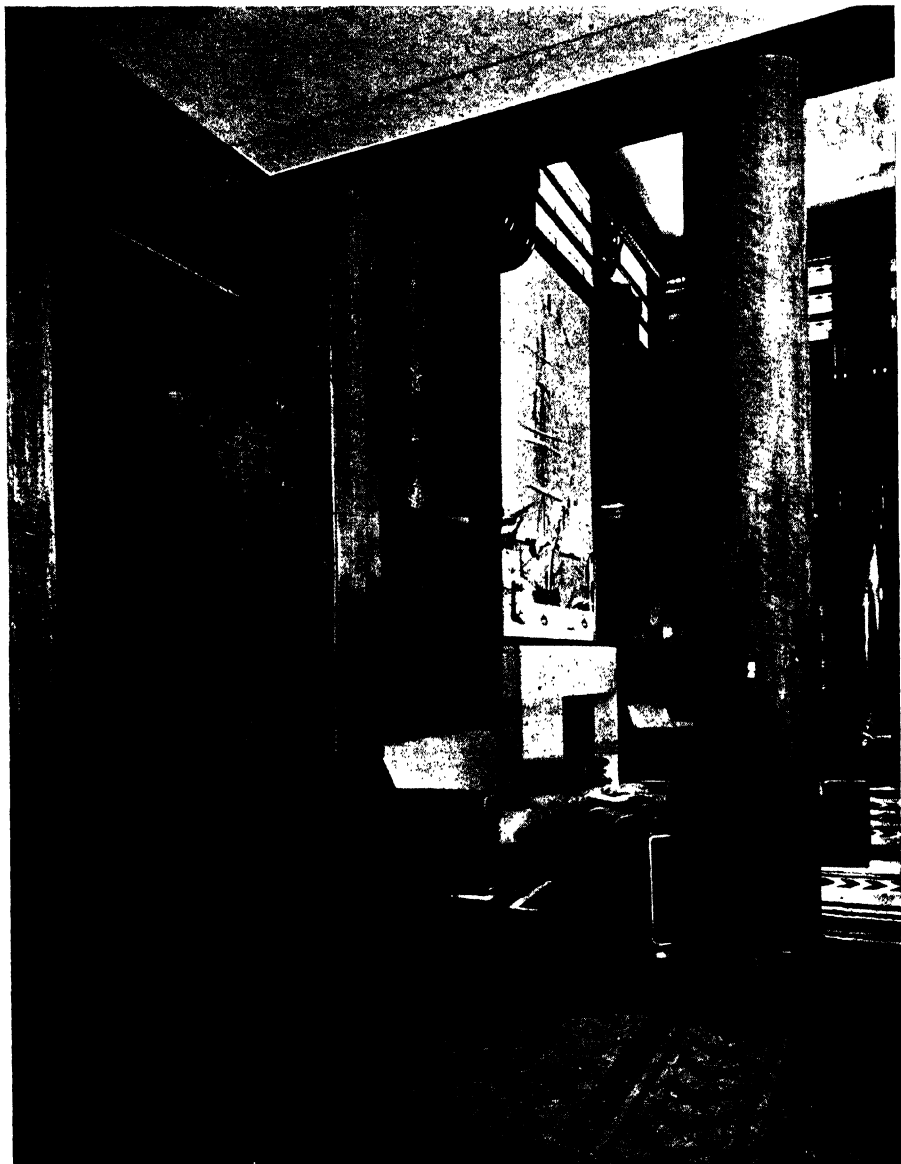

PLATE X.—CABIN SMOKING-ROOM, R.M.S. "QUEEN MARY."

A beautiful example of veneered work with English Pollard Oak laid on Gaboon Multi-ply. The arrangement of the veneers on the pillar on the left of the picture reveal "a veritable portrait of King Henry VIII." Woodwork by Messrs. Trollope & Sons Ltd., London.

# Oak

## QUERCUS Spp.

Alternative Trade Names.	Chief Sources of Supply of Timber.	Price Group.
As detailed below.	As detailed below.	General dimensional stock. $\frac{3}{16}$ " and $\frac{1}{2}$ " . . . 1 to 3. $\frac{1}{4}$ " . . . . . 2 ,, 6.
Thicknesses.	Sizes.	
$\frac{1}{8}$ " , $\frac{1}{10}$ " , $\frac{1}{16}$ " . . . $\frac{1}{16}$ " (0.8 mm.) is a common thickness.	4' to 10' long : quarter cut, from 6" to 16" wide.	

**Waste in making up Panels.**—If suitable lengths are available, waste should not exceed 20 per cent.

**Description.**—Oak is too well known to require any description. Oak veneers are imported into United Kingdom in very large quantities from U.S.A., Jugoslavia, Austria, Germany. Oak billets are also imported and, with British-grown logs, are cut into veneer in London. Generally purchased as quarter-cut figured or sliced-cut plain Oak. Veneer showing large splash figure is frequently "shelly." Sawn veneer should be used if large figure is necessary. All sliced Oak veneers are sold with parallel edges.

**American.**—Veneer cut in U.S.A. is sold in considerable quantities. May be purchased in special sizes for furniture or other mass-production work. The White Oak is generally preferred to the Red variety. The former is pale yellowish-brown in colour with pronounced grain when quarter cut. The grain is apt to be coarse. Red Oak is well described by its title and has distinct reddish tinge. Well cut, and shipped with parallel edges.

**Austrian.**—See *Slavonian*.

**British.**—Generally yellowish-brown; medullary rays show prominently when quarter cut. The plain Oak is attractive, and between this and the fully figured a great choice of figuring is available. Stains, fumes and limes well.

**Brown.**—English Oak trees are occasionally found with a decided brown heartwood, the tone varying from light tan through various shades to a rich walnut. These yield most beautiful veneer, which is not sufficiently well known. Generally cut  $\frac{1}{8}$ ". Waste may be as much as 25 per cent. When wood tends towards the "burry state" it is most decorative and gives a rich warm effect.

**Combed.**—Unfigured quartered veneers with straight grain are sometimes referred to as "Combed" Oak.

**Danzig.**—Of excellent colour and mild grain.

**English.**—See *British*.

**Japanese.**—Somewhat lighter in colour than British Oak, with less pronounced figure. Japanese billets are sliced in London. Refer to page 264 for commercial stocks.

**Polish.**—Quality of Polish Oak varies considerably, but the milder types, known as Volhynia, are largely cut into veneers in Poland and elsewhere. Excellent colour.

**Pollard.**—Known as Burry Brown Oak. Term was originally used in reference to Brown Oak, but should only be used to describe burrs. These are stimulated by cutting off the main stem of the tree, a process known as "Pollarding." Burrs have many faults which must be repaired; when this is done veneers are sold as "Prepared" Pollard Oak. Many beautiful types of veneer are available. Generally cut  $\frac{3}{16}$ ". Sizes, 3' to 6' long by 4" to 18" wide. Burrs are irregular—12" to 48" long by 8" to 20" wide. Waste is high on account of odd shape; in real burr this may be as much as 60 per cent. Price group, 6 to 12. Pollard Oak must be well cut.

**Russian.**—Generally somewhat darker in colour and coarser in grain than Slavonian Oak. A certain number of Oak billets are shipped from Memel, Riga and elsewhere, which are cut into veneer in London.

**Slavonian.**—Originally known as Austrian. One of the mildest Oaks, which cuts exceedingly well on the slicer when quarter cut. Beautiful figure is shown. Is cut into veneers in Jugoslavia, and exported in volume to United Kingdom and elsewhere.

**Tiger Oak.**—See *Brown*.

**Volhynia.**—See *Polish*.





FIG. 113.

A beautiful pink Sycamore "crotch" matched in four pieces, giving the St. Andrew's Cross effect.



FIG. 114.

Sycamore Butt laid in four pieces matched for figure and colour.

# Sycamore

## ACER PSEUDOPLATANUS

Alternative Trade Name.

Chief Sources of Supply of Timber.

Price Group.

Mainly GREAT BRITAIN, but found elsewhere in EUROPE.

Plain Rotary . . . . .	1 to 2.
Plain Sliced . . . . .	1 ,, 2.
Well Figured . . . . .	4 ,, 6.
Weathered Choice Figured	6 ,, 10.
Silver Grey Choice Figured	7 ,, 10.

Thicknesses.

Sizes.

$\frac{3}{16}$ " Sliced for figured veneers.

Up to 8' long: quarter cut, 6" to 10" wide; cut across the crown, up to 26" wide.

**Waste in making up Panels.**—Approximately 20 per cent.

**Description.**—A choice veneer. To retain beautiful satin-white colour, logs must be carefully handled and cut during winter months only. Veneers frequently show a delicate and attractive fiddle-back figure. Turns creamy colour on exposure to sunlight.

*Grey Sycamore (Greywood or Harewood).*—The silver-grey colour, which at first is most attractive, is produced by a chemical process. Details otherwise as above. The grey colour is apt to assume a "pink" or "greeny-grey" tone after exposure to sunlight, which is anything but attractive.

*Weathered Sycamore.*—This is a very beautiful veneer, which may vary from shell pink to a rich tan colour. A wealth of figuring is available. The colour is natural and does not fade. Sizes run smaller than for White Sycamore, and the waste, therefore, may be somewhat higher. This is a delightful veneer.

**Working Notes.**—The grain is close and the wood very hard. Glues well; a white glue should be used. Cleans well on scraper or belt sander. Takes an excellent polish.

# Satinwood. East Indian

## CHLOROXYLON SWIETENIA

Alternative Trade Name.

Chief Sources of Supply of Timber.

Price Group.

CEYLON and INDIA.

6 to 12.

Thicknesses.

Sizes.

Generally  $\frac{3}{16}$ ". Veneers must be carefully cut to avoid fractures.

6' to 9' long: quarter cut, 4" to 8" wide; across the crown, up to about 18".

**Waste in making up Panels.**—Will vary from 25 to 35 per cent.

**Description.**—A beautiful veneer of golden-yellow colour which frequently shows narrow ribbon stripe broken by "block mottle." The figuring, at times, is very attractive.

**Working Notes.**—Too large a figure should be avoided. The most durable veneer is that showing small figure. Must be glued with care and carefully finished on belt sander. The dust from this wood is injurious to some people. Takes brilliant finish.

# Walnut

## JUGLANS REGIA

Alternative Trade Names.	Chief Sources of Supply of Timber.	Price Group.
As detailed below.	Are suggested by trade names.	Prices vary very considerably according to figure. Figured . . . . . 2 to 4. Butty . . . . . 6 „ 12. Burrs . . . . . 9 „ 12.
<b>Thicknesses.</b>		<b>Sizes.</b>
Usually $\frac{3}{8}$ ” ; thicker veneers can be specially cut.		4’ to 10’ long ; width varies considerably.

**Waste in making up Panels.**—Varies very greatly, from 20 per cent. for figured stocks to as much as 75 per cent. for burrs.

**Description.**—Colour and figure vary considerably, generally in various shades of brown, the darkest being the most valuable when figured. It is impossible to give a general description. Veneers cut from straight-grain boles are generally “cut across the crown” on the slicer.

For the first inch or so veneers are more or less sappy, and it should be remembered that when buying complete logs these sappy veneers must be taken. The area of darker heartwood grows, the best colour being obtained around the heart. If the heart is faulty, this is cut away, leaving two narrow, very straight-grained veneers, which are valuable for cross-banding and quartering. Sapwood is used for backing.

Other logs may be cut on the quarter to show the most desirable figure. In U.S.A., butts are frequently cut on the “stay log,” which yields larger veneers of unusual figure.

**Working Notes.**—Cleans well on sander or scraper. Glues well, and takes lasting and beautiful polish.

**Types of Walnut veneer :**

*Ancona.*—There is no such thing as Ancona Walnut. This name is at times used to describe any streaky walnut veneer of dark colour.

*Caucasian and Circassian.*—Supplies are becoming very scarce, but much choice Walnut has been shipped from these regions. This veneer, when available, is of choice colour.

*English.*—Colour generally richer and darker than French Walnut. Figure similar. Logs are frequently irregular in shape, and long parallel edges are difficult to obtain.

*French.*—As a rule, logs show a considerable amount of sapwood of greyish-brown colour, the heartwood being darker brown, frequently well marked by black and golden-brown streaks. Much is straight-grained, but veneers showing “mottle,” “fiddle-back” or wavy “roey” figure are highly prized.

*Italian.*—Very little Walnut from Italy has been shipped for some years past. Those trees growing in the higher regions are darker and richer in colour than the Walnut from certain parts of France. *Juglans Nigra* is much grown in Italy.

*Spanish.*—Not often available. Very difficult to distinguish from French.

## American Black Walnut

### JUGLANS NIGRA

Alternative Trade Names.	Chief Sources of Supply of Timber.	Price Group.
BLACK WALNUT. WANEY BLACK WALNUT.	Eastern and Central Parts of NORTH AMERICA.	$\frac{1}{2}$ " and $\frac{1}{4}$ " . . . . . 2 to 4. $\frac{3}{8}$ " . . . . . 3 ,, 6. Figured and Claro . 4 ,, 10.
<b>Thicknesses.</b>	<b>Sizes.</b>	
$\frac{1}{8}$ ", $\frac{1}{4}$ ", $\frac{3}{8}$ ". Sliced, or cut on stay log.	6' to 10' long; 12" to 20" wide. Wider veneers are occasionally available.	

**Waste in making up Panels.**—Should not exceed 15 per cent.

**Description.**—Generally sound, straight-edged veneer of uniform, rich deep brown colour with purplish tinge. As a rule, much sounder than European Walnut. Little contrast in colouring. Texture is very hard, with close grain.

**Working Notes.**—Works easily, glues well, takes excellent finish on scraper or sander, and polishes exceedingly well. Attractive figuring is at times obtained by cutting on "stay log." Quarter-cut flitches, cut on slicer, produce at times highly figured veneer.

*Claro (California) Walnut.*—A highly figured veneer cut in U.S.A.,  $\frac{1}{8}$ " thick. Very dark colour, with prominent light gold streaks, and frequently has a most beautiful mottle.

## Nigerian Golden Walnut

### LOVOA KLAINEANA

Alternative Trade Names.	Chief Sources of Supply of Timber.	Price Group.
APOPO. AFRICAN WALNUT. BENIN WALNUT. SIDA. DIBÉTOU (Fr.). NOYER DU GABON (Fr.).	NIGERIA, GOLD COAST, IVORY COAST.	2.
<b>Thicknesses.</b>	<b>Sizes.</b>	
Generally $\frac{1}{8}$ ". Sliced.	6' to 10' long. Quarter cut, 10" to 20" wide.	

**Waste in making up Panels.**—Should not exceed 10 to 15 per cent.

**Description.**—"Sapwood—narrow, buff or pale brown, usually well differentiated from heartwood, with an occasional narrow transitional zone. Heartwood—walnut brown, with ribbon grain, showing dark and light zones; highly lustrous, almost sparkling." "Strongly resembles a walnut in colour and superficial appearance, but in structure and other respects it resembles African Mahogany." When quarter cut and sliced a decided ribbon grain is produced which, on occasions, shows a "blister" figure. The Ivory Coast wood is frequently soft and woolly in texture.

**Working Notes.**—Works easily. Glues and finishes well on belt sander or scraper. Care is required when finishing quarter-cut veneers to prevent "plucking." Filing is necessary. Takes excellent polish.

Extracts of descriptive matter are taken from *Nigerian Timber*, published in connexion with exhibit at Empire Exhibition, Scotland, 1938.

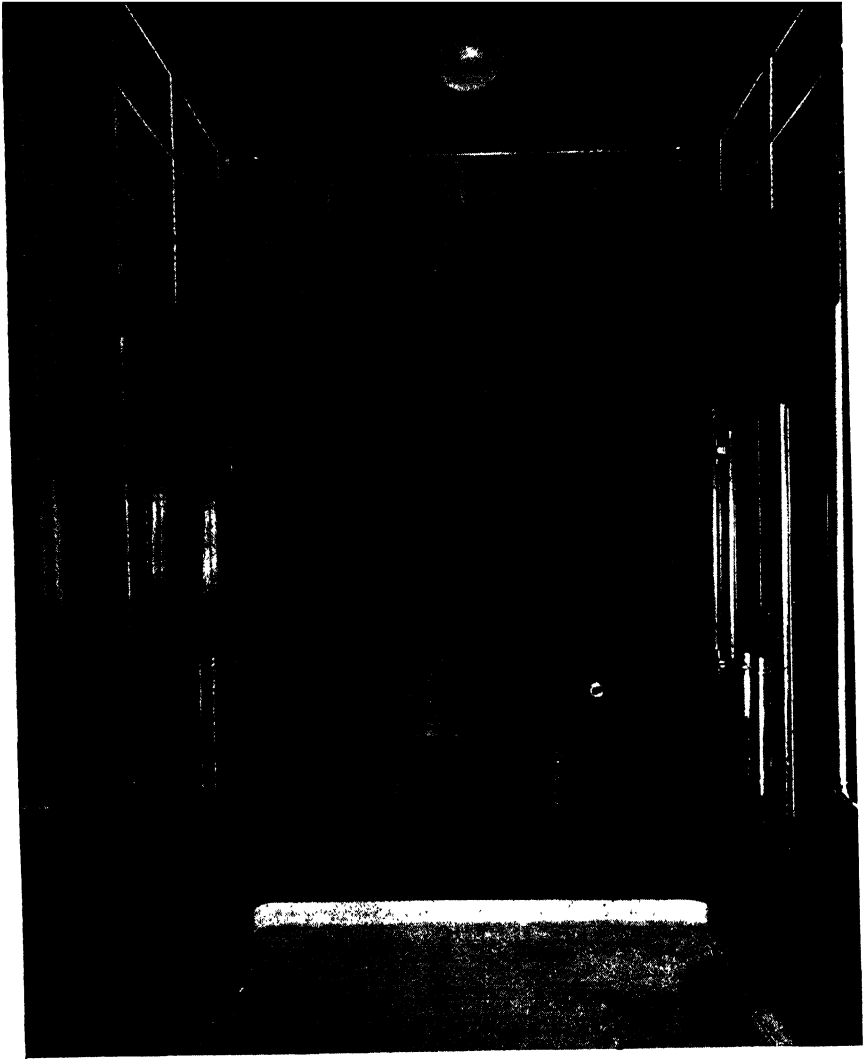

PLATE XI.

Vestibule at offices of Messrs. H. Morris & Co. Ltd., Glasgow. Walls and ceiling are of plywood veneered with highly figured Teak.

# Teak

## TECTONA GRANDIS

### Alternative Trade Names.

MOULMEIN TEAK.  
BURMA TEAK.  
JAVA TEAK.

### Chief Sources of Supply of Timber.

INDIA, BURMA, JAVA, SIAM.

### Price Group.

Figured . . . 3 to 5.  
Highly Figured . 8 ,, 10.

### Thicknesses.

Generally  $\frac{3}{4}$ " . Other thicknesses can be cut.  
Sliced.

### Sizes.

Up to 10' long : quarter cut up to 18" wide,  
generally narrower.

**Waste in making up Panels.**—Should not exceed 20 per cent.

**Description.**—Colour is light golden-brown which darkens with age. Occasionally, logs are received beautifully figured, generally with wavy mottled grain. Frequently has dark, almost black, streaks which add to the general appearance of the wood. The choicest Teak is expensive, but its beauty is unsurpassed by any other veneer. Has oily surface.

**Working Notes.**—Many logs show violet stains at ends which may be an objection, in which case they must be cut out, adding considerably to the waste. Must be glued with care. Cleans up well on sander to take an excellent polish.

# Zebrano

(INDÉTERMINÉ)

### Alternative Trade Names.

ZINGANA.  
BOIS ZÉBRE.

### Chief Sources of Supply of Timber.

WEST COAST OF AFRICA, GABON and  
CAMEROONS.

### Price Group.

2 to 6.

### Thicknesses.

$\frac{1}{2}$ " (0.8 mm.). Sliced.

### Sizes.

7' to 12' long : quarter cut, 4" to 12" wide.

**Waste in making Panels.**—Should not exceed 20 per cent.

**Description.**—A zebra-like striped wood : light brown background, with stripes of varying width in darker colour. Generally used for cross-banding and for small quartered panels.

**Working Notes.**—Must be glued with care. Finishes well on belt sander. Should be carefully treated with a clear filler before polishing.



[By courtesy of Messrs. VICKERS-ARMSTRONGS LTD., BARROW-IN-FURNESS.]

FIG. 115.—“S.S. STRATHEDEN.”

Two views of the aft staircase panelled in Gaboon Multi-ply veneered *Betula* with Walnut bandings. The staircase was erected by Messrs. Waring & Gillow (1932) Ltd. The white-enamelled boundary rails are of  $\frac{3}{4}$ " Oregon Pine : the ceiling of  $\frac{1}{2}$ " plywood.

## PART VIII

### THE PLYWOOD TRADE IN THE UNITED KINGDOM

#### CHAPTER I

##### (a) CONSTITUTION OF TRADE

**B**EFORE describing the constitution of the trade in imported plywoods in the United Kingdom, a short review of the "introducing" era will not be out of place.

There is some doubt as to the date of the first shipments of commercial plywood to this country, but records of importations have been traced back to 1896. The quantities, however, were inconsiderable, and the plywood was of poor quality, suitable only for box-making, backs of mirrors and picture frames. Towards the end of the nineteenth century plywood, in the form of chair seats and shooks, commenced to arrive in larger quantities, and these were followed by shipments of Alder in standard sizes up to about 54"×46". This plywood was imported by a few merchants purely as a speculation.

It is doubtful if any of these early traders imagined that what they then considered to be a cheap substitute for thin lumber would ultimately lead to a revolution in the application of wood. Cabinet-makers and joiners were reluctant to use the material for purposes where it could be seen, and considerable difficulty was experienced in persuading shop-keepers to accept furniture with backs or drawer-bottoms made of plywood. The prejudice against plywood grew, and not without justification, as early specimens were frequently badly glued. Much trouble was experienced with plies lifting and corrugating; moreover, due to the crude methods of rotary cutting and drying, uneven surfaces and warpage were common faults. The pioneers of this new industry persevered and eventually succeeded in overcoming many of their manufacturing problems; from the year 1906 plywood was produced well glued and reasonably flat. It was not until 1912, however, that the manufacture had improved sufficiently to induce furniture and joinery manufacturers to use plywood in place of thin lumber for such work as carcass-backs, dust-boards and drawer-bottoms.

The trade in plywood progressed slowly but steadily until 1914 when, with the outbreak of war, an enormous number of hutments were



required for the housing of troops. These were made with tongued and grooved boards and, when it was found necessary to provide a lining, it was realized that plywood was ideal both as regards its suitability and the speed with which it could be erected. There also developed a great demand for boxes and containers of various kinds for which the cheap European plywoods were suitable.

As has been mentioned earlier, American, German and British engineers devoted much time to the study of plywood-making machinery, while chemists set about the task of evolving waterproof adhesives. The Americans succeeded in producing excellent Birch and Walnut plywood which met the urgent demands for aircraft construction, shell-cases, dash-boards and a variety of other war-time uses. A Dutch mill commenced the production of large multi-ply boards from Okoumé, suitable for bulkheading, ceilings and linings for ships. Holland, being a neutral country, supplied large quantities of these boards to Great Britain.

During the war years a considerable quantity of plywood was manufactured in Great Britain, chiefly from Birch and Ash.

Prior to and during this period there were only about a dozen merchants in Great Britain who had seriously considered plywood and its future possibilities. Timber importers and merchants were not enthusiastic, doubtless, because they had staked their faith in solid wood, but a second and perhaps more important reason was that during the war and for a year or so afterwards the businesses built up by this small number of pioneer traders were capable of absorbing all the plywood which the foreign mills were prepared to ship to this country. It was difficult, therefore, for others to gain entry to the trade. Meanwhile, existing European mills were re-organizing to meet the increased demand, and new units were being installed, so that there was soon a considerable increase in available supplies.

Important timber agents perceived that plywood was becoming increasingly popular as a substitute for thin lumber and, realizing the opportunity to participate in the trade, sent representatives to European countries to establish agencies with a view to widening the channels of distribution in Great Britain on similar lines to those of the older sections of the timber trade.

### AGENTS AND BROKERS

Foreign manufacturers and exporters of plywood, following the practice of established softwood and hardwood shippers, appointed agents in the United Kingdom and elsewhere to negotiate sales, to

administer contract terms and conditions and, generally, to look after their interests in foreign markets.

Agency firms usually made it their business to pay frequent visits to the producing countries and, with their knowledge of the requirements of British buyers, were able to present to their principals a balanced picture of the requirements of their home markets. Furthermore, agents were in a position to acquaint their circle of buyers with details of the specifications which could be produced most economically by the mills and, as a general rule, they succeeded in reaching a fair compromise between the requirements of buyer and manufacturer.

Importers found it necessary to handle a wide variety of plywoods and, owing to variations in specification, quality and construction, they invariably found it prudent to buy similar plywoods, more especially Birch and Alder, from several different sources in order to procure a complete range of sizes and grades.

Manufacturers of plywood have usually found it to be to their ultimate advantage to sell their products through more than one importer, as no one firm could adequately cover the requirements of all consuming industries. The demand for plywoods varied considerably in different parts of the country. For example, certain stocks which found a ready market in London were practically unsaleable in Scotland, and *vice versa*, but the agent, by co-ordinating sizes, thicknesses and qualities, was able to produce contracts which made it possible for the mill to market its standard production.

The granting of advances to their foreign principals against contracts had, for many years, been a recognized practice of wood agents, and during the years following 1918 some plywood manufacturers found this particular function of the agent invaluable, when it was necessary to borrow money for log supplies, or to purchase new equipment. Buyers, too, appreciated the financial facilities of agency firms, more especially when particularly large contracts were made. In such cases, when an importer required financial assistance, the agent would take payment by three-months' bill, or he might discount other trade bills which the importer had been obliged to draw on his customers.

The agent therefore formed a most important link between manufacturer and distributor.

## PLYWOOD IMPORTERS

The designation "plywood importer" is misleading as, although such operators import their goods, their chief function is that of merchant.

There are many plywood merchants who do not import, and such firms buy from importers, but nevertheless the ratio of the importers' sales to merchants and to consumers is about 20 per cent. to 80 per cent. Strictly speaking, therefore, importers are primarily merchants but, as it would be quite impossible for importers to sell to the large number of small buyers, there is, and always will be, a place in the trade for the retail merchants who distribute plywood in their particular localities as often as not along with other timber supplies.

Every mill must sell for forward delivery and in bulk ; no manufacturer could possibly arrange his production to deal with the varied requirements of thousands of small buyers, and consequently the majority of importers found themselves obliged to carry large stocks, including most of the popular woods, in a wide assortment of sizes, thicknesses and qualities. The merchant, on the other hand, catering only for his local customers, confined his stock to a few of the most popular items which he purchased from the importer ex-quay or ex-stock.

The cost of raw materials, labour and freight varied, each having a direct bearing on manufacturing costs ; furthermore, pre-1939 trading was frequently made more complex by fluctuations in currency exchanges. In making their purchases for delivery spread over several months, importers had to take the risk of the rise or fall in values, whereas the retail merchant, by buying landed stocks, was able to avoid, or certainly to limit, his risk. Some merchants also bought selected parcels from importers on a c.i.f. basis.

It would therefore appear that the plywood importer is essential to the manufacturer, the consumer and the merchant, and it is doubtful if any change in trading conditions would alter this state of affairs.

For a number of years foreign manufacturers have made a practice of paying regular visits to importers and the latter have visited the mills. Such exchanges were invaluable to both parties. Consumers and merchants also benefited indirectly, as their requirements were made known to the manufacturer by people who possessed first-hand knowledge of the needs of the user and who also had some knowledge of the facilities of the mills to meet special demands.

The importer generally contracted for specified quantities of European plywoods in multiples of the cubic metre ; Douglas Fir, on the other hand, was bought in square feet on " a  $\frac{1}{4}$ " thickness basis," which meant that the total quantity in square feet varied according to the average thickness specified in subsequent declarations. In other words, the cubic footage and value were controlled. The importer, having made his contract for a given quantity, made regular declarations to the agent in which were specified the thick-

nesses, qualities and quantities to be shipped to stated ports. One of the weaknesses in this system was the difficulty experienced in obtaining declarations against contracts during periods of bad trade.

### (b) VARIOUS ASSOCIATIONS

One of the most important landmarks in the history of the British plywood trade was the formation in 1923 of the Plywood Section of the Timber Trade Federation of the United Kingdom. By this step the plywood trade became a recognized branch of the trade and an integral part of the Federation which represents the common interests of all sections of the trade. The Executive Council gave consideration to the desirability of forming a Plywood Section under the auspices of the Federation and appointed an influential committee to make preliminary inquiries and confer with leading members of the trade. The committee reported to the Executive Council that such an organization, under the rules of the Federation, would be generally approved by firms in that branch of the wood industry for the purpose especially of negotiating collectively with the railway companies and dock authorities and generally in securing uniformity in the conduct of the plywood trade.

A meeting of firms interested in the trade was accordingly held when it was resolved that they approved of the formation of a Plywood Section. The members present at that meeting formed the nucleus of the new section. Regular meetings of the Section were arranged and representation was secured on the Executive Council which has often been described as "The Parliament of the Trade."

The Section having been inaugurated, attention was directed immediately to its consolidation with a view to the Section becoming a firmly established unit in the organization of the trade. In the first instance its objects were agreed and specified, *inter alia*, that the Section existed to defend and advance the joint and several interests of those engaged in the purchase and importation of plywood into this country and to secure mutual support and co-operation in this endeavour. The Section was divided into two sub-sections (1) comprising agents and brokers, and (2) importers, provision being made for separate meetings of these two sub-sections and for them to safeguard the interests peculiar to each sub-section. Having agreed to its constitution, the Section formulated rules and regulations governing its procedure.

On its first task of organization being accomplished, the Section then proceeded to examine the conditions obtaining in the plywood trade. It was considered of paramount importance that there should be

uniformity in the conditions relating to the purchase of plywood from abroad and as a result of long and protracted negotiations with shippers, a standardized c.i.f. plywood form of contract was formulated and became known as the "RUFOD" form. This superseded many forms of contract containing varying conditions which were in use by individual plywood agents. This first standard document remained in operation for a number of years until it became necessary to revise certain clauses in order to bring the form into conformity with changed conditions. A new contract form was negotiated in 1934 and received the code name of "MORGA." Further changes in the "MORGA" contract became necessary and a new document, known as the "WITHY" form, was agreed with shippers and issued in 1937. This form superseded the "MORGA" form and is still in use in the plywood trade to-day. A copy of the clauses is reproduced on pages 458 to 460.

In connexion with the agreed form of contract a panel of arbitrators was constituted, comprising experts in plywood technology and business practice. The members of the panel have been constantly called upon to deal with disputes arising in connexion with contracts negotiated on the agreed form. The Section has also secured uniformity in the conditions relating to the insurance of plywood shipments with the result that insurance clauses, known as the Plywood Insurance Clauses, are embodied in the plywood form of contract. Another instance of standard trade documents is the Importers' Terms of Sale for use in connexion with sales to their buyers. The importers' sub-section drew up terms of sale which importers were recommended to adopt for sales made ex-dock or ex-warehouse, and these terms are reproduced on page 461.

From time to time efforts were made to agree with the leading shippers an approved list of plywood agents and importers, and following many conferences the first list was issued and became operative on 1st January 1939.

With a view to developing the plywood trade of this country the Section approached the problem of finding ways and means which would enable the trade to take full advantage of the increased production of plywood coming not only from the mills which had been extended and modernized, but also from new units erected in plywood-producing countries. The action taken in this connexion had a most far-reaching effect and was the precursor of the Plywood Development Association.

Negotiations were opened with the railway companies concerning the conditions and classification for the carriage of plywood by rail, and finally an agreement was reached. Another problem concerned the conditions in the handling and storage of plywood at docks.

## THE PLYWOOD DEVELOPMENT ASSOCIATION

The Plywood Development Association was formed by the Plywood Section of the Timber Trade Federation in January 1926 and functioned until 1929.

A carefully designed series of advertisements was prepared by the late Sir Lawrence Weaver and published in *The Times*, *Daily Mail*, *Daily Chronicle*, *Manchester Guardian*, *Good Housekeeping*, *Ideal Homes*, and *Homes and Gardens*. From these advertisements over 13,000 replies were received and descriptive literature was sent to all inquirers. These inquiries were followed up by correspondence and personal contact by members of the Association. The Association exhibited at the Ideal Home Exhibition, and the unique character of the stand attracted a great deal of attention. A series of lectures illustrated by lantern slides was delivered at technical colleges and other institutions. Publicity in the technical press, articles on plywood in the leading technical journals and research work provided other useful spheres for the Association's activities.

A deputation consisting of three members of the Association visited the Continent for the purpose of studying the uses of plywood abroad, and the result of these investigations helped the Association considerably in planning propaganda for the expansion of the use of plywood in Great Britain.

The activities of the Plywood Development Association had a far-reaching effect and contributed to a great extent to the rapid extension of the use of plywood in this country.

## PLYWOOD SALES ASSOCIATION

The Plywood Sales Association was formed by a group of importers interested in Russian plywoods and, when first formed in 1936, was interested primarily with purchases from the U.S.S.R. Once contracts for the 1938 productions had been made, this Association, which then consisted of thirteen members, agreed to a sales policy covering all re-sales to importers and merchants and published fixed price lists. Deposits were made of varying sums up to £1000, according to the value of contracts made. The deposit represented a "good faith" token, which was liable to forfeiture for any breach of the conditions, and was refunded once the terms of the price agreement had been fulfilled. On the whole this re-selling scheme functioned satisfactorily.

## TEA CHEST BUYERS' ASSOCIATION

This Association consisted of six companies interested in the buying of plywood for tea and rubber chests and in the re-selling of such chests. The group negotiated with the various shippers of Birch plywood with whom they agreed as to quantities and prices, according to market conditions, in the East.



*[By courtesy of Messrs. Gordon Russell Ltd.]*

FIG 116.

Bureau formed entirely of multi-ply, using a small radius corner with grain following round.

## (c) TRADE JOURNALS AND PERIODICALS

Interesting articles on plywood appear in several journals published in England and elsewhere ; the more important developments throughout the world are generally reviewed in trade papers printed in London. The following list is by no means complete, but includes publications which devote a reasonable amount of space to plywood matters :—

*Timber Trades Journal* (London) is published weekly and covers the activities of the plywood trade.

*Timber and Plywood* (London) is also published weekly and devotes a section to the plywood trade.

*Wood* (London). A well-illustrated monthly journal which has printed many interesting articles on plywood utilization.

*Veneers and Plywood* (Indianapolis, U.S.A.). A monthly journal and the only one devoted exclusively to the veneer and plywood trades.

*Timberman* (Portland, Oregon, U.S.A.), monthly, deals mainly with the timber and associated trades on the North-West Pacific Coast of America.

*The Australian Timber Journal* (Sydney, N.S.W.), published monthly, is the official organ of the Timber Development Association of Australia.

Occasional articles appear in :—

*The Architectural Review* (London);

*The Cabinet-maker* (London);

*Plastics* (London);

and several other trade periodicals covering Architecture, Shipbuilding and Engineering.



## CHAPTER II

### CONTRACTS, CLAIMS, DISPUTES, ARBITRATION

(1) Contracts for the sale of plywood have for many years past contained clauses governing disputes and arbitration. The standard clauses as adopted by the Plywood Section of the Timber Trade Federation on the 21st June 1938 are contained in the c.i.f. contract form and are printed in the appendix. A similar arbitration clause is to be found in the Plywood Importers' Sale Note, the full terms of which are given on page 461.

(2) *Claims.*—Claims in respect of defective quality and/or manufacture must be made in accordance with Clause 13 of the standard c.i.f. contract form.

When inspection discloses damage or shortage formal notice of claim must be lodged promptly with :—

- (a) Shipping Company ;
- (b) Insurance Company ;
- (c) Shippers' Agent or Broker ;
- (d) Lighterage Company (if involved).

Once liability has been established and the amount of damage agreed, a debit-note for damage or shortage will be issued to the Company responsible.

### DISPUTES AND ARBITRATION

The law regarding arbitration is now contained in the Arbitration Act, 1889, as amended by the Arbitration Act, 1934. These two statutes, together with two statutes of minor scope, the Arbitration Clauses (Protocol) Act, 1924, and the Arbitration (Foreign Awards) Act, 1930, are known together as the Arbitration Acts, 1889 to 1934.

The submission of disputes to arbitration does not, of course, entirely exclude the jurisdiction of the ordinary Courts of Law—it may be necessary to apply to the Court to enforce an award, or to require an arbitrator to state his award in the form of a special case ; it may be necessary to apply to the Court to enforce the reference to arbitration.

If, notwithstanding the arbitration clause, any party takes legal proceedings in any Court against any other party to the contract in respect of any dispute arising out of the contract, the party sued may at

any time after entering an appearance " and before delivering any pleadings or taking any other steps in the proceedings " apply to the Court to stay the proceedings. To obtain a stay of legal proceedings the applicant must satisfy the Court that he was, at the time when the proceedings were commenced, and still remains, ready and willing to do all things necessary to the proper conduct of the arbitration. The application to stay must be made before a defence has been delivered or any active step, such as taking out a summons for further time to deliver a defence, has been taken by the defendant. Mere communication between solicitors, whether verbal or by an exchange of letters, does not amount to a " step in proceedings "—but it is advisable that any application to stay should be made as early as possible.

The power of the Court to stay proceedings is discretionary—and a stay may be refused if the dispute referred to arbitration involves a question of fraud, or if the applicant is merely aiming at delay, or if the principal matter in dispute is a question of law or the proper construction of an agreement.

But in the plywood industry most of the disputes that arise relate to technical matters which are essentially suitable for decision by an arbitrator drawn from the panel.

It is seldom that any difficulty arises in the plywood industry in constituting the Arbitration Tribunal since the clause adopted by the trade is carefully designed to avoid any delay in the appointment of an arbitrator from the approved panel. If the dispute is for an amount not exceeding £25 the reference must be to a single arbitrator and it can be to a single arbitrator in all cases if the parties so agree. If, in cases where a single arbitrator is required, the parties fail within seven days to agree upon an arbitrator, or if, in other cases, either party fails within seven days after receiving a request by registered letter or cable to appoint an arbitrator, then the appointment is to be made by the chairman for the time being of the Plywood Section of the Timber Trade Federation or, failing him, by the deputy chairman.

No special form of appointment is required.

If the reference is to two arbitrators there is a statutory obligation on them to appoint an umpire immediately on their appointment and before they enter upon the arbitration.

The procedure contemplated by the Arbitration Acts is that the umpire is substituted for the two arbitrators in the event of the arbitrators being unable to agree and delivering to any party to the submission or to the umpire a notice in writing to that effect. The duties of an umpire do not arise until the authority of the arbitrators has lapsed. For this reason it is a common practice in commercial arbitrations for the two arbitrators to

express their disagreement in writing before formally hearing the evidence; this enables the evidence to be taken before the umpire and the two arbitrators sitting together, or before the umpire alone, and thus saves the expense of a double hearing.

The Court may at any time after the appointment of an umpire on the application of any party order that the umpire shall enter on the reference in lieu of the arbitrators and as if he were a sole arbitrator.

In commercial disputes arbitration is often preferred to litigation on the ground that a speedier decision can be obtained. The former provisions contained in the Arbitration Act of 1889 as to time for making an award and the arbitrator's rights to enlarge his time for making the award were repealed by the Arbitration Act of 1934, which now provides (Section 6) that the Court may, on the application of any party to a reference, remove an arbitrator or umpire who fails to use all reasonable dispatch in entering on and proceeding with the reference and making an award.

### CONDUCT OF THE REFERENCE

The first principle for any arbitrator or umpire to observe is the duty to try the case impartially; to act fairly between the parties and to exercise his skill and judgment in reaching a correct decision on the evidence. An arbitrator is not a mere valuer, he has judicial functions to perform. It is the duty of an arbitrator to decide the questions submitted to him according to the legal rights of the parties and not according to what he may consider fair and reasonable in the circumstances.

An arbitrator on receipt of his appointment should see that the appointment is in order, and if it is not, should have it put in order before he proceeds with the arbitration. The appointment of an arbitrator is not effective until the person appointed agrees either expressly or by implication to exercise the functions of his office.

It is customary in all but the simplest arbitrations for the arbitrator to arrange a preliminary meeting between the parties in order to give directions on the following points :—

- (a) for filing particulars of the claim, defence and counterclaim (if any) ;
- (b) for discovery and inspection of documents ;
- (c) for inspection of the goods, if necessary, (i) by the parties, and (ii) by the arbitrator ;
- (d) for the fixing of a time and place of hearing, if required ;
- (e) for arranging other matters intended to shorten or facilitate the hearing.

Among the provisions that by virtue of the Arbitration Acts are deemed to be included in any submission to arbitration, unless a contrary intention is expressed, is a provision for the complete disclosure of all relevant documents : " The parties to the reference, and all persons claiming through them respectively, shall, subject to any legal objection, submit to be examined by the arbitrators or umpire, on oath or affirmation, in relation to the matters in dispute, and shall, subject as aforesaid, produce before the arbitrators or umpire all books, deeds, papers, accounts, writing and documents within their possession or power respectively which may be required or called for, and do all other things which during the proceedings on the reference the arbitrators or umpire may require."

In order that it may be known what relevant documents are within the possession or power of the parties to the arbitration and persons claiming through them respectively, it is necessary that the parties should either make a list or an affidavit of such documents, and although there is no direct authority on the point it seems that as an ancillary to the power of the arbitrator to require production of documents he has power to order a list or an affidavit of documents to be prepared and exchanged. The production of documents in the possession of third parties and the attendance of witnesses to give evidence can be enforced by subpoena as in a case before a Court of Law.

Every arbitrator has the right to inspect the property which is the subject-matter of the dispute, but it is entirely in the arbitrator's discretion whether he will view or not and if it is necessary for a fair trial of the dispute between the parties the arbitrator, following the ordinary rules for the administration of justice, is at liberty to order the goods or other property which is the subject of the dispute to be inspected by either party.

An arbitrator has no power to require either party to give security for costs, nor has the arbitrator any power to order evidence to be taken on commission.

The procedure at an arbitration should be assimilated as near as may be to proceedings in a Court of Law. The rules of evidence and the rules of administration of justice must be observed. In particular an arbitrator must not hear one party or his witnesses in the absence of the other party or his representatives. An arbitrator must not receive information from one side which is not disclosed to the other, whether the information is given orally or in the shape of documents.

If it is the intention of either party to be represented at the hearing by Counsel, there is a duty to give notice of such intention to the opponent, in sufficient time to permit of his being similarly represented, should he

so desire. If proper notice has not been given, the arbitrator should at the request of the other party grant an adjournment.

All legal grounds of defence are open in answer to a claim in an arbitration, including the Statutes of Limitations (Arbitration Act, 1934, Sec. 16 (1)).

The arbitrator must decide neither more nor less than the dispute submitted to him ; otherwise the award may be set aside.

As a result of the amendments introduced by the Arbitration Act of 1934, the arbitrators or umpire now have the same power as the Court to order specific performance of any contract other than a contract relating to land. The arbitrators or umpire may also, if they think fit, make an interim award.

An award is subject to a stamp duty of 10s. under the Revenue Act, 1906. The sum to be paid under the award carries interest, unless the award otherwise directs, as from the date of the award and at the same rate as a judgment debt, *i.e.* 4 per cent. per annum.

There is no direct appeal from the award of an arbitrator, which is a final determination of the facts referred to the arbitration tribunal.

If a point of law arises in the course of the reference the arbitrator or umpire may himself decide it or, by virtue of Sec. 9 (1) of the Arbitration Act, 1934, he may state the point of law in the form of a Special Case for the decision of the Court. If an arbitrator or umpire refuses to state his award in the form of a Special Case either party may apply to the Court for an order directing him to do so.

In order that the Court may be in a position to decide upon the point of law raised in a Special Case the arbitrator must set out affirmatively or negatively all the facts necessary for the Court to give a decision and the contract and other relevant documents should be set out or annexed to the Special Case. The award, though in the form of a Special Case, must be final so that the Court has merely to decide the law and thereupon automatically one or other alternative decision of the arbitrator comes into operation.

Subject to the leave of the Court an award may be enforced in the same manner as a judgment. An application for leave to enforce an award is made by an Originating Summons ; where leave is given to enforce an award, judgment is entered in the terms of the award.

The Arbitration Clause quoted above gives to the arbitrator or umpire complete discretion as to the manner in which costs are to be awarded and paid. Apparently all expenses, including any special expenses to which both parties agree, incurred in an arbitration can be dealt with by the arbitrator or umpire.

It is common for the arbitrator or umpire to fix his own fees, but if

any arbitrator or umpire refuses to deliver his award except on payment of the fees demanded by him the Court may on an application for the purpose order that the fees demanded shall be paid into Court and taxed by the Taxing Master (Arbitration Act, 1934, Sec. 13).

The Court has power to set aside an award on any of the following grounds :—

(1) Misconduct on the part of the arbitrator or umpire. Instances of misconduct which would justify an award being set aside are : improperly rejecting or receiving evidence, permitting the examination of a party in the absence of the other, excluding persons entitled to be present and improper delegation of duties.

(2) Mistake, or error, whether of fact or of law, that is apparent on the face of the award, and is not immaterial to the decision.

(3) Fraudulent concealment of facts by one party to the reference, or wilful deception of the arbitrator.

(4) If the award lacks any of the requisites of an award, e.g. if it is uncertain or not final or *ultra vires*.

Instead of setting an award aside, the Court may remit it for reconsideration. This is the normal course in the case of some obvious defect or omission or mistake, or where new evidence has become available since the hearing of the dispute.

The award must be certain in its terms, whether in the form of a Special Case or not. In the plywood trade the common form of arbitration award in current use is as follows :—

“ A DISPUTE having arisen between  
 (hereinafter called the SELLERS), and  
 (hereinafter called the BUYERS), in regard to  
 Plywood shipped per S.S. for  
 under a Contract (No. ) dated  
 made by as BROKERS, IT WAS AGREED, in  
 accordance with the terms of the Contract above mentioned, to refer the matter in  
 dispute to the arbitrament of appointed by the  
 SELLERS and appointed by the BUYERS.

NOW WE the Arbitrators above referred to do HEREBY DECIDE AND  
 AWARD that SELLERS shall pay to BUYERS the sum of  
 in full and final settlement of all claims on the above parcels.

AND WE further DECIDE AND AWARD that the costs of this reference  
 including expenses and stamp amounting in all to  
 be paid as follows :—

by SELLERS.  
 by BUYERS.  
 for SELLERS.  
 for BUYERS.”



*[By courtesy of Messrs. A. H. McIntosh & Co. Ltd.]*

FIG. 117.

A double writing-desk, largely constructed of plywood, for a bank.



*[By courtesy of Messrs. H. Morris & Co. Ltd.]*

FIG. 118.

A writing-desk of modern design with gables and top of laminboard.  
The decorative veneer is Macassar Ebony.

## CHAPTER III

### (a) MARKETING PLYWOOD AND VENEERS

IMPORTERS and merchants market their stocks of plywood in terms of shillings and pence per 100 square feet, except when quantities are small or in the case of plywoods veneered with expensive veneers when the prices are quoted per square foot.

Consumers should make themselves familiar with brands of plywood suitable for their particular business and, once they have discovered suitable material, will be well advised to refrain from any temptation to change to some cheaper manufacture merely to save a few pence per 100 square feet.

Any established dealer will gladly turn over stocks for the inspection of consumers or architects and by so doing the various grades and manufactures may be compared. The system adopted by the shipyards of inspecting timber and plywood in merchants' yards is an excellent one, as the inspector is invariably brought into touch with all new stocks as they make their appearance.

When inquiries are issued the following particulars should be given:—

Thickness, wood, quality, quantity, size, construction and delivery.

It frequently happens that an architect may desire to exclude some particular type of grain figuration, such as wild-grain Douglas Fir, in which event the fact should be clearly stated. No manufacturer would accept such a stipulation for forward delivery, but certain merchants would supply provided the buyer is willing to pay a premium to recoup the seller for the labour involved in opening packages and making the necessary selection.

If waterproof cement is required this fact should be added. It will be of assistance to the larger dealer if mention is made of the purpose for which the plywood will be used. Complicated specifications should not be issued. For example, one of the main line railway companies issued specifications which read "3-ply laminated plywood to selection" with "Pine core blocks not less than  $\frac{3}{4}$ " wide." The absurdity of this wording will be obvious; contradictory specifications of this nature merely tend to confuse.

Commercial plywoods, in regular thicknesses and sizes, are generally sold to consumers in complete crates. When a special size, thickness or



quality is necessary, by paying an additional price, the buyer may purchase his exact requirements from those merchants who carry a comprehensive range of plywoods in their own warehouses. Panels may be cut to special requirements from stock boards by merchants who cater for this business. A point worthy of note is that, although large sizes are invariably more expensive than smaller ones in the same class of plywood, it will be found that where waste in cutting up is unavoidable economies may be made by paying the higher price for the largest available boards. By so doing sizeable off-cuts will be obtained which will come in useful for other work, whereas off-cuts an inch or two wide generally find their way into the furnace.

Important quantities in special sizes were manufactured at the mills and large contracts for forward delivery over a stated period were made covering what came to be known as "Cut Sizes."

*In buying plywood it must be remembered that the direction of the grain of the outer plies is indicated by the first dimension, the second dimension indicating the width.*

When required for exterior work a proprietary brand of resin-bonded plywood of known repute should be specified, failing which care should be taken to purchase plywood bonded with full-strength resin adhesives. Never attempt to buy resin-bonded plywood purely on a price basis; boards made with extended synthetic resins, while cheaper, must not be used for exterior work.

Specifications calling for panels veneered with decorative woods must be carefully drawn up and clear distinction made between:—

1. Veneered plywoods to be taken from stock.
2. Plywoods to be veneered to specification.

#### I. VENEERED STOCK PLYWOODS

In this case it will be sufficient for the inquirer to give the thickness, size, quality, quantity and nature of face veneers required thus:—

- (a) Birch plywood faced one side with figured Oak, 1st Quality  
10 boards 72" × 36" × 6 mm.

If it is desired to make a selection of some particular type of figure the specification may read:—

- (b) Plywood to selection. Faced Figured Oak 1 side, small rain figure desired. Plain Sliced-cut Oak reverse.

15 boards 84" × 48" × 9 mm.  
10 ,, 84" × 36" × 9 mm.

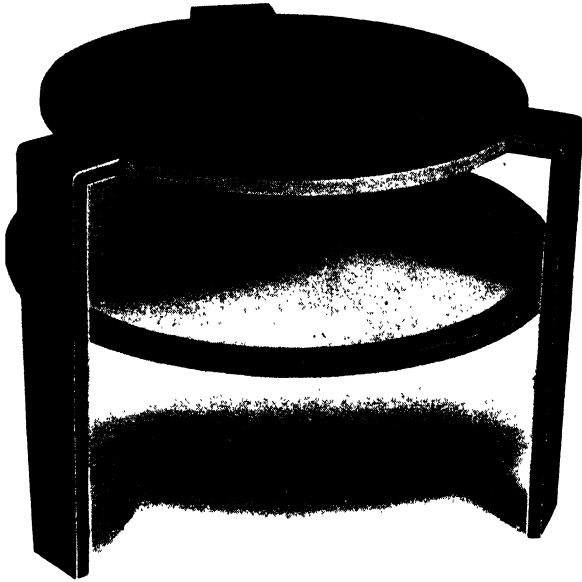

*{By courtesy of Messrs. Gordon Russell Ltd.*

FIG. 119.

A coffee-table almost entirely formed with Birch and Walnut plywood.

Such a specification will indicate that the tenderer must allow for such additional price as is necessary to cover the expense of opening bundles and turning over stock to obtain the desired material.

## 2. PLYWOODS TO BE SPECIALLY VENEERED.

A simple specification might read :—

$\frac{1}{2}$ " laminboard (of approved brand) Gaboon throughout ; to be veneered on face side with figured Oak with a compensating veneer on the back. Sizes, design and arrangement of panels to detailed drawing. Face veneers to be well finished on belt sander ready for polishing.

By issuing a specification in this form the architect will ensure that the panels will be well balanced, each of a similar type of grain figuration and texture.

More elaborate work is generally shown in specifications as being a P.C. (Prime Cost) item, and special quotations obtained for the completed job from firms specializing in this work. Such concerns will gladly co-operate with architects in the selection of suitable veneers and plywood

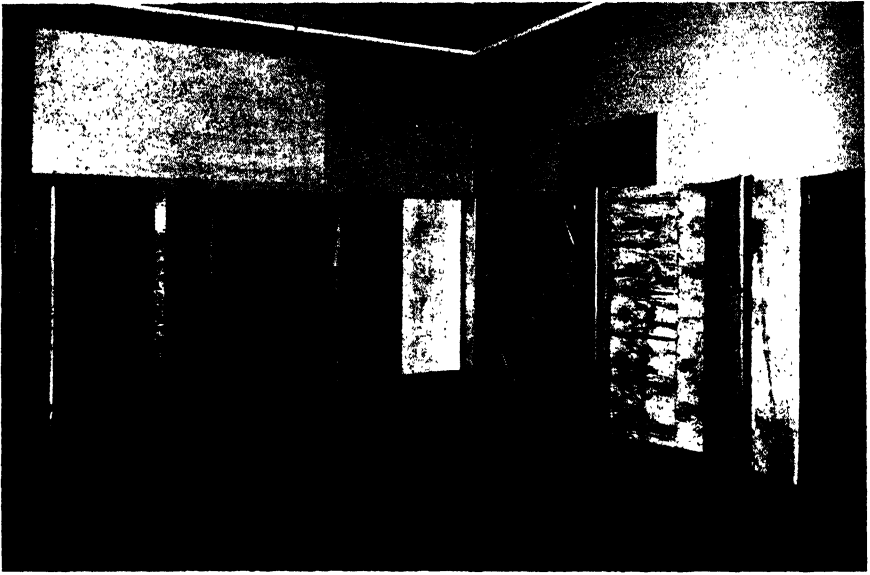

FIG. 120.

Two views of the showrooms of Messrs. Veneercraft Ltd. in which are displayed to advantage a large variety of veneered panels and flush doors.

so essential to work which demands a high degree of craftsmanship. Veneered work of this nature cannot be supplied at prices to compete with plywoods mass produced in veneering factories by semi-skilled labour.

The most satisfactory method of putting such work in train is for the architect to supply to specialized firms a plan and elevation of the job, at the same time giving his views on (1) figure, (2) colour.

The veneers should then be selected by the specialized firm and a colour drawing of the job prepared showing the balance and colour tones. Large-size sample pieces of the veneer suggested should be laid and polished, and accompany the drawings.

For important work of this nature the architect or his client may think it desirable to inspect various types of veneer before making a final selection, in which case the specialist should make a preliminary selection of available stocks of sound texture and suitable size. The architect will be ill advised to make the selection himself as he is seldom in a position to judge the texture of a veneer or to calculate the waste which will be involved in making up the panels, as he cannot know where the veneer layer will have to make his joints or where he will have to trim.

### BUYING VENEER

The man who attempts to purchase veneer purely on a price basis will soon discover that he has been "penny wise and pound foolish." In no other branch of the timber trade is quality of manufacture of such vital importance.

Much of the high-class decorative veneer sold in the United Kingdom is cut in England, but home production is supplemented by imports from continental countries, America and elsewhere. In the years immediately preceding the outbreak of war the value of veneers imported into the United Kingdom was :—

1936	.	.	.	£750,397
1937	.	.	.	£931,269
1938	.	.	.	£742,797

In the year 1938 practically one-half of the total was shipped from France.

Veneers cut in England are generally sold direct by the cutters to all branches of the wood-working trades. Quantities of selected stocks are purchased by merchants and re-sold by them, or they may deliver their own logs of figured wood to the veneer-cutters to be converted into veneer and re-delivered to their instructions.

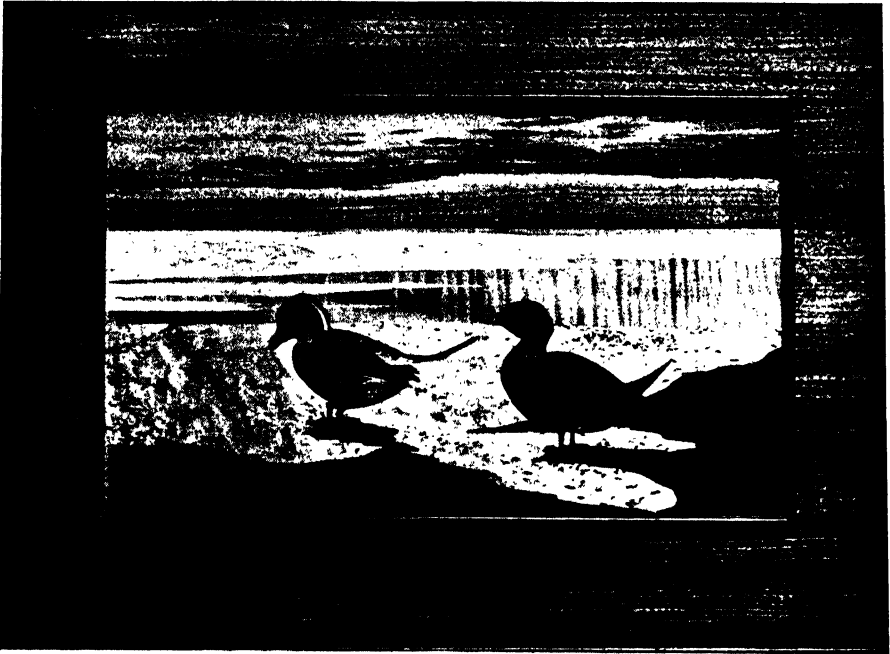

[By courtesy of Messrs. A. H. McIntosh & Co. Ltd.]

FIG. 121.

In the execution of this picture, which is laid on  $\frac{1}{8}$ " laminboard, the following veneers were used:—

Harewood in 3 shades.	Coromandel.	Ebony.
Masur Birch.	English Ash.	Sycamore.
Maple.	Satinwood.	Austrian Beech in 3 shades.
Italian Walnut.	Barcino.	Dyed wood in 6 shades.
American Burr Walnut.		Rosewood.

During recent years large quantities of quartered-oak veneer have been shipped to Britain to meet the demand from the furniture trade. A few foreign cutters were prepared to manufacture veneers to buyers' requirements, but more frequently the latter were obliged to accept specifications stipulating average, or minimum, widths and lengths. In forward business of this nature, contracts should be made only with known shippers through a reliable agent or importer.

When buying landed stocks a user should, whenever possible, inspect the veneers offered and satisfy himself as to the class of figure, thickness and general specification, lengths and widths being selected to yield the panel sizes without excessive waste. The texture and manufacture of the stock is all-important. Buckley or brittle veneer will give the layer much unnecessary trouble, while wood which is porous or "droxy" (having soft woolly patches), no matter how beautiful it may be, had better be left severely alone.

Small hand-samples can rarely give a fair idea of the nature of the figure in any one leaf of veneer and, if it is impossible to examine veneer stocks, sample leaves should be taken from the top, middle and bottom of selected fitches. These will give a good idea of the variation in figure which may be expected.

Having selected suitable material the buyer must decide whether he will purchase a complete log or fitch at one price or pay a higher price for that part of the fitch which is of most interest to him.

Architects and buyers will be well advised to leave the question of thickness to the veneer-cutters who know from long experience the most suitable thickness for different species of wood. In Part VII. the most common thicknesses cut have been indicated. In this country, as in America,  $\frac{1}{4}$ " veneer, which after sanding should finish about  $\frac{1}{32}$ ", has proved to give excellent results with the majority of woods. If logs have to be cut to a special thickness the buyer will require to pay a considerable price premium, in addition to which no guarantee can be given that the log will yield a sufficient quantity of veneers of any particular type.

In the veneer trade, more than any other section of the timber trade, cheap stocks should be avoided as invariably these are poorly cut; on the other hand, buyers are counselled against paying a fancy price for some freak veneer for which the merchant has coined a fancy name of his own.

The value of any veneer depends upon its beauty of colour and figure, length, width, thickness and quality of manufacture—therefore variations within fairly wide limits must be expected.

### (b) SALESMEN AND SALESMANSHIP

The men who are directly responsible for the sale of plywoods should have a sound knowledge of the relative merits of the different constructions and, if they are to do their work thoroughly, should be able to discuss with prospective buyers the application of plywood to any particular job. It cannot be expected that salesmen of plywood become practical cabinet-makers, joiners or shopfitters, but if a youth is given a thorough training in a warehouse handling a large variety of plywoods he will accumulate a thorough knowledge of the wares he will later have to sell and come into direct contact with many of his future buyers. If he has a practical mind he will soon pick up useful information during visits to different workshops and in course of time should become a helpful friend to his customers. The salesman must keep abreast of developments in the industry, study the problems of his

buyers and make a serious endeavour to produce the plywood which will best meet any particular need.

Too many people look upon plywood as a "side line" to the more important timber trade and in consequence consider that any timber traveller can add plywood to his stock sheets without any trouble or expense. This may carry a certain amount of truth in so far as the jobbing joiner is concerned, but there it ends.

It was unfortunate that once plywood had become established as a valuable commodity large parcels should have been bought by firms having little or no practical knowledge of the trade; thus a fair proportion of the cheaper plywoods fell into the hands of speculators whose one idea was to make a quick profit on these purchases. Travellers having little or no knowledge of the material endeavoured to make sales from a priced stock sheet in much the same way as they would have tackled the sale of writing-pads or pencils.

An eminent member of the Architectural Association once referred to the four "big" modern building materials as steel, concrete, plywood and glass. To those who really matter in the wood-working and allied trades, as in architecture and engineering, plywood is a worthy material and as such it deserves the best possible presentation to all buyers be they large or small. Architects, and firms engaged on high-class woodwork, generally welcome any salesman who has a thorough knowledge of his trade as only from such can the busy buyer or architect keep abreast of current developments. They will also know that such a salesman will not recommend any material unless it is eminently suitable for the work in contemplation.

The wise buyer will appreciate helpful advice from such a knowledgeable salesman, who will recommend the most economical and useful form of plywood for any particular job. The wise salesman, on the other hand, will soon realize that it will pay him to allow an order to go to a competitor who is in a position to supply more satisfactory material than he himself can offer.

The ethics of salesmanship was well covered in an article which appeared some years ago in *Veneers and Plywood*, and is worthy of repetition.

"Some men boast that they could sell refrigerators to Eskimos, which means something he does not need. The ability to do this may be all right but to do it is all wrong and what is more is not profitable.

"A salesman with a good personality and persuasive line of talk may make a sale, but what will be remembered after the

salesman has departed is that he has sold something that could not be used for the purpose intended and 'pulled a fast one' on the buyer. These are things that many super-salesmen have learned to their sorrow."

### (c) HANDLING OF SHIPPING DOCUMENTS AND PASSING OF CUSTOMS ENTRIES

The following is a résumé of the general procedure followed in the majority of ports in the United Kingdom.

On arrival of a vessel in a United Kingdom port the captain reports to the Customs authorities. The rate of exchange ruling at the time of reporting is applied for converting into sterling all invoices for goods, and other charges, in foreign currency which have to be so converted for Import Duty purposes or for payment of freight.

No goods will be released to an importer until the following procedure has been completed :—

1. The Dock and Town Dues must be paid to the local Dock Authority. The amount payable will be ascertained from the schedule of charges fixed by the Dock Board or Harbour Authority and an account will be obtained from the office concerned.

2. The following documents must be lodged with the Customs Authorities at the Customs House :—

Form 107 (Sale) in quintuplicate.

Form C 105.

Shipper's Invoice in duplicate (one set to be marked "For Customs").

If it is intended to reclaim Duty or part Duty at a later date an additional copy of Invoice and Specification is required in order to have Invoice stamped by Customs for drawback. In such cases the invoice must be marked "To be stamped for drawback."

Original Bill of Lading endorsed on the back by the importer.

Original Certificate of Insurance.

Original Certificate of Origin (only required in the case of goods of Empire origin).

These documents are generally held for twenty-four hours. The amount of Duty leviable must be paid immediately either in cash or, if the total Duty payments exceed £500 in any one week, by a banker's cheque. The importer's own cheque will not be accepted.

When a complete set of shipping documents is available a "Perfected



Entry " is prepared on Form 107 (Sale) and the following items shown separately :—

- (a) the value of the shipment ;
- (b) the Sterling Cost of Insurance ;
- (c) the freight as ascertained from the Bill of Lading or from the shipping office ;
- (d)  $\frac{1}{10}$  of 1 per cent. to cover cost of Dock Dues and Landing Charges.

The Duty is calculated on the grand total of *a*, *b*, *c* and *d*, at whatever rate is applicable.

In the event of documents not being available when the vessel reports, it will be necessary to obtain preliminary Customs Clearance by means of a Bill of Sight (Form No. 21 (Sale)). As much information as possible is obtained from the manifest at the steamship office, and this should enable the correct amount of Freight and Dues to be ascertained. An approximation of the value of the shipment can be assessed from contract records and the amount will be paid to H.M. Customs "on deposit." When the documents arrive, the "Perfected Entry" can be made in the ordinary way and the "on deposit" Duty payment adjusted as may be required.

When imported goods are not dutiable—*e.g.* if from a Dominion—the documents must still be passed on Form 107 (Sale) which is marked "Exempt" in the space provided and the entries marked "Canadian (or other Dominion) Origin, we claim preference."

Form C 105 must be completed and signed by the importer and a declaration made that "the price shown is the ultimate *c.i.f.* price, *viz.* the last *c.i.f.* price prior to importation."

3. After being sighted by H.M. Customs, the endorsed Bill of Lading must be handed to the Shipping Company along with a cheque in payment of freight, unless this charge has been prepaid by the shipper. In exchange, a delivery order will be handed over and, unless a copy of the Bill of Lading has already been received direct from the shipper, one should be obtained from the Shipping Company and filed for future reference. In every instance a receipted account for the freight should be obtained at the time payment is made.

In the event of the original Bill of Lading not being received at the time of arrival of the vessel an Indemnity to cover the value of the shipment should be obtained from the Bank. This will be issued by any Commercial Bank to its clients ; a small charge is made and the document must be returned to the Bank once the original Bill of Lading is received. This Indemnity is lodged with the Shipping Company together with a cheque for the freight in exchange for which the Delivery Order will be handed over.

4. The Delivery Order, Paid Customs Entry and Customs Copy of Shipper's Invoice must be handed to the Customs Officer at the dock in which the vessel is berthed. These documents will be examined, the shipment inspected and, if everything is in order, he will endorse the Delivery Order accordingly. This is handed to the master porter at the dock and arrangements can then be made to have the goods removed from the quay.

It frequently happens that Shipping Companies, or Shipping Agents, are appointed to act on behalf of an Importer in passing Customs Entries. In such cases Form C and E No. 648 addressed to H.M. Customs and Excise at the port of entry must be completed and signed by the Importer. This enables the Agent to complete Form 107 (Sale) but the Importer must himself sign Form C 105.

When plywood is imported into London the Port of London Authority (P.L.A.) make the necessary arrangements for storage or for delivery from quay. The receipted Customs Entry and released Bill of Lading should be sent to the P.L.A. together with disposal instructions and a copy of the specification if the plywood has to be stored.

If the consignment is over 15/20 tons weight the goods may be taken overside into lighter for delivery direct to destination. In this event receipted Customs Entry, released Bill of Lading, Delivery Order, Consignment Note and final instructions should be handed to the Lighterage Company.

#### (d) DRAWBACK ON PLYWOOD AND VENEERS SUPPLIED TO REGISTERED SHIPBUILDING YARDS

1. The Import Duties (Drawback) (No. 5) Order 1934 provided for Duty to be allowed and paid on, *inter alia*, "plywood and veneers imported as such."

2. Certain conditions were laid down as necessary to establish a title to Drawback, the first essential being that the material must be supplied to the shipyard "by the Importer or by some person who has taken delivery thereof directly from the Importer."

3. The Commissioners of Customs and Excise formulated rules regarding information to be furnished and records to be kept and produced to substantiate any Claim which may be made. Firms intending to claim Drawback of Duty must sign an Undertaking to conform to these requirements and must also enter into Bond: either "Ordinary" or "General" in respect of intended Claims. The former Bond is given for a single consignment but the latter is advantageous when a series of "Exportations" are to be covered.

4. The methods of claiming Drawback of Duty may vary, but the following notes indicate general procedure.

5. The form used is No. 135 (Sale), adapted to the special requirements of goods removed or, as it is termed, "exported" to a registered shipbuilding yard. The form consists of two sheets, one marked "Original" and the other "Duplicate," practically identical: the chief difference being that the former provides an acknowledgment of receipt of the goods at destination where the latter provides for a Certificate of Shipment. Although printed "in duplicate" the form is required to be lodged in triplicate and as can readily be imagined the extra or fourth sheet out of each two forms serves usefully as a filing copy for subsequent reference and the verification of Drawback received.

The claimant to Drawback has the option of having the goods examined by the Customs Officer: (a) at place of packing, or (b) at the shipbuilding yard. In the case of (a) Form No. 135 (Sale) should be completed in triplicate, the original and triplicate being sent to the officer visiting the shipyard and the duplicate to the local Officer of Customs and Excise. The duplicate should be in the hands of this officer at least twenty-four hours before despatch or at such time as will give him a reasonable opportunity of attending the packing.

When option (b) is exercised the "Notice to Pack" is amended to show "examination will take place at.....," the name and address of the shipbuilding yard being inserted. The form in this case is lodged in triplicate with the officer who visits the shipbuilding yard. (Permission was given to lodge the "triplicate" only with the appropriate officer at least twenty-four hours before despatch, this being followed at the earliest possible moment by the Original and Duplicate Forms. This was a very necessary concession, as it was frequently found that, for example, in the case of new arrivals full details were not available of the value of the material on which Duty was payable.) The lodging of the Shipping Bills twenty-four hours prior to despatch is termed "Pre-entry," and if Pre-entry is not secured to the satisfaction of the officer visiting the shipyard the claim for Drawback will fail. It follows therefore that the onus is on the supplier to the yard to ensure that the latter will not lose the concession obtained by Drawback by securing Pre-entry. On the other hand, as material required for certain jobs carried out by the shipyard do not come within the category of being eligible for Drawback, the shipyard should at all times make it clear to the merchant whether or not Drawback of Duty should be claimed.

As previously indicated, Drawback can be claimed where the "Exporter" to the yard has purchased the material from a firm who were the direct Importers. In such circumstances the procedure is

slightly more involved. Duty is then said to be claimed "by assignment": Pre-entry must still be secured by lodging No. 135 (Sale) in triplicate, but across the columns which provide for the value of the goods, Rate of Exchange, Duty Paid and details of importation, the "Exporter" inserts a note to the effect that these particulars will be supplied by . . . . . (the original Importer) "to whom all interest in the Duty has been assigned." At the same time another form No. 57 (Sale) must receive attention. This form is a single sheet printed on both sides, one termed Part A and the reverse Part B. "Part A" forms the "Declaration of Assignment" to be completed by the "Exporter" who forwards the form to the "Supplier" (the Importer). The latter completes "Part B" and also another form—termed the Importer's Statement—No. 134 (Sale). When duly completed and signed these two forms are lodged with the appropriate Officer of Customs and Excise.

In due course, the Claim is verified at the office of the Exporter by the local Customs and Excise Officer. Stock records must be produced which show clearly the "history" of the transaction—Date of Importation, vessel's name, Invoice Reference, Specification, Price, Rate of Exchange, etc., and the entry of the sale showing date, Delivery Order or similar reference, Specification, and balance of stock, if any, carried down. Any balance showing at the date of the visit may be subjected to a physical check by the officer.

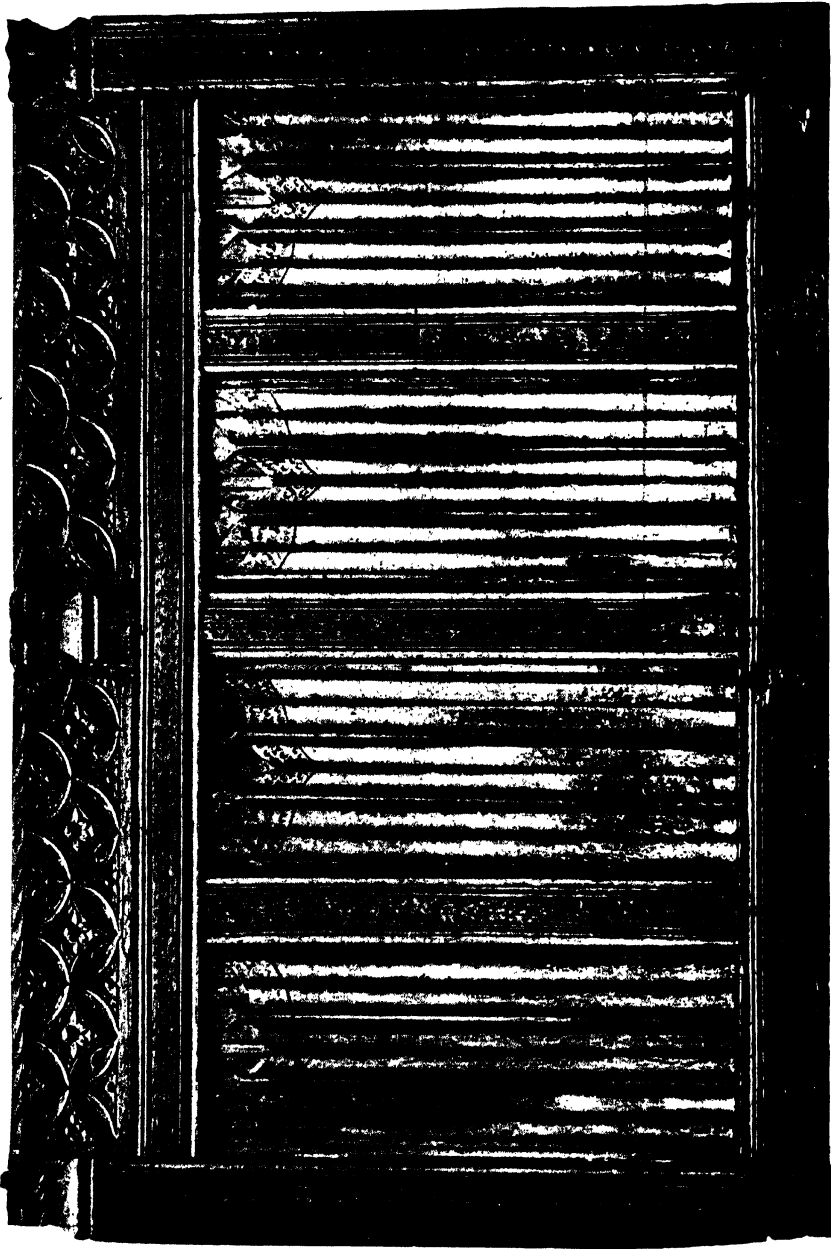

*Crown Copyright reserved.*

*[By courtesy of the Victoria and Albert Museum, London.*

PLATE XII.—EARLY SIXTEENTH CENTURY.

An excellent example of early panelling carved with the linen-fold pattern.

## PART IX

### THE DEVELOPMENT OF WALL PANELLING

THERE are two main theories which have guided designers of both interiors and exteriors since the earliest days of architecture.

The first is that the decoration should form an essential and integral part of the structure to which it gives final expression. The second, and alternative theory, is that the decoration should be no more than surface ornament used to conceal the actual structural material.

One of the first well-defined conceptions of wall decoration<sup>1</sup> in the form of panelling comes from the early Romans who laid their stones in such a way that certain portions were allowed to project, thus forming an outline to flat surfaces which were frequently decorated. This practice of relieving large flat areas by breaking them into panels has remained ever since. The Athenians loved colour, and many of their panelled surfaces were decorated by paintings executed in tempera, oil or caustic direct to the plaster of the walls.

Richly coloured marble was one of the earliest materials to be used, combining structural with decorative form. In the time of Augustus, slabs of marble 5 inches or more thick lined the walls of the great halls, serving the structural function of filling the apertures between granite or marble columns or pilasters, and at the same time enriching the architecture with beautiful colouring.

During the second or third century A.D. thick slabs of marble gave place to pieces no more than 1 inch thick which functioned primarily as a decorative medium, to all intents and purposes acting as a veneer covering the structural materials.

In England, about the time of Edward the First, wood appears to have been introduced as a form of decoration for the lower part of walls which otherwise were plastered and painted or hung with tapestry. Little work of the thirteenth century has survived, but during the ensuing century the woodworker and woodcarver gradually began to make their influence felt. By 1400 A.D. they had established themselves as master craftsmen and, with the development of Gothic architecture in which decoration of all kinds became more and more important—

<sup>1</sup> Various excavations in Egypt have established the fact that types of wall decoration were known to the ancient Egyptians, but these do not appear to have influenced subsequent design to any extent.

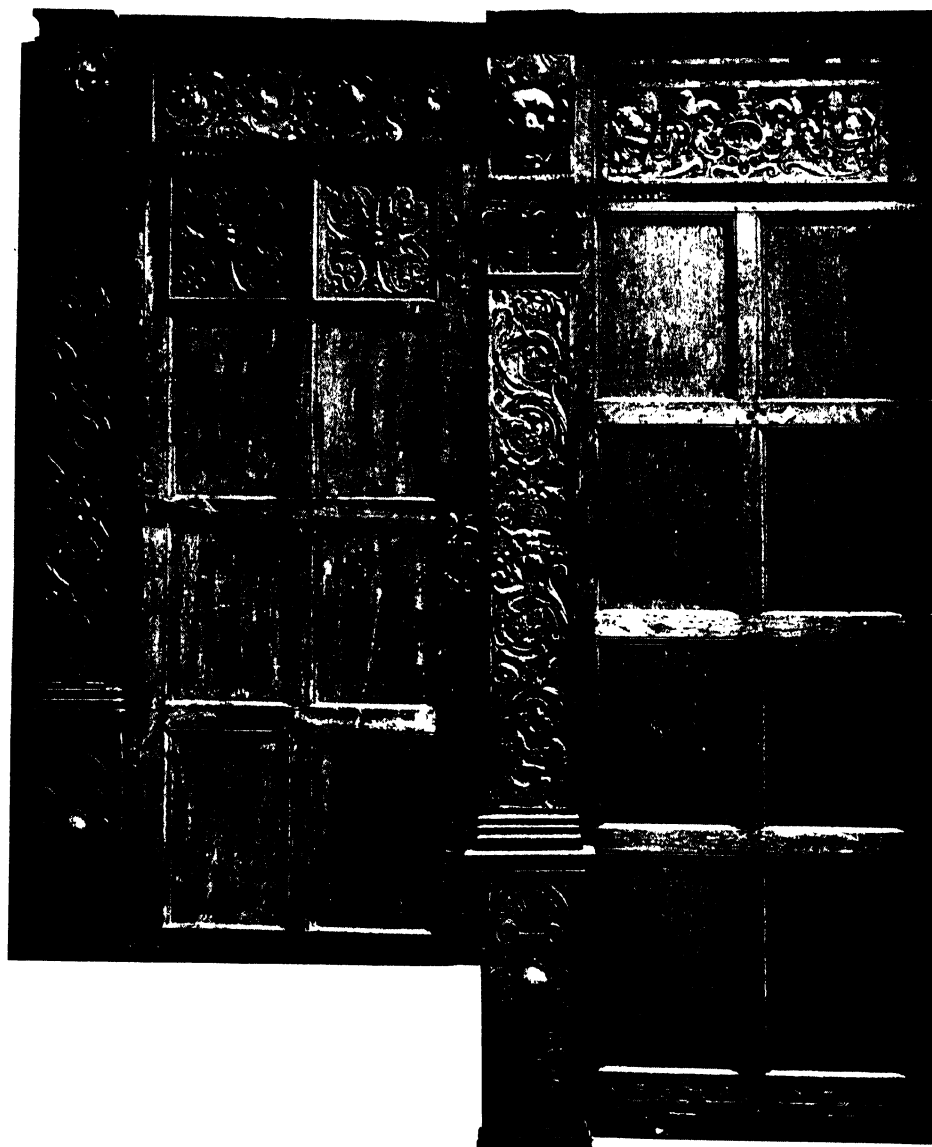

*Crown Copyright reserved]*

*[By courtesy of the Victoria and Albert Museum, Lond*

PLATE XIII.—LATE SIXTEENTH-CENTURY PANELLING IN QUARTERED OAK.

being used to emphasize rather than to conceal structural essentials—the woodworker proved his worth and has left us many beautiful examples of his craftsmanship.

It may be of interest to mention that the Guild of Carpenters of London obtained their Charter of Incorporation in the year 1477, so it may safely be assumed that their work, even at this early date, had become of considerable importance. The joiners of the period made tables and furniture of all sorts, including much of the decorative woodwork of the churches, and worked under the supervision of the master carpenters.

It is from the churches of the fifteenth and early sixteenth centuries that our ideas of the earliest forms of wood panelling in Britain have been formed. In every church built during this period are to be found numerous screens erected in the form of a rectangular framework, the lower part frequently being divided by mouldings; panels were carved, painted in oils, or at times gilt. Some beautiful examples of this very early form of decorative woodwork have survived.

At a somewhat later date a framework, similar in design to the church screen, was fixed to the walls of wooden buildings and mansion-houses and served to cover up beams and other structural members.

Through the courtesy of the Director and Secretary of the Victoria and Albert Museum, which houses many treasures of early woodwork, we illustrate in Plate XII. a beautiful example of carving in what is known as the "linen-fold" design which was one of the favourite methods of decorating panels of wood used both for furniture and for wall decoration. This piece of early sixteenth-century workmanship and design was removed from a farmhouse near Taunton, Somerset.

The section of late sixteenth-century panelling illustrated by Plate XIII. marks the advanced refinement of the times. This is the typical form of early Tudor panelling which has had its influence on forms of wall decoration ever since. The small rectangular panels are framed by long rails and muntins which are secured at the joints by oaken dowels. The panels are surrounded on three sides by a simple moulding, the panelling itself being divided at intervals by carved pilasters. Mouldings used in the middle of the sixteenth century were frequently more elaborate and were often applied.

Plate XIV. illustrates a choice example of the period of James the First. In this room each wall from floor to cornice is covered with Oak panels in various sizes, set in moulded framing, and divided at intervals by carved pilasters. The elaborately carved chimney-piece should be noted as this was one of the outstanding features of room decoration during the early seventeenth century. Design in the second half of the seventeenth



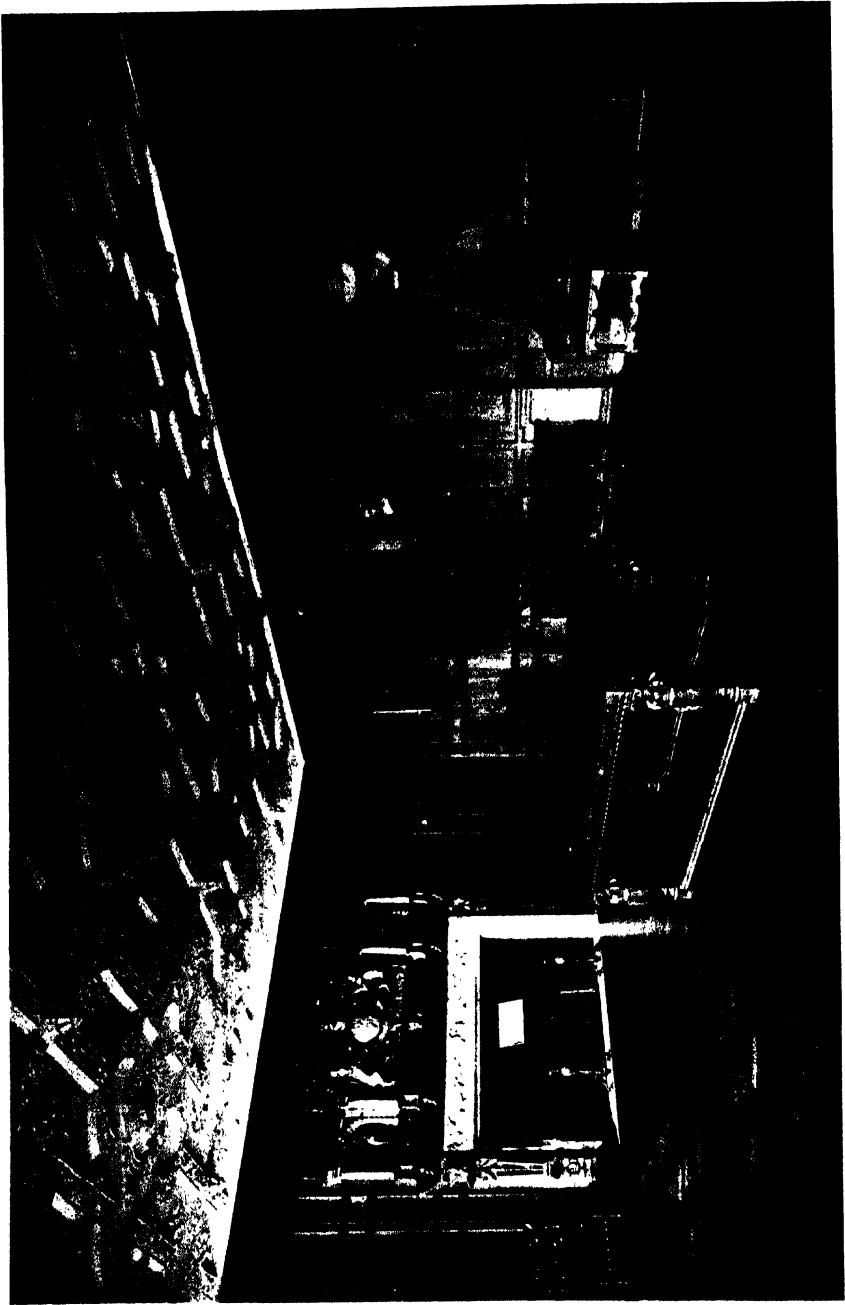

*Copyright reserved*

PLATE XIV.

*[By courtesy of the Victoria and Albert Museum, London.*

panelling removed from a house known as "The Old Palace" at Bromley-by-Bow, Middlesex. Date 1606.

century was greatly influenced by the antique and shows a marked Italian Renaissance flavour which was strongly developed in the work of Inigo Jones.

A room typical of this period is illustrated by Plate XV., the panelling consisting of raised panels of figured Oak with bolection mouldings and applied carvings of Cedar. By the end of the seventeenth century this type of decoration had replaced the earlier forms of small rectangular panels. The upper panels, running from chair-rail to enriched cornice, were frequently decorated with full-length portraits.

Oak being plentiful and cheap provided the principal building wood, but when mansion-houses were built in country districts for the nobility and gentry, timber grown on their estates was frequently cut; thus we find that Walnut, Sycamore and Deal (Pine) were also commonly used.

During the early eighteenth century Deal or Pine panelling was in popular favour, generally being designed in long fielded panels supported within a framework of similar wood. The panelled walls were frequently painted or gilt.

The influence of the brothers Adam began to make itself felt in the middle of the eighteenth century and wooden panelling gave way to "a decorative convention based on the remains of Greek and Roman buildings and adapted to new purposes with astonishing resource." "The effect upon interior decoration was profound. A complete harmony was obtained in the design of the ceiling and walls, the pattern of the carpet, the furniture and fittings, all being brought within the compass of a single style, logically conceived and consistently worked out."<sup>1</sup>

The decoration of this period is described by the eminent architect Isaac Ware in his *Complete Body of Architecture*, published about 1763:—

"The decorations of the inside of the rooms may be reduced to three kinds—first, those in which the wall itself is properly finished for elegance—that is, where the materials of its last covering are of the finest kind and it is wrought into ornaments plain or uncovered; secondly, where the walls are covered with wainscot; and thirdly, where they are hung; this last article comprehending paper, silk, tapestry and every other decoration of this kind."

During the nineteenth century no pronounced change in design was manifest.

A dining-room in the mansion-house of the Victorian era frequently had a dado of wainscot or mahogany to chair-rail height, the upper

<sup>1</sup> Quotations are made by kind permission of Sir Eric Maclagan, C.B.E., Director and Secretary of the Victoria and Albert Museum, London, from the Introduction to Volume IV., *Catalogue of English Furniture and Woodwork*, which was prepared by Mr. Ralph Edwards.

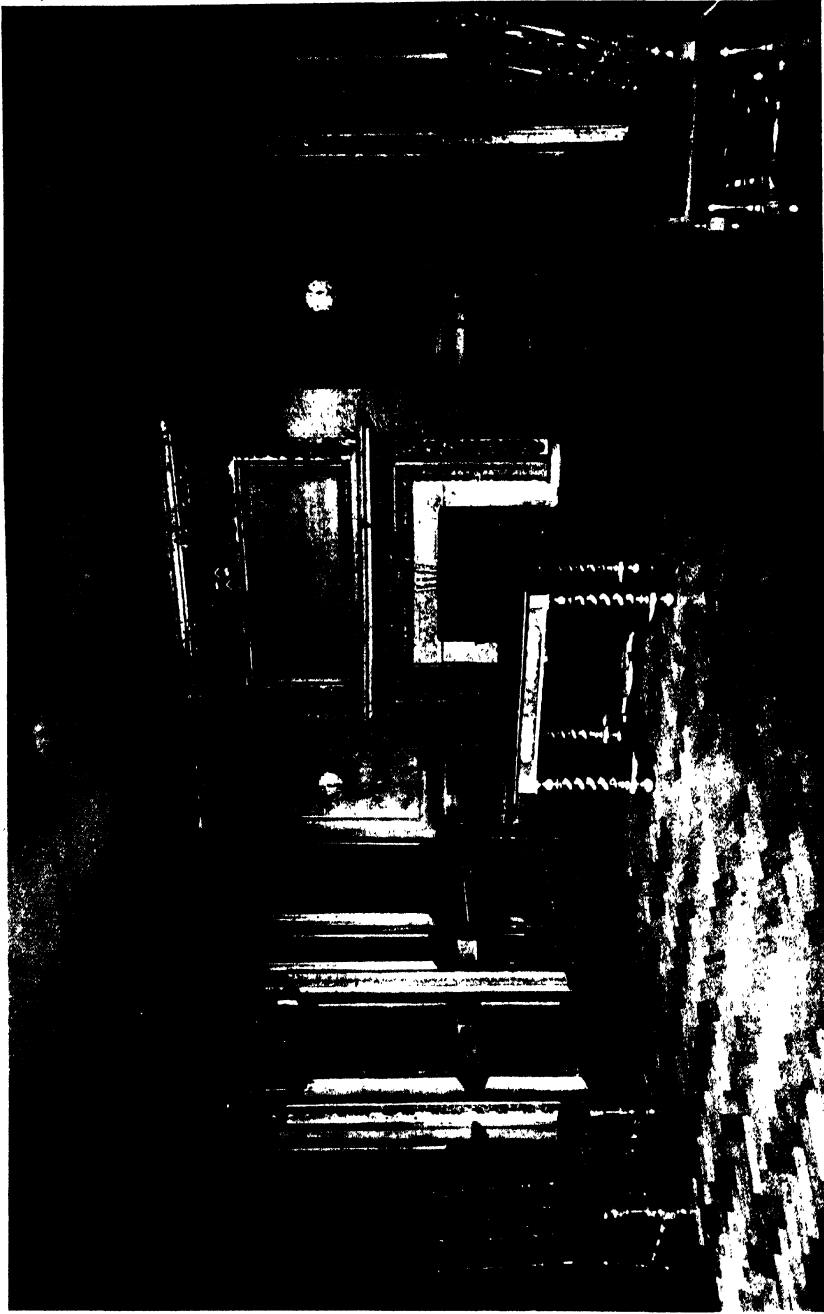

*Crown Copyright reserved.*

PLATE XV.

Oak panelling removed from a room at No. 3 Clifford's Inn, London, about 1686-88.  
The heavy bolection mouldings should be noted.

*By courtesy of the Victoria and Albert Museum, London.*

part of the wall being plastered and decorated with wallpaper or paint. In cases when entire walls were panelled the design was invariably based upon one of the earlier forms which have been described. As often as not small rectangular panels or larger fielded panels were set into a rebated framework, the panels being recessed  $\frac{1}{4}$ " or more, an arrangement which tended to cover the inevitable shrinkage of the wood.

The fact that this particular form of decoration has retained its popularity throughout four centuries is worthy of note as one proof of the truism that architecture should represent nature. One never tires of the beautiful in wood. It is fundamental that architecture demands sincerity in the application of materials; thus wood effects should come from wood and not from steel or composite material faked to represent the grain of a particular wood. Substitutes have their days but generally fade into a forgotten past. The beauties of wood are ever with us; many improve with age.

When plywood was introduced to the building trade and had proved itself worthy of some consideration as a decorative material, the commercial designer and architect followed the traditional course of applying the new material in the old forms, and little progress in design can be recorded until the third decade of the present century. The introduction of reliable laminboards gave a fine opportunity to the modern architect to create an entirely new type of design, and a new technique gradually developed.

The modern designer re-discovered the intrinsic beauties in the grain-pattern of many woods, and in creating his design he took full advantage of the many decorative veneers which were to hand. The large surfaces of plywood enabled him to do away with much applied woodwork in the form of stiles, rails, and mouldings which had been such essential features in the earlier types of panelling.

He went a step further when he realized that he had to hand a medium which, in addition to being decorative, was a constructional material of great strength and utility.

## THE APPLICATION OF PLYWOOD TO WALL PANELLING

The two theories mentioned at the beginning of this Part may be applied to the selection of plywood as a medium for wall panelling. That is, it can be made to serve one of two functions :—

The first, in which the plywood forms an essential part of the structure and gives final expression thereto.

The second, in which the plywood is used merely as surface ornament.

That plywood is one of the most useful and versatile materials available to the designer or builder for the covering of walls is an acknowledged fact. It may be used in the form of an inexpensive commercial plywood to be decorated by paint or enamel, or as a richly figured veneered board which will disclose for all time the natural beauty of the selected wood. Between these two extremes lies a choice of decorative material to meet every possible taste and bill of cost. Each type has its uses, and in each the modern standards of simplicity



*(By courtesy of the Editor of "Wood.")*

FIG. 122.—PANELLING IN PRIVATE RESIDENCE.

A good example of Period Panelling in modern style. Panels are of  $\frac{1}{2}$ " blockboard veneered quartered Oak.

and hygiene are met. The plates have been selected to illustrate a wide variety of modern panelling.

Let us consider the application of plywood as surface decoration.

#### (a) PERIOD PANELLING

The three styles of panelling which have been mentioned as having retained their popularity throughout the last four centuries still act as a basis for much modern design and are generally described as Period

Panelling. In such schemes plywood can be used to good effect in place of the solid panels of yester year.

Rectangular panels in a framework of stiles and rails differ from the old-style panelling in that they are prepared in a wide variety of designs and a still wider range of woods many of which could not possibly have been used before the advent of plywood. Practically any of the methods of laying veneer described in Part X., Chapter I., may be used. The framework is generally run out of solid timber to match,



*By courtesy of Messrs. D. Burkle & Son Ltd., London*

FIG. 123.—PANELLING IN PRIVATE RESIDENCE.

Plywood panels, veneered with Blackbean, give a rich effect to this imposing entrance hall at Eltham Hall.

or contrast with, the panels. The edges of stiles and rails may be square or moulded. In contradistinction to the fears of the earlier craftsmen, who were continually faced with the problem of movement of wooden panels, the present-day woodworker has no such worries in that all possible movement in even the largest plywood panels may be disregarded. For this reason a simplification of the framing is made practicable and there is no necessity to pre-fabricate an expensive framework in the workshop. Examples of Period Panelling in modern style are illustrated in Plate IX. and Fig. 122.

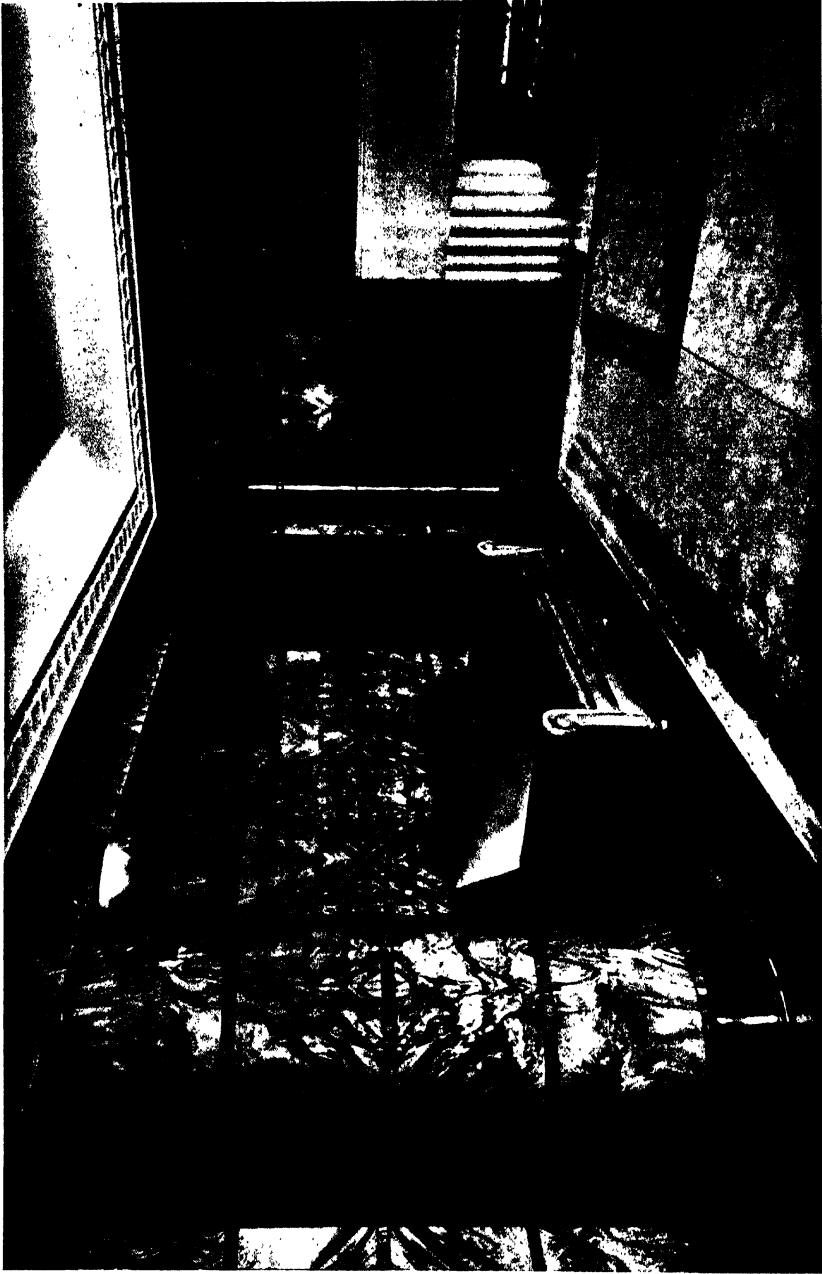

[By courtesy of Messrs. Veneercraft Ltd.]

PLATE XVI.—PANELLING IN GOVERNMENT OFFICES.

A corner of the apartment of the Secretary of State for Scotland in St. Andrew's House, Edinburgh. The wall panels are of  $\frac{1}{4}$ " Gaboon Multi-ply veneered with Walnut Burr. The burr was cut from a tree planted by Mary Queen of Scots at Balmorino Abbey.

*(b)* DECORATIVE PANELLING OF MODERN DESIGN

The new technique which has been developed by the modern architect has, to a very large extent, eliminated applied woodwork. By the judicious use of laminboards, or large cross-grained multi-ply boards  $\frac{5}{8}$ " to  $1\frac{1}{4}$ " thick, the entire area of a wall can be covered, or a divisional wall erected, without a single break to mar the flush surface. In building up large areas the widest available boards should be used in order that the number of joints be reduced to the minimum, but it will be obvious that the panels must not be so large that they cannot be "entered" through doors or window space. The plywood should be tongued and glued or held together by dowels at 9" to 12" intervals in the manner illustrated in Fig. 126 and then carefully flushed off. The complete surface is then overlaid with a cheap but sound veneer such as Poplar or Plain Mahogany on both sides and thereafter the face veneers assembled and glued to the prepared surface. In this manner all danger of the joints showing through the face veneer is eliminated. The reverse side should be veneered with an inexpensive backing; or, if hidden and likely to be subjected to any undue strain, straps running the full height of the panels may be screwed behind the joints. The monotony of large surface areas is relieved by the arrangement of the veneers which will be matched in the manner calculated to disclose the figuring in its most decorative form. The illustrations will show more clearly than words the handsome effects which can be obtained. Such work is expensive and is seldom used except in decoration of the highest class.

Curved surfaces can be prepared and worked into the decorative scheme, as is described later in this chapter. Handsome effects can also be obtained by the judicious use of fielded or raised panels, either as a feature to a panelled room or as a general form of panelling. These can be prepared by any one of the methods illustrated on page 432. The actual arrangement of panels is a matter of choice.

The necessity for concealing nails or screws used in the fixing of panelling has set the woodworker many a problem, and one suggestion which has been successfully applied is illustrated. This is an ingenious arrangement which will only be used in the best work.

Quite interesting forms of plywood panelling may be erected by the careful selection of standard-sized sheets faced with decorative veneer. A wide choice is available at modest cost. The arrangement of panels offers a wide scope to the designer and, by giving some thought to the placing of vertical and horizontal lines or to the judicious utilization of light or dark woods, an impression of spaciousness can be given to quite



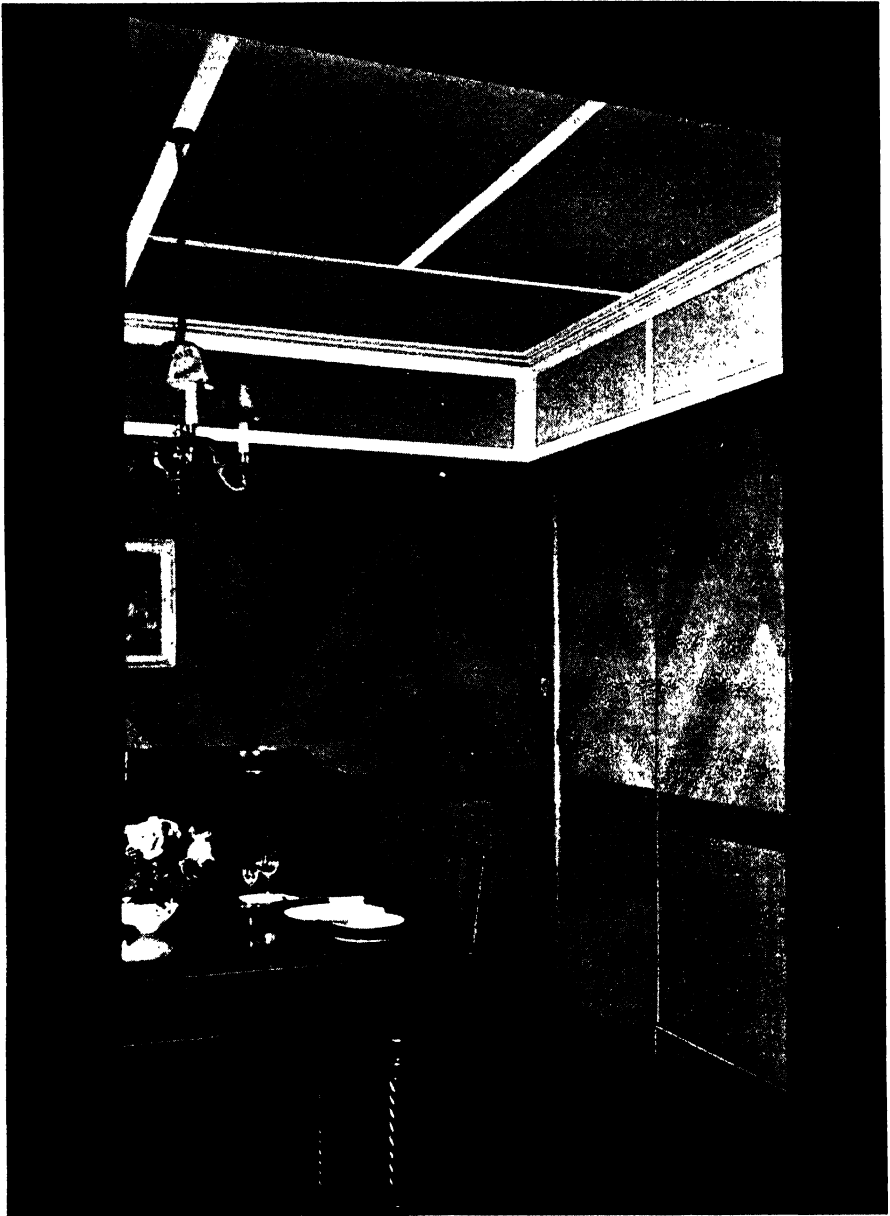

PLATE XVII.—DINING-ROOM.

A modern panelling scheme carried out in half-quartered figured Oak with a banding at chair-rail height of Elm Burr. The panelling was designed and executed for Mr. A. D. Wood by Messrs. H. Morris & Co. Ltd., Glasgow. The doors are of double laminboard as shown in plan on the opposite page.

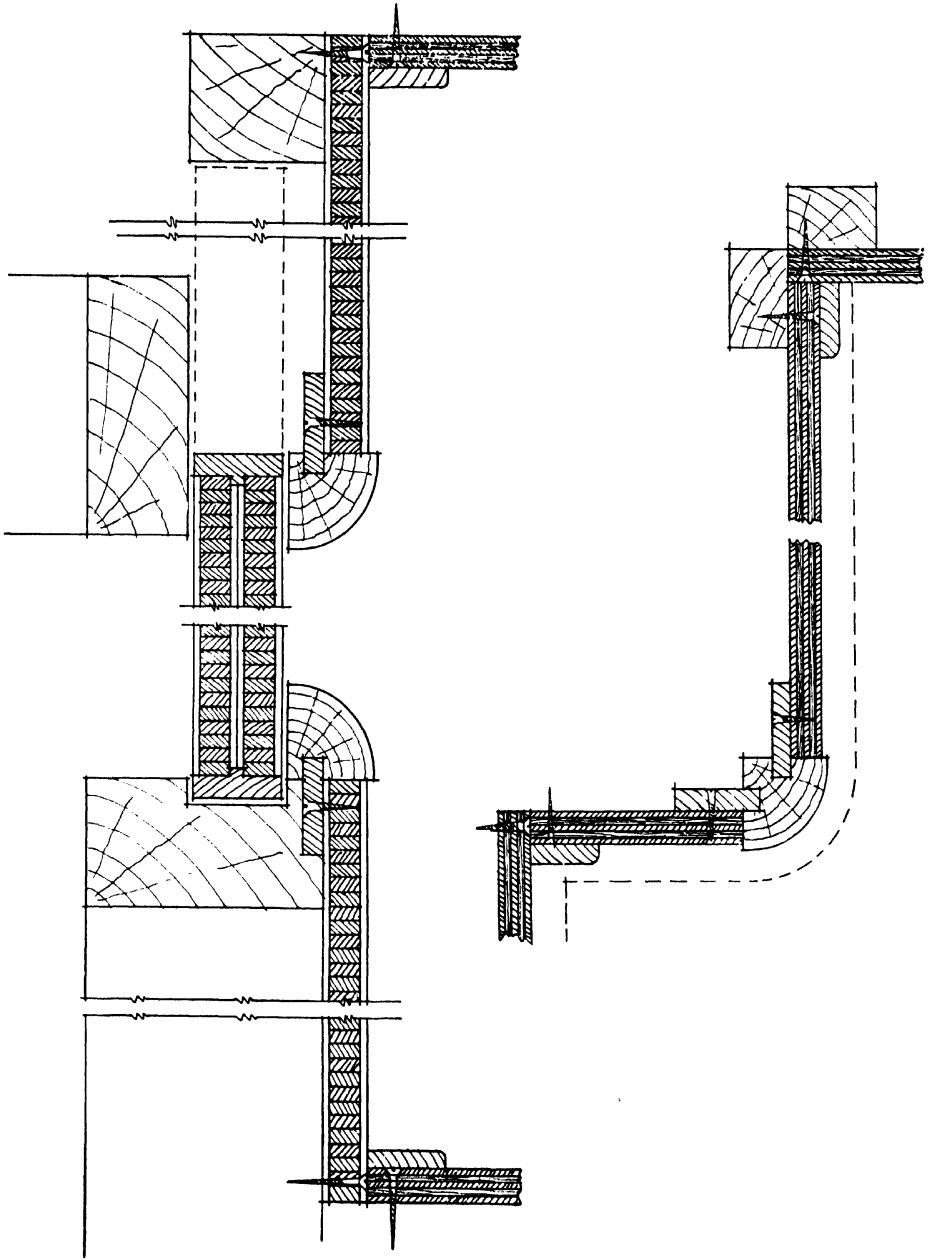

FIG. 124.

Detail of panelling illustrated opposite. The sliding door is built up with two thicknesses of  $\frac{3}{8}$ " Gaboon laminboard and veneered on both sides. The wall panels at this door are  $\frac{3}{8}$ " thick, elsewhere  $\frac{1}{2}$ " Gaboon Multi-ply served as the base.

Detail showing method of fixing panelling at internal and external corners.

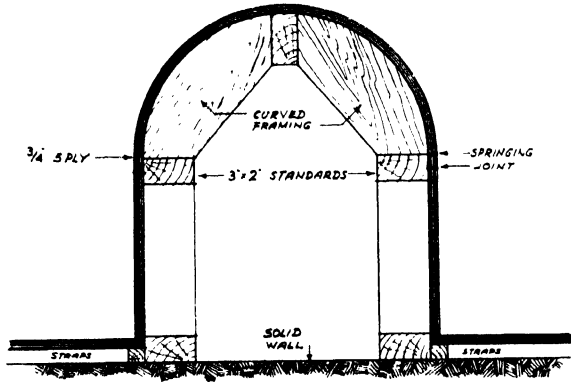
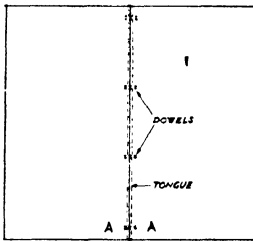
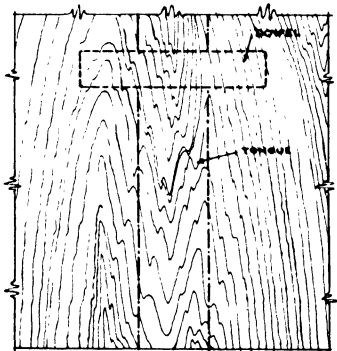

FIG. 125.

Method of constructing casing to the projection illustrated on page 340.



ELEVATION OF PANELS SHOWING POSITION OF TONGUE & DOWELS



DETAIL ELEVATION AT 'A-A'

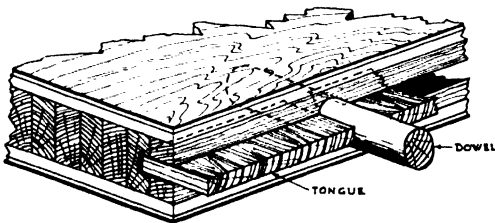

SKETCH SHOWING TONGUE & DOWEL

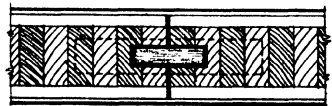

DETAIL PLAN AT 'A-A'

Method of jointing large laminated veneered panels with tongue and dowels

FIG. 126.

small areas. This suggestion is worthy of special consideration when dealing with rooms of irregular shape.

In combination with the plywood panels, mouldings or straps, elaborate or simple in design, raised or sunk, may be used. Various suggestions are illustrated. When stiles or rails are wide, plywood veneered on face and both edges should be used in preference to solid wood. In less expensive work set off by square-edged stiles and rails, straps may be cut from  $\frac{1}{4}$ " or  $\frac{3}{8}$ " plywood faced with selected veneer, with grain running lengthwise or crosswise. The edges disclosing the construction of the plywood must be carefully filled with a good wood mastic and painted or cellulosed to tone with the panels. Alternatively, edges of  $\frac{3}{8}$ " or thicker plywood may be hidden by pinning a neat moulding to the plywood.

When panels are small, and for specifications calling for less expensive woods, any of the commercial plywoods  $\frac{1}{4}$ " or  $\frac{3}{8}$ " thick will give excellent service. For more pretentious work the decorative veneers should be specially laid to a base of  $\frac{1}{2}$ " or  $\frac{3}{8}$ " laminboard or well-manufactured Gaboon multi-ply.

A further method of jointing plywood panels is by means of metal mouldings, one example being illustrated. The face of the mouldings may be rendered inconspicuous or may be featured by the use of cellulose paint. This method of fixing eliminates wood mouldings and all nails are concealed.

It is possible to make satisfactory butt joints with plywood, and in this

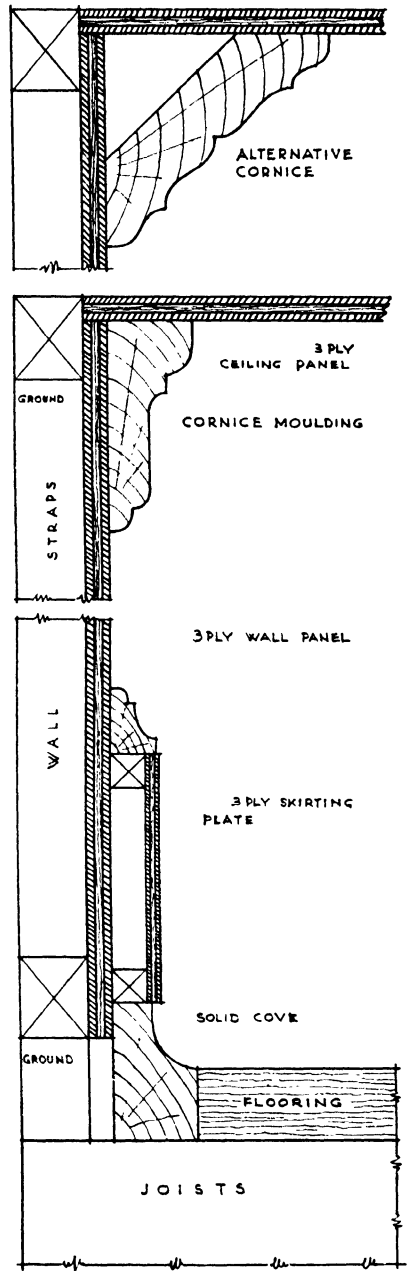

FIG. 127.

A simple but effective method of erecting wall panels and ceiling of plywood.

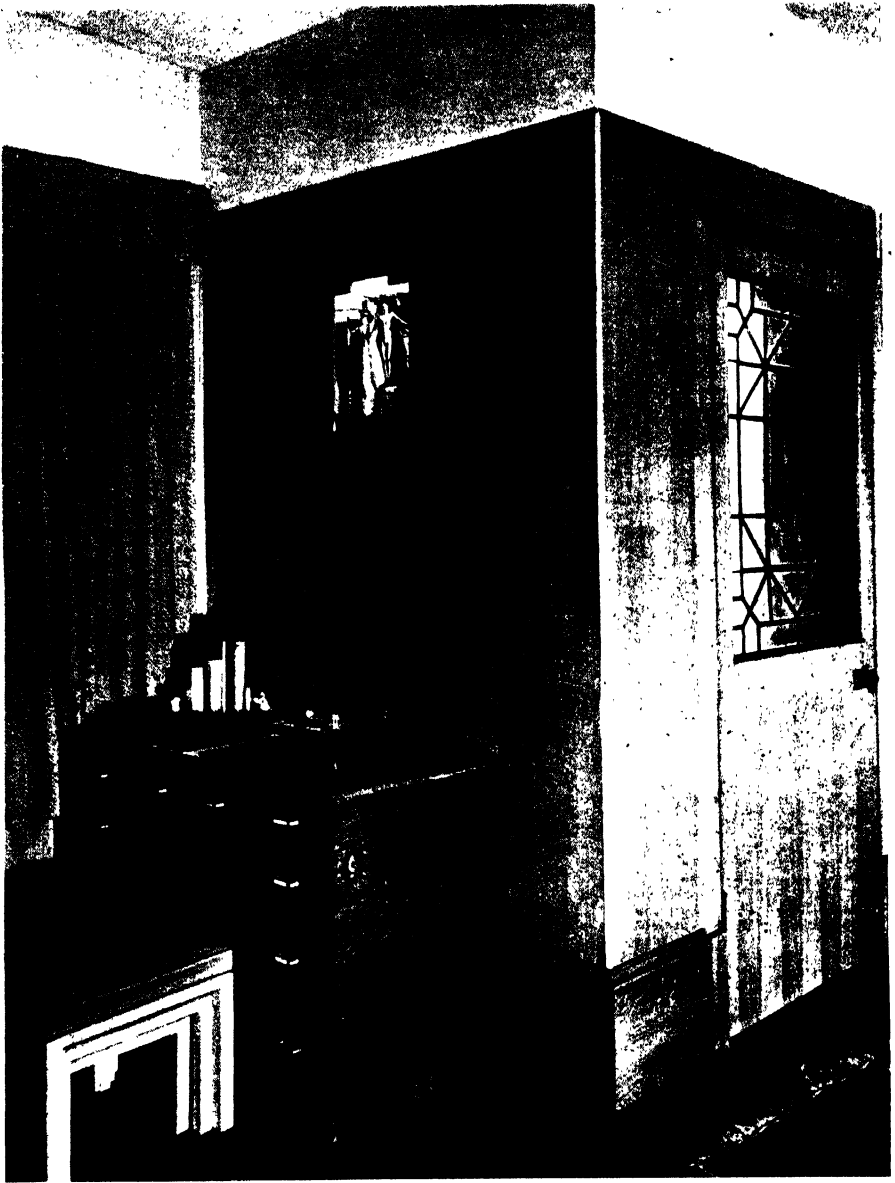
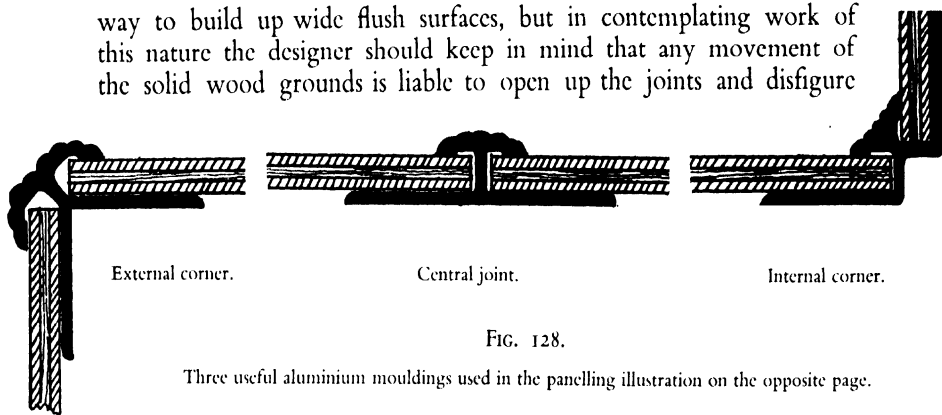

PLATE XVIII.—LOUNGE.

Corner of entrance lounge. Panelling in figured Oak with metal mouldings. The niche was designed and made by Mr. A. D. Wood, using  $\frac{1}{8}$ " plywood, monel-metal plymax and peach-tinted silvered glass.

way to build up wide flush surfaces, but in contemplating work of this nature the designer should keep in mind that any movement of the solid wood grounds is liable to open up the joints and disfigure



External corner.

Central joint.

Internal corner.

FIG. 128.

Three useful aluminium mouldings used in the panelling illustration on the opposite page.

the finished job. If this method of forming joints is used, the risk of movement may be reduced considerably by pinning narrow strips of  $\frac{1}{4}$ " plywood to the battens, subsequently gluing and pinning the face panels to this plated surface in the manner shown on this page.

When plywood is glued direct to a framework with battens spaced at 18 in. centres, the strength and rigidity of the structure is greatly increased. Tests made by the U.S. Forest Products Laboratory on walls 9 ft. high by 14 ft. long demonstrated the relative rigidity and strength of frame-walls constructed with different materials. The published figures are as follows:—

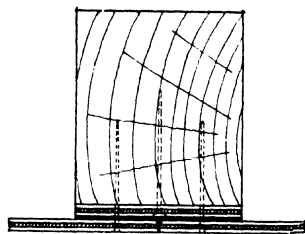
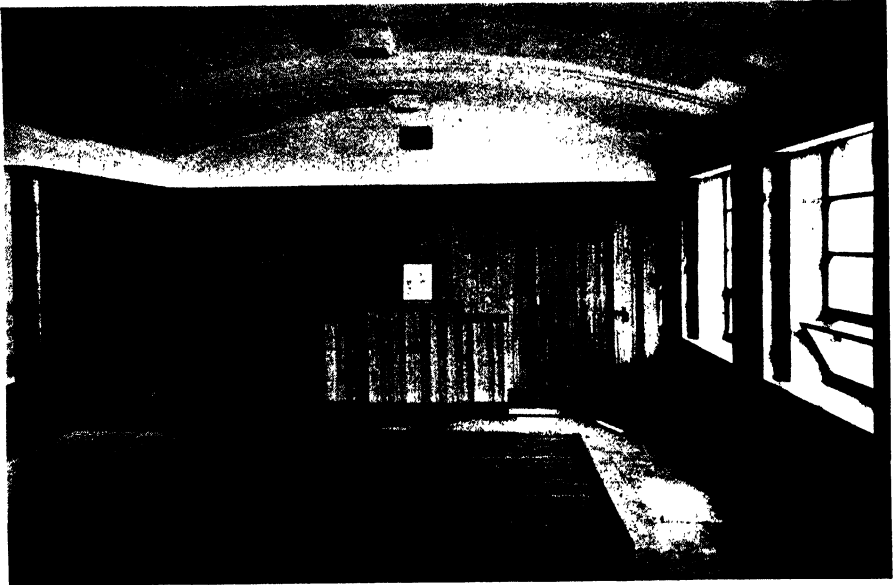

FIG. 129.

	<i>Relative Rigidity.</i>	<i>Relative Strength.</i>
Horizontal wood sheathing	1·0	1·0
Diagonal wood sheathing	4·3	8+
Plaster on wood lath (no sheathing)	7·2	4·4
Plaster on wood lath (over diagonal sheathing)	9·2	7·8
$\frac{1}{4}$ " Douglas Fir plywood sheathing (nailed)	5·9	7·0
$\frac{1}{4}$ " Douglas Fir plywood sheathing (glued)	14·4	8·6

Skirtings when employed, can be built of plywood set out from the panels by an inch or so, and capped with a neat moulding. If a small solid cove is laid to fill the angle made where the skirting meets flooring boards, it will prevent dust collecting at this point and make for easy cleaning. Cornice plates can be cut from one or two lengths of plywood or blockboard and mitred at the angles to meet ceiling and frieze.



One view of a private office. The walls are of  $\frac{3}{4}$ " plywood veneered with Australian Walnut and banded with Macassar.

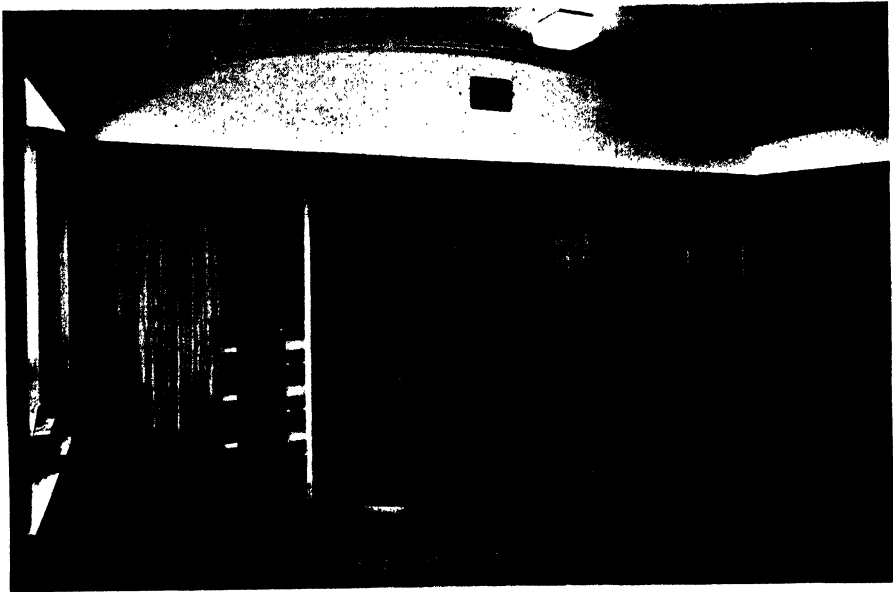

[By courtesy of Messrs. Walter Pickering & Son, Bradford.]

FIG. 130.—PANELLING IN PRIVATE OFFICE.

Another view of the same office showing built-in fittings. On the right a cupboard for coats, on the left the private filing cabinet, which are hidden when the flush doors are closed. Doors are  $1\frac{3}{4}$ " thick plywood construction.

When designing plywood panelling the use of solid wood should be restricted to the greatest possible extent: by so doing the risk of movement will be greatly reduced. There is no necessity to use solid wood except for ground work and occasionally for narrow mouldings and straps.

### ERECTION OF PLYWOOD PANELLING

In a newly erected building the walls of brick, breeze or concrete must be given an opportunity to dry out before any start is made on the woodwork. If this is not done, and the job is unduly rushed, trouble is almost bound to result.

All wood selected for groundwork must be thoroughly dry with moisture content approximating that in the interior of the building. The idea of using any cheap wood for this hidden work must not be countenanced, nor should air-dry timber be used in a building which will be centrally heated. Grounds should be cut from good square edged stuff,  $2'' \times 1''$  or  $1\frac{1}{2}'' \times \frac{3}{4}''$  for  $\frac{1}{4}''$  or  $\frac{3}{8}''$  panels,  $2'' \times 2''$  for panels  $\frac{3}{8}''$  or thicker, and securely fixed to the wall by wooden dooks or other means, particular care being taken to ensure that they are in proper alignment vertically and horizontally. The spacing of the grounds will depend upon the rigidity of the plywood to be erected and the width of the sheets to be used.  $\frac{3}{8}''$  and  $\frac{1}{4}''$  panels should be supported across the grain of the face veneer at intervals of  $18''$  to  $20''$ , with the grain every  $30''$  to  $36''$ . Battens spaced at  $24''$  or  $30''$  centres will be ample to support  $\frac{3}{8}''$  panels across the grain. Thicker boards will require very little support, except at the edges, or in positions where joints will be made.

It is of vital importance that spaces be provided at top, bottom and sides of this groundwork to ensure free circulation of air between wall and panelling, so preventing the formation of sealed air-spaces behind the plywood which might become charged with damp air. Continued exposure to damp in a confined space must have a damaging effect on the wood fibres and in all probability will result in the development of mould.

When panelling will be fixed against an external wall or new brick- or plaster-work, the backs and edges of the plywood, and the solid wood battens, should be carefully coated with red lead or a damp-resistant bituminous paint as is described on page 429.

The panels, which must be of equal thickness, are nailed around all four edges to the grounds at regular intervals:  $6''$  apart for  $\frac{3}{8}''$  and  $\frac{1}{4}''$  will suffice, while the spacing of the nails holding thicker boards may be wider. Panels over  $24''$  wide should be secured to central supporting battens by nailing with panel pins at regular intervals. These should be punched



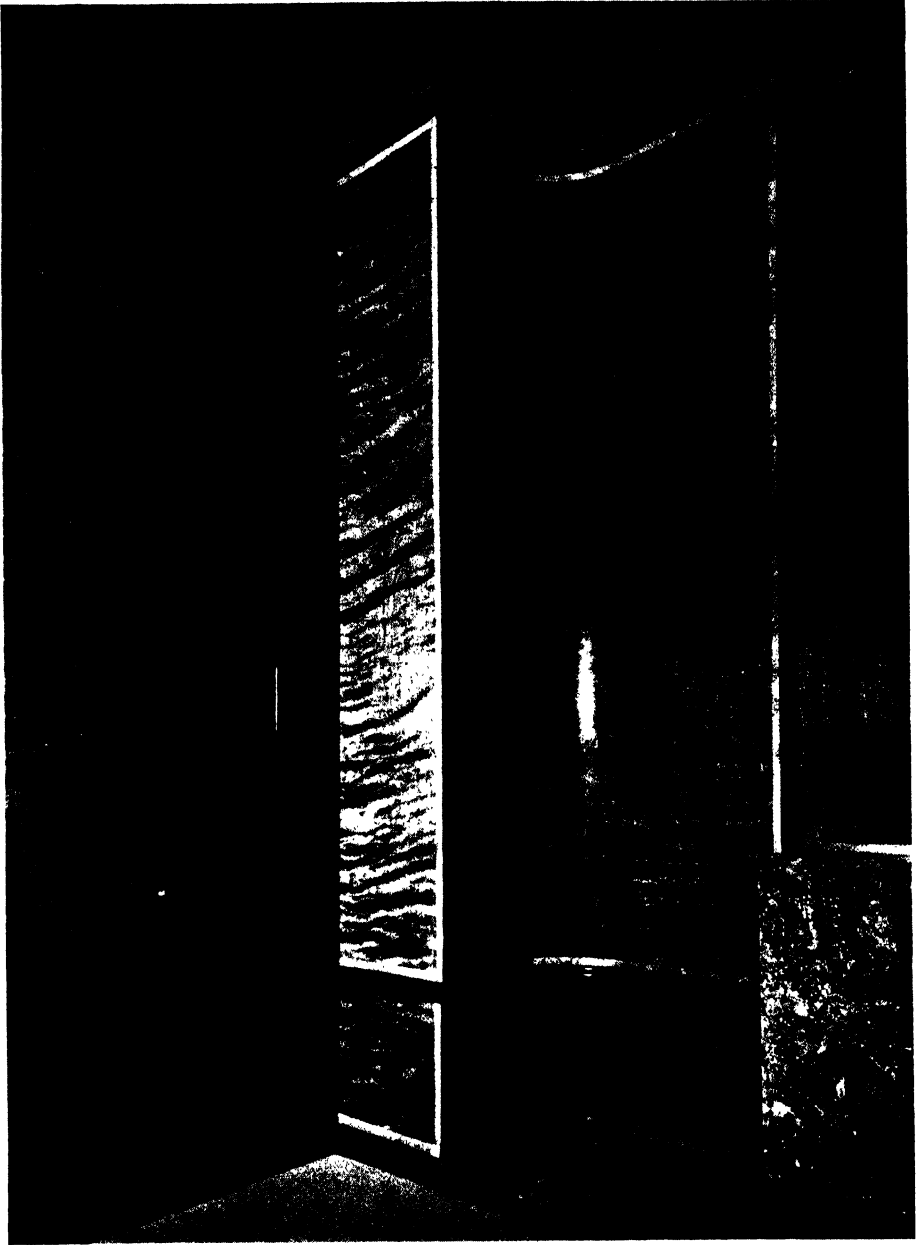

*[By courtesy of Messrs. John Sadd & Sons Ltd.]*

PLATE XIX.—PANELLING IN THE MAYOR'S ROOM, NEW TOWN HALL, DAGENHAM.

An attractive corner treatment carried out in  $\frac{3}{4}$ " Gaboon Multi-ply veneered with Flame Birch (pale shell pink) banded with Sycamore. The curve was fabricated in specially constructed forms.

below the face veneer and the holes carefully filled with wood mastic. Heavier panels,  $\frac{3}{8}$ " and up, should be secured into position by concealed screws. Surface mouldings when used are applied in the usual way.

The fixing of large or small plywood panels is a simple matter. All edges to be joined together should be trued up in the shop and, when the panels are delivered to the job, they can be erected speedily and without any upset. This frequently is a matter of great importance to the architect, as for instance during the reconstruction of a busy store. When the job can be done in sections, only one small part need be partitioned off while business in other departments is conducted in the usual way.

Against what may be a higher initial cost—and this factor depends primarily upon the type of plywood which is selected—there can be offset a considerable saving in labour and economy in upkeep. A well-designed panelling scheme will outlive the building in which it is installed. Plywood does not damage easily and all that is generally required is a periodical "touch-up" or re-polish. The face of polished panels does not collect dust in the same way as wallpaper or textiles, and savings in re-decorating will be considerable during the lifetime of the panelling.

### SHAPED AND CURVED SURFACES

Many of the finest examples of panelling erected during recent years demonstrate how very successfully the present-day architect and designer has correlated graceful curves with large flush veneered surfaces. In many instances moulded plywood has been used and has been made to serve a most useful function in rooms which are irregular in shape or which have outstanding structural projections. Good examples of work in this field are the swept corner illustrated opposite, the columnar casings to the stanchions in the *Queen Mary* smoking-room, and the casing to the projection illustrated in Plate XVI. By the judicious use of shaped plywood, veneered to harmonize with the adjacent wood-work, these points have been transformed into important architectural features in the general decorative scheme.

Curved work of this nature demands careful workmanship, and may be executed in several different ways :—

The sections may be specially moulded to the desired contour at the time of pressing, as has been described in Part IV., Chapter III.

Plywood in flat panels may be specially treated and thereafter bent to shape.

The requisite curve may be built up by using a combination of solid wood framing and thin plywood.

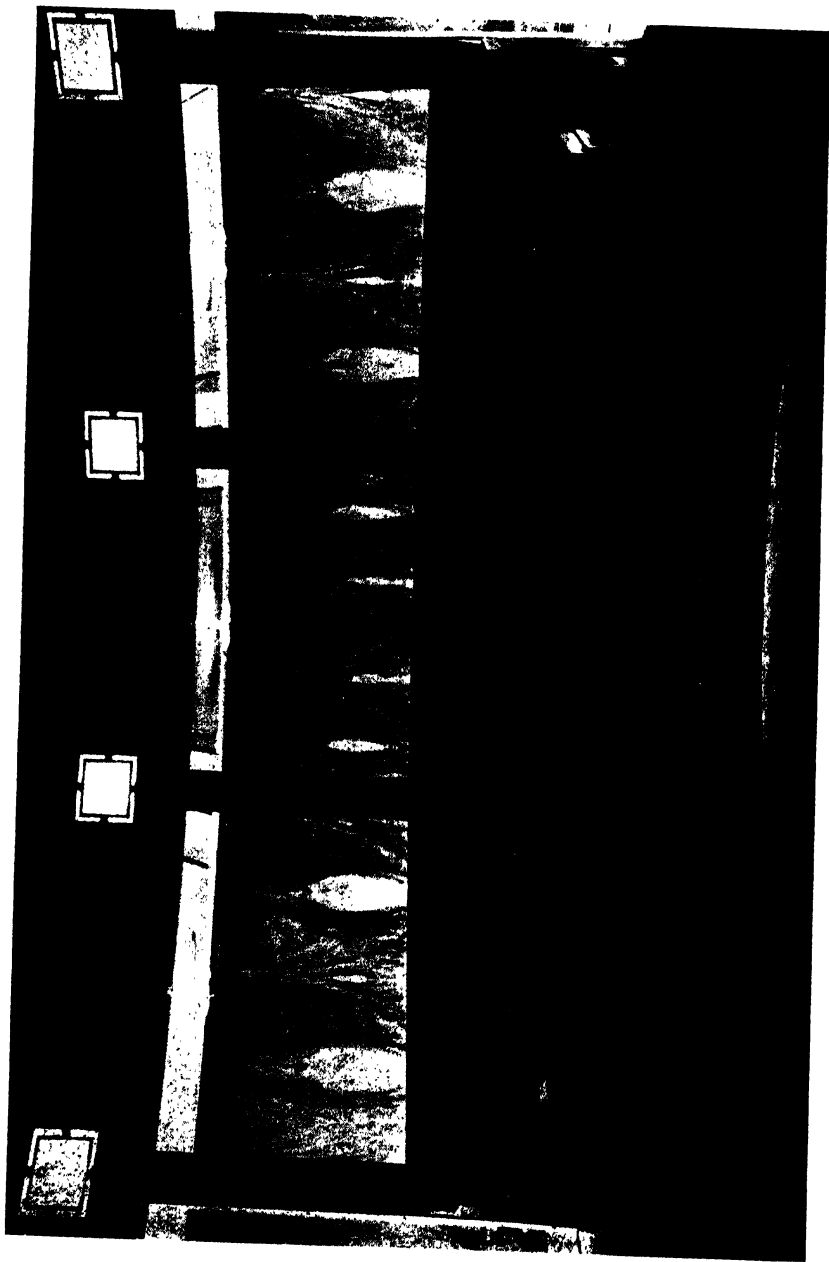

*By courtesy of Messrs. John Sudd & Sons Ltd.*

PLATE XX.—PANELLING IN A COUNCIL CHAMBER, THE NEW TOWN HALL, DAGENHAM.

Panelling is carried out with  $\frac{3}{4}$ " Gaboon Multi-ply Veneered with figured French Walnut banded with Betula.

Waterproof plywood may be steamed, or soaked in water for twenty-four hours, until pliable and thereafter bent to the curve required. This is the method most frequently used in the construction of barrels or tubes. The plywood should be bent across the grain of the outer veneers. It is essential that only well-made plywood free from gaps in the core be used, otherwise, when pressure is applied, the outer veneers covering the gap will fracture. Thicker plywood (6 mm. and up) may be bent by saw-kerfing the back of the board to relieve the resistance of the back veneer and cross-banding. The kerfing is generally done by a carefully set power-driven hand-saw—the frequency of the saw-cuts will depend upon the thickness of the plywood and the radius desired. Provided the kerfing has been properly done and the cuts neither too deep nor too far apart, plywood can be bent to practically any radius without undue risk of fracture. This method is occasionally used to obtain a shaped plywood base on which to lay decorative veneer by the vacuum veneering process.

Figure 193 (*b*) illustrates how plywood has been cut and bent in the production of a radio cabinet, but larger panels may be worked in similar fashion. To bend plywood to a radius of 12" saw-cuts  $\frac{1}{8}$ " wide spaced  $\frac{1}{4}$ " apart should be ample. Once the bend has been effected it is advisable to glue a veneer to the back of the panel, retaining the shape until the adhesive has set hard. This method is practised on quite a large scale, but for high-class veneered work moulded panels should be used whenever possible. Saw-kerfs are apt, in course of time, to cause slight ridges to form on the face of the curved panel opposite each saw-cut.

Wide sweeps or curves of smaller radius may be built up with little difficulty by covering a shaped framework of solid wood with one or more sheets of well-made plywood. The thickness of the 3-ply boards will vary from  $1\frac{1}{2}$  mm. to 6 mm. according to the radius of the curve or the sweep of the shape. It is advisable to both glue and pin the plywood to the solid framework. In cases where a veneered surface is desired, the base, prepared in the manner just described, is covered by another thickness of 3 mm. plywood faced with a selected wood. Two-ply is frequently used in America for this purpose, or the back veneer and a little of the core may be sanded off a 3-ply board in order to make it more flexible. The bending must be carefully done to avoid any fracture of the face veneer. If the bend is convex the face veneer may crack under tension if the bend is less than 16" radius. For curves of small radius veneer backed with canvas can be used.

Various other methods of combining solid wood with plywood to form interior or exterior corners are illustrated.

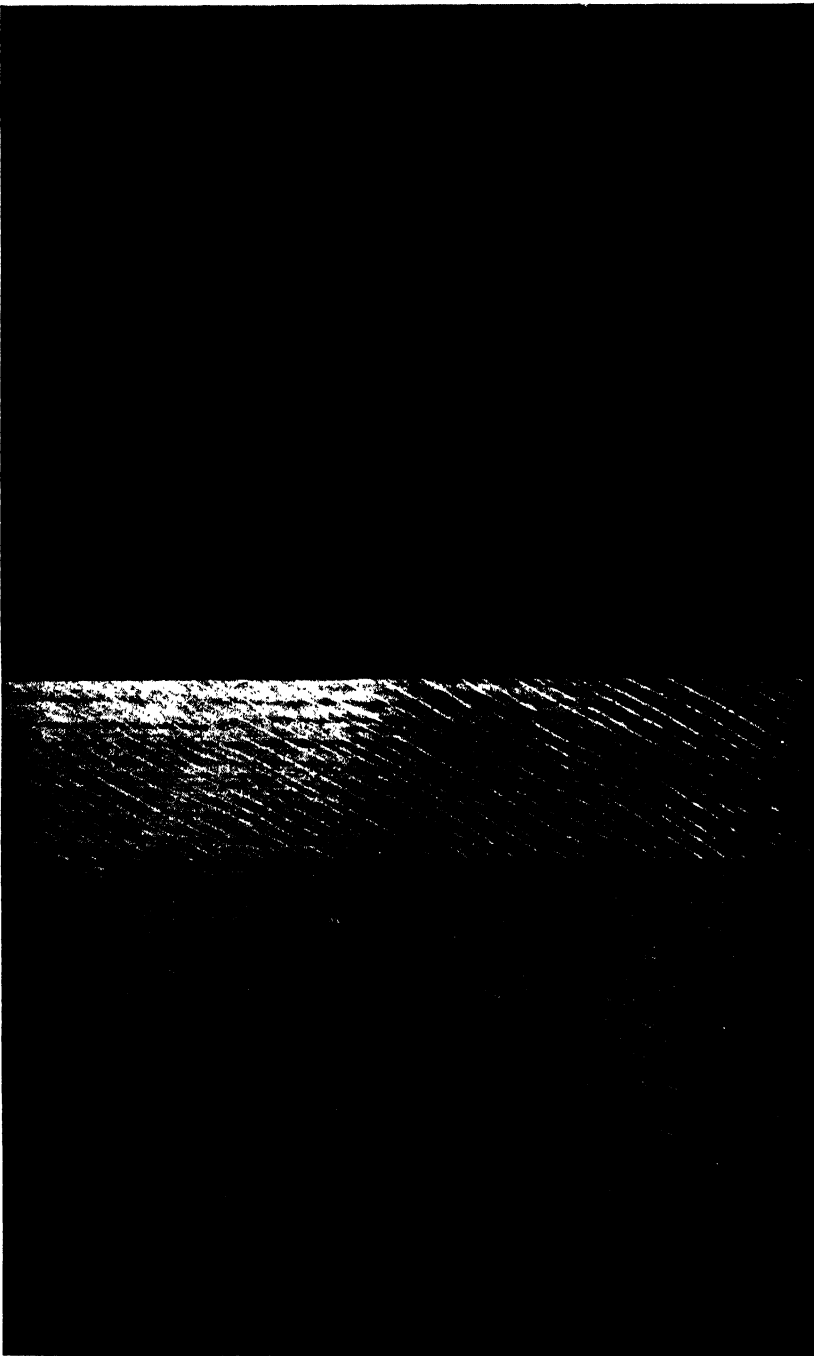

FIG. 131A.  
Quartered Oak veneers, 2-piece "side-matched."  
(See first arrangement, Fig. 132.)

FIG. 131B.  
Quartered Oak veneers, 2-piece "book-matched."  
(See second arrangement, Fig. 132.)

# PART X

## APPLICATION

### CHAPTER I

### VENEERING

SEVERAL useful text-books devoted to this subject are available and should be consulted by those who are interested in the highly skilled art of laying decorative veneers.

We shall deal with matters which are of interest to architects and to those who use veneered plywoods as a medium for wall decoration.

The veneering of plywood may be quite a straightforward operation as in the manufacture of veneered boards of commercial quality, or a highly complicated one as is frequently the case in high-class cabinet-making and panelling work.

“BUILT-UP” AND “VENEERED” PLYWOODS. In the production of decorative plywoods the face veneer may be part of the general assembly to be glued with the core and cross-bandings in one operation, or it may be laid to a prepared core as a subsequent operation. This latter procedure is the more satisfactory in that perfectly level surfaces can be obtained before the veneers are laid. Several continental manufacturers of Oak and other decorative plywoods adopted this method and the quality of their manufactures, known as “built up” boards, gave ample proof of the merit of the system, a decorative face veneer and a less expensive compensating veneer being glued to a three- or multi-ply cross-grained core. Manufacturers in England and elsewhere glued decorative veneers to one or both sides of commercial plywoods, generally dry-glued Birch, Alder or Gaboon, the product being known as a “veneered board.” The quality varied very considerably.

We have already stressed the importance of retaining the veneers in sequence as they were cut from the flitch. Unless this is done it will be well-nigh impossible to obtain the accurate matching so essential to good workmanship. Bundles of veneer are crosscut to the length required, generally an inch or two longer than the panels it is desired to produce; having been re-dried to the proper moisture content and trimmed on the veneer jointer, the leaves are made up to the necessary width on the taper

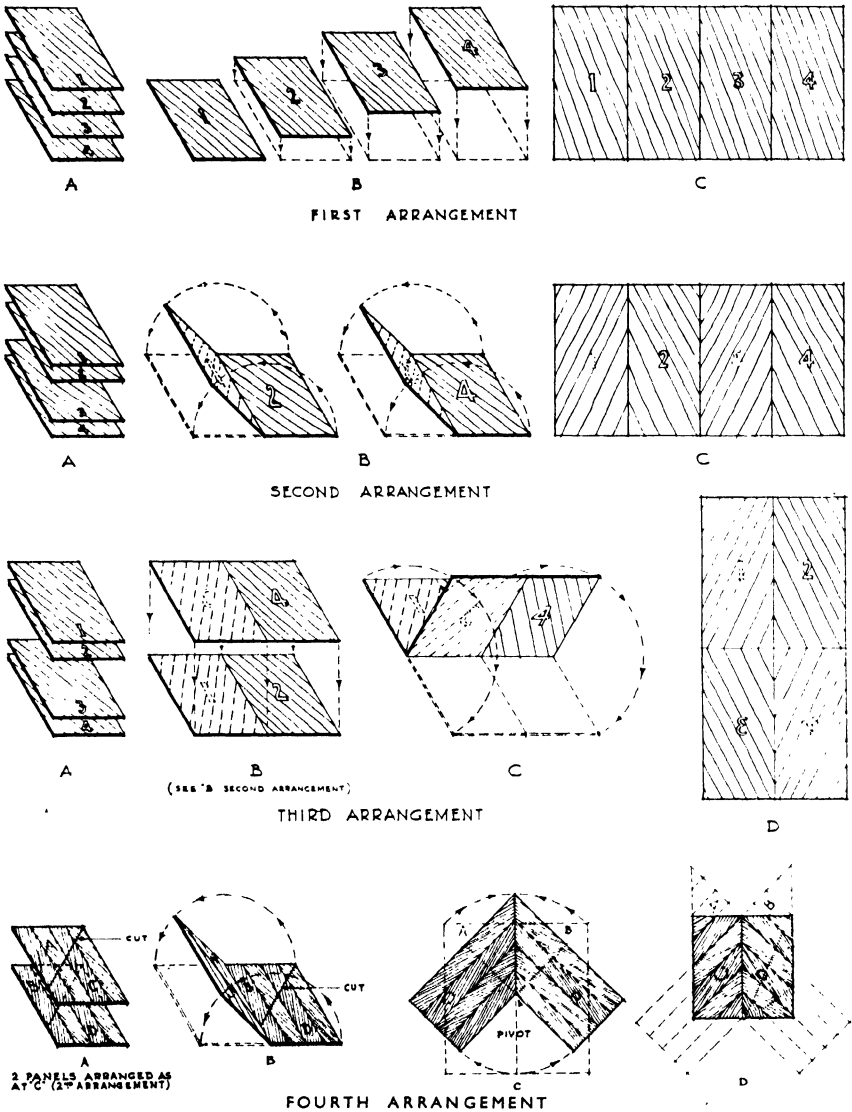

FIG. 132.—FOUR METHODS OF MATCHING DECORATIVE VENEERS.

First arrangement, "side-matched" or "drawn across."  
 Second arrangement, "book-matched" or "turned over."  
 Third arrangement, quartered.  
 Fourth arrangement, half-quartered.

or tapeless jointer in the manner already described. Leaves of veneer may be assembled in one of two ways.

1. They may be "side-matched" or "drawn across" (first arrangement, Fig. 132), which means that the tight side of each leaf will be exposed once the panel has been glued up and that the figuration of the leaves will be repeated across the width of the panel as is demonstrated in Fig. 131A.

2. Alternatively the veneers may be "book-matched" or "turned-over" (second arrangement, Fig. 132), that is to say each pair of veneers is opened bookwise so that on the finished panel the tight-cut side will be exposed on each alternate leaf. If the veneer shows a diagonal stripe or ripple this method of jointing gives a "herringbone" effect and, when carefully done, perfect matching should be obtained at each joint. This is the most popular way of matching sliced veneers, but it will be appreciated that only well-cut stock should be laid in this fashion. Poorly cut veneers showing cutting checks and ruptured fibres on the reverse side will cause endless trouble. To many people the striped effect, most prominent in poorly cut veneers, which results from the light striking the fibres of the tight-cut faces at different angles to the loose-cut backs is distasteful. When well-cut stock is used, although the bands of light and shade cannot always be eliminated, the general decorative appearance of the panels is not diminished.

By keeping the made-up sheets of veneer in proper sequence it is possible to obtain a series of panels from one flitch which will show a gradual alteration in the grain figuration, and the time spent in numbering the panels will be amply repaid when the boards are marketed. Buyers of such stock will be able to carry out panelling jobs which are well balanced and more pleasing than is frequently possible when plywood selected from commercially graded stocks is used.

**DECORATIVE PANELS.** The diagrammatic drawings and illustrations demonstrate a variety of the more usual methods of matching veneers in the preparation of high-class decorative panels.

Two-piece "book" or "leaf" matched panels have a central joint, so it will be obvious that the maximum width must be something less than double the width of the leaves of veneer used.

"Cathedral matching" is a term applied to describe two-piece book-matched veneers laid so that the grain figuration of one leaf runs from the foot of the panel to meet its mate at the central joint some distance up the panel.

As a general rule sliced veneers are used to obtain matched effects, but a good craftsman can obtain excellent results with rotary-cut veneers as for example the two-piece matched panel illustrated in Fig. 133.

Quartered panels may be laid in a great variety of ways. In making





FIG. 133.

Rotary-cut Indian Silver Greywood, two-piece matched.



FIG. 133A.

Quarter-cut Indian Silver Greywood, laid in four quarters, diamond matched. Note excellent matching at all points of contact.

up small panels four successive leaves of veneer are required, the method of assembling being demonstrated by the third arrangement, Fig. 132. The craftsman frequently makes use of a pair of mirrors set at right angles, and by varying the position of these on a leaf of veneer the reflection in the mirrors reveals the general effect which will be obtained by quartering in any particular way.

Half-quartered panels are obtained by book matching veneers to form two sheets in whatever width may be required, cutting these two sheets at an angle of 45 degrees and jointing up in the manner shown by the fourth arrangement, Fig. 132. The triangular pieces required to complete the rectangular panel (sketch D) are cut from off-cuts marked A and B (sketch A).

More intricate matching of veneers, inlaying and cross-banding, falls within the province of the expert cabinet-maker and is, therefore, outwith the scope of this volume.

In European countries plywoods, multi-ply, laminboards or blockboards, are used almost exclusively as the base for veneer work. In America lumber-core stock is manufactured for this purpose. The choice of base must depend upon the value of the panelling; the relative costs of veneers are indicated in Part VII., and while these can serve only as a very rough guide it may be observed here that the cost of many veneers when made up justifies the use of the best base-board available.

The most important large-scale veneer work undertaken during the past decade was in connexion with the two liners *Queen Mary* and *Queen Elizabeth* and in these vessels Gaboon Mahogany multi-ply in thicknesses from  $\frac{1}{2}$ " to 1" was specified as the base for all decorative panelling. Laminboard is used largely for the same purpose in high-class cabinet-making and general panelling. The thickness may vary from  $\frac{3}{8}$ " upwards according to the size of the panels and method of erection. In the illustrations the thickness of the base-boards used in panelling schemes has been mentioned wherever possible.

The inspection of core stock requires care. Surfaces of well-made plywood should be flat, entirely free from bumps or undulations and be of equal thickness. It is wise to test the boards at several places about 1" from each edge to make certain that there is no variation in thickness and that the edges have not been sanded off. In such cases perfect adhesion at the edges cannot be obtained. If re-surfacing is necessary either the scraper or triple drum sander may be used—scraping is generally found to be the more satisfactory method where thickness is under  $\frac{3}{8}$ ".

The moisture content should also be checked and if necessary the boards re-dried to a percentage to meet the requirements of the adhesive to be used.



*[By courtesy of Messrs. Shapland & Pelter Ltd.]*

FIG. 134.

Sideboard of Period design. Doors and carcass constructed of plywood veneered with Mahogany curl.

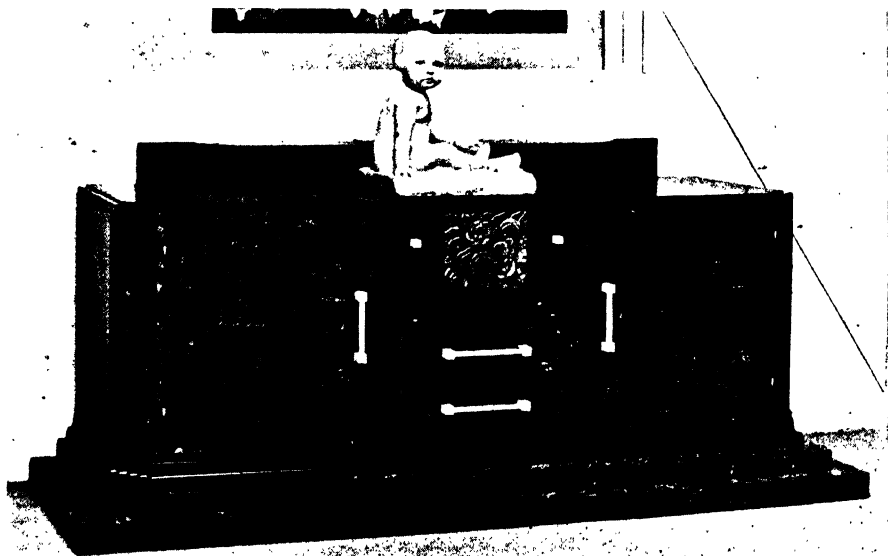

*[By courtesy of Messrs. The Bath Cabinet Makers Co. Ltd.]*

FIG. 135.

Sideboard constructed of Gaboon laminboard with facings and edgings of Honduras Mahogany. The laminboard was underlaid on both sides before the face veneers of figured Bubinga were applied.

The method of laying veneers to plywood differs only in slight degree from the gluing process in the manufacture of plywood. The choice of adhesive will be decided by the nature of the veneers to be laid, the value of the finished product, liability to stain and other conditions. Resin adhesives are largely used ; casein mixtures, animal and skin glues, all have their uses.

When laying light-coloured woods which are prone to glue penetration and stain a white adhesive must be used or the veneers glue-sized with a bleached hide glue as a preliminary to the actual gluing process.

It is the considered opinion of some authorities that the heat required to "harden" certain adhesives of the phenolic-resin type is damaging to many fine veneers and that the depth of beauty seen in Masur Birch or Maple can only be retained by the use of a cold adhesive. The panel illustrated on page 280 is one such case, and it is doubtful if the entire beauty of this veneer could have been retained if it had been laid at a temperature over 75° C.

Care must be taken to lay the decorative veneer at right angles to the grain of the ply to which it is glued.

For a first-class job when highly figured decorative veneers, burrs or curls are used, it is advisable to lay a veneer of plain African or Honduras Mahogany between the rotary-cut Alder or Gaboon face of the core stock and the decorative veneer. This process, known as underlaying, prevents any disturbance of the comparatively inelastic decorative veneer should changes in atmospheric conditions cause a slight surface movement of the core. In jobs where the grain of the decorative veneer is required to run horizontally and the grain of the outer ply runs vertically the "underlay" should be laid with its grain at an angle of 45 degrees to that of the decorative veneer.

When flush laminated doors form part of the decorative scheme the laminations and the grain of the decorative veneer should run in the same direction ; for choice, in a vertical direction. It is sometimes desirable from the design point of view that decorative veneer on a flush laminated door should run horizontally, which can be effected by underlaying or by allowing the laminations to run horizontally, using well-designed solid hardwood clamps on the edges to keep the door true and free from warp. Both sides of the plywood must be veneered in exactly the same way ; thus, if a veneer be laid vertically on one side and horizontally on the other, the balance will be completely upset and the panel will twist.

The laying of veneer is a fascinating art which demands much skill and careful thought in order to obtain the best results. It is work which should be entrusted to an expert in his own sphere.

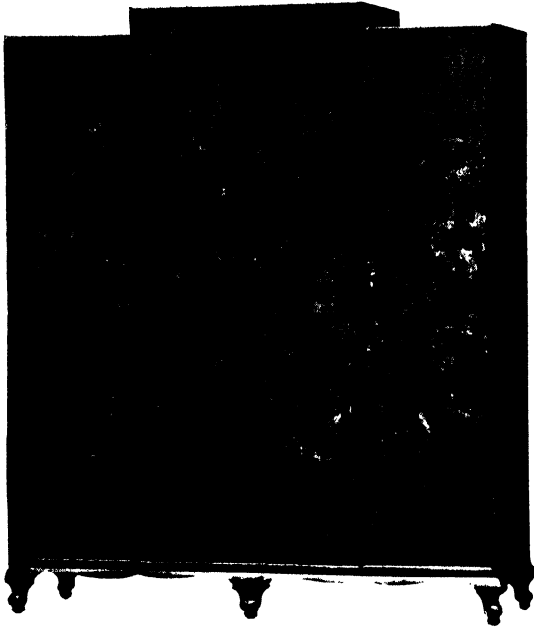

Wardrobe and chest in figured Walnut. The careful matching of veneers on wardrobe doors and chest drawers should be noted. Robe doors of  $\frac{7}{8}$ " Gaboon lamin-board. Chest doors  $\frac{1}{2}$ " Gaboon laminboard.

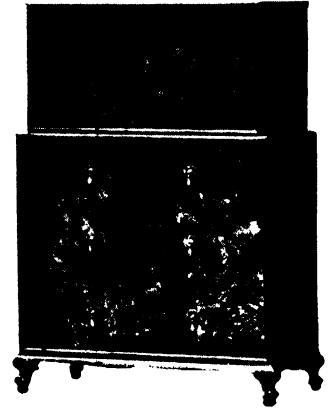

[By courtesy of Messrs. A. H. M'Intosh & Co. Ltd.

FIG. 136.

Fitted wardrobes incorporating thick moulded plywood of similar construction to that illustrated on page 130.

## CHAPTER II

# FURNITURE MANUFACTURE AND GENERAL WOODWORK

**F**ACTORIES equipped for the mass production of office and household furniture use large quantities of plywood, and during the years 1930-39 the requirements of British furniture manufacturers had a profound influence upon the plywood markets of Europe. For example, the Finnish output of blockboards consisted largely of boards made specially for parts of furniture, and the fortunes of this particular section of the plywood industry depended largely upon the prosperity of furniture factories in Britain and elsewhere.

Present-day furniture, from the cheapest to the most expensive, is largely plywood-built. The difference between good and bad furniture lies, as in most manufactured articles, in the quality of the workmanship which is expended upon good or bad material. Some of the rubbish sold as bedroom furniture was made from thin plywood veneered with a cheap veneer or stained to represent hardwood; it is little wonder therefore that at one time a section of the public was afraid to buy plywood furniture as being "cheap" and demanded a "solid" article. That their idea of "solid" was formed by the weight of the piece was by no means unsound reasoning, and few would credit the statement that well-made veneered plywood furniture is frequently far more expensive than "solid" furniture. In point of fact the chief reason that veneered plywoods are not exclusively used for gables in bedroom furniture is their cost in comparison with certain hardwoods.

From Finland, Poland and elsewhere, valuable quantities of multi-ply and blockboards were shipped to the United Kingdom cut to buyers' exact requirements for doors, gables, haffets, tops and bottoms, blind panels, bed ends and so forth. Furniture manufacturers altered the layout of their plants so that these pieces could be veneered, machined, assembled and polished on mass-production lines. For some work panels veneered to buyers' requirements on one or both sides were imported. These plywoods made it possible for furniture manufacturers to produce well-designed household suites at prices which enabled a large proportion of the population of modest means to refurnish their homes in modern style.

The construction and thickness of plywood selected for veneered



[By courtesy of Messrs. The Bath Cabinet Makers Co. Ltd.]

FIG. 137.

A bedside fitment and tallboy chest of drawers of attractive design veneered with quarter-cut straight-grained fiddle-back English Walnut with horizontal beads of Bombay veneer.

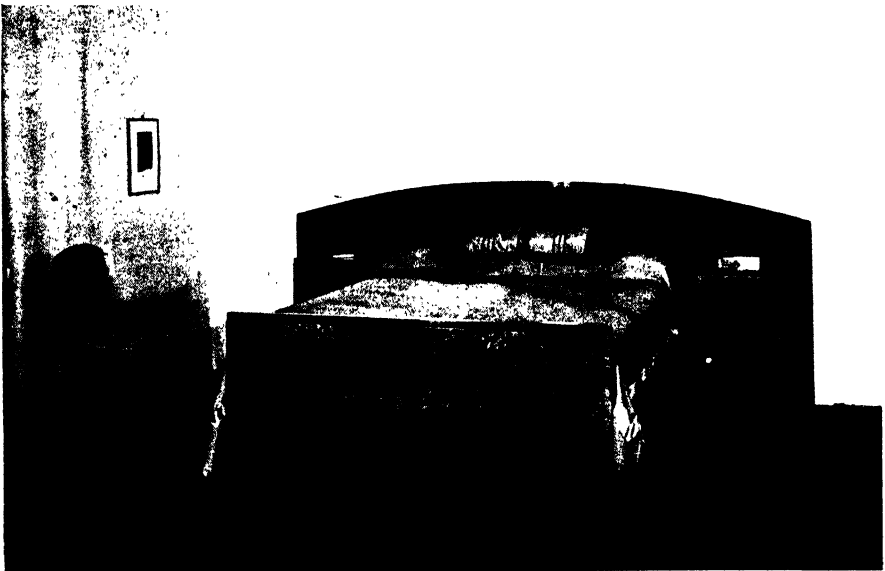

[By courtesy of Messrs. The Bath Cabinet Makers Co. Ltd.]

FIG. 138.

A bedside fitment constructed throughout of Gaboon laminboard veneered with fine English Walnut Burr with cross-bandings of straight-grain French Walnut. For such fitments  $\frac{1}{2}$ " laminboard is frequently used for the head-board and similar material  $\frac{7}{8}$ " to  $1\frac{1}{4}$ " thick for the foot-board.

carcass work is decided by the price of the finished article, the method of assembly and the experience and reputation of the manufacturer.

### CABINET-MAKING

For quality pieces finished in rich veneers, Gaboon or Alder-faced laminboards are largely used and have enabled the designer and craftsman to create furniture of artistic merit and a beauty of line which must remain a feature of twentieth-century design. Cabinet-making and the art of veneering are inseparable, and we have endeavoured to illustrate as large a variety of veneered plywood-built furniture made by well-known cabinet-makers as space permits. Wherever possible the thickness of plywood used has been indicated, but it should be observed that individual manufacturers have their own preferences in regard to both thickness and construction of plywood employed for divers purposes.

### BEDSTEADS

The modern bedstead is invariably constructed of two pieces of veneered plywood to which the iron framework of the bed is fixed. The thickness of plywood used varies according to design; for work of good quality  $\frac{7}{8}$ " or 1" laminboard is commonly selected for the foot panel and similar material  $\frac{1}{2}$ " or  $\frac{3}{8}$ " thick for the head-board. More elaborate fitments are also constructed of laminboard, an excellent example of this type of work being illustrated. Plywood is frequently cut to shape on bandsaw or spindle, and edged with solid hardwood fillets before the decorative face veneers are applied or, alternatively, the edges may be veneered to match, or contrast with, the face veneers.

Some manufacturers set the veneered laminboard into frames while for light and less expensive bedsteads  $\frac{1}{4}$ " veneered multi-ply is frequently used in combination with a hardwood framework.

### GENERAL UTILIZATION IN CABINET-MAKING AND ALLIED TRADES

Methods of assembling furniture, cabinets and fitments vary considerably and do not come within the scope of this work. Nevertheless the treatment of the edges of plywood is a matter of considerable importance and various suggestions are illustrated; sections showing corner treatments which may be applied to cabinet-making or to general joinery work have been included on pages 430 and 431.

The general comments which follow cover the most important uses of plywood in the cabinet-making and allied trades.





[By courtesy of Messrs. The Bath Cabinet Makers Co. Ltd.]

FIG. 139.

Carpet showrooms for Messrs. James Templeton & Co. The fitments illustrated are constructed with Alder blockboards, the decorative veneer for panels, tops, etc., being quarter-cut English Elm. Radiator covers are of plywood of special construction made by The Bath Cabinet Makers Company.

*Gables.*—Gables of wardrobes, chests and fitments are commonly constructed of plywood generally in one piece of laminboard or blockboard  $\frac{3}{8}$ " to 1" thick lipped with a strip of hardwood to match the face veneer.

Edging strips may be fixed before or after the decorative veneers have been laid and are generally tongued to the plywood. For smaller chests and cabinets plywood panels may be set into grooved corner posts, in which event the thickness will rarely exceed  $1\frac{5}{8}$ ". When a thicker panel is desirable, in order to retain the maximum strength in the solid post, the plywood may be "backed-out" as demonstrated by Fig. 191.

*Haffets.*—These are generally formed of one piece of multi-ply, blockboard or laminboard  $\frac{1}{2}$ " to  $\frac{7}{8}$ " thick.



FIG. 140.

$\frac{1}{4}$ " moulded plywood makes an attractive window-sole on which to display gowns.

*Doors.*—Laminboards or blockboards have come into general use for doors of wardrobes, chests, sideboards and other fittings; edges which are exposed to the eye being covered with a hardwood fillet. The thickness may vary from  $\frac{1}{2}$ " to 1" according to design. If weight is of importance doors may be built up by covering a light batten framework on both sides with 4 mm. plywood. The edges of the framework may be concealed by any of the methods illustrated on page 438.

*Tops of Chests, Tables and Desks.*—Thickness used varies according to the construction of the article. When laminboard or blockboard tops are used they should be edged with solid hardwood strips. When the tops are veneered after the edging strips have been fixed in the manner illustrated in Fig. 186, the square edges and corners may be moulded to any desired contour on the spindle. Fig. 80 illustrates a suggested treatment in the preparation of tops covered with lino, leather or plastic.

In the construction of large thick table-tops it is advisable to use a laminboard of "centre-ply" construction described on page 274 rather than a piece of laminboard or blockboard over  $1\frac{1}{2}$ " thick. Alternatively two pieces of  $\frac{3}{8}$ ",  $\frac{3}{4}$ " or  $\frac{7}{8}$ " blockboard or laminboard may be glued together to give the desired thickness. Fig. 143 illustrates a section cut from two

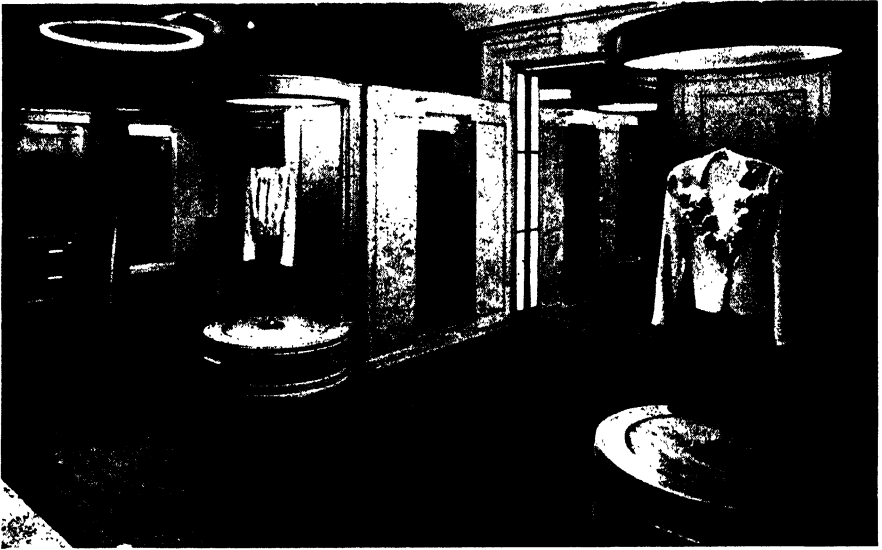

[By courtesy of Messrs. George Parnall & Co. Ltd.]

FIG. 141.

A section of the attractive blouse department, Messrs. Debenham and Freebody, London. The panelling is plywood veneered with figured Sycamore and Maple, cross-banded and inlaid with Indian Laurel.



[By courtesy of Messrs. George Parnall & Co. Ltd.]

FIG. 142.

Lounge at fitting-rooms, Messrs. Simpson, Piccadilly. The panelling is of plywood veneered Ash Burr. The display table round the column is of similar construction with solid facing of maple.

$\frac{3}{4}$ " Finnish Birch blockboards glued together and edged with Oak prior to being veneered.

*Bench and Table-tops* for factories may be built with large sheets of  $\frac{5}{8}$ " or  $\frac{3}{4}$ " multi-ply or blockboard and covered with linoleum, rubber or metal as may be required. Large smooth surfaces which will give years of service can be economically and quickly erected.  $\frac{1}{4}$ " plywood can be nailed to old benches and flat surfaces quickly re-formed. If the top is liable to damage it is as well to screw squares of  $\frac{1}{4}$ " plywood to a base when, immediately any section is badly cut, it can be removed and reversed or replaced by a new piece of sound plywood.

*Tops and Shelves of Wardrobes.*— $\frac{3}{8}$ " to  $\frac{3}{4}$ " multi-ply is frequently used for tops of wardrobes and shelves in chests and other fitments. These may be dovetailed or half-checked into the gables, the front edges of shelves and tops being lipped by a strip of solid wood when necessary.

*Drawer Bottoms, Blind Panels, Dust Boards.*—Three-ply or multi-ply 4 mm. to 9 mm. thick is largely used, the quality and wood being selected according to the value of the job.

*Backs.*— $\frac{1}{8}$ " to  $\frac{3}{8}$ " multi-ply in one or more pieces may be rebated into solid framing or secured to plywood gables by half-checking the latter to the thickness of the plywood. Backs covering large fitments are generally panelled up with solid muntins.

*Mirror Backs.*—Plywood is universally used for backing large or small frameless or framed mirrors. It is essential that well-made stock free from twist is selected. Thickness for frameless mirrors is generally  $\frac{1}{2}$ ";  $\frac{3}{8}$ " plywood may be used on small mirrors and  $\frac{3}{8}$ " on particularly large ones. 3 mm. or 4 mm. Birch or Alder is commonly selected for framed mirror backs.

## SHOPFITTING

Shopfitting has become a craft closely allied to that of the cabinet-maker and, in recent years, veneered plywood has been used on an extensive scale for the decoration of showrooms and shops, in the construction of fitments, showcases and so forth. The illustrations demonstrate the attractive results which can be obtained by the judicious use of veneers and plywood. Display cases are largely plywood built with the doors hung or to slide in a manner designed to occupy the least possible space. In the construction of window-soles  $\frac{1}{2}$ " or  $\frac{3}{8}$ " Oregon Pine or Birch multi-ply makes an excellent base on which to lay a decorative covering of parquetry, veneered plywood or other material. Backs of windows may be made removable or inter-changeable in order that they may be altered to harmonize with the window display.

Waterproof plywood is used by the shopfitter for outdoor signs,

cut-out letters and, to a lesser degree, in the construction of shop fronts. Cut-outs and display boards are popularly used as a means of advertising fabrics and a large variety of products. In some cases elaborate displays are prepared which are removed from town to town. Plywood being much stronger lasts longer than competitive materials of the pulp board nature and, as a result, is largely used for this purpose.

### RADIO AND GRAMOPHONE CABINETS

The manufacture of radio and gramophone cabinets has become an industry in itself and, although various experiments have been made in the field of plastics, for work of importance veneered plywoods are largely and successfully used. The consumption of plywood by this trade is quite large and, in future years, one can predict an interesting future for plywoods fabricated to shape on moulding presses. In the construction of the cabinets plywood is used in various thicknesses. For example, a walnut radio-gramophone of well-known make is built up as follows :—

Gables.—15 mm. multi-ply Birch veneered Walnut.

Front and bottom.—15 mm. multi-ply Birch in one piece, saw-kerfed, bent to shape. See Fig. 193 (*b*).

Hinged top.—18 mm. blockboard veneered Walnut with solid shaped front as illustrated in Fig. 193 (*a*).

Baffle-board.—18 mm. Finnish Birch screwed to front. There is no better material to use for a radio baffle-board than  $\frac{3}{8}$ " or  $\frac{3}{4}$ " Oregon Pine or Birch plywood.

Division between radio and gramophone 8 mm. Birch.

Base to carry radio and gramophone 12 mm. Finnish Birch.

A portable set which has given good service is entirely constructed of plywood covered with rexine. The outer case is 9 mm., the inner frame 3 mm. with top of 9 mm. to carry certain instruments, the back 6 mm., all being of Finnish Birch.

### GENERAL JOINERY

Plywood is used in the joiner's shop in all sizes from pieces a few inches square to the largest available sheets. We can only touch upon the more important uses.

*Flush Doors.*—In normal times large quantities of plywood in a variety of woods were imported cut to special sizes for the faces of hollow

flush doors. The internal construction of these varied with the price from a simple framework held together with corrugated metal fasteners to an elaborate arrangement of narrow battens running longitudinally and secured to top, bottom and lock rails. It is generally advisable to leave air spaces through the top and bottom rails to ensure a free circulation of air within the spaces formed by the framework. Although 4 mm. Alder, Beech, Birch and Gaboon, having one reasonably good side suitable for painting, is commonly used in the production of cheap doors, for better-class work thicker plywoods in similar woods should be

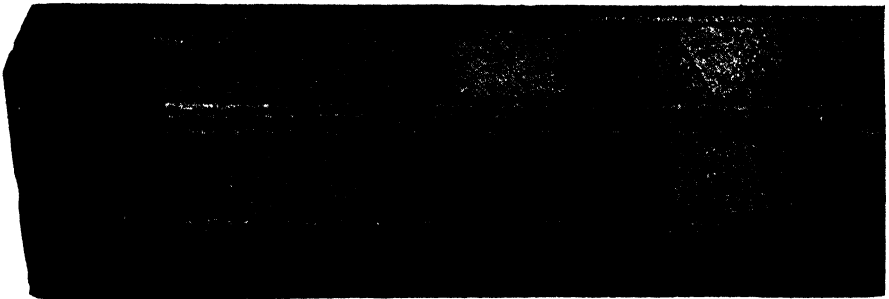

FIG. 143.

Base for large door or table-top built-up with two boards of  $\frac{3}{4}$ " Birch blockboard and edged with solid Oak.

selected.  $\frac{1}{4}$ " Oregon Pine in the "AA/BB" grade was a favourite stock for doors to be stained.

For high-class veneer work and for specially large doors many prefer to use two thicknesses of laminboard or blockboard glued together as demonstrated by Fig. 143. Doors made in this fashion, although heavy, are very reliable. A door which in effect is plywood-built with three thicknesses of  $\frac{1}{2}$ " Canadian Western Red Cedar and two facing sheets of plywood is illustrated in Fig. 202. Where lightness is of importance sections of the core can be omitted or lighter material substituted in certain positions; the core of the "Rezo" door is extremely light and

consists of an ingenious arrangement of 4 mm. veneer assembled on the egg-box partition principle.

When doors must be insulated against heat and cold the core may incorporate Slab cork, Kapok, Balsa wood or some other suitable insulating material. Insulated doors for cold storage rooms are frequently faced with metal-faced plywood.

In the construction of flush doors the plywood may be carried to the extreme edges of the framework or the stiles may be recessed to the thickness of the plywood which is then sprung into position. Methods of lipping the edges of flush doors are demonstrated in Figs. 143 and 201.

All doors to be painted should be given a priming coat before leaving the factory or immediately on delivery at the site to reduce the risk of any change taking place in the moisture content of the timber or plywood:

*Panel Doors.*— $\frac{1}{4}$ " and  $\frac{3}{8}$ " Oregon Pine plywood has held the field since it was first introduced for door panels, and large contracts were placed by the larger door manufacturers in the United Kingdom for panels which were supplied cut to exact sizes. Various other plywoods such as Birch and Alder have been used on a smaller scale while  $\frac{3}{8}$ ",  $\frac{1}{2}$ " or  $\frac{5}{8}$ " plywoods are occasionally used for single-panel doors.

*Cupboard Doors.*—Cupboard doors may be built up on a light framework in much the same way as interior doors; a light braced frame door is illustrated in Fig. 196. Alternatively doors may be cut from multi-ply, laminboard or blockboard, which is at least  $\frac{1}{2}$ " thick. The core of the laminboard or blockboard should run vertically and, when the finish is paint, enamel or cellulose, both sides of the plywood and all four edges must be finished in a like manner. By so doing air will be excluded from the wood and changes in the atmospheric humidity will not have any effect upon the stability of the door. Methods of veneering flush doors have been described on page 361. To save space sliding doors may be incorporated into the design in which event well-made laminboard or blockboard should be selected in preference to multi-ply. Sliding doors may be designed to run on T pieces of plastic or compressed fibre as shown in Fig. 197, or if close-fitting doors are not essential, guides may be cut from  $\frac{1}{4}$ " plywood and laid in the manner illustrated. Cupboard doors in laboratories, kitchens, warehouses and factories, or swing doors at service-rooms in restaurants and in similar positions where they are subject to rough usage, should be protected with metal-faced plywood.

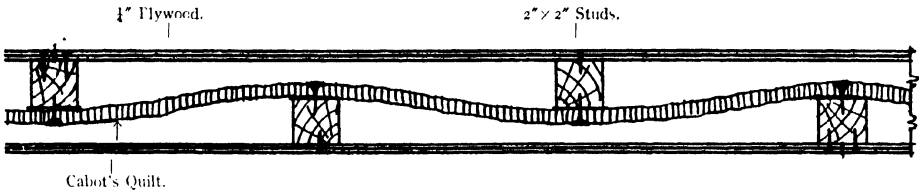

FIG. 144.

A simple but effective method of erecting a double-sided plywood partition using Cabot's Quilt as deafening agent.

## PARTITIONS

The versatility of plywood is well illustrated in the construction of partitions. Here plywood may serve as an essential part of the structure and give final expression to the decorative scheme. In the modern office built of steel and concrete, the practice is to let off sections of floor area to be divided into rooms to suit the requirements of individual tenants. Such buildings offer remarkable scope for the use of plywood, and partitions can be speedily and cheaply erected. These, having no weight to carry, may consist of a single sheet of thick plywood, a light framework covered by thin plywood on both sides, or a dividing wall may be constructed in the form of built-in cupboards serving one or two rooms.

Oregon Pine or Finnish Birch blockboards  $\frac{3}{4}$ " or  $\frac{7}{8}$ " thick makes a strong divisional wall and may be quickly erected in much the same manner as ships' bulkheading, running from floor to ceiling. In certain positions a screen, the upper portion fitted with glass, is necessary for the passage of light, and in such cases the lower portion can be built of a single sheet of thick plywood and the glass held in position by two mouldings as shown alongside. The glass should be bedded on rubber or leather.



Where it is essential that the divisional wall be made sound-proof a satisfactory wall can be inexpensively erected on the lines suggested in Fig. 144. Alternatively, one of the composite boards illustrated on page 10 incorporating a sound-insulating material may be used. The plywood faces of composite boards may be veneered with any selected wood, metal, synthetic resin laminated sheet, or asbestos composition. Decoration by planting veneered plywood on divisional partitions of  $\frac{3}{4}$ " or  $\frac{7}{8}$ " plywood as described on page 389 is constructionally sound and is effective.





*[By courtesy of Douglas Fir Plywood Association.]*

FIG. 145.

The built-in cabinets are constructed with Douglas Fir plywood. The ceiling, also of plywood, was covered with muslin before being painted. Subfloor under the linoleum is also of Douglas Fir plywood.

### BUILT-IN FITMENTS AND CABINETS

Every business man or woman appreciates a well-designed built-in cabinet, while to the housewife, more especially in the kitchen, such fitments carefully thought out to house the many household utensils are a boon and a blessing.

The construction of built-in cabinets is a very simple matter.

In the office or factory divisional walls built in the form of double cabinets will be reasonably sound-proof, but if special precautions are necessary, composite insulating boards as the central division will achieve this purpose. If a double thickness is used and the joints staggered, excellent results will be obtained.

In order to save space in small rooms or narrow passages, sliding doors are an advantage. Methods of fixing sliding plywood doors are shown in Fig. 197.

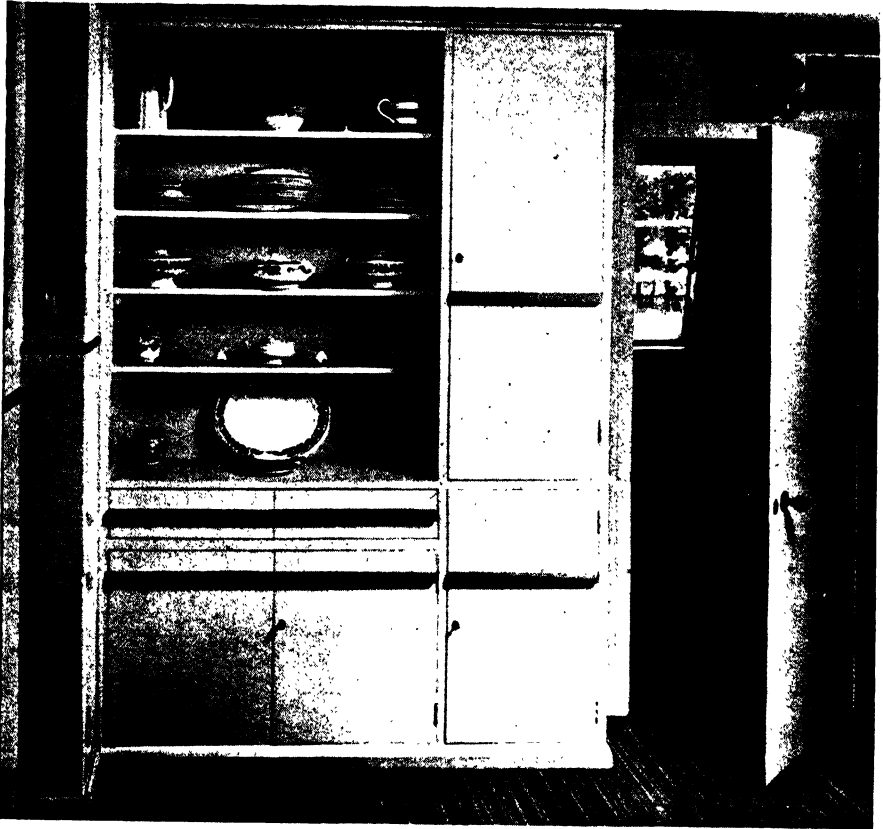

*By courtesy of Messrs. Veneta Ltd.*

FIG. 146.—KITCHEN FITMENT OF SIMPLE DESIGN.

Cupboard doors are of 1" laminboard enamelled white with Walnut strip handles. The pass-door is plywood-built, being enamelled white on one side and veneered Walnut on the other.

Fitted furniture is appealing to more and more. It is practical in that it is easily cleaned and does away with much bulky and heavy furniture. Such fitments give an air of spaciousness to any room.

In the construction of new buildings, built-in fitments or cabinets should be placed carefully. They will be of special value in bedrooms, dressing-rooms, kitchens and vestibules, and should be designed specially to accommodate the many articles which the careful housewife wants to keep out of sight, such as sewing-machines, ironing-boards, vacuum cleaners, kitchen pots and pans, brushes and cleaning materials.

The inside of these fitments will be perfectly smooth, making it a simple matter to keep them clean. In the kitchen, as frequent washing

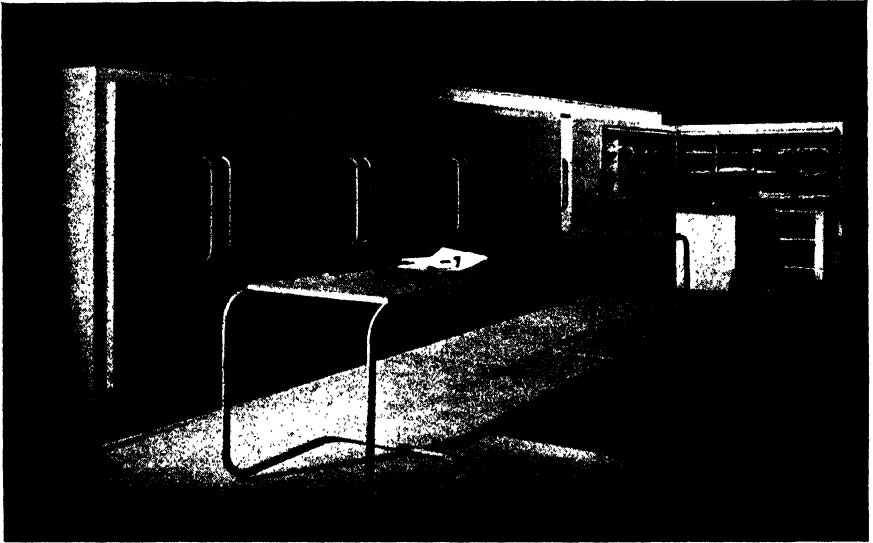

[By courtesy of Messrs. Venesta Ltd.

FIG. 147.

Mail order department, Cresta Silks Ltd. Flush doors of silk case are constructed with  $\frac{3}{4}$ " blockboards faced with Oak. The parcels fixture in the background is built of 1" and  $\frac{1}{2}$ " Gaboon blockboard and painted. The counter-top is of 1" Oak-faced blockboard with solid Oak edges.

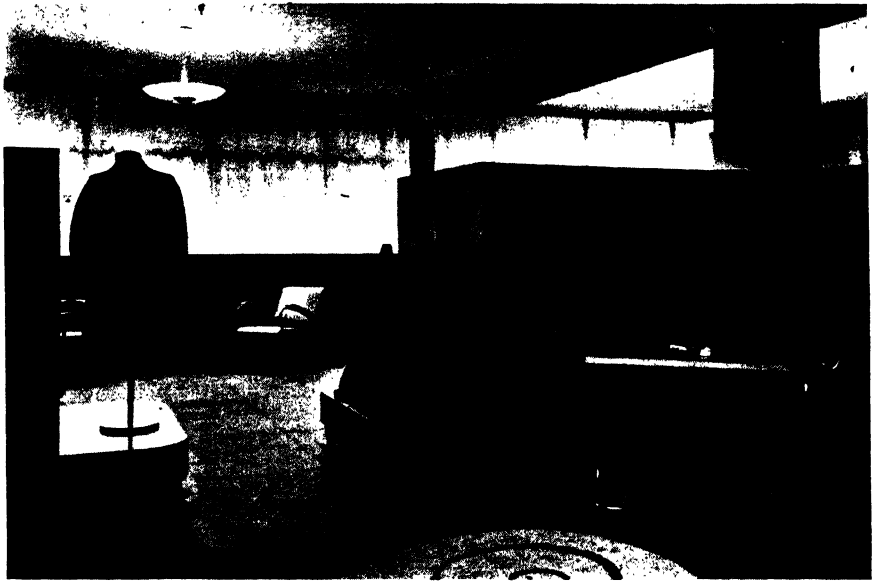

[By courtesy of Messrs. The Bath Cabinet Makers Co. Ltd.

FIG. 148.

Corner in the gentlemen's department, Messrs. Simpsons, Piccadilly, showing fitments largely constructed of plywood, faced with quartered figured English Oak. The doors are of laminboard, 1" thick.

is generally the rule, the construction should be as simple as possible, all difficult angles being avoided. The various illustrations demonstrate practical and decorative effects.

*Cost.*—The first cost is the final one, but this may vary considerably, depending upon the type of veneer selected for the job. In the case of kitchens, commercial plywoods, such as Douglas Fir or Finnish Birch blockboards, are used in large quantities and are generally finished by being painted, enamelled or cellulosed. In the case of Douglas Fir, panels must be specially treated to prevent the grain of the wood showing through the enamelled or painted surface. The cost of such fitments is very reasonable. Elaborate schemes employing decorative veneers will be more expensive, but bedroom and dining-room fitments built of selected veneered plywood should not cost more than hand-made furniture.

### STAIRWAYS

In new work balustrades can be erected without great expense by using a single sheet of thick plywood set into a wood or metal handrail or by erecting a light framework and covering this with  $\frac{1}{4}$ " plywood on both sides. Two suggested methods are illustrated on page 432. Plywood balustrades are easily kept clean and reduce the risk of draughts. Old-fashioned stairways can be simply and economically modernized by covering the turned wooden, or metal, balustrade rails with  $\frac{1}{4}$ " plywood.

### RADIATOR COVERS

Well-made laminboard can be successfully used for enclosing steam radiators and pipes. One well-designed scheme is illustrated on page 366. It is advisable to line the top of plywood radiator covers with asbestos, plated with metal-foil.

### FLOORING

In considering flooring problems few people think of plywood whereas in point of fact this versatile material can be both usefully and economically employed in several ways.

*Subflooring in New Buildings.*—When it is intended to cover floors in new buildings with Parquetry, Hardwood Strips, Linoleum or Rubber, much trouble in after years may be avoided if plywood is used in place of the conventional  $\frac{3}{8}$ " or  $1\frac{1}{8}$ " tongued and grooved softwood flooring. Plywood offers several advantages. It is speedily laid, the number of joints through which dust, dirt or cold air can

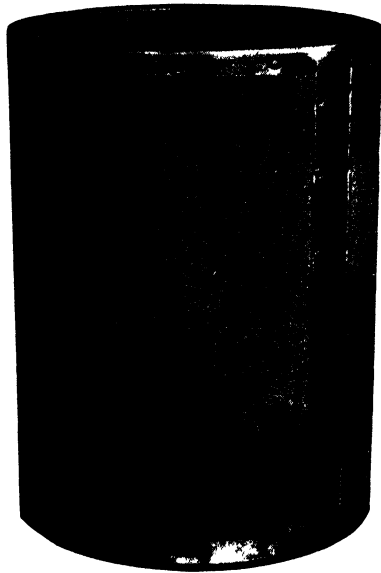

FIG. 149.—VENESTA PLYWOOD CONTAINER.



[By courtesy of *Pacific Forest Industries, Tacoma.*

FIG. 150.

Curved fronts of display shelves are simply made with  $\frac{3}{4}$ " Oregon Pine bent round solid wood frames. The thickness of the shelves may vary from  $\frac{1}{4}$ " to  $\frac{1}{2}$ " depending upon the weight to be carried.

percolate is greatly reduced, there is a marked freedom from cupping, shrinkage and squeaking. Above all, plywood entirely obviates the risk of that distasteful pattern made by the joints of narrow flooring boards showing through and ruining the effect of a carefully chosen rubber or linoleum covering.

The plywood which will prove to be most economical both in prime cost and in labour is  $\frac{5}{8}$ " or  $\frac{3}{4}$ " Oregon Pine 48" wide, in standard lengths of 7 or 8 ft. ; the spacing of the joists will determine the best length of sheets to use. For subfloors at ground-level resin-bonded plywood is recommended.

The sheets should be laid with the grain of the outer plies running across the joists, butting the joints as closely as possible. The edges of each board must be well nailed to joists and stringers with nails spaced about 6" apart ; the spacing of nails in the centre of the board may be about 12". All joints should be filled with a good wood mastic and, when set, flushed off and sanded smooth. To prevent drumming—a matter of great importance—a layer of felt or other suitable material should be pinned between wood joists or stringers and the plywood.

*Subflooring in Old Buildings.*—Where existing tongued and grooved flooring boards have become uneven or splintered through wear and tear they can be rapidly and cheaply renovated by the judicious use of plywood. Should the floor be badly worn it will be necessary to level up with mastic or other medium before covering with 5 mm. or 6 mm. plywood in sheets not over 50" square. If the floor is in good condition, 3 mm. or 4 mm. Birch 3-ply in sizes about 60" square or the larger sheets available in  $\frac{3}{8}$ " Oregon Pine may be used. It will be clear that the plywood must be well made, flat and free from open defects. With the exercise of care during laying, an excellent underfloor will be obtained: the smooth surface which results will add considerably to the life of linoleum, rubber or any other type of resilient floor covering.

*Surrounds and Borders.*—Plywood makes a most economical and useful surround to a centrally placed carpet : when the area between carpet and wall is completely filled with plywood the result is decorative and hygienic. The carpet should be placed in position and used for 4 to 6 weeks to allow it to "settle." Plywood of approximately the same thickness as the carpet ( $\frac{1}{4}$ " will generally prove to be satisfactory) should then be cut to fill the area between carpet and walls. The panels must be scribed to make a snug fit at walls and projections and care taken to make all joints tight—it is advisable to mitre the corner joints.

A good grade of Birch or Oak plywood, provided the face veneer

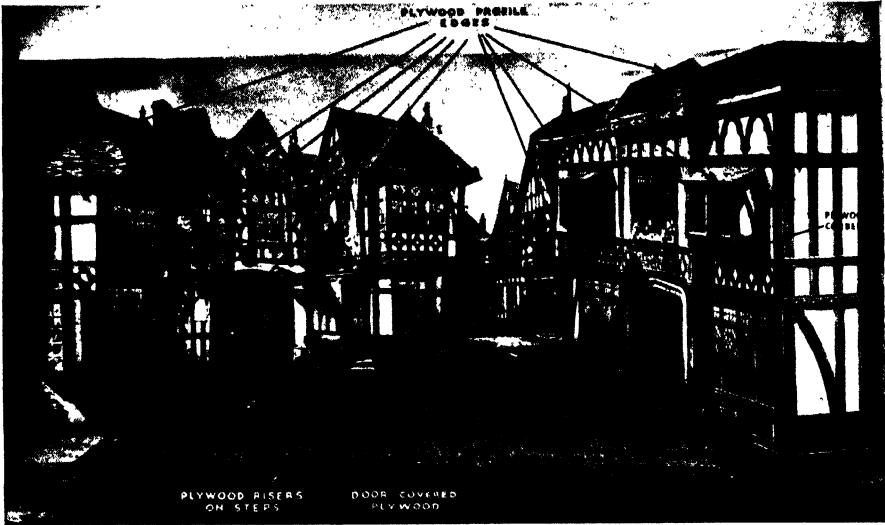
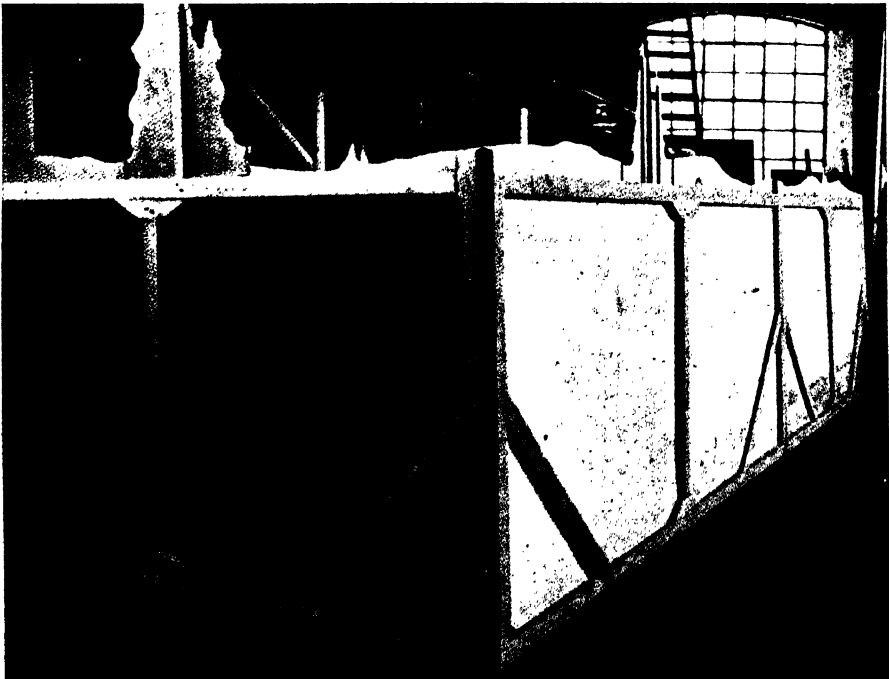

FIG. 151.

A stage setting showing positions where plywood serves well.



*From "Designing for the Stage"*

[By courtesy of Miss Doris Zinkeisen.]

FIG. 152.

Back view of a "ground row" built of plywood showing the light supporting framework. Plywood enables the subject to be cut out leaving strong yet sharp-cut top edges as shown in this illustration.

is at least 1 mm. thick, will give excellent results both from decorative and utility points of view. Plywood may be laid, in sizes large or small, with alternating grain, or woods of contrasting colours can be incorporated into the design. The plywood must be glued to the subfloor with a good hide glue and pinned at intervals of 6 to 9 inches. The surface should be well waxed before use.

## CEILINGS

In shipwork, plywood is invariably used for ceilings throughout the accommodation but it has not been used to any great extent in commercial buildings and the advantages of a plywood ceiling are seldom appreciated. A practical demonstration of the utility of such a ceiling was given some years ago in one of the offices owned by the authors' Company. Following a very severe frost burst pipes overhead caused serious flooding; plaster ceilings cracked and fell while a  $\frac{1}{4}$ " plywood ceiling in one room was little the worse although many hundreds of gallons of water must have passed through the joints. These were tightened up and the same plywood is still in position after a period of ten years.

A plan and elevation of a ceiling panelled in sand-blasted Oregon Pine which has been greatly admired is illustrated in Fig. 198. Ceilings can be quickly erected and a little thought given to the arrangement will be well worth while. The thickness may vary from  $\frac{3}{16}$ " to  $\frac{1}{2}$ " depending upon the area to be covered; the sizes will be selected to meet the spacing of the ceiling joists and the general decorative scheme.

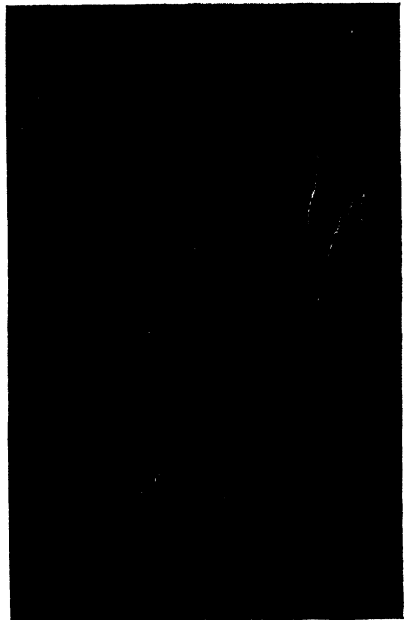
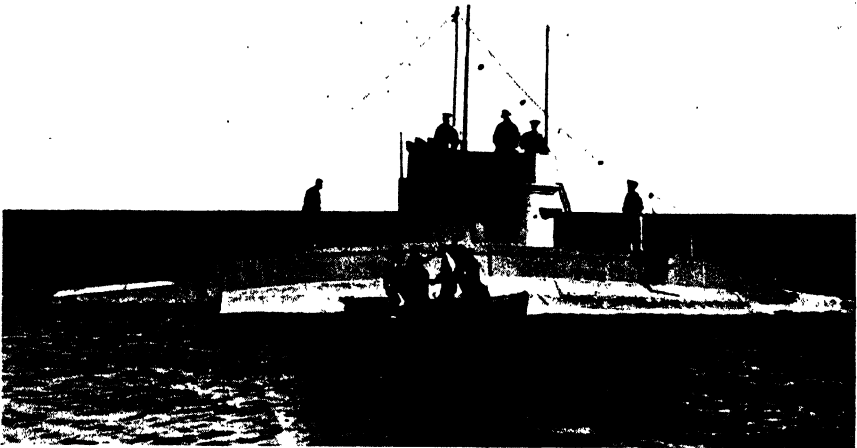

FIG. 153.  
Sand-blasted Oregon Pine.





[By courtesy of General Film Distributors Ltd.

FIG. 154.

A plywood-built submarine which actually put to sea off Weymouth during exterior filming of the Gaumont-British film "Jack Ahoy."

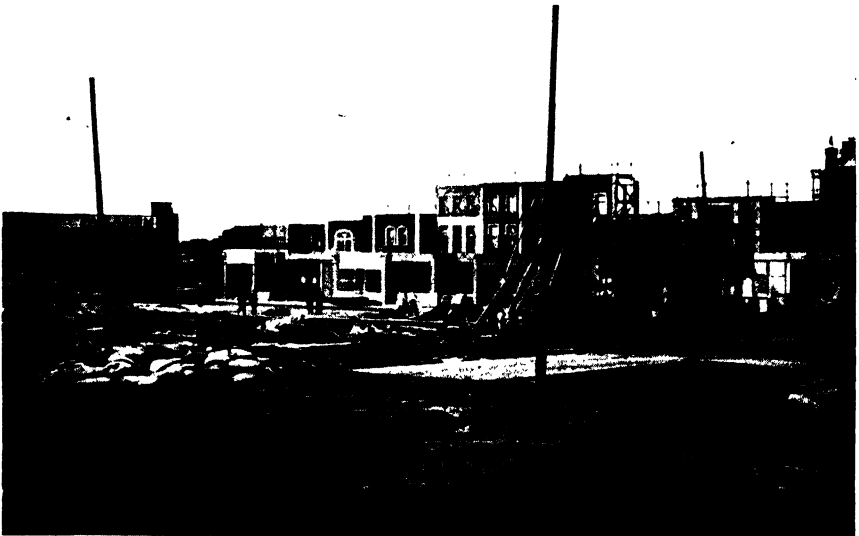

[By courtesy of General Film Distributors Ltd.

FIG. 155.

A London street in course of construction at the Gaumont-British location ground, Northolt, Middlesex, for the film "Sabotage." The fronts of buildings are all plywood-built.

## STAGE AND STUDIO JOINERY

Theatrical scenery manufacturers and erectors find plywood a useful material which is light but exceedingly strong. It gives an appearance of solidity to stage properties and enables "flats" to be produced with those sharp-cut edges which give reality to the finished scene. Smaller "ground rows" are generally built of plywood, 3 mm. to 5 mm. thick, backed by light battens in the manner shown in Fig. 152. For larger "ground rows" canvas construction over a wooden framework is generally used, with just enough plywood fixed to edges which call for an irregular outline. Figures, bushes, trees or any object or group of objects are cut out of plywood and supported in much the same way as the "ground rows."

Scenery built of plywood stands up to constant handling and there is less chance of the edges being broken than would be the case with cardboard or fibre board.

The thicknesses in most general use are 3 mm., 4 mm., 5 mm., 9 mm., 15 mm. and 18 mm. All stocks must be subjected to a fireproofing process as is described in Part IV., Chapter 3.

## STUDIO SETS

Large-sized panels of plywood are used extensively in the construction of film settings. Thicknesses range from  $1\frac{1}{2}$  mm. to 1 inch according to the object under construction. Alder, Birch, Oregon Pine and Gaboon are commonly used.

Birch plywood  $1\frac{1}{2}$  mm. thick covers a great variety of uses such as flat cut-outs for balustrades, profile trees, instrument panels in cars and aeroplanes, roof slates and by model departments for miniature work; 3 mm. is in general use in the making of "flats," being fastened with panel pins to a batten framework, the plywood being covered with hessian and plaster to represent brick, stone or plain finish; 6 mm. plywood is suitable for general constructional work covering bigger jobs such as streets, battleships, tube trains, railway carriages and so forth; 9 mm. plywood is used for tiles on terraces, painted to appear as marble slabs, parquet floors, while columns and pillars may be treated to represent stone.

Both exterior and interior sets are largely plywood-built and enable the carpenters to erect large surfaces with great rapidity.

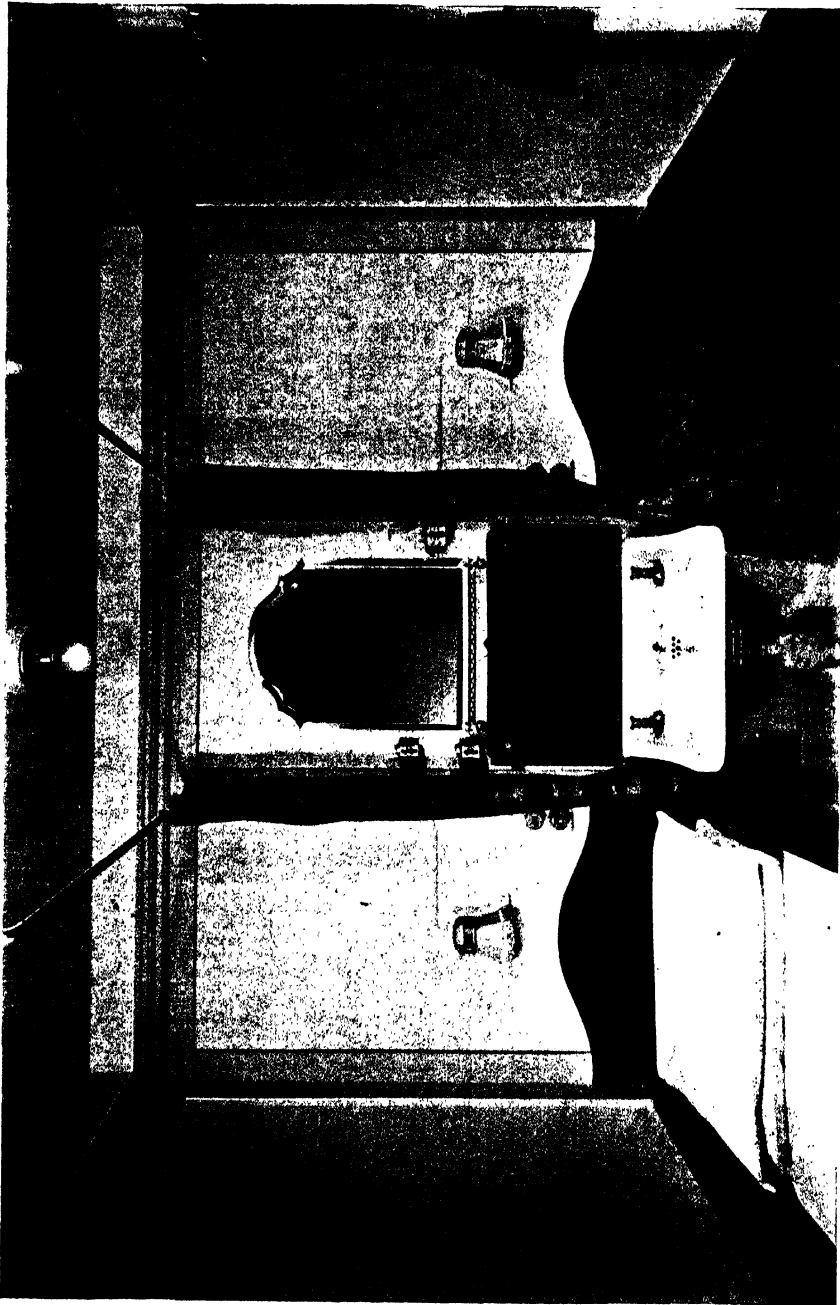

[By courtesy of Messrs. Wm. Denny & Bros. Ltd., Dumbarton.

FIG. 156.—TWO-BERTH CABIN IN CROSS-CHANNEL STEAMER.

The cabin bulkheads are of  $\frac{3}{4}$ " Oregon Pine plywood enamelled.  $\frac{3}{8}$ " plywood is commonly used for ceilings in this class of work.

## CHAPTER III

### SHIPBUILDING AND LIGHT CRAFT CONSTRUCTION

PLYWOOD is specified by naval architects and shipowners for passenger vessels, merchant ships and light craft, both for constructional work and as a means of decoration.

For at least thirty years the typical 3- or 5-ply board has been used in a few shipbuilding yards in the manufacture of furniture and, occasionally, for wall panelling, but it was not until the introduction of reliable waterproof adhesives that plywood was acknowledged by shipbuilders as being a suitable material for constructional work. Gradually the heavier types of multi-ply boards superseded the conventional tongued and grooved or framed-up redwood bulkheading and lining which, from both constructional and hygienic points of view, offered many objections.

Shipbuilders are large consumers of plywood: the quantities used vary with the type of vessel being built, from the 11,000 square feet in the standard type of cargo vessel to the 1¼ million square feet which went into the construction of the *Queen Elizabeth*.

#### BULKHEADING

The builders of passenger ships were the first to appreciate the advantages in being able to erect partitions and walls in large unbroken sections which required only an occasional pilaster or post to stiffen the structure. The era of flush panelling followed shortly thereafter. Builders were quick to realize that considerable savings in labour, time and cost could be effected by using plywood in place of the older types of bulkheading, and in modern shipbuilding plywood is used almost exclusively for this class of work. The strength of plywood being so much greater than that of solid wood made it practicable to use the former in thicknesses of  $\frac{7}{8}$ " and  $\frac{3}{4}$ " in place of  $1\frac{1}{4}$ " or  $1\frac{1}{8}$ " solid; the total cubic content of wood thereby being reduced by almost one-third.

For painted or enamelled bulkheading plywood manufactured from Oregon Pine (Douglas Fir) has come into general use. The lengths of standard-sized boards (viz. 84", 90", 96", 102", 108", 120") make it possible to cut practically any between-deck height without serious waste. Standard widths run from 36", rising by 6" to a maximum of 84"; special sizes can also be manufactured.



STAIRWAY TO SPORTS DECK.

PLATE XXI.—R.M.S. *Queen Mary*.

The walls are of  $\frac{3}{4}$ " Multi-ply Gaboon veneered Satinée, with Dado veneered English Elm Burr.  
Woodwork by Messrs. Waring & Gillow (1932) Ltd., Lancaster.

Okoumé (Gaboon Mahogany) plywood is specified by a few British and some foreign owners for enamelled bulkheading in passenger vessels, but the quantity so used is small when compared with the total purchases of thick plywood by British shipbuilders.

Various methods of erecting bulkheading are employed, the more usual forms of fixing being illustrated on page 390. These vary in a few minor essentials as between passenger liners and cargo vessels; briefly the general practice is as follows:—

The cants are screwed down to the deck composition or bolted to lugs welded to the steel deck; the runners are then plumbed up and bolted securely to the steel beams. Door standards, corner posts and intermediate posts are erected and fixed into their positions. The dimensions of the plywood panels are taken from detail battens, which are drawn in full size from the general arrangement plans. Before being removed to the ship the plywood is cut in the joiners' shop, each panel being clearly marked with the position it will finally occupy and given a priming coat to reduce unnecessary surface damage and restrict changes in moisture content. On the ship the panels are fitted directly to their allotted places and screwed into position.

Flannel is frequently used as a packing between plywood and solid corner posts to reduce creaking during the movement of the ship in heavy weather. Spaces, between the beams and above the runners supporting divisional bulkheads, are filled with plywood in order to isolate one stateroom from another, while expanded metal frames frequently take the place of plywood and form ventilation around the boundary walls.

The methods used to obtain a satisfactory flush joint vary, but inexpensive, strong and satisfactory joints are made by using corrugated fasteners spaced at 9" to 12" intervals and staggered on opposite sides of the panels. If thought advisable the edges of the panels may be glued before the fasteners are hammered home. Joints are flushed off and a layer of cement applied to the entire surface makes an excellent foundation for the coats of paint and enamel which follow.

Where the decorative scheme permits of an occasional break in the flush surface, plywood boards in any standard width may be erected, and the joints covered by pilasters or mouldings. Where strips or mouldings are used it is imperative that these be run from thoroughly seasoned wood.

When plywood was first introduced to the shipbuilding industry, panels were joined together by means of groove and slip feather, and this is the method still adopted when erecting veneered bulkheading. To obtain a strong joint it is essential that the feather be cut from hard-

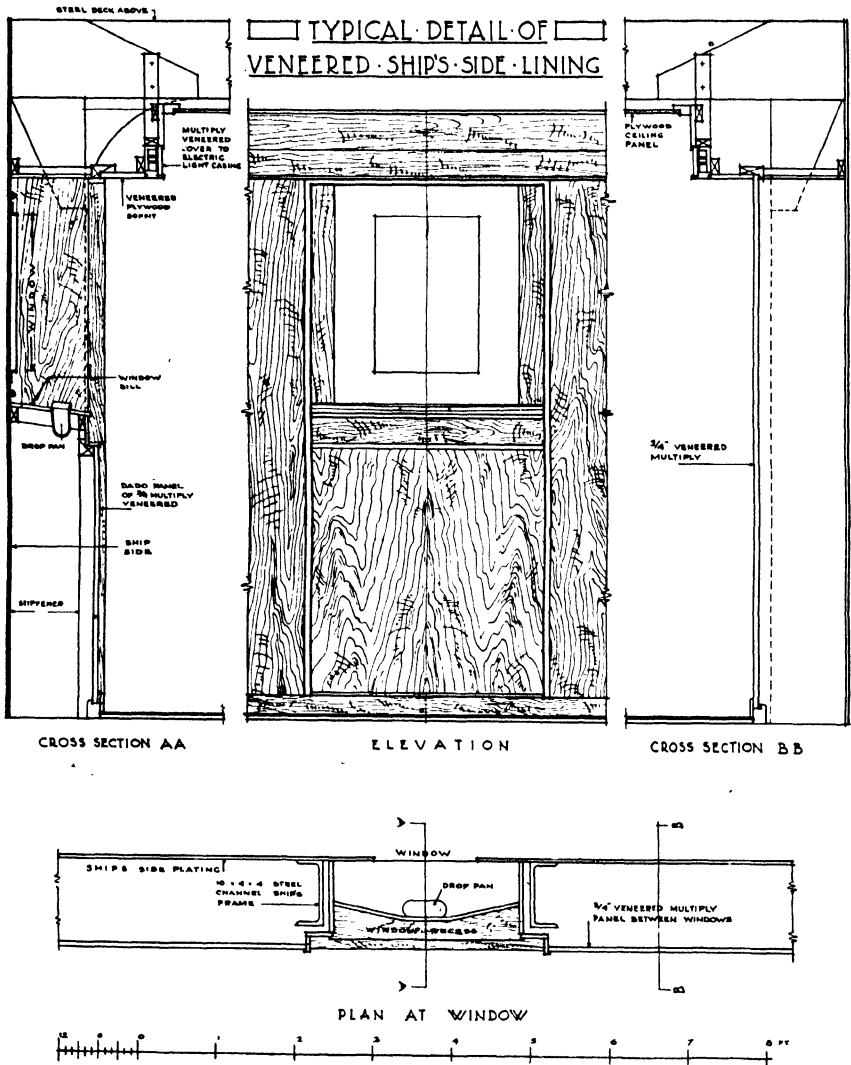

FIG. 157.

wood with the grain running at right angles to the joint, as is shown in Fig. 126. As an additional safeguard, dowels can also be used.

The large flush plywood walls lend themselves to decoration in a variety of ways: by paint or enamel, by covering with fabric or other decorative material, or panels veneered with one of the rarer and more exotic woods can be incorporated in the decorative scheme. Gaboon Mahogany is considered the most suitable base for veneered work, while Oregon Pine is more generally specified for other forms of decoration. It has been found in practice that well-made multi-ply wood, free from voids in the core, is more satisfactory than boards constructed on the laminated principle.

Prior to 1930 veneered plywood panels had been used to a limited extent in the decoration of public rooms, private staterooms and so forth, but it was the *Empress of Britain* which set the fashion in the use of large flush veneered panels as a decorative medium for divisional and boundary bulkheads at staterooms and corridors, as also for the corresponding ships' side linings throughout the accommodation.

Large plywood sheets enabled the architects to break away from the traditional form of panelling in rebated framework, which had been a feature in ships' joinery for so many years, and to create a new type of design which would not have been possible when working with solid wood.

The use of veneered plywood panels in ships' decoration has increased considerably and there can be no finer examples of this type of decoration than the R.M.S. *Queen Mary*, so aptly termed "The Ship of Beautiful Woods," and her sister ship the *Queen Elizabeth*.

The illustration of the Stairway to the Sports Deck of the *Queen Mary* shows how completely the use of plywood has revolutionized the covering of a wall with wood. This particular form of decoration was only made possible by using large sheets of plywood.

In certain parts of a ship—at entrance halls and main stairways—very large areas of wall surface call for decoration, and these can be plated from skirting to ceiling in one flush panel by judicious use of veneered plywood. The artist is thus able to take full advantage of the decorative possibilities offered by many of the finer veneers of wood. As the veneers can be laid vertically or horizontally, a wide variety of design and combinations of wood can be evolved.

Where elaborate veneered work is not desired, very pleasing effects can be obtained by using  $\frac{1}{4}$ " or  $\frac{3}{8}$ " thick panels in Oak, Mahogany or Walnut. Rough bulkheads of Oregon Pine are erected in the usual manner and the veneered plywood panels planted to these to give the desired panelled effect. The joints can be covered by raised mouldings,



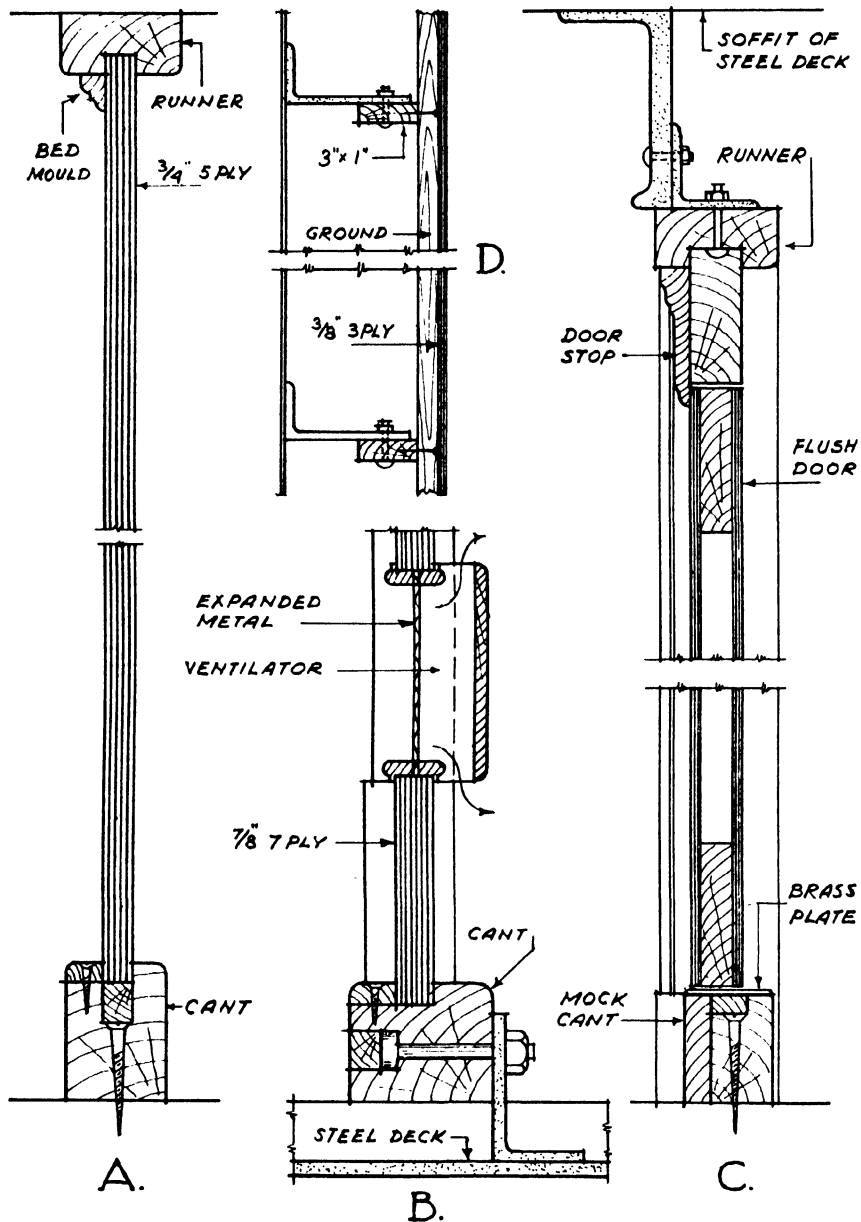

FIG. 158.

- A. Section through bulkhead showing method of fixing to runner and cant screwed to deck composition.
- B. Section through bulkhead at ventilator showing method of fixing cant to steel deck.
- C. Section through bulkhead at flush door.
- D. Method of securing plywood to ship's side.

or sunk mouldings can be fixed between the panels, as illustrated on page 436.

In corridors, where the veneered surface is liable to damage as luggage is being carried to or from staterooms, similar methods are adopted and  $\frac{1}{4}$ " panels veneered to dado height fixed to the bulkheads. When any section is damaged beyond repair, it can be removed and replaced by a new panel without any great difficulty.

As has been explained on page 137 when plywoods are bonded with phenolic resins a considerable increase in the resistance to fire is obtained.

### SHIPS' SIDE OR SKIN LINING

Large plywood sheets for ships' side linings are a boon to shipowners when inspection of the steel becomes necessary. On such occasions the loss of material and time is negligible when compared with the older type of tongued-and-grooved lining. Straps of 3" by 1" whitewood (deal) are secured to the ship's side frames or stiffeners as is indicated in Fig. 158 D; the  $\frac{3}{8}$ " or  $\frac{1}{2}$ " plywood being screwed to this wooden framework. Joints are covered to work into the general decorative scheme of the stateroom or cabin. It is essential that the backs of plywood panels so used be coated with red lead or some other protective and waterproofing agent before being fixed into position. Care should also be taken to ensure that air is permitted to circulate freely between the steel ship's side and the plywood lining. This is of particular importance in tankers and other vessels due to trade in the tropics. Sealed air spaces must be avoided.

### CEILINGS

In no part of the ship are the advantages of plywood better displayed than when used for ceilings in public rooms and corridors. By the judicious use of 9 mm. and 12 mm. crosswise-jointed multi-ply Gaboon panels in lengths up to 200", ceilings in public rooms, at entrances and elsewhere can be tastefully designed and rapidly erected in a material which has the merits of being both strong and light. The maximum rigidity can only be given to these panels if the inner plies have been jointed in their length by one of the methods mentioned on page 70. The larger the boards the fewer will be the number of surface joints exposed to view.

Oregon Pine plywood,  $\frac{3}{8}$ " thick, is largely used for ceilings throughout the accommodation. A or B quality should be specified and either will prove to be economical material for this purpose and will give excellent service. AA/BB grade is occasionally used but, unless all

broken knots appearing on the reverse side are repaired, there will always be a risk of damp collecting at the glue line exposed around the fractured knot, resulting in the growth of mould. It will be more economical to purchase the higher grades of Oregon Pine plywood than attempt to repair open defects in the joiners' shop.

Ceilings may be made quite flush by screwing the plywood to a framework bolted to the steel beams, as shown below, or, if all

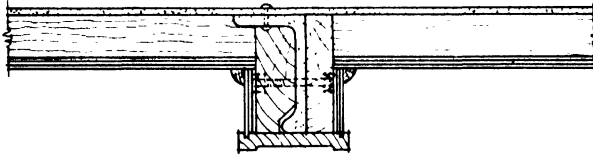

(a) Ceiling with boxed beams.

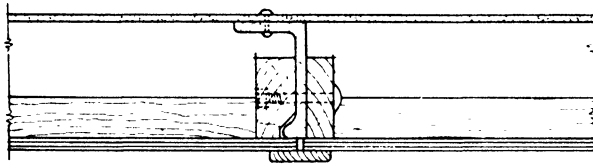

(b) Method of forming flush ceiling with plywood.

FIG. 159.

available height is required, the beams may be boxed. In either case should it be necessary to remove any one section this can be done without undue trouble or damage to the plywood.

The back of every plywood ceiling panel should be protected in the same way as the ship's side linings.

### BRIDGES, DECKHOUSES, ETC.

The introduction of resin-bonded plywood has made possible the use of plywood in many places on board ship in which solid Teak has previously held the field. The illustration opposite depicts the navigation bridge of a merchant vessel which was constructed with plywood painted white to harmonize with the two lower steel bridges. Resin-bonded plywood has been successfully used in the construction of deckhouses and life-boats in places where strength and rigidity, in combination with light weight, are essential.

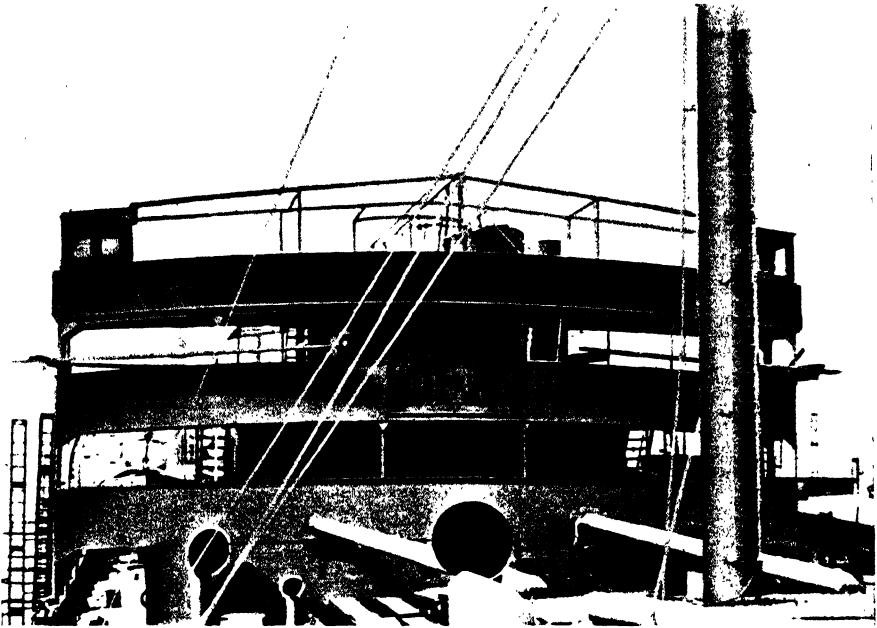

*By courtesy of Messrs. Lithgows Ltd., Port Glasgow.*

FIG. 160.

“Resweld” Oregon Pine plywood in standard sized sheets has replaced the conventional Teak boards on the navigation bridge of this vessel.

## FLOORS

Plywood makes an excellent underlining between rubber or linoleum and wood decking. 4 mm. or 5 mm. Birch plywood is generally used in a similar manner to that described on page 379. The grain of the outer plies must run at right angles to the joints of the decking. Plywood so used not only prevents joints showing through the covering but also prolongs the life of the material.

Thick multi-ply, laminboard or blockboard serves well when used in the construction of half-way landings on stairways or for balcony floors. Thickness may range from 1" to 2" according to the span between supporting steel joists.

## FURNITURE

While plywood has revolutionized the construction and decoration of divisional and boundary bulkheads, it has completely altered the layout of the modern stateroom. Built-in fittings made from plywood

vencered to harmonize with the walls are a feature both practical and pleasing to the eye. For work of a decorative nature and in the construction of ships' furniture, wood in the form of plywood and veneer has to a very large extent supplanted the older form of dressed lumber.

Compactums, dressing-tables, crews' lockers and furniture may be built almost entirely with plywood. Various examples and methods of construction are illustrated.

### USES OF METAL-FACED PLYWOOD

Plywood faced with galvanized steel on one side is frequently used to line pipe-spaces, galleys and storage-rooms, for table-tops in galleys and bars, for bulkheading at lavatories, bathrooms and crews' quarters, for lining walls and ceilings in engine-rooms and for many other purposes where walls are liable to hard wear or subjected to rough usage.

### LIGHT CRAFT

Plywood has been used to a very limited extent for internal work by builders of yachts, motor-boats, and other types of light craft, since reliable waterproof adhesives were first introduced; only a few of the more venturesome builders, however, had the courage to experiment with waterproof plywoods for the skin of speed-boats, canoes, light dinghies and so forth. In recent years resin-bonded plywoods have been used on an ever-increasing scale in the construction of similar craft. With the newer forms of plywood, bonded to shape with synthetic resins in special presses, the scope for this material in boat-building is truly great. Furthermore, methods of frame construction with plywood have been evolved suitable for all manner of craft from kayaks to 100-foot motor-launches, and these have been proved successful in actual service both in Europe and America. The boating and yachting journals of the post-war period should make interesting reading to the plywood man with a love of the sea. Unfortunately, in this volume, space forbids us to do more than touch upon these most interesting developments.

Instead of the old method of building the boat round moulds which are afterwards removed, transverse frames and transoms cut from plywood take the place of the moulds and the boat is built around these. Before the evolution of this form of construction solid Oak or Ash frames were, in certain highly stressed parts, reinforced with plywood gusset-plates. These, when glued and screwed to the solid frame, ran from deck-beams to the bottom frames and resulted in a considerable increase in rigidity. In the latest method of construction, the position of

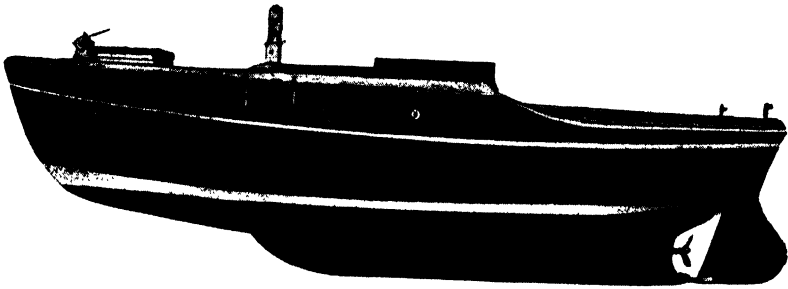

*[By courtesy of Messrs Alfred Lockhart (Marine) Ltd.]*

FIG. 161.

21-foot cabin auxiliary cruiser, with side and bottom planking, decks, bulkheads and frames built of "Resweld" Oregon Pine.

solid wood and plywood is reversed, the actual framing being of plywood to which are fixed fillets of solid Rock Elm, Ash or Oak. The fillets should be glued and screwed to the plywood, or glued and through-fastened; the outside planks and decking in turn being screwed to these hardwood fillets. Alternatively, stressed angle plywood strips, such as those illustrated on page 172 may be glued and through-fastened to both plywood frame and decking. These angle pieces may also be used for securing chines to the plywood frames.

For small boats, frames and fillets may be of light section, while for larger craft it is necessary to enlarge both thickness and dimensions in order that the necessary loads be carried safely.  $\frac{5}{8}$ " or  $\frac{3}{4}$ " Oregon Pine is handy stock for boats up to 30 feet long, while similar stock  $1\frac{1}{4}$ " thick, and 1" Canadian Birch have given excellent results when used in craft up to 100 feet in length.

In cabin cruisers, full-decked sailing craft and various types of motor-boat, a tremendous amount of joinery work may be cut out where frames have been carefully designed. These may be made to form parts of fitments or uprights to carry bunks or seats. Plywood has proved itself to be an excellent material for planking, and can be simply and speedily positioned in the building of square chine boats; the compound curves necessary in rounded bilge work offer difficulties, but that these can be overcome is seen from Fig. 161 which depicts how successful the builders have been in bending in a two-way curve  $\frac{5}{8}$ " Resweld Oregon Pine. This was done by soaking the sections in linseed oil and gradually bending the plywood to shape. The planking may vary in

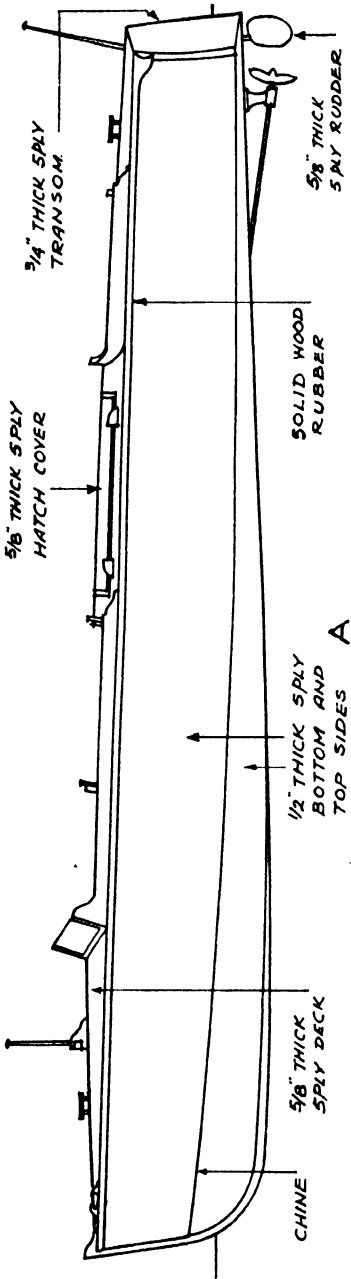

TYPICAL 20' - 30' HARD CHINE SPEED BOAT

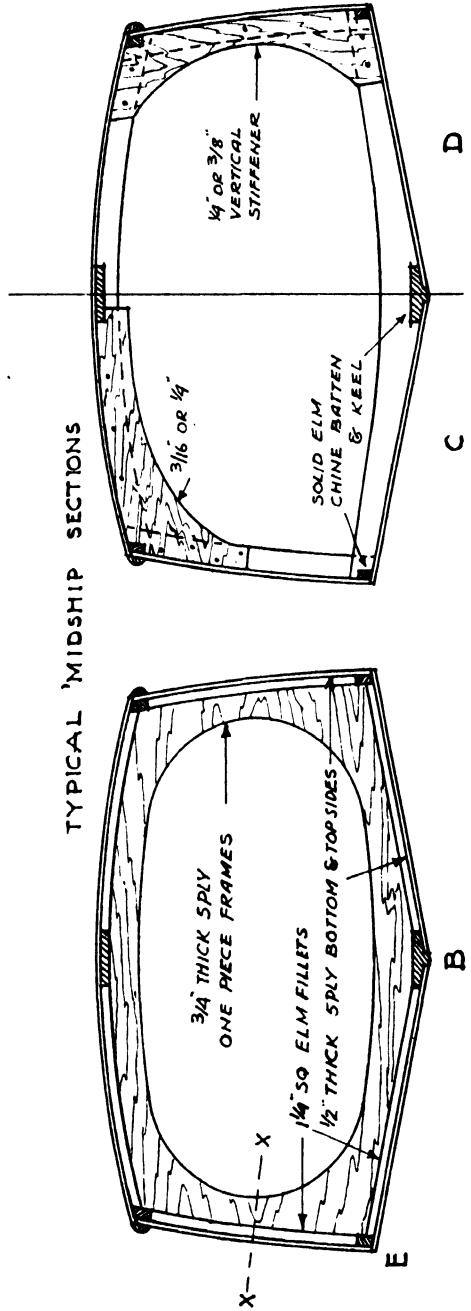

FIG. 162.

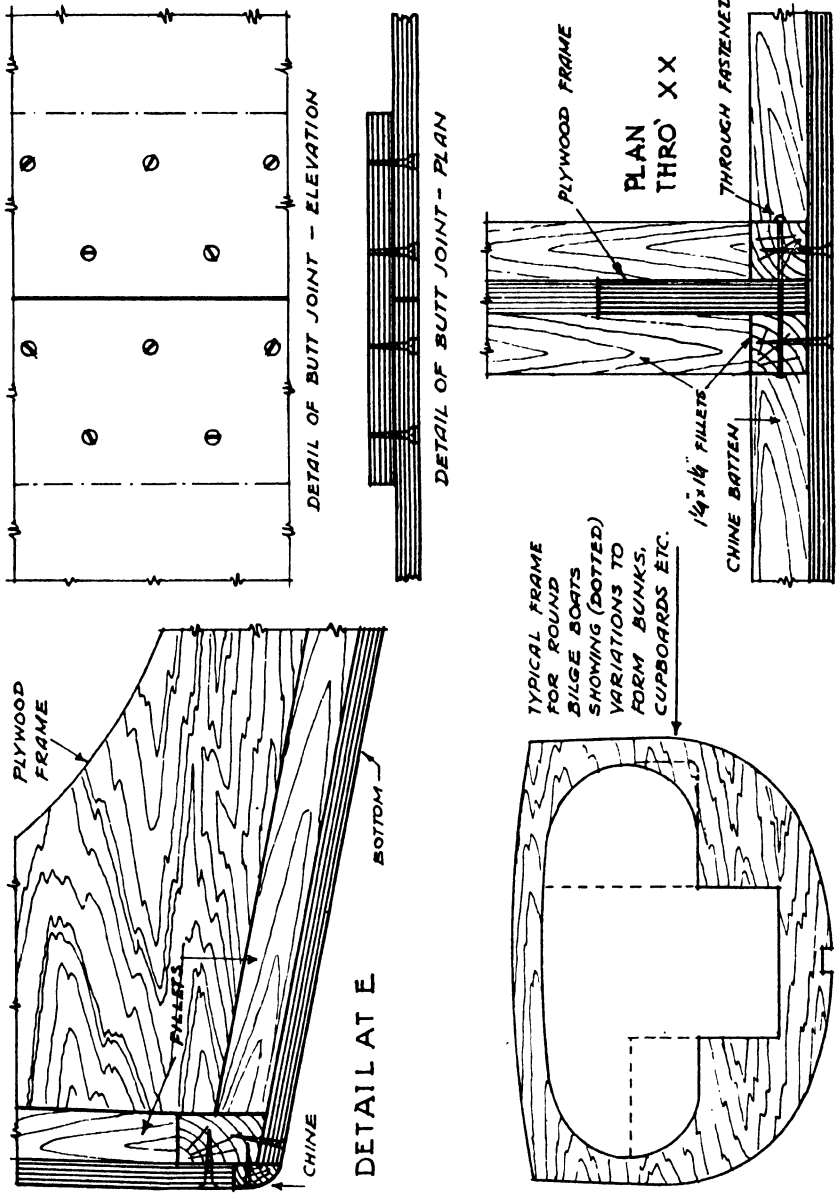
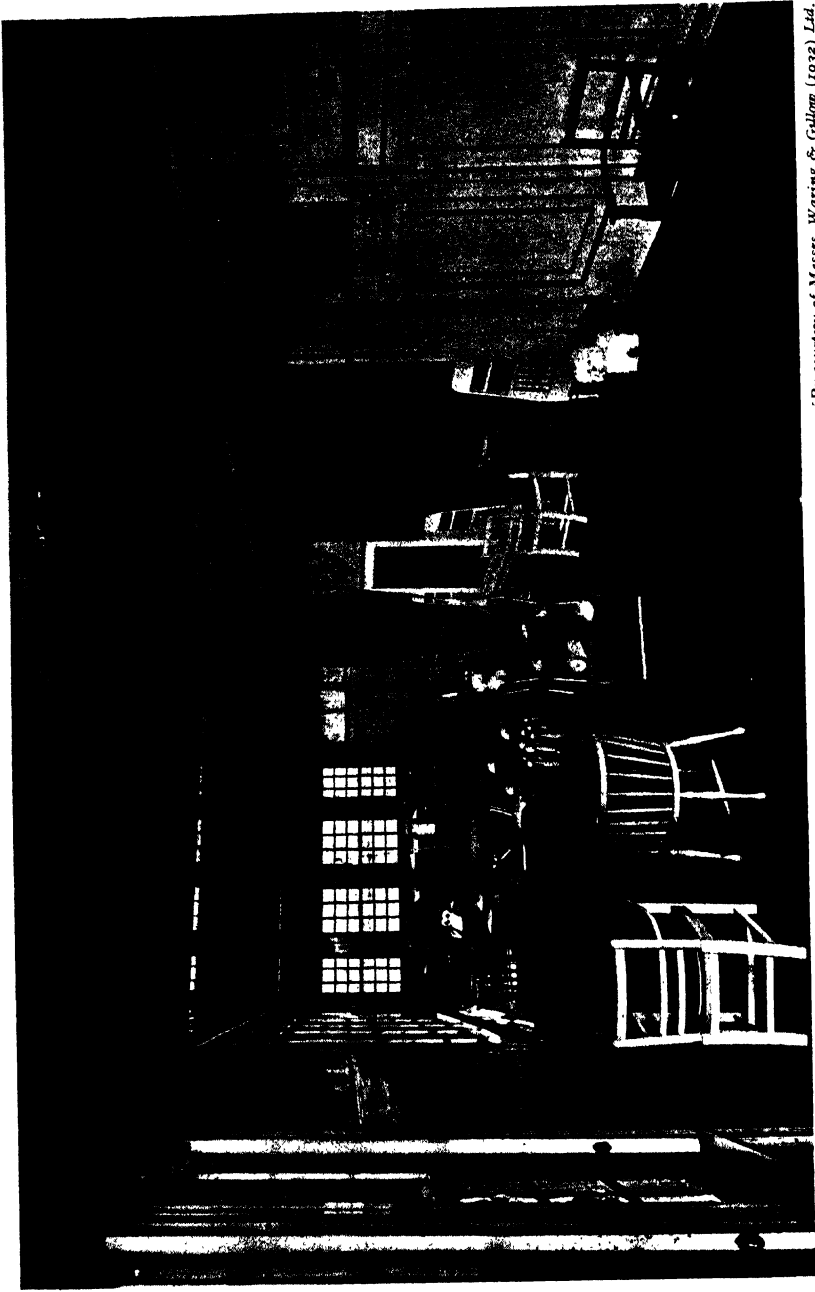

FIG. 163.





[By courtesy of Messrs. Waring & Gilroy (1932) Ltd.]

PLATE XXII.—CHILDREN'S PLAYGROUND, R.M.S. ANDANIA.

The walls are of Okoumé Multi-ply veneered Sycamore and polished champagne colour with sealing-wax red mouldings and fillets. Ceilings are of  $\frac{3}{4}$ " Okoumé Multi-ply painted.

thickness from  $\frac{1}{4}$ " for rowing-boats, canoes, etc., to  $\frac{5}{8}$ " or  $\frac{3}{4}$ " for heavier craft.

In square chine construction plywood may be scarf-jointed, thereby making it possible to position the planking in two pieces one on each side of the keel. The sides also may be scarfed and put on in two lengths. The scarf should be at least eight times the thickness of the boards, *i.e.* with plywood 1" thick the scarf should be at least 8" in length measured along the surface of the board.

Decks can be fitted in two pieces, *i.e.* one piece on each side of the king-plank: the number of pieces required will vary according to the deck plan and should be kept to a minimum. It will be found that  $\frac{3}{8}$ " plywood will bend nicely to shape. As the strength of the deck is of considerable importance thicker plywood  $\frac{5}{8}$ " to  $\frac{3}{4}$ " is frequently used. Douglas Fir or Birch plywood are eminently suitable and, as a general rule, are covered with 8- or 10-ounce canvas set in marine glue, filled and painted in the usual way.

It should be unnecessary to add that nothing but resin-bonded plywood of known and tested repute should be used for framing, planking or decking. Similar material may also be usefully employed in the constructions of cabin tops, locker tops, bunk sides, doors, etc. It is advisable to use one of the cold-setting resin cements such as "Beetle Cement 'A'," or high-grade marine glue, for all marine work, and to ensure that all joints are clean and close fitting before the cement is applied. Ample time should be given to allow the cement to harden properly before further work on the job commences. Care is required with  $\frac{1}{4}$ " plywood to make certain that screws are not driven too far home; in  $\frac{3}{8}$ " stock they may be countersunk not more than  $\frac{3}{4}$ ". Brass or bronze screws should be used.

Rudders can also be cut from  $\frac{5}{8}$ " or  $\frac{3}{4}$ " plywood, the leading edge being elliptical and the trailing edge sharp.

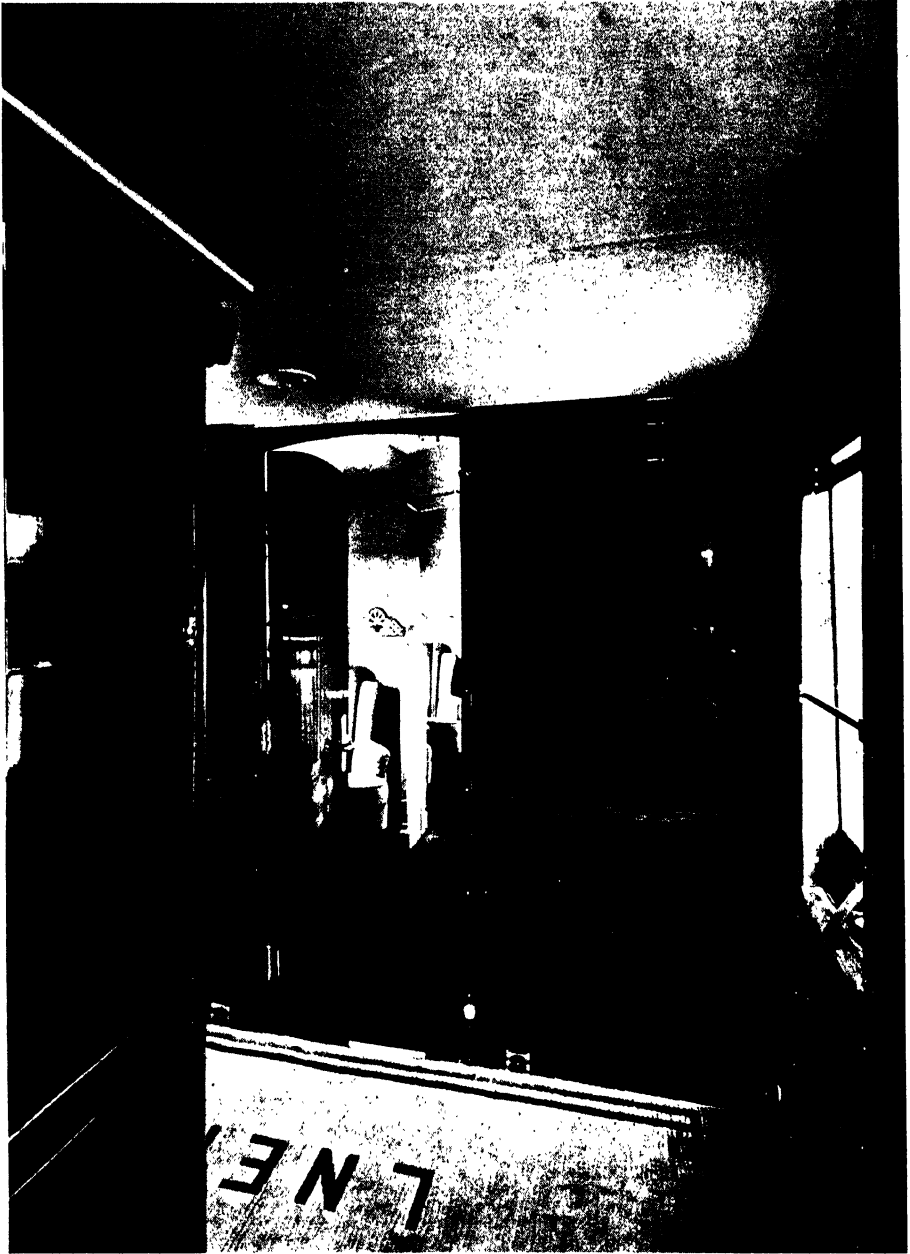

*[By courtesy of London & North-Eastern Railway.]*

PLATE XXIII.

Corridor to first-class coach on the famous "Coronation" train. Roof of painted plywood, veneered panels and partitions are also of plywood.

CHAPTER IV  
UTILITY SERVICES AND MOTORS  
RAILWAYS

THE railway companies consume large quantities of plywood annually. As a general rule, inquiries are put out to tender, and acceptances are subject to the approval of the company's inspector on delivery or at the tenderer's depot before despatch is made.

Plywood was first used in the construction of railway coaches for interior panelling, door panels and ceilings, but during recent years its use in the constructional field has been greatly extended. It is an interesting fact that, after twenty years' experience with steel Pullman cars, wood and plywood are again becoming more generally used in the construction of passenger and freight cars by railway companies in Canada and the United States of America. Experience has proved that by so doing, better insulation against exceptional heat and cold is obtained while maintenance costs are considerably lower.

*Passenger Cars.*—In America and Australia resin-bonded plywood is being successfully used for the exterior sheathing of passenger cars, refrigerator cars and goods wagons. Many thousand freight cars on the transcontinental lines of America have been built with external walls and internal linings of resin-bonded Douglas Fir plywood. Similar material 1" thick forms light but exceedingly strong subfloors in passenger cars being covered with  $\frac{3}{8}$ " linoleum or some composition.

*Corridor and Compartment Ceilings* which follow the curvature of the roof are commonly built with  $\frac{3}{16}$ " (4.5 mm. or 5 mm.) Birch plywood with the grain of the outer plies running crosswise or lengthwise, according to the construction of the ceiling. Outer plies must be free from open defects.

*Partitions between Compartments and Corridor Screens* are built of laminboard or blockboard varying in thickness from  $\frac{7}{8}$ " to  $1\frac{1}{2}$ ". These may be faced with Birch or Gaboon for painted finishes or veneered with any decorative wood. Alternatively, veneered panels  $\frac{3}{16}$ " to  $\frac{3}{8}$ " thick may be planted on the blockboard once the corridor partitions have been erected. By this means the travelling public have been introduced to many choice woods from the British Dominions.

*Interior Finish to Sleeping- and Restaurant-Cars.*—Plywood is almost

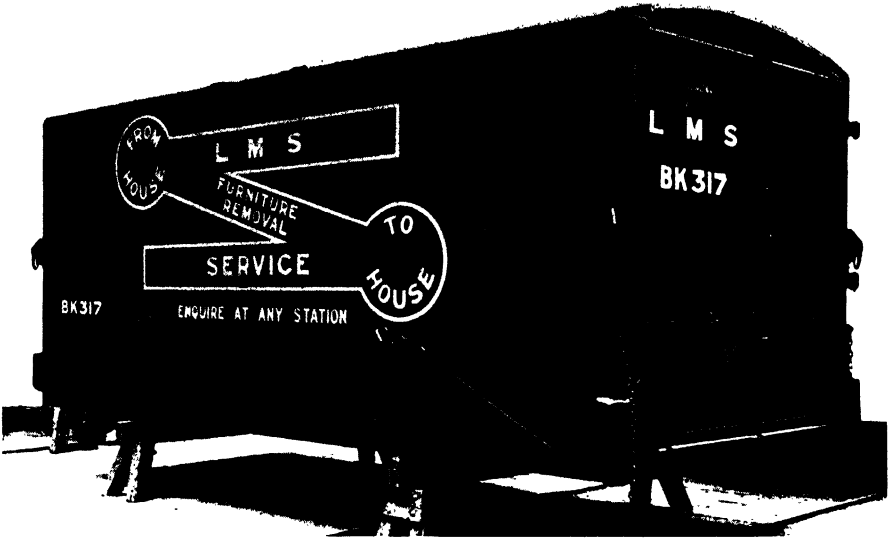

[By courtesy of London, Midland & Scottish Railway.

FIG. 164.—RAILWAY CONTAINER.

Roof of  $\frac{3}{8}$ " Multi-ply. End, sides and door of blockboard.

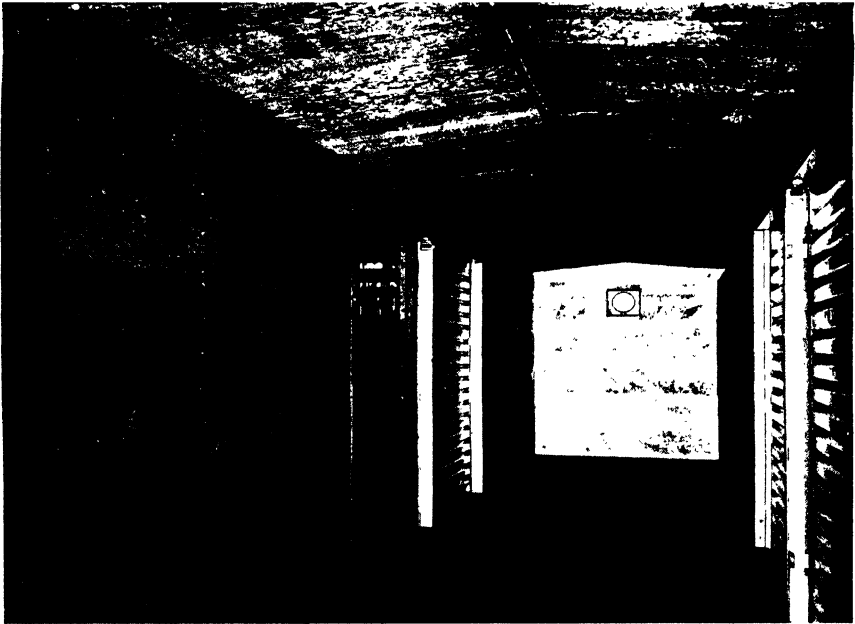

[By courtesy of Pacific Forest Industries.

FIG. 165.

This illustration depicts the interior of one of some 2000 freight-cars on the Chicago, Milwaukee, St. Paul and Pacific Railway. Sides and roof are lined with waterproof Oregon Pine plywood which is kick proof and prevents condensation. After four years' constant service these panels were found to be in excellent condition and no repairs were necessary.

exclusively used for this purpose being selected from  $\frac{3}{8}$ ",  $\frac{5}{8}$ " or  $\frac{3}{4}$ " Gaboon multi-ply to supply the requisite rigidity and frequently faced with a 0.8 mm. decorative veneer. Lavatory walls are lined with  $\frac{3}{8}$ " to  $\frac{5}{8}$ " thick Gaboon or Birch multi-ply, and painted or covered with rexine or plastic.

*Containers.*—A large number of containers for furniture or small goods have been built by British railway companies with sides, ends, floors and doors of blockboard, 1" or more thick. The experience of one of the main line railways has shown that blockboard is not entirely satisfactory from the strength point of view, but a study of the figures on page 447 would indicate that the necessary additional strength would be obtained by substituting multi-ply.  $\frac{3}{8}$ " multi-ply Gaboon is commonly used for the roof, being well canvassed over before the external finish is applied. Metal-faced plywood is used for the external facing of certain type of refrigerator and insulated meat containers.

*Covered Goods-Wagons.*—By using plywood for the lining of doors and internal lining in place of tongued-and-grooved lining, the smaller lineal footage of joints greatly reduces the infiltration of dust during service.

*General Work.*—In the panelling of stations, erection of offices, booths and general work, plywood is largely used. Resin-bonded plywood can be successfully used for tool-sheds and workers' huts. If these are made in sections they can be quickly erected or dismantled, and their removal from one location to another is greatly simplified.

## TRAMWAY CARS AND OMNIBUSES

Plywood is used to a moderate extent in the construction and decoration of tramway cars and omnibuses.

The cross partitions and sides, both interior and exterior, are frequently built of plywood; metal-faced plywood being used for the external coachwork. The latter takes enamel exceedingly well, and has proved to give lasting service. By using plywood for both external and internal lining the objectionable "drumming" of metal sheeting is eliminated. Resin-bonded Birch plywood  $\frac{5}{8}$ " or thicker, moulded to requisite shape, is used for the floors of double-deck trams and buses. Such floors are frequently supplied in one piece, giving the maximum strength with minimum weight.

Thinner plywood  $\frac{1}{8}$ " or  $\frac{1}{4}$ " Birch or Gaboon is useful for roof linings and is used in much the same manner as in railway-coach construction.

All perforated seats, at one time so largely used, were of plywood while the more modern upholstered seating relies upon plywood,  $\frac{1}{4}$ " to  $\frac{1}{2}$ " thick according to the size, to give a rigid base for backs and bottoms.

## AIRCRAFT

During the 1914-18 war, and for some years afterwards, plywood and solid spruce were largely used in the construction of aircraft but, with the development of new and lightweight metals, wood gradually lost favour. The all-metal plane was evolved, and for several years held the field both for military and commercial work. Once resin adhesives had been proved to yield a reliable waterproof plywood, this improved product of wood again became of interest to aircraft designers, who were alive to the fact that plywood possessed certain structural advantages over metal. By using plywood a saving both in weight and power is effected. Plywood-covered wings have no rivets to offer resistance to the air, do not easily retain a static charge of electricity, and are not liable to dent as are coverings of thin metal. "Plywood construction requires no special and expensive tooling beyond the tools and machinery found in the standard wood-working shop. Electrolytic action and excessive vibration do not cause the wood to 'tire.'"<sup>1</sup> It does not corrode.

Plywood made from European or Canadian Birch is most generally used as it combines strength with light weight; it has long life and is capable of resisting strains and stresses to a marked degree. The construction varies according to requirements, and the thickness selected

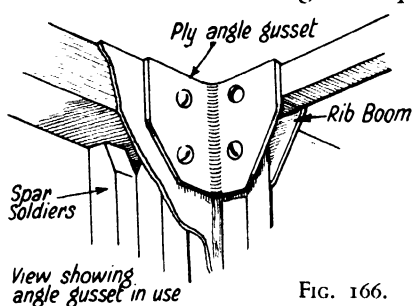

FIG. 166.

depends upon the degree of rigidity required; this may range from 0.6 mm. to 8 mm. Plywood for use in aircraft must be manufactured in accordance with British Standard Specification 5V3 for stressed parts and V34 for unstressed parts. Resin-film adhesive is commonly used and continuous control under inspectors is maintained during manufacture.

Plywood built with Birch veneers which are of even texture and straight grain is essential for all stressed parts; knotty, curly grained wood must not be used, as such wood is liable to crack along the annual rings when subjected to strain. The inner core and glueing is finally tested by passing thin sheets of plywood over a specially constructed box housing lights of high intensity. By so doing the course of the grain is easily followed and any defects can be spotted by the inspector.

"Diagonal" plywood is used as a safeguard against torsion in positions

<sup>1</sup> *American Hardwood Plywood*, published by the U.S. Department of Commerce.



[By courtesy of Pacific Forest Industries.]

FIG. 167.

A mock-up or full-scale model of a Boeing aircraft. Oregon Pine plywood is used in the construction of many important features.

liable to be subjected to heavy strains. The grain direction of the plies should be specified by the designer and, as a general rule, the grain of the two outer veneers runs at angles from  $45^{\circ}$  to  $60^{\circ}$  to the edges of the sheet. Both outer plies run in the same direction and are crossed by the grain of the core which is also cut at an angle of  $45^{\circ}$  to  $60^{\circ}$  to the edge of the sheet. Diagonal plywood can be made to give the maximum resistance against diagonal strains. It is expensive, as the waste of veneer is very heavy.

Birch plywood,  $1\frac{1}{2}$  mm. thick, is commonly used for covering the fuselage and wings being glued to the longerons, struts and stiffeners with special casein or synthetic resin adhesives. In order to add strength to flanges, to the ribs and at other joints, small triangular gusset-plates of  $1\frac{1}{2}$  mm. Birch plywood are glued and screwed to the solid spruce as demonstrated by Fig. 166. By scarf-jointing several boards together, the entire upper surface of a wing running from the centre line of the front spar to the trailing edge may be covered in one operation, being glued



and fastened to the wing framings which, themselves, are built of spruce and plywood.

Commercial plywood is also used in aircraft factories for jig covering, templates and much other work. Fig. 167 illustrates a full-sized dummy reproduction of a new type in project at the Boeing Aircraft Company's Seattle plant. Such "mock-ups" are made almost entirely of Oregon Pine plywood and are as accurately fashioned as the finished plane will be when it takes the air, thus enabling the testing of control positions, passenger accommodation, etc.

Metal-faced plywood is used for lining baggage compartments, while plywood incorporating Balsa wood in the core being resilient, sound absorbent and light, is invaluable for sound-proofing cabins, and is used also in certain non-stressed parts.

Improved and compressed wood is used for parts of furniture in addition to roots of propeller blades. In certain types of plane of cantilever construction, the main member is a spar of improved wood tapering from considerable thickness at the wing root to small dimensions at the tip.

## MOTORS

Plywood in many thicknesses is used by motor-body builders for coach-built and all-steel bodies of private cars and many types of commercial vehicle.

The properties and advantages of resin-bonded plywoods are not yet fully appreciated but, once the private motor-car resumes its place on the assembly-line, an increase in the uses of plywood in body-building may be anticipated.

In the following résumé the chief thicknesses of plywood used are mentioned, but it will be well to remember that some manufacturers prefer to use solid wood or metal in positions such as flooring-boards, heel-boards, battery-boxes, etc.

*Dashboards* may be of Birch plywood or preferably of single-sided galvanized steel or aluminium metal-faced plywood at least  $\frac{3}{8}$ " thick. Thinner double-faced stock is at times used. The metal side is fixed facing the engine. Dashboards are made up to the special shapes required by the manufacturers with any vulnerable edges protected.

Plywood dashboards help to eliminate engine noises and prevent the passage of fumes and heat into the driver's compartment.

*Floor- and Heel-Boards.*— $\frac{5}{8}$ " multi-ply Birch is frequently used for the former,  $\frac{1}{2}$ " for the latter.

*Battery-Boxes and Packing-Pieces.*—A few manufacturers make use of plywood for these jobs, others prefer metal or solid wood.

*Seat-Boards and Backs.*—Birch multi-ply from  $\frac{3}{8}$ " to  $\frac{5}{8}$ " thick is invariably used for seat-boards, the thickness being selected according to size and span.  $\frac{3}{8}$ " to  $\frac{3}{4}$ " Birch makes the best possible support for the covering material used for bucket-seat backs while the backboards or rear squabs may be  $\frac{1}{4}$ " to  $\frac{5}{8}$ " thick.

Plywood is extensively used for tacking-strips in all-metal bodies; these strips are attached to the metalwork by means of drive-nails or screws and the trimming fixed to the plywood.  $\frac{1}{8}$ " to  $\frac{3}{8}$ " Birch is handy stock for trim-fillets being covered with cloth, leather or leather-cloth, and used along the cant rails, down pillars, across the header and around back lights and door pads. Similar plywood is used for door-casing boards, and in many other positions.

*Instrument Panels.*—For cars in the higher-priced range the instrument panel is generally made from  $\frac{5}{8}$ " or  $\frac{3}{4}$ " plywood faced with a decorative veneer. Plywood gives excellent service and adds to the appearance of the finished job.

*Running-Boards.*—Running-boards of thick metal-faced plywood are used by a few manufacturers.

*Commercial Vans.*—In the commercial field the consumption of resin-bonded plywoods should show a steady increase in future years. The exterior panels for side, roof and doors may be built of resin-bonded or metal-faced plywood. Either will give excellent service and be less liable to fracture than boards of the compressed fibre type. For insulated vans metal-faced plywood is the better stock to use, double-sided galvanized steel or aluminium will, in addition to giving greatly increased strength to the body-work, make a serviceable and hygienic surface for the interior. In using plywood for exterior work, the joints and all bottom edges must be carefully protected to prevent any penetration of damp. This is best done by coating the edges of the plywood and filling the joints with a white lead-paint, or with a mastic having a bituminous base.

Furniture-van bodies are subjected to considerable strain when brakes are suddenly applied, or when negotiating sharp corners, and must be strongly constructed. Excellent results have been obtained by using thin single-sided metal-faced plywood and with  $\frac{3}{8}$ " and  $\frac{1}{4}$ " resin-bonded Birch and Douglas Fir. The plywood should be glued to the Ash framework as is done in the aircraft construction. It has been reported to us that resin-bonded plywood used for this purpose has given excellent service, and a marked reduction in petrol consumption has resulted from the saving in weight compared with the earlier types of metal body.

Additional strength can be added to the junction of roof and side if plywood gusset-plates are cut to shape and bolted through the frames in a similar manner to that illustrated in Figs. 162 and 166.

Excellent results have been obtained by using  $\frac{7}{8}$ " Resweld Oregon Pine in combination with metal for the sides, ends and bottoms of the tip-up lorries depicted in Fig. 168. By using the plywood under the metal a lighter gauge was made possible with a corresponding saving in weight.



FIG. 168.

Roofs of all types of commercial vans, lorry cabs and private cars may be constructed of thin metal-faced plywood or of resin-bonded plywood.

Resin-bonded and metal-faced plywoods are used on a considerable scale in the building of hand carriers for delivery of milk, bread and other food-stuffs.

## TRAILERS AND CARAVANS

In the construction of trailers and caravans it is advisable to use a material which offers the greatest possible strength in relation to its weight; in other words the trailer should be as light as is possible having regard to the necessary standards of strength. When on the road, as each curve is negotiated, the trailer will tend to pull sideways, the force of the pull varying in direct ratio to the weight of the trailer and the speed of travel. It will be obvious, therefore, that the question of weight is of supreme importance. Should the trailer be too heavy in relation to the weight of the towing-car and if the corner be taken at too fast a speed, the centrifugal forces may prove too violent and cause the driver to lose control of the car.

Used in conjunction with a framework of solid wood, resin-bonded plywood meets all requirements both for exterior covering and internal panelling. It is decorative and utilitarian, in addition to which, if properly employed and glued to the solid framework, it can be made to serve as a structural member on much the same lines as it is used in the aircraft industry. The gain in strength over nailing obtained by this method of construction is referred to on page 347. Added strength can be obtained at angles where walls join or on curves where walls meet the roof by the judicious use of plywood gussets.

When the floor of the caravan trailer is made from two or three

pieces of  $\frac{3}{8}$ " resin-bonded plywood, Oregon Pine will be found to give most satisfactory service and be the most economical ; securely glued and screwed to 4"×4" Ash or Chestnut frames, a rigidity to the structure will be obtained which cannot be excelled by any other material of like weight.

External walls should be about  $\frac{3}{8}$ " thick. Resin-bonded Birch, Oregon Pine or Okoumé may be used or, in more expensive models, decorative effects may be obtained by selecting plywood faced with hardwood veneer such as Teak or Honduras Mahogany, and finishing with a clear waterproof spar varnish.

The roof should be  $\frac{1}{8}$ " thick which can be bent to the contour of the framework. As this part will be exposed to the elements more than any other it is generally covered with a heavy waterproof canvas and finished with cellulose dope or some such material. The internal panelling and ceiling may be either  $\frac{1}{8}$ " or  $\frac{3}{8}$ ". If a painted or enamelled finish is desired Birch or Okoumé may be used ; alternatively, any of the decorative plywoods may be selected. Similar material will be used for cabinets and doors, for which purpose construction may demand a heavier plywood, say  $\frac{1}{4}$ " in thickness. As the interior of a caravan is liable to be exposed to damp, resin-bonded plywood is recommended for internal as well as external work. Wherever possible the plywood should be glued and nailed to the framework.

It has been estimated that the approximate weight of the exterior covering required for a caravan 16 feet long by 6 feet 6 inches wide is :—

(a) of resin-bonded plywood	. 250 lb.
(b) of 20-gauge steel	. . 540 lb.

Apart from this considerable saving in weight the insulation of a plywood-built caravan is, both against sound and heat, much more satisfactory than its steel-covered counterpart.

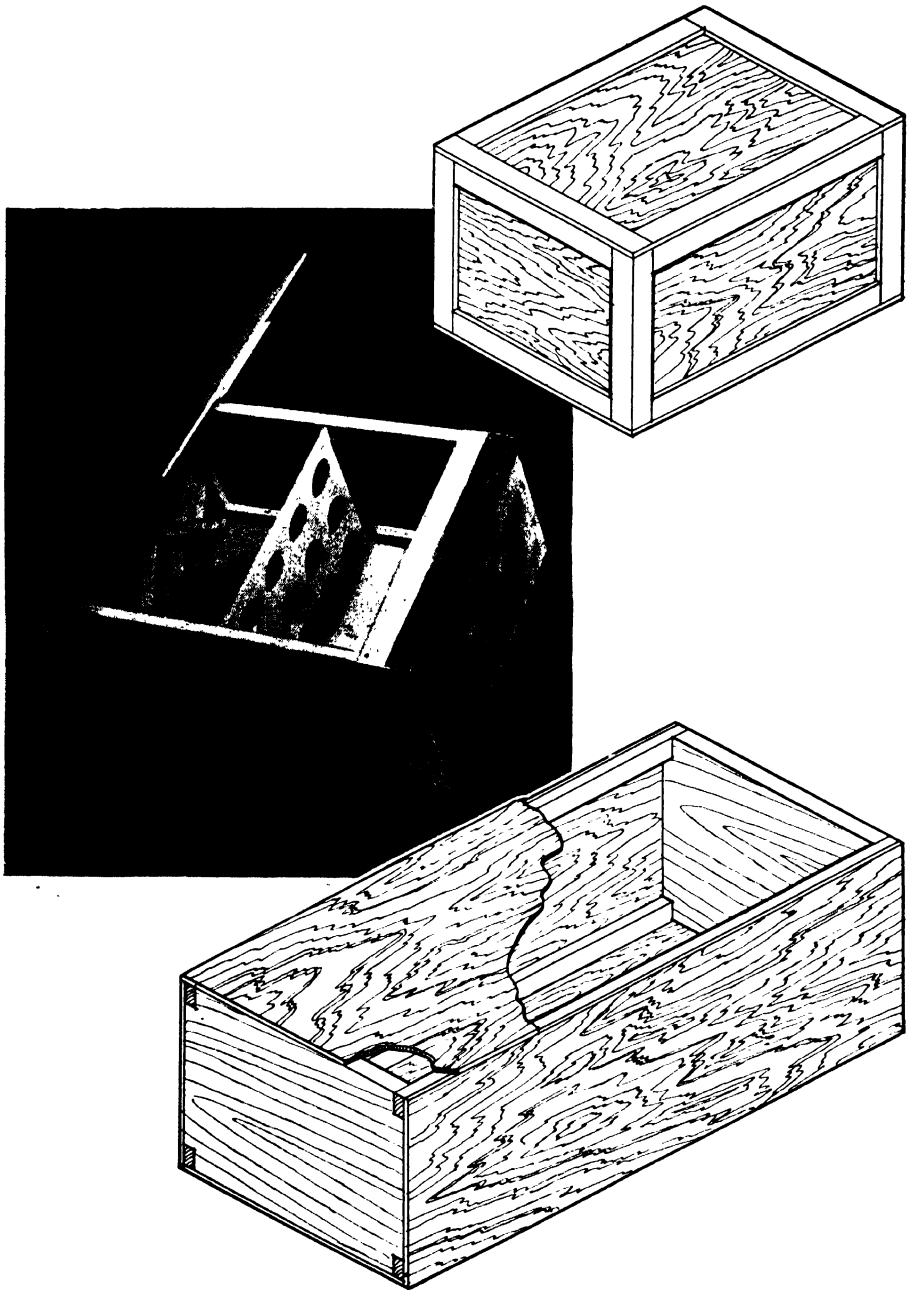

FIG. 169.—PLYWOOD BOXES AND CASES.

*Top.* Plywood case with solid battens.

*Centre.* Plywood whisky case; the cubic measurement being one cubic foot.

*Lower.* Plywood case with solid wood ends.

## CHAPTER V

### BOXES, BARRELS, REELS, BASKETS, TRAYS

THE earliest outlet for 3-ply wood on a large scale was in the production of tea-chests, and it is therefore somewhat surprising to find that further development in the field of box- and case-making was slow. A few firms did concentrate on the manufacture of plywood containers, but for many years the average box-maker preferred his solid timber. In the case of the whisky trade, it was not until the early 1930's that shippers of whisky thought it worth their while to experiment seriously with this form of packing.

Plywood containers large and small are now commonly used to carry a variety of commodities.

The advantages offered by plywood cases over those made from strawboard and/or solid timber may be summarized as follows :—

1. They offer the maximum strength with the minimum weight and so save freight on a tonnage basis.
2. They are compact and occupy less space than a case of solid wood, thereby showing a saving on a measurement basis.
3. They are durable, and very rigid, and will withstand blows of some severity without denting.
4. They are well-nigh pilfer proof.

Furthermore, the plywood itself acts as an insulator against extremes of heat and cold, gives protection against insects and rodents, does not absorb moisture as does strawboard, and offers an excellent surface for colour printing or branding.

In point of fact, plywood is the ideal material to use for commercial cases, 4 mm. Birch being in greatest demand ; for very cheap cases 3 mm. Alder in low grades is commonly used. Birch is strong, not unduly heavy, and has neither taste nor smell which might have a deleterious action on food-stuffs coming into direct contact with it.

There are several patented types of plywood case on the market some of which are collapsible, others are made in various sizes so that the smaller empty cases may nest in the larger ones and so save freight on returnable crates. Although the first costs of these " knock-down " returnable cases may be more expensive than others made with competitive materials, plywood cases, weight for weight, will give longer and better

service and so prove the more economical in the end. It may be of interest to know that all the provisions for the Everest Expedition of 1933 were packed in plywood boxes to carry 30 or 40 lb. These cases were subjected to most severe handling but nevertheless appeared to give satisfaction when kept intact until the contents were required, although Mr. Rutteledge in his admirable record of this journey makes the comment that they will not stand up against a determined thief or a series of obstreperous yaks! Fortunately commercial cases do not normally require to resist such harsh treatment.

The following notes cover the most important outlets for plywood in commercial box-making.

### TEA AND RUBBER CHESTS

The prosperity or otherwise of the tea and rubber plantations has a direct effect upon the production of plywood in Finland, the Baltic States, Russia and Poland. A study of the table on page 456 which sets out the total import of chests into various Eastern countries during the years 1930, 1935 and 1938, will give an indication of the important quantities of plywood consumed in the form of tea and rubber chests. The outside measurement of the most popular chest is 19"×19"×24" and, as the tops, bottoms and sides are of plywood, approximately 17½ square feet is required for each. 4 mm. 3-ply Birch is generally used.

The tea and rubber chest business is handled by a few firms with long-standing connections in the East; it is a highly specialized trade.

Plywood-made chests are very strong and have a uniform tare which is a matter of some consequence to the wharfingers handling both commodities at the London docks.

*Tea-Chests.*—There are two main types of chest: the eight-batten type and the twelve-batten type. The former is the more popular, the battens being fixed at top and bottom in the manner illustrated opposite; the sides are held together by riveting metal edging strips to the plywood. The twelve-batten chest has four additional strips running down the sides; in this case the plywood is nailed to the battens and metal edging strips are not required.

Shooks are shipped to the East made up in packages containing 100 pieces of one size; thus there will be six packages for each 100 chests, one containing tops, one containing bottoms and four containing the sides. Fittings such as metal edging, nails, rivets and linings, are packed separately.

The tea-chest illustrated is marketed by the original makers of the plywood chest. For this type, shooks for the sides measure 18½" wide,

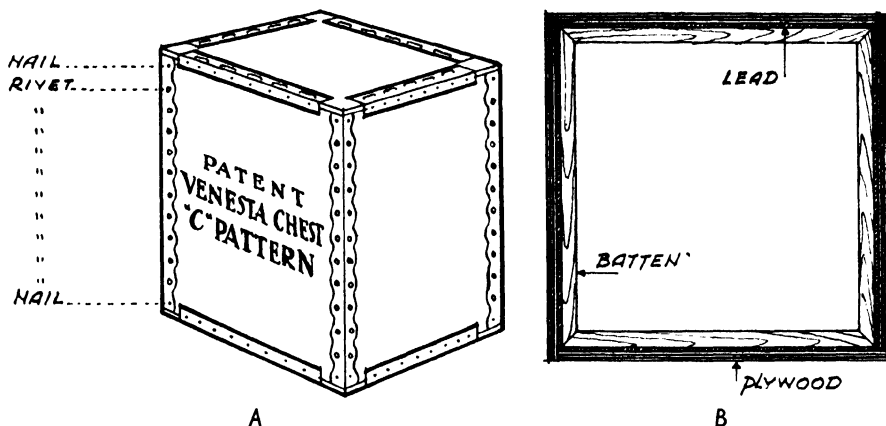

FIG. 170.

and by laying one shook to the outside of one edge and inside at the other edge the outside measurement of the chest is exactly 19". The suppliers of tea-chests issue instructions for assembling the various parts.

The absence of any objectionable smell or resin in plywood made from European Birch prevents tea from becoming tainted, a factor of extreme importance which precludes the use of many other timbers in tea-chest construction.

The 19"×19"×24" chest carries approximately 100 lb. of tea.

*Rubber Chests.*—The chief difference between the tea-chest and the rubber chest is that, whereas in the former the battens are permanently secured to the plywood sides, in the latter they are fixed to the top and bottom and come away when either is removed, the principal idea being that when the top or bottom of the chest is taken off there are no battens left secured to the sides which might prevent the semi-solid rubber from being emptied out when the chest is turned upside down.

The sub-committee of the Rubber Trade Association recommended that 3-ply chests measuring on the outside 24"×19"×19" be used for packing. A chest of this description occupies a space of exactly 5 cubic feet, any eight of which are equivalent to a ton of 40 cubic feet. These chests carry approximately 200 lb. of rubber.

## WHISKY CASES

Plywood cut to special sizes for whisky cases met with a steady demand and many millions of "sets" were imported annually. Methods of construction vary, but makers succeeded in reducing the external



measurement of the one dozen quart case to one cubic foot, an accomplishment of considerable value to shippers who were thus enabled to obtain the maximum of forty cases to each shipping ton of 40 cubic feet. A saving of anything up to  $2\frac{1}{2}$  lb. in the net weight of each case was effected while it was calculated that the saving in measurement averaged 4·8 per cent. 4 mm. Finnish Birch is commonly used for tops and bottoms, sides and ends. Some makers prefer to use solid ends with plywood tops, bottoms and sides. A special whisky box grade was shipped, one side being free from open defects, yielding a smooth surface suitable for printing. Internal divisions and supports when used were cut from 3 mm. or 4 mm. IVth grade Polish Alder.

*Meat Boxes.*—Considerable quantities of 4 mm. Birch plywood were shipped each year to the Argentine to be made into boxes which carried the products of the meat factories back to European and other markets. A grade having one fairly clean side, suitable for printing, was required.

*Tinplate Boxes.*—In this business plywood has to compete with Scandinavian brown kraft cardboard and English Elm; the latter is the cheapest form but occupies more space than either plywood or the kraft board. The inside measurement of the basic box (which carries 112 sheets of tinplate each  $20" \times 14"$  weighing 108 lbs.) is  $20\frac{1}{2}" \times 14\frac{1}{2}" \times 1\frac{1}{2}"$ . Boxes are made up with  $1\frac{3}{4}" \times \frac{7}{8}"$  sides and ends of Canadian Birch or Baltic Softwood. When plywood is used for tops and bottoms 4 mm. "C" quality Russian or "WG" Finnish Birch is good enough. Only about 10 to 15 per cent. of the total annual consumption of boxes embody plywood in their construction, so there is scope for improvement in this trade.

## LAUNDRY BOXES, CATERING CASES, EGG BOXES, ETC.

Boxes for such purposes are commonly made with hinged lids, the edges of the plywood being reinforced with wooden or metal bands or straps. Internal fittings can be arranged to meet special requirements. Such boxes are strong and light, and when properly constructed withstand much hard usage, giving years of service.

## DECORATIVE BOXES AND CASES

Decorative boxes are made up with veneered plywoods or may be fabricated to special shape in moulding presses similar to those described on page 132. In the design of cases to house cutlery or various scientific and precision instruments plywood is frequently embodied in combination with plush, felt or baize. The

thickness of plywood used varies from  $\frac{1}{16}$ " to  $\frac{3}{8}$ " according to size and method of construction. Fireside boxes, to hold a removable coal scuttle, from  $\frac{1}{2}$ " or  $\frac{5}{8}$ " WG Finnish Birch multiply covered with hammered brass-work, are strong and serviceable. The scope for the use of plywood in all types of decorative cases is considerable.

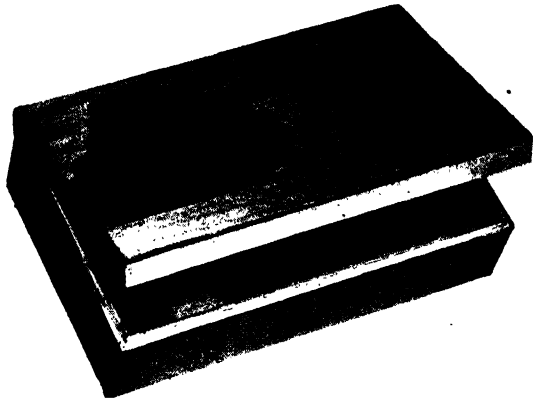

FIG. 171.

A decorative cigarette box constructed entirely of plywood. The lid is inlaid with various veneers.

### CABIN TRUNKS, TRAVELLING CASES AND BOXES

For many years 3 mm. BB or WG Finnish Birch plywood has given excellent service in the construction of cabin trunks. It is generally steamed before being bent around the solid wood ends, and subsequently covered with canvas on the outside and fabric on the inside. Tray bottoms are also made from 3 mm. or 4 mm. Birch 3-ply. Wardrobe trunks are of somewhat stronger construction, the plywood walls varying from 6 mm. to 12 mm. thick according to size. Coat-hangers, cut from one piece of 6 mm. Birch 4-ply, have proved to be an invaluable component part of this form of trunk. Divisions and drawers are formed with 4 mm. to 6 mm. Birch.

Attractive and light week-end cases and hat-boxes are made from  $\frac{1}{16}$ " BB grade Birch plywood covered with decorative leather or fabric. In Finland and Scandinavian countries hat-boxes and many other forms of travelling case are commonly made from a good grade of Birch bent to shape and finished with a clear varnish.

### BARRELS, CYLINDRICAL CONTAINERS OR DRUMS

A machine has been developed which fabricates complete shells of barrels from prepared veneers. These are fed into the machine, wrapped

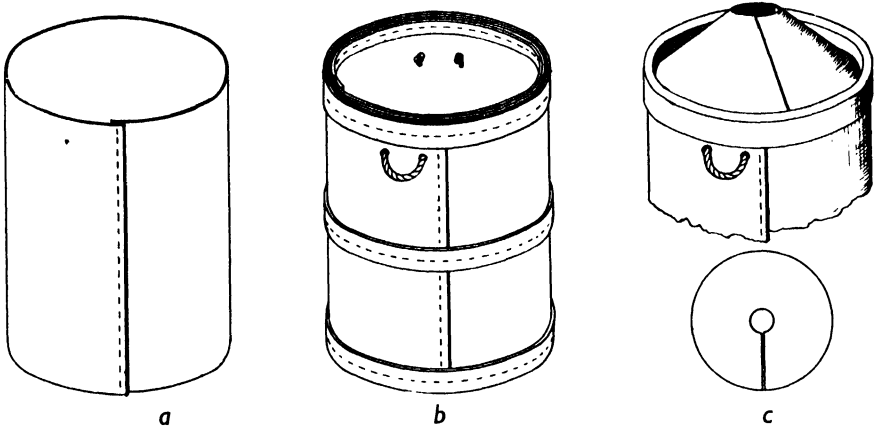

FIG. 172.—POTATO BARREL.

- (a) Two ends are stitched together.  
 (b) Two pieces of 1" wide plywood and one piece 2" wide are stitched to top and bottom of cylinder making a total thickness of 12 mm. One piece 2" wide is stitched to waist.  
 (c) Method of forming plywood top.

around special drums and subjected to heat and pressure which moulds them to shape. The shells, which can be made in a variety of thicknesses, when ejected from the machine are ready for the application of tops and bottoms.

The more economical and more convenient method of making a plywood barrel is to steam  $\frac{3}{8}$ " or  $\frac{1}{4}$ " Birch plywood and bend it on specially set rollers to whatever diameter is necessary. The largest manufacturers of this form of container use one piece of plywood for drums up to 10 inches in diameter and two pieces for the larger drums with inside diameters up to 25 inches. In the case of the latter the two vertical joints are secured by narrow strips of plywood on the inside or covered with metal jointing pieces on the outer surface. These strips are riveted to the plywood shell which is further reinforced with two or three bands of plywood running around the body, butt-jointed together and secured with metal tabs. The bottoms and lids are cut from plywood and, being in one piece, fit closely to shell.

Fig. 149 illustrates a well-constructed barrel, the cylindrical shape of which makes for easy stacking. These containers take up less space than the bilge type and offer the maximum capacity for the outside measurement. They are largely used for packing and transporting aniline dyes, chemicals, chemical manures, glues, china and glassware, fine cereals and other food-stuffs.

These containers can be lined to carry commodities with high moisture content, and specially insulated drums are also available.

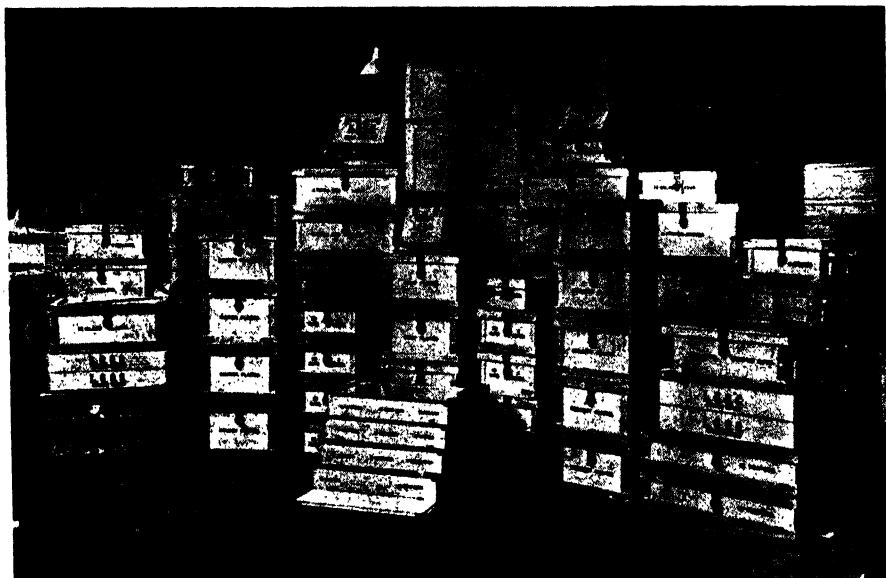

*[By courtesy of Messrs. Venesta Ltd.]*

FIG. 173.

These caterers' boxes and trays are largely plywood-built. They are strong and have given long and excellent service.

### POTATO BARRELS

Polish manufacturers of wet glued Alder shipped a considerable quantity of 3 mm. low grade plywood each season to the Channel Islands for the potato trade. These were supplied in sets consisting of one piece 24"×51", three pieces 53"×2" and four pieces 53"×1". The sketches opposite show the usual method of assembling the barrels. The foot is generally of  $\frac{1}{2}$ " solid; the covers may be of plywood, sacking or wire netting.

### TRAYS

Plywood is universally used for the bottoms of trays of all sorts and sizes. Useful and decorative household or display trays are made with veneered plywood or Birch plywood covered with a decorative fabric, glass or plastic. In the factory, where numbers of small parts must be kept separate, plywood trays divided into a number of sections on the egg-box principle are useful.

Bakers and confectioners use a considerable number of plywood trays and, as these must be kept scrupulously clean, resin-bonded Birch plywood will give good service and permit of scouring with boiling

water or steam. As a general rule, plywood for bakers' trays is supplied in a grade having one good side and in a variety of sizes with grain running crosswise. For trays up to 54" long the general thickness is 6 mm. 4-ply. 4 mm. is used for light trays up to about 36" long and 9 mm. for specially large trays. Confectioners' trays are smaller and, as they are not called upon to carry much weight, 4 mm. Birch or Alder may be safely used for sizes up to about 36"×18". The plywood is generally screwed to sides and ends of dressed whitewood  $1\frac{1}{8}$ " to  $\frac{7}{8}$ " thick. Light and cheap trays may be held together with wire nails instead of screws.

Where exceptional strength or a hard-wearing surface is required metal-faced plywood set into a grooved hardwood frame will give lasting service, but trays so made are not inexpensive.

In paper-making and printing works flat platforms are made from  $\frac{3}{4}$ " Oregon Pine plywood on which paper in various sizes can be laid and kept in good shape. These platforms can be removed fully loaded from one part of the works to another.

### FRUIT BASKETS

*Veneer Boxes and Baskets.*—Very large quantities of Pine veneer are cut each year in Australia and New Zealand for the production of cheese and butter boxes: the thickness of veneer used varies considerably. In Britain fruit baskets are stamped out of rotary-cut veneer and stapled together to form the various shapes of basket which are so well known to all as convenient carriers for tomatoes, plums and soft fruits.

### REELS FOR ELECTRICAL CABLE AND WIRE

The flanges of reels on which electric flex is wound are generally cut from 6 mm. Finnish Birch. This gives excellent protection to insulated wire or cable. For small reels 4 mm. plywood is occasionally used, while for those over 16 inches in diameter, 8 mm. or 9 mm. Birch is preferred. A number of patented reels are used which embody plywood in their construction.

### BOBBINS

Bobbin-heads for the linen, jute and other spinners, are turned from specially manufactured plywood. For this work it is essential that the veneers be well cemented together and that the plywood is free from gaps in the inner plies. Birch or Beech outer plies, cut between 2 mm. and 3 mm. in thickness, are generally specified. The thickness of the plywood used varies from 12 mm. to 32 mm.

## CHAPTER VII

### EXTERIOR WORK

RESIN-BONDED plywood is frequently referred to as "Exterior" plywood. This is an apt description as experiments conducted over several years have proved that it can be exposed to the elements without any fear of ply-separation. It should be borne in mind, however, that this comparatively new material is a product of wood and, as such, it must be treated with paint or varnish in much the same way as doors, window frames or other exposed woodwork. Resin-bonded plywood gives the architect and engineer a material of considerable structural value. It is not a synthetic product made to imitate some well-tried and well-known substance but retains all the natural beauty of the timber from which it has been made.

When resin-bonded Birch and Oregon Pine plywoods were first marketed in Britain the authors instituted a series of tests by incorporating these plywoods in various structures, some of which were painted and varnished, others left unprotected.

The sitting-boxes and movable pens illustrated below have been in use for fully five years; both are in excellent condition notwithstanding the fact that the original paintwork has not been renewed. One out-building, constructed of Oregon Pine, for experimental purposes was left unprotected. After about eighteen months' exposure it was noticed that surface checks had

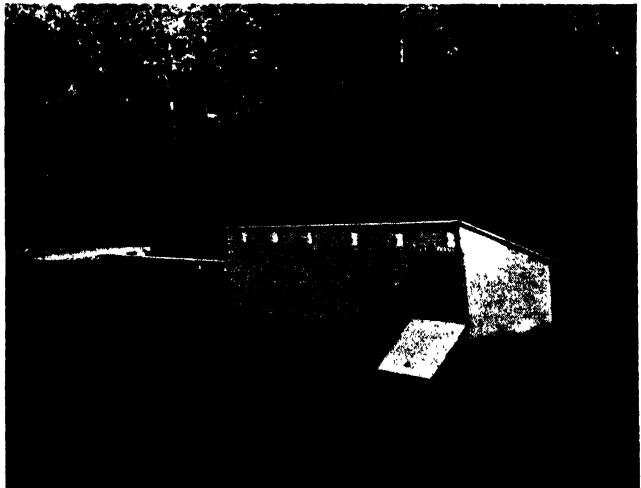
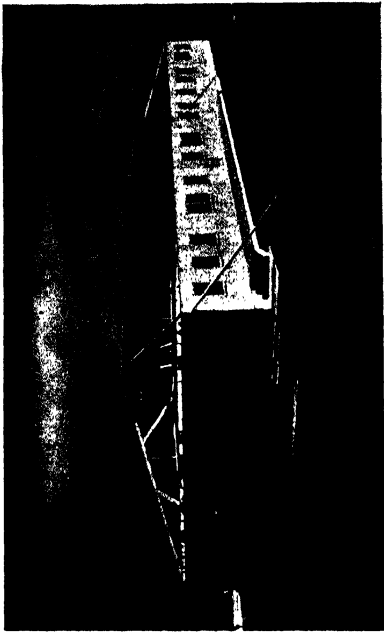

FIG. 174.

Sitting-boxes made of resin-bonded plywood are light and easily kept clean.



(b)



(d)



(a)

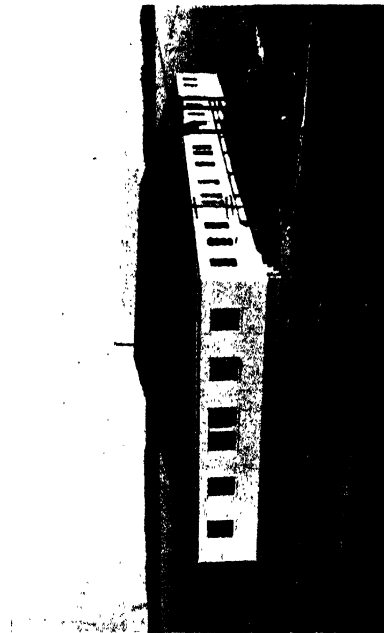

(c)

FIG. 175.

(a), (b) and (c). Three views of a pre-fabricated office building in course of erection on a temporary location at Seattle. Resin-bonded Douglas Fir is used for exterior and interior walls and the roof.  
 (d) Movable pens made from  $\frac{1}{4}$ " Resweld Birch which have been in constant use for five years.

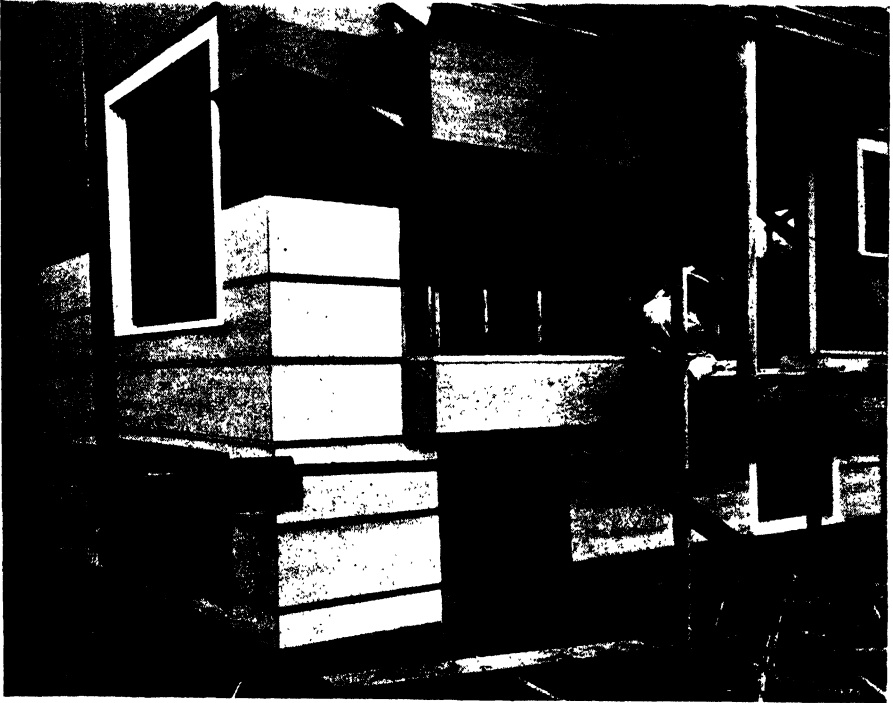

FIG. 176.

New offices for Messrs. B. C. Plywood Ltd., Vancouver, in course of erection. Resin-bonded Douglas Fir plywood is used throughout for the external sheathing.

commenced to appear but the resin bond remained intact; there were no indications of ply-separation. The sign illustrated on page 85 consists of letters cut from Birch, painted on all exposed edges, superimposed upon a base of Oregon Pine which was clear varnished. Many of these Resweld signs have been exposed to the elements in various parts of Britain for a number of years and remain in perfect condition.

Experiments conducted in America have confirmed that exterior plywood fully justifies the name, and in 1938 the Federal Housing Association accepted resin-bonded plywood for sheathing.

Commenting upon investigations into the behaviour of resin-bonded Douglas Fir when exposed to the weather Messrs. Stamm and Seborg, senior and assistant chemists to the U.S. Forest Products Laboratory, observe: "As the outer surface of the outer plies is not restrained like the inner surface, differential stresses will be set up across these plies and, eventually, will result in face checking. Because of these stresses, plywood



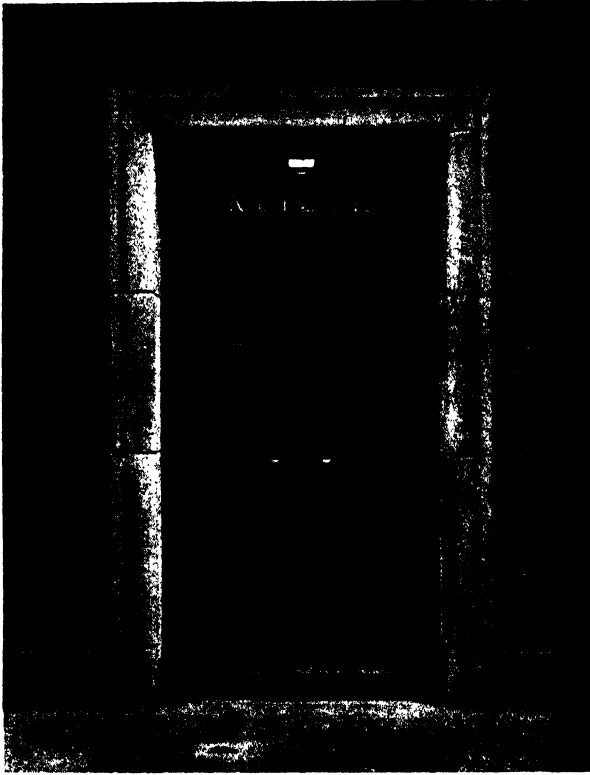

FIG. 177.

Exterior flush doors constructed with resin-bonded Teak plywood.

is much more subject to surface checking than a solid board of the same size. It has been found that applying an anti-shrink treatment to veneers not only minimizes checking under weathering conditions but adds other desirable properties."

To overcome all risk of surface checking the Research Department of the Douglas Fir Plywood Association recommends that "exterior plywood be finished with high grades of paint and that these paints be properly applied." This conclusion has been reached after much experimental work and practical experience and, if the advice given on page 429 be followed, Douglas Fir (or other) resin-bonded plywood may be confidently used in work which will be permanently exposed to the elements. Exterior plywood is a high-grade product which deserves reasonable treatment; even the finest steel-work will not remain in good condition unless given an occasional coat of paint.

Resin-bonded plywood has been used on a much wider scale in America than in Europe but nevertheless important quantities were marketed in Great Britain during 1939. In the same year the United States Army Air Corps specified Douglas Fir plywood for the exterior sheathing of barracks in eleven air-fields, over one million square feet being used on this project alone.

When used for external lining the joints may be made flush or they may be covered by mouldings and so become part of the design. In the former case it is advisable to ship-lap the edges of the panels by cutting the face of one panel and the back of its mate to a corresponding depth on a spindle. The edges at these joints should be filled with white lead and then nailed to the framing with nails of the galvanized or non-corrosive type spaced about two inches apart.

Resin-bonded plywood is usefully employed in farm buildings and for poultry and livestock houses. Partitions are made by coating the edges with heavy asphaltum or roofing cement and crowding the joints closely together. Walls so constructed may be whitewashed or sprayed in the usual manner and are vermin-proof.

In the field of pre-fabricated temporary or permanent structures exterior plywood is invaluable and offers many advantages over competitive materials. Several uses have already been mentioned and many more possible outlets will be conjectured in the mind of the practical reader.

### CONCRETE SHUTTERING

Wallboards, in addition to plywoods of various kinds, have for many years been used for form linings. About 1936 a new technique was developed whereby one thick board of resin-bonded plywood was made to serve the dual function of sheathing and form-lining ; in the years immediately following, the use of this type of construction increased rapidly.

Exterior plywood  $\frac{3}{8}$ " or  $\frac{3}{4}$ " thick is strong and rigid and gives to the engineer a material with which large forms can be designed and built with safety, accuracy and a great saving in labour costs. Douglas Fir was first used both in America and Britain for this work and has remained in popular favour since, mainly on account of the fact that it is available in large standard-sized sheets at moderate cost. These boards are easily handled and even an 8'×4' panel can be erected by one or at most two men.

Only well-made plywood should be used for concrete work as it is important that the plies lying immediately under the outer plies be solid and free from splits or cracked knots.

Large plywood boards reduce the number of joints considerably and

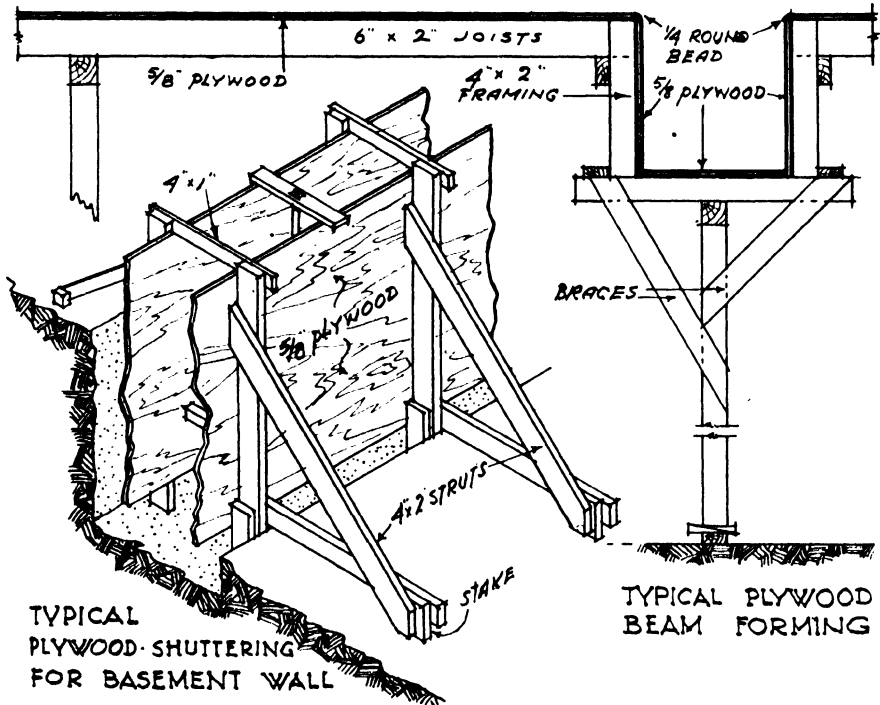
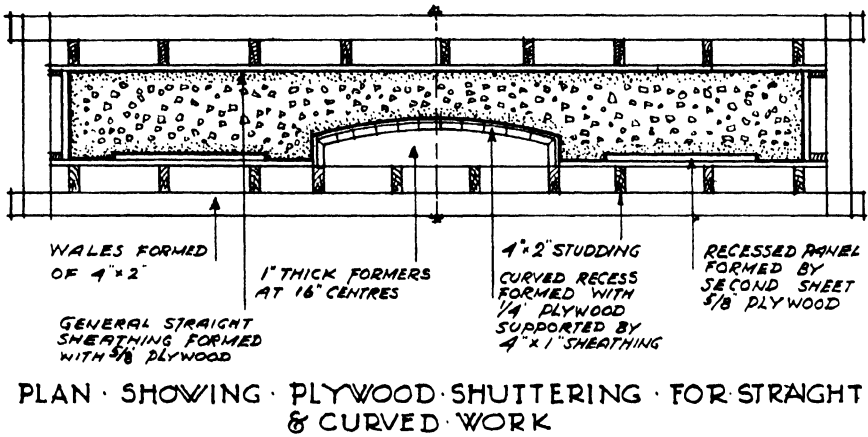

DETAILS · SHOWING · THE · USE · OF · PLYWOOD · for · REINFORCED · CONCRETE · SHUTTERING · ETC.

FIG. 178.



FIG 179.

Erecting  $\frac{3}{8}$ " Resweld Oregon Pine plywood shuttering.

so eliminate a corresponding number of "fins"—a matter of considerable importance in the erection of concrete buildings of architectural merit which demand large flat surfaces. In such work all joints between the plywood forms should be pointed with water putty or a mixture of equal parts of tallow and Portland cement; by so doing a considerable saving in the cost of rubbing and finishing will be effected.

It has been estimated that the total length of joint lines on a wall 12' high and 40' long is reduced from approximately 1000 lineal feet when 6" boards are used, to 128 feet with plywood panels 8'  $\times$  4'.

Past experience will generally guide the contractor in the selection of timber to use for the supporting framework: 4"  $\times$  2" battens at 12" centres are commonly employed with the grain of the plywood running across the battens. On work of importance it is advisable "to estimate the anticipated loads, compute the stresses and design the members to

suit." The deflection charts on pages 448-449 should prove of value for this purpose.

As has been demonstrated on page 29, plywood can be nailed or screwed close to the edges without splitting, but the number of nails used should be kept to a minimum and be as small as practicable. Reverse



FIG. 180.

Moulding strips fixed to resin-bonded plywood produced a cut-stone appearance on the finished surface of the concrete. Reverse moulds may be nailed to the plywood shuttering, as demonstrated in Fig. 180, without the fear that subsequent movement will disfigure the finished surface of the concrete. Wherever possible, reverse moulds should also be built of plywood. By pinning small reverse mouldings along the joints of the plywood and varying the sizes of the panels it is possible to obtain many striking results.

For curved work  $\frac{1}{4}$ " plywood should be used as a lining in conjunction with solid shuttering.

Care must be exercised in stripping the forms; it should be remembered that the number of re-uses will largely depend upon the care with which forms are handled. Stripping plywood forms is more rapidly done than are those of solid wood and, as soon as possible, they should be thoroughly cleaned. A wide blunt blade will prevent "gouging."

All surfaces to be exposed to the raw concrete must be given a thin even coating of form oil and all traces of free oil removed before erection.

## TREATMENT AND DECORATION

THE finishing of veneered plywoods is a matter for the practical polisher and does not concern us. The only point which may be stressed, is the importance of removing all traces of fine sander-dust from the pores of the veneer before filling is attempted. A stiff-bristle brush will serve well.

In the event of blisters being discovered in the finishing shop these should be slit open with a sharp knife, and after inserting a small quantity of animal glue, covered with paper and a piece of plate glass weighted and left until the glue has set. The repaired surface should then be carefully sanded by hand.

Alder and Birch plywoods present little difficulty in the finishing shop and can be stained, painted, enamelled or cellulosed. Alder is inclined to be "woolly," and should be sanded after the stain or priming coat has been applied; it should only be used for stained work provided boards are available free from brown "flecks." Plugged boards should never be stained.

Okoumé presents certain difficulties to the painter or decorator and careful preparation of all surfaces is necessary. The grain invariably rises during treatment but this may be circumvented to some extent by wiping the surface with a damp sponge and sanding before applying the priming coat or stain. Gaboon must be carefully filled, otherwise the open pores of the wood will eventually show through the painted surface.

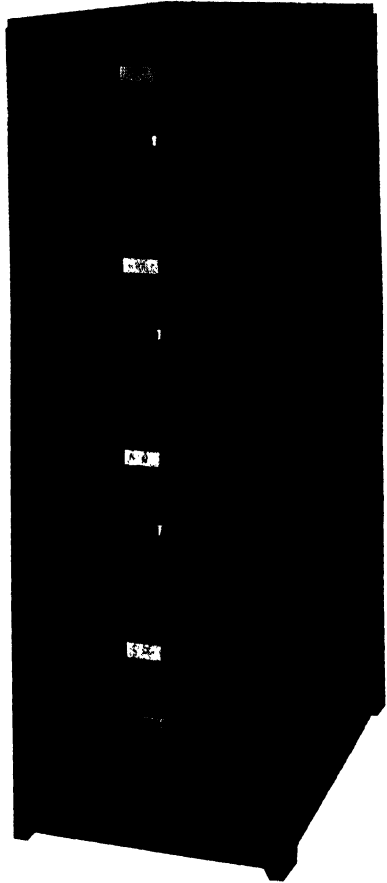

[By courtesy of Messrs. Gordon Russell Ltd.

FIG. 181.

A filing-cabinet constructed with gables, backs and drawer-fronts of plywood.

eventually show through the

*Douglas Fir.*—Were it not for the difficulty in preventing the grain pattern of Douglas Fir from showing through painted or enamelled surfaces this particular plywood would be used to a greater extent than is at present the case. Experiments with resin sealers have given promising results ; one product, produced by Messrs I. F. Laucks & Co., of Seattle, when properly applied, considerably reduces the tendency to “ grain-rise.”

In order to subdue the marked contrast between spring-wood and autumn-wood Douglas Fir plywood may be bleached by any proprietary mixture. Such treatment leaves rough surfaces which should be sanded smooth and subsequently treated as follows :—

1. Apply one coat of clear shellac mixed with powdered white lead, allow to dry and rub down with No. 1 steel wool.
2. Apply one light coat of oil paint in any colour, thinned with turpentine, wipe off until the desired colour tone is obtained and allow to dry.
3. Give one or two coats of clear dull varnish, allow to dry and rub down with steel wool.

A similar finish may be obtained at some reduction in cost by substituting the following for the bleaching process :—

Mix : 6 lb. flat undercoat, with  $3\frac{1}{2}$  quarts pure turpentine and 1 quart linseed oil. Apply one coat to the Douglas Fir plywood, allow to dry, sand with 000 sandpaper and then proceed with painting process in the above-mentioned stages 1, 2 and 3.

When all colour is omitted this treatment gives a bleached effect, subduing the vivid grain but leaving sufficient grain and colour to make the surface interesting.

### SAND-BLASTING OR “ WEATHERED ” EFFECTS

By sand-blasting Oregon Pine plywood the softer spring-wood is removed, to a greater or less degree, leaving the harder autumn-wood in bas-relief. The effects obtained are striking, as is seen in Fig. 153, and look handsome when used for ceiling panels and painted white.

Many varied effects can be obtained by the use of stains and pigments ground in oil. After staining, a paste filler of lighter colour is applied and, after a short interval, wiped off again, leaving a part of the pigment in the softer spring-wood. Endless variations are possible along these lines ; in each case any of the usual top finishes can be used.

The effect is that of shot silk of a moiré pattern.

## TREATMENT OF BACKS AND EDGES

It has been mentioned elsewhere that in order to keep plywood in good condition all exposed surfaces should be protected against moisture. This is doubly important when plywood is used for wall panelling or for ship's side lining where it will remain in place for many years and be subjected to damp or humid conditions. In such cases backs and all edges of the plywood should be given two or preferably three coats of red lead or a good oil paint. Cheap paints are useless. The most reliable results will be obtained by using aluminium flake paint extended with turpentine or, to save expense, a mixture of one part aluminium paint with three or four parts bituminous paint may be safely used. Three coats of this mixture should be applied.

Where resin-bonded plywood is used for permanent exterior work it must be carefully painted and, in this connexion, the following extract from "Notes on the Painting Characteristics of Douglas Fir Plywood when Exposed to the Weather," issued by the Douglas Fir Plywood Association, may be helpful:—

"We have been considerably impressed by the performance of high-grade exterior paint on plywood which was primed with a high percentage of linseed oil. The value of oil in reducing checking has been recognized in our weather and meter studies, our exposure fence studies, and in a number of commercial applications that have come to our attention. We believe that oil renders the wood more plastic so that when stresses are set up by changes in moisture, they relieve themselves without separating the fibres. We therefore believe it advisable to recommend the use of plenty of oil whenever possible."

"The best quality paints sold for three-coat jobs contain high percentages of white lead and oil and, to the best of our knowledge, give good service on plywood."

If one face of a piece of plywood is prevented from absorbing or giving off moisture during changes of humidity while the second face is free to do so, warping will result. It follows, therefore, that except in cases where the plywood is rigidly secured on all four edges, both sides must be treated alike. Even when the second side is not exposed to view, as, for example, a sliding door or pull-out table-top, the hidden surfaces should be sealed with paint or varnish.



CONSTRUCTIONAL DETAILS

DETAILS OF INTERNAL AND EXTERNAL CORNERS

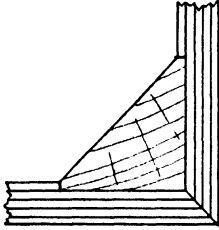

EXTERNAL AND INTERNAL ANGLE

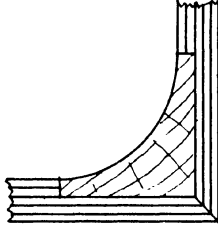

INTERNAL ANGLE

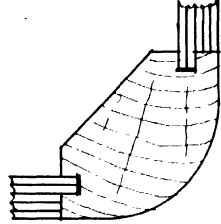

EXTERNAL ANGLE

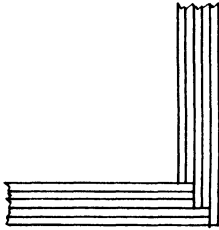

INTERNAL ANGLE

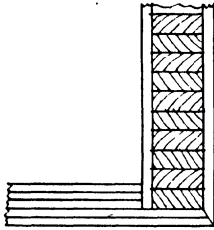

EXTERNAL ANGLE

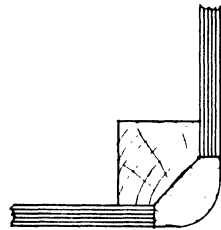

EXTERNAL ANGLE

FIG. 182.

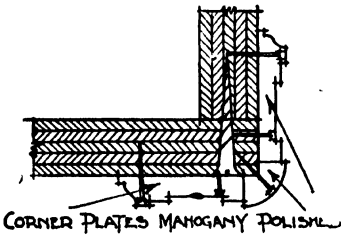

CORNER PLATES MAHOGANY POLISH

FIG. 183.

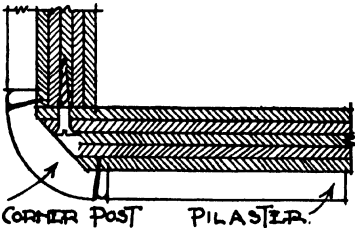

CORNER POST PILASTER

FIG. 184.



(a)



(b)

FIG. 185.

Illustrating construction of gables and top of radio cabinet, described on page 132. Alternatively, one piece of plywood may be veneered and the area indicated by the solid wood in Fig. 185 (a) removed on spindle and router.

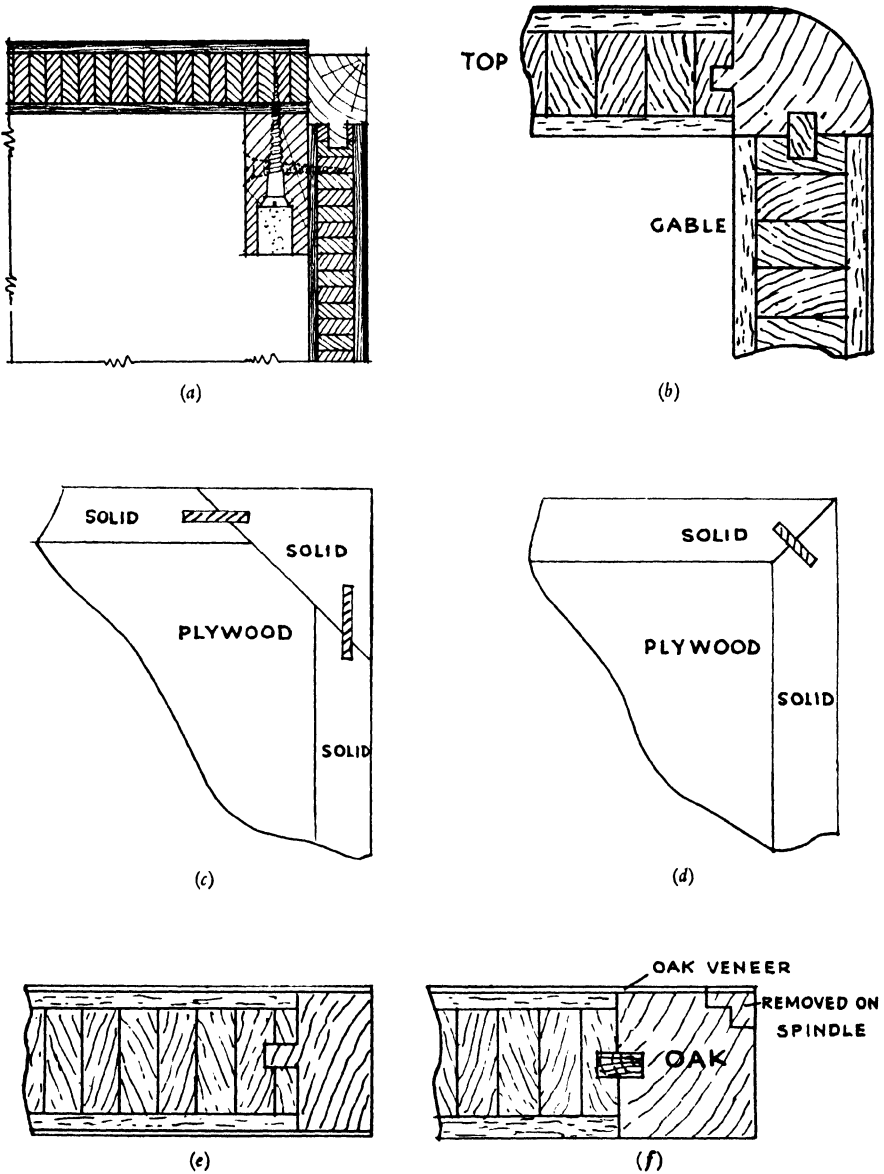

FIG. 186.

- (a) Section through side of dressing-table showing solid edge and plastic covered top.
- (b) Section through corner of writing-desk.
- (c) and (d) Methods of fixing solid edge to plywood before laying face veneers.
- (e) Section through door edged and veneered.
- (f) Section through table-top edged, veneered and moulded on spindle.

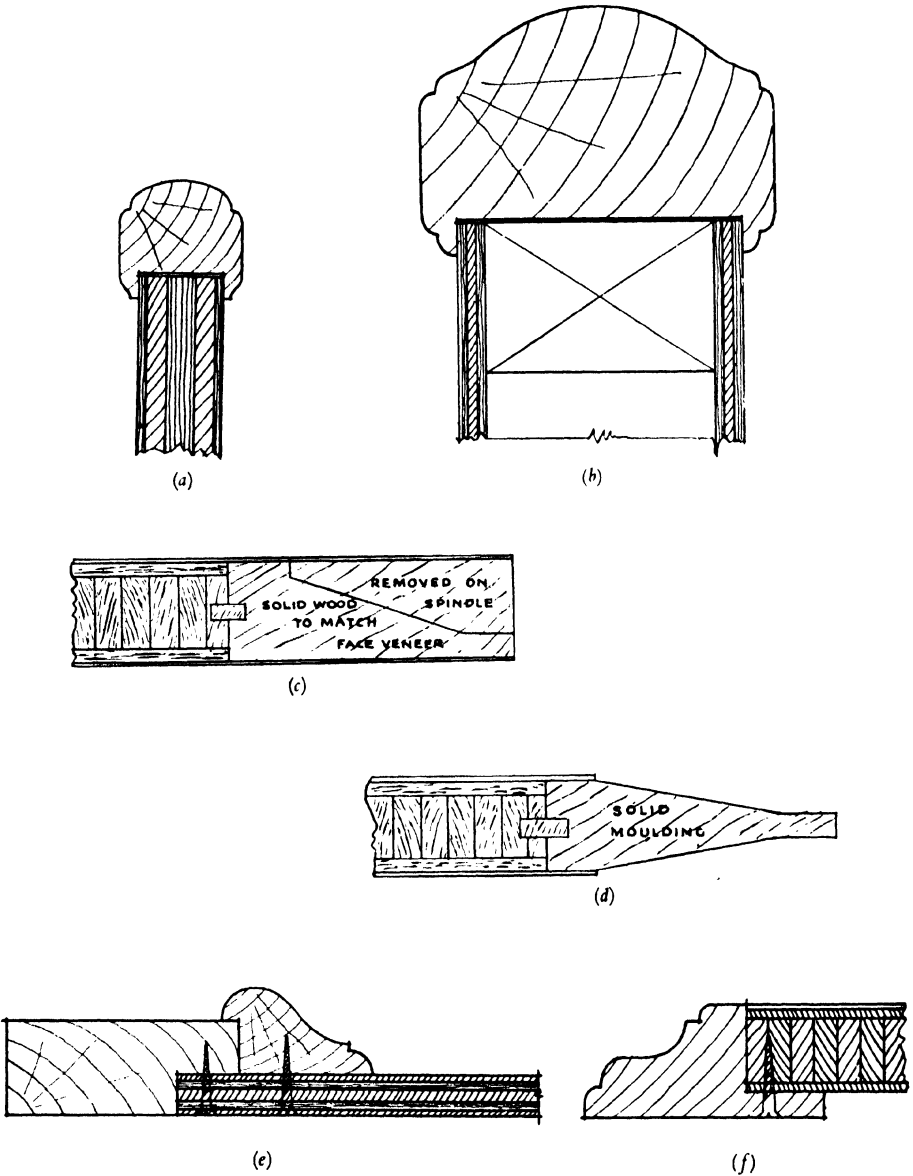

FIG. 187.

- (a) Section through balustrade of  $\frac{3}{4}$ " Oregon Pine plywood with solid cap.  
 (b) Section through balustrade with  $\frac{1}{4}$ " plywood on both sides of solid framework.  
 (c) and (d) Methods of forming fielded or raised panels.  
 (e) Section through recessed panel.  
 (f) Section through raised panel.

DETAILS OF JOINTS

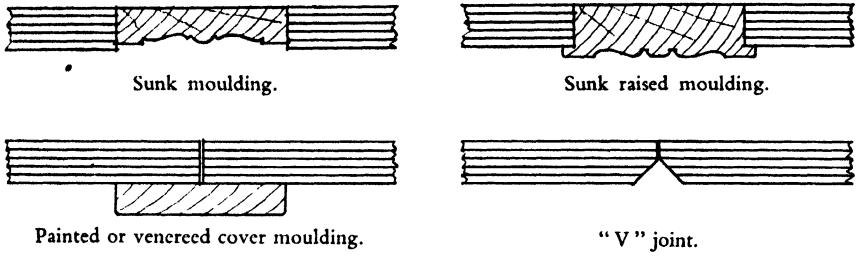

FIG. 188.



FIG. 189.  
Veneered laminboard tongued, with cover moulding.



FIG. 190.  
Veneered laminboard checked into solid post.

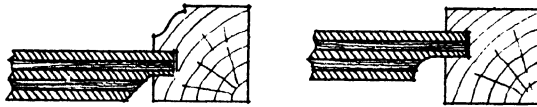
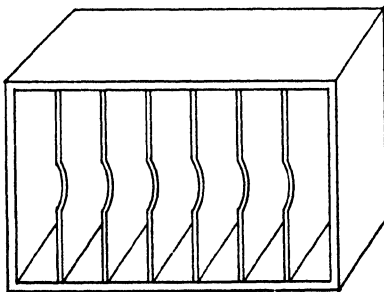
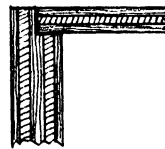

FIG. 191.

Plywood "backed-out" to retain greatest possible strength in grooved posts.



(a)



(b)

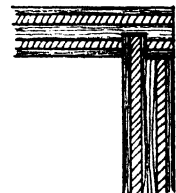

(c)

FIG. 192.

- (a) Ledger rack made entirely from plywood.
- (b) Sides, top and bottom half checked to take  $\frac{1}{8}$ " plywood back.
- (c) Method of jointing sides to top and bottom all of  $\frac{1}{4}$ " multi-ply.

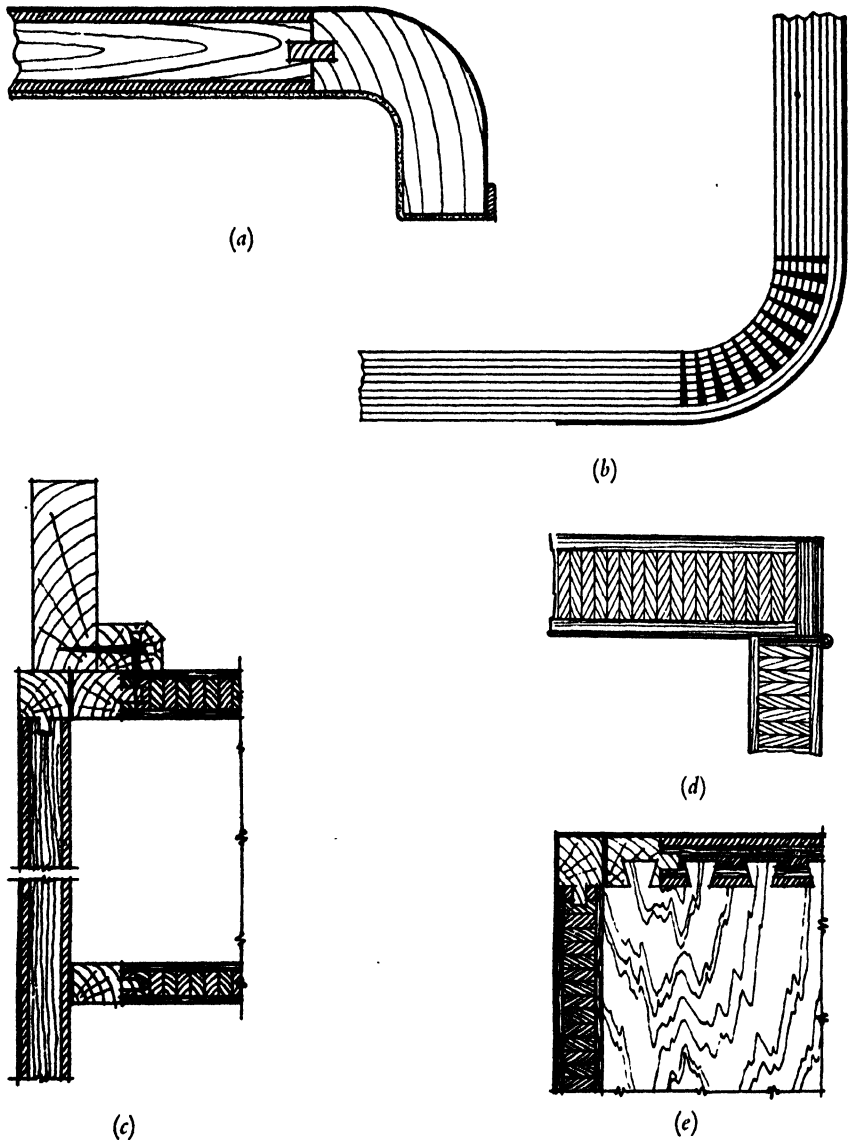

FIG. 193.

- (a) Section through radio top.  
 (b) Section through corner of radio cabinet "saw-kerfed" and bent.  
 (c) Section through compactum at door showing solid edging at door, top and shelf.  
 (d) Section at hinged door.  
 (e) Plan of compactum top.

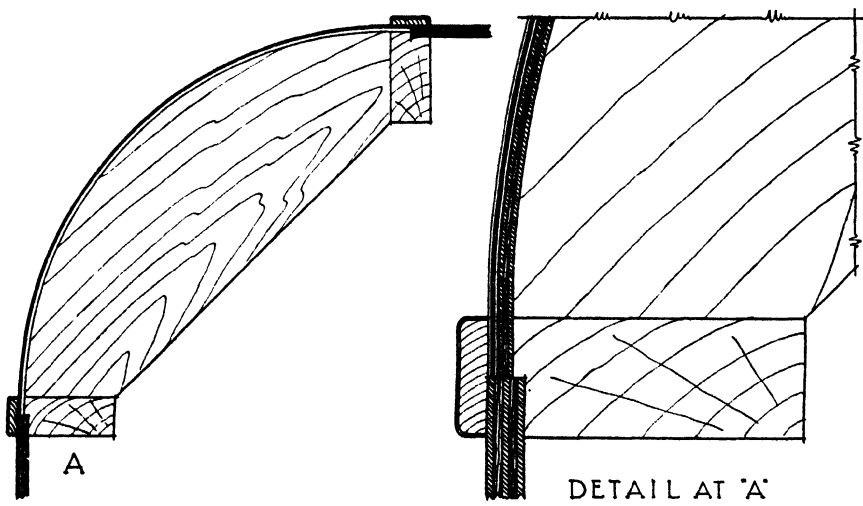
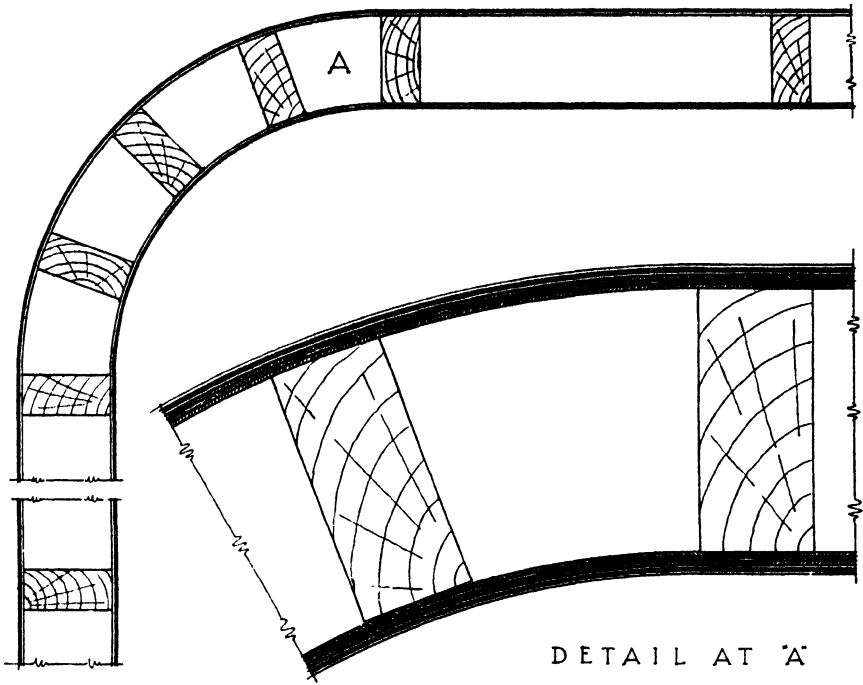
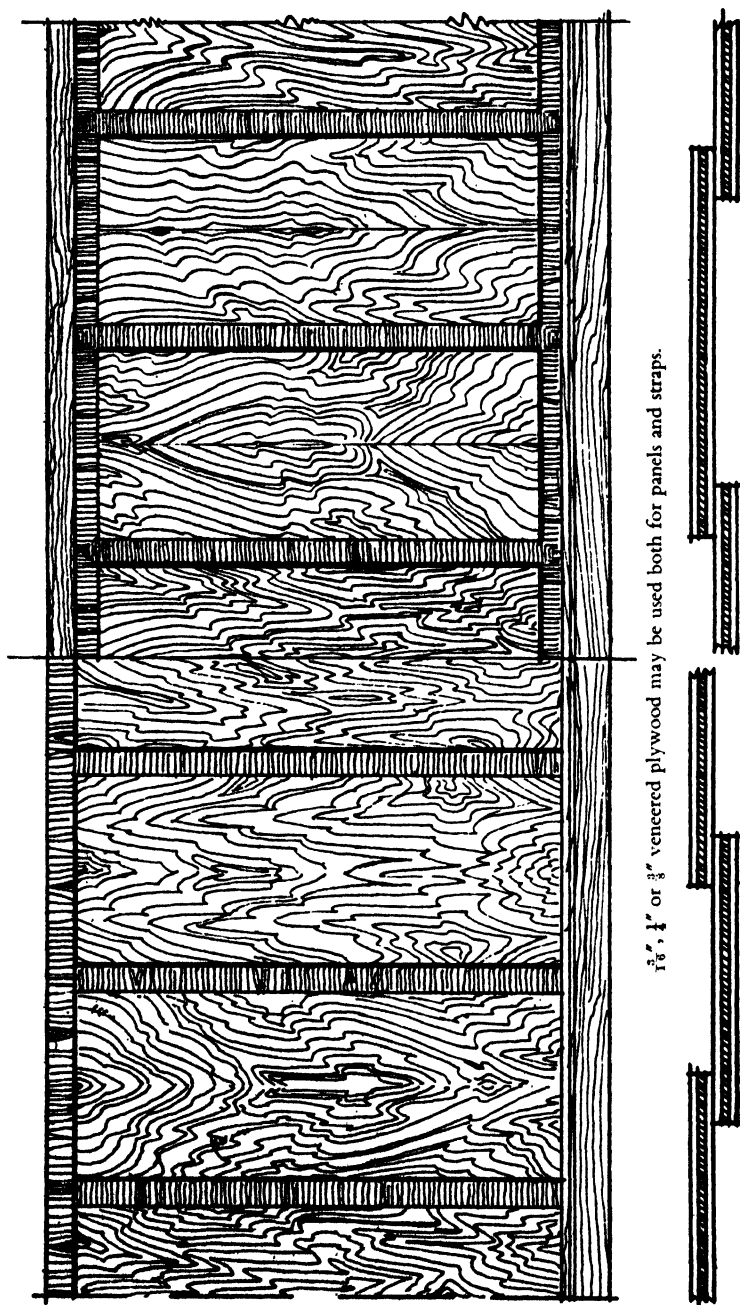

FIG. 194.—CONSTRUCTION OF CURVED CORNERS.

*Upper.*—Showing method of building partition wall with external and internal curved corner using two thicknesses of  $\frac{1}{4}$ " plywood.

*Lower.*—A typical rounded external corner treatment, using one piece  $\frac{3}{8}$ " Douglas Fir plywood to which is glued a 3-ply veneered board  $\frac{1}{4}$ " thick.



1/8", 1/4" or 3/8" veneered plywood may be used both for panels and straps.

Plywood cover straps planted over panels.

Plywood panels laid on top of straps giving raised effect.

FIG. 195.

Two suggestions for inexpensive panelling using plywood straps which can be cut from stock boards. The panels can be pinned direct to light batten framework or, in ship-work, to a bulkhead of 3/4" Oregon Pine plywood.

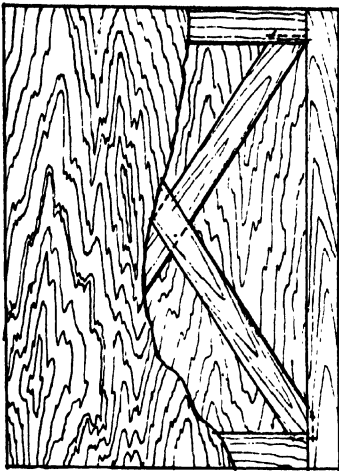

FIG. 196.

Braced frame cupboard door.

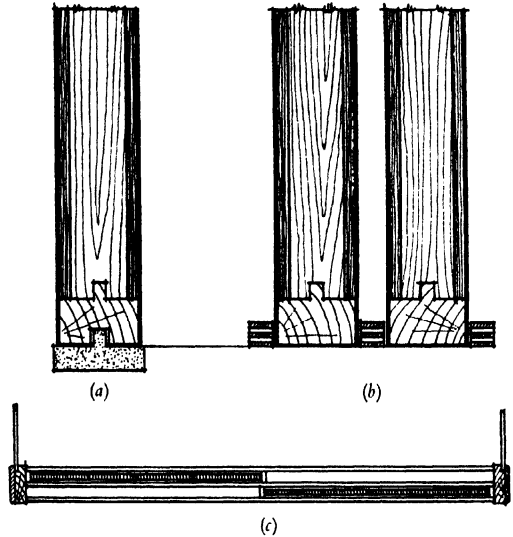

FIG. 197.—SLIDING DOORS.

(a) and (b) Elevation showing two methods of construction.  
(c) Plan of sliding doors shown in elevation at (b).



DETAIL SECTION THRO' X-X

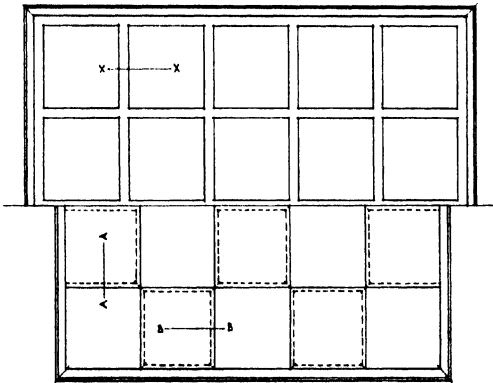

FIG. 198.—CEILING TREATMENT.

Upper. Combination of  $\frac{1}{4}$ " plywood and  $\frac{1}{2}$ " insulating board. Attractive effects can be obtained by using sand-blasted Oregon Pine for the panels.

Lower. A simple but effective arrangement.

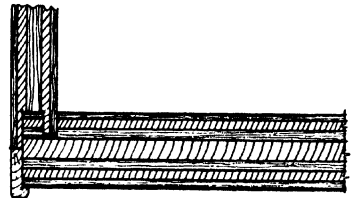

FIG. 199.

All-plywood drawers are made with  $\frac{5}{8}$ " or  $\frac{3}{4}$ " veneered or painted fronts,  $\frac{1}{2}$ " sides and back,  $\frac{3}{8}$ " bottom. Method of fixing side to veneered front. The small wood fillet is glued and pinned in position and conceals plywood construction when door is closed.

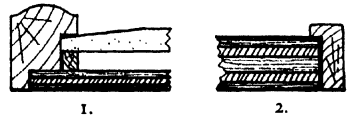

FIG. 200.

1. One method of mounting a framed mirror to prevent contact between silvered back and plywood.
2. Section through edge of notice board showing green baize carried over edge of  $\frac{1}{2}$ " plywood and secured by hardwood fillets pinned to plywood. Fillets are mitred at corners.



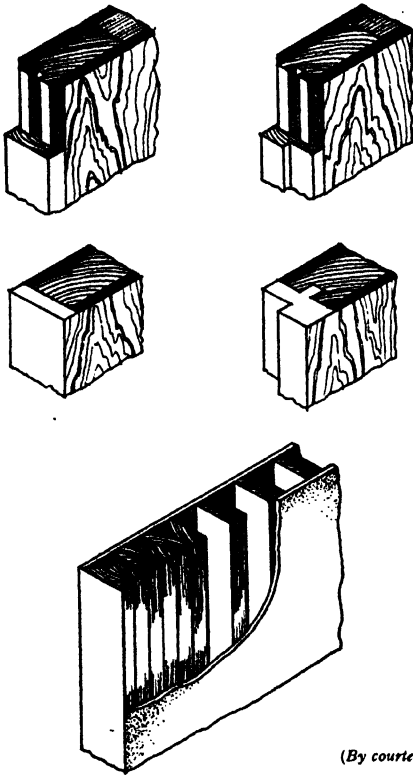

FIG. 201.  
Various methods of covering edges of flush doors.



FIG. 202.  
Isometric drawing of RGC patented flush door which is of plywood construction.

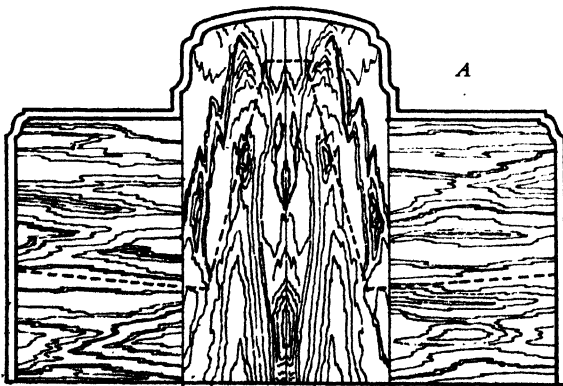
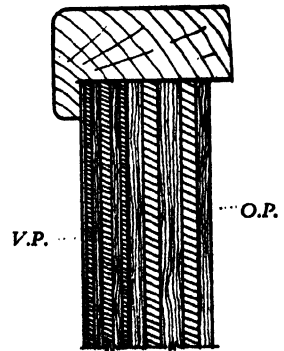

FIG. 203.  
Settee-end constructed with  $\frac{3}{4}$ " Oregon Pine plywood faced with  $\frac{3}{8}$ " veneered plywood. The dotted lines indicate line of upholstery.



Cross-section at A.

# APPENDIX

---

## TERMS AND DEFINITIONS

[\* Abstracted by permission from British Standard Specifications, No. 565—1934. “British Standard Terms and Definitions applicable to Softwoods,” official copies of which can be obtained from the British Standard Institution, 28 Victoria Street, London, S.W.1. Price 2s. 2d., post free.]

**ADHESIVE.**—Compound used to weld the veneers to one another.

**AIR-DRY.**—A term used when the moisture content of timber is in approximate equilibrium with surrounding atmospheric conditions.

**BACK.**—The surface opposite the face side.

**BANDING.**—(Also referred to as “railing.”) A portion of wood of any specified kind (generally selected to match the face veneer) extending around one or more sides of a piece of core usually with its grain extending the long way. This banding of solid wood facilitates shaping the edges of the piece or may be finished flat to cover the several colours presented in the end or side grain or the core and cross-banding.

**BARK.**—The natural exterior, or rough skin, of the tree.

**\*BATTENBOARD.**—A board having a core of battens, each not exceeding 3 inches in width, which is cemented or glued between two or more outer plies with the direction of the grain of the core battens running at right angles to that of the adjacent outer veneers. (Refer page 11.)

**BIRD'S-EYE.**—Bird's-eye is due to local sharp depressions in the annual rings, accompanied by considerable fibre distortions. Once the depressions are formed, succeeding growth rings follow the same contour for many years. In rotary veneer the depressions are cut through crosswise and show a series of circlelets, portions of annual rings, suggesting, rather remotely, a bird's eye.

**B/L.**—Bill of Lading.

**BLISTER FIGURE.**—Blister figure consists of seeming knoll-like elevations in the wood. It is due to an uneven contour of the annual rings, and not to blisters or pockets in the wood as the name might indicate.

**BLOCK.**—The section of the log, usually 6 to 12 feet long, from which veneers are cut on the rotary-lathe.

**\*BLOCKBOARD.**—A board having a core of blocks, each not exceeding 1 inch in width, cemented or glued face to face to form a slab which is cemented or glued between two or more outer plies, with the direction of the grain of the core blocks running at right angles to that of the adjacent outer veneer. (Refer page 11.)

\***BLUE STAIN.**—A form of sap stain producing a bluish discoloration. It is usually confined to the sapwood and is caused by the growth of certain fungi which derive their nourishment from the cell contents, but do not decompose the fibres of the wood (blueing).

**BOLE.**—The trunk of the tree.

\***BRACK.**—Noun: timber de-graded or marked down (cull). Verb: to grade.

\***BRIGHT.**—A term applied to timber which is free from discoloration.

**BURL.**—A type of figure produced by cutting through burls, which are wart-like protuberances on trees. They contain the dark pith centres of a number of large undeveloped buds presenting a contorted grain when cut.

\***BUTT.**—The lowest portion of the stem of a tree (butt end, butt log).

**CAUL.**—Flat sheets of metal, plywood, or fibre board used to support the glued assemblies in the pressing operation.

\***CHECK.**—A separation of the fibres extending longitudinally, which does not go through the whole cross-section of a piece of timber. (Cf. SHAKE, SPLIT.)

**C.I.F.**—Cost, Insurance, Freight.

**CLAMPS.**—The device, usually consisting of I-beams and turnbuckle rods, which holds the package of plywood under pressure supplied by the press, used in the glue pressing operation.

**CLIPPER.**—The shearing machine or guillotine used to cut veneers to width.

**CONVEYOR.**—The device, usually consisting of a series of belts on rolls, which transports material from one department to another, or from one machine to another.

**CORES.**—(1) Cores, sometimes also referred to as centres, are the innermost portions of plywood. They may be of sawn lumber, either one piece or several pieces joined and glued, or they may be of veneer. (2) Also the centre of the block which cannot be peeled owing to being held by the chucks of the lathe.

**CROSS-BANDING.**—Veneer used in the construction of plywood with five or more plies. In 5-ply construction it is placed at right angles between the cores and faces. Also a term used in veneering to describe an ornamental banding laid around four edges of a central panel.

**CROSS-GRAINED.**—A sheet of plywood is termed cross-grained when the width of the sheet is greater than its length.

**CROTCH.**—That part of a tree from which "curl" veneers are cut. (Cf. CURL.)

**CULL.**—(Cf. BRACK.)

\***CUP (AD. CUPPING).**—A curvature occurring in the transverse section of a board or plank.

\***CURL.**—The figure produced by the grain when the junction of two or more branches, or of the stem and a branch, is cut in a suitable direction.

- \***DEAD KNOT (AUSTRALIA ENCASED KNOT).**—A knot not firmly jointed throughout to the surrounding wood, sometimes including bark.
- \***DECAY.**—A decomposition of timber by fungi and/or other agents. (*See also* INCIPIENT DECAY.)
- DEFECT.**—Any fault, or imperfection, in the veneer or finished panel that may lower its strength, durability or utility value.
- DEFECTS (OPEN).**—Checks, splits, open joints, cracks, loose knots, worm holes or other defects interrupting the smooth continuity of the surface.
- DRIER.**—The kiln, or chamber, through which veneers or timber are passed to remove excess moisture.
- FACE SIDE.**—The side from which timber or plywood is usually judged for appearance and utility.
- FIGURE.**—Figure is the pattern formed by peculiar arrangement of the elements within the tree and by reflected light caused by the peculiar arrangement of the wood fibres, and by the exposure of the medullary rays. The various kinds of figure are known by many different terms such as bird's-eye, burl, crotch, blister, etc. Figure may also be caused by inherent colouring matter.
- FLAKE (BROKEN).**—A breaking or loosening of the flake (medullary ray) of quartered material; Oak veneer is frequently subject to this defect.
- FLAT-SAWN.**—Timber converted so that the growth rings meet the face over at least half its width at an angle of less than 45° (plain-sawn, slash grain, flat grain).
- \***FLECKS.**—Spots, dapples, or marks caused by extraneous matter or by local irregularities in the grain.
- F.O.B.**—Free-on-board.
- F.O.R.**—Free-on-rail.
- \***GAP.**—A void in the inner ply or plies, generally visible when the board is viewed on edge, due either to open splits in the inner ply or plies or to improperly joined veneers when joined veneers are used in the inner plies.
- \***GRAIN.**—A term used to indicate the general direction or arrangement of the fibres and other wood elements, or the figure which is produced thereby on the surface of the converted timber.
- HAIR LINE.**—A thin perceptible line usually showing at a joint.
- HALF ROUND.**—A manner of cutting veneer to bring out certain beauty of figure, accomplished in the same manner as rotary cutting except that the piece being cut is secured to a "stay log," a device that permits the cutting of the log on a wider sweep than when mounted with its centre secured in the lathe.
- HARDWOODS.**—A general term used to designate the lumber produced from broad-leaved (belonging to the botanical group Angiosperms) or deciduous trees in opposition to the so-called softwoods, produced by evergreen or coniferous trees.

- HOLLOW.**—A depression discernible on the surface of plywood, generally due to out-fallen knots or gaps in the inner ply or plies.
- INCIPIENT DECAY.**—An early stage of decay caused by wood-destroying fungi.
- JOINTS (OPEN).**—A joint in which the two adjacent pieces of veneer do not fit tightly together.
- \*KERF.**—The width of the saw-cut.
- \*KILN.**—A chamber used for drying timber, in which the temperature and humidity of the circulating air can be suitably varied and controlled.
- KNOT.**—Cross-section of a branch or limb whose grain usually runs at right angles to that of the piece in which it occurs.
- KNOTS (OPEN).**—Where a portion of the wood substance of the knot has dropped out or where cross checks have occurred to present an opening.
- \*KNOTS (PIN).**—A knot less than  $\frac{1}{4}$  inch in diameter.
- \*LAMINBOARD.**—A board having a core of veneer or strips, each not exceeding 7 mm. (0.28 inches) in thickness, cemented or glued face to face to form a slab which is cemented or glued between two or more outer plies, with the direction of the grain of the core strips running at right angles to that of the adjacent outer veneer.
- LOG POND.**—The reservoir of water where the reserve supply of logs and blocks are stored, usually adjacent to the plywood mill.
- \*LOOSE KNOT.**—A dead knot shrunken away from the surrounding wood.
- MANUFACTURE DAMP.**—A defect in plywood resulting from improper drying. (Refer page 116.)
- MATCHING, BOOK.**—Turning alternate adjacent sheets of veneer over.
- MATCHING, SLIDE.**—Laying adjacent sheets of veneer tight side up without turning.
- \*MOISTURE CONTENT.**—The amount of moisture in timber expressed as a percentage of its oven-dry weight.
- MULTI-PLY.**—(See PLYWOOD.)
- \*OVERLAP.**—A ridge-like elevation discernible on the surface of plywood, generally due to overriding of the inner plies if joined inner plies are used.
- PANEL.**—Referring to a sheet of plywood.
- PATCHES.**—Insertions of sound wood placed and glued into panels from which defective portions have been removed.
- PEELER (or PEELER LOG).**—The trade name of a log suitable for producing rotary-cut veneer.
- \*PIN-HOLE.**—A small round hole not larger than  $\frac{1}{8}$  inch in diameter made by pin-hole borers.
- \*PIN KNOT.**—A knot  $\frac{1}{4}$  inch or less in diameter.
- PITCH-POCKET.**—Well-defined lens-shaped openings, which contain or have contained resin, and which may occur between the growth rings of certain coniferous woods (resin pocket).

- PITCH STREAK.**—An excessive local accumulation of resin in the form of a streak which may occur in the wood of certain conifers (resin-streak).
- \*PLY.**—Thin slices of timber used in the construction of plywood or similar laminated forms of construction. (See **VENEER.**)
- PLYWOOD.**—A product in which several plies or pieces of veneer are glued to each other or to a lumber core. The grain of any one ply is usually at right angles to the adjacent layer or layers. The use of the term is broadening, and “plywood” may be considered to include products referred to as blockboards, laminboards, stripboards. Boards formed of more than three layers of veneer are usually designated “MULTI-PLY.”
- PRESS.**—The machine in which uniform pressure is applied to the panels after glue is spread to bring the sheets of veneer into intimate contact.
- QUARTERED.**—A method of producing veneer by slicing or sawing to bring out a certain figure produced by the medullary rays which is especially conspicuous in Oak. The log is flitched in several different ways to allow the cutting of the veneer in a radial direction.
- RETAINING BOARD.**—Heavy cauls generally made of plywood used in the cold pressing operation.
- ROTARY (CUT).**—A manner of cutting veneer by which the entire log is mounted in a lathe and turned against a broad cutting knife which is set into the log at a slight angle.
- ROUGH PATCH.**—A rough area on the surface of veneer due generally to twisted or oblique grain.
- \*RUPTURE.**—A tearing of the fibres across the grain (thunder-shake, felling-shake, transverse-shake, cross fracture, upset).
- SAP.**—An abbreviated term for “sapwood.”
- SAP STAIN.**—A discoloration of felled timber, resulting from the growth of certain fungi, which is principally confined to the sapwood of coniferous timber.
- \*SAPWOOD.**—Timber from the outer layers of the log which, in the growing tree, contained living cells. The sapwood is generally lighter in colour than the heartwood.
- \*SHAKE.**—A partial or complete separation between adjoining layers of fibres.
- SHIM.**—A long, narrow patch glued into the panel.
- SLICED.**—A manner of cutting veneer by which logs or sawn flitches are held securely in a slicing machine and thrust against a large knife which shears off the veneer in sheets.
- \*SOFTWOOD.**—A conventional term used to denote the timber of trees belonging to the botanical group Gymnosperm. Commercial timbers of this group are practically confined to the class Coniferæ or Conifers.
- SOUND KNOT.**—A tight knot free from decay and cracks, firmly joined throughout to the surrounding wood (live knot).

- SPLIT.**—A separation of the fibres extending from face to face of the veneer and running parallel with the grain.
- SPREADER.**—The device used for distributing glue on the veneers.
- SPRING (AD. SPRINGING).**—A curvature of a board or plank in its own plane (edge bend).
- STAIN.**—Any discoloration of the wood substance. Common veneer stains are often produced by the chemical action of the iron in the cutting knife with the tannic acid in the wood and by the chemical action of glue. May also be caused by fungi.
- STUMP.**—The part of a tree left in the ground after the trunk is cut down.
- SWIRLS.**—Irregular grain usually surrounding knots or crotches.
- TAPE.**—The strip of gummed paper, or cloth, used to hold the edges of veneer together previous to glueing.
- TEXTURE.**—Surface characteristics of a piece of veneer or wood.
- TIGHT SIDE.**—This term and its opposite, "loose side," are used to refer to veneer cut with a knife. The product as it is cut by the wedge-shaped or bevelled knife may be curved, thus producing small ruptures on the convex side known as the "loose side." The opposite surface, strained slightly in compression, but free from any ruptures is known as the "tight side."
- \*TWIST.**—Spiral distortion (winding).
- \*VENEER.**—Timber in the form of a thin layer of uniform thickness.
- \*WARP (AD. WARPING).**—Distortion due to stresses causing departure from a plane or true form.

## WEIGHT OF PLYWOOD

A certain tolerance must always be allowed in estimating the weight of plywoods to compensate for such variables as density of the wood, nature of adhesive and number of glue lines. The weights given below are approximate and may be taken to represent a fair average for each thickness.

### AVERAGE WEIGHT PER 100 SQUARE FEET UNPACKED.

Thick-ness.	ALDER.		EUROPEAN BIRCH.		OKOUMÉ.	
	Kilos.	lbs.	Kilos.	lbs.	Kilos.	lbs.
3 mm.	17'5	38'5	20'4	45	14'1	31
4 mm.	22'2	49	26'8	59	18'7	41'2
5 mm.	27'7	61	32'8	72'4	23'1	51
6 mm.	32'6	72	40'3	89	27'9	61'5
9 mm.	50'4	111	62'6	138	41'8	92
12½ mm.	68'5	151	87'2	192	58'1	128
15 mm.	85	187'3	102	225	69'7	153'6
18 mm.	104'5	230'3	122'5	270	84	185
22 mm.	125	275	153	337	102'2	225'2
25 mm.	140	308'5	170	375	116'1	256

Thick-ness.	OKOUMÉ OUTER PLYS. PINE BLOCK CORE.		OKOUMÉ OUTER PLYS. OKOUMÉ LAMIN CORE.		DOUBLE OUTER PLYS BIRCH. PINE BLOCK CORE.	
	Kilos.	lbs.	Kilos.	lbs.	Kilos.	lbs.
10 mm.	43'2	95'2	46'4	102'3	—	—
13 mm.	56'2	123'8	60'4	133	—	—
16 mm.	69'2	152'5	74'4	164	87	192
19 mm.	82'1	181	88'3	194'5	104	230
22 mm.	95'1	209'5	102'2	225'2	120	264'5
25 mm.	108	238	116'1	256	135	297'5
30 mm.	129'6	285'5	139'4	307'2	—	—

### AIRCRAFT BIRCH.

	<i>lbs per 100 square feet.</i>		<i>lbs. per 100 square feet.</i>
0'6 mm.	10'8	1'5 mm.	25'6
0'8 mm.	14'1	2'0 mm.	33'1
1'0 mm.	17'8	2'5 mm.	40'9
1'2 mm.	21'5	3'0 mm.	46'7



WEIGHTS OF OREGON PINE PLYWOOD, INCLUDING FIBRE CARTONS.

	lbs. per 100 square feet.		lbs. per 100 square feet.
$\frac{3}{8}$ "	61	$\frac{5}{8}$ "	183 $\frac{1}{2}$
$\frac{1}{2}$ "	77	$\frac{3}{4}$ "	225 $\frac{1}{2}$
$\frac{5}{8}$ "	110	$\frac{7}{8}$ "	263 $\frac{1}{2}$
$\frac{1}{2}$ "	146	1"	299

WEIGHT OF METAL-FACED PLYWOOD.  
(In pounds per square foot.)

DESCRIPTION.	TYPE.	THICKNESS.					
		$\frac{1}{8}$ "	$\frac{3}{16}$ "	$\frac{1}{4}$ "	$\frac{5}{8}$ "	$\frac{1}{2}$ "	$\frac{3}{4}$ "
Steel on one side only	1 GS 12	1'0	1'2	1'4	1'8	2'1	2'9
Aluminium on one side only	1 AL 18	0'75	0'95	1'15	1'55	1'85	2'65
Steel on both sides	2 GS 12	1'5	1'7	1'9	2'3	2'6	3'4
Aluminium on both sides	2 AL 18	1'0	1'2	1'4	1'8	2'1	2'9

The following table gives a comparison of the approximate thicknesses of Plymax (metal-faced plywood) Mild Steel Plate and Birch Plywood for the same rigidity. By courtesy of Messrs. Venesta Ltd.

PLYMAX (with Steel both sides).		STEEL PLATE.			BIRCH PLYWOOD.	
Thickness.	Weight.	SWG	Thickness.	Weight.	Thickness.	Weight.
$\frac{1}{8}$ in.	per sq. ft.			per sq. ft.	$\frac{1}{4}$ in.	per sq. ft.
$\frac{3}{16}$ in.	1'5 lbs.	13	0'092 in.	3'75 lbs.	$\frac{3}{8}$ in.	0'83 lbs.
$\frac{1}{4}$ in.	1'7 lbs.	10	0'128 in.	5'21 lbs.	$\frac{1}{2}$ in.	1'24 lbs.
$\frac{5}{16}$ in.	1'9 lbs.	9	0'144 in.	5'87 lbs.	$\frac{3}{4}$ in.	1'68 lbs.
$\frac{3}{8}$ in.	2'3 lbs.	6 $\frac{1}{2}$	0'184 in.	7'5 lbs.	$\frac{1}{2}$ in.	2'33 lbs.
$\frac{1}{2}$ in.	2'6 lbs.	5	0'212 in.	8'63 lbs.	$\frac{3}{4}$ in.	2'95 lbs.
$\frac{5}{8}$ in.	3'0 lbs.	3 $\frac{1}{2}$	0'242 in.	9'86 lbs.	1 in.	3'37 lbs.
$\frac{3}{4}$ in.	3'4 lbs.	2 $\frac{1}{2}$	0'264 in.	10'75 lbs.	1 $\frac{1}{4}$ in.	3'78 lbs.

MEAN VALUES OF MECHANICAL PROPERTIES OF MULTI-PLY LAMINBOARD AND BLOCKBOARD AS DETERMINED BY TESTS MADE AT THE FOREST PRODUCTS RESEARCH LABORATORY, PRINCES RISBOROUGH.

TYPE OF BOARD.	THICKNESS.		MODULUS OF ELASTICITY.	LOAD PER $\frac{1}{2}$ " DEFLECTION—LB.	SAFE COMPRESSIVE LOAD—LB. <sup>1</sup>
	Nominal.	Actual.			
Gaboon Block-board . . .	$\frac{7}{8}$ "	$\frac{1\frac{3}{8}}$ "	650,000	54	570
Gaboon Lamin-board . . .	$\frac{7}{8}$ "	$\frac{1\frac{3}{8}}$ "	520,000	42	455
Douglas Fir Multi-ply . . .	$\frac{7}{8}$ "	$\frac{7}{8}$ "	1,680,000	138	1575
Gaboon Multi-ply	$\frac{3}{4}$ "	$\frac{3}{4}$ "	670,000	54	405
Douglas Fir Multi-ply . . .	$\frac{3}{4}$ "	$\frac{3}{4}$ "	1,650,000	99	970

<sup>1</sup> Estimated from Euler Formula for long slender columns, with a factor of safety of three, using modulus of elasticity values in bending, and based on actual thickness of panel.

The modulus of elasticity, which is the principal property influencing the stability or rigidity of the panels under load on the top and bottom edges, was determined from static bending tests made on narrow boards 1" in width. Each panel was loaded over a span of 6' 6", and deflections measured for small increments of load. From these results the value for modulus of elasticity was obtained. In addition, the load necessary to deflect the panel  $\frac{1}{2}$ " at the centre of its span was noted. Three panels of each type of board were tested. Although three samples of the  $\frac{3}{4}$ " Douglas Fir multi-ply were tested, they were cut from one large board, and the mean value of modulus of elasticity obtained (for this material) should therefore be accepted with reserve.

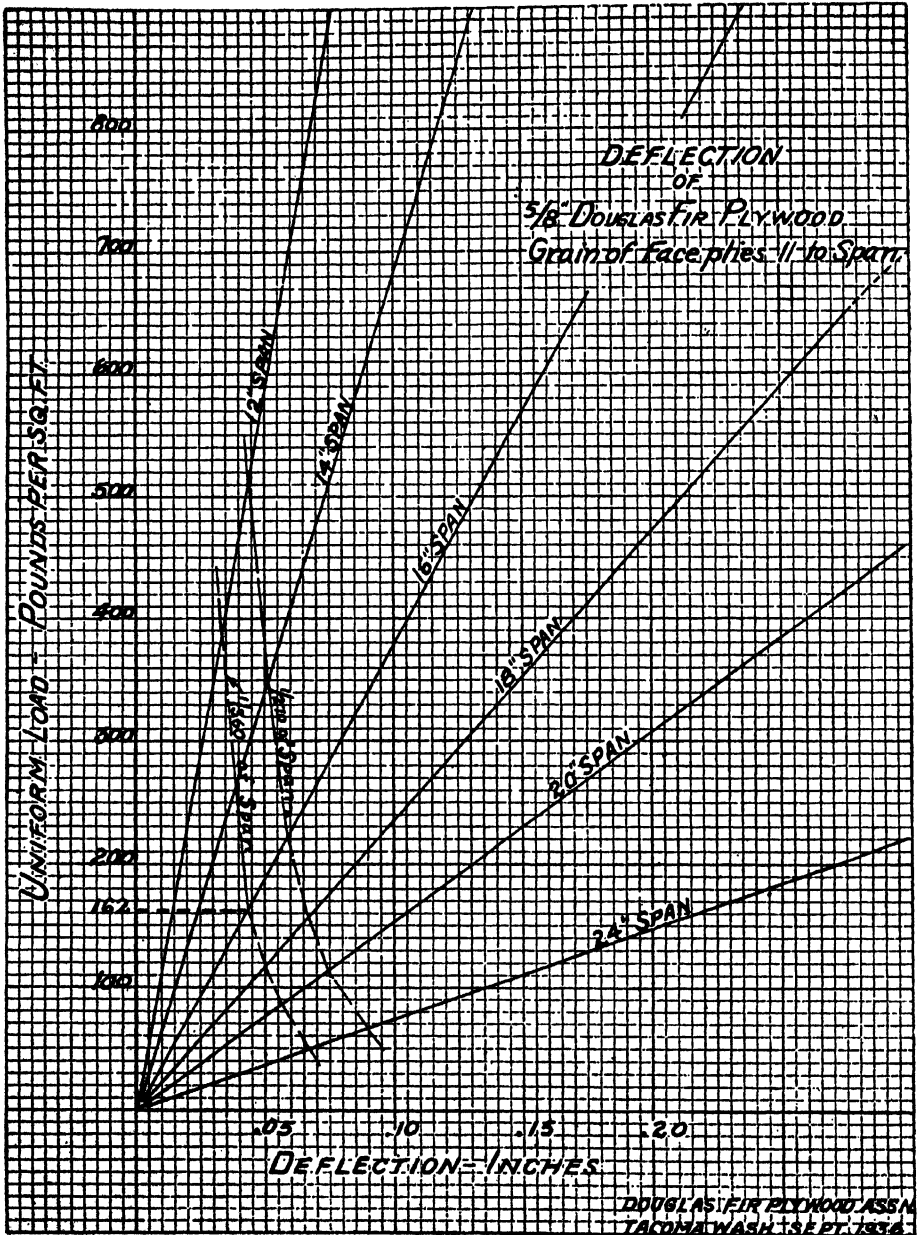

For convenience, lines have been added to show deflections of  $\frac{1}{80}$ th and  $\frac{1}{70}$ th of the various spans. For example, using  $\frac{5}{8}$ " plywood over a 16" span, with deflection limited to  $\frac{1}{70}$ th of span, as in most concrete work, a loading up to 221 lb. per sq. ft. may be used. If the supports are placed only 12" apart, the loading may be increased to 510 lb. per sq. ft.

If load is continuous over two or more spans, the deflection will be approximately half that shown, and, therefore, twice the load shown may be used.

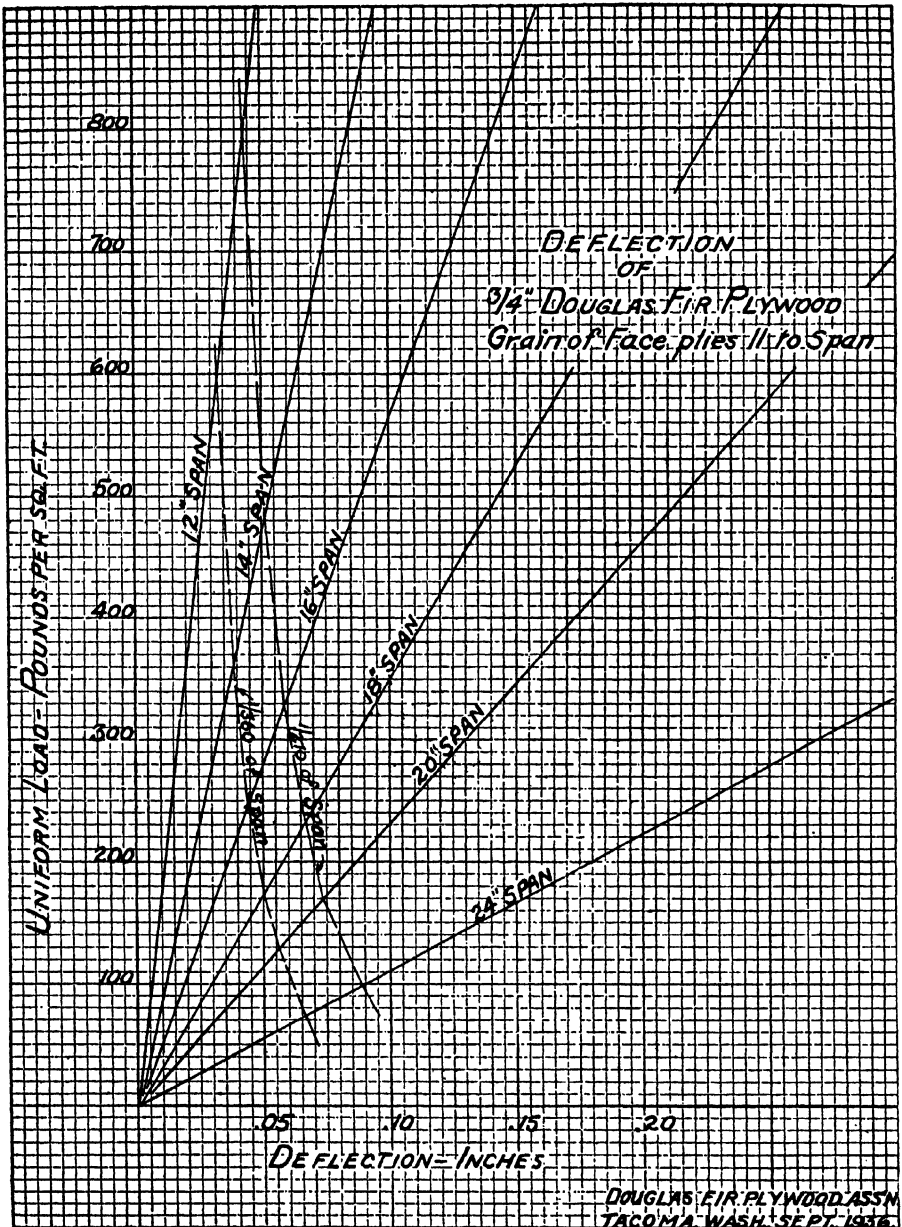

The charts show the deflections of Douglas Fir plywood when the grain of the face plies is parallel to the span, i.e. when panels are placed lengthwise across the supports. When panels are placed parallel to the supports, the loads causing any given deflection will be smaller than shown on the charts, as follows:—

For  $\frac{5}{8}$ " thickness, use 50 per cent. of load on chart ;

For  $\frac{3}{4}$ " thickness, use 75 per cent. of load on chart—

for any given span and allowable deflection.

MEAN VALUES OF TENACITY OF WOOD-SCREWS IN MULTIPLY, LAMINBOARD AND BLOCKBOARD AS DETERMINED BY TESTS MADE AT FOREST PRODUCTS RESEARCH LABORATORY, PRINCES RISBOROUGH.

TYPE OF BOARD.	POSITION OF SCREW.	TENACITY—AVERAGE LOAD (LB.).		
		No. 6— $\frac{3}{4}$ " Brass.	No. 10—1" Brass.	No. 14— $1\frac{1}{4}$ " Steel.
Gaboon Block-board 1" width core	Face A	218 (10)	368 (8)	508 (10)
	B	236 (9)	369 (8)	473 (10)
	End Grain A	194 (6)	224 (7)	401 (8)
	B	185 (7)	288 (8)	391 (9)
	Side Grain	261 (12)	373 (10)	594 (10)
Gaboon Lamin-board $\frac{3}{16}$ " width core	Face A	224 (7)	292 (6)	504 (6)
	B	243 (8)	327 (6)	459 (6)
	End Grain A	164 (6)	197 (6)	326 (6)
	B	184 (6)	224 (6)	322 (6)
	Side Grain	206 (8)	320 (7)	476 (7)
Gaboon Multi-ply	Face	218 (12)	333 (12)	532 (11)
	End Grain (centre ply)	152 (12)	246 (12)	364 (11)
	Side Grain (centre ply)	169 (12)	273 (12)	393 (11)
Douglas Fir Multi-ply	Face	275 (12)	382 (12)	524 (10)
	End Grain (centre ply)	238 (6)	315 (7)	420 (7)
	Side Grain (centre ply)	245 (6)	345 (7)	445 (8)

Figures in brackets indicate number of tests.

NOTE.—A. Inserted between joints of inner core.

B. Inserted in inner core.

For each size a suitable lead hole was machine-drilled in the test-piece, the screw being inserted to a depth equal to approximately two-thirds its length. In the case of the blockboard and the laminboard, the screws were inserted in the face and in one edge-end grain—between the core joints and also in the core.

The tenacity of the wood-screws in the blockboard and, to a less degree, in the laminboard, depends mainly on the density of the core, the individual strips of which varied considerably.



## CUBIC MEASURE

1 cubic metre	= 35·31658 cubic feet
	= 1·308021 cubic yards.
1 cubic decimetre	= 61·02705 cubic inches.
1 cubic inch	= 16·3861 cubic centimetres.
1 cubic foot	= 0·028315 cubic metre.
1 cubic yard	= 0·764513 cubic metre.
1 shipping ton (40 cubic feet)	= 1·1326 cubic metres.

## MEASURE OF WEIGHT

1 centigramme (cg.)	= 0·1543 grain avoirdupois.
1 gramme (gm.)	= 15·4324 grains avoirdupois, or 0·03213 oz. troy.
1 kilogramme (kg.)	= 2·20462 lb. avoirdupois.
1000 kilogrammes	= 2204·62 lb.
or 1 tonne (tonneau)	or 0·9842 tons.

## AVOIRDUPOIS WEIGHT

1 ounce	= 28·34954 grammes.
1 pound	= 0·45359265 kilogramme.
1 cwt.	= 50·802397 kilogrammes.
1 ton	= 1016·0475 kilogrammes. = 1·0160 tonneaux.

<i>Thickness.</i>	<i>Equivalent of 100 cubic feet in square feet of the thicknesses indicated.</i>	<i>Equivalent in cubic feet of 1000 square feet of thicknesses indicated.</i>	<i>Equivalent of 1 cubic metre in square feet of the thicknesses indicated.</i>
3 mm. . . .	10,159	9·843	3,588
4 mm. . . .	7,620	13·123	2,691
4½ mm. . . .	6,773	14·764	2,392
⅝" . . . .	6,400	15·625	2,261
5 mm. . . .	6,096	16·404	2,153
6 mm. . . .	5,080	19·685	1,794
¾" . . . .	4,800	20·833	1,696
9 mm. . . .	3,387	29·528	1,196
⅜" . . . .	3,200	31·25	1,133
12 mm. . . .	2,540	39·371	897
12½ mm. . . .	2,439	41·011	861
½" . . . .	2,400	41·66	848
15 mm. . . .	2,032	49·214	718
⅜" . . . .	1,920	52·082	677
18 mm. . . .	1,693	59·055	598
19 mm. . . .	1,606	62·336	567
¾" . . . .	1,600	62·5	565
21 mm. . . .	1,453	68·898	513
22 mm. . . .	1,384	72·179	489
⅞" . . . .	1,371	72·916	485
25 mm. . . .	1,220	82·021	431
1" . . . .	1,200	83·33	424

## BRITISH MEASURES WITH METRIC EQUIVALENTS

Decimal of an Inch.	Fraction of an Inch.	Decimal of a mm.	Decimal of an Inch.	Fraction of an Inch.	Decimal of a mm.
·015625	1/64	·396875	·515625	33/64	13·096875
·031250	1/32	·79375	·53125	17/32	13·49375
·046875	3/64	1·190625	·546875	35/64	13·890625
·0625	1/16	1·5875	·5625	9/16	14·2875
·078125	5/64	1·984375	·578125	37/64	14·684375
·093750	3/32	2·38125	·59375	19/32	15·08125
·109375	7/64	2·778125	·609375	39/64	15·478125
·125	1/8	3·175	·625	5/8	15·875
·140625	9/64	3·571875	·640625	41/64	16·271875
·15625	5/32	3·96875	·65625	21/32	16·66875
·171875	11/64	4·365625	·671875	43/64	17·065625
·1875	3/16	4·7625	·6875	11/16	17·4625
·203125	13/64	5·159375	·703125	45/64	17·859375
·21875	7/32	5·55625	·71875	23/32	18·25625
·234375	15/64	5·953125	·734375	47/64	18·653125
·25	1/4	6·35	·75	3/4	19·05
·265625	17/64	6·746875	·765625	49/64	19·446875
·281250	9/32	7·14375	·78125	25/32	19·84375
·296875	19/64	7·540625	·796875	51/64	20·240625
·3125	5/16	7·9375	·8125	13/16	20·6375
·328125	21/64	8·334375	·828125	53/64	21·034375
·34375	11/32	8·73125	·84375	27/32	21·43125
·359375	23/64	9·128125	·859375	55/64	21·828125
·375	3/8	9·525	·875	7/8	22·225
·390625	25/64	9·921875	·890625	57/64	22·621875
·40625	13/32	10·31875	·90625	29/32	23·01875
·421875	27/64	10·715625	·921875	59/64	23·415625
·4375	7/16	11·1125	·9375	15/16	23·8125
·453125	29/64	11·509375	·953125	61/64	24·209375
·46875	15/32	11·90625	·96875	31/32	24·60625
·484375	31/64	12·303125	·984375	63/64	25·003125
·5	1/2	12·7	1	1	25·4



## PRICES PER CUBIC METRE WITH EQUIVALENTS PER 100 SQUARE FEET

	3 mm.		4 mm.		4½ mm.		5 mm.		6 mm.		7 mm.		8 mm.		9 mm.		10 mm.		12½ mm.		15 mm.		16 mm.	
	1½d.	3½d.	2½d.	4½d.	5d.	7½d.	2½d.	5½d.	3½d.	7d.	10½d.	4d.	8d.	4½d.	9d.	5d.	11d.	5½d.	7d.	7d.	8d.	1/4½	1/5½	5/-
10/-	3½d.	4½d.	5d.	6½d.	7½d.	10½d.	10½d.	10½d.	10½d.	10½d.	10½d.	10½d.	10½d.	10½d.	10½d.	10½d.	10½d.	10½d.	10½d.	10½d.	10½d.	10½d.	10½d.	10½d.
15/-	4½d.	6½d.	7½d.	8½d.	10½d.	10½d.	10½d.	10½d.	10½d.	10½d.	10½d.	10½d.	10½d.	10½d.	10½d.	10½d.	10½d.	10½d.	10½d.	10½d.	10½d.	10½d.	10½d.	10½d.
41	6½d.	9d.	10d.	11d.	11d.	1/3½	1/3½	1/4½	1/4½	1/4½	1/3½	1/3½	1/6	1/8	1/8	1/10	1/10	2/3	2/4	2/9	2/9	3/-	41	
2	1/11	1/6	1/8	1/10	2/3	2/7½	2/7½	3/-	3/4	3/4	3/4	3/4	3/4	3/4	3/4	3/9	3/9	4/6	4/8	5/7	5/7	6/-	2	
3	1/8	2/3	2/6	2/10	3/4	3/11	3/11	4/6	5/-	5/7	5/7	5/7	4/6	5/-	5/7	5/7	5/7	6/9	6/11	8/4	8/4	8/11	3	
4	2/3	3/-	3/4	3/9	4/5	5/2	5/2	5/11	6/8	7/5	7/5	6/6	7/5	8/4	8/4	8/4	8/4	8/11	9/3	11/2	11/2	11/11	4	
5	2/9½	3/9	4/2	4/8	5/7	6/6	6/6	7/5	8/4	9/4	9/4	7/9½	8/11	10/-	10/-	10/-	10/-	11/2	11/7	13/11	13/11	14/11	5	
6	3/4	4/6	5/-	5/7	6/8½	7/9½	7/9½	8/11	10/-	11/2	11/2	8/11	10/5	11/8	11/8	11/2	11/2	13/5	13/10	16/9	16/9	17/10	6	
7	3/11	5/2½	5/10	6/7	7/6	8/10	8/10	7/6	8/10	9/1	9/1	9/1	10/5	11/8	11/8	11/8	13/-	15/8	16/3	19/6	19/6	20/10	7	
8	4/5½	6/-	6/8	7/6	8/5	10/-	10/-	8/5	10/-	11/8	11/8	10/5	11/10	13/4	13/4	14/10	14/10	17/10	18/6	22/3	22/3	23/10	8	
9	5/-	6/9	7/6	8/5	9/3	11/2	11/2	8/5	10/-	11/8	11/8	10/5	11/10	13/4	15/-	16/9	16/9	20/1	20/11	25/1	25/1	26/9	9	
10	5/7	7/5	8/4	9/3	10/2	11/2	11/2	8/5	10/-	11/8	11/8	10/5	11/10	13/4	15/-	16/9	16/9	20/1	20/11	25/1	25/1	26/9	10	
11	6/1½	8/2	9/3	10/2	11/2	12/3	12/3	10/2	11/2	12/3	12/3	14/3	16/4	18/5	20/5	20/5	22/4	24/6	25/7	30/8	30/8	32/9	11	
12	6/8	8/11	10/2	11/1	13/5	15/7	15/7	11/1	13/5	15/7	15/7	14/3	16/4	18/5	20/5	20/5	22/4	24/6	25/7	30/8	30/8	32/9	12	
13	7/3	9/8	10/10	12/1	14/6	16/11	16/11	12/1	14/6	16/11	16/11	14/3	16/4	18/5	20/5	20/5	22/4	24/6	25/7	30/8	30/8	32/9	13	
14	7/11	10/5	11/8	13/-	15/7	18/2	18/2	13/-	15/7	18/2	18/2	14/3	16/4	18/5	20/5	20/5	22/4	24/6	25/7	30/8	30/8	32/9	14	
15	8/4	11/2	12/6	13/11	16/9	19/6	19/6	13/11	16/9	19/6	19/6	14/3	16/4	18/5	20/5	20/5	22/4	24/6	25/7	30/8	30/8	32/9	15	
16	8/11	11/11	13/4	14/10	17/10	20/10	20/10	14/10	17/10	20/10	20/10	14/3	16/4	18/5	20/5	20/5	22/4	24/6	25/7	30/8	30/8	32/9	16	
17	9/6	12/8	14/2	15/9	19/-	22/1	22/1	15/9	19/-	22/1	22/1	14/3	16/4	18/5	20/5	20/5	22/4	24/6	25/7	30/8	30/8	32/9	17	
18	10/-	13/5	15/-	16/9	20/-	23/5	23/5	16/9	20/-	23/5	23/5	14/3	16/4	18/5	20/5	20/5	22/4	24/6	25/7	30/8	30/8	32/9	18	
19	10/7	14/1	15/11	17/8	21/2	24/9	24/9	17/8	21/2	24/9	24/9	14/3	16/4	18/5	20/5	20/5	22/4	24/6	25/7	30/8	30/8	32/9	19	
20	11/2	14/10	16/8	18/7	22/3	26/-	26/-	18/7	22/3	26/-	26/-	14/3	16/4	18/5	20/5	20/5	22/4	24/6	25/7	30/8	30/8	32/9	20	

	18 mm.	19 mm.	20 mm.	21 mm.	22 mm.	25 mm.	25.4 mm.	30 mm.	32 mm.	34 mm.	36 mm.	37.5 mm.	38 mm.	
5/-	1od.	1od.	11d.	1/-	1/-	1/2	1/2	1/4½	1/6	1/7	1/8	1/9	1/9	5/-
10-	1/8	1/9	1/10	1/11½	2/0½	2/3½	2/4	2/9½	2/11½	3/1½	3/4	3/6	3/6½	10/-
15/-	2/6	2/7½	2/9	2/11½	3/0½	3/5½	3/6	4/2½	4/5½	4/8½	5/-	5/3	5/3½	15/-
£1	3/4	3/6	3/8½	3/11	4/1	4/7½	4/8½	5/6	5/11	6/4	6/8	7/-	7/1	£1
2	6/8	7/-	7/5	7/10	8/2	9/3	9/5	11/2	11/11	12/7	13/5	13/11	14/2	2
3	10/-	10/7	11/2	11/8	12/3	13/11	14/2	16/9	17/10	19/-	20/1	20/11	21/3	3
4	13/5	14/1	14/10	15/8	16/4	18/6	18/11	22/4	23/10	25/3	26/9	27/11	28/4	4
5	16/9	17/8	18/7	19/6	20/5	23/3	23/8	27/10	29/9	31/7	33/5	34/10	35/4	5
6	20/1	21/2	22/3	23/4	24/6	27/9	28/4	33/5	35/8	37/10	40/2	41/10	42/5	6
7	23/5	24/8	26/-	27/4	28/7	32/6	33/-	39/-	41/8	44/2	46/10	48/9	49/5	7
8	26/10	28/4	29/9	31/3	32/8	37/1	37/10	44/7	47/7	50/6	53/6	55/9	56/6	8
9	30/2	31/9	33/5	35/2	36/10	41/9	42/6	50/2	53/7	56/9	60/2	62/9	63/7	9
10	33/5	35/4	37/2	39/-	40/11	46/5	47/3	55/9	59/6	63/1	66/11	69/8	70/8	10
11	36/9	38/10	40/10	42/11	45/-	51/-	52/-	61/3	65/5	69/5	73/7	76/8	77/8	11
12	40/1	42/4	44/7	46/9	49/1	55/8	56/8	66/10	71/5	75/8	80/3	83/7	84/9	12
13	43/6	45/11	48/4	50/9	53/2	60/4	61/5	72/5	77/4	82/-	87/-	90/7	91/10	13
14	46/10	49/5	52/-	54/8	57/3	64/11	66/1	78/-	83/4	88/4	93/8	97/7	98/11	14
15	50/2	53/-	55/9	58/6	61/4	69/8	70/11	83/7	89/3	94/7	100/4	104/6	106/-	15
16	53/6	56/6	59/5	62/7	65/5	74/3	75/7	89/2	95/3	100/11	107/-	111/6	113/-	16
17	56/10	60/-	63/2	66/4	69/6	78/10	80/3	94/9	101/1	107/3	113/9	118/6	120/1	17
18	60/2	63/7	66/11	70/3	73/7	83/6	85/-	100/3	107/2	113/7	120/5	125/5	127/2	18
19	63/7	67/1	70/7	74/2	77/8	88/2	89/9	105/10	113/1	119/10	127/1	132/5	134/3	19
20	66/10	70/8	74/4	78/-	81/9	92/10	94/6	111/5	119/-	126/2	133/9	139/4	141/4	20

IMPORTS OF THE UNDER-MENTIONED DESCRIPTIONS (b) CHESTS AND CASES INTO BRITISH MALAYA, NETHERLANDS EAST INDIES AND BRITISH INDIA IN 1930, 1935 AND 1938, (DISTINGUISHING IMPORTS FROM THE COUNTRIES SPECIFIED (Abstracted from the respective official trade returns.)

	1930.		1935.		1938.	
	Quantity.	Value.	Quantity.	Value.	Quantity.	Value.
<b>BRITISH MALAYA</b>	<i>Number.</i>	<i>Straits \$.</i>	<i>Number.</i>	<i>Straits \$.</i>	<i>Number.</i>	<i>Straits \$.</i>
Rubber cases of 3-ply wood (complete)		3,299,244		1,069,859		1,024,462
Total Imports	3,299,837	=£384,911	2,045,980	=£124,816	1,358,138	=£119,520
Of which from—						
Germany . . . . .	742,730	780,509	42,900	20,345	308,350	250,247
Finland . . . . .	1,538,410	1,439,597	794,900	464,841	290,900	228,528
Japanese Empire . . . . .	90,400	56,439	521,465	155,469	209,870	114,871
United Kingdom . . . . .	505,787	594,214	418,552	295,942	173,450	167,759
Poland . . . . .	2,710	2,498	24,100	10,656	107,717	75,694
Soviet Union . . . . .	(a)	(a)	53,500	22,799	53,200	34,516
Estonia . . . . .	(a)	(a)	79,700	41,372	25,200	21,536
Latvia . . . . .	102,800	75,114	(a)	(a)	(a)	(a)
Other European countries . . . . .	305,950	342,460	108,250	56,539	185,050	127,619
<b>NETHERLANDS EAST INDIES</b>	<i>Number.</i>	<i>Gulden.</i>	<i>Number.</i>	<i>Gulden.</i>	<i>Number.</i>	<i>Gulden.</i>
Wooden cases of 3-ply		3,838,989		1,188,170		3,013,995
Total Imports	2,429,685	=£317,534	2,708,431	=£280,228	3,773,288	=£339,032
Of which from—						
Japan . . . . .	463,407	634,607	990,366	285,988	1,722,614	1,035,873
Finland . . . . .	4,500	7,289	1,024,160	483,781	677,292	677,788
Netherlands . . . . .	121,420	202,583	307,134	168,056	348,892	314,906
Former Russian provinces on the Baltic coast . . . . .	(c)	(c)	26,415	11,878	276,204	255,351
Soviet Union . . . . .	(c)	(c)	19,000	8,079	247,715	220,601
United Kingdom . . . . .	505,816	869,560	123,676	65,687	205,467	166,071
Sweden . . . . .	8,200	13,122	113,851	115,081	110,702	158,492
Poland . . . . .	(c)	(c)	62,000	27,123	146,083	151,612
Germany . . . . .	1,262,250	2,006,151	25,829	13,904	3,108	3,624
<b>YEAR ENDED 31ST MARCH.</b>						
<b>BRITISH INDIA</b>	1931.	<i>Rupees.</i>	1936.	<i>Rupees.</i>	1938.	<i>Rupees.</i>
Tea-chests, entire or in Sections, of wood . . . . .		60,74,670		53,14,526		69,15,560
Total Imports . . . . .		=£455,600		=£398,598		=£518,667
Of which from—						
United Kingdom . . . . .		45,45,959		37,28,009		45,88,946
Estonia . . . . .	Not available.	=£340,946	Not available.	=£279,600	Not available.	=£344,171
Finland . . . . .		8,90,615		10,10,147		9,22,496
Germany . . . . .		3,32,053		2,15,183		4,69,745
Japan . . . . .		1,72,115		2,13,088		2,67,043
Latvia . . . . .		76,434		60,960		2,21,924
Soviet Union . . . . .		..		..		1,98,238
France . . . . .		42,995		11,508		38,114
Sweden . . . . .		..		..		49,312
Poland . . . . .		6,891		25,871		48,787
		418		122		..

(a) Not separately specified, but included in "other European countries."

(b) Being the only items relevant to tea and rubber chests contained in the respective trade returns.

(c) Not separately specified.

*Average rates of Exchange:—*

British Malaya : 1 dollar is equivalent to 2s. 4d. British India : 1 rupee is equivalent to 1s. 6d. Netherlands East Indies : In 1930, 12.09, in 1935, 7.24, and in 1938, 8.89 gulden to the £ respectively.

# IMPORTS OF PLYWOOD INTO THE UNITED KINGDOM FROM 1926 TO 1938 INCLUSIVE

(Reproduced by courtesy of MESSRS. FLATAU, DICK & COMPANY, LONDON.)

FINLAND			JAPAN			ESTONIA		
	Cubic Feet	Value £		Cubic Feet	Value £		Cubic Feet	Value £
1938	4,892,983	1,352,691	1938	382,664	179,271	1938	259,072	77,877
1937	5,776,139	1,608,907	1937	942,206	389,018	1937	336,754	91,359
1936	5,098,563	1,284,615	1936	660,693	269,094	1936	301,102	82,172
1935	4,225,741	1,103,186	1935	344,024	162,206	1935	289,318	68,868
1934	3,159,386	814,034	1934	351,523	172,354	1934	237,877	61,115
1933	2,568,370	544,581	1933	223,402	90,727	1933	174,665	40,412
<i>Square Feet</i>			<i>Square Feet</i>			<i>Square Feet</i>		
1932	118,349,229	625,715	1932	6,448,818	83,839	1932	23,850,058	104,090
1931	108,254,171	623,814	1931	3,006,591	48,223	1931	22,935,268	140,202
1930	123,567,458	706,668	1930	2,008,233	40,358	1930	24,113,048	198,292
1929	134,701,778	928,607	1929	4,319,816	90,488	1929	27,131,293	191,424
1928	117,511,249	641,957	1928	2,607,711	55,882	1928	28,967,674	172,581
1927	87,391,372	518,501	1927	1,279,653	29,226	1927	33,091,544	189,625
1926	89,232,066	527,232	1926	1,129,328	25,514	1926	25,666,108	190,317
RUSSIA			CANADA			SWEDEN		
	Cubic Feet	Value £		Cubic Feet	Value £		Cubic Feet	Value £
1938	2,247,903	572,885	1938	365,708	127,915	1938	217,643	62,410
1937	3,834,502	1,024,335	1937	528,327	181,316	1937	259,389	82,058
1936	3,980,813	967,289	1936	247,795	91,925	1936	339,226	100,515
1935	4,003,174	1,007,378	1935	7,998	2,867	1935	256,875	76,021
1934	3,153,061	635,065	1934	19,946	7,049	1934	143,288	39,367
1933	2,637,820	438,817	1933	23,043	8,038	1933	176,824	40,827
<i>Square Feet</i>			<i>Square Feet</i>			<i>Square Feet</i>		
1932	209,203,940	572,775	1932	969,634	9,655	1932	5,045,926	34,097
1931	96,106,267	262,186	1931	743,381	6,981	1931	3,759,813	30,296
1930	89,559,558	399,245	1930	167,644	1,460	1930	3,415,008	29,931
1929	76,260,698	371,194	1929	271,762	3,080	1929	4,238,749	38,228
1928	36,147,411	160,981	1928	292,578	3,623	1928	1,219,556	12,674
1927	25,376,382	116,846	1927	390,154	4,127	1927	955,426	8,865
1926	14,543,725	72,460	1926	523,671	4,572	1926	1,416,881	12,381
LATVIA			GERMANY			FRANCE		
	Cubic Feet	Value £		Cubic Feet	Value £		Cubic Feet	Value £
1938	913,872	286,658	1938	199,239	155,266	1938	118,480	61,229
1937	1,214,224	380,476	1937	416,334	229,150	1937	120,158	66,104
1936	1,108,911	314,900	1936	367,515	198,025	1936	66,158	38,141
1935	918,187	267,203	1935	482,294	239,727	1935	55,740	31,775
1934	744,822	233,720	1934	429,836	197,164	1934	12,050	7,033
1933	598,680	157,999	1933	440,162	166,154	1933	6,296	2,951
<i>Square Feet</i>			<i>Square Feet</i>			<i>Square Feet</i>		
1932	44,325,389	201,996	1932	20,285,517	179,402	1932	699,543	8,024
1931	49,770,842	285,526	1931	16,802,546	200,341	1931	3,359,499	41,470
1930	59,895,119	358,724	1930	14,722,253	219,517	1930	4,761,146	50,756
1929	53,158,751	330,921	1929	22,184,046	363,886	1929	11,041,276	112,432
1928	34,834,843	189,148	1928	14,223,860	278,859	1928	7,216,883	80,964
1927	31,452,520	157,170	1927	10,193,445	141,232	1927	3,995,701	48,437
1926	31,675,579	175,033	1926	10,093,222	178,269	1926	1,736,857	25,846
POLAND			U.S.A.			LITHUANIA		
	Cubic Feet	Value £		Cubic Feet	Value £		Cubic Feet	Value £
1938	555,998	192,946	1938	278,155	95,093	1938	136,753	61,069
1937	967,607	336,391	1937	546,159	190,173	1937	282,293	123,398
1936	733,582	234,674	1936	806,216	280,926	1936	262,318	111,582
1935	920,434	272,589	1935	421,758	112,337	1935	245,573	102,622
1934	449,668	154,098	1934	943,354	317,995	1934	187,575	73,522
1933	203,311	55,219	1933	663,898	148,186	1933	131,900	47,061
<i>Square Feet</i>			<i>Square Feet</i>			<i>Square Feet</i>		
1932	16,876,929	57,994	1932	14,260,324	123,248	1932	3,195,373	33,545
1931	25,983,202	80,581	1931	15,157,534	132,101	1931	4,838,402	47,532
1930	31,616,745	126,555	1930	12,007,959	121,126	1930	3,493,941	34,800
1929	64,215,216	293,266	1929	7,851,290	94,603	1929	3,604,317	50,347
1928	60,793,064	244,421	1928	6,873,000	85,027	1928	4,191,629	44,015
1927	45,615,481	166,024	1927	4,834,906	56,415	1927	2,600,869	23,311
1926	40,718,817	155,703	1926	3,942,974	52,844	1926	7,659,742	76,946

## ROUMANIA

	Cubic Feet	Value £
1938 .	108,881	46,739
1937 .	87,502	33,844
1936 .	22,182	7,812
1935 .	2,370	1,014

## CZECHO-SLOVAKIA

	Cubic Feet	Value £
1938 .	93,749	41,074
1937 .	103,175	45,848
1936 .	23,481	9,482
1935 .	27,076	9,984
1934 .	3,550	1,575

	Square Feet	Value £
1927 .	194,108	1,182
1926 .	280,874	729

## BELGIUM

	Cubic Feet	Value £
1938 .	58,274	40,684
1937 .	78,085	51,592
1936 .	49,740	30,202
1935 .	30,650	8,870
1934 .	5,803	2,195
1933 .	11,145	2,690

	Square Feet	Value £
1932 .	1,718,414	12,328
1931 .	3,987,831	38,729
1930 .	4,349,091	41,549
1929 .	968,134	18,289
1928 .	642,301	13,047
1927 .	287,437	4,519
1926 .	93,086	1,007

## SWITZERLAND

	Cubic Feet	Value £
1938 .	26,019	15,391
1937 .	30,336	18,489
1934 .	33,202	17,428
1933 .	46,464	13,375

	Square Feet	Value £
1932 .	365,551	6,774
1931 .	57,439	826
1930 .	122,952	1,593
1928 .	42,178	690

## NETHERLANDS

	Cubic Feet	Value £
1938 .	29,181	11,806
1937 .	39,513	19,395
1936 .	85,790	39,378
1935 .	54,217	19,832
1934 .	26,952	8,663
1933 .	24,214	9,724

	Square Feet	Value £
1932 .	1,039,380	9,905
1931 .	2,398,835	40,155
1930 .	5,131,170	63,132
1929 .	4,483,999	81,015
1928 .	3,863,633	71,737
1927 .	3,877,806	59,748
1926 .	5,219,204	59,217

## YUGOSLAVIA

	Cubic Feet	Value £
1938 .	17,994	8,161
1937 .	59,455	27,338
1936 .	34,720	15,410
1935 .	7,050	2,763
1934 .	27,374	10,368
1933 .	29,620	9,621

	Square Feet	Value £
1932 .	241,935	5,861
1931 .	335,286	1,420
1929 .	300,161	1,032
1927 .	81,289	672

## AUSTRALIA

	Cubic Feet	Value £
1938 .	7,668	6,507
1937 .	6,027	5,206
1936 .	9,649	6,492
1935 .	14,824	7,371
1934 .	10,294	5,059
1933 .	5,506	2,214

	Square Feet	Value £
1932 .	373,684	3,922
1931 .	253,810	3,441
1930 .	34,498	910
1929 .	51,125	673

## NORWAY

	Cubic Feet	Value £
1938 .	7,773	4,083
1937 .	46,809	23,283
1936 .	50,982	24,099
1935 .	50,879	26,593
1934 .	44,328	21,201
1933 .	55,160	20,585

	Square Feet	Value £
1932 .	2,059,401	14,886
1931 .	2,477,592	16,811
1930 .	1,164,551	13,125
1929 .	600,965	4,251
1928 .	2,669,708	25,137
1927 .	4,771,355	45,120
1926 .	5,184,216	40,924

## HUNGARY

	Cubic Feet	Value £
1938 .	5,450	2,823
1937 .	12,976	6,486
1936 .	12,245	6,220
1935 .	9,838	3,910
1934 .	4,011	1,589

## AUSTRIA

	Cubic Feet	Value £
1938 .	7,144	2,634
1937 .	9,605	3,646
1936 .	9,716	3,576
1935 .	30,792	11,944
1934 .	68,630	25,970
1933 .	50,109	17,123

	Square Feet	Value £
1932 .	277,975	6,229
1931 .	43,453	1,268
1930 .	83,079	3,384
1929 .	27,349	1,091
1928 .	344,162	3,283

## DENMARK

	Cubic Feet	Value £
1938 .	1,630	627
1937 .	16,278	4,480
1936 .	3,065	1,076
1935 .	8,683	2,109
1934 .	4,555	1,583
1933 .	12,336	3,351

	Square Feet	Value £
1932 .	1,598,226	6,421
1931 .	684,575	3,509
1930 .	449,440	2,999
1929 .	120,843	2,450
1928 .	128,530	1,129
1927 .	601,042	3,483
1926 .	146,064	1,159

## ITALY

	Cubic Feet	Value £
1937 .	84,505	21,083
1935 .	22,744	4,626
1933 .	11,749	1,940

	Square Feet	Value £
1932 .	45,757	1,018
1931 .	493,905	4,523
1930 .	138,631	2,428
1929 .	295,525	5,334
1928 .	274,788	7,284
1927 .	205,968	2,680

## SPAIN

	Cubic Feet	Value £
1937 .	3,852	1,802
1936 .	16,591	7,522
1935 .	39,407	19,482
1934 .	48,917	22,427
1933 .	62,044	25,807

	Square Feet	Value £
1932 .	2,944,599	19,651
1931 .	1,271,317	9,206
1930 .	431,976	5,944
1926 .	47,491	585

## TOTAL IMPORTS

	Cubic Feet	Value £
1938 .	10,935,909	3,358,194
1937 .	15,813,753	4,969,940
1936 .	14,295,119	4,126,507
1935 .	12,475,264	3,567,402
1934 .	10,126,208	2,736,571
1933 .	8,099,659	1,848,003

	Square Feet	Value £
1932 .	474,310,840	2,122,479
1931 .	362,899,506	2,021,031
1930 .	382,019,377	2,489,384
1929 .	416,167,297	2,904,121
1928 .	322,893,308	2,093,789
1927 .	257,637,716	1,581,669
1926 .	239,916,810	1,606,264

# PLYWOOD CONTRACT FORM

## QUALITY.

1. Sellers guarantee that the goods shipped under this contract will be of their average quality and manufacture as at present supplied to the United Kingdom.

## SIZES.

2. The terms "press" or "as falling" to cover a variation of 10 per cent. in length and/or width from the sizes mentioned in the contract.

## QUANTITY VARIATIONS.

3. In the case of stock or press sizes or boards "as falling" the Sellers at their option may ship  $2\frac{1}{2}$  per cent. in footage more or less than the contract quantity of each item of the specification. In the case of boards to be cut to special sizes the exact quantity must be shipped as called for in the contract.

## PACKING.

4. The goods to be properly packed as customary for the class of goods concerned, and to be despatched in undamaged condition from the warehouse and/or quay of shipping port. In each shipment there shall be uniformity as regards the numbers of boards in packages which are uniform as regards both size and thickness of contents. Each package to contain only one size, one thickness and one quality. Where cross-grained boards are allowed the same, if any, to be packed and marked separately. The number of pieces of cut sizes per package shall be left to the discretion of the sellers unless otherwise arranged.

## MARKING.

5. Every package shipped under this contract to be legibly marked with size, quality, thickness, number of pieces, package number, in addition to any other marks herein specified. Where packages bear a trade mark the country of origin must be legibly marked.

## INSURANCE.

6. Unless otherwise agreed Marine Insurance to be covered by Sellers or their brokers for c.i.f. value plus 10 per cent. with Lloyds or a first-class British company (or a foreign company if mutually agreed upon in writing between Buyer and Seller) under policies payable in sterling in Great Britain including the Plywood Clauses printed hereon. Cost of War and Strike Risks (as defined by the Institute War and Strike Clauses in force at the time the contract of insurance is entered into) to be borne by Buyers, but these Risks shall be covered, if possible, by Sellers or Sellers' Agents (unless otherwise agreed) at Buyers' expense. If these Risks be covered by Buyers proof of insurance must be lodged with the Sellers' Agents before shipment. If these Risks cannot be covered within one month from the date goods are due and ready for shipment, Buyers shall have the option of cancelling such part of the contract as cannot be insured. If Buyers request shipment of goods with these Risks uninsured they shall forthwith open a confirmed Bank Credit in London in favour of Sellers' Agents available against shipping documents.

## SHIPPING.

7. Shipment means placing goods on board at original shipping port unless otherwise stated herein. All goods to be stowed under deck.

## PROPERTY IN GOODS.

8. Property in goods to be deemed for all purposes (except retention of vendor's lien for unpaid purchase price) to have passed to Buyers when goods have been shipped. Invoice to be finally adjusted on proved contents of packages in case of shortage and/or wrong dimensions and/or wrong descriptions.

## PAYMENT.

9. Payment for invoice amount to be made to the Agents hereunder by cash without discount on presentation of and in exchange for shipping documents.

## PRESENTATION OF DOCUMENTS.

10. If the documents are not presented to Buyers prior to the arrival of the steamer, the Buyers shall nevertheless take up the documents on presentation, but any charges incurred through delay

in presentation of documents shall be payable by Sellers unless previous sufficient particulars of shipment have been supplied to enable the consignment to be handled without delay or extra expense unless the delay in presentation of the documents is due to causes beyond Sellers' control. Any dispute under this clause as to Sellers' liability for extra charges shall be submitted to arbitration under Clause 15. Unless prepaid the freight to be deducted from the invoice and paid by Buyers in terms of customary Bill of Lading.

Shipping documents shall consist of on board Bill of Lading, Specification, Invoice, Certificate of Origin where required, and Policy or Certificate of Insurance, provided that the latter certifies all the risks in the contract to be covered. The Bill of Lading shall not be rejected on the ground that a number of packages (not exceeding 2 packages or 10 per cent. whichever is the greater) be signed for in dispute but shall be taken up on a satisfactory indemnity.

#### **DUTIES.**

11. Export Duty if any to be paid by the Sellers. Import Duty if any to be paid by the Buyers.

#### **CANCELLATION.**

12. Should shipment be delayed beyond the time stipulated Buyers shall have the right (without prejudice to their rights under this contract) to cancel such part of the contract as does not comply with the stipulated shipment dates, but only if they give due notice in writing to the Agent in time to enable them to notify Sellers by cable before the goods are despatched from the mill. Should Buyers' cancellation instructions be received by Sellers after the goods have left the mill Sellers to notify Buyers to this effect within three clear days from the receipt of Buyers' cancellation instructions, and documentary evidence in support to be furnished to Buyers within a reasonable period if so required. Buyers to be entitled to cancel on failure of Sellers to comply with these provisions, Cut sizes and cut sizes sold in sets which have been manufactured before receipt at the mill of telegraphic cancellation instructions must be accepted by Buyers provided the specification is supplied promptly and the goods shipped within twenty-one days. If cut sizes are sold in sets Buyers shall only be required to accept complete sets.

Shippers not to be responsible for non-delivery or delay in shipment if arising from causes beyond their control.

Subject to the Sellers proving force majeure to the satisfaction of the Buyers or the Arbitrators appointed hereunder, the Buyers shall not cancel this contract unless the delay in shipment will exceed four weeks from the shipment date stipulated in the contract, and the Sellers shall not be held liable for delivery under this contract beyond a period of three months. Should the parties be desirous of continuing the contract or part thereof shipment shall be resumed at the earliest possible moment and in such instalments as may be mutually agreed.

When the contract calls for declarations and/or destination and Buyers fail to give same as called for under this contract the Sellers shall have the option of cancelling the contract to the extent of the missing declaration and/or destination, or, in the case of stock sizes, of shipping an average specification, and, in the case of cut sizes, the option of shipping an equivalent number of cubic feet of stock sizes, in the grades, thickness and quality contracted for, in such specification as may suit the Sellers, and at stock size prices in force at the time the contract was signed. Such shipment to be made to the port of Buyers' domicile or nearest available thereto, and to be accepted and paid for by Buyers as provided in this contract, Sellers to notify Buyers by cable which option hereunder, if any, they propose to exercise. Failure by Sellers to avail of these options shall not affect in any way their rights under this contract.

#### **CLAIMS.**

13. No claim for defective quality and/or manufacture (except for bad gluing, manufacture damp and metal fastenings) shall be made in respect of any goods shipped under this contract unless written notice of claim is made to the Sellers through their agents within 17 days from the final delivery of goods into original Public Dock, Warehouse, or Wharf or Private Premises, within the limits covered by the Marine Insurance Policy. Packages opened not to exceed 10 per cent. or ten packages, whichever is the greater. Buyers have the right to deal with any package or packages on which there is no claim.

**BAD GLUING.**

14. Claims for bad gluing shall be considered by the Shippers within six months from the final delivery of goods into original Public Dock, Warehouse, or Wharf or Private Premises, within the limits covered by the Marine Insurance Policy, but such claims must be proved against the goods as originally shipped.

**MANUFACTURE DAMP AND METAL FASTENINGS.**

15. Plywood containing faults enumerated below shall not constitute good delivery against the contract :—

- (a) Plywood in which manufacture damp is present.
- (b) Plywood (other than Boxboards) containing clips, wire or other metal fastenings in any form.

Buyers may reject in whole or in part during a period of twelve months after delivery into original warehouse as in Clause 13, any plywood containing any of the above enumerated defects. Proof of identity must be furnished.

**ARBITRATION.**

16. Should any dispute arise under this contract which it may be found impossible to settle by amicable arrangement Buyers shall not reject the goods herein specified provided they reasonably comply with the contract ; but shall accept and pay for them in terms of the contract ; such payment shall not prejudice the Buyers' right of claim for allowance or damages. Such dispute shall forthwith be referred to the decision of a third party to be mutually agreed upon, or in default of agreement to two Arbitrators, one Arbitrator to be appointed by the Sellers and one by the Buyers ; such Arbitrators shall previously to entering upon the arbitration appoint an Umpire, and the arbitration shall be subject to the English Arbitration Act of 1889 or any subsisting statutory modification thereof or substitution therefor. In the case of a claim not exceeding £25, the dispute shall, if not amicably settled, be referred to one Arbitrator. In the event of either party failing within seven days after receipt of request by registered letter or cable direct or through the agents under this contract to appoint or to agree to the appointment of an Arbitrator, or in the case of the parties being unable within seven days as above to agree, in the case of the claim not exceeding £25, on a single Arbitrator, or in the case of the Arbitrators being unable to agree on an Umpire, the appointment shall be made by the Chairman, or failing him the Deputy-Chairman for the time being of the Plywood Section of the Timber Trade Federation of the United Kingdom on the application of either party, whose appointment shall be binding upon the parties. Unless otherwise mutually agreed every Arbitrator and/or Umpire shall be selected from the approved list of Arbitrators issued by the Plywood Section of the Timber Trade Federation of the United Kingdom or shall be directly engaged in the Plywood Trade.

Any Arbitrator and/or Umpire shall be domiciled in the United Kingdom. Any award shall be final and binding upon both parties. The costs of such arbitration shall be left to the discretion of the Arbitrators or Umpire who, in deciding as to costs shall take into consideration the correspondence between the parties relating to the dispute and the respective efforts to arrive at a fair settlement.

This clause shall not apply to any parcel shipped to countries other than the United Kingdom, Northern Ireland and Eire.

**NON-COMPLIANCE.**

17. In the case of the non-compliance by the Buyers with any of the terms of this contract, Sellers to have immediate power of resale for Buyers' account after 7 days' notice in writing has been given.

**Contracts were also endorsed with the following clauses :—**

1. Property in goods to be deemed for all purposes (except retention of vendors' lien for unpaid purchase price) to have passed to Buyers when goods have been shipped on board at original shipping port. Invoice to be finally adjusted on proved contents of packages in case of shortage and/or wrong dimensions and/or wrong descriptions.

2. This purchase is subject to Sellers confining their sales until the Contract is completed to the firms contained in the Approved List of Plywood Importers now in force or to any firms whose names may be added to the Approved List before the completion of this Contract.



## (a) PLYWOOD IMPORTERS' SALE NOTE

*(Adopted and recommended by the Plywood Importers' Sub-section, 29th September 1936.)*

1. Sellers shall not be liable for non-shipment, non-delivery, damage or delay, arising from circumstances beyond their control. Should shipment be delayed beyond the time stipulated Sellers will on request accept notice of cancellation, but any goods which are manufactured or in course of manufacture must be accepted by the Buyers.

2. The goods are not offered or sold for use for any specific purpose. In the event of any claim Sellers' liability shall in no circumstances exceed the invoice price of the defective board or boards.

3. Goods sold on Ex Docks or Warehouse terms, unless removed, are to be at Sellers' risk in respect of fire, but Sellers' liability ceases at the expiration of the free rent period stated on Delivery Orders. Sellers are to be free from liability for delays at Docks, Wharves and Warehouses, or for damage or delays during transport.

4. No claim will be entertained on any goods unless Buyers can establish complete identification. No claim will be recognized unless made within seven days after receipt of the goods.

5. Should any dispute arise under this sale which it may be found impossible to settle by amicable arrangement, the same shall forthwith be referred for settlement to an Arbitrator or, in case one be not mutually agreed, to two Arbitrators for settlement, one to be named by each party, and such Arbitrators shall previously to entering upon the Arbitration, appoint an Umpire, whose Award or that of the Arbitrator or Arbitrators shall be final and binding upon both parties. In the case of a claim not exceeding £25, the dispute shall, if not amicably settled, be referred to one Arbitrator. Buyers shall not reject any goods herein specified, but shall pay for them in terms of sale. Buyers shall not be entitled to any allowances or claim unless payment has been made in accordance with the sale terms. In the event of either side failing to appoint their Arbitrator within seven days after one party has appointed an Arbitrator and requested the other to do so, the appointed Arbitrator shall act as Sole Arbitrator in the dispute and his decision shall be final and binding upon both parties. The liability for the cost of an Arbitration to be as Arbitrator, Arbitrators or Umpire may decide. The Arbitrators and/or Umpire shall be resident and directly engaged in the Plywood Trade in the United Kingdom. The Arbitration shall be held in the U.K., and shall be subject to the English Arbitration Act of 1889 and 1934 or any subsisting statutory modification thereof or substitution therefor.

# INDEX

NOTE.—*Figures in italic denote main subject-matter.*

## A

ABACHI, 278  
Aboudikro, 289  
Abrasive paper, 109, 112  
Abura, 277  
*Acanthopanax Ricinifolium*, 248  
Accelerator, 86  
*Acer pseudoplatanus*, 295  
Acetone, 84, 86  
Adhesion, 76  
Adhesives, 76-91, 439; *see also* Resin  
Admiralty, 136, 145  
Africa, Continent of, 173  
— West Coast of, 14, 173, 265, 277, 278  
*Agathis Australis*, 267  
Agents and brokers, 302, 303  
Aircraft, 6, 84, 91, 134, 150, 151, 404-406  
— plywood, 15, 190, 212, 214, 226, 404, 445  
Air-dry, 123, 439  
Air-screw blades, 151  
Alcohol, 84, 86  
Alder, 14, 35, 48, 70, 94, 109, 118, 119, 155, 189, 191, 192, 225, 241, 245, 246, 272, 273, 274, 301, 303, 411, 427, 445  
— Lesbel, 234  
— wet-glued, 156, 163, 225, 234, 246  
Alkali, 115, 147  
*Alnus glutinosa*, 245, 246  
Aluminium, 146, 147, 446  
Ammonia, 115  
Ammonium bromide, 138  
— chloride, 138  
— phosphate, 138, 139  
Annual rings, 18, 19, 21, 30, 32  
Anti-pyrene salts, 136, 137, 138, 139  
Apopo, 297  
*Araucaria Cunninghamii*, 268  
Arbitration, 310-315, 461  
— form of award, 315  
Arbitrator, 306, 311, 312  
*Architectural Review, The*, 309  
Argentina, 80  
Asbestos, 134, 139, 140

Asbestos cement, 139  
— paper, 140  
— wood, 140  
Ash, 12, 247  
— burr, 368  
—, silver, 186, 279  
Assembling, 73-75, 124  
Associations, 305  
*Aucoumea klaineana*, 265, 266  
Australia, 14, 93, 103, 184-187, 261, 401, 458  
*Australian Timber Journal*, 186, 309  
Austria, 199, 274, 458  
Automatic clipper, 49-51, 195  
Autumn-wood, 18, 428  
Avodiré, 79, 87, 115, 285

## B

BACK, 439  
“Backing-out,” 433  
Bacteria, 86, 88, 90  
Baekeland, Dr., 83  
Bahia, 277  
Bakelite, 83, 141  
Baltic States, 48, 71, 241, 253  
Balustrades, 377, 432  
Banding, 439  
Bark, 18, 36, 439  
Barking-lathe, 180  
Barrels, 12, 353, 378, 415, 416  
Baskets, veneer fruit, 12, 418  
Basswood, 197, 222, 276  
Bath Cabinet Makers Co. Ltd., 360, 364, 366, 376  
Battenboard, 10, 11, 117, 125, 439  
B.C. Plywoods Ltd., 83, 197, 421  
Bedsteads, 364, 365  
Beech, 12, 14, 17, 21, 35, 94, 109, 198, 249, 273, 274  
Beeswax, 75  
“Beetle” cement W., 88, 90  
Belgium, 219-221, 247, 260, 263, 275, 458  
Bending, resistance to, 28

Betula, 281, 300  
 — *alba*, 252, 253  
 — *lutea*, 250, 281  
 — *odorata*, 201, 251  
 — *verrucosa*, 201, 251  
 Bill of Lading, 325  
 — —, indemnity in lieu of, 326  
 — of Sight, 326  
 Birch, 14, 19, 35, 48, 70, 71, 94, 109, 119,  
 125, 150, 155, 156, 160, 189, 241, 273,  
 274, 303, 401, 405, 407, 411, 412, 427,  
 445  
 —, Canadian, 195, 197, 241, 250, 281, 404  
 —, curly, 281  
 —, Finnish, 10, 44, 46, 158, 163, 201-207,  
 251, 373, 414  
 — flame, 281, 350  
 —, Masur, 30, 126, 280, 281, 361  
 —, Russian, 155, 234, 235, 236, 237, 252,  
 414  
 Bisco laminated board, 118, 192  
 Black Bean, 283, 339  
 Bleaching plywood, 428  
 Blister figure, 439  
 Blisters, 113, 114, 427  
 Blockboard, 10, 11, 55, 94, 107, 109, 110,  
 117, 118, 122-124, 143, 167, 170, 174,  
 190, 199, 206, 214, 215, 216, 231, 240,  
 271, 273, 274, 366, 367, 371, 372, 393,  
 401, 402, 403, 439, 445, 450  
 Board of Trade, 135; also Acknowledg-  
 ment page  
 Boat-building, 84, 394-397, 399  
 Bobbins, 10, 198, 249, 418  
 Bois zébre, 299  
 Bole, 16, 440  
 "Book-matched," 354, 356, 357  
 Borax, 80, 138  
 Boric acid, 138  
 Borneo, British, 14, 259  
 Bossé, 278  
 Boxes, 52, 410-415  
 —, cigar, 70, 219, 220  
 —, decorative, 414, 415  
 British Columbia, 93, 194, 195, 258  
 — Malaya, 456  
 — Standard specification, 88, 161, 404  
 — Standards Institution, 8, 153  
 Bronze, 146, 147  
 Bubinga, 360  
 Built-in fitments, 348, 374-377, 393  
 "Built-up" plywood, 355

Bulgaria, 199, 458  
 Bulkheads, 134, 141, 209, 385-389, 390  
 Bundles, crates, 163, 164, 165, 169  
 Burkle, Messrs. D., & Son Ltd., 126, 339  
 Burl or burr, 5, 12, 16, 35, 41, 65, 81, 288,  
 361, 364, 440

## C

*Cabinet-maker and Upholsterer's Drawing-  
 Book*, 3  
*Cabinet-maker (The)*, 309  
 Cabinet-makers, 5, 117, 118  
 Cabinet-making, 365  
 Cabinets, radio and gramophone, 370, 430,  
 434  
 California, 182  
 Cambium, 18  
 Canada, 14, 194-197, 241, 275, 276, 281,  
 291, 457  
 Canadian, 155, 165, 258  
 Caravans, 408, 409  
 Carboic acid (phenol), 84  
*Cardwellia sublimis*, 261  
 Case-hardening, 58, 61  
 Casein, 53, 77, 79-81, 84, 97, 101, 104, 106,  
 143, 145, 185  
 Cases, whisky, 410, 411, 413, 414  
*Castanospermum Australe*, 283  
 Catalin Ltd., 87  
 Catalyst, 86, 87, 88  
 "Cathedral matching," 357  
 Cauls, 73, 74, 75, 120, 123, 129, 132, 440  
 —, aluminium, 75, 124  
 —, metal, 73, 75, 102  
 —, wood, 73, 75, 120  
 —, zinc, 75, 124, 129  
 Caustic soda, 90  
 Cedar, Western Red, 196, 254, 371  
 Ceilings, 381, 391, 392, 437  
 Cements, 77, 145  
 "Centre-ply" construction, 274  
*Ceratopetalum apetalum*, 279  
 Check, 440  
 Checks, cutting, 35, 40, 45  
 Chemical laboratories, 182  
 Chestnut, 125  
 Chests, tea, 5, 6, 189, 204, 205, 236, 412,  
 413, 457  
 —, rubber, 189, 204, 205, 412, 413, 457  
 Chippendale, Thomas, 1  
*Chlorophora excelsa*, 277

*Chloroxylon swietenia*, 295  
 Claims, 310, 460  
 Clamp carrier, 125  
 Clamps, hand, 93, 94  
 —, retaining, 95, 120, 440  
 Clippers, 47, 48, 440  
 Coachwood, 186, 279  
 Coe Manufacturing Company, 45, 59, 60,  
 Cohesion, 76  
 Colloidal solution, 88  
 Columbian pine; *see* Douglas Fir  
 Composite boards, 10, 15, 139-141  
 Compressed cork, 141  
 Compressed wood, 149-151, 241, 406  
 Compression, 27, 43, 45, 144, 151  
 Concrete shuttering, 257, 423-426  
 Conifers, 17  
 Coniferous woods, 90  
 Constructional details, 430-438  
 Containers, cylindrical, 378, 416  
 Contract, form of, 306, 310, 459-461  
*Contreplaqué*, 9  
 Conveyor, 47, 440  
 Conveyors, belt, 180, 181  
 Copper, 146, 147  
 Cores—core stock, 3, 43, 45, 48, 57, 61, 67,  
 74, 79, 105, 113, 117, 118, 119-124,  
 131, 177, 272, 273, 274, 440  
 Corner treatment, 430, 431, 434, 435  
 Costs, manufacturing, 84, 227, 304  
 Cottonwood, 182, 275  
 Craft, light, 134, 394-397, 399  
 Crayford, 136  
 Cross-banding, 3, 67, 74, 113, 117, 125,  
 177, 440  
 Cross-grained construction, 29, 69, 265, 404  
 Crotch, 5, 12, 16, 35, 41, 65, 287, 291, 294,  
 440  
 Cubic metre, 304, 452, 454, 455  
 Curl, 16, 38, 81, 286, 287, 360, 440  
 Curved work, 148, 341, 344, 351, 353, 434,  
 435  
 Customs entries, passing of, 325, 326, 327  
 Cut sizes, 157, 205, 271, 318  
 Cutter-blocks or heads, 65, 69, 70  
 Czecho-Slovakia, 14, 200, 249, 273, 274,  
 458

## D

DAGENHAM, New Town Hall, 350, 352  
 Daugava, river, 189

Decay, 30, 441  
 Defect, 441  
 Defects, manufacturing, 113-116  
 Denmark, 233, 458  
 Diagonal plywood, 404, 405  
 Distance pieces, 122, 123  
 Doors, cupboard, 372, 437  
 —, flush, 174, 198, 245, 249, 256, 348, 370-  
 372, 390, 438  
 —, sliding, 372, 429, 437  
 Douglas Fir, 14, 24, 31, 35, 36, 47, 48, 51,  
 62, 71, 82, 89, 90, 94, 95, 109, 115, 137,  
 153, 155, 157, 158, 165, 176, 178-183,  
 194, 195, 217, 239, 241, 255-258, 373,  
 374, 378, 381, 385, 389, 392, 393, 395,  
 401, 402, 423, 428, 436, 446, 447, 448,  
 449, 450  
 — — Plywood Association, 154, 182, 374,  
 422, 429, 448, 449  
 Douka, 277  
 Drawback of duty, 327, 328  
 Drawer bottoms, 369  
 "Drawn across," 356, 357  
 Drier, breather, 57, 58  
 —, channel, 55, 56, 106, 123  
 —, conveyor, 59, 61  
 —, platen, 57, 58  
 —, proctor, 59, 61  
 —, progressive kiln, 55, 181  
 —, roller, 59, 61  
 Dry-cementing process, 52, 116, 227  
 Drying kiln, 122, 123  
 Dues, dock, 325

## E

EBONY, 20, 38  
 — Macassar, 317  
 Egypt, 174  
 Egyptians, 38, 79, 93  
 Eindhoven, 70, 219  
 Eipen (elm), 219  
 Electrical industry, 151  
 Electricity, resistance to, 25  
 Els, red, 174  
 —, wit, 174  
 Enamel, 147, 427  
*Endiandra Palmerstoni*, 270  
 England, *see* United Kingdom  
*Entandophragma cylindricum*, 289  
 "Epines," 155, 266  
 Equalizing, 107  
 Estonia, 14, 155, 188, 189, 253, 456, 457

*Eucalyptus saligna*, 174  
Exhibition stalls, 139  
Exterior work, 419-423

## F

*Faces and Figures*, 177  
*Fagara* spp., 278  
*Fagus sylvatica*, 249  
Fibre boards, 27, 144  
— saturation point, 22, 24, 25  
Fielded panels, 284, 335, 341, 432  
Figure, 441  
—, fiddleback, 34  
Film producers, 134  
— settings, 382, 383  
Finland, 14, 47, 48, 71, 72, 101, 117, 119,  
155, 156, 201-208, 241, 251, 262, 263,  
273, 274, 281, 456, 457  
Fir, 117, 118, 122, 192, 231  
Fireproofing processes, 134-139  
Fire-resistant paints, 135, 138, 139  
"Firply," 183  
Flecks, 427, 441  
Flexible panels, 141  
*Flindersia brayleyana*, 291  
— *pimenteliana*, 291  
— *pubescens*, 279  
— *schottiana*, 279  
Flich, 24, 32, 36, 38, 40, 41, 47  
Floors, 283, 377, 379, 381, 393, 408, 409  
Forest Products Institute, Pretoria, 175  
— — Laboratory, Madison, 35, 87  
— — —, Princes Risborough, 447, 450  
Formaldehyde, 67, 84, 90  
Formica, 141  
France, 14, 40, 80, 129, 151, 209-213, 260,  
263, 266, 457  
*Fraxinus excelsior*, 247  
— *mandschurica*, 248  
Free moisture, 22, 24  
French West Africa, 173, 209, 212, 277  
Fruit baskets, 12, 43  
Fungus, 86, 90  
Furniture manufacture, 363

## G

GABOON Mahogany; see Okoumé  
Gantry, overhead, 168

Gaps, 69, 74, 113, 114, 441  
Gas-proof plywood, 141  
Gel, 77  
German—Germany, 14, 83, 88, 100, 117,  
214-218, 241, 260, 263, 265, 272, 274,  
456, 457  
Glue-spreaders, 73, 79, 81, 86, 88, 90, 91, 92,  
124  
— stains, 115  
Glues and cements, 77  
Glues, animal or hide, 65, 67, 77, 78, 79,  
92, 96, 104, 107, 115  
—, blood albumin, 53, 77, 81, 84, 96, 104  
—, soya bean, 81, 82, 181, 185, 224  
—, vegetable, 77  
Grading, 153-157, 255  
Grain, 441  
Greywood, 295  
—, Indian silver, 282, 283, 358  
*Guarea cedrata*, 278  
— *Thompsonii*, 278  
Guild of Carpenters of London, 333  
Guillotine, 47, 48, 51, 58, 68, 70  
Gum, 125  
Gums, wood, 136

## H

HALF-QUARTERED panels, 342, 356, 359  
Half-round cutter, 12, 13, 47, 441  
Hardener, 88, 91  
Hardwood, 441  
Harewood, 6, 295  
Heartwood, 20, 180  
Hemlock, Western, 196, 276  
—, West Coast, 182  
High-frequency currents, 103  
Holland, 14, 70, 80, 219-221, 262, 263, 265,  
272, 274, 275, 302, 458  
Humidity, 22, 26, 28, 29, 54, 56, 57, 429  
Hungary, 200, 249, 263, 274, 458  
Hygrometer, 56  
Hygroscopic moisture, 22, 24

## I

IBUS laminated board, 118  
Imperial Chemical Industries, 136  
Import duties, 175, 184, 187, 212, 218, 221,  
242  
Importers, plywood, 303, 304, 462

Importers' terms of sale, 306, 462  
 Improved wood, 149-151, 241, 406  
 Inspectors, 62, 181  
*Interessengemeinschaft Deutscher Sperrholz-fabriken*, 155, 157, 216  
 Intumescence, 138, 139  
 Iouya and Touya, 1  
 Iroko, 277  
 Ironwood, 174  
 Italy, 221, 458  
 Ivory Coast, 277, 278, 285, 287, 296

## J

JAPAN, 14, 93, 165, 222-224, 248, 259, 264, 276, 456, 457  
 Japanese Plywood Exporters' Association, 223  
 Joinery, general, 370-381  
 —, stage and studio, 383  
 Joints, open, 442  
*Juglans nigra*, 297  
 — *regia*, 296  
 Jugoslavia, 199, 249, 458

## K

KAMBALA, 277  
 Keizer, L., & Co. Ltd., 142, 168, 170  
 Kejaat, 174  
 Kerf, 442  
 Kerosene, 75  
*Khaya ivorensis*, 287  
 Kiln trucks, 90  
 Knots, 43, 44, 442  
 Kümmel, Richard, 118

## L

LACEWOOD, 261  
 Laminboard, 10, 11, 56, 65, 69, 94, 99, 107, 109, 110, 116, 117-122, 124, 135, 143, 170, 174, 190, 216, 220, 271, 272, 273, 337, 341, 343, 359, 360, 364, 365, 367, 372, 401, 442, 445, 447, 448  
 Latex, 145  
 Lathe, veneer; *see* Rotary-cutter  
 Latvia, 14, 119, 155, 156, 158, 161, 163, 189-191, 193, 245, 246, 253, 262, 263, 269, 456, 457  
 Lauan, 14, 174, 211, 223, 259

Laurel, Indian, 284, 285  
 "Layer-up," 73, 74  
 Lead, 141  
 Light craft, 134, 394-397, 399  
 Lignin, 18  
 Limba, 260, 272  
 Lime, 198  
 Lithuania, 14, 189, 191, 245, 272, 274, 457  
 Log yard, 35, 442  
 Loose side, 444; *see also* Veneer  
*Lovoa klaineana*, 297  
 Lumber core boards, 1, 117, 125, 176, 177  
 Luther, Mr. Christian, 79, 93, 188  
 Lyford-Pike, Mr., 135

## M

M'INTOSH, Messrs. A. H., & Co. LTD., 316, 322, 362  
 Magnesium borate, 138  
 — chloride, 138  
 Mahogany, 3, 12, 21, 34, 80, 81, 117, 118, 153, 360  
 —, African, 287  
 —, cherry, 289  
 —, sapele, 21, 210, 289  
 Makoré, 277, 286, 288, 289  
 Manchuria, 248, 458  
 "Manufacture damp," 106, 116, 442, 461  
 Maple, 12, 21, 79, 115, 125, 291, 361  
 —, bird's eye, 30, 291, 439  
 —, blistered, 291  
 —, Queensland, 290, 291  
 —, quilted, 291  
 Market Bosworth, 136  
 Marketing plywood, 317-319, 321  
 Marquetry picture, 152, 322  
 Mastic, 122  
 Matching, 5, 41, 356, 357, 442  
*Mauritania*, 141  
 Mechanical loader, 102  
 — properties, 447  
 Medullary rays, 17, 24, 32  
 Memel, 191, 192  
 Merchants, plywood, 304, 316, 318  
 Mersey Docks and Harbour Board, 9  
 Meta-cresylic-acid, 90  
 Metal-faced plywood, 141, 144-148, 240, 394, 403, 406, 407, 408, 418, 446  
 Metal forms, 127, 129  
 Metal mouldings, 345, 346, 347

Metropolitan Museum, New York, 2  
 Micarta, 141  
*Mimusops* spp., 277, 289  
 Mirror backs, 369, 437  
*Mitragyne stipulosa*, 277  
 Modulus of elasticity, 447  
 Moisture content, 22, 25, 26, 54, 55, 56, 86,  
 90, 91, 104, 105, 106, 110, 116, 119,  
 122, 123, 124, 125, 158, 167, 182, 349,  
 359, 442  
 Monel metal, 146  
 Morris, H., & Co. Ltd., 72, 298, 316,  
 342  
 Motor-boats, 394-397  
 Motor-cars, 406, 407  
 Mould, 88, 90  
 Moulded plywood, 127, 130, 133, 362, 367  
 Moulds, 127, 128, 133, 134  
 Multi-ply, 9, 15, 63, 443; *see also* Plywood

## N

NEW BRITAIN, 186  
 — Guinea, 186  
 — South Wales, 279  
 — Zealand, 80, 187, 267  
 Niemen, river, 192  
 Nigeria, 277, 278, 287, 296  
 Norway, 14, 15, 155, 229, 230, 266, 269,  
 458  
 "Nose-bar," 42  
 Notice-boards, 437

## O

OAK, 12, 14, 17, 18, 21, 33, 35, 41, 67, 80,  
 81, 115, 117, 153, 219, 220, 235, 262,  
 263, 292, 293, 335, 338, 342, 346, 354  
 —, Australian silky, 14, 186, 261  
 —, brown, 293  
 —, combed, 293  
 —, *faux quartier*, 34  
 —, Hokkaido, 222  
 —, Japanese, 184, 222, 223, 264  
 —, pollard, 292, 293  
 —, quarter-cut, 32, 33, 34, 38, 39, 354  
 —, red tulip, 279  
 —, Slavonian, 199, 262, 292  
 —, Volhynian, 263, 292  
 Obechi, 278  
 "Oceana" moulded panels, 129, 130, 133,  
 210

Okoumé, 14, 25, 35, 45, 49, 58, 94, 106,  
 109, 111, 115, 117, 118, 119, 155, 159,  
 160, 174, 209, 210, 219, 229, 239, 240,  
 242, 265, 266, 271-274, 302, 340, 350,  
 359, 387, 389, 403, 427, 445, 447, 450  
 Olon, 278  
 Omnibuses, 403, 404  
 Opepe, 277  
 Oregon and Washington (States of), 153,  
 178, 241, 254, 256  
 Oregon Pine; *see* Douglas Fir  
 Oriental wood, 270  
 Outer plies, 72, 125  
 Overlaps, 69, 113, 442  
 Oxholm, Mr. Axel H., 183  
 "Oxylene" process, 138

## P

PACIFIC COAST OF AMERICA, 47, 72, 82,  
 90, 93, 94, 178-183, 239, 241  
 — Forest industries, 89, 153, 157, 164, 165,  
 183, 378, 405  
 Packing, 163-165  
 Paint, 54, 427, 428, 429  
 Panelling, 334-353  
 —, erection of, 349, 350  
 Paraffin wax, 75  
 Parenchyma cells, 17, 19  
 Parnall, Messrs. George, & Co. Ltd.,  
 368  
 Partitions, 373, 435  
 Patapsco, 291  
 Patches, 442  
 Patching, 61, 70, 71, 112, 182  
 Payment, 303  
 Pearwood, 278  
 "Peeler" logs, 179, 442  
 Period panelling, 338, 339  
 Philippines, 14, 223  
 Phosphoric acid, 138, 139  
*Picea excelsa*, 269  
 Pickering, Messrs. Walter, & Son, 348  
 Picus, 70, 219, 220  
 Pine, 14, 18, 30, 35, 105, 117, 118, 122, 155,  
 192, 215, 216, 269, 272, 273, 274  
 —, Californian yellow, or Western, 30,  
 182, 276  
 —, hoop, 14, 184, 185, 186, 268  
 —, Kauri, 186, 187, 267  
 —, Norwegian, 269

- Pine, Queensland, 268  
 —, Swedish, 108, 155, 269  
 —, Western white, 196  
*Pinus Monticola*, 196, 276  
 — *ponderosa*, 276  
   *sylvestris*, 269  
 Piston pumps, 96, 98, 100  
 Pistons, 96  
 Planing machine, 122  
*Plastics*, 309  
 Platform-truck, 124  
 Pliny, the younger, 3  
 Plugging, 70, 71, 109, 112, 206  
 Plymax, 145, 148, 446  
 Plywood, aircraft, 75, 404, 405, 445  
 —, construction of, 28, 29  
 —, deflection of, 447, 448, 449  
 — Development Association, 306, 307  
 —, expansion of, 30  
 — Importers' Sale Note, 462  
 —, jointed, 206, 244-270  
 —, jointing of, 341, 342, 344, 345, 346, 347, 387, 433  
 — manufacturers, 25, 173  
 —, nail-holding properties, 29, 450  
 —, rigidity of, 447, 448, 449  
 — Sales Association, 307  
 —, shrinkage of, 28, 29, 30  
 —, strength of, 28, 30  
 —, tenacity of screws in, 450  
 —, treatment of, 427-429  
 —, weight of, 445, 446  
 Poland, 14, 47, 48, 53, 54, 71, 156, 163, 189, 225-228, 241, 245, 246, 247, 253, 262, 263, 269, 272, 273, 456, 457  
 Pollarding, 21  
 Polling, 21  
 Poplar, 117, 125, 131, 150, 209, 219, 220, 274, 275  
 —, black, 117, 118  
*Populus canescens*, 275  
 — *deltoides*, 275  
 — *tremuloides*, 275  
 Port of London Authority, P.L.A., 163, 327  
 Poultry houses, 423  
 Pre-fabricated buildings, 420, 423  
 Press, cold hydraulic, 75, 82, 91, 93, 94, 95, 106, 120, 181  
 — daylight, 98, 101, 102  
 —, hand, 93, 94  
 —, hot hydraulic, 81, 84, 85, 86, 88, 90, 94, 96-105, 106, 124, 133, 176, 177, 181, 185  
 —, moulding, 132  
 —, platens of, 97, 98, 99, 100, 102, 105  
 —, rams, 96, 98, 100  
 —, ratchet, 127  
 Presses and pressing, 93-105  
 Pressmarks, 114  
 Press-table, 98, 99  
 Pressure bar, 41, 43, 45  
 —, barometric, 129, 130  
 Price scale, 244  
 Pripet, river, 225  
 Production manager, 73  
*Pseudotsuga taxifolia*, 178, 256, 257, 258  
 Punch, 71  
 Pyrometer, 101, 105
- Q
- QUARTER CUT, 32  
 Quartered, 443  
 — panels, 4, 356, 358, 359  
*Queen Elizabeth*, 141, 359, 385, 389  
*Queen Mary*, R.M.S., 8, 141, 292, 359, 386, 389  
 Queensland, 185, 261, 267, 268, 279, 283, 291  
 — Forest Service, 185, 279  
*Quercus spp.*, 262, 263, 264, 292  
 Quibell, late Mr., 1
- R
- RACKS, storage, 170  
 Radiator covers, 366, 377  
 Railway containers, 402, 403  
 Railways, 401-403  
 Reactive stage, 84, 85  
 Re-drying, plywood, 56, 106, 116, 123, 125  
 Redwood, Californian, 182  
 Reels, cable, 418  
 Rehfelde, 118  
 Resin, 35  
 Resin-bonded plywood, 255, 318, 392, 394, 401, 403, 407, 408, 419  
 Resin (synthetic) adhesives, 30, 82-91, 97, 101, 103, 127, 133, 134, 141, 176, 177  
 — — —, "Catabond," 87  
 — — —, "Kaurit," 86  
 — — —, "Lauxite," 90  
 — — —, "Tego" film, 86, 249



- Resin, cresylic, 149  
 — emulsion, 88  
 — laminated veneer sheets, 141, 143  
 —, phenol-formaldehyde (phenolic), 77, 83, 84, 85, 86, 90, 105, 136, 149, 150  
 — synthetic, cure of, 84, 105  
 —, —, film, 77, 83, 85, 86, 91, 104, 105, 141, 149  
 —, —, hardening of, 84  
 —, —, varnish, 85, 86, 87, 91, 104, 141  
 —, urea, 77, 84, 88, 90, 105  
 Resins, thermo-hardening, 84  
 —, thermo-plastic, 84, 133  
 "Resitol" stage, 84, 85  
 "Resweld Firply," 183, 282  
 Resweld plywood, 85, 393, 408, 421, 425  
 Retaining boards, 75, 443  
 — clamps, 96, 120  
 Reval, 5, 79, 93, 188, 253  
 Riehle testing machine, 87, 159  
 Riesener, Jean Henry, 1, 3  
 Riga, 189, 253  
 Roots, 12  
 Rotary-cutter, 5, 12, 13, 14, 30, 36, 41, 43, 46, 47, 116, 180, 181  
 — pumps, 96, 100, 101  
 — veneer core, 177  
 Rough cutting, 116  
 Roumania, 14, 198, 199, 249, 274, 275, 458  
 Router, 71, 430  
 Royal Architect (Egypt), 38  
 Russell, Messrs. Gordon, Ltd., 308, 319, 427  
 Russia; see U.S.S.R.  
 Rutherford, Mr. Henry, 93  
 Rye flour, 87, 88, 90
- S
- SADD, Messrs. John, & Sons Ltd., 350, 352  
 St. Andrew's House, Edinburgh, 282, 340  
 Sakkara, step pyramid of, 1  
 Salesmen and salesmanship, 323, 324  
 Sand-blasting, 381, 428, 437  
 Sander, 106, 109, 110  
 — belt, 110, 111  
 — drum, 109, 110, 181  
 Sanding, 116  
 —, defects, 116
- Sapele, 210, 289  
 Sapwood, 20, 180, 443  
*Sarcocephalus diderrichii*, 277  
 Satinay, Queensland, 186, 279  
 Satinée, 386  
 Satinwood, 38, 295  
 Saw, 32, 38, 148  
 —, double cut-off, 107  
 —, drag, 36, 37, 180  
 —, frame, 122  
 — kerfing, 353, 434  
 —, pit, 5, 38  
 —, portable, 36, 37  
 — segment, 38  
 —, veneer, 39  
 Sawing, 13, 38  
 Saws, barrel, 71  
 —, equalizing, 107, 109  
 —, parallel, 107  
 Scarf joint, 69, 399  
 Scenery, stage, 380  
 Schaumans Fanerfabrik A/B, 201  
 Scaper, 107, 109, 110, 111, 112  
 —, hand, 107  
 —, knife stock or carrier, 111  
 Scraping, 116, 359  
 Seasoning, 24  
 Semi-dry glued, 52, 246  
 Sen, 14, 223, 248  
 Serayah, 14, 259  
 Settee-ends, 438  
 Shapland & Petter Ltd., 360  
 Shear, 27, 28, 30  
 — plate, 49  
 — test, 87, 159, 160, 161  
 "Shell" (grain), 39  
 Sheraton, Thomas, 1, 3, 117  
 Shina, 276  
 Shipbuilding, 134, 209, 215, 241, 256, 260, 265, 385-393  
 Shipping documents, handling of, 325  
 Ship's side-lining, 388, 390, 391, 429  
 Shopfitting, 147, 260, 369, 370  
*Shorea spp.*, 259  
 Side-matched, 354, 356, 357  
 Signs, outdoor, 83  
 Silkwood, maple, 291  
 "Skids," 106  
 Skirtings, 345, 347  
 Slicer, veneer, 41  
 —, horizontal veneer, 13, 40  
 —, vertical veneer, 13, 40, 185

Sodium silicate, 80, 139  
 Softwood, 443  
 Solomon Islands, 186  
 Spain, 15, 239, 266, 458  
 Spanish Guinea, 173  
 Speed-boats, 134  
*Sperrholz*, 9  
 Split, close, 115, 444  
 —, open, 115  
 Splits, 115, 182  
 Splitting, 29, 30  
 Spreader, glue-, 74, 79, 81, 86, 91, 92  
 Springwood, 18, 428  
 Spruce, 14, 30, 231, 269, 272, 273, 274  
 Spur-knife, 42  
 Stain, 444  
 Stairways, 377  
 —, half-way landings, 393  
 Stay-log, 12, 13, 16, 47  
 Steaming vats or pits, 35, 36  
 Steel, galvanized, 144, 145, 146, 147, 446  
 —, stainless, 146  
 Stinkwood, 174  
 Storing plywood, 167-170  
 — veneers, 171, 172  
 "Straight-line" production, 181  
 Strip boards, 125, 273  
 Stump, 12, 16, 35, 444  
 Surfacer, 122, 125  
 Sweden, 14, 231, 232, 269, 281, 456, 457  
*Swietenia macrophylla*, 287  
 Switzerland, 14, 239, 260, 272, 274, 458  
 Sycamore, 19, 20, 21, 34, 38, 79, 294, 295,  
 368  
 —, weathered, 295  
*Syncarpia Hillii*, 279

## T

TABLES, conversion, 451, 452, 453, 454, 455  
 Tacoma, Washington, 182, 183  
 Tamo, 223, 248  
 Tannic acid, 80  
 Tape, gummed, 65, 66  
 —, perforated, 66, 67  
 Tapeless jointer or splicer, 65, 67, 68, 69  
 Tapes, removal of, 106, 107  
 Taping machines, 65-67  
*Tarrietia argyrodendron*, 279  
 Tea Chest Buyers' Association, 308  
 Teak, 142, 153, 298, 299  
 "Tempering" process, 90, 106

Tensile strength, 151, 161, 162  
 Tension, 27, 29, 45, 144  
*Terminalia bialata*, 283  
 — *superba*, 260  
 — *tomentosa*, 285  
 Termites, 88  
 Testing, 158-162  
 — machines, Avery, 159  
 — —, Riehle, 87, 159  
 Textile mills, 151  
 "The Timberman," 103, 309  
*The Times*, 1, 307  
 Theatrical producers, 134  
 Thebes, sculpture of, 38  
*Thuja plicata*, 254  
 "Tie" rods, 95  
 Tight side, 444; *see also* Veneer  
*Tilia cordata*, 275  
 — *glabra*, 276  
 Timber and plywood, 309  
 Timber Trade Federation, Plywood section, 305  
 — — — of the U.K., 116, 153, 305  
*Timber Trades Journal*, 309  
*Tischlerplatten*, 117  
 Tolerances, thickness, 158  
 —, length and width, 159  
 Tooothing knife, 112  
 Tops, bar and table, 141, 143, 147, 367,  
 369, 429, 431  
 —, bench, 369  
 Tracheids, 17  
 "Traffolite," 141  
 Tramway cars, 403, 404  
 Trays, 417  
 Trees, growth of, 19  
 Trier, Mr. O. L., 118  
 Trimming, 48  
*Triplochiton scleroxylon*, 278  
 Trollope & Sons Ltd., 293  
 Trunks, travelling, 415  
*Tsuga heterophylla*, 276  
 "Turned-over," 356, 357  
*Turræanthus africana*, 285  
 Twisting, 116  
 Tyne Plywood Works Ltd., 68, 73, 120,  
 157

## U

"UNDERLAYING," 360, 361  
 Union of South Africa, 174, 175

United Kingdom, 15, 88, 117, 119, 136, 153, 157, 240, 250, 260, 262, 265, 272, 273, 274, 301, 302, 321, 355, 456  
 — —, plywood imports, 457, 458  
 — States of America, 14, 47, 93, 94, 103, 117, 125, 134, 176-183, 256, 257, 275, 401, 457  
 Urea, 84  
 U.S. Department of Commerce, 76, 176, 178  
 — Forest Products Laboratory, Madison, 176, 183, 347, 421  
 — National Bureau of Standards, 255  
 U.S.S.R., 6, 14, 48, 96, 163, 189, 192, 198, 234-238, 241, 245, 246, 247, 252, 456, 457  
 University of Edinburgh, 135

## V

VACUUM veneering process, 127, 129, 131  
 Vans, commercial, 407  
 Varnish, 54, 428  
 Veneer, 3, 5, 6, 7, 8, 28, 29, 55, 57, 61, 65, 67, 71, 72, 74, 106, 110, 113, 115, 116, 120, 125, 127, 129, 130, 134, 150, 155, 171, 172, 177, 188, 195, 196, 199, 200, 204, 205, 211, 214, 240, 256, 355-361  
 Veneer Association, Chicago, 177  
 Veneer buying, 321-323  
 —, decorative, 12, 63, 79, 117, 171, 174, 215, 280-298  
 —, rotary-cut, 6, 12, 13, 30, 41-47, 63, 118, 119, 203, 209, 219, 247, 250, 256, 258, 260, 261, 263, 270, 272-274  
 —, sawn, 12, 13, 38, 222, 283, 287  
 —, sliced, 12, 13, 31, 32, 40, 41, 118, 119, 222, 260, 261, 263, 270  
 — cutters, manufacturers, 12, 16, 21, 38, 39, 47  
 Veneer-core boards, 176  
 — decorative, 280-299  
 —, drying of, 55-59, 61  
 Veneer, face, 43, 67, 74, 79, 177; *see also* decorative  
 — "hammer," 93  
 — jointers, 63-65, 67  
 —, loose-cut, 45, 116, 124  
 —, texture of, 322  
 —, "Tight cut," 41, 42, 45, 357, 444  
 —, quarter-cut, 32

Veneercraft Ltd., 69, 126, 128, 282, 320, 340  
 Veneered plywood, 318, 319, 355, 436  
 Veneering, 355-361  
 — limed boards, 9  
*Veneers and Plywood*, 177, 309, 324  
 — storage room, 61  
 — trimmers, 63, 65  
 Venesta Ltd., 93, 145, 155, 189, 375, 376, 446  
 Victoria and Albert Museum, 4, 6, 330, 332, 334, 336  
 Vinyl esters, 84

## W

WALLBOARDS, 134  
 Walnut, 12, 19, 20, 21, 47, 81, 86, 153, 296, 340, 352, 364  
 —, African, 297  
 —, American black, 131, 297  
 —, Nigerian golden, 297  
 —, Queensland, 14, 21, 186, 270, 348  
 Wardrobes, 369  
 Ware, Isaac, 335  
 Waring & Gillow (1932) Ltd., Messrs., 300, 386, 398  
 Waterproof plywood, 161, 183, 195  
 Wet glueing, 52, 53, 54, 252  
 "Whippage," 43  
 White Russia, 14  
 Whitewood, American, 117  
*Wood*, 149, 202, 309, 338  
 Wood, figure in, 19, 30, 32  
 —, elements of axial, 17, 25, 29, 32  
 —, — radial, 17, 25, 32, 34  
 —, — tangential, 17, 25, 29, 31  
 —, moisture in, 22  
 —, properties of, 27, 28  
 —, shrinkage of, 22, 24, 25  
 —, structure of, 17  
 —, twisting of, 24

## X

X-RAY, 141

## Y

YELLOWWOOD, 174

## Z

ZEBRANO, 126, 299  
 Zinc chloride, 90, 138



DATE OF ISSUE

This book must be returned within 3/7/14 days of its issue. A fine of ONE ANNA per day will be charged if the book is overdue.

---

--	--	--	--	--	--

