

**BIRLA CENTRAL LIBRARY**

PILANI (RAJASTHAN)

Call No. 629.13432

K512 A

Accession No. 32238





THE AEROPLANE  
STRUCTURE

ALSO BY A. C. KERMODE

## MECHANICS OF FLIGHT

"Can be thoroughly recommended."—*Journal of the Royal Aeronautical Society.*

"Clear and readily understandable to the ordinary reader."—*English Mechanic.*

"May be confidently recommended to all students and apprentices, as well as to that larger public who desire to understand this modern form of transport."—*Junior Institution of Engineers.*

247 pp. Illustrated. 7s. 6d. net.

## FLIGHT WITHOUT FORMULAE

"Speaks a language all can understand. In other words, it takes the sigh out of science, and reads as easily as a thriller. We particularly commend it."—*Aeroplane.*

"This book is thoroughly good. . . . Can be recommended."—*Flight.*

240 pp. Illustrated. 6s. net

PITMAN





STUDY OF A GULL BANKING STEEPLY, SHOWING THE STRUCTURE OF  
THE WINGS AND TAIL, AND THE RETRACTED UNDERCARRIAGE

(A.64)

(*Frontispiece*)

# THE AEROPLANE STRUCTURE

THE DESIGN AND PURPOSE OF THE  
PARTS OF AN AEROPLANE  
EXPLAINED IN SIMPLE  
LANGUAGE

BY

A. C. KERMODE

B.A., F.R.Ae.S., M.I.Ae.E.

Author of "Méchanics of Flight" and "Flight Without Formulae"



LONDON  
SIR ISAAC PITMAN & SONS, LTD.

1945



*Reprinted 1942*  
*Reprinted 1945*

SIR ISAAC PITMAN & SONS, LTD.  
PITMAN HOUSE, PARKER STREET, KINGSWAY, LONDON, W.C.2  
THE PITMAN PRESS, BATH  
PITMAN HOUSE, LITTLE COLLINS STREET, MELBOURNE  
UNITED BUILDING, RIVER VALLEY ROAD, SINGAPORE  
27 BECKETTS BUILDINGS, PRESIDENT STREET, JOHANNESBURG

ASSOCIATED COMPANIES

PITMAN PUBLISHING CORPORATION  
2 WEST 45TH STREET, NEW YORK  
205 WEST MONROE STREET, CHICAGO  
SIR ISAAC PITMAN & SONS (CANADA), LTD.  
(INCORPORATING THE COMMERCIAL TEXT BOOK COMPANY)  
PITMAN HOUSE, 381-383 CHURCH STREET, TORONTO



THE PAPER AND BINDING OF  
THIS BOOK CONFORM TO THE  
AUTHORIZED ECONOMY STANDARDS

---

MADE IN GREAT BRITAIN AT THE PITMAN PRESS, BATH  
D5-(A.64)

TO  
G



## PREFACE

FOR more than twenty years I have been wanting to write this book—and at last it is done. Once started, such a book should be written quickly, because otherwise the first chapters are out of date before the later ones are written. Unfortunately, however, this book, short and simple as it may seem, has been on the stocks for nearly five years. No speed of writing could have kept pace with aircraft development during that period, and I have been compelled to revise the earlier chapters continually—even now, one hesitates to send it to the publishers lest it should become old-fashioned during the period of printing. However, there is some justification in feeling that recent development has been exceptional and that for some years to come steady progress will be the rule rather than radical change.

My reason for wishing to write this book is quite simple. During all these years I have been in contact with aeroplanes and people who fly aeroplanes and people who look after them. Such people think and talk and argue about aeroplanes from morning until night, and they are, for the most part, anxious to extend their knowledge, whether it be for the purpose of increasing their efficiency, in order to pass examinations, or merely as a matter of interest. For those who have a good knowledge of mathematics and mechanics there is no especial difficulty—many good books are available, and they will be well repaid by reading them. But many others, often through no fault of their own, have never reached that standard of mathematics and mechanics which would enable them to read such books,

and once the chance has been missed at school, it is far from easy to make up for it afterwards. For these I have always had much sympathy, and it is for them that this book has been written. At the same time, I hope that it may appeal to younger ones who at a later stage may well be able to read more advanced books. In short, it is dedicated to all who are interested in aeroplanes but who, for one reason or another, cannot, or will not, read the so-called "highbrow" books.

On the other hand, neither this book nor its companion, *Flight Without Formulae*, are intended to be "popular" books in the usual sense of the word. They have not been written to provide entertainment, amusement, or merely idle interest. They are definite attempts to convey to the reader in simple everyday language the fundamental principles according to which aeroplanes are designed. I have tried—with what success only the reader can judge—to give to the ordinary normal person the same knowledge as is claimed by the expert. No one, after reading this book alone, could possibly design an aeroplane—the book was never intended for that purpose—but what I do hope is that anyone, after reading it, will have a sound knowledge of the sort of problems which confront the designer and of the engineering principles involved in design. With this knowledge at his disposal, his life and work in connection with aeroplanes should have an added interest.

There is nothing original or new in this book, except perhaps in the method of presentation. I freely acknowledge my gratitude to all who have written before me, and to all designers and constructors of aeroplanes who, by their success or failure, have taught us all we know about aeroplanes. Special thanks are due to Mr. P. H. Legg, who has produced the diagrams

which so amply illustrate the text; to many friends for reading through the manuscript and proofs and giving valuable help and suggestions; and to the proprietors of *Flight* and the various aircraft firms who have allowed me to reproduce their photographs. Others, too, have given me assistance, and I take this opportunity of thanking them also.

Finally, to my readers, I hope that if you will take the trouble to read through the following pages you will find therein something at least which will enable you to understand an aeroplane better than you did before. It is for you that I have written, and it is according to your verdict that I shall be satisfied, or not, with the results of my very interesting labours.

A. C. K.

1940.



# CONTENTS

PREFACE . . . . .	7
-------------------	---

## CHAPTER I

GENERAL PRINCIPLES . . . . .	19
------------------------------	----

Introductory—The skeleton—Names of parts—Weight—Strength and safety—External shape—Materials—Covering—Cost—Theory of flight

## CHAPTER II

HOW AN AEROPLANE IS DESIGNED . . . . .	31
--	----

Specification—Weight—Wing area—General lay-out—Stressing—Drawings—Manufacture—Measurement of weight and centre of gravity—Testing—Service—General trend of design—Conclusion

## CHAPTER III

THE LOADS ON THE STRUCTURE . . . . .	49
--------------------------------------	----

Normal horizontal flight—Horizontal flight at varying attitudes—Nose-dive—Turns—Upside-down flight—Landing—Acrobatics

## CHAPTER IV

STRENGTH, WEIGHT, AND SAFETY . . . . .	62
--	----

Safety first—Head resistance—Complication—Weights of component parts—Materials—Factors of safety—Elastic limit, yield point, ultimate strength—Fatigue—The engineering "factor of safety"—Load factor—More load factors—Weak links—Strength tests

## CHAPTER V

FRAMEWORKS . . . . .	102
----------------------	-----

The ideal framework—Deficient, perfect, and redundant frames—The wire-braced frame—Panel bracing—Geodetic construction—Space frames—External and internal loads



## CHAPTER VI

	PAGE
TIES, STRUTS, AND BEAMS . . . . .	130
Tension members—Compression members—Beams— Bending moments—Shear—Longitudinal shear—Resis- tance of a beam to bending and shear—Strength/weight ratio of beams—Deflection of beams	

## CHAPTER VII

THE MAIN-PLANE STRUCTURE . . . . .	160
The four main structural units—Percentage weights— Fabric—Ribs—Main spars—Landing loads—Drag bracing —Conventional and unconventional wing structures	

## CHAPTER VIII

THE FUSELAGE STRUCTURE . . . . .	184
----------------------------------	-----

## CHAPTER IX

THE UNDERCARRIAGE STRUCTURE . . . . .	194
Landing loads—Retractable undercarriages—Types of structure—Types of axle—Tyres and wheels—Brakes— Tail wheel or skid	

## CHAPTER X

THE TAIL UNIT. . . . .	209
------------------------	-----

## CHAPTER XI

THE STRUCTURE IS HANDED OVER TO YOU . . . . .	215
One hundred questions about the aeroplane structure	
INDEX . . . . .	230

# LIST OF ILLUSTRATIONS

FIG.	PAGE
Study of a Gull Banking Steeply . . . . .	<i>Frontispiece</i>
1. A Tie. . . . .	20
2. A Strut . . . . .	20
3. A Beam . . . . .	20
4. A Tie and a Beam . . . . .	21
5. A Strut and a Beam . . . . .	21
6A. Front Elevation: Names of Parts . . . . .	22
6B. Plan View: Names of Parts . . . . .	23
6C. Side Elevation: Names of Parts . . . . .	23
7. Main Plane: Names of Parts . . . . .	24
8A. Fuselage: Names of Parts . . . . .	25
8B. Fuselage with Fairing: Names of Parts . . . . .	25
9. Streamlining . . . . .	26
10. Streamlining . . . . .	43
11. Streamlining . . . . .	51
12. Distribution of Lift . . . . .	51
13. Horizontal Flight at Varying Attitudes . . . . .	53
14. Loads in a Nose-dive . . . . .	55
15. Proportions of the Total Weight . . . . .	65
16. Proportions of Empty Weight . . . . .	69
17. Reduction in Weight of Internal Combustion Engines . . . . .	71
18. Strength and Weight of Various Materials . . . . .	77
19. How the Materials Stretch under Load (within the Elastic Limit) . . . . .	78
20. Stretching a Material . . . . .	81
21. Factors of Safety . . . . .	84
22. Load Factors and Factors of Safety . . . . .	88
23. Load Factors and Factors of Safety . . . . .	103
24. Load Factors and Factors of Safety . . . . .	103
25. Pin Joint and Rigid Joint . . . . .	103
26. Perfect Frames . . . . .	105
27. Deficient Frames . . . . .	106

FIG.		PAGE
28.	Deficient Frames under Load . . . . .	106
29.	Redundant Frames . . . . .	107
30.	Which is the Better Structure? . . . . .	109
31.	Which is the Better Structure? . . . . .	109
32.	Perfect and Redundant Framework . . . . .	111
33.	The Wire-braced Frame . . . . .	112
34.	Another Type of Wire-braced Frame . . . . .	113
35.	Perfect Frame in Three Dimensions—the Tetra- hedron . . . . .	116
36.	Deficient Frame in Three Dimensions . . . . .	116
37.	Perfect Frame . . . . .	116
38.	How the External Loads are Distributed . . . . .	119
39.	How much Load in Each String? . . . . .	122
40.	Strings Inclined at Different Angles . . . . .	123
41.	Effects of Inclination of Undercarriage Struts . . . . .	124
42.	Which is the Best Structure? . . . . .	125
43.	Single-bay Best for Small Machine . . . . .	126
44.	Three-bay Best for Large Machine . . . . .	126
45.	Three Two-bay Biplanes: Which is the Best? . . . . .	127
46.	Struts . . . . .	132
47.	Effect of Bending . . . . .	133
48.	I-section and Box-section . . . . .	134
49.	Strut Sections of Same Cross-sectional Area and Same Weight . . . . .	135
50.	Parallel and Tapered Strut . . . . .	137
51.	Effects of End Fittings on the Bending of Struts . . . . .	138
52.	Loads not Central . . . . .	139
53.	Beams with End Loads . . . . .	141
54.	Simple Cantilever . . . . .	142
55.	Beam with Load in Centre . . . . .	142
56.	Axle Loading . . . . .	142
57.	Cantilever with Distributed Load . . . . .	142
58.	Beam Supported at Both Ends and Carrying Distri- buted Loads . . . . .	142
59.	Beams with Various Types of Loading . . . . .	144
60.	Shear Force . . . . .	146
61.	Shear Force . . . . .	146
62.	Vertical Shear and Horizontal Shear . . . . .	147

## ILLUSTRATIONS

15

FIG.		PAGE
63.	Cantilever Carrying 10 lb. Weight . . . . .	148
64.	Simple Cantilever Designed to Resist Bending and Shear . . . . .	148
65.	Shear Forces Produced by Various Loads . . . . .	150
66.	How the Beam Resists the Bending Moment . . . . .	151
67.	Principles of Corrugation . . . . .	154
68.	How Beams Deflect under Load . . . . .	157
69.	How the Structure Weight is Made Up . . . . .	162
70.	Loading on a Rib . . . . .	167
71.	Spar Sections . . . . .	171
72.	Loading in Biplane and Monoplane Structures . . . . .	173
73.	Drag and Incidence Bracing . . . . .	176
74.	Loads on a Fuselage . . . . .	186
75.	The Trend of Things . . . . .	219

## PLATES

PLATE	PAGE
I. "Clothed" . . . . .	48
II. "Naked" . . . . .	48
III. Fast Bomber . . . . .	48
IV. A Service Float-plane . . . . .	48
V. Single-engined Army Co-operation Monoplane	48
VI. Large Bomber Transport . . . . .	48
VII. Dignity and Impudence . . . . .	48
VIII. Ribs . . . . .	48
IX. Riblets . . . . .	48
X. Testing the Strength of a Rib . . . . .	48
XI. Testing the Strength of a Spar . . . . .	48
XII. Failure of a Flange under Test . . . . .	48
XIII. Failure of a Web under Test . . . . .	48
XIV. Failure of a Spar due to Elastic Instability .	48
XV. The Wright Biplane in Flight, 1903 . . . . .	48
XVI. The Bleriot, 1909 . . . . .	48
XVII. The Bristol "Box Kite," 1910 . . . . .	48
XVIII. Bristol "Scout," 1914 . . . . .	48
XIX. B.E.2c, 1914 . . . . .	48
XX. Avro 504K, 1915 . . . . .	48
XXI. Bristol Monoplane, 1916 . . . . .	49
XXII. S.E.5A, 1917 . . . . .	208
XXIII. The Bristol "Fighter," 1917 . . . . .	208
XXIV. D.H.4, 1917 . . . . .	208
XXV. Handley Page o/400, 1917 . . . . .	208
XXVI. Bristol Triplane, 1918 . . . . .	208
XXVII. Bristol "Bulldog," 1927 . . . . .	208
XXVIIIa. Monospar . . . . .	208
XXVIIIb. Monospar Tail Boom . . . . .	208
XXIX. The Bristol "Blenheim" Bomber . . . . .	208
XXX. Modern Wing Construction . . . . .	208
XXXI. Modern Wing Construction . . . . .	208
XXXII. Geodetic . . . . .	208

PLATE	PAGE
XXXIII. Welded Joints . . . . .	208
XXXIVa. Monocoque Fuselage Construction—Interior	208
XXXIVb. Monocoque Fuselage Construction—Exterior	208
XXXIVc. Nose Portion of Monocoque Fuselage . . . . .	208
XXXV. Riveting the Stressed Skin . . . . .	208
XXXVI. Retractable Undercarriage . . . . .	208
XXXVII. V-type Undercarriage . . . . .	208
XXXVIII. Envoi . . . . .	209



# THE AEROPLANE STRUCTURE

## CHAPTER I

### GENERAL PRINCIPLES

**Introductory.** The word "structure" is derived from a Latin word meaning to "join together" or "build." Each part of a structure has a definite purpose to fulfil as an individual member of that structure, but it can only fulfil that purpose when the members have been joined together and thus the building is completed.

We are all familiar with various structures in their finished form. Bridges, cranes, buildings, ships, aeroplanes—these and many others are common types. In some of these, such as bridges and cranes, we can still see the individual members after the completion of the structure, but most buildings and ships are so disguised by their outer "skins" that only those who have watched the actual process of building are familiar with their internal workings. The ordinary aeroplane does not come exactly under either category, some parts of its structure being exposed to view, others hidden by fabric or metal skin (Plate I); but, fortunately for our purposes, it is easier to strip the skin from an aeroplane than from a ship or building, and that is exactly what we propose to do (Plate II).

**The Skeleton.** And here we are, left with just the skeleton. It looks very complicated, but it is not



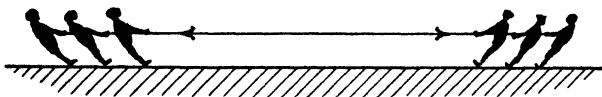

FIG. 1. A TIE

really. It is composed of three different kinds of members—

(1) *Ties* (Fig. 1), i.e. members which are in tension, which tends to make them grow longer.

(2) *Struts* (Fig. 2), i.e. members which are in compression which tends to make them grow shorter.

(3) *Beams* (Fig. 3), i.e. members which carry loads at right angles to their length; these loads tend to bend them.

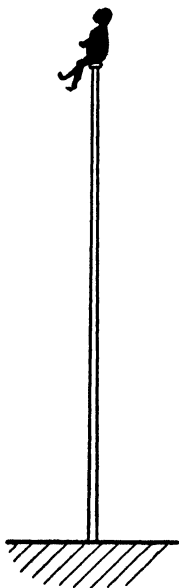

FIG. 2. A STRUT

Unfortunately it is not possible to classify all the members exactly under these three headings. In the first place, some of them may act as ties under some conditions, as, for instance, when the aeroplane is in normal flight, and as struts under other conditions, as when the aeroplane is resting on the ground. Some of the members may even serve two purposes *at the same time*, e.g. a member can act as both a

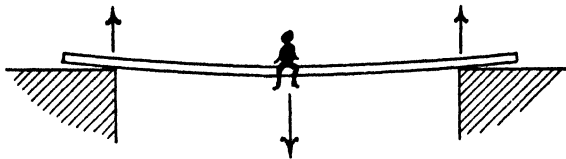

FIG. 3. A BEAM

tie and a beam (Fig. 4), or as a strut and a beam (Fig. 5). It might seem absurd to suggest that a

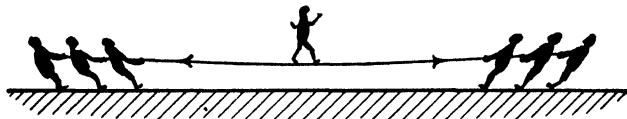

FIG. 4. A TIE AND A BEAM

member can be both a strut and a tie at the same time, but it is not really so ridiculous because the member may be in compression due to one kind of

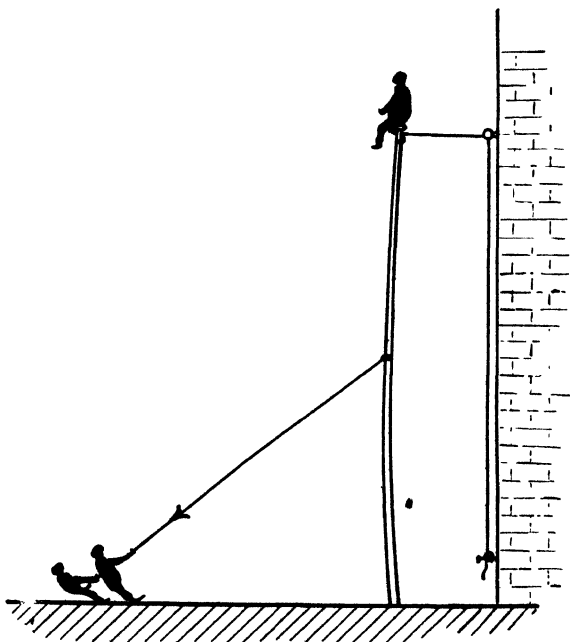

FIG. 5. A STRUT AND A BEAM

load and in tension due to another kind. Of course, the net result will be that the tension and compression will tend to neutralize each other and only one or the other will be left, but it is easier to consider the two conditions separately.

**The Names of Parts.** We cannot describe details of the structure until we have assigned names to the various members. This in itself is quite a big task, partly because of the large number of members, and

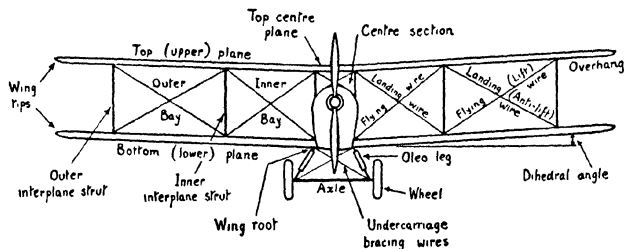

FIG. 6A. FRONT ELEVATION: NAMES OF PARTS

partly because there are, in many instances, alternative names. There is considerable divergence between British and American nomenclature, and even in this country the same part may be given different names according to the point of view of the person concerned; for instance, most practical workers on aeroplanes call a landing wire a *landing* wire, but the official glossary of terms calls it an *anti-lift* wire. However, what's in a name? The accompanying diagrams of the skeleton structure (Figs. 6, 7, and 8) show the names which will be used throughout this book (alternatives are shown in brackets). Only the principal parts are named at present, other names will be given as required.

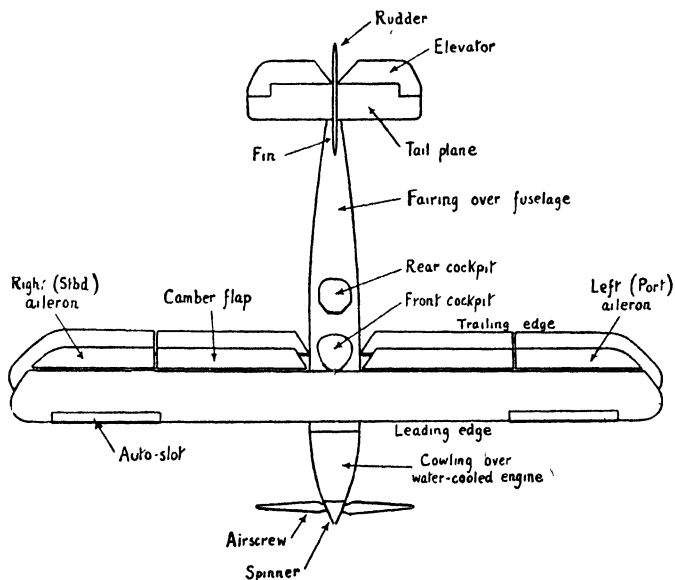

FIG. 6B. PLAN VIEW: NAMES OF PARTS

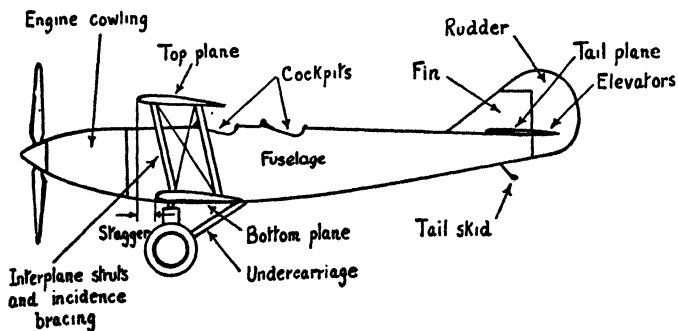

FIG. 6C. SIDE ELEVATION: NAMES OF PARTS

**Weight.** In nearly all modern engineering an attempt is made to reduce weight. Whether it be bridges, buildings, motor-cars, or even the female figure, the tendency is the same. But it is only in the construction of an aeroplane that this question of the reduction of weight assumes primary importance. Every unnecessary pound added to the weight of an aeroplane not only tends to spoil the performance, but it means so

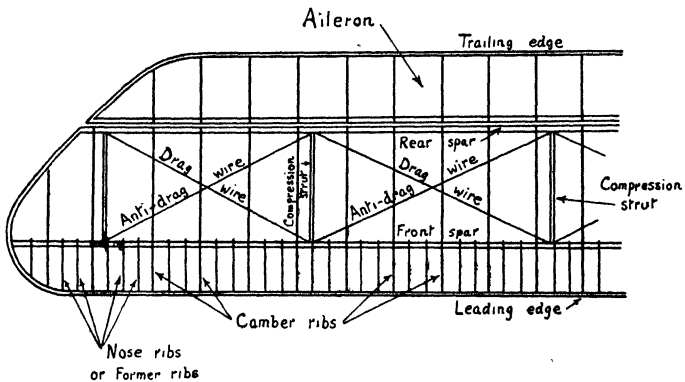

FIG. 7. MAIN PLANE: NAMES OF PARTS

much extra weight for the various parts to carry. This means that these parts must be made stronger so as to be capable of carrying the extra weight, and in order to make them stronger they must be larger and therefore heavier. Here is a vicious circle, if you like. It means, in effect, that if we add a pound to the weight of an aeroplane we must add more than a pound—and, of course, since we add more than a pound we must, by the same argument, add more than more than a pound—and, by the same argument—but that is enough! It may sound nonsense—but it is not; it is the truth.

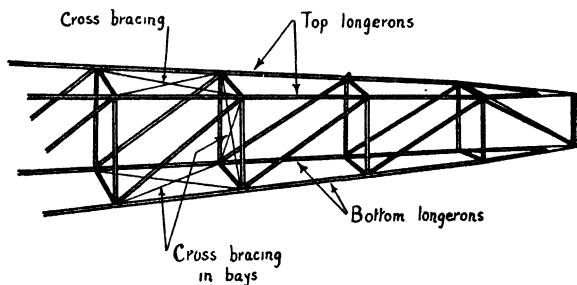

FIG. 8A. FUSELAGE: NAMES OF PARTS

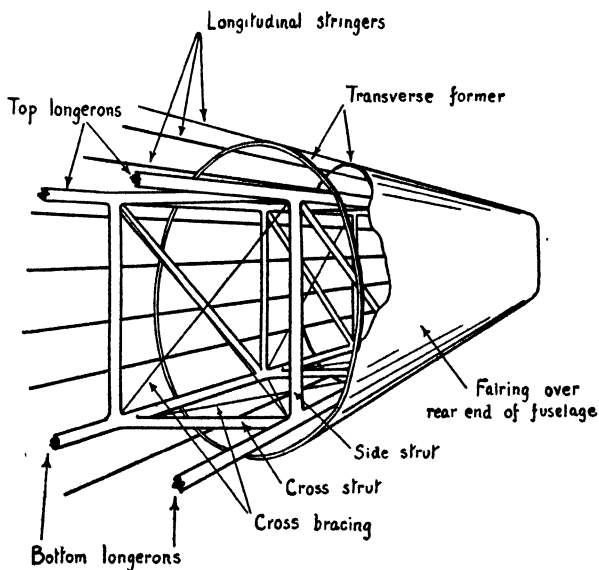

FIG. 8B. FUSELAGE WITH FAIRING: NAMES OF PARTS

**Strength and Safety.** So tempting is the idea of reducing weight in an aeroplane structure that strict regulations have to be made to ensure safety. The argument given above can be reversed. If by some means we can reduce the weight of the structure, we shall not only improve the performance, but the mere

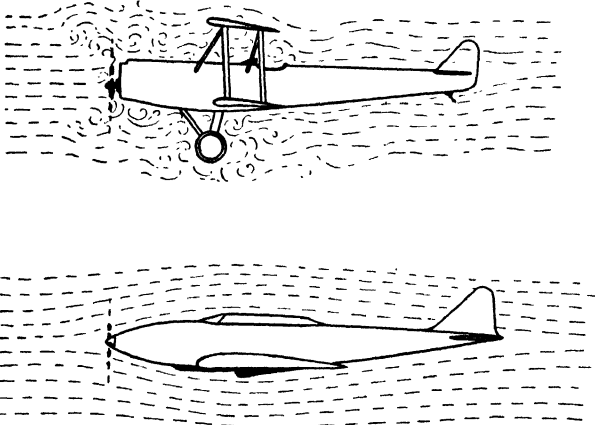

FIG. 9. STREAMLINING

fact that the structure is lighter will give the parts less to carry and so they can in turn be reduced in weight. So long as this reduction in weight can be effected without unduly sacrificing safety, it is good design; but immediately we overstep the mark good design changes into dangerous design. In nearly all countries Governments have found it necessary to frame rules and regulations which prevent designers from overstepping this mark.

**External Shape.** In order to obtain the best possible performance an aeroplane must be so shaped that it offers as little resistance as possible to its motion through

the air. This process is known as *streamlining* (Fig. 9), and it has considerable influence on the design of the internal structure. The importance of this is not always realized when the structure of an aeroplane is compared with other types of engineering. The designer of a bridge considers that it is his main aim to design a bridge which will be strong enough to carry some specified load from one side of the river to another. It is true that he may take the trouble to estimate the effect of wind on his bridge, and he may even have an eye to beauty and try to make the shape of the bridge harmonize with its natural surroundings; but these are secondary considerations. An aeroplane designer, on the other hand, is as much concerned with the external shape as with the internal structure. He would be a poor designer whose sole aim was to create a structure strong enough to carry the weight of the aeroplane.

**Materials.** The materials used for the structure of an aeroplane must have a high ratio of strength to weight. They must also be consistent in quality and as free as possible from liability to corrosion due to atmospheric conditions or, in the case of seaplanes, sea water. If possible, they should be non-inflammable.

The following materials have been used for the main structural parts of aircraft—

1. Wood (chiefly spruce or ash).
2. Steels of various types.
3. Light alloys of aluminium and magnesium.

None of these three groups can be considered ideal for the purpose—each has its advantages and its disadvantages, and when these are summed up there is little to choose between the three. The modern tendency seems to be towards a composite structure of all three groups, each material being used for those parts for which it is most suitable. Some firms, however,



still prefer to pin their faith to one type of material for all the main parts.

**Covering or "Skin."** We have already mentioned that it is the *skeleton* which forms the real structure of the aeroplane, and that this skeleton is only revealed after we have removed the covering or "skin." Until a few years ago this covering usually consisted of a fabric of Irish linen treated by various varnishes and dopes to make it air-tight and proof against weather and sunlight. Such a covering was required to take the pressure of the air due to the wind flowing over it, but it could not be counted upon to provide any real contribution towards the strength of the skeleton structure.

Sometimes three-ply wood or thin sheet metal was used as a covering instead of fabric. One of the advantages claimed for this form of construction was that the skin would contribute towards the strength of the structure and, in some instances, internal bracing could be dispensed with altogether.

To a large extent this theory has been justified, and modern practice tends to favour this "stressed-skin" form of construction, which has the additional advantage of providing a very smooth surface. Owing to the tremendous increase in speed during the past few years, and possibility of still further increases, it may well be that this smoothness of surface will be the deciding factor in giving metal skin the victory over fabric except perhaps for aeroplanes of very light and cheap construction. But, in the meantime, a rival to the metal skin is appearing in the form of "plastics"-moulded materials, similar to the already well-known bakelite, which can easily be made of any desired shape, size, or thickness, and which can be still further improved by being reinforced with fabric.

**Cost.** In many types of engineering the question of expense is a vital consideration in the design; in aeroplane construction it is *comparatively* unimportant. It is more important that an aeroplane should be safe than that it should be cheap. Safety can only be ensured by careful design, the use of the best materials, and a high degree of accuracy in workmanship. All these cost money. Similarly, high performance can only be had at a price, and high performance is sought after both for military purposes, where it may mean superiority over the enemy, and for commercial purposes, where it may add still further to the aeroplane's advantages over land and sea transport. Furthermore, most aeroplanes are sold to Governments or to large firms (often receiving a Government subsidy), a state of affairs which unfortunately tends towards extravagance. The steady increase in popularity of the privately owned aeroplane, with consequent competition and price-cutting, is bound to increase the relative importance of low cost in comparison with mere performance; but safety cannot be sacrificed too far, and one doubts whether expense will ever reach the same position in order of importance as it has done in certain other branches of engineering.

**Theory of Flight.** As mentioned in a previous paragraph, most of the loads imposed upon the internal structure of an aeroplane are due to the air pressure on the external covering. This air pressure varies considerably over the different parts, and according to the particular conditions of flight. For this reason the student is advised to have some knowledge of what is normally termed the Theory of Flight before studying the structure of the aeroplane. Sufficient information may be found in the companion volume, *Flight Without Formulae*, or in any other simple book on this subject.

**Summary.** We may sum up this introductory chapter by the following conclusions—

1. To understand an aeroplane structure, remove the *skin* and examine the *skeleton*.

2. The skeleton consists of *ties*, *struts*, and *beams*.

3. The *weight* of the structure must be reduced to the *absolute minimum consistent with safety*.

4. *Regulations* have been introduced to prevent reduction of weight being carried to extremes.

5. The *external shape* of an aeroplane has great influence upon its *internal structure*.

6. Materials used for aeroplane structures are chiefly *wood*, *steel*, or *light alloys*.

7. The *covering* surface may be *fabric*, *three-ply wood*, *sheet metal*, or possibly, in the near future, *plastics*.

8. *Expense* is a comparatively unimportant item in aircraft design.

9. It is advisable to have some knowledge of the *Theory of Flight* before studying the internal structure.

## CHAPTER II

### HOW AN AEROPLANE IS DESIGNED

THE structure of an aeroplane becomes much more interesting when we understand the various processes through which it has passed before assuming its present shape and arrangements. Think of some aeroplane with which you are familiar—possibly the product of some well-known aircraft firm. This aeroplane has a good performance; you know its top speed, its rate of climb, its ceiling. Was it designed to have this performance? Or was it just designed and then tested to see what it could do?

It has an engine of a certain horse-power—why was this engine chosen? It is a biplane—who decided that it should be a biplane, and why? Think of all the innumerable details—the area of the wings, the chord, the span, the angles at which they are set, the shape of the aerofoil section, the number of bays, the size of the wires, and so on throughout the structure. Who decided all these, and why were these particular values, shapes, and sizes chosen? You may content yourself by answering “Why, the designer, of course; that’s his job.” Maybe it is his job, or, shall we rather say, his responsibility; but let us see if we can understand a little further how he came to his various decisions.

Do not misunderstand me—I am not going to tell you how to design an aeroplane. That is a long and complicated job, requiring considerable knowledge of mathematics and mechanics and a great deal of patience. You and I, practical workers on aeroplanes, have probably neither the knowledge nor the patience.

All I am going to do in this chapter—and, for that matter, throughout this book—is to try to give you more interest in your aeroplane by helping you to understand why it is built in the various shapes and sizes that you know it to be. For this purpose let us consider the steps through which the design will pass.

1. **Specification.** An aeroplane is designed to a certain specification, that is to say the designer has in front of him a definite performance, and he tries to design an aeroplane which will, at the least, attain that performance. The specification may originate from the Government, from a commercial firm of aircraft operators, or from the designer himself. It will include such important items as maximum speed, minimum speed, rate of climb, ceiling, useful load to be carried, and range. The Government (which, in Great Britain, means the Air Ministry) may ask for a single-seater fighter with a speed of at least 300 m.p.h. at 10,000 ft., a landing speed not greater than 70 m.p.h., and a service ceiling of 35,000 ft., to carry pilot, parachute, two or more machine-guns, so many rounds of ammunition, oxygen apparatus, wireless, various instruments, and so on and so forth.

On the other hand, Imperial Airways may require a fourteen-seater passenger aeroplane with a cruising speed of at least 150 m.p.h., a range of 1000 miles, and a landing speed of 50 m.p.h.

Lastly, the designer may say to himself: "Neither the Air Ministry nor Imperial Airways knows what they really want; I can produce a much better machine to my own specification and, when they see it, they will be so pleased with its performance that they are sure to buy it." There can be little doubt that the last method is the best *if*—ay, there's the rub!—if the designer can be sure that they will buy it. If he designs

it according to what they asked for, and if it fulfils these conditions (as it probably will, provided they are reasonable), then they cannot very well refuse it; but if, on the other hand, he invents his own specification, they can always say that it is not what they require.

The last method has produced some of the most brilliant aeroplanes; but it is a gamble, and unfortunately there are not many aircraft firms that can afford to gamble. Shortly after the last war a well-known daily newspaper sponsored a competition for light aeroplanes—rules were framed, and aeroplanes were designed to come within these rules. Large prizes were won—and lost. One of these rules limited the power, or, to be more correct, the cubic capacity of the engines. In the meantime a famous firm decided what they thought a light aeroplane ought to be like, and they built one to their own specification, although it involved the use of an engine of greater cubic capacity than the rules allowed. The machine was therefore ineligible for the competition and the prizes. But it won a much greater prize.

It was not long before the public realized that this particular aeroplane was far more suitable for the private owner than those machines which had won the big prizes. Therefore the private owner bought it, and since that day that particular firm has supplied more aeroplanes to private owners than any other firm in the world.

That is a good example of how it pays to decide your own specification, and others could be quoted, even some where machines designed in this way have been supplied for Service purposes. But, on the other hand, there have been failures, and many firms cannot afford to risk these failures and therefore prefer to confine themselves to Government specifications. It is

an interesting problem, and when aeroplanes become more popular it will probably solve itself in much the same way as it has done with motor-cars. Consider your favourite car—did you ask for a motor-car of that type, or did the firm decide what a motor-car ought to be like and then offer it to you? You will probably say that the firm decided, but that they knew what you wanted and they had the common sense to design it accordingly. Perhaps, and perhaps not. But, in any case, aircraft firms may also have common sense.

.Well, wherever it came from, let us assume that we have a *specification*: in other words, we know what we want—we have something to aim at.

**2. Weight.** Behind all good design there is *one* brain. A committee cannot design an aeroplane or anything else. Eventually the work will be shared out, but to get the best results there must be one directing genius. And so to the designer, the real creator of the aeroplane, must fall the lot of sketching out the outline design. Some people imagine that this is simple—but is it? A firm may employ the best draughtsmen, the best workmen; the detail design, the workmanship, and the finish may be perfect; but unless the original design is good they will never produce a good aeroplane. The art of creative design is a gift possessed only by a few. A designer needs experience; but most of all he needs an eye that tells him whether a thing “looks right” or not, and when a thing “looks right” to a good engineer, it usually *is* right.

Now, the designer’s first step is to decide the *weight* of his aeroplane, the weight of an aeroplane which is not yet started. How can he know the weight, when he does not know the size or shape of any of the parts? Well, he must guess it. This may surprise you, and perhaps “guess” is not quite the right word to use.

Shall we say he must *estimate* it? But what information has he got on which he can form an estimate? Only the specification? No, not quite; he has got his past experience—he must look up the weight of any similar machine which his firm has designed in the past, he must add to or subtract from this if he thinks there is any reason to do so owing to the different material he is using, or owing to improved methods of construction, or because the specification is slightly different. Perhaps he may investigate the weight of similar machines designed by other firms—this he will certainly do if he has not had enough experience of his own designs. Whatever the methods, he must decide the weight. And he must get it right. The whole design is going to depend on this estimated weight, every part of the aeroplane will be influenced by it. Suppose the finished aeroplane turns out to be *heavier* than his estimate, then each part of the aeroplane, having been designed to carry the lighter machine, will be too weak. He will either have to start again, or reduce the loaded weight of the aeroplane by omitting some of the useful load such as petrol, passengers, or ammunition. This will probably mean that the aeroplane will not fulfil the required specification.

If, on the other hand, the final weight is *less* than his estimate, he need have no fear for the safety of his aeroplane, and its performance will probably come up to the specification; but the position is very annoying because the aeroplane ought to weigh *less still* and have an even better performance.

Do you understand why this is so? Each part has been designed to carry the heavier aeroplane, and it is therefore unnecessarily strong and so unnecessarily heavy. If he is sensible, he will make a new estimate—less even than the weight of his first finished aeroplane



—and he should then obtain a really super performance. Fortunately it is not necessary actually to build the aeroplane in order to find out its final weight—a very accurate estimate can be made when the detail drawings have been completed. It should also be mentioned that the first original “guess” is often very close to the final weight.

We now have the *specification*—and the *estimated weight*.

3. **Wing Area.** The next step is to find the wing area required. This depends mainly on three things: (1) The *weight* of the aeroplane, (2) the type of *wing section* used, and (3) the *landing speed*.

Of these, the question of *weight* has been fully discussed in the last paragraph, and we can assume that it has been decided.

The type of *wing section* (or aerofoil) will depend to a large extent on the kind of work for which the aeroplane is required, in other words, on the specification. More information on this subject will be found in the companion book, *Flight Without Formulae*. Suffice it to say here that the choice of wing sections is very large, and the designer, in choosing a suitable section, will remember that a deep camber will give him good lift at low speeds but a poor maximum speed; whereas a thin wing will give him a higher maximum speed but a high landing speed unless he uses an excessively large wing area. From the structural point of view a deep wing means good spars, as we shall see later. Slots, flaps, or variable-camber devices may be used to combine the advantages of both types of aerofoil, and these must be taken into account when calculating the wing area.

Strange as it may seem, the *landing speed* is the item which has most influence upon the wing area to be

used, and hence on the whole design of the machine. The landing speed may be given as part of the specification, or it may be left to the discretion of the designer. If the weight, wing section, and landing speed are decided, the wing area required can be calculated by a simple mathematical formula. We do not intend to enter into the mathematics of the design, and we will sum up by saying that, other things being equal—

1. A large total weight means a large wing area.
2. The greater the camber, the less the wing area. (The same applies if slots, flaps, or any form of variable camber are used.)
3. The higher the landing speed, the less the wing area. Of these, the last has the most effect, and if we try to aim at a really low landing speed (a desirable quality on all machines), the wing area becomes absurdly large and quite unpractical.

Hence all kinds of compromises and important decisions must be made before the designer can claim to have decided all the following: *Specification, Weight, Wing Section, Landing Speed, Wing Area.*

4. **The General Lay-out.** This is the stage when the designer must use his eye. He has already had to make important decisions and do some simple calculations. But now the art of design comes in.

Considering his wing area and the qualities required of the machine, he must decide between a *monoplane* and a *biplane*.

If it is to be a biplane, he must settle what proportion of the wing area he will assign to each plane and, incidentally, he will have to increase his total wing area slightly, because the wings of a biplane interfere with each other and are therefore not so efficient as those of a monoplane.

*Span, chord, taper (if any), angle of incidence, dihedral*

*angle*, and, in a biplane, *gap* and *stagger*—all these he must decide, partly by his experience and partly by his “eye.” Soon he reaches the stage when he can sketch out a rough front elevation of the main-plane bracing showing the proportions of the bays, the inclination of struts, wires, and so on.

The question of the *engine* must be settled. It is usual to choose an engine which has already been designed and tested, the advantages of this method being obvious. In making the choice of engine he will be most concerned with its weight and horse-power, but such considerations as reliability, fuel consumption, type of cooling, head resistance, ease of maintenance, and so on, will be taken into account. He may also consider the advantages of employing two, three, or more smaller engines instead of one big one.

Of the two main questions, weight and horse-power—other things being equal, the less the weight of the engine the better in every way; and the greater the horse-power, the greater will be the maximum speed.

The design of the front portion of the fuselage will depend very largely on the type of engine chosen, and he will now be in a position to sketch out a side elevation of his fuselage, the length of which must be decided by his experience from the point of view of providing adequate stability and control. After he is satisfied with the outside shape he will consider the internal structure and sketch in the longerons, struts, and wires, also the positions of the cockpits, seats, tanks, and so on. At an early stage he will have to make an estimate as to the probable position of the *centre of gravity* of the finished aeroplane, because this will settle the points of attachment of the wings and the under-carriage to the fuselage. These points of attachment will, in turn, influence the design of that important

part of the fuselage which has to carry the main loads of landing and flying. He may then turn his attention to the tail unit, sketching in the fin and rudder, tail plane, and elevators.

In this way, little by little, the aeroplane will take shape. Eventually it will begin to look like the finished product which he will some day hope to see in the air. But at present it exists only in his brain, and on paper—and even so it is merely a line drawing, just a sketch as it were of the positions and lengths of the various parts, the struts, the ties, and the beams. The exact sizes and dimensions of these are not known, and no detail fittings of any kind have been designed.

Up to this stage the aeroplane that is to be is essentially the designer's pigeon—it is a "one-man job." The process has not been in any sense automatic; it has been a question of creation, of vision, the work of a special kind of artist. But from now onwards a change takes place, and the work may be shared out among various members of the staff—the designer, if he is a wise one, taking a fatherly interest in the progress of his new baby, a progress which has now become much more automatic.

**5. Stressing.** The next stage of design is usually called *stressing*, and it is performed by the "stress merchants" with their drawing-boards and their slide-rules. The total weight of the aeroplane and the weights of the component parts have to be distributed to the various points in the structure. All the forces must be assumed to act at the joints, and then "stress diagrams" are drawn. These diagrams are simply an extension of the well-known theorem of the polygon of forces. This is not a book on Mechanics, and it is not our intention to explain how stress diagrams are drawn. Our intention is to help the reader to understand

the practical purpose and usefulness of such methods. If he has learnt Mechanics, so much the better; but if he has never learnt any he should still be able to follow everything in this book, and perhaps, when he has reached the end, he may want to learn more. If so, there are books without number available for him. If, on the other hand, he feels that he understands something about aeroplanes without doing all the donkey work of Mechanics—well, we shall still be satisfied, because that is the purpose of this book. But let us return to our stress diagrams. By measuring the lengths of the lines in these strange diagrams (which bear no resemblance whatever to the actual aeroplane), the forces in the members can be calculated, and by inspection of the diagrams we can tell whether any member will be in tension or compression. All this must be done under several conditions, e.g. for ordinary normal flight, for a nose-dive, and for landing. The forces found in this way are multiplied by a *load factor* (explained later), which has to allow for extraordinary conditions of flight and other eventualities (Chapter IV). Then, after deciding the material to be used for each part, its dimensions can be calculated. For ties this is a comparatively simple matter, but for struts and beams several complications occur. At this stage many of the detail fittings can be designed.

**6. Drawings.** Gradually the work will be handed over from the stress merchants to the draughtsmen, whose job it is to make accurate drawings of all the various parts, so that these parts can be made in the workshops. It is here that the Government first steps in with its system of inspections, because the drawings and dimensions, weight estimates, and so on must be submitted to a special department of the Air Ministry, who have to approve them before an Airworthiness

Certificate can be granted to the aeroplane. This applies whether the machine is for civilian or Service use, but, of recent years, owing to the need for rapid expansion of the Royal Air Force, many regulations have been relaxed and firms have enjoyed more freedom in checking and testing their own designs in their own way.

After the detail drawings have been made, the mathematicians get their turn again, and revised estimates are made of the total weight, centre of gravity, and performance. These can now be made very accurately, and there is usually little divergence between them and the finished aeroplane. If, however, they differ widely from the original estimates, the only wise course is to scrap the design and start again. After all, it is easier, less expensive, and less dangerous to scrap a lot of drawings than to risk a disaster to a real live aeroplane. But let us assume that all is well.

**7. Manufacture.** The drawings are now handed to the workshops, and the machine is built. Even during this process, slight modifications may have to be made, the amount depending very much on the practical foresight and experience of the designing staff and draughtsmen. If they have been able to foresee practical difficulties, little modification should be necessary. Some of the smaller fittings may actually be designed and made in the workshops and the drawings made afterwards, this being a reversal of the usual process.

Government inspection again steps in during manufacture; officials of the Aeronautical Inspection Directorate (A.I.D.), who are often attached to the firm for a period of years, inspect all material, each completed part of the structure, and finally the whole aeroplane. After the first machine of a type has been

built, the inspection is left more in the hands of the manufacturer, but it remains equally thorough whether carried out by the A.I.D. or by members of the firm.

If there is any doubt about the strength of any component parts, such as spars, ribs, or even a complete fuselage, these may be built and then "tested to destruction," i.e. loads similar to those of real flight but increasing in magnitude are applied to them until they actually break. This test has even been made on complete aeroplanes. It is, of course, costly in material, but it gives a very comforting *proof* of the strength of the structure.

#### 8. Measurement of Weight and Centre of Gravity.

Before its first flight the aeroplane will be weighed and the measured weight compared with the estimate. We have already discussed how important it is that there should not be any large discrepancy between the two, but fortunately such a situation does not often arise. While weighing the machine the position of the centre of gravity is also checked. This is done by weighing on the wheels and tail skid and then working out, by the principle of moments, how far the centre of gravity is behind the wheels.

But it is also necessary to know the height of the centre of gravity, and this can be found by weighing the aeroplane in two, or preferably three positions, e.g. (a) in rigging position with the datum line of the fuselage horizontal; (b) with the tail on the ground; (c) with the tail as high as it is safe to raise it without overbalancing (Fig. 10). From these readings the position of the centre of gravity can be found. Although it is not sufficiently accurate for practical purposes, the following method illustrates the principle. When the machine is weighed with the tail down, calculate the distance of the centre of gravity behind

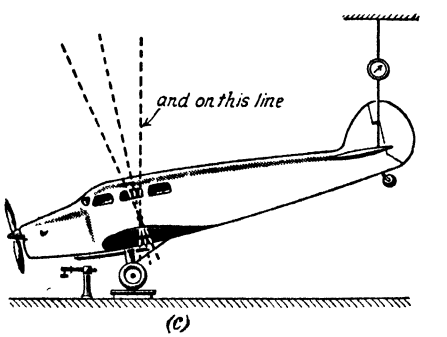
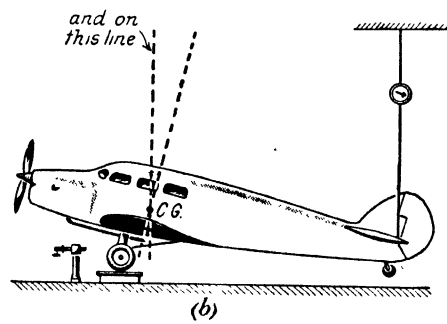
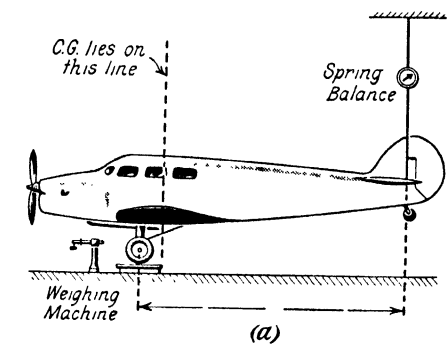

FIG. 10



the wheels, hang a plumb-line down the side of the fuselage at this position, and chalk this line on the fuselage. With the machine in rigging position, carry out the same operation, when the second chalk line will cross the other at the centre of gravity. The third position can be used as a check. By a large-scale drawing a much more accurate determination can be made, or, alternatively, the position can be calculated.

**9. Testing.** After the aeroplane has been built it is tested in flight. This may, in the first place, be done by the firm's own test pilots, but if it is the first machine of a new type it must be tested by special Government pilots before it can be accepted for either Service or civilian use. This testing is very thoroughly carried out at certain Government establishments, one reserved for land planes and one for seaplanes. The machine is put through its paces and a full report given upon it, with suggestions for any alterations which might be likely to improve its performance. While the main object of this test is to find out its performance, the degree of stability and control which it possesses, and to detect any vicious habits, it does, at the same time, make quite certain of the strength of the structure, because it is put through all the most violent manœuvres which it is ever likely to have to perform. It therefore reflects great credit on those who have been responsible for the structural design of the aeroplanes that, neither in these tests nor in subsequent service, have weaknesses in the structure been discovered except on very rare occasions. The same cannot always be said of performance, stability, and control, but with these qualities we are not concerned in this book.

**10. Actual Service.** An aeroplane which has successfully passed these tests may be put into service. If for civilian use, it will be granted a Certificate of

Airworthiness, which must be renewed annually; if for Government use, it will be bought for service with the Royal Air Force or the Fleet Air Arm.

The manufacturer is now at liberty to build any number of the *same type* with much less supervision as regards inspection and testing; but if he decides on a new type of machine, the same procedure must be carried through from the start. It is one of the difficulties of aircraft manufacturers that, at the present stage in our knowledge of aeronautics, they must always be experimenting and trying out new types and consequently any form of real mass production is out of the question.

If any part of the structure fails or proves unsatisfactory during its service life, a *modification* is put into force, and the change must be carried out before a new Certificate of Airworthiness will be granted. In Service units this modification is usually dealt with immediately by the personnel of the R.A.F.

Even under service conditions regular inspections are carried out, ranging from a rough "look-over" between each flight to complete overhauls after a certain number of hours' flying. For the complete overhauls the machines are usually returned to the manufacturers, but all other inspections and minor repairs are carried out on the spot, on civilian aircraft by ground engineers, and on Service aircraft by R.A.F. mechanics.

It must be remembered that the life of an aeroplane is short when compared with that of other structures, and that it is usually measured in *hours* of actual flying time rather than in years of service. A life of a thousand hours may be considered a long one, and the flying time is usually much less than this before an aeroplane becomes unserviceable either through a crash or old age.

**11. General Trend of Design.** The average aeroplane of a few years ago differed very little in its type of construction from those of the 1914-18 war or even those very early types before that war. The old Avro 504K—perhaps the most famous type of aeroplane ever built—was typical of this type of construction. It was a biplane complete with all its flying and landing wires, interplane struts and incidence wires, drag and anti-drag wires inside the planes, two spars and a complete set of ribs, and a fuselage built like a box with four longerons and struts and wire bracing on all four sides, with internal wires to prevent twisting. Such was the construction of an aeroplane—especially a British aeroplane—from the early days of flight until, say, 1935. During this time metal construction had come—and come to stay—but at first metal construction made very little difference. The same aeroplanes—the same types of construction—were reproduced in metal as they had been in wood.

Then, rather suddenly, there came a change. It is not easy to detect why the change came about, and especially why it came so suddenly, but the fact remains that during recent years methods of construction have changed considerably. Most noticeable of all, the monoplane has come into its own again, even in this country, the last stronghold of the biplane. Speeds have gone up—rapidly. Wing areas have been reduced. Frontal areas have been reduced. Streamlining has improved. External bracing has been eliminated. Undercarriages are retractable, surfaces are smoother. All this is obvious, even by external observation, but what is not quite so obvious is that at the same time as these external changes have been taking place, designers have been experimenting with new types of construction. These will be described in more detail in

a later chapter ; suffice it to say for the present that the general tendency has been towards the elimination of struts and wires, whether internal or external. The result has been neater, faster, and altogether better aeroplanes, but unfortunately the skeleton of such types is not so obvious, even when the skin is removed.

In many ways it is true to say that the principle, the ideas underlying the construction, still remain the same ; they are, after all, nothing but the old-established engineering principles. We hope, therefore, that the reader will forgive us if, throughout this book, we appear to be a little old-fashioned, to be thinking perhaps of that "old-fashioned Avro of mine," when we ought to be thinking of the very latest high-speed monoplane. There is method in our madness ; we think that an understanding of the older type of construction will give you sound ideas—and these sound ideas, in their turn, will help you the more easily to understand modern methods. Much the same conclusion has been reached in courses of training in the practical rigging and maintenance of aircraft. Modern airframes can hardly be rigged at all in the old-fashioned sense, and the tendency is to replace rather than repair damaged parts ; but most courses of training incorporate some knowledge and experience of the older types.

**Conclusion.** After this short story of the life history of an aeroplane, I hope that the reader will be more interested in the structure of his aeroplane. Let us recapitulate—

1. *Specification.* The aim, as it were, in front of the designer.

2. *Estimate of Total Weight.* The first great "guess" on which so much depends.

3. *Wing Area.* Decided from weight, wing section, and landing speed.

4. *General Lay-out.* The designer's pigeon—the creation of an artist.

5. *Stressing.* Drawing-boards and slide-rules—line diagrams.

6. *Drawings.* The turn of the real draughtsmen—the parts begin to assume their final shape.

7. *Manufacture.* The thing becomes real—a period of careful workmanship and inspection.

8. *Measurement of Weight and Centre of Gravity.* Practical checks for comparison with estimates.

9. *Testing.* To answer the question "Has our aim been achieved?"

10. *Actual Service.* The purpose of the design is fulfilled.

11. *General Trend of Design.* Towards monoplane without wire bracing.

Of course, there is a lot more in it than this, and the same method may not always be applied; each country has its own particular way of ensuring safety, each firm has its own little idiosyncrasies, and one has even heard of an aeroplane designed, built, and flown by one man. Nor does it follow that the system which has been outlined is necessarily the ideal one. There is a lot to be said, and a lot has already been done, towards giving manufacturers more freedom in deciding their specifications, methods of stressing, inspection, testing, and so on; after all, if the aeroplanes are not safe, the public will not buy them and insurance companies will not insure them, so they will probably build aeroplanes which are just as safe as at present—and they may achieve a better performance. But all this is a debatable question, almost a political question, and as such is outside the scope of this book. Sufficient has been said to give the reader some idea of how his aeroplane was designed.

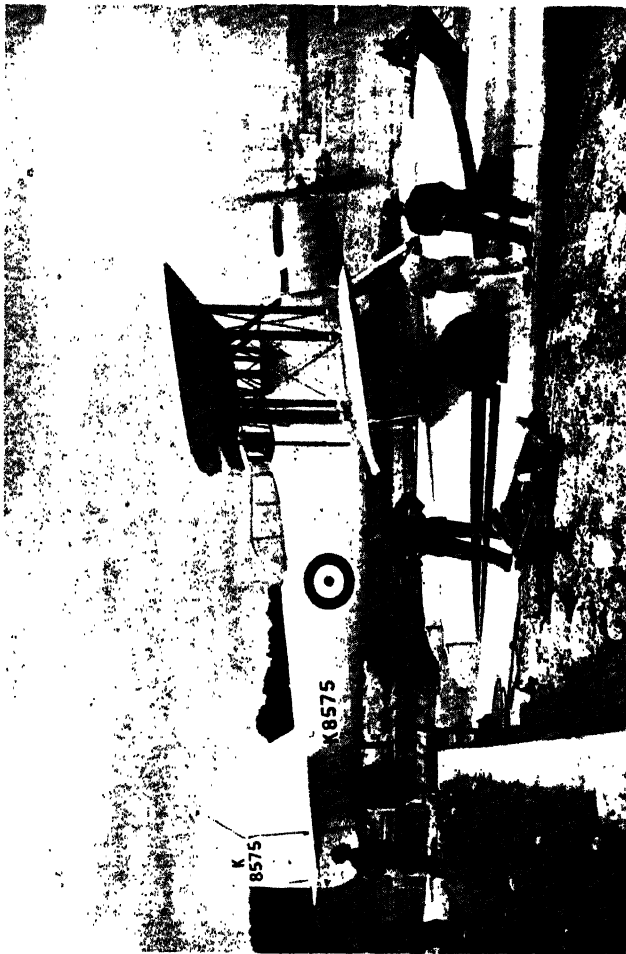

PLATE IV. A SERVICE FLOAT-PLANE

The Fairey "Seafox." Weight about 2½ tons.

(By courtesy of "Flight" and the Fairey Aviation Co. Ltd.)

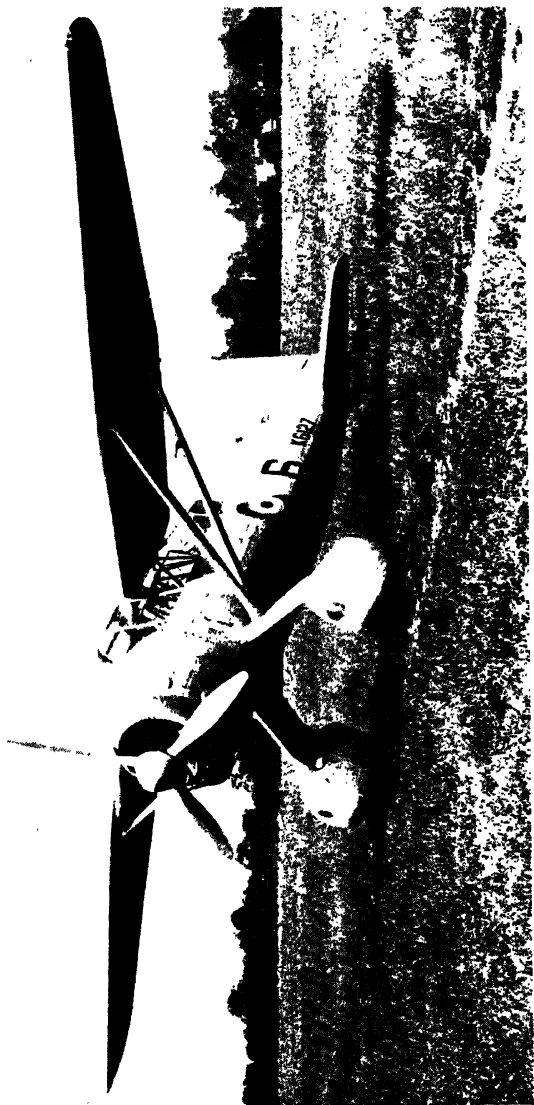
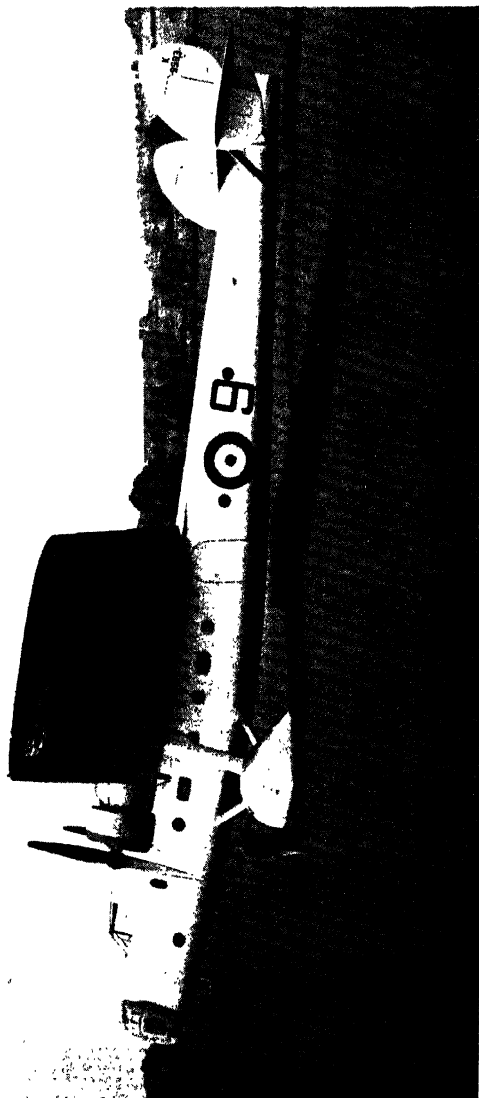

PLATE V. SINGLE-ENGINED ARMY CO-OPERATION MONOPLANE

The Westland "Lysander." Weight about 2½ tons

(By courtesy of Westland Aircraft Ltd.)



**PLATE VI. LARGE BOMBER TRANSPORT**

This picture gives a good idea of a large modern monoplane. It is the Bristol "Bombay" bomber transport, which can carry twenty-four fully-armed troops in addition to a crew of three. Total loaded weight about 15 tons.

*(By courtesy of the Bristol Aeroplane Co. Ltd.)*



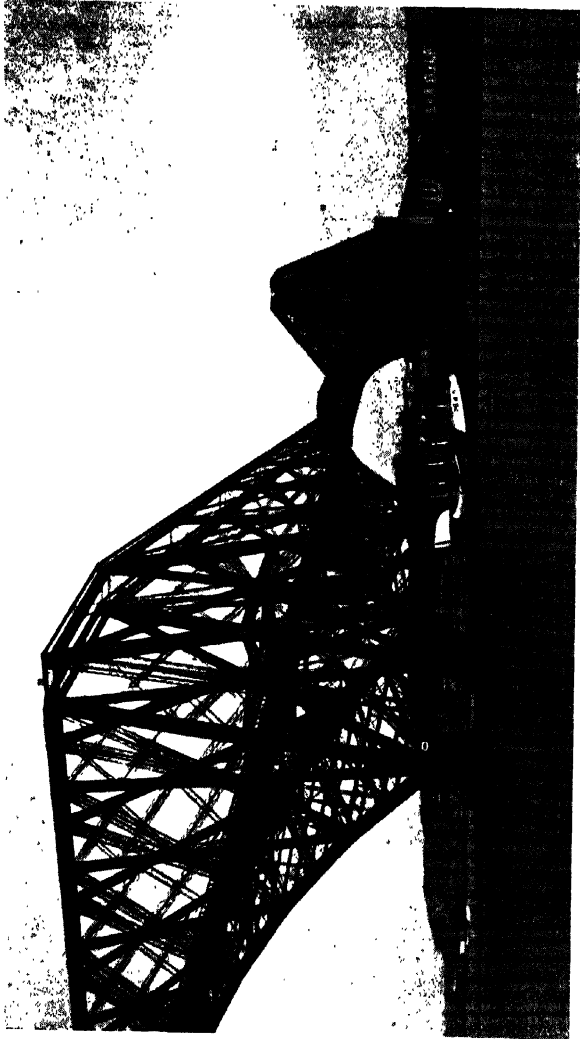
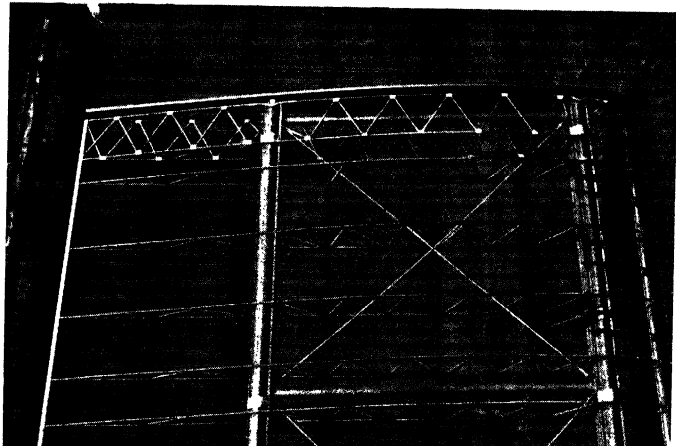

PLATE VII. DIGNITY AND IMPUDENCE

A contrast between a gigantic structure, such as the Forth Bridge, and a flying boat. The Forth Bridge is like a huge bending-moment diagram fashioned in metal, as it is of the cantilever type of construction, in which the largest bending moments, and therefore the greatest weights, come over the points of support. The weight of the bridge structure itself is, of course, far greater than any loads of trains that it has to carry, and in this respect it forms an interesting contrast to an aeroplane spar, of which the weight is insignificant compared to the loads imposed upon it in flight.

(By courtesy of "Flight")



### PLATE IX. RIBBETS

This picture shows the leading-edge ribs between the front spar and the leading edge of a Bristol "Blenheim" wing structure. It also gives a very good idea of the deep I-section spars which are used in this wing.  
(By courtesy of the Bristol Aeroplane Co. Ltd.)

### (Left) PLATE VIII. RIBS

In addition to showing the ribs very clearly, this illustration shows a very typical main-plane structure; the plane is resting on its leading edge, the front spar comes next, then the rear spar, and at the top the trailing edge. Vertically are the ribs, of very simple Warren girder construction; the strong tubular members are the drag struts, and these are braced by the drag and anti-drag wires, the whole forming a typical wire-braced frame. Notice that the portion of the wing behind the rear spar is an unbraced deficient structure. Even the hangar door is interesting with its cross-bracing and corrugated metal skin.  
(By courtesy of "Flight")

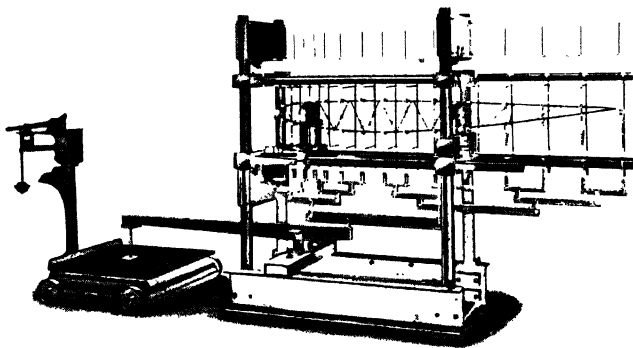

PLATE X. TESTING THE STRENGTH OF A RIB  
*(By courtesy of Messrs. Armstrong Whitworth Aircraft Ltd.)*

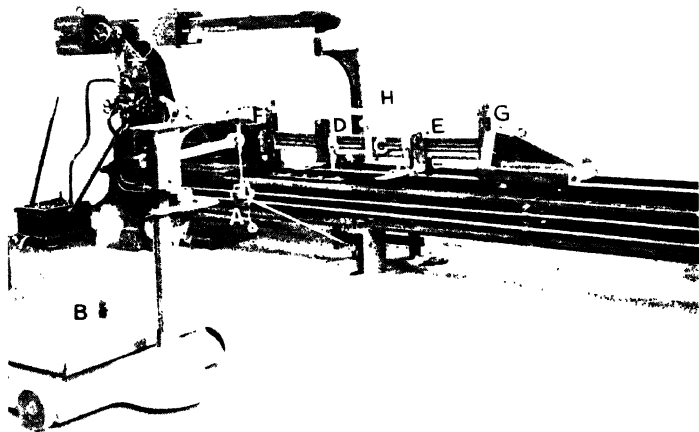

PLATE XI. TESTING THE STRENGTH OF A SPAR

By this ingenious arrangement a small weight placed on the balance arm of the weighing machine at *A* is magnified on the actual weighbridge *B*, and again by the long lever so that a large load is applied at *C* to the centre of a small length of spar; the spar is supported at *D* and *E*, while at the two ends, *F* and *G*, a compressive end load can be applied, thus simulating the worst conditions of actual flight. The instruments at *H* measure the deflection.

*(By courtesy of Messrs. Armstrong Whitworth Aircraft Ltd.)*

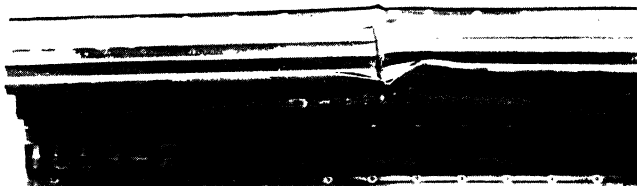

PLATE XII. FAILURE OF A FLANGE UNDER TEST  
*(By courtesy of Messrs. Armstrong Whitworth Aircraft Ltd.)*



PLATE XIII. FAILURE OF A WEB UNDER TEST  
*(By courtesy of Messrs. Armstrong Whitworth Aircraft Ltd.)*

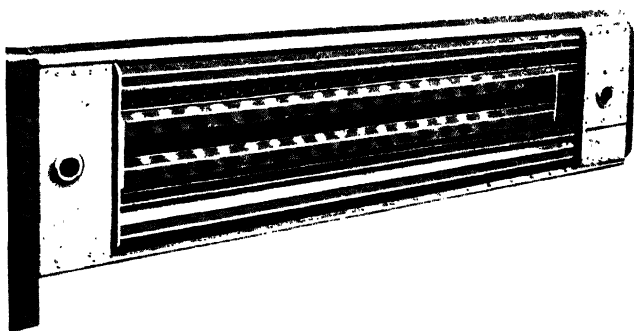
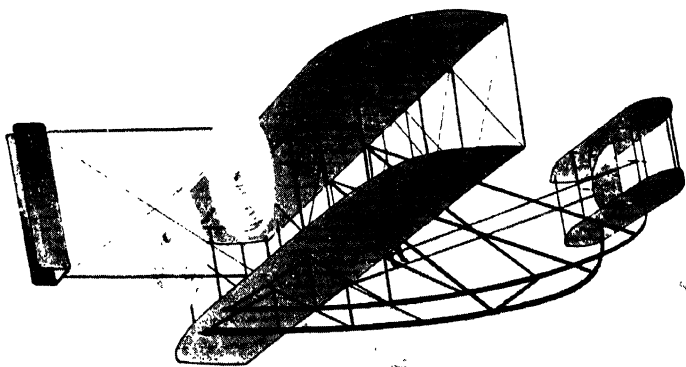

PLATE XIV. FAILURE OF A SPAR DUE TO ELASTIC  
INSTABILITY

This remarkable photograph shows how the web has formed itself into a series of ripples due to elastic instability; remedies for this would be to increase the thickness of the metal or design a more elaborate form of corrugation.

*(By courtesy of Messrs. Armstrong Whitworth Aircraft Ltd.)*



### PLATE XV. THE WRIGHT BIPLANE IN FLIGHT, 1903

The machine which made the first power-driven flight. A contraption of struts and wires, flying tail first, landing on skids. The two airscrews were driven by chain drive from a single engine. An interesting point, so far as the structure is concerned, is that the front spar forms the leading edge, the front struts and wires being right at the front of the main planes. This was a feature of the very early types, but it was soon found that a stronger spar could be made at a deeper portion of the wing farther back.

*(By courtesy of "Flight")*

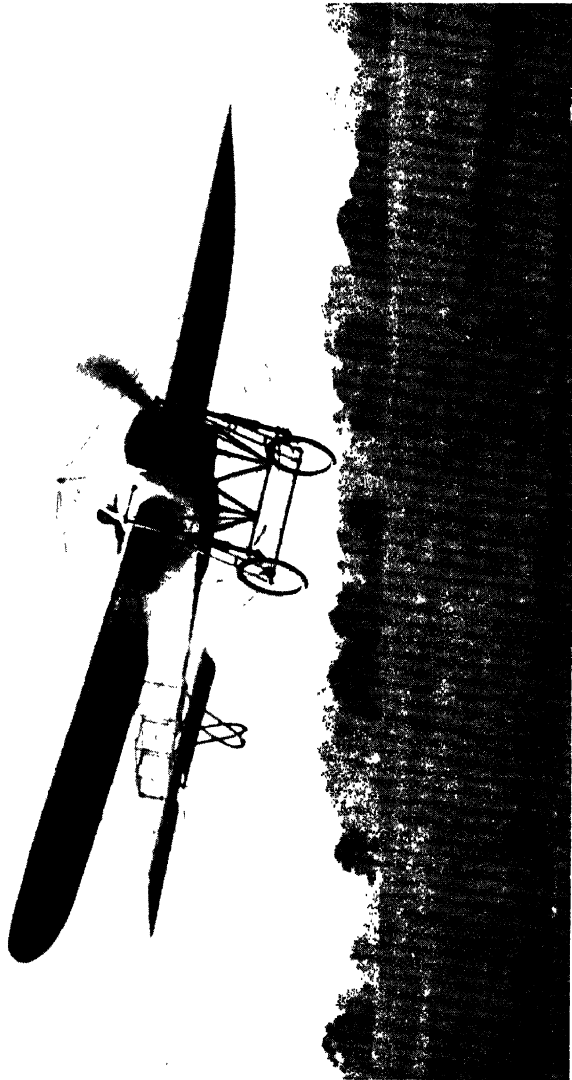

PLATE XVI. THE BLÉRIOT, 1909

Notice that, although this is a monoplane, it differs from modern types in that it is braced top and bottom by landing and flying wires; these wires are very "flat" and so do not perform their function so efficiently as in a biplane, and thus it came to be thought that the biplane would always make a lighter and better structure.

(By courtesy of "Flight")

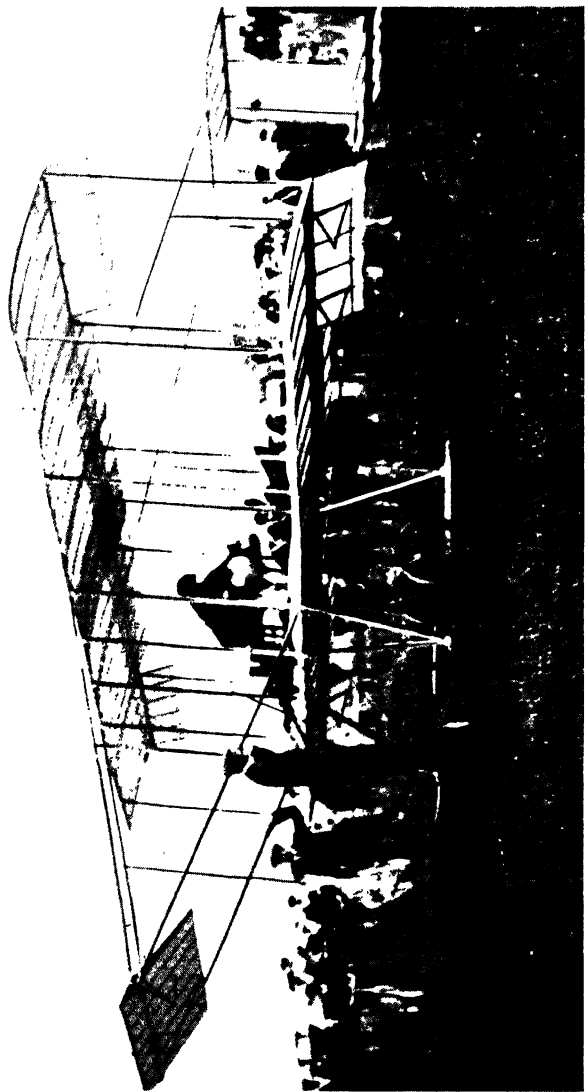

PLATE XVII. THE BRISTOL "BOX KITE," 1910

This was the first aeroplane ever to fly at the Army manoeuvres, slightly reminiscent of the Wright machine; but notice that the tail is now at the back (although the elevator remains at the front). The undercarriage now has wheels. The front spar and struts are still at the leading edge. There is no need to explain why this was nicknamed the "Box Kite".

(By courtesy of the Bristol Aeroplane Co. Ltd.)



PLATE XVIII. BRISTOL "SCOUT," 1914

Before its time? The only military machine in production at the outbreak of war in 1914, and the forerunner of the other war time scouts or fighter aeroplanes. Very typical of the wire-braced biplane construction of conventional type. Fitted with an 80 h.p. Gnome rotary engine.

(By courtesy of the *Bristol Aeroplane Co. Ltd.*)



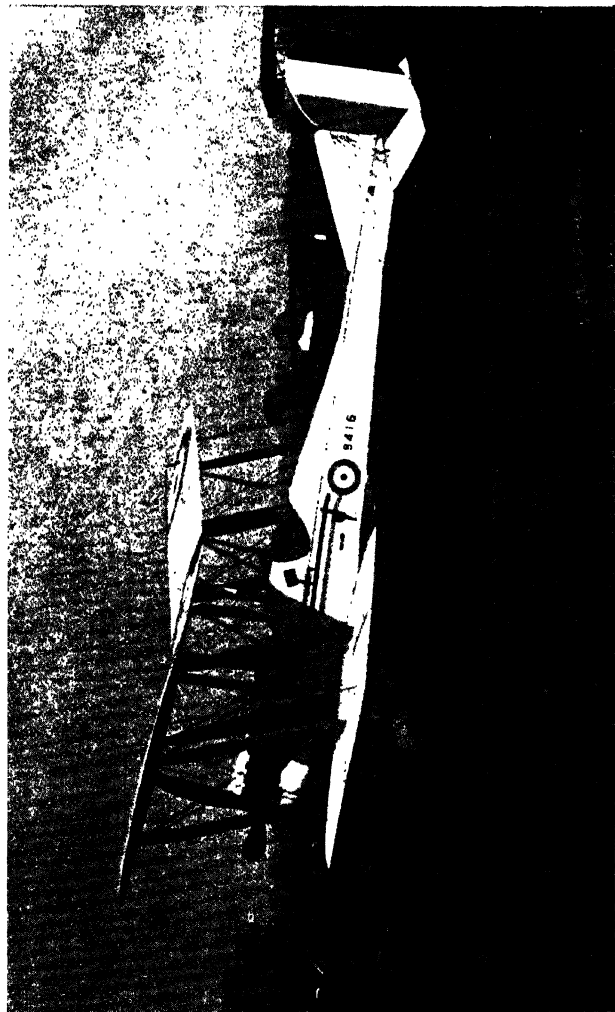

PLATE XIX. B.E.2c, 1914

Product of the Royal Aircraft Factory at Farnborough, but designed by one of the famous de Havilland family. The "family likeness" can be traced in the output of the firm of that name for many years afterwards, perhaps even to the present day. A conventional biplane in structure, it owed its fame, or notoriety, more to its flying qualities and to its war-time history than to any structural peculiarity.

## CHAPTER III

### THE LOADS ON THE STRUCTURE

BEFORE going into the details of the internal structure we must investigate the externally applied loads. These loads are caused chiefly by the air pressure acting on the surfaces of the aeroplane, although there are some exceptions, as for instance the shock from the ground on to the undercarriage when landing.

Most of the strength in an aeroplane structure, or for that matter in any structure, is required to withstand externally applied loads; nevertheless extra stresses may sometimes be introduced into the structure by internal effects in the structure itself, such as the excessive tightening of a wire when cross-bracing is employed.

The externally applied loads will vary very much, according to the particular condition of flight; as an instance, the loads in upside-down flight will obviously differ from those in normal flight. Therefore we will consider the loads on the aeroplane under certain definite conditions. The reader will find great help in discovering why these loads occur if he reads the companion volume, *Flight Without Formulae*. In this chapter we will simply detail the various loads without explaining how they arise.

**1. Normal Horizontal Flight.** The aeroplane is assumed to be travelling at its normal cruising speed; it is neither losing nor gaining height, and its attitude is approximately that of its "rigging position," i.e. the longitudinal axis is horizontal.

be the forward thrust or pull of the airscrew and backward drag caused by the combined air resistance of all the component parts. The total of this drag will be equal to the thrust. Roughly speaking, about half of this drag will be contributed by the main planes themselves, and the remainder by fuselage, undercarriage, and tail unit (the drag of the latter being called parasitic drag). The total drag will not be more than about one-fifth, and may be as low as one-tenth, of the total weight.

*Parts of the Structure Most Concerned in Normal Horizontal Flight.* All the "flying" bracing, i.e. wing spars, ribs, fabric or metal covering, and attachments of main planes to fuselage. In a biplane, flying wires and interplane struts in addition to the above.

**2. Horizontal Flight at Varying Attitudes.** It must not be forgotten that an aeroplane can fly horizontally, i.e. without losing or gaining height, in attitudes quite different from that of normal horizontal flight. If the aeroplane is travelling horizontally, the wind will, in effect, be coming to meet it horizontally (except in up or down currents), and the wings may strike this horizontal wind at any angle, provided the lift on the wings can be kept equal to the weight. In practice this means that this angle (the angle of attack) may vary from about  $1^\circ$  or  $2^\circ$  to about  $15^\circ$ , the former corresponding to the maximum speed of level flight and the latter to the slowest or stalling speed.

At all these attitudes the lift will still be equal to the weight, and it might therefore be thought that there would be little difference in the effect on the structure. Actually, however, the different attitudes are very important, because, as the angle of attack changes, although the total lift remains the same, its distribution alters, i.e. *the centre of pressure moves*. It will be seen

later that this movement of the centre of pressure has important effects on the design of the main planes. The extent to which the centre of pressure moves depends on the shape of the wing sections; but in general it can be said that its most forward position (say one-quarter of the chord from the leading edge) is at large angles of attack, i.e. at slow speeds, and its most backward position (say three-quarters of the chord) is at small angle of attack at high speeds (Fig. 13).

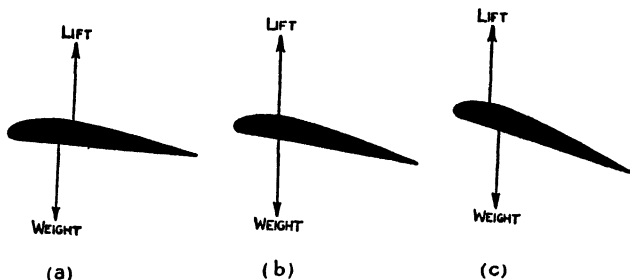

FIG. 13. HORIZONTAL FLIGHT AT VARYING ATTITUDES

- (a) High speeds, small angle, C.P. back.
- (b) Normal horizontal flight.
- (c) Low speeds, large angle, C.P. forward.

The effect on the drag of this alteration of attitude is rather interesting. We have remarked that the lift remains constant, i.e. equal to the weight. Now, the drag must remain equal to the thrust; but the question is whether the thrust must be changed, by opening or closing the throttle, if level flight is to be maintained. The reader may perhaps be puzzled as to how the lift can be kept constant if the speed changes, and the answer is that the increase in angle compensates for the decrease in speed, and vice versa.

There will be a similar compensating effect on the drag, the increase in angle tending to make it larger.

and the decrease in speed tending to lessen it. But the compensation is not complete, because the ratio of lift to drag is usually at its best in normal horizontal flight and decreases for either smaller or greater angles of attack. If the lift remains constant and the lift/drag ratio decreases, the drag must increase. Therefore the drag (and the thrust) is slightly greater at the extreme speeds of level flight than it is in normal horizontal flight.

(*Note.* In the foregoing argument the thrust has been assumed to remain horizontal. Actually it will move with the attitude of the aeroplane and have slight effects on the lift and drag.)

*Parts of the Structure Most Concerned in the Question of Horizontal Flight at Varying Attitudes.* Same as for normal horizontal flight, but the chief consideration is the effect of the movement of the centre of pressure.

**3. Nose-dive.** If an aeroplane is dived vertically towards the ground, its speed will increase until it reaches a steady maximum velocity called its *terminal velocity*. This is the highest velocity at which the aeroplane is capable of travelling, and it makes very little difference whether the engine is running or not.

The weight of the aeroplane must now be supported by the drag forces, which will therefore be much larger than in normal horizontal flight, and so all the drag bracing will be seriously affected (Fig. 14).

There will be a downward load on the front portion of the main planes and an upward load on the rear portions. These loads will not only put severe stresses on the front portion of the ribs (downwards, i.e. in the opposite direction to those of normal flight), but they will also tend to twist the main planes off at the root (Fig. 14).

In a biplane structure, the front landing wires and

rear flying wires are likely to be heavily loaded by the twisting action.

To counteract this twisting effect on the main planes there will be a large downward force on the tail plane;

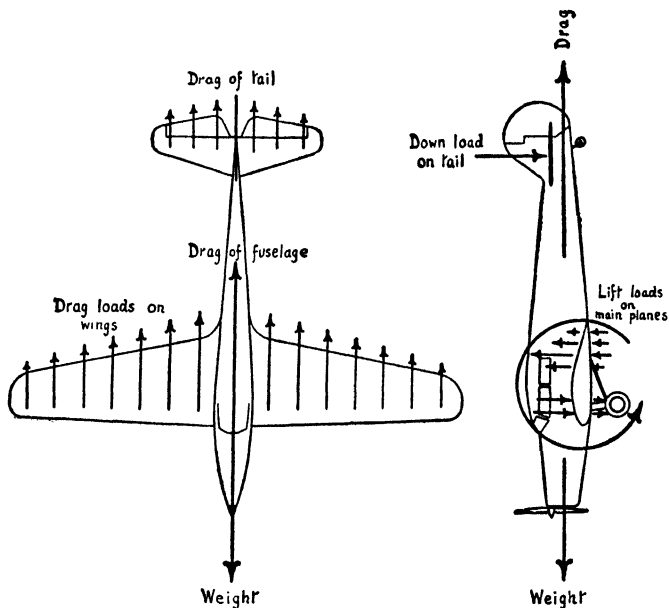

FIG. 14. LOADS IN A NOSE-DIVE

this will not only put stresses in the tail plane and its external bracing (if any), but will tend to bend the fuselage.

(Note the use of the term "downward" as applied to a load to mean that it will have the same effect on that part of the structure as a downward load would have in normal flight. In a nose-dive these so-called "downward" loads are really horizontal.)

*Parts of the Structure Most Concerned in a Nose-dive.*

All drag bracing (internal and external drag wires and drag struts), front portion of ribs and root fittings of main planes; tail plane and its bracing; longerons, side struts, and side bracing wires of the fuselage. In a biplane, front landing wires and rear flying wires.

4. **Turns.** An aeroplane is made to turn by applying the rudder. This will cause side loads, not only on the rudder itself, but on the fixed fin, which is usually in front of the rudder. These loads will tend to bend the fuselage sideways, and therefore cause stresses in the bracing wires and struts at the top and bottom of the fuselage.

If, as is usually the case, most of the surface of fin and rudder is above the centre-line of the fuselage, any loads upon these members will tend to *twist* the fuselage in addition to bending it.

The effect of such a twist is rather complicated, and may concern all the fuselage bracing, top, bottom, sides, and internal.

Apart from these loads, the effect of a turn upon the structure is simply to increase the ordinary loads of normal flight.

In a perfect turn, little or no side-slipping should take place; if the machine does side-slip, quite heavy loads may be put on all the side surfaces, which include not only fin, rudder, fuselage, engine nacelles, wheels, floats, and so on, but in a biplane the rather large side area of the interplane struts which, being already in compression, should not be subjected to too much in the way of bending loads.

*Parts of the Structure Most Concerned in a Turn.* Fin and rudder. Top and bottom bracing of fuselage.

5. **Upside-down Flight.** The effect of upside-down flight is practically to reverse the loads of normal flight.

The wings, of course, are very inefficient in their capacity as aerofoils, but if horizontal flight can actually be maintained, then the lift must still be equal to the weight. This result will probably be obtained by using rather a large angle of attack and at considerable expense of engine power.

The reversal of the load will have little effect on such parts as the interplane struts and the spars, which are usually equally strong in either direction. The drag effects will be similar to normal flight. The loading on the ribs will be in the opposite direction, and the effect of this may need consideration; but the main difference in a biplane structure is that the landing wires now replace the flying wires as the main lift bracing which carries the weight of the machine. This will probably cause greater loads on the landing wires than they will normally be required to carry on landing, and thus inverted flight may be the chief consideration in the design of the landing wires.

*Parts of the Structure Most Concerned in Upside-down Flights.* Wing structure. Landing wires (in a biplane).

**6. Landing.** Landing puts loads upon the structure which are of considerable importance, because they differ so much from those of flight. There are, of course, landings—and landings! A certain degree of bad landing must be catered for; small breakages on landing are not so serious as in flight, but they can be a source of much annoyance and loss of time.

The case of landing really covers the condition of resting on the ground, and also of taxiing, because the loads of landing are, in general, similar—only more so. How much more so depends on what degree of bad landing we allow for, or, in other words, what we assume will be the maximum vertical velocity with which the aeroplane may strike the ground.



The effect of landing on the important parts of the structure will depend also on the smoothness and travel of the shock-absorbing mechanism.

The tyres and wheels take the first shock. This is transferred to the axle and the undercarriage struts—which usually include an oil shock-absorbing device—and thence to the main fuselage structure. The weight of the wings will now come upon the interplane struts and landing wires in a biplane, and the root fittings in a monoplane; but it should be noticed that these only carry the weight of the wings, whereas in inverted flight they carry most of the weight of the aeroplane. Nevertheless, if there is much shock on landing, the load on the landing bracing or fittings will be considerably increased, owing to the inertia of the wings, i.e. their tendency to continue moving in the downward direction.

As a result of the tail skid (or wheel) striking the ground, there will be loads upon the rear portion of the fuselage tending to bend it upwards—these will affect the longerons and side bracings of the fuselage. Some types of tail skid have a considerable braking effect which tends to wrench off the rear portion of the fuselage.

The weight of engine or engines and all the weights which may be carried in the fuselage become very important when landing is concerned. These include such items as tanks and fuel, pilot, passengers and luggage, wireless apparatus and instruments of all kinds, bombs, guns, and ammunition. When engines or tanks or other heavy loads are carried on the wings, considerable loads will be put upon the wing bracings, especially in the centre section.

*Parts of the Structure Most Concerned in Landing.*  
All parts of undercarriage and shock-absorbing devices.  
Landing wires and root fittings. Tail skid (or wheel)

and rear portion of fuselage. All fuselage and wing bracing at those parts where heavy loads are carried.

7. **Acrobatics.** It would be a long job to consider all the manœuvres of which an aeroplane is capable, and to decide which parts of the structure are most affected by each manœuvre.

Fortunately this process is unnecessary. An instrument, called an accelerometer, is able to detect the loads on the structure caused by these manœuvres, and thus we can easily compare them with the loads of normal flight. As a result of the use of this instrument during all the ordinary acrobatics such as loops, spins, and rolls, we have discovered that, as would be expected, the loads during the manœuvres are usually greater than those of normal flight. In the hands of a good pilot, performing only recognized manœuvres, the loads are only very rarely as much as four times the loads of normal horizontal flight, and usually lie between loads of one-half normal and three times normal. A careless, clumsy pilot will cause far greater loads in the structure than will a skilful pilot performing exactly the same manœuvre.

So much for "recognized" manœuvres; if, on the other hand, the aeroplane is dived vertically downwards and then suddenly pulled out of the dive (not a recognized manœuvre), the loads may be as much as ten or more times normal. Similarly that dangerous stunt, the "outside loop"—during which the pilot is on the outside of the loop—will cause large negative loads (i.e. on landing wires).

A manœuvre which deserves mention, if only because of its rarity, is the "tail slide." This may occur when the nose of the aeroplane is raised until the machine is in the vertical, or nearly vertical position. It will lose its upward velocity, stand still as if hesitating

for a moment, and then it *may* slip backwards tail first. It is *much more likely* that its nose will drop and it will fall into a dive as after a steep stall, or that it will go over the vertical and fall on to its back. But real proper tail slides, though admittedly rare, have undoubtedly occurred, and from the structural point of view they are interesting because they have not been allowed for in design, and it is the unexpected nature of the loads, rather than the size of them, which is liable to cause damage. One has seen instances in which aileron, elevator fittings, and control wires have been badly damaged, and it is easy to see that severe loads will be put on the controls under such circumstances. A much more common, though less violent, example of the same sort of thing occurs when an aeroplane is left on the aerodrome with its tail towards a strong wind. Whether on the ground or in the air, an aeroplane is always safest when it is head to wind, since this is the condition for which it was designed.

It is never safe to quote rules without mentioning possible exceptions. On rare occasions it has been found advisable to peg down an aeroplane tail to wind to prevent it from taking off when it is supposed to be resting on the ground! This should only be done in an emergency, such as a severe gale; the greater the force of the wind, the more firmly will the aeroplane be rooted to the ground—but it is not good for the structure, and special care must be taken with the control surfaces. This treatment is certainly not advised with flying boats, which are safer if left to “fly at their moorings” while lying head to wind.

Very bad weather effects, gusty winds, bumps, and air pockets may cause severe stresses in flight, but in general these will be no worse than those involved in the recognized manœuvres.

*Parts of the Structure Most Concerned in Acrobatics.* Practically any part of the structure may be affected, but the loads are similar to those of normal flight multiplied by a factor which is usually not greater than 4. Exceptional loads may be experienced in unrecognized manœuvres such as the outside loop or tail slide.

## CHAPTER IV

### STRENGTH, WEIGHT, AND SAFETY

THIS is a subject of such importance that it surely deserves a chapter to itself. Every part of an aeroplane, however small and however unimportant it may be, contributes to the total weight. We can only hope to reduce that total weight, and thus improve the performance of the aeroplane, if we take the trouble to consider the possibility of reducing the weight of *every* part of it. No part must escape our attention; there must be no unnecessary material, no unnecessary complication. That last word "complication" introduces an important idea. If we are not careful, an aeroplane is apt to become a very complicated contraption, and complication is not usually conducive to reduction of weight—it is *simplicity* we want. In the words of a well-known phrase, we must try to "*simplify* and add more lightness."

**Safety First.** In our efforts to reduce weight we must beware of falling into one or two traps. The first of these is more or less obvious, and for that reason not likely to be overlooked. *Strength must not be sacrificed.* But as we have already mentioned, there is a double safeguard in this respect, because not only is the designer unlikely to be so foolish as to risk his reputation by reducing the strength below the limit of safety, but he is actually prevented from doing so by Government regulations and inspections.

**Head Resistance.** Secondly, *we must beware that by reducing weight we do not increase head resistance.* Suppose circular steel tubes are used as interplane

struts and that these tubes have been surrounded by metal casings of streamline shape. To remove these casings will decrease the total weight of the aeroplane, but it will *not* improve its performance. Many similar instances might be cited.

**Complication.** Thirdly, reduction of weight can *sometimes* only be achieved by complication which entails extra labour, time, and expense of manufacture. These three factors are, of course, important in all engineering, but they are of less relative importance in aircraft design than in any other branch of engineering. Nevertheless they must be considered.

**Weights of Component Parts.** In this particular book we are concerned with the *structure* of the aeroplane, and it might therefore be thought that, when considering the question of weight, we need only concern ourselves with the weight of the structure. But this is not really so. The job of the structure is to support the weight of *all* the aeroplane, so let us look a little more deeply into the relative weights of the various parts.

Modern power-driven aeroplanes vary in weight from under half a ton to over twenty tons. But it is not so much the total weight that interests us as the proportions of the respective weights which go to make up that total. It would be interesting—and instructive—to select various types of aeroplane and to divide the weights up into say the following categories—

1. *The power unit*, i.e. engine(s), airscrew(s), and all accessories.

2. *The useful load*, i.e. pilot, passengers, freight, mails, bombs, guns, ammunition, etc.

3. *Consumable load*, i.e. fuel, lubricating oil, water, etc.

4. *Structure*.

If we could do this both for modern aeroplanes and for those in the earlier stages of the history of flight, we should get some idea as to how we are progressing and what hopes there are for the future. Our object, after all, is to make Item 2, the useful load, as large as possible in proportion to the others, and from such a series of figures we could see whether we have made much progress in this direction. We could also see whether, for instance, we had improved the useful load by reducing the proportional weights of engine or of structure. It would, as we have said, all be very interesting; but it is of no avail to work up too much enthusiasm on the subject, because unfortunately it is quite impossible to compile such a table of weights.

There are several reasons for this. First, it would of course entail a great deal of labour, but this, in itself, would not be sufficient to deter us if it could otherwise be done and if it was felt to be worth while. Secondly, such a table could never be really trustworthy, because of the difficulty of deciding into which category, for instance, we should put the fuel and oil tanks, the engine mounting (is this part of the power unit, or is it part of the structure?), instruments of various kinds, and many other doubtful items. Thirdly, and this is the real stumbling-block, aircraft firms do not usually disclose details of the weights of the various parts, and when they do, it is not at all easy to find out just what they mean. This secrecy as regards weights is quite apart from any Government regulations as regards new machines which are on the secret list—such secrecy is understandable to all—but it is not so easy for ordinary people to realize why they should not be told the weight of any part of a comparatively old aeroplane. However, since such details are kept as trade secrets in most aircraft-producing countries, there is no doubt some very

good reason for it. Fig. 15 gives a very rough average of the percentage weights of an average aeroplane.

In the absence of such information as one would wish for, all that one can do is to try to analyse such figures as are available to the public. These, though lacking in many respects, will undoubtedly give us some useful ideas, and the reader is asked to examine the following tables very carefully and to see what knowledge he can gain from them. They are, of course, only average figures, but they have been carefully

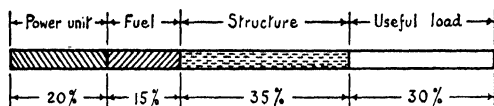

FIG. 15. PROPORTIONS OF THE TOTAL WEIGHT

compiled from the latest British and American sources and thus do represent modern practice. To give more reality to the figures, a series of definite types of aeroplane has been chosen. These types vary in weight from a private light aeroplane of less than a ton to a large passenger machine of over twenty tons.

In the first table we are going to see what proportion of the total fully loaded weight of the aeroplane is *useful load*. This term "useful load" needs defining. As it has been taken in this table, it is the same as what is often called the "disposable load," that is to say it includes pilot as well as passengers, fuel and oil, mails and freight for civilian machines, and bombs and guns for Service machines; it is, in short, the difference between the total loaded weight and the empty weight. In this sense the useful load, as we have called it, is not at all the same thing as the "pay load," which a director of a commercial air line might prefer to think



of as the "useful load" from his point of view. The pay load, of course, would not include the pilot, who is necessary for the flight of the machine, nor any of the crew, nor the fuel—these all have to be paid for instead of bringing in revenue; they are, as it were, necessary evils to anyone considering the commercial side of air transport. But to us it is as an aeroplane that we are considering our flying machine, rather than as a paying proposition; and, as an aeroplane, we want to know how much it can carry without being very much concerned as to whether what it carries is pilot, petrol, mails, or passengers, or even bombs. So here is our first table—examine it; you will find it interesting—

Type of Aeroplane	Total Loaded Weight in Tons	Useful Load as Percentage of Total Weight
1. Private light aeroplane (biplane) . . . . .	1	37
2. Single-engined commercial machine (monoplane) . . . . .	1½	35
3. Single-seater fighter (biplane) . . . . .	2	23
4. Service float plane (biplane) . . . . .	2½	30
5. Fast day bomber (monoplane) . . . . .	5	38½
6. Large night bomber (monoplane) . . . . .	10	41
7. Service flying-boat (biplane) . . . . .	12	33
8. Large commercial flying-boat (monoplane) . . . . .	18	41
9. Large four-engined passenger land plane (monoplane) . . . . .	21	41

(*Note.* It will help the reader to understand the significance of the figures given in tables such as these if he has always before him at least a mental picture of the types of aircraft which he is considering. If he is not familiar with the types mentioned, he will find

photographs of most of them either in this book, or in the companion, *Flight Without Formulae*.)

If it does not do anything else the table should give you a good idea of the total weight of the various types of aeroplane. As comparisons, remember that an ordinary motor-car may weigh anything from half a ton to two or three tons, a lorry or bus up to ten tons, a railway locomotive up to 400 tons, and a ship up to 50,000 tons or more. Since the large locomotive and the big ship can transport far more "useful load" than any aeroplane, the most interesting comparison must be with motor vehicles. You will realize that in spite of all our efforts to reduce weight, the aeroplane is by no means a featherweight. Perhaps the next thing to notice from the table is that Service machines show up badly so far as useful load is concerned, and among Service machines the fighter is by far the worst. This is, perhaps, hardly surprising. In the fighter, particularly, performance is aimed at before everything else, even fuel being cut down to a minimum. Guns and ammunition there must be, but heavy bombs are unnecessary, while even the pilot may be small and still do the job required of him.

Another point suggested is that large machines carry a good proportion of useful load, although once again the Service flying-boat does not show up too well.

From the figures given there does not seem to be much to choose between monoplane and biplane so far as useful load is concerned. If the monoplane does seem the most promising, it is only fair to add that if a single-seater fighter monoplane had been given, its useful load would be just about as bad as for the biplane—in other words, it is the nature of the job required of the aeroplane rather than its form of construction that settles the useful load.

Perhaps we may sum up this first table by saying that about one-third of the total weight of the average aeroplane is useful load in the sense in which we have defined it. (The actual "pay load" may be taken as roughly one-half of this, i.e. about one-sixth of the total weight.)

Now let us analyse the remaining two-thirds, that is to say the *empty* weight of the aeroplane. This is made up of the *engine*, the *structure* (in which we are naturally most interested), and what we will call "the rest." This last item is a very miscellaneous collection of tanks, airscrews, instruments, seats, and such-like. It does not sound very interesting; but as the table will show, it is no mean item from the weight point of view.

The aeroplanes are of the same types as before and are given in the same order, but this time you will notice that we start with the empty weight, in other words the remainder after subtracting the useful load.

Type of Aeroplane	Percentages of Empty Weight		
	Structure	Engine	The Rest
1. Private light aeroplane (biplane) .	48	26	26
2. Single-engined commercial machine (monoplane) . . . . .	51	22	27
3. Single-seater fighter (biplane) .	50	30	20
4. Service float plane (biplane) .	56	22	22
5. Fast day bomber (monoplane) .	50	20	30
6. Large night bomber (monoplane) .	50	15	35
7. Service flying-boat (biplane) .	52	23	25
8. Large commercial flying-boat (monoplane) . . . . .	50	18	32
9. Large four-engined passenger land plane (monoplane) . . . . .	49	20	31

This table is really interesting from our point of view. Surely the most outstanding feature of it is the remarkable consistency of the structure weight as 50 per cent of the empty weight in almost every type. The one exception is the float plane. This might be expected, because a float plane has all the structure of a land plane, with the floats as an extra. The flying-boat, on the other hand, is able to dispense with the undercarriage, and this largely compensates for the

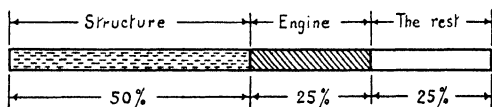

FIG. 16. PROPORTIONS OF EMPTY WEIGHT

heaviness of the hull. Modern flying-boats are a great improvement on older types so far as structure weight is concerned. This is largely due to the increase in structure weight of other types, owing to heavier undercarriages of the retracting type and the construction of fuselages and so on being very much on the same lines as a flying-boat hull.

Our second table shows very clearly that it is *not* the structure weight which accounts for the poor useful load of the fighter—the engine is the culprit. Similarly the good useful load of large machines is explained by the reduction in the proportion of engine weight for these types. All this brings us back to the conclusion that the structure weight is about *one-half the empty weight*, which means roughly *one-third of the total weight*, for all sizes and types. Fig. 16 summarizes the position in a pictorial way.

Now, the way to improve the performance, or the useful load, or the pay load of an aeroplane is to reduce

the weight of all the other parts. Just consider for a moment what it would mean if we could, say, reduce the structure weight by 10 per cent. Since structure weight is half-empty weight, this would mean 5 per cent less empty weight. But empty weight is about two-thirds of total, whereas useful load is only one-third and pay load only about one-sixth. Therefore 5 per cent saved on empty weight means 10 per cent more useful load or 20 per cent more pay load—and that is surely worth thinking about. If you have followed that argument, you will begin to see how important all this weight-saving is, and why we have to split all the weight up into the various components and consider the possibilities of saving in each.

What, for instance, are our hopes as regards the power unit? In the early days of aviation the whole possibility of heavier-than-air flight was wrapped up in the question of the weight per horse-power of internal combustion engines. In fact, it is almost true to say that aeroplanes were simply waiting for the engines to make flight possible. When suitable engines did arrive, they were still heavy for their power output. Attempts to decrease the weight led, almost inevitably, to lack of reliability. However, steady progress was made in both directions, and the modern aero engine has reached a degree of perfection which seems to be approaching a limit. This is well illustrated by the table on p. 71.

Fig. 17 shows the improvement pictorially and makes it quite obvious that we cannot hope for any great improvement in weight-reduction of the *present type* of engine, and therefore the question of reliability is receiving most attention from engine designers. We emphasize the *present type*, because there are many people who pin their faith to other possibilities, some of them already in existence, others mere dreams of the

Year	Average Weight per Brake Horse-power of Internal Combustion Engine <sup>1</sup>
1900 (Before power-driven flight) . . . . .	12.0 lb.
1903 (First flight) . . . . .	7.0 lb.
1908 (First flight in Great Britain) . . . . .	5.4 lb.
1914 (Beginning of Great War) . . . . .	4.0 lb.
1918 (End of Great War) . . . . .	2.5 lb.
1925 (Post-war development) . . . . .	1.8 lb.
1939 (Present day) . . . . .	1.4 lb.

future. All are interesting, but unfortunately we cannot afford the space to consider them in detail, nor is it wise to prophesy or dogmatize in such matters. Let

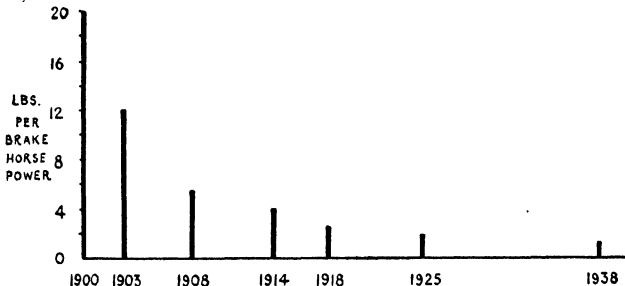

FIG. 17. REDUCTION IN WEIGHT OF INTERNAL COMBUSTION ENGINES

us wait and see. The two-stroke, the Diesel type, an internal combustion turbine, rocket propulsion, electric motors deriving power by wireless or even the energy of the atom—who knows which of these, or what type yet unknown, will be used to propel the aeroplanes of

<sup>1</sup> These figures represent an *average* of good engines of the period rather than the best value. To-day, for instance, a value of as low as 1 lb. per b.h.p. is claimed by at least one manufacturer.

the future? And what weight per horse-power will then be reached? Ah, that is the question; but at present it hardly arises, and we must be content with a prospect of only slight reductions in weight.

After dismissing the engine, we may well wonder what can be done about that very considerable item—"the rest." Perhaps there is least hope of all in this respect. Airscrews have increased in weight since their pitch became controllable; the use of plastics may help to counteract the increase, but that is about all. Tanks we must have, and it is difficult to see how they could be made much lighter. Instruments, seats, control systems, and all the thousands of small but necessary gadgets give us very little hope, partly because lightening has already been carried almost to the limit, and partly because the number of these small gadgets seems to increase rather than decrease.

Before we investigate our own department—the structure—let us think back again to what we have called the useful load. Perhaps it cannot really be claimed that we wish to reduce the weight of this item. After all, it is the object of the aeroplane to carry *as much useful load as possible* from one place to another as quickly as possible. However, there are some interesting considerations involved—for instance, suppose that letters were written on a thinner and lighter paper, then mail machines could either carry more letters, or carry the same number of letters and yet show a better performance. In a sense the "useful load" will have been decreased, but not the "usefulness" of the aeroplane. Air mail and freight charges exert much influence on this kind of thing, and therefore need careful consideration and possibly some revision. It may seem curious that one of the chief uses to which the commercial aeroplane is most suited is the transport of

exceptionally heavy (and valuable) metals such as gold, silver, and platinum. But the space in an aeroplane is small, and thus it lends itself well to a freight of high density, much value, much weight, but stored in a small space.

Nor is there much hope for reduction in the consumable load, the necessary weight of which depends on the economy of engines and the use of the best fuels. There is obviously little point in decreasing the weight of an engine if it thereby becomes more extravagant in fuel or oil. Again, it must be remembered that high density is not necessarily a disadvantage in a fuel. Assuming two fuels to have the same heating value (calorific value) per pound weight, and to be otherwise equally suitable as regards economy and so on, then the heavier fuel will be the better choice, because, being less bulky, it will not need such large tanks and therefore will mean a reduction in total weight. One must never jump to conclusions when considering aeroplanes.

Now let us return to our *structure* and we will naturally consider it in more detail—not only just because it is our own subject, but because it seems to show the most hope for future reduction of weight. It must be admitted that up to the present, progress does not seem to have been as rapid as, for instance, in the case of engines.

One would have liked to give you a table to show how structure weight had improved parallel with engine weight, but, quite apart from the difficulty of compiling such a table, one finds that there is not much sign of improvement, and it may even be negative. But we must be careful, and not jump to conclusions; for such figures, like many statistics, are apt to be misleading.



The weight of the structure depends chiefly on two things—

1. The type of material used.
2. The margin allowed for safety.

**Materials.** During the period under review there have been startling changes in material, and regulations have been formed to ensure safety. It might be argued that the changes have been due to progress and experience, and that they should therefore have contributed towards a reduction in weight. On the other hand, it must be remembered that the change from wood to metal was not made solely on account of the superiority of metal, but rather owing to the difficulty of obtaining suitable wood, especially in war-time. Also the performance required of modern aeroplanes has tended to stiffen up, rather than slacken, the regulations affecting strength.

The question of the choice of material for the structure is a most interesting one. *Other things being equal*, the best material is the one which gives *the greatest ratio of strength to weight*. That delightful phrase "other things being equal" serves, as usual, to cover up a multitude of difficulties, because in the materials under consideration, other things are by no means equal. "Other things" include such questions as resistance to corrosion, consistency of quality, liability to fire, ease of manufacture, cost, sources of supply, and so on. Even when we confine ourselves to the consideration of the ratio of strength to weight we are up against a difficulty in the definition of the word "strength."

If we steadily increase the load on a material it passes through various stages before it finally breaks, and for all practical engineering purposes it is quite useless long before it does break. The elastic limit, the yield point,

the proof stress, the ultimate load—all these have been used as a measure of strength, yet all are, in their way, unsatisfactory. What is more, in certain materials some of these critical points cannot even be detected. Some materials are more suitable for tension than compression, and vice versa. Some are more subject to the phenomenon of fatigue than others.

There is yet another point to be considered. In modern high-speed aircraft the question of degree of flexibility of the structure is becoming of great importance, and although we cannot go into this subject deeply at this stage, we can at least say that the tendency is towards rigidity and therefore we cannot use materials which stretch too much under load.

Enough has been said to show that the problem of choice of material for our structure is a very complex one. The authorities at the Air Ministry and the designers themselves have not succeeded in settling it, so we poor ordinary mortals are not likely to do so; yet, for what it is worth, we offer the following comparison of the four main groups of possible materials, i.e. wood, steels, light alloys, and plastics (all figures are approximate only).

## I. WOOD

*Ratio of strength to weight*<sup>1</sup>: Spruce, 160; ash, 200.

*Advantages*: Easy and cheap in manufacture, especially for new types or for small numbers, easy to repair, lighter for parts carrying small loads.

*Disadvantages*: Inconsistent in quality, difficult to obtain in sufficient quantities and in long lengths, liable to fire, liable to shrinkage, and not very suitable

<sup>1</sup> I.e. breaking strength in tons per square inch divided by weight in lb. per cubic inch.

for use in the tropics. It distorts considerably under load. For hulls and floats, liable to water soakage.

It should be noted that many of these disadvantages have recently been overcome by extending the principle of three-ply and by compressing the wood. Thin strips of wood are glued together to form a multi-ply type of construction, the grain running in different directions in the various layers. The whole is impregnated with glues and plastics, and compressed to less than half of the original volume. The result is, of course, a denser material, but the ratio of strength to weight is improved and there are many other advantages.

## 2. STEELS

*Ratio of strength to weight:* Mild steel, 124; Medium steel, 228; High-tensile steel, 315.

*Advantages:* Good supply. Consistent in strength. Can be suited to varying requirements by suitable heat treatment and alloying. Stainless steel is practically non-corrodible. Most types weldable. High strength/weight ratio of high-tensile varieties (*but* notice corresponding disadvantages).

*Disadvantages:* Poor strength/weight ratio except in high-tensile varieties, and when used in high-tensile state the strength is so great that the metal is often very thin, and thus it is liable to crinkling and buckling. Complicated corrugation is necessary in such cases for spars and struts, and hence expensive machinery is required for rolling and drawing.

## 3. LIGHT ALLOYS

*Ratio of strength to weight:* Duralumin (aluminium alloy), 242; Electron (magnesium alloy), 303.

*Advantages:* Their greater bulk for the same weight

makes them less liable to local crinkling. Easily worked after simple heat treatment.

*Disadvantages:* Subject to corrosion which spreads to the interior of the metal, especially bad from sea water.

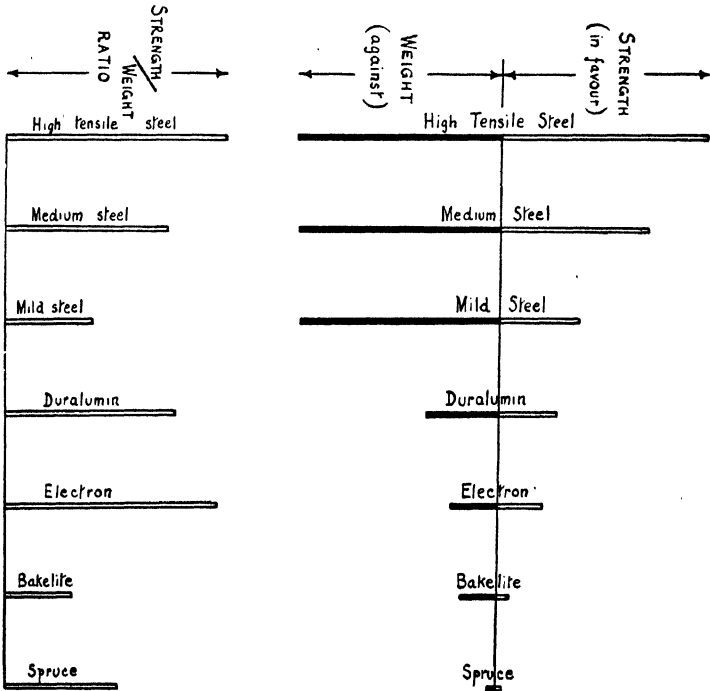

FIG. 18. STRENGTH AND WEIGHT OF VARIOUS MATERIALS

#### 4. PLASTICS

*Ratio of strength to weight:* Bakelite, 96.

*Advantages:* Non-corrodible, unlimited supply, suitable for mass production with unskilled labour, good insulating qualities for wireless apparatus, etc.

*Disadvantages* : Chiefly, at present, lack of experience. Although strength/weight ratio has been improved by reinforcement with fabric, the value of Young's



FIG. 19. HOW THE MATERIALS STRETCH UNDER LOAD  
(WITHIN THE ELASTIC LIMIT)

Modulus is still low, which means that the material stretches badly under small loads.

We see that, taken all round, there is not much to choose between the materials available, and in consequence we still find all four groups in use. Fig. 18 sums up the position in a pictorial way, while Fig. 19

shows how much each material stretches under a given load.

**Factors of Safety.** Well, so much for the choice of material. The other factor which has most effect on the structure weight is *the margin allowed for safety*. This question of degree of safety is one of the most interesting of all aircraft structural problems.

The idea of having some kind of "factor of safety" is a very elementary one. If you want to hang up a weight of 10 lb., you do not choose a piece of string which will break at  $10\frac{1}{2}$  lb. Why not? Well, because you know that, while this string might carry the weight if it remained absolutely still, the slightest jerk would break it. What strength of string do you choose? What you probably do is to use any bit of string you can find which is *obviously strong enough* for the job. And that, in effect, was what was done in the old days of engineering—the great cathedrals, castles, and other ancient buildings were hardly "designed" in the modern sense of the word. This does not mean that there was no artist at work (no one would doubt that), but rather that there were no "stress merchants" to calculate, for instance, the necessary diameter of a pillar to support the roof. That pillar was made of such a size that any fool could see that it would be strong enough—in fact, just like your piece of string.

Now, there are certain types of modern structures, such as aeroplanes, bridges, and even buildings, in which *the chief weight which the structure has to carry is the weight of the structure itself*. Therefore the lighter the structure, the less weight it will have to carry, and therefore the lighter it will be. The same old vicious (or rather virtuous) circle. This decrease in weight not only improves performance (as in the aeroplane), but means less material, less labour, and

less expense. The cathedral designers did not have to worry their heads about these three items to the same extent as the modern aeroplane designer.

Let us return to your string. Here is a new problem for you. Suppose, for some reason, that you must hang up the 10 lb. weight with a piece of string which must be strong enough for the job but *which must weigh as little as possible*. Here you have the problem of the aeroplane designer. There is no "obvious" about it this time; "any fool" cannot decide what strength of string to use. You will seek out the type of string which is *strongest for its weight*—in other words, you will first decide your *material*. This done, you may find strings of this material which will break at 10 lb., 15 lb., 20 lb., 25 lb., and so on. Which shall it be? Try some experiments. Hang the weight on the 15 lb. string—swing it about, and it will probably break. Try the 20 lb.—jerk it a little, and again it breaks. Proceed in the same way with the 25 lb., 30 lb., 35 lb. strings, until you find one which will not break under any *reasonable* movements of the weight. Say you decide on the 40 lb. string. Even now, will you be quite happy? Are you quite sure that this string will stand up to 40 lb.? Will every piece of it be the same strength? Will it deteriorate with age, dampness, etc., until it becomes too weak? Will it pass over any sharp edges and be liable to fray? Perhaps after all you had better go a little higher than 40 lb. But how much? Ah, there's the rub! Do you see the difficulty? All right, that is enough for the moment.

Your difficulty is the same as that of the designer. He, too, must make each part of the structure strong enough for any *reasonable* conditions—and then some more. That word "reasonable" is, in itself, a means of avoiding quite a big difficulty—just as it is when used

in its legal sense of a "reasonable man," "reasonable precautions," and so on—so we must decide what is meant by "reasonable conditions"—and also by "How much more?"

**Elastic Limit, Yield Point, Ultimate Strength.** But our difficulties are not yet ended. Most materials, especially those used in engineering construction,

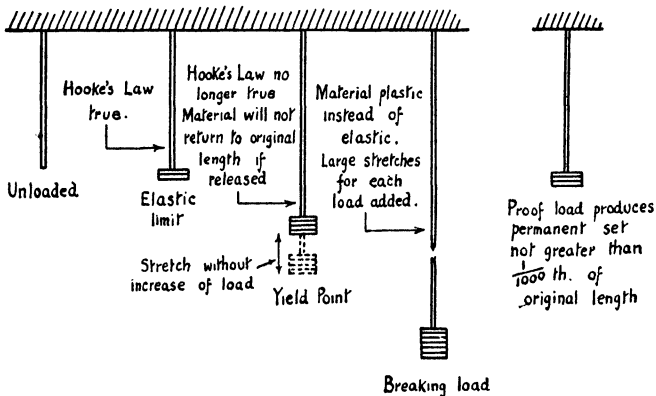

FIG. 20. STRETCHING A MATERIAL

become useless for all practical purposes long before they break. If we take a mild-steel wire and apply a gradually increasing load to it, it will pass through several stages (Fig. 20).

1. Up to a certain load (called the *elastic limit*), if we release the load the wire will return to its original length. During the same stage the well-known rule called *Hooke's law* is very nearly true; that is to say, the stretch will increase in proportion to the load. It is interesting to recall that Hooke, who first stated this important law, was Sir Christopher Wren's engineer



and adviser. Wren was the artist—Hooke the stress merchant!

2. Very shortly after the elastic limit, the *yield point* is reached, at which there is a large visible stretch without adding further load.

3. After the yield point further loads must be added, and very large stretches take place for each addition. If the material is released from load, there is quite a large *permanent set*, i.e. the wire remains permanently extended. Eventually the greatest possible load is reached, and shortly after that the material forms a "neck" and breaks. This is called the *ultimate load* or *breaking load*.

It is really more sensible to talk of "stress" than "load," the intensity of stress in a material being the load divided by the area of cross-section which is carrying the load.<sup>1</sup> If the load is measured in tons, the stress will be in tons per square inch. By "stress," used in this sense, we mean the *intensity* of stress.

In a particular test on mild steel, the elastic limit was 17 tons per square inch, the yield point 19 tons per square inch and the breaking stress 35 tons per square inch. Other materials behave differently, but it is true of them all to say that they become useless under a stress which is considerably less than the breaking stress. After all, a material cannot be of much practical use if it gets longer each time it is loaded—therefore the elastic limit would seem to be the *practical* strength of the material. In some materials, especially the high-tensile steels, there seems to be no real elastic

<sup>1</sup> In the interests of convenience, rather than truth, it is usual to divide the load by the *original* area of cross-section, i.e. the area before any load was put on. When the load is applied, and the material is stretched in the lengthwise direction, the cross-sectional area naturally shrinks, and thus the *real* stress in the material is higher than the load divided by the original cross-sectional area.

limit, and we have to choose an artificial point called the *proof stress*, which produces a certain specified extension in the material.

**Fatigue.** But modern engineers have had to face yet another difficulty. If the load on a material is repeatedly applied, then released, and so on; or if it frequently fluctuates between tension and compression, a phenomenon called *fatigue* sets in, and the material becomes weaker and weaker, according to how many times the load is changed. Very fortunately there is a limit to this, and after about ten million changes of load (a frequent occurrence in practice) there is no longer any weakening of the material. None the less, it is already serious, and the ultimate stress of mild steel may drop from 35 tons per square inch to 25 tons per square inch, and the elastic limit from 17 tons per square inch to 12 tons per square inch.

**The Engineering "Factor of Safety."** So much for the problem. The solution has been largely one of trial and error; that is to say, various rules have been adopted, and experience has shown whether they are adequate or not. Aircraft engineers have followed rather different lines from those adopted in other branches of engineering, but their aim has been the same, namely to produce a structure with the maximum of strength for the minimum of weight. The ordinary engineer lays a little more emphasis on the *maximum of strength*, the aircraft engineer on the *minimum of weight*.

It is much easier to understand the aircraft method if we first examine the standard engineering method. The term *factor of safety*, used in engineering, means ultimate load/working load, e.g. if a certain part of a structure is, under certain conditions, carrying

working load of 50 lb., and if that same part will break at 1000 lb., then its factor of safety is, *under those conditions*,  $1000/50$ , i.e. 20. If, under some other conditions that same member carries a load of 200 lb., its factor of safety will be reduced to 5. Now if, as often happens, the load in a member varies considerably according to the conditions, all we need do is to find out the *lowest factor of safety*. For instance, in the example already

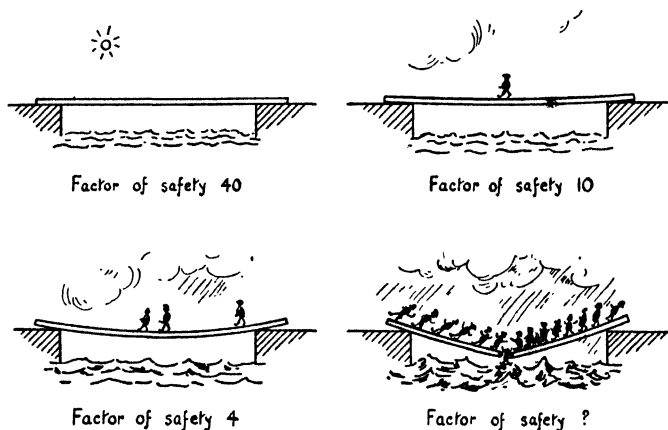

FIG. 21. FACTORS OF SAFETY

given, there is no need to worry about the load of 50 lb., when, at another time, there is a load of 200 lb. If, however, 200 lb. is the largest load likely to be encountered in practice, then we could say that the factor of safety of that member was 5, meaning really that 5 was the *least* factor of safety. But we must still be careful, because, whereas that particular set of conditions caused the greatest load in that particular member, some *other* set of conditions may cause the greatest load in some *other* member. So we

really have to find the worst likely conditions for each member.

Let us consider a bridge as a typical example—say a large railway bridge. On a fine summer day, at a time when there are no trains on the bridge, and when there is no wind, the only loads on the members of the bridge will be caused by its own weight, this being called the *dead load*. The loads in the various members can be calculated for this condition, and we will imagine that some particular member carries a load of 1 ton. Now, when a train goes over the bridge, the load in this member will probably vary according to the position of the train, and so we must find the load when the train is in the worst position.

Not only this, but we must imagine the train to be the heaviest train ever likely to cross the bridge—in fact we shall probably allow for two trains passing at this particular point. In addition, the speed and vibration of the trains will further add to the load, this being called the *live load*. Then a gale of wind may be blowing at the same time from the worst possible direction, causing quite heavy loads in the bridge. When all this is considered, in other words taking the worst possible conditions the bridge is ever likely to experience, the load in our particular member may have gone up to, say, 10 tons. Now, over and above all this, we allow a *factor of safety* of, say, 4. And we design for this member a piece of material which will break at 40 tons. Thus the factor of safety of this member will be as much as 40 on the fine summer day, but *may* be reduced to 4 under a rather unlikely series of coincidences. We certainly seem to have made sure, and the reader may wonder why there is any necessity for the 4 at all. In the old days it was called a “factor of ignorance”—just in case some of the calculations had gone astray!

But it is still found advisable to allow this factor, although engineers are much more sure of their theories. Why? Well, there are at least four reasons—

1. The particular member will *break* at 40 tons; but for all practical purposes it will become useless at its elastic limit, which may be as low as 20 tons, thus reducing the *real* factor to 2 instead of 4. There is also, in some cases, the question of “fatigue.”

2. The material of which the member is composed will certainly deteriorate with age and weather conditions, thus losing some of its original strength.

3. There still remain possibilities of errors and uncertainties in the methods of design and calculation.

4. There may also be errors and uncertainties in the workmanship, in consistency of material, and so on. On the whole, then, we were probably wise to allow this factor—and experience has proved it to be advisable. The collapse of a railway bridge is a serious matter—and it is not unknown, in spite of the factor of safety.

**Load Factor.** Now, what shall we do about the aeroplane structure? The unloaded bridge on the fine summer day corresponds, very roughly, to the condition of steady flight known as *normal horizontal flight*. What corresponds to trains passing over the bridge? There is no exact parallel, but the manœuvres of the aeroplane—turns, spins, rolls, and acrobatics generally—have much the same effect. That is to say, they increase the loads in all the parts of the structure.

Which, then, of these manœuvres will cause the greatest loads? Here is our first difficulty. I suppose the supreme test of the strength of an aeroplane would be to dive vertically into the ground—but we do not attempt to make it strong enough to do that without breaking. The worst thing that a pilot can do to an

aeroplane, without actually coming into contact with the ground, is to dive it vertically at its terminal velocity and then suddenly pull the stick back so that it comes out of the dive. The effect of this is limited by such things as the pilot's strength, but it may quite easily cause loads which are ten or more times those of normal horizontal flight. Suppose we now allow our factor of safety of 4, we must make each member forty times as strong as is necessary for normal horizontal flight.

If the reader has followed the argument up to this point he will be shocked to hear the truth. The parts of an aeroplane are usually made about six to eight times as strong as is necessary for normal horizontal flight. That is the truth, the whole truth, and nothing but the truth, and at first it is somewhat alarming. This factor, i.e. *the ultimate strength of the member divided by the load it carries in normal horizontal flight*, is called the *load factor*.<sup>1</sup>

Let us be optimistic and assume that our aeroplane has a load factor of 8. This means that in normal horizontal flight our real factor of safety is 8—that sounds reasonable enough. But when the aeroplane is suddenly pulled out of a nose-dive, it is 8/10—less than 1! The aeroplane is *expected* to break! Besides, what about the deterioration of the material, the uncer-

<sup>1</sup> This is an old definition of the term *load factor*, and, strictly speaking, the term is not now used quite in this sense. The difference in definition is of great importance to the man who has actually to work out the strength of an aeroplane structure and who will naturally be familiar with the current official regulations; but for our purpose it is better to try to understand the underlying principles, and these seem to be better illustrated by the older—and simpler—methods. If details were given of the modern regulations, the reader would not find it easy to see the wood for the trees. However, later on in this chapter we will amplify the definition to some extent.

tainties of design and all the other things we allowed for in the bridge?

Having thoroughly frightened the reader—especially

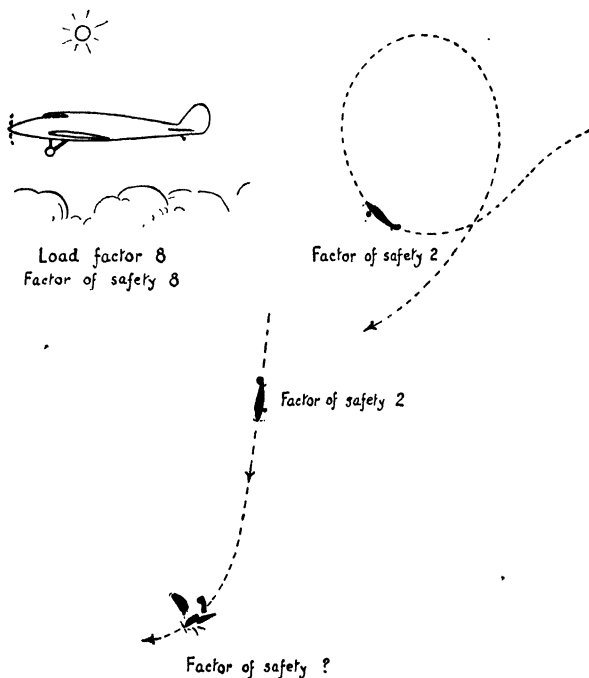

FIG. 22. LOAD FACTORS AND FACTORS OF SAFETY

if he is a pilot—let us cheer him up again. It is not quite so bad as it sounds.

Aeroplane designers realized, long ago, that if aeroplanes were designed on the ordinary engineering lines, they would be so heavy that flight would be almost impossible. The particular manœuvre mentioned (the terminal velocity nose-dive followed by a sudden pull

out of the dive) is not a necessary part of the performance of an aeroplane. Experiments have been performed to discover the loads in an aeroplane structure during "reasonable" manœuvres, those required by a commercial machine in its ordinary work (including conditions of bad weather), those stunts usually used for exhibition purposes and pleasure flying, and the acrobatics which are necessary in military machines for fighting purposes. The experiments show that, provided these requirements are not exceeded, the loads, in the hands of a good pilot, never rise above three or four times those of normal horizontal flight. Thus, with a load factor of 8, we shall always have a factor of safety of at least 2—in the worst "reasonable" conditions. Actually the load factor is not usually as high as 8, and may only be 5 or 6 according to type of machine. So it is easy to see that we are cutting things to very fine limits.

Obviously, if we are to cut things as fine as this, we must reduce all errors and uncertainties to a minimum. Let us again investigate the reasons for applying the factor of safety in ordinary engineering, and see how we can deal with them in aircraft structures—

1. *The Discrepancy between Ultimate Strength and Elastic Limit, and the Effects of Fatigue.* It might be thought that we would try to design to the elastic limit instead of to the ultimate strength, but this is not altogether satisfactory owing to the difficulty of obtaining an accurate estimate of the elastic limit in many materials. The modern tendency is to use a "proof stress" instead of the ultimate strength.<sup>1</sup>

<sup>1</sup> The definition of Proof Stress will be quite easily understood by those who have learnt the elementary principles of the strength of materials. So long as Hooke's law is true, the extension of a member under tension is proportional to the load applied to it, or, to be more precise, the strain (extension divided by original length) is



Where members are liable to fatigue, the consequent reduction in ultimate strength or proof stress is taken into account.

To sum up this point, a greater accuracy of tests and specifications is applied to aircraft materials than to those used in ordinary engineering. *Every* piece of material for *every* part of *every* aeroplane is inspected before use.

2. *Deterioration of Material.* All possible precautions are taken to eliminate this danger from aircraft structures. Elaborate anti-corrosion measures are specified, sometimes two or three anti-corrosive processes being used on the same part of the structure. (An example of this is where Alclad—a material consisting of a sandwich of duralumin between sheets of pure aluminium—is anodically treated and then enamelled.) Thus, to protect the duralumin from the corrosive action of the atmosphere or sea water there is first a layer of aluminium, then a layer of aluminium oxide due to the anodic treatment, then the enamel.

Frequent inspection of parts is carried out, often between every flight, and if there is the slightest suspicion of a fault, the part is replaced by a new one. Last, but not least, the "life" of an aeroplane is comparatively short, and throughout its short life the parts of an aeroplane ought to remain as good as new.

3. *Uncertainties of Design.* These cannot be entirely eliminated, but where there is doubt, the error is always made so as to make the strength of material on

proportional to the stress (load divided by cross-sectional area). The Proof Stress is the stress at which the material departs from Hooke's law by a certain specified amount, e.g. the 0.1 per cent proof stress (the one most often specified) is that stress at which the material has stretched by 0.1 per cent (i.e. one-thousandth) of its original length *over and above what it would have stretched had Hooke's law remained true.*

the right side. The aeroplane is given the benefit of the doubt. In many instances whole parts of the aeroplane are made and tested to destruction so as to remove all uncertainty. This method has been used not only for such parts as ribs and spars, but for complete fuselages, main planes, and even the aeroplane itself. As previously mentioned, all drawings and calculations must be submitted to Government inspection.

4. *Errors in Workmanship.* This, too, cannot be completely eliminated. In aircraft work it applies not only to the original construction of the machine, but to the care used in maintenance and rigging. There is constant supervision by Government authorities during manufacture, and only highly skilled and intelligent men are used for maintenance purposes. Both in civilian and Service work the men must pass recognized tests and examinations before they are allowed to inspect, repair, or rig aeroplanes. A very high degree of accuracy is insisted upon in all aircraft work—the modern aeroplane cannot be considered as fool-proof.

Enough has been said to show that every possible precaution is taken to make the aeroplane safe in spite of its low factor of safety. But there is no room for liberties to be taken. You need have no fear to fly in an aeroplane provided you have a good pilot, knowing just what his aeroplane will do, and provided proper care has been taken of the aeroplane when on the ground; but woe betide you in the hands of a fool of a pilot, or even of a fool to look after it on the ground. When you understand the small margin of safety which is allowed, and when you reflect on the *extraordinarily small number of aeroplane accidents which have resulted from the failure of some part of the structure in the air*, you will realize that great credit is due to the designers, craftsmen, inspectors, pilots, and mechanics

employed on aircraft work. It has even been suggested that our aircraft are *too strong*, and that some of the regulations might be relaxed in order that weight might be reduced and performance improved. This might be possible in certain instances—and, in fact, some modifications have been made in this direction—but it would be disastrous if carried too far.

**More Load Factors.** We have now got a good general idea of the meaning of a load factor, i.e. the strength of a member divided by its load in normal horizontal flight. You will remember that, when considering a bridge, we made a point of the fact that one set of conditions might have the worst effect on one particular member, but a totally different set of conditions might prove the worst case for some other member. So too with our aeroplane. To reduce the idea almost to an absurdity, we should hardly suggest making an under-carriage eight times as strong as it need be for normal horizontal flight. We would surely take a normal *landing* as our criterion, and apply some factor of safety to cover bad landings. Similarly, landing wires on biplanes are of no importance in normal horizontal flight, yet of vital importance in *inverted flight*, and there are many instances of the same kind. Therefore the problem grows a little more complicated, and for normal horizontal flight we must substitute some phrase, such as “standard conditions of flight or landing.”

Fortunately it is not necessary to choose all the conditions which might occur, because the whole idea of the load factor was to cover acrobatics. The conditions chosen are really those which have widely different effects on different parts of the aeroplane, as for instance the cases of landing and inverted flight, mentioned above. It is even found advisable to

consider *two* conditions of level flight, one at high speed (when the centre of pressure is a long way back on the chord of the aerofoil) and one at low speed (when the centre of pressure is well forward).

The following cases are usually considered—

	Load Factor Required
1. Normal flight—centre of pressure forward . . . . .	9
2. Normal flight—centre of pressure back . . . . .	6
3. Vertical up or downward gust (of 25 ft. per second) when flying at top speed . . . . .	2
4. Vertical dive at terminal velocity . . . . .	2
5. Fast glide (at speed 50 per cent more than normal top speed) . . . . .	2
6. Upside-down flight (in two different attitudes) . . . . .	4.5
7. Landing . . . . .	4.5

The figures show the load factors required of civil aeroplanes in what is called the “acrobatic category,” and it is interesting to note that they have been decided by estimating the loads encountered in *reasonable* acrobatics in the hands of a *good* pilot, and then multiplying by 2, so that, in effect, there will always be a *real* factor of safety of 2. There is also a “normal category” in which the load factors are slightly less and some of the conditions, such as inverted flight and terminal velocity dive, are omitted altogether. Aeroplanes of “normal category” are not permitted to fly inverted, nor to perform any violent acrobatics. Service aircraft are designed to practically the same load factors as civil aircraft, of acrobatic category, except that special conditions are sometimes laid down in the specification. The load factor is fixed by the Air Ministry, not the designer, and the designer is bound to conform to a load factor *at least as high as that laid down*. He may, of course, employ a higher one, but this will be his own loss, because he will have extra weight, unnecessary strength, and lowered performance.

Therefore, strange as the statement may sound, the designer tries to make his aeroplane *as weak as regulations allow*.

A simple example will make the use of the load factor clear. Suppose (in an aeroplane of 10,000 lb. total weight) a rear flying wire is found to carry a load of 1000 lb. when the centre of pressure is in its backward position, 800 lb. when the centre of pressure is in its most forward position, and 3000 lb. in a nose-dive. During landing and inverted flight the loads need not be considered. Now, the respective load factors are 6, 9, and 2. Thus the strengths required of this flying wire for each case are 6000 ( $1000 \times 6$ ), 7200 ( $800 \times 9$ ), and 6000 ( $3000 \times 2$ ).

Obviously, therefore, we shall choose the standard-size wire having a strength next above 7200 lb.

The same principle is applied to each part of the structure, and in this way the dimensions of spars, struts, wires, longerons, and so on are determined.

*Note.* Before leaving this important subject of Load Factors, it may be advisable to warn the reader once again that we have tried to give him the *general idea* rather than the precise methods of design procedure. The latter will be found in the official publications on the subject, e.g. Air Publication 1208 for civilian aircraft and Air Publication 970 for Service aircraft, and also in certain text-books. If and when the reader explores so far he will find that it is all a little bit more complicated than we may have led him to suppose. As instances of this complication we might mention that even the normal flight cases are not quite straightforward, because the aeroplane is assumed to be *accelerating* instead of in steady normal flight. After all, this is only reasonable, because the increased loads—for which the load factor is allowed—are almost

entirely due to changes of attitude and speed, i.e. to accelerations. But the application of accelerations at right angles to the direction of flight means that, in effect, the weight of the aeroplane is increased. This means that in the above example, for instance, instead of thinking of the weight of the aeroplane as 10,000 lb., we ought to have multiplied this by the load factor (e.g. 6 for C.P. back) and found the load in the flying wire due to an aeroplane of weight 60,000 lb. Strange as it may seem, this is not *exactly* the same thing as finding the load due to an aeroplane of weight 10,000 lb. and then multiplying by 6. Sometimes we have to multiply the weight by half the load factor, and then multiply the answer by 2, and this gives an answer different from both other methods. But such differences are slight, and the reader will probably have a much clearer picture of the meaning of load factors if he neglects the differences—for the moment.

**Weak Links.** *A chain breaks at its weakest link*, and in just the same way the aeroplane structure will fail at the weakest spot. It is useless to adopt all these elaborate methods for securing safety unless we make sure that our system includes *every* part of the structure, no matter how insignificant it may seem. The failure of some small fitting, or even a bolt, may cause just as great a disaster as the collapse of the whole structure of the aeroplane. For this reason, great care is taken in the detail design to see that all the end fittings of wires are at least as strong as the wires themselves, and the same principle applies to the attachment of the planes to the fuselage and centre section, of under-carriage struts to fuselage, and so on.

Thus there should be no weak link. And where does a chain break if all the links are equally strong? The answer is: "At the weakest link"—or, putting it

another way, it is impossible, in practice, to make every part of exactly equal strength, and the weakest point will soon be revealed if too great a load is put upon the structure. We emphasize this because it brings in rather an important idea.

Because one part of a structure breaks, it must not be assumed that that part was necessarily very much weaker than the other parts. Suppose a chain is made by a row of strong men holding their arms out horizontally and grasping each other's hands; now apply a gradually increasing pull at each end of the chain. Eventually the time will come when one man will release his grip and break the chain. Do not be deceived by the smiles of satisfaction from the others into thinking that it had been proved that the man who gave in was much weaker than the others. If you could have read their thoughts *just before this man gave in*, you would have found that each man was himself on the point of surrender. But *as soon as the chain was broken* the load was relieved—hence the smiles. So with the structure—after one part has broken all the other parts may appear unaffected; but, if it is a well-designed structure, all the other parts must also have been *on the point of breaking*—they have probably, at least, passed their elastic limits, and the obvious moral is that if one part should break (and if the aeroplane should survive), a very careful inspection of all other parts should take place.

To return to our simile of the human chain. Suppose the same team were subjected to several tests, and that *the same man always gave in first*—then one would be justified in assuming that he was the weakest man. If all the men were equally strong, *all would be equally likely to fail*, and repeated tests would cause one after another to prove himself the weak spot. So too with

the structure—or with any part of it. If the wing structure of an aeroplane is loaded up and “tested to destruction,” it should be impossible to predict whether it will be the ribs, spars, struts, or flying wires which will be the first to fail. If several such wings are tested, failures should occur at different parts each time. If they always occur at the same part, that part is not up to strength. Similarly, if a spar is tested, it should be quite uncertain at which part of the spar failure will take place.

All this is more or less common sense. But what is not quite so obvious is that it is almost as great a sin to make any part *too strong* as it is to make it too weak. If one man in the human chain *never* failed, in spite of repeated tests, one would assume that he was stronger than all the rest. In the case of the structure, the extra strength of this kind is unnecessary, and simply means so much extra weight.

There are exceptions to every rule, and instances do occur when it is advisable to make a part stronger than its calculated strength. Two interesting examples of this may be mentioned—

1. When the calculated strength means that the member would be of such small dimensions that it would not be a practical proposition as part of an aeroplane structure. This difficulty is especially likely to arise when a very strong material, such as steel, is used for parts which only carry fairly small loads, such as ribs. In some small aeroplanes of wooden construction the calculated size of certain parts of the ribs may be no larger than a match. That sounds bad enough; but suppose we substitute steel for the wood, then only one twenty-fifth, or for some high-tensile steels only one-fiftieth of the cross-sectional area of the match would be required—in theory! If the cross-sectional



area of the member is increased until it is of a practicable size, then, of course, it will be a great deal heavier in steel than in wood. This is a definite disadvantage of the use of steel for parts which only carry small loads, and it accounts, to some extent, for the modern tendency towards a composite structure of steel, light alloys, and even wood, rather than all-steel construction.

2. It is bad practice to have a very strong member in close proximity to a very weak one, even if the weak one is up to the required calculated strength. For instance, a flying wire should not be *very much stronger* than the landing wire in the same bay, nor a drag wire than the corresponding anti-drag wire. The chief objection to this is the danger of a clumsy rigger tightening up the strong wire to such an extent that it will put dangerous initial loads in the weaker wire. It is rather like using a large spanner to a very small nut. But whereas the remedy for the latter case is to use a small spanner, the only possible remedy in our structure is to strengthen up the weaker wire—and thus increase the weight.

**Strength Tests.** The reader will have gathered by now that there is a fair amount of uncertainty, not to say guesswork, about aeroplane design. This must be admitted, although, as has already been pointed out, the final test is the strength of the aeroplane in the air, and in such tests the aeroplane structure has shown up quite favourably when compared with other types of engineering structure. But flight tests do not by any means tell us all that we want to know. On the rare occasions when structural failure does occur it is usually accompanied by disastrous loss of life and material, and in spite of careful examinations by accident investigators it is often impossible, among the general wreckage, to discover what part actually failed. On the other hand, absence of structural failure is really negative evidence

which tells us very little. An aeroplane which does not break may be much too strong, and that is only a little less sin than being too weak.

But there is a very useful intermediate step between theory and practice, and that is the *strength testing—on the ground—of separate parts such as spars or ribs, of whole components such as fuselage or wing, and even of complete aeroplanes*. This is not a new idea (even during the war of 1914–18 one out of every batch of fifty or so aeroplanes was sometimes tested to destruction), but one that has recently been revived by the Air Ministry allowing firms to prove the strength of their designs by practical tests as an alternative to theoretical calculations. This concession has been particularly useful when new types of construction have been introduced.

But it must not be imagined that even such tests are plain sailing.

For instance, how are we to know that the loads we apply during the test are the same as will be applied during flight?

When does an airframe, or part of an airframe, collapse? Or, what is more important—at what stage does it become so distorted that we should consider it unfit for flying?

Since tolerances and allowances must be made for all workmanship, how are we to know that the parts subsequently built for use will be of exactly the same dimensions—and strength—as the parts tested?

In view of these and other uncertainties the Air Ministry have been forced to draw up stringent regulations about such tests. For instance, a specimen tested will probably be what is called a “typical” component, i.e. one taken from the workshops at random; this will give better results than a “standard” component, which

is one in which every dimension is the smallest allowed by the various tolerances. For this reason a "typical" component has to stand 20 per cent more than the load factor laid down. Again, to guard against undue distortion, the structure must still be of such shape as to be airworthy during and after a proof load (75 per cent of the total) has been applied for one minute.

Let us sum up the many important conclusions we have arrived at in this chapter—

1. Simplicity means lightness.
2. Weight must be reduced, but not at the expense of strength or head resistance.
3. The "useful load" carried by an average aeroplane is about one-third of the total weight, but only about half of the "useful load" is actual "pay load."
4. Of the empty weight, the structure forms about half and the engine about one-quarter.
5. Weights of power units have been reduced from 12 lb. per horse-power in 1900 to 1.4 or less lb. per horse-power in 1939.
6. Useful load is the part which we wish to *increase*.
7. Reduction in consumable load depends on raising the efficiency of engines and the production of better fuels.
8. There has not been much improvement in structure weights.
9. *Other things being equal*, the best material is the one with the greatest strength/weight ratio.
10. Parts of a structure must be made stronger than the normal load for which they are required, for the following reasons—
  - (a) Abnormal loads and conditions.
  - (b) Fatigue.
  - (c) Materials become useless long before their breaking point is reached.

(d) Deterioration of the material.

(e) Uncertainties of methods of calculation and design.

(f) Errors and uncertainties of workmanship.

11. The load factor and the reasons for careful design, workmanship, and maintenance of aeroplane structures.

12. There must be no weak spots in the structure.

13. Unnecessary strength means unnecessary weight and loss of performance.

14. Very strong material, such as high-tensile steel, is not suitable for lightly loaded parts.

15. Strong members should not be counter-braced by weak ones.

16. Strength testing of various components is now accepted as an alternative to calculations of strength.

## CHAPTER V

### FRAMEWORKS

THE skeleton structure of our aeroplane is a *framework* composed of a strange mixture of struts, ties, and beams. To engineers there are many different kinds of frameworks; in the present chapter we will examine some of these and see if we can discover how the designer—or rather the “stress merchant”—finds out the loads in the various members which go to make up the framework. Finally we will steal into the designer’s office, and stealthily remove some of his results so that we can find out what loads the important parts have to carry. Just think how much more interesting it would be if we knew what load our flying wire was carrying in flight—and at what load it would break!

**The Ideal Framework.** A framework, like most other things, is not always exactly as we should like it to be. From an engineer’s point of view a structure would be an ideal one (*a*) if all its members were struts or ties, i.e. if it contained no beams, (*b*) if all the joints were pin joints, which means that they would act like hinges, and (*c*) if all the loads on the structure were applied at the joints. (Fig. 23 shows an ideal structure in which all the members are in tension, and Fig. 24 shows the same structure but with different loads which put two of the members in compression.)

In real structures all these three conditions are rarely fulfilled; some types of crane are probably the nearest approach to such an ideal framework. The spars and ribs of an aeroplane, the main girders of a bridge, the rafters of a roof, are examples of beams forming

important parts of a structure. As for pin joints, it is not often that the joints in a structure are actually in the form of a hinge; none the less it is true to say that many

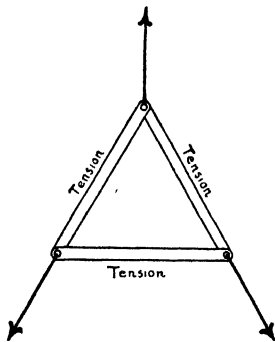

FIG. 23

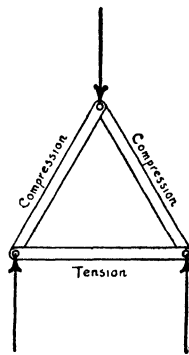

FIG. 24

joints, especially in an aeroplane, are, *in effect*, pin joints. Imagine one of the interplane struts in a biplane. If the top plane is removed and we pull sideways at

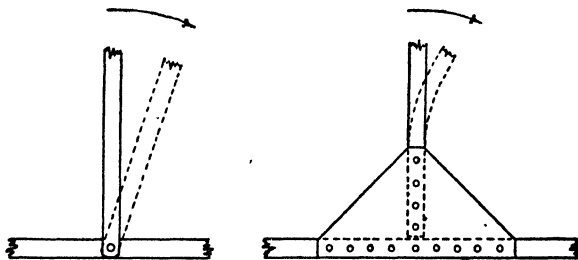

FIG. 25. PIN JOINT AND RIGID JOINT

the top of the strut, it is probable that the joint will give rather than that the joint will remain rigid and the strut bend. This will apply even if the bottom of the strut rests in a socket. The purpose of the socket

is to prevent the strut from moving out of its position rather than to provide a rigid joint. Fig. 25 shows the difference between pin joints and rigid joints. The relative advantages of each type will be discussed later.

Although we usually try to arrange for loads to be applied at the joints of the structure, this condition, too, cannot always be fulfilled. Aeroplane spars again provide an example, since the load due to the air pressure is distributed all along the spar; similarly a train cannot always rest on the joints of a bridge but must pass from one joint to another.

All these departures from the ideal framework cause complications when we try to calculate the loads in the various parts.

**Deficient, Perfect, and Redundant Frames.** Imagine for the moment that we are considering ideal frameworks, i.e. those with only struts and ties, pin-jointed together and loaded at the joints. Let us assume also that all the members of our frameworks are sufficiently rigid to take either tension or compression as required, that is to say we have no wires which could take tension only.

Even such a framework can exist in three distinct types. It may be *perfect*, which means that it has *just sufficient members to keep its shape whatever loads we apply at the joints* (provided, of course, they are not so great as to distort it or break it). Notice that we say "just sufficient"; if it has "more than sufficient" it is said to be *redundant*, and if it has less than sufficient members it is called *deficient*. A triangular frame work is the most simple example of a perfect frame, and all perfect frames are made up of series of triangles (see Fig. 26). Add up the number of joints in each of these perfect frames, multiply the number by 2, subtract 3, and you will find that the answer is the same as the

number of members in the framework. Putting this in an algebraic form: If  $n$  is the number of joints, the

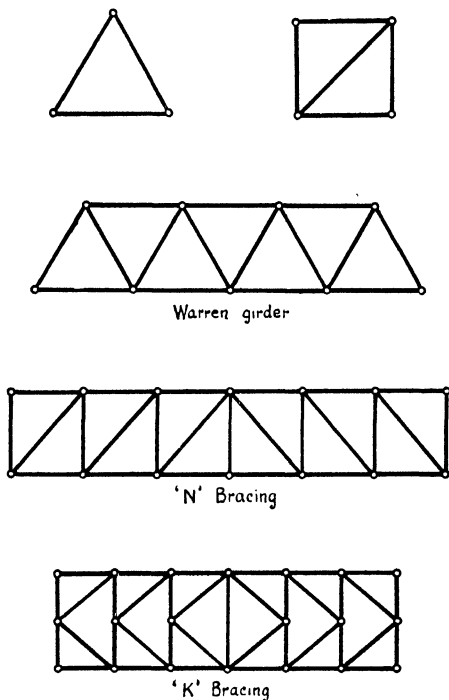

FIG. 26. PERFECT FRAMES

number of members required to make a perfect frame is  $2n - 3$ .

**Deficient Frames.** Fig. 27 shows examples of deficient frames. These may be able to keep their shape under *certain* conditions of loading, but it is obvious that, *if the loads change*, the shape of the frame will alter (as in Fig. 28), the joints acting as hinges. If the joints are



made *sufficiently rigid*, the framework may be made into a practical proposition; but, in a sense, it is no longer a framework at all, at any rate not what we

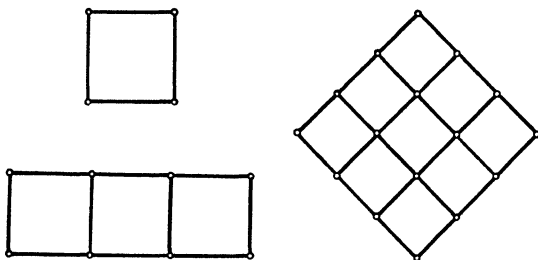

FIG. 27. DEFICIENT FRAMES

have called an ideal framework. Deficient frames are very rarely used in real engineering, let alone in aircraft. They are, however, extensively used in simple woodwork, such as tables and chairs and even certain

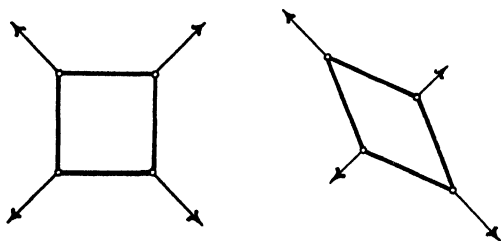

FIG. 28. DEFICIENT FRAMES UNDER LOAD

types of roof truss; but in all these instances the joints are made very strong and rigid—and, as already stated, they are therefore no longer frameworks.

Wooden construction lends itself to rigid joints rather than to pin joints, but even so, everyone has come across enough rickety chairs and tables to realize why

this system is not used in more serious engineering. Deficient frames may be discovered in certain unimportant parts of aircraft structures where there are no loads tending to distort them (e.g. in that part of the wing structure behind the rear spar), but they are never found in any of the main bracing. In certain fuselages a square unbraced frame is used instead of the usual internal bracing, but, as will be explained later, this

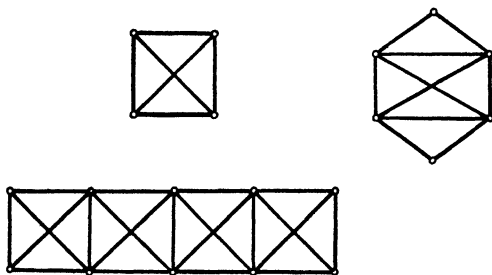

FIG. 29. REDUNDANT FRAMES

does not really mean that the frame is a deficient one, because no bracing may be necessary in these particular bays. Moreover, in such instances the joints are often stiffened by triangular plates, or even by small struts.

**Redundant Frames.** Fig. 29 shows redundant frameworks. Remember that all the members are rigid and capable of taking tension or compression. A consideration of the redundant frame brings us to one of the most interesting arguments in the whole of engineering. Ask anyone who has not studied the subject what he thinks is the advantage of the redundant frame over the perfect frame. He will probably answer you at once—and, what is more, his answer will be correct. But ask him the disadvantages of the redundant frame, and he will only be able to tell you a small part of the

truth, and even that small part may not be so truthful or so obvious as he thinks it is. You may have noticed that we have put *advantage* in the singular, but *disadvantages* in the plural. This was done with a reason—the redundant frame has one advantage (which you have probably guessed correctly) which is so important that it balances, or even overbalances, *all* the disadvantages. I refer, of course, to the fact that if a member breaks, the framework will still be at least perfect, and therefore able to carry on. On the other hand, if any one member of a perfect frame breaks, the whole structure will probably collapse. The danger of a member breaking has a special significance in military aeroplanes, where a machine-gun bullet or a piece of shrapnel may easily destroy some important part of the structure.

What of the disadvantages of the redundant frame? The half-truth mentioned above will probably be that obviously it will mean extra weight. It *may* mean extra weight; but why “obviously”? Well, you will say, because of the extra member. I have purposely put the argument in this simple and apparently logical form so that you will be the more surprised to see the fallacy in it. Is the weight of a structure proportioned to the number of members in it? Certainly not. Figs. 30 and 31 show two aeroplanes of similar dimensions, but with different types of wing structure. From your own experience you will agree that the type of Fig. 31 is a bad design. Exactly—and why? Because, if it is built to be of the same strength, it will be heavier than the type of Fig. 30. Yet it has *fewer* members. That is an example of the whole principle of design, and it serves to show that the weight of a structure is dependent, *not* on the number of members, but on the *ability of the designer to distribute the load in the best*

*possible way throughout the structure.* That, in a nutshell, is the art of good design, and it is that which will decide the final weight of the structure. So, to return to our redundant frame, *if* we could distribute the load satisfactorily throughout the members of the framework, there is no logical reason why a redundant frame should be any heavier than a perfect one. *IF*—that is the point.

Supposing we know the loads applied to the joints of a perfect frame, it is a comparatively simple matter to

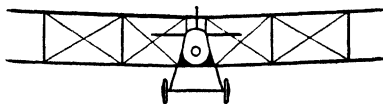

FIG. 30. WHICH IS THE BETTER STRUCTURE?

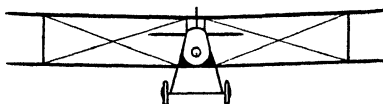

FIG. 31. WHICH IS THE BETTER STRUCTURE?

find out the corresponding loads in the various members of the framework. It is all done by drawing stress diagrams, which are simply a practical application of the well-known theorems of the triangle and polygon of forces. (We do not propose to go into the system in this book, because it is so well known, and can be found in any elementary book on Statics; the reader who does not know the system is advised to consult such a book and to study the method, because it will give him a much better idea as to how structures are designed.)

*Now, these simple stress diagrams cannot be drawn for a redundant framework.* That is the fly in the ointment. It is true that elaborate processes have been evolved to

solve the problem, but these contain somewhat advanced mathematics, not to mention a good deal of guesswork. For these reasons a redundant structure is said to be *indeterminate*, which means that the forces in the members cannot be discovered by the ordinary methods of Statics, methods which are so simple that they are learnt by nearly every schoolboy.

Now, you may not feel very impressed by the information that we are unable to find the loads in a redundant structure by the methods of simple Statics. But we shall soon see that this fact results in all kinds of practical repercussions. In the first place, it provides the *real* reason why a redundant structure does usually mean extra weight. The most simple way to design a redundant structure is to leave out any unnecessary member while calculating the strength of the parts, and then add the redundant member as a precaution in case of accidents. If this method is followed, it really is *obvious* that the extra member means so much extra weight. But there is a great deal more in it than this. Have a look at the perfect and redundant frameworks in Fig. 32. We shall soon see *why* it is difficult to find out the loads in the redundant structure as compared with the perfect. Suppose the member  $AB$  in the perfect framework were to grow half an inch longer owing to a local rise in temperature, or alternatively that it had been made half an inch too long in manufacture. What would be the result? Well, it is true that the framework would not be exactly the correct shape or size, the joints would act in their capacity as hinges and give slightly; *but there would be no appreciable difference in the loads in the various members.*

Now suppose the member  $A'B'$  in the redundant frame to be half an inch too long; here we find a very different state of affairs. The incorrect length of this

member will mean that it has to be *forced* into position, it will itself be in compression, and it will cause large forces in all the other members. If the member  $C'D'$  is adjustable, we will be able to relieve some of these loads by shortening it; but the whole point is that each member is dependent one on the other, and that *large initial loads may be caused in the structure* quite apart from the effect of the externally applied loads. If you have followed this argument you will have seen that it

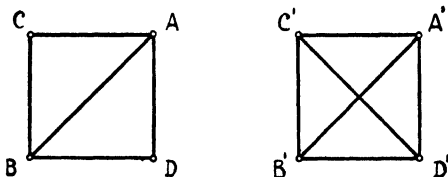

FIG. 32. PERFECT AND REDUNDANT FRAMEWORK

explains *why we can never be sure* as to what the loads will be in a redundant structure, and you will also have realized that it explains some of the other disadvantages of the redundant structure, namely that *greater accuracy is needed* in workmanship, some *means of adjustment* should be provided, and *great care must be taken in making adjustments*. Even so, large unexpected loads may occur in the structure. We shall see later that some of the main problems confronting a rigger arise when he has to deal with a redundant structure. Incidentally, extra difficulties of design and construction mean, inevitably, more expense.

We have said enough to show the reader that the redundant frame has plenty of disadvantages—yet, in spite of them all, its one advantage is so overwhelming that it is very often used, even in aeroplane structures

(we might almost say *especially* in aeroplane structures) where there is so much need to save weight.

**The Wire-braced Frame.** We cannot leave this subject without referring to the wire-braced frame which has been so extensively used in aircraft structures, and, to a certain extent, in other branches of engineering. In the early days this system was usually employed for the whole structure of the aeroplane, and even now, when it is often replaced by a more rigid system in certain parts, there are very few types of aeroplane in which the wire-braced frame does not

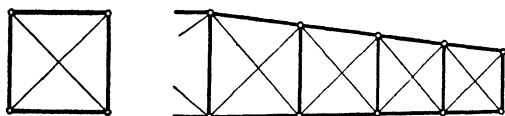

FIG. 33. THE WIRE-BRACED FRAME

appear in some part of the bracing. This type of bracing may be assumed to include all forms of cross-bracing where the members which constitute the cross-bracing are so small in cross-section that they are unable to carry compression (Fig. 33).

Should this system be classified as a perfect or as a redundant frame? Although it is sometimes considered as a form of perfect frame, it cannot really be correctly assigned to either type. What is more strange, in view of its wide use in aircraft, is that it seems to possess most of the disadvantages of *both* types. Let us examine it in more detail. Does it possess the great advantage of the redundant type? What will happen if one member breaks?

It depends—it depends on the system of loading, and it depends on which member breaks. For instance, if a landing wire is shot away during flight, it will probably

not affect the strength of the aeroplane *during flight*, but it will do so when the aeroplane lands. On the other hand, if an interplane strut is shot away, the structure will become unsafe under both conditions. Again, what is the position as regards the exact length of the members, difficulties of rigging and initial loads in the members due to bad adjustments? Once more, it depends—if one of the tension members is too long, either through incorrect manufacture or incorrect adjustment, the other members will be unaffected; but if it is too short, then it will have the same effect as in a redundant structure.

But the great feature of this system is its *low weight*, and consequent large ratio of strength/weight—and it is

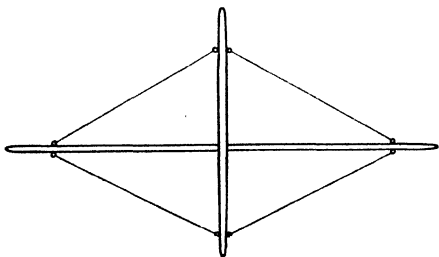

FIG. 34. ANOTHER TYPE OF WIRE-BRACED FRAME

this which accounts for its use. This advantage is especially noticeable when the cross-bracing members are very long, and it is due to the fact that while tension members may be any length, long compression members always have a large weight and are uneconomical from the strength/weight point of view. For instance, it is not economical to replace the flying and landing wire by one strut, owing to its great length and consequent weight—yet in the smaller fuselage bays a system of rigid bracing may provide the best strength/weight ratio.

A disguised form of this bracing was sometimes found in the top and bottom wire bracing of tail planes and



in the main planes of certain old-type monoplanes (Fig. 34). This was, in effect, exactly the same as the cross-bracing system, and it possessed all the same features.

**Panel Bracing.** A large proportion of the aeroplane structure is sometimes covered with fabric, which, due to the application of dope, may be in a high state of tension.

The fabric will, to a certain extent, act as a cross-bracing to the various bays; but its strength is small, and any good effects which it may have are not normally taken into account. On the other hand, certain parts of the structure, notably the ribs, will be put into compression due to the tautness of the fabric, which may thus tend to decrease their strength.

If, however, the fabric is replaced by a three-ply or sheet-metal covering or "skin," the story is different. There is no initial tension to cause any bad effects, yet, on the other hand, the strength of the skin will be sufficient to reinforce the cross-bracing and in some instances replace it altogether. In this way planes have been covered with both three-ply and metal skins and the drag bracing wires have been dispensed with, while nearly all the bracing in a fuselage may be avoided in the same way. The skin will be very thin, and only capable of taking tension without buckling; therefore a panel covered in this way has some of the characteristics of cross-bracing with wires, and its strength is sometimes calculated in the same way. But methods of calculation are rather uncertain, and therefore destruction tests are usually carried out to prove the strength of this type of bracing. Corrugation of the sheets may add greatly to the rigidity of the panels and prevent them from buckling.

When the skin is made so strong that it can carry all

the loads in the structure without the help of any internal members, the system of construction is called *monocoque*. Even in this method some reinforcing and stiffening of the skin is advisable if local crinkling is to be avoided. The usual practice is to have a series of ribs in the form of hoops at regular intervals inside the skin, these being connected together by longitudinal members—called stringers—which run the whole length of the structure. These are essentially stiffeners rather than strength members. True monocoque construction leaves the interior completely free of obstruction, and it is very suitable for fuselages. In main planes there is not usually sufficient depth for monocoque construction to be employed, and the so-called stressed-skin method is really a compromise in which the spars are used to take the main lift loads, while the skin takes the smaller drag loads and prevents the wing from twisting.

**Geodetic Construction.** In this system, the outer contour of fuselage or wings is formed by a lattice-work of girders in the form of "geodetics."<sup>1</sup> Only fabric need be employed as a covering, and no internal bracing is necessary. Thus advantages are claimed over both stressed-skin and the ordinary girder construction. On the other hand, manufacture is rather more complicated repairs to damaged parts may prove difficult, and the structure is liable to be too flexible. But whatever its advantages or disadvantages, it is a type of construction worth watching.

**Space Frames.** We have, up to the present, tended to consider frameworks as if they existed in *two dimensions*

<sup>1</sup> A geodetic is the line taken up by a string stretched between two points and following the contour of the surface; in other words, it is the shortest distance between those two points provided the outside contour is followed.

only, i.e. plane frames. The reader may have wondered why we have not mentioned the *three-dimensioned* or "space-frame," because he knows that nearly all practical frameworks have bracings in three dimensions; certainly the aeroplane has. The answer is simple—namely that the space frame is much more difficult to understand, and it will be a great help towards it if we can first consider the plane frame. It is not at all easy to think in three dimensions; the ordinary plane geometry is child's play compared to solid geometry, and we are severely handicapped by not being

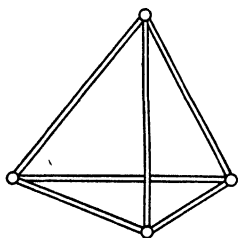

FIG. 35. PERFECT  
FRAME IN THREE  
DIMENSIONS—THE  
TETRAHEDRON

able to draw diagrams in three dimensions. But in spite of the difficulty we must do our best to understand space frames, because it is with them that we have to deal in real practical life.

As the triangle is the basis of the perfect frame in two

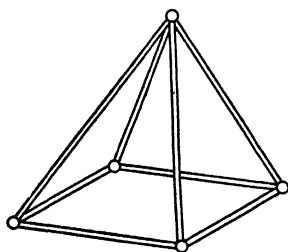

FIG. 36. DEFICIENT FRAME  
IN THREE DIMENSIONS

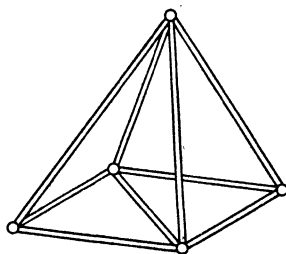

FIG. 37. PERFECT  
FRAME

dimensions, so the *tetrahedron* is the basis of the perfect space frame (Fig. 35). This frame has four joints and

six members, and therefore does not obey our rule of  $2n - 3$ . The number of members in a perfect space frame is given by the formula  $3n - 6$ , where  $n$  is the number of joints. If you look at a square pyramid resting on its base (Fig. 36), you may at first think that it is a perfect frame; but it has five joints and only eight members, whereas according to the rule it should have nine members. You have been deceived by thinking of its base as necessarily remaining flat; but if you think again you will soon realize that such a pyramid is by no means rigid but is deficient, and can even be completely folded up. A diagonal member across the base will make it perfect, and will, in fact, convert it into two tetrahedrons (Fig. 37). This simple example is given just to show you how much more difficult it is to think in three dimensions than in two.

In the instance just quoted it was easy to jump to the conclusion that a deficient frame was a perfect one—other instances will be found in which a frame appears to be deficient but is really perfect, or appears perfect when it is really redundant. In a V-shaped undercarriage only the front bay of the V need be braced, and the rear bay then appears to be a deficient frame. Actually the undercarriage structure, *in itself*, is deficient (as will be discovered by counting the joints and the number of members), but when taken in conjunction with the fuselage the *whole structure* may be perfect and unable to alter in shape. When counting members in frameworks where wire bracing is used, the two counter-bracing wires count as one member. The student is often surprised to discover that in a biplane structure, the main-plane incidence bracing (not the centre-section incidence bracing) and some bulkhead wires in the fuselage are unnecessary from the point of view of keeping the shape of the main planes or fuselage

structures—yet a careful examination will reveal that they may be dispensed with and the structure still remain rigid.

The reader who finds difficulty in visualizing three-dimensional structures is advised to construct a few simple frames for himself, commencing with the tetrahedron. They can easily be made from a Meccano set, or, if such is not available, a few laths of wood will serve the purpose quite well. The joints should be as free as possible to hinge in any direction; they can be made with wire links or even with pins. Do not be ashamed of such crude and simple experiments as they may prove of much help to you. You are, as it were, only making drawings in three dimensions, and some of us find it difficult enough to draw in two dimensions. There are many quite experienced practical men who have failed to grasp the true significance of whether a framework is redundant or not, when considered in three dimensions. The effect of overtightening one member in a redundant plane frame is easy to visualize—but it is not nearly so easy in a space frame.

**External Loads on a Framework.** After sketching out the disposition of the members in his framework—a question of “eye” and experience—the designer’s next job is to consider the *externally applied loads*. The weight of the structure itself must be included among these external loads and is sometimes one of the main loads which have to be carried. In a bridge there will be the weight of the bridge, weight of trains, etc., downwards, and the upward forces at the various supports. Since the whole structure must be kept in equilibrium, the external forces must balance out, e.g. in the case of the bridge the total of the upward forces at the supports will equal the total of the weights carried. Similarly, if there is any side force on the bridge

due to wind, there must be an equal and opposite side force at the supports.

All the methods which are employed to find the *internal loads* on the parts of the structure depend on the loads being applied at the *joints*. If, therefore, the

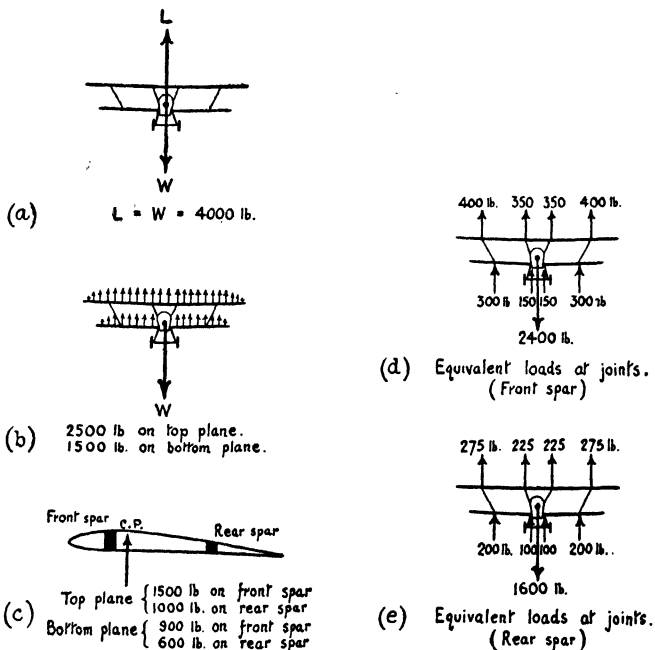

FIG. 38. HOW THE EXTERNAL LOADS ARE DISTRIBUTED

external loads do not act at the joints, an estimate must be made of the *equivalent* loads acting at the joints, i.e. the loads which, if they acted at the joints, would have the same effect as the true loads. In a bridge, for instance, the weight of the main girders,

though really distributed all the way along the girders, must be split up into equivalent weights at each joint.

The external loads on an aeroplane in flight consist entirely of the weights, the thrust of the airscrew, and the air pressures on the various surfaces. In normal horizontal flight, the upward lift forces on the wings will be equal to the total weight of the aeroplane (Fig. 38*a*). But the total lift forces are distributed all over the wings (Fig. 38*b*). In a biplane a certain proportion will be in the top plane, the remainder on the lower plane (Fig. 38*b*). The load on each plane is distributed along the spars, some on the front spar, the remainder on the rear, the proportions depending on the position of the centre of pressure (Fig. 38*c*). Finally, the distributed load along each spar must be replaced by the equivalent load at the joints (Fig. 38*d* and *e*). Similarly the weight must be proportioned between the various joints. The sketches in Fig. 38 should help to make the process clear.

**Internal Loads in the Framework.** After the external loads have been discovered, there are various methods of finding out the internal loads in the members of the structure. These methods will be found in any elementary book on the Theory of Structures, and we do not propose to go into them here. If the framework is perfect, the stress-diagram system is most often used, or, alternatively, if we only want to find out the load in one or two members, the method of sections. The latter consists in imagining that the structure has been broken at some convenient part, and then stating that the forces in the broken members must have balanced the external forces on the remaining portions. If the framework is redundant, one method is to omit the redundant members, calculate as if for a perfect framework, then replace the members, omit some others

so as to make the structure perfect again, and again calculate to find the loads in the redundant members. A better but much more complicated method is to take into account the stretches and changes of shape in the structure which take place when it is loaded. The great advantage of the latter method is that the redundant members actually take some share of the load, whereas in the former they are merely additions. Obviously, the more we are able to *share* the load among all the members, the lighter will be the structure for the same strength.

Without going into the methods involved in finding the internal forces, we will give some of the results so obtained; we cannot really understand the purpose of the various parts of the aeroplane unless we have some idea of the *magnitude* of the forces which those parts have to carry. It is surprising how many students who can work out any simple problems on the triangle or polygon of forces, or even draw stress diagrams, do not seem to have any idea of the practical meaning of the results which they obtain. For instance, many of them, when asked what will be the approximate load in the inclined strings shown in Fig. 39, give the most ridiculous answers, usually thinking that there will be less than 5 lb. in each—and, what is more, that the flatter the angles of the strings the less will be the tension in them. To crown it all, they sometimes state that if the string is pulled quite horizontal(!) there will still be a pull of 5 lb. “in each side of it.” The same students are perfectly capable of drawing a triangle of forces and proving their stupidity—it is simply that they have not studied sufficiently the *results* obtained from examples worked out at school. This is a common failing of technical schools, where the students learn to work out answers for examination purposes; but they do not connect the



results with practical life. In consequence they do not acquire that invaluable engineering *instinct* which tells a designer what sort of loads there will be in a structure. For this reason no apology is made for giving a few answers to such simple problems.

Here, then, are the answers to Fig. 39: (a) 5 lb. in each string; (b)  $5\frac{1}{2}$  lb. in each string; and (c) 10 lb. in

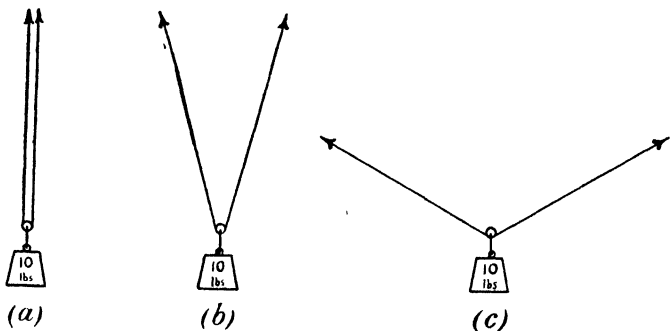

FIG. 39. HOW MUCH LOAD IN EACH STRING?

each string. Thus making it quite clear that the nearer the strings are to the horizontal the greater will be the pull in them. As for pulling them horizontal, it is impossible; or, put into mathematical terms, the force will then be infinite. Even if there were no weight hanging on the string, its own weight would cause it to take up a very slight curve, however hard it was pulled, a state of affairs which has been so delightfully expressed in a mathematical treatise by Whewell—

No force on earth, however great,  
Can stretch a string, however fine,  
Into a horizontal line  
That shall be absolutely straight.

Fig. 40 illustrates the effect of inclining one string at a different angle from the other. The results show, as

would be expected, that the string which is nearest the vertical will carry the greater share of the load.

Notice, in both these examples, how the total of the forces in the two strings added together grows less as one or both of the strings becomes nearer to the vertical. This illustrates the rather obvious fact that if you want to lift a weight, the most efficient direction in which to pull it is vertically upwards. But, however obvious it

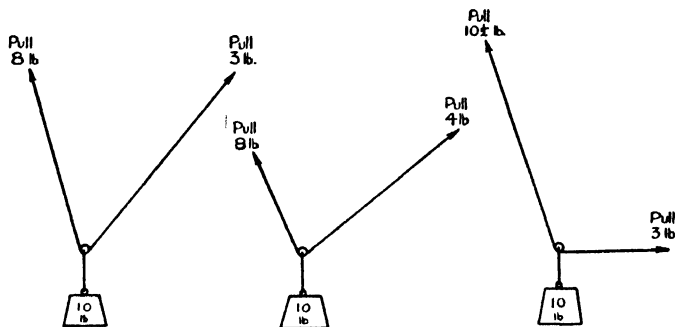

FIG. 40. STRINGS INCLINED AT DIFFERENT ANGLES

Notice how the sum of the pulls in the two strings is increasing as one of the strings becomes "flatter".

may be, it is a very important principle. The main object of the struts in an undercarriage is to take the upward force from the ground on landing—the more the undercarriage struts are splayed out from the vertical in either direction, the greater will be the loads in them (Fig. 41). Flying wires must carry the upward lift force; therefore the more vertical they are, the less will be the load in them; and the more horizontal (or the "flatter") they are, the greater will be the load. Of course, they also have to transfer the load inwards to the fuselage, and therefore if we make them very "steep" we shall need more bays, which may mean

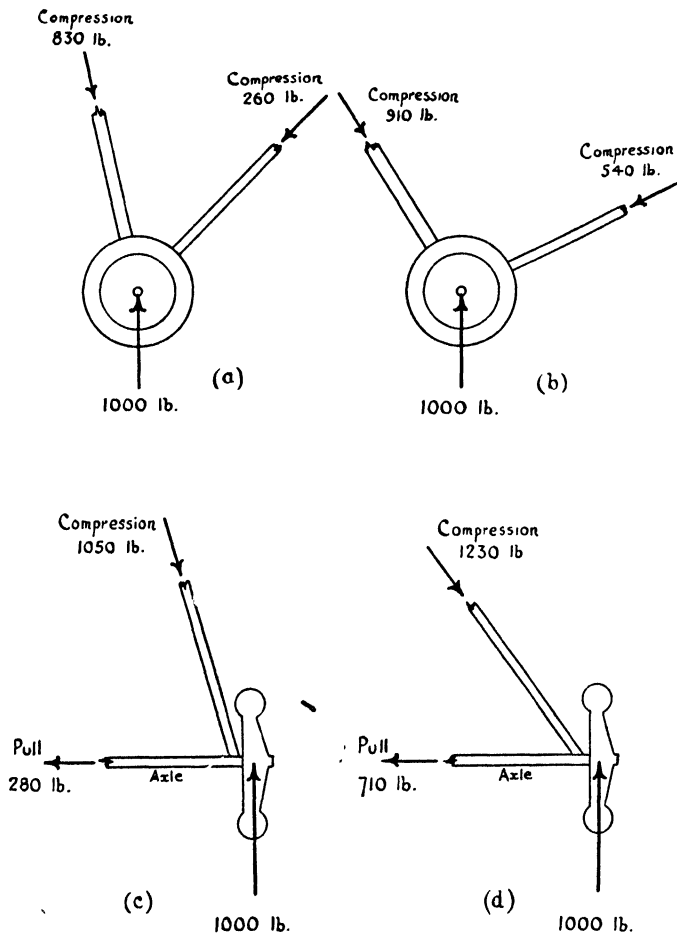

FIG. 41. EFFECTS OF INCLINATION OF UNDERCARRIAGE STRUTS

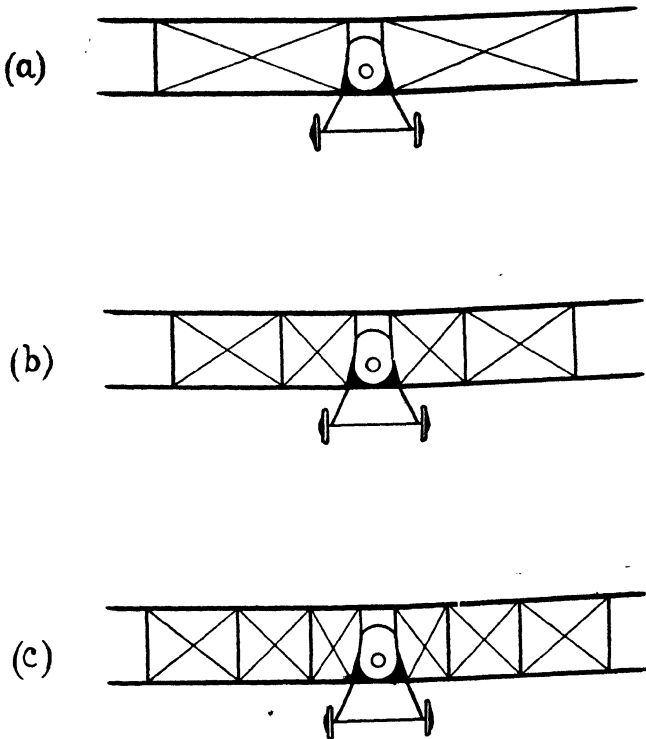

FIG. 42. WHICH IS THE BEST STRUCTURE?

*Answer:* The Two-bay (b).

*Reason:* Assuming that the aeroplane weighs about 10,000 lb., the tensions in the top spars of (a) are about 8300 lb. (compression) and in the flying wires about 7800 lb. (tension). In (b) the loads in the top spar are 4800 lb. (compression) in outer bay and 7300 lb. (compression) in the inner bay; 4200 lb. tension in the outer flying wire and 5300 lb. (tension) in the inner flying wire. Thus all loads are less in (b) than in (a), and there is the further great advantage that the unsupported lengths of the top spar are shorter and thus would be less likely to bend even if they had to carry the same loads. In (c) we have gone too far; the loads are less than in (b), but this does not make up for the extra weight caused by the greater number of members in the structure.

more weight. Fig. 42 illustrates three biplanes of the same span and gap and the same total lift load. The loads are greatest (hence the members are largest) in the single-bay and least in the three-bay machine—the three-bay machine contains the greatest lengths of

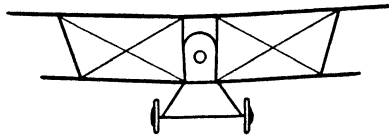

FIG. 43. SINGLE-BAY BEST FOR SMALL MACHINE

struts and wires, and the single-bay the least. *But the two-bay machine is by far the best design*; that is to say it gives the best ratio of strength to weight. Yet for a smaller machine (Fig. 43) a single-bay gives the best results, and for a larger machine (Fig. 44) three bays

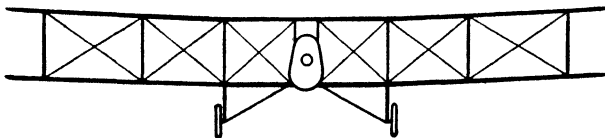

FIG. 44. THREE-BAY BEST FOR LARGE MACHINE

are best. This is where the art of design comes in, and a designer soon learns to know what arrangement is best. Fig. 45 shows three two-bay biplanes, one with the inner bay longer than the outer one, one with equal bays, and the other with the outer bay longer than the inner one. The last is the usual arrangement, and is much the best because of the large compression in the top inner-bay spar, which is therefore made as short as possible. If it is sufficiently short it will be less liable to bend, and it can therefore be kept of the

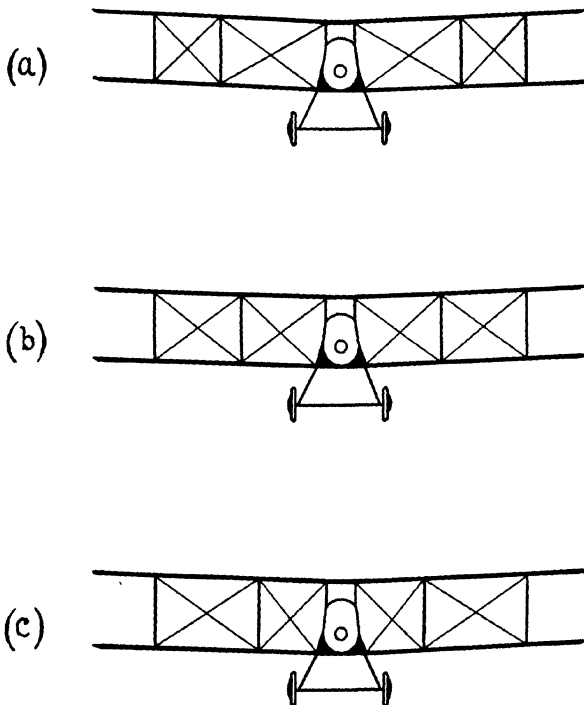

FIG. 45. THREE TWO-BAY BIPLANES: WHICH IS THE BEST?

*Answer:* (c).

*Reason:* For a 10,000-lb. aeroplane the loads in the top spars are approximately as follows (all in compression)—

Outer bay: (a) 3000 lb. (b) 3900 lb. (c) 4800 lb.  
 Inner bay: (a) 7900 lb. (b) 7600 lb. (c) 7300 lb.

The loads in the flying wires are as follows (all in tension)—

Outer bay: (a) 3600 lb. (b) 3900 lb. (c) 4200 lb.  
 Inner bay: (a) 6700 lb. (b) 6000 lb. (c) 5300 lb.

Notice that the greatest loads are always in the inner bay, and the greatest of these are in (a), next in (b), next in (c). What makes it worse is that as these loads in the inner bay increase from (c) to (b) to (a), so do the lengths of the members carrying them increase, and this increase of both load and length is very serious, especially in compression members such as the top spars. Thus (c) is best, then (b), then (a).

same cross-section as the remainder of the spar. Although we have taken our examples from biplanes, since their structure provides the clearest illustration, the principles apply just as well to the internal bracing of aeroplane wings, to fuselage structures, and, in fact, to all engineering structures.

On some of the figures given in this chapter the approximate loads in the various parts of the structure have been shown, and the reader is advised to study these results very carefully. If he remembers that it is these figures which decide the strength, and hence the weight, of each member, he will realize the difference between good and bad design, and he may even acquire something of the art of design. In drawing any conclusions he must remember that whereas the weight of tension members is directly proportional to the load in them, compression members are very much influenced by *length* and the *nature of the cross-section* (e.g. whether solid or hollow) as well as by the load. If he finds a long compression member carrying a heavy load, such as the top inner spars in Fig. 45*a*, he may be sure that it is going to be an extra-heavy member. Another point to notice in the diagrams is how the load is comparatively small in the members which pull or push in the right direction (e.g. in the flying wires of Fig. 42*c*), and large in the members which pull or push too much to one side (e.g. in the very flat flying wire of Fig. 42*a*). The whole thing boils down to a *compromise*—the less the number of bays of bracing, the less the total length of wires and struts but the greater the loads in them—the more the number of bays, the greater the total length of wires and struts but the less the loads in them. The compromise which gives the best ratio of strength to weight is the best design, and the good designer can usually find this compromise by “*eye*” and *experience*.

To sum up—

1. An ideal framework would consist only of struts and ties, pin-jointed and loaded at the joints.

2. Even an ideal framework may be deficient, perfect, or redundant.

3. Deficient frameworks are not used for important parts of engineering structures.

4. Perfect frameworks are the lightest, and the loads in them are easily calculated.

5. Redundant frameworks have the great advantage that if one member fails they can still carry on; on the other hand, they have several important disadvantages.

6. The wire-braced frame has some of the features of a perfect frame and some of those of the redundant; it has a good strength/weight ratio.

7. Panel bracing and monocoque construction have very real advantages.

8. To understand aeroplane construction, one must study the "space" or three-dimensioned frame.

9. In estimating the loads in a framework, the equivalent external loads at the joints are first calculated, and then stress diagrams are drawn to find the internal loads.

*Note.* The methods of finding the internal loads may be found in any good book on Statics. The reader who wants to go a little farther than the more elementary books should read Morley's *Theory of Structures*; or, if he wishes to find examples applied to aircraft, *Aeroplane Structures*, by Pippard and Pritchard (revised edition); *Aircraft Structures*, by Howard; *Structures*, by Haddon.



## CHAPTER VI

### TIES, STRUTS, AND BEAMS

As we have already discovered, the structure is made up of three types of members, i.e. those subject to tension, called *ties*; those subject to compression, called *struts*; and those subject to forces which tend to bend them, called *beams*. In the present chapter we will take each of these in turn and consider a few of the special points which apply to their design.

**Tension Members.** The tie, or tension member, is by far the easiest of the three from the design point of view, and we will consider it first. Once we have found the load in the member from the stress diagram (or other method), we need only multiply it by the load factor, and then, by taking into account the strength of our material, we can easily deduce the cross-sectional area required. A simple numerical example will make this clear—

Suppose the load in the member is 1000 lb. and the load factor laid down is 6, then the tie must be capable of standing up to 6000 lb. We will assume that this is the worst of the cases to be considered (see page 93). If the ultimate strength of the steel to be used is 50 tons per square inch, then the cross-sectional area required is  $6000/(50 \times 2240) = 0.054$  sq. in. (In this instance we have designed on the ultimate strength, since we are not given a value for the proof stress.)

If the member is required to take tension only, a wire may be used; but if it may be required to take tension or compression, then either it must be counter-braced by another wire, or else a rigid member such as

a tube must be used. It is quite probable that *standard* wires or tubes having known breaking strengths will be available; if this is so, the standard size having a breaking strength next above 6000 lb. will be chosen, i.e. a  $\frac{1}{2}$  in. B.S.F. R.A.F. wire.

Nearly all important tension members, such as flying wires, are made of *steel*, even in those aeroplanes in which other parts are made of wood or of light alloys.

Great care must be taken to see that the end fittings are at least as strong as the ties themselves—there is not much point in having a strong flying wire with a weak fitting at the end.

**Compression Members.** It is much more difficult to design a strut than a tie. This is because a strut is liable to *bend*; therefore the strength of the strut *does not depend only on the kind of material and the area of the cross-section, but also on the length, on the shape of the cross-section, and on the type of fittings used at each end of the strut.*

Strictly speaking, it is not the length which matters, but a comparison between the length and the cross-section. A pencil might be considered as a *long* strut and a pillar in a building as a *short* strut. Although the pillar may be many times as long as the pencil, the length of the pillar divided by the diameter of its cross-section will probably be much less than the length of the pencil divided by its diameter. Remembering this, we can almost divide struts into three distinct types—

1. Long struts, i.e. those which are very long in comparison to their width.

2. Medium-length struts.

3. Short struts, i.e. those which are very short in comparison to their width.

Such a division cannot, of course, be exact; but we must try to make some distinction, because the design

of the strut is so very different for the three categories. The real test as to which class a strut belongs to is to put a series of struts under compression loads until they fail. *Those which always fail by bending or buckling belong to the class of long struts ; those which always crush*

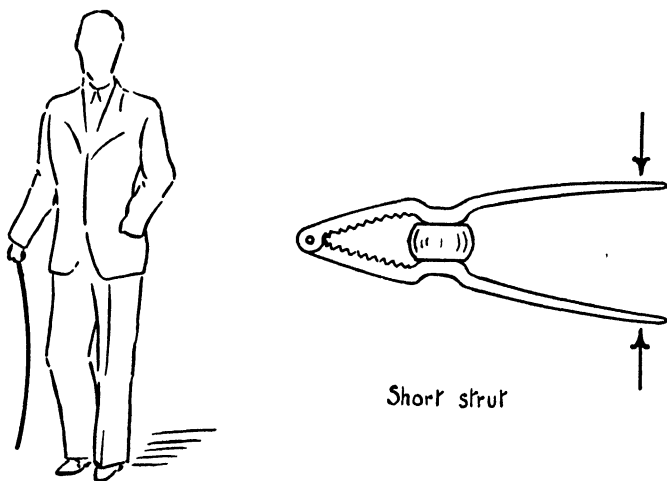

Long strut

Short strut

FIG. 46. STRUTS

*before they begin to bend will be short struts ; and those which sometimes bend and sometimes crush, or which do a bit of each, will be classed as medium.* It is not everyone who is in a position to carry out such tests, and the reader will probably ask for something more definite, such as numerical relationship between length and diameter for each class. But this cannot be given, because it is not just a question of diameter or width ; the liability to bend depends also on the *shape* of

cross-section and whether it is solid or hollow. As a rough guide, steel tubes might be considered as long struts if the length is more than 30 times the outside diameter, and as short struts if the length is less than 5 times the outside diameter.

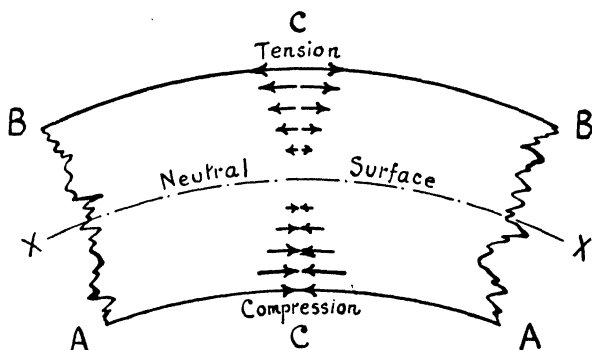

FIG. 47. EFFECT OF BENDING

We have mentioned steel tubes as an example, and the reader must have noticed from everyday experience that a strut is usually made hollow, whereas a tie is so often made from a solid rod or even a wire. A wire would make a poor strut, not because of its lack of strength, but because of its liability to bend. Now, what is the essential difference between a wire and a hollow tube? Simply that material has been removed from the centre and placed at the outside. When a member is in tension, the load should be equally distributed all over the area of cross-section, and, indeed, the same should be true of pure compression such as we get in a short strut. But when there is any tendency to *bend*, the greatest stresses will always occur at the outside and at the inside of the bend: tension on the outside and compression on the inside. (See Fig. 47.)

At the centre portion, called the neutral surface or neutral axis, there will be hardly any stress, and consequently the material is simply wasted at the centre and will be better employed at the outside. Now, a beam usually tends to bend in one particular direction, and therefore the material is moved to the outside, away from the particular axis about which the beam tends to bend, thus forming the familiar I or box shapes of beam. (See Fig.

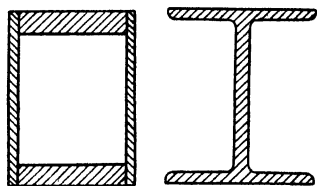

FIG. 48. I-SECTION AND BOX-SECTION

48.) But a strut is equally liable to bend in any direction, and therefore the material should be removed from the centre and placed equally round the outside, and thus it follows that the *hollow tube is the best shape for a strut*. So important is

this principle that even in wooden construction, where hollow struts are difficult to make, such struts have been successfully used and proved to have a very high ratio of strength to weight.

Up to a certain limit, the farther the material is removed from the centre, the greater will be the resistance of the strut against bending (Fig. 49); but, of course, as the material is spread farther outwards, i.e. as the tube becomes of larger diameter, the walls of the tube will become thinner, and eventually they will become so thin that the strut will fail in a new way. Instead of the whole strut bending in a smooth, steady curve, the load will reveal some local weak spot in the thin walls; the metal will crinkle at this point, the crinkle will immediately spread, and the whole strut will collapse. This effect is because the thin walls are, as it were, *unstable*; that is to say that, once the weak

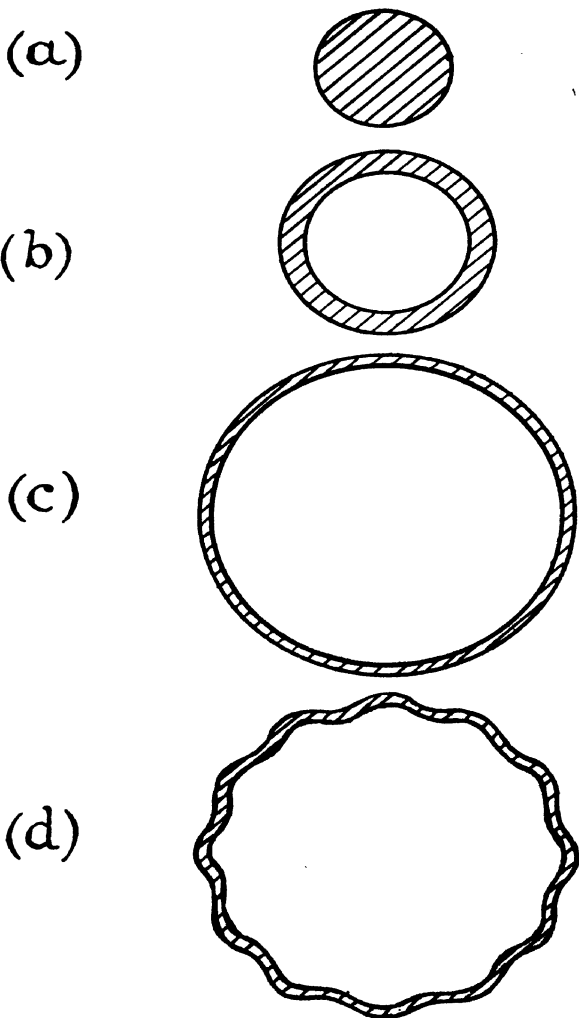

FIG. 49. STRUT SECTIONS OF SAME CROSS-SECTIONAL AREA AND SAME WEIGHT

(b) is a better strut than (a).

(c) is better than (b), but walls are too thin.

(d) is the strongest possible strut for this weight.

spot has been found, once the crinkle has commenced, there is no hope of recovery, and the condition of the strut can only become worse and worse. The phenomenon is sometimes called *elastic instability*, and it may easily be illustrated by rolling a piece of paper into the form of a tube and applying a load to it until it collapses. Try this two or three times, and watch carefully to see how the trouble begins. Compare this with the way in which a solid rod such as a knitting needle will bend when put in compression. Thus we see how both hollow and solid struts can fail, and the best strut will be the compromise which can equally resist both kinds of failure.

As a result of a large number of tests on mild-steel struts, it has been found that the crinkling is not likely to take place unless the outside diameter of the tube is greater than one hundred times the thickness of the walls, but it is usual to keep the diameter within sixty times the thickness. For weaker materials, such as duralumin and wood, the ratio of diameter to thickness must not be so great; that is to say, the walls must be thicker if the same diameter is used. This, however, does not prove a serious disadvantage to the use of these materials, because owing to their relative weakness more material will, in any case, be necessary to carry a given load. It can almost be argued that the weakness of the material is an advantage, because its greater bulk will provide more resistance to bending. This would be a very false argument if these weaker materials were of the same weight as steel, but by some strange accident of fate—or, as some would prefer to put it, design of nature—what these materials lose in strength they make up for in their lightness.

A strut may be strengthened against elastic

instability by suitable *corrugation* of the walls; more will be said about this in connection with beams.

The use of struts on the external parts of the aeroplane, such as the interplane and undercarriage struts, provides an interesting example where the increase in diameter of a strut may mean a decrease in weight but will certainly mean an increase in head resistance, and

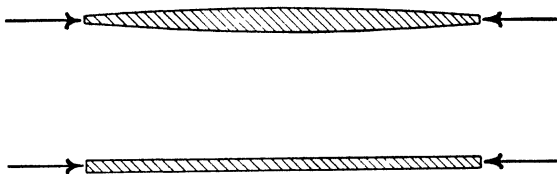

FIG. 50. TAPERED AND PARALLEL STRUT

thus may prove a net loss to the performance of the aeroplane.

If a strut is of the *parallel* type, i.e. if it is of the same cross-section throughout its length, it will always be most liable to bend at the centre of its length. If, therefore, we remember the principle that there should be no weak or strong spots in any part of the structure, it follows that the strut should be tapered in such a way that it is equally liable to fail at any part of its length. Fig. 50 shows a tapered and a parallel strut. This tapering can be easily done in wooden struts, but owing to the method of manufacture by "drawing" it is not so easy in metal tube construction, and as a result of this difficulty parallel struts are most often used.

The type of end fitting has considerable effect on the liability of a strut to bend. Fig. 51 shows respectively how a strut will bend (*a*) if both ends are held in rigid sockets, (*b*) if one end is held rigid and the other end is pin-jointed, and (*c*) if both ends are pin-jointed. One



would expect the rigid joints to increase the strength of the strut, and experiment shows that with long struts this is true, (a) being about four times, and (b) about twice, as strong as (c). This, however, is not the end of the story. The rigid joints are in themselves heavy, and any slight distortion of the structure

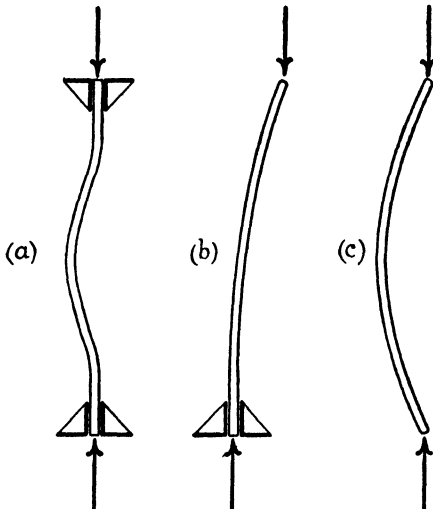

FIG. 51. EFFECTS OF END FITTINGS ON THE BENDING OF STRUTS

with rigid joints may cause severe bending effects in many parts of the structure. In fact, in aeroplane construction at any rate, the extra strength of rigid joints does not normally compensate for the disadvantages, and they are seldom used. It is true that the ends of the struts may be fitted into sockets, but these sockets are to prevent the end of the strut from moving rather than to hold the strut rigid. The end of the strut is also usually bolted in some way so that it can

take tension if necessary, but in *effect* it can be said that most aeroplane struts are pin-jointed at both ends. A welded joint is an interesting case, and it is not easy to decide whether the corresponding members should be considered as rigid or pin-jointed; official regulations have got over this by considering one end as rigid and



FIG. 52. LOADS NOT CENTRAL

the other as pin-jointed; presumably the idea is that the two wrong assumptions will just about cancel out.

Another factor which will make a strut liable to bend is if the loads applied to it are *not exactly central*. (See Fig. 52.) This also depends very much on the type of end fitting and the accuracy of workmanship, although it may sometimes be a necessary feature of design that the loads are not quite central, in which case the strut must be made stronger to compensate for the increased liability to bend.

The reason why a strut is liable to bend if the load is not central is that there will be more compression, and therefore more contraction, on one side of the strut than on the other. The same effect will occur after a strut has commenced to bend, even if the loads were initially central. The bend will cause the outside of the curved strut to be in tension and the inside to be in compression, while at the same time the compressive end load will tend to put compression on *both* sides. Thus, whereas on the outside the compressive end load will be lessened by the tension due to the bend, on the inside it will be increased by the compression due to the bend. Therefore, after the strut has commenced to bend (unless by doing so it relieves the load, as sometimes

happens), it will become even more likely to bend farther. This is an important consideration in the design of all struts and beams.

From the foregoing it is clear that a strut which is initially *not straight* will be more liable to bend than one which is straight. This is entirely a question of workmanship and inspection, and only a very slight and specified error from the straight can be tolerated without seriously weakening the strut.

There is one rather interesting phenomenon connected with long struts. So long as the load on the strut is less than the load required to buckle it, the strut will remain perfectly straight (provided, of course, it is straight before it is loaded). Once, however, the buckling load is reached, the strut becomes unstable, and any bend that develops will go from bad to worse unless the load is relieved, as it often is in practice, because the mere bending of the strut automatically reduces the load upon it. Theoretically, when carrying the actual buckling load, the strut will remain with any degree of bend. In other words it is neutrally stable. This can easily be tested by leaning on a flexible cane: with the *same* load it can be maintained with any degree of bend; at any *greater* load it will collapse completely.

Enough has been said for the reader to gather that the design of a strut is no child's play, but so much experimental work has now been done on the subject that, for the practical designer, it has become a matter of consultation of experimental results rather than of theoretical calculations.

**Beams.** Beams are those parts of a structure on which the loads, instead of acting along their length, act at an angle (very often at right angles) to their length Fig. 3).

The beams in an aeroplane include many of the most important parts of the structure, such as the main spars, the ribs, and the axle.

As explained in Chapter I, many beams act, at the same time, as ties or struts; when they are also ties, the tension will *relieve* the tendency to bend (Fig. 53*b*), but when they act as struts, the compression may

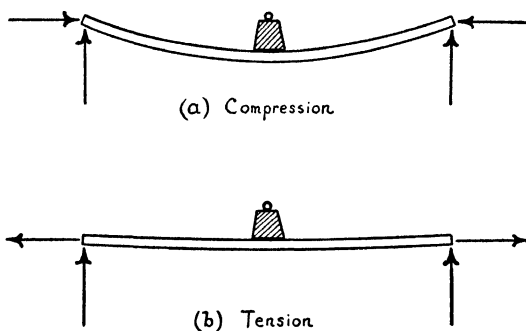

FIG. 53. BEAMS WITH END LOADS

seriously *increase* the tendency to bend (Fig. 53*a*). Those parts of the aeroplane which act both as beams and struts require very special considerations in design. The tension or compression acting along the length of a beam is sometimes called an *end load*.

**Bending Moments.** Fig. 54*a* shows a simple cantilever beam (i.e. a beam supported at one end) carrying a single concentrated load. You will see that the greatest deflection is at the end which carries the load, but this does not mean that the greatest *bend* is at this point. Any simple experiment will show that if such a beam is not tapered, it will break at the other end, i.e. at its support. It is, in fact, true to say that the tendency to bend—or *bending moment*—is greatest at the

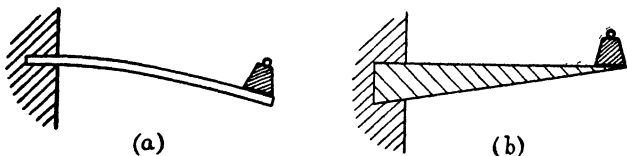

FIG. 54. SIMPLE CANTILEVER

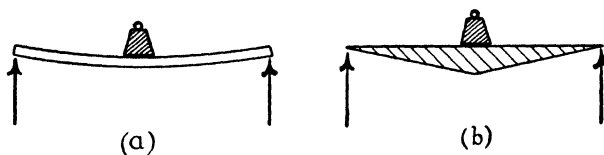

FIG. 55. BEAM WITH LOAD IN CENTRE

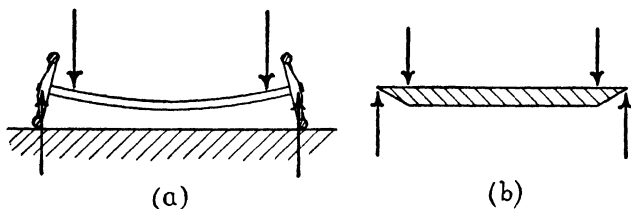

FIG. 56. AXLE LOADING

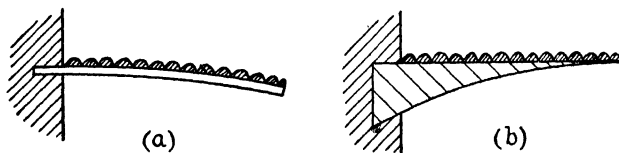

FIG. 57. CANTILEVER WITH DISTRIBUTED LOAD

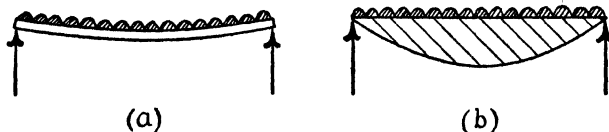

FIG. 58. BEAM SUPPORTED AT BOTH ENDS AND CARRYING DISTRIBUTED LOADS

fixed end, and decreases uniformly to nothing at the free end. Therefore, following our usual principle of making every part equally likely—or unlikely—to break, we ought to taper such a beam from the fixed end to the free end. (Fig. 54*b*.)

Fig. 55 (*a*) shows a beam *simply supported at each end* and carrying a *single concentrated load at the centre*. In this example, not only the greatest deflection, but also the greatest tendency to bend, is at the centre, and this is where it would eventually break if the load were sufficiently increased. Such a beam should be shaped as in Fig. 55 (*b*) to make it equally strong at all points.

Fig. 56 (*a*) shows how an axle is loaded. This is a particularly interesting example, because although the greatest deflection will be at the centre, the tendency to bend is *equally great* all the way between the two inner points of support, and the shape should be as shown in Fig. 56 (*b*).

The loads on a beam are often *distributed* rather than concentrated. Fig. 57 shows a cantilever beam, and Fig. 58 a beam supported at each end, both carrying an evenly distributed load. Although, in each example, the greatest tendency to bend is at the same point as with the corresponding concentrated loads, the correct shapes of the beams are in the form of curves, rather than in the straight lines of the previous examples.

Fig. 59 shows the shapes required for some other types of loading. The shapes have simply been used to indicate the tendency to bend at the various parts of the beam, and the reader will have realized that, although beams used in practice do faintly resemble these shapes, they do not seem quite in accordance with the shape of actual beams or structures with which he is familiar. There are three reasons for this

discrepancy. First, we have so far neglected the tendency of the beam to *shear*; secondly, it is sometimes both inconvenient and costly to make a beam with a

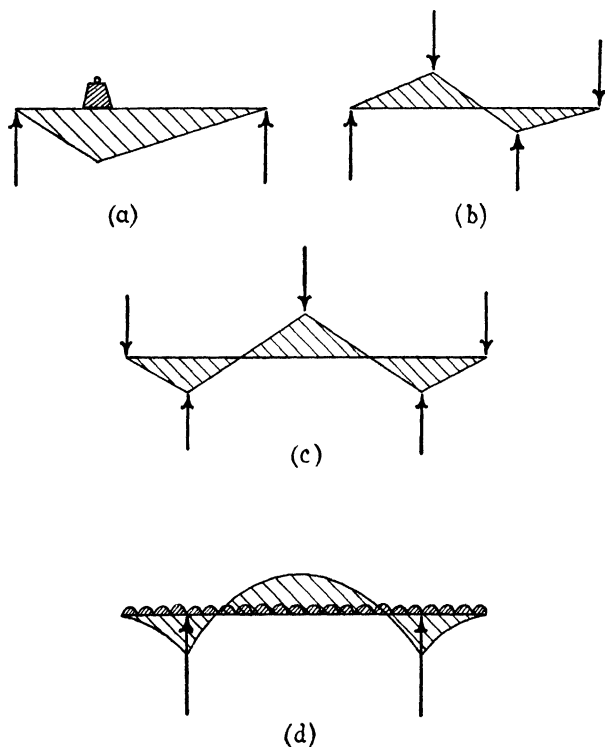

FIG. 59. BEAMS WITH VARIOUS TYPES OF LOADING

cross-section which is continually changing along its length; and thirdly, increase of depth is not the only way of increasing the strength of a beam, because this can also be done by concentrating more of the material

at the outsides of the beam, i.e. as far as possible away from the neutral axis, as has been explained in the case of struts. Axle tubes usually remain of the same cross-section throughout their lengths and while main spars are often tapered in monoplanes and outside the outer struts in biplanes, it is not usual to alter the cross-sections of spars in the main bays of a biplane.

The reader may wonder why in some parts of the beams the tendency to bend is shown above the horizontal datum line of the beam, and in other parts below. This is merely convention. When above the line, it means that the beam is tending to *sag*, the centre being lower than the ends. The opposite to the sagging of a beam is called *hogging*, the ends bending down compared to the centre, forming, as it were, a hog's back. If the beam is of the same material throughout, it does not make much difference to the shape of cross-section whether the beam is sagging or hogging, and no distinction between the two has been made in the diagrams except in Fig. 59 (*b*), (*c*), and (*d*), where both types of bending exist in the same beam. When sagging, the bottom of the beam will be in tension, the top in compression; when hogging, the top in tension, the bottom in compression.

**Shear.** But to return to the first point, the question of *shear*. Imagine a cantilever beam made up of a series of wooden blocks all glued together as in Fig. 60. If, for some reason, the glue at the joint *A* were suddenly to become very weak, then the whole of the right-hand side of the beam would drop off; a sliding, or shearing action taking place at the joint *A* (Fig. 61). A little consideration will show that even when the glue is holding, there is still the same *tendency* for this to happen, and that, at each joint along the beam, the right-hand portion is tending to move downwards



relative to the left-hand portion, or, what amounts to the same thing, the left-hand portion is tending to move upwards relative to the right-hand portion.

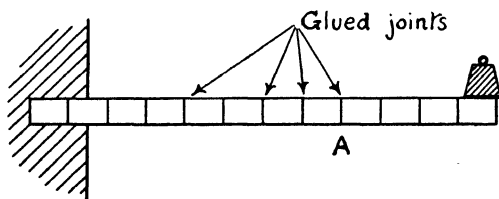

FIG. 60. SHEAR FORCE

There is, in short, a vertical *shear force* at each joint. One need not stretch the imagination much farther to realize that the same tendency exists if the beam is continuous and there are no glued joints.

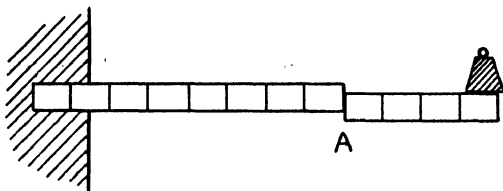

FIG. 61. SHEAR FORCE

**Longitudinal Shear.** But this is not the end of the story. The reader may realize that there is this tendency to shear, but he may be inclined to think that it is unimportant compared to the bending, and that a beam is never likely to break in this way in practice. Unfortunately the shearing effect cannot be dismissed as easily as this. In the first place, the tendency to shear is often greatest at these parts of the beam where the tendency to bend is least, and where, therefore, we

might try to economize in material. Secondly, whenever there is a vertical shear there is also a horizontal shear. This can be easily realized if we imagine a small cube of material at any part of the beam (Fig. 62). From the previous argument, the material on the right-hand side of this cube will be trying to push it downwards along the face  $BC$ , while the material on the

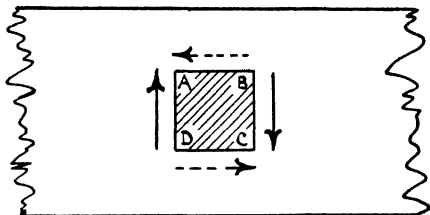

FIG. 62. VERTICAL SHEAR AND HORIZONTAL SHEAR

left of the cube will try to push it upwards along the face  $AD$ . Therefore, *if there were no other forces acting* on the cube, it would rotate in a clockwise direction. This it most emphatically does *not* do; and since the only means of preventing this rotation are corresponding horizontal shear forces along the faces  $AB$  and  $CD$  (these tending to rotate the cube in the opposite direction), it is reasonable to assume that these horizontal shear forces must exist, and that they will be as great as the vertical shear forces.

Now let us consider how this tendency to shear varies along the length of the beam. In the simple cantilever of Fig. 63 the tendency to shear will be 10 lb. all the way along the length *if we neglect the weight of the beam itself*. Now, the tendency to bend in this beam is nothing at the free end, and we therefore decided that, *from the bending point of view*, the beam should be tapered to a point, as in Fig. 54 (b). If this were done,

the beam would undoubtedly shear off near the end, and therefore we shall have to make it some such shape as is shown in Fig. 64. This provides an interesting example of the necessity of taking shear into account.

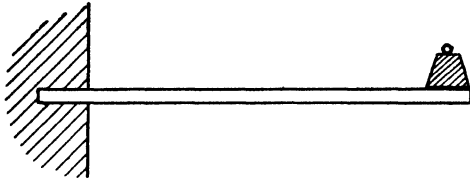

FIG. 63. CANTILEVER CARRYING 10 LB. WEIGHT

We have used the phrase "if we neglect the weight of the beam itself," and in actual practice there are many instances when it is quite reasonable to do this.

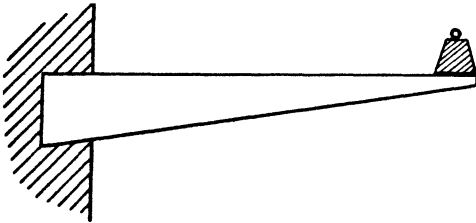

FIG. 64. SIMPLE CANTILEVER DESIGNED TO RESIST BENDING AND SHEAR

The weight of an aeroplane spar is usually quite small compared to the other loads it has to carry, and there is very little need to take its own weight into account when designing the spar. Furthermore, since the weight acts downwards and the main loads likely to bend the spar in flight are upwards, the weight will actually tend to *relieve* the tendency to bend or shear. This provides an example of several instances in design

work where we allow a small error and console ourselves by saying that any error is, at any rate, "on the right side."

If, however, we do decide to take into account the weight of the beam, whether considering bending or shear, the effect is simply that of a load evenly distributed along the beam. In the simple cantilever, if the weight of the beam is taken into account, the shearing force will accumulate as we go along the beam from the free end to the fixed end, and therefore the tendency to shear will be greatest at the fixed end.

Fig. 65 shows the places in various beams where the tendency to shear is greatest and where it is least or zero. Notice that the shear is usually greatest near to the points of support and least in the centre of a span, i.e. just where the tendency to bend is greatest.

As in the diagrams of bending moment, there is no real significance (from the point of view of the practical design of the beam), whether the diagram is above or below the horizontal datum line of the beam. If it is above the line, in the diagrams of shear force, it simply means that the right-hand side is tending to shear upwards compared to the left-hand side, but at the same time the left-hand side is tending to shear downwards, that is to say the shear is really both ways. Our pictures show what the right-hand side is tending to do compared to the left.

**Resistance of a Beam to Bending and Shear.** Having considered the tendency of a beam to bend or shear at various points along its length, let us now try to discover how a beam is enabled to resist this tendency. Its ability to do this will depend on the strength of the material used, and the dimensions and shape of the cross-section.

Fig. 47 shows a beam which has been bent. *XX* is

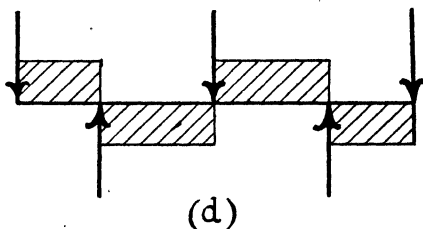
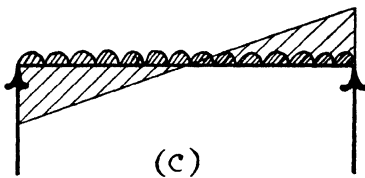
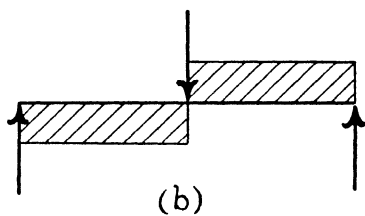
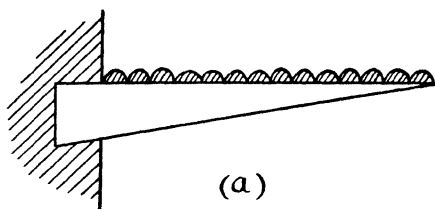

FIG. 65. SHEAR FORCES PRODUCED BY VARIOUS LOADS

called the neutral axis or surface, which will be in the centre if the cross-section is of symmetrical shape. Along this line the beam will remain the same length as it was before bending took place. All parts above this will have been stretched and are in tension, the greatest stretch taking place along  $BB$  at the outside of the bend. Similarly all parts below the neutral surface will be shortened, the greatest compression being along  $AA$  at the inside of the beam. Now imagine the beam cut in half along the section  $CC$ . Fig. 66 shows the forces which were acting on the right-hand portion of the beam when the other portion was in place. These forces are trying to turn the right-hand portion in an anti-clockwise direction, while the external forces are trying to turn it in a clockwise direction.

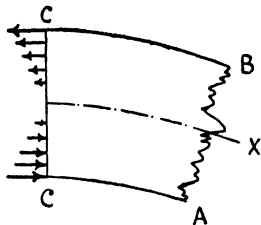

FIG. 66. HOW THE BEAM RESISTS THE BENDING MOMENT

If it does not turn, then the total turning effect of all the internal forces in the beam (called the *moment of resistance*) must balance the turning effect of all the external forces on either side of this part of the beam (called the *bending moment*). Thus we see that the greater the tendency of the beam to bend at any point along its length, the greater will be the internal forces for which we must cater in the design of the beam.

**Strength/Weight Ratio of Beams.** Now, as usual, we wish to obtain the maximum of strength for the minimum of weight. The attainment, or otherwise, of this ideal will depend on—

1. Suitable choice of material.
2. The depth of the beam.
3. The shape of the cross-section of the beam.

As regards material, the stresses in many beams, especially aeroplane spars, may be considerable, and often necessitate the use of very strong material in order to obtain the best ratios of strength to weight. Special high-tensile steels of ultimate strength as high as 60–100 tons per square inch are often used for spars.

The beam resists the tendency to bend by means of the *moment* of the internal forces, and therefore we will lessen the forces themselves if we can increase their distance apart: in other words, increase the depth of the beam. Unfortunately this is extremely difficult in many instances of beams in aeroplane structures, and especially so in the main spars, when the depth is strictly limited by the depth of the aerofoil section. So important, in fact, is this question of the depth of the spar that it exerts considerable influence on the design of the aerofoil section. (See companion volume, *Flight Without Formulae*.) It is easier to obtain greater depth in the spars of a monoplane than in those of a biplane, but, on the other hand, the tendency to bend is usually greater in the monoplane spar. Another important factor is that the rear spar cannot usually be of the same depth as the front spar, and this also influences the design of the aerofoils and points to the use of an aerofoil in which the movement of the centre of pressure is small. (See also *Flight Without Formulae*.)

The shape of the cross-section offers more scope for our ingenuity. For a given area of cross-section (which corresponds to a given weight of material) we shall increase the moment of resistance if we concentrate the material at those parts of the cross-section which has the largest part to play in resisting the tendency to bend; in other words, as is clearly shown by the figures, at the outside of the beam. This leads to the I- or box-sections, so common in general engineering and

illustrated in Fig. 48. The tops and bottoms of the I- or box-section are called the *flanges*, and the connecting piece the *web*. Thus there are two webs in the box-section. The student may wonder why this simple and undisguised I- shape is not so much used in aircraft work. The answer takes us back to our old friend "elastic instability." The stronger the material we use, and the more we spread it out away from the neutral axis, the thinner does it come, and thus the more liable to a local crinkle or buckle which may well cause the collapse of the whole beam. In wooden construction, owing to the comparative weakness of the material, the I- or box-section is actually used, but with both duralumin and steel it is disguised by corrugation. After much experimental work this corrugation has now been reduced to a fine art, and, even with very thin material, spars can be designed which are elastically stable, i.e. as the load is increased they will not crinkle before the material commences to fail in pure tension or compression. The actual form of corrugation differs considerably according to the ideas of the various manufacturers, but certain general rules are common to all. The guiding principle is *curvative* (Fig. 67). Flat portions of the cross-section, if they exist at all, must be short; the thinner the metal, the shorter must they be. A large radius of curvature will have nearly the same effect as flat portions, and therefore radii should be less than thirty times the thickness. A small radius should be inserted between two large radii, otherwise the gradual change from one large radius to another would, in effect, be a flat portion. Care must be taken that any lip at which two parts of the metal section are riveted together is not, in itself, liable to crinkle. Each flange is often a complete tube in itself; the webs may be single or double.



Buckling is most likely to start in the most highly stressed parts, i.e. the flanges; therefore the corrugations in the flanges are usually more elaborate than in the webs.

From what has been said, the reader must not imagine that the web or webs are unimportant. Far

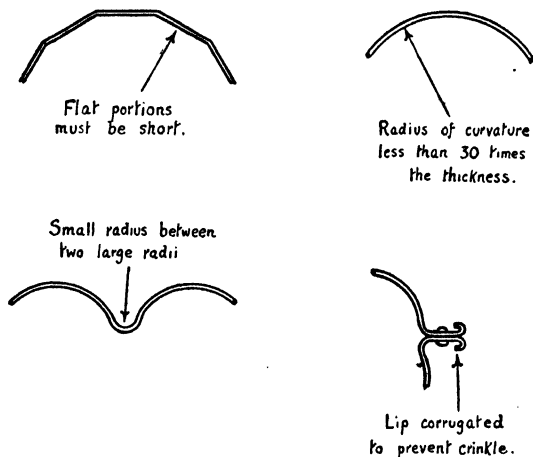

FIG. 67. PRINCIPLES OF CORRUGATION

from it. It is true that the designer of a beam usually designs it so that the flanges, without any assistance from the webs, are strong enough to carry the stresses due to bending, and thus provide the necessary moment of resistance. But the webs, beside forming the essential connecting link between the two flanges, have also to bear the brunt of the stresses due to shear. From theoretical considerations it can be shown that the shear stress may often be most intense at the neutral surface, and it is quite common practice to assume that all the shear force must be carried on the web.

The figures have shown the variation of bending moment and shear force along beams loaded in various ways. In so far as they suggest shapes for these beams, the diagrams assume that the only means of strengthening a beam is to increase its depth. But, as we mentioned in passing, it is not always convenient to vary the depth of an aeroplane spar according to the bending moment. We see now that the best way of catering for large bending moments is to strengthen up the flanges, while the webs should be strengthened where the shear forces are large. This is often done in practice by the addition of extra plates to flanges or webs respectively. The careful observer will notice this sort of thing throughout an aeroplane structure, but it is usually most apparent in such structures as large bridges. The Forth Bridge (Plate VII) is nothing more or less than a large bending moment diagram fashioned in metal, and many other famous bridges likewise owe their shapes to the bending moments and shear forces which are much influenced by the types of loads they have to carry, the lengths of their spans, and so on.

**Deflection of Beams.** Just as a tie increases in length under a tension load, so a beam will bend, or deflect, under the bending moments and shear forces which it has to carry. Such deflections are by no means negligible; the wing tip of an aeroplane may move upwards relative to the root a matter of several inches in a large machine, and a different deflection of the front and rear spars may cause the wing to twist. Such deflections not only alter the rigging dimensions on which correct flight depends, but they are the primary cause of a phenomenon that is assuming more and more importance as speeds of flight increase—namely flutter. This will be mentioned again in connection with the

actual wing and tail structures. The property of a beam which enables it to resist deflection is called stiffness, and it seems very probable that stiffness may become a more important factor than actual strength.

Fig. 68 shows how beams bend and deflect under various types of loading. Study this figure carefully; it brings out various important points. Notice that in the simple cantilever (*a*) the deflection is greatest at the free end but the largest bending moment is at the fixed end. In (*b*), however, a simply supported beam, loaded in the centre and therefore sagging, the deflection is greatest at the centre point *Y*, where the bending moment is also greatest. The beam shown in Fig. 68 (*c*) corresponds to the loading of Fig. 59 (*b*). Notice how it bends; first sagging, then hogging, the points *Y* representing the greatest bending moments in each direction. But most interesting is the point *X*. This is where the bend changes from sag to hog, in other words just at this point there is *no bending*, and this corresponds exactly to where the diagram crosses the line in Fig. 59 (*b*). Such a point is called a *point of inflection*, or sometimes *point of contraflexure*. It is clearly a point at which the flanges have very little to do, and they are often joined at this point. But the webs, of course, should be joined at other parts—where there is no shear. Points of inflection are often very noticeable in bridge construction; sometimes there is only a pin joint, the pin carrying the shear and at the same time allowing the bridge to hinge, to take up temperature stresses. In Fig. 68 (*d*), which corresponds to the loading of Fig. 59 (*c*), notice the three points of maximum bending (*Y*), and the two points of inflection (*X*), again corresponding to the diagram of bending moment crossing the line.

Fig. 68 (*e*) shows the deflection of the spar of a

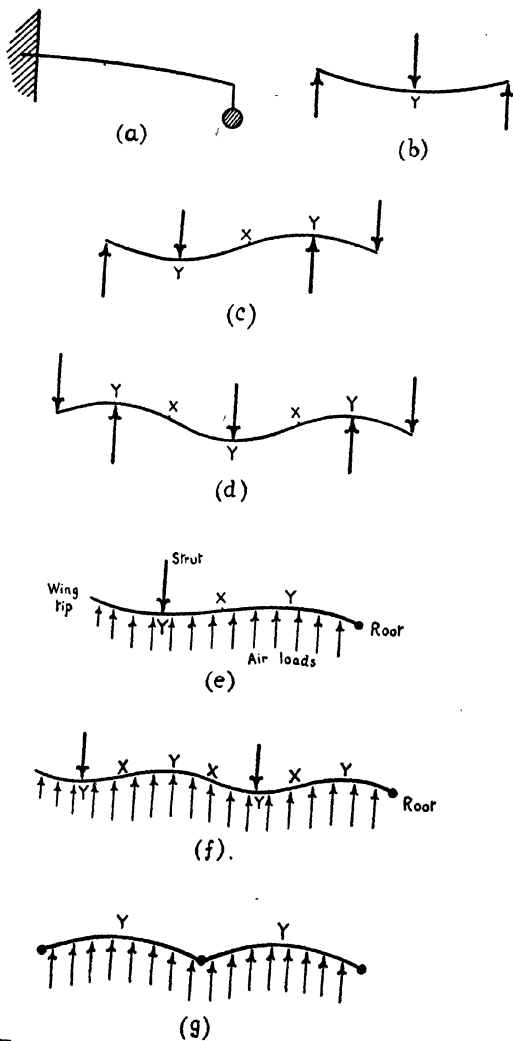

FIG. 68. HOW BEAMS DEFLECT UNDER LOAD

single-bay biplane,  $Y$  being the points of greatest bending moment,  $X$  being a point of inflection; and Fig. 68 ( $f$ ) shows a two-bay biplane spar with four points of greatest bending ( $Y$ ) and three points of inflection ( $X$ ).

The distinction between ( $f$ ) and ( $g$ ) is interesting. The spar of Fig. 68 ( $f$ ) is what is called a *continuous beam*, that is to say it runs continuously through the points of support. The same applies to the other beams shown. But in Fig. 68 ( $g$ ) the beam is hinged at the centre support, and in consequence bends in quite a different manner; in fact, just like two separate beams. Notice how different is the result. In ( $g$ ) the deflections at the centres of the spans are greater, there are no bending moments at the points of support, and there are no points of inflection. Such a beam is much weaker, and is not often used in practice when a continuous beam is possible, but a continuous beam is like a redundant framework in that the calculation of its strength is much more difficult than that of a simply supported beam.

Now to sum up this chapter—

1. Tension members are easy to design.
2. Struts are classed as long, medium, or short.
3. Long struts fail by bending, short struts by crushing.
4. Hollow tubes make the best struts.
5. If the walls of the tube are too thin, the strut is elastically unstable, and crinkles under load.
6. Struts should be tapered, but parallel struts are easier to make.
7. The type of end fitting affects the strength of the strut.
8. Loads on a strut should be central, and the strut should be initially straight.

9. Beams carry loads acting at right angles to their length.

10. We have seen how the tendency to bend—or bending moment—varies along beams loaded in different ways.

11. There is also a tendency to shear in a beam. This shear force has been examined for different types of loading.

12. When there is a shear force across the beam there is also a shear force longitudinally in the beam.

13. At some part of the cross-section of a beam there is a neutral surface where there is no tension or compression in the fibres due to bending.

14. The tension and compression due to bending are greatest at the outside of the beam, and decrease to zero at the neutral surface.

15. The strength/weight ratio of a beam depends on the material, the depth of the beam, and on the shape of cross-section.

16. In practice I- or box-sections are used; the flanges taking the bending, the webs the shear.

17. Spars are corrugated to prevent elastic instability.

18. Large bridges are often shaped like the bending-moment diagrams for the loads they have to carry.

19. It is important to visualize how a beam deflects under load.

20. A point of inflection is where the beam changes from a sagging to a hogging bend; at this point there is no bending moment.

21. Continuous beams are stronger than those hinged at each support.

## CHAPTER VII

### THE MAIN-PLANE STRUCTURE

**The Four Main Structural Units.** The structure of an aeroplane consists of four main units—

1. The main planes.
2. The fuselage (or nacelle or hull, according to the type of machine).
3. The undercarriage.
4. The tail unit.

Each of these has its own definite functions to fulfil, and, although eventually they must all form part of one and the same aeroplane, and must be developed accordingly, they are each in themselves such complete units that we may well consider them separately.

In an earlier chapter we attempted to analyse the comparative weights of the structure and the other main parts of the aeroplane. Now we should be wise to split the weight of the structure itself into its four component parts and consider the relative weight of each portion. As before, we shall find a very wide variation, and we can only give rough averages, but they are interesting nevertheless. We have selected the same types of aeroplane as those given in Chapter IV, so as to preserve some kind of continuity of argument.

**Percentage Weights.** *Note.* The figures in the table give the weights of the component parts as percentages of the weight of the complete aeroplane, while Fig. 69 gives the average weights of the four main structural units, but in this case as a percentage of the structure weight.

Type	Main Planes	Fuse- lage	Under- carriage	Tail Unit
1. Private light aeroplane (biplane) .	20	17	8	3
2. Single-engined commercial machine (monoplane) . . . . .	26	11	11	3
3. Single-seater fighter (biplane) .	26	12	9	3
4. Service float plane (biplane) . .	21	13	19	3
5. Fast day bomber (monoplane) . .	26	11	10	3
6. Large night bomber (monoplane)	22	18	8	2
7. Service flying-boat (biplane) . .	21	24	2	5
8. Large commercial flying-boat (monoplane) . . . . .	21	23	2	4
9. Large four-engined passenger land plane (monoplane) . . . . .	24	15	8	3

At first glance this table seems to suggest that the division of the weights among the four main units differs considerably for the various types of machine, but such an impression is caused chiefly by the differences between the land planes, the float planes, and the flying-boats. Such differences are only to be expected; in a flying-boat, the hull acts both as fuselage and undercarriage, and we find that the weight of hull (plus wing floats) is very much the same as the combined weight of fuselage and undercarriage for a land plane. In a float plane we would expect the weight of the undercarriage to be high, but unfortunately the float plane also needs a fuselage, and the two together put it at a disadvantage when compared with either flying-boat or land plane. This accounts for the high structure weight of the float plane. The large percentage weights of the tail units on flying-boats is interesting. There are probably two reasons for this: first, the tail unit must stand the buffeting of spray and perhaps even waves; secondly, large forces may be needed on the tail plane to provide adequate equilibrium and control (see *Flight Without Formulae*).



Notice the large percentage weight of main planes in the high speed machines—the single-seater fighter, the fast day bomber, and the single-engined commercial monoplane. This is to be expected in view of their high wing loadings; the wings are small, but they must be very strong. Fig. 69 sums up the position for an average land plane; if we remember that the total structure weight is about half the total weight of the

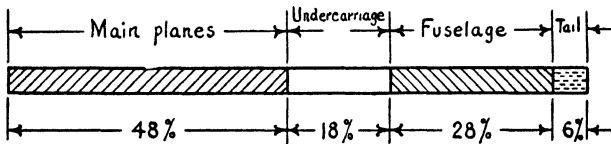

FIG. 69. HOW THE STRUCTURE WEIGHT IS MADE UP

aeroplane, the figures (as percentages of the total weight) become—

Main planes, 24 per cent; undercarriage, 9 per cent; fuselage, 14 per cent; tail unit, 3 per cent.

Unfortunately, by making the undercarriage retractable we have increased its weight, but the figures given have taken this into account and represent modern practice.

In the following chapters we will consider each of the four main structural units in some detail.

First, the main planes.

The internal structure of the plane usually consists of two *main spars*, braced together by a system of *struts* and *wires*; the aerofoil shape is maintained by a series of *ribs*, and the whole structure is covered with *fabric*. We shall think of this, at any rate, as the standard type of structure, and leave any different types for consideration later.

We know from our knowledge of the mechanics of flight that in ordinary normal flight there are four main forces acting on the aeroplane, namely lift, weight, thrust, and drag. The conditions of balance for steady flight are that lift must equal weight, and thrust must equal drag. By far the major portion of the lift must be borne by the main planes, and they will also bear at least a share of the drag, possibly as much as 50 per cent of the total. The lift forces will tend to bend the whole main plane structure upwards from the fuselage and outwards; the drag will tend to bend the planes backwards.

**Fabric.** The first line of resistance against both lift and drag forces must be the fabric which receives the loads from the air.

It is not always realized that the fabric is a definite part of the structure from the strength point of view, and not merely a covering for the planes. For this reason aeroplane fabric, which is unbleached Irish linen, must be subjected to a tensile test similar to that applied to other aircraft materials; the strength demanded is at least 90 lb. per inch width of fabric.

If we divide the total weight of an aeroplane by the total wing area we shall get a rough estimate of the *average* wing loading (as it is called) in pounds per square foot, but this in itself gives us very little idea of the load really carried by the fabric because this varies tremendously from one part of the wing surface to another. For instance, the upper plane carries more than its share compared to the bottom plane, even if they are of the same area; secondly, the load is very unequally divided between the upper and lower surfaces of the wing; thirdly, it is unevenly distributed along the chord, being greatest near the leading edge; and fourthly, it is not evenly distributed along the span.

Thus whereas the *average* wing loading may vary from about  $1\frac{1}{2}$  lb. per square foot on a sail plane to 30 lb. or more per square foot on a fast, heavy machine, the actual *maximum* pressure on the fabric will probably be at least ten times these values. But even if we can estimate this maximum pressure at right angles to the fabric we still get very little idea of the tensile forces in the fabric itself, which depend also on the tautness produced by the dope.

Owing to the uncertainty in the whole matter it was decided to standardize a fabric which is *amply strong enough* for all ordinary values of wing loading. Experiments have shown that the test of 90 lb. per inch ensures that such fabric will withstand even the maximum pressure due to a high wing loading in addition to the effects of tautening by the dope. No attempt is made to vary the strength of the fabric according to the varying loads it has to carry. Strictly speaking, of course, according to the principles enunciated in previous chapters, we ought to do so, but we satisfy our consciences by saying that, in any case, the weight of the fabric is so small (about  $\frac{1}{4}$  lb. per square yard), and that any attempt to vary its strength and thickness would involve such practical difficulties as to make it not worth while.

After a plane has been covered, the fabric is "doped." This dope serves several purposes: it strengthens the fabric, makes it more durable in withstanding the effects of weather, and renders it waterproof. It also tautens the fabric which, though it will help to preserve the aerofoil shape under the air pressures, will, on the other hand, put considerable loads in the wing structure. Pigments in the dope, and varnishes applied over it, both help to prevent sunlight from reaching the fabric; this would cause it to deteriorate very rapidly.

**Ribs.** After the fabric, the *ribs* form the next line of defence (Plate VIII). The method by which the fabric hands the load to the ribs may appear to the ordinary engineer to be rather beneath his dignity, but he cannot deny that it is both light and effective, even if it does have to be done with a needle and thread! The fabric is, in effect, *sewn* to the ribs. During ordinary flight, the fabric on the lower surface will be forced up against the lower boom of the ribs, and any attachment to that boom is unnecessary from the strength point of view; but on the top surface the state of affairs is very different. Here the fabric will tend to be "sucked up" off the top boom of the ribs, and it must be held down by stitching it to this boom. Now, it is not easy to attach the top boom of a rib to the spars, but the bottom boom will rest up against them, therefore not only is the top boom connected to the bottom by the bracing of the rib itself, but very often the *top surface fabric* is sewn not only to the top, but also to the bottom boom of the ribs. Since the top surface fabric carries by far the larger share of the load, it will be clear that much of the weight of the aeroplane in addition to its pilot, passengers, luggage, and so on, are all carried on the *threads* by which the fabric is thus attached to the ribs. So remember, when you are flying, that you are, quite literally, hanging on a thread, or, at any rate, threads. Be assured, however, that for this very reason the Air Ministry has laid down that even such thread must come up to the required specification for strength and other necessary qualities.

The ribs themselves fulfil two distinct functions: they are, as we have seen, the intermediary which enables the fabric to convey the loads to the spars; secondly, they are responsible for keeping the shape of the aerofoil, the importance of which the reader will

fully realize if he has studied the mechanics of flight. The ordinary ribs are sometimes called *camber ribs*, since they maintain the camber, but also to distinguish them from *compression ribs*, which are ribs specially strengthened so that they can form part of the internal bracing of the wing.

Very often small extra riblets, called former ribs or nose ribs, are fitted between the front spar and the leading edge of the wing (Plate IX). These fulfil two important functions: they provide extra strength at the most heavily loaded part of the wing, and they help to keep the correct aerofoil shape just where the exact shape is most important. Even so we are not satisfied, and this part of the wing is usually further reinforced by being covered with three-ply wood or thin sheet metal in addition to the fabric.

The sort of loading which a rib must carry in normal flight is shown in Fig. 70 (a), and Plate X is particularly interesting as showing how these loads are reproduced when a rib is tested for strength. The complicated system of levers is so designed that the application of a single load on the weighing machine applies just the right proportion of load to every joint of the rib. You will notice that it is not any nice simple loading such as we considered in the last chapter when dealing with beams, but none the less now that we have the main ideas we can see how it will tend to bend—this is shown in exaggerated form in Fig. 70 (b), complete with points of inflection and so on. The depth of a rib is more or less decided by the shape of the aerofoil which has been adopted, and we cannot therefore strengthen it by adding to the depth. However, you will notice that it is fairly deep and strong where strength is most needed, i.e. at the spars and in the centre of the span between the spars. The ribs may be of I-section,

channel-section, box-section, or built up by girder work. They form a good example of a part which really suffers from not having enough load to carry. That is to say,

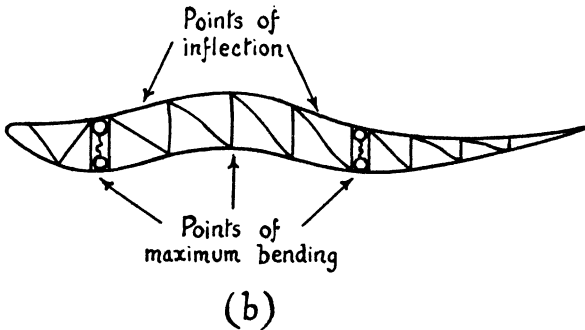
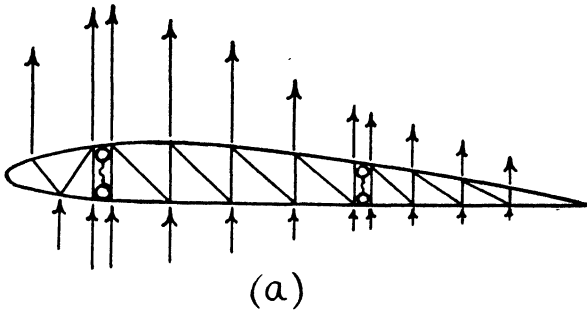

FIG. 70. LOADING ON A RIB

the loads on them being comparatively small, they are apt to be too flimsy and thin, especially if made of a strong material like steel, and thus they may easily get bent or twisted, or buckle through carelessness in handling and so on. On a certain light aeroplane, of

wooden construction, the ribs consisted of two flanges braced together by a Warren girder work. The members of this girder work, allowing for the required load factor, were worked out to be about the size of an ordinary match. If they had been made of steel, the required size would have come out to be about one-twentieth of this size! Such small sizes are not practicable in an engineering structure, and thus we are reluctantly compelled to add extra weight simply for the sake of making the thing of what we might almost call "sensible" dimensions. This idea is important, and it crops up in many of the lightly loaded parts of the structure.

The load carried by each rib will clearly depend on how far apart they are spaced; but here again there is a practical limitation, owing to the necessity for keeping the correct shape of the wing and preventing too much sagging of the fabric between ribs. For these reasons we cannot place the ribs more than about 18 in. apart when fabric is used for covering.

**Main Spars.** The ribs, in their turn, hand the load on to the spars. The rib is in much the same relation to the spar as the fabric is to the rib, that is to say the bottom boom of the rib rests up against the spar, while the top boom, which cannot easily be attached to the top of the spar, is connected to the bottom boom and so transmits its load through the latter to the spar.

The proportion of the load to be carried by each of the two spars will naturally depend on the position of the centre of pressure; if the centre of pressure is nearer the front spar, that spar will carry the greater share of the load; similarly the rear spar will take the greater share if the centre of pressure is more than half-way back between the two spars. Unfortunately, however, as we have seen previously, the centre of

pressure is liable to move as the attitude of flight changes, and on some aerofoils it moves so much that in what is called the "C.P. forward" condition (at large angles of attack, slow-speed flight) the centre of pressure is near the front spar, whereas in the "C.P. back" condition (small angles of attack, high-speed flight) it is near the rear spar. It is easy to see that this movement of the centre of pressure across the chord will affect the stability of the machine, but in this book it is the structure with which we are concerned, and the effect of such movement on the structure is interesting and important. Perhaps the most interesting way of thinking about it is to compare an aeroplane fitted with an aerofoil section such as that mentioned above in which the centre of pressure is liable to move from one spar to another, and an aeroplane which is to be designed for similar purposes but is to be fitted with an ideal aerofoil section on which the centre of pressure remains stationary, whatever may be the angle of attack (there is no real section of which this is quite true, but some approach very nearly to it). Now, in the former case *both front and rear spars* must be made strong enough to carry the *whole weight* of the aeroplane, because under *some* condition of flight the whole effective weight will be on each of the two spars. What applies to the spars, applies equally to that portion of the ribs near the spar in question, to the wing covering, and, in a biplane, to the flying wires and interplane struts. In short, both front and rear bracing must each by itself be capable of carrying all the weight.

Now compare this with the latter case. The aerofoil has a stationary centre of pressure. Let us assume that it is half-way between the two spars; wherever it is it will not affect the argument. Each of the two spars



need only be capable of carrying *half* the weight of the aeroplane. As before, what applies to spars applies to ribs, covering, struts, and flying wires. Therefore all parts of the wing will have less load to carry, and therefore they can be made lighter. But that is not all—our old “virtuous circle” again comes into play.

The wing construction will be lighter, therefore the whole aeroplane will be lighter. But what is the purpose of the wings? To lift the aeroplane. If they have less weight of aeroplane to lift, they can again be lighter, and being lighter . . . But let us leave it at that, for the moment.

Now, the purpose of the tail plane is to provide stability. If the centre of pressure on the main planes does not move, the tail plane will have smaller loads to carry, and can therefore be made of lighter construction, therefore the whole aeroplane will be lighter, therefore the wings will be lighter, therefore . . .!

But what is the purpose of the fuselage? To carry the loads imposed on it by the tail. Less loads on tail—less loads on fuselage—lighter fuselage—lighter aeroplane—lighter wings—etc.!

For what is the undercarriage? To support the aeroplane on the ground. Less weight to support—lighter undercarriage—lighter aeroplane—lighter wings—etc.!

By now our aeroplane is so reduced in weight that we can surely attain the same performance with a less powerful and lighter engine. This will only need a smaller and lighter airscrew. It will use less petrol and oil—but that is enough; the reader is probably convinced by now that an aerofoil with a stationary centre of pressure will have a profound effect on the structure of the whole aeroplane!

This argument may perhaps seem a little exaggerated or far-fetched, and in a sense I suppose it is rather an

extreme instance, but none the less the principle involved is a perfectly sound one, and it surely provides one of the best possible illustrations of how the theory of flight is wrapped up with the design of the structure, and how each part of the structure reacts on every other part.

To return to the spars. They are essentially beams,

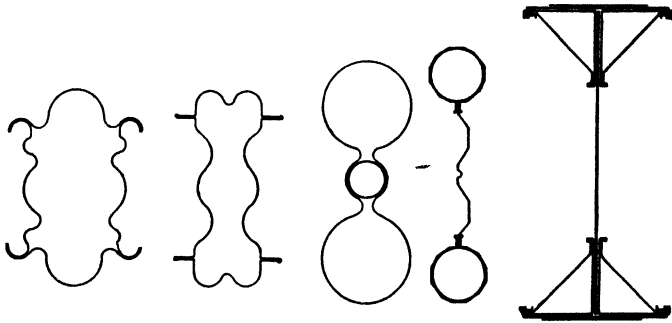

FIG. 71. SPAR SECTIONS

and they are one of the most important parts of the whole structure. In many monoplanes they are pure cantilevers, sticking out each side of the fuselage, and they must be of enormous strength to resist bending, especially near the root. In a biplane structure, and in some monoplanes, they are braced to form continuous beams which also carry end loads of tension or compression. We have considered the spars, from this point of view, in a previous chapter.

Although main spars differ considerably in shape of cross-section (Fig. 71), this is due more to the whims of the respective designers than to any logical principle. Each, whatever its shape, has two flanges and a web or webs to connect them together. If, as is often the

case, they are made of high-tensile steel, they will be of thin gauge, and liable to buckle due to elastic instability, and therefore rather elaborate corrugations may be necessary. For a weaker material like duralumin, the walls will be thicker and less corrugation necessary. If the spars are made of wood, an ordinary I- or box-section will be stiff enough.

Plate XI is interesting; it shows how a rib is tested for strength. Plates XII, XIII, and XIV show respectively: the failure of a flange due to excessive bending moment, the failure of a web under shear, and, most remarkable of all, the ripples in the thin metal due to elastic instability.

The spars transfer the loads to the fuselage. In a monoplane the whole load passes through the root fittings, which must be of considerable strength. In a biplane it is conveyed, via interplane struts and flying wires, to the centre section of the top plane and to the root fittings of the bottom plane. At the root fitting, especially in a cantilever monoplane, there will be a large shear force as well as tension at the lower joint, and compression at the top joint, owing to the maximum bending moment (Fig. 72).

**Landing Loads.** We have dealt, so far, with those parts of the structure designed to carry the upward lift loads on the main planes during flight. As explained in an earlier chapter, the loads during landing will be reversed in direction. The same applies in upside-down flight and certain not very common manœuvres. How is the wing structure designed to carry these reversed loads?

So far as the air loads are concerned, in upside-down flight for instance, fabric, ribs, and spars will already be amply strong enough to carry the reversed loads without any special bracing. The same applies to the

root fittings, the only difference being that the bottom joint will take compression where it previously took tension, and the top joint tension instead of compression. In a biplane structure, however, the flying wires

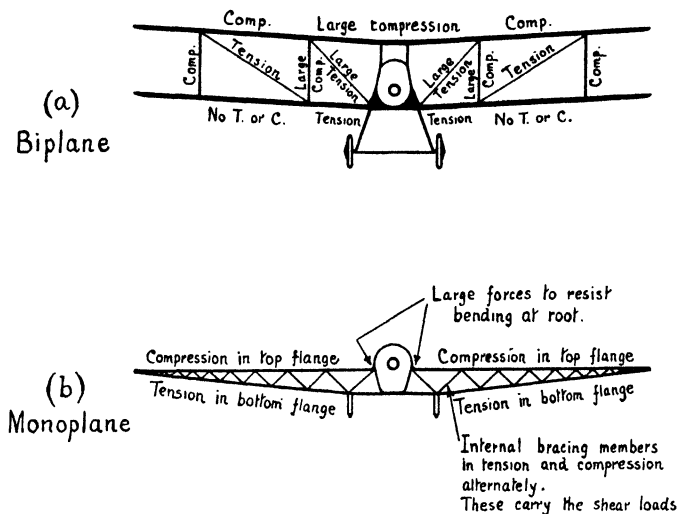

FIG. 72. LOADING IN BIPLANE AND MONOPLANE STRUCTURES

cannot take the reversed loads, since they would be in compression; therefore they are cross-braced by landing (or anti-lift) wires. The landing wires need not be so strong as the flying wires, since the reversed loads are not likely to be so large as the loads in the normal direction; this is chiefly because there is no need to allow the same load factor for upside-down acrobatics.

But what the wing structure must cater for are the inertia loads caused, in landing and taxiing, by heavy weights in the wings. Engines, petrol tanks, bombs,

floats, and a multitude of smaller accessories—all tend to continue travelling downward when the aeroplane lands. Some of these are among the heaviest individual items in the aeroplane, and if they are to be carried by the wing structure it must be of very sturdy construction, especially inboard of the positions of the weights themselves. Therefore, if such weights must be carried in the wings, they should be put as near the fuselage as possible. This is not always easy. Engines, for instance, must be placed so that there is room for the airscrews to rotate without hitting each other or anything else. Wing-tip floats can hardly serve their purpose unless they are near the wing tips. The methods of strengthening up the structure to carry these large loads cannot be given in detail, since they are varied according to circumstances. Sometimes it is merely a question of adding extra strength to the root fittings and spars inboard of the weights. In such instances, to the outward eye, it may all look quite simple; but, believe me, the designer has had to think about it all.

In other cases, the extra strength has not been so easily concealed, and extra struts or wires are obvious for all to see. The former method is, of course, the better one, except perhaps that it does not provide such a good illustration of the point we are trying to make. However, when you see pictures of aeroplanes, or, better still, when you see real aeroplanes with engines, tanks, and so on in the wings, have a good look to see if you can detect the designer's method of dealing with the loads. Think, too, how he must hate all these heavy things like engines and bombs. Not only do they give him so much weight to carry while the aeroplane is flying, but he must also provide means of supporting them when the aeroplane is on the ground, and—this is the real trouble—these “means

of supporting them" are so much extra weight to be carried in the air. The old vicious circle this time. Perhaps he will forgive the engines—they do at least give him the power to fly; but what of the bombs? However, we are trying to understand the aeroplane structure, not why aeroplanes must carry bombs!

**Drag Bracing.** We now have a wing structure which is amply braced against movements upwards or downwards. Our next task is to prevent it from moving backwards or forwards. It will tend to move backwards in all conditions of flight in which the wings are striking the air at a small angle of attack, that is to say at high speeds, and especially in a steep dive. On the other hand, it will tend to move forward (relative to the fuselage) on landing, because the wings, and again the heavy weights in the wings, will tend to continue travelling forward owing to their inertia. Under certain conditions of flight also, namely at large angles of attack, the wings will tend to move forward in the plane of the chord. This is not easy to understand at first, and if the reader is in difficulties about it he should consult the companion volume. But it does not matter much, because he will understand the inertia loads and these will probably be bigger than those in flight.

To prevent the backward or forward movement of the wings, the spars are usually braced together by a system of struts and wires, the struts being called compression or drag struts, and the wires drag wires (those which prevent the wing moving backward) and anti-drag wires (those which prevent it moving forward) (Fig. 73 and Plate VIII). As in the lift bracing, the loads to be carried increase from the wing tip inwards; in consequence the bracing usually gets stronger towards the fuselage, and often too the bays are

shorter. The drag struts are usually steel or duralumin tubes, sometimes duplicated, one being placed above the other to prevent the spars from twisting. In wooden machines it was often the practice to strengthen

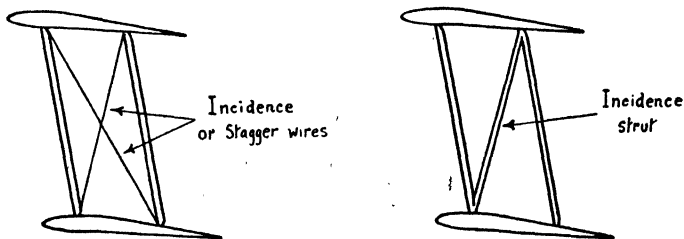
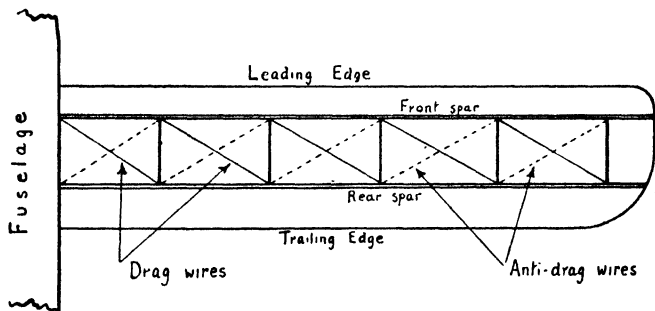

FIG. 73. DRAG AND INCIDENCE BRACING

up a special rib—called a compression rib—and call upon this to act as a drag strut as well as a rib. Our rather troublesome engines, and other weights in the wings, will add considerably to the loads on the inboard anti-drag bracing, owing to the inertia effects on landing; while, when wing engines are employed, the

thrust of the airscrews will pull the wings forward in flight, and these loads too will have to be transmitted by the anti-drag bracing to the fuselage. So once again we must look for extra strong wings between the root and the engines.

In a biplane structure there is usually stagger, that is to say the top plane is forward of the bottom one, and the two planes are braced together by the interplane struts and incidence (or stagger) wires in addition to the landing and flying wires. Owing to the stagger the interplane struts are inclined to the vertical. This means that the loads in them are increased and they help to carry the drag loads from one plane to another. The incidence wires also do this, although in a sense these wires are redundant (except in the centre section) because, except for their natural flexibility, the wings would keep their shape without them. Sometimes one incidence strut replaces the two incidence wires (Fig. 73).

**Conventional and Unconventional Wing Structures.** The wing structure which we have so far imagined may be said to be of the conventional type, complete with two spars, drag and anti-drag bracing, ribs, and fabric covering; the two planes, in the case of a biplane, being braced together by interplane struts, flying, landing and incidence wires. This, as it were, is the typical aeroplane structure, used not only on our old friend the Avro 504K, but on nearly all the famous machines in the history of flight. It is, in fact, interesting to look back and notice how little the structure of the average aeroplane has changed until very recently. Our illustrations show some of the aeroplanes which have made history. The Wright machine (Plate XV) that made the first power-driven flight, with its interplane struts, flying and landing wires, two



spars, drag and anti-drag wires, was very like some of the biplane structures in use at the present day. The Blériot (Plate XVI), which first flew across the Channel, was a monoplane, but braced like a biplane with flying and landing wires, typical of the early monoplane structures. The Bristol "Box Kite" was the first military aeroplane (Plate XVII). The author has a soft spot for the little Bristol "Scout" (Plate XVIII), nicknamed "bullet," because, being a single-seater, it was the first machine he had to fly without any instruction, and it was then used for "passing out" fighter pilots! The B.E.2c was the forerunner of all the biplanes used in the 1914-18 war (Plate XIX) and was designed by one of the famous de Havilland family, who for so long afterwards remained faithful to this conventional design and still, to this day, are trying to cling to the wooden construction that has served them so well. The Avro 504K (Plate XX) is perhaps the most conventional of all conventional structures, a training machine, not only for pilots, but for all who design or build or rig aeroplanes. The Bristol monoplane of 1916 is shown in Plate XXI. The S.E.5A (Plate XXII) was the conventional biplane structure on a small fighting scout. Plate XXIII illustrates the far-famed Bristol "Fighter." The D.H.4 (Plate XXIV), still, for obvious reasons, bearing resemblance to the B.E.2c, was the machine used so extensively by the British and American forces towards the end of the last war. Of large machines, the Handley Page 0/400 (Plate XXV) is a representative type. There were various experimental triplanes (Plate XXVI). And still, after that war, so many that we cannot illustrate them all, there were the De Havilland "Moth," Bristol "Bulldog" (Plate XXVII), Gloster "Grebe" and "Gauntlet," Armstrong Whitworth "Siskin," Westland "Wapiti," Hawker

"Hart" and "Fury," Fairey "Fox" and "Firefly," Vickers "Vildebeste," Short and Blackburn flying-boats, and very many more, all differing in detail, but all typical, all conventional in so far as the main wing structure was concerned.

The examples quoted have been mainly British types, but, with the possible exception of Germany, a similar list could be compiled from types produced by the comparatively few other countries which have manufactured aircraft on a large scale. In Germany, the monoplane found favour, even in the days of that earlier war, and there is no doubt that what we have called the conventional structure is less suitable for monoplane than biplane, and so it is not surprising to find that the Germans have for a long time been exploring less conventional types. Another influence has probably been their long experience on Zeppelin construction, which is very similar to what in this country has been called geodetic construction.

In general, the less conventional types may be divided into the following main categories—

1. *Monospar*, in which, as its name implies, the two-spar system is replaced by one built-up spar which is sufficiently rigid to withstand twisting and drag and anti-drag loads as well as the flying and landing loads (Plates XXVIII A and B).

2. *Multi-spar* (also explained by its name), in which a series of small spars replaces the two strong main spars. In dismissing this form of construction in a few lines, we do not wish to infer that it is unimportant, or even comparatively so. It has many adherents and may yet prove even more popular than it is at present. The sole reasons for such a short description of it is that it involves no new principle.

3. *Monocoque, or Stressed-skin Construction*, in which

a metal or three-ply skin surrounds a series of hoops with stringers running longitudinally. This system is especially adaptable to fuselages and hulls of flying-boats, but has also been used for wing construction. The metal skin not only replaces fabric in its capacity as a covering, but it is sufficiently strong to carry the twisting and drag loads and perhaps even the lift and landing loads without internal bracing in the form of spars, ribs, and wires. It has one great advantage in that the interior of wing or fuselage is left comparatively free from bracing and can conveniently be used for the stowage of petrol tanks, bombs, retractable wheels, mails, and even passengers (Plate XXIX).

There are always snags: in this case there is the old bogy of elastic instability. The skin will take its tensile and compressive stresses even when it is comparatively thin, and therefore light; but it is very liable to crinkle on the compression side, and once this starts the whole wing is liable to buckle up. The hoops and stringers are intended to prevent this; but if we add too many such stiffeners, this type of structure is liable to become heavier than the conventional one. This is an instance where duralumin, or even magnesium alloys such as electron, may come into their own; being weaker than steel, greater thickness of skin is needed and greater thickness gives greater stiffness, yet the weight may still be less than the equivalent steel structure.

One way of stiffening the skin is to corrugate it, as is clearly shown in Plates XXX and XXXI.

Another snag of this method of construction is that it does not lend itself at all readily to theoretical calculation. The only satisfactory way is to make a part and test it. Such a method is apt to be slow and expensive.

But, whatever the disadvantages, one feels that, in

some form or other, this type of construction has come to stay. From the aerodynamic point of view the metal surface is vastly superior to fabric, and if we are to have a metal surface we may as well use the metal to contribute to the strength of the structure.

4. *Geodetic Construction.* This is a kind of hybrid. A framework is used, but it is employed round the outside of the wing or fuselage, leaving the centre free of obstruction, as in the stressed-skin method. Ordinary fabric covers this framework, or a very thin metal skin may be used, since it will not be required to carry any main stresses. The framework itself is in the form of intersecting spirals forming a lattice work. Unfortunately, photographs of the internal construction may not yet be published, but Plate XXXII shows that in external form the appearance is much the same as any other modern type of construction.

Although the elastic instability trouble should be avoided, there is still the difficulty that the stresses are difficult to calculate, and there is also the problem shared by the stressed-skin construction, of allowing openings for doors, insertion of petrol tanks, and so on. If a hole is cut, the whole idea is spoilt, as the skin or the geodetic members are broken and cannot therefore continue to carry the load. The only way of overcoming this difficulty is to insert rather heavy frameworks round such openings, but this adds considerable weight, whereas the whole idea was to save weight. It is surprising, too, how many such openings are required.

5. *The Use of Plastics.* All who are interested in aeroplanes must always be looking to the future, and, fortunately or unfortunately, they do not have to wait very long before they find out whether their ideas were

sound or not. Therefore it is rather rash to prophesy, but at least it should be said that yet another possible type of wing structure may come into being with the employment of plastic materials. Bakelite is already well known for many household purposes, but all the time we are learning more and more about plastics and their great possibilities. Airscrews moulded out of such material have already been tested; will it be long before we have reinforced plastic wings? Such a wing could be solid at the thinner parts near the wing tip, hollow near the root, it could be reinforced by a steel spar of very thin gauge, the plastic material serving to prevent the steel from buckling. The wing surface could be beautifully smooth and carefully shaped, free from all rivets or projections, and the structure should be reasonably rigid. Naturally there are snags; but snags are meant to be overcome, especially when one can see so many advantages.

Well, let us leave it at that, and let us sum up our wing structure.

*First, then, the conventional type—*

The fabric is the first line of resistance.

Fabric hands on load to ribs.

Ribs to spars.

Spars to fuselage, in monoplane via root fittings, in biplane via flying wires, interplane struts, and root fittings.

Landing loads are taken in monoplane by root fittings, in biplane by landing wires, interplane struts, and root fittings.

Drag bracing consists of drag struts and drag and anti-drag wires.

*Secondly, unconventional wing structures—*

Monospar—with one spar.

Multi-spar—with many spars.

Monocoque or stressed skin—thin metal or plywood skin on hoops and stringers.

Geodetic outer framework, fabric-covered.

Possibility of use of plastic materials.

Before finally leaving the wing structure one point might be mentioned which would otherwise be puzzling to those whose work brings them into really close contact with the actual parts of the structure. It will be noticed that great care has been taken to bring all metal parts of the aeroplane into *electrical contact* with all the other parts, they are *bonded* together. Sometimes this may be done simply by ensuring that the parts in contact are free of any paint and are held closely together. In other cases, such as between a moving control surface and the main structure, the bonding may consist of short lengths of flexible copper wire. These seemingly elaborate precautions have, of course, nothing to do with the structural strength, but they do have two very important effects. The whole metal network of the airframe forms an earth for the wireless installation and, secondly, the static electricity in the atmosphere cannot charge one part of the framework to a higher potential than some other part and so cause an electric spark to pass between them. This bonding applies not only to the wings, but to the whole structure of the aircraft.

## CHAPTER VIII

### THE FUSELAGE STRUCTURE

FROM the point of view of efficiency in flight, the ideal aeroplane is a "flying wing." The wing structure is necessary: without it, flight is impossible; but we cannot say the same of fuselage, undercarriage, or even tail unit. Their position is aptly described when we give the name of "parasitic drag" to the resistance which they cause. They are parasites, existing only to hinder the wing in its passage through the air. At least, that is how we must think of them when we are striving for the best possible performance out of our machine.

Unfortunately, the flying wing has not yet been fully achieved. Most wings are not large enough to house the engines and crew; tail units are needed for stability and control; the undercarriage, however, is only needed for landing, and so we have learnt to pull it in out of the way during flight; this surely was a step in the right direction, one stage nearer to our ideal.

The fuselage cannot very well be retracted, but it can be contracted, and this has been done in the case of racing machines to such an extent that the fuselage is practically fitted to the pilot—and it is a close fit, too. What is done in racing machines must at least be aimed at in ordinary types, and in the everlasting search for efficiency in performance the designer has been forced to reduce the frontal area of his fuselage to such an extent that he has great difficulty in getting everything inside it.

In machines with one engine, or three engines, or

in fact any odd number of engines, one of these will be fitted in the nose of the fuselage, and this engine, together with all its accessories, just about fills this portion of the structure. When the engines are all in the wings, this nose portion usually carries the pilot and some of the crew, who thus get an excellent view, and freedom from much of the noise and disturbing effect of engine, airscrew, and slipstream.

Then comes the real body portion: here are the pilots, crew, passengers, instruments, and so on. It has been justly called the "brain centre," and likened to the bridge of a ship; but it is more than that, it is bridge and engine room, chart room, wireless cabin, and a few other things combined. To this portion, too, the wings are usually fitted and often the undercarriage, so it is also the structural centre of the aircraft where all the main members link up.

The rear portion of the fuselage has jobs all of its own: it acts as a "fairing" to the wide part of the body, giving it something like a streamline shape; it supports the tail, the elevators, the fin, and the rudder, and must transmit all the loads which come upon these surfaces; it carries the tail wheel or skid and from it receives all the shocks of landing and taxiing.

Thus we see that there are really three distinct parts of a fuselage (Fig. 74)—

1. The nose portion, a cantilever carrying the engine or crew.

2. The body portion, a box-like structure, the "centre" of the aircraft.

3. The tail portion, another cantilever, long, thin, and tapering.

The whole forms a double cantilever such as is used in bridge construction, and thus it has a bridge-like shape except in so far as it is disguised by streamlining.



But there is an even closer parallel than a bridge. Have you ever noticed the large horizontal cranes in a dock-yard? The top portion is a double cantilever; turn it upside down, and you have an aeroplane fuselage! Why this striking likeness? Simply because the loads are similar, and engineering structures are designed to

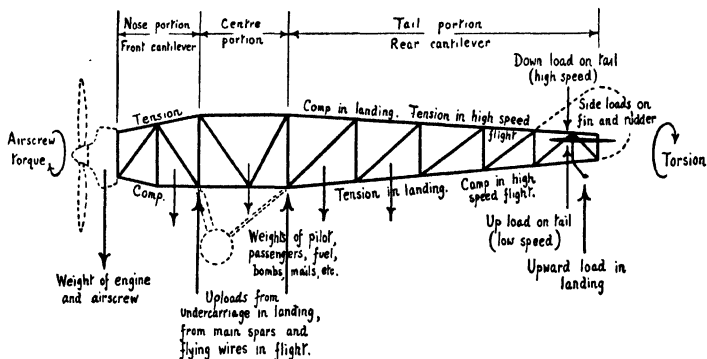

FIG. 74. LOADS ON A FUSELAGE

suit the loads. As previously explained, a bridge is merely a bending-moment diagram, and so is a crane, so is a fuselage.

Let us consider what loads each portion of the fuselage will be called upon to carry, and how the designer has catered for these loads. In doing so we will once again think first of the "conventional" fuselage, one that is built up very much like our crane or bridge, with four main longitudinal members (called longerons), one at each corner, the four being braced together on all four sides by a system of struts and ties, usually with internal cross-bracing at each bay where this does not interfere with the loads to be carried.

On the nose portion comes the weight of the engine,

tending to put the top longerons in tension and the bottom ones in compression, and both in shear. The thrust of the airscrew tends to pull the engine out of the fuselage, and thus the bolts which hold the engine to its mounting, the mounting itself, and the front part of the fuselage structure must all be capable of standing up to this thrust. The airscrew torque exerts an equal and opposite torque on the engine, and, through the engine, on the fuselage, so that the nose tends to twist. In some way or other the centre portion must resist this twist, so that it is almost as if the centre of the fuselage were held in a vice and a twist applied at the nose. The front portion must therefore be rigid in torsion.

The centre portion must be large and strong. In its capacity as support for the nose cantilever, the tail cantilever, the wing structure, and the undercarriage, it needs to be deep and wide and to be formed of some of the strongest and most rigid members in the whole structure. In its capacity as housing for pilot and crew and as providing entrances and exits, it must be free from obstruction in the form of internal bracing and perhaps even side or top bracing. Herein lies one of the difficulties in fuselage design, and one of the great arguments in favour of some kind of monocoque construction for this portion at any rate.

The rear portion is comparatively simple to design. It is true that it has to carry many different kinds of load, but as they are mostly applied at the same place (the tail), they can fairly easily be estimated, and they are all of similar magnitude. The loads on the tail plane itself may be up or down. Up in slow-speed flight, putting the top longerons in compression, the bottom in tension; down in high-speed flight, and especially in a nose-dive, which is the worst case to be

considered for loads in this direction. The down loads put the top longerons in tension, the bottom in compression. Similarly, the use of the elevator will cause up or down loads with the corresponding effects on the fuselage structure. On landing and in taxiing there will be an upward load on the tail wheel, which will have much the same effect on the fuselage structure as any other up load on the tail. In fact, for up loads, this is probably the worst case, as it is liable to be more sudden and violent than corresponding forces in the air (when a skid is employed, there will be not only up loads, but a rather vicious backward pull on the fuselage). In addition to the longerons, the side bracings of the fuselage will carry these up and down loads at the tail.

There may be sideways loads on fin and rudder, especially in a sudden turn. These will tend to bend the fuselage sideways, and this will call into play not only the longerons, but the top and bottom bracing also. The fact that fin and rudder are usually above the centre-line of the fuselage will mean that the whole will tend to twist, and then we shall need the bracing on all four sides and probably the internal bracings as well, although these are really redundant and the structure may be made sufficiently rigid without them.

Not only is it convenient from the design point of view to consider the fuselage as consisting of three distinct parts, but the modern tendency is towards actually building it as such, especially when geodetic or stressed-skin construction is used compared to a single unit. The portions are more easily handled on separate jigs, they are more accessible from the point of view of the fitting of accessories, and, perhaps most important of all, they are easily transported and fitted as spare parts to damaged aeroplanes. Each portion

can be made complete in itself, fully equipped with accessories, pipe-lines, and so on, and the units are all built in jigs so as to be interchangeable. Thus fitting one portion to another involves nothing more than the use of one of two spanners and a screwdriver.

To turn again to the types of structure used. The engine bearers and the front portion are usually of steel tube construction in the form of some kind of "N" girder work. This is strong, light, and rigid and, a point which is sometimes worth considering, folds up nicely in the event of a crash. There are many types of accident in which some part of the aeroplane, especially the nose portion of fuselage or the undercarriage, can act as a very efficient shock-absorber if it crumples up without splintering, and in this way many lives have been saved.

The centre box-like portion is usually either of the same type of construction or monocoque. In both cases, strong reinforcing hoops are usually inserted where doors, cockpits, or other openings are needed.

The rear portion was at one time almost invariably a box girder work with four wooden (or tubular metal) longerons, the whole being divided into bays separated by vertical and horizontal struts (also of wood or metal tube), each bay being cross-braced on all four sides and internally by steel wires—in fact, the old bird-cage construction—our old friend the Avro 504K. When this system was used, a light fairing was often added, being made of thin wooden laths, to round off the fuselage and give it a better streamline shape.

As metal construction became more popular, the cross-wire system began to be replaced by a more rigid bracing, of "N" or Warren girder type, composed entirely of metal tubes, either steel or duralumin. Though perhaps not quite so light, the extra rigidity

and simplicity were well worth while, and once assembled the structure was less likely to get out of shape and did not need periodical adjustment—in fact such adjustment became impossible, because there was nothing to adjust. This tendency has been noticeable throughout the whole aircraft structure, until rigging, in the old sense of the word, has practically ceased to exist. For fuselage purposes, the metal tubes used are often of square rather than circular section, making for simpler joints. There has been some controversy as to the best type of joint. So many types have been used that it is not easy to classify them, but most will come under one of three headings—

1. Rigid riveted joints, employing some kind of angle plates.
2. Pinned or ball and socket joints.
3. Welded joints (Plate XXXIII).

The relative advantages and disadvantages of the first two have already been discussed when considering general engineering structures. The welded joint was for long regarded with suspicion for aircraft work, especially in this country. This was not without reason; we know now that our methods were wrong in every respect—we were using the wrong kind of steels to weld together, the wrong kind of welding rods, the wrong methods of welding. Since those times—not very long ago—tremendous strides have been made in the art and science of welding; this applies not only to aircraft, but to general engineering. Bridges, motor-car chassis, aeroplane hangars, and even ships are being welded together, no bolts or rivets being employed anywhere. It is cheaper, it is lighter, it is a neater job in every way—provided we can have faith in it. The difficulty has been to obtain this faith, partly because to a certain extent it must be a blind

faith. No inspector, however clever, can be sure of detecting a poor weld. X-rays have been used, all sorts of methods have been devised; but in many instances the only real test is to test to destruction, and we cannot do that on the parts we wish to use! In any case, because one weld is perfect under test, it does not follow that all those not tested are perfect. However, it is rather pleasant to find a job where real skill is still required, and there is no doubt that with modern methods a skilful welder can make a complicated joint of over 100 per cent efficiency, i.e. the joint is stronger than the original tube. (A point that needs watching in welding is that although the joint itself is strong enough, the tube may be weakened on either side of the weld.) At some junctions in a fuselage structure there may be as many as nine or ten tubes all converging on the same point, and one has only to look at the corresponding riveted and welded joints to see the advantages of the latter. The only fault of the latter is that, if it has a fault, one cannot see it.

Regulations as regards the use of welding in British aircraft have been considerably relaxed during recent years. Oxy-acetylene, electric arc and spot welding are now allowed under certain specified conditions, the chief being that welded joints may only be used in places where the failure of any one weld will not cause the collapse of the structure: in other words, there must be an alternative path by which the load may be transmitted (this same rule used to be applied to the important parts where cross-wire bracing was used). Also, whatever the hoped-for efficiency of the weld, the designer must not reckon on it being more than 100 per cent!

When we turn to monocoque construction we find the fuselage, especially the rear portion, very adaptable to this form of construction (Plates XXXIV, A, B, and C,

and XXXV), and it was sometimes used even in the days of wooden construction, the "skin" being made of three-ply. The fuselage may be of round or oval shape, and this is much better than the aerofoil shape of the wings from the point of view of monocoque construction; it is also better than the square or rectangle of ordinary girder work from the point of view of streamlining. The fuselage, in effect, simply becomes a large-size tube. This tube, as we have already seen, must withstand considerable bending moments due to forces on the tail. This means that one side of it will be in compression, and, if it is thin, it is therefore liable to crinkle and buckle while still well within its strength as regards pure compression. It is the old, old tale, and the worst of it is that the skin of a fuselage of this sort must be very thin—in comparison with diameter, which is what matters—if the structure is to be of light weight. Armour plating may be all very well at the front and centre portions, where it may also serve the purpose of deflecting bullets on military machines, but we cannot afford to armour plate this long tail portion.

To prevent this elastic instability, we must therefore insert stiffening hoops or ribs at regular intervals, and longitudinal members, or stringers, running the length of the fuselage. So much of this stiffening process may be necessary that it really becomes a strengthening process as well, and so we can afford to make the skin thinner and rely on the framework for much of the strength. This process of evolution has actually occurred, and we find ourselves using neither pure framework, nor pure monocoque, but that mixture of both which gives us the greatest strength and rigidity for the least weight—and that, after all, is what we are always after. Duralumin, because it can be used thicker than steel for the same weight, has definite

advantages for monocoque construction, and possibly some magnesium alloy, such as electron, may yet come into its own for this purpose. One way of stiffening without adding so much extra weight is to corrugate the tube, and some firms have used this idea very successfully not only for fuselages but for flying-boat hulls, which are usually very similar in construction to monocoque fuselages.

Geodetic construction is also more suitable for fuselage than wing, and it certainly gives a light structure with remarkable freedom from internal obstruction.

With all these unconventional methods there is the same difficulty as with wings, that they do not allow of any simple estimation of the stresses involved; one has to make them and find out.

This chapter has been short, and there is not much to sum up—

We may divide the fuselage into three portions: nose, centre, and tail.

The whole forms a double cantilever.

We have outlined the loads on each portion, and the methods of carrying them.

Fuselage structures may be of the following types: Cross-wire bracing, Girder, Monocoque, Geodetic.

Joints may be riveted, bolted, or welded.



## CHAPTER IX

### THE UNDERCARRIAGE STRUCTURE

WHAT might have been termed the conventional or V-type undercarriage has almost disappeared, and we cannot quote the old Avro as typical even of this old-type undercarriage, because its undercarriage was decidedly unconventional.

Before considering the different types of undercarriage structure, let us think for a moment of what its duties are. That, after all, is the order in which the designer must think about it, and we shall always find structures more interesting if we try to put ourselves in the position of the designer, even though we may never hope to be, perhaps never want to be, in such a responsible position ourselves.

**Landing Loads.** The chief duty of the undercarriage, namely to support the aeroplane when on the ground, is obvious enough to anyone; but, as usual, it is not quite so simple as all that. In the first place we must allow for landing and, what is more, for a reasonable degree of bad landing; and it is not at all easy to decide what is reasonable and what is not. The ordinary law of the country has a lot to say on what a "reasonable" man is expected to do under all kinds of circumstances, but one doubts whether even a learned judge would express an opinion as to how bad a landing a reasonable pilot may be allowed to make. The chief difference between a good landing and a bad landing, in so far as it affects the structure, is that in the former the aeroplane comes into contact with the ground with hardly any vertical velocity, whereas in the latter the vertical velocity may be considerable. Unless the

ground is very rough and bumpy, the horizontal velocity does not matter very much in so far as the shock of landing is concerned; in fact, the higher the horizontal velocity, the less the danger of the machine losing its necessary flying speed and falling on to the ground. The vertical velocity, however, is all-important, because it all has to be absorbed by the undercarriage structure before the aeroplane can be brought to rest in a vertical direction. This is a matter in which experience must decide; it is easy enough to calculate the strength of a structure capable of standing up to almost any vertical velocity, but what we cannot calculate is the human element. Some pilots will "fly into the ground," that is to say the aeroplane will still be on its glide, and thus still have a vertical velocity, when it comes into contact with the ground; other pilots will flatten out too soon and try to land while they are a foot or two, or maybe ten or twenty feet, above the ground, and the machine will "pancake" and fall on to the ground. Between these two is the ideal, the perfect landing, the pilot judging it so nicely that he skims the blades of grass just as his aeroplane is losing its flying speed. All this is very easy to write about, but it is not at all easy to do. In a large machine the pilot himself is still well above the ground when the wheels make contact, and it is far from easy to judge this distance within the limits of the height of a blade of grass! Furthermore, the visibility from the average cockpit is not by any means so good as it might be, or as the pilot would like it to be, and such visibility as there is usually becomes rapidly worse as the nose is raised up to the attitude of landing. Thus it is clear that one must allow for a certain amount of misjudgment, even in the hands of a "reasonable" pilot. The usual question arises as to how much.

The vertical velocity must eventually be lost, but this cannot happen instantaneously, or the shock would be colossal. What really matters is the rate at which the downward momentum—or mass multiplied by velocity—is to be destroyed. By Newton's second law, it is this rate of destruction of momentum which decides the force which will be put on the structure of the undercarriage. But while the momentum is being lost, the aeroplane will continue to travel downwards, and thus there must be some device or devices to allow it to do so. The greater the travel allowed, the less will be the shock, but, on the other hand, the more clumsy will the undercarriage structure become.

The most gentle way of reducing the vertical velocity is by some type of spring which will also have the property of restoring the undercarriage to its proper shape after the shock has been taken. Unfortunately, however, springs are apt to be too good in this respect, and as soon as they have stored up the energy, they give it back in the form of a rebound and the aeroplane bounces into the air again. By now it has lost some of its horizontal velocity, is probably unable to gain sufficient lift from its wings, and falls on to the earth even more violently than before; the springs again perform their duty, and off it goes again. Such bouncing may be prevented by absorbing the energy rather than storing it, and thus a shock-absorber of some kind becomes necessary.

We have still not decided what degree of badness of landing can be catered for. In such matters there is no better guide than the official requirements which have been laid down for a certificate of airworthiness. We may be fairly sure that these are on the safe side, so there will be no point in making the undercarriage any stronger—and heavier—than they tell us to, and

even if we think they are unnecessarily cautious we have no option but to accept them if we ever wish our aeroplane to be allowed to fly. The rule is that the undercarriage must be capable of carrying a load equal to four and a half times the fully loaded weight of the aeroplane.

An interesting point about the strength of the undercarriage is that we are almost told that we must not make it very strong; we are advised to make it the weakest part of the whole structure. The reason for this is that if the landing is so bad that it exceeds the capability of our shock-absorbing devices, the next best thing that can happen (or should we say the least bad thing that can happen?) is that the undercarriage structure itself shall crumple up as a means of absorbing the shock, thus perhaps saving more valuable parts of the machine, not to mention the pilot and crew. Many hundreds of lives have been saved in this way, and, conversely, there are cases on record in which, in a very bad landing, the pilot has died of a fractured skull, while the undercarriage has stood up manfully to the shock. If such extreme cases are comparatively few, there must be hundreds of thousands of instances where a mere bent axle has saved the structure from major damage.

So far we have assumed that all the load on the undercarriage is vertical in direction, but both in landing and taxiing loads may come from the side and from the front. Side loads are usually caused by landing or taxiing across wind. They should not occur very often, nor are they likely to be very severe except in certain emergency landings; but they all have to be allowed for in design, and so we must make the undercarriage structure capable of standing a reasonable side load. Once again official regulations come to

our rescue—one wonders how aeroplanes were ever designed when one had to guess all these things—and we are told to allow for certain definite side loads on the undercarriage structure.

There will often be loads from the front tending to push the wheels back relative to the fuselage. This will happen when the engine is being run up on the ground and chocks are used to prevent the aeroplane from moving forward, also when the aeroplane is running over sticky or bumpy ground, but most of all when wheel brakes are used to pull the machine up quickly after landing. It is strange to think how we managed for so long without brakes on aircraft; there was a time when they were thought to be unnecessary, or at the least an impracticable proposition. Perhaps the wish was father of the thought, because, however advantageous they may be to the pilot, they have given the poor designer many new problems to solve, and solving new problems usually means putting on more weight (to the aeroplane, not to the designer; the latter more likely to lose weight through worry).

One of the problems of brakes is that they impose fairly severe loads backwards on the lower portion of the undercarriage, the remainder of the aeroplane, owing to its momentum, tending to shear off the top of the undercarriage.

**Retractable Undercarriages.** Of all the parasites that hinder the aeroplane during flight, the undercarriage is surely the worst. Its weight is considerable, its head resistance even more so. Situated as it is, in such a position that it cannot be shielded by other parts, it contributes more than its fair share of the total drag—and what an awkward shape it is to streamline! On top of all this it cannot even be made to serve any really useful purpose during flight, although some

designers have tried to coax it into doing so by making the axle fairing into a little aerofoil, complete with an angle of incidence. What a temptation to drop the thing altogether, once one has used it to take off from the ground! It was estimated that a certain long-distance record-breaking machine could travel another 1000 miles if its undercarriage were dropped when it started on a record flight. So strong, in fact, is the temptation that it has more than once been yielded to, and officials responsible for drawing up competition rules have been obliged to put in a clause to the effect that the machine must not only be capable of leaving the earth but of returning to it again whole and undamaged.

Then came the suggestion of retracting it—tucking it away so that at least it could not be seen during flight (Plate XXXVI). It was not quite such a good idea as getting rid of it altogether, but it was better than nothing. Aviation has progressed so rapidly that it is not at all easy to put ourselves back a few years. We find ourselves, for instance, in a world that takes streamlining for granted; it is difficult for us to believe that very little more than twenty years ago people did not think it was worth while streamlining struts or wires on aeroplanes, let alone streamlining motor-cars or locomotives. But it is only a very few years ago that quite intelligent people were saying that the retractable undercarriage was not a practical proposition. And so instead they proceeded to disguise the said structure with trousers, and spats, and such-like, until one wondered whether it was still there or not. Yet the retractable undercarriage has come, and the same intelligent people are now saying that it is a wonder that it did not come sooner. At the same time they tell us that internal combustion turbines, rocket propulsion, construction with plastic materials,

and so on are not practical propositions and, what is more, they expect us to believe them! But though it may be wise to look ahead, let us beware of going to the other extreme of imagining that all these things are easy of attainment. They are not, nor was the retractable undercarriage. The bugbear here was extra weight. Not only had the undercarriage to be wound in and out, but it had to be capable of being locked firmly in either position, and also wings and other parts had to be modified so that when it was tucked away it really was out of the air stream. Not only that; pilots began to forget that they had not got an undercarriage, so that they had to be warned about it with lights and hooters and what not. More complication, more weight, more things to go wrong, more things to prevent them going wrong. If there ever was a "house that Jack built," it was a modern aeroplane.

**Types of Structure.** The type of structure has been greatly modified by the improvement in shock-absorbing devices, the use of brakes, and the adoption of the retractable undercarriage.

In the old wooden V-type, so extensively used during the last war and for some years afterwards, the vertical loads were taken on the two Vees and the side loads on the cross-bracing wires. The shock was absorbed, or intended to be absorbed, by the tyres and wire wheels, and by wrapping a long length of shock-absorber elastic round the axle and the bottom of the Vee; and usually, though this was not intended, by the bending of the axle.

Crude as these methods were, they served their purpose up to a point, and, for small machines at least, they were light in weight. The chief disadvantages were that the rubber shock-absorber was extremely perishable, and being in reality elastic rather than

absorbent of shocks, it caused bouncing of the machine on landing.

The first great improvement was the oleo leg: one part of the main undercarriage struts was made to telescope inside the other, and, in so doing, it forced oil through small holes or a needle valve. This was a real shock-absorber and fulfilled its function admirably, the trouble now being that the system lacked elasticity, and once the legs were fully compressed there was nothing to extend them again except the action of gravity on the lower portion of the legs, and this could only have effect during flight, so that the undercarriage would remain unsprung while resting on the ground. This difficulty was overcome by introducing some elastic means of extending the leg again—partially, at any rate—after the shock of landing had been taken. Rubber blocks in compression, steel springs, and compressed-air chambers have all been used for this purpose, and there is not much to choose between them, each having some advantages and disadvantages compared with the others. So successful was the oleo leg, in spite of the extra weight involved, that it quickly gained in favour and, except for very light types of machine, became generally used.

The introduction of the oleo leg caused only a slight modification in the general shape of undercarriage structures. In the old V-type it was usual to incline both struts of the Vee in such a way that both took a fair share of the load and both were equally rigid, but it would have been most uneconomical to have two oleo legs on each side of the undercarriage, and so one strut (usually the front one) was made almost vertical and took the whole of the upward load on landing, and in this was incorporated the oleo shock-absorbing mechanism. The other portion of the Vee became of secondary



importance, acting only as a radius rod, its joints being free enough to allow the wheels to move up and down, or, to be more correct, on the arc of a circle, through a distance of several inches. Incidentally, another result of the use of oleo legs was that wooden struts become unsuitable, and thus the undercarriage structure was one of the first parts of the airframe in which metal construction was normally employed. Furthermore, it lent itself to the use of steel tube, and, with very few exceptions, steel tubes are now used in nearly all undercarriages.

Thus, though the undercarriage structure had not changed much in appearance, it was really different in principle; but it still retained the straight-through axle, which had for very long remained one of the most conservative features of British design.

**Types of Axle.** When considering bending moments and shear forces in beams, axle loading was mentioned, and the reader may remember that this type of loading caused a uniform shear force between wheels and points of support, there being no shear force along the main length of the axle, i.e. between these two points of support themselves. On the other hand, throughout this long portion the bending moment was constant and at its maximum value. Thus the whole axle had to be equally strong, and consequently heavy, it offered much head resistance, and it was apt to come in contact with long grass or rough ground when taking off. It complicated the problem of retracting the undercarriage, and it was very much in the way of dropping bombs or of stowing torpedoes. It all sounds very convincing now, but for some reason or other we seem to take a lot of convincing before we can persuade ourselves to change our ideas of what an aeroplane ought to look like. The fact remains that, at a time

when nearly every British aeroplane had a straight-through axle (Plate XXXVII), certain authorities in America would not even accept such a design in their contracts.

However, as so often happens, once we had been convinced, we set to work to design other types of axle, and made a very good job of it. The reader may ask what is the alternative to a straight-through type of axle—or perhaps one should say that he might have asked it in those days. By now he will probably be familiar with the more modern types. If he had asked for an alternative, he would probably have been given the answer as a split axle. At first, this simply implied hinging the axle at the centre and providing an extra stay at this point to prevent the hinge from acting as a hinge. That does not sound very helpful, and in fact this type of axle was in many ways more clumsy than its predecessor; but it is interesting to note that such a change did modify the bending moment on the axle, and the centre portion, having less to do, could be made lighter.

The great step forward, however, was so far to split the axle that it became two axles, one for each wheel, but each only of such length as was absolutely necessary. For very large machines this idea had always been used. In such types, the wheels had to be so far apart to provide lateral stability on the ground that a straight-through axle would have been so long as to appear absurd. The change in ideas was really in the adoption of two separate axles for comparatively small types of aircraft. As in all new ideas, there were difficulties to be overcome, but so great were the attractions, especially as regards reduction of resistance and retractability, that the new types have rapidly gained in favour.

The reproduced photographs illustrate some of the many types of undercarriage structure that have been used. In some instances the design has been so far simplified that the undercarriage seems to consist of nothing more than two vertical struts, each with one wheel. Of course, one must not jump to the conclusion that such is the ideal arrangement; possibly it may offer the least resistance, but it is sure to be very heavy, because that one strut must be capable not only of taking all the up loads but, in addition, the backward loads due to brakes, and the sideways loads in a cross-wind. A slightly more complex structure will probably be lighter, and if it can be so arranged that it can be tucked away during flight, the extra drag will only be felt during take-off and landing, when it is comparatively unimportant.

**Tyres and Wheels.** Although tyres and wheels can hardly be considered as part of the structure, they are none the less important in that they have to take the whole load of landing and at the same time contribute to the elastic and shock-absorbing qualities of the undercarriage. If large low-pressure tyres are used, hardly any wheel is necessary, and so effective is the compressed air and springiness of the rubber of the tyre itself that in some instances oleo legs have been dispensed with altogether, and the shock-absorbing qualities have remained quite good—even when a tyre has been punctured. It is also claimed for these large tyres that they actually offer less head resistance, and that they are less liable to sink into soft ground. The high-pressure smaller tyre, on the other hand, means shorter axles and probably less weight; with an ordinary wire wheel its shock-absorbing qualities are quite good, and on hard-surfaced aerodromes it causes less resistance during the take-off.

One interesting development is the internally sprung wheel; in this we are offered, all in one unit as it were, wheel, tyre, and springing and shock-absorbing device, enabling us to use rigid struts, which can thus be made smaller yet stronger.

**Brakes.** We were slow to adopt brakes in aircraft—especially in this country—but we are not concerned here with the pros and cons of providing some means of stopping the fastest means of transport. What does concern us, and concern us very considerably, is the effect of brakes on the undercarriage structure. The braking of the wheel will cause a tendency for the aeroplane to tip on to its nose. This was a very constant danger in the early days of brakes, but it can be largely overcome by moving the undercarriage farther forward. This in turn will put greater loads on the tail wheel (or skid) and also increase the tendency of the fuselage to bend. These parts must therefore be strengthened up, and thus we get an interesting example of how the fitting of some extra part—in this case the brakes—may cause an addition of weight to the structure that is out of all proportion to the mere addition of the extra weight of the part concerned. Just to remind the reader of the old vicious circle, let us remember again that extra weight in the fuselage will mean more weight for the wings to carry, hence heavier wings, heavier aeroplane, heavier undercarriage, and so on.

But the most interesting result of the brakes is the torque which they set up. In effect, the method of braking, as in a motor-car, is to make it difficult for the wheel to rotate relative to the fixed parts of the chassis or undercarriage; on the other hand, the friction between tyre and ground tends to force the wheel to rotate, the wheel in turn tending to rotate the undercarriage with it, the undercarriage in its turn trying to

rotate the aeroplane and tip it on to its nose. If we resist this tendency, there will still be the torque applied to the undercarriage chassis. Of course, in the extreme case, if we lock the brakes, wheels and chassis become one unit, and either the machine must turn on to its nose or the torque on the chassis will cause something to shear, or—the least of all the evils—the wheels will skid along the ground. These are extremes, but they may help us to understand that any degree of braking will cause a corresponding torque on the chassis. The oleo leg must not be allowed to bend, because that would interfere with its telescopic action, so the best method is probably to fit some special torque member direct to axle or hub and thus to counteract the turning effect. There has been some indication that the use of wheel brakes may cause the old tricycle or even four-wheeled undercarriage to come into favour again. A wheel in front of the two main wheels prevents the aeroplane from tipping on to its nose even if the brakes are vigorously applied, and, what is perhaps even more important, this type enables a high-speed landing to be made with the tail up, which may sometimes prove a great advantage in modern aeroplanes.

**Tail Wheel or Skid.** Although the main undercarriage supports the major part of the aeroplane, there is always a secondary support at the tail. In old machines a skid was used, and by dragging along the ground, sometimes even by digging into it, it acted as a fairly efficient brake. Its action, however, was unreliable in this respect because it depended so much on the nature of the ground, and, moreover, the sudden backward tugs which it was liable to exert had to be transmitted through the rear portion of the fuselage, which was often damaged, and had to be strengthened up for this

special purpose. When brakes were fitted on the main undercarriage, a tail wheel began to displace the tail skid except for small types of aeroplane. The extra resilience of the tyres, together with a more efficient shock-absorbing device of springs or even a miniature oleo leg, all tended to lessen such violent shocks on the fuselage. Both skid and wheel may be made steerable to assist manoeuvrability on the ground, but it must be remembered that as air speed is increased, in taking off or fast taxiing, the tail either leaves the ground or carries a very small load, and so the rudder soon becomes a more efficient steering device than wheel or skid. The same argument applies to the question of fitting brakes to the tail wheel. While tail-wheel brakes have the advantage—as compared to main-wheel brakes—of not tending to tip the nose over, they cannot exert anything like the same braking power, because this depends on the vertical reaction between tail wheel and ground, which is only about one-tenth of the weight of the aeroplane at low-speed taxiing and decreases to nothing as the speed increases. Thus it is that three-wheel brakes have not come into their own as have four-wheel brakes on cars.

Quite apart from the question of brakes, the modern tail wheel, complete with springing and shock-absorbing devices, and steering gear and controls, has no inconsiderable weight; furthermore, its head resistance is far from negligible, especially when the main undercarriage has been neatly tucked away. So it too must be retracted—more gear, more controls, more weight—one cannot help pitying the poor designer, who is out all the time for the maximum efficiency; everything he does to improve his aeroplane brings with it some extra disadvantage, and in nine cases out of ten that extra disadvantage is more weight, the one thing which

he had set out to keep down! However, up goes the tail wheel, and we are one stage nearer to our ideal—the flying wing.

To sum up—

The main duty of the undercarriage is to take the upward reaction from the ground in landing.

It must have sufficient resilience and shock-absorbing qualities.

It must also be prepared for side loads and braking loads.

Modern undercarriages are often retractable.

The oleo leg displaced the old V-type of structure.

The straight-through axle has decreased in popularity.

Tyres and wheels are important parts of the structure.

Brakes influence the design of the undercarriage structure.

The tricycle undercarriage may come back.

Tail skids are often replaced by tail wheels when brakes are used.

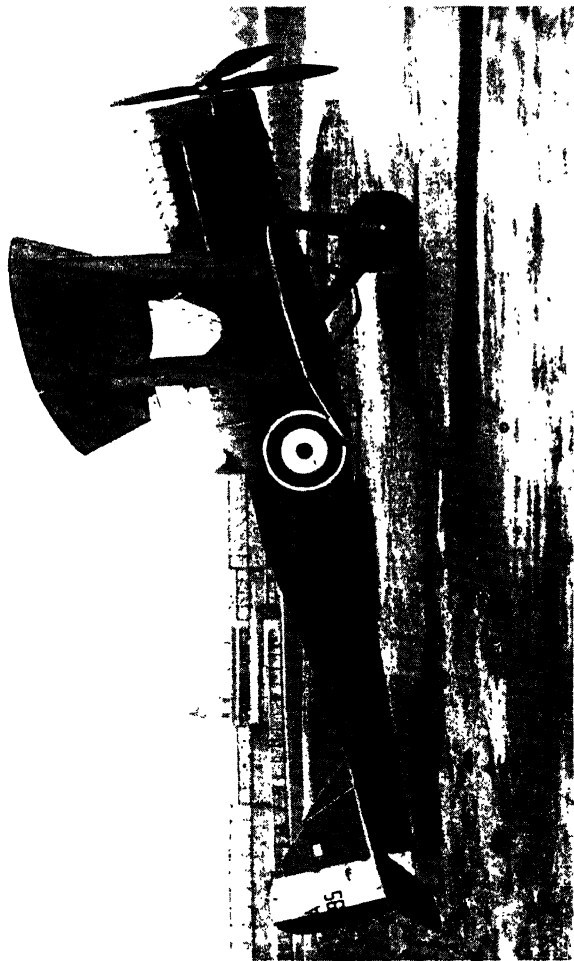

PLATE XXIV. D.H.4, 1917

One of the greatest of all famous de Havilland productions, used during the last war and afterwards converted into civilian varieties. Very conventional two-bay biplane structure, strongly reminiscent of the B.E.2c. The equally famous D.H.9 was very similar, except that it had a different engine.

*(By courtesy of "Flight")*





PLATE XXV. HANDLEY PAGE O/400, 1917

This forerunner of all large bombers was extensively used during the last war; the structure was typical of large machines of the day, being the usual wire-braced framework with a considerable extension of the top planes over the bottom.

*(By courtesy of Messrs. Handley Page Ltd.)*

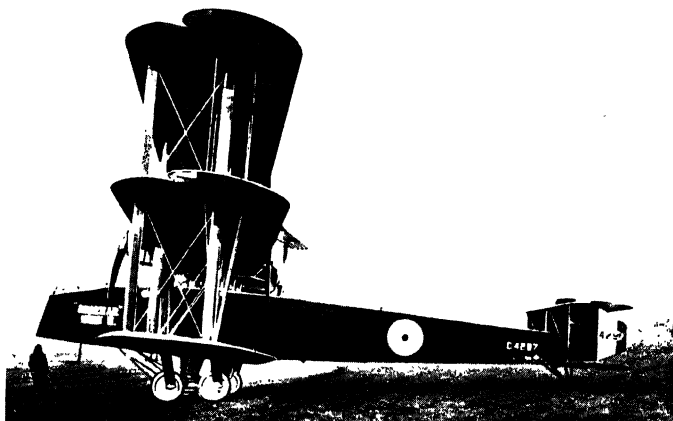

PLATE XXVI. BRISTOL TRIPLANE, 1918

Thirty of these were ready to bomb Berlin when the armistice was signed. They represent the familiar wire-braced frame applied to a triplane structure, and some people thought that the large machine of the future would be like this—but history has proved otherwise, and the triplane structure has disappeared, maybe for ever.

*(By courtesy of the Bristol Aeroplane Co. Ltd.)*

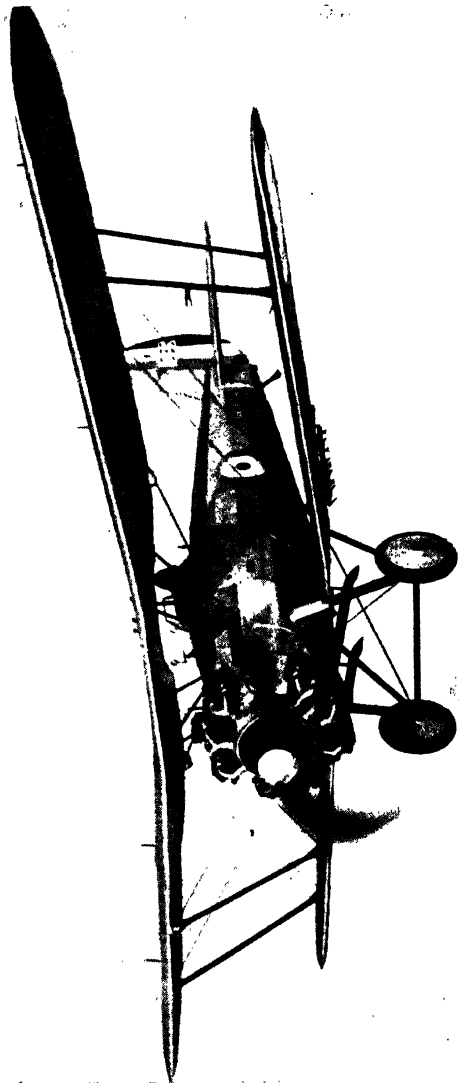

PLATE XXVII. BRISTOL "BULLDOG," 1927

One of the most famous representatives of the typical biplane structure, but notice that the top plane is growing in comparison to the lower; we are already trying to get the advantages of a monoplane. This machine may be considered as typical of those which came between the two wars and which never had the opportunity of proving their value as fighting aircraft.

(By courtesy of the Bristol Aeroplane Co. Ltd.)

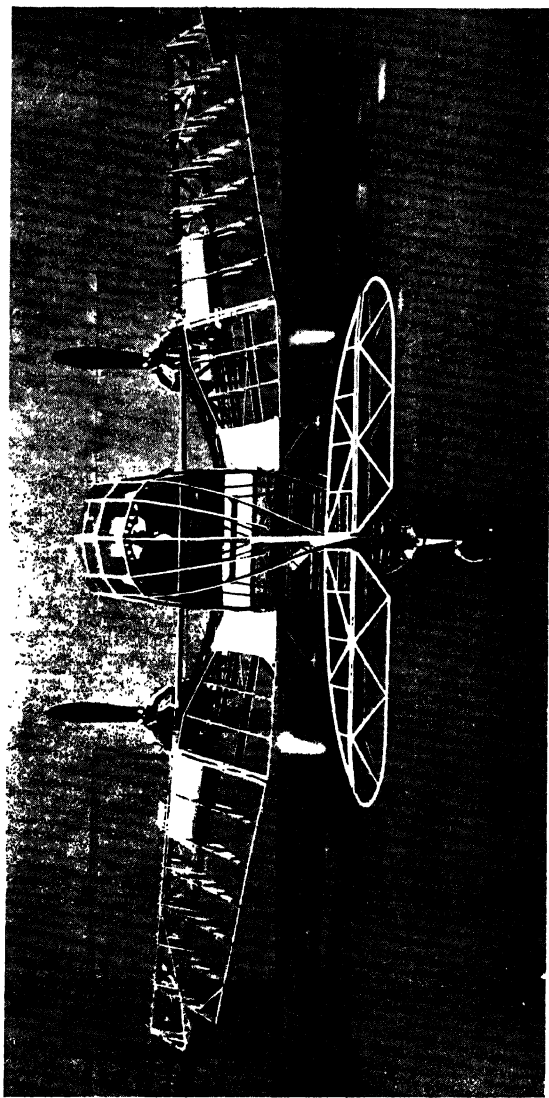
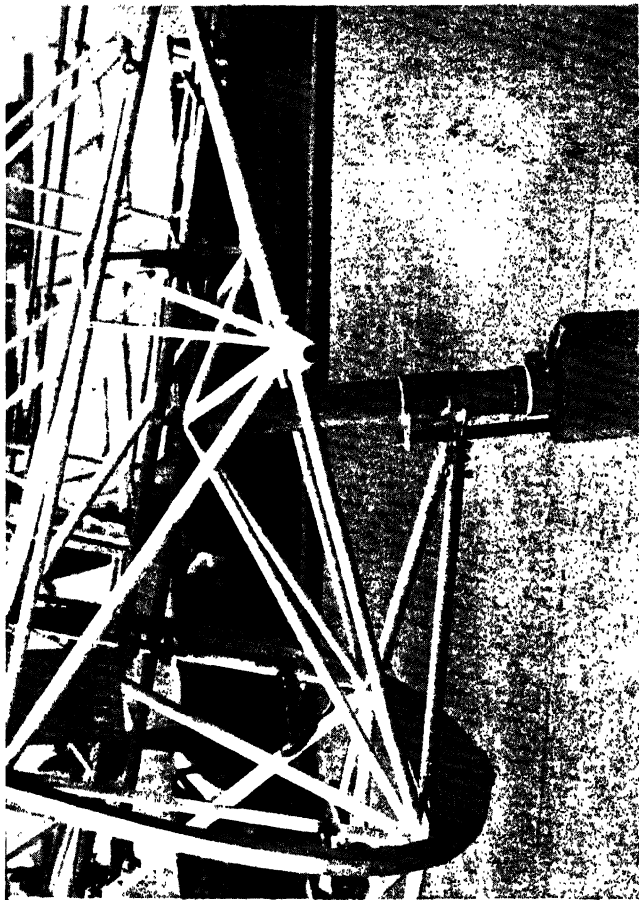

PLATE XXVIII. MONOSPAN.

The skeleton of an aeroplane designed on the monospar principle.

(By courtesy of "*Flight*".)



**PLATE XXXIII. WELDED JOINTS**

This photograph shows very clearly welded joints in the rear portion of the fuselage of the Westland "Lysander."  
(By courtesy "Flight.")

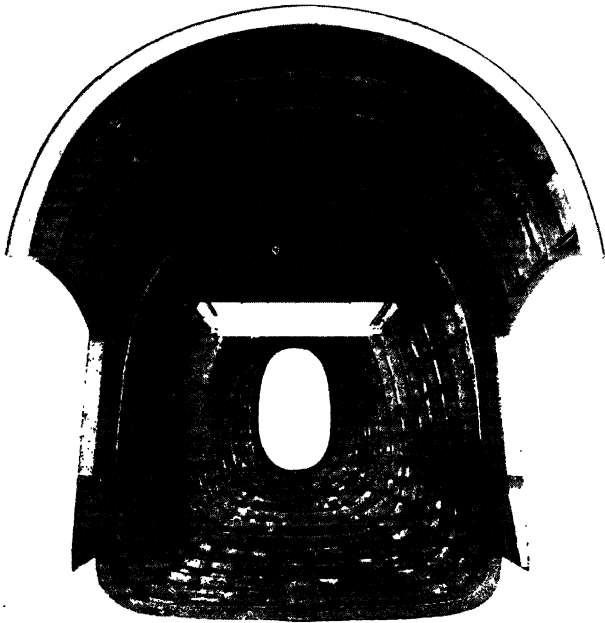

PLATE XXXIVA. MONOCOQUE FUSELAGE CONSTRUCTION  
—INTERIOR

This picture of the rear portion of the stressed-skin monocoque construction of the Bristol "Blenheim" shows the complete absence of any internal bracing.

*(By courtesy of the Bristol Aeroplane Co. Ltd.)*



PLATE XXXIVB. MONOCOQUE FUSELAGE CONSTRUCTION  
—EXTERIOR

This shows the external view of the same portion of the fuselage,

*(By courtesy of the Bristol Aeroplane Co. Ltd.)*

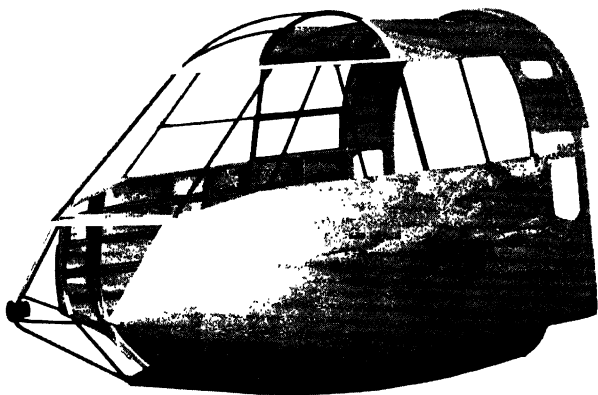

PLATE XXXIVc. NOSE PORTION OF MONOCOQUE FUSELAGE

This is the nose portion of the Bristol "Blenheim" fuselage, and gives a very clear impression of the framework and the skin.

*(By courtesy of the Bristol Aeroplane Co. Ltd.)*



PLATE XXXV. RIVETING THE STRESSED SKIN

Riveting the stressed skin on the fuselage of a Bristol "Blenheim."

*(By courtesy of the Bristol Aeroplane Co. Ltd.)*

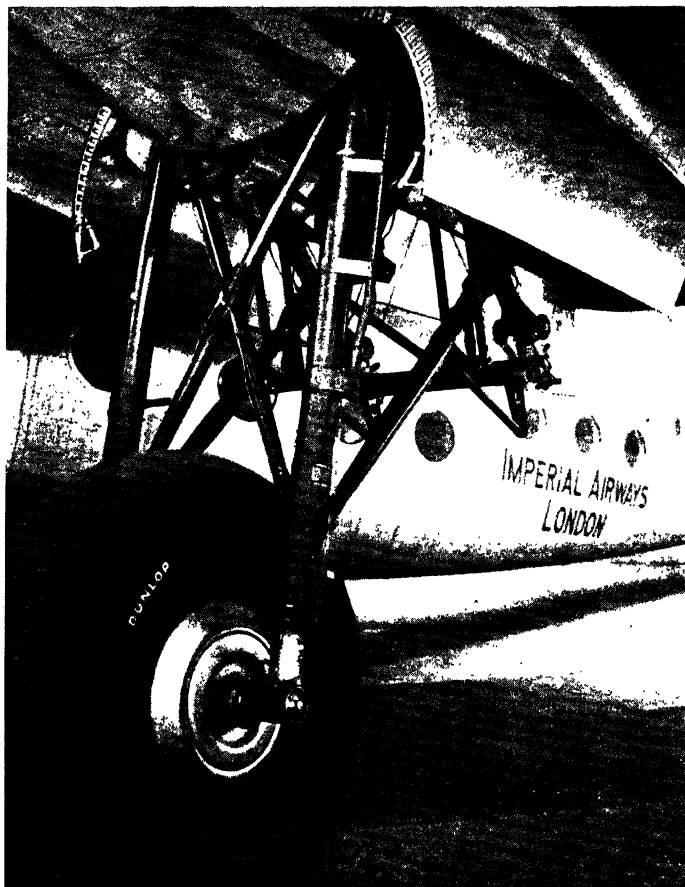

PLATE XXXVI. RETRACTABLE UNDERCARRIAGE

Retractable undercarriage on the Armstrong Whitworth "Ensign."  
The illustration gives some idea of the elaborate system of links used to raise, lower, and lock the mechanism. It must be realized, however, that this is an undercarriage of a very large machine weighing as much as 20 tons. On small machines the mechanism is usually much simpler, although even greater ingenuity is needed to design it without unduly adding to the weight.

*(By courtesy of "Flight")*

## CHAPTER X

### THE TAIL UNIT

WITH our undercarriage and tail wheel retracted we seem to be nearing the approach of our ideal—but the fuselage still remains. Now, there are many justifications for the retention of the fuselage; it can be made of very good shape, it serves many purposes, often housing engine and all accessories, pilot, crew and passengers, luggage, fuel, oil, bombs, wireless, and other instruments, and, last but not least, it acts as the lever by which the forces experienced by the tail unit are transmitted to the main body of the machine. So important is the latter function of the fuselage that when attempts have been made to eliminate it, often in the very early days of aeroplanes, some substitute has had to be found to carry the tail—and some of these substitutes were a good deal worse than the fuselage. The “Pterodactyl,” or so called tailless machine, was no exception to this rule, the sweeping back of the wings replacing the leverage of the fuselage. In some of the famous old “pushers”—the Maurice and Henry Farman, and the F.E. of the last war—tail booms were used to support the tail. Most curious of all was the French Caudron, which, although it had a normal tractor engine and airscrew, had a perfect birdcage of booms and struts instead of a fuselage. At the end of the birdcage was the tail unit. This machine must surely have gained the same respect with the French as the Avro 504K did with us; it used to fly at Hendon on Saturdays before the last war, and was still flying in France many years after that war—per-



haps even now! The author has a soft spot for it too, because he learnt to fly on it, and discovered that whichever way up one turned it on the ground, the pilot could remain quite safe in the centre of the birdcage.

But the reader may well be asking what all this has got to do with tail units. Just this—it leads us to the conclusion that all types of aeroplane need a tail unit, and that since some support must be found for that tail unit, the most logical one is the fuselage, which, thus justified, can be made use of for all the other purposes mentioned above. There is thus no immediate prospect of dispensing with either fuselage or tail unit, and so the best we can do is to make them both as light and efficient as is practicable.

It will be realized that, in more senses than one, fuselage and tail unit are linked together, and we have already mentioned the forces on the tail unit when considering their effects on the fuselage structure. There are usually four distinct parts in the tail unit—tail plane, elevators, fin, and rudder. Each has a distinct purpose, though they may help each other to fulfil that purpose. For instance, the tail plane is provided for longitudinal stability, i.e. to make the machine naturally stable fore and aft; the elevators are for longitudinal control, i.e. to raise or lower the nose at the pilot's will during flight; but when the elevators are raised or lowered, the pressure is altered over the tail plane as well as the elevator, and thus the tail plane helps the elevator to give control, and conversely the elevator helps the tail plane to give stability. Similarly the fin and rudder are designed to give directional stability and control respectively, but so far can the rudder act as a fin that the latter is sometimes dispensed with altogether.

Forces on the tail plane and elevators may be up or down, according to conditions; they are not very large, and are about equal in either direction, probably greatest *downwards* (in a nose-dive and coming out of such a dive). So the tail plane and elevators are made rather like the main planes and ailerons, usually with one or two spars, ribs, and so on, and covered with fabric or a metal skin. As in the main planes, the chief structural members may be of wood, steel, or duralumin, and where steel is used there is the usual choice between welded tubes and riveted high-tensile steel strip. Clever design has brought the weight of some tail units down to figures of less than  $1\frac{1}{2}$  per cent of the total weight of the aircraft. Loads on the fin and rudder will be sideways, again about equal in either direction, again not very large, but rather difficult to estimate at all accurately. These, too, are built up on some kind of spar with ribs running across it, the fin often being almost triangular in form and more than justifying its existence by the extra stiffness which it can give to the rear end of the fuselage and the tail unit.

This question of stiffness is a vital one in so far as the tail is concerned. Have you ever looked at the tail of an aeroplane in flight, on a gusty day, or during violent manœuvres? If you have not, do not start to do so! Have you ever *sat* in the tail of an aeroplane—after a good meal? I remember one which I could swear used to move up and down by at least a foot. Even if you have not done any of these exciting things, you have probably watched a tail being held down by mechanics while the engine is run up on the ground—and that should be quite enough to convince you that the tail end of an aeroplane is not a rigid structure. Now, a certain amount of flexibility is all very well in its way, the trouble arises when periods of vibration

are liable to coincide and add up. Two things are apt to cause vibrations in aeroplane structures: the forces due to the air pressure, and the elastic forces set up in the structure by distortion. Now, the air pressure causes the distortion; the distortion in its turn means that the wing, or tail, or whatever it may be, twists or bends under the air load. The twisting or bending results in changes in the air loads which may either cause further distortion or, what is worse, they may reverse and allow the distorted part to spring back, thus setting up a vibration or flutter, which may build up in intensity. Every elastic structure has a natural period of vibration, and the aim in design is so to arrange matters that these natural periods are such that they do not interact and build up in a dangerous manner. Stiffening the structure will tend to make it vibrate with greater rapidity, and this may take it outside the dangerous range; but the higher speeds become, the greater will be the degree of stiffness required. Another point is that one has to consider stiffness in different directions—a wing or tail plane may be very stiff as regards bending but flexible in twist, and it is often this stiffening in twist that it is most important—and most difficult—to achieve. Periods of vibration are dependent not only on the stiffness, but also on the distribution of mass in the structure, and by suitable placing of masses flutter periods may be avoided. More weight!

The danger of flutter was mentioned previously when considering the main-plane structure, but in no part of the airframe is it more likely to occur than in the tail unit, so one makes no apology for bringing it all up again. Not only is the tail unit likely to suffer from control flutter of rudder or elevators and from natural periods of vibration in the fin and tail plane, but

the troubles may be aggravated by buffeting due to the uneven flow of air from the main planes and the pulsating blows of the slipstream.

To prevent all this, stringent rules have been drawn up as regards stiffness as well as mass balancing of rudder and elevators and so on. One precaution is that elevators must be rigidly connected together, thus making it impossible for one to move without the other. Balancing and trimming tabs on the control surfaces have caused new flutter problems, but, let it be said in their favour, they have made one great contribution to the stiffness and general cleanness of design of tail unit by rendering the adjustable tail plane unnecessary. Except in so far as repairs or interchangeability are required, tail planes and fins can now be built rigidly into the fuselage structure, and thus for once we get a stiffer and better aeroplane—and save weight.

The danger of flutter, and the method of preventing it by mass balance, has had one interesting effect on the structure of control surfaces such as rudder, elevators, and ailerons. The placing of a mass in front of the hinge of the control surface certainly helps to prevent flutter, but from other points of view it is just so much extra weight which detracts from the performance of the aeroplane. Now, the amount of weight which must be placed in front of the hinge depends on the weight of the control surface behind the hinge, and therefore if we can lighten the latter we reduce the former at the same time. This is the reason why there is a tendency in modern design to make that portion of control surfaces which lies behind the hinge of very light construction covered with fabric, whereas the front portion has a comparatively heavy metal skin which in itself acts as a mass balance in addition to helping the strength and stiffness of the whole structure

of the control surface. This is the sort of thing which might well prove puzzling—if one did not know the answer.

So much for the structure of the tail unit; we will hope that we have made it stiff enough for any emergency, but, none the less, let us be thankful that it is the part of the structure which we least often look at during flight.

Summary—

Tail unit and fuselage are inevitably linked together.

Forces on the tail unit are up and down and sideways.

Structure is of spars and ribs, with fabric or metal covering.

Question of stiffness to prevent flutter is very important.

## CHAPTER XI

### THE STRUCTURE IS HANDED OVER TO YOU

IN this little book I have tried to tell you something about an aeroplane structure, how it is designed, and what each part is for. I have told you very little of how it is actually built; that in itself is an absorbing story, but I should hate to try to write a book about it. By far the best way is to go and watch it being done, unless you have the opportunity to do it yourself, which would be still better.

This suggestion brings me to the last stage of the book; you, whoever you may be, are—if you have read thus far—in some way interested in aeroplanes. You may be helping to build them, you may be looking after them on the ground, perhaps a pilot, perhaps merely a passenger, perhaps too young as yet to take any active part in this great industry and merely hopeful that some day you will fly. There is only one thing that I hope you are not: that is anyone concerned with the design of aeroplanes, because in such a position you will realize how little, how very little, of all the intricate problems of design I have even been able to mention.

Whatever your interest in aeroplanes may be, I hope that by reading through these pages you will have gleaned some little extra knowledge which will really help you to understand an aeroplane. There is no other type of building, no other structure, in which every single part performs such a definite duty and yet has been so reduced in weight that it is only just able to

do that duty. The designer has used all the experience, the brains, and the skill at his command, and he now hands over his work to you, to build the aeroplane, to maintain it, to fly it, or whatever your job may be. Sometimes, maybe, you will criticize the designer: some part may be exceptionally difficult to make or fit, some item may have been put in a most inaccessible place, one member of the structure may be weak and constantly need repair. These little defects should help to emphasize, rather than otherwise, the good job that he has made of his very difficult task. After all, the main thought that has pervaded his mind has been to produce an aeroplane of good performance, strong enough and safe enough to do what is required of it. If he has done that—and very few designers have failed in that respect—he has successfully accomplished most of what is required of him.

But each of you, according to the nature of your specialist jobs, will look for more than this.

The pilot will expect a machine that is easy and pleasant to handle—not only in the air, but on the ground; not only in straight flight, but in turns, glides, climbs, loops, spins, rolls, and all the other manœuvres.

The constructor, the mechanic, or the rigger, on the other hand, will be quite oblivious to these nice points of flying; to him the all-important questions are whether the aeroplane is easy to make, whether the parts fit together properly, and whether all parts that need inspection or repair are easily accessible.

The designer is fully aware of these needs—if he is not, he will soon be reminded of them by official regulations and inspectors—but he is often in the unfortunate position of realizing the grim truth that performance, strength, safety, good flying qualities, and accessibility do not always go hand in hand. He is continually being

forced to sacrifice one or another of these aims in order to enhance another quality which he thinks of more importance. Whatever he does, some specialist will criticize him, and perhaps he may even find some consolation in thinking that he has made the best compromise if *all* the specialists criticize him in a fairly mild manner. Taking one consideration with another—and this book has been an attempt to tell you of some of these considerations—the designer's life can hardly be considered a happy one. If, as the result of what you have read, you feel a little sympathy with him, this book will not have been written in vain.

In future, when you see an aeroplane, when you fly in one, or build one or repair one, you may well try to see more in it than you did before. The fabric or metal skin will seem almost transparent; through it you will see all the skeleton. You will see the air loads trying to bend and shear the spars, and the flanges and the web preventing them. You will see all the ties stretching—ever so little, because they are all within the elastic limit (we hope!)—all the struts shortening. You will realize that as the aeroplane takes off, as it bumps over the ground, the wings are tending to break off downwards; as soon as it becomes airborne, the wings bend upwards and carry the weight of the aeroplane. These deflections, due to the stresses and strains in the various parts, are, of course, small, *but they are very real and very important*. They are not usually visible in the ordinary sense of the word, but they could easily be measured by instruments of quite ordinary accuracy.

In some very large machines the upward movement of the wing tips during take-off has been clearly noticeable, and it may well be a matter of inches. The rigger should remember that when an aeroplane is rigged on



the ground it is *not* under the same conditions as in flight; such measurements as rigger's angle of incidence, dihedral, stagger, and so on will *definitely* alter when the aeroplane is in the air. In some instances, allowances are made for this, and in all instances an intelligent rigger will realize that they occur, and that they may account for idiosyncrasies of the machine in flight. All structures under load are distorted, but an airframe is an exceptionally flexible structure. It is true that this very flexibility may have certain advantages—for instance, a slight give in one member may pass the load on gently to another member, whereas the sudden snap of a brittle material would put a sudden stress on other parts, which might break in turn.

On the other hand, flexibility, which really means the liability of the structure to alter its shape when under load, may not only lead to the flying faults mentioned above, but may also be one of the main contributory causes of that most alarming of all phenomena associated with aircraft, namely, flutter. We have hardly been deep enough into the subject to understand fully how flutter develops, but at least you will realize that it is dependent on the liability of wing or tail to bend and to twist, and on the movements of all the air pressures when these surfaces do bend and twist. With a wing or tail structure of normal flexibility it is only liable to occur at very high speeds. Since, however, such speeds are now becoming attainable, designers are finding it necessary to stiffen up the structure to a greater degree than was once considered necessary. It probably means more weight, but surely there was never a clearer instance of prevention being better than cure—if, indeed, there is a cure. Notice, therefore, how modern aeroplanes are becoming more rigid as speeds are increased; notice, too, that they

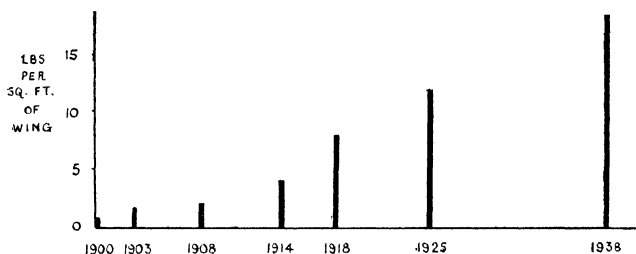

(a)

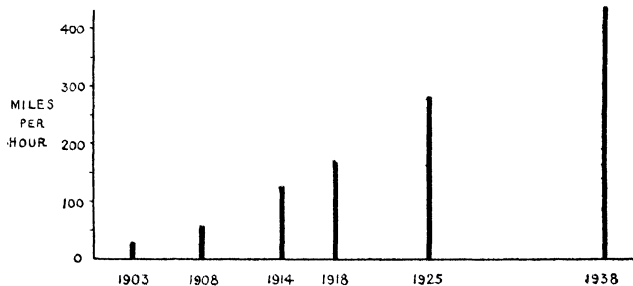

(b)



(c)

FIG. 75. THE TREND OF THINGS

- (a) Wing loadings are going up.  
 (b) Speed is increasing.  
 (c) Power loading is coming down.

*Power loading* means the total weight carried per brake horse-power of the engine; the fall in the power loading accounts for the improvement in performance, and it is being brought about by increasing the power output of engines and decreasing the weight of engines and aircraft in proportion to the power. If, after reading this book, you have doubts as to whether we are "getting anywhere," these graphs should put your mind at rest. Every picture tells a story, and the story that this picture tells is not only that aeroplanes are improving, but that they are likely to improve still more. Continue the graphs, and you will see whether we are going!

are becoming smaller, and may yet become even smaller. Wing loadings are going up (Fig. 75 *a*), all the parts are being made stronger and stiffer to carry the increased loads; the whole nature of the aeroplane is changing from the old "birdcage" construction, a flexible framework of sticks and wires, to a rigid, strong, metal-covered structure with beams, struts, and ties that remind one more and more of those used in heavier types of engineering construction. It all sounds very heavy, rather opposed, perhaps, to our original ideas of saving weight, but one must remember that we have reduced its overall size. For weight per square foot of wing area it is certainly heavier; but we give it more work to do, we can justify the use of the best steels, and thus our strength/weight ratio remains as good as—or better than—ever.

In conclusion, ask yourself the questions which follow. If you can answer them to your own satisfaction, I feel—and I think you will be justified in feeling—that you have gained something by reading these pages and that you will understand an aeroplane better in future. If, on the other hand, you cannot answer them, turn back and see if you can find the answers in the preceding chapters. If you still feel some doubt—well, there are plenty of other books on the subject.

## QUESTIONS

1. What do you understand by a "beam" in an engineering structure?

2. Think of some part of an aeroplane structure which acts simultaneously (a) As a tie and a beam. (b) As a strut and a beam.

3. Explain the phrase "If we add a pound to the weight of an aeroplane, we must add more than a pound."

4. Describe the various stages through which an aeroplane passes from specification to performance tests.

5. What is the position if an aeroplane, when built, is found to weigh more than the estimated weight?

6. What is the corresponding position if it weighs less than was estimated?

7. How does the question of landing speed influence the design of an aeroplane?

8. What function do the "stress merchants" perform in the process of design?

9. How is the centre of gravity of an aeroplane found?

10. What are the external forces acting upon the aeroplane in normal horizontal flight?

11. What parts of the structure will be most affected in a nose-dive?

12. Describe the loads imposed on the structure in landing.

13. How are acrobatics allowed for in design?

14. What is the approximate proportion of the weight of the structure to the weight of the fully loaded aeroplane?

15. What are the approximate proportions of the weights of the four main structural units?

16. What do you understand by the terms "elastic limit" and "proof stress"?

17. State the relative advantages and disadvantages of the use of the following materials for aircraft construction: (a) Timber, (b) High-tensile steel, (c) Duralumin, (d) Plastics.

18. What is a factor of safety? Why is it allowed?

19. What is meant by "fatigue"?

20. What is meant by the term "load factor" as applied to aircraft?

21. What load factors are required in British aircraft?

22. Why is high-tensile steel not suitable for all parts of the structure?

23. In what respects do real frameworks differ from the ideal framework?

24. Explain the difference between deficient, perfect, and redundant frames.

25. Can you think of any deficient frameworks used: (a) In the home? (b) In aircraft construction?

26. What are the advantages and disadvantages of the redundant framework?

27. Would you class the wire-braced frame as perfect or redundant?

28. What are the advantages of stressed-skin construction?

29. What is meant by geodetic construction?

30. What is the simplest three-dimensional perfect frame?

31. Explain the various steps by which we eventually find out the loads carried by each part of the aeroplane structure.

32. Why is it much easier to design a tie than a strut?

33. How would you tell whether a strut was "short" or "long"?
34. What parts of an aeroplane or aero engine would you class: (a) as "short" struts, (b) as "long" struts?
35. What do you understand by the "neutral axis" in a beam?
36. What is meant by elastic instability?
37. How does the type of end fitting affect the strength of a strut?
38. Explain why it is so important that the load on a strut should be applied centrally and that the strut should be initially straight.
39. Show how the tendency to bend varies along a beam of the following types—
- (a) A cantilever with a load at the end.
  - (b) Simply supported at each end with load in centre.
  - (c) Loaded like an axle.
  - (d) A cantilever with evenly distributed load.
40. What do you understand by "shear" in a beam?
41. What part of the beam is designed to carry the shear, and why?
42. Explain the advantages of the I- or box-shaped beam.
43. Why do most metal spars differ from the ordinary I- or box-section?
44. What is a point of inflection in a beam?
45. What is a continuous beam?
46. Explain how the air loads on the wing fabric are conveyed to the fuselage in the conventional type of biplane.
47. What are the functions of the ribs in a conventional wing design?
48. Distinguish between drag and anti-drag wires.

49. What is (a) a monospar wing, (b) a multi-spar wing?

50. Describe the loads carried by the fuselage structure in the various conditions of flight and landing.

51. What types of construction are most used for fuselages?

52. What are the advantages and disadvantages of welded joints in fuselage construction?

53. Describe what is meant by monocoque construction of a fuselage.

54. What loads must an undercarriage structure be designed to carry?

55. What complications are introduced by the fitting of brakes to aeroplane wheels?

56. Describe the advantages of making an undercarriage retractable, and the problems associated therewith.

57. What modifications in undercarriage structure have taken place since the old V-type with straight-through axle?

58. What are the four parts which together make up the tail unit, and what is the purpose of each part?

59. When do you think there will be the greatest load on the tail unit (a) in an upward direction and (b) in a downward direction?

60. Why are elevators and rudder often covered with fabric when the remainder of the machine is metal-covered?

61. Why is the inner bay of a two-bay biplane usually shorter than the outer one?

62. Describe the various methods of making joints in metal aeroplane structures.

63. Sketch the cross-section of a typical spar (a) made of wood, (b) made of duralumin, (c) made of high-tensile steel.

64. What are the main changes that have taken place in aeroplane structures during the past five years?

65. Explain how the movement of the centre of pressure reacts on the whole structure of the aeroplane.

66. Give some examples where an increase in weight (beyond what is required for strength) can be justified.

67. Why can an aeroplane be built with less real factor of safety than, say, a bridge?

68. Sketch the front elevation of a two-bay biplane, indicating on each part the type of load carried in normal flight, and give some idea of the magnitude of the various loads.

69. Repeat Question 68 for a similar machine in inverted flight.

70. Sketch a Warren girder, "K" and "N" type of bracing.

71. Show by a sketch how the air load is distributed along the span of a monoplane.

72. Explain why a tube is the most logical shape of cross-section for a strut, and why it is not ideal for a beam.

73. Explain why there must be a longitudinal shear in a beam.

74. Sketch four typical metal spar sections.

75. What parts of an airframe are most likely to suffer damage in a bad landing?

76. What do you think are the advantages and disadvantages of (a) stressed-skin construction, (b) geodetic construction?

77. Describe the loads carried by the three sections of a fuselage.

78. What are the advantages of the tricycle form of undercarriage?

79. How are sideways loads allowed for (a) in an



old-type V-undercarriage, (b) in a modern undercarriage?

80. Explain the action of an oleo leg.

81. Do you think a "flying wing" will ever become a practical proposition?

82. Will wooden construction come into its own again?

83. Why has the monoplane become so popular during recent years?

84. Give the names of some reasonably modern types of machine in which the fuselage is—

(a) Of all-wooden construction.

(b) Of steel-tube construction.

(c) Of light alloy tubular construction.

(d) Of stressed-skin construction.

(e) Of geodetic construction.

85. From the structural point of view, what steps can be taken to prevent flutter?

86. Sketch the internal bracing of a conventional two-spar wing.

87. Why does a stressed-skin wing not need any drag and anti-drag wires?

88. Compare the structural merits of the biplane and monoplane forms of construction.

89. Sketch the mechanism of some retractable undercarriage with which you are acquainted.

90. Why should a medium or long strut be tapered, and why is it not usually so in practice?

91. What form of construction do you think is most suitable (a) for making the first of a type, (b) for mass production?

92. What are the relative advantages of tail skid and tail wheel?

93. What is the purpose of the incidence (or stagger) bracing in a biplane?

94. What is (a) electron, (b) compressed wood, (c) duralumin?

95. If both flanges and webs of a spar are to be joined, at what part of the length of the spar should each be joined?

96. Why is fabric "doped"?

97. Why are all the metal parts of an aeroplane bonded together?

98. Wing loadings have been going up—have they reached the limit?

99. Write down a specification of what *you* think a two-seater passenger aeroplane should be capable of for private use.

100. Sketch the front elevation, side elevation, and plan view of *your* idea of such an aeroplane.

## AD ASTRA

IF, as I hope, your appetite has been whetted, and you wish to go a little further with *your* aeroplane—I am *not* going to say that it is all quite easy—I can truthfully say that it can be done provided you will take the trouble to read some more advanced book on the subject, to learn or brush up some simple mechanics and structures, and provided you have a great deal of patience. Comparative amateurs have designed, built, and flown their own aeroplanes. Perhaps that is why the Government will take care to inspect your work, and will not allow you to build an aeroplane in which there is much fear of killing yourself—or anyone else.

But, as I said at the beginning, this book was never intended to tell you how to design an aeroplane, but simply to give you a more intelligent interest in its structure. If it has succeeded in doing that I shall be fully satisfied, and I feel confident that, as a result of such intelligent interest, all aeroplanes which may come under your care will receive more sympathetic treatment and will in consequence perform their tasks more efficiently.

The following was written by Lord Londonderry, who was then Secretary of State for Air, in a foreword to the Prospectus of the Aeronautical Engineering Department of Loughborough College. It seemed so apt as an ending to this book that I asked the permission of the Principal of the College to quote it. If nothing else in this book is worth reading, this is; and I feel that I cannot do better than leave you with words from a more fluent pen than mine.

“There is plenty of room for boldness and courage and endurance, but we are opposing our combined wits and our fragile machines against powerful and hardly calculable forces of nature, and we have learnt by mournful experience that the clearest possible thinking and the most accurate knowledge are indispensable foundations of all our work. Therefore mathematicians, engineers, and scientists unite with pilots and navigators in one common endeavour, and in whichever capacity a man serves his generation in the craft of flying, he will find that he relies upon the others, and they on him, for success.”

# INDEX

- ACCELEROMETER, 59  
Acrobatics, 59  
Aerofoils, 57  
Aeroplanes, types of, 66  
A.I.D., 41  
Alloys, light, 76  
Angle of incidence, 37  
Area of wing, 36  
Axle, types of, 202
- BAKELITE, 77  
Beams, 130, 140, 155  
Bending moments, 141  
Biplane construction, 52  
Bracing, drag, 175  
Brakes, 205  
Breaking load, 82
- CENTRE of gravity, 42  
Certificate of airworthiness, 45  
Compression members, 131  
Cost, 29  
Covering or "skin," 28
- DEFICIENT frames, 105  
Deflection of beams, 155  
Design, trend of, 46  
Deterioration of material, 90  
Diesel engine, 71  
Drag bracing, 175  
Drawings, 40  
Duralumin, 76
- ELASTIC limit, 81  
Electron, 76
- FABRIC, 163  
Factors of safety, 79, 83  
Fatigue, 83  
Fin and rudder, 56  
Flight, theory of, 29
- Frameworks, 102  
——, external loads on, 118  
——, internal loads in, 120  
Fuselage structure, 184
- GEODETIC construction, 115, 181
- HEAD resistance, 62  
Hooke's law, 81  
Horizontal flight, 49
- IMPERIAL Airways, 32  
Inverted flight, 92
- LANDING, 57  
—— loads, 172, 194  
Lay-out, 37  
Light alloys, 76  
"Line" load, 85  
Load factor, 86, 92, 118  
Longitudinal shear, 146
- MAIN-PLANE structure, 160  
—— spars, 168  
Manufacture, 41  
Materials, 27, 74  
——, deterioration of, 90  
Measurement of weight, 42  
Monocoque construction, 179
- NAMES of parts, 22  
Nose dive, 54
- PANEL bracing, 114  
Parts, names of, 22  
Percentage weights, 160  
Plastics, 77, 181  
Power unit, 63
- REDUNDANT frames, 107  
Retractable undercarriages, 198  
Ribs, 165

- SAFETY, factors of, 79  
Shape, 26  
Shear, 145  
Side-slipping, 56  
Skeleton, 19  
Skid, 206  
Space frames, 115  
Spars, main, 168  
Specification, 32  
Steels, 76  
Streamlining, 27  
Strength and safety, 26, 62  
— tests, 98  
Stressed skin, 28  
Stressing, 39  
Struts, 130
- TAIL unit, 209  
Tension members, 130  
Testing, 44  
Theory of flight, 29  
Ties, 130  
Trend of design, 46
- Turns, 56  
Types and wheels, 204  
— of axle, 202  
— of structure, 200
- ULTIMATE load, 83  
Undercarriage, retractable, 198  
—, structure, 194  
Upside-down flight, 56
- WEAK links, 95  
Weight, 24, 34, 63, 160  
Wheels and tyres, 204  
Wing area, 36  
— structures, 177  
Wire-braced frame, 112  
Wireless, 58  
Wood, 75  
Workmanship, errors in, 91
- YIELD point, 82  
Young's Modulus, 78

# YOU SHOULD READ THESE VALUABLE BOOKS

## LEARNING TO FLY

By FRANK A. SWOFFER, M.B.E., *Late Chief Instructor to the Hampshire Aeroplane Club, and the Central Flying School, R. A. F., Upavon.*

A very carefully compiled work for those learning to fly and for all interested in the study of flying.

170 pp.

7s. 6d. net.

illustrated

*"An excellent book for the beginner."*—AEROPLANE.

*"Easily the best book on the subject."*—SPECTATOR.

## A PRIMER OF FLYING

By G. W. WILLIAMSON, O.B.E., M.C.

Deals only with the most elementary flying in the simplest terms.

71 pp.

2s. 6d. net

cloth

*"The short chapters, the simple language and the simpler diagrams commend the book to the reader."*—FLYING.

## HOW TO FIND YOUR WAY IN THE AIR

By G. W. FERGUSON, M.C., A.F.C., M.I.Loco.E.

Provides a practical course of instruction in cross-country flying.

80 pp.

3s. 6d. net

cloth

*"Useful book . . . Can be thoroughly recommended."*—JOURNAL OF THE ROYAL AERONAUTICAL SOCIETY.

## A SIMPLE STUDY OF FLIGHT

By J. D. HADDON, B.Sc.

A straightforward treatment of the theory of flight for students of moderate mathematical ability.

88 pp.

4s. 6d. net

illustrated

*"Captain Haddon not only writes well, but he illustrates much of what he says by many excellent and useful examples in his text."*—JOURNAL OF THE ROYAL AERONAUTICAL SOCIETY.

# PITMAN





**CENTRAL LIBRARY  
BIRLA INSTITUTE OF TECHNOLOGY & SCIENCE**

**Call No.            PILANI (Rajasthan)            Acc. No.,**

**DATE OF RETURN**

---

--	--	--	--

