

Birla Central Library

PILANI (Jaipur State)

Engg College Branch

Class No :- 744

Book No :- L34P

Accession No :- 31716

REQUEST

IT IS EARNESTLY DESIRED THAT THE BOOK BE HANDLED WITH CARE AND BE NOT MARKED, UNDERLINED OR DISFIGURED IN ANY OTHER WAY OTHERWISE IT WILL HAVE TO BE REPLACED OR PAID FOR BY THE BORROWER IN THE INTEREST OF THE LIBRARY.

LIBRARIAN.

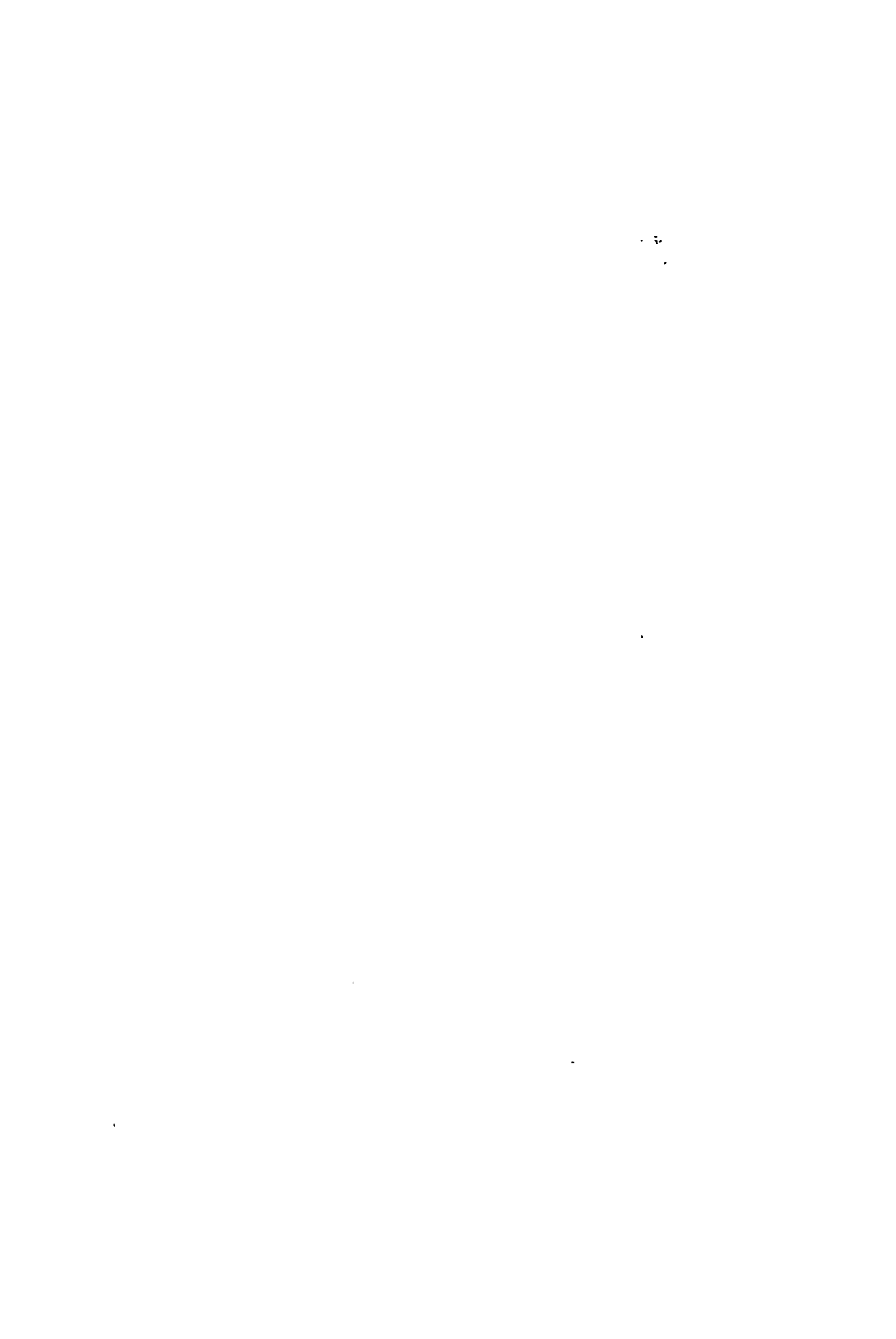

PRACTICAL
PERSPECTIVE DRAWING

*The quality of the materials used in
the manufacture of this book is gov-
erned by continued postwar shortages.*



From an engraving after Hogarth. In this picture Hogarth deliberately introduced most of the common errors described in Chapter XI.

Practical Perspective Drawing

BY
PHILIP J. LAWSON
Pratt Institute

FIRST EDITION
SEVENTH IMPRESSION

McGRAW-HILL BOOK COMPANY, Inc.
NEW YORK AND LONDON
1943

PRACTICAL PERSPECTIVE DRAWING

COPYRIGHT, 1943, BY THE
MCGRAW-HILL BOOK COMPANY, INC.

PRINTED IN THE UNITED STATES OF AMERICA

*All rights reserved. This book, or
parts thereof, may not be reproduced
in any form without permission of
the publishers.*

C
744
L34 P
31716

ORI

PREFACE

It is not the purpose of this book merely to add another title to a formidable list already in existence. Such a volume would be both superfluous and unsalable. To be worth the effort and expense of writing and publishing, a new book on perspective should do several things. It should include material neglected in previous books or scattered among several, avoid the presentation of its subject matter in too specialized a manner, and be so arranged that it may be used as a reference book by the practicing artist.

There is no question that the classroom demonstration by a good teacher will lead to quicker understanding than the solitary study of books. This is partly due to the stimulating personal relation and partly to the ability of the lecturer to answer questions as they occur to the student. No textbook can hope to offer a substitute for these.

Another quality of classroom demonstration *can* be, but rarely *is*, captured in a book—that is to say, the *progressive* quality. By “progressive” is meant, not radical departures in teaching methods, but the following of a solution step by step.

When the teacher draws a diagram on the blackboard, he does not do it in an instant and present the astonished student body with the complete result. The real teacher works out his solution step by step, and the students are able to follow him and see how he achieves his result.

For the same reason the illustrations given here have been broken down into parts. In each part a major step of the whole operation is performed. This, it is felt, answers the most pressing of student questions, “What do I do first?” “Then what?” Equally important, it avoids diagrams so loaded with construction lines and so complex in appearance as to be puzzles rather than demonstrations. Moreover, where it is impracticable to break down an illustration into steps, the letters identifying various points show, in most cases, by their alphabetical order the sequence in which the points were established.

The goal of including all important material without making the book as formidable as an encyclopedia has been sought by attempting to demonstrate the versatility of various constructions. Apart from its complexity, the task of drawing an office building does not differ from that of drawing a bungalow; the drawing of a lamp is more intricate, but not fundamentally different in method from the drawing of a bottle. Some books attempt to demonstrate perspective principles by solving a vast number of specific problems. This results in two faults. First, the book, to remain within reasonable bounds, must omit material outside a limited field; second, its

reader learns to work only specific problems. He can draw a chair but not a sofa, a period chair but not a modern chair, a house but not a hotel, etc. The method here is to present fundamental principles that may be applied anywhere, not specific rules for specific jobs. There are billions of specific jobs. To be sure, specific problems are given in this book, but the purpose is to show how fundamental principles are used, not to give rules for every conceivable situation.

The next objective is partly an outgrowth of the preceding one. Many excellent books on perspective treat the subject from the specialist's point of view. A book on perspective by an architect is rarely useful to a commercial artist, and vice versa. The practitioner of the fine arts writes as though only easel painting were worthy of consideration.

The subject matter has been arranged as far as possible to make the book useful as reference material, without interfering with the primary function of a textbook. Both the chapter headings and the index should make possible the rapid finding of essential information, and, for the practicing professional and the advanced student, the illustrations should solve most problems with little reference to the text.

ACKNOWLEDGMENTS

The preparation of this book was greatly aided by the generous cooperation of a number of people, to whom the author wishes to express thanks. James C. Boudreau, Director of the Art School of Pratt Institute, gave much invaluable advice. William L. Longyear, Supervisor of the Department of Advertising Design; Donald R. Dohner, Supervisor of the Department of Industrial Design; James Patterson, Supervisor of the Department of Interior Design; Cecil C. Briggs, Supervisor, and Lyle Boulware, of the Department of Architecture, all provided much valuable material through the facilities of their departments at Pratt Institute. Walter Civardi, Head of the Department of Photography, furnished the photographs. The author wishes to express his gratitude for the loyal cooperation of Robert Renac, Michael Schwartz, and Vincent Solomita, in the preparation of the illustrations. Mrs. C. L. Morrison gave indispensable help in the editing and preparation of the manuscript. And most of all the author thanks his wife for her constant encouragement and assistance.

PHILIP J. LAWSON.

NEW YORK,
July, 1943.



CONTENTS

	PAGE
PREFACE	V
CHAPTER	
✓ I. Basic Principles	1
✓ II. The Cube.	9
III. Measurement	31
IV. The Circle, Ellipse, and Other Two-Dimensional Curves	59
v. Three-Dimensional Curves	77
✓ VI. Compound Forms	96
VII. Plastic and Soft Forms.	124
VIII. Perspective Composition and Figures in Perspective	137
✓ IX. Laborsaving Devices.	154
✓ X. One-point and Three-point Perspective.	163
XI. Common Errors.	171
XII. Working from Blueprints and Other Mechanical Drawings	180
XIII. Practical Suggestions.	190
XIV. Conclusion	205
INDEX.	213

PRACTICAL PERSPECTIVE DRAWING

CHAPTER I

BASIC PRINCIPLES

1. All ordinary perspective drawing is based upon a simple conception, *viz.*, that, between the eye of the observer and the object to be drawn, there stands a transparent plane, a sort of window, called the *picture plane*, on which the form of the object is projected. This picture plane may be a window in the most literal sense, and, if the reader will make the following experiment, the real meaning of the phrase will be much clearer to him.

2. Select a window having large, undivided panes, and obtain a china marking pencil such as is used in stores to put prices on china and glassware. (In order to prevent domestic friction, it is also advisable to have some benzine or other dry-cleaning fluid to take it off afterward.) Stand at the window at such a distance that it is just convenient and comfortable to mark on it with the arm outstretched. Keeping the head as nearly stationary as possible, trace on the window the outlines of the things seen through it. The result is a perspective drawing on the picture plane itself.

3. If the image upon the window is now examined, and if it includes buildings or other objects containing straight lines and right angles within its view, several characteristics of that image may be noted, all having the greatest importance in the practice of perspective drawing. First, all lines appear to be shorter than their true length, and the shortening effect increases as the distance of the object line increases. Second, vertical lines, such as tree trunks, corners of buildings, and telephone poles, appear truly vertical, whereas horizontal lines, with the exception of those at the eye level, do *not* appear horizontal. Third, groups of horizontal lines running in a *single* direction appear to converge toward a *single* point. Other groups of horizontals having *different* directions have *different* points toward which they converge. Fourth, these points of convergence for horizontal lines all lie on a horizontal line, level with the eye of the observer. This effect may be seen vividly, even without using a window, simply by looking down a long straight railway track and noting how the rails seem to vanish at a point directly opposite the eye.

4. Other effects are also noticeable. The apparent shortening of a line seen obliquely is one example. This effect, called *foreshortening*, is somewhat more subtle, though often more drastic, than that of distance, and it

exerts a strong effect on the appearance of the picture. The apparent flattening of circles, resulting in the ellipses that cause students so much trouble, is another. (Strictly speaking, this is also foreshortening.) If there are circles within the view embraced by the window, a study of them alone will well repay the trouble.

5. The function of the window may be briefly described as follows: Since vision is impossible without light, it is assumed that a ray of light enters the eye from each point on the object. On the way from object to eye, each of these rays passes through or, in technical language, *pierces* the picture plane. The spot where the ray from any given point on the object pierces the picture plane is the *perspective projection* of that point. When all the rays from all the (visible) points on the object have produced their respective perspective projections, the sum total is the perspective projection upon the two-dimensional picture plane of the three-dimensional object beyond. Although, theoretically, each line of the object, and consequently each line of its perspective projection, is composed of an infinite number of such points, it is necessary in actual practice to consider only the two points at each end of any given straight line. These two points alone are sufficient to establish the length and location of the line in question. Curves are another matter and are discussed in detail in Chaps. IV and V.

6. It is at this point that the artist enters. If he intends a literal transcription of what he sees, he simply transfers to a piece of paper or canvas that projection upon the picture plane. Note that he copies not the object itself (that is possible only in sculpture) but its projection upon the picture plane. In actual drawing, of course, it is impractical to set up a piece of glass between artist and object. The picture plane is purely imaginary, and the artist transfers his impression directly to the paper. Nevertheless, though the picture plane is in itself imaginary, it has a vital function in drawing, just as vital, in fact, as the imaginary lines of latitude and longitude without which navigation would be nearly impossible.¹

7. It is not absolutely necessary to know the theory of the picture plane in order to make passable perspective drawings, but such knowledge will make it easier to understand the rest of the subject. It will also aid in learning to produce special effects such as the illusion of enormous size, bird's-eye views, etc.

8. The picture plane is usually considered perfectly vertical, because our upright posture and the position of our eyes forces us normally to look straight ahead. This is the case in the window drawing experiment already described. On the other hand, had the science of perspective been worked

¹ Attempts have really been made to set up an actual screen between artist and model. Albrecht Dürer made some interesting experiments with the purpose of achieving speedy and accurate perspectives with the aid of a screen of wire spaced in a wide square mesh, but the apparatus has always proved too cumbersome to compete with conventional methods.

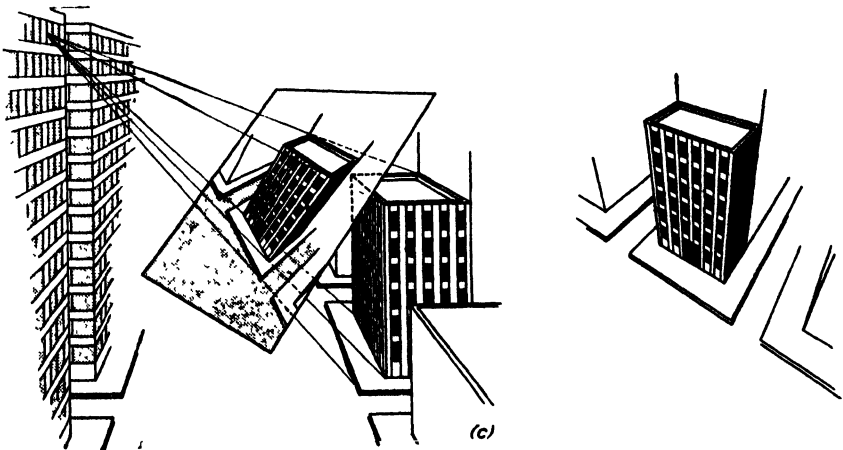
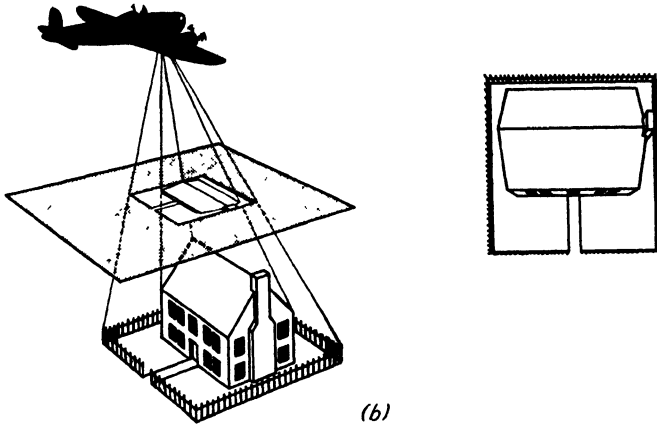
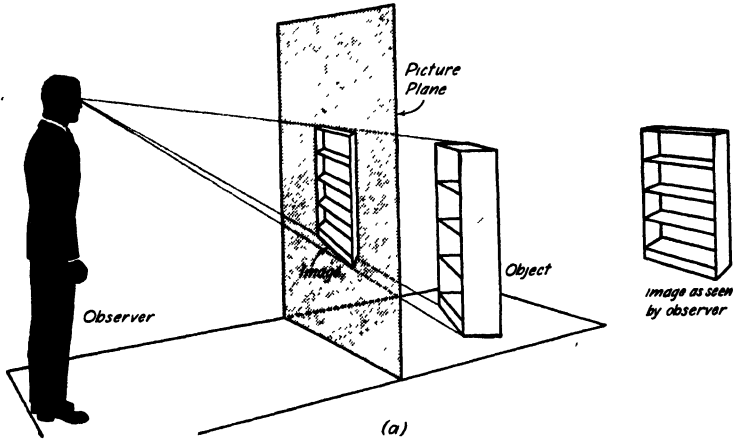

FIG. 1.—The effect seen here in the oblique views of the picture planes—the perspective images of perspective images—is the same as that produced by sitting too far forward and too far to one side of the screen in a motion picture theater.

out by a bird, we should probably have a convention of a horizontal picture plane. Occasionally it is expedient to assume the picture plane to be neither perfectly horizontal nor perfectly vertical, but tilted. These three alternatives are illustrated in Fig. 1, together with the resulting images. As is to be expected, each produces a perspective image having noteworthy individual characteristics, and each has its special uses. Figure 1a shows the sort of picture given by the vertical picture plane. The vertical lines of the object, being parallel to the picture plane, appear still vertical, still parallel, and still in their true *proportions* (*not scale*) in the image. Except in the special case of one-point perspective, discussed in Par. 10, the other two sets of lines do not appear in their true directions, parallelism, or scale. Figure 1b shows the character of the picture obtained with a horizontal picture plane. Here the verticals lose their original character, while the parallel horizontals remain parallel and in true proportion. Lastly, in Fig. 1c we have a case in which the picture plane, not being parallel to any of the principal lines of the object, produces an image in which *no* lines appear as parallels or in true proportion.

9. The picture plane may also be assumed to be at any given or desired distance from the eye. When it is close to the eye and distant from the object, we see an image small in size compared to the size of the object; when it is close to the object and distant from the eye, the image approaches the actual size of the object. It is even possible to assume for it a position *behind* the object, in which case we get an enlarged image. This is what the microscope does for us—pushes the picture plane back of the object under examination. In each of the cases shown in Fig. 2 and, as a matter of fact, in all perspective drawings, the rays from the object converging in the eye form a cone with the eye as apex. When, as in Fig. 2a, the picture plane cuts across this cone near the apex, the resulting cross section is necessarily very small. In Fig. 2b the cross section is taken near the larger end and is thus relatively large. The third position, illustrated in Fig. 2c, calls for some exercise of the imagination. Although the rays do not, in *fact*, continue beyond the object, there is no reason why, if it suits our convenience, we should not assume that they do. As will be seen later, this may be of practical value when actual dimensions are too minute for clear and comfortable presentation in a picture.

10. In any rectangular object there are three sets of parallel lines, mutually perpendicular to each other. These are: first, lines running from top to bottom; second, lines running from side to side; third, lines running from front to back. It was noticed in Fig. 1c, for instance, that each set of lines, actually parallel in the object, tends in the image to converge toward a point in the distance. Since there are three such sets of lines, there are consequently three such points. When the picture plane is parallel to any one of these sets of lines (usually the vertical set as in Fig. 1a), one of the points disappears and the lines in question appear truly parallel in the per-

spective image. Occasionally the picture plane is parallel to two sets of lines in the object. In this case two of the three sets of lines will appear

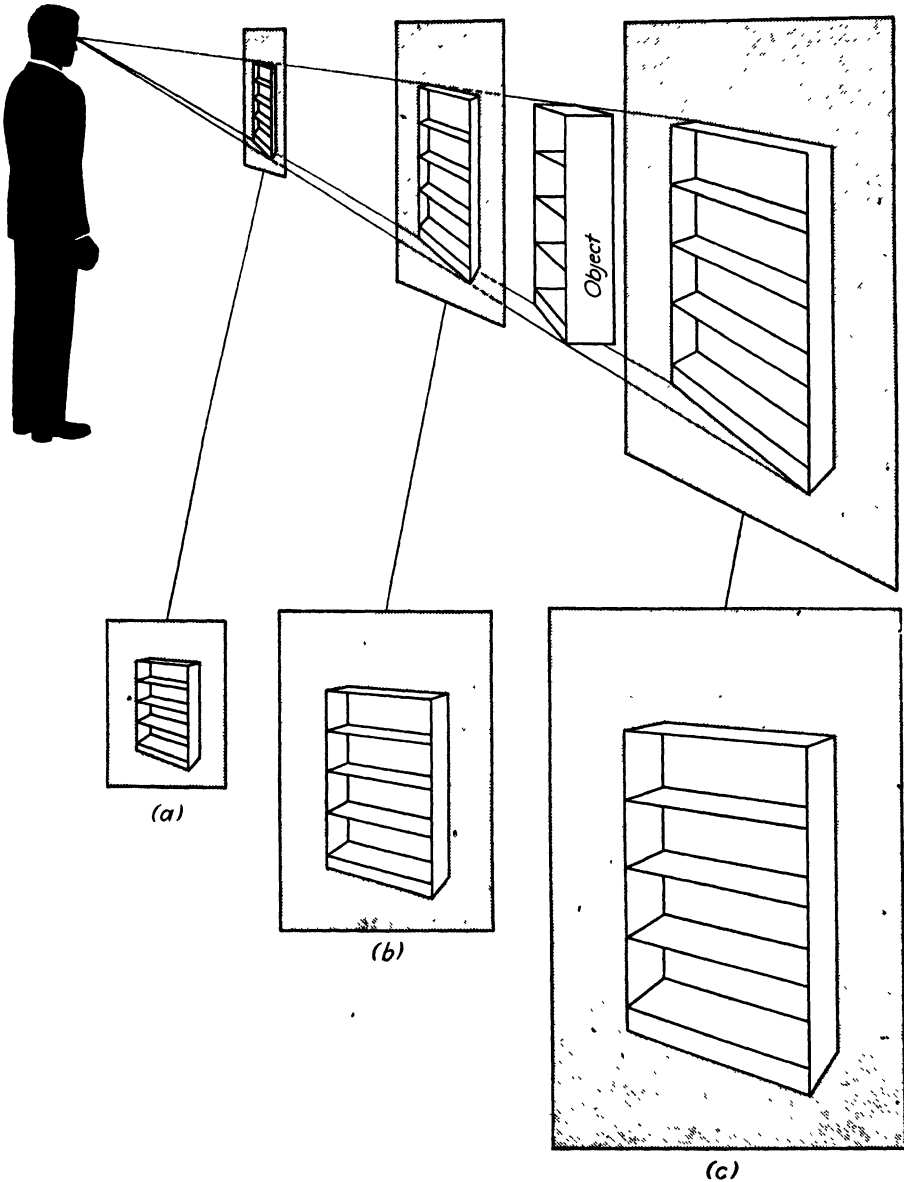

FIG. 2.—Note that only size changes, the appearance of the images being otherwise unaltered.

truly parallel in the perspective, and only one point of convergence is needed. It is obviously impossible for the picture plane to be parallel to all three sets. For this reason it is impossible to make a realistic drawing of a solid without using at least one such point of convergence, but per-

fectly satisfactory pictures of plane objects, such as textile designs, printed pages, etc., may be, and usually are, made with no such points whatever.

11. These points in perspective images are called *vanishing points* and are of fundamental importance in making perspective drawings. The three main variations are shown in Fig. 3. These are called, respectively, *three-point*, *two-point*, and *one-point* perspective. One-point perspective is also called *parallel* perspective. Three-point perspective, as in Fig. 3a, results when the picture plane is not parallel to any of the principal lines

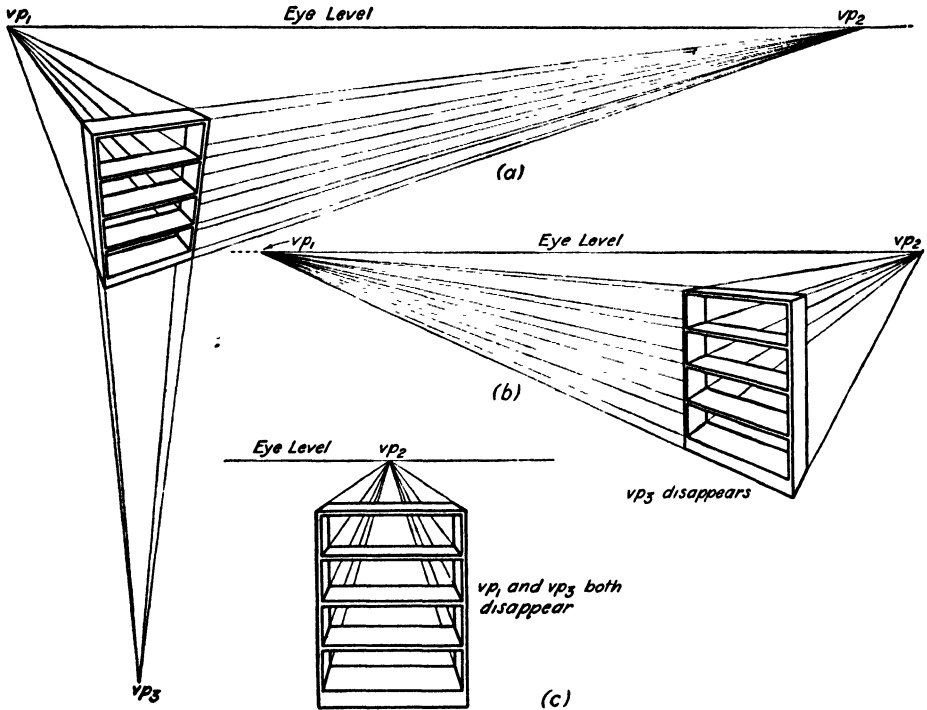

FIG. 3.

of the object. This is the case when the picture plane is tilted, as in Fig. 1c. When the picture plane is vertical, the usual case, it is naturally parallel to vertical lines in the object, which then appear truly vertical, as in Fig. 3b, and naturally parallel to each other. Moreover, the two vanishing points of the horizontal lines both lie on the same horizontal line. This fact is of great importance in drawing, as will be seen in Chap. II. Lastly, when the picture plane is parallel not only to the vertical lines, but to one of the sets of horizontals as well, these horizontals appear as truly horizontal in the image. This case, with the single remaining vanishing point, is shown in Fig. 3c. When, as often happens, there are sets of lines in an object that are not parallel to the three principal sets listed in Par. 10, these lines have

separate vanishing points of their own. The peaked roof of a house, for example, requires two auxiliary vanishing points, one for each side. Thus a two-point perspective of such a house would actually have four vanishing points. It is called a two-point perspective nonetheless, for only the vanishing points for the principal lines are counted.

12. Two-point perspective is used in about 90 per cent of ordinary drawings. One-point perspective should be used when only one plane of an object is of interest, and perspective is needed only to suggest depth. Three-point perspective is valuable when we want to suggest the effect of looking down from a great height, such as the top of a tall building or an airplane in flight. It is also useful for the exact opposite, looking up at such a building from the street level. In Fig. 4a, three-point perspective illustrates the effect of looking down on a tall building from a still taller one; Fig. 4b shows the effect of looking up on it from below.

13. In the course of this chapter we have briefly surveyed some of the theory, that is to say, the "why" of perspective—why vertical lines usually appear parallel and in true proportion, why we sometimes tilt the picture plane, etc. The remainder of the book is largely devoted to technique, *i.e.*, to "how"—how to draw lines in true perspective, how to obtain correct proportions along lines where a scale cannot be used, how to draw a circle seen obliquely, and numerous other problems. This does not mean that we shall cease to consider theory altogether, but merely that from here on it will serve mainly to clarify the principles of practical working methods.

14. Before beginning the following chapters we must emphasize one idea that must be kept firmly in mind. All drawing is easier and sounder if it includes a firm grasp of the structural elements of the object drawn. Better life drawings are made when the artist appreciates that the appearance of the human body is the result of the internal structure of bony skeleton and the attached muscles and adipose tissue. Most students try to copy outline, to draw from the skin in, producing in that way figures almost as amorphous as a potato, limp as warm butter, and lacking in vigor, action, and style. The experienced illustrator does not *draw* the skeleton in every figure, of course, but he *thinks* it, and the result is a firmness and a feeling of action difficult or impossible to achieve otherwise. It is for this reason that anatomy is usually taught along with and as a necessary part of courses in life drawing. It is not always recognized that good still-life drawing, the principal subject of this book, depends equally upon a clear comprehension of the anatomy of inanimate things. The still-life model is so docile, never getting tired and droopy and impatient, that it is easy to form the habit of copying. This slack manner of working produces slack, lifeless drawings, tiresome to make and more tiresome still to look at. Moreover, the copying of outline is in the long run much harder work than sound construction, infinitely less interesting to do, and far less accurate. Even so simple an affair as a stool is more easily drawn if its structure is

understood—that it is not simply a circular slab of wood with three sticks hanging therefrom, but three stout legs, set at an angle calculated to give the most strength and rigidity, and firmly imbedded in the top. So important is this clear knowledge that in at least one school the general term *drawing* is not used in referring to courses including perspective and related subjects, but in its stead the specific phrase *structural representation*.

CHAPTER II

THE CUBE

15. In the preceding chapter several characteristic features of perspective images were mentioned. Some of these were apparent decrease in size with increase in distance from the eye, foreshortening of lines oblique to the picture plane, and apparent convergence of parallel lines toward vanishing points. To make good perspective drawings it is not enough merely to know that a distant object will look smaller than an identical one near by; it is also essential to know *how much* smaller. In addition to the fact that vanishing points exist, it is also necessary to know *where*. These questions, and others related to them, are answered in this and the next chapter. Since these characteristics are present in obvious or hidden form in every perspective drawing, we begin our study of them by using the simplest three-dimensional form—the cube. The importance of the cube in building a drawing can scarcely be exaggerated. It can safely be said that, until a student can draw a cube from memory in any position and any size, he has not really learned to draw at all. Fortunately this ability can be acquired in a few days. Once it is mastered, the remainder of the subject becomes much easier. This is because the cube is not only an important form in itself, but also the measuring unit for innumerable other forms.

16. *Perspective is really a very simple science.* What causes trouble in most cases is not the principles of perspective, which are few and easy to learn, but the subject matter of our drawings, which is often intricate. Fundamentally a typewriter is no more difficult to draw than a cup and saucer; it is only the number and complexity of the parts that make for trouble. Once the reader understands thoroughly everything in this chapter on the cube, he may be said to understand the subject of perspective as a whole; all other work on this line being a matter not of learning perspective per se, but of acquiring techniques for its rapid and efficient utilization.

17. Fortunately, most complex forms can be drawn easily if not quickly, provided we bear in mind that many of the parts are repetitions of some easily drawn form. For example, one key on the typewriter is exactly like the next one; when you have drawn one you have drawn them all. Furthermore, most such repeated parts are arranged in systematic order—four rows of identical keys, two symmetrically placed and identical ribbon reels, etc. There are methods for drawing these groups *as groups*, rather than laboriously as individuals. The methods for drawing the individual forms

will be taken up in this chapter and in Chaps. III, IV, and V, while the remaining chapters are devoted to methods for combining these forms into larger and more complex units.

18. In order to understand what follows, and in order to make *mechanical perspectives*, i.e., perspective drawings made from scale measurements and with the aid of drafting instruments rather than by estimation, it is essential that the reader understand the *nonperspective* drawings from which the perspectives are derived. Since the use of such drawings is an everyday part of their work, architects, industrial designers, and engineers will understand

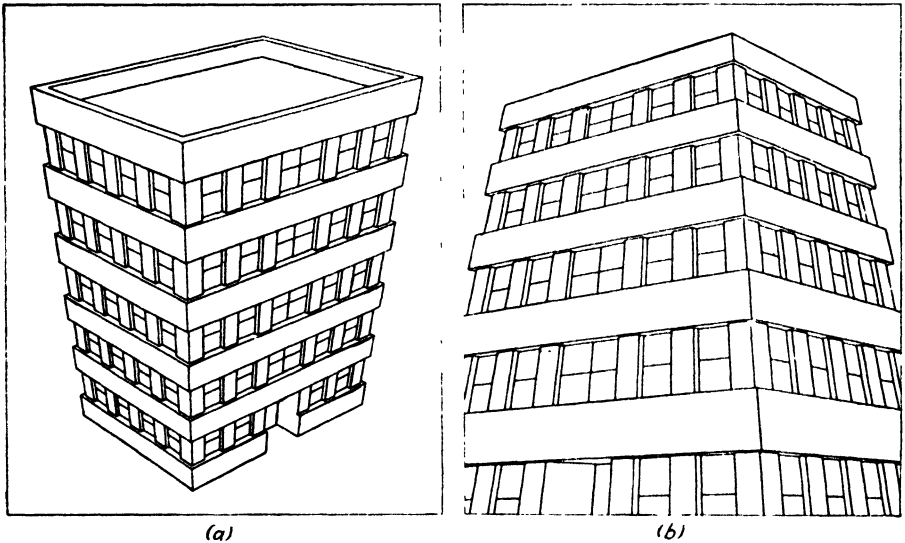

FIG. 4.

them without trouble. For readers not technically trained a word of explanation is in order. The nonperspective drawing used here is generally called *mechanical drawing* or *orthographic projection*. In mechanical drawing objects are depicted, not as they appear to the eye with lines diminished in length because of distance and as disappearing toward vanishing points, but as they really are. When the object is very large, as is the case with buildings, the draftsman cannot make his drawings actual size and therefore uses a smaller *scale*, letting a quarter inch represent a foot, for instance. Nevertheless, the parallel lines of the object appear as truly parallel in the *mechanical drawing*, and lines at a distance are represented at the same scale as those close by.

19. Nearly everyone is familiar with blueprints showing architects' plans for buildings. These are mechanical drawings. The architect usually includes, in addition to his floor plans, four *elevations* showing the details of each wall. For our present purpose, such elaborate work is unnecessary, one *top view* or *plan* of the object and picture plane, and one

side view or elevation of the same being all that is needed. The terms *top view* and *side view* are customary in engineering, while the terms *plan* and *elevation* are used in architecture. There are technical reasons for this, and minor differences in meaning that need not concern us here. In this book, where mechanical drawings are needed, the engineering terms will be used,

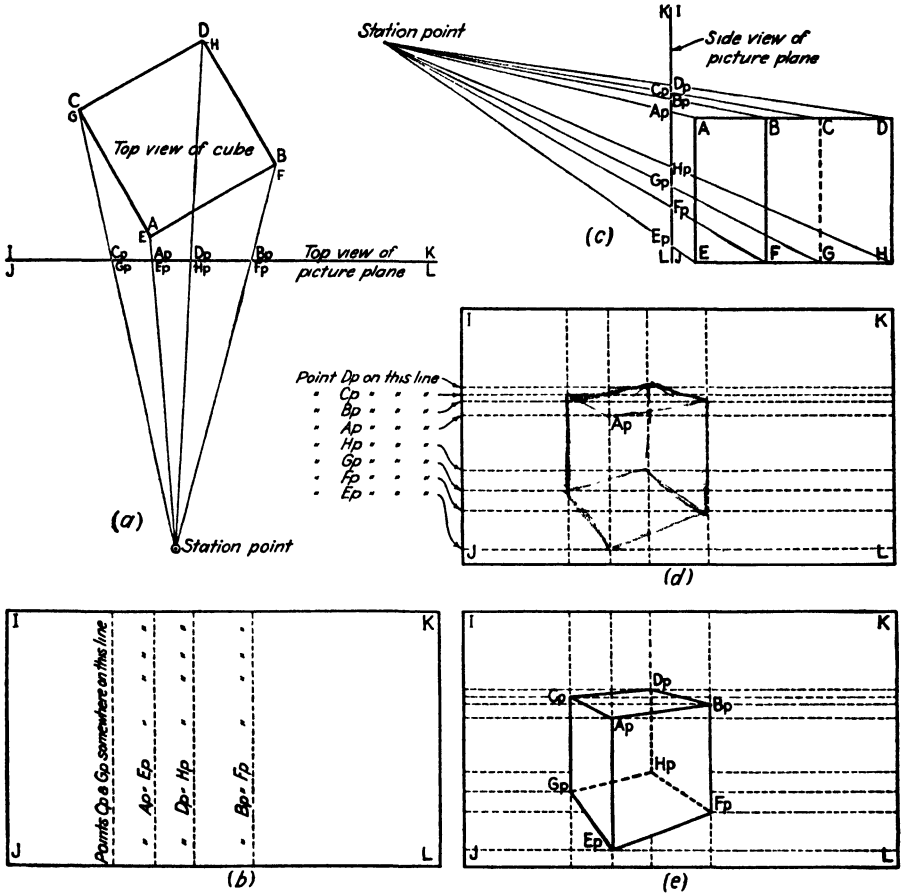

FIG. 5.

for they seem more understandable to the layman, except where specifically architectural problems are concerned. An important convention of mechanical drawing should be noted—necessary invisible lines are represented by dotted lines.

20. Figure 5a is the top view of a cube, picture plane, and observer, and of the rays passing through the picture plane to the eye of the observer. The eye is represented as a point, *sp*. These letters stand for *station point*, the customary term in perspective drawing. It is our purpose to draw the cube as seen from *sp*. Since Fig. 5a is a mechanical drawing, only the top of the cube is seen. This appears as a true square, *ABCD*. In mechanical

drawings there is no convergence of parallel lines, and so the vertical edges are invisible, and the bottom corners of the cube, $E, F, G,$ and $H,$ are directly beneath $A, B, C,$ and $D,$ respectively. To make this clearer $E, F, G,$ and H are shown in smaller letters. Remember that $AE, BF, CG,$ and DH are lines equal in length to $AB, BD,$ etc. The picture plane, seen edge on, appears simply as a line $IK.$ The rays from each point of the cube to the eye of the observer are known technically as *lines of sight.* Lines of sight from each point on the cube enter the eye at sp and in doing so pierce the picture plane. Thus, in Fig. 5a the line of sight from A pierces the picture plane at $Ap,$ that from B at $Bp,$ etc. Lines of sight come also from points $E, F, G,$ and $H,$ piercing the picture plane at $Ep, Fp,$ etc. Since the lines $A-sp$ and $E-sp$ lie one over the other, they are not seen as separate lines in Fig. 5a, but it must be remembered that they are two distinct lines.

21. It follows that Ap and Ep, Bp and Fp in Fig. 5a, though appearing as single points, are really separate and will appear in the front view of the picture plane (Fig. 5b) as distinct from each other. We now know how far these points are from the left and right edges of the picture plane, but not how high or low on it; so in Fig. 5b we merely say that they lie on certain lines of as yet undetermined extent. The height of the points is established in Figs. 5c and 5d.

22. Figure 5c is a side view of the same group as the top view of Fig. 5a. None of the relationships of object (cube), picture plane, and observer has changed, the only change being in the angle from which they are shown. The line representing the ground plane is now visible, and the relative heights of $sp, A, B,$ etc. The lines of sight $sp-A, sp-B,$ etc., are again shown. Two important things, not seen in Fig. 5a, are visible in Fig. 5c. First, $sp-A$ and $sp-E, sp-B$ and $sp-F,$ are seen as separate and distinct; second, the exact height of the points $Ap, Bp, Ep,$ etc., is shown. Thus we are now able to add to the information contained in Fig. 5b the heights derived from Fig. 5c. We may therefore draw horizontal lines *across* the picture plane, as in Fig. 5d, showing the various heights. We now have both a vertical and a horizontal on which point Ap must lie. Since the only point common to both lines is their intersection, it must be there. All the other points are established in the same way.

23. Figure 5e shows these points connected together. This is how the cube looks to the observer at $sp.$ Various characteristics of perspective drawings, already noted in Chap. I, are clearly seen in this figure. The vertical edges of the cube, being parallel to the picture plane, remain vertical and parallel to each other in the image. The horizontal edges, such as AB and $CD,$ being oblique to the picture plane, do not appear as true parallels in the image but instead appear to converge toward a point in the distance. If this point were determined by extending $ApBp$ and $CpDp,$ it would be found to be at the same height as the station point. This height is the eye level; it is very important and will be treated in detail later on.

Lastly, the line BF , being farther from the eye than AE , appears in the image as the line $BpFp$, much shorter than $ApEp$.

24. Naturally, the practicing artist does not go through all these steps in making an actual drawing; but, in order to handle perspective intelligently and well, he should *understand* them. When great accuracy is required, there are several methods of producing drawings by a combination of the foregoing steps or by using them in abbreviated form. Two of these methods are described here, and they should be studied and thoroughly understood, but it should be remembered that these methods are not a substitute for a sense of proportion or for the graphic skill that every artist must acquire by continual practice. Once the principles are learned, it becomes fairly easy to make a sound drawing, even though the geometrical construction is not laid out at all, provided the principles are kept constantly in mind and are mentally applied throughout.

25. When the student first works out a problem in perspective by either of the methods shown in Figs. 6 and 7, it is usually helpful for him to work with the aid of T square and triangle. This will enable him to concentrate on the principles and will not subject him to the additional strain of attempting to draw freehand with the needed accuracy. As he acquires practice and experience, accuracy in freehand drawing comes easily, but the task of understanding the principles discussed in this chapter need not be complicated by the additional problems in technique. In later chapters, partly in the one on measurement, and particularly in those dealing with curves, it will be wise to do more and more of the work freehand, and the goal should be ultimately to draw with equal ease either freehand or with instruments. Once the student has drawn the cube instrumentally a few times, he will have acquired a knowledge of perspective construction that will aid greatly when he comes to draw more directly. Eventually, he will be able to draw the cube, and from the cube other forms, without the aid of either instruments or construction lines.

26. The professional aim of the student should be considered in deciding whether freehand or instrumental drawing is more important. In the fine arts and in fiction illustration little use is made of instruments, and good freehand control is a prerequisite. Human and animal figures usually dominate such work, and they certainly cannot be drawn with T square and triangle. In advertising illustration instruments are used largely because they speed up work and facilitate the achievement of the hairline precision demanded by some clients. Industrial designers and architects, as a rule, make free-hand preliminary sketches and then use instruments to work out their final presentations. Most engineers consider it unprofessional to make a free-hand line or curve.

27. In Fig. 6 we start with the same material as in Figs. 5a and 5b and, by eliminating some steps and combining others, arrive at the same result with less effort. The procedure is this: The top view (orthographic) of the

cube and picture plane is drawn and the station point selected, approximately opposite the center of the cube and *not less than twice its width away from it*. The reason for this precaution may be seen by reference to Fig. 9c, in which the distorted appearance of the cube results from its neglect. Lines are drawn from each corner of the cube toward the station point. These lines determine where rays from these points pierce the picture plane, and it is unnecessary to continue them beyond it. In this drawing we have also indicated points *E, F, G, and H* in smaller letters to show that they lie

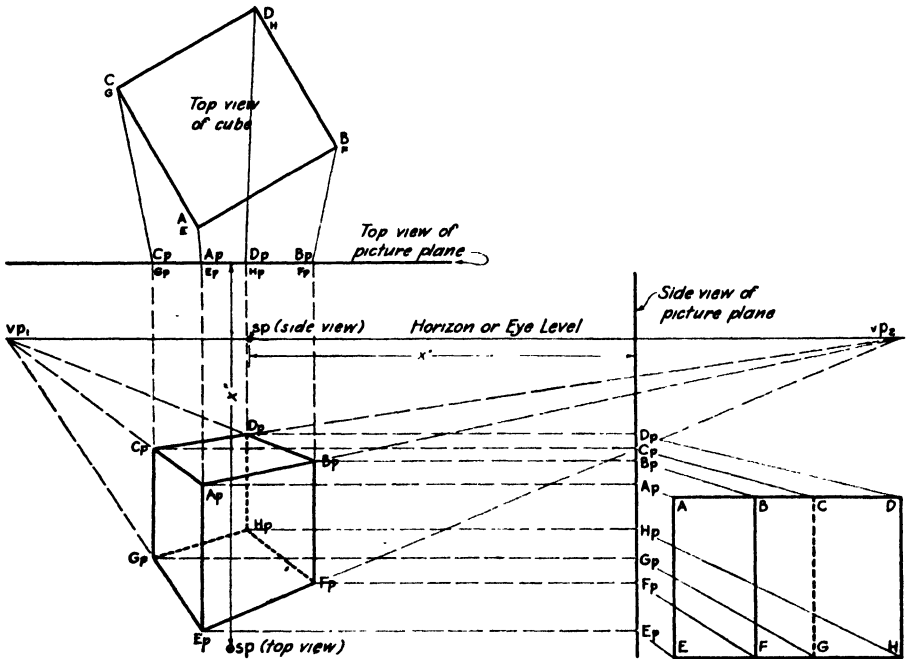

FIG. 6.

directly beneath *A, B, C, and D*, respectively. In this view the line of sight from *A* appears to lie directly over that from *E*, and it follows that *Ap* appears to lie directly over *Ep*. The same applies to the other three corners. In other words *Ap* and *Ep*, *Cp* and *Gp*, etc., appear to be single points. By dropping verticals from *Ap-Ep*, *Cp-Gp*, etc., we obtain a result similar to that of Fig. 5b.

28. Now, instead of drawing a separate view, as in Fig. 5c, we place it below and to the right of what has already been drawn. This gives us the side view (or right edge) of the picture plane, and an oblique side view of the cube. The station point must naturally be the same distance (*X* in the figure) from the picture plane as before, and this time the height of the station point, as measured from the ground or bottom of the cube to the eye level, must also be established. It may be above the cube, below it, or anywhere in between; but, since the view from above is commonest, we

have placed it there. As before, lines are drawn toward the station point from points on the side view of the cube until they pierce the picture plane, and from the points so determined lines are run out horizontally to the left. The line from Ap in the top view crosses the line from Ap in the side view and determines the perspective position of point Ap . The same procedure determines point Bp and all the rest. By connecting these points we obtain a perspective view of the cube which is mathematically accurate.

29. It will be noted, in Figs. 5 and 6, that the points Ap , Bp , etc., appear at several places, namely, on the top view of the picture plane, on the side view, and on the complete perspective view. This is not because they are *different* points; they are the *same* points seen from different positions. This can be better understood if a real drawing of a cube is made on a piece of paper. If we now turn the paper so as to look at only the top edge, every point in the picture will appear to be in that edge. The same thing is true if we look at the right edge of the paper. The picture plane is represented in exactly this way in the top and side views of Fig. 6.

30. The method of perspective construction just described is of use chiefly to architects, engineers, and industrial designers, who frequently have to draw unfinished structures from plans or mechanical drawings and whose work requires a high degree of precision. A complete system based on this method is given by Ernest Irving Freese in his admirable book "Perspective Projection." The average artist does not require such hair-splitting accuracy. It is given here for its help in understanding the principles involved in all perspective drawing, and for occasional use as a check.

31. If the horizontal lines of the perspective image in Fig. 6 are extended back, it will be seen that they form two groups. $ApCp$, $EpGp$, $BpDp$, and $FpHp$ form one group, and $ApBp$, $CpDp$, $GpHp$, and $EpFp$ form the other. All the lines of the first group meet in vp_1 (vanishing point No. 1), and all the lines of the second group meet in vp_2 . Since the vertical lines of the cube are parallel to the vertical picture plane, they appear still vertical in the perspective view.

32. If the two vanishing points are now connected by a line, it will be seen that they are on the same level, that the line is horizontal, and that it coincides in level with the side view of sp . As mentioned before, this line, the horizon, is of the greatest importance in drawing, for its position determines much of the character of the picture. If it is high, objects in the picture appear small in height or appear to be seen from an elevated viewpoint. If it is low, the objects appear to be tall and overpowering in size. Intelligent use of this and other simple principles permits a great variety of dramatic and other effects, and ignorance of them will sometimes produce ludicrous results. A doll drawn with a low horizon appears as a gigantic dummy, while a tall building drawn with the horizon near the top appears as an insignificant model of itself.

33. Figure 7 shows a method of construction similar to that of Fig. 6, but simplified and shortened so as to be of more use to the practicing artist who wants greater speed without sacrifice of accuracy. Carefully used, the method of Fig. 7 is capable of just as much accuracy as that of Fig. 6. The side view of Fig. 6 is omitted, and only the top view is used. This is sufficient to determine the vertical lines. The horizon may be placed wherever convenient. In order to show the similarity of results regardless of method, we have placed it in the same position as in Fig. 6. In Fig. 6

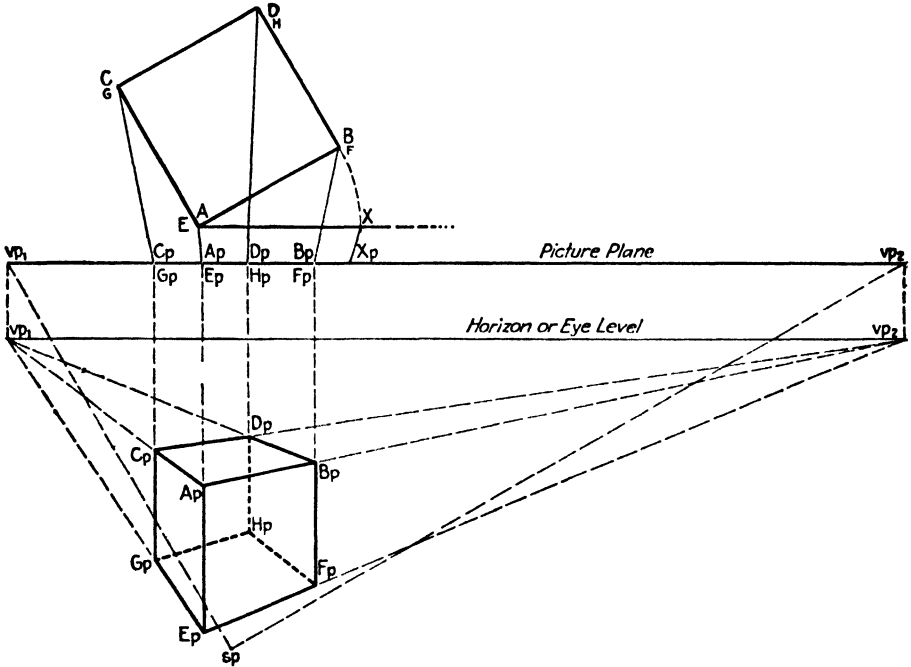

FIG. 7.

the vanishing points were located after the drawing was completed, and need not have been found at all. In the method of Fig. 7, the vanishing points must be found at the beginning, for they control the drawing.

34. To determine the vanishing points, a line is drawn from *sp*, parallel to *AC, BD, EG*, etc., and meeting the picture plane at *vp1*. Again from *sp*, a line parallel to *AB, CD, GH*, etc., meets the picture plane at *vp2*. To place these points on the horizon, simply drop verticals from the picture plane to the horizon. As in Fig. 6, lines are drawn from the various points on the cube to meet the picture plane in *Ap, Cp*, etc., and verticals are dropped from these points. These lines will, as before, give us the apparent width of the cube; but, since the side view is not used, we cannot obtain the various heights directly.

35. Since the vertical sides of the cube are parallel to the picture plane, the various vertical lines will remain vertical in the perspective. The length

of these lines, however, will appear less than the true length, because they lie behind the picture plane. Fortunately, if we can determine the perspective length of any one vertical, the rest will be automatically determined, as will be seen later.

36. The process is as follows: Since all edges of a cube are equal, line AB is the same length as the height AE . The length AB , drawn through A , parallel to the picture plane, will enable us to get the perspective length of AE . A line is so drawn, through A , parallel to the picture plane. On this line the length AX is laid off equal to AB . From X a line is drawn toward sp , intersecting the picture plane at Xp . The length $ApXp$ is the perspective length of AE . This length is now laid off on the vertical dropped from Ap in the picture plane. It is placed high or low on this line according to whether the cube is to appear to be above or below the eye. In Fig. 7, it has been placed in the same position as in Fig. 6. Point Ap is the upper end of this length, and point Ep is the lower. From these two points lines are drawn to the vanishing points vp_1 and vp_2 . Where these lines intersect the verticals from $CpGp$ and $BpFp$ in the picture plane, we have the points Cp , Gp , Bp , and Fp , which automatically give the heights of the verticals. From Cp a line is drawn to vp_2 , and from Bp to vp_1 . Where these intersect we find point Dp . If we wanted to find the invisible point Hp , similar lines to vp_2 and vp_1 would be drawn from Gp and Fp , respectively.

37. As a check on our results, a tracing of Fig. 7 laid on Fig. 6 will show the two perspectives to be alike in every detail.

38. It is often convenient to put the front edge, AE , right in the picture plane. This eliminates the need for drawing the line AX and determining its perspective length, since the line AE will then appear in its true length in the perspective.

39. The foregoing gives the procedure for determining the appearance of a cube seen from an eye level above its top plane. Figure 8a shows this same cube as it appears when the eye level is part way between the top and bottom planes, and Fig. 8b shows it as it appears when the cube is above eye level. Since the difference between these and Fig. 7 is one of degree, rather than one of principle, and since the figures are practically self-explanatory, no detailed discussion is necessary, but the figures themselves should be carefully studied.

40. Occasionally a picture is made with the principal object so far above or below the eye level that its projection upon a vertical picture plane has a distorted appearance. This is shown in Figs. 9a and 9b. As a rule of thumb, the following is useful: The angle $FpEpGp$ should never be allowed to be sharper than 90 deg. and for preference should not be less than 100 deg. When this rule is ignorantly violated or carelessly ignored, we get the painful results so often seen in beginner's drawings. The verticals appear abnormally stretched out, or spreading in one direction or another, and the whole drawing appears to be strained and bursting at the seams.

41. To overcome this the station point may be moved farther from the object, or the picture plane may be tilted, giving us a *third* vanishing point. The result is the same as when we look downward or when we lean back to look at an airplane or high building. In actual practice it is more convenient

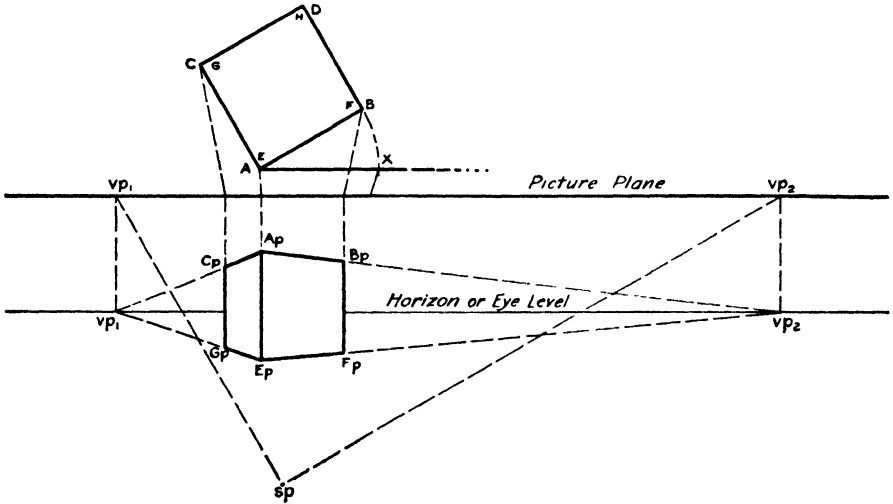

FIG. 8a.—Object on eye level.

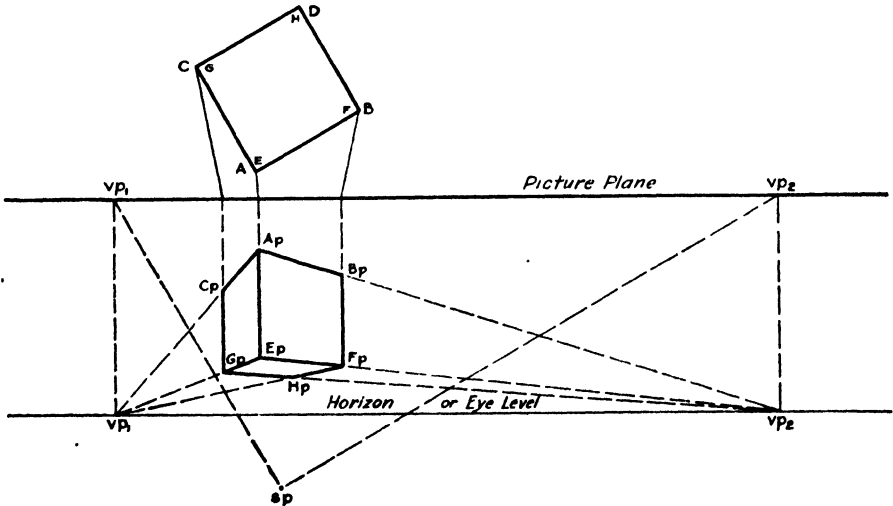

FIG. 8b.—Object above eye level.

to represent the picture plane as vertical and the object as tilted. Naturally these corrections would be unnecessary where distortion is deliberately sought for design or dramatic effect. As far as results are concerned, the effect is the same whether the picture plane or the object is tilted, and construction is simpler where the object is tilted and the picture plane kept vertical, for the latter can then still be represented as a single line Figure

1c shows this tilted picture plane, and Figs. 10a and 10b show how it works out in practice. Except for its added complication of tilting, Fig. 10 is worked out in exactly the same manner as Fig. 6. Such perspectives are rarely used in technical fields, and general illustrators usually work them out freehand, but the principles of Fig. 10 will be found useful in exacting work.

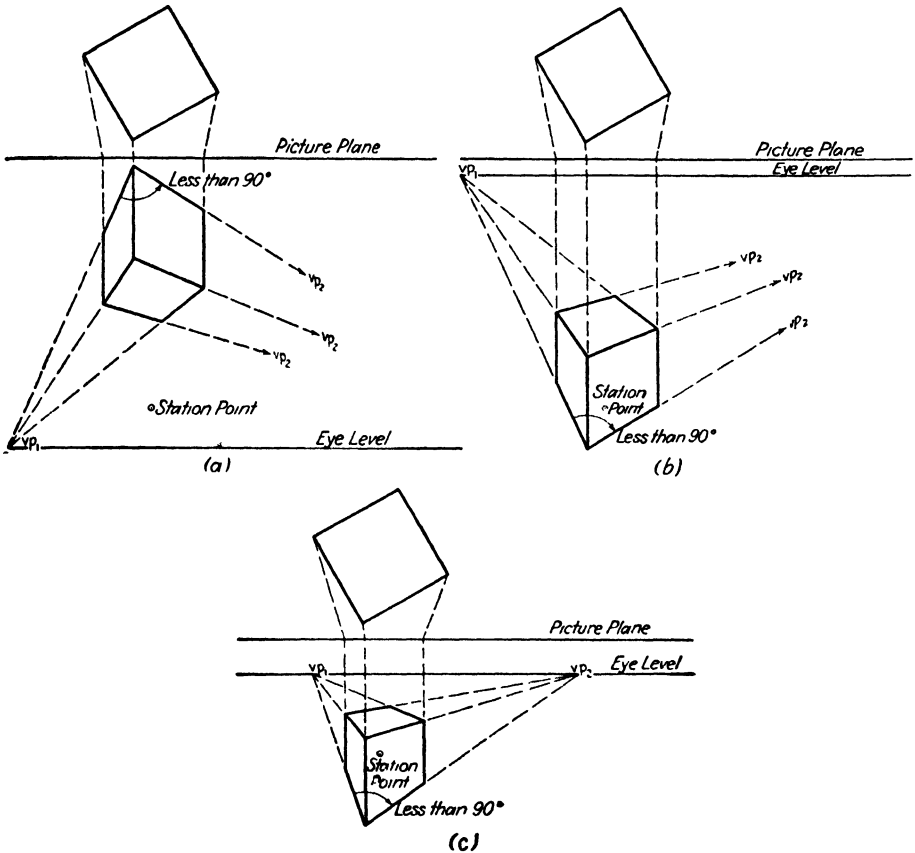

FIG. 9.—(a) Object too far above eye level for good representation on vertical picture plane; (b) object too far below eye level for good representation on vertical picture plane; (c) station point too close to object.

42. Tilting the picture plane in this manner gives three points of convergence, one for each set of parallel lines in the object. As explained in Chap. I, this method is suited for expressing tremendous height or the opposite. It is also extremely useful where the top or bottom of an object is to be the principal feature of a drawing, and when composition, design, or the function of the drawing demands a high, or bird's-eye view.

43. So far we have discussed two-point and three-point perspective, so called from the number of principal vanishing points necessary. Basic-

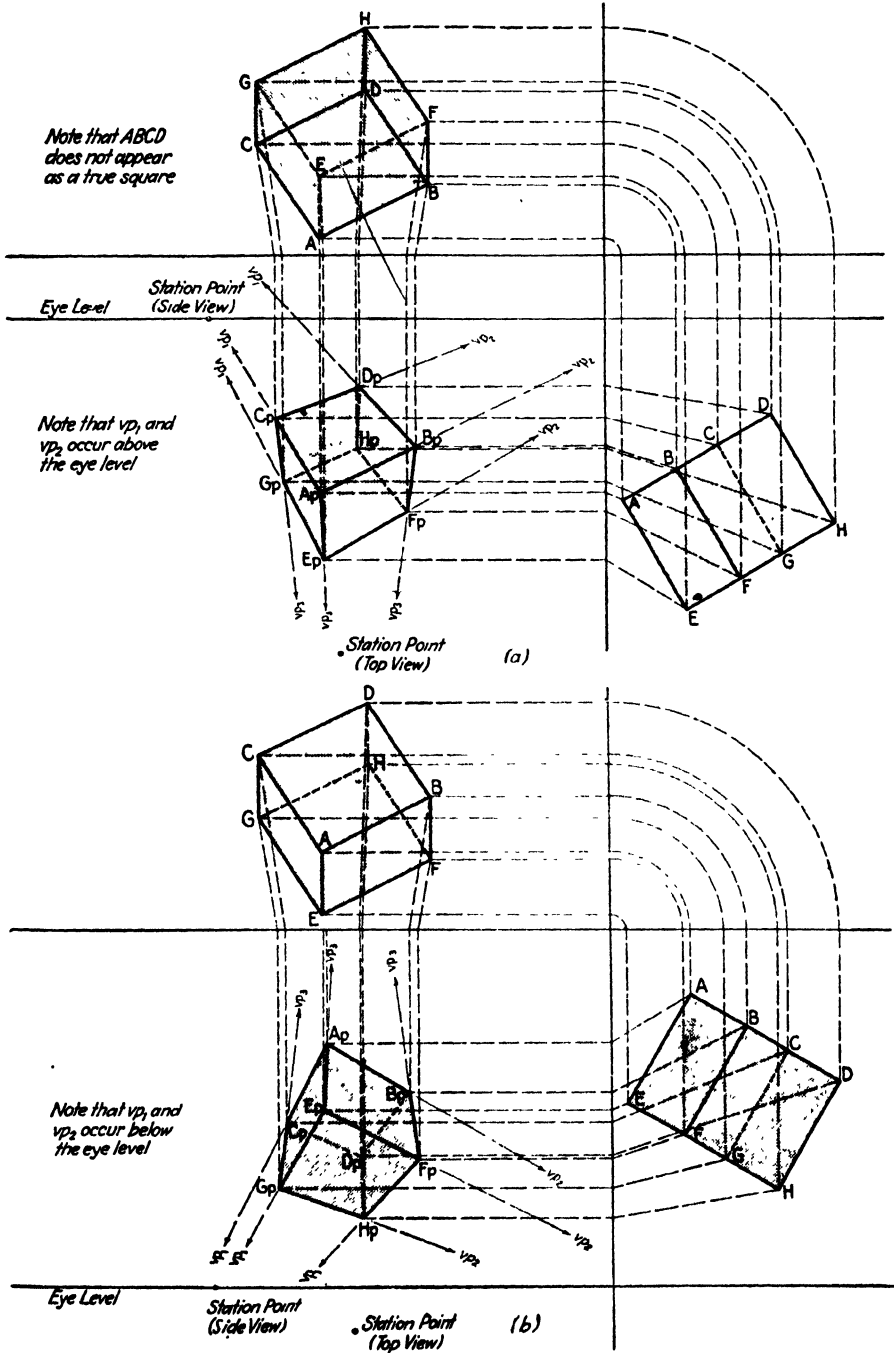

FIG. 10.

ally, two-point perspective is simply a special case of three-point perspective, in which the vanishing point of the vertical lines is infinitely far away. The third class of perspective drawings might be considered a special case of two-point perspective. In *one-point*, or *parallel*, perspective both the verticals and *one* set of horizontal lines are parallel to the picture plane, with the result that there is only one principal vanishing point.

44. The construction of this type of perspective is the simplest of all, although it does present some pitfalls for the unwary. Figures 11a, b, and c are practically self-explanatory, but it can do no harm to call attention to one or two points. First of all, since plane *ABEF* is already parallel to the picture plane, it is not necessary to determine the perspective height by rotating *AB*. *ApBp* is automatically determined by the construction, and the height *ApEp* is equal to it. This also makes *ApBpEpFp* a true square. This makes it possible to use the method of Fig. 7 and to simplify it still further. Secondly, since lines *AB*, *CD*, *EF*, and *GHI* are all parallel to the picture plane, they will appear truly horizontal upon it. This is a great convenience in drawing, especially with instruments, for all horizontal lines parallel to the picture plane can be laid out with the T square. It is important to keep the single vanishing point somewhere near the vertical center line of the object in the drawing. Neglect of this results in distortion and occasionally in drawings that are quite unintentionally funny. The reasons and a few horrible examples of this and other errors are given in Chap. XI.

45. One term that is sometimes useful in discussing perspective problems is *center of vision*. This is the point on the picture plane directly opposite the eye, *i.e.*, a line of sight from the eye, perpendicular to the picture plane, pierces the picture plane at the center of vision. This point is of no great importance in most constructions, but, in *one-point*, or *parallel*,

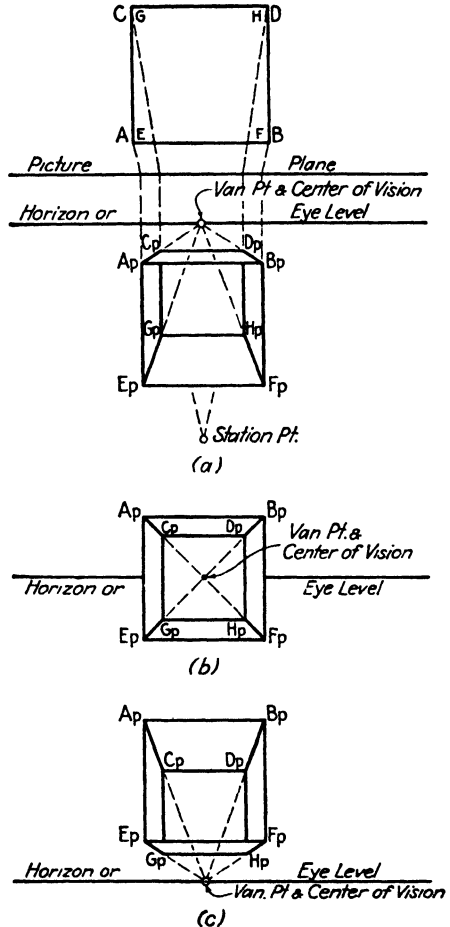

FIG. 11.—(a) Cube below eye level. Front open for clearness; (b) eye level at center of cube; (c) cube above eye level.

perspective, it coincides with the single principal vanishing point. Therefore, if one is determined, the other is also.

46. The three cases described in this chapter cover all the basic requirements for practically any perspective drawing. Theoretically it is necessary only to know how to get the perspective of any point in order to construct any perspective drawing. To draw the perspective of a circle, for example, it would be necessary only to take a number of points on the circle, determine their perspective positions, and draw a smooth line through them.

47. Though this method would work, it would involve hours of laborious construction to draw a couple of simple circles, while a sphere would take days. For this reason, a number of methods that yield the same results

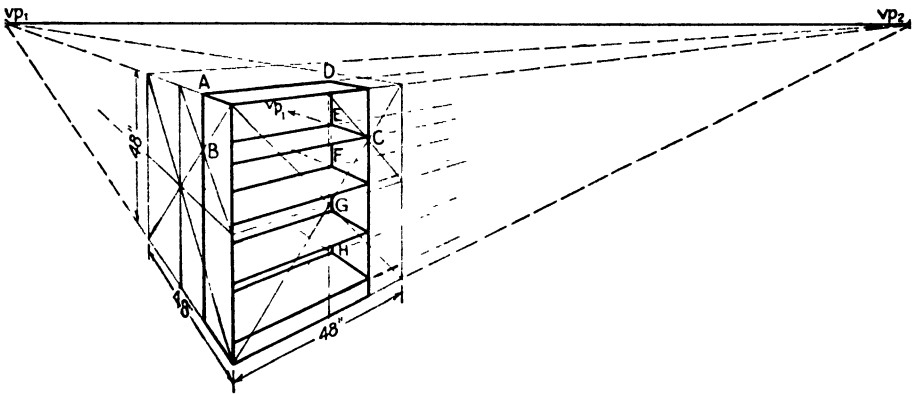

FIG. 12.

in a fraction of the time, and with equal accuracy, have been worked out. These methods are covered in detail in Chaps. III through IX. At this point it will be sufficient to give one illustration of how the cube may be utilized to construct one simple rectangular form, once the cube itself has been accurately drawn. The method described in the following paragraphs is shown in Fig. 12.

48. The set of shelving shown in Chap. I (Figs. 1a, 2, and 3) will serve our purpose very well. Let the base be 4 in. high, each shelf 11 in. high, the width 36 in., and the distance from front to back 12 in. This makes the total height 48 in. For simplicity we ignore the thickness of the boards.

49. For most drawings a cube like that of Figs. 6 and 7 will be most suitable, and it will be helpful to have the vanishing points within the limits of the drawing. Keeping the vanishing points so close together puts a drastic restriction on the size of the image we can construct without distortion, but for our present purpose this is unimportant. In Chap. IX methods will be given whereby accurate perspective may be obtained without vanishing points on the paper or even on the drawing board beyond the limits of the paper.

50. Assume that the cube is 48 in. on a side. Then the 12 in. from front to back of the shelving is a quarter the distance from front to back of the cube. This fraction can be accurately laid off by means of diagonals, as explained in the next chapter. If it is done on the side of the cube, the point where the top edge of the cube is cut by the vertical line of the back of the shelving will show where the back horizontal edge of the shelves should be drawn, *viz.*, from that point *A* to vanishing point 2. By subtracting a quarter from the width of the cube, we get the 36-in. width of the shelves. This is done in the same manner as the front to back measurement, except that three-quarters instead of one-quarter of the cube face are used.

51. The horizontal lines of the shelving require a more elaborate treatment. There are several ways in which they may be laid off accurately, of which one is given here, and others in the next chapter.

52. Since the vertical lines are parallel to the picture plane, vertical measurements are not affected by foreshortening. The four inches of the base height is one-twelfth of the total height. If any one of the vertical lines happens to have a height that can be divided into 12 convenient units (such as quarter inches, half inches, etc.), we simply measure one such unit above the base line on that vertical and draw the needed perspective horizontals through that point. If no convenient unit can be found, lay off one-twelfth of the height on the nearest vertical with a pair of dividers. Since each shelf occupies a quarter of the remaining vertical height, the dividers may again be used to lay off the correct heights for these.

53. The rear corner line, from *D* down, is now drawn in lightly. From the right end of each shelf front, lines are drawn toward vp_1 , meeting this line at points *E*, *F*, *G*, and *H*. From each of these, lines are drawn toward the left, but pointing toward vp_2 . This completes the picture.

54. Best of all, where scientific precision is not called for, a cultivated sense of proportion permits accurate estimates of these various heights. It should be noted that there is a vast gulf between estimating and guessing. The guesser makes a wild stab in the hope of coming somewhere near the mark. The estimator calculates, mentally but precisely, what his objective is and achieves it without fumbling.

DRAWING THE CUBE FREEHAND

55. So far this chapter has been concerned with the solution of perspective problems by geometrical methods involving the use of such basic drafting instruments as the T square, triangle, and scale. This was done for two reasons: first, to establish certain principles and standards by which freehand drawings may be judged; second, to provide working methods for those drawings in which instruments are used in part or in full.

56. In freehand drawing many of the steps described for instrumental work are abbreviated or omitted entirely. For instance, it is hardly worth

while to make a plan or top view and project to the picture plane, for this would only add to the complexity of the job without any gain in precision. But working instrumentally in this manner demonstrated the characteristics of *all* perspective drawings, thereby providing a guide for work done freehand.

57. A recapitulation of these, revised to apply more particularly to the needs of freehand drawing, is as follows:

a. Vertical lines appear vertical in the drawing except in bird's-eye or "worm's-eye" views.

b. Horizontal lines appear to converge toward vanishing points in the horizon or eye level, and there is one, and only one, such point for each set of horizontals.

c. One-point, or parallel, perspective is an exception to rule *B*, because one set of horizontals has no vanishing point and appears as truly horizontal.

d. Lines of equal length appear smaller as their distance from the eye increases. This effect is governed by the convergence of the horizontals.

e. Lines not parallel to the picture plane are foreshortened. This effect may, and usually does, occur in addition to the shortening due to distance.

f. If the object is about 5 ft. or less in height, or if it is seen from an elevated viewpoint, the horizon is usually above it. If it is taller than 5 ft., or is standing on a shelf or table, which brings the top above that level (approximately), the horizon should cross it. Should the object be suspended above the eye level, the horizon should be below it.

58. Since this chapter is concerned only with the cube, we shall show how these rules are applied in drawing this solid. In subsequent chapters their extension to more complex figures will be shown.

59. Freehand drawing depends so largely on individual working methods that only the skeleton of the procedure can be discussed in a book. Every practicing artist has his pet method of working. Accordingly we shall describe only the indispensable steps and give suggestions as to how to solve some of the minor difficulties. Should the student find that slightly different procedures give him equally good results and with less trouble, he need not hesitate to vary. A word of caution is in order. Before using methods differing from those recommended, be sure your own are not more time-consuming. Remember that the beginner tends to do things the hard way. Variations in procedure under the guidance of an experienced teacher are of course another matter.

60. The first step is to lay out the space required. For this it is sufficient to rough out the area with a pencil. It need not be an accurate drawing of the cube but may be the crudest approximation so long as it sets roughly the boundaries of the drawing ultimately planned. Since this work is only tentative, it should be done with a very light touch. If the cube is to be used as the basis of a more elaborate figure, the entire unit should be planned for as well as that part of it the cube will form. Since we must

start somewhere, the nearest vertical corner is usually the most convenient. This will establish the approximate height. The face most directly seen, such as $ApBpEpFp$ in Fig. 6, is next roughed in. The edges $ApBp$ and $EpFp$ must converge toward a point above and to one side of point A , if the drawing is to represent a cube less than 5 ft. tall, provided it is not set on a table or shelf bringing it above this height. This point should be at a considerable distance from the image.

61. In freehand work it is undesirable to locate this point. It is better to *imagine* its position and draw toward it as though it could actually be seen. Obviously this places a heavy demand on the judgment and skill of the artist. First attempts will probably score more misses than hits, but it is surprising how soon skill is acquired. After a few weeks' practice, even the most inept students find themselves drawing freehand with almost instrumental accuracy, provided they take pains to practice often. This is important, for in many drawings one or both the principal vanishing points may need to be off the drawing board.

62. The face of the cube that is not so directly seen comes next. The procedure is the same as before except that the horizontals will converge toward a different point, which will be nearer the center. This point must also lie on the horizon that was established by the first vanishing point. Frequently this vanishing point will be sufficiently close to be drawn on the paper, obviating the need for the tricky estimation required in drawing the other plane. There are, of course, times when both faces show equally, and the vanishing points are equally distant from the center. Except in this case care must be exercised to foreshorten the horizontals sufficiently to avoid making this face appear not quite square but rather wider than high. The face $ApCpEpGp$ in Fig. 6 shows this. The remaining two lines at the top are now drawn, and the preliminary work is complete.

63. So far all this work should be done in a direct manner, without too much effort for exactness. It is best to draw the entire cube rather freely, for the proportions may best be compared when this is done. The beginner too often tries to polish up a single line before completing the figure, forgetting that the line is correct or incorrect not by itself, but only in its relation to other parts of the whole. Should some line be too obviously out of drawing, it is better not to erase it but to set down a new and more nearly correct one beside it.

64. At this stage the pencil should be laid down. Up to now the artist has probably kept his eye rather close to the drawing. This produces good results where short individual lines are concerned but makes it hard to see the drawing as a whole. The drawing should now be held at a distance in order to judge the general effect. If desirable, it may be left on the table and examined from a standing position. Another trick, popular with professional artists, is holding it up to a mirror. This gives two effects at once, that of distance, and that of reversal. When the left and right sides

are inverted by the mirror, errors that ordinarily would pass unnoticed become easy to see.

65. Here the worker should ask himself several questions. Do the verticals appear truly vertical? Does each set of horizontals (there will be at least three in each set) appear to converge toward its own single vanishing point? Does each face appear truly square, *i.e.*, the same length on all its sides? Remember, these sides should only *appear* to be the same length; they rarely *are* the same in perspective drawings. Apply this question to the top also. Lastly, are the straight lines straight? If you have trouble in judging this, pick the paper up and sight obliquely along the line, as you might sight along a billiard cue to see if it is free from warping.

66. Wherever the answer to one of these questions is "No," the correction should be made at once, still freely and without immediately erasing the incorrect line. Sometimes, of course, no correction will be necessary, but it is improbable that this happy result will occur in early attempts.

67. By this time the drawing will have become rather messy. Several methods of cleaning up are possible.

68. If the greatest spontaneity and directness of treatment are desirable, a completely new drawing may be made, using the old one as guide, or the old drawing may be laid away entirely and a new one made utilizing only the experience gained in making the first. By this means the freshness of the first attack is preserved completely, but often several tries are necessary before a satisfactory result is achieved. One fine illustrator of the author's acquaintance works entirely in this manner. He once said that in making a series of 15 illustrations he got the right effect on 14 of them at the first try. On the final picture, however, he threw away 17 drawings before making one that satisfied him. One virtue of this method is that it imposes a rigorous discipline against fumbling, and the drawings never look labored and tired. As a further reward it speeds up the work tremendously.

69. Another method of working consists simply in using the eraser to remove all tentative lines. In this way much of the original freshness is preserved, and some increase in accuracy is obtained.

70. Where maximum precision is wanted, tracing paper is often used. A sheet of this is laid over the first rough, and those lines which seem most nearly correct are traced through. At this point further refinement is often necessary. The result of the error that occurs most frequently is that lines AB and EF will converge as they should, and lines AB and CD will also converge. One often forgets, however, that all three must converge toward the *same point*. The result is the inconsistency shown in Fig. 13a. Figure 13b shows the correction. Both these have been drawn freehand. This error may be rectified either by erasure of the offending lines and their replacement with correct ones or by the use of still another sheet of tracing paper. In either case it is advisable to draw the hidden lines DH , FH , and GH . When these do not meet properly at H , the inaccuracy is made clear.

Comparison with the instrumentally drawn Figs. 6 and 7 will help in realizing the necessary relationships.

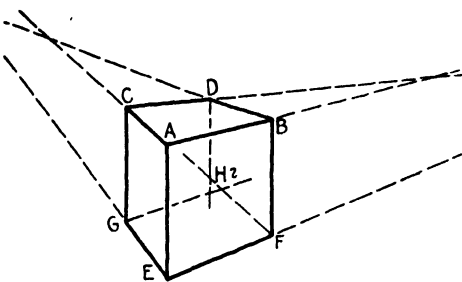

FIG. 13a.—Draw hidden lines to expose errors.

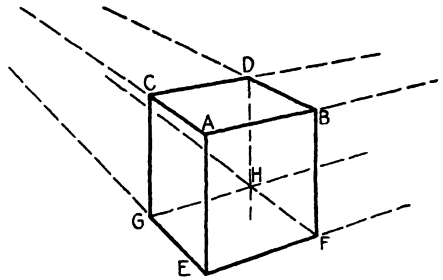

FIG. 13b.—Always extend lines enough to see that they converge properly.

71. Another stumbling block in freehand drawing is failure to realize that *both* vanishing points must lie on the horizon, even if the vanishing points and the horizon are not actually drawn. Figure 14a shows the appearance of a drawing in which this has been disregarded; Fig. 14b shows the correction. The cube in Fig. 14a appears to be sliding downhill toward the reader. In Fig. 14b the lines *AC*, *BD*, and *GE* have been made to con-

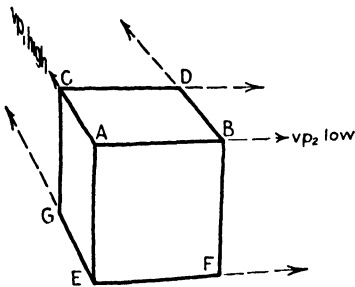

FIG. 14a.—Vanishing points on different levels.

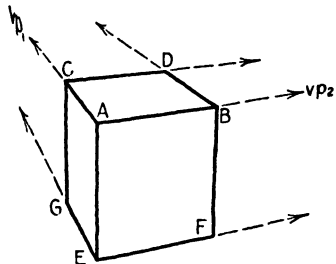

FIG. 14b.—Vanishing points on same level.

verge more sharply, thereby bringing *vp*₁ down, while the slope of *AB*, *CD*, and *EF* has been increased slightly, thereby raising *vp*₂ to the same level as *vp*₁. Students often fall into this trap when they begin drawing without the aid of actual vanishing points located on the drawing board with pins; and, although they may recognize that the drawing seems distorted, they are usually unable to do anything about it. This is because the source of the trouble, being less obvious than that of Fig. 13, is more difficult to recognize. Whenever a drawing, despite having correctly vertical sides, appears to be climbing up or downhill, look for vanishing points on different levels. This very error, committed deliberately and intelligently, can be the basis of amusing cartoons in which a car or wagon can be made to appear almost alive and straining on a hilly road.

72. There are two drawbacks to the tracing-paper method. For one, if the final picture is to appear on an opaque paper, the tracing must be rubbed on the back with pencil, and the drawing must be transferred by tedious retracing of every line with a hard pencil or stylus. The lines thus transferred are smudgy and must be cleared up by going over them directly with pencil or pen. Consequently we find that, even after the drawing is

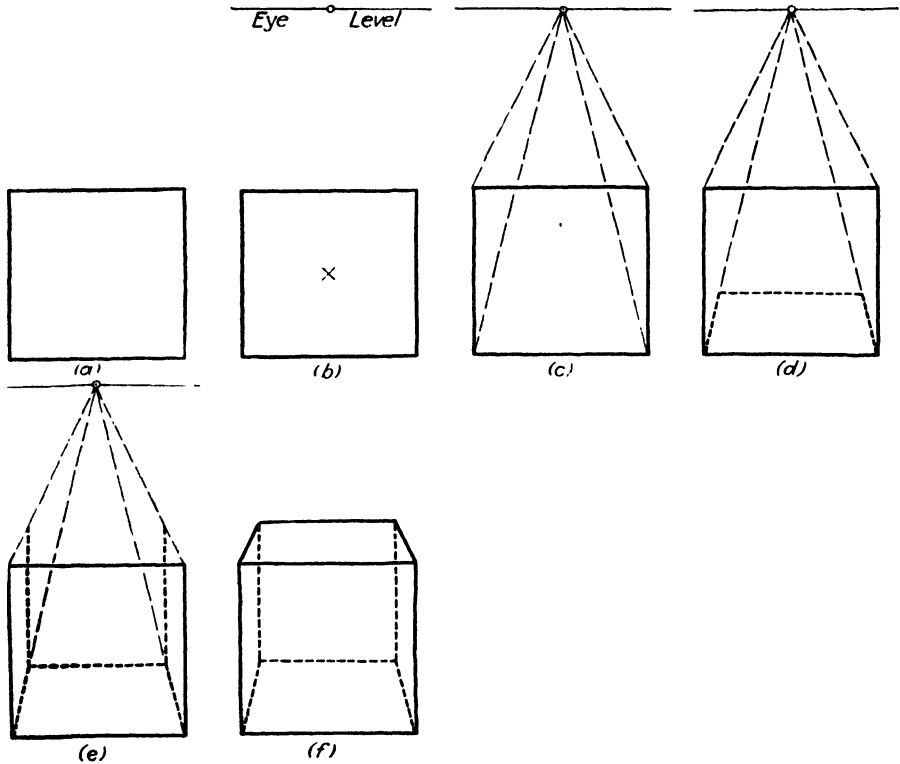

FIG. 15.

fully corrected, the work must be done twice more, an operation that can only be tiresome. Moreover, the process of tracing inevitably loses some accuracy, for lines frequently shift quite badly in the steps of tracing, rubbing, transferring, and redrawing. The principal advantage of working on tracing paper is that it preserves the delicate surfaces of some drawing papers, such as cameo, which cannot stand erasures.

73. Commercial illustrators, pressed for both speed and accuracy, usually use a method that gives the results of tracing without the tedious reworking and litter of paper. The work is done from first to last on the paper it is to be finished on. This naturally requires a rather tough surfaced drawing paper, such as the best grade of Bristol board, or a fine water-color paper. Such paper is relatively expensive but is worth many times its cost in time saved. The preliminary work is done lightly with a

medium hard pencil. Care should be taken to use a light touch and avoid digging grooves in the paper. The whole drawing is then rubbed off with kneaded rubber. Kneaded rubber is used because it leaves behind just enough of the original lines to serve as a guide for redrawing, whereas a more efficient eraser would remove the preliminary work so completely as to require a complete new start. On a first-class Bristol this may be repeated several times, if necessary.

74. Freehand drawing of one-point, or parallel, perspective is exceedingly simple. A square is first drawn, having truly vertical lines at the

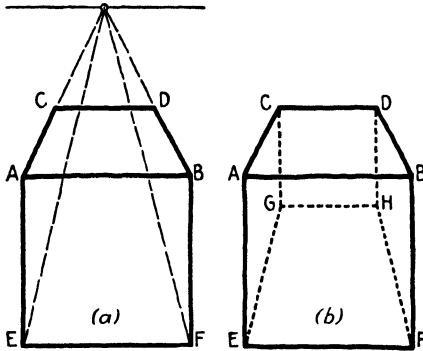

FIG. 16a and b.—Exaggerated proportions in cube below eye level.

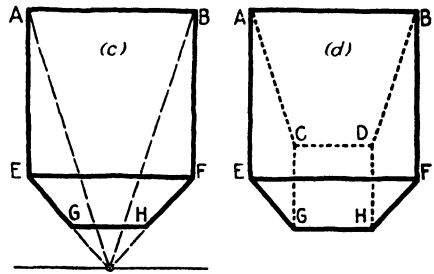

FIG. 16c and d.—Exaggerated proportions in cube above eye level.

sides and truly horizontal lines top and bottom. The eye level is next selected, and the one vanishing point placed on it as near the vertical center line of the square as possible. From each corner of the square lines are drawn back to the vanishing point. In this case it is usually essential to draw the hidden lines. Starting with the base or top of the square, whichever is *farther* from the eye level, the back line of the base or top plane (square) of the cube is drawn in where it looks best. From the new back corners verticals are drawn to meet the other pair of lines drawn to the vanishing point. This will determine the two remaining corners, which are now connected, and the drawing is complete. These steps are shown in Fig. 15.

75. A common source of trouble in parallel perspective is in beginning to lay off the depth of the cube on the plane nearer the eye level, such as plane $ABCD$ in Fig. 16a or $EFGH$ in Fig. 16c. When this is done, the tendency is to make the whole cube too deep, leading to the distortion of the plane $EFGH$ in Fig. 16b and of $ABCD$ in Fig. 16d. The distortion is not obvious in the first stage, as in Figs. 16a or 16c, only becoming apparent when the other planes are drawn. Since the cube is mostly used to derive other forms, this may necessitate much tedious redrawing.

76. In all perspective drawing it must be remembered that the eye is the final arbiter of correctness, and that, if a drawing looks wrong, it is wrong, and some cure must be sought.

77. Drawing a three-point perspective freehand is much easier than doing it instrumentally, although some problems do arise. The vanishing points of horizontals usually have to be at a considerable distance above or below the drawing, and there must be a new vanishing point for the verticals. Furthermore, since they are not now parallel to the picture plane, there will be foreshortening of the verticals as well as of the horizontals, and heavier demands are thereby placed on the sense of proportion. Apart from these considerations, three-point perspectives require no more knowledge than two-point and, with a little practice, may be handled just as easily.

78. Freehand drawing is useful even in instrumental work. It is difficult to visualize in advance the result of a particular scale and angle of view. By making a preliminary rough freehand, the artist will be able to decide more easily where to place the vanishing points and the station points to produce the best appearing drawing. The rough drawing is quickly made; then, simply by extending the horizontals until they meet, the approximate position for the vanishing points is located. When this has been done, the instruments are taken up, and the work is refined and completed.

CHAPTER III

MEASUREMENT

79. The attainment of accurate proportion in drawing is always troublesome for the beginner. One reason for this is his failure to look at his work while it is in progress. This sounds like a drastic statement, but every teacher knows it to be true. The beginner observes only the line his pencil, charcoal, or what not, is tracing at the moment; he sees it as something complete in itself, and not as a unit in a larger scheme.

80. The experienced draftsman, on the other hand, pauses now and again to appraise the progress of his picture as a whole and to ask himself if this window fits that room, if this bowl of flowers is the right size for that table, if a normal person could go through the door just drawn without knocking his head, etc. If the answer is negative, he makes his corrections before drawing a dozen accessories to fit an object that is not itself correctly fitted. By making his changes before too many other things have to be altered, he spares himself much tedious labor.

81. The novice omits this simple precaution. In a life drawing, for example, he draws a head and trunk, then an arm, arriving finally at the ticklish job of drawing the hand. This engages his whole attention; he concentrates, sits back at last to survey the result of his labors—and discovers to his horror that the delicate young lady of the picture has a hand in which she could mislay a football.

82. Now everyone has a sense of proportion, whether he be a trained artist or not. Learning to apply this sense to a practical problem in draftsmanship presents some difficulties. Some of these may be overcome by practice and some by the use of one or more of the expedients given in this chapter. In general it may be said that life drawing, and the drawing of plastic forms in general, demands practice, while the methods given here are most applicable to still life. There is much overlapping, however, and a knowledge of some of the geometrical principles involved in still-life work makes life drawing easier. The understanding of these principles also illuminates that practice and makes it more profitable.

83. Once the methods of measurement described here are thoroughly understood, and a habit of self-criticism during the construction of a drawing is cultivated, the methods may be applied mentally, many construction lines merely being imagined in their places on the paper and never actually drawn. The result will be cleaner and fresher drawings.

84. The first method of measurement has already been discussed briefly in Chap. II and applied in Fig. 12. It is a method permitting

endless variations, of which we shall discuss only a few. A little ingenuity will enable the reader to work out many others.

85. Suppose the shelving in Fig. 12 to have been worked out in its over-all proportions but not in the proportions of individual shelves or base. This is shown in Fig. 17a. In order to show the object itself as large as

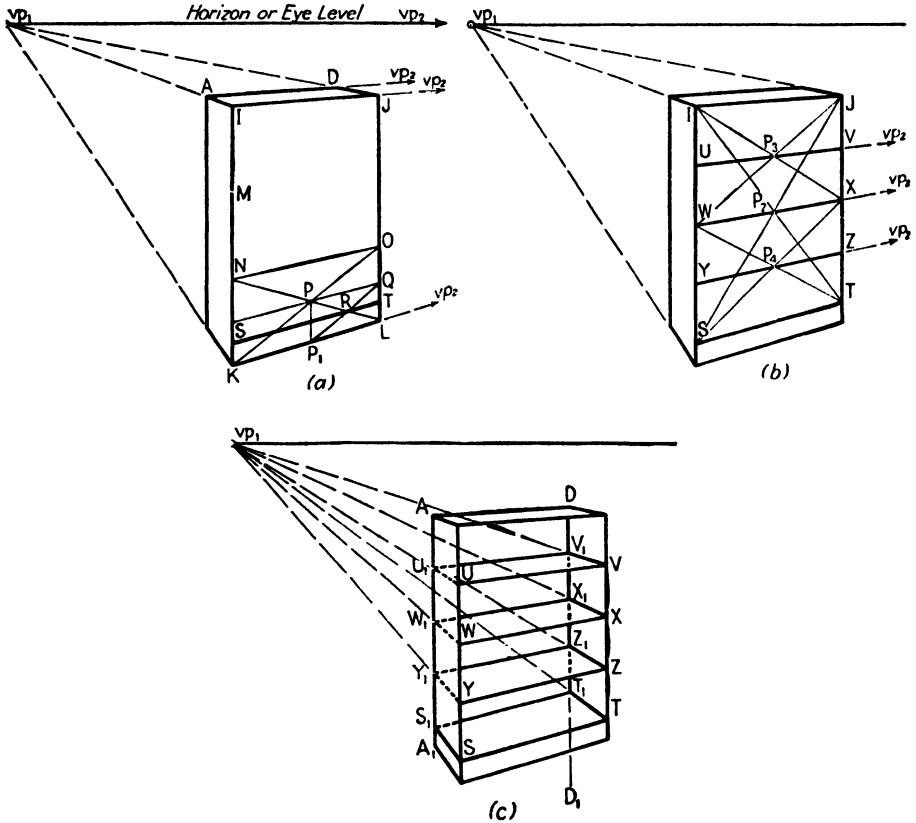

FIG. 17.

possible, it was necessary to let vp_2 be off the paper to the right. However, its relative position is the same as in Fig. 12, as you may see if you place another piece of paper alongside Fig. 17a and extend lines AD and KL until they meet in the horizon at vp_2 .

86. Since the skirting or baseboard of the shelving is the only odd dimension on the front plane, it is best to calculate this first. The height of the shelves will then be a simple quarter of the remaining height. The construction described here takes several paragraphs of writing but may be performed on the drawing in less than 2 minutes.

87. First, divide vertical IK (or JL if more convenient) into thirds with dividers, scale, or paper-edge measurement. This last is described later. This will give the two points M and N in Fig. 17a. Through the

lower of these points, draw line NO , toward vp_2 , cutting both front verticals to form the rectangle $NOKL$, the lowest 16 in. of the front face. Since the baseboard is 4 in. high, it is necessary to lay off the lowest quarter of $NOKL$.

88. To do this, first draw diagonals NL and KO . Where they intersect at P , draw a line toward vp_2 until it meets the right-hand edge at Q , and drop a vertical from P to intersect the bottom edge at P_1 . This will give a rectangle PP_1QL , which is 8 in. high.

89. One diagonal of this rectangle is already in place, *viz.*, PL . Now draw diagonal P_1Q , intersecting PL at R . A line is now drawn through R toward vp_2 and cutting the left- and right-hand edges at S and T , respectively. This line is the top of the baseboard. It is 4 in. above the floor, no more and no less. There is no need to stop and see whether it is quite right, as would be necessary when guessing at its position. You *know* it is 4 in. and not $4\frac{1}{2}$, or $3\frac{3}{4}$, or any other approximation. By eliminating doubt, hesitation, and fumbling, about 3 minutes are saved for every minute spent in drawing diagonals.

90. It will be noted in this and succeeding examples that the procedure, wherever possible, has been to lay out, first of all, the gross, over-all dimensions. Only after this is done are details worked out. Beginners tend to work the opposite way. A moment's thought will show how absurd this is. If we had started Fig. 17 by drawing one shelf and had made an error in the height of the shelf of $\frac{1}{2}$ inch, the over-all error would be multiplied by four—2 in., which is serious, especially where heights must be matched, as is often the case in drawing interiors. Later on we shall encounter problems where building up from small units is a necessity, but it should be avoided wherever possible.

91. In Fig. 17b the positions of the shelves are determined. The shelves are each 11 in. high, and there remains 44 in. to put them in, so this height must be divided into four equal parts. The easiest way, but not the only way, is shown here. First, draw diagonals JS and IT . Second, draw a line through their intersection P_2 toward vp_2 and extend it to meet the vertical sides in W and X . This divides the available height in halves. With the same procedure, the diagonals of each half are drawn, locating P_3 and P_4 , and giving us UV and YZ . That is all there is to it. Not more than a minute is needed for this operation, and the result is not *about* right; it is *just* right.

92. In Fig. 17c the job is completed. First, drop a vertical from D . Second, from the points U , V , W , X , Y , Z , S , and T draw lines toward vp_1 . These lines will intersect the rear vertical edges in points U_1 , V_1 , W_1 , etc. Third, connect U_1 with V_1 , W_1 with X_1 , Y_1 with Z_1 , and S_1 with T_1 .

93. It will be noticed that a great many lines are used in this construction that will not be visible in the completed drawing. It is difficult for the student to appreciate the enormous importance of these invisible lines. We

should be spared many feeble drawings if it were fully realized that each visible line or plane implies much unseen structure. The habit of drawing only what can be seen leads to drawings of such objects as chairs with three feet off the floor, tables with legs sunk six inches into the floor, cylinders open in the back, and similar miracles. If your figure of a man floats a foot above the ground, you should be illustrating H. G. Wells on purpose, not because you can't help it. Draw the invisible lines while constructing

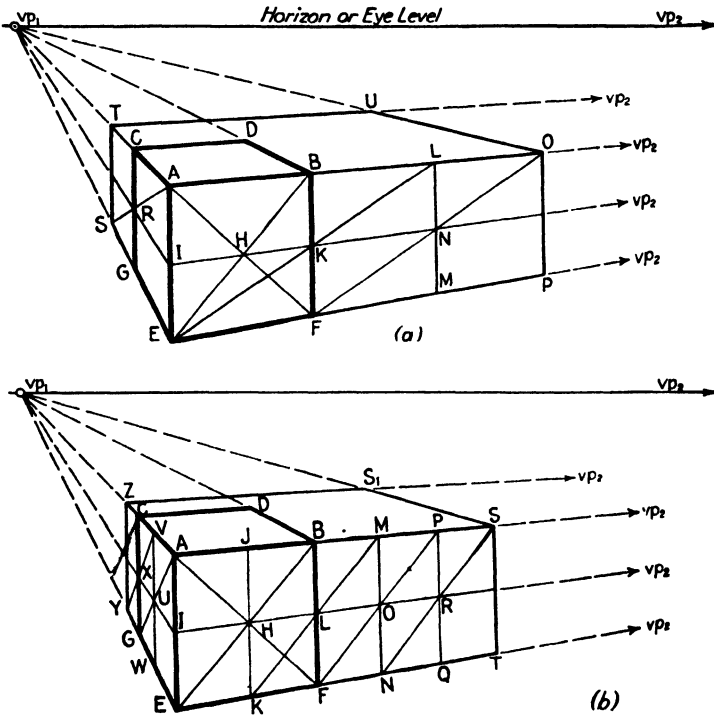

FIG. 18.

your drawing, and take them out later. Then you can keep miracles in their place.

94. The direct use of diagonals just discussed shows how areas may be *divided* into halves, quarters, eighths, etc. Diagonals may also be used for the *multiplication* of areas. Figure 18 shows two ways to do this. Either of them, or a combination of both, might be used to solve a similar problem.

95. Suppose we are required to draw a box 2 in. high, 4 in. wide, and 6 in. long. Since we already know how to draw a cube (which we may consider as having sides of 2 in.) it is merely necessary for us to reproduce it three times in one direction and twice in another. Since this presents an opportunity for multiplying small errors, the original cube should be laid out with care. We must also be careful to see that the figure, when completed, does not cover too wide an angle of view.

96. Figure 18a shows how the first type of multiplication is performed. Begin by drawing the cube $ABCDEFGH$ and extending its horizontal edges to vp_1 and vp_2 . Next, draw diagonals AF and BE on the face of the cube. Where they intersect at H , draw a line toward vp_2 and extend it far enough to the left to intersect AE at I . This line will also cut the right-hand edge BF at K . I and K are the mid-points of verticals AE and BF . Draw EK and extend it to meet the extension of the top edge at L . Drop vertical LM . This will make $BLFM$ the duplicate, in perspective, of square $ABEF$. In the same way, where vertical LM intersects the extension of IK at N , draw FN and extend it to O . From O drop vertical OP . The square $LOMP$ is now the perspective equivalent of $ABEF$. Thus we have now multiplied our original 2-in. square by three, so that the plane $AOEP$ has become 2 by 6 in.

97. Now from I draw a line toward vp_1 . This line will determine the mid-points of vertical lines in the side plane, giving the mid-point R in CG . Draw AR and continue it to meet the extension of EG in S . At S erect vertical ST . The square $STCG$ is now a perspective equivalent of square $ACGE$ of the original cube, making the plane $TASE$ 2 by 4 in.

98. The work is completed by drawing a line from O toward vp_1 and from T toward vp_2 . These two lines cross at U , and the corners $AOEPTUS$ identify the required rectangular solid.

99. Figure 18b shows how a 2-in. cube may be utilized to produce a rectangular box 2 by 3 by 5 in. (It should be noted, to avoid confusion, that the lettering of points is not quite the same as in Fig. 18a.) As before, the diagonals AF and BE are drawn, meeting in H . Through H , the vertical center line JK is now drawn, meeting the bottom in K . As before, the horizontal edges of the cube are extended toward the vanishing points, and a line is drawn through H toward vp_2 , which will intersect all verticals on the front plane at their mid-points. This line will cut BF at L . The line KL is drawn and extended to meet line $A-vp_2$ at M . Now drop vertical MN . This will add rectangle $BMFN$ to the original square $ABEF$. $BMFN$ is half the width of the square, hence 1 by 2 in. In the same way FO is extended to P , where a new vertical is dropped, adding another 1- by 2-in. rectangle. The line NS , drawn through R , determines a third rectangle of this size and completes the front plane $ASET$, which is now 2 by 5 in.

100. The line $I-vp_1$ is now drawn, determining the mid-point X of the vertical CG . Draw diagonal AG , and where it crosses $I-vp_1$ erect vertical VW . Draw VX , extend it to Y on the lower edge, and erect vertical YZ . This completes the side plane $ZAYE$, making it 2 by 3 in.

101. The box is now completed by drawing the lines $Z-vp_2$ and $S-vp_1$. They intersect at S_1 , and the complete box is identified by the corners $ASETS_1ZY$.

102. The ingenious student will see endless ways in which the above methods of diagonal multiplication and division may be applied. For example, the methods of Fig. 18a and 18b might be combined to lay out

precisely a box of 3 in. height, 5 in. width, and 7 in. depth. The only problems would be in the determination of width and depth, since the height may be obtained by simple measurement based on AE as a unit. Line AE is already known to be 2 in. To make it 3 in. simply make it half again longer. AE being parallel to the picture plane, this direct measurement is perfectly accurate, for there is no foreshortening to be allowed for. The method of Fig. 18a might be used to shorten the work of laying out Fig. 18b. The method of diagonal division given in Fig. 17 might be used in combina-

tion with the multiplying methods of Fig. 18; and so long as we multiply or divide by two or its multiples, there need be no difficulty, though occasionally other methods will be more convenient.

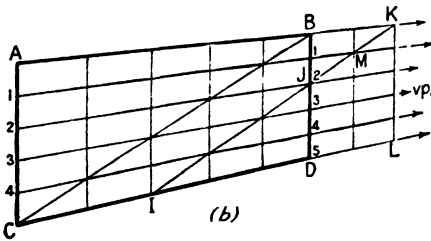
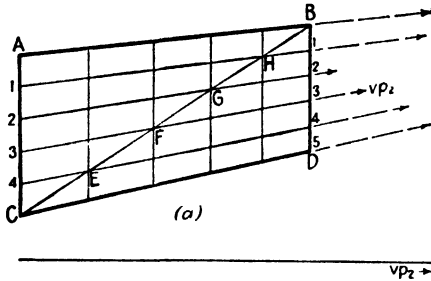

FIG. 19.

104. Suppose it is necessary to divide a rectangle (Fig. 19a) into five vertical sections of equal perspective size. First divide the side AC into five equal parts with dividers, or with a ruler if this division comes out conveniently in even inches or fractions of an inch. Then, if vp_2 is on the paper or drawing board, draw a line from each of the points thus determined toward vp_2 and cutting the side BD in corresponding points. If vp_2 is too far away, simply divide BD also into five equal parts and join corresponding division marks on both sides. Either method will give lines 1, 2, 3, and 4, dividing the rectangle into five equal horizontal parts. To convert these into vertical divisions draw diagonal BC (or AD if more convenient) and at each place where this diagonal cuts the horizontal lines, erect a vertical line. These give the required vertical divisions.

105. Sometimes, as when plotting a wallpaper pattern or a series of identical panels, it is necessary to continue such divisions beyond the original rectangle. In Fig. 19b the problem was to add two more vertical divisions

106. Sometimes, as when plotting a wallpaper pattern or a series of identical panels, it is necessary to continue such divisions beyond the original rectangle. In Fig. 19b the problem was to add two more vertical divisions

to those already existing. Beginning at *I*, the base of the second vertical from the left, a new diagonal is drawn, perspectively parallel to the first. This will pass through *J*, the second horizontal from the top, cutting horizontal No. 1 at *M* and the top at *K*, thus determining the positions of the new vertical lines.

106. By continuing this process we may extend these divisions as far as we like, either to the right or the left. Moreover, by continuing the verticals higher and using other diagonals, we may establish new horizontal lines above the existing rectangles, as shown in Figs. 20*a* and 20*b*. Although these figures are practically self-explanatory, a brief description may be helpful.

107. In Fig. 20*a* the original diagonal *CB* and a new one *NO* are extended a short distance above the top edge. The verticals *PQ*, *RS*, *TU*, and *LK* are likewise extended. The intersections of verticals and diagonals establish points *V*, *W*, *X*, and *Y*. By connecting *V* with *X*, and *W* with *Y*, and extending the lines thus determined, we obtain the new horizontal lines. In Fig. 20*b* the same procedure is used except that the diagonals run in the opposite direction, the result being the same. Other factors being equal, the method of Fig. 20*b* is somewhat preferable, because it is easier to determine intersections accurately when the diagonal is drawn in the shorter direction.

108. It is often necessary to lay off similar proportional parts in a horizontal plane. Except in parallel, or one-point, perspectives, no edge of such a horizontal plane will be parallel to the picture plane. The solution of this problem, though less direct, is no more difficult than that shown in Fig. 20.

109. Suppose, in Fig. 21, that it is required to lay out the perspective of a rectangular table top 16 by 20 in. The edges of this table are formed by four pieces of wood 4 in. wide and mitered at the corners, and the center is a single piece 8 by 12 in. Figure 21*a* shows a top view.

110. In Fig. 21*b* the rectangle *ABCD* has already been laid out in perspective, and the operation of placing rectangle *EFGH* correctly within it is performed. Beginning at *A*, a vertical line is drawn down any convenient distance. Measuring from *A*, five equal spaces of any convenient size are

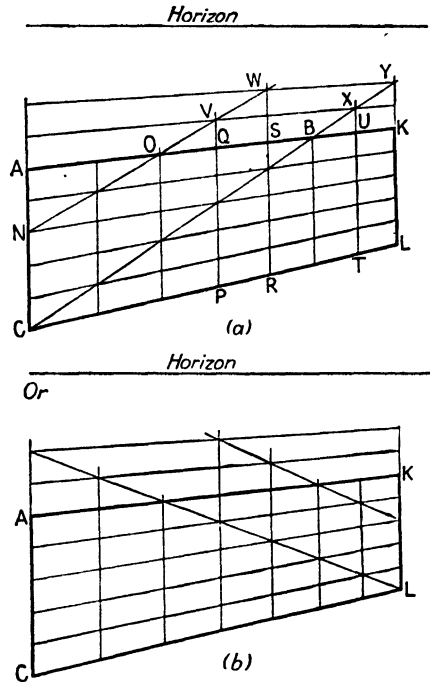

FIG. 20.

laid off, establishing the points $A_1, A_2, A_3, A_4,$ and A_5 . From each of these points a line is drawn toward vp_2 . From B another vertical is drawn down to intersect these lines in points $B_1, B_2,$ etc. The diagonal AB_5 (or BA_5) is drawn, intersecting A_1B_1 at I , and A_4B_4 at J . From I and J verticals are extended upward, meeting AB in O and P . The point O is then one-fifth of AB from point A , and point P is one-fifth of AB from B . Since AB is 20 in. long, these points are 4 in. from the end. Lines OT and PS are drawn toward vp_1 , cutting off a 4-in. strip from each end of the rectangle.

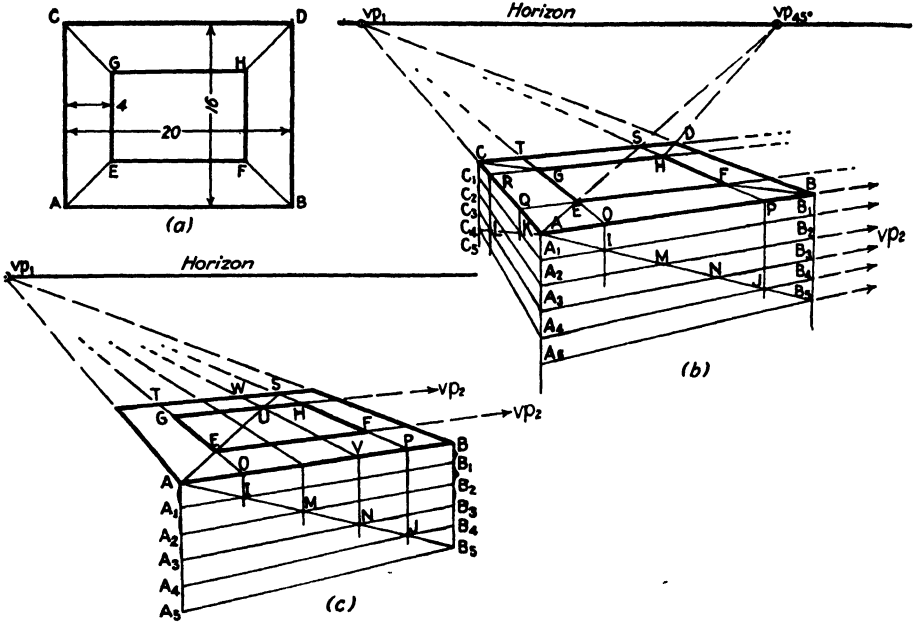

FIG. 21.

111. In the same way lines are drawn from $A_1, A_2, A_3,$ and A_4 toward vp_1 . (A_5 is not needed in this step.) Dropping a vertical from C will establish $C_1, C_2, C_3,$ and C_4 . Diagonal AC_4 is now drawn, cutting A_1C_1 at K and A_2C_2 at L . As before, verticals from these points are brought up to AC , cutting it at Q and R . These points will be one quarter of AC , or 4 in., from A and C , respectively. Lines drawn toward vp_2 from Q and R will consequently cut 4-in. strips from front and back, respectively. The combination of these lines and those established as shown in Par. 110 gives the small rectangle $EFGH$. Connecting A and E, H and $D,$ etc., gives the diagonal lines of the miter.

112. As an extra check on the accuracy of the work, $AE, HD, RT,$ etc., may be extended. Since they are horizontal lines they should meet in the horizon at a point that is the vanishing point for all 45-deg. lines in this direction. There is another 45-deg. vanishing point for lines $BF, GC, OQ,$ etc., but this is far to the left of the area shown.

113. Sometimes it is difficult to obtain accuracy in the plane AC_4 , owing to extremely sharp convergence toward vp_1 . In this case, and sometimes simply for convenience, the method of Fig. 21c is preferable. In this figure the plane AB_5 is divided as before, and lines are projected upward from I, M, N , and J to the top edge and then back toward vp_1 . This will divide the top plane into five parts. The line AS is then drawn diagonally to cross four of these five parts. Where it crosses OT at E , it determines a point one-quarter of the distance from O to T (*i.e.*, from the front to the back of the top plane). Where it crosses the line VW at U , it determines a point one-quarter of the distance from W to V (*i.e.*, from the back toward the front of the top plane). Lines are now drawn toward vp_2 through E and U . As before they will determine the rectangle $EFGH$.

114. Although nearly thirty paragraphs have been devoted to the uses of the diagonal, we have given only a hint of its usefulness. Its enormous versatility can hardly be realized until hundreds of drawings have been made. It can safely be said that there are very few drawings in which it cannot be helpful in one or more ways. The foregoing pages gave the basic means of using the diagonal. These means may be modified and compounded to perform special jobs of almost infinite variety, provided the draftsman is willing to use a little ingenuity.

115. A great many of the operations just described depend upon the ability to divide a line into equal parts. There are several principal methods. First is the use of a ruler or scale, convenient when a line is to be divided into exact inches, centimeters, or usable fractions of these. Second is the use of dividers, excellent and usually precise, but sometimes injurious to drawing paper and inaccurate for large numbers of small divisions. Since this is not a treatise on mechanical drawing, familiarity with dividers will be assumed. Third is the geometrical method, and fourth is the paper-edge method, both described on the following pages.

116. The geometrical method is particularly useful in dividing lines of odd length, such as $7\frac{3}{32}$ in. into any given number of parts, or lines of such a length as 6 in. into seven parts, for example. There being no such divisions on scales or rulers, the mere arithmetic required to calculate the nearest equivalent in sixteenths or thirty-seconds would consume a lot of time. Suppose the line AB in Fig. 22 is to be divided into seven parts. Its exact length need not concern us, for we merely want to see that the divisions are equal and accurate. To divide AB into seven parts, draw any line AC at any angle with AB . Lay off on it seven equal units of *any* con-

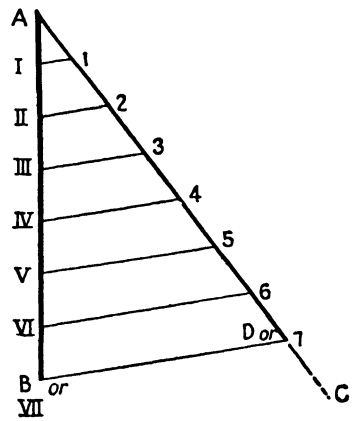

Fig. 22.

venient length. These units may be measured with a ruler. So long as they are equal, it does not matter whether they are inches, centimeters, the width of a coin, or whatever. Draw from the seventh of these points the line *DB*. From each of the others draw a line parallel to *DB*, cutting *AB* at I, II, III, etc. Even though calculation shows the nearest approximation on the scale to be $5\frac{5}{64}$ in., you will have had to use nothing but even divisions in your work, economizing both time and profanity. Points I, II, etc., are the required divisions, and that is all there is to it.

117. As described above, this method is suitable only for lines parallel to the picture plane and not for those oblique to it, for the method as given

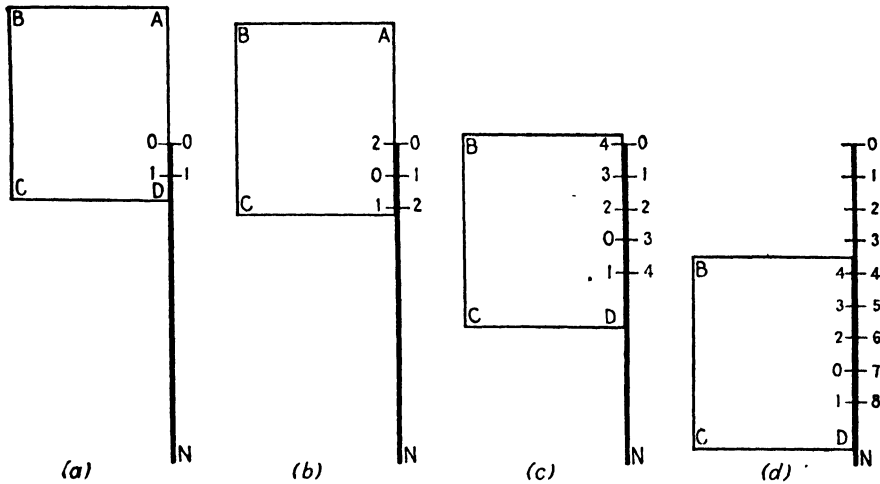

FIG. 23.

does not account for foreshortening. Later on we shall show how this method may be applied to oblique lines also.

118. Paper-edge measurement is applied where it is desirable to lay off a considerable number of equal parts on a line but where the exact length of the line is immaterial, such as the line *AC* in Fig. 22. The method described here and illustrated in Fig. 23 is so simple that probably most people already know it. Often, however, these simple things are neglected by reason of their very simplicity, and, since it is such a useful dodge, repetition here can do no harm.

119. In Fig. 23a *ON* is a line of indefinite length on which it is necessary to lay off eight units of equal length. These need not occupy the entire length of the line. One such unit, *O-1*, has already been laid off. The piece of paper *ABCD* is placed alongside the line *ON* so that its lower edge is a short distance below point 1 and the points *O* and 1 are marked on the paper and lettered accordingly. Next, in Fig. 23b, the paper is moved down the line so that point *O* on the paper is opposite point 1 on the line. Point 1 on the paper will then determine point 2 on the line, and point *O*

on the line will determine point 2 on the paper. In Fig. 22c the paper is once more shifted lower down the line to bring point 2 on the paper opposite point 2 on the line. Points O and 1 on the paper will then determine points 3 and 4 on the line, while points 1 and O on the line will determine points 3 and 4 on the paper. Once more, in Fig. 23d, the paper is shifted to bring points 4 on paper and line opposite each other. Points 3, 2, O , and 1 on the paper will then determine points 5, 6, 7, and 8 on the line.

120. The procedure outlined above, like most other graphic operations, requires more time to describe than to perform. Though the figure looks formidable, the whole operation should not require a full minute, and it will be just as accurate as your pencil is sharp.

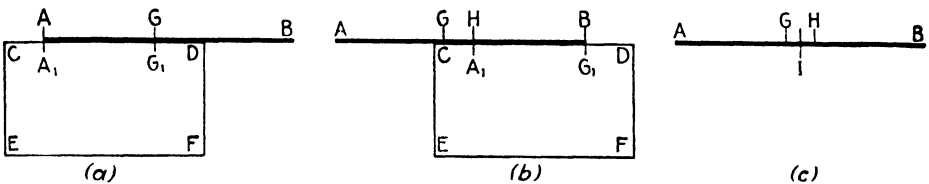

FIG. 24.

121. Figure 24 details another use for paper-edge measurement. It is often necessary to bisect lines accurately when no instruments, even a ruler, are available. Line AB (Fig. 24a) represents such a line. To bisect it, lay a piece of paper $CDEF$ alongside, and mark off the point A_1 , opposite A on the line. Now estimate where the mid-point of AB should be, and mark off G on the line and G_1 on the paper. Move the paper along the line until G_1 is opposite B , and mark off point H opposite the new position of A_1 , as shown in Fig. 24b. The true mid-point will lie somewhere between G and H . Since this is a very short distance, the margin for error is small, and it will be easy to estimate the position of true mid-point I (Fig. 24c) with great accuracy. If extreme precision is desired, the process may be repeated, using G and H in the same way that A and B were used. Incidentally, had AG been more than half of AB , G and H would have changed places, but point I would still lie halfway between them.

122. By modifications of this method, which the reader can easily work out for himself, it is possible to trisect a line or divide it into any necessary number of parts.

123. Before proceeding to more complex methods of obtaining exact perspective measurement, it might be well to discuss a subject that, despite its seeming simplicity, is frequently a serious source of trouble to the beginner, *i.e.*, the problem of what may be called *minor measurements*. These include the thickness of boards, the width of individual bricks, the size and relative protuberance of knobs, handles, and the like; in short, those subsidiary dimensions that do not affect over-all proportions but can make or break a drawing through their good or bad execution.

124. It is difficult at first to estimate these correctly and particularly difficult to foresee the effect they will exercise on a finished drawing. For instance, if the thickness of table legs, top, etc., are overestimated, the whole piece will appear ponderous and ugly and, by a curious perversity due to upsetting the standard of comparison, *undersized*. If these same minor dimensions are underestimated, the piece will appear to be, at the same time, large and fragile. As skill is acquired, artificial aids to accurate drawing of small parts may be dropped, and the eye alone becomes the measuring instrument, but temporarily a system of comparisons will be helpful.

125. Suppose it is necessary to estimate the apparent thickness of a table top for a drawing. The table itself is known to be 18 in. wide and 30 in. long, with the top $\frac{3}{4}$ in. thick. The nearest dimension is 18 in., and the comparative size is 3 to 72. The most expert eye would be taxed to produce an accurate estimate. Fortunately, somewhere in the construction there is usually a dimension of small size, offering a usable standard of comparison.

126. The bookcase illustrated in Figs. 12 and 17 offers just such a problem. In both these figures the thickness of the material was ignored for the sake of illustrating the principles then under discussion. In Fig. 25a we show orthographic front and side views of a bookcase made of real boards, having tangible thickness. In addition, the baseboard, which was flush with the front and sides in the earlier illustrations, is here set back an inch. Simple as they look, these offsets are not so easy to draw as they look, owing largely to neglect of the simple procedure outlined below. The *over-all* dimensions of the bookcase shown in Fig. 25a are identical with those of Fig. 17, and the methods already described will give us Fig. 25b, identical with Fig. 17c except for the lettering. The letters used in Fig. 25b are used also in Fig. 25a, showing the position of the various points relative to material of tangible thickness. It is worth noting that the letters *C, D, E, F, G,* and *H* represent not actual points of intersection in Fig. 25a but rather *implied* intersections. Implied points, lines, planes, and solids are of immense importance in the development of all drawings. This fact will be appreciated more and more as the student enters and performs professional work.

127. In Fig. 25c the line *IK* is divided into four equal parts. Since *IK* represents 4 in., each part represents 1 in., and the distance *II₁* is the thickness of any given board. Consequently, *II₁* may be used as a measurement for *AA₁, CC₁, EE₁, and GG₁*. Lines drawn from *A₁, C₁, E₁, G₁, and I₁* will then define the lower front edges of the boards forming the top and shelves. Also, a line drawn from *I₁* toward *vp₁* will show the left lower edge of the lowest shelf.

128. The thickness of the vertical boards constituting the sides may easily be estimated by comparison with the horizontal thickness already

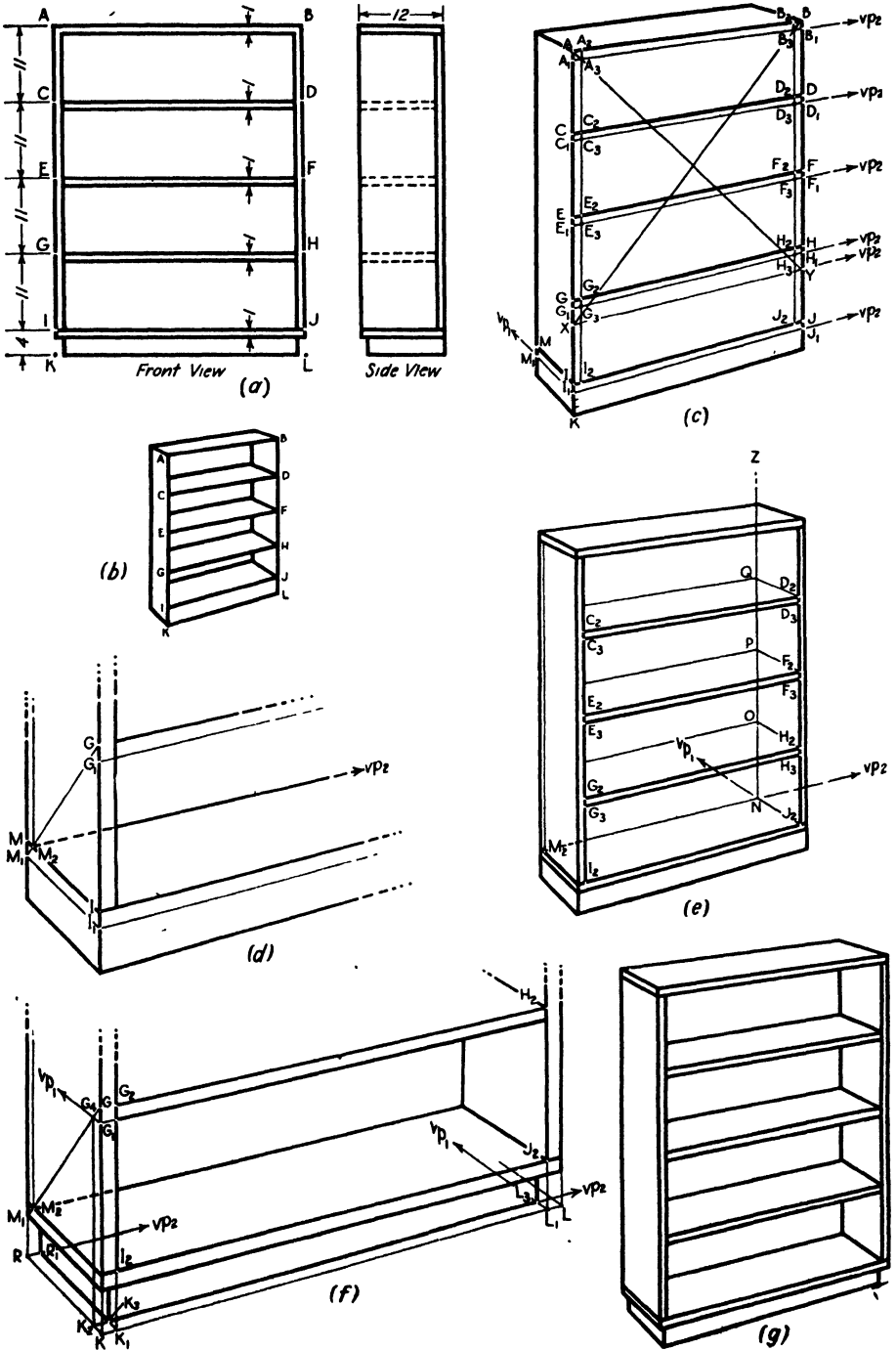

FIG. 25.

drawn. However, if the strictest accuracy is wanted, the diagonal may again be put to work.

129. At the risk of being tedious, here are a few words to explain the inclusion of such a lengthy discussion of a simple subject. First, it is difficult for the student to estimate correctly the *perspective* equivalence of certain proportions. This is not due to any lack of ability on his part but simply to unfamiliarity with the drastic effects of foreshortening, which may reduce a dimension by any amount up to 100 per cent, in other words, to nothing. Consequently, there is a tendency always to overestimate the size of foreshortened dimensions. Second, there are occasions when it is essential for the draftsman to be absolutely certain of the correctness of all, even the smallest of his dimensions.

130. The professional artist or perspective draftsman seldom bothers with laborious constructions for obtaining his finer dimensions. This is because, through experience, his eye has become such an accurate measuring instrument that he can dispense with geometrical assistance, but he never arrives at this skill unless he has an opportunity to know with certainty what true proportion is. Many men go through their professional careers producing second-rate work without knowing what is wrong with it. The making of one or two drawings with scientific accuracy would reveal much to them. It is not expected that the student will follow the procedure detailed here in more than one or two drawings. After he has done this once or twice, he will be able to perform these steps mentally, and even unconsciously. This abbreviation follows the lines described in the section on freehand drawing in Chap. II. Before he can do this, however, he must have learned, by actual performance, what correct proportion is, so that he will know *what it is not*.

131. Once the thickness of the horizontal boards has been established, the thickness of the verticals is obtained as follows: Using the scale established between I and K , find a point X , 3 in. below G , and by drawing a line from X toward vp_2 establish the point Y , 3 in. below H . As may be seen by referring to Fig. 25a, these points will then be 36 in. down from the top, and $ABXY$ will be a perspective square. If the diagonal AY is now drawn, it will cut the lower horizontal edge of the top, A_1B_1 , at a point A_3 , exactly 1 in. *perspectively* to the right of the left-hand edge. A vertical is drawn through A_3 down to I_2 , and the inside front edge of the left side of the book-case is established. With the aid of diagonal BX the inside front edge of the right side is similarly established.

132. It is now necessary to work out the rear edge of each shelf. In Fig. 25d the line I_1M_1 is 12 in. long. The line GI_1 is also 12 in.; consequently the diagonal GM_1 is the diagonal of an implied square. Where this diagonal crosses the line MI at M_2 , it cuts off a distance, MM_2 , of 1 in. A vertical erected here defines the front edge of the backboard, and a line drawn from M_2 toward vp_2 defines the back edge of the bottom shelf.

133. In Fig. 25e it will be seen how this line, M_2vp_2 , is used to establish a number of other essential lines. Draw a line from J_2 toward vp_1 . This will cross M_2vp_2 at N . At this point erect vertical NZ . From H_2 , F_2 , and D_2 draw lines toward vp_1 . These will intersect NZ at O , P , and Q , respectively. From these points lines are drawn toward the left, respectively parallel to C_2D_2 , E_2F_2 , etc. That is to say, draw these lines so they would meet in vp_2 . They define the back of each shelf.

134. The process of locating the baseboard exactly is shown in Fig. 25f. Point R would be the lower left rear corner if the baseboard were not set back an inch. A line is drawn from R toward vp_2 . The line G_2I_2 is extended downward to meet KL at K_1 . A line is drawn from K_1 toward vp_1 , meeting Rvp_2 at R_1 , and a vertical is drawn up from R_1 , giving the rear vertical edge of the baseboard. To get the setback from the right side, the vertical H_2J_2 is continued to meet KL at L_1 . From L_1 a line is drawn toward vp_1 .

135. Since the front edge of the baseboard is set back an inch from the front of the shelves proper, it is also necessary to locate this edge. The diagonal GM_1 has already been drawn. If a line is now extended from G_1 toward vp_1 , it will cut this diagonal at G_4 , 1 in. back from the front edge. A vertical dropped from this point will locate K_2 , 1 in. back from K . A line is drawn from K_2 , respectively parallel to KL , locating the actual front corners of the baseboard, K_3 and L_3 . The construction lines are now erased, and the drawing appears as in Fig. 25g.

136. It has taken eight drawings and ten paragraphs of writing to discuss the procedure of making a few simple and apparently unimportant measurements. This is likely to give an exaggerated idea of the difficulty of the job. If the reader will take the trouble to work out the problem for himself, following the procedure step by step, he will find that it is, as Mark Twain said of Wagner's music, "better than it sounds." Like any operation that must be done graphically, it is easier to perform than to describe. Indeed, that is why it is a graphic operation in the first place.

137. The subject of minor measurements is more important than the term would seem to imply. Reference was made to this in Par. 123, and we wish to emphasize it by repeating it here. The artist will find, as his experience grows, that minor measurements constitute 50 per cent or more of most drawings. Consequently, though "minor," they cannot be considered trivial. This is all too frequently neglected by the student who has mastered most of the important laws of perspective. This neglect leads him to produce drawings full of "minor" absurdities—tables with legs of differing thicknesses, windows with muntins 6 in. across and little room left for the glass, doorknobs so large as to need two hands to turn them. Apart from the ridiculous appearance, such drawings lose scale—the bungalow becomes a doll house, and the soaring airplane a fragile toy.

138. The method of constructing a drawing by multiplying and dividing cubes will be found satisfactory for most purposes, particularly freehand

work. Occasionally, though, the artist is called upon to produce drawings of great precision from plans or blueprints. This is not the exception but the rule with the architectural and the industrial design renderer. Two methods are detailed below. These methods are closely related to each other and should be studied together. They are particularly suited to the peculiar requirements of the renderer but may profitably be studied by anyone who wants to understand perspective thoroughly.

139. In Fig. 5, Chap. II, we attempted to show the reasoning behind the appearance of a perspective drawing of a cube. The demonstration was developed in five steps. All these steps may be combined on one sheet of paper and used for the development of a perspective drawing of any form whatever, provided we have accurate mechanical drawings of it to begin with. This was done with a cube in Fig. 6. We show here how it may be applied to any other form.

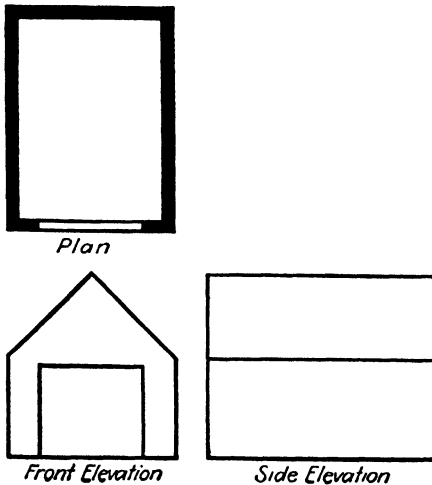

(a)
FIG. 26a.

140. Figure 26a shows the plan and two elevations of a small garage. These have been reduced to the utmost simplicity, in order that the simple principles involved may not be lost in a multitude of details. Later on, in Chaps. VI and VIII, and succeeding chapters more realistic examples will be used. They will

involve no new principles, merely an extension of those used here.

141. In Fig. 26b, as in Fig. 6, we show the plan or top view of this garage. The roof peak line is also included here, because it is necessary in establishing certain points that will be wanted later. The plan is so placed, relative to the station point and picture plane, that the observer will see the door and the right-hand wall. If we wished to show the left-hand wall, the plan would be turned so that the door faced off toward the lower right instead of the lower left of the picture. It is now necessary to work out an oblique elevation. This is done by projecting from the plan as shown, using either a compass centered on the intersection of the two views of the picture plane, as in Fig. 10, or a 45-deg. triangle as shown here. Either will give the same results, the triangle being more convenient, but *be sure you use a 45-, not a 30- 60-deg. triangle.* Heights are derived directly from the given heights of Fig. 26a. The oblique elevation may be located on a ground line placed wherever convenient. From here on the procedure is identical with that of Fig. 6, except that the oblique elevation has been placed at the left side instead of the right, in order to avoid having important details concealed.

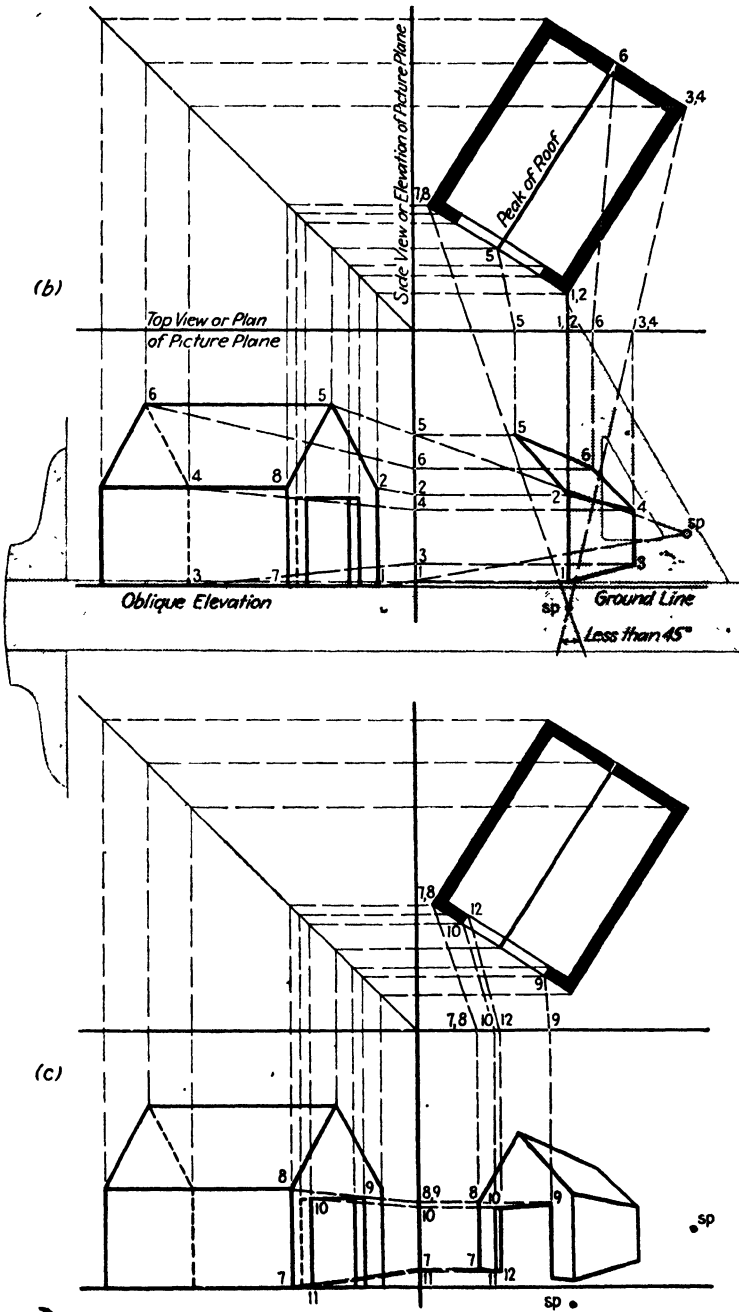

FIG. 26b and c.

142. The station point is located first, relative to the plan view. It should be situated at such a distance from the object that the angle included by the outer lines of sight *sp-3*, *sp-7*, does not exceed 45 deg., and for the best appearance 30 deg. or less is preferable. Failure to observe this results in distressing distortion. An example of this distortion was given in Chap. I. Geometrically, it is perfectly correct. Pictorially it is vile. Photographers are often forced to this kind of distortion, owing to the fact that physical obstacles prevent them from working at sufficiently distant viewpoints, but this situation need not trouble the artist. It should be remembered that the human eye sees clearly only in a cone of about 15 to 30 deg. or even less. Beyond this, vision becomes more and more vague, although forms are dimly recognized out to about 90 deg. From there on, *form* is practically indistinguishable, although light and dark are recognized out to the point where the nose and eyelashes shut off the view. Drawings utilizing this twilight zone are occasionally useful for dramatic effect. The rule applies also to the other view—the angle *sp-1*, *sp-5*, is subject to the same restriction.

143. The observance of this precaution should not lead the artist to make the opposite error. If the angle in either view becomes much less than 15 deg., perspective depth starts to disappear, and the uncomfortable flatness of the isometric takes its place.

144. Whenever practical, the distance of the station point from the object (don't forget it's the same in both views) should be placed where a normal observer would be. You wouldn't examine a house—though you might examine a brick—from a distance of 2 in.; you couldn't see it. On the other hand, it would be idiotic to march off 60 paces to inspect a cigarette case through a pair of binoculars.

145. One more precaution—the station point should be so located that a line from it to the center of the object makes approximately a right angle with the picture plane in the plan view. In the elevation it should be placed at a height above the ground line corresponding to the eye level of a normal observer. This is about 5 ft. We are now ready to begin.

146. In Fig. 26*b* the corner of the plan nearest the eye (*sp*) represents the front right corner of the building. The top and bottom of this corner are points 1 and 2, which appear to coincide in the plan. A line is drawn from each of these points in each view, toward the station point, until the lines strike the picture plane in points similarly numbered. The T square is now placed with the edge of the blade at point 1 in the side view of the picture plane. A triangle is then placed on the T square with its vertical edge on point 1 (1, 2) in the top view of the picture plane. By sticking the point of a pencil in the corner formed by the top edge of the T square and the vertical edge of the triangle, as shown by the phantom view in Fig. 26*b*, point 1 in the image is located. Keeping the triangle in the same position on the T square, the latter is moved up until the upper edge of the blade meets

point 2 in the side view of the picture plane. The pencil in the corner will now locate point 2 in the image. When these points are connected, the front right corner is complete.

147. Points 3 and 4, being one above the other, are located in the same way, and connecting 1, 2, 3, and 4 completes the right-hand wall. Points 5 and 6, not being on the same vertical line, must be separately determined. Drawing the lines 2 to 5, 5 to 6, and 6 to 4 completes the visible side of the roof. From here on the procedure is merely more of what has gone before and does not differ essentially in other drawings, no matter how complex the structure. Figure 26c shows how the job is finished.

148. More details require locating more points; that is all. As familiarity with the method is acquired; considerable speed is possible in laying out perspectives with absolutely impeccable accuracy. In practical work when using this method, it is strongly urged that the reader number or otherwise code his points, as has been done in Fig. 26. Failure to do this will lead to confusion, such as combining the right side lower rear corner with the front corner, thereby causing the entire right-hand wall to disappear. For a fuller treatment of this method, consult the book "Perspective Projection," by Ernest Irving Freese, mentioned in Chap. II.

149. A much more common, and for some objects simpler, method is shown in Fig. 27. This is an extension of the method already given in Fig. 7, Chap. II, where it was used to derive the perspective of a cube.

150. In Fig. 27a, we show three orthographic views of a small box with a hinged cover. In Fig. 27b the top view, or plan, is drawn at the desired angle to the direction of vision. If a mechanical drawing is already available, all that is necessary is to place it under a sheet of tracing paper and proceed. Lines are now drawn from sp parallel to the side and front edges of the box. These will locate the positions of vp_1 and vp_2 in the picture plane. In Fig. 7 the horizon was placed below the line indicating the picture plane, but here we have simplified matters by combining them. It should be remembered that the one line really represents two different things.

151. Next it is necessary to determine the apparent height of the box under the given position of picture plane, station point, etc. In order to do this, imagine the box to be inclosed in a rectangular solid just large enough to contain it with the lid up. If this is done, all heights may be referred to the nearest corner of the imaginary solid where they may be determined with accuracy.

152. Since the reasoning has already been given in Chap. II, only the procedure will be detailed here. A line is drawn parallel to the picture plane from the corner of the subject nearest the station point. It makes no difference whether this line is drawn toward the left or toward the right. It was drawn toward the right in Fig. 27b only because this avoided interference with other construction lines. On this line the distances from point

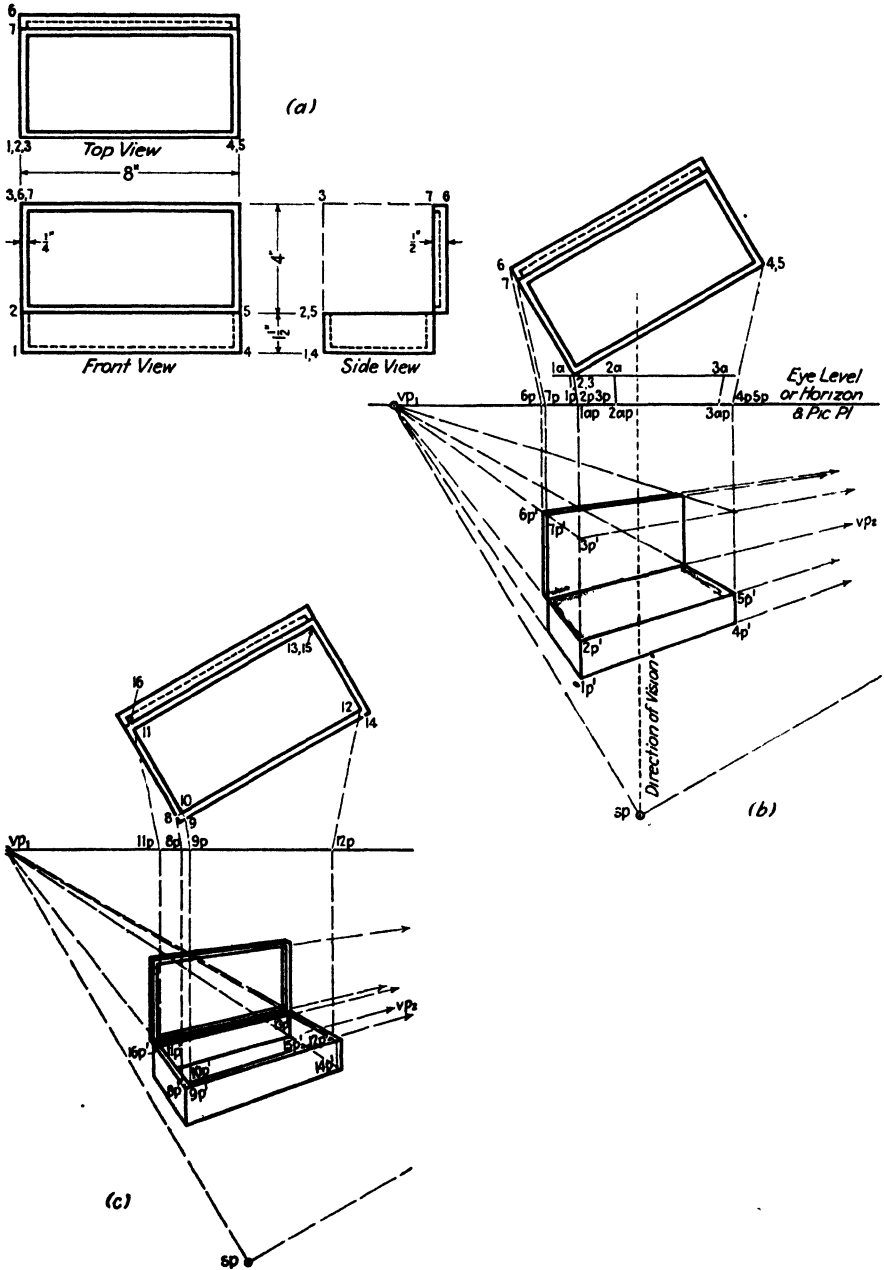

FIG. 27.

1 to point 2 and 1 to 3 are laid off as $1a$ to $2a$ and $1a$ to $3a$. These measurements are obtained directly from Fig. 27*a*, front view. Point $1a$ is made to coincide with point 1. From $1a$, $2a$, and $3a$ lines are drawn toward sp to meet the picture plane at $1a_p$, $2a_p$, and $3a_p$. It is noteworthy that, although the point 3 is imaginary, it serves to locate many real points later on.

153. It is now necessary to determine the exact position of the nearest corner of the box, including the imaginary portion. A line is drawn from point 1, toward sp , and meeting the picture plane at 1_p (coinciding with $1a_p$), and a vertical is dropped from 1_p . Since 1, 2, and 3 all lie in the same vertical line, their perspective images $1_p'$, $2_p'$, and $3_p'$ will all lie in the line just drawn. Exactly where depends on the discretion of the artist but is governed by respect for normal appearance, unless some special effect is deliberately sought. Since the problem of locating the box relative to the eye level may prove to be a serious pitfall, it will be wise to give the following careful attention.

154. According to Fig. 27*a*, the over-all height, including cover, is $5\frac{1}{2}$ in. Objects of this size are usually placed on tables. This brings them relatively close to the eye level. A seated person would have his eye level between 10 and 20 in. above the table, and consequently the same distance above the point 1, which rests on the table. Now the line $1a_p-3a_p$ represents the *perspective* length $5\frac{1}{2}$ in. on the vertical dropped from $1a_p$. Hence the point $1_p'$ must be placed at least twice this distance below the eye level. Since, in Fig. 27, eye level or horizon and the line representing the picture plane coincide, the point $1_p'$ is placed about twice the length $1a_p-3a_p$ below it.

155. Once point $1_p'$ is located, it is simply a matter of measurement to determine $2_p'$ and $3_p'$. The length $1a_p-2a_p$ is stepped off above $1_p'$, and this locates $2_p'$. In the same way $1a_p-3a_p$ determines point $3_p'$.

156. Lines drawn toward sp from points 6 and 7 intersect the picture plane at 6_p and 7_p . Verticals dropped from these points show the lines in which $6_p'$ and $7_p'$ must lie. A line from 4, 5 toward sp gives a similar vertical. A line is now drawn from $3_p'$ toward vp_1 , and, where it cuts the verticals from 6_p and 7_p , it marks off the top left edge of the cover. A line from $2_p'$ toward vp_1 marks off the bottom left edge of the cover and the top left edge of the box proper. Where the front left edge of the cover and the top left edge of the box intersect, a line is drawn toward vp_2 . A line drawn from $5_p'$ toward vp_1 will intersect this line at the bottom right-hand corner of the cover. A vertical is erected here, and a line is drawn from $7_p'$ toward vp_2 . These will intersect in the top front right corner of the cover. A short line is drawn from here toward vp_1 , and a line to meet it is drawn from $6_p'$ toward vp_2 . This completes the outline of the cover.

157. Lines from $1_p'$ and $2_p'$ toward vp_2 will determine $4_p'$ and $5_p'$, and a line from $1_p'$ toward vp_1 will complete the external outline.¹

¹ The term *outline* is here used to designate any line bounding a surface, not necessarily an "outer outline"; hence the need for the redundancy "external outline."

158. The "inner outlines" are similarly laid out, but, as in Fig. 25, lines that do not actually run out to the edges are referred to the edges for accuracy in locating them. Consequently, in Fig. 27c, points 8 and 9 are

found by extending the left and front inner edges to meet the outer edges. Points $8_p'$ and $9_p'$ are determined as before, and from them lines are drawn toward vp_2 and vp_1 , respectively. They will cross at $10_p'$, the inner front left-hand corner. Points $11_p'$ and $12_p'$ are determined by projection to these lines. From $11_p'$ a line toward vp_2 , and from $12_p'$ a line toward vp_1 will intersect at $13_p'$, the top rear right-hand corner.

159. Extend the line $13_p'-12_p'$ forward to the outside front edge, and from here drop a vertical. By comparison with such distances as $8_p'-10_p'$, it will be easy to estimate the position of point $14_p'$, which is this same distance (thickness of the base) above the bottom of the box. A line drawn from this point toward vp_1 establishes the inside lower right edge of the box. (Note the important part played by the invisible line.) A vertical dropped from $13_p'$ will intersect this line at $15_p'$, and a line from vp_2 through $15_p'$ gives the lower rear inside edge of the box.

160. The top, or cover, of the box is constructed similarly. Inasmuch as no new principles are involved, we shall leave it to the reader to work out for himself. Most of the various points can be established in two or more ways. This is valuable because it permits checking results.

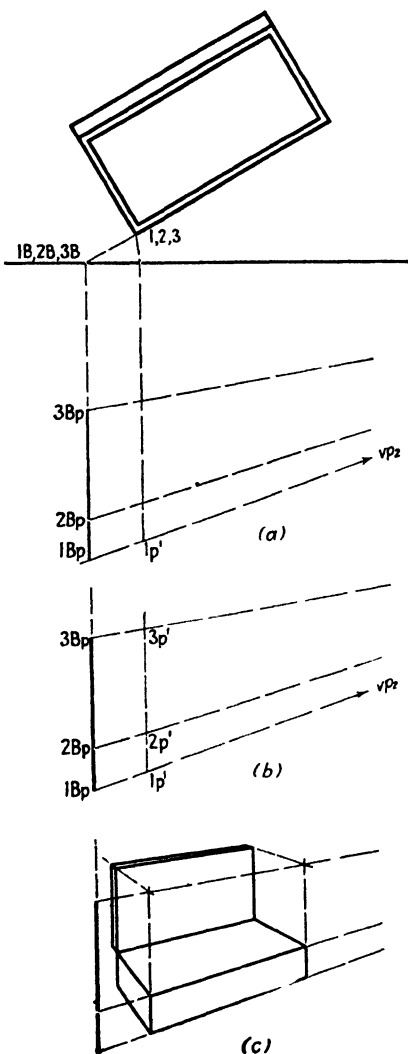

FIG. 28.

161. The method of finding perspective heights shown in Fig. 27b and in Fig. 7 is perfectly satisfactory but somewhat cumbersome. Where only two or three heights need be determined, it serves perfectly well, but, when there are many levels to be fixed, the method of Fig. 28 is more convenient. In order to show that results are the same regardless of method, we have used the same subject as before. Basically, the method consists in moving

the height line 1, 2, 3 into the picture plane. In Fig. 28a this is done by extending the front edge of the box in the top view until it meets the picture plane line at 1*B*, 2*B*, and 3*B*. Point 1'_{*p*}' is found as already described in Pars. 153 and 154. A line is drawn from *vp*₂ through 1'_{*p*}' and extended toward the left. A vertical is dropped from 1*B*, 2*B*, 3*B* in the picture plane. It will meet the extension of line *vp*₂-1'_{*p*}' in point 1*B*_{*p*}. Since this point is in the picture plane, measurements from it, either up or down, will be in the same scale as measurements on the top view. We may therefore use the ruler or scale directly to lay off 2*B*_{*p*} and 3*B*_{*p*} on this vertical.

162. In Fig. 28*b* lines are drawn from 2*B*_{*p*} and 3*B*_{*p*} toward *vp*₂. Where these meet the vertical from 1'_{*p*}' they fix points 2'_{*p*}' and 3'_{*p*}'. The drawing is completed in Fig. 28*c* in the same way as in Fig. 27*c*.

163. Two more methods of measurement remain to be discussed in this chapter. Others are given in later chapters in special applications. One is an extension of the method shown in Fig. 22 and described in Pars. 116 and 117. By means of this extension the method is made to apply to lines not parallel to the picture plane. Figure 29*a* shows the principle of the method, and Fig. 29*b* shows its application. If you wish, you may omit reading the demonstration of the principle and concentrate on learning the method. An understanding of the principle, however, will make it easier to remember the method.

164. Suppose the front of the box already drawn is to be divided into five equal vertical panels. Referring back

to the plan, or top view, shown in Fig. 27, we use the method already given (Fig. 22) to divide the line into five equal parts. Now project the line *OX*, which is used for this purpose, into the picture along with the box itself. This will give us the line *O_pX_p* (Fig. 29*a*), which, since *OX* is parallel to the picture plane, will be a horizontal line.

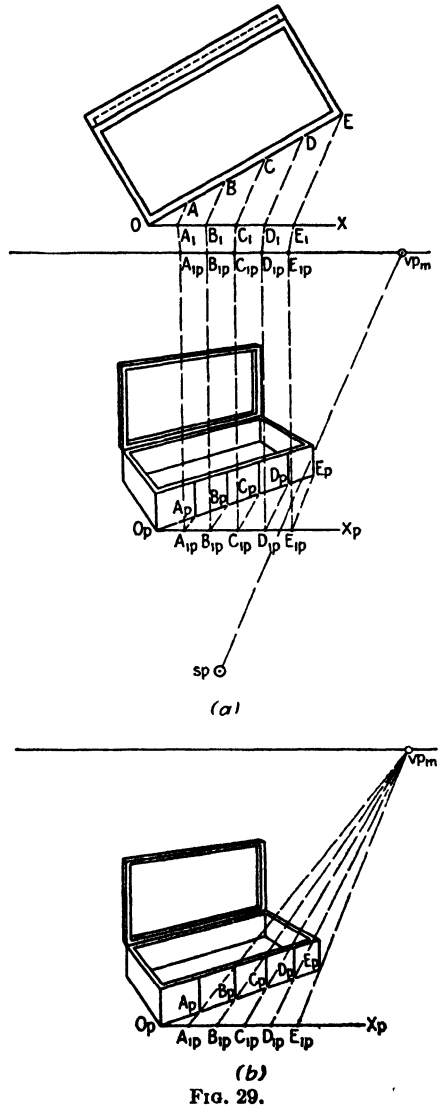
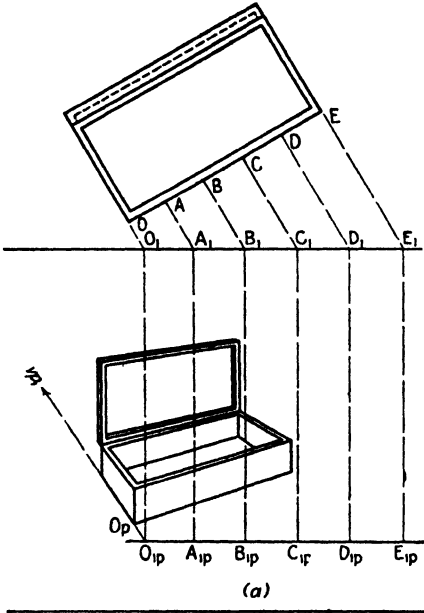

FIG. 29.

165. Since the lines AA_1 , BB_1 , etc., are parallel to each other, their perspective equivalents A_pA_{1p} , B_pB_{1p} , etc., will have a common vanishing point vp_m (vanishing point of measuring lines). Since they are horizontal, this point will lie in the horizon. Consequently, if we determine the positions of A_{1p} , B_{1p} , etc., by projection from the top view, and the position of vp_m by drawing a line from sp , parallel to AA_1 , BB_1 , etc., to intersect the picture-plane line (also the eye level, or horizon, line), we can use vp_m by drawing lines toward it from A_{1p} , B_{1p} , etc. These will cut the lower front edge of the box in points A_p , B_p , etc. Verticals drawn up from these points will produce the required vertical divisions.



166. It would be foolish to use such a roundabout method to locate A_p , B_p , etc., when they might be projected directly from the plan. The above analysis was given merely to show the reasoning. It is possible to eliminate the plan or top view altogether and still get accurate results. This is what is done in actual practice

167. Since OE_1 may be any convenient length so long as it is equally divided into five parts, the length of line O_pE_{1p} may also be anything so long as the divisions are equal. Moreover, since E_p is already known, being the outer corner of the box already drawn, vp_m may be determined simply by extending $E_{1p}E_p$ to the eye level without projection from the plan at all.

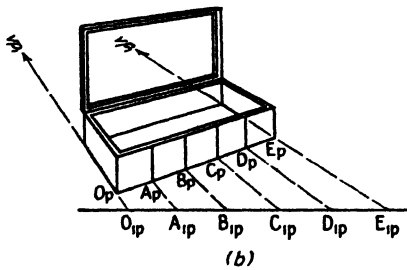

FIG. 30.

168. The method in practice is shown in Fig. 29b. We start with the box already drawn and the eye level known. Draw O_pX_p horizontally and hence parallel to the picture plane. Measure off on it any convenient five equal units O_pA_{1p} , $A_{1p}B_{1p}$, etc. Connect E_{1p} to E_p and extend this line to the eye level. This gives vp_m . Draw lines from A_{1p} , B_{1p} , C_{1p} , and D_{1p} to vp_m . They will cut O_pE_p at A_p , B_p , C_p , and D_p . Erect verticals at these points, and the job is done.

169. The method just described is most useful when the plan or top view is not given. Figure 29a was used to prove the validity of the method,

not because it was necessary in working the problem. When a projection is made from a plan, as is usually done in architectural work, the following method, shown in Fig. 30, is preferable. This method is related to the method of finding heights shown in Fig. 28.

170. In Fig. 30a the box itself is drawn just as before. On the top view the points A, B , etc., which divide OE into five equal parts, are placed, and from them lines parallel to the ends of the box are drawn to meet the picture plane at O_1, A_1, B_1 , etc. From each a vertical is dropped. The lower left edge of the *perspective* image is extended forward from O_p . Where this crosses the vertical from O_1 , the point O_{1p} is established. A horizontal is now drawn through this point, crossing the other verticals and establishing points A_{1p}, B_{1p} , etc.

171. Figure 30b shows how these are used. From each a line is drawn back toward vp_1 , to meet the lower front edge in O_p, A_p, B_p , etc. Erecting verticals at each of these completes the work.

172. The alert reader will see that this is a widely useful method. Not only divisions of this kind, but unequal divisions as well may be obtained by it. Moreover, there is no need to confine it to dividing lines already established. It may be used also to establish the length of any horizontal on the ground plane and, by projection, of any horizontal, whatever its level. Since no new principle would be demonstrated by discussing these applications in detail here, we shall leave it to the ingenuity of the reader to find other uses for this versatile construction.

173. A problem that causes more worry to the student than its real difficulty warrants is that of placing correctly lines that are not parallel to one of the three principal directions of the average rectangular object. That the difficulty is more apparent than real is evident when we go back to two basic principles. First, *any* perspective problem can be solved by locating sufficient points; second, any straight line can be determined by referring it to already established lines. This problem may be solved both two-dimensionally and three-dimensionally.

174. In Fig. 31a an example of the two-dimensional problem is solved. This figure shows a corner of a backgammon board with the six triangles lying within the rectangle $ABCD$. The points Q, R, S, T , and U , where the bases of these triangles meet, is determined by perspective division as already explained. The vertical rectangle $CDVW$ is now drawn using

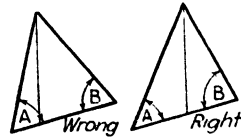
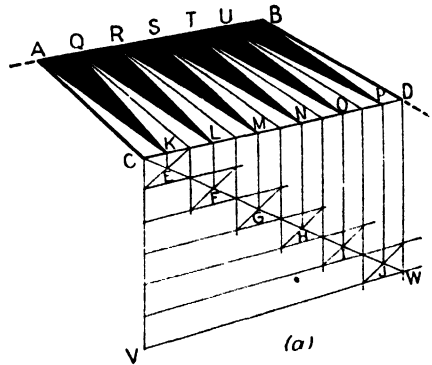

(b)
FIG. 31.

any convenient height CV , and this height is divided into six equal parts by direct measurement. At each of the divisions a perspective horizontal is extended toward the right, and the diagonal CW is also drawn. Where these cross the diagonal, verticals are now drawn, leaving the series of small rectangles lying along the diagonal CW . By drawing the opposite diagonal in each of these small rectangles, the points $E, F, G, H, I,$ and J are located and, by projection to line CD , the points $K, L, M, N, O,$ and P . These are the vertexes of the triangles, and the complete figures can now be drawn in.

175. Such a careful construction would not be necessary were it not for the difficulty of estimating the correct placing of lines not parallel to one of the three main directions. One of the commonest faults in professional work (not in that of beginners) is the tendency to draw triangles and other nonrectangular figures with a slightly drunken list. This usually results from forgetting that foreshortening affects angles as well as lines. The effect of ignoring this fact is diagramed in Fig. 31*b*. The first, wrong, picture is an attempt to draw a vertical isosceles triangle. The angles A and B have been made *literally*, rather than *perspectively* equal. They therefore appear *unequal*, and the apex of the triangle does not lie above the midpoint of the base, as it should in any well-behaved isosceles. This effect sometimes produces ludicrous results, as when a diamond-patterned wallpaper appears to stick out into the room instead of remaining quietly pasted to the wall. Sometimes the opposite effect is innocently achieved—the venturesome wallpaper goes striding out into the yard, and the wall itself seems to dissolve into smoke. The unskilled worker usually tries to overcome this wandering with ill-advised tones and modeling. This can only produce dirty-looking pictures. These remarks, of course, do not apply where such effects have been deliberately sought for decorative or aesthetic purposes.

176. The bread pan in Fig. 32*a* illustrates one method for determining angular lines where the problem is three-dimensional, *i.e.*, where the lines in question do not lie in any of the three principal planes. The pan illustrated is 4 in. high, 4 in. wide, and 8 in. long. The sides taper down to a base 3 in. wide and 7 in. long, *i.e.*, $\frac{1}{2}$ in. smaller on all sides than at the top.

177. The method used to locate the base accurately, relative to the top, and thus to give the correct inclination to the corner lines, is a standard procedure, indispensable for all but the most elementary perspective drawings. Instances of it have already occurred in this book, but Fig. 32*a* represents the first full-dress example of “freezing the form in a block of ice,” *i.e.*, representing the object as being enclosed in a transparent rectangular solid just large enough to contain it completely.¹ The proportions of this block are estimated or measured by any convenient one of the methods

¹ It is sometimes convenient to allow minor protuberances to project beyond the transparent enclosing solid, *e.g.*, the eaves of a house, knobs, raised ornament, and the like.

described in this chapter and are then used as a reference for the actual dimensions.

178. In Fig. 32a the rectangular solid $ABCDEFGH$ is the "block of ice." The actual base of the pan must be centered within the rectangle $EFGH$. This centering is sometimes ignored, and one of the intoxicated utensils shown in Fig. 32b results. Since the base rectangle of the pan is exactly $\frac{1}{2}$ in. smaller all around than the rectangle $EFGH$, the corners of the pan will be set in 45 deg. from the corners $E, F, G,$ and H . Since $EFGH$ is 4 by 8 in., it can be bisected into two perfect squares $EFIJ$ and $IJGH$. The diagonals of these squares will then give the necessary 45-deg. lines.

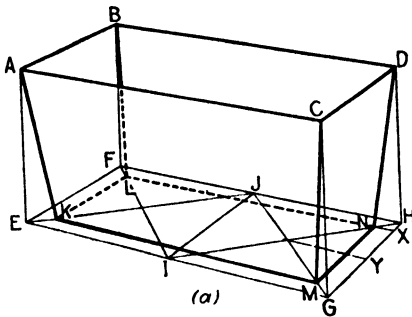

FIG. 32a.—For the sake of clarity the rounded corners and the heading have been omitted, and the taper has been exaggerated.

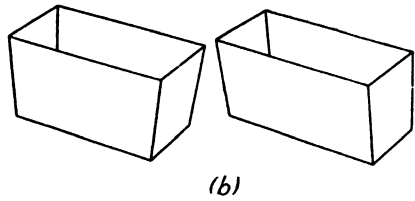

FIG. 32b.

179. Any corner may now be selected from which to measure the necessary $\frac{1}{2}$ -in. taper. The corner H is used here because it affords the least confusion of overlapping lines. The distance HX is one-eighth of HG ($\frac{1}{2}$ in. in 4 in.). This eighth may be measured in any one of the ways already described, or it may be estimated fairly accurately by first laying off HY , which is half of HG , and estimating HX as a *quarter* of HY . In any case the point X is established one perspective half inch from H . XN is drawn, perspectively parallel to HF , cutting the diagonal HI at point N , one corner of the pan. This line is extended from N to meet the diagonal FI , where the intersection establishes the corner L . From L a line is drawn perspectively parallel to FE , meeting diagonal EJ at the corner K . From K a parallel to EG meets diagonal GJ at M , and the fourth corner is established. Connecting M and N completes the base, and drawing lines $AK, BL, DN,$ and CM completes the drawing.

180. More often than not this problem occurs in simpler form. An object with a square top, such as a table leg, diminishes to a smaller square where it touches the floor. In this case we simply draw the diagonals of the base and use them directly for establishing the position of the offset corners.

181. In fields where high precision is not required, many of the calculations described in this chapter will not be needed. In fiction illustration,

for instance, a free method of working, relying on the judgment of the well-trained eye, serves as well as, or better than, the exact geometrical constructions given here. To a lesser extent this is true also of advertising illustration. Even in these fields, scientific accuracy of measurement is sometimes wanted, while in architecture, industrial design, and engineering, exactness is usually a prerequisite. Considerable freedom is of course allowable in preliminary sketches and roughs, but, once a design has been crystallized, the renderer had best stick quite closely to the facts for fear of creating a false impression through abuse of artistic license.

CHAPTER IV

THE CIRCLE, ELLIPSE, AND OTHER TWO-DIMENSIONAL CURVES

182. The square, which is two-dimensional, and the cube, which is three-dimensional, constitute the basic building blocks for all *rectilinear* forms, *i.e.*, all forms consisting of straight lines and flat planes.¹ In the same way the circle (two-dimensional) and the sphere (three-dimensional) are the basic materials of most *curved* forms. There are certain curved forms the drawing and construction of which cannot be reduced to such simple terms. These are usually called *plastic* forms and are dealt with in Chaps. VII and VIII. There are also certain curves that do not fit precisely into either category. Most of these occur rarely in drawing, but some of them are briefly dealt with here in order that the reader may be prepared for exceptional cases.

183. The circle seen in perspective, *i.e.*, in a plane not at right angles to the line of sight, appears as another type of two-dimensional curve—the ellipse. Much toil is expended by art students laboring to reconcile the flat geometric abstraction of the mathematician's ellipse with the spatial character of a drawing. The mathematician describes the ellipse in terms of axes, conjugate diameters, conjugate foci, and other terms useful for calculation but of small artistic value. Nevertheless, there are times when it is useful for the artist to know some of the mathematical terminology. The important terms are, first, the *major axis*, which may be described as a straight line across the greatest *length* of the figure; second, the *minor axis*, a straight line across the greatest *width* of the figure; and third, the *geometric center*, which is where these lines cross. This last must not be confused with the *perspective center*, of which more later. These terms, except *perspective center*, are illustrated in Fig. 33.

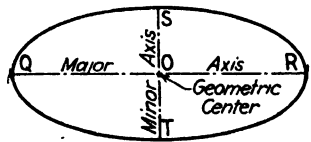

FIG. 33.—Ellipse.

184. The ellipse is a figure that can vary quite widely. It can be enormously large (the earth's orbit is an ellipse) or extremely minute. Moreover, the two axes may be in any proportion to each other. The ratio between them determines the appearance of the curve. When the

¹ The term *flat plane* is of course redundant. It is used here to avoid the loose artistic usage in which the word *plane* means merely a surface or part of a surface, regardless of whether it is curved or flat.

minor axis is almost as long as the major axis, the ellipse resembles a circle. On the other hand, when the minor axis is very short in comparison to the major axis, the curve becomes long and thin, like a cigar. When the minor axis is reduced to nothing, the ellipse becomes a straight line, which is sometimes considered as a "degenerate" ellipse. All these variations turn up in everyday drawing, sometimes in a single picture. Because the drawing in which ellipses or parts of them do not occur is a rarity, it is important to have plenty of practice in drawing them.

185. The circle in any perspective drawing is most easily placed and sized if constructed within a square. This is because no direct measurements are possible on a curve. Furthermore, the visualization of proportions of curves is much easier when it can be referred to rectilinear figures. In Fig. 34a we have drawn a circle enclosed in a square.

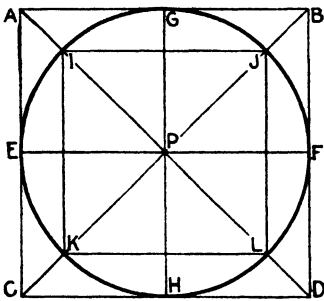

(a)
FIG. 34a.

The diagonals of the square are drawn, crossing at the common center of both square and circle. Also through this center are drawn the lines *EF* and *GH*, connecting the mid-points of the sides of the square. Notice that the circle touches the sides of the square exactly at points *E*, *F*, *G*, and *H*, and nowhere else. Notice also that the points *I*, *J*, *K*, and *L*, where the diagonals cross the circle, can be connected by lines that form another square, smaller than the first, and parallel to it on all sides. Point *P* is the center for inner square, circle, and outer square.

186. Suppose this figure to be made of wire. To hold it together the joints are soldered at all the lettered points. Holding the figure by the points *E* and *F*, we turn it until it is horizontal and somewhat below

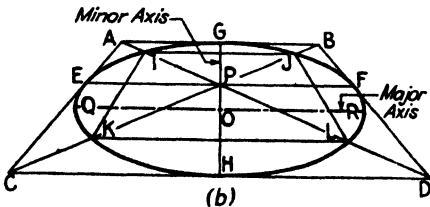

(b)
FIG. 34b.—Note that, although *QR* is the longest line in the ellipse, it does not extend to the sides of the square.

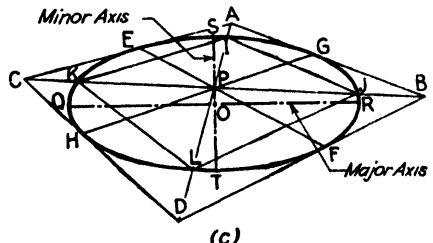

(c)
FIG. 34c.—Perspective forced to clarify discussion.

the eye level. This will make the wire *CD* come up and forward; the wire *AB* will go down and back. The square *ABCD* will now appear as in Fig. 34b. Remember that the joints are firmly soldered! The mere act of turning will not dislodge them. The diagonals *AD* and *BC* will still cross at the

common center, *i.e.*, at point P . The lines EF and GH will still meet the sides of the square at the same points where the circle comes tangent to it. The circle will still touch the square at the points and these points only. The lines IJ , JL , etc., will still form an inscribed square parallel to the circumscribed square $ABCD$. The general tendency is for students to "unfasten" these joints, and it must be avoided.

187. The result of this turning will be that the circle will appear as the ellipse of Fig. 34b. In this particular case the minor axis coincides with the line GH . It is important to remember that this occurs only when the center of the enclosing square lies exactly above or below the center of vision and when two sides of the square are parallel to the picture plane. These two conditions occur rarely in drawing groups but are very useful in drawings of single circular and cylindrical figures as shown in Chap. V.

188. Suppose that the square $ABCD$ is now turned about point P as a pivot. It will then appear as in Fig. 34c. Will this affect the appearance of the circle? Not at all; a circle is the same from any side. Notice that the diagonals AD and CB still cross at P , and that they still intersect the circle at the points I, J, K , and L . E, F, G , and H remain the tangent points for circle and square. Both squares, and the various diagonals, have changed in appearance with the change in position, although their relationship has remained the same, but there is no effect on the appearance of the circle. So here is a rule to remember: no amount of rotating about its own center will change the appearance of a circle.

189. Figures 34a, b, and c together demonstrate certain properties of circles and their perspective counterparts, ellipses, which are highly important to the artist. As has already been pointed out, a circle enclosed in a square will have the same center as the square (see Fig. 34a). It will be tangent to (*i.e.*, just touch) that square at the mid-point of each side. It will intersect the diagonals of the square at points (I, J, K, L) somewhat more than two-thirds of the distance from center to corner. (The exact figures are $PJ = 1/1.414PB$.) Moreover, PF equals PJ , which gives us another useful comparison. More completely stated, PF, PG, PE , and PH , which are obviously all equal, are equal also to PJ, PI, PK , and PL . Connecting the points $IJKL$ will produce a smaller inscribed square parallel to the outer or circumscribed square. The inscribed square is not a necessity for construction purposes but is very useful for checking, to ensure getting the curvature the same in all four quarters.

190. Certain comparisons between the mathematical ellipse of Fig. 33 and the artist's ellipse of Figs. 34b and 34c will be worth making at this point. So far as the curve itself is concerned, the two are identical, but, because of their different uses, they must be differently handled. To the scientist, the mathematical ellipse is the basis of certain problems in analytic geometry and calculus, the orbits of astronomical bodies, and other things that do not concern us. To the artist the ellipse is useful in just one

way, as the perspective image of the circle. This one use is enormously important.

191. The differences are most easily seen in comparing Fig. 33 with Fig. 34c. The most important thing by far is the fact that the *geometric* center O , of the mathematical ellipse, is *not* the same as the perspective (or optical) center P , of the artist's ellipse. Point O is the center of the ellipse as ellipse, which is seldom important in drawing, whereas point P is the center of the circle of which the ellipse is the image. Reference to Fig. 35a will make this clear. Point P is therefore highly important in drawing, for it is here that the hub of a wheel, the pivot of a compass, the pivot for the hands of a clock, etc., must be located. Confusion between these two is responsible for many strange-looking drawings.

192. Figure 34b shows another way in which the scientific and the graphic ellipses may be confused. When the perspective circle is drawn in this way, the line EF is often confused with the major axis QR . Sometimes the two occur so close together that the error is negligible; but, when the perspective is sharp, *i.e.*, when the station point is close to the object, the difference is marked. Note that QR , although longer than EF , does not quite reach the sides of the perspective square. This is because of the divergence of these lines as they come forward. When we try to make EF the major axis, we get this result:

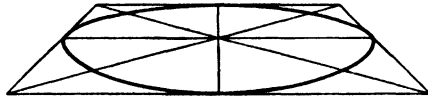

193. Figure 35 may help to make these distinctions clearer. In Fig. 35a we have drawn a diagram showing the top view of a circle as seen from sp . To make the distinctions clear, a rather forced view, with sp intentionally too close to the circle, has been used. The outermost lines of sight just touch the circle at Q and R . These are connected by a straight line that crosses the diameter GH at O . When the image of Fig. 35b is drawn, it will be seen that QR forms the major axis of the resulting ellipse and that O is the center of the ellipse *but not of the circle*. If O is used as the hub of a wheel, for instance, serious distortion will result. P , the center of the *circle*, is decidedly not the center of the *ellipse*. Note also that EF , although actually longer than QR , as can be seen in Fig. 35a, *appears* shorter in the perspective image of Fig. 35b.

194. Suppose we want to draw a circular table top having the diameter EF . Its position relative to the eye level and the line of sight will have been determined by the other conditions of the picture, as will be shown in Chap. VIII on perspective composition. By the methods already demonstrated in Chaps. II and III, a perspective square $ABCD$ is drawn having sides equal to EF . The diagonals of this square are now drawn, giving us a result like Fig. 36a. Through P , where the diagonals intersect, we draw a line

perspectively parallel to AC and BD , and another line perspectively parallel to AB and CD . These lines will touch the sides of the square at $E, F, G,$ and H , where the ellipse (perspective circle) about to be drawn comes tangent to the square. A little practice will enable anyone to judge relative distances with remarkable accuracy. Choosing PC because it is less fore-

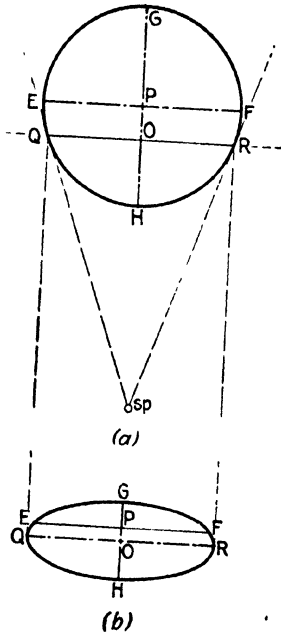

FIG. 35.

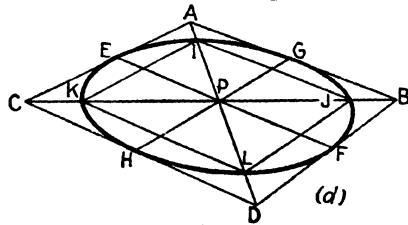
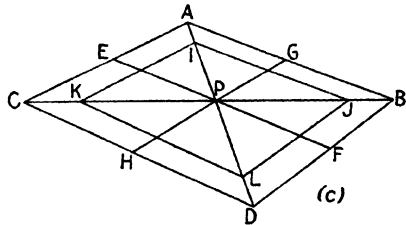
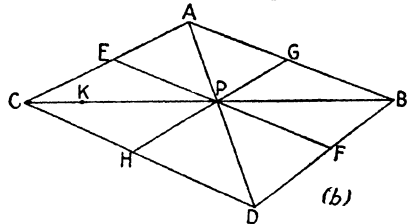
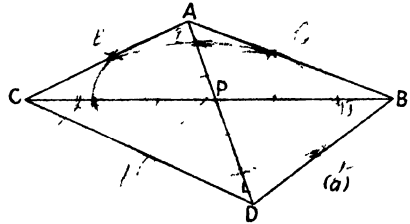

FIG. 36.

spectively parallel to AB , and finally connecting J and L produces the inscribed square. We now have eight points through which the ellipse must pass (see Fig. 36c). If a smooth curve is now drawn through these points, it will be the desired ellipse shown in Fig. 36d.

195. The importance of the square in constructing the circle is seldom appreciated by the student as long as he confines himself to isolated objects of circular or cylindrical form. But when he attempts the more complex drawing, involving more than one such object, he finds himself lost. Drinking glasses, for example, will often appear to be floating above the table

rather than resting firmly upon it. The enclosing square for the circle and the enclosing rectangular solid for the cylinder will prevent such errors.

196. There are certain properties that should be borne in mind whenever the curve of Fig. 36*d* is to be drawn. If it is thought of as a circle seen obliquely, rather than as an ellipse per se, many unnecessary errors will be avoided. First, the diagonals of the square, and hence of its perspective image, always cross at the *true center* of the *circle*, which is *never* the same as the center of the ellipse (*i.e.*, the geometric center), although it sometimes approaches it so closely that the difference can safely be neglected. Second, the sharpest parts of the curve are always in the sharpest corners of the perspective square, and *the sharpness of the curvature is proportional to the sharpness of the angle in which it is drawn*. Compare the curvature of *FLH* in the obtuse angle *FDH* with the curvature of *FJG* in the acute angle *FBG* in Fig. 36*d*. Third, it must be reemphasized that the perspective circle is *always* tangent to the perspective square at the perspective mid-points of its sides, *i.e.*, at points *E, F, G, and H*. Another rule to be remembered is that neither the ellipse nor the circle of which it is the image has any corners. The queer results that follow neglect of one or more of these principles are shown in Fig. 37.

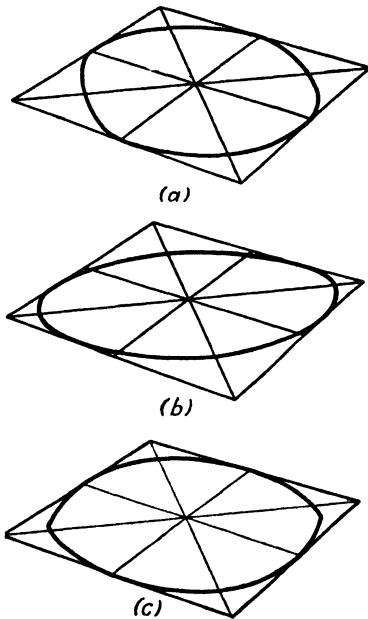

FIG. 37.—(a) Curves in sharp-angled quadrants not sharp, (b) ellipse not tangent to square at proper points, (c) corners on a circle.

equal exactness. The placing and size are taken care of by the enclosing square, as before. With the square established, it is possible to plot with mathematical precision 12 points through which the curve must pass. According to plane geometry, the lines joining any point on the circumference of a circle to the ends of a diameter will form a right angle. Since the use and not the proof concerns us here, we shall confine ourselves to demonstrating the method.

198. Figure 38*a* shows the same square and inscribed circle as Fig. 34*a* but with different interior lines. Suppose that we begin simply with the square *ABCD*, the inscribed circle, and the center lines *EF* and *GH*. Again consider the figure as made of wire. We now take another piece of wire and with it join *A* and *H*. Next we locate the point *S*, halfway between *A* and *E*. This point is joined to *G*. The wires *AH* and *SG* will cross at point *2*, and this point will lie on the circle. Moreover, similar wires connecting

197. It is often necessary, particularly in large drawings, to draw ellipses with great exactness and to place them in position with

A to F and T to E (T being halfway between A and G) will intersect at point 3, also on the circle. The points E and G , as already shown, are on the circle.

199. If the circle were not already in place, the points E , 2, 3, and G would show us, in part, where to place it. Consequently, by an extension of this construction, we are enabled to draw any circle or ellipse. In Fig. 38*b* the square of Fig. 38*a* is seen as lying on a horizontal plane. If we call E point number 1, then 2 and 3 follow clockwise, and G becomes

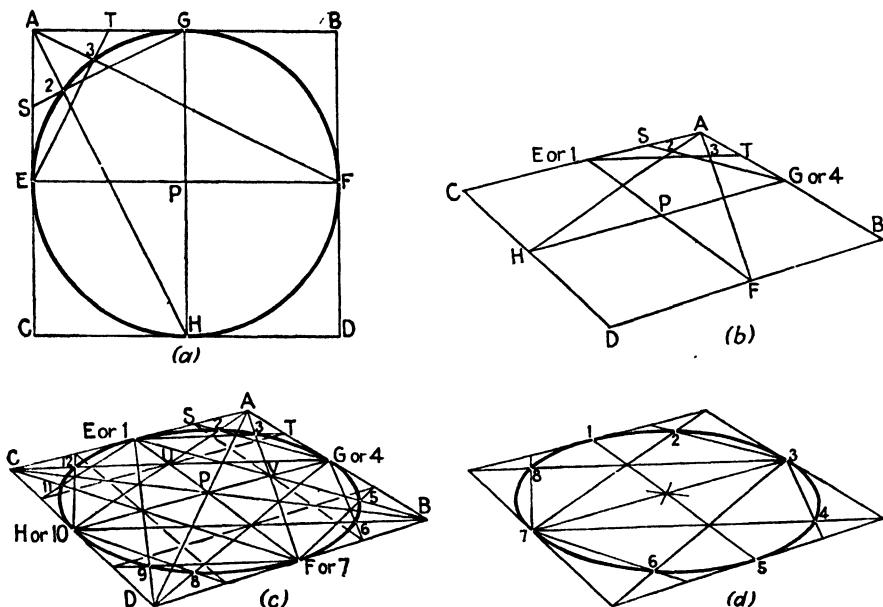
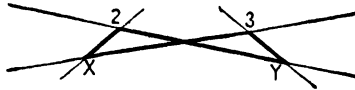

FIG. 38.

point 4 at the beginning of the next quadrant. We now have four points through which the circle must go. Extension of the method to the other three quadrants will give us 12 points in all, as shown in Fig. 38*c*.

200. We can now formulate a working method for use of the foregoing principles. A circle is to be drawn in a given square $ABCD$. The construction is shown in Fig. 38*c*, and the steps are as follows: Draw the diagonals AD and BC . Their intersection is the point P , common perspective center of both square and circle, and true center of the original figure (38*a*). Through P draw lines perspective parallel to the sides of the square. These will determine points E , F , G , and H . Put a number 1 next to point E . From A draw lines to H and F . These lines will cross EF and GH at U and V , respectively. A line through U , parallel to AC , cuts AB at the point T , and a line through V , perspective parallel to AB , cuts AC at the point S . Connect S with G . SG will intersect AH at point 2. Connect T with E . TE will intersect AF at point 3. Put a 4 next to

point *G*, and proceed with the same steps in the next quadrant. This will give points 5 and 6, etc. A caution is in order at this point. If you look at the figure closely, you will notice that points 2 and 3 occur at the outer vertexes of a little pair of triangles like this:



Students often try to use the inner pair, *X* and *Y*, and come to grief trying to fit the curve to them.

201. The construction of the 12-point circle can be stated in general terms, as follows: Given a square, either true or perspective, draw the circle in it. First, find the mid-points of each side. Second, find the quarter points of each side (*S*, *T*, etc., in Fig. 38). Third, from one corner draw lines to the mid-points of the two opposite sides. Fourth, from the nearest quarter point of each adjacent side draw a line to the mid-point of the other adjacent side. Fifth, mark the *outer* pair of intersections (2 and 3, 5 and 6, etc., in Fig. 38*c*). Sixth, through these points and the mid-points of the adjacent sides draw a smooth curve. Repeat in each quadrant.

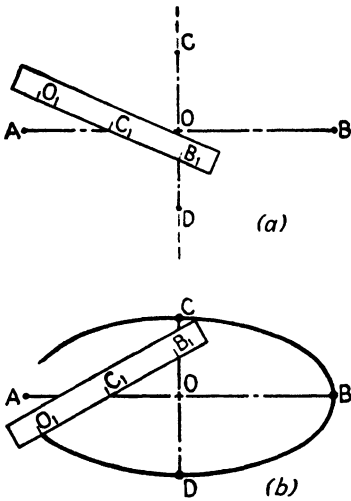

FIG. 39.

202. A simpler variant of the foregoing method is illustrated in Fig. 38*d*. Called the eight-point circle, it omits four of the points located in the above construction. Though not quite so accurate as the 12-point circle, it

is sufficiently so for most practical purposes. Since the construction is exactly the same, and since the figure is practically self-explanatory, we shall not bother with more description. Incidentally, in Fig. 38*d* not all the construction lines have been drawn in, and the diagonals are represented only by that portion where they intersect to determine the perspective center.

203. For the rare occasions when the artist really wants to draw an ellipse as an ellipse and not as the image of a circle, the trammel method, illustrated in Fig. 39, is sometimes useful.

204. In order to make use of the trammel method, the major and minor axes must be known. Take a strip of paper somewhat longer than half the major axis and mark off on it O_1B_1 equal to OB , half the major axis. Now lay off O_1C_1 equal to OC , half the minor axis. Place B_1 on the minor axis and C_1 on the major axis, and make a dot on the drawing where O_1 lies. This dot will be a point on the ellipse. By swinging the strip into various positions, but keeping B_1 always on the minor axis and C_1 always on the

major axis, any desired number of points can be located. It is advisable to extend the ends of the minor axis on long, narrow ellipses, since B_1 sometimes extends beyond C or D .

205. There are other mechanical methods of drawing ellipses, but they are of so little value to the artist as not to warrant description in this volume. They will be found in works on architectural or engineering drawing, for they are principally useful in orthographic or isometric projection.

206. So far we have discussed the ellipse as though it were always seen in a horizontal position. This is because the basic principles could most easily be demonstrated in this way. Wheels, handles, etc., are usually vertical, however, while many other circular objects are seen at various inclinations. This does not pose any additional problems if the enclosing square is used in the construction. The toy wagon illustrated in Fig. 40, though it properly belongs to Chap. V, shows some features of the image of the circle in a vertical plane which need to be emphasized here.

207. We begin by drawing the wagon body and four square blocks, as shown in Fig. 40a. The square has a width and height equal to the diameter of the wheel, and the thickness of the block is equal to the thickness of the wheel. In each of the squares a perspective circle is now drawn, using methods already described. This is shown in Fig. 40b. The next step would be to draw a similar circle on the rear square of each block, but, since this process is covered more fully in the next chapter, we omit it here.

208. The completed drawing with construction lines removed is shown in Fig. 40c. Notice particularly that the major axis of the ellipse is not vertical. It never is unless the center of the circle is on the eye level. This fact is often puzzling to beginners, who feel that there is something a bit unfair in the ellipse's behavior. Nevertheless, it is important to remember that a vertical ellipse does not necessarily have a vertical major axis—rarely does, in fact. We have drawn in a dotted line showing the line of the axle. Notice that the *major axis* of the ellipse is *perpendicular to it*. This is important in drawing wheels and all other objects having cylindrical character, and particularly important when drawing the ellipse freehand, as discussed in Pars. 210 through 214. When drawing an ellipse with the aid of the enclosing square, the axes can be left to take care of themselves.

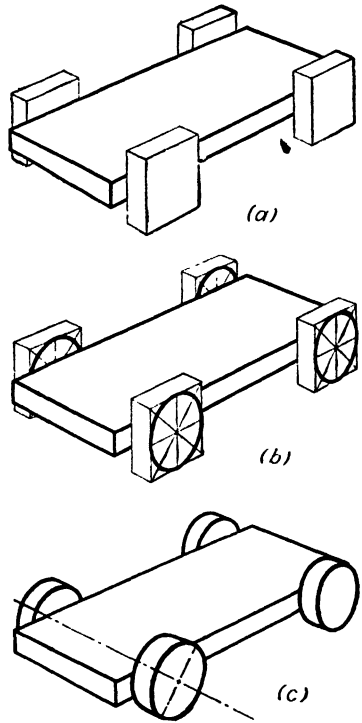

FIG. 40.

209. If we are drawing a circle lying in an inclined plane, neither vertical nor horizontal, the only difficulty is in drawing the enclosing square. This problem is covered elsewhere in this book and so will not be repeated here. Once the square has been drawn, the procedure is the same as before.

210. When drawings do not require the absolute maximum of precision, it is quicker to draw the ellipse freehand and without the aid of the enclosing square. As a matter of fact, the ellipse itself, and most other curves as well, is almost always drawn freehand, even in drawings where the enclosing square is drawn instrumentally. French curves are used only where a high degree of slickness is wanted. Often the square is also drawn freehand. What we refer to here is drawing the ellipse without the aid of these controls. The square sets both size and degree of roundness (which is dependent on its position relative to the eye level) for the ellipse, and it naturally requires more skill and experience to do without it. Since these are only acquired by practice, it is urged that practice be begun at once.

211. The form of the ellipse has by now become fairly familiar through the controlled drawings made with the aid of the square. This provides us with a standard by which freely drawn ellipses may be judged. If an ellipse drawn freely does not compare well with those in Figs. 33 through 40 (except Fig. 37), corrections should be made.

212. Apart from size, the most important characteristic of an ellipse is its roundness. It may be almost a perfect circle, or it may thin out to a straight line. A circle just on the eye level appears as a straight line; as it is raised or lowered, it becomes more and more like a circle. A common water tumbler illustrates this very nicely. If you will hold one about 15 or 20 in. away and with the top of the glass level with the eye, you will notice that the opening at the top disappears into a straight line, while the base has marked roundness. Closing one eye helps to see this effect. If the tumbler is now lowered an inch or two, the top becomes a narrow ellipse (one with a relatively short minor axis) while the base becomes still more round in appearance. The top never overtakes the base (both become more and more nearly circular in appearance as the glass is lowered) but the base is always a bit ahead. If the glass is raised instead of lowered, the change is of course reversed. These effects are discussed at greater length in Chap. V.

213. No two people will want to work in quite the same way; consequently we can only give suggestions here as to methods for free drawing of the ellipse. Whatever the method, we must start by setting the size, *i.e.*, the length of the major axis. The roundness is governed by the length of the minor axis, which may or may not be drawn in, depending on preference, though it will usually be found helpful. The next step is to rough in the shape of the curve itself. This can be approached in either of two ways. One is to work slowly, trying to get the shape nearly right in a single stroke. The other is to use "whirling," in which the pencil

is swung rapidly around several times, trying roughly to keep it to the size set by the two axes. The natural motion of the hand and wrist (or arm in the case of large ellipses) gives a good approximation of the ellipse. This can then be refined and improved in one of the ways described in the section on freehand drawing in Chap. II.

214. Modifications or combinations of either of these methods of working will naturally be made by the individual worker according to personal preference. In any case considerable practice will be needed, and it is suggested that a series of ellipses of various shapes and sizes, like those in Fig. 41, be used as an exercise in acquiring facility with this most useful of all curves.

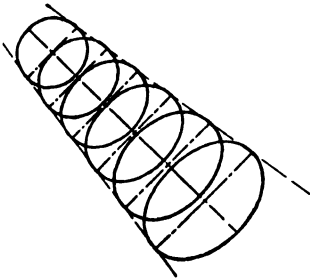
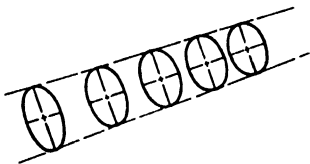
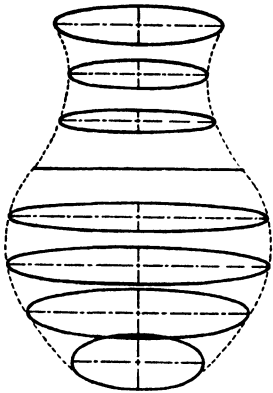

FIG. 41.

215. The circle occurs in innumerable objects in incomplete form, more frequently indeed than it does in complete form. This is even more true of the three-dimensional extension of the circle—the cylinder. When a part of a circle is used to round off a corner, it is usually spoken of as a *radius* to distinguish it from the flattened corner, which is a *bevel* or *chamfer*. The table top in Fig. 42 shows, in its rounded corners, the use of the radius. It will be noted that each corner is a quarter of a circle, the remainder of which is indicated by the dotted portion. Two features of the illustration warrant special attention. First, the cen-

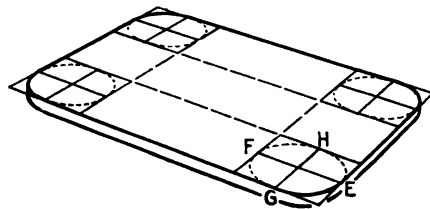

FIG. 42.

ter lines of the square, EF and GH , show exactly where the straight edge meets the curve. Second, the squares may be projected from corner to corner, as indicated, to ensure getting all four radii perspectively the same size.

216. Another problem comes up when a circle is to be divided into sectors like a pie. Spoked wheels pose this problem, usually with the added difficulty of thickness. The radiating high lights of a phonograph record or the top of a silk hat are examples. The problem is a simple one, often unnecessarily confused by the habit of thinking of the ellipse as such, rather than as the circle it represents. In Fig. 43a we show the curiously flat

result that comes from thinking of the circle in perspective as purely a geometrical ellipse. In this picture the geometric center of the ellipse has been used as the center of the circle. It is important to remember that the center of the ellipse and the center of the circle do not coincide. If the perspective of the circle is drawn in a square, as in Fig. 43b, the true center is automatically determined by the crossing of the diagonals. It is from this point *P*, not *O*, that the high lights radiate.

217. Figures 43a and b involve another problem illustrated in Fig. 44. This is the problem of concentric circles, which turns up whenever the open end of a hollow cylinder is to be drawn. It also occurs in many other cases,

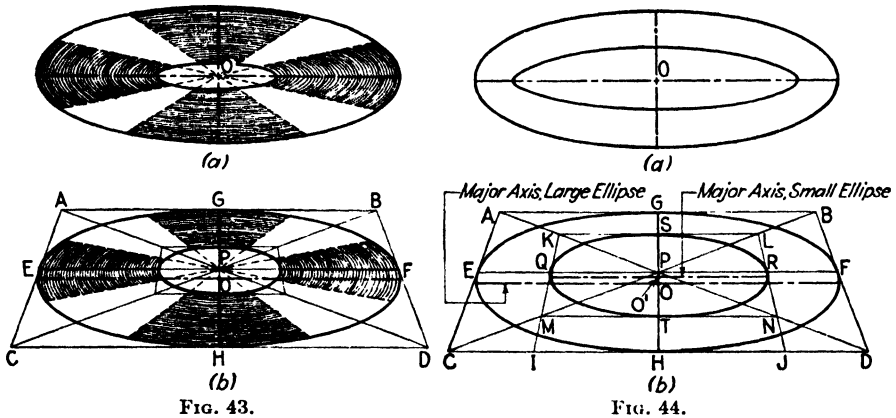

FIG. 43.

FIG. 44.

such as the afore-mentioned phonograph record, wheels, etc. As usual, the difficulties arise from conceiving the circle as an abstract geometrical ellipse, rather than as a circle whose position in space gives it the appearance of an ellipse. The twisted appearance of Fig. 44a is very common in beginner's drawings. The problem is to draw a large circle and a smaller circle inside it.

218. Knowing that a circle appears as an ellipse, the beginner draws an ellipse to represent the outer circle. So far, so good. Then, knowing that the smaller circle is parallel to (concentric with) the larger, he proceeds to draw a smaller ellipse that is geometrically parallel to the larger, not realizing that there is a foreshortening of the distance between the circles, as well as of the circles themselves. He also fails to realize that concentric circles do not appear as concentric ellipses. The common center is the center of the circle itself, not the center of the ellipse. This of course has already been pointed out repeatedly, but the confusion causes so much trouble that we bring it up once more.

219. The correct solution of the problem is shown in Fig. 44b and involves, as before, the enclosing square. This square is so essential to the thorough understanding of the nature of the circle in perspective that its use should not be dispensed with until the correct conformation of every

circle is a matter of instinct. Moreover, the less we think of circles in terms of ellipses the better. The term ellipse has been avoided in this book as far as possible as being misleading. Fundamentally, the fact that the circle in perspective is an ellipse is as unimportant as that the square in perspective is a nonrectangular quadrilateral or the right triangle a scalene. These ponderous terms serve only as a barrier between the student and true three-dimensional thinking. To draw well instinctively he must think of his paper, not in terms of a two-dimensional plane, but in terms of the *space* the plane represents.

220. It will be noted that Fig. 44b is drawn in parallel perspective, as is Fig. 34b. It is preferable to do this whenever possible, because it permits direct measurement on the lines AB , EF , and CD . Any of these may be selected according to convenience. Whenever a problem involves circles or cylinders alone, parallel perspective can be used. Such cases are quite common, and the convenience of it will be shown in the next chapter and in the chapter on Perspective Composition. It may be useful to point out here that, since each of these lines is parallel to the picture plane, the proportions of the two circles can be established on the lines by direct measurement. In other words, if the small circle is two-thirds the diameter of the larger, simply make QR two-thirds of EF , or IJ two-thirds of CD , etc., in Fig. 44b.

221. Compound circular curves frequently turn up. They may consist of a number of equal arcs arranged in rows or chains; they may alternate the direction of their curvature or repeat it; they may consist of a group of complete circles, of semicircles, of arcs more or less than semicircles, or of any combination of any or all. In Fig. 45 a few of the simplest combinations are diagramed, but a volume could be filled with them without repeating. The important thing to remember in drawing compound circular curves is that each circular arc should be treated as though the whole circle were to be drawn, and careful attention should be paid to the size relations and connecting points. The latter are often pitfalls, but a careful use of the enclosing square will help until facility is acquired.

222. Figure 45 uses the same lettering found on previous diagrams of the circle, and, since the figures are self-explanatory, we shall not trouble to

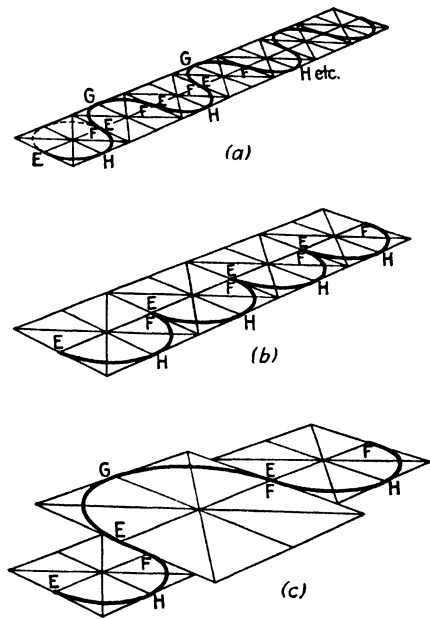

FIG. 45.

analyze them in the text. It is strongly urged, however, that the student try a few compound curves for himself.

223. It is difficult to find examples from the world of practical things which will typify problems involving pure circles, most real objects, even the phonograph record discussed above, having substantial thickness. For this reason, concrete examples of circular curves in practical drawing problems are mostly deferred to Chap. V and the following chapters. Nevertheless, Fig. 46 may be considered as the top of an ornamental garden

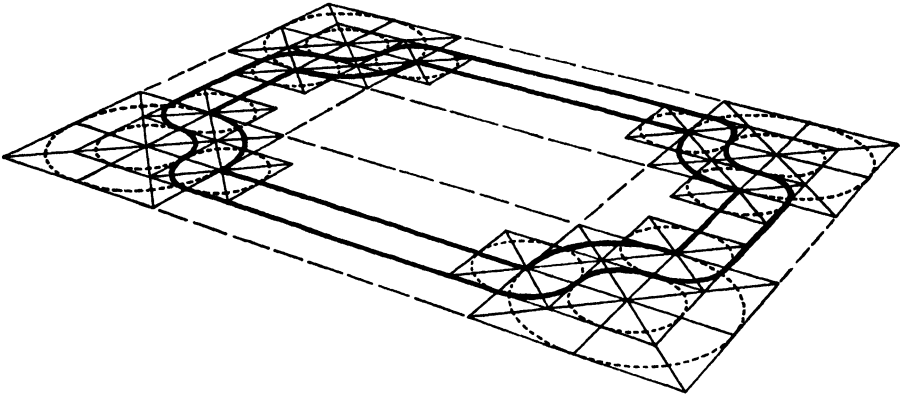

FIG. 46.

pond, and as such it offers an example of the use of circular curves. No explanation is needed, because all construction lines are indicated in the figure.

224. The order of work is worth setting down, however. A rectangle is drawn having the outside proportions of the pond. A second rectangle is then drawn inside the first, indicating the wall thickness. On each corner a square is drawn having sides equal to twice the thickness of the wall, and a second set of squares is circumscribed about the first set with sides equal to *four* times this thickness. Directly adjacent to the first set of squares is a second set, identical in size, of which there are eight in all, two to each corner. When circles are drawn in each of the squares, it is seen that each of them contributes a quarter arc of its circumference to the outline as a whole.

225. A problem that is puzzling by reason of its very simplicity is illustrated in Fig. 47. This is the drawing of an ellipse that is really an ellipse, not a circle seen in perspective. This curve turns up frequently in both complete and incomplete forms in trays, arches, tables, and numerous other forms. It was very popular for picture and mirror frames during the Victorian period. Suppose Fig. 47*a* to represent the top of an elliptical table, as seen from directly above (orthographic projection). Now suppose that we look at it in the normal way, from a point a foot or so above the plane of the table and a line of vision parallel to the minor axis of the ellipse.

This will give us a new ellipse (Fig. 47*b*) differing from the original only in its degree of roundness. Here is a puzzle: the perspective of a circle is an ellipse whose degree of roundness or flatness is dependent on its closeness to the eye level; the perspective of an ellipse is another ellipse whose degree of roundness or flatness is dependent on its closeness to the eye level, plus the flattening of the original curve. What then is to distinguish the perspective of an ellipse from that of a circle similar in size, but somewhat closer to the eye level?

226. This is no mere academic question. The author had exactly this problem to contend with at a time when he was rather green, and when a fast approaching deadline left little time for solving puzzles. The job involved the drawing of an interior consisting of an elliptical room—elliptical floor, ceiling, lamps, walls, stair treads, screens, and even a concentric pattern of ellipses in the elliptical rug on the floor.

227. The solution, of course, is very simple. It consists in *avoiding* parallel perspective for the enclosing rectangle, thereby bringing the ellipse into such a position that its long axis is not horizontal (Fig. 47*c*). When a circle lying in a horizontal plane is drawn in perspective, the ellipse so produced will have a long axis that is horizontal except under forced angles of view. This will be true no matter what the angle of the enclosing square (see Figs. 34*b* and *c*). This holds true of the perspective image of the ellipse also only if the enclosing rectangle is drawn in parallel perspective.¹ Putting the enclosing square in parallel perspective, a sensible and timesaving expedient in drawing a circle, is productive of misleading results when applied to its relative, the ellipse. Hence, in Fig. 47*c*, the rectangle is shown with neither side parallel to the picture plane. It is apparent at once that this is not merely an *elliptical image* but the image of an ellipse.

228. It sometimes happens that a circle will appear like this. This distorted effect is the result of the circle's being too far away from the center of vision, and of the artificial assumption of flatness in the picture plane. Since it is impractical to draw on spherical sheets of paper, we have two alternatives. Whenever possible a station point should be so chosen as to avoid forced perspective. Photographers who use wide-angle lenses will appreciate the importance of this. When circumstances make it difficult or

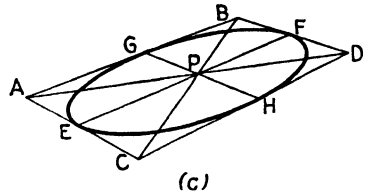
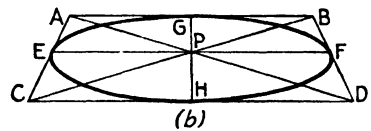
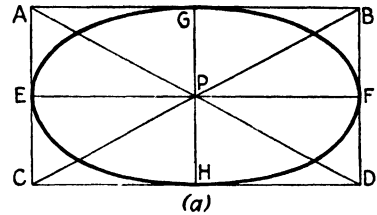

FIG. 47.

¹ There is no apparent difference, except closeness to the eye level, when a rectangle and a square are drawn in parallel perspective.

impossible to establish a sufficiently distant station point to avoid an overly wide cone of vision, we must resort to a little judicious forcing. The result of this forcing is more truthful than the geometrically correct solution which ignores the basic *untruth* of overwide angles of vision. The method of this forcing will be given in the next chapter.

229. A curve frequently confused with the ellipse is the oval. As its etymology indicates, the word *oval* means egg-shaped. Strictly speaking, the oval is the longitudinal section of the egg. In its commonest form the oval consists of half an ellipse, cut on the minor axis, joined to half a circle, as in Fig. 48a. The oval may also consist of halves of two ellipses of different

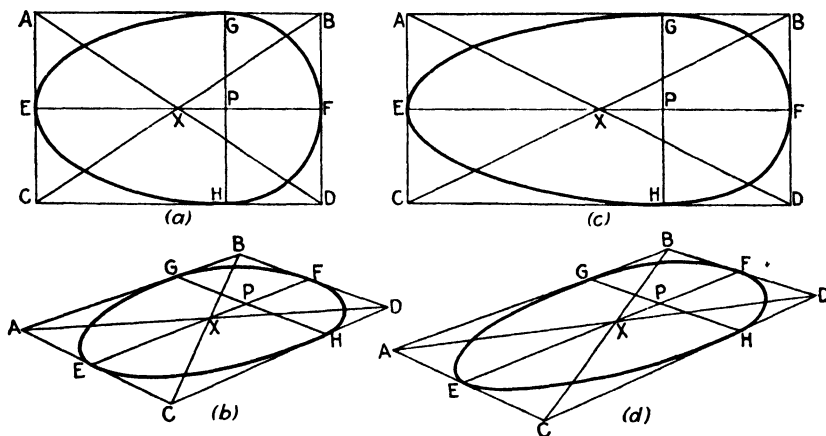

FIG. 48.—Note that X , the center of the rectangle, does not coincide with P , the center of curvature.

roundness but equal minor axes (Fig. 48c) or even, more rarely, of two ellipses in which the minor axis of one is the major axis of the other. These curves are all related to the forms called *streamlined*. In Chap. V we shall see their application to three-dimensional forms.

230. As with all curves so far discussed, the oval in all its variations may be referred to a rectangle for purposes of measurement and construction. The perspective drawing presents no difficulties once we understand the principles that govern their shape. Since the perspectives of two of the variations discussed above are clearly shown in Figs. 48b and 48d, no further elaboration is needed here.

NOTE: The remainder of this chapter concerns curves which, while often useful in drawing, are not so common as those previously discussed. If the teacher or reader so desires, this section may be omitted now and returned to after the rest of the book has been read.

231. A curve closely related to the ellipse is the parabola. This relationship is not evident to the nontechnical reader, but the hyperbola, the parabola, and the ellipse are all what the mathematician calls *conic sections*. The reasons for this name need not detain us here. The parabola is a curve

fundamentally important in certain objects of technical use—searchlight reflectors, for example. It is often met with in the decorative arts as the profile of a bowl or vase, and, with the progress of modern design, it is being used as a motif for many beautiful forms. These are usually the three-dimensional *paraboloid of revolution* described in Chap. V, although, in the form of supporting arches for bridges, etc., the two-dimensional parabola is often seen.

232. One method of constructing the parabola by purely graphic methods is shown in Fig. 49a. In Fig. 49b this same construction is put into a perspective view. It is rarely necessary for perspective drawings to be made with such elaborate precision. The simpler construction of Fig. 49c is usually sufficient.

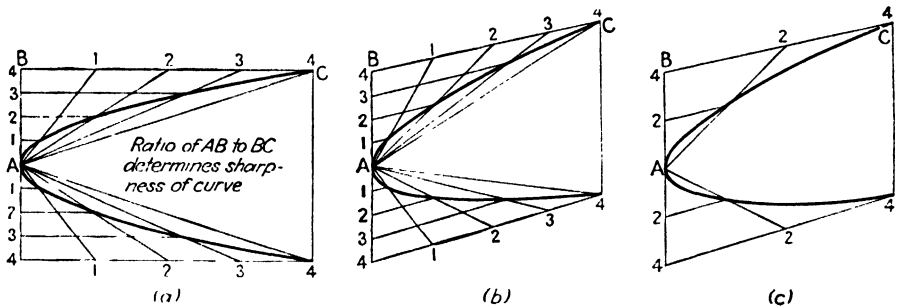

FIG. 49.

233. One more curve is met often enough in practical drawing to be worth analyzing here. This is the spiral. There are several types of spiral: logarithmic, Archimedean, etc. The one shown here is Archimedean, which may be described as the path taken by a point rotating about a fixed point and approaching the fixed point at a rate proportional to its angular movement. This is approximately the type of curve found in watch springs, heating coils, etc.

234. Figure 50 shows this construction. Once again we refer the curve to a rectangular figure, a square in this case. Figure 50 represents a spiral that makes three revolutions before ending in the center P . To construct it we draw EF and GH through the center P . The spiral will then cut each of these lines in turn after each quarter revolution, and, since each complete revolution brings it one-third nearer P , each quarter revolution brings it one-quarter of one-third, or one-twelfth nearer P . Divide EP , FP , GP , and HP each into thirds by points E' , E'' , G' , G'' , etc. Call point E number 1. Now place a point (2) one-quarter of the way from G to G' . One-half of the way from F to F' is point 3. Three-quarters of the way from H to H' is point 4. Point 5 is point E' and the beginning of the second revolution. Point 6 is located one-quarter of the way from G' to G'' , point 7 one-half of the way from F' to F'' , and so on until we come to point 13, which coincides with P . A smooth curve through these points makes the spiral.

235. The spiral may, of course, be curved in the opposite way, and either case may be thought of as expanding *from* the center rather than contracting *toward* it, as it has been treated here. These changes make no practical difference in the drawing procedure.

236. In Fig. 50b the perspective is shown. Fundamentally there is nothing difficult about it. In the instance shown, points E' , E'' , F' , and F'' may be located by direct measurement (EF being parallel to the picture plane) and G' , C' , H' , and H'' located by means of diagonals (not shown in

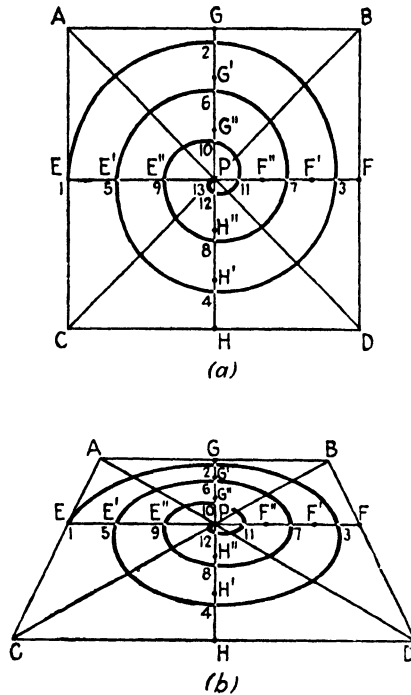

FIG. 50.

Fig. 50b) parallel perspective to BC or AD . If the drawing being made makes it impractical to use the parallel perspective of Fig. 50b, one of the methods given in Chap. III may be used.

237. The spiral need not be constructed in a square, which gives it a roughly circular form. It may also be drawn in a rectangle of any desired proportions. The rows of material in an ordinary rag rug are often arranged in this way.

238. There are innumerable plane curves other than those described here, but they are of little importance in drawing. The curious reader should consult works on analytic geometry, descriptive geometry, calculus, or engineering drawing, if he has occasion to draw such curves as the hyperbola, sine curve, cycloid, conchoid, etc.

CHAPTER V

THREE-DIMENSIONAL CURVES

239. Paradoxically, it is necessary to introduce this chapter with two forms that are not, strictly speaking, three-dimensional curves. Though the cylinder and the cone occupy space rather than mere area, their curvature itself is entirely two-dimensional. All other forms described in this chapter are true three-dimensional curves.

240. It is regrettable that it should be necessary to phrase this so abstractly. However, if the foregoing paragraph is not clear to the reader untrained in mathematics, it is no great misfortune, for an understanding will develop along with practice in drawing, and with the specific examples given below. The eventual aim of all except the most abstract decorative drawing is the creation of form and space, and the study of drawing will eventually cultivate what artists variously speak of as a "sense of space" or the "third-dimensional concept." This comes more with practice than with conscious study, and with its acquisition the meaning of Par. 239 will become clear.

241. The acquisition of a sense of space is the reward of practice and experience. At first it is necessary for the artist or draftsman consciously to realize that a certain line goes from here to there in space and that this must be represented graphically by a line going from this point to that on a sheet of paper, but eventually he ceases to think of the paper as flat at all, subconsciously identifying it with the space he is depicting, just as some musicians can "hear" the notes of a musical score. Naturally this ability is not cultivated in a day. Even though it should require years, that is no reason for discouragement, for conscious effort will serve the same purpose at first, and one day the artist will realize that he has acquired it unaware.

242. Figure 51 illustrates some of the mistakes beginners make when they start to draw cylinders. Once more we must repeat that two of these troubles would be avoided from the start if care were taken to think of the picture of the circle seen at an angle to the picture plane as still a circle, and only apparently an ellipse.

243. In Fig. 51*a* we illustrate an unnecessary error that turns up frequently. The upper end of the cylinder is fully visible, and no difficulty is encountered. When the worker gets down to the bottom, however, he simply draws a curved line between the two verticals and considers his duty done. This gives him a lower circle with right- and left-hand corners. Circles do not have corners. The falsity is revealed by continuing the curve

a little farther, when it is seen not to curve around the cylinder at all, but to wander off into space. The cure may be summed up in a precept that holds good in a thousand other instances: "*draw the invisible lines.*" Never forget that the back of the cylinder is there, even though you can't see it. The second cylinder in Fig. 51a is drawn with the invisible part of the lower circle indicated. It should be noted how the visible part of the curve

merges imperceptibly into the vertical outline, giving the feeling of true roundness, rather than the squashed effect of the first "cylinder."

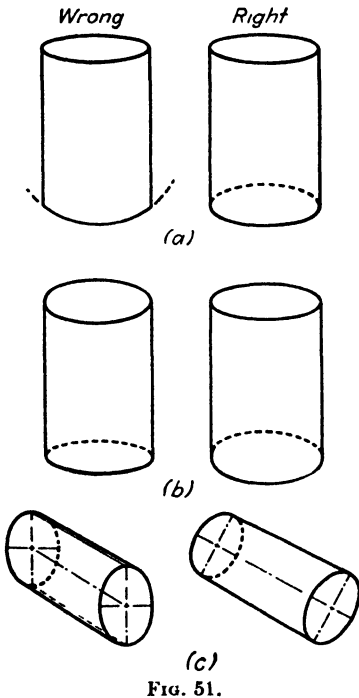

FIG. 51.

merges imperceptibly into the vertical outline, giving the feeling of true roundness, rather than the squashed effect of the first "cylinder." **244.** There are times, particularly in decorative or nonrepresentational drawings, when the effect decreed here is acceptable or even preferable. Since this involves considerations of design and aesthetics, which are outside the scope of this book, we shall not discuss them here, except to say that such results should be the product of design and forethought, not ignorance. **245.** Figure 51b shows a subtler error. The draftsman has learned that the circle has no corners, but he has forgotten that, as the plane of that circle gets farther from the eye level, its elliptical appearance becomes more open. Had the first cylinder in Fig. 51b been drawn in a square prism, the error would have been evident; standing alone it is harder to detect. The general rule is this: a circle in a horizontal plane at the eye level appears as a straight line; as this plane rises above, or drops below the eye level, it appears as an ellipse. When the plane is close to the eye level, the ellipse is long and narrow; when it is far from the eye level, either above or below, the ellipse is more open, *i.e.*, more nearly circular, and the change in a curvature is proportional to the distance from the eye level.

246. In Fig. 51b the first cylinder shows a disregard of this; the lower ellipse, though farther from the eye level, showing the lesser curvature.

247. Figure 51c shows the third common error, easily avoided by drawing the cylinder in a square prism as in Fig. 54a. In the left-hand drawing of Fig. 51c the axis of the ellipse on the end is vertical. This seems only natural—vertical plane, vertical axis. Unfortunately, it isn't so. Ordinarily, the axis of the ellipse will be approximately at right angles to the axis of the cylinder, as shown in the right-hand drawing of Fig. 51c. We say approximately true, because it is strictly true only when the cylinder is near the center of vision. There is one important exception to this general

rule: when the cylinder is parallel to the picture plane, its axis is never perpendicular to the major axes of the end circles except when it lies on the eye level.

248. Figure 52 shows the steps involved in drawing a cylinder accurately. The first step, shown in Fig. 52a, is to draw a rectangle having the same height as the desired cylinder and a width equal to its diameter. An eye level is chosen consistent with the size and position of the cylinder according to the principles outlined in Chaps. I and II. The vanishing point is then located on this eye level and for convenience is centered above (or below) it.

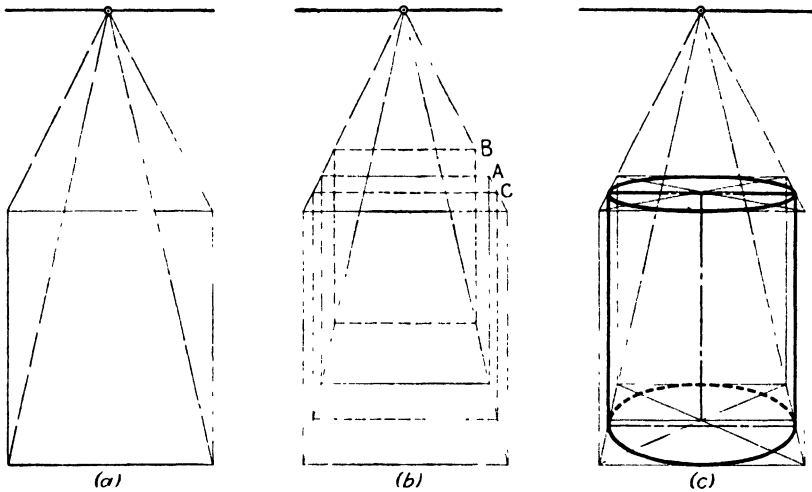

FIG. 52.

Lines are now drawn from the four corners of the rectangle to the vanishing point.

249. A peculiar question now arises. Where shall we place the back of the square prism we are constructing? As long as we are drawing just this isolated cylinder this question has no specific answer. Generally we may say, "wherever it looks right." Planes *B* or *C* would do as well, for purely geometric reasons, as plane *A*, actually selected. The only difference is that plane *B* implies an excessively close view, while plane *C* implies an excessively distant view. Thus, while there is no geometrical reason for preferring the position of plane *A*, there is a very compelling appearance reason.

250. When the square prism is completed, the remainder is simple, with one important caution: *never draw the side outlines first*. Always begin by drawing the top and bottom circles. The sides are then added by drawing verticals at each side so that they are just tangent to the two circles. If this order of work is not followed, there is a tendency to force the ellipses out of shape to conform to a preconceived side outline.

251. In the foregoing paragraph the words *ellipse* and *circle* were both used in reference to the same parts of the cylinder. This was done advisedly. The term *circle* was used in referring to the ends of the cylinder, because these ends *are* circles in fact, and must be so thought of, if a real three-dimensional concept is to be cultivated. When referring to the side out-

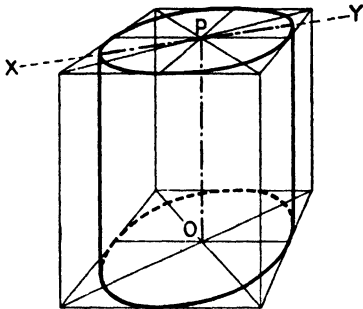

(a)

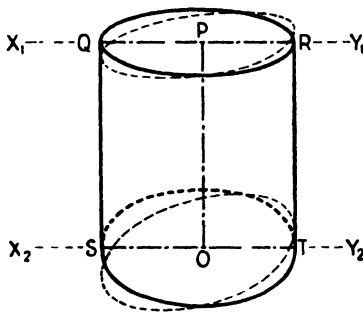

(b)

FIG. 53.—The form shown at (a) must be used when the cylinder is shown in relation to rectangular forms such as a square tiled floor surrounded by round columns. The form at (b) is more convincing when the cylinder stands by itself.

lines touching the ends, it was necessary to speak of the *ellipses* because in this instance it was the *apparent* shape that had to be considered.

252. Figure 53 demonstrates a principle that was briefly referred to in Chap. IV, Par. 228. When a cylinder occurs near the edge of a picture its angular distance from the line of vision will cause it to appear distorted, as in Fig. 53a. This results mainly from the artificial assumption that the picture plane is truly flat. As long as the angle of view is not too great, this assumption works well enough; but, when circumstances force a greater angle than about 30 deg., it becomes necessary to compensate in some way.

253. In Par. 247 we pointed out that the major axis of the ellipse representing the circle on the end of a cylinder is usually perpendicular to the axis of the cylinder, but in Fig. 53a the axis *XY* is not perpendicular to *OP*. However, if we take a figure like 53a and then draw, through *O* and *P*, *X₁Y₁* and *X₂Y₂* perpendicular to *OP* and meeting the sides in *Q*, *R*, *S*, and *T*, we may then draw two new ellipses using *QR* and *ST* as axes. This will give Fig. 53b, which has the

same width as the cylinder in Fig. 53a but with the ellipses on the ends in a better relation to the cylinder axis. Though this figure is not geometrically correct, it is optically more convincing and hence more sound in work of a pictorial nature.

254. Figure 54a illustrates a cylinder “lying down.” Basically the problem is no different from previous examples. A square prism is drawn; in each end of the prism circles are constructed; and the outlines of the form are finished by drawing lines above and below, tangent to the circles at each end. Note that angles *aa* and *bb* are right angles.

255. Figure 54b shows the case of a horizontal cylinder with its axis parallel to the picture plane. The construction is identical with that of

Fig. 54a. It can be seen, however, that angles aa and bb are not right angles. Here again a little judicious forcing would improve the appearance of the figure.

256. The clock in Fig. 54c is a favorite trick problem in perspective classes, because most beginners can be relied on to get themselves trapped in the clock tower. If the student will bear in mind that there is another face that he cannot see behind each of those he can see, the relation of major axis and cylinder axis will reveal itself, and no difficulty need be experienced. If the circle is constructed within the square as described in the preceding chapter, this difficulty will also be avoided. But when the student attempts to draw the ellipse and use the vertical center line of the square as its axis he is bound to get into trouble.

257. When a cylinder stands by itself and there is no need to set it exactly on any particular horizontal plane, it is possible to construct it by the shortcut method of Fig. 55. The procedure is as follows: Draw a rectangle having the height AC of the cylinder and a width AB equal to the diameter of the cylinder. Let AB be the major axis of the top, and CD the major axis of the bottom ellipse. Find the mid-points P and O , of each of these. Through O draw GH at right angles to CD . Make GH less than CD and $GO = HO$. EF is drawn through P in the same manner, but EF must be smaller than GH , because the plane of the top is nearer the eye level. If the cylinder were to be shown as above the eye level, the reverse would be true. Now draw the ellipses $AEBF$ and $CGDH$, and the cylinder is complete.

258. In Fig. 55, if the line AB had shrunk to a point, changing the rectangle $ABCD$ to a triangle PCD , the figure derived from it would have been a cone, standing on its base. If CD had shrunk instead, the cone would be standing on its apex. If AB should be made somewhat shorter than CD ,

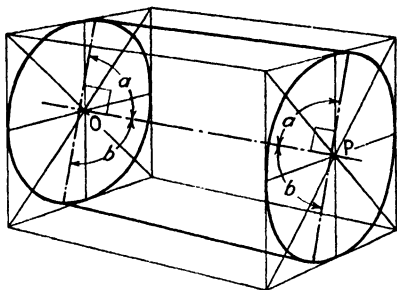

(a)

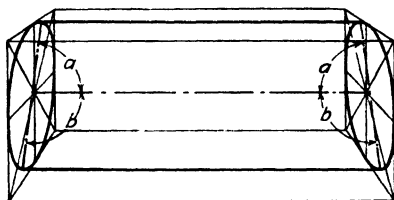

(b)

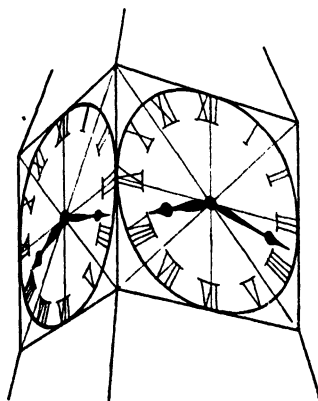

(c)

FIG. 54.

making a trapezium instead of a triangle, the result would be a *truncated cone*. Since these forms are constantly turning up in practice, it is well to remember that, by making the above modifications in the rectangle, they may be constructed in the same manner as the cylinder.

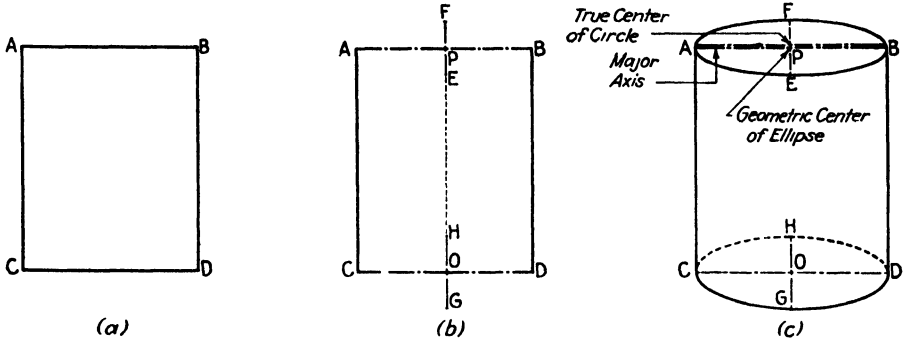

FIG. 55.

259. It is not generally realized that a cylinder need not be circular in cross section, and moreover that the axis need not be perpendicular to the planes at the ends. The type of cylinder that meets these conditions is

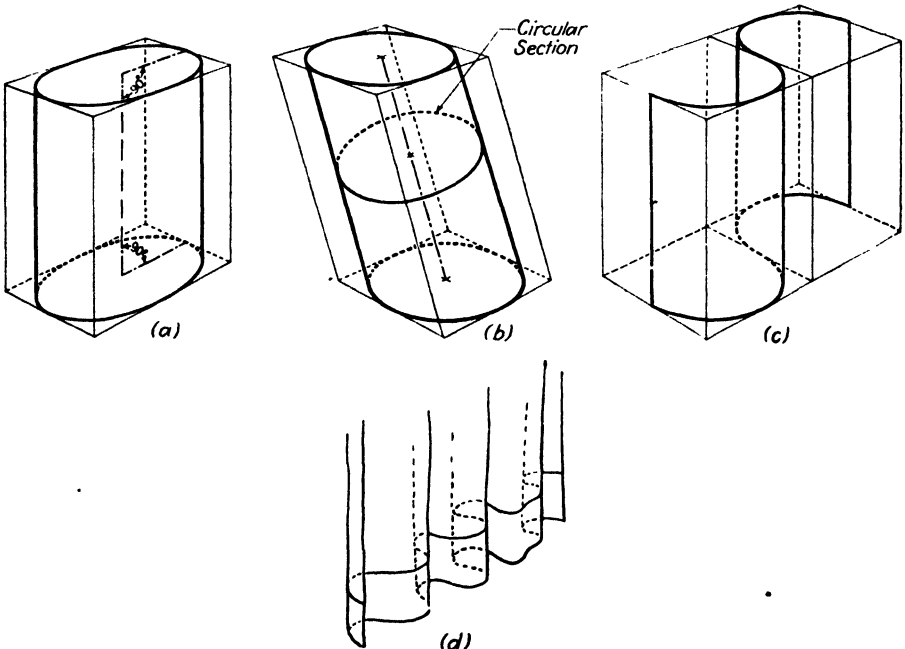

FIG. 56.—Nonright-circular cylinders.

called, in geometry, a *right circular cylinder*. Other types are sometimes met, and a few of these are shown in Fig. 56. Figure 56a shows a *right elliptical cylinder*, *i.e.*, a cylinder having an elliptical cross section and an

axis perpendicular to the end planes. Figure 56b is an *oblique circular cylinder*. In this case the cross section is circular and the axis is not perpendicular to the end planes. The end planes are elliptical because of the angle they make with the axis, but the cross section at 90 deg. to the axis is truly circular. Figure 56c shows an open curve giving a compound

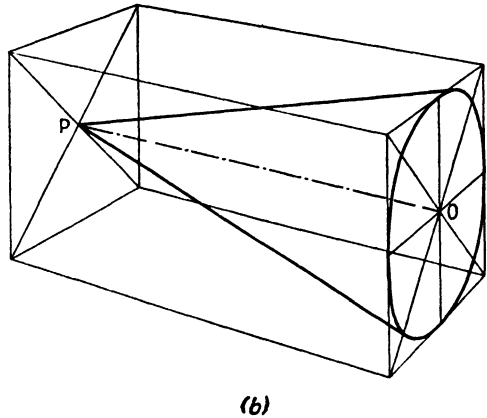
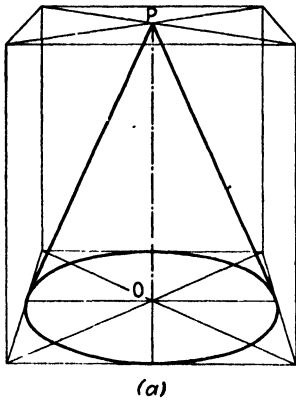

FIG. 57.

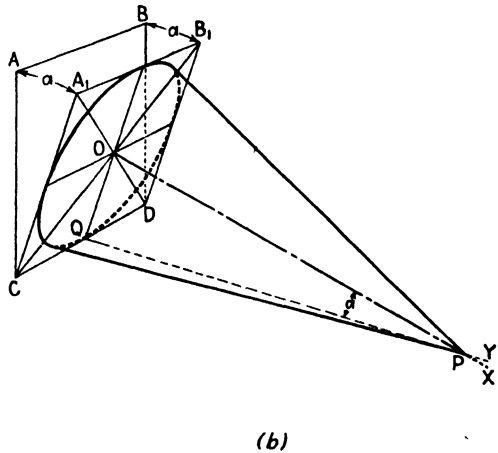
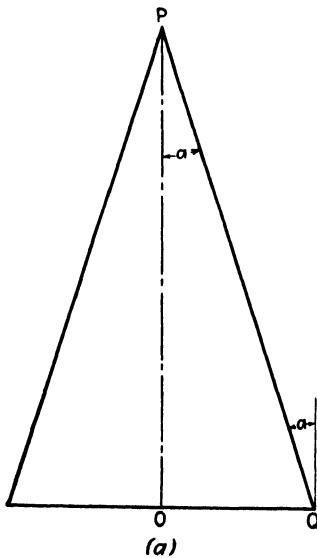

FIG. 58.

cylinder with the axes perpendicular to the end planes. Figure 56d shows the bottom of a curtain. Note its kinship with 56c.

260. Drawing the cone is even simpler than drawing the cylinder. In Fig. 57a the construction for a right circular cone standing on its base is shown. The construction is identical with that for a right circular cylinder except that, instead of a circle at the top, the sides come together at the

point P , which is called the apex. When the axis of the cone is horizontal the construction is that of Fig. 57b.

261. When the cone is lying down on a horizontal plane, accurate construction is a little more difficult. Suppose Fig. 58a represents the elevation or orthographic projection of the cone in question. Any line QP (called an element) makes the angle a with the vertical. The construction is shown in Fig. 58b. Draw a perspective square $ABCD$ having sides equal to the diameter of the base of the cone; then tip the square so that angles ACA_1 and BDB_1 are equal to angle a . Draw a perspective circle inside the new square A_1B_1CD . From the center O , and perpendicular to the plane A_1B_1CD ,

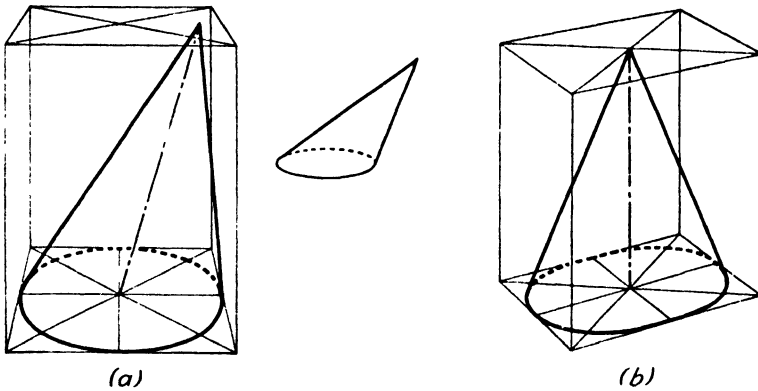

FIG. 59.

draw OX . From Q draw QY so as to make angle a with OX . Where OX meets QY is the apex P . From P draw tangents to the base circle. The foregoing construction is not necessary in ordinary pictorial work, estimation being usually sufficient, but it may be needed in technical illustration.

262. Although they occur rarely in drawings, other cones than the right circular type we have been discussing do occasionally turn up. The oblique circular cone of Fig. 59a is simple to construct. It is a form sometimes seen in such objects as air ducts, delivery chutes, etc. It may even take the extreme form illustrated in the small sketch in Fig. 59a. Figure 59b shows a right elliptical cone. Since the similarity of construction to the cylinder is so complete, we shall not bore the reader with an explanation of it.

263. One of the commonest forms encountered in drawing is the *truncated* (cut off or incomplete) cone. An ordinary water tumbler is one example. When great precision is required, the best method of drawing it is that of Fig. 60a. A square prism having a width AB equal to the diameter of the larger end of the cone is drawn in one-point perspective. At the lower end CD the actual width EF of the lower circle is laid off and projected back toward the vanishing point. When the diagonals of the lower square are drawn, they will cross lines Evp and Fvp at points $G, H, I,$

and *J*. These points determine the square within which the lower circle is drawn. When the sides are drawn, tangent to the two circles, the drawing is complete.

264. For ordinary work the quicker method of Figs. 60*b* and 60*c*, which is similar to that shown in Fig. 55 for the cylinder, is more practical. This method may be used in the majority of drawings, provided certain characteristics are taken into account. Note, first, that it produces a larger image than does the method of Fig. 60*a*, and, second, that it makes no provision for the exact placing of the glass on its supporting plane. Thus, though several times quicker in execution, it places greater demands on the judgment and skill of the artist.

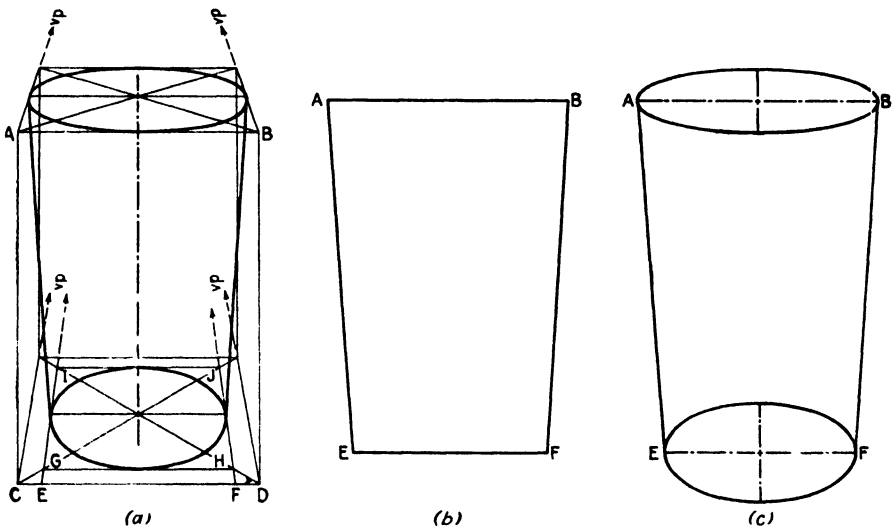

FIG. 60.

265. Ordinarily, in drawing such a glass as this, the thickness must be taken into account, although this is often so slight that it would be included in the width of the outline. In the case of heavy glass, where the thickness is appreciable, it is simply a matter of drawing a slightly smaller cone inside the first one. Any slight curvature of the base would be invisible in a pure outline drawing and hence could only be indicated by rendering, which is beyond the scope of our subject.

DOUBLE-CURVED FORMS

266. We have already remarked that the cylinder and the cone are solids having single or two-dimensional curvature. If you lay a pencil against the side of a cylinder parallel to the axis, it will touch the cylinder throughout its length. If the pencil were placed against the side of a cone and pointed to the apex, it would again touch throughout its length. If you make this test with any sphere, such as a tennis ball, or any of the other

double-curved solids described below, you will find it impossible to make the pencil touch more than one point. Another way of demonstrating the difference between the curved solids just discussed and those we are coming to is to bend a rectangular sheet of paper around until the ends meet. A very neat cylinder is formed. By making the seam overlap more at one end than at the other, we can form a passable truncated cone. By carrying this overlap to the limit, we obtain a perfect cone except for the base.

267. No amount of bending, however, will make it possible to form even a poor *sphere* with a sheet of paper without puckering. For this reason, manufacturers of tennis balls, baseballs, and the like, form the material with which they cover their products like this:

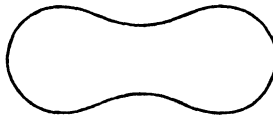

When two pieces of this shape are stitched or cemented to a spherical core, they permit a minimum of puckering. Even so, they are not quite perfect, as a careful examination will show; there are usually some traces of strain at the seams.

268. We may seem to have strayed rather a long way from the subject of drawing, but this distinction between two- and three-dimensional curves is not usually made clear enough, and lack of knowledge of it leads students into unnecessary difficulties. A few one-sentence descriptions may be put down as follows:

1a. *Single-curved surfaces* (cylinder and cone) contain some straight lines, or rather, straight lines can be drawn on them in certain positions.

1b. *Double-curved surfaces* (sphere, ellipsoid, ovoid, etc.) contain no straight lines, and straight lines cannot be drawn on them.

2a. *Perfect single-curved surfaces* may be made from flat material without puckering.

2b. *Perfect double-curved surfaces* may be made only by molding, forging, carving, or some other process that will alter the shape in three directions at once.

269. Many others might be listed, but 2b is particularly important because it contains the essence of much that is highly important in all the plastic arts. The double-curved surfaces treated in this chapter are all of a relatively simple character. Further on, we shall encounter surfaces of subtle and irregular curvature. These are called *plastic* forms. The sphere, etc., are the connecting links between the forms we have been treating, called *architectonic* or *tectonic*, and the plastic forms. Since plastic forms are the most difficult to draw, it will pay the reader to study carefully the remainder of this chapter, even though it may be rather heavy going. This effort will be well repaid in increased facility of understanding later on.

270. It will be recalled that the circle can be drawn in a square. Its three-dimensional relative, the sphere, can be drawn in a cube. In drawing a circle we find it convenient to draw the two diameters at right angles to each other. In drawing the sphere it is helpful to draw three *cross sections* through the center at right angles to one another. These cross sections are circles of the same diameter as the sphere.

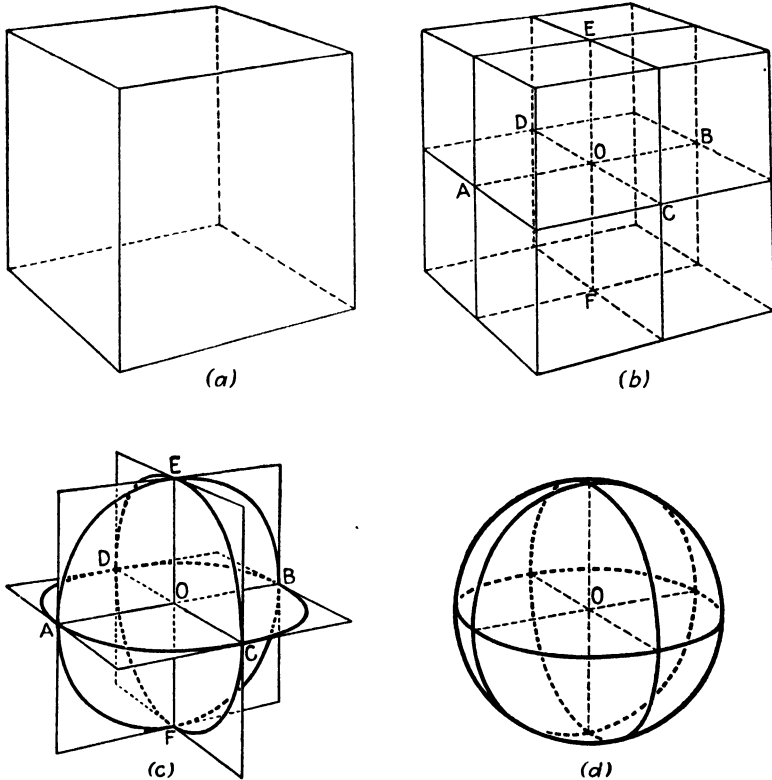

FIG. 61a to d.—In *d* compass center for outline of sphere is slightly below point *O*.

271. In drawing a sphere the first step (Fig. 61a) is to draw a cube having sides the same length as the diameter of the desired sphere. This is unnecessary in cases where the exact location of the sphere is not important, for the outline is a circle and may be drawn as such; but, when the sphere must be located with precision, the following procedure or the abbreviation of it described in Par. 275 and in Fig. 62 must be used. In any case these steps should be studied, as they are basic in the drawing of a large number of more complex forms.

272. The next step (Fig. 61b) consists in locating and drawing three planes through *O*, the center of the cube, one plane being parallel to the top and bottom, one to the front and back, and one to the sides. This is easily done by methods given in Chap. III. These planes will cross in lines *AB*,

CD , and EF , and the points A, B, C , etc., are the points where the sphere just touches the cube. These points of tangency are important when locating the sphere relative to other objects.

273. It is really these cutting planes, rather than the cube itself, which we use in this construction. On them three perspective circles, $ACBD$, $AEBF$, and $ECFD$, are drawn, as shown in Fig. 61c.

274. In the final stage (Fig. 61d), a smooth curve is drawn around the outside of the circles. This is the outline of the sphere. If the sphere is at or near the center of vision, this outline will itself be a circle and may be

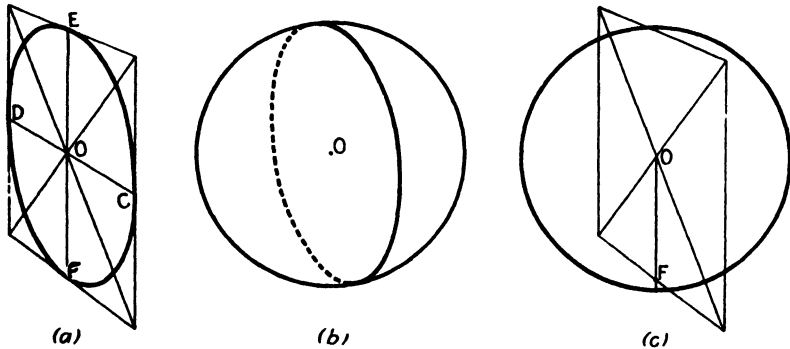

FIG. 62.

drawn with a compass. If too wide an angle of vision has been used and the sphere is near the outer limits, it will have a somewhat distorted outline if strict geometric accuracy is adhered to. In most pictorial work it is better to force the circular outline in such cases, for the result will be visually more pleasing for reasons similar to those given in the case of the cylinder (Pars. 252 and 253). Further explanation of these reasons will be found in Chap. XIV.

275. It is possible to eliminate many of the operations detailed in the preceding paragraph and in Fig. 61. These were given in full in order to promote structural comprehension and to make easier the understanding of some of the forms that are related to the sphere and are described in the remainder of this chapter. Figure 62 shows the method most useful in practice. Any one of the central planes may be located without the trouble of drawing the rest of the cube. In this figure we have used $ECFD$ because it happened to be convenient, but either of the other two would have served. (In locating the sphere on a horizontal plane, one of the vertical sections should be chosen.) When the required plane has been located and the ellipse drawn, the compass point is then placed at O and a circle drawn which just touches the ends of the ellipse. If great exactness is not required, it is sufficient to locate O and simply to swing a circle with a radius a trifle greater than OF , not troubling to draw the ellipse at all. This is shown in Fig. 62c.

NOTE: The remainder of this chapter deals with forms of a more subtle and unusual character than those discussed so far. Though they occur frequently in practical drawing, a knowledge of them is not absolutely vital to the understanding of the general subject of perspective. The reader or teacher may therefore find it desirable to omit this section for the time being, returning to it after the balance of the book has been studied. A study of these forms will aid greatly in the comprehension of advanced drawing problems, particularly those involving plastic forms, although it may be wise to delay consideration of them until the whole subject of perspective has been digested. The forms are discussed in this chapter for systematic reasons—since they are space curves, they come naturally under the chapter heading.

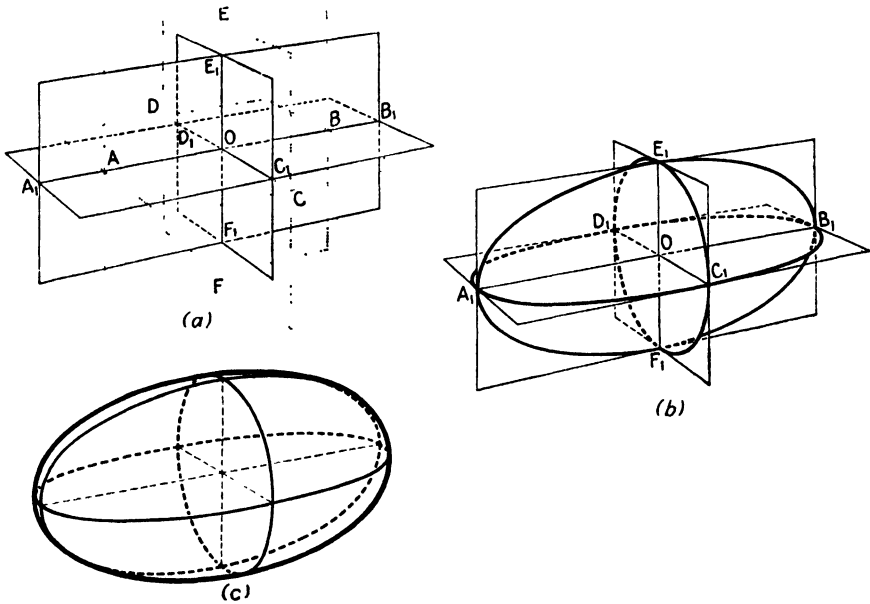

FIG. 63.

276. The sphere has three close relatives, all of which may be constructed by using the method of Fig. 61. Unfortunately, the quick method of Fig. 62 is not available for these forms, since they are not compass curves. The first of these is best exemplified by the ordinary football (American—not English). It is one variety of *ellipsoid* and is called a *prolate spheroid*. If an ellipse is revolved about its major axis, it will generate this form. It is not necessary for the reader to remember these names, but the construction of the forms is often useful.

277. The construction of this solid can easily be understood if we think of a stretched-out sphere. If it is stretched along one line, it will shrink at right angles to that line. In Fig. 63a we start with a set of squares at right angles to each other, just as in Fig. 61b, then stretch the line AB to the length A_1B_1 . To compensate for this, the lines CD and EF shrink to C_1D_1 and E_1F_1 . This gives us the new cross-sectional planes, indicated by solid lines, of Fig. 63a. Two of these planes become longer and narrower,

while $ECFD$ becomes smaller but keeps its square shape. If we now draw the three curves that naturally fit these rectangles, we shall have the result shown in Fig. 63b. If this is compared with Fig. 61c, it will quickly be seen what essential change has been made. These curves form the skeleton for drawing the new form.

278. In Fig. 63c the skeleton has been covered with an outline. This produces the prolate spheroid, which is often confused with the egg form, or ovoid, just as the ellipse is often confused with the oval. The construction of the ovoid is shown further on.

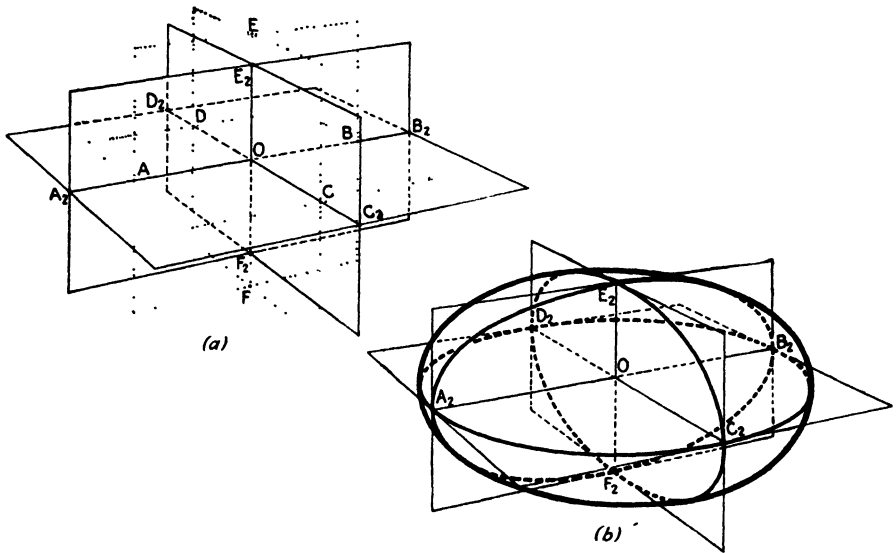

FIG. 64.

279. If our imaginary rubber ball is compressed instead of stretched, the result will be the *oblate spheroid*, shown in Fig. 64. In this case one of the axes *shrinks* (EF in Fig. 64). The compression along this line causes expansion along the other two axes, AB and CD , extending them to the new lengths A_2B_2 and C_2D_2 . The plane $A_2C_2B_2D_2$ is a perspective square,¹ and a perspective circle may be drawn in it. The other two planes $A_2E_2B_2F_2$ and $C_2E_2D_2F_2$ are rectangles of unequal sides and thus contain ellipses. These curves are drawn in Fig. 64b, and the outline is added. This form does not turn up as often in drawing as some others, but an example may be seen in the average doorknob. On a vastly larger scale, the earth itself, being slightly flattened by the effect of its rotation, is an oblate spheroid.

280. Figure 65 illustrates a form susceptible of wide variation. Bird's eggs are this type of form. It is this which gives the name ovoid to this

¹ The word *plane* is used here in its popular sense as something having length and width or height and width only, no thickness. In geometry a plane is considered to have no limit in its two dimensions.

form. If the oval of Fig. 48 in Chap. IV is rotated about its axis, it will cut an ovoid path through the air. If the sphere of Fig. 61 is stretched from B to B_3 as shown in Fig. 65*a*, it will produce the same result. The part of the ovoid to the left of plane $CEDF$ is half of a sphere. The part to the right of this plane is half of a prolate spheroid.

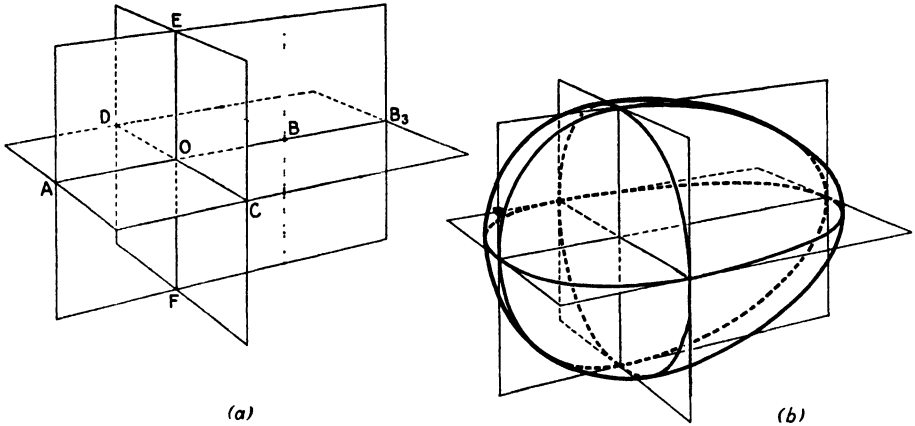

FIG. 65.

281. The ovoid may also be made up of halves of prolate spheroids of different degrees of curvature, and in a long narrow form is familiar as the “streamline” shape, which is the basic shape of airplane hulls. This form is important in many applications, since it offers a minimum of resistance to movement through air or water and has so captured the popular imagination that we now have “streamlined” iceboxes and stoves. Since shapes of this kind are constantly turning up in the practice of drawing, it is well worth studying.

282. The drawing construction for the ovoid presents no difficulties if the construction of the preceding figures (61 through 64) has been understood. Consequently, it need not be repeated here.

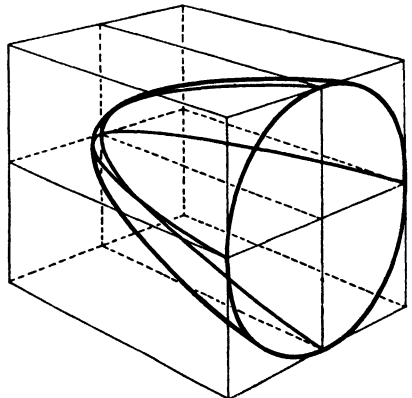

FIG. 66.

283. If the parabola of Fig. 49 in Chap. IV is rotated about its axis, it generates a *paraboloid*, shown in Fig. 66. To construct it the three cross sections are drawn. Two of these are parabolas, the third a circle. This form is found in special-purpose reflectors of many kinds: automobile headlights, military searchlights, hand flashlights, desk lamps, and wherever light must be concentrated in a beam. It differs from the sphere and the

spheroids in being open at one end, but the drawing construction involves nothing new. Its curvature may vary from a shape almost as long and narrow as a cigar to something as nearly flat as the crystal of a watch. Of the latter, the most spectacular example is the new 200-in. reflector of the Mount Palomar telescope. Naturally this type of form will turn up oftener in technical drawing than in general illustration.

284. Machine screws, springs, circular (so-called "spiral") staircases, some varieties of ornament, coils of many kinds, etc., are based on the *cylindrical helix* shown in Fig. 67. The helix is sometimes mistermmed *spiral*, after its two-dimensional relative. If you wind a piece of string around a pencil, you will have a very good helix.

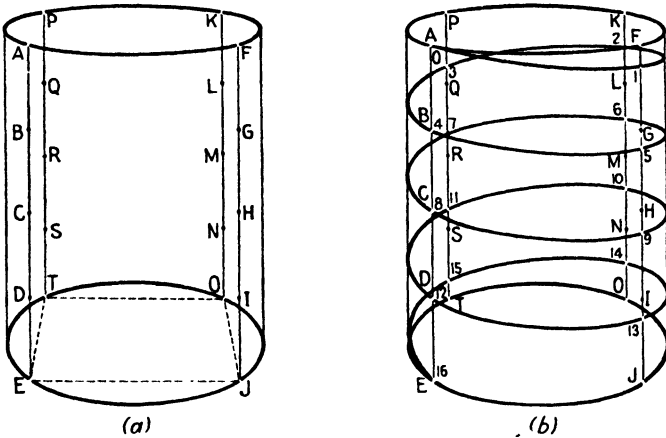

FIG. 67.

285. Suppose a helix is to make four complete turns in descending from top to bottom of a cylinder. To draw it the procedure is as follows: Draw a cylinder, locate on its base four points equally spaced about the circumference, and erect verticals at each of these points. Divide each of these verticals into four parts. (If, as in Fig. 67a, the helix starts at point A, it will have reached point B, one-quarter of the distance AE, at the end of its first revolution. Furthermore, at the end of its first *quarter* turn it will have dropped *one-quarter* of this distance, or one-sixteenth of the entire drop. This means that, by the time it has reached the line FJ, it will have dropped one-quarter of FG. When it reaches the next line KQ it will have dropped one-half of KL, at PT three-quarters of PQ, and will finish its revolution at point B.) Let point A be 0 (zero), then point 1 is $\frac{1}{4}$ FG below F, point 2 is $\frac{1}{2}$ ($\frac{3}{4}$) KL below K, point 3 is $\frac{3}{4}$ PQ below P, and point 4 is $\frac{3}{4}$ AB below A, *i.e.*, point B is point 4. Similarly point 5 is $\frac{1}{4}$ GH below G, and so on until we reach E, which is point 16. The curve is now drawn through these points.

286. Although less common than the cylindrical helix of Fig. 67, the conical helix of Fig. 68 does occur, particularly in technical work. The procedure is practically the same except that the four points *A*, *F*, *K*, and *P* at the top of the cylinder come together at the apex *V* of the cone. In order to prevent overlapping, in this figure the four equidistant points *E*,

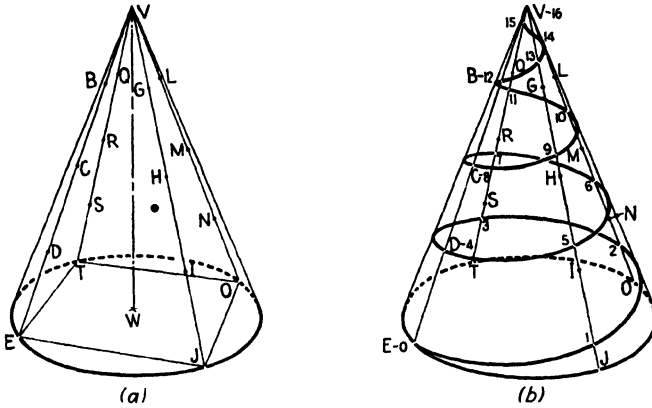

FIG. 68.

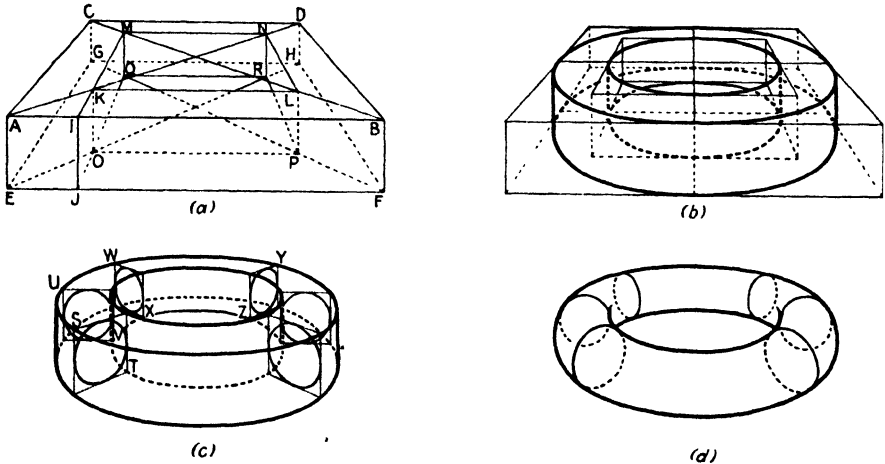
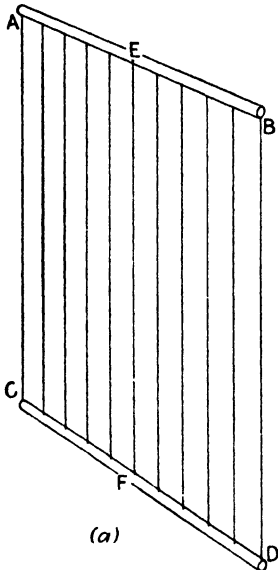

FIG. 69.

J, *O*, and *T* at the base are placed so that lines connecting them will not be parallel to the picture plane or the line of sight. In this case it is more convenient to start the drawing from the base of the cone rather than the top, as was done with the cylinder. The nontechnical artist need not concern himself with this form, since it appears rarely in practice.

287. We come now to one of the most difficult of all the curved forms—the torus. The doughnut is a torus. The commonest example of this curve is the inner tube of a tire, while the shoe of the tire is a modification

of the same curve. Advertising illustrators sometimes get around the difficulty by tracing photographs, but this help is not always available, or sometimes the size and position are wrong. Consequently it has seemed worth while to describe the construction here. Since the construction given is helpful in laying out details such as tire tread, etc., it is given in some detail.



(a)

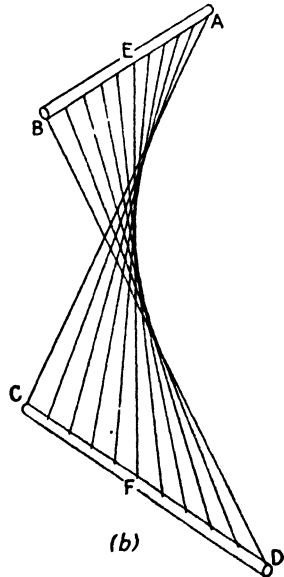

(b)

FIG. 70.

288. The torus may be described as a cylinder bent around in a circle until the ends meet. It is therefore a "curved curve."

289. Suppose we are drawing an inner tube. We start by drawing a square $ABCD$ (Fig. 69a) having sides equal to the over-all diameter of the form. The square $EFGH$ is now drawn, parallel to the first square and separated from it by the distance IJ (or BF , etc.) equal to the thickness of the tube. We now have to construct the "hole in the doughnut." Since the tube proper is circular in cross section, the hole will be a distance IK , perspectively equal to IJ , in from the outside. So we draw the square hole $KLMN-OPQR$, centered inside the square solid $ABCD-EFGH$, using the diagonals as guides. Circles are drawn in each of these squares, as in Fig. 69b, and the sides connected to form inner and outer cylinders, giving us the "square ring" of Fig. 69c. Cross-sectional squares ST , YZ , etc., are now drawn at convenient positions, and circles are drawn inside them. The outlines drawn around these circles completes the job, as shown in Fig. 69d.

290. If the reader has had trouble following the description of the steps involved in this construction, it is suggested that he take pencil and paper and try performing them himself. If understanding still eludes him, it might be well to pass it up for the time being and return to it after studying the succeeding chapters. With further practice this form will seem much less formidable.

291. There exist many other three-dimensional curves, but most of them are of interest only to the mathematician or the engineer. For the curious a

book on descriptive geometry and one on calculus will show the properties of such curves as the hyperboloids, conoid, hyperbolic paraboloid and others. They turn up too rarely in drawing to warrant discussion here.

292. One more form, however, may be mentioned before we end this chapter. This is the *warped surface*. If you take two sticks and fasten rubber bands of equal length, equally spaced, between them, as in Fig. 70a, they will mark out a sort of plane between stick *AB* and stick *CD*. If you now twist these sticks to that they are no longer parallel to each other, you will get the result shown in Fig. 70b, which is an exaggerated illustration of what happens when a plank of wood warps. The line *EF* will retain its original length while the others will stretch, with the maximum stretch occurring at *AC* and *BD*. The lines will all remain straight, and yet the surface they lie on will be curved.

293. This type of curvature has considerable value in drawings where a feeling of movement is to be captured, and it has been widely used in modern sculpture where its value in design is enormous. It is on the borderline of the plastic forms discussed in Chap. VII.

294. The past two chapters have been rather abstract in subject. The reason is the natural one that very few real objects are perfect examples of the forms discussed in these chapters, being rather modifications or compounds of them. It was therefore felt to be more advisable to defer discussion of such real objects until they could be dealt with in their proper order, rather than to drag them in where they would tend to confuse rather than enlighten.

295. In this chapter the distinction between outline and edge has become important. Outline does not really exist except in a drawing, but an edge is a positive and measurable thing. Outline is the demarcation between an object and surrounding space, whereas an edge may be wholly within an object. A sphere has no edges, while a cube has both. A cylinder has edges at top and bottom and none at the sides. These terms are frequently confused. The small sketches below should make the difference clear.

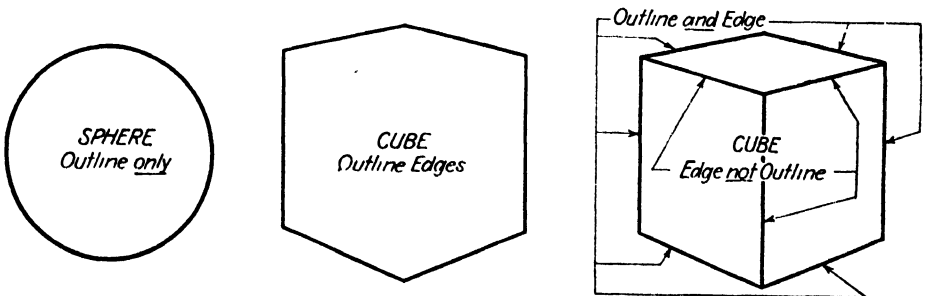

Remember: Edges may be outlines, or outlines may be edges, but many outlines are not edges, and many edges are not outlines.

CHAPTER VI

COMPOUND FORMS

296. Practically all real objects are compound forms, *i.e.*, instead of being cubes, spheres, rectangular prisms, etc., they are combinations of two or more of these, or in some cases of two or more of the same class of forms. Even when an object seems to be a simple cylinder, for example, it will usually be found that its thickness makes it, for drawing purposes, not one but two cylinders, one inside the other. Even more frequently we find parts of forms combined with other partial or complete forms, and the bewildering variety that may be built up from these is likely to confuse the student until experience shows him that nearly every object, no matter how complex, may be resolved into one or more of the basic geometric forms or into the plastic and soft forms discussed in Chap. VII.

297. Since the number of variations, not counting size, of forms in actual daily use runs into the billions, it is impossible to discuss in this chapter more than a few typical examples. Our purpose here is to provide working methods, not to solve every problem ever to be encountered.

298. In actual drawing practice the student will find that it pays him well in time saved and in soundness of drawing to take a few minutes to make a mental analysis of the object he is drawing with the purpose of noting into what basic forms it may be resolved. To illustrate the meaning of this as well as to demonstrate a working method, most of the examples in this chapter are presented in semireverse order. First we shall show the complete drawing; then we shall go back to the beginning and show how it was built up.

299. No two persons will proceed in exactly the same manner, and it is not our purpose to inculcate a rigid formula. Such variations as the reader may find suited to his temperament are all to the good, provided it is borne in mind that solid construction and thorough understanding of the anatomy of the thing drawn must precede the finishing. No amount of fussy ornament, flourishing signature, or slick airbrush work can do anything to make a bad drawing good, but it is surprising how well a good drawing can survive poor technique. This must not be taken as an argument for bad technique, of course, and it will usually be found that good technique grows naturally out of good drawing.

300. The drawing of compound forms will turn out to be less difficult in practice than one would at first expect, because construction lines may usually be made to serve for two or more parts of the form. Furthermore,

some small details need not be completely analyzed. The scale of the drawing and the thickness of line used will usually suggest where to stop in fineness of detail. Still further, much work may be saved by treating repeated forms, such as stair steps, fluting, reeding, decorative moldings, etc., as groups rather than as individual units. Methods for doing this were shown in Chap. III and will be further elaborated in this chapter.

301. In Fig. 71*a* we show a form that is really quite simple, consisting purely of a combination of rectangular solids all of the same thickness. Despite the simplicity it is surprising how often students have difficulties with this type of structure. The main source of trouble is inability to see the basic simplicity. For this reason we show the complete article in Fig. 71*a*, then show in the following figures how the drawing is built up from its elements.

302. The article from which the illustration was made was a display table built for the exhibition of small articles and having the dimensions shown. Since the material used was 1-in. plywood throughout, thickness dimensions have been omitted.

303. In drawing an article of this kind it is convenient to use a standard of measurement that will compare with the principal dimensions in as easy a ratio as possible. In this case a 2-ft. cube was taken, as indicated by the shaded section. The reason for using this was that the given dimensions all make easy ratios: 6 in. is one-quarter of 2 ft.; 1 ft. is one-half of 2 ft.; 3 ft. is one and one-half times 2 ft., etc. A 3-ft. cube might have been used with a trifling gain in accuracy due to the larger scale, but it would not be worth the additional trouble of performing graphic division by three. Division by two involves nothing but finding the intersection of two diagonals; division by three involves other measurements as well.

304. In this instance all the gross dimensions fit exactly into the fractions and multiples of the 2-ft. cube used as a standard of measurement. Should this happy state not exist, it need cause no trouble. A matter of an inch or so, over or under the exact half, quarter, or what not, may be estimated and allowed for by eye measurement with adequate accuracy. But should the artist not trust his own accuracy at estimation, or be under strict limits of tolerance or precision, the cube may be broken down into eighths, or even sixteenths. With such refinement it is possible to form estimates literally quite as accurate as the most careful projection from plans. Unfortunately, it is just as much trouble, too.

305. The first major step in the work is the construction of two rectangular solids, as shown in Fig. 71*b*. The first of these is the larger one, 2 ft. high, 3 ft. wide, and 5 ft. long. In terms of the cube this solid is constructed by multiplying the cube by one and one-half to get the width, and by two and one-half to get the length. The second of the two solids is another cube, 3 ft. on a side. This solid is set back 1 ft.—one-half of the unit cube—from the front edge and centered on the length. All these operations may

easily be managed by the methods given in Chap. III for the multiplication and division of cubes.

306. Figure 71b is interesting in that it gives a simple instance of what may be called *implied volumes*. That is to say, while there is no actual material in the space below the shelves, nevertheless the table occupies this amount of space, and it must be allowed for, as will be seen in the chapter on Perspective Composition.

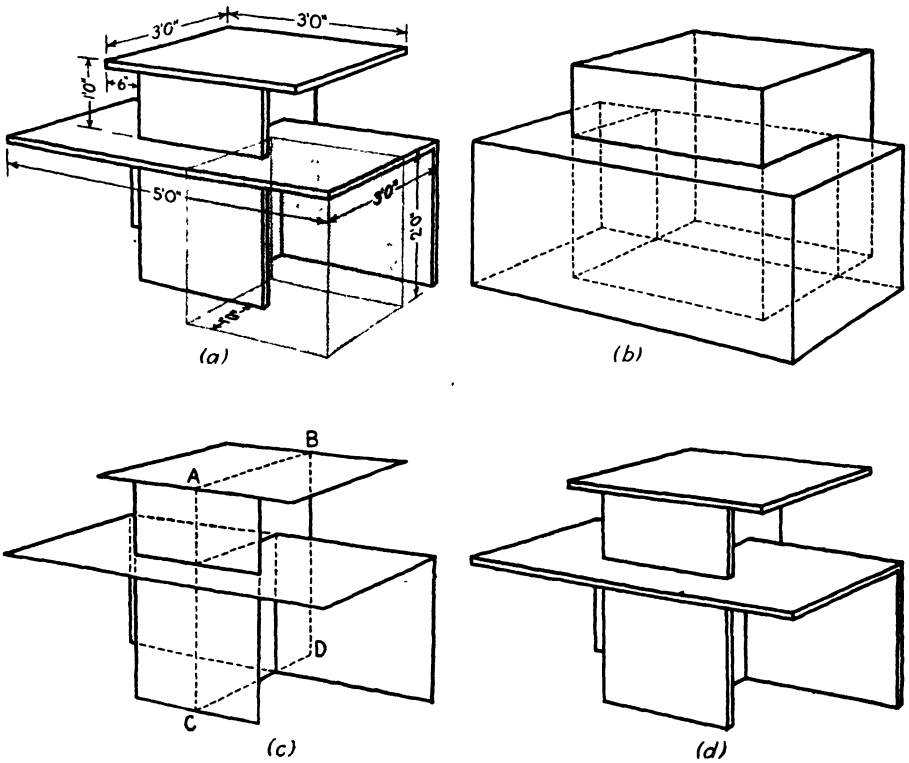

FIG. 71.

307. Quite incidentally, and as a sort of bonus for work conscientiously done, the breaking down of a drawing into basic forms gives us a clear insight into the intentions of the designer. In this instance we have a fairly simple example of the “interpenetration of volumes,” which is a fundamental procedure in contemporary design. Indeed the drawing of various objects is one of the ways of studying principles of design and will show the logic behind good ones (including natural forms such as trees) and the chaotic lack of logic in a bad one.

308. The gross solids having been established, the next step (Fig. 71c) consists simply in reducing these solids to the actual planes of the object itself. No attempt should be made at this stage to work out the thicknesses; to do so will only confuse the work. The only actually new construction in

Fig. 71c is the insertion of the central supporting member *ABCD*. The construction of this is too simple to require comment.

309. The final step, shown in Fig. 71d, consists in the addition of the minor dimensions—the thicknesses of the various members. Except for the necessity of watching the direction in which these are added—down from the horizontal planes, back from the front vertical, and forward from the rear vertical—these should give no trouble. Carelessness about these directions may add a couple of inches to one of the volumes, quite destroying the proportions. The central supporting member warrants a bit of extra attention, because its thickness should be calculated both right and left of the plane *ABCD* of 71c, *i.e.*, $\frac{1}{2}$ in. each way. Although this may seem unduly fussy, it is surprising how obvious a slight error of centering can become.

310. Though the table of Fig. 71 happens to be an unusually simple example, practically every object, however complex, can be broken down into elementary forms that are, in themselves, easy to draw. Once this basic simplicity has been discovered, the remainder of the drawing becomes largely a process of combination and refinement. It is difficult at first for the student to see the importance of this, but with continued graphic experience he comes to practice this analysis into basic forms almost instinctively and without effort. This almost unconscious habit is one of the things that contributes to that ease and sureness of the professional artist which is the despair of every beginner.

311. The next example introduces a combination of curved and plane rectangular forms. Figure 72a shows a wastebasket of simple design. Analyzed into its elements, it consists of two half cylinders, 8 in. in diameter and 12 in. high, attached together by two rectangles 4 in. wide and 12 in. high.

312. In beginning the drawing (Fig. 72b), a rectangular solid 12 in. high, 12 in. wide and 8 in. thick is first constructed. The width is divided into three parts (Chap. III showed how to do this) by planes *AB* and *CD*. The space from front to back is divided in halves by the plane *EF*. This gives us two squares at the top, *AGHI* and *CJKL*, overlapping by half, and a similar pair of squares at the bottom.

313. In each of these four squares a circle is drawn (Fig. 72c). These form the ends of two overlapping cylinders. The outer halves of each of the cylinders are joined by the rectangles *ACMN* and *GJBD*, which complete the basic form.

314. In Fig. 72d the bead is added. The dotted line indicates the top outline of Fig. 72c. Since the bead is so small, its proportions must be estimated, for all construction would be swallowed up in the width of a pencil line. On the near side all of the bead is visible both above and below the original outline, but on the far side only the upper part of the bead is visible. Attention should also be given to the transition of outlines at the

left and right sides of the drawing. Failure to handle this correctly will result in a drawing in which the bead seems to expand on the far side.

315. Figures 73a and 74a show, in elevation, a type of form often encountered. These are forms in which all variation in shape takes place

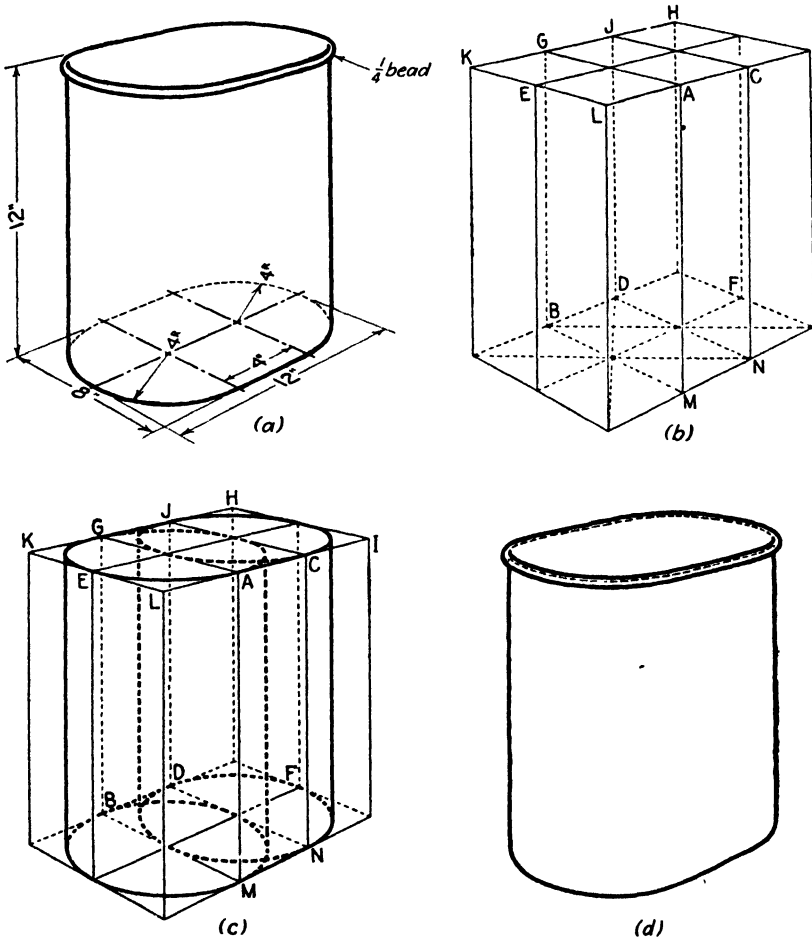

FIG. 72.

along an axis. A cross section, taken anywhere along the axis, is always circular, but the circle may vary enormously in diameter. Because so many manufactured articles are made on the lathe and the potter's wheel and its modern descendants, this is perhaps the commonest form we encounter. One cannot look around the most sparsely furnished room without seeing a dozen examples—drawer pulls, table legs, bottles (from molds made on the lathe), lamp sockets (stamped from lathe made dies), dishes, and others in wide variety.

316. Because of the wide use of forms of this type, we are describing in detail two methods for their construction. The first method, detailed in Fig. 73, should be used where a high degree of accuracy is wanted and where the object is to be the principal or only part of a picture. The second method, detailed in Fig. 75, is sufficiently accurate for nearly all purposes and is much quicker to use, but this second method will be used more intelligently if that of Fig. 73 is understood thoroughly.

317. Figure 73a is the elevation, or front view, of a spun-metal vase. It is our task to convert this elevation into a perspective drawing. To facilitate this we draw first a rectangle $ABCD$, which just encloses the entire outline, and the line EF , which passes through the joint between bowl and base.

318. The first step in making the perspective is the "expansion" of the rectangle $ABCD$ into a solid or square prism. The method for this was given in Chap. V, Pars. 248 and 249, and in Fig. 52. The vanishing point may most conveniently be located at about twice the height of the rectangle and should be directly above center. When the solid is drawn from the rectangle, lines should also be projected back from E and F , to give the square $EFKL$.

319. The next step is extremely important and is frequently forgotten—with weird results. It is shown in Fig. 73c. The diagonals of the two lower squares are drawn; then from M , N , O , and P lines are drawn back toward the vanishing point. These will intersect the diagonals at points E_1 , F_1 , K_1 , etc., locating the small squares $E_1F_1K_1L_1$ and $C_1D_1I_1J_1$. These small squares will then be properly centered. In each of them (Fig. 73d) a perspective circle is drawn, and one is also drawn in the large top square $ABGH$.

320. The next step, also shown in Fig. 73d, is the most difficult but is essential to full understanding and sound drawing. It consists in drawing the curved lines A_2E_2 , B_2F_2 , RT , etc. These lines are the edges that would be produced were the vase to be cut straight down by a saw, starting at A_2 , B_2 , R , etc. Such imaginary cuts are called *sections* and are important in the drawing of many types of forms. We shall meet them again in the chapter on plastic forms. They must be considered as "ribs" and must not be confused with the outline.

321. Having produced the skeleton of the form in Fig. 73d, the next step (Fig. 73e) consists in drawing the outline so that it just fits snugly over the skeleton. This is the same process described in Chap. V for the sphere and its relatives. The base merely requires completing the cylinder.

322. Figure 74 is worked out by a process that does not differ essentially from that of Fig. 73. To facilitate construction, planes are passed through the joint of neck and bowl and through the level of maximum width. It should be noted that the outline of the neck does not join the outline of the bowl. The two arrows of Fig. 74c indicate this feature. This fact is often overlooked when the quick method of Fig. 75 is used, with the result that the neck appears to be pushed back.

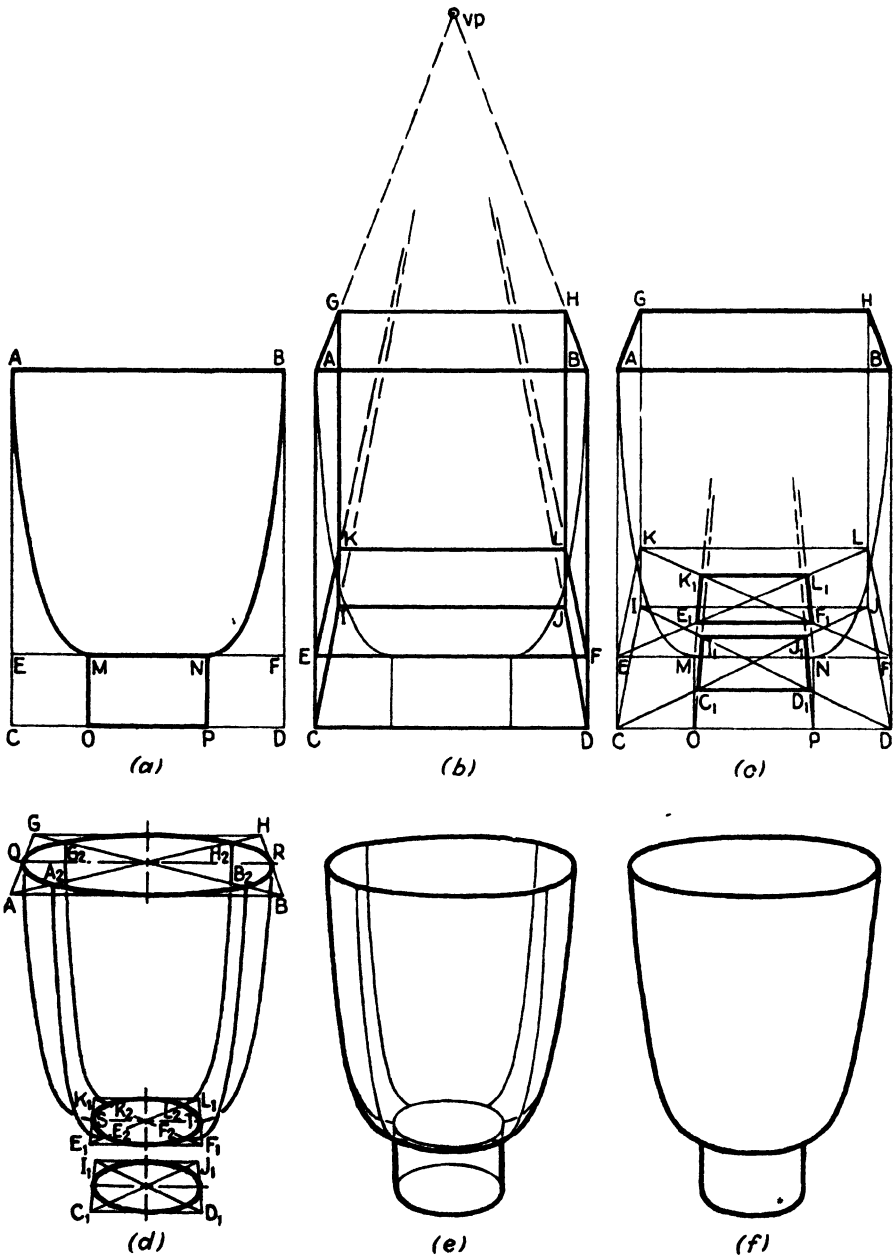

FIG. 73.

323. In actual practice the methods just described are not used except in work requiring maximum precision. The method shown in Fig. 75 is quite accurate enough for all ordinary purposes and permits the work to be done very quickly. It is simply an extension of the quick method of drawing the cylinder illustrated in Fig. 55, Chap. V, and described in Par. 257.

324. Figure 75*a* is the elevation or front view of a lamp. The base of the lamp is identical with the vase of Fig. 74 except for the addition of a cap over the top to support the fixture.

325. The actual work is done in Fig. 75*b*. Instead of drawing an enclosing rectangular solid, the various horizontal lines, *A*, *C*, *E*, etc., are used directly as the major axes of ellipses. The only difficulty is to determine

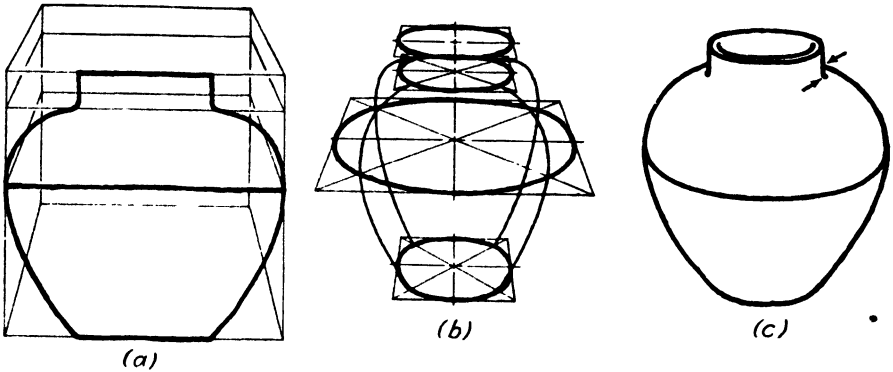

FIG. 74.

the correct degree of roundness or sharpness of curvature of the ellipses. Remember that the ellipse nearest the eye level at *A* should not be so open as that at *G*.

326. With a little practice this becomes quite easy to estimate correctly, but at first the following method is recommended as giving good control and as aiding in estimating the curvature of the intermediate ellipses. The ellipses at each end, *A* and *G*, are first drawn, with the horizontals as major axes. The minor axes will lie on the center line. The ellipse at *A*, near the eye level, should be made quite long and narrow, while that at *G* should be relatively round, though by no means circular. The lines *AB* and *GH* are now drawn. It will be noted that these lines appear to converge toward the upper right as though drawn toward a vanishing point. It may be convenient to extend the lines to locate such a point, although it is not usually necessary. Similar lines are now drawn at each of the horizontals, as at *C* and *E*. (Those for the neck of the base have been omitted from the diagram to avoid confusion.) The slopes of these lines are intermediate between the slopes of *AB* and *GH*, as though all were drawn to the vanishing point. The points *D* and *F*, determined by the intersections of these lines with the center lines, will give points through which the ellipses must be drawn in order to have the right curvature.

327. In completing the ellipses it should be remembered that we are here using the geometric rather than the optical centers, and that the ellipse should pass at an equal distance above and below the major axis. For

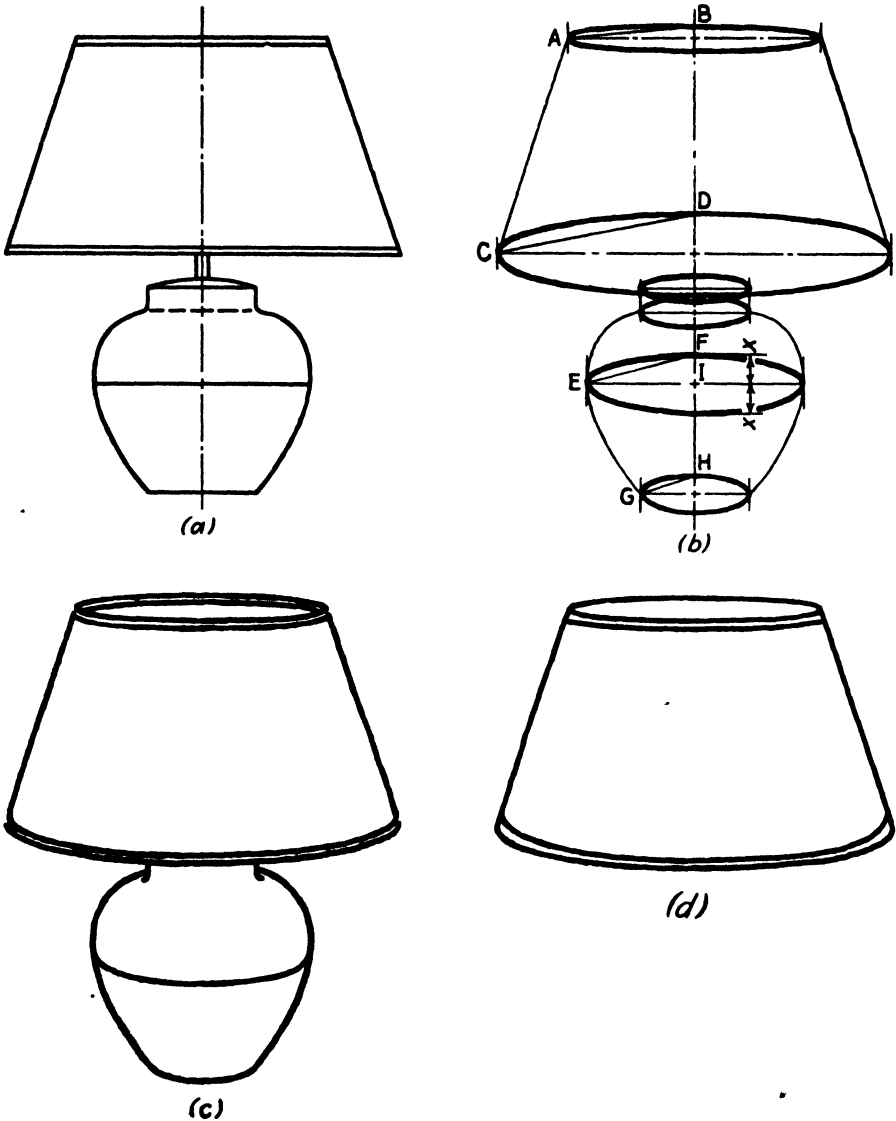

FIG. 75.

instance, at *E*, the minor axis extends the equal distances x , x above and below the center *I*.

328. The method described for determining the curvature of the ellipses is not geometrically exact but provides sufficient control for most work.

are connected by the square $JKLM$, completing the rectangular solid within which the cylinder is drawn.

332. The above described method for drawing the cap is necessary only when the picture is large and of a character requiring rigid accuracy in its construction. Ordinarily the cap would be drawn as shown in Fig. 76c. The center A would be found by means of the diagonals and the major and

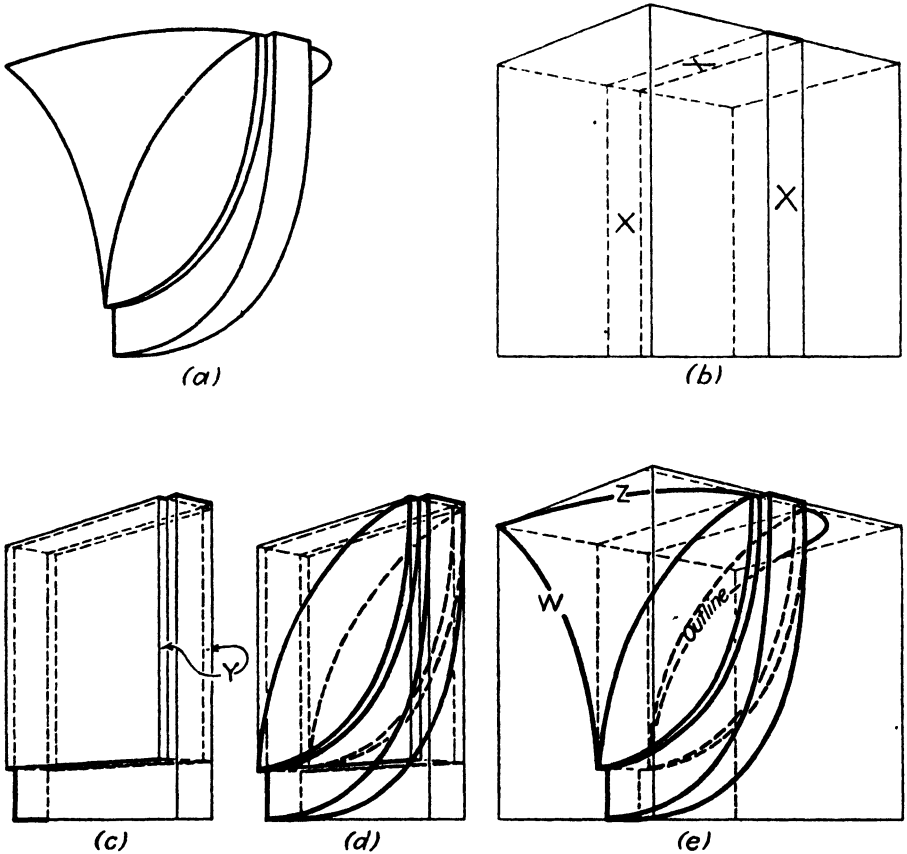

FIG. 77.

minor axes of the lower ellipse drawn through it. Care should be taken to make the major axis horizontal. The height of the cap is estimated and the point N placed at this height above A . The vertical sides of the cylinder are drawn up from the lower ellipse. A horizontal through N meets these verticals at O and P . This horizontal is the major axis of the top ellipse. The minor axis QR is drawn through N , perpendicular to OP . It must be slightly shorter than ST .

333. The light fixture illustrated in Fig. 77 shows how a more complex form is built up. (Notice that, since this object is designed to be hung high on a wall, only the lowest part is at eye level, the rest being above it.)

Since the figures are nearly self-explanatory, we shall call attention here to only a few salient features.

334. In Fig. 77b we show the rectangular solid that would be the first step in constructing the drawing. This solid would enclose the entire

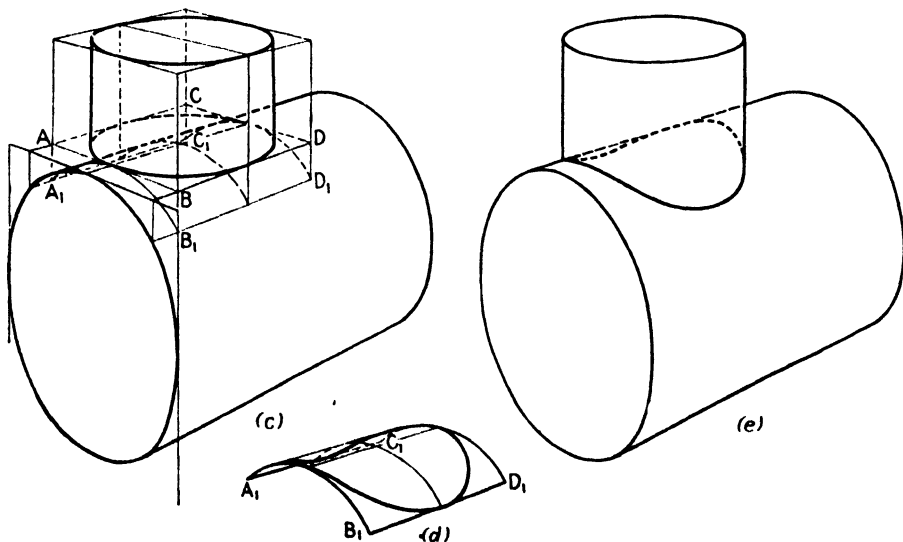
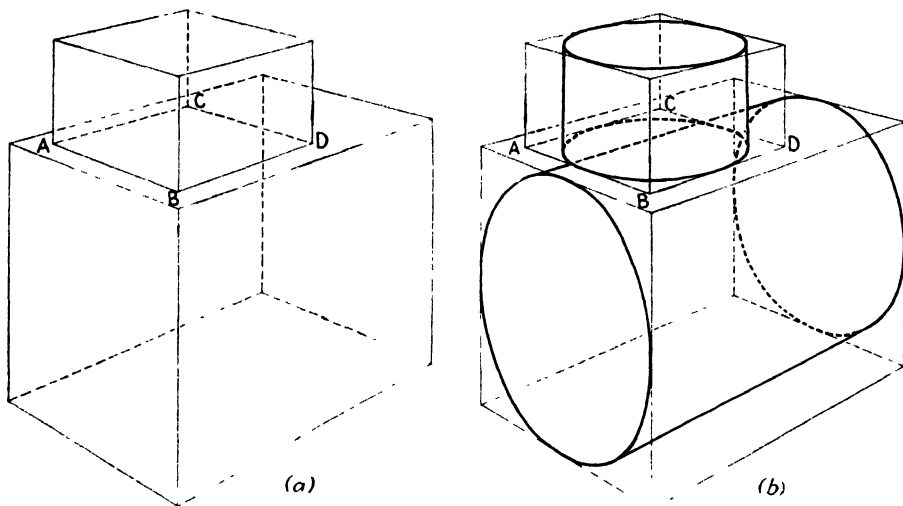
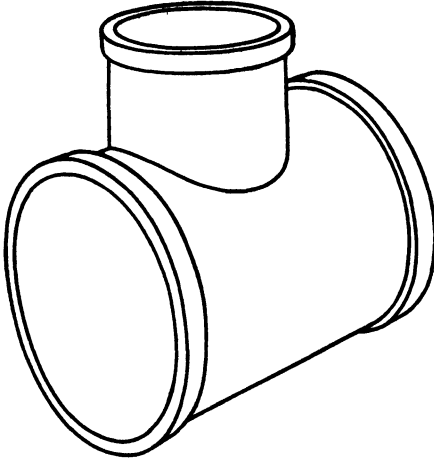

FIG. 78a to e.

fixture. The slab, denoted by X 's in the figure, is drawn vertically through the center, setting the width and height of the central member of the fixture.

335. In Fig. 77c the two subsidiary slabs, denoted by Y , are added to the thicker central slab.

336. In Fig. 77*d* the curves are added. In Fig. 77*e* the figure is extended to the left and right faces of the original enclosing solid, and the curves *W* and *Z* are drawn. Notice the dotted outline, which is almost, but not quite, like *W*.



(f)

FIG. 78*f*.—An application of the abstract forms, diagramed in Figs. 78*a* through *e*, is the pipe fitting shown here. The only difference between this and Fig. 78*e* is the thickness and bead at each opening. With different proportions and a few rivets we could have the boiler and smokestack of a locomotive. Other instances will no doubt occur to the reader.

340. The building shown in Fig. 81 demonstrates several types of compounding of forms. Analysis of the complete drawing in Fig. 81*a* will show

337. Figure 78 illustrates a problem that causes much grief, although it is not nearly so hard as it looks. This is the intersection of two cylinders. The meeting line of a locomotive smokestack and boiler is an example. The problem is fairly simple when the axis of the small cylinder is perpendicular to that of the other. The method is shown in the figure and needs no explanation.

338. When the axis of the small cylinder is oblique to the axis of the larger one, the job is a bit more difficult. The procedure is shown in Fig. 79.

339. Occasionally we have one cylinder meeting another off center. This case, and the construction, is shown in Fig. 80.

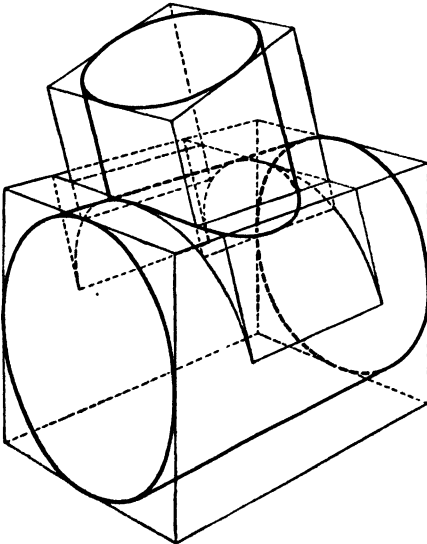
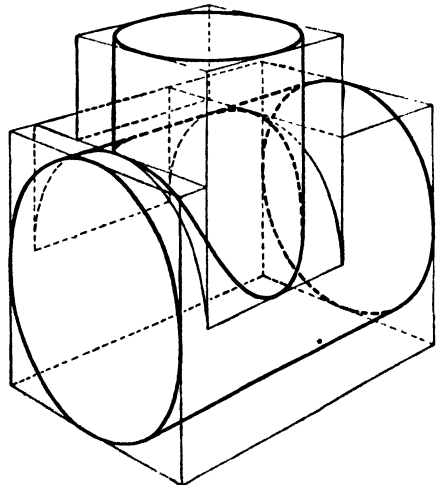
**FIG. 79.****FIG. 80.**

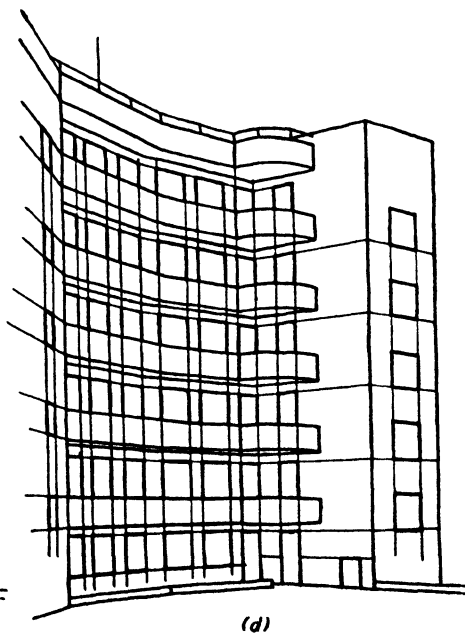
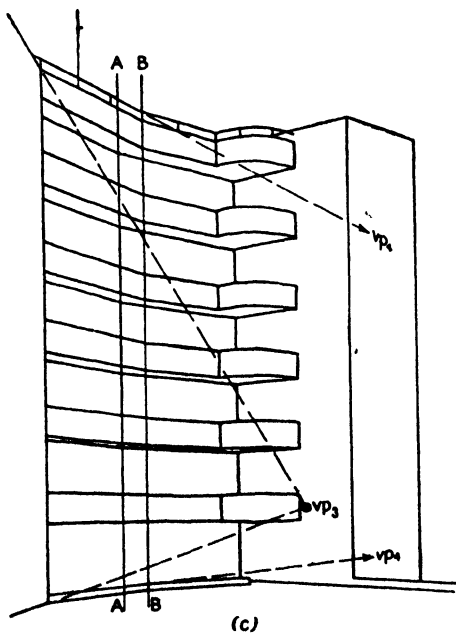
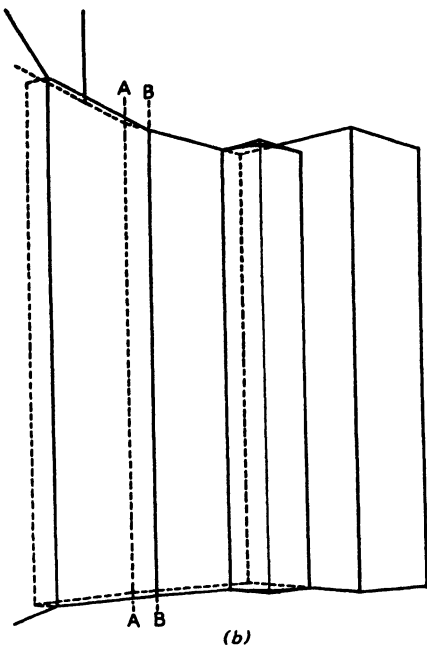
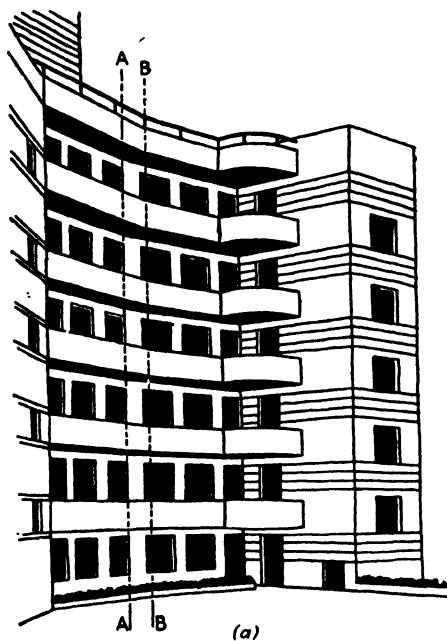

FIG. 81.

how the complex form may be broken down into a few simple forms. First we have the plane of the left-hand wall. Next there are the *two* planes of the main wall meeting each other at a slight angle along the line *AA*, and finally the rectangular solid of the wing on the right. These major forms are the first to be drawn, as shown by the dotted lines in Fig. 81*b*.

341. The six balconies come next. As shown by the solid lines in Fig. 81*b*, these are drawn first as though they were continuous from top to bottom and are then pierced in Fig. 81*c*. The reason for this procedure is that the horizontal dimensions and forms, including the quarter cylinder at the right, can thus be settled for all six balconies at once. The space between the balconies is then laid off on any convenient vertical such as *BB* (notice its relation to *AA*), and the necessary horizontals are drawn. For drawings of this kind, where planes meet each other at angles greater or less than a right angle, it is often convenient to determine extra vanishing points, as indicated by the lines pointing toward *vp*₃ and *vp*₄ in Fig. 81*c*.

342. The various vanishing points serve for all subsidiary horizontals, such as the tops and bottoms of the windows and doors and the decorative bands on the wing to the right.

343. The student is usually appalled when confronted with the task of drawing anything so apparently complex as the average architectural work. In Fig. 81 alone, highly simplified though it is, there are 53 windows and doors visible or partly visible. Fortunately, the difficulty is more apparent than real. These windows are another example of multiple or repeating forms and are drawn by mass-production methods.

344. In Fig. 81*d* the rectangular opening each window and door makes in the outer surface of the wall is laid out. Notice that each vertical line serves as boundary, not for only one, but for five or six windows or doors. Similarly, horizontals in the central part of the building each serve to set the tops of seven windows at once. Only the left and right wings require special treatment, and even here the decorative bands do double duty, and the upper horizontal of each window is set by a height similar to that of its neighbor below. The positions of the various lines are laid out in accordance with the principles of measurement set forth in Chap. III or with projection methods discussed in Chap. XII.

345. The reveals of the windows and doors are next worked out. These measurements are likely to give some trouble, since they are so small in comparison with other dimensions. As a result they are likely to be exaggerated, and care should be taken to guard against this.

346. When the construction lines are cleared away, the result will be Fig. 81*a*.

347. The half round table of Fig. 82*a*, although much simpler than the building of Fig. 81, poses a much more subtle and difficult drawing problem. This statement usually comes as a surprise to the student, who is likely to feel that anything simple is, *ipso facto*, easy and, conversely, that anything

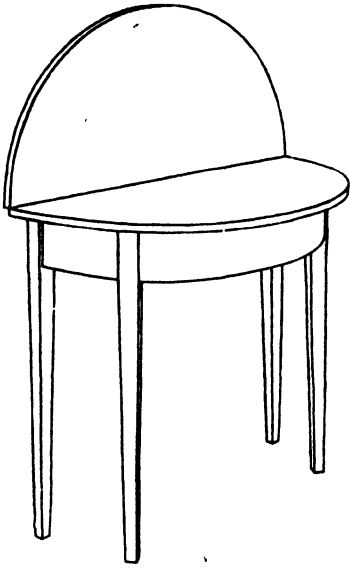

(a)

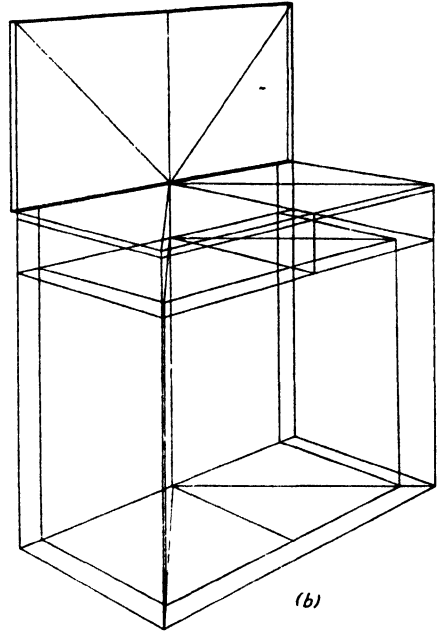

(b)

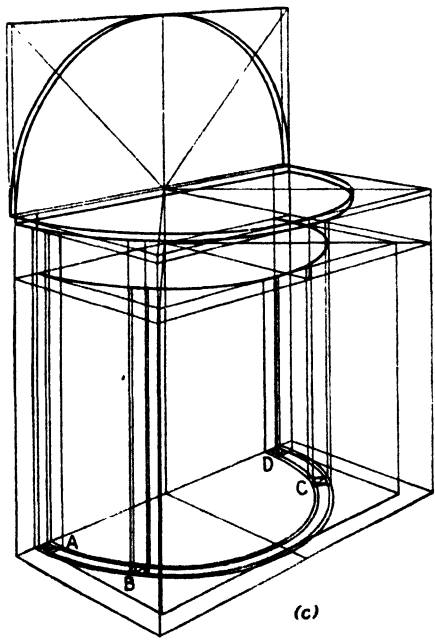

(c)

FIG. 82.

intricate must be difficult. We have already shown the facility with which Fig. 81 may be constructed. The simple table of Fig. 82 requires much more care.

348. In Fig. 82*b* the rectangular enclosing solid is shown with the principal subsidiary divisions already laid out. In Fig. 82*c* these are used to lay out the curves of the actual table and the half ring on which the legs must touch the floor. The taper of the legs is also established. Particular attention should be given to the way this taper is worked out. The legs are first drawn as though without taper. The squares where they touch the floor (*A*, *B*, *C*, and *D*) are drawn at the full size. The smaller squares are then *centered* within by means of diagonals. Unless this is done the whole table will appear to lean.

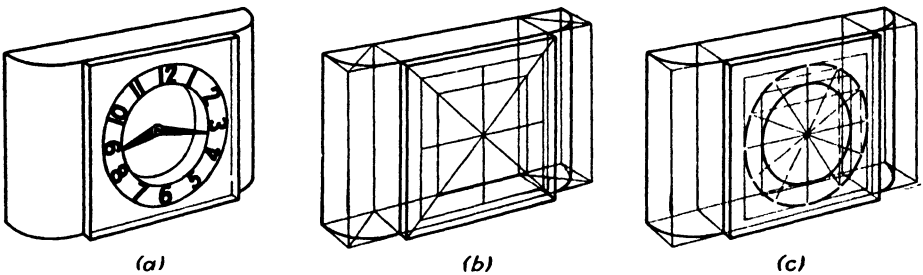

FIG. 83.

349. The clock in Fig. 83 is an interesting problem. The building up of the external form is relatively simple, as shown in Fig. 83*b*, but the placing of the numerals about the dial is rather tricky. In most cases it will be sufficient to work by trial and error, but occasionally rigid accuracy is wanted in placing the numerals exactly 30 deg. apart. In Fig. 83 the estimation method is used. Figure 92 shows more exact procedures.

350. Even when the figures are placed by estimation, the greatest obtainable accuracy is desired. To get this it is best to start by estimating the division into even thirds of one of the less sharply curved quadrants; that from 3 to 6 is used here, as shown in Fig. 83*c*. When the circle is drawn within a square, the figures 12, 3, 6, and 9 are placed by the mid-lines already drawn; 10 and 11 are now easily located by lines drawn through the center of the circle from 5 and 4, respectively.

351. The locations of the figures 1 and 2, and 7 and 8 are then determined as follows: From the point on the outer circle where 10 touches it, a perspective horizontal is drawn to the right, locating a similar point for 2. A line from this point through the center of the circle locates 8. From the point where 5 touches the outer circle, a vertical is drawn upward to locate the point where 1 touches it. (These operations could just as easily be performed on the inner circle, but by using the larger one we can have greater accuracy with less eyestrain.) By drawing a line from 1 through the center the figure 7 is located.

352. Although the method described above is not perfectly accurate, it will be found sufficiently so for ordinary purposes. Where great precision is wanted, it is best to work by projection from orthographic drawings. Ordinarily, in high-precision work this would be done as a matter of course.

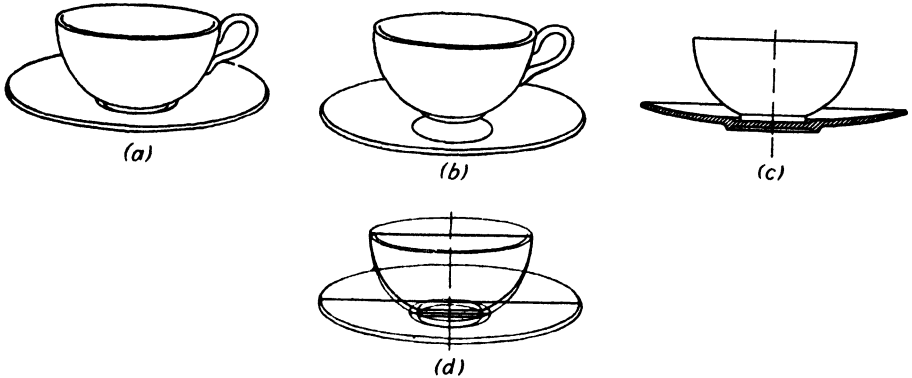

FIG. 84.—The front half of the saucer in the elevation at (c) is shown as though cut away in order to show the base of the cup.

Since mechanical projection methods are discussed in detail in Chap. XII, we shall not take them up here. There are other methods for obtaining mechanical accuracy without resort to projections. One of these is shown in Fig. 92.

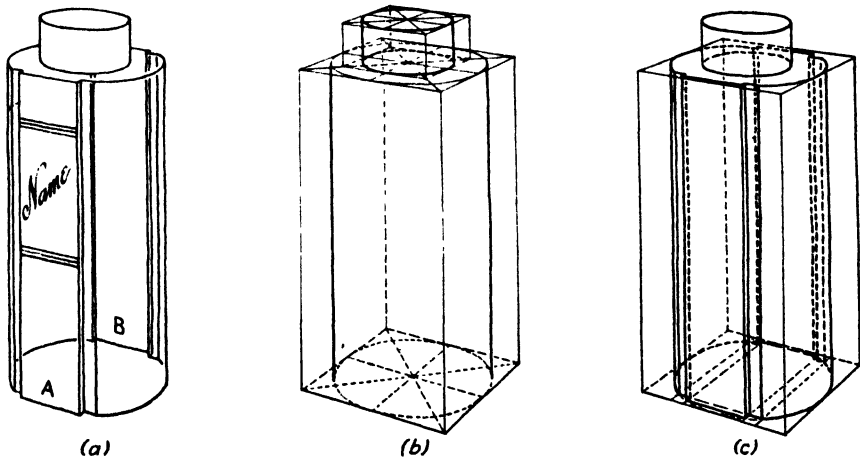

FIG. 85.

353. The cup and saucer of Fig. 84 belong to the class of turned forms. The thing that troubles most beginners is the weird tendency of the cup to float perversely in the air above the saucer. This phenomenon is illustrated in Fig. 84b. It results from using the plane of the rim of the saucer instead of the bottom of the inner surface as a place to rest the cup. The cup is

made to behave itself in Figs. 84*c* and *d*. When using this approximate method, a slight correction must be made to avoid having the cup appear to be too far forward in the saucer as a result of using the geometric rather than the true center of the ellipse as the center of the saucer.

354. Somewhat surprisingly, such simple forms as that shown in Fig. 85, which are produced merely by cutting away pieces of a larger but still simpler form—a cylinder in this case—give trouble out of all proportion to their intrinsic lack of complexity. The cause is the tendency to think in terms of drawing only. If the artist imagines himself in the place of the person who originally made the object, and mentally follows his work, the problem of drawing becomes enormously easier. In this instance, the original of this illustration was a model for a perfume bottle. It was made from a cylindrical bar of transparent plastic, 3 in. in diameter and 6 in. long. Two longitudinal slices were sawed off opposite sides, leaving the flat surfaces *A* and *B*. Rectangular notches were then cut on each side of these flats. The resulting modified cylinder was then topped with an opaque cylindrical cap 2 in. in diameter and $\frac{3}{4}$ in. in height.

355. The drawing should follow *graphically* the same steps. The construction of one large and one small cylinder in correct proportions and having the same axis presents no new problem. In Figs. 85*b* and *c* we see how the remaining *physical* operations are followed *graphically* by the artist.

356. This brings us back to an interesting point, first mentioned in Chap. I. When this book was first outlined it was the author's intention to call it "Structural Perspective." It was found, however, that this title would be misleading, causing prospective readers to expect a text dealing entirely with buildings, bridges, and the like. At the suggestion of James C. Boudreau, director of the Pratt Institute Art School, it was changed to its present title as being more expressive of its purpose. Nonetheless, the structural approach to drawing—the manner whereby any picture is built up, whether it be of a bottle or a locomotive—is still important. It is the author's belief that any drawing is easier if the structure of the model is understood. That of Fig. 85, for instance, becomes almost absurdly easy, and the rule holds good throughout all subjects.

MULTIPLE FORMS

357. By the term *multiple forms* we refer to the sort of thing that is repeated in identical shape two or more times in a single object. These are almost always arranged in some kind of systematic order that greatly facilitates the work of drawing them. We have already spoken of one instance in the building of Fig. 81 and have let others pass unremarked. Multiple forms occur in almost every object; indeed it is difficult to find objects in which they do not occur. Since this greatly reduces the labor of drawing, it is something for which to be thankful.

358. As we have said, examples abound, but the specific mention of a few can do no harm. Almost any table will have three or four identical legs. The keys of a piano, of a typewriter, the drawers of a chest, the panes of a window and a thousand others suggest themselves.

359. One of the simplest of these is the diaper-patterned wallpaper illustrated in Fig. 87*a* and *b*. Before this job is undertaken, it will be helpful to recapitulate some of the material of Chap. III in order to show how it applies to our special needs here. Our reason for doing this is that *all* flat repeat patterns—wallpapers, fabrics, bricks, tiles, etc.—can be

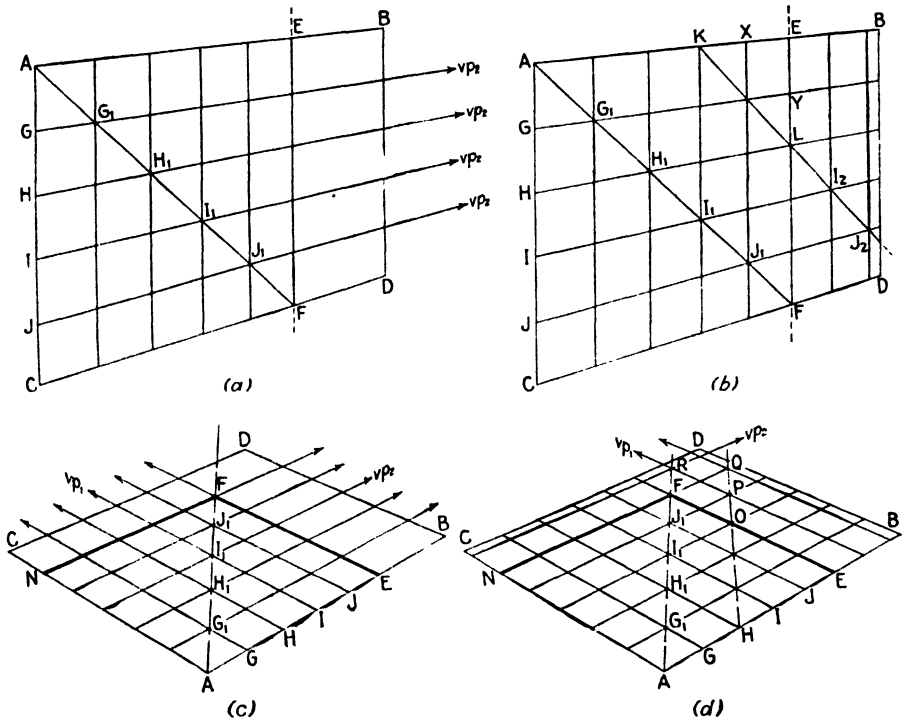

FIG. 86.

drawn most easily and accurately by referring them to the common checker-board pattern and modifications thereof. It is the modifications that sometimes cause trouble, and in Fig. 86 we show how to manage them.

360. Suppose that we are drawing an interior and that the rectangle *ABCD* in Fig. 86*a* represents one of the walls, not including the baseboard, and suppose that we want to divide it into squares of such a size that just five of them fit into the height of the wall. To do this we first draw a vertical *EF* at such a position that *AE* and *CF* are perspectively equal to *AC* or, in other words, so that *AEFC* is a perspective square. The vertical *AC* is now divided into five equal parts, by means of marks at points *G, H,*

I, and *J*. From each of these, lines are now drawn toward vp_2 . We now draw diagonal *AF*. (*EC* would also serve, but not quite so well.) This diagonal would cross the horizontals at G_1 , H_1 , etc., and at each of these points verticals are drawn. We now have part of the wall divided into squares of the required size.

361. The reader will have noticed that the procedure just described is simply the process of perspective division given in Chap. III. The remainder of the work, shown in Fig. 86*b*, is simply an application of the principles of perspective multiplication.

362. We now draw a line from *K* through *L*, which gives us a new diagonal. This is extended to cross the horizontal through *I* at I_2 , and the horizontal through *J* at J_2 . When verticals are erected at these points, we have completed the laying out of the necessary squares.

363. Had the wall been longer than here, the process could have been repeated as many times as necessary. Students are sometimes puzzled when the available wall space is too narrow to permit drawing a full square on it. In this case we may either imagine an extension of the wall beyond the actual corner or start with a smaller unit, such as a square 3 by 3 instead of 5 by 5.

364. It is also possible in Fig. 86*b* to use the points *X* and *Y* as guides for the second diagonal. This would make it possible to establish more new points in one operation, which would be more convenient in the case of a long wall. The drawback is that two points so close together will not determine the direction of a line through them accurately enough for a drawing of this type, where any error is multiplied along with the squares.

365. More often than not, the height of the small squares will be such that there will be part of a square left over, *i.e.*, the wall may be $5\frac{7}{8}$ times as high as the individual square. Any such fraction is simply disregarded, the lines *AB* and *CD* being drawn at the top and bottom of the uppermost and lowest *complete* squares. The remaining spaces will take care of themselves, as they do at the right end by *BD*.

366. Figures 86*c* and *d* apply the principles of Fig. 86*a* and *b* to a similar space in a horizontal plane. In this case we have no vertical that can be directly divided by measurement, so we must make use of one of the methods given in Chap. III. The most convenient is probably the measuring line method described in Pars. 163 through 171. Once *G*, *H*, *I*, and *J* have been placed, the procedure is practically the same as before.

367. Figure 87*a* shows one use of the checkerboard in a vertical plane, the dotted lines being the same as the solid lines of Fig. 86*b*. This is a pattern that repeats completely in each of the squares. Using the dotted lines as guides, the double diagonals are easily drawn. In the center of every diamond of every second horizontal row, the floral motif is drawn. Even if it were practical to construct so many of these precisely, it would not be necessary, since their scale is so small that a rough indication is sufficient.

However, it is well to remember that perspective affects even the appearance of the flowers

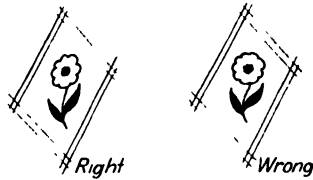

like this. not this.

If this simple difference is ignored the flowers will appear to be growing out of the wall instead of being printed on it. This is the reverse of the usual difficulty, which is the production of an appearance of three-dimensional solidity on the paper. Here it is essential to avoid this solidity; otherwise, instead of a flat wall, we shall have an excessively formal garden.

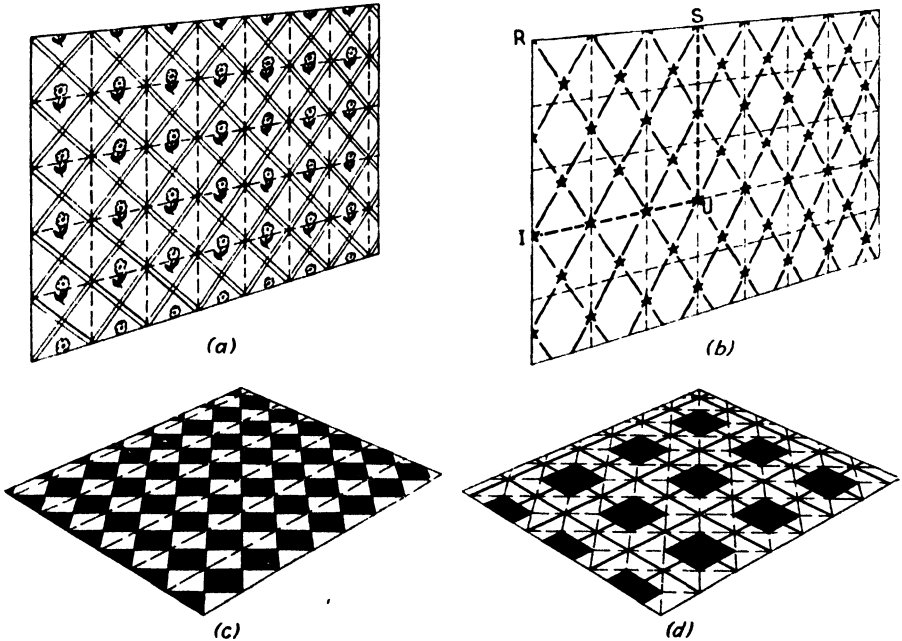

FIG. 87.

368. Figure 87b is a slightly more subtle application. Here the diamonds are not the same in both dimensions, being half again higher than wide. At first glance this would seem to preclude the use of squares. Nearly all printed patterns, however, repeat in squares of 36 in. or simple fractions thereof (18, 9, 6, $4\frac{1}{2}$, 3), and, by taking an area of 3 by 3 squares, we can include a complete unit. Each diagonal is drawn so that it goes from the corner of one square, to the right or left two squares and up three

squares. The position of the stars is determined by the crossing of the diagonals.

369. Figures 87c and d show similar applications to floor patterns such as tile or linoleum. The figures are self-explanatory.

370. Figure 88 is an example of three-dimensional multiple form. The eighty-odd members of a piano keyboard would make a tedious job if they had to be constructed one by one, but it is a simple matter to handle them en masse. For the sake of clarity the slight overhang of the ivory facings of the tops of the white keys has been omitted from this illustration, and

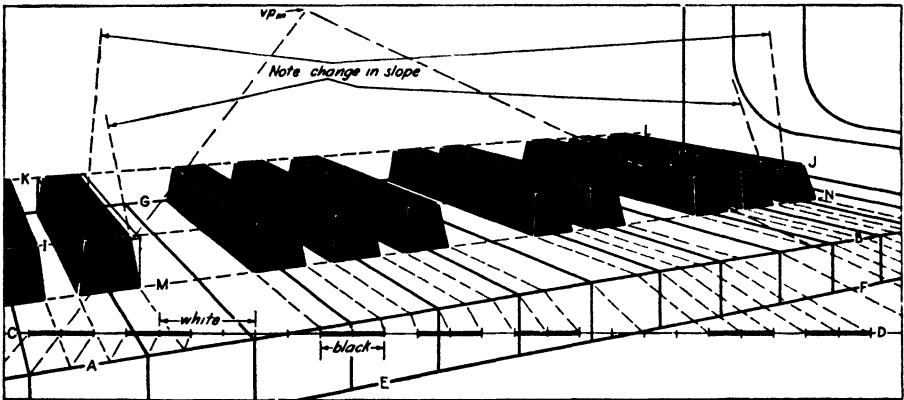

FIG. 88.

the line AB represents the usually unseen intersection of the front and top planes.

371. Construction is begun by laying out the limits of the keyboard, *i.e.*, the front lines AB and EF , the rear line GH , as well as the left and/or right ends if they appear in the picture. The measuring line CD is drawn wherever convenient and is used to lay off on AB the widths and positions of the black keys. These are then projected back to GH and down to EF , as shown.

372. The drawing of the black keys is similar to the drawing of the bread pan in Chap. III, Fig. 32. No such elaborate construction is necessary, of course, and, once the construction of a single one has been completed, the rest may be estimated with the aid of lines IJ and KL . A couple of critical details should be pointed out here. Notice that, while the front and the two side planes of each black key slope away from the vertical, the rear plane has no such slope. Note also how the *apparent* slope of the rear corner line of the black keys changes according to whether the keys are to the left or right of the picture. It is unnecessary to calculate the various slight changes, and, though there is a vanishing point, it is too far above the picture to be useful. However, by careful drawing of the keys at each extremity the intervening slopes may easily be estimated. Even this precaution will be necessary only in a close-up.

373. Figure 89, while actually simpler than Fig. 88, offers some important features. For the first time we introduce the problem of scale and its relation to the amount of detail that can reasonably be included. This usually comes up in architectural work and exteriors where the scale of subject matter is nearly always large, while detail may be quite fine and delicate. For example, a tree a hundred feet high may have leaves only an inch or so long. In this case such detail is treated more as *texture* than as *structure*, and as such it comes under the head of rendering.

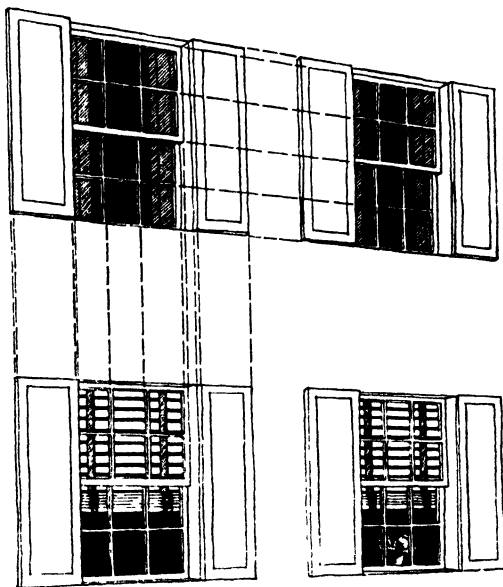

FIG. 89.

374. In this instance it is impossible in a drawing so small to include any moldings in the window muntins, and for the sake of clarity the track for the upper sash and the piercing of the shutters has been omitted. In spite of these omissions, five main planes show clearly in each window, namely, that of the curtains or Venetian blinds, the front plane of the lower sash, the front plane of the upper sash, the plane of the outer wall (which is also the rear plane of the shutters), and the front plane of the shutters.

375. The principal interest of the figure lies in the way in which dimensions established for one window are made to serve for others. The upper left-hand window is drawn in full. Its horizontal lines also serve by projection for the upper right-hand window, leaving only the determination of verticals for this. Similarly the vertical lines of the upper left-hand window are extended downward to become those of the *lower* left-hand one. The two windows thus derived become in their turn the "parents" of the window to the lower right. The method for doing this is so apparent that the lines have been omitted from the diagram to avoid confusion. It is

this ability of such identical forms to “reproduce their kind” that makes the work of drawing them much less trouble than might be expected.

376. The staircase in Fig. 90 shows how principles already demonstrated may be applied to forms repeating on different levels. The rectangle $ABCD$ sets the height of the staircase and the distance from the front of the lowest step to the front of the top step. The line CE sets the width of the stairs.

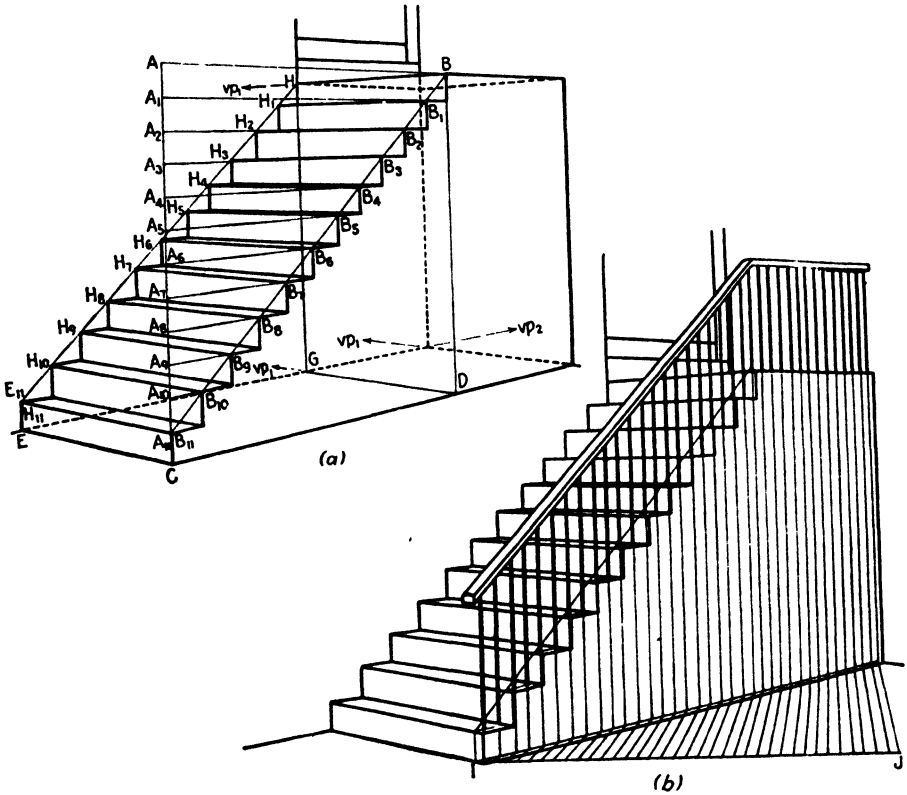

FIG. 90.

The heights of the risers are marked off on AC at A_1, A_2, A_3 , etc. Since AC is a true vertical, these divisions may be made directly. From the top near corner of the lowest step, A_{11} in Fig. 90a, a line is drawn to B . This line gives the slope of the stairs. From A, A_1 , etc., perspective horizontals are now drawn toward vp_2 . These will cut the line $A_{11}B$ at B_1, B_2, B_3 , etc. Short verticals dropped from each of these points will define the end of each riser, while the horizontals will define the end of each tread.

377. The point G is now determined by the intersection of lines from E toward vp_2 and from D toward vp_1 . Next the point H is found at the intersection of a vertical from G and a perspective horizontal from B toward vp_1 . A vertical from E and a perspective horizontal from A_{11} toward vp_1 intersect to determine E_{11} . The line $E_{11}H$ gives the slope of the far side

of the stairs. Horizontals toward vp_1 from $B_1, B_2,$ etc., meet $E_{11}H$ at $H_1, H_2,$ etc. From each of these a vertical is drawn and a horizontal toward vp_2 . This completes the drawing of the stairs proper.

378. The construction of the railing and its supporting posts is most easily done by eye, if care is taken that the height of the rail from the steps is kept perspectively constant from bottom to top. This is most easily

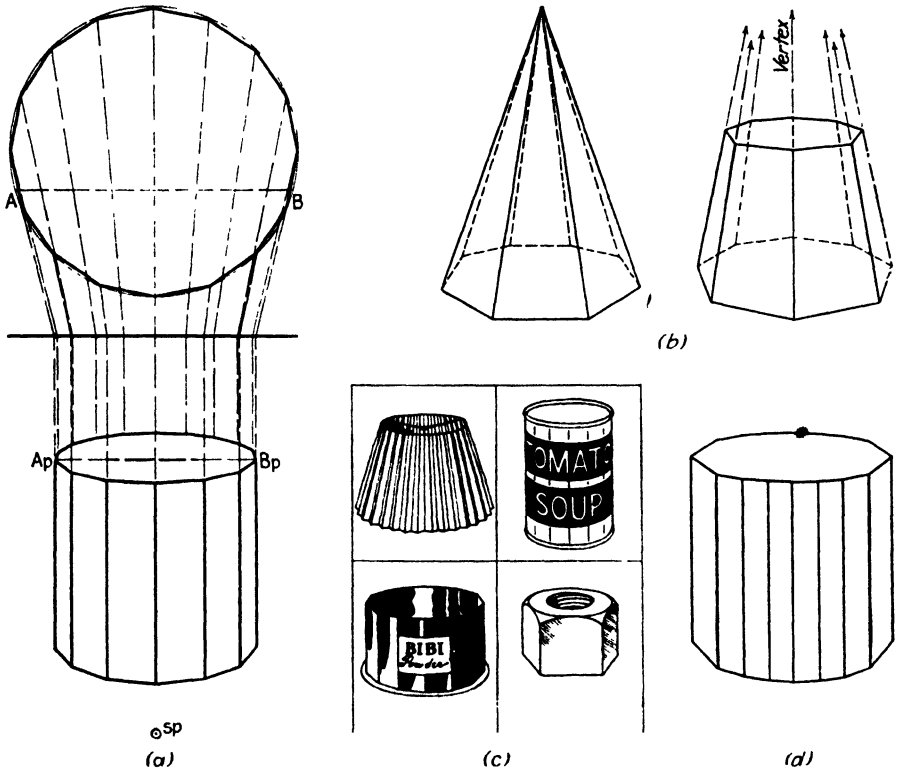

FIG. 91.

accomplished if it is remembered that this line has a common vanishing point with $A_{11}B$ and $E_{11}H$ of Fig. 90a. It is rarely necessary to find this point, for a careful estimate, guided by the slope of other lines, will usually serve, but should it be wanted it can be found by extending either $A_{11}B$ or $E_{11}H$ to meet a vertical from vp_2 . If estimation is not close enough for the given requirements, the vertical posts may be spaced more precisely by the measuring line method along the line IJ , as shown in Fig. 90b.

379. It is often necessary to draw circles, cones, or cylinders, polygons, prisms, or pyramids, divided into perspectively equal parts. Since such forms usually appear as secondary details, a good eye estimate is ordinarily correct enough, but study of Fig. 91a will make such estimation more intelligent. In this figure we have used a 16-sided prism as presenting a

typical problem. A similar solution may be used to derive the forms shown in Fig. 91*b*. Four real objects related to the above forms are shown in Fig. 91*c*.

380. In drawing such forms as that of Fig. 91*a* by eye rather than by projection, most workers fail in that they make the natural but erroneous assumption that the eye sees halfway around the form. Thus they expect to see 8 of the faces on a 16-sided prism. When the drawing is made accordingly, there results a sense of crowding and flatness. Reference to the projected drawing in Fig. 91*a* reveals the source of the error. With the prism aligned as it is there, note that only 6 of the 16 faces are visible on the near side. (By turning the cube one thirty-second of a revolution it would be just possible to see seven of the faces.) Thus while the front half of the ellipse $ApBp$ is divided into only six parts, the rear half is divided into ten. Failure to take this into account results in the distorted form of Fig. 91*d*. (Should the foregoing seem somewhat obscure, the reader should refer back to the discussion of the circle and ellipse in the first part of Chap. IV, particularly Fig. 35 Par. 193.)

381. Another error often made in drawing forms of this class freehand is illustrated in Fig. 91*d*. It arises from failure to recognize that not all the faces will appear of equal width to the eye. Since the remedy is evident, in Fig. 91*a*, we need not elaborate on it.

382. The clock in Fig. 92*a* shows how a circle in a vertical plane may be divided into perspectively equal parts. The simple method of Fig. 92*a* will work only when the circle is to be divided into an even number of parts. When the number is odd, the more complete construction of Fig. 92*b* must be used. When the number of divisions is a multiple of four, as is the case with the clock, the alternative construction of Fig. 92*c*, in which points I and J are used to locate all remaining points, may also be used when convenient. This is a more exact example of the similar problem in Fig. 83, without the estimation of spacing used there.

383. Returning to Fig. 92*a*, we have the rim of the dial drawn within the perspective square $ABCD$. The problem is to locate the 5-minute marks adjacent to each numeral. This problem is solved by swinging the circle *out* of the plane $ABCD$, in which the angles cannot be measured directly, into a new plane, parallel to the picture plane, in which they can be measured directly. The procedure is as follows: Draw a horizontal line starting from F toward the right. On this line lay off the distance FO_1 equal to FB . Using O_1 as a center, draw a circle with O_1F as radius. Using T square and 30-60-deg. triangle, divide the circle into 12 parts. From the points I_1, J_1, K_1, L_1 , thus located, draw horizontals to meet the line BD at I_2, J_2 , etc. From each of these points draw *perspective* horizontals to meet the *perspective* circle at I, J , etc. These will locate the 5-, 10-, 20-, and 25-minute marks. (The quarters, of course, are already known.) It is unnecessary to locate the other divisions in this manner. As can be seen,

the 35-minute mark is set by drawing a line from the 5-minute mark through the perspective center O , the 40-minute mark by a line from the ten, etc. The single minute divisions may now be estimated with ease and accuracy, but, if perfect precision is required, the above method may be extended by use of a protractor or dividers.

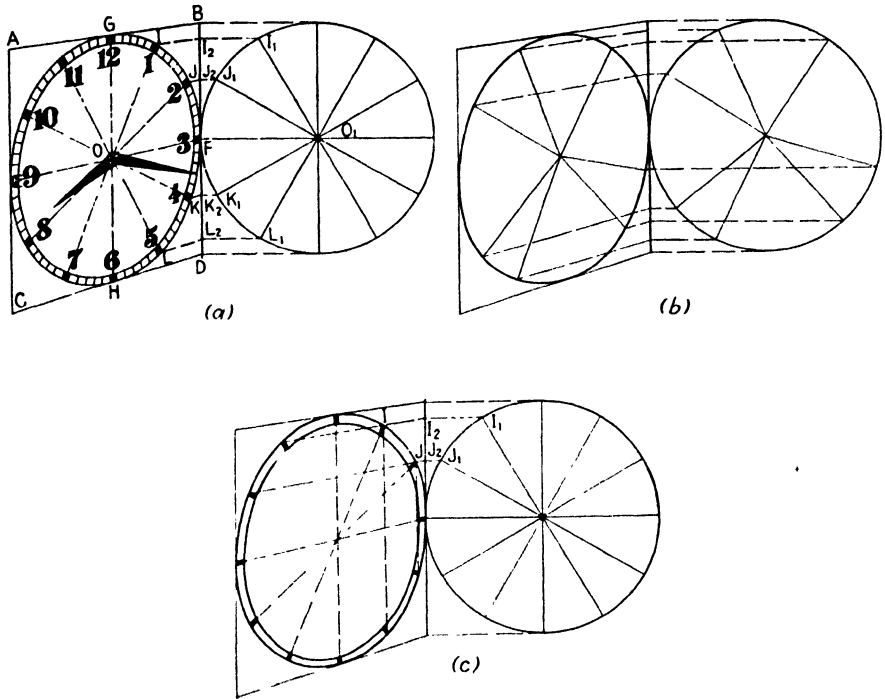

FIG. 92.

384. If it happens to be more convenient, the work may be done to the left of the dial, using AC as BD was used and radius equal to EA . An alternative method for drawing this with only I and J as references is shown in Fig. 92c.

385. With the single minute marks worked out we now have a convenient set of reference marks to establish the position of the numerals. Care should be taken to see that the perspective height of all numerals is kept uniform.

CHAPTER VII

PLASTIC AND SOFT FORMS

386. The various objects and forms discussed so far have been mainly of the class known as *tectonic* or *architectonic*.¹ It is now necessary for us to consider another class, generally called *plastic* forms. Since these make up fully half, or more than half, of the objects we may be called upon to draw, their importance is clear. The drawing of these requires an approach rather different from that used in drawing tectonic forms. While the remarks in the following few paragraphs may not at first appear to bear directly on the subject of drawing, experience will show that they have a very important bearing indeed, and that a better understanding of the nature of plastic forms facilitates the drawing of them.

387. What is meant by the term *plastic*, and in what way does it differ from *tectonic*? A mere dictionary definition will not help us here. It is essential that the difference be made visually and structurally clear. Speaking generally, we can say that tectonic and architectonic forms are those made by cutting, simple bending, and/or combining relatively rigid materials such as lumber, metal sheets, rods, tubes, bricks, tiles, etc. Thus a brick is a tectonic form, and by joining together a large number of bricks a wall is built, the wall being architectonic. Such a form is easily drawn by reference to its height, width, and thickness. Tectonic forms need not necessarily be straight-sided or characterized entirely by plane surfaces. A drum, a conical lamp shade, or a glass tumbler are all tectonic forms despite their curvature. What characterizes plastic forms particularly is the fact that cross sections taken at different places will ordinarily differ in both size and shape. If a glass water tumbler were to be sawed across at two different places in a direction parallel to the base, the resulting cuts would be identical circles. A conical goblet would yield circles of different sizes, but, since both are circles, their essential character would remain unchanged. These two instances are shown in Fig. 93a. The vase illustrated in Fig. 93b is a step away from the purely tectonic form of Fig. 93a; although the cross sections remain circular, the size of the circles varies with the doubly curved profile. In Fig. 93c the plastic quality of the form is dominant, the cross sections varying in both size and shape.

¹ Though the words *tectonic* and *architectonic* are, according to Webster, synonymous, they are coming to have a distinction of meaning into objects constructed for use on a relatively small scale, such as boxes, tables, shelves, etc., (*tectonic*), as contrasted with houses, office buildings, dams, bridges, etc. (*architectonic*).

388. The examples shown in Fig. 94 bring out the contrast by using pairs of subjects. Figure 94a is tectonic, consisting basically of half a sphere with a cone attached. No such simple description can be applied to the pitcher of Fig. 94b. The hood and fender of the old-style car in Fig. 94c,

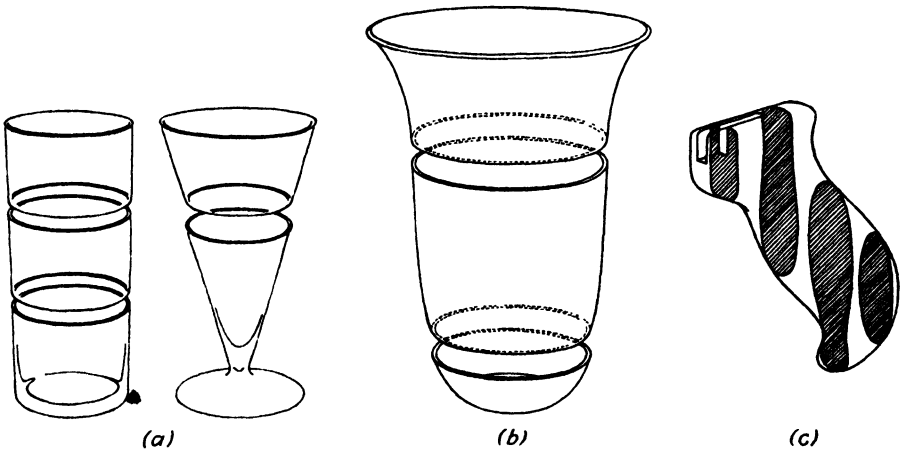

FIG. 93.

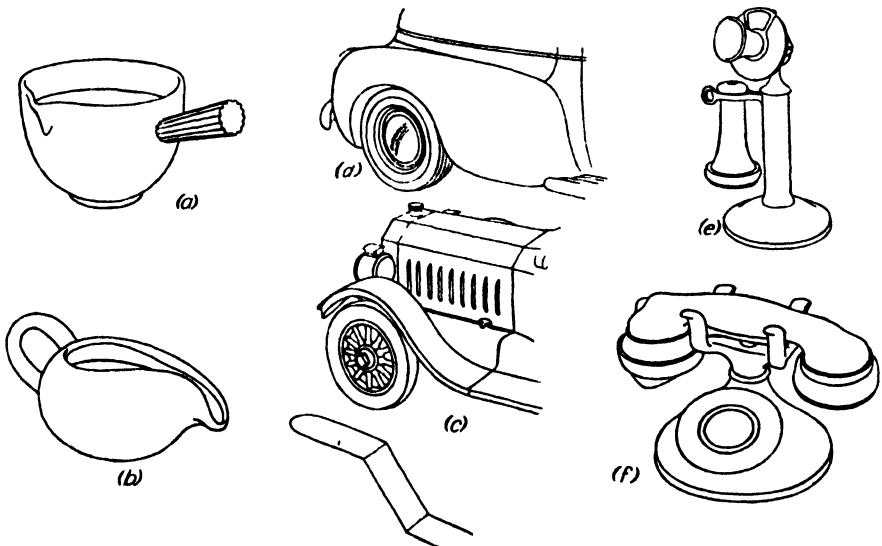

FIG. 94.

formed of flat sheets of metal, unchanged except for cutting, bending, and joining, are distinctly tectonic forms. At the time of writing (1942) American manufacturers universally use such forms as Fig. 94d, in which hood and fender are each formed from a single piece of cold metal sheet, forced by gigantic pressures to flow into the plastic forms. The old type

telephone of Fig. 94e, now almost extinct, gave way to the plastic form of Fig. 94f.¹

389. A careful study of the structural differences in these examples will show that a different method of drawing construction is demanded by the plastic form. Plastic forms are nearly always simpler in detail than corresponding tectonic forms; unfortunately, they are at the same time more subtle and demand more skill and understanding. The necessary edges, axes, planes, etc., of tectonic forms are inherent in the material; in plastic forms they must be searched for.

390. Most perspective texts ignore plastic forms altogether. There are two principal reasons for this. First, a majority of the texts are written by architects, and emphasis on the architectonic naturally predominates. Second, tectonic and architectonic forms were almost universal in manufactured articles until quite recently. This was because older manufacturing methods inevitably produced this type of form. Where many articles were once produced by relatively laborious cutting, bending, and joining operations, they are now turned out more easily and quickly by stamping, drawing, molding, and die casting. These newer processes make a necessity of a type of form that was formerly rare and costly to produce. One need only consider the enormous growth in the use of plastics in the past 10 years to appreciate this. Thus modern technology affects not only our mode of life but our mode of drawing.

391. As was demonstrated in Fig. 93, the plastic form with continually changing cross section cannot be drawn by methods suited for tectonic forms. In a strict sense a really complete structural analysis is impossible with plastic forms. When we have the length and one cross section of a cylinder, we know all we need to know to make an accurate drawing of it, but in the nose of an airplane no two cross sections are alike. An ordinary house could be described sufficiently in a couple of hundred written measurements, no longer than the customary list of specifications, and an architectural renderer could make a passable picture of it, but measurements alone do not sufficiently describe plastic forms.

392. This does not mean that plastic forms cannot be accurately drawn or that they need a tremendous number of construction lines. On the contrary, the drawing process is usually simple, but also subtle.² Our first example of practical construction is the sauceboat shown in Fig. 95a, which gives the three needed orthographic views.

393. *Complete* measurements and construction for a form of this kind are, as already explained, impossible, but the really *necessary* measurements and

¹ The instruments now being manufactured have returned partly to tectonic form, owing to the combining of the ringing mechanism with the base.

² Plastic forms bear about the same relation to tectonic forms that the infinitesimal calculus bears to algebra. Indeed there is more than just an analogy here, the calculus having been devised for the purpose of measuring areas and volumes of the more subtle types of curvature.

construction are relatively easy. The secret lies in finding the *critical* lines, those which determine the character of the form, which define the place where a curve changes from convex to concave, for example, the axial lines in symmetrical forms, the limiting lines and planes, etc. Thus, while complete construction is impossible, fortunately it is also unnecessary.

394. The experienced professional will often draw forms of this type without using even the construction given here. This is because his training permits him to *imagine* this construction without actually setting it down. The student, however, is advised not to omit the construction.

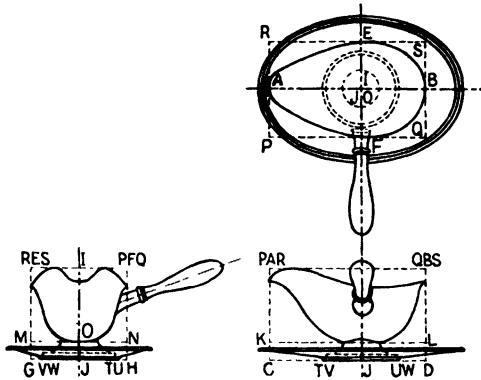

(a)
Fig. 95a.

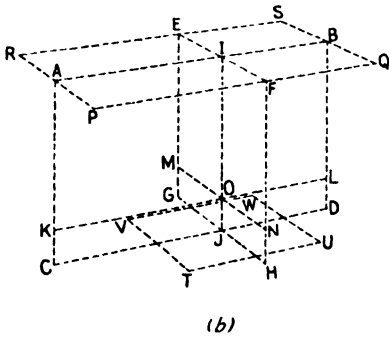

(b)

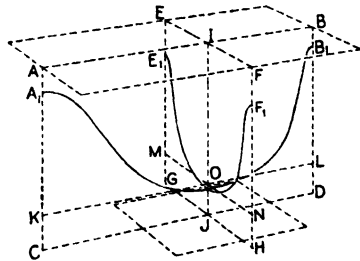

(c)

Fig. 95b and c.

395. If the bowl is considered alone and the tray and handle are disregarded for the present, the first step, shown in Fig. 95b, is to establish the rectangle $ABCD$, which passes longitudinally through the center and sets the *over-all* height and length. This plane is highly important, for it divides the object into symmetrical halves. The rectangle $EFGH$ is next drawn, perspectively perpendicular to $ABCD$ and passing through the center of the foot. The vertical line IJ , where these two rectangles cross, is the vertical axis of the foot. The lines KL and MN are now drawn through O , slightly above the lowest point of the bowl. These two lines are not absolutely necessary but will be helpful in establishing the curves needed later on. The rectangle

PQRS is now drawn, and finally *TUVW*, which is a square and sets the limits for the circular base of the foot.

396. Now imagine that the sauceboat has been sawed in halves vertically lengthwise, *i.e.*, by a saw cutting through in the plane *ABCD*, and that another such cut has been made in the plane *EFGH*. These imaginary cut edges, known technically as *sections*, form the skeleton of our picture.

397. In Fig. 95c these are constructed. The plane *ABCD* is taken first. The point *A*₁, the lowest point of the lip, is marked off at the proper distance

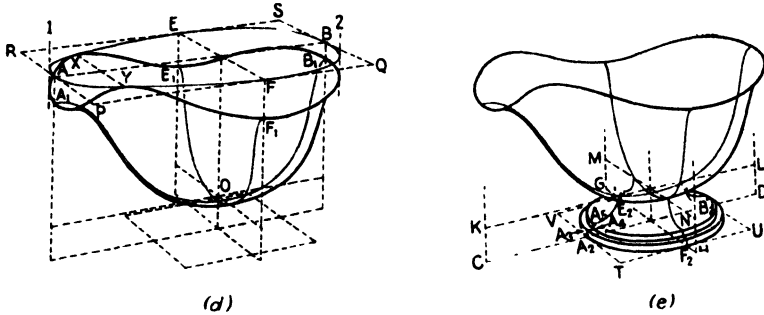

FIG. 95d and e.

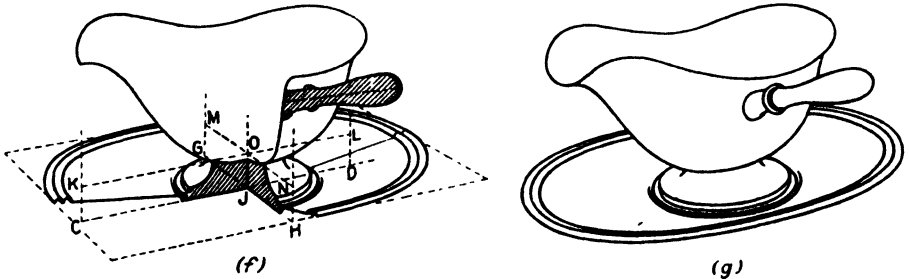

FIG. 95f and g.

below *A*, and the point *B*₁, the rear extremity, at the proper distance below *B*. The curve *A*₁*B*₁ may now be drawn freehand with considerable accuracy, owing to the precise establishment of these *control points*. The curve *E*₁*F*₁ of the transverse section is similarly drawn. It should be noticed that these two section lines correspond to the profiles shown in the side and front views, respectively, of Fig. 95a.

398. The top edge of the bowl is the most difficult *line* to draw. It is not only a subtle curve but a three-dimensional one. It is almost impossible to grasp the spatial character of such lines without a great deal of practice. The type of analysis used here, however, will permit the student to get correct results even without experience and, by aiding comprehension, will serve to diminish somewhat the amount of practice needed.

399. Imagine the top view of Fig. 95a to be drawn in a perspective similar to that we have been using. The top edge of the bowl would then be represented by the curve *AFBE* in the rectangle *PQRS* of Fig. 95d. The

rectangle, which has already been drawn, serves as a guide for making a perspective of the top view of Fig. 95a (not a perspective of the top of the bowl!). The resulting curve $AFBE$ is the *horizontal component* of the space curve we want, and, by confining ourselves to this for the moment, we can attend to one difficulty at a time.

400. We are now ready to complete the curve by adding the vertical component, *i.e.*, the third dimension. The points X and Y , where the edge actually touches the plane $PQRS$, are established first. The points A_1 , B_1 , E_1 , and F_1 are already set. Two vertical lines, 1 and 2 in Fig. 95d, tangent to the extremities of the curve, are drawn to indicate the limits at each end. We now have six points through which the edge line passes, as well as lines 1 and 2, which it just touches. This gives us eight guide-posts in all, making it relatively easy to draw the edge accurately by making a smooth curve through them.

401. It is possible to establish any desired number of intermediate points on this curve, and in some industrial applications such high precision may be desirable, but in general pictorial work the eight guides used here will, with a little practice, prove more than enough.

402. The next step is the outline of the bowl. Since this is a tangent to the section lines A_1B_1 and E_1F_1 , it may be drawn quite easily with these and the edges as guides. Care should be taken that outline and section line are not confused where they are close together as at A_1 .

403. The construction of the foot, shown in Fig. 95e, presents no problems not already covered in Chap. VI. Nevertheless it may be more convenient for the reader if we summarize it here. The square $TUVW$, having sides equal to the diameter of the base circle, has already been drawn. This establishes points A_2 , B_2 , E_2 , and F_2 . Next the cross-section lines $A_2A_3A_4A_5$ and B_2 , etc., are drawn. These are the perspective equivalent of the side view in Fig. 95a. The section lines from F_2 and E_2 are not essential but may help in understanding the form. They are identical with the lines just drawn. The stepped cylinders that can now be built up, plus the curved neck above, may now be easily drawn.

404. The construction of the handle and of the tray is shown in Fig. 95f. Since no new principles are involved, we need not discuss it in the text. Figure 95g shows the finished article.

405. The reason that this illustration has been discussed at such length is that the principles thus established hold good for all varieties of plastic form. We shall cover a few other objects to show certain special features, but it will be seen that the methods of Fig. 95 apply with slight variations to suit varied circumstances. These methods may be listed in the form of a program showing order of operations. These would run about as follows:

1. Lay out rectangle giving over-all height and length.
2. Lay out rectangle giving over-all height and width.
3. Lay out rectangle giving over-all length and width.

NOTE: Wherever possible these should pass through such parts of the form as will give "significant sections" or profiles such as A_1B_1 and E_1F_1 in Fig. 95.

4. Draw in the section lines (as A_1B_1 , etc.)

5. Wherever the surface is cut, determine the edge (as $A_1E_1B_1F_1$).

6. If necessary, lay out supplementary rectangles and determine supplementary sections.

7. Enclose these sections or profiles in an outline—as skin covers the skeleton—without waste to achieve smoothness, and yet be generous enough to avoid lumpiness.

406. Number 7 merits some further comment. There is more than an accidental analogy between drawing construction and the construction of the human form. By putting down outline without regard for the

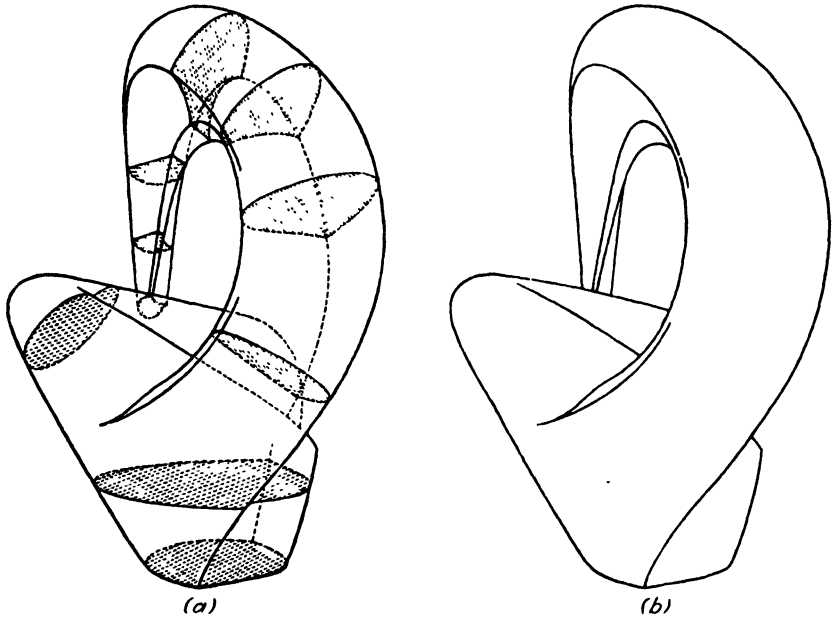

FIG. 96.

skeleton of section lines, a type of drawing is inevitably produced that is forcibly reminiscent of fatness. In the hands of an artist of skill and experience, this may be just a pleasing softness. Less skillful work produces a drawing indicative of pathological corpulence, with the smooth but flabby outline of a sausage or balloon. The effort to avoid this by stretching the "skin" or outline too tight produces a bony and emaciated effect that is nevertheless healthier in a drawing than is the opposite. Moreover, it is far easier to correct than "overweight."

407. Where the form in question has no symmetry about an obvious axis, the drawing problem is more difficult. Human and animal forms present an infinite number of such problems. Though laid out symmetrically, the human form is rarely seen that way except in the artificial

posture of the soldier standing at attention. Even a single live model never looks twice alike, because of large or small variations in posture, muscular effort, etc. It is largely because of this variability that, while a single course in still-life drawing may embrace *all* types of inanimate forms, however complex, a *single* type of *living* being, such as the human figure, requires as much and more study.

408. In order not to overload this book with complexities that would tend to obscure rather than reveal the principles involved, we use in Fig. 96 a piece of abstract sculpture to illustrate one type of asymmetrical form and the problem of drawing it. The drawing of a form of this kind can be handled most readily by working directly on the visible outlines and edges at the start, then checking and correcting with the aid of sections taken at various places calculated to characterize the form. This procedure in

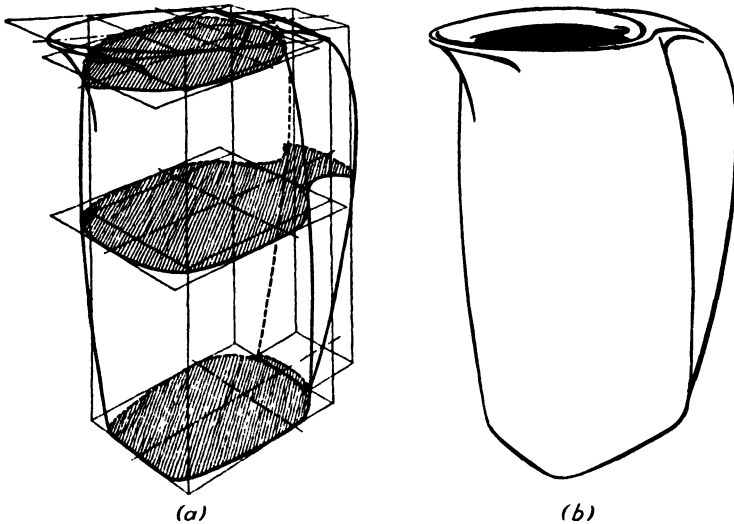

FIG. 97.

drawing is just the reverse of that we advocate for the less subtle forms such as Fig. 95 and should not be adopted by beginners, for they are likely, quite innocently, to abuse the freedom of the method and inadvertently to draw the boneless forms referred to above. On the other hand, when the student has been well drilled in the anatomy of inanimate objects, he may safely be trusted to draw the outline without any preliminary or corrective framework at all, this part of the work being performed in his head. Not even the practicing professional can afford to ignore the existence of the framework, even though he omits it in actual drawing. When modeling, which is beyond the scope of the present volume, is undertaken, the importance of the section is still greater.

409. The pitcher of Fig. 97 shows problems similar to but not identical with those of Fig. 95. The construction will repay close study.

410. Figures 98 and 99 show, respectively, aircraft and automobile. These two objects are constantly being required of the illustrator both of fiction and of advertising. Since, as a drawing problem, the airplane is the simpler, its procedure is given first. Because more can be learned from

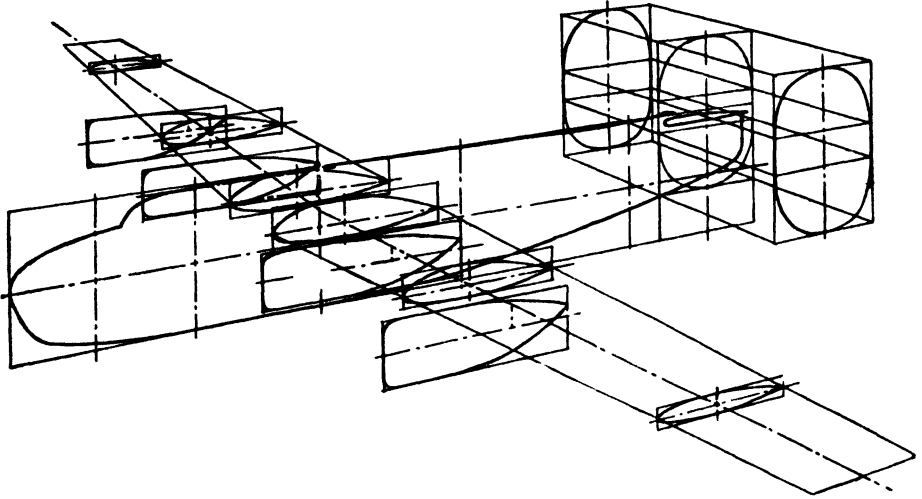

FIG. 98a.—(Reproduced by courtesy of *Air Trails Magazine*.)

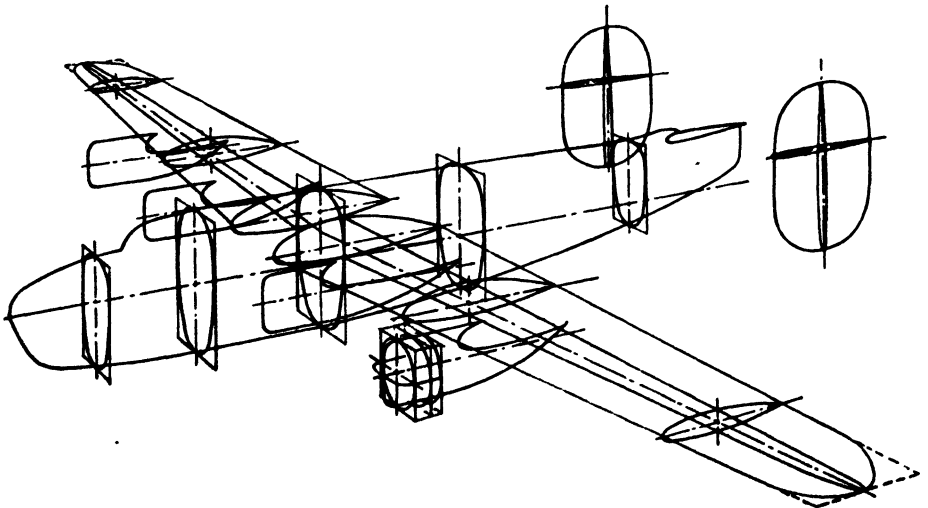

FIG. 98b.—(Reproduced by courtesy of *Air Trails Magazine*.)

a study of the figures than from any amount of discussion, we shall give only the briefest summary here.

411. The first thing to settle in a picture of this kind is the direction of flight. This determines the *action*. It is given by the center or thrust line of the fuselage. Next, size and relation to the available space must be fixed, as shown in Fig. 98a. Both these factors are taken care of by the

long rectangle that encloses the fuselage profile and the two tapering quadrilaterals that enclose the wings. Note that the latter are deflected upward slightly to take care of the dihedral angle. These set the over-all dimensions.

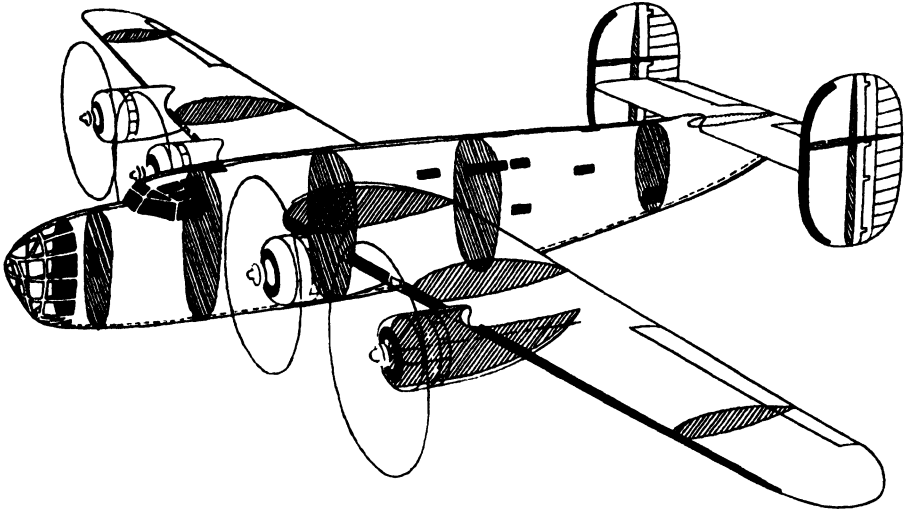

FIG. 98c. - (Reproduced by courtesy of Air Trails Magazine.)

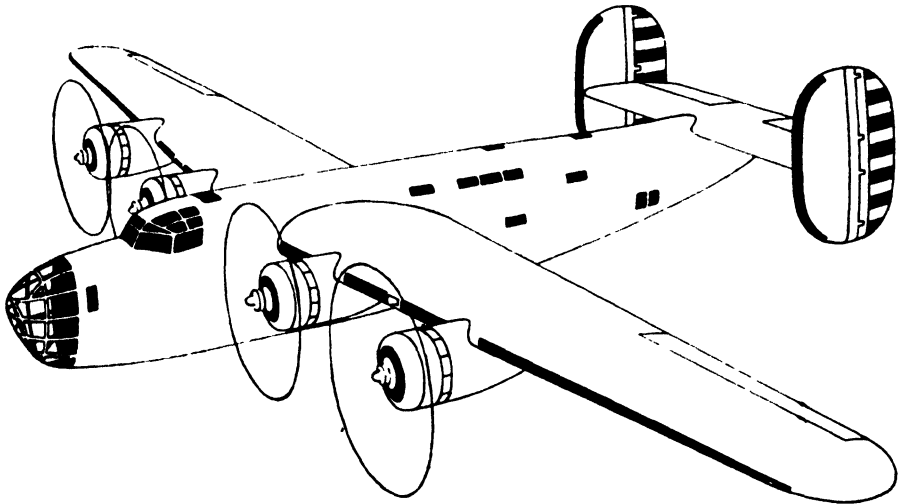

FIG. 98d. - (Reproduced by courtesy of Air Trails Magazine.)

412. These rectangles are now used to draw the fuselage and wing profiles. When these have been drawn the various cross sections are then added. Particular care should be given to the cross sections of tail members. Though these sections are quite thin, they are by no means negligible, and failure to take them into account will result in a rather papery appearance.

413. Engine nacelles are largely round in cross section and are therefore relatively easy, but care must be taken that the axes are correctly placed, since on many craft these are not in the center plane of the wing.

414. Fuselage cross sections are useful in establishing the positions of the bombardier's compartment in such a craft as that of Fig. 98, pilot's

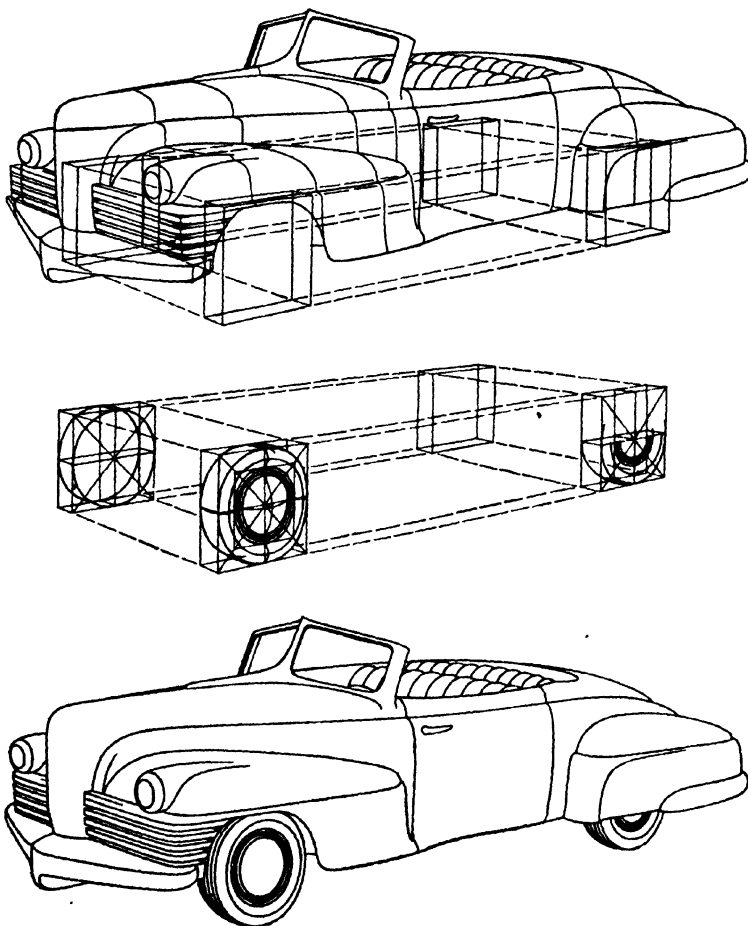

FIG. 99.

cabin, turrets if any, etc. In a transport, private passenger, or fighter plane, there will, of course, be fewer such details.

415. Wing cross sections must also be drawn, and, when the "skin" is drawn over these, the work is complete, except for erasing the internal structure. In cutaway drawings made for educational purposes, the structure is deliberately left in.

416. The body of a motorcar is much less a functional part of the mechanism than is the fuselage of an airplane. Any number of protuberances

may be added to it on the ground of "improving" its appearance without interfering with operation. For this reason a drawing made in the more superficial manner "from the skin in" will often prove perfectly adequate. Nevertheless, there are sharp limits to the allowable superficiality, and great care must be exercised to see that fenders match in height and that a feeling of straightness and symmetry is preserved through all the curvature and jungle of accessories. The wheels are particularly troublesome and have been treated separately in Fig. 99 in order to show the construction. When a strictly factual representation is required, it is a good idea to begin with the four spots where the wheels touch the ground to set the size, and to build up from there.

SOFT FORMS

417. Soft forms are even more difficult to define than are plastic forms, and, unless well understood, they are very hard to draw well. This applies to all drawing and was well expressed in an aphorism of a teacher who used to say, "To *draw* well, you must *know* well." As nearly as it can be expressed, soft forms are made along tectonic lines but acquire plastic character by reason of the material they are made of. The only important class of this type is that of upholstery, cushions, etc. These materials are so constantly with us and so much used in pictures that careful study of them is advisable. Of course it should be remembered that the complete constructions used in making these illustrations are used here for purposes of explanation and need be performed only by the student tackling such work for the first time. As facility is acquired, he may omit or telescope much of this work, provided, as always, that it is performed mentally. Failure to do this results in either a disagreeable hardness of appearance or its counterpart, a formless mushiness.

418. The rectangular sofa cushion of Fig. 100 shows all the basic principles involved. In making a cushion of this type the upholsterer takes two large rectangular pieces of cloth for the top and bottom and a long strip of material about four inches wide for the sides. From these he forms a sort of shallow cloth "box," which, if it were stiff enough, would look like Fig. 100a. When the stuffing is added, it causes the flexible fabric to bulge out. This raises the center of the top, lowers that of the bottom, etc. The material has to come from somewhere, and so the corners contract into curves. By passing planes vertically through the center, we may calculate this change for drawing purposes, as shown in Figs. 100b and c. In Figs. 100d and e, the drawing is completed, as for any plastic form.

419. The beginner and the incompetent professional are likely to leave drawings of such things in the preliminary stage of Fig. 100a, which suggests a plinth, or a base for a stone column, rather than a restful cushion. Such a quality in an advertising illustration for furniture is fatal, since no one wants to spend his money for upholstery stuffed with concrete. At one time the writer was afflicted with an assistant who could not be persuaded

to take account of this. Therefore he could be trusted only to draw things with straight lines and simple curves. Workers of this kind naturally gravitate to the lowest grade of client, who is willing to overlook incompetence in order to get his work done cheaply.

420. Figure 101 shows these principles applied to a more typical problem. The steps shown in Figs. 100*b*, *c*, and *d* are almost never performed in professional practice. The average worker goes directly from the tectonic

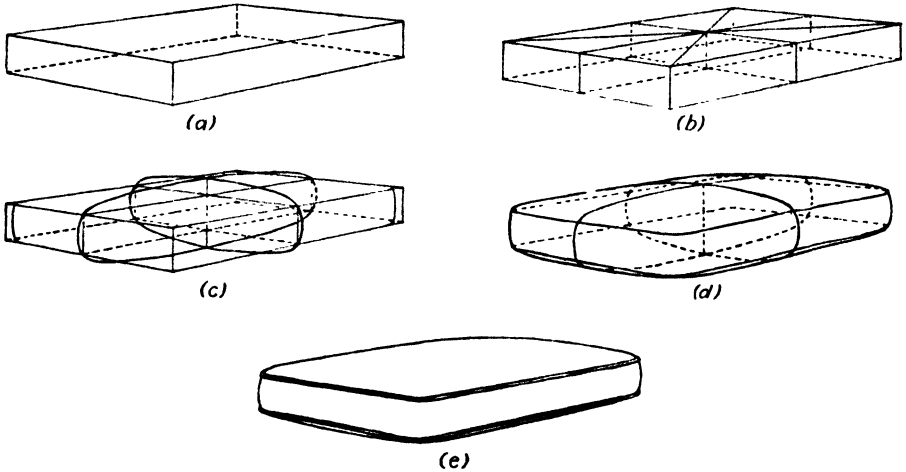

FIG. 100.

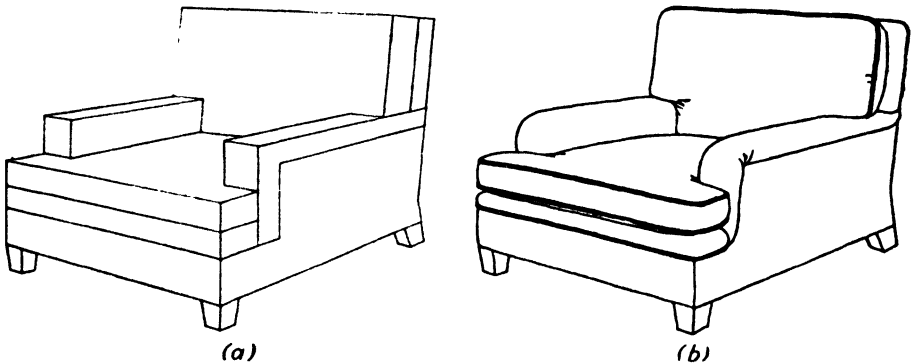

FIG. 101.

form, roughly drawn in to set the size and relation of parts, to the soft form of the actual object. This is the evolution of Figs. 101*a* and 101*b*. After some years' experience the professional may even condense the work of Fig. 101*a* to a few lines, performing the remainder of the construction mentally or even subconsciously. Even then such telescoping of operations can be carried too far, with an uncertainty and inaccuracy of result that will not satisfy an exacting client. Incidentally, it is interesting to note how the rigid lines of the tectonic form persist in Fig. 101*b* in those parts of the chair where the framing is near the surface.

CHAPTER VIII

PERSPECTIVE COMPOSITION AND FIGURES IN PERSPECTIVE

421. We have concerned ourselves thus far with the drawing of individual objects. Though this is undoubtedly the important part of drawing *per se*, it does not tell us how to make *pictures*, which in most cases consist of *groups* of objects. Although one object usually dominates a picture, it is rare that it will stand alone, and a disregard of accessories is likely to convey a lifeless appearance.

422. The term *perspective* composition is used here to distinguish it from *aesthetic* composition. The latter, which is concerned with the arrangement of pictures so that a pleasing or beautiful impression may be given or a vivid emotion or experience conveyed, is in itself a highly complex subject and not within the scope of this book. *Perspective* composition, on the other hand, is concerned with the grouping of objects in pictures in such a way that they shall bear proper size and distance relationships to each other, and that no two or more objects shall appear to occupy the same space at the same time. Though relatively easy to manage, these relationships are often overlooked, and one sometimes sees pictures (and not always by beginners) in which two pieces of crockery appear to be fused together, or a table top seems to pass clear through the waist of some unfortunate diner.

423. Nearly all objects in the visible world are resting on horizontal planes of one sort or another, or attached to vertical planes. The only exceptions are birds, flying insects, aircraft, etc. There is no need to consider these separately if the problem posed by earth-bound objects is properly solved.

424. One other problem of perspective composition is that of direction—the way objects face. This is also relatively easy to handle and will be treated later in this chapter.

425. Because nearly all objects rest or hang on something, the problem of perspective composition resolves itself in most cases to a consideration of the ground plan. The term *ground* is used here in the broadest sense to include any horizontal surface on which an object rests. (When we have to consider a group of objects hung on a wall, the same procedure is followed with the *plan* rotated to a vertical position.) In most cases this causes no difficulties, but occasionally an object must be drawn that is larger at the top than at the base. Here one often goes astray. There being no obvious conflict of areas on the ground, a drawing like Fig. 102a may be produced.

Figure 102*b* shows the top view (orthographic) of such a placement, and Fig. 102*c* shows the overlapping needed to make possible such an arrangement. These miracles are best avoided. Figure 102*d* shows the correction.

426. This type of error is the more annoying in that it often passes unnoticed until a picture is completed, and much time and pains have been spent on careful rendering. Though not obvious to the untrained eye, it induces a sense of uneasiness that is fatal to the success of some pictures.

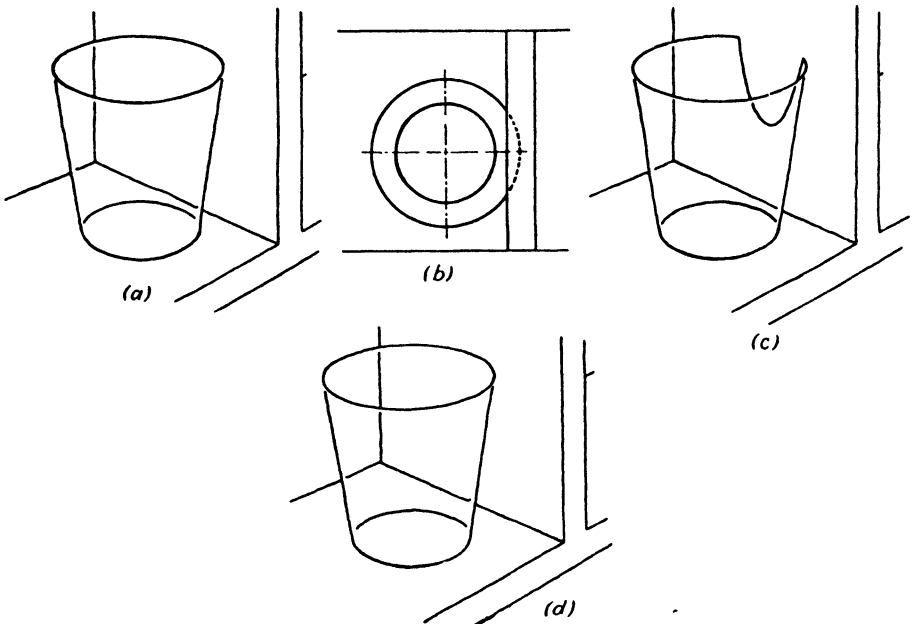

FIG. 102.

427. When he has become conscious of this trap, the student may try to avoid it by exaggerating his spacing, but the picture may again be ruined by diffuseness and disorganization. A more exact control is needed.

428. The architectural renderer, who works from plot plans carefully calculated as to spacing, is fortunate in this respect. The problem of perspective composition is automatically solved when he projects from this plan, and his only difficulty is in the choice of a suitable direction. In a case like this the entire plot may be considered a single object—the various trees, houses, hedges, etc., then being considered, not as objects in themselves, but as projecting parts or features of the plot.

429. If the general artist works, as does the architectural renderer, from a plan or top view, and projects this to form his perspective, as demonstrated in Chap. II and elaborated in Chap. XII, this same automatic spacing takes place, and the problem does not arise. Most pictures are drawn directly in perspective, however, without projection from a previously

prepared ground plan or top view. The solution in practice is to consider the maximum *horizontal* area required for each object and then to reserve that amount of space on the ground plane *as it is seen in perspective*. This may conveniently be done by laying out on the perspective of the ground plane the maximum lateral dimensions for each object. This will avoid overlapping and yet permit close spacing without waste. Such a precaution was taken in drawing Fig. 102d.

430. As time goes on, the student will acquire a *spatial sense* or *three-dimensional concept* that will enable him to dispense with these aids, but, no matter how great his experience, he will always find it helpful to think of each object in a picture in terms of the area of ground it covers.

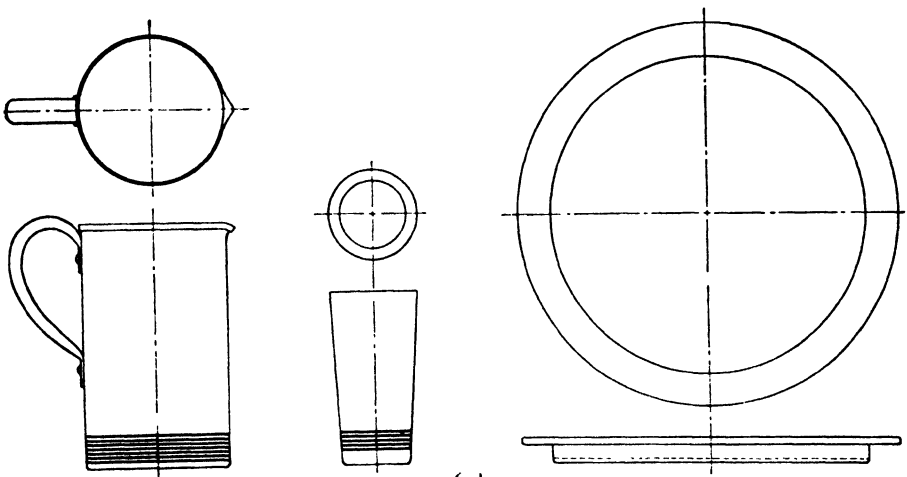

FIG. 103a.

431. In Fig. 103a we show, in orthographic projection, the proportions of a beverage set of spun copper. The problem is to make a drawing in which the pitcher and four of the tumblers will stand inside the rim of the tray without crowding or waste of space. It is also necessary to make the tumblers appear to be the same height.

432. Since this is not a job calling for high-precision work, it will be best to start by making a rough drawing that will set the various relations tentatively, as in Fig. 103b. At this stage we must try to get the sizes and proportions as nearly correct as possible by eye; but we must avoid overmuch erasing and correcting, for this will defeat the whole purpose of the rough draft and require more time for less accuracy than a complete projection from plans. It is particularly important to draw not only the visible but the hidden parts of the circular bases and to bear in mind that the bases of the tumblers must be separated by sufficient space to allow for their greater width at the top.

433. As the student gains in experience, he will find that his ability to estimate proportions of this kind grows to an accuracy astonishing to himself and that he may even proceed directly to the final rendering from this rough stage without going through the controlled procedure detailed below. Nevertheless, it is desirable that he perform the controlled procedure in

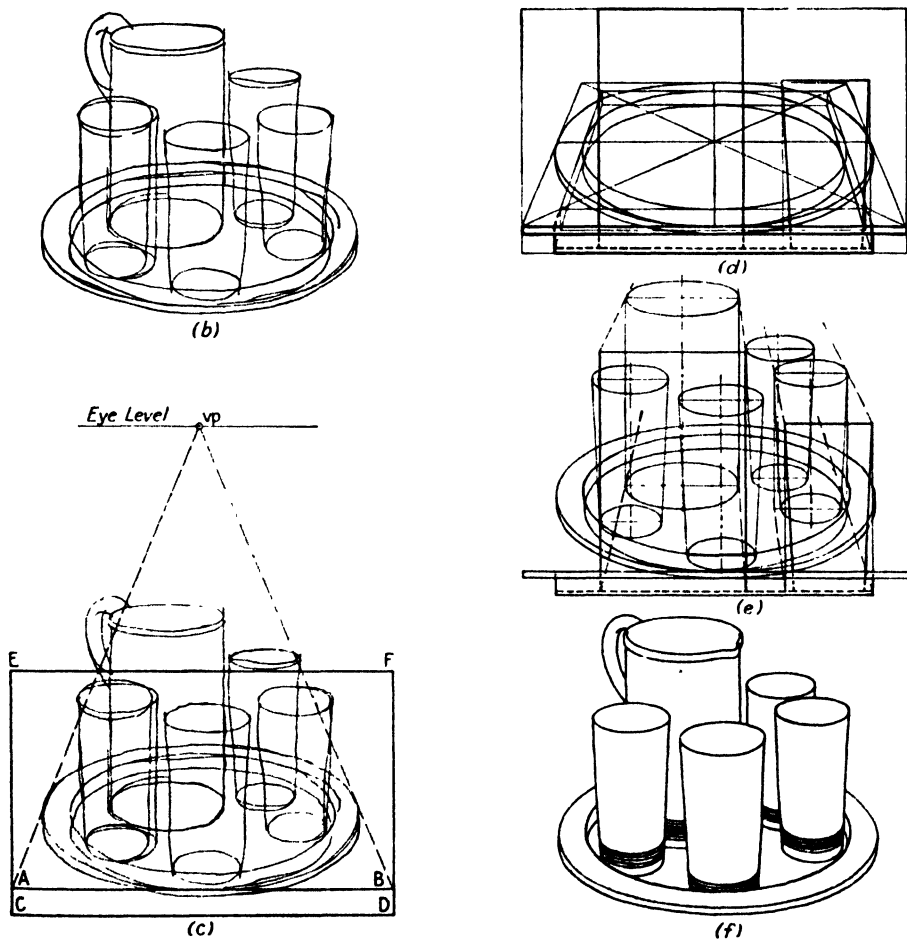

FIG. 103b through f.

order to get an insight into the laws involved and to achieve, while still inexperienced, a reasonable accuracy.

434. While the eye level has already been approximately placed by the rough sketch, it is now necessary to draw it in place, for it affects the relations of all the objects in the picture. The best position for it is from one and one-half to three times the height of the pitcher. This is most easily calculated by measuring the height of the pitcher through the centers of base and top and adding enough to bring the eye level to the desired height,

as shown in Fig. 103c. The eye level here used is about the normal one for such a group. Only one vanishing point is needed, because all the objects are round and one point is sufficient to calculate the relative apparent sizes. It is most convenient to place this point above the center of the tray.

435. With the vanishing point in place, lines are then drawn tangent to the sides of the tray, and a horizontal line is drawn tangent to the front of the tray as in Fig. 103c. The width of this horizontal is determined by the lines from the vanishing points intersecting it at points *A* and *B*. The line *AB* becomes the line by which all other lines are scaled. Using the line *AB* as the width, a rectangle *CDEF* is now drawn, with the height equal to the *proportional* height of the pitcher. For example, should the line *AB* be two-thirds the actual width of the tray, *CE* should be two-thirds the height of the pitcher. We may also arrive at the same result by considering

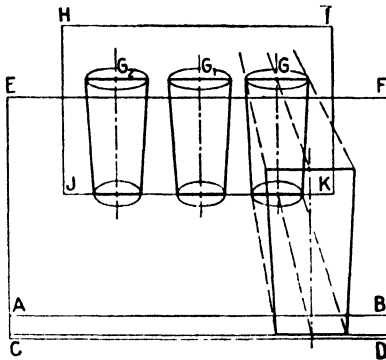

FIG. 104.

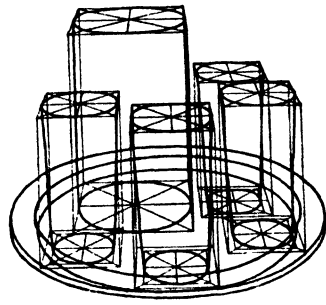

FIG. 105.

the ratio of size of pitcher and tray. This pitcher is $7\frac{1}{2}$ in. high, and the tray is $11\frac{3}{4}$ in. wide. The height of the rectangle should therefore be made about two-thirds of the width. The latter way of thinking of proportions is usually better, for we need to consider not the scale of the drawing, but only the relations of its parts.

436. Note that the base *CD* of the rectangle is put as far below *AB* as the base of the tray is below the rim. Obvious as this may seem, it is neglected more often than not by students, who leave the pitcher and tumblers floating in the air $\frac{3}{4}$ in. above the bottom of the tray.

437. In Fig. 103d an elevation of the tray, pitcher, and one tumbler is constructed in the rectangle. It is a good plan here to construct the perspective of the tray by the enclosing square method, in order to give accuracy to the one object that controls the position of all the others. The pitcher and the four tumblers may now be drawn by the more rapid approximate method described in Chap. V, Par. 257. These two steps are given in Figs. 103e and *f*.

438. It is worth noting that it is not necessary to draw the tumbler elevation exactly in a vanishing line with the image of each tumbler. One

such elevation suffices for all four, for this reason: in any one plane perpendicular to the line of sight, equal heights will appear equal. Thus, if we project back toward the vanishing point to get the height and width of a tumbler at G in plane $HIJK$ (Fig. 104) these same dimensions will serve equally well for tumblers at G_1 and G_2 . This principle is of great importance in perspective composition, and in freehand work it is wise to keep it in mind.

439. There are other ways in which this drawing may be managed. For example, it may be projected from a top view, or the more complete construction based on a group of rectangular solids may be used, as in Fig. 105. However, it is rarely desirable to use the projection from the top view when dealing with movable objects, for it is too inflexible and makes

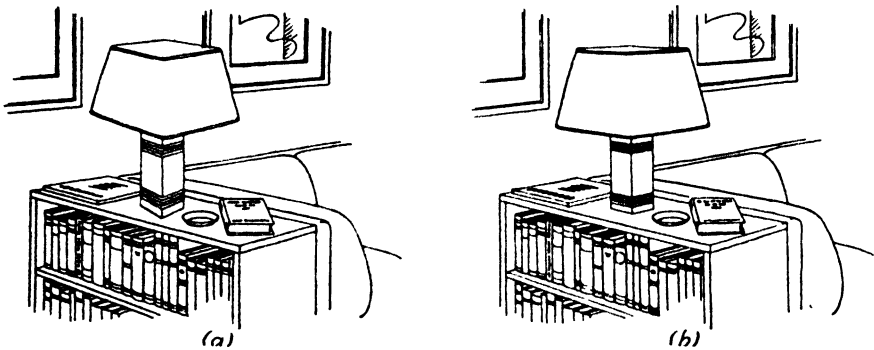

FIG. 106.

no allowance for improving the arrangement after the perspective has been drawn except going back and repeating the whole series of operations. In drawing an interior it is sometimes wise to project the floor plan, walls, and fixed furniture, leaving the movable pieces for direct drawing after the enclosing solid is set.

440. The procedure of Fig. 105 sometimes produces an interesting anomaly. When the angle of view is relatively wide the tops of the tumblers near the sides of the picture will appear as distorted ellipses. This effect was mentioned in Chap. V and is explained in detail in Chap. XIV. It is sufficient to say here that the approximation of Fig. 103 is really closer to what the eye sees than is the more exact work of Fig. 105.

441. The steps shown in Figs. 103c and d may be omitted if no great accuracy is required, and, once one tumbler has been drawn, the others may be compared directly to it.

442. Perhaps the simplest kind of group is that consisting of one object resting on another, such as the lamp and table of Fig. 106 and the bowl of flowers on the windowsill in Fig. 107. The commonest error in work of this kind is the failure to draw the vase, lamp, bowl, or whatever as though it were really resting on the supporting plane. This error, frequently seen

in the cheaper kind of professional work, results from forgetting that, however many objects the picture may contain, it can have but one horizon. The error in Fig. 106*a*, where the base of the lamp is square, is fairly apparent; in round objects, such as Fig. 107*a*, it is more subtle, and the correction often eludes beginners.

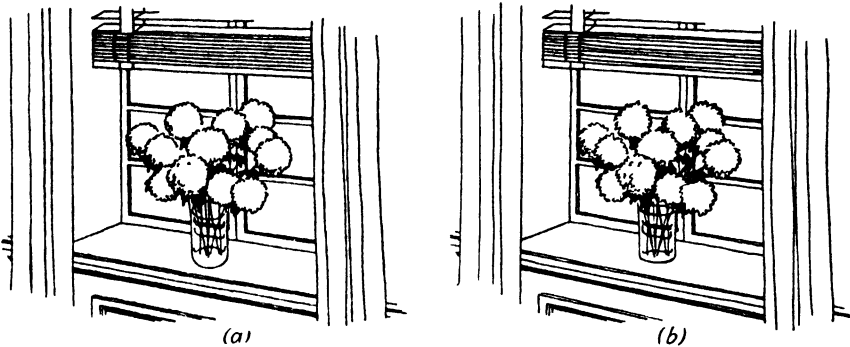

FIG. 107.

443. The drawing of interiors is excellent practice in group drawing in general, *i.e.*, in perspective composition. Another virtue of interiors is that even the simplest will introduce a dozen or more subsidiary problems, with the result that skill in a variety of jobs is quickly cultivated.

444. Since an interior has necessarily definite limits as to floor area and ceiling height, it is best to begin by setting down these limits at once, *i.e.*, by drawing first those lines which show the floor line, corner or corners, and sometimes the ceiling line as in Fig. 108*a*. This of course applies to cases where a particular room or type of room is to be depicted. The fixed features, such as windows, doors, etc., may also be outlined at this stage. In advertising illustration the movable furniture is usually the important part of the picture, the room being merely a background or setting for it. In this case the furniture may be drawn first and the room later drawn around it to fit. Even then it is wise to remember that there are physical limitations to room size and that a bedroom floor seeming to cover half an acre will look absurd, no matter how beautiful its furnishings.

445. Even before this first actual step, the artist should pause and consider what the picture should include and what point of view will show it to the best advantage. It is possible to show all four corners by means of a somewhat artificial convention shown in Fig. 109, but ordinarily a choice must be made. When only one or two pieces of furniture and perhaps a window or door are of importance, a single corner will serve as well as a more comprehensive view. Indeed, it will serve much better, for interest will not be squandered on nonessentials. Figure 110 is such a drawing. It is surprising how completely the character of a room may be conveyed by such a restricted view. The principal function of this sort

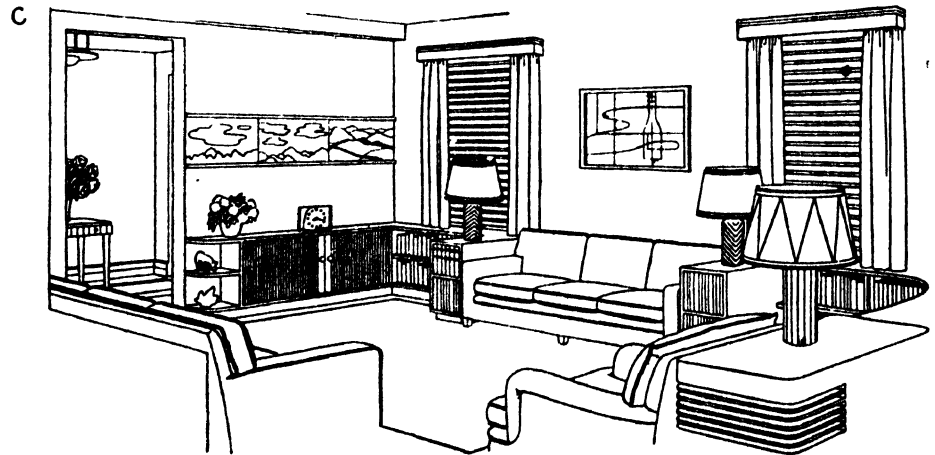
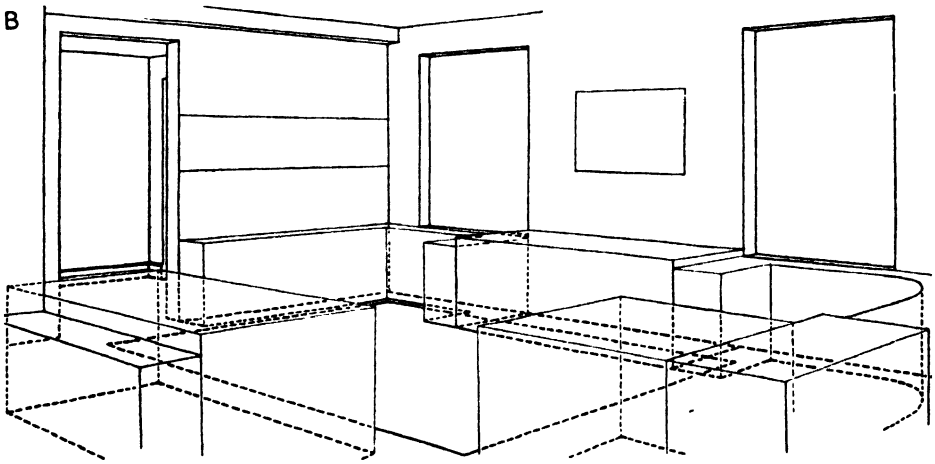
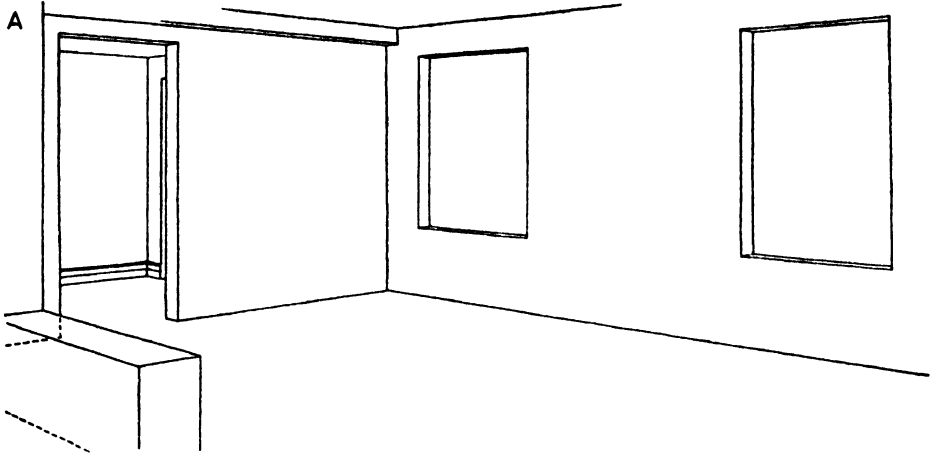

FIG. 108.

of picture lies in its ability to display important features, and it is frequently used in conjunction with and supplementary to a more complete view.

446. The most useful view for all-round purposes is that which will include most of two adjacent walls, as does Fig. 108. Nearly all the signifi-

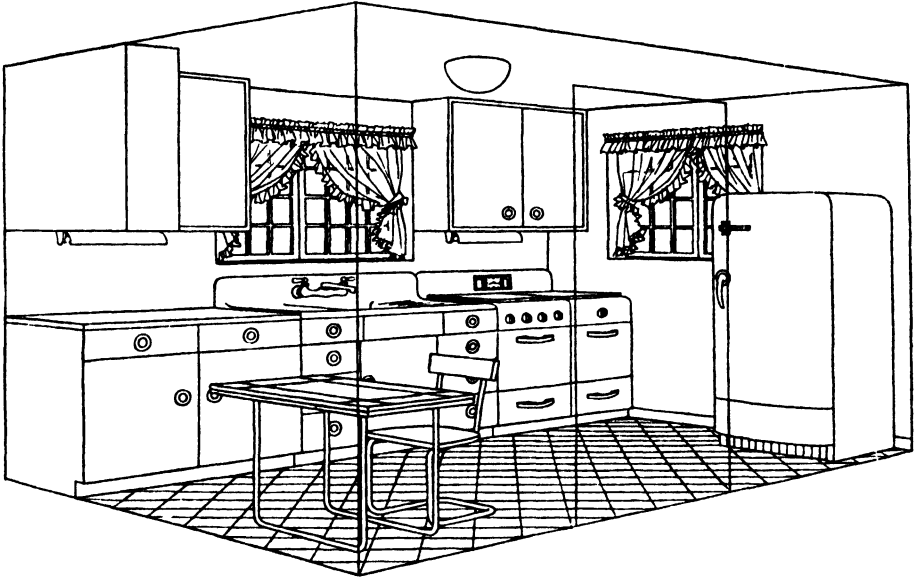

FIG. 109.

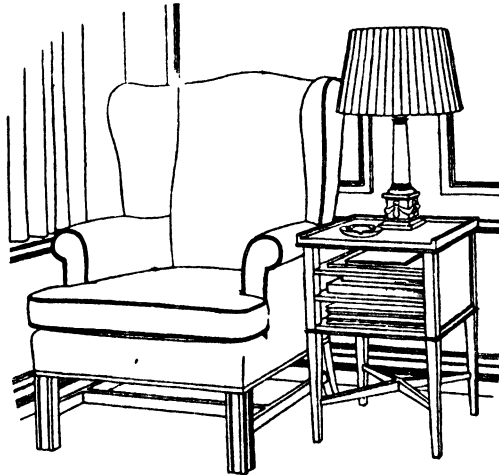

FIG. 110.—Drawing laid out instrumentally, using perspective graph method described in Chapter IX, paragraphs 479 through 483, then finished freehand.

cant pieces of furniture may be included in such a view, and the two visible walls will establish the character of the entire room. If some important part is perforce omitted because of being beyond the borders or behind the observer, it may be supplied in a supplementary view such as Fig. 110.

447. When it is necessary to crowd as much information as possible into a single ordinary view, it is usually best to make use of a one-point, or parallel, perspective, as in Fig. 111, although an improvement in interest of presentation is sometimes made by using a two-point perspective with

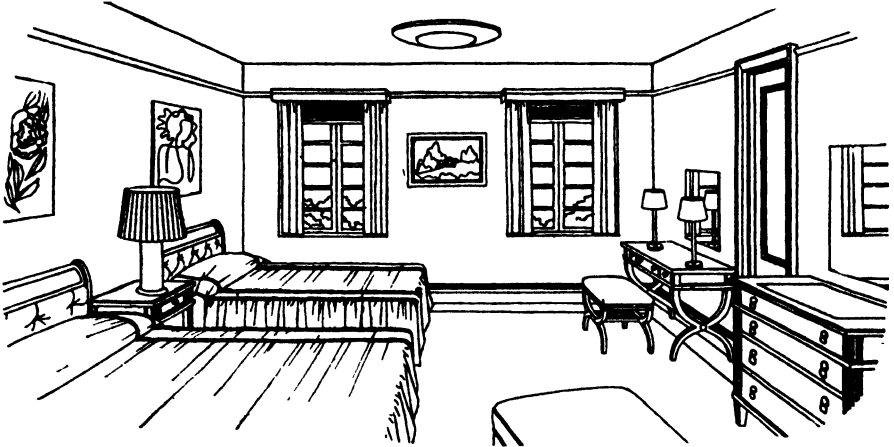

FIG. 111.

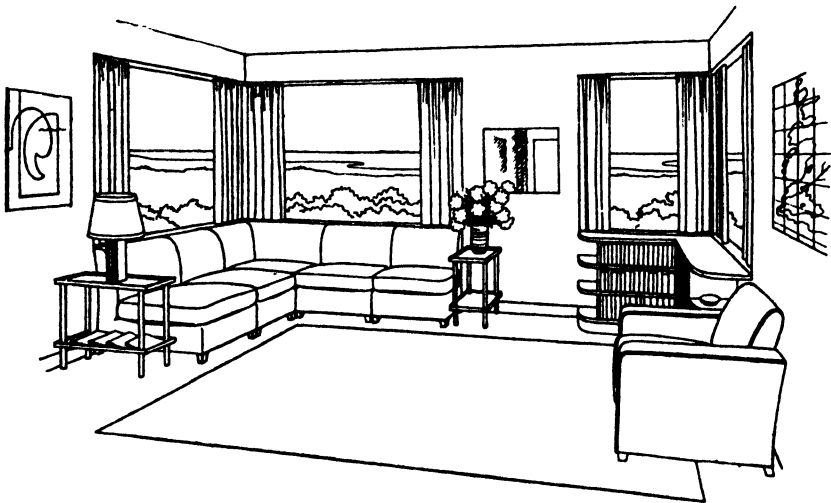

FIG. 112.

one point just off center and the second at a great distance, as in Fig. 112. These have the advantage of showing three walls at once and permitting complete information to be presented with the aid of one other view of one wall only.

448. When all possible information must be given in one view, it is customary to draw the room as though it had only two walls and no ceiling, and as though it were viewed from outside. Several variations of this are

possible. The omitted walls may be shown in outline as though made of glass, as was done in Fig. 109, or may be presented as though broken away. When any of these expedients is used, it is usually advisable to adopt a very high viewpoint in order to minimize the hiding of one piece by another. Such a drawing has the advantages of giving a maximum of explanatory detail in a minimum of space, and of doing it in a single operation; its disadvantage is that its artificiality may be puzzling to the layman. It is very useful to the architect or decorator, because it enables him to study the room as a unit.

449. Once the part of the interior that is to be represented has been selected, the placing of the eye level and vanishing points should be undertaken. It is surprising how strongly these control the effectiveness of the result. The eye level is usually put at 5 ft. or a trifle over, because this is the normal eye level of a standing person. If it is set too low, the room and all its equipment will appear to have been built for giants—if too high, for midgets. When special conditions, such as an awkward format calling for a frame taller than wide, must be met, it may be necessary to use a different eye level. In such a case it is best to make the departure from the norm drastic enough to be recognized for what it is, putting it at 12 or 15 ft. so that the change may clearly be a result of special requirements and not of incompetence. The eye level will ordinarily be about twice the height of an ordinary table, or about five-eighths of the height of the ceiling.

450. The vanishing points are governed by two considerations: they must be far enough apart to prevent a forced appearance, and they must be so placed that the most significant details are presented with the least foreshortening. For the former a simple rule that covers nearly all cases is as follows: keep the distance between the vanishing points equal to or somewhat greater than three times the width of the picture. When the picture is higher than it is wide, the height should be used as the unit. As to the second consideration, any plane that contains much important detail should be placed so that this detail requires a minimum of foreshortening. For example, a bed, in which the headboard and footboard alone have much character, should be shown with the vanishing point for the enclosing rectangles at some distance. The mattress, etc., between may have their principal vanishing point quite close by and may be drastically foreshortened. Since these parts are common to all beds of whatever pattern, there is no purpose served by complete delineation of them. This suppression of unnecessary detail is done in Fig. 113.

451. When there are equally significant features at right angles to one another, we must compromise by putting the vanishing points almost equally on each side of the center of vision. A perfect 45 deg. view is usually uninteresting, so it is a good plan to bring one slightly closer than the other.

452. When the angle of view that will most effectively present the important features has been selected, it is best to draw next the structural features, such as doors, windows, and beams, if any, and the built-in furniture, such as book-cases, etc., as also shown in Fig. 108*a*. Again an exception must be made for the advertising illustrator, who is free to arrange these features to suit the movable furniture, rather than the other way around. The illustrator of fiction has naturally even more freedom, since a room is for him only a background or stage set, and he need only see that his drawing of it does not violate fundamental laws or show absurdities of proportion.

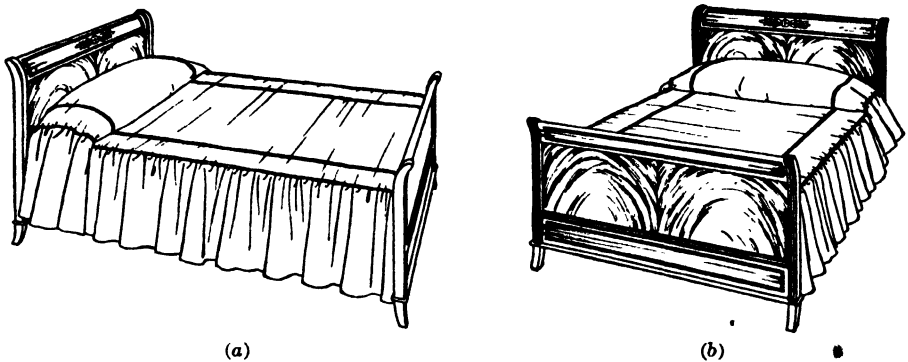

FIG. 113.—(a) Detail bad in headboard and footboard. (b) Subsidiary details subordinated by sharp foreshortening; important details emphasized.

453. The placing of the movable pieces is most easily done by roughing in their outlines and then carefully laying out the floor area each will require. The reason for such a proceeding is that it permits exact size comparisons among the individual pieces and the room itself. Furniture is thus placed in a drawing exactly as it is in a real room with regard to the floor area each piece occupies, and the floor space between pieces for adequate and easy traffic flow. This step is shown in Fig. 108*b*.

454. The final step, Fig. 108*c*, in drawing the interior consists simply in drawing the various pieces one by one as though they were so many separate drawings. It is safe to concentrate on the individual pieces at this stage, because the large relationships have now been solidly established. Beginners often start work on the details too soon, producing excellent drawings of details but never a picture. The interdependence of the parts of a picture must always be kept in mind; the horizon and vanishing points of a wall are the same as those for a table supposed to be parallel to it, and their scale must be the same as well.

455. It is strongly urged that the hidden lines of the furniture and walls be drawn in quite completely and erased only when the drawing is cleaned up for presentation. Naturally not all hidden detail need be drawn, since the overlapping lines would become impossibly confused, but all those which establish heights, spacing, and support should be kept.

456. In drawing interiors, as indeed in all drawing, it is helpful to think of oneself as actually placing real furniture in a real room. The skilled worker actually forgets that he is working on a plane and sees his paper instead as a portion of three-dimensional space in which he builds and places the objects of his picture.

FIGURES IN PERSPECTIVE

457. As was pointed out in the last chapter, it is impossible to draw plastic forms completely by the precise control methods possible with tectonic forms. Nevertheless, sufficient control for practical purposes is obtainable with inanimate objects of plastic character. When we come to the human figure with its myriad variations of position and posture, even these controls begin to lose their validity. Nevertheless, perspective principles apply just as inexorably to the appearance of the figure as to that of a house. This means, therefore, that practical control methods

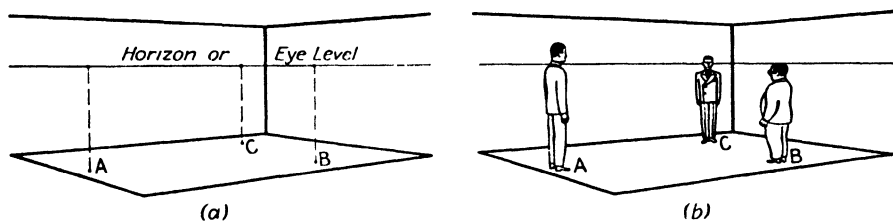

FIG. 114.

must be established for the principal perspective effects on the appearance of the figure.

458. Of these effects by far the most important is size, and ordinarily the height of the figure is the only dimension we need to establish, the remainder of the figure being proportioned to the height. Any of the methods described in the chapter on measurement would serve the purpose, but a number of simpler means are available for this particular job.

459. The simplest case is one in which a group of figures is seen, all standing on a flat plane such as a floor, courtyard, or level ground. If the eye level is at a normal height of slightly over 5 ft., the problem becomes very simple. Suppose, as in Fig. 114*a*, that there are to be persons standing at points *A*, *B*, and *C*. The heights are here determined by the simple device of drawing verticals up to the horizon. Now, if *A* is a rather tall person, his head will come entirely above the eye level. If *B* is rather short, his head will come below it, and if *C* is average, his head will be half above and half below the horizon. Once these proportions have been established, completion of the figure becomes strictly a matter of life drawing, with which this book is not concerned. In order to avoid an appearance of incompleteness, Fig. 114*b* shows the completed figures, highly simplified in order not to conceal construction.

460. The case illustrated in Fig. 115 is slightly more complex but should produce no real difficulties. Here the eye level is somewhat higher than normal. The line XY is drawn at about 5 ft. 3 in. above the floor. This is done by any of the methods described in Chap. III. To find the height of the man at A , a line is drawn from A perspectively perpendicular to the floor line. This locates point A_1 . From A_1 a vertical to XY locates A_2 . From A_2 a line is now projected back to meet the vertical from A at A_3 . AA_3 will then be 5 ft. 3 in. high. Since this man is more than usually tall, all of his head comes above A_3 . The sizes of the men at B and C are similarly determined, the head of the short man at B being entirely below B_3 , while that of the man at C will have C_3 near its center.

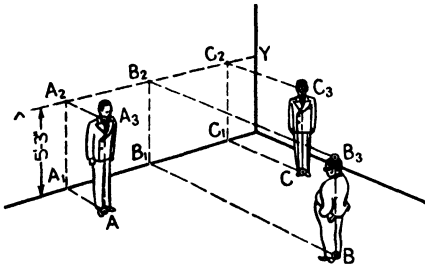

FIG. 115.

461. When the required figures are to be drawn as standing on an open level lawn or field, the problem becomes even simpler. This case is illustrated in Fig. 116. In order to show a different effect the eye level here has been placed rather low, as though the scene were viewed by a spectator reclining in a lawn chair. Since the wall line here is not suited to the purpose, the measuring line may be placed wherever convenient, and the construction may be simplified by using parallel perspective. With any convenient method, the vertical MX is established as 5 ft. 3 in. or slightly

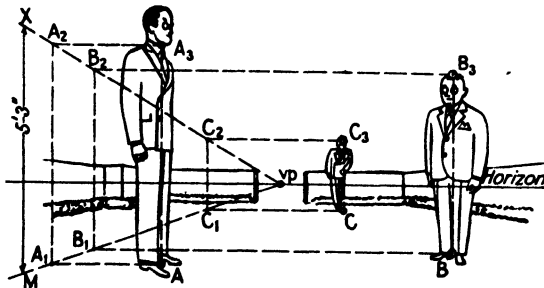

FIG. 116.

more. This line may be put wherever it is wanted, preferably well to the side in order to keep the construction lines away from the principal parts of the picture. Through M and X lines are drawn to any convenient point vp on the horizon. To find the height of the man at A , a horizontal line is drawn from A to meet Mvp at A_1 . A vertical from A_1 meets Xvp at A_2 . From A_2 another horizontal is drawn, and a vertical is erected on A . These two will meet at A_3 . This point is about at the chin of a man slightly taller than ordinary. The heights of the men at B and C are found in the same way.

462. The convenience of this method lies in the fact that the horizontal lines are true horizontals and need not be drawn toward a vanishing point. When instruments are used, these lines may be drawn with the T square.

463. When the height of one figure is already established, as when the principal figure is drawn first and the rest of the picture made to fit, a still

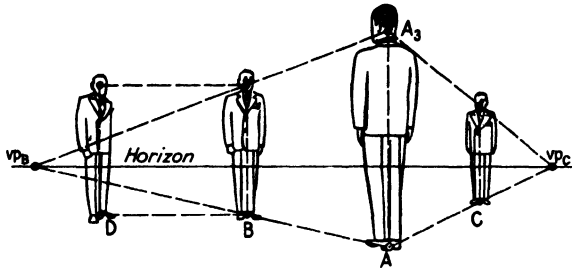

FIG. 117.

more direct method may be used. This is shown in Fig. 117. Suppose the figure at A has been drawn and the heights of persons at B and C are desired. A line is drawn from A through B and extended to meet the horizon at vp_B . From A_3 another line is drawn to vp_B . A vertical erected at B will meet A_3vp_B to give the required height. The height of the figure at C is found in the same way.

464. As many vanishing points may be used as there are figures, but many of these will not be needed. There are two reasons. First, all figures at the same distance from the picture plane will have the same scale; thus two men of the same height at B and D will appear to have the same height. In more practical terms we may say that, if the feet of B and D are on the same horizontal, they will have the same apparent height. We are of course disregarding individual differences in favor of simplicity. The second reason why a great many vanishing points will not be needed is that, when four or five figures have once been scaled at various distances, the remainder may be estimated or interpolated with considerable accuracy.

465. If one or more of the figures stands on a plane that is higher or lower than the principal figure, the problem is very little more difficult. Figures 118 and 119 illustrate such a situation. In Fig. 118 the standard height has been established at a convenient position, and the height of the man at A is set by projecting horizontals from A_1 and A_2 in the same

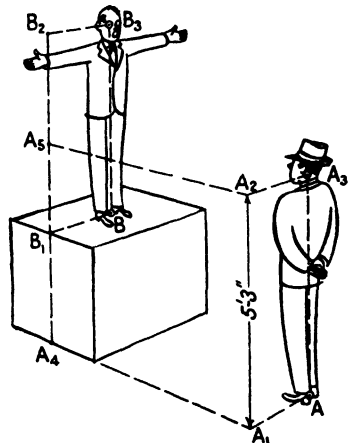

FIG. 118.

manner as in Fig. 115. The standard height is now projected back to the vertical A_4A_5 , which is aligned with point B by drawing BB_1 , as the figure shows. This vertical is continued up beyond A_5 . Taking B_1 as the base

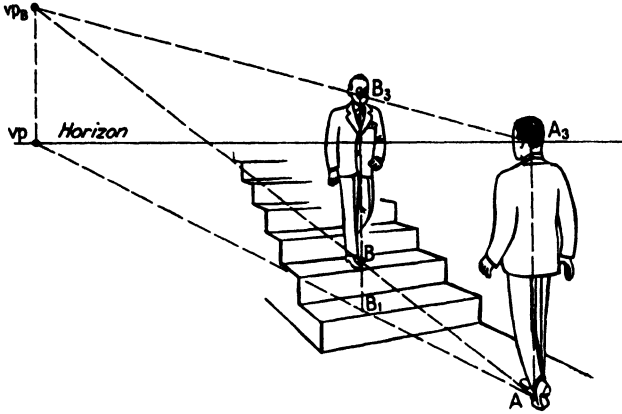

FIG. 119.

point, B_1B_2 is measured off equal to A_4A_5 . A vertical from B and a horizontal from B_2 will now intersect at B_3 , giving the height of the figure at B .

466. Another method of accomplishing the same result is shown in Fig. 119. Here the height of the figure at A is used as the standard. The point B being set, the point B_1 must then be found directly below B on the same plane (the floor plane in this case) as point A . A line drawn from A through B_1 meets the horizon at vp . A vertical is drawn from vp . Next a line is drawn from A through B to meet this vertical at vp_B . A line is now drawn from A_3 , which was established by the conditions of the problem, to vp_B . A vertical erected at B will meet this line at B_3 and give the desired height.

The same method may be used for determining the height of a figure in a lower plane.

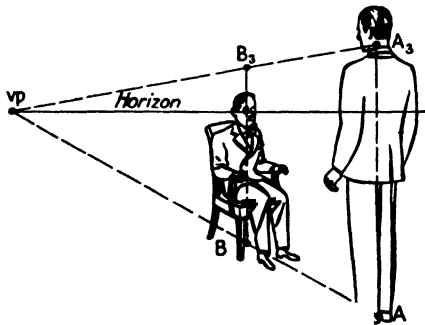

FIG. 120.—Note that the horizon passes through the eye of the seated figure, indicating that the observer was also seated. By means of such evidence, as well as the position of the vanishing points, it is possible to deduce the conditions under which a given picture was made, if drawn on the spot, or the conditions of projection, if drawn by geometric methods. Photographs may also be analyzed in this way, and, if they contain objects of easily determinable size, may yield much useful data.

467. We have deliberately confined ourselves to discussing a standing figure of average size. The 5 ft. 3 in. eye level (or head center, in some of the foregoing examples) has been chosen as being about average for an adult—a trifle higher than the average

woman's, and a trifle shorter than the average man's. Adjustments for slight variations in normal heights have already been mentioned.

468. A few general observations may be made. Construction will be much simplified if the artist uses the normal height of a standing adult human figure for *all* such perspective calculations, *even when drawing seated figures, children, or animals*. If separate standards were to be set up for each figure in a composition, the construction lines would become so numerous and complex that the paper would become a spiderweb of construction, and the picture would be completely lost.

469. The seated figure at *B* in Fig. 120 illustrates this method of working. By perspective comparison with the standing figure at *A*, the height of a standing figure at *B* is calculated; the seated height being obtained by subtracting the length of the femur, about a quarter of the eye-level height. Had the figure at *B* been a standing child 30 in. tall, it would simply be necessary to make the height a trifle less than half of BB_3 . Corrections for the relatively small variations in normal adults have already been discussed. Thus, by using a single standard height and then treating each figure as a study in life drawing, construction may be kept at a minimum.

470. One or two more precautions must be observed, particularly when working from models. First, if a figure in a composition is seen as from above, it is a capital error to put the model up on a high stand and then to draw from the studio floor. This practice, often followed by professional workers who should know better, results in the curious and irritating "floating" effect. Remember, too, that, if a figure is supposed to be standing on a plane above the eye level, it should not be drawn as though the top of the head were visible. Finally, a figure supposed to be at a great distance should not be drawn from too close a viewpoint. This last error is very hard to detect, but it does produce pictures with a subtle and disagreeable distortion.

CHAPTER IX

LABORSAVING DEVICES

471. The professional illustrator or renderer, who does much of his work under stringent limitations of time, finds it necessary to adopt many practices not essential in the more leisurely work of the fine arts. At the same time he must meet rather exacting standards of accuracy. Again the mere volume of his work makes it desirable to eliminate as much as possible of the routine of perspective construction or to perform it with the maximum speed consistent with technical requirements. As a result of these conditions, the distinction between freehand and instrumental drawing has largely broken down. The commercial worker uses instruments wherever that use will promote speed and accuracy, and he works freehand wherever it suits his purposes. Very few drawings are made either wholly instrumentally or wholly freehand.

472. By far the most useful instruments are a large drawing board, a good quality T square of the same length as the board, and two or three triangles. The triangles should be of fairly good size, one 30-60-deg. and one 45-deg. It is usually helpful to have a couple of small ones for fine work, and a lettering triangle. Some extra-long thumbtacks (half inch shank) and some standard quarter inch tacks or Scotch drafting tape are also needed. A complete set of drafting instruments is of great assistance, but, if they are not available, the artist should have at least one good compass.

473. The drawing board, T square, and one triangle will save an immense amount of time. To draw a good vertical freehand calls for slow and careful work, whereas it can be done in an instant with T square and triangle. Horizontals are made in almost no time with the T square, but for the making of perspective drawings the most useful application of instruments is that shown in Fig. 121.

474. The drawing is first laid out roughly freehand in order to get an idea of the final effect, and the position of the eye level is fixed. The extreme end lines of each principal plane are now extended in order to find approximately where the vanishing points will come. If vp_1 happens to be closer to the center of the picture than vp_2 , the paper should be kept to the left of the board to allow for this, as in Fig. 121a.

475. In the next step (Fig. 121b) the horizon or eye level of the drawing is aligned on the board with the T square, and the paper is then tacked or taped down. The position of the vanishing points may now be set tenta-

tively by laying a triangle along the top or bottom lines and marking the point where its edge crosses that of the T square. Since there will be some error in the freehand rough, some compromising will be necessary at this stage. For this the vanishing points may be moved back and forth *hori-*

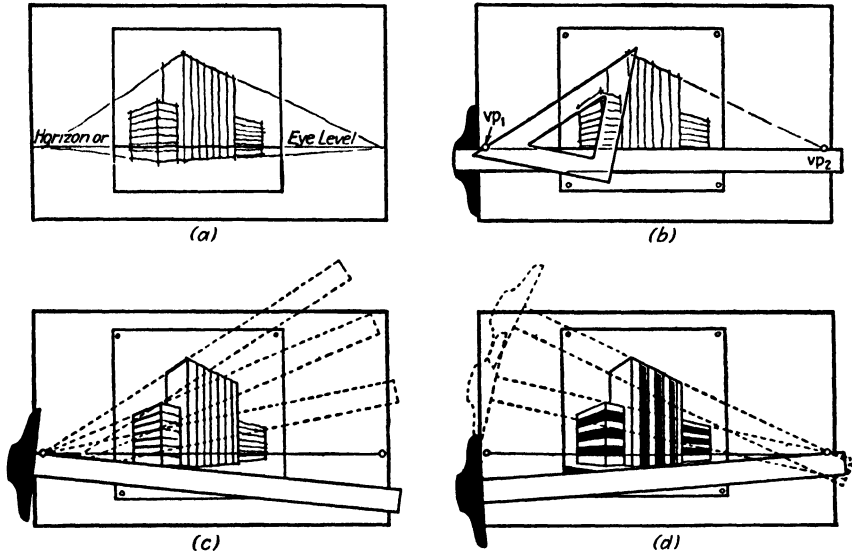

FIG. 121.

zontally until the most suitable position is found. The vanishing points must *never* be raised or lowered singly but may be moved up or down together by changing the horizon line as a whole.

476. Once the most practical position for the points has been found, a half inch thumbtack (or lacking these, a common pin) is driven about half-way into the board at each point. From here on the drawing of perspective correct lines becomes a simple matter of swinging the T square about the tacks as pivots, as shown in Figs. 121c and d. On a complex drawing this arrangement will save literally hours of trial and error. Turning the T square upside down prevents the head from catching the edge of the board.

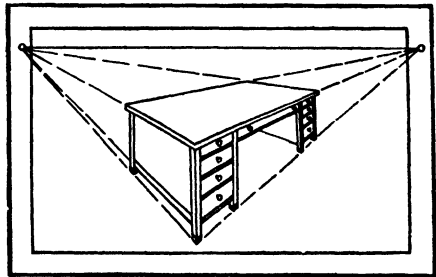

FIG. 122.

477. The procedure just described has its limitations. Since students are often obliged to carry work back and forth between home or dormitory and the classroom, they naturally prefer small and light drawing boards on account of their portability. Unfortunately, in the attempt to get both vanishing points within the limits of a small board, they will bring

them too close together. Every fall the teacher has to explain ten or fifteen times that such a picture as Fig. 122 is not satisfactory. Even a huge drawing board will not entirely eliminate this trouble, for extremely large drawings will sometimes require vanishing points at a great distance apart. Sometimes, also, it is desired to show one face of the object almost, but not quite, parallel to the picture plane. In this case the vanishing point may be situated 10 ft. or more from the board.

478. Artists more energetic than ingenious have been known in such cases to lay out their work on the floor and get their perspective lines by attaching a cord to a nail. Fortunately there are several ways in which such trouble may be avoided.

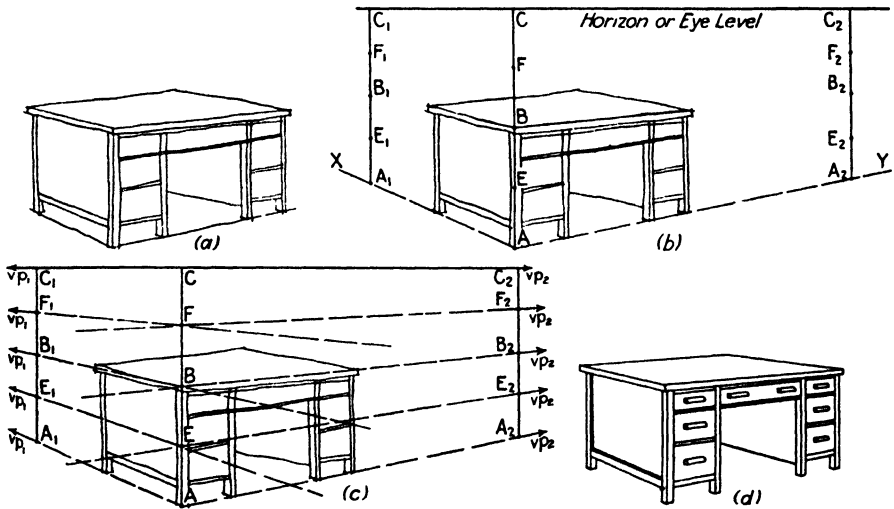

FIG. 123.

479. The method illustrated in Fig. 123 has the advantage of requiring no additional instruments or accessories. It consists essentially in making a *perspective graph*. The first step is the same as that of Fig. 121—a freehand rough to determine approximately the desirable placing of the horizon and vanishing points. This is shown in Fig. 123a. The desk shown would have a normal height of 29 or 30 in.—about half the eye-level height. In Fig. 123b, using the near corner AB as a measuring rod, and extending it upward by an amount equal to AB , we get point C such that $AB = BC$. The horizon is now drawn through C .

480. If the lines AX and AY are extended, both vanishing points will be off the board. But, since we have the horizon established, we can make a grid or graph of perspective correct lines which can then be used as a guide.

481. At any convenient place along AX the vertical A_1C_1 is erected. At any convenient place on AY the vertical A_2C_2 is erected. A_1C_1 , AC and

A_1C_2 now represent perspectively equal verticals, and, if each vertical is now divided into an equal number of parts, the lines connecting the divisions will be perspective horizontals and will vanish at vp_1 or vp_2 in the horizon. Any equal number of parts will serve, but, since AC is already divided into halves by point B , we begin by bisecting A_1C_1 and A_2C_2 . Each half thus formed is bisected in turn, giving the quarter divisions, AE , E_1B_1 , etc. This step is shown in Fig. 123b. In Fig. 123c the lines FF_1 , FF_2 , BB_1 , BB_2 , etc., have been drawn. *Note that they are continued beyond the points.*

482. We now have eight perspectively correct horizontal lines. It is relatively easy to judge the correct inclination of lines falling between these guides, and the rough drawing may now be corrected and completed, as shown in Fig. 123d.

483. Should more precision be wanted, it is an easy matter to divide the lines once more into eighths, and of course any number of divisions, even or odd, can be made by the use of the scale or dividers.

484. It is sometimes helpful, especially in interior work, to draw a perspective grid on the floor or ground plane. This can easily be established

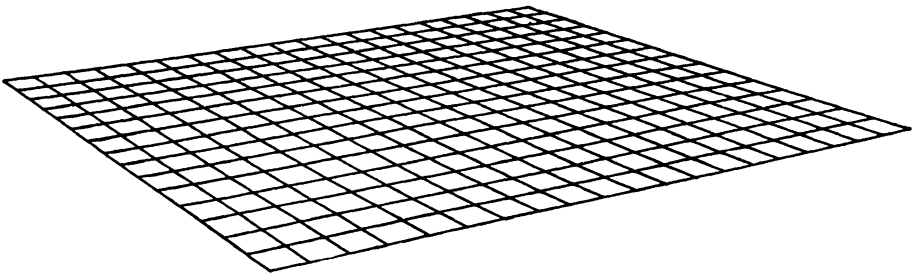

FIG. 124.

by any of the methods described in Chap. III. By making each square equal some standard unit, such as 6 in. or 1 ft., the individual pieces may be compared directly to the floor grid for size, instead of being projected from measuring lines in the picture plane. Such a grid is shown in Fig. 124.

485. Since the operation of laying out the grid is often tedious, charts have been published with the grid, and height lines as well, already laid out.¹ They provide two charts for parallel perspective, two for a 45-deg. view, two for a 30–60-deg. view, and two for a 60–30-deg. view. In each pair one chart is provided with a horizon and scale adapted to interior views, the other with horizon and scale adapted for exterior views. Figure 125 shows one of the charts.

486. Several instruments have been devised to aid in working with inaccessible vanishing points. Probably the most useful is the centrolinead.

¹ A set of eight such charts, designed by the author, may be purchased from the Reinhold Publishing Corporation, New York.

This instrument has a blade like a T square, but the head consists of two shorter blades attached to a pivot. They may be swung around the pivot to give any angle desired. By putting two thumbtacks in the drawing board and guiding the head against them, the effect of a distant vanishing point is obtained. This instrument is useful in laying out large architectural renderings. Another such instrument is the cycline.

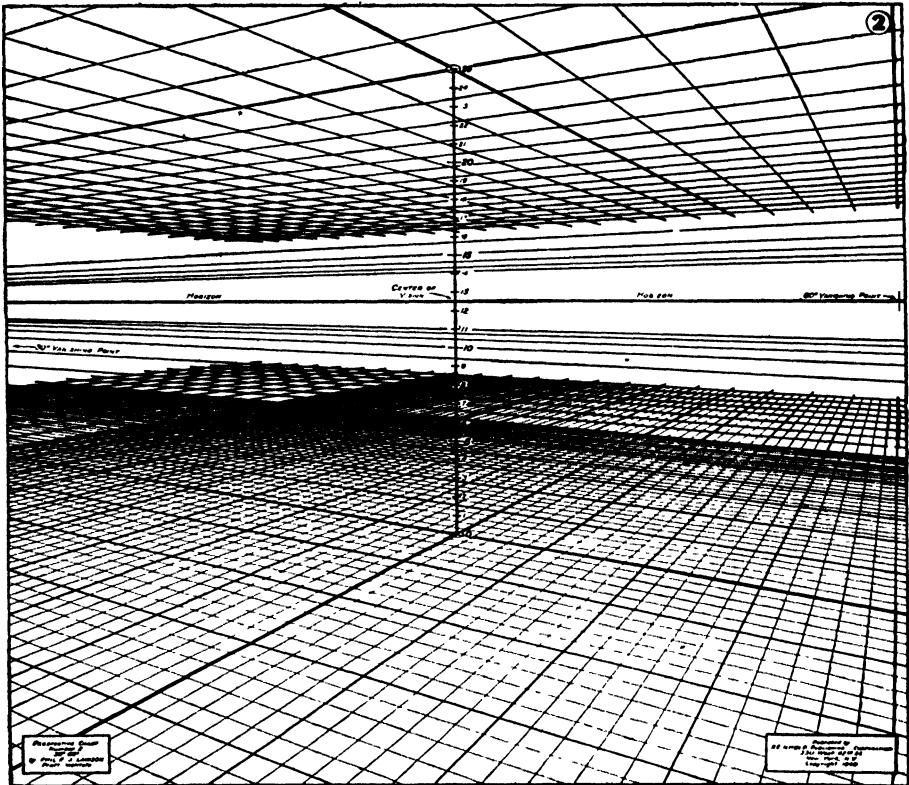

FIG. 125.—(Reproduced by courtesy of Reinhold Publishing Corporation.)

487. Another device helpful in architectural work is that of using curves cut from thick cardboard or celluloid and attaching them to T square and board. Briefly, the method is as follows: A sheet of the material used is cut into two pieces by a circular arc having a radius equal to the desired distance of the vanishing point *from the head of the T square*. The two pieces are then lined up as before cutting and are placed so that the center of the curve would lie on the horizon. The concave piece is put on the inside and the convex piece outside. Next, the T square is placed with its working edge on the horizon and its head lying on the convex piece. The concave piece is now attached to the board and the convex piece to the head of the square. If this is carefully done, it need not interfere with the

primary function of the square. The square may now be swung around with the two curves in contact, and the center of the curve will be the remote vanishing point.

488. When a slight error can be tolerated, it is customary to use only a single curve, the concave one, and to use the T square head as it is, swinging it around by corner contact. This will actually mean that the center of the blade rather than its working edge is the correct line, but the error is small enough that it may usually be neglected. Curves cut to certain standard radii are commercially available.

489. Other methods of obtaining correct results despite inaccessible vanishing points have been devised, but those described above are the

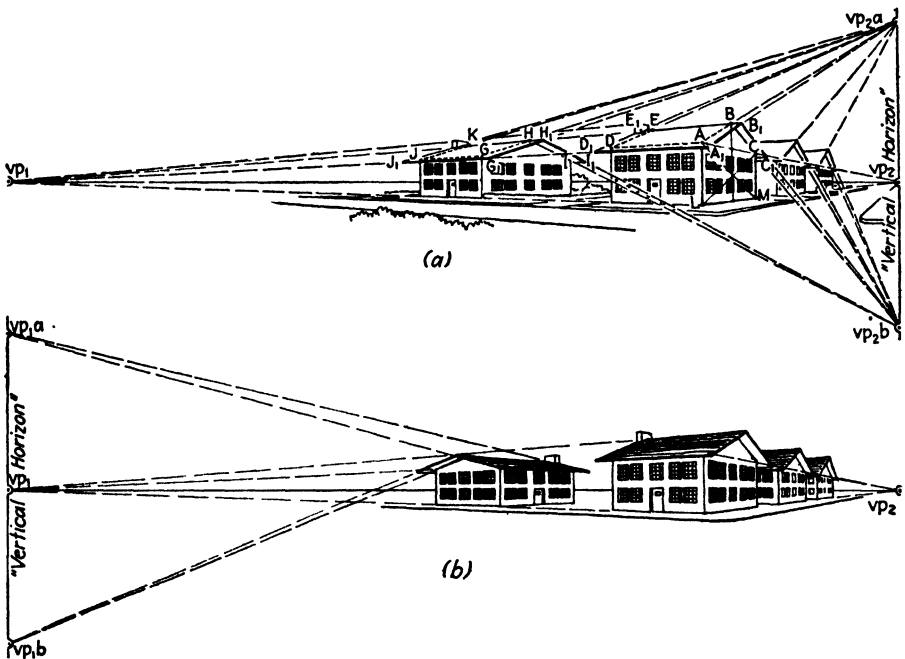

F.G. 126.

commonest. In the opinion of the author the perspective graph method is the most useful, because it does not depend on special instruments and may therefore be employed away from the studio or drafting room without the obligation of carrying awkward, delicate, and expensive equipment. However, where all drawings are made in one place, and where their nature is relatively specialized, as in architectural or interior rendering, the use of such instruments may be a great timesaver.

490. For centuries attempts have been made to devise a machine that would perform all the routine operations of perspective drawing. So far, however, the manipulation of the machines has proved to be more time-

consuming than the work they are designed to eliminate. One such machine recently designed cost about five thousand dollars, and a well-trained engineer was required to use it. It is possible that the problem will be efficiently solved in the future, but the widespread use of such elaborate equipment as will probably be needed is open to doubt.

491. In a drawing where a number of similar objects are shown, such as a line of houses, there are usually sets of parallel lines not belonging to one of the three principal groups. Figure 126 illustrates such a case. The roof lines AB , DE , GH , and JK are parallel to each other and so will have a common vanishing point. Since these lines are in the end planes of the buildings, this vanishing point will lie *directly above* vp_2 . Similarly the lines

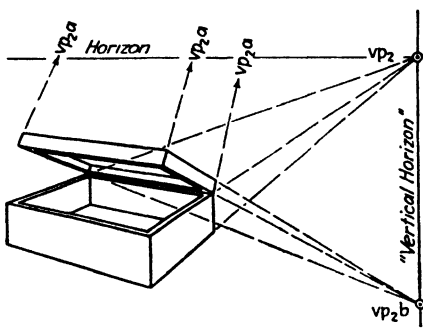

FIG. 127.

BC and HI will have a vanishing point *directly below* vp_2 . The vertical through vp_2 , in which these supplementary vanishing points lie, may be considered as a "vertical horizon." Though this is a contradiction in terms, it is nevertheless useful for descriptive purposes.

492. Once the slope of the two lines has been established, they may be used to find vp_2a and vp_2b . The usefulness of these supplementary vanishing points lies in the fact that the remainder of the roof lines may then be drawn by reference toward them.

493. The procedure is as follows: The rectangle $ACLM$ is first established and its center found by drawing the diagonals. A vertical is now drawn through this center, and the point B is placed at the desired height on the vertical. AB is drawn and extended to meet a vertical through vp_2 at vp_2a . A similar extension of BC determines vp_2b . DE , GH , and JK may now be drawn directly to vp_2a while HI may be drawn toward vp_2b . The overhang of the eaves is now established and lines A_1B_1 , D_1E_1 , H_1I_1 , etc., are also drawn by using these vanishing points.

494. It would be possible to get the same result by repeating the same construction as used on the plane $ABCML$ for each end of the building, but trouble, time, and construction are saved by the supplementary vanishing points.

495. Should one or more of the roofs have an opposite pitch, as shown in Fig. 126b, the supplementary vanishing points would then be in a vertical through vp_1 .

496. Although less necessary and less frequently useful than for the roof problem just described, the same construction may be used in drawing hinged members, such as the box of Fig. 127. No new principles are involved in this illustration.

497. Supplementary vanishing points may be applied also to sloping streets, as shown in Fig. 128. Here the principle is the same, but it is perhaps worth mentioning that window lines, etc., although they may be *stepped* up or down, do not partake of the sloping quality of the street but run to the regular vanishing points on the true horizon.

498. In working out such problems as that of Fig. 128, it is best if the buildings are first drawn as though on level ground, as shown by the dotted lines, and their measurements thereafter shifted up with the help of dividers or paper-edge comparisons. Note should also be taken of the small triangular sections that must be added to the base of each building to compensate for the uneven ground.

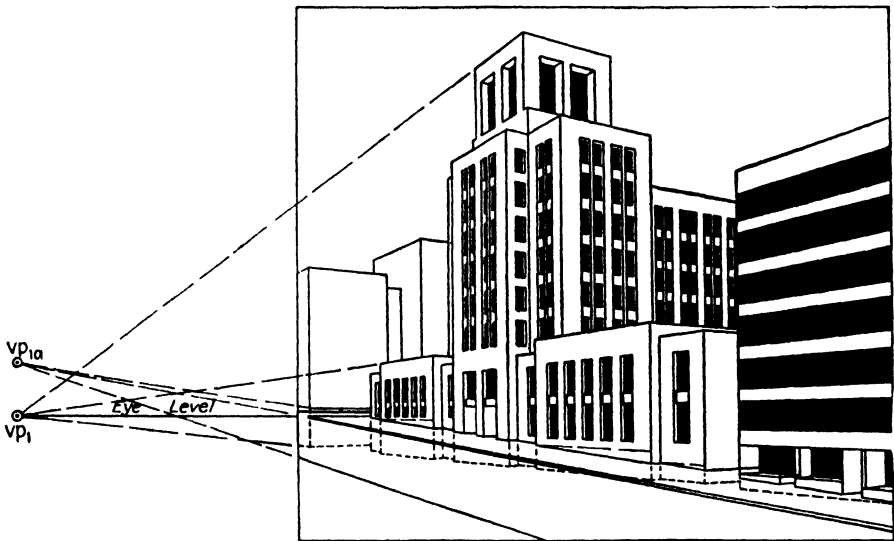

FIG. 128.

499. Where uneven, rolling ground is involved, it is best to establish only one or two slopes in this manner and the remainder by estimation. Otherwise the picture will be lost in a staggering amount of construction.

500. Where a large number of oblique horizontal lines must be drawn, as in the tile floor of Fig. 129, it is helpful to establish extra vanishing points for these also. These points will lie on the horizon proper and hence give little trouble. This figure, by the way, is similar to Fig. 87c in Chap. VI.

501. An ever-present difficulty in the work of any artist is a knowledge of when to stop in the rendition of detail. Though the answer is in large part dependent on what must be expressed in order to meet the requirements of the specific task, a few guiding principles may be given. The dominant rule in any case is this: *Do not attempt to render detail finer in dimension than the particular instrument in use.* Thus, if a pen making a line $\frac{1}{64}$ in. wide is being used, a width of $\frac{1}{100}$ in. cannot be expressed with it, and the single

line must serve for both extremities. Obvious as this may seem, it is frequently overlooked, and we often see drawings in which tiny details are inadvertently doubled in size and importance, while the whole lacks unity.

502. The subsidiary rules are, first, *details finer than a certain dimension (which depends on the style and judgment of the artist) but not so fine as to be smaller than the instrument in use should be treated as texture.* This principle is often used in the drawing of large crowds. The dominant and nearest figures are drawn carefully as individuals, while the crowd proper becomes simply a textural part of the area shown. Although this may seem mere indolence on the part of the artist, it actually contributes to the effectiveness of the result by preventing the scattering of interest on irrelevant or sub-

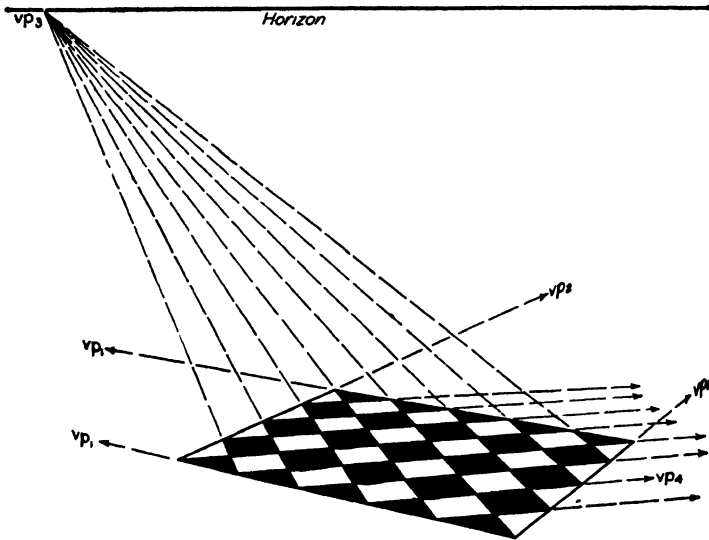

FIG. 129.

siduary background. Second, *all detail that does not contribute to the composition, effectiveness, or importance of the picture should be omitted entirely.* For example, although window muntins are usually enriched with moldings, it would be absurd to attempt to show them in an architectural rendering of a complete building.

503. In drawing lamps, vases, and other objects symmetrical about a central axis, much time may be saved by drawing carefully only half the object to one side of the other of the axis. Since half proportions are impossible to judge accurately, the whole should first be roughed in. One half is then refined to the required degree of accuracy. This half is then traced carefully with a sharp pencil and the rough half is erased. The axis should be drawn on both the drawing and the tracing. The tracing is then "flopped," *i.e.*, turned over and transferred to the other half of the drawing. It is unnecessary to rub the back of the tracing with lead for this job.

CHAPTER X

ONE-POINT AND THREE-POINT PERSPECTIVE

504. Though by far the greatest number of pictorial drawings are made with two principal vanishing points, there are certain specialized fields and types of drawing in which two vanishing points are either too many or not enough. Great simplification in measurement and manipulation is made possible by the use of a single vanishing point. Three-point perspective, on the other hand, permits spectacular effects and helps somewhat to overcome distortion, which we shall discuss later in this chapter. Since it is impossible in ordinary drawing to have more than three *principal* vanishing points, we need carry the matter no further.¹

505. One-point perspective is also called *parallel* perspective, because not only verticals but one of the two principal sets of horizontal lines will appear truly parallel in the drawing. This is a great convenience, since foreshortening and convergence need be calculated for only one principal set of horizontals. Measurements of vertical and horizontals in a particular plane may often be made directly with the scale.

506. One-point perspective is used largely where a single plane is of primary importance, as in showing the façade of a building. It is also useful where a number of buildings are grouped about a central concourse or street and where interest is distributed equally on either side. In interiors it is useful for showing three sides of a room in a single drawing. Because it is easy to execute it is speedy and, since scale measurements may be used, accurate.

507. These advantages are not obtained without some sacrifices. It is difficult to create an interesting or dramatic composition in one-point perspective, because it tends toward static rather than dynamic balance. In careless or ignorant hands it produces some painful distortions. Finally, in drawing buildings, cabinets, or other objects from the outside (*i.e.*, *positive volumes*) it permits us to show properly only one or two planes of the object, while two-point perspective permits showing two or three. When the attempt is made to show three planes in *parallel* perspective, distortion is unavoidable. This was often overlooked by the painters and

¹ It is arguable, according to modern physical concepts involving a multidimensional space, that more than three might one day be needed. If time is considered as the fourth dimension, the motion picture may be considered as having four-dimensional perspective. Attempts have been made from time to time to produce a four-dimensional perspective on paper or canvas, and the futurist school of painting based some of its theories on this concept.

engravers of the early Renaissance, to whom perspective was a new instrument, and the buildings in their pictures often appear to be out of square.

508. Probably the most useful application of parallel perspective is in that type of architectural rendering which is intended to show only a façade,

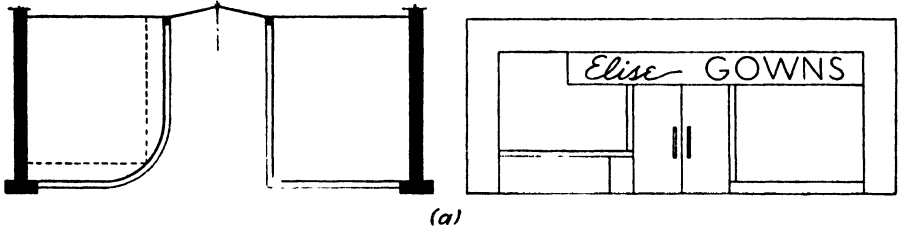

(a)

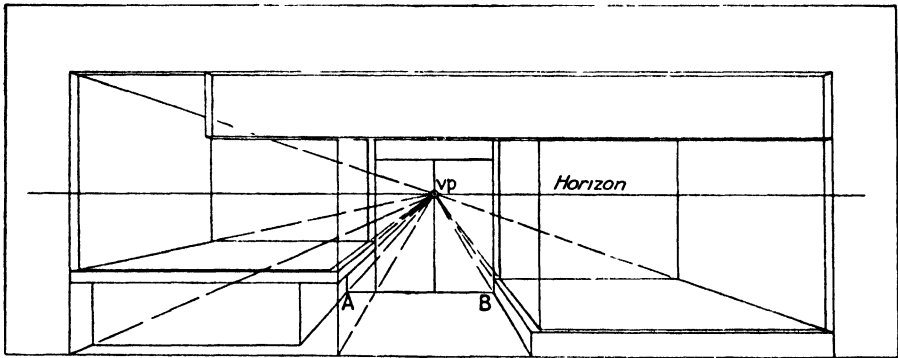

(b)



(c)

FIG. 130.

as in a building housing a store or group of stores. Rendered elevations are frequently used for this purpose, but they are difficult for the layman to understand and may be misinterpreted. Figure 130a shows the plan and elevation of such a structure. The translation of this into parallel perspective is extremely simple. The first step is to draw a new elevation on drawing or tracing paper and to establish on it the eye level or horizon.

The vanishing point is now placed at or near the center of the picture and on the horizon.

509. From each point on the elevation where two or more lines intersect, lines are now drawn to the vanishing point. These lines represent the boundaries of the receding planes (*i.e.*, planes perpendicular to the picture plane). Such planes include the ceiling, the floors of both show windows, and the floor of the entrance path.

510. The next thing that must be settled is, "How far back should the back plane of the show window appear in the perspective drawing?" There is no definite answer to this question; there is, rather, an infinite number of answers. If an observer whose eyes are 5 ft. 3 in. above the

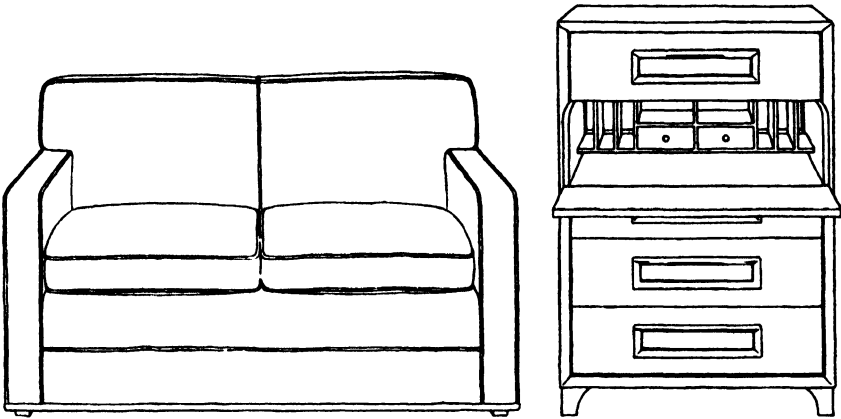

FIG. 131.—The practice of laying out the drawing instrumentally and then finishing free-hand is well suited to subjects of these types, and particularly to upholstered furniture. It makes for speed in setting the predominantly straight lines while permitting enough freedom to introduce the slight variations from perfect smoothness that characterize soft forms. In "hard" pieces, such as the chest-desk combination, this practice helps to relieve the overslick mechanical effect that would result from a drawing made wholly instrumentally.

ground stands at a point opposite the middle of such a building, his view will have an eye level and single vanishing point similar to those illustrated in Fig. 130b. If he is close to the structure, the rear plane of the show windows will appear *relatively* far back; if he is at a considerable distance, these same rear planes will appear *relatively* close to the front plane. Our only recourse is common sense. The line *AB*, representing the lower rear line of the door, is drawn where, in the judgment of the artist, it will give the entrance path the most truthful and pleasing appearance. Once this is done all the other lines follow. Figure 130c shows the complete picture.

511. It should be noted that all the horizontals involved in this picture are drawn either with the T square or with a straightedge centered on *vp*, except for the curves at the corners. Even these make use of the squares established by one or the other of these aids. This effects a great saving in time.

512. If the drawing above had been worked out by projection from the plan with a fixed station point, there would naturally be no necessity to rely on estimation as to whether the front and rear planes were properly related. Even here it is wise to remember that the station point must not be placed so close as to produce a violent perspective or so far away as to cause flatness. It is suggested that Chap. II, Pars. 42, 43, and 44 be reread.

513. The use of parallel perspective in connection with interiors has already been discussed in the last chapter and need not be repeated here. Its use is often advisable in the case of furniture and other objects where all the significant features lie in a single plane. Two such objects are shown in Fig. 131. It should be noted that there is very little more work involved in making these than in making simple front views or elevations.

THREE-POINT PERSPECTIVE

514. The dramatic possibilities of three-point perspective are so great that its use has naturally been seized upon by fiction and advertising illustrators whose business it is, not only to give information, but to capture attention and to convey excitement. That there are other proper uses for it has largely escaped the attention of artists and draftsmen outside these fields. There are several reasons for this. The first is that three-point perspectives, constructed by projection with geometric accuracy, are about three times as difficult to make as two-point perspectives, and about nine times as difficult as one-point perspectives. In fields where such projection is a routine procedure, such as engineering and architecture, they have therefore been practically ignored. Nevertheless, in spite of its difficulties, three-point perspective possesses definite advantages, apart from its dramatic quality, worthy of being explored by the architect, engineer, renderer, and the illustrator of merchandise for advertising, whose business it is only to tell the facts about his wares.

515. When external requirements dictate that objects must be shown from abnormally high or abnormally low viewpoints, the ordinary one- or two-point perspectives fail dismally. The two-point bird's-eye view, used in much architectural work, is satisfactory enough where all the buildings are low, but for the skyscrapers of a large modern city the parallel verticals employed in it produce painful distortion. On the other hand, little of the grandeur of a high ceiling and vaulting columns is conveyed by the common two-point perspective usually employed. In both these cases (the second is sometimes called a "worm's-eye" view), three-point perspective overcomes the drawbacks.

516. In Chap. II, Pars. 41 and 42, reference was briefly made to the principles of three-point perspective as applied to the cube. It can readily be seen that working out complete projections for an actual article or building is a job of considerable complexity. It can be done, but it is not ordinarily practical, especially since equal accuracy is attainable by simpler

means. There is nothing new in the procedure; it simply makes use of the cube and the methods of multiplying and dividing it, already described in Chap. III.

517. If great accuracy is wanted in a drawing in three-point perspective, the first step is to draw a standard measuring cube from the desired position of the station point, projecting it carefully to ensure accuracy, as in Fig. 10. This cube may now be used as the measuring standard. Before tackling an actual problem, it will be necessary to consider more carefully just how the three-point perspective of the basic cube is worked out. The procedure for drawing the cube of Fig. 10 is the same as that for Fig. 6

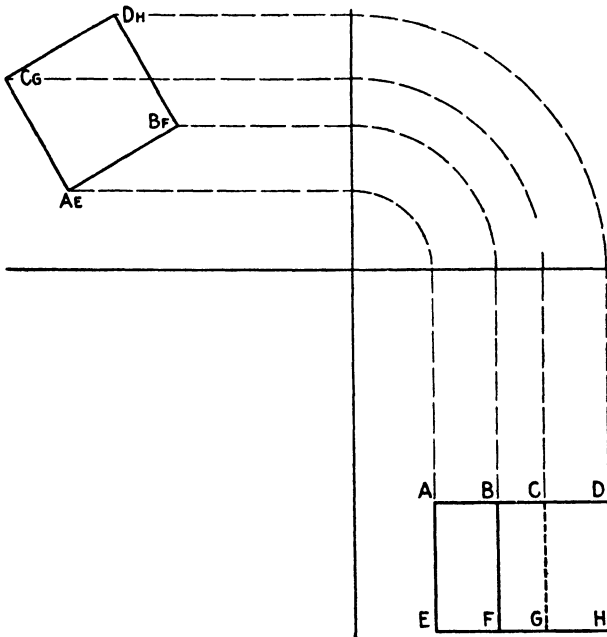

Fig. 132a.—Plan or top view drawn and oblique elevation projected from it.

except that the orthographic projections must be worked out in three steps, as shown in Fig. 132.

518. If the cube thus worked out is used as a standard, it is now possible to draw *accurately* a three-point perspective by the measurement methods of Chap. III. Figures 4a and 4b were drawn in this manner, and any number of applications will occur to the ingenious. The drawing may, if preferred, be completely worked out by projection, but the cube method is ordinarily more convenient, rapid, and equally accurate.

519. In advertising illustration, it is often necessary to place an illustration in an awkwardly tall and narrow space. By using a high viewpoint, a low, broad object may be made to use such a space comfortably, but the ordinary two-point perspective is unsatisfactory beyond certain limits.

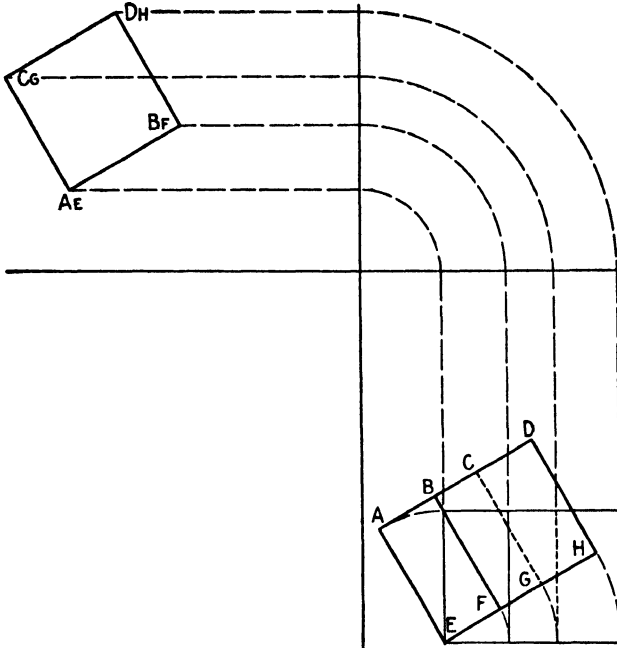

FIG. 132b.—Oblique elevation tilted.

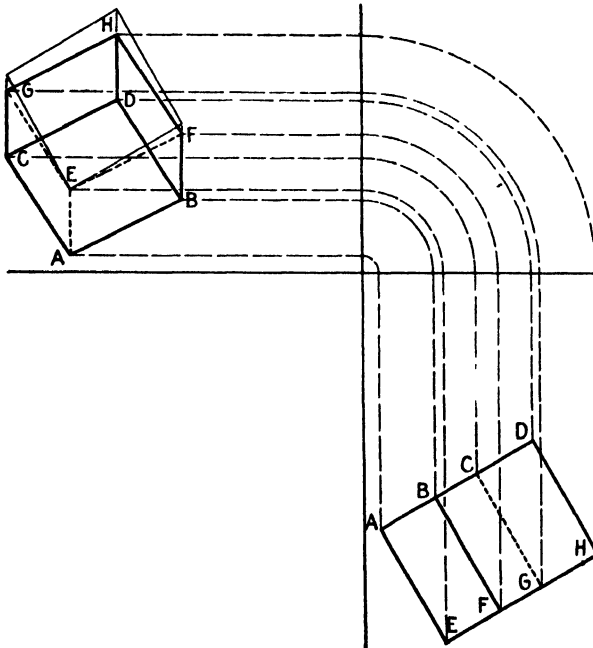

FIG. 132c.—Oblique elevation projected back to determine tilted "plan" or top view. (These projections could also be performed using 45° line through picture plane line intersection instead of arcs.)

In Fig. 133a for example, the desk as shown looks strained and artificial, even though technically correct. The three-point perspective of Fig. 133b,

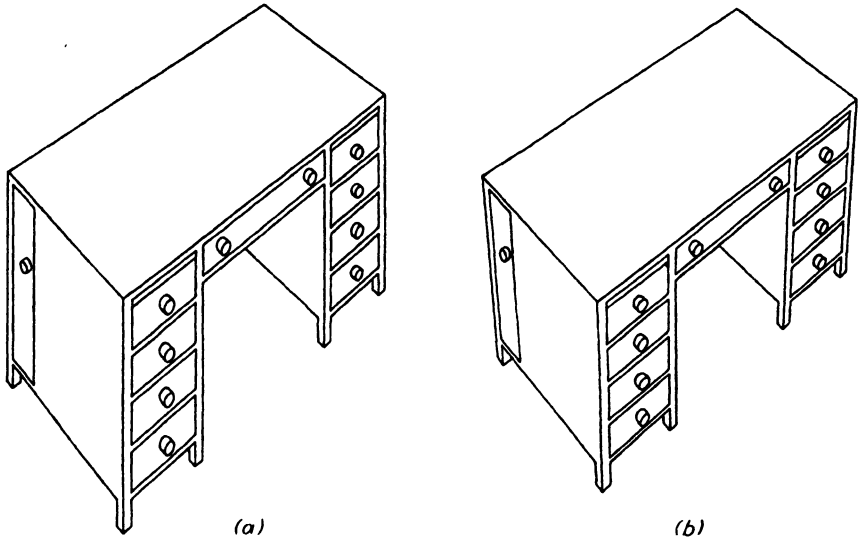

FIG. 133.

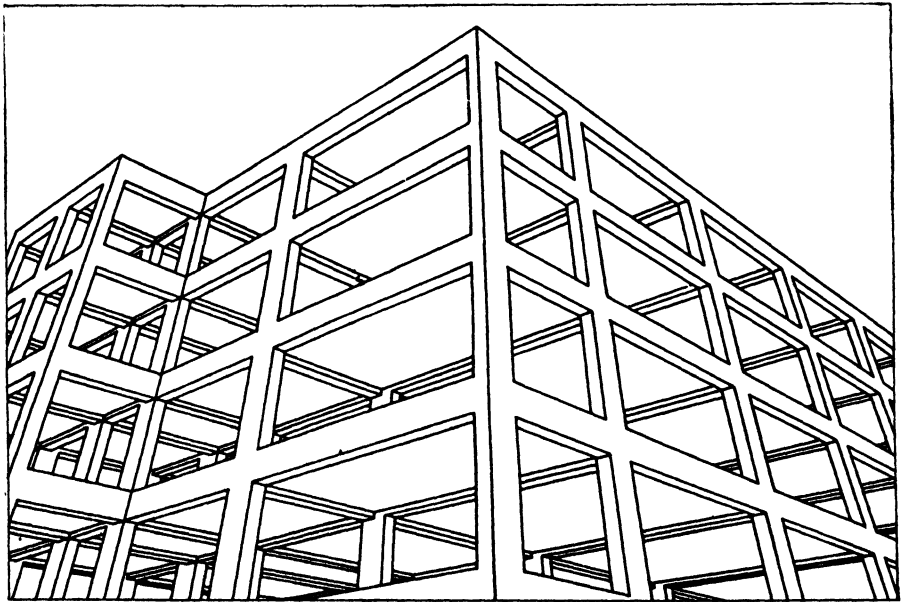

FIG. 134.

while somewhat of a novelty to the conventional eye, has a much more natural appearance, and one instinctively realizes that this is the way the object would *really* look if seen from an elevated position.

520. Similarly, the immense heights obtained in modern steel and concrete construction can be only feebly indicated by the conventional two-point perspective. Figure 134 gives a better idea of the scale of such work, and innumerable other examples may easily be found.

521. In most work it is unnecessary to work out the elaborate and precise perspective of Figs. 10 and 132. The average illustrator will find that he can get quite adequate accuracy by estimation alone, provided he bears in mind one cardinal fact—in three-point perspective the verticals as well as the horizontals must be foreshortened, and the shortening due to distance must also be taken into account. This is unnecessary in two-point perspective, because the verticals are parallel to the picture plane. Aside from this, the ordinary methods of freehand drawing already given in Chap. II apply.

CHAPTER XI

COMMON ERRORS

522. Most of the matters discussed in this chapter have already been touched on in other parts of the book. They are being set down here in a sort of perspective museum of horrors in order to aid the student in avoiding the pitfalls that trap the beginner and the weaknesses that betray the lazy or slipshod professional worker.

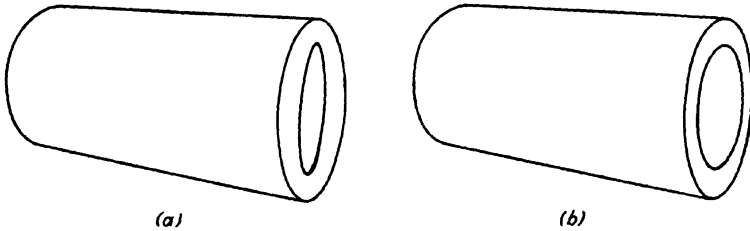

FIG. 135.

523. The ellipse, or circle in perspective, is responsible for a wide variety of errors. One of the commonest is shown in Fig. 135a. Here the outer cylinder was drawn correctly; then the inner curve, showing the opening, was drawn *geometrically* parallel instead of *perspectively* parallel to the outer curve. Chap. IV (Pars. 217 through 220, and Figs. 43 and 44) gives the reasoning involved.

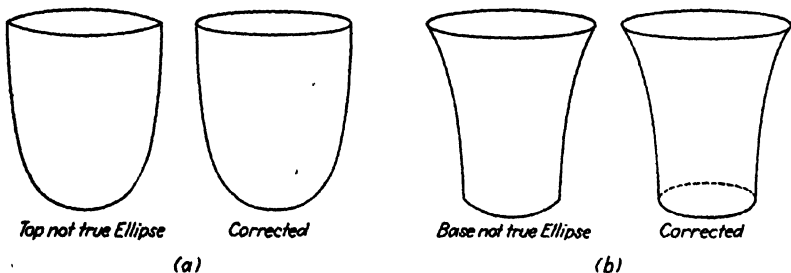

FIG. 136.

524. Perhaps the most distressing error in drawing the circle in perspective is the beginners' habit of putting corners on it. The absurdity is evident even to the layman, yet the habit is surprisingly common. The most obvious form of this error is shown in Fig. 136a. Here the supposed ellipse at the top is not an ellipse at all, but the intersection of two arcs.

A much more frequent error of the same type is shown in Fig. 136*b*. This is found often in the work of people who should know better. Here the upper curve is drawn correctly, and the lower one is simply an arc connecting the two side outlines. This arises from the superficial assumption that, since the rest of the curve cannot be seen, it isn't there. Well-trained professional workers make it a habit to draw lightly all of the curve, then to erase the hidden part, as shown on the right-hand side of Fig. 136*b*. This is also discussed in Chap. V, Pars. 242 through 244, and Fig. 51.

525. Another error is the result of giving the ellipse the wrong curvature for the plane on which it is supposed to lie. This difficulty may easily be avoided by use of the enclosing square.

526. In drawing by projection methods foreshortening is automatically taken care of, and the beginner is usually surprised at how drastic its effects are. In freehand drawing he tends to underestimate it with peculiar results. A desk 28 in. high and 30 by 50 in. horizontally should not appear as in

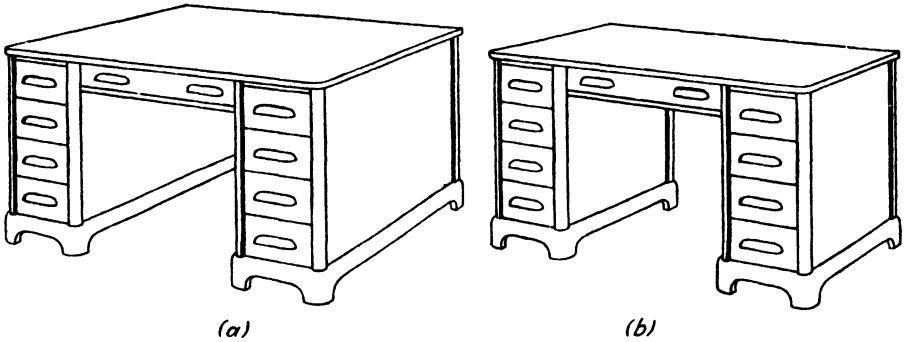

FIG. 137.

Fig. 137*a*. The distortion is easy enough to see after the drawing is finished. The hard part is to avoid it in the first place. The cure is to start by establishing the over-all proportions at once and never to start on details until these are satisfactorily accurate. Another habit may be cultivated to advantage. When judging the appearance of a drawing, try to forget that it is a drawing. Think past the picture to the object depicted, and try to judge the proportions as you would those of the real thing. Thus, not, "Does this *picture* of a chair seem to be well proportioned?" but, "Is that *chair* well proportioned?"

527. Although it is rather unusual, beginners sometimes achieve weird effects of transparency and reversed forms by running lines to the wrong vanishing points. This happens particularly in the shorter lines. The maker seems to feel that, though the lines must go to some vanishing point, any old point will do. Figure 138 illustrates this, the lines at the feet of the table being drawn to the vanishing points opposite the correct ones.

528. Closely allied to this and unfortunately much more common is the habit of treating short lines as though their direction did not matter.

This same trouble crops up when the line is far from the center of interest, or when the object being drawn is a subsidiary object in a group. In this

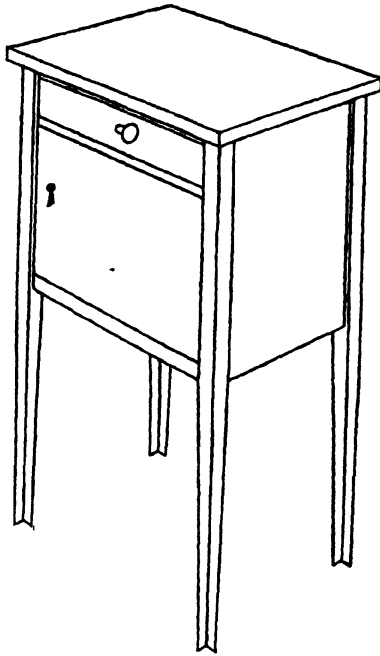

FIG. 138.

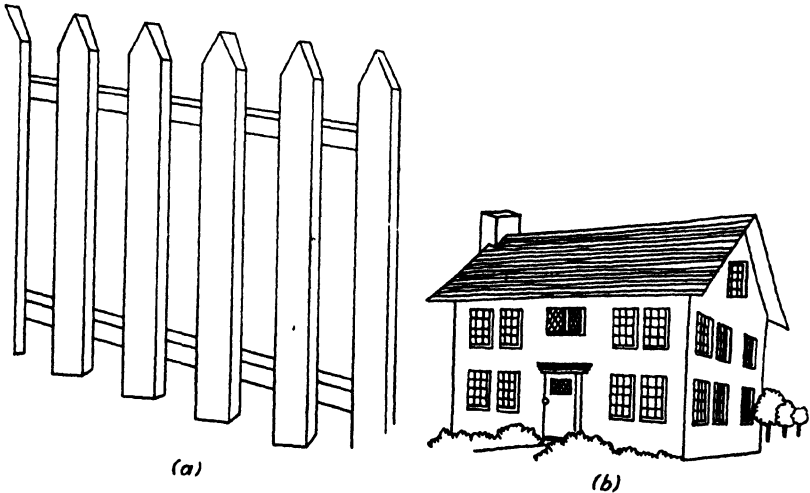

FIG. 139.

case the principal objects will be drawn carefully, and the subsidiary objects will be handled as though they had different horizons and vanishing points from the rest of the picture. Although the examples given in Figs.

139*a* and *b* may seem exaggerated, they often crop up in work supposed to be of professional caliber.

529. Carelessness about vanishing points for subsidiary objects causes great trouble when a number of objects are intended to be lying on a plane. Many a beginner sheds tears over efforts to make things "lie down," simply through failure to realize that there can be but one horizon in a given picture, and that, if two rectangles, such as the napkin or the enclosing square for

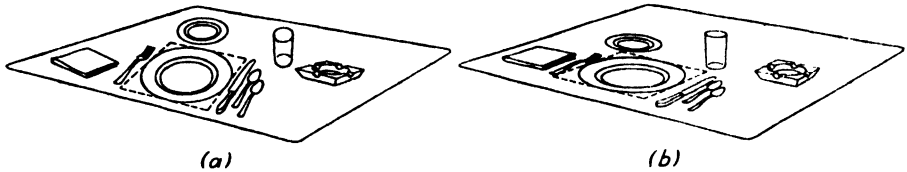

FIG. 140.

the plate and the table of Fig. 140*a*, are parallel on one pair of sides, they will be parallel on the other.

530. Sometimes, especially in freehand drawing, the importance of the horizon is forgotten, and such peculiar results as those shown in Fig. 141 occur. The reason for this error was demonstrated in Chap. II (Fig. 14 and Par. 71). It must never be forgotten that *all horizontal lines will vanish in the horizon* and that the *horizon must be horizontal*.

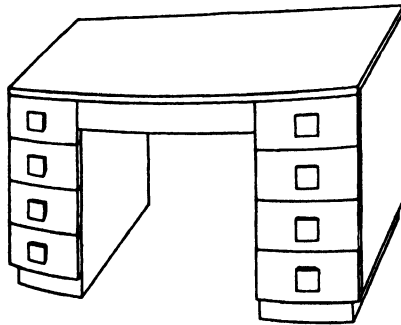

FIG. 141.—Left-hand vanishing point (vp_1) lower than right (vp_2); that is, the horizon is not horizontal.

531. When the horizon or eye level is wrongly placed, the person seeing the picture has the feeling that his sense of proportion is being deceived. The table in Fig. 142*a* looks gigantic—big enough to walk under erect—while that in Fig. 142*b* looks quite normal. It is simply a matter of having the eye level at a relatively correct height. The room in Fig. 143 looks as though it were built for midgets, and a tall man is likely to duck when he sees it. The rule in general is this: The eye level should preferably be placed where it would normally be for a person of average height. If it is too low, all objects will appear abnormally large; if it is too high, they will

appear insignificant. Since this is more a matter of judgment than of measurable fact, some discretion must be used in applying the rule. Circumstances frequently dictate the necessity for using especially high or low viewpoints. In such cases it is wise to make the departure from the norm sufficiently drastic to be recognized as a needed expedient and not the result of the artist's incompetence.

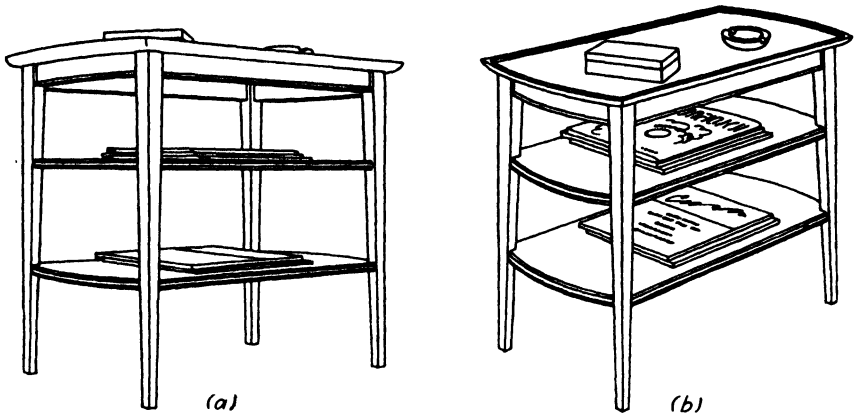

FIG. 142.—(a) A bad choice of eye level not only makes the table seem to be 10 ft. high but, by showing it at an angle from which it was not designed to be seen, gives it an unfavorable appearance. This is particularly important in advertising illustration. (b) Higher eye level gives correct scale.

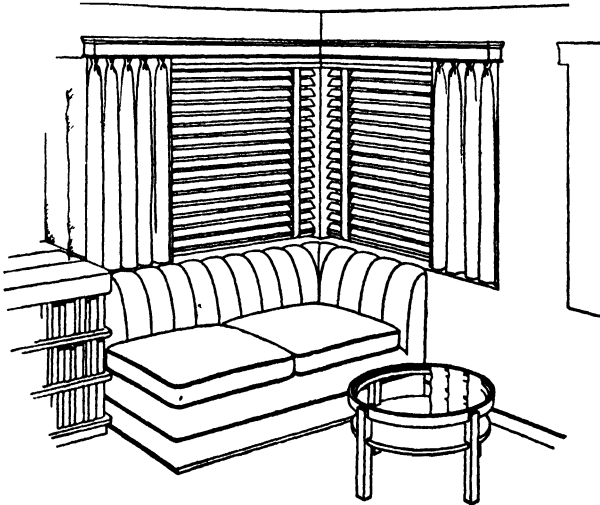

FIG. 143.

532. The hurried or careless worker often forgets that forms having a common axis in fact must have a common axis in the image. The lamp shade and base of Fig. 144 illustrate a frequent error of this sort. The error is often so slight that it passes unnoticed and is the more distressing because of its very subtlety, producing as it does a sense of unbalance, the cause

not being easily apparent. The remedy is clear, and it is well to make a habit of drawing center lines for forms of this type.

533. *Skew* lines cause much confusion. These are lines that are not parallel but do not intersect, because they lie in different planes. This is obvious enough in three-dimensional objects but by no means so obvious when the object is reduced to two-dimensional paper representation. The

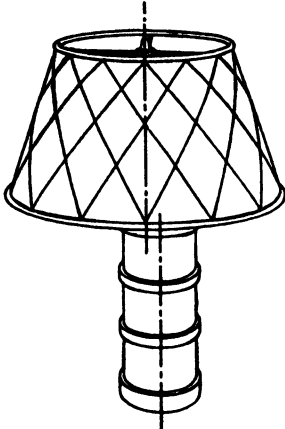

FIG. 144.

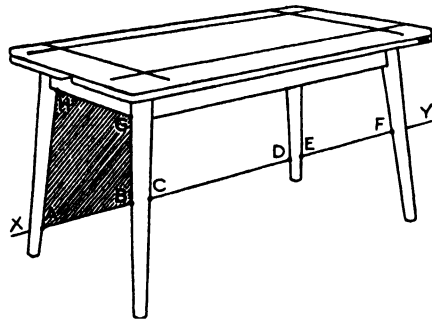
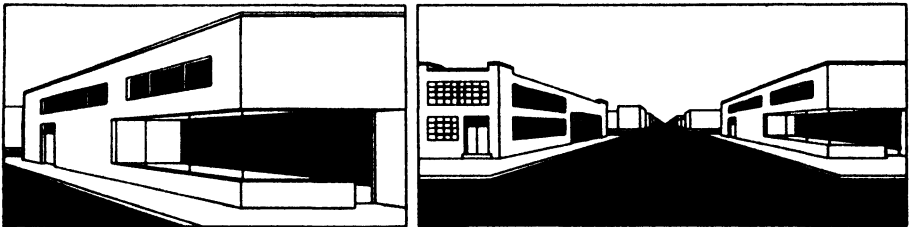

FIG. 145.

remedy for this confusion is the cultivation of a sense of what may be called "paper space," a feeling that the drawing is rather than merely *represents* space. Teachers call this the *three-dimensional concept* and recognize its acquisition as the most important part of the student's training, more important indeed than all his technique, and vitally necessary to aesthetic accomplishment. In Fig. 145, although the floor line *XY* runs behind the



(a)

(b)

FIG. 146.

table, it is at first difficult for the student not to feel that it somehow connects point *A* on the back leg to *B* on the front, *C* to *D*, and so on. Attempts will even be made to render this line as somehow a part of the table, and sections like *ABGH* will be treated as separate panels having nothing to do with the rest of the wall.

534. The abuse of parallel perspective illustrated in Fig. 146a was fairly common (and excusable) when the science of perspective was young.

There is nothing in this picture that is wrong by the standards of purely *geometrical* perspective. However, a picture of this kind must be not only *mathematically correct*, but *optically convincing*. Indeed, it is more important that it be convincing and sound-looking than that it be scientifically flawless.

535. If the reader will make the following experiment, the inherent absurdity of Fig. 146a will be explained. Stand in the center of a room and fix the eyes on the *end* wall. Now, without taking the eyes from the end wall, attempt to draw the wall to your left. If the room is a large one, a small part of the drawing, that representing the part of the left wall nearest the end you are looking at, may be represented with reasonable accuracy. The remainder will be a meaningless blur. Yet the maker of a drawing such as Fig. 146a asks us to imagine ourselves standing in the center of a street, staring straight down its length, and yet seeing clearly *what we are not looking at*.

536. Strangely enough, if the distortion is balanced, as it were, as in Fig. 146b, the distorted effect is not nearly so noticeable and may even be pleasing in its rather static symmetry.

537. A similar effect may be produced in two-point perspective, as in Fig. 147, where the object shown is far from the line of vision. The effect has been carried to an extreme here in order to make the point, yet such distortions are by no means rare. If such a picture were made really complete, it should show how the observer's nose and eyelashes obscure part of the image. This sort of distortion has its place where an unusual pictorial effect is the primary goal, but it is worse than useless for objective description.

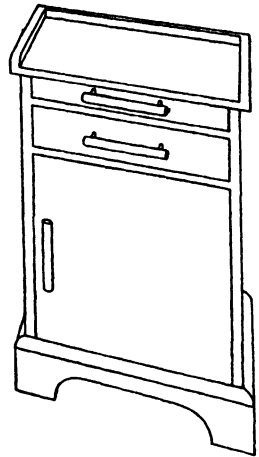

FIG. 147.

538. In Chap. IX, Fig. 122, Par. 477, and elsewhere in previous chapters, the error of keeping the vanishing points too close together was explained. The reason "violent" perspective appears so queer is the assumption of the artist that examination was made from too close a position. If the reader will stand 2 ft. away from a large table and attempt to draw it completely, he will understand this better than he would from reading any written explanation.

539. In Chap. VIII on Perspective Composition, the phenomenon of two solid forms occupying the same space simultaneously was discussed. It is advisable that the reader refresh his memory by rereading Pars. 422 through 429, for this is an error that occasionally slips by the most skillful.

540. One of the most frequent causes of flatness in a drawing was shown in Fig. 91d, the result of failure to recognize that evenly spaced divisions on a cylinder, such as fluting, reeding, or striping parallel to the

axis, will not appear evenly spaced in the image. This flat effect is sometimes exploited for decorative or amusing purposes; but, when it results from ignorance, the effect is tinny and emaciated. The artist must remember that all detail near the outlines of a cylinder is compressed *in the image*, into relatively small space, and that the effect is directly proportional to closeness to the outline. The method for calculating this effect, when

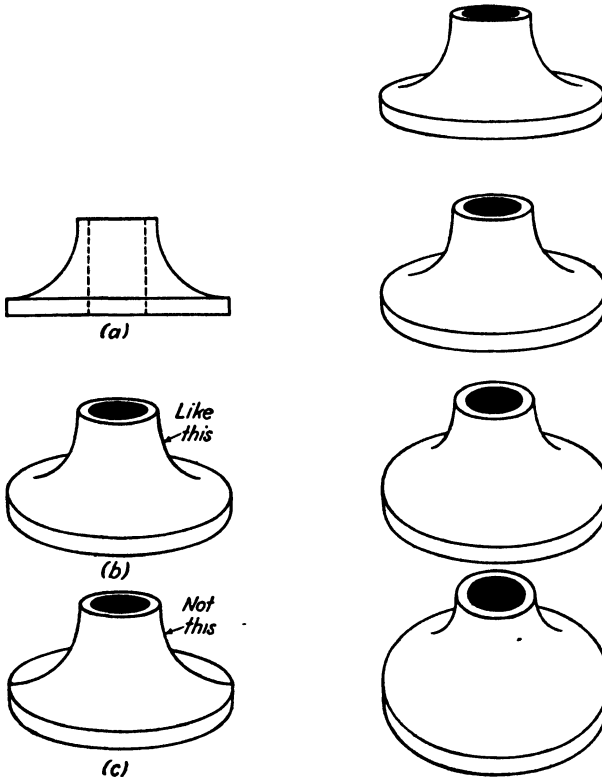

FIG. 148.

FIG. 149.

high precision is necessary, is given in Chap. VI, Pars. 379 through 381, in connection with Fig. 91.

541. Forms of the kind shown in Fig. 148a cause considerable trouble. There is an almost universal tendency to draw them as shown in Fig. 148c. The student feels that the side outlines of the neck of the article *ought* to extend down and out to the extremities of the base. Since he feels that this ought to be so, he *makes* it so in his drawing. This gives a pinched look to the object.

542. The error is another result of failure to distinguish between *edge*, which in any given object is fixed and positive, and *outline*, which may be fluid and movable. The outline of Fig. 148a, which is as the object would be seen on the eye level, is correctly carried down and out to the extremities

of the base. But this outline changes with every change in position of the object relative to the eye level.

543. It would be possible to get this outline correct for any given position by drawing in five or six cross sections at equal intervals between top and base, and it would do no harm for the student to do this on one or two drawings. Such a procedure is entirely too laborious for practical purposes, however. Practice in drawing three or four forms of this kind, such as bottlenecks, pipe flanges, silver hollow ware, etc., will soon give enough experience to permit sufficiently accurate judgment of the effect. This judgment may be guided by the knowledge that the effect increases in proportion as the object departs from the eye level. This variation is shown in Fig. 149. Incidentally, the rather strained effect of the last drawing in Fig. 149 is an interesting example of the bad results of carrying one- or two-point perspective too far. This drawing should make use of a third vanishing point for the verticals in order to avoid having them appear too long.

CHAPTER XII

WORKING FROM BLUEPRINTS AND OTHER MECHANICAL DRAWINGS

544. The making of perspective drawings from mechanical drawings alone, with no actual objects to work from, is routine practice in several fields, particularly architecture, interior design, industrial design, and, to a lesser extent, engineering. The purpose of perspective drawing in these fields is visualization for the client or employer of proposed objects or structures. This often necessitates the making of such perspectives from mechanical or orthographic drawings, which, while they convey much accurate information, give only a poor idea of what the proposed object will look like. The trained technician of course can visualize quite clearly with the aid of mechanical drawings, but in his relations with the layman the use of perspective drawings is important.

545. This is particularly true of architects, interior designers, and industrial designers who usually work with lay clients, and even the industrial designer working in a large organization under specially trained supervisors finds perspective drawing the quickest and most vivid way to convey his ideas. Until recently, perspective was to most engineers merely another tough branch of descriptive geometry. Lately, however, the stress of war conditions has produced a need for this kind of drawing.

546. This need is the outgrowth of the sudden shortage of trained personnel. It has been found that much time can be saved in training workmen if the training can be confined to teaching them their jobs and not spending additional weeks in teaching them to read blueprints. If the manner in which a given mechanism is to be assembled can be conveyed clearly by means of perspective drawings, there is no need for the man to spend additional unproductive time learning rules and conventions of technical drafting.

547. Two types of drawing meet this need. These are *cutaway* and *explosion* drawings. *Phantom* views are also sometimes used. In cutaway drawings part or parts of the external housing are drawn as though cut off to expose the internal construction. In phantom views the same result is achieved by drawing the housing as though it were transparent. Both these types of drawing have their uses, but the explosion drawing, often used in conjunction with a normal type of drawing, is probably the best method, since by its help all parts of a mechanism can be shown clearly and separately, and may even be dimensioned, while at the same time their

relation to each other is also made clear. The aircraft industry, requiring as it now does vast numbers of new personnel, and having unusually intricate problems of assembly, has pioneered in the use of this type of drawing and has developed it to a high point of usefulness.

548. The industrial designer, whose work frequently parallels or overlaps that of the engineer, also finds drawings of this type useful. Since there is no essential difference in the drawing problems of the industrial designer and the engineer, we shall treat them together here.



FIG. 150a.

549. Architects' and interior designers' work is often parallel also. In this chapter we are therefore treating these fields as a unit. Since we have already covered interiors in Chap. VIII, we shall concentrate on exteriors here.

550. In Chap. III (Pars. 140 through 148, and Fig. 26) one method of producing perspectives by projection methods was discussed. A second method was given in the same chapter in Pars. 149 through 172 and Figs. 27 through 30. Since the examples used in those figures were kept very

simple to avoid obscuring the basic principles, we give here further examples of a more practical and realistic kind. No new principles are involved, so we shall confine ourselves to showing the evolution of the results in the figures. The reader should refresh his memory by rereading that section.

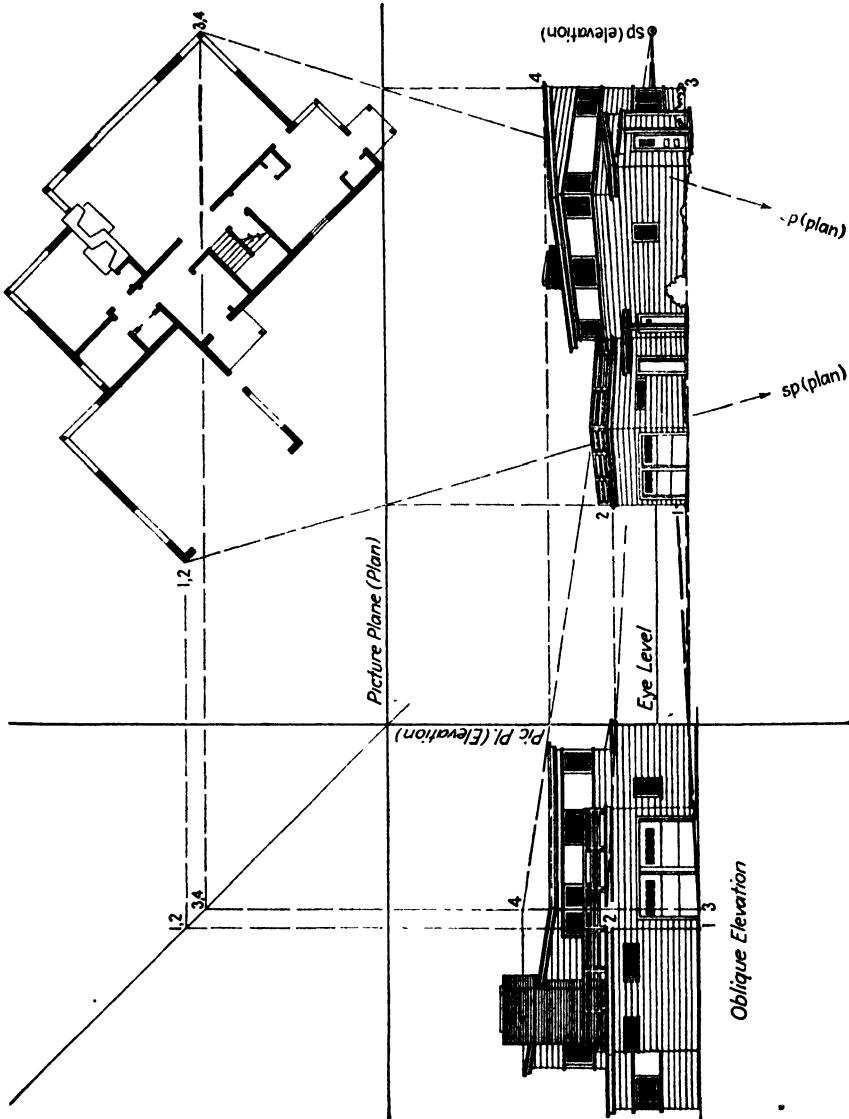

FIG. 150(b).—In working out such problems as this it is often helpful to use both first and second floor plans. The projection may be done on tracing paper, substituting one plan for the other as the work progresses. Care must be taken to see that corresponding points on the different plans are kept in corresponding positions.

551. Figure 150a shows the plans and elevations for a house. These are utilized in Fig. 150b in projecting a perspective of the house by the same methods as those of Fig. 26. In this instance only a few of the projection lines have been indicated.

554. In Fig. 151, using the opposite side of the house of Fig. 150, we show a more conventional method of working. This method is similar to that of Figs. 27 and 28, Chap. III, Pars. 149 through 162. In problems of this kind the use of the ground line to get horizontal measurements and of the vertical measuring line for vertical heights can be a great convenience because of the many small details that may thus be quickly and accurately established. In Fig. 151 two such *horizontal* measuring lines are shown, and the vertical corner *AB* of the house itself, being placed in the picture plane, becomes the *vertical* measuring line.

555. In all architectural perspectives the placing of the station point, *i.e.*, the position of the hypothetical observer, is of the highest importance. Unless some special purpose is to be served, the eye level should first of all be set at the height of a normal person. This can be considered as an even 5 ft., since the scale of architectural drawings is such as to make a difference of a few inches meaningless. The next consideration is the placing of the station point horizontally. Since we are working from plans, this is quite easy. First, the station point should be so situated that a line (*sp-X* in Fig. 151) drawn from it, perpendicular to the picture plane, would pass approximately halfway between the left and right extremities of the plan. If this is not done, distortion will result. Second, the station point must be situated at a distance from the object sufficient to avoid violent perspective, or, in other words, so that the angle *C-sp-D* of Fig. 151 is not so large as to imply abnormal vision.

556. These points are of great importance. They have already been covered in Chap. III, Pars. 142 through 145. In practical work some additional considerations may have to be taken into account. For example, although such a practice is unusual, it is sometimes wise to show a building as though seen from an upper story of a building opposite. This may help in avoiding distortion in the drawing of tall buildings, although it detracts somewhat from the dramatic quality by lessening the effect of towering height. Again a greatly elevated viewpoint makes possible certain advantages. The bird's-eye view (two-point perspective) is very valuable in giving information about groups of buildings, town plans, apartment building layouts, etc., without subjecting the layman to the technicalities of understanding and interpreting the architect's plot plan. Figure 152 shows such a use.

557. In crowded cities, where immense buildings are erected close together, it is impossible to get the long vistas necessary for full appreciation of large structures. Though decentralization may correct this condition in the distant future, we still have present realities to contend with. In these circumstances it is sometimes wise to place the station point closer to the object than normal and to accept the inevitable violent perspective in place of the artificial assumption that the observer stood at a distance of 500 or 600 ft. and saw the building in question through two or three inter-

vening structures as though they were invisible. In either case we have to compromise, and the result depends largely on the judgment of the renderer.

558. In many, if not most, cases, it is possible to place the near vertical corner of the building in the picture plane. A great saving in time may be effected by this means, since this line (AB in Fig. 151) will retain its true length in the perspective view and all height measurements may be made directly on it with the scale, just as they are given in the various elevations. By reference to this line, heights anywhere on the building may be determined quickly and accurately.

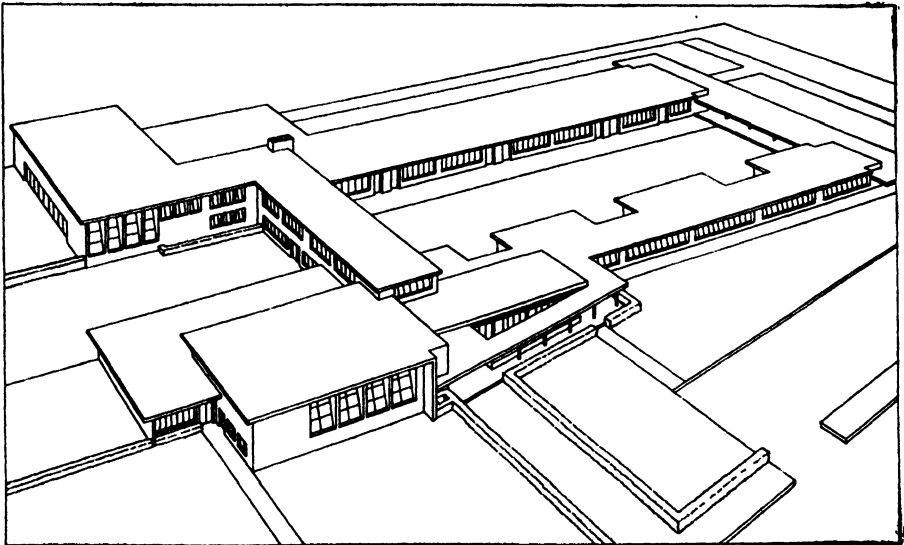

FIG. 152.—(From a design by Thomas Philibert.)

559. It is sometimes convenient to let some other vertical lie in the picture plane and to use that other line for height reference. Such a procedure was used in Fig. 28. The nearest corner is the most generally useful, however.

INDUSTRIAL PERSPECTIVE DRAWING

560. The same general considerations apply to the making of perspective drawings by the industrial designer and the engineer as to all other fields. That is, the station point should preferably be set at a normal eye level unless some special purpose can be served by raising or lowering it; it should not be so close to the object as to produce an abnormally wide angle of vision; the perpendicular from station point to picture plane should pass about halfway between the left and right extremities of the objects. All these rules may be violated to some extent for the fulfillment of special requirements, for example, the engineer, who is more concerned with giving precise

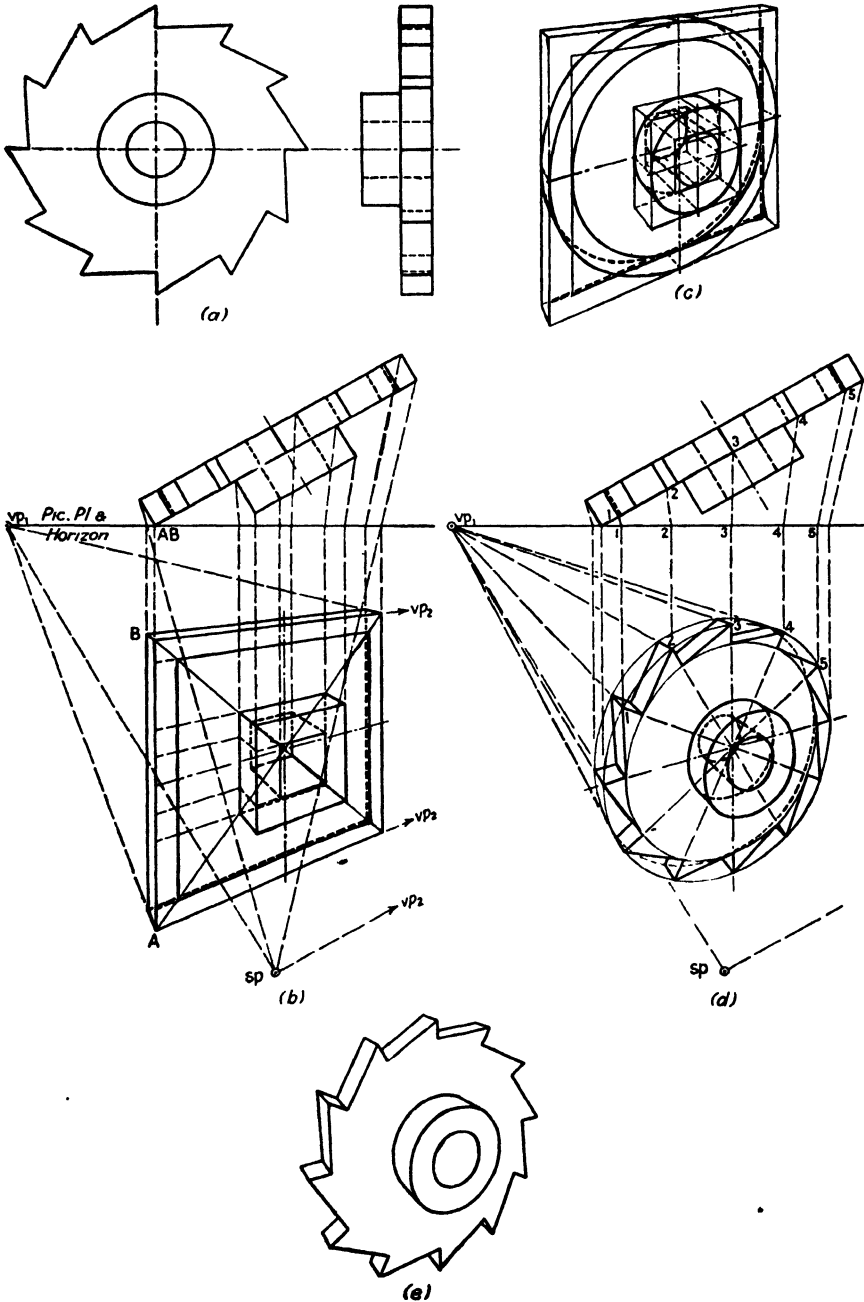
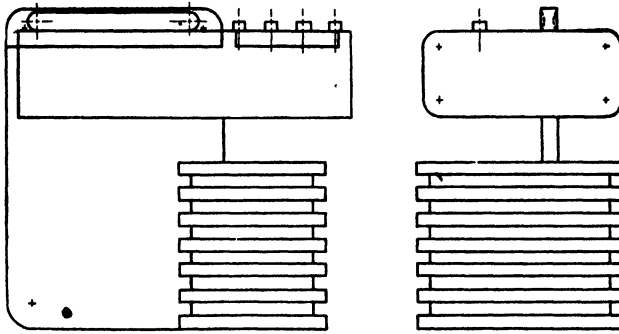
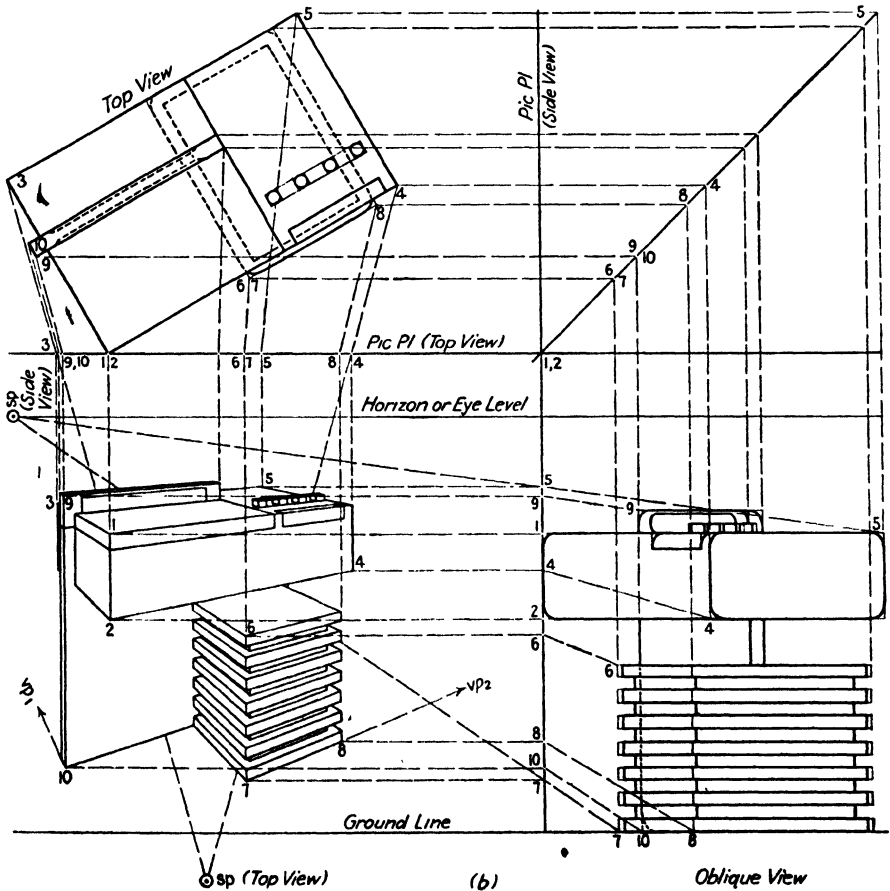

FIG. 153.—(a) Orthographic drawing of a ratchet. (b) Perspective of enclosing rectangles projected. Height and position of smaller rectangles measured on line *AB*, which appears at true length since picture plane passes through it. Viewpoint somewhat forced to clarify diagram. (c) Circles drawn in enclosing rectangles. (d) Teeth determined by projection to outer circle. Next inner circle determines depth of teeth. Use of index numbers helps to keep track of projection lines. (e) Perspective of ratchet.



(a)



(b)

FIG. 154.—(a) Orthographic front and side views. (b) The projections of only a few typical points are shown in this figure. More would be needed in working an actual problem. While not absolutely necessary in making perspectives by this method, the vanishing points may be found and used to save the labor of projecting every single point. Note that curves are not projected and that curved corners are projected as squares.

information than with appearance, may accept some distortion in preference to leaving some important piece of data obscure. Nonetheless, the above rules are the norm and should be departed from only when the benefits are clear.

561. In industrial work the scale of the objects is usually much smaller than in architectural work. The usual 5-ft. eye level will, more often than not, lie entirely above the object, and the horizon is consequently relatively high. Obviously, in drawing objects only a few inches to a foot in height, such an eye level is entirely too high, and compensation is achieved by drawing the object as though on a table. In general we can say that objects large enough to stand by themselves on the floor should be drawn from the normal 5-ft. level; smaller objects, normally placed on tables, should be drawn with an eye level calculated from the table top, *i.e.*, from $1\frac{1}{2}$ to $2\frac{1}{2}$

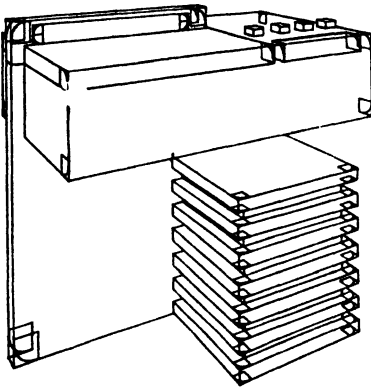

FIG. 154c.—Small squares drawn at corners and used as guides in drawing arcs.

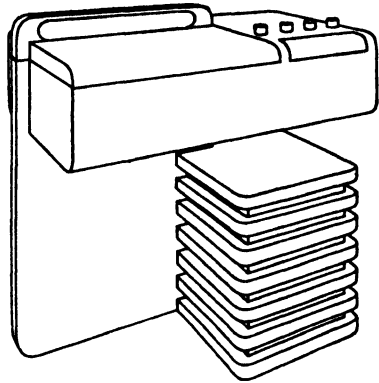

FIG. 154d.—Construction and guide lines removed.

ft.; objects normally suspended from walls or ceilings, such as light fixtures, should be drawn with the eye level below. Again much depends on the discretion of the artist.

562. Figure 153a is an orthographic drawing of a ratchet. In Fig. 153b and the following, the orthographic drawing is translated into a perspective. Since no new principles are involved, little purpose would be served by discussing this figure in the text, but careful study of the figure itself is recommended. In actual industrial practice the drawings are usually far more complex, but the basic method is the same and may be more readily understood in the simple example.

563. The method of Figs. 26 and 150 may also be adopted to advantage in work of this kind, particularly where the forms concerned are largely rectilinear. Figure 154 is an instance of this use. Note that the picture plane has been carried through the near corner, somewhat simplifying the construction.

564. Figure 155 shows an *explosion* drawing. This drawing was made by Richard Gerofsky, as a problem in industrial design at Pratt Institute. Careful study of this drawing is recommended. It conveys complete information as to both assembly and design, only dimensions being omitted.

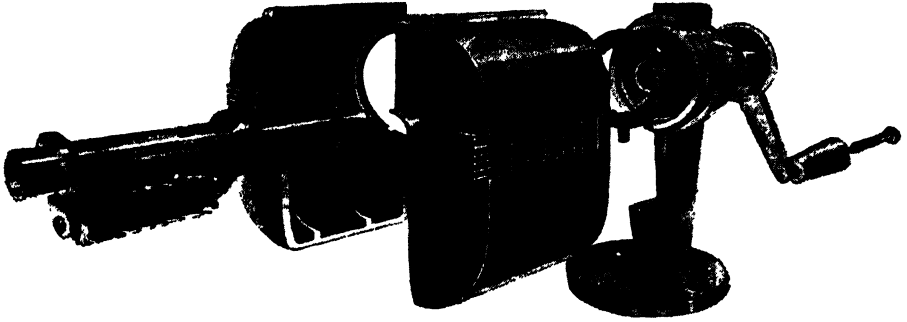

FIG. 155.—(Richard Gerofsky, courtesy of Pratt Institute.)

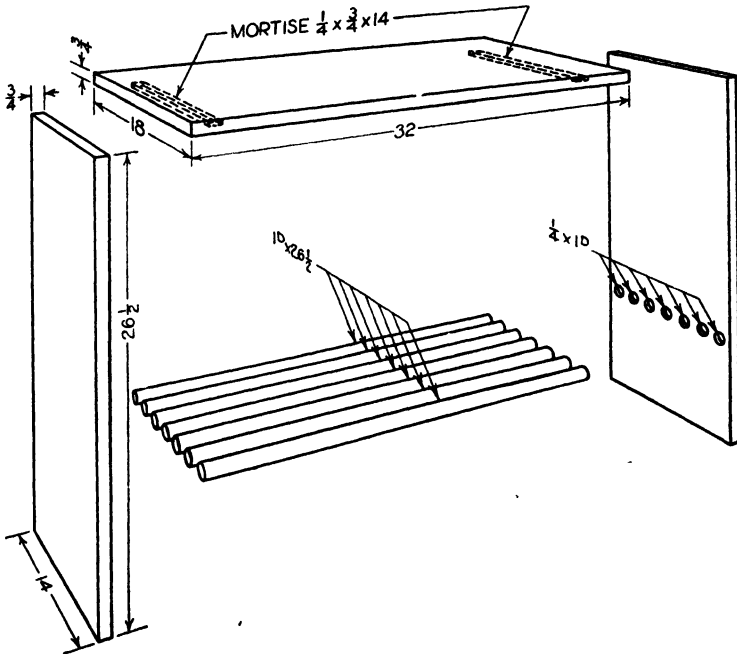

FIG. 156.

Because it is in perspective, it is comprehensible to the layman in a way that no orthographic representation can possibly be. On simple objects, such as the table of Fig. 156, dimensions may be included and the explosion drawing used as a complete working drawing. Though isometric drawings will serve the same purpose, the distorted appearance they present is troublesome to those untrained in technical drafting, and the perspective is usually more easily understood.

CHAPTER XIII

PRACTICAL SUGGESTIONS

565. In his everyday work the artist finds that the most frequently encountered problem is that of correct proportion. If he is working from mechanical drawings, this problem is solved automatically as a part of the projection process itself, although even then there is often some scope for judgment, especially in small or minor parts, in which the exactness gained by projection would not be worth the labor and confusion involved. But in freehand drawing, or in the combination of freehand and instrumental work customary in advertising illustration and in rendering, judgment of proportion is involved almost every time a line is put down. Since a single drawing may require a hundred or more decisions about proportion, the cultivation of a good "eye" is of the greatest importance. Geometric devices have already been given whereby proportion may be accurately gauged, but, as progress is made and experience and practice are acquired, it will be possible to dispense with much of this work by performing it mentally, effecting a saving of both time and labor.

566. Every artist acquires his own methods of judging proportions, and experience will form habits that become quite unconscious. There are, nevertheless, certain guides that can be used as the basis on which more individual methods can be evolved.

567. One of the most useful of these is the method of squares. This consists in visualizing, on the object to be drawn, squares based on the major dimensions. For example, suppose we are drawing the front of a house. This front is 19 ft. from ground to roof and 40 ft. long. We now visualize a square having the height of the house as the length of its side to be drawn on the front plane. It is now possible to visualize a second square laid alongside the first. These two squares would nearly, but not quite, reach the far end. The imaginary squares may now be lightly indicated in the drawing, the allowance for excess made and the proportions of the whole front thereby established. Using the same size square, the proportions of the end of the house may be similarly established.

568. The smaller parts, such as windows and doors, may now be worked out by breaking the squares down into smaller units. More lines may be imagined or visualized on the structure itself. We may visualize a line passing horizontally around the house midway between ground and roof and note that the tops of the first-floor windows come nearly to this line, while the bottoms of the second-floor windows pass about three feet over it.

This three feet itself may be estimated as a portion of a smaller square based on the half height. The top and bottom lines of the windows on both floors may be similarly placed with regard to roof and ground-lines.

569. The proportions of the windows themselves may be established similarly. Suppose them to be 3 ft. wide and 5 ft. high. Since the height has already been established, the width is worked out by drawing 5-ft. squares and then cutting off two-fifths from the width.

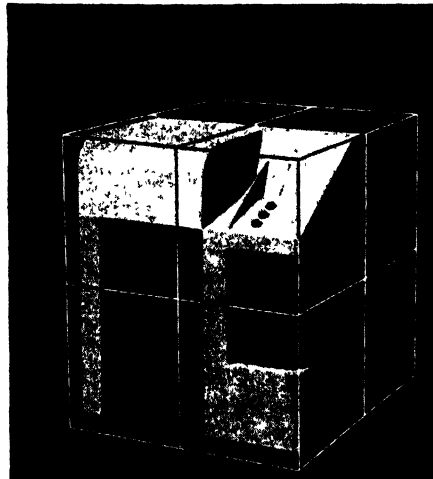
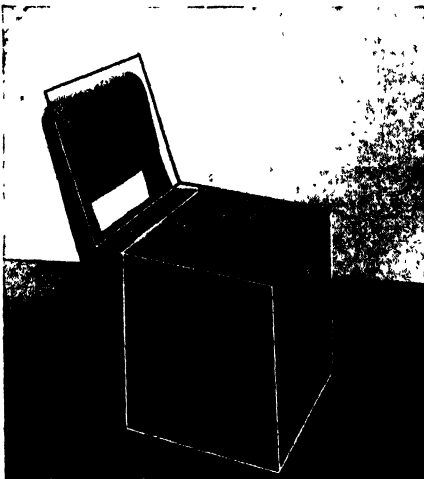
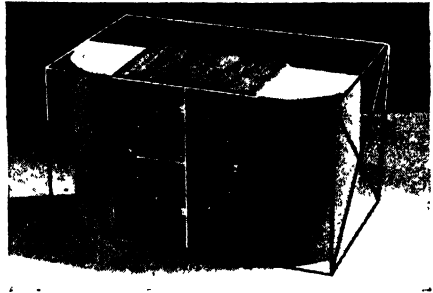
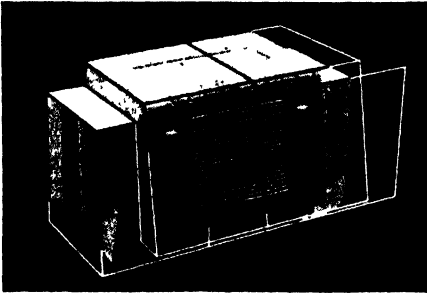

FIG. 157.—(Pratt Institute photographs.)

570. The foregoing gives only a hint of what may be done in estimating proportion by this means, and the individual must rely on his own ingenuity in applying it. Since every picture constitutes a new problem, no hard and fast rules can possibly be given. The photographs in Fig. 157 show how the various problems presented by these objects might be worked out. Note that it is not necessary that the lines of the imaginary squares actually pass through lines they are meant to locate. It is usually adequate to note that such and such a line on the object is a trifle above or below the half height, or a couple of inches to the left or right of the end of the (imagined) square, etc.

571. It is not always necessary actually to sketch the squares on the drawing, although it is usually helpful in the preliminary stages. As the work approaches completion, various actual lines take the place of the imaginary lines as guides and aids. Too many guide lines may so confuse the work as to be a hindrance, and the intelligent worker will always keep the number of extra lines to the minimum required for accuracy. As experience is acquired, it will be found possible to visualize some guide lines not only upon the object but upon the drawing itself.

572. Another method closely related to that just described makes use of actual measurement from a distance. It should be noted that this method is not approved by all teachers, for they feel that it slows up the student's cultivation of a sense of proportion. This is certainly true to some extent,

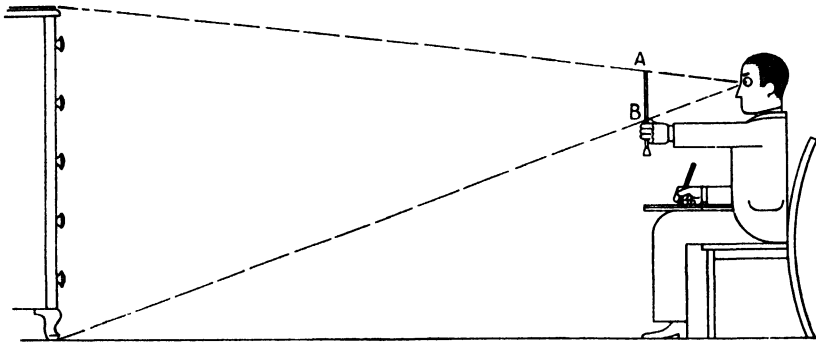

FIG. 158.

and the use of the method should be confined to establishing the principal proportions, because otherwise much time may be wasted and a habit of relying on artificial aid may be inadvertently cultivated.

573. In the simplest case suppose we are drawing a piece of furniture from a direct front view, *i.e.*, in parallel perspective, in which case there will be no foreshortening of height or width, and these dimensions will appear in their true proportion to each other. Taking a spare pencil, brush, or any piece of equipment that is conveniently long, straight, and not too thick or heavy, hold it vertically at arm's length, as shown in Fig. 158, and with one eye closed move it so that the top end is in line with the top end of the vertical line to be "measured." Place the thumbnail so as to align it with the lower end of the same vertical. The distance *AB*, between thumbnail and the tip of the brush handle or whatever, is now used as the vertical height on the drawing. The horizontal width is established in the same way.

574. Using the height and width thus determined, a rectangle is now drawn. Though smaller in scale than the original, this rectangle will have exactly the same proportions. The smaller proportions and details may now be worked out by the same process within the larger ones.

575. Care should be taken in using this device to avoid varying the distance of the brush handle from the eye and object between measurements. This means that the body must be erect and the arm thrust out to its fullest extent without twisting the shoulders. A chair with a stiff back is a great help in this respect.

576. This method is not exact enough for very refined measurements. It works well for getting the major proportions, but no attempt should be made to force it to work for which it is not fitted. For example, in Fig. 158 the height of the leg could probably be gauged quite well by this means, but for the drawer handles it would be entirely too coarse. Such details are much better judged by the eye, which is anyway the final court of authority in judging any drawing.

577. It is not always desirable to have the drawing the same size as measurements of this type will produce. Sometimes the size has been predetermined and the drawing must be made to fit. Sometimes the drawing so made would be too small to include sufficient detail or so large as to be awkward or to run off the paper. In case the measurements are too small, each of them may be doubled or trebled as it is transferred to the paper, or, if they are too large, they may be halved. Again some line, the width, for instance, may be set down at the desired size on the drawing, and the measurements may then be used indirectly by establishing the ratios only. For example, a horizontal line is drawn showing how large this width is to appear in the picture. The width of the object is now gauged with the brush handle, and then, without removing the thumb from its mark, the number of times this measurement can be fitted into the vertical height is determined. Suppose this is one and one-half. A vertical is now drawn one and one-half times the length of the previously drawn horizontal, and the correct proportion is thus established even though the original width was established quite arbitrarily.

578. Another convenient way of enlarging or reducing dimensions while maintaining proportions in their correct ratio is the diagonal method. This method is worth careful study, because it is applicable not only to perspective drawing but also to a wide variety of other work—layout, lettering, typography, the sizing of drawings for reproduction, and a host of other uses.

579. Suppose you are making a drawing on a piece of paper XZ , as shown in Fig. 159. Measurement by the brush-handle method just described gives the rectangle $ABCD$ for over-all proportions. In order to make full use of the paper, it is necessary to enlarge this rectangle while keeping its proportions constant. This is done as follows: Extend the lines AB and AC , draw the diagonal AD , and extend that. Now choose a convenient width (or height), such as AB_1 . Drop a vertical from B_1 . This will cut the diagonal at D_1 . A horizontal from D_1 will then cut the extended vertical AC at C_1 . $AB_1C_1D_1$ is the desired rectangle.

580. If more details are wanted, the procedure is illustrated in Fig. 159*b*. Since the lines *BD* and *CD* have been established as the control lines, all points that are to be used in fixing positions for the enlarged details must

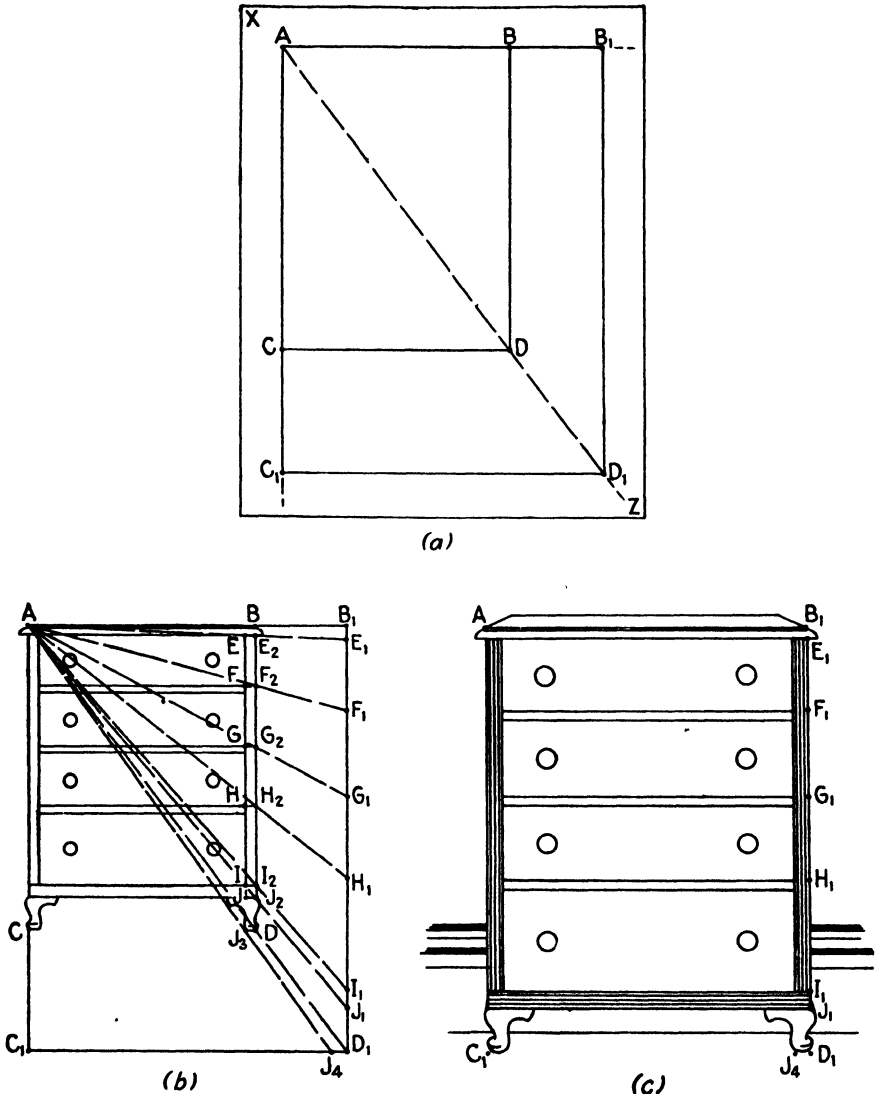

FIG. 159.

be referred to them. Thus the points *E*, *F*, *G*, *H*, *I*, and *J* are projected horizontally to the points *E*₂, *F*₂, etc., on the line *BD*, and the point *J* is also projected to the point *J*₃ on the base line *CD*, because it will be needed to establish the width of the vertical member. Lines are now drawn from *A* through *E*₂, *F*₂, etc., and extended to cut *B*₁*D*₁ in the points *E*₁, *F*₁, etc.

A line is also drawn from A through J_2 to cut C_1D_1 in J_4 . Figure 159c shows how these points are used in the construction of the enlarged drawing.

581. It should be noted that the left-hand vertical member need not be enlarged in this manner, for its width is determined by comparison with the right-hand one. Moreover, although it is perfectly possible to use the same procedure for all the details, such as the horizontals between the drawers and for the handles, it would result in a maze of construction lines while producing no sufficient increase in accuracy to justify the trouble.

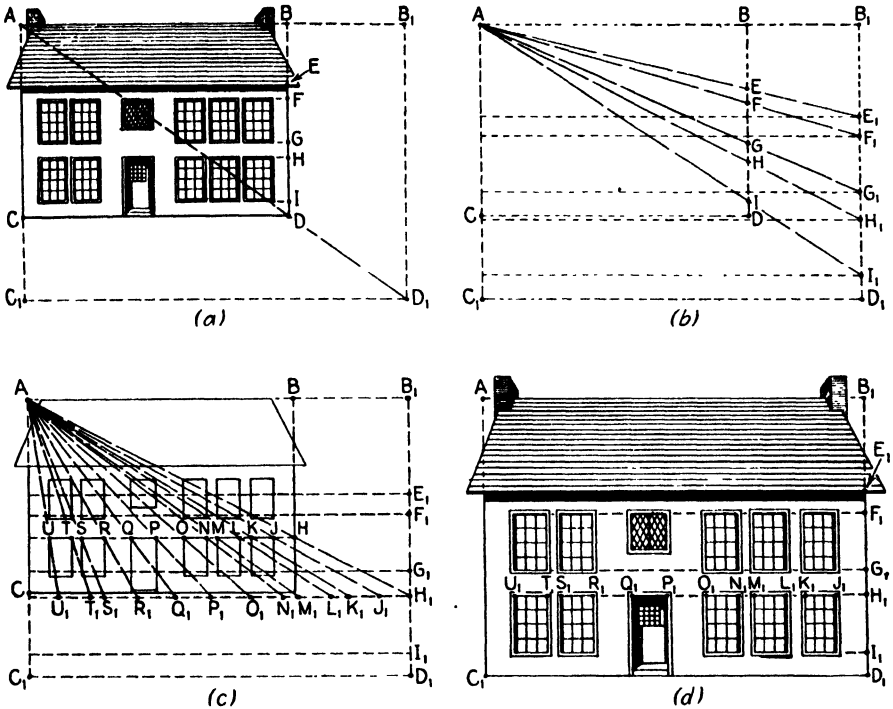

FIG. 160.

It is best, therefore, to draw the smaller details by eye or by methods described in earlier chapters.

582. It is possible to abbreviate slightly the work involved in getting internal details by the method just described. Once a given line has been established on the enlarged drawing, any points on that line may be located directly, rather than indirectly as in Fig. 159.

583. Figure 160 shows a more elaborate example using the same principles. Suppose we have obtained by brush-handle measurement the drawing contained within the small rectangle $ABCD$ in Fig. 160a, and wish to enlarge it to fill the rectangle $AB_1C_1D_1$. The principal horizontal lines are first extended to the right, locating points $E, F, G, H,$ and I on

589. The perspective length of diagonal lines or of lines that appear at an angle owing to perspective may also be measured in this way, provided always that the rule of keeping the brush handle parallel to the picture plane is observed.

590. It is often useful to have some kind of numerical standard for convenience in reckoning. In these cases it is possible to substitute a ruler for the brush handle, the usefulness of the printed scale being compensation for the added weight and awkwardness of the instrument.

591. The practicing professional artist soon acquires an ability to estimate the proper angle at which to draw the various perspective horizontals in a picture, and he will set them down freehand with a sureness and accuracy equal to that achieved by geometric methods. The ease with which the experienced worker does this is often discouraging to the beginner, who despairs of ever freeing himself from the necessity for geometric aid. There are two expedients that will greatly facilitate progress. These were touched on in Chap. II, and we shall briefly recapitulate them here.

592. The first of these is to draw the horizon on the paper or board whenever possible. Since the two principal vanishing points always lie in the horizon, it will be much easier to visualize their position if this line is drawn early in the work. It is often desirable to draw freely a few of the main lines of the subject or its enclosing rectangular solid before setting down the horizon, in order to determine a desirable location for it, but in any case it should be placed as soon as practicable. The artist who is working freehand and without actually setting down his vanishing points is somewhat in the position of a billiard player aiming at an imaginary ball—a real one is hard enough to hit accurately—but if he at least knows that the imaginary spot he is aiming at lies on a certain line, his task is much simplified. Frequently one or both vanishing points will lie within the limits of the board, in which case the problem does not arise; but the horizon should be drawn in any case. In very “deep” perspectives, *i.e.*, bird’s-eye and near bird’s-eye views, this may be impossible. In such work it is necessary to visualize the horizon and its vanishing points in the air beyond the board.

593. The horizon has another use in that it is perspective parallel to any and all horizontal lines’ regardless of direction. If those lines lying farthest from the horizon are first drawn at the desired inclinations, it will be relatively easy to estimate the correct inclinations for lines in between. This corresponds to the mathematical process of *interpolation*. *Extrapolation*, *i.e.*, working *beyond* the original lines, is possible also, provided care is taken that slight errors are not permitted to build up, as they are likely to do when working this way.

594. If trouble is experienced in drawing straight lines freehand, the following expedient may be useful: First draw the desired line freely and correct its obvious errors. Then, holding the drawing in a horizontal

plane close to the eye (or if it is tacked down, stooping to bring the eye close to the board), sight along the line as you might along a billiard cue or golf-club shaft to see if there is any warping. This sighting foreshortens the line so sharply that any curvature or change of direction becomes easily visible, and correction may be applied. It is well, however, to practice drawing straight lines, checking them afterward with a straightedge, in order to acquire as quickly as possible the ability to dispense with such time-consuming work.

595. Now and again problems come up that cause difficulty out of all proportion to the simplicity of the subject matter. The three-legged stool, shown orthographically in Fig. 162 is an example. The average

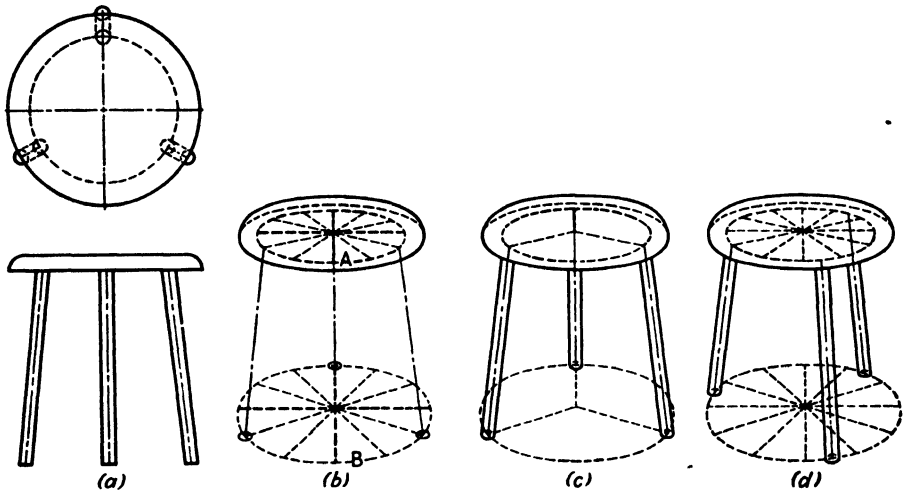

FIG. 162.

worker nearly always draws the two nearest legs too close together, giving an appearance of instability to the stool. The correct construction is given in Figs. 162*b* and *c*. The first step is to draw the circles *A* and *B*, which define the positions of the top and bottom of the legs. Now the *perspective* centers of each of these is found (it may be estimated accurately enough; see Chap. IV), and each circle is divided into four parts by horizontal and vertical lines passing through the centers. Each of these four parts is now divided into thirds, and the divisions thus determined are used as shown in Fig. 162*b* to locate the center lines of the legs. Care should be taken that these thirds are estimated correctly, with the foreshortening properly accounted for. These center lines are then used as shown in Fig. 162*c*. If an unsymmetrical placing of the legs is preferable, the same basic construction is used, but the center lines are located differently, as shown in Fig. 162*d*, the divided circles being used to keep the spacing of the legs perspective-correct.

596. While the division of the circles into 12 parts may at first seem unnecessarily elaborate, in problems of this character it so greatly facilitates estimation as to be well worth the trouble.

597. The drawing of any figure having a number of sides not divisible by four and not compounded of right angles always poses some problems.

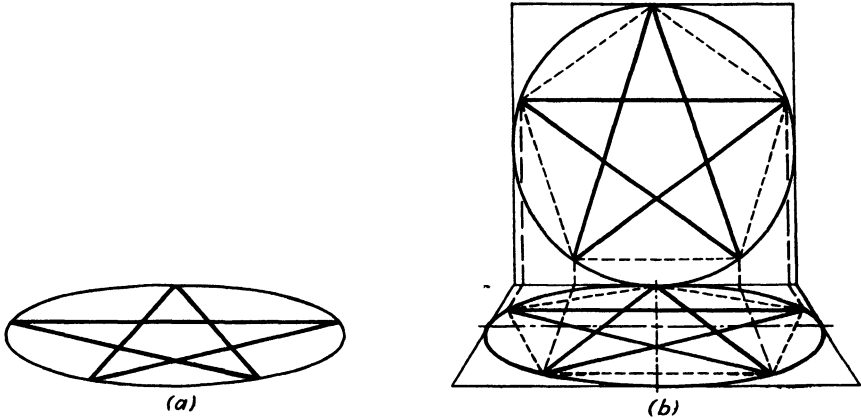

FIG. 163.

The stool just described was essentially a problem in triangles; a star, for example, is really a problem in drawing a pentagon. Any regular polygon may be drawn within a circle, and, as we have repeatedly emphasized, any circle may be drawn within a square. Thus a pentagon may be drawn accurately with the aid of a perspective square and a true square together,

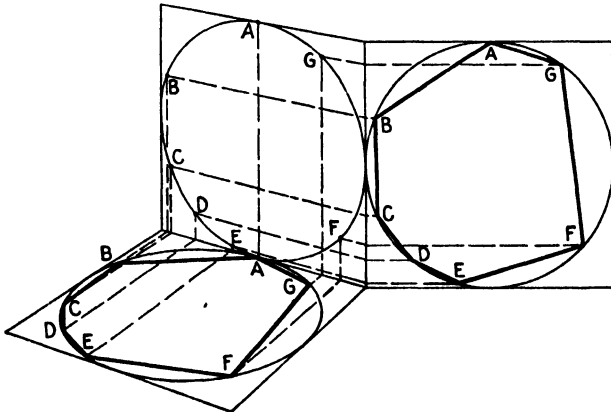

FIG. 164.

as in the clock problem in Fig. 92, and as shown in Fig. 163b. Note that the star in Fig. 163a appears *squashed*; it does not seem to be lying down. Although it is rarely necessary to draw stars with such care, the difference between the two parts of the Fig. 163 should be remembered even when they are drawn freely.

598. Any other polygon may be managed by the same process, provided it can be drawn in a circle. Sometimes, however, no side of the square used for drawing the circle will lie parallel to the picture plane. In this case it is necessary, where maximum accuracy is demanded, as in engineering and some architectural work, to resort to a double projection. An irregular hexagon constructed in this manner is shown in Fig. 164. The occasions when such an elaborate construction will be needed are rare but not unknown, and it is well to be prepared.

599. In drawing highly irregular plane figures, whether curved or composed of straight lines, it is sometimes helpful to work by first drawing a grid of squares. Graph or cross-section paper is very useful in such cases. Figure 165*a* shows an irregular plane figure obviously not "drawable" by

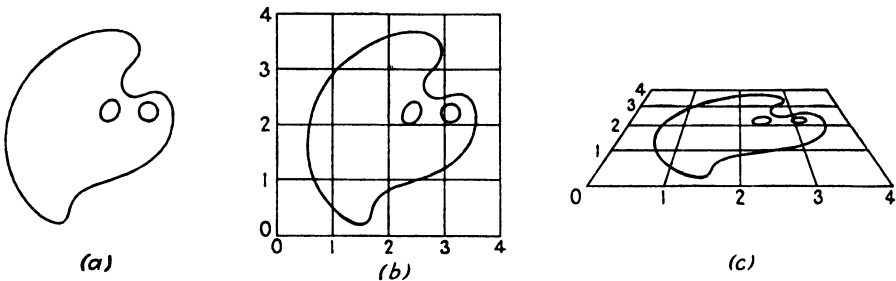

FIG. 165.

the ordinary methods applying to simple circles, polygons, etc. The mesh of squares shown in Fig. 165*b* is drawn over it, and the lines are numbered for easy identification. Letters or symbols will do just as well, but the numbers are sometimes convenient for measurement also. The grid is now drawn in perspective, and the various points and lines are drawn in place on the perspective grid, as shown in Fig. 165*c*.

600. The size of the individual squares may be anything desired but should be governed by the complexity of the figure and the degree of accuracy needed. With sufficiently small squares the accuracy can be as fine as the fineness of the pencil line will permit.

601. The grid method is also adapted to enlarging or reducing drawings, where a great deal of detail must be accurately transcribed from one scale to another. For this reason the method is in wide use by muralists. A grid of squares is first drawn over the original picture as in Fig. 166*a*. An enlarged or reduced grid is now drawn and numbered to correspond with the original. It is then a simple matter accurately to redraw the picture in its new size.

602. One caution should be observed—be sure the small squares are truly square in both grids, or serious distortion may result. Slight changes in proportion may be deliberately sought, however. One of the author's most successful pictures resulted from making the squares a trifle taller than they should have been in the enlargement.

603. One of the most troublesome of all repeat figures is that based on the hexagon. It refuses to be resolved into rectangles based on squares and thus makes estimation of size and proportion very difficult. There are numerous ways of managing this pattern, and some ingenuity is required to draw it correctly in perspective. We give here a solution for a typical problem. This may be varied to suit different conditions.

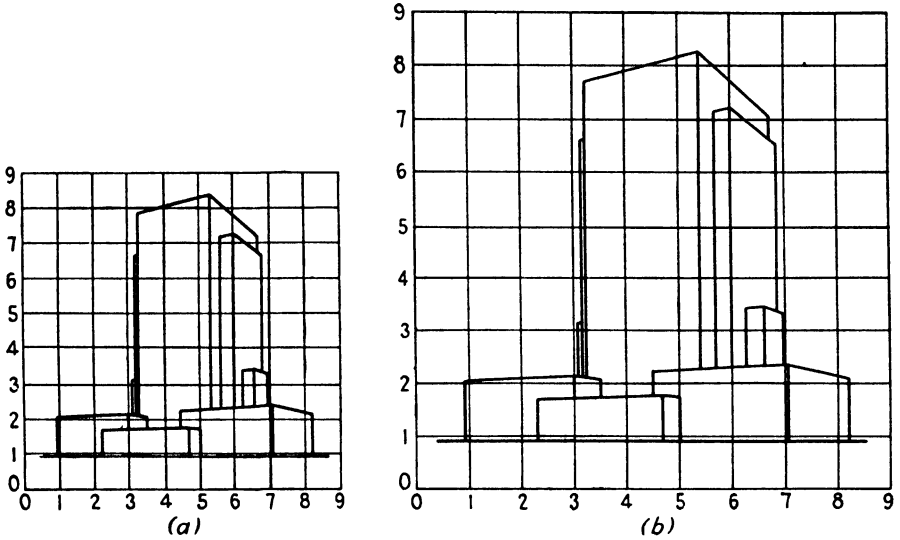

FIG. 166.

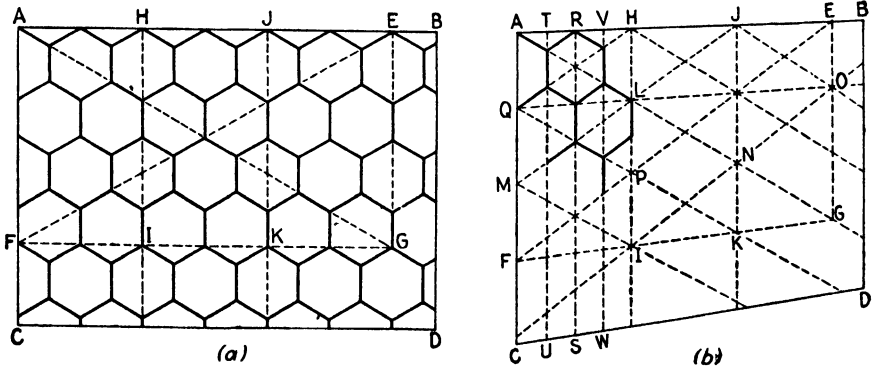

FIG. 167.

604. Suppose we are required to draw in perspective the pattern shown in the rectangle $ABCD$ of Fig. 167a. The first step is to draw the rectangle itself in perspective. Next, a smaller rectangle $AEFG$ is drawn as shown. This rectangle need not necessarily include six tiles horizontally and four vertically as shown here; but it must have this ratio of six to four, or three to two, or twelve to eight, etc., for its diagonals will only then have the correct slope, and it is on the diagonals that the whole construction depends.

In this particular case the rectangle $AEFG$ is next divided into thirds by the vertical lines HI and JK , and the diagonals AG and EF are drawn.

605. The individual hexagons may now be worked out in several ways. In Fig. 167*b* the line JM was drawn through point L , already established by the intersection of diagonal AG and vertical HI , and the line IO through N , which was similarly established. The point Q on a perspective horizontal with O was used to draw QK and QH ; then the lines RS , TU , and VW divided the rectangle $AHFI$ into quarters. From this point on the completion of the work is mainly a matter of filling in the lines and need not be elaborated on.

606. Inasmuch as the operations described above seem much more complex when described than when performed, it is advisable for the reader to take the trouble to follow the steps graphically, reproducing step by step the construction of Fig. 167*b*. The whole sequence will thereby become more understandable. It is well also, for the sake of practice, to complete the entire figure.

607. We have already had two occasions to deal with the problem of objects having hinged joints. The first was a rather elementary example in Chap. III, in which the hinged cover of a box was made to stand at a right angle to the body, a position fairly easy to deal with. The difficulties occur when we have to deal with the intermediate positions. In Chap. IX the problem was solved by the use of auxiliary vanishing points. Still a third method is possible, and in general it is the most practical. This makes use of the fact that a cover or door, swinging about its hinges, sweeps out a cylinder in space, with the hinges as its axis, and a diameter equal to the width of the door or cover. The circular compact shown in Fig. 168*d* may appear to be an exception, but it may be drawn according to the same principles.

608. The principle of using the cylinder as a guide for hinged members requires no explanation, a little study of Fig. 168 being sufficient. The great advantage of the method is that it permits the selection of any desired position in the whole 180 deg. of normal swing and may even be extended to cover the entire 360 deg., if such a free swing is permitted by the construction of the object. Care should be taken that calculations be made expressly for the plane in which the hinges lie, such as $ABCD$ in Fig. 168*b*, and not for other parallel planes, such as $EFGH$; otherwise distortion will result, as shown in Fig. 168*c*. This does not matter greatly when the swing is larger relative to the distance between planes, as in the door of Fig. 168*a*, but it is serious when dealing with thick covers such as Figs. 168*b* and *d*.

609. When lettering is to be done in perspective, as quite often occurs in architectural rendering of commercial exteriors, there is no unusually difficult problem involved. The same principles upon which any sound drawing is based should be utilized. Specifically, the lettering should be constructed in perspective just as it would be in elevation or direct view, except that the

guide lines showing thickness, spacing, width of letters, etc., must also be drawn in perspective.

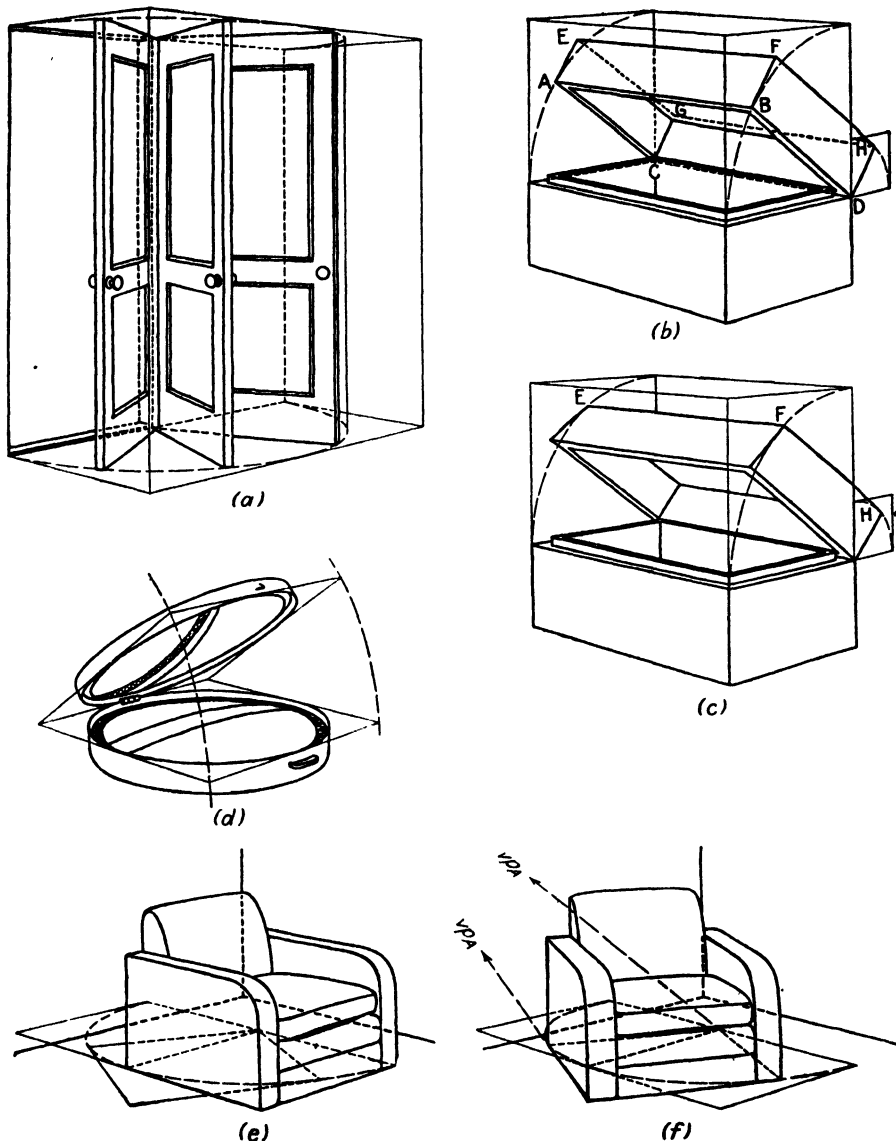

FIG. 168.—(e) The swinging method is very useful when furniture is to be drawn not parallel to the walls of a room. As shown here, the rectangle of the base is first rotated to the desired position; then (f) the piece is drawn on the new base, the sides of which may be extended to find the auxiliary vanishing points.

610. All important height measurements and the thickness of all horizontals should first be measured off on some convenient vertical, preferably the nearest, as shown in Fig. 169b. These are then projected toward the

vanishing points. This will therefore govern both the diminishing apparent height of the receding letters and the proportional diminishing thickness of the strokes. The width and spacing of the letters may most conveniently be governed by laying off equal spaces horizontally, as shown directly in Fig. 169a and perspectively in Fig. 169b. These may be any convenient width, but, for all-round usefulness, perhaps the best is a width equal to the height

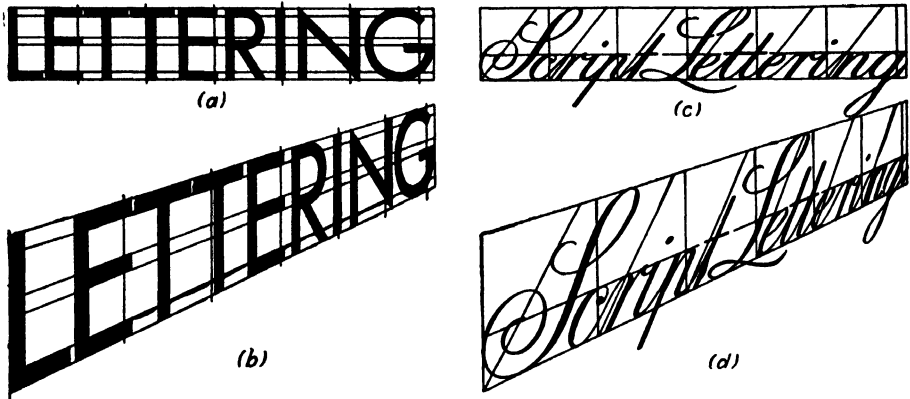

FIG. 169.

of the letter, giving a unit comparable to the printer's *em*, used in measuring type widths.

611. Script or italic lettering, as shown in Figs. 169c and d, need not cause any difficulty, provided the above described steps are supplemented by the use of a few guide lines for slope. Note that this slope, constant in Fig. 169c, does not appear quite constant in Fig. 169d. Although in small or short lines this slight change may safely be ignored, it should be taken into account in drawings where the lettering is a major part of the picture.

CHAPTER XIV

CONCLUSION

612. The foregoing chapters have been concerned principally with the subject of perspective as a practical working tool, as a part of the technical equipment of those artists whose work requires an objective realism of representation. In this chapter we shall discuss a few aspects of perspective not directly concerned with its value from a practical standpoint, yet important if the subject and its relation to the general knowledge required of the competent artist or draftsman is to be well understood.

613. Reference has already been made to the fact that the whole science of ordinary perspective is founded on the assumption that rays or lines of sight from the object pass through an imaginary transparent plane, projecting thereon an image of the object corresponding to that seen by an observer at a given position. Although this assumption serves perfectly well under all ordinary conditions, it must be admitted that there is a certain artificiality about it. To be strictly accurate we should assume, not a *plane*, but a section of a transparent *sphere*, because in actual fact the image of an object is projected, not upon a flat plane, but upon the inside of a sphere, specifically the retina of the eye. It will be seen that this artificiality is shared by both the usual drawings of the living artist and the inanimate camera.

614. This lack of strict scientific truth of representation need not be taken too seriously. There are three principal reasons for this. First, the use of the flat picture plane results in a picture that is psychologically more convincing than one drawn with the sphere as standard. Though in fact the eye sees straight lines away from the center of vision as curved, the brain compensates for this unconsciously, just as it does for the fact that the actual image on the retina is upside down. The various implications of these matters are properly a part of the study of psychology, and the curious reader is referred to teachers of that subject if he wishes to study them further.

615. Another reason why we do not ordinarily use a spherical picture "plane" is the fact that to do justice to it we should have to make our drawings on spherical surfaces. It is rather appalling to contemplate the problems of expense, storage, and transportation of drawings made on sections of spheres. Nevertheless, such drawings have their special purposes and have been made use of in museums and displays. More often cylindrical picture "planes" have been used. These applications provide

convincing views for wider angles than do the more conventional flat pictures.

616. The third reason for disregarding "spherical perspective" is the fact that the 15 to 30 deg. of spherical surface included in the normal view approximates a plane sufficiently well that the representation of the picture plane as truly flat does no great violence to our sensibilities, and the slight gain in scientific truth would consequently not be worth the labor involved.

617. This may be made clearer by an example. If you look at a terrestrial globe you will see the land areas of the world in their true proportion to one another. Now look at the kind of flat map of the world called a *Mercator projection*. In this type of map the parallels of latitude and meridians of longitude are spread out flat and drawn as if their distances one from another were equal. You will notice that the lands near the equator look practically the same as on the globe but that the farther you go from the equator the more they seem to spread out, until near the poles the proportions become utterly absurd. If the flat map is carried as far as 95° north latitude, a country like Greenland swells up until it looks bigger than all North America. This is a result of trying to represent too much of a sphere on a flat surface. However, if we consider a relatively small section of the globe, say North America, south from the Canadian border to the southern tip of Mexico, it will be seen that it can be represented quite well in the flat projection. As far as appearance is concerned, the difference can be detected only by careful comparison, and it is only when measurements are to be made that corrections for distortion must be applied.

618. The area just spoken of represents about 30 deg. either north and south or east and west—about the same as or slightly greater than the field of view of an average picture. We are therefore quite justified in disregarding the small differences.

619. It is when we begin to include cones of vision larger than 30 deg. that difficulties arise. Near the center of the picture all may be well, but near the margins odd things occur—circles change their appearance from ordinary ellipses to bent affairs that seem to climb or droop, cylinders take on an oval shape, round balls resemble footballs, and the corners of buildings take on an unearthly sharpness. These effects may be deliberately sought and exploited for their dramatic or amusement value, but in drawings requiring an objective visual realism they are serious drawbacks. Avoidance of these effects is easy and has been discussed in the preceding chapters.

620. The photographer often finds himself in a situation where these anomalies must be overlooked in the execution of a difficult job. With the aid of an extreme wide-angle lens, he makes the best of a bad situation, as he must when taken into a room and commanded to make a view showing three walls, ceiling, floor, and contents. With the aid of some really

remarkable optical equipment, lenses that seem to "see" behind them, he can do it—he can even show four walls if you insist. But the results are hardly convincing. Everyone is familiar with the banquet picture showing three or four hundred people in a confined space. The photographer gets them all in—at a price—but the people near the camera at the extreme left and right appear to have heads of rather original design—the chin is directly below one eye, and similar distortions affect the rest of the body.

621. No amount of refined *lens* grinding will correct this condition, but, by curving the picture plane into a cylinder, as is done in the Cirkut camera, the distortion is overcome for long horizontal groups.

622. Another conventional assumption in perspective drawing is that the observer views the scene with only one eye. This means that the effect of depth and solidity that is partly the result of binocular vision must be achieved by other means—change in size, shade, shadow, aerial perspective, etc. Although binocular (*i.e.*, two-eyed) vision is not of the greatest importance and is of negligible value in pictorial work, it has, nonetheless, certain important applications. Everyone is familiar with its uses in photography to enhance the sense of space. In certain fields, however, it may come to have considerable value. Three-dimensional figures in mathematical works may be more easily understood when seen stereoscopically than when drawn in ordinary perspective or, as is more common in technical works, isometrically.

623. The preparation of a stereoscopic drawing is a relatively easy matter, the only difficulty being that everything must be done twice. The work must be done very accurately, or double vision may result. There will be two station points instead of one and therefore two sets or four vanishing points, two sets of projection lines, and of course two images. These images will be similar but by no means identical. The customary rules as to distance from object to station point apply.

624. For ordinary purposes a distance of from $2\frac{1}{2}$ to 3 in. between the station points will serve. In a scale drawing this dimension must also be scaled in proportion. For special purposes this may be made greater, but making it smaller will usually destroy the effect. Increasing the separation will have the effect in the viewer of diminishing the apparent size of objects. (Stereoscopic views made from airplanes have been taken from hundreds or thousands of feet apart.)

625. The double perspective is projected just like any other, but the views must later be separated unless the two-color method is to be used.¹ It is usually convenient to make the two pictures rather large and photograph them down for use in a conventional viewer, taking into account the reduction in working out the station points. Figure 170 shows a simple

¹Details concerning this and other stereoscopic devices can be found in books and articles on stereoscopic photography.

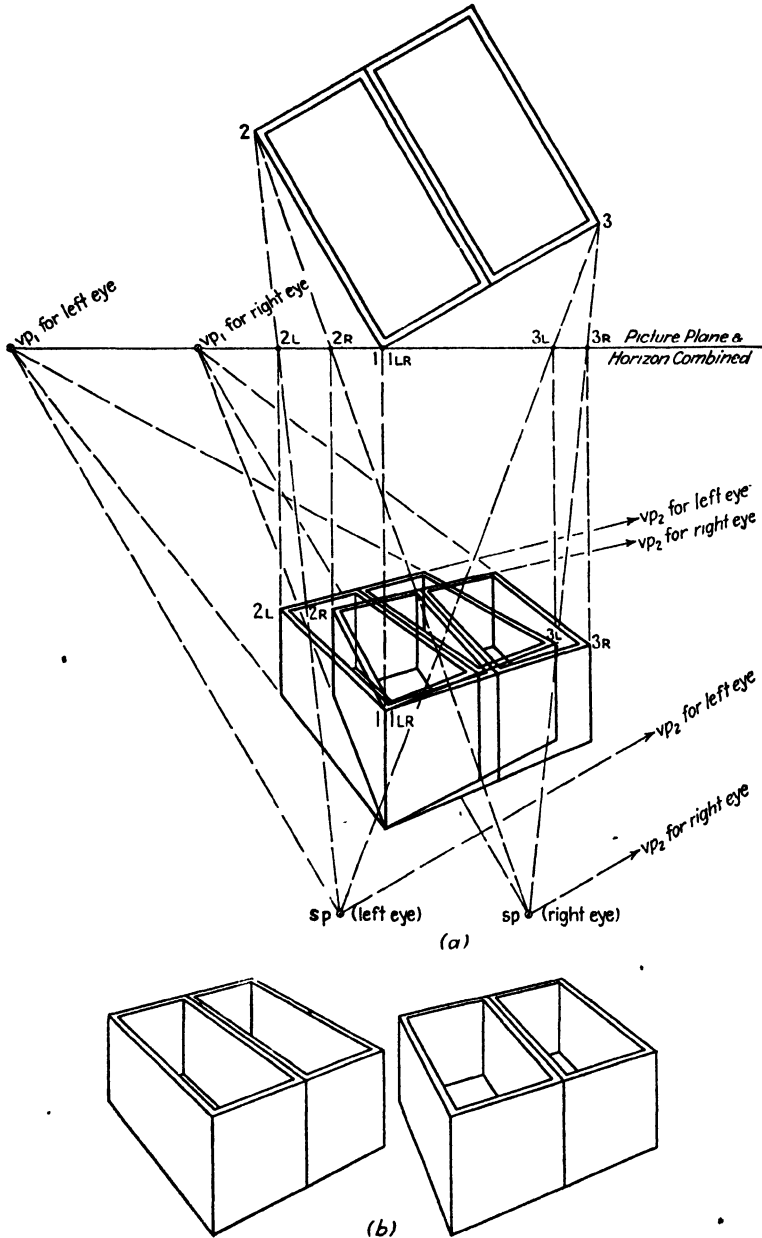

FIG. 170.—This illustration is not suitable for actual viewing, the perspective having been deliberately forced in order to emphasize the effect, making proper fusion of the two images impossible. In practice, a lower horizon and a more distant pair of station points would be needed.

example of binocular projection, and the interested reader may work out others by similar methods. To pursue the subject here would carry us beyond the scope of this text.

626. In order to know the subject of perspective as an isolated subject, it is only necessary to study carefully enough the principles and application of it. But thorough comprehension, in terms not merely of perspective in the abstract, but of the relation of perspective to the whole art and science of drawing, is another matter and is only acquired through much and constant practice. To be a master of the subject of perspective requires what is spoken of as the three-dimensional concept or sense of space, and a sense of objective spatial relations.

627. These phrases are by no means clear at first glance, but an analogy may help to illuminate them. In studying a foreign language one often begins by acquiring vocabulary, grammar, pronunciation, etc., which might be termed the "technique" of the language. Having mastered these, the budding linguist is usually able to read the language slowly and to write it even more slowly but at least comprehensibly. An American or Englishman studying French, for example, would at this stage be working out his thoughts in English, translating them into French, and then writing or speaking them slowly, but with practice a time arrives when the student finds himself thinking directly in French. His technique, *i.e.*, his grammar and pronunciation may be faulty, but he feels "at home" in the language.

628. The student of drawing goes through a similar development. There comes quite quickly with practice, a time, corresponding to the time when the linguist begins to think in French, when the drawing is no longer something on a piece of uncompromisingly flat paper. At this stage the paper disappears, as it were, becoming instead a section of space. The artist ceases to think of himself as translating solidity into flatness and feels himself to be drawing in space. The pencil no longer seems to trace a line from point to point on a plane surface but instead to be going from here to there in three-dimensional space. When this stage has been reached, however imperfect his technique, the worker is entitled to congratulate himself, and say, "*I can draw.*"

629. Notice that he does not say, "I can draw heads," or "I can draw automobiles," but simply, "I can draw." Handy little pamphlets are published on specialty drawing. The serious worker will learn little from them beyond what he can get from copying set poses, but if he can really draw, he can draw anything.

630. This does not mean that it is sufficient to know the geometric rules, or even to have a good spatial sense, to make a good drawing of a particular subject. It is necessary also to study the subject, to consider, as was urged in Chap. I, its anatomy, whether human, animal, or inanimate. The copying of surface appearances results inevitably in weak and superficial drawing. If you are drawing aircraft, don't stop at the outside

appearance, but think of how the ship is put together—learn what a nacelle is and why, what gives the wings their characteristic shape. As a reward for this extra effort you will find that the actual job of drawing becomes easier, while the picture itself gains in strength and solidity. Drawing made easy usually means drawing made weak, but knowledge of your subject as well as of the science of drawing can make drawing easier and more solid. We repeat the words of a fine teacher, "To draw well you must know well."

631. There is one more matter that should be brought to the attention of the art student but is not of particular importance to the reader who may wish to use perspective for technical or scientific purposes. This is that perspective is a science, or, more exactly, a technical tool, and is not and cannot be a substitute for design or aesthetic sense. On the other hand it is an absolutely essential part of the equipment of any artist or draftsman whose work requires a visually convincing realism, for whatever purpose. There is a tendency to assume that a picture is necessarily good because it is technically accurate. It must have more than technical accuracy; it must have design, interest, and a reason for being. A writer would not be considered even interesting, let alone important, were his sole claim to fame the fact that he possessed a large vocabulary and that his grammar was flawless.

632. At the same time the writer whose vocabulary was limited and whose grammar was sloppy would be inarticulate or incoherent. The writer's means of communication is the written word, and he must be competent to manage it. The objective or descriptive artist's means of communication is drawing or modeling, and a knowledge of perspective is essential to his competence in drawing. However noble or important the picture he may have stored up in his mind, it is of little value to him and none to the world at large if he is incompetent to communicate it. Inarticulate and incoherent drawing is by no means unknown. A sound knowledge of the craft is essential if this is to be avoided.

SUGGESTED READING

Not many books on the subject of perspective per se were consulted in the preparation of this volume because it is mainly the outgrowth of commercial work and classroom experience. However, two books may be recommended for readers interested principally in architectural perspective. These are: "Perspective Projection" by Ernest Irving Freese, Reinhold Publishing Corporation, New York, and "Handbook of Perspective Drawing" by James C. Morehead and James C. Morehead, Jr., published by James C. Morehead, Carnegie Institute, Pittsburgh, Pa.

For readers interested in drawing as applied to industrial needs, "Engineering Drawing" by Thomas E. French, McGraw-Hill Book Company, Inc., New York, is the standard text on the subject. Professor French's book treats perspective only in passing but is extremely valuable in that it gives very complete information, not only about the technique of technical, *i.e.*, orthographic drawing, but also about many kinds of mechanical equipment, as well as providing an admirable analysis of many important geometric and industrial forms.

"Line" by Edmund J. Sullivan, Charles Scribner's Sons, New York, is a book not concerned with perspective itself, but containing a great deal that is helpful about the subject of drawing in general.

"Drawing with Pen and Ink" by Arthur L. Guptill, Reinhold Publishing Corporation, New York. Although pen and ink drawing is not so much used now as at the time this book was written, the book contains so much of value concerning the arrangement of subject matter and general principles of rendering, particularly of architectural subjects, that it remains a very useful and comprehensive book.

For readers sufficiently interested in the processes that make seeing possible, "The Universe of Light" by Sir William Bragg, The Macmillan Company, New York, provides a good popular treatment of optical phenomena.

INDEX

A

- Addition and subtraction (*see* Division; Multiplication)
- Aircraft, 132–134, Fig. 98
- Architectonic forms, 124–126, Figs. 93, 94
- Automobile, 134, 135, Fig. 99
- Axes of ellipse, 59, Fig. 33; 62, 63, Fig. 35

B

- Binocular perspective, 207–209, Fig. 170
- Bird's-eye views, 184, Fig. 152

C

- Center of vision, 21, 22
- Charts, perspective, 157, Fig. 125
- Circle in perspective, 60, 61, Fig. 34
 - center, 62
 - division, 122, 123, Fig. 92
- Clock, 122, 123, Fig. 92
- Cone, division of, 121, 122, Fig. 91
 - lying down, 84, Fig. 58
 - nonright-circular, 84, Fig. 59
 - prism method, 83, 84, Fig. 57
 - rapid method, 81, 82
 - truncated, 84, 85, Fig. 60
- Cutaway drawings, 180
- Cylinder, axis relation in, 78, 79, Fig. 51;
 - 80, 81, Fig. 54
 - in composition, 139–142, Figs. 103–105
 - distortion in, 80, Fig. 53
 - division of, 121, 122, Fig. 91
 - errors in drawing, 77–79, Fig. 51
 - intersecting another, obliquely, 108, Fig. 79
 - off center, 108, Fig. 80
 - perpendicularly, 107, 108, Fig. 78
 - nonright-circular, 82, 83, Fig. 56
 - prism method, 79–81, Figs. 52–54
 - rapid method, 81, 82, Fig. 55

D

- Diagonals, use of, for division, by any number, 36, Fig. 19
 - in halves, 22, 23, Fig. 12; 33, Fig. 17

- Diagonals, use of, for multiplication, by any number, 36, 37, Figs. 19, 20
 - by two, 34–36, Fig. 18
 - for multiplication or division in horizontal planes, 37–39, Fig. 21
- Distortion, 17, Fig. 9
 - causes, 18, 19, 27, Figs. 9, 14
 - in circles and cylinders, 171, 172, Figs. 135, 136
 - in foreshortening, 172, Fig. 137
 - in one-point, or parallel, perspective, 29, Fig. 16
 - prevention, 18, 19
 - by reversed vanishing points, 172–173, Figs. 138, 139
 - in two-point perspective, 177, Fig. 147
- Division, by any number, 36, Fig. 19
 - of circles, by five, 199, Fig. 163
 - irregularly, 200, Fig. 164
 - by three, 198, Fig. 162
 - in halves by intersecting diagonals, 22, 23, Fig. 12; 33, Fig. 17
 - of horizontals, by extension to picture plane, 55, Fig. 30
 - by measuring line, 53, 54, Fig. 29
 - in horizontal planes, 37–39, Fig. 21
 - of lines, geometrical method, 39, 40, Fig. 22
 - paper edge method, 41, Fig. 24
- Double-curved forms, 85–95
- Double-projection method (*see* Freese method)

E

- Edge and outline, difference, 95
- Ellipse, 59, 60, Fig. 33
 - concentric, 70, Fig. 44
 - eight-point method, 66, Fig. 38
 - geometric and perspective centers, 62
 - inscribed-square method, 62, 63, Fig. 36
 - in perspective, 72, 73, Fig. 47
 - relation to eye level, 68, Fig. 41
 - sectors, 70, Fig. 43
 - trammel method, 66, 67, Fig. 39
 - twelve-point method, 64–66, Fig. 38

Ellipsoid (*see* Spheroid)

Enlarging and reducing, diagonal method, 193-196, Figs. 159, 160

grid method, 200, Fig. 166

Explosion drawings, 180, 181, 189, Figs. 155, 156

Eye level, 12

effect of relative height, 17, 18, Figs. 8, 9; 174, 175, Figs. 142, 143

(*See also* Horizon)

F

Figures, 149-153, Figs. 114-120

animal, 153

children, 153

on different levels, 151, 152, Figs. 118, 119

on level ground, elevated eye level, 150, Fig. 115

low eye level, 150, Fig. 116

normal eye level, 149, Fig. 114

seated, 152, 153, Fig. 120

secondary, from principal, 151, Fig. 117

Foreshortening, 1, 2

underestimated, 172, Fig. 137

Freehand drawing, 23-30

of one-point, or parallel, perspectives, 29, Figs. 15, 16

Freese, Ernest Irving, 15

method, 14, 15, Fig. 5; 46-49, Fig. 26; 182, 183, Fig. 150; 188, Fig. 154

Furniture (*see* Interiors)

G

Grid, on floor or ground, 157, Fig. 124

Grid method, for enlarging, 200, Fig. 166
for plane figures, 200, Fig. 165

H

Heights, determination of, 16, 17, Fig. 7; 49-51, Fig. 27; 52, 53, Fig. 28

Helix, conical, 93, Fig. 68

cylindrical, 92, Fig. 67

Hexagonal figures, 201, 202, Fig. 167

Hidden lines, to check errors, 26, 27, Fig. 13

Hinged joints, 202, Fig. 168

Horizon, 15

effect of varying height, 15

vanishing points in, 15, Figs. 6, 7

Horizontals, division of, by extension to picture plane, 55, Fig. 30

by measuring line, 53, 54, Fig. 29

I

Industrial perspective drawing, 185-189, Figs. 153-156

Instruments, 154

Interiors, 143-149, Figs. 108-113

order of work, 143, 148, Fig. 108

selection of viewpoint, 143-147

of eye level and vanishing points, 147

L

Lettering, 202-204, Fig. 169

M

Measurements, minor, 41-45, Fig. 25

paper edge, 40, 41, Figs. 23, 24

Measuring line method, 53, 54, Fig. 29

Minor measurements, 41-45, Fig. 25

Mechanical drawing, 10, 11

Multiple forms, 114-123

Multiplication, by any number, 36, 37, Figs. 19, 20

in horizontal planes, 37-39, Fig. 21

paper-edge method, 40, 41, Fig. 23

by two with diagonals, 34-36, Fig. 18

O

Oblique lines, locating, 55, 56, Fig. 31

Oblique planes, locating, 56, 57, Fig. 32

One-point perspective, abuse of; 176, 177, Fig. 146

distortion in, 29, Fig. 16

example, 6, Fig. 3c

freehand, 29, Fig. 15

limitations of, 163, 164

in practice, 163, 166, Figs. 130, 131

procedure, 21, Fig. 11

use of, 7

Orthographic projection, 10, 11

Outline and edge, difference, 95

Oval, 74, Fig. 48

Ovoid, 90, 91, Fig. 65

P

Paper-edge measurements, 40, 41, Figs. 23, 24

Parabola, 74, 75, Fig. 49

Paraboloid, 91, 92, Fig. 66

Parallel perspective (*see* One-point perspective)

Patterns, repeating, 115-118, Figs. 86, 87

"Perspective Projection," 15

Perspective projection, Freese method, 14, 15, Fig. 6
 with vanishing points, 16, 17, Fig. 7
 Phantom views, 180
 Picture plane, 1
 effect of distance from eye, 4, Fig. 2
 horizontal, 2, 4, Fig. 1b
 tilted, 4, Fig. 1c
 vertical, 2, Fig. 1a
 Plastic forms, 124-126, Figs. 93, 94
 asymmetrical, 131, Fig. 96
 procedure for drawing, 129, 130
 Prism, 121, 122, Fig. 91
 Projection, orthographic, 10, 11
 Projection, perspective, Freese method, 14, 15, Fig. 6, with vanishing points, 16, 17, Fig. 7
 Proportion, "brush-handle" method, 192, Fig. 158, 196, 197, Fig. 161
 judging, 190-197
 Pyramid, 121, 122, Fig. 91

R

Reducing (*see* Enlarging)

S

Single projection method, 16, 17, Fig. 7;
 49-53, Figs. 27, 28; 184, Figs. 151, 153
 Skew lines, 176, Fig. 145
 Soft forms, 135, 136, Figs. 100, 101
 Sphere, cube method, 87, 88, Fig. 61
 rapid method, 88, Fig. 62
 Spherical projection, 205, 206
 Spheroid, oblate, 90, Fig. 64
 prolate, 89, 90, Fig. 63
 Spiral, 75, 76, Fig. 50
 Staircases, 120, 121, Fig. 90
 Station point, 11
 best position, 14, 48, 184
 Subtraction and addition (*see* Division;
 Multiplication)
 Suggested reading, 211
 Supporting plane, relation to resting ob-
 ject, 142, 143, Figs. 106, 107

Surface, warped, 95, Fig. 70
 Symmetrical objects, 162

T

Tectonic forms, 124-126, Figs. 93, 94
 Three-point perspective, basic cube
 method, 167, Fig. 132
 example, 6, Fig. 3a, Fig. 4
 in practice, 166-170, Figs. 10, 132-134
 procedure, 18, 19, Fig. 10
 uses of, 7, Fig. 4
 Torus, 93, 94, Fig. 69
 Turned forms, 100
 prism method, 101-103, Figs. 73, 74
 rapid method, 103-105, Fig. 75
 Two-point perspective, example, 6, Fig. 3b
 wide use of, 7

U

Upholstery (*see* Soft forms)

V

Vanishing points, 4-7, Fig. 3
 auxiliary, for diagonal or oblique lines,
 164, Fig. 129
 for sloping planes, 160, 161, Figs. 126-
 128
 centrolinead method, 157, 158
 charts, 157, Fig. 125
 curve method, 158, 159
 determination of, 16, Fig. 7
 on different levels, 174, Fig. 141
 extra, for vertical planes, 109, 110, Fig.
 81
 horizon, relation to, 15
 pin and straight-edge method, 154, 155,
 Fig. 121
 reversed, 172, Fig. 138
 too close, 155, 156, Fig. 122

W

Warped surface, 95, Fig. 70

DATE OF ISSUE

This book must be returned within 3, 7, 14 days of its issue. A fine of ONE ANNA per day will be charged if the book is overdue.

94930/10
P 895
D
D
D
D
D

