

Birla Central Library

PILANI (Rajasthan)

Class No...729.2)

Book No ..C.8.9.5.P..

Accession No 55.36.7

REQUEST

IT IS EARNESTLY DESIRED THAT THE BOOK BE HANDLED WITH CARE AND BE NOT MARKED, UNDERLINED OR DISFIGURED IN ANY OTHER WAY, OTHERWISE IT WILL HAVE TO BE REPLACED OR PAID FOR BY THE BORROWER IN THE INTEREST OF THE LIBRARY.

ARCHITECTURAL AND BUILDING SERIES

Edited by ANTHONY M. CHITTY, M.A., F.R.I.B.A., A.M.T.P.I.

THE PRACTICAL APPLICATION OF
ACOUSTIC PRINCIPLES

OTHER BOOKS IN ARCHITECTURAL AND BUILDING SERIES

AN INTRODUCTION TO THE DESIGN OF TIMBER STRUCTURES.

By Phillip O. Reece, A.M.Inst.C.E., M.I.Struct.E., A.M.Inst.M.& CyE.

AN INTRODUCTION TO THE SCIENCE OF ARTIFICIAL LIGHTING.

By R. O. Ackerley, M.I.E.E., F.I.E.S.

AN INTRODUCTION TO STANDARDS IN BUILDING.

By D. Dex Harrison, A.R.I.B.A., A.M.T.P.I.

BUILDING SUPERVISION.

By W. R. M. Pippard.

COSTING FOR BUILDERS.

By W. Townsend, F.A.S.A., F.R.S.A., and L. Townsend, F.C.C.S.,
F.R.S.A.

FLOOR FINISHES.

By Penelope Whiting, A.R.I.B.A.

HEATING AND VENTILATING.

By Oscar Faber, O.B.E., D.C.L.(Hon.), D.Sc., M.Inst.C.E.,
M.I.Mech.E., A.M.I.E.E., P.Pres.Inst.Struct.E., P.Pres.I.H.V.E.,
F.C.G.I.

PAINTING AND DECORATING CRAFT PRACTICE.

By James Lawrance, F.I.I.B.D.

WOOD ADHESIVES.

By Edward H. Pinto.

Editor A. M. Chitty, M.A., F.R.I.B.A., A.M.T.P.I.

THE PRACTICAL APPLICATION
OF
ACOUSTIC PRINCIPLES

By
D. J. W. CULLUM



LONDON
E. & F. N. SPON LTD
57 Haymarket, S.W.1

1949

First Published in 1949

SPECIAL GOVERNMENT SANCTION
BIRLA ENGINEERING COLLEGE—
LIBRARY BOOKS.

MADE AND PRINTED IN GREAT BRITAIN BY
CHARLES BIRCHALL AND SONS LTD.,
LONDON AND LIVERPOOL

FOREWORD

IT is the purpose of this book to provide in a concise form useful information relating to architectural acoustics and soundproofing in buildings.

The book is written primarily for the person who is unversed in the technical aspect but who is interested in the general application of the technique.

Several important constructional features have been selected for analysis in the light of practical experience. Common acoustic faults are pointed out. Features which have given satisfaction are indicated and, where appropriate, illustrated with line drawings.

Only such mathematical treatment as is necessary for the understanding of practical cases is included. It is mainly confined to the first two Chapters and parts of Chapters VIII to XI. Relative absorption co-efficients, insulation values and a number of graphs and diagrams which the author has found useful are included to assist readers in the solution of their own problems, and Chapters XIII and XIV cover related matters of general interest.

Acoustics is not an exact science; practical experience is therefore essential. If this book assists its readers to acquire experience a little quicker by pointing out the grosser time-wasting factors, it will have accomplished all its author wished.

Grateful acknowledgments are made to the friends whose suggestions and criticisms helped in the preparation of the text book and the author is particularly indebted to Mr. Ian M. E. Aitken, B.Sc.(Eng.), A.M.I.C.E., M.I.Mech.E., M.I.E.E., M.I.W.E., for his share in the tedious business of proof reading.

London,
November, 1948

D.J.W.C.

CONTENTS

	PAGE
CHAPTER I. THE NATURE OF NOISE	15
I.1 Wanted Sounds.	
2 Unwanted Sounds.	
3 The Annoyance Factor of Noise.	
4 The Physical Properties of Sound.	
5 The Interpretation of Equivalent Loudness.	
6 The Interpretation of Relative Loudness.	
7 The Masking Effect of Noise.	
8 Vibration.	
„ II. SOME SPECIFIC ACOUSTIC DEFECTS ..	28
II.1 Auditorium Acoustics.	
2 Sound Control in Buildings.	
„ III. THE SPECIAL CASE OF WALLS AND PARTITIONS	48
III.1 General.	
2 Acoustic Defects.	
3 Reduction of Air-borne Noise.	
4 Other Considerations.	
5 Reduction of Vibration.	
6 Appendix—Tables 1-4.	
„ IV. THE SPECIAL CASE OF FLOORS AND CEILINGS	68
IV.1 General.	
2 List of Acoustic Defects.	
3 Avoidance and Cure of Defects.	
4 Measurement of Insulation Values.	
5 Flanking Transmission.	
6 Typical Floors.	
7 Suspended Ceilings.	
8 Appendix.	

CONTENTS—*continued*

	PAGE
CHAPTER V. THE SPECIAL CASE OF DOORS	82
V.1 General.	
2 Types of Door Seals.	
3 Protection of Seal Pads.	
4 Hinges.	
5 Sliding Doors.	
6 Panel Construction.	
7 Frame Construction.	
8 Door Fastening Devices.	
9 The use of Lobbies.	
„ VI. THE SPECIAL CASE OF SOUNDPROOF WINDOWS	101
„ VII. FORCED VENTILATION SYSTEMS ..	108
VII.1 Acoustic Defects.	
2 Avoidance of, and Treatment for, Acoustic Defects.	
3 Calculation of Noise Reduction.	
4 The Use of Splitters.	
5 Limitations of Noise Reduction in Straight Ducts.	
6 The Use of Bends.	
7 The Use of Baffles.	
„ VIII. THE SPECIAL CASE OF THE CINEMA THEATRE	124
VIII.1 General.	
2 Shape and Proportion.	
3 Echo.	
4 Flutter.	
5 Reverberation.	
6 Extraneous Noise	
7 Whom to Consult.	
8 Appendix A (Information required for Analysis).	
9 Appendix B (Typical Analysis).	

CONTENTS—*continued*

	PAGE
CHAPTER IX. THE ACOUSTICS OF SMALL ROOMS ..	143
IX.1 General.	
2 Natural Modes of Resonance.	
3 Frequency Absorption Characteristics.	
4 Catering for the Higher Frequency Range.	
5 Review of Treatment Methods	
„ X. ABSORPTION COEFFICIENTS	152
X.1 General.	
2 Appendix.	
„ XI. ISOLATION OF MACHINERY	167
XI.1 The Electrical Analogy of the Mechanical Low Pass Filter.	
2 The Calculation of a Filter Section.	
3 Recapitulation.	
4 The Special Significance of the Resonant Frequency in the Design of Low Pass Mechanical Filters.	
5 The Use of Rubber in Shear.	
„ XII. SOME OCCASIONS FOR ACOUSTIC TREATMENT	183
XII.1 General.	
2 Cases Calling Primarily for the Reduction of Source Noises by the Local Application of Sound-Absorbing Material.	
3 Cases Calling Primarily for Insulation against Noise Sources.	
„ XIII. THE LEGAL ASPECT	191
„ XIV. THE FATIGUE REACTION OF NOISE AND ITS APPLICATION TO INDUSTRIAL WELFARE AND ECONOMY ..	194
INDEX	198

ILLUSTRATIONS

		PAGE
Fig. 1	Decibel Level of Common Sounds	19
„ 2	Frequency and Intensity Limits of Normal Ear ..	20
„ 3	Equal Loudness Contours	21
„ 4	Per Cent. Relative Loudness Contours	23
„ 5	Power Handling Capacity and Overload in Theatre Amplifiers	25
„ 6	Masking Effect of Noise	26
„ 7 A-E	Decay Histories	28-31
„ 8	Optimum Reverberation Time and Audience Absorption <i>v.</i> Frequency	31
„ 9	Decibel Reduction <i>v.</i> Absorption Ratio	33
„ 10	Flanking Transmission	35
„ 11	Mechanical Low Pass Filter	38
„ 12	Transmission Characteristics of Low Pass Mechanical Filter	38
„ 13	Constraint to Limit Amplitude at Resonance ..	40
„ 14	Differential Coupling having Two Values of Compliance	41
„ 15	Compliance of Steel Spring and Rubber	41
„ 16	Frequent Sources of Structure-borne Noise	49
„ 17 A-B	Isolation of Vibration	50
„ 18 A-B	Insulation <i>v.</i> Logarithm of Mass	51-52
„ 19	Marginal Isolation of Partitions	55
„ 20	Coupling of Separate Partitions by Common Walls ..	56
„ 21	Methods of Bridging Cavities in Double Construction at Door and Window Openings	56
„ 22	Frames of Low Transverse Stiffness for Bridging Cavities in Double Construction	56
„ 23	Typical Examples of Complex Partitions	58
„ 24 A-B	Types of Floating Floors	71
„ 25	Joint between Floating Floor and Structural Wall ..	73
„ 26	Partitions Carried on Floating Floors	73
„ 27	Flanking Transmission Paths affecting Floating Floors	75
„ 28	Insulation of Services from Floating Floors	75
„ 29	B.R.S. Floating Floor	76
„ 30	C.S.S. Floating Floor	76
„ 31	Raft Floor	77
„ 32	Suspended Ceiling	77
„ 33 A-E	Door Seals	83
„ 34	Rubber Tube Seal	84
„ 35	Multiple Rebate	85

ILLUSTRATIONS—*continued*

		PAGE
Fig. 36	Seal on Door	85
„ 37	Seal to Sill	86
„ 38	Draught Excluder Seal	86
„ 39 A-E	Protection of Seal Pads	87
„ 40 A-E	Hinges	89
„ 41 A-B	Seal to Leading Edge of Sliding Door	90
„ 42	Trap Seal to Trailing Edge of Sliding Door	90
„ 43 A-B	Seal to Trailing Edge of Sliding Door	91
„ 44	Seal to Sill of Sliding Door	92
„ 45	Seal to Head of Sliding Door	92
„ 46	Trap Seal to Head of Sliding Door	93
„ 47	Simple Rubber Tube Seal to Sliding Door	94
„ 48	Seal to Sill on Floating Floor	96
„ 49	Reveal to Door Opening in Double Partition	97
„ 50	Cam Action Door Fastening Device	98
„ 51	Circular Cam Plate Door Fastening Device	98
„ 52	Hinged Cam Action to Close Sliding Door	99
„ 53	Lobby as Sound Trap	100
„ 54	Double Window Construction with 4½ in. Wall	102
„ 55	Double Window—One Floating Frame	103
„ 56	Double Windows in Double Wall	103
„ 57	Double Window—Recommended Treatment	104
„ 58 A-B	Double and Triple Windows with Splayed Reveals	104-105
„ 59	Local Ventilating System	106
„ 60 A-C	Three Simple Treatments of Standard Windows	107
„ 61 A-B	Local Fan Treatment	108
„ 62	Cross Talk Through Ducts	109
„ 63	Sources of Noise and Vibration	110
„ 64	General Treatment of Plenum Plant and Main Trunk	115
„ 65	Efficiency of Duct Cross-Sections	117
„ 66	Noise Reduction Coefficient for Ducts	118
„ 67	Effect of Splitter	118
„ 68	Efficiency of Splitters	120
„ 69	Bend in Duct	121
„ 70	Baffle in Duct	122
„ 71	Baffle Box	122
„ 72	Baffle over Inlet or Exhaust	123
„ 73	Opt. T of R <i>v.</i> Volume	129
„ 74A	Opt. T of R <i>v.</i> Frequency	130

ILLUSTRATIONS—*continued*

		PAGE
Fig. 74B	Opt. Absorption <i>v.</i> Frequency	130
„ 75	Additional Absorption Required <i>v.</i> Vol./Seat ..	131
„ 76	Opt. and Calculated T of R	133
„ 77	Plot of <i>m</i> against relative humidity	137
„ 78	Plan of Theatre—showing Diffusing Elements ..	149
„ 79	Plan of a Review Room (M.G.M. Studios)	149
„ 80	Elevation of a Review Room (M.G.M. Studios) ..	149
„ 81	Plan of Typical Construction of Diffusing Panel ..	151
„ 82	Variation of Absorption with Spacing of Holes in a Paintable Sheet Metal Cover (N.P.L.)	158
„ 83	Variation of Absorption with Spacing of Holes in a Hard Paintable Cover	160
„ 84	Variation of Absorption with Air-space Behind Louvred Metal Cover	161
„ 85	Variation of Absorption with Air-space Behind Per- forated Asbestos-cement Cover	162
„ 86	Variation of Absorption with Perforation in Oil- cloth Stuck to 1 in. Felt	163
„ 87	Variation of Absorption with Perforation in Painted Muslin Cover Stuck to Cullum Acoustic Felt ..	164
„ 88	Variation of Absorption with Thickness of Material	165
„ 89	Variation of Absorption with Thickness of Material	166
„ 90 A-B	Electrical Analogy—Rigid Mounting.	167
„ 91 A-B	Electrical Analogy—Resilient Mounting	169
„ 92	Transmission Characteristic for Low Pass Filter ..	169
„ 93	Electrical Analogy—Damped Resilient Mounting ..	170
„ 94 A-B	Electrical Analogy—Mass-Damped Resilient Mounting	171
„ 95 A-B	Methods of Resilient Mounting	172
„ 96	Electrical Analogy of Low Pass Filter Section ..	172
„ 97	Equivalent Dividing Network for Damped Isolator Mounting	173
„ 98	Equivalent Dividing Network for Damped Mass Mounting	174
„ 99	Compression (cms.) <i>v.</i> Resonant Frequency (fr) ..	178
„ 100	Compliance Characteristics of Steel Springs and Rubber Isolators	179
„ 101 A-B	Correct and Incorrect Loading Conditions for Rubber Isolators	180-181
„ 102	Vertical Mounting Isolator	181
„ 103 A-B	“ Shear ” Type Mountings	182
„ 104	Differential Modulus Type of Mounting	182

Chapter I

THE NATURE OF NOISE

I.1 WANTED SOUNDS

Wanted Sounds should be heard as perfectly as possible.

To expand:

WANTED sounds should be heard at the right level—not too loud, not too quiet. A balance should be struck between pain and strain.

They should be heard the right number of times—which is once, unless a repeat performance is specifically requested. Echo does not enhance clarity.

They should be produced in a room or auditorium, which is neither over-reverberant nor under-reverberant. The former state produces the hollow effect of the cathedral, reduces intelligibility, emphasizes unwanted sounds, and is generally uncondusive to comfortable hearing conditions; the latter state produces a flat uninteresting result and, if very exaggerated, adds an oppressive quality to the sound.

I.2 UNWANTED SOUNDS

Unwanted Sounds (noises) should be reduced to a minimum.

Unwanted sounds may be classified as such by virtue of two properties:

- (a) their character,
- (b) their loudness.

Usually the former property is the more distressing, after the fashion of our neighbour's noise, which is less welcome than our own, because it is his noise, not because it is louder. Similarly, the squeak from a motor car spring will cause more concern to the driver than the louder mixture of noise appropriate to a speed of 50 m.p.h.

One of the tantalising aspects of reducing unwanted sounds is that, where two or more sounds of similar magnitude are present simultaneously, to remove one of them entirely produces

only a small change in the total loudness. The process is like peeling an onion—removal of the large outer layer still leaves an onion almost as big as before.

It is stated that “unwanted sounds should be reduced to a minimum.” By this is meant, of course, “to an economic minimum”.

To revert to the example of the car, it is a practical and economic proposition to eliminate the major irritation of the squeaking spring; but any attempt to produce a large reduction in the general noise which accompanies the propulsion of a car over bad roads at high speeds, by means of a powerful internal combustion engine, verges on practical impossibility, both for scientific and financial reasons. This aspect of noise reduction is continually being encountered.

I.3 THE ANNOYANCE FACTOR OF NOISE

There is nothing inherently annoying about noise, except by definition. It requires an observer to suffer mental distress before annoyance can exist. But because the physiological and psychological make-up of all observers are largely coincident, certain generalizations can be made and related to physical laws. These laws may be invoked and applied to reduce or eliminate annoyance.

Some of these generalizations are listed below. A few minutes' reflection will suggest others. The list can be extended to cover more limited, conditional and personal applications. But the universal inference is that technical attempts to reduce noise are primarily conditioned by the personal interpretation of what is a *noisy noise*.

If, in the opinion of the observer, a noise can be reduced, that noise is immediately an annoying noise. This is an important aspect of noise which figures largely in legal considerations of the problem, but the more personal application is no less apparent.

Intermittent noises are more annoying than continuous noises. Each repetition provides a fresh distraction, and cannot be relegated, like a continuous noise, into a decreasingly conspicuous background.

Rhythm is a feature of physiological function and of psychological behaviour, and for these reasons rhythmic noises are more acceptable than non-rhythmic. At times, the sudden cessation of a rhythmic noise may be more distracting than its presence.

High-pitched sounds are more distracting than those in a lower key; squeaks and clatter more than rumble and low roars.

All noises which are inappropriate, or untimely, or which cannot be associated with obvious or necessary events, etc., have an annoyance factor for these reasons, apart from their other properties of loudness and pitch.

I.4 THE PHYSICAL PROPERTIES OF SOUND

The physical properties are those which can be measured and studied by instrumental methods. By control and manipulation of these factors, the Acoustic Engineer and the Architect can bring about—within limits—changes which can be previously assessed.

The two chief properties are Intensity and Frequency; the former is a measure of the quantity of sound energy, and the latter describes its quality. From a knowledge of the intensity, a determination may be made of the reduction necessary for the specific purpose, while the manner in which it is done will largely be decided by the frequency of the sound.

The speed of sound in air (1,100 ft/sec.) or in solids (much faster, and depending on the solid) is a factor which cannot in practice be modified. It enters, however, into the calculation of many problems in sound control.

The range of intensity normally of interest lies between the minimum audible level—the Threshold of Hearing—and the Threshold of Pain, where the sound is so great as to cause physical pain. For convenience in technical manipulation, some scale is required to divide up this range into convenient units, in the way that the centigrade scale divides the temperature range between freezing and boiling water.

The intensity of a sound is proportional to the square of the pressure of the sound wave, and exploration of the intensity range, with a meter connected to a pressure-operated microphone, reveals the rather disconcerting fact that the limits of the intensity range, at the middle frequencies, bear a ratio of approximately a million million to one. A scale whose top numbers may have twelve noughts in it is an inconvenient thing to juggle with, and liable to brand the acoustic art as Black Magic; besides, the ear is not conscious of such enormous variation.

However, while it remains necessary to measure and calculate these vast ratios, a compact scale can be devised which more

approximately represents the performance of the human ear. The logarithmic scale employed states that the same proportional change shall be covered by the same number of units, i.e., that a tenfold increase, from 1 to 10, or 10 to 100, or 100 to 1,000, shall be represented by a change of 10 units, from 0 to 10, or 10 to 20, or 20 to 30.

In this way the intensity range, 1 to 1,000,000,000,000, is covered by 120 units, each with the fascinatingly soft name of *decibel*.

Symbolically, the relationship is expressed by

$$N = 10 \log_{10} \frac{I_1}{I_2}$$

where N = number of decibels,

I_1 = intensity of louder sound,

I_2 = " " quieter " .

Certain convenient relationships emerge; for example:

a 10 fold change of intensity = 10 decibels (db.)

a 100 " " " " = 20 " "

a 2 " " " " = 3 " "

(or more exactly 3.01 because $10 \log_{10} 2 = 10 \times .3010$)

a 20 fold change of intensity = $10 + 3 = 13$ decibels (db.)

a 200 " " " " = $20 + 3 = 23$ "

It will be seen from the foregoing that two identical sources have a total intensity only three db. greater than one source acting singly. Conversely, if two identical sources are sounding simultaneously, the complete elimination of one of them will produce a reduction of only three db.

One decibel is approximately the smallest change of intensity which the human ear can appreciate.

If it is required to fix the intensity I_1 of a sound on the intensity scale, its numerical magnitude N is given by $N = 10 \log \frac{I_1}{I_2}$,

where I_2 is the intensity at the threshold of hearing—taken (for 1,000 c/s) at 10^{-16} watts/cm².

It is a compact, convenient and altogether beautiful scale. A pictorial representation showing typical intensity levels, is given in Fig. 1.

The Frequency Scale encompassed by the average human ear, has its lower limit at approximately 20 cycles per second, and its upper limit at approximately 15,000 c.p.s. Below the lower limit, the aural effect is lost, and distinct pulses are

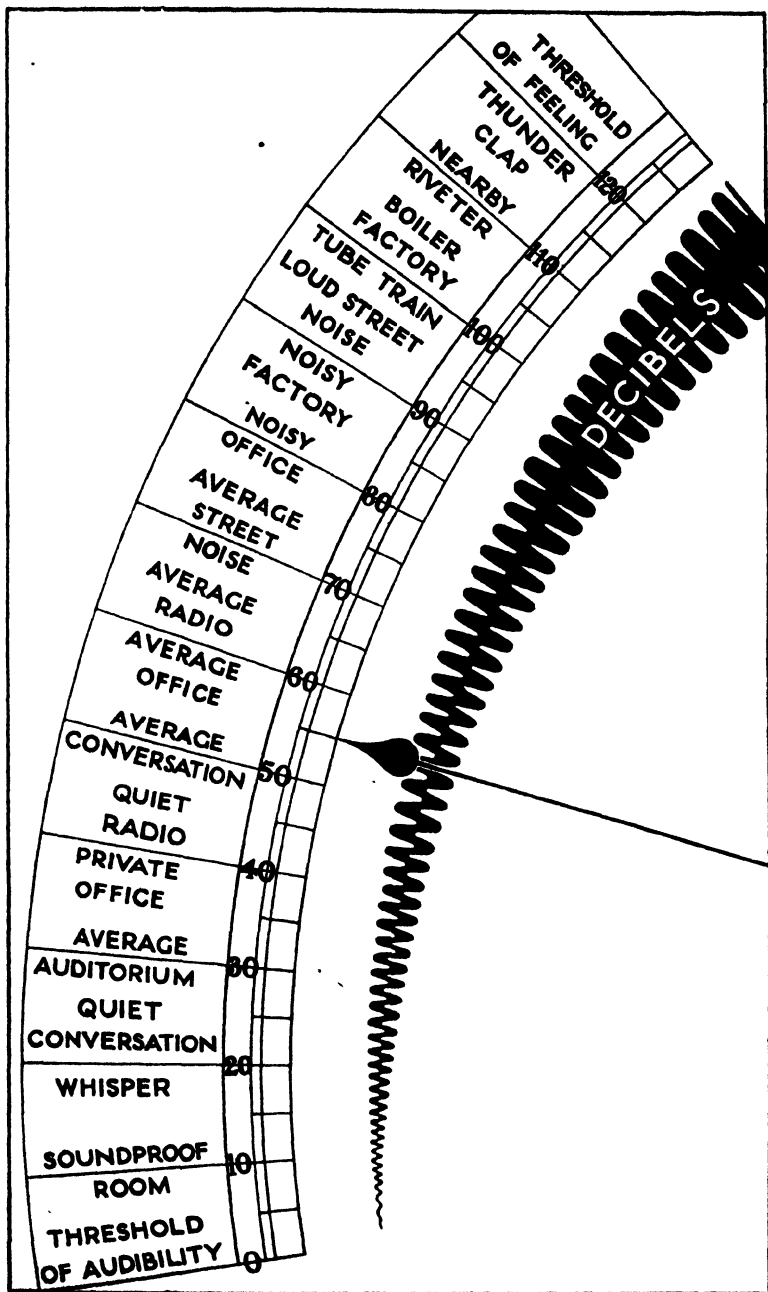

FIG. 1 DECIBEL LEVEL OF COMMON SOUNDS

ACOUSTIC PRINCIPLES

experienced. The upper limit is variable, decreasing with age, suffering temporary diminution with the common cold and related complaints, and is the usual part of the hearing range to suffer in cases of occupational deafness.

The pure tone of single frequency is rarely encountered; in fact, the production of a pure tone is fraught with some difficulty. The sounds commonly experienced are complex, containing components of various frequencies and magnitudes. When these components bear a harmonic relationship one to another, the complex sound is judged to be musical, but may still qualify as noise, if too loud or untimely. The frequency and intensity limits of the average human ear are shown in Fig. 2. The intervals on the base correspond to normal octaves.

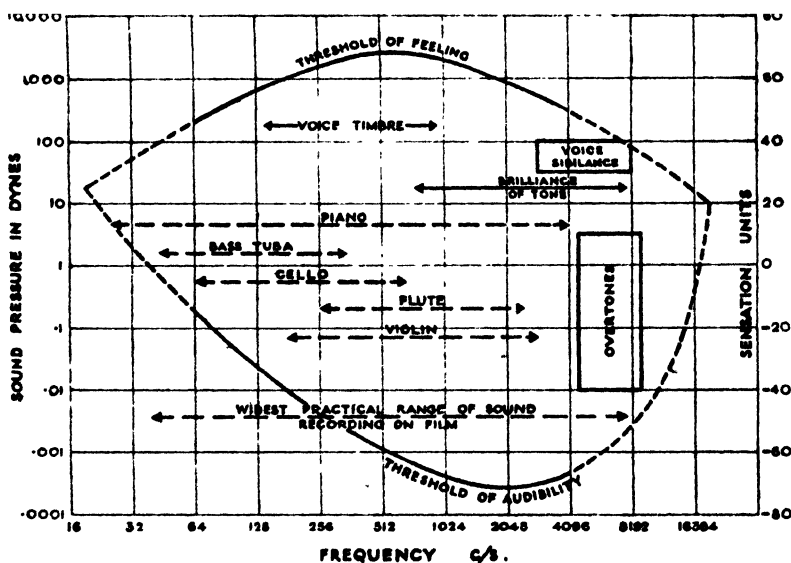

FIG. 2 FREQUENCY AND INTENSITY LIMITS OF NORMAL EAR

1.5 THE INTERPRETATION OF EQUIVALENT LOUDNESS

Intensity in Decibels (db.) and Frequency in Cycles per Second (c/s) are physical quantities, measured by mechanical or electrical methods and arbitrarily defined. There is no compulsion on the ear to interpret these quantities according to the same rules.

THE NATURE OF NOISE

The situation is analogous to the problem:—"Does a kick delivered with a velocity $2V$ hurt twice as much as a kick with a velocity V ?" or "Do two pins hurt twice as much as one, if they are simultaneously inserted?". The intensity of a sound and the velocity of a kick may be exactly measured; but their subjective interpretation cannot be so easily defined.

The chief obstacle, in the relationship between physical Intensity and subjective Loudness, is that the ear does not necessarily judge two sounds of like intensity to be of equal loudness, if they are of different pitch. If one sound is taken at very low pitch, and the other at very high pitch, the ear may judge a very large difference in loudness.

This problem has been partly dealt with by relating the loudness of a sound to the loudness of a standard sound whose properties are known. The procedure is similar to the rating of light sources, which are compared with a standard candle at a standard distance; the light is calibrated in terms of the standard—i.e. in foot—candles.

For the loudness scale, we replace the standard candle by a standard pure note of frequency 1,000 cycles per second, whose

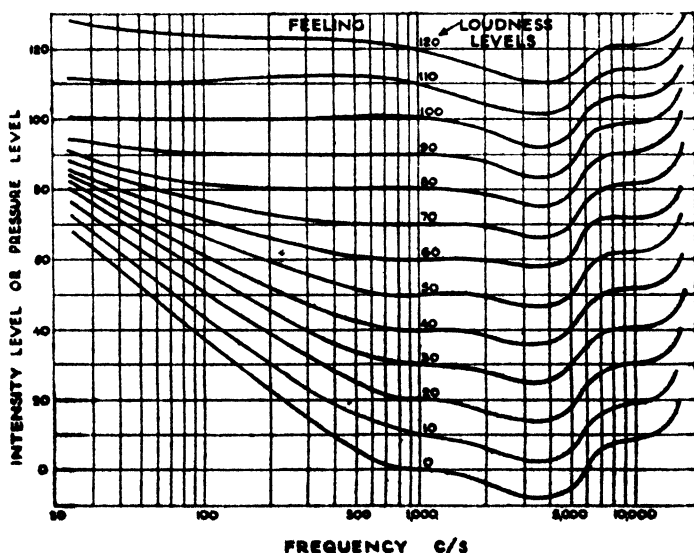

FIG. 3 EQUAL LOUDNESS CONTOURS

intensity can be varied by known and measurable amounts. The standard note is adjusted until it is judged by the ear to be as loud as the unknown sound.

The intensity of the standard 1,000 cycle tone is then measured (or read off a dial) as "n" decibels above the threshold of hearing, and the unknown sound is said to have an "equivalent loudness of 'n' phons," where the phon is the unit of subjective loudness.

In Fig. 3, contours of equal loudness are plotted against frequency, for different loudness levels. At 1,000 c/s the intensity level in decibels and the loudness level in phons are practically coincident. As the frequency decreases the loudness contours close up—i.e., at low frequencies, a loudness change of 3 phons is produced by an intensity change of less than 3 decibels.

Similarly, if two sources at 1,000 c/s sound simultaneously, the resultant intensity increase of 3 db. over one of the sources sounding alone corresponds to a loudness change of 3 phons; if the sources have a frequency of 50 c/s the two sounding together will produce a loudness change greater than 3 phons over the single source.

The relationship becomes even more complicated when several sounds of different frequency and intensity are added on a loudness basis.

In general, it may be said that the total loudness of such a complex sound is greater than would be deduced from the simple relationship which governs the adding of two identical sounds.

It will, of course, be realised that any technique of measuring Equivalent Loudness, involves the human element, which is notoriously frail, and liable to err. When general relationships are stated, as in Fig. 3, human variation is averaged out by taking the mean result of a number of measurements by many observers. Any single subjective balance made by one observer is liable to an error of the order of $\pm 3\text{-}4$ phons.

The human ear has ballistic properties, in that it will register the true loudness of a sound only if the sound persists for not less than a certain minimum period—approximately $1/5$ sec.

This property is of interest in the relationship of loudness and intensity for sounds of short duration, and also in connection with the apparent loudness of sounds with and without reverberation.

I.6 THE INTERPRETATION OF RELATIVE LOUDNESS

It was stated in I.4 that the elimination of one of two identical sources produces an intensity change of only 3 db., corresponding at 1,000 c/s to a loudness diminution of 3 phons.

In a loudness range of 120 phons, a change of only 3 phons does not seem much. On the other hand, the elimination of half the source of trouble seems to be quite a large step in the right direction.

What then is the connection on a relative loudness basis? In other words, how does the ear regard a *change* of 3 phons, or the *difference* between the loudness of one source and of two similar sources sounding simultaneously?

Measurements have been conducted in which observers were asked to adjust a pure tone until it was judged to be one half or one quarter as loud as a standard tone. Both tones were calibrated, so that a relationship might be recorded between Relative Loudness and Intensity.

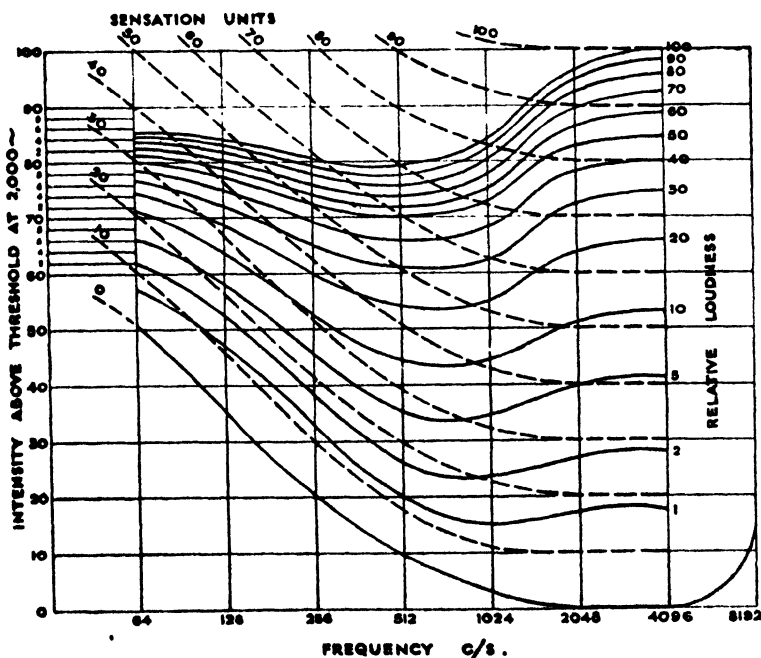

FIG. 4 PER CENT RELATIVE LOUDNESS CONTOURS

HARVEY FLETCHER. "Speech and Hearing."

The results of a series of measurements made by the Western Electric Co., Ltd., are shown in Fig. 4, where Equal Loudness Contours are plotted against frequency over the range 64-4,096 c/s.

100% Relative Loudness is taken as the loudness of a 4096 c/s tone at an intensity level of 100 db. above threshold. This frequency was chosen as the most sensitive part of the normal aural range.

Because of the smaller intensity range, at low frequencies, required to cover the loudness range between threshold loudness and the equivalent loudness corresponding to 100% relative loudness, the contours close up; so that, while changes from 100% to 50% and 25% loudness are produced by intensity changes of 10 db. and 23 db. respectively at 1,024 c/s, the same relative changes at 64 c/s are produced by intensity changes of only 5 db. and 9 db.

On the same basis, a change of 3 db. will produce Relative Loudness reduction from 100% Relative Loudness, at 1,024 and 64 c/s, to approximately 80% and 70%.

On the other hand, the contours of Relative Loudness are largely coincident with the contours of Equal Loudness developed by Munson, so that the connection between Phons and Relative Loudness shows very little variation with frequency—i.e. changes from 100% to 50% and 25% Relative Loudness are produced by changes of approximately 10 and 20 phons respectively at all frequencies.

I.7 THE MASKING EFFECT OF NOISE

The presence of noise increases the minimum sound intensity which can be distinguished in the presence of the noise. This increase is known as masking. Its effect is greatest when the frequency or frequency spectrum of the masking noise and of the wanted sound are similar. Under these conditions the masking level is substantially the loudness level of the masking noise if expressed in phons—or the intensity level if expressed in decibels. Where there is a difference in character, low frequency masking noises are generally worse offenders than high frequency noises. Particularly where the difference in character is large, the discriminating properties of the ear, together with the directional listening ability conferred by the

THE NATURE OF NOISE

use of two ears, enable the wanted sound to be picked out in the presence even of a louder masking noise.

The masking effect of a noise is of interest because it determines:

- (1) The minimum level of wanted sound which can be heard in its presence.
- (2) The insulation required from a wall or a partition.

The minimum level is of importance whenever it is required to listen to wanted sounds. Thus the masking noise in a cinema theatre, due to noise from plenum plant, projection room, audience, etc., fixes a limit to the minimum audible sound from the sound reproducing system. As the volume range (or intensity range) of the reproducing system is fixed, the masking noise also determines the average and maximum intensity levels required

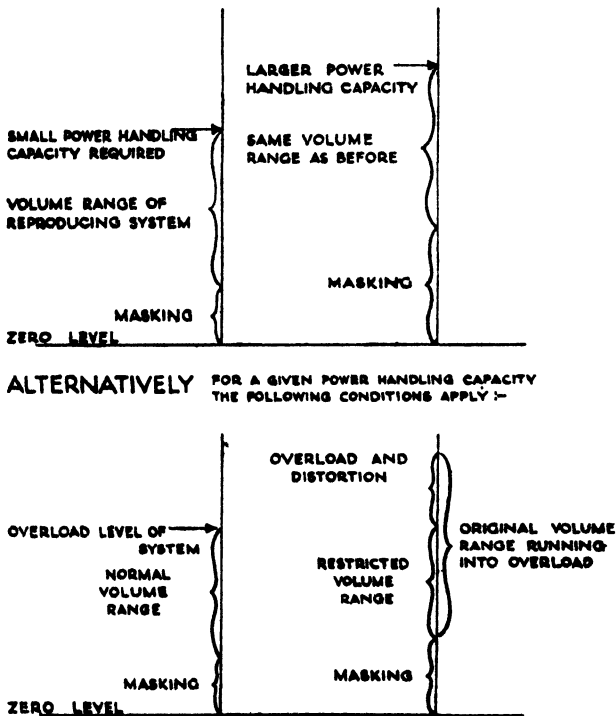

FIG. 5 POWER HANDLING CAPACITY AND OVERLOAD IN THEATRE AMPLIFIERS

ACOUSTIC PRINCIPLES

from the system, and hence the power handling capacity of amplifiers, etc. This point is illustrated in Fig. 5.

In a similar manner, a noisy environment in offices, due to typewriters, calculating machines and personnel, requires a greater vocal effort to maintain an adequate speaking level and renders conversation, particularly over the telephone, more difficult.

On the other hand, the application of a sound-absorbing treatment, such as Acoustic Tiles, to the ceiling of an office will render conversation easier at a lower loudness level due to the absorption of reverberant sound. Wanted sounds consequently stand out more clearly. Clarity is usually more important than loudness.

Where a noisy environment exists in a room, due to sources inside the room, and it is further required to insulate against noise outside the room, it is uneconomic to reduce the outside source to a level, inside the room, that is much below the level of the room environment. Thus if a room has a noise environment of 30 phons, and there is an electric motor which produces a loudness level of 70 phons in an adjacent room, the insulation required is just in excess of $70 - 30 = 40$ phons. In the foregoing the assumption has been made that the motor source and the room environment have similar frequency spectra; if they both had the same loudness level, the two together would have a combined loudness approximately 3 db. greater than the loudness of the environment.

The condition is shown graphically in Fig. 6.

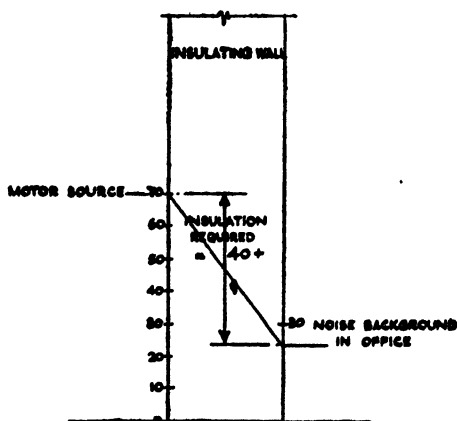

FIG. 6 MASKING EFFECT OF NOISE

I.8 VIBRATION

Vibration may be considered as a special case of noise, except that transmission takes place through a solid or liquid medium, instead of through air. Its manifestations are apparent in two ways:

- (1) because it produces movement of solid surfaces ; and
- (2) because these solid surfaces, under the influence of vibration, will radiate sound into the air.

In general, vibration effects are noticeable only in the lower frequency range.

Chapter II

SOME SPECIFIC ACOUSTIC DEFECTS

THERE are two main aspects which may be separately discussed under the headings of "Auditorium Acoustics" and "Sound Control in Buildings". The former deals chiefly with conditions to promote the comfortable hearing of wanted sounds—the latter with the avoidance or reduction of noise and vibration. Some features are common to both.

II.1 AUDITORIUM ACOUSTICS

II.11 General

When a sound is made in a room, sound waves travelling outward from the source are partially reflected, and partially absorbed, at the boundary surfaces. Hard plaster surfaces reflect 97% or more of the energy in a sound wave which strikes them. Thus, in the average room, many reflections are involved before the sound energy has decayed below the level of audibility; and, when all the surfaces are highly reflecting, some considerable time must elapse before this is accomplished.

The acoustic performance of a room or auditorium depends on the manner and the rate at which this decay of sound takes place, and acoustic defects are a measure of the departure from the optimum manner or rate of decay. Ideally, it is required that the sound energy should decay smoothly, at a rate determined

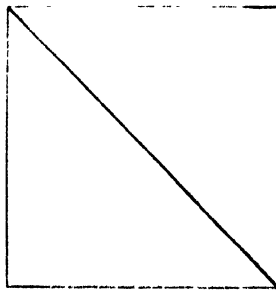

FIG. 7A DECAY HISTORY

SOME SPECIFIC ACOUSTIC DEFECTS

by the size of the room or auditorium and by the frequency of the sound in question (Fig. 7A.).

II.12 Echo

The simplest and most obvious departure from the ideal condition of smooth decay is echo, where, some time after the original sound has been heard, a great lump of reflected energy is directed back into the audience (Fig. 7B).

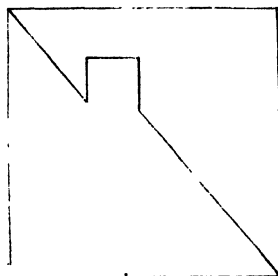

FIG. 7B DECAY HISTORY

The fault occurs when sound from the stage is reflected from a hard surface (usually the rear wall) into the audience at least $1/15$ second after the original sound has been heard. The effect of the echo is aggravated by any focussing provided by, for instance, a curved rear wall or a domed ceiling which has its focus near the audience.

Should the reflected energy be considerable, but occur less than $1/15$ sec. after the original, a blurring effect is noticed instead of a distinct repetition of the original.

Echo is chiefly confined to the upper frequency range (approximately 1,000 c/s upwards). Reference should be made to Chapter VIII for further discussion of this defect.

II.13 Flutter

Where hard parallel surfaces exist (as frequently in the case of side walls), there is a tendency for the sound energy to decay in a series of steps, rather like a series of echoes of diminishing intensity, where the interval between successive steps is the time for sounds to be reflected from one surface to the opposite surface (Fig. 7C). In this phenomenon, the high frequencies are involved almost exclusively—say, above 1,000 c/s. The aural effect is a hardness or harshness, particularly noticeable in speech.

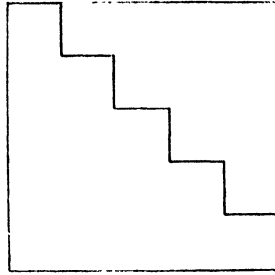

FIG. 7C DECAY HISTORY

II.14 Reverberation

For maximum intelligibility of speech, only the direct sound from the source is required. Because of reflection from the boundary surfaces, however, it follows that, at any given position in the seating area at any given moment, there exist simultaneously the direct sound from the stage, and random sound which has suffered reflection.

Probably because of continued usage, the ear expects a certain amount of reverberation in an auditorium, and rejects complete lack of it as unnatural; it insists, however, on the correct mixture. An excessively long reverberation time leads to overlapping of consecutive syllables with loss of intelligibility; too short a reverberation time produces a "dead" effect with loss of brilliance, usually due to disproportionate absorption of the higher frequencies (Fig. 7D).

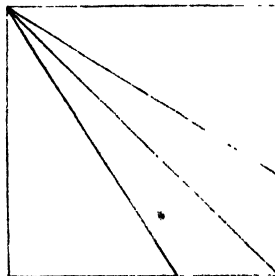

FIG. 7D DECAY HISTORY

The best or optimum Reverberation Time depends on a number of factors, of which the most important is the size of the auditorium. It varies with frequency, more reverberation being acceptable at low than at high frequencies. It is a

SOME SPECIFIC ACOUSTIC DEFECTS

significant fact that the inverse of the curve of Optimum Reverberation Time (i.e., relative absorption) v. Frequency closely follows the curve of Absorption v. Frequency for the audience (the audience provide the greater part of the absorption in the average auditorium). The Reverberation Time is defined as the time taken for a sound to decay through a range of 60 decibels (Fig. 8).

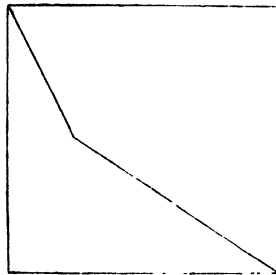

FIG. 7E DECAY HISTORY

II.15 Multiple Decay Rates

Even when the reverberation time approaches the optimum, there may be something lacking in the quality of the sound,

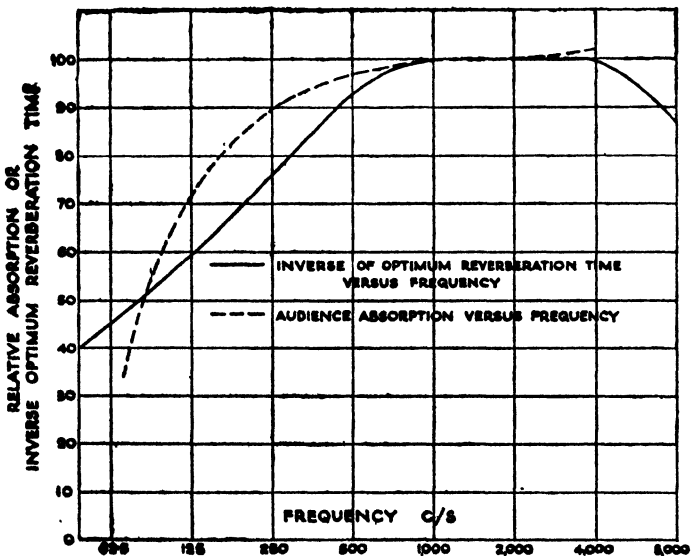

FIG. 8 OPTIMUM REVERBERATION TIME AND AUDIENCE ABSORPTION v. FREQUENCY

if more than one rate of decay is present (Fig. 7E). Conditions which are conducive to the effect are poor distribution of sound energy (large areas having flat unbroken surfaces), or coupled unequal volumes, such as exist in theatres with deep overhung balconies. Under these circumstances, both volumes have their local reverberation conditions, and the end of the longer decay will feed and sustain the less reverberant environment.

II.16 Calculation of Reverberation Times

The pertinent calculations are dealt with in Chapter VIII, which deals with the special case of the cinema theatre, and a typical analysis is worked out in the Appendix.

II.2 SOUND CONTROL IN BUILDINGS

II.21 General

There is a natural sub-division of the subject according to whether the sound in question is transmitted through air, or through structure, or whether a combination of both is involved.

II.22 Reduction of Air-borne Noise

The typical case here under consideration involves reduction of noise in a room, the noise being caused by a radiating source inside the room. Representative sources are typewriters, calculating machines and the general clatter associated with activity in offices, etc.

In the special case of traffic noise, the window may be considered as the source of noise. For variation with size of opening, see Chapter VI.

The procedure for noise reduction involves the introduction of sound-absorbing material in accordance with the principles described below.

For a continuously sounding source in an enclosure, the average energy inside the enclosure, due to the source reinforced by the reflected sound, will build up to a steady maximum value. At this maximum value, energy is being dissipated by absorption, and by transmission through the boundary surfaces, at the same rate as it is being fed from the source.

In the hypothetical case where the enclosure has no absorption, the average energy will build up until the transmission losses through the walls, etc., balance the supply from the source, and a relatively high intensity will result. At the other limit, where

SOME SPECIFIC ACOUSTIC DEFECTS

the boundary surfaces have 100% absorption, a relatively low intensity, due to the source energy alone, will be obtained.

For normal structural finishes, the losses due to absorption are of the order of 100 times the losses due to transmission through the boundary surfaces, and, in consequence, transmission losses may be neglected. Under this condition, the average energy density I inside an enclosure, due to a continuously sounding source is given by :—

$$I = \frac{4E}{cA}$$

where E = source rate of emission,

c = speed of sound in air,

and A = total absorption in enclosure.

Thus, doubling A will halve I , and the expression may be written:—

$$\frac{I_2}{I_1} = \frac{A_1}{A_2}$$

where I_1, I_2 are the final intensities for different conditions of total absorption A_1, A_2 . The intensity reduction in decibels due to the addition of absorbing material is given by:—

$$N = 10 \log \frac{I_1}{I_2} = 10 \log \frac{A_2}{A_1}$$

where the suffix 1 denotes conditions before, and suffix 2 denotes conditions after treatment.

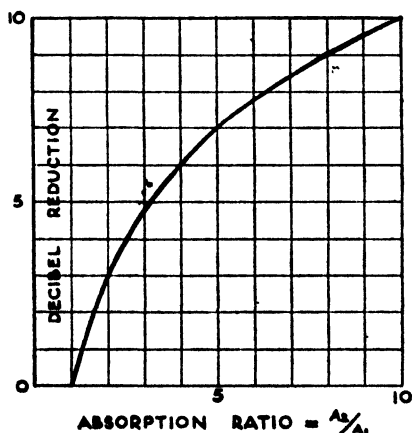

FIG. 9 DECIBEL REDUCTION *v.* ABSORPTION RATIO

Doubling the absorption will therefore produce a reduction of 3 decibels—a fourfold increase, 6 decibels, as shown in Fig. 9.

If a reference frequency for the source is taken at 1,000 c/s, the loudness reduction in phons is numerically the same as the intensity reduction in decibels.

For lower frequencies, a greater loudness reduction can be obtained (see Fig. 3).

To calculate the total absorption A of a room, the areas in square feet of the various surface finishes are multiplied by the appropriate absorption coefficient and summed. A list of representative absorption coefficients will be found in Chapter X.

Where the frequency structure of the noise is known (or estimated), it is economical to choose an absorbing material for treatment which has its peak absorption at the frequency of the loudest, or most annoying, component of the noise.

II.23 Transmission of Air-borne Noise

In an attempt to reduce the transmission of sound from one room to an adjacent room, the problem may be attacked at three points, as follows :—

- (1) by reducing the energy in the first or originating room ;
- (2) by interposing a barrier between the rooms ;
- (3) by reducing the energy in the second room.

(1) and (3) are achieved by introducing sound-absorbing material, chosen, if possible, so that it has maximum absorption at the frequency of that component of the noise which it is most necessary to reduce. The main features of this treatment are discussed above in II.22.

The effectiveness of a barrier (2) is dependant on mass, stiffness, discontinuity and air-tightness. The first three are most significant for low frequency sounds, and the last for high frequency sounds.

It is obvious that the heavier and stiffer a partition, the smaller the distance it will be moved by incident sound energy, and, in consequence, the smaller the radiation on the other side.

The insulation afforded by mass is proportional to the ratio of masses—i.e. a twofold increase of mass, either from 10 to 20 lbs/sq. ft. or from 50 to 100 lbs/sq. ft., produces the same improvement. For this reason, it becomes uneconomic to increase the mass of a partition beyond a certain structural limit. By the use of two separate partitions, completely isolated from each

other, i.e. by discontinuous construction, a considerable advantage may be reaped, because the two insulation values may be approximately added.

High frequency sounds, by virtue of their short wavelength, tend to find their way by tortuous paths wherever cracks or other small openings are found.

The criterion for high insulation against these frequencies is air-tightness.

II.24 Flanking Transmission

When, in the previous section, the interposition of a barrier between source and observer was postulated, it was, of course, inferred that the barrier should be continuous—i.e. that the source, or the observer, should be completely enclosed by it. This is usually the case when one or other or both are contained in rooms.

It is a logical deduction that all parts of the barrier should ideally have the same insulation; otherwise, the poor insulation of the weak section will nullify the high insulation of the more efficient sections. As the total insulation will be determined by the path of least insulation, it is uneconomic to increase the insulation of all paths.

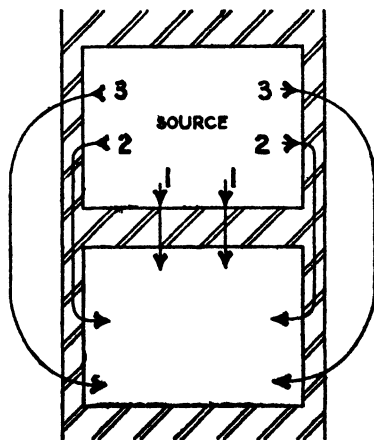

FIG. 10 FLANKING TRANSMISSION

Fig. 10 shows two adjacent rooms, separated by a very heavy partition, and having common side walls of very light

construction. Sound can pass from the source room to the other room through three alternative paths, thus:—

- (1) through the common heavy partition;
- (2) into the side walls of the source room, reappearing later, due to diaphragmatic vibration of the side walls of the other room; and
- (3) through the side walls of the source room, over an air path, and through the side walls of the other room.

If paths (2) and (3) have less insulation than (1), the high insulation of (1) is wasted.

The same type of flanking transmission also takes place through common floors and ceilings, air ducts, etc., so that the common partition cannot register its full insulation until the insulation from all the alternative paths is large compared with this maximum value. This condition may be approximately stated as follows:—

Assume transmission paths through partition and through floor, ceiling and two side walls of listening room and source room (neglect wall opposite partition).

Assume all surfaces of equal area—i.e. cubical rooms.

Assume that the insulation of each surface is proportional to the logarithm of its mass, as stated in II.23.

Assume all surfaces to have identical mass per unit area.

If energy contributed by partition is E , then energy contributed by the four other surfaces may be expressed approximately as $\frac{4E}{2} = 2E$.

$$\text{Insulation loss} = 10 \log \frac{2E}{E} = 3 \text{ db.}$$

Under these conditions, the four other surfaces are contributing between them as much as the partition.

Similarly, when the four other surfaces have four times the mass per unit area, the loss is 1.8 db., and for half the mass per unit area, the loss is 7.0 db.

Now, rather a number of assumptions have been made above; because, while it is quite true to say that the partition cannot behave efficiently while it is short-circuited by other transmission paths, neither is it economic practice to make the partition highly efficient, if this is to necessitate massive structure in the

flanking walls and ceiling. Besides, to provide higher insulation for the flanking walls than for the partition, means that now the partition itself is a weak link in the vertical chain, and will itself provide a flanking transmission path to the rooms above and below the source room.

The use of flanking walls, even as much as four times the mass of the partition, results in a minute increase in overall insulation (3 db. minus 1.8 db.), whereas flanking walls of half the partition weight give rise to a total insulation loss, between rooms, of 7.0 db. The most economical construction occurs when all walls have equal insulation.

Normal building practice, based on 9 in. brickwork, 6 in. hollow tile floors, etc., or their equivalent, with comparatively light construction for non-bearing partitions, puts a limit on the maximum insulation obtainable by traditional methods of about 50 db. at medium frequencies. When greater insulations are required, discontinuous construction is called for.

II.25 Transmission of Vibration through Structures

Vibration will travel long distances through homogeneous structures with very little attenuation; in consequence, the only effective way to reduce transmission is to isolate the source as far as possible by some sort of discontinuous structure.

As mentioned above, a perfectly discontinuous structure cannot be achieved in practice because, ultimately, all structures require support and the discontinuity fails at the points of support. However, the points of support may be so chosen and designed as to give a fair approximation to discontinuity, within certain limits.

The nearest practicable approach to discontinuity is, of course, an air-space which introduces the maximum deviation from homogeneous structure. Smaller, but effective changes in discontinuity are provided by fibrous and granular materials of light density, such as felts, asbestos and cork, while metal springs and resilient materials, like rubber and some corks, provide a special sort of discontinuity which is applied to the design of Mechanical Low Pass Filters.

The air space is effective because it provides a very inefficient coupling between structures—except in the special case of light partitions and small air-gap, discussed in II.27.

Changes in discontinuity of the type provided by felts, mats, etc., are effective because of the resistive dissipation caused by the frictional effects of the relative movement of fibres in the felt. Such materials are moderate couplings.

Low Pass Filters are couplings having very special characteristics. As the name implies, they pass low frequencies and attenuate high frequencies. Their performance is discussed in greater detail below, and particularly in Chapter XI.

An air space may be used to isolate two adjacent partitions, or a ceiling from the floor above. But other means must be found to isolate the two partitions at their base, if they are supported by a common structural floor. Similarly, machinery

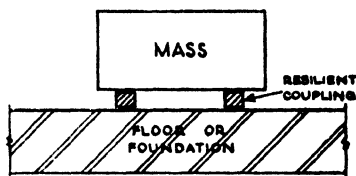

FIG. 11 MECHANICAL LOW PASS FILTER

and like sources of vibration must be isolated from the main structure; in their treatment, felt, cork, rubber or springs (i.e. solids) must provide the discontinuity.

When a mass is connected to another mass *via* a resilient coupling, a Mechanical Low Pass Filter is formed. The structure

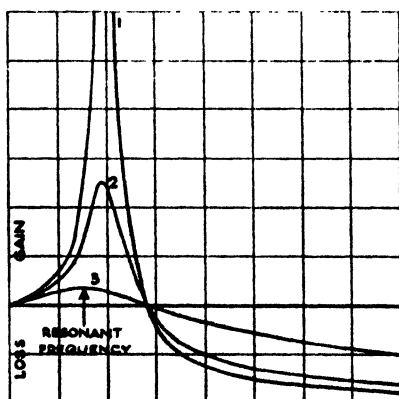

FIG. 12 TRANSMISSION CHARACTERISTICS OF LOW PASS MECHANICAL FILTER

SOME SPECIFIC ACOUSTIC DEFECTS

is shown in Fig. 11. If a source of vibration is applied to one mass, the energy transmitted through the coupling to actuate the second mass is a function of frequency, as shown in Fig. 12, Curve 1. It will be seen that low frequencies are transmitted freely and high frequencies are attenuated, while, at the resonant or natural frequencies, the transmission is greater than it would have been in the absence of the resilient coupling.

Where only those frequencies which are four or five times the resonant frequencies are concerned, the Low Pass Filter is a very efficient isolator. Design should aim at producing a filter where the resonant frequency is well below the frequency of the lowest component of the source under consideration.

If the resilient coupling also has a frictional component, the transmission characteristics are modified to that of Curve 2, where the transmission at the resonant frequency is reduced, and that at higher frequencies is slightly increased. A practical example of this mechanism was exemplified in an early design of motor car suspension, in which the mass of the body was coupled to the mass of the wheels *via* resilient springs, while frictional shock-absorbers reduced the large movement at resonance but increased transmission at high frequencies.

When the frictional component of the coupling is greatest, as in an inert material like a coarse hair felt, the characteristic of Curve 3 results.

A discussion of the properties of materials, in so far as they affect the performance of a Low Pass Filter when used as a coupling, here seems appropriate. That property of a resilient coupling which is of major interest is its "compliance", which is defined as the reciprocal of the "modulus of elasticity", and is a measure of the extent to which the mounting will compress under unit force. In other words, the greater the compliance, the less the stiffness. The greater the compliance, and the greater the mass it supports, the lower will be the resonant frequency, and the greater the insulation at high frequencies.

The other property of interest is the internal resistance of the coupling, i.e. that property which leads to the frictional coupling of the two masses. Usually this should be a minimum, except where it is specially required to reduce the transmission at the resonant frequency.

ACOUSTIC PRINCIPLES

Steel springs form couplings with very small internal resistance, and their compliance can be increased by increasing their length. To double the length of a helical spring is to double its compliance. The relationship is more complicated for multiple leaf springs, but the general principle holds. Rubber pads of small cross-sectional area have small internal resistance, and again, for a given cross-section, doubling the thickness approximately doubles the compliance. Rubber is, however, nearly incompressible, and its compliance is due to a change in shape, not to a change in volume, so that the compliance is greatly reduced for large areas which cannot change their shape appreciably. Cork has a compliance of the same order as rubber, but in general the internal resistance is higher.

Rubber and cork may vary very considerably in compliance and internal resistance. However, for a range of purposes, either material may successfully replace the other.

Hair and fibre felts and blankets usually have small compliance and large internal resistance. They also take a permanent set when loaded, and accordingly are not as a rule suitable as couplings where a Low Pass Filter characteristic is required.

It is sometimes required to combine the high frequency performance of a filter which has small internal resistance, with the smaller transmission at resonance of the heavily damped filter. Such a case would be the isolation of a motor which, on stopping and starting, runs through resonance.

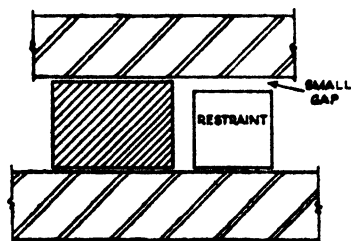

FIG. 13 CONSTRAINT TO LIMIT AMPLITUDE AT RESONANCE

A restraint may be applied, as in Fig. 13, to come into action only when certain amplitudes are exceeded; or the resilient coupling may be shaped as in Fig. 14, so that normally a large

SOME SPECIFIC ACOUSTIC DEFECTS

compliance (or small stiffness) is operative, while large movements will close the gap, increase the cross-sectional area of the couplings and reduce the compliance, thus temporarily removing the natural frequency of the filter to a higher and safer value.

It was stated above that the greater the compliance, the lower the resonant frequency. Now the modulus of elasticity and, therefore, the compliance of a spring is independent of load, except near the physical limits of compression and extension.

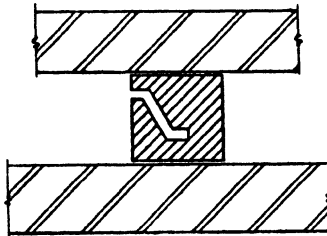

FIG. 14. DIFFERENTIAL COUPLING HAVING TWO VALUES OF COMPLIANCE

The same is not true of rubber, cork, etc., for which the compliance is linear with load up to a limiting value, after which it decreases with load as the limit of deformation is approached (see Fig. 15). This property must be borne in mind when designing filters to have a specific performance.

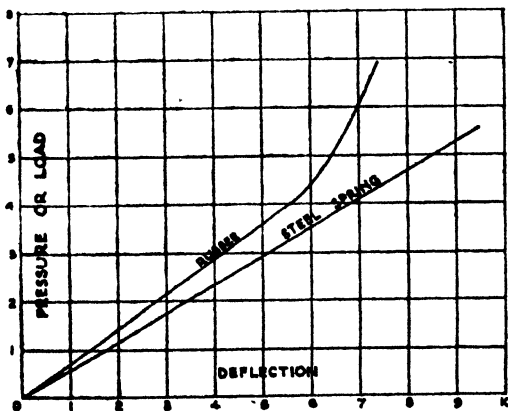

FIG. 15 COMPLIANCE OF STEEL SPRING AND RUBBER

ACOUSTIC PRINCIPLES

So far, consideration has been given to couplings used only in compression. Similar results may be obtained by using compliances in shear or extension, a field where rubber particularly finds many applications. Where sources of vibration are to be mounted on vertical surfaces, a mounting which takes the load in shear eliminates the structural complication of brackets, cantilevers, etc.

Finally, certain generalizations may be made respecting isolation from vibration in structures, as follows:—

- (1) Where possible, the source of vibration should be isolated from the structure by means of an air-space, as in the case of double partitions.
- (2) Where a solid connection is essential to support load, discontinuity of the Low Pass Filter type should be used, bearing in mind—
 - (a) that large compliances and small internal resistance are required to isolate against low frequencies, and large movement; and
 - (b) that large internal resistance is effective chiefly for higher frequencies and smaller movements, and to limit transmission at resonance.

Design data for Mechanical Low Pass Filters is contained in Chapter XI, "Isolation of Machinery".

II.26 Wave Transmission through Structures

In Chapter II.25, consideration was given to the condition where the vibrating sources produce mass movement of the structure, or of a part of the structure.

Energy may also be transmitted in the form of a compression wave through a solid structure, with very little loss, and may re-appear at a remote distance. Such compression waves may be initiated by scratching and by abrasive operations performed on the structure. Typical examples are scuffing of feet on the floor above, the dragging of hard objects across a hard floor, or the hiss arising from steam and water pipes.

The mechanics of wave transmission may be demonstrated by placing a number of pennies in line, so as to touch one another, all except the last being securely held against a flat hard surface. When another penny is moved to strike the first of the

SOME SPECIFIC ACOUSTIC DEFECTS

fixed coins, the free penny will be shot away from the far end of the line.

The rate of energy transmission may be reduced by two methods :—

- (1) by modifying the conditions which give rise initially to the wave transmission; or
- (2) by providing conditions in the path of the transmission which are inconducive to further transmission.

Since noises of an abrasive type are made by the relative movement of two hard surfaces, the originating condition may be considerably modified by superimposing on one of the hard surfaces a soft pliable finish. This is the procedure used when hard floors are covered with carpet or cork.

In optical phenomena, reflection takes place when a ray of light meets a medium of different density, whether it be a mirror or water, or, as in the case of a mirage, air which has a different density due to local heating. The same effects are observed for all forms of wave energy, including light, electricity and sound. The greater the difference in density, the greater is the reflection effect.

An air space represents the greatest change in density from solid building materials, and should be employed where possible. Where a structure has to be supported, however, materials like felt and cork are very effective. This effect is not to be confused with the effect produced when there is mass movement of the supported structure with respect to the supporting structure.

With a sandwich construction, the transmission suffers two reflections—one at each of the boundary surfaces which connect the light density medium to the heavy density medium.

In building construction, this principle finds its chief application in reducing the transmission of abrasive noises through floors, and in the insulation by flexible couplings of plumbing and heating services.

II.27 Coupling of Discontinuous Structures

Two structures side by side, or one above the other, may be coupled together by means of ties, common structures, common supports, plumbing and similar services, or by common air space between them. In other words, “discontinuous structure”

is only a relative term, varying from the maximum discontinuity that can be provided with an air space (subject to the special conditions discussed below), through the intermediate discontinuity provided by resilient pads and mats, to the very small discontinuities at the junction of materials possessing similar density and stiffness.

In general, the lighter the partitions, the more effective is any particular coupling, and the stiffer the coupling, the more effective it is as a coupling. The result in both cases is greater transmission of sound.

The obvious tie between adjacent structures is the usual metal tie which bridges a cavity wall. Suitable ties which give small coupling effect and adequate structural strength can be devised for most constructions (see Chapter III). The pads or mats which support a floating floor on a structural floor function as ties which have, by virtue of the final arrangement, the well-defined transmission characteristics described in Section 25 of Chapter II.

Ties exist when a double-partition construction is bridged by a common door or window frame, and here again design aims at a minimum stiffness in the coupling, commensurate with structural necessity.

Common structure is frequently met with when two flues, one on either side of a cavity wall, vent into a common chimney. Coupling can be reduced by the introduction of a partial discontinuity at that part of the structure where the isolated sections merge into the common structure (see Chapter IV).

Two otherwise structurally-isolated partitions may derive common support from a foundation or structural floor through which they are tightly coupled. This coupling may be reduced by introducing a partial discontinuity where the otherwise isolated partitions rest upon the common structure or foundation. Even in the case of separate foundations, the foundations are coupled through the earth, which is common to both. Where the change from structure to earth, and earth to structure, constitutes only a small discontinuity (e.g., if the foundations are into rock or heavy clay), a stiff coupling results, and little benefit results from separate foundations *per se*.

Plumbing, conduits, etc., may constitute ties between two otherwise isolated structures. To minimise their effect, they

SOME SPECIFIC ACOUSTIC DEFECTS

must be either connected to the separate structures in a discontinuous manner through some soft resilient support, or else a discontinuity must be made in the tie itself, as when a metal water pipe is broken for a short distance with a flexible connection (see Chapter III).

Where two partitions are separated by a narrow air space, the air space itself may have sufficient stiffness to form an efficient coupling between them. What happens, in effect, is that the two masses of the partition, and the elastic coupling of the air space, combine to form a Low Pass Filter of the type described in Section 25 of Chapter II.

Similar transmission characteristics are evident in that there is a resonant frequency for which the insulation is a minimum, below which it is small and above which it is large. The insulation at resonance may be inferior to the insulation of the single partition. (See Chapter III, Table 3).

As would be expected, the resonant frequency reduces as the mass of the partition is increased, and as the distance between the partitions is increased (i.e., as the stiffness of the coupling is reduced). Design should aim at a construction which keeps the resonant frequency well below the frequency of the lowest components of interest.

It will be deduced from the foregoing that couplings between two structures fall into two main categories, viz:—

- (1) those which primarily provide a change of density;
- (2) those which have considerable elastic properties, and are employed to obtain Low Pass Filter effects.

Generally, the former are of major interest for air-borne sound, wave transmission and vibration of small amplitudes, and the latter for vibration at large amplitudes (transients and impacts on the structure). One notable exception is the case of a double-glazed window, where, although the energy of incident noise may be small, the light sheets of glass will develop large amplitudes, and the coupling of the air-space becomes of major importance in its Low Pass Filter role. This point is discussed further in Chapter VI, "The Special Case of Sound-proof Windows".

It also follows that an attempt to improve insulation between partitions by filling the cavity with sound-absorbing material may have the reverse of the desired result, because, if the filling

touches both partitions, it acts as an additional coupling. The criticism applies particularly to light constructions where the coupling is proportionately large.

II.28 Absorption or Insulation?

There is much confusion in the lay mind over the difference between sound-absorbing properties and sound-insulating properties. It is frequently questioned why a sound-absorbing material, of very high efficiency, will not noticeably reduce the transmission of sound.

There is, of course, no reason why it should; the two properties are entirely unrelated. No one expects to obtain much absorption from 6 in. of armour plate. There is as little reason to expect high insulation from a comparatively thin, porous, sound-absorbing treatment applied to a partition.

To consider the matter further—the absorption co-efficient of a material indicates the ability of the material to reduce the loudness of a sound created in the same room, and measured in the same room. The insulating property of a material indicates its ability to reduce the loudness of a noise created in one room and measured in another room, separated from the first by a partition of the material in question.

The fallacy probably arises from the large absorption co-efficient measured for some materials—say, for example, 90%. The unconsidered reaction is that this should make a great difference. The use of sound-absorbing material to reduce the transmission of sound between adjacent rooms is effective only in so far as it reduces the loudness of the sound on one side or other of the partition. Now, as stated in II.22, the loudness reduction of a source due to increased absorption in the same room as the source is given by—

$$\text{Reduction (decibels)} = 10 \log \frac{A_2}{A_1},$$

where A_2 is the total absorption after treatment, and A_1 is the total absorption before treatment.

Thus, if an absorbent treatment is introduced to increase the total absorption in the source room tenfold (a very improbable condition), the loudness of the source will be reduced by only 10 db.

SOME SPECIFIC ACOUSTIC DEFECTS

It should be noted that approximately the same loudness reduction would be obtained by the use of N sq. ft. of co-efficient 0.90, as by $2N$ sq. ft. of co-efficient 0.45. This material may also be located anywhere in the room without appreciably affecting the result.

The reduction in the loudness of the source is independent of the co-efficient of the sound-absorbing material, and of its location; it depends only on the total change of absorption. This reduction is reflected in the loudness of the noise as heard on the other side of a partition, for the sole reason that there is less initial noise available for transmission.

It is hoped that the foregoing will sufficiently demonstrate that sound insulation should not be attempted by employing sound-absorbing materials of even the most imposing co-efficient.

Chapter III

THE SPECIAL CASE OF WALLS AND PARTITIONS

III.1 GENERAL

THE structural purposes of a wall or partition may be two-fold—viz., to act as an enclosure, and to carry loads superimposed from above. Where loads have to be supported, traditional practice calls for a structure of fairly considerable mass, which for this reason normally provides a fairly high degree of acoustic insulation.

In steel frame and reinforced concrete construction, however, the two functions of enclosure and load-bearing are largely divorced, and there is a natural economic tendency to provide light curtain partitions where enclosure or division is required. Because of their low mass, these light partitions, if of monolithic construction, provide poor acoustic insulation.

The first report of the Burt Committee on House Construction (Post-war Building Study No. 1, H.M. Stationery Office) recommends a minimum insulation against air-borne sound, between flats or houses, equivalent to that of a brick wall about 18" thick—namely 55 db. This is confirmed in *The Housing Manual* (1944) and the British Standard Code of Practice for Sound Insulation. If insulations of this order are to be provided in steel frame and reinforced concrete buildings by partitions of such high mass, one of the virtues of this type of building is destroyed.

The economic solution to the problem is to adopt a discontinuous form of partition which combines small mass with relatively good acoustic insulation.

III.2 ACOUSTIC DEFECTS

Transmission of air-borne sound by the diaphragmatic action of a partition, or by alternative routes round the partition, are problems which might arise wherever two rooms are separated by a partition.

WALLS AND PARTITIONS

Consideration should be given to all the routes by which air-borne sound may be transmitted, and the insulation over all paths should be designed for the same value, if the most economic treatment is to be achieved.

Noise or vibration may be transmitted transversely through a partition into the adjacent room, or by other routes into the main structure. The sources may be mounted in or on the partition itself, or may be mounted on a floor, ceiling or other wall which is rigidly connected to the first partition. Frequent sources of structure-borne noise are illustrated in Fig. 16.

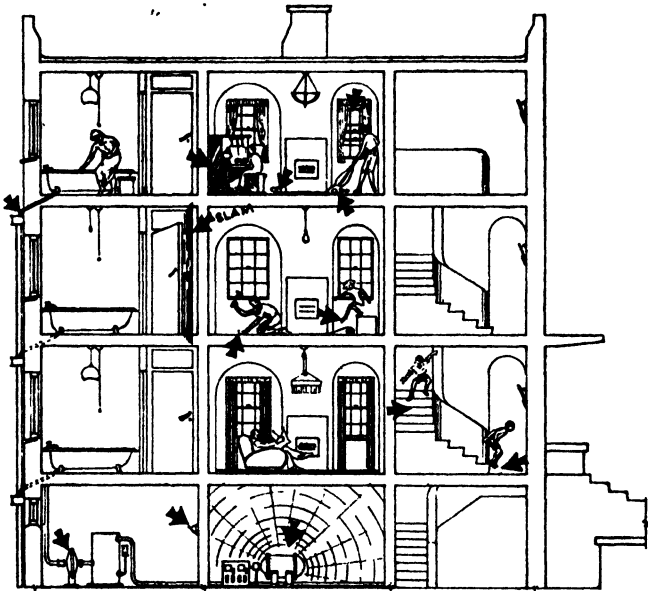

FIG. 16 FREQUENT SOURCES OF STRUCTURE-BORNE NOISE

Vibration should, ideally, be isolated at its source, but where this is unavoidably applied to a partition, the partition itself should be so designed and mounted as to provide maximum isolation from adjacent structures. This will at least ensure that vibration is not transmitted into the structure, but little can be done about transmission through the partition, and radiation into the adjacent room, unless a further partition, isolated from the first, but not necessarily from the structure, is erected as an additional barrier. The point is illustrated in Fig. 17.

ACOUSTIC PRINCIPLES

The sub-division mentioned in II.21 and the statements made in II.28 should be borne in mind, so that, if acoustical (sound-absorbing) material is added on the face or faces of the partition, only limited improvement will be anticipated.

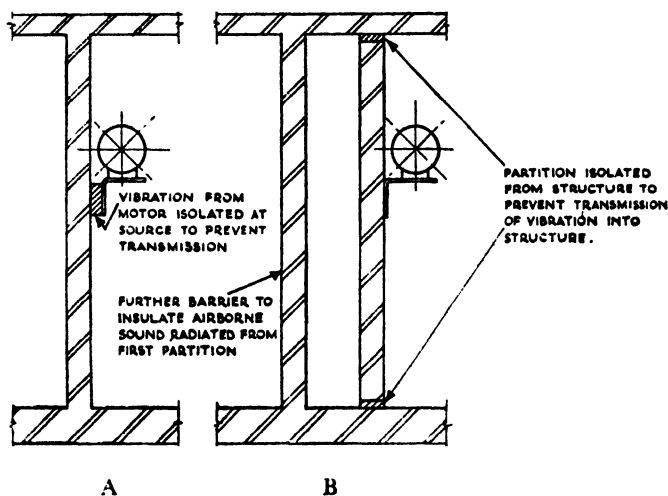

FIG. 17 ISOLATION OF VIBRATION

III.3 REDUCTION OF AIR-BORNE NOISE

III.31 Single Homogeneous Partitions

As mentioned in II.23, the insulation provided by a solid non-porous partition is proportional to the logarithm of its mass—i.e., the improvement achieved by doubling the mass per unit area is constant, whether the change be from 10 to 20 lb. per sq. ft., or 50 to 100 lb. per sq. ft. Thus, for solid partitions, a condition is reached where further increase in the weight per square foot becomes uneconomic. The economic maximum corresponds approximately to 9 in. of brick or 6 in. of concrete. These figures do not apply to porous partitions, through which transmission takes place with little loss *via* the small air passages in the material. If, however, the effects of porosity are nullified by plastering, or otherwise closing the porous surface, the above law holds. A good test of porosity can be made by attempting to blow cigarette smoke through the partition when applying the mouth to the surface.

WALLS AND PARTITIONS

However, it is not so simple to test unplastered brickwork where poor jointing, and even hair cracks, which may form in drying out, can seriously reduce the insulation.

Fig. 18A shows a series of curves for different frequency ranges, relating the insulation value with the mass for a number of solid homogeneous partitions. Mass is plotted (in lb./sq. ft.) on a logarithmic scale, and the resultant approximately straight lines bear out the close relationship of insulation and logarithm of mass.

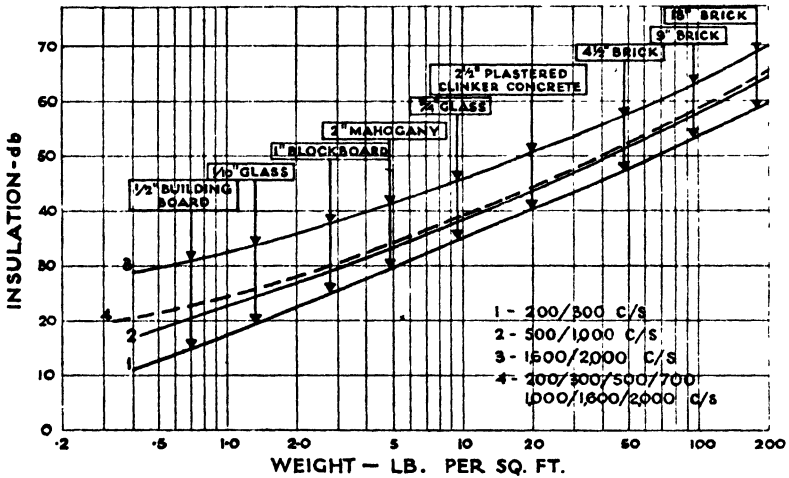

FIG. 18A INSULATION *v.* LOGARITHM OF MASS

These curves are based on measurements made at the N.P.L. involving the oblique direction of sound at a panel size 5 ft. 2 in. \times 3 ft. 10 in. between two isolated rooms lined with sound-absorbing material. (See Method 1 in table below).

Fig. 18B gives in graphical form the results of another series of measurements carried out by means of a later method. The full lines are obtained from the readings of the four materials indicated, and the broken line (average) is based on measurements on nine simple partitions ranging from 1.7 lb. to 95 lb. per sq. ft.

The heavier partitions effect about 6 db. reduction each time the weight is doubled, whereas the lighter partitions effect only 3 db. A reduction of 33 db. for a 10 lb./sq. ft. partition is a convenient value to remember. 45 db. for 4½" brickwork at 45 lb. per sq. ft. is also easily remembered.

ACOUSTIC PRINCIPLES

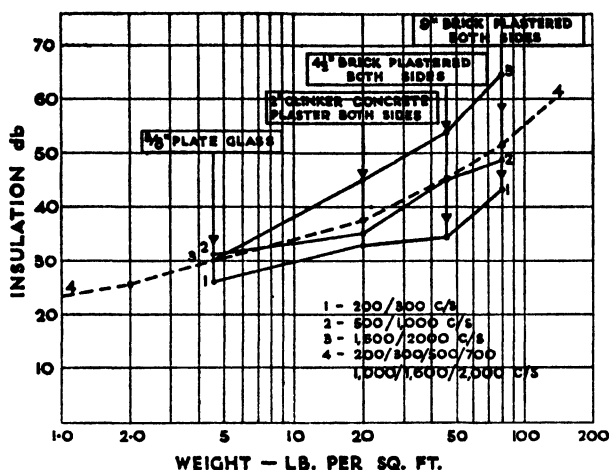

FIG. 18B INSULATION *v.* LOGARITHM OF MASS

This graph is for partitions size 9 ft. 8 in. × 7 ft. 9 in. with randomly incident sound and reverberant rooms on both sides of the test partition (Method 2).

Unplastered breeze (clinker concrete), 3 in. thick, weighing 17 lb. per sq. ft., has the following values and illustrates the necessity for a seal (Method 2):—

<i>Frequency bands</i>	200-300	500-1,000	1,600-2,000
Approximate db. reduction ..	19	22	29

When plastered on one face, $\frac{1}{2}$ in. thick, the following results are found (Method 2):—

<i>Frequency bands</i>	200-300	500-1,000	1,600-2,000
Approximate db. reduction ..	32	40	52

When plastered on both faces (weight of partition 27 lb. per sq. ft.), the results are slightly better and fall well above the mass curve:—

<i>Frequency bands</i>	200-300	500-1,000	1,600-2,000
Approximate db. reduction ..	33	44	56

A list of insulation values is contained in Table 1 of the

WALLS AND PARTITIONS

Appendix following this section, while the main features are listed hereunder:—

Weight of Partition per sq. ft.	Mean Value of Insulation for Frequencies 200, 300, 500, 700, 1,000, 1,500 and 2,000 c/s.	
	Method 1	Method 2
1 lb.	25 db.	20 db. (22)
2	30	25 (26)
5	35	30 (31)
10	40	35 (34)
20	45	40 (38)
40	50	45 (43)
80	55	50 (51)

The above figures are correct to the nearest 5 db., and while, as mentioned before, the absolute values of insulation will depend on local conditions, such as live or dead rooms, the differences of insulation may be fairly exactly applied. Figures in brackets are read off curve 4 Fig. 18B.

An interesting aspect of some light partitions is their disagreement with the log/mass law. Some fall above their appropriate positions on the curve, and some below. The best types might well repay further development with the object of attaining a really useful improvement of say 5—10 db.

III.32 Single Inhomogeneous Partitions

This group is mainly confined to hollow tile constructions, where an air space is contained within a rigid box of small dimensions. Such constructions are not to be confused with cavity walls, which consist of two or more masses substantially separated from each other by an air space, nor with complex partitions which consist of an assembly of materials having different mechanical properties.

This type of partition behaves substantially in the same way as the homogeneous partition, following the logarithmic relationship between mass and insulation. No benefit is conferred by the air-cells within the hollow tiles or blocks, because the outer faces of the tiles or blocks are very rigidly tied by the webs.

A list of insulation values is contained in the Appendix, Table 2.

III.33 Double Partitions

High insulation can be most economically obtained by the use of two or more partitions arranged with minimum coupling

between them, so that the separate insulations of the partitions may be added. Thus if a given partition has an insulation of N db., a solid partition of twice the thickness will have an insulation of approximately $(N+5)$ db. If, however, two partitions, each of insulation N db., are erected to form a double partition, the combined insulation is $(2N-M)$ db., where M is a factor depending on the degree of coupling between the partitions. By proper design, M may be made small.

The partitions may be coupled in a variety of ways, but design should always aim at keeping the total coupling to a minimum. This aspect of construction is now discussed in greater detail.

One unavoidable coupling is the air space between the two partitions, which, for small separations, has considerable stiffness. The heavier the partition and the greater the separation, the smaller the effective coupling. For partitions of the order of 20 lbs. per sq. ft., this separation should not be less than $2\frac{1}{2}$ in. Lighter partitions require a larger separation so that, in a double window of 21 oz. glass, a minimum separation of 6 in. should be obtained, particularly to insulate low frequencies.

Wall ties, as used in the traditional cavity wall, can form a very tight coupling. If ties must be provided, these should have a minimum stiffness compatible with the purpose they have to serve. It must here be borne in mind that the total amount of coupling depends on the number, as well as the nature, of the ties. Galvanized iron strip ties should be avoided in favour of twisted galvanized steel or copper wire ties of 9 to 12 S.W.G.* (according to mass per sq. ft. of partition) at maximum centres. Light sound-absorbent cavity fillings have, at times, been introduced with the desired purpose of "deadening". Where such fillings bridge the gap between partitions, however, they function as ties and only serve to increase the coupling.

With very light partitions and large separation, as in a double window construction, an improvement may be achieved by lining the edges of the cavity with sound-absorbing material. Here the lining does not act as a tie, but neither may it properly be termed a filling.

An absorbent quilt or blanket may be hung in the air space of a cavity construction and, under favourable conditions, may improve the insulation by 5 db. or slightly more.

*B.S. No. 1243.

WALLS AND PARTITIONS

Partitions are coupled together at their edges when they abut on a common wall, floor or ceiling structure; for a given type of joint, the heavier the partition the greater the effective coupling. This edge coupling can be reduced by insulating the edges with a resilient, or porous, material such as cork or felt strips. Obviously, this pliable joint must not be bridged by any form of rendering or plastering, and, equally, the joint

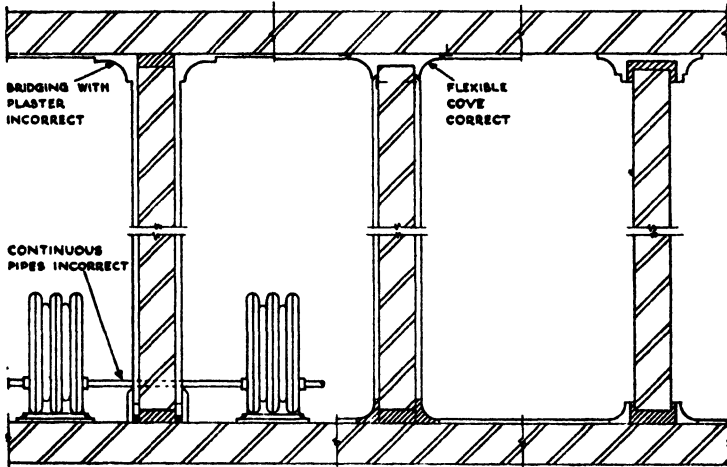

FIG. 19 MARGINAL ISOLATION OF PARTITIONS

must be reasonably airtight to minimise the transmission of high frequency sound through cracks, etc. Felt and cork do not make good-looking joints; if it is considered desirable to conceal them, this should be done in such a manner that the joints are in no way short-circuited. Various methods of insulating partitions from the contiguous floors, walls and ceilings are shown in Fig. 19.

Conditions sometimes arise where adjacent rooms have separate internal partitions (double partitions) but share a common external or corridor wall. Windows to the outside and doors to the corridor are required, as shown in Fig. 20, and it is rarely convenient to have double constructions at these points. Double doors in particular are to be avoided, except in very special cases, where a high insulation is of paramount importance. (Single doors, opening on to a common

ACOUSTIC PRINCIPLES

corridor, provide "double doors" between the rooms.) Tight coupling between the internal partitions and the common wall should be avoided, as in Fig. 20.

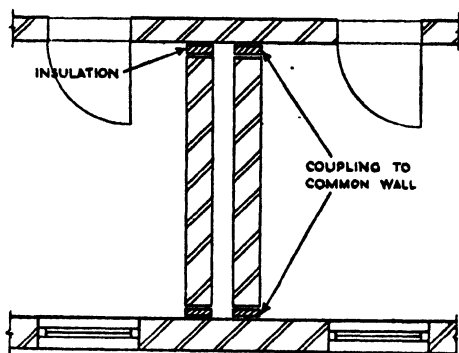

FIG. 20 COUPLING OF SEPARATE PARTITIONS BY COMMON WALLS

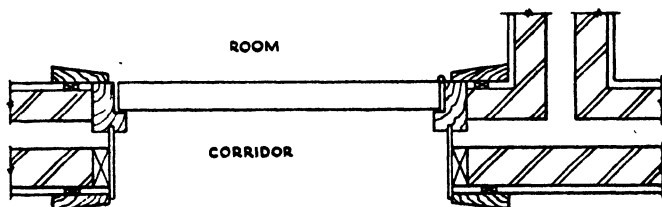

FIG. 21 METHOD OF BRIDGING CAVITIES IN DOUBLE CONSTRUCTION AT DOOR AND WINDOW OPENINGS

Where cavity constructions are pierced by doors or windows, some form of bridging is necessary to conceal the cavity. Coupling at these points may be reduced by isolating the door or window frame from one of the partitions, as illustrated in Fig. 21, or by using sheet metal frames designed to have small

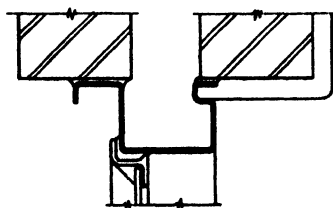

FIG. 22 FRAMES OF LOW TRANSVERSE STIFFNESS FOR BRIDGING CAVITIES IN DOUBLE CONSTRUCTION

WALLS AND PARTITIONS

stiffness in the transverse plane (as shown in Fig. 22). This point is covered further in Section 7 of Chapter V.

Similarly, the two elements of the double construction may be coupled by a common floor or ceiling structure, and attention should be directed to the horizontal joints.

Service pipes passing through cavity partitions should be insulated, by means of felt or some similar material packed between the pipes and the structure, and rendered reasonably airtight against the transmission of high frequencies. Moveable control rods must sometimes pass through both partitions; flexible diaphragms or glands provide the solution, according to the direction of movement. Ducts frequently form a coupling and should not pass directly through double walls.

When chimneys and flues are integral with double partitions, as in the case of adjacent living rooms with fireplaces back-to-back, some complication arises if it is required to vent into a common stack. Coupling may here be reduced by interposing a resilient mat below the point at which the separate structures are joined. Similar mats (e.g. asbestos) may be introduced below hearths and behind fire-backs to localise the noise caused by tending the fire.

Insulation values for typical cavity constructions are listed in the Appendix, Table 3. Note particularly the comparison with Single Homogeneous Partitions of the same mass, given (in brackets) in the last column.

III.34 Complex Partitions

Complex partitions have discontinuous structures of varying complication, and may or may not include an air-space between two elements, as in the case of the simple cavity wall.

A common form is the Stud Partition, in which non-porous surfaces (such as plaster on lath, plaster boards, fibre boards, etc.) are applied to both sides of a rigid stud framework. Such a partition may be constructed so as to have considerable stiffness, and in consequence will tend to introduce a fairly high insulation at high frequencies. Its performance at low frequencies is, however, largely determined by its mass per unit area, as with homogeneous partitions. With increasing mass, the difference between high and low frequency insulation will tend to become less.

When the two facing surfaces are separately mounted on separate studding, an increased performance results, due to

ACOUSTIC PRINCIPLES

the highly discontinuous nature of the structures, which then possess the additional virtue of the cavity wall. As with cavity walls, this increase should be greater for heavier construction, and for wider separations between the two elements.

Good insulation is achieved—equivalent to double studding—by applying felt strips to the studs and fixing plaster board with nails passing between the sheets and through a large washer of expanded metal. The usual precautions must be taken to prevent cracks occurring in the skim coat of plaster which is subsequently applied.

It is a common practice, with double studding, to stagger the two lots of studding in plan, so as to reduce the overall thickness of the partition; this inevitably results in a loss of insulation, due to the tighter coupling between the two elements.

Little purpose is served by using a cavity filler between the facing surfaces of a stud partition, unless the filler materially increases the mass per unit area of the assembly; the increased coupling balances the increased mass for most constructions.

The insulation of a complex partition may be slightly increased by attaching further elements, either by means of additional studding and non-porous surfaces, or by applying other surfaces through furring strips to the original surfaces. Similarly, complex structures may be combined with simple homogeneous structures, as when light non-porous surfaces are combined with brick or concrete partitions through studding, furring strips or, in an attempt to provide minimum coupling, through insulated clips.

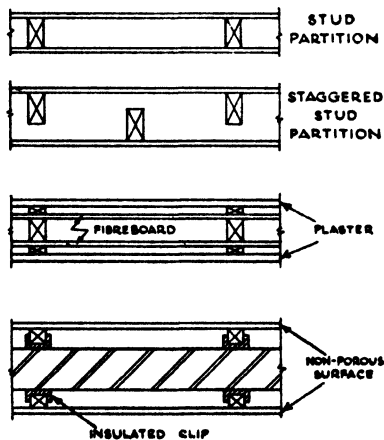

FIG. 23 TYPICAL EXAMPLES OF COMPLEX PARTITIONS

Typical examples of complex partitions are shown in Fig. 23. Insulation values for a number of partitions are listed in the Appendix, Table 4.

III.4 OTHER CONSIDERATIONS

III.41 Effective Insulation

The extent to which the sound in one room is reduced in an adjacent room is not entirely a function of the insulation of the partition dividing the rooms.

As mentioned in II.22, a steady source of sound will build up until the intensity in an enclosure reaches a maximum value determined by the total absorption in the enclosure. Thus a given partition will appear more "soundproof" when transmitting into a large, heavily-damped room than into a small reverberant room. Similarly, a large partition will transmit a greater quantity of energy than a small one, for the very obvious reason that there is a larger area doing the same amount of transmitting per unit area.

The relative insulation values may, however, be safely applied for similar constructions over a wide range of panel sizes. For dissimilar constructions (e.g. a solid masonry panel and a stud partition), it should be borne in mind that insulation is due to a combination of mass per unit area and to stiffness—the former being a constant for any given type of construction and the latter varying with the linear dimensions. Hence an assessment of the relative performance of very dissimilar constructions cannot safely be made from a knowledge of their relative performance in largely dissimilar panel sizes. Relative performance is not, of course, affected by conditions on either side of the partition.

III.42 Flanking Transmission

Flanking transmission has been discussed in II.24, and is another factor which modifies the performance of partitions. The leakage of air-borne sound is of special interest where adjacent rooms, isolated by means of inner partitions or shells, ventilate into a common court, or have doors giving access to a common hall or corridor. Air ducts ventilating into a common trunk often provide an easy transmission path over considerable distances unless steps are taken to prevent this (see Chapter VII).

Where door or window frames are improperly designed, and they bridge the inner partitions of the separate rooms to a

common corridor or external wall, structure-borne noise will be experienced. These frames are frequently the weakest links in the chain, and it becomes uneconomic to increase the insulation at other points much beyond that provided in the poorly-insulated places.

III.43 General

As in other connections, the acoustic performance of partitions will depend largely on the detail workmanship. Poorly-made joints in bricks and slabs, cracks, intended cavities bridged by plaster and cement, short-circuited isolating strips, etc., can reduce insulation values by large amounts.

The transmission of sound through the structure of wholly monolithic buildings appears to be rather greater than in buildings comprising a variety of materials. The numerous changes in density offer resistance to sound transmission, hence brickwork tends to be better than concrete, and breeze partitions resting on a concrete floor give slightly less trouble than a concrete wall under the same conditions. The corresponding improvements are, however, slight.

III.5 REDUCTION OF VIBRATION

Vibration may be transmitted into a partition in two ways:—

- (1) by a source of vibration mounted thereon, or
- (2) from another wall, floor or ceiling, to which it is rigidly connected.

Thereafter the partition may either

- (1) radiate acoustic energy into the room on either side, or
- (2) transmit vibration into other structures to which it is rigidly connected.

Sources of vibration, such as fans, motors, pumps or cisterns, should be isolated from structures, as discussed in Chapter XI. The ideal method is to tie the source down to a heavy mass, which is then coupled *via* resilient mountings to another heavy mass, to produce Low Pass Filter characteristics.

Partitions are not, as a rule, very massive, and sources of vibration should, where possible, be mounted on the greater mass of the floor; where the floor itself is built on Low Pass Filter principles, then the source may be rigidly fixed thereto.

To avoid the transmission of vibration into a partition from other parts of the structure, the partition should be isolated by

WALLS AND PARTITIONS

some kind of discontinuous joint at its edges, and should be mounted on a resilient material. Where the partition supports the source of vibration, it is necessary to prevent transmission into the rest of the structure by similar discontinuous jointing and mounting. Where the source of vibration mounted on the wall has other connections to the structure apart from the connection through the partition as in the case of a pump connected through pipes, or a fan connected through ducting, some discontinuity in the pipes or duct, in the form of a flexible joint, should be introduced between source and structure. Pipes, conduits, etc., which traverse a partition may be isolated therefrom by means of felt-lined clips, or other specially-designed flexible supports. If such services, in addition to sources of vibration, are also liable to radiate air-borne noise, they should be suitably enclosed.

III.6 APPENDIX

TABLE 1

TRANSMISSION OF AIR-BORNE SOUND THROUGH HOMOGENEOUS WALL SPECIMENS

- Note 1.* Measurements made at the N.P.L. on panels 5 ft. 2 in. × 3 ft. 10 in. between two isolated rooms lined with sound-absorbing material, and with incident sound directed obliquely at the Test Panel.
- Note 2.* This method of test has the effect of giving results approximately 5 db. greater than those obtained by employing the later method with larger partitions.
- Note 3.* Figures in brackets are insulation values measured off the curves in Fig. 18A for a single homogeneous panel of the same mass (average for different materials).

Description of Test Partition			Average Sound Reduction for Frequencies (cycles per second)			
Construction	Weight (lb./sq. ft.)	Thickness (in.)	200 & 300	500, 700 & 1,000	1,600 & 2,000	200, 300, 500, 700, 1,000, 1,600 & 2,000
			db.	db.	db.	db.
Ankardboard insulating board	0.64	$\frac{1}{4}$	15 (14)	21 (21)	31 (31)	22 (22)
Treetex insulating board	0.69	$\frac{1}{4}$	15 (15)	23 (22)	31 (31)	23 (23)
Lloyd wall board	0.77	$\frac{1}{4}$	20 (16)	25 (22)	32 (32)	26 (23)
Plywood	1.0	$\frac{1}{2}$	18 (18)	24 (24)	35 (34)	26 (25)
21 oz. window glass	1.3	$\frac{3}{8}$	20 (19)	27 (25)	37 (35)	28 (26)
Balsa wood panel	1.9	$1\frac{1}{8}$	18 (22)	23 (27)	34 (36)	25 (28)
Gaboon faced block board	2.7	1	26 (25)	27 (30)	38 (38)	30 (31)
Plate glass	3.8	$\frac{1}{2}$	28 (28)	33 (32)	45 (40)	35 (32)
Mahogany	4.9	2	28 (30)	36 (34)	44 (42)	36 (34)

ACOUSTIC PRINCIPLES

TABLE 1—continued

Description of Test Partition		Average Sound Reduction for Frequencies (cycles per second)				
Construction	Weight (lb./sq. ft.)	Thickness (in.)	Average Sound Reduction for Frequencies (cycles per second)			
			200 & 300	500, 700 & 1,000	1,600 & 2,000	300, 300, 500, 700, 1,000, 1,600 & 2,000
Wood-fibre slabs plastered on both faces . .	13.1	2	db. 36 (37)	db. 39 (41)	db. 42 (48)	db. 39 (41)
Cellular anhydrite blocks	14.3	3	39 (38)	42 (42)	52 (48)	44 (42)
Cellular anhydrite blocks plastered on both faces with Pioneer plaster . .	16.8	3½	40 (39)	48 (43)	50 (50)	46 (43)
3 in. Eonite blocks plastered on both faces . .	20.4	3¾	40 (40)	47 (45)	50 (51)	46 (45)
2½ in. clinker concrete, plastered on both faces	20.7	3½	40 (40)	47 (45)	52 (51)	44 (45)
Lignocrete composition bricks, lime-plastered on both faces . .	34.0	5¾	48 (44)	53 (49)	56 (54)	52 (50)
4½ in. Fletton brick, plastered on both faces (lime mortar, lime and sand plaster)	44.0	5½	46 (47)	50 (51)	58 (56)	51 (52)
4½ in. Fletton brick, plastered on both faces (cement mortar, hard plaster)	46.0	5½	45 (47)	51 (51)	59 (57)	52 (52)
4 in. reinforced concrete	50.8	4	45*	50†	58§	—
3 in. clinker concrete slab, plastered both sides on fibre board stuck to slabs	27.0	—	—	—	—	45 (47)
3 in. dense concrete, plastered both sides on fibre board stuck to concrete	45.0	—	—	—	—	50 (52)
4½ in. brick, plastered both sides on fibre board stuck to brick . .	47.0	—	—	—	—	53 (52)
9 in. panel of Portland cement and "foamed" slag, rendered on one face with cement and sand and plastered on the other with Sirapite	56.8	9¾	44 (49)	48 (54)	60 (58)	51 (54)

* For 300 cycles per second only.

† Mean for 500 and 1,000 cycles per second.

§ For 2,000 cycles per second only.

WALLS AND PARTITIONS

TABLE 2
SINGLE INHOMOGENEOUS PARTITIONS

- Note 1.* Measurements made at the N.P.L. on panels 5 ft 2 in. × 3 ft. 10 in. between two isolated rooms lined with sound-absorbing material, and with incident sound directed obliquely at the Test Panel.
- Note 2.* This method of test has the effect of giving results approximately 5 db. greater than those obtained by employing the later method with larger partitions.
- Note 3.* Figures in brackets are insulation values measured off the curves in Fig. 18A for a single homogeneous panel of the same mass (average for different materials).

Description of Test Partition		Average Sound Reduction for Frequencies (cycles per second)				
		Weight (lb./sq. ft.)	Thickness (in.)	200 & 300	500, 700 & 1,000	1,500 & 2,000
Plycrete partition blocks plastered on both faces	16.4	3½	db.	db.	db.	db.
Hollow tiles, lime- plastered on both faces	21.0	4½	38 (39)	45 (43)	48 (50)	43 (43)
3 in. hollow clay blocks, glazed on one face and plastered on the other	22.4	3¾	42 (41)	42 (45)	48 (51)	44 (45)
3 in. hollow clay blocks, plastered on both faces	23.2	3¾	42 (41)	48 (45)	48 (51)	46 (45)
4 in. hollow clay blocks, plastered on both faces	26.5	4¾	40 (42)	46 (46)	48 (52)	45 (46)
4 in. hollow clay blocks, plastered on both faces	26.5	4¾	41 (42)	46 (46)	48 (52)	45 (47)
Terra-cotta partition blocks	27.6	—	39*	46†	58‡	—
Hollow tiles, lime- plastered on both faces	27.7	4½	44 (43)	50 (47)	47 (53)	47 (48)
Fletton cellular bricks ..	31.8	—	40*	48†	56‡	—
4 in. Cranham blocks, plastered on both faces	37.0	6½	44 (46)	52 (48)	56 (54)	51 (50)

*For 300 cycles per second only.

†Mean for 500 and 1,000 cycles per second.

‡For 2,000 cycles per second only.

ACOUSTIC PRINCIPLES

TABLE 3 DOUBLE HOMOGENEOUS PARTITIONS

Measurement on panels 5 ft. 2 in. × 3 ft. 10 in. with oblique incident sound. Figures in brackets are for a solid partition of same mass (see Fig. 18A). *Note large drop in insulation at low frequencies as critical small separation is approached; for small separations, double construction behaves like solid partition of same mass. (Authority: Constable & Aston, N.P.L.)

Description of Test Partition			Sound Reduction for Frequencies (cycles per second)			
Construction	Weight (lb./sq. ft.)	Thickness (in.)	200 & 300	500, 700 & 1,000	1,600 & 2,000	200, 300, 500, 700, 1,000, 1,600 & 2,000
2 sheets of $\frac{1}{2}$ in. fibre board, separated by 24 in. air space	1.5	25	db. 33 (20)	db. 46 (26)	db. 65 (35)	db. 48 (27)
Double windows of 21 oz. glass with 8 in. separation	2.6	$8\frac{1}{16}$	40 (24)	52 (29)	66 (38)	53 (30)
Ditto, 2 in. separation ..	2.6	$2\frac{1}{16}$	23 (24)	49 (29)	64 (38)	46 (30)
*Ditto, $\frac{3}{4}$ in. separation ..	2.6	$\frac{11}{16}$	19 (24)	41 (29)	64 (38)	41 (30)
Ditto, $\frac{1}{2}$ in. separation ..	2.6	$\frac{1}{16}$	24 (24)	27 (29)	50 (38)	33 (30)

TABLE 3—continued

Measured on panels 9 ft. 8 in. × 7 ft. 9 in. with reverberant sound. Figures in brackets are for a solid partition of same mass (see Fig. 18B). ¹Note increased insulation due to reduced coupling between leaves at edges. *Note that conditions are substantially restored. (Authority: Constable & Aston, N.P.L.)

Two 2 in. clinker concrete slabs with 2 in. air space, plastered on outer faces	33	7	db. 45 (34)	db. 46 (41)	db. 56 (50)	db. 49 (42)
¹ As above, but edges of each leaf insulated with $\frac{1}{2}$ in. cork, unbridged by plaster	33	7	48 (34)	52 (41)	64 (50)	54 (42)
*As above, plastered over cork on both leaves ..	33	7	46 (34)	44 (41)	58 (50)	48 (42)
Two 3 in. clinker concrete slabs with 2 in. air space, plastered on outer surface	40	9	44 (34)	49 (44)	60 (52)	51 (44)

WALLS AND PARTITIONS

TABLE 3—continued

Measured on panels 9 ft. 8 in. × 7 ft. 9 in. with reverberant sound.
 *Note results for Single Holoplast Partition, below the log/mass curve, and variation on this material giving progressive improvement over the corresponding figures in brackets. (This investigation was carried out by the Author with the assistance of the National Physical Laboratory and the Building Research Station.)

Description of Test Partition			Sound Reduction for Frequencies (cycles per second)			
Construction	Weight (lb./sq. ft.)	Thickness (in.)	200 & 300	500, 700 & 1,000	1,600 & 2,000	200, 300, 500, 700, 1,000, 1,600 & 2,000
*Single Holoplast Partition, consisting of 2 sheets of material each $\frac{1}{8}$ in. thick bonded together with webs at 2 in. centres ..	2.4	1	db.	db.	db.	db.
Double Holoplast partition with 2½ in. spacing	4.8	4½	19 (24)	22 (29)	26 (25)	22 (26)
Double Holoplast partition with 5 in. air spacing	4.8	7	20 (27)	31 (31)	40 (30)	31 (30)
Double Holoplast partition with 5 in. air spacing	4.8	7	24 (27)	33 (31)	40 (30)	33 (30)
Double Holoplast partition with absorbent blanket between panels ..	5.2	4½	32 (27)	38 (31)	46 (30)	38 (30)
Double Holoplast partition filled with sawdust cement, absorbent quilt in air space	12	4½	43 (31)	49 (34)	48 (40)	47 (36)
Ditto, but each Holoplast partition filled with foamed slag sand in place of sawdust cement	11	4½	43 (31)	51 (34)	60 (39)	51 (35)
Ditto, but each leaf filled with dry sand	18	4½	48 (33)	58 (36)	65 (44)	57 (38)

ACOUSTIC PRINCIPLES

TABLE 4 COMPLEX PARTITIONS

- Note 1.* Measurements made at the N.P.L. on panels 5 ft. 2 in. × 3 ft. 10 in. between two isolated rooms lined with sound-absorbing material, and with incident sound directed obliquely at the Test Panel (Constable & Aston).
- Note 2.* This method of test has the effect of giving results approximately 5 db. greater than those obtained by employing the later method with larger partitions.
- Note 3.* Figures in brackets are insulation values measured off the curves in Fig. 18A for single homogeneous panels of the same mass (average for different materials).

Description of Test Partition	Average Sound Reduction for Frequencies (cycles per second)					
	Weight (lb./sq. ft.)	Thickness (in.)	200 & 300	500, 700 & 1,000	1,600 & 2,000	200, 300, 500, 700, 1,000, 1,600 & 2,000
A layer of $\frac{1}{2}$ in. fibre board on each side of a frame of wood, with 1 in. air space between layers ..	1.9	2.0	17 (22)	35 (27)	56 (36)	36 (28)
As above, 3 in. space between layers	2.6	4.0	23 (24)	43 (29)	62 (38)	42 (30)
A layer of $\frac{1}{2}$ in. fibre board on each side of 4 in. × 2 in. studding at 12 in. centres	4.5	5.0	24 (29)	42 (33)	56 (41)	41 (34)
A layer of $\frac{1}{2}$ in. Insulwood on each side of 4 in. × 2 in. studding at about 14 in. centres	4.3	5.0	27 (28)	40 (32)	58 (41)	42 (33)
A layer of $\frac{3}{4}$ in. Insulwood as above	5.2	5.5	30 (30)	37 (34)	50 (42)	39 (35)
2 layers of $\frac{1}{2}$ in. Insulwood on one side and one layer of $\frac{1}{2}$ in. Insulwood on other side of 4 in. × 2 in. studding at 14 in. centres	5.2	5.5	30 (30)	42 (34)	62 (42)	45 (35)
2 layers of $\frac{3}{4}$ in. Insulwood and one layer of $\frac{3}{4}$ in. Insulwood as above ..	6.2	6.25	26 (31)	45 (35)	61 (44)	44 (36)

WALLS AND PARTITIONS

TABLE 4—continued

Description of Test Partition		Average Sound Reduction for Frequencies (cycles per second)				
Construction	Weight (lb./sq. ft.)	Thickness (in.)	200 & 300	500, 700 & 1,000	1,600 & 2,000	200, 300, 500, 700, 1,000, 1,600 & 2,000
Staggered 4 in. × 2 in. studding with one layer of ½ in. Insulwood on one side, and on the other 2 layers of ½ in. Insulwood separated by 2 in. × ¾ in. fillets. Studs on 14 in. centres	7.3	7.0	db.	db.	db.	db.
As above, but ¾ in. Insulwood	8.4	7.75	38 (33)	47 (36)	68 (44)	50 (37)
As above, but ¾ in. Insulwood	8.4	7.75	36 (33)	49 (38)	78 (45)	54 (37)
A layer of ½ in. Insulwood on each side of 4 in. × 2 in. studding at 14 in. centres. One face plastered ¾ in. thick ..	11.6	5.75	38 (36)	46 (40)	60 (46)	47 (40)
As above, but ¾ in. Insulwood	12.2	6.25	36 (36)	46 (40)	66 (47)	49 (40)
As above, but ½ in. Insulwood and plastered both faces	18.8	6.5	42 (40)	51 (44)	62 (50)	52 (44)
As above, but ¾ in. Insulwood	19.3	7.0	44 (40)	52 (44)	67 (50)	54 (44)
1 in. matchboarding on 4 in. × 2 in. studding at 12 in. centres ..	5.4	5.0	28 (30)	24 (34)	31 (42)	27 (35)
Lath and 3 coat lime plaster on each side of 4 in. × 2 in. studding at 12 in. centres ..	16.4	6.0	38 (39)	45 (43)	63 (50)	48 (43)
As above, but hard plaster	17.0	5.5	43 (39)	54 (43)	63 (50)	53 (43)
A layer of 1 in. wood wool slabs on each side of 3 in. × 2 in. staggered studding at 16 in. centres. Each leaf and its studding insulated by ½ in. felt. Outer faces plastered ½ in. thick ..	21.9	9	52 (41)	54 (45)	66 (51)	57 (45)

Chapter IV

THE SPECIAL CASE OF FLOORS AND CEILINGS

IV.1 GENERAL

THE primary purpose of a floor is structural in that it has to support loads. Mass and stiffness are, therefore, inherent properties of a floor.

In blocks of flats, offices and multi-storeyed buildings generally, the usual Fire Precaution Laws call for a fire-proof construction; the practical interpretation of this requirement usually involves the use of an impervious material like concrete, and the final construction has fairly considerable mass and stiffness, and provides reasonably good insulation against air-borne noise.

The officially-recommended value for the reduction of air-borne sound through party floors is, as for party walls (see III.1), 55db.—i.e. the equivalent of 18" of brickwork.

This minimum requirement is closely approached in many forms of concrete floor, but it should be emphasised that:

- (1) it is a minimum requirement for working-class flats, and
- (2) to improve the insulation by increasing the mass is an uneconomic procedure.

The major defects of floors arise in connection with Impact Noises, Vibration and Wave Transmission, to which solid structures are particularly susceptible. The magnitude of the defects is specially aggravated in blocks of flats, where the floor is a main division between separate units. The convenient buffering arrangements which can be adopted in plan cannot be applied to the vertical relationship, and, in general, "the people upstairs" are more of a nuisance than the neighbour next door.

IV.2 LIST OF ACOUSTIC DEFECTS

IV.21 Transmission of Air-borne Noise

Transmission of Air-borne Noise through hollow-tile and concrete floors is usually the least of their shortcomings, and

minimum recommended values may be obtained without complicated construction.

When normal structural floors are properly modified by discontinuous construction to insulate against impact noises and vibration, the final assembly will provide a higher degree of insulation against air-borne noise. Similarly the use of a correctly-designed suspended ceiling will increase the performance of the floor above by a substantial amount. As in the case of partitions, flanking transmission up and down side walls will reduce the effective insulation of a floor, and the points mentioned in II.24 should be borne in mind.

Wood joist-and-board construction, with plaster, plaster board or fibre-board ceiling beneath, does not properly come within the scope of the discussion, since such construction is adopted with full realization of its traditional limitations. However, it is possible to improve this construction by "pugging" and other measures.

IV.22 Transmission of Structure-borne Noise and Vibration

The major sources of trouble are due to impact noises and vibration, which cause movement of the floor with consequent radiation from the lower surface into the room beneath. Typical examples of impact noises are footsteps, the dropping of hard and heavy objects on the floor, the "thump" of a piano or radio, the filling of cisterns, baths, and the use of w.c.'s, slamming of doors, and sometimes the operating of vacuum cleaners and electric switches. Common sources of vibration which differ from impact effects, chiefly by virtue of their continuous nature, are motors, engines and rotating and reciprocating gear generally. Abrasive sources of the type described in II.26 result in wave transmission of energy through the floor.

Sources of impact noise are usually accompanied by energy in the form of wave transmission. The proportion of energy resulting in mass movement of the floor to that resulting in wave transmission depends largely on the surface hardness of the floor and of the impacting object.

The floor surface is also of importance in connection with the room of which it forms the floor, because it contributes to the total absorption of the room, and also provides a source of noise to that room when subjected to impact or abrasion.

IV.3 AVOIDANCE AND CURE OF DEFECTS

IV.31 The Case of Pure Vibration (as due to out-of-balance forces of the type set up by rotating and reciprocating machinery)

The method of attack should be determined by the magnitude and frequency of the vibration, but is sometimes conditioned by special local requirements.

In general, where the movement is large and of low frequency, the Low Pass Filter is probably the only effective device, as discussed in Chapter XI.

For small movements and high frequencies, the energy may be dissipated resistively as discussed in II.25, or a combination of the two methods may be adopted, by the use of a highly-damped resilient mounting. This rather special aspect of floor insulation is, however, properly the province of Machinery Isolation, under which heading it is discussed in Chapter XI.

IV.32 The Case of Impact Forces accompanied by Wave Transmission

This case caters for the conditions commonly met with in floor construction, where it is required to reduce the transmission of the two usual types of noise—that initiated by mass movement of the floor, due to the impact of footsteps and other heavy objects, and the wave transmission produced by the frictional effect of abrasive sources.

Experience has proved that massive concrete and hollow tile floors have negligible insulation value in regard to impact noise. Some small degree of insulation may be obtained by covering such floors with a soft surface (e.g. carpet, rubber or felt) which partially dissipates the energy before it reaches the structural floor. In theory, a floor covering could be provided which was soft enough, and deep enough, to provide all the insulation required, but it would be a quite impracticable finish in all other respects.

For all practical purposes, then, it may be stated that all concrete floors are equally bad, and that no significant difference can be measured between them, and that normal floor coverings are of negligible use as insulation against impact noises, but will considerably reduce abrasive noises.

The solution to the problem of impact noises must be sought in some form of discontinuous structure. A highly satisfactory

FLOORS AND CEILINGS

arrangement is based upon the Mechanical Low Pass Filter (see II.25). In practice, this is realised by a floating floor isolated from the structural floor by means of a suitable compliance, such as rubber.

When a soft surface finish is applied to the floating floor, good insulation is obtained for the wave transmission of abrasive sources—first by dissipation in the soft surface, and then by partial reflection where there is a change of density at the junctions of the floating and the structural floors with the compliance.

As was shown in II.25, the Low Pass Filter may be designed with various degrees of damping, from the pure compliance of springs and small sections of rubber, to the highly-resistive fibrous mat which unites floating and structural members over the whole area available for contact. Generally, the lightly-damped construction is the more efficient if it is designed to suit the particular conditions.

The two versions of the floating floor are shown diagrammatically in Fig. 24. In both cases, the greater the mass of the floating floor, the smaller its movement in response to a given force, and, therefore, the less amplitude available for transmission through the coupling to the structural support. In the case of the pure compliance (Fig. 24A), the energy is largely confined to the circuit of the floating mass and the supporting compliance.

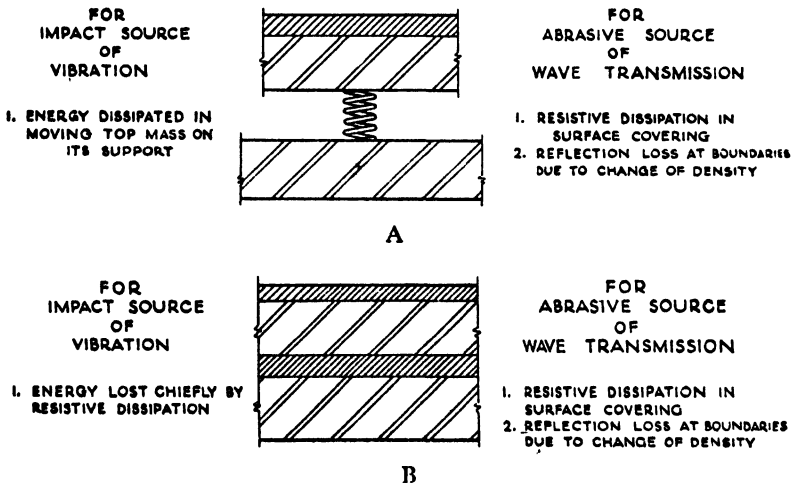

FIG. 24 TYPES OF FLOATING FLOORS

For the highly-damped condition (Fig. 24B), energy is chiefly dissipated by resistive methods in the mat, due to the frictional losses caused by relative movement of the mat fibres or granules.

In both cases, abrasive noises are reduced—firstly, by the soft floor covering, and secondly, by the partial reflection at the boundary surfaces, where there is a change of density from floating floor to air, and air to structural floor (Fig. 24A), or from floating floor to mat, and mat to structural floor (Fig. 24B).

Where a durable wearing surface to the floating floor is required, such as hardwood or granolithic, the conditions for transmission of abrasive noises are not so satisfactory; but the reflection losses are so large as to provide adequate insulation for all but the most unusual cases. This is particularly true where there is a large frictional component in the material which supports the floating floor.

Reverting to the subject of air-space, a few words should be added to explain the importance of an adequate separation between floating and structural floors. The structural elements of a Low Pass Filter are connected by means of a compliance, where the compliance is the reverse of stiffness. The greater the compliance (i.e., the less the stiffness), the more efficient is the filter. But a thin sandwich of air, of large area, can have very large stiffness. With air-gaps between the structural elements of $\frac{1}{2}$ in., and for areas of the order of 100 sq. ft., the stiffness of the air will be much greater than the stiffness of the ideal compliance. The effect of the tighter, or stiffer coupling is to increase the resonant frequency of the Filter (see II.25)—i.e., its performance in the attenuation range of frequencies is reduced. As will be seen from Table 1 in the Appendix to this Chapter, for floors of normal area this separation should not be less than 2 in.

It is obvious that the floating element of a floor should not be tightly coupled to the main structure at those points where the floor abuts against walls and partitions, which are themselves tightly coupled to the structure. At the same time, the joint between the floating element and the structure should be reasonably airtight, otherwise the additional insulation to air-borne noise, which is provided by the floating floor, will be reduced (Fig. 25). Fig. 26 shows the arrangement where the partitions are mounted on the floating floor. This design is adopted for the highest practicable insulation; for air-borne sound, about 80 db. reduction may be obtained by this means.

FLOORS AND CEILINGS

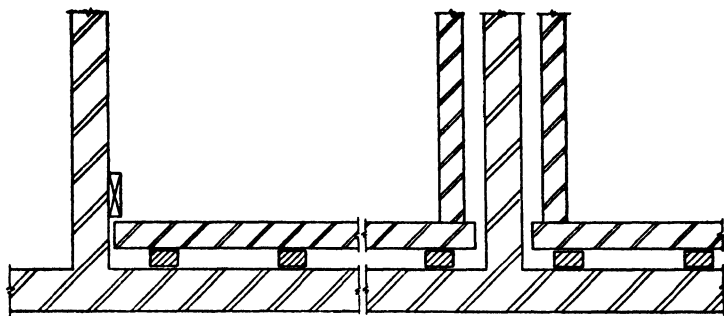

FIG. 25 JOINT BETWEEN FLOATING FLOOR AND STRUCTURAL WALL

FIG. 26 PARTITIONS CARRIED ON FLOATING FLOORS

IV.4 MEASUREMENT OF INSULATION VALUES

Methods of measuring insulation values for impact noise have not yet been satisfactorily determined. In the simple case of air-borne noise, the intensity may be measured on both sides of the floor in the same units. The magnitude of an impact may be stated only in terms of the force applied, the impacted and impacting masses, and the hardness and stiffness of the impacting object and the impacted floor. The end effect of all these quantities is a transmitted noise whose magnitude and frequency may be measured, for a given condition, in quite different units. Supposing this were done, little purpose would be served by a statement to the effect that a mass M_1 , of hardness H_1 falling with a velocity v , on to a floor of area a , mass M_2 and hardness H_2 , will produce a noise spectrum of frequencies F_1, F_2, F_3 , having intensities I_1, I_2, I_3 , in a room of volume V and absorption A . In consequence, an arbitrary and approximate method of describing the insulation of a soundproof floor has been devised, in which the performance of a test floor is compared with the performance of a concrete floor of similar shape and area. The technique involves the application of standard impact forces, first to a concrete floor, then to a "soundproof" floor of similar dimensions. The difference in the loudness of the two noises, as measured in similar rooms below the two floors, is taken as a figure of merit for the soundproof construction. Since all concrete floors, whether of hollow tiles, filler joists, or any similar construction, have

similar performance for impact noises, the method is reasonably accurate, and different observers evince close agreement. The standard impact forces are of two types—one due to a hard heavy object which produces a high proportion of energy in the form of wave transmission, and the other due to a soft-covered object which produces an impact source accompanied by negligible energy in the form of wave transmission. The weight of impact is approximately equal to a heavy footstep in each case. Thus the performance of the soundproof construction is assessed in terms of the two kinds of sources which are of greatest interest, and the results may be expressed in the convenient term of “ phons ” improvement over standard concrete construction. The Burt Committee Report on House Construction (see III.1) recommends minimum insulation values for impact and abrasive noises, measured in the manner described above, of 15-20 phons better than a standard concrete floor.

IV.5 FLANKING TRANSMISSION

With floors, as with partitions, flanking transmission can reduce the effective insulation. If use is to be made of the additional insulation of the floating floor in regard to air-borne sound, it is not enough to insulate the floating section of the floor at its edges, where it abuts against walls and partitions; because, although this will prevent transmission of vibration from the floating floor into the structure directly, it will not similarly affect air-borne sounds. As pointed out in III.42, the different paths for air-borne transmission (directly through the floor, or by flanking transmission down walls and partitions, or through common ventilating systems, etc.), should all have similar insulation values. Fig. 27 shows diagrammatically various flanking paths which might reduce the insulation of a floor in regard to air-borne noise.

Similarly, for impact and abrasive sources, no rigid ties should unite the floating section of the floor to the structure. Service pipes, for instance, should be attached to the structure, and, where they rise through the floating floor, they should be isolated therefrom by adequate clearances, packed with felt or some similar fibrous material, to provide a good seal against air-borne noise. Fig. 28 illustrates a few of the possible leakage paths.

FLOORS AND CEILINGS

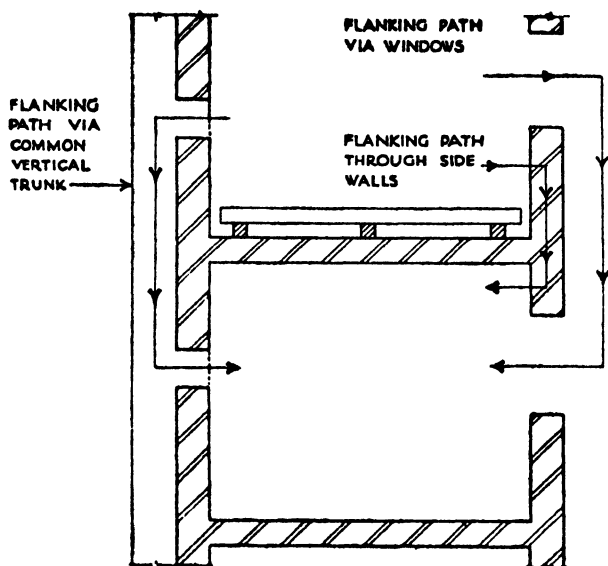

FIG. 27 FLANKING TRANSMISSION PATHS AFFECTING FLOATING FLOORS

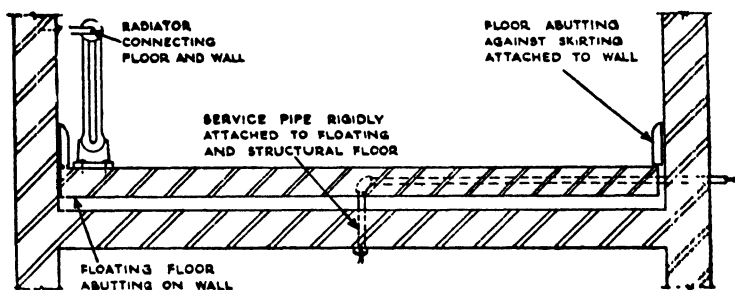

FIG. 28 INSULATION OF SERVICES FROM FLOATING FLOORS

IV.6 TYPICAL FLOORS

Fig. 29 shows a floating floor which consists of a heavy concrete raft, isolated from the structural floor by means of small cubes of rubber. This method of construction has been patented by the Building Research Station, and involves—

- (1) The laying of impervious paper, lapped at joints, over the entire structural floor.
- (2) The setting, at calculated intervals, of lengths of screwed barrel piping.

ACOUSTIC PRINCIPLES

- (3) The pouring of a concrete screed over the impermeable paper, to the level of the tops of the screwed barrel (and reinforced as required).
- (4) When the concrete has set, wooden cubes are first inserted and then jacks are inserted through the screwed barrel at appropriate intervals, and the screed is lifted to the designed height. The jacks and cubes are withdrawn one at a time; rubber cubes are inserted to replace the wooden cubes, and plugs are screwed into the barrels to bear on the rubber.

By this method, the floating slab is lifted clear of the structural floor and the loading of the rubber may be adjusted in accordance with the design requirements.

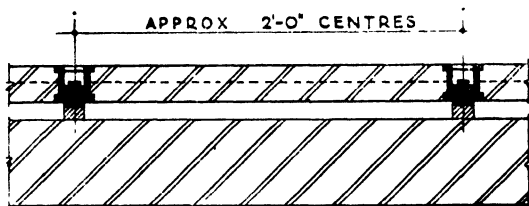

FIG. 29 B.R.S. FLOATING FLOOR

Fig. 30 shows another patented form of floating floor—the C.S.S. Here battens are laid on rubber blocks, spaced at the design intervals and fixed to them. Loading slabs of concrete are placed between the battens, clear of the structural floor, and below the top of the battens. These loading or inertia slabs are essential to provide the Low Pass Filter requirements of two heavy masses connected by a large compliance. A normal T. & G. flooring is then nailed transversely across the battens. Where

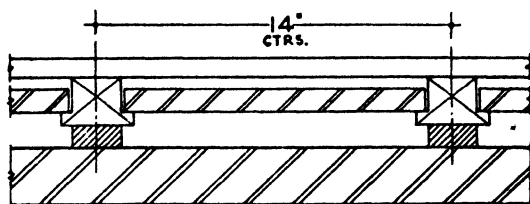

FIG. 30 C.S.S. FLOATING FLOOR

FLOORS AND CEILINGS

it is required to reduce the "hollow" sound of an uncovered board floor, the T. & G. boarding is nailed to the batten with a sandwich of corrugated cardboard, or similar material, to damp the resonance of the board flooring.

The concrete loading slabs perform such additional functions as preventing warp and twist in the battens, reducing bounce in the floor, and reducing the proportion of live load.

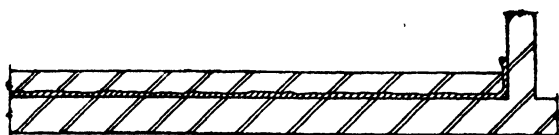

FIG. 31 RAFT FLOOR

Fig. 31 shows the construction of the highly-damped type of floating floor, in which a fibrous or granular mat is laid over the structural floor, covered with impermeable paper, lapped at the joints to prevent leakage of concrete, and then a screed poured over the mat to the required thickness. The fibrous or granular mat should be of such a robust nature as not to take an excessive permanent set, due to breakage of fragile fibres or deformation of granules, and the mass of the floating section of the floor should be large compared with any loads that will be superimposed (in order that the design consideration shall apply for all conditions of loading). Suitable wire reinforcement of the floating slab is necessary.

Orthodox building practice usually calls for a concrete screed cast on the surface of the structural concrete. A floating concrete screed may be employed instead, at a cost not much in excess of the cost of the resilient mat.

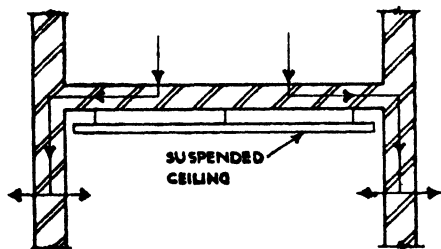

FIG. 32 SUSPENDED CEILING

IV.7 SUSPENDED CEILINGS

Where increased insulation to air-borne sound is required, the discontinuous structure of a floor and a suspended ceiling may be quite efficient. As in the case of double partitions, of which a floor and ceiling assembly is only a special case, the mass of the ceiling should be as great as possible, and the suspension (i.e. coupling) should have minimum stiffness commensurate with other requirements. For impact and abrasive noises, however, it cannot compete with the floating floor.

Fig. 32 shows a ceiling suspended beneath a structural floor. It will be obvious that, however many ceilings are suspended beneath the floor, impact and abrasive noises will be transmitted into the structure, to re-appear elsewhere. The suspended ceiling can reduce only the air-borne noise due to radiation from the lower face of the floor.

To recapitulate, suspended ceilings are effective insulators of air-borne sounds, and obey much the same laws as discontinuous partitions. They are incapable, however, of reducing vibrational energy transmitted into the structure.

Table 3 in the Appendix to this Chapter shows the extent to which a suspended ceiling will reduce the radiated sound from the soffit of a floor (whether this be solid or floating).

IV.8 APPENDIX

Insulation Gain due to various finishes superimposed on a Reinforced Concrete Floor, as measured by the National Physical Laboratory.

Note 1. The "Insulation Gain" due to a finish is the amount by which the noise set up in a room below the floor, caused by blows on the upper surface of the floor, differs from the noise produced in a similar manner by blows on the bare concrete floor.

Note 2. The blows are applied automatically by a machine which causes hammer heads of weight $1\frac{3}{4}$ lb. approximately to fall through a height of approximately 2 in. The hammers are faced with a hard ebonite surface or with rubber, to produce the different types of impact blows commonly met with in practice. The magnitude of the blow is greater than that of the blow caused by a man "marking time" in heavy rubber boots. The blows are delivered at the rate of 4 per second.

TABLE 1
CONCRETE FLOORS

Group Type	Details of Superimposed Finish or Construction	Insulation Gain	
		Dull Blows	Sharp Blows
		phons	phons
Simple coverings	1. None ; cement screed ; tiles ; granolithic ; terazzo ; or other hard finish	0	0
	2. $\frac{1}{4}$ in. linoleum with or without bitumen backing	0-5	5
	3. $\frac{1}{4}$ in. sheet rubber ; $\frac{1}{8}$ in. Axminster carpet ; $\frac{1}{2}$ in. linoleum on $\frac{1}{8}$ in. cork underlay	5	10
	4. $1\frac{1}{4}$ in. Douglas fir blocks	5	10
	5. $\frac{1}{8}$ in. Axminster carpet on $\frac{1}{4}$ in. underfelt ; $\frac{1}{4}$ in. rubber-cork	10	10
	6. $\frac{1}{8}$ in. rubber-cork on $\frac{1}{8}$ in. sponge rubber-cork	10	15
	7. 1 in. rubber cubes at various spacings and loadings, space between structural and floating floors 2 in. (loads on rubber 20-160 lb. per sq. in., pads spaced on 1 ft. 6 in. centres to 4 ft. centres)	25	25
	8. Ditto, space between structural and floating floors 1 in.	20	20
	9. Ditto, space between structural and floating floors $\frac{1}{2}$ in.	10	15
	10. $\frac{3}{4}$ in. (nominal) glass silk quilt, single layer	20	20
11. Ditto, double layer	25	25	
2 in. concrete resting on	12. $\frac{1}{2}$ in. (nominal) celgrass quilt, single layer	15	20
	13. Ditto, double layer	20	20
	14. $\frac{1}{2}$ in. (nominal) slag wool blanket, double layer	15	20
	15. $\frac{1}{4}$ in. asbestos fabric	10	15
	16. $\frac{1}{8}$ in. underfelt	5	10
	17. 2 in. bed of loose clinker	5	10
	18. 2 in. bed of loose clinker on $\frac{1}{8}$ in. underfelt	10	15
	19. 2 in. bed of mixed clinker and granulated cork	10	15
	20. 1 in. bed of granulated cork	10	15
	21. 1 in. steel wool pads (12 in. by 6 in.)	15	15
	22. $\frac{1}{2}$ in. wallboard composed of wood shavings and cement, on 1 in. steel wool pads	15	20
	23. 1 in. kapok, pads or layer, damp and dry	15-20	15-20

TABLE 1—continued

Group Type	Details of Superimposed Finish or Construction	Insulation Gain		
		Dull Blows	Sharp Blows	
3 in. concrete resting on	24. 1 in. rubber cubes, space between structural and floating floors 1 in.	25	25	
	25. Bare floor	0-5	10	
	26. Felt pads 1 in. thick	10	15	
	27. Asbestos fabric pads $\frac{1}{2}$ in. thick	5	15	
	28. Fibreboard pads $\frac{1}{2}$ in. thick	5-10	10	
	29. Rubber pads $\frac{1}{2}$ in. to 1 in. thick loaded 15-45 lb. per sq. in.	10-15	15-20	
	30. 6 in. by 6 in. by $\frac{1}{2}$ in. thick pads or 6 ft. by 6 in. by $\frac{1}{2}$ in. strips of wallboard composed of wood shavings bound with cement*	0-5	10	
	Wood raft of 1 in. boards on 2 in. by 2 in. battens resting on	31. 6 in. by 6 in. pads or 6 in. wide strips of $\frac{3}{4}$ in. (nominal) glass silk quilt, in double thickness*	10-15	20
		32. $\frac{3}{4}$ in. (nominal) glass silk blanket, single layer*	10-15	20
		33. Ditto, double layer*	15-20	20
34. $\frac{1}{2}$ in. (nominal) slag wool blanket, single layer*		5-10	15-20	
35. Ditto, double layer*		10	20	
36. $\frac{1}{2}$ in. eelgrass quilt, single or double layer*		10	20	
37. 3 in. bed of loose clinker		0-5	10	
38. 3 in. bed of course clinker on $\frac{1}{2}$ in. eelgrass quilt		15	25	

* Load on insulator 0.33—1.33 lb. per sq. in.

TABLE 2
TIMBER FLOORS

Construction or Finish	Insulation Gain	
	Dull Blows	Sharp Blows
	phons	phons
1. Normal floor, but with 8 in. depth of slag wool pugging laid on ceiling	3	3
2. Normal floor with 3 in. to 6 in. deep pugging of ashes laid on wood trays fixed between joists	5	5
3. Normal floor, but floor boards replaced by raft floor of $\frac{7}{8}$ in. boards on 2 in. by 2 in. battens resting on eelgrass blanket laid across the joists	5	10
4. As 3, but with glass silk blanket instead of eelgrass	10	10

TABLE 2—continued

Construction or Finish	Insulation Gain	
	Dull Blows	Sharp Blows
	phons	phons
5. As 2 (3 in. ashes), but floor boards replaced by raft floor resting on sheets of $\frac{1}{2}$ in. fibreboard laid across joists or on small pads of fibreboard nailed to joists	5	10
6. As 2 (3 in. ashes), but with the addition of a raft floor resting on eelgrass blanket laid on the floor boards	10	10
7. As 6, but glass silk instead of eelgrass blanket ..	15	15

TABLE 3
SUSPENDED CEILINGS

Floor or Ceiling Finish	Approximate Insulation Gain as heard from below (to nearest 5 phons)		
	Leather-faced Mallet	Impact Machine shod with	
		Rubber	Hard Fibre
	phons	phons	phons
CEILINGS :			
Expanded metal and $\frac{1}{2}$ in. plaster on battens held in felt-lined clips Plaster continuous with walls.	15	10	—
Plastered ($\frac{1}{4}$ in.) fibre board ($\frac{1}{2}$ in.) on battens held in felt-lined clips Plaster continuous with walls.	10	10	—
Plastered ($\frac{1}{4}$ in.) fibre board ($\frac{1}{2}$ in.) on joists resting on rubber pads on corbels in side walls Plaster stopped back at edges.	10	10	15
CEILINGS AND FLOATING FLOORS, combined :			
Concrete slabs (2 ft. by 2 ft. by $1\frac{1}{2}$ in. thick, lino covered) on 1 in. cubes of rubber loaded to 40-50 lb. per sq. in. (floating floor)*, plus plastered ($\frac{1}{4}$ in.) fibre board ($\frac{1}{2}$ in.) on battens held in felt-lined clips(ceiling) Plaster continuous with walls.	30	30	30

* Loads include an estimated "live load" for impact machine or operator.

Chapter V

THE SPECIAL CASE OF DOORS

V.1 GENERAL

IT would be nice to develop from first principles, and in a logical series of consecutive steps, a general formula or specification for soundproof door and window construction. Unfortunately, the subject does not lend itself to this convenient type of treatment. The different details of construction are so intimately related that minor changes to one usually involve consequent changes in one or more of the others. It is, therefore, proposed in this Chapter to enumerate those general design principles which demand special and particular attention, and then to discuss the pertinent aspects of constructional detail.

A high degree of insulation is sought by the application, where possible, of the usual principles of discontinuity, airtightness, mass and stiffness; it is achieved only by particular attention to detail, especially in the matter of seals at edges which abut against the structural wall or partition. A construction which is not airtight is not soundproof. The most difficult seal to contend with is at the sill of a door which has to cater also for wear and tear by traffic.

The importance of a tight seal cannot be too frequently stressed; good design—for doors particularly—turns chiefly on this one feature.

V.2 TYPES OF DOOR SEALS

Seals are usually provided by arranging that the door shall be closed into its frame against some soft material, usually rubber. Various methods of construction are shown in Fig. 33.

Fig. 33A shows a door of rectangular section closing against pads of felt or rubber which form an airtight, and therefore soundproof, seal. A high degree of precision in construction is necessary to ensure that the face of the door is in intimate contact with the pad over its entire length. Because of the large

THE SPECIAL CASE OF DOORS

area involved, the pressure necessary to produce minimum compression of the pad for adequate seal must be considerable, and a heavy strain will be put upon the fittings. Unless the door is exceptionally rigid, closing pressure must be applied at a number of points to eliminate gaps in the seal due to small distortions in the door. The problem of maintaining the close tolerances for tight fit is still graver. In fact, the method is not a good one.

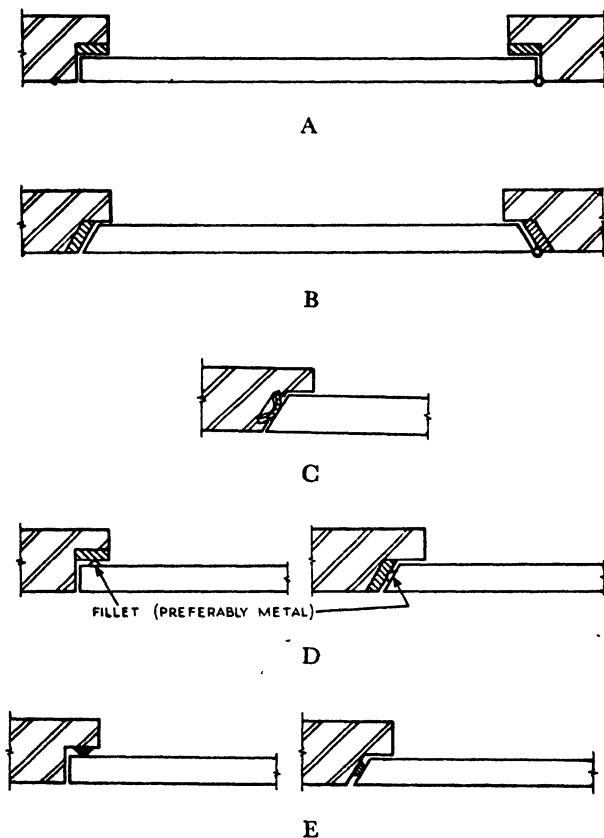

FIG. 33 DOOR SEALS

Fig. 33B shows door and frame with splayed butting surfaces. Less pressure is required for tight closure because of the oblique incidence of the contact surfaces, but again a high degree of precision is necessary to obtain—far less retain—an accurate

fit. In addition, there will be a large amount of friction between the door and the rubber on the closing stile, so that, in the final analysis, this modification offers little or no advantage over the construction of Fig. 33A.

Fig. 33C shows a rather complicated arrangement in which the rubber pad is bowed outwards to provide a softer contact which calls for less rigid constructional tolerances. The device serves chiefly as an example of the lengths to which effort can be mis-directed in the search for a good seal. However, a serviceable sill seal may be developed on these lines.

Fig. 33D shows a really useful modification to the construction of Figs. 33A and 33B in which, by the use of small fillets of semi-circular or triangular cross-section, the pressure required for closure is reduced considerably. Because the pads can be compressed to a greater extent over the small area of contact, the tolerances controlling the fit of the door in its frame may be relaxed.

Fig. 33E shows a modification of Fig. 33D which follows rather naturally, in which the rubber itself is made in the form of a strip of semi-cylindrical or triangular section, and against this a flat section is closed.

All the constructions discussed above suffer from one or more of certain inherent disadvantages. These may be listed as follows:—

- (1) The seal is completely invisible and the presence of a defect therein cannot be detected.
- (2) A fragile and impermanent finish results when the strip of rubber on the closing stile, and at the head and sill, has an edge exposed to abrasion.
- (3) In all the arrangements shown, a very limited compression is available resulting in, at the best, inconveniently small tolerances.

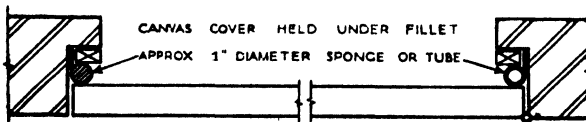

FIG. 34 RUBBER TUBE SEAL

These disadvantages are largely overcome by the simple and cheap construction of Fig. 34, where the seal is provided by

THE SPECIAL CASE OF DOORS

closure against a rubber tube of about 1 in. dia., and $3/32$ in. wall thickness, protected by a canvas cover (which also acts as a fixing). A right-angled return on both stiles and on sill and head provides a simple abutting surface all in one plane. The rubber tube is run continuously round the door frame to eliminate awkward joints at corners. The raised sill need have only minimum dimensions, while the canvas-bound pipe will be long-lasting and may easily be replaced. The chief advantage is probably the ability to observe compression of the tube and therefore to check the efficiency of the seal. Deformation of a protruding solid rubber strip provides a similar seal.

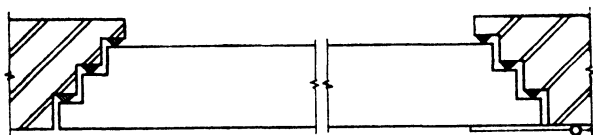

FIG. 35 MULTIPLE REBATE

Multiple seals may be used as shown in Fig. 35, provided that the significance of such multiplication is fully understood. The only legitimate reason for increasing the number of seals is to ensure that there is at least one complete and effective seal. It does not follow—in fact it is quite untrue—that two seals are twice as effective as one. The function of a seal is to close the air path to passage of the high frequencies, and, once this has been efficiently accomplished, little practical benefit is to be derived from repeating the process. A multiple seal does, however, cater for the case where, for one reason or

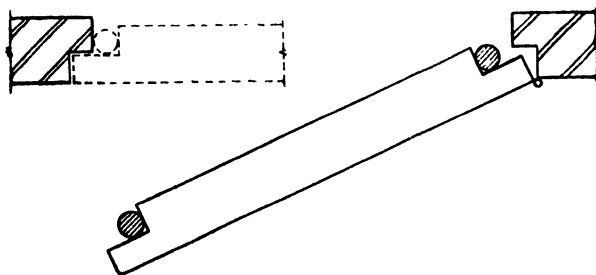

FIG. 36 SEAL ON DOOR

Note continuous seal located safely in rebate of door with seal proud, so that compression of same can be observed when door is closed.

ACOUSTIC PRINCIPLES

another, there is an imperfection in one of the seals. It is unlikely that gaps in different seals will be coincident, unless the whole door is warped, badly designed or poorly hung.

Provided that sound energy, in passing from one side of a door to the other, is compelled to follow a long and tortuous path, lined with sound-absorbing material, this may itself function as an adequate seal. With hinged doors this method is usually impracticable but it is frequently employed for sliding doors (under which heading it is discussed in greater detail).

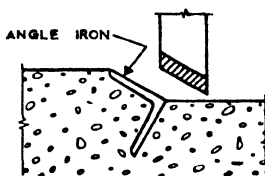

FIG. 37 SEAL TO SILL

Section at sill showing splayed panel, covered in felt, closing on door frame constructed of angle iron. Note durable construction of threshold when seal is applied to door panel.

Thick doors (6 in. or more), with splayed, felt-covered, edges on all four sides, may seal reasonably for the reason stated above. However, the soft surfaces are liable to be damaged and, at the foot particularly, to collect dirt and grit, so that the arrangement may become unhygienic and lose efficiency, as well as suffer the disadvantage of a clumsy appearance.

The arrangements shown in Figs. 36 and 37 have advantages in some applications.

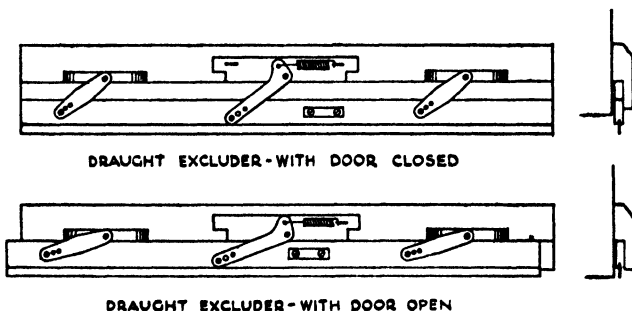

FIG. 38 DRAUGHT EXCLUDER SEAL

THE SPECIAL CASE OF DOORS

The mechanism which, in the simple draught excluder of Fig. 38, forces an external element downwards to complete a seal, may be modified to depress a seal under the bottom rail or to rotate an eccentric which in turn makes a seal under the bottom rail. This would obviate any sort of raised sill. Such a seal should be capable of taking up wear in the threshold; it must also form a continuous seal, or provide an airtight joint with the vertical seals on the closing and hanging stiles.

V.3 PROTECTION OF SEAL PADS

The best seal is obviously obtained with the use of a soft pad which, for a given pressure, will deform farther than a hard pad, thus relaxing tolerances on fit. At the same time, these pads are subject to shear and abrasive forces imposed by the closing and opening of the door against them, and to general wear and tear if in exposed positions.

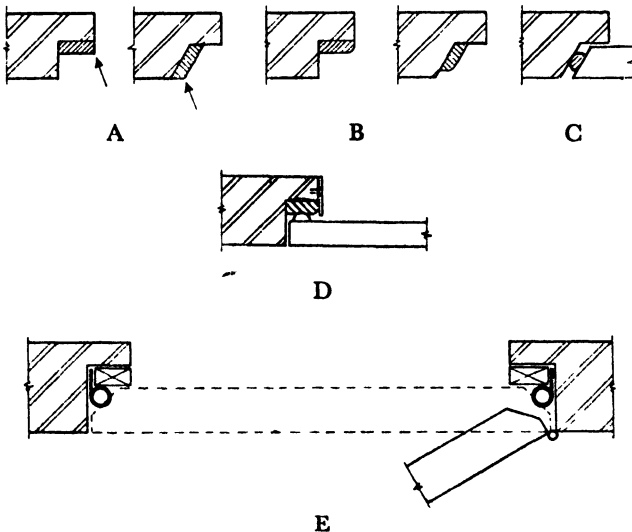

FIG. 39 PROTECTION OF SEAL PADS

Referring to Fig. 39, arrangements A are very liable to damage at the edges marked with an arrow. Arrangements B offer a small improvement as edge forces tend to be deflected tangentially, while a small setback removes the edge slightly from harm's way. The arrangement C is an extension of these two principles, and, by applying the pad to the door instead

of the door frame, damage due to traffic at the sill may be avoided. (In this connection, it is again emphasized that the seal must be aligned on all four edges to eliminate open joints at corners). At D, a strip protects the edge of the rubber, but leaves the seal completely invisible.

The logical development towards a soft and durable seal finds expression in the rubber tube construction at E, where a small initial pressure will produce a large deformation, while the assembly is inherently capable—especially if bound with canvas—of withstanding much mechanical abuse. The virtue of the arrangement resides primarily in the fact that, for small pressures, the resulting small deformation in shape imposes a negligible strain on the construction. Even heavy trucking operations, provided they only produce a deformation in shape, will not damage the sill seal. After the shape deformation has been carried to the limit, there will be considerable resistance to any further compression, and it is at this point that strain is imposed on the assembly. For sealing purposes, it is unnecessary to apply pressures of this magnitude.

Where soft felt is employed on the edges, as mentioned previously, some protection is given by a covering of canvas, hessian or similar fabric. It must be porous enough to permit the absorption of sound on which this method generally relies, and soft enough to bed well into the corners.

V.4 HINGES

Types of hinges are illustrated in Fig. 40. Fig. 40A shows the common butt hinge supporting a door which follows the construction of Fig. 33B. Certain disadvantages are immediately apparent, as follows:—

- (1) No seal may be arranged over the hinge itself. Since horizontal and vertical seals must be aligned in order to preserve the seal at corners, the space available for the construction of a seal (where the seal is applied as shown in Fig. 40A), is limited to the thickness of the door, less the width of the butt hinge. Butt hinges are traditionally dimensioned to support doors having a mass appropriate to a thickness just exceeding the width of the hinge; so either one has a multiplicity of hinges, or tailor-made hinges, or else one endeavours to cram the seal into what usually proves to be an inadequate space.

THE SPECIAL CASE OF DOORS

- (2) Even with the arrangement shown, closing at an angle, there is considerable tension on the hinge screws when the door is closed against the pressure of the seal. The screws are usually pulled loose, especially with the rather heavy construction that normally goes with soundproof doors.

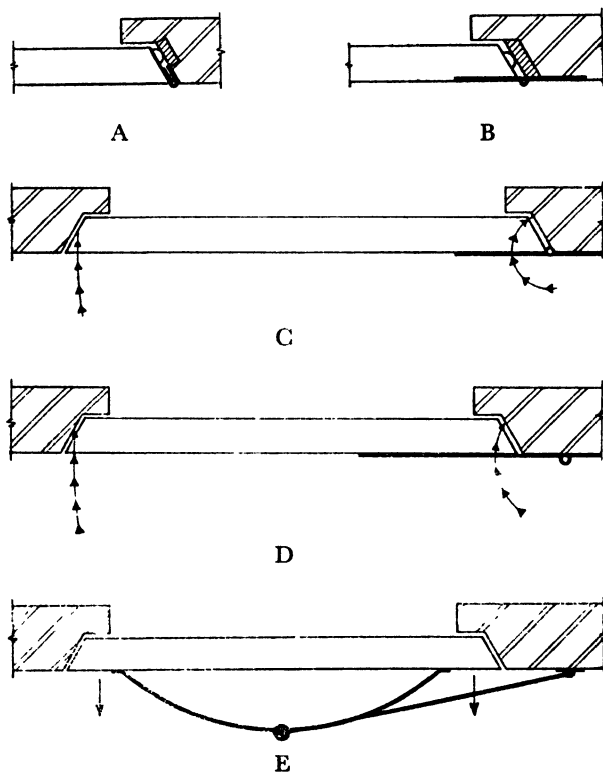

FIG. 40 HINGES

Fig. 40B shows the use of a strap hinge with the same construction, where the hinge does not encroach on the space required for the seal, and if necessary, a double seal can be accommodated. The hinge screws are now in shear, and the strap hinge may be designed to much more generous proportions than is practicable with the butt. A still more secure hinge may be obtained by bolting right through the door, and through a plate on the far side.

Both the butt and the strap hinge suffer from the disadvantage that pressure is applied to the seals on hinged and closing stiles in different directions, as shown in Fig. 40C.

This disadvantage, together with those associated with butt and strap hinges already discussed, is reduced in the offset hinge, illustrated in Fig. 40D. Here the hinge screws are in shear, and the direction of pressure at the seals is substantially the same at all butting surfaces.

The Safe type of hinge shown in Fig. 40E has the property of applying a thrust which automatically distributes an equal pressure at the periphery in a direction perpendicular to the plane of the door. The arrangement is rather impracticable for general application, due to its relatively high cost.

V.5 SLIDING DOORS

Certain modifications to seals may be made for a sliding door which moves in the plane of its framing partition; others are imposed by the same factor.

Dealing first with the seal at the closing edge, an efficient seal may be devised as shown in Fig. 41A. Here, because it is protected, the seal may be composed of a soft sponge rubber, backed by an air space to increase resilience.

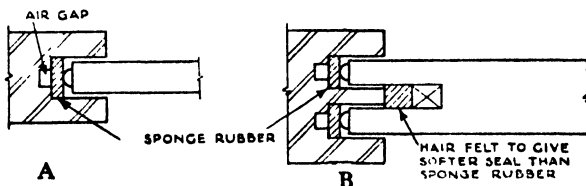

FIG. 41 SEAL TO LEADING EDGE OF SLIDING DOOR

For a double construction, the triple seal of Fig. 41B may be adopted when, although all three seals are completely obscured, reasonable confidence may be held that one effective seal is operative. A desirable feature of this construction would be to arrange for the centre seal to be softer than the outer seals, and to close slightly before them.

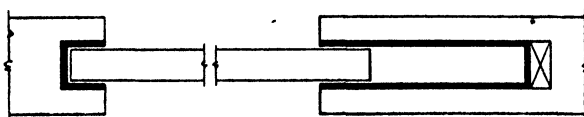

FIG 42. TRAP SEAL TO TRAILING EDGE OF SLIDING DOOR

THE SPECIAL CASE OF DOORS

The seal at the vertical edge remote from the closing edge (i.e., the trailing edge) offers certain practical advantages over the corresponding hinged door seal. In those cases where the door panel when open is accommodated inside a deep recess, it can be arranged that a part of this recess is still occupied by the door when closed. The narrow clearance between the door and the containing structures provides a very narrow duct with numerous bends, as shown in Fig. 42, which may be lined with sound-absorbing material.

The seal proper may be continued in the manner of Figs. 43A and 43B, where the former is of the type shown for the closing seal in Fig. 41. As in the case of the middle seal in Fig. 41B, so also should either the closing or closed seal be softer than its opposite number, to ensure that, when the first soft seal has been closed, further movement is possible to close the harder seal.

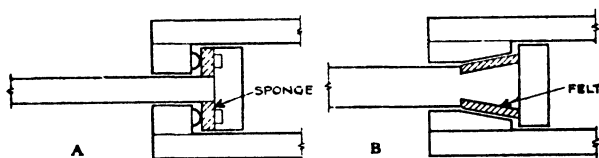

FIG. 43 SEAL TO TRAILING EDGE OF SLIDING DOOR

Fig. 43B shows a type of seal which permits of considerable movement in the direction of closing the door before the seal becomes hard and tight; yet, even in the condition of near but incomplete closure, only a very narrow slit duct with one highly absorbent wall remains, and this will provide a high degree of insulation in conjunction with the tortuous path which sound must follow round the construction.

If the sliding door is hung at a slight angle to the horizontal, the vertical component of the closing motion, in its final stage, may be employed somewhat in the fashion of Fig. 43A, to complete a seal at the sill. A cross-section of such a sill is shown in Fig. 44. This sill is arranged for heavy trucking operations across the steel channel and angle iron assembly. Sound-absorbing felt may be applied, as shown in the diagram, to increase the insulation over the tortuous path which must be followed by any sound escaping through the main seal, where the rubber pad abuts on the angle iron assembly.

ACOUSTIC PRINCIPLES

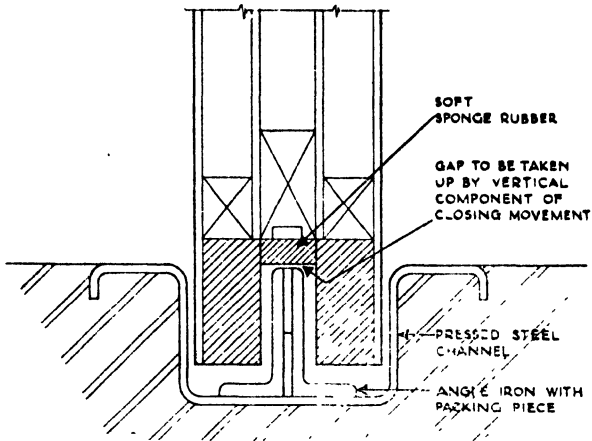

FIG. 44 SEAL TO SILL OF SLIDING DOOR

A continuous steel tongue may project from the foot of the door to run in a narrow channel formed in the floor. Clearance on each side of the tongue should be only sufficient to permit free movement, and some provision is advisable for cleaning. For example,

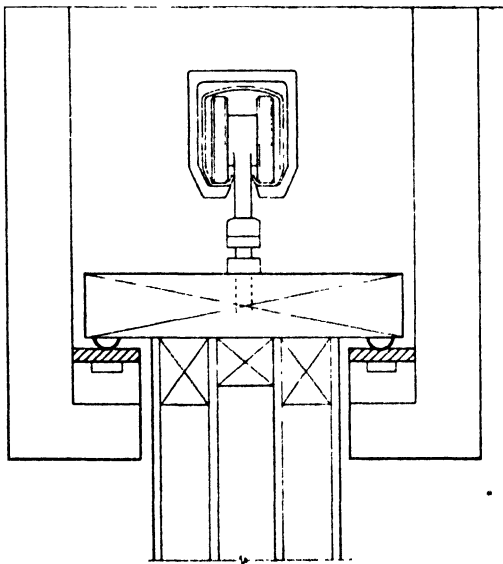

FIG. 45 SEAL TO HEAD OF SLIDING DOOR

THE SPECIAL CASE OF DOORS

the slot may be wider below floor level and a sump arranged at one end, in order that a plough forming one end of the projecting tongue may keep the channel clear.

The seal at the head of a sliding door may be continued by a parallel inversion of the type employed in Fig. 43A, where the seal elements are made to close either after, or preferably before (for ease of inspection), the corresponding seals on the sill. The arrangement is shown in Fig. 45.

With a pair of seals in both vertical and horizontal planes, arranged to act practically simultaneously, it is necessary to use rigid, reliable and accurately-fitted construction, and to employ soft seals to permit of small inaccuracies. For this reason, the seal at the head is frequently omitted in favour of the type of construction shown in Fig. 46, where a fair degree of insulation is obtained by virtue of the long slit which is formed between door and partition, and which is lined with sound-absorbing material.

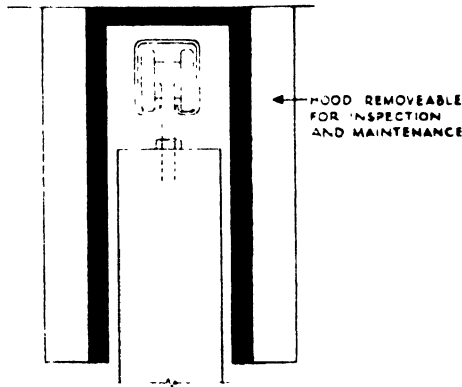

FIG. 46 TRAP SEAL TO HEAD OF SLIDING DOOR

Where a simple construction for a sliding door will meet the case, the arrangement shown in Fig. 47 is convenient, where $4\frac{1}{2}$ in. piers are formed on each side of the opening in a 9 in. wall. The leading edge of the door closes a seal supported on a 3 in. by 2 in. by $\frac{1}{4}$ in. steel angle rag-bolted to the pier, and the trailing edge carries a projecting strip which closes against a seal mounted on the side of the other pier. Methods for sealing at head and sill may be chosen from the simpler solutions discussed above, special care being given to the jointing of seals at corners.

ACOUSTIC PRINCIPLES

Vertical sliding doors are sometimes chosen to close large openings in the walls of film studios. With suitably-designed doors on each side of the opening, an insulation equivalent to that provided by the most efficient wall construction may be achieved—balance in efficiency of noise leakage paths being a

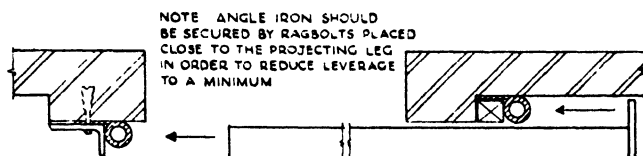

FIG. 47 SIMPLE RUBBER TUBE SEAL TO SLIDING DOOR

good design feature. A good seal is obtained by the application of felt or soft rubber on the vertical face of each door on all four edges, to be forced laterally against the frame.

An average size for doors of this type is 20 ft. \times 18 ft. wide, although larger doors, over 30 ft. high, have been employed in wind tunnel buildings used for the testing of aero engines and propellers, and in some film studios.

An alternative design has horizontal traverse. To close, it drops a small distance vertically, utilising the weight of the door to compress the seals and thereby permitting a flush sill. Average insulation is in the region of 60 db. for one door.

V.6 PANEL CONSTRUCTION

So far, the emphasis has been exclusively on the airtightness of seals, without which high-frequency insulation will be poor. There are occasions when the high-frequency insulation is of paramount importance—the performance of the door at low frequencies being of very secondary interest. An important instance of this bias towards high-frequency insulation is the ordinary telephone booth, where a fairly high level of noise from outside is tolerable, provided such noise does not mask the transmitted sound of the human voice. The chief requirement of the telephone system is that speech should be intelligible; quality is of secondary importance. For this reason, quality is deliberately sacrificed in telephone systems, and the effective frequency range is limited to 250-2,500 c/s approximately. The lowest octave of this range contributes only a small part of the overall intelligibility.

THE SPECIAL CASE OF DOORS

It is most important that the high-frequency noise above 1,000 c/s should be well attenuated—by the use of a fairly light yet airtight door. It is also required of telephone booths that they be reasonably small and light, with large areas of window. This combination of requirements is not conducive to good insulation at low frequencies.

Where, however, the exclusion of low-frequency sound is also required, recourse must be had to the inevitable properties of mass and stiffness. Well-braced panels will provide simultaneously the stiffness required for good insulation, and an assembly not prone to distort or leave gaps at the seals. Solid timber doors have been constructed from thick plywood or dense blockboards framed in a hardwood (e.g. teak), to give a massive uniform panel with small tendency towards warp. Reference to Fig. 18 (Insulation *v.* Log Mass) gives an insulation value of approximately 35 db. for this construction.

Large panels are frequently framed in angle or channel iron, and faced with mild steel sheet $\frac{1}{4}$ in. or more thick, rigidly welded together. In such cases, a large void is sometimes left between the faces, and this may accommodate an absorbent blanket.

Mass is conveniently available in the form of sand and concrete, and a construction may therefore be adopted where a steel frame is faced with light steel panels, and filled with one of these materials. If sand is used, horizontal shelves at close centres (approximately 12 in.) must be provided to prevent undue settling and packing, with consequent gaps and bulging of the steel panels, etc.

Where high insulation is required and massive panels are not convenient, two comparatively light doors are hung in the same door opening and linked to operate in the same direction.

V.7 FRAME CONSTRUCTION

Certain important features may be listed for the design of a frame to carry a soundproof door.

Since it provides one of the halves of the seal, it should be constructed like the door, rigidly and durably, so that there is no tendency to distort with pressure nor warp with time.

Where it is required to keep out of the main structure any noise made by closing the door, the frame should be isolated from the wall or partition by means of cork or felt or some similar material which will provide a measure of discontinuity.

ACOUSTIC PRINCIPLES

Particular attention should be paid to this point to ensure that the seal here is perfect, and likely to remain so. Materials should be used which retain their elasticity and form, and the additional precaution may be taken of covering the joint with some sort of cover-strip which does not itself couple the door frame to the structure. Since the tie which normally holds the frame to the structural wall is weakened by the use of a discontinuous joint, further provision must be made to ensure that the frame is not moved from its designed position by forces imposed on it when the door is opened or closed.

Where the frame is set in a cavity construction, precautions should be taken to ensure that the frame does not constitute a rigid coupling between the leaves of the wall, thus eliminating the advantage of the cavity construction. At the same time, the door, considered as a source of noise and vibration when closed forcibly, should be so supported in its frame as to have a minimum effect on that leaf which is required to be the quieter.

Particularly, any rigid connection should be avoided at the sill, where a soundproof floating floor is involved (see Fig. 48).

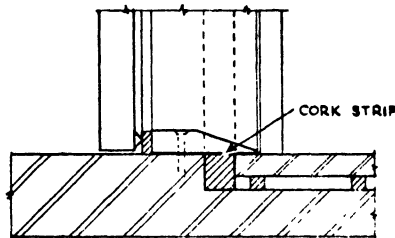

FIG. 48 SEAL TO SILL ON FLOATING FLOOR

Where a solid bridging frame is isolated from the structure by means of a cork or felt pad, as in the case of the frame in a single wall, the above requirement may be adequately met. Sometimes, however, it is required to tie the frame into one of the leaves of a double construction, in order to obtain adequate support. The procedure under these conditions is to provide what amounts to two separate frames, each tied to its particular leaf, and to provide a bridge between the two which conceals the gap yet provides minimum coupling between the two elements. The door, of course, is hung to the frame in the noisy wall—i.e., that wall which it is least necessary to isolate from noise and vibration. The principles are illustrated in Fig. 49.

THE SPECIAL CASE OF DOORS

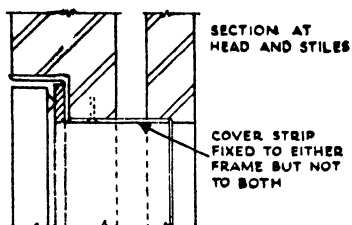

FIG. 49 REVEAL TO DOOR OPENING IN DOUBLE PARTITION

V.8 DOOR FASTENING DEVICES

In order to provide a tight seal, door-fastening devices always involve some mechanism by means of which the door panel is forced tightly into its frame.

For side-hung doors, whose dimensions exceed about 6 ft. 8 in. by 2 ft. 8 in., closing pressure must be applied at two points at least, unless the door panel construction is unusually rigid.

The refrigeration type of fastener with a spring-loaded toggle action is a convenient device for the lighter hinged doors. By means of a striker rod, this fastener may be operated from the remote side.

Usually, however, some sort of cam action, operated by means of a lever which provides some mechanical advantage, is the most effective way of applying the necessary pressure. The simplest version is probably the type associated with telephone kiosks where the cam action is provided by the handle bearing against a bevelled striking plate. The spindle may be extended through the door so that control is available from both sides.

With large hinged doors, it is difficult to hold the door against the pressure of the seal and at the same time to operate the lever handle. One device designed to overcome this difficulty utilises a horizontal bar hinged to the door frame, and closing with the door until resistance is encountered. The bar is at this point engaged with a hook fixed to the door frame at the closing stile. The door is then some 2 inches from its final closed position at the closing stile, initial compression having to be applied to the seal at the hinged stile. By the introduction of a wedge, or the use of a cam mechanism acting between the horizontal bar and the door, to increase their separation, the door may be forced tightly into place. The device is illustrated in Fig. 50.

ACOUSTIC PRINCIPLES

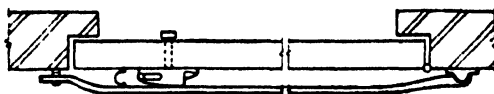

FIG. 50. CAM ACTION DOOR FASTENING DEVICE

A motor-operated device for closing heavy hinged doors works on the following principle. A projecting bolt on the door is engaged by a circular cam plate rotated through suitable reduction gear by an electric motor. The cam plate is mounted on the wall, with the spindle perpendicular thereto. Rotation of the cam plate applies increasing pressure *via* the bolt to force the door tight against its seal. The general principle is illustrated in Fig. 51. This device is of considerable use, for example in film studios, where much time is saved by electrical operation of all important doors from a central control point. The system may be coupled to a signalling circuit to give lamp indication of the state of closure of each door.

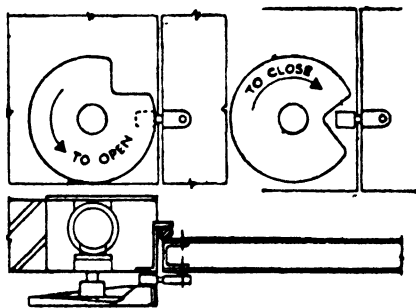

FIG. 51. CIRCULAR CAM PLATE DOOR FASTENING DEVICE

A sliding door may be forced home against its seal by the cam action illustrated in Fig. 52A, where rotation of the arm first releases the pressure and then lifts the locking bar. This type may be operated from both sides of the wall and is not further complicated if a thick acoustic lining is required on the walls. The simple devices indicated in Figs. 52B and 52C are not suitable if the door must be opened from both sides.

In the design of electrically-operated gear, it is necessary to install limit switches to prevent damage to the mechanism.

THE SPECIAL CASE OF DOORS

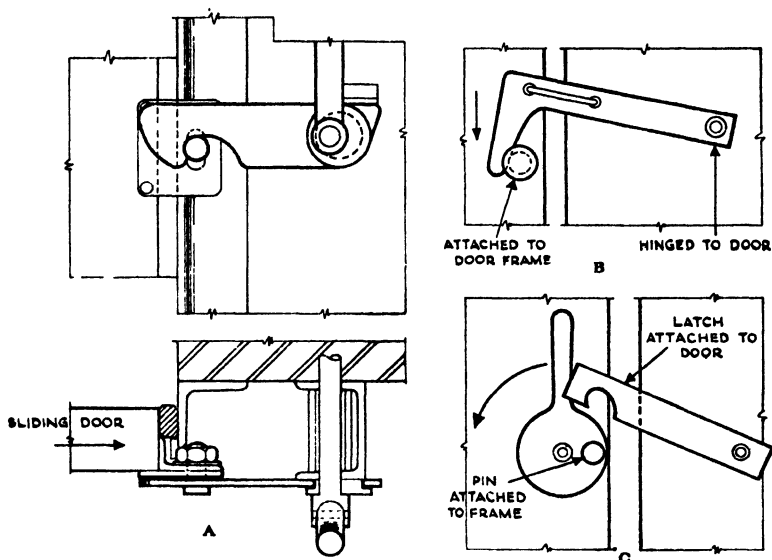

FIG. 52 HINGED CAM ACTION TO CLOSE SLIDING DOOR

Quick means of escape in the event of fire is always a desirable (and often a necessary) feature of soundproof doors. Quick release handles or panic bolts should be catered for in the design, and may be incorporated in the fittings discussed above.

Where doors are opened by means of a rotating handle, all the doors in any one building should be opened by rotation of their handles in the same direction. Preferably, a downward motion should be used. A simple instruction for opening should be clearly visible at all times.

V.9 THE USE OF LOBBIES

As in the case of cavity walls, so also with doors; thus, two poor doors together are usually better than one good door, because their individual performances are roughly additive while the single construction obeys the log-mass law.

Where, therefore, a lobby can be contrived, the design of the doors is considerably simplified. The doors may be lighter, looser tolerances on the fit may be accepted, and this in turn affords a degree of permanence which the single heavy door can retain only with much care and attention.

ACOUSTIC PRINCIPLES

The efficiency of the lobby may be increased by siting the doors at right angles, as shown in Fig. 53, and by acoustic treatment applied to the walls and ceiling of the lobby.

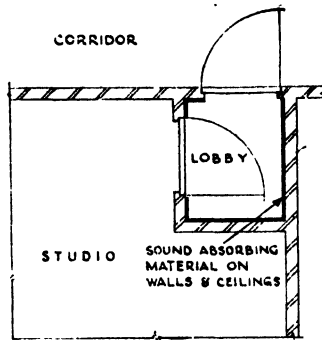

FIG. 53 LOBBY AS SOUND TRAP

Chapter VI

THE SPECIAL CASE OF SOUNDPROOF WINDOWS

WINDOWS, in order that a high degree of insulation may be obtained, must be of a double construction, so arranged in accordance with the general principles governing discontinuous structures that there is a minimum coupling between the two panes of glass. One obvious coupling is provided by the structure (the frame) which holds the glass panes at their edges; another is the stiffness of the air coupling between the panes of glass.

The frame coupling may be designed to have a negligible effect in a variety of convenient ways, as will be shown in the diagrams of representative constructions appearing later in this Chapter.

The air coupling effect may be reduced to a minimum by increasing the separation between the panes of glass, on the principle that the stiffness of the coupling varies inversely with distance. This effect is most important at low frequencies. The precise relationship between insulation and separation of two panes coupled by an air space is complex and does not admit of convenient calculation. The general effect is, however, clearly expressed in the following measurements made by Constable and Aston of the N.P.L. on a double window of 21 oz. glass.

Separation	Average Sound Reduction for Frequencies (cycles per second)			
	200 & 300	500, 700, & 1,000	1,600 & 2,000	200 to 2,000 (general average)
$\frac{1}{2}$ in.	18 db.	41 db.	64 db.	41 db.
1 "	20 "	42 "	65 "	42 "
2 "	23 "	49 "	64 "	46 "
3 "	28 "	52 "	64 "	49 "
6 "	36 "	50 "	67 "	51 "
8 "	40 "	52 "	66 "	53 "

ACOUSTIC PRINCIPLES

The surface of the framework between the two panes of glass (window reveal) provides a convenient site for the application of sound-absorbing material, which may contribute a further 4 to 6 db. towards the total insulation. An airtight seal must be achieved between each frame and the wall which surrounds it.

Where an air space is sealed between two panes of glass, condensation problems are common. It is advisable to put a small quantity of calcium chloride, or a tin of Silica Gel, inside the enclosure; a means of renewal must be provided.

For high degrees of insulation, the panes should of course have minimum area and maximum thickness; $\frac{1}{2}$ in. or $\frac{3}{8}$ in. glass is commonly used.

Where windows in partition walls act as inspection ports, as with engine test rooms, and there is a risk of fracture, armoured plate glass may be employed with advantage.

In accordance with these general principles, typical constructions are illustrated in Figs. 54 to 58, and their specific merits are pointed out.

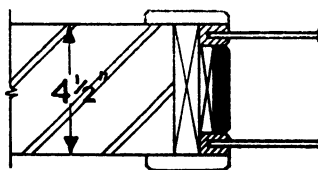

FIG. 54 DOUBLE WINDOW CONSTRUCTION WITH $4\frac{1}{2}$ IN. WALL

1. Maximum practicable spacing between panes in $4\frac{1}{2}$ in. wall.
2. Simple timber members without cutting to waste in forming rebates.
3. Absorbent material on reveals.

The following are weaknesses :

4. Glass inaccessible without removing architrave.
5. Glass bedded in felt which results in disproportionate compression at sill with possible permanent set and air leakage at head.
6. Although the greatest practicable spacing has been attempted, the air space is only about 3 in. wide (or 4 in. with plastered wall). This gives rather poor insulation at low frequencies. However the insulation of the $4\frac{1}{2}$ in. brickwork is also relatively poor at low frequencies.

SOUNDPROOF WINDOWS

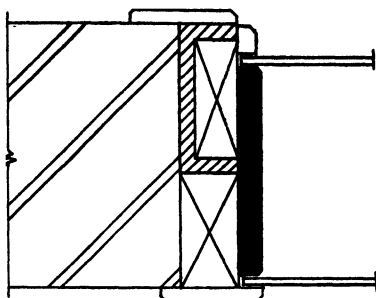

FIG. 55 DOUBLE WINDOW—ONE FLOATING FRAME

1. Good separation between panes. (9 in. brickwork indicated).
2. Edges of acoustic tile masked by architrave or fillet.
3. Isolation between frames achieved by having one floating frame which has no mechanical fixing into the wall.
4. One pane accessible by removal of fillet.

The following weaknesses are apparent :

5. Coupling between frames through acoustic tile.
6. There are some difficulties in erection. These might be reduced by employing rebated frames.

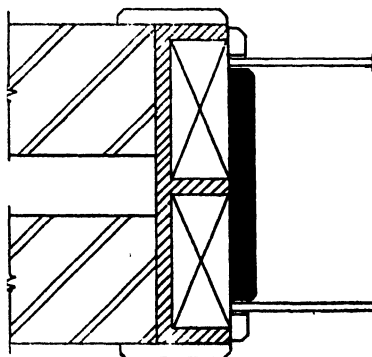

FIG. 56 DOUBLE WINDOWS IN DOUBLE WALL

The chief development from Fig. 55 is the provision of two frames which are kept together lightly by the acoustic tile, while the double assembly is fully floating.

Construction adaptable to a cavity wall.

Both panes accessible.

ACOUSTIC PRINCIPLES

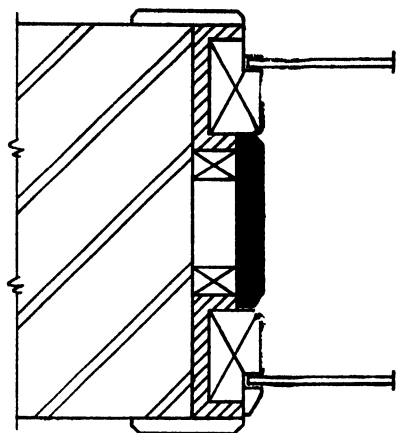

FIG. 57 DOUBLE WINDOW—RECOMMENDED TREATMENT

1. The chief development from Fig. 55 is that both frames are fully floating with no coupling through the acoustic tile. There should be no connection by nails or screws through felt into floating frames.
2. Construction shown is for a 14 in. wall. Acoustic tiles of standard width on reveal (6 in.).
3. Economy in use of timber.
4. Void between acoustic tiles increases absorption at low frequencies.
5. The design incorporates most of the desirable features of a soundproof window.

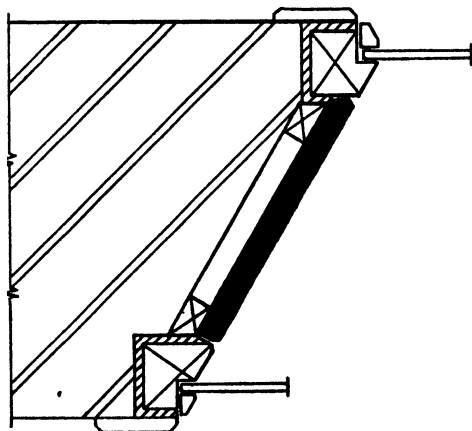

FIG. 58A DOUBLE WINDOW WITH SPLAYED REVEALS

1. A design for an observation port with an expanding angle of vision. The minimum cross sectional area may be used to give maximum insulation for the partition as a whole.
2. The construction also embodies most of the desirable features of soundproof window design.

SOUNDPROOF WINDOWS

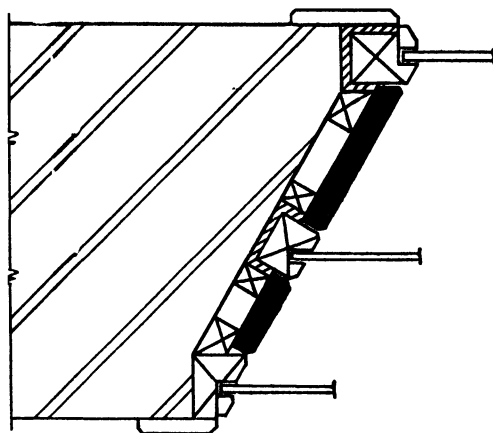

FIG. 58B TRIPLE WINDOW WITH SPLAYED REVEALS

1. A further design for an observation port with an expanding angle of vision. The minimum cross sectional area may be used to give maximum insulation for the partition as a whole.
2. This construction embodies most of the desirable features of soundproof window design, with increased insulation.

Where a small window is mounted in a partition, and the window has smaller insulation per unit area than the partition, the average insulation will lie somewhere between the two values. Where the area of glass is not less than $1/3$ of the total area, the average insulation is substantially the insulation of the window.

Similarly, where a window is open to admit noise from outside the difference between inside and outside levels will decrease rapidly with increasing area of open window. An approximation is given by Davis and Morreau, the difference in db. being expressed as $10 \log \frac{A}{S}$ where A = Total room absorption,

including the absorption of the open window, and S = area in square feet of the open section of the window.

Since, for this expression, A is always greater than S , because A is comprised of S plus room absorption, there will always be some difference in level between inside and outside.

ACOUSTIC PRINCIPLES

A window usually performs two functions—lighting and ventilation. When an attempt is made to achieve high insulation by means of an airtight construction, other means must be sought to ventilate the room. Where a central forced ventilating system is not installed, a local system serving one room may be installed on the lines of Fig. 59. A less tidy but more efficient system would follow the greater separation of inlet and exhaust grilles, as shown by the dotted outlines. Sound-absorbent lining is necessary on the internal sides of the ducts (see Chapter VII). Where only lighting is required, and even a clear view is unnecessary, glass bricks may be employed effectively on account of their considerable mass and stiffness. Inch-thick sheet glass in narrow widths, preferably in concrete framing, may provide an efficient and pleasing construction. Pavement

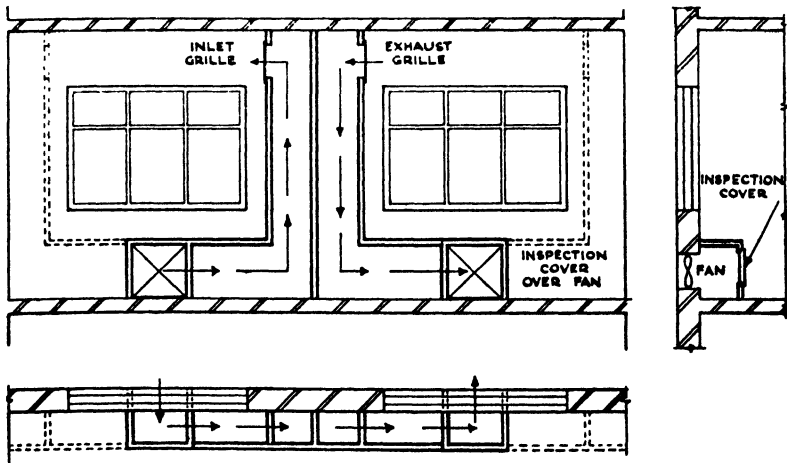

FIG. 59 LOCAL VENTILATING SYSTEM

lights in concrete roofs may serve a similar function in the horizontal plane, and find a use particularly in noisy workshops and engine test houses.

Where normal and traditional windows are of necessity employed, certain palliatives may be adopted which simultaneously provide light, ventilation and a small measure of sound insulation. Typical devices are illustrated in Figs. 60A-C.

SOUNDPROOF WINDOWS

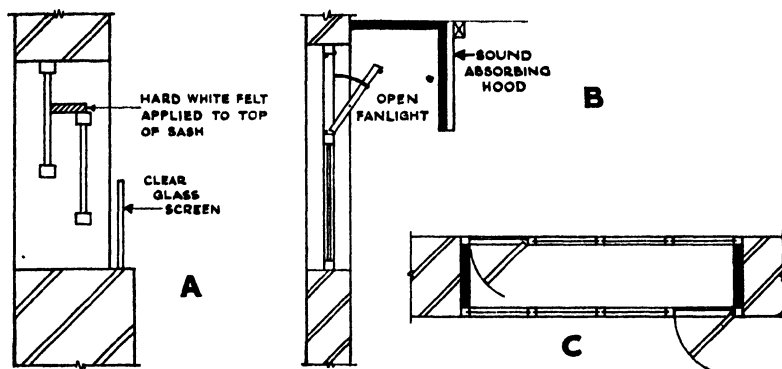

FIG. 60 THREE SIMPLE TREATMENTS OF STANDARD WINDOWS

Chapter VII

FORCED VENTILATION SYSTEMS

VII.1 ACOUSTIC DEFECTS

Consideration should be given to Forced Ventilation Systems:

- (a) as a path for noise transmission, equally with, and *against* air stream;
- (b) as a source of noise.

Figs. 61A and 61B are sectional views of simple types of forced ventilating systems in which fresh air is induced from one side of a room and exhausted from the other by means of a simple propeller fan, and a complementary outlet or inlet grille. Fans of this type are designed to work against low friction

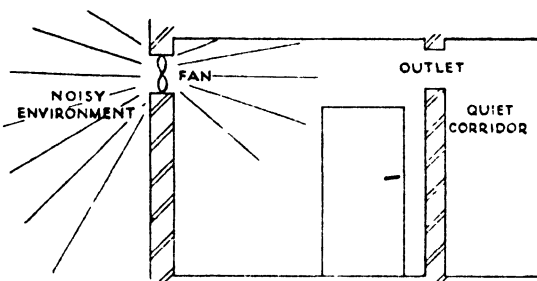

A

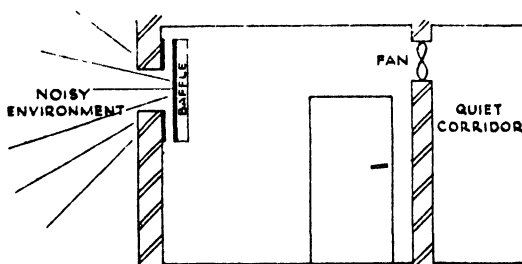

B

FIG. 61 LOCAL FAN TREATMENT

FORCED VENTILATION SYSTEMS

heads, such as are associated with mounting of the fan in an unobstructed orifice in a wall or partition.

In Fig. 61A, the fan faces a noisy environment outside the building. A more satisfactory arrangement is to work the fan into the relatively quiet corridor and to provide a baffled aperture to the noisy environment, as shown in Fig. 61B.

Factory walls and roofs are frequently perforated by ventilating ducts, which may allow noise to escape, either from the noisy operations within or from a high speed ventilating fan. Inlet or exhaust ducts are equally susceptible. Noise produced by a forced ventilating system may be conducted along associated ducts to reappear at undesirable places. Cross talk between rooms served by a common duct, and due to flanking transmission of various types, may arise as shown in Fig. 62.

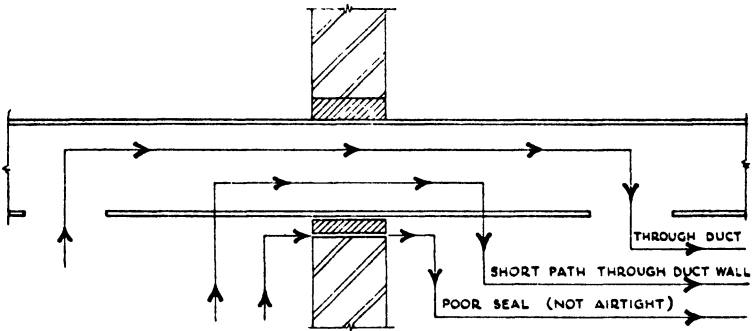

FIG. 62 CROSS TALK THROUGH DUCTS

The ducts and trunks associated with a ventilating system may provide a path for the transmission of vibration arising from or passing into any part of the structure to which they are connected.

A ventilating system may be a source of noise or vibration due to any or all of the movements of air and machinery associated with the system. The usual causes are:

- (a) Air turbulence created by the fan blades.
- (b) Mechanical noise in the fan, motor or drive.
- (c) Air turbulence due to the presence of obstructions, constrictions, elbows, branches, baffles, etc., which deflect or modify the steady flow of air.

ACOUSTIC PRINCIPLES

- (d) Air turbulence when a stream of air moving at high velocity impinges on the relatively quiescent air of a room.
- (e) Out-of-balance forces in the fan, motor and drive.
- (f) Air turbulence within the ducts, causing vibration of the duct wall.

It is usually the low frequency components of (a) and (b) which are the chief sources of trouble.

Typical examples of the various defects are illustrated in Fig. 63.

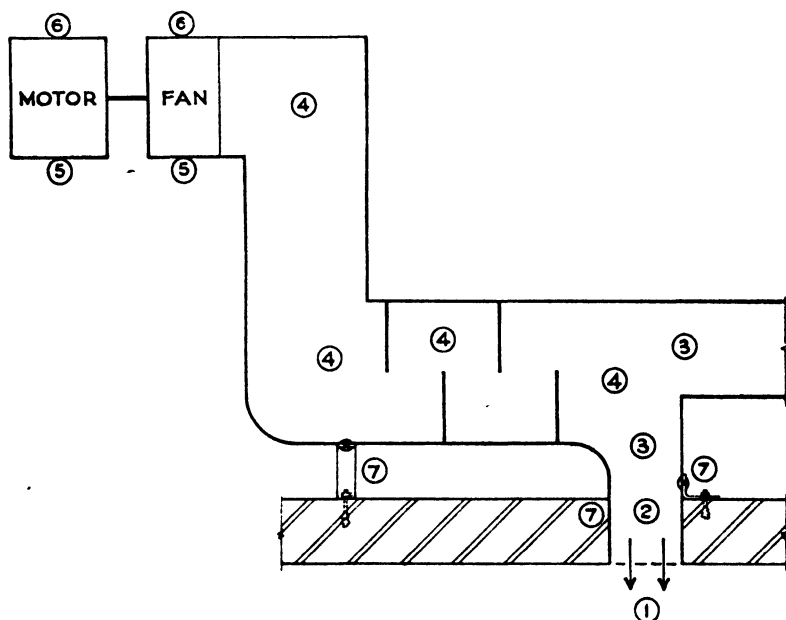

FIG. 63 SOURCES OF NOISE AND VIBRATION

1. Air turbulence where stream impinges on quiescent air in room.
2. Air turbulence where stream impinges on solid parts of grille.
3. Air turbulence due to change in shape and cross sectional area of duct.
4. Air turbulence where stream is diverted by bends, branches and baffles.
5. Noise due to fan blades, fan and motor.
6. Vibration due to fan and motor.
7. Vibration transmitted through rigid connections to structure.

VII.2 AVOIDANCE OF, AND TREATMENT FOR, ACOUSTIC DEFECTS

VII.21 Noise Reduction along Ducts

Where the insulation between adjacent rooms is inadequate, due to the flanking path provided by a common duct, the insulation may be increased in any of the following ways:—

- (1) By lining the duct with sound-absorbing material.
- (2) By interposing bends and baffles in the path of the noise.
- (3) By the use of “splitters”, constructed of or covered by sound-absorbing material.

In order to determine the extent and nature of any duct treatment along these lines, it is necessary to know the total insulation required between the adjacent rooms. It is not necessary to reduce the loudest sound in one room to the threshold of audibility in the other room. The background level of a room due to noise sources within that room, or from windows, etc., sets a minimum level below which it is uneconomic to reduce other sources. Thus if Room A has a background level under quiet conditions of 30 phons, and it is required to reduce to inaudibility the sound of speech at a level of 65 phons from Room B, the required degree of noise reduction through the duct (and of course through the dividing partition) is $65 - 30 = 35$ phons.

When considering ducts as possible conveyors of noise, it is essential to keep in mind this factor of background level. For instance, ducts discharging into or exhausting from noisy offices seldom need acoustic lining, whereas those connecting broadcasting, film or recording studios require comprehensive treatment to reduce noise to a level of about 10 db.

For a given length of duct, the most suitable type of insulation treatment may be selected and the insulation per foot may be calculated, as shown below in Section 3 “Calculation of Noise Reduction”.

Sound at high frequency (1,000 c/s or over) tends to travel in straight lines, and transmission at these frequencies may be reduced by introducing bends or angles, or—what amounts to the same thing—by the use of baffles in the ducts. Such devices should be applied with discretion, and with an eye to streamlined contours, wherever high air velocities are encountered, to avoid creating turbulence in the airflow.

ACOUSTIC PRINCIPLES

The beneficial effect of sound-absorbing lining is greatest when the duct run includes a series of bends, every four to six feet or so. This causes random reflection of the higher frequency sounds which would otherwise pass down the middle of a straight length of duct. Changing the direction through about 20° is all that is necessary. Further information on this point is given in Section 6 of this Chapter.

For low frequency sounds, the method of providing a tortuous path is useless. Insulation must be obtained by the use of sound-absorbing material, and this must be relatively thicker the lower the frequency of the noise.

Where a duct passes through a dividing partition between rooms which are required to have mutual insulation, flanking transmission paths may develop—

- (a) at the seal round the duct, and
- (b) through the wall of the duct adjacent to the partition.

The practice of running ducts through a partition is not to be encouraged on these grounds. It is preferable to plan the secondary duct system horizontally, without penetration or bridging of soundproof partitions, and to locate the main trunks in vertical shafts designed specifically for the purpose.

VII.22 Isolation of Ducts from Vibration

In order that a duct shall not act as a transmission path for vibration into and out of the general building structure, it must not be rigidly attached thereto. Simple cradles or brackets with a layer of felt interposed between the metal duct and the ultimate support is, usually, all that is necessary.

Where, for other reasons, rigid connection to the structure is essential, the continuity should be broken in the branch lines to locations which require a high degree of insulation. This may be accomplished by means of a canvas or fabric coupling.

VII.23 Air Turbulence

Turbulence due to the movement of fan blades through the air is a frequent source of noise. The effect of the fan blades is to give a quick succession of air pulses, which act as a powerful source of low frequency sound before the pulses are smoothed out into a continuous air stream.

The best solution is to use a fan of large diameter, and to keep the tip speed low. A value of 50 ft./sec. is reasonable, and is also

compatible with the low inlet velocities required (15 ft./sec.) to keep noise at inlet grilles down to a level suitable for average purposes.

Treatment of noise created by air turbulence necessitates the use of sound-absorbing material which possesses suitable low-frequency absorption characteristics since, as mentioned above, bends, baffles, etc., have little effect on low-frequency sounds.

Turbulence arises from any change of direction in the air stream imposed by the solid part of inlet grilles. If the velocity of the air stream is kept within the limits necessary to avoid turbulence when impinging on the stationary air in the room, it is improbable that any correctly-designed grille will give rise to trouble. To be on the safe side, grilles should be designed with small detail, so as nowhere to offer any large obstruction. Wire and strip meshes of large gap ratio are very suitable. Large, solid elements of light gauge metal should be avoided.

Turbulence, accompanied by noise, arises when a fast-moving stream of air impinges on a stationary volume of air. This occurs at all inlet apertures, and in order that noise may be kept within reasonable bounds, the velocity of the air stream at the aperture must be kept low. A speed of 900 ft./min. (15 ft./sec.) is a safe value, and should not be greatly exceeded where a quiet background level of about 35 db. must be observed. This requirement may be obtained by employing ducts with sufficient cross-sectional area to permit of a low inlet velocity, or the outlets may be flared (gradually, and to streamline contours, preferably at an included angle not over 15°), so as to reduce a high duct velocity to a low discharge velocity. This device will not, of course, reduce any noise which is already present in the air-stream due to a source farther back.

Any obstruction within the duct, such as a baffle, or any change of direction or cross-section, will promote turbulence. Where the rate of flow is slow, little trouble may be expected, but the effect may be considerable at high velocities.

The air-borne noise so created must be reduced by the use of sound-absorbing materials. It is a fortunate feature that any treatment in the final branch ducts, placed to reduce cross-talk between adjacent rooms, is in a suitable position for reducing noise introduced nearer the fan.

Severe turbulence due to high velocities may cause violent drumming of a metal duct, with all the difficulties attendant

upon this type of vibration. Circular ducts have more inherent rigidity than ducts of other sections, while little trouble is to be expected from ducts built in brick, hollow tiles, or similar builders' work.

VII.24 Mechanical Noise

Mechanical noise associated with the running of the fan and its motor, and of the drive which couples them, is liable to be transmitted along the airflow path.

Properly-designed equipment is the best answer—together, of course, with regular and careful maintenance. Ball and roller races are often sources of mechanical noise; plain bearings are quieter. Rotating parts should all be dynamically balanced. Housings should be rigid and tightened down. Commutating gear should be designed to minimise brush noise. Reputable suppliers of ventilating equipment are naturally aware of these design features, and may be relied on to provide suitably-designed equipment.

Again, it is the low frequency components of these noises which are the most troublesome, and their early elimination should be contrived by sound-absorbent duct lining.

VII.25 Mechanical Vibration

Any out-of-balance forces in the fan, motor and drive, as well as creating noise, may also be sources of vibration. Imperfect dynamic balance, resonant periods, ball and roller races, incorrect alignment of fan and motor, are the chief offenders—probably in that order of importance.

The fan-motor assembly should be isolated from the structure and from the duct system. Isolation from structure may be achieved by tying down the assembly to a heavy raft, and floating this in accordance with the principles of the Low Pass Filter, as described in Chapter XI.

The duct system should be isolated at the fan housing by means of a flexible fabric connection. Flexible drive between motor and fan, with separately-mounted bases, helps to prevent motor noise penetrating through the fan to the duct.

The importance of isolation cannot be too strongly emphasised. The fundamental frequencies involved are low, and once transmitted into the structure may be an endless source of trouble. Carelessness on the part of a workman, in

FORCED VENTILATION SYSTEMS

the form of concrete or rubble left as a bridge between the floating raft and the structure, may involve considerable expense to trace and rectify. The trouble cannot be satisfactorily remedied by adding sound-absorbent linings to the ducts.

VII.26 Vibration due to Airflow

The quick succession of pulses created by the fan blades of a high speed fan frequently produces violent drumming of sheet-metal ventilating ducts.

The section of duct susceptible to agitation should be isolated from the structure, and also, by means of a flexible fabric coupling, from the rest of the duct system.

Fig. 64 shows schematically how the major defects commonly met with in ventilating practices may be dealt with in a hypothetical case.

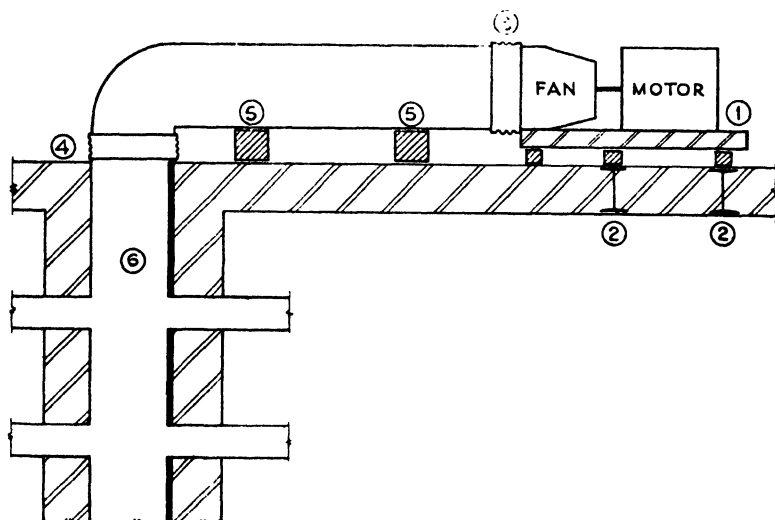

FIG. 64 GENERAL TREATMENT OF PLENUM PLANT AND MAIN TRUNK

1. Fan motor assembly isolated from structure.
2. Weight of fan motor raft taken on load-bearing members, not on panels.
3. Flexible coupling to isolate fan motor vibration from duct.
4. Flexible coupling to isolate vibration due to turbulence in duct from rest of duct system.
5. Section of duct most susceptible to vibration isolated from structure.
6. Main vertical trunk in builders' work lined on two adjacent sides with sound-absorbent material having high coefficient of absorption at low frequencies.

VII.3 CALCULATION OF NOISE REDUCTION

The following relationship may be applied to the approximate solution of problems involving ventilating ducts, where the airflow is slow and not itself a generator of noise (due to turbulence or thermal agitation), where the dimensions and geometry involved are not extreme, and where the complexity of the system is small. Quite different and usually specific techniques are found necessary in cases like aeroplane engine test houses.

It does not necessarily follow that the property of a material measured in a reverberation chamber in still air may be immediately applied to conditions where an airflow replaces the steady environment of the reverberation chamber. Similarly, the conditions of random incidence assumed for the reverberation chamber do not apply for sound propagated down a duct.

It has been observed, for instance, that a triangular section shows a performance superior to that of an equivalent rectangular section at the low frequencies, possibly at the expense of the high frequencies.

Where the duct is carrying air or gas at high speed, the kinetic energy of the molecules is a potential noise source, and may render abortive attempts to increase the efficiency of a duct by increasing the length of absorbent treatment. In such cases, removal or reduction of this energy is the first step in the attack on the main problem.

The noise reduction due to an absorbent lining in a duct is proportional to the length of the duct, the perimeter of the cross section, and the absorption coefficient of the lining; it is inversely proportional to the cross-sectional area.

The relationship may be expressed mathematically in the form:

$$\text{Reduction (db.)} = K \frac{Lp}{A}$$

Where L = length of duct in feet,

p = perimeter of duct in inches,

A = cross-sectional area of duct in square inches,

and where "K" is a constant involving the absorption coefficient. The empirical relationship $K = Qa^{1.4}$ has been deduced (ref. Hale J. Sabine, Celotex Corporation), where "Q" is a constant, and "a" is the absorption coefficient, i.e., "K" is proportional to the 1.4 power of the absorption coefficient.

FORCED VENTILATION SYSTEMS

Certain facts follow from the above relationship. For maximum efficiency, the ratio "p/A" should be a maximum. In the limiting case, this condition would be met by a duct having a cross-section in the form of a very thin slit. Similarly, the least efficient shape to contain a given cross-sectional area is a circle, with a square running it close.

From the same principles, the smaller the cross-sectional area of any given shape, the greater will be the ratio "p/A", and therefore the greater the reduction per unit length.

Therefore, the quantity "p/A" is determined by the shape of the cross-section, which should be designed within the limits of structural requirements to have as large a value as practicable; in other words, it is desirable to cram the maximum absorption into a given space. This point is shown diagrammatically in Fig. 65.

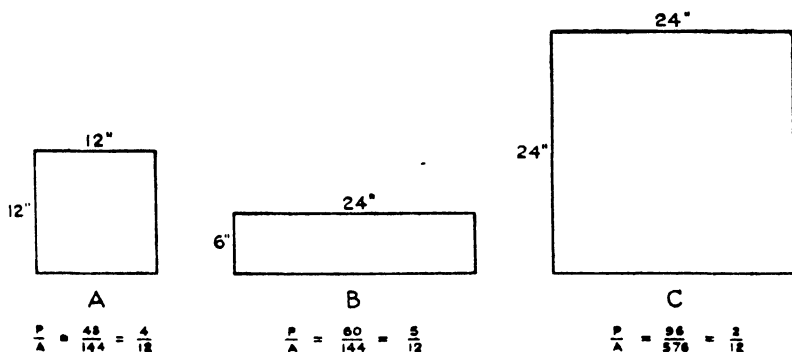

FIG. 65 EFFICIENCY OF DUCT CROSS-SECTIONS

Note. B is more efficient than A in the ratio 5 : 4.

A is more efficient than C in the ratio 4 : 2

Thus, increasing the dimensions of the cross-section by a factor 2 reduces the efficiency by a factor 2 also. Certainly more air will go through the larger duct, but the lining of absorbent material is being very wastefully used.

The factor "L" (= length of duct) needs no discussion. A duct of twice the length will provide twice the reduction apart from end effects which may be neglected when the length is large compared with the dimensions of the cross-section.

The constant "K" (= $Qa^{1.4}$) requires some further description. "a" is the absorption coefficient of the duct wall lining, and is fixed, no matter what the size or shape of the cross-section.

ACOUSTIC PRINCIPLES

“Q”, as mentioned above, is a constant. “K” is plotted against “a” in Fig. 66, with the appropriate units to satisfy the expression:

$$\text{Reduction db.} = K \frac{Lp}{A}$$

where “L” is in feet, while “p” and “A” are in inches and square inches respectively.

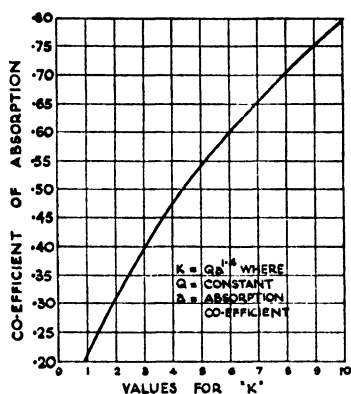

FIG. 66 NOISE REDUCTION COEFFICIENT FOR DUCTS

In applying the above expression to the calculation of any specific problem, “a” will be taken at the frequency of the loudest component of the noise, and a lining material should be chosen which has a substantial absorption coefficient at this frequency.

VII.4 THE USE OF SPLITTERS

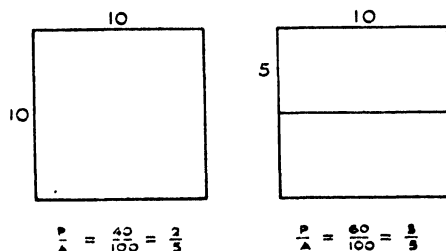

FIG. 67 EFFECT OF SPLITTER

Consider the two sections shown in Fig. 67. By the use of a splitting element down the centre, the perimeter “p” has

FORCED VENTILATION SYSTEMS

been considerably increased, while the cross section "A" would not, with normal construction, be appreciably diminished. In accordance with the principles announced in the preceding Section, the increase of the ratio "p/A" follows the following laws:

- (1) that small ducts are more efficient than large ducts,
- (2) that rectangular ducts are more efficient than square ducts.

By the use of a single splitter, the ratio "p/A", and therefore the efficiency per unit length, has been increased in the ratio 3 : 2.

It should be here emphasized that the efficiency increase is only for a unit length. If the sound-absorbing material were used to increase the length of the duct, the performances of the short duct with splitter and the long duct without splitter would be approximately similar (ignoring end effects).

To develop the general case for "N" splitters inside a duct, the following features should be borne in mind.

In order to obtain the maximum efficiency per unit length, the splitters should be laid parallel to the wider side of the duct, thus approaching the limiting condition of a slit which is all "p" and no "A".

The noise reduction may be calculated as before from:

$$\text{Reduction db.} = K \frac{Lp}{A}$$

except that "p" now includes both sound-absorbing sides of the splitter.

For square section ducts, the relationship between the noise reduction, with and without splitters, is given by:

$$R_s = R_d \left(1 + \frac{N}{2}\right)$$

where R_s = reduction with splitters,

R_d = reduction without splitters,

N = number of splitters.

For rectangular ducts of unequal sides, where the splitters are laid parallel to the wider side, the expression must be modified to:

$$R_s = R_d \left(1 + \frac{XN}{X+Y}\right)$$

where X = length of longest side,

and Y = length of shortest side,

ACOUSTIC PRINCIPLES

the same units (feet or inches) being used for both lengths. This information is summarised in Fig. 68.

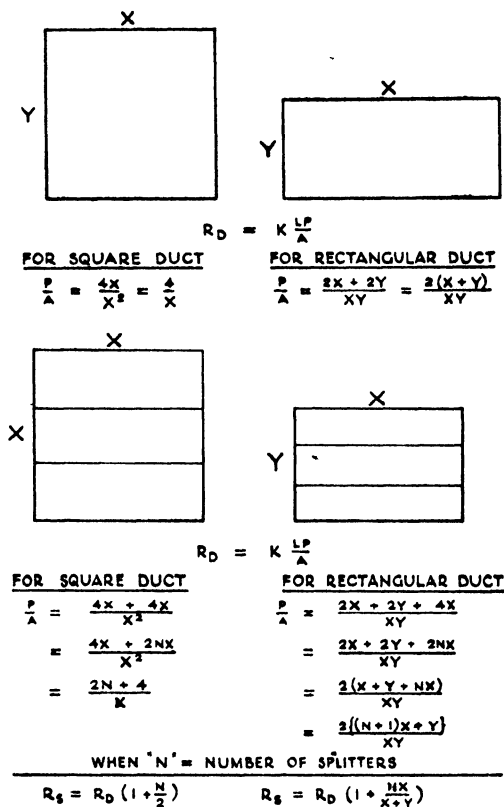

FIG. 68 EFFICIENCY OF SPLITTERS

VII.5 LIMITATIONS OF NOISE REDUCTION IN STRAIGHT DUCTS

In the simple mathematics of Sections 3 and 4 above, the assumption has been made that the sound inside the duct travels in a random manner, in order that the absorbent surfaces may act upon it. This is far from true at high frequencies—say above 1,000 c/s—which tend to travel straight down the duct. In consequence, only the edges of such a beam suffer loss by absorption, and the centre is comparatively unaffected.

An increase in efficiency may be obtained by the use of splitters at close spacing, but this is not making economic use of the acoustic material.

FORCED VENTILATION SYSTEMS

VII.6 THE USE OF BENDS

As indicated in Fig. 69, the provision of a bend in an air duct promotes, by reflection effects, a general diffusion of high frequency sounds, enabling the absorbent walls to register their effect. The duct should follow the new direction imposed by the bend for a distance large compared with the wavelength, in order that the diffusion shall be fully effective. Shortly, however, the original state of affairs tends to re-assert itself, although at reduced level, and again a bend must be introduced to promote further diffusion.

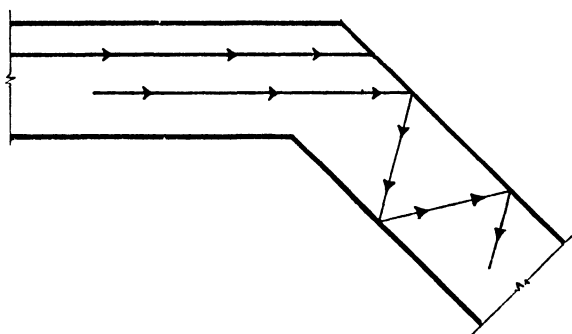

FIG. 69 BEND IN DUCT

Low frequencies decline to observe the laws of reflection which approximately apply to high frequencies, and bends have very little effect in reducing noise below 500 c/s. The National Physical Laboratory have measured, on a representative 15 in. wide duct, the following attenuation produced by a single 19° bend.

Frequency c/s	125	250	500	1,000	2,000	4,000
Additional Attenuation due to 19° Bend (db.)	0	0	0.5	2.5	5.0	8.0

Bends of the order of 20° may be fairly conveniently introduced in what would otherwise be straight ducts. The direction of bend can be changed at alternate bends to restrict the overall space, and the change of direction does not seriously affect the airflow within the duct.

VII.7 THE USE OF BAFFLES

It is generally not good practice to introduce a baffle into a duct because, while it is efficient acoustically, it seriously obstructs airflow, and for a given volume and rate of flow, it calls for a much larger cross-section.

Where, however, the airflow rate is very low, and there is no objection to a local increase in velocity, or to an increase in head due to a large restriction in the duct, the arrangement shown in Fig. 70 may be employed, where transverse baffles provide a series of noise traps.

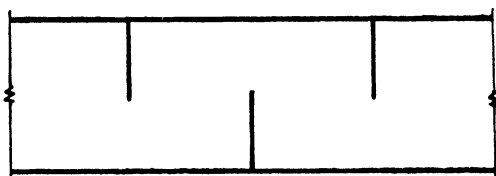

FIG. 70 BAFFLE IN DUCT

The rather tricky device shown in Fig. 71, or some similar method, may be adopted. Such expedients are not considered good aerodynamic practice.

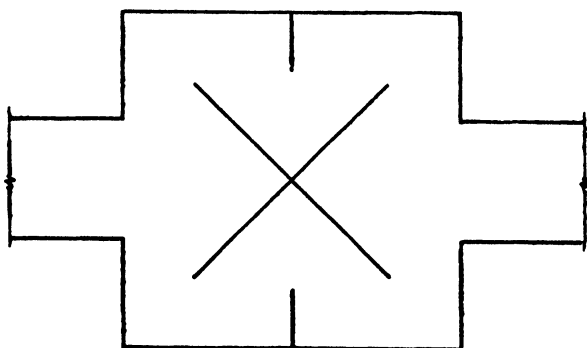

FIG. 71 BAFFLE BOX

Baffles find their legitimate use as the final defence at an outlet or inlet, as shown in Fig. 72. The use of an absorbent material on the appropriate faces will reduce any noise due to the ventilating system, and the use of a baffle of larger area

FORCED VENTILATION SYSTEMS

than the inlet opening automatically provides a device for slowing down the rate of flow at the point where it impinges on the main volume of air.

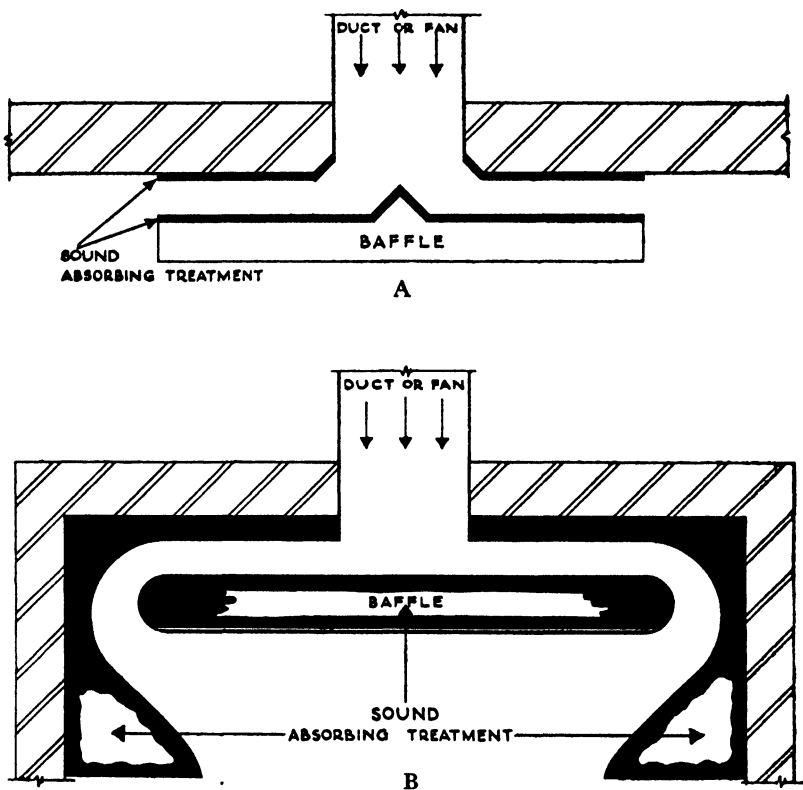

FIG. 72 BAFFLE OVER INLET OR EXHAUST

Chapter VIII

THE SPECIAL CASE OF THE CINEMA THEATRE

VIII.1 GENERAL

THE major defects encountered in Auditorium Acoustics were discussed briefly in Section 1 of Chapter II. The more immediate aspects, as they affect the Cinema Theatre, are here discussed in greater detail.

The Cinema Theatre suffers from certain initial disadvantages which render specially desirable any attention that can be paid to acoustic performance—preferably while the theatre is in the design stage. The major factors are listed below:

- (a) The loudspeakers behind the screen have a directional effect, particularly at high frequencies.
- (b) Because of (a), there are practical difficulties in covering the desired wide angle from the speakers.
- (c) The sound source is louder than its *viva voce* counterpart, partly to sustain the illusion appropriate to more than life-size figures on the screen, and partly because greater demands are made on the artificial source in the way of filling large theatres which would prove an excessive strain on the unaided human voice. The effect of the higher sound level is to increase the effective reverberation time of the auditorium.
- (d) A certain amount of reverberation is present in the film, imposed by the local acoustic conditions of the sets on which the picture was taken. Reverberation effects are enhanced in the recording, due to the use of a monaural instead of a binaural recording channel. (This effect can be simulated by closing one ear and listening with the other).
- (e) The sound recording and reproducing channels introduce distortion and, with old film prints, a background of noise.

VIII.2 SHAPE AND PROPORTION

There is no ideal shape of Cinema Theatre, but there are plenty of bad ones. Several generalizations may be made, and they should be observed in reason, but a liberal interpretation may be put upon most of them.

The seating plan towards the front of the theatre should be so arranged as to permit of an adequate coverage of the front side seats by the loudspeakers. The requirements are approximately the same as for good sight lines to the screen. If the patron can see properly, he may reasonably expect to get his fair share of direct sound from the loudspeakers; which is a start. Outside this area of normal coverage, there is a loss of high frequency sound, and a reduction of intelligibility, due to the directional properties of loudspeakers at these frequencies.

Balconies should be so designed that the opening under the balcony is high enough to admit sufficient sound energy to feed the rear of the stalls, bearing in mind that this part of the theatre usually has more than its share of the total absorption, with a consequent local decrease in loudness. For a deep overhang, something more generous should be allowed than bare line of sight from the rear stalls—as when the front of the balcony soffit just clears the sight-line to the screen top.

Concave rear wall surfaces, coves and domes should be avoided as examples of poor design—as discussed in Section 3 below. Echo, always undesirable, may be avoided by appropriate surface treatment.

The longitudinals and cross-sections of the auditorium should be planned with the general idea of keeping the volume reasonably small, so as to reduce the quantity of acoustic treatment required for optimum reverberation.

Continuously-diverging side walls are a pleasant design feature, since they eliminate any possibility of flutter across the theatre and also conform to a normal distribution of sound energy from the stage loudspeakers.

No rigid pronouncements can be made about general proportions. There are natural modes of vibration of the contained air in an enclosure, and for small regular rooms these frequencies may be troublesome. Some attention is worth while in these cases to proportion the three major dimensions so as to avoid reinforcement of these modes of vibration.

With enclosures of the dimensions appropriate to a cinema theatre, the natural modes are of very low frequency, and do not normally cause trouble; thus, provided no extreme proportions are adopted, of a type likely to prove offensive to the eye, reasonable confidence may be reposed in the behaviour of the main volume of air.

Small "pockets" do, however, sometimes creep into the design of a theatre. Where these have dimensions of the order of 10 ft., and a depth approximately the same, local resonances may be expected.

VIII.3 ECHO

The cinema theatre is particularly susceptible to echo; it is undoubtedly the most common acoustic defect, and is encountered, in a more or less serious form, in one theatre out of three.

Because the sound source is loud, any echo trouble is quickly apparent; by virtue of the highly directional sound source at high frequencies, conditions are ripe at the best of times.

In order to cover completely an audience seated over the entire floor area, a large proportion of the sound from the speakers behind the screen is inevitably directed at the hard surface of the rear wall, whence it is reflected, with very little loss, back towards the screen.

The geometry of the average cinema, imposed by the requirements of a clear view of the screen, usually results in the reflected sound being directed into the audience.

When the difference between the paths of the direct sound from the screen and the reflected sound from the rear wall exceeds some 50 ft., a distinct echo is heard. For smaller differences there may be appreciable interference of a less obvious nature. For greater differences (i.e., nearer the front of the theatre), the echo is still further delayed and therefore more apparent.

Before a theatre is built, the most economic plan is to insure comprehensively against trouble. Three things should be done:

- (a) Avoid curvilinear surfaces facing the screen which have a focus near the audience. Reduce rear wall area to a minimum.

THE CINEMA THEATRE

- (b) Break up all rear wall surfaces above a normal dado height with architectural detail designed to disperse sound in a random manner, instead of reflecting it in a regular manner. The ideal section for such detail is a half cylinder. Minimum dimensions are approximately 4 in. deep by 9 in. diameter.
- (c) Increase the effectiveness of (b) by the application of sound-absorbing material having a high coefficient in the upper frequency range.

The ideal arrangement is to combine (b) and (c) by making the architectural detail from a sound-absorbing material. Suitable prefabricated products are on the market.

After the theatre is built, and echo trouble arises, practices (b) and (c) above should be followed, preferably by the use of prefabricated absorbing and dispersing products. Where the necessary facilities exist, it is a good plan to ascertain which is the offending surface—if there is any doubt—by hanging a heavy folded curtain against the suspected surface. The curtain may, in fact, be left as a temporary treatment.

Where echo is heard in a theatre having rear wall surfaces both above and below a balcony, the source of echo is the stalls rear wall in nine cases out of ten. Occasionally, the front wall of the balcony is at fault, but with most theatres this feature is approximately level with the stage speakers, and no energy is reflected down into the lower seating area.

VIII.4 FLUTTER

The phenomenon of flutter is due to an ordered state of reflection, in which high frequency sounds tend to persist in a regular back and forth reflection between flat parallel reflecting surfaces.

The only surfaces in a cinema theatre which are likely to provide the necessary conditions for flutter are the side walls; in the vertical plane the floor surface is well broken by the audience and seating; in the longitudinal plane, the proscenium arch, screen, and—if present—the balcony, will obviate any state of ordered reflection.

The probable presence of the defect may be investigated by clapping the hands in the main body of the auditorium. If a "ring" is heard, conditions are suspicious. The effect on

ACOUSTIC PRINCIPLES

speech and music is to introduce a "hard" effect, the former suffering the larger deterioration in quality.

Before the theatre is built, the opportunity exists for planning to eliminate completely this type of acoustic fault. If the site permits, a fan-shaped plan with continuously diverging side walls should be adopted. Under these conditions, flutter cannot exist. The plan also conforms to the requirements for ideal coverage from the stage loudspeakers.

If a rectilinear plan is unavoidable, the following two courses are open, the former being the more effective:

- (a) Break the side wall surfaces, above a normal dado line, with architectural detail, to promote random reflection of incident sound energy, thus reducing the regular back and forth reflections. The ideal section—as in the case of echo treatment—is semi-cylindrical, in this case with a minimum depth of 6 in. and a minimum pitch of 12 in. The section is not critical, however, and any detail which conforms to the main requirements is effective. The greater part of the surfaces in question should be treated (approximately 60%), and the treatment should be evenly distributed, so that no large area is left untreated. Attention is directed to the freedom from "flutter" associated with the older "Variety" type of theatre, in which surfaces are well broken with fibrous plaster detail, boxes, balconies, etc.
- (b) An amelioration of "flutter" may be achieved by applying sound-absorbing material of high efficiency to the side walls, thus reducing the intensity of the reflected energy. This may be combined with treatment to reduce reverberation, but is less satisfactory in the former capacity.

After the theatre is built, only practice (b) may be adopted, unless major redecoration is undertaken.

VIII.5 REVERBERATION

VIII.51 General

The general nature of Reverberation has been discussed in Section II.14. Certain features peculiar to Cinema Theatres are, however, worthy of further comment.

THE CINEMA THEATRE

Rather shorter optimum reverberation time is required for reproduced than for original sound. This is due partly to the fact that sound is reproduced at a higher level than the original, and partly because some reverberation is already present in the recording.

The optimum time of reverberation increases with volume of theatre as shown in Fig. 73. It also varies with frequency, as shown in Fig. 74A. In Fig. 74B, the inverse of opt. relative T of R (i.e. optimum relative absorption), is plotted against

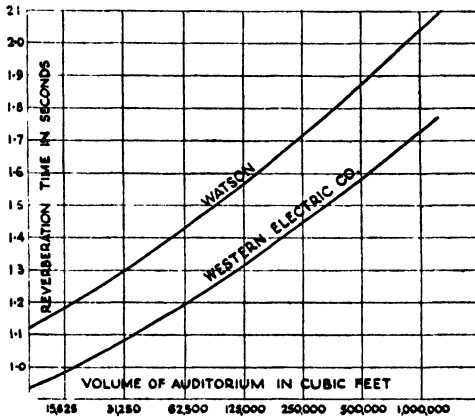

OPTIMUM REVERBERATION TIME OF AUDITORIA FOR 512 C.P.S.

FIG. 73 OPT. T OF R *v.* VOLUME

frequency, with the reference absorption taken as 100 units at 512 c/s., since most reverberation calculations are made in terms of absorption, and since 512 c/s is the usual key frequency. Fig. 74B may be conveniently used to calculate the relative optimum absorption for an auditorium at any frequency, once the optimum absorption at 512 c/s has been determined (see Appendix). Analyses of, and reverberation measurements in cinema theatres, show a tendency for the average frequency/absorption characteristic to have disproportionate absorption at high frequencies compared with that at low frequencies. Where treatment is required to reduce reverberation, a material with high absorption below 1,000 c/s and relatively less from 2,000 c/s upwards is usually the most suitable.

The greater part of the total absorption in a cinema theatre is provided by the audience itself. Since this absorption pays to

ACOUSTIC PRINCIPLES

come in, it would be uncivil not to make the most of it. By choosing the correct relationship between the volume and the average audience, an ideal reverberation time may be economically secured without recourse to additional treatment on this score.

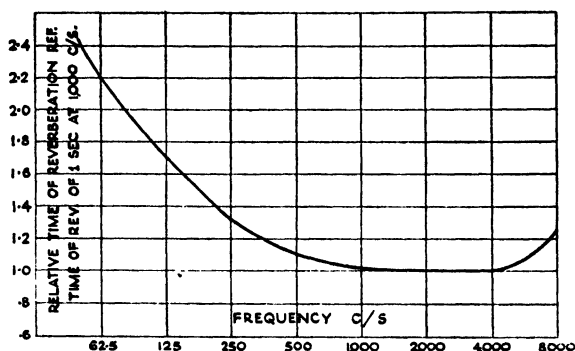

FIG. 74A OPT. T OF R V. FREQUENCY

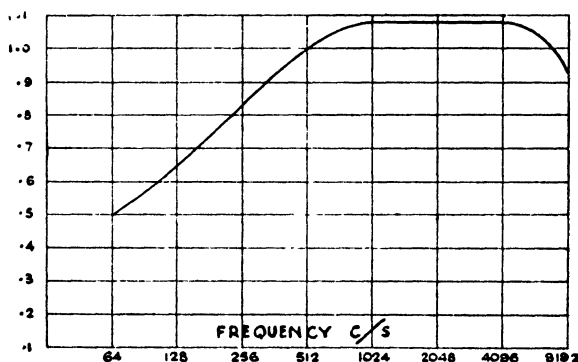

FIG. 74B OPT. ABSORPTION V. FREQUENCY

There will of course be variations above and below the average audience conditions; these variations may be reduced to a minimum by providing a good-quality, well-upholstered seat which has nearly as much absorption when empty as when filled. The variation may be still further reduced by the use of carpet runners between the rows of seats.

For all except abnormal conditions, the ratio between volume and number of seats is a very close indication of the reverberation performance of a theatre. The most convenient

THE CINEMA THEATRE

figure of merit is the volume in cubic feet divided by the total number of seats. Since optimum reverberation time increases with volume, so also will the factor Vol./Seat. It ranges from a volume of 130 for the smallest to 160 for the largest theatres.



FIG. 75 ADDITIONAL ABSORPTION REQUIRED *v.* VOL./SEAT

The optimum relationship between Volume, Seats, and Vol./Seat, for different volumes, number of seats and quality of seats, is shown in graph form in Fig. 75. Where the intercept of volume and seats for any theatre falls close to the datum line, that theatre will have satisfactory reverberation conditions with an attendance of $\frac{2}{3}$ full house (subject to certain special limitations to be discussed later). If the intercept falls markedly above or below the curve, the theatre will be under-damped or over-damped respectively, for $\frac{2}{3}$ full house conditions, and the extent of under- or over-damping may be approximately read off from the appropriate scale. Variation of reverberation with seats may be reduced, as mentioned above, by the use of a good-quality upholstered seat.

Much mention has been made of an attendance of $\frac{2}{3}$ full house. The attendance at a cinema theatre varies considerably, and some condition has to be chosen arbitrarily for which

optimum reverberation conditions should apply. The $2/3$ full house is considered a useful compromise, and recommendations for treatment are made on this basis, except where otherwise specified.

VIII.52 Departure of Reverberation Practice from Reverberation Theory

Whether the reverberation performance of a theatre is deduced from the Vol./Seat relationship, or is more accurately calculated from reverberation formulae and an acoustic analysis (as discussed in the next Section), certain assumptions are made. The chief of these are that the sound decays smoothly, and does so at the same rate everywhere. In theatres where flutter exists between parallel side walls, the first assumption does not hold, and large local variations from the ideal will occur.

When a theatre is built with a deep overhanging balcony, the auditorium is effectively divided into three volumes—the main void, the volume under the balcony and the volume over the balcony. Each volume has its own reverberation conditions which react with the other two. The most noticeable feature of these variations and inter-relations is that the main void usually has the longest reverberation period and the volume under the balcony the shortest. The energy under the balcony will tend to decay rapidly at first, and then, when the reverberation from the main void feeds into the heavily-damped area, at a slower rate.

In consequence, the application of any theory, or of any generalized computing device such as the Vol./Seat relationship, for the calculation of reverberation performance, must be made with the understanding of these facts.

One method of assessing the appropriate reverberation performance of a theatre with deep overhung balcony, is to ignore the volume and absorption under the balcony, and to consider the opening between balcony soffit and stalls floor as an absorbing surface with a coefficient of from 0.4 to 0.5 (depending on the pertinent factors).

VIII.53 Performing an Acoustic Analysis

The process consists of:

- (1) Measuring the areas of different surfaces in the theatre.
- (2) Multiplying by the appropriate absorption coefficient.

THE CINEMA THEATRE

- (3) Summing the values obtained to give a total value of absorption for, say, $\frac{2}{3}$ full house.
- (4) Relating this total to the absorption required for optimum reverberation conditions in a theatre of identical volume.

Absorption coefficients are usually measured over the frequency range 125 to 4,000 c/s, at octave intervals, and the summation process is usually extended over this range. Where a quick but less comprehensive solution is sought, the analysis is made at one frequency only, chosen at 500 or 1,000 c/s as reasonably representative of the chief range of frequencies.

Thereafter, it is convenient to work in terms of total absorption rather than reverberation times, because any adjustments will be made on an absorption basis—i.e. the area of material required may be computed easily from a knowledge of the calculated and the optimum total absorption.

The general layout of an Analysis Chart is shown in the Appendix.

The optimum total absorption at 500 c/s for the appropriate volume is calculated from the curve of Fig. 73 by means of one of the formulae relating Volume, Absorption and Reverberation Time (see below). The optimum total absorption at other

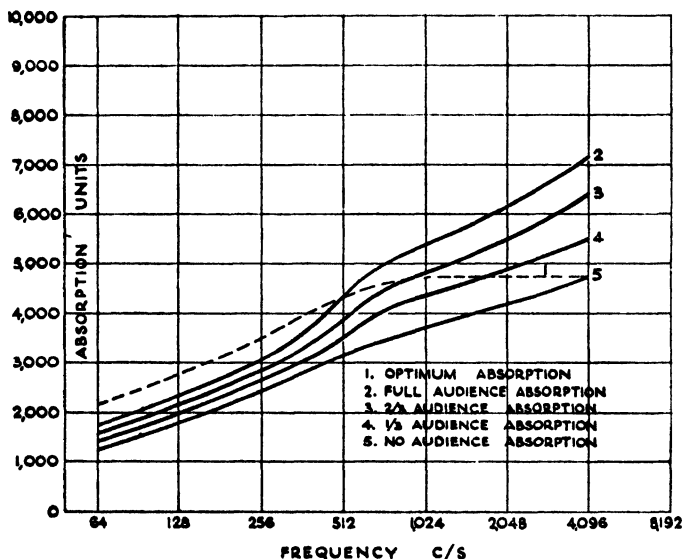

FIG. 76 OPT. AND CALCULATED T OF R

frequencies may be calculated by multiplying the value for 500 c/s by the approximate factor read off the curve of Fig. 74B.

If, now, two curves are drawn, one of which shows the relationship of optimum absorption with frequency and the other of calculated absorption with frequency, the differences between the two curves give a convenient picture of what is required of any necessary acoustic treatment. The frequency at which peak absorption is required is immediately apparent, and the total absorption required may be read off the absorption scale of the curve.

Fig 76 shows optimum and calculated absorption curves for the typical analysis set out in Appendix B (Section 9 of this Chapter).

The formulae relating Reverberation Time, Total Absorption and Volume are all approximations, because they all make assumptions concerning the nature of the decay of energy which do not necessarily occur in practice.

The first relationship was stated empirically by W. C. Sabine in the form:

$$T = \frac{0.05 V}{A} \text{ Where } T = \text{Reverberation Time in seconds.}$$

V = Volume in cubic feet.

A = Total Absorption.

“A” is determined as discussed above, by multiplying surface areas by absorption coefficients, so that the formula may be re-written:

$$T = \frac{0.05 V}{S a} \text{ Where } S = \text{Total Surface Area.}$$

a = Average Absorption Coefficient.

In the limiting case, where “a” approaches unity, this formula gives a false value of $T = \frac{0.05 V}{S}$

Obviously, one cannot have a reverberation time if no energy is reflected from the boundary surfaces.

Nevertheless, for all except heavily-damped rooms, Sabine's formula gives a fairly satisfactory answer, and is in quite general use.

C. F. Eyring developed an expression from first principles which gives:

$$T = \frac{0.05 V}{-S \log_e (1-a)}$$

This formula, besides taking account of the logarithmic nature of the energy decay, also gives an intelligent solution to the limiting case where "a" approaches unity. It is frequently used in connection with small dead rooms to give a calculated value of reverberation time much closer to the measured value than does Sabine's formula.

The validity of Eyring's formula has been extended by Millington, who has stated in effect that "the absorption is not evenly distributed over the entire surface area, but occurs in patches having different absorption coefficients. Let us represent this state of affairs in the formula."

This he gives as follows:

$$T = \frac{0.05 V}{-\Sigma S_1 \log_e (1-a_1)}$$

where the symbol Σ means "the sum of".

In other words, he follows the technique for the analysis in Appendix B (Section 9) and multiplies the areas of different materials according to the expression $S \log_e (1-a)$, then adds them all together, and divides the total into $0.05 V$.

Note.—In order that Logarithmic Tables may be used in the solution of these expressions, the Napierian Logarithm may be converted to the base 10 by dividing by a factor 2.3 —i.e.:

$$\text{Log}_e = 2.3 \log_{10}, \text{ whence } T = \frac{0.05 V}{-2.3 S \log_{10} (1-a)}$$

$$\text{or } a = 1 - \frac{1}{\text{antilog}_{10}\left(\frac{0.022 V}{T S}\right)}$$

All these expressions are liable to error because of the factor "0.05V" which involves the "mean free path" or average distance between reflections. The value of the mean free path varies appreciably for a sphere, a cube or a cylinder; there are similar small variations between theatres of different shapes.

Both Eyring's and Millington's formulae assume idealized conditions in the behaviour of energy decay, which do not occur in practice, and which may—as in the case of "flutter" or echo—be not even approached.

Despite these perhaps rather academic criticisms, it is a fact that for normal conditions, as found in the average cinema

theatre, the formulae do predict fairly accurately the reverberation performance of an auditorium, in the absence of serious departures from good design.

VIII.54 Variation of Reverberation Time with Humidity

At high frequencies (2,000 c/s and over), the absorption of sound in air has a considerable value, which is a function of temperature and humidity and also of the frequency of the sound in question.

For a homogeneous medium such as air, the loss due to air absorption is expressed by the relationship:

$$I_x = I_0 e^{-mx}$$

where x = distance from source

m = attenuation constant for the medium under consideration.

“ m ” is a measure of rate of attenuation, the absolute magnitude of which is expressed in the terms of the units employed for the space (or speed-time) ordinate.

Applying the above relationship to decadent sound in an auditorium, “ x ” is expressed as “ vt ” where “ v ” is the speed of sound and “ t ” is the time of decay.

Employing Eyring’s analysis, the decadent energy after a time “ T ” is given by:

$$E_t = E_0 e^{-\frac{v S \log_e (1-a) t}{4V}} e^{-mvt}$$

$$\therefore \text{whence } T = \frac{0.05V}{-S \log_e (1-a) + 4mV}$$

It will be appreciated that the magnitude of the attenuation is a function of T , the reverberation time during which it is operative.

A chart relating “ m ” and relative humidity for a series of frequencies is given in Figure 77. For frequencies up to and including 1,000 cycles per second, losses due to humidity are small and may be neglected. The peak values for “ m ” in the region 10 per cent. to 20 per cent. relative humidity are merely of academic interest, since such dry conditions are encountered only in desert regions.

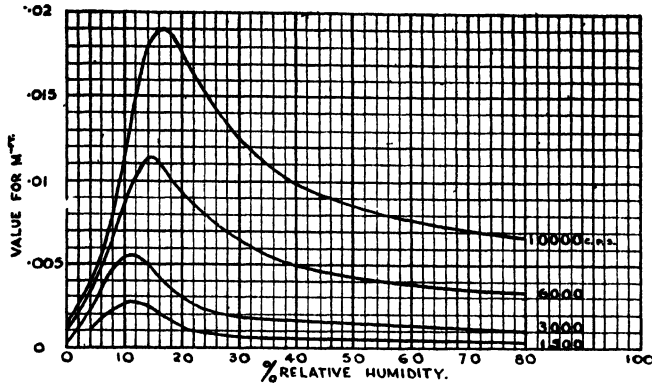

FIG. 77 PLOT OF M AGAINST RELATIVE HUMIDITY (AFTER KNUDSEN)

VIII.55 Treatment against Reverberation

The following procedure should be adopted while the theatre is in the design stage:

- (a) Co-ordinate the seating plan and the sections through the theatre, in such a manner as to obtain the optimum ratio of Volume/Seat for the auditorium as shown in the graph of Fig. 75, and so reduce the amount of acoustic treatment required.
- (b) Arrange to reduce the variation of Reverberation Time with number of audience, by employing a good quality heavily-upholstered seat, and by using carpet runners between rows of seats.
- (c) If the optimum Volume/Seat relationship cannot be obtained purely by geometric methods (due, for instance to special requirements in the way of decoration), the Reverberation Period should be modified by the application of sound-absorbing material. The area required should be calculated as explained in Section 53 above and in Appendix B (Section 9). In order to obtain as even a distribution of sound absorption as possible, such material should be applied to the side walls in the main void of the auditorium, because:
 - (i) The ratio of volume to absorption is greatest in this part of the auditorium.
 - (ii) Reflections in the vertical plane suffer adequate absorption and dispersion at the floor.

ACOUSTIC PRINCIPLES

Where possible, the side wall absorbent treatment should be combined with treatment to guard against flutter. For this purpose, prefabricated absorbent and dispersing products are very suitable.

Alternatively, absorption in the form of flat panels may be distributed, in small sections, between other areas of architectural detail whose function is solely to provide dispersion.

If a substantially flat surface is necessitated by the decoration scheme, the sound-absorbing material should be distributed over the surface area in small sections, to provide at least some measure of irregular reflection. However, it is a better idea to change the decorative scheme, which contributes less to the evening's entertainment than does the sound.

After the theatre is built, only practice (c) above may be adopted.

In severe cases of excessive reverberation, it may be necessary to extend treatment to the ceiling.

VIII.6 EXTRANEOUS NOISE

Extraneous noise, by virtue of its masking effect, tends to reduce intelligibility. A secondary effect lies in the temptation to increase the level of sound from the stage speakers, which in turn increases the effective Reverberation Time, and emphasises Flutter and Echo, if these are present.

Common sources of extraneous noise are the audience (scuffing of feet may be reduced by carpet runners), projection room equipment, ventilating systems, motors and generators, and sometimes street noises.

Ventilating systems, machinery isolation and insulation generally have already been discussed in this book.

VIII.7 WHOM TO CONSULT

The architect who specialises in the design of Cinema Theatres should be acquainted with approved practice and the currently available acoustic materials. In special cases, he may enlist the services of a specialist or consultant. For obvious reasons, the suppliers of acoustic materials or of sound-reproducing apparatus are ready to advise on aspects of Theatre Acoustics, which intimately affect the performance of their products.

Should trouble arise after the theatre is built, the initial step is probably to consult the service engineer who is responsible for the maintenance of the sound-reproducing equipment, or the circuit supervisor. These people, by virtue of their continual close association with a number of theatres, are usually in a position to indicate the specific nature of acoustic faults, and frequently are backed by a headquarters organisation capable of making appropriate recommendations.

Should a second opinion be desired, either a firm which markets acoustic materials, or an independent consultant, may be approached. To save much time, it is very desirable that they should be presented with all pertinent information at the outset. The chief features of an Acoustic Survey are listed below in Appendix A.

In Appendix B, a typical analysis is given for a Cinema Theatre seating 800, having a volume of 129,600 cubic feet, and an internal surface area of 17,838 square feet.

VIII.8 APPENDIX A

A typical acoustic analysis requires the following information:

- (1) Name and address of Theatre.
- (2) Maker of the sound-reproducing equipment. (It is assumed that this is in good order and that the quality of reproduction is satisfactory.)
- (3) Architect's drawings or, failing these, dimensioned sketches, showing, particularly, plan and long section. All curves in ceiling and walls should be shown.
- (4) As it may be necessary to apply treatment to the rear walls above and below the balcony (usually above a horizontal line about 5 ft. from the floor), and on selected areas of the side walls, the availability of these surfaces or their decorative detail should be accurately shown.
- (5) Precise details of location and quality of any carpets and curtains.
- (6) Number of seats (total).
- (7) Description of seats (e.g., upholstered seat, plywood below; padded back and arms).
- (8) Subjective impression of acoustic conditions—i.e., are echo and flutter audible, and where? Is reverberation excessive?

VIII.9 APPENDIX B

TYPICAL ANALYSIS OF CINEMA THEATRE

Volume—129,600 Cubic Feet.

Opt. T of R—1.32 Secs (Fig. 73).

Surface	Proscenium Opening	Fibrous Plaster	Plaster on Brick	Finished Wood	Plaster on Lath	Ventilation Grilles	Unlined Carpet	Total Surface Area = S
Front Wall Stalls ..	448	250	150	—	—	—	—	848
„ „ Balcony ..	—	150	—	—	—	—	—	150
Rear Wall Stalls ..	—	—	424	80	—	—	—	504
„ „ Balcony ..	—	—	396	80	—	—	—	476
Ceiling	—	—	—	—	4,000	240	—	4,240
Soffit	—	—	—	—	1,040	80	—	1,120
Proscenium Splay Walls ..	—	—	1,020	80	—	150	—	1,250
Side Walls	—	—	3,140	160	—	—	—	3,300
Floor Stalls	—	—	—	—	—	—	1,340	4,550
„ „ Balcony	—	—	—	—	—	—	572	1,400
Totals	448	400	5,130	400	5,040	470	1,912	17,838 = S

Material	Area	64		128		256		512		1024		2048		4096	
		a	A	a	A	a	A	a	A	a	A	a	A	a	A
Proc.: Opening	448	0.4	179	0.4	179	0.4	179	0.4	179	0.4	179	0.4	179	0.4	179
Fibrous Plaster	400	0.01	4	0.02	8	0.04	16	0.06	24	0.08	32	0.04	16	0.06	24
Plaster on Brick	5,130	0.01	51	0.01	51	0.015	76	0.02	103	0.03	154	0.04	205	0.05	256
" " Lath	5,040	0.01	50	0.02	101	0.03	151	0.04	202	0.05	252	0.03	151	0.03	151
Finished Wood	400	0.05	20	0.05	20	0.05	20	0.05	20	0.05	20	0.05	20	0.05	20
Grilles 10%	470	0.1	47	0.1	47	0.1	47	0.1	47	0.1	47	0.1	47	0.1	47
Unlined Carpet	1,912	0.1	191	0.15	287	0.2	382	0.25	478	0.35	669	0.4	764	0.45	860
Seats	800	1.0	8,00	1.5	1,200	2.0	1,600	2.5	2,000	3.0	2,400	3.5	2,800	4.0	3,200
Total Absorption with No Audience	—	1,342	1,893	2,475	3,053	3,753	4,737								

Note. Coefficients "a" are taken arbitrarily at simple values for ease of calculation.																
‡ Audience Differential*	..	267	0.5	133	0.6	162	0.75	200	1.5	400	2.0	534	2.5	667	3.0	800
Total abs. ‡ Aud.	1,475	2,055	2,675	3,453	4,287	4,849	5,537	6,337	7,137					
" " ‡ "	1,608	2,217	2,875	3,853	4,821	5,516	6,337	7,137						
" " Full	1,741	2,379	3,075	4,253	5,355	6,183	7,137							

*The above coefficient is the difference between an Occupied and an Unoccupied Seat.

ACOUSTIC PRINCIPLES

From Fig. 73, Opt. T of R at 512 c/s for a volume of 129,600 cubic feet = 1.32 secs.

$$\text{Hence } 1.32 = \frac{0.05 V}{-2.3 S \log_{10}(1-a)}$$

$$\begin{aligned} \therefore a &= 1 - \frac{1}{\text{antilog} \left(\frac{.022 V}{TS} \right)} \\ &= 1 - \frac{1}{\text{antilog} \left(\frac{.022 \times 129,600}{1.32 \times 17,838} \right)} \\ &= 0.24 \end{aligned}$$

$$\begin{aligned} \therefore \text{Total Optimum Absorption at 512 c/s} &= Sa = \\ &17,838 \times .24 = 4,282. \end{aligned}$$

From Fig. 74B, relative optimum absorption for the frequency range 64-4,096 c/s is:

Frequency	64	128	256	512	1,024	2,048	4,096
Absorption	50	65	82.5	100	108.5	108.5	108.5

Optimum absorption for the frequency range 64-4,096 c/s is:

Frequency	64	128	256	512	1,024	2,048	4,096
Absorption	2,141	2,783	3,533	4,282	4,646	4,646	4,646

This curve of Optimum Absorption *v.* Frequency is plotted, together with the four conditions of audience, as Fig. 76.

A glance at the curve shows that in general, the theatre is over-damped at high frequencies and under-damped at low. At 512 c/s, the auditorium is under-damped, for a condition of 2/3 attendance, to the extent of approximately 400 absorption units. Reference to Fig. 75 shows that a theatre of 129,600 cubic feet and 800 seats might normally be expected to show a deficiency of 800 absorption units at 512 c/s.

Chapter IX

THE ACOUSTICS OF SMALL ROOMS

Talks Studios; Preview Theatres; Scoring, Dubbing and Looping Rooms; etc.

IX.1 GENERAL

AS was stated in the previous Chapter, the laws dealing with the cinema theatre are not exact. The intelligent application of these laws will result in an auditorium whose acoustic properties will be generally acclaimed as satisfactory. Although the technique is based on approximations, and the results are also approximate, little more can in practice be done about it. This is no great matter, because the ear will accept variations in results of the same order as the approximations of the technique.

Where, however, the size of the room is continuously decreased, the approximations become increasingly evident as such. Moreover, while the cinema theatre has one specific function to perform, the uses of say, a small recording studio may be many. The Talks Studio and the Scoring Stage are required to cater for yet other (often quite dissimilar) purposes.

When dealing with these special auditoria, therefore, consideration must be given to the purposes to which they will be put, and these requirements must be considered in the light of the approximations which can be applied successfully to the large cinema theatre.

IX.2 NATURAL MODES OF RESONANCE

It has, for instance, been assumed that sound waves obey the reflection laws of light. For frequencies above 1,000 c/s, this is a legitimate assumption. It is upon this assumption that treatment is based to disperse regular reflection by means of diffusing surfaces. At low frequencies, this assumption may be grossly inaccurate—particularly where, as in small rooms, the reflecting walls, etc., have dimensions of the order of the wavelength of the sound.

A volume of air which is enclosed, or substantially enclosed, has the ability to resonate at a triple series of frequencies, one associated with each of the three major axes of the room. For large auditoria, these frequencies are very low, because of the large dimensions involved, and require much energy to excite because of the large volume of air which must be motivated. For these very sufficient reasons, room resonances may be neglected in cinema theatres.

Everyone, however, is familiar with the colourful resonances which, in a bathroom, enchant the singer, if not his neighbour. Pronounced resonances of this type are an everlasting curse in broadcasting or recording.

Such resonances may be excited by a source of identical frequency, or of closely-adjacent frequency, or by transients. (A transient may be described approximately as an energy pulse whose intensity changes over a wide range in a very short time.) Once excited, the resonance builds up very quickly, because of the small damping it suffers. When the excitation is removed, the intensity of the resonance decays logarithmically.

The objectionable resonances are largely confined to the frequency range 50-400 c/s and, because of this small range, coupled with the large number of possible resonances, it may happen that two resonances of nearly the same frequency combine together to produce a very unpleasant "beat note" whose frequency is the difference between the two resonant frequencies.

Very little can be done to eliminate resonances in small rooms where the conditions are conducive to such effects—i.e., where the dimensions are of the order of low-frequency wavelengths, and where energy is present at sufficient intensity to excite the resonances. It may be arranged, however, that a resonance in one plane does not coincide with a resonance at the same frequency in another plane, so avoiding mutual reinforcement. This may be achieved by arranging so that the three major axes of the room have sufficiently different dimensions.

Because resonances have a narrow band-width (i.e., they operate over a small range of frequencies), one resonance may excite an adjacent resonance if the frequency separation of their peak resonances is small. Therefore, the ratios of the major axes should be determined with these additional factors in mind.

Similarly, a resonance may excite another resonance which is removed one octave from it; harmonic relationship between the dimensions must accordingly be avoided.

If the smaller dimension is taken at $d = 1$ and the next dimension is taken at $d = 1\frac{1}{2}$, or $d = 2\frac{1}{2}$ or $1\frac{2}{3}$ or $2\frac{2}{3}$, close harmonic relationships between the two modes are avoided. Note that it is the fraction which is of importance, not the integer.

A more common basis for determining dimensions is to choose distances which bear a ratio to one another based on $\sqrt[3]{2} = 1.26$. Thus the smallest rooms, which most nearly approximate a cube, would have major dimensions in the ratio $1 : \sqrt[3]{2} : (\sqrt[3]{2})^2$ i.e., $1 : 1.26 : 1.58$. A more normal shape would be in the ratio $1 : (\sqrt[3]{2})^2 : (\sqrt[3]{2})^4$ —i.e., $1 : 1.58 : 2.56$.

The use of such ratios, if confined within limits of ± 5 per cent., will tend to produce an even distribution of resonances over the frequency range where they are of importance. This is the next best thing to their complete elimination, which is impossible for small rooms having normal sound-reflecting surfaces.

The condition of room resonances may be still further ameliorated by the correct distribution of sound-absorbing material. Should a mode of resonance exist in a horizontal plane between two highly reflecting surfaces, absorption on the floor and ceiling, or on the other two walls, will have a negligible effect on the resonance. The absorption in the room should be distributed so as to be effective in all three planes.

IX.3 FREQUENCY ABSORPTION CHARACTERISTICS

The relationship commonly used to correlate Reverberation Time and Frequency in the cinema theatre, and in large auditoria generally, is that shown in Fig. 74, Section VIII.51. This relationship was deduced theoretically by McNair, who postulated that the requirement for good listening was equal loudness decay. Later work by Fletcher and Munson on loudness suggested a small modification to the contour over the frequency range above 1,000 c/s, resulting in a small relative decrease of reverberation at these frequencies.

The consensus of qualified opinion in respect of listening conditions is now towards an increasingly flat characteristic as the volume of the auditorium is progressively reduced, particularly for speech.

Where it is also required to record, it must be borne in mind that recording systems are monaural channels. If one ear is sealed, so that no discriminatory adjustments can be made between direct and reflected sound, the aural effect is of increased reverberation. Once this effect has been recorded on a monaural system, the ears, though listening binaurally, can do nothing about it.

Such work as has been done on this subject is chiefly empirical in character. Various proportions of reverberation at different frequencies (varying with volume) have been suggested, put into practice, and checked by measurement and by listening to recorded programmes. Fortunately, preview theatres and small talks studios and recording studios frequently lend themselves to experiment and adjustment until the desired conditions have been achieved. Where possible, this procedure is to be recommended, and it usually means only one adjustment after completion of the calculated treatment.

In the practical solution of the problem of flat or nearly flat reverberation characteristics, the chief difficulty is to obtain high absorption at low frequencies, without over-damping at higher frequencies. As discussed in Section X.2, frequency absorption characteristics may be modified by methods of fixing, and by surface finish and treatment.

Other finishes which have useful low frequency absorption are plaster on expanded metal, wood panels, and similar light partitions backed by an air space. Such constructions have resonant properties, and care should be taken in their design to ensure that they are well damped, and that their resonant frequencies are distributed over a fairly wide frequency range. These constructions may very conveniently be applied as diffusing surfaces, and may be designed to have absorption in the range 100-250 c/s of the order of 0.20, according to the geometry and other physical properties of the assembly. Where pronounced resonance is experienced in small rooms, a comparatively small area of tuned panel absorbent, applied to the offending surfaces, may deal adequately with the narrow band of frequencies involved.

IX.4 CATERING FOR THE HIGHER FREQUENCY RANGE

In order to retain brilliance in small rooms at frequencies in the range above 5,000 c/s, it is desirable to avoid large areas of porous materials. Smooth hard finishes to panels of the type

described above are desirable (by varnishing, polishing, painting) provided, of course, that adequate means are taken elsewhere to promote good diffusion at these frequencies.

As mentioned earlier in this Chapter, the optimum reverberation/frequency response characteristic is partly a function of purpose, to which it must be adjusted within the general principle of increasingly flat characteristic with decreasing volume. For small preview theatres and recording studios up to 25,000 cubic feet, a substantially flat characteristic up to 7,000 c/s is usually considered preferable for listening and general recording purposes. In the frequency range above 7,000 c/s, requirements are often conflicting. Thus the considerable output from brass instruments—particularly the trombone and trumpet—in the region 7,000-10,000 c/s calls for a drooping reverberation/frequency characteristic. Where a flat characteristic is employed, brass sounds hard and brittle, and the effect is often discomforting to the performer and other members of the orchestra playing in a small room. On the other hand, a flat characteristic over the same high frequency range improves the quality of strings and wood-wind.

In the case of talks studios used solely as such, the compromise is between those voices rich in overtones, and those of a softer nature which are comparatively lacking in the higher frequencies; the former call for a shorter reverberation time at high frequencies than do the latter. Both types cannot be separately catered for, and the balance is struck by the responsible acoustic engineer, usually in favour of the over-damped condition, on the grounds that this causes the least average distress and promotes an intimate atmosphere appropriate to a talks studio. He can further support his choice by the contention that microphone placement enables him, in part, to adjust the relationship between direct and reverberant energy, according to requirements.

Scoring stages, of the type used for recording large bands and orchestras, have volumes up to 150,000 cubic feet. They are also pressed into service for a host of other recording purposes, calling for a large variety of acoustic conditions. In practice, the varying requirements are partly met by the use of portable flats which may be reflecting on one side and absorbent on the other, and partly by microphone technique where the polar characteristics and the placement of the microphone are used to modify local reverberation conditions.

Where treatment of scoring stages is incorporated in the structure, use is sometimes made of reversible or rotatable panels of differential absorption. One side of the panel may have its major coefficients distributed over the range up to 2,000 c/s with a sharp cut-off, and the other side may be covered with a porous material having a continuously-rising characteristic. An adequate seal around the edges is important if the calculated variation is to be realised in practice. For methods of sealing, see Section V.2 on Door Seals.

Low-frequency absorption may, as in the case of smaller studios, be conveniently incorporated in diffusing elements, as will be described in the next Section.

Ideally, scoring stages are planned in consultation with the responsible recording engineer, who usually has quite definite ideas concerning his requirements for acoustic treatment.

The two unifying requirements of all auditoria are that the reverberation frequency characteristics should be smooth and devoid of large variation, and that the decay curve for each frequency should also be reasonably smooth, without humps or bumps or changes of slope.

IX.5 REVIEW OF TREATMENT METHODS

Any effort to promote a diffuse condition of energy is particularly commendable in small rooms. As in the case of the cinema theatre, a substantially logarithmic decay, devoid of large variations about the mean, is desirable. The small room also makes more stringent demands in the matter of early reflections. The benefits which result from a smooth, logarithmic decay are reflected particularly in the latitude of microphone placement.

Hearing and recording requirements are best realized when direct sound from the source is heard in the presence of the correct proportion of diffuse reverberant energy. The early reflections from walls, ceiling, etc., when confined to an ordered state, tend to produce variations of high intensity during the initial part of the decay; the outstanding example is, of course, echo.

The desirable conditions may be promoted by the asymmetrical location of absorbing material, which eliminates the probability of heavily and lightly damped modes of reflection existing simultaneously, and by the use of diverging paired

THE ACOUSTICS OF SMALL ROOMS

surfaces and diffusing elements which promote a random reflection of energy, thus breaking up ordered modes which might otherwise exist (see Figs. 78, 79 and 80).

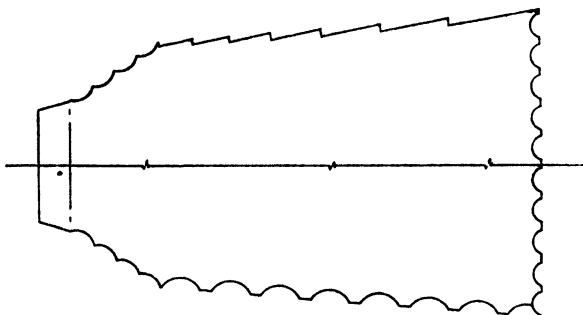

FIG. 78 PLAN OF THEATRE—SHOWING ALTERNATIVE DIFFUSING ELEMENTS

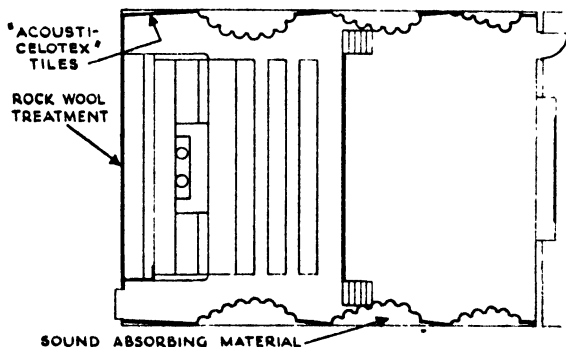

FIG. 79 PLAN OF A REVIEW ROOM (M.G.M. ELSTREE STUDIOS)

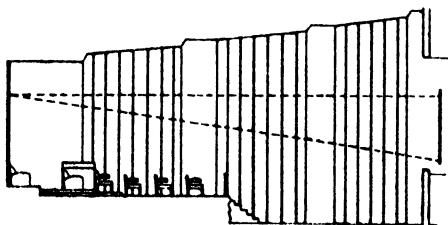

FIG. 80 ELEVATION OF A REVIEW ROOM (M.G.M. ELSTREE STUDIOS)

Where highly and lightly damped modes of reflection exist simultaneously, it is an obvious deduction that any absorbent material is being used inefficiently—i.e., it promotes a quick decay in the highly damped mode, but registers only a small effect in the lightly damped mode. A random distribution of absorption will therefore secure a more economic treatment on a purely financial basis.

Non-parallel opposite surfaces tend particularly to break up high-frequency ordered reflections; the occasion for their adoption frequently arises in the case of side walls.

Diffusing elements may be designed to take effect over a wide frequency range and, when properly designed, constitute the most effective treatment to obtain diffuse energy conditions.

Whereas, for the large auditorium, the shape and size of detail in the diffusing surface may be liberally interpreted, in the small room greater attention must be paid to efficiency. A convex section—preferably semi-cylindrical—produces greater dispersion of incident energy than a V-section of identical pitch and chord and depth. Because low frequencies are particularly troublesome, the dimensions of at least some of the elements should be comparable with the wavelengths involved. Considerable practical experience in the use of poly-cylindrical diffusing elements of the resonant type has confirmed the following as representing good practice:

- (1) The elements should have a chord varying from approximately 12 in. to approximately 48 in.
- (2) The corresponding depth should vary from approximately 3 in. to approximately 9 in.
- (3) The elements should be faced with some light flexible material such as plywood, attached to bracing members spaced at irregular intervals to avoid resonances confined to a narrow frequency band.
- (4) The facing material should be damped by fixing to the bracing members through some material like felt, or by packing the cavity with rock wool.
- (5) It is advantageous if the axes of the diffusing elements in the three planes are mutually at right angles.

THE ACOUSTICS OF SMALL ROOMS

- (6) Approximately 75 per cent of the wall and ceiling surfaces should be covered with diffusing elements, which should be evenly distributed over the available surfaces.
- (7) Where a cavity exists within the boundaries of the diffusing element, some sound-absorbing material with high efficiency at low frequencies should be used as a lining to reduce undesirable cavity resonance.

Details of a typical construction of diffusing panel are shown in Fig. 81.

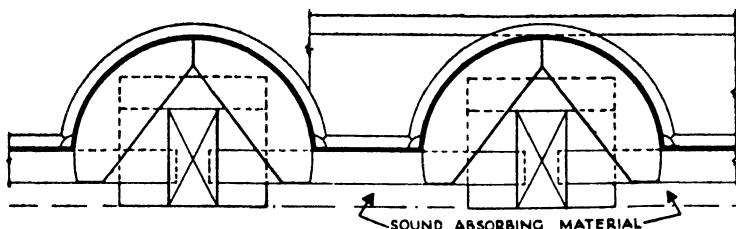

FIG. 81 PLAN OF TYPICAL CONSTRUCTION OF DIFFUSING PANEL

Chapter X

ABSORPTION COEFFICIENTS

X.1 GENERAL

THE absorption coefficient of an absorbing material was originally defined by Sabine as the ratio of the absorption of a square foot of the material to the absorption of a square foot of open window. The implicit assumption is that, of the sound energy incident on an open window, none is reflected. For a window whose dimensions are large compared with the wavelength of the sound in question, this is a reasonably true statement of fact—for a small area in the centre of the window. Where the dimensions are small compared with the wavelength, the open window may have considerable reflecting properties, and edge effects detract from the 100% transmission of any opening.

Nevertheless, the conception of a surface which has 100% absorption provides a useful theoretical standard, in terms of which the relative performance of physical materials may be stated.

The formulae which relate reverberation time with volume and absorption employ this conception of a unit of absorption as the absorption of a square foot of surface having 100% absorption, and the necessity arises for stating the performance of room furnishings and finishes in terms of the standard unit, so that the formulae may be applied to the facile computation of reverberation times.

The obvious procedure is to measure the reverberation time of a room before and after a known area of sound-absorbing material has been introduced, and then, by inserting these reverberation times separately into the formula, to calculate the total change of absorption due to the material. Division of this total absorption by the superficial area of the material will give the absorption coefficient in terms of the theoretical standard 100% absorption (subject to correction for the original surface absorption covered by the sound-absorbing material).

In practice, results do not work out quite so conveniently. As was mentioned in Section VIII.52, the reverberation

ABSORPTION COEFFICIENTS

formulae all assume that there is an equitable distribution of energy during reverberation, so that each element of surface receives its fair share of incident energy; only under these conditions can the surface register its true absorption coefficient. Where echo and flutter exist, the departure from equitable distribution is audibly manifest. Less obvious discrepancies between fact and theory affect the measured absorption coefficient, due to the same end cause. Thus if a highly-absorbent material is applied to one surface only of a rectangular room whose surfaces are otherwise highly reflecting, those modes of reflection in the two planes which do not involve the absorbent surface will be relatively uninfluenced by it. There will be a tendency, under these conditions, to measure a lower coefficient than would be the case were the material evenly distributed. If the same area of material is laid in a pattern of narrow strips, an edge effect occurs which tends to increase the effective absorption, thus increasing the apparent coefficient. Where the width of the strips and of the spacing between them are regular, a selective change of absorption with frequency is measured—i.e., the material itself may impose local changes in the energy distribution because, obviously, the difference is not due to a change in the material itself. Small areas of material in large reverberant rooms may register an effective absorption which represents a calculated coefficient much greater than unity.

Where, therefore, any attempt is made to calculate absorption coefficients by measuring differential reverberation times, the only deduction that may truly be made is that the material in question acts as if it has an absorption coefficient of X , when S square feet are applied and located in the manner specified for the test, and where the calculations are made from the appropriate formula; if the material is located in another room of different shape or volume, or in another situation, or in different amount, the same calculated coefficient of absorption will not necessarily apply.

That which is deduced and applied concerning the absorbing power of a material is therefore not a true absorption coefficient; it is rather a figure of merit, of variable magnitude, whose application calls for an appreciation of the factors involved.

The foregoing perhaps appears gloomy, but much can and has been done to straighten out a rather complicated situation. Efforts have been directed chiefly at eliminating and reducing

ACOUSTIC PRINCIPLES

variables in the reverberation chamber measurements of absorption coefficients, and results published by reputable authorities show a large measure of agreement, and provide a reasonably fixed basis for subsequent calculation and application. For instance, reverberation chambers are built of similar dimensions and proportions; opposite surfaces are arranged to avoid parallel areas; a standard area of material is employed for the test; the energy distribution throughout the room is averaged by warbling the test tone on either side of its nominal frequency, by rotating the pick-up microphone, or by continuously sampling the outputs from a series of microphones distributed throughout the reverberation chamber.

However, the practicing acoustic engineer is often concerned with the way in which absorption varies with frequency, rather than with the absolute value of the absorption at any given frequency. He can vary the total absolute value of his absorption by increasing or decreasing the total area; by the nature of things, small variations about a theoretical optimum are usually unimportant. But, nearly always, the acoustic engineer wishes to absorb chiefly the low frequencies or chiefly the high, or else he wants a standard absorption over a limited frequency range. Off-hand, the Author cannot recall an occasion when the absorption frequency characteristic of an acoustic treatment has not been of considerable importance. From the point of view of the man who pays the bill for treatment, it is of paramount importance that he should purchase an absorbent material which will most economically absorb at the frequency range of interest, nor does he want the job spoiled by excessive absorption at some other part of the frequency range where sufficient (or even too much) absorption already exists.

Now, where the absorption coefficients of a material, or of a group of materials, are measured by the same technique, and by the same authority, the relative magnitudes of these coefficients may be very clearly determined. Consider the following table of absorption coefficients of typical materials:

Frequency c/s	62.5	125	250	500	1,000	2,000	4,000
Material A ..	.1	.15	.2	.5	.7	.75	.8
Material B ..	.3	.35	.4	.5	.5	.4	.3

ABSORPTION COEFFICIENTS

Material A has a characteristic rising continuously with frequency, and it may be stated (provided the measuring authority is reputable) that the absorption at 250 c/s is twice that at 62.5 c/s and one fourth that at 4,000 c/s.

Material B has a quite different characteristic, peaking between 500 and 1,000 c/s, and having considerable low frequency absorption. It would be used for quite different purposes. Again, the same confident statements may be made regarding the way in which absorption varies with frequency. If the materials have both been measured by the same authority, it may also be stated that, within very small limits, both materials have identical absorption at 500 c/s.

Certain generalisations can be made concerning the frequency absorption characteristics of materials. For instance, high frequencies are absorbed by materials having surface porosity; no appreciable increase in high frequency absorption follows an increase in the depth of the surface porosity, or of the overall thickness of the material, beyond a certain maximum. Low-frequency absorption requires greater thickness; a fibrous structure, with intercommunicating air cells, is influenced by the density of the material and is increased by the flexibility of the material as a whole and by resilience of the surface. Surface porosity is not of such great importance for low-frequency absorption, although some perforation of the surface appears to be essential for the highest efficiency in this frequency range. Practical examples will illustrate the above points. Figs. 82 and 83 are particularly interesting in that large changes in the characteristic are produced merely by changing the centres of the perforation in a hard facing sheet. A thin carpet will have considerable high frequency absorption. If a felt underlay is added, the low-frequency absorption will be increased, but little change will be produced at high frequencies. A thick, soft felt, covered with a thin flexible skin, will have good low-frequency absorption, with decreasing absorption above, say, 1,000 c/s. The high-frequency absorption of this material may be increased by perforating the skin to increase surface porosity (see Figs. 86 and 87).

The method of application of an absorbent material provides a variable which affects the final absorption coefficient. In this connection, acoustic absorbents may be divided roughly into two classes—fabricated products or materials applied on site.

The first class is represented by tiles (such as Acousti-Celotex), wood wool boards, rock wool slabs, acoustic felts, etc. The second class includes acoustic plasters, mineral wool packed on site, sprayed fibre treatment, etc. For normal building methods, there is little danger of damaging the absorption during fixing the first class of materials, which are machine-made to a standard specification, and are mounted in traditional fashion. The second class is more susceptible to variation due to changes in the proportions of fibre and binder, to the rate of feed (if sprayed), or to trowelling operations, etc. Handling by indifferent craftsmen may ruin the performance of such materials as acoustic plaster, and great care should therefore be exercised when these materials are specified.

Quilts, blankets, etc., form an intermediate group because, while such materials are themselves stable and consistent products, the method of application may affect the results. Where such materials are applied directly to a wall or ceiling surface, close correlation may be anticipated with the reverberation chamber coefficients (assuming similar conditions for the two cases). However, because of the high transmission coefficient of such materials, a high proportion of energy passes through the material and is reflected by the hard backing surface. If an air-gap is left between the quilt or blanket and the reflecting surface against which it is mounted, increased absorption is obtained at the frequency for which the distance of separation is $\frac{1}{4}$ or $\frac{3}{4}$ or $1\frac{1}{4}$, etc., times the wavelength—i.e., at the position of maximum air-particle velocity. This property of highly porous materials is frequently employed in order to increase low-frequency absorption. In view of the random incidence of energy, the absorption is enhanced over a fairly wide band width which may be still further extended by varying the air-space behind the material.

The absorption coefficient of a material may be modified by decorative processes carried out on it. Materials which provide absorption chiefly by surface porosity are particularly susceptible, and acoustic plasters may be decorated only by means of non-clogging spirit stains or by the use of dyes incorporated in the original mix. If sprayed fibre is decorated with any product which reduces surface porosity, it may still retain considerable low-frequency absorption, provided (a) the total thickness is adequate, and (b) the decorated surface is sufficiently pliable.

ABSORPTION COEFFICIENTS

Tiles of the Celotex type derive their absorption from energy dissipation in holes drilled into the material; these tiles may be painted without loss of efficiency, providing the natural precaution is taken to avoid sealing the holes. Wood wool products, held with a cement binder, may be similarly decorated, provided the interstices are not closed.

Acoustic Felts are available with alternative surface finishes, chosen according to decorative requirements. The felt is usually fixed with adhesive to any flat continuous surface and the joints of adjacent strips "combed" to produce an unbroken surface. This is then given a coating of acoustic size which in turn secures the cotton surface fabric. For subsequent decoration by distemper or paint, a thin muslin is used for this purpose. It should be of open weave to retain some porosity after decoration. If the highest coefficient of absorption is required, the surface is afterwards perforated with pin-holes at $\frac{1}{4}$ in. to $\frac{1}{2}$ in. centres, which pass unnoticed on a ceiling. As this method may be repeated after further decoration, the treatment possesses a fair degree of permanence.

An alternative surface finish consists of a perforated thin oil-cloth stuck to the felt on site. It may have a natural cream or broken white surface which requires no decoration, and may be sponged clean with soap and water.

In so far as painting may stiffen up the surface of a material, low-frequency absorption may be affected. With all but the lightest and most flocculent materials, however, the relative change in stiffness between painted and unpainted conditions is small, and for all practical purposes its effect in the lower part of the frequency scale may be neglected. However, when fairly thick surface coverings (e.g. canvas), stretched out of contact with the acoustic material, are painted so as to seal the surface and render it impervious to the passage of air, considerable loss of efficiency is to be expected in the upper part of the frequency scale, and some loss in the middle band around 700 c/s.

X.2 APPENDIX

It is wished again to emphasize that absorption coefficients lend themselves to manipulation on a qualitative rather than a quantitative basis, and that good results depend on an experienced practical interpretation of all the pertinent factors rather than on a rigid application of theoretical absorption coefficients. With this proviso, the curves reproduced in Figs. 82-89 serve to

ACOUSTIC PRINCIPLES

indicate typical variations in absorption/frequency characteristics for different materials.

On the following page is a table of absorption coefficients which indicates the approximate relative values of common surfaces and finishes, together with some indication of relative performance over a limited frequency range. This list has been reprinted with the kind permission of Mr. Hope Bagenal, D.C.M., F.R.I.B.A., from one of his text books (*Practical Acoustics and Planning against Noise*, Methuen, London, 1942).

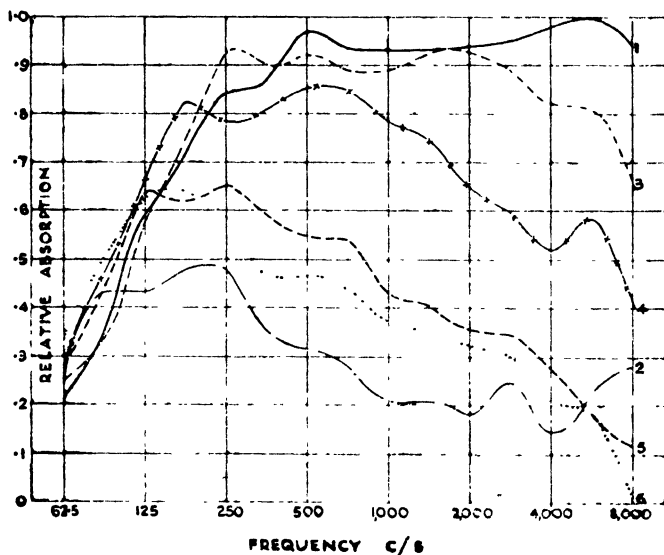

FIG. 82 VARIATION OF ABSORPTION WITH SPACING OF HOLES IN A PAINTABLE SHEET METAL COVER. (N.P.L.)

1. 3 in. rock wool.
2. 3 in. rock wool covered with 22 swg. steel sheet, unperforated.
3. 3 in. rock wool covered with 22 swg. steel sheet $\frac{1}{8}$ in., holes at $\frac{1}{8}$ in. centres.
4. 3 in. rock wool covered with 22 swg. steel sheet $\frac{1}{4}$ in., holes at $\frac{1}{4}$ in. centres.
5. 3 in. rock wool covered with 22 swg. steel sheet $\frac{1}{2}$ in., holes at $1\frac{1}{4}$ in. centres.
6. 3 in. rock wool covered with 22 swg. steel sheet $\frac{1}{2}$ in., holes at $1\frac{1}{2}$ in. centres.

Relative absorption is plotted against Frequency where the maximum absorption for Curve 1 is taken at 100 per cent.

ABSORPTION COEFFICIENTS

Material	C ₁ 62-5- 64	C ₂ 125- 128	C ₃ 250- 256	C ₄ 500- 512	C ₅ 1000- 1024	C ₆ 2000- 2048	C ₇ 4000- 4096	Authority
Brick, 18 in., in cement: unpainted	.021	.024	.025	.032	.042	.05	.07	W. C. Sabine
Brick, 18 in., in cement: painted 2 coats011	.012	.014	.017	.02	.023	.025	W. C. Sabine
Gypsum plaster on tile (partition blocks)012	.013	.015	.02	.028	.04	.05	W. C. Sabine
Lime plaster on wood lath: smooth finish	—	.024	.027	.03	.037	.019	.034	W. C. Sabine
Gypsum plaster on wood lath: 2 coats	—	.016	.032	.039	.05	.03	.028	P. E. Sabine
Gypsum plaster on metal lath: 2 coats	—	.02	.026	.04	.06	.058	.028	P. E. Sabine
Wood: pine varnished $\frac{1}{8}$ in. thick on studs 14 in. centres064	.098	.112	.104	.081	.082	.113	W. C. Sabine
Floor: wood block, pitch pine	—	.05	.03	.06	.09	.1	.22	B.R.S.
Carpet: thick pile	—	.09	.08	.21	.26	.27	.37	B.R.S.
Curtain: velour 18 oz.	—	.05	.12	.35	.45	.38	.36	P. E. Sabine
Curtain: cotton 14 oz.	—	.04	.07	.13	.22	.32	.35	P. E. Sabine
Curtain draped to half area	—	.07	.31	.49	.81	.66	.54	P. E. Sabine
Eel glass quilt: 2 layers, canvas on battens at 1 ft. 8 in. c.	—	.22	.42	.74	.77	.69	.44	B.R.S.
Rock wool: 4 in between 2 in. × 4 in. studs muslin facing	—	.46	.61	.82	.82	.64	.60	P. E. Sabine
Asbestos spray 1 in.: finished white asbestos, not painted	—	—	.6	.65	.6	.6	—	N.P.L.
Akoustikos felt 1 in.: muslin finished, distempered and pricked	—	—	.3	.75	.85	.7	.65	N.P.L.
Audience: men without overcoats per person	—	1.3	2.1	4.1	5.5	7.4	—	American Bureau of Standards
Theatre seat (padded): per seat	—	—	3.0	2.5	2.9	3.1	—	ditto
Plywood chairs: per chair	—	—	0.2	0.3	0.5	0.5	—	ditto

ACOUSTIC PRINCIPLES

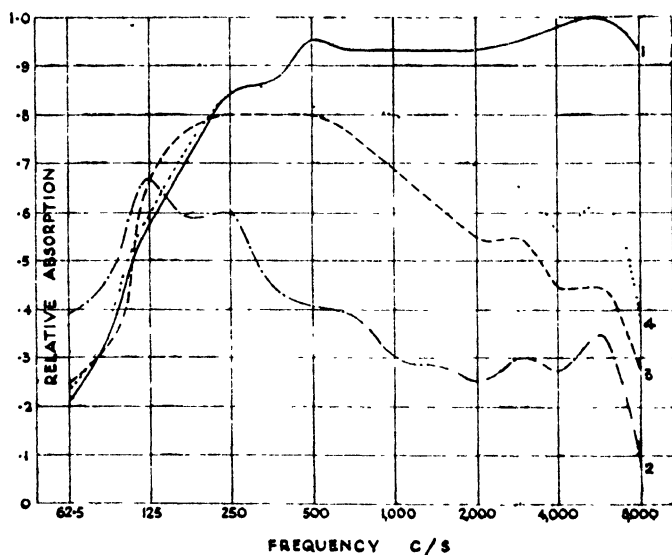

FIG. 83 VARIATION OF ABSORPTION WITH SPACING OF HOLES IN A HARD PAINTABLE COVR. (N.P.I.)

1. 3 in. rock wool.
2. 3 in. rock wool covered with hardboard $\frac{1}{2}$ in. thick, unperforated.
3. 3 in. rock wool covered with hardboard $\frac{1}{2}$ in. thick, holes at $\frac{1}{8}$ in.
4. 3 in. rock wool covered with hardboard $\frac{1}{2}$ in. thick, holes at $\frac{1}{4}$ in.

Relative absorption is plotted against Frequency where the maximum absorption for Curve 1 is taken at 100 per cent.

ABSORPTION COEFFICIENTS

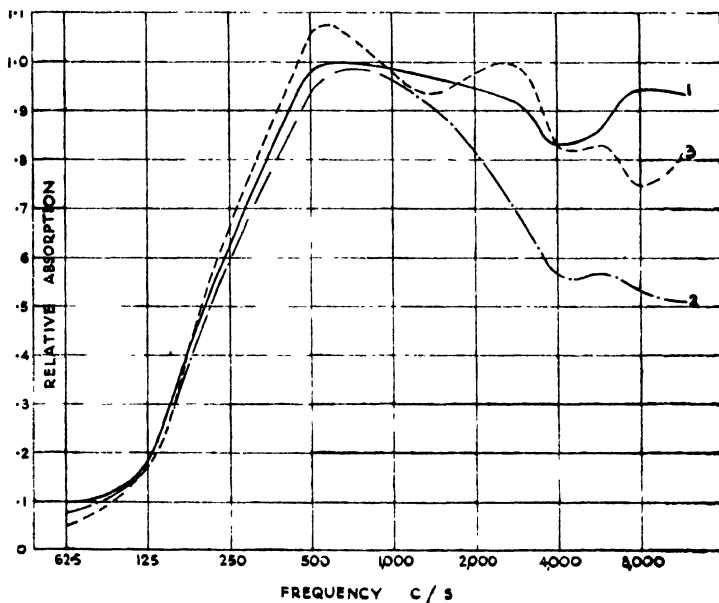

FIG. 84 VARIATION OF ABSORPTION WITH AIR-SPACE BEHIND LOUVRED METAL COVER

Curve 1. Rock wool.

2. Rock wool covered with Louvred No. 11 Z.G. zinc, spaced 1 in. from wool.

3. Rock wool covered with Louvred No. 11 Z.G. zinc, close (no space).

Relative absorption is plotted against Frequency where the maximum absorption for Curve 1 is taken at 100 per cent.

ACOUSTIC PRINCIPLES

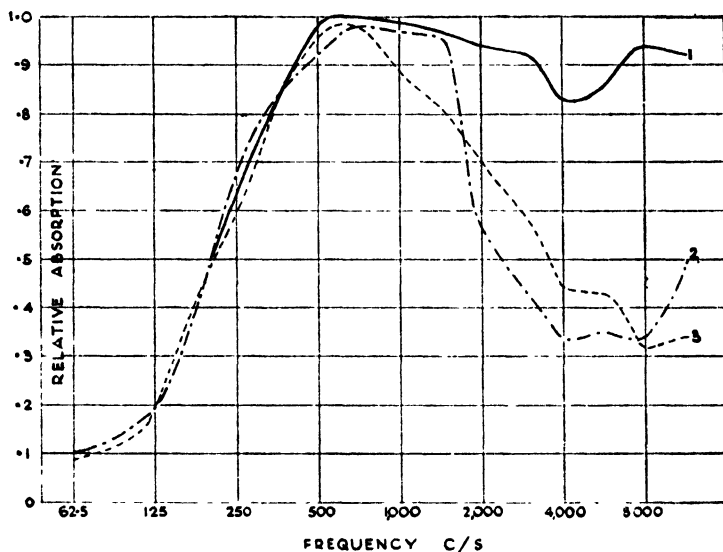

FIG. 85 VARIATION OF ABSORPTION WITH AIR-SPACE BEHIND PERFORATED ASBESTOS-CEMENT COVER

Curve 1. Rock wool.

2. Rock wool covered with perforated asbestos-cement sheet $\frac{1}{8}$ in. thick, spaced 1 in.

3. Rock wool covered with perforated asbestos-cement sheet $\frac{1}{8}$ in. thick, close.

Relative absorption is plotted against Frequency where the maximum absorption for Curve 1 is taken at 100 per cent.

ABSORPTION COEFFICIENTS

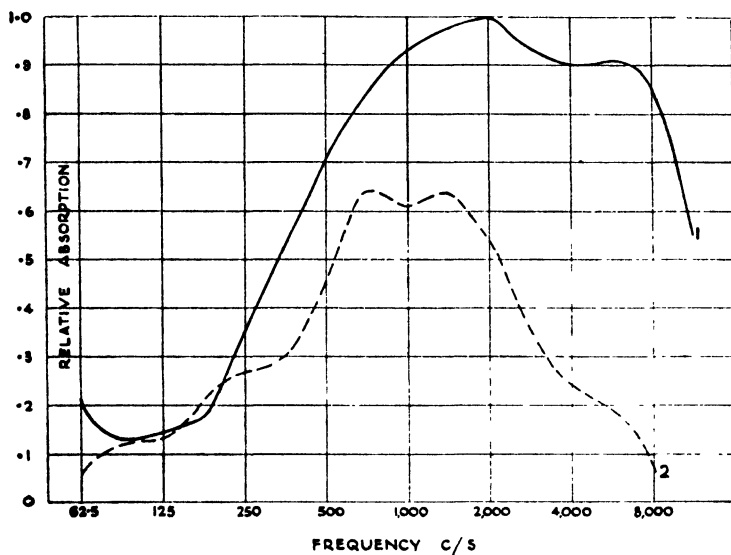

FIG. 86 VARIATION OF ABSORPTION WITH PERFORATION IN OIL-CLOTH STUCK TO 1 IN. FELT

- Curve 1. 1 in. Cullum Acoustic Felt, covered with perforated oil-cloth.
 2. 1 in. Cullum Acoustic Felt, covered with unperforated oil-cloth.

Relative absorption is plotted against Frequency where the maximum absorption for Curve 1 is taken at 100 per cent.

ACOUSTIC PRINCIPLES

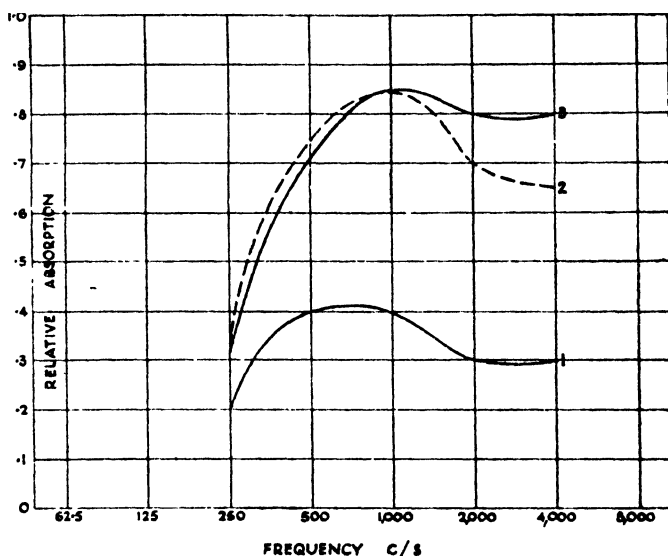

FIG. 87 VARIATION OF ABSORPTION WITH PERFORATION IN PAINTED MUSLIN COVER STUCK TO CULLUM ACOUSTIC FELT

- Curve 1. Painted 2 coats distemper.
 2. Painted 2 coats distemper, pin-hole perforated.
 3. Painted 2 coats distemper, but with additional pin-hole perforation.

The Absorption Coefficients plotted were obtained by Reverberation Chamber measurements. (N.P.L.)

ABSORPTION COEFFICIENTS

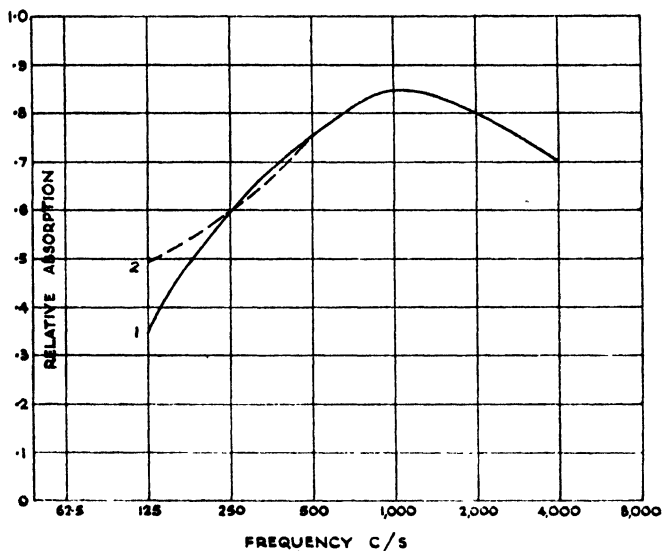

FIG. 88 VARIATION OF ABSORPTION WITH THICKNESS OF MATERIAL

Timber-framed Splitter Panels faced with perforated metal and packed with:

Curve 1. 3 in. rock wool.

2. 5 in. rock wool.

The Absorption Coefficients plotted were obtained by Reverberation Chamber measurements.

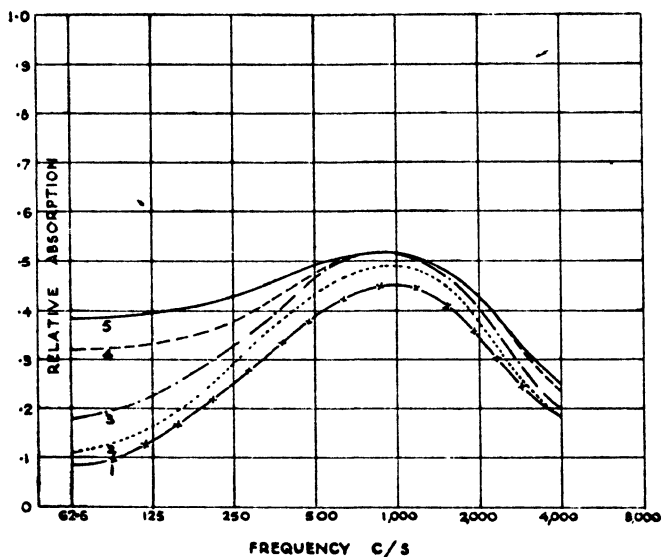

FIG. 89 VARIATION OF ABSORPTION WITH THICKNESS OF MATERIAL

- Curve 1. Felt, $\frac{3}{8}$ in. thick, covered with cotton fabric and painted.
- 2. Felt, 1 in. thick, covered with cotton fabric, and painted.
- 3. Felt, $1\frac{1}{2}$ in. thick, covered with cotton fabric and painted.
- 4. Felt, 2 in. thick, covered with cotton fabric and painted.
- 5. Felt, 3 in. thick, covered with cotton fabric and painted.

The Absorption Coefficients plotted were obtained by Reverberation Chamber measurements.

Chapter XI

ISOLATION OF MACHINERY

XI.1 THE ELECTRICAL ANALOGY OF THE MECHANICAL LOW PASS FILTER

WHEN an out-of-balance motor is mounted rigidly on a heavy base, as in Fig. 90A, the conditions may be analogously represented by the configuration of the electrical circuit in Fig. 90B. The mechanical and electrical equivalents are tabulated on p. 168.

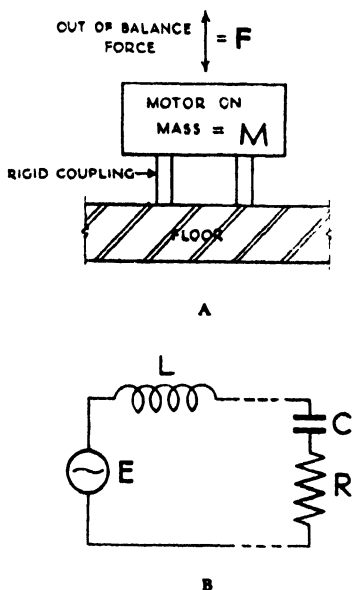

FIG. 90 ELECTRICAL ANALOGY—RIGID MOUNTING

In the electrical circuit, the mass M of the motor is represented by the inductance L , while the base (or floor), which is assumed to be very large compared with the mass M , is represented by a very small capacity C (corresponding to a high stiffness) in series with a resistance R . If the base were free to move, it

ACOUSTIC PRINCIPLES

Mechanical Units	Electrical Units
Force .. = F	Voltage .. = E
Velocity .. = V	Current .. = I
Mass .. = M	Inductance .. = L
Compliance .. = C	Capacity .. = C
Mechanical resistance .. = r	Electrical resistance .. = R

would of course be represented by another inductance. Usually, however, the base is a heavy concrete mass tied to the structure or fixed in the ground at the points where connection is made to the motor mass. It behaves locally as a high stiffness in series with a resistance.

There are two criticisms which may be levelled at this rigid method of mounting an out-of-balance motor. Firstly, since the impedance of $(R+C)$ is considerably greater than the impedance of L for low frequencies, the greater proportion of the out-of-balance force is applied across $(C+R)$, that is, to the base, whence it may be transmitted as vibration into the structure. For the frequency at which L and C are resonant, the out-of-balance force may be considerable. This gives rise to the second criticism that, because the energy transmitted to the base is conducted usually by bolts, the large strains set up at resonance are liable to lead to the failure of the bolts.

It is common practice to mount out-of-balance motors and similar equipment to a base by means of a resilient mounting (a compliance), as shown in Fig. 91A. The electrical analogy is shown in Fig. 91B where C_1 represents the compliance of the resilient support.

The inductance L and the capacity C_1 form the half-section of an electrical Low Pass Filter. C and R of the base are considered as the load into which the filter works.

The transmission characteristic of a L.P. Filter is such that, for frequencies above the resonant frequency, the output (across C_1) continually decreases as the frequency increases. This it does because the impedance of M increases with frequency, while that of C_1 decreases at the same rate. As the

ISOLATION OF MACHINERY

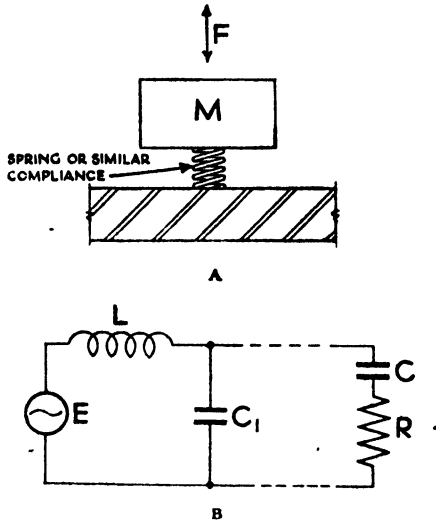

FIG. 91 ELECTRICAL ANALOGY—RESILIENT MOUNTING

frequency increases, therefore, a decreasing proportion of the input voltage is available across C_1 for application to the load. A typical characteristic for a filter of the type of Fig. 91B is plotted in Fig. 92, Curve A.

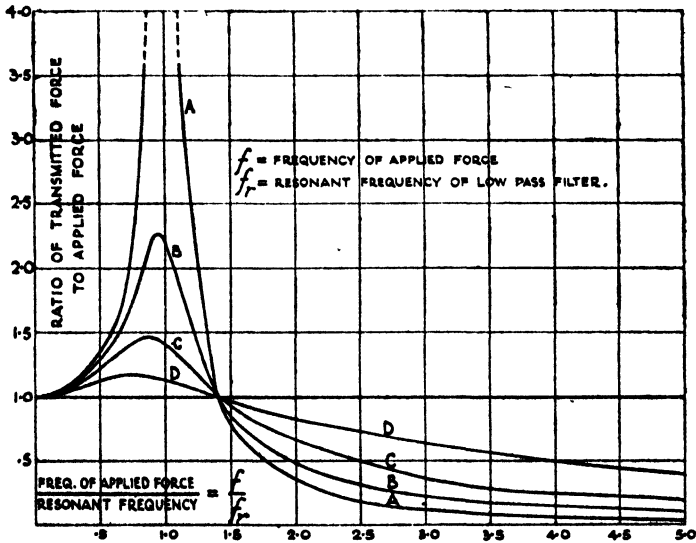

FIG. 92 TRANSMISSION CHARACTERISTIC FOR LOW PASS FILTER

The objection to a characteristic of this type is the large amplitude of vibration at the resonant frequency. A motor stopping or starting will pass through this frequency, and some method for limiting the large amplitudes is sometimes desirable under these conditions. This may be done by some form of damping.

If, instead of a spring, a material like cork or rubber is employed, frictional resistance is set up by relative movement of particles in the material, when the material is subjected to an alternating force. This resistance component may be represented in the electrical circuit of Fig. 91B, by adding an electrical resistance R_1 in series with C_1 , as shown in Fig. 93.

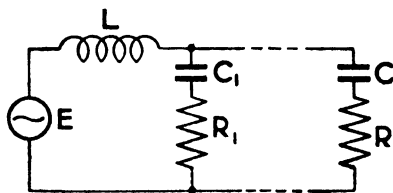

FIG. 93 ELECTRICAL ANALOGY—DAMPED RESILIENT MOUNTING

The effect of R_1 is two-fold; it limits the amplitude at resonance, because it is always in the circuit of the generator E , and it reduces the attenuation at high frequencies where its impedance is of the same order as C_1 (since $C_1 + R_1$ can never be less than R_1), so that in the limit of the voltage available for application to the load is determined by R_1 . The modified transmission characteristic is shown in Fig. 92, Curve B.

Alternatively, the mass M may be partly restrained by the application of a frictional device, as shown in Fig. 94A. The electrical equivalent is a resistance in parallel with the compliance of the mounting, as shown in Fig. 94B.

If damping is still further increased, transmission characteristics of the type shown in Fig. 92, Curves C and D, will result, where the efficiency of the filter at high frequencies is considerably reduced.

For the undamped and very lightly damped conditions, the filter becomes effective for applied forces where the frequency is not less than 3 times the resonant frequency ($f/f_r=3.0$). More heavily damped conditions necessitate a greater ratio of f/f_r for the same transmission loss.

ISOLATION OF MACHINERY

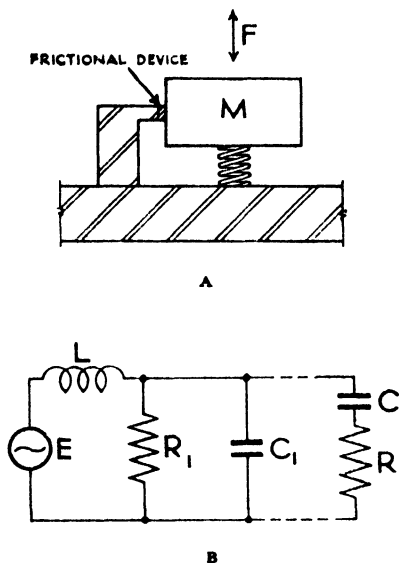

FIG. 94 ELECTRICAL ANALOGY—MASS-DAMPED RESILIENT MOUNTING

XI.2 THE CALCULATION OF A FILTER SECTION

In practice, the Mechanical L.P. Filter usually takes the form of either Fig. 95A or B. In both cases, the end result is that a compliance with a resistive component is inserted between the mass and the base to produce a structure whose electrical equivalent is as shown in Fig. 93, now redrawn in slightly different form in Fig. 96.

The information required to state the effectiveness of the filter of Fig. 96, is the way in which the current through the load CR is modified by the presence of the filter section LC_1R_1 . Now the load affects the performance of the filter section LC_1R_1 , as also does the impedance of the source. None of these quantities is known, nor are they amenable to calculation. The problem can, however, be approximately resolved by making certain assumptions and taking certain precautions.

If the base is made heavy and rigid, then the impedance of the load CR will at all frequencies of interest be large compared with the impedance of C_1R_1 , and the filter may be considered as working into an open circuit.

The source may be considered as having a constant voltage output of low impedance.

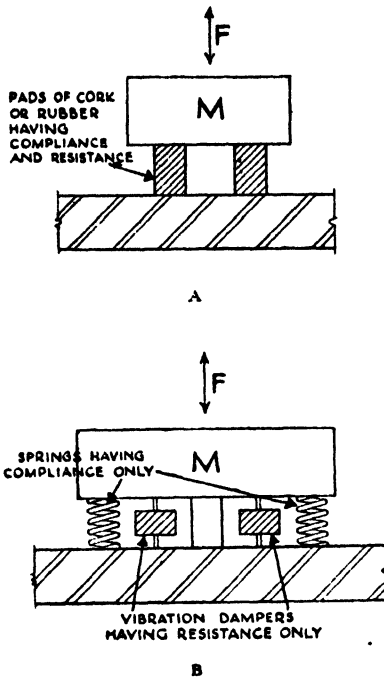

FIG. 95 METHODS OF RESILIENT MOUNTING

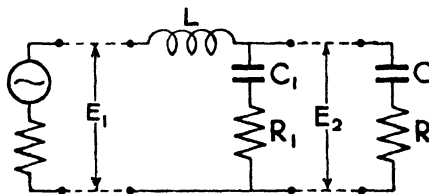

FIG. 96 ELECTRICAL ANALOGY OF LOW PASS FILTER SECTION

The information now required is the way in which the voltage developed across the load CR is modified by the presence of the filter section LCR_1 ; or, in other words, the way in which the voltage across C_1R_1 is modified.

The electrical circuit may now be redrawn as a simple potential-dividing network, in which the performance of the filter is specified at any frequency by the ratio of the voltage across C_1R_1 to the voltage across LC_1R_1 , as in Fig. 97.

ISOLATION OF MACHINERY

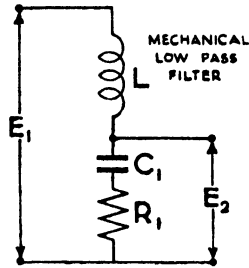

FIG. 97 EQUIVALENT DIVIDING NETWORK FOR DAMPED ISOLATOR MOUNTING

In the above, the voltage ratio

$$\frac{E_2}{E_1} = \frac{\text{Impedance of } (C_1 R_1)}{\text{Impedance of } (L C_1 R_1)}$$

$$= \frac{R_1 + j\omega C_1}{R_1 + j\omega L - \frac{1}{j\omega C_1}}$$

$$= \frac{\sqrt{R_1^2 + \left(\frac{1}{2\pi f C_1}\right)^2}}{\sqrt{R_1^2 + \left(2\pi f L - \frac{1}{2\pi f C_1}\right)^2}}$$

where $\omega = 2\pi f$,

$\pi = 3.142$,

$f =$ frequency of interest.

The loss in db. is given by:

$$\text{Loss db.} = 20 \log \frac{E_1}{E_2}$$

(The ratio $\frac{E_2}{E_1}$ is reversed for ease of calculation, to give a positive value of loss).

ACOUSTIC PRINCIPLES

For the case of Fig. 94A, and 94B, where the damping is applied to the mass M, the circuit of Fig. 94B may be redrawn as in Fig. 98.

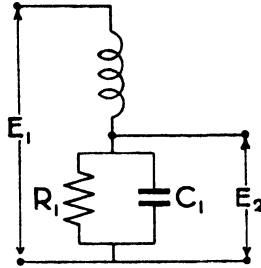

FIG. 98 EQUIVALENT DIVIDING NETWORK FOR DAMPED MASS MOUNTING

In the above, the voltage ratio

$$\begin{aligned} \frac{E_2}{E_1} &= \frac{\text{Impedance of } (C_1 R_1)}{\text{Impedance of } (L C_1 R_1)} \\ &= \frac{\frac{I}{R_1} + \frac{I}{j\omega C_1}}{\frac{I}{R_1} + \frac{I}{j\omega C_1} + j\omega L} \\ &= \frac{R_1}{1 + j\omega C_1 R_1} \div \frac{R_1}{1 + j\omega C_1 R_1} + j\omega L \\ &= \frac{R_1}{\sqrt{(R_1 - \omega^2 L C_1 R_1)^2 + (\omega L)^2}} \\ &= \frac{R_1}{\sqrt{R_1^2 - 2(2\pi f)^2 L C_1 R_1 + (2\pi f L)^2}} \end{aligned}$$

ISOLATION OF MACHINERY

Another design parameter is the resonant frequency. This must be designed, as inferred in Fig. 92, to occur at $1/4$ to $1/5$ the frequency of the out-of-balance force (or the lowest component thereof, if it is a complex quantity), and its value is given by:

$$f_r = \frac{1}{2\pi \sqrt{LC_1}}$$

The filter will pass all frequencies up to approximately half this value, i.e. up to $f = \frac{1}{4\pi \sqrt{LC_1}}$, and will attenuate all frequencies above.

In order to apply the mathematics of the electrical circuit to the mechanical filter, it is necessary to express L, C and R in terms of their mechanical equivalents—i.e., L becomes Mass in gramme units, C becomes compliance in cms/dyne, and R becomes mechanical resistance in mechanical ohms. Whereupon, for the case of Fig. 97 in which the damping is associated with the compliance:

$$\text{Loss (db.)} = 20 \log \frac{\sqrt{r^2 + \left(\frac{1}{2\pi f C}\right)^2}}{\sqrt{r^2 + \left(2\pi f M - \frac{1}{2\pi f C}\right)^2}}$$

and for the case of Fig. 90 in which the damping is associated with the mass:

$$\text{Loss (db.)} = 20 \log \frac{r}{\sqrt{r^2 - \{(2\pi f)^2 M C r\}^2 + (2\pi f M)^2}}$$

$$\text{and } f_r = \frac{1}{2\pi \sqrt{MC}}$$

Compliance is measured directly by observing the deflection of a sample under load. It is directly proportional to thickness and inversely proportional to the cross-sectional area of the sample, for a range of loads limited by the bulk compressibility of the material. (See Section XI.4.)

The Mechanical Internal Resistance "r" of a material is calculated from a study of the decay history of a mass supported on the material and moved from its position of rest. It is directly

ACOUSTIC PRINCIPLES

proportional to the cross-sectional area of the sample, and inversely proportional to its thickness. At frequencies remote from resonance, the effect of resistance is small compared with that of the compliance; in estimating the performance of a filter, it may be neglected and the expression for the case of Fig. 98 reduced to:

$$\frac{E_2}{E_1} = \frac{1}{2\pi fC - \frac{1}{2\pi fM}}$$

V.O. Knudsen gives the following figures for Compliance and Resistance of various materials, measured for samples 1 in. thick by 1 sq. cm. in cross-section.

Material	Description of Material	Approx. Upper Safe Loading in lb. per sq. in.	Compliance, c, in centimetres per Dyne	Resistance, r, in absolute Units
Corkboard ..	1.10 lb. per board ft.	12	0.25×10^{-6}	0.15×10^6
Corkboard ..	0.70 " "	8	0.50×10^{-6}	0.25×10^6
Flax-li-num ..	1.35 " "	4 to 6	0.60×10^{-6}	0.50×10^6
Celotex ..	Carpet Lining	10	0.40×10^{-6}	—
Celotex ..	Insulating board	12	0.18×10^{-6}	—
Insulite ..	" "	15	0.16×10^{-6}	—
Masonite ..	" "	15	0.12×10^{-6}	—
Anti-Vibro-Block	—	5	0.60×10^{-6}	—
Sponge Rubber..	25 lb. per cu. ft.	1 to 3	3.0×10^{-6}	—
Soft India Rubber	55 " "	3 to 6	1.2×10^{-6}	—
Hair felt.. ..	10 " "	1 to 2	1.5×10^{-6}	—

XI.3 RECAPITULATION

“fr,” the resonant frequency of a Low Pass Mechanical Filter, should be designed to occur at $1/4$ to $1/5$ the frequency of the lowest component of the out-of-balance movement which it is required to attenuate. The relationship is given by:

$$fr = \frac{1}{2\pi \sqrt{MC}}$$

where M = mass in grammes.

C = compliance in cms. per dyne.

Since the mass of the machine together with its base is known, C can be calculated.

ISOLATION OF MACHINERY

An estimate may then be made, from a knowledge of the compliance of various samples, approximately how the total C will be provided—i.e., what material, in how many cubes and of what dimensions.

When the geometry of the compliances has been determined, the total “ r ” may be calculated from a knowledge of the constants of the material.

Finally, the values of M , C and r may be inserted in the appropriate formulae to determine the loss for different values of f .

Inspection of these results will suggest any necessary modifications to the quantities M , C and r .

XI.4 THE SPECIAL SIGNIFICANCE OF THE RESONANT FREQUENCY IN THE DESIGN OF LOW PASS MECHANICAL FILTERS

The compliance is the reciprocal of the stiffness ($C=1/S$). It is a measure of the amount of compression (or extension) per unit force (cms. per dyne). Thus a cubic inch of soft rubber will have a larger compliance than a cubic inch of hard rubber because, for a given force, it will compress a greater amount. For the same reason, a pad of rubber 2 in. thick will have a greater compliance (twice) than a pad 1 in. thick of identical cross-section.

As mentioned above, a Low Pass Filter is usually effective at frequencies 4-5 times the resonant frequency ($f_r = \frac{1}{2\pi \sqrt{MC}}$).

To obtain the greatest efficiency, f_r should be designed as low as possible, and from inspection of the formula this will be when MC is greatest. For a given M , this will be when C is greatest.

The usual design requirement is to determine C when the mass M is known, and the maximum value for f_r can be stated by dividing the lowest component frequency of the out-of-balance force by 4-5. Now, it follows, from what has been said above concerning compliance, that a given value of compliance may be realized in two ways—by employing n units of

compliance C , or by employing $2n$ units of compliance $\frac{C}{2}$ —i.e., the same total compliance is obtained by using 4 blocks of rubber

ACOUSTIC PRINCIPLES

2 in. by 2 in. by 1 in. thick, or by using 8 blocks of the same rubber 2 in. by 2 in. by 2 in. thick. Note, however, that a standard load will compress the 4-1 in. blocks and the 8-2 in. blocks by the same amount—i.e., *the static deflection of a compliance under load is directly related to the resonant frequency of the assembly.*

This relationship is given almost exactly for pure compliances by:

$$d = \frac{25}{f_r^2} \text{ when } \begin{cases} f_r \text{ is in cycles/second} \\ d \text{ is in cms.} \end{cases}$$

$$\text{or } d = \frac{10}{f_r^2} \text{ when } \begin{cases} f_r \text{ is in cycles/second} \\ d \text{ is in inches.} \end{cases}$$

The curve relating “d” (cms) and “f_r” is drawn in Fig. 99, on which are also listed the approximate frequency ranges which may be accommodated by different compliances.

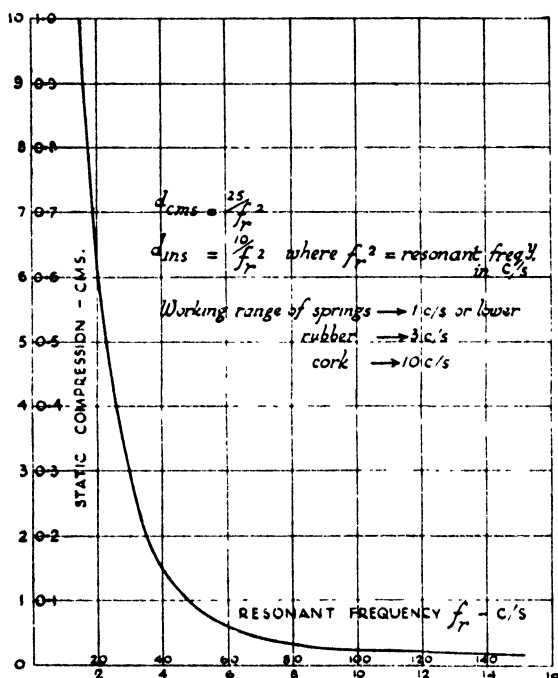

FIG. 99 COMPRESSION (CMS.) v. RESONANT FREQUENCY (f_r)

This curve may be used with the curve of Fig. 92 as a close first approximation in the design of L.P. Filters employing

ISOLATION OF MACHINERY

springs as compliances, and also for assemblies using rubber of small cross-sectional area, correctly loaded. For filters using large areas of soft rubber, cork or felt, other considerations are involved.

For materials such as rubber, the compliance is a function not only of the material, but also of the dimensions of the sample under test. When rubber is compressed, the reduction in height is accommodated by an increase in one or both of the other planes. When a large flat sheet is compressed, the material cannot extend its horizontal dimensions in proportion, and a condition of loading is rapidly reached when further loading increases the stiffness—i.e., reduces the compliance.

So that, while it is true that compliance is directly proportional to thickness and inversely proportional to cross-section, this law holds only for load conditions which are not appreciably limited by bulk deformation.

The compliance characteristics of rubber and steel springs are drawn in Fig. 100, where deformation in cms. is plotted against load (in lb. weight for springs and lb./sq. in. for rubber). The slope of the curve is the measure of the stiffness—i.e., a steep slope corresponds to a large stiffness, and therefore a small compliance such as would be provided by a strong spring or a hard rubber—while a flatter slope represents the relatively smaller stiffness or greater compliance of a weaker spring, or softer rubber, or thicker sample of the hard rubber.

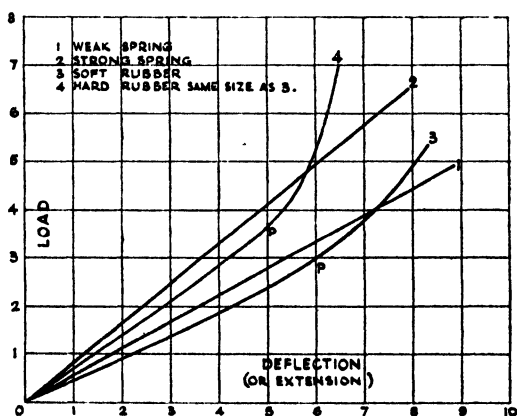

FIG. 100 COMPLIANCE CHARACTERISTICS OF STEEL SPRINGS AND RUBBER ISOLATORS

ACOUSTIC PRINCIPLES

From Fig. 100, Curves 1 and 2, it will be seen that a spring has a linear characteristic—i.e., for a given increase in loading, it will provide a consistent increase in deflection. In the limit, of course, the law will break down—usually due to fracture of the spring—but within the designed working limits the straight-line characteristics will apply. Springs, therefore, may be safely loaded with no other consideration than the purely mechanical one of physical break-down.

Curves 3 and 4 are for samples of rubber, which behave initially as springs—i.e. constant compliance with load. When, however, the bulk modulus becomes effective, to impose a restraint on deformation, the compliance is reduced (at the points P).

The point at which the slope changes sets a limit to the maximum loading which may be correctly applied to a sample of rubber.

Fig. 101A shows schematically an incorrect loading condition for rubber isolators. The static load of the motor and its base compresses the rubber nearly to the point where the slope of the curve changes—i.e., nearly to the point where the compliance will be reduced by further loading.

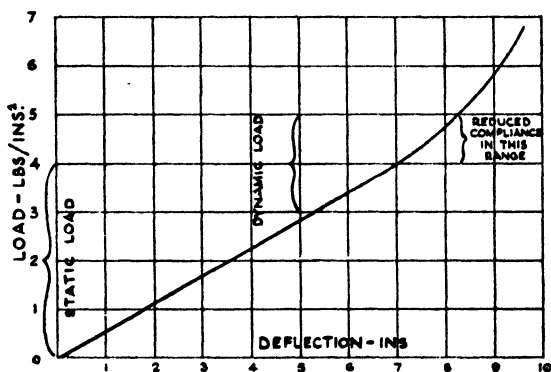

A

FIG. 101 CORRECT AND INCORRECT LOADING CONDITIONS FOR RUBBER ISOLATORS

If, now, out-of-balance alternating forces from the motor are applied in the direction of compression, this is equivalent to alternately increasing and decreasing the static load. The

ISOLATION OF MACHINERY

increased loading condition runs off the straight point of the curve into that section of the Load /Compression characteristic where the compliance is reduced.

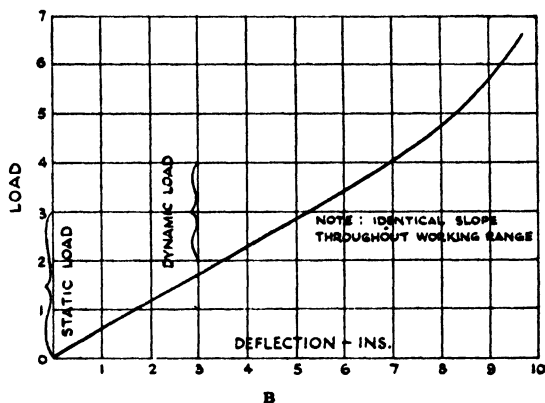

FIG. 101 CORRECT AND INCORRECT LOADING CONDITIONS FOR RUBBER ISOLATORS

The isolators should be loaded as in Fig. 101B, where the static load and the superimposed dynamic load are together, at all times, on the straight part of the curve which shows maximum compliance.

XI.5 THE USE OF RUBBER IN SHEAR

Rubber is frequently used in shear and may provide an efficient and compact mounting. Small motors and assemblies are supported on a dome or disc of rubber, clamped at its edges as shown in Fig. 102.

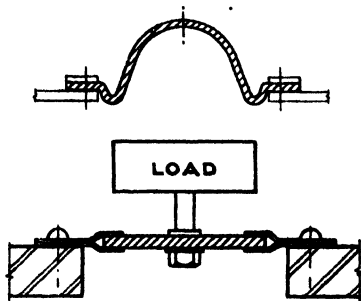

FIG. 102 VERTICAL MOUNTING ISOLATOR

ACOUSTIC PRINCIPLES

Shear mountings—particularly the type of Fig. 102—may be designed so that the bulk modulus is a negligible factor; in consequence, the load/compression curve more closely approaches the linear characteristic of a spring.

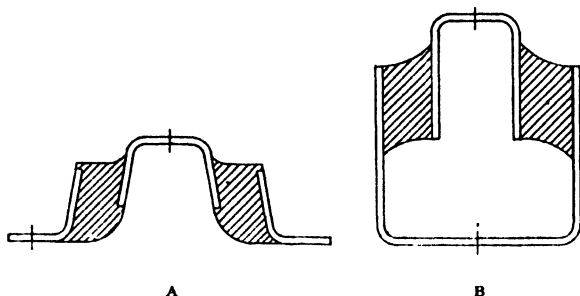

FIG. 103 "SHEAR" TYPE MOUNTINGS

Satisfactory methods of bonding rubber and metal have led in recent years to the development of mountings of the type shown in cross section in Fig. 103, where the usual nuts and bolts may be eliminated and loads may be applied by screws threaded into the metallic sections as required. Within limits, the required compliances may be obtained by cutting off the requisite amount from a length of the mountings.

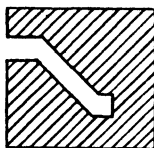

FIG. 104 DIFFERENTIAL MODULUS TYPE OF MOUNTING

Square section rubber may be cut as in Fig. 104 so as to work, when vertically loaded, partly in compression and partly in shear, until large amplitudes close the gap, when the isolator will work entirely in compression and with a reduced compliance. This device is often used to limit large movements at resonance, without adversely affecting performance at the working frequency of the mounting.

Chapter XII

SOME OCCASIONS FOR ACOUSTIC TREATMENT

XII.1 GENERAL

LISTED below are several types of rooms and buildings which particularly call for some form of acoustic treatment, partly to increase directly the efficiency of the processes conducted therein and partly to improve local conditions in such a manner as to result in enhanced performance of processes carried out elsewhere.

The pertinent factors are listed briefly, and the general procedure for cure and abatement is outlined.

The list is divided into two sections, according to whether treatment is required to reduce source noises by the local application of sound-absorbing material, or whether insulation is required by the interposition of partitions, discontinuities, soundproof floors, etc.

XII.11 Common Sound Sources

The following sound sources are frequently encountered, and are invariably the cause of annoyance and discomfort.

- (1) Telephone bells and buzzers.
- (2) Conversation.
- (3) Footsteps.
- (4) Banging of doors, windows, lift gates.

Note particularly the prevalence of the above sources in corridors which may form a common connection between rooms which require a quiet background. In buildings where no acoustic treatment has been included, the above sources are magnified by reverberation.

- (5) Accounting machinery.
- (6) Industrial processes generally.

ACOUSTIC PRINCIPLES

- (7) Ventilation.
- (8) Plumbing.
- (9) Cleaning processes.
- (10) Street traffic.

XII.2 CASES CALLING PRIMARILY FOR THE REDUCTION OF SOURCE NOISES BY THE LOCAL APPLICATION OF SOUND-ABSORBING MATERIAL

XII.21 Schools

There are very few class-rooms which would not be improved by acoustic treatment. Where sound absorption is applied to the ceilings, so as to reduce the general noise level due to the class itself and to sources outside the windows, benefit will be reflected in the better concentration of pupils in the more peaceful surroundings, and by the ability to control a larger number of pupils with less strain on the teacher.

Where discrimination between class-rooms is imposed for financial reasons, the greatest attention should be paid to lecture theatres, assembly halls and demonstration rooms; class-rooms should next receive attention, while laboratories, workshops, gymnasias, etc., will be the last to be considered.

The main assembly hall is, of course, a special case, since it has to cater for speeches (not always delivered by expert orators), school dramatic productions, concerts, important broadcasts, educational films, etc. Since this room is the centre of the school cultural programme, it has a special claim on the attention of the acoustic engineer, and the reverberation time/frequency characteristic should be suitably adjusted.

The usual dining hall clatter is probably responsible for more fatigue in the afternoon than is realised. A noisy environment calls for louder conversation, which increases the noisiness of the environment, and so on in a viciously increasing spiral. Treatment is discussed at greater length in Section XII.24 below.

XII.22 Hospitals

Kitchens and sluice rooms are notorious sources of noise in hospitals. For hygienic reasons, their surfaces are tiled or enamelled, and the reverberant energy may build up to a very distressing level.

SOME OCCASIONS FOR ACOUSTIC TREATMENT

Acoustic treatment for such rooms must be capable of taking a hard paint and should be vermin- and fire-proof. Suitable materials are perforated asbestos sheets or metal sheets over rock wool, perforated tiles, etc.

So far as treatment of wall or ceiling surfaces in wards is concerned, with a view to reducing noise levels therein, it should be borne in mind that no acoustic treatment is permitted in surgical wards.

XII.23 Flats, etc.

In the case of private houses and individual flats, there is, of course, rarely any urgent reason why sound-absorbing materials should be introduced. The troubles in these cases are chiefly confined to sound insulation.

In blocks of flats, however, corridors (particularly uncarpeted corridors), staircases, etc., which form a common connection to several units, may profitably receive attention by way of acoustic treatment on ceilings of corridors and soffits of staircases.

XII.24 Restaurants and Canteens

Extensive acoustic treatment to restaurants is not a good financial investment, because the customers tend to stay too long in such comfort.

For a similar reason, too bare an establishment, particularly when of a large size and too intimately associated with the service, will repel custom by virtue of the clatter and general air of restlessness which is conducive to indigestion. For the superior establishment which boasts a carpet and discreet service, additional treatment is usually deemed unnecessary. For large cafeterias, some ceiling treatment, particularly in the vicinity of service centres, is desirable.

Canteens generally come under the heading of cafeterias. They are subject to a large amount of noise connected with the service, and the workers who use them all take advantage of the lunch break to discuss simultaneously the more momentous matters of the day. The vicious noise spiral is very evident in these places. The canteen should provide a greater measure of relaxation for the workers in their short break than is obtainable when every person has to make himself heard above the usual reverberant clatter.

ACOUSTIC PRINCIPLES

The larger canteens are also used for lunch-hour concerts and other social activities to which their normally reverberant state is strongly antipathetic. The ceiling is usually the most convenient site for absorption, both in the canteen itself and in the kitchen (the cook doesn't like the clatter either). The kitchen ceiling is always exposed to high humidities, and since canteen ceilings are usually external roofs also, and therefore subject to much condensation, any acoustic treatment should be capable of sustaining these conditions without deterioration.

XII.25 Churches

A long reverberation time is traditionally associated with churches, but long usage does not *ipso facto* improve the listening conditions. These reverberant conditions have imposed a traditional method of intoning, and a slow tempo for sacred music; nevertheless poor intelligibility of speech and raggedness in singing are inevitably associated with the condition, and the masking effect of noise, whether internal or external, is particularly unfortunate.

With respect to reverberation, here is a unique case where a careful choice of normal building materials may influence the condition to an appreciable extent. Soft plaster has 3-4 times the absorption co-efficient of hard plaster; distemper has at any rate a higher co-efficient than hard paint; wood panelling and roofing may have fairly high co-efficients at low frequencies where reverberation is greatest. By judicious choice, the total absorption contributed by the wall and ceiling surfaces may be sufficient to avoid the excessive reverberation so frequently associated with church architecture.

Furnishings in the form of carpet runners, bench cushions, hassocks, etc., may aid materially in the reduction of reverberation time. Felt seat covers in the form of $\frac{1}{2}$ in. thick strips may be quickly rolled up or unrolled as required.

XII.26 Civic Centres

Acoustic treatment to adjust reverberation time and to provide adequate diffusion is called for in concert and assembly halls, bearing in mind that probably both original and reproduced speech and music must be catered for.

Acoustic treatment to reduce noise level and to provide comfortable conditions is desirable in enclosed swimming baths,

SOME OCCASIONS FOR ACOUSTIC TREATMENT

and particularly in libraries where the usual very reverberant conditions, in association with the explicit request for quiet, results in a very strained and nervous atmosphere.

The chilly welcome of large reverberant entrance halls or foyers may be improved by sound absorption, and public corridors feeding quiet offices should have ceiling treatment.

Large general offices, magistrates' courts, etc., are amenable to improvement by similar means.

XII.27 Post Offices, Banks, Booking Halls, etc.

The modern tendency towards smooth, hard surfaces in this type of room, which normally has a fairly large volume, tends to produce an excessive reverberation time which results in poor intelligibility and general acoustic discomfort. Ceiling treatment with an efficient material is usually all that is required. Such material should be capable of redecoration without loss of efficiency. Telephone exchanges may require a more comprehensive treatment in those rooms where operations are carried out by telephonists.

XII.28 Offices

In all offices, efficiency can be increased by means of acoustic treatment. The form and extent of treatment varies considerably—from the large bare general office with mechanical equipment, to the well-furnished private office. Similarly, external noise conditions differ widely. In board rooms, ordered reflections between the ceiling and a large table may frequently cause an unpleasant acoustic condition, even when the floor is carpeted. Treatment should be designed to minimize this defect.

XII.3 CASES CALLING PRIMARILY FOR INSULATION AGAINST NOISE SOURCES

XII.31 Schools

The broad principles of planning should be utilized in all cases where sites requiring a quiet environment are unavoidably associated with noisy environments. Music practice rooms, workshops, gymnasias, kitchens, swimming baths, changing rooms, staircases, etc., should not be located adjacent to lecture theatres and class rooms. In this connection, it may be repeated

that more effective insulation may be obtained in a horizontal than in a vertical plane, since the former is much less prone to impact noise sources.

Music practice rooms are particularly liable to trouble—especially from the pianoforte, which is a source of structure-borne vibration as well as air-borne sounds. The only satisfactory construction is to build each room as a separate cell, with walls supported on separate floating floors and carrying separate ceilings.

Common plumbing—such as may occur when radiators in a series of music practice rooms are fed from a common supply—will nullify the benefits of discontinuous structure. Electric heating from independent radiators is the most satisfactory solution.

When school buildings comprise two or more floors, the general problem of impact noise is bound to arise. Such sources as footsteps, banging of desk lids, etc., will be transmitted through solid floors with negligible loss, and some form of floating floor is essential to reduce these sources to a reasonably low level.

Ventilation should be the subject of careful planning, as discussed in the appropriate Chapter, and machinery, etc., should be properly isolated from the structure.

XII.32 Hospitals

The chief sources of noise calling for insulation are impact noises due to footsteps, etc. (which may be satisfactorily reduced by floating floors), and vibration sources associated with plumbing and other services. The normal system of planning imposed by the working function of a hospital usually results in the segregation of these noise sources from the wards themselves; but, as the nuisance is structure-borne, isolation from the structure should be thorough. The general use of shafts to carry vertical services is to be commended as an alternative to separate isolation at each floor level.

XII.33 Flats and Hotels

In large blocks of flats, noise sources calling for treatment by insulation may be due to two main causes—those created by the equipment and services which are associated with the building, and those created by the tenants.

SOME OCCASIONS FOR ACOUSTIC TREATMENT

Equipment noises are often attributable to:

- (a) Plumbing (water supply, waste, w.c's.)
- (b) Heating (accelerator pumps).
- (c) Electric switches.
- (d) Lifts.
- (e) Ventilation.

Noise created by tenants may again be subdivided, according to whether transmission is air-borne or structure-borne. The former involves normal occupational noises and should be dealt with by means of adequate partitions, good design and planning. The latter comprises chiefly footfalls, vibration from pianos and radios, cleaning processes, moving of furniture, and dropping of heavy articles. These sources may be adequately reduced only by means of an efficient floating floor.

With regard to planning, the unfortunate juxtaposition of quiet and noisy environments is to be avoided, both in the vertical and the horizontal plane, while the use of buffer rooms, passages and cupboards is generally adopted in the best design practice.

Hotels often provide a more complicated problem than flats, because of the necessity for providing larger areas of public (and therefore noisy) spaces, ballrooms, service rooms, and additional services such as forced ventilation.

XII.34 Civic Centres

Planning is probably the most important aspect of noise transmission in a unified collection of buildings serving vastly different functions. The public and assembly spaces are sources of high noise level, and should not share common dividing partitions or floors with offices, libraries, auditoria, etc.; in this connection, attention should be paid to flanking transmission over alternative paths.

The next important source of noise is the ventilating system, which should have a high standard of quiet.

Thereafter, services such as plumbing and heating may also cause trouble in those locations which demand quiet conditions.

XII.35 Factories

Factories fall into a rather different category; the acoustic problems associated with them divide into two main groups:

- (1) The prevention of noise transmission out of the building, with a consequent loss of amenity in the more immediate neighbourhood.
- (2) The reduction of noise inside the building with a view to increasing the efficiency of the employees.

With respect to (1), it should be borne in mind that the normal factory roof with "North lights" is a very poor insulating partition and much less efficient than even a light panel of $4\frac{1}{2}$ in. brick. Ventilation openings, doors and windows are also frequent sources of poor insulation. Where very noisy operations are carried out in factories located close to other premises which otherwise enjoy a quiet environment, a method of construction which eliminates the more grievous faults of traditional factory construction should be adopted, or else special consideration should be given to the siting of noise sources and to the more obvious features of poor insulation.

One of the most difficult problems today is the aero-engine test house where the loudness at the source may reach a level of 140 phons or more, and where large volumes of air required by the propeller are discharged into the open air. 18 in. brick walls and 10 in.-12 in. concrete roofs are normally required to confine radiation from the source to reasonable proportions, while special and complicated sound-absorbing ducts are required to reduce the noise level in the air stream before it emerges into the open air. By the adoption of the proper precautions, it is possible to reduce the noise level such that, at a distance of 200-300 yards, no serious interference is caused, whereas without treatment such a noise may be heard at a distance of over 5 miles. By care and design in planning, much expense can be saved in the reduction of these very loud noises.

With respect to (2), the planning of production processes, so as to segregate the noisy from the quiet operations, will confer an immediate benefit without any expense in the way of acoustic treatment.

Chapter XIII

THE LEGAL ASPECT

THE law may be invoked in respect of any action concerning noise, under two counts. Common Law is based upon the garnered wisdom of the ages, the national conception of liberty and good manners and, in the end, is administered by competent persons of the highest integrity. By its nature, however, the processes of Common Law are ponderous and expensive.

The heading under which an action may be brought at Common Law, and in the Civil Courts, is Nuisance. The definition of Nuisance is necessarily unexplicit, involving as it does conceptions of freedom, obligation, the rights of the individual, the rights of society, circumstances ordinary and extraordinary. It is laid down that noise constitutes a nuisance when it is deemed to exceed what might reasonably be expected, having regard to all the pertinent circumstances, and is continuous or repeated. Thus, a man who sets up a boiler-making factory in a residential neighbourhood would be committing a very unarguable nuisance, and a man who habitually turned his radio-gramophone on full in the small hours of the morning would be held guilty of the same offence, both by his neighbours and the law. Where the boiler-making factory is set up first, and a house is subsequently built adjacent to the factory, the tenant of the house has obviously not the same clear right to an abatement of noise.

The plaintiff at Common Law will seek to obtain an injunction to restrain, and the onus is on him to prove that the noise in question does in fact amount to a nuisance. (The disordered state of his outraged emotions is not, however, proof of the defendant's nuisance.) It may be taken for granted that, if a defendant will permit the case to go to court, he has been advised by competent Counsel that the plaintiff will have some difficulty in proving his charge. The usual Nuisance case involves the calling of many witnesses, expert and otherwise,

on both sides, and apart from any question of damages, the costs may be very high.

In Scotland, the unsupported evidence of an expert is not admissible—his evidence requires the support of a second expert witness. The best advice is, never create or cause to be created any noise which may be deemed a nuisance, and never enter into litigation except calmly, and upon the advice of Counsel skilled in the interpretation of Common Law respecting, particularly, Nuisance by excessive noise.

Statute Law is enacted, and at times revised, by Act of Parliament, and specifies much more precisely than does Common Law what shall or shall not be done, where and by whom. It deals with specific, instead of general, aspects—with the technicalities rather than with the morals. Its ramifications are extended by regional Bye-Laws, which amplify and define within local limits the main provisions of the Statute Laws and Regulations.

Another pertinent difference between Common and Statute Law is that the former is for the use of a man who wishes to proceed against his neighbour; the latter applies when Authority proceeds against the two of them with grim impartiality. Statutory offences are dealt with in the Courts of Summary Jurisdiction, and persons wishing to initiate a prosecution must do so by complaint to the police.

Statutory Law respecting noise comes under two main headings: The Road Traffic Act and the Regulations of the Minister of Transport both specify what conditions shall be observed by vehicular traffic on the public roads. The Public Health and Local Government Acts, extended by the bye-laws of local authorities, cover the wider range of Specific Noise Offences, such as street cries and shouting, fairs, noisy radios and gramophones, while various planning and zoning restrictions define areas wherein industrial noise (among other things) may or may not be permitted. Noise clauses may be inserted in agreements for the letting of flats and other dwelling places, and may be invoked by the landlord when the tenant ignores or neglects his written undertaking.

It will be obvious from the foregoing that a Nuisance may exist which cannot be remedied by invoking Statute Law (because this does not cover the situation), and will not be remedied by Common Law, since the citizen will be reluctant

THE LEGAL ASPECT

to burden himself with the expense of litigation where he is uncertain of the outcome. The gap has been partly bridged by the provisions of the Noise Nuisance section of the Public Health Act. To come within the scope of the Noise Nuisance section, the noise must be injurious or dangerous to health, and a noise nuisance is deemed to exist where "any person makes or continues, or causes to be made or continued, any excessive or unreasonable or unnecessary noise, and where such noise is:

- (a) Injurious or dangerous to health.
- (b) Capable of being prevented or mitigated, having due regard to the circumstances of the case."

However, if a noise is occasioned in the course of any trade, business or occupation, it may be deemed a good defence that the best practicable means of preventing or mitigating it, having regard to the cost, have been adopted.

Under this section, proceedings may be initiated directly by the local authority (where the provisions of the Act have been incorporated in the Local Act), or the local authority may act upon a complaint laid by not less than three householders or tenants living within hearing distance of the nuisance. The local authority may serve a notice on the offender requiring him to abate the nuisance within a specified time; in the event of failure to comply, they can bring him before a Court of Summary Jurisdiction, which will repeat the Order, and may impose a penalty for non-compliance, or alternatively, the Court may itself abate the nuisance and recover the costs. At its discretion, the authority may refer the case to the High Court.

Chapter XIV

THE FATIGUE REACTION OF NOISE AND ITS APPLICATION TO INDUSTRIAL WELFARE AND ECONOMY

ALTHOUGH a great many people have felt for some time that excessive noise may not only decrease the efficiency of a worker but may also be injurious to his health, the complexity of the problem has made it impossible to obtain much definite information on the precise effects of noise. The investigator must take into account the great variety of noises occurring in different places, as well as the individual reaction of the persons involved. If the results are to be of value, they must cover a wide variety of conditions and a large number of people. Considering these difficulties, it is hardly surprising that only a few investigations have been made, and that the amount of data on the subject is comparatively small. Consequently, any principles developed in connection with noise effects have to be applied broadly, with full realisation of their limitations.

However, the difficulties in obtaining reliable data do not minimise the importance of the problem, and it is therefore proposed to discuss generally the effects of noise and to touch upon some of the experimental work which has been completed in an effort to determine the approximate magnitude of fatigue.

It is often stated that the human ear can so accommodate itself to a noisy environment that in time it is capable of rejecting the noise, which then merges into an unnoticed background. This is actually true, in the sense that any continued nervous stimulation produces decreasing psychological results. While no conscious sensation of noise may exist under these conditions, since the power to perceive has declined by exhaustion, the nervous system still suffers full excitation. It is through this action that ill-health and decreased efficiency may result, in the form of more or less severe nervous and mental disorders.

THE FATIGUE REACTION OF NOISE

In extreme cases, continued exposure of the auditory nerves to excessive shock may result in impairment of the hearing mechanism. Examples of occupational deafness are quite common in trades such as boilermaking and riveting.

Under less severe noise conditions, the effects on the workers are naturally of a less obvious nature. The average person is sufficiently adaptable to enable him, when in a noisy environment, to make the additional effort required to maintain a reasonable standard of efficiency. This additional effort may be measured by the amount of energy consumed in doing a definite amount of work.

The following is a short account of some experimental work which has been carried out, chiefly in America, to determine the effects of noise on output and energy consumption.

D. A. Laird, of Colgate University, employed as a test chamber a room measuring 15 ft. by 6 ft. by 9 ft. high, equipped with a noise machine which was capable of reproducing electrically noises typical of an office facing on to a busy street in an industrial area. The wall surfaces were treated with removable sound-absorbing panels, to simulate conditions in an office before and after a normal acoustic treatment, and computed to reduce the loudness of any noise in the untreated room by one half of that value when the panels were erected. In the measurements, results were observed for the quiet and the noisy periods. Considerable care was taken to ensure that the subjects (typists of both sexes) were not exposed to any mental or physical strain during the period in which they were disengaged in the tests.

The typists were supplied with gas masks, and their energy expenditure was determined in terms of calories expended, by analysis of the exhaled air. The resting energy expenditure was measured after the subjects had rested in the test room for half an hour and thence, after commencement of typing, at fifteen-minute intervals. Measurements on any particular condition were extended over a minimum period of a week, in order to cater for the subjects adapting themselves to the experimental conditions.

The average increase of working over resting metabolism was 52 % for the quiet and 71 % for the noisy phase—an increase in energy consumption for the noisy condition of 19 %. The introspective observations of the test subjects indicated that,

in addition to a greater expenditure of energy in depressing the typewriter keys, the entire muscular system was tensed. The average gain in speed under quiet conditions for observed times on a test letter was 4.3%. However, this quantity varied considerably with the subject—a very slow worker showing no change, while the fastest recorded a change of 7.4%. This confirms the opinion, deduced from previous work, that the more highly skilled subject is adversely affected to a greater extent than the less efficient worker.

The information on the number of errors made is not conclusive. The slowest workers were slightly more accurate under noisy conditions and the expert typists slightly less. It is possible that the noisy conditions automatically induced a greater concentration in the slow workers, thus improving their performance in this respect at the expense of other factors.

The observations on fatigue in output are illuminating. The speed of typing the test letter increased towards the end of a two-hour test period for the quiet condition by an average of 4.5% and decreased by an average of 3.5% for the noisy condition. The increase or decrease was in both cases progressive.

A similar reaction to noise has been observed during experiments made on various subjects reading a paragraph. On the introduction of noise, there was an increased articulation on the part of the readers in an attempt to concentrate on their work. This occasioned an increase in respiration, and finally a decrease in the speed of readings due, in this case, both to physical effort and mental strain.

In a North London Factory, the men and women operatives recorded severe nervous strain on account of the noise of heavy punching machines. It was difficult to recruit labour and absenteeism was high. A visit to the works confirmed that less than half the machines were being operated, but even then the noise was very intense. The ceiling was treated with an acoustic material of high efficiency, and some months later the management reported that the problem of recruiting staff had disappeared.

In a European factory, experienced workers made 60 mistakes in the assembly of 80 temperature regulators when working next to a boiler shop. Upon removal to a quiet situation, only seven mistakes were made while assembling 110 regulators in the same time. It is probable that this type of work, which calls

THE FATIGUE REACTION OF NOISE

for constant mental application and involves delicate manipulation, suffers the greatest reduction in efficiency due to the presence of noise.

The following remarks were uttered by the Chairman of a Committee whose terms of reference were "Organization and Methods and its Effect on the Staffing of Government Departments". Publication was ordered by the House of Commons in August 1947, and a complete report is available through H.M. Stationery Office:—

"We have heard from time to time about reasons for delays in answering correspondence and the difficulty of getting hold of typists and so on. Can we be satisfied that the work of clerical workers is so planned as to get the best out of them, and can we be also satisfied that they really are doing work that is absolutely essential? May I just say a bit more about the first point as regards typists? In the O. & M. Bulletin of April 1947, on page 30, there is an article entitled *Trapping the Unseen Office Demon*, and it refers to the effect of noise on typists, and that if you will only insulate rooms and typewriters properly so that there is less noise you can get in the case of typists 29% reduction in errors and a 12% increase in production, and in the case of machine operators a 32% reduction in errors and a 37% increase in production, and as far as all employees are concerned a 37½% reduction in absenteeism and a 47% increase in production. Those figures are somewhat staggering.

"As arrears accumulate, those arrears are used as a justification for applications for increased staff, whereas if better methods or better working conditions had been provided those arrears in fact would not have originated, and in so far as they had not originated it would not have been necessary to put in for increased staff, and in so far as it was not necessary to get an increased staff there would have been more room available for other workers, who would then, as a result, have been able to get on with their work more efficiently."

The typical cases quoted above give a general indication of the manner in which efficiency may be improved following the application of acoustic treatment.

INDEX

- ABSORPTION:** (see Sound Absorption)
- Absorption, coefficient of:**
- definition of 152
 - effect of fixing on 156
 - effect of surface finishes on 157-158
 - list of 159
 - measurement of 152-154
 - of panels 146
 - use of 132-133, 139-142
 - variation with frequency of 154-155
- Aero-engine test houses** 94, 102, 116, 190
- Audience, absorption by** 31, 129, 141
- Auditoria:** (see also Cinema)
- acoustics of 28-29
 - flutter in 29, 127
 - recording in 145-146
 - reverberation in 30-31
- BAGENAL, Hope** 158
- Building Research Station** 75
- Burt Committee** 48
- CANTEENS** 185
- Ceilings, suspended** 69, 77-78, 81
- Churches** 186
- Cinema:**
- acoustic analysis of 132, 139
 - disadvantages of 124
 - echo in 126
 - flutter in 127
 - masking noise in 25
 - noise in 138
 - reverberation time of 128
 - shape of 125
- Classrooms** 184, 187-188
- Code of Practice** 48
- Compliance** 39, 168-182
- Concert Halls** (see Auditoria)
- Corridors** 99, 185
- Council Chambers** 186, 189
- DECAY rates, multiple** 31-32
(see also Reverberation Time)
- Decibel:**
- definition of 18
 - level of common sounds 19
- Diffusion** 126, 128, 148
- Discontinuous Constructions** 37-38, 43-45
(see also Sound Insulation)
- Doors, sound insulation of:**
- fasteners for 97-99
 - frames for 95-96
 - hinges for 88-90
 - seals for 82-88, 90-104
- Dubbing** (see Rooms, small)
- Dwellings:** (see also Rooms and Sound Insulation)
- insulation against air-borne sound 34-37, 48-49, 54-57, 59-60, 68-69, 77-78, 185, 188-189
 - insulation against impact sound 42-45, 69-72, 74-78, 185, 188-189
- ECHO** 15, 29, 126
- Eyring, C. F.** 134
- FACTORIES,** 19, 109, 189-190, 191-193, 194-197
- Flats** (see Dwellings)
- Flanking Transmission** 35-37, 59-60, 74, 112
(see also Sound Insulation)
- Fletcher** 23, 145
- Floors:** (see also Sound Insulation)
- air-borne sound insulation 68-69, 74
 - impact sound insulation 69-72, 74-76
 - vibration insulation 69-70, 74

INDEX

- Floors, concrete** 68, 70
Floors, timber 69, 80
Floor finishes 70-72
Floors, floating 71-72, 74-76
Flutter 29, 127
- GLASS** (see Windows)
- HOSPITALS** 184-185, 188
Houses (see Dwellings)
Housing Manual 48
Humidity, Effect of 136
- INDUSTRIAL Noises:**
 legal aspect of 191-193
 reduction of 189-190
- LOBBIES** 99
Loudness:
 equal contours 21
 equivalent 20-22
 in cinemas 124-125
 reduction of in rooms 46
 relative 22-24
- MACHINERY, isolation of:**
 analogy with electrical low-pass filter 167-170
 calculation of low-pass filters 171-175
 in ventilation systems 114-115
 on floors 69-70
 resonance frequency 177-180
 use of low-pass filters 37-42
 use of rubber in shear 181-182
- Masking effect** 24-26, 138
Mass Law 34, 50-53, 99
McNair 145
Millington 135
Munson 145
- NOISE: (see also Ventilation Systems)**
 annoyance factor of 16-17
 fatigue reaction of 194-197
 in cinemas 138
 legal aspect of 191-193
 masking effect of 24-27
 nature of 15-16
 sources of 49, 69, 109-110, 183, 187, 188
- Noise, Reduction of: (see also Sound Insulation)**
 in civic centres 186
 in hospitals 184-185
 in offices 187
 in restaurants 185-186
 in rooms 32-34, 46, 59
 in schools 184
- OFFICES** 187
- PARTITIONS (see Sound Insulation)**
Phon, Definition of 22
Planning for quiet 189, 190
Plumbing (see Service Pipes)
Practical Acoustics and Planning against Noise 158
Preview Theatres (see Rooms, small)
- ROAD Traffic Act** 192
- Rooms:**
 adjacent, insulation against
 air-borne sound 34-37, 46-47, 48-49, 55, 59, 68-69
 adjacent, insulation against impact sound 69, 70-72
 natural modes of resonance in 143-145
 noise reduction in 26, 32-34
 small, diffusion in 148-151
 small, high frequencies in 146-148
 small, reverberation characteristics of 145-146
 small, transients in 144
- Restaurants** 185-186
- Reverberation Time:**
 acoustic analysis for 139-142
 calculation of 134-135
 departure of practice from theory 132
 diffusion in small rooms 148-151
 in small rooms 145-148
 optimum 30-31, 128-131
 treatment against 137-138
 variation with humidity 136-137
- SABINE, W. C.** 134, 152
Schools 184, 187-188

INDEX

- Scoring, Dubbing, Looping
 Rooms (see Rooms, small)
- Seats, absorption by 130, 141
- Service Pipes 42, 43, 44, 57, 61, 188, 189
- Sound Absorption: (see also Absorption Coefficient and Reverberation Time)
- by air 136-137
 - in air ducts 111-112, 116-123
 - in cinemas 129-135, 137-138
 - in small rooms 145-152
 - measurement of 152-154
 - principle of 32-34, 46, 152
 - to reduce noise 26, 59, 99-100, 102, 184-197, 189-190
- Sound Insulation: Air-Borne Sound:
- compared with absorption 45-47
 - flanking effect 35-37, 59-60, 74, 112
 - in buildings 48-49, 183, 187-190
 - measurement of 73
 - National Physical Laboratory measurements of 61-67
 - of complex partitions 57-59
 - of doors (see Doors)
 - of double partitions 53-57
 - of floors 68-69, 77-78
 - of partitions 34-35
 - of single partitions 50-53
 - of windows (see Windows)
- Sound Insulation, Impact Sound: (see also Machinery)
- flanking effect 74
 - in buildings 48-49, 183, 187-190
 - measurement of 73-74
 - National Physical Laboratory measurements of 78-81
 - of floating floors 70-72, 74-77
 - of floors 42-43, 68, 69, 70
 - of suspended ceilings 77-78
- Sound, physical properties of 17-20
- Staircases 185
- TALKS Studios (see Rooms, small)
- Telephone Booths 94-95
- Transients 144
- Transmission of Sound (see Sound Insulation)
- Trapping the Unseen Office Demon* 197
- VENTILATION, forced:
- noise reduction in ducts 111-112, 116-118, 120
 - sources of noise in 109-110, 112-114
 - use of baffles in 122-123
 - use of bends in 121
 - use of splitters in 118-120
- Vibration: (see also Sound Insulation and Machinery)
- in ventilation systems, 110, 112, 114-115
 - reduction of 60-61
 - transmission through structures 26-27, 37-42, 49, 69-70
- WALLS, (see Sound Insulation)
- Wave Transmission through Structures 42-43, 69, 70
- Windows, insulation of:
- double 101-104
 - effect on total insulation of 104-105
 - effect on ventilation and lighting of 105-106
 - National Physical Laboratory measurements of 101

DATE OF ISSUE

This book must be returned within 3, 7, 14 days of its issue. A fine of ONE ANNA per day will be charged if the book is overdue.

--	--	--	--	--

