

CENTRAL LIBRARY

Birla Institute of Technology & Science  
PILANI (Rajasthan)

Call No. 621.32  
K994EI

Accession No. 37174

Acc. No.....

**ISSUE LABEL**

***Not later than the latest date stamped below.***

--	--	--



# ELECTRICAL ILLUMINATION

By

JOHN O. KRAEHENBUEHL

*Professor of Electrical Engineering  
University of Illinois*

NEW YORK

JOHN WILEY & SONS, INC.

LONDON: CHAPMAN & HALL, LIMITED

Copyright, 1942, by  
JOHN O KRAEHNBUHL

---

*All Rights Reserved*  
*This book or any part thereof must not*  
*be reproduced in any form without the*  
*written permission of the publisher.*

SIXTH PRINTING    SEPTEMBER, 1949

PRINTED IN U. S. A.

## PREFACE

This book deals with the principles underlying the specification and design of electrical lighting for commercial and industrial buildings. It is the result of a number of years of experience in teaching the subject to architects, architectural engineers, and electrical engineers and in consulting with architects. There are books available for teaching illuminating engineering and photometry, but it has been found desirable to present the subject to the groups mentioned above, since their needs are not covered by the books published up to the present.

No attempt has been made to treat every type of installation and equipment, but only the important principles that govern lighting practice. Both floodlighting and novelty lighting have been allotted what may seem to be excessive space. This is because of the frequency with which such information is demanded by both the profession and the students. Although general illumination design is capably handled by both architects and utility advisors, the methods available for designing floodlighting and novelty lighting are much less understood. The last chapter, "Wiring," represents the least that the designer of illumination should know concerning wiring so that voltages may be maintained on the lighting system.

By the use of simple algebra and trigonometry, a special effort has been made to eliminate complicated mathematical developments, which would be beyond the needs of university sophomores in both the engineering and fine and applied arts divisions. The author wishes to express his sincere appreciation to all the sources from which he has drawn his information. The material incorporated has been academically established or approved by the Committees of the Illuminating Engineering Society. In each instance where possible, direct credit has been given to the source listed in the bibliography, and only through oversight or lack of specific knowledge has this been neglected. The profession has contributed the material included in the text.

The author wishes to express his sincere thanks to Miss Wilma Richard for reading the manuscript, and to his wife, Kathryn W. Kraehenbuehl, for reading the manuscript, editing, and proofreading the work. The author recognizes in special appreciation the assistance given by Mr. Harry W. Horn and Mr. J. H. Smith, instructors in electrical engi-

neering at the University of Illinois, associated with him in the teaching of illumination, for reading the material for technical accuracy and contributing many suggestions on arrangement and content. Mr. Elmer F. Heater of the Engineering Experiment Station of the University of Illinois arranged and made the drawings.

J. O. K.

*Urbana, Illinois*  
*September, 1941*

## CONTENTS

CHAPTER	PAGE
1. Introduction . . . . .	1
2. Objective Specification of Illumination . . . . .	15
3. Subjective Specification of Illumination . . . . .	41
4. Color and Shadow . . . . .	70
5. Distribution Curves and Point-By-Point Method of Determining Illumination . . . . .	90
6. Electrical Incandescent and Gaseous Vapor-Light Sources . . . . .	123
7. Light Control . . . . .	156
8. General Illumination Design . . . . .	216
9. Luminous Architectural Elements . . . . .	256
10. Floodlighting . . . . .	282
11. Novelty Lighting . . . . .	311
12. Maintenance and Economics — Automatic Control . . . . .	349
13. Wiring . . . . .	373
APPENDIX . . . . .	427
AUTHOR INDEX . . . . .	429
TABLE INDEX . . . . .	431
SUBJECT INDEX . . . . .	433





## CHAPTER 1

### INTRODUCTION

The application of illumination to modern buildings, and to buildings being remodeled, in recent years has become increasingly important to both architects and engineers. Because the electrical engineer has developed the most efficient incandescent source, the science of applied illumination is closely associated with that profession; and the recent developments in vapor sources have followed the development of incandescent sources as a natural sequence, guided by researches for more efficient light sources.

Intense study of applied light and its influence upon the human being has developed only recently, and as yet it has not been given the consideration it deserves by those responsible for the specification and installation of safe and adequate lighting in industrial and commercial buildings. It has been the policy, in the past, for the architect to permit the contractor to assume responsibility for both the illumination and wiring of the building and to allow the client to choose whatever lighting equipment pleased him. In industry, the executive has often, heretofore, been influenced more by the sales talk of a representative from a fixture manufacturer than by the principles that should govern correct lighting installation for manufacturing and inspection. Since there are investigations which have demonstrated some of the essential fundamentals in choosing the lighting system and type of equipment, it behooves both the architect and the engineer to assume the responsibility of becoming informed in this field and either assuming that responsibility directly or delegating it to experts in lighting design.

**1. Division of Labor.** There are four divisions in the development of a lighting system which are separate, but must be considered collectively by the individual specifying the final installation. Design of equipment is one of the duties of the illuminating engineer, an individual who must be trained in the fundamental science of light and must have developed experience in the field of application. An efficient and satisfactory lighting fixture cannot be designed by the average architect and constructed by the local tinsmith.

The manufacturer may combine the functions of both equipment designer and manufacturer, but it is necessary that the means be available by which shapes can be constructed that follow accurately the intent of the designer as to the control of the light. Too frequently a manufacturer without a scientific background designs a lighting fixture, the sale of which depends upon its beauty rather than upon its quality.

The last operation in the sequence of application is the installation. Both the designer and the manufacturer must keep in mind the installation of the equipment and its maintenance. Actual installation of the equipment is the only task that belongs to the contractor.

A large number of individuals, both trained and untrained, are found in the lighting application field. Many architects assume the responsibility, and in other instances the task of specifying the lighting falls to the utilities. Few individuals are properly qualified to analyze the problems and recommend both an adequate and safe lighting system. The rapid growth of modern illumination has found the field lacking in trained personnel and, as in all new branches of engineering, every salesman and every man installing fixtures feels qualified to act as an expert. There are few consultants, and even those few are seldom consulted. There is no regulation or legal code which compels expert attention to the problem; therefore, no one is willing to pay for the consulting service because there is no fixed responsibility if the installation is not of the proper kind.

**2. Scientific Requirements for Prescribing Light.** The science of light calls for knowledge in advanced fields of mathematics and physics. In the development of illuminants, chemistry is the basis of much of the rapid progress that has been made in the last decade. The engineer holds the same position in the illumination field that he holds in all other branches. He is the one interested in the economical application of the product developed by the mathematician, the physicist, and the chemist. The most important function which the engineer performs (and which is seldom taught) is the one concerning economic considerations. Information may be available which recommends some specific amount of illumination or some special type of equipment but, since the equipment must be purchased and operated, its final selection as to the amount of illumination will be determined by balancing the benefits against the cost. Unfortunately this balancing is too often done without regard to the necessity of at least some benefits.

**3. The Human Element in Lighting.** Since lighting is for the benefit of the human race, the needs of the race must be considered

in selecting both the source and amount of illumination. A human being finds expression of feeling through the stimulation of physiological and psychological reactions of the body. The physiology of the eye and nervous system, which are sympathetic with stimulation through the act of seeing, is very complicated and must be accepted as it is, for only slow evolution can change it. The psychology of the human being may undergo changes as a result of proper training and conditioning. Without specific training mankind is more likely to choose that which is aesthetic rather than that which is comfortable. It is possible, however, for a salesman to create in a customer an artificial desire for something which is unpleasant both to the aesthetic senses and to comfort, though such a desire will seldom continue beyond the sale and through the full-life operation of the system. It is the prescribing of comfortable installations and the development of an appreciation of these which is needed most urgently at the present time. Some manufacturers and power organizations are attempting this program, but the natural suspicions of people concerning these sources of information hinder the rapid adaptation of that which is new even though it may be of merit. It is the task of both the architect and the application engineer to become informed concerning the merits of special equipment and special installations, and to have a thorough background in the basic information available from technical societies and committees so that they can make judgments and form opinions, not from hearsay, but from scientific knowledge. To do this, there must be training in vocabulary and fundamental sciences and knowledge concerning particulars of many and varied successful installations.

**4. Professional Interest.** Many professions contribute their knowledge and interest to the problem of proper seeing conditions for the human race. Both artificial and natural light are studied in relationship to each other and to people. The installation of a pleasing and satisfactory lighting system must be a cooperative movement entered into by several professions, for it would be practically impossible for any one individual to be qualified to prescribe in all branches of the lighting field. The final systematic coordination, however, is the responsibility of one individual — usually the architect or engineer — who must develop an appreciation of the varied interests of the different professions involved. It is essential that some one individual be able to appreciate that each profession has a reason for advocating practices peculiar to its own interests, although they may be directly opposite to those advocated by another group, and to weigh the various viewpoints carefully in the final solution of the problem.

The medical profession has the primary interest in the physical well-being of the individual, and physicians feel that any lighting system which has a detrimental physiological effect should be eliminated. Those in the three basic fields of science solve the fundamental problems, and it is necessary for the designers to supply the needed illuminants and the control of the illumination. The architect and engineer are the ones expected to make available to the public correct scientific developments for specific use. Another group of specialists who have not often been consulted in planning are the interior decorators. Unless their problem is included in the design, they may find it impossible to produce the desired effects.

With so many different professions interested in one problem, it is necessary that there be a detailed planning of any lighting installation, that proper consideration be given to each phase, and that all phases be made to complement each other. A lighting system and its installation for pleasing and functional illumination is as important as the structure itself. The determination of the lighting is not to be planned after the structure has been completed, but before it is started. Tolerance and cooperation must be the keynote if the lighting system is to be permanent throughout the life of the structure.

**5. The Architect and Illumination.** In the design of buildings for commercial or industrial purposes as well as in the design of a public building, the architect is the central figure. Consultants in the various fields of heating, ventilation, sanitation, power, and lighting must work through him, and their work becomes part of his general plan. This does not mean that the architect arbitrarily fixes the design and invites others to contribute their parts without any consideration for their needs.

Frequently the architect assumes the responsibility for every division of the building, a method which is likely to produce a much distorted conception of the problem. It is not possible for one person to be an expert in all the technical problems that enter into the construction of a modern building. There is a lack of fundamental knowledge in many fields and of contact with the rapid expansion of nearly all fields. An expert in each field would approach the problem directly through knowledge based on scientific research, and not on individual judgment. It is essential that an architect develop a vocabulary and an understanding of the different phases of building, but only inasmuch as he needs it for his services as administrator of the plan. The architect must have this much knowledge because his clients demand it. The publicity given the development of new illuminants and their

use attracts the attention of the client, and he will ask questions pertaining to these developments with the expectation of receiving intelligent and valuable answers.

With the advent of the luminous architectural element, another phase of architecture has been developed. Whereas before illumination was attached to the architecture, it is now possible to think of illumination as *being* the architecture. In many public buildings and theaters this is quite true. It is desirable that the architect develop a pleasing architecture with the lighting elements, but it is absolutely necessary that these elements perform the primary function for which they are installed, that is, illumination in proper kind and quantity.

To consider lighting for the good of those who use it, it is necessary that the architect alter and often put aside some preconceived ideas. The architect who puts a glaring direct light into a school room, because of preconceived ideas concerning the looks of some system which is practically indirect, has not only violated an obligation to his client, but has allowed personal likes and dislikes to cause discomfort to the students. He has created an unbearable condition for these individuals from which they are certain to sustain physical and financial losses which will increase through the course of years. In so doing, in addition to failing in a professional sense, he has also failed in civic responsibility. Opinions should be based upon sound judgments backed by knowledge; personal prejudices should never be the guiding force.

**6. Extent of Knowledge on Correct Illumination.** Much of our present knowledge concerning human needs for artificial illumination is subjective rather than objective. The word science, because of its glamour, has been applied in some instances to that part of the subject which as yet has no objective unit. In other branches, units have been assigned, often only of relative values, and the investigations are of a quantitative nature capable of being reproduced. Photometry and the measurement of many human traits contributing to comfortable seeing have been investigated, and an intelligent solution prescribing that which is valuable for human hygiene is being built upon these objective measurements.

The eye was developed under conditions in which illumination was high in value and the tasks did not require close or detailed attention. It has a sensitivity for detecting light far in excess of the most elaborate instruments, but its adaptability is so high that it cannot readily appreciate a change in illumination, nor can it measure accurately the difference between the amount of illumination at one point and that at another.

Much information concerning human behavior has been accumulated when only very small samples were available, and sometimes these samples were chosen under circumstances that would not preclude some conditioning produced by atmosphere or association. Research, that should become the basis of a better understanding of the problem, has been limited to adult population, and the formative years in which lifelong damage comes to the eye and nervous system have not been investigated. The problem has created much concern, and efforts are being made to obtain a clearer understanding; but no objective answer which would permit the prescribing of illumination for any specific task beyond the question of a doubt has been established. There is much to support the contentions concerning proper light control and the need for illuminations of higher intensity than are being used today, but what these absolute needs are has not been determined. It is not even known what the highest allowable values of illumination are.

The average individual does not give much thought to either art or comfort, but accepts that which is supplied and seeks no further. The salesman sells the equipment by personal appeal and salesmanship, and prescribes the amount of illumination by rule-of-thumb methods, using formulas no better than the limits under which they are evolved. Frequently sale of the equipment depends upon what the salesman has available rather than upon such merits as economy and service.

In subjects in which the specific knowledge is as limited as it is in illumination, it behooves those specifying the types and character of the lighting system to obtain all the objective knowledge available. Those who purchase lighting systems should recognize the difficulty of specifying proper lighting and entrust their problem to a disinterested expert who is trained to bring to bear upon the problem all that is known concerning it, and who keeps informed of every new development and research which will make the solution more reliable.

**7. The Point of View of the Architect on Illumination.** The foregoing paragraphs have given the approach of the engineer to the analysis of the problem of illumination. It would be well to investigate the point of view of the architect concerning the need for a detailed consideration of illumination and its application to the building. The following excerpts have been taken from a monograph prepared by Professor Stanley McCandless<sup>5</sup> of Yale University and are that portion of the monograph considering the problem in general.

... practically all architects, from the school of Frank Lloyd Wright to those who continue to bear with Ralph Adams Cram,

seem to agree that at night the lighting makes things fit and even dramatizes the design. There are also sufficient every-day examples to indicate that lighting, properly used, is a great asset and promises to influence design far beyond its purely utilitarian aspects.

Utilities and manufacturers have launched elaborate drives to make people more light-conscious. New developments are quickly announced in the press. Designers and architects are flooded with printed matter and sales talks until there is danger that modern lighting may be considered only a passing fad. No doubt in many instances the uses of light have been too ambitious, but no architect who has faced the problem of lighting one of his buildings can deny that his knowledge of how to use light more effectively is indefinite and confused. He may even have come to feel that fundamentally lighting must be designed with the rest of the building and that its final effect is not so much the problem of the illuminating engineer but his own responsibility.

Practically all training in the design of architecture, sculpture, and painting has been carried on under the conditions of natural illumination. These conditions are almost impossible to produce with artificial light short of the flexibility provided by stage lighting equipment. Assuming that artificial lighting were able to produce the precise conditions of natural illumination, which it cannot efficiently, the designer might continue in his present methods comfortably, but the inefficient and exorbitant use of power would be as anachronistic and wasteful as the erection of an all steel building designed to simulate stone architecture. As long as artificial lighting does not create nature's conditions upon which the design is usually based, the appearance of any visual composition is bound to be altered. It comes down to the choice of accepting a questionable appearance under artificial illumination, using no artificial lighting, or designing for *both* natural and artificial illumination. Certainly the last is the only tenet to follow.

Centuries of tradition have accustomed us to judging the visual arts as they appear under natural light. Inasmuch as our sense of taste has been developed under these conditions, what should be the basis for judgment under artificial illumination where the field of visual expression is so much broader? Some will question its offering greater opportunity for expression because present-day equipment does not permit the simulation of natural effects. It is obviously necessary to judge artificial lighting, even as it can be produced today, from a different point of view than by the traditional measuring stick applied to the visual arts, those designed alone for natural lighting. Ultimately taste must evolve in terms of our appreciation of these arts as we are accustomed to see them. From a practical point of view, with the small electric lamp as the unit of expression, puny and microscopic compared to the sun, we are forced to see beauty abstractly and not as nature shows it. The standards are similar to those of the architect designing a modern building devoid of traditional elements, but insofar as the human



being responds to the beauty of visual effects developed under natural light most completely, so the function of lighting, even though abstractly expressed, is to satisfy these conditions.

If the original conception of a design is somewhat complicated by this additional problem, it is considerably offset by the extension of the field of expression. The stability of natural lighting as an asset is less important than the flexibility of well planned artificial illumination when used as a basis for design. The ability to emphasize or suppress form, to enforce composition, to lend mystery and scale, to play with color, and beyond all these to be able to alter the appearance of essentially static elements, appeals to the designer. These are obvious possibilities of artificial illumination, but they will seldom be realized until the designer accepts the added complications, and treats them as added opportunities.

From one point of view, lighting can be thought of as a structural material which is used in a building to help it serve various functions. Lighting has certain characteristics which determine its use and design like other materials, such as brick, steel, stone, and concrete. It should be designed by the architect as definitely as when he uses these materials. Unfortunately today it is common practice to treat lighting like furniture and decoration; equipment that can be added after the building has been designed. It is something the engineer and the fixture manufacturer can supply after the building is pretty well started. If this latter point of view persists, lighting practice is bound to continue in the same channel. Difficult as it may be to visualize lighting as a structural element in architectural design, this consideration must eventually exist as a conviction in the mind of the designer.

It is hardly necessary to amplify this idea further. Out of all the welter and turmoil caused by modern design, very few detail suggestions are forthcoming. The distillation ejects such terms as functionalism, simplicity, frank use of materials, and keeping abreast of the changing functions of modern business, methods, materials, and living. Perhaps each designer should be free to choose his own interpretation of these fundamentals. The same is true with lighting. It is possible to outline the fundamental characteristics of lighting but the details of application must be left to the designer and engineer.

If the function of the designer is to visualize in terms of beauty, efficiency, and functionality; the engineer should undertake the task of supplying the technical equipment and advice that help to make the vision a reality. It is no doubt true that there are many technical improvements to be made to supply this need, but the engineer is helpless when forced to violate physical laws to fit lighting into a condition for which it was not planned. The situation is as fundamentally wrong as expecting gravity not to work in figuring the weight on building foundations. A great deal of the criticism of lighting to-day is due to this procedure. Generally the designer involved blames the engineer unconsciously because he has not realized his own responsibility in the case. An

engineer is a technician and a scientist, not a designer, as a rule. What architect would expect or even allow a contractor to build his building from a verbal discussion? Yet this is approximately the procedure of lighting of most buildings to-day.

Lighting is mentioned as one of the new materials which are now available for architectural design only to support the point that it should be designed with the building, and that since the development of the electric lamp, new uses beyond that of giving visibility where and when natural light does not exist, have become apparent. The design of lighting has three important aspects; 1. Functions; 2. Characteristics; and 3. Technical Developments.

. . . One of the steps in the appreciation of visual beauty, such as a picture, is the composition or pattern of light rays that enter the eye. Broadly speaking all painting, sculpture, and architecture are static elements in the seeing process. They reflect, transmit, absorb, and color the rays of natural light that fall on them and present a picture or visual impression. The part light plays in conveying the beauties of the visual arts to the observer is an accepted condition of their existence. The designer's degree of dependence upon the constant factors in natural lighting becomes obvious when these conditions do not exist as in the case of most artificial lighting.

Where there is no light, objects cannot be seen. Therefore, light gives *visibility*. Bare lamps make things visible, but they cause eyestrain at the same time. Good design is of no value unless it can be seen comfortably. Good lighting can even make it possible to see things with greater *comfort* than under the uncontrollable conditions of natural illumination. A careful use of artificial light enables the designer to determine a definite visual *composition*, to disclose some things and to suppress others, and at will, to be able to change the appearance of static objects. In the process the chief motive in the designer's mind is to provide a composition which creates the feeling of appropriate *atmosphere*.

A homely example may serve to point out these general functions of lighting more clearly. We bring a lamp of ample wattage or candlepower into a darkened room so that we can *see*. We put a shade on it to eliminate glare from our eyes and make it *comfortable*. We place it in the room to advantage and select the color of the shade and the brightness of the lamp to give a *satisfactory appearance*. And we find that we have established with the other elements in the room a certain *atmosphere* which we call home-like. These functions extend the usefulness of lighting beyond that of giving just visibility; visibility which may be adequate in terms of illumination but which is uncomfortable, which gives a bad composition to things in the line of vision and finally which does not create the right atmosphere.

. . . Artificial lighting does not automatically provide the best illumination for comfortable vision. The motive behind the re-

removal of the efficient bare lamp hung in the center of the room and the substitution of several types of shaded lamps placed about the room involves a sense of selection that places the *efficiency of effect* above cost of current. The difference between natural light and the arbitrary effect of artificial illumination requires a careful application of the principles of composition.

Traditional sources, such as lamps, candles, and ornamental fixtures, will continue to have a place in the scheme of lighting until something better is provided. Their chief recommendation is the associations they recall; certainly not their efficiency, because they fail to satisfy so often the functions of visibility and comfort. Lighting should not be thought of in terms of fixtures but as a plastic medium subject to design. Concealed or exposed fixtures are incidental to the space filling and revealing characteristics of light.

This makes lighting essentially a problem of modern design. It is practically without tradition, so that every principle of pure design:—unity, harmony, and balance—must be applied to supply composition as well as visibility, comfort, and atmosphere. An arbitrary expression may be as different from any natural or traditional design we may know, as long as it serves these functions. Certainly the abstract beauty of lighting occasionally seen in revues and musical comedies can encourage us to believe that the beauties available with artificial light are more extensive than those normally found in nature.

... If things we see seem to possess a certain quality that involves our relation to them, something intangible that creates feeling described as "home-like," "peaceful," "exciting," etc., lighting must conspire with the inanimate surfaces on which it falls to help to create this atmosphere. The designer must be impressed with the care that is exerted in the theater to make the lighting assist in expressing the mood of the play. How far does the final effect of an interior reproduce the well-studied rendering prepared by the designer? In its final form how far does the lighting create the atmosphere planned? Let us have more designs showing how rooms *can* look not simply how some one *would like* them to look.

Even the natural light illuminating the room establishes the composition and atmosphere by the orientation and fenestration of the building. Perhaps a serious study of window placement, the use of reflectors and colored shades might reveal new possibilities in creating different compositions and atmospheres with daylight. Certainly an atmosphere consistent with the function of the room or building ought to be provided by the designer.

... Lighting in these terms (intensity, color, distribution, movement) is the result of the application of taste and intuition by the artist. He must be articulate so that his vision can be interpreted by the engineer with available material. The most difficult problem in creating a definite composition and atmosphere is

that it is impossible to anticipate the exact technical requirements which may be necessary to achieve the proper results. In any plans where the designer has ambition to attempt to employ all the functions of lighting, he must be ready to provide the utmost flexibility for creating the results. It is not always economical and sometimes highly experimental, but probably no more so than many of the gadgets and methods which are constantly being used because they produce results.

... One of the tenets of modern design is the frank and efficient use of materials according to their physical characteristics. This imposes definite limitations on design which are not easily overcome, but within which ingenuity soon finds considerable latitude for expression. The artist is one who capitalizes the particular characteristics of his medium and makes a virtue instead of a liability out of its peculiar qualities. Tradition enables us to appreciate the difference between brick and stone architecture. It may not yet be time to judge rightly the most aesthetic use of steel and concrete in architecture, but one of the bases of judgment of a building lies in the feeling that the material has been efficiently and honestly used to produce a beautiful effect. This feeling is probably awakened by the physical laws involved in the use of the various materials.

The electric lamp has removed so many of the technical limitations incident to the use of artificial light that it can now be considered as a new material available for use in design. The physical laws which light rays obey explain many of their fundamental characteristics.

We know that the use of steel is based on laws of gravity and that it is capable of bearing certain loads, resisting shear and bending, and can be obtained in certain practical forms. Many of the phenomena of light previously confined to the laboratory can now be employed practically. This development indicates that lighting can be used to serve more nearly the functions outlined in the previous section. However, this must always be related to the practical equipment which is available.

... Technical aspects of artificial lighting involve problems dealing with light sources, fixtures, distribution, and the objects to be lighted. The available equipment, methods of use, and the design of the space elements determine the technique of procedure.

The designer must coordinate his plans with the characteristics of light and electrical equipment. Inasmuch as the architect generally considers the appearance of his design under the determinable effects of natural light, this added problem in design for artificial lighting makes his duties considerably more involved.

The status of technical equipment is such that only a limited number of ideas can be expressed successfully. The final result always depends upon the care with which the designer has conceived in terms of the possible. From an exaggerated point of

view, inasmuch as lighting is probably more limited and less understood than any other medium of design, it might be well to consider lighting first in any design. In this way certainly the designer would not conceive effects that were impossible to produce with the available means of expression.

A thorough knowledge of the relationship of the technical factors and the characteristics of light can only be gained through experience and the actual handling of equipment. The selection of the available light sources and equipment for modeling light, their installation and use, are the practical methods whereby the resultant distribution can be created most effectively in relation to the objects to be illuminated.

. . . Obviously, no artificial light source can meet the conditions supplied by the sun, but with the sources available the disadvantage is offset somewhat by the ability to exert a degree of control over them. The extent to which the various qualities of light can be produced and controlled through artificial light sources is the foundation upon which the structure of lighting technique is built.

. . . Fixtures are in a sense accessories to the light source and are generally designed to shape or model the rays of direct emanation. If they are concealed, they can be essentially functional in form. Traditionally, decoration has provided us with such a range of ornamental fixtures that even if we now have a much more efficient source, there is often good reason for affording the extra cost of the use of the ornamental metal and glass for decorative purposes. Regardless of the design of the exterior of the fixture, the optical apparatus contained within should satisfy all the physical characteristics to which light is subject. In particular, the location and design of a fixture is determined by the desire to create a definite distribution in view of its position and the object or surface to be lighted. Where several fixtures are to be used, the distribution from one must be related to the distribution of the others.

. . . By all odds the greatest contact with the outside world is due to the presence of the light rays in the space in which the objects exist. The resulting form of the density, color, and direction of light rays projected into space from all the fixtures of various types that are used to create the visual composition, is considered under the heading of *distribution*.

In order to distinguish objects in a natural or specially selected manner so that the proper visibility, comfort in seeing, composition, and atmosphere are given, a definite distribution of light must be provided. In view of the available equipment and traditional practice, certain methods of lighting have been developed, but for the most part they have been established due to limitations which recently have been overcome. As long as the designer treats lighting as a plastic medium, his method will be of secondary

importance and determined by the development of equipment, for each new problem that is presented.

The inability of the fixture to give a range of the qualities of light, as a rule necessitates the use of several. These fixtures must be placed about in available positions, and as a result the directions of the light rays and the intensities and colors of the light sources determine the form of distribution, which not only illuminates various static objects but fills the space in which moving objects, such as people, may pass. Distribution considers particularly the density and the direction of the light rays from all the instruments and their additive effect at any point in space. The illumination of objects and space by several instruments is determined by the additive effect of all the rays that are superimposed at any point on the object lighted.

. . . The general term "object" is applied to things which are not self-luminous but which are seen because of the light reflected from them to the eye. Inasmuch as most of the things we see are not self-luminous, their appearance depends upon the qualities of the illuminating light. From the standpoint of the object itself, its pigment, surface texture, shape, size, and position, (which are usually, though not always, fixed) are determining factors in its appearance under the illumination that is provided. The position of the observer in relation to the direction of the light rays illuminating the object is also another important factor. Although the consideration of the object in this section suggests individual subjects, the relation between all the objects in the field of vision determines the visual image or composition.

The appearance of objects under natural light is the accepted condition for pictorial design, so that when their appearance under artificial light is being determined, the same subjective standard of taste applies. The difference between the two, however, demands a broader conception of the use of pigment, form, texture, and position of objects in order to achieve results with artificial illumination comparable to design under natural light. As has been suggested before, there are many new possibilities, such as changing the apparent form and color of objects by means of artificial light in a way which cannot be approached under natural conditions. On the other hand, in view of the technical limitations imposed by the inflexibility of the equipment available and the physical laws which govern the distribution of light, the design of the static objects in the field of vision must be related to the lighting.

. . . The designer should become thoroughly acquainted with the functions, the characteristics, and the general technical elements involved in the use of light before he can hope to use it successfully in his practice. The psychological aspects of lighting are as yet too general to make it possible to predetermine precise visual effects. For this reason the designer is cautioned to provide adequate flexibility in any design for adjustment after the installa-

tion and the building have been completed, and he should take care not to try to use light beyond the point where his own information or good engineering advice will reasonably guarantee the practical effectiveness of his plans. Lighting is essentially in its early stages, and it should be permitted all the favors of an experimental material, but it bids fair to become the most important new development in architectural design that has occurred since the beginning of steel construction.

Architects were slow to realize that a material used in building bridges could be employed to advantage in architectural construction. When they learned the possibilities and characteristics of steel, an entirely new style of architecture came into being. It is possible that a similar evolution with regard to lighting may take place. Many old conceptions of design must be dropped and new tastes must be developed before lighting can be used most effectively in design practice.

The foregoing quotations show that the architect who is seriously considering illumination uses it as a medium of architecture to be considered and designed with the building as a whole, not something to be applied after the building is complete. Illumination has possibilities that up to the present have hardly been touched, and it is an art expected to be developed, producing new tastes in the acceptance of designs.

#### BIBLIOGRAPHY

1. H. H. HIGBIE, *Lighting Calculations*, John Wiley & Sons, 1934.
2. W. KUNERTH, *Textbook of Illumination*, John Wiley & Sons, 2nd ed., 1936.
3. P. MOON, *The Scientific Basis of Illuminating Engineering*, McGraw-Hill Book Co., 1936.
4. W. E. BARROWS, *Light, Photometry and Illuminating Engineering*, McGraw-Hill Book Co., 1938.
5. S. McCANDLESS, *Lighting for Designers*, Monograph, Yale Univ. Press, 1938.
6. WESTINGHOUSE ELECTRIC AND MANUFACTURING Co., *Artificial Light and Its Application*, 1940.

## CHAPTER 2

### OBJECTIVE SPECIFICATION OF ILLUMINATION

#### DEFINITIONS AND MEASUREMENTS

Illumination in the amount required to give the desired degree of comfort depends more upon psychological and physiological laws than upon actual physical measurements of the light. Therefore, since these factors enter into the specification of the amount of illumination and the type of system required for a specific task, the problem of proper and adequate lighting is one which is both objective and subjective, with the subjective factors probably of more importance.

The objective measurements of light depend upon establishing fundamental units and upon the response of an instrument as sensitive to every wavelength of light as is the normal eye. The normal eye responds to the sensations of light according to a curve which has been determined by many observations on the eye reactions of a large experimental group of human subjects.

Even though the units for light measurement depend upon subjective data and the human eye still plays an important part in the duplication of standards, the fundamental units can be duplicated to a high degree of accuracy for the purposes of comparison. With the advent of new devices and methods in physical photometry, it is hoped that in the near future standards may be established entirely free from the element of human error.

**1. The Nature of Light.** *Light<sup>2</sup> is defined\* as radiant energy evaluated according to its capacity to produce visual sensation.* Two different approaches are used in the measurement of light:

a. the radiant flux ( $\Phi$ , symbol; expressed in ergs per second or in watts, the unit) which is the time rate of flow of radiant energy applicable to *any* part of the spectrum;

b. luminous flux, ( $F$ , symbol; lumen, the unit; abbreviation of the unit, l.), the time rate of flow of light applicable to the *visual region* of the radiant spectrum.

\* All definitions in the text will be given according to those of the American Standards Association for "Illuminating Engineering Nomenclature and Photometric Standards", approved December 19, 1932.



Luminous flux has been the quantity used by those applying illumination, but in the future it is probable that more interest will be taken in units that include the two regions adjacent to the visible region. Figure 1-2<sup>2</sup> shows the curve of relative visibility. This curve is so arranged that unity will occur at a wavelength of maximum visibility. The color allocation on the scale represents the usual accepted classification. It will be seen that the blue and red ends of the spectrum contribute little to visibility. When measured in wave-

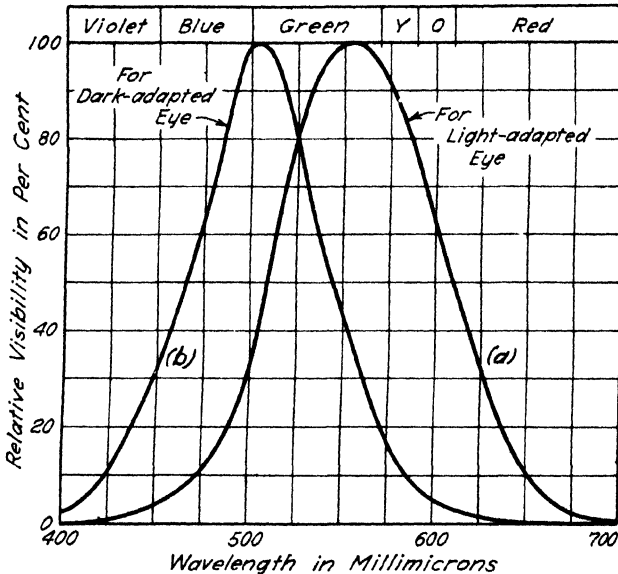

FIG. 1-2.<sup>2</sup> The visibility curves for the normal eye. The relative brightness of spectrum colors at various wavelengths based on equal energy amounts. For the light-adapted eye the maximum occurs at 555  $m\mu$  and for practical purposes is 0 at 400 and 700  $m\mu$ . Light-adapted eye brightnesses greater than one equivalent foot-candle. Dark-adapted eye brightnesses less than 0.0005 equivalent foot-candle.

lengths, at the red end the wavelengths are longer; at the violet end the frequency is higher (wavelengths are shorter).

The curve of visual response (Fig. 1-2a) has been plotted for the relative visibility factors recommended by the International Commission on Illumination,<sup>2</sup> with recommendations that these represent the relative visibility factors for general use. In special cases which are concerned with end regions of the spectrum or with peculiar conditions these provisional values may be uncertain; care should then be taken to select and use the values which correspond to the particular problem. Figure 1-2b shows also the response curve for the dark-adapted

eye. The transition from curve *a* to curve *b* is most marked between 0.2 and 0.001 ft.-L. The term *visibility factor*<sup>2</sup> (in lumens per watt: lumens divided by the power rating of the source), for the radiation at some particular wavelength, is the ratio of the luminous flux at that wavelength to the corresponding radiant flux, and the *relative*

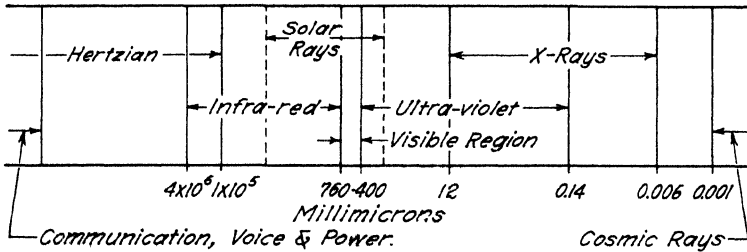

Fig. 2-2. The radiant spectra of which the visible spectrum is a part.

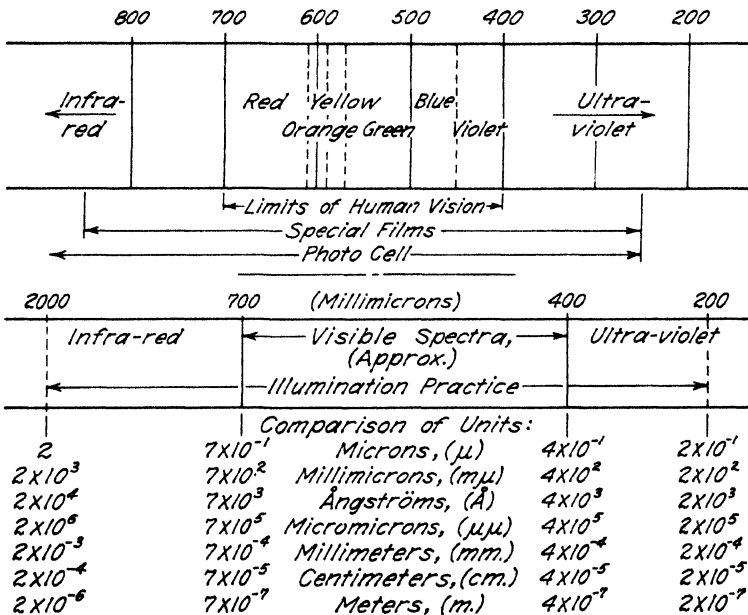

Fig. 3-2. The region of the radiant spectra used in illumination practice. The listing gives the comparison between units. The millimicron is the most practical unit for use in illumination.

*visibility factor*,<sup>2</sup> for a particular wavelength, is the ratio of the visibility factor for that wavelength to the maximum value of the visibility factor.

The application of illumination was first concerned with only the visible spectrum and was definitely confined to the definition given for

light. Recent expansion of the field into both the ultra-violet and infra-red covers the specification of radiant energy sources not within the visible spectrum. In these fields are the sun lamps, sterilizing lamps, and infra-red drying installations.

Figure 2-2 shows the relative position of the region of the radiant spectra considered in the field of visibility and indicates the additional expansion of the field into non-visible radiation. Figure 3-2 is an enlarged section of the region to which the illumination engineer, the lighting specialist, and the architect confine their interests. The other portions of the radiant spectra are considered by both the pure and applied sciences.

The present trend makes it evident that soon those specifying lighting and the use of radiant energy in the practice of illuminating engineering and kindred subjects must become conversant with the radiant spectra and understand the special units designating it.

The various portions of the radiant spectra have units so assigned that, in practice, the least use must be made of excessively large or small numbers. These units are:

$$\begin{aligned}
 1 \text{ micron } (\mu) &= 1 \times 10^6 \text{ micromicrons } (\mu\mu) \\
 &= 1 \times 10^4 \text{ Ångstrom units } (\text{Å}) \\
 &= 1000 \text{ millimicrons } (m\mu) \\
 &= 0.001 \text{ millimeter } (\text{mm.}) \\
 &= 1 \times 10^{-4} \text{ centimeter } (\text{cm.}) \\
 &= 1 \times 10^{-6} \text{ meter } (\text{m.}) \\
 &= 0.039370 \text{ mil} \\
 &= 3.937 \times 10^{-5} \text{ inch } (\text{in.})
 \end{aligned}$$

In the working range for use in applied illumination, the common units are:

$$\left. \begin{array}{l} \text{Infra-red} \\ \text{Visible region} \\ \text{Ultra-violet} \end{array} \right\} \text{ millimicron } \left\{ \begin{array}{l} 2000 \text{ to } 760 \\ 760 \text{ to } 400 \\ 400 \text{ to } 200 \end{array} \right.$$

**2. Physical Phenomena and Analysis.** The physical phenomena fall into three divisions: cause, opposition, and effect. Objective measurements are made in each division, and the units are assigned to each group. The laws of the interrelationships between these three divisions constitute the objective consideration of physical phenomena.

To make the objective measurements and the deductions for the operation of the physical laws, the subject is studied as to definitions, statistical facts, general laws (mathematics), and, lastly, derivations. The latter depend upon the logical combination of the specific statistical findings with the general natural laws in order to obtain conclu-

sive proof of actual occurrences or to predict possible results which may be expected. For example, to solve for the amount of illumination upon a certain surface when the total output from the source is known, subtract from this total output the amount of light absorbed by the surroundings. Before such problems can be solved, all analysis must be reduced to a language applicable to the specific subject; therefore, the definitions, the units, and the means of measuring the units are of the greatest importance.

**3. Luminous Intensity.** Luminous intensity is a characteristic applicable to a source, and for definitional purposes the source is a point source of light. This characteristic is expressed by the layman as the brightness of the source, but technically this classification is incorrect and should be avoided.

Luminous intensity<sup>2</sup> or candlepower ( $I$ , symbol; unit, the candle; abbreviation of unit, *c.*) is the solid-angular flux density in the direction in question. Hence, it is the luminous flux on a small surface normal to that direction divided by the solid angle (in steradians) which the surface subtends at the source of light. In practice, it is impossible to have a point source of light; but it has been accepted that, if the diameter of the source is 20 per cent of the distance from the measuring instrument, the source acts as a point source for practical purposes. A ratio of ten to one is used for very accurate scientific purposes.

The unit of luminous intensity which is used in the United States within the limits of uncertainty, is the international candle (1909), and it is a specific fraction of the average horizontal candlepower of a group of 45 carbon-filament lamps (preserved at the Bureau of Standards) when the lamps are operated at a *specific voltage*. This is a secondary standard, but it is hoped that at some early date an accepted primary standard can be found for specifying the international candle. The candle is a basic unit in the determination of other units for measuring light and its effects.

In photometry,<sup>1</sup> which is the specialized branch of science dealing with the measurement of light, several different types of standard lamps are maintained and used. Since these standards are lamps of the incandescent type, and the measuring equipment used by the engineer in the field must be frequently checked by the standards, it is necessary that the illuminating engineer have in his vocabulary the words for differentiating between these standards. They are:

*a.* Primary standards<sup>2</sup> — a source of luminous intensity that can be reproduced from specifications.

b. Secondary standards <sup>2</sup>— a source calibrated by comparison with a primary standard. These are the basic standards of the present for there are no primary standards that are satisfactory. Their values are accepted by agreement.

c. Working standards <sup>2</sup>— a source used in laboratory measurements.

d. Comparison lamps <sup>2</sup>— a source used to compare test lamps and working standards. Not calibrated for luminous intensity.

e. Test lamp <sup>2</sup>— the lamp to be tested.

Figure 4-2 shows a point source of light of one unit, and when it is observed at any distance and from any position the photometer  $P$  (obeying the response curve) should record the same value. This is

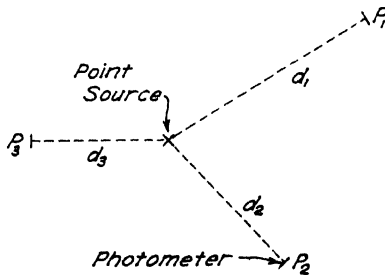

FIG. 4-2. Intensity is independent of distance and position when a point source of light is considered.

assumed. In practice, sources may not have the same intensity in every direction and may even be asymmetrical in the distribution of luminous intensity in all directions. To express a representative distribution from such sources, the following terms have been applied in defining regional intensities:

a. *Mean horizontal candlepower* <sup>2</sup> ( $I_h$ , symbol; unit, candle; abbreviation, mhcp.) is the average candlepower in the horizontal plane passing through the luminous center of the source. It has been assumed that the source is mounted in the normal manner.

b. *Spherical candlepower* <sup>2</sup> ( $I_s$ , symbol; unit, candle; abbreviation, scp.) is the average candlepower of the source in all directions in space.

c. *Hemispherical candlepower* <sup>2</sup> is the average candlepower of the source in the hemisphere considered.

d. *Zonal candlepower* <sup>2</sup> is the average candlepower of the source over the given zone.

Figure 5-2 represents the readings taken to obtain the values defined above. The average of the values in the plane  $P_1$  to  $P_3$  is the

mean horizontal candlepower; the average for the whole sphere is the spherical candlepower. The definitions of the hemispherical and zonal candlepowers are self explanatory when Fig. 5-2b is examined.

**4. Luminous Flux.**<sup>2</sup> Since this is the time rate of flow, the luminous flux multiplied by the time will give the total quantity of

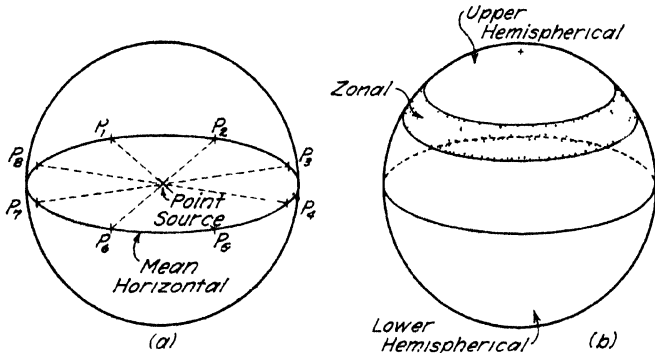

FIG. 5-2. (a) Readings for determining the mean horizontal candlepower. The mean of the readings for the whole sphere is the mean spherical candlepower. (b) The other definitions for regional candlepower are indicated.

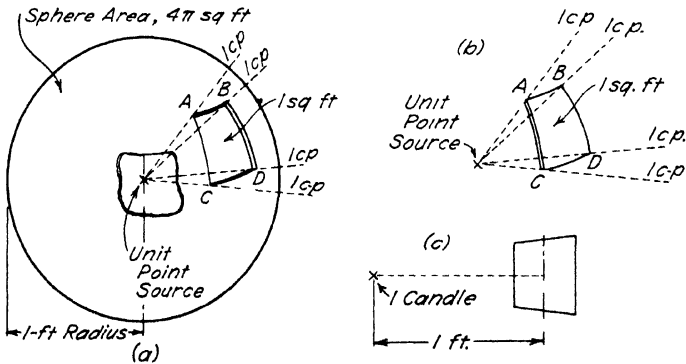

FIG. 6-2. (a) Relationship between intensity, rate, and illumination. (b) The foot-candle using the point source. (c) The foot-candle using practical considerations (apparent foot-candles).

light. The total luminous flux from a point source of one candle with one candlepower in every direction will be  $4\pi$  (12.57) l. The lumen<sup>2</sup> is defined as the flux through a solid angle (steradian) from a unit point source of one candle, or the flux on a unit surface, all points of which are at unit distance from a uniform point source of one candle.

Figure 6-2 shows a physical demonstration of the relationship between the candle source and the luminous flux. Any sphere, if it has

a radius of one unit, will have  $4\pi$  units of area; therefore, a unit candle placed at the center of such a sphere and obeying the latter portion of the definition will be emitting  $4\pi$  units of light per unit of time.

The mean spherical candlepower of any light source is a measure of the source output, for the mean spherical candlepower multiplied by  $4\pi$  gives the lumens of the source. In photometric work, the time element is usually neglected, and the lumen is considered as the quantity of light, which, in a strict scientific sense, it is not.

**5. Illumination.** Illumination<sup>2</sup> ( $E$ , symbol; unit, foot-candle; abbreviation, ft-c.) is the density of the luminous flux on a surface; it is the quotient of the flux divided by the area of the surface when the latter is uniformly illuminated. The foot-candle is the unit of illumination when the foot is used as the unit of length.

Figure 6-2, since it is drawn with a unit radius of 1 ft., shows the relationship between the three important basic units used in describing light and specifying illumination. The source in Fig. 6-2 is 1 c.; the flux from the source is  $4\pi$  lumens, and the area  $ABCD$  is illuminated to 1 ft-c. If Fig. 6-2c is considered, the surface, though a square foot, is not illuminated uniformly for it is not equidistant from the source. Also, if the source ceases to be a point source, the basic relationships change. Since both these conditions are normally encountered in practice, the definitions used in application of the art of illumination consider not true foot-candles but apparent foot-candles. The *apparent candlepower*<sup>2</sup> of an extended source of light measured at a specific distance is the candlepower of a point source of light which would produce the same illumination at that distance.

The flux from any source may be considered in two parts or as a whole, where

*total flux*<sup>2</sup> is the flux from the source in all directions;

*upward flux*<sup>2</sup> is the flux from the source above the horizontal plane passing through its center, and

*downward flux*<sup>2</sup> is the flux from the source below the horizontal plane passing through its center.

In summary, the relationships may be expressed as:

basic units are candles or candlepower

lumens ( $F$ ) =  $4\pi \times \text{scp}$ .

foot-candle ( $E$ ) =  $F \div \text{area}$

these being properly used for either theoretical or practical application.

*Example a.* Determine the lumen output of an incandescent lamp that has a mean spherical candlepower of 780 c.

$$F = 4\pi \times 780$$

$$F = 12.57 \times 780 = 9800 \text{ l.}$$

*Example b.* If a surface having a reflection factor of 80% is illuminated to 20 ft-c. and measures 2 ft. by 4 ft., determine the number of lumens required to produce this average illumination.

$$E = \frac{F}{\text{area}}$$

$$F = 20 \times (2 \times 4) = 160 \text{ l.}$$

**6. Brightness.<sup>2</sup>** Brightness ( $B$ , symbol; unit, candle per unit area or foot-Lambert; abbreviation, ft-L.) is the quotient of the luminous intensity of a surface measured in a given direction divided by the area of this surface projected on a plane perpendicular to the direction considered. The brightness of a surface is usually not uniform but varies with the angle at which it is viewed. This fact should be considered in making statements of brightness. Figure 7-2 shows the relationship between the source of illumination and the measure of brightness (the projected area being considered).

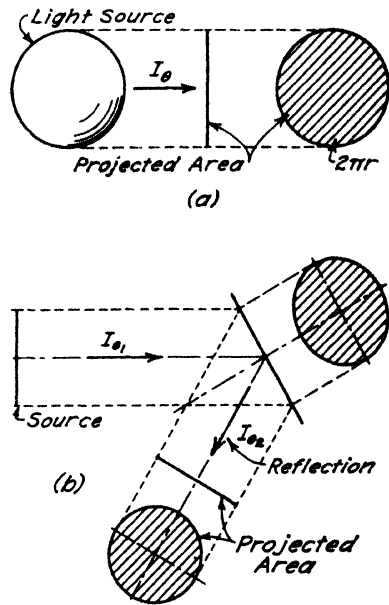

FIG. 7-2. (a) Brightness from a source. (b) Brightness from a reflecting surface.

The unit, foot-Lambert, is equal to the average brightness of any surface emitting or reflecting light at the rate of 1 l. per sq. ft., or the uniform brightness of a perfectly diffusing surface emitting or reflecting light at that rate. The average brightness (in foot-Lamberts) of any reflecting surface is, therefore, the product of the illumination in foot-candles multiplied by the reflection factor of the surface ( $E$  times  $\rho$ ). Candles per square inch multiplied by 144 $\pi$  (452) will give the brightness in foot-Lamberts for diffusing surfaces.

*Example c.* What will be the brightness of the surface in example b?

$$B = 20 \times 0.8 = 16 \text{ ft.-L.}$$

The entire subject of brightness is complicated and should be approached with caution in order to avoid erroneous conclusions. The



first work in illumination considered the problems caused by brightness, but when the lumen method of evaluating illumination became the common practice brightness was neglected. Recently, there has been a revival of the use of this factor and it seems logical to consider the specification of proper lighting from the point of view of brightness instead of foot-candles. In Chapter 3, the subject of brightness plays a more important part in determining the ability to see than do foot-candles, since brightness includes the difficulty of the task as well as the illumination.

**7. Illumination Influenced by the Angle of Inclination of the Surface.** In discussing the illumination of a surface, it has been assumed that the surface is normal at all points to the beam of light. Most surfaces are not curved but flat; therefore, the quotient of the lumens

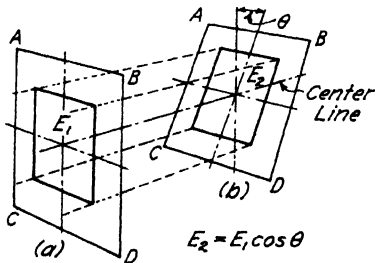

FIG. 8-2. Illumination on surfaces not normal to the light.

divided by the area will give the apparent illumination, since most sources are not at such a distance as to give parallel beams of light. In a room where the light is well diffused, the quotient represents the average illumination on the surface.

Figure 8-2 shows a surface normal and inclined to a beam of parallel light rays. In Fig. 8-2a, with the surface ABCD normal to the beam, the rays are intercepted by the part illuminated. In Fig. 8-2b, the surface ABCD is inclined at an angle  $\theta$  with the plane normal to the beam, and the area exposed to the same flux is larger. Its illumination will therefore be less, or the expression for the illumination on Fig. 8-2b will be  $E_1 \cos \theta$ .\* In computing illumination for specific surfaces and in making measurements of illumination, this must be kept in mind or errors will result.

*Example d.* A beam of light, if normal to the surface, would produce an illumination of 15 ft-c. Determine the average illumination on the surface if the surface is so inclined that the angle between the original position and the new position is 30 degrees.

$$\begin{aligned} E &= 15 \times \cos 30^\circ \\ &= 15 \times 0.866 = 12.99 \text{ ft-c.} \end{aligned}$$

**8. Inverse Square Law.**<sup>1</sup> This is a common law of nature which does not apply to light alone. A statement of the law is: The illumi-

\* Functions for common angles will be found in the Appendix.

nation is proportional to the intensity of the source and inversely proportional to the square of the distance of the source from the surface. This may be expressed as

$$E = \frac{I_{\theta}}{d^2}$$

where  $E$  is the illumination,  $I_{\theta}$ , the luminous intensity in the direction considered, and  $d$ , the distance from the source to the surface. Figure 9-2 demonstrates the truth of the law, for, if the point source of light illuminates alternately surfaces 1, 2, and 3 ft. from the surface, the area included at these points will be 1, 4, and 9 sq. ft.

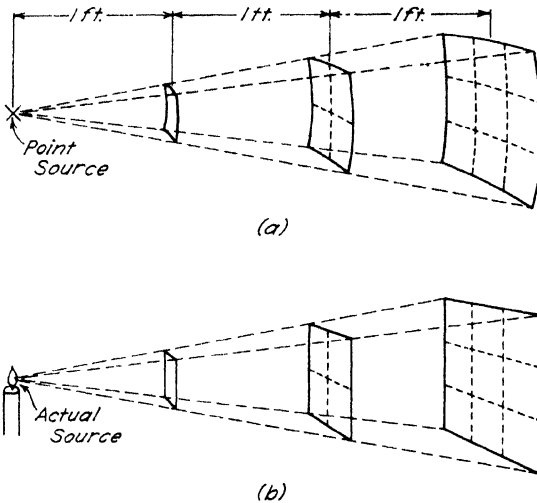

FIG. 9-2. (a) The square law and the point source. (b) The square law in application (apparent illumination).

The law as expressed does not consider atmospheric absorption of the light and applies to point sources only. This would not permit an analysis of the practical problem, for parallel rays of light and light sources with appreciable dimensions would be excluded. As mentioned on page 22, the law does apply for practical purposes if the distance is five times the diameter of the light source.

**9. Horizontal and Vertical Illumination at a Point.** The *inverse square law*<sup>1</sup> is used in photometric calculations and was used extensively in the prediction of the illumination provided by a lighting system early in the development of the art of illumination. Since reflected light from side walls and ceiling added to the direct light component supplied by the source, there was the necessity of using

factors, determined almost entirely by empirical means. This method is cumbersome, and the lumen method was developed for predicting interior illumination, though the point-source method was still retained for lighting systems where there was no additional light by reflection. Recent lighting has developed a semi-direct system of lighting by which the direct component of light is supplied by sources which may be considered point sources, and the component of indirect light is supplied by luminaires. This new development has made the point-by-point method of calculation necessary, and the determination of illumination at a given point has regained some of its previous prominence.

Figure 10-2 shows the construction for the calculation of the hori-

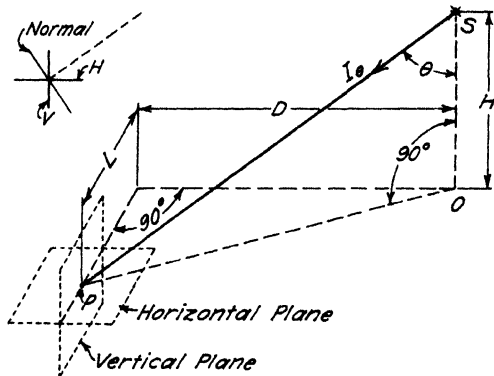

FIG. 10-2. Illumination on the horizontal and vertical plane from a light source.

zontal and vertical illumination on a surface. In this figure, the distance  $H$  is the mounting height of the source, either above or below the point to be considered,  $D$  is the distance from the axis of the source to a plane parallel to the axis and through the point, and  $L$  is the offset distance from  $D$  to the point  $P$ . By trigonometric calculations,

$$OP = \sqrt{D^2 + L^2}$$

$$SP = \sqrt{OP^2 + H^2}$$

$$E_{P_n} = \frac{I_\theta}{(\sqrt{OP^2 + H^2})^2} \quad \text{illumination on the normal}$$

$$E_{P_h} = \frac{I_\theta}{(\sqrt{OP^2 + H^2})^2} \cos \theta \quad \text{horizontal illumination}$$

$$E_{P_v} = \frac{I_\theta}{(\sqrt{OP^2 + H^2})^2} \times \frac{D}{\sqrt{D^2 + L^2}} \times \sin \theta \quad \text{vertical illumination}$$

These may be reduced to simple trigonometric forms and may be expressed as

$$E_{P_n} = \frac{I_\theta \cos^2 \theta}{H^2}$$

$$E_{P_h} = \frac{I_\theta \cos^3 \theta}{H^2}$$

$$E_{P_v} = \frac{I_\theta \cos^3 \theta}{H^2} \times \frac{D}{H}$$

The tables in the Appendix may be used for obtaining the values of the powers of the trigonometric functions.

*Example e.* Determine the (1) normal, (2) horizontal, (3) vertical illumination at a point on a surface 8 ft. below the source, if the point lies 8 ft. to the left and 6 ft. in front of the source, which has an intensity of 400 c-p. in the direction of the point. (Fig. 10-2.)

Distance source to point:

$$OP = \sqrt{8^2 + 6^2} = 10 \text{ ft.}$$

$$SP = \sqrt{8^2 + 10^2} = 12.8 \text{ ft.}$$

$$\sin \theta = \frac{10}{12.8} = 0.782$$

$$\cos \theta = \frac{8}{12.8} = 0.623$$

$$E_n = \frac{400}{(12.8)^2} = 2.5 \text{ ft-c.}$$

$$E_v = 2.5 \times \frac{8}{\sqrt{8^2 + 6^2}} \times 0.782 = 1.56 \text{ ft-c.}$$

$$E_h = 2.5 \times 0.623 = 1.56 \text{ ft-c.}$$

### MEASUREMENTS IN THE ART OF ILLUMINATION

As Chapter 3 will show, there are many factors entering into the design of proper and adequate illumination that cannot be measured in specific units and for which measuring instruments are not available, but there are three factors for which we have satisfactory portable measuring equipment. Though the measurements of these factors are not conclusive, the information obtained is essential in making reasonable judgments and specifying illumination that will prove satisfactory.

**10. Measuring Illumination.** The foot-candle meter for measuring illumination was discovered early in the development of the art, and until very recently it was the only satisfactory instrument with which the layman could gage and compare lighting installations.

The foot-candle meter is to illumination what the thermometer is to the measurement of heat. Neither of these instruments indicates

the comfort that may be derived from the installation. Each instrument, in its field, was early taken as the index of the working of the installation and is even now thought of by most individuals as the means for measuring the results. Comparing these two in parallel, it is found that comfort depends upon:

#### HEATING COMFORT

1. Temperature
2. Humidity
3. Air motion
4. Radiation surfaces

#### ILLUMINATION COMFORT

1. Foot-candles
2. Brightness
3. Uniformity (contrast)
4. Glare

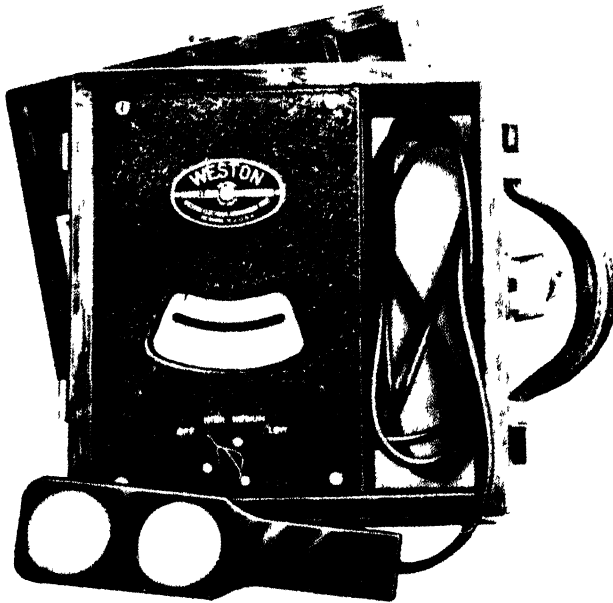

FIG. 11-2A. Weston illumination meter.

In each instance, the normal measuring instrument measures only a small part of the requirements that must be met if the individual is to be comfortable and the installation is to give minimum irritation to the nervous system.

Measurements with early foot-candle meters depended upon matching lighted surfaces. Since the eyes of the individuals using the meters varied, there was seldom close agreement in measurements among them, and training was necessary before a person could measure the illumination with any degree of agreement with previous readings. This type of foot-candle meter has passed with the advent of the

barrier-layer cell in which the photoelectric effect is used to show an indication on a meter. It is possible with this type of equipment to duplicate measurements and for each individual to obtain results that will agree with results obtained by others.

The positiveness of these physical photometers gives a false security, for there are still many unreliable factors present. There are many improper uses of the equipment which lead to serious errors which are ignored, because of the positive indication of the meter. Figure 11-2 shows two types of these instruments. As will be shown later, a foot-candle meter in which the cell may be used in any position with the indicating meter available for reading is the best type because it has the greatest adaptability.

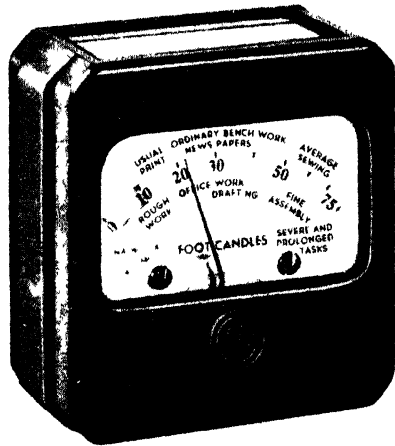

FIG 11-2B General Electric light meter.

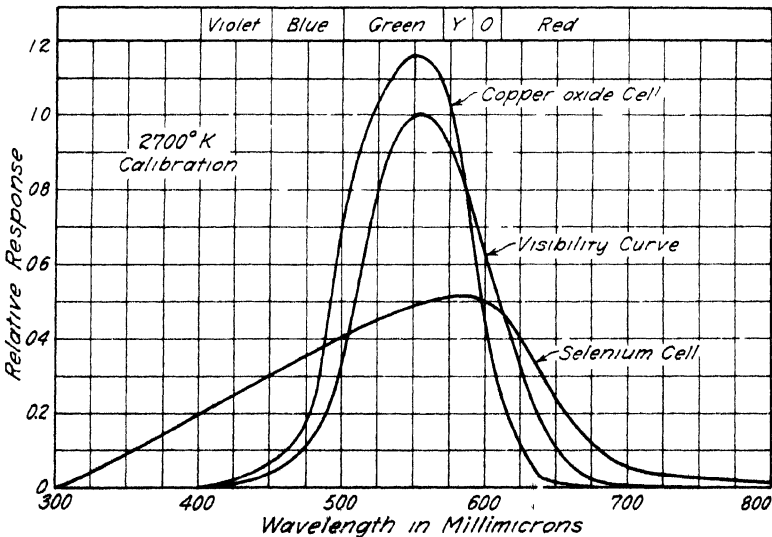

FIG. 12-2.<sup>9</sup> Response curves for barrier-layer cells.

**11. Barrier-Layer Foot-Candle Meters.<sup>9</sup>** The instruments shown in Figure 11-2 are of the barrier-layer type and are equipped with

selenium cells. Figure 12-2 shows the response curves of the two types of cells and the standard visibility curve. It is possible to use a filter with the selenium cell so that it also approaches the standard visibility curve. The use of these filters means that the cell sensitivity is sacrificed, and the instrument is not useful for low illumination readings. The importance of this type of meter was recognized by the Illuminating Engineering Society, and a committee was appointed to study it.<sup>9</sup>

TABLE I-2<sup>5, 7, 9</sup>

CALCULATED MULTIPLYING FACTORS FOR REPRESENTATIVE BARRIER-LAYER CELLS CALIBRATED AT 2700° K

Color Temperature *	Factors by which Readings Are Multiplied for True Illumination	
	Copper Oxide	Selenium
2000° K	1 101	0.874
2400° K	1 045	0.965
2670° K 50-w. incandescent lamp		
2700° K	1 000	1.000
2705° K 75-w. incandescent lamp		
2740° K 100-w. " "		
2810° K 200-w. " "		
2848° K	0 986	1 011
2990° K 1000-w. incandescent lamp		
3000° K	0 973	1 019
4000° K	0.910	1.011
Equal energy spectrum	0 883	0.888
Mercury (L.P.)	0 883	1.123
Mercury (H.P.)	0 851	1.191
Sodium	1.044	1.450
Mercury, yellow line	0 889	1.69
Mercury, green line	0.833	1.99
Mercury, blue line	0 438	0.061
Mercury, violet line	0 198	0.003

\* Degrees Kelvin.

The committee found that for continuous spectra, which include most of our electric illuminants and daylight, smaller errors were made with selenium cells than with the copper-oxide cell, though the latter does more nearly approach the standard visibility curve in its responses.

All manufacturers do not calibrate their cells at the same color temperature (color temperatures are measured from absolute zero, -273° C, the usual calibrating region used is that ranging from 2700° K to 3000° K); therefore, it is necessary to follow the practice of the

manufacturer when the cells are to be checked. It is also essential that correction factors be used if lights from other than continuous spectra sources are being examined. Table I-2<sup>o</sup> contains calculated multiplying factors for representative barrier-layer cells calibrated with a source of 2700° K and Table II-2 is a table suggesting corrections to be used with the meters shown in Fig. 11-2. Individual cells will vary considerably and this is particularly true with monochromatic light. For this reason, it is necessary for more accurate results to obtain factors for the specific instrument that is being used. With

TABLE II-2<sup>o</sup>  
MEASURED MULTIPLYING FACTORS FOR  
BARRIER-LAYER CELLS. CELLS WITHOUT FILTERS.

Color Temperature	Westinghouse Photox	Weston Photronic (Fig. 11-2a)	General Electric (Fig. 11-2b)
2400° K	1.020		
2700° K		1.000	1.000
2848° K			0.99
2870° K	1.016		
3000° K	1.000		0.96
3400° K	0.890		
Direct sunlight		1.000	0.81
Overcast sky			0.67
Mercury (L.P.)		0.920	
Mercury (H.P.)	0.810	1.400	1.06
Sodium	1.220	1.350	1.37
Neon		0.940	
Carbon arc (white flame)		0.920	

the advent of fluorescent light, it may become necessary to determine the illumination of systems of various colors.

The committee suggested that the error of the cell should not exceed  $\pm 10$  per cent when it is used for measurements involving the incandescent lamp, a figure which should be kept in mind in discussion of average illumination or point illumination measured with this type of instrument. These meters may not keep their calibration and should be checked frequently if in constant use and, if used intermittently, just before making measurements. Neglecting this precaution has often caused embarrassing situations, as in the case of an installation which was measured first by a sales representative and later by an engineer, each using instruments which were not stand-



ardized. Their results were so far from agreement that the purchaser doubted the veracity of the manufacturer's representative.

There are other sources of error besides those of color temperature of the source and spectra distribution. The cell consists of a steel plate with a coating of copper oxide or selenium which must make positive and unvarying contact with the external conductor to the microammeter. Each manufacturer uses a different method to accomplish this result and each makes claims as to the expediency of his method. The cell proper is covered, for protection, by a glass window. This glass and the holding edge, under adverse measuring conditions, may be a source of error.

**12. Error because of the Angle of Incidence.**<sup>9</sup> The angle of incidence at which the light strikes the cell will sometimes cause considerable error. In large rooms, with direct lighting, where the walls and ceiling are of minor consideration, the readings are approximately correct, but in rooms using a semi-direct enclosing glassware, the illumination may be 5 to 10 per cent higher than the meter reading, and in rooms using an indirect system or semi-indirect system the reading should be 10 to 15 per cent higher. In making daylight readings with windows on one side of the room, the reading may be as much as 25 per cent more than that read from the scale.

If this causes a feeling of uneasiness in the use of the foot-candle meter, the readings may be checked by determining the reflection factor of a diffusing standard. The reflection factor of a piece of white blotting paper is the easiest to obtain. It is first necessary to determine the reflection factor for the paper (the method is described in Art. 13). Place a piece of blotting paper about 12 in. square in the plane to be considered for illumination measurements and, with the cell facing the blotter, move the meter away from it until the reading remains constant with movement (about 2 to 4 in.). To determine the illumination,

$$E = \frac{\text{reading} \times 1.25}{\text{reflection factor}}$$

The empirical constant 1.25 is necessary in the above equation because of the diffusing of the light, which is incident on the cell almost equally from all angles.

The committee mentioned before reported that to keep the error below 10 per cent the angle between the source (if a point source) and a normal to the cell should not exceed 34°. If a large source is used, the limit is 48° and, for an infinite source (as out of doors), the error will be 27 per cent. A large room with indirect lighting will approach

this last condition. The reading of the foot-candle meter in each instance should be corrected for the conditions under consideration.

Temperature effect at normal range is small and may be neglected for, from 0° F to 100° F, the error is only  $\pm 4$  per cent, which is well within the probable accuracy of the instrument.

The cell does have a fatigue characteristic; that is, if exposed to a high degree of illumination, a slight change of current will occur, the greater part of which takes place during the first 15 min. The error

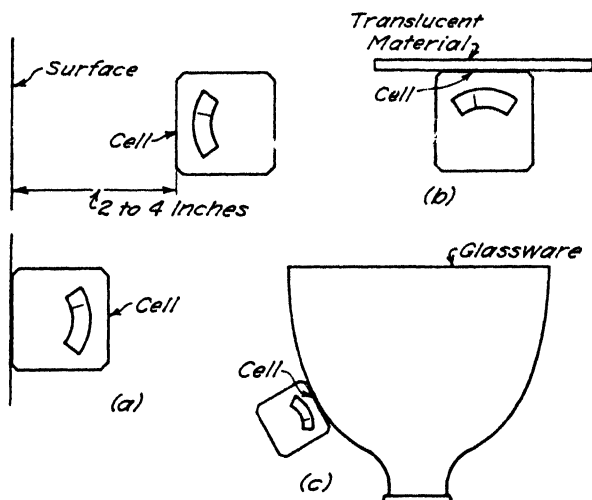

FIG. 13-2.7 (a) The use of the barrier-layer cell for determination of reflection factor, (b) determination of transmission factor, (c) measurement of brightness.

causes a decrease in current, resulting in a lower reading which amounts to about 5 per cent. This does not cause a permanent injury to the meter.

**13. Other Uses for the Foot-Candle Meter.**<sup>7</sup> As mentioned in Art. 10, it is desirable to have a meter which may be used with the cell and microammeter scale at right angles. This permits the taking of readings on the meter while the cell is pointed toward a surface. The use of multipliers allows for measurement over a wide range of illumination. The response characteristic of the cell is not seriously affected by using a mask over a portion of the sensitive surface, because the response is proportional to the surface exposed.

Figure 13-2a shows the use of the meter in determining the reflection factor of a surface. In the second position, the meter measures the illumination incident upon the surface. Here, care must be taken that errors mentioned before are not introduced in the reading. In the

first position, the foot-candle meter is used to measure the reflected light. In making the first measurement, the meter is placed against the surface and withdrawn until the reading remains constant (2 to 4 in.). The ratio of the readings:

$$\frac{\text{reading for reflected light (first position)}}{\text{reading for incident light (second position)}}$$

gives an approximate reflection factor. To obtain results which are more nearly accurate, a calibration standard may be used. In the first position shown in Fig. 13-2a, a standard surface is measured and then the unknown is measured. The ratio:

$$\frac{\text{reading for unknown}}{\text{reading for known}} \times \text{reflection factor of known}$$

gives the reflection factor for the unknown. The surfaces whose reflection factors are to be determined should measure at least 12 in. square for reasonable results.

The measurement of the transmission factor (Fig. 13-2b) is very simple. The illumination of incident light is measured; then the material is placed over the cell, the resultant ratio:

$$\frac{\text{reading through material}}{\text{reading from source}}$$

gives the transmission factor.

These measurements are not of the precise nature needed in research work, but the results are applicable to any of the problems encountered in the applied field and may be used where information of this type is necessary. The barrier-layer cell foot-candle meter should be used in all these measurements as well as in determining the illumination, thereby giving additional information upon which to base judgments in determining the proper lighting installation to specify.

**14. Measuring Brightness.**<sup>7, 8</sup> As will be seen in Chapter 3, brightness is one of the subjective characteristics which must be considered in specifying lighting. Only recently has convenient equipment for making this important measurement been available.

The foot-candle meter mentioned in the preceding article may be used for making brightness measurements, with a degree of accuracy usable under ordinary conditions. Figure 13-2c shows the cell being held close to a piece of translucent glassware. In this position, the meter reading multiplied by 1.25 indicates the brightness in foot-Lamberts. If the brightness is very high and it is desired to obtain the brightness in candles per square inch, a plate with two number 29

holes in it placed over the cell will cause the meter reading divided by 10 to give these units. The plate may be held in place by using the multiplier clip. The other types of foot-candle meters may be calibrated in the same manner.

**15. Brightness Meters.**<sup>8</sup> In the foregoing article, the use of the foot-candle meter for making reasonably accurate brightness measurements was discussed. Figure 14-2 shows two forms of simple and easily operated brightness meters. Figure 14-2A shows an instrument with a range of 0.025 to 50,000 ft-L., and Fig. 14-2B shows a less expensive type which has a range from 0.01 to 75,000 ft-L. The instrument shown in Fig. 14-2B uses the General Electric Light Meter as a

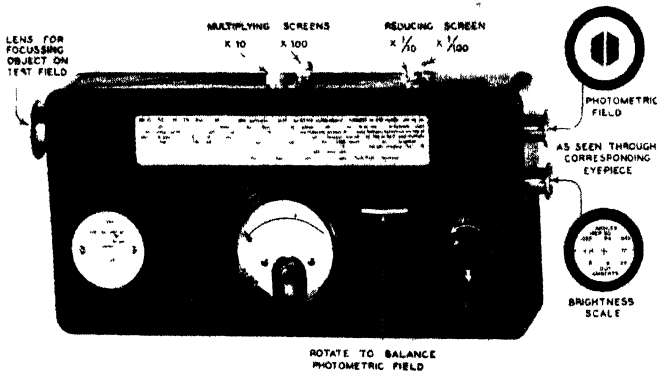

FIG. 14-2A. Luckiesh-Taylor brightness meter.

measuring device. This same foot-candle meter may be used for measuring brightness as discussed in the previous article, but its range is limited from 1 to 94 ft-L. and from 0.1 to 7.5 c. per sq. in.

In both types of instruments, the photometric balance is obtained by turning a knob and balancing the surface viewed in the finder against a diffusing surface. This surface is illuminated by means of a miniature lamp (operated from flashlight dry cells) the output of which is controlled by a film gradient. The film gradient guards against modification of the color quality. When both the viewed and standard surfaces, by means of optical systems, are brought to the same plane and are balanced photometrically, the recording on the internal scale of the larger instrument, or the foot-candle meter readings in the smaller instrument, are a measure of the brightness of the surface. The large range is obtained by inserting ratio filters in either or both the viewing and standard photometric fields.

The large meter has an optical system so arranged that the surface covered is 1 ft. wide at approximately 500 ft. This last feature provides for measuring the brightness in a restricted area and for this reason the maximum and minimum values of brightness for surfaces of any size for lighting equipment may be readily determined.

**16. Visibility Meter.**<sup>4</sup> Figure 15-2 shows a visibility meter of domestic make, the simplest of these measuring devices. It consists

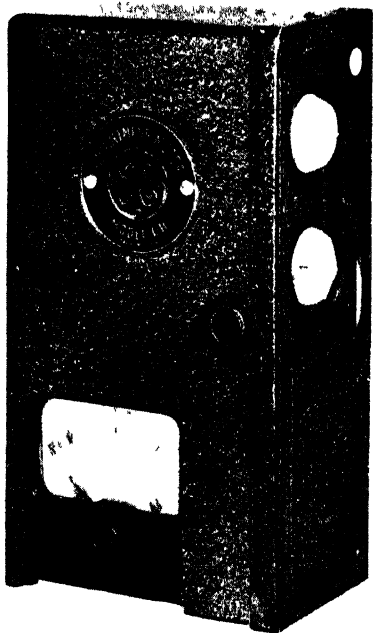

FIG. 14-2B. Luckiesh-Holladay brightness meter.

of two photographic filters (circular in shape) using gradients of a density specified by those developing the equipment. It is the grading of these filters which classifies the instrument as one of subjective rather than objective measurement. To the filters is attached a scale of relative visibility (this is not the quantity defined in Art. 1), logarithmic in nature and approximating the law of Weber and Fechner. The expression for the scale is:

$$S = C \log \frac{I}{I_0}$$

where  $S$  is the sensation;  $I$ , the intensity of the light stimulus;  $I_0$ , the least perceptible value of intensity, and  $C$ , a constant. The intensity of the source is a physical quantity, but the stimulation of the nerve endings on the retina produces a sensation which is mental and purely subjective.

Since the filters approximate the above conditions, the scale could be absolute if desired, but only in so far as any material based upon experimental psychology can be absolute. Those not agreeing with the calibration of the above instrument can easily plot a curve which fits their conception of actual conditions.

The value of the instrument depends upon the recognition of two important factors: brightness and contrast. It removes from the individual the necessity of comparing tasks and depending upon judgment alone for a determination of the probable requirements upon the nervous system of the individual performing the task. A modification

of the calibration of the scale and the recommended foot-candles on an auxiliary scale should not be attempted unless it is based upon extensive research. In illumination, there is too much prejudiced opinion and opinionated prejudice to depend upon the results obtained by any group of individuals. It is well to follow the findings of organized committees of scientific societies which represent all phases of thought.

**17. Lighting Survey.** To eliminate opinion and to obtain actual facts, it is necessary to make a survey of lighting in terms which may be considered objective. This is accomplished by using the foot-candle meter and determining the actual amount of light at salient points. No hard-and-fast method can be prescribed, for the judgment of the surveyor must be used in each case. Concise and all-inclusive

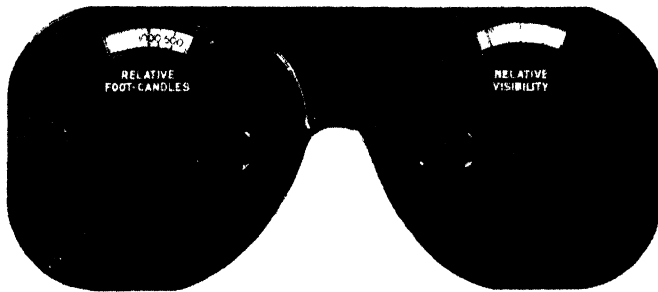

FIG. 15-2. Luckiesh-Moss visibility meter.

notes and comments should be incorporated in the report since foot-candles alone do not give a fair picture of the lighting from a system. At work positions, brightness and visibility measurements should be taken.

Some precautions should be taken into account:

- a. All probable errors discussed in the first part of this chapter.
- b. Watch shadow and reflections. Do not stand in the way of an important lighting source. Watch reflections from specular surfaces.
- c. Place meter as closely as possible to the point where the illumination is to be measured. The square-law error may become appreciable.
- d. Record data on standard forms — not on material likely to create confusion.
- e. Be sure that readings are taken at a sufficient number of points. Specific tools, work positions, and machines should be sketched to show the positions where readings are taken.

The above precautions refer to readings in general and to the data to be taken for task positions in a plant, store, or public building.

In addition to the specific work-position survey, a survey of the *general lighting* should be made. Conditions should be normal if the resultant recommendations are to be checked. No special cleaning or maintenance should be effected before the survey if a check of the improvement is to be made later. A survey between 10 A.M. and 2 P.M.

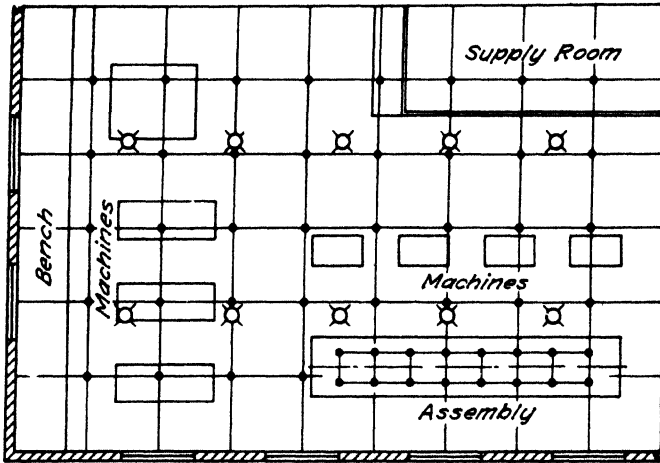

(a)-Special Points on Equipment

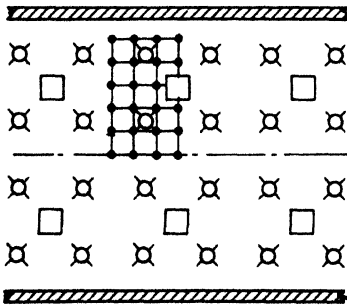

(b)-Large Room - Symmetrical  
X - Lighting Units  
• - Test Stations

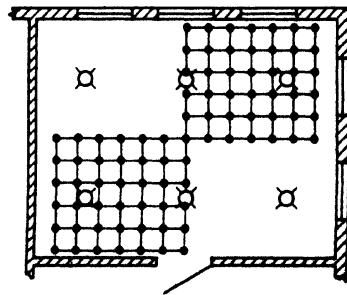

(c)-Unsymmetrical Lighting  
• - Test Stations

FIG. 16-2. Illumination survey. (a) Special measurements at working points. (b) Measurements in large, symmetrical rooms. (c) Measurements in rooms where the light is unsymmetrical. Machines may need special analysis.

is representative for daylight surveys, and the night survey can be made at any time after dark. A clear day with only such lights burning as would be used normally is the correct condition for a daylight survey. In each survey, the same stations should be taken in each room. Some investigators make an additional survey, on a clear day,

at from 4:00 to 4:30 P.M. to simulate conditions usually found on cloudy days.

There is always a question as to how many readings should be used in a lighting survey and how the positions should be located. Enough readings should be taken so that additional readings in similar locations will not change the average reading. It is well to take readings in a pattern representative of the lighting system. Figure 16-2 shows some suggested schemes for doing this. In small rooms it may be necessary to survey the whole room, whereas in large rooms only representative sections are needed. One must be sure, in choosing the representative sections, that those influenced by daylight alone, artificial light alone, and combinations of artificial light and daylight are selected.

When daylight enters into the problem, it will be found that there will be considerable difference in readings from one observation to another, for many factors enter into the variation of daylight lighting.

### PROBLEMS

*Note:* Assume point source of light in all problems.

1. A 500-w. lamp is rated at 10,000 l. Determine the mean spherical candlepower of the lamp.
2. If a light source has a uniform distribution of 300 c-p. in all directions, what is its rating in lumens?
3. A surface 4 ft. by 4 ft. receives half the lumens from the 500-w. lamp in problem 1. (a) What is the apparent illumination? (b) What is the apparent brightness if the reflection factor is 65 per cent?
4. If the surface in problem 3 makes an angle of  $30^\circ$  with the normal to the light source, what will be the surface illumination?
5. A light has an intensity of 400 c-p. in the direction of a point in a horizontal plane 6 ft. below the source. The point is located in the plane 12 ft. from the center line of the source. What is the apparent illumination (a) at the point normal to the source, (b) in the horizontal plane, (c) on a vertical plane?
6. A surface brightness obeys a cosine law, that is, the brightness with the viewing angle is  $I_\theta = I_m \cos \theta$ . What is the apparent normal illumination 20 ft. below and 30 ft. to the right of the surface if  $I_m = 3000$  c-p.?
7. In problem 6 what would be the apparent illumination on (a) a horizontal plane, (b) a vertical plane at the point?
8. Plot a curve of desired candlepower at all angles if a source is to illuminate a table 8 ft. below it to 20 ft-c. The table is 20 ft. long and the lamp is mounted at the center.
9. Repeat problem 8 with the source mounted over one end of the table.
10. Measurements of the illumination at a point are:  $E_n = 5.0$  ft-c.,  $E_r = 3.9$  ft-c.,  $E_h = 3.12$  ft-c. If the lamp is mounted 10 ft. above the surface in which point is located, what is the intensity in the direction of the point?



## BIBLIOGRAPHY

1. NELA PARK, "Illumination Terms," *Bulletin* 7-D, 1930.
2. ILLUMINATING ENGINEERING SOCIETY, "Illuminating Engineering Nomenclature and Photometric Standards," December 19, 1932.
3. W. N. GOODWIN, JR., "The Photometric Illumination Meter," *I. E. S. Trans.*, v. 27, No. 9, December, 1932.
4. M. LUCKIESH and F. K. MOSS, "Visibility: Its Measurement and Significance in Seeing," *Frank. Inst. J.*, v. 220, No. 4, October, 1935.
5. M. E. FOGLE, "New Color Correction Photronic Cells for Accurate Light Measurements," *I. E. S. Trans.*, v. 31, No. 8, September, 1936.
6. A. E. KENNELLY, "The Adoption of the Giorgi MKS Absolute System of Practical Units by the International Electrotechnical Commission," *I. E. S. Trans.*, v. 31, No. 7, July, 1936.
7. C. L. DOWS and C. J. ALLEN, "The Light-Meter and Its Use," *I. E. S. Trans.*, v. 31, No. 7, July, 1936.
8. M. LUCKIESH and F. K. MOSS, "A Brightness Meter," *J. O. S. A.*, v. 27, March, 1937.
9. COMMITTEE ON PHOTOELECTRIC PORTABLE PHOTOMETERS, Report, *I. E. S. Trans.*, v. 32, No. 4, April, 1937.
10. R. F. CISELL and C. L. AMICK, "Methods of Light Control — Parts II and III," *Light*, v. 8, No. 8, p. 31, December, 1939.
11. R. F. CISELL, "Distribution Curves," *Light*, v. 9, No. 1, pp. 35-39, January, 1940.
12. BRITISH STANDARD SPECIFICATIONS, BS/ARP, July, 1940.

## CHAPTER 3

### SUBJECTIVE SPECIFICATION OF ILLUMINATION

#### PHYSIOLOGY AND PSYCHOLOGY

In this chapter the field which, though the most important to be considered in the illumination specification, is the least understood and the most controversial, will be examined. The subjective elements in illumination depend upon physiological and psychological reactions of the human being. These are not directly measurable nor subject to non-varying specifications. It is possible to determine the normal response but this statistical material, even when *carefully collected and representative of the whole*, cannot be applied to any one individual under observation without regard to his or her specific reaction.

The study of these human reactions falls into the fields of experimental psychology and physiology, and requires the meticulous patience of those experienced in research who are motivated only by the search for the truth. A mass of data without proper diversity of such data cannot be applied to other than the group investigated, and at best such information is only indicative, not absolute. Most of the information obtained to date is highly instructive, and it points toward problems that must be answered. It is, however, of questionable scientific worth in direct application, for the information does not answer specific questions, but shows only the responses of experimental subjects (under controlled conditions) to established criteria. When, as in medical science, large sample groups are divided into two balanced halves, one subjected to what is considered optimum seeing conditions, the other to usual conditions, then it may be possible to obtain results that are unquestionably of real value in answering the difficult problem of what kind and how much of both light and control are necessary in a lighting system to give an illumination which does the least injury to the physiological structure of the body and to the nervous system.

Leonard T. Troland<sup>5</sup> compiled a bibliography in 1931 in which will be found material which could form the basis of limitless research into the subjective side of lighting specified for best vision. The material is so extensive in the fields of psychology and physiology and so many problems are raised that individuals interested in and qualified for conducting research on existing problems are much needed at present.

In recent years Dr. M. Luckiesh and Dr. F. M. Moss of the General Electric Lighting Research Laboratory have contributed greatly to the investigation of the complicated phenomena involved. They have popularized the use of the single word "seeing" to cover the interrelationship of light and vision in the performance of visual tasks. Their results are highly indicative of the reactions experienced by the human being under controlled methods normally used by the experimental psychologist. These investigations, however, are performed by two able physicists. No one interested in the advancement of the art of illumination can ignore the published results of the investigators and the evidence which has accumulated with the application of some of their fundamental recommendations.

In this chapter the evaluation of even a small part of the material that is now available for study will not be attempted. Its purpose will be to indicate those factors that are applicable to the improvement of lighting systems already installed or system arrangements that are being considered.

**1. Factors Influencing Seeing.** Ability to see may be considered to depend upon four basic variables: size, contrast, brightness, and time of exposure. It is understood, in considering the factor of size, that either the distance is assumed to be fixed or the size is assumed to be adjusted if the distance is varied. It would be justifiable to include distance as a factor, but it is less complicated to consider the foregoing relationship between distance and size.

*Size*, for seeing measurements, depends upon the visual angle (normal vision — 1 min.; best vision — 40 sec.), and visual acuity is measured by the minimum size seen. The absolute size cannot ordinarily be altered, but the visual size may be altered by changing the distance.

*Contrast* is a relative matter and may be best expressed in per cent by

$$\text{per cent contrast} = \frac{\text{background brightness} - \text{object brightness}}{\text{background brightness}}$$

Expressed in this way, the contrast of a perfectly non-reflecting body on a body reflecting all light will be 100 per cent.

*Brightness* indicates the average brightness of the object. If the surface is mainly background, the brightness approaches the brightness of the background; but, if the surface is composed of a mixture of objects or bodies of various brightnesses, then brightness means the apparent brightness and it is measured by the methods discussed in Chapter 2.

*Time of exposure* is an important factor in production tasks and in automobile driving. The longer an object is exposed, the more clearly can its presence and its details be distinguished.

The influence of these factors upon the ability either to see or recognize an object is self-evident. The lack of any one item must be compensated for by the others if the same ease of seeing is to be maintained. By the adjustment of the four factors, unless the object is microscopic, the object may be made visible to such a degree that the task may be performed upon it with the least effect upon the nervous system of the subject. In most instances all but the brightness is fixed; therefore, the importance of the problem of adequate and proper illumination is of prime consideration.

**2. The Probable Factors Influencing the Effectiveness of Lighting Systems.** The development of systems for artificial lighting is continually changing. The recommended amount of illumination, the methods of control, and the costs have necessarily changed together. Today electrical energy costs less, illuminants cost less, and the efficiency of the illuminants is higher; therefore, it is possible to recommend higher levels of illumination in order to make the task easier, without increasing the cost.

In summary, it may be said that those factors contributing to a successful lighting system are:

- a. Quantity of illumination for proper brightness.
- b. A good quality of illumination.
  - (1) No direct glare from the source.
  - (2) A minimum of reflected glare from the work or surroundings.
  - (3) Uniform lighting on the work surface.
  - (4) Illumination free from shadow.
  - (5) Surroundings illuminated with the proper brightness contrast.
- c. Comfort.
  - (1) Elimination of opinions based on past experience.
  - (2) Sufficient time to determine the reaction to the illumination supplied.
- d. Work surface considered with relation to lighting.

The developments in this chapter are intended to analyze the topics outlined above in conjunction with the information available for treating them.

**3. The Lighting Specialist.** Articles 1 and 2 established the reason why a person trained in lighting system design and installation is

needed. The eye, once crippled, cannot be cured but only aided by the oculist or the optometrist prescribing properly fitted eyeglasses. These glasses are of prime importance and should not be neglected, for even the best-designed and best-controlled lighting system cannot supply this necessity.

A lighting system designed by a competent lighting specialist will have the essential requirements for correct light control and will be adequate for the task which is to be performed. The system will be designed in accordance with the most modern knowledge and within the limits imposed by good economic practice. The design should not end the responsibility of the specialist; this responsibility should continue to the supervision of the installation and recommendations for the proper maintenance and operation of the system.

The design must be correct in both quantity and quality of light for the task; direct glare must be eliminated and reflected glare reduced to a minimum; the light itself should be diffused and properly distributed. There may be recommendations as to contrasting brightnesses by controlling the color of the background and the speed at which the task is performed.

The designer of any lighting system should understand thoroughly the nature of the task that must be performed and the aesthetic desires of the client. Too often the lighting specialist loses sight of the fact that the one desiring the light has specific requirements that must be met, and that when the system is installed it must be comfortable. A system of light designed for an organist may be perfect from the point of view of lighting service, but it may place the light in such a position that the organist cannot turn his music and it may be so unsightly that his aesthetic sense is irritated. Such a system is inadequate because it does not bring a sense of comfort.

Until very recently, lighting system design was considered of minor importance and frequently the responsibility was shifted to someone whose prime interest was the installation of the wiring service and who was wholly uninformed of the requirements of good lighting systems. Even today it is not uncommon to find the air-conditioning specialist specifying the lighting system as a side line. Until the importance of light and lighting is considered seriously, just that long will the various tasks involved in work and pleasure be a source of nervous reactions which bring distress and unhappiness to the human race.

**4. The Quantity of Illumination.** If the required optimum amount of illumination could be specified, the illumination system could without doubt be developed for producing the proper quality of light.

The eye, which acts as a camera does, has the same essential parts: a lens, a shutter, and a film, corresponding to the cornea, iris, and retina of the eye. Each part of the eye has a special function and muscles to control the adjustments. The lens is shaped by the ciliary muscles and focuses the image upon the retina; the iris is closed or opened to admit more or less light, and the muscles attached to the eyeball focus the two eyes upon the same object. These functions are classified as:

- a. Accommodation — the lens adjustment
- b. Adaptation — the iris adjustment
- c. Convergence — focusing both eyes upon one object.

The retina is the light-receiving mechanism, and its nerve system in conjunction with the brain reproduces the visual image focused upon it.

The eye has evolved from a rudimentary mechanism until it has a sensitivity far beyond that of any device man has ever created. On bright, summer days the illumination in the open may reach 10,000 ft-c., which is, at best, not too comfortable, but 1000 ft-c. under the shade of a tree is not objectionable. At the other extreme, a bright, moonlight night has an illumination of approximately 0.04 ft-c., and some people make claims that they can read a newspaper with this amount of illumination.

The eye has the ability to adjust itself to a wide range of illuminations, and this particular ability is the worst enemy of those wishing to correct faulty illumination, for it is a common belief that if it is possible to see with any degree of comfort the illumination is satisfactory. The last hundred years have brought the worker from the outdoors into buildings and from tasks using distance vision to tasks most of which are performed about 14 in. from the eyes. All of these changes have been accompanied by a decrease of illumination — almost 99 per cent in most instances.

It seems reasonable that eyes can tolerate and do need more light than they are given under our modern working conditions. Any physiology book lists the detrimental effects upon the whole system if the sight is defective. Table I-3 lists the increase, with age, of one of the eye defects. This is probably traceable to our inadequate lighting systems — particularly those in the schools where children, during the eye-developing period, are confined to poorly lighted rooms for study.

Recommendations for the number of foot-candles which at present is considered an adequate and economical specification for specific tasks will be found in Art. 11. The Illuminating Engineering Society

has standing committees which are attempting to determine proper values for all tasks and keep these values revised as knowledge develops and higher specifications become economical.

**5. Effectiveness of Illumination.** Illumination has an effectiveness that is not directly proportional to increase of light but follows a geometric law. Figure 1-3 shows arbitrary units of effective seeing plotted against the amount of illumination. In Fig. 1-3a these data are plotted in rectangular coordinates; in Fig. 1-3b they are plotted in semi-logarithmic coordinates. Since much illumination information is plotted to the latter scale, it is well to be familiar with the particular tendency of the semilogarithmic paper to give linear characteristics and thus a false impression of direct proportionality. This scheme of

TABLE 1-3  
EYE DEFECTS

Class	Per Cent Nearsightedness	Age	Per Cent Defective Eyes
Infant	3	under 20	23
Preschool	7	30	39
Elementary school	9	40	48
High school	24	50	71
College	31	60	82
		over 60	95

plotting is frequently used for propaganda purposes. It is in the lower values of illumination where the most rapid gain is made and where benefits may be obtained at the lowest cost. One foot-candle has been taken as the basis for zero effectiveness for any type of applied work; this is arbitrary, but since effectiveness is only relative the choice of the starting point is not important.

From the foregoing, it would seem desirable to double the foot-candles to obtain an equal benefit in improved seeing. This does not mean that small increases in illumination do not make for a better working condition but that adequate increase in seeing is only obtained by following a geometric law. To follow this law without regard to the other contributing factors may defeat its purpose, for a rapid increase in glare may offset all the benefits obtained from increased illumination. Though the various subjective factors must be treated separately in textual material, all good and bad features of a lighting system are operative at the same time, and only the sum total of all factors

produces the effect on the individual working under the resultant illumination.

**6. Brightness.** When an object or surface emits or reflects light, it is said to be bright and because of its brightness it is visible. Visibility does not always mean comfortable seeing. In the early 1920's, as much consideration was given to brightness as to illumination. But, with the necessity of shielding the source completely because of its brightness, this factor for a time disappeared from the literature, and not until recent years has it been seriously considered again. With

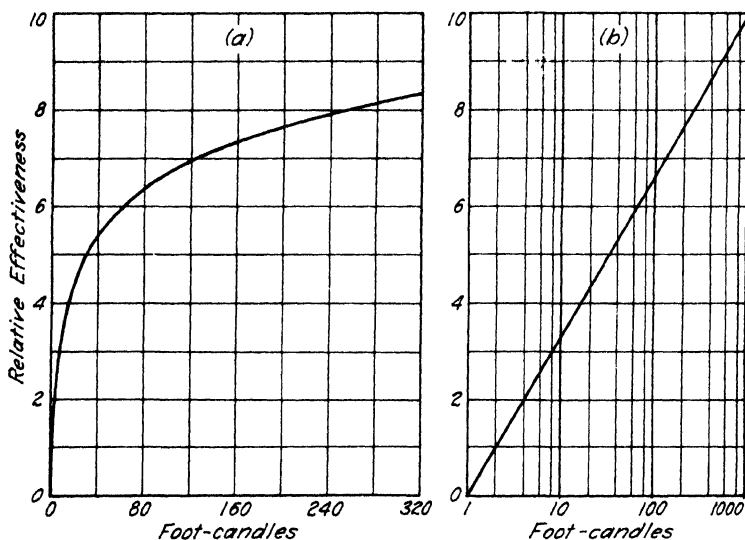

FIG. 1-3.7 Effectiveness of seeing and illumination. (a) Plotted to regular coordinate scales. (b) Plotted to semilogarithmic scales.

the continued increase of work-surface illumination, it was necessary to increase the brightness of the equipment in direct lighting and the brightness of the ceiling in indirect lighting.

It has been assumed that with indirect light there would be no necessity to study the ceiling brightness, because the surface was large enough to preclude the possibility of excessive brightness. When the usual installation of indirect lighting exceeded an illumination of 30 ft-c., particularly in a long, low room, there was as much objection to it as to direct lighting units. The ceiling was covered with numerous bright spots causing excessive brightness contrast, and the whole brightly lighted surface was in the range of vision.



Since illumination produces brightness upon a work surface, it is interesting to investigate the probable limit of illumination governed by permissible brightness. A value of 75 ft-L. has been set as the permissible brightness of lighted panels constantly in view. Assuming that this is correct, white paper with writing and a reflection factor of 80 per cent would require an illumination of approximately 95 ft-c.; sewing with black thread on dark cloth with a reflection factor of 4 per cent would require approximately 1850 ft-c. for the same brightness. The task is a factor in determining the illumination, for with vastly

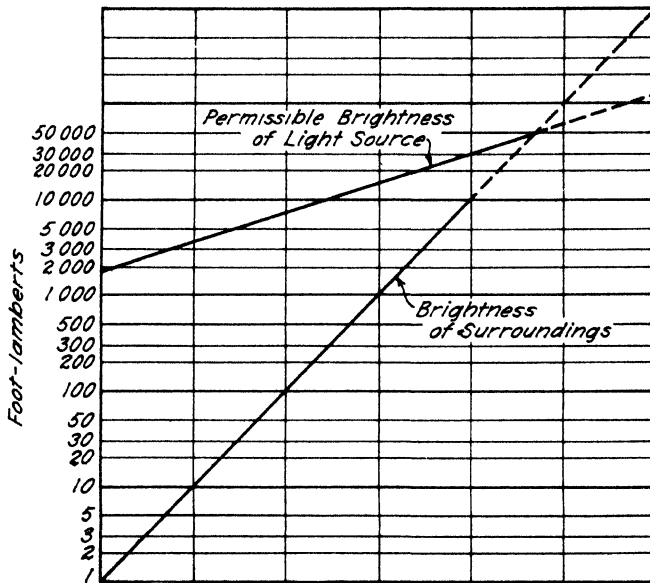

FIG. 2-3.<sup>12</sup> The relationship between brightness of light source and brightness of surroundings.

different amounts of illumination the two objects mentioned will be of equal brightness to the eye (neglecting the psychological effects of the different colors).

*Brightness ratio* is the ratio of the brightness of any two surfaces, and when these surfaces are adjacent the brightness ratio is commonly called the "brightness contrast." The desirable value of this ratio is variously stated as 10 to 1 and 20 to 1. The Medical Societies recommend a surrounding illumination of 20 per cent of the work-surface illumination. Figure 2-3 shows brightness of surroundings and the corresponding permissible brightness of the source which may be used. These sources cannot be classified as point sources in direct glare effect. An increase of the surrounding brightness from 1 to 10 will not

allow a corresponding increase in source brightness because double source brightness can only be tolerated.

Another factor, the mounting height, enters into the problem of equipment brightness. To double the height of the equipment above the eye level will make it appear to be only half the diameter in size. At a fixed illumination a globe of double diameter ( $2D$ ) may be only as bright as a globe of unit diameter ( $D$ ) mounted at half the height. Ward Harrison<sup>13</sup> summarizes these effects as follows:

1. When the light output of a source is increased ten times, its brightness should be decreased to not more than one-half, or perhaps even to one-fifth, of its former value; in other words, the light output of a source cannot be increased as fast as its area, but it is safe to increase the output as fast as the diameter.
2. Increasing the general level of lighting in a room ten times permits only doubling the brightness of the light source.
3. Doubling the mounting height of a unit permits increasing approximately three times the lumen output of the lamp which may be used in the unit.

These are not recommended as precise, but are suggestive of the correct order of magnitude, and the experiments of P. G. Nutting verify these statements accurately enough for practical application.

From the foregoing, it can be deduced that in an average room enclosing globes would limit the general illumination to 10 or 15 ft-c. of direct light, and that indirect lighting would reach a maximum of from 35 to 45 ft-c. before the ceiling would become prohibitively bright. High values of illumination may be obtained, but in each case it must be through the study of the specific problem rather than by the specification of standard catalog equipment. Table II-3 gives some comparative data for size of enclosing glassware for lamps of different sizes.

**7. Glare.** When brightness becomes an annoyance, it is called *glare*. It is any brightness within the field of vision causing discomfort, interference with vision, or eye fatigue. It is a sensation governed by the surroundings and is variable with the individual; therefore it is subjective. Much research has been directed toward a study of the effect of glare, but it is very difficult to measure. Glare may be caused by:

- a. High brightness of the source
- b. High contrast between source and background
- c. Location of source in field of view
- d. Total volume of light entering the eye
- e. Time of exposure to the source.

Correction may be made by removing the offending source from the line of vision. The angle above the line of vision at which the source should be mounted is approximately from 14 to 18 degrees. As stated before, the visual size of the source is proportional to the distance from the observer.

Glare may be classified as *direct* and *reflected*. Usually the annoyance from the first is so marked that immediate steps are taken to correct the cause; the reflected glare, however, is much more subtle and may do its damage without the victim's being aware of its presence until the physiological effects become acute. Reflected glare is sometimes called *glint*, and this property is used to recognize small

TABLE II-3  
BRIGHTNESS OF ENCLOSING UNITS

Lamp Size (Watts)	(1938) Lumen Output	RLM* Size	(1938) ASA** School Lighting	(1937) U. of I.† Bul. 29	Calculated‡‡ (Art. 6)
100	1,580	10"		14"	12"
150	2,610	12"	14"	16"	20"
200	3,640	14"	16"	18"	28"
300	5,910	16"	18"	20"	45"
500	10,050	18"			
750	14,550	20"			

\* Reflector and Lamp Manufacturers Association.

\*\* American Standards Association.

† University of Illinois.

‡‡ Assuming brightness of 12" glassware for 100 w. correct.

objects or to inspect material; in this case the specular reflection of the light is utilized.

To avoid the annoyance from direct glare, it has been recommended that brightness in the central portion of the visual field should not exceed 2 to 3 c. per sq. in. (500 to 1300 ft.-L.) of apparent area for casual observation and  $\frac{1}{2}$  c. per sq. in. (225 ft.-L.) of apparent area when viewed continuously. These limits are for smaller areas with correct contrasts. Compare this with the recommendations of 75 ft.-L. where the field of vision includes nothing but the luminous element. These candlepower-per-square-inch quantities are not from recent studies but from early studies. They were neglected for a long time, but had to be recognized in the end as distressing effects developed from newer recommendations of foot-candles and new designs of equipment. It may be said that there was available information for specifying safe and adequate lighting systems long before either the

development of the source or the economical factors made possible high foot-candle installations.

Reflected glare should be reduced to a brightness which approximates that specified in Art. 7. The reflected glare cannot be brighter than the source, because it depends upon the intrinsic brilliancy of the source and it is reduced in proportion to the reflection factor of the surface viewed. It may be corrected by remodeling the lighting system, or, if caused by a study lamp, by repositioning the lamp on the work surface. It is possible with the I. E. S. specified study lamp to have an objectionable glare because the limit of bowl brightness is set at 3 c. per sq. in. which produces a reflected brightness of 2.4 c. per sq. in. from white paper of 80 per cent reflection factor. This is approximately 1100 ft.-L., much more than the limits of either 75 or 225 ft.-L.

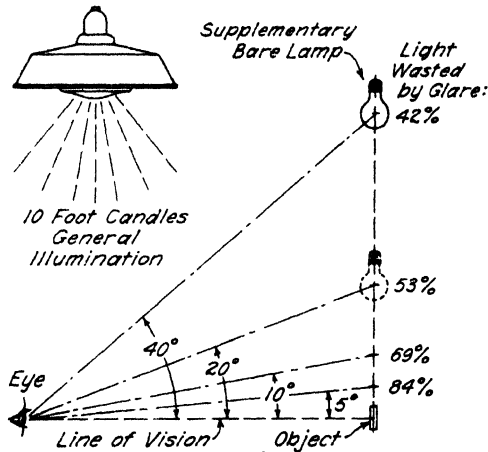

FIG. 3-3. Effect of glare on seeing.

discussed in the preceding paragraph. This is why the study surface should be large enough to permit the location of the lamp so that only the reflected light from a low source brightness is returned to the eye. If the surface is too small for a desk lamp, a floor lamp should be used and so located with respect to the table that it will produce the desired effect.

In researches conducted on glare it has been discovered that glare affects the factor of discomfort in a different manner than it affects visibility. The latter is less likely to be influenced by subjective factors and is, therefore, more precise; the first, however, gives a more sensitive appraisal. Figure 3-3 shows, in pictorial form (with relative evaluation of effects), the influence upon seeing when a glare source is placed in the line of vision with the general illumination remaining the same.

**8. Uniform Lighting and Shadows.** Uniform lighting eliminates shadows and the act of seeing can be performed without shadow; however, shadows are quite necessary where recognition of the object is of importance. For decoration and restfulness, shadow is important, but for a drafting table it can be very annoying and may be the source of considerable fatigue. The quality of the lighting in a room may be judged by means of the shadow thrown by a pencil placed in a vertical position on any white surface in the plane being investigated.

Where close work is being done, a soft shadow is allowable if complete absence of shadow is impossible. Harsh (sharp and black) shadows may be the cause of accidents, particularly where there are moving machine parts; dark shadows often cause a marked brightness contrast, which has been pointed out as very undesirable. The more diffused the light, the less shadow there will be. For this reason, the indirect system is free from objectionable shadow, whereas a direct system of lighting causes shadows which are very pronounced. The lack of shadow in an indirect lighting system is the reason the light seems to have low illuminating properties and produces a cold, unpleasant feeling. The use of a semi-indirect lighting system helps to obtain effects between these two extremes.

For uniform lighting within limits acceptable in practice, a general rule is that the lighting sources, whether from the unit or ceiling, be spaced not in excess of one and one-half times the height of the sources above the work surface. This rule holds for the illumination of any surface, even for the transmitting surface of a luminous element, in which the light sources behind the luminous surface must be spaced at not more than one and one-half times the distance from the lamp to the surface. The spacing of the luminous elements in the room must, in turn, follow the same rule.

**9. Physiological and Psychological Effects in Illumination.** It is difficult to differentiate between the results from physiological and psychological effects, because they are very closely related in the emotional reactions influencing the physical well-being of an individual. Studies concerning these types of reactions must be made on a large number of subjects and over long periods of time in order to eliminate secondary influences from other than the particular criterion being studied.

The range of studies in experimental psychology is extensive in that all subjects of considerable controversy and all phases of human reaction have been given attention at some time. It can be said, as a general statement, that no one could originate a totally new problem

for investigation; in contrast, it may be stated in the same general way that probably not even one phase has been thoroughly investigated.

Though there had been some investigation before 1920 upon the following subjects:

- a. Visual acuity
- b. Convergence reserve of the ocular muscles
- c. Contrast sensitivity
- d. Nervous muscular tension
- e. Heart action
- f. Frequency of blinking

only since that year has experimental psychology been applied to illuminating engineering. Most of the early experimental work was centered upon the illuminant and its use without regard to the human elements in the use of the light. Possibly 1928 marked the beginning of a new era, in which a study of the reaction of the human being was recognized as probably the most important factor in the lighting installation. To Dr. M. Luckiesh and Dr. F. K. Moss must be accredited the application of a series of objective research studies that have done most to direct the attention of the medical, psychological, and ophthalmological professions (and even the commercial and publicity departments of the lighting industry) to the welfare of the individual using the light.

The results, when confined to the scientific field, are more indicative than conclusive and, when examined as used by advertising and publicity agents, are frequently found to be nothing but sales propaganda. For those who wish to understand thoroughly the problem of adequate and comfortable lighting, it is necessary to become familiar with the worth-while information that has been published (scientific papers) and to analyze the data as given, at the same time viewing with suspicion those writings that proclaim unusual advancement in the art, especially if they further the interests of some commercial group.

a. *Visual acuity* is probably the first criterion to be studied, and data were published concerning this one reaction before it was seriously considered with light. The ability to see as related to size of letter and amount of light is so self-evident that it is axiomatic. Upon investigation under controlled laboratory conditions, it was found that:

Illumination	1 ft-c.	10 ft-c.	100 ft-c.
Visual acuity	100%	130%	170%

represented the benefits that the individual gained with an increase in illumination.

b. *Convergence reserve* is measured by the ability of the eye to focus upon an object and to produce one image. By means of a prism, the eyes may be subjected to an action such that two images will be seen, one with each eye. By measuring the amount of the prism needed for producing this phenomenon, it is possible to determine the muscular resistance exerted to produce normal vision. The subjects were required to read for an hour; then measurements were taken to determine how much resistance the eye muscles would exert to the forming of two independent images. The results were:

Illumination	1 ft-c.	10 ft-c.	100 ft-c.
Convergence reserve decrease	20%		7%

In addition to this ability to withstand the effort to force the eyes to produce two images, the reader was able to read 10 per cent faster under 100 ft-c. than under 1 ft-c.; this is another indication that the human effort expended under high illumination was probably less than that under low illumination.

c. *Contrast sensitivity*, or the ability of the visual sense to distinguish brightness differences, is an important factor in the recognition of subjects. Research results show that:

Illumination	1 ft-c.	10 ft-c.	100 ft-c.
Contrast sensitivity	100%	280%	450%

This is one of the most decisive results recorded. If the illumination is low, the eye encounters difficulty in distinguishing the operations or details of the task, with the result that the visual mechanism must work harder.

d. *Nervous muscular tension* is the result of either nervous tension or fatigue or both, and the tightening of the muscles may be measured by mechanical or electrical means. The "lie detector" may be classed as one type of this kind of equipment. Though the operation of the "detector" is said to be caused by a change in glandular secretion, it is likely also to be caused by a tightening of the muscles in an involuntary act of resistance. The effects of illumination on muscular tension can be illustrated by the different results obtained from driving an automobile in the daytime and at night. If a man drives the same road in daytime and at night, he will experience much more fatigue in driving it at night, because his muscular tension will be greater then — he will grip the steering wheel more tightly and strain to see into the darkness ahead. Measurements of the effect of light on muscular tension in reading have been taken by means of mechanical instruments. By measuring the amount of tension at the end of an hour's reading under different levels of illumination, it was found that:

Illumination	1 ft-c.	10 ft-c.	100 ft-c.
Muscular tension	63 g.	54 g.	43 g.
	100%	86%	68%

In correlating these figures with the known facts about driving, we can see that an individual driving at night may be subjected to a fatigue as severe and as trying as the fatigue caused by physical labor.

*e. Heart rate depression* has been noted after the application of stimuli that are known to produce fatigue. It is questionable whether mental effort will produce this effect unless there is a corresponding physical fatigue. An investigation of one hour's reading under low and high illumination shows that:

Illumination	1 ft-c.	10 ft-c.	100 ft-c.
Heart rate decrease	10%	5%	1%

This is accounted for by the reflex stimulation of the central nervous system which is produced by the effort of the seeing act. The end result is that the inhibitory nerve of the heart is stimulated. It is agreed that the resultant decrease of the heart rate indicates a fatigue, even though the physiological reactions are doubtful.

*f. Frequency of blinking* of the eye is one of the recent reactions to be investigated. In the early 1930's psychologists began to consider seriously an interpretation of the blinking of the eyes, an involuntary act of the individual variable when investigated against time. In 1937 reports of an investigation with respect to illumination were given, and the results show that:

Illumination	1 ft-c.	10 ft-c.	100 ft-c.
Frequency of blink	100%	77%	65%

Rapid blinking of the eyes measures fatigue when examined in the study of other stimuli; therefore, it is reasonable to assume that the same is true under an investigation where the illumination is the stimulus. The frequency of blinking is now included among the probable measures of the comfort of the complete lighting installation and is of particular interest in that its measure is simple, direct, and easily applied. Research has shown that both the severity and duration of a visual task will cause an increase of the rate of blinking. The measuring of the initial blinking rate and the determination of the absolute fatigue of the individual have now been established as procedures of merit.

Since the frequency of blink seems to be one of the more important reactions of the individual to illumination, the following data on the response of the human subject under other than illumination criteria



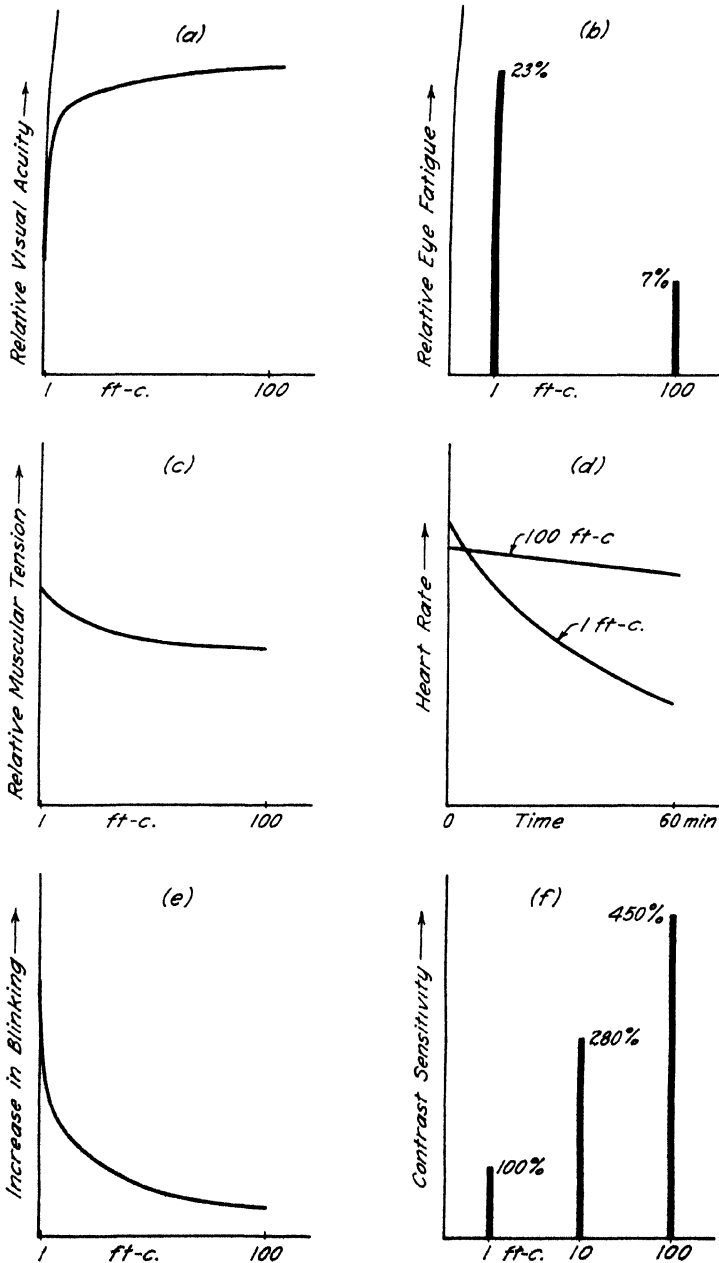

FIG. 4-3.<sup>6, 7, 10, 11, 14, 15</sup> Benefits of increased illumination: (a) visual acuity; (b) eye fatigue; (c) muscular tension; (d) heart rate; (e) blinking; (f) contrast sensitivity.

are interesting. These data are listed as percentages but are independent of each other.

Illumination (one hour's reading)	100 ft.-c.	10 ft.-c.	1 ft.-c.
	8%	31%	71%
Type size	12-point	6-point	
	100%	148%	
Glare (25-w. lamp at 20°)	without	with	
	100%	156%	
Ophthalmic correction	$\frac{1}{2}$ diopter	plano	$-\frac{1}{2}$ diopter
	152%	100%	145%

Since blinking constitutes a relief mechanism, its application may be varied as a measuring tool and research to date discloses that it has unusually high sensitivity.

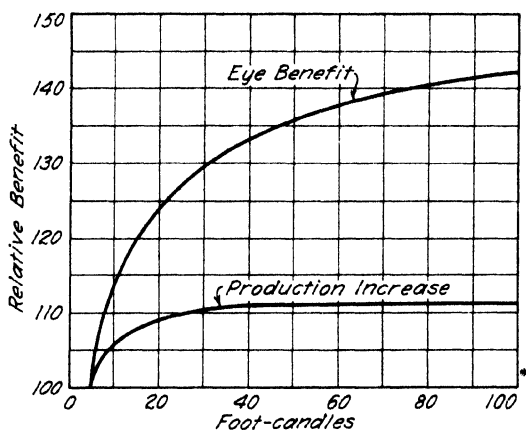

FIG. 5-3.7 Comparison of production benefit and eye benefit with increased illumination.

**10. Summary of Eye Comfort Conditions.** Figure 4-3 shows, in summary, the effect of the various criteria given in the preceding articles. The effects follow approximately logarithmic laws with a rapid rate of gain at first which quickly decreases. The procedure used in plotting these data to logarithmic coordinates is often misleading. The gains are in proportion to the necessary increase in the stimulus to obtain corresponding degrees of better visibility. If this is true, the researches are consistent and worth consideration. The results of the research are indicative of the trend but should be carefully weighed in attempting to make any application of the data.

Figure 5-3 shows the relative benefit gained through illumination for productive labor and for the individual. The productive gains

seem to stop at about 30 ft.-c., whereas the benefit to the physical and mental condition of the worker continues as far as present-day investigation has gone. Undoubtedly there will come a time when the illumination stimulus will pass safe limits and the human being will suffer, but at present economic conditions limit the illumination to a point below the high levels used in any researches.

The following quotation from a paper by Dr. Walter B. Lancaster<sup>17</sup> rather tersely summarizes the problem from both the medical and engineering points of view. He says:

In brief, it may be stated that the amount of light required depends (a) on the eyes. The eyes have to be considered in deciding on the level of illumination because, if the eyes are deficient, they need more light. This has been so conclusively demonstrated so many times that no further argument is needed as to the validity of the general proposition. (b) On the work. For such a standard task as reading 12-point type on good paper (assuming normal eyes), 10 foot-candles will do, 15 foot-candles is better. When the work is finer or when the contrast is less, more light is needed. When speed is required and accuracy is important, more light is needed.

Of course, daylight out of doors is much brighter. This does not prove that the eyes need an equivalent level of illumination for efficient work. The eyes are marvellously adaptable to different levels of brightness and the only way to settle such a question is by actual trial, not by theory. On the other hand, the fact that the eyes perform satisfactorily in bright daylight shows that there is no danger of getting artificial light too bright *provided* its distribution is correct — properly diffused and free from glare.

**11. Foot-Candle Prescriptions.**<sup>18</sup> Though foot-candles are measured in an objective manner, the prescribing of the amount to use is strictly governed by subjective analysis. The amount of illumination needed is only one factor, the other being that of making the system economical. The economic factor has been to the advantage of more illumination, for considering the cost of lamps, the increase of lamp efficiency, and the reduction in power rates, it is possible to obtain today, for a given amount of money, two and one-half times as much light as could be obtained for the same amount of money in 1925.

Probably the more reasonable way of specifying illumination is by the task to be performed rather than by foot-candles (Fig. 6-3). This would include the brightness, the relative visibility, and the foot-candles — all in their proper relationship. There are instruments available for measuring these properties (discussed in Chapter 2). On this basis, it may be suggested that the following illumination will prove satisfactory:

*100 ft-c. or more.* By supplementary lighting where the task is severe and prolonged, the details very small, the contrast low, and the speed of operation high.

*50 to 100 ft-c.* By supplementary lighting for close work where speed is not a factor and the work is small in size.

*20 to 50 ft-c.* It is better to supply this by local lighting if convenient, for the range is the upper limit of general illumination. The

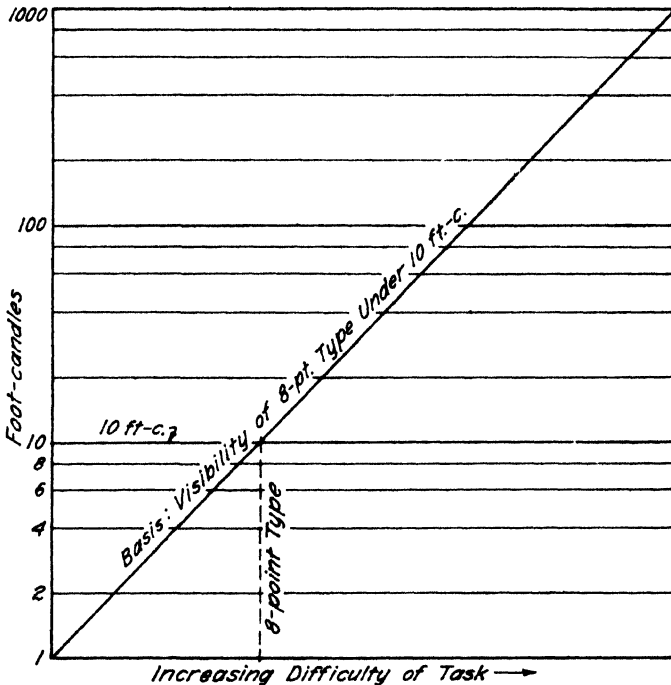

FIG. 6-3.<sup>13</sup> Relative foot-candle prescription of light based on the task.

normal industrial and commercial tasks for close desk and office work fall into this group.

*10 to 20 ft-c.* Applicable to most recreational needs and ordinary tasks that are not prolonged throughout the working day; easily obtained with general lighting.

*5 to 10 ft-c.* Obtained by general lighting; work in which seeing is important but not confined; where the contrast is good, the object fairly large, and the speed of movement slow.

*Lower than 5 ft-c.* For casual seeing and for passageways. This amount of light will be sufficient for walking and for handling large objects. In shipping departments, markings of the proper size can be checked under this illumination.

TABLE

## RECOMMENDED MINIMUM STANDARDS OF

	Ft.-c.		Ft.-c.
<b>Armories</b>		<b>Halls and Interior Passageways</b>	
Drill sheds and exhibition halls (This does not include lighting circuits for demonstration booths, special exhibit spaces, etc.)	10	(15 w. per running foot)	5
<b>Art Galleries</b>		<b>Hospitals</b>	
General	5	Lobby, reception room	10
On paintings (100 w. per running foot of usable wall area)	50-100	Corridors (8 w. per running foot)	2
<b>Auditoriums</b>	5	Wards (including allowance for convenience outlets for local illumination)	10
<b>Automobile Show Rooms</b>	20	Private rooms (including allowance for convenience outlets for local illumination)	10
<b>Banks</b>		Operating room	20
Lobby	10	Operating tables or chairs (Major surgeries — 3000 w. per area; minor surgeries — 1500 w. per area. These two figures include allowance for directional control. Special wiring for emergency systems must also be considered.)	100
Counters (75 w. per running foot including service for signs, small motor applications, etc.)	50-100	Laboratories	20
Offices and Cages	20	<b>Hotels</b>	
<b>Barber Shops and Beauty Parlors</b> (This does not include circuits for special equipment.)	20	Lobby (not including provision for conventions, exhibits)	10
<b>Bowling</b>		Dining room	5
Alley runway and seats	10	Kitchen	10
Pins (300 w. per set of pins)	30-50	Bed rooms (including allowance for convenience outlets)	10
<b>Billiards</b>		Corridors (10 w. per running foot)	2
General	10	Writing room (This includes allowance for convenience outlets.)	30-50
Tables (450 w. per table)	30-50	<b>Library</b>	
<b>Churches</b>		Reading rooms (This includes allowance for convenience outlets.)	30-50
Auditoriums	5	Stack room (12 w. per running foot of facing stacks)	10
Sunday School rooms	10	<b>Moving Picture Theater</b>	
Pulpit or rostrum	15	During intermission	5
<b>Club Rooms</b>		During pictures (These figures do not include auxiliary circuits for color or other spectacular effects.)	0.1
Lounge	5		
Reading Rooms (The above two uses are so often combined that the higher figure is advisable. It includes provision for convenience outlets.)	30-50		
<b>Court Rooms</b>	10		
<b>Dance Halls</b> (No allowance has been included for spectacular lighting, spots, etc.)	5		
<b>Drafting Rooms</b>	30		
<b>Fire Engine Houses</b>	2-10		
<b>Gymnasiums</b>			
Main floor	15		
Shower rooms	10		
Locker rooms	5		
Fencing, boxing, etc.	20		
Handball, squash, etc.	30		

III-34\*

ILLUMINATION FOR COMMERCIAL INTERIORS

	Ft.-c.		Ft.-c.
Museum		Show Windows	
General	10	* <i>Large Cities</i>	
Local illumination of special exhibits (Allow wattage for local illumination equal to total calculated for general lighting.)	50-100	Brightly lighted district (350 w. per running foot of glass frontage)	200
Office Buildings		Secondary business locations (250 w. per running foot of glass frontage)	100
Private offices (no close work)	10	Neighborhood stores (150 w. per running foot of glass frontage)	50
Private offices (with close work)	20	* <i>Medium Cities</i>	
General offices (no close work)	10	Brightly lighted districts (250 w. per running foot of glass frontage)	100
General offices (with close work)	20	Neighborhood stores (150 w. per running foot of glass frontage)	50
File room, vault, etc.	10	* <i>Small Cities and Towns</i>	
Reception room	5	(150 w. per running foot of glass frontage)	50
Post Office		<i>Lighting to Reduce Daylight Window Reflections</i>	
Lobby	10	(750 w. per running foot of glass frontage)	500
Sorting, mailing, etc.	20	*10% reduction for glass on 2 sides	
Storage, file room, etc.	10	*25% reduction for glass on 3 sides	
Professional offices		*40% reduction for island windows	
Waiting rooms	10	Stores — Department, Specialty and Miscellaneous	
Consultation rooms	20	Large	20
Operating offices	20	Main floor	15
Dental chairs (600 w. per chair)	30-50	Other floors	15
Railway		Stores in Outlying Districts	
Depot — waiting room	10	Theaters†	
Ticket offices — general	10	Auditoriums (This figure does not include auxiliary circuits for color or other spectacular effects.)	5
Ticket counters (75 w. per running foot)	30-50	Foyer	10
Rest room, smoking room	10	Lobby	15
Baggage room	10	Wall Cases (50 to 75 w. per running foot, depending on height and depth)	50-100
Concourse	5		
Train platform	5		
Restaurants, Lunch Rooms and Cafeterias			
Dining area	10		
Food displays (100 w. per running foot of counter [including service aisle])	30-50		
Schools			
Auditoriums	6		
If used as a study hall	15		
Class and study rooms	15		
Drawing room	25		
Laboratories	15		
Manual training	15		
Sewing room	25		
Sight saving classes	30		
Show Cases (40 w. per running foot)	50-100		

\* Handbook of Interior Wiring Design — Industry Committee on Interior Wiring Design, 1937.  
 † See Table IV-11 for more detailed recommendations.

These recommendations cannot be made without qualifications. These quantities are very likely to increase as more is known concerning human requirements, as the sources become more efficient, and as power costs decrease.

Tables III-3A and III-3B are tables of recommended illumination for specific tasks compiled from *Transactions of the Illuminating Engineering Society*, April, 1939, and the recommendations of the Industry Committee on Interior Wiring Design as reported in the *Handbook of Interior Wiring Design*. The Illuminating Engineering Society had a representative on this committee and was a sponsor.

The use of these tables and foot-candle recommendations without regard to the equipment, its location, or the comfort of the operators performing a task is a form of negligence which it is hoped will soon disappear from the practice of the architect, the engineer, and the salesman promoting better lighting systems.

TABLE III-3B<sup>21</sup>

## INDUSTRIAL ILLUMINATION

Recommended Minimum Standards of Illumination for Industrial Interiors (These foot-candle values represent order of magnitude rather than exact levels of illumination.)

	Minimum Operating Foot-Candles (Measured on the Work)		Minimum Operating Foot-Candles (Measured on the Work)
Aisles, Stairways, Passageways	5	Breweries:	
Assembly:		Brew house	5
Rough	10	Boiling, keg washing and filling	10
Medium	20	Bottling	15
Fine	B*	Candy Making:	
Extra Fine	A*	Box department	20
Automobile Manufacturing:		Chocolate department	
Assembly line	B*	Husking, winnowing, fat	
Frame assembly	15	extraction, crushing and	
Body manufacturing —		refining, feeding	10
Parts	20	Bean cleaning and sorting,	
Assembly	20	dipping, packing, wrap-	
Finishing and inspecting	A*	ping	20
Bakeries	20	Milling	C*
Book Binding:		Cream making:	
Folding, assembling, pasting, etc.	10	Mixing, cooking, and mold-	
Cutting, punching, and stitching	20	ing	20
Embossing	20	Gum drops and jellied forms	20

\* See reference footnote at end of table.

TABLE III-3B — Continued

	Minimum Operating Foot-Candles		Minimum Operating Foot-Candles
Hand decorating	C*	Coal Tipples and Cleaning Plants:	
Hard Candy		Breaking, screening, and cleaning	10
Mixing, cooking and molding	20	Picking	A*
Die cutting and sorting	C*	Construction — Indoor:	
Kiss making and wrapping	C*	General	10
Canning and Preserving	20	Dairy Products	20
Chemical Works:		Elevators — Freight and Passenger	10
Hand furnaces, boiling tanks, stationary driers, stationary and gravity crystallizers	5	Engraving	A*
Mechanical furnaces, generators and stills, mechanical driers, evaporators, filtration, mechanical crystallizers, bleaching	10	Forge Shops and Welding	10
Tanks for cooking, extractors, percolators, nitrators, electrolytic cells	15	Foundries:	
Clay Products and Cements:		Charging floor, tumbling, cleaning, pouring, and shaking out	5
Grinding, filter presses, kiln rooms	5	Rough molding and core making	10
Molding, pressing, cleaning and trimming	10	Fine molding and core making	20
Enameling	15	Garages — Automobile:	
Color and glazing	20	Storage — live	10
Cleaning and Pressing Industry:		“ dead	2
Checking and sorting	20	Repair department and washing	C*
Dry and wet cleaning and steaming	10	Glass Works:	
Inspection and spotting	A*	Mix and furnace rooms, pressing and Lehr, glass blowing machines	10
Pressing		Grinding, cutting glass to size, silvering	20
Machine	20	Fine grinding, polishing, beveling, etching, and decorating	C*D*
Hand	C*	Inspection	B*D*
Receiving and shipping	10	Glove Manufacturing:	
Repair and alteration	C*	Light goods —	
Cloth Products:		Pressing, knitting, sorting	10
Cutting, inspecting, sewing —		Cutting, stitching, trimming and inspecting	20
Light goods	20	Dark Goods —	
Dark goods	A*	Cutting, pressing, knitting, sorting	20
Pressing, cloth treating (oil-cloth, etc.)		Stitching, trimming, and inspection	A*
Light goods	10		
Dark goods	20		

\* See reference footnote at end of table.



TABLE III-3B — Continued

	Minimum Operating Foot-Candles		Minimum Operating Foot-Candles
Hangars — Aeroplane:		Meat Packing:	
Storage — live	10	Slaughtering	10
Repair department	C*	Cleaning, cutting, cooking, grinding, canning, packing	20
Hat Manufacturing:		Milling — Grain Foods:	
Dyeing, stiffening, braiding, Cleaning and refining —		Cleaning, grinding, and rolling	10
Light	10	Baking or roasting	20
Dark	20	Flour grading	30
Forming, sizing, pouncing, flanging, finishing and ironing —		Offices:	
Light	15	Bookkeeping, typing, and accounting	30
Dark	30	Business machines — power driven	
Sewing —		(Transcribing and tabulating) —	
Light	20	Calculators, key punch, bookkeeping	B*
Dark	A*	Conference room	
Ice Making — Engine and Compressor Room	10	General meetings	10
Inspection:		Office Activities — See Desk work	
Rough	10	Corridors and stairways	5
Medium	20	Desk work	
Fine	B*	Intermittent reading and writing	20
Extra fine	A*	Prolonged close work, computing, studying, designing, etc.	C*
Jewelry and watch manufacturing	A*	Reading blueprints and plans	30
Laundries	20	Drafting	
Leather Manufacturing:†		Prolonged close work — art drafting and designing in detail	C*
Leather Working:†		Rough drawing and sketching	30
Locker Rooms	5	Filing and index references	20
Machine Shops:		Lobby	10
Rough bench and machine work	10	Mail sorting	20
Medium bench and machine work, ordinary automatic machines, rough grinding, medium buffing and polishing	20	Reception rooms	10
Fine bench and machine work, fine automatic machines, medium grinding, fine buffing and polishing	B*	Stenographic work	
Extra fine bench and machine work, grinding —		Prolonged reading short-hand notes	C*
Fine work	A*	Vault	10

\* See reference footnote at end of table.

† An I. E. S. research study of lighting in this industry is now in progress.

TABLE III-3B — Continued

	Minimum Operating Foot-Candles		Minimum Operating Foot-Candles
Packing and Boxing	10	Imposing stones	A*D*
Paint Mixing	10	Proofreading	A*
Paint Shops:		Photography:	
Dipping, simple spraying, firing	10	Dry plate and film	2000
Rubbing, ordinary hand painting and finishing; art, stencil, and special spraying	20	Wet plate	3000
Fine hand painting and finishing	B*	Printing on metal	2000
Extra fine hand painting and finishing (automobile bodies, piano cases, etc.)	A*	Electrotyping:	
Paper Box Manufacturing:		Molding, finishing, leveling molds, routing, trimming	B*
Light	10	Blocking, tinning	C*
Dark	20	Electroplating, washing, backing	20
Storage	5	Photo engraving:	
Paper Manufacturing:		Etching, staging	20
Beaters, grinding, calendering	10	Blocking	C*
Finishing, cutting, trimming, paper-making machines	20	Routing, finishing, proofing	B*
Plating	10	Tint laying	A*
Polishing and Burnishing	15	Receiving and Shipping	10
Power Plants, Engine Room, Boilers:		Rubber Manufacturing and Products:†	
Boilers, coal and ash handling, storage battery rooms	5	Sheet Metal Works:	
Auxiliary equipment, oil switches and transformers	10	Miscellaneous machines, ordinary bench work	15
Engines, generators, blowers, compressors	15	Punches, presses, shears, stamps, welders, spinning, medium bench work	20D*
Switchboards	C	Tin plate inspection	B*D*
Printing Industries:		Shoe Manufacturing (Leather):	
Type foundries —		Cutting and stitching	
Matrix making, dressing type	A*	Cutting tables	10
Font assembly — sorting	B*	Marking, buttonholing, skiving, sorting, vamping, and counting —	
Hand casting	C*	Light materials	20
Machine casting	20	Dark materials	C*
Printing plants:		Stitching	
Presses	C*	Light materials	C*
	C*	Dark materials	B*
		Making and finishing	
		Stitchers, nailers, sole layers, welt beaters and scarfers, trimmers, welters, lasters,	

\* See reference footnote at end of table.

† An I. E. S. research study of lighting in this industry is now in progress.

TABLE III-3B — *Continued*

	Minimum Operating Foot- Candles		Minimum Operating Foot- Candles
edge setters, sluggers, randers, wheelers, treers, cleaning, spraying, buffing, polishing, embossing —		Rough bench and machine work	10
Light Materials	20	Medium bench and machine work	20
Dark Materials	C*	Fine work — buffing, polishing, etc.	B*
Storage, packing, and shipping	10	Extra fine work	A*
Shoe Manufacturing (Rubber):		Blacksmith shop	10
Washing, coating, mill run compounding	10	Laboratories (chemical and physical)	15
Varnishing, vulcanizing, calendering, upper and sole cutting	C*	Carpenter and pattern shop	20
Sole rolling, lining, making and finishing processes	C*	Storage	2
Soap Manufacturing:		Stone Crushing and Screening:	
Kettle houses, cutting, soap chip and powder	10	Belt conveyor tubes, main line shafting spaces, chute rooms, inside of bins	5
Stamping, wrapping and packing, filling and packing soap powder	20	Primary breaker room, auxiliary breakers under bins	5
Steel and Iron Manufacturing:		Screens	10
Billet, blooming, sheet bar, skelp and slabbing mills	5	Storage Battery Manufacturing:	
Boiler room, power house, foundry and furnace rooms	5	Molding of grids	10
Hot sheet and hot strip mills	10	Store and Stock Rooms:	
Cold strip, pipe, rail, rod, tube, universal plate and wire drawing	10	Rough bulky material	5
Merchant and sheared plate mills	15	Medium or fine material requiring care	10
Tin Plate Mills —		Structural Steel Fabrication	10
Hot strip rolling and tinning machine department	10	Sugar Grading	30
Cold strip rolling	15	Testing:	
Inspection —		Rough	10
Black plate	C*	Fine	20
Bloom and billet chipping	C*	Extra fine instruments, scales, etc.	A*
Tin plate and other bright surfaces	B*D*	Textile Mills (Cotton):	
Machine shops and maintenance department		Opening, mixing, picking, carding and drawing	10
Repair shops —		Slubbing, roving, spinning	20
		Spooling, warping on comb	20
		Beaming, and slashing on comb —	
		Grey goods	20
		Denims	B*
		Inspection —	
		Grey goods (hand turning)	C*
		Denims (rapidly moving)	A*

\* See reference footnote at end of table.

TABLE III-3B — *Continued*

	Minimum Operating Foot- Candles		Minimum Operating Foot- Candles
Automatic tying-in, weaving	B*	Twisting, dyeing	10
Drawing-in by hand	A*	Drawing-in, warping —	
Silk and Rayon Manufacturing:		Light goods	15
Soaking, fugitive tinting, and		Dark goods	30
conditioning or setting of		Weaving —	
of twist	10	Light goods	15
Winding, twisting, rewinding,		Dark goods	30
and coning, quilling, slash-		Knitting machines	20
ing	30	Tobacco Products:	
Warping (silk or cotton sys-		Drying, stripping, general	10
tem)		Grading and sorting	A*
On creel, on running ends,		Toilets and Wash Rooms	5
on reel, on beam, on warp		Upholstering—Automobile, Coach	
at beaming	C*	Furniture	20
Drawing-In —		Warehouse	5
On heddles	A*	Woodworking:	
On reed	A*	Rough sawing and bench work	10
Weaving —		Sizing, planing, rough sanding,	
On heddles and reeds	5	ing, medium machine and	
On warp back of harness	10	bench work, gluing, ve-	
On woven cloth	30	neering, cooperage	20
Woolen:		Fine bench and machine	
Carding, picking, washing,		work, fine sanding and	
combing	10	finishing	C*

\* Lighting recommendations for the more difficult seeing tasks, as indicated by A, B, C, and D in the foregoing table, are given in the following:

#### GROUP A:

These seeing tasks involve (a) the discrimination of extremely fine detail under conditions of (b) extremely poor contrast (c) for long periods of time. To meet these requirements, illumination levels above 100 ft.-c. are recommended.

To provide illumination of this order a combination of at least 20 ft.-c. of general lighting plus specialized supplementary lighting is necessary. The design and installation of the combination systems must not only provide a sufficient amount of light but also must provide the proper direction of light, diffusion, eye protection, and in so far as

possible must eliminate direct and reflected glare as well as objectionable shadows.

#### GROUP B:

This group of visual tasks involves (a) the discrimination of fine detail under conditions of (b) a fair degree of contrast (c) for long periods of time. Illumination levels from 50 to 100 ft.-c. are required.

To provide illumination of this order a combination of 10 to 20 ft.-c. of general lighting plus specialized supplementary lighting is necessary. The design and installation of the combination systems must not only provide a sufficient amount of light but also must provide the proper direction of light, diffusion, eye protection, and in so far as possible must eliminate direct and reflected glare as well as objectionable shadows.

## GROUP C:

The seeing tasks in this group involve (a) the discrimination of moderately fine detail under conditions of (b) better-than-average contrast (c) for intermittent periods of time.

The level of illumination required is of the order of 30 to 50 ft-c. and in some instances it may be provided from a general lighting system. Oftentimes, however, it will be found more economical and yet equally satisfactory to provide from 10 to 20 ft-c. from the general system and the remainder from specialized supplementary lighting. The design and installation of the combination systems must not only provide a sufficient amount of light but also must provide the proper direction of light, diffusion, eye protection, and in so far as possible must eliminate direct and reflected glare as well as objectionable shadows.

## GROUP D:

The seeing tasks of this group require the discrimination of fine detail by utilizing (a) the reflected image of a luminous area or (b) the transmitted light from a luminous area.

The essential requirements are (1) that the luminous area shall be large enough to cover the surface which is being inspected and (2) that the brightness be within the limits necessary to obtain comfortable contrast conditions. This involves the use of sources of large area and relatively low brightness in which the source brightness is the principal factor rather than the foot-candles produced at a given point.

\*\* In these areas many of the machines require one or more supplementary lighting units mounted on them in order effectively to direct light toward the working points.

## BIBLIOGRAPHY

1. P. G. NUTTING, "Effects of Brightness and Contrast in Vision," *I. E. S. Trans.*, v. 11, No. 10, p. 943, December, 1916.
2. WARD HARRISON, "Light without Glare," *Trans. A. I. E. E.*, v. 41, June, 1922.
3. L. L. HOLLADAY, "The Fundamentals of Glare and Visibility," *Jour. Opt. Soc. of Amer.*, v. 12, No. 4, April, 1926.
4. E. PONDER and W. P. KENNEDY, "On the Act of Blinking," *Quar. Jour. Exper. Physiol.*, v. 18, p. 89, 1927-28.
5. L. T. TROLAND, "Analysis of the Literature Concerning the Dependency of Visual Functions upon Illumination Intensity," *I. E. S. Trans.*, v. 26, No. 2, February, 1931.
6. M. LUCKIESH and F. K. MOSS, "Seeing," Williams & Wilkins Co., 1931.
7. M. LUCKIESH and F. K. MOSS, "Lighting for Seeing," *Nela Park Bulletin* LD-2, 1931.
8. C. W. TELFORD and N. THOMPSON, "Some Factors Influencing Voluntary and Reflex Eyelid Response," *J. Exper. Psych.*, v. 16, p. 524, 1933.
9. COMMITTEE, "How Much Light," *Elec. Eng.*, October, 1933.
10. M. LUCKIESH and F. K. MOSS, "Fatigue of Convergence Induced by Reading as a Function of Illumination Intensity," *Amer. J. Ophth.*, v. 18, No. 4, April, 1935.
11. M. LUCKIESH and F. K. MOSS, "The Effect of Visual Effort Upon the Heart-Rate," *J. Gen. Psych.*, 1935.
12. M. LUCKIESH and F. K. MOSS, "Prescribing Light and Lighting," *I. E. S. Trans.*, v. 32, No. 1, January, 1937.

13. WARD HARRISON, "What is Wrong with Our 50-Foot-candle Installations?" *I. E. S. Trans.*, v. 32, No. 2, February, 1937.
14. M. LUCKIESH and F. K. MOSS, "The Eye Reflex as a Criterion of Ocular Fatigue," *J. Exper. Psych.*, v. 20, No. 6, June, 1937.
15. M. LUCKIESH and F. K. MOSS, *The Science of Seeing*, D. Van Nostrand Co., 1937.
16. M. LUCKIESH and F. K. MOSS, "Effects of Leading on Reading," *J. Applied Psych.*, v. 22, No. 2, April, 1938.
17. W. B. LANCASTER, "Illumination Levels and Eye Comfort Conditions," *I. E. S. Trans.*, v. 33, No. 10, December, 1938.
18. H. L. LOGAN, "Specification Points of Brightness," *I. E. S. Trans.*, v. 34, No. 8, pp. 881-906, September, 1939.
19. M. LUCKIESH and F. K. MOSS, "A Summary of Researches Involving Blink-Rate as a Criterion of Ease of Seeing," *I. E. S. Trans.*, v. 35, No. 1, pp. 19-32, January, 1940.
20. M. LUCKIESH and F. K. MOSS, "Supra-Threshold Visibility," *J. O. S. A.*, v. 30, No. 2, pp. 62-69, February, 1940.
21. J. C. FORBES, "Lighter Colored Desk Tops," *Magazine of Light*, v. 10, No. 1, pp. 24-26, February, 1941.
22. H. L. LOGAN, "Modeling with Light," *I. E. S. Trans.*, v. 36, No. 2, pp. 202-216, February, 1941.

#### Reports of I. E. S. Committee on Lighting Practice

- COMMITTEE ON THE LIGHTING OF SPECIFIC INDUSTRIES, Report, *I. E. S. Trans.*, 1936.
- COMMITTEE ON INDUSTRIAL AND SCHOOL LIGHTING, "Progress Report on Lighting in the Printing Industry," *I. E. S. Trans.*, v. 31, pp. 277-313, 1936.
- COMMITTEE ON INDUSTRIAL AND SCHOOL LIGHTING, "Report on Lighting in the Textile Industry — Grey Goods and Denim," *I. E. S. Trans.*, v. 32, pp. 247-281, 1937.
- COMMITTEE ON INDUSTRIAL AND SCHOOL LIGHTING, "Report on Lighting in the Shoe Manufacturing Industry," *I. E. S. Trans.*, v. 32, pp. 289-314, 1937.
- COMMITTEE ON INDUSTRIAL AND SCHOOL LIGHTING, "Report on Lighting in the Candy Manufacturing Industry," *I. E. S. Trans.*, v. 32, pp. 483-504, 1937.
- COMMITTEE ON INDUSTRIAL AND SCHOOL LIGHTING, "Studies in Lighting of Intricate Production, Assembly and Inspection Processes," *I. E. S. Trans.*, v. 32, pp. 1019-1053, 1937.
- COMMITTEE ON INDUSTRIAL AND SCHOOL LIGHTING, "Lighting for Silk and Rayon Throwing and Wide Goods Weaving," *I. E. S. Trans.*, v. 33, pp. 17-52, 1938.
- COMMITTEE ON INDUSTRIAL AND SCHOOL LIGHTING, "Lighting for the Machining of Small Metal Parts," *I. E. S. Trans.*, v. 34, pp. 21-54, 1939.
- COMMITTEE ON INDUSTRIAL AND SCHOOL LIGHTING, "Lighting of Power Presses," *I. E. S. Trans.*, v. 34, pp. 153-175, 1939.

## CHAPTER 4

### COLOR AND SHADOW

Both color and shadow are factors of more value in recognition and aesthetic interpretation than in seeing. If all objects were black and white, it would still be possible to apply quantity and quality of illumination to make the visual task more comfortable, but there would be the loss of the effective third dimension and the beauty that lies in color.

In Chapter 3, seeing was discussed as a very complex process more dependent upon the physiological and psychological senses than upon either objective measurements or upon color and shadow. Aside from the purely mechanical function of the eye, the nerve centers, and the brain, the two recognition factors may be considered as subjects to be studied in the field of psychology. Much work has been done in this field, and there has been considerable controversy.

The difficulty with color and shadow lies in reproduction of identical effects when these are desired. It is practically impossible to reproduce colors in paints, fabrics, or even colored lights with any degree of accuracy. In the past, this judging of colors has been entrusted to the eyes of specifically trained people who used a process of matching that was confined to three standard colors. Recently, equipment and methods have been developed which will permit the establishment of objective standards not dependent upon the eye for matching. The problem will not lie in determining whether or not the colors do match but in the reproduction of colors that will match positively.

**1. Color.** Color is subjective evaluation by the eye of that quality of light which is determined by its spectral distribution. Colors may be specified by their brilliancy, hue, and saturation. Figure 1-2 (page 16), shows the response of a hypothetical eye to different wavelengths of light, and Fig. 3-2 (page 17) shows the regions of the various colors in the visible portion of the radiant spectrum. Where brilliancy, hue, and saturation are psychological, the above two figures are representative of the measurements which belong to the objective. The reconciling of each to the other has been the specific advancement of color analysis in the last few years, and the introduction of color into the

problems of the illuminating engineer has been even more recent. Definite knowledge concerning color has become a necessity to the architect and others responsible for the designing of lighting installations.

**2. Nomenclature of Color.** In order to express the sensation of color, there has been developed in the study of the phenomena by experimental psychologists a terminology which will undoubtedly be permanent even if objective specifications are accepted. Man has tried from a very early period to capture the variety and beauty with which nature invested the surrounding sky, landscape, and flora. Much has been reproduced with pigment, but never with the brilliancy of natural colors. With the availability of lights and control of light, something further can be produced that cold pigments have not been able to simulate; therefore, the engineer and architect must become acquainted with the vocabulary of colors with a different object in view.

*a. Brilliancy* is a measure of magnitude. Any color may be dark or light depending upon the amount of light reaching the retina and the response of the retina to the quantity of light. This characteristic is the brightness or luminosity of the light given off in the color and is independent of the wavelength. In objective measurements, this characteristic is referred to the visibility curve.

*b. Hue* is the property of color by which the various spectral regions are characteristically distinguished (Fig. 3-2, page 17). All colors except purples and white may be matched in hue with spectral colors. In the case of purple, the spectral hue which is complementary to the hue of the purple is ordinarily used for scientific designation. By this designation a color is known to be red, green, blue, purple, etc.

*c. Saturation (chroma)* of a color is the degree of freedom from admixture with white. Monochromatic spectral light may, for purposes of measurement, be considered as having a saturation of 100 per cent. As white is added, the saturation decreases until, when the hue entirely disappears, the saturation is zero. White is the limiting color having no hue and zero saturation, but it may have any degree of brilliancy.

*d. Complementary hues.* Two hues are complementary if they may be mixed to produce white. Whenever lights of two or more hues are mixed, the resultant light, though it may have some dominant hue, will ordinarily be evaluated subjectively as having an admixture of white.

Upon these four definitions, three types of specifications depend; that is, chemical, physical, and psychological, the last of which is



undoubtedly the final analysis, for color, like light, must be non-irritating to give comfort. There will always be the common language according to which no color could be accurately matched; on the other hand, the language of the physicist specifies the tristimulus coefficients or dominant wave, the brightness and the purity of color — a system only the specialist will understand. These measurements made by the physicist will be discussed at the end of the chapter.

**3. Production of Colored Light.** Various methods are used to produce colored light. Chemicals may be burned which give off very selective wavelengths. This method was formerly used on the stage, but the risk makes it prohibitory for this purpose; however, displays

TABLE I-4  
THE EFFECT OF COLORED LIGHT  
ON THE APPEARANCE OF COLORED OBJECTS

Natural Color of Object	Color of Light Illuminating the Object					
	Red	Orange	Yellow	Green	Blue	Violet
Black	Red-black	Orange-black	Yellow-black	Green-black	Blue-black	Violet-black
White	Red	Orange	Yellow	Green	Blue	Violet
Gray	Red shade	Orange shade	Yellow shade	Green shade	Blue shade	Violet shade
Red	Red	Scarlet	Orange	Brown	Purplish black	Reddish black
Orange	Red	Orange	Yellow-orange	Greenish yellow	Black	Black
Yellow	Orange-red	Yellow-orange	Yellow	Yellowish green	Greenish black	Black
Light Green	Red shade	Yellow-green	Greenish yellow	Green	Blue-green	Bluish shade
Deep Green	Black	Greenish black	Yellowish green	Green	Greenish blue	Blue-black
Light Blue	Violet	Dark gray	Yellowish shade	Blue-green	Blue	Violet
Deep Blue	Purple	Blue-gray	Gray	Blue-green	Blue	Blue-violet
Violet	Reddish black	Red-purple	Gray	Blue	Violet-blue	Blue-black
Purple	Red shade	Red shade	Red shade	Black	Blue	Violet
Rose	Red tint	Red tint	Red tint	Greenish black	Blue shade	Violet shade

of pyrotechnics form a part of many fairs and celebrations. Filters of various types may be used, which when placed in front of a light source with a continuous spectrum will allow only certain wavelengths to pass and will absorb the remainder. The selection of the filter is often governed by cost and permanency; glass filters are least likely to show fading, whereas some dyed materials fade very rapidly. Colored reflecting surfaces may be the source of light; this is frequently accomplished in theaters with light arrangements in coves.

Most colors, as we see them, are due to selective reflection. White light represents a light forming a continuous spectrum of equal energy in the visible spectrum. If the reflecting color were pure, only the one wavelength would be reflected, but this is seldom true since very few colors are fully saturated. The eye is not necessarily capable of responding equally or with the same interpretation to the same color at

different times, because the surroundings have a marked effect on the interpretation. A pure red light upon a pure blue surface would cause the surface to appear black because all the red light would be absorbed and none would be returned. This is equally true, in an absolute sense,

TABLE II-4  
TRANSMISSION EFFICIENCY OF COLOR MEDIA \*

Color Media	Blue %	Green %	Red %	Amber %
Natural glass bulbs	0.6	8.7	3 0	45.0
Roundels and caps	7.5	8.5	21.0	33.0
Gelatin	1.3	17.0	5 2	48.0
Dyes and lacquers	5 0	2.5	20.0	50.0
Inside colored lamps	0.4	3.5	5.7	50.0
Average	2 9	8.0	10.9	45.0

\* See Table II-11 (page 343).

for any pure colored light on a colored (pure colors) surface except for the color that corresponds to the color of the light. If the light and surface have mixed colors, various results may be obtained that are not always predictable, unless all the physical properties of both

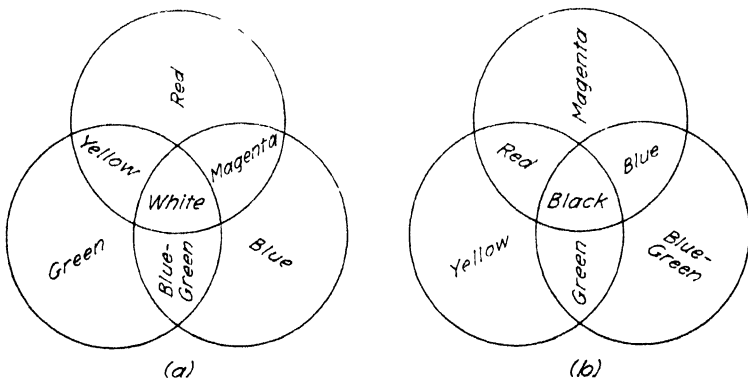

FIG. 1-4. Color mixture (a) by addition of wavelengths of light; (b) by subtraction of wavelengths of light.

light and color are known. Table I-4 is a chart showing some common light and pigment combinations.

With the advent of the new fluorescent lamps, which have efficient color light characteristics, it is possible to have light sources by other than subtractive means. The poor efficiency of the subtractive means

of obtaining color light is shown by a study of Table II-4. This table lists the common types of colored light sources available in addition to the fluorescent lamps.

**4. Mixing Colors.** Colors have been measured for physical specifications by matching against three primary colors. It is possible to obtain, by choosing and mixing three properly selected primary colors, the visual sensations for any color, including white, which is a mixture of all colors. There are two methods for mixing colors; the additive

TABLE III-4  
ADDITIVE MIXING OF COLORS

Dimmer Setting — Per Cent			Color
200 w. Red	200 w. Blue	160 w. Green	
100	0	0	Red
100	55	60	Light red
100	90	15	Magenta
100	20	60	Orange
100	10	75	Amber
100	30	95	Yellow
50	10	100	Yellow-green
0	0	100	Green (yellow tint)
35	55	100	Light green
0	100	100	Green-blue
20	100	25	Blue
30	100	55	Light blue
0	100	0	Dark blue
50	100	0	Violet
55	100	30	Purple
90	100	100	White

and the subtractive. Figure 1-4 shows color mixture of light by both the additive and subtractive methods. In the first figure (Fig. 1-4a), using a red filter free from blue, a green filter on the yellow side, and a blue filter free from red, the resultant color depends upon light projection. If these lights are projected in the correct proportion upon a neutral screen, the mixtures shown will be produced. Table III-4 gives a chart for the production of colored light by mixture (additive method).

The subtractive filters should be blue-green, yellow, and magenta with white light being passed through them. The result, shown in Fig. 1-4b, is obtained by passing the light through a set of these filters

in such a manner that the circular discs of light projected overlap each other. These three primary colors for subtractive projection correspond to the three pigments used for color mixing. The three primary colors of the additive and subtractive groups are complementary.

Besides the mixture of the primary colors, the character of the color may be changed by the addition of white and black forming what are called *tints* and *shades*, respectively.

**5. Physiology and Psychology of Color.** How it is possible to see and distinguish color has not been definitely established. There are several explanations and theories prevalent, but it is not usual for these to need specific consideration in the lighting system. On the other hand, psychology, in the study of human behavior, is attempting to answer the questions of most interest to students of traffic and merchandizing. In theaters, window displays, show cases, public buildings, and public meeting places there has always been an effort to consider psychological effects and to contribute to comfort and pleasure by the use of colors. There is at present some recognition of the fact that not only during the hours of recreation but also during working hours more attention should be given to the surroundings, in which color may well play a part.

Those factors that are of interest to the lighting specialist are:

- a. Sensations and reactions
- b. Color contrast
- c. Color-matching

**6. Behavior Reactions to Color Sensations.** In general, the red end of the spectrum is stimulating and tends toward warmth, whereas the blue end may be cold and depressing. In large work areas a tendency to blue will produce a feeling of comfort. Combinations of several colors will be found more satisfactory than single pure colors and, if one color must be used, it should be a tint. Though psychology studies human behavior rather than the behavior of the two sexes, in the use of color and particularly in stores and window displays, it is well to examine the reactions of the sexes. All human beings react to bold colors of great vividness and those which are unquestionably primaries. This is of considerable advantage in making up display signs, for visibility is increased by use of strong colors. The human being seems most interested in the extremes of the spectrum though the midportion is the more visible: the woman chooses first red and then blue; the man chooses first blue and then red. Other factors aside from abstract selection may enter into the choice, because highly advertised current colors may influence any short period of research.

Although the above is true for color as a pigment or for reflected light, it is not true for colored light. The lower order of animals is interested in the bold and vivid colors of light, but the human race does not like this type and has a marked preference for tints. Men and women reverse their likes and dislikes in colored lighting, for the men now choose the red and the women the blue end of the spectrum. As suggested before, these factors are not independent, because the presence of numerous colors and contrast has an important place. The control of reaction to the stimulation of the color sensation cannot be reduced to an exact science, but the tendencies should be given close attention.

*White and black*, though technically not colors, are thought of as such in common practice. Allegorically, they represent life and death. Black will not be found in a true sense except in deep recesses of special shape, and though it is used to symbolize woe, mystery, hopelessness, and evil, it is one of the most decorative colors because it harmonizes well. White, on the other hand, is commonly used to symbolize light, purity, humility, peace, innocence, delicacy, and timidity and is frequently associated with gaiety. (White has the property of removing the baseness from black and their combination represents the highest humility, resolution, and prudence.) With different races, the meaning of black and white, as associated with death, varies. Written statements concerning the reactions to color are seemingly more positive than they should be considered, for the interpretation and investigation of color reaction must include training and social practice.

*Gray* is a neutral color, being a compromise between white and black. Though associated with quietude, it can represent that which is sullen and sad. Including black and white in the same decoration scheme is not the same as using gray, for the first colors represent individually a liveliness that gray cannot approach.

Using the generally accepted arbitrary division of the spectrum into color regions, (the wavelength region is included because of the necessity of familiarity) the accepted reaction is:

*Red* (610-700  $m\mu$ ) is the most lively color and has the suggestion of action. With this color are associated danger, anger, blood, brotherhood, health, heat, fire, and martyrdom. It is suggestive of the hot days of summer. (When rose is considered, it is associated with love, vivacity, and gaiety and is an adjunct to beauty.)

*Orange* (590-610  $m\mu$ ) retains color properties which are strong in the red, but heat and fire are reduced to warmth. The other characteristics of red are lost sight of just as the extremes of summer fade into the soft tones of autumn. Orange is a pleasant color, meeting with little objectionable comment.

*Yellow* (570–590  $m\mu$ ), though frequently used, is less esteemed than any other color. It belongs to youth; it is cheerful and light, but at the same time it stands for cowardice, illness, and evil. Its dual meaning probably causes it to be used so frequently.

*Gold* is a variation of yellow that is of marked importance. It represents power and splendor and all that is precious and expensive.

*Green* (500–570  $m\mu$ ) is probably the turning point in color atmosphere; it is neither warm nor cold but is restful and neutral. It is the most common color in living nature, and therefore is a symbol of spring and resurrection, the outdoors, and the refreshing. Since it is restful and soothing to the eye, it should be one of the factors included in lighting comfort.

*Blue* (450–500  $m\mu$ ) is definitely cool, soothing, and subduing. A symbol of night and of winter, it is the color of the sky and has a faint suggestion of future existence. It is a color that easily harmonizes, for the human race has become accustomed to its predominance. It symbolizes fidelity, truth, and serenity.

*Violet* (400–450  $m\mu$ ) — the sunrise, the sunset, and the landscape mark the atmosphere of this color. It is the producer of interest, and yet it is depressing and suggests age.

*Purple*, the close associate of violet, suggests the rich and royal and represents the pompous and the dignified.

The subject of human reaction to color has been widely studied, and much material has been published. The results of research are often in conflict, but the influence of color is recognized by all, even though neither the vocabulary nor the scientific means of measurement is available for devising unquestionable specifications. The foregoing comments are introduced to act as a warning that those specifying lighting should hesitate and give considerable thought to human reaction to mixtures of color and colored light in designing any installation.

**7. Color Contrast.** It is difficult to separate this from brightness contrast in making measurements and it is not uncommon to consider brightness contrast as color contrast. Color contrast may be influenced by the brightness, hue, or saturation difference or even by the texture of the material. A green with a purple background will appear much lighter than the same green on a yellow background; this shows that the environment is also an important factor in color contrast. This characteristic interests the advertiser and those working with traffic control.

Considering color contrast as a purely psychological reaction not to be measured by objective means, it still has important meaning to the

artist and is the basis of any color design. Any textbook on the use of color devotes a major portion of the space to this topic.

**8. Color-Matching.** This is an important consideration in specific types of industry and commercial sales. In the past, corrected light has been produced by a subtractive method using filters, but with the advent of the newer fluorescent sources it can be accomplished with more economy; that is, if production control on these sources will compare with the limits maintained in the manufacture of incandescent lamps.

Color-matching is essential in many instances and should be independent of the light source. To choose a standard color for matching is very difficult, though a north light, because of reasonable consistency, has special recommendations. Spectral quality, saturation, and brightness may each influence the attempt to match color by use of the eye; therefore, it is desirable to use some method by which specifications can be made which do not depend upon the judgment of the human eye. The trend is toward a duplication of spectral qualities, thereby matching colors without regard to the illuminating source.

Light absorption has the ability to produce in color a luster which is called "bronze." It is most noticeable when color is applied to a black surface, because the black surface absorbs the light transmitted by the film of color, and the reflected light gives the surface a metallic luster. Such a luster may become an annoying source of glare.

**9. Color Blindness.** Color blindness is a characteristic found in from 4 to 5 per cent of the population, with approximately 0.4 per cent of the women being affected and 4 per cent of the men. This defect contributes to automobile accidents on streets and highways. The degree of color blindness may range from complete inability to distinguish any color to the lack of perception of, or discrimination between, some hues. This characteristic must be taken into account, for some of those afflicted do not realize the fact; therefore, the client and designer may not agree upon color combinations. Those afflicted with color blindness have relatively low visual acuity, yet they are able to distinguish between colored light and white light, not as color, but because of intensity difference.

**10. Objective Color Specifications.** The International Commission on Illumination (I.C.I.) has chosen as a basis for standardization the response to color of three sets of nerves (assuming that they exist) in the eye, as shown in Fig. 2-4. These curves ( $\bar{x}$ ,  $\bar{y}$ ,  $\bar{z}$ ) have been given tristimulus values, (shown proportionally in Fig. 2-4) with  $\bar{x}$  having a

maximum sensitivity in the red,  $\bar{y}$  in the green, and  $\bar{z}$  in the blue. These tristimulus values are those of a hypothetical observer established by the Commission, attempting, through the medium of tables, to classify color according to the stimulation on the eye of one observer situated at any laboratory. A color analyzed with respect to these

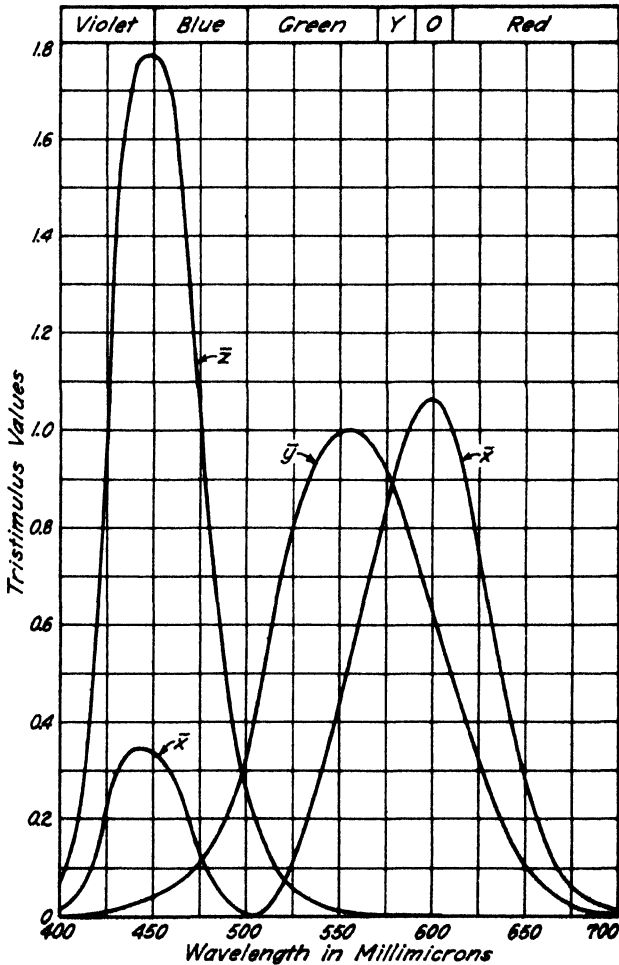

FIG. 2-4. Tristimulus values for the standard I.C.I. observer.

curves of stimulation will be classified as one specific sensation-producing color. The use of these curves in specifying color must be considered in conjunction with the spectral distribution curve of the color.

Originally, the obtaining of specific spectral curves was a difficult problem requiring time and training of a highly specialized type. With



the beginning of colored photography and colored motion pictures, the scientists interested were stimulated to develop equipment which could be depended upon to do the task quickly and accurately. Dr. Arthur C. Hardy developed a machine which determines the spectral curve and records the data. After the initial development, the General Electric Company adapted the fundamental principles to equipment which could be produced on a commercial basis. The rapid adoption of this equipment by the interested industries and the development of colored light sources seem to indicate that color has at last entered permanently into our daily lives.

Figure 3-4 shows the spectral distribution of a colored paint re-

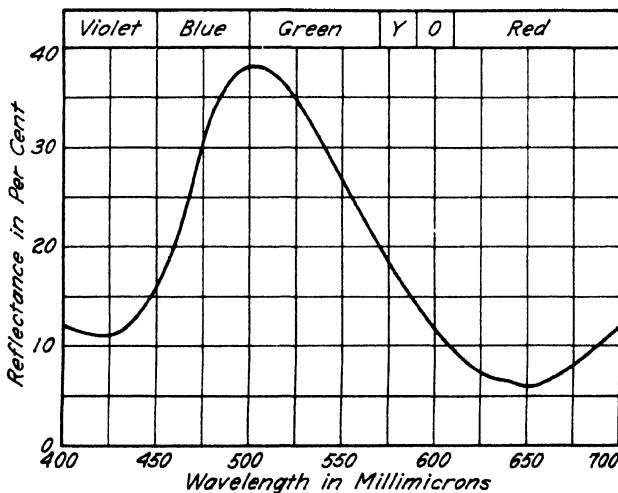

FIG. 3-4. Spectral reflection from a colored surface.

fecting light. This color would be classified by various observers as either green, blue, bluish green, or greenish blue. This reflectance curve, when reproduced, signifies one color and one alone, a color which will match under every color of light to every observer. If this is true, it seems that it would only be necessary to have this type of record for specifying the colors and that the standard I.C.I. observer would not be needed.

The observer is needed, however, so that a simplified method of color designation may be developed. It is seldom that a color must have a universal match. Three standard sources of light have been found and specified which are representative of all conditions normally met with in practice. These three sources are called:

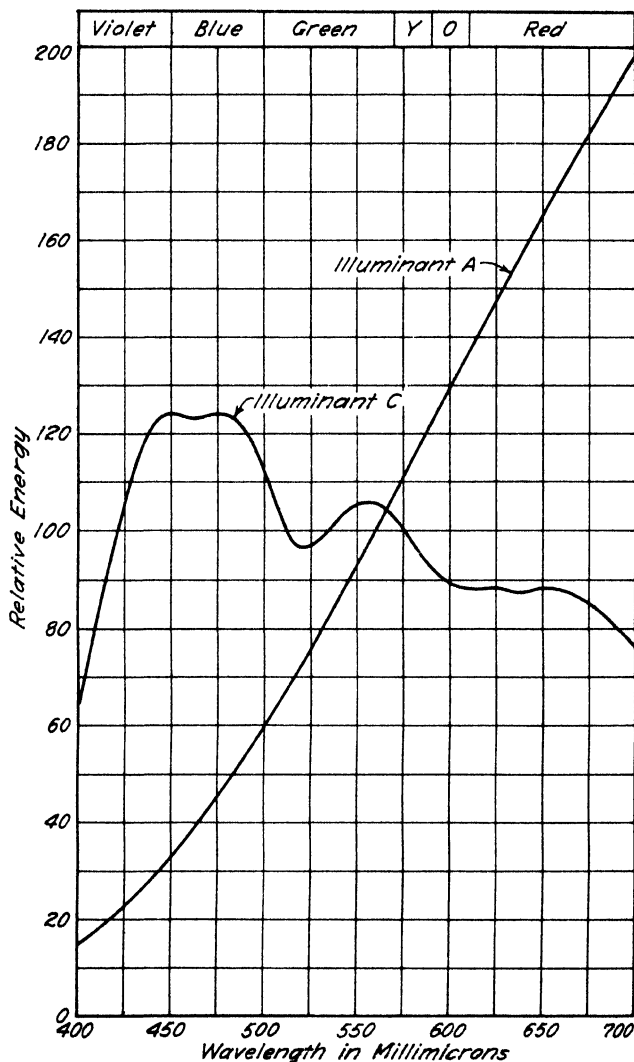

FIG. 4-4. Relative spectral distribution of energy in I.C.I. illuminant A (incandescent lamp) and illuminant C (average daylight).

		STANDARDS			
	$x$	$y$			
Source A	0.4476	0.4075	Tungsten lamp	(2848° K)	(Fig. 4-4)
Source B	0.3485	0.3518	Mean noon sunlight	(4800° K)	
Source C	0.3101	0.3163	Average daylight	(6500° K)	(Fig. 4-4)

and Fig. 4-4 shows the relative energy distribution of the sources A and C throughout the visible spectrum. It is possible to determine the

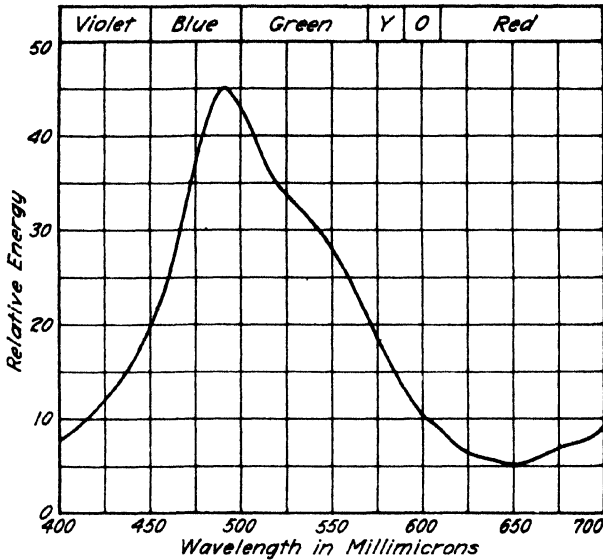

FIG. 5-4. Relative spectral distribution of energy from color in Fig. 3-4 under illuminant C.

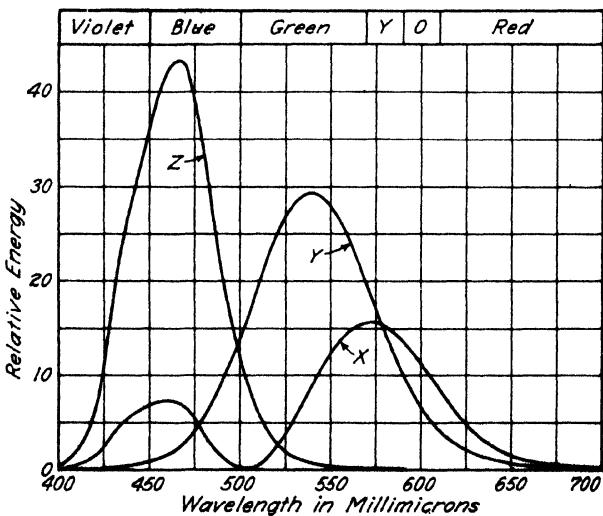

FIG. 6-4. Tristimulus values for the color in Fig. 3-4 under illuminant C.

relative response of the standard observer to a color by using a combination of a standard light source (Fig. 4-4), the reflectance data for the color (Fig. 3-4), and the reaction of the standard observer.

In the process, the curve of the standard illuminant is multiplied by the spectral reflectance curve of the color to determine the energy distribution of the light reflected by the color (Fig. 5-4). The resultant curve of energy distribution is in turn multiplied by the three sensitivity curves,  $\bar{x}$ ,  $\bar{y}$ ,  $\bar{z}$ , creating three new curves (Fig. 6-4). These curves represent the effect the color has upon the stimulation of the nerve endings of a standard observer in the red, green, and blue regions, respectively. The color may be designated as  $X = 16$ ,  $Y = 24$ ,  $Z = 20$ , which is satisfactory for objective specification when assuming a standard illuminant  $C$ , but is meaningless in describing the color and does not utilize the vast amount of experimental data based upon brightness, hue, and saturation.

Figure 7-4 shows the method of designation adopted by the I.C.I. for specifying the color as to its dominant hue, brightness, and purity. It is necessary to convert the values of  $X$ ,  $Y$ , and  $Z$  into trichromatic coefficients by the conversion forms:

$$x = \frac{X}{X + Y + Z}$$

$$y = \frac{Y}{X + Y + Z}$$

$$z = \frac{Z}{X + Y + Z}$$

which in this particular instance give the values  $x = 0.261$ ,  $y = 0.398$ ,  $z = 0.341$ , and in every evaluation,  $x + y + z = 1$ . The chromaticity diagram of Fig. 7-4 shows the color plotted at  $b$  and the illuminant at  $a$ . A line through  $a$  and  $b$  intersects the wavelength line at  $c$ , approximately  $513 \text{ m}\mu$ , and this designates the dominant hue. A complete specification from the diagram will be:

Dominant color	513 m $\mu$	
Brightness	24%	( $Y$ ) column 10, Table IV-4
Purity	17%	ratio $ab/ac$

This is a specification which correlates with the studies of the psychologists

PSYCHOLOGICAL	OBJECTIVE SPECIFICATION
Brilliance (value)	Brightness
Hue	Dominant wave
Saturation (chroma)	Purity

The curves of spectral distribution and these methods of color specification have been appearing in illumination literature since the advent of the fluorescent lamp and the development of infra-red dry-

ing. The process is one in which the energy distribution of the light, either in the source, through the transmitting media, or from the reflected surface, is determined by some spectrophotometric means. The coefficients for the energy distribution are determined and the

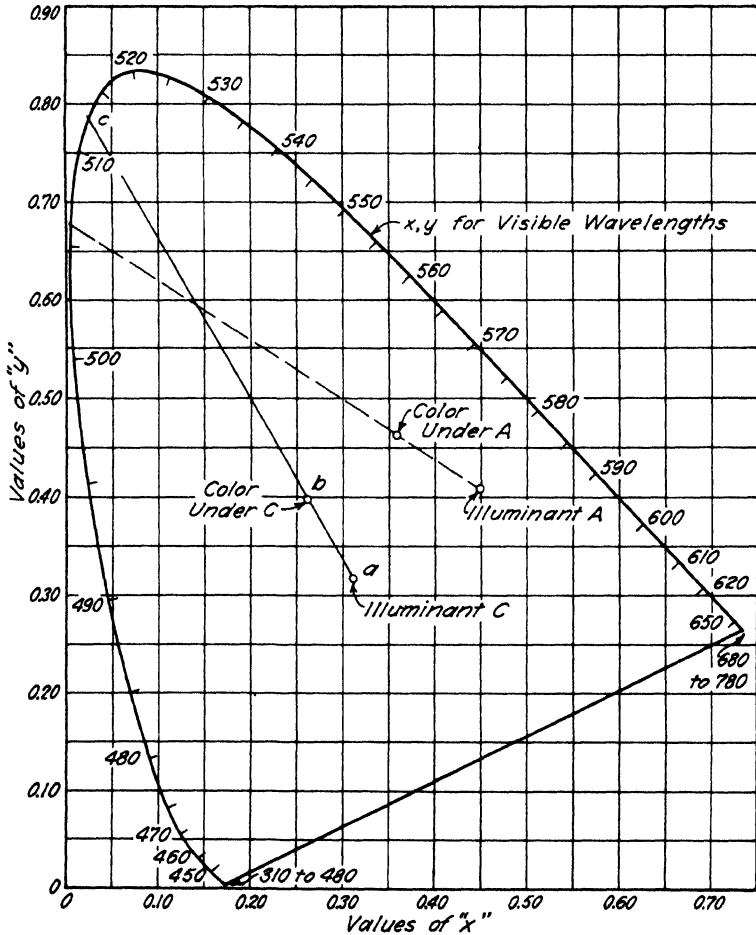

FIG. 7-4. Chromaticity diagram for the color Fig. 3-4 under illuminant A and illuminant C.

curves plotted by the use of tables and computing machines according to a predetermined method which is accepted and prescribed as standard.

*Example a.* Determine the color specifications for the spectral reflection curve given in Fig. 3-4 when the source is illuminant C. From Fig. 3-4, the



reflection factor  $\rho$  is obtained (assuming that the sample calculation will be at a wavelength of 500  $m\mu$  (5000 Ångstrom units).

$$\rho = 0.380 \text{ direct reading from Fig. 3-4}$$

Under the first column in Table IV-4, the reflection factors for every 10  $m\mu$  will be found. The next step requires that the reflection factor  $\rho$  be multiplied by the relative energy of the source considered (Fig. 4-4, illuminant C),

$$\rho E_c = 0.380 \times 112.10 = 42.5980$$

which gives the relative energy from the reflecting color (Fig. 5-4).

The relative energy reflected from the color is in turn multiplied by the three tristimulus values and

$$\rho E_c x = 42.5980 \times 0.0049 = 0.2087$$

$$\rho E_c y = 42.5980 \times 0.3230 = 13.7592$$

$$\rho E_c z = 42.5980 \times 0.2720 = 11.5867$$

which will be the tristimulus values of the color.

If the summation of the values for each 10  $m\mu$  is ratioed to the stimulus of a reflecting surface having unity reflection (which will be

$$X_t = 1042.53$$

$$Y_t = 1064.26$$

$$Z_t = 1255.35$$

obtained by adding the values of  $\rho E_c x$ ,  $\rho E_c y$ , and  $\rho E_c z$  for the 10- $m\mu$  intervals, the tristimulus values when the reflection factor  $\rho$  is unity), the resultant values will be

$$X = \frac{161.311}{1042.53} = 0.1547$$

$$Y = \frac{251.111}{1064.26} = 0.2359 \text{ (Reflectance)}$$

$$Z = \frac{252.907}{1255.35} = 0.2015$$

This describes the color by the tristimulus values, which are meaningless to the practicing architect or engineer. These values may be converted into trichromatic coefficients by

$$x = \frac{0.1547}{0.5921} = 0.261$$

$$y = \frac{0.2359}{0.5921} = 0.398$$

$$z = \frac{0.2015}{0.5921} = 0.341$$

where the sum of  $x$ ,  $y$ , and  $z$  will be unity. The values  $x$  and  $y$  may be located on the chromaticity diagram (Fig. 7-4). The illuminants A and C are also located on this diagram and from their coefficients which were previously listed. When illuminated by illuminant C, the attributes of the color are:

Dominant wave	513 m $\mu$	( <i>ab</i> intersecting wavelength curve)
Brightness	24%	(the <i>Y</i> value was 0.2359)
Purity	17%	(ratio <i>ab/ac</i> )

*Example b.* Determine the color specifications for the spectral reflection curve given in Fig. 3-4 when the source is illuminant *A*.

This problem may be solved in the same manner as Example *a* and with the same degree of accuracy. By using ten selected ordinates as outlined by Hardy,<sup>4</sup> the following values will be obtained:

<i>X</i> = 15.6	<i>x</i> = 0.357
<i>Y</i> = 20.7	<i>y</i> = 0.462
<i>Z</i> = 8.1	

which, by using the chromaticity diagram (Fig. 7-4), gives the following values:

Dominant wave	506 m $\mu$
Brightness	21%
Purity	20%

Comparing this with the result under illuminant *C*, the color may be interpreted under both average daylight and incandescent illumination to show the relative effect that may be expected.

It is not necessary for the architect and the engineer to produce these specifications, but it is becoming increasingly important for him to understand how these values and diagrams are obtained. When the use of I.C.I. color specifications becomes universal, it will be possible to specify colors and combinations of color and light with complete assurance of the desired end results. This method of color designation will be used in Chapter 6 in a study of the various illuminants available.

**11. Summary.** To the chemist, color may be reduced to a formula, without any sensation having been introduced to the eye. To the physicist, the spectral curve supplies all the information necessary and may be regarded as a permanent record which, when duplicated, assures a match of sensation under any illumination to any observer. To the psychologist and physiologist, something more is needed, because the human element and the response to sensation must be accounted for and interpreted. The tristimulus values for color insure the matching of color under identical lights or permit an interchange of like colors to be made. From these coefficients, the brightness change in the same colors is definitely represented. An objective analysis is obtained by use of trichromatic coefficients, which may be interpreted in terms of sensation, and therefore this method enables several branches of study to correlate results.



**12. Shadow.** Shadow, so important to recognition, cannot be examined objectively. It is important, however, and must be given serious consideration if good lighting results are to be secured. The proper use of shadows will lend character to statuary, monuments and interiors treated with relief or scroll work. A picture obtains much of its depth from the correct use of shadows.

In the drafting room, shadow will interfere with the work and cause eyestrain; in the shop, where there are fast-moving machines, a harsh shadow means a point of danger and may be the cause of an accident. Where work is being done, the shadow should be soft and should never have sharply defined outlines. There should also be enough shadow to allow the recognition of form and details but not enough to hide moving machine parts. The more direct the light, the more pronounced the shadow. Semi-indirect and indirect light reduce and fade the shadow. In the home and places of leisure, shadow is restful and brings repose and comfort.

Eye fatigue may be produced by shadow because of brightness contrast, because a dark shadow and a light area in the visual field will have definite contrast. The placement of lighting equipment in order to balance shadow and glare is essential. It is not infrequent that correction of one of these factors causes distress from the other. It is necessary to consider seriously the effect of shadow on merchandising counters and work places, such as switchboards and desks.

In inspection work, it is sometimes necessary to develop a sharp shadow on the inspected object to disclose faults, but a shadow cast by the object itself might be very objectionable. Driving at night may require the reverse, for the shadow cast by an object is often the easiest way to detect its presence. The control of the brightness contrast in shadow and light can be used to good effect by the architect for decoration. In gaining these good effects, however, the architect often disregards the principles of good illumination.

#### BIBLIOGRAPHY

1. INTERNATIONAL PRINTING INK Co., *Color as Light*, Monograph 2, 1935.
2. INTERNATIONAL PRINTING INK Co., *Color in Use*, Monograph 3, 1935.
3. INTERNATIONAL PRINTING INK Co., *Color Chemistry*, Monograph 1, 1935.
4. A. C. HARDY, *Handbook of Colorimetry*, Technology Press, Massachusetts Institute of Technology, 1936.
5. M. LUCKIESH, *Color and Colors*, D. Van Nostrand Co., 1938.
6. PAPERS. October Issue v. 28, No. 10, *J. O. S. A.*, 1938.
7. DEANE B. JUDD, "Hue Saturation and Lightness of Surface Colors with Chromatic Illumination," *J. O. S. A.*, v. 30, No. 1, pp. 2-32, January, 1940.
8. DOROTHY NICKERSON and WALTER C. GRANVILLE, "Hue Sensibility to

- Dominant Wave-Length Change and the Relation between Saturation and Colorimetric Purity," *J. O. S. A.*, v. 30, No. 4, pp. 159-162, April, 1940.
9. DEANE B. JUDD, "Erratum: Hue, Saturation, and Lightness of Surface Colors with Chromatic Illumination," *J. O. S. A.*, v. 30, No. 7, pp. 296, July, 1940.
  10. DEANE B. JUDD, "Munsell Color System (Foreword)," *J. O. S. A.*, v. 30, No. 12, pp. 574, December, 1940.
  11. DOROTHY NICKERSON, "History of the Munsell Color System and Its Scientific Application," *J. O. S. A.*, v. 30, No. 12, pp. 575-587, December, 1940.
  12. JOHN E. TYLER and ARTHUR C. HARDY, "Analysis of the Original Munsell Color System," *J. O. S. A.*, v. 30, No. 12, pp. 587-591, December, 1940.
  13. KASSON S. GIBSON and DOROTHY NICKERSON, "Analysis of the Munsell Color System Based on Measurements Made in 1919 and 1926," *J. O. S. A.*, v. 30, No. 12, pp. 591-609, December, 1940.
  14. JAMES J. GLENN and JAMES T. KILLIAN, "Trichromatic Analysis of the Munsell Book of Color," *J. O. S. A.*, v. 30, No. 12, pp. 609-617, December, 1940.
  15. SIDNEY M. NEWHALL, "Preliminary Report of the O. S. A. Sub-committee on the Spacing of the Munsell Colors," *J. O. S. A.*, v. 30, No. 12, pp. 617-646, December, 1940.
  16. LEGRAND H. HARDY, "The Bases of Color Vision," *I. E. S. Trans.*, v. 36, No. 3, pp. 295-312, March, 1941.
  17. DEANE B. JUDD, "Color Systems and Their Interrelation," *I. E. S. Trans.*, v. 36, No. 3, pp. 336-372, March, 1941.
  18. PARRY MOON, "Color Determination," *I. E. S. Trans.*, v. 36, No. 3, pp. 313-335, March, 1941.
  19. DOROTHY NICKERSON, "The Illuminant in Color Matching and Discrimination (How Good a Duplicate Is One Illuminant For Another?)," *I. E. S. Trans.*, v. 36, No. 3, pp. 373-399, March, 1941.

## CHAPTER 5

### DISTRIBUTION CURVES AND POINT-BY-POINT METHOD OF DETERMINING ILLUMINATION

An understanding of photometric reports on equipment (issued by testing laboratories) will enable the architect and engineer to apply the correct equipment for obtaining the desired results. The distribution curve is an important photometric determination for the individual applying illumination to industry and commerce. These curves, for specific equipment, may be either single curves or groups of curves, depending upon the nature of the equipment.

Curves may be plotted to polar or rectangular coordinates and may be isocandle or isofoot-candle (isolux) curves, each having its special interpretation. In the past, curves have been plotted to polar coordinates but some of the advantages of the curve drawn to Cartesian coordinates may make this type more popular in the future. Figure 1-5 shows several distribution curves for lighting equipment, with curves for one type of equipment in both systems of plotting.

#### 1. Photometric Nomenclature for Equipment Distribution Curves.

The Committee on Nomenclature and Standards of the Illuminating Engineering Society has published a specific descriptive vocabulary to be applied to light distribution curves and the accepted practice in application. These terms should not be used indiscriminately if specifications are to be precise.

*Characteristic Curve.* A characteristic curve is a curve expressing a relationship between two variable properties of a luminous source, such as candlepower and volts and candlepower and fuel consumption.

*Curve of Light Distribution.* A curve of light distribution is a curve showing the variation of luminous intensity of a lamp or luminaire with the angle of emission.

*Curve of Horizontal Distribution.* A curve of horizontal distribution is a curve, usually polar, representing the luminous intensity of a lamp or luminaire at various angles of azimuth in the horizontal plane through the light center of the lamp.

It is recommended that, for horizontal distribution curves, the relative positions of parts of the equipment affecting the symmetry of distribution be indicated.

*Curve of Vertical Distribution.* A curve of vertical distribution is a curve, usually polar, representing the luminous intensity of a lamp or luminaire at various angles of elevation in a vertical plane passing through the light center of the lamp.

Unless otherwise specified, a vertical distribution curve is assumed

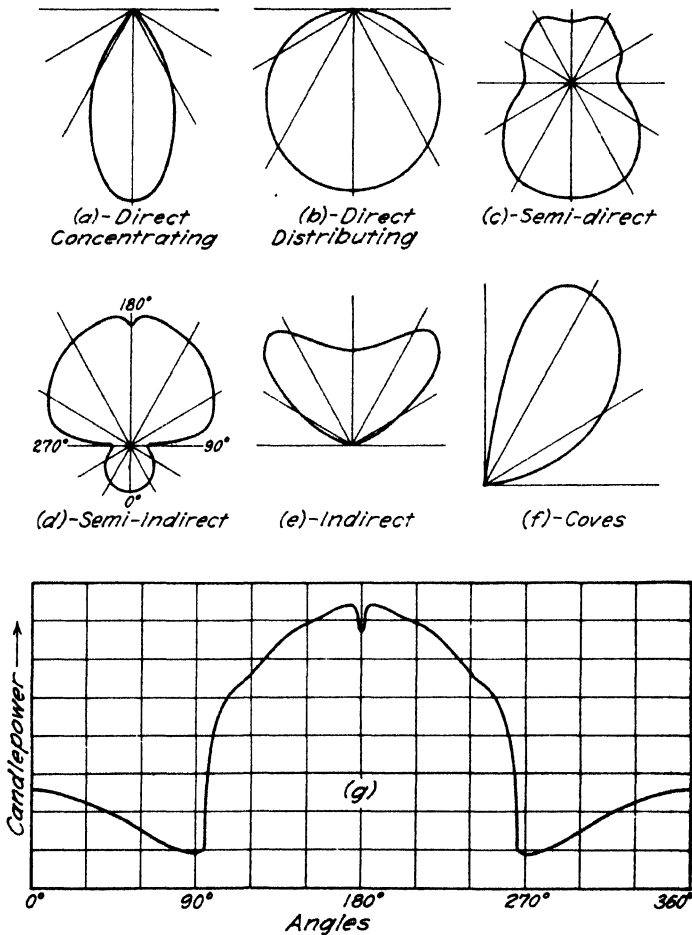

FIG. 1-5. Typical distribution curves for illumination equipment; (g) distribution curve of figure (d) plotted to Cartesian coordinates.

to be an average vertical distribution curve, such as may be obtained by rotating the unit about its axis and measuring the average intensity at different angles of elevation.

*Solid of Light Distribution.* A solid of light distribution is a solid whose surface is such that the radius vector from the origin to the

surface in any direction is proportional to the luminous intensity of the light source in the same direction.

*Symmetrical Light Distribution.* A symmetrical light distribution is one in which the curves of vertical distribution are substantially the same for all planes.

*Asymmetrical Light Distribution.* An asymmetrical light distribution is one in which the curves of vertical distribution are not the same for all planes.

A study of the foregoing indicates that the most important distribution is that of the vertical plane. Figure 2-5 is the vertical distribution curve for a semi-indirect luminaire.

**2. Testing Specifications for Lighting Equipment.<sup>2,6</sup>** The testing specifications for lighting equipment may be divided into the testing of four types of equipment, namely:

- a. Diffusing enclosing glassware
- b. Semi-indirect and indirect luminaires
- c. Narrow-beam enclosing projectors
- d. Asymmetric show-window reflectors.

A copy of the specifications should be in the possession of every architect or engineer for ready reference, because a knowledge of the methods used in determining the distribution curves and the meaning of the specific tests is essential to the development of reliable judgments in applying luminaires to the task or the room.

The details of the selection of equipment, laboratory, method of test and reporting should be worked out according to the above specifications; only the resultant curves and their use in making interpretations will be discussed.

**3. Diffusing Enclosing Glassware and Semi-Indirect and Indirect Luminaire Distribution Curves.<sup>2,6</sup>** The results of the test, though listed under two separate heads, are very much the same and the same interpretation applies to both. Figure 2-5 will be used as a typical test curve.

The curve itself is of little value unless it states clearly under what conditions the data were taken, and these conditions should be as near installation conditions as possible. If special conditions are specified by the manufacturer of the equipment in order to show high efficiencies, a comparison of two sets of curves for comparable equipment will give a false rating to the competitive material. Either the I. E. S. standards should be followed in every detail or the modification should be recorded by the laboratory making the tests if it is a reliable in-

stitution. To insure comparable tests, the report should be marked, *Tested According to I. E. S. Standard Specifications*. Insistence upon these requirements by all architects and engineers would soon eliminate

LABORATORY AND MANUFACTURER'S DATA  
CANDLEPOWER DISTRIBUTION

LAMP - 500 Watts; 115 Volts; 9800 Lumens; PS40 Inside Frosted, Gas-Filled Bulb; C-7A Filament; Mogul Base; General Service.

DESCRIPTION OF BOWL - Alabaster Glass.

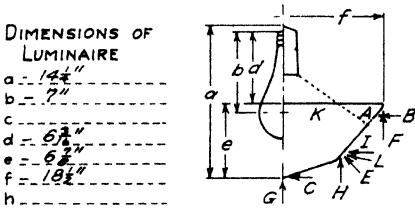

LUMINAIRE DISTRIBUTION DATA  
Mean Vertical

MID-ZONE ANGLES	CANDLE-POWER AT 10 FEET	ZONAL LUMENS	MID-ZONE ANGLES	CANDLE-POWER AT 10 FEET	ZONAL LUMENS
180°ZEN.	1490		90°HOR	129	
175°	1630	152	85°	93	105
165°	1520	436	75°	90.5	96
155°	1570	725	65°	109	108
145°	1560	980	55°	129	116
135°	1470	1142	45°	150	116
125°	1330	1192	35°	164	103
115°	1150	1141	25°	183	85
105°	980	1038	15°	194	55
95°	455	529	5°	203	19
			0°NADIR	204	

LIGHT FLUX VALUES

ZONE	LUMENS		PER CENT TOTAL LUMENS BARE LAMP	PER CENT LIGHT OUTPUT
	LAMP	LUMINAIRE		
0°-60°	2560	494	5	83
0°-90°	5019	803	8	
90°-180°	4778	7335	75	
0°-180°	9797	8138	83	

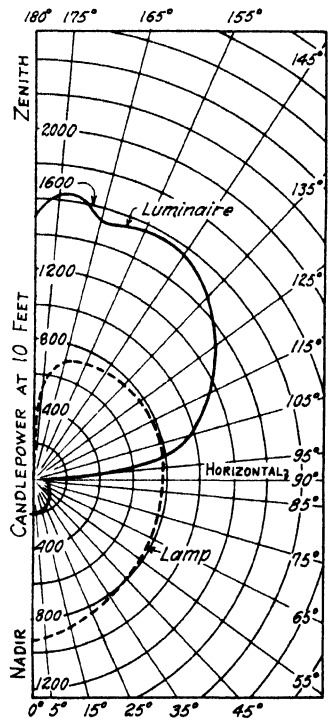

LUMINAIRE BRIGHTNESS  
CANDLEPOWER PER SQUARE INCH

ARROWS INDICATE LOCATION AND ANGLE OF VIEW

LOCATIONS-	A	B	C	D	E	F	G	H	I	J	K	L	M
CP. PER Sq. IN.-	0.5	0.5	1.1		1.4	0.3	1.2	1.1	1.3		0.5	1.3	

Fig. 2-5. Typical photometric report on a luminaire.

inferior equipment from the market. Such elimination is favored by the manufacturers of the better grade of glassware and luminaires.

A study of the output, which is determined from the distribution curve, is divided into three groups.

*Zone 0°-60°.* This zone is the most effective in putting light upon the working surface when such a surface is in horizontal position.

*Zone 60°-90°.* This zone is the most effective for vertical lighting.

*Zone 60°-85°.* This zone may be considered the principal glare zone. In large offices that are relatively long and low, the region which may cause the most annoyance will be the 70°-80° zone.

*Zone 90°-180°* The light emitted in this zone goes to the ceiling and upper wall surface where a portion is reflected back to the vertical and horizontal work or viewing surface. This portion is never very efficiently used, but control of the ceiling and side wall reflection factor will allow a maximum return. This light is very effective in shadow control.

*Any Zone Spread.* Since the report gives the lumen output of the luminaires by 10-degree zones, it is possible to investigate any part of the distribution curve which may be of special interest in the problem under consideration.

The general shape of the distribution curve is a rapid index to the expected distribution of the installation and the best probable mounting height. The individual candlepower readings are used in calculations in the point-by-point method. Candlepower at 90° and lumens in the 0°-90° and 90°-180° zones are used in determining the utilization factor, important in the lumen method of calculation. Both of these methods will be considered later.

Since the test is made on representative equipment of mean output, using 200-w. lamps, a question arises concerning the reliability of the test and what deviation may be expected in the delivered manufactured product. The results of a test following the specifications give a fair indication of the distribution of the light output and the efficiency for the type of luminaire. The Committee reported that the general variation will not be more than 5 per cent above and 7 per cent below the value shown in the report.

Lamp position and (in enclosing globes) the reflection factor of the fitter as well as the type of lamp will influence the efficiency. In making comparisons for the determination of choice of equipment, the architect and the engineer should make sure that all equipment investigated by use of distribution curves and test data has been reduced to the same basis. In addition to the data which have been mentioned, the appearance of the equipment is of major importance to the designer of interiors, especially where a specific atmosphere is sought. Probably the best test is the use of sample units, making a visual inspection for dark areas, spotty lighting, thin places in the glassware or plastic, and the ability to hide the lamp filament.

**4. Brightness Data on the Photometric Report.** In Chapter 3 the importance of brightness of lighting equipment and the resultant brightness contrast and glare were discussed. The effect of brightness directed toward the eye cannot be interpreted unless the conditions of use are thoroughly understood and the effect of mounting and distance from the eye has been discussed. A reduction of brightness will reduce glare and will promote comfort in the use of the lighting system. Since these subjective factors have been discussed and the brightness readings have been reported, the purpose of making these readings will be considered.

The Committee has listed fourteen important and descriptive readings of brightness necessary for the interpretation of the operation of a luminaire in a lighting installation. Some types of equipment will not have all of these measurements and the totally indirect unit will

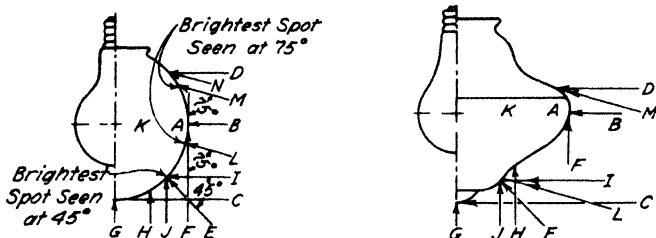

FIG. 3-5.<sup>2</sup> Points on the luminaire which are measured for brightness.

not have a single point of luminaire brightness that is interesting; in indirect equipment the annoyance from glare may come from ceiling brightness or brightness contrast. The listing of these brightness points is from A to M (see Fig. 3-5).

*Point A.* Read with the photometer pointed as nearly as possible tangent to the luminaire in the horizontal plane passing through the light source. Unit rotating.

A is at right angles to B in making the readings.

*Point B.* Read with the photometer pointed toward the light source in the horizontal plane as in A. Unit rotating.

B is at right angles to A and F and at 45° to K.

*Point C.* Read with the photometer pointed horizontally, as nearly as possible tangent to the bottom of the luminaire. Unit rotating.

*Point D.* Read at the brightest part of the upper third of the luminaire with the photometer pointed horizontally in a vertical plane through the luminaire axis. Unit rotating.



*Point E.* Read at the brightest spot visible when the globe is viewed in a direction approximately  $45^\circ$  from the nadir, with the photometer pointed at  $45^\circ$  from the nadir in a vertical plane through the luminaire axis. Unit stationary.

*E* is at  $45$  degrees to both *I* and *J*.

*Point F.* Read on the circumference, where the horizontal plane through the light source intersects the globe with the photometer pointed vertically along the luminaire axis, parallel to the luminaire axis. Unit rotating.

*F* is at right angles to both *B* and *G*.

*Point G.* Read with the photometer pointed vertically along the luminaire axis, offset if necessary, to avoid the opening in the globe. Unit rotating.

*G* is at right angles to *F*.

*Point H.* Read with the photometer pointed vertically, parallel to the luminaire axis and halfway between positions *G* and *F*. Unit rotating.

*Point I.* Read toward the same point defined as *E*, with the photometer pointed horizontally, in the vertical plane through the luminaire axis. Unit stationary.

Point *I* is read at  $45^\circ$  to *E*.

*Point J.* Read toward the same point defined as *E* with the photometer pointed vertically, parallel to the luminaire axis. Unit stationary.

Point *J* is read at  $45^\circ$  to *E*.

*Point K.* Read toward a point midway between the center and circumference of the globe with the photometer pointed horizontally in the horizontal plane through the light center. The line of sight makes an angle of  $45^\circ$  with the normal to the globe at the same point. Unit rotating.

Point *K* is read at  $45^\circ$  to *B*.

*Point L.* Read toward the brightest spot visible below the plane of greatest diameter of the globe when the globe is viewed in a direction approximately  $75^\circ$  from the nadir with the photometer pointed at  $75^\circ$  from the nadir in a vertical plane through the luminaire axis. Unit stationary.

This reading is important in large rooms, particularly if the ceiling is low.

*Point M.* Read toward the brightest spot visible above the plane of greatest diameter of the globe when the globe is viewed in a direction approximately  $75^\circ$  from the nadir with the photom-

eter pointed at 75° from the nadir in a vertical plane through the luminaire axis. Unit stationary.

This reading is important in large rooms, particularly if the ceiling is low.

*Point N.* Maximum brightness above maximum diameter viewed at 80° from the nadir.

In making the brightness readings, the area observed is confined to approximately 1 sq. in. and the brightness is reported in candlepower per square inch. A study of the brightness readings at these various angles will give some indication of the diffusing power of the luminaire. As stated in the outline, *A* and *B*, *C* and *G*, *B* and *F* are at right angles to each other; one normal toward the light source, the other at nearly grazing incidence, and

$$\frac{\text{brightness at grazing incidence}}{\text{brightness at normal incidence}}$$

should be approximately 0.65 or of higher value, whereas

$$\frac{\text{brightness at 45°}}{\text{brightness at normal incidence}}$$

should be approximately 0.8 or of higher value.

**5. The Point-By-Point Method of Calculating Illumination.** This method of calculating illumination was one of the earliest developed, but it was later discarded for the lumen method because of increased simplicity. With the specification of a combination of units and downlights in store installations, the point-by-point method has again gained in favor as it lends itself to these calculations. The method has always been in use wherever the direct component of light-producing illumination has been investigated.

Computations by the point-by-point method depend upon the inverse square law which was discussed in Chapter 2. From the candlepower distribution curve of a reflector, the foot-candles at any point may be determined from the expressions:

$$\text{foot-candles} = \frac{\text{candlepower}}{(\text{distance})^2} = \frac{\text{c-p.}}{d^2}$$

when the illumination is normal to the beam, or

$$\text{foot-candles} = \frac{\text{candlepower}}{(\text{distance})^2} \times \text{cosine } \theta = \frac{\text{c-p.}}{d^2} \cos \theta$$

when the illumination on the horizontal plane is computed. Figure 4-5a shows the quantities used in the above expressions, and Fig. 4-5b

TABLE  
POINT-BY-POINT

UPPER FIGURES — ANGLE BE-  
LOWER FIGURES — FOOT-CANDLES ON A HORIZONTAL

		HORIZONTAL DISTANCE															
		0	1	2	3	4	5	6	7	8	9	10	11	12	13	14	15
4	0° 0'	14°	27°	37°	45°	51°	56°	60°	63°	66°	68°	70°	72°	73°	74°	75°	
	6.259	5.707	4.472	3.200	2.210	1.524	1.066	.764	.559	.419	.320	.249	.198	.159	.130	.107	
5	0° 0'	11°	22°	31°	39°	45°	50°	54°	58°	61°	63°	66°	67°	69°	70°	72°	
	4.000	3.771	3.202	2.522	1.904	1.414	1.050	.785	.595	.458	.358	.283	.228	.185	.152	.126	
6	0° 0'	9°	18°	27°	34°	40°	45°	49°	53°	56°	59°	61°	63°	66°	67°	68°	
	2.778	2.673	2.372	1.987	1.600	1.260	.982	.766	.600	.474	.378	.305	.249	.205	.170	.142	
7	0° 0'	8°	16°	23°	30°	36°	41°	45°	49°	52°	55°	58°	60°	62°	63°	65°	
	2.041	1.980	1.814	1.585	1.336	1.100	.893	.722	.583	.478	.385	.316	.261	.218	.183	.154	
8	0° 0'	7°	14°	21°	27°	32°	37°	41°	45°	48°	51°	54°	56°	58°	60°	62°	
	1.563	1.527	1.427	1.283	1.118	.953	.800	.640	.562	.458	.381	.318	.267	.225	.191	.163	
9	0° 0'	6°	13°	18°	24°	29°	34°	38°	42°	45°	48°	51°	53°	55°	57°	59°	
	1.235	1.212	1.148	1.054	.943	.825	.711	.607	.515	.437	.370	.314	.267	.228	.196	.168	
10	0° 0'	5° 43'	11°	17°	22°	27°	31°	35°	39°	42°	45°	48°	50°	52°	54°	56°	
	1.000	.985	.943	.879	.801	.716	.631	.550	.476	.411	.354	.305	.263	.227	.196	.171	
11	0° 0'	5° 12'	10°	15°	20°	24°	29°	32°	36°	39°	42°	45°	48°	50°	52°	54°	
	.826	.816	.787	.742	.686	.623	.559	.496	.437	.383	.335	.292	.255	.223	.196	.171	
12	0° 0'	4° 46'	9°	14°	18°	23°	27°	30°	34°	37°	40°	43°	45°	47°	49°	51°	
	.694	.687	.668	.634	.593	.546	.497	.448	.400	.356	.315	.278	.246	.217	.191	.169	
13	0° 0'	4° 24'	9°	13°	17°	21°	25°	28°	32°	35°	38°	40°	43°	45°	47°	49°	
	.592	.587	.571	.547	.517	.481	.447	.404	.366	.329	.295	.263	.235	.200	.187	.166	
14	0° 0'	4° 5'	8°	12°	16°	20°	23°	27°	30°	33°	36°	38°	41°	43°	45°	47°	
	.510	.506	.495	.477	.454	.426	.396	.365	.334	.304	.274	.248	.223	.201	.180	.162	
15	0° 0'	3° 49'	8°	11°	15°	18°	22°	25°	28°	31°	34°	36°	39°	41°	43°	45°	
	.444	.442	.433	.419	.401	.380	.356	.331	.305	.280	.256	.233	.212	.192	.174	.157	
16	0° 0'	3° 35'	7°	11°	14°	17°	21°	24°	27°	29°	32°	35°	37°	39°	41°	43°	
	.391	.388	.382	.371	.357	.339	.321	.300	.280	.259	.238	.219	.200	.183	.167	.152	
17	0° 0'	3° 22'	7°	10°	13°	16°	19°	22°	25°	28°	30°	33°	35°	37°	39°	41°	
	.346	.344	.339	.331	.319	.306	.290	.274	.256	.239	.222	.205	.189	.174	.159	.146	
18	0° 0'	3° 11'	6°	9°	13°	16°	19°	21°	24°	27°	29°	31°	34°	36°	38°	40°	
	.309	.307	.303	.297	.287	.276	.264	.250	.236	.221	.206	.192	.178	.165	.152	.140	
19	0° 0'	3° 1'	6°	9°	12°	15°	18°	20°	23°	25°	28°	30°	32°	34°	36°	38°	
	.277	.276	.273	.267	.260	.251	.240	.229	.217	.205	.192	.180	.167	.156	.145	.134	
20	0° 0'	2° 51'	5° 43'	9°	11°	14°	17°	19°	22°	24°	27°	29°	31°	33°	35°	37°	
	.250	.249	.246	.242	.236	.228	.219	.210	.200	.190	.179	.168	.158	.147	.137	.128	
21	0° 0'	2° 44'	5° 28'	8°	11°	13°	16°	18°	21°	23°	25°	28°	30°	32°	34°	36°	
	.227	.226	.224	.220	.215	.210	.201	.194	.185	.176	.167	.158	.149	.139	.131	.122	
22	0° 0'	2° 36'	5° 10'	8°	10°	13°	15°	18°	20°	22°	25°	27°	29°	31°	33°	34°	
	.207	.206	.205	.201	.196	.192	.185	.179	.171	.164	.155	.148	.140	.132	.124	.114	
23	0° 0'	2° 29'	4° 58'	7°	10°	12°	15°	17°	19°	21°	24°	26°	28°	29°	31°	33°	
	.189	.189	.187	.184	.181	.176	.171	.165	.159	.153	.146	.139	.132	.125	.118	.111	
24	0° 0'	2° 23'	4° 45'	7°	10°	12°	14°	16°	18°	21°	23°	25°	27°	28°	30°	32°	
	.174	.173	.172	.170	.166	.163	.158	.154	.148	.143	.137	.130	.124	.118	.112	.106	
25	0° 0'	2° 17'	4° 34'	7°	9°	11°	14°	16°	18°	20°	22°	24°	26°	27°	29°	31°	
	.160	.160	.158	.157	.154	.151	.147	.143	.138	.133	.128	.123	.117	.112	.106	.101	
27	0° 0'	2° 7'	4° 14'	6°	8°	10°	12°	15°	17°	18°	20°	22°	24°	26°	27°	29°	
	.137	.137	.136	.135	.133	.130	.128	.124	.121	.117	.113	.109	.105	.100	.096	.092	
30	0° 0'	1° 54'	3° 50'	5° 43'	8°	11°	13°	15°	17°	18°	20°	22°	23°	25°	28°	29°	
	.111	.111	.111	.109	.108	.107	.105	.103	.100	.098	.095	.092	.089	.086	.083	.080	
33	0° 0'	1° 44'	3° 28'	5° 12'	7°	9°	10°	12°	14°	15°	17°	18°	20°	22°	23°	24°	
	.092	.092	.091	.091	.090	.089	.087	.086	.084	.082	.080	.078	.076	.074	.073	.069	
36	0° 0'	1° 36'	3° 11'	4° 46'	6°	8°	9°	11°	13°	14°	16°	17°	18°	20°	21°	23°	
	.077	.077	.077	.076	.076	.076	.075	.074	.073	.072	.070	.069	.067	.066	.064	.061	
40	0° 0'	1° 28'	2° 52'	4° 17'	5° 43'	7°	9°	10°	11°	13°	14°	15°	17°	18°	19°	21°	
	.063	.062	.062	.062	.061	.060	.060	.059	.058	.057	.056	.055	.054	.053	.051	.051	
45	0° 0'	1° 16'	2° 33'	3° 49'	5° 5'	6°	8°	9°	10°	11°	13°	14°	15°	16°	17°	18°	
	.049	.049	.049	.049	.049	.048	.048	.047	.047	.047	.046	.045	.045	.044	.043	.042	
50	0° 0'	1° 9'	2° 17'	3° 26'	4° 34'	5° 43'	7°	8°	9°	10°	11°	12°	14°	15°	16°	18°	
	.040	.040	.040	.040	.040	.039	.039	.039	.039	.038	.038	.037	.037	.036	.036	.035	
55	0° 0'	1° 2'	2° 5'	3° 7'	4° 10'	5° 9'	6°	7°	8°	9°	10°	11°	12°	13°	14°	15°	
	.033	.033	.033	.033	.033	.032	.032	.032	.032	.032	.032	.031	.031	.031	.030	.030	
60	0° 0'	0° 57'	1° 55'	2° 53'	3° 50'	4° 46'	5° 43'	7°	8°	9°	10°	11°	12°	13°	14°	15°	
	.028	.028	.028	.028	.027	.027	.027	.027	.027	.027	.027	.026	.026	.026	.026	.026	
70	0° 0'	0° 49'	1° 38'	2° 34'	3° 16'	4° 5'	4° 54'	5° 43'	7°	7°	8°	9°	10°	11°	11°	13°	
	.020	.020	.020	.020	.020	.020	.020	.020	.020	.020	.020	.020	.020	.020	.019	.019	

\* For foot-candles on the vertical plane by a source of 100 candlepower use the horizontal distance

I-5A

CALCULATIONS \*

TWEEN LIGHT RAY AND VERTICAL.

PLANE PRODUCED BY A SOURCE OF 100 CANDLEPOWER.

FROM UNIT — FEET

16	17	18	19	20	22	24	26	28	30	32	34	36	40	44	48	52
76°	77°	78°	78°	79°	80°	81°	81°	82°	82°	83°	83°	84°	84°	85°	85°	86°
.090	.075	.064	.055	.047	.037	.028	.022	.018	.015	.012	.010	.008	.006	.005	.004	.003
73°	74°	74°	75°	76°	77°	78°	79°	80°	81°	82°	82°	83°	84°	84°	85°	85°
.106	.090	.077	.066	.057	.044	.034	.027	.022	.017	.015	.012	.010	.008	.006	.005	.004
69°	71°	71°	72°	73°	75°	76°	77°	78°	79°	80°	80°	81°	82°	83°	83°	84°
.120	.102	.088	.076	.066	.051	.040	.032	.026	.021	.017	.015	.012	.010	.009	.007	.005
66°	68°	69°	70°	71°	72°	74°	75°	76°	77°	78°	79°	80°	81°	81°	82°	82°
.131	.113	.097	.084	.074	.057	.045	.036	.029	.024	.020	.017	.014	.010	.008	.006	.005
63°	65°	66°	67°	68°	70°	72°	73°	74°	75°	76°	77°	78°	79°	80°	81°	81°
.140	.121	.106	.091	.080	.063	.050	.040	.032	.026	.022	.019	.016	.012	.009	.007	.006
61°	62°	63°	65°	66°	68°	69°	71°	72°	73°	74°	75°	76°	77°	78°	79°	80°
.146	.126	.110	.097	.085	.067	.053	.043	.035	.029	.025	.021	.018	.013	.010	.008	.006
58°	60°	61°	62°	63°	66°	67°	69°	70°	72°	73°	74°	74°	76°	77°	78°	79°
.149	.130	.115	.101	.089	.071	.057	.046	.038	.032	.027	.022	.019	.014	.011	.009	.007
56°	57°	59°	60°	61°	63°	65°	67°	69°	70°	71°	72°	73°	75°	76°	77°	78°
.150	.132	.117	.104	.092	.074	.060	.049	.040	.034	.028	.024	.021	.015	.012	.009	.007
53°	55°	56°	58°	59°	61°	63°	65°	67°	68°	69°	71°	72°	73°	75°	76°	77°
.150	.133	.119	.106	.094	.076	.062	.051	.043	.036	.030	.026	.022	.017	.013	.010	.008
51°	53°	54°	56°	57°	59°	62°	63°	65°	67°	68°	69°	70°	72°	74°	75°	76°
.148	.133	.119	.106	.096	.078	.064	.053	.044	.037	.032	.027	.023	.017	.013	.011	.008
49°	51°	52°	54°	55°	58°	60°	62°	63°	65°	66°	68°	69°	71°	72°	74°	75°
.146	.131	.118	.107	.096	.079	.065	.054	.046	.039	.033	.028	.024	.018	.014	.011	.009
47°	49°	50°	52°	53°	56°	58°	60°	62°	63°	65°	66°	67°	69°	71°	73°	74°
.142	.129	.117	.106	.096	.079	.066	.055	.047	.040	.034	.029	.025	.019	.015	.012	.009
45°	47°	48°	50°	51°	54°	56°	58°	60°	62°	63°	65°	66°	68°	70°	72°	73°
.138	.126	.115	.105	.095	.080	.067	.056	.048	.041	.035	.030	.026	.020	.016	.013	.010
43°	45°	47°	48°	50°	52°	55°	57°	59°	60°	62°	63°	65°	67°	69°	71°	72°
.134	.122	.112	.103	.094	.079	.069	.057	.048	.042	.036	.031	.027	.021	.016	.013	.010
42°	43°	45°	47°	48°	51°	53°	55°	57°	59°	61°	62°	63°	66°	68°	69°	71°
.129	.119	.109	.100	.092	.079	.067	.057	.049	.042	.036	.032	.028	.021	.017	.013	.011
40°	42°	43°	45°	46°	49°	52°	54°	56°	58°	59°	61°	62°	65°	67°	68°	70°
.124	.115	.106	.098	.090	.077	.066	.057	.049	.042	.037	.032	.028	.022	.017	.014	.011
39°	40°	42°	44°	45°	48°	50°	52°	54°	56°	58°	60°	61°	63°	66°	67°	69°
.119	.111	.103	.095	.088	.076	.066	.057	.049	.043	.037	.033	.029	.022	.018	.014	.012
37°	39°	41°	42°	44°	46°	49°	51°	53°	55°	57°	58°	60°	62°	64°	66°	68°
.114	.107	.099	.092	.086	.075	.065	.056	.049	.043	.038	.033	.029	.023	.018	.015	.012
36°	38°	39°	41°	42°	45°	47°	50°	52°	54°	56°	57°	59°	61°	63°	65°	67°
.109	.102	.096	.091	.084	.073	.064	.056	.049	.043	.038	.033	.029	.023	.019	.015	.012
35°	36°	38°	40°	41°	44°	46°	49°	51°	53°	54°	56°	57°	60°	62°	64°	66°
.105	.098	.092	.087	.081	.071	.063	.055	.049	.043	.038	.033	.030	.023	.019	.015	.013
34°	35°	37°	38°	40°	43°	45°	47°	49°	51°	53°	55°	56°	59°	61°	63°	65°
.100	.094	.089	.084	.079	.070	.061	.054	.048	.042	.037	.033	.030	.024	.019	.016	.013
33°	34°	36°	37°	39°	41°	44°	46°	48°	50°	52°	54°	55°	58°	60°	62°	64°
.096	.091	.086	.081	.076	.068	.060	.053	.047	.042	.037	.033	.030	.024	.019	.016	.013
31°	32°	34°	35°	37°	39°	42°	44°	46°	48°	50°	52°	53°	56°	58°	61°	63°
.087	.083	.079	.075	.071	.064	.057	.051	.046	.041	.037	.033	.030	.024	.020	.016	.013
28°	30°	31°	32°	34°	36°	39°	41°	43°	45°	47°	49°	50°	53°	56°	58°	60°
.077	.073	.070	.067	.064	.058	.053	.048	.043	.039	.036	.032	.029	.024	.020	.017	.014
26°	27°	29°	30°	31°	34°	36°	38°	40°	42°	44°	46°	47°	50°	53°	56°	58°
.067	.063	.062	.060	.058	.053	.049	.045	.041	.037	.034	.031	.028	.024	.020	.017	.014
24°	25°	27°	28°	29°	31°	34°	36°	38°	40°	42°	43°	45°	48°	51°	53°	55°
.059	.057	.055	.053	.052	.048	.044	.041	.038	.035	.032	.030	.027	.023	.020	.017	.014
22°	23°	24°	25°	27°	29°	31°	33°	35°	37°	39°	40°	42°	45°	48°	50°	52°
.050	.049	.047	.046	.045	.042	.039	.037	.034	.032	.030	.028	.026	.022	.019	.016	.014
20°	21°	22°	23°	25°	28°	30°	32°	34°	36°	38°	39°	41°	44°	47°	49°	51°
.041	.040	.040	.039	.038	.036	.034	.032	.030	.028	.027	.025	.024	.021	.018	.016	.014
18°	19°	20°	21°	22°	24°	26°	27°	29°	31°	33°	34°	36°	39°	41°	44°	46°
.035	.034	.033	.033	.032	.031	.029	.028	.027	.025	.024	.023	.021	.019	.017	.015	.013
16°	17°	18°	19°	20°	22°	24°	25°	27°	29°	30°	32°	33°	36°	39°	41°	43°
.029	.029	.028	.028	.027	.026	.025	.024	.023	.022	.021	.020	.019	.018	.016	.014	.013
15°	16°	17°	18°	19°	20°	22°	23°	25°	27°	28°	30°	31°	34°	38°	41°	43°
.028	.028	.024	.024	.024	.023	.022	.021	.021	.020	.019	.018	.018	.016	.015	.013	.012
13°	14°	14°	15°	16°	17°	19°	20°	22°	23°	24°	26°	27°	30°	33°	34°	37°
.019	.019	.019	.018	.018	.018	.018	.017	.016	.016	.015	.015	.014	.013	.012	.012	.011

as the height and the vertical distance as the h:

TABLE  
POINT-BY-POINT

UPPER FIGURES — ANGLE BE-  
LOWER FIGURES — FOOT-CANDLES ON A HORIZONTAL

Height of Light Source above Surface to be Lighted — Feet	80	0° 0'	0° 43'	1° 26'	2° 9'	2° 52'	3° 35'	4° 17'	5° 0'	5° 43'	6°	7°	8°	9°	10°	11°
	100	0° 0'	0° 34'	1° 9'	1° 43'	2° 17'	2° 52'	3° 26'	4° 0'	4° 34'	5° 9'	5° 43'	6°	7°	8°	9°
	125	0° 0'	0° 28'	0° 55'	1° 22'	1° 50'	2° 17'	2° 45'	3° 12'	3° 40'	4° 7'	4° 34'	5° 2'	5° 29'	6°	7°
	150	0° 0'	0° 23'	0° 46'	1° 9'	1° 32'	1° 55'	2° 17'	2° 40'	3° 2'	3° 26'	3° 49'	4° 11'	4° 34'	4° 57'	5° 20'
	175	0° 0'	0° 20'	0° 39'	0° 59'	1° 19'	1° 38'	1° 58'	2° 17'	2° 37'	2° 57'	3° 16'	3° 36'	3° 55'	4° 15'	4° 34'
	200	0° 0'	0° 17'	0° 34'	0° 52'	1° 9'	1° 26'	1° 43'	2° 0'	2° 17'	2° 35'	2° 52'	3° 9'	3° 26'	3° 43'	3° 0'
		15.825	15.616	15.610	15.592	15.567	15.534	15.494	15.447	15.393	15.345	15.270	15.186	15.093	14.930	14.817
		10.000	9.999	9.994	9.987	9.976	9.963	9.946	9.927	9.905	9.880	9.852	9.826	9.785	9.761	9.712
		6.400	6.399	6.398	6.391	6.390	6.381	6.378	6.370	6.36	6.351	6.339	6.326	6.313	6.297	6.286
		4.444	4.444	4.443	4.442	4.440	4.437	4.434	4.430	4.421	4.416	4.415	4.409	4.402	4.395	4.387
		3.265	3.265	3.265	3.264	3.263	3.261	3.260	3.258	3.255	3.252	3.249	3.246	3.242	3.238	3.234
		2.500	2.500	2.500	2.499	2.499	2.498	2.497	2.495	2.494	2.492	2.490	2.489	2.487	2.484	2.482

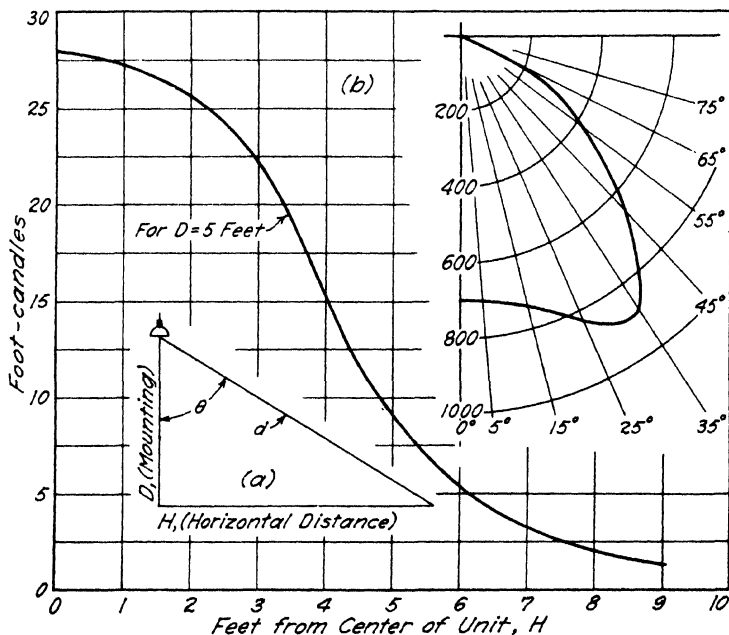

Fig. 4-5. Point-by-point method of determining illumination on a horizontal surface. (a) Angle and distances considered. (b) Distribution curve of equipment and graph of foot-candles on the horizontal.

shows a candlepower distribution curve with the corresponding graph of the foot-candle distribution on the horizontal plane.

When specialized equipment is to be used and the amount of reflected light from surrounding surfaces may be neglected, the reflector must be studied not only from the standpoint of efficiency and light control, but also from the standpoint of candlepower distribution. With such a curve it is possible to compute the illumination at any

I-5B

CALCULATIONS \*

TWEEN LIGHT RAY AND VERTICAL.

PLANE PRODUCED BY A SOURCE OF 100,000 CANDLEPOWER.

11°	12°	13°	13°	14°	15°	17°	18°	19°	21°	22°	23°	24°	27°	29°	31°	33°
14.748	14.623	14.491	14.412	14.269	14.031	13.708	13.441	13.161	12.789	12.489	12.182	11.870	11.138	10.492	9.848	9.212
9°	10°	10°	11°	11°	12°	14°	15°	16°	16°	18°	19°	20°	22°	24°	26°	27°
9.630	9.571	9.539	9.474	9.439	9.330	9.175	9.048	8.914	8.819	8.627	8.475	8.319	7.993	7.654	7.305	7.014
7°	8°	8°	9°	9°	10°	11°	12°	13°	14°	14°	15°	16°	18°	19°	21°	23°
6.250	6.223	6.209	6.178	6.163	6.113	6.059	6.001	5.938	5.872	5.828	5.756	5.681	5.521	5.384	5.207	5.022
6°	6°	7°	7°	8°	8°	9°	10°	11°	11°	12°	13°	14°	15°	16°	18°	19°
4.370	4.364	4.349	4.342	4.324	4.309	4.280	4.249	4.216	4.195	4.158	4.119	4.078	4.008	3.984	3.834	3.751
5° 13'	5° 33'	6°	6°	7°	7°	8°	8°	9°	10°	10°	11°	12°	13°	14°	15°	17°
3.225	3.220	3.213	3.210	3.199	3.191	3.174	3.164	3.145	3.124	3.112	3.089	3.064	3.024	2.980	2.933	2.869
4° 34'	4° 52'	5° 9'	5° 26'	5° 43'	6°	7°	7°	8°	9°	9°	10°	10°	11°	12°	14°	15°
2.476	2.473	2.470	2.468	2.463	2.457	2.446	2.440	2.428	2.415	2.408	2.393	2.385	2.360	2.332	2.294	2.262

point from one or more units. The diameter of the light source must be not more than one-fifth the distance from the point to the source.

Since the task of solving for the horizontal illumination is laborious, Table I-5 may be used to reduce the labor necessary in determining isolux or isofoot-candle diagrams. The table is based on unit value (100 c-p.), and covers a wide range of mounting heights and horizontal distances. There is also included a table which is based on a unit value of 100,000 c-p. to be used for large equipment mounted high above the horizontal surface.

*Example a.* Determine the horizontal illumination 8 ft. from a unit if the mounting height is 10 ft. and the intensity at this angle is 600 c-p.

From Table I-5:

angle 39°  
foot-candles 0.476

for each 100 c-p.; therefore, for 600 c-p. the illumination will be

$$\frac{600}{100} \times 0.476 = 2.86 \text{ ft-c.}$$

The following example gives the method for determining the isolux diagram of the specific equipment shown in Fig. 4-5b. For uniform illumination along the line of symmetry of a group of units, the spacing should be such that the horizontal foot-candle curves cross at 50 per cent of the maximum foot-candle value.

*Example b.* With the equipment mounted 5 ft. above the surface, a surface 8 ft. wide is to be lighted by a reflector having the distribution curve shown in Fig. 4-5b. Determine the spacing and the isofoot-candle diagram.

From Table I-5 read the degrees and foot-candle factor.

From Fig. 4-5b read the candlepower intensity at the angle determined from Table I-5.

By using the candlepower multiplied by 0.01, which is in turn multiplied by the foot-candle factor, the illumination on the horizontal and along the center line of the lamps is found. The listing below gives the foot-candles for the equipment considered.

TABLE COMPUTED FROM TABLE I-5 AND FIG. 4-5b

Distance (feet)	0	1	2	3	4	5	6	7	8	9
Degrees	0	11	22	31	39	45	50	54	58	61
Factor	4.000	3.771	3.202	2.522	1.904	1.414	1.050	0.785	0.595	0.458
Candlepower	700	720	800	880	800	650	500	430	320	280
Foot-candles	28	27.1	25.6	22.2	15.2	9.2	5.3	3.4	1.9	1.3

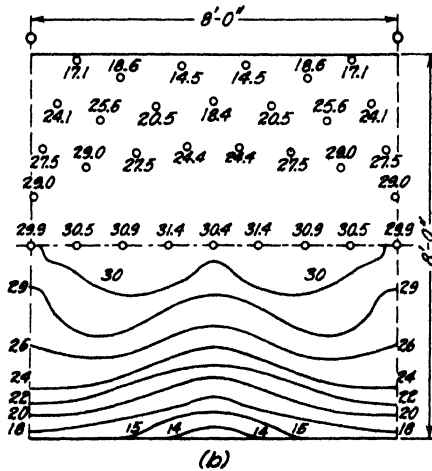
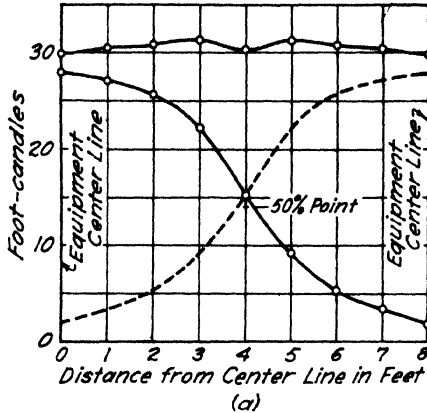

FIG. 5-5. (a) Horizontal foot-candles. (b) Isofoot-candle plot.

Figure 5-5a shows the resultant foot-candle distribution along the center line of the table if the units are spaced on 8-ft. centers, crossing at approximately the 50 per cent point. Figure 5-5b shows the location of specific points on one-half of the table and the isofoot-candle lines on the other half.

The points are obtained by adding the foot-candles which occur at the point from the various units. Since only two units are considered, these points

are at the intersection of concentric foot-candle circles from a point directly below two mounting points of the units.

If the candlepower distribution curve is given for one size of lamp but another is to be used, it is usually sufficiently accurate to assume that the intensity is directly proportional to the lumen output of the lamps. This will not be exactly true if the light center is shifted when the lamps are interchanged.

**6. Using the Distribution Curve.** The distribution curve does not represent the quantity of light that may be expected to be delivered from the equipment; it represents the candlepower and the various directions in one plane. The polar distribution curve is in one plane

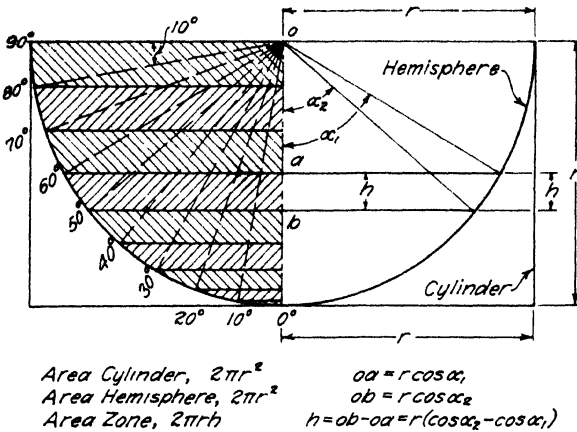

Fig. 6-5. Area of zones subtended by equal angles.

which passes through the candlepower distribution solid, and the analysis of results is three-dimensional. Since most equipment has axial symmetry, only that type will be considered here and the asymmetrical equipment will be discussed later.

Since one of the main uses of the distribution curve is the comparing of equipment for a given service, it is necessary to be able to analyze the total lumens delivered and the quantity delivered in each specific direction. Figure 6-5 shows a hemisphere with a cylinder circumscribed. Since the cylinder is a solid the quantitative solution of which is familiar, it makes an easy guide for the determination of surface values on zone and sphere surfaces. The hemisphere has been divided into zones each subtending angles of  $10^\circ$ . By inspection of the projected surface of the zones in the plane of Fig. 6-5, it will be seen that these zones do not represent equal areas and that the escape



of light from a source of uniform distribution would not be the same through each zone. Those zones subtending equal angles near the horizontal permit the greater part of the light to escape. The surfaces of the zones and the hemisphere compare as follows:

- a. The area of the circumscribed cylinder,

$$A_{cc} = 2\pi r^2$$

- b. The area of the hemisphere,

$$A_{hs} = 2\pi r^2$$

TABLE II-5A  
ZONAL FACTORS FOR DETERMINING LUMENS FOR 5° ZONES

Zone		Candlepower Angle		
Lower Hemisphere	Upper Hemisphere	Lower Hemisphere	Upper Hemisphere	Lumen Constant
0°-5°	175°-180°	2.5°	177.5°	0.0239
5°-10°	170°-175°	7.5°	172.5°	0.0715
10°-15°	165°-170°	12.5°	167.5°	0.118
15°-20°	160°-165°	17.5°	162.5°	0.165
20°-25°	155°-160°	22.5°	157.5°	0.210
25°-30°	150°-155°	27.5°	152.5°	0.253
30°-35°	145°-150°	32.5°	147.5°	0.294
35°-40°	140°-145°	37.5°	142.5°	0.334
40°-45°	135°-140°	42.5°	137.5°	0.370
45°-50°	130°-135°	47.5°	132.5°	0.404
50°-55°	125°-130°	52.5°	127.5°	0.435
55°-60°	120°-125°	57.5°	122.5°	0.462
60°-65°	115°-120°	62.5°	117.5°	0.486
65°-70°	110°-115°	67.5°	112.5°	0.506
70°-75°	105°-110°	72.5°	107.5°	0.523
75°-80°	100°-105°	77.5°	102.5°	0.535
80°-85°	95°-100°	82.5°	97.5°	0.543
85°-90°	90°-95°	87.5°	92.5°	0.548

- c. The area of the zone,

$$A_z = 2\pi rh$$

The area of the sphere is the same as the area of the surface of the circumscribed cylinder with the same altitude. In trigometric terms, the area of the zone will be

$$2\pi r^2 (\cos \alpha_2 - \cos \alpha_1)$$

The functions of the angles will be found in the Appendix and in Tables II-5A and II-5B the zonal factors for the 5° and 10° zones are given

for convenience. The average candlepower of the zone must be multiplied by these factors to obtain the lumens represented by the zone. An inspection of the zonal factors shows that the effectiveness of transmission of flux is approximately as follows:

0°- 45°	15 %
45°-135°	70 %
135°-180°	15 %

The 45°-135° region is the most important in the equipment for controlling the efficiency.

Another way of determining the flux in any zone or group of zones is to use the candlepower scale of the distribution curve. If, in any 10°

TABLE II-5B  
ZONAL FACTORS FOR DETERMINING LUMENS FOR 10° ZONES

Zone		Candlepower Angle		
Lower Hemisphere	Upper Hemisphere	Lower Hemisphere	Upper Hemisphere	Lumen Constant
0°-10°	170°-180°	5°	175°	0.0954
10°-20°	160°-170°	15°	165°	0.283
20°-30°	150°-160°	25°	155°	0.463
30°-40°	140°-150°	35°	145°	0.628
40°-50°	130°-140°	45°	135°	0.774
50°-60°	120°-130°	55°	125°	0.897
60°-70°	110°-120°	65°	115°	0.992
70°-80°	100°-110°	75°	105°	1.058
80°-90°	90°-100°	85°	95°	1.091

zone, a measurement of the horizontal distance between the vertical axis and the point where the candlepower curve crosses the center of that zone is increased by 10 per cent and multiplied by the candlepower scale, the result will be the lumens in that zone. If several zones are considered, the sum of the individual horizontal distances is increased by 10 per cent and multiplied by the scale. This method is accurate within 0.2 of 1 per cent, neglecting the possible error of measurement.

*Example c.* Using the method of measuring horizontal distances from Fig. 2-5, determine the lumens in the 90°-120° zone. (1) Determine the value by one measurement; (2) by measurements of 10° zones; (3) check by the use of zonal factors.

The scale is 400 c-p. to 43 units.

By measurements:

DISTRIBUTION CURVES

Angle	Units	Candlepower
95°	49	456
105°	101	980
115°	113	1170

(Units + 10%)

Angle	Units	Units + 10%	× scale = lumens	Candlepower	Factor	Lumens
95°	49	53.9	503	456	1.0911	497.5
105°	101	111.0	1032	980	1.0579	1036.7
115°	113	124.3	1158	1170	0.9926	1161.1
	<u>263</u>		<u>2693</u>			<u>2695.3</u>

$$263 \times 1.1 \times \frac{400}{43} = 2692 \text{ l.}$$

- (1) By one measurement at 105° 1032 l.
- (2) By 10° zones (individual) 2693 (summation) 2692
- (3) By zonal factors 2695 From report (Fig. 2-5) 2708

By considering the zone subtended by 30°, the result given under (1) as 1032 is far from correct. Where the curve is changing rapidly, the size of the zones should be limited.

Figure 7-5 shows two distribution curves having the same total lumens of light. The difference in the curves also shows that the area of the distribution curve is very misleading in estimating the output from equipment.

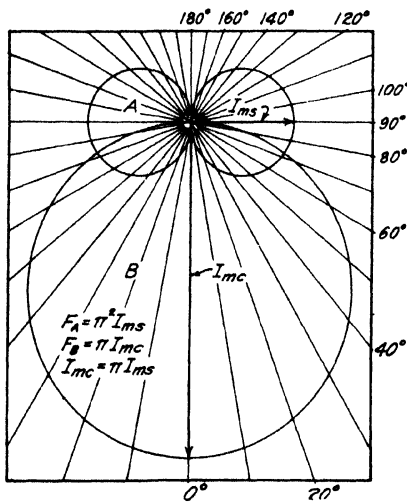

FIG. 7-5. Distribution curves for equipment having equal lumen outputs.

**7. Theoretical Distribution Curves.**<sup>1</sup> Many of the luminaires have distribution curves which approximate theoretical curves, but the most important consideration of the theoretical curve is its effective illumination upon the work surface. The inverse square law has been so thoroughly stressed that many attempt to analyze all lighting installations by this law. There are four cases of particular interest:

- I. Uniform distribution
- II. Cosine distribution
- III. Sine distribution
- IV. Large surface sources

Case I concerns the light from a point source in which the distribution is uniform as shown in Fig. 8-5a. A distribution of this type will be obtained from a completely enclosing spherical globe which gives a uniform illumination at a fixed distance in every direction. For this type of equipment

$$I_{\theta} = I_m$$

$$F = 4\pi I_m$$

$$E = \frac{I_m}{d^2}$$

where  $d$  is distance.

The illumination at any point is inversely proportional to the square of the distance of the point from the source. Since the distance is

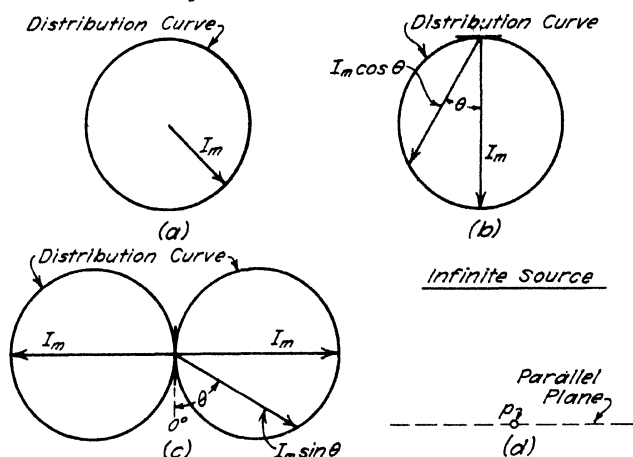

FIG. 8-5. Theoretical distribution curves.

usually more than five times the diameter of the source, this expression is found to be satisfactory in a general discussion.

Case II is illustrated by Fig. 8-5b which shows the distribution curve representing the cosine law. Normally direct lighting equipment follows this law. For example, the curve of an RLM reflector (Reflector and Lamp Manufacturers specification) is very much like that of Fig. 8-5b. For this type of equipment

$$I_{\theta} = I_m \cos \theta$$

$$F = \pi I_m$$

$$E = \frac{Q}{d^2} = \frac{BA}{d^2}$$

where  $Q$  is the total quantity of light, brightness times area, and  $d$  is the distance to the edge of the disc, not normal to the equipment

as in the first case. It will be well to compare the distributions of Case I and Case II equipment (one unit radius and concentrated).

Assume that we have two points at distances of 1 and 5 units, respectively, from each of two sources. The first source will have uniform distribution (Case I); the other will have cosine distribution (Case II). The illumination directly under the source will be:

*Case I.* By the square law, the illumination at 1 unit will be 25 times more than at 5 units.

*Case II.* In the second case the illumination will be as 26 to 2, or 13 times more at 1 unit than at 5 units, for a disc with unit radius.

This difference of analysis may enter into measurements from any diffusing surface if the area is large and the measurements are made near the surface. If the source is small, the inverse square law is sufficiently accurate.

*Case III.* Figure 8-5c shows the sine type of distribution. This law applies as a close approximation to the actual distribution of cylindrical tubes that are being used as sources and in which the diameters are small compared to the length. For this type of distribution

$$I_{\theta} = I_m \sin \theta$$

$$F = \pi^2 I_m \text{ per unit length}$$

$$E = \frac{Q}{2d} = \frac{BA}{2d}$$

or the illumination varies inversely as the distance to the point. The square law in this instance is not even a crude approximation.

*Case IV.* Figure 8-5d represents the condition of an infinite plane source radiating light to a parallel plane. Skylights and indirect lighting installations approximate this case, for in each instance the source of light is very large and the surface approximates one of perfect diffusion. The illumination on a parallel plane from an infinite source is

$$E = \pi B$$

where  $B$  is the source brightness. With lighting of this type, the illumination is independent of the distance between the point and the source. This explains the lack of importance of ceiling height in indirect illumination.

**8. Projector and Open Types of Floodlights.**<sup>3</sup> Figure 9-5 gives a typical report for a specified test on a floodlight projector. The information given is self-explanatory and the use of the embodied information will be discussed in the following articles.

FLOODLIGHT PROJECTOR

Rendered to: -----  
 REFLECTOR: Shape-Front section parabolic, center section spherical, rear section parabolic.  
 Material - Mirrored Glass.  
 COVER GLASS: Lightly stippled lens.  
 LAMP: 1500 Watts; 115 Volts; 33,000 Lumens; R552 Clear, Gas-filled Bulb; C7A Filament; Mogul Base; General Service.  
 Filament Dimensions - 25.9mm. high x 34.9mm. wide. Light center length - 9 1/4 inches.  
 Diameter - 19 inches.

PROJECTOR DATA

Total Lumens	25650	Beam Efficiency	48.5%
Total Efficiency	71.5%	Beam Spread, Vertical	38.5%
Beam Lumens	15990	Beam Spread, Horizontal	44%
Maximum Beam Candelper	117000		

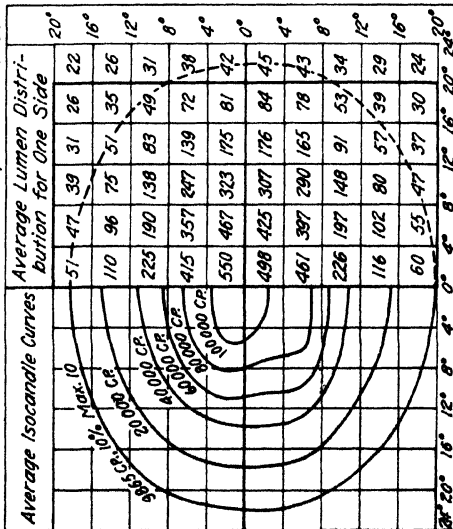

Total Lumen Distribution (Average for One Side)		70°	60°	50°	40°	30°	20°	10°	0°	10°	20°	30°	40°	50°	60°	70°
15	13	11	9	7	4	2										
42	37	29	17	10	5	3										
73	72	67	47	22	7	3										
95	91	85	76	44	13	4										
128	116	101	89	63	23	5										
4072							137	100	76	34	5					
							181	105	80	38	6					
							191	108	80	40	7					
							4219									
							149	100	78	34	6					
							178	146	117	90	59	22	4			
							124	111	99	75	38	12	3			
							91	85	70	41	18	6	2			
							42	36	24	13	7	4	2			
							8	8	6	5	4	3	1			

Angles	Candlepower Distribution Through Axis	
	Horizontal Plane	Vertical Plane
75°	164 L	136
65°	525	308
55°	2 100	1 290
45°	3 600	2 450
35°	4 330	3 200
25°	7 000	4 350
15°	33 800	19 000
5°	107 000	93 000
0°	117 000	117 000
5°	104 000 R	94 000
15°	35 000	20 100
25°	7 300	5 900
35°	4 480	4 180
45°	3 900	3 000
55°	2 350	1 940
65°	540	288
75°	185	134

Fig. 9-5. Typical photometric report on a floodlight.

The specifications in "Testing Procedure for Narrow Beam Enclosed Projectors" of the Illuminating Engineering Society (1935) are equally applicable to open- and broad-beam equipment. The National Electrical Manufacturers Association, through its committees, has expanded these specifications to include the latter two types of equipment. The data obtained from the *isocandle curves* and the *average lumen distribution diagram* are the bases for the determination of the

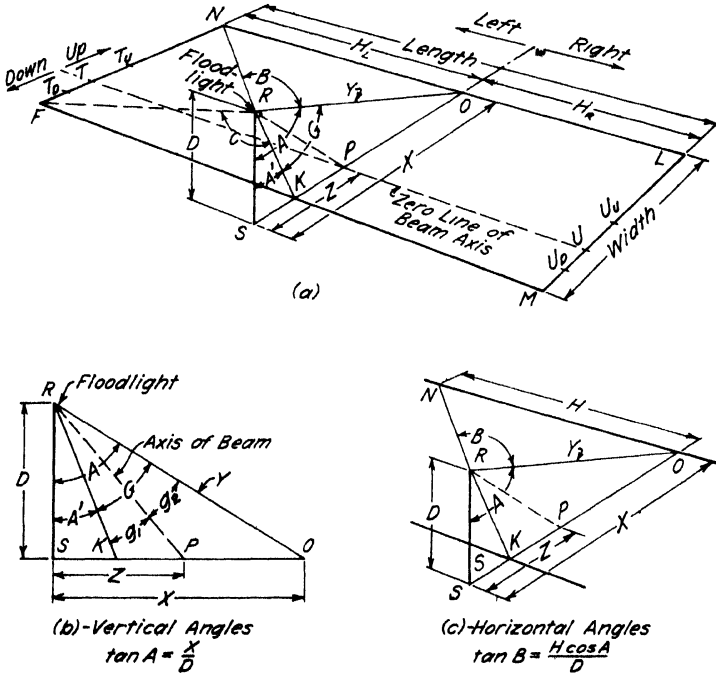

FIG. 10-5. Illumination of a surface by a floodlight. (a) General layout. (b) Vertical angles. (c) Horizontal angles.

effective lumens available from the unit studied in relationship to its directional distance from the surface to be lighted. The same procedure applies whether the surface is horizontal or vertical, and it will be outlined in detail in the solution of an example based upon the data given in Fig. 9-5.

**9. A Method for Determining the Effective Lumens Available from One Floodlight Unit.** The use of this method leads to a solution for the unit as a whole (average illumination) and does not enter into the details of specific illumination at a point. Though the method is

applicable to any unit, it is most effectively used with the open-type equipment in which the light is widely dispersed and the utilization factor is low. This method is of special value when the entire beam

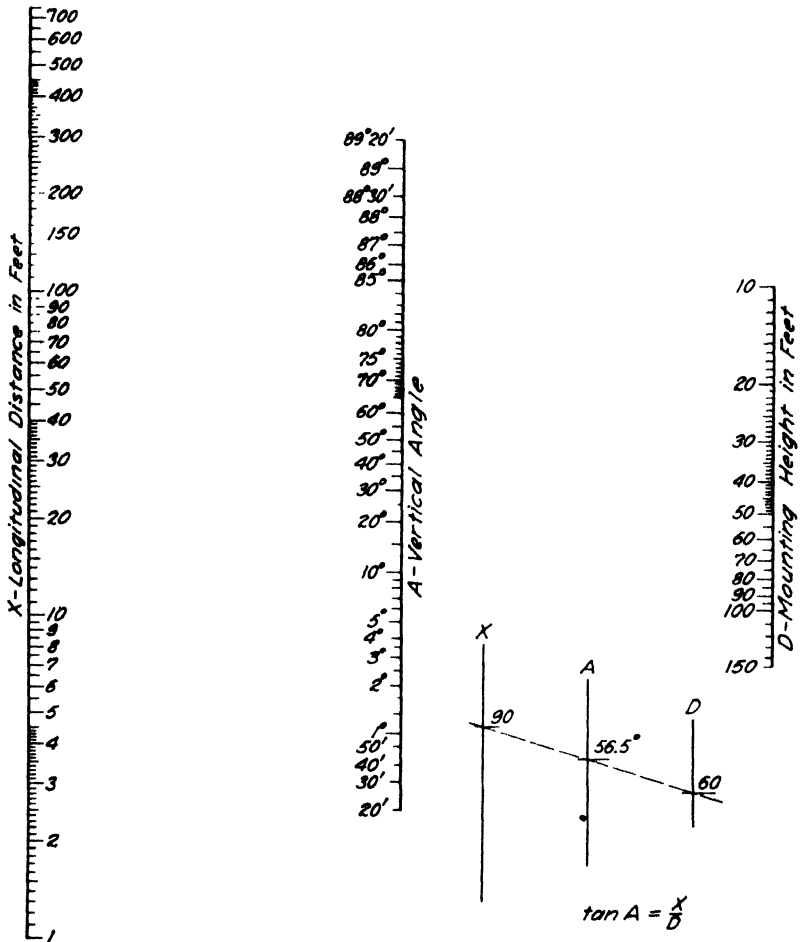

FIG. 11-5. Nomographic chart for vertical angles.

does not fall on the area involved and the effectiveness of part of the output of the floodlight must be determined.

By determining the vertical and horizontal angles to the points which will outline the area, it is possible to plot the surface on the *lumen distribution diagram* in such a manner that the lumens inside



the area may be determined. These lumens, divided by the area, will give the average illumination to be expected. By trying several tilting angles and several locations of the floodlight, it is possible to determine both the angle and position which will give the best utilization factor and greatest intensity. Tilting the beam shifts the entire diagram of the area the required number of degrees up or down on the *lumen distribution diagram*, whereas relocation of the floodlight mounting requires the relocation of the outline points on the diagram.

*Example d.* Using the data in Fig. 9-5 and those tabulated below, determine the lumens that are effective on the surface from a floodlight located 20 ft. from the side. The position of the equipment with respect to the center line of the surface is shown in Fig. 10-5.

$$\begin{array}{ll} FM = NL = 50 \text{ ft.} & SO = X = 90 \text{ ft.} \\ SR = D = 60 \text{ ft.} & FN = ML = 70 \text{ ft.} \\ OL = H_R = 20 \text{ ft.} & ON = H_L = 30 \text{ ft.} \end{array}$$

Every point on the periphery of the surface will be located by a vertical and a horizontal angle (see angle  $B$ , Fig. 10-5c); for instance, point  $N$  is located by the vertical angle  $A$ , which is given by

$$\tan A = \frac{X}{D} \text{ (general angle } \theta \text{)}$$

determined from computation and the table of angular functions in the Appendix or from the nomograph in Fig. 11-5. The horizontal angle will be angle  $B$ , which is given by

$$\tan B = \frac{H_L \cos A}{D} \text{ (general angle } \alpha \text{)}$$

determined from computation and the table of angular functions in the Appendix or from the nomograph in Fig. 12-5.

Applying these expressions, the value for

$$\tan A = \frac{90}{60} = 1.500$$

$$A = 56.5^\circ \text{ and } \cos A = 0.552$$

$$\tan B = \frac{30 \times 0.552}{60} = 0.276$$

$$B = 15.5^\circ$$

By using this procedure the vertical and horizontal angles are determined for the points at the four corners and on the zero line of the beam axis and four more points are needed to locate definitely the outline of the surface. By either the nomographs or computations, the values obtained may be listed as:

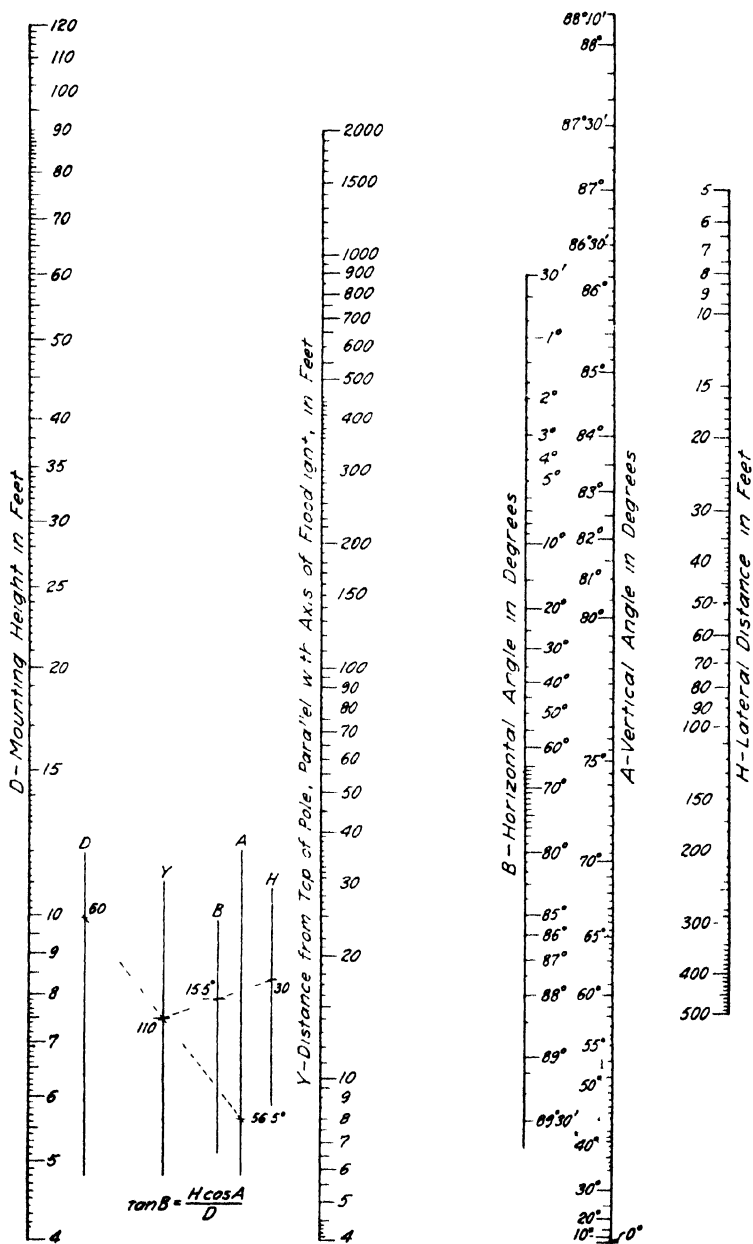

FIG. 12-5. Nomographic chart for horizontal angles.



		FIELD TO LEFT OF UNIT									
Vertical Zone	0°-4°	550	415	225	110	38	498	461	226	116	45
	4°-8°	467	357	190	96	35	425	397	197	102	41
	8°-12°	323	247	138	75	29	307	290	148	80	35
	12°-16°	175	139	83	51		176	165	91	57	28
	16°-20°	81	66	28	10		84	78	53	39	
	20°-24°	13	0					22	33	24	
		Summation of above lumens = 15,326									

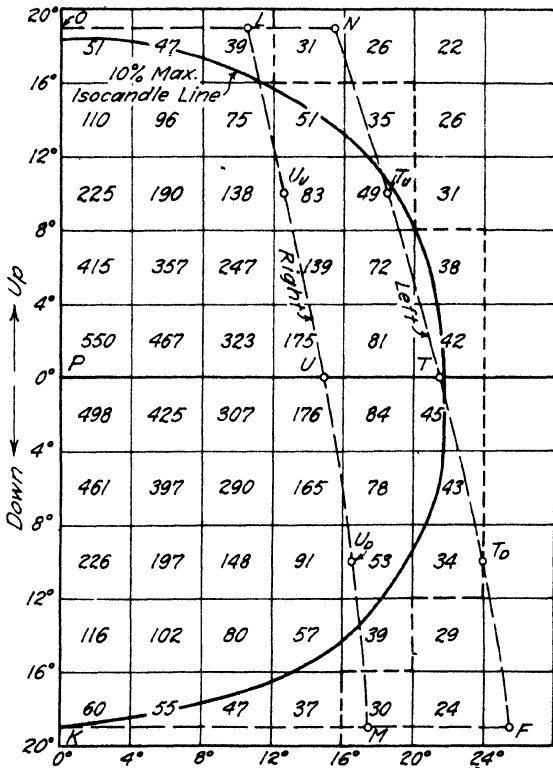

FIG. 13-5. Lumen distribution diagram for a floodlight with the surface represented upon it.

These lumens are effective and are included in the squares outlined by the dotted lines on Fig. 13-5. The amount of the lumens in the squares is approximately the same as the effective lumens within the isocandle line which marks the 10 per cent of the maximum candles. The exact number of lumens within the isocandle line could be obtained, or the surface could be located on the total lumen distribution diagram of Fig. 13-5 (which also includes the spill light). Dividing the lumens by the area

$$\frac{15,431}{180 \times 70} = 1.22 \text{ ft-c. (approximately)}$$

the average illumination on the surface. This does not, however, indicate the character of the light distribution. The foregoing method permits a rapid analysis of equipment, location, and adjustments in order to obtain the best utilization factor and intensity. If the area involves several floodlights, it is only necessary to add together the outputs of similarly located units plus the outputs of those units which need special treatment.

To control the uniform distribution of illumination, it is necessary to have enough units to give the required intensity. The intensity of the area covered by these units should be uniform. For the open type of floodlight unit, the spacing of the units should not be over one and one-half the mounting height, that is, when the mounting height is adjusted to cover in the direction of the vertical angle.

In Example *d*, the assumption was made that the floodlight was pointed directly across the area and that the angles  $g_1$  and  $g_2$  were equal. It was also assumed that the area was a regular polygon. This is not necessary, for any surface and any direction for the beam axis of the floodlight may be assumed. When a problem not conforming to symmetry is confronted, it is necessary to determine a large number of points, but the general method is the same.

The foregoing method is used only to determine the average illumination, and when it is necessary to know the illumination at specific points, the point-by-point method will be found satisfactory. If isolux plots are desired, however, the point-by-point method becomes extremely laborious; therefore, the method of plotting (foot-candle) recommended by the Sub-Committee of the National Electrical Manufacturers Association (1934) is satisfactory. That method is beyond the scope of this book.

**10. Asymmetric Reflectors.**<sup>4</sup> The most important information concerning asymmetrical equipment, like that of floodlighting equipment, is not the distribution curve but the lumen distribution diagram. Also as in floodlighting equipment, the *lumen distribution diagram* should be obtained from reliable tests, either through the manufacturer or through individually arranged tests. Though the specifications are primarily written for show-window reflectors and so specified by the Illuminating Engineering Society, the test method can be used for finding the average illumination and distribution of illumination of other asymmetric sources or prismatic plates. The resultant illumination may be found over the area of any restricted

horizontal or vertical surface. The Illuminating Engineering Society Report gives the vertical and horizontal angles to be used with the lumen factors for different areas in the diagram.

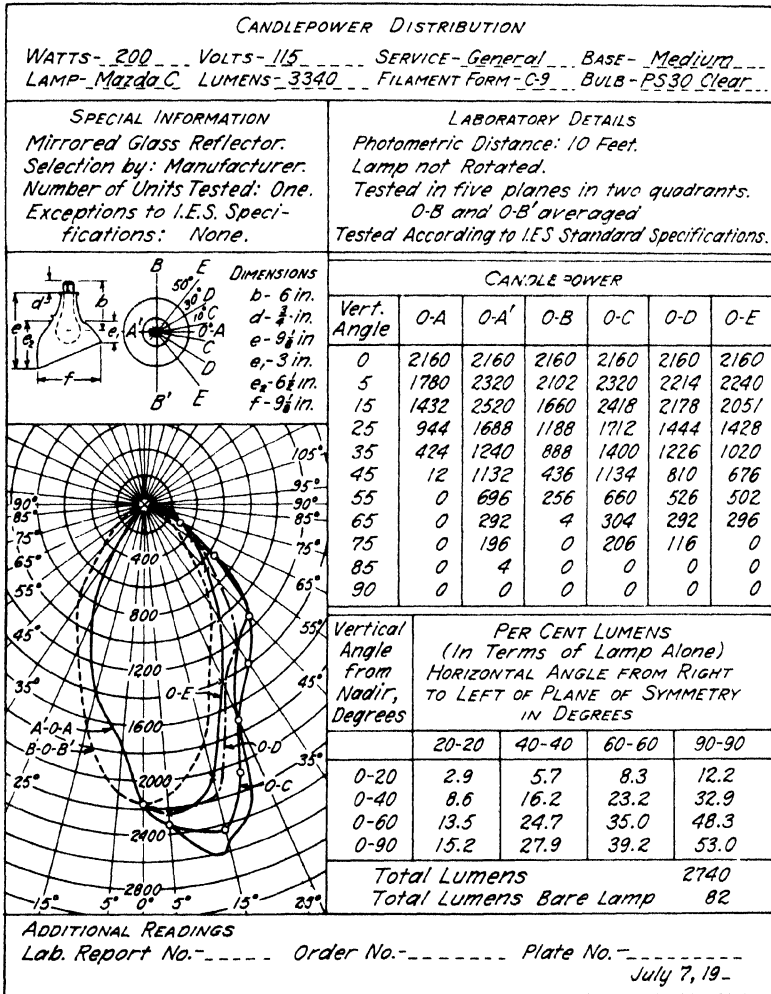

Fig. 14-5.<sup>4</sup> Typical photometric report for asymmetric reflectors.

Figure 14-5 shows a photometric report for a show-window reflector which is asymmetrical in its light distribution. The unit will, however, have light symmetry but with respect to a plane rather than an axis. This report is not convenient for the average user, because

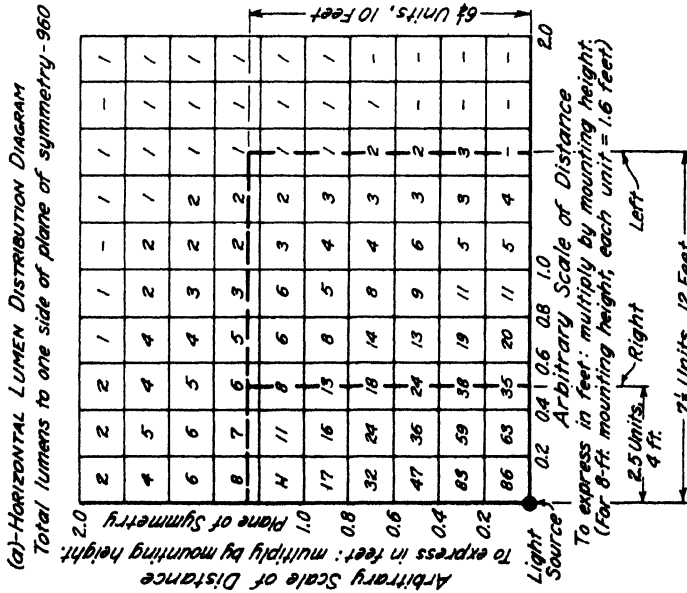
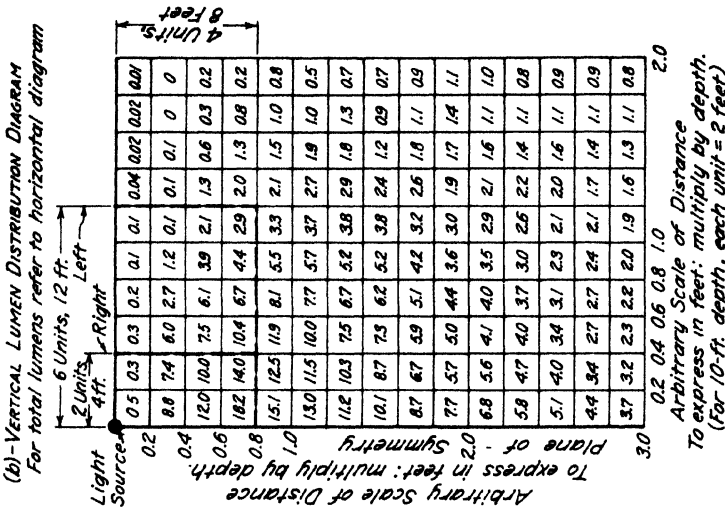

FIG. 15-5. Horizontal and vertical distribution diagrams for a show-window reflector. Window platform and back wall surfaces represented on the distribution diagrams.

it concerns only one of the diversified uses of this type of equipment. It gives a general description of the behavior of the unit, but only by very tedious calculations could the actual illumination in a show window be determined. *Lumen distribution diagrams* are very much more convenient and accurate and, if based on ratios of mounting height and depth, they are flexible and may be used for any application.

Figure 15-5 shows the horizontal and vertical lumen distribution diagram of an asymmetrical unit. The floor and back wall surface of a show window are plotted on this same diagram in order to determine

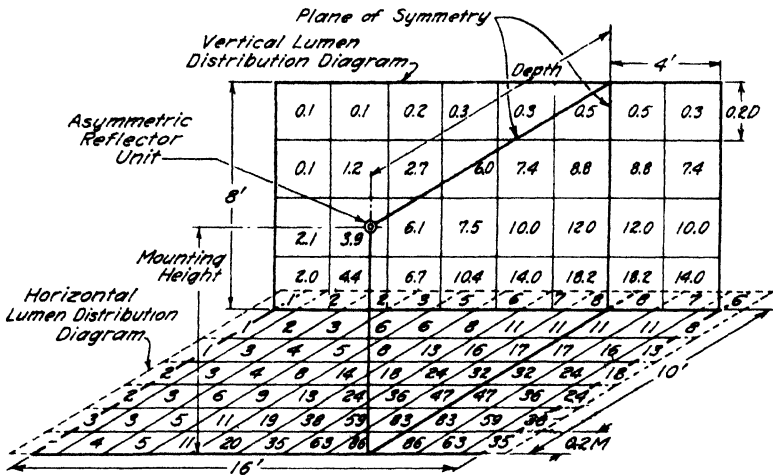

FIG. 16-5. Information from Fig. 15-5 shown in the horizontal and vertical plane of the show window.

the average foot-candles on the floor and back wall. The following example will clearly demonstrate one use to which the lumen distribution diagram may be put.

*Example e.* Determine the average illumination on the floor and back wall of a show window 16 ft. long, 10 ft. deep, and 8 ft. high if the unit is located 4 ft. from the right end of the show window.

Plot the floor and back wall surface on the lumen diagram (as in Example d). Since the mounting height is 8 ft. and the depth is 10 ft. the arbitrary scale may be converted into feet, drawing another diagram as in Fig. 16-5. A more simple method, however, is to convert the mounting height and depth into units on the arbitrary scale.

Fig. 15-5a	Horizontal Distribution
Right side	4 ft. or 2.5 units
Left side	12 ft. or 7.5 units
Depth	10 ft. or 6.25 units



Fig. 15-5b	Vertical Distribution
Right side	4 ft. or 2 units
Left side	12 ft. or 6 units
Mounting	8 ft. or 4 units

Plot these areas in their respective lumen distribution diagrams, and the lumens in each area will be the total lumens on the surface considered. This, divided by the square feet, will give the average illumination.

Location	Area	Lumens
Left floor	$10 \times 12 = 120$ sq. ft.	808.9
Right floor	$10 \times 4 = 40$ sq. ft.	557.5
Left wall	$12 \times 8 = 96$ sq. ft.	125.9
Right wall	$4 \times 8 = 32$ sq. ft.	71.2

$$\text{Illumination, floor: } \frac{1366.4}{160} = 8.54 \text{ ft-c.}$$

$$\text{Illumination, back wall: } \frac{197.1}{128} = 1.54 \text{ ft-c.}$$

The calculations in the example have been for one light only. If there is a single row or if there are several rows of light units, it is necessary only to determine the lumens for each unit and add them together; however, in this summation care must be taken to distinguish between the plane of symmetry of the reflector and the center line of the window (because these have a different relationship to each other in the calculation for each reflector).

Approximate values for the total number of lumens or the average illumination may be obtained by multiplying the contribution of a single unit (placed 25 per cent of the distance from the end) by the number of units in the show window. This method includes only the incident light and does not take into account the return from the window or the interreflection between the back wall, the floor, and the ends. This interreflection tends to increase the illumination. For the determination of average conditions of illumination depreciation must be considered.

**11. Summary.** The distribution curve for symmetrical equipment gives the necessary data for equipment analysis, but for floodlights and asymmetric equipment more information can be obtained from the lumen distribution diagram. The distribution curves and the lumen distribution diagrams are of special use wherever the unit can be considered a point source or where only a portion of the light from the unit falls upon the surface under consideration. Those specifying lighting installations are finding it increasingly important to be able to specify, with reasonable accuracy, various types of specialized light which may be analyzed by the methods given in this chapter.

## PROBLEMS

1. Solve by the point-by-point method and check with tables the horizontal and vertical illumination at a point 12 ft. from the unit shown in Fig. 2-5 when it is mounted 8 ft. above the horizontal plane containing the point.

2. Make an isofoot-candle plot for the surface in Example *b* if the equipment in Fig. 2-5 replaces that of Fig. 4-5.

3. The equipment in Fig. 4-5 was equipped with a 200-w. lamp having an output of 3700 lumens when the distribution curve was taken. Determine the efficiency of the luminaire from the curve given.

4. Determine the efficiency for the luminaire reported in Fig. 2-5 if a 200-w. lamp having an output of 3700 lumens is used instead of the 500-w. lamp.

5. Using the method of measured distances, determine the lumens in the 45- to 90-degree zone from the distribution curve given in Fig. 4-5. Check the results by using zonal factors.

6. Determine the lumen output, the candlepower, the horizontal and normal illumination for a point source of light with a maximum intensity of 1000 c-p. for a point 8 ft. below the source and located 14 ft. from a point directly below the source.

7. The source in problem 6 is replaced by one which obeys Lambert's Law. Determine the candlepower, lumen output, the normal and horizontal illumination. The maximum intensity is 1000 c-p.

8. The source in problem 6 is replaced by a tubular source with a maximum intensity of 1000 c-p. Determine the candlepower, lumen output, normal and horizontal illumination.

9. The ceiling in a very large room has a brightness of 250 ft-l. What will be the illumination at the center of the room if the ceiling height is (a) 10 ft., (b) 20 ft.?

10. Using the data of Example *d*, determine the lumens that are effective on the surface if the distance *Z* is increased 20 per cent by tilting the floodlight.

11. Using the data of Fig. 9-5, determine the average illumination on a surface 20 ft. by 20 ft. which is normal to the beam and 100 ft. distant. How many lumens will fall on the center four square feet of the sign?

12. Using the data given for the show-window equipment in Fig. 14-5 and Fig. 15-5, determine the average illumination on the (a) back wall, (b) floor, for a window 8 ft. long and 7 ft. deep with the unit mounted at the center of the window and 7 ft. from the floor.

## BIBLIOGRAPHY

1. E. B. ROSA, "Photometric Units and Nomenclature," *Bur. Standards Bul.*, v. 6, p. 543, 1910.
2. COMMITTEE REPORT, "Specifications for Testing Diffusing Type Inclosing Glassware," *I. E. S. Trans.*, v. 28, No. 6, pp. 479-493, June, 1933.
3. COMMITTEE REPORT, "Testing Procedure for Narrow Beam Inclosed Projectors," *I. E. S. Trans.*, v. 28, No. 6, pp. 494-511, June, 1933.
4. COMMITTEE REPORT, "Specifications for Testing Asymmetric Show-Window Reflectors," *I. E. S. Trans.*, v. 28, No. 6, pp. 512-525, June, 1933.
5. E. B. HALLMAN, "Floodlighting Design Procedure as Applied to Modern Setback Construction," *I. E. S. Trans.*, v. 29, No. 4, April, 1933.

6. COMMITTEE REPORT, "Specifications for Testing Semi-indirect and Indirect Luminaires," *I. E. S. Trans.*, v. 32, No. 8, p. 827, September, 1937.
7. FRANK BENFORD, "Illumination from Extended Sources Computed by the Theory of the Integrating Sphere," *J. O. S. A.*, v. 30, No. 1, pp. 33-40, January, 1940.
8. E. H. WAKEFIELD, "A Simple Graphical Method of Finding Illumination Values from Tubular, Ribbon, and Surface Sources," *I. E. S. Trans.*, v. 35, No. 2, pp. 142-150, February, 1940.
9. COMMITTEE REPORT, "Specifications for Testing Lighting Equipment (Section 1 — Specification No. C-1-1940, Luminaires for General Lighting)," *I. E. S. Trans.*, v. 35, No. 3, pp. 267-275, March, 1940.
10. H. H. HIGBIE, "Prediction of Illumination at a Point from Source of Any Shape," *I. E. S. Trans.*, v. 36, No. 1, pp. 79-98, January, 1941.
11. FRANK BENFORD and JOHN E. BOCK, "Chart for Transferring Spherical Coordinates," *J. O. S. A.*, v. 31, No. 3, pp. 239-244, March, 1941.

## CHAPTER 6

### ELECTRICAL INCANDESCENT AND GASEOUS VAPOR-LIGHT SOURCES

The history of the development of the incandescent lamp has been one of constantly increasing efficiency. The recent development of gaseous lamps of high efficiency came at a time when apparently insurmountable difficulties threatened further progress. The history of electrical lighting did not begin with Thomas Edison (1879) and Peter Cooper Hewitt (1901), but years before in the physical laboratories. These two inventors do, however, mark the beginning of the use of electrical energy for incandescent and vapor-light sources. The ability to create a vacuum economically was the foundation for this epoch in lighting, and the sources in use today are only modifications and developments of the early ones.

The first lamp developed by Edison produced light at the rate of 1.4 l. per w. (power unit) input to the lamp; today the large incandescent lamps produce 20 l. per w., and special gaseous light sources produce 80 l. per w. The mechanical equivalent for light is given as 621 l. per w. (with the wavelength of light at 555 m $\mu$ ) which, even when using the best incandescent electrical source (20 l. per w.), definitely marks the production of visible radiation as very inefficient. A firefly produces radiant energy with an efficiency of approximately 98 per cent; this greatly surpasses our most efficient sources. The production of artificial light offers a broad field for development, and *cold light* (as produced by the firefly) has for years attracted the efforts and attentions of many scientists.

**1. Lamp Efficiency.** In all branches of engineering, the term "efficiency" in its correct interpretation is a ratio of energy, though it is most frequently expressed as a ratio of power, because the time is the same for the output as for the input. The power output in ratio with the power input, expressed as

$$\eta = \frac{\text{output}}{\text{input}}$$

is universal in engineering. The term has been used rather loosely in illumination, and there are two definitions in use, depending on

whether the term is used by those applying principles or those investigating fundamentals.

*Luminous efficiency* is the ratio of the luminous flux to the radiant flux,

$$\text{luminous } \eta = \frac{F}{\phi}$$

which is expressed in lumens per watt of radiant flux.

*Light source efficiency* for electrical sources of light is the ratio of the total luminous flux to the total power consumed, or

$$\eta = \frac{F}{\text{watts}}$$

which is expressed in lumens per watt. This, however, is a *definition of effectiveness*, not efficiency, and probably the proper designation should be efficacy, leaving *lamp efficiency* as the ratio of the energy effective in the luminous region to the total energy radiated by the source.

**2. Development of Lighting Sources and Practical Analysis.** The chief interest in the early electrical light sources was to obtain an efficient light generator. The history of the incandescent lamp shows a steady increase in light output for a fixed amount of power input. During this period of development the research of the illuminating engineer was confined to the visible spectrum. Because of the sensitivity of the eye, (*d*) in Fig. 1-6, in the visible region of the spectrum, developments in the incandescent lamp were stimulated (*d*<sub>1</sub>), and they are now supplemented by various gaseous sources. Recent demands in both the ultraviolet and near infra-red bands have influenced the type of thinking that must be applied to the evaluation of radiant sources.

Figure 1-6 shows the factors that must be considered by individuals specializing in the specification of sources of radiation. All the lamps are classified as illumination sources, though many of the specialized sources do not fall within the region generally known as the light region. The color-matching region (*c*) must be duplicated by artificial light if this task is to be performed anywhere outside of properly located and timed daylight exposure. The daylight fluorescent lamp (*c*<sub>1</sub>) is the answer to this problem. The ultra-violet region must be supplied for two purposes: erythema (*b*), and germicidal (*a*), and it is supplied by the radiation from sunlamps (*b*<sub>1</sub>), and sterilizing lamps (*a*<sub>1</sub>). The most recent lamp application is to industrial drying, using electrical lamp radiation sources. The heat penetration (*e*) is supplied by infra-red, CX-250-w., and 250-w. drying

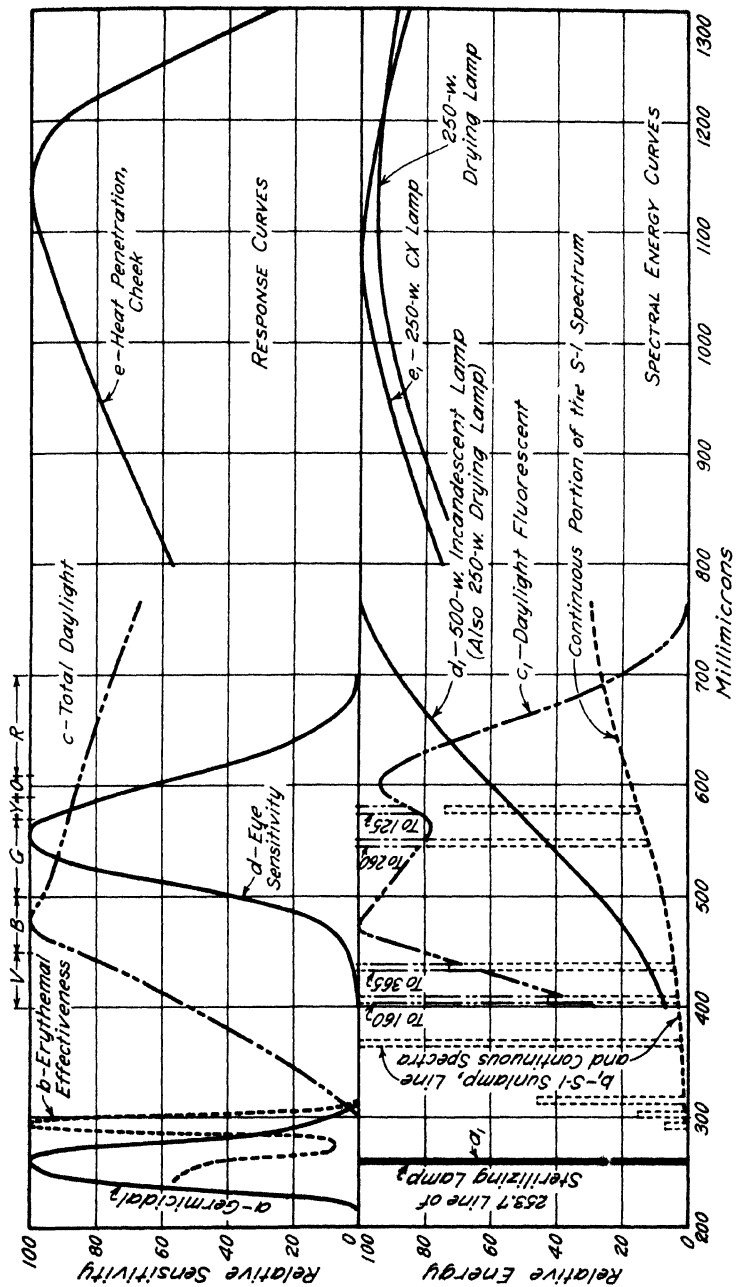

FIG. 1-6.<sup>34</sup> Relative sensitivity in the radiant energy spectra considered by the illuminating engineer and the source of relative energy where equipment has been developed for specific tasks in the sensitivity region.

lamps. This development promises to become one of the important industrial developments in the use of lamps. Its wide use will demand attention in both knowledge and vocabulary from lighting salesmen and illuminating engineers.

As it is necessary to expand the present knowledge to include the radiant spectrum, it is equally necessary to understand a method of measuring the effectiveness of the newer electrical radiating sources. This is particularly true if there is color in the source, because the effectiveness will be modified by passing through color media and reflections from colored reflectors. By combining the eye sensitivity (Fig. 1-6d) with the relative output of the source, the *luminosity curve* (Fig. 1-6d) with the relative output of the source, the *luminosity curve* is obtained; this states graphically the effectiveness of the light for

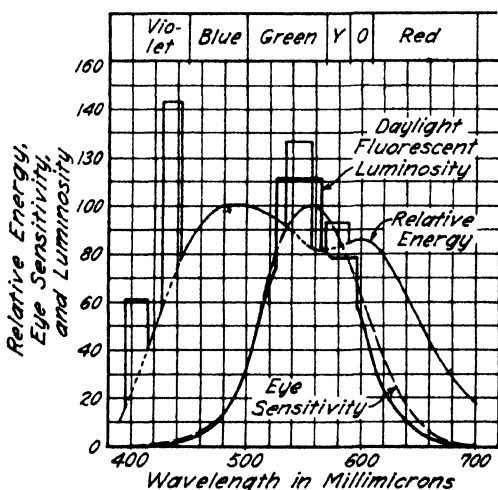

FIG. 2-6.<sup>18, 21</sup> Luminosity curve for daylight fluorescent lamps.

use by the eye, at every wavelength. A *luminosity curve* is a curve showing the luminous flux per element of wavelength as a function of wavelength. It gives, wavelength by wavelength, the product of the radiant flux and the visibility. Figure 2-6 shows the *luminosity curve* for the daylight fluorescent lamp.

The new concepts of light sources, like those of the early discoveries in lighting, can be, and have been, distorted by commercially influenced reports. It is possible to plot the luminosity curve in such a way as to present equipment at an unfair advantage as was possible with the candlepower distribution curve already discussed (page 106).

The shape of the luminosity curve is partially dependent upon the width (in wavelength) of the region in which the relative energy measurements are made. If a source has pronounced lines and is not a

continuous spectrum, the slit opening used in making measurements is very important. A knowledge of the method of making measurements of radiant energy is necessary for correctly interpreting the readings.

TABLE I-6  
COLOR TEMPERATURE OF SOME ILLUMINANTS

Illuminant	Color Temperature*	Illuminant	Color Temperature*
40-w. Incandescent	2760°	500 cx	3015°
100-w. "	2865°	250 cx	2950°
500-w. "	2980°	60 cx	2825°
1000-w. "	2990°	250-w. Photoflood	3475°
1500-w. "	3025°	1000-w. "	3360°
900 Projection	3200°	I.C.I. illuminant A	2848°
500 "	3190°	I.C.I. illuminant B	4800°
		I.C.I. illuminant C	6500°

\* Degrees Kelvin.

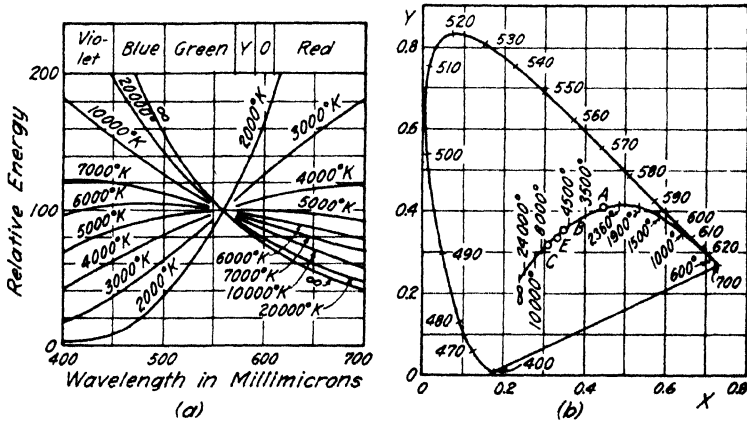

FIG. 3-6. (a) Relative spectral energy for black-body radiation at various temperatures. (b) Chromaticity of a black body and the I.C.I. standard illuminants. *E* is the equal-energy spectrum.

**3. Color Temperature.** Color temperature differs from the temperature of the filament in the lamp. Both temperatures are assigned to continuous spectra or nearly continuous spectral sources which give a spectral distribution of energy somewhat like that from a *black-body* (or *complete*) radiator. A *black-body* radiator gives, in all parts of the



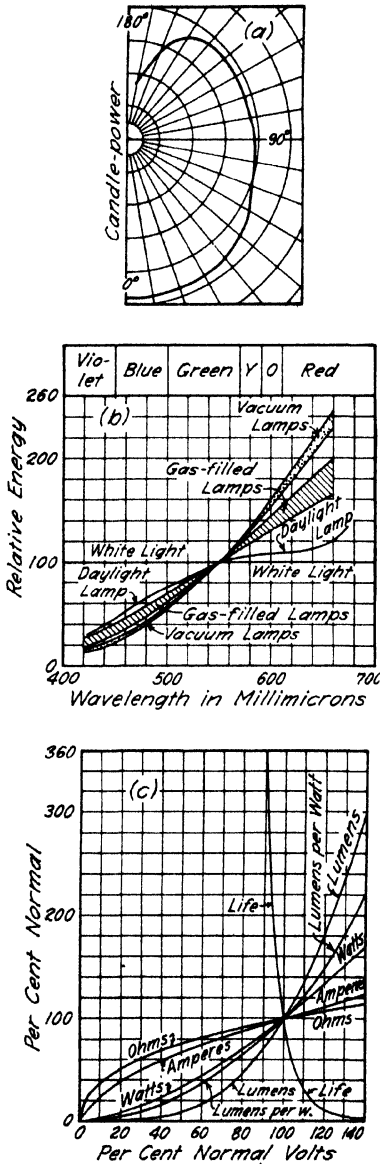

FIG. 4-6. (a) Candlepower distribution curve for an incandescent lamp. (b) Spectral energy distribution for incandescent lamps. (c) Characteristics of incandescent lamps.

spectrum, the maximum rate of emission of radiant energy which it is possible to obtain as a result of thermal temperature alone. It is a *black body* in the sense that it will absorb completely all radiation incident upon it.

The color temperature of a lamp is the temperature at which the black body must be operated to produce a color matching that of the source in question. Color temperatures are measured from absolute zero ( $-273^{\circ}\text{C}$ ), and representative daylight (I.C.I. illuminant C) is at  $6500^{\circ}\text{K}$ . Table I-6 lists the color temperature of the sources interesting to the illuminating engineer. The color temperature is an index number which is, for practical purposes, a coefficient representing the information available from a luminosity curve.

Figure 3-6a shows the distribution of relative energy in the visible region, and Fig. 3-6b shows the chromaticity of the I.C.I. illuminants and the locus of radiation from a black body. Tests on barrier-layer cells and color-correction filters are specified and described in color temperatures.

#### 4. Incandescent Lamps.<sup>12, 25</sup>

The general service type of incandescent lamp is the most widely used lamp in industrial and commercial illumination. Figure 4-6 shows the candlepower distribution curves of the most common type of lamp. The type of filament

and the output in lumens per watt influence the shape of the curves.

The lamps are sold in voltage ratings of 110, 115 and 120 v., and lamps having the correct voltage rating should be chosen, for the lumen output varies exponentially with respect to the voltage. Table II-6 shows the effect of voltage variation upon the operating characteristics of the lamp. Though there are lamps made for high voltage

TABLE II-6  
TYPICAL PERFORMANCE OF LARGE INCANDESCENT LAMPS BURNED BELOW  
RATED VOLTAGE

120-Volt Lamps Operated at (Volts)	% of Normal Voltage	% of Normal Light Output	% of Normal Watts	% of Normal Efficiency
120	100.0	100.0	100.0	100.0
119	99.2	97.3	98.8	98.2
118	98.3	94.4	97.4	96.9
117	97.5	91.8	96.1	95.4
116	96.7	89.2	95.0	93.8
115	95.8	86.4	93.6	92.3
114	95.0	84.0	92.4	90.8
113	94.2	81.5	91.2	89.4
112	93.3	78.0	89.8	87.7
111	92.5	76.6	88.7	86.2
110	91.7	74.1	87.5	84.8
108	90.0	69.5	85.0	81.7
106	88.3	65.0	82.5	79.4
104	86.7	60.8	80.3	75.8
102	85.0	56.6	77.9	72.8
100	83.3	52.0	75.5	69.7

service, voltages higher than those given above should be avoided. There are many special service lamps, and the manufacturers' schedules give information as to base, filament, voltage, and service. The lumen output of the lamps is also given in these schedules, but the output changes with every development in efficiency; therefore, except for estimating purposes, Tables III-6A and III-6B should not be used without checking the latest reports from the manufacturers.

Figure 5-6 shows the parts of the lamps and the various standard shapes in which they are manufactured. Lamps are designated by shape and size; for example, PS-35 means that the bulb is pear-

shaped and is 35 units in diameter. The unit of size measurement is  $\frac{1}{8}$  of an inch (a 35 lamp measuring  $4\frac{3}{8}$  inches).

TABLE III-6A\*  
LUMEN OUTPUT OF VARIOUS  
LAMP TYPES AND SIZES  
General Service Lamps  
At Rated Voltage (Inside frost)  
(March, 1941)

Watts	Volts		
	110 120	220 240	110-120 Daylight
	Lumens		
6	38		
10	79		
15	150		
25	270	215	
40	465		
50	660	480	
60	835		540
75	1,100		
100	1,650	1,250	1,050
150	2,600		1,700
200	3,700	2,950	2,400
300	5,950	4,850	3,700
500	10,000	8,750	6,500
750	14,000	13,500	
1000	21,500	19,500	
1500	*33,500		

\* Not manufactured with inside frost.

The names of the different sized bases are:

SCREW	BIPOST
Miniature	Medium
Candelabra	Mogul
Intermediate	
Medium (average lamp)	
Mogul (large lamp)	

The filament is made from tungsten wire coiled in the form of a helical spring; however, in the new "coil-coil" filaments, the helical spring is coiled the second time. The lead-in wires conduct the current from the base to the filament. The filament is supported in position by one of several different types of supports. Particular attention

should be given to the manufacturers' instructions as to the position of the base while the lamp is burning, for in certain types of lamps the

TABLE III-6B\*

LUMEN OUTPUT OF  
LAMPS FOR MISCELLANEOUS  
SERVICE  
(March, 1941)

Watts	Hours	Lumens
6	1,500	38
10	1,500	79
30	500	340
60	1,000	835

## 28- to 32-Volt Lamps

15	1,000	175
25	1,000	340
50	1,000	820
100	1,000	1,800

## Projection Lamps

50	50	790
100	50	1,900
200	50	4,250
300	25	7,350
500	50	13,000
750	25	
1,000	50	27,500

## Floodlight

100	200	1,380
250	800	3,750
400	200	8,000
500	800	8,800
1,000	800	19,500

support for the filament is such that the lamp will be quickly destroyed if it is not burned in the proper position.

If the lamp is to simulate a point source of light, the filament is concentrated into a very small space, and where vibrations are present it may be necessary to use a lamp with a special filament form and more rigid supports. Contrasted to the filament in a small space

(projector and floodlight lamps) is the lumiline lamp in which the filament is extended the full length of a long tube.

Incandescent lamps may be bought in various types of finishes:

- |               |                 |
|---------------|-----------------|
| Clear         | Inside sprayed  |
| Inside frost  | Silver bowl     |
| White bowl    | Outside colored |
| Colored glass |                 |

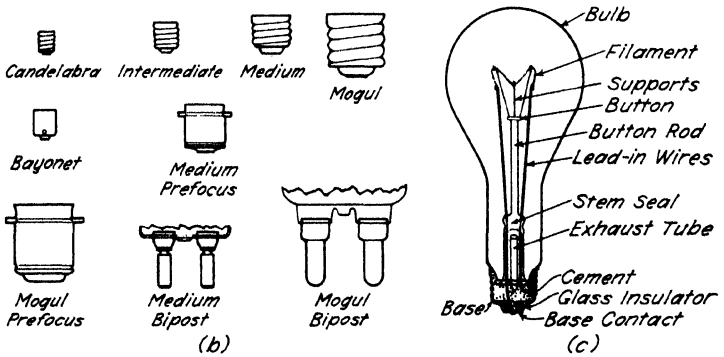
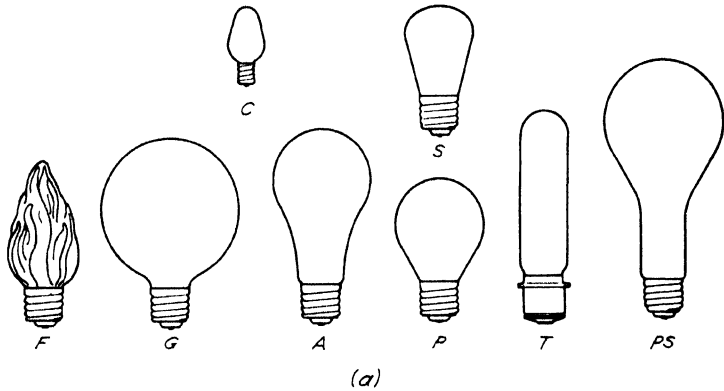

FIG. 5-6. (a) Incandescent lamp bulb designs. (b) Incandescent lamp base designs. (c) Parts of the incandescent lamp.

The inside frosted (with only a 2 per cent light loss) is the most commonly used type of lamp and should be used in all luminaires in which it is desired to eliminate streaks, striations, and shadows from the fixture supports. Neglect of this feature may cause an otherwise pleasing lighting installation to be unsightly.

The silver-bowl lamp is a piece of lighting equipment in itself (where it is used the equipment merely shields the neck of the lamp

and acts as an ornamental device), because it has a permanent coating of mirrored silver on the outer surface of the bowl. This coating is a part of the lamp and acts as a shield to protect the eye from the filament of the lamp. It also acts as an efficient indirect reflector if it is burned with the base up. There are lamps on the market with the silver coating on any portion of the lamp which the user desires. Silver-bowl lamps give the best service if the bulb has an inside frosting.

The light output of the silver-bowl lamp is 96.4 per cent of that of the standard inside-frosted lamp, and in 1000 hr. the light depreciation will be 1.4 per cent more than the standard lamp. The high temperatures under which the lamp operates will extend its life about 20 per cent beyond the life of the unsilvered lamp. Figure 6-6 shows the comparative candlepower distribution curves for the silvered and unsilvered lamp.

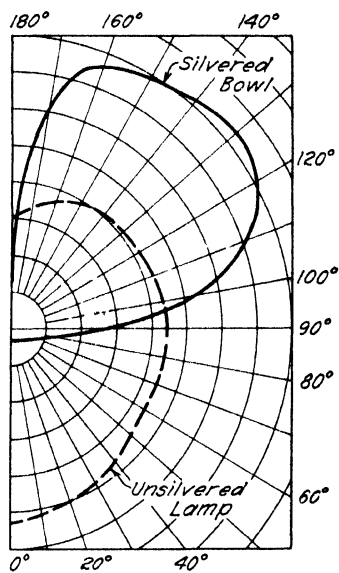

FIG. 6-6.<sup>4</sup> Candlepower distribution curves for the unsilvered and the silver-bowl incandescent lamps.

A recent development is the projector lamp (Table IV-6A). A section of the lamp unit and the distribution curves are shown in Fig.

TABLE IV-6A  
INSIDE MIRRORRED LAMPS  
(March, 1941)

	Watts	Lumens Beam	Spread Beam
Projector lamp			
Spotlight	150	990	15°
Floodlight	150	1500	30°
Reflector lamp			
Spotlight	150	700	15°
Spotlight	300	1450	15°
Floodlight	150	700	30°
Floodlight	300	1600	30°

7-6. The mirrored surface is on the inside of the lighting unit rather than on the outside as it is in the silver-bowl lamp, and this surface is

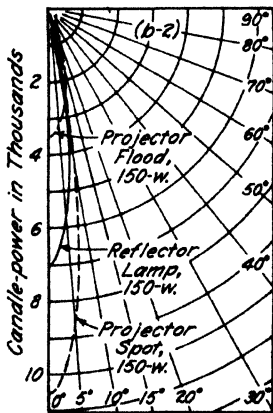
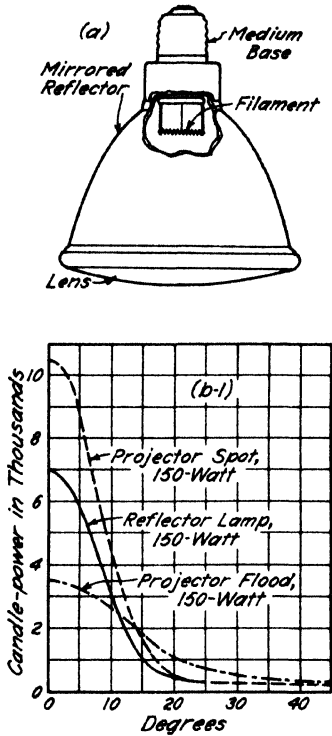

both efficient and durable. The filament is of the new "coil-coil" type with the lens, reflector, and filament combined into a single sealed unit. Of this same type of mirror construction (used only for interior service) is the reflector lamp which furnishes a narrow beam and is suitable for increasing the illumination over small areas.

The bipost-base incandescent lamps permit installation of the large-size incandescent lamps in restricted space (Table IV-6B). Figure 8-6 shows the shape of the lamp and base and

TABLE IV-6B  
BIPOST-BASE  
INCANDESCENT LAMPS  
(March, 1941)

Watts	Lumens
750	14,000
1,000	19,500

also the light distribution curve. Their use makes possible the manufacture of a comparatively small fixture which will harmonize with the interior even where it is necessary to have high values of illumination. These lamps are tubular and are made of hard glass. The interior incorporates a gauze screen which collects filament evaporation and protects the inclosing glass against blackening. In this way, a high percentage of light output is maintained throughout the life of the lamp.

FIG. 7-6. (a) Assembly of a projector type lamp. (b-1) Distribution curves for projector- and reflector-type lamps to rectangular coordinates. (b-2) Plotted to polar coordinates.

The incandescent lamp development and manufacture is an ever-changing industry. New types of lamps are continually being produced, and changes in the characteristics of established products are being made from month to month. When it is necessary to design or specify lighting, the latest information available concerning new developments in lamps should be consulted.

The life of a lamp may be adjusted to any value desired, but the economics of operation is influenced by the choice of long-lived or short-lived equipment. For the general service lamp, 1000 hr. of life has been accepted as the best balance between lamp renewal and

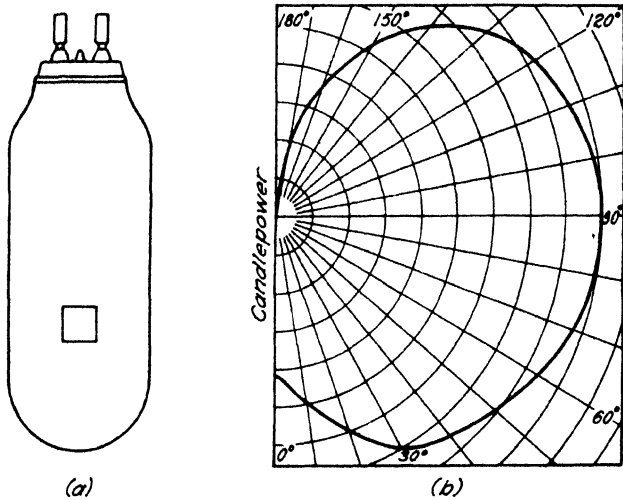

FIG. 8-6. (a) Bipost base lamp. (b) Distribution curve for bipost lamps.

electrical current cost. Special lamps have a range in length of life from a small part of a second to thousands of hours.

**5. Drying Lamps.**<sup>22</sup> The latest use of the incandescent filament lamp is that of drying with the near infra-red radiation. The ability to control the process is so satisfactory that it is rapidly replacing other drying devices and processes. The 250-w. drying lamps operate at a filament temperature of 2500° K and have a life of from 10,000 to 20,000 hr. The lumen output is one-third that of a similar radiation lamp in the visible region. The low light output makes it possible to install large banks of these lamps without objectionable glare. Figure 9-6 shows the radiation distribution of the lamp and the effectiveness of the infra-red in drying some common lacquers. Since 80



to 90 per cent of the radiation of the incandescent lamp is in the infra-red, these lamps make very successful heaters for drying. For best drying results, the energy should be supplied where it is most effective in vaporizing the common washes and solvents.

As shown in Fig. 9-6, the radiation from the type of lamps now

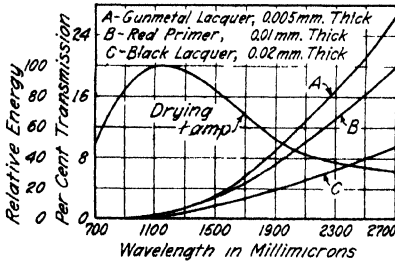

FIG. 9-6.<sup>22</sup> Characteristic spectral energy curve for a drying lamp and the transmission of infra-red radiation by various lacquers.

available is too generalized for the desired effectiveness, but there may be individual lamps developed in the future for specific purposes. Then the trade will not have to depend upon a lamp which, though good for general application, is inefficient in many specific cases. Figure 10-6 shows the ability of various materials to reflect infra-red energy. The reflectors are parabolic in shape so that they can concentrate the heat upon the material to be dried.

The drying lamp process will produce a dry surface within 5 to 15 per cent of the time required by heaters and air dryers.

The method is so new that there is little information available and

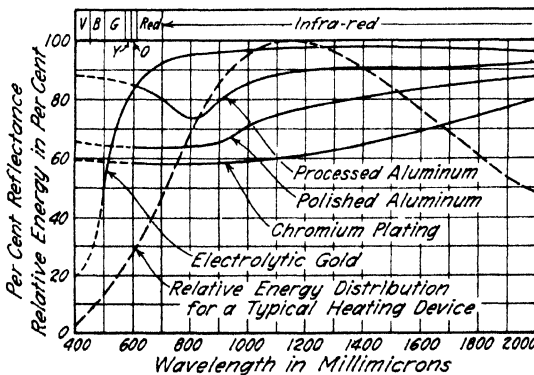

FIG. 10-6.<sup>22</sup> Efficacy of various metals as reflectors for infra-red radiation.

each installation is in the nature of an experimental investigation. The fumes and vapors from the material being dried will depreciate the equipment; therefore, it is desirable to provide for their removal in a manner that will have the least effect upon the material that is drying and upon the maintenance of the reflector.

**6. Gaseous Discharge Lamps.**<sup>2, 10, 13, 15, 16, 23, 25</sup> The gaseous discharge lamp differs from the incandescent lamp in that the luminous effect is obtained from a gaseous discharge rather than from a heated metallic ribbon. To be successful, both types of lamps should operate on low voltages (110 to 120 v.) and on either alternating or direct current, and both should produce lumens efficiently. The incandescent lamp has the advantages of unity power factor, of independence of auxiliary devices, and of the ability to operate equally well on both types of electricity. It has, however, definite limits of efficiency. The gaseous discharge lamps have only one advantage, that of high lumen output per watt. The power factor at best is approximately 90 per cent; auxiliary devices must be used with the equipment, and the operation is not as satisfactory on direct current as on alternating current. When comparing the gaseous conduction and incandescent lamp, the comparison of lumen output should be made on the basis of volt-amperes rather than on watts.

As was stated above, gaseous discharge lamps do not function as well on direct current as on alternating current, and they are more sensitive to ambient temperature. The gaseous discharge lamp has essentially the characteristics of an arc lamp, and the conducting gas does not limit the current. This current-limiting must be accomplished in direct current by a series resistance (energy used by the stabilizing device is 25 to 50 per cent of the total), and in alternating current by a reactance which produces an extremely low power factor.

There are many types of gases used in gaseous discharge lamps, but only a few types of the lamps are of specific commercial importance. They are:

- a. Low-pressure mercury vapor lamp.
- b. High-intensity mercury vapor lamp.
- c. Neon lamps (used mostly for signs).
- d. Sodium lamps (used for highway lighting and being considered for possible industrial lighting).
- e. Fluorescent lamps.

In the first four, the color of the illumination depends upon the gas used; the last depends upon a combination of mercury gas and the fluorescent phosphor used in coating the inside of the tube. As in the incandescent lamps, the difficulties in the gaseous lamps lie in the development of the scientific problems encountered in manufacturing and in improving the product rather than in problems of application of the lamps in practice.

One of the objectionable features of the gaseous discharge lamp is the stroboscopic effect. When a moving object is illuminated by a

light that is flickering, multiple images of the object are produced. This is stroboscopic effect. The number of images formed depends upon the frequency of the flicker and discontinuity of the vision. The stroboscopic effect may become a hazard where the lighting is used for

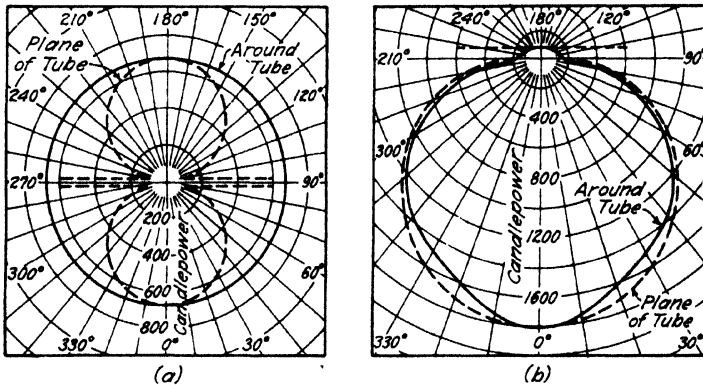

FIG. 11-6.<sup>5</sup> Distribution curves for low-pressure mercury vapor lamps. (a) A bare lamp. (b) A lamp using a reflector.

industrial purposes, because the reflections from high-speed rotating and reciprocating machines confuse the vision.

Circuits recently developed for the fluorescent lamps are so arranged that both the flicker and power factor have been corrected.

TABLE V-6A  
LOW-PRESSURE MERCURY VAPOR LAMP

Type	Power Factor	Watts
Early reactive ballasting	52%	380
Resistive ballasting	88%	450
Resistive ballasting and rectifier starting	88%	450
Reactive ballasting, high-speed starter, power-factor corrections	86 to 90%	350

**7. Low-Pressure Mercury Vapor Lamps.**<sup>17</sup> The low-pressure vapor lamp encountered in commercial and industrial installations is known as the Cooper-Hewitt lamp. The quality of the light is definitely of a line spectra type and the lamps cannot be used where color is an important factor.

The low-pressure mercury vapor lamp usually consists of a long tube (approximately 50 in. long) and an auxiliary unit. Figure 11-6 shows the candlepower distribution curves for the bare lamp and for the lamp with the reflector equipment, which is a part of the auxiliary unit. Figure 12-6a shows the wiring diagram of a modern auxiliary which has a high power factor. Table V-6A lists the power factors for the various types of auxiliaries used. Because the light source is long and the lamp has a low brightness per square inch, it may be mounted at low heights without excessive glare. Tables VI-6A and VI-6B give data for mounting, and the light distribution for the 450-w. Cooper-Hewitt lamp, respectively.

Figure 12-6b shows the operating characteristics of the Cooper-Hewitt lamp with a fluctuation of the line voltage. To correct for the line voltage variation in different localities, the manufacturer incorporates voltage taps in the auxiliary and these should be used correctly after determining the voltage at the point where the lamp is installed. Figure 12-6c shows the visual utilization of the low-pressure mercury vapor lamp. The shaded area rep-

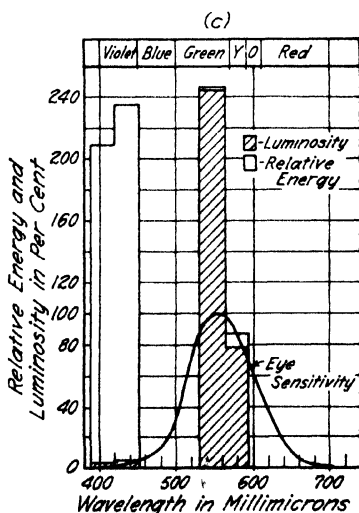
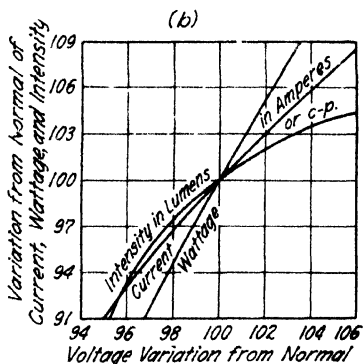
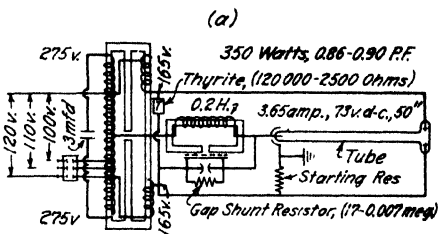

FIG. 12-6.<sup>5, 23</sup> Characteristics and circuit for a low-pressure mercury vapor lamp. (a) A modern power factor corrected circuit. (b) Characteristics of the lamp with respect to voltage. (c) Spectral energy distribution.

resents the portion utilized by the eyes, and the unshaded portion represents the output from the lamp. It will be noted that, though there is considerable radiation from 460 to 400  $m\mu$ , it has little effective value for seeing.

TABLE V-6B<sup>5</sup>

## GENERAL CHARACTERISTICS OF VARIOUS GASEOUS CONDUCTION LAMPS

Source	Method of Operation	Power Factor	Watts in Aux.	Watts in Arc	Tube Diam., Inches	Arc Amps.	Arc Length, Inches	Arc Voltage	Watts per Lin. Inch	Lumens per Lin. Inch	Candles per Sq. In.	Overall Lumens per Watt
H. V. Neon	React. Trans.	55	4	36	0 45	0 03	100	2050	0 24	5 8	1 30	14 5
H. V. Neon	React. Trans.	55	5	50	0 60	0 05	100	2000	0 30	7 2	1 20	13 0
H. V. Mercury	React. Trans.	55	5	45	0 45	0 03	100	2300	0 20	1 6	0 36	3 2
H. V. Mercury	React. Trans.	55	10	85	0 60	0 05	100	2100	0 55	1 9	0 32	2 0
L. V.-L. P.-Hg.	110 V. D. C.	—	135	250	1 00	3 5	50	71	4 1	120 0	12 2	16 0
L. V.-L. P.-Hg.	A. C. Rect. Res. Bal.	90	175	275	1 00	3 7	50	74	4 6	135 0	13 6	15 0
L. V.-L. P.-Hg.	A. C. Rect. Res. Bal.	90	100	150	1 00	3 7	22	40	4 6	135 8	13 6	12 0
L. V.-L. P.-Hg.	A. C. Rect. Res. Bal.	90	125	175	0 75	2 5	35	70	4 2	115 0	15 4	13 5
L. V.-H. C.-Neon	A. C. Rect. Res. Bal.	90	300	300	1 00	3 5	18	70	11 7	275 0	27 8	10 0
H. P.-Quartz-Hg.	Uviarc-D.C.	—	250	650	0 70	4 0	6	160	100 0	3600 0	520 0	24 0
High Int. Hg. *	Full Wave A. C. Ind. Bal.	65	25	400	1 30	2 9	6	160	63 0	2250 0	175 0	32 0
Sodium — 10,000 *	Full Wave A. C. Ind. Bal.	65	25	200	3 00	6 0	9	25	15 5	1100 0	37 0	45 0
Sodium — 6000 *	Full Wave A. C. Ind. Bal.	65	15	150	2 50	5 0	7	20	14 3	850 0	34 5	36 0

\* Tentative data based on a depreciation of about 15 per cent for each successive one-thousand-hour interval of operation, from a rated rather than actual initial output. Intrinsic brilliancy based on total emitting surface area of tube or bulb.

TABLE VI-6A

## INTENSITIES PRODUCED BY ONE 450-WATT COOPER-HEWITT LAMP AT VARIOUS HEIGHTS AND DISTANCES

Height	Horizontal Distance in Feet																						
	0	1	2	3	4	5	6	7	8	9	10	11	12	13	14	15	16	17	18	19	20	25	
4	90.0	80.4	58.8	39.2	25.0	15.8	10.5	7.1	5.0	3.5	2.5	1.9	1.5	1.4	1.1	.9	.8	.65	.55	.45	.37	.18	.18
5	59.7	53.4	43.3	32.2	23.5	15.9	11.2	8.1	5.9	4.2	3.2	2.3	1.9	1.7	1.4	1.1	.9	.75	.65	.55	.46	.28	.28
6	41.8	38.5	32.7	26.1	20.0	14.8	11.0	8.0	6.2	4.7	3.6	2.9	2.2	2.0	1.6	1.3	1.1	.85	.75	.65	.56	.28	.28
7	30.7	28.5	25.3	21.2	17.3	13.5	10.5	8.1	6.3	5.0	4.0	3.1	2.4	2.2	1.7	1.5	1.2	1.1	.90	.76	.65	.28	.28
8	23.3	22.1	20.1	17.4	14.6	12.0	9.7	7.9	5.9	5.1	4.1	3.2	2.7	2.3	1.9	1.5	1.4	1.2	1.0	.90	.75	.37	.37
9	18.5	17.6	16.4	14.5	12.6	10.8	8.9	7.4	6.1	5.0	4.0	3.2	2.8	2.4	2.0	1.6	1.5	1.2	1.1	.90	.75	.45	.45
10	14.9	14.4	13.4	12.2	10.9	9.5	8.0	6.8	5.7	4.8	3.9	3.4	2.9	2.4	2.0	1.8	1.6	1.3	1.2	1.0	.85	.55	.55
12	10.3	10.1	9.7	8.8	8.1	7.3	6.5	5.8	5.0	4.4	3.8	3.2	2.8	2.3	2.0	1.8	1.6	1.4	1.3	1.1	.90	.55	.55
14	7.6	7.4	7.2	6.8	6.3	5.9	5.4	4.9	4.2	3.8	3.4	3.0	2.6	2.1	2.0	1.7	1.6	1.5	1.3	1.1	1.0	.55	.55
16	5.8	5.7	5.5	5.3	5.1	4.7	4.3	4.0	3.7	3.4	3.0	2.8	2.5	2.1	1.9	1.6	1.5	1.4	1.2	1.1	1.0	.65	.65
18	4.6	4.6	4.4	4.3	4.1	3.9	3.6	3.4	3.1	2.9	2.8	2.6	2.3	1.9	1.8	1.5	1.5	1.3	1.2	1.1	1.0	.65	.65
20	3.7	3.7	3.7	3.5	3.4	3.2	3.0	2.8	2.7	2.6	2.2	2.2	2.0	1.6	1.4	1.3	1.3	1.3	1.1	1.1	1.0	.65	.65
25	2.4	2.4	2.3	2.2	2.1	2.1	2.1	1.9	1.9	1.9	1.8	1.7	1.6	1.2	1.1	1.0	1.0	.9	.9	.75	.65	.65	.65

8. High-Intensity Mercury Vapor Lamps.<sup>7, 9, 11</sup> The high-intensity mercury vapor lamp is now listed as a Type-H lamp. It differs from the low-pressure lamp, which operates at approximately 0.025 mm. pressure, in that it operates at pressures ranging from  $\frac{1}{2}$  to 8 atm. and

from 30 to 40 l. per w. Type H-6 is a special lamp operating at pressures of from 75 to 80 atm., and has approximately 65 l. per w. Table VII-6A lists the Type-H lamps and gives the output of each.

The unsatisfactory feature of the high-pressure lamp is its slow starting operation; it takes from 10 to 12 min. to reach normal operating conditions. Where there are frequent interruptions of the system, this operation could not be tolerated; however, continuity of service is

TABLE VI-6B

INTENSITIES PRODUCED BY SIXTEEN 450-WATT COOPER-HEWITT LAMPS  
SYMMETRICALLY SPACED

Horizontal Distance Between Lamps												
Height	8	9	10	11	12	13	14	15	16	18	20	24
4	55.0	40.4	24.5	23.0	17.9	15.7	11.8	9.7	7.0	5.7	3.9	1.4
5	62.1	55.4	39.6	27.6	21.6	19.7	15.4	12.2	9.2	7.4	5.4	2.3
6	65.2	58.6	42.5	30.7	24.5	22.6	17.8	14.3	10.9	7.8	6.6	3.2
7	65.2	58.4	44.3	33.0	26.5	25.0	19.3	15.9	12.5	9.9	7.7	4.0
8	64.2	57.4	45.0	34.2	28.2	27.2	20.9	17.3	13.9	11.0	9.1	4.7
9	62.1	55.2	43.7	34.8	29.2	28.0	22.0	18.3	15.1	11.9	9.6	5.3
10	59.7	53.0	42.3	34.3	29.6	27.6	22.8	19.1	16.0	12.7	10.1	5.8
11	57.0	50.6	40.8	33.3	29.5	27.0	23.0	19.4	16.6	13.3	10.8	6.2
12	54.1	46.0	39.2	32.3	29.0	26.2	22.5	19.5	16.7	13.7	11.2	6.3
13	51.2	45.6	37.7	31.3	28.3	25.5	22.0	19.4	16.6	14.0	11.3	6.5
14	48.0	42.8	36.2	30.2	27.4	23.8	21.3	19.2	16.4	14.2	11.4	6.6
15	44.5	38.6	34.7	29.1	26.7	23.7	20.7	18.7	16.1	14.1	11.4	6.7
16	40.6	34.6	33.1	28.0	25.7	22.9	19.3	18.2	15.7	13.8	11.2	6.7
18	36.6	33.1	30.0	25.5	23.5	20.9	17.7	16.9	14.9	13.0	10.7	6.7
20	32.6	29.7	26.7	23.0	21.1	18.4	15.2	15.3	13.9	11.2	10.3	6.6
Approximate Watts per Square Foot of Horizontal Surface												
	7.0	5.5	4.5	3.7	3.1	2.5	2.3	2.0	1.7	1.4	1.1	.78

usually expected in most industrial sections. A combination of incandescent and high-intensity mercury vapor lamps will permit continued operation of production lines and manufacturing processes even when the mercury lamps are not functioning normally.

Figure 13-6 shows the construction of a 400-w. lamp and the circuit using a transformer. A condenser is also used for correcting the power factor. Table VII-6A gives the line power factor for the Type-H lamps commonly used in general lighting. Since the high-intensity lamp is influenced by temperature, its construction is differ-

ent from that of the low-pressure lamp. The Type-H lamp has two tubular bulbs, one inside the other, the arc being formed in the inner bulb. At each end of the tube is an electrode consisting of a coil of tungsten wire specially treated to produce a large supply of electrons when the lamp is in its initial operating stage. There is also a third electrode (shown in Fig. 13-6) which assures positive starting in cold weather and reduces the time required for restarting. The inner tube

TABLE VII-6A <sup>26</sup>

## MERCURY LAMPS

Designation	S-1	S-2	H-1 *	H-2	H-4 †	H-5 ‡	H-6
Service	Sunlight	Sunlight	General	General	General	General	Proj. & Photo
Lamp watts (rated)	400	130	400	250	100	250	1,000
Watts, with auxiliary (approx.)	500	175	450	300	120	280	1,200
Lumens (at 100 hr.)	7,200 <sup>a</sup>	1,600 <sup>a</sup>	16,000	7,500	3,500	10,000	65,000
Lumens per watt, lamp (approx.)	18	12 <sup>3</sup>	40	30	35	40	65
Lumens per watt, overall	14 <sup>4</sup>	9 <sup>1</sup>	36 <sup>6</sup>	25	29 <sup>2</sup>	35 <sup>8</sup>	54 <sup>1</sup>
Rated av. lab. life, hours	400	300	2,000	2,000	1,000	1,000	50
Lamp starting volts (approx.)	30	30	150	132	190	190	1,200
Lamp operating volts (approx.)	14 <sup>5</sup>	15	143	70	130	140	840
Lamp starting amperes (approx.)	9 <sup>5</sup>	2	5	5	1 <sup>3</sup>	2 <sup>9</sup>	2 <sup>6</sup>
Lamp operating amps. (approx.)	27 <sup>5</sup>	8 <sup>5</sup>	3 <sup>0</sup>	3 <sup>9</sup>	0 <sup>9</sup>	2 <sup>2</sup>	1 <sup>4</sup>
Transformer primary voltage	115	115	115,230	115,230	115,230	115,230	115,230
Power factor (approx.)	50%	50%	65 or 90% <sup>b</sup>	45 or 85% <sup>b</sup>	50%	50%	60%
Starting time to full output	5 min.	8 min.	7 min.	7 min.	3 min.	4 min.	2 sec.
Restarting time	0	0	7 min.	4 min.	3 min.	4 min.	2 sec.
Burning position	0-90° <sup>c</sup> Base up	0-90° <sup>c</sup> Base up	Vertical <sup>d</sup>	Any	Any	Any	Horis.
Bulb	PS-22	A-17	T-16	T-9	T-10	T-14	T-2
Finish	I.F.	I.F.	Clear	Clear	Clear	Clear	Clear
Base	Mogul	Ad- medium	Mogul	Medium	Ad- medium	Mogul	Ad- Sleeve
Maximum overall length, inches	8 <sup>7</sup> / <sub>8</sub>	4 <sup>3</sup> / <sub>4</sub>	13	8	5 <sup>1</sup> / <sub>2</sub>	8	3 <sup>1</sup> / <sub>4</sub>
Light center length, inches	5	3 <sup>3</sup> / <sub>4</sub>	7 <sup>1</sup> / <sub>4</sub>	5	3 <sup>1</sup> / <sub>4</sub>	5	
Pressure, atmospheric (approx.)	9	9	1	1 <sup>1</sup> / <sub>2</sub>	8	4	80
Number of electrodes	2	2	3	3	3	3	2

\* A-H1 is base-up burning; B-H1 base-down.

† B-H4 has T-16 red-purple bulb for fluorescence; maximum overall length, 5 <sup>1</sup>/<sub>2</sub> in. C-H4 has PAR-38 bulb and admedium skirted screw base; maximum overall length, 5 <sup>1</sup>/<sub>2</sub> in. D-H4 has PAR-38 bulb and medium skirted screw; maximum overall length 5 <sup>1</sup>/<sub>2</sub> in. S-4 for Sunlamps has same electrical characteristics as A-H4 but uses an A-21 ultra-violet transmitting bulb.

‡ B-H5 lamps with admedium screw bases are available.

<sup>a</sup> S-1 and S-2 lumens are initial. The total ultra-violet output of the S-1 unit is 68,000 E-vitons; of the S-2 unit, 8,000, and of the S-4 unit, 68,000.

<sup>b</sup> The higher power factor is obtained with auxiliaries incorporating integral correction.

<sup>c</sup> Maximum ultra-violet output at vertical base-up.

<sup>d</sup> Lamps may be operated in a horizontal position only in connection with specially designed magnetic deflecting coils.

contains the mercury and a small amount of argon to facilitate starting the arc. The outer tube is a heat-insulating jacket.

When the lamp is first turned on, the argon gas immediately supports the arc, the heat from the arc discharge starts vaporization of the mercury, and a blue glow fills the tube. The starting operation requires about 5 amp. at 20 v., which gradually changes to 2.9 amp. at 150 v., and the glow in the tube becomes concentrated into a fine brilliant stream as the lamp begins to operate under normal and ef-

ficient conditions. If the electrical service is interrupted, the arc is quenched and the lamp must cool to a pressure value at which the arc

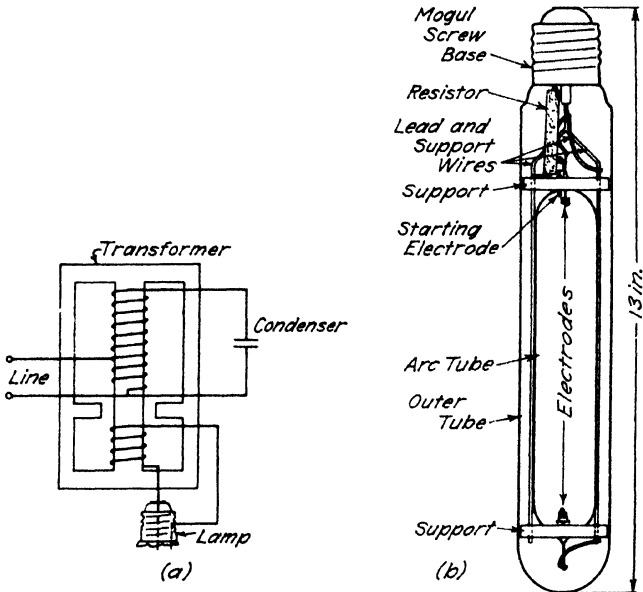

Fig. 13-6.<sup>9</sup> (a) Circuit for a high-intensity Type-H lamp. (b) Construction for the Type-H lamp.

TABLE VII-6B<sup>28</sup>  
SPECTRAL CHARACTERISTICS OF MERCURY LAMPS

	Relative Ultra-violet (Below 3800 A)	4358 A Blue		5461 A Green		5780 A Yellow		Continuous (Visible)		Relative Infra-red (7600-26,000 A)
		Lumens	%	Lumens	%	Lumens	%	Lumens	%	
H-1, 400 w.	2.1	110	0.7	7860	49.1	6800	42.5	1230	7.7	40.9
H-2, 250 w.	1.2	55	0.7	3770	50.3	3245	43.3	430	5.7	14.6
H-3, 85 w.	(The first commercial type of capillary lamp — replaced by the H-4)									
H-4, 100 w.	1.6	25	0.7	1735	49.6	1255	35.9	485	13.8	14.7
H-5, 250 w.	4.6	70	0.7	4630	46.3	4040	40.4	1260	12.6	32
H-6, 1000 w.	33.5* 100.†									62* 100†

\* Glass water jacket. † Quartz water jacket.

can be reestablished. The period of time required to relight varies according to the ambient temperature surrounding the lamp. In in-



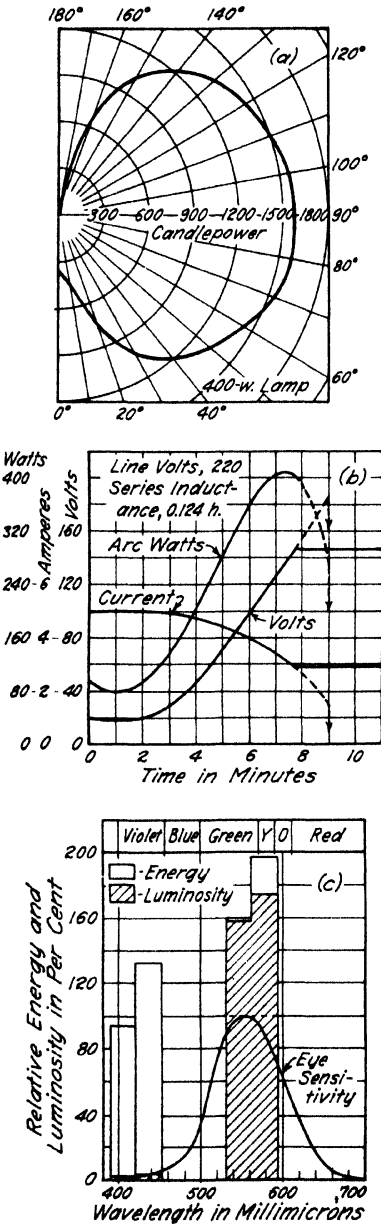

closing equipment this period will be longer than in the open type of equipment.

Because of its high efficiency, the Type-H lamp is very desirable in industrial installations, but it must be mounted 10 ft. or more above the task because of its high brilliancy. The color is of line spectra (radiation at specific wavelengths only) type (Table VII-6B) as it is in the low-pressure lamp, and, therefore, unsatisfactory where color must be considered. Figure 14-6 shows the voltage characteristics, the candlepower distribution curve, and the spectral energy distribution of a Type-H lamp. The higher visual efficiency of this lamp over the low-pressure lamp is due to the concentration of a greater portion of the light in the 540-580 mμ region. (Shown in Fig. 14-6c. Compare with Fig. 12-6c.)

**9. Combining Mercury Vapor Lamps and Incandescent Lamps.<sup>4</sup>**

There are two factors that influence the desirability of combining mercury arc and incandescent lamps in the same lighting system: (a) the assurance of continuity of light; (b) the correction of the color of the light source by additive means. The mercury arc radiates a high per cent in the blue region whereas the incandescent lamp radiates mostly in the red region, and a proper combi-

FIG. 14-6.<sup>5</sup> (a) Candlepower distribution curve for a 400-w. Type-H lamp. (b) Characteristics of the lamp at starting. (c) Spectral energy distribution.

nation of the two tends to produce what may be called a commercial white light. Though this light is not a color-matching light, it is one that blends readily with daylight where a combination of natural and artificial light is to be used.

As a general rule, for low-pressure lamps the mixture is made on the basis of 2 w. of incandescent light for each watt of mercury; for Type-H mercury lamps the combination is made upon a lumen-for-lumen basis — a 400-w. Type-H-1 lamp with a 750-w. incandescent lamp.

**10. Sodium Vapor and Neon Lamps.** The sodium vapor lamp (Table V-6B) radiates most of its energy in the yellow portion of the visible spectrum. Figure 15-6 shows the visual utilization of the sodium lamp; by comparison it is more efficient than the mercury vapor lamps. Because of objectionable color characteristics, the lamp is not recommended for interiors; because of its high efficiency (45 l. per w.), however, it is used and recommended for highway lighting.

Neon tubes (Table V-6B) are used almost entirely for advertisement, though there are some interior installations. They prove to be quite satisfactory in interiors for ornamental designs and spot lighting, but it is doubtful whether or not they should be recommended for general lighting. They lack flexibility and the stroboscopic effects are rather severe. The tubes operate on from 8000 to 12,000 v.

The characteristic orange-red color is obtained by the use of neon gas; mercury, argon, carbon dioxide, and colored tubes in combination with the gases are used to obtain the different color effects. As in all gaseous vapor lighting units, the power factor is low, so that any studies for comparative purposes should be made on the basis of volt-amperes rather than watts.

**11. Ultra-Violet Lamps.**<sup>1, 25</sup> Ultra-violet radiation, though infrequently used with general lighting, is finding an increasing number of applications. The ultra-violet radiation is obtained by the use of Type-S (Table VII-6A) and Type-G lamps, each application of which

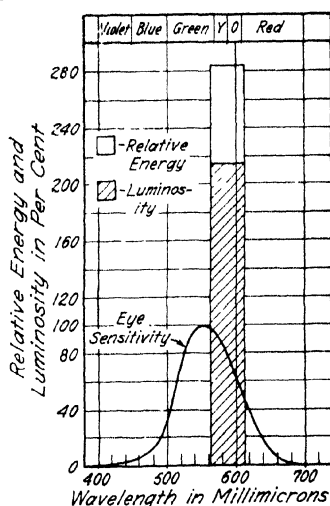

FIG. 15-6.<sup>5</sup> Spectral energy distribution and visual utilization of light from a sodium lamp.

brings up a problem for special consideration. It requires from 5 to 8 min. for the lamps to reach their maximum output operation and the power factor is approximately 50 per cent.

**12. Sterilizing Lamps.**<sup>26</sup> A special lamp which concentrates its effectiveness at 253.7 m $\mu$  is called a "Sterilamp" or "Germicidal" lamp. This lamp will be used in industrial and commercial organiza-

TABLE VIII-6<sup>26</sup>  
GERMICIDAL LAMPS

	15-watt (same as fluorescent)	5-watt	3-watt
Overall length	17 $\frac{3}{4}$ in.	7 $\frac{7}{8}$ in.	5 $\frac{7}{8}$ in.
Diameter	1 in.	1 $\frac{1}{4}$ in.	$\frac{1}{2}$ in.
Operating voltages	100-125 v. 60 cy.	110-125 v. 50-60 cy.	60 cy.
Nominal lamp amperes	30	048	.050
Watts including reactor	19	5	4
Life	2000 hr.	1500 hr.	1000 hr.
U. V. output	20 to 25 $\mu$ w. per sq. cm. of 2537 Å at 1 m.	1 $\mu$ w. per sq. cm. at 1 m.	5 to 6 $\mu$ w. per sq. cm. at 1 m.
Base	FA-1 cap	Med. screw	Radio No. 4108
Operating auxiliary	Same as for 15-w. T-8 fluorescent lamp	None required	67G50
Burning position	Any	Any	Any
Bulb	T-8	T-10	T-4

tions which store and handle foods and also in hospitals. It operates in the ultra-violet region most effective for germicidal action at the same output as the fluorescent lamp (253.7 m $\mu$  in the ultra-violet). Table VIII-6 gives the technical data concerning these lamps.

**13. Fluorescent Lamps.**<sup>8, 18, 19, 21</sup> The fluorescent lamp is a gaseous discharge lamp of the mercury vapor type, making use of ultra-violet energy (maximum output 253.7 m $\mu$ ) to activate a coat of fluorescent material on the inside of the tube. The material used to coat the in-

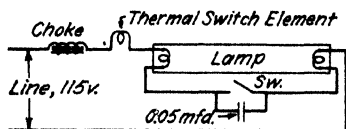

(a-1)-Thermal Switch Auxiliary, Power Factor 50% Lagging

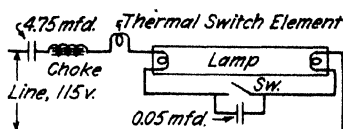

(a-6)-Power Factor 80% Leading

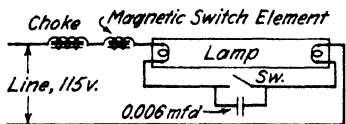

(a-2)-Magnetic Switch Auxiliary, Power Factor 50% Lagging

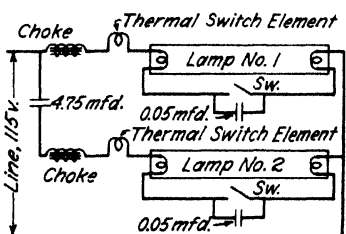

(a-3)-Two Lamp Unit Auxiliary, Power Factor 95% to 100%

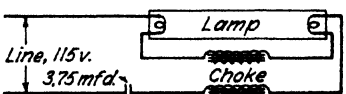

(a-4)-Resonant Auxiliary, Power Factor 60% Leading

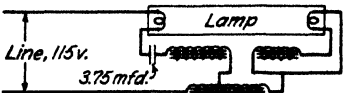

(a-5)-Resonant Auxiliary, Power Factor 60% Lagging

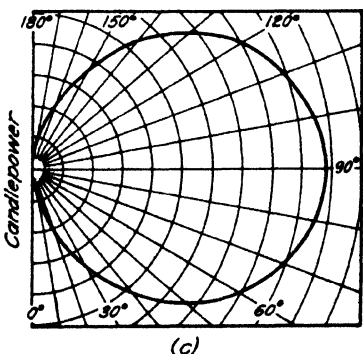
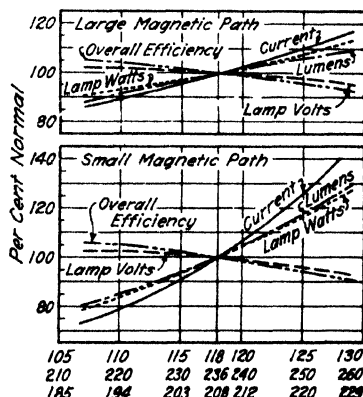

FIG. 16-6.<sup>30</sup> (a) Circuits for fluorescent lamps. (b) The characteristics of fluorescent lamps with voltage change. (c) Candlepower distribution curve for fluorescent lamps.

side of the tube is called a "phosphor," and it transforms the short waves in the ultra-violet (253.7 mμ) into the longer waves (400 to 700 mμ) of the visible spectrum. The phosphors are produced syn-

thetically in order to control the purity, and one or more of these various chemicals are used in producing the various colors in which the fluorescent lamps are manufactured. To facilitate emission and produce the starting arc, mercury and a slight amount of argon are introduced into the tube. When the phosphor and the maximum energy output wavelength are adjusted to each other, a very efficient light source is produced since the light from the visible spectrum of the arc and the radiant energy from the ultra-violet are both utilized.

Auxiliary equipment is required for fluorescent lamps just as it is for the other gaseous types, and the lagging power factor of an uncorrected unit is approximately 60 per cent. By the use of special circuits and a condenser of suitable capacity, it is possible to improve this power factor to 95 or 100 per cent. Recent developments in auxiliary equipment have eliminated all objectionable features except the hum, which is an inherent feature of the choke. Figure 16-6a shows six circuits for connecting auxiliaries, condensers, and fluorescent lamps. The circuit using two lamps is a very satisfactory arrangement, for it corrects power factor and reduces flicker or stroboscopic effect. Circuits combining leading and lagging arrangements may be used for producing unity power factor.

Figure 16-6b shows the characteristics of the fluorescent lamps. It will be noted that the variation of the characteristic is not independent of the auxiliary used. With the thermal type of switch (small magnetic path), 1 per cent variation in voltage causes a 2 or 3 per cent change in lumen output; with the magnetic type of switch (large magnetic path), the same change in voltage produces only a 1 per cent change in lumen output. Where the lamps are installed on a system with marked voltage rise, it is well to use the more expensive magnetic switch auxiliary. For reliable and efficient operation, the lamps should never be operated at less than 105 (210) v. or more than 125 (250) v. Figure 16-6c shows the candlepower distribution of the fluorescent lamp. This curve has a characteristic resembling that of a theoretical line source discussed in Chapter 5.

In replacing incandescent lamps with the new fluorescent lamps, the wiring cannot be determined from the wattage but must be calculated from the volt-amperes. In an economic study of such replacements, it is necessary to consider the auxiliary both as to power consumption and power factor, because part of the lighting unit and the lumen output of both types of lamps should be weighted in volt-amperes and not in watts.

The chief advantage of fluorescent lamps lies in the production of colored light at efficiencies much higher than those using the subtrac-

TABLE IX-6\*  
CHARACTERISTICS OF FLUORESCENT LAMPS AND BALLASTS  
(March, 1941)

Wattage Size*	6	8	14	15	20	30	40	65	100
Nominal length, inches	9	12	15	18	24	36	48	36	60
Diameter	5/8 in.	5/8 in.	1 1/8 in.	1 in.	1 1/2 in.	1 in.	1 1/2 in.	2 1/8 in.	2 1/8 in.
Bulb	T-5	T-5	T-12	T-8	T-12	T-8	T-12	T-17	T-17
Approx. lamp amperes	0.15	0.18	0.37	0.30	0.35	0.34	0.41	1.35	1.45
Approx. lamp volts	45	54	41	56	62	103	108	50	72
Circuit voltages	110-125	110-125	105-125†	110-125	110-125	199-216 220-250 110-125	199-216 220-250 110-125	110-125	199-216 220-250 110-125
Rated aver. life, hr. **	750	750	1500	2500	2500	2500	2500	2000	2000

Wattage Size,\* Lumen Outputs, † and Brightnesses\*\*\*

Wattage Size	6		8		14		15		20		30		40		65		100	
	Lumens	Foot-Lamberts	Lumens	Foot-Lamberts	Lumens	Foot-Lamberts	Lumens	Foot-Lamberts	Lumens	Foot-Lamberts	Lumens	Foot-Lamberts	Lumens	Foot-Lamberts	Lumens	Foot-Lamberts	Lumens	Foot-Lamberts
White	180	2450	300	2440	460	1300	615	2150	900	1650	1450	2475	2100	1750	2100	1530	4200	2180
Daylight	155	2100	250	2030	370	1050	495	1750	730	1350	1200	2050	1700	1400	1800	1310	3350	1750
Soft white					325	920	435	1550	640	1200	1050	1800	1500	1250				
Blue						315	1125	460	850	780	1350							
Green						900	3200	1300	2400	2250	3900							
Pink						300	1050	440	800	750	1300							
Gold						375	1650	540	1000	930	1600							
Red						45	160	60	110	120	210							

High Power Factor Single-Lamp Ballasts — 60 Cycles  
(Power factor above 90 %)

Lamp Watts	Circuit Voltage	Overall Dimensions Inches	Weight Pounds	Approx. Watts Loss
15	110-125	1 7/8 x 2 1/4 x 8 3/4	1 1/2	4 1/2
20	110-125	1 7/8 x 2 1/4 x 8 3/4	1 1/2	4 1/2
30	110-125	1 7/8 x 2 1/4 x 14 1/4	3 1/2	10
	199-216	1 7/8 x 2 1/4 x 10 5/8	2 1/2	8
40	220-250	1 7/8 x 2 1/4 x 10 5/8	2 1/2	9
	110-125	1 7/8 x 2 1/4 x 14 1/4	3 1/2	13
65	199-216	1 7/8 x 2 1/4 x 10 5/8	2 1/2	12
	220-250	1 7/8 x 2 1/4 x 10 5/8	2 1/2	13
100	110-125	2 3/8 x 3 3/8 x 14 1/4	9 1/2	24
	110-125	2 3/8 x 3 3/8 x 14 1/4	10 1/4	24
	199-216	2 3/8 x 3 3/8 x 14 1/4	10 1/4	24
	220-250	2 3/8 x 3 3/8 x 14 1/4	10 1/4	24

\* Add auxiliary watts for total.

† Voltage range for two-in-series operation in which a specially designed filament lamp (60 v. 1/2 amp., S-11 outside-white bulb, intermediate-screw base) is used as a resistance ballast. Total wattage of two lamps and ballast is 45 on alternating current, 38 on direct current.

\*\* Under specified test conditions.

‡ Lumen output ratings apply at the end of 100 hr. of operation. The efficiency of daylight and white Type F lamps at 70 per cent of rated life is about 85 per cent of initial rating.

\*\*\* Maximum values at center of lamp perpendicular to the lamp. 1 c. per sq. in. = 452 ft.-L.

The type RF lamp is a special type of fluorescent lamp used on rectified current from specially designed auxiliary equipment. The lamps are rated at 85 w., 3000 hr. life with an output of 4000 l. Available in two colors, designated as "blue-white" and "industrial white."

TABLE IX-6—Continued  
 High Power Factor Tulamp Ballasts — 60 Cycles  
 (Power factor corrected to 95–100 %)

Lamp Watts	Circuit Voltage	Overall Dimensions, Inches	Weight, Pounds	Approx. Watts Loss
15	110–125	$1\frac{1}{2} \times 2\frac{1}{4} \times 14\frac{1}{4}$	$3\frac{3}{8}$	9
20	110–125	$1\frac{1}{2} \times 2\frac{1}{4} \times 14\frac{1}{4}$	$3\frac{3}{8}$	9
30 *	110–125	$2\frac{3}{8} \times 3\frac{3}{8} \times 9\frac{1}{2}$	7	$14\frac{1}{2}$
	199–216	$2\frac{3}{8} \times 3\frac{3}{8} \times 9\frac{1}{2}$	$6\frac{3}{4}$	12
	220–250	$2\frac{3}{8} \times 3\frac{1}{8} \times 9\frac{1}{2}$	$6\frac{3}{4}$	$12\frac{1}{2}$
40 *	110–125	$2\frac{3}{8} \times 3\frac{3}{8} \times 9\frac{1}{2}$	7	$17\frac{1}{2}$
	199–216	$2\frac{3}{8} \times 3\frac{3}{8} \times 9\frac{1}{2}$	$6\frac{3}{4}$	$13\frac{1}{2}$
	220–250	$2\frac{3}{8} \times 3\frac{1}{8} \times 9\frac{1}{2}$	$6\frac{3}{4}$	$14\frac{1}{2}$
65	110–125	$2\frac{3}{8} \times 3\frac{1}{2} \times 14\frac{1}{4}$	$10\frac{1}{4}$	24
100	110–125	$2\frac{3}{8} \times 3\frac{3}{8} \times 19\frac{1}{4}$	$14\frac{1}{2}$	35
	199–216	$2\frac{3}{8} \times 3\frac{3}{8} \times 19\frac{1}{4}$	$14\frac{1}{2}$	35
	220–250	$2\frac{3}{8} \times 3\frac{1}{8} \times 19\frac{1}{4}$	$14\frac{1}{2}$	35

\* Starting compensator is necessary when 30- and 40-w. Tulamp ballasts are used. Overall size  $1\frac{1}{4}$  by  $1\frac{1}{4}$  by  $4\frac{1}{4}$  in.

live method. Table IX-6 gives the ratings and outputs of the lamps now available. It is possible to obtain daylight conditions (6500° K, I. C. I. daylight) at approximately 30 l. per w.; a performance much superior to that of any type of filter system. The same is true for all other colors; however, when the white light (incandescent light) characteristics are desired, the first cost must be considered as well as the cost of power. In air-conditioned rooms and buildings, the problem of heat dissipation is a factor in favor of the fluorescent lamp; however, its advantage must be justified by a study of cost, not by opinion alone.

Figure 17-6 gives the spectral distribution curves for fluorescent lamps having equal wattages but different colors. The continuous spectrum is shown with the energy in the four visible lines of the mercury spectrum which is plotted to slit widths of 200 m $\mu$ . With the exception of the red and gold lamps, the energy in the mercury lines should be added to the continuous spectra in plotting the complete distribution. The gold has absorbed the 404.7-m $\mu$  and the 435.8-m $\mu$  lines, and all four lines are absorbed in the red lamp.

Tables X-6A and X-6B show the distribution of the radiant energy from the lamps previously discussed compared with that from the fluorescent lamp. Table X-6B shows, in detail, the distribution of the power entering the daylight fluorescent lamp and the incre-

ments of power delivered from the lamp in the various radiant regions. It should be noted that only 50 per cent leaves by convection and conduction. That is why the lamp is called a cool light source. Previous

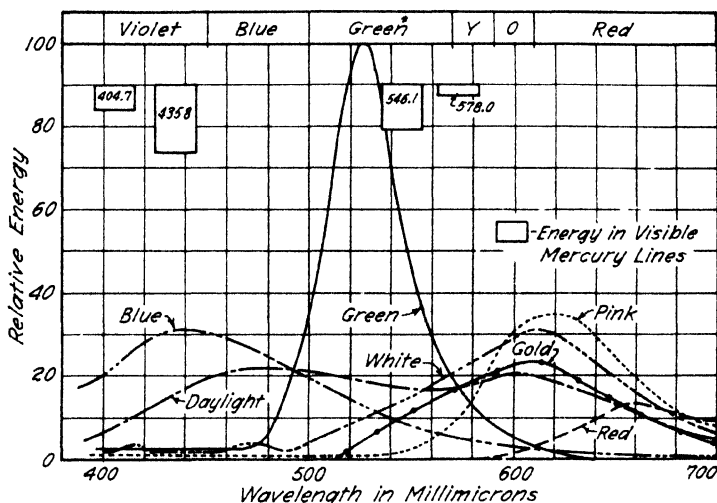

FIG. 17-6.<sup>24</sup> Spectral distribution curves for fluorescent lamps.

studies have shown that the actual temperature rise in a room from an incandescent light source is approximately 0.3° F per w. per sq. ft., which, for an installation of 5 w. per sq. ft. is 1.5° F, not enough to account for the discomfort caused by light units during hot weather.

TABLE X-6A<sup>25</sup>  
LAMP ENERGY DISTRIBUTION

Type	Convection and Conduction Per cent	Radiant Energy Per cent	Light Per cent
500-w. incandescent	19	70	11
400-w. H-1 mercury	38	51	11
15-w. fluorescent	53	34	13
1000-w. H-6 mercury	62	10	28

That distress is caused by the radiant energy, a fact which has been recognized for some time by those studying human comfort with respect to air conditioning. The fluorescent lamp, with only 47 per cent in radiant energy as compared with the 81 per cent of the incandescent lamp, will seem relatively cool.



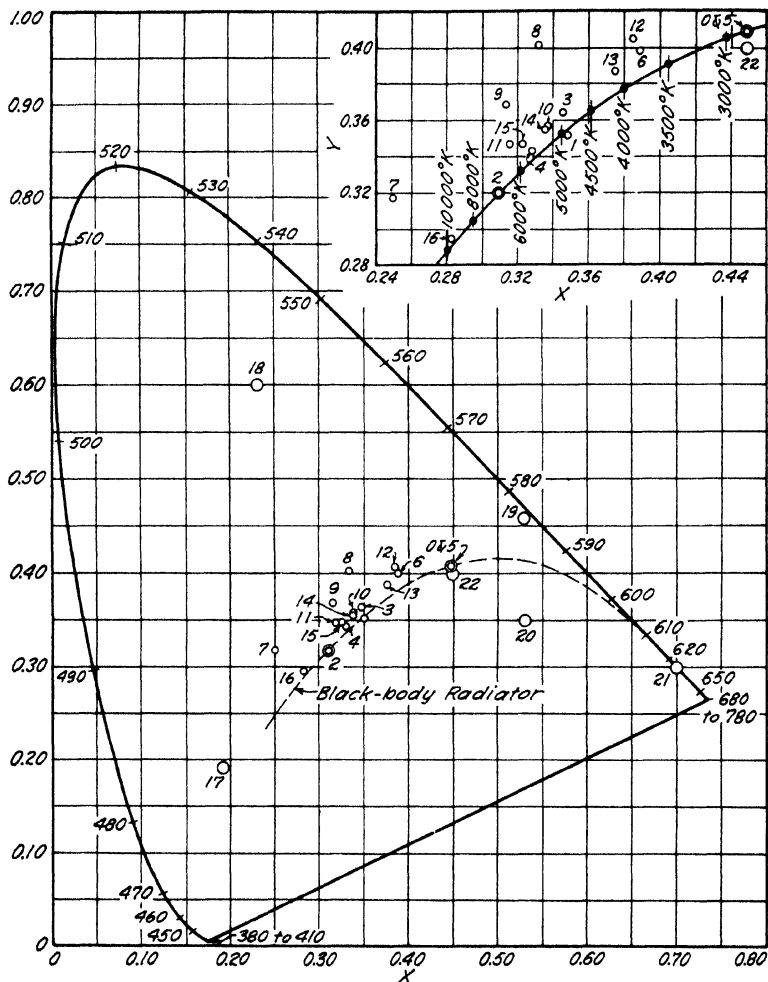

- |   |                                  |
|---|----------------------------------|
| 0 - Illuminant A  | 5 - 200-w. Incandescent          |
| 1 - Illuminant B  | 6 - 300-w. Daylight Incandescent |
| 2 - Illuminant C  | 7 - 50-in., L.P. Mercury         |
| 3 - Noon Sunlight - June                                      | 8 - 400-w. Type H-1 Mercury      |
| 4 - Average Daylight - June                                   | 9 - 250-w. Type H-2 Mercury      |
| 10 - 50-in. Mercury + 2-200-w. Incandescent                   |                                  |
| 11 - 50-in. Mercury + 4-75-w. Incandescent                    |                                  |
| 12 - Type H-1 Mercury + 4-200-w. Incandescent                 |                                  |
| 13 - Type H-2 Mercury + 2-200-w. Incandescent                 |                                  |
| 14 - Ivanhoe Trutint Noon Sunlight Unit, 200-w. Incandescent  |                                  |
| 15 - Corning Na 590 Daylight Glass, 5mm., 200-w. Incandescent |                                  |
| 16 - Ivanhoe Trutint North Skylight Unit, 200-w. Incandescent |                                  |
| Fluorescent - 17 - Blue                                       | 18 - Green                       |
| 19 - Gold   | 20 - Pink                        |
| 21 - Red  | 22 - White                       |
| 2 - Daylight  |                                  |

Fig. 18-6.<sup>14, 20</sup> Chromaticity diagram showing the location of incandescent, mercury vapor, and fluorescent lamps.

The configuration of tubular fluorescent lamps necessitates different types of reflector design than those accepted in the normal lighting system. The reflectors must be so shaped that little of the light from the reflector is redirected onto the lamp itself, for it is opaque in nature and such light would be lost.

**14. Chromaticity of Gaseous Conduction Lamps.**<sup>14, 20</sup> All of the gaseous discharge lamps have such definite color characteristics that their analysis is not complete until these characteristics have been studied. Figure 18-6 gives the chromaticity diagram for incandescent, mercury, and fluorescent lamps of various colors.

The use of gaseous lamps by themselves or in conjunction with

TABLE X-6B<sup>25</sup>  
ENERGY DISTRIBUTION DAYLIGHT FLUORESCENT LAMP

15 w. input	Ultra-violet	7.5 w.	(at 253.7 mμ)		
	Visible Light	0.2 w.			
	Infra-red Convection Conduction	7.2 w.			
15 w. output	Visible	2.0 w.	13%	7.5 w.	13 w. 87%
	Infra-red	5.5 w.	37%		
	Convection	5.8 w.	39%	7.5 w.	
	Conduction	1.7 w.	11%		

other lamps makes it necessary to analyze the spectral qualities before a reasonable prediction of the resultant effect can be made. The spectral curves given for the sources may be studied with respect to the reflectance curves of any material or with the transmission curves of transmitting material. The combination of source and surface may be studied in conjunction with the visibility curve in order to determine the luminosity curve, from which the luminous efficiency or luminous utilization of the installation can be calculated.

BIBLIOGRAPHY

1. A. B. ODAY and L. C. PORTER, "The Use of Ultraviolet Sources for the General Illumination of Interiors", *I. E. S. Trans.*, v. 28, No. 2, February, 1933.
2. L. J. BUTTOLPH, "A Review of Gaseous Conduction Lamps," *I. E. S. Trans.*, v. 38, No. 2, February, 1933.

3. J. D. WHITTAKER, "Applications of Silver Processed Incandescent Lamp with Technical Data," *I. E. S. Trans.*, v. 28, No. 5, May, 1933.
4. D. R. GRANDY, "Combining Mercury Vapor and Incandescent Lamps to Produce Commercial White Light," *I. E. S. Trans.*, v. 38, No. 9, November, 1933.
5. L. J. BUTTOLPH, "The Characteristics of Gaseous Conduction Lamp and Light," *I. E. S. Trans.*, v. 30, No. 2, February, 1935.
6. WARD HARRISON, "Applications of the New Gaseous-Conductor Lamps," *I. E. S. Trans.*, v. 30, No. 2, February, 1935.
- 7: O. P. CLEAVER, "The Practical Application of Sodium and High Intensity Mercury Vapor Lamps," *I. E. S. Trans.*, v. 30, No. 9, November, 1935.
8. L. J. BUTTOLPH and L. B. JOHNSON, "Ultraviolet Radiation and Fluorescence," *I. E. S. Trans.*, v. 31, No. 1, January, 1936.
9. J. A. ST. LOUIS, "Characteristics of 400-watt and 250-watt Type-H Mercury Lamps," *I. E. S. Trans.*, v. 31, No. 6, June, 1936.
10. L. A. HAWKINS, "The Status of Vapor Lamps," *I. E. S. Trans.*, v. 32, No. 1, January, 1937.
11. D. S. GUSTIN, "Characteristics of the 85-watt, High Intensity Mercury Vapor Lamp," *I. E. S. Trans.*, v. 32, No. 3, March, 1937.
12. W. E. FORSYTHE and E. O. ADAMS, "The Tungsten Filament Incandescent Lamp," *Denison Univ. Bul.*, v. 32, April, 1937.
13. L. B. JOHNSON, "Photometry of Gaseous Conducting Lamps," *I. E. S. Trans.*, v. 32, No. 6, June, 1937.
14. M. LUCKIESH, A. H. TAYLOR, and G. P. KERR, "Artificial White Light," *G. E. Review*, February, 1938.
15. C. G. FOUND, "Fundamentals of Electric Discharge Lamps," *I. E. S. Trans.*, v. 33, No. 2, February, 1938.
16. J. B. McMATH, "Development and Use of Gaseous Conductor Tubes," *I. E. S. Trans.*, v. 33, No. 7, July, 1938.
17. R. C. KELTING and L. J. BUTTOLPH, "Improvements in the Low Pressure Mercury Vapor Lamp," *I. E. S. Trans.*, v. 33, No. 7, July, 1938.
18. G. E. INMAN, "Characteristics of Fluorescent Lamps," *I. E. S. Trans.*, v. 34, No. 1, January, 1939.
19. W. MARDEN, N. C. BEESE, and C. J. MEISTER, "Effect of Temperature on Fluorescent Lamps," *I. E. S. Trans.*, v. 34, No. 1, January, 1939.
20. W. HARRISON, "Fluorescent Lamps," *The Magazine of Light*, v. 7, No. 2, March, 1939.
21. A. H. TAYLOR, "Daylight Fluorescent Lamps," *The Magazine of Light*, v. 7, No. 2, March, 1939.
22. L. S. ICKIS, JR. and HOWARD HAYNES, "Drying with Near Infra-red Radiation," *G. E. Review*, v. 42, No. 4, April, 1939.
23. R. C. KELTING and L. J. BUTTOLPH, "A More Efficient Cooper-Hewitt Lamp," *G. E. Review*, v. 42, No. 4, April, 1939.
24. C. E. WEITZ and R. F. CISELL, "Spectral Analysis of Radiant Energy," *I. E. S. Trans.*, v. 34, No. 5, May, 1939.
25. C. E. WEITZ, "Mazda Lamps," *Nela Park Bulletin* LD-1, August, 1939.
26. L. C. PORTER, "Three Germicidal Lamps," *The Magazine of Light*, v. 8, No. 6, September, 1939.
27. A. B. ODAY and R. F. CISELL, "Fluorescent Lamps and Their Application," *I. E. S. Trans.*, v. 34, No. 10, pp. 1165-1188, August, 1939.
28. D. CANNELL, E. Q. ADAMS, and J. C. FORBES, "A Means of Minimizing

- Radiant Heat from High Level Lighting Systems," *I. E. S. Trans.*, v. 34, No. 7, July, 1939.
29. L. C. PORTER, "Three Germicidal Lamps Offer Wider G. E. Service In New Field," *The Magazine of Light*, v. 8, No. 6, p. 15, September, 1939.
  30. B. T. BARNES, W. E. FORSYTHE, and W. J. KARASH, "Spectral Distribution of Radiation from Lamps of Various Types," *G. E. Review*, v. 42, No. 12, pp. 540-544, December, 1939.
  31. A. B. ODAY and R. F. CISELL, "Fluorescent Lamps and Their Applications," *I. E. S. Trans.*, v. 34, No. 10, pp. 1165-1188, December, 1939.
  32. A. H. TAYLOR, "The Fluorescent Mazda Daylight Lamp," *The Magazine of Light*, v. 9, No. 3, pp. 11-14, April, 1940.
  33. H. F. BARNES, "Choosing the Right Lamp for the Job," *The Magazine of Light*, v. 9, No. 4, p. 16, May, 1940.
  34. L. C. PORTER and P. W. NEIDHARDT, "Germicidal Lamps — A New Tool for Industry and a Contribution to Health," *G. E. Review*, v. 43, No. 5, pp. 202-206, May, 1940.
  35. E. S. MILLS and J. H. CAMPBELL, "Fluorescent Lamps and Radio Reception," *The Magazine of Light*, v. 9, No. 5, pp. 30-31, June, 1940.
  36. A. H. TAYLOR, "Influence of Fluorescent Lighting on the Colors of Decorations and Furnishings," *I. E. S. Trans.*, v. 35, No. 7, pp. 625-628, July, 1940.
  37. ALLAN E. PARKER, "Measurement of Illumination from Gaseous Discharge Lamps," *I. E. S. Trans.*, v. 35, No. 9, pp. 833-848, November, 1940.
  38. R. F. HAYS and D. S. GUSTIN, "Alternating Current Circuits for Fluorescent Lamps," *I. E. S. Trans.*, v. 35, No. 10, pp. 939-948, December, 1940.
  39. H. C. RENTSCHLER, "Bactericidal Ultraviolet Radiation and Its Uses," *I. E. S. Trans.*, v. 35, No. 10, pp. 960-980, December, 1940.
  40. HOWARD HAYNES, "The Use of Radiant Energy for the Application of Heat," *I. E. S. Trans.*, v. 36, No. 1, pp. 61-78, January, 1941.
  41. J. W. MARDEN and N. C. BEESE, "Ultraviolet Excitation of Fluorescent Compounds," *I. E. S. Trans.*, v. 36, No. 2, pp. 235-242, February, 1941.
  42. LEWIS R. KOLLER, "Infrared: Production and Transmission Reflection and Measurement," *G. E. Review*, v. 44, No. 3, pp. 167-174, March, 1941.

## CHAPTER 7

### LIGHT CONTROL

The term "light control" in its broadest sense should be applied to any factor which will influence the light output. If defined in this manner, this classification will include room size and color as well as the characteristics of specific equipment.

A study of light control will include the following classifications:

- A. Classes of substances used
  - 1. Transparent
  - 2. Translucent
  - 3. Opaque
  
- B. Light-beam control
  - 1. Reflection
  - 2. Transmission
  - 3. Refraction
  
- C. Surfaces and media used
  - 1. Diffusing
  - 2. Redirecting
  - 3. Scattering
  
- D. Luminaires
  - 1. Direct
  - 2. Semi-direct
  - 3. General diffusing
  - 4. Semi-indirect
  - 5. Indirect
  - 6. Supplementary
  
- E. Installation
  - 1. Room dimensions
  - 2. Candlepower distribution of luminaire
  - 3. Color of ceiling and side wall
  - 4. Utilization factor

**1. Classes of Substances.**<sup>2</sup> In screening and directing light, three classes of substances are used: *transparent*, *translucent*, and *opaque*.

The *transparent* materials transmit a large portion of the light that strikes the surface without either diffusing or redirecting it; therefore, objects may be seen clearly through a transparent material. Most prominent in this class are the flint, crystal, and clear glasses. Polished plate glass, from which surface irregularities have been removed by grinding and polishing, making the planes of its two surfaces approximately parallel, and window glass, in which there is a characteristic waviness of surface, belong in this classification. Transparent materials are used for admitting daylight and for seeing from interiors, but with present-day high brightness light sources, it cannot be used for light control without excess glare from the source. When illuminating by diffused light, or from sand-blasted or carved edges, transparent materials have excellent decorative values.

*Translucent* substances transmit light, but scatter it in such a way that objects cannot be clearly seen through it. In this group are found the various glasses used in carrying out designs using different types of luminaires and light elements. The following describes the properties of the various subdivisions of this class:

**OPAL GLASS** is a highly diffusing glass having a nearly white, milky, or gray appearance. The diffusing properties are an inherent, internal characteristic of the glass.

**OPALESCENT GLASS** is a type of opal glass which selectively transmits and diffuses light and has a resultant *fire* appearance when used with a concentrating incandescent source of light.

**ALABASTER GLASS** is a glass simulating natural alabaster and having a gray or paraffin-like appearance. Comparatively, it usually has less diffusing power than opal glass.

**CASED GLASS** is a glass composed of two or more layers of different glasses, usually a clear, transparent layer to which is added a layer of opal, opalescent, or colored glass.

**ENAMELED GLASS** is a glass which is coated with enamel. The enamels may be white or colored and have varying degrees of diffusion.

**DECORATED GLASS** is a glass to which etchings, stains, enamels, or other finishes have been applied, primarily for decorative purposes.

**MATTE SURFACE GLASS** is a glass whose surface has been altered by etching, sand blasting, grinding, or other means to increase the diffusion. Either one or both surfaces may be treated.

**CONFIGURATED GLASS** is a glass with a patterned or irregular surface. The surface configuration is usually applied during fabrication. Descriptive adjectives are needed for each particular type of surface.

**PRISMATIC GLASS** is a clear glass into the surface of which is fabricated a series of prisms, the function of which is to direct the incident light in desired directions.

**ANTIQUÉ GLASS** is a glass relatively smooth of surface, but having a slight degree of non-uniform diffusion because of the intentional presence of bubbles, striae, or fissures.

Any of the above glasses may carry a descriptive adjective defining color or special treatment; however, it would be well to follow closely the classification of the committee to avoid confusion in specifying the material desired.

*Opaque* materials are used for redirecting light. These do not transmit any of the light; it is either reflected or absorbed. The polished metals, mirrors, dull- or matte-finished surfaces are found in this class.

**2. Reflection, Transmission, and Absorption.** A beam of light travels along a straight line until it is modified or redirected by some object. When the beam of light encounters an object, the light may be reflected, transmitted, or absorbed. At least two of these phenomena always take place.

In an algebraic sense the operation characteristics may be combined into the following expression:

$$\rho + \gamma + \alpha = 1$$

where  $\rho$ , the *reflection factor*, is the ratio of the reflected light to the incident light;  $\gamma$  is the *transmission factor* and is equal to the ratio of the transmitted light to the incident light;  $\alpha$  is the *absorption factor* and is the ratio of the absorbed light to the incident light. Since the sum of these factors is unity any two of them is unity minus the third.

Both surfaces and media have special characteristics which modify the distribution of light, but these characteristics are so closely associated with reflection, transmission, and absorption that they must be studied together. *Diffusing surfaces* are those which break up the incident light and distribute it in accordance with the cosine law (rough plaster and opal glass are examples). *Redirecting surfaces* change the direction of the light in a definite manner (mirrors or prisms). *Scattering surfaces* redirect the light into a multiplicity of separate pencils by reflection or transmission (configured glass). Figure 1-7 shows characteristic reflection and transmission patterns for the various classes of media and surfaces. If color is involved in the material or the surface, the result is a *selective reflection* in which only those color wavelengths present will be reflected; the remaining ones will be absorbed.

The simplest form of reflection is that from a polished redirecting surface, upon which the angle of reflection is equal to the angle of incidence (classified as *regular* or *specular reflection*). When light strikes a diffusing surface, the result is *diffused reflection*, because the light is reflected in all directions. This becomes a *perfectly diffused reflection* when the redirected light is distributed in accordance with the cosine law so that the reflecting surface appears equally bright from any direction. The coefficients expressing these types of reflection are:

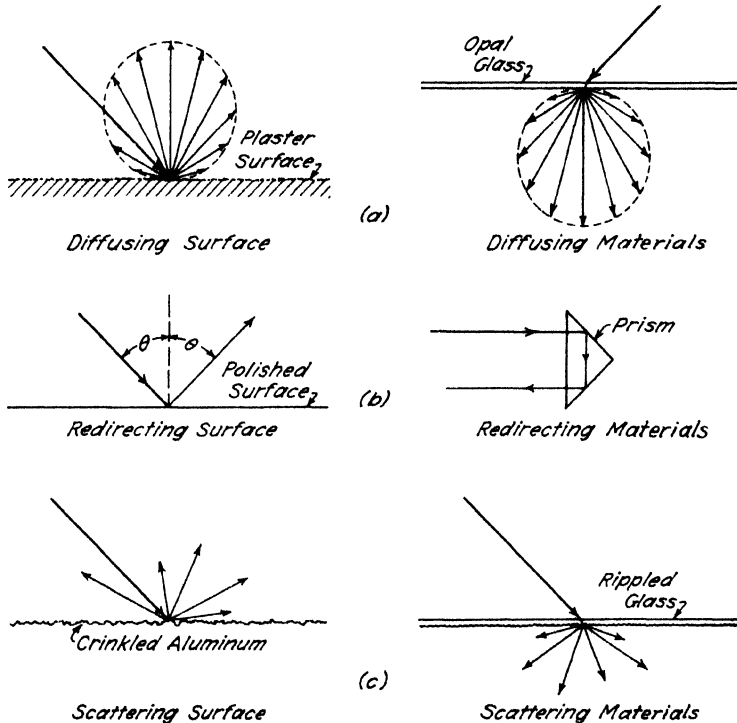

FIG. 1-7. Characteristic reflection and transmission patterns for various materials and surfaces. (a) Illustrates Lambert's cosine law:  $I = I_m \cos \theta$ .

Regular reflection factor of a body is the ratio of the regular reflected light to the incident light.

Diffused reflection factor of a body is the ratio of the diffusely reflected light to the incident light.

The reflection from any surface may be a mixture of specular and diffused reflection; in fact, this is true in most instances. Figure 2-7a shows two types of reflection.

Transmitting material finds wide application in illumination where it diffuses or reflects light. The transmitting properties of a material



have as specific characteristics as do the reflecting properties. *Regular transmission* is that in which the transmitted light is not diffused. The direction of a transmitted pencil of light has a definite geometrical relation to the corresponding incident pencil and, if the direction is not changed, the characteristic is called *direct transmission*. If the transmission is such that the transmitted light is distributed in accordance with the cosine law so that the surface of the transmitting body

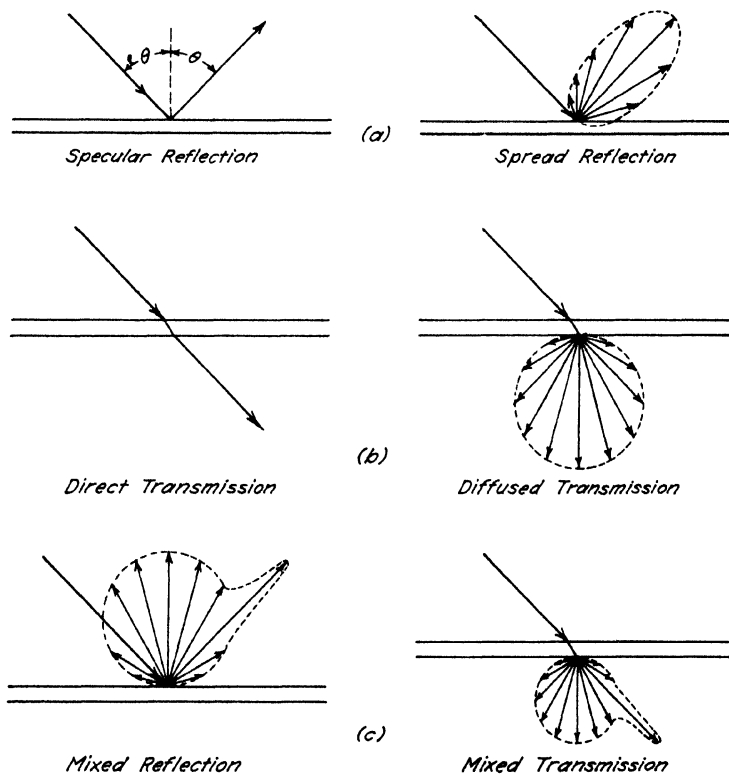

FIG. 2-7. Types of reflection.

appears equally bright from all angles, it is said to have perfectly diffused transmission. A resultant transmitted light which is emitted in all directions from the transmitting body is said to have diffused transmission. The transmission from bodies has coefficients expressing the different types of transmission:

**REGULAR TRANSMISSION FACTOR** is the ratio of the regularly transmitted light to the incident light.

TABLE I-7A<sup>a</sup>TRANSMISSION, REFLECTION, AND ABSORPTION FACTORS FOR TYPICAL  
TRANSLUCENT MATERIALS

Type	Thickness	Trans- mission	Reflection	Absorption
	Inches	Per Cent	Per Cent	Per Cent
Clear glass		80-92	8-10	2-10
Clear glass (silvered)			82-93	7-18
Configurated, obscure clear glass	.12-.23	57-90	7-24	3-21
Clear glass:				
Satin finish:				
toward source	.075	89	8	3
away from source	.075	85-88	6-8	4-9
Acid etched:				
toward source	.08	82-88	7-9	5-10
away from source	.08	63-78	12-20	10-17
Sand-blasted:				
toward source	.08-.12	77-81	11-16	7-11
away from source	.08-.12	70-77	13-18	10-16
Alabaster glass	.125-.19	60-70	20-30	10
Other opalescent glasses	.09	58-84	13-28	2-14
Marble (CaCO <sub>3</sub> ):				
one side polished	.29-.39	3-8	30-71	24-65
impregnated	.12-.20	12-40	27-54	11-49
Alabaster (CaSO <sub>4</sub> ):				
veined	.44-.53	17-30	49-67	14-21
colored	.25	34-50	27-29	21-39
White ceramic coated clear glass				
varying diffusion	.125	40-64	24-50	10-13
Flashed opal glass:				
Group 1	.08-.11	47-66	31-45	3-10
Group 2	.11-.13	27-35	54-67	8-11
Composition				
White diffusing	.010-.025	0-41	32-75	7-27
Clear matte (typical sample)	.010	68	15	17
Solid opal glass				
Group 1	.07-.14	12-38	40-66	20-31
Group 2	.07-.10	37-51	43-54	6-11
Group 3	.06-.14	13-35	65-78	4-10

DIFFUSED TRANSMISSION FACTOR is the ratio of the diffusely transmitted light to the incident light.

In practical application there is usually a superposition of regular and diffused transmission. It will be noted that the above factors refer to the light emerging from a body; therefore, the factors include

losses caused by reflection and absorption. Figures 2-7b and 2-7c show types of transmission.

Transmission and reflection factors depend upon the angle of incidence. This angle, therefore, should be stated as well as the factor;

TABLE I-7B<sup>1</sup>  
REFLECTION FACTORS FOR TYPICAL OPAQUE MATERIALS

Material	Reflection
<b>Paint:</b>	
Flat white	75-85
Gloss white	75-80
<b>Vitreous porcelain enamel on steel:</b>	
Matte white	60-83
Glazed white	65-77
<b>Plaster — white</b>	90-95
<b>Terra cotta:</b>	
White and cream — smooth and matte	60-80
<b>Sandstone — one sample</b>	41
<b>Limestone</b>	35-58
<b>Marble (CaCO<sub>3</sub>):</b>	
One side polished	30-71
Impregnated	27-54
<b>Alabaster (CaSO<sub>4</sub>):</b>	
Veined	49-67
Colored	27-29
<b>Matte-finished metal:</b>	
Oxidized or etched aluminum	70-89
Aluminum paint	60-65
Alzak aluminum etched	80
<b>Polished metal:</b>	
Silver	90-92
Chromium	63-66
Aluminum	62
Monel metal	49-55
Chromium-nickel (stainless) steel	55
Alzak aluminum polished	85
Cadmium	62
Nickel plate steel	63

wherever the angle is not stated, it is assumed to be normal. Since reflection and transmission may be selective, the above factors should be stated in accordance with the illuminant used. For correct specifications a report of either the reflection or transmission should include:

1. Type of surface
2. Angle of incidence
3. Types of illuminant

Figure 2-7c shows mixed reflection and transmission

Since it is difficult to measure absorption of a surface or a material, it is determined by subtracting the sum of the reflected light and the transmitted light from the incident light. Tables I-7A and I-7B give the reflection, transmission, and absorption factors of typical translucent and reflecting materials.

Redirecting surfaces are of interest because the light is refracted (changed in direction). Any lens system belongs to this class, and all

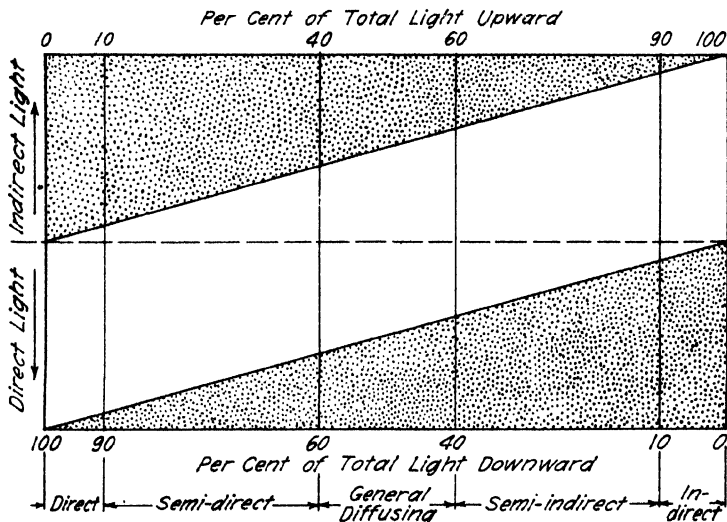

FIG. 3-7. Classification of luminaires.

fresnel and prism glasses or lighting units refract light. It is possible to obtain total reflection with a prism, but its application consists of installations in which a wide spread of light is desired. Factory rib glass, commonly used in industrial plants, is one example of this type of control.

**3. Luminaires.** At the beginning of the chapter, a listing of the various classifications of luminaires was given. For many years it has been the practice in this country to use three classifications: direct, semi-indirect, and indirect. Continental practice has always included a fourth class, the semi-direct, and recently the new school code and industrial code has added a fifth class, the *general diffusing*, as recom-

mended by the International Commission on Illumination. Table II-7 gives the approximate proportion of light upward and downward, and Fig. 3-7 gives a graphic representation of the classification. In addition to the characteristic of the light source, there is also control of the illumination by the position and number of units. *Unidirectional illumination* is produced by a single light source of relatively small dimensions. It is characterized by the fact that a small, opaque object placed near the illuminated surface casts a sharp shadow. *Multi-directional illumination* is produced by several sources of relatively small area, and a small, opaque object placed near the illuminated surface casts several shadows. *Diffused illumination* is produced by primary or secondary light sources having dimensions relatively large with respect to the distance from the point illuminated, and scattering

TABLE II-7<sup>4, 6</sup>  
TYPES OF LUMINAIRES

Classification	Approximate Distribution of Output	
	Upward Per Cent	Downward Per Cent
Direct	0-10	90-100
Semi-direct	10-40	60-90
General diffusing	40-60	40-60
Semi-indirect	60-90	10-40
Indirect	90-100	0-10

the light in all directions; it is marked by a relative lack of shadow. The most diffused light comes from the open sky. In a practical installation, using any of the types of luminaires listed in Table II-7, there is a mixture of diffused and directional illumination.

A *luminaire* is defined as a complete lighting unit consisting of a source together with its direct appurtenances, such as globe, reflector, refractor, housing, and such support as is an integral part of the housing. The term is used to designate completely equipped lighting fixtures, wall brackets, portable lamps, so-called removable units, or street-lighting units. Since there is some confusion as to the meaning of some of the descriptive terms, those defined by the Illuminating Engineering Society are given as:

*Reflector* — A reflector is a device, the chief use of which is to redirect the light of the lamp by reflection in a desired direction or directions.

*Refractor* — A refractor is a device which redirects the light of a lamp in desired directions principally by refraction.

*Shade* — A shade is a device, the chief use of which is to diminish or to interrupt the light from a lamp in certain directions where such light is not desired. Frequently the function of a shade and a reflector are combined in the same unit.

*Globe* — A globe is an enclosing device of clear or diffusing material; the chief uses of a globe are to protect the lamp, to diffuse or redirect its light, or modify its color.

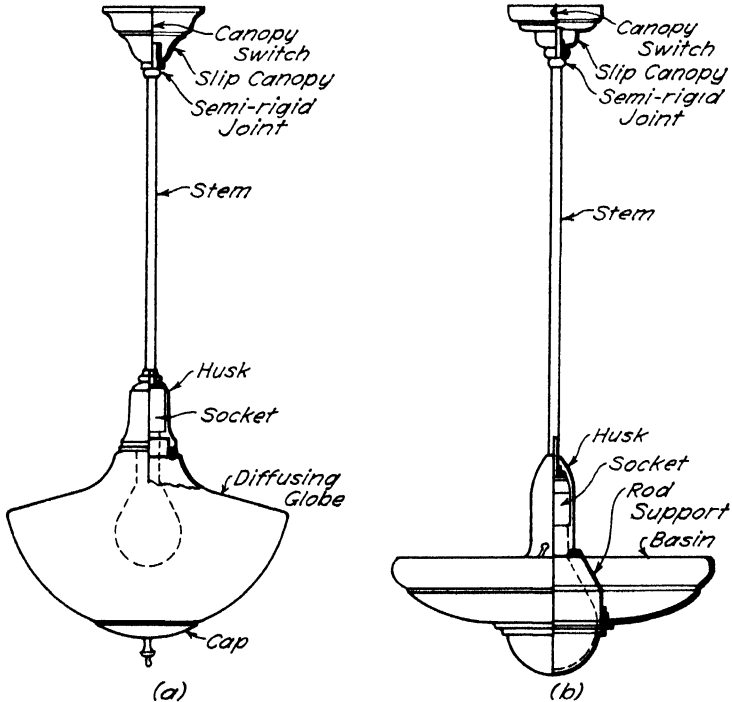

FIG. 4-7. Parts of a luminaire.

*Lamp* — Lamp is a generic term for an artificial source of light.

*Electric Incandescent Lamp* — An electric incandescent lamp is a light source consisting of a glass bulb containing a filament electrically maintained at incandescence. (Bulb in automotive practice is used to designate the incandescent lamp because the luminaire in this field is called a lamp.)

Figure 4-7 shows the parts of the luminaire for both the indirect and general diffusing types of units.

**4. Direct Lighting.** Figure 5-7 shows the light distribution from a direct luminaire and illustrates other typical direct units. A direct

LIGHT CONTROL

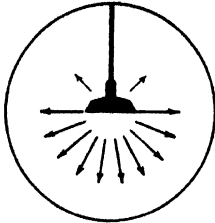

Direct Lighting  
Upward 0-10%  
Downward 90-100%

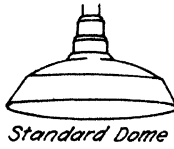

Standard Dome

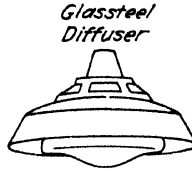

Glassteel  
Diffuser



Angle



Concentrating  
Highbay

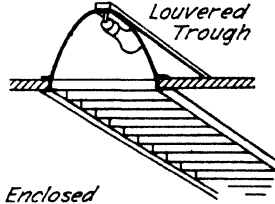

Louvered  
Trough

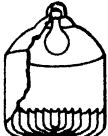

Focusing Type  
Downlight

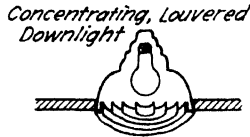

Concentrating, Louvered  
Downlight

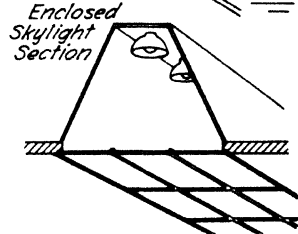

Enclosed  
Skylight  
Section

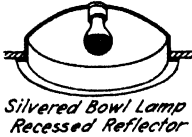

Silvered Bowl Lamp  
Recessed Reflector

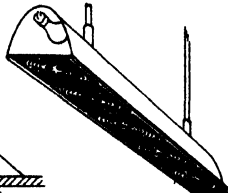

Suspended  
Counter-  
Lighting  
Unit

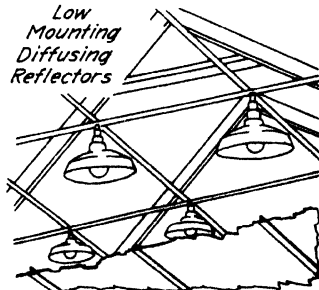

Low  
Mounting  
Diffusing  
Reflectors

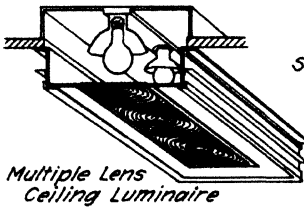

Multiple Lens  
Ceiling Luminaire



Single Lens  
Ceiling Box

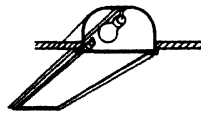

Reflecting Trough  
with Flush  
Diffusing Cover

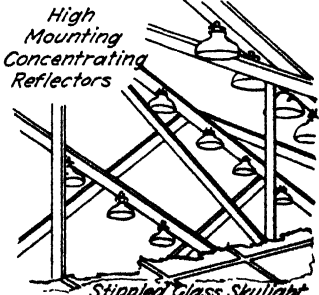

High  
Mounting  
Concentrating  
Reflectors

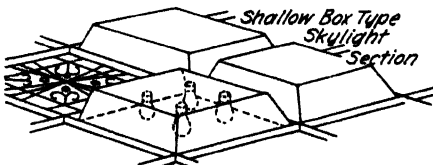

Shallow Box Type  
Skylight  
Section

FIG. 5-7.<sup>3</sup> Typical direct lighting luminaires.

lighting installation can be defined as a lighting system in which practically all (90 to 100 per cent) of the light of the luminaire is directed in angles below the horizontal and directly toward the usual working areas. It is the most common luminaire used in the general lighting systems of industrial plants. Although in general such systems provide efficient illumination on the working surfaces, the workers must contend with other factors, such as excessive contrast with surroundings, sharp shadows, and reflected glare. Care should be taken when installing the equipment to avoid exposing the workers' eyes to glare

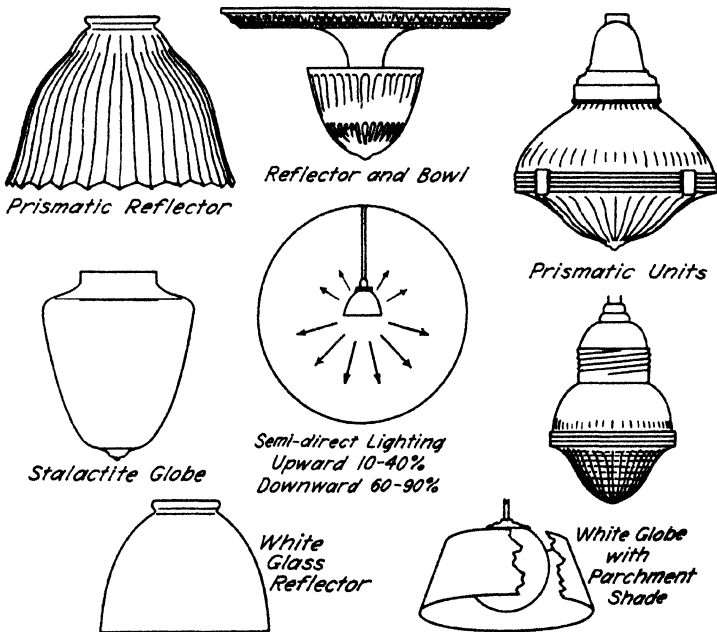

FIG. 6-7.<sup>3</sup> Typical semi-direct lighting luminaires.

from brilliant lamp filaments or excessive contrasts between the light source and its background.

Direct lighting systems may range from concentrating louver and spotlight equipment through the many bowl and dome types of reflectors, even to extended sources, such as large glass panels and skylights. Louvers and prismatic lenses are used to eliminate possible irritating brightness which would otherwise shine directly into the eyes. If the unit is large in area with low brightness and wide diffusion, the direct lighting system will have characteristics similar to those of the indirect system.



The equipment is usually classified into two groups: that which concentrates and that which distributes the light. The first is used in high-bay installations, because it is designed for high mounting and concentration of the light on the working surface; the second type is used for low mounting, and the cutoff of light should in no case be less than 15 degrees below the horizontal. There is another group of lighting equipment which rightfully belongs to the direct lighting group and is a special application of concentrating reflectors; it is called sup-

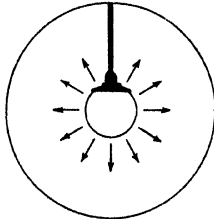

*General Diffusing  
Upward 40-60%  
Downward 40-60%*

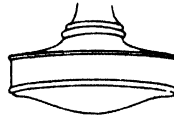

*White Glass  
Enclosing  
Globe*

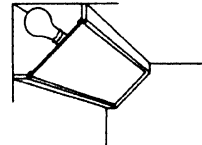

*Cornice Type  
Diffusing Panels*

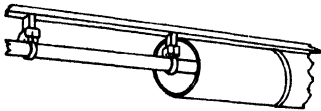

*Lumiline or Fluorescent*

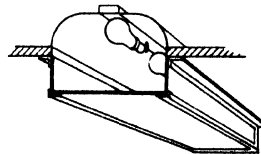

*Built in Ceiling,  
Diffusing Panel  
Sides and Bottom*

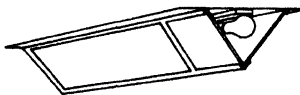

*Extended Ceiling Elements  
V-shaped Diffusing Panels*

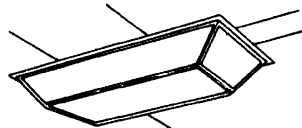

*Box with Diffusing Panels*

FIG. 7-7.<sup>3</sup> Typical general diffusing lighting luminaires.

plementary lighting. In both commercial houses and industrial plants it is frequently desirable to illuminate some small area far in excess of the necessary general lighting. Various types of equipment have been designed to meet this need. These will be discussed more fully in Art. 9.

**5. Semi-Direct Lighting.** Figure 6-7 shows the light distribution from a semi-direct lighting unit and pictures several typical units. In this classification, 60 to 90 per cent of the output of the luminaire is directed downward to the working surface. There is, however,

some contribution to the illumination on the working plane from light which is directed upward and reflected by the ceiling and upper wall areas. For the most part, luminaires in this class are of the open-bottom type, though some inclosing glass units are included. Semi-direct units are often used for lighting corridors, wash rooms, gymnasiums, and locker rooms.

**6. General Diffusing Lighting.** Figure 7-7 shows the light distribution from a general diffusing lighting unit and illustrates other typical units. In this class, the predominant illumination on the horizontal working surfaces comes directly from the lighting units, but there is a certain amount contributed from light directed upward and reflected back from the ceiling and upper wall area. Most of these luminaires are of the glass diffusing inclosing-globe type and are found as general lighting units in offices, stores, and other commercial and industrial installations. Where the capacity of the wiring is limited, it may be necessary to use this type of equipment, for it has a good *utilization factor* permitting high illumination with a limited wattage capacity. In Chapter 3, the brightness of luminaires is discussed and Table II-3 (page 50) should be consulted as a guide in specifying the size of lamp to be used with an inclosing unit.

In general, unless oversized glassware is used, these units are of questionable value in offices, school rooms, and other locations where long hours of attention to details is required. This type of equipment may be lamped to rather high values if a parchment shade is put over the glassware to reduce brightness toward the eyes, and to redirect the light for more efficient use on the work surface. If parchment shades are used and the globe is lamped to a high lumen output, attention must be given to the possibility of objectionable reflected glare. It may be safely stated that this type of lighting has been applied in many instances in which a semi-indirect system would be desirable.

**7. Semi-Indirect Lighting.** Figure 8-7 shows the light distribution from a semi-indirect lighting unit and pictures some other typical units belonging to this class. In this system of lighting, 60 to 90 per cent of the luminaire output is emitted upward toward the ceiling and upper side wall, while the rest is directed downward. Since this system utilizes the ceiling as the main source of light, careful attention should be paid to its color and maintenance factor. The paint should have a matte finish with high reflecting characteristics and should be easy to clean. This system gives a good quality of light with a slightly higher lumen output than does the indirect system, but there may be some direct and reflected glare that is undesirable. This should be the

lowest grade of lighting permitted in school rooms and offices where long hours are spent upon tasks which require marked attention to detail.

If possible, the brightness of the semi-indirect bowl should not exceed 500 ft-L. (approximately 1 c. per sq. in.). The use of an inside frosted lamp with the equipment will make it more pleasing in appearance and more uniform in brightness. It is difficult to determine when and where to use the semi-indirect in preference to the indirect system; the problem is usually one of economics.

**8. Indirect Lighting.** Figure 9-7 shows the lighting distribution from an indirect unit and illustrates some of the commercial units that would be grouped under this classification. This can be defined as a lighting system in which practically all of the light (90 to 100 per

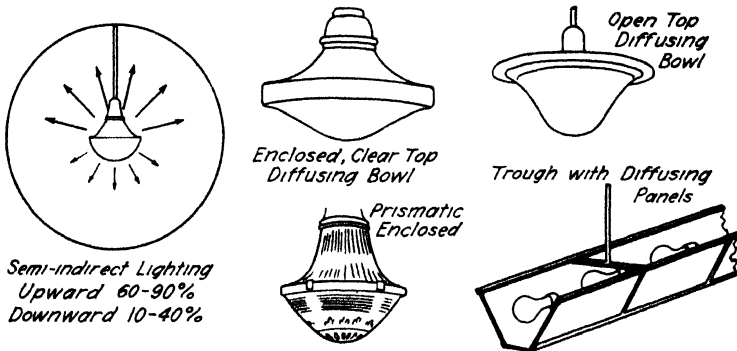
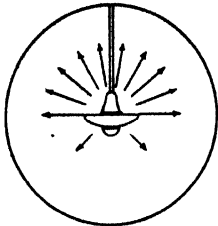

FIG. 8-7: Typical semi-indirect lighting luminaires.

cent) is directed to the ceiling and upper side walls, from which it is reflected diffusely to all parts of the room. With such a large area serving as the source of light, there is little direct glare. Some installations have been made in which the brightness contrast between the equipment and the ceiling directly above the equipment has been so severe that it caused considerable irritation. When indirect lighting is installed in long, low rooms, the large illuminated surface within the region of vision may be a source of glare; when the general illumination is to be in excess of 30 ft-c., any normal installation, regardless of the system, may prove unsatisfactory because of glare. It is well to study with special care any installation requiring a high illumination.

Since, with this system, the ceiling and upper side walls are the sole source of light, they should be of as light a color as possible and the surface should have a matte finish so that the light will be well diffused. The units are built with either opaque or luminous bottoms,



Indirect Lighting  
Upward 90-100%  
Downward 0-10%



Opaque Spinnings  
Metal or  
Mirrored

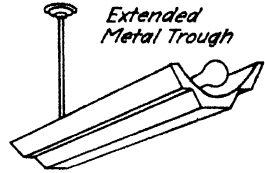

Extended  
Metal Trough

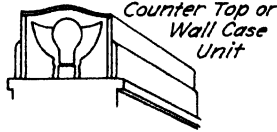

Counter Top or  
Wall Case  
Unit

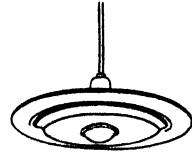

Silvered Bowl Lamp  
with Decorative Shield

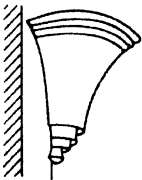

Wall  
Urn

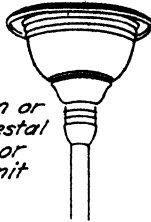

Urn or  
Pedestal  
Floor  
Unit

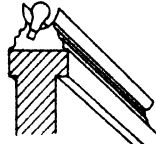

Trough Section  
for Bank Screens  
and Low  
Partitions

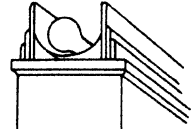

Trough Reflector  
on Book Cases  
or Shelving

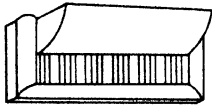

Wall Box

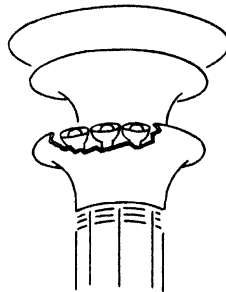

Flared Column  
Cove

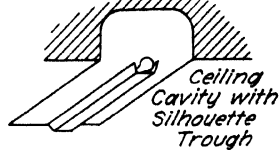

Ceiling  
Cavity with  
Silhouette  
Trough

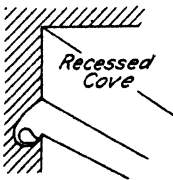

Recessed  
Cove

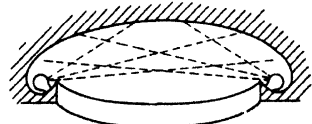

Shallow Ceiling  
Coffer

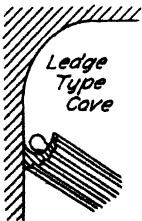

Ledge  
Type  
Cove

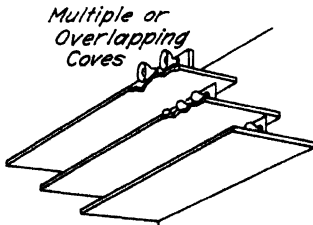

Multiple or  
Overlapping  
Coves

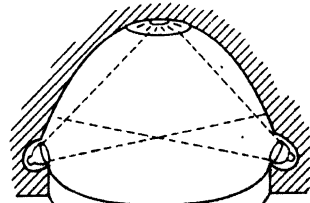

Cross Lighting of a Ceiling  
Dome

FIG. 9-7.<sup>3</sup> Typical indirect lighting luminaires.

the latter being obtained by a translucent material in the bowl or by spill light. Dirt inside the lighting equipment is more detrimental to the lighting installation than the same amount of dirt on the outside. Since this is true, indirect lighting equipment, particularly of the open-bowl type, must be frequently cleaned. Inside-frosted lamps should be used to eliminate streaks, shadows, and filament striations projected to the ceiling from the lamp and equipment.

Light from this type of system may be characterized as soft, and a subdued atmosphere is created by low brightness and absence of sharp shadows. The equipment has possibilities for wide variation in design which will harmonize well with the architectural elements of the room. Because of the excellent diffusion and low brightness of an indirect lighting system, it is probably the best the illuminating engineer has to offer at present as a solution to the problem of hygienic seeing conditions, but it is correspondingly the most expensive to install and to operate correctly.

**9. Supplementary Lighting.** This kind of lighting is a means of obtaining, within the limits of reasonable economy, enough light for a specific task. When the general lighting system fails to deliver enough light in specific areas, these areas may be lighted with local equipment. This has been called "lighting plus" but is more accurately designated as supplementary lighting. Since the surrounding light must equal at least 10 per cent of the work surface light, the amount of supplementary lighting which can be used is readily determined. The safe amount of this type of lighting to add would be:

General Lighting Foot-Candles	Supplementary Lighting Foot-Candles
5	50
10	100
20	200
40	400

Care must be taken that the lighting thus added does not produce glare, harsh shadows, or severe contrasts between the brightly lighted area and its surroundings. In specifying the supplementary equipment, it is well to determine what is required in the way of lumens and the best type of lighting to employ for the task. If equipment is available, the experimental method is probably the most reliable way to discover the best design, but if it is not possible to try the equipment, the distribution curve may be used for making a point-by-point calculation. These special installations are essentially systems

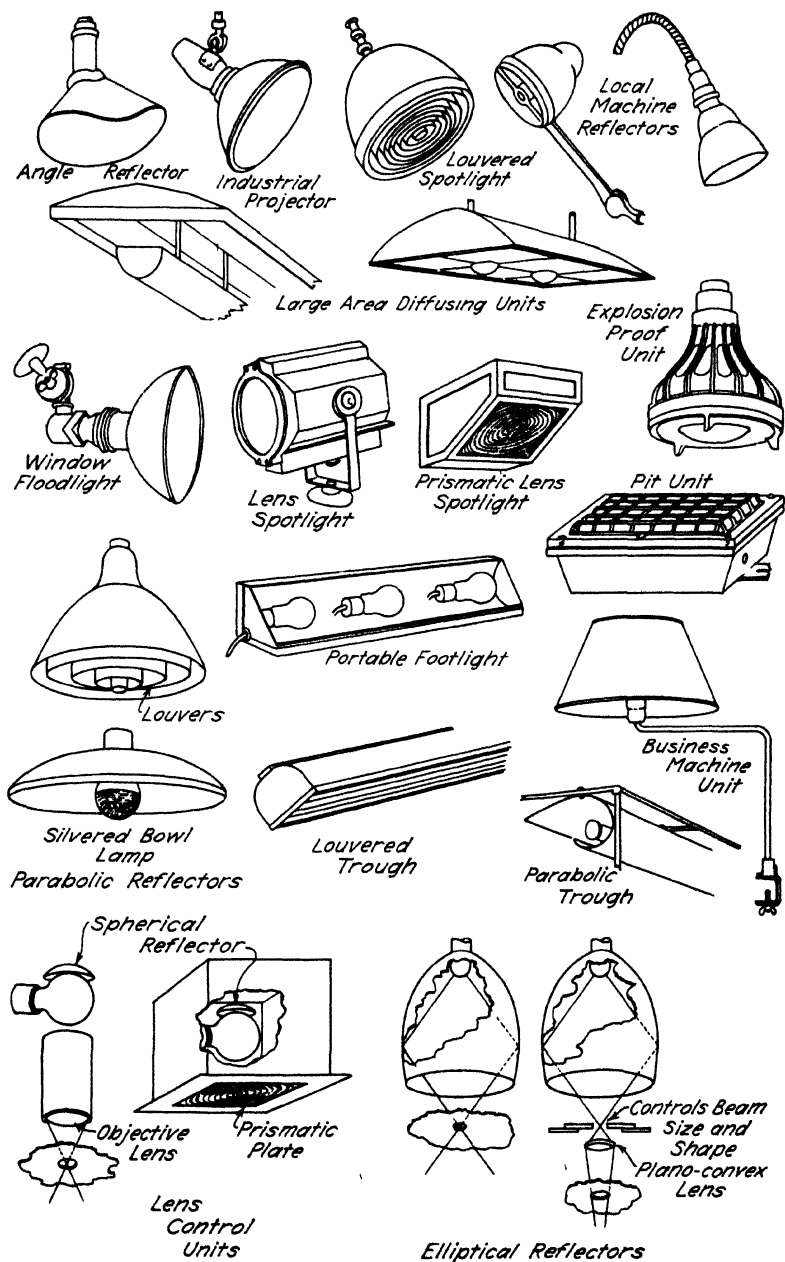

FIG. 10-7.<sup>3</sup> Typical supplementary and special lighting luminaires.

of direct lighting and computed foot-candles, for the illumination from the supplementary equipment can be added directly to the illumination from the general lighting system.

A detailed discussion of the various methods and types of equipment for supplementary lighting is not within the scope of this book, but to acquaint the student with some of the methods, a brief summary of these types will be given in the following pages:

- a. Special applications
- b. Show windows and display cases
- c. Interior merchandise display
- d. Industrial application
- e. Artificial daylight and color match

Figure 10-7 shows typical supplementary equipment for special lighting problems. The recommended foot-candles may be classified as:

- a. 100 ft-c. or more — extremely fine details, material of extremely low or poor contrast, and performance of task of prolonged duration.
- b. 50-100 ft-c. — fine detail, medium contrast in materials, and the performance of task not prolonged.
- c. 30 to 50 ft-c. — moderately fine detail, average contrast of materials, and intermittent performance of the task.

**10. Special Applications.** *a. Art Galleries.* A special solution is usually necessary for each installation. In general the hanging areas should be lighted in some such manner as illustrated, with concealed projectors behind stippled- or ribbed-glass sections. Illumination of the order of 50 ft-c. will be provided by 300-w. daylight lamps spaced  $1\frac{1}{2}$  to 2 ft. apart. The supplementary lighting is usually coordinated with an artificial skylight which may furnish about 5 ft-c. of general illumination.



Broad, flat cases may be lighted by trough equipment as illustrated.

*c. Hospital—Operating Tables.* The best practice is to use a localized general system with concentrating reflectors or lens plates to concentrate the light on the operating zone from all directions in order to avoid harsh shadows. Two hundred or more foot-candles should be provided. Adjustable spotlights will also be found



useful when used with general illumination of 20 ft-c. or more to relieve contrasts and shadows.

*d. Dental Chairs.* General illumination of at least 20 ft-c. should be supplemented with two or three 150-w. lens units or louvered spotlights directed at the operating area.



*e. Counters and Dealing Shelves.* In bank cages and ticket offices supplementary trough lighting equipment is usually located at the top of the cages to produce a band of light lengthwise of the counter. Troughs may be covered with diffusing glass or fitted with longitudinal louvers to shield the lamps. Sixty-watt lamps on 15- to 18-in. centers will generally be adequate.



*f. Business Machine Lighting.* Where power is brought to the desk for the operation of business machines and where the work is of a kind that is particularly difficult to see, units of bracket type similar to the I.E.S. reading lamp, permanently positioned on key-punch machines, copy holders, and index references will, when equipped with 100-w. lamps, provide 60 ft-c. of supplementary lighting on the work. For ordinary typing work, general lighting of 30 ft-c. is recommended.

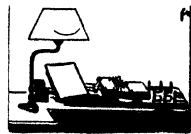

*g. Reading and Writing Rooms.* In hotels, libraries, waiting rooms, and hospitals, supplementary lighting should be provided by means of portable reading lamps, in addition to the general illumination. Certified I.E.S. lamps in floor, table, and wall models are recommended from the standpoint of diffusion and distribution of light. On writing desks, the best location for portables is at the left-hand side of the desk.



**11. Show-Window and Display Cases.** *a.* Standard show-window equipment should be chosen to fit window dimensions and to concentrate light on the trim line. Mirrored glass, polished metal, or prismatic units offer the control necessary to proper distribution. Reflectors should be concealed by valances or enclosed mounting. Louvers or stippled-glass cover plates prevent glare where a row of units is exposed to the observer.

The better windows in brightly lighted districts use 300- and 500-w. units on 15- to 18-in. centers. At least 200-w. on 12-in. centers will be required for downtown city stores; 150-w. lamps for secondary business districts; 75- or 100-w. lamps for neighborhood stores and small towns.



Recommended foot-candle standards serve principally as a relative gage of requirement for different localities. Adjacent displays, traffic exposure, color, type, and arrangement of merchandise and background are also prime factors in window effectiveness and emphasis.

b. Show cases and wall cases require from two to four times as many foot-candles as the general illumination throughout the store if they are to stand out prominently and command attention. Standard show-case equipment is available for tubular bulb, Lumiline, and

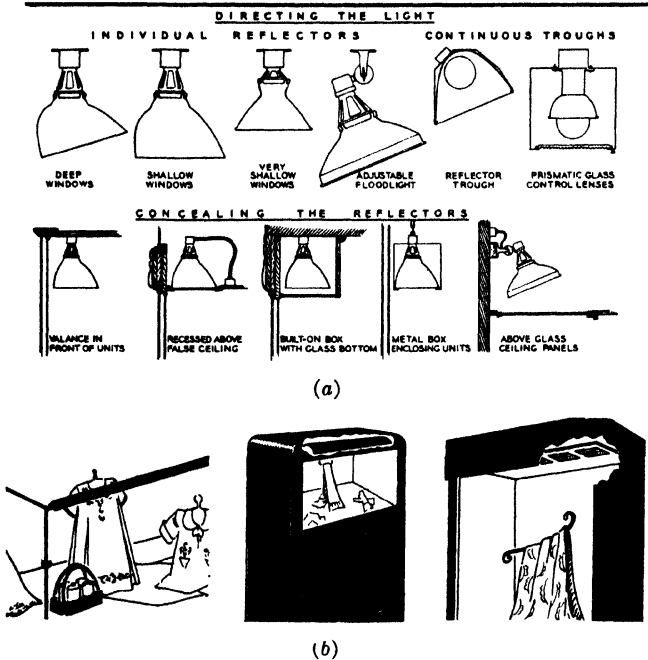

fluorescent lamps and in individual mirrored reflectors taking the A bulb lamps, also mirrored show-case lamps.

A common shortcoming in the lighting of wall cases is the use of wide distribution reflectors which fail to concentrate the light on the merchandise display, but produce predominant and oftentimes distracting light on the upper background. Small compact parabolic aluminum trough reflectors or other concentrating distribution units are best applied in most cases.

Large, shallow cases may often best be lighted by a row of concentrating prismatic lens plates built in the top of the case.

From 40 to 60 w. per running foot of show case will be required to supply 50 to 100 ft.-c. along a normal curve of trim.

**12. Interior and Display Cases.** *a.* The problem in lighting mirror alcoves is to light the person and not the mirror. The sketch shows the use of a large aluminum ceiling reflector with a 500-w. silvered-bowl lamp; also louvered vertical trough reflectors with 40-w. clear or 60-w. daylight lamps on 6-in. centers.

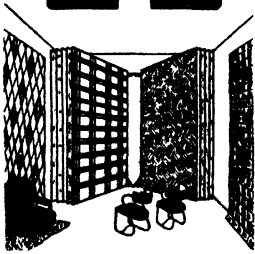
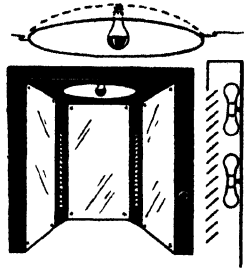

*b.* Rug racks should be lighted as uniformly as possible from top to bottom. Concentrating units or parabolic trough reflectors with 150-w. lamps on 2-ft. centers will provide 30 to 50 ft-c. Units should be aimed at the lower third of the rug.

*c.* Louvered spotlights with 150-w. lamps, located at the upper intersections of the mirrors, offer a simple means of supplementary lighting; shown also is a plan for vertical recessed luminous elements built in at the edge of the three sections of mirror, and using 60-w. Lumiline lamps.

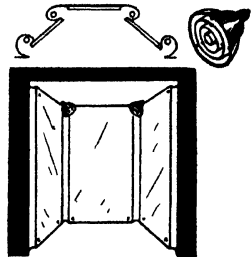

*d.* For ready-to-wear displays, it is desirable to secure fair uniformity both vertically and laterally and to provide from 50 to 100 ft-c. Illumination of this order is necessary to perceive and to identify coloring, tints, and textures and is equivalent to the daylight near a window or door. A parabolic metal trough 8 to 12 in. out from the case with 60- to 100-w. general service

lamps spaced 12 in. apart is a very satisfactory method.

*e.* Fitting-room mirrors entail the same requirements as other mirrors. The lighting emphasis may be obtained by louvered spots, built-in trough or lens plates, by luminous panels or louvered troughs. Where booths have white ceilings general illumination from indirect wall urns or indirect floor lamps will make the room more attractive.

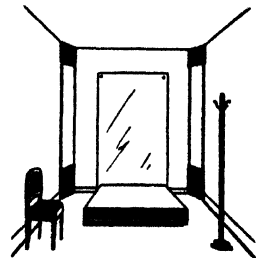

*f.* For necessary items such as groceries, where attention rather than critical seeing is the requirement, less engineering refinement is



needed in shelf lighting equipment. Concentrating trough reflectors which incorporate luminous panels for changeable advertising copy are satisfactory. Sockets 1 ft. apart may be lamped with 40 to 100 w., as conditions dictate.

*g.* Small vanity table mirrors require only a 60-w. white Lumiline lamp in a portable reflector holder on

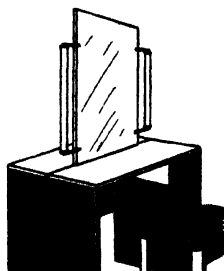

each side of the mirror for acceptable lighting for millinery fitting. Larger vanity and dresser mirrors may have large built-in vertical panels.

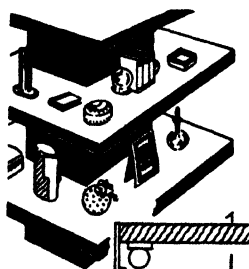

*h.* For lighting displays on columns or built-in shelving, a metal nosing along the front edge of

each shelf effectively conceals small 25-w. tubular lamps as shown in the sketch. Lamps should be spaced not more than 12 in. apart. Lumiline lamps are, of course, equally suitable in many cases.

*i.* Beauty parlor booths present various lighting problems, depending on the construction of the booth and the seeing task involved. The sketch shows a large-area aluminum reflector with a 200- or 300-w. silvered-bowl lamp, adaptable as a low brightness source to individual open-top booths.

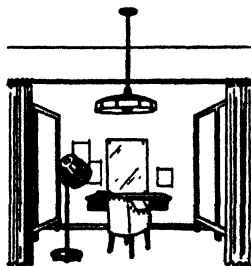

*j.* Displays of glassware and bottled goods are highly attractive and colorful if lighted by transmitted light as shown. An opal glass panel, illuminated uniformly from behind with lamps spaced not more than  $1\frac{1}{2}$  times their distance back of the glass, will provide a suitable luminous background.

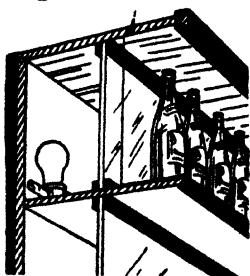

*k.* Continuous trough reflectors for counters, tables, island displays, mounted 3 ft. above display, with 40- to 60-w. lamps 10 to 15 in. apart, should produce 50 to 100 ft-c. on the merchandise. Translucent panels in the sides provide effective changeable advertising.

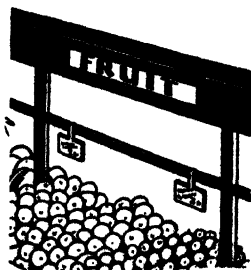

l. Small compact lens spots available in both 250- and 400-w. size mounted on columns, or ceiling brackets, give sales emphasis to small counter or table displays. These are adjustable in spot size for 12- to 48-in. diameter spot at 10 ft. The 250-w. unit at 10 ft. will deliver from 200 to 250 ft-c., with a 12- to 15-in. spot size; the 400-w., 350 to 450 ft-c.

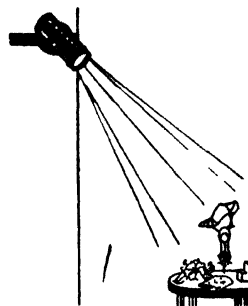

m. Individual counter brackets about 2 ft. above merchandise, spaced 3 ft. apart and lamped with 60- to 100-w. lamps, will provide 75 to 100 ft-c. on the display. Daylight lamps are used effectively for colored ornaments, costume jewelry, and notions.

n. Louvered concentrating reflector spotlights available in 200- to 500-w. sizes give a less sharply defined beam than lens units. Spot size cannot be adjusted except by changing projection distances. A 200-w. unit at 10 ft. will produce about 90 ft-c.

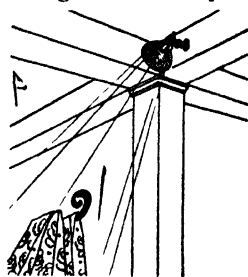

o. For small individual table displays, an I.E.S. table lamp with 100- or 150-w. lamp will provide 30 to 60 ft-c. directly on the display contributing also to general lighting. Creates intimate, attractive display setting

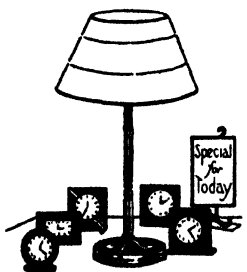

p. Lens plates or concentrating louvered reflectors may be built in a foot or two ahead of the vertical trim line, either in the soffit or floor of open display platforms or niches. One-hundred- to 200-w. lamps will produce highlighting of 100 ft-c. or more on the display.

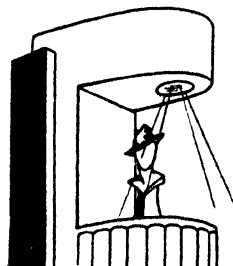

q. Small metal bracket type reflectors with Lumiline or regular 25- or 40-w. tubular bulb lamps effectively emphasize small vertical display racks, stands, and cabinets.



r. For extended vertical surface displays — rugs, tapestries, draperies, paintings — a series of

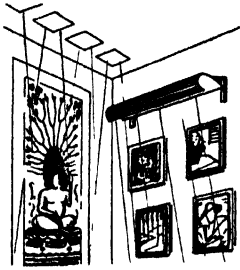

150- or 200-w. lens plate units at the ceiling is suitable for fixed display locations. Bracket-type parabolic, polished-metal troughs produce equivalent results and have some advantage in greater mobility.

s. Counter units for accurate color-matching of hose and shoes, thread and fabrics, use blue glass absorbing filters to produce white light.

A 300-w. unit with a 50 per cent absorption plate ( $5000^{\circ}$  K color temperature) should produce 200 ft-c. at 18 in. A second circuit with clear, unmodified lamps to produce approximately the same illumination should be provided for comparison purposes.

Daylight fluorescent units are efficient and satisfactory.

t. Footlight-type trough lighting for counter and shelf displays ranges from single Lumiline reflectors for counter cards and small displays to extended shelf troughs as illustrated. Trough footlights with changeable, luminous sign panels transform waste space into valuable display.

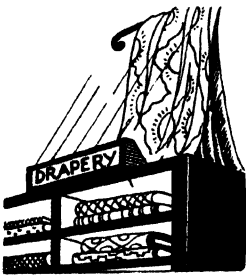

**13. Industrial Applications.** a. *Commercial Color-Correcting Equipment.* For color work, north skylight and noon sunlight equipments have long been available. One shortcoming of such equipment is the high wattage required, which too often results in a compromise on the matter of foot-candles produced. With the daylight fluorescent lamps high levels of lighting of daylight quality ( $6500^{\circ}$  K) can be provided with no discomfort from radiant heat. The sketch shows a unit equipped with three 30-w. daylight fluorescent lamps, mounted 3 ft. above the task, and producing a minimum of 100 ft-c. over a relatively large area.



b. *Concentrated Beam Sources.* Industrial spotlights will provide high illumination over restricted areas where critical seeing requires from 50 to 250 ft-c. Such requirements are encountered in thousands of applications in the machine tool, woodworking, printing, textile

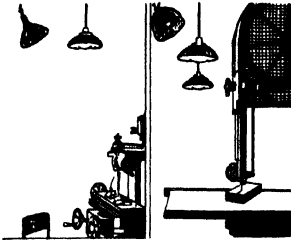

industries, etc. When properly louvered and positioned such units will provide glare-free lighting. Particular care must also be exercised in their location so that confusing shadows are not introduced.

*c. Semi-Concentrating Equipment.*

This type of equipment has a very high utilization over an area approximately 5 ft. in diameter, when located 9½ ft. above the loom. It is designated for locations, such as over small looms, where a relatively high level of lighting is desired over an area of appreciable size. Equipped with a 200-w. lamp, approximately 50 ft.-c. are provided; at the same time sufficient spill light is obtained to illuminate satisfactorily the spaces between the main working areas.

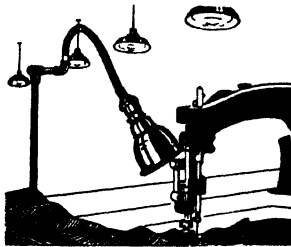
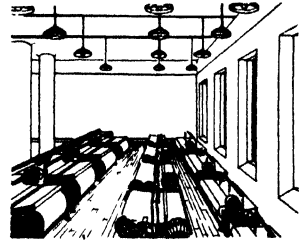

*d. Adjustable Local Lighting.* Deep-bowl porcelain enameled or aluminum reflectors, with substantial supports, holders, and adjustment features, are suitable for individualized purposes such as sewing machines and linotype. Half-shade reflectors, even though adjusted to the satisfaction of the operators, are likely to be glaring to others.

Twenty-five- to 60-w. inside-frosted lamps will provide 50 to 150 foot-candles at a distance of 6 in. For many purposes, such as sewing, daylight lamps are being used because of the whiter quality of the light.

*e. Luminous Panels.* Open-weave fabrics and translucent materials, such as glass, paper, plastics, and liquids, will often reveal certain kinds of faults and defects by transmitted light. Large, luminous panels may be built in conveyor lines over which the material flows, or special inspection units, such as illustrated, may be employed. While the illumination requirements may vary considerably with the specific task, panel brightness of the order of 100 ft.-L. is a fair average.

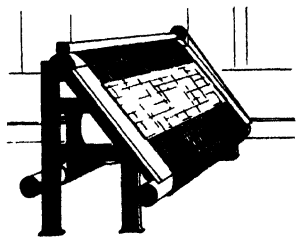

*f. Vapor- and Explosion-Proof Equipments.* These units are designed for locations where corrosive vapor, inflammable gases, or

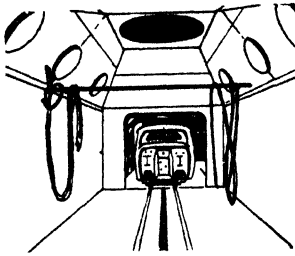

explosive dusts are likely to be encountered. In moisture-laden atmospheres, such as steam processing rooms, engine rooms, shower baths, and also where gases and vapors are present from such processes as battery charging, oil refining, paint and varnish making, spray lacquer painting, units of this character are recommended.

Mandatory requirements are covered in the National Electric Code.

The sketch shows the application of vapor-proof equipment in a spray paint booth. Equipments include both angle and symmetrical types of reflectors in the range from 75- to 500-w. sizes.

*g. Fluorescent Lamp Trough Units.*

Sources of large luminous area and relatively uniform brightness may be obtained by employing the fluorescent lamps in suitably designed specular trough reflectors. Units of this type produce high illumination of good quality. Because the radiant heat from fluorescent lamps is only one-quarter that of incandescent lamps for equal foot-candles, a source of this type can furnish several hundred foot-candles without the discomfort from heat formerly associated with high foot-candles.

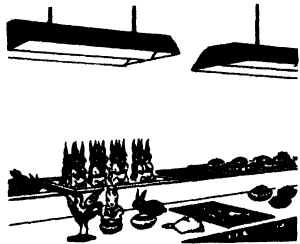

*h. Bench, Assembly, and Inspection.*

Bench work and assembly and inspection operations require a high level of good-quality illumination which, in general, can best be supplied by equipments of the type illustrated in *g*, *h*, and *i*. Where a high degree of diffusion is not required, the Glassteel diffuser, the RLM dome reflectors equipped with white-bowl lamps, or the deep-bowl porcelain enameled reflectors will produce the desired result.

Each job requires analysis to meet specific requirements. In some instances, dual facilities must be provided:

- (1) diffuse lighting for certain defects;
- (2) directional lighting producing "glint" (reflected glare) which may be essential to reveal others.



*i. Large-Area Sources of Uniform Brightness.* Developed initially for lighting the type on imposing stones, units of this type



are particularly applicable for those operations involving detail upon polished surfaces, such as scribing. If the source is uniformly bright, the detail on the specular surface will not be obscured in a confusing background, as frequently results when small sources or sources of varying brightness are employed.

*j. Directional Light.* Surface flaws, irregularities in surface shape, pit marks, scratches, and cracks in materials are most easily seen by lighting which strikes the surface obliquely, casting a shadow and revealing the irregularities by shadow contrast. Thus, wrinkles in roofing materials, such as illustrated, are revealed by small shadows, emphasized by sharp directional light. The light may be undiffused for mat surfaces, but diffused at the source for polished or shiny materials.

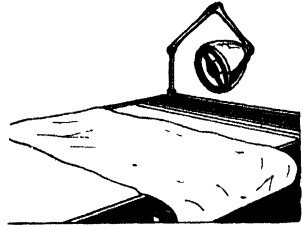

*k. Refraction.* Transparent materials such as plate glass, bottles, bulbs, and clear plastic, will reveal bubbles, blisters, cracks, chips, and whorls or distortions by high lights. Alternating the observation between dark and luminous backgrounds introduces movement which aids in locating and identifying defects.

Similarly, surface distortions and irregularities in polished sheet metal are revealed by the distortion of reflected images of straight-lined bars or strips laid on the luminous background.

*l. Polarized Light.* The detection of strains and defects in glass, mounted lenses, radio tubes, transparent plastics, etc., is readily accomplished by polarized light. The strained areas appear as color fringes in the material. With transparent models



of structures and machine parts, it is also possible to see how they are strained under operating conditions.

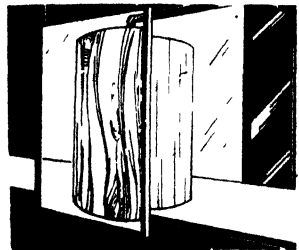

*m. Machine-Tool Lighting.* The seeing tasks in the majority of machine-tool operations are similar, consisting of reading indicating scales, dials, and micrometers, as well as observing the progress of the work. Because these measuring instruments generally have a semi-polished background, it is desira-



ble to employ a large-area source to minimize reflected glare and obtain high visibility. A concentrating source is frequently desirable to project light into deep-boring operations.

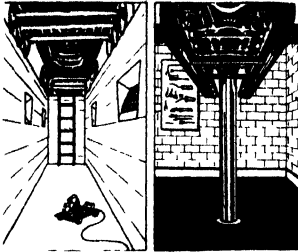

*n. Repair Pit and Auto-Lift Lighting.* On auto lifts 6 units on each side of the wheel track with 50- or 100-w. rough service lamps and a protecting strip to eliminate direct glare are quite satisfactory. Recessed units with lens-type cover plates or special heavy-duty pit lighting equipment with prismatic covers and wire guards are used for automotive, trolley, and roundhouse repair pits, as illustrated. Units on 6- to 8-ft. spacing on each side of the pit with 100- to 200-w. lamps are recommended. Supplementary lighting can be provided by a portable floodlight, as illustrated.

*o. Portable Garage and Repair Standards.*

Portable equipment of this type can be used to good advantage in airplane hangars and garages. The unit consists of 5 angle reflectors mounted on a portable rack with outlets for electrical tools. Two-hundred-watt lamps are recommended. The usual extension cord equipped with 50- or 100-w. rough service lamps in a guard is provided for internal inspection.

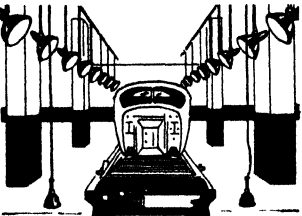
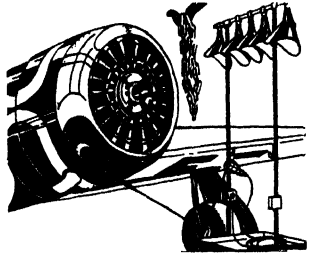

*p. Special Purpose Projectors.* Enclosed industrial projectors employing mercury or incandescent lamps find many applications in specialized lighting for many seeing tasks encountered in industry, such as finishing and inspection. The application, illustrated, shows the use of projector units with fluted cover glasses to spread a high, level band of light on the vertical surfaces of an auto body. With 300-watt units, equipped with spread lens and spaced 5 ft. apart, the illumination on the working surface is of the order of 100 foot-candles. A single 200-w. unit, without a spread lens, will provide about 200 foot-candles over an area of 7 to 8 sq. ft. at a distance of 5 ft.

*q. Angle Reflectors.* Units of this type can be used to supplement the general overhead lighting and to build up the lighting on vertical surfaces. They may also be used to light individual machines, auto wash racks, and operations that demand special distribution or direction of light. Special care is necessary in locating and shielding

them to avoid their becoming glare sources to workers who face the units.

For fairly uniform lighting laterally along a vertical surface, the spacing between units should not exceed  $1\frac{1}{2}$  times their distance out from the lighted surface.

*r. Business Machine Lighting.* Where power is brought to the desk for the operation

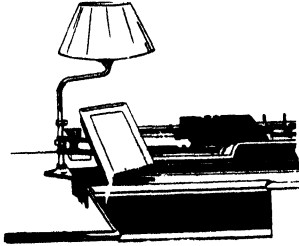

of business machines and where the work is of a kind that is particularly difficult to see, bracket-type units, similar to the familiar study lamps meeting I.E.S. specifications, permanently positioned on key-punch machines, copy holders, and index references, will, when equipped with 100-w. lamps, provide approximately 50 foot-candles of supplementary lighting on the work. For ordinary typing 30 foot-candles are recommended.

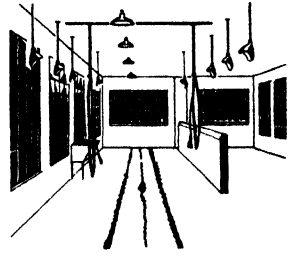

**14. Artificial Daylight, Color-Matching, Color-Modifying Equipment.** The duplication of natural daylight is confined largely to those industrial and commercial applications involving accurate color discrimination or color rendition in varying degree, depending upon the specific requirements. Even in this field difficulties arise because the colorist has been accustomed, perhaps through years of habit, to a specific daylight quality peculiar to his location. It is practical and expedient, however, to provide exact reproductions of daylight for any given requirement with the attendant advantage of constancy and 24-hr. availability.

Although color quality is accurately specified by color temperature designations, equipments for reproducing daylight for working purposes may be grouped roughly into (1) skylight units, (2) sunlight units, and (3) units which provide a whiter light than the common types of general lighting equipment, but not so white as those discussed under *a* and *b*.

*a.* Equipments of this character employ accurately correcting filters by means of which it is possible to duplicate the color of outdoor daylight. Such equipment is generally designed for localized lighting over counters in stores, for small areas or special operations in industrial plants where precision in color



North skylight

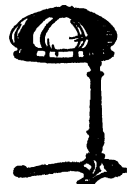

identification, grading, and other color inspection is required. Illumination of the order of 100 foot-candles is desirable for this sort of work.

Color factories, paint and dye mixing, art studios, chemical analysis, dental mechanics, surgery, textile and cigar sorting and grading are examples suggesting the application of skylight-reproducing equipment.

As compared to unmodified artificial light, from 6 to 8 times the voltage is required for the same foot-candle values.

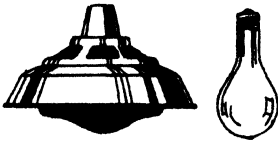

Noon sunlight

b. Enclosing globes of special crystal blue glass frosted on the inside modify the light from a lamp to approximate the color of direct sunlight at noon. Their applications are to some extent the same as skylight units, the actual choice depending on specific requirements; in general, noon sunlight equipment is used for less exacting color discrimination. For example, ink and dye mixing and inspection may be done locally under skylight quality, and a general system of noon sunlight equipment may be installed in certain rooms or over small areas restricted to manufacturing operations requiring clear color rendition such as lithographing processes, color printing, and tobacco grading. One hundred or more foot-candles are recommended.

As compared to unmodified artificial light, from 2 to 3 times the wattage is required for the same foot-candle values.

c. Lamps with blue bulbs, commercially known as "daylight" lamps, emit a whiter light which is but a partial step toward daylight whiteness. In many instances of color rendition, their use gives sufficient color correction to be of con-



'Daylight' lamps

siderable advantage over the warmer tones of unmodified light. The light blends well with natural daylight; in fact, in many cases it is about the same color as the daylight which one gets indoors, taking into account the prevalence of warm tones in window shades, walls, and hangings; for this reason the use of daylight lamps in offices and many other places will be found to correct an unsatisfactory mixture of ordinary artificial light and inadequate daylight.

The next larger size of lamp will be required to produce approximately the foot-candle level as computed for a clear lamp of a given size. "Daylight" lamps can be used in all common types of equipment.

d. Enclosing globes with a slight bluish ingredient do not appreciably modify the color quality of illumination for utilitarian purposes,

but have a considerable field of application by virtue of their whiter appearance. Such equipment corrects the yellowish tone commonly noticeable with ordinary opal glassware. These usually give far less color correction than daylight lamps. The units are very pleasing; they appear white and clean and are often more satisfactory than units of yellowish tone, particularly when supplementing natural daylight. The spectral quality of illumination is usually not far from that of a clear-bulb C lamp.

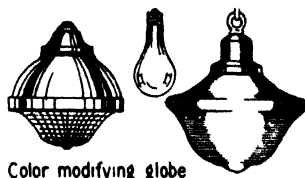

Color modifying globe

The illumination will be from 10 to 30 per cent less than for the same type of unmodified globe.

e. The line spectrum of mercury vapor sources produces a characteristic color quality of light. It has a faint blue line, predominant yellow and green lines, with but a trace of red.

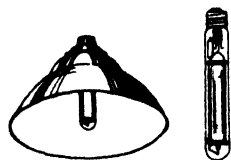

Mercury lamps

The proportion of energy represented by each line varies slightly, depending on the specific type of lamp. The source itself, or the light reflected from a white surface, appears bluish white, but colored objects are much distorted in color appearance; blues become purplish black, yellows and greens are emphasized, reds appear black.

Although colors cannot be reliably identified under mercury light, color contrast may be very pronounced. For this reason, it may often be used as an auxiliary inspection source to reveal impurities and imperfections by introducing high color contrast that would not be apparent under white light.

f. By combining mercury lamps lacking in red with incandescent lamps rich in red and orange, the resultant light is a very pleasing synthetic white light that seems cool and mixes well with natural daylight. There is still an excess of yellow, and for that reason it is not a "color-discriminating" white because of the emphasis it gives yellow colors, but is very satisfactory for many industrial



Combination-Mercury-Incandescent

and commercial uses where accurate color discrimination of materials is not encountered. Combination low-pressure Cooper-Hewitt tubes and incandescent lamps offer a somewhat better color balance than combination of the new Type-H vapor sources with incandescent lamps, but the latter combination is more efficient.

In general, equal lumens from incandescent and from mercury lamps are recommended for most applications of combination units.

g. The daylight fluorescent lamp has a color-temperature of 6500° K, which measurements have shown to be approximately the average color temperature of daylight on a horizontal plane. The light emitted by the fluorescent lamp consists of a continuous spectrum radiated by the fluorescent coating and the line spectrum produced by the mercury arc between the electrodes. In most bands, the difference between the daylight fluorescent light and natural daylight is small, and the green and yellow mercury lines do not unbalance the color, whereas the red deficiency of the fluorescent lamp is principally in the deep red where the luminosity is very low.

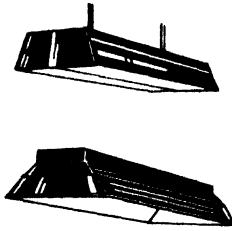

### INSTALLATION

The control of light is not independent of the installation, for the same equipment may give quite different results if used under varying conditions. The size of the room, the character of the light distribution from the equipment, and the color of the finish on the ceiling and side wall all lead to a coefficient called the *utilization factor* which, multiplied by the equipment efficiency, gives the *coefficient of utilization*.

The *coefficient of utilization* of a lighting installation on a given plane is the total flux received by that plane divided by the total flux from the light sources. When not otherwise specified, the plane of reference is assumed to be a horizontal plane 30 in. from the floor. The resultant illumination from the installation is the average illumination, and to describe how effective this average illumination is, the following terms of variation are used:

1. *Variation factor* of an illumination installation is the ratio of either the maximum or minimum illumination on the given plane to the average illumination on that plane.

2. *Variation range* of illumination on a given plane is the ratio of the maximum illumination to the minimum illumination on that plane.

**15. Room Index.** In general, large rooms use light more efficiently than do small rooms, because there is less wall area to absorb light in proportion to the floor space. Raising the light source tends to increase the proportion of wall area to floor area, and thereby reduces the relative efficiency of high-bay installations.

The *room index* is approximately equal to the width of the room divided by the height, but for determining the room index where the

elevation of the work surface varies and the lamp mounting varies, the following two expressions are used:

- a. Direct, semi-direct, and general diffusing units,

$$\text{room index} = \frac{\text{room width } (w)}{2 \times \text{height from plane of work to lamps } (h_d)}$$

- b. Semi-indirect and indirect units,

$$\text{room index} = \frac{0.75 \times \text{room width } (w)}{(\text{height from plane of work to ceiling}) (h_c)}$$

The above values are for rooms that are square. There are some empirical forms that approximate closely the room index for rectangular rooms. The method which has proved to be the most nearly accurate in the investigations of Harrison and Anderson, in which the utilization coefficients for the room were used, is described in Art. 18.

Two sets of expressions are often given.

$$a. \quad RI = \frac{0.9w + 0.1l}{H}$$

where  $w$  is the width of the room,  $l$  the length of the room, and  $H$  the height of the room (floor to ceiling). This form is good for both the direct and indirect equipment if normal mountings for direct units are used.

$$b. \quad RI = \frac{0.6\sqrt{wl}}{h_m} \quad \text{direct units}$$

$$RI = \frac{0.8\sqrt{wl}}{H} \quad \text{indirect units}$$

where  $h_m$  is the mounting height of the direct unit. The last two forms will give values slightly higher than those in the tables; the first and simpler general form gives values closely approximating those of the table. It is affected more than the latter, however, by variations in mounting height. Table III-7 gives values of room index for the usual room proportions found in practice. The use of these tables, though not as accurate as some other methods, is quick and of comparable accuracy with the other factors involved in a practical lighting problem. The architect and engineer should not lose sight of the fact that illumination must be either doubled or halved before the change is appreciable to the eye. For this reason, it seems unnecessary to discuss seriously a difference of a few per cent.

*Example a.* Determine the room index for a room 12 ft. high, 20 ft. wide, and 20 ft. long with the work surface at 30 in. and a unit mounted at

TABLE

## ROOM INDEX FOR NARROW AND AVERAGE ROOMS

Equipment A* } Use Ceiling Height }		FEET						
		9 and 9½	10 to 11½	12 to 13½	14 to 16½	17 to 20	21 to 24	25 to 30
		FEET						
Equipment B† } Use Mounting Height }		7 and 7½	8 and 8½	9 and 9½	10 to 11½	12 to 13½	14 to 16½	17 to 20
		ROOM INDEX						
Room Width (Feet)	Room Length (Feet)							
9 (8½-9½)	8-10	1.0	0.8	0.6	0.6			
	10-14	1.0	0.8	0.8	0.6			
	14-20	1.2	1.0	0.8	0.6	0.6		
	20-30	1.2	1.2	1.0	0.8	0.6	0.6	
	30-42	1.5	1.2	1.0	0.8	0.6	0.6	0.6
	42-up	2.0	1.5	1.2	1.0	0.8	0.6	0.6
10 (9½-10½)	10-14	1.2	1.0	0.8	0.6	0.6		
	14-20	1.2	1.0	0.8	0.6	0.6	0.6	
	20-30	1.5	1.2	1.0	0.8	0.6	0.6	
	30-42	1.5	1.2	1.2	1.0	0.8	0.6	0.6
	42-60	2.0	1.5	1.2	1.0	0.8	0.6	0.6
	60-up	2.0	1.5	1.5	1.0	1.0	0.8	0.6
12 (11-12½)	10-14	1.2	1.0	0.8	0.8	0.6	0.6	
	14-20	1.5	1.2	1.0	0.8	0.6	0.6	
	20-30	1.5	1.2	1.2	1.0	0.8	0.6	0.6
	30-42	2.0	1.5	1.2	1.0	0.8	0.6	0.6
	42-60	2.0	1.5	1.5	1.2	1.0	0.8	0.6
	60-up	2.0	2.0	1.5	1.2	1.0	0.8	0.6
14 (13-15½)	14-20	1.5	1.2	1.0	1.0	0.8	0.6	0.6
	20-30	2.0	1.5	1.2	1.0	0.8	0.6	0.6
	30-42	2.0	1.5	1.5	1.2	1.0	0.8	0.6
	42-60	2.0	2.0	1.5	1.5	1.0	0.8	0.6
	60-90	2.5	2.0	2.0	1.5	1.2	1.0	0.6
	90-up	2.5	2.0	2.0	1.5	1.5	1.2	0.8
17 (16-18½)	14-20	2.0	1.5	1.2	1.0	0.8	0.6	0.6
	20-30	2.0	1.5	1.5	1.2	1.0	0.8	0.6
	30-42	2.5	2.0	1.5	1.2	1.0	1.0	0.6
	42-60	2.5	2.0	2.0	1.5	1.2	1.2	0.8
	60-110	2.5	2.0	2.0	1.5	1.2	1.2	0.8
	110-up	3.0	2.5	2.0	2.0	1.5	1.2	1.0
20 (19-21½)	20-30	2.5	2.0	1.5	1.2	1.0	0.8	0.6
	30-42	2.5	2.0	2.0	1.5	1.2	1.0	0.8
	42-60	2.5	2.5	2.0	2.0	1.5	1.2	0.8
	60-90	3.0	2.5	2.0	2.0	1.5	1.2	1.0
	90-140	3.0	2.5	2.5	2.0	1.5	1.5	1.0
	140-up	3.0	2.5	2.5	2.0	1.5	1.5	1.0
24 (22-26)	20-30	2.5	2.0	2.0	1.5	1.2	1.0	0.8
	30-42	3.0	2.5	2.0	1.5	1.2	1.2	0.8
	42-60	3.0	2.5	2.5	2.0	1.5	1.2	1.0
	60-90	3.0	2.5	2.5	2.0	1.5	1.5	1.0
	90-140	3.0	3.0	2.5	2.0	2.0	1.5	1.2
	140-up	3.0	3.0	2.5	2.0	2.0	1.5	1.2
30 (27-33)	30-42	3.0	2.5	2.5	2.0	1.5	1.2	1.0
	42-60	3.0	3.0	2.5	2.5	1.5	1.5	1.0
	60-90	4.0	3.0	3.0	2.5	2.0	1.5	1.2
	90-140	4.0	3.0	3.0	2.5	2.0	2.0	1.5
	140-180	4.0	3.0	3.0	2.5	2.0	2.0	1.5
	180-up	4.0	3.0	3.0	2.5	2.0	2.0	1.5
36 (34-39)	30-42	4.0	3.0	2.5	2.0	1.5	1.5	1.0
	42-60	4.0	3.0	3.0	2.5	2.0	1.5	1.2
	60-90	5.0	3.0	3.0	3.0	2.0	2.0	1.5
	90-140	5.0	4.0	3.0	3.0	2.5	2.0	1.5
	140-200	5.0	4.0	3.0	3.0	2.5	2.0	1.5
	200-up	5.0	4.0	3.0	3.0	2.5	2.0	1.5
40 or more	42-60	5.0	4.0	3.0	These values are given on the opposite page			
	60-90	5.0	4.0	4.0				
	90-140	5.0	4.0	4.0				
	140-200	5.0	5.0	4.0				
	200-up	5.0	5.0	4.0				

\* EQUIPMENT A —  
† EQUIPMENT B —

III-7

ROOM INDEX FOR LARGE HIGH ROOMS

Equipment A* } Use Ceiling Height }		FEET								
		14 to 16½	17 to 20	21 to 24	25 to 30	31 to 36	37 to 50			
		FEET								
Equipment B† } Use Mounting Height }		10 to 11½	12 to 13½	14 to 16½	17 to 20	21 to 24	25 to 30	31 to 36	37 to 50	
		ROOM INDEX								
Room Width (Feet)	Room Length (Feet)									
14 (13-15½)	14-20	1.0	0.8	0.6	0.6					
	20-30	1.0	0.8	0.6	0.6					
	30-42	1.2	1.0	0.8	0.6	0.6				
	42-60	1.5	1.0	0.8	0.6	0.6	0.6			
	60-90	1.5	1.2	1.0	0.6	0.6	0.6	0.6		
	90-up	1.5	1.5	1.2	0.8	0.6	0.6	0.6		
17 (16-18½)	14-20	1.0	0.8	0.6	0.6					
	20-30	1.2	1.0	0.8	0.6					
	30-42	1.2	1.0	1.0	0.6	0.6	0.6			
	42-60	1.5	1.2	1.2	0.8	0.6	0.6	0.6	0.6	
	60-110	1.5	1.2	1.2	0.8	0.6	0.6	0.6	0.6	
	110-up	2.0	1.5	1.2	1.0	0.8	0.6	0.6	0.6	
20 (19-21½)	20-30	1.2	1.0	0.8	0.6	0.6				
	30-42	1.5	1.2	1.0	0.8	0.6	0.6			
	42-60	2.0	1.5	1.2	0.8	0.6	0.6	0.6		
	60-90	2.0	1.5	1.2	1.0	0.6	0.6	0.6	0.6	
	90-140	2.0	1.5	1.5	1.0	0.8	0.8	0.6	0.6	0.6
	140-up	2.0	1.5	1.5	1.0	1.0	0.8	0.6	0.6	0.6
24 (22-26)	20-30	1.5	1.2	1.0	0.8	0.6	0.6			
	30-42	1.5	1.2	1.2	0.8	0.6	0.6			
	42-60	2.0	1.5	1.2	1.0	0.8	0.6	0.6		
	60-90	2.0	1.5	1.5	1.0	0.8	0.6	0.6	0.6	0.6
	90-140	2.0	2.0	1.5	1.2	1.0	0.8	0.6	0.6	0.6
	140-up	2.0	2.0	1.5	1.2	1.0	0.8	0.6	0.6	0.6
30 (27-33)	30-42	2.0	1.5	1.2	1.0	0.8	0.6	0.6		
	42-60	2.5	1.5	1.5	1.0	1.0	0.8	0.6	0.6	
	60-90	2.5	2.0	1.5	1.2	1.0	0.8	0.6	0.6	0.6
	90-140	2.5	2.0	2.0	1.5	1.2	1.0	0.8	0.6	0.6
	140-180	2.5	2.0	2.0	1.5	1.2	1.0	0.8	0.6	0.6
	180-up	2.5	2.0	2.0	1.5	1.2	1.0	0.8	0.6	0.6
36 (34-39)	30-42	2.0	1.5	1.5	1.0	0.8	0.8	0.6	0.6	
	42-60	2.5	2.0	1.5	1.2	1.0	0.8	0.6	0.6	0.6
	60-90	3.0	2.0	2.0	1.5	1.0	1.0	0.6	0.6	0.6
	90-140	3.0	2.5	2.0	1.5	1.2	1.0	0.8	0.6	0.6
	140-200	3.0	2.5	2.0	1.5	1.5	1.2	1.0	0.8	0.6
	200-up	3.0	2.5	2.0	1.5	1.5	1.2	1.0	0.8	0.6
42 (40-45)	42-60	3.0	2.0	1.5	1.2	1.0	0.8	0.8	0.6	0.6
	60-90	3.0	2.5	2.0	1.5	1.2	1.0	0.8	0.6	0.6
	90-140	3.0	2.5	2.5	2.0	1.5	1.2	1.0	0.6	0.6
	140-200	3.0	2.5	2.5	2.0	1.5	1.2	1.0	0.8	0.6
	200-up	3.0	2.5	2.5	2.0	1.5	1.5	1.2	1.0	0.8
50 (46-55)	42-60	3.0	2.5	2.0	1.5	1.2	1.0	0.8	0.6	0.6
	60-90	3.0	3.0	2.5	1.5	1.5	1.2	1.0	0.6	0.6
	90-140	3.0	3.0	2.5	2.0	1.5	1.5	1.2	0.8	0.6
	140-200	3.0	3.0	2.5	2.0	2.0	1.5	1.2	0.8	0.6
	200-up	3.0	3.0	2.5	2.0	2.0	1.5	1.2	1.0	0.6
60 (56-67)	60-90	4.0	3.0	2.5	2.0	1.5	1.2	1.0	0.8	0.6
	90-140	4.0	3.0	3.0	2.5	2.0	1.5	1.2	1.0	0.6
	140-200	4.0	3.0	3.0	2.5	2.0	1.5	1.5	1.0	0.6
	200-up	4.0	3.0	3.0	2.5	2.0	2.0	1.5	1.0	0.6
75 (68-90)	60-90	5.0	4.0	3.0	2.5	2.0	1.5	1.2	0.8	0.6
	90-140	5.0	4.0	3.0	2.5	2.0	1.5	1.5	1.0	0.6
	140-200	5.0	4.0	4.0	3.0	2.5	2.0	1.5	1.2	0.6
	200-up	5.0	4.0	4.0	3.0	2.5	2.0	1.5	1.2	0.6
90 or more	60-90	5.0	4.0	3.0	2.5	2.0	1.5	1.2	1.0	0.6
	90-140	5.0	5.0	4.0	3.0	2.5	2.0	1.5	1.2	0.6
	140-200	5.0	5.0	4.0	3.0	2.5	2.0	1.5	1.2	0.6
	200-up	5.0	5.0	4.0	3.0	3.0	2.5	2.0	1.5	0.6

Semi-indirect, indirect.

Direct, semi-direct, general diffusing, luminous elements.



9½ ft. (a direct system). Use the various forms given and compare with Table III-7.

$$RI = \frac{w}{H} = \frac{20}{12} = 1.67$$

$$RI = \frac{0.9w + 0.1l}{H} = \frac{20}{12} = 1.67$$

$$RI = \frac{w}{2h_d} = \frac{20}{2 \times 7} = 1.43$$

$$RI = \frac{0.6\sqrt{wl}}{h_m} = \frac{12}{9.5} = 1.26$$

Table III-7 = 1.5

*Example b.* Assume the room in Example *a* to be 40 ft. long, then determine the room index by the various methods and compare with Table III-7.

$$RI = \frac{0.9w + 0.1l}{H} = \frac{22}{12} = 1.83$$

$$RI = \frac{0.6\sqrt{wl}}{h_m} = \frac{16.97}{9.5} = 1.79$$

Table III-7 = 2.0

The empirical forms have been set up for reasonable conditions; they give fairly accurate results up to the point where the length does not exceed 10 times the mounting or ceiling height.

**16. Candlepower Distribution Curves.** The general shape of the candlepower distribution curve determines the type of illumination that may be expected. The control of the efficiency of the installation depends upon which zones deliver the greater part of the illumination. The test data associated with the curve allow the unit to be properly classified into the general groups previously given. If the particular equipment has been designed and does not belong to any one of the standard groups of equipment, the *utilization factors* and the coefficient of utilization may be determined from the distribution curve. The calculations for the coefficients and factors will be discussed in Art. 18.

**17. The Ceiling and Side Walls as Reflecting Surfaces.** A paint finish in a room has two major functions in light control: that of "hiding" (the elimination of undesirable surface conditions) and that of reflecting light. The economic value of paint lies in its ability to perform these two functions with high efficiency, at a low cost per square foot. Figure 11-7*a* shows the changes taking place in a black-and-white squares test under brush-out tests, and curves on Fig. 11-7*b* show the effect of age upon paint.

TABLE IV-7<sup>1</sup>

## REFLECTION FACTORS FOR LIGHT FROM INCANDESCENT LAMPS

Paint					
Class	Color	Per Cent	Class	Color	Per Cent
Very Light (70% and up)	Gloss white	84	Fairly Dark (50% to 30%)	Bright sage and ivory tan	48
	Flat white	82		Medium gray	44
	Eggshell white	81		Buff stone	41
	Ivory white	80		French gray	40
	Caen stone	76		Pale azure	40
	Primrose	78		Buff stone and pale azure	39
	Pearl gray	72		Bronze	38
	Ivory	71		Sky blue	37
	Very light gray	70		Tan	35
	Cream	70			
Fairly Light (70% to 50%)	Aluminum	65	Very Dark (30% and down)	Dark gray	28
	Buff	64		Olive green	21
	Lichen gray	63		Forest green	20
	Ivory tan	63		Cardinal red	20
	Light gray	60		Very dark gray	19
	Satin green	56		Cocoanut brown	19
	Pale azure and white	55			
	Shell pink	54			
	Silver gray and caen stone	52			
Others					
Class	Material	Per Cent			
Very light	White paper	80			
Fairly light	Light wall paper	50			
Fairly dark	Light oak wood	34			
Very dark	Dark wall paper	25			
	Natural cement	25			
	Dark oak wood	13			
	Natural brick	13			
	Books	10			
	Mahogany wood	8			
	Walnut wood	7			

The color of the paint is another important factor of light control in the room. Table IV-7 gives the reflection factors for paints and other materials used for inside finish when the exciting source is in-

candescent lighting. The character of the spectral distribution of light is very important in determining the reflectance of any colored surface. Fig. 12-7 shows the light reflecting characteristics of various types of wall paint as influenced by time.

The paints used on wall surfaces should have aesthetic value as

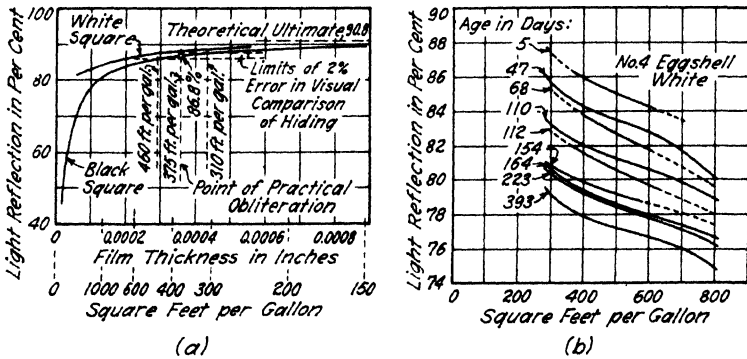

FIG. 11-7.<sup>5</sup> (a) Changes taking place in light reflection in black and white squares of standard brush-out test. (b) Effect of time on the light reflection from a white eggshell paint.

well as the property of light reflection. Using light color paints reduces the brightness contrast between the window and wall surface

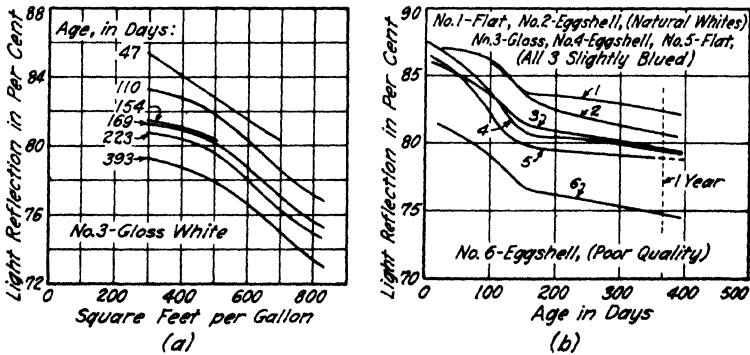

FIG. 12-7.<sup>5</sup> (a) Per cent light reflection of paint with age for different film thicknesses. (b) Per cent light reflection with age for different qualities of paint.

and provides a high utilization of artificial light. The color scheme may also be extended to work surfaces and machines to improve visibility by proper contrasts. Paint specifications which are adjusted to a scheme of better lighting recommend ceiling reflection factors of 75 per cent or more and side wall reflection factors of from 50 to 60 per cent.

Ceilings are preferably painted an off-white, but tints may be used for decorative effects and these should be bluish white, light cream, or ivory. The walls should be tinted, for bright and very light surfaces may cause an annoying glare; the portion of a room below the eye level may be dark in color. Where warmth and cheer are desired, buff colors with very little yellow may be used; cool effects can be obtained by using combinations predominantly blue or green. If the ceiling and side walls are kept within the limits given above, the color temperature of the room will be about 100° K below that of the source of illumination used.

**18. Utilization Factors and Coefficients of Utilization.** If the utilization factor for a specific equipment in a room can be determined, it is a simple matter to determine the average foot-candles, and the design of the lighting system is relatively simple. The conditions existing in a rectangular room with its multiple reflections are far too complicated to be expressed by means of a mathematical expression. The determination of light control and of the resultant effects of illumination by empirical methods was initiated by Ward Harrison and E. A. Anderson (1920).<sup>\*</sup> These methods are capable of giving high degrees of accuracy, but are reduced to table form in manufacturers' publications, the normal inaccuracy of which will probably not exceed an error of 10 per cent; however, the error may be as much as 50 per cent in extreme cases. Familiarity with the original data will be useful in determining the performance of equipment for which candlepower distribution curves can be predicted or of new equipment for which the distribution curves have already been calculated.

The method consists of analyzing the candlepower distribution into three components (types of lighting to illuminate the work surface): indirect, horizontal, and direct. The direct component is in turn divided into three types of distribution: broad, medium, and narrow. This classification is based upon the following arbitrary percentage of flux in the 0°-40° zone:

Broad	35-40%
Medium	40-45%
Narrow	45-50%

(left, center, and right figures, Table V-7) determined from the following expression:

$$\text{percentage} = \frac{\text{lumens in } 0^{\circ}\text{-}40^{\circ}\text{ zone}}{\text{lumens in } 0^{\circ}\text{-}90^{\circ}\text{ zone}}$$

<sup>\*</sup> *I. E. S. Trans.*, March, 1920, v. 25, No. 2, p. 97.

LIGHT CONTROL  
TABLE V-7  
COMPONENT UTILIZATION FACTORS  
Ceiling Reflection Factor 0%

Wall reflection factor	0%	10%	20%	30%	40%	50%	60%	70%	80%	
RI	Utilization Factor									
0.50	Ind. Hor. Dir.	.0 03 19	.0 04 20	.0 05 23	.0 06 25	.0 07 28	.0 08 33	.0 11 37	.0 13 41	.0 16 48
0.60	Ind. Hor. Dir.	.0 06 28	.0 07 29	.0 08 32	.0 09 34	.0 10 37	.0 12 41	.0 14 45	.0 17 49	.0 20 56
0.70	Ind. Hor. Dir.	.0 08 35	.0 09 36	.0 10 39	.0 11 41	.0 13 44	.0 15 48	.0 17 52	.0 20 56	.0 23 62
0.80	Ind. Hor. Dir.	.0 09 41	.0 10 42	.0 11 44	.0 12 46	.0 14 48	.0 16 52	.0 19 55	.0 22 59	.0 25 65
0.90	Ind. Hor. Dir.	.0 10 45	.0 11 46	.0 12 48	.0 13 49	.0 15 51	.0 17 54	.0 20 57	.0 23 61	.0 26 67
1.00	Ind. Hor. Dir.	.0 11 48	.0 12 49	.0 13 51	.0 14 52	.0 16 55	.0 18 58	.0 21 62	.0 24 65	.0 27 68
1.10	Ind. Hor. Dir.	.0 12 50	.0 13 51	.0 14 53	.0 15 54	.0 17 55	.0 19 58	.0 22 61	.0 25 63	.0 28 69
1.25	Ind. Hor. Dir.	.0 13 53	.0 14 54	.0 15 56	.0 16 57	.0 18 58	.0 20 61	.0 23 63	.0 26 66	.0 29 71
1.50	Ind. Hor. Dir.	.0 15 57	.0 16 58	.0 17 60	.0 18 61	.0 20 62	.0 22 65	.0 25 68	.0 28 70	.0 31 76
1.75	Ind. Hor. Dir.	.0 17 61	.0 18 62	.0 19 64	.0 20 65	.0 22 66	.0 24 69	.0 26 72	.0 29 74	.0 32 78
2.00	Ind. Hor. Dir.	.0 19 64	.0 20 65	.0 21 67	.0 22 68	.0 24 70	.0 26 71	.0 28 73	.0 30 75	.0 33 78
2.25	Ind. Hor. Dir.	.0 21 67	.0 22 68	.0 23 70	.0 24 71	.0 25 73	.0 27 74	.0 29 75	.0 31 78	.0 34 82
2.50	Ind. Hor. Dir.	.0 22 70	.0 23 71	.0 24 72	.0 25 74	.0 26 75	.0 28 76	.0 30 78	.0 32 80	.0 35 83
3.00	Ind. Hor. Dir.	.0 25 73	.0 26 74	.0 27 75	.0 28 76	.0 29 77	.0 30 79	.0 32 80	.0 34 81	.0 36 83
3.50	Ind. Hor. Dir.	.0 27 76	.0 27 77	.0 28 78	.0 29 79	.0 30 80	.0 31 81	.0 32 82	.0 33 84	.0 35 85
4.00	Ind. Hor. Dir.	.0 29 78	.0 29 81	.0 30 82	.0 30 83	.0 31 84	.0 32 85	.0 33 86	.0 34 87	.0 35 88
5.00	Ind. Hor. Dir.	.0 31 81	.0 31 84	.0 32 85	.0 32 86	.0 33 87	.0 34 88	.0 35 89	.0 36 90	.0 37 90

RI—Room Index

TABLE V-7 (Continued)  
Ceiling Reflection Factor 10%

Wall reflection factor	0%	10%	20%	30%	40%	50%	60%	70%	80%	
RI	Utilization Factor									
0.50	Ind. Hor. Dir.	.01 04	.01 05	.02 06	.02 07	.02 08	.02 10	.03 12	.04 15	.04 19
		19 24 29	21 26 31	24 28 32	26 30 34	29 33 37	34 37 40	38 41 44	42 45 48	49 51 53
0.60	Ind. Hor. Dir.	.02 07	.02 08	.02 09	.03 10	.03 11	.03 13	.04 16	.04 19	.04 23
		28 33 38	30 35 40	33 37 41	35 39 43	38 42 46	42 45 48	46 49 52	50 53 56	57 59 61
0.70	Ind. Hor. Dir.	.02 09	.02 10	.02 11	.03 12	.03 14	.03 16	.04 19	.04 23	.05 26
		35 40 45	36 41 46	39 43 47	41 45 49	44 48 52	48 51 54	52 55 58	56 59 62	63 65 67
0.80	Ind. Hor. Dir.	.02 10	.02 11	.03 12	.03 13	.03 15	.04 17	.04 20	.05 24	.05 28
		41 46 51	42 47 52	44 48 52	46 50 54	48 52 56	52 55 58	55 58 61	59 62 65	66 68 70
0.90	Ind. Hor. Dir.	.02 11	.03 12	.03 13	.03 14	.04 16	.04 19	.04 22	.05 25	.05 29
		45 50 55	46 51 56	48 52 56	49 53 57	51 55 59	54 57 60	57 60 63	61 64 67	68 70 72
1.00	Ind. Hor. Dir.	.03 12	.03 13	.03 14	.04 15	.04 17	.04 20	.05 23	.05 26	.06 30
		48 53 58	49 54 59	51 55 59	52 56 60	53 57 61	56 59 62	59 62 65	63 66 69	69 71 73
1.10	Ind. Hor. Dir.	.03 13	.03 14	.03 15	.04 16	.04 18	.04 21	.05 24	.05 27	.06 31
		50 55 60	51 56 61	53 57 61	54 58 62	55 59 63	58 61 64	61 64 67	65 68 71	70 72 74
1.25	Ind. Hor. Dir.	.03 15	.03 16	.04 17	.04 18	.04 20	.05 23	.05 26	.06 29	.06 33
		53 58 63	54 59 64	56 60 64	57 61 65	58 62 66	61 64 67	64 67 70	67 70 73	72 74 76
1.50	Ind. Hor. Dir.	.03 17	.04 18	.04 19	.04 20	.05 22	.05 25	.05 28	.06 31	.06 35
		57 62 67	58 63 67	60 64 68	61 65 69	62 66 69	65 68 71	67 70 73	70 73 76	75 77 79
1.75	Ind. Hor. Dir.	.04 19	.04 20	.04 21	.05 22	.05 24	.05 27	.06 30	.06 33	.07 36
		61 66 70	62 67 70	64 68 71	65 69 72	66 70 73	69 72 75	71 74 78	73 76 78	77 79 81
2.00	Ind. Hor. Dir.	.04 21	.04 22	.05 23	.05 24	.05 26	.06 28	.06 31	.07 34	.07 37
		64 69 73	65 70 73	67 71 74	68 72 75	69 73 76	72 75 77	73 76 78	75 78 80	79 81 83
2.25	Ind. Hor. Dir.	.04 23	.05 24	.05 25	.05 26	.06 28	.06 30	.06 32	.07 35	.07 38
		67 72 75	68 73 76	70 74 77	71 75 78	73 76 78	75 78 80	76 79 81	78 80 82	81 83 85
2.50	Ind. Hor. Dir.	.05 25	.05 26	.05 27	.06 28	.06 30	.06 32	.07 34	.07 36	.08 39
		70 74 77	71 75 78	72 76 78	74 77 79	75 78 80	77 80 82	79 81 83	80 83 84	82 84 86
3.00	Ind. Hor. Dir.	.05 27	.05 28	.06 29	.06 30	.06 32	.07 34	.07 36	.07 38	.08 40
		74 77 79	74 77 79	75 78 80	76 79 81	77 80 82	80 83 84	81 83 84	82 84 85	84 86 87
3.50	Ind. Hor. Dir.	.05 29	.06 30	.06 31	.06 32	.07 33	.07 35	.07 37	.08 39	.08 41
		76 79 81	76 79 81	78 80 82	79 81 83	80 82 83	82 84 85	83 85 86	84 86 87	86 88 89
4.00	Ind. Hor. Dir.	.06 31	.06 32	.06 33	.07 34	.07 35	.07 36	.08 38	.08 40	.08 43
		78 81 83	79 81 83	80 82 84	81 83 84	82 84 85	83 85 86	84 86 87	86 87 88	88 89 90
5.00	Ind. Hor. Dir.	.06 33	.06 34	.07 35	.07 36	.07 37	.08 38	.08 39	.08 41	.09 43
		81 83 84	81 83 84	82 84 85	83 85 86	84 86 87	86 87 88	87 88 89	88 89 90	89 90 91

RI—Room Index

TABLE V-7 (Continued)  
Ceiling Reflection Factor 20%

Wall reflection factor	0%	10%	20%	30%	40%	50%	60%	70%	80%	
RI	Utilization Factor									
0.50	Ind. Hor. Dir.	.02 04	.03 05	.03 06	.04 07	.04 10	.04 12	.05 14	.06 17	.07 21
		19 24 29	21 26 31	24 28 32	26 30 34	29 33 37	34 37 40	38 41 44	42 46 48	49 51 53
0.60	Ind. Hor. Dir.	.03 08	.04 09	.04 10	.05 11	.05 13	.06 15	.07 18	.08 22	.09 26
		28 33 38	30 35 40	33 37 41	35 39 43	38 42 46	42 46 48	46 49 52	50 53 56	57 59 61
0.70	Ind. Hor. Dir.	.04 10	.04 11	.05 12	.05 13	.06 15	.06 17	.07 20	.08 24	.10 28
		35 40 45	37 42 47	40 44 48	42 46 50	45 49 53	49 52 55	53 56 59	57 60 63	63 65 67
0.80	Ind. Hor. Dir.	.04 11	.05 12	.05 13	.06 14	.06 16	.07 19	.08 22	.09 26	.10 30
		41 46 51	42 47 52	44 48 52	46 50 54	49 53 57	53 56 59	56 59 62	60 63 66	66 68 70
0.90	Ind. Hor. Dir.	.05 12	.05 13	.06 14	.06 16	.07 18	.07 21	.08 24	.09 28	.11 32
		45 50 55	46 51 56	48 52 56	50 54 58	52 56 60	55 58 61	58 61 64	62 65 68	68 70 72
1.00	Ind. Hor. Dir.	.05 13	.06 14	.06 15	.07 17	.07 19	.08 22	.09 25	.10 29	.11 33
		48 53 58	49 54 59	51 55 59	52 56 60	54 58 62	57 60 63	60 63 66	64 67 70	70 73 74
1.10	Ind. Hor. Dir.	.06 14	.06 15	.07 16	.07 18	.08 20	.08 23	.09 26	.10 30	.12 34
		50 55 60	51 56 61	53 57 61	54 58 62	56 60 64	59 62 65	62 65 68	66 69 72	71 73 75
1.25	Ind. Hor. Dir.	.06 16	.07 17	.07 18	.08 20	.08 22	.09 25	.10 28	.11 32	.12 36
		53 58 63	54 59 64	56 60 64	57 61 65	59 63 67	62 65 68	65 68 71	68 71 74	73 75 77
1.50	Ind. Hor. Dir.	.07 18	.07 19	.08 21	.08 23	.09 25	.09 28	.10 31	.11 34	.13 38
		57 62 67	58 63 67	60 64 68	61 65 69	63 67 70	66 69 72	68 71 74	71 74 77	76 78 80
1.75	Ind. Hor. Dir.	.07 20	.08 21	.08 23	.09 25	.09 27	.10 30	.11 33	.12 36	.13 40
		61 66 70	62 67 70	64 68 71	65 69 72	67 71 74	70 73 76	72 75 77	74 77 79	78 80 82
2.00	Ind. Hor. Dir.	.08 22	.09 23	.09 25	.10 27	.10 29	.11 32	.12 35	.13 38	.14 41
		64 69 73	65 70 73	67 71 74	68 72 75	70 74 77	73 76 78	74 77 79	76 79 81	80 82 84
2.25	Ind. Hor. Dir.	.09 24	.09 25	.10 27	.10 29	.11 31	.11 33	.12 36	.13 39	.14 42
		67 72 75	68 73 76	70 74 77	71 75 78	74 77 79	76 79 81	77 80 82	79 81 83	82 84 86
2.50	Ind. Hor. Dir.	.09 26	.10 27	.10 28	.11 30	.11 32	.12 34	.13 37	.14 40	.15 43
		71 75 78	72 76 79	73 77 79	75 78 80	76 79 81	78 81 83	80 82 84	81 83 85	84 86 87
3.00	Ind. Hor. Dir.	.10 29	.11 30	.11 31	.12 33	.12 35	.13 37	.13 39	.14 42	.15 45
		75 78 80	75 78 80	76 79 81	77 80 82	78 81 83	80 83 85	82 84 85	83 85 86	86 88 89
3.50	Ind. Hor. Dir.	.11 31	.11 32	.12 33	.12 35	.13 37	.13 39	.14 41	.15 43	.16 46
		77 80 82	77 80 82	79 81 83	80 82 84	81 83 84	83 85 86	84 86 87	85 87 88	88 89 90
4.00	Ind. Hor. Dir.	.12 33	.12 34	.13 35	.13 36	.14 38	.14 40	.15 42	.15 44	.16 47
		79 82 84	80 83 84	81 83 85	82 84 85	83 85 86	84 86 87	85 87 88	87 88 89	89 90 91
5.00	Ind. Hor. Dir.	.12 36	.13 37	.13 38	.14 39	.14 40	.15 42	.15 44	.16 46	.17 48
		82 84 85	82 84 85	83 85 86	84 86 87	85 87 88	87 88 89	88 89 90	89 90 91	90 91 92

RI—Room Index

TABLE V-7 (Continued)  
Ceiling Reflection Factor 30%

Wall reflection factor	0%	10%	20%	30%	40%	50%	60%	70%	80%	
RI	Utilization Factor									
0.50	Ind. Hor. Dir.	.04 05 19 24 29	.04 06 21 26 31	.05 07 24 28 32	.05 08 26 30 34	.06 10 29 33 37	.07 12 34 37 40	.08 15 38 41 44	.09 19 43 46 49	.11 24 50 52 54
0.60	Ind. Hor. Dir.	.05 08 28 33 38	.05 09 30 35 40	.06 10 33 37 41	.06 11 35 39 43	.07 13 38 42 46	.08 16 43 46 49	.09 19 47 50 53	.11 23 51 54 57	.13 28 58 60 62
0.70	Ind. Hor. Dir.	.06 11 35 40 45	.06 12 37 42 47	.07 13 40 44 48	.07 14 42 46 50	.08 16 45 49 53	.09 19 49 52 55	.10 22 53 56 59	.12 26 57 60 63	.14 31 64 66 68
0.80	Ind. Hor. Dir.	.06 12 41 46 51	.07 13 42 47 52	.07 14 45 49 53	.08 16 47 51 55	.09 18 50 54 58	.10 21 54 57 60	.11 24 57 60 63	.13 28 61 64 67	.15 33 67 69 71
0.90	Ind. Hor. Dir.	.07 13 45 50 55	.07 14 46 51 56	.08 16 48 52 56	.09 18 50 54 58	.10 20 52 56 60	.11 23 56 59 62	.12 26 59 62 65	.14 30 63 66 69	.16 35 69 71 73
1.00	Ind. Hor. Dir.	.08 14 48 53 58	.08 15 49 54 59	.09 17 51 55 59	.10 19 53 57 61	.11 21 55 59 63	.12 24 58 61 64	.13 27 61 64 67	.15 31 65 68 71	.17 36 71 73 75
1.10	Ind. Hor. Dir.	.09 15 50 55 60	.09 16 51 56 61	.10 18 53 57 61	.10 20 55 59 63	.11 22 57 61 65	.12 25 60 63 66	.13 28 63 66 69	.15 32 66 69 72	.17 37 72 74 76
1.25	Ind. Hor. Dir.	.09 17 53 58 63	.10 18 54 59 64	.11 20 56 60 64	.11 22 57 61 65	.12 24 59 63 67	.13 27 62 65 68	.14 30 65 68 71	.16 34 68 71 74	.18 39 74 76 78
1.50	Ind. Hor. Dir.	.10 20 57 62 67	.11 21 58 63 67	.12 23 60 64 68	.12 25 61 65 69	.13 27 63 67 70	.14 30 66 69 72	.15 33 69 72 75	.17 36 72 75 78	.19 41 77 79 81
1.75	Ind. Hor. Dir.	.11 22 61 66 70	.12 23 62 67 70	.13 25 64 68 71	.13 27 65 69 72	.14 29 67 71 74	.15 32 70 73 76	.16 35 72 75 77	.18 38 75 78 79	.20 43 80 79 81 83
2.00	Ind. Hor. Dir.	.12 24 64 69 73	.13 25 65 70 73	.14 27 67 71 74	.14 29 68 72 75	.15 31 70 74 77	.16 34 73 76 78	.17 37 75 78 80	.19 40 77 80 82	.21 45 81 83 85
2.25	Ind. Hor. Dir.	.13 26 67 72 75	.14 27 68 73 76	.15 29 70 74 77	.15 31 71 75 78	.16 33 74 77 79	.17 36 76 79 81	.18 39 77 80 82	.19 42 80 82 84	.21 47 83 85 87
2.50	Ind. Hor. Dir.	.14 28 71 75 78	.15 29 72 76 79	.16 31 73 77 79	.16 33 75 78 80	.17 35 77 80 82	.18 38 78 81 83	.19 41 80 83 84	.20 44 82 84 86	.22 49 85 87 88
3.00	Ind. Hor. Dir.	.16 31 75 78 80	.16 32 75 78 80	.17 34 76 79 81	.17 36 77 80 82	.18 38 79 82 84	.19 41 81 83 85	.20 43 82 84 85	.21 46 84 86 87	.23 50 87 89 90
3.50	Ind. Hor. Dir.	.17 33 77 80 82	.17 34 77 80 82	.18 36 79 81 83	.18 38 80 83 84	.19 40 82 84 85	.20 43 83 85 86	.21 46 84 86 87	.22 49 86 88 89	.24 51 89 90 91
4.00	Ind. Hor. Dir.	.18 36 79 82 84	.18 37 80 82 84	.19 38 81 83 85	.19 40 82 84 85	.20 42 84 86 87	.21 44 85 87 88	.22 47 86 88 89	.23 50 88 90 91	.24 52 90 91 92
5.00	Ind. Hor. Dir.	.19 39 82 84 85	.19 40 82 84 85	.20 41 83 85 86	.21 43 84 86 87	.21 44 86 88 89	.22 46 88 90 90	.23 48 89 90 91	.24 50 90 91 92	.25 53 91 92 93



TABLE V-7 (Continued)  
Ceiling Reflection Factor 40%

Wall reflection factor	0%	10%	20%	30%	40%	50%	60%	70%	80%	
RI	Utilization Factor									
0.50	Ind. Hor. Dir.	.05 05 19 24 29	.05 06 21 26 31	.06 07 24 28 32	.06 08 26 30 34	.07 11 29 33 37	.08 14 34 37 40	.10 17 38 41 44	.12 21 43 46 49	.15 26 50 52 54
0.60	Ind. Hor. Dir.	.07 08 28 33 38	.07 09 30 35 40	.08 11 33 37 41	.09 12 35 39 43	.10 14 38 42 46	.11 17 43 46 49	.13 21 47 50 53	.15 25 52 55 58	.18 30 59 61 63
0.70	Ind. Hor. Dir.	.08 11 35 40 45	.08 12 37 42 47	.09 14 40 44 48	.10 15 42 46 50	.11 17 45 49 53	.12 20 49 52 55	.14 24 53 56 59	.16 29 58 61 64	.19 34 65 67 69
0.80	Ind. Hor. Dir.	.09 12 41 46 51	.09 13 42 47 52	.10 15 45 49 53	.11 17 47 51 55	.12 19 50 54 58	.13 22 54 57 60	.15 26 57 60 63	.17 31 62 65 68	.20 36 68 70 72
0.90	Ind. Hor. Dir.	.10 14 45 50 55	.10 15 46 51 56	.11 17 49 53 57	.12 19 51 55 59	.13 21 53 57 61	.14 24 57 60 63	.16 28 60 63 66	.18 33 64 67 69	.21 38 70 72 74
1.00	Ind. Hor. Dir.	.11 15 48 53 58	.11 16 49 54 59	.12 18 52 56 60	.13 20 53 57 61	.14 22 55 59 63	.15 25 59 62 65	.17 29 62 65 68	.19 34 66 69 72	.23 39 72 74 76
1.10	Ind. Hor. Dir.	.12 16 50 55 60	.12 18 51 56 61	.13 20 54 58 62	.14 22 55 59 63	.15 24 57 61 65	.16 27 60 63 66	.18 31 63 66 69	.20 36 67 70 73	.23 41 73 75 77
1.25	Ind. Hor. Dir.	.13 18 53 58 63	.13 20 54 59 64	.14 22 57 61 65	.15 24 58 62 66	.16 26 60 64 68	.18 29 63 66 69	.20 33 66 69 72	.23 38 69 72 75	.26 43 75 77 79
1.50	Ind. Hor. Dir.	.14 21 57 62 67	.15 23 58 63 67	.16 25 61 65 69	.17 27 62 66 70	.18 29 64 68 71	.19 32 67 70 73	.21 36 70 73 76	.23 40 73 76 79	.26 45 78 80 82
1.75	Ind. Hor. Dir.	.15 23 61 66 70	.16 25 62 67 71	.17 27 65 69 72	.18 29 66 70 73	.19 32 68 72 75	.20 35 71 74 77	.23 39 73 76 78	.26 43 76 79 81	.28 47 80 82 84
2.00	Ind. Hor. Dir.	.17 25 64 69 73	.18 27 65 70 73	.19 29 68 72 75	.20 31 69 73 76	.21 34 71 75 78	.23 37 74 77 79	.24 41 75 78 80	.26 45 79 81 83	.27 49 82 84 86
2.25	Ind. Hor. Dir.	.18 27 67 72 75	.19 29 68 73 76	.20 31 71 75 78	.21 33 72 76 79	.22 36 75 78 80	.23 39 77 80 82	.25 43 78 81 83	.27 47 81 83 85	.28 51 84 86 88
2.50	Ind. Hor. Dir.	.19 29 71 75 78	.20 31 72 76 79	.21 33 74 78 80	.22 35 76 79 81	.23 38 78 81 83	.24 41 79 82 84	.26 45 81 83 85	.28 48 83 85 87	.29 52 86 88 89
3.00	Ind. Hor. Dir.	.21 32 75 78 80	.22 34 76 79 81	.23 36 77 80 82	.24 39 78 81 83	.25 41 80 83 85	.26 44 82 84 86	.28 47 83 85 87	.29 50 85 87 88	.30 54 88 90 91
3.50	Ind. Hor. Dir.	.23 35 77 80 82	.23 37 78 81 83	.24 39 80 82 84	.25 42 81 83 85	.26 44 83 85 86	.27 46 84 86 87	.28 49 85 87 88	.29 52 87 89 90	.31 56 90 91 92
4.00	Ind. Hor. Dir.	.24 38 79 82 84	.25 39 81 83 85	.26 41 82 84 86	.27 44 83 85 86	.28 46 85 87 88	.29 48 86 88 89	.30 51 87 89 90	.31 54 89 90 91	.32 57 91 92 93
5.00	Ind. Hor. Dir.	.25 41 83 85 86	.26 42 83 85 86	.27 44 84 86 87	.28 46 85 87 88	.29 48 87 89 90	.30 50 89 90 91	.31 53 90 91 92	.32 55 91 92 93	.33 58 92 93 94

RI—Room Index

TABLE V-7 (Continued)  
Ceiling Reflection Factor 50%

Wall reflection factor	0%	10%	20%	30%	40%	50%	60%	70%	80%	
RI	Utilization Factor									
0.50	Ind. Hor. Dir.	.06 06 19	.07 07 21	.08 08 24	.08 09 27	.09 12 30	.10 15 34	.12 19 40	.15 22 44	.19 29 51
0.60	Ind. Hor. Dir.	.08 09 28	.09 10 30	.10 11 33	.11 13 36	.12 16 39	.13 19 43	.15 22 47	.18 27 52	.22 33 59
0.70	Ind. Hor. Dir.	.10 11 35	.11 12 37	.12 14 40	.13 16 43	.14 19 46	.15 22 50	.17 26 54	.20 30 59	.23 36 65
0.80	Ind. Hor. Dir.	.11 13 41	.12 14 42	.13 16 45	.14 18 47	.15 21 50	.17 24 54	.19 28 57	.22 32 62	.25 38 68
0.90	Ind. Hor. Dir.	.12 15 45	.13 16 46	.14 18 49	.15 20 51	.16 22 53	.18 26 57	.20 30 63	.23 34 64	.26 40 70
1.00	Ind. Hor. Dir.	.13 16 48	.14 18 49	.15 20 52	.16 22 54	.17 25 56	.19 28 59	.21 32 65	.24 36 66	.27 42 72
1.10	Ind. Hor. Dir.	.14 17 50	.15 19 51	.16 21 54	.17 23 56	.19 26 58	.21 29 61	.23 33 67	.25 37 70	.28 43 74
1.25	Ind. Hor. Dir.	.16 19 53	.17 21 54	.18 23 57	.19 25 59	.21 28 61	.23 31 64	.25 35 70	.27 39 73	.30 45 78
1.50	Ind. Hor. Dir.	.18 22 57	.19 24 58	.20 26 61	.21 29 62	.23 32 64	.25 35 67	.27 39 73	.29 43 76	.32 48 79
1.75	Ind. Hor. Dir.	.19 25 61	.20 27 62	.21 29 65	.22 32 66	.24 35 68	.26 38 71	.28 42 77	.30 46 79	.33 51 81
2.00	Ind. Hor. Dir.	.21 27 64	.22 29 65	.23 31 68	.24 34 69	.26 37 71	.28 40 74	.30 44 79	.32 48 81	.34 53 84
2.25	Ind. Hor. Dir.	.23 29 67	.24 31 68	.25 33 71	.26 36 72	.27 39 75	.29 42 77	.31 46 82	.33 50 84	.35 55 86
2.50	Ind. Hor. Dir.	.24 31 71	.25 33 72	.26 35 74	.27 38 76	.28 41 78	.30 44 81	.32 48 84	.34 52 86	.36 57 89
3.00	Ind. Hor. Dir.	.26 34 75	.27 36 78	.28 38 80	.29 41 81	.30 44 83	.32 47 85	.34 51 88	.36 55 89	.38 61 91
3.50	Ind. Hor. Dir.	.28 37 77	.29 39 80	.30 41 82	.31 44 83	.32 47 85	.34 50 88	.36 54 90	.38 58 91	.40 65 94
4.00	Ind. Hor. Dir.	.30 40 79	.31 42 81	.32 44 82	.33 46 83	.34 49 85	.35 52 88	.37 56 90	.39 60 91	.41 68 93
5.00	Ind. Hor. Dir.	.32 43 83	.33 45 83	.34 47 84	.35 49 85	.36 52 87	.38 56 89	.39 60 92	.40 64 93	.42 71 94

TABLE V-7 (Continued)  
Ceiling Reflection Factor 60%

Wall reflection factor	0%	10%	20%	30%	40%	50%	60%	70%	80%	
RI	Utilization Factor									
0.50	Ind. Hor. Dir.	.07 06	.08 07	.09 08	.10 10	.11 13	.12 16	.15 20	.18 25	.22 31
		19 24 29	21 26 31	24 28 32	27 31 35	30 34 38	35 38 41	39 42 45	44 47 50	51 53 55
0.60	Ind. Hor. Dir.	.10 09	.11 10	.12 12	.13 14	.14 17	.16 20	.19 24	.22 28	.26 35
		28 33 38	30 35 40	33 37 41	36 40 44	39 43 47	44 47 50	48 51 54	53 56 59	60 62 64
0.70	Ind. Hor. Dir.	.12 12	.13 13	.14 15	.15 17	.16 20	.18 23	.21 26	.24 31	.28 39
		35 40 45	37 42 47	40 44 49	43 47 51	46 50 54	50 53 56	54 57 60	59 62 65	66 68 70
0.80	Ind. Hor. Dir.	.13 14	.14 15	.15 17	.16 19	.18 22	.20 25	.23 30	.26 35	.30 41
		41 46 51	43 48 53	46 50 54	48 52 56	51 55 59	55 58 61	58 61 64	63 66 69	69 71 73
0.90	Ind. Hor. Dir.	.15 16	.16 17	.17 19	.18 21	.20 24	.22 27	.25 32	.28 37	.32 43
		45 50 55	46 51 56	49 53 57	51 55 59	54 58 62	58 61 64	61 64 67	65 68 71	71 73 75
1.00	Ind. Hor. Dir.	.16 18	.17 19	.18 21	.19 23	.21 26	.23 29	.26 34	.29 39	.33 46
		48 53 58	49 54 59	52 56 60	54 58 62	56 60 64	60 63 66	63 66 69	67 70 73	73 76 77
1.10	Ind. Hor. Dir.	.17 19	.18 21	.19 23	.21 25	.23 28	.25 31	.27 36	.30 41	.34 47
		50 55 60	51 56 61	54 58 62	56 60 64	58 62 66	62 65 68	65 68 71	69 72 75	75 77 79
1.25	Ind. Hor. Dir.	.19 21	.20 23	.21 25	.23 27	.25 30	.27 33	.29 38	.32 43	.36 49
		53 58 63	54 59 64	57 61 65	59 63 67	61 65 69	64 67 70	67 70 73	71 74 77	77 79 81
1.50	Ind. Hor. Dir.	.21 24	.22 26	.23 28	.25 31	.27 34	.29 37	.31 42	.34 47	.38 52
		57 62 67	58 63 67	61 65 69	63 67 71	65 69 72	68 71 74	71 74 77	74 77 80	80 82 84
1.75	Ind. Hor. Dir.	.23 27	.24 29	.25 31	.27 34	.29 37	.31 40	.33 46	.36 50	.39 55
		61 66 70	62 67 71	65 69 72	67 71 74	69 73 76	72 76 77	74 77 79	77 80 82	82 84 86
2.00	Ind. Hor. Dir.	.25 29	.26 31	.27 33	.29 36	.31 39	.33 42	.35 47	.38 52	.41 57
		64 69 73	65 70 73	68 72 75	70 74 77	72 76 79	75 78 79	80 82 80	82 83 85	84 86 88
2.25	Ind. Hor. Dir.	.27 31	.28 33	.29 35	.31 38	.33 41	.35 44	.37 49	.39 54	.42 59
		67 72 75	68 73 76	71 75 78	73 77 80	76 79 81	78 81 83	80 83 85	83 86 87	86 88 90
2.50	Ind. Hor. Dir.	.29 33	.30 35	.31 37	.33 40	.35 43	.37 46	.39 51	.41 56	.44 61
		71 75 78	72 76 79	74 78 80	77 80 82	79 82 84	80 83 85	83 86 87	85 87 89	88 90 91
3.00	Ind. Hor. Dir.	.32 37	.33 39	.34 41	.35 44	.37 47	.39 50	.41 55	.43 59	.46 63
		75 78 80	76 79 81	77 80 82	79 82 84	81 84 86	82 85 87	85 87 88	87 89 90	90 92 93
3.50	Ind. Hor. Dir.	.34 40	.35 43	.36 44	.37 47	.39 50	.41 53	.43 57	.45 61	.47 66
		78 81 83	78 81 83	80 82 84	82 84 86	84 86 87	85 87 88	87 89 90	89 91 92	92 94 95
4.00	Ind. Hor. Dir.	.36 43	.37 45	.38 47	.39 50	.41 53	.43 56	.44 59	.46 63	.48 67
		80 83 85	81 83 85	82 84 86	84 86 87	85 88 89	87 89 90	89 91 92	92 93 94	94 95 96
5.00	Ind. Hor. Dir.	.38 46	.39 48	.40 50	.41 53	.43 56	.45 59	.46 62	.48 66	.49 69
		84 86 87	84 86 87	85 87 88	86 88 89	88 90 91	90 91 92	92 93 94	93 94 95	95 96 97

RI—Room Index

TABLE V-7 (Continued)  
Ceiling Reflection Factor 70%

Wall reflection factor	0%	10%	20%	30%	40%	50%	60%	70%	80%	
RI	Utilization Factor									
0.50	Ind. Hor. Dir. 19 24 29	.08 07 08 29	.09 08 31	.10 09 32	.11 11 35	.13 14 38	.15 17 41	.18 21 45	.22 27 50	.27 33 56
0.60	Ind. Hor. Dir. 28 33 38	.12 10 11	.13 11 14	.14 13 17	.15 15 18	.17 18 21	.19 21 25	.22 25 31	.26 31 37	.31 37 44
0.70	Ind. Hor. Dir. 35 40 45	.14 13 14	.15 14 16	.16 16 18	.17 18 20	.19 21 23	.21 23 26	.24 26 30	.28 31 36	.33 41 48
0.80	Ind. Hor. Dir. 41 46 51	.16 15 16	.17 16 18	.18 18 20	.19 20 22	.21 22 25	.23 25 28	.26 28 32	.30 33 38	.35 44 51
0.90	Ind. Hor. Dir. 45 50 55	.17 17 18	.18 18 20	.19 20 22	.21 22 24	.23 25 27	.25 27 30	.28 30 34	.32 35 40	.37 46 54
1.00	Ind. Hor. Dir. 48 53 58	.19 18 19	.20 20 22	.21 22 24	.23 24 26	.25 27 29	.27 30 33	.30 33 37	.34 43 50	.39 48 57
1.10	Ind. Hor. Dir. 50 55 60	.20 20 22	.21 22 24	.22 24 26	.25 26 28	.27 29 32	.29 32 36	.32 35 40	.35 44 51	.39 50 58
1.25	Ind. Hor. Dir. 53 58 63	.22 22 24	.23 24 26	.25 26 28	.27 29 32	.29 32 36	.31 34 38	.34 41 47	.37 47 54	.41 53 61
1.50	Ind. Hor. Dir. 57 62 67	.25 25 27	.26 27 29	.28 30 32	.30 32 35	.32 35 39	.34 38 42	.37 45 50	.40 50 58	.44 56 64
1.75	Ind. Hor. Dir. 61 66 70	.27 28 30	.28 30 32	.30 32 35	.32 34 37	.34 38 42	.36 43 48	.39 48 55	.42 53 61	.46 59 67
2.00	Ind. Hor. Dir. 64 69 73	.30 31 32	.31 32 34	.32 34 36	.34 36 39	.36 40 44	.38 46 51	.41 51 58	.44 56 64	.48 61 70
2.25	Ind. Hor. Dir. 67 72 75	.32 33 35	.33 34 36	.34 36 38	.36 38 41	.38 42 46	.40 48 53	.43 53 60	.46 58 66	.50 63 72
2.50	Ind. Hor. Dir. 71 75 78	.34 35 37	.35 36 38	.36 38 40	.38 40 43	.40 44 48	.42 50 55	.45 56 63	.48 60 69	.51 65 74
3.00	Ind. Hor. Dir. 75 78 80	.37 39 41	.38 40 42	.39 41 44	.41 43 46	.43 47 51	.45 54 60	.47 58 65	.50 63 72	.53 68 77
3.50	Ind. Hor. Dir. 78 81 83	.40 42 44	.41 43 45	.42 44 47	.44 46 49	.46 50 54	.48 57 63	.50 61 68	.52 66 75	.55 71 80
4.00	Ind. Hor. Dir. 80 83 85	.42 44 46	.43 45 47	.44 46 49	.46 48 51	.48 52 56	.50 60 66	.52 64 72	.54 68 77	.56 73 82
5.00	Ind. Hor. Dir. 84 86 87	.45 47 49	.46 48 51	.47 49 52	.48 50 53	.50 54 58	.52 62 68	.54 66 74	.56 70 79	.58 75 84

TABLE V-7 (Continued)  
Ceiling Reflection Factor 80%

Wall reflection factor	0%	10%	20%	30%	40%	50%	60%	70%	80%	
RI	Utilization Factor									
0.50	Ind. Hor. Dir.	.09 07 19	.10 08 21	.11 09 24	.12 11 27	.14 14 30	.17 18 35	.21 22 41	.25 26 48	.31 32 56
0.60	Ind. Hor. Dir.	.13 10 28	.14 12 30	.15 14 33	.16 16 36	.18 18 39	.21 22 44	.25 27 50	.29 32 53	.35 36 61
0.70	Ind. Hor. Dir.	.16 13 35	.17 15 37	.18 17 40	.19 19 43	.21 22 46	.24 26 50	.28 30 54	.32 33 58	.38 40 65
0.80	Ind. Hor. Dir.	.18 15 41	.19 17 43	.20 19 46	.22 22 48	.24 25 51	.27 29 55	.30 34 59	.34 40 64	.40 47 71
0.90	Ind. Hor. Dir.	.20 17 46	.21 19 47	.22 21 50	.24 24 52	.26 27 55	.29 31 59	.32 36 62	.36 43 66	.42 48 72
1.00	Ind. Hor. Dir.	.22 19 49	.23 21 50	.24 23 53	.26 26 55	.28 29 58	.31 33 61	.34 38 64	.38 44 68	.44 51 74
1.10	Ind. Hor. Dir.	.23 21 51	.24 23 52	.26 25 55	.28 28 57	.30 31 59	.33 35 63	.36 40 66	.40 46 70	.46 53 76
1.25	Ind. Hor. Dir.	.25 23 54	.26 25 55	.28 28 58	.30 31 60	.32 34 62	.36 38 66	.39 43 69	.43 49 73	.47 56 79
1.50	Ind. Hor. Dir.	.28 26 58	.29 29 63	.31 32 66	.33 35 68	.36 38 72	.39 42 76	.42 47 78	.46 53 79	.50 59 83
1.75	Ind. Hor. Dir.	.31 29 62	.32 32 66	.34 35 68	.36 38 72	.39 42 75	.42 46 77	.45 51 79	.48 56 82	.52 62 85
2.00	Ind. Hor. Dir.	.34 32 65	.35 35 68	.37 38 71	.39 41 75	.42 45 78	.45 49 81	.48 54 83	.51 59 82	.54 66 87
2.25	Ind. Hor. Dir.	.36 34 68	.37 37 69	.39 40 72	.41 44 74	.44 48 77	.47 52 80	.50 57 84	.53 62 85	.56 67 89
2.50	Ind. Hor. Dir.	.38 36 71	.39 39 72	.41 42 74	.43 45 77	.46 50 80	.49 54 82	.52 59 84	.55 64 87	.58 69 90
3.00	Ind. Hor. Dir.	.42 40 75	.43 43 78	.45 46 81	.47 50 83	.49 54 85	.52 58 87	.55 62 89	.58 67 90	.61 73 92
3.50	Ind. Hor. Dir.	.45 44 78	.46 47 82	.48 50 84	.50 54 85	.52 58 87	.54 62 89	.57 66 91	.60 70 92	.63 74 94
4.00	Ind. Hor. Dir.	.48 47 80	.49 50 84	.51 53 86	.53 57 87	.55 61 89	.57 64 90	.59 68 91	.61 73 94	.64 76 96
5.00	Ind. Hor. Dir.	.51 51 84	.52 54 85	.54 57 88	.56 60 89	.58 64 90	.60 67 92	.62 71 94	.64 74 95	.66 78 97

RI—Room Index

Whenever an analysis of the distribution curve shows a horizontal component in addition to the direct component, the expression takes the form:

percentage of flux in 0°-40° zone

$$= \frac{\text{lumens } 0^{\circ}\text{-}40^{\circ} \text{ zone} - 0.65 \text{ (c-p. at } 90^{\circ}\text{)}}{\text{lumens } 0^{\circ}\text{-}90^{\circ} \text{ zone} - 5.0 \text{ (c-p. at } 90^{\circ}\text{)}}$$

The last terms in the numerator and denominator represent the number of lumens in the 0°-40° and the 0°-90° zones for the horizontal component. Experience shows that the medium direct component (shown in bold-face type in Table V-7) may be used in almost every practical installation without error. Table V-7 shows the factors which have been determined by experimental methods for the three components of all types of equipment. Of the three values given in bold type in each square, the first figure is the ratio of total flux on a horizontal reference plane (working plane) to the flux emitted by a totally indirect unit, or in other words it is the percentage of total flux above the horizontal plane passing through the center of the unit which is intercepted by the horizontal plane of work equal in area to the floor area. The second bold-face number is the fraction of total flux emitted by the unit (having approximately toroidal solid candle-power distribution) which reaches the horizontal working plane. The last is for the fraction of total flux emitted by the unit below the horizontal plane which passes through the center of the unit and which is intercepted by the horizontal work plane. These data are for square rooms having room indexes as shown. For rectangular rooms the most satisfactory method for determining the ultimate coefficient is to determine the factors for two square rooms in which the length is the dimension for one room, and the width is the dimension for the other room; these are then combined to give the following expression for the coefficient of the rectangular room:

$$CU = CU_w + \frac{1}{2}(CU_l - CU_w)$$

where  $CU$  is the coefficient of utilization for the rectangular room;  $CU_w$  the coefficient of utilization for a square room with  $w$  (width) as its dimension, and  $CU_l$  the coefficient of utilization for the square room with  $l$  (length) as its dimension.

In the determination of the factors given in Table V-7, all floors were oak with a reflection factor of 14 per cent, the most common reflection factor for interior floors. Comparing the effect of very light ceilings with different side wall colors, the following effective ratios were established:

Ceiling	Walls	RI	Floor Reflection			
			0%	14%	40%	80%
80%	0%	1.0	1.00	1.00	1.01	1.02
		2.0	0.99	1.00	1.05	1.08
	40%	1.0	0.99	1.00	1.02	1.05
		2.0	0.98	1.00	1.05	1.12
	80%	1.0	0.97	1.00	1.06	1.15
		2.0	0.95	1.00	1.09	1.22

A white floor may increase the effective illumination to a great extent in large rooms.

*Example c.* Using the data given in Fig. 2-5 (page 93) for a luminaire, determine the utilization factor and coefficient of utilization for a room with an index of 1.25, and ceiling and side wall reflection factors of 60 and 40 per cent, respectively.

From Fig. 2-5:

Lamp, 500 w.	9800 l.
Candlepower at 90°	129 c.
0°-90°	803 l.
90°-180°	7335 l.
0°-180°	8138 l.
Luminaire efficiency	83%

From Table V-7:

Indirect component factor	0.25
Horizontal component factor	0.30
Direct component (med.) factor	0.65

Determine from the data given the lumens in the three component curves, the algebraic sum of which will be the total lumens.

$$\text{Horizontal} \quad 129 \times \pi^2 = 1272 \text{ l.}$$

The horizontal component is a toroidal distribution where  $F = \pi^2 I_m$ .

$$\text{Indirect} \quad 7335 - \frac{1272}{2} = 6699 \text{ l.}$$

$$\text{Direct} \quad 803 - \frac{1272}{2} = 167 \text{ l.}$$

$$\text{Total} \quad \underline{8138 \text{ l.}}$$

To determine the useful lumens on the work surface emitted by the luminaire, each of the components must be multiplied by its component factor.

Horizontal	$1272 \times 0.30 = 382$
Indirect	$6699 \times 0.25 = 1675$
Direct	$167 \times 0.65 = 109$
	<u>2166 l.</u>

From this the utilization of the equipment in the room is shown to be

$$UF = \frac{\text{work surface lumens}}{\text{luminaire lumens}} = \frac{2166}{8138} = 0.266$$

$$CU = \frac{2166}{9800} = 0.221$$

Since the efficiency is 83%

$$CU = UF \times \text{luminaire efficiency} = 0.266 \times 0.83 = 0.221 \quad (\text{check})$$

which determination of the utilization coefficient is the product of the *utilization factor* ( $UF$ ) and the *equipment efficiency* ( $\eta$ ).

By the same process all the utilization factors in Table VI-7 have been determined and similar tables may be determined for any type of equipment.

**19. Coefficients of Utilization for Combination Units.** For successful merchandising it is necessary to have a large component of light of a direct nature and at the same time it is desirable to have the ceiling illuminated and the general lighting in the room similar to indirect lighting. One method of solving this problem is to recess equipment into the ceiling for direct lighting on the merchandise and use an indirect system for general lighting. To meet the demand for this combination lighting effect, equipment has been developed which has both a direct and an indirect component of light. Besides incandescent luminaires of this type the development of the fluorescent lamp introduced a type of equipment which in general has a distribution showing combination characteristics. The range of this combination equipment may be from little less than direct to practically all indirect distribution.

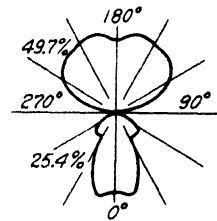





FIG. 13-7. Candlepower distribution curve for an equipment of the combination type.

Figure 13-7 shows the distribution curve for an equipment of the combination type. It is possible to determine the coefficient of utilization for this equipment from the utilization factors given in Table VI-7. It is only necessary to determine the coefficient of utilization for the direct and indirect distribution separately and add the two together. The direct and indirect distribution curves are checked for similarity to those in the table and computations are made in the regular manner.

*Example d.* Determine the coefficient of utilization for the fixture having the distribution shown in Fig. 13-7, if the room measures 17 ft. by 40 ft. and has a 13-ft. ceiling. The ceiling has a reflection factor of 75 per cent and



TABLE  
UTILIZATION





TYPE OF DISTRIBUTION AND EFFICIENCY CLASSIFICATION	TYPICAL EQUIPMENT REPRESENTATIVE OF EACH GROUP	Colling	75%			50%			30%		
		Walls	50	30	10	50	30	10	30	10	
		Room Index	ROOM UTILIZATION FACTOR								
 <p><b>A</b> High Bay Open Reflectors. Prismatic, Mirrored glass, Polished metal. MF 70%</p>		0.6	57	54	51	56	54	51	56	51	
		0.8	69	66	66	67	66	64	66	61	
		1.0	73	73	71	71	71	70	71	69	
		1.2	79	77	77	77	74	74	74	73	
		1.5	83	80	79	79	79	77	79	76	
		2.0	86	84	83	84	83	81	81	80	
		2.5	91	87	86	89	86	86	86	84	
		3.0	93	90	87	90	89	86	86	86	
		4.0	93	91	90	91	89	89	89	87	
		5.0	94	93	91	91	90	89	89	89	
 <p><b>B</b> Parabolic Polished Metal Reflectors. Louvered trough Inside frosted lamps. Open reflectors Silvered bowl lamps. MF 70%</p>		0.6	58	54	52	56	54	52	56	52	
		0.8	68	66	64	68	64	64	64	62	
		1.0	74	72	72	72	72	70	72	68	
		1.2	78	78	76	76	76	74	76	72	
		1.5	82	80	78	80	78	76	78	76	
		2.0	86	84	84	84	84	80	82	80	
		2.5	92	88	86	88	86	84	84	84	
		3.0	92	90	88	90	88	86	86	84	
		4.0	94	92	90	92	88	88	88	88	
		5.0	94	92	92	92	90	88	88	88	
 <p><b>C</b> Prismatic Glass or Polished Metal Reflectors Enclosed lens plates Open louvers MF 70%</p>		0.6	57	53	53	57	53	53	57	53	
		0.8	70	67	67	67	67	63	67	63	
		1.0	73	73	70	73	70	70	70	70	
		1.2	80	77	77	77	73	73	73	73	
		1.5	83	80	80	80	77	77	77	77	
		2.0	87	83	83	83	83	80	83	80	
		2.5	90	87	87	87	87	87	87	83	
		3.0	93	90	87	90	87	87	87	87	
		4.0	93	90	90	90	90	87	87	87	
		5.0	93	93	90	93	90	90	90	87	
 <p><b>D</b> Open Reflectors, RLM dome porcelain enamel Inside frosted lamp Mirrored or prismatic Inside frosted lamp, MF 75%</p>		0.6	45	39	32	45	39	32	37	32	
		0.8	56	51	45	56	49	44	49	44	
		1.0	61	57	52	60	56	52	56	52	
		1.2	67	63	57	65	61	57	60	56	
		1.5	71	67	61	69	65	61	64	60	
		2.0	77	73	68	76	72	68	71	68	
		2.5	83	79	75	81	77	75	77	75	
		3.0	85	81	77	84	80	77	80	77	
		4.0	89	87	84	88	85	83	84	81	
		5.0	92	89	87	89	88	85	87	84	

DIRECT CONCENTRATING

DISTRIBUTING





VI-7

FACTORS

TYPE OF DISTRIBUTION AND EFFICIENCY CLASSIFICATION	TYPICAL EQUIPMENT REPRESENTATIVE OF EACH GROUP	ceiling	75%			50%			30%		
		Walls	50	30	10	50	30	10	30	10	
		Room Index	ROOM UTILIZATION FACTOR								
 MF 75%	Open Reflectors.	0.6	49	43	38	49	43	38	42	38	
	RLM dome porcelain enameled	0.8	61	55	52	60	54	51	54	51	
	White bowl lamp, RLM dome	1.0	66	60	57	65	60	57	60	57	
	deep bowl porcelain enameled	1.2	71	66	63	69	66	63	66	63	
	Inside frosted lamp.	1.5	74	69	66	72	69	66	69	66	
		2.0	80	77	74	78	75	72	75	72	
		2.5	86	83	80	85	82	78	82	78	
		3.0	88	85	82	86	83	80	83	80	
		4.0	92	89	86	91	88	85	88	85	
		5.0	94	91	88	92	89	88	89	86	
 MF 70%	Large Area Diffusing Reflectors.	0.6	48	40	35	47	40	35	38	35	
	RLM Glassteel diffuser Clear	0.8	60	53	48	58	52	47	50	47	
	lamp, RLM dome	1.0	65	60	55	63	58	55	57	53	
	Silver bowl lamp, Enclosing globe and parchment shade	1.2	72	65	60	68	63	60	62	58	
		1.5	75	70	65	72	67	63	65	63	
		2.0	82	77	73	78	75	72	72	70	
		2.5	88	83	78	85	80	77	78	77	
		3.0	90	87	82	87	83	80	80	78	
		4.0	95	92	88	92	87	85	85	83	
		5.0	98	93	90	93	90	87	87	85	
 MF 70%	Large Area Diffusing Panels, Extended trough reflector with opal glass cover.	0.6	47	40	35	45	40	35	38	35	
	Enameled metal reflector with diffusing cover glass.	0.8	58	53	47	56	51	47	51	47	
		1.0	64	58	54	62	58	54	56	54	
		1.2	69	64	60	67	64	58	62	58	
		1.5	73	67	64	69	65	64	65	64	
		2.0	78	75	71	76	73	69	73	69	
		2.5	84	80	76	82	78	76	78	76	
		3.0	87	84	78	84	82	78	80	78	
		4.0	91	87	84	87	85	84	84	82	
		5.0	93	89	87	91	87	85	85	84	
 MF 65%	Large Area Diffusing Panel Trough reflector with solid opal or enameled glass cover, Enclosed skylights	0.6	47	40	35	45	40	35	40	35	
		0.8	58	52	47	58	50	47	50	47	
		1.0	63	58	55	63	57	55	57	55	
		1.2	68	63	60	68	63	60	60	60	
		1.5	73	68	63	70	65	63	65	63	
		2.0	78	75	70	78	73	70	73	70	
		2.5	85	80	75	83	80	75	78	75	
		3.0	87	83	80	85	80	80	80	78	
		4.0	90	87	85	87	85	83	85	83	
		5.0	93	90	87	90	87	85	85	85	

DIRECT DISTRIBUTING

TABLE VI-7

	TYPE OF DISTRIBUTION AND EFFICIENCY CLASSIFICATION	TYPICAL EQUIPMENT REPRESENTATIVE OF EACH GROUP	Calling	75%			50%			30%	
			Walls	50	30	10	50	30	10	30	10
			Room Index	ROOM UTILIZATION FACTOR							
↑ DIRECT DISTRIBUTING	I  MF 60%	Combination Skylight	0.6	48	40	36	48	40	36	40	36
			0.8	56	52	48	56	52	48	52	48
			1.0	64	60	56	64	60	56	60	56
			1.2	68	64	60	68	64	60	60	60
			1.5	72	68	64	72	64	64	64	64
			2.0	80	76	72	76	72	72	72	72
			2.5	84	80	76	80	80	76	80	76
			3.0	88	84	80	84	80	80	80	80
			4.0	92	88	84	88	84	84	84	80
			5.0	92	88	88	88	88	84	88	84
↓ SEMI - DIRECT	J  MF 70%	Vapor-proof Enclosing Globe Prismatic glass Vapor-proof fitting enameled steel.	0.6	30	24	20	28	22	18	20	18
			0.8	38	32	27	35	29	25	28	24
			1.0	43	37	32	39	34	30	32	28
			1.2	47	40	36	42	37	33	34	31
			1.5	52	45	40	47	41	37	38	35
			2.0	58	52	45	52	47	43	43	40
			2.5	63	57	51	57	52	47	48	45
			3.0	66	60	55	59	54	50	50	47
			4.0	71	66	60	64	59	56	55	52
			5.0	74	69	64	67	62	58	57	55
	K  MF 60%	Large Opaque Reflector Open Bowl Diffusing	0.6	32	25	20	30	24	20	23	20
			0.8	40	33	29	38	32	27	31	27
			1.0	45	38	34	43	37	33	35	30
			1.2	49	42	37	46	40	36	38	34
			1.5	54	48	42	50	45	40	43	39
			2.0	60	54	49	56	51	46	48	45
			2.5	66	59	53	60	56	51	53	50
			3.0	69	64	57	64	59	54	56	51
			4.0	75	68	64	69	63	60	59	58
			5.0	77	71	66	71	66	63	63	61
	L  MF 70%	Enclosing Globe and Shades. Prismatic glass enclosing unit. Open glass reflector with white bowl lamp.	0.6	36	30	27	34	29	26	27	25
			0.8	43	39	36	41	36	34	35	32
			1.0	49	44	41	45	41	39	39	36
			1.2	54	49	45	49	45	42	42	40
			1.5	57	52	47	52	49	45	46	42
			2.0	62	57	54	57	54	50	50	46
			2.5	67	61	57	61	57	54	54	51
			3.0	70	65	60	64	60	56	56	52
			4.0	75	70	65	68	62	60	59	56
			5.0	77	72	69	70	65	62	61	59

(Continued)









	TYPE OF DISTRIBUTION AND EFFICIENCY CLASSIFICATION	TYPICAL EQUIPMENT REPRESENTATIVE OF EACH GROUP	Celling	75%			50%			30%	
			Walls	50	30	10	50	30	10	30	10
			Room Index	ROOM UTILIZATION FACTOR							
GENERAL DIFFUSING	 M MF 75%	Stalactite Unit and Projecting Luminous.	0.6	24	17	13	21	15	12	13	11
		Elements, White glass enclosing units. Projecting elements with cased glass sides and opal bottom.	0.8	30	24	19	27	21	17	19	16
			1.0	35	28	23	31	25	21	22	18
			1.2	39	32	27	34	28	23	25	21
			1.5	44	37	31	38	32	27	29	25
			2.0	50	43	37	43	38	33	33	29
			2.5	55	48	41	47	42	37	37	33
			3.0	59	51	45	50	45	40	40	36
			4.0	64	58	51	55	50	46	44	41
			5.0	67	61	55	58	52	49	46	44
	 N MF 75%	Enclosing Translucent Bowls, White glass enclosing globe, Projecting luminous element with cased opal panels	0.6	30	25	21	27	22	20	20	17
		0.8	37	31	29	34	29	25	26	24	
		1.0	42	36	32	37	32	30	30	27	
		1.2	46	41	37	41	36	34	34	31	
		1.5	51	45	40	45	40	36	36	34	
		2.0	56	51	46	50	45	41	40	37	
		2.5	61	55	50	54	49	45	44	41	
		3.0	65	59	54	55	51	47	46	44	
		4.0	69	64	59	60	55	52	50	47	
		5.0	71	66	62	62	57	55	51	50	
SEMI-INDIRECT	 O MF 70%	Enclosing Translucent Bowls. Prismatic glass Cased glass bottom, etched top	0.6	20	15	11	15	11	9	7	6
		0.8	25	20	16	20	15	12	11	9	
		1.0	30	24	20	22	17	15	14	10	
		1.2	34	29	24	26	21	17	15	12	
		1.5	37	31	26	29	24	20	17	15	
		2.0	44	37	32	34	27	25	21	17	
		2.5	47	41	36	36	31	27	24	21	
		3.0	51	45	40	39	34	30	26	24	
		4.0	57	51	46	42	39	36	29	28	
		5.0	60	55	50	46	41	39	31	29	
	 P MF 65%	Open Top Translucent Bowls Dense glass bowl Plastics.	0.6	21	17	15	16	12	11	9	7
		0.8	27	22	20	20	16	15	11	10	
		1.0	31	26	24	22	19	17	14	11	
		1.2	36	31	26	26	22	20	15	14	
		1.5	39	34	30	29	25	22	16	15	
		2.0	44	39	35	32	27	26	19	17	
		2.5	49	42	39	35	31	29	21	20	
		3.0	51	46	42	37	34	31	22	21	
		4.0	56	52	49	40	37	35	25	24	
		5.0	59	55	51	42	40	37	27	26	

TABLE VI-7 (Continued)

TYPE OF DISTRIBUTION AND EFFICIENCY CLASSIFICATION	TYPICAL EQUIPMENT REPRESENTATIVE OF EACH GROUP	Ceiling	75%			50%			30%	
		Walls	50	30	10	50	30	10	30	10
		Room Index	ROOM UTILIZATION FACTOR							
 Q MF 65%	Shallow Bowl Reflectors and Shields. Metal Bowl IF Lamp. Metal Shield Silver Bowl Lamp.	0.6	20	16	13	13	11	9	5	5
		0.8	25	20	19	17	13	12	8	7
		1.0	29	24	21	19	16	13	11	8
		1.2	33	28	24	23	19	17	11	11
		1.5	36	32	28	26	21	19	12	11
		2.0	41	36	33	28	24	21	13	13
		2.5	45	40	37	29	27	25	16	15
		3.0	48	44	40	32	29	27	17	16
		4.0	53	49	45	35	33	31	19	19
		5.0	56	52	49	37	35	33	21	19
		 R MF 60%	Deep Metal Bowls and Troughs	0.6	20	15	14	12	11	9
0.8	25			20	18	17	14	12	8	8
1.0	29			25	22	18	15	14	9	8
1.2	34			29	25	23	18	17	11	9
1.5	37			31	28	25	22	18	12	11
2.0	42			37	31	28	26	22	14	12
2.5	46			40	37	31	28	25	15	15
3.0	49			45	40	32	29	28	17	15
4.0	54			49	46	35	32	31	18	18
5.0	55			52	49	38	35	32	22	18
 S MF 60%	Wall Urn Column Urn Wall Box			0.6	20	16	13	13	11	9
		0.8	25	20	18	16	15	13	7	7
		1.0	29	24	22	18	16	15	11	7
		1.2	33	29	24	24	18	16	11	11
		1.5	36	31	27	25	22	18	13	11
		2.0	42	36	33	27	24	22	15	13
		2.5	45	40	36	29	27	25	16	15
		3.0	49	44	40	33	29	27	16	16
		4.0	53	49	45	35	33	31	18	18
		5.0	57	53	49	38	35	33	22	18
		 T MF 55%	Recess Covs Coffers	0.6	20	15	12	12	10	10
0.8	27			20	17	17	15	12	7	7
1.0	30			25	22	20	15	15	10	7
1.2	32			27	25	22	20	17	10	10
1.5	37			32	27	25	20	20	12	10
2.0	42			37	32	27	25	22	15	12
2.5	45			40	37	30	27	25	15	15
3.0	47			45	40	32	30	27	17	15
4.0	52			50	45	35	32	30	20	17
5.0	55			52	50	38	35	32	20	20
 U MF 55%	Close Ceiling Covs			0.6	20	16	12	12	8	8
		0.8	24	20	16	16	16	12	8	8
		1.0	28	24	20	20	16	16	8	8
		1.2	32	28	24	24	20	16	12	8
		1.5	36	32	28	24	20	20	12	12
		2.0	40	36	32	28	24	24	16	12
		2.5	44	40	36	32	28	24	16	16
		3.0	48	44	40	32	28	28	16	16
		4.0	52	48	48	36	32	32	20	16
		5.0	56	52	48	40	36	32	20	20

INDIRECT

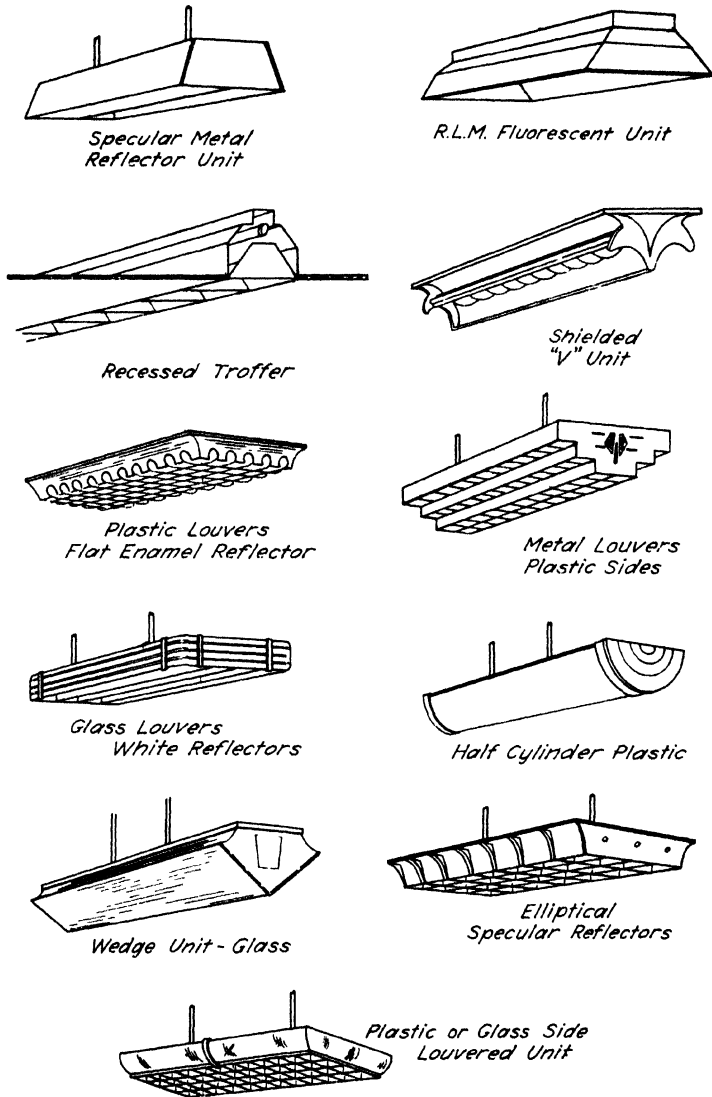

FIG. 14-7. Typical fluorescent lamp luminaires.

the side wall a reflection factor of 50 per cent. The fixture is mounted 11 ft. from the floor.

Direct component (25.4 per cent) similar to B, Table VI-7:

$$\begin{aligned} \text{Room index} & 1.2 \\ UF & = 0.78 \\ CU & = 0.78 \times 0.254 = 0.198 \end{aligned}$$

Indirect component (49.7 per cent) similar to *Q*, Table VI-7:

$$\begin{aligned} \text{Room index} & 1.5 \\ UF & = 0.35 \\ CU & = 0.35 \times 0.497 = 0.174 \end{aligned}$$

The coefficient of utilization for the combination will be the sum of 0.198 and 0.174 or 0.372.

Figure 14-7 shows some of the types of fluorescent lighting equipment, many of which are of the combination distribution type as shown by the distribution curves of Fig. 1-8*B*.

**20. Summary Concerning Utilization Factors and Coefficients of Utilization.** The ability to analyze by an empirical method the characteristic control of all the factors involved in a practical installation enables the designer to predict the average illumination that may be expected. There is no doubt that utilization coefficients will be determined for other types of lighting installations in the future (show-window, street, flood).

Direct, semi-direct, and general diffusing units, all have large direct components and have utilization coefficients of from 50 to 30 per cent; the coefficients of those having large indirect components range from 30 to 15 per cent. The effect from the floor is of little importance unless the room is large and the ceiling and walls as well as the floor are light; then the effect may be as much as 20 per cent. The effect of the walls alone will not exceed 25 per cent in any event. It has been suggested that the wall surface should be considered as having approximately a 30 per cent reflection factor for the determination of the utilization of the unit under average working conditions. Since in any instance the reflection factors may easily be determined as described in Chapter 2, it is usually necessary only to study the actual conditions.

### PROBLEMS

1. If 5000 l. per sq. ft. strike the satin finish on a clear glass surface, how many lumens will be (a) transmitted, (b) reflected, (c) absorbed? What will be the brightness of the surface?
2. The output from a 300-w. lamp strikes an etched Alzak aluminum reflector. Neglecting any loss due to internal reflection, how many lumens will be reflected?
3. Determine the classification as to *type of luminaire* of the following equipment in Fig. 1-8*A*: (a) No. 8; (b) No. 23; (c) No. 21.
4. Determine the classification as to *type of luminaire* of the following equipment in Fig. 1-8*B*: (a) A; (b) E; (c) K.
5. Determine the utilization factor for the following equipment in Fig. 1-8*B*: (a) H; (b) J; (c) K.

6. Compute, by all methods, the room index for a direct lighting luminaire mounted 10 ft. from the floor in a room 24 ft. by 75 ft. having a 13-ft. ceiling. Check the results against Table III-7.

7. Repeat problem 5 using an indirect luminaire. Check the results against Table III-7.

In the following three problems determine the utilization factor with due consideration to the three characteristic components in the direct light component calculation. Determine the coefficient of utilization for the specific equipment and determine the *type of luminaire*.

	8	9	10
Room index	1.75	3.5	0.90
Reflection factor ceiling, %	80	75	50
Reflection factor sidewall, %	60	55	30
Lamp size, watts	500	200	300
Luminaire efficiency, %	83	84.5	80.2
Candlepower at 90°	129	201	426
Lumens in 0°-40° zone	262	420	550
Lumens in 0°-90° zone	803	1533	2664
Lumens in 90°-180° zone	7335	1232	2113

## BIBLIOGRAPHY

1. D. L. GAMBLE, "The Influence of the Reflecting Characteristics of Wall Paints upon the Intensity and Distribution of Artificial and Natural Illumination," *I. E. S. Trans.*, v. 28, No. 4, April, 1933.
2. JOINT COMMITTEE ON ILLUMINATION GLASSES, Report, *I. E. S. Trans.*, v. 29, No. 8, September, 1934.
3. WARD HARRISON and C. E. WEITZ, "Illumination Design Data," *Nela Park Engineering Dept. Bulletin* LD-6A, 1936.
4. COMMITTEE REPORT, American Recommended Practice for School Lighting, *I. E. S. Trans.*, v. 33, No. 4, April, 1938.
5. J. A. MEACHAM, "Light Reflection from Painted Surfaces," *I. E. S. Trans.*, v. 34, No. 1, January, 1939.
6. COMMITTEE REPORT, Recommended Practice of Industrial Lighting, *I. E. S. Trans.*, v. 34, No. 4, April, 1939.
7. WARD HARRISON, "The Need for More and Varied Types of Fluorescent Equipment," *Mag. of Light*, v. 9, No. 4, pp. 7-11, May, 1940.
8. ANON., "A Review of Fluorescent Luminaire Design," *Mag. of Light*, v. 9, No. 9, p. 7, November, 1940.
9. W. M. POTTER and W. G. DARLEY, "The Design of Luminaires for Fluorescent Lamps," *I. E. S. Trans.*, v. 35, No. 9, pp. 759-785, November, 1940.



## CHAPTER 8

### GENERAL ILLUMINATION DESIGN

In Articles 9 through 14 of Chapter 7 special lighting was discussed as supplementary or local lighting. There must, however, be a general lighting system to supply illumination for the room as a whole. The point-by-point method is usually used to determine the specifications for the local lighting, but it is impractical for designing the general system. The *lux* or *lumen method* makes the problem of general design comparatively easy, and it consists mainly of using the utilization factor (discussed in Chapter 7) to calculate the average illumination throughout the room.

In using the lumen method to develop a design, it is necessary to follow a logical procedure as outlined below:

1. Selection of equipment
2. Spacing and arrangement of equipment
3. Determination of desirable illumination
4. Determination of room index (*RI*)
5. Determination of utilization factor (*UF*)
6. Determination of maintenance factor (*MF*)
7. Computation of lamp size

**1. Selection of Equipment.** In the selection of equipment the architect and the illuminating engineer will be guided frequently by the desire of the client. It is also the responsibility of the designer to determine whether or not the equipment chosen will fulfill the requirements for the specific task. It must be applicable to the particular atmosphere desired by the client, a matter which cannot be evaluated directly by objective analysis, for it is essentially a subjective factor in selection. Hundreds of different types of lighting equipment are on the market, and it would be impossible to discuss each make individually, but under each class of equipment there is a wide choice of styles and characteristics. Fundamentally, every equipment falls under the classification given in Chapter 7. In the choice of equipment, the comparison of competitive styles should be based upon the following:

- a. The quality of the workmanship
- b. The quality of the material

- c. Freedom from direct glare
- d. Minimum of reflected glare
- e. Efficiency when installed
- f. Illumination on vertical and oblique surfaces
- g. Freedom from harsh shadows
- h. Ease of maintenance
- i. Any special color or other requirements that must be met.

This is a summary of those factors which enter into obtaining an adequate and comfortable lighting system.

The brightness limits depend upon the task and the type of exposure encountered. The brightness of any source in the field of vision should not exceed 3 to 3.5 c. per sq. in. (approximately 1500 ft-L.), and wherever work must be performed over a period of time and the worker's eyes are exposed to the source, the brightness should be reduced to about one-third of the above value. Brightness contrast between different parts of the equipment or between the surroundings and the equipment should not be neglected in making the selection.

Direct glare may be removed and the equipment might still have an objectionable reflected glare. This may appear in bright spots reflected from work surfaces or from displayed material. Location of the unit may be a possible solution, but it is far better to control the original brightness and diffusion by a wise selection of the equipment. Inclined surfaces are particularly likely to cause discomfort from reflected glare, for they seldom receive a sufficient amount of illumination to aid in reducing the annoyance. In installations where the inclined or vertical plane is prominent in the design of the lighting system, it is usual to install some form of supplementary lighting or units with wide angles of distribution.

**2. Equipment Efficiency.** If efficiency and equipment characteristics are not considered seriously, it is possible for one installation to give from 15 to 18 ft-c. while another gives from 25 to 28 ft-c. for the same watts per square foot. Maintenance is a very important factor in the continued efficiency of a unit.

A report on a series of tests on an indirect lighting unit indicates the importance that must be placed upon the distribution of light from the equipment.<sup>7</sup> The test data represent actual installation conditions. The equipment used for the test was arranged in several different ways for study, and the light output ranged from 85 to 66 per cent. The difference of 19 per cent was caused by light center location (6 per cent), husk extension (7 per cent), and inside-frosted lamp instead of a clear lamp (6 per cent). Since the efficiency of the equipment is part













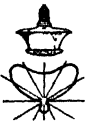



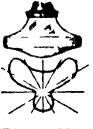

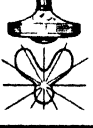



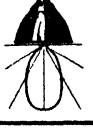

<p><b>1</b></p> <p>RLM White Bowl Lamp</p> <p>90° to 180°—0% 0° to 90°—66%</p> 	<p><b>10</b></p> <p>Enclosed Semi-Indirect Enamelled Bottom Etched Top Skeleton Glass Holder</p> <p>90° to 180°—50% 0° to 90°—27%</p> 	<p><b>20</b></p> <p>Enclosed Semi-Indirect Enamelled Deflector</p> <p>90° to 180°—48% 0° to 90°—10%</p> 	
<p><b>2</b></p> <p>Glassed Diffuser Clear Lamp</p> <p>90° to 180°—7% 0° to 90°—60%</p> 	<p><b>11</b></p> <p>Enclosed Semi-Indirect Enamelled Bottom Etched Top</p> <p>90° to 180°—48% 0° to 90°—32%</p> 	<p><b>21</b></p> <p>Deep Bowl Enamelled Steel Clear Lamp</p> <p>90° to 180°—0% 0° to 90°—65%</p> 	
<p><b>3</b></p> <p>RLM Dome Dust-tight Cover</p> <p>90° to 180°—0% 0° to 90°—54%</p> 	<p><b>12</b></p> <p>Enclosed Semi-Indirect Enamelled Bottom Etched Top (Close Ceiling Only)</p> <p>90° to 180°—53% 0° to 90°—22%</p> 	<p><b>22</b></p> <p>Prismatic Reflector Clear Lamp</p> <p>90° to 180°—20% 0° to 90°—74%</p> 	
<p><b>4</b></p> <p>RLM Dome Clear Lamp</p> <p>90° to 180°—0% 0° to 90°—76%</p> 	<p><b>13</b></p> <p>Enclosed Semi-Indirect Cased-Glass Bottom Etched Top</p> <p>90° to 180°—31% 0° to 90°—21%</p> 	<p><b>23</b></p> <p>Mirrored Glass Reflector Clear Lamp</p> <p>90° to 180°—0% 0° to 90°—69%</p> 	
<p><b>5</b></p> <p>Concentrated Prismatic Reflector Aluminum Cover Clear Lamp</p> <p>90° to 180°—5% 0° to 90°—72%</p> 	<p><b>14</b></p> <p>Enclosed Semi-Indirect Prismatic Glass</p> <p>90° to 180°—69% 0° to 90°—17%</p> 	<p><b>24</b></p> <p>Concentrating Aluminum Reflector Dust-tight Housing</p> <p>90° to 180°—0% 0° to 90°—57%</p> 	
<p><b>6</b></p> <p>Mirrored Glass Reflector Clear Lamp</p> <p>90° to 180°—3% 0° to 90°—73%</p> 	<p><b>15</b></p> <p>Open Semi-Indirect Enamelled Deflector Medium Density Glass Bottom Plate</p> <p>90° to 180°—54% 0° to 90°—18%</p> 	<p><b>25</b></p> <p>Vapor-proof Fitting Enamelled Steel Reflector with Glass Enclosing Globe</p> <p>90° to 180°—0% 0° to 90°—68%</p> 	
<p><b>7</b></p> <p>Oxidized Aluminum Reflector Clear Lamp</p> <p>90° to 180°—0% 0° to 90°—72%</p> 	<p><b>16</b></p> <p>Enclosed Laminous Bowl Indirect</p> <p>90° to 180°—64% 0° to 90°—4%</p> 	<p><b>26</b></p> <p>Vapor-proof Fitting Prismatic Enclosing Globe</p> <p>90° to 180°—28% 0° to 90°—57%</p> 	
<p><b>8</b></p> <p>Flattened White Glass Enclosing Globe</p> <p>90° to 180°—35% 0° to 90°—45%</p> 	<p><b>17</b></p> <p>Open Indirect</p> <p>90° to 180°—80% 0° to 90°—0%</p> 	<p><b>27</b></p> <p>Angle Reflector Enamelled Steel</p> <p>Output 74%</p> 	
<p><b>9</b></p> <p>Prismatic Glass Enclosing Unit</p> <p>90° to 180°—77% 0° to 90°—53%</p> 	<p><b>18</b></p> <p>Dense White Glass Reflector Frosted Lamp</p> <p>90° to 180°—12% 0° to 90°—70%</p> 	<p><b>19</b></p> <p>Round and Stalactite Globes</p> <p>90° to 180°—38% 0° to 90°—43%</p> 	<p><b>28</b></p> <p>Local Lighting Unit Substantial Reflector and Holder Cover Plate</p> <p>Output 45-55%</p> 

FIG. 1-8A. Typical lighting equipment.

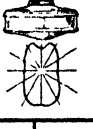
of the operating cost and appears in each monthly bill, it is an important factor to consider. Any lighting system worthy of the title "designed lighting system" should not be based on a single design and a single type of equipment, but upon an exhaustive study of all

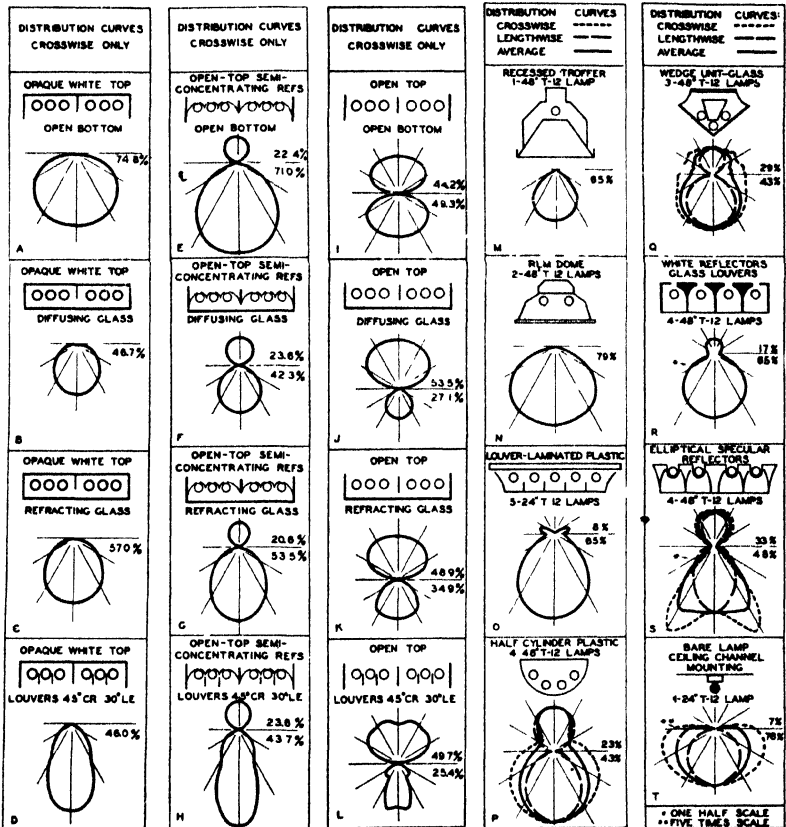

## MAINTENANCE FACTORS

75% — A, D, M, N, T

70% — B, C, E, H, I, L, O, R, S

65% — F, G, J, K, P, Q

FIG. 1-8B. Distribution curves for typical fluorescent lighting equipment for problem purposes.

materials that are available within the economic limits prescribed. Figure 1-8 shows various equipment with the distribution curves and the efficiency of the units.

To aid in the selection of equipment and the determination of its probable characteristics and maintenance, the following classification,

EQUIPMENT  
(See distribution)

Class	Typical Equipment	Average Conditions Maintenance Factor	Characteristics
A	Direct concentrating, high-bay open reflectors  Prismatic glass Mirrored glass Polished metal	70%	LIGHT OUTPUT RANGE—68 to 75%. SOURCE BRIGHTNESS—low at normal angles of view because of large shielding angle. FT-C. ON VERTICAL—fair. REFLECTED GLARE—likely to be severe because of reflected source brightness. Enameled reflectors of this shape do not produce a concentrated distribution and should not be confused with high-bay reflectors.
B	Direct concentrating, parabolic polished metal reflectors  Louvered trough inside-frosted lamps Open reflectors silvered-bowl lamps	70%	LIGHT OUTPUT RANGE—45 to 60% depending on louver design and reflector size. Louvered troughs are likely to average 10% less, open silvered-bowl lamp units may range from 10 to 20% higher than the values shown. Specular surface parabolic reflectors essential. SOURCE BRIGHTNESS—very low at normal angles of view. FT-C. ON VERTICAL—relatively low. REFLECTED GLARE—likely to be severe with the louvered equipment. An effective means of securing high-level illumination with low brightness contrasts.
C	Direct concentrating, prismatic glass or polished metal reflectors  Enclosed lens plates Open louvers	70%	LIGHT OUTPUT RANGE—27 to 35%—depending on adjustment or type of louver used. Specular surface parabolic reflectors are essential. SOURCE BRIGHTNESS—low. FT-C. ON VERTICAL—extremely low. Care must be taken in location of units to avoid reflected glare from polished surfaces. Adaptable to many applications in combination with a fair proportion of indirect lighting. Lens plate units designed for wider distribution will have a higher output.
D	Direct distributing, open reflectors  RLM dome porcelain enamel inside-frosted lamp Mirrored or prismatic inside-frosted lamp	75%	LIGHT OUTPUT RANGE—75% for RLM dome; 70 to 80% from extensive distribution prismatic or mirrored reflectors. SOURCE BRIGHTNESS—uncomfortably high unless mounted either above 20 ft. or below eye level so that reflector shields the bright filament. FT-C. ON VERTICAL—fairly high. REFLECTED GLARE—extremely severe from polished surfaces. Highly efficient but limited in application to locations where conditions permit avoidance of direct and reflected glare.
E	Direct distributing, open reflectors	75%	LIGHT OUTPUT RANGE—63 to 68%. SOURCE BRIGHTNESS—moderately high but acceptably good for moderate levels of

## CHARACTERISTICS

curves, Table VI-7.)

Class	Typical Equipment	Average Conditions Maintenance Factor	Characteristics
	RLM dome porcelain enameled white-bowl lamp RLM dome deep-bowl porcelain enameled inside-frosted lamp		illumination. Ft.-C. ON VERTICAL — fairly high. REFLECTED GLARE — considerably less than clear lamp units — the dome rating better than the deep-bowl shape. The RLM-white-bowl-lamp combination particularly, suitably meets a variety of industrial lighting requirements.
F	Direct distributing, large-area diffusing reflectors  RLM Glassteel diffuser clear lamp RLM dome silver-bowl lamp Enclosing globe and parchment shade	70%	LIGHT OUTPUT RANGE — The standard Glassteel 80% down, 7% up; the silvered-bowl lamp and reflector 60 to 65% down, no upward light; the shaded enclosing globe 50% down, 20% up; coefficients of utilization all about the same. SOURCE BRIGHTNESS — relatively low. Ft.-C. ON VERTICAL — moderately high. REFLECTED GLARE — suitably low for most industrial requirements. A group of equipment essential to high-quality industrial lighting.
G	Direct distributing, large-area diffusing panels  Extended trough reflector with cased opal glass cover Enameled metal reflector with diffusing glass cover	70%	LIGHT OUTPUT RANGE — 50 to 60% depending on reflector efficiency and transmission of glass cover plates. SOURCE BRIGHTNESS — generally low, and controllable by increasing area; brightness limits for comfort range from 400 to 1000 ft.-L. Supplementary indirect lighting is often used to relieve brightness contrasts against an otherwise dark ceiling.
H	Direct distributing, large area diffusing panel  Trough reflector with solid opal or enameled glass cover Enclosed skylights	65%	This group is classified separately only because of lower light output. LIGHT OUTPUT RANGE — 35 to 45%, depending on construction and transmitting material; with extra heavy solid opal glass or low transmission plastics, the efficiency range may extend to even lower limits. SOURCE BRIGHTNESS — controllable by source area and diffusion. The size and disposition of luminous panels and artificial skylight sections are matters largely regulated by architectural composition.
I	Direct distributing, combination skylight	60%	LIGHT OUTPUT RANGE — may vary over a considerable range, depending on construction features and type of glass used. Skylights serving both natural and artificial lighting penalise efficiency because there is no help from multiple reflections. Skylight framing and mullions and mechanical control devices likewise lessen efficiency. Quality factors with respect to direct and reflected glare and shadows are highly favorable.

## EQUIPMENT CHARAC-

(See distribution curves,

Class	Typical Equipment	Average Conditions Maintenance Factor	Characteristics
J	Semi-direct, vapor-proof enclosing globe  Prismatic glass Vapor-proof fitting enameled steel	70%	LIGHT OUTPUT RANGE—70 to 85%. SOURCE BRIGHTNESS—moderately high but acceptable in low-wattage units, or where seeing requirements are casual. FT-C. ON VERTICAL—fairly high. REFLECTED GLARE is moderately severe. Used where corrosive vapor, inflammable gases, or explosive dust are present.
K	Semi-direct, large opaque reflector, open-bowl diffusing	60%	LIGHT OUTPUT RANGE—70 to 80%. SOURCE BRIGHTNESS AND GLARE—low because of the diffusing quality of both bowl and reflector. Free from sharp shadows.
L	Semi-indirect, enclosing globes and shades  Prismatic glass enclosing unit Open glass reflector with white-bowl lamp	70%	LIGHT OUTPUT RANGE—75 to 85%. SOURCE BRIGHTNESS—moderately high but acceptable in low-wattage units, or where seeing requirements are more casual than fixed. FT-C. ON VERTICAL—fairly high. REFLECTED GLARE—moderately severe. These units, though highly efficient, represent some compromise with certain quality factors; suitable for many store and commercial applications.
M	General diffusing, stalactite unit and projecting luminous elements  White glass enclosing units Projecting elements with cased glass sides and opal bottom	75%	LIGHT OUTPUT RANGE—75 to 85%. SOURCE BRIGHTNESS—some control limited by size of enclosing globe. FT-C. ON VERTICAL—good. REFLECTED GLARE—average. Used in waiting rooms, stores, and banks where distribution is important.
N	General diffusing, enclosing translucent bowls  White glass enclosing globe Projecting luminous element with cased opal panels	75%	LIGHT OUTPUT RANGE—80 to 85% for the best quality diffusing glass; 65 or 70% for dense molded glass. SOURCE BRIGHTNESS—moderate, controllable within limits by globe size or luminous area. FT-C. ON VERTICAL—fairly high. REFLECTED GLARE—fairly low. This group typifies many different contours of white glass enclosing globes. Elongated or stalactite globes give better illumination on vertical surfaces but with more glare and 10% lower coefficients of utilization.
O	Semi-indirect, enclosing translucent bowls  Prismatic glass Cased glass bottom, etched top	70%	LIGHT OUTPUT RANGE—75 to 85%; downward light 15 to 30%. SOURCE BRIGHTNESS—usually satisfactory, should not exceed 800 ft-L. for office and school applications. FT-C. ON VERTICAL—somewhat less than semi-direct units. REFLECTED GLARE—inherently low. Enclosed units have the obvious advantage of slower depreciation and ease of maintenance.

## TERISTICS (Continued)

Table VI-7.)

Class	Typical Equipment	Average Conditions Maintenance Factor	Characteristics
P	Semi-indirect, open-top translucent bowls  Dense glass bowl Plastic	65%	LIGHT OUTPUT RANGE — 70 to 80% (with desirable position of light source); downward light 5 to 15%. SOURCE BRIGHTNESS — very low. Other quality characteristics excellent, but open-bowl units should get a lower rating for depreciation than the enclosed units; the open units, however, are likely to be more satisfactory from the brightness standpoint.
Q	Indirect, shallow-bowl reflectors and shields  Metal bowl, inside-frosted lamp Metal shield, silvered-bowl lamp	65%	LIGHT OUTPUT RANGE — 70 to 80%. Indirect lighting inherently receives superior ranking from the standpoint of source brightness, reflected glare, shadows, and other quality considerations. Wide angle distribution makes for a more uniform ceiling brightness but results in a slightly lower utilization in small rooms than units of equal output whose distribution is strongly upward.
R	Indirect  Deep metal bowls and troughs	60%	LIGHT OUTPUT RANGE — 60 to 70%; inherent quality of indirect lighting. This group comprises many indirect units of current design and styling where output efficiency has been sacrificed to some extent to achieve pleasing reflector contour, smaller diameter, and decorative features.
S	Indirect  Wall urn Column urn Wall box	60%	LIGHT OUTPUT RANGE — 50 to 60%; may vary considerably but well-designed equipment should attain average outputs of 55%. Limitations of space and the size and contour of special types of indirect reflectors generally sacrifice efficiency to achieve the balance and harmony called for in the general design plans. Reflector design must avoid spill light and high brightness on the walls or columns above the units.
T	Indirect  Recessed coves Coffers	55%	LIGHT OUTPUT RANGE — 35 to 45%. In small wall coves and ceiling coffers where lamps must be deeply recessed, or where the lip of the coves must be extended to a predetermined sight line, the free opening is often relatively small and the cove output is correspondingly reduced.
U	Indirect Close ceiling coves	55%	This classification indicates a general zone of light output; assuming a 25% output downward from secondary reflecting surfaces. Usually custom built to fit individual architectural conditions; no general data are certain to apply to specific cases. Although reflector output may be studied for its distribution to secondary reflecting surfaces, the actual utilization is likely to vary over a wide range. In large important projects, it may be necessary to build scale models to predetermine results.



corresponding with that given in Table VI-7 (utilization factors), is given. This outline lists the performance of and variation in typical commercial equipment and does not represent those of any one manufacturer's product.

**3. Spacing, Mounting, and Number of Units.** There are two factors in a lighting system that are antagonistic: economy and spacing. The spacing should be such that the illumination is uniform. In the

TABLE I-8<sup>3</sup>  
SPACING OF OUTLETS \*

Ceiling Height (Height in the Clear)	Spacing between Outlets		Spacing Between Outside Outlets and Wall		Approximate Area per Outlet (At Usual Spacings)
	Usual	Maximum (For Units at Ceiling)	Aisles or Storage Next to Wall	Desks, Workbenches, etc., against Wall	
(Feet)	(Feet)	Not more than		Not more than	(Square Feet)
8	7	7½	Usually  one-	3	50-60
9	8	8		3	60-70
10	9	9		3½	70-85
11	10	10½		3½	85-100
12	10-12	12		3½-4	100-150
13	10-12	13	half	3½-4½	100-150
14	10-13	15		4-5	100-170
15	10-13	17	actual	4-5	100-170
16	10-13	19		4-6	100-170
18	10-20	21	spacing	4-6	100-400
20	18-24	24	between	5-7	300-500
22	20-25	27		5-7	400-600
24	20-30	30	units	6-8	400-900
26	25-30	33		8-9	600-900
30 and up	25-30	40		8-10	600-900

\* Concentrating louvered downlights or lens plates provide varying degrees of concentration. The spacing between units to provide uniformity over a general area, or lengthwise of a counter or work table, should be regulated by the actual distribution characteristics of the unit. In general, the usual purpose is fulfilled by a spacing about *one-third* to one-half the values given.

Semi-indirect and indirect systems diffuse the light widely from the ceiling as a secondary source of large area and the spacing between units may be about 2 ft. greater than indicated.

Alternate mercury and incandescent units in combination systems should provide a fair degree of uniformity with either system used alone, and should permit overlapping and blending of the light when used in combination. An alternate staggered layout with the spacing between units not to exceed 0.8 of the mounting height above the floor is recommended.

most economical system, both as to first cost and operation, economical design demands few and large lamps. To obtain uniformity it is necessary to place the lamps close together, and this requires a large number of small lamps. As in other engineering problems, it is necessary to obtain spacing and lamp size which produce a satisfactory balance between the two opposing factors.

Fairly definite relationships exist between the height at which lighting units are mounted above the work surface and the distance

by which they may be separated in order to provide a reasonably uniform illumination. The light must come from a sufficient number of directions so that shadows will not prove troublesome. In general, the permissible distance between units should not be more than  $1\frac{1}{2}$  times the height of the light source above the work; closer spacing can do no harm and is often desirable, but if this spacing is exceeded, the illumination midway between units falls off perceptibly.

Tables I-8 and II-8 are useful in the determination of the proper

TABLE II-8<sup>1</sup>  
MOUNTING HEIGHTS OF LIGHTING UNITS

Equipment B *				Semi-indirect and Indirect Lighting	
Actual Spacing between Units	Distance of Units from Floor	Desirable Mounting Height in Industrial Interiors	Desirable Mounting Height in Commercial Interiors	Actual Spacing between Units	Recommended Suspension Length (Top of Bowl to Ceiling)
(Feet)	(Feet)			(Feet)	(Feet)
7	8	12 ft. above floor if possible, to avoid glare, and still be within reach from stepladder for cleaning.	The actual hanging height should be governed largely by general appearance, but particularly in offices and drafting rooms, the minimum values shown should not be violated.	7	1-3
8	8½			8	1-3
9	9			9	1-3
10	10			10	1½-3
11	10½			11	2-3
12	11			12	2-3
14	12½	Where units are to be mounted much more than 12 ft. it is usually desirable to mount the units at ceiling or on roof trusses.		14	2½-4
16	14			16	3-4
18	15			18	3-4
20	16			20	4-5
22	18			22	4-5
24	20			24	4-6
26	21			26	4-6
28	22			28	5-7
30	24			30	5-7

\* Equipment B — direct, semi-direct, general diffusing.

spacing and mounting of the units in rooms of various ceiling heights. The modifications necessary for indirect, downlights, and mercury vapor-incandescent combinations are also included. The design of the spacing begins with the height of the ceiling; this is modified by the type of equipment to be used in the installation. Having determined the spacing, the proper mounting height is obtained by reference to Table II-8.

The arrangement of units in interiors requires special ingenuity on the part of the designer. The adoption of well-designed general light-

ing systems eliminates the need for a great many forms of special lighting, but there are locations where manufacturing operations, peculiar machine grouping, and high machines require localized illumination. The following layouts are suggestions of ways by which the arrangement problem can be approached:

1. To conform with structural design:

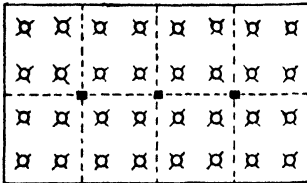

a. Four units per bay. This is the most common system for the square bay of usual dimensions.

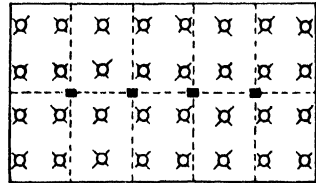

b. Four-two system. Equivalent to three units per bay, and alternative to four per bay where spacing allows.

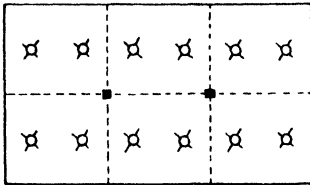

c. Two units per bay. Usually applicable only in narrow bays where the width is less than two-thirds the length.

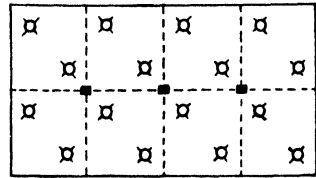

d. Two units per bay (staggered). Acceptable in large interiors where permissible spacing does not dictate four per bay. Less favorable appearance, and some areas near the walls may be inadequately lighted.

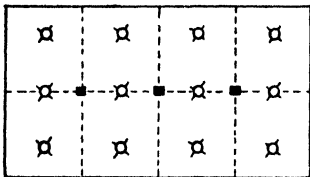

e. Interspace layout. Applicable in rectangular bays, but suited only where the center row will not interfere with future structural changes such as added office partitions.

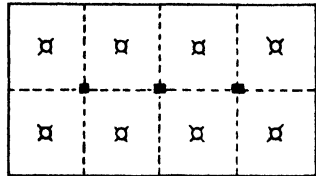

f. One unit per bay. Satisfactory only where the bay size is no greater than the maximum allowable spacing. An unusual condition except in high-ceilinged rooms.

2. To conform to machine arrangement:

g, h, i. In industrial interiors with standard machine arrangement, the general lighting system can best be arranged primarily with respect to the machine layout, and secondarily with regard to structural features. Particularly in the textile, paint, paper, and printing industries, and

over special assembly and inspection tables, it is thus possible to favor the principal work surfaces and still achieve uniform lighting if the machinery

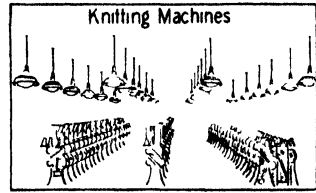
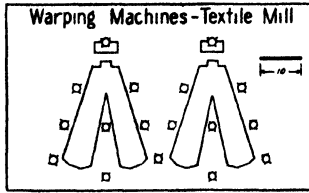

were removed. If factories have bulky machinery, such as flour mills with intricate conveyor systems, which use specialized machinery, any plan of general lighting will encounter obstacles, which will obstruct the light and prevent it from reaching important and vital points. The best arrangement for the general lighting should be studied and supplementary lighting applied wherever required.

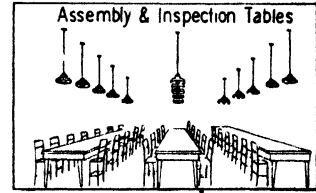

### 3. Layouts for special applications:

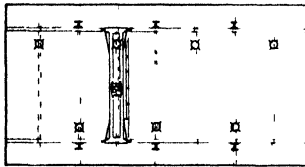

*j.* **Craneways.** Mount the units on truss chords, or hang conduit from messenger cable. Stagger units as shown to prevent traveling crane from blocking off all light.

*k.* **Bench lighting.** If the general lighting system is well planned, special bench lighting is unnecessary except where the benchwork is very fine and requires much higher illumination than is provided throughout the room.

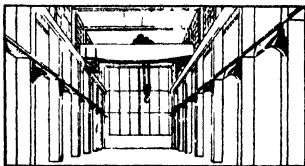
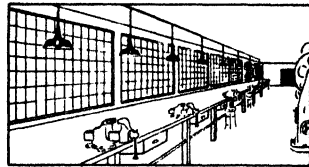

*l.* **Angle units.** In assembly shops with high bays, angle units along the walls (20 ft. high) will provide additional light for vertical surfaces. Similarly, large high machines or special operations frequently require supplementary units, mounted perhaps on columns or walls.

*m.* **Special purpose units.** Some cases require special study because of peculiar requirements. This is illustrated where special units are required to spread a high illumination band of light on the vertical surface of an automobile body during finishing and inspecting.

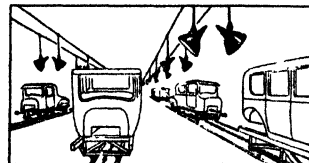

The number of units which will produce both the most economical and the most uniform illumination is determined by using the information for spacing in Table I-8. Assuming the spacing to be uniform, that is, the units on the corners of imaginary squares, the approximate area per unit will be the square of the spacing. Since the floor area is known, it is a simple matter to determine how many units should be used. Seldom is it possible to use this exact number of units, for the spacing will be unsymmetrical. However, this does give a check upon the spacing, guarding against an absurd number of units.

*Example a.* A direct system of lighting is to be used in a room 40 by 50 ft. and 12 ft. high. Determine the number and the spacing of the units.

Table I-8: spacing 10 to 12 ft. making the area per unit 100 to 144 sq. ft. Economical number of units to give uniform lighting lies between

$$\frac{40 \times 50}{144} = 14 \quad \frac{40 \times 50}{100} = 20 \text{ units}$$

If the units are spaced on 10-ft. centers and are 5 ft. from the side walls, 20 units would be used. This would give the most uniform system within the limits of economy. If possible, it is well to attempt to space for the least number of units.

**4. Room Index and Utilization Factor.** Both the room index and the utilization factor have been discussed in detail in Chapter 7. Tables III-7 and VI-7 are necessary in the determination of the lamp size to be used in a given installation. From the dimensions of the room and the type of equipment the room index (*RI*) is chosen from Table III-7. The utilization factor can be determined after classifying the chosen equipment under the proper class in Table VI-7 and finding the room control; this consists of combining the ceiling and side-wall reflection factors with the proper room index.

**5. Computation for Lamp Size.** From the definition of the foot-candle (the illumination on a surface 1 sq. ft. in area uniformly lighted by a flux of 1 l.), it is possible to determine the number of lumens required to give the *average illumination*. When the efficiency of the complete lighting system for utilizing the output from the luminaires is known, the number of lumens required in the lamp may be calculated. From Table III-6A the nearest size lamp may be chosen.

The lumens leaving the incandescent lamp are dissipated as follows:

- a. By the equipment
- b. By the room proportions
- c. By the color of the room

which leads to the initial illumination, and by

d. Depreciation

as the lamp becomes dark and the dust and dirt accumulate on the lamp, ceiling, walls, and the equipment. After all four items have been properly considered, the resultant illumination is the average illumination which is an average in a double sense; an average as to the work surface area and an average, in time cycle, between maintenance periods.

The total lamp lumens required per outlet may be expressed as:

$$\text{total lamp lumens per outlet required} = \frac{E \times A}{\eta \times UF \times MF}$$

where  $E$  is the illumination required in foot-candles;  $A$  is the area per outlet in square feet;  $\eta$  is the efficiency of the luminaire;  $UF$  is the utilization factor, and  $MF$  the maintenance factor.

*Example b.* Design the illumination for a drafting room 37 by 52 ft. The room is located in a factory building, has a 13-ft. ceiling painted white and walls painted gray. Fixture No. 15 (Fig. 1-8A) has been selected.

The ceiling height of the room controls the spacing, and therefore the number of outlets. Table I-8 specifies spacings of from 10 to 12 ft. for direct lighting in a 13-ft. room. The footnote, however, allows an increase of 2 ft. for a semi-indirect unit, and since the equipment is semi-indirect, the spacing can be from 12 to 14 ft. This spacing allows 144 to 196 sq. ft. per outlet.

To determine the probable number of outlets:

$$\frac{37 \times 52}{196} = 9.8 \quad \frac{37 \times 52}{144} = 13.3$$

where 13 units would be an upper limit giving uniform light but high first cost and operation cost, and 10 units would give a less uniform lighting with more economy.

A layout of the room suggests that a spacing of 13 ft. in each direction would fit the proportions, that is, the units are spaced 13 by 13 ft. with a 6-ft. 6-in. spacing at the end walls and a 5-ft. 6-in. spacing at the side walls.

To calculate the total lamp lumens for the 12 units, it is necessary to determine:

Foot-candles	30	Table III-3B
Room index	3	Table III-7
Efficiency	72%	Fig. I-8A
Utilization factor	0.51	Table VI-7
Maintenance factor	0.65	Table VI-7

$$\text{Coefficient of utilization} = 0.72 \times 0.51 = 0.37$$

$$\text{Area per outlet} = \frac{37 \times 52}{12} = 160.3 \text{ sq. ft.}$$

$$\text{Lumens per square foot required at lamp} = \frac{30}{0.37 \times 0.65} = 124.74$$

Lumens per outlet  $160.3 \times 124.74 = 19,996$   
 Table III-6A Select 1000-w. lamp (21,500 lumens)

$$\text{Average illumination in service} = \frac{21,500}{19,996} \times 30 = 32.3 \text{ ft-c.}$$

$$\text{Initial illumination} = \frac{32.3}{0.65} = 49.7 \text{ ft-c.}$$

$$\text{Watts per square foot} = \frac{1000}{160.3} = 6.24 \text{ w.}$$

It is essential that the equipment chosen accommodate the size of lamp determined above.

Example *b* is typical of problems in general illumination using standard manufactured luminaires and custom-built equipment for which utilization factors have been determined. The method is simple, but experience and detailed study are necessary for selecting the best equipment and layout arrangement for comfortable and adequate illumination within the limits of good economy.

#### COVE LIGHTING

Cove lighting is a system of indirect lighting in which the lamps and reflectors are concealed by a molding or some other suitable structural element around the edge of the area to be illuminated. The light is directed to the ceiling, from which it is diffusely reflected. This type of lighting is in such general use that it will be considered separately though it could be classified with the luminous architectural elements.

**6. Cove Lighting Design.** The actual design of a cove lighting system — the number of lamps and the determination of the probable initial and average foot-candles — is not different from the design of any general indirect lighting system. Since the walls and ceiling are secondary lighting surfaces, they should be as light as possible and should have high diffusing quality. These systems are thought of as being very inefficient but this is characteristic of all indirect lighting; for example, a good porcelain-enamel trough will have an equipment efficiency of approximately 70 per cent.

The desirability of using the new fluorescent lamp in air-conditioned spaces makes fluorescent lighting a possibility in conjunction with coves. The coves may have continuous light sources, incandescent lamps of the concentrated type, or reflectors. A combination of lamps and reflectors may also be used for special treatments in very

wide rooms where the normal incandescent installation will not illuminate the center of the floor area.

Figure 2-8 shows the types and the important features of cove lighting design. Considering the various parts of the figure, the special features may be summarized as follows:

*a.* If the cove is placed too close to the ceiling, the midsection of the ceiling will be dark and there will be a very bright line of light along the two side walls. A minimum ratio for mounting should be approximately 1 to 5; that is, for every foot the unit is mounted down from the ceiling the distance of illumination will be satisfactory for 5 ft. The lower the unit is mounted, the more uniform will be the lighting of the ceiling.

*b.* The shape of the ceiling will have an important bearing on the resultant effect. It is very difficult to illuminate a true arc of a circle with cove lighting. If possible the wall and ceiling surfaces should be at right angles and have fillets in the corners.

*c.* The plaster cove formed at the time of installation of the wall and ceiling finish has been used frequently as a means of concealing the lighting equipment. The distribution follows the cosine law closely but does not produce a very satisfactory system of lighting. There is a lack of control, a lower efficiency, and a tendency to have a severe brightness contrast between the various ceiling areas.

*d.* The use of reflectors increases the efficiency and the control of the system. With reflectors, the coves may be mounted closer to the ceiling and approximately uniform light may be obtained over the ceiling surface.

*e.* When it is necessary to mount the equipment close to the ceiling, the prismatic lens is the one satisfactory method for controlling the light. The lens will refract the light in the direction for which it is designed, and the possibilities for controlling the light are limitless.

*f.* Wherever the ceiling is treated with some form of relief, it is essential to eliminate harsh shadows. These shadows will occur if the cove lighting comes from one side and strikes the relief treatment. To eliminate these harsh shadows, the relief work should be cross-lighted from the two sides. Cross lighting may be used effectively where it is desired to illuminate the ceiling with uniform light.

*g.* The presence or absence of scalloped lighting effects is a matter of choice for the designer. Some designers require scalloped effects in cove lighting to give it interest; others condemn the practice. There is a tendency for most illuminating engineers to desire uniform lighting effects, but it must be remembered that those whose primary interest is the aesthetic may have good reason for either a brushed or scalloped



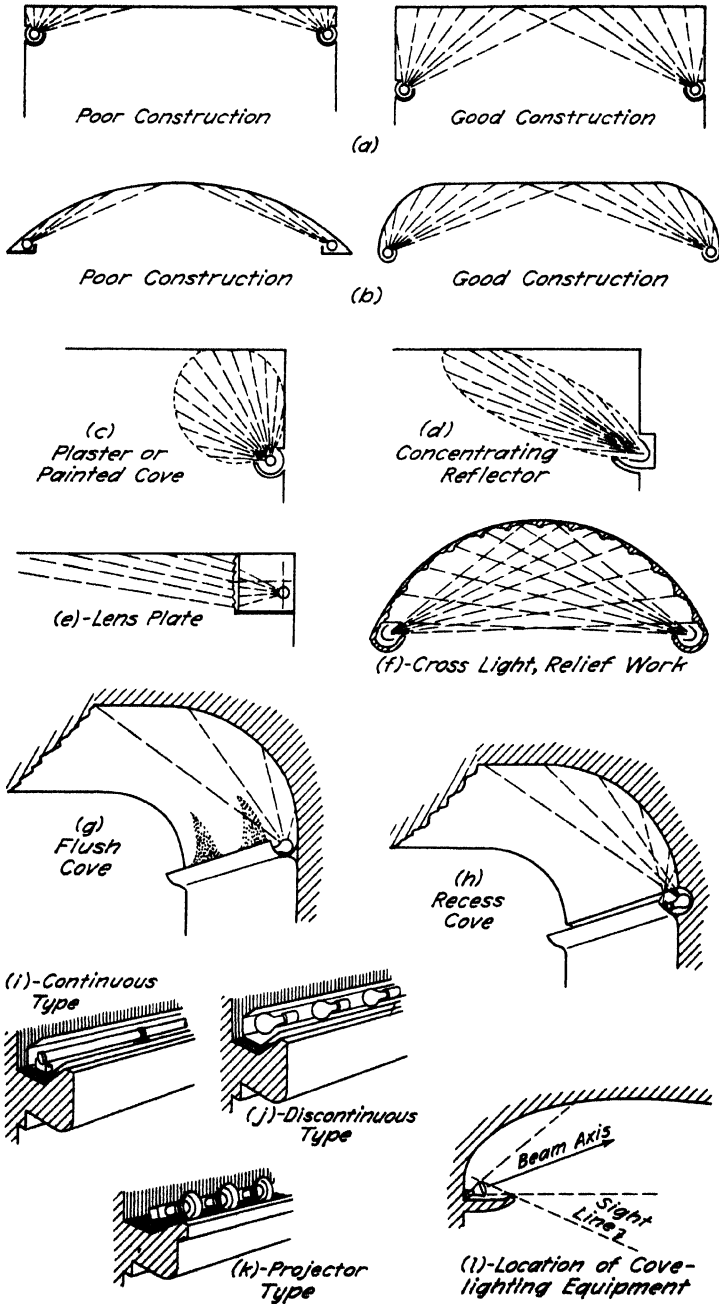

FIG. 2-8.1 Cove lighting

effect. The scalloped effect is produced by using inside-frosted lamps so that the direct light falls upon the wall or cove and produces a severe brightness contrast in the region near the lamp. This is an effect which approximates the inverse square law control of illumination. A brushed effect may be obtained by using clear lamps in the same kind of cove with the result that striations from the lamps resemble brushed streaks of light.

*h.* The recessed cove (Fig. 2-8*h*), with a secondary reflector in front of the lamp, produces an efficient means of obtaining uniform

TABLE III-8<sup>1</sup>  
AVERAGE FOOT-CANDLES IN A TYPICAL ROOM  
LIGHTED BY SEVERAL KINDS OF COVES  
(Original table converted to lumens of Table III-6A.)

Type of Cove	Reflector	Watts	Lamp Finish	Service	Spacing	Avg. Ft.-c.	Initial Ft.-c.
Open	Polished chromium	60	Clear	Lumiline	Continuous	15.0	27.3
Open	Matte white	60	Clear	Lumiline	Continuous	15.1	27.5
Recessed	Polished chromium	60	Clear	Lumiline	Continuous	13.9	25.3
Recessed	Matte white	60	Clear	Lumiline	Continuous	12.2	22.2
Recessed	Translucent glass	60	Clear	Lumiline	Continuous	15.7	28.5
Open	Matte white	60	I.F.	General	18-in.	18.5	33.6
Recessed	Matte white	60	I.F.	General	18-in.	16.4	29.8
Recessed and reflector	Silvered glass	60	I.F.	General	18-in.	16.5	30.0

The ceiling has a 75% reflection factor and the walls a 30% reflection factor. The units are 20 in. from the ceiling. The room is indefinite in length, 14 ft. wide and 8½ ft. high. The wall is curved to meet the ceiling as in Fig. 2-8*b*. The maintenance factor is assumed as 0.55

cove lighting. The direct light from the lamp is reflected from a secondary reflector near the source and falls directly on the cove only in that region where the square law becomes effective.

In the open type of cove (Fig. 2-8*g*), it is necessary to place the lamps on 6- to 9-in. centers; in the recessed cove the lamps may be spaced 12 to 18 in. apart. The recessed cove, using larger but fewer lamps, is more economical in outlets and operating cost but more expensive in cove construction.

*Example c.* Determine the average and initial illumination in a room 14 by 20 ft. with a 9-ft., 75 per cent reflection factor ceiling and a 30 per cent reflection factor wall surface. The illumination is from a cove (Fig. 2-8*g*) using 60-w. inside-frosted lamps on 18-in. centers.

60-w. lamps 835 l. each		Table III-6A
Efficiency (porcelain-enamel reflector 65-77% Table I-7B)	70%	
Room index	2.0	Table III-7
Class T equipment		Table VI-7
Utilization factor	0.37	Table VI-7
Maintenance factor	0.55	Art. 2

13 units on each side. Total of 26 units.

$26 \times 835 = 21,710$  total lumens from lamps

$$\frac{21,710 \times 0.70 \times 0.37 \times 0.55}{14 \times 20} = 11.1 \text{ ft-c. average illumination}$$

$$\frac{11.1}{0.55} = 20.1 \text{ ft-c. initial illumination}$$

$$\frac{26 \times 60}{14 \times 20} = 5.57 \text{ w. per sq. ft.}$$

TABLE IV-8  
COVE LIGHTING DESIGN FACTORS \*

Ceiling	Very Light			Fairly Light		
	Fairly Light	Fairly Dark	Very Dark	Fairly Light	Fairly Dark	Very Dark
Walls						
Room Proportions						
Width approximately 4 times ceiling height	3.5	4.0	4.5	5.0	5.5	6.0
Width approximately twice ceiling height	5.0	5.5	6.0	6.5	7.5	8.5
Width approximately equal to ceiling height	6.5	7.5	9.0	9.5	11.0	13.0

\* Based on 70% equipment efficiency and a 70% depreciation. Multiply work surface lumens by design factor.

Table III-8 gives a report on the average illumination obtained in a room 14 ft. wide of indefinite length. Approximate values for illumination with fluorescent lamps under the same conditions may be obtained by correcting the data for the lumiline lamps by the lumen ratio.

Table IV-8 gives a series of factors for rapid design of cove lighting. The work surface lumens times the correct factor determines the lamp lumens.

#### LOUVER AND BUILT-IN TRANSMITTING SYSTEMS

Installations of louver or built-in plate equipment (Figs. 3-8 and 4-8) are designed by the same methods as all general lighting installa-

tions. The maintenance factor and utilization factor are approximately the same for the various types of lighting but the efficiency is influenced by the design. The material given in this section shows what factors are operative and what part each plays in this influence.

**7. Louver Equipment.** Wherever it is desired to have bright directional light without glare, louvered equipment gives the best results. The brilliancy obtainable gives contrasting shadows, thus strengthening detail and adding to the power of attraction in store installations,

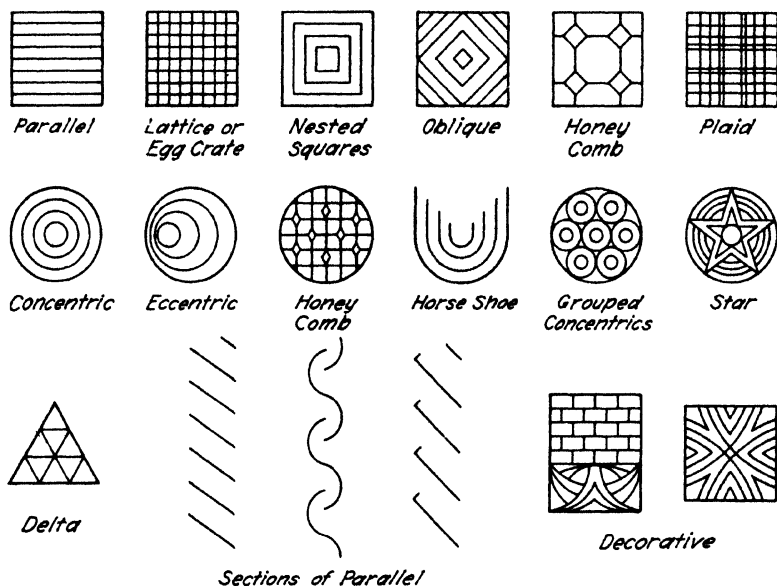

FIG. 3-8.1.<sup>4</sup> Louver patterns.

such as show-window displays. The equipment is constructed by using a series of metal fins which conceal the source and control the spill light. These fins can be decorative as well as useful.

The louver produces the following modification of the lighting system:

- a. Introduces loss
- b. Amount depends on reflector characteristics
  1. Concentrating most efficient
  2. Diffusing causes losses
  3. Diffusing plates with louvers increase the loss.

**8. Louver Design.** The two types of louvers (*source-concealing* and *general concealing*) make it necessary to allow from 15 to 50 per

cent additional lamp lumens because of the low efficiency. The *source-concealing louver* has a cutoff of about 10 degrees from the vertical, whereas the general concealing louver (reflector and lamp) has a cutoff of about 30 degrees from the vertical. The louver must eliminate the brightest areas of the lamp (about 180 c. per sq. in. in the filament); the other portions of the louver have a brightness of from 3.5 to 4 c.

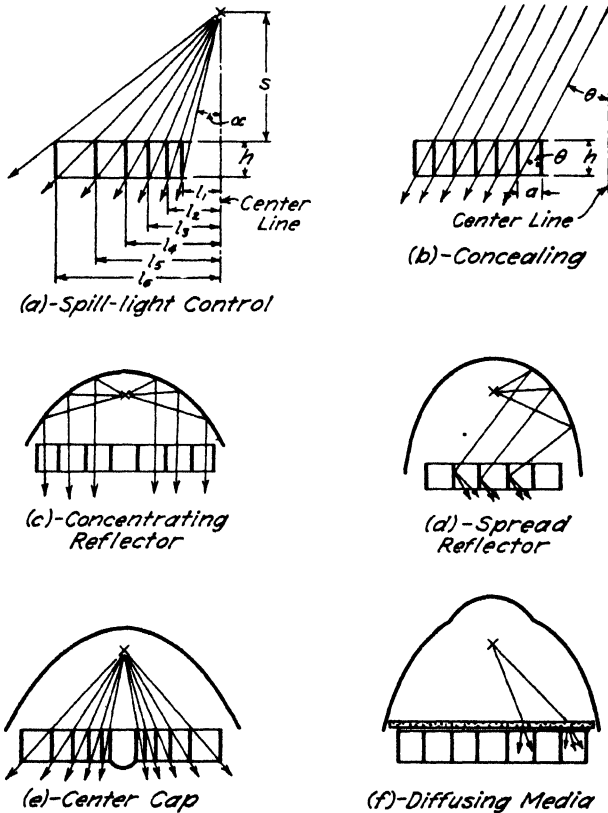

FIG. 4-8.3.4 Considerations in louver design.

per sq. in. Up to 45 degrees with the vertical the louver must be controlled for brightness. At anything less than 45 degrees, the eyebrows shield the eyes from direct glare when the vision is in a normal direction.

In the design of louvers: *a*, only the smallest possible surface should interfere with the passage of light; *b*, thin edges are less obstructive; *c*, the louver should be parallel to the light beam if possible; and the over-all efficiency of a good louvered equipment will be, for

the source-control type, 70 to 85 per cent; for a general concealing type, from 50 to 75 per cent. The materials of which the louver is constructed and the various finishes on the louver may have a marked influence on the efficiency. Any combination of the following materials or finishes may be used:

MATERIALS USED FOR LOUVERS	FINISH ON LOUVERS
Sheet Steel	Black (source-concealing)
Aluminum	White
Bronze	Brown (reddish)
Glass	Gray (medium)
Plastics	Aluminum (bright)
Castings	Aluminum (deep etched)
Aluminum	
Zinc alloy	(All finishes should be heat resisting.)

The louver shape may be varied as shown by Fig. 3-8. The most common type is the concentric louver, which early became of general use in the control of the beam of light from floodlights, both interior and exterior.

The design of the reflector and spacing of the louver, which should be left to the manufacturer, is being developed frequently in the office of the architect where the recessed equipment is considered a part of the building. The general concealing type of louver should be based on the cutoff angle selected. Figure 4-8b is used as a guide in the following development for spacing. In *general concealing equipment*, the spacing should be:

$$a = h \tan \theta$$

where  $h$  is the height of the louver and  $\theta$  the selected angle of cutoff. Usually an angle of 30 degrees is a satisfactory cutoff angle for commercial installations.

For the *source-concealing* type (Fig. 4-8a) the louvers are not spaced in a regular manner because the reflector is not considered, but the source must be invisible from all angles. These are usually designed by the cut-and-try method, but the following expression will solve the problem.

The louvers (Fig. 4-8a) are spaced according to a geometrical progression, where

the first term is:  $(h + s) \tan \alpha$

the ratio is:  $\left(\frac{h}{s} + 1\right)$

and the last term is:  $\frac{(h + s)^n}{s^{n-1}} \tan \alpha$

Here the last term, the distance  $l$ , is measured from the center of the louver;  $h$  is the height of the louver;  $s$  is the distance from the source to the top of the louver, and  $n$  the number of louvers counting out from the center line. If a cap is used to conceal completely the lamp filament (Fig. 4-8e), it is not counted as one of the louvers. The first

TABLE V-8<sup>5</sup>

RATIO SPACING TO MOUNTING HEIGHT OF LIGHT CENTER ABOVE HORIZONTAL PLANE FOR ILLUMINATION OF A PREDETERMINED UNIFORMITY

(Inside-frosted lamps and deep-etched aluminum louvers used with all equipments)

Reflector		Spacing/Mounting Height Ratio					
Shape	Surface	Max./Min. ft.-c. 1½:1			Max./Min. ft.-c. 2:1		
		7-ring Louver	5-ring Cup Combination Louver	Plaid Louver	7-ring Louver	5-ring Cup Combination Louver	Plaid Louver
Parabolic	Polished Aluminum	0.35	0.4	0.32	0.4	0.5	0.42
	Deep-etched aluminum	0.80	1.1	0.78	0.95	1.1	0.94
	White	0.85	1.2	1.05	1.1	1.4	1.3
Spherical	Polished Aluminum	0.46	0.48	0.48	0.53	0.54	0.54
	Deep-etched aluminum	0.80	1.1	0.78	0.95	1.1	1.05
	White	0.85	1.2	1.05	1.1	1.4	1.3

NOTE: When the parabolic polished reflector was fitted with parallel deep-etched louvers and a ribbed-glass plate, the spacing/mounting ratio 90° to the glass ribs was 0.68 for a max./min. ft.-c. 1½:1 and 0.75 for a max./min. ft.-c. 2:1.

Elliptical polished aluminum reflector with concentric conical section louvers has spacing/mounting ratios of 0.90 and 0.95 respectively.

louver is at the cutoff angle. The distance as expressed by the last term above is not easy to use if there are several fins to be designed. It is easier to multiply the terms progressively by the ratio as given.

*Example d.* Determine the spacing of louver fins for a general concealing unit having an angle of cutoff of 30 degrees. It is desired to use louver fins 2 in. high.

$$a = h \tan 30^\circ$$

$$\text{spacing, } a = 2 \times 0.577 = 1.11 \text{ in.}$$

*Example e.* Determine the distance of the third louver fin from the center line of a source-concealing louver unit, if the cutoff of the first fin is 10 degrees and the distance from the source to the louver is 12 in. with a fin 3 in. high.

$$l_n = \frac{(h + s)^n}{s^{n-1}} \tan \alpha$$

$$l_s = \frac{(3 + 12)^2}{12^2} \tan 10^\circ$$

$$l_s = \frac{3375}{144} \times 0.176 = 4.13 \text{ in.}$$

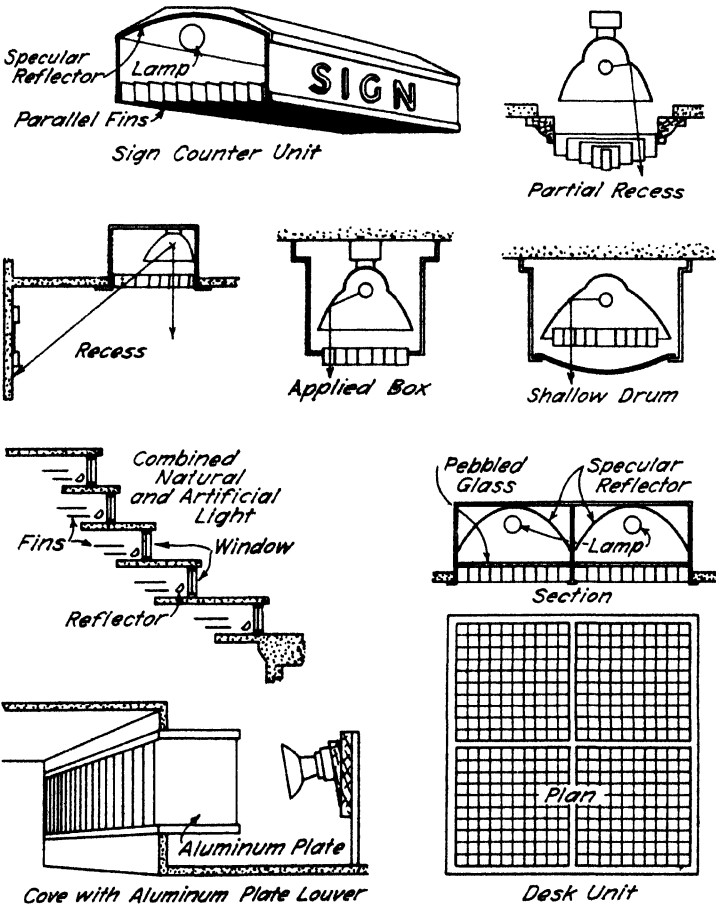

FIG. 5-8.<sup>4</sup> Recessed louvers and louvers used with coves.

**9. Louver Application.** Figures 5-8 and 6-8 show several applications of louvers in illumination design. There are a great number of general lighting luminaires that embody louvers in their design. Counter units and spill-ring units may be classified as louvered equipment. Many of the supplementary lighting units use source-concealing louvers to reduce annoyance from the installation.



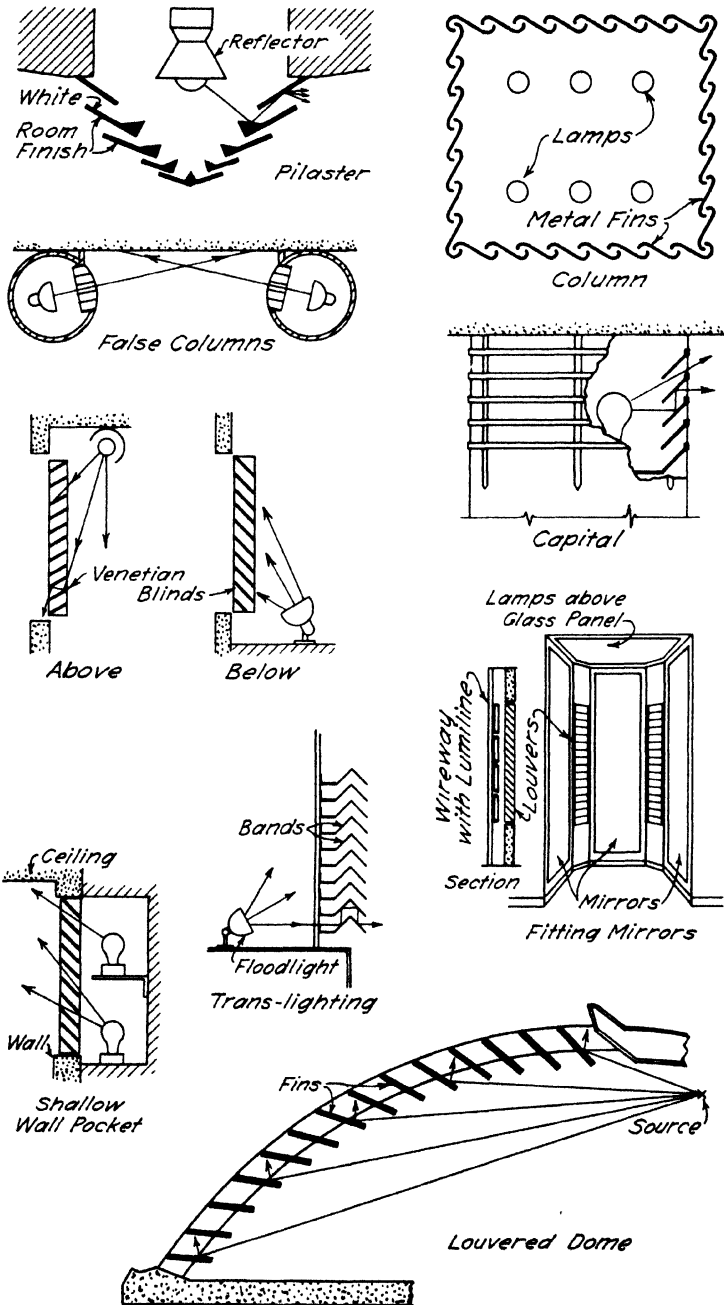

FIG. 6-8.<sup>4</sup> Louvers in columns, pilasters, and architectural elements.

Table V-8 is a table of spacing and mounting height ratios for reflectors of different shapes, and Fig. 7-8 shows the influence of the shape of the reflector in two sets of curves. Parabolic reflectors have

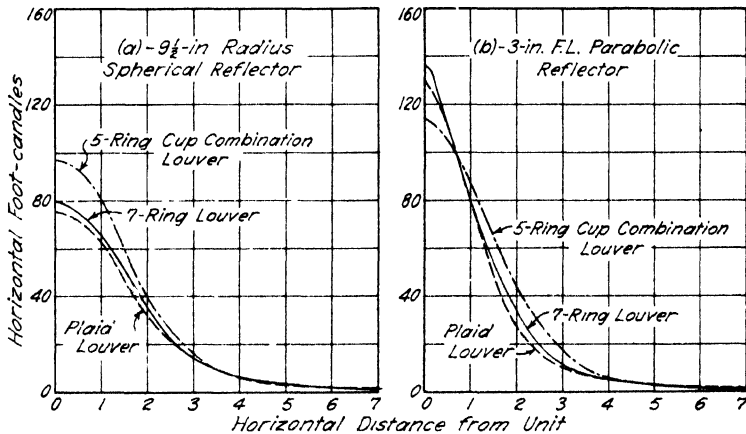

FIG. 7-8.<sup>4</sup> Effect of shape of louver upon the efficiency.

a more concentrating beam of light if the lamps are placed at the focus (Fig. 4-8c) and are correspondingly more efficient, but spherical reflectors have a greater range of spread and may be spaced farther apart. The spherical reflector is suitable for a greater variety of applications than is the parabolic. The loss of light because of the use of a louver with a spread type of reflector is shown in Fig. 4-8d. An elliptical reflector (Fig. 10-7, page 173) will give a second focal point outside itself which is equivalent to locating the reflector at the external point. This permits a reduction in the louver depth, for these louvers designed parallel to the beam are at right angles to the viewing direction.

Figure 8-8 shows the effect of reflector finish with louver equipment; Table VI-8 and Fig. 9-8 evaluate the effect of the finish of the louver upon the performance of the louvered equipment, and Table VII-8 combines the composite effects of reflector finish, louver finish, and type of louver. The finish of the louver should be such that there

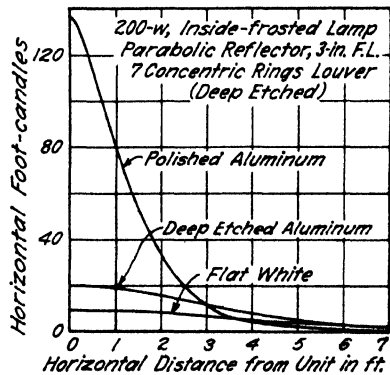

FIG. 8-8.<sup>5</sup> Effect of reflector finish upon the efficiency of louver equipment.

TABLE VI-8<sup>5</sup>

EFFICIENCIES OF POLISHED ALUMINUM ELLIPTICAL REFLECTOR WITH AND WITHOUT LOUVERS OF FOUR CONCENTRIC CONICAL SECTIONS (100-w. Inside-Frosted Lamps)

No louvers	78
Polished aluminum louver (R.F. 81%)	56
Deep-etched aluminum louver (R.F. 80%)	53
Flat white louver (R.F. 72%)	50
Flat gray louver (R.F. 32%)	40
Black louver (R.F. 4%)	34

TABLE VII-8<sup>5</sup>

COMPARISON OF THE EFFICIENCIES OF LOUVERED REFLECTORS INSIDE-FROSTED LAMPS IN ALL UNITS

Louvers		Reflectors		
Form	Finish	Polished Aluminum Surface	Deep-Etched Aluminum Surface	Flat White Paint Surface
7 concentric rings	Polished Aluminum	47	38	34
	Deep-etched Alumi-num	65	57	53
	Flat white	54	42	36
	Flat gray	44	31	24
	Black	40	26	19
5-ring and cup combination	Polished aluminum	54	40	33
	Deep-etched alumi-num	57	47	43
	Flat white	56	43	
	Flat gray	50	37	
	Black	47	34	
Plaid	Polished aluminum	40	28	21
	Deep-etched alumi-num	53	40	34
	Flat white	46	25	
	Flat gray	29	15	
	Black	26	12	
4 rings	3 parchment 1 opaque white	54	44	39
No louvers		83	80	77

is no annoyance from reflected glare, but it is not always necessary to take away interest by using a black finish. A sparkling and lively effect may be obtained by the use of glass, plastic, or polished aluminum louvers. The color of the louver may harmonize with the decorations. Care should be taken that the brightness of the louver does not cause

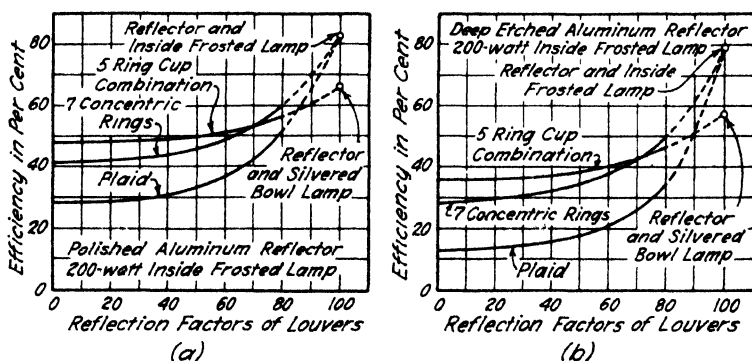

FIG. 9-8.<sup>4</sup> Effect of the louver finish upon the efficiency.

a severe brightness contrast with the surrounding surface. Table VIII-8 gives some comparative data of brightness in louver surfaces. The design of the louver will have an influence on its brightness. One which is brightly polished may act as a mirror and produce multiple filament or lamp images. This type of louver should never be used with clear lamps. The silver-bowl lamp adapts itself to varying types of louver designs.

Sometimes it is desirable to use a cover glass in conjunction with the louver, and in every instance the glass should be above the louver, to reduce louver losses and lower equipment brightness (Fig. 4-8f). This enhances the appearance of the installation and will eliminate striations in the beam pattern. A group of curves showing the effect of the cover glass upon the distribution of the light from the complete equipment is given in Fig. 10-8. The plate reduces the light output from 5 to 11 per cent (92 per cent transmission plate), but this factor depends upon the type of material used in the plate.

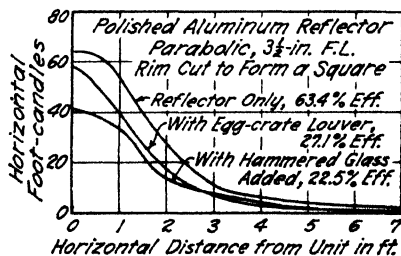

FIG. 10-8.<sup>5</sup> Effect upon the efficiency of louver equipment when diffusing glass is used.

**10. Built-In Transmitting Systems.** Like cove and louver equipment, built-in transmitting systems, which are usually confined to small box coffers (12 by 12 in.), could be classified with the luminous elements; but since they obey the principles of general lighting

TABLE VIII-8<sup>s</sup>  
LOUVER BRIGHTNESS  
(Candles per Square Inch)

Louver	Lamp	Reflector Surface					
		Polished			White		
		Rim	Mid- dle	Center	Rim	Mid- dle	Center
7-ring deep-etched	I.F.	1.0	7.0	25.0	2.5	10.0	25.0
7-ring white	I.F.	0.5	1.7	8.25	0.88	1.63	8.5
7-ring gray	I.F.	0.07	0.25	4.5	0.35	2.0	5.0
7-ring black	I.F.			0.25			0.3
7-ring white	Silver Bowl	0.18	1.2	0.13	0.6	1.26	0.65
7-ring deep-etched	Silver Bowl	1.7	4.0	0.4			
13-ring gray	I.F.	1.0	2.0	4.0	1.4	2.0	4.0
5-ring and cup — deep-etched	I.F.	3.0	3.0	20.0	3.0	5.0	25.0
Plaid — deep-etched	I.F.	0.5	7.5	13.0	1.1	9.0	13.0
4-ring 3-in. gray	I.F.	0.09	0.7	2.5	0.4	1.4	2.0
7-ring gray and hammered glass	I.F.	0.1	0.9	4.0	0.35	1.2	2.5
4-ring gray and hammered glass	I.F.	0.12	0.35	2.0	0.35	1.5	1.4
13-ring gray and hammered glass	I.F.	0.9	2.0	2.5	1.0	2.5	3.0

schemes using luminaires, it seems advisable to include them. For general designing, the utilization factors as given are applicable, though wherever they are used for supplementary lighting equipment, the point-by-point method gives results of practical accuracy. Though the units may be classified and utilization factors obtained, the efficiency and spacing as well as the unit brightness require special attention.

The light boxes commonly used may be divided into two classes: those which are covered with some form of transmitting medium which is translucent and acts as a light diffuser, and those which have prismatic lens plates where the source acts as a point source of light and the lens is designed for accurate flux control. In louvered units, the shape and finish of the reflector, control the light distribution, and the louver itself controls the brightness; in the built-in box units, the cavity shape, its reflection factor, and the type of media all enter into both the distribution and the brightness.

**11. Boxes with Diffusing Media.** Figure 11-8a shows the effect of the reflection factor upon the efficiency of the unit. In this type of

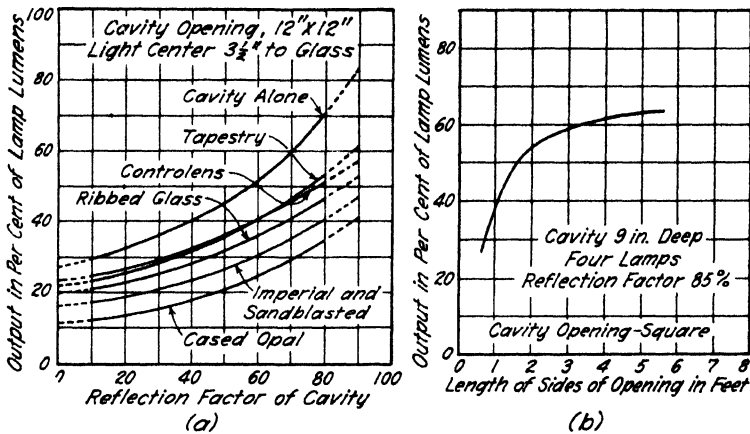

FIG. 11-8.<sup>6</sup> Effect upon the efficiency of light boxes with translucent cover material. (a) Various materials used as a cover. (b) Effect of cavity dimensions.

unit, the shape of the cavity (because of the diffusing properties of the plate) is not as important as the reflection factor of the box. The cavity may be finished with Alzak aluminum, porcelain enamel, aluminum, or casein paint. All reflector finishes, however, should have high reflection factors and be heat resisting. Cavities will follow the same law as room size (room index) in returning the light through the cover media; the probable efficiency with cavity size is shown in Fig. 11-8b. Except for the small box units, these systems should be considered as an architectural luminous element and treated as in Chapter 9.

**12. Prismatic Lens Plate Systems.** Where accurate control of the light beam is desired, both the reflecting surface and the transmitting medium must control the light accurately. Spherical reflectors return the light to the source and thereby reinforce it. They are of value

only when they subtend a solid angle with the primary source which is the angle equal to that subtended by the lens plate. If the light leaves the source in parallel rays (parabolic reflectors with source at focus), simple lenses, prisms, or ribbed glass will control the beam; but where the light leaves the source in a radial direction, the design of the control lens will be elaborate.

Figure 12-8 shows the effect of lamp filament position on the distribution of the light from the lens plate. The light distribution becomes wider as the light source is moved toward the lens and narrower as it is moved away. If the light source is offset, the beam of

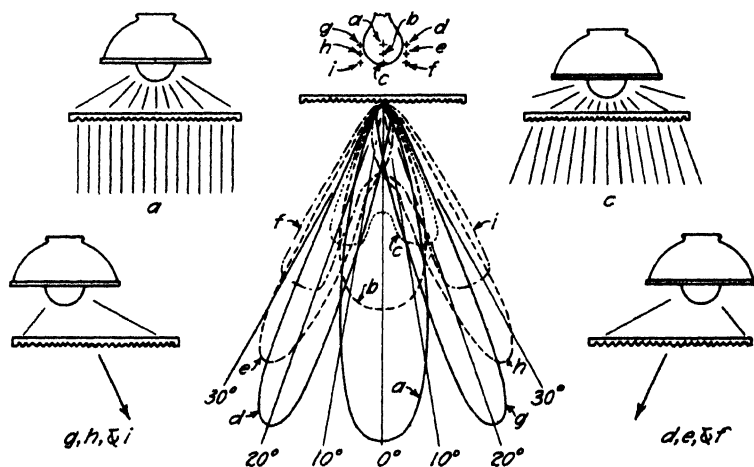

FIG. 12-8. The effect of lamp position behind a prismatic control lens.

light is offset in the opposite direction. It, therefore, follows that by changing the position of the lamp filament a wide range of light distribution may be obtained. If colored lamps are placed behind the lens plates and the correct offset is used, it is possible to have selective color distribution in show windows for novelty effects. Since the design of the lens depends upon the assumption of a point source of light, the clear lamp makes for better control than does the inside-frosted lamp. The table shows the comparative candlepower output from clear and inside-frosted lamps:

WATTS	INTENSIVE LENS PLATE	EXTENSIVE LENS PLATE
100	2	5
200	14	7
300	26	13

The increased spread from the larger lamps is caused by the distributing characteristics of the lamp itself.

TABLE IX-8\*

DESIGN DATA FOR APPLYING DIRECT TRANSMITTING EQUIPMENTS

Type of Glass	Ceased Opal		Sandblasted	Tapestry	Imperial- Random Pris- matic Patterns	Skytex- Medium Ribbed	Controlens 774 V.F.
	3 1/2 in. Spotty	7 in. Uniform					
Lamp	200-w. I.F.	200-w. I.F.	200-w. I.F.	200-w. I.F.	200-w. I.F.	200-w. I.F.	200-w. I.F.
White Box R.F. = 0.68							
Output % lamp lumens of Candlepower	27.3 369	23.9 322	33.2 473	44.7 620	33.7 706	39.7 621	43.4 1300
Ratio, spacing/mounting height (for 1 1/2:1 max./min. ft.-c. uniformity, between units)	1.90	1.65	1.6	1.75	1.45	1.75	1.1
Ratio, width of area/mounting height (for 2:1 max./min. ft.-c. uniformity, over area)	0.95	0.9	0.95	1.4	0.75	0.95	0.5
Ratio width of area/mounting height (for 3:1 max./min. ft.-c. uniformity, over area)	1.05	1.5	1.5	1.8	1.15	1.3	0.85
For a Number of Rows:							
Ratio, spacing/mounting height (for 1 1/2:1 max./min. ft.-c. uniformity, center of diagonal between units)	1.90	1.55	1.55	1.8	1.3	1.5	0.95
Ratio, spacing/mounting height (for 2:1 max./min. ft.-c. uniformity, center of diagonal between units)	1.8	1.75	1.7	1.95	1.45	1.6	1.05
White Box with Reflector							
Output % lamp lumens of Candlepower	30.4 405	22.0 309	39.7 629	53 780	38.9 992	45.0 1070	50.2 1675
Ratio, spacing/mounting height (for 1 1/2:1 max./min. ft.-c. uniformity, between units)	1.05	1.60	1.5	1.65	1.3	1.4	1.00
Ratio, width of area/mounting height (for 2:1 max./min. ft.-c. uniformity, over area)	1.0	0.95	0.9	0.85	0.75	0.8	0.5
Ratio width of area/mounting height (for 3:1 max./min. ft.-c. uniformity, over area)	1.55	1.55	1.45	1.5	1.1	1.1	0.8
For a Number of Rows:							
Ratio, spacing/mounting height (for 1 1/2:1 max./min. ft.-c. uniformity, center of diagonal, between units)	1.6	1.6	1.5	1.6	1.2	1.25	0.9
Ratio, spacing/mounting height (for 2:1 max./min. ft.-c. uniformity, center of diagonal, between units)	1.8	1.8	1.65	1.75	1.3	1.35	1.0



TABLE X-8  
 BRIGHTNESS — CANDLES PER SQUARE INCH  
 (Brightest square inch at angles indicated — cavity 12 by 12 in. with transmitting medium)

Type of Glass	Cased Opal	Sand-Blasted	Tapestry	Imperial-Random Prismatic Pattern	Skytes-Medium Ribbed	Controlens 765	Controlens 774	Controlens 796	Controlens 796
Lamp	200-w. I.F.	200-w. I.F.	200-w. I.F.	200-w. I.F.	200-w. I.F.	200-w. C.L.	200-w. C.L.	100-w. C.L.	100-w. I.F.

White Cavity

Lamp center position above glass	5 in.		3½ in.		3¼ in.		3½ in.	
	4.1	6.2	98.0	47.1	57.8	57.8	56.8	56.8
0	4.1	6.2	98.0	47.1	57.8	57.8	56.8	56.8
10	4.1	6.2	96.1	50.2	55.2	55.2	51.9	51.9
20	4.0	6.1	89.5	47.5	31.6	31.6	20.0	20.0
30	4.0	6.0	89.5	47.5	15.5	15.5	8.3	8.3
40	3.9	5.8	78.9	24.5	10.3	10.3	5.6	5.6
50	3.7	5.6	58.8	8.3	3.5	3.5	2.8	2.8
60	3.5	5.3	41.3	29.2	4.4	4.4		
70	3.0	4.5	12.3					
80	2.0	2.8	3.5					

White Cavity with Reflector

Lamp center position above glass	3½ in.		3½ in.		3½ in.		3½ in.		3½ in.		3½ in.		3¼ in.		3¼ in.		3¼ in.		2¾ in.	
	8.4	8.4	38.7	92.9	20.9	53	53	159	100	151	123	141	141	141	141	141	141	141	90	90
0	8.4	8.4	38.7	92.9	20.9	53	53	159	100	151	123	141	141	141	141	141	141	141	90	90
10	8.4	8.4	36.8	88.8	47.3	53	53	152	90	134	102	141	141	141	141	141	141	141	45	45
20	8.3	8.3	33.5	84.5	52.2	46	46	138	83	120	87	117	117	117	117	117	117	117	12	12
30	8.3	8.3	29.7	77.4	49.8	44	44	129	77	108	57	108	108	108	108	108	108	108	8	8
40	8.1	8.1	24.4	65.7	54.7	34	34	117	61	91	19	91	91	91	91	91	91	91	5	5
50	7.0	7.0	19.4	46.4	57.0	15	15	102	5	18	9	18	18	18	18	18	18	18	4	4
60	7.4	7.4	14.2	29.7	52.6	6	6	77	3	9	3	9	9	9	9	9	9	9	3	3
70	6.4	6.4	8.1	11.5	39.3	4	4	5	2	4	2	4	4	4	4	4	4	4	2	2
80	4.3	4.3	3.5	1.8	11.3	5	5	4	1	1	1	1	1	1	1	1	1	1	1	1

\* P = ribs perpendicular to plane of rotation.  
 † H = ribs parallel to plane of rotation.  
 ‡ D = ribs diagonal (45°) to plane of rotation.

**13. Spacing and Brightness.** The spacing and brightness characteristics of built-in types of small lighting coffer are given in the Tables IX-8 and X-8. Data given in Table IX-8 may be used in calculating the illumination and determining the limits of spacing for a given illumination uniformity. When the coffer are used in single row application (over work surfaces or store counters), the width of the area that can be illuminated to a predetermined ratio of maximum to minimum foot-candles over the given area can also be calculated from Table IX-8. Data in Table X-8 tabulate the brightness in candlepower per square inch at several angles. Assuming the element to be horizontal at normal heights, the most disturbing zone lies between 40 and 70 degrees. Brightness in the 0- to 30-degree zone will depend upon the use of the equipment; for small merchandise where sparkle and scintillation are desirable, the brightness may be high, but if extended areas are exposed to the beam, the reflected glare may be very annoying and objectionable. Only where the rooms are low and long will there be a likelihood of disturbance from the 70- to 80-degree angle.

**14. The General Lighting Problem.** The solution of the general lighting problem centers around the determination of the utilization factor and the efficiency of the equipment. The utilization factor has been determined for special classes of equipment and these values are satisfactory for practical purposes. The efficiency, however, must be determined for each specific piece of equipment to be used, and it must be used under the same arrangement in the installation. The control of the quality of the light, including distribution, shadow, glare, brightness contrast, and appearance, must be obtained by experience with the factors previously discussed. Table XI-8 gives a rapid method for determining the probable average illumination from coefficients of utilization.

In addition to the point-by-point and flux methods of lighting design, there is the watts-per-square-foot method. Since the number of foot-candles that can be used economically for lighting is continually changing, the watts-per-square-foot factor would have to change correspondingly. For satisfactory work in designing, even in the practical field, experience and data from a great number of working installations are required for any degree of reliability.

TABLE  
COMPUTED ILLUMI-

Area in Square Feet per Lamp	Size of Lamp		COEFFICIENT OF UTILIZATION																		
	Watts	Lumens	.14	.16	.18	.20	.22	.24	.26	.28	.30	.32	.34	.33	.40	.45	.50	.55	.60	.65	.70
			FOOT-CANDLES																		
60	100	1500	2.5	2.8	3.1	3.5	3.8	4.2	4.5	4.9	5.3	5.6	5.9	6.3	7.0	7.9	8.8	9.8	10.5	11.4	12.3
	150	2500	4.1	4.7	5.3	5.9	6.3	7.0	7.6	8.2	8.8	9.3	10.0	10.5	11.7	13.1	14.6	16.0	17.5	19.0	20.4
	200	3400	5.5	6.3	7.1	7.9	8.7	9.5	10.3	11.1	11.9	12.7	13.5	14.3	15.9	17.8	19.8	21.8	23.8	25.8	27.8
	300	5500	9.0	10.3	11.6	12.8	14.1	15.4	16.7	18.0	19.3	20.5	21.8	23.1	25.7	28.9	32.1	35.3	38.5	41.7	45.0
	500	9800	16.0	18.3	20.3	22.9	25.2	27.5	29.7	32.0	34.3	36.6	38.9	41.2	45.8	51.5	57.2	62.9	68.6	74.4	80.0
70	100	1500	2.1	2.4	2.7	3.0	3.3	3.6	3.9	4.2	4.5	4.8	5.1	5.4	6.0	6.8	7.5	8.3	9.0	9.8	10.5
	150	2500	3.5	4.0	4.5	5.0	5.4	6.0	6.5	7.0	7.5	8.0	8.5	9.0	10.0	11.3	12.5	13.8	15.0	16.1	17.3
	200	3400	4.7	5.5	6.1	6.8	7.5	8.2	8.9	9.5	10.2	10.9	11.5	12.2	13.6	15.3	17.0	18.7	20.4	22.1	23.8
	300	5500	7.7	8.8	9.9	11.0	12.1	13.2	14.3	15.4	16.5	17.6	18.7	19.8	22.0	24.8	27.5	30.2	32.9	35.6	38.3
	500	9800	13.7	15.7	17.6	19.6	21.6	23.5	25.5	27.4	29.4	31.4	33.3	35.3	38.2	44.1	49.0	54.0	58.8	63.5	68.5
80	100	1500	1.8	2.1	2.4	2.6	2.9	3.1	3.4	3.7	3.9	4.1	4.4	4.6	5.2	5.9	6.6	7.2	7.9	8.5	9.2
	150	2500	3.1	3.5	3.9	4.4	4.8	5.3	5.7	6.1	6.6	7.0	7.4	7.9	8.8	9.8	10.9	12.0	13.1	14.2	15.3
	200	3400	4.2	4.8	5.4	5.9	6.5	7.1	7.7	8.3	8.9	9.5	10.1	10.7	11.9	13.4	14.9	16.4	17.9	19.3	20.8
	300	5500	6.7	7.7	8.7	9.6	10.6	11.5	12.5	13.5	14.5	15.4	16.4	17.3	19.3	21.6	24.1	26.5	28.9	31.3	33.7
	500	9800	12.0	13.7	15.5	17.2	18.9	20.5	22.3	24.0	25.7	27.5	29.1	30.9	34.4	38.6	43.0	47.2	51.5	55.8	60.0
90	100	1500	1.6	1.9	2.1	2.3	2.6	2.8	3.0	3.3	3.5	3.7	4.0	4.2	4.7	5.2	5.8	6.4	7.0	7.6	8.2
	150	2500	2.7	3.1	3.4	3.9	4.2	4.7	5.1	5.5	5.8	6.2	6.6	7.0	7.8	8.8	9.7	10.7	11.7	12.6	13.6
	200	3400	3.7	4.2	4.8	5.3	5.8	6.4	6.9	7.4	7.9	8.5	9.0	9.5	10.6	11.9	13.2	14.5	15.9	17.2	18.5
	300	5500	6.0	6.9	7.7	8.6	9.4	10.3	11.1	12.0	12.8	13.7	14.5	15.4	17.1	19.3	21.4	23.5	25.7	27.8	30.0
	500	9800	10.7	12.2	13.7	15.2	16.8	18.3	19.8	21.4	22.9	24.4	25.9	27.4	30.5	34.3	38.1	42.0	45.9	49.8	53.5
750	14550	15.8	18.1	20.4	22.6	24.9	27.2	29.4	31.7	34.0	36.2	38.5	40.7	45.3	51.0	56.6	62.3	67.9	73.5	79.2	
100	100	1500	1.5	1.7	1.9	2.1	2.3	2.5	2.7	2.9	3.1	3.4	3.6	3.8	4.2	4.6	5.3	5.8	6.3	6.8	7.4
	150	2500	2.5	2.8	3.2	3.5	3.8	4.2	4.6	4.9	5.3	5.6	6.0	6.3	7.0	7.9	8.8	9.6	10.5	11.4	12.3
	200	3400	3.3	3.8	4.3	4.8	5.2	5.7	6.2	6.7	7.1	7.6	8.1	8.6	9.5	10.7	11.9	13.1	14.3	15.5	16.7
	300	5500	5.4	6.2	6.9	7.7	8.5	9.2	10.0	10.8	11.5	12.3	13.1	13.9	15.4	17.3	19.3	21.3	23.2	25.0	27.0
	500	9800	9.6	11.0	12.3	13.7	15.1	16.5	17.7	19.2	20.6	21.9	23.3	24.7	27.4	30.9	34.3	37.7	41.2	44.6	48.0
750	14550	14.3	16.3	18.3	20.4	22.4	24.5	26.5	28.6	30.6	32.6	34.7	36.7	40.8	45.9	51.0	56.1	61.2	66.3	71.4	
110	100	1500	1.3	1.5	1.7	1.9	2.1	2.3	2.5	2.7	2.9	3.0	3.2	3.4	3.8	4.3	4.8	5.2	5.7	6.2	6.7
	150	2500	2.2	2.5	2.9	3.2	3.5	3.8	4.1	4.5	4.8	5.1	5.4	5.7	6.4	7.2	8.0	8.8	9.5	10.3	11.1
	200	3400	3.0	3.5	3.9	4.3	4.8	5.2	5.6	6.1	6.5	6.9	7.4	7.8	8.7	9.7	10.8	11.9	13.0	14.1	15.2
	300	5500	4.9	5.6	6.2	7.0	7.7	8.4	9.1	9.8	10.5	11.2	11.9	12.6	14.0	15.7	17.5	19.2	21.0	22.7	24.5
	500	9800	8.7	10.0	11.2	12.5	13.7	14.9	16.2	17.5	18.7	20.0	21.2	22.5	25.0	28.1	31.2	34.3	37.5	40.6	43.7
750	14550	13.0	14.8	16.7	18.5	20.4	22.2	24.0	26.0	27.8	29.6	31.5	33.4	37.1	41.7	46.3	51.0	55.6	60.2	64.8	
120	100	1500	1.2	1.4	1.6	1.8	1.9	2.1	2.3	2.5	2.6	2.8	3.0	3.1	3.5	3.9	4.4	4.8	5.2	5.7	6.1
	150	2500	2.0	2.3	2.6	2.9	3.2	3.5	3.8	4.1	4.4	4.7	5.0	5.3	5.8	6.6	7.3	8.0	8.8	9.5	10.2
	200	3400	2.8	3.2	3.6	4.0	4.4	4.8	5.2	5.6	5.9	6.4	6.7	7.2	8.0	9.0	10.0	11.0	12.0	13.0	14.0
	300	5500	4.5	5.1	5.8	6.4	7.1	7.7	8.4	9.0	9.6	10.3	10.9	11.5	12.8	14.4	16.0	17.7	19.2	20.8	22.4
	500	9800	8.0	9.1	10.3	11.4	12.6	13.7	14.9	16.0	17.2	18.3	19.4	20.6	22.9	25.7	28.6	31.4	34.3	37.2	40.0
750	14550	11.9	13.6	15.3	17.0	18.7	20.4	22.1	23.8	25.5	27.2	28.9	30.6	34.4	38.2	42.5	46.7	51.0	55.2	59.4	
130	100	2500	1.9	2.2	2.4	2.7	2.9	3.2	3.5	3.8	4.0	4.3	4.6	4.8	5.4	6.1	6.7	7.4	8.1	8.8	9.4
	200	3400	2.6	2.9	3.3	3.7	4.0	4.4	4.8	5.1	5.5	5.9	6.2	6.6	7.3	8.2	9.2	10.1	11.0	11.9	12.8
	300	5500	4.1	4.7	5.3	5.9	6.5	7.1	7.7	8.3	8.9	9.5	10.1	10.6	11.8	13.3	14.8	16.3	17.8	19.2	20.7
	500	9800	7.4	8.4	9.5	10.6	11.6	12.7	13.7	14.8	15.8	16.9	18.0	19.0	21.1	23.8	26.4	29.0	31.7	34.3	37.0
	750	14550	11.0	12.5	14.1	15.6	17.2	18.9	20.4	22.0	23.6	25.0	26.7	28.2	31.3	35.2	39.1	43.0	47.0	50.8	54.7
140	100	2500	1.8	2.0	2.2	2.5	2.7	3.0	3.3	3.5	3.8	4.0	4.3	4.5	5.0	5.6	6.3	6.9	7.6	8.1	8.7
	200	3400	2.4	2.7	3.1	3.4	3.7	4.1	4.4	4.8	5.1	5.4	5.8	6.1	6.8	7.6	8.5	9.2	10.2	11.0	11.9
	300	5500	3.8	4.4	5.0	5.5	6.0	6.6	7.1	7.7	8.2	8.8	9.3	9.9	11.0	12.4	13.7	15.1	16.5	17.9	19.3
	500	9800	6.9	7.8	8.8	9.8	10.8	11.8	12.8	13.7	14.7	15.7	16.7	17.6	19.8	22.4	25.0	27.6	29.9	31.9	34.3
	750	14550	10.2	11.7	13.1	14.6	16.0	17.5	18.9	20.4	21.8	23.3	24.8	26.2	29.1	32.8	36.4	40.0	43.7	47.3	51.0
150	100	2500	1.6	1.9	2.1	2.3	2.5	2.8	3.0	3.3	3.5	3.7	4.0	4.2	4.7	5.3	5.8	6.4	7.0	7.6	8.2
	200	3400	2.2	2.5	2.9	3.2	3.5	3.8	4.1	4.4	4.8	5.1	5.4	5.7	6.3	7.1	7.9	8.8	9.5	10.3	11.1
	300	5500	3.6	4.1	4.6	5.1	5.6	6.2	6.7	7.2	7.7	8.2	8.7	9.2	10.3	11.5	12.8	14.2	15.4	16.7	18.0
	500	9800	6.4	7.3	8.2	9.1	10.1	11.0	11.9	12.8	13.7	14.6	15.5	16.4	18.2	20.6	22.8	25.2	27.4	29.7	32.0
	750	14550	9.5	10.8	12.2	13.6	14.9	16.3	17.7	19.0	20.4	21.7	23.1	24.4	27.2	30.6	34.0	37.3	40.7	44.1	47.5
160	100	2500	1.5	1.8	2.0	2.2	2.4	2.6	2.8	3.1	3.3	3.5	3.7	3.9	4.4	4.9	5.5	6.0	6.6	7.1	7.7
	200	3400	2.1	2.4	2.7	3.0	3.3	3.6	3.9	4.2	4.5	4.8	5.1	5.4	5.9	6.7	7.4	8.2	8.9	9.7	10.4
	300	5500	3.4	3.9	4.3	4.8	5.3	5.8	6.3	6.7	7.2	7.7	8.2	8.7	9.6	10.8	12.0	13.2	14.4	15.6	16.8
	500	9800	6.0	6.9	7.7	8.6	9.4	10.3	11.2	12.0	12.9	13.7	14.6	15.4	17.2	19.3	21.4	23.5	25.7	27.9	30.0
	750	14550	8.9	10.2	11.4	12.7	14.0	15.3	16.6	17.8	19.1	20.4	21.7	22.9	25.4	28.6	31.8	35.0	38.2	41.4	44.5
1000	20700	12.7	14.5	16.3	18.1	19.9	21.7	23.5	25.4	27.2	29.0	30.8	32.6	36.2	40.8	45.3	49.8	54.3	58.9	63.4	
170	100	2500	1.4	1.6	1.9	2.1	2.2	2.5	2.7	2.9	3.1	3.3	3.5	3.7	4.1	4.6	5.1	5.7	6.2	6.7	7.2
	200	3400	2.0	2.2	2.5	2.8	3.1	3.4	3.6	3.9	4.2	4.5	4.8	5.0	5.6	6.3	7.0	7.7	8.4	9.1	9.8
	300	5500	3.2	3.6	4.1	4.5	5.0	5.4	5.9	6.4	6.8	7.2	7.7	8.2	9.1	10.2	11.3				

XI-8<sup>1</sup>

NATION VALUES<sup>1</sup>

Area in Square Feet per Lamp	Size of Lamp		COEFFICIENT OF UTILIZATION																											
			FOOT-CANDLES																											
	Watts	Lumens	.14	.16	.18	.20	.22	.24	.26	.28	.30	.32	.34	.36	.40	.45	.50	.55	.60	.65	.70									
180	150	2500	1.4	1.5	1.8	1.9	2.1	2.3	2.5	2.7	2.9	3.1	3.3	3.5	3.9	4.4	4.9	5.3	5.8	6.3	6.8									
	200	3400	1.9	2.1	2.4	2.6	2.9	3.2	3.4	3.7	4.0	4.2	4.5	4.8	5.3	6.0	6.6	7.3	7.9	8.6	9.3									
	300	5500	3.0	3.4	3.9	4.3	4.7	5.1	5.6	6.0	6.4	6.8	7.3	7.7	8.6	9.8	10.7	11.8	12.8	13.9	15.0									
	500	9800	5.3	6.1	6.9	7.6	8.4	9.1	9.9	10.7	11.4	12.2	12.9	13.8	15.3	17.2	19.1	21.0	22.8	24.8	26.7									
	750	14550	7.9	9.1	10.2	11.3	12.4	13.6	14.7	15.8	17.0	18.1	19.2	20.4	22.6	25.4	28.3	31.1	34.0	36.8	39.6									
	1000	20700	11.3	12.9	14.5	16.1	17.7	19.3	20.9	22.6	24.2	25.8	27.4	29.0	32.2	36.2	40.2	44.2	48.3	52.3	56.3									
200	200	3400	1.7	1.9	2.1	2.4	2.6	2.9	3.1	3.3	3.6	3.8	4.0	4.3	4.8	5.4	6.0	6.6	7.2	7.7	8.3									
	300	5500	2.7	3.1	3.5	3.8	4.2	4.6	5.0	5.4	5.8	6.2	6.5	6.9	7.7	8.7	9.6	10.6	11.6	12.5	13.5									
	500	9800	4.8	5.5	6.2	6.9	7.6	8.2	8.9	9.6	10.3	11.0	11.7	12.4	13.7	15.5	17.2	18.9	20.6	22.3	24.0									
	750	14550	7.1	8.1	9.2	10.2	11.2	12.2	13.2	14.3	15.3	16.3	17.3	18.3	20.4	22.9	25.4	28.0	30.6	33.1	35.6									
	1000	20700	10.2	11.6	13.1	14.5	16.0	17.4	18.8	20.3	21.7	23.2	24.6	26.1	29.0	32.6	36.2	40.0	43.5	47.2	50.8									
	1500	33000	15.2	18.5	20.8	23.2	25.4	27.7	30.0	32.4	34.6	37.0	39.2	41.6	46.3	52.0	57.8	63.6	69.4	75.2	81.0									
220	200	3400	1.5	1.7	2.0	2.2	2.4	2.6	2.8	3.0	3.2	3.5	3.7	3.9	4.3	4.9	5.4	6.0	6.5	7.0	7.6									
	300	5500	2.4	2.8	3.1	3.5	3.8	4.2	4.5	4.9	5.2	5.6	5.9	6.3	7.0	7.9	8.8	9.6	10.5	11.4	12.3									
	500	9800	4.4	5.0	5.6	6.2	6.9	7.5	8.1	8.7	9.3	10.0	10.6	11.2	12.5	14.4	15.6	17.2	18.7	20.3	21.8									
	750	14550	6.5	7.4	8.3	9.3	10.2	11.1	12.1	13.0	13.9	14.8	15.7	16.7	18.8	20.9	23.2	25.5	27.8	30.2	32.5									
	1000	20700	9.2	10.5	11.9	13.2	14.5	15.8	17.1	18.5	19.7	21.1	22.4	23.7	26.4	29.6	33.0	36.2	39.5	42.8	46.1									
	1500	33000	14.7	16.8	18.9	21.0	23.1	25.2	27.3	29.4	31.5	33.7	35.7	37.9	42.1	47.3	52.6	57.8	63.1	68.4	73.6									
240	200	3400	1.4	1.6	1.8	2.0	2.2	2.4	2.6	2.8	3.0	3.2	3.4	3.6	4.0	4.5	5.0	5.5	5.9	6.4	6.9									
	300	5500	2.2	2.6	2.9	3.2	3.5	3.8	4.2	4.5	4.8	5.1	5.4	5.8	6.4	7.2	8.0	8.8	9.6	10.4	11.2									
	500	9800	4.0	4.6	5.2	5.7	6.3	6.9	7.4	8.0	8.6	9.2	9.7	10.3	11.4	12.9	14.3	15.8	17.2	18.6	19.9									
	750	14550	5.9	6.8	7.6	8.6	9.3	10.1	11.0	11.9	12.7	13.6	14.4	15.3	17.0	19.0	21.2	23.5	25.7	27.9	30.0									
	1000	20700	8.5	9.7	10.9	12.1	13.3	14.5	15.7	16.9	18.1	19.4	20.6	21.7	24.2	27.3	30.2	33.2	36.3	39.2	42.2									
	1500	33000	13.5	15.4	17.4	19.3	21.2	23.1	25.0	27.0	28.9	30.8	32.7	34.7	38.6	43.4	48.2	53.0	57.8	62.6	67.3									
260	200	3400	1.3	1.5	1.6	1.8	2.0	2.2	2.4	2.6	2.7	2.9	3.1	3.3	3.7	4.1	4.6	5.0	5.5	6.0	6.4									
	300	5500	2.1	2.4	2.7	3.0	3.3	3.6	3.9	4.2	4.4	4.7	5.0	5.3	5.9	6.7	7.4	8.2	8.9	9.6	10.4									
	500	9800	3.7	4.2	4.7	5.3	5.8	6.3	6.9	7.4	7.9	8.5	9.0	9.5	10.6	11.9	13.2	14.5	15.8	17.2	18.5									
	750	14550	5.5	6.3	7.1	7.8	8.6	9.4	10.2	10.9	11.8	12.6	13.3	14.1	15.7	17.6	19.6	21.6	23.5	25.4	27.4									
	1000	20700	7.8	8.9	10.0	11.2	12.3	13.4	14.5	15.6	16.7	17.9	19.0	20.1	22.3	25.1	27.9	30.7	33.5	36.3	39.1									
	1500	33000	12.5	14.2	16.0	17.8	19.6	21.3	23.1	24.9	26.7	28.5	30.2	32.0	35.6	40.0	44.5	49.0	53.5	57.9	62.3									
280	200	3400	1.2	1.4	1.6	1.7	1.9	2.1	2.3	2.4	2.6	2.8	3.0	3.1	3.5	3.9	4.4	4.8	5.1	5.7	6.0									
	300	5500	1.9	2.2	2.5	2.8	3.0	3.3	3.6	3.9	4.1	4.4	4.7	5.0	5.5	6.2	6.9	7.6	8.3	8.9	9.6									
	500	9800	3.4	3.9	4.4	4.9	5.4	5.9	6.4	6.9	7.3	7.9	8.3	8.8	9.8	11.0	12.3	13.5	14.7	15.9	17.2									
	750	14550	5.1	5.8	6.5	7.3	8.0	8.7	9.5	10.2	10.9	11.6	12.3	13.1	14.6	16.4	18.2	20.0	21.8	23.7	25.5									
	1000	20700	7.2	8.3	9.3	10.3	11.4	12.4	13.5	14.5	15.5	16.5	17.6	18.6	20.7	23.2	25.9	28.4	31.0	33.6	36.2									
	1500	33000	11.6	13.2	14.9	16.5	18.2	19.8	21.4	23.1	24.7	26.4	28.0	29.8	33.0	37.2	41.3	45.5	49.5	53.5	57.5									
320	200	3400	1.0	1.2	1.3	1.5	1.6	1.8	1.9	2.1	2.2	2.4	2.5	2.7	3.0	3.4	3.7	4.1	4.5	4.9	5.2									
	300	5500	1.7	1.9	2.2	2.4	2.6	2.9	3.1	3.4	3.6	3.9	4.1	4.3	4.8	5.4	6.0	6.6	7.2	7.8	8.4									
	500	9800	3.0	3.4	3.9	4.3	4.7	5.1	5.6	6.0	6.4	6.9	7.3	7.7	8.6	9.7	10.8	11.9	12.9	14.0	15.0									
	750	14550	4.5	5.1	5.7	6.4	7.0	7.8	8.3	8.9	9.5	10.2	10.8	11.5	12.7	14.3	15.9	17.7	19.1	20.6	22.3									
	1000	20700	6.3	7.3	8.2	9.1	10.0	10.9	11.8	12.7	13.6	14.5	15.4	16.3	18.1	20.4	22.9	25.0	27.2	29.4	31.7									
	1500	33000	10.1	11.6	13.0	14.5	15.9	17.3	18.7	20.2	21.7	23.2	24.6	26.0	28.9	32.5	36.1	39.6	43.4	47.0	50.6									
360	300	5500	1.5	1.7	1.9	2.1	2.4	2.6	2.8	3.0	3.2	3.4	3.6	3.8	4.3	4.8	5.3	5.9	6.4	7.0	7.5									
	500	9800	2.7	3.0	3.4	3.8	4.2	4.6	4.9	5.3	5.7	6.1	6.5	6.9	7.8	8.6	9.5	10.5	11.4	12.4	13.4									
	750	14550	4.0	4.5	5.1	5.7	6.2	6.8	7.4	7.9	8.5	9.1	9.6	10.2	11.3	12.8	14.2	15.6	17.0	18.4	19.8									
	1000	20700	5.6	6.4	7.2	8.0	8.9	9.7	10.5	11.3	12.1	12.9	13.7	14.5	16.1	18.1	20.2	22.2	24.2	26.2	28.2									
	1500	33000	9.0	10.3	11.6	12.8	14.1	15.4	16.7	18.0	19.3	20.6	21.8	23.1	25.7	28.9	32.1	35.3	38.6	41.8	45.0									
	400	300	5500	1.4	1.5	1.7	1.9	2.1	2.3	2.5	2.7	2.9	3.1	3.3	3.5	3.9	4.3	4.8	5.3	5.8	6.3	6.7								
500		9800	2.4	2.7	3.1	3.4	3.8	4.1	4.5	4.8	5.1	5.5	5.8	6.2	6.9	7.7	8.6	9.4	10.3	11.2	12.0									
750		14550	3.6	4.1	4.6	5.1	5.6	6.1	6.6	7.1	7.6	8.2	8.7	9.2	10.2	11.5	12.7	14.0	15.3	16.5	17.8									
1000		20700	5.1	5.8	6.5	7.3	8.0	8.7	9.4	10.2	10.8	11.6	12.3	13.1	14.5	16.4	18.1	20.0	21.8	23.6	25.4									
1500		33000	8.1	9.3	10.4	11.6	12.7	13.9	15.0	16.2	17.3	18.5	19.7	20.8	23.2	26.0	28.9	31.8	34.7	37.6	40.5									
450		300	5500	1.2	1.4	1.6	1.7	1.9	2.1	2.2	2.4	2.6	2.8	3.0	3.1	3.5	3.9	4.4	4.8	5.1	5.6	6.0								
	500	9800	2.1	2.4	2.7	3.1	3.4	3.7	4.0	4.3	4.6	4.9	5.2	5.5	6.1	6.9	7.6	8.4	9.2	9.9	10.7									
	750	14550	3.2	3.6	4.1	4.5	5.0	5.4	5.9	6.3	6.8	7.2	7.7	8.1	9.1	10.2	11.3	12.4	13.6	14.7	15.8									
	1000	20700	4.5	5.2	5.8	6.6	7.1	7.7	8.4	9.0	9.7	10.3	10.9	11.6	12.9	14.5	16.1	17.7	19.4	21.0	22.6									
	1500	33000	7.9	8.2	9.3	10.3	11.3	12.4	13.4	14.4	15.4	16.4	17.5	18.5	20.6	23.2	25.7	28.3	30.8	33.4	36.0									
	500	300	5500	1.1	1.2	1.4	1.5	1.7	1.8	2.0	2.2	2.3	2.5	2.6	2.8	3.1	3.5	3.8	4.2	4.6	5.0	5.4								
500		9800	1.9	2.2	2.5	2.7	3.0	3.3	3.6	3.8	4.1	4.4	4.7	4.9	5.5	6.2	6.9	7.6	8.2	8.9	9.6									
750		14550	2.8	3.3	3.7	4.1	4.5	4.9	5.3	5.7	6.1	6.5	6.9	7.3	8.1	9.2	10.2	11.2	12.2	1										

**PROBLEMS**

Form to be used when recording data for illumination design problems:

Layout

Use _____	Ceiling Color _____
Location _____	Side Wall Color _____
Kind of Work _____	Luminaire _____
Ceiling Height _____	Mounting _____
Outlet Spacing _____	Room Index _____
Side Wall Spacing _____	Class of Equipment _____
Number of Outlets _____	Luminaire Efficiency _____
Foot-Candles _____	Utilization Factor _____
Area per Outlet _____	Maintenance Factor _____
Lumens per Square Foot _____	Coefficient of Utilization _____
Lumens per Outlet _____	Average Illumination _____
Lamp Size _____	Initial Illumination _____
Watts per Square Foot _____	

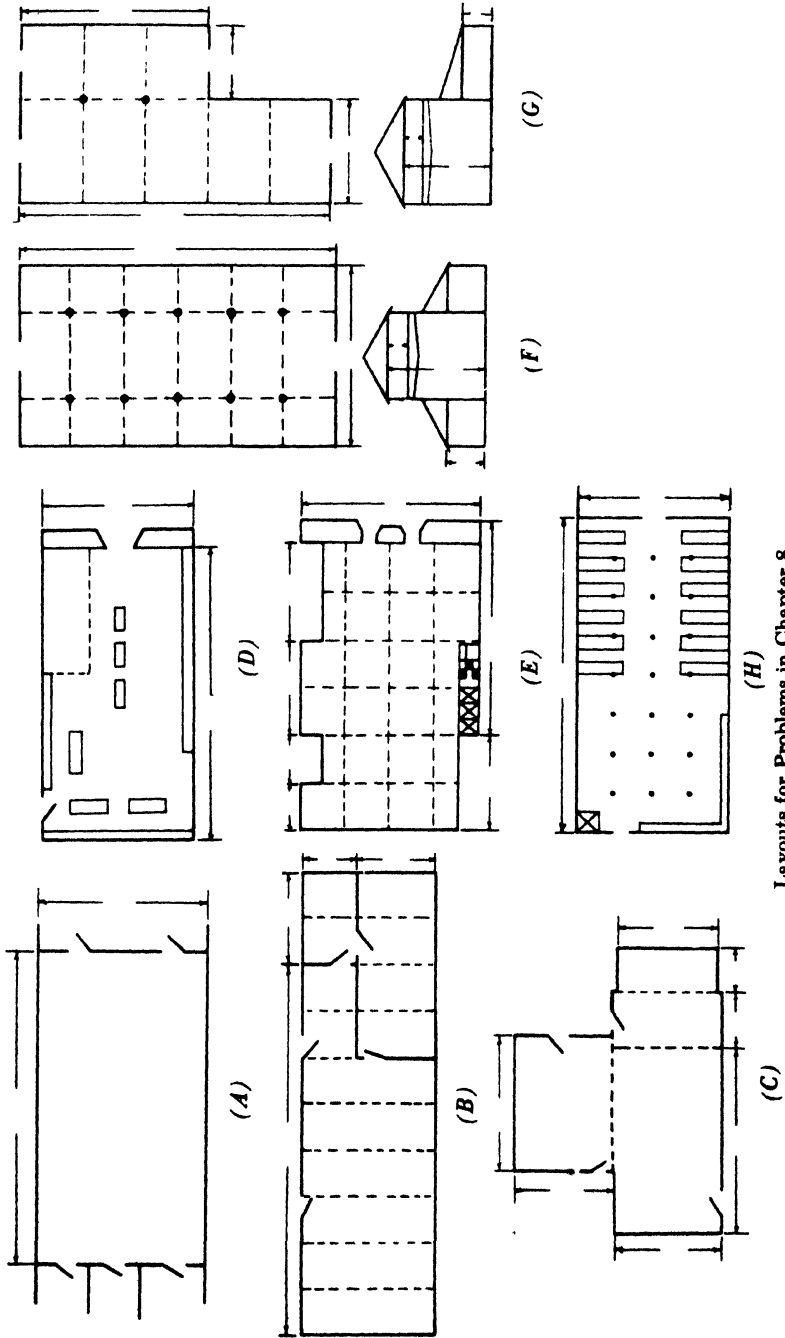

Layouts for Problems in Chapter 8.

1. Using layout *A* design the illumination for a general business office (unit 12 of Fig. 1-8A). The office is 60 ft. by 22 ft., and has a ceiling height of 13 ft. The ceiling is painted eggshell white and the side walls buff. Desks are along the walls.

2. Design fluorescent lighting for the office in problem 1, using a recessed troffer unit (*M* of Fig. 1-8B).

3. Using layout *B*, design the illumination for a school library (unit 15 of Fig. 1-8A). The library consists of the main reference room of six bays 20 ft. by 40 ft., and an entrance of two bays 20 ft. by 10 ft., a small reading room of two bays 20 ft. by 10 ft., and a cataloging room of four bays 20 ft. by 30 ft. The ceiling is 12 ft. high and painted a pearl gray; the side walls are painted medium gray.

4. Design fluorescent lighting for the library in problem 3, using the open-top unit (*J* of Fig. 1-8B).

5. Using layout *D*, design the illumination for a small hardware store 24 ft. by 46 ft. (unit 9 of Fig. 1-8A). There are wall shelves and counters in the room. The ceiling is 13 ft. and painted very light; the side wall is painted fairly light.

6. Design the fluorescent lighting for the hardware store in problem 5, using the lens unit (*C* of Fig. 1-8B).

7. Consider layout *E* for a ladies' apparel shop located in the theater district of a large city, using unit 21 of Fig. 1-8A. The ceiling is a matte white, the side walls ivory tan above a 7-ft. walnut wainscoting. The ceiling is 19 ft. 6 in. high and the bays are 25 ft. by 25 ft.

8. Repeat problem 7, using fluorescent lighting obtained by means of luminaire *E* of Fig. 1-8B.

9. The manufacturing plant represented by layout *F* uses the high-bay section for assembly work and the low bays for rough machine work. The high-bay portion is divided into 20- by 36-ft. bays, the low-bay portion into 20- by 20-ft. bays. The low bays are 14 ft. high and the high bays 34 ft., with the crane 9 ft. below the roof truss. The walls are of factory glass construction with white paint on glass-free surfaces. The ceiling is painted white. Determine the lighting design with unit 5 (Fig. 1-8A) in the high bay and unit 2 (Fig. 1-8A) in the low bay.

10. Design the low-bay lighting in problem 9, using RLM fluorescent unit *N* (Fig. 1-8B).

11. A turbine shop shown in layout *G* uses unit 6 (Fig. 1-8A) in the high bay and unit *N* (Fig. 1-8B) in the low bay. The high bay has 25- by 52-ft. bays, the low bay 25- by 25-ft. bays. The high bay is 40 ft. high and the top of the crane is 34 ft. from the floor; the low bay is 12 ft. high. Determine the lighting design if percentage of window area is large and the interior is finished in factory white. The craneway is used for medium assembly and the low bay is used for medium bench and machine work.

12. Layout *H* is for a women's cloak and suit factory and measures 54 ft. by 117 ft. 6 in. The elevator end is used for cleaning, pressing, finishing, and inspection. The other end is used for sewing machine benches. There are 8 machines per table. The ceiling is 12 ft. high, the walls fairly dark, the ceiling fairly light. Design the lighting, using unit 2 (Fig. 1-8A).

13. In a room 40 ft. by 50 ft., having a 12-ft. ceiling, fixture 2 (Fig. 1-8A) is mounted 11 ft. from the floor. The side wall has a reflection factor of 10% and the ceiling a reflection factor of 30%; results in an illumination of 10 ft-c.

when using a 500-w. lamp. In remodeling the store, fixture 9 (Fig. 1-8A) with a 300-w. lamp mounted 9 ft. from the floor, was chosen; the side wall was painted tan, and the ceiling a very light gray. If this change is made, (a) what will be the illumination when the system is operated initially, (b) what is the average illumination which may be expected?

14. Equipment 8 (Fig. 1-8A) has been chosen at a 9-ft. mounting; also ivory white for the ceiling with medium gray for the side wall and a 500-w. lamp for the fixture in redecorating and renovating an office 20 ft. by 30 ft. with a 12-ft. ceiling. What will be the resultant average illumination if the present measured conditions show 5 ft.-c., a side wall reflection factor of 15% and a ceiling reflection of 40% when using a 300-w. lamp in the fixture?

15. A classroom 37 ft. by 52 ft. and 17 ft. high uses a 300-w. lamp in a No. 8 (Fig. 1-8A) luminaire. The ceiling is fairly light and the side wall fairly dark, with a resultant illumination of 7 ft.-c. Using approximately the same wattage (as close as possible and still consistent with the wattage of fluorescent lamps), equipment O (Fig. 1-8B) is to be installed and the room is to be repainted with the ceiling an eggshell white and the side walls a satin green. What will be the improvement in illumination if the units are mounted 30 in. from the ceiling?

## BIBLIOGRAPHY

1. C. S. WOODSIDE, "Cove Lighting Design," *I. E. S. Trans.*, v. 31, No. 3, March, 1936.
2. J. L. STAIR and L. H. GRAVES, "Louvered Lighting," *I. E. S. Trans.*, v. 31, No. 3, March, 1936.
3. NELA PARK, "Illumination Design Data," *Bulletin LD-6A*, October, 1936.
4. W. E. FOLSON, "Control of Light with Louvers," *I. E. S. Trans.*, v. 32, No. 7, July, 1937.
5. J. M. KETCH and G. R. LA WALL, "Engineering Aspects of Direct Lighting, Part I — Louvered Systems," *I. E. S. Trans.*, v. 33, No. 6, June, 1938.
6. J. M. KETCH and L. G. GIANINI, "Engineering Aspects of Direct Lighting, Part II — Transmitting Systems," Annual Convention I. E. S., *Paper 32*.
7. WARD HARRISON, "Indirect Luminaires — Efficient and Inefficient," *I. E. S. Trans.*, v. 34, No. 3, March, 1939.
8. WILSON ROSEBRAUGH, "Design of Built-in Luminaire Constructions for Safe Thermal Operation," *I. E. S. Trans.*, v. 35, No. 3, pp. 203-217, March, 1940.
9. WILLIAM FOULKS, "Discussion — The Application of Continuous Source Luminaires," *I. E. S. Trans.*, v. 35, No. 9, pp. 786-794, November, 1940.
10. "Guide for Estimating Number of Lamps Required for 50 Footcandle Installations," *Mag. of Light*, v. 10, No. 1, p. 19, February, 1941.



## CHAPTER 9

### LUMINOUS ARCHITECTURAL ELEMENTS

The development of the use of luminous elements following the Century of Progress Exposition in Chicago marked a period of rapid transition in architecture. Where before the lighting was an accessory to the building, the luminous elements now became architecture itself. New light sources, new building materials, and new transmission media all aided in holding the interest of the designer. This marked a radical departure from the suspended light which was the normal source position from the beginning of the development of artificial light. The art of lighting having taken a new trend, cooperation came from every side: the designer could eliminate unsightly fixtures and develop individual treatments; the utilities found an outlet for more energy, and the client was willing to pay the additional price because of increased advertising value. With all these in accord, there is little doubt that luminous architectural elements are established as a permanent method of artificial illumination.

**1. Luminous Elements.**<sup>1, 2</sup> The luminous element may be used for either exteriors or interiors of buildings. In this connection, the new luminous store fronts of glass block construction, which is taking its place among the new media with which the architect may work, must be considered. The luminous element is essentially for custom-built installations as contrasted to the built-in boxes with translucent materials (discussed in Chapter 8). No general design data can cover all the variables encountered in the many designs; both the space limitations and the variety of materials introduce characteristics beyond the control of the designer. In general, an attempt is made to obtain a panel of uniform brightness, but if the depth is limited or the material is very translucent, a spotted effect will result. There are some typical forms which have been studied seriously and these forms are subject to design procedure. Others, however, must be designed by an experienced architect or illuminating engineer and, if possible, models should be tested. The methods reported for testing standard sections are equally applicable to specific models.

Though the major portion of the designs requires a uniform illumination of the panel, it is possible to design non-uniform elements when they are desired. The graduation of the brightness of the element surface is accomplished by reflector design and illumination of the element from one side. The character of the material used as a translucent cover will influence the character of light distribution.

The design of the usual luminous element may be reduced to a general lighting problem. The utilization factors for the various types (flush and projecting) are given in Table VI-7 (page 208), and the enclosed type has a higher maintenance factor (approximately 75 to 80 per cent) than the ordinary suspended luminaire. Luminous elements are of very low efficiency as compared with the customary types of luminaire (not more than 50 per cent for flush panels of highest efficiency). When the reflector is properly designed, efficiencies as high as 66 per cent can be obtained. In contrast with the procedure in a general lighting problem using luminaires, the designer does not adopt some manufactured unit for which brightness and efficiency is established, but actually designs the unit, thereby controlling both the efficiency and the brightness.

**2. Brightness of Elements.** The use of elements on the exterior is mainly for advertisement and, as such, must be prominent in comparison with the surroundings; at least the brightness contrast must be as high as is economical. Factors influencing the brightness are:

- a. Extent of pattern and size of element.
- b. Character of business — theaters need high brightness.
- c. Relative brightness in whole design, for emphasis requires more brightness — signs should always have a higher brightness than the surroundings.
- d. Character of surrounding lighting both as to size and brilliancy.
- e. Lower brightness is permitted if colored light is used.

Table I-9 gives the suggested brightness for various surfaces as to surroundings and materials of construction.

The brightness of the element in an interior is governed by the principles of good seeing. Glare and excessive brightness contrast must be avoided, and the illumination must be such that it will give enough light for the task that must be performed. At present, luminous architectural elements are still used for their particularly attractive effect, and are therefore more an element of display than of utility. In executing applications of luminous elements for interiors, the designer should keep in mind the following facts:

a. The higher the element is mounted the brighter it may be (as with luminaires).

b. Higher brightness may be used in passages and places where no close visual tasks are performed.

TABLE I-9  
SUGGESTED BRIGHTNESS VALUES FOR EXTERIOR APPLICATION

Type and Application of Luminous Element	General Brightness of District		
	Low	Medium	High
	Foot-Lamberts		
Decorative flush elements (principal units in design) (includes panels and recesses)	30-100	50-150	100-300
Decorative projecting elements (principal units in design)	50-130	70-170	150-300
Decorative elements (as spandrels and niches, particularly when subordinate elements in design)	30-60	40-80	50-150
Luminous background signs	90-150	120-200	150-350
Luminous letter stroke signs	150-200	200-400	300-600
Small luminous facades (as small entirely luminous store fronts and buildings)	80-120	100-150	120-200
Marquee and entrance soffits and marquee fascias	80-150	100-250	200-400
Luminous beams under canopies and marquees (restricted size, as for gasoline service stations)	150	250	400
Pylons (as for gasoline service stations, entrance markers, etc.)	100	200	300

TABLE II-9  
SUGGESTED BRIGHTNESS VALUES  
FOR INTERIOR APPLICATION

	Foot-Lamberts
Protruding ceiling elements, 20 ft. or more above floor	500
For elements in low ceilings, particularly in larger rooms (lower over mezzanine)	250
Wall panels or recesses in passages	200
Wall panels and niches not usually in line of sight	125
Decorative panels constantly in view	75

c. Because of direct glare, the larger elements cannot be as bright as small ones.

d. Care must be taken not to exceed the usual allowable brightness contrasts. In a well-lighted area, the element can be made correspondingly brighter. For equal glare effect, the illumination

must be increased 10 times to permit doubling the brightness of the element.

Table II-9 gives values for brightness which are advisable to use for luminous elements in specific locations. Note that where the element is to be viewed directly, the brightness is limited to 75 ft-L. (approximately 0.17 c. per sq. in.) which is far less than that allowed for luminaires because the area of the unit is greater by comparison.

**3. Materials.** The designer of luminous elements is interested in both translucent and transparent materials. Building materials themselves are of interest in the exterior; light terra-cotta, plasters, and porcelains (matte finished), as well as stone and concrete, have reflection characteristics following closely the cosine law, and they, therefore, appear to have equal brightness at every angle. Color is also important, for white surfaces and colored surfaces under artificial white light may be two entirely different media of expression. The use of stainless steel, monel metal, aluminum, and enameled steel for building material has given to the designer using light a means of producing effects far different from the older method of whitewashing which produced a sameness influenced only by the architectural treatment. By using the new materials and luminous elements, it is possible to produce in the same building or in buildings of the same design a variety of treatments providing special interest at night. The treatment may range from the elaborate and bizarre fronts on theaters and places of amusement to conservative treatments in keeping with more dignified places of business.

For the interior, there are even more materials from which to choose. Chapter 7 lists, in Tables I-7A and I-7B, various materials, both translucent and opaque, that may be embodied in luminous element design. Glazed and enameled materials supply high lights and glitter and, if properly arranged, have multiple reflections which hold interest through their novelty. Glazed and polished materials must be used judiciously, however, for there is a possibility of reflected glare that may be very annoying. The transmitting glasses are the most important of these materials and, of these, flashed opal, with its high efficiency and its uniform appearance, is best for useful as well as decorative light. This material gives maximum diffusion and efficiency. The flashed opal material made by the early manufacturing processes was not uniform but it is now obtainable in a degree of uniformity comparable to any other material except the plastics, which are excellent diffusing transmitters of light. Adjoining sheets of any material should avoid a marked difference in appearance or brightness.

and when it is necessary to replace broken elements, it is essential that duplicate material be obtained.

The use of grill work or glass with pressed designs is important in attractive lighting designs. The grill work tends to break the monotony of a large expanse of luminous surface. Pressed designs may be uniformly illuminated so that the difference of density in the thin and thick parts of the design are emphasized; or the design may be illuminated non-uniformly with the light at one side producing very interesting treatments which may be even more accentuated by the use of several colors. The colors will blend at various depths of the design.

For certain lighting results, onyx or alabaster in thin plates and marble with special cutting in structural weights make rich and appealing media for lighting effects. These materials may be carved to produce interest in both the unlighted and lighted state.

In using ground and roughened surfaces, the efficiency may be increased by turning the rough side toward the light. For day appearance the surfaces will appear whiter if the reflection factor is high. Materials which transmit light readily will have a gray appearance when not lighted. This appearance of the surface under daylight may make it necessary to select materials of lower light efficiency.

**4. Adaptation of Luminous Elements.** Modern design has tended toward mass, form, and line which is an ideal preparation for the adaptation of luminous elements to fit the architectural lines and produce patterns with brightness and color variation. Light in itself is an interest-producing agent and has been recognized as such from an early date. The addition of color to this is another step, and the advent of mobility introduced an interest which cannot be resisted by even the least observant individual.

The technique is new and therefore should be attempted only where there is a combination of both technical and artistic skill. The new forms appear as pylons, columns, pilasters, panels, parapets, spandrels, soffits, beams, coves, coffers, moldings, niches, and decorative panels. Structurally, the lighting equipment lies in cavities—recesses either open or enclosed. Proper provisions must be made for servicing and maintaining the element, and not infrequently the question of ventilation must be considered. The element can be so constructed that it can be opened at regularly spaced sections permitting access to all the equipment and the glass for cleaning. Large units may be serviced from catwalks above the equipment or through doors in the rear. Large pilaster installations have been serviced by

having the lighting equipment on belts which may be withdrawn for quick and easy access. This would be independent of the method of cleaning the glassware.

The design of luminous elements may be classified under:

- a. Luminous panels
- b. Luminous recesses or cavities
- c. Niche illumination
- d. Pylons and columns

These may be for permanent installations or for temporary use. The lobbies and rooms of bank and office buildings as well as stores will be of permanent construction and the materials are costly, whereas temporary decorations in dance halls, places of amusement, and expositions are built of cardboards, building board, and plastics placed upon wire mesh. Molded organic materials with or without wire mesh can be used outside as well as inside. Colored media called "cellophanes" are both tough and durable for temporary installations.

Luminous panels lend themselves to all forms of decoration; they are substantially a part of the wall and ceiling and may be very inconspicuous when not lighted. The elements should be a part of the general design, and provisions for the recesses should be made during the general construction. If enough depth is available, however, this type of unit may be installed at any time when remodeling is being done. The design of the lighting requirements will influence to some degree the element design. It would be very poor policy to have an architect place the element and design its general dimensions without considering the brightness of the surface when the unit is lamped for the desired illumination. If the lighting and architectural divisions will cooperate on the design, it is possible, by proper consideration, to produce a design correct in both appearance and lighting utility. The glass used will control the character and appearance of the installation; the cavity shape and finish, the spacing, and brightness of the unit will control its utility for comfortable seeing. Though uniform panels have been the general choice for more installations, it would be more desirable to obtain subtle and charming results with graded brightness and color by using high lights and introducing sparkle and shimmer. This method is as subject to good design as the more accepted method of uniform lighting. Beams, molds, and soffits belong to the panel type of element and are in some instances more easily applied to a remodeling design than the recessed panels.

Recesses and cavity luminous elements depend upon the wall or ceiling surface for redirected light. The cove may be classified under

this group. These are well adapted to supply a high illumination to a room. Coffers and recesses may be illuminated from the edges or from narrow opaque strips suspended from the recess, the method depending upon the architectural effect desired. The efficiency is affected by the form of the cavity, and the color of the recess, though providing architectural interest, is always accompanied with a lower light efficiency when the surface color is other than flat white. Color effects are produced with either painted recesses or colored lamps, and the efficiency is lowered about the same amount by either process.

The niche has always been used for architectural enhancement, and it becomes doubly effective if it is also illuminated. The illumination of the niche is for decorative purposes; therefore, it need not be very bright. The light, if not too bright, will give added interest to the background, statuary, or grills which may be used in its design. Those materials (glass rods, frosted tubes, molded sections, and crystal arrangements) which are not commonly used for a niche may become of prime importance when light is used. If the niche is to contain statuary, ship models, flowers, or other three-dimensional forms, the lighting must be so designed that it will be properly directed to produce the effect desired.

Pylons, columns, and pilasters create a luminous atmosphere in the room. Whereas the recess and panel type of lighting may go unobserved by the casual individual, this not is true of the lighted element directly in line with the eye. The light is present and recognized as such. Since these elements are usually made an object of beauty in themselves, recent expositions have used them along walking and driving lanes and in courts between buildings. Pylons (both in interiors and exteriors) may be used to hide the installation of indirect or floodlighting systems.

**5. Element and Lamp Spacing.** The lamp spacing will depend upon whether the element is to have a uniform or a graduated brightness. If the unit is to have uniform brightness the lamps are spaced 1.5 times the distance of the filament behind the glass in any direction (width or length). Variation from this rule will be according to the curves given in Fig. 1-9, for various types of glasses have different properties of diffusion. Where the lamps are placed in opaque (silhouette) troughs or small coves along the recess, the spacing for the lamps thus concealed, as well as the distance between the troughs, should obey the same law.

To produce a graduated brightness it is only necessary to shape the reflecting surface correctly and space the lamps with respect to the

reflecting surface. A great variety of effects may be obtained by this process, but the resultant illumination in the room may be calculated just as it would be for the uniform unit. If it is desired to produce uniform brightness in one direction and shaped distribution in the other, the lamps are placed so that the spacing is controlled in the uniform direction and the surface produces the graduated brightness.

In spacing the architectural luminous element in a room, the general rule of a spacing not in excess of 1.5 times the mounting height should be used (Table I-8, page 224). Even though the advantage of luminous elements lies in the individual and intimate treatment as required for the different areas and the layout is principally concerned with architectural harmony and appearance, the arrangement and

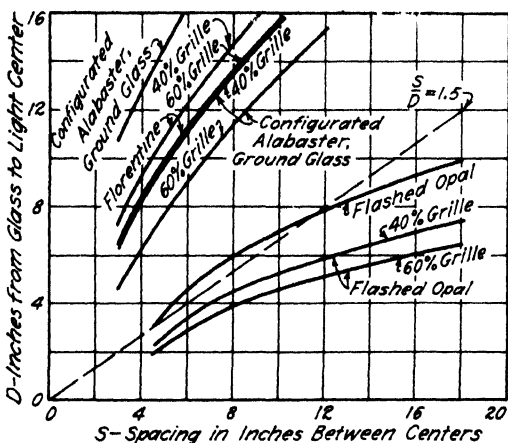

Fig. 1-9.<sup>1</sup> Lamp spacing for acceptable uniformity of brightness.

spacing of the elements should produce approximately uniform lighting for the visual requirements which must be met. Even with proper spacing it is difficult to obtain uniform lighting from wall panels or lighted columns and pilasters, the ratio of minimum to maximum lighting being from 0.58 to 0.005. If the distance between element and work is increased or if rectangular instead of circular elements are used, the illumination becomes more nearly uniform.

**6. Design of Luminous Elements.** The design of the luminous element itself is a problem distinct and separate from the design of the installation in the room. The installation is designed as in any general lighting system, spacing being determined from Table I-8, and the flux method being used after determination of the utilization factor. Just as with light boxes, the efficiency of the unit itself is the variable which is the most doubtful.



Three computations must be made to determine the unit to use for delivering a specific average illumination upon the work surface. They are:

$$\text{fixture lumens} = \frac{\text{foot-candles} \times \text{floor area}}{\text{utilization factor}}$$

which gives the amount of light flux leaving the element:

$$\text{lamp lumens} = \frac{\text{fixture lumens}}{\text{efficiency} \times \text{maintenance factor}}$$

which gives the light flux the lamps must furnish:

$$\text{luminous area in square feet} = \frac{\text{fixture lumens}}{\text{foot-Lamberts}}$$

In order to control the brightness of the element, its area must be considered. The area combined with the length of the element gives the width and establishes the lamp spacing and the general element design. The utilization factor, the needed foot-candles, the element brightness, and the maintenance factor are all obtained from tables and only the efficiency must be determined for each specific installation. The efficiency will depend upon the following factors:

- a. Transmission factor of cover glass
- b. Reflection factor of the reflector
- c. Contour of the reflector

These will be discussed in detail, because it is necessary to understand the influence of each factor to determine the limits of variation that may be used in a design.

Directly, the transmission of the cover glass is one of the important factors influencing the efficiency of the unit, but it must always be considered in conjunction with the effect desired. The complete removal of the glass leads to the highest efficiency, just as a bare lamp source is more efficient than any type of enclosing glassware, but both the appearance and the comfort must be considered as well. Figure 2-9a shows the variation of efficiency with transmission, and Fig. 2-9b shows the maximum-to-minimum-brightness ratio with respect to the location of the filament with the glass surface. Figures 2-9c and 2-9d give a method for approximating rapidly the size of lamp that may be used in tentative calculations. From Fig. 2-9c the brightness factor may be determined; this, when used with the foot-Lamberts and the area of the translucent material (in square inches per lamp), gives the approximate lamp size for normal conditions. This method should be used for preliminary determinations or approximations; otherwise the flux method should be used.

The reflection factor and shape of the reflector will influence the efficiency of the unit. Figure 3-9 shows the effect of the reflection

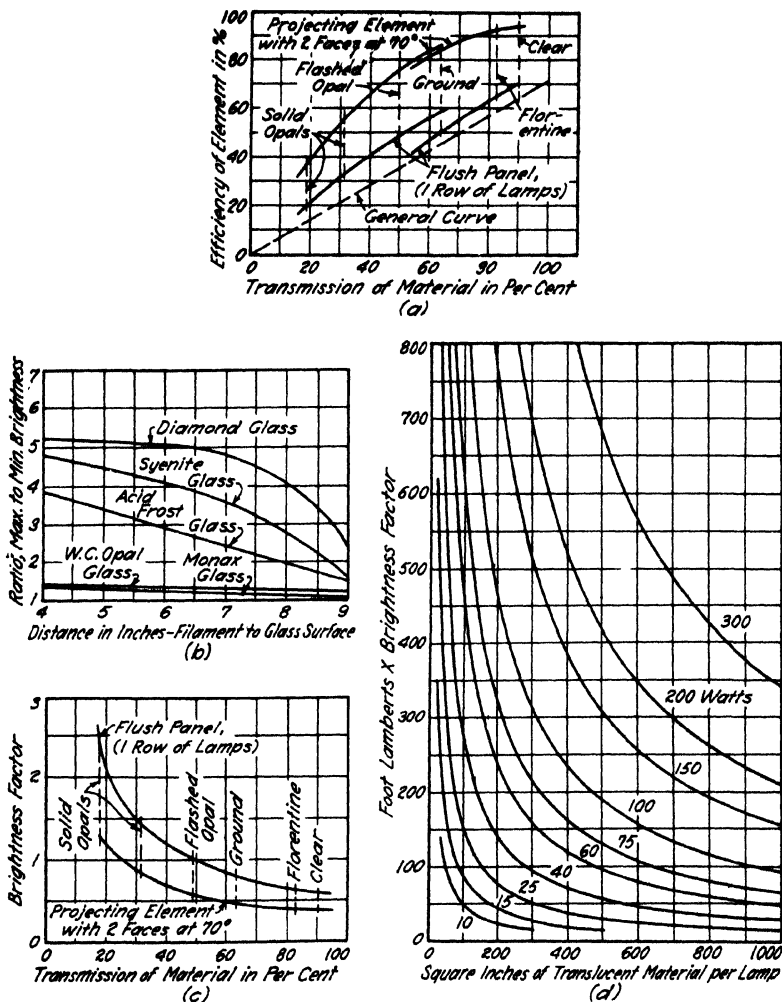
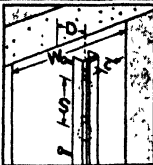
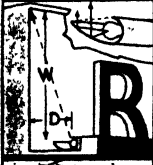
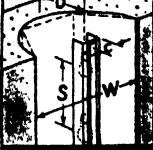
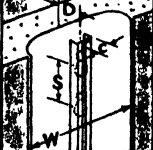
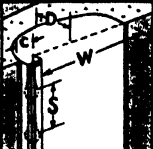
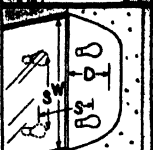
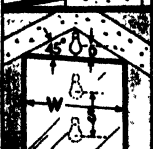

FIG. 2-9.<sup>1,2</sup> (a) Efficiency of translucent materials for several degrees of diffusion. (b) Diffracting glasses show a greater degree of variation in brightness ratio than opal glasses. (c) Brightness factor for translucent materials of several degrees of diffusion. (d) Area-wattage-brightness relation for diffusing elements.

factor of the reflector upon the efficiency when different types of cover glass are used. The contour after a test made with flashed opal glass showed:

TABLE  
ELEMENT FORMS AND EF-

TYPE OF ELEMENT	Dimensional Ratios	REFLECTION OR TRANSMISSION FACTOR						
		0.20	0.30	0.40	0.50	0.60	0.70	0.80
1	 <p>D = 0.33 W S = 0.50 W S = 1.5 D A = (W - C) S</p>	ELEMENT EFFICIENCY						
		8	12	16	20	24	28	32
2	 <p>D = 0.25 W S = 0.56 W S = 2.25 D A = WS</p>	ELEMENT EFFICIENCY						
		7	10	13	17	20	23	27
3	 <p>D = 0.5 W S = 0.95 W S = 1.9 D A = (W - C) S</p>	ELEMENT EFFICIENCY						
		12	17	23	28	34	40	46
4	 <p>D = 0.17 W S = 0.25 W S = 1.5 D A = (W - C) S</p>	ELEMENT EFFICIENCY						
		10	15	20	25	30	35	40
5	 <p>D = 0.33 W S = 0.33 W S = D A = (W - C) S</p>	ELEMENT EFFICIENCY						
		7	10	13	17	20	23	27
6	 <p>(For 2 rows of lamps) D = 0.33 W S = 0.50 W S = 1.5 D A = 0.50 WS</p>	ELEMENT EFFICIENCY						
		25	35	44	51	56	61	65
7	 <p>D = 0.40 W S = 0.60 W S = 1.5 D A = WS</p>	ELEMENT EFFICIENCY						
		26	37	46	54	60	66	70

III-9

EFFICIENCIES IN PER CENT

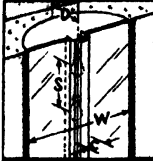
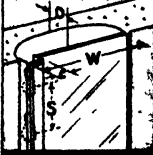
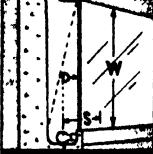
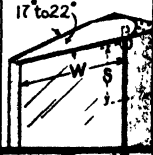
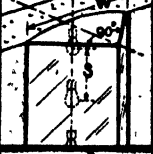
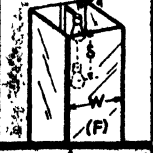
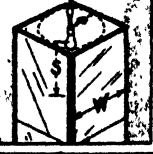
TYPE OF ELEMENT	Dimensional Ratios	REFLECTION OR TRANSMISSION FACTOR						
		0.20	0.30	0.40	0.50	0.60	0.70	0.80
 <p>8</p> <p><math>D = 0.33 W</math>  <math>S = 0.66 W</math>  <math>S = 2 D</math>  <math>A = (W - C) S</math></p>	ELEMENT EFFICIENCY							
	13	17	21	25	29	33	37	Indirectly-lighted transilluminated elements of this character may use any type of translucent material, the choice being governed by the unlighted appearance, texture and efficiency
 <p>9</p> <p><math>D = 0.17 W</math>  <math>S = 0.30 W</math>  <math>S = 1.8 D</math>  <math>A = (W - C) S</math></p>	ELEMENT EFFICIENCY							
	8	12	15	17	19	20	21	A graduated brightness will be obtained by a single trough located on one side; uniformity if lamps are placed at each side with the ratios as given. See No. 8.
 <p>10</p> <p><math>D = 0.10 W</math>  <math>S = 0.20 W</math>  <math>S = 2 D</math>  <math>A = WS</math></p>	ELEMENT EFFICIENCY							
	13	20	26	31	35	38	40	With highly diffusing translucent materials, the contour of the reflecting background is unimportant. With less diffusing materials, the shape affects the graduation of brightness as does the angle of view.
 <p>11</p> <p><math>S = 0.40 W</math>  <math>A = 2 WS</math></p>	ELEMENT EFFICIENCY							
	24	35	45	51	—	—	—	Wedge-type elements use a polished aluminum parabolic trough reflector with lamps centered at focus. The slight graduation of brightness (approximately 2 to 1) with cased opal glass sides maintains an effective luminous background for sign letters or decorative patterns.
 <p>12</p> <p><math>D = 0.36 W</math>  <math>S = 0.54 W</math>  <math>A = 1.43 WS</math></p>	ELEMENT EFFICIENCY							
	33	45	55	65	73	79	83	Lamps should be centered on a line equidistant from both sides; in larger units the shallow cavity may be eliminated.
 <p>13</p> <p><math>D = 0.50 W</math>  <math>S = 0.75 W</math>  <math>A = 3 WS</math></p>	ELEMENT EFFICIENCY							
	41	55	66	74	80	84	86	Lamps should be centered in the square cross-section. Efficiencies apply to the complete element but the face (F) will be about 25% brighter than the sides when highly diffusing material is used.
 <p>14</p> <p><math>D = 0.50 W</math>  <math>S = 0.70 W</math>  <math>A = 4 WS</math></p>	ELEMENT EFFICIENCY							
	49	64	76	83	87	90	92	Lamps should be centered in the column whether the cross-section is square, circular, or of other form. Lamps should be positioned as shown to avoid socket shadows and conduit risers should be brought up in one corner or on an inconspicuous side.

Flush elements — Class G, Table VI-7, MF 70%.

REFLECTOR SECTION	EFFICIENCY
Rectangular	47%
Truncated cone	49%
Circular	50%

a 3 per cent difference caused by contour alone.

Table III-9 shows 14 typical designs, giving the element efficiency based on the section form. A 75 per cent reflection factor is assumed for the cavity used with the transmission factor of the cover glass. Other forms may be estimated by comparing with these standards, but the size of the element will not seriously affect the end results.

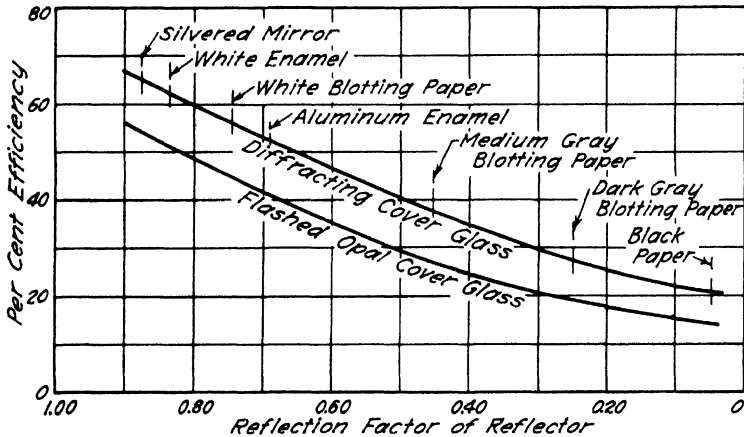

FIG. 3-9.<sup>1</sup> Relation between reflection factor of reflector and efficiency of the unit.

The proportions of the element are given on the diagrams and lettered as:

- $W$  = width of the element
- $D$  = distance from the filament to the surface
- $S$  = spacing between light centers of the lamp
- $A$  = luminous area per lamp

and if there is a deviation from the per cent reflection factor of the cavity, correction can be made according to the following:

REFLECTION FACTOR OF CAVITY SURFACE	RELATIVE BRIGHTNESS AND EFFICIENCY
0.85	122%
0.75	100%
0.50	63%
0.25	40%

The use of the table is best demonstrated by the solution of a typical problem.

*Example a.* Design the illumination for the hat department in a department store situated in a small town. The luminous element is to be similar to Type 12 (Table III-9) with a 70° instead of a 90° angle. Use flashed opal glass (65% transmission factor). The room measures 75 by 125 ft., is 18 ft. high, and has a cream ceiling and tan side wall. The brightness of the element must be approximately 250 ft.-L. (Fig. 4-9 shows sketch.)

Cream (reflection factor)	70%	Table IV-7
Tan (reflection factor)	35%	Table IV-7
Foot-candles (general light)	15	Table III-3A
Room index	2.5	Table III-7
Maintenance factor (class N)	75%	Chapter 8
Utilization factor (class N)	55%	Table VI-7

$$\text{fixture lumens} = \frac{15 \times 75 \times 125}{0.55} = 255,682 \text{ lumens}$$

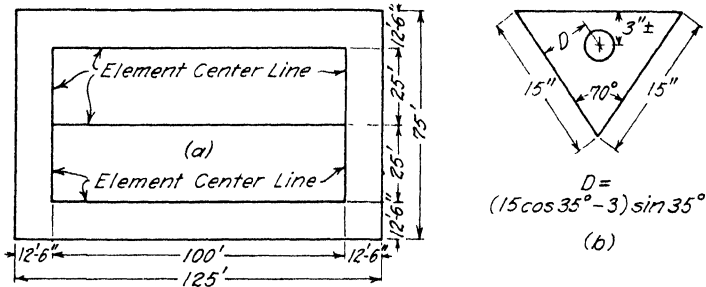

FIG. 4-9. Figure for problem in luminous elements.

The efficiency of the unit is obtained from Table III-9. Type 12, with a 65% transmission factor for the glass, gives an efficiency of 76 %.

$$\text{lamp lumens} = \frac{255,682}{0.76 \times 0.75} = 448,565 \text{ l.}$$

$$\text{luminous area (square feet)} = \frac{255,682}{250} = 1022.7 \text{ sq. ft.}$$

$$\text{width of element glass} = \frac{1022.7}{400} = 2.56 \text{ ft. or } 30.7 \text{ in.}$$

The glass will be 15 in. on a side, or a total of 30 in. wide. This will increase the brightness slightly.

By construction or by calculation, *D* (Fig. 4-9b) may be determined (Type 12, Table III-9):

Construction:  $D = 5.33 \text{ in.}$

$$S = 1.5D \quad S = 1.5 \times 5.33 = 7.995 \text{ in.}$$

Use an 8-in. spacing for lamps.

$$\text{number of lamps} = \frac{400 \times 12}{8} = 600$$

$$\text{size of lamp in lumens} = \frac{448,565}{600} = 747$$

Required:

a 60-w. lamp (835 l.)

$$\text{Watts per square foot} = \frac{60 \times 600}{75 \times 125} = 3.84 \text{ w.}$$

$$\text{Average illumination: } \frac{835}{747} \times 15 = 16.8 \text{ ft-c.}$$

$$\text{Average brightness: } \frac{30.7}{30} \times \frac{835}{747} \times 250 = 286 \text{ ft-L.}$$

These computations have been made on the assumption that the filament is 3 in. from the surface. If the determination of the lamp size shows this to be mechanically wrong another calculation must be made to correct the error. Seldom does the solution of a problem determined by the first calculation satisfy all conditions.

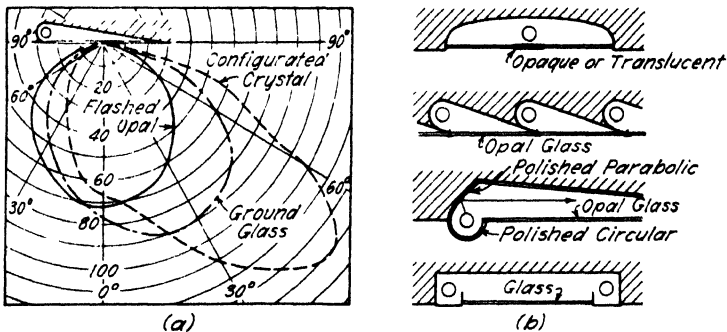

FIG. 5-9.<sup>2</sup> (a) How candlepower varies with angle of view for various glasses. (b) Forms of non-uniform lighted luminous elements.

Figures 2-9c and 2-9d are for rapid checking and computing, for normal conditions of maintenance, of the brightness, brightness factor, the surface per lamp as given. As when similar computing methods are given, this is not for final determinations but for preliminary computations.

**7. Special Elements.** The non-uniform brightness element has been discussed before, and Fig. 5-9a shows how the candlepower varies with the angle of view for various cover glasses. It is not necessary to have the usual uniform illumination without spotty effects, unless it is of value, because multiple rows of lamps, when placed close to the glass and staggered, will produce a latticed effect. It may be necessary, whenever the glass contains etchings or is molded, to produce the correct spotty lighting by arrangements of lamps. Again, where a spotty

element does occur, because of space limitations, it may be removed by the use of decorations or grills separating the regions of high brightness contrast. Figure 5-9b shows some types of cavities which may be used for interesting gradation and shading of brightness across the panel. The edge lighting of carved glass or molded sections should be considered for its ornamental value, for the pattern is revealed in high lights.

Figure 6-9 shows typical arrangements of special elements for effective illumination, and the variations in shape and material of the backgrounds offer an unlimited range of effects in recessed elements. For small channels, tubular, lumiline, and the new fluorescent lamp are possible solutions.

**8. Glass Blocks.** Glass blocks as a building material have reached considerable importance in the last few years. Their use provides a unique combination of simplicity of form and a textural richness which greatly increases the designing possibilities for commercial interiors as well as for factory lighting. They have been suggested for partition walls in office buildings and, as such, are considered as a light-transmitting partition. As building material, there are claims of sound insulation, heat insulation, and wind resistance, but the illuminating engineer is interested in their properties for the control of light. The blocks are made of crystal glass with the greater portion of the surface available for the transmission of light. The transmission of light through a glass block is similar to that of some of the configurated glasses. It will depend upon the direction in which the light strikes the block, the pattern on the block, the width of the joints, and the thickness of the blocks. Clear blocks will transmit from 50 to 70 per cent of the incident light, and configurated blocks from 40 to 75 per cent. Table IV-9 shows the measurements of the transmission of various patterns as given by the manufacturer; other materials are given for a relative check on the transmission factors. The apparent brightness, when viewed directly, is 12 per cent less than that of window glass. When the blocks are assembled in a wall or partition, there is a reduction of the transmission area caused by the cement and structural support, and this causes a lower transmission factor for the assembled wall proportionate to the useful surface in the wall (see Walette; Table IV-9).

There are some things that must be considered in the use of glass blocks. They do not form a window, and ventilation must be provided elsewhere. There is also a question of whether a window is not as useful to see through as for admitting light. If blocks are to be



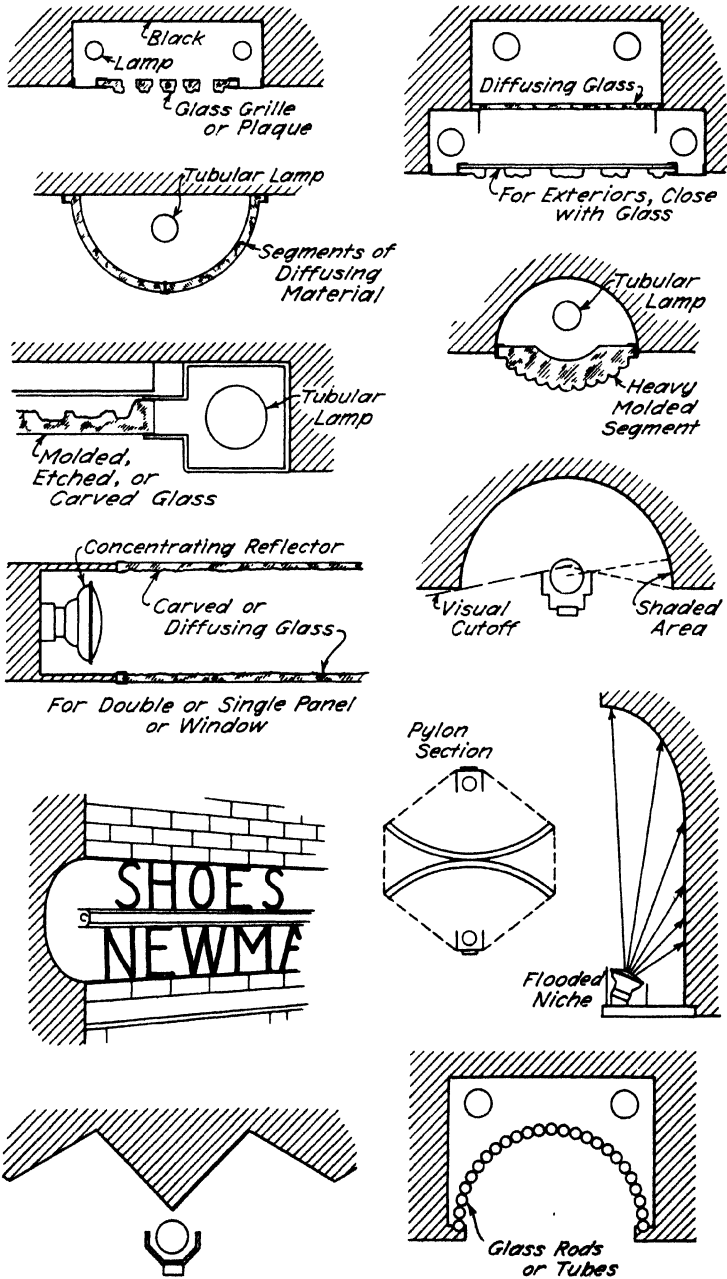

FIG. 6-9.<sup>2</sup> Special forms of luminous elements.

used for obscuring vision into a space, the patterns must be such that even the silhouette is eliminated, and this lowers the transmission considerably. Regardless of how much the transmission is lowered, within reason, direct sunlight upon glass blocks causes an uncomfortable glare in the interior and it is, therefore, necessary to use some means of shading the light. If, because of the pattern design or because of variations in manufacture, focusing beams of light are pro-

TABLE IV-9  
TRANSMISSION FACTORS FOR GLASS BLOCKS

Classification	Catalog
Owens-Illinois Glass Company	
Pattern: 1	78.5%
2	73.4%
3	27.6%
5	11.7%
7	84.4%
11	86.5%
16	84.4%
17	84.0%
Pittsburgh Corning	
Pattern: Decora	73.5%
Argus	74.2%
Special	59.0%
Wallette (2 ft. square) of Argus Blocks	51.5%
Plate Glass	80-90%
Flashed Opal	55-70%
Configurated	75-80%

duced, the beams may ignite window shades or any material upon which they are focused.

The glass blocks may be made up in the form of luminous elements with incandescent lights behind them. In this instance, they may be treated as corresponding to the general forms given in Table III-9. It is the transmission factor of the structure which will determine the efficiency of the unit for calculations. Where these elements are used for either exterior or interior luminous elements, they are used essentially for attraction rather than task illumination. The efficiency should be determined for the type of installation, using the transmission as determined from available information which is satisfactory.

The glass blocks are available for use in some of the following locations:

1. Interior decorative work in restaurants, bars, cafeterias, and commercial display rooms.
2. In residences for daylight lighting and architectural interest at night.
3. Light panels in modernizing and in installing air conditioning.
4. Store fronts, bulk heads, cellar illumination, and floodlight effects from interiors.
5. Bands and panels in all forms of commercial installations.
6. Corridor walls, partitions, and inner building construction.

Wherever used for task illumination, large surfaces presented by glass blocks diffuse shadow, but at the same time produce irritating glare because of the large expanse of lighted surface in the line of vision. Because of this large expanse of illuminated surface, the brightness should never exceed 75 ft-L. If color is used in conjunction with the blocks, the proper amount of attraction and interest may be obtained with very low brightnesses.

To light glass blocks properly, consideration should be given to structural requirements. The purpose of the lighted wall will determine the nature of the structure, but at best the daylight obtained from a block wall will have to be supplemented by artificial light on the side of the room farthest from the wall. If the wall is used for decoration, consideration need seldom be given to natural light.

#### **WHERE DAYLIGHT TRANSMISSION IS UNNECESSARY**<sup>10</sup> (See page 275)

A. The use of show-window reflectors to light a furred-out wall. Concentrating reflectors are mounted in the cavity above the top course of blocks. This is done to eliminate objectionable brightness of the top course. Reflectors are placed on 6- to 9-in. centers. The cavity should be from 6 to 12 in. deep.

B. A paracyl reflector used to supply light provides an excellent distribution of light on the background of a shallow recess. The cylinder part redirects the light from the lamp back to the optical axis, and the parabolic section produces a concentration of light in a plane at right angles to the optical axis of the reflector. By recessing the cylindrical portion of the reflector above the glass blocks, the space between the glass blocks and background may be kept to 4 in.

C. On a furred-out wall, individual reflectors for each block will provide a uniform brightness. Bare lamps or small individual reflectors may be used. The general rule of spacing at 1.5 times the depth of the filament behind the block should be used.

D. The illumination of a corrugated metal reflecting background of parabolic shape may be used for panels from 3 to 15 ft. in height.

*E.* A flat surface painted white may be used as a background. This surface should be pitched or curved for an even distribution of light. This scheme is good for panels from 3 to 10 ft. in height. This gives a more diffused light than *D*, but lacks the sparkle produced by the specular corrugated background.

*F.* A method to use if the wall or panel is more than 10 ft., as shown in *E*. The vertical background is lighted with reflectors installed on both sides of the panel, and will illuminate the blocks evenly

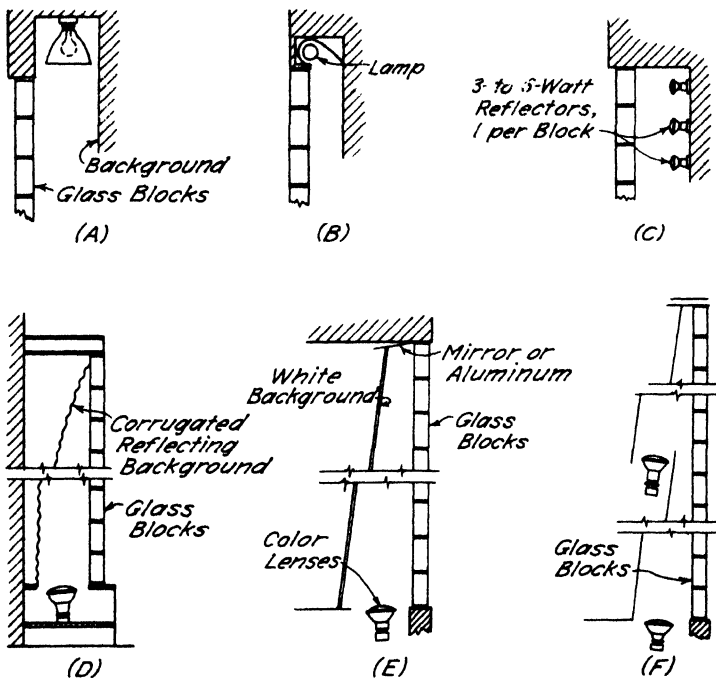

to any desired height. The distance between the glass blocks and the background should be at least 8 in. or increased according to the height of the glass panel.

**DAYLIGHT TRANSMISSION AND NIGHT EFFECTS<sup>10</sup>** (See page 276)

*G.* A free-standing wall may be illuminated with show-window reflectors protected by louvers. In these situations, a relatively dark background must be assumed unless the building is lighted at night. As in show windows, the reflectors are mounted on approximately 12-in. centers. If the room is lighted, the wall has a better appearance.

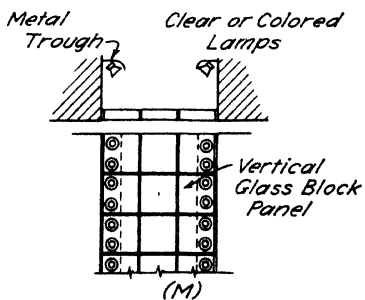
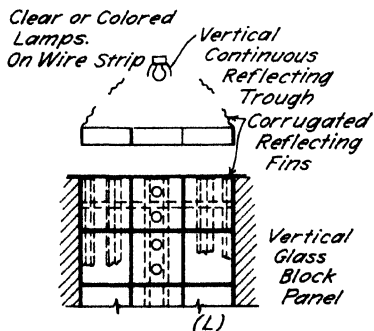
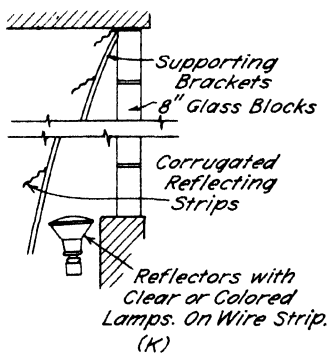
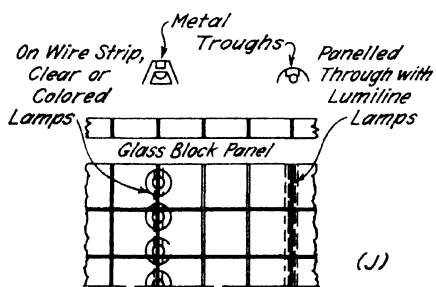
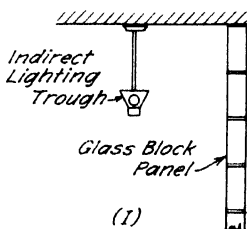
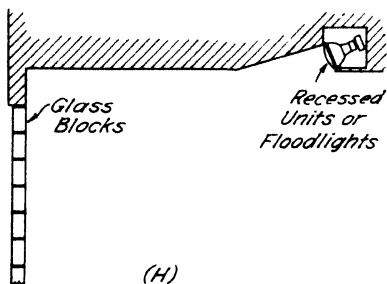
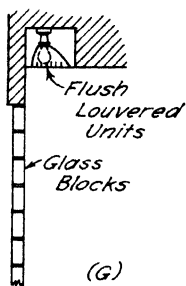

*H.* The inner wall of glass blocks may be floodlighted. The design of the block determines the number of floodlights that is necessary. The finer the rib, the better the pick-up of light, and the fewer units needed.

*I.* Indirect lighting equipment, such as a trough or luminaires installed near the glass blocks, will provide a uniformly illuminated ceiling area which will serve as a luminous background.

*J.* Direct rather than reflected light is recommended where the block pattern is of a diffusing rather than a decorative type. The illumination is obtained from vertical light strips with reflectors. The lamps should be from 18 to 24 in. from the blocks and the strips 24 to 36 in. apart. The design should follow the luminous element design in general.

*K.* Reflector louvers may be used to redirect the light. A series of corrugated reflecting fins can be so arranged that they form a minimum obstruction to daylight and at the same time prevent spilling of light from reflectors upon the ceiling or wall of the room. The metal supporting members can be spaced approximately 6 ft. apart. Venetian blinds will serve the same purpose.

*L.* A reflector section with corrugated metal strips leaving openings for the daylight to pass through may be used. The wattage of the lamp depends on the panel width and the block brightness desired. The equipment can be supported by structural members spaced about 6 ft. apart.

*M.* Narrow panels may be illuminated rather uniformly by border lighting. This method can be used on larger panels with the same effect produced as in other types of luminous element lighting. The equipment can be of the same type used for lighting show windows. In this type of lighting, lumiline lamps and fluorescent lamps may be used.

#### COLUMNS, PILASTERS, AND TOWERS<sup>10</sup> (See page 278)

*N.* When there is access to the lamps from the back, type (a) installation may be used. If this is impossible, an installation with a cover as shown in (b) will be satisfactory. Here again will be found use for lumiline and fluorescent lamps. Where color is used, the last are the most economical.

*O.* Towers and columns may be illuminated from within. The methods will vary according to the size and structural characteristics of the tower or column. The lighting equipment must be far enough back of the glass blocks to give a uniform appearance.

Regardless of the type of lighting installation used, the background influences the appearance. White backgrounds, though they give an

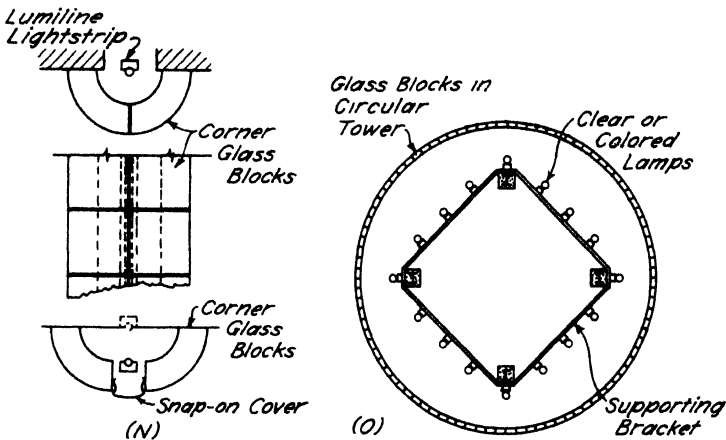

even distribution of light, give a very uninteresting appearance to the wall. The white-painted reflector may be given interest by scattering coarse metallic particles on the fresh paint; this adds life to the glass

TABLE V-9

SUGGESTED AVERAGE BRIGHTNESS VALUES

Store Front	Brightness Foot-Lamberts		
	Low	Medium	High
District Brightness			
Store fronts, transoms, backgrounds, signs	80-150	100-250	200-400
Projecting units:			
Dominant character	30-100	50-150	100-300
Subordinate character	30-60	40-80	50-150
Decorative flush units:			
Dominant character	50-130	70-170	150-300
Subordinate character	30-60	40-80	50-150
Translucent letters:			
Opaque background	150-200	200-400	300-600
Marquees, pylons, gasoline service stations	80-150	100-250	200-400

blocks. Corrugated reflecting surfaces, if specular in finish, add sparkle to the installation. When decorative effects are desired, painted designs and colored lighting can be used for numerous variations.

**9. Luminous Store Fronts.** Another use of the luminous element is the store front which, because of its additional attractive power for sales, has become an important factor in the design of the building. Whereas the only important lighting problems were formerly confined to the interior, the advertising power of light in intensity, color and combinations of color, and mobility has made the exterior of considerable importance.

The standard arrangements in Table III-9 can be used in signs and on store fronts, and the design will follow the practice described in Art. 6. The recommended brightness is given in Table V-9.

The lamp size for colored material must be increased in proportion to the transmission factor of the glass if equal brightness is desired. For the various colored materials the following recommendations are made for specific colors:

COMPARED FOR DESIGNS USING WHITE GLASS

Same as White	Lamp Size One Larger than for White	Lamp Size Two Larger than for White
Ivory	Pastel green	Irish green
Yellow	Sea green	Dark green
Bright yellow	Apple green	Dull green
Light orange	Light blue	Medium blue
Deep orange	Baby blue	
Chinese red		
Brilliant red		
Bright red		

The increase necessary may be from 1 to 5 times the wattage required for white glass and for general specifications:

Amber	1.5	Green	3.0
Red	2.0	Blue	5.0

The installation of large surfaces of glass in the elements becomes a problem in safety and weatherproof installations. The glass used must be shock resisting; tempered glasses are favored because they will withstand the shock caused by sleet or cold rain striking a hot glass surface. These glasses are safe because, if for any reason they do break, they immediately disintegrate into small crystal pieces which will not cause injuries if they fall upon pedestrians in front of the store. Since the glass store front must be supported by structural webs, these should be of special types, designed for this service and pleasing in appearance. They should also be waterproof and should not cast objectionable shadows.



## PROBLEMS

Form to be used when recording data for luminous element design:

Layout

Use _____	Ceiling Color _____
Location _____	Side Wall Color _____
Kind of Work _____	Element Number _____
Ceiling Height _____	Element Brightness _____
Foot-Candles _____	Lamp Lumens _____
Room Index _____	Luminous Area _____
Class of Equipment _____	Width of Unit _____
Utilization Factor _____	Number of Units _____
Total Area _____	Length of Unit _____
Fixture Lumens _____	Depth-Light Center _____
Transmitting Media _____	Space-Light Center _____
Transmission Factor _____	Number of Lamps _____
Brightness Factor _____	Size of Lamp _____
Unit Efficiency _____	Average Foot-candles _____
Maintenance Factor _____	Average Unit Brightness _____
Watts per Square Foot _____	

1. A glass block wall is made up of sections of Element No. 6., 24 in. wide. The wall is to have a brightness of 80 ft-L. and the glass block has a transmission of 27.6%. Design the proper lighting for the element. Use incandescent lamps.
2. Repeat the design in problem 1 using fluorescent lamps.
3. Using Element No. 10, design the background for a sign to have a brightness of 40 ft-L. The sign is 30 in. high and 12 ft. long. High-transmission opal glass is to be used for the background.
4. Design the luminous element for a hallway 12 ft. wide and 80 ft. long with a 12-ft. ceiling. The ceiling is very light and the side walls are fairly light. Use Element No. 4 with a 70% reflecting surface and an element brightness not to exceed 250 ft-L.
5. In problem 4 modify the design to use wall panels made up like Element No. 8 with flashed opal glass (low transmission) and having a brightness of 125 ft-L.
6. Design the illumination for a small hat store 20 ft. by 30 ft. with an 11-ft. ceiling. The side walls and ceiling are very light in treatment, and Element No. 3 painted with a 75% reflection factor paint is used.
7. A 24-in. wedge-shaped sign similar to Element No. 11 is to be illuminated to 60 ft-L. and the letters are painted on clear matte composition glass. Design the unit and specify an incandescent installation.
8. A ballroom 300 ft. by 200 ft. with a 20-ft. ceiling is to be illuminated with Element No. 4. The ceiling is primrose and the side walls are bronze. The luminous elements are to be arranged in the form of squares on the ceiling. Design the element and use fluorescent lamps for obtaining the illumination.
9. Design the illumination for problem 8 using luminous light panels of Element No. 8 with a heavy flashed opal glass and incandescent lamps.
10. A luminous pylon 21 in. on a side and of a type similar to Element No. 14 is to be used for a sign at a filling station. Design the element to 40 ft-L. brightness using blue fluorescent lamps. The pylon is to be built of Argus type glass blocks. Letters will be silhouetted against the background.

## BIBLIOGRAPHY

1. E. W. BEGGS and C. S. WOODSIDE, "Technical Aspects of Architectural Lighting," *I. E. S. Trans.*, v. 26, No. 10, December, 1931.
2. W. M. POTTER and P. MEAKER, "Luminous Architectural Elements," *I. E. S. Trans.*, v. 26, No. 10, December, 1931.
3. H. H. HIGBIE and W. A. BYCHINSKY, "Illumination Distribution Measurements from Surface Sources in Sidewalls," *I. E. S. Trans.*, v. 29, No. 3, March, 1934.
4. H. L. LOGAN, "The Influence of Built-in Lighting Forms on Direct Lighting Methods," *I. E. S. Trans.*, v. 29, No. 8, September, 1934.
5. C. S. WOODSIDE, "The Illumination of Structural Glass," *I. E. S. Trans.*, v. 29, No. 10, December, 1934.
6. H. H. HIGBIE, "Illumination Distribution from Surface Sources in Rooms," *I. E. S. Trans.*, v. 31, No. 2, February, 1936.
7. A. M. LYON, "Luminous Surfaces for Architectural Lighting," *I. E. S. Trans.*, v. 32, No. 7, July, 1937.
8. C. S. WOODSIDE, "Artificial Illumination of Glass Blocks," *I. E. S. Trans.*, v. 33, No. 3, March, 1938.
9. H. M. ALEXANDER, "Practical Aspects of Luminous Store Fronts," *I. E. S. Trans.*, v. 34, No. 3, March, 1939.
10. CURTIS LIGHTING, INC., *How to Illuminate Glass Block*, 1939.

## CHAPTER 10

### FLOODLIGHTING

Floodlighting can serve many purposes, but on the exterior of the building its prime objective is advertisement. It is one of the most powerful media for attracting attention to a building. In the interior, it is also used to attract attention to some one object or objects of special interest. The advertisement value of floodlighting is proved by the number of established business organizations that are willing to make the large investment needed to light their buildings. The practice has spread to buildings of civic interest also, where the motive is one of pride rather than commerce. This civic pride does not emanate from the officials alone, for once a project has been established, discontinuation is met immediately with protest from the public. Though there are many applications for floodlighting, for both horizontal and vertical surfaces, the principles are the same in all instances, and only that applied to the buildings will be considered here.

The addition of color to floodlighting is another step toward increased attracting power, and when the colors are changing (mobile color), the illumination engineer has offered his most powerful attraction.

**1. Lighting Effects.** Floodlighting should be designed to produce an effective harmony with the object to be lighted. Seldom is it possible to duplicate a daylight effect; therefore, the effect must be a study in itself. The light may be combined with the architectural elements of the structure, and its effect will be determined by:

- a.* Projector location
- b.* Architectural conformation and details
- c.* Type of business organization
- d.* Surroundings

The architect who designs a building for daylight depends upon delicate shadows to produce the desired effect. If the building is to be visible both by day and night, the problem is a question of two aesthetic viewpoints. Probably the best design may be obtained by designing the building for daytime appearance and then using light of proper

intensity, color, control, and location to produce a second aesthetic effect. When buildings and statuary are designed for lighting by the sun, it does not necessarily mean that other effects obtained from sources of different magnitude and location will be objectionable. Daylight design and effects of the sun deal with parallel rays of light, whereas the floodlighting problem is one of diverging rays. The difficulties of floodlighting design lie in the control of harsh and multiple shadows and a non-uniform shadow.

The small building, simple in treatment, designed for utilitarian purposes, should be uniformly lighted. If possible, the night appearance should approximate the daytime appearance. This type of lighting emphasizes the strength, mass, and solidity of the building in general. The building is free from shadow, and floodlights placed at a distance of about 200 ft. will accomplish this for a small building.

For the large building, with features of towers and set backs, the grace and height of the building can be emphasized. The effect of height is obtained by throwing the light almost parallel with the building. An attempt should be made to emphasize the architectural features of a large building. Locating floodlights on the setbacks, with the light directed toward the top, will produce very interesting contrasts between the various parts of the building.

The illumination at the top of a building should be two to four times the illumination at the bottom. The greater brightness at the top gives the impression of height and climaxes the effect obtained. It is also necessary to illuminate the top at a higher illumination in order to obtain the same apparent brightness all over the building.

Columns may be floodlighted from in front or behind. The whole effect of the column is lost if the column and the background are illuminated to the same intensity, for columns show at their best when there is a marked contrast between the column and its background.

Statuary and monuments should always be lighted in collaboration with the artist, for the effect to be achieved might be destroyed by shadows at the wrong points or from the wrong angles. Distortion and change in facial expressions of statues may be produced by inaccurate shadows.

**2. Projector Locations.** Floodlights may be located at a distance or upon the building itself. When the lighting comes from a distant point, there may be some choice as to the angles and location of the equipment, but if it is on the building itself, the latitude is rather limited. The location of the projector should be analyzed by an individual with trained judgment and in accord with the:

- a. Location of surrounding buildings
- b. Topography of the surroundings
- c. Area to be lighted
- d. Economical aspects

If the floodlights are to be located away from the building, the choice of position can be classified as:

- a. Roofs of other buildings
- b. Electric service poles
- c. Street lighting standards
- d. Ground with shrubbery or special concealment
- e. Poles

If the floodlights are located upon the building itself, the parts of the structure, such as,

- a. Ledges
- b. Cornices
- c. Back of parapets

will conceal the equipment.

In addition to the placement point for the floodlight, the location of the equipment will influence the effect produced. When the length of the building face is not greater than the distance of the floodlights from the building, the floodlights can be grouped together; otherwise the equipment should be placed in several groups. The general rule for placing lamps or lighting equipment which can be adhered to, is that the banks of floodlights should not be separated more than one and one-half the distance from the illuminated surface. Dividing the equipment into groups gives a greater utilization factor and reduces harsh shadows at recesses, windows, and ledges.

The placing of floodlighting equipment on marquees or in ornamental standards along the curb produces harsh shadows and usually fails to produce uniform lighting. The heavy shadows caused by the window ledges give the building a surprised look. This type of location has been used with some success on buildings up to four stories, but it is better to limit it to buildings of three stories at the most.

Equipment behind parapets should be located as high as possible and still be hidden. This keeps the equipment out of snow and dirt. Units behind parapets will produce non-uniform lighting effects. Good practice requires that the units be distributed along the parapet instead of in groups, so that the illumination will be as uniform as possible.

Columns, monuments, and statues require either exposed equipment or special concealing construction. Lights at the base of columns

have been used to advantage but care must be taken to remove scallops of light, and this requires that the reflectors be moved back from the column.

It is essential that the floodlight units be so placed that they can be easily serviced and adjusted. Equipment may be grouped in banks and the floodlights arranged in rows. In addition to easy access, provision must be made for the safety of the attendant, for the equipment is usually located some distance from the ground. When the equipment is located on poles, platforms should be provided.

Commercial and industrial concerns do not attempt to illuminate the first floor with floodlights. If this is necessary, the units are placed close to the wall and hidden in shrubbery or trees. Care should be taken that the light from the floodlight does not cause annoyance to pedestrians or motorists. If the floodlight is at least 15 degrees above the horizontal line of vision of a person standing anywhere in the lighted area, the glare will not be objectionable.

**3. Floodlight Equipment Characteristics.** In Chapter 5, the distribution of light from a floodlight was considered with the determination of the illumination from these curves as applied to the single floodlight. The general design problem is concerned with the analysis of a group of units.

Floodlighting units are usually grouped into three classes of beam spread:

- a. Narrow
- b. Medium
- c. Broad

and for long distances and special application in aviation and navigation, narrow beam equipment is classified as search lights. Search lights are sometimes used on prominent parts of buildings or monuments where it is necessary to light the feature from a distance.

*Beam spread* is the angular divergence of a beam, measured in degrees. Since only precise equipment could have a very sharply defined beam, by general agreement the beam spread has been defined by the manufacturers. It has been agreed that the beam limit of a floodlight unit should be considered as the point at which the beam candlepower is 10 per cent of the maximum beam candlepower. The spill light outside of this point — beyond the 10 per cent point — is disregarded. Figure 1-10 shows the beam spread for both narrow and wide beam units. The dotted lines show the portion of the distribution curve which lies beyond the 10 per cent point. Usually the reports on floodlighting equipment give only one-half of the curve shown

in Fig. 1-10, for the distribution is symmetrical. By basing the efficiency of the floodlight unit on this arbitrary agreement, only the useful light is considered, but care must be taken in determining what is meant by *total beam lumens* when making comparative studies of floodlighting equipment.

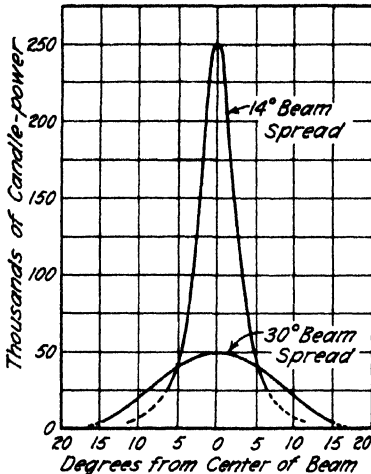

Fig. 1-10.<sup>3</sup> Characteristic beam spreads.

Essentially, the floodlight depends upon its reflector for its characteristics. The material and the contour of the reflector are the two important factors in its efficiency and distribution. Silvered glass, chromium plate, and polished aluminum are the surfaces normally employed for reflectors. Where silvered glass can be used, greater efficiency is obtained. Open types of floodlights are either painted

white or have porcelain enameled surfaces. Often, however, dependence is placed upon the reflecting characteristics of the material of which the equipment is made. The reflection factors for various materials are given in Table I-7B (page 162).

The design of the reflector contour is the balancing of conflicting factors, for high beam candlepower conflicts with maximum quantity of light. Table I-10 shows that the beam lumens increase with the spread of the equipment, but correspondingly the beam candlepower will be less. Where it is necessary to throw the light a considerable distance, the shape of the reflector is that of a parabola (Fig. 2-10a) and is relatively shallow; for the divergence of the beam decreases as the focal length increases. For a given focal length, the diameter of the reflector must be increased in

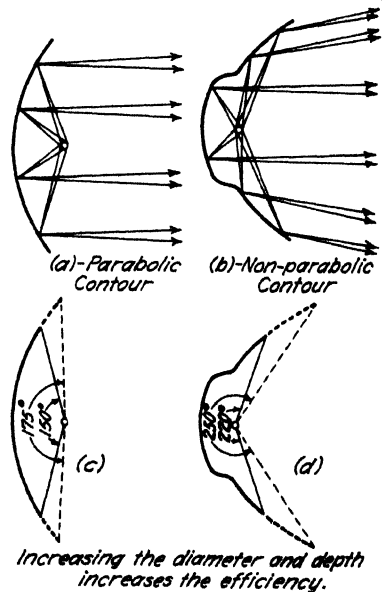

Fig. 2-10.<sup>3</sup> The effect of contour shape on beam spread.

order to increase the effective angle and thereby obtain a greater quantity of light (Fig. 2-10c).

If it is desired to have a greater beam divergence (medium and wide beam equipment), a deep reflector is required, and these are obtained by the use of compound reflectors made up of two different surfaces (Fig. 2-10b). It requires skillful design to proportion the reflectors and control the spread of each part so that the resultant beam will be uniform. Figure 2-10d shows how the effectiveness of lumen output of the non-parabolic reflector may be increased.

TABLE I-10<sup>2</sup>  
BEAM LUMENS OF TYPICAL FLOODLIGHTING UNITS

Beam Spread	Projectors Designed for Floodlight Lamps*		Projectors Designed for General Service Lamps		
	Lamp Size in Watts	Average Beam Lumens	Lamp Size in Watts	Average Beam Lumens	
				Reflector Dia. 12" to 16"	Reflector Dia. 18" to 24"†
Narrow 15° and Less	250	1100	300	1400	
			500	2500	
	500	2600	750		5500
			1000		7800
		1500		10500	
Medium 16° - 29°	250	1150	300	1700	
			500	3000	
	500	2800	750	4900	6000
			1000	7000	8500
		1500		12500	
Broad 30° and Over	250	1200	300	1900	
			500	3400	
	500	2900	750	5200	6200
			1000	7400	8800
		1500		13000	

\* These lamps have concentrated filaments and can be burned in any position except within 45° of the vertical, base up.

† These large units are recommended for long throws, or where the installation will be kept in operation for at least 5 years, or where there are unusually severe operating conditions.

The contour of the reflector limits the control of the light beam; but not completely, for by the use of cover glasses and focus of the filament in the unit, some control may be gained over the beam spread. Data for the equipment are usually given with the cover open and the filament of the lamp at focus, and this is the test for the characteristics of the reflector.

Figure 3-10a shows the effect on the beam pattern caused by changing the cover glass. The ordinary cover glass for a floodlight is clear and smooth and is used merely to protect against dirt and weather. The glass must be heat resistant to withstand the difference



in temperature within and without the unit during winter weather. The clear glass may be replaced by stippled or ribbed glass, and either colored cover glass or inner colored screens may be used. Frosting or sand blasting the cover glass will spread the beam. Replacing the reflectors with stippled, fluted, or prismatic materials will have the effect of eliminating any filament striations and spreading the beam.

Figure 3-10b shows the effect on the light distribution curve when the lamp is moved back of the focus point. The fact that this ad-

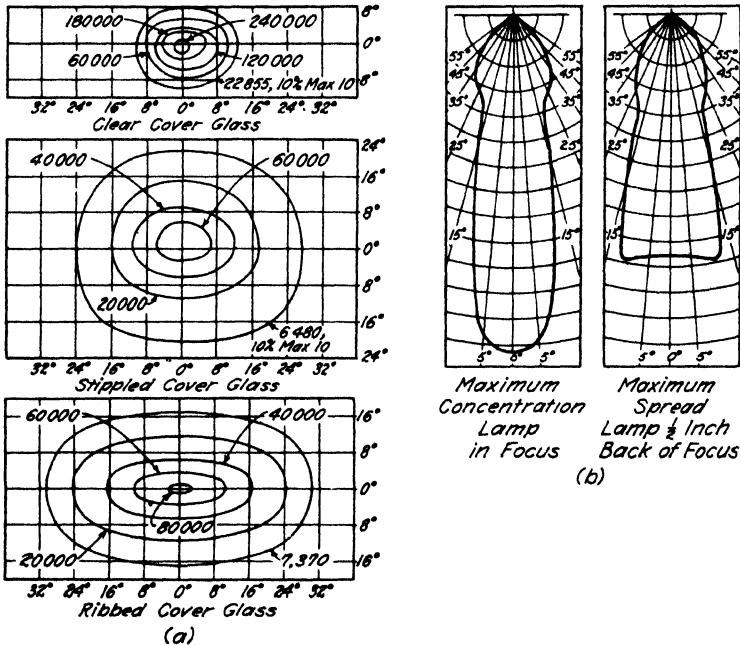

FIG. 3-10.<sup>1</sup> (a) The effect of cover glasses upon beam spread. (b) The effect of focus upon beam spread.

justment is somewhat critical makes it necessary to pay particular attention to this feature when the equipment is being cleaned so that the lamp position in the housing is not changed.

**4. Control of Spill Light.** When floodlighting equipment is located at any position except upon the building, there may be portions of the light beam that will prove annoying to the occupants in other buildings or to people on the street. The design may be correct and the beam properly focused and yet there will be a spill that must be controlled. It is necessary either to absorb or deflect this irritating source of non-useful light. This may be accomplished by:

- a. Spill rings
- b. Spill shield
- c. Specially constructed screens
- d. Visors
- e. Partially sand-blasted or configured cover glasses

A spill ring (Fig. 4-10a), if carefully designed, is compact and effective in accomplishing the result, but it is also wasteful of light and

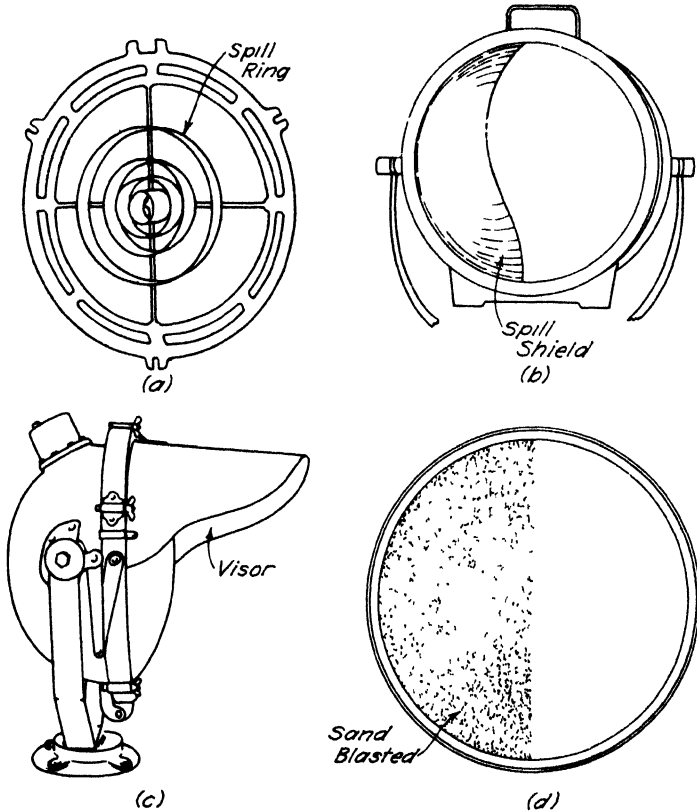

FIG. 4-10. Methods of controlling spill light from a floodlight.

should not be used except where the confinement of the beam is more important than the efficiency of the installation. A spill shield (Fig. 4-10b) serves to cut off spill light in one direction, and a whole bank of floodlights may be controlled by a metal or wood screen properly placed. These large screens may be built to control light from any angle and to cut off lights at the edge of the building to keep the spill light from falling into streets, used areas, or other occupancies. The

visor (Fig. 4-10c) may be used not only as a shield but to gather up the objectionable spill light and direct it into a desired area. Cover glasses partially sand-blasted (Fig. 4-10d) will eliminate objectionable glare in a specific direction.

**5. Selecting the Type of Floodlight.** Equipment should be selected so as to have good mechanical construction. The frame may be of cast iron, sheet steel, a combination of the two, or aluminum and

TABLE II-10<sup>2</sup>  
THE PROPER BEAM SPREAD

Representative Floodlighting Applications	Usual Distance Away	Proper Beam Spread
Buildings two or three stories high, lighted from marquees or posts at curb	10-30 ft.	Broad
Buildings lighted from across street or some distance away:		
Areas less than 3000 sq. ft.	50-100 ft.	Medium
Areas more than 3000 sq. ft.	50-100 ft.	Broad
Areas less than 3000 sq. ft.	100-150 ft.	Narrow
Areas more than 3000 sq. ft.	100-150 ft.	Medium
Areas less than 10000 sq. ft.	150-300 ft.	Narrow
Areas more than 10000 sq. ft.	150-300 ft.	Medium
Buildings of the setback type:		
Setbacks 1 or 2 stories high	On building	Broad or medium
Setbacks 3 or more stories high	On building	Medium or narrow
Columns and ornaments	2-10 ft.	Narrow
Construction work, parking spaces, gaso- line stations, etc.	At edge	Broad
Football stadiums	50-100 ft.	Medium

copper. Aluminum and copper are desirable particularly where there must be resistance against corrosion. The reflector should be chosen for high efficiency and effectiveness. The focusing mechanism, permitting adjustments of the lamp position, should be of sturdy construction, simple design, and positive operation. The swivel base and trunions should permit universal motion for adjustment and should be so designed that adjustments can be made without special tools. The question of maintenance and cleaning should be thoroughly considered.

Table II-10 can be used as a guide to the selection of proper beam spread. Narrow beam equipment would be used for small areas with the projector at a distance, and the wide beam equipment for large

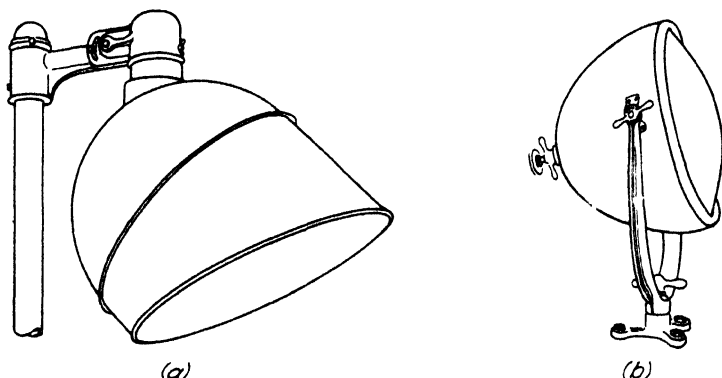

FIG. 5-10.<sup>2</sup> Types of floodlight equipment. (a) Open floodlight. (b) Projector.

areas with the projector close to the surface to be lighted. It is desirable to use as wide a beam as possible (with a reasonable spill), for wide beam equipment is more efficient than medium or narrow beam equipment.

There are two types of floodlights: the open and the enclosed (Figs.

TABLE III-10  
CHARACTERISTICS OF FLOODLIGHTING  
LAMPS  
(110, 115, 120 volts)  
(March, 1941)

Lamp Watts	Type	Lumens
100	Spot	1,380
250	Spot	4,400
250	Flood	3,750
400	Spot	8,000
500	Flood	8,800
1,000	Spot	22,500
1,000	Flood	19,500

5-10a and 5-10b). The open type has a low initial cost and reduces installation costs because it is light of weight. Open projectors do not provide an accurate control of the light and, since the reflecting surface and lamp are both exposed, the dirt accumulation lowers the

TABLE  
REPRESENTATIVE FLOOD-

Narrow Beam Equipment — 15' and Less

Manufacturer	Designation	Reflector	Lamp Watts	Lamp Type	Beam Angle
General Electric Co.	Form L-30B	14 $\frac{3}{4}$ " Smooth	500	Floodlight	12°
	Form L-31B	14 $\frac{3}{4}$ " Smooth	1000	Floodlight	13°
	Form L-24B	18 $\frac{3}{4}$ " Smooth	100	Floodlight	13°
Crouse-Hinds Co.	LDE 12	12" Smooth	250	Floodlight	14°
	ADA 12	11 $\frac{1}{2}$ " Smooth	250	Floodlight	12°
	LDE 16	16" Smooth	500-1000	Floodlight	9°
	LCE 24	24" Smooth	1500	Floodlight	11°
Curtis Lighting, Inc.	25-C	11" Smooth No. 821	250	Floodlight	15°
	25-C-10527 E. S.	11" Smooth No. 821	200	Gen. Ser.	15°
	37-C	14 $\frac{1}{4}$ " Smooth No. 831	500	Floodlight	15°
	37-C-10339 E. S.	14 $\frac{1}{4}$ " Smooth No. 831	500	Gen. Ser.	15°
	49	19 $\frac{3}{4}$ " Smooth No. 841	1000-1500	Gen. Ser.	10°
Electric Service Sup- plies Co.	Type A-1016	10" Smooth	250	Gen. Ser.	10°
	Type A-1419	14" Smooth	500	Gen. Ser.	9°
	Type A-2430	24" Smooth	1000-1500	Gen. Ser.	10°
Pittsburgh Reflector Co.	FL 500	16" Smooth	300-500	Gen. Ser.	13.6°
	FLC 1002	16" Smooth	1000	Floodlight	13.6°
Pyle National Co.	Type 1045	10" Smooth	250	Floodlight	12°
	Type 1275	12" Smooth	250	Floodlight	14°
	Type 1480	14" Smooth	500	Floodlight	12°
	Type 2375	23" Smooth	1000-1500	Gen. Ser.	14°
Westinghouse Co.	CA-10	10" Smooth Chromium	250	Floodlight	10°
	CA-14	14" Smooth Chromium	500	Floodlight	12°
	CA-16	16" Smooth Chromium	1000	Floodlight	10°
	CSA-24	24" Smooth Chromium	1000-1500	Floodlight	9°

Medium Beam Equipment — 16° to 29°

General Electric Co.	Form L-29B	10 $\frac{1}{2}$ " Smooth	250	Floodlight	18°
	Form L-29A	10 $\frac{1}{2}$ " Smooth	200	Gen. Ser.	27°
	Form L-30A	14 $\frac{3}{4}$ " Smooth	500	Gen. Ser.	23°
	Form L-31A	14 $\frac{3}{4}$ " Smooth	750-1000	Gen. Ser.	24°
	Form L-24A	18 $\frac{3}{4}$ " Smooth	1000-1500	Gen. Ser.	19°
Crouse-Hinds Co.	ADA 12	11 $\frac{1}{2}$ " Smooth	200	Gen. Ser.	27°
	ADA 16	16" Smooth	1000	Gen. Ser.	23°
	LCE 20	16" Hammered	1000	Gen. Ser.	23°
	LCE 20	16" Smooth	1000	Gen. Ser.	19°
	LCE 24	24" Hammered	1500	Gen. Ser.	20°
	LCE 24	24" Smooth	1500	Gen. Ser.	18°
Electric Service Sup- plies Co.	Type A-1016	10" Smooth	300-500	Gen. Ser.	22°
	Type A-2016	20" Smooth	750-1000	Gen. Ser.	19°
Major Equipment Co., Inc.	No. 2540	11" Smooth	250	Floodlight	18°
	No. 5001	11" Smooth	500	Floodlight	18°
Pittsburgh Reflector Co.	FLC 250	10" Smooth	250	Floodlight	16°
	FLC 501	16" Smooth	300-500	Gen. Ser.	19.6°
	FLC 1001	16" Smooth	1000	Gen. Ser.	19.6°
	FL 1500	18" Smooth	1500	Gen. Ser.	22°

IV-10<sup>2</sup>

## LIGHTING EQUIPMENTS \*

## Medium Beam Equipment — 16° to 29° (Continued)

Manufacturer	Designation	Reflector	Lamp Watts	Lamp Type	Beam Angle
Pyle-National Co.	Type 1275	12" Smooth	200	Gen. Ser.	17°
	Type 1680	16" Smooth	750-1000	Gen. Ser.	16°
	Type 18180	18" Smooth	1000	Gen. Ser.	16°
Reflector and Illuminating Co.	Sterling Flood-O-Lite No. 3000-C	11" Smooth	250	Floodlight	18°
	Sterling Flood-O-Lite No. 4000-C	13¾" Smooth	300-500	Gen. Ser.	18°
	Sterling Flood-O-Lite No. 5240-C	16" Smooth	500-1000	Gen. Ser.	24°
Westinghouse Co.	CA-10	10" Smooth Chromium	200	Gen. Ser.	20°
	CA-14	14" Smooth Chromium	300-500	Gen. Ser.	20°
	CA-16	16" Smooth Chromium	750-1000	Gen. Ser.	16°
	CA-20	20" Smooth Chromium	1000-1500	Gen. Ser.	22°
	CSA-24	24" Med. Beam Chromium	1000-1500	Gen. Ser.	20°

## Broad Beam Equipment — 30° and Over

General Electric Co.	Form L-30A	14¾" Sectional	500	Gen. Ser.	60°
	Form L-30B	14¾" Sectional	500	Floodlight	44°
Crouse-Hinds Co.	ADA 12	11½" Hammered	200	Gen. Ser.	34°
	ADA 16	16" Hammered	1000	Gen. Ser.	32°
Curtis Lighting, Inc.	25 E	11" Corrugated No. 823	250	Floodlight	110°
	25 E-10527 E. S.	11" Corrugated No. 823	200	Gen. Ser.	110°
	37 E	14¾" Corrugated No. 833	500	Floodlight	110°
	37 E-10539 E. S.	14¾" Corrugated No. 833	500	Gen. Ser.	110°
Electric Service Supplies Co.	Type A-1419	14" Prismatic	500	Gen. Ser.	34°
	Type A-1016	10" Prismatic	250	Floodlight	30°
Major Equipment Co., Inc.	No. 2001	11" Smooth	200	Gen. Ser.	42°
	No. 3001	11" Smooth	300	Gen. Ser.	46°
Pittsburgh Reflector Co.	FL 300	12" Fluted	300-500	Gen. Ser.	100°
	FL 750	16" Plain and Fluted	750-1000	Gen. Ser.	
Reflector and Illuminating Co.	Sterling Flood-O-Lite No. 3000-I	11" Stippled	250	Floodlight	100°
	Sterling Flood-O-Lite No. 5240-I	16" Stippled	500-1000	Gen. Ser.	115°
Westinghouse Co.	CA-14	14" Wide Beam Chromium	300-500	Gen. Ser.	30°

\* For problems.

NOTE: This classification is based on normal beam spread, to 10 per cent of maximum beam candlepower, with clear cover glass and lamp at focus. Many of these projectors are so designed that by moving the lamp out of focus the beam spread may be increased considerably without losing uniformity of beam. A number of the projectors may also be equipped with diffusing or prismatic cover glasses or reflectors which will give either a wider beam than normally procured, or a definite beam pattern for specific purposes. Reference should be made to the latest manufacturers' catalogs for specifications.

efficiency rapidly. The open type is used for recreational and filling station lighting where accurate control is not necessary and where the light is projected only a short distance.

The enclosed type of equipment usually is used in building lighting. The housing is dust- and moisture-proof; therefore, the unit is easy to maintain and its efficiency will continue to be high even after a long period of operation. Accurate control of the light is obtained by using reflectors with definite contours, equipped for focal adjustment. The equipment has a better appearance and will project the light a greater distance. The projector costs more than does the open floodlight.

There are two types of incandescent lamps used in the enclosed type of floodlight: the floodlight lamp, and the general service lamp. In the open floodlight, there is no advantage in using the concentrated filament lamp. Table III-10 gives the lumen output of floodlight lamps. These lamps have a concentrated filament and can be burned in any position except within 45 degrees of the vertical, base up.

In selecting the equipment, the larger lamp sizes are the more efficient in energy consumption, and the number of units will be reduced; this, all other things being equal, means less first cost. Floodlights in the 18- to 24-in. class or larger are recommended for long throws or for installations which will be kept in operation for at least 5 years. The large equipment is best wherever severe operation conditions are encountered. Table IV-10 gives some commercial types of equipment.

**6. Foot-Candle Recommendations.** In determining the amount of illumination for floodlighting, it is necessary to be guided by accepted practice, for the Illuminating Engineering Society has not made specific recommendations through its committees. Table V-10, based upon general practice, gives suggested illumination values. The buildings are divided into four groups depending upon the classification of the building surface, and into three groups depending upon the size of the city. It is assumed that the larger cities will have a higher surrounding illumination than the smaller towns. The recommendations are given for downtown districts. For buildings in outlying districts, use the values recommended for downtown buildings of the next smaller city classification. Buildings having reflection factors of less than 20 per cent cannot be economically illuminated unless there is a large amount of light trim.

**7. Floodlighting Design.** The solution of floodlighting problems depends on two factors:

- a. The number of projectors to produce the required illumination.
- b. The number of projector patterns to cover the surface.

If these two requirements are the same, an ideal installation is possible. For high illuminations, more units than are necessary for coverage will be required; for low illuminated surfaces, the number for coverage will usually exceed the number required for illumination. In both the vertical and horizontal planes, there must be some overlapping of the light beams so that the illumination will be uniform. This depends, however, on the candlepower distribution of the floodlight beam.

TABLE V-10  
FOOT-CANDLE RECOMMENDATIONS FOR FLOODLIGHTING APPLICATIONS

Buildings and Monuments					Utilitarian and Protective Purposes		
Representative Building Materials	Approximate Reflection Factors Per Cent	Foot-Candles for Downtown* Buildings in Cities of:					
		Over 50,000	50,000 to 5,000	Under 5,000			
White terra cotta	75	15	10	5	Construction work	5	
Cream terra cotta					Dredging	2	
Light marble					Gasoline service stations:		
Light gray limestone	50	20	15	10	Buildings and pumps	20	
Bedford limestone					Yard and driveways	5	
Buff limestone					Parking Spaces	1	
Smooth buff face brick					Protective Industrial	0.2	
Briar Hill sandstone	35	30	20	15	Quarries	2	
Smooth gray brick					Shipyards (construction)	5	
Medium gray limestone					Special Applications		
Common tan brick					Trees	5-20	
Dark field gray brick	20	50	30	20	Flags	30	
Common red brick					Loading docks	5	
Brown stone					Loading platforms	5	
					Signs	30	
					Smokestacks	15	
					Art glass windows	20-200	
					Waterfalls	10	
					Water tanks	15	

\* For buildings in outlying districts use the foot-candles recommended for downtown buildings in cities of the next smaller classification.

NOTE: Buildings composed of material having a reflection factor much below 20% cannot economically be floodlighted unless there is a large amount of light trim.

On square and rectangular surfaces, the amount of light wasted becomes less as the number of projectors increases, because less light spills over the edge of the surface.

The angle which the beam axis makes with the surface to be illuminated controls the shape of the pattern and the area of the beam pattern. If the axis is perpendicular to the surface, the pattern is that of a circle (Fig. 6-10a). There is no sharp line of demarcation as shown, because the light "washes out" from the highest brilliancy to darkness. The pattern will have a pleasing soft edge. Figure 6-10b shows the more general case of floodlighting pattern, where the beam



axis makes some angle with the surface, and it should be noticed that the aiming point does not fall upon the center of the lighted area. The aiming point is the point used in adjusting the floodlight — not the center of the ellipse. The area below the aiming point receives one-half of the beam lumens, and the area above the other half. This means that the illumination in the lower portion is higher than that in the upper portion as divided at the aiming point. Figure 6-10c shows the beam axis parallel to the surface, a situation which is closely approached when the face of a building is illuminated from an offset.

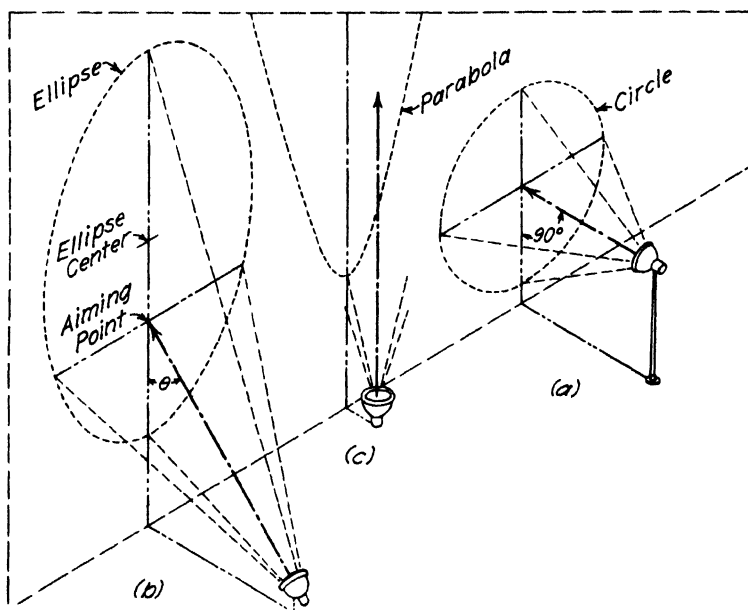

FIG. 6-10.<sup>5,6</sup> Influence on the beam pattern caused by the angle of tilt.

If the design of the floodlighting is followed in an orderly fashion, as in the general room illumination design, it is easier to check and there is less likelihood of error. The steps of the problem should be considered in the following order:

- a. The lighting effect desired.
- b. The amount of illumination (Table V-10).
- c. Location of the projectors.
- d. Beam spread of projector (Table II-10).
- e. Type and size of lamp (Table I-10).
- f. Choice of projector (Table IV-10).
- g. Determination of the number of projectors. The number of projectors is calculated by use of the following expression:

$$\text{number of projectors} = \frac{\text{area} \times \text{foot-candles}}{0.7 \times \text{beam lumens}}$$

where the area is the surface to be lighted, the foot-candles are the number desired (from Table V-10), and the beam lumens are taken from Table I-10. If specific equipment is to be used, the beam lumens given for the special equipment will be used instead of the quantities given in Table I-10, for these values are representative of standard equipment. The maintenance factor is assumed to be 70 per cent for all classes of equipment.

*h.* Assurance of uniform coverage. The check can be easily accomplished by use of Table VI-10, the values of which have been de-

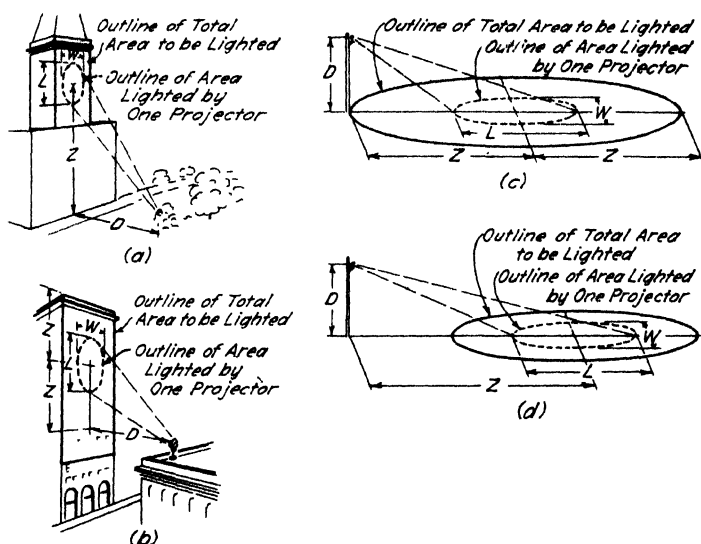

Fig. 7-10.<sup>2</sup> Figures to be used with Table VI-10.

rived in conjunction with Fig. 7-10. Table VI-10 gives dimensions and area covered by projectors of various beam spreads from different distances and with different angles of throw. The number of projectors required is obtained by dividing the total area to be lighted by the area covered by one projector. The area of the pattern is used in checking the coverage, but the length and width of the pattern are useful in problems dealing with the lighting of details and limited areas and also for checking the overlapping of pattern on the surface layout. The terms  $D$  and  $Z$  are shown in Fig. 9-10.

Table VII-10 is a rapid check table for floodlighting installations. The tables are representative for beam efficiencies of 45 per cent and maintenance factors of 70 per cent; and, as has been stated previously

TABLE

SPOT SIZES — DIMENSIONS

(Representing average effective coverage for va-

D	10° BEAM				15° BEAM			20° BEAM			25° BEAM		
	Z	Area	Length	Width	Area	Length	Width	Area	Length	Width	Area	Length	Width
15	0	5	3	3	10	4	4	18	5	5	30	7	7
	10	8	4	3	20	6	5	33	8	7	50	10	8
	20	21	7	4	50	11	7	93	16	9	160	20	12
	30	52	14	6	130	21	9	250	30	13	460	41	17
	40	113	22	8	290	37	12	620	55	17	1300	83	23
25	0	11	4	4	25	7	7	44	9	9	70	11	11
	20	23	7	5	50	11	8	100	15	12	150	19	14
	40	71	16	8	170	25	13	330	34	17	540	45	22
	60	195	31	11	490	49	18	1030	73	25	1960	105	34
	80	450	54	15	1200	90	24	2920	145	36	7270	251	53
50	0	38	9	9	90	13	13	155	18	18	210	20	20
	20	47	11	9	110	15	14	195	21	19	320	26	24
	40	81	14	11	190	22	17	330	30	23	550	38	29
	60	150	22	14	340	33	20	630	45	28	1070	58	36
	80	260	32	17	600	49	25	1160	68	35	2060	90	45
75	0	67	13	13	170	20	20	310	26	26	480	33	33
	40	110	17	14	250	25	22	440	34	30	710	43	38
	80	220	28	18	540	43	29	1010	59	39	1630	75	50
	120	530	48	25	1210	74	38	2320	102	52	3930	135	67
	160	1040	76	32	2500	119	49	5050	171	67	9060	238	88
100	0	120	17	17	310	26	26	490	35	35	770	44	44
	40	150	20	19	390	31	28	610	41	38	980	52	48
	80	250	29	22	580	44	34	1050	59	46	1700	75	58
	120	470	43	28	890	66	41	2000	90	56	3290	116	72
	160	830	63	33	1950	98	51	3700	136	69	6340	180	89
200	1300	80	42				6650	201	84				
150	0	270	26	26	610	39	39	1100	53	53	1740	67	67
	40	300	28	27	680	42	41	1230	57	55	1940	71	69
	80	400	34	30	900	51	45	1630	69	60	2580	87	76
	120	570	43	34	1310	65	51	2380	89	68	3820	113	87
	160	860	57	39	1970	86	58	3610	117	79	5920	151	100
200	1280	74	44				5550	156	91				
200	0	480	35	35	1090	53	53	1940	71	71	3090	89	89
	40	510	37	36	1160	55	54	2080	73	72	3280	92	91
	80	600	41	38	1360	61	57	2470	82	77	3910	104	96
	120	770	48	41	1730	72	61	3160	97	83	5030	123	104
	160	1080	58	45	2330	87	68	4240	118	91	6800	150	115
200	1370	71	50				5800	146	102				
300	0	1080	52	52	2460	79	79	4400	106	106	6940	133	133
	40	1110	53	53	2520	80	80	4520	108	107	7140	136	134
	80	1200	56	54	2720	85	82	4990	114	110	7740	143	138
	120	1350	61	57	3070	92	85	5530	123	114	8790	156	144
	160	1580	68	60	3590	102	90	6480	137	120	10300	173	152
500	0	3010	87	87	6810	132	132	12200	176	176	19300	222	222
	40	3030	88	88	6870	133	133	12300	177	177	19500	223	222
	80	3120	90	89	7070	135	133	12700	181	179	20100	228	225
	120	3270	93	90	7410	139	135	13300	187	181	21100	235	228
	160	3490	97	92	7900	145	138	14200	195	185	22500	246	238

$D$  = the distance from the projector to the plane of the lighted surface or area, measured per-  
 $Z$  = this measurement determines the average angle of throw and consequently determines

VI-10\*

AND AREAS (Fig. 9-10)

rious beam spreads and locations of projectors)

		30° BEAM				35° BEAM			40° BEAM					50° BEAM		
D	Z	Area	Length	Width	Area	Length	Width	D	Z	Area	Length	Width	Area	Length	Width	
15	0	45	8	8	60	9	9	15	0	80	11	11	130	14	14	
	10	80	12	10	110	14	12		5	110	13	12	175	17	16	
	20	240	26	14	360	32	17		10	150	17	14	260	22	18	
	30	790	56	21	1430	79	27		15	310	25	19	530	33	25	
	40	2900	133	33	8690	262	50		20	630	43	23	1250	63	30	
25	0	100	13	13	140	16	16	25	0	185	18	18	305	23	23	
	10	140	16	15	170	19	17		10	240	22	20	400	26	26	
	20	220	23	18	310	28	20		20	450	34	24	800	44	32	
	30	430	36	21	660	45	27		30	970	55	32	2050	83	44	
	40	920	59	28	1430	75	34		40	2300	98	42	6950	187	66	
	50	1930	94	37	3270	131	45		50	6450	194	60				
50	0	350	27	27	510	32	32	35	0	320	26	26	520	33	33	
	20	450	33	29	650	37	34		10	380	28	27	580	37	32	
	40	800	46	35	1160	55	41		20	510	35	32	890	47	39	
	60	1590	73	44	2440	90	53		30	850	49	35	1550	67	47	
	80	3200	117	56	5300	151	69		40	1490	71	43	3000	105	59	
75	0	700	40	40	970	47	47	45	0	470	33	33	780	42	42	
	20	790	43	42	1070	51	49		10	520	35	34	820	44	42	
	40	1060	53	46	1460	63	54		20	650	40	37	1070	52	47	
	60	1590	69	53	2200	83	61		30	890	49	42	1550	67	53	
	80	2480	93	61	3620	114	73		40	1320	66	46	2460	91	62	
	100	4000	128	72	5780	160	84		50	2100	87	55				
100	0	1130	54	54	1560	63	63	55	0	640	40	40	1030	51	51	
	40	1430	63	58	1980	74	68		20	790	46	44	1300	59	56	
	80	2550	92	70	3560	110	82		40	1320	66	51	2330	88	68	
	120	5050	146	89	7510	180	106		60	2650	104	65	5250	152	88	
	160	10300	234	112					80	5600	172	83				
125	0	1760	67	67	2440	79	79	70	0	1020	51	51	1680	65	65	
	40	2130	73	71	2870	88	83		20	1180	55	54	1940	72	69	
	80	3090	97	80	4350	116	96		40	1680	71	60	2860	93	78	
	120	5200	138	96	7430	167	113		60	2700	98	70	5000	135	94	
	160	9140	200	116					80	4700	142	84				
150	0	2540	80	80	3510	95	95	85	0	1500	62	62	2460	79	79	
	40	2880	86	85	3900	102	97		20	1680	67	64	2750	85	82	
	80	3820	105	92	5300	125	108		40	2130	78	69	3600	102	90	
	120	5700	135	107	8000	166	123		60	3080	100	78	5400	133	103	
	160	10300	234	112					80	4750	132	92				
200	0	4500	107	107	6250	126	126	100	0	2100	73	73	3400	93	93	
	40	4800	111	109	6660	132	129		20	2280	76	74	3700	98	96	
	80	5700	125	116	7950	149	136		40	2700	86	79	4500	112	102	
	120	7500	150	127	10300	178	148		60	3500	104	87	7800	138	113	
	160	10200	184	141					80	5000	130	98				
									100	7300	168	110				

pendicular to the surface. Length (L) and width (W), Fig. 9-10.  
the average area covered by each projector.

TABLE VII-10\*

DESIGN DATA FOR OPEN AND CLOSED TYPE FLOODLIGHTS

Average Foot-Candles

Area per Floodlight (Sq. ft.)	General Service Lamps										Floodlight Lamps						Mercury Lamps			
	100	150	200	300	500	750	1000	1500	250	400	500	1000	250	400	500	1000	250	400		
	w.	w.	w.	w.	w.	w.	w.	w.	w.	w.	w.	w.	w.	w.	w.	w.	w.	w.		
500-575	.9-1.0	1.4-1.6	2.0-2.3	3.2-3.7	5.5-6.5	8-9	11-13	18-21	2-2	3.0-3.5	3.6-4.2	10-12	4.0-4.7	9-10						
575-650	.8-9	1.2-1.4	1.8-2.0	3.0-3.2	5.0-5.5	7-8	10-11	16-18	1.8-2.0	2.8-3.0	3.2-3.6	9-10	3.6-4.0	8-9						
650-750	.7-8	1.1-1.2	1.5-1.8	2.5-3.0	4-5	6-7	8.5-10	14-16	1.5-1.8	2.5-2.8	2.8-3.2	8-9	3.1-3.6	7-8						
750-850	.6-7	1.0-1.1	1.3-1.5	2.2-2.5	3.7-4.0	5.5-6.0	7.5-8.5	12-14	1.3-1.5	2.1-2.5	2.5-2.8	7-8	2.8-3.1	6-7						
850-1000	.8-1.0	1.1-1.3	1.9-2.2	3.0-3.7	4.5-5.5	6.5-7.5	10-12	1.1-1.3	1.8-2.1	2.1-2.5	6-7	2.4-2.8	5-6							
1000-1150	.7-8	1.0-1.1	1.6-1.9	2.8-3.0	4.0-4.5	5.5-6.5	9-10	1.0-1.1	1.6-1.8	1.8-2.1	5-6	2.0-2.4	4-5.0							
1150-1300	.6-7	.9-1.0	1.4-1.6	2.5-2.8	3.5-4.0	5.0-5.5	8-9	.9-1.0	1.4-1.6	1.6-1.8	4.5-5.0	1.8-2.0	4.0-4.4							
1300-1500	.8-9	1.2-1.4	2.0-2.5	3.0-3.5	4.3-5.0	7-8	8-9	1.2-1.4	1.4-1.6	4.0-4.5	1.6-1.8	3.4-4.0								
1500-1750	.7-8	1.1-1.2	1.8-2.0	2.5-3.0	3.7-4.3	6-7	7-8	1.0-1.1	1.2-1.4	3.4-4.0	1.3-1.6	3.0-3.4								
1750-2000	.6-7	.9-1.1	1.6-1.8	2.3-2.5	3.3-3.7	5-6	6-7	.6-7	.9-1.0	1.0-1.2	3.0-3.4	1.2-1.3	2.5-3.0							
2000-2250	.8-9	1.4-1.6	2.0-2.3	2.9-3.3	4.5-5.0				.8-9	.9-1.0	2.6-3.0	1.0-1.2	2.2-2.5							
2250-2500	.7-8	1.3-1.4	1.8-2.0	2.6-2.9	4.0-4.5				.7-8	.8-9	2.4-2.6	.9-1.0	2.0-2.2							
2500-3000	.6-7	1.1-1.3	1.5-1.8	2.2-2.6	3.5-4.0				.6-7	.7-8	2.0-2.4	.8-9	1.7-2.0							
3000-3500		.9-1.1	1.3-1.5	1.9-2.2	3.0-3.5					.6-7	1.5-1.7	.6-7	1.3-1.4							
3500-4000		.8-9	1.1-1.3	1.6-1.9	2.6-3.0						1.3-1.5	1.5-1.7	1.1-1.3							
4000-4500		.7-8	1.0-1.1	1.4-1.6	2.3-2.6						1.1-1.3	1.1-1.3	1.0-1.1							
4500-5250		.6-7	.9-1.0	1.2-1.4	2.0-2.3						1.0-1.1	1.0-1.1	.8-1.0							
5250-6000		.8-9	1.1-1.2	1.7-2.0							.8-1.0	.8-1.0	.7-8							
6000-7000		.7-8	.9-1.1	1.5-1.7							.7-8	.7-8	.6-7							
7000-8000		.6-7	.8-9	1.3-1.5							.6-7	.6-7	.6-7							
8000-9000		.7-8	.9-1.1	1.1-1.3							.7-8	.7-8	.6-7							
9000-10000		.6-7	.6-7	1.0-1.1							1.0-1.1	1.0-1.1								

Beam efficiency 45%; maintenance factor 70%.

of this type of table, if either the efficiency or the maintenance factors vary from the above, it is necessary to make proportional corrections.

*Example a.* Design the floodlighting for the illumination of the front of a department store located in the business district of a town of 30,000 population. The building front is 75 ft. high and 150 ft. wide, measuring 15 ft. to the second floor. The effect is to be a uniform illumination with the projectors located on a 20-ft. building 52 ft. away on the opposite side of the street. The front of the building to be lighted is of terra cotta (Fig. 8-10a).

10 ft-c. of illumination	Table V-10
Wide (broad) beam spread	Table II-10
General service lamp in a 12- to 16-in. projector	Table I-10
1000-w. general service lamp	Table I-10
7400 beam lumens	Table I-10
Crouse-Hinds ADA-16, 32°	Table IV-10
Maintenance factor 70%	

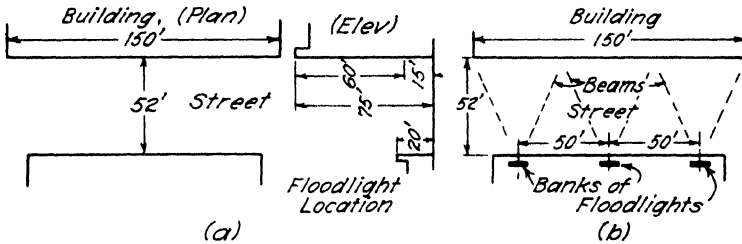

FIG. 8-10.\* Problem in floodlighting.

$$\text{number of projectors} = \frac{10 \times 60 \times 150}{0.7 \times 7400} = 17 \text{ (approximately)}$$

The beam pattern area, length, and width are obtained from Table VI-10. Approximate solution for number of projectors to cover the surface is

$$D = 52 \text{ ft.}$$

$$Z = 27.5 \text{ ft.}$$

Neither value falls on values given in the table but may be obtained by interpolation. Since several of these computations must be made if there is an adjustment of results, first solutions may be crude approximations.

$$\begin{aligned} \text{Area} &= 600 \text{ sq. ft. (by interpolation)} \\ \text{Length} &= 40 \text{ ft.} \\ \text{Width} &= 32 \text{ ft.} \end{aligned}$$

Units necessary for complete coverage (approximate).

$$\frac{60 \times 150}{600} = 15$$

Since 17 units are required to give the illumination and 15 are required to cover the area, the solution seems reasonable. At this point, it would be

well to lay out to scale the pattern on the building, check the area and coverage, and determine the correct aiming for the projectors. Table VI-10 makes allowance for necessary overlapping in computing the spot size.

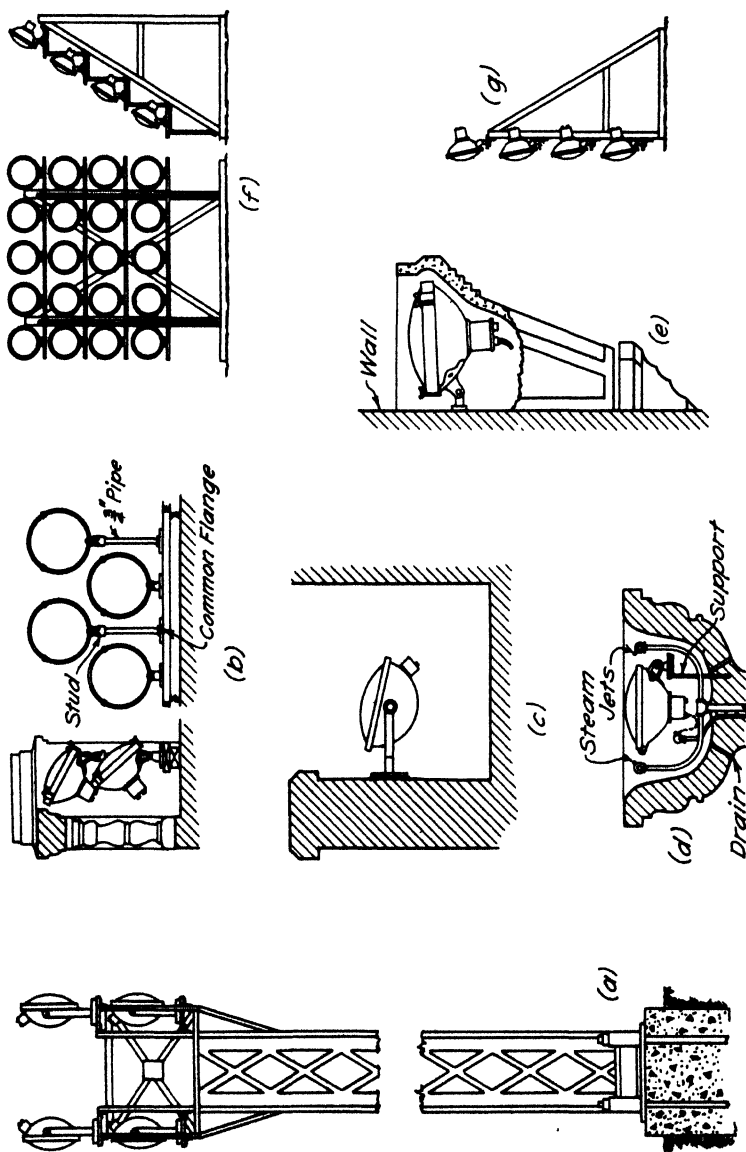

Fig. 9-10. Methods of mounting floodlights.

Figure 8-10b shows a layout grouping the equipment in three groups to control the shadows. Eight in the center bank with 4 in each end bank, making a total of 16 units, would be close enough for a solution.

Figure 9-10 shows some of the methods used in mounting floodlights and in placing them into lighting banks. Any problem should be tried with several solutions, considering number, size, and arrangement of equipment. After experimentation the final determination should be made on an economical as well as an effective basis.

*Example b.* Check example *a* by means of Table VII-10.

$$\text{beam efficiency} = \frac{7,400}{21,500} = 0.344$$

The beam lumens equal 7,400 (Table I-10) and the lamp lumens for a 1000-w. lamp equal 21,500 (Table III-6A).

$$\text{area per lamp} = \frac{60 \times 150}{17} = 530 \text{ sq. ft.}$$

From Table VII-10, 538 sq. ft. and a 1000-w. lamp shows an illumination of 11 to 13 ft-c. Since the maintenance factor is the same but the efficiency is different, the illumination will be:

$$(11 \text{ to } 13) \times \frac{0.344}{0.45} = (8.4 \text{ to } 9.9) \quad 9.2 \text{ average}$$

a close check to the value of 10 ft-c. assumed in the solution of example *a*.

**8. Design of Floodlighting where Distance from Projector to the Illuminated Surface is Small.**<sup>4</sup> Article 7 describes a method that will prove satisfactory for installations where angle  $\theta$  (Fig. 6-10b) is relatively large ( $45^\circ$  or more), but in modern setback construction it may be necessary to place the projector within 10 or 15 ft. of the surface to be illuminated. Under these circumstances the beam pattern is far from uniformly illuminated. In Art. 7, it was pointed out that the area of the ellipse from the aiming point to the end of the ellipse nearer the floodlight receives half the lumens from the light beam and the remainder receives the other half; this means that the former area mentioned will be illuminated to a higher illumination than the latter because the same amount of light is confined within a smaller area.

Recognizing the necessity for a simple and accurate method of designing this type of lighting, E. B. Hallman<sup>4</sup> divided the beam pattern into sixteen equal areas and analyzed the per cent of light falling into these areas for:

*a.* General service and floodlight lamps.

*b.* Practically every type of parabolic reflector used in floodlight work from the shallow parabolic reflectors, both plain and prismatic or hammered, to deep composite-type reflectors.

*c.* Three types of cover glass (plain, ribbed, diffusing).

*d.* The products of many different manufacturers.



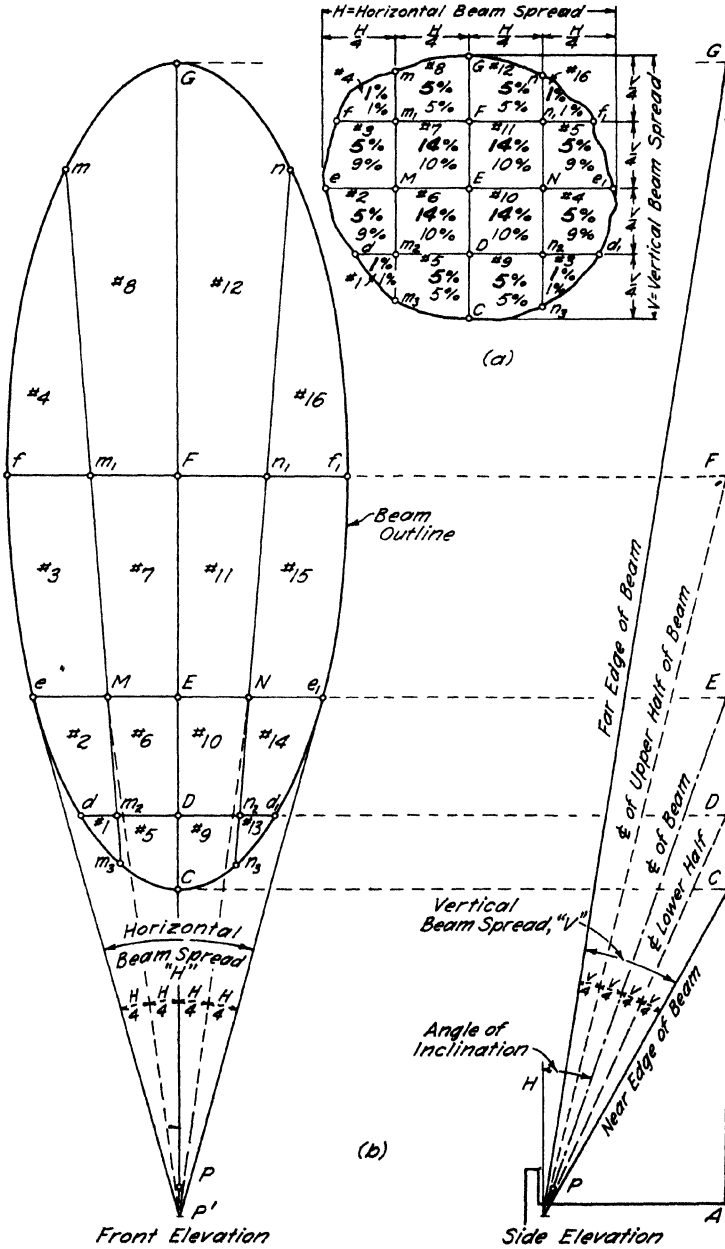

FIG. 10-10.<sup>4</sup> (a) Per cent lumens falling into various parts of the floodlight pattern. Lower figures for accurate parabolic reflectors with C 7-A filament lamp. Bold-face type figures for general floodlights. (b) Problem in offset lighting.

It was found that, with the exception of the concentrated floodlight filament (C 7-A) burned with a shallow, accurately made parabolic reflector and plain cover glass, the distribution of light was essentially the same. Figure 10-10a shows in the diagram of sixteen squares the per cent of total lumens within beam limitation (10 per cent maximum candlepower) set by the squares.

To make use of this information, it is only necessary to draw the front and side elevations of the beam and beam pattern, within the limits of the beam spread and throw, and determine the area and illumination in each of the sixteen parts as shown in Fig. 10-10b. The lumens are determined from the total beam lumens with the correct percentage assigned to each square. The area of each part is taken from the drawing (by a planimeter or approximate integration). The ratio of lumens to square feet will give the illumination in the region considered. The following example is the one given in the report.

*Example c.* Figure 10-10 shows the conditions for a typical medium beam floodlight projector burning at 1500 w., a PS-52 bulb, general service lamp. The specification for the floodlight is: beam lumens 12,386, horizontal beam spread  $22^\circ$ , vertical beam spread  $20^\circ$ . The projector is located 10 ft. (AP) from a vertical surface.

Using Fig. 10-10b as a guide, and having the axis of the beam trained to make an angle ( $HPE$ ) of  $20^\circ$  with the vertical, the far edge of the beam ( $PG$ ) strikes at 56 ft. 8 in.; the center of the top half of the beam ( $PF$ ) at 37 ft. 4 in. above; the center of the beam ( $PE$ ) at 27 ft. 6 in. above; the center of the lower half of the beam ( $PD$ ) at 21 ft. 5 in. above, and the near edge of the beam ( $PC$ ) at 17 ft. 4 in. above the projector.

SECTION OF THE BEAM	AREA SQUARE FEET	ILLUMINATION FOOT-CANDLES
#1 and #13	2.6	48
#2 and #14	14.4	43
#3 and #15	26.6	23
#4 and #16	21.2	6
#5 and #9	8.5	73
#6 and #10	16.5	105
#7 and #11	31.5	55
#8 and #12	78.6	8
	<u>399.8</u>	

To determine the average as by Art. 7, the illumination obtained by dividing 12,386 by 399.8 is 31 ft-c. Compare this with the illumination column and it will be seen how far the average result deviated from the actual condition.

By means of templates for various types of equipment, it is possible to study the economics of the installations under consideration. The

values for other mounting heights may be obtained directly from tabulation given in example *c* because distances will vary directly as the mounting height and areas will vary as the square. The method permits the combination of patterns and the determination of composite effects.

**9. Floodlighting with Color.** Color is attention compelling, high in advertising value, and aesthetically pleasing. Color adds to the exterior lighting and attractiveness, and the effect is one of subtle liquid shades. Effects may be changed frequently by merely changing the cover glasses. The height of color effectiveness and beauty, with attracting interest, occurs with the application of mobile light where

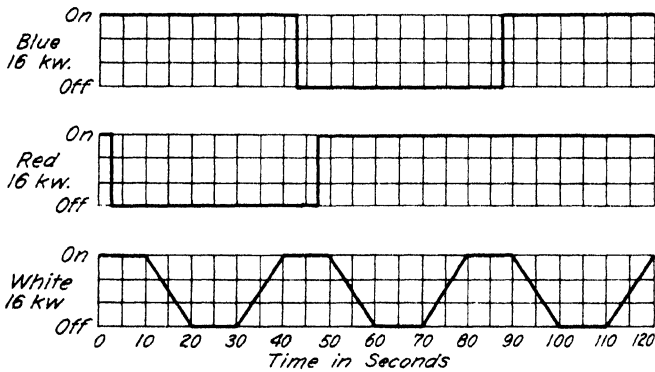

FIG. 11-10.<sup>1</sup> Time cycle for mobile floodlight control.

the color effect is changing continually through some predetermined cycle.

There are two systems of mobile lighting control: (a) the wash system and (b) the cycle system. In the wash system the colored light is on continually and white light moves from zero to maximum to zero again. There is a gradual dilution and fading of the colored light as the white light is brought up, and periodically the building comes up to a high brightness of white. At other times there are deep, rich hues and, in the interim, a variety of tints of these hues. This system is expensive for the colored lights are on, even when they are not adding anything to the effect.

The cycle system changes both the colored and the white light according to some predetermined time cycle. Figure 11-10 shows such a cycle for three colors. Fifteen seconds after the start of the cycle as shown, the red is off, the blue is on full, and the white is at half maximum; the resultant effect is a blue tint. These changes may be produced by mechanical or electronic devices. This system has the

economic advantage that the colored light, as well as the white light, is controlled and off when not needed.

Since refinement of spectral quality is seldom required in floodlighting, the depth of the coloring in color equipment should be such as to afford as high a transmission factor as possible, or

Amber	40 to 60%	Green	5 to 10%
Red	15 to 20%	Blue	3 to 5%

To go higher than this will cause the effect to appear washed out and lacking in color. If the coloring is deeper there is too much loss of light for economy. It is fortunate that surfaces in colored light need not be brought to the same degree of brightness as white surfaces for the same effectiveness. The following listing can be used to act as a guide of effectiveness:

COLOR	WATTAGE COMPARED TO WHITE
Amber	150%
Red	200%
Green	300%
Blue	500%

This is due principally to the range in the transmission values of color equipment, with modifications based upon the different psychological effects and the different penetrating powers of light of various colors. These effects can be partially traced through the visibility curve.

In estimating the probable power requirements for color lighting of a building, a fair figure is approximately 3 w. per sq. ft. for white light and 6 w. per sq. ft. for colored light. In each specific case the actual power consumption should be determined so that adequate wiring can be installed for proper voltage regulation and thereby the most economical operation.

**10. Summary of Floodlighting Design.** Three methods of dealing with floodlighting design have been discussed in the text material. The first, in Chapter 5, is useful where only a portion of the light from a floodlight reaches the surface or where specific isolux determinations are to be made. The other two methods, given in this chapter, have been shown in specific application. Each method gives a degree of accuracy comparable to its recommended application. The methods given here may be used in a like manner for interior floodlighting installation design, but because of interreflections from ceilings and side walls, there will be a higher illumination attainable than calculated. The amount of increase, of course, depends upon the utilization coefficient of the room.

**PROBLEMS**

Form to be used when recording data for floodlighting design:

Layout

Use \_\_\_\_\_

Location \_\_\_\_\_

Surface Material \_\_\_\_\_

Available Location for Floodlights \_\_\_\_\_

Lighting Effect \_\_\_\_\_

Remarks \_\_\_\_\_

\_\_\_\_\_

Foot-Candles \_\_\_\_\_ Coverage \_\_\_\_\_

Beam Spread \_\_\_\_\_ Mounting Height \_\_\_\_\_

Type of Lamp \_\_\_\_\_ Number of Banks \_\_\_\_\_

Size of Lamp \_\_\_\_\_ Projectors per Bank \_\_\_\_\_

Type of Projector \_\_\_\_\_ Rows per Bank \_\_\_\_\_

Number of Projectors \_\_\_\_\_ Watts per Square Foot \_\_\_\_\_

1. Design the floodlighting for an office building in a city of 75,000. The building surface material is terra cotta of cream color and the front measures 100 ft. wide and 120 ft. above the second story. The roof of a one-story building across a 75-ft. street is to be used to house the projector equipment.

2. Design the floodlighting for an automobile parking lot measuring 300 by 250 ft. The lamps are to be mounted on 35-ft. poles on the periphery of the parking space.

3. Design the floodlighting for a bank building with a light marble front, the building located in a city of 100,000. The building is 75 ft. wide and measures 140 ft. from the second story to the top. The best location available for the equipment is a 60-ft. building 90 ft. from the surface to be lighted.

4. A 500-w. general service lamp is placed in a projector which has a beam efficiency of 45%. If the projector is located so that it covers 1000 sq. ft., determine the average illumination on a surface if the maintenance factor is 70%.

5. A General Electric Form L-31B floodlight was used to illuminate a surface 50 ft. above the projector and 200 ft. away from the projector. If the surface measures 120 ft. high and 65 ft. wide, what will be the average illumination if a 1000-w. lamp is used? What is the efficiency of this combination?

6. Design the floodlighting for an outdoor sign 200 ft. long and 30 ft. high with a system of projectors located behind shrubs located 75 ft. in front of the sign. The bottom of the sign is 25 ft. above the projectors.

7. A temporary display 30 ft. wide and 60 ft. high was illuminated by two floodlights obtained out of stock. One was located 20 ft. to the left of the display, 40 ft. in front of it, and 12 ft. below; the other 40 ft. to the right and in line with the center of the display. The first equipment was a Westinghouse CA-16 with a 750-w. general service lamp and the second a Crouse-Hinds LDE-16 750-w. projector. Determine the average illumination on the display and the per cent of beam lumens which are not effective.

8. Design the lighting for a municipal swimming pool which is 75 by 35 ft. The projectors are to be mounted on the corners of the pool on 30-ft. poles and the general illumination should average 5 ft-c.

9. Compare the per cent lumens lost from the beam of a narrow, medium, and broad floodlight, each equipped with a 500-w. general service lamp and placed 100 ft. from a surface 10 ft. square. What is the average illumination in each case?

10. A medium beam floodlight using a 1000-w. lamp is located 15 ft. from a vertical surface and tilted at an angle of 30°. Compare the average illumination in each of the 16 regions shown in Fig. 10-10 when computed as a projector close to a surface and as in a general floodlighting problem. Express the comparisons in percentage.

## BIBLIOGRAPHY

1. PITTSBURGH REFLECTOR Co., "Floodlighting," *Bulletin*, 1, 1930.
2. NELA PARK, "Floodlighting," *Bulletin* LD-16, 1931.
3. CURTIS LIGHTING, INC., Floodlighting Catalog, 1932.
4. E. B. HALLMAN, "Floodlighting Design Procedure as Applied to Modern Setback Construction," *I. E. S. Trans.*, v. 29, No. 4, April, 1934.
5. NELA PARK, "Illumination Design Data," *Bulletin* LD-6A, 1936.
6. WESTINGHOUSE ELECTRIC AND MANUFACTURING Co., *Artificial Light and Its Application*, 1938.

7. R. J. SWACKHAMER, "Lighting Major League Baseball Fields," *G. E. Review*, v. 42, No. 9, pp. 387-390, September, 1939.
8. R. J. SWACKHAMER, "Winter Sports under Lights," *Mag. of Light*, v. 8, No. 8, pp. 24-28, December, 1939.
9. A. F. DICKERSON, "Revival of Building Floodlighting with Better Load Factor," *G. E. Review*, v. 43, No. 3, p. 139, March, 1940.
10. R. J. SWACKHAMER and G. G. BOBST, "Lighting for Night Sports," *I. E. S. Trans.*, v. 35, No. 5, pp. 447-457, May, 1940.
11. J. A. SUMMERS and DEAN M. WARREN, "Protective Lighting for Industrial Plants," *Mag. of Light*, v. 9, No. 8, pp. 35-43, October, 1940.

## CHAPTER 11

### NOVELTY LIGHTING

Novelty lighting is closely associated with showmanship, and its appeal must be that of attraction. Some novelty installations are designed for permanence, but for the most part the design is for temporary use only. As long as its novelty lasts it will attract but, after seeing the installation a few times, the average patron turns to another attraction that is new. The novelty lighting design is usually associated with some form of luxury or entertainment, for it caters to a public that is restless and must be entertained or it will become bored.

Theaters, expositions, restaurants, cocktail bars, night clubs, and dance halls must produce stimulating attractions to draw patrons to their doors; therefore, these concerns are always alert for the unusual in schemes of decoration. It would be impossible to discuss the thousands of schemes that have been developed but, since all of them are built upon the same fundamental principles, these principles will be discussed, and a series of suggestions which may be modified will be given.

**1. Elements Involved in Novelty Lighting Schemes.** The basic elements which are combined or used singly in all forms are few. A list of them will contain:

- a. Projection:
  - Clear image
  - Diffused image
- b. Color
- c. Motion
- d. Shadow
- e. Silhouette

Under color will be included the light sources which produce various color effects, such as mercury, sodium, and ultra-violet.

As discussed in Chapter 3, color and shadow are factors of importance in recognition, but they may be used to confuse as well, and, because of human dependence upon these factors in recognition, they may lead to the development of illusions. Often the most striking effects are the most simple to construct and operate.



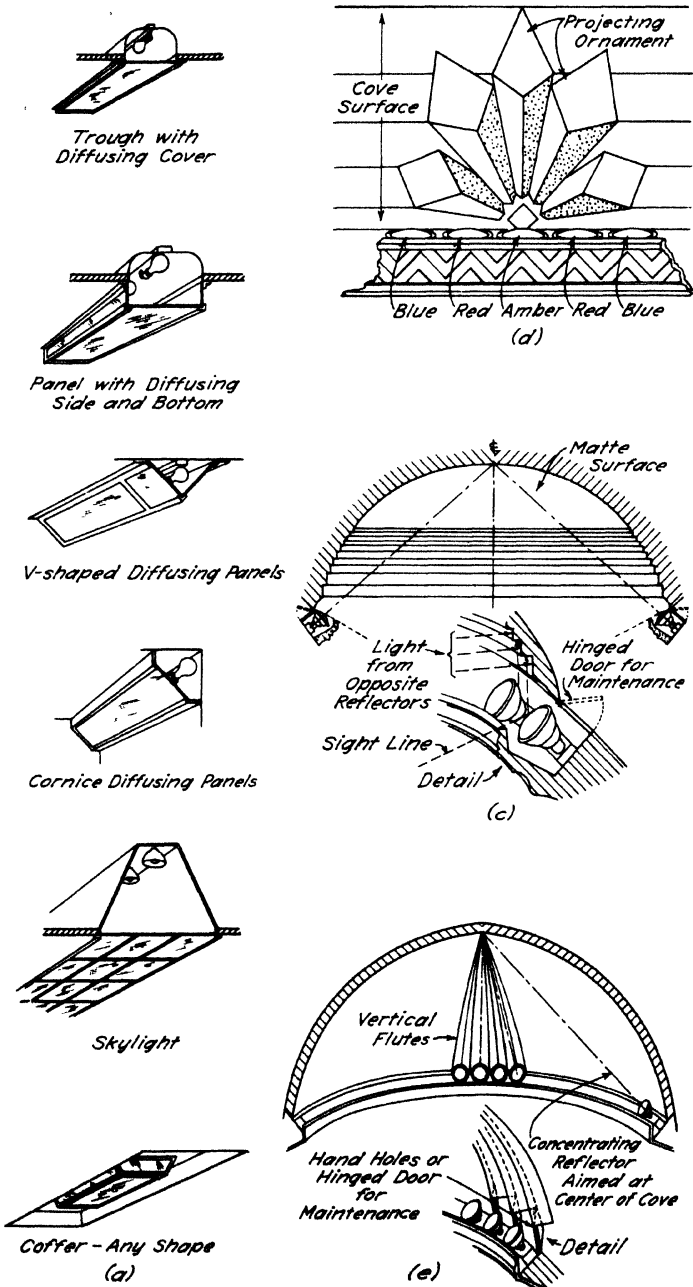

Fig. 1-11A.<sup>4,22</sup> Lighting equipment and covers may be converted for novelty lighting.

The examples given are difficult to classify, because in each several of the basic principles may be present. The classifications are, therefore, based upon the major factor that is operative in producing the effect.

**2. Novelty with Luminous Elements.** In Chapter 9, the luminous element was discussed from the viewpoint of utility in furnishing lighting for some specific task. The elements are even more important in their possibilities for novel effects. Any of the standard elements as shown in Fig. 1-11 may be arranged into the architecture of the club, theater, or night club and treated with color or special glasses for sparkle or diffusion, thus providing novel effect. The character and location of the element will be a matter of aesthetic design. The usual precautions must be taken in installing these units, and the de-

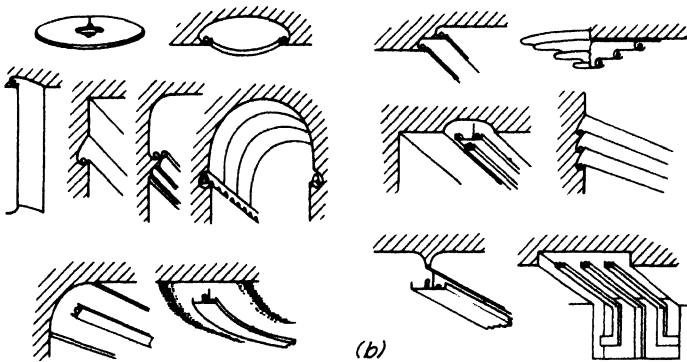

FIG. 1-11B.<sup>33</sup> Luminous elements used for novelty lighting.

gree of brightness must be controlled as in any luminous element, but it is seldom that places of amusement require high illumination. It is more usual to have a very subdued, but interesting, lighting system. Combining the luminous element with various forms of down-light permits the most satisfactory treatment of the novelty element without a sacrifice of necessary illumination. The down-light leaves the ceiling dark and this darkness is useful in extenuating the color and sparkle of the luminous element.

In the class of the luminous element are coves and coffers. Figure 1-11B shows some of the variations that may be used in making this type of element interesting in a decorative way. Where several rows of lamps are needed, it is possible to use lamps of different colors in the various coves.

If a single lighting strip is used, a very interesting novelty can be obtained by arranging lamps of different colors alternately in the strip

and putting them on separate circuits so that they can be controlled for blending or periodic changes.

The ceiling as a cove proper may be made unusually interesting with many forms of pattern, shadow, and multilayer lighting. Figure 1-11c illustrates a form of surface treatment of a cove which will give striations of color if lighted from opposite sides (cross projection), for the spill light from one cove will light its own undersurface and its vertical surface will be lighted from the projector on the far side.

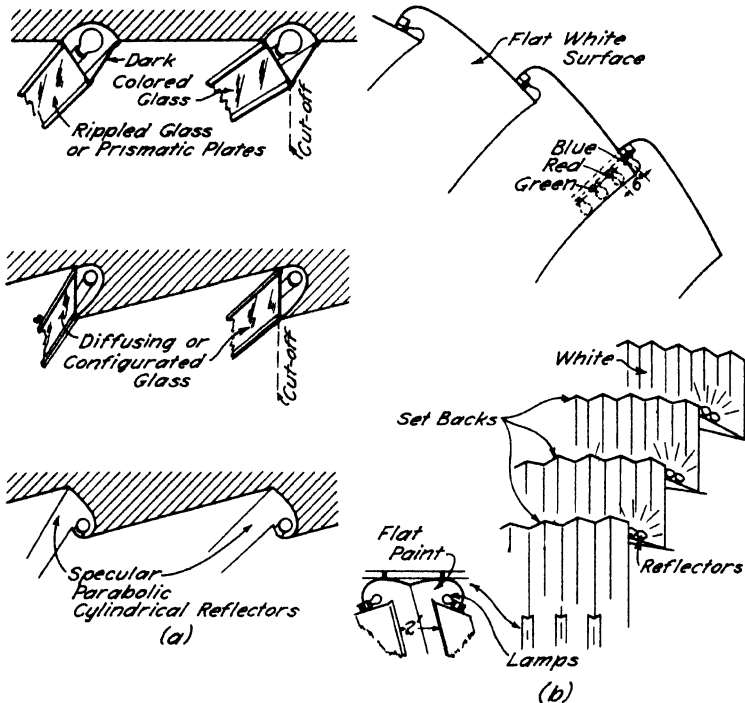

FIG. 2-11.17.<sup>22</sup> Luminous elements and setbacks used for novelty lighting.

Figure 1-11d shows the effect of placing a relief in the cove purposely to throw interesting shadows. If various colored lights are used in conjunction with the pattern in relief, the effect will be that of a colorama, which will be discussed later. Soft shadows are the result of a diffusing light and harsh shadows may be obtained by using plain lamps with colored glass or clear lamps. If reflectors are used, they will give a better utilization of the light but will also tend to smooth the edge of the shadow. Usually the shadows will be sharp enough for the effect desired. Figure 1-11e shows the cove equipped with vertical flutes, and these angular flutes change the entire appearance of

the cove. The reflectors are so placed that each will light one individual flute. In small coves natural colored lamps can be used, but a concentrating reflector is necessary in the large ones.

Directive luminous elements as shown in Fig. 2-11a are of special value in novelty lighting. These may be used where it is desirable to control the light in one direction. If ceilings are low and the patrons

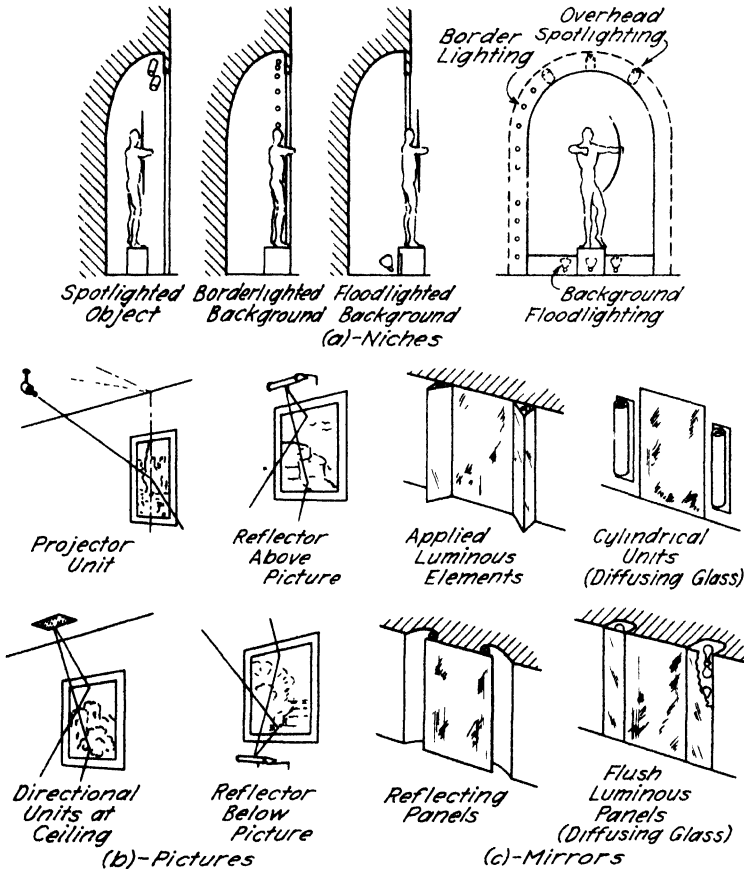

FIG. 3-11.<sup>33</sup> Niches, mirrors, and pictures have effective uses in ornamental lighting.

are facing so that the dark side of the element is in the line of vision, it will be considerably more comfortable than facing an exposed light, and at the same time the lighting will be subdued. These methods are also applicable for under balcony lighting, and even the ceilings of large halls and auditoriums have been treated in this manner. Figure 2-11b shows a directive unit which can be used as a background for a band stand or for a shell for stage performances.

In the luminous element class are three devices that may be used either for attraction or decoration. Figure 3-11a shows three methods of lighting niches, either large or small. These niches are excellent for turns in stairways, lobbies, corridors, and lounging rooms, and are enhanced by statuary and cutout designs. Light from behind the object produces silhouette effects and translucent material may be of a particularly expressive nature if lighted from one side. Figure 3-11b

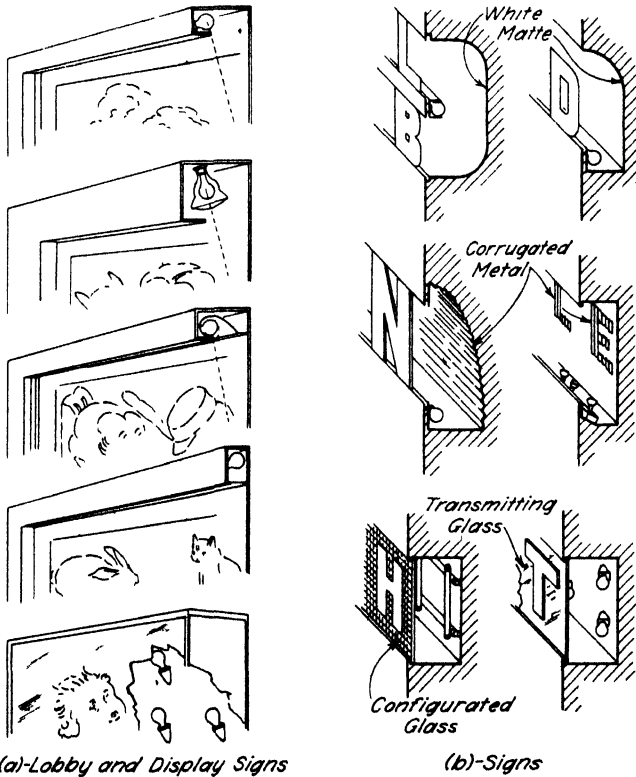

FIG. 4-11.<sup>23</sup> Signs must have the element of attraction.

shows several methods of illuminating pictures or announcements, and even arrangements of small mounted objects. A picture should be evenly lighted without any annoying reflected glare. Highest candle-power of the distribution curve of the equipment should fall on the lowest part of the picture or announcement. If the light is from below the reflected light is upward and out of the range of vision, but it is difficult to arrange such lighting without unsightly equipment. Such architectural treatment as medallions and large murals are frequently

lighted by floodlighting arrangements properly concealed. The lighting in a niche or on a picture should be at least 5 or 10 times more than the surrounding light to give it the proper prominence. Figure 3-11c shows various methods of lighting mirrors. Lighting for a mirror should fall, as much as possible, on the object to be viewed rather than on the mirror. A diffused source of low brightness is the best source of light. One of the most serviceable lighting methods is a completely hidden light source from which the light upon the object is indirect. Statuary, flowers, and various materials form attractive novelties when placed before the mirror.

Figure 4-11 suggests several means of lighting displays and announcements and some methods of producing silhouette signs or attractive pattern schemes for novelty. The cases shown in Fig. 4-11b are subject to all types of modification. Instead of a corrugated material for a background, a crumpled foil is particularly attractive.

**3. Novelty with Color.** Chapter 4 dealt with color in an objective manner, giving means of mixing and methods of producing. Color lends itself so easily to attractive lighting in so many various forms that it is the one device used most extensively for advertisement and attraction.

Figure 5-11a shows an arrangement which will produce a wide sweep of mixed and elusive colors over a screen. (The wheel is thrown out of focus with respect to the screen.) If several wheels are rotated in the beam from the spot light and are not synchronized, the pattern will be always changing, and the use of alternate wheels going in opposite directions is very successful. Introducing several wheels of configurated glass and a color screen in the beam is another method of producing unusual novel effects. Wheels have been used which were made up of several sections containing pieces of broken cut or embossed glass, so that there was a continuous change of pattern as the wheel rotated. There is no limit to the combination that may be made with revolving wheels of materials and color screens thrown upon a screen out of focus. One unusual effect is produced by geometric figures cut out and placed in one of the revolving discs.

The kaleidoscope consists of two mirrors inclined at some angle which is a submultiple of 360 degrees. Figure 5-11b shows an arrangement with the mirrors inclined at an angle of 36 degrees; the resultant image is made up of ten patterns. The mirrors form a symmetrical arrangement of the images, and they are formed in great varieties as the particles are agitated, usually by rotating the end pieces before the mirrors, changing the patterns unexpectedly from one graceful

form to another. This figure shows the observing tube tapered from its base to the end. This is not necessary, and more light is available if the mirror tube is straight. It is difficult to obtain enough light through the objective lens to produce a large image, but the results are startling and interesting, making this device worthy of effort in developing novelty effects.

The usual method of mixing colors on a neutral background by the use of dimmers (additive color scheme) has been used for a very long time, and draperies carefully arranged with the correct color lighting still forms one of the most attractive effects produced with color.

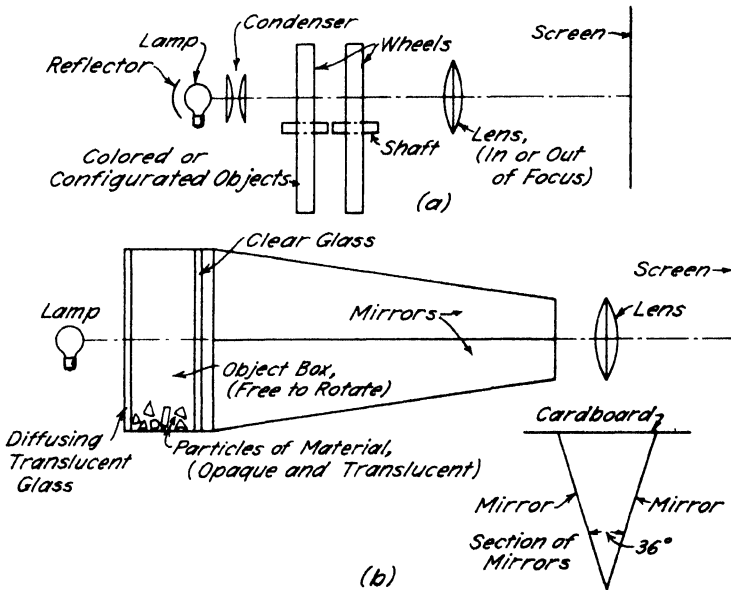

FIG. 5-11. Color wheels and kaleidoscope may be used for projected patterns.

The folds of the drapery or curtain produce the finest kind of shadings, and the mellow shadow involved adds a characteristic that cannot be obtained by any other means. Direct incident light produces strong, bold effects and the cross lights produce color mixtures and subtle light effects.

Some of the more common ways of making color light for novelty most effective are given in the following examples:

Glass blocks (Fig. 6-11a) have been previously discussed as a means of general lighting or for light panels. Special formed glasses may be substituted for glass blocks. They give a more subtle effect in novelty lighting. The fluted and embossed surfaces modify pronounced light

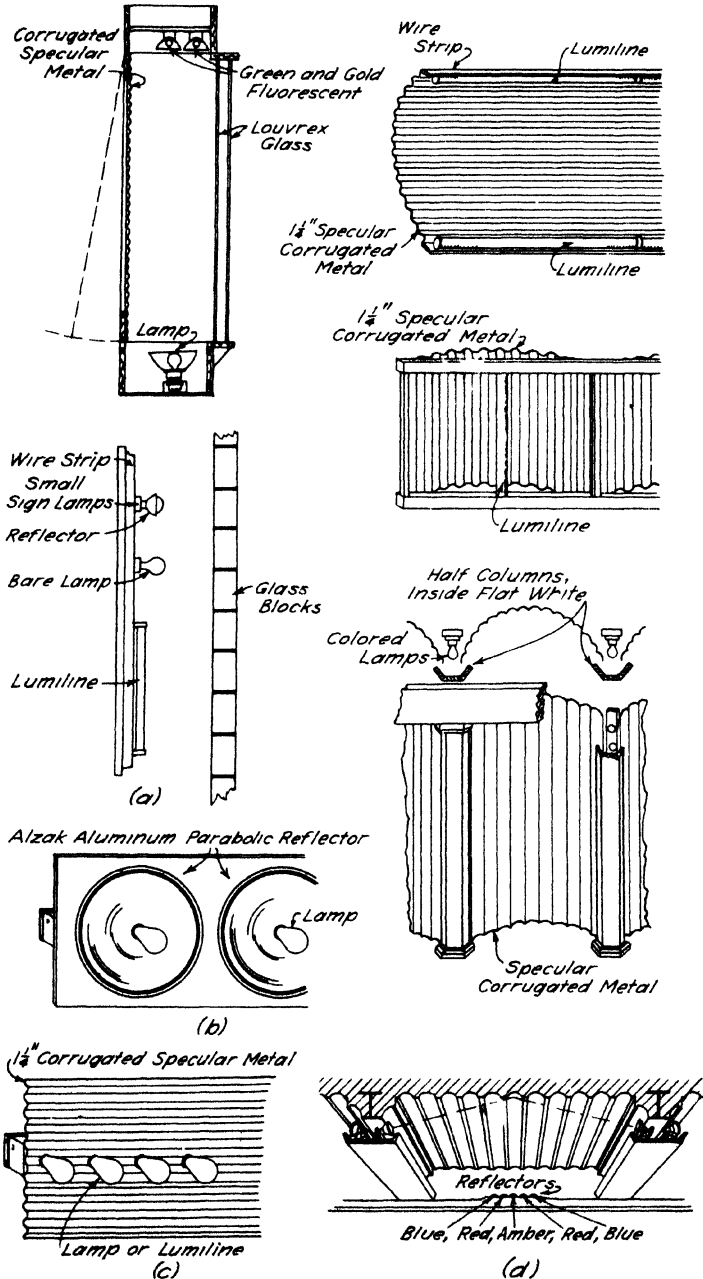
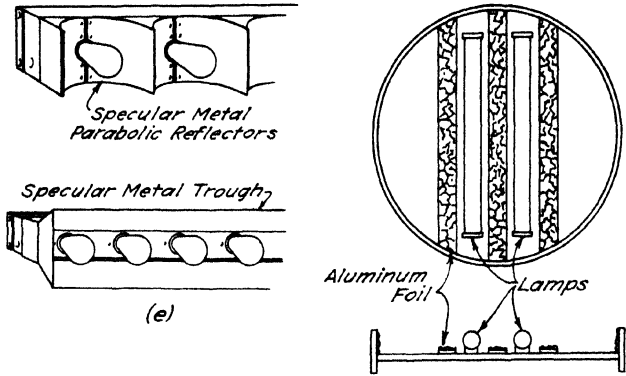

FIG. 6-11A.<sup>1, 4, 28</sup> Configured glasses, glass blocks, and corrugated metals may be used for novelty effects.





Metal or Cardboard Patterns with Lamp in Center. Sparkle from Ground Glass or Crinkle Foil

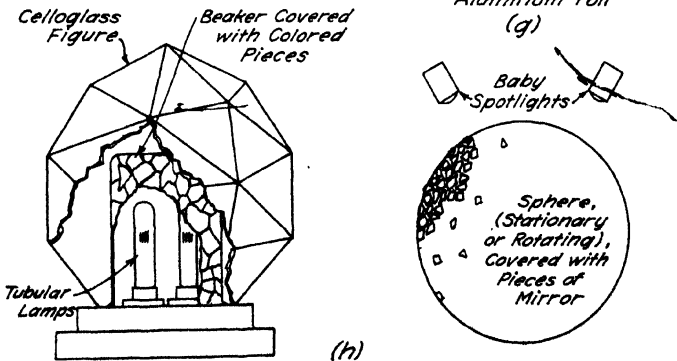
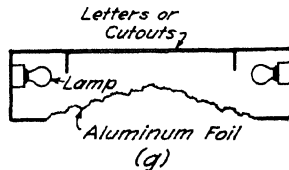
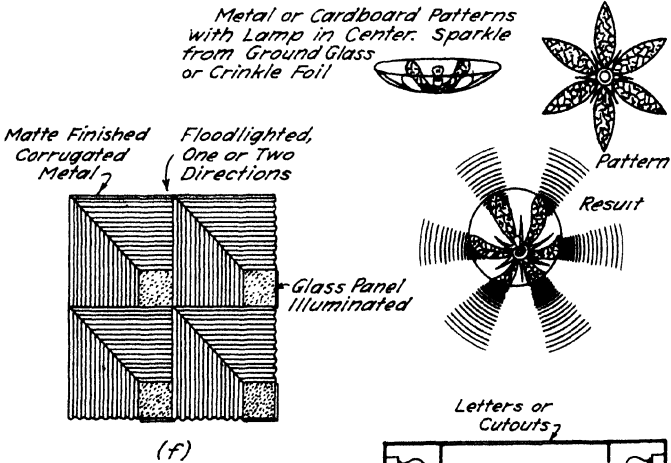

FIG. 6-11B.<sup>17, 22, 23</sup> Foils, plastics, shaped troughs or any glittering materials respond under the play of light.

beams. If the fluting is such that flutes are at right angles to each other, the designs will be of particular effectiveness when lighted with lumiline, fluorescent, or incandescent lamps, or with small sign units which include the lamp and the reflector as one unit. The line light sources may all be in one direction, but if placed at right angles to each other, either parallel to the sides of the blocks or on diagonals, the effect becomes doubly interesting. The line (lumiline and fluorescent) sources may be combined with incandescent lamps for new designs. Neither color scheme nor arrangement need be fixed, and the design may be mobile.

The illusion of falling water may be obtained by using a slowly moving endless belt of silver cloth, properly illuminated, as a background. The best illusion is obtained with glass blocks that are ribbed or cross ribbed, or have ribs running in a horizontal direction. The effect is for relatively close viewing.

Other interesting and spectacular effects may be obtained with polished corrugated metal as a background in conjunction with colored lamps. Rotating wheels having line source and incandescent lamps with or without reflectors fastened to the wheel produce ever-changing effects at small cost. If streamers of colored cellophane are located between the source and the panel and agitated with a fan, moving color effects may be produced. Sheets of crushed colored cellophane between the source and the wall will have special effects of interest. A random painting or daubing of the background with color will produce a color effect somewhat different from those brought out by colored lamps directly behind the glass block. A mirror placed to reflect the image from a color wheel on the blocks is another method of obtaining mobile color combinations.

## COLOR

*Reflectors* and any number of reflector arrangements with colored lights give an interesting control of a multiplicity of pattern effects.

a. (Fig. 6-11b.) Spun oxidized aluminum reflectors of parabolic shape with the lamp at focus, collect the light and send a major portion of it in one direction. Clear lamps can be used but more interest is obtained when the end of the lamp is colored or has a colored cap. The use of a silver-bowl lamp will produce a striking effect. The lamps should be small in size so that no annoying glare is produced.

b. (Fig. 6-11c.) A polished corrugated metal reflector (flat or shaped) lamped with a row of incandescent lamps or a combination of incandescent and line sources is one of the latest practices which

has been very successful. Since the metal gives specular reflection, the lighted lamps produce a multiplicity of sparkling images. The reflected light from any one lamp is spread in one direction only, so that bands of light just as wide as the lamp are formed in each instance.

Brushed stainless steel can be used in a similar manner to give somewhat the same appearance. The effect will be color bands of high brightness, but there will be less sparkle than from the corrugated material.

c. (Fig. 6-11d.) Curving the corrugated polished material and using it with line sources produces an entirely different effect. Here again different colors may be used — and a contrasting one if desired. The lamps at the focal point will cause a long series of stripes as each edge picks up the light. These may be placed either horizontally or vertically in making up the length of the design.

d. (Fig. 6-11e.) Specular reflectors of various shapes may be used for housing colored lamps, thereby producing multiple images. Two forms of reflectors that have found recent use are: those of parabolic shape in a series of reflectors, one beside the other, and the continuous trough with a trapezoidal shape attached to a rectangular section.

e. (Fig. 6-11f.) The use of oxidized aluminum or porcelain enameled sections with corrugations at right angles and framing a colored light box may be made of particular interest if the translucent material serves as a contrast while the whole is floodlighted in color. The enameled surfaces may be of different colors on the various sides.

Any of the strip lights discussed may be made into many designs, of which the element may be the unit part. Unit elements of some types can be used to build up letters arranged into signs.

*Crushed foil* (Fig. 6-11g) may be used in many forms of lighting to give a different and attractive background. If foil or light sheet metal (either specular or depolished) is crushed at random, there will be facets at every angle so that a light source in the vicinity of the crushed surface will be reflected from all angles. If several colored light sources are present, some facets will reflect one source and others adjoining but at another angle will reflect other sources. The polished material produces highlights and sparkle; the diffusing types of surfaces produce a softer light and give a pastel effect.

*Globes and geometric forms* (Fig. 6-11h) lighted from either the interior or the exterior with colored light are used as centerpieces or for light dispersion. The simplest form is the molded sphere which is covered with pieces of broken mirrors and is illuminated by baby spotlights. If the spotlights are clear and white, the result is a dazzling,

sparkling device. Rotating the sphere or other geometric form results in a series of bright spots moving over the whole interior. If the baby spotlights are colored, the result is a multitude of colors reflected to all surroundings. When the room has mirrored side walls, the interreflections are doubly interesting.

If the ball or geometric figure (usually an icosahedron) is made of translucent material, colored light can be introduced into the interior and the whole will be illuminated. One scheme uses two tubular lamps under a large beaker which is mottled with transparent colors in any form of arrangement or random spotting desired. There will be projected color on the translucent surface. If the light is made mobile or if flicker buttons are used with the lamps, there is a series of colored patterns drifting over the surface continually.

*Fleurets* (Fig. 6-11g) are devices often used for tree decorations during the holiday season but need not be confined to this period. The pattern is a part of the lamp proper or a special reflector. The fleurets remove the monotony of festooning and outline lighting and add accent and finish to the design. They may consist of small reflectors formed in floral or geometric shapes and, where the design is large or to be viewed from some distance, these are best, but if the design will be viewed closely, as in interiors, the lamp may be stenciled in color or may have a cutout stencil over it in order to produce luminous designs on the reflector. With stencils, polished reflectors are used, but with colored lamps a matte reflector gives the best results. The smaller units may be combined into large pattern designs.

**4. Mobile Color Lighting.** Mobile color lighting is the basis of many novelty lighting effects. There are several methods of control, namely,

- a. Resistance dimmers
- b. Autotransformer dimmers
- c. Reactor dimmers

which are used to blend primary colors to produce brightness and quantity gradations with smooth regulation. Dimmers may be manually or mechanically controlled through some predetermined cycle. The equipment may be applied to the smallest show-window display or to the most elaborate floodlighting system for a large building.

*Resistance dimmers* (Fig. 7-11c), the oldest type of control, operate on an energy waste principle. The dimmer must be designed for the exact load carried, for an overload will destroy it, and if it is not fully loaded, it is not effective in dimming. Figure 7-11a shows the charac-

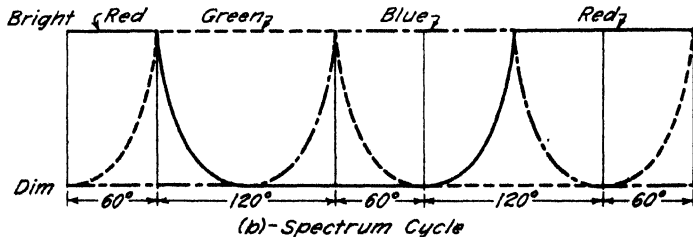
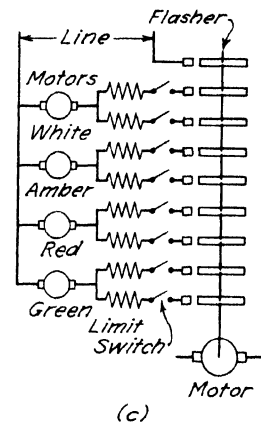
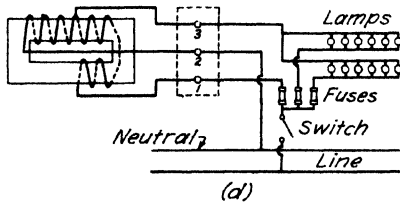
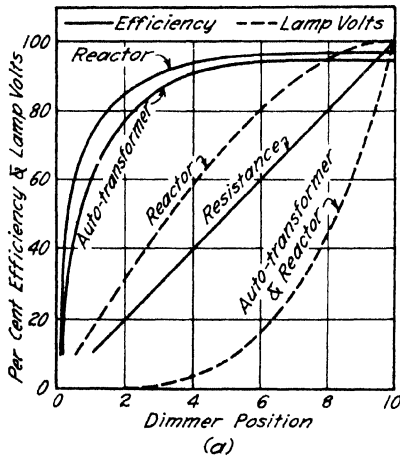
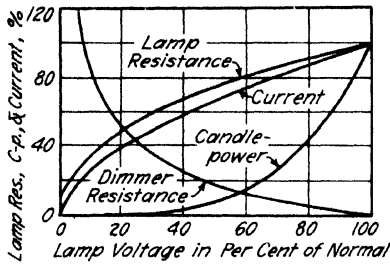

FIG. 7-11.<sup>23</sup> Methods used for light control with dimmer equipment.

teristic curve of the incandescent lamp and the dimmer resistance necessary to cause a uniform dimming with a proportional movement of the control handle. If dimming is to be effective and without flicker, it is necessary to have about 100 points on the dimmer plate.

*Autotransformer dimmers* (Fig. 7-11d) are more desirable than resistance dimmers in that, instead of controlling through the current flow, they control through the voltage change. This prevents waste of energy as compared to the resistance dimmer, and removes the heat problem which is encountered with large switchboards and control boards.

*Reactor dimmers* (Fig. 7-11e) are also of the voltage control type and depend upon a "choking action." The two windings are so connected on a common magnetic path that they can be caused to react upon one another. One winding, carrying the alternating current, is connected to the lamps and the other (center leg winding) is supplied with direct current. When direct current is flowing, the iron core is saturated by the magnetic field, and the lights will burn brightly, but if the direct current is removed, the reactance is increased and the lights are dimmed. The control is smooth and easily applied at any distance from the reactor by means of a low-voltage signal system. The direct current may be supplied by thyratrons which are subject to fine and accurate control through their grid circuits. A complete and complicated control of this type for the most elaborate system of the finest opera house can be placed within easy reach of one operator.

All of these systems can be made subject to automatic control and to any cycle which may be desired. Figure 7-11b shows a complete color spectrum cycle. The equipment must be correctly maintained, and wherever contacts are embodied in the equipment, they must be kept clean and adjusted. The autotransformer and reactor controls are only good for the control of light in a-c. systems. If only a d-c. system is available, it will be necessary to change it over to a-c., or if this is not economical, resistance dimmers must be used. If abrupt changes are not objectionable, or the action of the sequence requires periodic quick changes, a sign flasher may be used.

Some efforts have been made, and some success claimed, in coordinating color and music. The motion picture house early recognized possibilities along this line. The possibilities depend upon psychological coordination between color and light, which may produce pleasing or undesirable reactions. The music must have a color cue, and the colors are played at a keyboard according to the cue sheet. This is a field that is practically open in all its forms for the experimenter in novelties.

**5. The Colorama.** An interplay between color and shadows provides a wide variety of color and pattern effects. Even the simplest system is expensive compared to the other methods of producing novel effects. If a single color is thrown upon a surface, the result will be

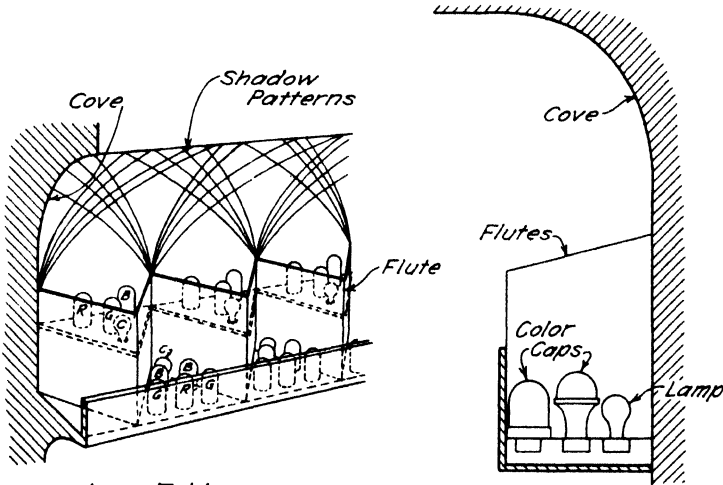

Lamp Table

Front of Flutes		
Color	No.	Watts
Blue	2	200
Green	2	60
Red	1	60
Clear	1	200
Back of Flutes		
Color	No.	Watts
Blue	1	200
Green	1	100
Red	1	150
Clear	1	100

(a)

Lamp Table

Color	Group I		Group II	
	No.	Watts	No.	Watts
Royal Blue	2	50	2	50
Ruby Red	2	25	1	50
Tree Green	2	25	1	25
Inside Frost	1	25	1	25

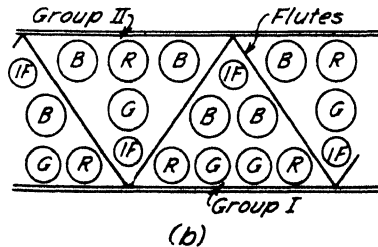

(b)

FIG. 8-11A. The colorama and its construction.

an illuminated surface of that color but, if an object is interposed between the light source, a shadow will be cast which is a surface of zero light. Now, if a different color source is thrown on the same surface the result will be an illumination of the shadow in this second color, a mixture of the two colors, and another shadow from the second

color illuminated by the color of the first source. The shadows will be illuminated by every color except the one causing it to be formed, and all areas free from shadows will be illuminated by a mixture of all the colors. In using this principle, the resultant effects will be limited only by the variety of shadows and color combinations.

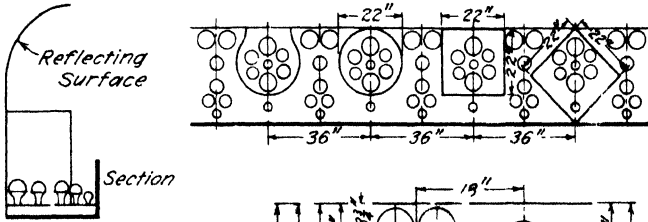

By using the various pattern boxes, all of one type or mixed, any number of different kinds of colorama may be formed.

Lamp Table

Group I		
Color	No.	Watts
Blue	2	300
Red	2	200
Green	2	150
Clear	2	75
Group II		
Color	No.	Watts
Blue	2	300
Red	2	200
Green	2	150
Clear	1	75

(c)

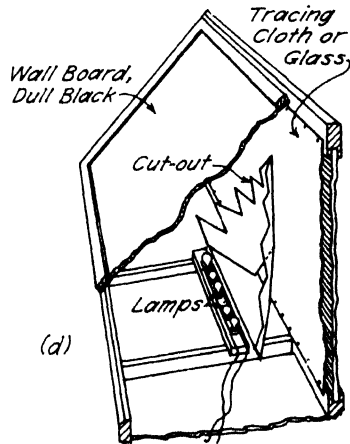
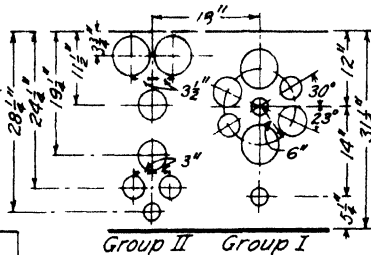

FIG. 8-11B.<sup>1,4</sup> The colorama and its construction.

Figure 8-11 outlines some of the possibilities in this type of lighting. The layout schemes in the figure and the table of lamp sizes with each unit are sufficient for making up a design. Though natural color lamps are available for use, it is better to use color caps and standard lamps. The colorama can be controlled by any form of mobile lighting desired. If methods of switching alone are used, the pattern may be changed as desired.



**6. Pattern Projection.** The projection of patterns may be through regular optical projectors or upon the camera obscura principle. Endless novelty effects and patterns may be projected from slides. Color can be introduced by means of regular methods of slide coloring or with natural color photography, and actual color in scenes or from art

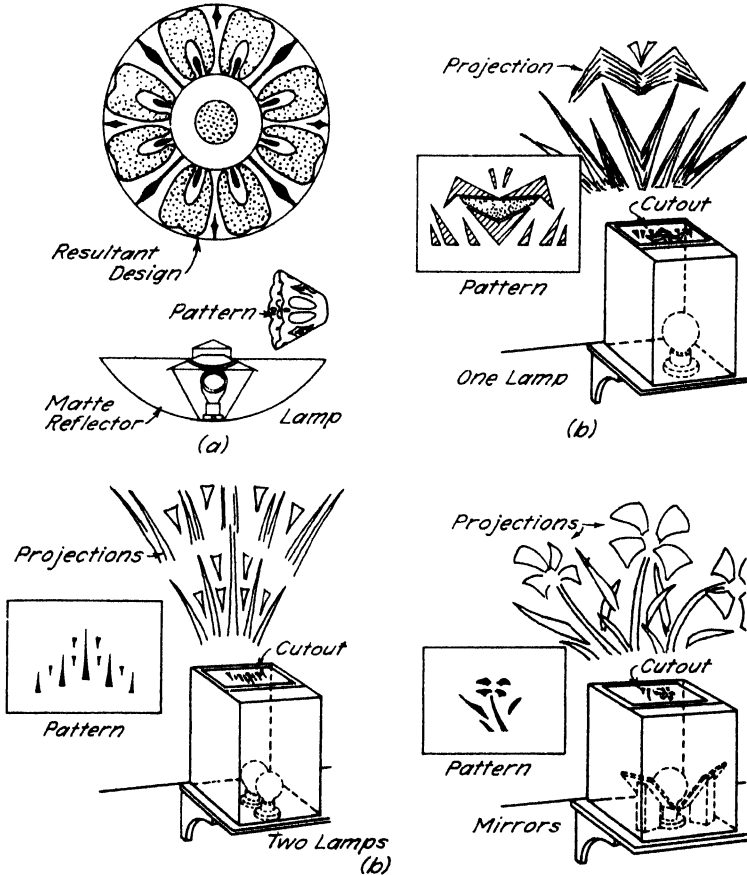

FIG. 9-11A.1.9 Projected patterns.

work may be reproduced in natural colors. A series of these projectors hidden behind screens, coves, or architectural elements of the room may project whole murals or scenes upon the walls. By using continuous projection machines, the scenes may be changed or a decoration may be given the elements of actuality. This method has been used to reproduce a detailed under-ocean scene, and a scheme was once

introduced showing a tower in which a clock recorded the correct time by means of projection.

In addition to the methods mentioned which have found such general use, there are others which depend upon simple devices not requiring optical equipment. Some of these are:

*Chromaflectors* (Fig. 9-11a) depend for their effect upon a changeable cone introduced between the light source and the reflector. It is a simple device consisting of a reflector with a matte or semi-matte surface and a lamp over which is placed a truncated cone in a decorative pattern filled in with color media. Endless changes in color and pattern may be made by changing the design on the cone. The reflectors may be made of cardboard for temporary installations and of spun metal for permanent fixtures. The possibility of giving a new aspect periodically is useful to the decorator.

*Projected light patterns* (Fig. 9-11b) are a form of decoration which may be easily changed at will and may be made up very inexpensively. The method employed is the camera obscura, and is the same principle as the Linneback lamp used on the stage to throw whole scenes on a background. The pattern is cut out of some opaque material and placed over a box painted black on the interior and containing a concentrated filament clear lamp. Projection and floodlight lamps are best, but the mill type of clear lamp is satisfactory. The rays of light emitted from the filament pass through the cutout and the image is reproduced on the wall or ceiling surface. The picture may be reproduced in color by using colored material over the openings in the cutout. Cellophane serves this purpose inexpensively.

The number of images may be multiplied by using additional lamps or by placing mirrors at proper angles in the box.

If colored bands are used instead of a cutout and two lamps on cycle equipment are used, there will be a fan-like set of colored streaks on the surface and correct timing of two or more lamps will produce an apparent sweep of colored light rays across the surface. The cutouts need not be large, and small lamps (even automobile lamps) may be used; therefore it is possible to install a system of this type in a very small space (Fig. 9-11c). For permanent installations, glass and metal may be used on the cutout proper; the wiring may be of wire channel type connected to mobile light equipment.

The lighting need not be confined to frieze, mold, or cove but may be embodied in the individual fixtures. Stencils (Fig. 9-11c) confined in the edges of the equipment or wire shadow patterns in the top will each produce a pattern effect on the ceiling. This is particularly good for application in a small interior where economy is of utmost im-

portance. Here a play on color can be inexpensively obtained and, since any large central fixture is usually made up of several circuits, the use of these individual circuits for flexibility in pattern may be a simple solution for a variation of effect.

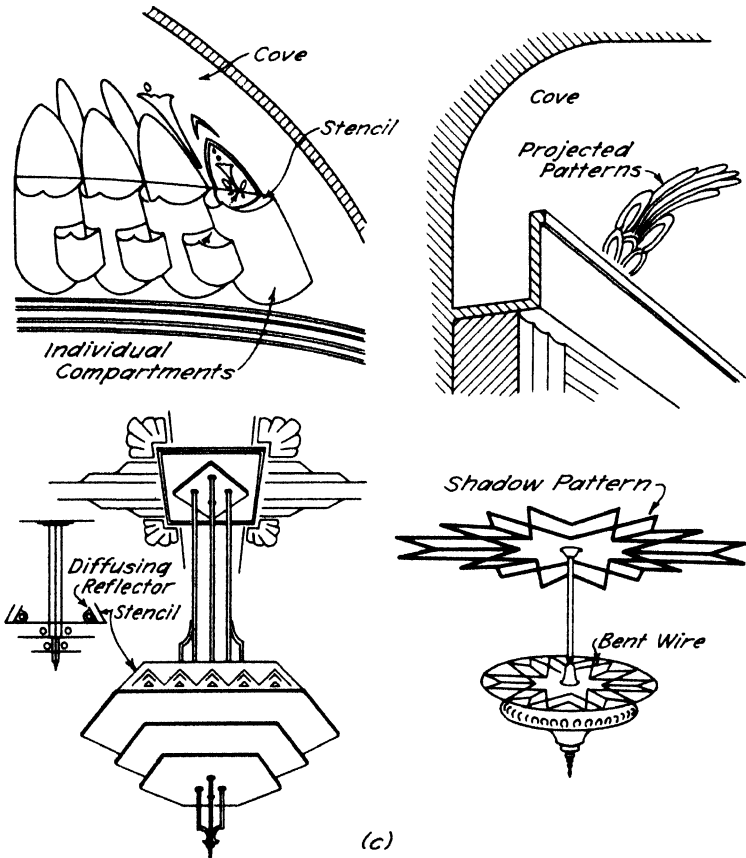

FIG. 9-11B.4.<sup>23</sup> Projected patterns.

**7. Conduction of Light.** The conduction of light through media has played probably the smallest role of any type of novelty lighting, but with the development of plastics and the use of plate glass and glass rods with proper characteristics, many suggestions can now be made for the use of this method in obtaining effects.

Lighting plate glass strips from the edge permits the forming of geometric or futuristic patterns in various lines of design and color. The lights are hidden and the glass, acting as a light fin, forms an

attractive pattern. A combination of rods and glass sheets on edge introduces another method for building up designs.

*Cane glass* (Fig. 10-11) may be bent into various forms and designs which will conduct the light and be of unusual interest. The lengths of glass must be suitable for high light transmission and low refraction. Quartz, though best, is very expensive, and Pyrex has been used successfully for this purpose. Since the light is conducted through the rod, it has a pleasant glow, and if the ends are exposed, there will be a bright spot of light. Faults and blemishes in the glass will glow interestingly, and slight etchings will stand out prominently. The

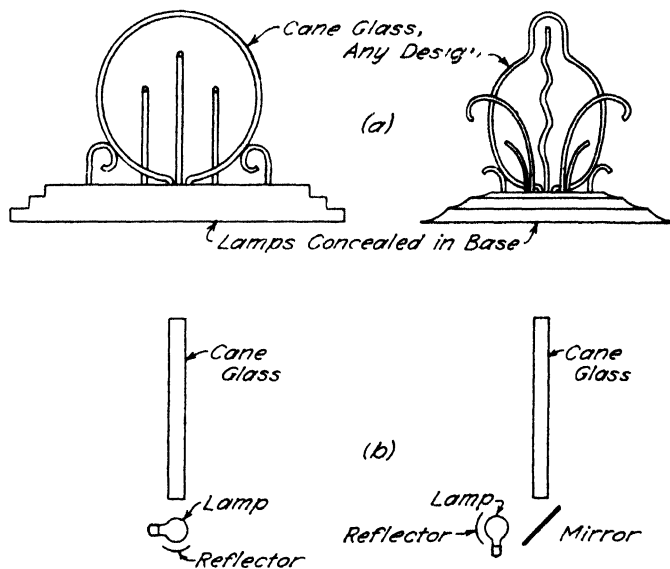

FIG. 10-11.<sup>9</sup> Cane glass and plastic rods.

light is introduced into the rod by using concentrated lamps concealed in a housing or by prisms and mirrors used to bend the beam at the rod. This forms a dignified and restrained decoration.

**8. Shadows and Silhouettes.** Shadow and color combinations have been discussed previously, but shadow in itself can be made an object of attraction. Soft shadows are thrown by diffused light; sharp, harsh shadows are formed by projectors. Screens of various shapes made of tracing cloth, tracing paper, etched or sand-blasted glass, or translucent material will pick up shadows projected from the rear. Plants, draperies, furniture, or heterogeneous arrangements placed in front of a light and behind the screen will act as a decorative unit. Frequently, suspended streamers of crepe paper when agitated will

form a background for other demonstrations which are characterized by movement. The shadoscreen has been used in various forms of entertainment in which the action was projected on the screen in silhouette by using projectors behind the actors.

*Superposed color elements.* In this group are included silhouette signs and architectural elements applied to the special purpose of decoration. The principles permit the use of contrasting colors in juxtaposition. It is possible to create an impression of depth and translucency in opaque materials. There is available a variety of textures for backgrounds, and by means of superimposed color and relative brightness, soft patterns having a contraction and expansion are produced that cannot be produced with light in any other form. These methods may be used in both small and large designs.

Trees, flowers, and any number of geometric forms including signs may be arranged in superimposed colors. A control can be devised for giving continuous changing effect, or the color scheme (if static) may be changed periodically.

*Cutout patterns* of any subject (Fig. 11-11A) may be interpreted in single layers or multilayers. The multilayer scene may be lighted in various colors for each separate step, and this lighting may be of different degrees producing depth and a positive third dimension. This may be used in signs and in drawing attention to merchandise of various types. Exploded and skeleton cutout patterns may be illuminated to attract attention to the special features embodied in a device.

*Shadoscreens* (Fig. 11-11b) are made of some translucent material (a good material is lacquered muslin) which intercepts the shadow of a flower or other artistic arrangement. The interest may be accentuated with two or more colors of light, and these may be static or changing. The pattern is necessarily of low brightness and is to be used in subdued light. It may carry a simple design for daylight appearance, and then be illuminated for night. Whenever illumination is used, the design of the material making up the pattern will not affect the shadow picture. The screen may be used for background, or the change of action may take place behind the screen and become a part of the design scheme. Shadoscreens have been used for profile photography and for the demonstration of shadow graphs made by forming the hands into interpretive designs.

*Light mosaics* (Fig. 11-11c) depend upon cutouts and separately lighted compartments or upon separate boxes of individual light arranged in mosaic pattern. There are many shapes of cast and blown glass and geometric luminous forms which may be applied upon a

surface, either ceiling or wall. These are often arranged in patterns on boards. They are made of flashed opal glass and are available in different sizes. White or colored light or a mixture of several colors

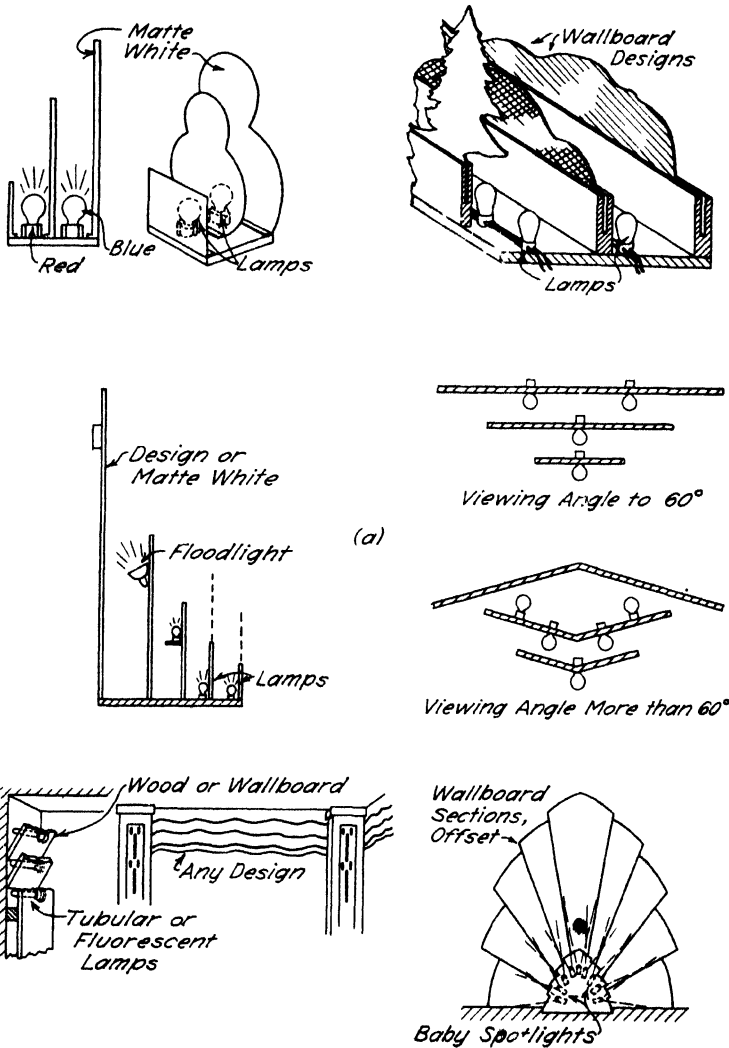

FIG. 11-11A.<sup>1, 6, 22</sup> Setbacks.

in any pattern arrangement may be used. The glass has a transmission factor which compares with ordinary enclosing glassware.

Painted boxes, indirectly lighted, when placed in a pattern of alternate light and dark surfaces will produce a checkerboard effect

which may be used for framing openings or for backgrounds. These effects may be obtained in either static or mobile color. The boxes

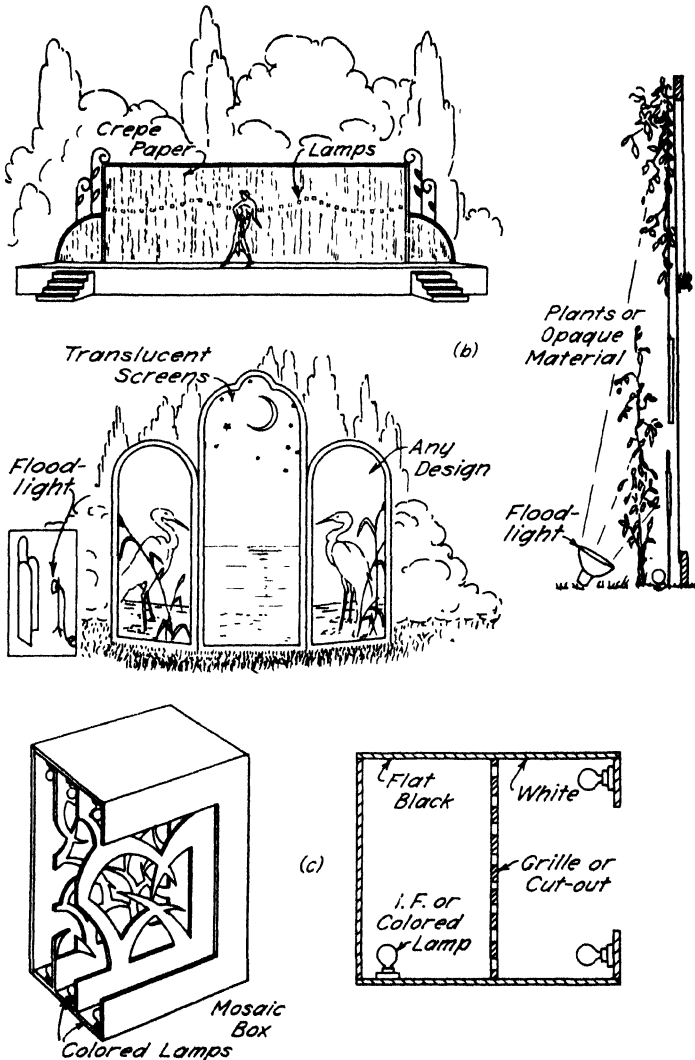

FIG. 11-11B.<sup>1,9</sup> Screens and mosaics.

of light panels need not be square but can have any desired shape. Forms of grill work built up in this manner are interesting, and a grill built of a series of troughs which are illuminated may be used to form a mosaic effect.

If several grills are placed in a box in such a manner that the first is quite open, the next partially obscuring, and so on, each grill being lighted by its own individual set of lamps, a very interesting mosaic is formed. If the lamps in the various compartments are of different color and are under manual or automatic control, the pattern may be changed with each change of lights. By placing each offset under a cycle system, none of which repeats regularly with another, a limitless number of varying patterns may be formed. If dimmers are used as well as a cycle change, colors changing in intensity may be superimposed upon pattern and mobile change. This is a form of novelty lighting which has limitless opportunities, for as one looks at such a decoration from different angles, the colors blend into a marvelous mosaic.

An interesting variation of the general scheme employs a grill or plate of cast glass with ornamental openings, which may be tinted or etched. This plate is mounted in a box with a white background having two rows of lamps, one in front and one behind the plate. When the front row is lighted, the surface shows up by reflected light, but when the back row is lighted, the surface is illuminated by transmitted light. In addition to the reflected light when the front is lighted, there is an intermingling of shadows which is very attractive. It is also possible to use various color combinations in these arrangements.

**9. Pylons, Columns, Pilasters, and Mushrooms.** These forms have been the hand tools of designers of expositions and Christmas street decorations in the past, but now there is a place for most of these designs in interiors of more dignified and interpretive moods as well as exteriors designed for magnificence and grandeur. These devices can be used in either permanent or in temporary form, using materials the choice of which is governed by economic considerations. The materials used in other types of novelty design can be used in a vertical plane as well as in the horizontal plane, as is the usual practice.

Pylons (Fig. 12-11a) are useful for decorations out of doors and in large interiors. The expositions of the last ten years have made much use of this device. There is no limit to design with respect to form, color, and animation. The pylon may be a luminous element, as discussed in Chapter 9, with colored glass or colored light in the inside. Interesting pylons are also illuminated from troughs or light strips placed on the outside of the pylon. The surface may be straight or curved and the lighting equipment may be in focus or out of focus.



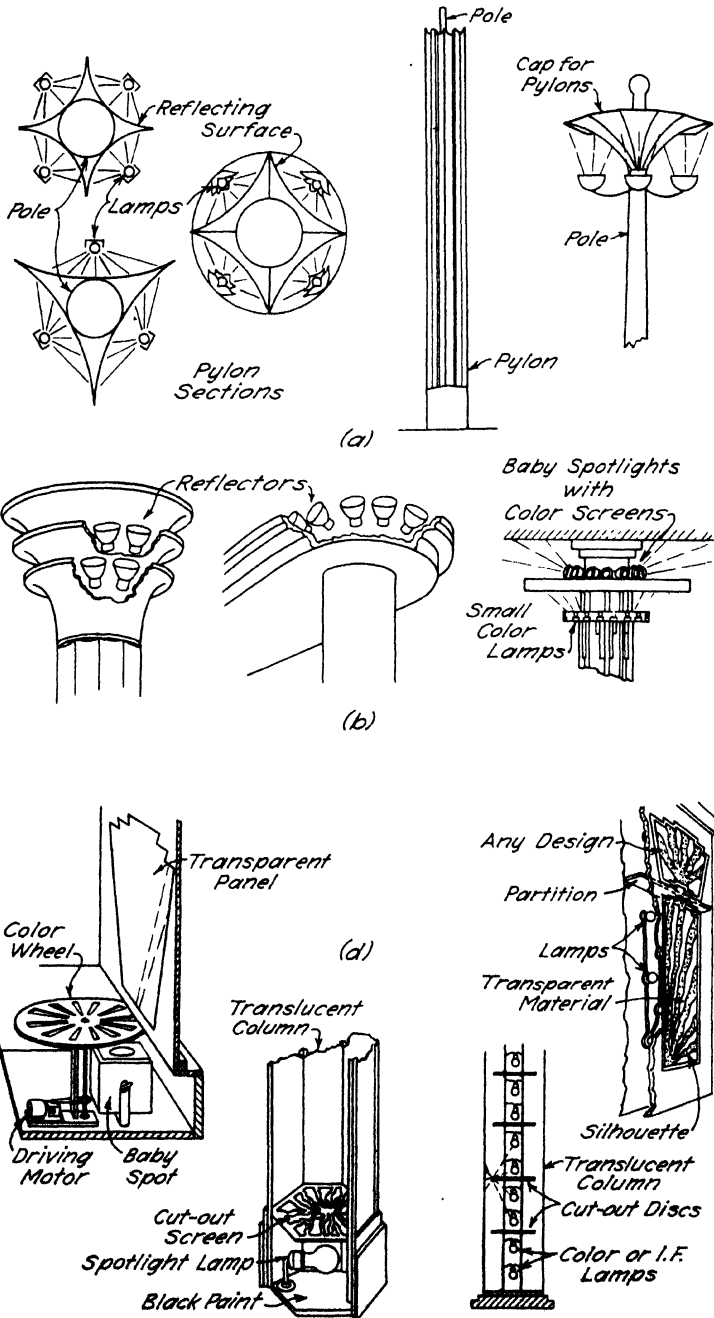

FIG. 12-11A.<sup>1,2,3</sup> Columns, pilasters, and pylons.

Columns (Fig. 12-11b) may be treated in various ways either by illumination of the complete column or by special treatment of the capital. If the column alone is treated, it may be done in the same manner as a pylon. Colored lights inside the column (either static or

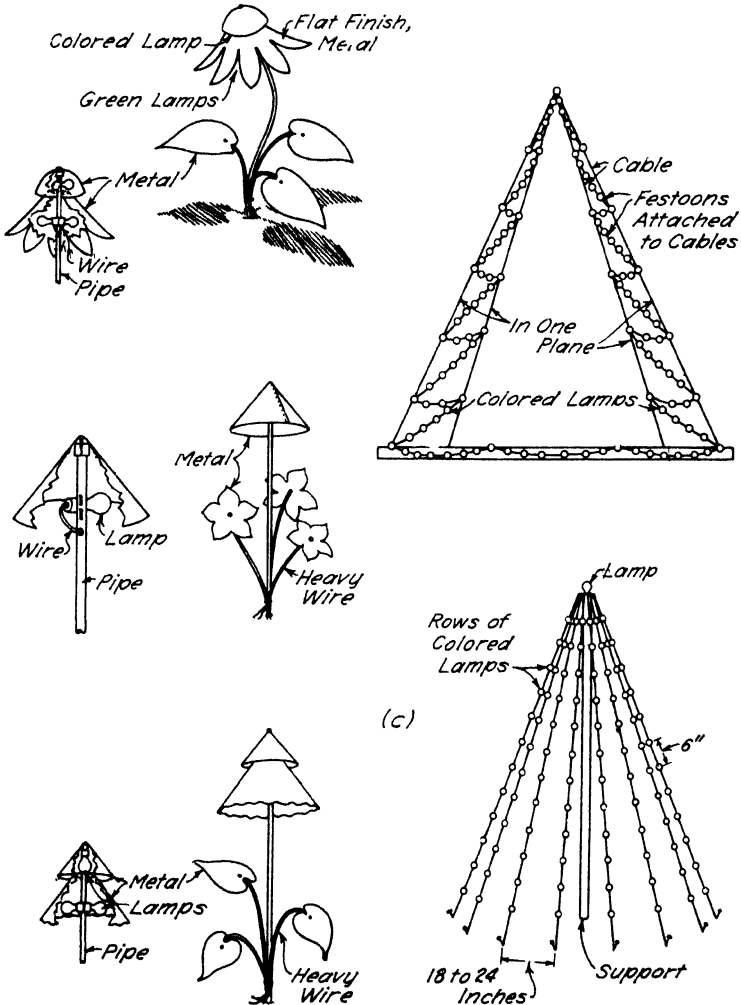

FIG. 12-11B.<sup>15</sup> Mushroom lights and trees.

mobile), together with a baffle of colored material or a glass with color treatment using a projection lamp underneath, will produce projected light streaks on the column. These may in turn be given mobility by rotating the screen or baffle. If the column is broken up into sections by means of cutouts and if lights of different colors are intro-

duced into each section, there will be a colorama effect on the surface of the translucent material.

The capital can be fluted and have variously colored light hidden behind the flutes to light the surfaces in different colors. Small incandescent lamps may be used as a jeweled band around the column in any manner desired, and baby spotlights may be used in concealment behind the capital to produce radiating rays of colored light from the top.

*Mushroom lights* (Fig. 12-11c) have been used at expositions and along paths for garden lighting. It is not necessary to confine this type of equipment to the exterior, for it can be used around centerpieces in ballrooms and other places of entertainment. The total height of the fixture is from 30 to 36 in., and the greater part of the light is thrown downward by means of an opaque or translucent reflector. Colored plastic material will make both an efficient and a colorful reflector. There is no limitation to the number of shapes that the so-called mushrooms may take; they range from geometric forms to the representation of flowers. The pedestal may be made luminous and ornamental if this is desired.

Similar to the mushroom is the arrangement of festoons of lights against flat surfaces and in the form of cones. These may be of any size. Since they are formed with exposed clear or colored lamps, there is more sparkle and glitter from them than from the mushroom, which is more dignified and subdued.

**10. Ultra-Violet Luminescent Effects.** Because effects are produced with ultra-violet light in which all but 1 or 2 per cent of the visible light has been filtered out, the term "black light" is the popular name given to installations and demonstrations of this comparatively new source of light. Luminescence (*cold light*) is a term applied to all light produced except by incandescence; therefore the term *cold light* signifies, at present, a light that may not be as cool as that produced by fluorescence. The new fluorescent lamp is an example, for though frequently called *cold light*, it is only in a technical sense that the light is cold because there is actually still far more energy wasted than is wasted by the firefly, with correspondingly lower efficiency.

#### LUMINESCENT PAINTS AND MATERIALS

There are two kinds of luminescent materials: those which glow only during the period of excitation from the source (fluorescent) and those which will glow for a period of time after the exciting source is

withdrawn (phosphorescent). These two kinds of materials have two very different luminous effects. Many compounds and geological specimens will show these characteristics. For novelty effects, it is essential that the colors come out brightly under the least amount of excitation. A long list of materials could be given, but only those considered active enough for special lighting effects will be listed.

GEOLOGICAL (FLUORESCENT MINERALS)	PHOSPHORESCENT
Wernite	Calcium sulphide
Calcite	Barium sulphide
Willemite	Strontium sulphide
Brucite	
Fluorite	FLUORESCENT (IN SOLUTION)
	Anthracene in benzol
FLUORESCENT	Eosine in water or alcohol
Calcium sulphide (bluish)	Esculin in water
Zinc sulphide (green)	Fluorescein (slightly alkaline)
Rhodamine (red)	Naphthalene red in alcohol
Uranium glass (yellow green)	Quinine sulphate in water
Greases and vaselines	Resorcin blue in water
Oil and kerosene	

#### SOME USEFUL MIXTURES

*Blue-violet.* Dissolve 5 parts of vaseline and 12 parts of white paraffin wax of melting point 140° F in 175 parts of benzine and add, by stirring in, 5 parts of finely powdered calcium salicylate. Five parts of aesculin may be substituted for the calcium salicylate.

*Apple green.* The same mixture as above, using anthracene for the calcium salicylate.

*Brilliant green.* Dissolve 20 parts of cellulose acetate in 300 parts by weight of chloroform into which one part of vaseline to 15 to 37 parts of chloroform are dissolved. Mix thoroughly and add 10 to 30 parts of finely powdered potassium uranyl sulphate.

*Orange-yellow.* Substitute zinc sulphite containing one part in 1000 of manganese for the potassium sulphate in the above formula.

*Red.* Mix 100 parts of zinc with 20 parts of cadmium sulphate and incorporate in gum. The consistency of the mixture determines the brilliancy of the resulting hue.

Materials and paints for fluorescent decorations are rather expensive, but they are available even for outside sign use. They have been used for novelty decorations on exposition buildings. The mixture of the materials as given depends a great deal upon the technician, and it is not in every instance equally easy to obtain results. Many of the printed materials purchased in a dry goods store give unusual effects, for most materials dyed with aniline dyes will show

fluorescence. If a vivid pattern of cloth printing which will respond to ultra-violet rays is chosen, it will be the basis of a novelty design in itself.

### ULTRA-VIOLET SOURCES

It is the near ultra-violet which is useful for the production of fluorescent and phosphorescent effects. This is the band of radiation just beyond the visible violet. There are many sources of ultra-violet, but for energizing paints and materials for decorative or novelty effect,

TABLE I-11 \*

Source	Watts	Reflector	Filter	Maximum Distance at which Lamp is Effective	Maximum Spread in Feet
Nico lamp (50-in. mercury tube)		Porcelain trough	Nickel cobalt tube	13 ft.	30-35
High Intensity Mercury Vapor	400	Oxidized aluminum, high-bay mounting unit	Red purple ultra tube No. 584	*15 ft.	*12-15
High Intensity Mercury Vapor	250	Oxidized aluminum, high-bay mounting unit	Red purple ultra tube No. 584	*10 ft.	*8-10
Sunlamp (Type S-1)	450	G-E Model E (Oxidized aluminum)	Corning No. 597 plate	12 ft.	12-15
Sunlamp (Type S-2)	175	G-E Bermuda (Oxidized aluminum)	Corning No. 597 plate	8 ft.	8-10
Mazda CX lamp	500	Polished aluminum	No. 587 plate	12 ft.	9-11
Mazda CX lamp	250	Polished aluminum	No. 587 plate	10 ft.	7-9
Mazda CX lamp	60	Polished aluminum	No. 587 plate	3 ft.	2½-3½
Photofood	No. 1	Polished aluminum	No. 587 plate	9 ft.	8-10
Photofood	No. 1	Polished aluminum	No. 587 and 428 plate	6 ft.	6-8
Argon Glow lamp	2	Polished aluminum	None	2 ft.	1-1½
†Spotlight (baby)	500		No. 587 plate	10 ft.	6-8
†Spotlight	1000		No. 587 plate	20 ft.	10-12
†Arc lamp			No. 587 plate	100 ft.	20-25
H3-Capillary	100	G-E Model E (Oxidized aluminum)	Corning No. 597 plate	12 ft.	12-15

\* Calculated.

† From Stroblite Company folder.

it is necessary to eliminate the visible light, because the radiated light from the materials has very little energy, and the room or space must be comparatively dark. Table I-11 lists the available sources from which the equipment which will satisfy the conditions to be met may be selected.

Reflectors of porcelain and silvered glass will do well for the near ultra-violet, and Alzak aluminum reflectors are good for producing beams of concentrated ultra-violet. Filters may be introduced in the path of the ultra-violet light to eliminate the visible rays, or the filter

may be incorporated in the lamp itself. This latter practice is the more desirable, for the light is then well screened and the cost of a lamp with the correct filter glass is very little more than that of a clear lamp which must be used with an external filter.

**11. Polarized Light.** Though the effect of crystal patterns and polarized light has been known for years, only recently has a polarizing surface, large enough to be useful in making these phenomena available for producing light patterns upon surfaces and screens, been made available. A material "Polaroid," is now available in sheet

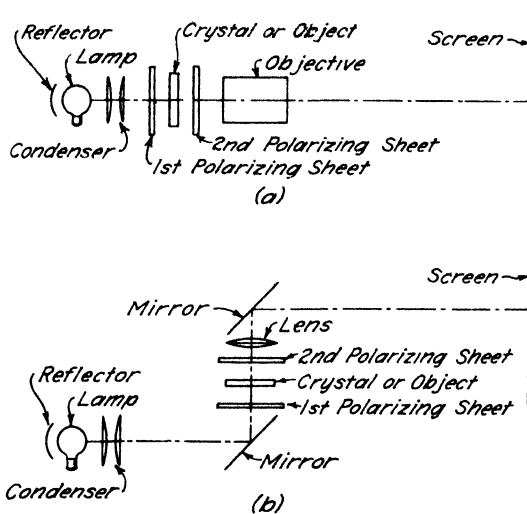

FIG. 13-11. Equipment for polarized light effects.

form in sizes the customer may desire. Two sheets of this material used with projection equipment will open up a new field of novelty lighting. Figure 13-11 shows the arrangement to be used for projecting a mosaic pattern from natural crystals and interference patterns of a stepped retarding plate.

Natural crystal slides may be made from the following materials:

Caffeine	Sodium chloride
Acetamide	Tartaric acid
Hypo	Sodium nitrate
Benzoic acid *	Hydroquinone
Silver nitrate	Elon

Acetamide melts at about  $115^{\circ}\text{C}$ ; therefore, it is readily used in crystal formation. To prepare it, a small amount is melted on a warm

\* This is the most successful for storage.

cover glass and covered with another; the crystals will form between the glasses held tightly together and may be used for projection at any time, or if they are heated to the point where the crystals are dissolved, they will reform in the projector as the material cools, and the forming mosaic pattern may be seen. Benzoic acid forms one of the best crystals for clear and brilliant patterns and may be used indefinitely. The other materials will form crystals in the heat from the projector as the saturated solution crystallizes, and the progress of the crystal growths can be seen.

Other interesting effects may be obtained by placing crushed cellophane between two glass slides; a multicolored mosaic will be formed because of light interference in the various layers of the material. If a piece of celluloid is carved so that the carving has many depths, the resultant pattern that is projected will be of varied color.

If the two polarizing surfaces are placed so that all light is eliminated, the various materials between the polarizing sheets will show up in their characteristic colors. By rotating one sheet of the material the colors will change so that mobile color may be introduced into the scheme. Though the method has been demonstrated, it has yet to be used on a large scale for novelty lighting. This is, however, not true of fluorescent effects.

**12. Fountains.** By placing lighting equipment under water and jetting the water, many varieties of interesting effects may be obtained. The projector type of lamp may be successfully used for this purpose in small installations; for large installations special equipment is available. Projector-type lamps, since they are water-proof and can be placed in simple fittings (being enclosing units themselves), are excellent for temporary displays.

There are several types of jets and sprays which may be used singly or in combination to produce colored water effects. *Solid jets* are for high water effects, and, up to 20 ft., may be depended upon to be formed by the service pressure; beyond that, it is necessary to use fire nozzles. They may be set vertically and in groups if desired. The effect is a plume-shaped hood of water. *Ring jets* consist of a series of small nozzles set on a ring and separated by a few inches. When the ring is placed in a vertical position a cylinder of water with a plume-shaped crest is formed. By inclining the jet outward an umbrella-shaped head is formed and, when inclined inward, the result is a dome-shaped head. *Straight-line jets* are used for curtains of water which act as backgrounds for displays and, if illuminated by clear floodlights, the curtain can be used as a screen for setting a stage for

a pageant, because of the brilliant sparkle to the water when thus illuminated. Straight-line jet fountains are made up of small nozzles spaced a few inches apart. *Cone sprays* are produced by nozzles with spirals or deflectors to produce a cone of the required angle. Internal spirals may be set to give the angle desired; deflectors are used externally. *Flat sprays* have a very narrow divergence in one plane and a wide divergence in the other. Ingenuity in combining the jets and in locating the nozzles produces the final effect.

There are two ways to illuminate the sprays and jets: either in the stream of water itself, which is the most desirable method, or by floodlighting the water from projectors placed at strategic points.

TABLE II-11 "   
 NOVELTY LIGHTING COLOR MEDIA

	Colors Available	Purity of Color	Efficiency of Color Production	Initial Uniformity of Color	Permanence of Color	Maintenance of Light Output in Equipment	Cost of Producing Color		
							Initial	Overall	
ACCESSORIES APPLIED TO LAMPS	Natural-Colored Lamps	Few	Excellent	Excellent	Fair	Excellent	Good	Average	Average
	Inside-Sprayed Lamps	Limited number of standard colors	Fair	Poor	Fair	Fair	Poor	Low	Average
	Outside-Sprayed Lamps	Limited number of standard colors	Fair	Poor	Fair	Poor	Poor	Low	Average
	Dipped and Lacquered Lamps	Many	Excellent	Excellent	Fair	Poor	Fair	Low	Average
	Color Caps and Hoods	Few	Good to excellent	Good to excellent	Good	Excellent	Fair to good	Average	Low
	Colored Roundels and Plates	Few	Good to excellent	Good to excellent	Good	Excellent	Excellent	High	Low
Colored Gels and Plates	Many	Excellent	Excellent	Good	Poor	Good	Low	Average	

Color changes and the various types of colors are obtained by color screens and mobile lighting equipment as in any other type of novelty lighting. Large fountains with a multiplicity of pumps and color equipment require the services of a specialist, as does any major lighting installation.

**13. Materials for Novelty Lighting.** Any catalog of theatrical supplies and advertisement materials of electrical nature will open the path to the selection of suitable materials to work into a design. In addition to these standard products, all the materials for lighting construction (which range from the opaque control material through the translucent and transparent in all colors, whether the color is an ingredient of the material or an accessory) have possibilities in the field of novelty lighting. Table II-11 gives a list of the various methods



of controlling color and the range as well as the reliability and economy of each method.

Sources of light may be the natural-colored, clear, or frosted incandescent lamp, but in this special color field, the economy and

TABLE III-11A<sup>33</sup>

APPROXIMATE WIDTHS OF IMAGES PROJECTED BY LANTERN SLIDE PROJECTORS \* OF VARIOUS FOCAL LENGTHS AND AT VARIOUS DISTANCES

Focal Length	Projection Distance — Feet												
	10	20	30	40	50	60	70	80	90	100	110	120	
	Picture Width — Feet and Inches												
6"	4'10"	9'9"	14'9"	19'9"	24'9"								
8"	5'5"	7'3"	11'0"	14'9"	18'6"	22'3"	26'0"						
10"		5'9"	8'9"	11'9"	14'9"	17'9"	20'3"	23'9"					
12"		4'9"	7'3"	9'9"	12'3"	14'9"	17'3"	19'9"	22'3"	24'9"			
14"		4'4"	6'5"	8'7"	11'9"	12'11"	15'0"	17'2"	19'4"	21'5"	23'7"		
16"			5'6"	7'6"	9'5"	11'2"	13'2"	15'0"	17'0"	18'9"	20'8"	22'6"	
18"			4'9"	6'5"	8'1"	9'9"	11'5"	13'1"	14'9"	16'5"	18'4"	20'0"	
20"			4'3"	5'3"	7'3"	8'9"	10'3"	11'9"	13'3"	14'9"	16'6"	18'0"	
22"				5'3"	6'7"	7'11"	9'4"	10'5"	12'0"	13'5"	14'9"	15'10"	
24"				4'9"	6'0"	7'3"	8'6"	9'7"	11'0"	12'3"	13'9"	15'0"	
28"						6'7"	7'8"	8'6"	9'7"	10'10"	11'11"	12'11"	
32"							6'8"	7'7"	8'6"	9'5"	10'4"	11'3"	

\* Size of slide and opening  $2\frac{3}{4}$  in. high by 3 in. wide.

TABLE III-11B<sup>33</sup>

APPROXIMATE DIAMETER OF IMAGES PROJECTED BY SCIOPTICONS WITH SPECIAL WIDE-ANGLE LENSES AT VARIOUS DISTANCES

Focal Length	Projection Distance — Feet									
	10	15	20	25	30	35	40	45	50	
	Picture Width — Feet									
4"	24	48								
6"	18	32	44	56						
8"	12	18	23	28	33	38	43	48	53	
10"	8	12	16	20	24	28	32	36	40	
12"	6	10	13	17	21	24	27	30	34	

Effective diameter of opening: 5 in.

efficiency of the fluorescent lamps is superior to other methods of obtaining colored light directly from the source. The light source may be placed into various types of floodlights and spots, coffers, luminous elements, and projectors. Table III-11 gives information on

the expected size of surface covered by projectors and sciopticons having objectives of various focal lengths.

TABLE IV-11<sup>23</sup>  
WATTAGE ESTIMATING CHART FOR THEATER ILLUMINATION\*

Applications	Theater Seating Capacity	Recommended Foot-Candles	Required Watts per Square Foot			
			Small Exposed Lamps	Luminous Elements	Indirect Lighting	Down-lighting
Under Marquee	2500 or more	100 up	40-50	40-50	Less effective for outdoor use	25-35
	1200 to 2500	50-100	20-40	20-40		12-25
	700 to 1200	30-50	12-20	12-20		10-15
	300 to 700	30	10-15	10-15		8-11
Lobby †	2500 or more	20	8-11	7-9	10-20	6-8
	1200 to 2500	15	5-7	5-7	8-16	3-4
	700 to 1200	10	3-5	4-6	5-10	2-3
	300 to 700	10	3-5	3-5	5-10	2-3
Foyer	2500 or more	5	4-6	3-5	6-12	3-4
	1200 to 2500	5	4-5	3-4	5-10	3-4
	700 to 1200	3	3-4	2-3	4-8	2-3
	300 to 700	3	3-4	2-3	4-8	2-3
Rest Rooms	2500 or more	10	Likely to be glaring	4-6	6-12	3-5
	1200 to 2500	5		3-5	4-8	2-3
	700 to 1200	5		3-4	4-8	2-3
	300 to 700	5		3-4	4-8	2-3
Lavatories	2500 or more	15	4-6	4-6	6-12	3-4
	1200 to 2500	10	3-4	3-4	4-8	2-3
	700 to 1200	10	3-4	3-4	4-8	2-3
	300 to 700	10	3-4	3-4	4-8	2-3
Passageways	2500 or more	2	Likely to be glaring	0.4-0.6	0.6-1.2	0.3-0.5
	1200 to 2500	2		0.4-0.6	0.6-1.2	0.3-0.5
	700 to 1200	1		0.2-0.4	0.4-0.8	0.2-0.3
	300 to 700	1		0.2-0.4	0.4-0.8	0.2-0.3
Auditorium Standee Spaces	2500 or more	1	Likely to be glaring	1-1.5	2-4	0.5-1
	1200 to 2500	1		1-1.5	2-4	0.5-1
	700 to 1200	1		1-1.5	2-4	0.5-1
	300 to 700	1		1-1.5	2-4	0.5-1
Intermission	2500 or more	5	2-3	2-3	3-6	2-3
	1200 to 2500	5	2-3	2-3	3-6	2-3
	700 to 1200	5	2-3	2-3	4-8	2-3
	300 to 700	5	3-4	3-4	4-8	2-3
During Pictures	2500 or more	0.1-0.2	Varies, depending upon type of lighting and especially color used. With three colors use wattage for each circuit corresponding to requirements for intermission.			Dim intermission downlights
	1200 to 2500	0.1-0.2				
	700 to 1200	0.1-0.2				
	300 to 700	0.1-0.2				

\* Above data based on average efficiencies of lamp and equipment in usual sizes of room and finishes of ceiling and sidewalls; the additional wattage necessary to provide colors and tints as generally used in the various parts of the theater are taken into consideration.

† For advertising effectiveness, posters require approximately 10 times the illumination of surroundings.

In construction, special steel forms may be used for permanent installations; standard lumber may be used for those that are tem-

porary. In temporary installations, the surfaces may be of building papers or cardboard of various thicknesses rather than plaster. Various forms of construction board are easily shaped and mounted for cutout designs. In place of expensive translucent glasses, tracing paper, tracing cloth, Celloglass, cheesecloth, and treated muslin may be used. Liberal treatments of various colored paints where white light is to be used and good white paints with high reflection factors where color is to be used are highly important in good design. Painted surfaces can be treated with clear sands, broken and crushed glass, and ground metallic materials in order to produce glitter and sparkle.

Manufacturers of glass have developed many fluted, ribbed, and configured patterns adaptable or specially designed for novelty lighting effects. Also, glass block takes a prominent position in this field.

Because the theater represents the whole of the desirable levels of lighting for attraction, advertisement, and novelty, Table IV-11 is given as a suggestion to guide the designer in the selection of illumination and wiring capacities for this special type of service. This table is only suggestive, for all the designs should, in the end, be governed by the principles set forth in the previous chapters governing general, luminous element, and floodlighting design.

#### BIBLIOGRAPHY

1. A. L. POWELL and ALSTON RODGERS "Engineering Features of Built-in Lighting," *Lighting*, November, December, 1930; January, 1931.
2. H. H. MAGDSICK, "Building Prosperity Avenue," *I. E. S. Trans.*, v. 25, No. 5, May, 1930.
3. NELA PARK, "Coordination of Light and Music," *Bulletin L.P.*-101, 1930.
4. C. M. CUTLER, "Light as a Decoration in the Theater Auditorium," *So. Arch. and Build. News*, May, 1931.
5. NELA PARK, "Christmas Lighting," *Bulletin L.P.*-103, December, 1931.
6. ANON., "Decorative Materials for Christmas Lighting," *The Magazine of Light*, September, 1932.
7. A. L. POWELL, "Garden Lighting," *The Magazine of Light*, v. 2, No. 7, Summer, 1932.
8. R. L. ZAHOUR, "Magic in Light," *Elec. Jour.*, November, 1933.
9. G. R. LAWALL and C. M. CUTLER, "Examples of Lighting for Decoration and Festivity," *I. E. S. Trans.*, v. 28, No. 3, March, 1933.
10. H. E. LIPPMAN, "Fountain Lighting," *Elec. Jour.*, v. 30, No. 4, April, 1933; v. 30, No 5, May, 1933.
11. A. STROBL and R. L. ZAHOUR, "Ultraviolet Luminescent Effects and their Use," *I. E. S. Trans.*, v. 28, No. 7, July, 1933.
12. C. M. CUTLER, "Lighting Ideas from the Fair," *The Magazine of Light*, v. 3, No. 2, 1933.
13. W. D'A. RYAN, "Illumination of a Century of Progress Exposition, Chicago, 1933," *I. E. S. Trans.*, v. 29, No. 2, February, 1934.

14. C. M. CUTLER, "Century of Progress Exhibit Lighting," *I. E. S. Trans.*, v. 29, No. 2, February, 1934.
15. G. R. LAWALL and C. M. CUTLER, "Holiday Season Calls for Light," *The Magazine of Light*, December, 1934.
16. C. S. WOODSIDE, "Illumination of Structural Glass," *I. E. S. Trans.*, v. 29, No. 10, December, 1934.
17. C. M. CUTLER, "Reviewing the 1934 Century of Progress," *The Magazine of Light*, Fall, 1934.
18. C. M. CUTLER, "New Lighting Features of the 1934 Century of Progress Exposition," *I. E. S. Trans.*, v. 30, No. 10, December, 1930.
19. G. R. LAWALL and W. M. PORTER, "Factors in the Design of Opaque Patterns on Luminous Background," *I. E. S. Trans.*, v. 30, No. 5, May, 1935.
20. G. H. STICKNEY, "Notes on Lighting of S. S. Normandie," *I. E. S. Trans.*, v. 30, No. 10, December, 1935.
21. C. M. CUTLER, "Lighting Ideas from the Fair," *The Magazine of Light* v. 3, No. 2, 1935.
22. ANON., "Holiday Lighting," *The Magazine of Light*, Fall, 1935.
23. A. RODGERS, "Light and Color at the San Diego Exposition," *The Magazine of Light*, v. 5, No. 1, January, 1936.
24. ANON., "Two Feature Exhibits at the San Diego Exposition," *The Magazine of Light*, v. 5, No. 2, February, 1936.
25. C. M. CUTLER, "Plan Your Garden Lighting," *The Magazine of Light*, v. 6, No. 4, April, 1937.
26. L. C. PORTER and J. P. DITCHMAN, "Black Light," *The Magazine of Light*, May, 1936.
27. C. M. CUTLER, "Illumination of Texas Centennial Central Exposition," *I. E. S. Trans.*, v. 31, No. 9, November, 1936.
28. F. M. FALGE, "New Lighting Methods for Theater Lighting," *The Magazine of Light*, December, 1936.
29. M. R. MATTESON, "Original Lighting Effects with Standard Equipment," Modern Theater Section, *Boxoffice*, December 12, 1936.
30. C. M. CUTLER, "Texas Centennial Central Exposition," *The Magazine of Light*, v. 5, No. 9, Exposition Number, 1936.
31. W. D. RIDDLE, "Great Lakes Exposition," *The Magazine of Light*, v. 5, No. 9, Exposition Number, 1936.
32. F. M. WOLFF, "A New Trend in Window Display Lighting," *I. E. S. Trans.*, v. 33, No. 1, January, 1938.
33. NELA PARK ENGINEERING DEPT., "Theater Lighting," General Electric Co., *Bulletin* L.D.-8, January, 1938.
34. C. S. WOODSIDE, "Artificial Illumination of Glass Blocks," *I. E. S. Trans.*, v. 33, No. 3, March, 1938.
35. A. F. DICKERSON, "The Lighting of the Golden Gate International Exposition," *I. E. S. Trans.*, v. 34, No. 7, July, 1939.
36. F. M. FALGE, "Black Light: Another Tool of Showmanship," *Better Theatres*, April, 1938.
37. J. A. RADLEY and J. GRANT, "Fluorescence Analysis in Ultra-violet Light," D. Van Nostrand Co., 3rd ed., 1939.
38. A. F. DICKERSON, "Color: New Synthesis in the West," *G. E. Review*, v. 42 No. 7, pp. 291-307, July, 1939.
39. C. M. CUTLER and H. J. CHANON, "What the Theatre Man Needs to Know about 'Black Light,'" *Better Theatres*, June, July, September, 1940.

40. W. E. FORSYTHE and E. Q. ADAMS, "Polarized Light," *G. E. Review*, v. 42, No. 8, pp. 346-353, August, 1939.
41. Pages from "Extending Yuletide Greetings," *The Magazine of Light*, v. 8, No. 7, pp. 18-22, November, 1939.
42. "Holiday Suggestions for Home Lighting Advisors," *The Magazine of Light*, v. 9, No. 8, pp. 44-48, October, 1940.
43. H. J. CHANON and F. M. FALGE, "'Black Light' for Theatre Auditoriums," S. M. P. E. Convention, Hollywood, California, October 21-25, 1940.
44. "Air Corps Uses Invisible Light In Night Flights," *The Magazine of Light*, v. 9, No. 10, pp. 14-16, December, 1940.
45. J. O. KRAEHENBUEHL and H. J. CHANON, "The Technology of Brightness Production by Near-Ultraviolet Radiation," *I. E. S. Trans.*, v. 36, No. 2, pp. 151-168, February, 1941.

## CHAPTER 12 \*

### MAINTENANCE AND ECONOMICS — AUTOMATIC CONTROL

The technical details of the design of a lighting system for recreation or labor are only a partial solution of the problem of satisfactory lighting operation, and installation of the system is only the beginning, for numerous factors contribute toward its rapid depreciation. The most important of these factors are the blackening of the lamp, the accumulation of dirt and dust upon lamps and equipment, and discoloration and fading of paint or other finish in the room. In the original design, provision must be made to clean the equipment, and any design should carry with it a schedule of adequate maintenance. The attention needed to keep the lighting system as near as possible to its original efficiency passes out of the hands of the designer when occupancy begins and the building management assumes the responsibility. In every instance a number of designs should be considered from an economic point of view and the best chosen.

There is also an economic consideration in every lighting installation, for the system should deliver the maximum lumens possible for the minimum original investment and the lowest operating cost. This last statement is made upon the assumption that the system is designed to supply light which is comfortable and adequate for performing the specific visual task.

**1. Maintenance of Illumination.** Systems which are adequate when first installed will rapidly depreciate if not properly maintained. This is equally true for natural or artificial lighting. Maintenance is not a thing which should be entrusted to the average caretaker without proper supervision; it should be based upon a regular and systematic schedule and should include a system of reports and checks. When the illumination in an installation (as checked with a foot-candle meter) decreases to 75 per cent of its initial value, the equipment should be cleaned and, if economical, a group replacement of lamps should be made at that time.

The maintenance schedule should include paint washing and renewing. The more the ceiling and side walls act as reflectors the more

\* Sample solutions given are based on current data at time of solution. Since source lumen output is always changing, the examples show methods and not specific, applicable results.

necessary it is to pay particular attention to these surfaces. The period between the servicing of the lighting system and the room surfaces depends upon the nature of the surrounding work. In very

TABLE I-12<sup>10</sup>  
MAINTENANCE OF ILLUMINATION \*

Operation	Per Cent of Final Illumination	Per Cent Gain
Illumination as found	49	12
Repainting	61	20
Lamps and reflectors cleaned	81	19
New lamps and proper voltage	100	
Total gain in illumination		51%

\* A plant where conditions were unfavorable for maintenance.

TABLE II-12<sup>6</sup>  
MAINTENANCE AND REPLACEMENT STUDY \*

		Room A Foot-Candles	Room B Foot-Candles	Cost per Room Dollars
Original	Maximum	2.5	3.5	
	Minimum	0.9	0.5	
	Average	1.2	1.5	
New lamps	Maximum	2.8	2.9	3.00
	Minimum	1.5	1.0	
	Average	2.2	2.3	
Gain, per cent		83	53	
Paint	Maximum	4.0	4.5	48.43
	Minimum	2.0	2.3	3.00
	Average	3.4	3.4	51.43
Gain, per cent		55	48	
Paint	Maximum	5.8	6.3	48.43
	Minimum	2.5	2.8	3.00
	Average	4.3	4.8	8.10
Gain, per cent		26	41	59.53
Foot-candles gained, per cent		258	220	
Ratio maximum to minimum — initial		2.78	7.00	
Ratio maximum to minimum — final		2.32	2.25	

\* Clean conditions.

clean surroundings, it is possible to lengthen the periods considerably, whereas under very dirty conditions, it may be necessary to wipe the equipment every day or two and wash it at least once a week if il-

lumination is to be maintained at 75 per cent of initial levels. A well-designed system, which has been considered according to the needs of the task, deserves this additional attention. Table I-12 lists the benefits gained by proper maintenance of the illumination. Table II-12

TABLE III-12A

ILLUMINATION INCREASES OBTAINED BY REMOVING VARIOUS KINDS OF DIRT FROM LAMPS SELECTED FROM ACTUAL SERVICE CONDITIONS

Watts	Kind of Dirt on Lamp	Be- fore Clean- ing (Foot- Cand- les)	After Wip- ing (Foot- Cand- les)	Per Cent In- crease in Illumi- nation	After Wash- ing (Foot- Cand- les)	Per Cent In- crease in Illumi- nation
200	Dry machine shop dirt	14.0	23 0	64	23.0	64
200	Dry machine shop dirt	5.5	16 0	191	16.0	191
75	Smoke and dust	8.0	11 0	38	11.0	38
40	Smoke and dust	4.5	8 5	89	8.5	89
40	Acid fumes	7.0	11 0	57	11.0	57
200	Fly specks and office dirt	11 5	14 0	22	16 0	39
100	Rosin vapor	2.75	3 75	36	3.75	36
50	Linseed oil	1.75	2 75	57	2.75	57
150	Coke, lamp black, graphite dust	8.0	17.0	112	17.0	112
40	Dust and vapor from lamp black manufacture	2.75	4 5	64	4.5	64
40	Dust and vapor from lamp black manufacture	2.0	3.75	87	3.75	87
100	Coke dust	2 75	6 5	136	6 5	136
25	Oily dirt from lathes	1.5	2.75	83	5.0	234
25	Oily dirt from lathes	2.2	4.5	104	5.5	150
100	Asphaltum vapors	8.5	11.0	29	11.0	29
100	Gum vapors	5.5	8.0	45	10.0	82
40	Paint	3.6	5.5	39	8.0*	122
60	Dry gypsum dust	8.0	10.0	25	10.0	25
60	Dry gypsum dust	11.0	14.0	27	14.0	27
	Averages			68.6		86.3

\* Organic solvent used in cleaning this lamp.

illustrates clean conditions in contrast to the dirty conditions listed in Table I-12.

**2. Luminaire Depreciation Caused by Dust and Dirt.**<sup>2</sup> Several studies have been made to determine the actual effect of dirt and dust upon the luminaire. The results of an early investigation (1922) by a



committee are tabulated in Table III-12. At that time it was found that 60 per cent of the users did not clean lamps, 33 per cent cleaned them at infrequent intervals, and only 7 per cent cleaned them at regular intervals. By merely wiping the lamps, a 68.6 per cent of light increase was noted, and washing gave an increase of 86.3 per

TABLE III-12B

Classification of Dirt on Lamps	Average Per Cent Increase in Illumination after Wiping	Average Per Cent Increase in Illumination after Washing
I. Dust and dry dirt	77.7	78.4
II. Oily dirt	84.7	147.0
III. Paints, tars, and pitches	37.2	67.2
IV. Acid fumes *		
V. All lamps	68.6	86.3

\* Bulbs were badly attacked by HF and bases badly corroded by HCl and HNO<sub>3</sub>; therefore, candlepower measurements were not included.

TABLE IV-12<sup>2</sup>

## RELATIVE DEPRECIATION IN FOUR LOCATIONS

Luminaire	Relative Depreciation Location			
	A	B	C	D
Deep steel bowl — open reflector, clear lamp	100		31	138
Diffusing globe, no vent in bottom	100	114	28	200
Dense semi-indirect opal bowl, open	100	226	70	218
Average	100	170	43	185

*Location A.* Factory warehouse adjoining a room for lamp manufacture. Washed air furnished for part of the factory. Dust dry, fine, and powdery. Space steam-heated, windows part open.

*Location B.* Top floor of a 12-story office building. More oily, sooty dust here than at A.

*Location C.* Fairly clean office building in suburban district.

*Location D.* Furnace and blowing room of a glass factory. Hot, dry, and dusty.

cent, based on initial lighting as found before cleaning. These data are based on lamp cleaning alone, not on luminaire cleaning.

In 1924 E. A. Anderson and J. M. Ketch<sup>2</sup> made an extensive study of luminaire depreciation resulting from the accumulation of dirt and dust. The paper presented gives much detailed information concerning specific types of equipment, some of which have become

obsolete; but from those given the effect can be projected to present-day equipment. Table IV-12 gives the relative depreciation of equipment at four locations. The experiments show that bottom venting of the equipment increases its depreciation. It can be easily shown by theoretical considerations that dust and dirt on the inner surface of glassware will lower the efficiency more rapidly than the same amount of dirt on the outside. The rate of loss by actual tests showed a doubling of depreciation for enclosing globes and a trebling of the depreciation for semi-indirect lighting equipment where dirt and dust could accumulate on the inside. The table shows the necessity of a cleaning schedule for every installation. It is not possible to detect this necessity by the eye alone.

**3. Group Lamp Replacement.**<sup>3 4</sup> Where it is easy to reach the lighting equipment, and relamping during business or working hours

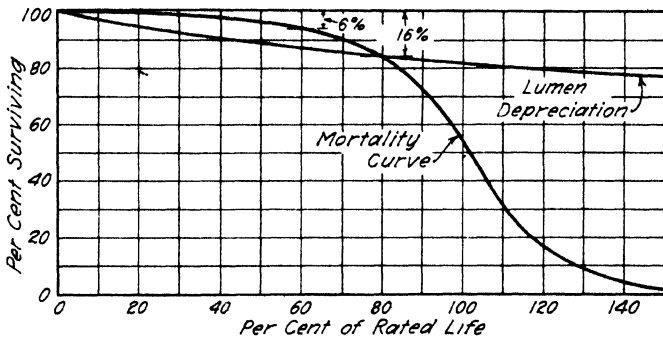

FIG. 1-12.<sup>12</sup> Mortality and depreciation curves for incandescent lamps.

does not interfere, lamps are usually replaced as they burn out. Frequently lamps that have burned out during the day are replaced at night when the establishment is closed. There is another method of replacement (called group replacement) by which all the lamps are renewed at one time after a predetermined period of lamp burning.

The failure of lamps in service follows the law of probability as shown by the curve in Figure 1-12. The ideal condition would be to have each lamp last 100 per cent of its expected life; group replacement would then be the only method to use in replacing lamps, for just before the time for all lamps to burn out, they would be renewed. In actual life distribution, however, if a replacement is made at 60 per cent of the life of the lamp, it would be expected that only 6 per cent would be burned out, but if the replacement is made at 80 per cent of the lamp life, it would be expected that 16 per cent of the lamps would be out of service.

The answer as to where group replacement is desirable is a question of the economics of the situation. If the lamp cost is high and replacement cost low it is not feasible to replace lamps. In places where lamps are very difficult to reach and special equipment is needed or scaffolds must be erected, thereby involving high labor cost, group replacement is desirable. Another factor that will control the group replacement will be the rate charged for electricity. As the lamp ages, it is less efficient in lumen output, and there is a corresponding increase in cost per lumen. Figure 2-12 shows the characteristic performance curves for incandescent lamps. Some lamps have a lumen maintenance of 85 to 90 per cent, so that their light output during the last 100 or 200 hr. is between 70 and 80 per cent of that of a new lamp.

It is possible to consider the subjective value of a group replace-

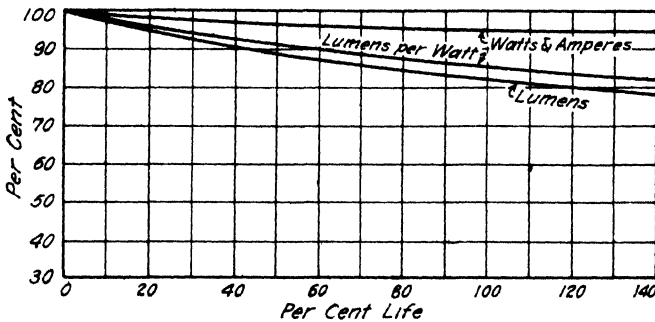

Fig 2-12<sup>12</sup> Typical performance curves for incandescent lamps

ment rather than merely the objective economic value. A new lamp placed between two old lamps will cause a rather spotty effect, whereas group replacement achieves uniformity. Also, group replacement can be accomplished more safely than individual lamp replacement, for the staff and equipment will be prepared for the task at hand. An individual replacing lamps singly as they burn out will take considerably more chance with unsafe methods of reaching equipment. If lamps are replaced in areas where customers are likely to be present, it is quite possible that a damage suit might arise because of some unintentional act of the workman.

In group replacement, it is not necessary to discard all the lamps removed; only those which show a marked blackening should be thrown away, and the others should be used in areas where replacement is simple. Basement areas and store rooms are excellent places for using the best of the partially depreciated lamps removed during group replacement.

Street lighting systems, traffic signals, and electrical signs have been relamped under group relamping for many years, but the value of such relamping is coming to the attention of other interested groups, such as the supervisors of auditoriums and commercial buildings.

**4. Lamp Characteristics.**<sup>12</sup> Figure 3-12 and Table V-12 show the effect that may be expected if the voltage of the lamp varies from the voltage for which it is designed. If the voltage is high, the life of the lamp decreases, and the lumen output increases, with low voltage, the reverse is true. With very high electrical energy cost and low lamp cost, it is economical to use over-voltage on the lamp; but where

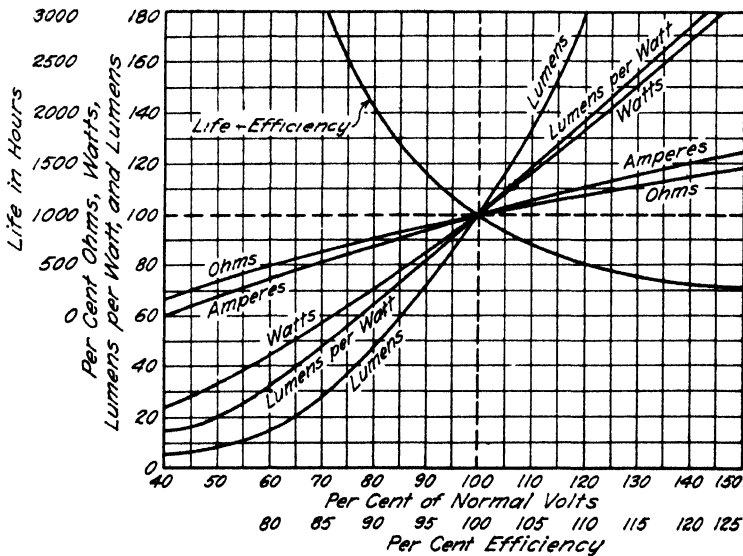

FIG. 3-12.<sup>12</sup> Characteristic curves for incandescent lamps.

the power is less expensive and the lamp costs relatively expensive, it is more economical to make the lamp last as long as possible.

Lamp characteristics are established by the manufacturer, and the user can obtain the best possible results only from the equipment at hand. Since it is not uncommon to neglect this part of the installation design, it can be safely said that more saving can be made by watching this than by buying paints and fixtures which are supposed to add some small per cent of efficiency to the lighting system at a correspondingly high cost.

Why does the manufacturer set the life of a lamp at 1000 hr. (this is normal for the common types of lamps) rather than at some value

such as 3000 hr.? The following example may aid in answering this question:

*Example a.*<sup>8</sup> Compare the operating cost of a 60-w. lamp designed for 1000 hr. of burning with the cost of a hypothetical lamp that will burn 3000 hr. giving the same light output.

A lamp which will burn 3000 hr. will operate at a 15% reduced efficiency, and to produce the same amount of light its wattage must increase 17.7%.

TABLE V-12<sup>8</sup>

## THE EFFECT OF VOLTAGE UPON LAMP PERFORMANCE

Socket Voltage in % of Rated Lamp Voltage	Watts Consumed in % of Rated Watts	Lumens of Light in % of Normal	Lamp Cost per 1000 Hr. in % of Normal	Cost of Light * (Lumen-Hours) in % of Normal
90	85	70	24	113.9
92	88	75.5	33	110.4
94	91	81	44	107.5
95	92.5	84	50	105.9
96	94	87	59	104.7
98	97	93	77	102.3
100	100	100	100	100.0
102	103	107	130	98.4
104	106.5	114	168	97.6
105	108	118	191	97.4
106	109.5	122	215	97.1
108	113	129	278	98.4
110	117	136	350	100.5

\* Applies only to 200-w., 115-v. lamps at a list price of 35 cents and energy at 2½ cents per kw-hr. For other lamps and other energy rates the costs would be slightly different.

A lamp would have to be rated at 70.6 w. to produce the same amount of light as a 60-w., 1000-hr. lamp.

Assuming that it will cost the same to make both lamps:

70.6 w., 3000-hr. lamp:

Lamp cost	\$ 0.15
70.6 w. for 3000-hr. at 4.7 cents per kw-hr.	9.95
	<u>10.10</u>

60-w. 1000-hr. lamp

Lamp cost (3 1000-hr. lamps)	\$0.45
60 w. for 3000 hr. at 4.7 cents per kw-hr.	8.46
	<u>8.91</u>

Economy with standard lamp	\$1.19
----------------------------	--------

The cost of the lamp proper is a small part of the light cost, being generally less than 10 per cent of the total cost. The energy consumption of the lamp is the principal cost and represents approxi-

mately 90 per cent of the light cost. Figure 4-12 shows the gain in efficiency that has been made in the manufactured incandescent lamp. Table VI-12 gives a comparative cost of light since 1800, and this

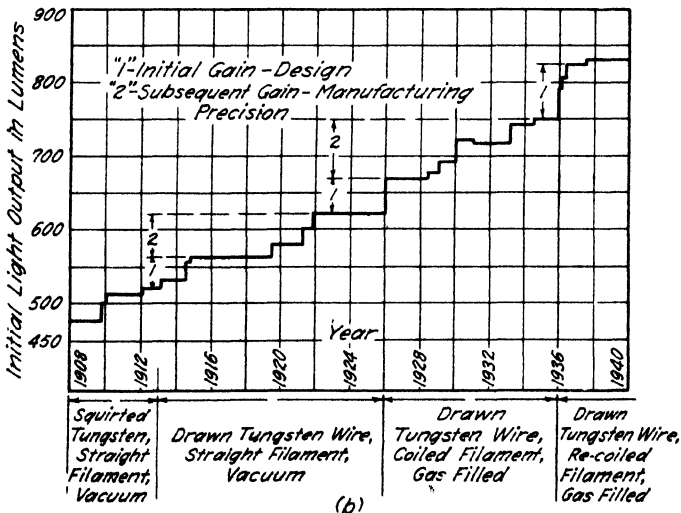
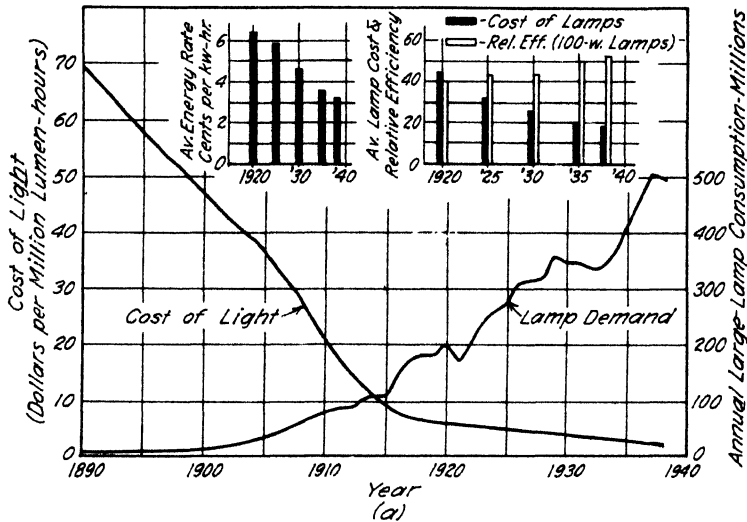

FIG. 4-12.<sup>1, 12</sup> Improvement and sales of incandescent lamps.

table gives evidence of the possibility and economy of using much more light now both for pleasure and for necessary tasks. (A million lumen hours represents approximately the light output for the life of a 100-w. lamp at an output rated at 70 per cent of its life.)

Lamps are built for various voltages, and the correct voltage lamp should be used. Figure 5-12 shows the trend toward a standardizing

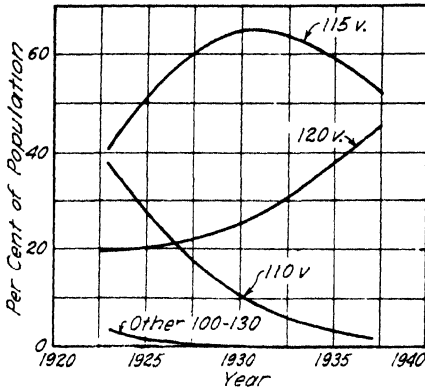

FIG. 5-12 Per cent of population served by various voltages

of voltage at 120 v., and with the voltage regulation equipment now available, this would remove one of the greatest obstacles to the use of lamps at correct voltage. That voltage is of interest in the operation of the incandescent lamp will be seen by another example for demonstration purposes:

*Example b.* A 200-w., 115-v., lamp is burned at 5% under voltage (approximately 109 v.). Determine the increased cost of light during 1000 hr. under these conditions, with current costing 2.5 cents per kilowatt-hour.

The 200-w. lamp costs 35 cents, is rated at 750 hr., and has 3640 l. as the initial output.

Under normal voltage:

$$\begin{aligned} \frac{200}{1000} \times 1000 \times \$0.025 &= \$5.00 \text{ for power} \\ \text{Lamp cost } \frac{1000}{750} \times \$0.35 &= 0.47 \\ & \underline{5.47} \end{aligned}$$

At 5% under-voltage:

$$\begin{aligned} \frac{200 \times 0.925}{1000} \times 1000 \times \$0.025 &= \$4.63 \text{ for power} \\ \text{Lamp cost } \$0.47 \times 0.50 &= 0.23 \\ & \underline{4.86} \end{aligned}$$

(0.925 and 0.5 taken from Table V-12.)

Less light has been obtained at the lower voltage in ratio of 1.00 to 0.84; therefore, the actual cost for equal light will be:

$$\frac{1.00}{0.84} \times \$4.86 = \$5.79$$

This is a loss of 32 cents, which represents 6% of the cost of the light. It is seldom that this much could be gained by the purchase of a more efficient type of luminaire than that normally offered on the market.

In lighting as in other forms of economics, too often all the attention is directed toward that which seems phenomenal in results, and the more positive methods of gain are ignored.

**5. Efficient Light Production.**<sup>4</sup> This article is not presented with the intention of encouraging computation of a complex problem, but to establish firmly the factors that go into economic considerations in producing light. Material is available in publications for specific uses, but care must be taken that the tables are up to date, for changes in lamp cost and efficiency will change the values.

The cost per unit of light may be considered as being influenced by two elements: the cost of energy and the cost of renewals. The two elements may be subdivided into two parts: a fixed and a vari-

TABLE VI-12<sup>5</sup>  
COMPARATIVE COST OF LIGHTING

Light Source	Date	Cost per Million Lumen-Hours
Tallow candle	1800	\$500.00
Sperm oil lamp	1850	100.00
Kerosene lamp	1870	75.00
Gas flame	1880	40.00
Carbon incandescent lamp	1900	35.00
60-w. incandescent lamp	1907	15.00
60-w. incandescent lamp	1937	3.75
Average Cost Figures for 1938		
Wax candle		\$400.00
Kerosene lamp		13.50
Carbon lamp		17.60
60-w. lamp (incandescent)		3.30
150-w. lamp (incandescent)		2.65
200-w. lamp (incandescent)		2.55

able; or either of the two elements may be fixed or variable, depending upon the conditions to be met in the community being studied. Calculations are made when the variable factors are considered as parameters. The controlling factors may be tabulated as:

- a. Cost of energy
- b. Rate system under which energy is bought
- c. Cost of lamp
- d. Contract for securing lamps
- e. Initial efficiency of lamp
- f. Conditions under which lamps are renewed (per cent life)
- g. Variation of wattage and candlepower during life
- h. The uniformity of the lamps



An analysis of these items shows that the question of securing the most economical service from a lamp is mainly a question of the efficiency at which it is operated. It is assumed that there is a uniform energy rate and a fixed price for the lamps. Any system of charging leads to this final analysis, because the company adjusts its rate to cover the conditions of consumption.

Since the highest lumen efficiency for the lamp occurs when burning as near to incandescence as possible and since the life of the lamp depends upon filament evaporation, the problem evolves into that of the voltage at which a specific type of lamp should be operated. New and efficient designs in incandescent lamps specify burning the lamp at the highest incandescence with the least evaporation of the filament. Progressively, the filament has been changed, the supports reduced, inert gas placed within the bulb, and a coil-coil filament has been developed which has increased lamp efficiency.

Computations for the cost of light are based upon the unit *a million lumen-hours* (approximately the total life output of a 100-w. lamp).<sup>4</sup>

$U$  = unit cost of light per million lumen-hours

$E$  = average lumens per watt through life

$P$  = net cost of lamp throughout life (including delivery)

$W$  = average watts consumed by lamp throughout life

$L$  = average lamp life in thousands of hours

$C$  = cost of lamps; cents per kw-hr. ( $P/WL$ )

$R$  = cost of lighting energy; cents per kw-hr.

Unit cost of light (dollars per million lumen-hours),

$$U = \frac{10}{E} (C + R)$$

In order to use this formula intelligently, one should have considerable information concerning the lamp. The lamp manufacturer can and will furnish information based on many tests that must be made to maintain the quality of the lamp. To determine these values by private investigation requires special technique and an outlay of money which is seldom justifiable. The purchase of the lamp is evidence of confidence in the manufactured product.

The solution of a typical problem will show the value of the equation in the determination of unit costs.

*Example c.*<sup>4</sup> A customer wishes to know which is the more economical lamp to burn; a 110-, 115-, or 120-v. lamp on a 115-v. system. The energy rate is 2.17 cents per kw-hr. and the cost of a 200-w. lamp — the one to be used — is 30 cents.

	110-v. Lamp		115-v. Lamp	120-v. Lamp	
	At 110	At 115	At 115	At 115	At 120
Average watts ( $W$ )	195.2	209.1	195.2	182.8	195.2
Average lumens per watt ( $E$ )	16.97	18.30	16.84	15.48	16.70
Average life ( $L$ ) in thousands of hours	0.75	0.42	0.75	1.34	0.75
Cost of one lamp in cents ( $P$ )		.30	.30	.30	
Kw-hr. consumed per lamp ( $WL$ )		87.8	146.4	245.2	
Cost of lamp, cents per kw-hr. ( $C$ )		0.34	0.20	0.12	
Energy cost, cents per kw-hr. ( $R$ )		2.17	2.17	2.17	
Then $C + R$		2.51	2.37	2.29	
Cost per million lumen-hours ( $U$ )		\$1.37	\$1.41	\$1.48	

Under these conditions, the customer would obtain about 3% more light for his money by using 110-v. lamps on the 115-v. system, and if 120-v. lamps were used, the cost of light would be 8% more than with the 110-v. lamps. The lamps would last longer and leave the impression of a saving, but actually the cost would be greater.

The problem shows the advantage of deviating from the voltage marked on the lamp under a specific condition in which the power cost is relatively low, but any departure from rated voltage must be backed with evidence such as the table in the example shows. This case is typical, for voltage is delivered to the customer by the service company at some specified value which must fall within certain limits, usually set by legislation.

A poor lamp may be expensive because of the loss encountered in its use, and conditions of operation may be such that considerable breakage takes place. It is of more importance if lamps of long life are used, because the number of lamp-hours lost when a lamp is broken increases as the average life of the lamp increases. Though this factor may not enter into the general problem, it is necessary not to lose sight of the fact that it may be of great importance in an inferior lamp that fails because of poor construction or internal breakage early in its life.

$L$  = average life with no breakage

$Z$  = average breakage interval (average number of burning hours between breakage in one socket)

$S$  = average life service

$$S = Z(1 - e^{-L/Z})$$

Since a lamp becomes less efficient as it grows old in service, there comes a time when it is justifiable to take the lamp and smash it. This is called the *smashing point* (Fig. 6-12). This is the point where the cost of energy consumed per million lumen-hours exceeds the aver-

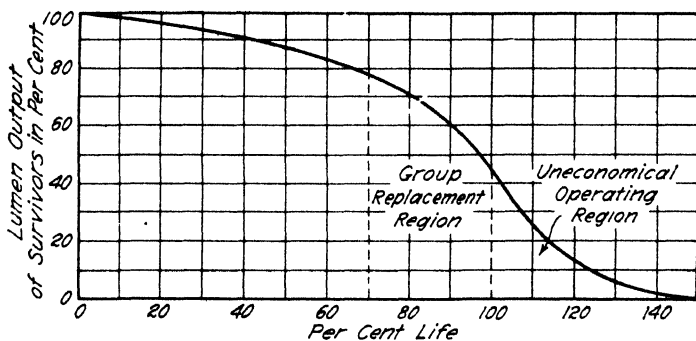

FIG. 6-12.<sup>12</sup> Group replacement region and uneconomical regions in the use of incandescent lamps.

age cost of light produced up to that time, including both lamp and energy. Below is listed the legitimate smashing point for some conditions:

Lamp	Cost Cents	Rate per Kw-hr.	Smashing Point	
			Per Cent of Life	Lamps Remaining
200 w.	30	2 17	120	10%
200 w.	30	4.34	72	95
If lamps are operated at 5% under-voltage				
200 w.	30	2.17	80	90

Under-voltage burning justifies scrapping the lamps at a lower percentage of average life.

**6. Light Cost Affected by Wiring.** As seen previously, the voltage is an important factor in illumination economics; therefore, it becomes of importance in the wiring design. It affects both the uniformity and the economy with which the lighting installation operates. Chapter 13 is devoted to the design of wiring systems which will deliver adequate and economical voltage to all lamps in the installation.

Since the energy purchased is measured at the main switchboard, the cost of the light is projected to that point. It would be logical to make the same economical study of the wiring system as that made for the lamps, but there are so many variables and so much is governed by definite legislation for safety that the problem would be very involved. It is better to be guided by the factors established by empirical solutions. The size of the wire must be justified by the saving on the cost of energy. After a specific installation has been calculated, the allowance for future expansion is an important consideration. In recent years many buildings have been wired in such a manner that they were obsolete for lighting adequacy before the power was turned onto the circuits. This kind of installation is expensive, for it requires additional expense when an attempt is made to increase its capacity to the new requirements.

**7. Economic Consideration of Fluorescent Lamps.**<sup>9, 11</sup> The rapid development of gaseous conduction lamp illumination in the last few years makes it desirable to consider whether or not it is cheaper to use the new sources, with their attending cost of special auxiliary equipment and higher cost of lamps, or the older forms of incandescent lighting. The problem of the fluorescent lamp is directly connected with the problem of power factor as well as with the problem of special and different installation. Though the load from fluorescent lamps has as yet not materially affected the utilities, it is necessary for them to make rates accordingly if the power factor of the fluorescent lamps is not corrected and the load becomes appreciable. As discussed in Chapter 6, this problem has been solved, but only at an additional cost to the user.

The June, 1939, issue of the *Magazine of Light* has an article by W. C. Brown and J. C. Forbes,<sup>11</sup> which in a simple and interesting manner gives a typical answer to the question of how the cost of fluorescent lighting in itself compares with that of incandescent lighting. Their solution is reproduced here and, though it is specifically devoted to the question above, it is a method which may be used on any comparative computation for two systems of lighting. From March, 1939, to March, 1940, the unit cost for a typical fluorescent installation decreased 44 per cent as compared with the 1939 figures; therefore a text problem of this type is limited to method, not specific information. Before recommending a fluorescent installation in preference to an incandescent system a study of this type should be made.

*Example d.* Compare the incandescent and fluorescent costs for a room 40 by 60 feet with a 11½-ft. ceiling. The ceiling surface has a reflection factor

of 75% and the side wall a reflection factor of 50%. Lights will operate for 2000 hr. a year and the illumination will be 30 ft-c. (For graphic representation, see Fig. 7-12a.)

## COEFFICIENT OF UTILIZATION

Fluorescent	
Bare lamps on ceiling	0.65
Luminaire with metal louvers	0.52
Louverglas box	0.46
Coffers 4 by 6 ft.	0.67
Totally indirect Alzak trough	0.38
Incandescent	
Enclosing globe	0.52
Enclosing globes with shades	0.54
Coffers	0.64
Indirect luminaires	0.40

(Customer on \$10,000 discount basis)

Fluorescent 48-in., T-12, 40-w. daylight lamp

Price per lamp \$2.80; output, 1600 l.; life, 2000 hr.

Auxiliary cost, including power factor correction, \$3.50 net

Luminaires (owning cost amortized in 6 yr.)

First cost (wiring of unit)	100%
Yearly cost of auxiliaries	
Interest, taxes, insurance, maintenance	10%
Depreciation	15%
Total yearly owning cost	25%

Existing branch circuits and other wiring assumed to be adequate in each case.

## COMPUTATION

	Incandescent (500 w.) Enclosing with Shade	Fluorescent 40-w. Louvered Direct
1. Lamps per luminaire	1	6
2. Initial lumen output (per lamp)	10,050	1600
3. Utilization factor	0.54	0.52
4. Number of Lamps	24	144
5. Foot-candles in service	38	35
6. Hours, life of lamp	1000	2000
7. Net cost per lamp	\$ 0.87	\$ 1.88
8. Yearly net cost of lamps	42.00	270.00
9. Cost of luminaire proper	8.00	40.00
10. Cost of luminaires	192.00	960.00
11. Cost of auxiliaries		432.00
12. Cost of sockets		72.00
13. Cost of power factor correction		72.00
14. Total cost of luminaires (items 10, 11, 12, 13)	192.00	1536.00

15. Yearly cost of luminaires (25% of Item 14)	48.00	384.00
16. Wattage of lamps and auxiliary	12,000	6642
17. Annual energy cost		
at 1 cent per kw-hr.	\$ 240.00	\$ 132.00
2 " " "	480.00	265.00
3 " " "	720.00	398.00
4 " " "	960.00	530.00
6 " " "	1440.00	795.00
8 " " "	1920.00	1060.00
10 " " "	2400.00	1325.00
18. Cost per foot-candle year (items 8, 15, 17 divided by item 5)		
at 1 cent per kw-hr.	\$ 8 70	\$ 22.40
2 " " "	15 00	26.20
3 " " "	21.30	30.10
4 " " "	27.60	33.80
6 " " "	40.30	41.30
8 " " "	52.90	49.00
10 " " "	65.50	56.50
19. Cost per foot-candle year in per cent of filament installation.		
at 1 cent	257%	
2	175	
3	141	
4	123	
6	102	
8	93	
10	86	

By using this method of computation, the information for the curves on Fig. 7-12 was obtained. Though each individual installation is a problem by itself, and should be studied as such, the curves are indicative of what may be expected in the economic consideration of the new sources of light which are frequently recommended as highly efficient. This statement is true in comparing this unit with the incandescent unit, but the terms "high efficiency" and "highly economical" will not necessarily be synonymous.

Figure 7-12a shows a comparison of the relative cost and energy rates for the largest (40-w., 48-in.) fluorescent lamp available and a 500-w. incandescent lamp. It is assumed that the wiring is the same in both instances. In Fig. 7-12c, the comparison is on the basis of fluorescent cost in per cent of filament lamp cost. Six types of installations are considered. Curves *D*, *E*, *F*, and *G* illustrate typical installations of fluorescent lamps with the lower efficiencies. Figure 7-12b compares the high-intensity mercury-vapor light source with the incandescent lamp (H. W. Sharp and J. F. Parsons).<sup>9</sup>

New curves will have to be determined for the more efficient fluorescent lamps that will be developed as researchers discover the

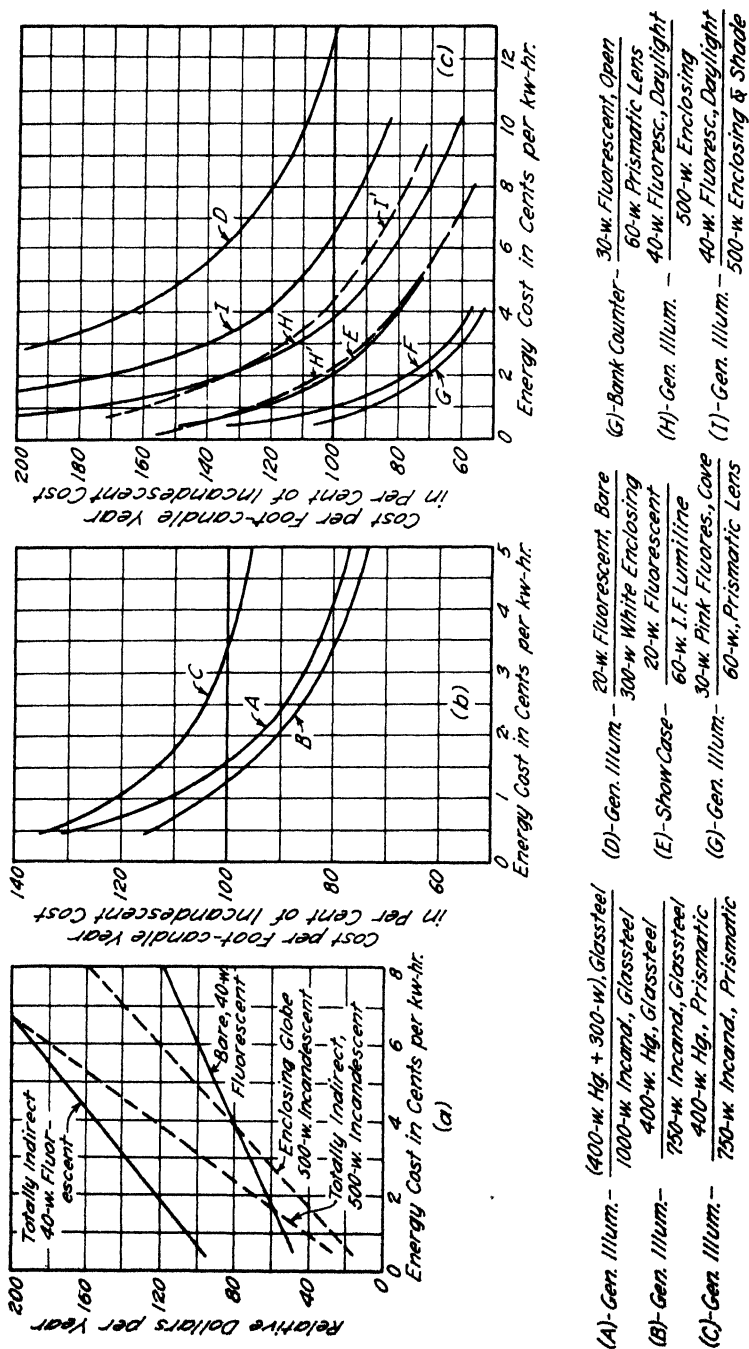

FIG. 7-12.<sup>1</sup> Comparison of cost for incandescent, high-intensity mercury vapor, and fluorescent lamps. The dotted curves show the computation based on data of March, 1941.

use of lamps of greater capacity. The method of computation is applicable to any new problems that may arise and is free from involved developments usually encountered in economic studies. This method should be more frequently used by the architect and illuminating engineer when studying any installation. It need not be confined to a study comparing two different light sources, but may be used with equal success in comparing different arrangements of similar light sources.

#### AUTOMATIC CONTROL OF LIGHTING

Another device which may enter into the economics of illumination is photoelectric control of room lighting. With the higher amounts of illumination needed for the tasks to be performed, it is essential to use artificial light only when it is necessary and in those parts of the room which are below the required illumination. Photoelectric control performs the double function of guarding the worker against insufficient light for performing the task with the least amount of eyestrain, and at the same time guarding against unnecessary waste of electrical energy when there is no need for the artificial light.

**8. Photoelectric Control.** The equipment consists of three essential parts: the cell proper, the amplifier (in some equipment), and the relay. The light, impinging upon the cell, generates electrical energy which is amplified to operate a relay, and this, in turn, causes the lights to be put in and out of operation. The current from the cell is proportional to the light that is present. When the room illumination falls below a predetermined value, the relay functions, turning on the light; and when the illumination is above a predetermined value, the relay turns off the light.

Figure 8-12 shows two different types of control, both functioning upon the same principle of current generated when light falls upon a photoelectric cell. Because the light cell is very sensitive, the relay will function on changes of very short duration; this is objectionable at times. As an example, if there happens to be a series of clouds passing by, these will cause the natural light to change very rapidly and, therefore, change the artificial light correspondingly. To reduce this effect, a thermal timer is added to the equipment to cause a time delay long enough so that the circuit will not function unless the delay in the dark period extends over a specified time interval. At present the photoelectric control of interior illumination is, for the most part, confined to schoolroom use, but its economic value will introduce the device to both industrial and commercial interests.



**9. Installation of Photoelectric Controls.** It is not possible to give a set of rules for the installation of the equipment, for each room presents an individual problem. It should be located where it will receive daylight illumination on its vertical surface, changing simultaneously with the illumination on the work surface. This requires that the cell be turned toward an unobstructed sky — the source of the natural light. The more sky area that it is possible to include with the cell surface, the more will relay functioning approach average light conditions. If the cell is pointed toward the open sky, when

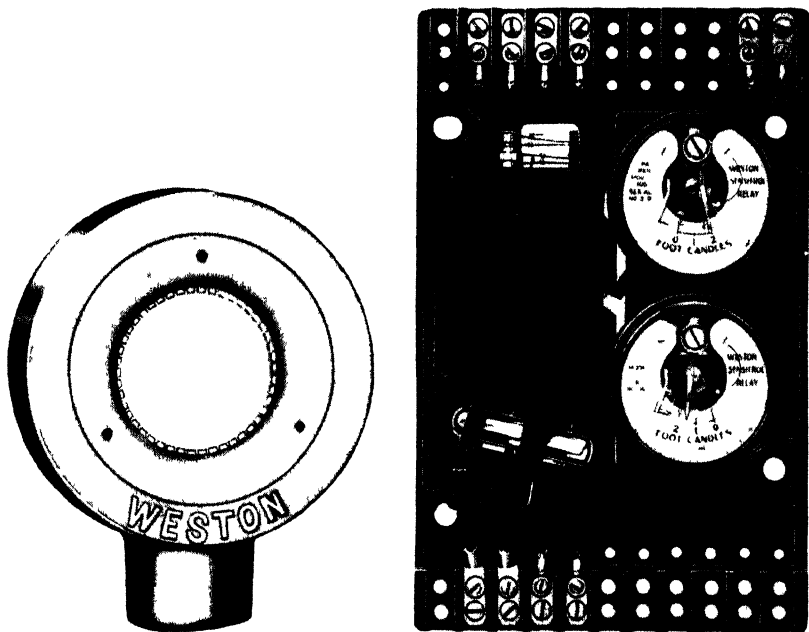

Fig. 8-12A Automatic light control equipment. Weston Electrical Instrument Corp. cell and amplifier.

direct sunlight enters the room the shade is drawn, and if the light reduction is severe the lights will be turned on automatically.

The tube or cell should not be located where the direct sunlight will fall upon it, and must not be so placed that the reflected light from the ceiling or side walls, when the artificial light is on, falls upon the cell. The unit should be placed high enough so that it will be out of walking height and out of reach. If placed where individuals can obscure the light falling upon the photoelectric cell, it will function when someone walks past. It should be high enough so that no unauthorized individuals can tamper with its adjustment. When several

positions seem equal in choice of location, the one requiring the least wiring should be used.

Figure 9-12 shows some arrangements for control locations. Figure 9-12a shows the most desirable location; that is, 5 to 8 ft. from the

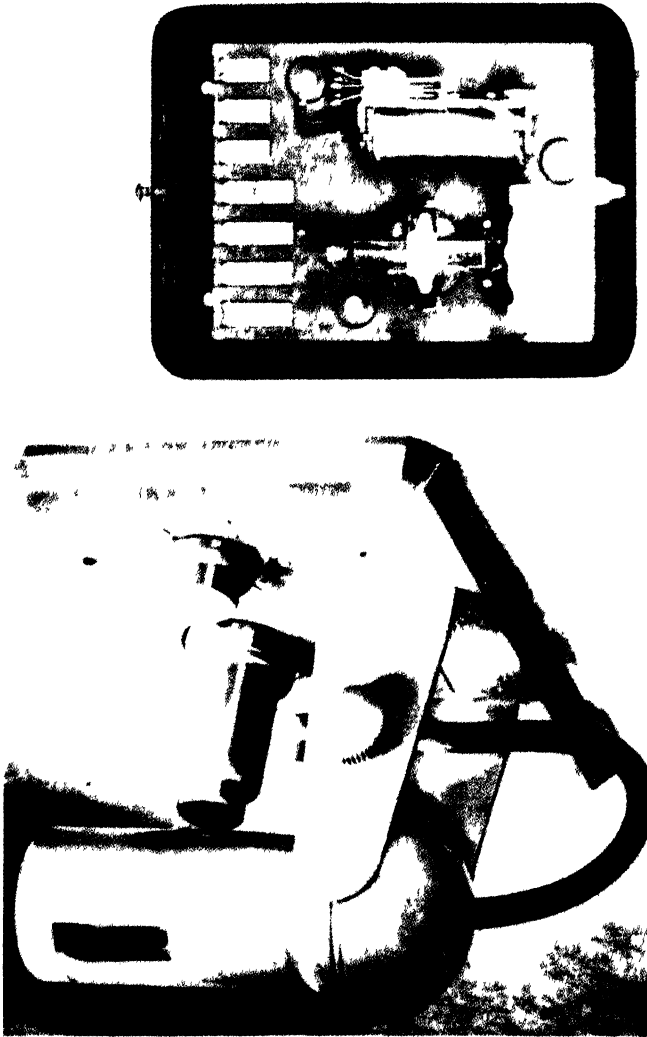

FIG. 8-12B. Automatic light control equipment. General Electric cell-amplifier unit and relay.

window on either the front or back wall, provided that the wall is not too far from the end window. If the wall is more than 3 or 4 ft. from the window, a better control may be obtained by mounting the unit on a support from the ceiling approximately the above distance

from the line of the end of the window. The remainder of the parts of Fig. 9-12 show methods of avoiding obstructions which may be found outside the building window. If it is necessary to place the cell across the room from the window and the room has much depth, it may be necessary to put a visor over the cell to keep it from functioning when

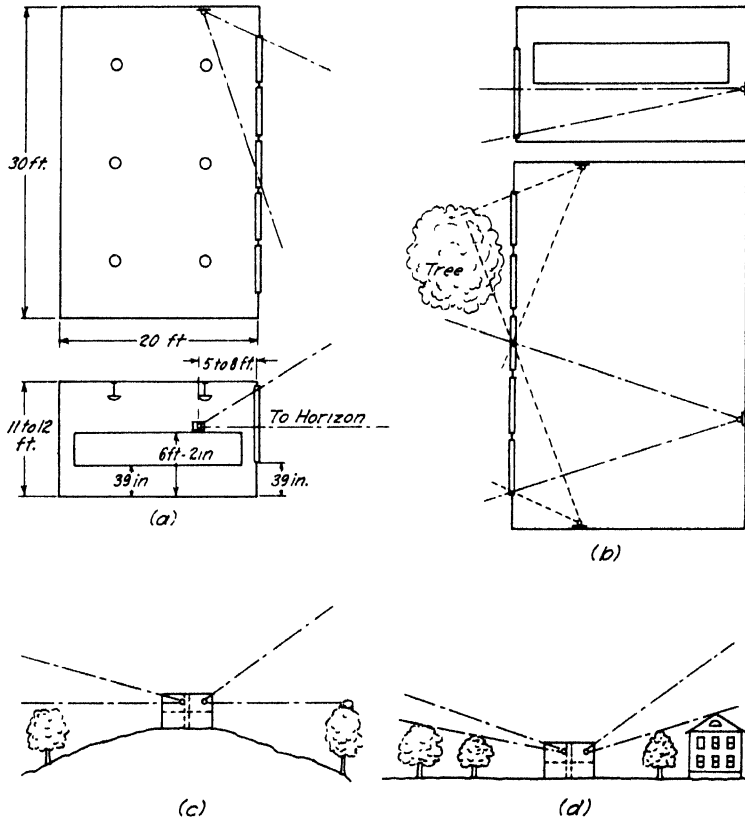

FIG. 9-12. Location of photoelectric control units. (a) Most desirable location. (b) Located to avoid an obstruction. (c) High ground vertical control, best condition. (d) Avoiding obstructions in the vertical plane.

the room lights are turned on, thereby turning them off again, a process which causes "chattering" of the relay and which would be annoying because of blinking.

To function in a positive manner, the cell should have at least 3 ft-c. of illumination. If more than 20 ft-c. fall upon the cell proper from the lighting system it will not control properly. In installing the automatic photoelectric control, the precautions to observe are:

- a. Place the unit out of reach of all unauthorized individuals.
- b. Expose the cell to as much unobstructed sky as possible.
- c. Do not expose to direct sunlight.
- d. At least 3 ft-c. should be on the cell when the point is reached where artificial light is necessary.
- e. The illumination on the cell should increase at least 2 ft-c. as the work plane illumination increases approximately 5 ft-c.
- f. The cell should not receive more than 20 ft-c. of light.
- g. Care must be taken that other light sources are not controlling the action of the cell and that the lights controlled do not cause the cell to function.

**10. Controlling Several Rooms.** It has been suggested that one cell could control several rooms having the same sky exposure. This should not be done as a rule, and it is doubtful if any such installation will give a satisfactory operation. In addition to introducing several questions in economic operation, too much depends upon the operation of the window shades in the various rooms. If this type of installation is to be attempted, the cell should be located in the most unfavorable location. If the rooms are on several floors the difficulty is increased even more, for the lower rooms will probably suffer more from surroundings than the rooms on the upper floors.

Opposed to the method of controlling several rooms with one unit is that of having several units in one room. This is not necessary in a normal room, and where tests have been made in schoolrooms, the cell on the light circuit located farthest from the window functioned so infrequently that there was not enough saving to justify its cost. Where there are two window exposures on opposite sides of the room and the rooms are very large (as in factories and drafting rooms), more than one cell control may be economical.

**11. Illumination Controlled.** The control of illumination can be studied from an economic standpoint, for the saving in electrical energy, lamps, and lamp maintenance must be sufficient to justify the investment in auxiliary equipment and added wiring plus the replacement and maintenance which may be necessary.

The ideal lighting system would include:

- a. Adequate wiring
- b. Adequate and comfortable lighting
- c. Automatic light control

each item justifying its adaptation by being proved to be economical. The automatic control should add to the system the following features:

- a. Maximum value received from the illumination
- b. Increase in working efficiency by the correct illumination at all times
- c. Increasing safety and preventing fatigue
- d. Making manual attention to lighting unnecessary.

Relays always make a noise when they operate; therefore, it is well to locate the relays outside the room in corridors if possible. The cell itself and its auxiliaries are free from noise. Most cases of dissatisfaction with automatically controlled installations have resulted from faulty installation. Conditions are so variable that it is necessary for the designer to have more than a superficial knowledge of the problems before attempting to specify conditions of installation and operation.

#### BIBLIOGRAPHY

1. N. E. L. A., "Lamp Efficiency," *Bulletin* 101, 1912.
2. E. A. ANDERSON and J. M. KERCH, "Depreciation of Lighting Equipment Due to Dust and Dirt," *I. E. S. Trans.*, v. 19, No. 1, January, 1924.
3. N. R. LOWELL, JR., "Better Service by Group Lamp Replacement," *I. E. S. Trans.*, v. 29, No. 8, September, 1934.
4. G. S. MERRILL, "The Economics of Light Production with Incandescent Electric Lamps, with Particular Reference to Operating Voltage," *I. E. S. Trans.*, v. 32, No. 10, December, 1937.
5. E. W. BEGGS, "The Value of Quality in Mazda Lamps," *Elec. Jour.*, v. 34, No. 12, December, 1937.
6. J. O. KRAEHNBUHEL, "Problems in Building Illumination," Univ. of Ill. Experiment Station, *Circular* 29, 1937.
7. S. G. HIBBEN, "Lamps and Lumens — Their Consumption and Cost," *Elec. Jour.*, v. 35, No. 10, October, 1938.
8. WESTINGHOUSE ELECTRIC AND MANUFACTURING CO., *Artificial Light and Its Application*, 1938.
9. H. W. SHARP and J. F. PARSONS, "Lighting Cost Comparison," *Elec. World*, v. III, No. 4, p. 48, April 8, 1939.
10. COMMITTEE REPORT, "Recommended Practice of Industrial Lighting," *I. E. S. Trans.*, v. 34, No. 4, April 1, 1939.
11. W. C. BROWN and J. C. FORBES, "Costs of Lighting with Fluorescent Lamps," *Mag. of Light*, v. 8, No. 4, June, 1939.
12. NELA PARK ENGINEERING DEPT., *Mazda Lamps*, 1939.
13. D. P. CAVERLY, "An Analysis of Photoelectric Classroom Lighting Control," *I. E. S. Trans.*, v. 34, No. 8, pp. 907-922, September, 1939.
14. G. J. TAYLOR, "Maintenance — A Dirty Fixture Is Only Half A Fixture," *The Mag. of Light*, v. 9, No. 5, p. 35, June, 1940.
15. C. E. WEITZ, "Lamp Prices and Lighting Costs," *The Mag. of Light*, v. 9, No. 7, p. 14, September, 1940.

## CHAPTER 13

### WIRING

As demonstrated in Chapter 12, the economics of illumination depends upon the voltage at which the lamp is burned; therefore, it is essential that the voltage be correct. To obtain the correct voltage at the lamp it is necessary to design the wiring system so that regardless of the load on the system, approximately constant voltage will be maintained.

It would take excessively large wires to insure a voltage with no appreciable variation; therefore, the loss of voltage depends upon the economical wire size that can be used, and this leads to an empirical choice of allowable voltage drop. There may be a variation as to what this allowance should be in various design procedures, but it will not be over a very wide range. The design of the wire for adequacy is only part of the problem, for the wiring must also be designed for safety, and this is governed by state and local legislation.

It is necessary that the wiring system be adequate before adequate illumination for the task can be designed. Since this is true, the illuminating engineer and the architect are interested in having the wiring properly designed. Once the building is erected and the wire installed, any alteration is very costly, but while the building is being erected, wire sizes can be increased and allowance made for future expansion with only a small per cent increase in cost. Wiring represents only a very small part of construction cost.

**1. Codes and Regulation.** Since electrical circuits, if not properly installed, are hazardous both to the building and the occupants, safety as well as performance must be considered. The National Electrical Code, which is a part of the fire insurance contract, is distributed by the National Board of Fire Underwriters. Inadequate inspection and lack of building codes which protect against fire increase fire insurance rates. This fact causes each community and state to pass some form of electrical wiring regulation which, in all instances, is as strict as the Code, and in many instances much more strict, setting very definite limitations on the use of certain approved classes of construction material. In addition to being acquainted with the National Electrical

Code, it is necessary for the designer and inspector to be familiar with state and city requirements.

The National Electrical Code, which is the basis for most legislation, originates with, and is revised by, the Electrical Committee of the National Fire Protection Association. The main committee is composed of subcommittees having specialists in each field of inspection and practice with which they are associated. The rules of this committee are approved by the American Standards Committee and the National Board of Fire Underwriters; the latter distributes the various revisions of the Code to the fire marshals of the states and the local inspectors.

Lighting and power circuits which are designed to satisfy the requirements of the Code, and which are properly maintained, will never be a hazard. Fires and accidents caused by electrical circuits

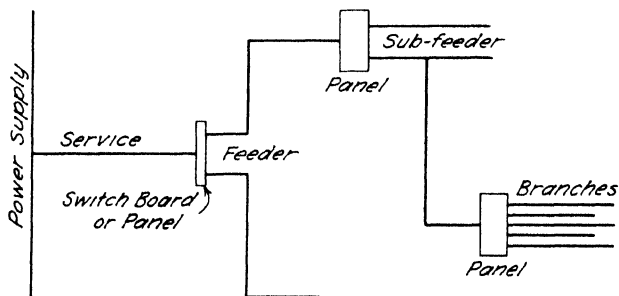

FIG. 1-13. The distribution system in building wiring.

are usually caused by faulty equipment or circuits, or by improper maintenance of circuit protection. It is essential that the latest revision of the Code be used when specifying the requirements for an electrical circuit. The Code is revised approximately every two years.

**2. The System Layout.** The distribution of electrical energy in a building starts from the service supplied by the power company. Figure 1-13 shows the schematic layout of the distribution system. The current follows

- a. the service
- b. feeder
- c. sub-feeders
- d. branches

to the lamp or motor load. The various parts of the system are connected in panel boxes or on open panels, and except in special cases, the wires must be correctly fused at these points. Each wire becomes progressively smaller from the service to the branch. Never is a

smaller wire placed ahead (nearer the source) of a larger wire in an electrical installation.

The location of the panels or panel boxes in the building will be controlled by the load center. It is desirable to place the distribution center as near the load center as possible, whether it is the main panel or some minor center. There can be no hard-and-fast rule for locating the distribution panels, for they cannot be placed in important business areas or where they are not easily and quickly accessible for fusing or switching. However, if consideration is given the location of the load center, though it may be theoretical and not practical, it will act as a guide for placing the distribution center in the most reasonable and practicable location.

The exact location of the load center is obtained by adding the products of the current times the distance (from the distribution center to each lamp or motor) and dividing the total sum by the sum of the currents. The sum of the positive products plus the sum of the negative products must equal zero.

*Example a.* Determine the load center for the loads shown on the circuit in Fig. 2-13a.

If the load center is assumed to be at the 10-amp load on the left, the product of amperes and distance will be:

$$\begin{array}{r}
 10 \times 0 = 0 \\
 40 \times 50 = 2,000 \\
 20 \times 150 = 3,000 \\
 10 \times 190 = 1,900 \\
 10 \times 250 = 2,500 \\
 20 \times 275 = 5,500 \\
 \hline
 110 \qquad \qquad 14,900
 \end{array}$$

The load center will be:

$$\frac{14,900}{110} = 135.455 \text{ ft. from the distribution panel}$$

To check this result, the load center as calculated (135.455) is used; the product of amperes and distance will be:

$$\begin{array}{r}
 10 \times 135.455 = 1354.55 \\
 40 \times 85.455 = 3418.18 \\
 \hline
 \text{Negative} \quad 4772.73
 \end{array}
 \qquad
 \begin{array}{r}
 20 \times 14.545 = 290.91 \\
 10 \times 54.545 = 545.45 \\
 10 \times 114.545 = 1145.45 \\
 20 \times 139.545 = 2790.91 \\
 \hline
 \text{Positive} \quad 4772.72
 \end{array}$$

This actual load center location is shown in the second illustration of Fig. 2-13a.

The concept of load centers can be extended to include a complete layout for locating the ideal place to put the feeder distribution panel.



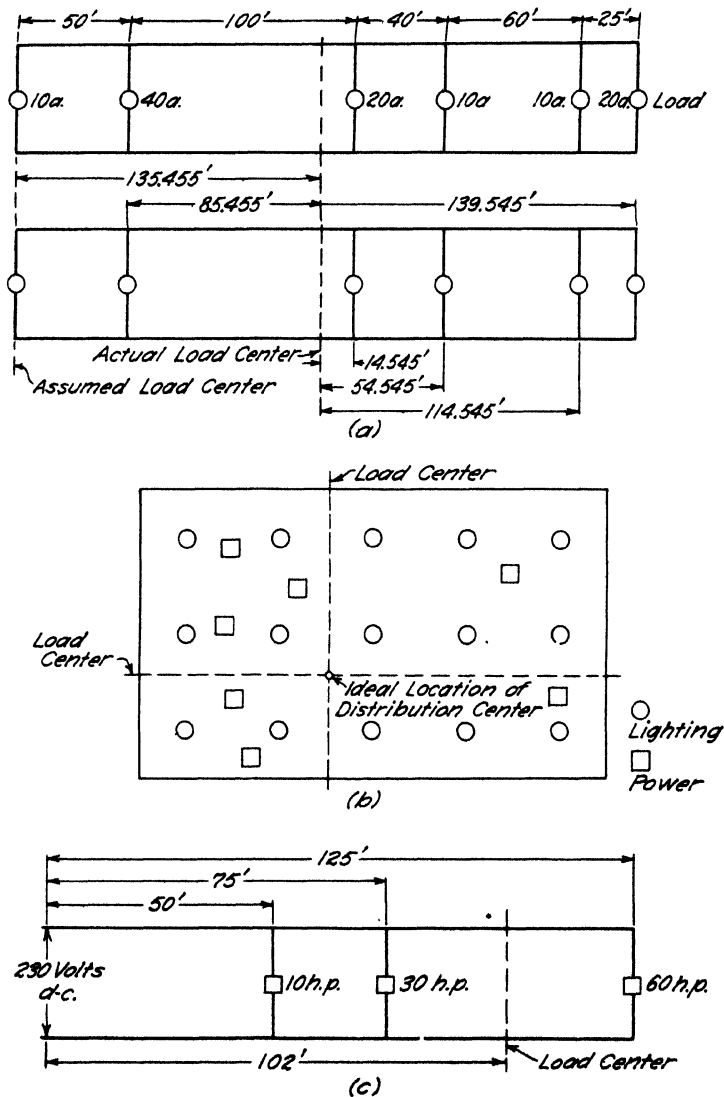

FIG. 2-13. The determination of load centers. (a) An analysis for a load center. (b) Load centers used for determining distribution centers. (c) Load center for a feeder.

This method of layout analysis, however, must not be used in an arbitrary fashion but with judgment. Figure 2-13b shows the probable location of a distribution panel in a simple layout.

One of the most important uses of the load center is that of simplifying the determination of voltage drop in the wiring system. Instead of calculating the voltage lost to each individual load on the circuit, the load can be assumed to be concentrated at the load center, and the resultant voltage drop calculated to this point will be the greatest expected voltage loss on the system. Figure 2-13c shows a circuit diagram for a feeder which supplies three motors; the demonstration problem shows how to determine the concentrated load and the load center.

*Example b.* Determine the current and load center for a 230-v. d-c. feeder which supplies three motors of 10, 30, and 60 h.p. located 50, 75, and 125 ft., respectively, from the supply panel.

(See Table III-13)

H P.	Current	Distance Feet	$D \times I$	Load Center = $\frac{37025}{363} = 102$ ft.
10	38	50	1,900	Load Current 363 amp.
30	110	75	8,250	
60	<u>215</u>	125	<u>26,875</u>	
	363		37,025	

As shown, the load center lies in the center of the distance-current characteristic of the distribution. To reduce the voltage drop, it is best to locate the distribution centers at this point. It is also efficacious, in designing the risers or laterals for the wiring system, to observe this same rule so that the greatest advantage may be taken in equalizing voltage losses. Figures 3-13a to 3-13d show various methods of locating the panels on the feeders to distribute the load from a riser system. Figure 3-13a shows a desirable system which is expensive, but is used where the load on each floor or at each point justifies an independent feeder. The other systems are marked according to desirability, and the one shown in Fig. 3-13c is the one used in the average construction and design. Figure 3-13f shows the same principle applied to lateral runs in a large building.

It is impossible to say that any one system should be used every time, or that any one system should never be used, for this depends upon the circumstances controlling the plans for the installation. Careful study must be made of the building plans and the probable load center to determine the best locations for distribution panels. The final design will be governed by best maintenance and operation

location in conjunction with the least voltage drop. The determination of the voltage drop will be discussed later.

**3. Systems of Distribution.** It is possible to distribute electrical energy by various systems, classified as:

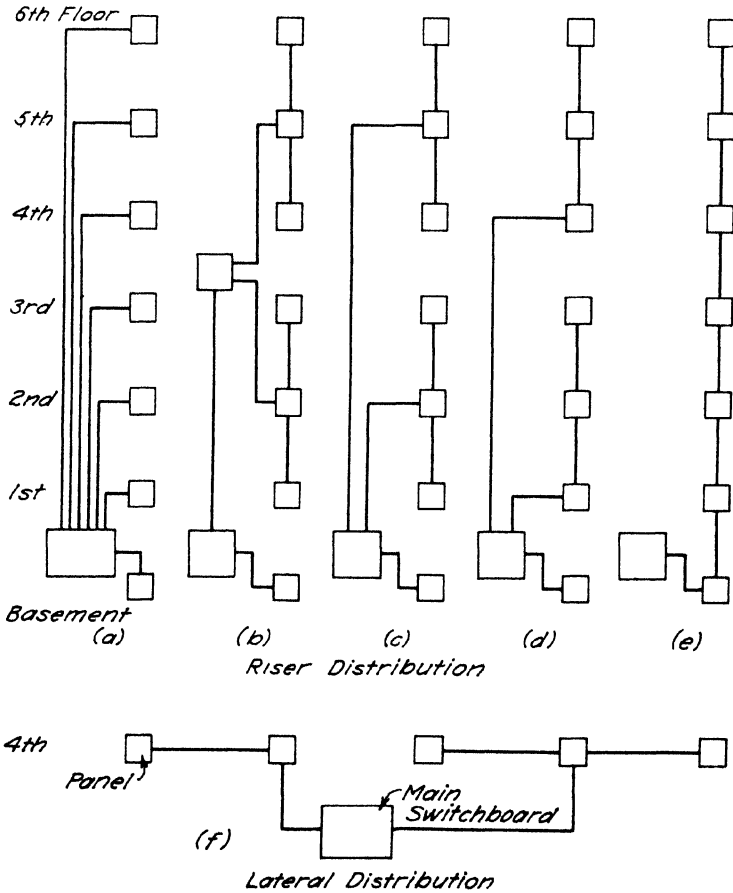

FIG. 3-13. Riser and lateral distribution. (a) Expensive. (b) Ideal. (c) Usual. (d) Undesirable. (e) Bad. (f) Lateral.

- a. Two-wire distribution
- b. Three-wire distribution
- c. Three-phase, three-wire distribution
- d. Three-phase, four-wire distribution
- e. Two-phase distribution

*Two-wire distribution* may be used either for alternating or direct current. The a-c. system will be single phase. This distribution is used for the ordinary branch circuit in lighting installations, for small motors in a-c. systems, and for all d-c. motors. Since this type of

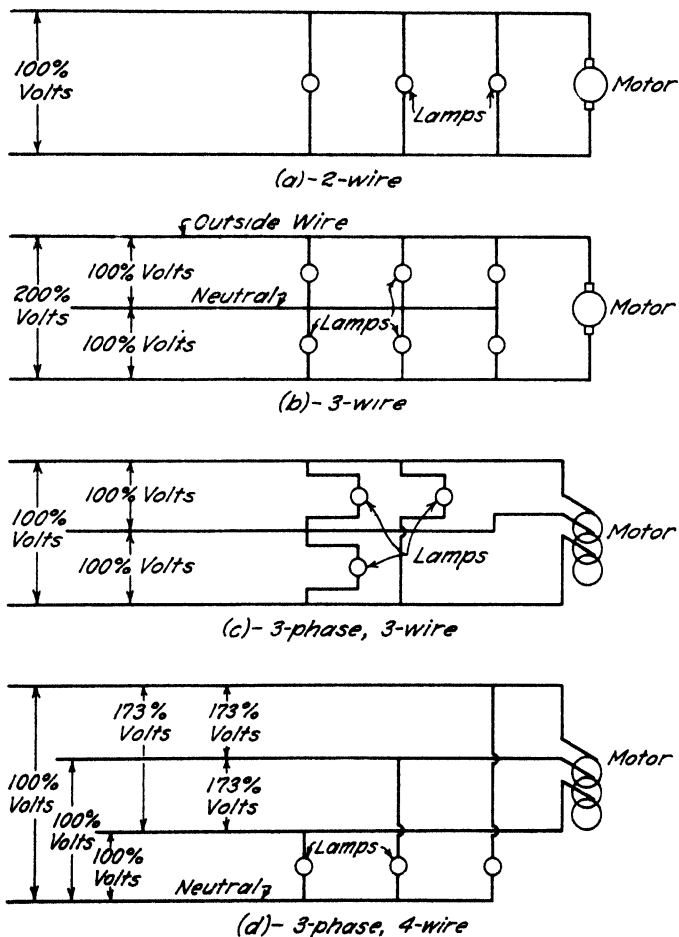

FIG. 4-13. Different types of distribution systems, (a) and (b) for direct current and single-phase alternating current; (c) and (d) for three-phase alternating current.

wiring is used for minor distribution, it is by far the most extensive in the whole system but is of correspondingly smaller wire size in most instances.

*Three-wire distribution* is either d-c. or single-phase alternating current. The voltage between the outside wires is twice the voltage from either outside wire to the neutral. The load is equally divided

(in the design) between the neutral and the two outside wires. The advantage of this system lies in the saving of copper, and it is used for lighting feeders and for branch circuits to large appliances. In some installations motors are operated on the two outside wires and the lighting is operated from the neutral to the outside wires.

*Three-phase, three-wire distribution* is an a-c. system and is primarily used for power distribution. It has been used for lighting feeders, but it must show definite economic savings and a well-balanced lighting load before it can be justified. For motors, it is used both for the feeder and the branch circuit, since three wires are essential for the

TABLE 1-13  
COPPER REQUIREMENTS FOR SYSTEMS OF DISTRIBUTION

System	Voltages	Copper for Constant Voltage Drop *	Copper for Constant Load †
2-wire a-c. and d-c.	100%	100%	100%
3-wire a-c. and d-c.	100-200%	37.5%	75%
3-phase 3-wire	100%	75%	87%
3-phase 4-wire	100-173%	33.3%	67%
2-phase 4-wire	100%	100%	100%
2-phase 3-wire (Neutral 141% of outside wire)	100-141%	73%	85%

\* Constant voltage drop, load, and voltage — adequate and safe.

† Constant load and voltage — only short runs — safe.

three-phase motor. Single-phase power may be obtained from any one of the three phases of the three-phase, three-wire distribution.

*Three-phase, four-wire distribution* is the latest innovation in the distribution of power in a modern building, combining the lighting and power load on one distribution system. The power is delivered over the three-phase system at 208 v., and the lighting is obtained between either of the three-phase lines and the neutral at 120 v. The lighting load should be well balanced and should represent approximately 90 per cent of the total load. The four-wire system is used for feeders. Though there are definite advantages in the four-wire system for secondary distribution of the utilities, most of these advantages disappear when it is applied to buildings. There are metering problems, light flicker caused by motor starting, and balancing of lighting loads — all of which make doubtful the economic gains. If a

building is an addition to a group of buildings using other than 120 v. lighting distribution and is serviced by the same maintenance service, there is the probability of lamping both systems with lamps designed for another voltage. Having to stock lamps of different voltages may in itself cause more expense than is gained by this more complicated system.

Figure 4-13 shows, in simple diagrams, the various systems, and Table I-13 shows the relative economic considerations for the various

TABLE II-13  
CALCULATION OF CURRENT

2-wire d-c.	$\frac{\text{watts}}{\text{volts}} = \text{current}$
3-wire d-c.	$\frac{\text{watts}}{\text{highest voltage}} = \text{current}$
2-wire 1 $\phi$ a-c.	$\frac{\text{watts}}{\text{volts} \times \text{power factor}} = \text{current}$
3-wire 1 $\phi$ a-c.	$\frac{\text{watts}}{\text{highest voltage} \times \text{power factor}} = \text{current}$
3-wire 3 $\phi$ a-c.	$\frac{\text{watts}}{1.73 \times \text{volts} \times \text{power factor}} = \text{current}$
4-wire 3 $\phi$ a-c. balanced	$\frac{\text{watts}}{1.73 \times \text{volts} \times \text{power factor}} = \text{current}$
4-wire 2 $\phi$ a-c.	$\frac{\text{watts}}{2 \times \text{volts} \times \text{power factor}} = \text{current}$
	<i>Outside Wire</i>
3-wire 2 $\phi$ a-c.	$\frac{\text{watts}}{2 \times \text{volts} \times \text{power factor}} = \text{current}$
	<i>Common Wire</i>
	$\frac{\text{watts}}{2 \times \text{volts} \times \text{power factor}} \times 1.41 = \text{current}$

NOTE: 746 watts = 1 h.p.

$$\text{watts} = \frac{\text{h.p.} \times 746}{\text{efficiency}}$$

types of systems considered from the standpoint of safety and adequacy. The two-phase system is now obsolete and although it may be encountered, its installation should be discouraged even though the supply happens to be two-phase. It is possible to convert any two-phase system to a three-phase system by using a static device called a Scott transformer, and when later a three-phase system is installed (which is always a possibility), the building distribution is ready for a direct connection.

**4. System Currents.** Usually the equipment current is given in the catalog or may be determined from tables. The current for individual equipment, considered in proper relationship, determines the current for the system. It is necessary to determine the current for the individual loads first. These are then combined for the branch

TABLE III-13<sup>11</sup>

FULL-LOAD MOTOR CURRENTS † — D-C. MOTORS — AMPERES

H.p.	115 v.	230 v.	550 v.
½	4.5	2.3	
¾	6.5	3.3	1.4
1	8.4	4.2	1.7
1½	12.5	6.3	2.6
2	16.1	8.3	3.4
3	23.0	12.3	5.0
5	40	19.8	8.2
7½	58	28.7	12.0
10	75	38	16.0
15	112	56	23.0
20	140	74	30
25	185	92	38
30	220	110	45
40	294	146	61
50	364	180	75
60	436	215	90
75	540	268	111
100		357	146
125		443	184
150			220
200			295

\* National Electrical Code, 1940.

† These values of full-load current are average for all speeds.

circuit; the branch circuit currents are combined to determine the sub-feeder currents, and these in turn are combined to determine the feeder current. The proper summation of the feeder currents determines the size of the service and service equipment.

In d-c. systems the current is determined from the power rating and the voltage, and in the a-c. system it is necessary to consider the power factor as well. If the system is three-phase, it is necessary to

introduce a constant (1.73) as well. Table II-13 gives a series of expressions which may be used in determining the current demanded by any electrical device or machine. Tables III-13 to VI-13, inclusive, give the current required by d-c. and a-c. motors of various types and sizes. These tables cover the usual commercial sizes. Table VII-13 gives the power factors for motors and devices usually encountered in building wiring systems. Computation for the amount of current required by any part of the system is comparatively easy.

*Example c.* Determine the current required for six 300-w. incandescent lamps operating on a 110-v. system.

TABLE IV-13 " \*  
SINGLE-PHASE A-C. MOTORS — AMPERES

H.p.	110 v.	220 v.	440 v.
$\frac{1}{8}$	3.34	1.67	
$\frac{1}{4}$	4.8	2.4	
$\frac{1}{2}$	7	3.5	
$\frac{3}{4}$	9.4	4.7	
1	11	5.5	
$1\frac{1}{2}$	15.2	7.6	
2	20	10	
3	28	14	
5	46	23	
$7\frac{1}{2}$	68	34	17
10	86	43	21.5

For full-load currents of 208- and 200-v. motors increase corresponding 220-v. motor full-load current by 6 and 10%, respectively.

\* National Electrical Code, 1940.

Since the power factor for incandescent lamps is unity (Table VII-13), the computation for alternating current or direct current will be the same.

$$\frac{6 \times 300}{110} = 16.4 \text{ amp.}$$

*Example d.* Determine the current required for 5 500-w., 115-v. mercury vapor lamps (old style).

The power factor for these mercury vapor lamps will be 85% (Table VII-13).

$$\frac{5 \times 500}{115 \times 0.85} = 25.6 \text{ amp.}$$

If loads on d-c. systems are to be combined, the currents are added but, if loads on a-c. systems are to be combined, it is necessary to



take into consideration the power factor. The following system problem shows how this calculation is made; it gives both accurate and approximate methods satisfactory for building wiring problems.

TABLE V-13 " \*  
TWO-PHASE A-C. MOTORS (4-WIRE) †

H.p.	Induction Type Squirrel-Cage and Wound Rotor Amperes					Synchronous Type Unity Power Factor Amperes			
	110 v.	220 v.	440 v.	550 v.	2200 v.	220 v.	440 v.	550 v.	2200 v.
1/2	4.3	2.2	1.1	.9					
3/4	4.7	2.4	1.2	1.0					
1	5.7	2.9	1.4	1.2					
1 1/2	7.7	4.0	2	1.6					
2	10.4	5	3	2.0					
3		8	4	3.0					
5		13	7	6					
7 1/2		19	9	7					
10		24	12	10					
15		33	16	13					
20		45	23	19					
25		55	28	22	6	47	24	19	4.7
30		67	34	27	7	56	29	23	5.7
40		88	44	35	9	75	37	31	7.5
50		108	54	43	11	94	47	38	9.4
60		129	65	52	13	111	56	44	11.3
75		156	78	62	16	140	70	57	14
100		212	106	85	22	182	93	74	18
125		268	134	108	27	228	114	93	23
150		311	155	124	31		137	110	28
200		415	208	166	43		182	145	37

\* National Electrical Code, 1940.

† Common wire 1.41 times values given.

*Example e.* Determine the current and the power factor for a circuit which supplies a lighting load of 5.5 kw. and a 10-h.p. motor from a single-phase, 110-v., 60 cycle, a-c. source.

Figure 5-13 shows the various parts developed in the problem, and the solution for total current and power factor will be an accurate solution.

TABLE VI-13<sup>11</sup>  
THREE-PHASE A-C. MOTORS

Induction Type Squirrel-cage and Wound Rotor Amperes						Synchronous Type Unity Power Factor Amperes			
H.P.	110 v.	220 v.	440 v.	550 v.	2200 v.	220 v.	440 v.	550 v.	2200 v.
½	5	2.5	1.3	1					
¾	5.4	2.8	1.4	1.1					
1	6.6	3.3	1.7	1.3					
1½	9.4	4.7	2.4	2.0					
2	12	6	3	2.4					
3		9	4.5	4					
5		15	7.5	6					
7½		22	11	9					
10		27	14	11					
15		38	19	15					
20		52	26	21					
25		64	32	26	7	54	27	22	5.4
30		77	39	31	8	65	33	26	6.5
40		101	51	40	10	86	43	35	8.6
50		125	63	50	13	108	54	44	10.8
60		149	75	60	15	128	64	51	13
75		180	90	72	19	161	81	65	16
100		246	123	98	25	211	106	85	21
125		310	155	124	32	164	132	106	26
150		360	180	144	36		158	127	32
200		480	240	195	49		210	168	42

Values given are for unity  
power factor.

90% × 1.1

80% × 1.25

For full-load currents of 208- and 200-v. motors increase the corresponding 220-v. motor full-load current by 8 and 10%, respectively.

\* National Electrical Code, 1940.

Example e (Continued)

$$\text{Lighting load} = \frac{5.5 \times 1000}{110} = 50 \text{ amp.}$$

Motor load:

(Table IV-13)

Motor current 86 amp.

(Table VII-13)

Motor power factor 84%

Lighting load  $I_L = 50 \text{ amp.} \cos \theta_L = 1.00$

$\sin \theta_L = 0.00$

Motor load  $I_M = 86 \text{ amp.} \cos \theta_M = 0.84$

$\sin \theta_M = 0.543$

TABLE VII-13  
POWER FACTORS

Equipment	Power Factor
Incandescent lamps	100%
Heating equipment	100
Arc lamps	60
Low pressure mercury vapor lamps (old type)	85
Low pressure mercury vapor lamps (new style)	90
High pressure mercury vapor lamps (uncorrected)	50-70
High pressure mercury vapor lamps (corrected)	94
Fluorescent lamps (uncorrected)	60
Fluorescent lamps (corrected)	95
Motors (Full Load) *	
1 horsepower	70
2	75
3	80.5
5	82
7½	82.5
10	84
15	86
20	88
25	88
30	88.5
40	89
50	89
60	90
75	90.5
100	91
125	92.5
150	94
200	96
Motor (starting)	50

\* Single- and polyphase motors — not synchronous motors.

Example e (Continued)

$$I_t = \sqrt{(I_L \cos \theta_L + I_M \cos \theta_M)^2 + (I_L \sin \theta_L + I_M \sin \theta_M)^2}$$

$$I_t = \sqrt{(50 \times 1 + 86 \times 0.84)^2 + (50 \times 0 + 86 \times 0.543)^2}$$

$$I_t = \sqrt{(122.24)^2 + (46.70)^2} = 130.9 \text{ amp.}$$

$$\text{Power factor} = \text{ratio } (122.24 \text{ to } 130.9) \times 100 = 93\% \\ = \cos \theta_t$$

*Example e (Continued)*

To determine the approximate current and the approximate power factor, it is necessary only to add numerically the current values and obtain the weighted mean for the power factors. In the two methods the procedure is the same except that currents are

	Current Amperes	Power Factor Per Cent	Current $\times$ Power Factor
Lighting	50	100	5,000
Motor	86	84	7,224
	<u>136</u>		<u>12,224</u>
Current	136 amp.	3.9% error (high)	
Power factor	$\frac{12,224}{136} = 90\%$	3.5% error (low)	

both of which are on the safe side — a desirable condition in all engineering. An inspection of the wire table (Table VIII-13) shows that wire sizes are

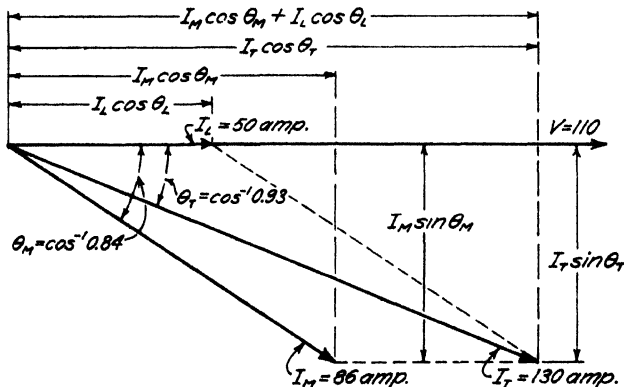

FIG. 5-13. Vector diagram for combining currents of different power factors.

more widely separated; in fact, so much so that 4 or 5% would not have to be considered. The example chosen represents about as wide a variation in types of load as may be expected, and, therefore, the extreme of probable error.

**5. Selection of Wire Size for Safety.** Tables VIII-13 and IX-13 are taken from the National Electrical Code which gives the minimum wire sizes to be used in the distribution system, on the basis of the current requirements. Any wire stipulated by the Code will be safe, but it may not be economical because of excessive voltage drop.

Table VIII-13 is used for determining the wire size for all circuits except motor branch circuits, and includes combination lighting feeders, power feeders, sub-feeders, and lighting branch circuits. Table IX-13 is used to determine the wire size for motor branch circuits,

TABLE VIII-13A  
 ALLOWABLE CURRENT-CARRYING CAPACITIES OF CONDUCTORS IN AMPERES\*  
 Not More Than Three Conductors in Raceway or Cable  
 (Based on Room Temperature of 30° C, 86° F)

Size AWG MCM	Rubber Type RW Type R	Synthetic Type SN	Rubber Type RHT Type RH	Paper	Asbestos Var-Cam Type AVA Type AVL	Impregnated Asbestos Type AI	Asbestos Type A
		Type RU		Synthetic Type SNA			
		Rubber Type RPT Type RP		Asbestos Var-Cam Type AVB			
				Var-Cam Type V			
14	15	18	22	23	28	29	32
12	20	23	27	29	36	38	42
10	25	31	37	38	47	49	54
8	35	41	49	50	60	63	71
6	45	54	65	68	80	85	95
5	52	63	75	78	94	99	110
4	60	72	86	88	107	114	122
3	69	83	99	104	121	131	145
2	80	96	115	118	137	147	163
1	91	110	131	138	161	172	188
0	105	127	151	157	190	202	223
00	120	145	173	184	217	230	249
000	138	166	199	209	243	265	284
0000	160	193	230	237	275	308	340
250	177	213	255	272	315	334	372
300	198	238	285	299	347	380	415
350	216	260	311	325	392	419	462
400	233	281	336	361	418	450	488
500	265	319	382	404	468	498	554
600	293	353	422	453	525	543	612
700	320	385	461	488	562	598	668
750	330	398	475	502	582	621	690
800	340	410	490	514	600	641	720
900	360	434	519	556			
1000	377	455	543	583	681	730	811
1250	409	493	589	643			
1500	434	522	625	698	784		
1750	451	544	650	733			
2000	463	558	666	774	839		

## CORRECTION FACTOR FOR ROOM TEMPERATURES OVER 30° C

C	F						
40	104	0.71	0.82	0.88	0.90	0.94	0.95
45	113	0.50	0.71	0.82			
50	122	0.00	0.58	0.75	0.80	0.87	0.89
55	131		0.41	0.67			
60	140		0.00	0.58	0.67	0.79	0.83
70	158			0.35	0.52	0.71	0.76
75	167			0.00			0.97
80	176				0.30	0.61	0.69
90	194					0.50	0.61
100	212						0.61
120	248						0.51
140	284						0.72
							0.63

\* National Electrical Code, 1940.

TABLE VIII-13B

ALLOWABLE CURRENT-CARRYING CAPACITIES OF CONDUCTORS IN AMPERES\*

Single Conductor in Free Air

(Based on Room Temperature of 30° C, 86° F)

Size AWG or MCM	Rubber Type R	Rubber Type RP	Rubber Type RHT Type RH	Synthetic Type SNA	Asbestos Var-Cam Type AVA	Impreg- nated Asbestos Type AI	Asbestos Type A	Slow- Burning Type SB
				Asbestos Var-Cam Type AVB				Weather- proof Type W
				Var-Cam Type V				Type SBW
14	20	24	29	30	39	40	43	23
12	26	31	37	40	51	52	57	30
10	35	42	50	54	65	69	75	40
8	48	58	69	71	85	91	100	53
6	65	78	94	99	119	126	134	70
5	76	92	110	115	136	145	158	80
4	87	105	125	133	158	169	180	90
3	101	122	146	155	182	194	211	100
2	118	142	170	179	211	226	241	125
1	136	164	196	211	247	264	280	150
0	160	193	230	245	287	306	325	200
00	185	223	267	284	331	354	372	225
000	215	259	310	330	384	410	429	275
0000	248	298	358	383	446	476	510	325
250	280	338	403	427	495	528	562	350
300	310	373	446	480	555	592	632	400
350	350	421	504	529	612	653	698	450
400	380	457	547	575	665	710	755	500
500	430	517	620	660	765	814	870	600
600	480	577	691	738	857	912	970	680
700	525	632	756	813	942	1003	1065	760
750	545	655	785	846	981	1044	1118	800
800	565	680	815	879	1020	1085	1150	840
900	605	728	872	941				920
1000	650	782	936	1001	1163	1238	1332	1000
1250	740	890	1066	1131				
1500	815	980	1174	1261	1452			1360
1750	890	1070	1282	1370				
2000	960	1155	1383	1472	1713			1670

CORRECTION FACTOR FOR ROOM TEMPERATURES OVER 30° C.

C F	0.71	0.82	0.88	0.90	0.94	0.95	
40 104	0.71	0.82	0.88	0.90	0.94	0.95	
45 113	0.50	0.71	0.82				
50 122	0.00	0.58	0.75	0.80	0.87	0.89	
55 131		0.41	0.67				
60 140		0.00	0.58	0.67	0.79	0.83	0.97
70 158			0.35	0.52	0.71	0.76	0.93
75 167			0.00				
80 176				0.30	0.61	0.69	0.89
90 194					0.50	0.61	0.86
100 212						0.51	0.82
120 248							0.72
140 284							0.63

\* National Electrical Code, 1940.

and for these circuits alone. Table IX-13 gives fuse sizes for motor branch circuits; these may also be determined from the percentage

TABLE VIII-13C  
PROPERTIES OF CONDUCTORS

AWG	CM	Ohms per 1000 Ft. 15°C-59°C	Bare Conductor		Concentric Lay Stranded Conductors. Rubber, Paper, Asbestos, Varnished Cambric, Asbestos Varnished Cambric	
			Diam. Inches	Area Sq. Ins.	No. of Wires	Diam. Each Wire Inches
14	4,107	2.475	0.064	0.003	7	0.024
12	6,530	1.557	0.081	0.005	7	0.030
10	10,380	0.9792	0.102	0.008	7	0.038
8	16,510	0.6158	0.128	0.013	7	0.048
6	26,250	0.3872	0.184	0.026	7	0.061
5	33,100	0.3071	0.213	0.035	7	0.068
4	41,740	0.2436	0.232	0.042	7	0.077
3	52,630	0.1961	0.261	0.053	7	0.086
2	66,370	0.1532	0.292	0.067	7	0.097
1	83,690	0.1215	0.332	0.087	19	0.066
0	105,500	0.09633	0.375	0.110	19	0.074
00	133,100	0.07639	0.419	0.138	19	0.083
000	167,800	0.06058	0.470	0.173	19	0.094
0000	211,600	0.04804	0.528	0.219	19	0.105
	250,000	0.04147	0.594	0.276	37	0.082
	300,000	0.03457	0.641	0.323	37	0.090
	350,000	0.02963	0.688	0.370	37	0.097
	400,000	0.02592	0.734	0.423	37	0.104
	500,000	0.02074	0.828	0.540	37	0.116
	600,000	0.01729	0.892	0.628	61	0.099
	700,000	0.01481	0.968	0.735	61	0.107
	750,000	0.01382	1.000	0.785	61	0.110
	800,000	0.01296	1.031	0.835	61	0.114
	900,000	0.01153	1.094	0.938	61	0.121
	1,000,000	0.01036	1.172	1.039	61	0.128
	1,250,000	0.00829	1.290	1.320	91	0.117
	1,500,000	0.00692	1.422	1.580	91	0.128
	1,750,000	0.00593	1.546	1.872	127	0.117
	2,000,000	0.00518	1.630	2.084	127	0.125

table listed as Table X-13. Table IX-13, however, can be used more rapidly.

*Example f.* Determine the feeder size necessary to carry 279 amp. using three Type RP copper wires in conduit.

From Table VIII-13 use 400,000 cir. mils, the next largest wire to the carrying capacity required.

*Example g.* Determine the size of Type RP copper wire to use in a conduit for a 3-phase motor branch circuit carrying 86 amp.

From Table IX-13 use #1 wire.

The fuse will depend upon the type of motor and the method of starting.

**6. Selection of Conduit Size.** The selection of the size of conduit for carrying the wires of any circuit is governed by the National Electrical Code. Table XI-13 gives the size of conduit, when all the wires are the same size, and the necessary information for selecting conduit size for heterogeneous groupings of wires is found in Table XII-13. Reference must be made to the Code for the special regulations on maximum conditions and the classes of circuits permitted in a common conduit. The limitations imposed in the tables must be met regardless of whether the wire is selected for safety and adequacy or for safety alone.

*Example h.* Determine the size conduit for two 900,000 and one 300,000 cir. mil cables using Type RP copper wire.

All information is from Table XII-13:

(Table A) for 3 conductors, 43% of the conduit to be used by the wire.

(Table B)	Area two 900,000	3.2 sq. in.
	Area one 300,000	0.67 sq. in.
	Total	3.87 sq. in.

$$\text{Conduit area} = \frac{3.87}{0.43} = 9 \text{ sq. in.}$$

(Table G)  $3\frac{1}{2}$ -in. conduit has an area of 9.90 sq. in. and must be used for the installation.

### 7. Selection of Wire Size for Adequacy.

As previously discussed, the wire should meet not only the safety requirements of the National Electrical Code but should provide for adequate voltage delivery and for future expansion. To satisfy the requirements for initial and final adequacy, the voltage lost in the system and the probable additional load at some future date must be studied. Figure 6-13 represents the effect caused by voltage drop on the performance of incandescent lamps, heaters, and general purpose induction motors. These simple

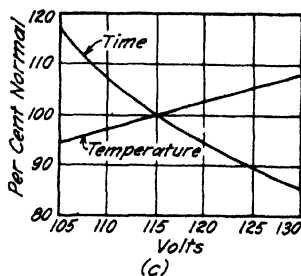
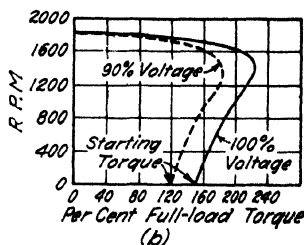
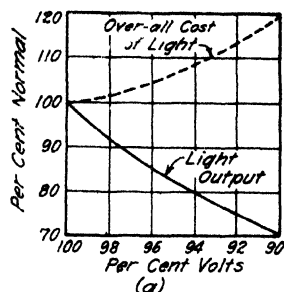

FIG. 6-13.<sup>11</sup> Effect of voltage variation on (a) lamps, (b) motors, (c) heaters.





SELECTION OF WIRE SIZE FOR SAFETY

13	12	14	20	16.25	40	35	30	20
14	12	14	20	17.50	45	35	30	20
15	12	14	20	18.75	45	40	30	20
16	12	14	20	20.00	50	40	35	25
17	10	12	25	21.25	60	45	35	30
18	10	12	25	22.50	60	45	40	30
19	10	12	25	23.75	60	50	40	30
20	10	12	25	25.00	60	50	40	30
22	8	10	30	27.50	70	60	45	35
24	8	10	30	30.00	80	60	50	40
26	8	10	35	32.50	80	70	60	40
28	8	10	35	35.00	90	70	60	45
30	6	8	40	37.50	90	70	60	45
32	6	8	40	40.00	100	80	70	50
34	6	8	45	42.50	110	80	70	50
36	6	8	45	45.00	110	90	80	60
38	5	6	50	47.50	125	100	80	60
40	5	6	50	50.00	125	100	80	60
42	5	6	50	52.50	125	110	90	70
44	4	5	60	55.00	125	110	90	70
46	4	5	60	57.50	150	125	100	70
48	4	5	60	60.00	150	125	100	80
50	3	5	60	62.50	150	135	100	80
52	3	5	70	65.00	175	150	110	80
54	3	4	70	67.50	175	150	110	80
56	2	4	70	70.00	175	150	120	90
58	2	3	70	72.50	175	150	120	90
60	2	3	80	75.00	200	150	120	90
62	2	3	80	77.50	200	175	125	100
64	2	3	80	80.00	200	175	150	100
66	1	3	80	82.50	200	175	150	100
68	1	2	80	85.00	225	175	150	110
70	1	2	90	87.50	225	175	150	110
72	1	2	90	90.00	225	200	150	100
74	0	2	90	92.50	225	200	150	100
76	0	2	100	95.00	250	200	150	100
78	0	1	100	97.50	250	200	150	110
80	0	1	100	100.00	250	200	150	110
82	0	1	110	102.50	250	225	175	125
84	0	1	110	105.00	250	225	175	125
86	00	1	110	107.50	300	225	175	150

\* National Electrical Code, 1940.



SELECTION OF WIRE SIZE FOR SAFETY

130	250	000	00	175	162.50	400	350	300	200
135	250	000	00	175	169.00	450	350	300	225
140	250	000	00	175	175.00	450	350	300	225
145	300	0000	000	200	181.50	450	400	300	225
150	300	0000	000	200	187.50	450	400	300	225
155	300	0000	000	200	194.00	500	400	350	250
160	350	250	000	200	200.00	500	400	350	250
165	350	250	0000	225	206.00	500	450	350	250
170	350	250	0000	225	213.00	500	450	350	300
175	400	300	0000	225	219.00	600	450	350	300
180	400	300	0000	225	225.00	600	450	400	300
185	400	300	0000	250	231.00	600	500	400	300
190	500	300	250	250	238.00	600	500	400	300
195	500	350	250	250	244.00	600	500	400	300
200	500	350	250	250	250.00	600	500	400	300
210	600	400	300	250	263.00	600	600	450	350
220	600	400	300	300	275.00	600	600	450	350
230	600	500	300	300	288.00	600	600	500	350
240	700	500	350	300	300.00	600	600	500	400
250	700	500	350	300	313.00	600	600	500	400
260	750	600	400	350	325.00	600	600	500	400
270	800	600	400	350	338.00	600	600	600	450
280	800	600	500	350	350.00	600	600	600	450
290	900	700	500	350	363.00	600	600	600	450
300	1000	700	500	400	375.00	600	600	600	450
320	1250	750	600	400	400.00	600	600	600	500
340	1500	900	600	450	425.00	600	600	600	600
360	1750	1000	700	450	450.00	600	600	600	600
380		1250	750	500	475.00	600	600	600	600
400		1500	900	500	500.00	600	600	600	600
420		1500	1000	600	525.00	600	600	600	600
440		1750	1250	600	550.00	600	600	600	600
460			1250	600	575.00	600	600	600	600
480			1500	600	600.00	600	600	600	600
500			1500	600	625.00	600	600	600	600

graphs show the necessity of giving the matter of voltage drop careful attention.

Those interested in adequate installations for lighting and motors have for years advocated larger wires than the Code requires, but even today, and in some of the more advanced architectural offices, the designs fall far short of meeting adequate specifications and fail to take into consideration future demands which continued research in

TABLE X-13A " \*

MAXIMUM RATING OR SETTING OF MOTOR-BRANCH-CIRCUIT PROTECTIVE DEVICES FOR MOTORS MARKED WITH A CODE LETTER INDICATING LOCKED ROTOR KVA

Type of Motor	Per Cent of Full-Load Current		
	Fuse Rating	Circuit-Breaker Setting	
		Instan- taneous Type	Time- Limit Type
All a-c. single-phase and poly- phase squirrel-cage and syn- chronous motors with full- voltage, resistor or reactor starting:			
Code Letter A	150		150
Code Letter B to E	250		200
Code Letter F to R	300		250
All a-c. squirrel-cage and syn- chronous motors with auto- transformer starting:			
Code Letter A	150		150
Code Letter B to E	200		200
Code Letter F to R	250		200

Synchronous motors of the low-torque, low-speed type (usually 450 rpm. or lower), such as are used to drive reciprocating compressors, pumps, etc., which start up unloaded, do not require a fuse rating or circuit-breaker setting in excess of 200% of full-load current.

\* National Electrical Code, 1940.

illumination may make on the wiring system. The extra cost of conduit a size or two larger is relatively small, and its use will permit appreciable load increase by the installation of wires up to the conduit capacity. Never should conduits for feeders or sub-feeders be installed without allowing for future installation of wire of at least two sizes larger than that used in the original installation.

If the current requirements are fulfilled, the Code is satisfied, because the fire hazard is removed, but from an illumination standpoint

the voltage lost may represent an appreciable lighting loss, and, as the system becomes overloaded by the addition of more load to meet new illumination requirements, the whole lighting system will suffer accordingly. Table XIII-13 gives the normal allowances for voltage drop for both lighting and power. Practice in different offices and

TABLE X-13B<sup>11</sup> \*

MAXIMUM RATING OR SETTING OF MOTOR-BRANCH-CIRCUIT PROTECTIVE DEVICES FOR MOTORS NOT MARKED WITH A CODE LETTER INDICATING LOCKED ROTOR KVA

Type of Motor	Per Cent of Full-Load Current		
	Fuse Rating	Circuit-Breaker Setting	
		Instantaneous Type	Time-Limit Type
Single-phase, all types	300		250
Squirrel-cage and synchronous (full-voltage, resistor and reactor starting)	300		250
Squirrel-cage and synchronous (autotransformer starting)			
Not more than 30 amp.	250		200
More than 30 amp.	200		200
High-reactance squirrel-cage			
Not more than 30 amp.	250		250
More than 30 amp.	200		200
Wound-rotor	150		150
D-c.			
Not more than 50 h.-p.	150	250	150
More than 50 h.-p.	150	175	150

Synchronous motors of the low-torque, low-speed type (usually 450 rpm. or lower), such as are used to drive reciprocating compressors, pumps, etc., which start up unloaded, do not require a fuse rating or circuit-breaker setting in excess of 200% of full-load current.

\* National Electrical Code, 1940.

personal opinion may divide this table into different allowances for the various parts, but the overall drop should not be exceeded.

Some designers and most contractors like to use demand factors which are applied to the design of the system. The use of these factors is based upon the assumption that the complete capacity of the system is never in use at any time. These demand factors have the effect of decreasing wire sizes below those calculated, and nullify any effect to be gained by oversize design to adjust for voltage drop.

TABLE XI-13A<sup>11</sup>\*

NUMBER OF CONDUCTORS IN CONDUIT OR TUBING  
ONE TO NINE CONDUCTORS RUBBER-COVERED — TYPES R, RW, RP, RH, AND RHT —  
600 v.

Size of Conductor	Number of Conductors in One Conduit or Tubing								
	1	2	3	4	5	6	7	8	9
No. 18	$\frac{1}{2}$	$\frac{1}{2}$	$\frac{1}{2}$	$\frac{1}{2}$	$\frac{1}{2}$	$\frac{1}{2}$	$\frac{1}{2}$	$\frac{1}{2}$	$\frac{3}{4}$
16	$\frac{1}{2}$	$\frac{1}{2}$	$\frac{1}{2}$	$\frac{1}{2}$	$\frac{1}{2}$	$\frac{1}{2}$	$\frac{3}{4}$	$\frac{3}{4}$	$\frac{3}{4}$
14	$\frac{1}{2}$	$\frac{1}{2}$	$\frac{1}{2}$	$\frac{1}{2}$	$\frac{3}{4}$	$\frac{3}{4}$	$\frac{3}{4}$	1	1
12	$\frac{1}{2}$	$\frac{1}{2}$	$\frac{1}{2}$	$\frac{3}{4}$	$\frac{3}{4}$	1	1	1	$1\frac{1}{4}$
10	$\frac{1}{2}$	$\frac{3}{4}$	$\frac{3}{4}$	$\frac{3}{4}$	1	1	$1\frac{1}{4}$	$1\frac{1}{4}$	$1\frac{1}{4}$
8	$\frac{1}{2}$	$\frac{3}{4}$	1	1	$1\frac{1}{4}$	$1\frac{1}{4}$	$1\frac{1}{4}$	$1\frac{1}{4}$	$1\frac{1}{2}$
6	$\frac{1}{2}$	1	$1\frac{1}{4}$	$1\frac{1}{4}$	$1\frac{1}{2}$	$1\frac{1}{2}$	2	2	2
5	$\frac{3}{4}$	$1\frac{1}{4}$	$1\frac{1}{4}$	$1\frac{1}{4}$	$1\frac{1}{2}$	2	2	2	2
4	$\frac{3}{4}$	$1\frac{1}{4}$	$1\frac{1}{4}$	$1\frac{1}{2}$	2	2	2	2	$2\frac{1}{2}$
3	$\frac{3}{4}$	$1\frac{1}{4}$	$1\frac{1}{4}$	$1\frac{1}{2}$	2	2	2	$2\frac{1}{2}$	$2\frac{1}{2}$
2	$\frac{3}{4}$	$1\frac{1}{4}$	$1\frac{1}{2}$	$1\frac{1}{2}$	2	2	$2\frac{1}{2}$	$2\frac{1}{2}$	$2\frac{1}{2}$
1	$\frac{3}{4}$	$1\frac{1}{2}$	$1\frac{1}{2}$	2	2	$2\frac{1}{2}$	$2\frac{1}{2}$	3	3
0	1	$1\frac{1}{2}$	2	2	$2\frac{1}{2}$	$2\frac{1}{2}$	3	3	3
00	1	2	2	$2\frac{1}{2}$	$2\frac{1}{2}$	3	3	3	$3\frac{1}{2}$
000	1	2	2	$2\frac{1}{2}$	3	3	3	$3\frac{1}{2}$	$3\frac{1}{2}$
0000	$1\frac{1}{4}$	2	$2\frac{1}{2}$	$2\frac{1}{2}$	3	3	$3\frac{1}{2}$	$3\frac{1}{2}$	4
250,000	$1\frac{1}{4}$	$2\frac{1}{2}$	$2\frac{1}{2}$	3	3	$3\frac{1}{2}$			
300,000	$1\frac{1}{4}$	$2\frac{1}{2}$	3	3	$3\frac{1}{2}$	$3\frac{1}{2}$			
350,000	$1\frac{1}{4}$	$2\frac{1}{2}$	3	$3\frac{1}{2}$	$3\frac{1}{2}$	4			
400,000	$1\frac{1}{4}$	3	3	$3\frac{1}{2}$	4	4			
450,000	$1\frac{1}{2}$	3	3	$3\frac{1}{2}$	4	$4\frac{1}{2}$			
500,000	$1\frac{1}{2}$	3	3	$3\frac{1}{2}$	4	$4\frac{1}{2}$			
550,000	$1\frac{1}{2}$	3	$3\frac{1}{2}$	4	$4\frac{1}{2}$	5			
600,000	2	3	$3\frac{1}{2}$	4	$4\frac{1}{2}$	5			
650,000	2	$3\frac{1}{2}$	$3\frac{1}{2}$	4					
700,000	2	$3\frac{1}{2}$	$3\frac{1}{2}$	$4\frac{1}{2}$					
750,000	2	$3\frac{1}{2}$	$3\frac{1}{2}$	$4\frac{1}{2}$					
800,000	2	$3\frac{1}{2}$	4	$4\frac{1}{2}$					
850,000	2	$3\frac{1}{2}$	4	$4\frac{1}{2}$					
900,000	2	$3\frac{1}{2}$	4	$4\frac{1}{2}$					
950,000	2	4	4	5					
1,000,000	2	4	4	5					
1,250,000	$2\frac{1}{2}$	$4\frac{1}{2}$	$4\frac{1}{2}$	6					
1,500,000	$2\frac{1}{2}$	$4\frac{1}{2}$	5	6					
1,750,000	3	5	5	6					
2,000,000	3	5	6						

\* National Electrical Code, 1940.

A demand factor should be used with the utmost discretion and should be approved by the inspector or authority enforcing the code. Where

TABLE XI-13B \*  
NUMBER OF CONDUCTORS IN CONDUIT OR TUBING  
LEAD-COVERED TYPES RL, RPL, AND RHL — 600 V.

Size of Conductor	Number of Conductors in One Conduit or Tubing											
	Single Conductor Cable				2-Conductor Cable				3-Conductor Cable			
	1	2	3	4	1	2	3	4	1	2	3	4
14	1½	¾	¾	1	½	1	1	1¼	¾	1¼	1½	1½
12	1½	¾	¾	1	¾	1	1¼	1¼	1	1¼	1½	2
10	1½	¾	1	1	¾	1¼	1¼	1½	1	1½	2	2
8	1½	1	1¼	1½	1	1¼	1½	2	1	2	2	2½
6	¾	1¼	1½	1½	1¼	1½	2	2½	1¼	2½	3	3
4	¾	1¼	1½	1½	1¼	2	2½	2½	1½	3	3	3½
3	¾	1¼	1½	2	1¼	2	2½	3	1½	3	3	3½
2	1	1¼	1½	2	1¼	2	2½	3	1½	3	3½	4
1	1	1½	2	2	1½	2½	3	3½	2	3½	4	4½
0	1	2	2	2½	2	3	3	3½	2	4	4½	5
00	1	2	2	2½	2	3	3½	4	2½	4	4½	5
000	1¼	2	2½	2½	2	3	3½	4	2½	4½	4½	6
0000	1¼	2½	2½	3	2½	3	3½	4½	3	5	6	6
250,000	1¼	2½	3	3					3	6	6	
300,000	1½	3	3	3½					3½	6	6	
350,000	1½	3	3	3½					3½	6	6	
400,000	1½	3	3	3½					3½	6	6	
450,000	1½	3	3	4					4	6	6	
500,000	1½	3	3½	4					4	6		
600,000	2	3½	4	4½								
700,000	2	4	4	5								
750,000	2	4	4	5								
800,000	2	4	4½	5								
900,000	2½	4	4½	5								
1,000,000	2½	4½	4½	6								
1,250,000	3	5	5	6								
1,500,000	3	5	6	6								
1,750,000	3	6	6									
2,000,000	3½	6	6									

\* National Electrical Code, 1940.

ever the wiring is being designed for lighting, it is best to use a 100 per cent demand factor.

A study of the allowable expenditure for an adequate wiring system for lighting or power is a difficult economical problem. This



matter was considered by a committee which selected a floor plan (9600 sq. ft.) from a building and submitted the problem in all its variations to contractors in various sections of the United States.

TABLE XI-13C<sup>11</sup>\*

NUMBER OF CONDUCTORS IN CONDUIT OR TUBING  
SMALL-DIAMETER BUILDING WIRE, TYPES RHT AND RPT, 600 V. ONE TO NINE CONDUCTORS

Size of Conductor	Number of Conductors in One Conduit or Tubing								
	1	2	3	4	5	6	7	8	9
14	½	½	½	½	½	½	½	¾	¾
12	½	½	½	½	½	¾	¾	¾	¾
10	½	½	½	½	¾	¾	¾	¾	1
8	½	½	¾	¾	1	1	1	1	1¼

\* National Electrical Code, 1940.

TABLE XI-13D<sup>11</sup>\*

NUMBER OF CONDUCTORS IN CONDUIT OR TUBING  
SYNTHETIC, TYPE SN AND TYPE RU, 600 V. ONE TO NINE CONDUCTORS

Size of Conductor	Number of Conductors in One Conduit or Tubing								
	1	2	3	4	5	6	7	8	9
14	½	½	½	½	½	½	½	½	½
12	½	½	½	½	½	½	½	½	¾
10	½	½	½	½	½	½	¾	¾	¾
8	½	½	½	¾	¾	¾	1	1	1
6	½	¾	¾	1	1	1¼	1¼	1¼	1¼
5	½	¾	¾	1	1¼	1¼	1¼	1¼	1½
4	½	¾	1	1	1¼	1¼	1¼	1½	1½
3	½	1	1	1¼	1¼	1¼	1½	1½	2
2	½	1	1	1¼	1¼	1½	1½	2	2
1	¾	1¼	1¼	1½	1½	2	2	2	2½
0	¾	1¼	1¼	1½	2	2	2	2½	2½
00	¾	1¼	1½	2	2	2	2½	2½	2½
000	¾	1¼	1½	2	2	2½	2½	3	3
0000	1	1½	2	2	2½	2½	3	3	3

\* National Electrical Code, 1940.

The bids were carefully scrutinized and submitted to statistical study, with the following conclusions:

a. Reduced wiring specification represents a false economy, and the difference in investment will be offset in a year or two.

b. The investment does not increase in direct proportion with the increased wattage capacity.

c. To double the wattage capacity increases the investment 33 per cent, and a 50 per cent increase in wattage capacity adds only from 15 to 18 per cent to the investment.

TABLE XI-13E<sup>11</sup>\*

NUMBER OF CONDUCTORS IN CONDUIT OR TUBING  
MORE THAN NINE CONDUCTORS RUBBER-COVERED TYPES R, RW, RP, AND RH —  
600 v.

Size of Conductor	Maximum Number of Conductors in Conduit or Tubing						
	Inches						
	$\frac{3}{4}$	1	$1\frac{1}{4}$	$1\frac{1}{2}$	2	$2\frac{1}{2}$	3
18	13	22	38	53	87	124	191
16	11	19	33	45	74	106	163
14		11	19	26	43	61	95
12			15	21	34	50	77
10			12	16	27	38	60
8				13	22	31	49
6						14	22

\* National Electrical Code, 1940.

TABLE XII-13A<sup>11</sup>\*

CONDUIT FOR COMBINATION OF CONDUCTORS  
PER CENT AREA OF CONDUIT OR TUBING

	Number of Conductors				
	1	2	3	4	Over 4
Conductors (not lead covered)	53	31	43	40	40
Lead-covered conductors	55	30	40	38	35
For rewiring existing raceways with thinner insulated conductors	60	40	50	50	50

\* National Electrical Code, 1940.

Since 2 or 3 per cent of the total building cost represents the portion allotted to wiring, a 50 per cent increase in this cost is a negligible part of the construction cost; and since this task was undertaken by a committee whose impartiality could not be questioned (there being no reason for misrepresenting the facts), it would be well to use the findings as a starting point in a study of additional original investment in adequate wiring.

TABLE XII-13B<sup>11</sup>\*

CONDUIT FOR COMBINATION OF CONDUCTORS  
 DIMENSIONS OF RUBBER-COVERED CONDUCTORS  
 TYPES R, RW, RP, AND RH

Size AWG-CM	Approx. Diam. Inches	Approx. Area Sq. In.	Size CM	Approx. Diam. Inches	Approx. Area Sq. In.
18	0.14	0.0154	450,000	1.08	0.91
16	0.15	0.018	500,000	1.12	0.99
14	0.20	0.031	550,000	1.17	1.08
12	0.22	0.038	600,000	1.22	1.16
10	0.24	0.045			
8	0.30	0.071	650,000	1.25	1.23
			700,000	1.29	1.30
6	0.41	0.13	750,000	1.33	1.38
4	0.45	0.16	800,000	1.36	1.45
2	0.52	0.21			
1	0.59	0.27	850,000	1.39	1.52
			900,000	1.43	1.60
0	0.63	0.31	950,000	1.46	1.68
00	0.67	0.35	1,000,000	1.49	1.75
000	0.72	0.41			
0000	0.78	0.48	1,250,000	1.68	2.22
			1,500,000	1.79	2.52
250,000	0.86	0.58	1,750,000	1.90	2.85
300,000	0.92	0.67	2,000,000	2.00	3.14
350,000	0.98	0.75			
400,000	1.03	0.83			

\* National Electrical Code, 1940.

TABLE XII-13C<sup>11</sup>\*

CONDUIT FOR COMBINATION OF CONDUCTORS  
 DIMENSIONS OF CONDUCTORS  
 Small-Diameter Building Wires,  
 Types RHT and RPT

Size AWG	Aprox. Diam. Inches	Approx. Area Sq. In.	Size AWG	Approx. Diam. Inches	Approx. Area Sq. In.
14	0.162	0.0206	10	0.200	0.0314
12	0.179	0.0252	8	0.261	0.0535

\* National Electrical Code, 1940.

TABLE XII-13D<sup>11</sup> \*  
 CONDUIT FOR COMBINATION OF CONDUCTORS  
 DIMENSION OF CONDUCTORS  
 Synthetic Insulation, Type SN  
 Type RU Insulation

Size AWG	Approx. Diam. Inches	Approx. Area Sq. In.	Size AWG	Approx. Diam. Inches	Approx. Area Sq. In.
14	0.130	0.0133	2	0.423	0.1405
12	0.147	0.0170	1	0.496	0.1935
10	0.168	0.0220	0	0.537	0.226
8	0.227	0.0405	00	0.583	0.267
6	0.314	0.0775	000	0.634	0.316
4	0.363	0.1035	0000	0.692	0.376

<sup>11</sup> National Electrical Code, 1940.

TABLE XII-13E<sup>11</sup> \*  
 CONDUIT FOR COMBINATION OF CONDUCTORS  
 DIMENSIONS OF LEAD-COVERED CONDUCTORS  
 Types RL, RPL, and RHL

Size of Conductor AWG-CM	Single Conductor		Two- Conductor		Three- Conductor	
	Diam. Inches	Area Sq. In.	Diam. Inches	Area Sq. In.	Diam. Inches	Area Sq. In.
14	0.28	0.062	0.28 × 0.47	0.115	0.59	0.273
12	0.29	0.066	0.31 × 0.54	0.146	0.62	0.301
10	0.35	0.096	0.35 × 0.59	0.180	0.68	0.363
8	0.41	0.132	0.41 × 0.71	0.255	0.82	0.528
6	0.49	0.188	0.49 × 0.86	0.369	0.97	0.738
4	0.55	0.237	0.54 × 0.96	0.457	1.08	0.916
2	0.60	0.283	0.61 × 1.08	0.578	1.21	1.146
1	0.67	0.352	0.70 × 1.23	0.756	1.38	1.49
0	0.71	0.396	0.74 × 1.32	0.859	1.47	1.70
00	0.76	0.454	0.79 × 1.41	0.980	1.57	1.94
000	0.81	0.515	0.84 × 1.52	1.123	1.69	2.24
0000	0.87	0.593	0.90 × 1.64	1.302	1.85	2.68
250	0.98	0.754			2.02	3.20
300	1.04	0.85			2.15	3.62
350	1.10	0.95			2.26	4.02
400	1.14	1.02			2.40	4.52
500	1.23	1.18			2.59	5.28

<sup>11</sup> National Electrical Code, 1940.

TABLE XII-13F<sup>11</sup>\*

CONDUIT FOR COMBINATION OF CONDUCTORS  
 DIMENSIONS OF ASBESTOS-VARNISHED-CAMBRIC INSULATED CONDUCTORS  
 Types AVA, AVB, and AVL

Size AWG C.M.	Type AVA		Type AVB		Type AVL	
	Approx. Diam. Inches	Approx. Area Sq. In.	Approx. Diam. Inches	Approx. Area Sq. In.	Approx. Diam. Inches	Approx. Area Sq. In.
14	0.245	0.047	0.205	0.033	0.320	0.080
12	0.265	0.055	0.225	0.040	0.340	0.091
10	0.285	0.064	0.245	0.047	0.360	0.102
8	0.310	0.075	0.270	0.057	0.390	0.119
6	0.395	0.122	0.345	0.094	0.430	0.145
4	0.445	0.155	0.395	0.123	0.480	0.181
2	0.505	0.200	0.460	0.166	0.570	0.255
1	0.585	0.268	0.540	0.229	0.620	0.300
0	0.625	0.307	0.580	0.264	0.660	0.341
00	0.670	0.353	0.625	0.307	0.705	0.390
000	0.720	0.406	0.675	0.358	0.755	0.447
0000	0.780	0.478	0.735	0.425	0.815	0.521
250,000	0.885	0.616	0.855	0.572	0.955	0.715
300,000	0.940	0.692	0.910	0.649	1.010	0.800
350,000	0.995	0.778	0.965	0.731	1.060	0.885
400,000	1.040	0.850	1.010	0.800	1.105	0.960
450,000	1.085	0.925	1.055	0.872	1.150	1.040
500,000	1.125	0.995	1.095	0.945	1.190	1.118
550,000	1.165	1.065	1.135	1.01	1.265	1.26
600,000	1.205	1.140	1.175	1.09	1.305	1.34
650,000	1.240	1.21	1.210	1.15	1.340	1.41
700,000	1.275	1.28	1.245	1.22	1.375	1.49
750,000	1.310	1.35	1.280	1.29	1.410	1.57
800,000	1.345	1.42	1.315	1.36	1.440	1.63
850,000	1.375	1.49	1.345	1.43	1.470	1.70
900,000	1.405	1.55	1.375	1.49	1.505	1.78
950,000	1.435	1.62	1.405	1.55	1.535	1.85
1,000,000	1.465	1.69	1.435	1.62	1.565	1.93

\* National Electrical Code, 1940.

In addition to loss of light when using reduced voltage, the economic loss caused by the wiring system may be appreciable. A specific example of a floor area 60 by 100 ft. lighted by 300-w. lamps on 10-ft. centers showed these figures by actual bids <sup>11</sup>:

## 1. Cost of installation

(a) Minimum code	\$ 626
(b) Adequacy standards	\$ 737
Difference	\$ 111

TABLE XII-13G <sup>11</sup> \*

CONDUIT FOR COMBINATION OF CONDUCTORS  
DIMENSIONS OF CONDUIT OR TUBING

Size	Internal Diameter Inches	Area Square Inches	Size	Internal Diameter Inches	Area Square Inches
½	0.622	0.30	3	3.068	7.38
¾	0.824	0.53	3½	3.548	9.90
1	1.049	0.86	4	4.026	12.72
1¼	1.380	1.50	4½	4.506	15.95
1½	1.610	2.04	5	5.047	20.00
2	2.067	3.36	6	6.065	28.89
2½	2.469	4.79			

\* National Electrical Code, 1940.

TABLE XIII-13 <sup>11</sup>

VALUES OF MAXIMUM VOLTAGE DROP ALLOWABLE

Lighting		Power	
Branches	2.0%	Branches	2.0%
		Sub-feeder	2.0%
Feeders	2.0%	Feeder	6.0%
Total	4.0%		10.0%

## 2. Energy loss because of resistance

(a) Minimum code	1497 kw-hr.
(b) Adequacy standards	640 kw-hr.
Difference	857 kw-hr.

## 3. Extra cost of operating for 1500 hr. annually on a minimum or Code installation at a rate of 4 cents per kw-hr. \$ 34.28

The extra cost of \$34.28 for minimum (Code) installation can be capitalized, and it will be found that considerably more than \$111 can be invested in additional wire.

Too often new buildings are erected, their life estimated at 50 years of useful service, and yet they lack an adequate wiring system at the time of construction; consequently, at the end of a year or two of service, they are full of makeshift wiring and have conduit and molding placed on exposed surfaces.

TABLE XIV-13  
CORRECTION COEFFICIENTS TO BE USED WITH FORMULA METHOD

System	$K_1$	$K_2$	$K_3$
2-wire d-c.	2	1	1
3-wire d-c. (drop to neutral)	1	1	1
2-wire 1 $\phi$ a-c.	2		1
3-wire 1 $\phi$ a-c. (drop to neutral)	1		1
3-wire 3 $\phi$ a-c. (watch spacing)	1	Figs. 7-13 8-13	1.73
4-wire 3 $\phi$ a-c. (balanced; watch spacing)	1		1.73
4-wire 2 $\phi$ a-c.	2		1
3-wire 2 $\phi$ a-c. (approximate) Will do for normal problem		Outside wire regular way	
	1	Figs. 7-13 8-13	1
		To this add 0.707 drop in common wire	
	1	Figs. 7-13 8-13	0.707

Effective spacing:

1 $\phi$  use spacing given.

3 $\phi$  3-wire spacing 50% greater than given.

3 $\phi$  3-wire (transposed) spacing 25% greater than given.

3 $\phi$  4-wire spacing same as 3 $\phi$ , 3-wire.

2 $\phi$  4-wire spacing as given.

2 $\phi$  3-wire spacing as given.

**8. Determination of Voltage Drop.** The voltage drop, just as the determination of the current demand for a load, depends upon the type of electricity and the wiring system. Table XIV-13, in conjunction with the following expression, is used to determine the voltage drop.

$$VD = \frac{11 \times I \times D}{\text{cir. mils}} \times K_1 \times K_2 \times K_3 \quad (a-13)$$

where 11 is the specific resistance of a circular-mil-foot of copper wire at temperatures encountered in building installations;  $I$  is the line current in amperes;  $D$ , the distance in feet between the point of supply and the load;  $K^1$ , the coefficient which corrects the distance

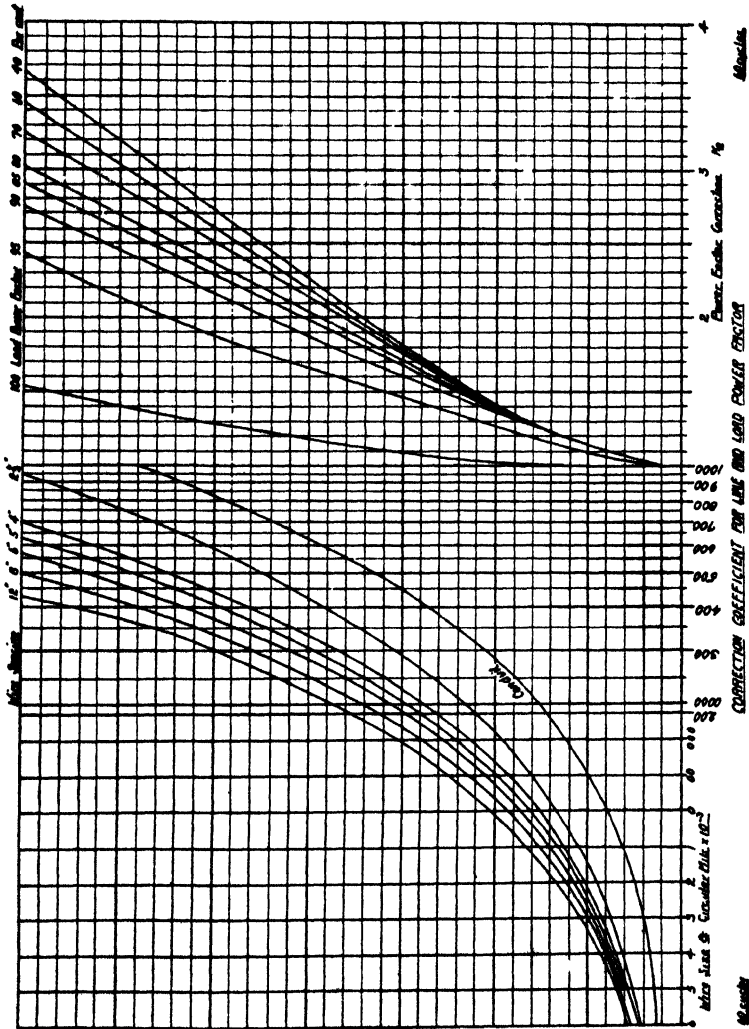

Fig. 7-13. Correction coefficients for load and line power factor for a 60-cycle system.

to the number of feet of wire;  $K_2$ , the coefficient which corrects for the line and load power factor, and  $K_3$  is the coefficient necessary to adjust for the number of phases. Coefficient  $K_2$  is obtained from Figs. 7-13 (60-cycle systems) and 8-13 (25-cycle systems). Figure 9-13 shows how to use the graphical charts for determining  $K_2$ .



In the d-c. system, the coefficients  $K_2$  and  $K_3$  are unity, but they depend upon the wire size, spacing, power factor, and type of system for their values in the a-c. system, though for the smaller size wire  $K_2$

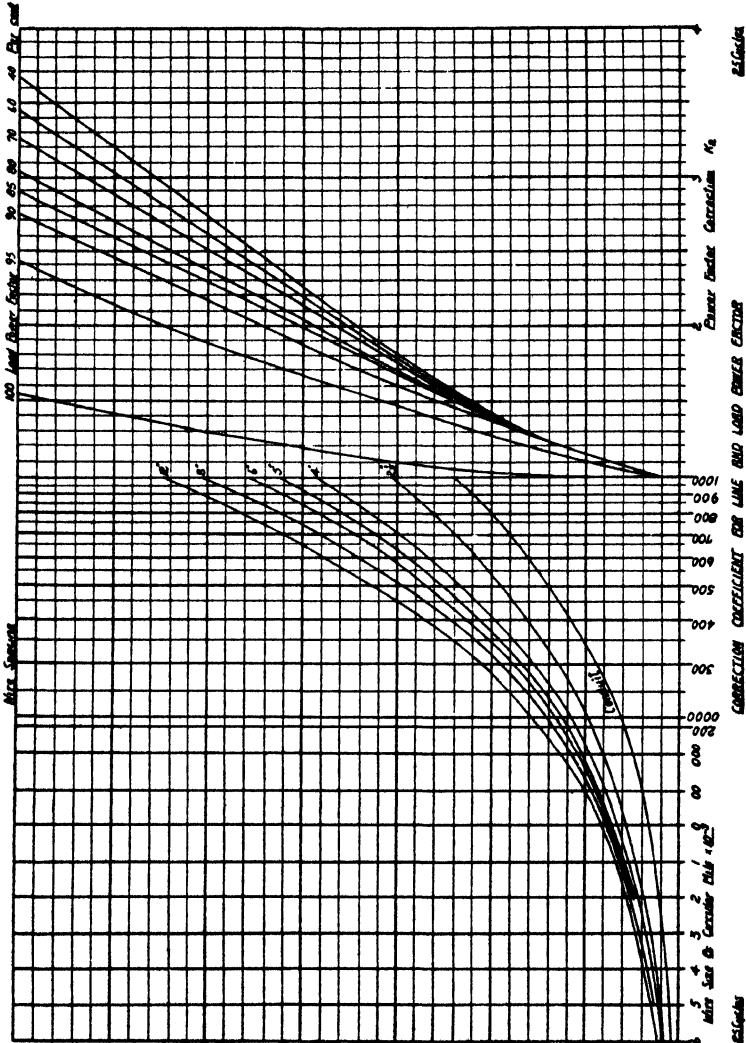

Fig. 8-13. Correction coefficients for load and line power factor for a 25-cycle system.

has little effect on the results. This is also true where the power factor is unity.

*Example i.* Determine the coefficient  $K_1$  for a 3-phase, 25-cycle system using No. 3 wire on 4-in. centers if the load has a power factor of 88%. From Table XIV-13, the effective spacing will be 6 in.

From Fig. 8-13 (25 cycles), follow the path as shown on Fig. 9-13 from No. 3 to the 6-in. spacing curve; then to the 88% power factor and down to 1.05, which is the value of  $K_2$ .

*Example j.* Determine the voltage drop in the system given in example *i*, if 64 amp. are transmitted for a distance of 150 ft.

From Table XIV,  $K_1 = 1$ ,  $K_2 = 1.05$ , and  $K_3 = 1.73$  for a 3-wire, 3-phase system. From Table VIII-13, a No. 3 wire has 52,630 cir. mils.

From the expression given for the voltage drop (a-13),

$$VD = \frac{11 \times 64 \times 150}{52,630} \times 1 \times 1.05 \times 1.73 = 3.61 \text{ v.}$$

**9. Lighting and Appliance Branch Circuits.** Figure 10-13 shows the approximate wattage per square foot required to give different amounts of illumination. The flattening of the curve for commercial interiors after 4 w. per sq. ft. is because of the requirements for auxili-

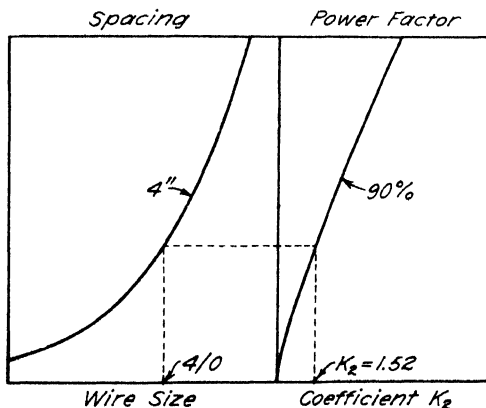

FIG. 9-13. Method of using Figs. 7-13 and 8-13.

aries in offices and stores requiring higher amounts of illumination. It is better to calculate the wattage requirements from the illumination designs, but if this is impossible, estimates may be made from the amounts indicated in the figure.

Table XV-13 gives the various capacity branch circuits that are recognized and the limits set if the circuits are designed for adequacy. The minimum number of branch circuits should be based upon actual load calculations or upon the requirements given in Fig. 10-13. It is well to use no wire smaller than No. 12 in any circuit, and where the distance from the first light to the panel exceeds 50 ft., the next largest wire, as given under adequacy, should be used. Runs in excess of 100 ft. to the first outlet should be discouraged unless the load is so small that the voltage drop will not exceed 2 per cent. If the runs

tend to be long, it is better to relocate the distribution panel or to install another panel.

Convenience outlets should be on separate circuits, and No. 12 wire should be used except where the run is more than 100 ft., when it is better to use No. 10 wire. Table XVI-13 lists the recommended number of circuits per square foot of floor space in different task areas and the number of convenience outlets per circuit. Ordinary outlets

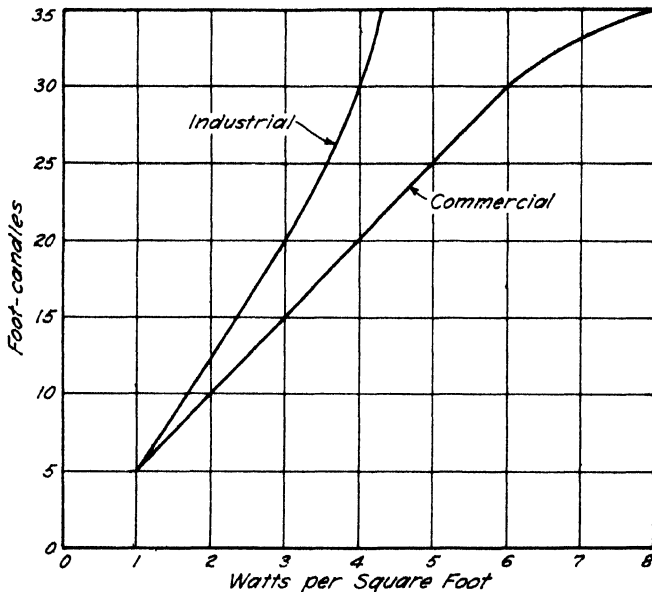

Fig. 10-13.<sup>11</sup> Suggested watts per square foot to be specified for lighting wiring in industrial and commercial interiors.

are of the duplex type, while single outlet receptacles are used for heavy-duty circuits.

The design of lighting and appliance branch circuits is a matter of rule with an attempt to use wires of such a size that the voltage drop will not exceed 2 per cent. and will satisfy the safety requirements of the Code. Table XVII-13 shows the requirements for circuits of varying capacities computed for a maximum drop of 2 per cent in a two-wire, 120-v. system.

**10. Motor Branch Circuits.** Having determined the motor current from Tables III-13 to V-13, it is only necessary for the designer to refer to Table IX-13 to determine the wire size and the fuse protection. Table IX-13 is based upon an allowance of 25 per cent more

than the rated full-load motor current, with the over-current protection figured from the percentages in Table X-13.

*Example k.* Determine the size of the branch circuit wire, the branch circuit fuse protection, and the voltage drop for a 30-h.p., 230-v., d-c. motor

TABLE XV-13<sup>10, 11</sup>  
LIGHTING AND APPLIANCE BRANCH CIRCUITS

Branch Circuit	Code	Adequacy Watts	Adequacy Wire
15-amp.	#14 wire 15-amp. fuse 12-amp. portable 6-amp. fixed	1000	#12
20-amp.	#12 wire 20-amp. fuse 15-amp. portable 15-amp. fixed	1500	#10
25-amp.	#10 wire 25-amp. fuse 20-amp. portable 20-amp. fixed	2500	#8
35-amp.	#8 wire 35-amp. fuse 35-amp. max. load (not in dwellings)	3000	#6
50-amp.	#6 wire 50-amp. fuse 50-amp. max. load (not in dwellings)		

at the end of a 150-ft. run using Type RP copper wire spaced on 5-in. centers.

Table III-13      I = 110 amp.  
Table IX-13      Use #2/0 wire.  
Table IX-13      Use 175-amp. fuse.

$$VD = \frac{11 \times 110 \times 150 \times 2}{133,100} = 2.72 \text{ v.}$$

Per cent voltage drop 1.2%

Required: 2 #00 wires  
2 175-amp. fuses  
VD = 2.72 v. or 1.2%

*Example l.* Determine the branch circuit wire size, the protection and the voltage drop for a 30-h.p., 3-phase, 220-v., 60-cycle, squirrel-cage induction

motor, using an autotransformer for starting, where the run is 150 ft. and the wire is Type RP copper run open on 4-in. centers.

Table VI-13	I = 77 amp.
Table IX-13	Use #1 wire.
Table IX-13	Use 175-amp. fuse.
Table XIV-13	$K_1 = 1$
Table XIV-13	$K_2 = 1.73$
Figure 7-13	Effective spacing 6 in. Wire #1 Table VII-13 power factor 88.5%
$K_3 = 1.23$	

TABLE XVI-13<sup>10</sup>

## AREA PER CONVENIENCE OUTLET

Office space	800 sq. ft. per circuit, duplex outlet on 20-ft. centers.
Manufacturing space	1200 sq. ft. per circuit, duplex outlet each bay.
Stores	400 sq. ft. per circuit, duplex outlet each column.
	Windows — outlet each 5 ft. of glass.
	Duplex outlet per 50 sq. ft. platform.

## Recommended Convenience Outlets Per Circuit

Barber shops, beauty parlors	2
Medical, dental, and similar	2
Store windows (spotlights)	3
Retail display areas	6
School classrooms	6
Manufacturing spaces	6
Office spaces	8
Storage spaces	10

$$VD = \frac{11 \times 77 \times 150 \times 1 \times 1.23 \times 1.73}{83,690} = 3.23$$

$$\% VD = 2.20 \times 100 = 1.5\%$$

Required: 3-#1 wires

3-175-amp. fuses

$VD = 3.23$  volts or 1.5%

*Example m.* Determine the branch circuit wire size, fuse protection, and the conduit size for a 100-h.p., 3-phase, 25-cycle, 440-v., reactance starting, squirrel-cage induction motor at the end of a run of 400 ft. if the voltage drop is specified at 1% and type RP copper wire is to be used.

Table VI-13  $I = 123$  amp.  
 Allowable drop 1% or 4.4. v.  
 Table VII-13 Power factor 91%  
 Table IX-13 Use #000 wire.

$$VD = \frac{11 \times 123 \times 400 \times 1 \times 1.06 \times 1.73}{167,800} = 5.92 \text{ (not adequate)}$$

The wire #000 satisfies the code or safety requirements but does it satisfy the voltage requirements?

$$\text{circular mils} = \frac{11 \times 123 \times 400 \times 1 \times K_2 \times 1.73}{4.4}$$

TABLE XVII-13

WIRE SIZE REQUIRED

Computed for Maximum of 2-v Drop on 2-wire, 120-v. Circuits

Load per Circuit	Current 120-V. Circuit	Length of Run (Panel Box to Load Center) — Feet																			
		Watts	Amp.	30	40	50	60	70	80	90	100	110	120	130	140	150	160	170	180	190	200
500	4.2		14	14	14	14	14	14	12	12	12	12	12	12	10	10	10	10	10	10	
600	5.0		14	14	14	14	14	14	12	12	12	12	12	10	10	10	10	8	8	8	8
700	5.8		14	14	14	14	12	12	12	12	10	10	10	10	10	10	8	8	8	8	8
800	6.7		14	14	14	12	12	12	12	10	10	10	10	10	8	8	8	8	8	8	8
900	7.5		14	14	12	12	12	10	10	10	10	10	8	8	8	8	8	8	8	8	6
1000	8.3		14	14	12	12	10	10	10	10	10	10	8	8	8	8	8	8	6	6	6
1200	10.0		14	12	12	10	10	10	10	8	8	8	8	8	6	6	6	6	6	6	6
1400	11.7		14	12	10	10	10	8	8	8	8	8	8	6	6	6	6	6	6	6	6
1600	13.3		12	12	10	10	8	8	8	8	8	6	6	6	6	6	6	6	6	4	4
1800	15.0		12	10	10	10	8	8	8	6	6	6	6	6	6	6	4	4	4	4	4
2000	16.7		12	10	10	8	8	8	6	6	6	6	6	6	4	4	4	4	4	4	4
2200	18.3		12	10	10	8	8	8	6	6	6	6	6	4	4	4	4	4	4	2	2
2400	20.0		10	10	8	8	8	6	6	6	6	6	6	4	4	4	4	4	2	2	2
2600	21.7		10	10	8	8	6	6	6	6	6	4	4	4	4	4	4	4	2	2	2
2800	23.3		10	8	8	8	6	6	6	6	6	4	4	4	4	4	4	2	2	2	2
3000	25.0		10	8	8	6	6	6	6	6	4	4	4	4	4	4	2	2	2	2	2
3500	29.2		10	8	8	6	6	6	4	4	4	4	2	2	2	2	2	2	2	2	2
4000	33.3		8	8	6	6	6	4	4	4	4	4	2	2	2	2	2	2	1	1	1
4500	37.5		8	6	6	6	4	4	4	2	2	2	2	2	2	1	1	1	1	1	1

Since the factor  $K_2$  depends on the circular mil size of the wire the problem becomes one of "trial and error." Determine the ratio of circular mils/ $K_2$  and select a wire that will be satisfactory.

circular mils/ $K_2 = 212,400$   
 250,000 CM Wire } Fig. 8-13  
 Conduit }  
 Power factor 91% }  $K_2 = 1.1$

$$VD = \frac{11 \times 123 \times 400 \times 1 \times 1.1 \times 1.73}{250,000} = 4.12 \text{ v.}$$

which is adequate.

Required: 3 250,000 cir.-mil wires    2½-in. conduit  
 3 500-amp. fuses                      VD = 4.12 v. or 0.94%

**11. Lighting Feeders.** The lighting feeder load is governed by the number of circuits connected to it. Lighting circuits are assumed to

TABLE XVIII-13A <sup>11\*</sup>

## DEMAND FACTORS

Type of Occupancy	Wattage Based on Area Served	Demand Factor in Per Cent
Single-family dwellings †	2500 or less	100
	Excess over first 2,500	30
Multifamily dwellings (other than hotels) and apartment houses with provisions for cooking by tenants †	3000 or less	100
	Excess over first 3000 but not more than 120,000	35
	Excess over 120,000	25
Hospitals ††	50,000 or less	40
	Excess over first 50,000	20
Hotels ††	20,000 or less	50
	Excess over first 20,000 but not more than 100,000	40
	Excess over 100,000	30
Office buildings	20,000 or less	100
	Excess over first 20,000	70
Schools	15,000 or less	100
	Excess over first 15,000	50
Storage warehouses	12,500 or less	100
	Excess over first 12,500	50

\* National Electrical Code, 1940.

† The small appliance load may be included with the lighting load and subject to the demand factors specified. If the load in single-family dwellings, individual apartments of multifamily dwellings, and in hotel suites having serving pantries, is subdivided through two or more feeders, the computed load for each shall include not less than 1,500 w. for small appliances.

†† For sub-feeders to areas where entire lighting is likely to be used at one time, as in ballrooms, dining rooms, operating rooms, etc., a demand factor of 100% shall be used.

be 1000 w. for each 15-amp. branch, and each convenience outlet circuit is assumed to be 1000 w.; all spare circuits are assumed at 500 w. each. Other circuits are considered to be fully loaded. Table XVIII-13 gives the demand factors listed in the National Electrical

TABLE XVIII-13B<sup>11</sup>\*

## DEMAND FACTORS FOR ELECTRIC RANGES

The values in the table below apply to one or more cooking and baking appliances but are not applicable to other appliances.

Number of Ranges	Demand Factor (Per Cent)	
	Column I (Ranges over 1650 w. and under 3500 w )	Column II (Ranges 3500 w. and over)
1	80	80
2	75	65
3	70	55
4	66	50
5	62	45
6	59	43
7	56	40
8	53	36
9	51	35
10	49	34
11	47	32
12	45	32
13	43	32
14	41	32
15	40	32
16	39	28
17	38	28
18	37	28
19	36	28
20	35	28
21	34	26
22	33	26
23	32	26
24	31	26
25	30	26
26-30	30	24
31-40	30	22
41-50	30	20
51-60	30	18
61 and over	30	16

The demand factor for one range may also be applied to the conductors of a range branch circuit.

\* National Electrical Code, 1940.



Code and should be used with discretion. The author has more than once seen service conductors and transformers excessively hot where demand factors have been used on lighting designs. Though a demand factor may be good for 99 per cent or more of the time, the need for full capacity for an hour or two only once in the life of the building may cost more than the initial investment in additional wiring capacity. If proper allowance is made for future expansion, there is plenty of reserve service, but too frequently the wiring is designed for the present load in accordance with a demand factor, leaving no surplus capacity. This is very likely to be the case where the design of the wiring system is allotted to the contractor who in competitive bidding must reduce every item to a minimum for protection. It is not fair to the contractor to force him to design the wiring system; this is a function of the building designer and his staff.

For future expansion, an allowance of 50 per cent increase of the initial feeder capacity should be made. If this ultimate feeder size does not exceed No. 4 wire, the final feeder should be installed immediately. Where the final size of feeder is not installed immediately, the raceway should be large enough for the oversized wire. This may involve larger or additional raceways.

The feeder terminates in a panel board which contains the terminals of the branch circuits. One spare circuit for every five active circuits should be installed and provisions should be made for delivering these spare circuits to the floor level for which they are intended. In these panels (or distribution centers) protection provisions must be made for immediate connection. Arrangements must also be made for ultimate protection if not originally installed.

*Example n.* Determine the wire size, the fuse protection, and the voltage drop for (a) a 2-wire, (b) a 3-wire d-c. feeder to supply 60 1000-w. lighting branch circuits on appropriate panels. The feeder run is 200 ft. and is of Type RP copper wire. The specifications require that the voltage drop shall not exceed 1.5% for either the 110 v. 2-wire or the 110 to 220-v. 3-wire system.

Two-wire system:

$$\frac{1000 \times 60}{110} = 545 \text{ amp.}$$

2,000,000 cir. mils for safety, which is also adequate; an impractical size of wire, so the three wire supply would have to be used.

Three-wire system:

$$\frac{1000 \times 60}{220} = 273 \text{ amp.}$$

$$\text{circular mils} = \frac{11 \times 273 \times 200 \times 1}{110 \times 0.015} = 364,000$$

From Table VIII-13, 400,000 cir. mils would be safe and adequate.  
The design requires 400,000 cir. mils.

Table VIII-13A      300 amp. fuse  
Table XI-13A        3-in. conduit

$$VD = \frac{11 \times 273 \times 200 \times 1}{400,000} = 1.5 \text{ v.}$$

Better to use two 200,000 cir. mil feeders in parallel, or two separate feeders, one with each panel.

Required: 3 400,000-cir.-mil wires  
          2 300 amp. fuses  
          3-in. conduit  
           $VD = 1.5$  volts or 1.4%

*Example o.* Determine the wire size, fuse protection, and panel voltage for a 1 $\phi$ , 3-wire, 60-cycle, 110-220-v. a-c. lighting feeder which over a run of 200 ft. of Type RP copper wire supplies panels (distributing current to 60 1000-w. branch circuits). The service voltage fluctuates from 217 to 223 v. and the specifications call for a maximum drop of 3%.

A 3% drop will be 3.3 v.

Supply voltage  $217/2 = 108.5$  v.; therefore,  $110-108.5 = 1.5$  v. used by line voltage fluctuations, leaving  $3.3-1.5 = 1.8$  v. to be used in the feeder.

$$\frac{1000 \times 60}{220} = 273 \text{ amp.}$$

400,000 cir. mils from Table VIII-13 is safe.

Conduit	}	Fig. 7-13
400,000 cir. mils		
Power factor 1.0		

$$VD = \frac{11 \times 273 \times 200 \times 1 \times 1.07 \times 1}{400,000} = 1.61 \text{ v. (adequate)}$$

Therefore, the 400,000-cir.-mil wire is satisfactory.

Required: 3 400,000-cir.-mil wires  
          2 300-amp. fuses  
          3-in. conduit

108.5 will be the lowest voltage on distribution panel.

106.7 will be the lowest voltage on the branch circuit panel.

**12. Power Feeders.** The power feeder is designed to permit starting of the largest motor when all other equipment on the system is operating. It should have a current-carrying capacity of not less than 125 per cent of the full-load rating of the largest motor plus the sum of the full-load current of the rest of the connected load and, if several of the motors are the same capacity, only one shall be considered the largest for the computation of the feeder size. For the protection of the feeder, the largest rating or setting of the branch-circuit protection for any motor of the group together with the full-load rated current

of the remainder of the connected load, determines the amount of protection permitted.

The power branch circuit and the feeder must have a flexibility that is not required in the lighting branch circuit and feeder. It must be adequate not only for wire capacity, but also for the following provisions:

- a. Safety and reliability
- b. Avoidance of excessive voltage drop
- c. Avoidance of excessive copper loss
- d. Flexibility in changing location of equipment
- e. Provisions for supplying increased load

These items apply more to general industrial installations than to the power system in the average building, since ventilation, elevators, pumping, and air conditioning are as permanently located as the lighting system itself. It is for motors and machines which are likely to be moved or replaced with larger equipment that flexibility is necessary.

The allowable overall voltage drop and frequency change are set normally at 10 per cent; that is, the motor will function and give satisfactory economical service if the voltage and frequency are within 10 per cent of the name-plate rating. The frequency furnished by the modern utility varies only for a small part of a cycle, so that the average frequency is, for practical purposes, constant. The recommended allowable maximum voltage drop given in Table XIII-13 is 10 per cent, which is commonly accepted as an economical value in most installations, but 5 per cent would be much more satisfactory, and even less may be more economical where the motors are operating 24 hr. a day at full capacity. Here, as in all economic problems, a fixed rule cannot be set which will apply to all the problems that may arise. Only an analysis of the individual problem leads to a justifiable solution.

In buildings of the commercial and office type, the power feeders should be designed, as are the lighting feeders, for future expansion of power requirements. In the industrial plant where the system is exposed and appearance is not of prime importance, it is satisfactory to supply the immediate demands with only casual allowances for future expansion, since panels and additional circuits may be supplied without damaging the building or interfering with the equipment already in place. If the industrial plant is large and there are several buildings, it is desirable to consider the economics of the primary voltages and the distribution system of the entire plant — a matter best analyzed by a specialist in these designs.

*Example p.* Determine the design for the branch circuits and the feeder to supply (A) a 25-h.p., 150-ft. run branch circuit motor and (B) a 50-h.p., 100 ft. run branch circuit motor, both on 230 v. direct current, if the 200-ft. feeder of Type RP copper wire is open wiring spaced on 4-in. centers.

Table III-13

Table IX-13

Branch	<i>I</i>	Wire	Fuse	<i>VD</i>	% <i>VD</i>
A	92	#0	150	2.88	1.2
B	180	300,000	300	1.32	0.6
	<u>272</u>				

$$VD_A = \frac{11 \times 92 \times 150 \times 2}{105,500} = 2.88$$

$$VD_B = \frac{11 \times 180 \times 100 \times 2}{300,000} = 1.32$$

Feeder running current 272 amp.

Starting current  $(180 \times 1.25) + 92 = 317$  amp.

Wire size 500,000 cir. mils

Fuse protection  $300 + 92 = 392$

Select 400-amp. fuse.

$$\text{Voltage drop} = \frac{11 \times 272 \times 200 \times 2}{500,000} = 2.4 \text{ v. or } (1.04\%).$$

Drop to motor A 5.3 v.

Drop to motor B 3.7 v.

The allowable drop for motor service is 10%, or 23 volts for a 230-v. system. This design is both safe and adequate.

*Example q.* Determine the design for the branch circuits and feeder for the following motors on a 25-cycle, 220-v., 3-phase a-c. system:

A. 25-h.p., auto transformer starting, squirrel-cage induction motor, 150-ft. run

B. 50-h.p., resistance starting, synchronous motor operating at 90% power factor, 100-ft. run with the feeder 200 ft. long using Type RP copper wire in open wiring, spaced on 4-in. centers.

Table VI-13

Table VII-13

Table IX-13

Branch	H.p.	<i>I</i>	P.F. %	Wire
A	25	64	88	#3
B	50	119	90	#000
		<u>183</u>		

Table IX-13 *VD* % *VD*

Fuse	<i>VD</i>	% <i>VD</i>
150	3.64	1.65
400	1.58	0.72

$K_1 = 1$  Table XIV-13  
 $K_1 = 1.73$  Table XIV-13

Fig. 8-13  $\left\{ \begin{array}{l} \#3 \text{ wire} \\ 6\text{-in. spacing} \\ \text{power factor } 88 \end{array} \right.$

$K_1 = 1.05$

$$VD_A = \frac{11 \times 64 \times 150 \times 1 \times 1.05 \times 1.73}{52,630} = 3.64 \text{ v.}$$

$K_1 = 1$  Table XIV-13

$K_2 = 1.73$  Table XIV-13

Fig. 8-13  $\left\{ \begin{array}{l} \#000 \text{ wire} \\ 6\text{-in. spacing} \\ \text{power factor } 90\% \end{array} \right.$

$K_2 = 1.17$

$$VD_B = \frac{11 \times 119 \times 100 \times 1 \times 1.17 \times 1.73}{167,800}$$

$VD_B = 1.58 \text{ v.}$

Feeder: Load current 183 amp.  
 Power factor 89%  
 Wire #0000  
 Fuse 500 amp.  
 $VD = 4.03 \text{ v.}$

$K_1 = 1$   $K_2 = 1.73$  Table XIV-13

Fig. 8-13  $\left\{ \begin{array}{l} \#0000 \text{ wire} \\ 6\text{-in. spacing} \\ \text{power factor } 89\% \end{array} \right.$

$K_2 = 1.22$

$$VD = \frac{11 \times 183 \times 200 \times 1 \times 1.22 \times 1.73}{211,600}$$

$VD = 4.03 \text{ v.}$       %  $VD = 1.83\%$

The allowable drop for motor service is 10% or 22 v. for the 220-v. system. The system is both safe and adequate.

**13. Combination Lighting and Power Feeders.** The combining of feeders for power loads and lighting loads should be discouraged as much as possible. The three-phase, four-wire installation is a system of this type. Since power feeders allow more voltage drop than do the lighting feeders, a combined feeder will have to be designed for the voltage drop of the lighting system rather than that of the power system. If the power requirement is very large (over 10 per cent) using the combined feeder results in the necessity for very large wires.

Combined feeders should not be used where motors are continually being started and stopped (as in elevator service), as there is likely to be a pronounced flicker of the light at each starting, unless feeders are so large that they are uneconomical. There are special cases where the proper design uses combined feeders, such as in small factories or in buildings where the ventilating fans are far removed from the main service panel and the running of extra feeders for power would be expensive. As a rule, the suggested use of combined feeders should be

studied carefully before such a system is decided upon as adequate and economical. The advantages which have accrued to the utilities by the use of three-phase, four-wire secondary distribution has in many instances led to the use of these systems for office and commercial building installations without any thought being given to the probable disadvantages attending such systems.

The combined feeder wire size and protection design is determined by addition of the requirements for the power feeder and the requirements for the lighting feeder. The current obtained by the summation of the current for the lighting and power feeders taken independently determines the size of the combined feeder; the same is true for the protection.

*Example r.* Determine the voltage drop, the size of Type RP copper wire, the fuse size, and conduit size for a combined 115-230-v. three-wire, d-c. feeder to service panels for 60 1000-w. lighting branch circuits and to 25- and 50-h.p., 230-v. motor branch circuits. The combined lighting and power feeder has a run of 200 ft.

PART	LOAD CURRENT	WIRE SIZE	FUSE SIZE
Motor	272	500,000	400
Lighting	261	400,000	275
Feeder	533	1,750,000	4-325 parallel fuses

$$VD = \frac{11 \times 533 \times 200 \times 1 \times 1 \times 1}{1,750,000} = 0.75 \text{ v.}$$

The 1,750,000 cir.-mil wire is safe and adequate but it is doubtful if such a wire size is economical. Often it is more satisfactory to run two wires in parallel to carry the load. It is good practice to separate lighting and power loads whenever possible.

Conduit requirements:

Table XII-13A — 3 conductors

43% of the conduit to be used by wire.

Table XII-13B 2.85 area of 1,750,000 cir. mil

0.83 area of 300,000 cir. mil

6.53 sq. in. area of wire

Table XII-13D  $6.53/0.43 = 15.2$  conduit area

$4\frac{1}{2}$ -inch conduit 15.95 sq. in.

**14. Service Conductors.** The size of the service conductors depends upon the capacity and the number of feeders supplying the initial load. For future expansion, approximately a minimum of 50 per cent additional capacity should be allowed. If the capacity for the initial load does not exceed 267 amp., the service conductor for the ultimate load should be installed; if it does exceed this value, the problem should receive special study to determine the economical

procedure. Table XIX-13 gives the adequacy standards for service entrance conductors and service switch size.

**15. Recapitulation.** It is not the intent of this chapter to give all the details of the mechanical requirements and the design of the wiring system, but to give only enough information for the occasional design of a system part or for the checking of designs for adequacy. For an extended design for a commercial or industrial building, it is necessary to be familiar with the requirements as stated in

- a. The National Electrical Code
- b. The National Electrical Code Handbook
- c. Handbook of Interior Wiring Design.

TABLE XIX-13<sup>10</sup>

## SERVICE ENTRANCE ADEQUACY STANDARDS

Initial Load Amperes	Switch Amperes	Conductor B & S
1- 23	60	8
24- 33	60	6
34- 47	100	4
48- 60	100	2
61- 67	100	1
68- 83	200	0
84-100	200	00
101-117	200	000
118-133	200	0000
134-150	400	0000
151-167	400	250,000
168-183	400	300,000
184-200	400	350,000
201-217	400	400,000
218-267	400	500,000

The first gives the basic requirements and should be supplemented by state and local codes. The second interprets the clauses of the National Electrical Code, and the supplementary notes and diagrams are functionally a dictionary explaining both terms and practice with the intent and object of the ruling as given in the Code. The third gives the requirements for adequacy and future expansion allowances which must be provided. The requirements for a first-class installation are more rigid than those required by the Code. The sample specifications and the sample problems in this last reference give a systematic approach to an adequate design with an assurance that, if enforced, adequate requirements will be met by the contractor whose

responsibility is confined to the actual mechanical installation and not to the design of the wiring system, as too often is the case.

The following outline has been suggested as a method to follow in making wiring layouts and designing the wiring system:

#### LIGHTING

1. Location and wattage for lighting
  - (a) General lighting
  - (b) Supplementary lighting
  - (c) Show-window and display lighting
  - (d) Miscellaneous lighting outlets
2. Location of convenience outlets

#### POWER

1. Location and current for power

#### LIGHTING AND POWER

1. Branch circuits and control
2. Panel boards
3. Feeders
4. Feeder distribution center
5. Service conductors and equipment
6. Miscellaneous applications
  - (a) Signal and telephone systems















































































For clarity, the complete layout (see method of marking, Table XX-13) should be shown on all the building plans that may be necessary. It is best to use different plans for lighting and power systems in order to avoid confusion. There should be schedules for panel boards and feeder distribution centers, and each circuit and distribution center should be designated by some code number.

The design and layout begin with the branch circuits and include a bill of material indicating the necessary material for its installation. The bill can be as elaborate as necessary for making estimates and should be in detail if contractors are to bid competitively. The schedules for the individual branch circuits from a single panel determine the data for the panel board schedule. The individual panel board schedules are compiled for the feeder distribution center schedule. The last schedule determines the character of the service. By a systematic set of these schedules, changes may be made in the design, and the layout may be checked without the necessity for time consuming delays after the plans have been completed or the work is started.



TABLE XX-13<sup>10</sup>

## ELECTRICAL SYMBOLS FOR ARCHITECTURAL PLANS\*

CEILING WALL	GENERAL OUTLETS	PANELS, CIRCUITS, AND MISCELLANEOUS
	Outlet.	 Lighting panel.
	Capped outlet.	 Power panel.
	Drop cord.	 Branch circuit — ceiling or wall.
	Electrical outlet — for use only when circle used alone might be confused with columns, plumbing symbols, etc.	 Branch circuit — floor.
	Fan outlet.	 Note: Any circuit without further designation indicates a two-wire circuit. For a greater number of wires indicate as follows:  (3 wires),  (4 wires), etc.
	Junction box.	 Feeders. Note: Use heavy lines and designate by number corresponding to listing in feeder schedule.
	Lamp holder.	 Underfloor duct and junction box — triple system. Note: For double or single systems eliminate one or two lines. This symbol is equally adaptable to auxiliary system layouts.
	Lamp holder with pull switch.	 Generator.
	Pull switch.	 Motor.
	Outlet for vapor discharge lamp.	 Instrument.
	Exit light outlet.	 Transformer.
	Clock outlet (lighting voltage).	 Controller.
	CONVENIENCE OUTLETS	 Isolating switch.
	Duplex convenience outlet.	
	Convenience outlet other than duplex. 1 = single, 3 = triplex, etc.	AUXILIARY SYSTEMS
	Weatherproof convenience outlet.	 Push button.
	Range outlet.	 Buzzer.
	Switch and convenience outlet.	 Bell.
	Radio and convenience outlet.	 Annunciator.
	Special purpose outlet.	 Telephone.
	Floor outlet.	 Telephone switchboard.
	SWITCH OUTLETS	 Clock (low voltage).
	Single-pole switch.	 Electric door opener.
	Double-pole switch.	 Fire alarm bell.
	Three-way switch.	 Fire alarm station.
	Four-way switch.	 City fire alarm station.
	Automatic door switch.	 Fire alarm central station.
	Electrolier switch.	 Automatic fire alarm device.
	Key-operated switch.	 Watchman's station.
	Switch and pilot lamp.	 Watchman's central station.
	Circuit breaker.	 Horn.
	Weatherproof circuit breaker.	 Nurse's signal plug.
	Momentary contract switch.	 Maid's signal plug.
	Remote control switch.	 Radio outlet.
	Weatherproof switch.	 Signal central station.
	SPECIAL OUTLETS	 Interconnection box.
	Any Standard Symbol as given above with the addition of a lower case subscript letter may be used to designate some special variation of standard equipment of particular interest in a specific set of architectural plans.	 Battery.
		 Auxiliary system circuits.
		 Note: Any line without further designation indicates a 2-wire circuit. For a greater number of wires designate with numerals in manner similar to  — 12-No. 18W- $\frac{1}{2}$ "-C., or designated by number corresponding to listing in schedule.
		 SPECIAL AUXILIARY OUTLETS
	When used they must be listed in the key of symbols on each drawing and, if necessary, further described in the specifications.	 Note: Subscript letters refer to notes on plans or detailed description in specifications.

\* These symbols have been prepared by a technical subcommittee of ASA, Committee Z32, Standardization of Graphical Symbols and Abbreviations for use on Drawings, and have been submitted for approval as an American Standard to replace the symbols shown in ASA C10-1924. The electrical symbols for architectural plans as finally approved by the ASA as an American Standard will be announced by that body in due course of time.

## PROBLEMS

1. Determine the load center for a system which feeds three motors: motor A, 20 h.p., 200 ft. from the switchboard; motor B, 40 h.p., 50 ft. from the switchboard, and motor C, 50 h.p., 150 ft. from the switchboard. A single feeder supplies the motors from a 230 d-c. panel. What current would be concentrated at this load center?

2. Determine the current drawn by five 250-w. high-intensity mercury vapor lamps (power factor corrected) operating from a 220-v. source.

3. How much current will a 75-h.p. induction motor draw from a 230-v. line if its efficiency is 92%?

4. Determine the current and power factor for a circuit which combines sixty 400-w. uncorrected high-intensity mercury vapor lamps with a 60-h.p. load made up of six 10-h.p., single-phase motors. The line voltage is 220 v. and the loads are fed from one power center. What will be the approximate current and power factor of this load?

5. Design the branch circuit wire and fuse protection for a 25-h.p., 230-v., d-c. motor. The branch is 125 ft. long and in open wiring, spaced on 4-in. centers using Type R wire for the conductor. Determine the allowable wire size and the voltage drop.

6. Design the branch circuit and branch circuit protection for a 30-h.p., 3-phase, 440-v., 25-cycle, synchronous motor at 90% power factor, using an auto-transformer for starting. The branch circuit is 100 ft. long and in open wiring spaced 6 in. apart, using Type RP copper wire. Determine the wire size and the voltage drop.

7. A limit of 1.5% is specified as the allowable voltage drop for a branch circuit to supply a 40-h.p., 115-v., d-c. motor. The run is 250 ft. and Type RP copper wire is used. Determine the wire size, the fuse protection, and specify the conduit size.

8. A 2% voltage drop is specified on a motor branch circuit supplying a 125-h.p., 3-phase, 60-cycle, 440-v., squirrel-cage, induction motor with reactance starting. The run is 400 ft. and is installed in conduit using Type R copper wire. Design the wire size and the fuse protection and specify the conduit size.

9. What size conduit would be used for three #000, two #6, and four #12 Type RP copper wires?

10. Design the three-wire, d-c. feeder to supply forty-two 1000-w. branch circuits from a 110/120-v. d-c. supply. The run is 250 ft.

11. Repeat problem 10 to operate from an a-c. supply instead of a d-c. supply.

12. A 220-v. power feeder supplies the following motors:

Two 15-h.p., squirrel-cage, autotransformer starting induction motors

One 25-h.p., 80% power factor, reactance starting synchronous motor.

Use Type RP wire for the 3-phase, 60-cycle, 4-in. spacing supply line which has a run of 350 ft. Determine the wire size and fuse protection for both safety and adequacy.

13. For comparison purposes problem 12 was redesigned for 230 v., direct current. Determine the wire size and fuse protection for both safety and adequacy under these conditions.

14. Design a combined lighting and power feeder to carry the following load:

40 lighting branches having five 200-w. lamps each

One 25-h.p., 230 v., d-c. motor

One 50 h.p., 230-v., d-c. motor.

The feeder is to be a 3-wire, Type R copper wire installation. Determine the voltage drop, the size wire, the size fuse, and the conduit size for installing a feeder with a run of 250 ft. Consider the system for both safety and adequacy.

15. A circuit 275 ft. in length and consisting of three #000 Type RP copper conductors in conduit, connects a 110-v., 3-phase, 60-cycle source to a load. The line drop is limited to 2%. Calculate (a) the power which can be supplied to a unity power factor load; (b) the power which can be supplied to an 80% lagging power factor load.

#### BIBLIOGRAPHY

1. E. B. DAWSON, "Electric Power for Buildings," *Amer. Arch.*, June 5, 1926.
2. NATIONAL ELECTRIC LIGHT ASSOCIATION, "Lighting Service Manual, Part III," Committee Report, August, 1928.
3. ELECTRIC ASSOCIATION, "Franklin Specification for Good Lighting," *A. I. A.* File No. 31 f 13-18, 1929.
4. NATIONAL ELECTRIC LIGHT ASSOCIATION, "Minimum Specification for Adequate Wiring of Lighting Circuits in Commercial and Public Structures," March 30, 1930.
5. C. E. WEITZ, "Correct Wiring Saves," *Elect. Prod.*, November, 1931.
6. G. H. STICKNEY, "'Adequate Wiring' Proceedings, International Illumination Congress," Glasgow, September 4, 1932.
7. L. V. JAMES, "Modernization Limited," *Skyscraper Management*, October, 1932.
8. G. H. STICKNEY and WALTER STURROCK, "Adequate Wiring of Buildings an Essential for Good Illumination," *A. I. E. E. Trans.*, 1932.
9. EMIL KUN, "Simplified Calculations Alternating-Current Wiring," *The Electric Journal*, v. 32, No. 6, p. 250; v. 32, No. 7, p. 294, 1935.
10. INDUSTRY COMMITTEE ON INTERIOR WIRING DESIGN, Handbook of Interior Wiring Design, 1937.
11. NATIONAL FIRE PROTECTION ASSOCIATION, "National Electrical Code," Committee Report, November 1, 1940.
12. A. L. ABBOTT, National Electrical Code Handbook, McGraw-Hill Book Co., latest ed.

## APPENDIX

### TRIGONOMETRY — SIMPLE FUNCTIONS

1. The sine (sin) of an angle =  $\frac{\text{opposite side}}{\text{hypotenuse}}$
2. The cosine (cos) of an angle =  $\frac{\text{adjacent side}}{\text{hypotenuse}}$
3. The tangent (tan) of an angle =  $\frac{\text{opposite side}}{\text{adjacent side}}$
4.  $\sin A = \frac{a}{c}$
5.  $\cos A = \frac{b}{c}$
6.  $\tan A = \frac{a}{b}$

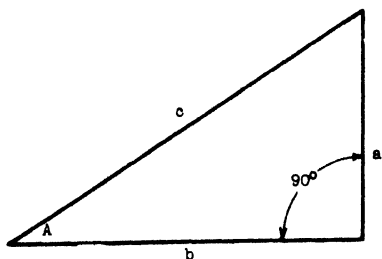

TRIGONOMETRIC FUNCTIONS

Read down for  $\cos \alpha$ ,  $\tan \alpha$ ,  $\cos^2 \alpha$ , and  $\cos^3 \alpha$ .

$\cos \alpha$	$\tan \alpha$	$\alpha$	$\cos^2 \alpha$	$\cos^3 \alpha$	$\alpha$	$\cos \alpha$	$\tan \alpha$	$\alpha$	$\cos^2 \alpha$	$\cos^3 \alpha$	$\alpha$
1.00	.000	0	1.00	1.000	90	.694	1.04	46	.482	.335	44
.99985	.0175	1	.999	.999	89	.682	1.07	47	.465	.317	43
.9994	.0349	2	.998	.998	88	.669	1.11	48	.447	.299	42
.998	.0524	3	.997	.996	87	.656	1.15	49	.430	.282	41
.997	.0699	4	.995	.993	86	.643	1.19	50	.413	.265	40
.996	.0875	5	.992	.988	85	.629	1.23	51	.395	.249	39
.994	.105	6	.989	.983	84	.615	1.28	52	.379	.233	38
.992	.123	7	.985	.978	83	.602	1.33	53	.362	.218	37
.990	.1405	8	.981	.971	82	.588	1.38	54	.345	.203	36
.988	.1584	9	.975	.963	81	.573	1.43	55	.329	.189	35
.985	.176	10	.970	.955	80	.559	1.48	56	.312	.175	34
.982	.194	11	.963	.946	79	.544	1.54	57	.296	.161	33
.978	.212	12	.957	.936	78	.530	1.60	58	.280	.149	32
.974	.230	13	.949	.925	77	.515	1.66	59	.265	.137	31
.970	.249	14	.941	.913	76	.500	1.73	60	.250	.125	30
.966	.268	15	.933	.901	75	.485	1.80	61	.235	.113	29
.961	.287	16	.924	.888	74	.469	1.88	62	.220	.103	28
.956	.306	17	.914	.874	73	.454	1.96	63	.206	.0936	27
.951	.325	18	.904	.860	72	.438	2.05	64	.192	.0843	26
.945	.344	19	.894	.845	71	.423	2.14	65	.178	.0755	25
.939	.364	20	.883	.830	70	.407	2.25	66	.165	.0673	24
.933	.384	21	.872	.814	69	.391	2.35	67	.152	.0596	23
.927	.404	22	.859	.797	68	.375	2.47	68	.140	.0526	22
.920	.424	23	.847	.780	67	.358	2.60	69	.128	.0460	21
.913	.445	24	.834	.762	66	.342	2.75	70	.117	.0400	20
.906	.466	25	.821	.744	65	.325	2.90	71	.106	.0345	19
.899	.488	26	.808	.725	64	.309	3.08	72	.0955	.0295	18
.891	.509	27	.794	.707	63	.292	3.27	73	.0855	.0250	17
.882	.532	28	.779	.688	62	.275	3.48	74	.0759	.0209	16
.874	.554	29	.764	.669	61	.259	3.73	75	.0670	.0173	15
.866	.577	30	.750	.649	60	.242	4.01	76	.0586	.0142	14
.857	.601	31	.735	.630	59	.225	4.33	77	.0506	.0114	13
.848	.625	32	.719	.610	58	.208	4.70	78	.0432	.00899	12
.838	.649	33	.703	.590	57	.191	5.14	79	.0363	.00686	11
.829	.675	34	.687	.570	56	.173	5.67	80	.0301	.00520	10
.819	.700	35	.671	.550	55	.156	6.31	81	.0244	.00379	9
.809	.726	36	.655	.529	54	.139	7.11	82	.0193	.00268	8
.798	.753	37	.637	.509	53	.122	8.14	83	.0148	.00181	7
.788	.781	38	.621	.489	52	.1045	9.51	84	.0109	.00115	6
.777	.810	39	.604	.469	51	.0872	11.43	85	.00760	.000661	5
.766	.839	40	.587	.449	50	.0697	14.30	86	.00486	.000339	4
.754	.869	41	.569	.430	49	.0523	19.08	87	.00274	.000144	3
.743	.900	42	.552	.410	48	.0349	28.64	88	.00122	.0000425	2
.731	.932	43	.534	.391	47	.0174	57.29	89	.000306	.0000053	1
.719	.966	44	.517	.372	46	.00	$\infty$	90	.0000	.0000	0
.707	1.00	45	.500	.353	45						

Read up for  $\sin \alpha$ ,  $\sin^2 \alpha$ ,  $\sin^3 \alpha$ .

## AUTHOR INDEX

Abbott, A. L., 426  
Adams, E. O., 154, 348  
Alexander, H. M., 281  
Allen, C. J., 40  
Amick, C. L., 40  
Anderson, E. A., 189, 195, 372

Barnes, B. T., 155  
Barrows, W. E., 14  
Beese, N. C., 154, 155  
Beggs, E. W., 281, 372  
Benford, F., 122  
Bobst, G. G., 310  
Brown, W. C., 372  
Buttolph, L. J., 152, 154  
Bychinsky, W. A., 281

Campbell, J. H., 155  
Cannell, D., 154  
Caverly, D. P., 372  
Chanon, H. J., 347, 348  
Cissell, R. F., 40, 154, 155  
Cleaver, O. P., 154  
Cram, R. A., 6  
Cutler, C. M., 346, 347

Darley, W. G., 215  
Dawson, E. B., 426  
Dickerson, A. F., 310, 347  
Ditchman, J. P., 347  
Dows, C. L., 40

Falge, F. M., 347, 348  
Fogle, M. E., 40  
Folson, W. E., 255  
Forbes, J. C., 69, 154, 372  
Forsythe, W. E., 154, 155, 348  
Foulks, W., 255  
Found, C. G., 154

Gamble, D. L., 215  
Gianini, L. G., 255  
Gibson, K. S., 89  
Glenn, J. J., 89

Goodwin, W. N., Jr., 40  
Grandy, D. R., 154  
Grant, J., 347  
Granville, W. C., 88  
Graves, L. H., 255  
Gustin, D. S., 154, 155

Hallman, E. B., 121, 303, 309  
Hardy, A. C., 80, 88, 89  
Hardy, L. H., 89  
Harrison, W., 49, 68, 69, 154, 189, 195,  
215, 255  
Hawkins, L. A., 154  
Haynes, H., 154, 155  
Hays, R. F., 155  
Hewitt, P. C., 123  
Hibben, S. G., 372  
Highie, H. H., 14, 122, 281  
Holladay, L. L., 68

Ickis, L. S., 154  
Inman, G. E., 154  
  
James, L. V., 426  
Johnson, L. B., 154  
Judd, D. B., 88, 89

Karash, W. J., 155  
Kelting, J. D., 154  
Kelting, R. C., 154  
Kennelly, A. E., 40  
Kerr, G. P., 154  
Ketch, J. M., 255, 372  
Killian, J. T., 89  
Koller, L. R., 155  
Kraehenbuehl, J. O., 348, 372  
Kunerth, W., 14

Lancaster, W. B., 58, 69  
LaWall, G. R., 255, 346, 347  
Lippman, H. E., 346  
Logan, H. L., 69, 281  
Lowell, N. R., Jr., 372  
Luckiesh, M., 40, 42, 53, 68, 69, 88, 154  
Lyon, A. M., 281

- McCandless, Stanley, 6, 14  
McMath, J. B., 154  
Magdsick, H. H., 346  
Marden, W., 154, 155  
Matteson, M. R., 347  
Meacham, J. A., 215  
Meaker, P., 281  
Meister, C. J., 154  
Merrill, G. S., 372  
Mills, E. S., 155  
Moon, P., 14, 89  
Moss, F. K., 40, 42, 53, 68, 69
- Neidhardt, P. W., 155  
Newhall, S. M., 89  
Nickerson, D., 88, 89  
Nutting, P. G., 49, 68
- Oday, A. B., 152, 155
- Parker, A. E., 155  
Parsons, J. F., 372  
Ponder, E., 68  
Porter, L. C., 154, 155, 347  
Potter, W. M., 215, 281, 347  
Powell, A. L., 346
- Radley, J. A., 347  
Rentschler, H. C., 155  
Riddle, W. D., 347
- Rogers, A., 347  
Rosa, E. B., 121  
Rosebraugh, W., 255  
Ryan, W. D'A., 346
- St. Louis, J. A., 154  
Sharp, H. W., 372  
Stair, J. L., 255  
Stuckney, G. H., 347, 426  
Strobl, A., 346  
Sturrock, Walter, 426  
Summers, J. A., 310  
Swackhamer, R. J., 310
- Taylor, A. H., 154, 155  
Taylor, G. J., 372  
Telford, C. W., 68  
Thompson, N., 68  
Troland, L. T., 68  
Tyler, J. E., 89
- Wakefield, E. H., 122  
Warren, D. M., 310  
Weitz, C. E., 154, 215, 372, 426  
Whittaker, J. D., 154  
Wolff, F. M., 347  
Woodside, C. S., 255, 281, 347  
Wright, F. L., 6
- Zahour, R. L., 346

## TABLE INDEX

(Table numbers are in boldface type.)

- Ballasts, characteristics of, **IX-6**, 149  
 high power factor tulamp, **IX-6**, 150
- Barrier-layer cells, calculated multiplying factors, **I-2**, 30  
 multiplying factors for, **II-2**, 31
- Beam lumens, floodlighting units, **I-10**, 287
- Beam spread, for floodlighting, **II-10**, 290
- Branch circuit, appliance, **XV-13**, 411  
 lighting, **XV-13**, 411
- Brightness, enclosing units, **II-3**, 50  
 exterior luminous elements, **I-9**, 258  
 interior luminous elements, **II-9**, 258  
 light box, **X-8**, 248  
 louver, **VIII-8**, 244  
 store front, **V-9**, 278
- Coefficients, for formula method, **XIV-13**, 406  
 of utilization, **VI-7**, 210-213
- Color, analysis, **IV-4**, 85  
 temperature of illuminants, **I-6**, 127
- Color media, **II-11**, 343  
 transmission efficiency of, **II-4**, 73
- Colored light, effect of, **I-4**, 72
- Colors, additive mixing, **III-4**, 74
- Conductors, current-carrying capacities, **VIII-13A, B**, 388  
 number in conduit or tubing, **XI-13A, B, C, D, E**, 398-401  
 properties of, **VIII-13C**, 390
- Conduit, dimensions of conduit or tubing, **XII-13G**, 405  
 for combinations of conductors, Types R, RW, RP, and RH, **XII-13B, C, D, E, F**, 402-404  
 per cent area used, **XII-13A**, 401
- Convenience outlet, area per, **XVI-13**, 412
- Copper for systems of distribution, **I-13**, 380
- Cost of lighting, **VI-12**, 359
- Cove lighting, design factors, **IV-8**, 234
- Coves, room lighted by, **III-8**, 233
- Current, calculation of, **II-13**, 381
- Demand factors, **XVIII-13A**, 414  
 electric ranges, **XVIII-13A**, 414
- Depreciation in four locations, **IV-12**, 352
- Design data, cove lighting, **IV-8**, 234  
 direct transmitting equipment, **IX-8**, 247  
 floodlighting, closed type, **VII-10**, 300  
 open type, **VII-10**, 300
- Direct transmitting equipments, design data, **IX-8**, 247
- Efficiencies, aluminum elliptical reflectors, **VI-8**, 242  
 element forms, **III-9**, 266
- Electric ranges, demand factors, **XVIII-13B**, 415
- Enclosing units, brightness of, **II-3**, 50
- Eye defects, **I-3**, 46
- Factors, utilization, **VI-7**, 208
- Floodlighting, beam lumens of equipment, **I-10**, 287  
 equipment, **IV-10**, 292  
 foot-candle specification, **V-10**, 295
- Floodlights, design data, closed type, **VII-10**, 300  
 open type, **VII-10**, 300  
 spot sizes, **VI-10**, 298
- Foot-candles, commercial interiors, **III-3A**, 60  
 floodlighting, **V-10**, 295  
 industrial interiors, **III-3B**, 62-67
- Formula method, coefficients, **XIV-13**, 406
- Glass blocks, transmission factors for, **IV-9**, 272
- Illuminants, color temperature of, **I-6**, 127



- Illumination, increases by maintenance, **III-12A**, 351  
     maintenance of, **I-12**, 350  
     theater, **IV-11**, 345  
 Illumination values, **XI-8**, 250  
 Lamps, bipost base, **IV-6B**, 134  
     characteristics of floodlighting, **III-10**, 291  
     characteristics of fluorescent, **IX-6**, 149  
     dirt, **III-12B**, 352  
     energy distribution, **X-6A**, 151  
         daylight fluorescent, **X-6B**, 152  
     gaseous conduction, **V-6B**, 140  
     germicidal, **VIII-6**, 146  
     illumination from Cooper-Hewitt, **VI-6B**, 141  
     incandescent performance on low voltage, **II-6**, 129  
     inside mirrored, **IV-6A**, 130  
     low-pressure mercury vapor, **V-6A**, 138  
     lumen output, **III-6A**, 130  
         for miscellaneous service, **III-6B**, 131  
     mercury, **VII-6A**, 142  
         spectral characteristics of, **VII-6B**, 143  
 Light box, brightness, **X-8**, 248  
 Lighting units, mounting heights, **II-8**, 225  
 Louver, brightness, **VIII-8**, 244  
 Louvered reflectors, efficiencies of, **VII-8**, 242  
 Luminaires, types of, **II-7**, 164  
 Luminous elements, brightness values,  
     exterior, **I-9**, 258  
     interior, **II-9**, 258  
 Maintenance, **II-12**, 350  
 Motor branch-circuit protective device rating, **X-13A**, **B**, 396  
 Motors, amperes, d-c., **III-13**, 382  
 Motors — *Continued*  
     single-phase, a-c., **IV-13**, 383  
     three-phase, a-c., **VI-13**, 385  
     two-phase, a-c., **V-13**, 384  
     conductor sizes, **IX-13**, 392  
     overcurrent protection, **IX-13**, 392  
 Mounting height, light center, **V-8**, 238  
 Outlets, spacing of, **I-8**, 224  
 Point-by-point tables, **I-5A**, **B**, 98-100  
 Power factors, **VII-13**, 386  
 Reflection factors, **IV-7**, 193  
     for typical opaque materials, **I-7B**, 162  
 Reflectors, aluminum elliptical, efficiencies, **VI-8**, 242  
 Replacement, study, **II-12**, 350  
 Room index, **III-7**, 190  
 Scepticons, image size, **III-11B**, 344  
 Service entrance, adequacy standards, **XIX-13**, 422  
 Slide projector, image size, **III-11A**, 344  
 Sources, ultra-violet, **I-11**, 340  
 Store front, average brightness values, **V-9**, 278  
 Symbols, for architectural plans, **XX-13**, 424  
 Translucent materials, transmission factors, **I-7A**, 161  
 Utilization, coefficients of, **VI-7**, 210-213  
 Utilization factors, **VI-7**, 208  
 Voltage drop, allowable maximum, **XIII-13**, 405  
 Voltage, effect on lamp performance, **V-12**, 356  
 Wire, size required, **XVII-13**, 413  
 Zonal factors, 5° zones, **II-5A**, 104  
     10° zones, **II-5B**, 105

## SUBJECT INDEX

- Absorption, 158
- Accidents, 374
- Acid, benzoic, 342
- Acuity, visual, 53
- Adequacy, standards of, 422
- Advertisement, 257, 282
- Air-conditioning, 44, 230, 274, 418
- Alabaster, 157, 260
- Aluminum, 259
  - oxidized, 322
- Amplifier, 367
- Angle of incidence, 162
- Applications, special, 174
  - artificial daylight, 185
  - color matching, 185
  - color modifying, 185
  - display cases, 175, 177
  - industrial, 180
  - interior, 177
  - show-window, 175
- Argon, 142
- Atmosphere, 9
- Automobile driving, 43
  
- Balance, 10
  - photometric, 35
- Ballrooms, 338
- Band stands, 315
- Bases, 130
  - bipost, 134
- Black, 76
- Black body, 127
- Blinking, 53, 54, 370
- Blue, 77
- Body, non-reflecting, 42
- Boxes, light, 245
- Branch circuit, 382
  - appliance, 409, 411
  - lighting, 409, 411
  - motor, 410
    - conductors, 392
    - fuse protection, 410
    - wire size, 410
  - schedule, 423
- Brightness, 23, 47, 83, 95, 97, 170, 248, 264
  - apparent, 42
  - contrast, 36, 42, 43, 47, 48, 88, 194, 257
  - graduate, 262
  - limits, 217
  - louvers, 243, 244
  - luminous architectural elements, 257, 264, 278
  - measuring, 34
  - meter, 35
  - ratio, 48
  - values, luminous elements, 258
- Brilliance, 70, 71, 83
- British standard specifications, 40
- Bronze, 78
- Building wiring, 384
- Bulb, 165
  
- Candle, 20
  - international, 19
- Candlepower, 19
  - apparent, 22
  - distribution curve, 103, 192
  - hemispherical, 20
  - mean horizontal, 20
  - spherical, 20, 22
  - zonal, 20
- Ceilings, 195
- Cellophane, 261, 321, 329, 342
- Cells, barrier-layer, 29
  - fatigue, 33
  - multiplying factors, 30, 31
  - response curves, 29
- copper oxide, 30
  - response curves, 30
- photoelectric, 367, 368, 370
  - installation, 368
  - location, 370
  - selenium, 30
- Chattering, 370
- Chemicals, colored light, 72
- Chroma, 71

- Chromaffectors, 329  
 Chromaticity, 152  
 Clear glass, 157  
 Cocktail bars, 311  
 Code, 373, 374  
   local, 422  
   National Electrical, 373, 374, 387, 391, 422  
   state, 422  
 Coefficients, correction, power factor, 407, 408  
   trichromatic, 86, 87  
   tristimulus, 72  
   utilization, 188, 195, 208, 213  
     fluorescent lamp, 364  
 Coffers, 262  
   novelty lighting, 313  
 Color, 70, 282, 311, 317, 321, 326  
   dominant, 83  
   luminous elements, 259  
   mobile, 282, 306, 323  
   novelty lighting, 317  
   selective distribution, 246  
 Color blindness, 78  
 Color contrast, 75, 77  
 Color coordination with music, 325  
 Color matching, 75, 185  
 Color media, 73, 343  
 Color mixing, 74, 318  
   cycle system, 306  
   wash system, 306  
 Color modifying, 185  
 Color nomenclature, 71  
 Color physiology, 75  
 Color psychology, 75  
 Color sensation, 75  
 Color specification, International Commission, 87  
 Color temperature, 30, 127, 128  
 Colorama, 326, 327  
 Columns, 262, 277, 283, 335, 336, 337  
 Combination units, coefficients of utilization, 207  
 Comfort, 9, 43  
 Composition, 9  
 Concealing louvers, 236, 237  
 Conduction, 151  
 Conductors, motor branch circuits, 392  
   properties, 390  
   service, 421  
 Conduit, number conductor, 398, 399, 400, 401, 402, 403, 404  
   selection of size, 391  
 Contrast, brightness, 36, 42, 43, 47, 48, 88, 194, 257  
   color, 75, 77  
   sensitivity, 53, 54  
 Control, automatic, 367  
   equipment, 368  
   several rooms, 371  
   traffic, 77  
 Convection, 151  
 Coordinates, Cartesian, 90  
   rectangular, 46  
   semi-logarithmic, 46  
 Copper, requirements, 380  
 Cost, comparative lamp, 366  
   of light, 356, 359, 360  
 Current, calculations of, 381  
   direct, 382  
   motor, direct-current, 382  
   single-phase, 383  
   three-phase, 385  
   two-phase, 384  
 Current systems, 382  
 Curves, characteristic, 90  
   distribution, 90, 103, 172  
   candlepower, 103, 192  
   direct, 207  
   equipment, 219  
   fluorescent lamp, 150  
   horizontal, 90  
   indirect, 207  
   lumen, 110  
   polar, 103  
   theoretical, 106  
   vertical, 91  
   isocandle, 90, 110  
   isofoot-candle, 90  
   luminosity, 126  
   performance, lamps, 354  
   response, barrier-layer cell, 29  
     copper-oxide, 30  
     eye, 16  
     visibility, 30  
     visual, 16  
   spectral, 79, 83  
     energy, 128  
 Cutout, 329  
   patterns, 332

- Daylight**, 39  
     **artificial**, 185  
**Daylight survey**, 38  
**Decoration, interior**, 274  
**Demand factor**, 399, 414, 415, 416  
**Depreciation**, 349  
     **luminaire**, 351, 352  
**Design factors, cove lighting**, 234  
**Design, floodlighting**, 294, 303, 307  
     of luminous elements, 257, 261, 263  
     **pressed**, 260  
     **reflector**, 257, 286  
**Diagram, vector**, 387  
**Dimmers**, 318  
     **autotransformer**, 325  
     **reactor**, 325  
     **resistance**, 323  
**Dirt**, 172  
**Display cases**, 175  
**Distribution**, 11, 12, 217  
     **center**, 376  
     **cosine**, 106  
     **lateral**, 378  
     **light**, 246  
         **solid of**, 91  
         **symmetrical**, 92  
     **panel**, 377  
     **selective color**, 246  
     **sine**, 106  
     **three-phase, four-wire**, 380  
     **three-phase, three-wire**, 380  
     **three-wire**, 379  
     **two-wire**, 379  
     **uniform**, 106  
**Distribution system**, 374, 379  
**Drafting room**, 88  
**Drawing symbols**, 424  
**Drying, industrial**, 124  
     **infra-red**, 83  
     **lamps**, 135  
**Dyes, aniline**, 339  
  
**Economics**, 349, 354  
     **fluorescent lamp**, 363  
     **wiring**, 405  
**Effectiveness**, 124  
     **control**, 43  
     **illumination**, 46  
     **lighting system**, 43  
**Efficiency, floodlighting**, 301  
  
**Efficiency** — *Continued*  
     **lamp**, 123  
         **luminous**, 124, 245, 256  
**Elements, luminous, architectural**, 5,  
     244, 245, 256, 259, 273, 332, 335  
     **brightness**, 257, 258, 264, 278  
     **cavity**, 261  
     **design**, 257, 261, 263  
     **directive**, 315  
     **efficiency**, 264  
     **forms**, 266  
     **lamp and element spacing**, 262  
     **novelty lighting**, 313  
     **special**, 270  
**Elevators**, 418, 420  
**Energy, radiant**, 15, 151  
     **rate**, 360, 365  
     **spectral**, 128  
**Environment**, 77  
**Equipment, automatic control**, 368  
     **characteristics**, 220, 223  
     **cycle**, 329  
     **direct transmitting**, 247  
     **efficiency**, 217  
     **floodlighting**, 282, 343  
     **number of units**, 224  
     **selection**, 216, 219  
**Expositions**, 311  
**Exposure time**, 42, 43  
**Eye**, 5, 15, 45, 58  
     **accommodation**, 45  
     **adaptation**, 45  
     **age**, 45, 46  
     **comfort**, 57  
     **convergence**, 45  
     **dark-adapted**, 16  
     **defects**, 46  
     **fatigue**, 49, 88  
     **lens**, 45  
     **light-adapted**, 16  
     **response curves**, 16  
     **retina**, 45  
  
**Factor, absorption**, 158  
     **maintenance**, 217, 349  
     **reflection**, 32, 48, 94, 158, 193, 265  
     **utilization**, 169, 188, 192, 195, 196,  
         204, 228, 244, 264, 307  
     **variation**, 188  
     **visibility**, 17

- Fatigue, cell, 33  
   eye, 49, 88  
 Feeders, capacity, 416  
   combination, 420, 421  
   lighting, 414, 418  
   power, 417, 418  
 Filament, 131  
   coil-coil, 130  
 Filters, 72, 340  
   additive, 74  
   subtractive, 74  
 Fires, 374  
 Fixtures, 11  
 Fleurets, 323  
 Flexibility, 8, 11, 13  
 Floodlighting, 282, 343  
   design, 294, 303, 307  
   design table, 300  
   equipment characteristics, 285  
   lamps, 291  
   large building, 283  
   location, 284  
   maintenance factor, 301  
   power, 307  
   projector location, 283  
   recommended foot-candles, 294  
   small building, 283  
   total beam lumens, 286  
 Floodlighting equipment, angle of tilt,  
   296  
   beam divergence, 287  
   beam lumens, 287  
   beam pattern, 303  
   beam spread, 286  
   broad beam, 292  
   contour shape, 286  
   cover glass, 287  
   efficiency, 301  
   enclosed, 291  
   focusing mechanism, 290  
   forms, 308  
   maintenance factor, 301  
   medium beam, 292  
   mounting, 302  
   narrow beam, 291, 292  
   open type, 108, 286, 291  
   projector, 291  
   reflector designs, 286  
   spill light control, 288  
 Fluorescence, 338  
 Fluting, 321  
 Flux, downward, 22  
   luminous, 15, 16, 17, 21  
   method, 263  
   radiant, 15  
   total, 22  
   upward, 22  
 Foils, 320  
   crushed, 322  
 Foot-candle, 22, 264  
   in floodlighting, 294  
   prescriptions, 58  
   recommendations, commercial, 60-61  
   industrial, 62-68  
 Foot-Lambert, 23  
 Forms, floodlighting design, 308  
   illuminating design, 252  
   luminous element, 266  
   design, 280  
 Fountains, 342  
   cone spray, 343  
   solid jet, 342  
   straight-line jet, 342  
 Functions, trigonometric, 27, 428  
 Geological specimens, 339  
 Geometric forms, 322  
 Glare, 49, 95, 169, 170, 257, 274, 290  
   direct, 43, 50, 217, 258  
   indirect, 43  
   influenced by, 49  
   reflected, 43, 50, 51, 217, 259  
 Glass, alabaster, 157  
   antique, 157  
   blocks, 256, 271, 318, 319, 346  
   daylight transmission, 275  
   night effects, 275  
   transmission factor, 273  
   cane, 331  
   cased, 157  
   clear, 157  
   configurated, 157, 319  
   crystal, 157  
   decorated, 157  
   enameled, 157  
   flint, 157  
   matte surface, 157  
   opal, 157  
   opalescent, 157  
   plate, strips, 330

- Glass** — *Continued*  
 prism, 163  
 prismatic, 157, 158  
 ribbed, 163  
 tempered, 279  
 translucent, 346
- Globes, 165, 322
- Gold, 77
- Gray, 76
- Green, 77
- Grill, 335
- Grill work, 260
- Group replacement, 353, 354, 362
- Harmony, 10
- Heart action, 53, 55
- High bay, 168
- Hue, 70, 71, 83
- Human element, in lighting, 2  
 needs, 5
- Icosahedron, 323
- Illuminating Engineering Society, 15,  
 40, 45
- Illumination, 14  
 automatic control, 367  
 average, 228  
 benefits of increased, 56  
 controlled, 371  
 diffused, 164  
 effectiveness, 46  
 horizontal, 25, 191  
 maintenance, 350  
 multidirectional, 164  
 objective specification, 15  
 physiology, 41, 52  
 quantity, 44  
 specification (theater), 345  
 unidirectional, 164  
 vertical, 25
- Index, author, 429  
 table, 431
- Industry Committee on Interior Wiring  
 Design, 422, 426
- Infra-red, 18  
 drying, 83
- Installations, industrial, 418
- Intensity, luminous, 19, 23, 90
- Interiors, commercial, 410  
 industrial, 410
- International Commission on Illumi-  
 nation, 78  
 color specification, 87
- Kaleidoscope, 317
- Lamp, 165  
 characteristics, 129, 355  
 comparative cost, 366  
 comparison, 20  
 drying, 135  
 efficiency, 123  
 floodlighting, 291  
 fluorescent, 73, 137, 146, 277, 321, 344  
 distribution curve, 150  
 gaseous, 123, 137  
 group replacement, 353, 354, 362  
 hours, 361  
 improvement, 357  
 incandescent, 123, 128, 132, 165  
 life, 135  
 Linneback, 329  
 lumiline, 132, 277, 321  
 mercury arc, 144  
 mercury, high-intensity, 137, 138, 140,  
 224  
 low-pressure, 137, 138, 140, 224  
 neon, 137, 145  
 performance curves, 354  
 portable, 164  
 projector, 133  
 sales, 357  
 silver bowl, 132  
 size, 228  
 sodium, 137, 145  
 special, 129  
 sterilizing, 124, 146  
 sun, 124  
 test, 20  
 Type-G, 145  
 Type-H, 140, 142, 144  
 Type-S, 145  
 ultra-violet, 124, 145  
 voltage, 358  
 voltage rating, 129
- Latticed effect, 270
- Law(s), cosine, 24, 107  
 geometric, 46  
 inverse square, 24, 97  
 Lambert's, 24  
 Weber and Fechner, 36

- Layouts, wiring, 423  
 Lens, control, 246  
     fresnel, 163  
     prismatic, 167, 231  
 Light, black, 338  
     cold, 123, 338  
     cost of, 356, 359, 360  
     direct, 49, 165  
     distribution curves, 90  
     distribution of, 92, 246  
         asymmetrical, 92  
     efficient production, 359  
     indirect, 47, 49, 86, 92, 170, 277  
     monochromatic, 31  
     polarized, 183, 341  
     reflected, 335  
     sources, 11, 123  
     spill, 314  
         control in floodlighting, 288  
         transmitted, 335  
 Lighting, artificial, 7  
     source, 12  
     branch circuit, 409, 411  
     cove, 230, 261  
         average foot-candle, typical room, 233  
         design, 230  
         design factors, 234  
         novelty, 313  
         recessed, 233  
     equipment test, 92  
     feeders, 414, 418  
     fixtures, 164  
     garden, 338  
     general, 172  
     general diffusing, 169  
     natural, 7, 10  
     novelty, coffers, 313  
         color, 317  
         cove, 313  
         luminous elements, 313  
         materials, 343  
         schemes, 311  
     semi-direct, 168  
     semi-indirect, 88, 92  
     supplementary, 168, 172  
     survey, 37  
     uniform, 52  
 Load center, 375, 376  
 Louver, 167, 234  
 Louver — *Continued*  
     application, 239  
     brightness, 243, 244  
     concentric, 237  
     design, 235  
     efficiency, 243  
     equipment, 235  
     finish, 243  
     general concealing, 237  
     in architectural elements, 240  
     in columns, 240  
     in pilasters, 240  
     recessed, 239  
     shape, 241  
     source, concealing, 236  
     with coves, 239  
 Lumen, 22, 216, 228  
     distribution curve, 110  
     distribution diagram, 111, 115  
         horizontal, 119  
         vertical, 119  
     effective, 110, 115  
     floodlighting, 286  
     method, 26  
 Luminaire, 90, 163, 164  
     depreciation, 351, 352  
     direct, 163  
     general diffusing, 163  
     indirect, 163  
     semi-direct, 163  
     semi-indirect, 163  
 Luminescence, 338  
 Luminescent mixtures, 338  
 Lux, 216  
  
 Maintenance, 217, 349  
     illumination, 350  
 Marble, 260  
 Materials, opaque, 157  
     phosphorescent, 339  
     translucent, 157, 259  
     transparent, 157, 259  
 Medallions, 316  
 Merchandising, 207  
 Metal, corrugated, 274, 319  
     monel, 259  
 Meter, foot-candle, 27  
     barrier-layer, 29  
     General Electric, 29  
     use, 33

- Meter — Continued**  
 Weston, 28  
 visibility, 36
- Micron, 18**
- Mirrors, 315, 317**
- Monuments, 283**
- Mosaics, 332, 334**
- Mounting height, 49**
- Murals, 316**
- Mushrooms, 335, 337, 338**
- Music, 325**  
 color coordination, 325
- National Electrical Code, 373, 374, 387, 391, 422**  
 Handbook, 422, 426
- Natural lighting, 7, 10**
- Nela Park, 40**
- Neon, 145**
- Niche, 262, 315, 316**
- Night clubs, 311**
- Nomenclature, 15**  
 color, 71  
 photometric, 90
- Object, 13, 43, 47**  
 under colored light, 72
- Oculist, 44**
- Offices, 170**
- Onyx, 260**
- Optometrist, 44**
- Orange, 76**
- Outlets, convenience, 412**  
 mounting, 224  
 number, 224  
 spacing, 224
- Paints, 194**  
 luminescent, 338
- Panels, luminous, 261**
- Phosphor, 147**
- Photography, natural color, 80, 328**  
 profile, 332
- Photometer, physical, 29**
- Photometry, 5, 19**
- Physical phenomena, analysis, 18**
- Physiology, 41**  
 color, 75  
 effects of illumination, 52
- Pictures, 315**
- Pilaster, 260, 262, 335, 336**
- Plastics, 320**
- Plates, prismatic, 116, 245**
- Point-by-point method, 26, 97, 116, 216, 244**
- Polaroid, 341**
- Power factor, 137, 145, 363, 382**  
 correction coefficients, 407, 408  
 lagging, 148  
 loads, 386
- Prism, 163**
- Productive task, 43**
- Projection pattern, 328, 329**
- Projectors, 108**  
 floodlighting, 291  
 lantern slide, 344  
 location for floodlighting, 283  
 narrow beam, 92
- Protective devices, setting, 396, 397**
- Psychology, 41**  
 color, 75  
 effect of illumination, 52
- Pumping, 418**
- Purity, 83**
- Pylons, 262, 335, 336**
- Pyrex, 331**
- Quartz, 331**
- Radiation, non-visible, 18**
- Radiator, complete, 127**
- Recess, 261, 262**
- Red, 76**
- Reflection, 37, 158**  
 diffused, 159  
 perfectly, 159  
 selective, 72, 158  
 specular, 322
- Reflection factor, 32, 48, 94, 158, 193, 265**
- Reflector, 164, 231, 314, 321**  
 aluminum, 321, 340  
 asymmetric 92  
 source, 116  
 contour, 264  
 control, 245  
 corrugated metal, 321  
 design, 257, 286  
 elliptical, 241  
 louvers, 277  
 parabolic, 241, 246, 303



- Reflector — *Continued*  
   paracyl, 274  
   show-window, 116, 117, 274  
   specular, 322  
   spherical, 241, 245  
 Refractor, 165  
 Relamping, 353  
 Relay, 367  
 Research, 6  
 Reserve, convergence, 53, 54  
 Responsibility, development of lighting design, 1  
   for illumination design, 1  
   of architect, 3, 4, 6, 11  
   of interior decorator, 4  
   of medical profession, 4  
 Restaurants, 311  
 Riser, 378  
 Rods, plastic, 321  
 Room index, 188, 228  
  
 Saturation, 70, 71, 83  
 Schedule, branch circuit, 423  
   panel board, 423  
   power system, 423  
 School rooms, 170  
 Sciopticons, 344  
 Seeing, 42  
   criteria, 53  
   factors influencing, 42  
 Sensitivity to contrast, 53, 54  
 Setback, 332  
   construction, 303  
 Shade, 75, 165  
 Shadoscreen, 332  
 Shadow, 37, 40, 52, 88, 164, 274, 311, 326, 331  
   graphs, 332  
   harsh, 231  
 Show-windows, 175  
   reflectors, 116, 117, 274  
 Signs, silhouette, 317, 332  
 Silhouette, 331, 332  
 Silhouette effects, 316  
 Size, 42  
   visual, 42  
 Smashing point, 362  
 Solid of light distribution, 91  
 Sources, 11, 123  
   artificial lighting, 12  
   Sources — *Continued*  
     asymmetric reflector, 116  
     development, 124  
     fluorescent, 78  
     large surface, 106  
     point, 20  
     radiant, 124  
     ultra-violet, 18, 338  
   Specifications, lighting equipment test, 92  
   Spectra, continuous, 30  
   Spectrum, 15, 75  
     radiant, 15, 126  
     visual region, 15  
   Specular effect, 321  
   Spill-ring, 239, 289  
   Spotlights, baby, 338  
   Standards, photometric, 15  
     primary, 19  
     secondary, 20  
     working, 20  
   Statuary, 283  
   Steel, enameled, 259  
     stainless, 259  
     brushed, 322  
   Stencils, 329  
   Sterilizing, 18  
   Store fronts, luminous, 279  
   Stroboscopic effect, 137, 145, 148  
   Sun, 12  
   Surfaces, diffusing, 158  
     redirecting, 158  
     scattering, 158  
     study, 51  
     work, 43, 47  
   Survey, 37  
     daylight, 38  
     lighting, 37  
     night, 38  
   Switch, magnetic, 148  
     thermal, 148  
   Symbols, 424  
  
   Temperature, ambient, 143  
     color, 30, 127, 128  
   Tension, muscular, 53, 54  
   Theaters, 311  
     illumination specifications, 345  
   Thermometer, 27  
   Third dimension, 70

- Thyratrons, 325  
Timer, thermal, 367  
Tints, 75  
Towers, 277  
Tradition, 11  
Transmission, 158  
    cover glass, 264  
    daylight, with glass blocks, 275  
    diffused factor, 161  
    direct, 160  
    factor, 34, 158  
    regular, 160  
Transmitting equipment, 247  
Transmitting systems, 234, 244, 247  
Trigonometry, 427  
Troughs, shaped, 320  
  
Ultra-violet, 18, 338  
Unity, 10  
Utilization, coefficient of, 188, 195, 208,  
    213  
Variation range, 188
- Vector diagram, 387  
Ventilation, 418  
Visibility, 9, 47  
Vision, 42  
Voltage, drop, 377, 406  
    variation, 391  
  
Walls, 195  
Water effects, 342  
Watts-per-square-foot method, 249  
Wave, dominant, 72  
Wheels, 317  
White, 76  
Wire, current-carrying capacity, 388  
    size, 387  
    size adequacy, 391  
Wiring, 362, 373  
    building, 384  
    economics, 405  
    layouts, 423  
  
Yellow, 77



