

Birla Central Library

PILANI (Rajasthan)

Class No :- 621.384

Book No :- P476R v.2

Accession No :- 31526

CLIMATREATED*

TRANSFORMER PRODUCTS

FOR

AMPLIFIERS & OTHER

ELECTRONIC EQUIPMENT



By

TRANSFORMER CORPORATION OF INDIA

Phone :- { 42497
41253

RAWAL BUILDING,
LAMINGTON ROAD,
BOMBAY 4

Grams
TRUETOLIFE

* Copyright of TCI

HOME FOR RELIABLE RADIO ACCESSORIES

- * **PRECISION** Soldering irons—Standard and De-Lux types, Handy & durable.
- * **PHONO PLUGS** suitable for RCA Radios.
- * **Finest Quality AERIAL WIRES**, available in 100 ft lengths.
- * **75 Watts 700 Ohms POWER RESISTORS**, adjustable type.
- * **MICROPHONE CONNECTORS** similar to Amphenol types PCIM and MCIF
- * **HOOK UP WIRES**, Stranded and Single, Cotton cover.

For Prices and details write to

PRECISION MANUFACTURING CO.

NEW QUEEN'S ROAD,

BOMBAY 4

RADIO REFERENCE MANUAL

VOL. 2

BY

R. K. PHATAK

L.E. (Elec. & Mech.), A.M.I.R.E.

*Consulting Radio Engineer; Author, Radio For The Millions,
Radio Reference Manual Vol. I; Editor, Radio Services
Magazine; Editor, Vyawaharik Dnyankosh; Partner,
The Radio Services, Bombay*



SIGMA RADIO PUBLICATIONS

417, LAMINGTON ROAD, BOMBAY 4

INDIA

1944

SECOND EDITION

(Revised and Enlarged)

1944

PREFATORY NOTE

This is the second, revised and enlarged edition of this book. In Section II of this book, further data on volume controls has been added, and, with due regard to the requests of friends and various readers, an entirely new section on Logarithms is introduced. The introduction of this new section will undoubtedly facilitate the study of gain calculations.

Bombay,
4th December 1944.

S. R. P.

Printed by R. R. Bakhale at the Bombay Vaibhav Press, Servants of India Society's Building, Sandhurst Road, Bombay. 4, and Published by Mrs. Sarojini Phatak for Sigma Radio Publications, 417, Lamington Road, BOMBAY 4.

AUTHOR'S FOREWORD

(FIRST EDITION)

This volume covers the reference data for such components, of a radio receiver, as are left out from the first volume. The arrangement of the subject matter of this book is just on the same lines as of volume one, and the treatment of the subject being on the 'Component Basis.' Besides the sections on components, two important sections dealing with Testing Instruments and Decibels have been purposely added to the text. In day to day servicing, the testing gear forms an important item in a radio workshop, and as such, the addition of information on the care, maintenance and use of meters will fully acquaint the reader with the intricacies of such instruments, whereas the section on decibels, along with the relative tabulated data, will be useful in many ways.

It is hoped that the subject matter treated with such brevity and without any intricate theoretical discussion will appeal to those who have needed a reference book of this type. To make the book a pure and simple reference work, the extensive theoretical treatment had to be purposely avoided, but, where absolutely essential a very concise resume of some portion of the theory is included.

In writing these two volumes, the author's aim has been to render some sort of help to the service engineer when he is actually confronted with some service problem, the solution for which can be gleaned through the theoretical portion of radio engineering. As a result, it is hoped that despite the necessary limitations of space, this book with its companion volume will provide a complete reference aid to the service engineer, and present a concise resume of modern radio engineering as required in a service workshop.

Bombay,
14-9-1942.

R. K. PHATAK

TABLE OF CONTENTS

<i>Section</i>	<i>Page</i>
<p>I RESISTORS </p> <p style="padding-left: 40px;">Types—Wire wound Resistors—Metalised Resistors—Carbon Resistors—Resistors in Series—Resistors In Parallel—Resistor & Condenser In Series—Resistor & Condenser In Parallel—Power Ratings of Resistors—Current Ratings of Standard Resistors—RMA Standard Colour Code—Tolerance Values—Odd Value Resistors—Moulded Resistances—Flexible Resistors—Common Values of Resistors In Colour Code—Philco Colour Code—Voltage Divider Resistors—Design of Voltage Dividers—Bias Resistors—Bias Resistor In Phase Inverter Circuit—Peculiar Fault In Bias Circuits—Filament or Heater Resistor—Different Current Ratings Heaters In Series—Resistance Wire tables—Common Values of Resistors In Different Stages.</p>	<p>1</p>
<p>II VOLUME CONTROLS AND TONE CONTROLS</p> <p style="padding-left: 40px;">General Discussion—Replacement of Volume Control—Volume Control And Tone Control Values In Different Continental and British Sets—Volume Control And Tone Control In Philips And Mullard Receivers.</p>	<p>29</p>
<p>III VALVES </p> <p style="padding-left: 40px;">Amplification Factor—Plate Resistance—Mutual Conductance—Valve Characteristics—Valve Equivalents—2 Volt Battery Valves—4 Volt A. C. Mains Valves—Universal AC/DC Valves—Rectifiers—Marconi Osram American Equivalents—Philips American Equivalents—Nomenclature of Philips Valves—Valve Conversion Factors—American Valve Types—Rectifiers—Rectifier Doublers—Tuning Indicators—Converters And Mixers—Power Amplifiers—Voltage Amplifiers, Detectors, Oscillators—</p>	<p>39</p>

<i>Section</i>	<i>Page</i>
Diode Detectors—Diode Detectors with Amplifiers— Junior Bantams—Acorn Tubes.	
IV DECIBEL 	62
General Discussion—Power Output In Watts— Decibel Gain—Gain of Amplifiers—Decibel Rela- tionships—Decibels Expressed As Power And Voltage Ratios—Power And Voltage Ratios Expressed As Decibels—Decibels Above And Below Reference Level.	
V COILS 	77
Units of Inductance—Inductances In Series— Inductances in Parallel—Inductive Reactance— Inductance of a Coil (air core)—Inductance of a Coil (magnetic core)—Resonant Frequency—LC Values For Different Frequencies—Q of the Coil— Oscillator Coils—Oscillator Coil Repairs—Oscillator Coils with Universal Winding—Universal Adjustable Inductance Coils—R. F. Coils—Repairs To R. F. Coils—Antenna Coils—Repairs To Antenna Coils— Coils In Sections—Coil Shields—60 And 90 Metre Bands—Parallel Inductance Method—Parallel Capacity Method—Series Inductance Method— Series Capacity Method—Measurement of Induc- tance—Impedance Method—Comparison Method— Impedance Calculations—Circuit Having Resistance And Capacity—Circuit Having Resistance And Inductance—Circuit Having Resistance, Inductance And Capacity.	
VI SERVICE INSTRUMENTS 	103
Types—Moving Coil Meter—Moving Coil Volt- meters—Sensitivity of Voltmeter—Extending Volt- meters Ranges—Multiplier Resistors—Converting Milliammeters Into Voltmeters—Milliammeters And Microammeters—When Meter Resistance is Not Known—Meter Resistance Value _s —Meter Resis- tance—Half Deflection Method—Meter Polarity—	

<i>Sections</i>	<i>Page</i>
Ohmmeters—Zero of Ohmmeters—Calibration Formula For Series Type Ohmmeter—Calibration Formula For Shunt Type Ohmmeter—Any Meter As Ohmmeter—Voltmeter As Ohmmeter—Zero Adjuster—Components of A Moving Coil Meter—Coils—Magnets—Pivots—Jewels—Pointers—Springs—Counterweights—A. C. Measurements—Electronic D. C. Voltmeters—Repairs To Meters—Mechanical Faults—Electrical Faults.	
VII VIBRATORS	130
General—Energising The Vibrator—Types of Vibrators—Buffer Condenser—Vibrator Transformer—Vibrator Hush—Vibrator Repairs—Vibrator Filters—Vibrapacks.	
VIII DRIVER TRANSFORMERS	134
General—Half Secondary Ratio Formulæ For Finding Out Ratio.	
IX USE OF LOGARITHMS IN GAIN CALCULATIONS	136
Logarithms—Tables—Antilogarithms—Minus Decibels	

ALL RIGHTS RESERVED BY THE AUTHOR

No part of this book may be reproduced in any form without permission, in writing, from the author.

SECTION I

RESISTORS

TYPES

The resistors employed in radio receivers can be classified under the following three types, on the basis of the resistance element employed.

Wire Wound Resistors

In these resistors it will be invariably found that use is made of Nickel Chrome alloy in the form of a wire. In the fixed and semi-adjustable types the wire is usually wound around a ceramic tube, cylindrical in shape, and a protective coating is applied to insulate the entire assembly. The protective coating is generally a vitreous enamel of some kind or the other. Cement or varnish too is sometimes used by some manufacturers. It is said that the vitreous enamel coating is prepared from a mixture of about twenty to twenty-five different chemicals and minerals. Those places in a radio receiver where very high temperatures are encountered, these resistors best serve the purpose since they can be safely operated at very high temperatures. For example these resistors are best employed as bias resistances on power tubes and as voltage dividers. Extreme stability, dependability and permanance are the three most outstanding qualities of these resistors.

Metalised Resistors

A thin coating of metal or some resistive material on a glass or ceramic base goes to form resistors of this type. Due to the superior construction these resistors have fairly constant resistance value up to several hundred megacycles.

Carbon Resistors

These small-sized resistors are made by compressing carbon powder and some binding material together. Flexible pigtail wires are provided at both ends. The manufacturing cost of these resistors being very low they are extensively used in radio receiver circuits where high currents are not encountered.

RESISTORS IN SERIES

$$R_T = R_1 + R_2 + R_3 \dots\dots\dots R_N$$

where R_T = Effective value of all resistors connected in series

$R_1 R_2 R_3 \dots\dots R_N$ = Individual Resistors

RESISTORS IN PARALLEL

$$\frac{1}{R_T} = \frac{1}{R_1} + \frac{1}{R_2} + \frac{1}{R_3} \dots\dots\dots \frac{1}{R_N}$$

$$\text{or } R_T = \frac{1}{\frac{1}{R_1} + \frac{1}{R_2} + \frac{1}{R_3} \dots\dots\dots \frac{1}{R_N}}$$

Where R_T = Effective value of all resistors connected in parallel

$R_1 R_2 R_3 \dots\dots R_N$ = Individual Resistors

RESISTOR AND CONDENSER IN SERIES

The total impedance offered by such a combination is

$$Z = \sqrt{R^2 + X_c^2}$$

When the value of impedance and the value of either R or X_c is known the remaining unknown quantity can be found out by the use of the two formulæ given below :—

$$R = \sqrt{Z^2 - X_c^2} \quad \dots \quad \dots \quad \dots \quad (1)$$

$$X_c = \sqrt{Z^2 - R^2} \quad \dots \quad \dots \quad \dots \quad (2)$$

In any receiver, be it modern or old, such combinations of resistors and condensers are plenty. A very striking illustration will be that of a tone control which usually consists of a variable resistance and a condenser connected in series.

RESISTOR AND CONDENSER IN PARALLEL

The total impedance offered by such a combination is

$$Z = \frac{X_c R}{\sqrt{R^2 + X_c^2}}$$

When the value of impedance and the value of either R or X_c is known, the remaining unknown quantity can be found out by the use of the following two formulae.

$$R = \frac{Z X_c}{\sqrt{X_c^2 - Z^2}} \quad \dots \quad \dots \quad \dots \quad (1)$$

$$X_c = \frac{Z R}{\sqrt{R^2 - Z^2}} \quad \dots \quad \dots \quad \dots \quad (2)$$

The diode load resistance and the by-pass condenser across it or the bias resistor and its associated by-pass condenser are good illustrations of such combinations in modern radio receivers.

POWER RATING OF RESISTORS

Power rating of resistors is an important consideration and very careful attention must be paid to it. In many cases and mostly by the inexperienced servicemen, 'power rating' of a resistor is neglected beyond excuse. There have been cases where half a dozen 5 watt resistors are blown off by connecting them in circuits that demanded the use of 20 watt resistors.

The power rating of resistors can be easily calculated by the application of any of the four formulæ given below:—

$$W = I^2R \quad \dots \quad \dots \quad \dots \quad \dots \quad (1)$$

$$W = \frac{E^2}{R} \quad \dots \quad \dots \quad \dots \quad \dots \quad (2)$$

$$W = E \times I \quad \dots \quad \dots \quad \dots \quad \dots \quad (3)$$

Where W = Wattage rating in watts

E = Voltage drop in the resistor

R = Value of resistor in ohms

I = Amperes flowing through the resistor

When calculations are to be made on the basis of milliamperes flowing, the following formula becomes handy:

$$W = \frac{I^2R}{1,000,000} \quad \dots \quad \dots \quad \dots \quad (4)$$

Where I is in milliamperes

CURRENT RATINGS OF STANDARD RESISTORS

10 WATTS TYPE

Resistance (ohms)	Current (ma)	Resistance (ohms)	Current (ma)
5	1.41 Amp.	1000	100
10	1.00 Amp.	1500	82
15	817	2000	70
20	707	2500	63.4
25	634	3000	58
30	578	4000	50
50	448	5000	45
100	316	6000	41
200	224	7000	38
300	183	7500	37
400	158	8000	35.4
500	141	10,000	32
750	115		

25 WATTS TYPE

Resistance (ohms)	Current (ma)	Resistance (ohms)	Current (ma)
100	500	3000	91
200	354	4000	79
300	292	5000	71
400	250	6000	64.5
500	224	7000	59.8
750	183	8000	56
800	177	10,000	50
1000	158	12,000	46
1500	129	15,000	41
2000	112	20,000	35.4
2500	100	25,000	32

50 WATTS TYPE

Resistance (ohms)	Current (ma)	Resistance (ohms)	Current (ma)
100	707	6000	91
200	500	7000	85
300	408	7500	82
400	354	10,000	71
500	316	12,000	62
750	258	15,000	58
1000	224	20,000	50
1500	183	25,000	45
2000	158	30,000	41
3000	129	40,000	35.4
4000	112	50,000	32
5000	100		

75 WATTS TYPE

Resistance (ohms)	Current (ma)	Resistance (ohms)	Current (ma)
500	388	7500	100
750	316	10,000	88
1000	274	12,000	80
1500	224	15,000	71
2000	193	20,000	61
2500	172	25,000	55
3000	158	30,000	50
4000	137	40,000	44
5000	122	50,000	39
6000	112	60,000	36
7000	104	75,000	32

100 WATTS TYPE

Resistance (ohms)	Current (ma)	Resistance (ohms)	Current (ma)
100	1000	7500	115
150	815	10,000	100
250	631	15,000	81
500	447	20,000	70
750	365	25,000	63
1000	316	30,000	57
1500	258	40,000	50
2000	223	50,000	44
2500	200	75,000	23
5000	141	100,000	10

RMA STANDARD COLOUR CODE FOR RESISTORS

The radio manufacturers did not find it convenient and practical to indicate the ohmic value on the resistor itself and therefore devised a system of code based on different colours. The colour code so devised is confined to ten colours and figures, as follows :—

FIGURE	COLOUR	Tip	Spot	Body
0	Black			
1	Brown			
2	Red			
3	Orange			
4	Yellow			
5	Green			
6	Blue			
7	Violet			
8	Gray			
9	White			
		End Band	Centre Band	Body
				

FIG. 1

The Fig. 1 illustrates two methods that are adopted in colouring the resistors according to the code.

All servicemen must necessarily memorise this code so that they can identify the value of all such resistors practically at a glance. If one is weak at memorising things easily, it is suggested that he should remember the following name with all the supposed degrees coming after it.

B. B. ROY Esq. G. B. V. G. W.

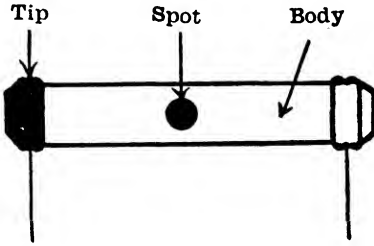
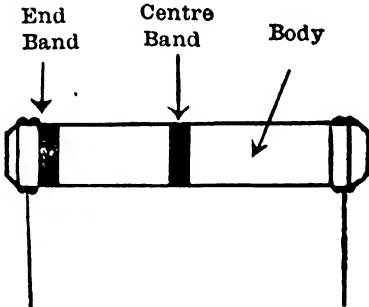
In this particular name, it is indicated that the ten letters B-B-R-O-Y-G-B-V-G-W stand for the different colours. The figures will be assigned in order beginning from B equals zero and so on.

TOLERANCE VALUES

The rated ohmic value of all commercial resistors is apt to vary within certain limits. The 10% and 20% limit is very common. If a resistor of 10,000 ohms has $\pm 10\%$ tolerance, it means that the ohmic value will vary from 9000 to 11,000 ohms. The problem of coding resistors of the same ohmic value but of different tolerances is solved by using the next higher coded value for the resistor with larger tolerance. This means that in order to distinguish the wide tolerance resistors from the lower tolerance resistors, the second figure is increased by one in the wide limit ones. For example if the nominal value of two resistors is 100,000 ohms, the resistor with 10% tolerance will be coded as 100,000 ohms and the one with wide limit of 20% tolerance will be coded as 110,000 ohms. (Note that the second digit is increased by one).

ODD-VALUE RESISTORS

Ohmic value such as 1200, 27,000 etc. are not very uncommon in radio receivers of to-day. For such odd-value resistors there is a different method of coding. Three colour dots and bands are used and are read consecutively the same as the body, end and dot colours on regular carbon resistances. For example if the bands are red followed by violet and orange the resistance will be 27,000 ohms.

MOULDED RESISTORS

One often comes across moulded type of resistors that more or less look like mica condensers. These resistors are

normally black carrying three coloured dots. The dot colours are consecutively read as illustrated by an example above.

FLEXIBLE RESISTORS

Flexible fabric-covered wire-wound resistors are also coded the same way as carbon resistors. Some have colours woven into the fabric itself. The smallest thread colour is read as dot, the larger thread grouping as the end and the body colour as usual.

COMMON VALUES OF RESISTORS IN R. M. A. COLOUR CODE

Resistance in ohms	Body colour	Tip or end colour	Dot colour
50	Green	Black	Black
75	Violet	Green	Black
100	Brown	Black	Brown
150	Brown	Green	Brown
200	Red	Black	Brown
250	Red	Green	Brown
300	Orange	Black	Brown
350	Orange	Green	Brown
400	Yellow	Black	Brown
450	Yellow	Green	Brown
500	Green	Black	Brown
600	Blue	Black	Brown
750	Violet	Green	Brown
1,000	Brown	Black	Red
1,500	Brown	Green	Red

Resistance in ohms	Body colour	Tip or end colour	Dot colour
2,000	Red	Black	Red
2,500	Red	Green	Red
3,000	Orange	Black	Red
3,500	Orange	Green	Red
4,000	Yellow	Black	Red
4,500	Yellow	Green	Red
5,000	Green	Black	Red
6,000	Blue	Black	Red
7,000	Violet	Black	Red
7,500	Violet	Green	Red
8,000	Grey	Black	Red
9,000	White	Black	Red
10,000	Brown	Black	Orange
12,000	Brown	Red	Orange
13,000	Brown	Orange	Orange
15,000	Brown	Green	Orange
17,000	Brown	Violet	Orange
18,000	Brown	Grey	Orange
19,000	Brown	White	Orange
20,000	Red	Black	Orange
22,000	Red	Red	Orange
25,000	Red	Green	Orange
27,000	Red	Violet	Orange
30,000	Orange	Black	Orange
35,000	Orange	Green	Orange
40,000	Yellow	Black	Orange
45,000	Yellow	Green	Orange
50,000	Green	Black	Orange
60,000	Blue	Black	Orange
70,000	Violet	Black	Orange

Resistance in ohms	Body colour	Tip or end colour	Dot colour
75,000	Violet	Green	Orange
80,000	Grey	Black	Orange
90,000	White	Black	Orange
100,000	Brown	Black	Yellow
120,000	Brown	Red	Yellow
150,000	Brown	Green	Yellow
200,000	Red	Black	Yellow
250,000	Red	Green	Yellow
300,000	Orange	Black	Yellow
350,000	Orange	Green	Yellow
400,000	Yellow	Black	Yellow
450,000	Yellow	Green	Yellow
500,000	Green	Black	Yellow
600,000	Blue	Black	Yellow
750,000	Violet	Green	Yellow
1 Meg.	Brown	Black	Green
1.5 Meg.	Brown	Green	Green
2 Meg.	Red	Black	Green
2.5 Meg.	Red	Green	Green
3 Meg.	Orange	Black	Green
4 Meg.	Yellow	Black	Green
5 Meg.	Green	Black	Green
6 Meg.	Blue	Black	Green
7 Meg.	Violet	Black	Green
8 Meg.	Grey	Black	Green
9 Meg.	White	Black	Green
10 Meg.	Brown	Black	Blue

PHILCO COLOUR CODE

The Philco Radio Factory uses an altogether different system of colour code, for convenience in the factory.

It must have been noticed that the part numbers for Philco fixed resistors consist of a prefix of two figures and a body of six figures. The prefix in almost all cases is number '33'. The first three figures of the body number refer to value of the resistance in ohms and correspond to standard RMA code.

The first figure of the body number indicates dot colour of the RMA colour code (number of zeros after the first two figures of resistance value).

The second figure indicates the body colour of the R.M.A. code i. e. the first figure of the resistance value.

The third figure of the body number indicates the tip colour of the RMA code i. e. the second figure of the resistance value.

The fourth figure indicates the wattage rating of the resistors based as follows :—

Figure	Watts
1	$\frac{1}{4}$
2	$\frac{1}{2}$
3	$\frac{1}{2}$
4	1
5	2
6	3

The fifth figure denotes the tolerance value and the sixth denotes the manufacturing code of the particular resistor.

Example :—A Philco resistor numbered 33-215343 is a 1500 ohm— $\frac{1}{2}$ watt type insulated resistor.

VOLTAGE DIVIDER RESISTORS

The output voltage of any rectifier varies in accordance with the load connected across it. With no load, the voltage may shoot up as high as the peak value of the secondary voltage. It, therefore, becomes obligatory that some means should be employed to check up this abnormal rise in voltage when there is no load.

One method will be to use filter condensers to withstand these high voltages, but this will involve great costs. As against this, an efficient and cheap method will be to use resistors for providing the minimum load when the tubes are removed and set turned on or when the load is removed due to some defect in the receiver.

Resistors when they are so connected are known as voltage dividers because they divide the available voltage according to the requirements of different circuits. Besides this, they give protection to the condensers against overloads and provide a certain degree of voltage regulation i.e. they maintain a fairly constant voltage with varying load. These voltage dividers are also known as 'Bleeders' or 'Bleeder Resistors' because they "bleed off" a constant value of current and regulate the power supply regardless of load variations. Good regulation is easily possible by using a larger bleeder current compared to variations in load current but since the bleeder current is nothing but a waste, it is not advisable to make it abnormally more. The usual practice is not to allow it to go more than 20 ma.

DESIGN OF VOLTAGE DIVIDERS

In the design of voltage divider resistors the first important point is to know the desired voltages and exact currents at each tap on the voltage divider. When current calculations are to be made, an important point that must be remembered is that current does not flow from the tap point through the resistor to ground or negative terminal but rather from the positive side, then through the tap then through the device to ground.

(1) Calculate the voltages required at each tap and determine the current to be drawn from it (Tube manuals may be referred).

(2) Determine the bleeder current. The determination of the value of bleeder current will be dependent upon the total milliamps drain of all the tubes and the total milliamps available from the power supply without any undue heating.

(3) Ascertain the current that will flow in each section of the voltage divider.

(4) Calculate the resistance of each section.

(5) Find out the power rating of the divider.

Example :—Design a four section voltage divider which shall give 300 volts at 30 ma. for plates of all tubes, 150 volts at 10 ma. for the screens of all the tubes and 75 volts at 2 ma for the detector tube. The divider is to be connected across a power supply of 350 volts at 62 ma.

On referring to Fig. 2 it will be clear that the different sections of the voltage divider are numbered as 1, 2, 3 and 4.

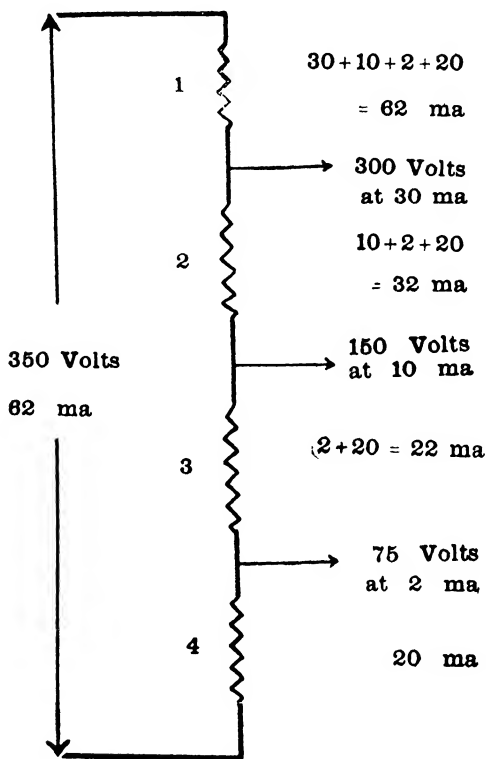

FIG. 2

SECTION 1

This section will have to be so designed as will safely allow a flow of 62 ma ($30 + 10 + 2 +$ bleeder current of 20 ma) and drop the voltage from 350 to 300 i.e. 50 volts drop.

$$\therefore \text{Resistance of section 1} = \frac{50}{.062} = 806 \text{ ohms}$$

SECTION 2

The 30 ma current that flows through section 1 will not flow through this section and therefore the current in this section will be only 32 ma (10+2+ 20) and the voltage is to be dropped down from 300 to 150 volts i.e. 150 volts drop.

$$\therefore \text{Resistance of section 2} = \frac{150}{.032} = 4687 \text{ ohms}$$

SECTION 3

The current that flows through this section is 2 ma plus the bleeder current of 20 ma i.e. a total of 22 ma. The voltage has to be dropped from 150 down to 75 volts i.e. 75 volts drop.

$$\therefore \text{Resistance of section 3} = \frac{75}{.022} = 3409 \text{ ohms}$$

SECTION 4

Through this section only the bleeder current of 20 ma flows and the voltage drop required in this section is 75 volts.

$$\therefore \text{Resistance of this section} = \frac{75}{.02} = 3750 \text{ ohms}$$

Adding the individual resistances of all the four sections, the total resistance of the voltage divider is

$$806 + 4687 + 3409 + 3750 = 12652 \text{ ohms}$$

The wattage rating of each section as also the entire divider can be computed as follows :—

WATTAGE RATING OF SEC. 1

$$E \times I = \text{Watts}$$

$$50 \times .062 = 3.1 \text{ Watts}$$

WATTAGE RATING OF SECTION 2

$$E \times I = W$$

$$150 \times .032 = 48 \text{ Watts}$$

WATTAGE RATING OF SECTION 3

$$E \times I = W$$

$$75 \times .022 = 1.65 \text{ Watts}$$

WATTAGE RATING OF SECTION 4

$$E \times I = W$$

$$75 \times .02 = 1.5 \text{ Watts}$$

If a single resistor, with three taps, is used as voltage divider, the wattage rating of such a resistor will be

$$\begin{aligned} &= I^2 R = (.062)^2 \times 12652 \\ &= 50 \text{ Watts approx.} \end{aligned}$$

If separate four resistances are to be employed to constitute the voltage divider the power rating of these four resistances should be

Section 1—3 Watts

Section 2—5 Watts

Section 3—2 Watts

Section 4—2 Watts

As against this, if the voltage divider is to be of uniform power rating utilizing one single tapped resistance then the largest current i. e. 62 ma has to be considered and the wattage rating must be considered on the basis of this maximum current. In the above case the maximum current that flows through some part of the resistor—section 1—is 62 ma therefore the power or wattage rating of such a single tapped resistance will be equal to 50 watts as shown above.

If a voltage divider is not used the rectifier output voltage will rise up to the peak value of the transformer secondary voltage and since this abnormal high voltage will get impressed upon the filter condensers there is a probability of the condensers getting damaged. Condensers with high voltage rating could be used to withstand this high voltage but the cost prohibits this. Provision of high voltage condensers will be comparatively costlier than the provision of a voltage divider. The bleeder current value is kept somewhere between 10 to 20 per cent of the total current drawn from the power supply.

BIAS RESISTORS

Where self-biasing is used, the value of the bias resistor can be calculated by using the following formula.

$$R = \frac{E_g \times 1000}{I_c \times N}$$

Where

E_g = Grid bias required

I_c = Total cathode current in milliamps.

N = Number of tubes involved

In the case of triodes, the total cathode current is equal to the plate current of the tube.

For tetrodes and pentodes, the total cathode current is the sum of the plate and screen currents.

For pentagrid converters, the cathode current is equal to the sum of plate, screen and oscillator anode currents.

CATHODE RESISTOR FOR TUBES IN PUSH-PULL

$$R = \frac{E_g \times 1000}{I_c \times 2}$$

Example :—What is the value of bias resistor required for two 6 F 6 tubes in push-pull with 250 volts applied to the plates ?

With 250 volts applied to the plate the grid bias required is 16.5 volts and the plate current is 34 ma whereas the screen current is 6.5 ma.

$$\therefore R = \frac{16.5 \times 1000}{40.5 \times 2} = 203 \text{ ohms}$$

(The information about plate current, screen current grid bias etc. will be found in any tube manual).

POWER RATING OF BIAS RESISTOR

Any of the two formulae given below can be used :—

$$\text{Watts} = I^2R \text{ or } \frac{E^2}{R} \quad \dots \quad \dots \quad \dots \quad (1)$$

$$\text{Watts} = \frac{I^2R}{1,000,000} \quad (\text{I is in milliamps.}) \dots \quad (2)$$

BIAS RESISTOR VALUES

The following is a table giving the approximate values of bias resistors commonly found with common tube types.

Tube	Bias Res. ohms.	Wattage rating
2A3	750-800	3-5
2A5	400-700	1-5
6A3 (Single)	750	3
6A3 (P.P.)	850	5-10
6A6	850	1/2-1
6A7	200-300	1/2-1
6A8	300	1/2-1
6C5	1000	1/2
6D6	300-3000	1/2
6F5	1200-1800	1

Tube	Bias Res. ohms.	Wattage rating
6F6 (Single)	400-650	1-2
6F6 (P.P.)	250-750	3-5
6J5	900	1
6K6	500-700	1
6K7	250-450	1/2-1
6N7	850	1
6L5	750-1200	1
6L6 (Single)	150-375	1/2-2
6L6 (P.P.)	125-200	5
6L7	300-500	1
6J7	1000-10000	1/2-1
6K8	250	1/2
6K5	7000	1
6Q7	4000-7000	1
6S7	300-3000	1
42	400-700	1-5
41	500-700	1
75	2500-11000	1
78	250-600	1/2-1
76	2500-100000	1
12A7	1000-1250	1
25B6-G	300-350	2
25L6	150-200	1
25L6-G	150-200	1
25C6-G	150-400	2

BIAS RESISTOR IN PHASE INVERTER CIRCUIT

For service in phase inverter circuit, the cathode bias resistor can be left unby-passed. This omission of the by-pass condenser is a great help in balancing the output voltages. If hum has got to be minimised then only a condenser may be used.

PECULIAR FAULT IN BIAS CIRCUITS

On many occasions the serviceman finds that the cathode voltage is abnormally high. Where normally it is required to be 3 to 8 volts it is sometimes found that the voltage is as high as 80 to 125 volts. The associated components do not show any fault. The bias resistor is also checked for value and it tests o.k. In most of such cases the bias resistance gets open as soon as the set is switched on. The question that strikes one's mind is that when the cathode

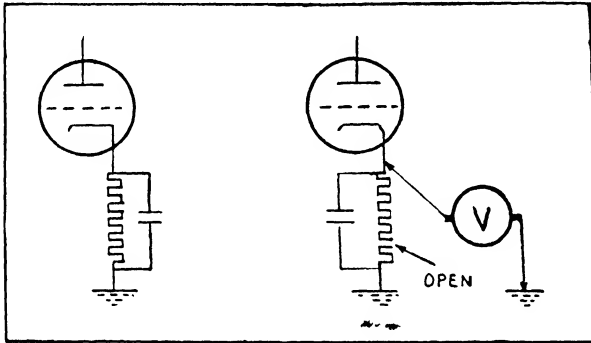

FIG. 3

resistance is open, how on earth the the meter registers this high voltage on the cathode? The reason for this high voltage at the cathode can be atonce imagined when the sensitivity of the voltmeter, that is being used for measurements, is taken into consideration. As shown in Fig. 3 the open cathode resistor gets shunted by the resistance of the voltmeter and the plate current flows through the meter and gives a reading of high voltage on the cathode.

FILAMENT OR HEATER RESISTOR—(Heaters in parallel)

Invariably in an A. C. set all the heaters of tubes are connected in parallel (except some of the more recent A. C. sets where they are connected in series too) and the heater supply is taken from a transformer.

In case of battery sets where the 2 volt filament tubes are to be operated from dry cells a resistor is usually required to procure two volts from a supply of 3 volts—voltage of two dry cells connected in series. The value of the resistor is found out by the following formula.

$$R = \frac{E_B - E_T}{I_T} \quad \dots \quad \dots \quad \dots \quad (1)$$

Where E_B = Battery voltage
 E_T = Rated voltage of a single tube
 I_T = Total heater current in Amperes

Example :—What will be the value of filament resistor to operate three 30 type tubes and two 31 types from two dry cells connected in series giving a voltage of 3 volts ?

Since $E_B = 3$ volts
 $E_T = 2$ volts
 $I_T = (3 \times .06) + (2 \times .13) = 0.44$ amps.
 $R = \frac{3 - 2}{0.44} = 2.2$ ohms

HEATER RESISTOR (Heaters in series)

The following formula is useful for finding out the ohmic value of a resistor required for such a service.

$$R = \frac{E_S - E_T}{I_T} \quad \dots \quad \dots \quad \dots \quad (2)$$

Where E_S = Supply voltage
 E_T = Total rated voltage of all tubes to be connected in series
 I_T = Rated heater current of a single tube

Example :—Calculate the value of resistor required to operate the following valves with their filaments connected in series

6A7, 6K7, 6Q7, 43, 25Z5

The supply voltage is 230 volts A. C. or D. C.

Total rated voltage of tubes

$$\begin{aligned} E_T &= (3 \times 6.3) + (2 \times 25) \\ &= 18.9 + 50 \\ &= 68.9 \text{ volts} \end{aligned}$$

$$I_T = .3 \text{ amperes}$$

$$\therefore R = \frac{230 - 68.9}{.3} = 537 \text{ ohms}$$

The power rating or the wattage rating can be found out by either of the three methods :

$$W = I^2R, W = \frac{E^2}{R}, W = E \times I$$

$$\text{i. e. } W = (.3)^2 \times 537, W = \frac{(161.1)^2}{537}, W = 161.1 \times .3$$

$$\therefore W = 48.33 \text{ Watts}$$

A resistor of this wattage rating will not be available in commercial sizes and so it is advisable to select the next higher rating. In the above case a 50 watt resistor may be selected. Similarly, a resistor of the exact value of 537 ohms will not be available in the market and so a variable resistance of suitable value—say of 750 ohms—should be ordered out.

DIFFERENT CURRENT RATING HEATERS IN SERIES

When it is required to connect in series, valves having different heater current ratings, each tube having a lower heater current must have a shunt resistor connected across its heater terminals to pass the excess current. The value of the shunt resistor can be found out by the following formula :

$$R_{SH} = \frac{E_L}{I_H - I_L} \quad \dots \quad \dots \quad \dots \quad (3)$$

Where R_{SH} = Shunt Resistance

E_L = Heater volts of tube having lower heater current

I_H = Heater current of tube having higher current rating.

I_L = Heater current of tube having lower current rating.

Example :—In an AC/DC set using the following valves, the 6K7 tube is to be replaced with the new Philips valve EF39, what will be the value of shunt resistance required to be connected across the heater terminals of EF39 ?

6K7 — 6Q7

6A7 — 25L6

6K7 — 25Z5

All these tubes have a heater rating of .3 amps. The EF39 has a heater rating of .2 amps. only.

$$R_{SH} = \frac{6.3}{.3 - .2} = 63 \text{ ohms}$$

So a resistance of 63 ohms will have to be connected across the heater terminals of EF39

Example 2 :—If a 6N7 valve is to be used in a series heater circuit of several other 6.3 volts tubes having a heater rating of .3 amps. what precautions need be taken ?

In the first example above, the valve EF39 had a lower current rating than the series group in which it was to be connected but in this case the valve 6N7, having a higher current rating of .8 amperes is to be connected in a series group which has a lower heater current of .3 amps. only. Therefore, in this case each one of the tubes, except the 6N7, will have to be operated with a shunt resistor connected across the heater terminals. The value of the shunt resistance can be calculated as follows :

$$R_{SH} = \frac{6.3}{.8 - .3} = 12.6 \text{ ohms}$$

Calculations of the value of series voltage dropping resistor for tubes having one or more shunt resistors should be done on the basis of the tube having the highest heater current rating. That means in the above case the I_T in formula 2 (Page 22) will be .8 amps and not .3 amps.

RESISTANCE WIRE TABLES

EUREKA WIRE

S. W. G.	Dia mils.	Ohms per 1000 ft.	Lbs per 1000 ft.	Feet per ohm	Current ma.
20	36	220.4	3.90	4.53	650
21	32	279.1	3.12	3.58	510
22	28	364.0	2.38	2.75	390
23	24	496.0	1.75	2.02	300
24	22	590.0	1.47	1.70	250
25	20	714.0	1.21	1.40	210
26	18	882	.99	1.13	170
27	16.4	1062	.82	.94	140
28	14.8	1305	.67	.76	117
29	13.6	1545	.56	.64	101
30	12.4	1858	.47	.54	85
31	11.6	2123	.41	.47	75
32	10.8	2450	.35	.41	66
33	10.0	2857	.304	.35	57
34	9.2	3376	.257	.296	49
35	8.4	4049	.215	.25	41
36	7.6	4947	.175	.202	35
37	6.8	6179	.140	.161	29
38	6.0	7936	.109	.126	23
39	5.2	10,565	.082	.094	19
40	4.8	12,395	.070	.080	16
41	4.4	14756	.059	.067	13
42	4.0	17855	.049	.056	11
43	3.6	22045	.039	.045	9.5
44	3.2	27888	.031	.0359	8.0

NICHROME WIRE
(For Heating Elements etc.)

S. W. G.	Dia mils.	Ohms per 1000 ft.	Lbs per 1000 ft.	Current ma.
20	36	520	3.58	...
21	32	659	2.83	...
22	28	861	2.17	...
23	24	1170	1.60	...
24	22	1390	1.33	...
25	20	1680	1.12	...
26	18	2080	.89	400
27	16.4	2510	.74	350
28	14.8	3080	.60	300
29	13.6	3650	.51	250
30	12.4	4390	.427	230
31	11.6	5010	.373	205
32	10.8	5780	.324	185
33	10.0	6750	.276	165
34	9.2	7970	.235	145
35	8.4	9560	.195	125
36	7.6	11,690	.160	110
37	6.8	14,600	.128	91
38	6.0	18,700	.100	76
39	5.2	24,900	.075	62
40	4.8	29,200	.064	55
41	4.4	34,800	...	48
42	4.0	42,180	...	41
43	3.6	52,000	...	35
44	3.2	65,900	...	30
45	2.8	86,100	...	25

COMMON VALUES OF RESISTORS

R. F. STAGE

H. F. Pentode Bias Resistor

Approx. ohms

50—500

S. G. Bias Resistor

75—450

	Approx. ohms.
Grid Circuit Decoupling	20,000—500,000
Screen Circuit Decoupling	100—1000
Anode Circuit Decoupling	500—10,000
Grid Leak	1—2 Meg.
Grid Stopping Resistor	50—300
Plate Stopping Resistor	100—600

DETECTOR STAGE

Bias Res.—Anode Bend Det.	2,000—10,000
Anode Coupling Grid Det.	20,000—50,000
Anode Coupling Anode Bend Det.	.1—3 Meg.
Grid Leak—Grid Det.	.1—5 Meg.
Load Resistance Diode Det.	.1—5 Meg.

I. F. STAGE

Grid Circuit Decoupling	20,000—500,000
Screen Circuit Decoupling	100—1000
Anode Circuit Decoupling	500—10,000
Grid Leak	1—2 Meg.
Grid Stopping Resistor	100—700
Plate Stopping Resistor	100—600

A. F. AND OUTPUT STAGE

Bias Res.—L. F. Triode	500—2000
„ Output Triode	500—1000
„ Output Pentode	150—5000
Grid Circuit Decoupling	50,000—250,000
Screen Circuit Decoupling	2000—10,000
Anode Circuit Decoupling	5000—100,000
Anode Coupling	10000—100,000
Grid Leak	.1—1 Meg.
Grid Stopping Resistor	1000—10,000
Plate Stopping Resistor	50—150

POWER SUPPLY

Series Resistance } in AC/DC Sets }	200—750 ohms (50 to 80 watts)
--	----------------------------------

PHILIPS RESISTORS

Classification of the imprints on the Philips Resistances used in 1938 Receivers

1st Figure	2nd Figure	Tolerance
0 = 1 ohm	0 = $\times 1$	A $\pm 10\%$
1 = 10 ohms	1 = $\times 1.25$	B $\pm 5\%$
2 = 100 ohms	2 = $\times 1.6$	
3 = 1000 ohms	3 = $\times 2$	
4 = 10,000 ohms.	4 = $\times 2.5$	
5 = 0.1 Meg.	5 = $\times 3.2$	
6 = 1 Meg.	6 = $\times 4$	
7 = 10 Meg.	7 = $\times 5$	
	8 = $\times 6.4$	
	9 = $\times 8$	

Examples :—

- (1) A 0.1 megohm resistance with a tolerance of $\pm 10\%$ will have an imprint 50 A
- (2) A 400 ohms resistance with a tolerance of $\pm 5\%$ will have an imprint 26B

SECTION II

VOLUME CONTROLS AND TONE-CONTROLS

It will be found that the modern radio receivers employ the method of diode detection very widely ; and no set is without A. V. C. circuit. Because of these two circuits, the manual volume control has got to be necessarily incorporated in the audio stage of the receiver. The volume control can be mostly traced down in the grid circuit of the first A. F. tube. But receivers using three winding I. F. Transformers may have the volume control in the I. F. circuit. In some of the older receivers the method of volume control amounted

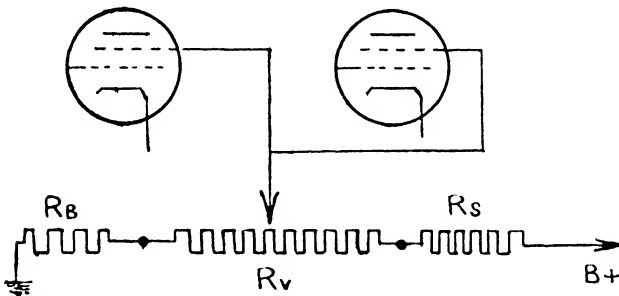

FIG. 4

to the variable control of screen voltages of either the R. F. tubes or the I. F. tubes, or both, as shown in Fig. 4. The voltage is reduced to the proper value required for screen grids by the resistor R_S . The variable resistor R_V , which is the volume control, varies the screen voltages of both the tubes and thereby controls the volume. The resistor R_B is the bleeder resistance specifically provided to prevent the screen

voltage from reaching zero when R_v is set at minimum voltage position.

Practically all volume control arrangements employ variable resistors of either the carbon or wire-wound type. The following are the most usual faults developing in volume controls.

- 1 Dirty contacts.
- 2 Insufficient pressure between resistance strip and the moving arm.
- 3 Sharp burrs on the surface of the resistance strip.
- 4 Noisy operation.
- 5 Intermittent operation.

Dirty contacts can best be cleaned either by carbon tetra-chloride, gasoline or alcohol.

REPLACEMENT OF VOLUME CONTROL

(When it is suspected that hum or whistles are due to faulty volume control).

On many occasions a serviceman does come across peculiar faults connected with the volume controls. There have been cases where hum has been located in a faulty volume control and whistles had their origin in a defective volume control. In such cases one has to substitute a new volume control and find out whether the fault is really with the old volume control. Suppose the volume control value is 2 megohms, and, it can be had in the market at one or two stores at a fairly high price. Since the serviceman is not very sure that the hum or whistle will go away by changing the volume control he rather hesitates to buy a costly new control only perhaps for the sole purpose of checking by substitution. If the serviceman purchases the new

control and finds out, after connecting, that the defect has disappeared then it is well and good but on the contrary if he finds that the replacement does not remedy the fault, the new volume control has to remain in stock for some possible use in the future. However, the fact remains that to day the serviceman's money—however small be the amount—is locked up unnecessarily. For a serviceman with a very small

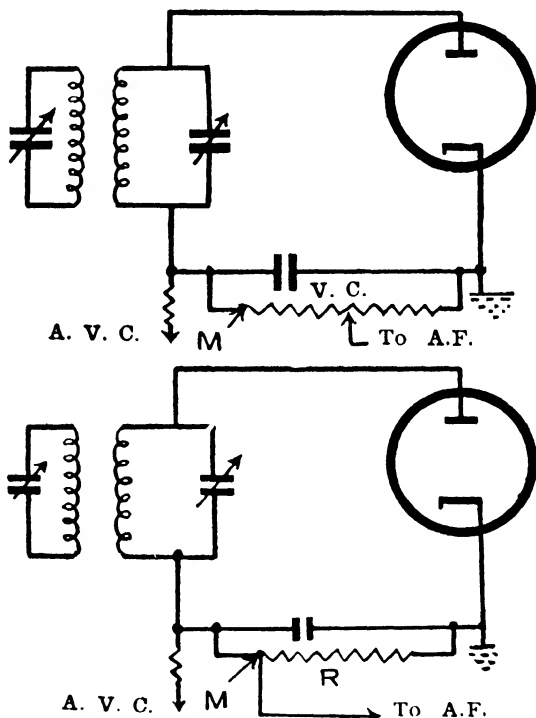

FIG. 5

capital outlay and for all service agencies in times of war, when every available pie is to be carefully spent, such locking of money will do more harm than any good. To avoid all this it is suggested that the following cheaper and quick method be employed for checking the suspected volume controls.

Instead of actually connecting a new volume control, a resistor of correct ohmic value—in the above case 2 megohms—should be connected as shown in the lower portion of Fig. 5. The point M is the maximum output or maximum volume point on the resistance. The point which is connected to the moving arm of the volume control in the top portion of Fig. 5 should be connected to point M in the lower portion of Fig. 5. The set should then be tried remembering always that the volume of the set has no control and that it is set at maximum. If the defect disappears, a new volume control can be safely bought, but if the defect persists it is a definite indication that the fault is not in the volume control but somewhere else.

REPLACEMENT OF VOLUME CONTROL

(*When the ohmic value is not known*)

Due to varying circuit constants in different sets, it has been the experience of many that exact ohmic values of volume controls are of paramount importance. In some cases a low output resulted when a lower value was used whereas in other cases a low output was the result when higher value was used. Under these circumstances it is an advantage to know the correct value of volume controls, and to be not in possession of this knowledge will be a great disadvantage. The following two methods are therefore suggested for finding out the almost correct value of such volume controls.

Method 1:—Dismantle the volume control and measure the resistance of the strip in sections and add up to get the ohmic value of the volume control.

Method 2:—When the carbon is rubbed off in various places or when the volume control strip is charred down exceedingly, the Method 1 will not be suitable. In such cases it is advised that .25, .5, .75, 1, 1.5 and 2 megohm

resistors should be connected as shown in Fig. 5 and tried one by one. The set should be tried particularly on short waves. The resistance that gives the maximum output, fairly indicates the correct ohmic value of the volume control to be used.

VOLUME CONTROL AND TONE-CONTROL VALUES USED IN ENGLISH AND CONTINENTAL SETS

ALBA

Model	Volume Control	Tone Control
212	25,000	—
430	25,000	—
870	500,000	—
540	500,000	—
230	500,000	5000
825	250,000	—
801	250,000	—

BEETHOVEN

P107	15000	—
------	-------	---

BURNDEPT

Model	Volume Control	Tone Control
AWSG	500,000	10,000
AWTU	100,000	—
271 AAV4	10,000	—
267	500,000	—

COSSOR

Model	Volume Control	Tone Control
3864	500,000	25,000
535	1 Megohm	50,000
737	500,000	20,000
376	1 Megohm	—
6864	500,000	20,000
583	500,000	20,000
3952	500,000	20,000

DECCA

Model	Volume Control	Tone Control
55 Trans.	500,000	—
66	500,000	—
PT/ML	500,000	50,000
PT/AG	500,000	50,000
PG/AC	500,000	50,000
99	500,000	500,000

EKCO

Model	Volume Control	Tone Control
PB 199	500,000	—
AW 98	1 Megohm	1.5 Megohm
AW 69	850,000	40,000
AC 86	250,000	500,000
BC 7	1 Megohm	250,000
AW 83	1 Megohm	1.5 Megohm
EX 402	850,000	500,000
EX 401	850,000	20,000
EXU-401	850,000	20,000

G. E. C.

Model	Volume Control	Tone Control
AW6	500,000	50,000
AW8	500,000	50,000
BC 3754	500,000	50,000
BC 3440	10,000	50,000
BC 3750	400,000	50,000
BC 3760	400,000	50,000
BC 3762	400,000	50,000
BC 3758	400,000	50,000
BC 3867	1 Megohm	1 Megohm
BC 3972	1 Megohm	55,000
BC 4172	500,000	55,000

G. E. C.

Model	Volume Control	Tone Control
BC 4177	500,000	55,000
BC 4178	500,000	55,000
BC 3780	500,000	1 Megohm
BC 3781	500,000	1 Megohm
BC 3788	500,000	1 Megohm
BC 4237	1 Megohm	—

H. M. V. (English)

Model	Volume Control	Tone Control
471	0.25 Megohms	Step by Step
469	2 Megohms	{ 2 Megohms Ba. 1 Megohms Br.
656	2 Megohms	Var. Condenser
675	2 Megohms	—
698	2 Megohms	Var. Condenser
699	2 Megohms	Var. Condenser
1024	2 Megohms	Var. Condenser
1025	2 Megohms	Var. Condenser
1026	2 Megohms	Var. Condenser
1027	2 Megohms	Var. Condenser
5211	1 Megohm	50,000
5212	1 Megohm	50,000
5311	1 Megohm	50,000
5312	1 Megohm	50,000
6212-A	2 Megohms	50,000

K. B.

Model	Volume Control	Tone Control
830	500,000	50,000
835	500,000	50,000
730	500,000	500,000
735	500,000	50,000
750	500,000	500,000

LISSEN

Model	Volume Control	Tone Control
8302EB	500,000	2 Megohms
8325	500,000	2 Megohms
8407	500,000	2 Megohms
8427	500,000	2 Megohms
8437	500,000	2 Megohms
8441	500,000	2 Megohms
8571	500,000	2 Megohms
8572	500,000	2 Megohms
8574	500,000	2 Megohms
8577	500,000	2 Megohms
8608	500,000	2 Megohms

LOEWE

Parlrizier G. W. (Ch. No. 186 E)	250,000	—
-------------------------------------	---------	---

LUMOPHON

WD 475K	1 Megohm	—
---------	----------	---

MENDE

WK 6	20,000	--
------	--------	----

MARCONI

Model	Volume Control	Tone Control
222	500,000	Condenser Type
219	500,000	—
234	500,000	—
268	125,000	—
299	250,000	Step by Step
315	125,000	—
389	500,000	Condenser Type
347	250,000	Condenser Type
367	250,000	Condenser Type
382	500,000	—
399	500,000	Condenser Type
375	100,000	3000
345	250,000	Condenser Type

365	250,000		Condenser Type
346	250,000		Condenser Type
366	250,000		Condenser Type
562	250,000		Condenser Type
561	1 Megohm	Bass 50000	Brilliance 1 Megohm
564	1 Megohm	Bass 50000	Brilliance 1 Megohm
538	2 Megohm	Bass 2 Meg.	Brilliance 1 Meg.
539	2 Megohm	Bass 2 Meg.	Brilliance 1 Meg.
821	2 Megohms		Var. Condenser
822	2 Megohms		Var. Condenser
827	2 Megohms		Var. Condenser
828	2 Megohms		Var. Condenser
829	2 Megohms		Var. Condenser
830	2 Megohms		Var. Condenser
858	2 Megohm		Var. Condenser
1125	1 Megohm		50,000
1135	1 Megohm		50,000
2125	1 Megohm		50,000
2135	1 Megohm		50,000
2126-A	2 Megohms		50,000

PHILIPS

Model	Volume Control	Tone Control
493 AN	500,000	—
493 HN	500,000	—
335 A	500,000	50,000
462 A	500,000	—
727 U	1 Megohm	—
313 A	0.28M + 70,000	50,000

RAP

Model	Volume Control	Tone Control
Oceanic		
Universal 8	500,000	25,000
Oceanic		
A. C. 7	500,000	25,000

	SCOUTER	
5 Valve A. C.	500,000	—
	MULLARD	
X24A	—	1 Megohm
	TELEFUNKEN	
A55WK	1 Megohm	—

VOLUME CONTROL AND TONE CONTROL IN PHILIPS AND MULLARD RECEIVERS

In some of the Philips and Mullard Receivers the volume and tone controls are so provided that the replacement becomes a tough job. If the original controls are available then the solution is easy. But when the original parts are not available the replacement can be effected out of American controls in the following way.

The resistance segment of the faulty control has to be replaced with another resistance segment from a new control. The resistance strip should be taken out from any American control (new) of required ohmic value and this should be rivetted inside the original volume control body. The mechanical arrangement will naturally remain intact. Particularly the resistance strips from UTAH controls are a good match dimensionally.

SECTION III

VALVES

The relationships that exist between the currents and voltages of the valve electrodes are known as valve constants which are many in number but the following three are more important.

AMPLIFICATION FACTOR (μ)

It is equal to the rate of change of the plate voltage with change of grid voltage, the plate current being constant. In simple words it means that the effective change in plate voltage to produce a given change in plate current—divided by the effective change in grid potential to produce the same plate current change is known as the Amplification Factor of the valve.

PLATE RESISTANCE (R_P)

It is the rate of change of plate voltage with change of plate current, the grid potential being constant. In other words the change in plate voltage divided by the corresponding change in plate current is the Plate Resistance of the valve.

MUTUAL CONDUCTANCE (G_M)

It is the rate of change of plate current with change of grid voltage, the plate voltage being constant. The other way round it means that the change in plate current divided by the change in grid voltage gives the Mutual Conductance of the valve.

All these three constants are related to one another and this relationship is based upon the following formula :—

$$\mu = G_M \times R_P$$

Or

$$G_M = \frac{\mu}{R_P} \quad \text{Or} \quad R_P = \frac{\mu}{G_M}$$

The A.C. resistance or the plate resistance (R_p) of a valve is expressed in ohms, whereas the Mutual Conductance is expressed in 'milliamps per volt' (mA/V)

VALVE CHARACTERISTICS

The most widely used method of expressing valve characteristics is that of curves. These curves indicate the experimental results obtained on that particular valve. There are three kinds of characteristic curves known as Plate characteristics, Mutual characteristics and Constant Current characteristics. In the Plate characteristics the plate current is plotted against the plate voltage. Each of such curves is for a constant grid voltage. In Mutual characteristics the plate current is plotted against the grid voltage the plate voltage being constant for each curve and lastly in constant current characteristics the plate voltage is plotted against grid voltage and the plate current is constant for each curve.

The Plate characteristics and the Mutual characteristics are generally used for most of the applications whereas the constant current characteristics are widely used in case of R. F. power amplifiers.

VALVE EQUIVALENTS

In U. S. A. all the manufacturers of valves have put their products on a standardised basis. This results in making the replacements more easy, If a R. C. A. 6A7 valve blows off, it can be immediately replaced by a G. E., Sylvania or Raytheon valve having the same type number i.e. 6A7. Unfortunately, such is not the case with the European valve manufacturers. There is absolutely no standardisation either on the continent or in England itself. If a Mullard valve PM2A blows off it can be replaced by a PM2A Mullard only or some other valve, of a different manufacturer, having equivalent characteristics but different type number. For instance this particular valve PM2A can be replaced by Mazda Valve P220 or Marooni LP2. On the following few pages will be found equivalent valve tables showing nine different makes of valves which are directly interchangeable without change of base or change in circuit.

2 VOLT BATTERY VALVES

VALVES

Type of Service	Marconi Osram	Mullard	Mazda	Tungram	Cossor	Lissen	Brimar	Philips
L. F. Triode	L21	PM2DN PM2DL	L2	LL2 PD220	210LF	L2	—	—
L. F. Triode	LP2	PM2A	P220	LP220	220PA	L2P	PB1	—
L. F. and Power	P215	PM2	P215	P215	220P	P220	—	B205
Super Power	P2	PM202	P220A	SP220	230XP	PX240	—	—
Output Tetrode	KT2	PM22A	Pen220	PP222	220 OT	PT225	—	—
Output Tetrode High Slope	KT21	PM22D	Pen231	—	—	—	—	—
Double Triode Class B	B21	PM2BA	PD220A	CB220	—	BB220A	—	—
Double Pentode	QP21	—	—	240QP	—	—	—	—

Type of Service	Marconi Ostram	Mullard	Mazda	Tungsram	Cossor	Lissen	Brimar	Philips
Screen Grid	S23	PM12	SG215	SS210	215SG	SG215	—	—
Screen Grid	S24	PM12A	S215B	SS210	220SG	SG215	—	—
Variable mu Screen Grid	VS24	PM12M	S215VM	SE211	220VS	SG2V	—	B255
Variable mu Pentode	VP21	—	VP215	—	210VPT	—	—	—
Variable mu H. F. Pentode	W21	VP2	VP210	HP211	—	SP2V	—	—
H. F. Screened Pentode	Z21	SP2	SP210	HP210	210SPT	SP2	—	—
Heptode Frequency Changer	X22	FC2 FC2A	—	VO2	—	FC2	—	—
Triode Hexode Frequency Changer	X23	—	—	—	—	—	—	—

Type of Service	Marconi Osram	Mullard	Mazda	Tungstam	Coscor	Lissen	Brimar	Philips
Triode-high Magnification	H2	PM1A	H2	R208	210RC	—	—	A225
General Purpose Triode	HL210	PM1HF	HL210	H210	210HF	—	—	A225
Medium Impedance Triode	HL2	PM1HL	1HL2	HR210	210HL	HL2	HLB1	B228
Double Diode Triode	HD23	TDD2A	HL21DD	DDT2	210DDT	L2D	—	—
Double Diode Triode	HD22	TDD2A	HL21DD	DDT2	210DDT	L2D	—	—
Medium Impedance Triode	L210	PM1LF	—	LG210 LD210	210DET	L2	—	A209
Q. P. P. Double Pentode	—	QP22A	QP240	—	—	—	—	—
Class B Double Triode	—	PM12B	PD220	CB220	220B 240B	—	—	B240

4 VOLTS—A. C. MAINS

Type of Service	Marconi Osram	Mullard	Mazda	Tungram	Cosmor	Lissen	Brimar	Phillips
Screen Grid	MS+	S+V	—	—	4MSG	—	—	—
Screen Grid	MS+B	S+VA S+VB	AC/SG ACS2	AS+120	MSG/LA MSG/HA	AC/SG	SGA1	E+52T
Variable Mu Screen Grid	VMS+	MM4V	AC/SGVM	AS+125	MV/SG	AC/SGV	VSGA1	E+55
Variable Mu Screen Grid	VMS+B	MM4V	—	AS+125	MV/SG	—	—	—
Variable Mu Pentode	VMP4 (5 Pin)	VP+	—	HP4106	—	—	9A1	E+47
Variable Mu Pentode	VMP+G (7 Pin)	VP4A	AC/VPI	HP4115 HP4106	MV/SPen	AC/SPV	—	—
Variable Mu Pentode	W+2	—	—	—	MV/SPenB	—	—	—

Type of Service	Marconi Osram	Mullard	Mazda	Tungstam	Cossor	Lissen	Brimar	Philips
H. F. Pentode	MSP4	SP4	AC/S2Pen	HP+101	MS/Pen	AC/SP	SA1	E446
Heptode Frequency Changer	MN+0	FC4	—	MH+105 VO+	41MPG	—	15A2	—
Triode Hexode Frequency Changer	N+1	TH4 TH4A	AC/TH1	TX4	+1STH	AC/FC	—	—
Heptode Frequency Changer	N+2	FC+	—	MH+105 VO+	41MPG	—	15A2	—
Triode High Impedance	MH+1	90+V	AC2/HL	—	41MH	—	—	F460
Triode Det. and L. F.	MH4	35+V	AC, HL	HL++	+1MHF	AC/HL	HLA2	E438
Triode Medium Impedance	MHL4	24+V	—	—	41MLF	—	—	E42+N
Triode Low Impedance	ML4	10+V	AC/P	—	41MP	—	—	—

Type of Service	Marconi Osram	Mullard	Mazda	Tungsram	Cossor	Lissen	Brimar	Philips
Double Diode Triode	MHD4	TDD4	Ac/HLDD	DDT4	DDT	—	11A2	—
Double Diode	D41	2D4A	V914	DD4	DD4	—	DDA1	—
Power Output Triode— Directly heated	PX4	ACO44	PP3/250	P12/250	4XP	—	—	D404
Power Output Triode— Directly heated	PX25	DO24	PP5/400	P27/500	—	—	—	F410
Power Amplifying Tetrode	MKT4	Pen+VA	AC/Pen	APP4A	MPPen	—	—	—
Output Tetrode	KT41	Pen+VB PenA4	AC2/Pen	—	42MPPen	AC/PT	7A3	—
Output Tetrode	KT42	Pen+VA	AC/Pen	APP4A	MPPen	—	7A2	E+63
Double Diode Output Pentode	DN41	—	AC2, penDD	DDPP4B	420TDD	—	—	—

Type of Service	Marconi Osram	Mullard	Mazda	Tungsram	Cossor	Lissen	Brimar	Philips
Output Pentode	N40	Pen+VA	AC Pen	APP4120	MIPPenA	—	7A2	E463
Output Pentode	N41	Pen+VB PenA4	AC2/Pen	APP4/B	42MP/Pen	—	7A3	—
Pentode	425PT	PM24	Pen+25	PP415	415PT 410PT	—	—	B443
Output Pentode 8 watts	PT4	PM24M	—	APP/4100	PT41	—	PenA1	E443H
Output Pentode 25 watts	PT25	PM24D	—	—	—	—	—	F443N

UNIVERSAL AC/DC VALVES (Pin Bases)

Type of Service	Marconi Ostram	Mullard	Mazda	Tungstam	Cossor	Lissen	Brinar	Philips
Triode Hexode Frequency Changer 13V—31A	X31	TH13C	—	—	—	—	—	—
Octode Frequency Changer 13V—2A	—	FC13C	—	VO13	13PGA 202MPG	—	15D1	—
Variable Mu. H. F. Pentode 13V—2A	—	VP13C	VP1322	VO13B	—	—	—	—
H. F. Pentode 13V—2A	—	SP13C	—	SP13B	—	—	—	—
Double Diode Detector 13V—2A	—	2D13C	DD620	DD13	—	—	10D1	—
Double Diode Triode 13V—2A	—	TDD13C	HL DD1320	DDT13	13DHA 202DDT	—	11D3	—
Medium Impedance Triode 13V—2A	—	HL13C	HL1320	HL13	—	—	4D1	—

UNIVERSAL AC/DC VALVES (Pin Bases)

Type of Service	Marconi Osram	Mullard	Mazda	Tungsram	Cossor	Lissen	Brimar	Philips
Output Pentode 13V—,5A	—	Pen13C	Pen1340	—	—	—	7D8	—
Output Pentode 35V—,2A	—	Pen36C	Pen3520	PP35	—	—	7D6	—
Half Wave Rectifier 20V—,2A	—	UR1C	U4020	V30	40SUA	—	1D5	—
Multiple Rectifier 30V—,2A	—	UR3C	—	—	—	—	—	—

RECTIFIERS

Type of Service	Marconi Osram	Mullard	Mazda	Tungstam	Cossor	Lissen	Brimar	Philips
Directly heated Full wave 4V—1A	U10	DW2	—	PV495	506BU 408BU	—	—	1821 506
Directly heated Full wave 4V—2A	U12	DW3 DW4/350	UU120/350	PV4	442BU	—	—	1807
Directly heated Full wave 4V—2A	U12/14	DW3 DW4/350	UU120/350	PV4	442BU	—	—	1807
Indirectly heated Full wave 4V—2.4A	MU12 MU12/14	IW3 IW4/350	UU4	APV4	—	—	1A7	1867
Indirectly heated Full wave 4V—2.4A	MU14	IW4	UU5	—	—	—	—	1861
Directly heated Full wave 4V—2A	U14	DW4 DW4/350	—	PV4200	460BU	UU43	—	1561
Indirectly heated Full wave 4V—1.2A	—	IW2	UU2 UU60/250	—	—	—	R1	1881

Marconi Osram	American
X61M X64 X63 KTW63 KTZ63 H63 DH63 D63 L63 KT63 KT66 KT32 U31 U50 U52 KT61 KT33C	6K8 6L7—G 6A8—G { 6K7—G { 6U7—G 6J7—G 6F5—G 6Q7—G 6H6—G 6J5—G 6F6—G 6L6—G 25L6—G 25Z6—G 5Y3—G 5U4—G 6F6—G 25C6—G
Philips	American
EBC33 EF39 ECH33 EL31 EL32	6Q7 6K7 6K8 6F6 6F6
$I_f = 0.2$ amps.	$I_f = 0.3$ amps.

NOMENCLATURE OF PHILIPS VALVES

The Philips Valves are manufactured in numerous types and there is a definite system of nomenclature adopted by the manufacturers. The first letter of the type number indicates the heater rating and the second letter and the third letter, if any, denotes the type of valve. The numeral indicates the serial number. When an existing valve construction is improved and brought out in a new variety, the next higher consecutive number is used which indicates that the same type has been further improved.

First Letter	Second Letter and Third Letter, if any.
A = 4 Volt A. C. Series B = 180 mA D. C. Series C = 200 mA AC/DC Series E = 6.3 Volts A. C. & Car. Radio Series F = 13 Volts Car Radio Series H = 4 Volts Battery Series K = 2 Volts Battery Series	A = Single Diode B = Duodiode C = Triode (other than Power Valve) D = Triode Power Valve E = Tetrode F = Pentode, H. F. Amplifier H = Hexode K = Octode L = Output Pentode M = Tuning Indicator X = Full wave Rectifier (Gas Filled) Y = Half wave Rectifier (High Vacuum) Z = Full Wave Rectifier (High Vacuum)

For example the Philips valve type number EK2 indicates that it is a 6.3 volt A.C. series octode valve whereas the type KK2 indicates that it is a 2 volt battery octode.

Similarly, the type ABI signifies that it is 4 volt A. C. Duodiode and the type ACH1 indicates that it is 4 volt A. C. triode-hexode, the letter C standing for triode and the letter H for hexode.

VALVE CONVERSION FACTORS

The operating conditions for any valve, as published in tube manuals, specify a typical case. For example the tube manual gives the operating conditions for 6A8 for plate voltages of 250 volts and 100 volts. But it is often found in practice that neither 230 nor 100 volts are no the plate. The voltage being of some intermediate valve—say 200. And therefore in such a case the published screen, anode-grid and control grid voltages cannot be depended upon because those are either for a condition when 250 plate voltage is available or for a condition when 100 plate voltage is available. But in this case the plate voltage is 200 and we should have corresponding voltages for screen, anode-grid and control grid.

The 6A8 valve characteristics as published

Plate voltage :—	250 volts
Screen voltage :—	100 volts
Anode-grid voltage :—	250 volts
Control-grid voltage :—	—3 volts

The voltage conversion factor will be

$$\frac{200}{250} = 0.8$$

and the following will be the different voltages when plate voltage is 200.

$$\text{Screen voltage} = 100 \times .8 = 80 \text{ volts}$$

$$\text{Anode-grid voltage} = 250 \times .8 = 200 \text{ volts}$$

$$\text{Control-grid voltage} = -3 \times .8 = -2.4 \text{ volts}$$

AMERICAN VALVE TYPES

On the following few pages all the american valves for receivers are classified on the basis of heater volts and type of service

RECTIFIERS

Full Wave Vacuum type

6.3 Heater Volts :—6X5, 6X5-G 6X5-GT, 84,
6ZY5-G, 7Y4

5 Heater Volts :—5T4, 5U4-G, 5X4-G, 5Z3, 5W4,
5W4-GT, 5Y3-G, 5Z4, 5Y4-G 80,
5V4-G, 83-v

Full Wave Mercury Vapour

2.5 Heater Volts :—82

5 Heater Volts :—83

Half Wave

Heater Volts, } :—12Z3, 35Z3-LT, 35Z4-GT, 35Z5-GT,
12 and above } 45Z5-GT

Half-Wave with Beam Power Amplifier

70 Heater Volts :—70L7-GT

Half Wave with Power Pentode

Heater Volts } :—12A7, 25A7-G
12 and above }

RECTIFIER DOUBLERS

25Z6, 25Z6-G, 25Z6-GT, 25Z5, 117Z6-GT, 50Y6-GT

TUNING INDICATORS

REMOTE CUT-OFF

6.3 Heater volts :—6AB5, 6U5, 6G5, 6N5, 6AB5/6N5,
6U5/6G5, 6AD6-G,

SHARP CUT-OFF

6.3 Heater volts :—6E5, 6AF6-G,

CONVERTERS AND MIXERS

Pentagrid Converters

6.3 Heater volts :—6SA7, 6A8, 6A8-G, 6A8-GT, 6D8-G,
6A7, 7B8-LM, 6SA7-GT

12 Heater Volts :—12SA7, 12A8-GT, 12SA7-GT

2.5 Heater Volts :—2A7

2 Heater Volts :—1C7-G, 1C6, 1D7-G, 1A6

1.4 Heater Volts :—1A7-G, 1A7-GT, 1R5

Triode Hexode Converters

6.3 Heater Volts :—6K8, 6K8-GT, 7J7

12 Heater Volts :—12K8

Octode Converters

6.3 Heater Volts :—7A8

Pentagrid Mixers

6.3 Heater Volts :—6L7, 6L7-G

Triode Heptode Converters

6.3 Heater Volts :—6J8-G

POWER AMPLIFIERS

BEAM POWER TUBES

(Without Rectifier)

1.4 Heater Volts :—1Q5-GT, 1T5-GT, 3Q5-GT,

6.3 Heater Volts :—6L6, 6L6-G, 6V6, 6V6-G, 6V6-GT,

6Y6-G, 7C5-LT, 7A5, 6U6

Heater Volts } :—25L6, 25L6-G, 25L6-GT, 35A5-LT,
12 and above } :—35L6-GT, 50L6-GT*(With Rectifier)*Heater Volts } :—70L7-GT, 32L7-GT, 117L7-GT,
12 and above } :—117N7-GT

TRIODES

(Single Unit—Low Mu)

2 Heater Volts :—31

2.5 Heater Volts :—2A3, 45

6.3 Heater Volts :—6A3

(Single Unit—High Mu)

2 Heater Volts :—49

2.5 Heater Volts :—46

6.3 Heater Volts :—6AC5-G, 6AC5-GT

12 and above :—25AC5-GT

(Twin Unit—High Mu)

1.4 Heater Volts :—1G6

2 Heater Volts :—1J6-G, 19

2.5 Heater Volts :—53

6.3 Heater Volts :—6N7, 6N7-G, 6A6, 6Z7-G, 79,
6Y7-G.

PENTODES

(Single Unit)

1.4 Heater Volts :—1A5-G, 1C5-G, 1S4, 1A5-GT
1C5-GT

2 Heater Volts :—1F5-G, 1F4, 1G5-G, 33

2.5 Heater Volts :—2A5, 47, 59

6.3 Heater Volts :—6F6, 6F6-G, 42, 6K6-G, 6K6-GT,
41, 6G6-G, 38, 6A4, 89, 7B5-LT

12 and above :—25A6, 25A6-G, 43, 25B6-G.

(Twin Unit)

2 Heater Volts :—1E7-G

(With diode and triode)

1.4 Heater Volts :—1D8-GT

(With Medium Mu triode)

6.3 Heater Volts :—6AD7-G.

(With Rectifier)

Heater Voltt } :—12A7, 25A7-G.
12 and above }

DIRECT COUPLED AMPLIFIERS

6.3 Heater Volts :—6B5, 6N6-G.

VOLTAGE AMPLIFIERS—DETECTORS
OSCILLATORS

TRIODES

(Single Unit—Medium Mu)

1.4 Heater Volts :—1G4-G

2 Heater Volts :—1H4-G, 30

2.5 Heater Volts :—27, 56

6.3 Heater Volts :—6C5, 6C5-G, 6J5, 6J5-G, 6J5-GT,
6L5-G, 76, 37, 6P5-G: 5AE5-GT,
6P5-GT, 7A4.

12 Heater Volts :—12J5-GT

(*Twin Unit—Medium Mu*)

6.3 Heater Volts :—6C8-G, 6F8-G, 6AE7-GT

(*Twin Plate—Medium Mu*)

6.3 Heater Volts :—6AE6-G

(*Medium Mu—with power Pentode*)

6.3 Heater Volts :—6AD7-G

(*Medium Mu—with Diode and Power Pentode*)

1.4 Heater Volts :—1D8-GT

(*Single Unit—High Mu*)

6.3 Heater Volts :—6SF5, 6F5, 6F5-G, 6F5-GT,
6K5-G.

(*Twin Unit—High Mu*)

6.3 Heater Volts :—6SC7, 7F7

12 Heater Volts :—12SC7

(*High Mu—with Diode & R. F. Pentode*)

1.4 Heater Volts :—3A8 GT

(*High Mu—with Pentode*)

Heater Volts } :—12B8—GT, 25B8—GT.
12 and above }

TETRODES

(*Remote cut-off*)

2.5 Heater Volts :—35

(*Sharp cut-off*)

2 Heater Volts :—32

2.5 Heater Volts :—24-A

6.3 Heater Volts :—36

PENTODES

(*Remote cut-off with Triode*)

6.3 Heater Volts :—6F7

(*Remote cut-off*)

1.4 Heater Volts :—1T4

2.0 Heater Volts :—1D5—GP, 1A4-P, 34

2.5 Heater Volts :—58

6.3 Heater Volts :—6SK7, 6K7, 6K7-G, 6K7-GT, 78,
6S7, 6S7-G, 6U7-G, 6D6, 6W7-G,
39/44, 7A7-LM, 7B7, 6AB7, 6AC7,
6SK7-GT

12 Heater Volts :—12SK7, 12K7-GT

(*Sharp cut-off*)

1.4 Heater Volts :—1N5-G, 1N5-GT, 1P5-GT,

2 Heater Volts :—1E5-GP, 1B4-P, 15

2.5 Heater Volts :—57

6.3 Heater Volts :—6SJ7, 6J7, 6J7-G, 6J7-GT, 6C6,
77, 7C7,

12 Heater Volts :—12SJ7, 12J7-GT

(*Sharp cut-off with Diode & High Mu Triode*)

1.4 Heater Volts :—3A8-GT

DIODE DETECTORS

6.3 Heater Volts :—6H6, 6H6-G, 7A6, 6H6-GT.

DIODE DETECTORS WITH AMPLIFIERS

(One Diode with High—Mu Triode)

1.4 Heater Volts :—1H5-G, 1H5-GT.

(One Diode with High—Mu Triode and R. F. Pentode)

1.4 Heater Volts :—3A8-GT

(One Diode with Medium Mu Triode and Power Pentode)

1.4 Heater Volts :—1D8-GT

(One Diode with Pentode)

1.4 Heater Volt :—1S5

(Double Diode with Medium Mu Triode)

2 Heater Volts :—1B5, 1H6-G,

2.5 Heater Volts :—55

6.3 Heater Volts :—6SR7, 6R7, 6R7-G, 85, 6R7-GT, 7E6,

12 Heater Volts :—12SR7

(Double Diode with High Mu Triode)

2.5 Heater Volts :—2A6

6.3 Heater Volts :—6SQ7-GT, 6SQ7, 6Q7, 6Q7-G,
6Q7-GT, 6T7-G, 6B6-G, 75, 7C6,
7B6-LM.

12 Heater Volts :—12SQ7, 12Q7-GT

(Double Diode with Pentode)

2 Heater Volts :—1F7-GV, 1F6

2.5 Heater Volt :—2B7

6.3 Heater Volts :—6B8, 6B8-G, 6B7, 7E7

12 Heater Volts :—12C8

JUNIOR BANTAMS

HY 113	—1.4	Volts.....	.07 amp.
HY 114	—1.4	Volts.....	.12 amp.
HY 115	—1.4	Volts.....	.07 amp.
HY 125	—1.4	Volts.....	.07 amp.

All these four valves are manufactured by Hytron for operation on a single cell of 1.25 Volts. They are very compact measuring 2.19 inches overall.

ACORN TUBES

Old Types

954—955—956

New Types

957	—1.25	Volts.....	.05 amp.
958	—1.25	Volts10 amp.
959	—1.25	Volts.....	.05 amp.

1620	—similar to	6J7
1621	—similar to	6F6
1622	—similar to	6L6
7000	—similar to	6J7—G
7700	—similar to	6C6

SECTION IV

DÉCIBEL

The technical literature on radio is so full of the term 'decibel' that one has got to properly understand it. Many do not know, and some do know but fail to understand, the significance of specifications—in decibels—of amplifiers and microphones. The correct understanding and the right interpretation of the decibel specifications is no doubt important to the service engineer, but to the dealer and importer its significance is vital. The large scale indenting of equipment, if done with proper understanding of the term decibel, will put an end to many worries and uneasy moments that are experienced by many dealers when the equipment on arrival does not give the same performance as was expected on the strength of the catalogue data.

When the size of two footballs is to be compared we say that Football No. 1 is as large or half as large or two times as large as Football No. 2. Thus we get an idea about the size of the two footballs in relation to one another. Now if a third football No. 3 comes in the field and if its size is to be compared we will have either to say that No. 3 is as large or half as large as No. 2 or to say that No. 3 is as large or half as large as No. 1. And now imagine the confusion that will take place if a fourth football comes in for comparison of size. To avoid such a confusion we should have a standard 'reference size'. Once this is accepted and fixed we can go on classifying and comparing not one or four but thousands of footballs. Suppose the 'reference size' is fixed as '2 Inch Diameter' when fully inflated, and, there are three footballs specified as Size 4, Size 8 and

Size 16, then the comparison is very easy. The Size 16 will be eight times as large as the standard reference size, the Size 8 will be four times as large and Size 4 will be twice as large as the standard reference size. If another football manufacturer keeps his reference size as '1 Inch Diameter' then the Size 16, Size 8 and Size 4 of that manufacturer will materially differ from the sizes of the previous manufacturer whose reference size was '2 Inch Diameter.' Size 16 in the first case signifies that it is 8 times larger whereas in the second case Size 16 signifies that it is 16 times larger. This clearly shows that simply saying that the particular football is 8 times larger or 16 times larger is of no avail unless we know the reference sizes.

Let us now divert the discussion to amplifiers. When we come to the comparison of different amplifiers we can say that an amplifier of 10 watts output is five times as powerful as the amplifier having 2 watts output, but the words '2 watts output' and '10 watts output' have no value unless the 'reference level in watts' is known to us. If one and the same reference level has been used by both the manufacturers it is well and good and, the comparison could be fair but if different "reference levels" have been used, the comparison will be unfair. Therefore, the design of radio and amplifier equipment calls for some kind of "reference level". This 'reference level' is, so far, not standardised to perfection. Once the standardisation is fully accomplished there will not be any necessity of specifying the 'reference level' in the specification of the equipment; but till then it is absolutely essential to demand the information on 'reference level' from the manufacturers. And at the time of selecting different lines of amplifiers for import purposes, full importance must be attached to the reference levels used by the different manufacturers. 6 milli-

watts or .006 watt is a very widely used reference level, whereas reference levels of 1 milliwatt, 10 milliwatts and 12.5 milliwatts are also used by some manufacturers. The RCA uses 12.5 milliwatts.

So far we have studied the necessity of a 'reference level' in the selection or comparison of amplifiers. Let us now proceed further and see how the *Decibel* comes in the field. When we say that the output of one amplifier is double that of another it does not make the whole position very clear. This method of comparing these two amplifiers may satisfy a layman but will not be accepted by a technician because he knows that the doubling of the power output does not necessarily mean the doubling of sound level i. e. apparent volume. The difference in apparent volume as detected by our ears is directly proportional to the logarithm of the ratio of the two volume levels and not to the ratio itself, because the mechanism of the human ear is such that it is comparatively more sensitive to small sounds than to large sounds. If the human ear responded equally to small and large sounds, the impact of sound from a cannon fire or some such other big noise will be enough to rupture the ear drum. The response of our ear falls off as the intensity of the sound rises, meaning thereby, that although increased energy means louder sound, the gain in audible effect is greater for weak stimuli than for strong stimuli. and since this peculiar mechanism of the ear is the ultimate standard by which the amplifiers are to be judged, the communication engineers found it advisable to devise a system of comparing different power levels or sound intensities, that is based on the mathematical law that governs the response of the human ear to different sounds. Therefore, for all power and sound energy measurements the 'Decibel' is the only unit that is very extensively employed. It is a unit for measuring the

amplification expressed as a common logarithm of a power or energy ratio. Bel is the real unit for such purposes but it being too large for practical use, the decibel, which is 1/10th of a Bel, is widely used.

The following table gives an idea of amplification in terms of decibels :—

0 decibel	indicates an amplification of 1
10 decibels	indicate an amplification of $10 = 10^1$
20 decibels	indicate an amplification of $100 = 10^2$
30 decibels	indicate an amplification of $1000 = 10^3$
40 decibels	indicate an amplification of $10,000 = 10^4$
50 decibels	indicate an amplification of $100,000 = 10^5$
60 decibels	indicate an amplification of $1,000,000 = 10^6$

A study of the above figures quickly reveals one interesting point which would help memorising the relations in a simple manner. Power ratio of 10 indicates a decibel gain of 10 decibels and ratio of 100 shows a gain of 20 decibels. Proceeding like this we can at once put down that gain of 70 decibels indicates the power ratio or amplification which is equal to seven ciphers on 1 i. e. 10,000,000. Gain of 80 decibels means power ratio which is equal to eight ciphers on 1 i. e. 100,000,000 and so on.

To express a ratio between any two powers it is convenient and customary to use a logarithmic scale because the logarithms facilitate making the conversions in positive or negative directions between the number of decibels and corresponding power, voltage or current ratios.

Sound level increase or decrease of 1 db. (decibel) is barely perceptible to the ear whereas an increase or decrease of 2 db. is only slightly detectable. An amplifier of say 3 watts and another of 4.75 watts will not make any difference

as far as our ears are concerned. The output of the latter will sound, more or less, as high or as low as that of the former, because there is an increase of 2 db. in sound level which is very slightly detectable to the ear. This amply proves the necessity of judging the amplifier output and gain of amplifiers in terms of decibels.

The power output in watts of any amplifier can be easily converted into decibel output by the following formula based on Briggsian scale of logarithms :

$$\text{Db} = 10 \times \text{Log}_{10} \frac{W_1}{W_2}$$

where Db = Power level in decibels

W1 = Amplifier output in watts

W2 = Reference level in watts

Applying this formula, the power level in decibels of an amplifier of 3 watts undistorted output can be calculated as follows :

$$\begin{aligned} \text{Db} &= 10 \times \text{Log}_{10} \frac{W_1}{W_2} \\ &= 10 \times \text{Log}_{10} \frac{3}{.006} \\ &= 10 \times \text{Log}_{10} 500 \\ &= 10 \times 2.69 \\ &= 26.9 \text{ decibels} \end{aligned}$$

Similarly, if the power level of an amplifier is given in decibels, it can be converted in watts by the use of the following formula :

$$\begin{aligned} W &= \text{Reference level in watts} \times \text{Antilog} \frac{\text{Db}}{10} \\ &= .006 \times \text{Antilog} \frac{\text{Db}}{10} \end{aligned}$$

For example the power level of 26.29 decibels of an amplifier expressed in watts will be $.006 \times \text{Antilog } \frac{26.9}{10} = 2.9$ or nearly 3 watts.

It is always a better and reliable practice to form the judgment about amplifiers on the basis of output wattage or power level in decibels and the decibel gain of the amplifier. The output of any amplifier necessarily depends upon the input voltage and if the input voltage is not mentioned in the specification of any two 30 watts amplifiers that are to be compared from the available catalogue data, the comparison will be useless; and to say that both are identical in all respects will be ridiculous even though the output of both is stated to be 30 watts. The important point is at what input voltage the amplifiers give 30 watts output. If one amplifier gives 30 watts output with an input voltage of 2 volts and the other gives 30 watts output with an input voltage of 1 volt, the latter has a higher decibel gain than the former and it must be undoubtedly preferred to the former because of its higher sensitivity. So judging the amplifiers by virtue of their output wattage alone is enormously erroneous. The input voltage and the decibel gain should also be considered. The decibel gain is proportional to 20 times the logarithm of the voltage amplification or the voltage gain. For example a circuit having a voltage gain of 43, will have a decibel gain of about 33. The decibel gain is always computed on the basis of input impedance used, and so, along with the decibel gain figure, the input impedance figure is also important. Decibel gain is very commonly expressed on the basis of 100,000 ohms input impedance.

If the specification of an amplifier gives the input and output voltage or the input and output power, the following

two formulae can be used for finding out the gain in decibels.

$$(1) \text{ Gain in db} = 10 \times \text{Log} \frac{W_o}{W_i}$$

Where W_o = Output power in watts

W_i = Input power in watts

Example :—An amplifier is driven by an input power of 2 watts. After amplification the output is 12 watts. What is the gain of the amplifier ?

$$\begin{aligned} \text{Solution} \quad \text{db} &= 10 \times \text{Log}_{10} \frac{W_o}{W_i} = 10 \times \log_{10} \frac{E_o^2}{E_i^2} \\ &= 10 \times 2 \times \log_{10} \frac{E_o}{E_i} \\ &= 20 \times \log_{10} \frac{E_o}{E_i} \\ &= 10 \times \text{Log}_{10} \frac{12}{2} \\ &= 10 \times \text{Log}_{10} 6 \\ &= 10 \times .778 \\ &= 7.78 \text{ decibels} \end{aligned}$$

$$(2) \text{ Gain in db} = 20 \times \text{Log}_{10} \frac{E_o}{E_i}$$

Where E_o = Output voltage

E_i = Input voltage

Example :—A certain amplifier has a 2 : 1 ratio input transformer and the output valve has an amplification factor of 110. What is the gain in decibels at an input voltage of 1 volt ?

Solution :—Voltage gain = $2 \times 110 = 220$

$$\begin{aligned} \text{db} &= 20 \text{ Log}_{10} \frac{220}{1} \\ &= 20 \times 2.342 \\ &= 46.8 \text{ decibels} \end{aligned}$$

(*Note* :—In Formula No. 2 it is supposed that output and input impedances are equal)

Consider two amplifiers, one of 60 watts and other of 120 watts having the same decibel gain of 125 Db. Now the question before us will be as to what is the difference between the two besides the difference in wattage. The decibel gain of both is the same and since one amplifier gives double the output of the other, it clearly shows that 120 watt amplifier requires a higher input voltage than the 60 watt amplifier. Similarly if we consider two 60 watts amplifiers having gain of 80 db and 100 db, the amplifier of 100 db gains will require a lower input voltage than the amplifier of 80 db gain i.e. it will be more sensitive than the 80 db amplifier.

It is, however, absolutely essential to know that correct decibel gain calculations are done on the basis of input and output impedances. The above decibel gain formula No. 2 will be as follows when impedances are considered.

$$\text{Db Gain} = 20 \text{ Log}_{10} \frac{E_o}{E_i} + 10 \text{ Log}_{10} \frac{Z_i}{Z_o}$$

Z_i = Input Impedance

Z_o = Output Impedance

The use of 'deribel' to indicate the "power ratios" as well as the absolute powers makes the situation confusing. To avoid this confusion a new unit for measuring absolute power is slowly coming into the field. And the unit is known as 'Volume Unit' abbreviated as VU.

DECIBEL RELATIONSHIPS

There are three main types of such relationships. One is the decibels expressed as power and voltage ratios, the second being power and voltage ratios expressed in decibels and the third relationship relates to the decibels above and below reference level expressed in watts and volts. On the following pages all these three relationships are tabulated for convenient reference.

TABLE 1
DECIBELS EXPRESSED AS POWER AND
VOLTAGE RATIOS

Voltage Ratio	Power Ratio	db	Voltage Ratio	Power Ratio
1.0000	1.0000	0	1.000	1.000
.8913	.7943	1	1.122	1.259
.7943	.6310	2	1.259	1.585
.7079	.5012	3	1.413	1.995
.6310	.3981	4	1.585	2.512
.5623	.3162	5	1.778	3.162
.5012	.2512	6	1.995	3.981
.4467	.1995	7	2.239	5.012
.3981	.1585	8	2.512	6.310
.3548	.1259	9	2.818	7.943
.3162	.1000	10	3.162	10.000
.2818	.07943	11	3.548	12.590
.2512	.06310	12	3.981	15.850
.2239	.05012	13	4.467	19.950
.1995	.03981	14	5.012	25.120
.1778	.03162	15	5.623	31.620
.1585	.02512	16	6.310	39.810
.1413	.01995	17	7.079	50.12
.1259	.01585	18	7.943	63.10
.1122	.01259	19	8.913	79.43
.1000	.01	20	10.000	100.00
.0560	.00316	25	17.78	316.20
.03162	.001	30	31.62	1,000.00
.01778	.000316	35	56.23	3,162.00
.010	.0001	40	100.00	10,000.00
.0056	.0000316	45	177.80	31,620.00
.003162	.00001	50	316.20	100,000.00
.001	.000001	60	1000.00	1,000,000.00
.0003162	.0000001	70	3162.00	10,000,000.00
.0001	.00000001	80	10000.00	100,000,000.00
.00003162	.000000001	90	31620.00	1,000,000,000.00
.00001	.0000000001	100	100000.00	10,000,000,000.00

Note:—Power Ratio is equal to number of milliwatts to reference level of 1 milliwatt. Voltage ratio is equal to the number of volts to reference level of 1 volt.

TABLE 2
POWER AND VOLTAGE RATIOS
EXPRESSED IN DECIBELS

Ratio	db (Power Ratio)	db (Voltage Ratio)
1.0	0	0
1.1	0.414	0.828
1.2	0.792	1.584
1.3	1.139	2.279
1.4	1.461	2.923
1.5	1.761	3.522
1.6	2.041	4.082
1.7	2.304	4.609
1.8	2.553	5.105
1.9	2.788	5.575
2.0	3.010	6.021
2.1	3.222	6.444
2.2	3.424	6.848
2.3	3.617	7.235
2.4	3.802	7.604
2.5	3.979	7.959
2.6	4.150	8.299
2.7	4.314	8.627
2.8	4.472	8.943
2.9	4.624	9.248
3.0	4.771	9.542
3.1	4.914	9.827
3.2	5.051	10.103
3.3	5.185	10.370
3.4	5.315	10.630
3.5	5.441	10.881
3.6	5.563	11.126
3.7	5.682	11.364
3.8	5.798	11.596
3.9	5.911	11.821

Ratio	db (Power Ratio)	db (Voltage Ratio)
4.0	6.021	12.041
4.1	6.128	12.256
4.2	6.232	12.465
4.3	6.335	12.669
4.4	6.435	12.869
4.5	6.532	13.064
4.6	6.628	13.255
4.7	6.721	13.442
4.8	6.812	13.625
4.9	6.902	13.804
5.0	6.990	13.979
5.1	7.076	14.151
5.2	7.160	14.320
5.3	7.243	14.486
5.4	7.324	14.648
5.5	7.404	14.807
5.6	7.482	14.964
5.7	7.539	15.117
5.8	7.634	15.269
5.9	7.709	15.417
6.0	7.782	15.563
6.1	7.853	15.707
6.2	7.924	15.848
6.3	7.993	15.987
6.4	8.062	16.124
6.5	8.129	16.258
6.6	8.195	16.391
6.7	8.261	16.521
6.8	8.325	16.650
6.9	8.388	16.777

Ratio	db (Power Ratio)	db (Voltage Ratio)
7.0	8.451	16.902
7.1	8.513	16.025
7.2	8.573	16.147
7.3	8.633	16.266
7.4	8.692	16.385
7.5	8.751	17.501
7.6	8.808	17.616
7.7	8.865	17.730
7.8	8.921	17.842
7.9	8.976	17.953
8.0	9.031	18.062
8.1	9.085	18.170
8.2	9.138	18.276
8.3	9.191	18.382
8.4	9.243	18.486
8.5	9.294	18.588
8.6	9.345	18.690
8.7	9.395	18.790
8.8	9.445	18.890
8.9	9.494	18.988
9.0	9.542	19.085
9.1	9.590	19.181
9.2	9.638	19.276
9.3	9.685	19.370
9.4	9.731	19.463
9.5	9.777	19.554
9.6	9.823	19.645
9.7	9.868	19.735
9.8	9.912	19.825
9.9	9.956	19.913
10.0	10.000	20.000

TABLE 3
DECIBELS ABOVE AND BELOW REFERENCE
LEVEL EXPRESSED IN WATTS AND VOLTS

DB DOWN		Power Level	DB UP	
Volts	Watts		Volts	Watts
1.73	6.00×10^{-3}	-0+	1.73	.00600
1.54	4.77×10^{-3}	1	1.94	.00755
1.38	3.87×10^{-3}	2	2.18	.00951
1.23	3.01×10^{-3}	3	2.45	.01200
1.09	2.39×10^{-3}	4	2.75	.01510
.974	1.90×10^{-3}	5	3.08	.0190
.868	1.51×10^{-3}	6	3.46	.0239
.774	1.20×10^{-3}	7	3.88	.0301
.690	9.51×10^{-4}	8	4.35	.0387
.615	7.55×10^{-4}	9	4.88	.0477
.548	6.00×10^{-4}	10	5.48	.0600
.488	4.77×10^{-4}	11	6.15	.0755
.435	3.87×10^{-4}	12	6.90	.0951
.388	3.01×10^{-4}	13	7.74	.1200
.346	2.39×10^{-4}	14	8.86	.1510
.308	1.90×10^{-4}	15	9.74	.1900
.275	1.51×10^{-4}	16	10.93	.2390
.245	1.20×10^{-4}	17	12.27	.301
.218	9.51×10^{-5}	18	13.76	.387
.194	7.55×10^{-5}	19	15.44	.477
.173	6.00×10^{-5}	20	17.32	.600
.0974	1.90×10^{-5}	25	30.8	1.90
.0548	6.00×10^{-6}	30	54.8	6.00
.0308	1.90×10^{-6}	35	97.4	19.00
.0173	6.00×10^{-7}	40	173.0	60.00
.00974	1.90×10^{-7}	45	308.0	190.00
.00548	6.00×10^{-8}	50	548.0	600.00
.00173	6.00×10^{-9}	60	1,730.0	6,000.00
.000548	6.00×10^{-10}	70	5,480.0	60,000.00
.000173	6.00×10^{-11}	80	17,300.0	600,000.00

Note:—Reference level 6 mW into 500 ohms.

TABLE 4
DECIBELS AND VOLTAGE RATIOS

Decibels	$\frac{V_2}{V_1}$	$\frac{V_1}{V_2}$
0.1	1.0116	0.98855
0.2	1.0233	0.97724
0.3	1.0351	0.96605
0.4	1.0471	0.95499
0.5	1.0593	0.94406
0.6	1.0715	0.93325
0.7	1.0839	0.92257
0.8	1.0965	0.91201
0.9	1.1092	0.90157
1.0	1.1220	0.89125
1.2	1.1482	0.87096
1.4	1.1749	0.85114
1.6	1.2023	0.83176
1.8	1.2303	0.81283
2.0	1.2589	0.79433
2.2	1.2882	0.77625
2.4	1.3183	0.75858
2.6	1.3490	0.74131
2.8	1.3804	0.72444
3.0	1.4125	0.70795
3.5	1.4962	0.66834
4.0	1.5849	0.63096
4.5	1.6788	0.59566
5.0	1.7783	0.56234
5.5	1.8836	0.53088
6.0	1.9953	0.50119
7.0	2.2387	0.44668
8.0	2.5119	0.39811
9.0	2.8184	0.35481
10.0	3.1623	0.31623

Decibels	$\frac{V_2}{V_1}$	$\frac{V_1}{V_2}$
12.0	3.9811	0.25119
14.0	5.0119	0.19953
16.0	6.3096	0.15849
18.0	7.9433	0.12589
20.0	10.0000	0.10000
22.0	12.589	0.07943
24.0	15.849	0.06310
26.0	19.953	0.05012
28.0	25.119	0.03981
30.0	31.623	0.03162
32	39.811	0.02512
34	50.119	0.01995
36	63.096	0.01585
38	79.433	0.01259
40	100.000	0.01000
42	125.890	0.00794
44	158.490	0.00631
46	199.530	0.00501
48	251.190	0.00398
50	316.230	0.00316
52	398.11	0.00251
54	501.19	0.00199
56	630.96	0.00158
58	794.33	0.00126
60	1,000.00	0.00100
65	1,778.30	0.00056
70	3,162.30	0.00032
80	10,000.00	0.00010
90	31,623.00	0.00003
100	100,000.00	0.00001

SECTION V

COILS

UNITS OF INDUCTANCE

Henry, Millihenry and Microhenry are the three units usually employed in inductance measurement, and they are related to one another as follows :—

$$1000 \text{ Microhenrys} = 1 \text{ Millihenry}$$

$$1000 \text{ Millihenrys} = 1 \text{ Henry}$$

Millihenry is abbreviated as mH and Microhenry as μH .

INDUCTANCES IN SERIES

$$L = L_1 + L_2, \dots \text{etc.} \quad \dots \quad \dots \quad (1)$$

Where L = Total Effective Inductance

L_1, L_2 = Individual Inductances

In the above formula it is assumed that the inductances L_1 and L_2 are far enough apart so that the mutual inductance is entirely negligible, making the coupling loose.

When “mutual inductance” has to be considered the formula would be as follows for series connection :—

$$\begin{aligned} L \text{ series} &= (L_1 + M) + (L_2 + M) \\ &= L_1 + L_2 + 2M \quad \dots \quad \dots \quad \dots \quad (2) \end{aligned}$$

Where M = Mutual Inductance

INDUCTANCES IN PARALLEL

$$L = \frac{L_1 L_2}{L_1 + L_2} \quad \dots \quad \dots \quad \dots \quad (3)$$

As before it is assumed that mutual inductance is negligible. The correction for mutual inductance will be as follows :-

$$L \text{ Parallel} = \frac{L_1 L_2 - M^2}{L_1 + L_2 - 2M} \quad \dots \quad \dots \quad \dots \quad (4)$$

Where M = Mutual Inductance

Formulae (2) and (4) are based on the assumption that the coils (inductances) are connected in such a way that all flux linkages are in the same direction i.e, the coils are wound in the same direction. If the coils are in opposition(-M) should be substituted in place of M in formulae (2) and (4).

INDUCTIVE REACTANCE

The property of an inductance to oppose a change in current is known as its Inductive Reactance which is expressed as X_L and calculated as follows :—

$$X_L = 2 \pi f L \quad \dots \quad \dots \quad \dots \quad (5)$$

Where X_L = Inductive Reactance in ohms

$$\pi = 3.142 \left(\frac{22}{7} \right)$$

f := Frequency in Cycles

L = Inductance in Henrys

In the above formula (5) inductance L can be expressed in millihenrys provided frequency f is expressed in Kilocycles. Similarly, if inductance need be expressed in microhenrys then the frequency must necessarily be expressed in Megacycles.

By transposition of formula 5

$$L = \frac{X_L}{2 \pi f} \quad \dots \quad \dots \quad \dots \quad (6)$$

or

$$f = \frac{X_L}{2 \pi L} \quad \dots \quad \dots \quad \dots \quad (7)$$

INDUCTANCE OF A COIL (having air core)

There are a number of formulæ for calculation of inductance of coils, and to avoid confusion, when reference is sought, only a few important ones are given here :—

$$L = \frac{0.2 A^2 N^2}{3A + 9B + 10C} \dots \dots \dots (8)$$

Where L = Inductance in microhenrys

A = Mean diameter of coil in inches

B = Length of winding in inches

C = Radial depth of winding in inches

N = Number of turns

In calculations of single layer coils the quantity 10 C can be safely neglected.

By transposition of the above formula No. 8, a useful derivation is arrived at for calculating the number of turns in a single layer coil

$$N = \sqrt{\frac{3A + 9B}{0.2A^2} \times L} \dots \dots (9)$$

Example :—What will be the inductance of a coil having 36 turns of No. 30 D. S. C. wire, wound on a 1.5 inch coil form ?

On referring to wire tables it is found that 36 turns of No. 30 D. S. C. wire will occupy about .51 inch length. So the value of B in formula (8) should be taken as .51 whereas A is given to be equal to 1.5 and N equal to 36

$$\begin{aligned} \therefore L &= \frac{0.2 \times (1.5)^2 \times (36)^2}{(3 \times 1.5) + (9 \times .51)} \\ &= 61 \text{ microhenrys} \end{aligned}$$

There is another formula due to Mr. J. H. Reyner which gives the inductance direct in microhenrys for air core coils

$$L_{\mu H} = \underbrace{\frac{0.2n^2D^2}{3.5D + 8l}}_{\text{1st term}} \times \underbrace{\frac{D - 2.25d}{D}}_{\text{2nd term}} \dots \quad (10)$$

Where D = Diameter of coil

l = Length of coil

d = Radial depth of winding

n = Number of turns

All dimensions necessary in the above formula are in inches. According to Mr. Reyner the formula holds good for practical purposes where slide rule accuracy is not required, and, has an accuracy of about 2% within the following limits:

$$\frac{d}{D} = 0 \text{ to } \frac{d}{D} = 0.3$$

and

$$\frac{l}{D} = 0 \text{ to } \frac{l}{D} = 2.0$$

In the above formula (10) only the first term is required for single-layer coils whereas the second term is the correction necessary for calculations of multilayer coils.

According to Nagaoka's method, the inductance of a single-layer close-wound coil wound on a cylindrical former is calculated by the following formula:—

$$L = \frac{\pi^2 d^2 n^2 l k}{1000} \dots \dots \dots \quad (11)$$

Where L = Inductance in microhenrys

d = Diameter of coil in centimetres

l = Length of coil in centimetres

n = Number of turns per centimetre

K = Nagaoka's constant

$$\pi = 3.142 \left(\frac{22}{7} \right)$$

The following table gives the values of K for different d/l ratios.

$\frac{d}{l}$	K	$\frac{d}{l}$	K
0.00	1.000	2.00	0.5260
0.10	0.959	2.25	0.4972
0.20	0.920	2.50	0.4719
0.30	0.884	2.75	0.4545
0.40	0.850	3.00	0.4292
0.50	0.818	3.25	0.4117
0.60	0.788	3.50	0.3944
0.70	0.761	3.75	0.3743
0.80	0.735	4.00	0.3654
0.90	0.711	5.00	0.3200
1.00	0.6880	6.00	0.2850
1.25	0.6381	7.00	0.2580
1.50	0.5950	8.00	0.2370
1.75	0.5579	9.00	0.2180
		10.00	0.2030

For a single layer close-wound coil, the coil of maximum inductance, from a given length of wire is given by the following ratio :—

$$\frac{\text{Diameter}}{\text{Length}} = 2.4 \dots \dots \dots (12)$$

INDUCTANCE OF A COIL (having magnetic core)

$$L = \frac{1.257 \times N^2 P}{10^8} \dots \dots \dots (13)$$

Where L = Inductance in henrys

N = Number of turns

P = Permeability of core material

It is evident from the above formula that inductance of a magnetic core coil is proportional to the square of the number of turns and also to the permeability of the core material. This effect gives greater values of inductance with a given number of turns of wire wound on magnetic core than would be possible with an air core.

RESONANT FREQUENCY

At resonant frequency the Capacitive Reactance is always equal to Inductive Reactance :

$$2\pi fL = \frac{1}{2\pi fC}$$

$$\text{or } f^2 = \frac{1}{4\pi^2 LC}$$

$$\text{or } f = \frac{1}{2\pi\sqrt{LC}} \quad \dots \quad \dots \quad (14)$$

where f = Frequency in cycles

L = Inductance in henrys

C = Capacity in farads

To facilitate radio frequency calculations the following formula using smaller units of Inductance and Capacity may be used.

$$f^2 = \frac{25330}{LC} \quad \dots \quad \dots \quad \dots \quad \dots \quad (15)$$

$$L = \frac{25330}{f^2 C} \quad \dots \quad \dots \quad \dots \quad \dots \quad (16)$$

$$C = \frac{25330}{f^2 L} \quad \dots \quad \dots \quad \dots \quad \dots \quad (17)$$

Where f = Frequency in megacycles

L = Inductance in microhenries

C = Capacity in micro-microfarads

Wave-length of an oscillatory circuit is given by formula given below :

$$\text{Wave-length (Metres)} = 1885 \sqrt{LC} \dots (18)$$

Where L = Inductance in microhenrys

C = Capacity in microfarads

When inductance and capacity are fixed the circuit will resonate only at one frequency. But since it is desired to receive numerous frequencies, the capacity (gang condenser) is kept variable.

LC VALUES FOR DIFFERENT FREQUENCIES

Metres	Megacycles	$L \times C$ ($\mu\text{H} \times \mu\text{fd}$)
10	30	0.0000282
15	20	0.0000635
20	15	0.0001129
25	12	0.0001755
30	10	0.0002530
35	8.5	0.0003446
40	7.5	0.0004500
45	6.67	0.0005700
50	6.00	0.0007040
55	5.45	0.0008520
60	5.00	0.001014
85	3.52	0.002030
90	3.33	0.002280
95	3.15	0.002541

Metres	Kilocycles	$L \times C$ ($\mu\text{H} \times \mu\text{fd}$)
190	1579	0.01015
200	1500	0.01126
210	1429	0.01241
220	1364	0.01362
230	1304	0.01489
240	1250	0.01621
250	1200	0.01759
260	1154	0.01903
270	1111	0.02050
280	1071	0.02210
290	1034	0.0237
300	1000	0.0253
310	968	0.0270
320	938	0.0288
330	909	0.0306
340	883	0.0325
350	857	0.0345
360	834	0.0365
370	811	0.0385
380	790	0.0406
390	769	0.0428
400	750	0.0450
410	732	0.0473
420	715	0.0496
430	698	0.0520
440	682	0.0545
450	667	0.0570
460	652	0.0596
470	639	0.0622
480	625	0.0649
490	612	0.0676
500	600	0.0704

It will be observed from the above tables that higher the frequency (lower the wave-length) lower the LC value required. LC value required for the foreign shortwave band (10 meters to 50 meters) is from .0000282 to .000704 whereas LC value for the broadcast band (200 meters to 500 meters) is from .01126 to .0704. In due consideration of the fact that C (the variable gang condenser) in modern radio sets remains the same, the L i. e. coils for shortwave band must have lower inductance than that required for broadcast band coils. This indicates that coils on foreign shortwave band will have lowest number of turns and the broadcast band coils will have the highest number of turns.

‘Q’ OF THE COIL

The ratio of inductive reactance of a coil to its resistance is called Q :—

$$Q = \frac{2\pi fL}{R} = \begin{array}{c} \text{Goodness Factor} \\ \text{or} \\ \text{Factor of Merit} \end{array} \quad \dots \quad \dots \quad (19)$$

An ideal coil should have large Q. When the length of the coil is made equal to its diameter it gives high Q. Diameter of wire and the spacing between them influence the Q of the coil. Spaced winding increases the Q. In the above formula, R is the sum of the D. C. resistance and A. C. resistance of the coil.

OSCILLATOR COILS

A vast majority of modern radio receivers employ the “Tickler—Feed-back” in the oscillator section.

Fig. 6 shows the conventional tickler feed-back employing the tickler coil and the secondary. Those few radio sets that do

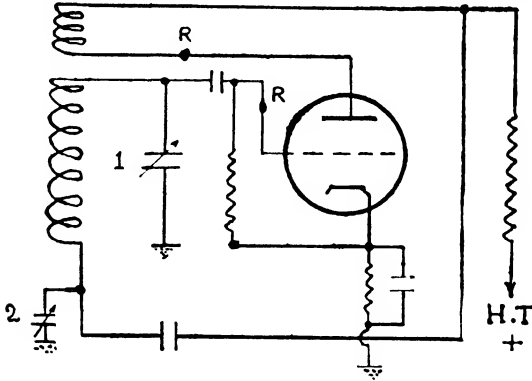

1 = Gang Condenser

2 = Padder

FIG. 6

not employ the tickler feed-back are made to oscillate by virtue of feed-back across a padding condenser, as shown in Fig 7.

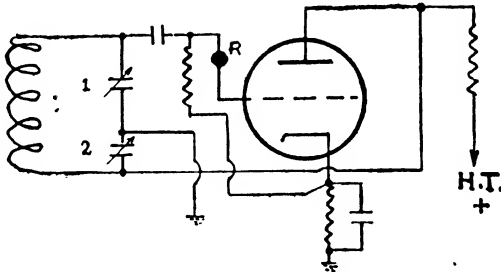

1 = Gang Condenser

2 = Padder

FIG. 7

OSCILLATOR COIL REPAIRS

Coil breakdowns are common faults and many a times a tough service problem. In majority of cases exact replacement is not available in India. As has been stated above a vast majority of oscillator circuits consist of a low

impedance "tickler coil" coupled to a tuned secondary. The tickler coil serves to feedback energy from plate circuit into grid circuit and thus create oscillations. It is the 'tickler coil', that carries the D. C. voltage to the plate, usually fails. Either it develops short circuit or an open circuit.

It is common experience that in the short wave oscillator coils, the tuned secondary is wound in single layer and the tickler winding is wound in another single layer adjacent to or sometimes over or at times between the turns of the secondary. In such cases if the tickler fails, it is easy to remove it and put a new winding in its place.

Before any attempt is made to remove the defective tickler coil, care must be taken to adopt the following procedure :—

- (1) Draw a rough sketch showing the position of the coil
- (2) Make a note of the different connections i. e. wires going to the different lugs on the coil
- (3) Make special note of the lugs to which the defective tickler is connected.

Now disconnect the coil and proceed as follows :—

- (1) Note the direction of the winding. This is very important. Wrong direction means no oscillations
- (2) Count the number of turns very carefully
- (3) Note carefully the spacing, if any, between the turns
- (4) Find out the gauge of wire used
- (5) Look for the insulation employed. Enamel, S. C. C. or S. S. C. etc,

In cases where a tickler exhibits a small break, it is possible to take out the entire length of wire as a guide to take the new wire of exactly the same length and wind it on the former. In such cases if only the space occupied by the tickler is noted before hand, it is not necessary to count the number of turns very carefully. Having taken the exact length it should be wound in the space till you finish the wire. When the winding is removed the marks left behind on cement or wax serve as a guide for locating the position of the tickler, and spacing between turns and length occupied by the winding.

On many occasions it so happens that being in haste, a slipshod sketch of lug connections is drawn, the coil taken out and estimate given to the customer. The customer takes a week or two to approve of the estimate and in the meantime the sketch is lost somewhere or if at all it is there, nothing could definitely be gathered from the sketch, the latter having been drawn in a slipshod manner. When such confusion arises try out and find the tickler direction as follows. :

Since only the tickler is removed the tuned secondary is still on the former. Find out the grid end of the secondary and follow around the turns of the secondary and proceed to the tickler in the same direction. Then one enters the tickler at the low potential end and ends at the plate.

Sometimes it is observed that after winding the tickler coil and connecting it in its proper place, whistles, twitter and a sort of over-oscillation is produced. When a thing like this happens, if possible reduce the number of turns of tickler coil otherwise a suppressor resistance of 10 to 100 ohms value may be connected at points R shown in Figs. 6 and 7.

OSCILLATOR COILS with (Universal Criss-Cross winding)

The discussion so far was confined to oscillator coils of single layer construction only. But in many sets coils of universal type of winding are not uncommon. A rough classification of the construction of such coils would be as follows :—

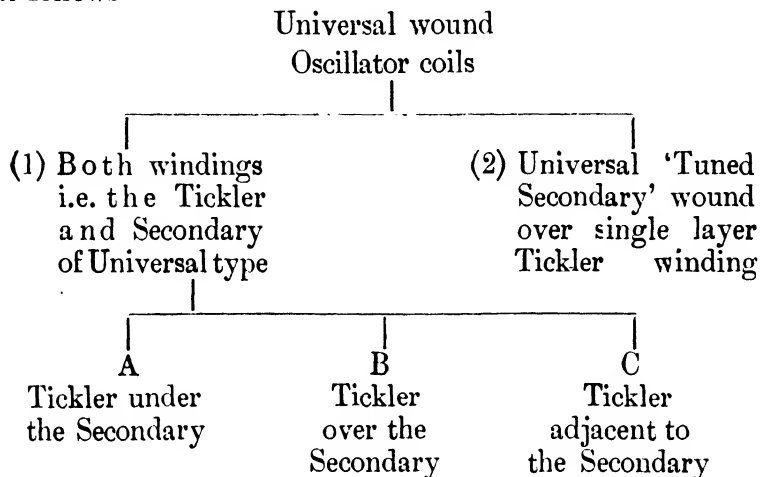

Out of the whole lot shown above, the repair to type A is very difficult. When the tickler of this type develops some fault, the secondary, which is wound above the tickler, has first to be taken out very carefully. The secondary should not be unwound while being taken out, but an attempt to take out as it is should be first made by carefully warming the coil former just below the secondary winding and then forcing the winding as a whole to slide out and away from the former. If the attempt meets with any success well and good ; otherwise the tickler and the secondary have both to be rewound. Take exact length of the wire of exact gauge as of the old coil and rewind a new coil, on a machine that gives the universal winding. If such machine is not available a machine giving honey-comb effect will do.

If by mistake the tickler gets too many turns than required, parasitic oscillations will result and if the turns are less the set may fail to oscillate at the high capacity end of the gang condenser. If the direction of the winding is not correct the set will not oscillate at any point.

Type B and C are comparatively convenient for repairs, the tickler being above and adjacent to the secondary.

UNIVERSAL ADJUSTABLE INDUCTANCE COILS

These are available in the market and should prove of immense value where time at disposal is very short. The coil, after connecting, can be quickly adjusted to match the dial calibration of the set. All such coils carry with them complete instructions about connecting them and the subsequent calibrations.

R. F. COILS

The R. F. coil system used in modern receivers can be classified as shown below :—

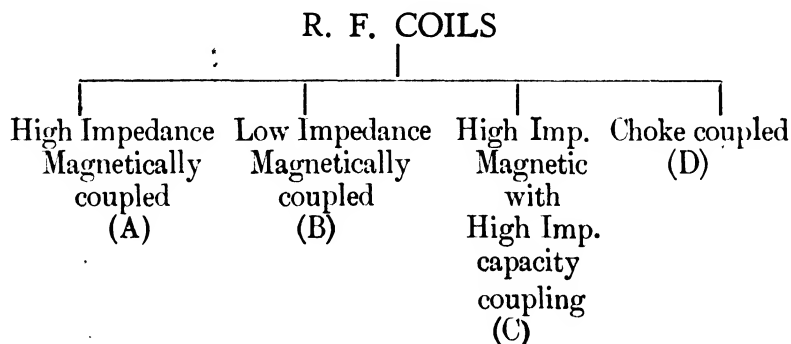

The type A is universally used in broadcast range of receivers. It has good gain and a good image ratio.

Type B gives the highest gain and as such is universally used on short wave band. Type C also will be found in many receivers and so also Type D.

REPAIRS TO R. F. COILS

In the r. f. coil system, usually the primary winding fails due to open circuit or short circuit. As in oscillator coils here too the secondary is wound with close tolerances of inductance. In case of oscillator coils the "tickler" and in case of R. F. coils the primary has broad tolerances of inductance. These are the coils that fail in majority of receivers and since they have broad tolerances the repairs do not present a big problem. The primaries of short wave band usually consist of few turns of No. 34 to 38 S. S. E. wire

Before taking out the coil proceed on the same lines as you would proceed with the repairs of oscillator coils. After repairs place the coil in position and re-align the receiver. If it is found while aligning that more capacity at 600 KC is necessary then move the rewound primary farther away from the secondary. On the other hand if the capacity is more at 600 KC move the primary closer to the secondary. A convenient method, due to Mr. L. V. Sorenson of checking tuning capacity at 600 KC is given below :—

"Connect signal generator and feed a signal of 600 KC to the receiver with an output meter connected to it. Now insert a thin piece of celluloid, between the plates of tuning condenser, while watching the output meter. This action will add a little capacity to one section of the tuning condenser without changing the tuning of the other circuits. If the meter reading increases when the celluloid piece is inserted, the capacity is too low and primary should be moved away from the secondary. If the meter reading decreases the capacity may be correct or high. The primary should then be moved gradually nearer to the secondary till a point is reached on the meter when it is about to show an increase."

ANTENNA COILS

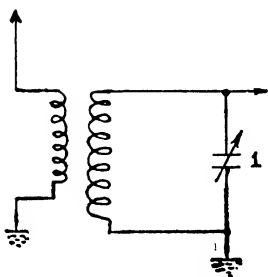

High Imp. Primary
Inductive coupling
1 = Tuning condenser
FIG. 8

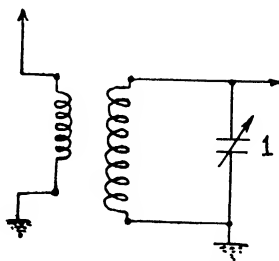

Low Imp. Primary
Inductive coupling
1 = Tuning condenser
FIG. 9

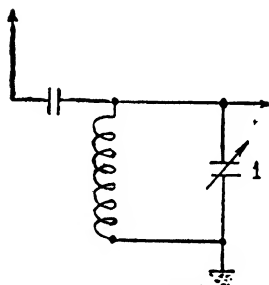

High Impedance
Capacitive coupling
1 = Tuning condenser
FIG. 10

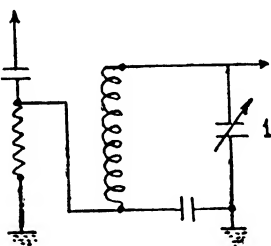

Low Impedance
Capacitive coupling
1 = Tuning condenser
FIG. 11

The antenna coils employed in modern receivers are of the following four types:-

- 1 High Impedance Primary-Inductive coupling
- 2 High Impedance Capacitive coupling
- 3 Low Impedance Primary-Inductive coupling
- 4 Low Impedance Capacitive coupling

Of the above four types No. 1 is commonly used in broadcast range of receivers. It has a good image ratio and reasonable gain. The No. 2 has a poor image ratio and is directly coupled to the grid through a condenser of 1 to 10 mmfd. It is said that No. 3 is cheaper to manufacture than No. 1 and because of the higher antenna gain this type is exclusively used in short wave band. The type No. 4 is very commonly found in automobile receivers. It has very high gain and excellent image ratio. Figs 8-11 show all these types of antenna coils.

REPAIRS TO ANTENNA COILS

Same precautions, as in case of oscillator and R. F. coils, should be taken before and after taking out the antenna coils for repairs or rewinding.

COILS IN SECTIONS

In many receivers it will be found that some windings have been sectionalised. Such a coil is shown in Fig. 12

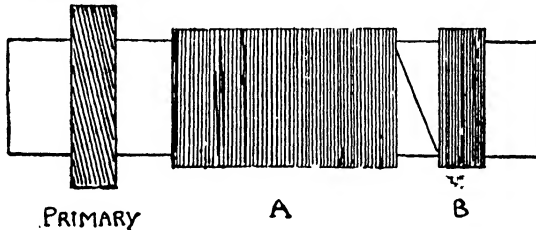

FIG. 12

where the secondary is wound in two sections A and B. The purpose of this type of coil construction is to facilitate correct single dial tuning. Such a coil gives better tracking throughout the broadcast range. Therefore, if a coil of this type has to be rewound care must be taken to mark carefully the place where section 'A' ends and the section 'B' begins. It is a good practice to count the number of turns in both the sections.

COIL SHIELDS

In almost every receiver the coils are shielded. The shield reduces the inductance of a coil and on the other hand increases its distributed capacity, with the result that the effective inductance of the coil changes. Round-shaped shields are preferable to square-shaped ones because of the higher Q of the former. The shields of all the coils should be perfectly grounded. If there is a poor contact between the shield and the chassis the coil inductance will change and proper alignment may not be possible, and so also "dead" spots may result.

For 'Inductance of a coil when shielded' Section II of Volume I should be referred.

60 AND 90 METRE BANDS

With the introduction of 60 and 90 metre broadcasts by All India Radio these bands assumed a great importance. Onwards 1940, almost all the imported sets included factory calibrated 60 and 90 metre bands but previous to that many sets arrived in the market without these bands and such models are still in use in numbers. The owners of such models do require their service engineers to incorporate the 60 and 90 metre bands in their sets. There are four methods described below, that are recommended for such conversion.

'PARALLEL INDUCTANCE' METHOD 1

In this method use is made of parallel inductances (coils) connected across the oscillator, antenna and R. F. coils. The operation to be carried, being on the medium wave section of the set, does not disturb the calibration of the short wave range and the stray capacities due to additional coils, connecting wires, switch etc. have very negligible effect on the medium wave band. The wave range incorporated by these parallel inductances across the medium wave band coils, will nicely cover the 60 and 90 metre bands. The question is often asked by some, as to why not the additional coils, in series. If the resonant frequency formula No. 16, on page 82, is considered the answer to the above question is not far away.

$$L = \frac{25330}{f^2 C}$$

The medium wave band has a frequency coverage of, from 1500 KC to 600 KC whereas the frequency coverage desired for 60 and 90 metre band is from 5000 KC to 3500 KC.

The capacity C of the gang condenser being constant, within limits, L the inductance of the coil will have to be reduced. Connecting inductances in parallel reduces the effective inductance whereas if the additional inductance is connected in series the total effective inductance will be increased. A suitable double pole single throw toggle switch will have to be provided to 'cut in' and 'cut out' the additional coil.

First wind about 20 to 30 turns of No. 30 to 32 S. W. G. enamelled wire on a $\frac{1}{2}$ " cylindrical former. Connect this coil across the tuned secondary of the medium band oscillator coil. Now switch on the receiver to the medium wave band. Feed a signal from the signal generator to the grid of the mixer valve and find out the range to which the receiver now tunes. Sometimes it may be noticed that the signal frequency can be tuned at two dial pointer positions. Since it is advisable to have the oscillator frequency higher than the signal frequency, the high frequency setting of the dial pointer should be used. Having done this the number of turns on the additional coil can be decreased or increased to cover the 60 and 90 metre bands. About 25 to 30 turns of 31 S. W. G. enamelled wire close-wound on a $\frac{1}{2}$ " cylindrical former may serve the purpose all right, as far as the oscillator section is concerned.

Having finished with the oscillator section the aerial circuit may now be touched. Wind another coil on half inch cylindrical former with 30 to 40 turns of No. 30 to 32 S. W. G. enamelled wire, close-wound. It should be noted, however, that the coil should be first wound with a few more turns than are required for the oscillator coil. Now the coil should be connected across the tuned secondary of the medium wave band antenna coil. Before connecting the coil,

care should be exercised to see that the A. V. C. voltage that is being applied to the mixer stage should not get shorted due to this new coil. If there are chances of such a short circuit, it is advisable to connect a suitable capacity—preferably a value between .003 to .007 mfd—in series with the new coil.

In case of oscillator coil the signal frequency from the signal generator was fed at the grid of the mixer valve, but in the aerial coil it should be applied to the aerial and earth post of the receiver. Feed a signal of 4 megacycles and tune the receiver for maximum output. This can be done either aurally or with the help of an output meter. However, the exact trimming may be done by a tuning wand. If the response increases when the brass end of the tuning wand is inserted in the coil the number of turns may be decreased. Increase of audio response, with the iron end inserted in the coil, is an indication that more turns are required. When the coil is properly trimmed the insertion of either end of the wand will result in decreasing the audio output. If on the other hand it is found that either end of the tuning wand has no effect on the output, it clearly means that the number of turns on the new coil are far away from the correct value.

For a receiver having a R. F. stage proceed as in case of aerial coil and connect the new coil across the medium band r. f. tuned coil.

'PARALLEL CAPACITY' METHOD 2

So far the discussion had been centred around the method of parallel inductance across the original medium wave band coils. If we further study the following formula three more methods, of incorporating .60 and 90 metre bands, strike our imagination.

$$L = \frac{25330}{f^2 C} \quad \text{or} \quad LC = \frac{25330}{f^2}$$

To decrease L, the C has to be increased. In the above case the L was decreased by adding parallel inductances across the original inductances on medium wave band i. e. it was a case of going to high frequency (60 and 90 metres or 5 and 3.5 magacycles) from original lower frequency (600 to 1500 KC). In the other method one has to work out from higher frequency (7 to 22 magacycles) to a lower frequency (3 to 5 magacycles). This means the f in the above formula is lower and consequently the product LC should be higher for 3 to 5 magacycles than what it is for 7 to 22 magacycles. And if it is decided not to touch the short wave inductance, it stands to reason to say that the LC product can be increased to desired value by increasing C. And this can be done by providing capacity in parallel with the short wave coils i. e. across the short wave trimmer capacities. This system is expensive than the first one and usually results in a particularly narrow band coverage due to the small variation of capacities possible towards the high frequency end of the tuning condenser. The variable capacities that are usually required for such use, in different sets, generally vary between 20 to 60 mmfd. All such capacities must be adjusted for correct value with the help of a signal generator and by adding or subtracting small capacities, One such small trimmer across each coil (oscillator, aerial and r. f. coil system) will have to be provided and a suitable toggle switch will have to be arranged for. In connecting these additional trimmers utmost care has to be taken to see that the connecting wires between the toggle switch and the trimmers do not dangle about over the wiring of the set. This will result in disturbing the calibration of the short wave band due to the distributed capacity of the wires. The best method is to adopt connecting bus wires instead of ordinary hook-up wire.

These bus wires being thick do not dangle about and disturb the calibration. The exact values of such additional trimmers are determined and set on the basis of the fact that the set must resonate when the 60 and 90 metre band signals are fed to the set from a signal generator.

Out of the above two methods the second—parallel capacity—is very commonly used by servicemen but the author, from his own experience, can put it down that the method of parallel inductances is far better in performance than the other one. When it is only a question of adding either 60 or 90 metre band the 'Parallel Capacity' method may be resorted to since it is comparatively less laborious than the 'Parallel Inductance' method.

'SERIES INDUCTANCE' METHOD 3

If a further study of the same formula is made, yet another method strikes the imagination. This method, as will be presently seen, consists of providing inductances in series with the short wave coil. The LC product can be increased by increasing L which means by adding inductances in series with the short wave coil. But since the dimensioning of the extra inductances required and the switching arrangement becomes complicated this method will not be very popular.

'SERIES CAPACITY' METHOD 4

For achieving results from this method it is obvious that the operations are to be performed on the medium wave band tuned section of the receiver. The LC product has to be decreased. In case of the first method i.e. 'parallel inductance', the LC product was decreased by providing parallel inductances across the medium band it can be clearly observed that the same decrease in LC product can be achieved by providing capacities in series with the medium wave band trimmers, since such provision lowers the effective

capacity. This method too, being as complicated as method No. 3, will not find much encouragement.

In cases where the long wave band (500 meters and above) is already there, the 60 and 90 metre band can be incorporated by removing the long wave coils and connecting new coils that will cover a band width of say 50 to 100 meters. Such trials can be made by winding 50 to 80 turns of 32 to 34 S. W. G. enamel wire on $\frac{1}{2}$ " former, for aerial and r. f. coils and about 40 to 60 turns of the same gauge of wire on $\frac{1}{2}$ " former for oscillator coil.

MEASUREMENT OF INDUCTANCE

There are two methods that are generally employed in the measurement of Inductance. The first being the 'Impedance Method' and the second being the 'Comparison Method'. In routine day to day servicing, one seldom comes across occasions where measurement of inductance has to be carried out, but it should be a distinct advantage to know the most simple and practical methods for this measurement, should such occasion arise.

IMPEDANCE METHOD (for air core coils)

This method involves the use of an ammeter, a voltmeter and a wattmeter. The inductance for any coil can be found by measuring the current that flows through the coil when an alternating voltage is impressed across the coil. Then the impedance Z of the coil will be equal to voltage divided by current.

$$Z = \frac{E}{I} \text{ ohms}$$

If the d. c. resistance of the coil is negligible the inductive reactance of the coil (X_L) can be assumed to be equal to the impedance of the coil (Z).

$$Z = X_L = 2\pi fL \text{ or } L = \frac{X_L}{2\pi f} \text{ Henries}$$

In cases where the d. c. resistance is not considered to be negligible and accurate results are desired the following formula will be more useful :—

$$L = \frac{\sqrt{\left(\frac{E}{I}\right)^2 - R^2}}{2\pi f} \text{ Henries}$$

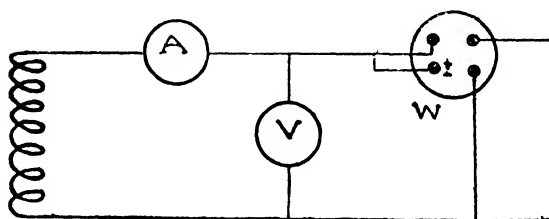

FIG. 13

The actual circuit for the measurement is shown in Fig. 13, where A, V and W are ammeter, voltmeter and wattmeter respectively. The readings of each meter are noted after impressing an a. c. voltage of known frequency. And the interpretation of the readings obtained on the meters can be done on the basis of the following formulae :—

$$I^2R = W$$

$$R = \frac{\text{Watts}}{I^2} \text{ ohms} \quad \dots \quad \dots \quad (1)$$

$$\text{Impedance} = Z = \frac{E}{I} \text{ ohms} \quad \dots \quad \dots \quad (2)$$

$$\text{Inductive Reactance} = X_L = \sqrt{Z^2 - R^2} \text{ ohms}$$

$$L = \frac{X_L}{2\pi f} \text{ Henries}$$

For a. c. voltage of 50 cycles frequency the inductance will be equal to

$$\begin{aligned} & \frac{X_L}{2\pi \times 50} \\ & = 0.0031 X_L \text{ Henries} \end{aligned}$$

Coils of one millihenry or higher can be measured at power frequencies but those below this value should be measured at radio frequencies with the aid of V. T. Voltmeters. This method and another, where the inductance of the coil can be determined by resonating the coil with a calibrated condenser, are beyond the scope of this book.

COMPARISON METHOD

This method involves the use of the famous bridge circuits and standard inductances. This method too will not be discussed here, because it is more or less an aid to the designer and not to the serviceman, and therefore, the latter will hardly find anything interesting in it.

IMPEDANCE CALCULATIONS

The simple application of ohm's law will not be justified when a circuit containing resistance and capacity or resistance and inductance or resistance, inductance and capacity is to be considered. Since Capacitive Reactance and Inductive Reactance offer a resistance to the flow of alternating current, these reactances have also to be considered along with the d. c. resistance.

CIRCUIT HAVING RESISTANCE AND CAPACITY

$$Z = \sqrt{R^2 + \left(\frac{1}{2\pi fC}\right)^2}$$

Where Z = Impedance in ohms

R = Resistance in ohms

$\frac{1}{2\pi fC}$ = Capacitive Reactance in ohms

CIRCUIT HAVING RESISTANCE AND INDUCTANCE

$$Z = \sqrt{R^2 + (2\pi fL)^2}$$

Where Z = Impedance in ohms

R = Resistance in ohms

$2\pi fL$ = Inductive Reactance in ohms

CIRCUIT HAVING RESISTANCE, INDUCTANCE AND CAPACITY

$$Z = \sqrt{R^2 + \left(2\pi fL \infty \frac{1}{2\pi fC} \right)^2}$$

Where Z = Impedance in ohms

R = Resistance in ohms

$\frac{1}{2\pi fC}$ = Capacitive Reactance in ohms

$2\pi fL$ = Inductive Reactance in ohms

∞ = Numerical difference between the two quantities.

If a 15 henry choke, a 4 mfd condenser are connected in series across a 50 cycle source of voltage, what will be the impedance offered by this combination? The d. c. resistance of the choke is 20 ohms.

$$\begin{aligned} X_L = \text{Inductive Reactance} &= 2 \pi fL \\ &= 6.28 \times 50 \times 15 \\ &= 4725 \text{ ohms (approx.)} \end{aligned}$$

$$\begin{aligned} X_C = \text{Capacitive Reactance} &= \frac{1,000,000}{6.28 \times 50 \times 4} \\ &= 796 \text{ ohms (approx.)} \end{aligned}$$

Substituting the above values in the Impedance formula, the impedance

$$Z = \sqrt{(20)^2 + (4725 \infty 796)^2} \text{ ohms}$$

SECTION VI

SERVICE INSTRUMENTS

TYPES

There is a vast variety of meters available for testing purposes. For different applications there are different meters. There are cheap meters and costly too. One is said to be moving coil type whereas the other as moving vane type and a third is called electrostatic voltmeter. Whether it is this or that, the entire metre family can be classified in only two basic types.

- 1 Electrostatic Meter
- 2 Current Meter

The Electrostatic Meter operates due to the stationary electric charge whereas the operation of the Current Meter is dependent on the moving electric charges. Voltmeters (except the electrostatic voltmeters) Ammeters, Wattmeters, Db. Meters, V. T. Voltmeters, Thermocouple Meters, Moving Iron Meters, Moving Vane Meters, Moving Coil Meters etc. are basically Current Meters. The meter that is very widely and extensively used in every radio workshop is the Current Meter of Moving coil variety, and therefore, this chapter will mainly deal with this type alone.

MOVING COIL METER

This meter is basically a d. c. meter. It consists of a moving coil which can rotate, upon pivots, within an air gap provided by a horseshoe magnet. The electrical law, that coil in a magnetic field carrying electric current will shift its position in such a way as to embrace greatest number of lines of force, governs the operation of this kind of meter. The magnetic field provided by the horseshoe

magnet and the magnetic lines of force due to current in the coil will so interact that the coil gets a motion. If a pointer is now attached to this moving coil, the circular displacement of the coil can be calibrated in terms of amperes, volts or ohms, all calculations depending upon the ohm's law.

MOVING COIL VOLTMETERS

The voltmeters that are extensively used in radio servicing are nothing but milliammeters, with high resistors connected in series. If the current that flows through these high resistances is known then the voltage at the terminal of the resistances can be found out by the simple application of the ohm's law. Everytime to find out all this and calculate, will be a great botheration, and therefore, to save all these troubles and to enable quick measurements the meter is calibrated directly in volts. This means that even the slightest deflection of the pointer is read in terms of volts. Since the range desired depends upon the series high resistance (also called multiplier resistors) it is evident that the same basic meter movement can be adapted for different ranges. By providing high multiplier resistors, high voltage ranges can be obtained. The ohmic value of the multiplier resistor for each additional range will depend upon the sensitivity of the meter.

SENSITIVITY OF VOLTMETER

This is always expressed in "ohms per volt" and is equal to the total resistance of the meter divided by number of volts indicated at full scale deflection. If a 0-10 Voltmeter has a resistance of 10,000 ohms the the sensitivity will be equal to $\frac{10,000}{10} = 1000$ ohms per volt and the meter

will require a current of 1 ma for full scale deflection. If another voltmeter of 0-10 range has a resistance of only 1000 ohms the sensitivity will be 100 ohms per volt and it will require 10 ma to move the meter pointer to full scale deflection.

To understand the significance of the sensitivity of a voltmeter is very important. Voltage measurements are carried out thousand times a day in radio workshops. In some cases these measurements do give the desired solution but in others they have proved a stumbling block to many servicemen who have not understood the correct implications of the sensitivity requirements.

'Ohms per volt', as has been said above, is a measure of the sensitivity of voltmeter and equals the total resistance of the meter divided by the number of volts indicated at full scale deflection. A meter of 20,000 ohms per volt will have a resistance of 200,000 ohms for a voltage range of 0-10 volts and it will require 50 micro-amperes for a full scale deflection. Higher the sensitivity of the meter, lower the current required for full scale deflection and higher the resistance of the meter. The high resistance voltmeters differ very basically from the low resistance ones. Low resistance or low sensitivity meters have a coil of comparatively thicker wire, more air-gap and an ordinary magnet whereas the high resistance or high sensitivity meters incorporate coils of very thin wire, a short air-gap and a strong magnet of special alloy. The basic meter movement in the high resistance voltmeters is very sensitive and therefore all attempts, at converting low sensitivity meters into high sensitivity ones by mere addition of resistances, will undoubtedly fail. This procedure will only result in the reduction of pointer deflection.

For measurements in radio servicing the high sensitivity meter should always be preferred to a low sensitivity one. Low current high resistance circuits, as are common in radio receivers, would require a meter which will not take too much current to actuate the coil of the meter otherwise the readings registered on the meter would be awfully faulty. For instance if 100 volts are applied across a series combination of two resistors R 1 and R 2 of 8,000 and 2,000 ohms respectively. the voltage drop will divide as follows :-

$$\text{Across R 1} = 80 \text{ volts}$$

$$\text{Across R 2} = 20 \text{ volts}$$

There should not be any doubt about the correctness of the above voltage drop figures because these are arrived at after a little juggling with the ohm's law.

Let us now take three voltmeters of different sensitivity and try to measure the voltage across R 1.

1—VOLTMETER OF 100 'OHMS PER VOLT' SENSITIVITY.

$$\text{Range used} = 1 \text{ to } 100 \text{ volts}$$

Resistance of the

$$\text{meter} = 100 \times 100 = 10,000 \text{ ohms}$$

This resistance of the meter shunts the resistance R 1 while taking measurements, and the actual resistance now is 4444 ohms, and the voltage that will be registered on the voltmeter will be

$$\frac{4444}{6444} \times 100 = 68.9 \text{ volts}$$

2—VOLTMETER OF 1000 'OHMS PER VOLT' SENSITIVITY

$$\text{Range used} = 1 \text{ to } 100 \text{ volts}$$

$$\text{Resistance of the meter} = 100 \times 1000 = 100,000 \text{ ohms}$$

The resistance of the meter shunts the resistance R1 as before and the actual resistance now is 7407 ohms, and therefore, the voltage reading will be

$$\frac{7407}{9407} \times 100 = 78.7 \text{ Volts}$$

3—VOLTMETER OF 20,000 'OHMS PER VOLT' SENSITIVITY

Range used = 1 to 100 Volts

Resistance of the meter = $100 \times 20,000 = 2,000,000$ ohms

As before, this resistance shunts R1 and the actual resistance is 7968 ohms. The voltage reading on the meter will be

$$\frac{7968}{9968} \times 100 = 79.9 \text{ Volts}$$

If all the above three readings are analysed it will be found that the meter with the lowest sensitivity i.e. 100 ohms per volt, registered a reading with about 15% error, the meter having 1000 ohms per volt sensitivity registered a reading with about 3% error whereas the meter having the highest sensitivity registered a reading having only 0.1% error. This clearly shows that reading obtained on meter No. 1 has been awfully misleading, the meter No. 2 gave the reading nearer to correctness and the meter No. 3 registered almost the correct reading.

Many manufacturers of radio receivers give, in their service manuals, the sensitivity of the meter used in preparing the socket voltage chart. Importance of this data will now be correctly understood and while checking up the socket voltages due regard must be paid to the sensitivity of the meter that is being actually used.

EXTENDING VOLTMETER RANGES

The following formulæ can be used in finding out the ohmic value of multiplier resistors required for extending the ranges of voltmeters.

WHEN METER RESISTANCE IS KNOWN

$$R = R_M (F - 1)$$

Where R_M = Meter Resistance for original range

F = Factor by which the range is to be multiplied

R = Multiplier Resistor

When a 10 volt range is to be increased to 100 volt, the F in the above formula will be equal to $\frac{100}{10} = 10$

WHEN METER SENSITIVITY IS KNOWN

If the sensitivity of the meter is known the multiplier resistor value can be found out easily as follows :

Resistance of Multiplier Resistor =

Sensitivity of the meter \times volts to be added to the range.

A meter of 1000 ohms per volt sensitivity requires 1000 ohms for every volt added. If a voltmeter of 1000 ohms per volt sensitivity having a range of 0—10 volts has to be converted to read 0 - 100 volts then

$$\begin{aligned} R &= \text{Meter Sensitivity} \times \text{Volts to be added} \\ &= 1000 \times (100 - 10) \\ &= 1000 \times 90 \\ &= 90,000 \text{ ohms} \end{aligned}$$

Similarly, if the range has to be increased from 150 to 750 volts, the multiplier resistor is calculated on the same lines as above.

$$\begin{aligned}
 R &= \text{Meter Sensitivity} \times \text{volts to be added} \\
 &= 1000 \times (750 - 150) \\
 &= 1000 \times 600 \\
 &= 600,000 \text{ ohms.}
 \end{aligned}$$

EXAMPLE :—

The 150 volt range of a voltmeter of 1000 ohms per volt sensitivity is to be extended to 750 volts, what value of multiplier resistance will have to be used ?

SOLUTION :—

$$\text{Multiplying factor} = \frac{750}{150} = 5$$

$$\text{Sensitivity of the meter} = 1000$$

$$\text{Original range} = 150$$

$$\begin{aligned}
 \therefore \text{Multiplier Resistor } R &= 1000 \times 150 \times (5 - 1) \\
 &= 1000 \times 150 \times 4 \\
 &= 1000 \times 600 \\
 &= 600,000 \text{ ohms.}
 \end{aligned}$$

For temporary measurements the 600,000 ohms resistance can be connected to the + 150 volt terminal of the meter. The -ve test lead goes to the -ve terminal of the meter and the + test lead goes to the other end of the resistor, one end of the resistor being already fixed in the terminal, marked + 150 volts. The readings taken on the 0—150 volt scale of the dial have to be multiplied by 5 to get the true voltage reading when the resistance is thus added externally.

MULTIPLIER RESISTORS

These are usually of 1 watt type and mostly wire wound. Some meters use a single tapped resistor whereas others use separate resistors for different ranges. The resistors should not have a tolerance value of more than 3 per cent.

CONVERTING MILLIAMMETERS INTO VOLTMETERS

The following tables shows values of multiplier resistors required to convert d.c. milliammeters into voltmeters having any of the several ranges specified in the table

Voltage Range Required	0—1 Milliammeter	0—3 Milliammeter	0—5 Milliammeter
0 to 10	10,000	3,330	2,000
0 to 30	30,000	10,000	6,000
0 to 50	50,000	16,700	10,000
0 to 100	100,000	33,300	20,000
0 to 150	150,000	50,000	30,000
0 to 300	300,000	100,000	60,000
0 to 500	500,000	167,000	100,000
0 to 1000	1 Meg	333,000	200,000
0 to 2000	2 Meg	666,000	400,000

The following formula is used for the multiplier resistor calculations when a milliammeter is to be converted into a voltmeter

$$R = \frac{E}{I} - R_M$$

Where R = Multiplier Resistor

E = Full scale voltage required

I = Full scale current of the milliammeter

R_M = D.C. resistance of the meter

EXAMPLE :—

A d. c. Milliammeter having a range of 0-1 ma is to be converted into a d. c. voltmeter having a range of 1000 volts. Meter Resistance is 27 ohms.

SOLUTION

If an attempt is made to measure a voltage of say 1000 volts by this milliammeter, as it is, then the meter will definitely be burnt out. For full scale deflection of the meter, a current of only 1 ma is required whereas when 1000 volts are applied to it the current that will rush through the meter will be

$$\begin{aligned} I &= \frac{E}{R} \\ &= \frac{1000}{27} \\ &= 37 \text{ Amperes} \\ &= 37,000 \text{ milliamps} \end{aligned}$$

Naturally the meter coil will burn out, because the thin wire of the moving coil is not rated to carry so high a current. This particular meter is rated to carry one milliamp maximum. In order that the current through the coil shall not be more than 1 ma when 1000 volts are applied to it some current limiting resistance has to be provided in series with the moving coil. The value of this resistance is calculated as follows :—

$$\begin{aligned} R &= \frac{E}{I} \\ &= \frac{1000}{.001} \\ &= 1,000,000 \\ &= 1 \text{ Megohm} \end{aligned}$$

This is how the value of the multiplier resistors is arrived at and the above table is prepared accordingly. It is to be pointed out, however, that meter resistance is not taken into consideration. For high precision work meter resistance must be considered.

MILLIAMMETERS AND MICROAMMETERS

The number of milliamps or microamps of current required for the full scale deflection of a milliammeter or a microammeter is known as the sensitivity of the meter. For example a meter having a sensitivity of 10 milliamps requires a current of 10 milliamps for full scale deflection.

SHUNT RESISTORS

Following formula is extensively used in calculating the value of shunt resistor required.

$$R_{SH} = \frac{R_M}{K - 1}$$

Where R_{SH} = Shunt Resistor

R_M = D. C. Resistance of the meter

K = Desired multiplying ratio i.e.

$$\left(\frac{\text{Range desired in milliamps}}{\text{Original range in milliamps}} \right)$$

EXAMPLE :—

A milliammeter having a range 0—1 milliamp is to be converted for reading currents upto 10 milliamps.

SOLUTION :—

Multiplying ratio = 10

Meter Resistance = 27 ohms

$$\therefore R_{SH} = \frac{27}{10 - 1}$$

= 3 ohms

WHEN METER RESISTANCE IS NOT KNOWN

The internal resistance of the meter is an important item in arriving at the value of meter shunt. When the internal resistance of the meter is unknown the following method may be adopted for finding out the value of suitable shunt for that meter for any increase in range.

A 0—20 ma milliammeter is to be extended to read 100 milliamps maximum. In this case it means that the original range has to be multiplied by 5. Now connect 1.5 volt dry cell in series with the meter and a variable resistance R of about 400 ohms, keeping the moving arm of the variable resistance at maximum resistance position (Fig. 14).

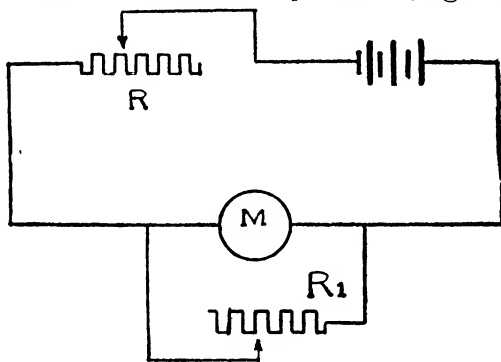

FIG. 14

After having connected the meter, resistance and the battery as above, the variable resistor R should be so adjusted that the meter gives the full scale deflection which in this particular case is 20 milliamps. Then another variable resistance R_1 should be connected directly across the meter terminals and R_1 should be so adjusted that the meter now reads $\frac{1}{5}$ th of the previous reading i.e. the meter should now read 4 milliamps. After having done this, the exact value of the shunt resistance can be found out by measuring that portion of R_1 which is in the circuit. With this shunt

connected and with the same old scale of 0—20 ma, every reading that is obtained will have to be multiplied by 5 to get the true reading. When selecting shunt resistors particular attention must be paid to the wattage rating so that they will carry the required current without undue heating.

In many commercial meters it will be noticed that some resistors that are connected in the circuit look like having been filed at the middle. In order to get at the correct value of shunts the resistors are scraped and filed in the middle portion thus increasing the resistance to the correct value required.

METER RESISTANCE VALUES

The following is a table showing internal resistance of Weston milliammeters.

Weston 0—1 ma—27 ohms
Weston 0—1.5 ma—18 ohms
Weston 0—2 ma—18 ohms
Weston 0—3 ma—18 ohms
Weston 0—5 ma—12 ohms
Weston 0—10 ma—8.5 ohms
Weston 0—15 ma—3.5 ohms
Weston 0—20 ma—1.5 ohms
Weston 0—25 ma—1.2 ohms

As seen previously it is quite necessary to know the meter resistance for arriving at the value of the meter shunt. And for this reason the utility of the above information will be readily understood.

METER RESISTANCE.

When no information is available as regards the internal resistance of a particular meter, the method described below, known as 'Half Deflection Method', should be used for finding out the internal resistance of any meter.

HALF DEFLECTION METHOD

A variable high resistance R is connected in series with the meter and a battery, and the meter is adjusted to read full scale reading by adjusting R (Fig. 14). Now another variable resistance R_1 is connected directly in shunt across the meter and by manipulating R_1 the meter reading should be brought down to exact half scale. Measure the resistance of the portion of R_1 that is in the circuit and this is equal to the meter resistance.

Never attempt to measure the resistance of the meter by ohmmeter. It will not give the correct reading and there will be a possibility of damaging the meter. On occasions when there is a doubt about the continuity of the meter coil, it can be checked by another ohmmeter with a series resistance in the circuit and using the lowest range of ohms and then putting the test prods directly on the terminals of the meter that is to be tested.

METER POLARITY

D. C. moving coil meters have the polarity indications marked on the terminals. The +ve terminal of the meter should always be connected to the +ve side of the circuit under test and the -ve terminal of the meter should be connected to the -ve end of the circuit. A. C. Meters have no polarity.

OHMMETERS

There are three types of ohmmeters as described below.

Series Type :—In this types of instrument the resistance that is to be measured is connected in series with the meter and battery.

Shunt Type :—This is a type wherein the resistance to be measured is connected in shunt with the meter.

Series-Shunt Type :—This is a combination of series and shunt types ; the meter circuit being so arranged that the meter serves as a series type for high resistance ranges and shunt type for low resistance ranges.

'ZERO' OF OHMMETERS

In the 'series' type of ohmmeter the left end of the scale represents 'infinite' resistance and the right end indicates zero. Such being the case, all high resistance markings are towards the left and low resistance markings are at the right.

In the 'shunt' type of ohmmeter the 'zero' is at the left end and highest resistance marking at the right end and therefore low resistance markings are towards the left and high resistance markings towards the right.

In the series-shunt type two different scales—one for 'High ohms' and the other for 'Low ohms'—are used ; and the markings are as described above.

CALIBRATION FORMULA FOR SERIES TYPE OHMMETER

$$R_x = \frac{R_c (m - n)}{n}$$

Where R_x = Resistance being measured

R_c = Calibrating resistance, in ohms, connected in series with the meter

m = Full scale range of the meter (in milliamps)

n = Meter reading in milliamps when resistance R_x is connected to the terminals of the meter.

Example :—A 0—1 milliammeter is connected in series with a 5000 ohms calibrating resistance and a 4.5 volts

battery. When a resistance R_x is connected to the terminals, the meter reads .5 ma. What is the value of resistance ?

$$\begin{aligned} R_x &= \frac{R_c (m - n)}{n} \\ &= \frac{5000 (1 - 0.5)}{0.5} \\ &= \frac{5000 \times 0.5}{0.5} \\ &= 5000 \text{ ohms} \end{aligned}$$

Following the calculations shown above, various meter readings can be obtained for different value resistors, and a 'ohms' scale prepared.

Another method of calibration will be to use several accurate resistors of known value and find out the correct readings in ma for different ohmic values of the known resistors.

CALIBRATION FORMULA FOR SHUNT TYPE OHMMETER

$$R_x = \frac{R_m}{\left(\frac{m}{n}\right) - 1}$$

Where R_x = Resistance to be measured

R_m = Resistance of the meter

m = Full scale reading of meter in ma.

n = meter reading in ma when R_x is connected to the terminals of the meter

Example :—A 0—1 milliammeter of 25 ohms internal resistance gives a reading of .5 ma when the unknown resistance is

connected to the terminals. What is the value of resistance ?

$$\begin{aligned}
 R_x &= \frac{R_M}{\left(\frac{m}{n}\right) - 1} \\
 &= \frac{25}{\left(\frac{1}{0.5}\right) - 1} \\
 &= \frac{25}{2 - 1} \\
 &= 25 \text{ ohms}
 \end{aligned}$$

ANY METER AS OHMMETER

On occasions when a calibrated ohmmeter is not available any meter can be rigged up to check resistance value or continuity tests. If it is a milliammeter the meter should be connected in series with a battery of say 1.5 volt and sufficient resistance to give full scale reading. The unknown resistance can then be found out by calculation. If it is a voltmeter, the multiplier of the meter will serve as the series resistance and then only a battery is required to be connected in series with it.

VOLTMETER AS OHMMETER

A voltmeter can be used as ohmmeter when such emergency arises. The voltmeter has to be connected in series with a battery and the resistor to be measured. Two readings of the voltmeter have to be noted. One reading is obtained when the resistor to be measured is included in the circuit and the other without it. Having obtained these two readings the following formula should be used to find out the value of resistance.

$$R = R_M \left(\frac{E_1}{E_2} - 1 \right)$$

Where R = Resistance to be measured

R_M = Meter Resistance

E_1 = Voltmeter reading with R out of circuit

E_2 = Voltmeter reading with R in the circuit

The meter resistance R_M in the above formula can be found out by multiplying the sensitivity—in ohms per volt—of the meter by the voltage range of the meter used. If a meter has a sensitivity of 2000 ohms per volt the meter is said to have a resistance of $2000 \times 100 = 200,000$ ohms on the 0 – 100 volt range.

Example :—Suppose that in a particular case the reading E_1 is 10 volts and the reading E_2 is 2 volts 0–100 volt scale of ‘2000 ohms per volt’ sensitivity meter is used. What will be the value of resistance ?

SOLUTION

$$\begin{aligned} R &= 2000 \times 100 \left(\frac{10}{2} - 1 \right) \\ &= \frac{200,000}{1} \times 4 \\ &= 800,000 \text{ ohms} \end{aligned}$$

ZERO ADJUSTER

The zero adjusting variable resistance is always provided in ohmmeter for compensating the variations in the battery voltages.

There are two distinct methods of providing these ‘zero adjusters’

The first and the simplest method of doing it is to provide it in the series with the meter. When the voltage of the battery drops, the variable resistor i.e. zero adjuster is

adjusted until "zero" reading is again obtained. But in doing so the circuit resistance changes. And this introduces inaccuracy in meter readings. If the battery voltage drops by say 15 per cent, all the resistance values indicated by the meter will be 15 per cent higher. This method of providing Zero Adjuster will these days be found only in cheaper type of meters. The second method described below is more reliable and efficient.

The errors in resistance values that are introduced by the method described above can be avoided by connecting the "Zero Adjuster" in parallel to the meter instead of in series. In some meters it will be found that only a variable resistor (zero adjuster) is in shunt with the meter whereas in other meters it will be found that the zero adjuster variable resistance is connected in series with a fixed resistor of low value and this combination is connected in parallel with the meter. Whether it is a single or combination type both are called "shunt type zero adjusters." These shunt type zero adjusters give a greater degree of accuracy in meter readings than what a series type zero adjuster would give, and, therefore an ohmmeter having a shunt zero adjuster should be preferred to one having a series type zero adjuster.

COMPONENTS OF A MOVING COIL METER

The meter is an assembly of various delicate parts, each of which requires high accuracy in design and greatest precision in the manufacture.

COILS

The design of coils is usually limited to a current carrying capacity of about 30 millamps maximum. Any quantity exceeding 30 millamps is measured by means of the use of shunts. The d. c. resistance of the coils will naturally depend upon the number of millamps that are

required for a full-scale deflection. Resistance of the coil increases as the full-scale deflection of the meter decreases, because the decrement in full scale deflection means a lower current flow which necessitates a greater number of turns in the coil to set up a proper magnetic field and the resulting torque. The electromagnetic field that is required around the coil depends upon 'ampere-turns' and therefore any reduction in amount of current means increase in the number of turns or any increase in the current should result in the decrease in the number of turns in the coil. Thus if the table on page 114 is seen it will be found that the meter resistance of 0-5 milliammeter is greater than that of 0-25 meter. The resistance of 0-5 meter is 12 ohms whereas that of 0-25 meter it is only 1.2 ohms.

Therefore when rewinding the meter coil special attention must be paid to the gauge of wire used and the number of turns i. e. resistance of the coil. The shape of the coil is rectangular, wound on aluminium rectangular frame. Some meters, however, do not employ the aluminum frame but the coils are made self-supporting.

MAGNETS

The magnets of the modern meters are made from material that cannot be demagnetised easily. Such material is called "High-coercive Force" material. As against this the material that can be demagnetised easily is called "Low-coercive Force" material. The manufacturers specify the type of material, employed, in their specifications. Naturally the meter that employs "High-coercive Force" magnet should be preferred.

PIVOTS

These are metal supports attached to both ends—upper and lower—of the coil structure. Such pivots are

usually made up of hardened steel, carbon steel, chrome steel, tungsten steel or molybdenum alloy. The shape of the pivot is conical.

JEWELS

There are made of sapphire, diamond or corundum. The surface of these jewels is made concave to take the conical point of the pivot that rotates in it.

POINTERS

Since aluminium is very light, the pointers are necessarily made of this substance.

SPRINGS

The majority of meters provide two such springs—one at the upper end of the coil structure and the other at the lower end. These are spiral in shape and they oppose the twisting motion of the meter movement. When the current in the meter ceases to flow the torque on the coil is removed and then it is due to the tension of these springs that the pointer is restored to its normal zero position. These springs are non-magnetic having very very low resistance and good elastic qualities. Their cross-section is rectangular and their thickness varies from .01 to .0006 inches. The two coils are always coiled in opposite directions. Some cheaper type meters employ only one spring.

COUNTERWEIGHTS

The balancing of the entire weight of the moving coil assembly on the pivots is attained through the use of very small counterweights in the form of threaded nuts or coils of wires that can slide on the extensions of the pointer itself.

A. C. MEASUREMENTS

The d.c. meter described above can be adapted for use in a c. circuits with the addition of a copper oxide bridge rectifier unit. The accuracy of the d.c. portion of a combined

A.C.—D.C. meter depends upon the accuracy of the meter movement, the multiplier and shunt resistors employed. Usually the manufacturers guarantee an accuracy of about 1 to 3 per cent of full scale deflection. The accuracy of the a. c. portion besides being dependent upon the above factors is also dependent upon the inherent resistance of the copper oxide rectifier and the frequency error that is introduced by it. The frequency error is due to the capacity between the discs of the rectifier which bypass the higher frequencies. The frequency error thus introduced is the greatest disadvantage of a meter employing copper oxide rectifier for a. c measurements. The recent advent of meters with tube rectifier such as 6H6 etc. solves this difficulty and therefore tube rectifier type meters should be preferred to copper oxide rectifier type meters.

ELECTRONIC D. C. VOLTMETERS

To measure direct current voltages at points such as the grid or plate of a vacuum tube, high frequency oscillator stage, A. V. C., A. F. C., R. C. coupled high fidelity audio circuits, the electronic voltmeter is a most handy instrument. Such an instrument serves to measure operating and control voltages at a point, where a signal is present, without upsetting the circuit. The R. C. A.—Rider Chanalyst is the most popular example of such an electronic meter that permits measurements under dynamic operating conditions.

VACUUM TUBE VOLTMETERS (V. T. V. M.)

With these meters it is possible to have direct measurements without the circuit getting affected when the meter is connected. Because of its high input impedance exact bias voltages etc. can be measured.

The V. T. V. M. can be used for

- (1) Measuring the bias voltages
- (2) Measuring ripple and peak voltages in power supply

- (3) Checking the balance of signal in phase inverter circuits
- (4) Finding out the correct over-all gain of an amplifier
- (5) Determining the dynamic regulation of power supply
- (6) Judging the stability of any amplifier
- (7) Checking R. F. Voltages
- (8) Finding out the Q of coils and condensers.

REPAIRS TO METERS

Servicing the meters is a very delicate operation. As far as possible greatest care should be exercised to see that the meter is neither misused nor roughly used. A multi-meter is very often misused in the sense that unknowingly an attempt is made to measure a. c. voltages on D. C. position, or D. C. voltages on a. c. position or voltages on resistance position. A glaring example of the rough use of the meter is the operation of the range selector switch of the meter. Some servicemen have been found to turn this switch very roughly and with lightning speed thereby posing to show that they are the greatest experts to be found on the face of earth. But they do not understand that this is the way to spoil the meter and not a profitable way to impress the people or their superiors.

There are two types of repairs that are to be carried out on meters. One type is the pure and simple mechanical adjustments and the other is fundamentally electrical.

MECHANICAL FAULTS

A meter may develop a fault in several ways. The most common mechanical defect encountered is the sticking of the pointer. Very often the pointer refuses to travel over the entire scale and sticks up somewhere, making any move-

ment impossible even if current is applied to it. In other cases the pointer does give the desired reading but fails to return to the zero position. It gets stuck up on the return journey towards the zero position. Such kind of pointer sticking may be due to

- (1) A tiny particle of fuzz or hair getting into the path of the pointer. This tiny particle may directly be in the path of the pointer or may obstruct the free movement of the top or bottom hair spring
- (2) A tiny particle of fuzz or hair in the path of the tail of the pointer
- (3) The warped paper scale of the meter.
- (4) Foreign matter getting in the air-gap between core and poles of the magnet
- (4) The coil being loose in jewels
- (6) The coil being tight in jewels
- (7) Defective Hair springs

A magnifying eye-glass such as used by watch repairers, a pair of tweezers and a darning needle will be required to remove the abovenamed obstructions. To locate the exact point where the pointer sticks, an attempt should be made to take measurements till the pointer actually sticks. Then by the help of magnifying eye-glass examine the air-gap, the entire meter assembly and when the fuzz or the foreign matter is located remove it very carefully either with the darning needle or tweezers. Any non-magnetic matter that may be in the air-gap should be pushed to the bottom by the needle or a thin strip of a visiting card. In cases where the foreign matter is located between the coil frame and core, it should be removed with the help of a piece of thin cardboard. In many cases the sticking of the pointer is due to the hair-springs at the lower or upper end having gone

out of shape. The spiral of the hair-spring originally is of a regular shape but due to rough use of the meter this regular shape distorts to a considerable extent with the result that when measurements are taken the individual turns of the spiral get entangled between themselves or a single turn gets entangled in the tail of the pointer. And unless and until the entangled turns are released with the help of the tweezers or the darning needle, the pointer will not be released. Sometimes the pointer sticks due to the moving coil of the meter having gone loose in the jewel bearings. To remedy this kind of fault both the jewels must be tightened. The jewel-screw is locked up by a lock-nut, and, therefore no attempt should be made to adjust the jewel-screw without first loosening the tiny lock nut. While loosening the nut the jewel-screw should be held tight by a small screw-driver so that it will not move along with the nut. Having loosened the locking nut, tighten the jewel screw very carefully. Too much pressure will restrict the pointer movement and may damage the pivot of the coil. Having tightened the jewel screw, hold it at that correct position by means of the screwdriver and tighten the lock nut. Now the screw driver may be removed and the movement of the pointer checked again. On many occasions, loosening the bottom jewel bearing, a bit, removes the sticking of the pointer.

There are many instances when the pointer has been completely blown off. In such cases another pointer made of very thin aluminium sheet will serve the purpose. It can be fixed to the movement with the help of durofix or gasket cement.

The meter pointer should always rest at the zero position irrespective of meter position. Whether the meter is lying flat on the table or kept in a vertical position, the pointer must rest at the zero position. If the pointer behaves

otherwise the trouble can be removed by the proper balancing of the coil movement which can be done by adjusting the counterweight springs or nuts provided in the meter.

The zero-adjusters also are a cause of trouble at times when any movement of the zero-adjuster will not result in the desired movement of the pointer. The zero-adjusters always work against the top hair spring between the zero-adjusting fork. The zero-adjuster screw transmits the motion to the fork and the fork in turn actuates the top spring which imparts the motion to the pointer. The zero-adjusting fork must have gone too loose or the top spring convolution may have jumped over the support.

ELECTRICAL FAULTS

In the long series of electrical faults that may develop in a meter, the coil burn-out is a most common one. The coil burn-out is 99 per cent a vote of censure against the serviceman who brings it about. It is due definitely to an inexcusable misuse of the meter. Using low milliamp range for measurements of currents beyond that range or some such neglected act brings about such mishaps to the meter and with a little care these can be avoided. A quick check for the continuity of the coil will be to use another ohmmeter with a series current limiting resistor in between and using the low range scale. With this series resistance in, the test prods of another ohmmeter should be simply touched to the terminals of the suspected meter. If the coil of the suspected meter is open, both the meters will not give any deflection. If it is not open, both meters may give deflection or the suspected meter may not give any deflection but the new meter would. The reason for the suspected meter not giving any deflection eventhough the coil is not open, is that the movement may have got jammed.

Having once confirmed that the coil is open, it becomes necessary to remove the coil for replacement or repairs. If a spare coil assembly is available it is better practice to replace the entire assembly. But as the conditions that exist in India no dealer has yet thought it prudent to stock spare coil assemblies. Under the circumstances it stands to reason to get the coil repaired.

It is a great misfortune that many of our stockists are not in a position to give any data as regards the meter resistance. Had this data been made available much labour could have been saved. Because when a meter coil gets open, the only way to arrive at the resistance value of the coil is to count the number of turns very carefully and rewind the entire coil with the proper gauge of wire. Unless this is done the resistance value will not be correct. Rewinding of coils should be done in the same winding direction as was originally there. Self-supporting coils are a difficult job. Coils having aluminum or other frames are comparatively easy for rewinding. It is recommended that no attempt should be made to rewind self-supporting coils. If it cannot be avoided then it should be done very carefully.

When taking out the coils from the meters, greatest care should be exercised as regards the top and bottom hair-springs. When these are to be disengaged from the coils they have to be unsoldered and it so happens that while doing this the shape of the hair-spring gets distorted. Once this happens the entire calibration of the meter goes erratic. Not only this but when the coil assembly is being assembled, a great difficulty is experienced in getting the normal free movement of the pointer. To reshape the hair-spring is a very difficult task. Only trained and experienced hands alone could do that.

When the trouble with the meter is limited to a particular voltage range or millamp range or the ohms range the associated components such as series resistors, shunt resistors of that particular range should be examined and necessary replacement effected.

When the trouble with the meter is only with the a.c. side it is almost sure that the rectifier has to be changed. In some meters capacitors are used as multipliers taking advantage of their reactance. These capacitors develop faults and the meter registers low a. c. readings. All such condensers should be checked by substitution process. The capacitor multipliers are usually used on low voltage ranges.

When dismantling a meter look out for small tiny metal and insulated washers, and their respective positions. Sometimes the bottom spring support is insulated and if the insulated washer is missing a short circuit will occur in the meter. Some meters have one side grounded with the magnet, and, if the other lead makes any contact with any metal portion of the movement, a short circuit is sure to occur.

SECTION VII

VIBRATORS

The modern battery operated receiver gets its operating potentials from the vibrator. The vibrator type power supply for battery receivers is very common and most widely used because of its lower cost than that of the rotary power supply. In the vibrator type, a rapidly vibrating reed interrupter rapidly interrupts the battery current and produces a pulsating d. c. As soon as this pulsating d. c. is fed to the transformer a high voltage a. c. is obtained in the secondary of the transformer. This high voltage a. c. is rectified either by means of a half-wave or full wave rectifier or by mechanical methods in the vibrator itself.

ENERGISING THE VIBRATOR

There are two methods of energising the vibrator. One is called the Shunt Driver System and the other Series Driver System. In the former system the driver coil of the vibrator is shunted across the vibrator contacts whereas in the Series System the driver coil is in series with the vibrator contacts.

TYPES OF VIBRATORS

The family of vibrators can be classified into two major types ; depending upon the method of rectification that is employed :

- (A) Tube Type (Also called Interrupter type)
- (B) Self Rectifying Type (Also called Synchronous type)

The type A requires a rectifier tube to rectify the high voltage A. C. and the type B does not require any such tube.

The rectification in type B is attained through mechanical means, by providing extra contacts on the vibrator.

BUFFER CONDENSER

When the vibrator is being energised the action that takes place in the vibrator is that the contacts make and break the input voltage circuit and thus feed a pulsating d. c. to the transformer. In so doing the contacts have to connect and disconnect the d. c. from the primary of the transformer. When this is happening powerful surges of current are developed that do a considerable damage to the vibrator contacts. The remedy, therefore, to save the life of contacts is to 'arrest' these powerful surges by some means and methods. And this can be done either by connecting a condenser across the primary of the transformer or by providing a capacity across the secondary of the transformer. The latter method of connecting a condenser across the secondary is preferred because the condenser required in this case is comparatively much smaller than the condenser required across primary. Such a condenser is called 'Buffer Condenser'.

VIBRATOR TRANSFORMER

The core material used for this transformer is usually of a flux density varying from 65,000 to 85,000 lines per square inch. The important and most conspicuous difference between the ordinary a. c. power transformer and the vibrator transformer is that the latter requires a dual or a centre-tapped primary. The wire size required for this winding is very large compared to the wire size required for the primary of the ordinary a. c. power transformer, and the primary winding is always wound over the secondary winding. Because of the large wire size needed for the primary winding and the extra primary winding, the

size of the vibrator transformer is considerably larger than that of an a. c. transformer of the same out-put. The turns per volt for vibrator transformer is kept low to reduce the leakage inductance of the transformer. Generally it varies from 4 to 6 turns per volt.

VIBRATOR HASH

The vibrator hash has its origin in the transient voltage surges at high frequency. The buffer condenser described previously will not act as a remedy for suppressing this 'hash'. The best methods that are employed for hash suppression are perfect magnetic shielding, perfect electrostatic shielding, proper grounds, efficient r. f. filters which comprise of by-pass condensers and r. f. chokes. 0.1 to 1.0 mfd condensers are common values for hash suppression.

VIBRATOR REPAIRS

The most common trouble with the vibrator units is dirty and pitted contacts. The contacts either stick together or are very noisy. In such cases the vibrator contact should be cleaned by placing a small file between two surfaces of contacts and filing both together. Before filing and after, the contacts may be cleaned by petrol. The air-gap provided in the contacts is on an average from 0.003 to 0.007 of an inch. If 'Feeler Gauges' are available the air-gap can be accurately checked. The correct alignment of the stationary points can be done either by adjusting the springs or by adjusting the screws provided in some vibrators.

VIBRATOR FILTERS

When it is desired to check the vibrator filter circuits under no load conditions, the vibrator should be removed from its place. If the vibrator is allowed to remain there and if the vibrator contacts are in closed position, the readings will be faulty.

VIBRAPACKS

There are available in the market complete units known as vibrapacks containing the vibrator, vibrator transformer and the associated filter system. Vibrapacks manufactured by Mallory are very popular and efficient. The Mallory manufacturers have put on the market the following types of vibrapacks for different types of service :—

Model	Type	Output Voltage	Input Voltage
VP—551	Self Rect.	125-150-175-200	6.3
VP—552	Self Rect.	225-250-275-300	6.3
VP—553	Tube Rect.	125-150-175-200	6.3
VP—554	Tube Rect.	225-250-275-300	6.3
VP-G556	Self Rect.	225-250-275-300	12.6

Tube rectifier types are meant only for applications where B-ve cannot be at ground potential. Model VP—552 and VP—554 can handle a load of about 35 watts whereas VP—551 and VP—553 can handle about 18 watts at 6.3 volts input.

RECTIFIER TUBES

The tubes 0Z4, 6X5 and 6ZY5—G are most commonly used in tube type vibrapacks. When a total current of more than 50 ma is to be drawn from VP—553 the original 6X5 tube may be replaced with 0Z4. The 6X5 can be replaced by 6ZY5—G under conditions where the total drain is less than 40 ma.

SECTION VIII

DRIVER TRANSFORMERS

The input transformer which is usually called Intervalve Transformer or Interstage Transformer, is styled as "Driver Transformer" when used in class B circuits.

In class B circuits the grids are driven positive resulting in a grid current flow. In the case of strong signals the grid current may attain a value as high as 20 to 30 milliamps. And if the resistance of the secondary winding of the driver transformer is high, a considerable power loss will occur. To avoid this, the design and construction of driver transformer is essentially different from ordinary intervalve transformer. The driver transformer is consequently made a step-down transformer having a large primary impedance and very low secondary D. C. resistance. The secondary winding besides being centre tapped should be of such design as will provide easy path for the heavy grid currents that flow from the grids of B valves.

The driver transformer Ratio is usually expressed as Half-Secondary ratio i. e. Primary to Half-Secondary. The following two formulae can be used in finding out the ratio:

$$T = \sqrt{\frac{\text{Impedance of driver valve}}{\text{Input Impedance of B valves.}}} \quad \dots \quad 1$$

In the above formula driver valve is the valve that precedes the transformer and B valve are the valves that follow the transformer. T is Primary to Half Secondary.

In cases where the data about the input impedance of the B valves is not available the following formula may be applied with advantage. Even though this formula is an

approximation it will give results that can be safely relied upon for all practical purposes. An example worked out below will clearly show the negligible error that is likely to be introduced.

$$T = \frac{E_P \text{ Max}}{E_g \text{ Peak}} \dots \dots 2$$

Whers T = Primary to Half Secondary Ratio

$E_g \text{ Peak}$ = Total Peak A. F. Grid Voltage of B Valves.

$$E_P \text{ Max} = 0.8 \mu E_{gd}$$

For finding out the value of $E_P \text{ Max}$ it should be noted that

μ = Amplification Factor of Driver Valve

E_{gd} = Grid Bias on Driver Valve for normal class A1 operation.

Example :—If a single 6F6 Triode is to drive two 6F6 valves, what should be the half secondary ratio of the driver transformer ?

Solution

If page 76 of RC—13, RCA Tube manual is turned, the following information that is required is available :

$\mu = 7$ for single 6F6 Triode connection

$E_{gd} = 20$ = Grid Bias on 6F6 for class A1

$E_g \text{ Peak} = 82$ = Total Peak A. F. Grid Voltage of B valves.

Utilising the above information

$$\begin{aligned} E_P \text{ Max} &= 0.8 \times 7 \times 20 \\ &= 0.8 \times 140 \\ &= 112 \end{aligned}$$

And E_g Peak = 82

$$\begin{aligned}\therefore T &= \frac{112}{82} \\ &= 1.4 : 1\end{aligned}$$

The results thus obtained through the use of the formula should now be corroborated. The Thordarson Transformer catalogue will be of use. If page 10 of Cat. 400 EX is turned it will be found that driver transformer No. T—17D01 recommended for such use has a half secondary ratio of 1.7 : 1.

SECTION IX

USE OF LOGARITHMS IN GAIN CALCULATIONS

A knowledge of logarithms may not be absolutely necessary in day to day routine servicing work but its importance and utility cannot be denied by the progressive engineer, who has an aptitude for a study of more complicated radio and amplifier problems. A glance, at one of the previous chapters, on decibels, will at once reveal the necessity of knowing some facts about logarithms.

First of all let it be understood by one and all that decibel gain computations will always involve the use of

logarithms because firstly, decibel itself is a unit for measuring the amplification expressed as a common logarithm of a power or energy ratio, and secondly, the difference in apparent volume as detected by our ears is directly proportional to the logarithm of the ratio of the two volume levels and not to the ratio itself, since the mechanism of our ear is such that it is comparatively more sensitive to small sounds than to large sounds. Logarithmic scale is therefore convenient to express a ratio between any two amounts of power or voltage or current. There is yet another advantage of using logarithmic scale, and that is, the facility of making conversions in positive or negative directions between the number of decibels and corresponding voltage, current and power ratios.

LOGARITHM

The logarithm of a number is usually made up of two parts. One is called the *Characteristic* and the other is styled as the *Mantissa*. In a number, the integral portion, to the *left* of the decimal point, is the characteristic and the figure or figures to the right of the decimal point is the Mantissa. For example if we take a logarithm 6.3432 then 6 which is to the left of the decimal point will be the characteristic and 3432 will be the mantissa. In the logarithmic tables it is only the mantissa that appears. Such a table—called four figure logarithmic table—is given on some of the following pages. The characteristic is always dependent on the position of the number with relation to the decimal point whereas the mantissa is independent of the position of the decimal point.

Now let us take a few numbers and their logarithms as follows and study them carefully.

Number	Logarithm	
8821.	3.945	(a)
882.1	2.945	(b)
88.21	1.945	(c)
8.821	0.945	(d)
.8821	-1.945	(e)
.08821	-2.945	(f)
.008821	-3.945	(g)
.0008821	-4.945	(h)

If the above figures are carefully studied it will be seen that the characteristic is algebraically equal to the number of places minus one and is first significant figure to the left of the decimal point.

In (a) the number constitutes of four figures to the left of the decimal point and the corresponding characteristic of the logarithm is 3, in (b) the number constitutes of three figures to the left of the decimal point therefore the characteristic is 2 and so on till we come to (d) where the characteristic is zero because the number at (d) has only one figure (i.e. 8) to the left of decimal point. At (e) the characteristic is -1 because there is no figure before the decimal point. At (f) the characteristic is -2 because there is one zero to the right of the decimal point and before the number. At (g) the characteristic is -3 because of two zeros after the decimal point and at (h) the characteristic is -4 because of three zeros. Therefore, the conclusion to be drawn is that for a number greater than one, the characteristic is one less than the number of significant figures in the number and that for a number that is wholly a decimal the characteristic is negative and numerically one greater than the number of ciphers immediately following the decimal point.

We have now to see how the tables can be used in finding out the logarithms. Suppose it is required to find out the logarithm of the number 7548. Since the number is composed of four significant figures, the characteristic will be one less than four i.e. 3 and this figure will be to the left of the decimal point. So the characteristic of the logarithm has been found out to be 3 and for finding out the mantissa we will have to refer to the tables. The first two figures of the number are 75. We have to locate the figure 75 in column M in the tables. Having found out this, we have to move to the right till we come to the column headed 4 and here we find a number 8774. Add to this, the number we get under the column 8 (small columns to the extreme right). The final number so derived is $8774 + 5 = 8779$ which is the mantissa of the logarithm. The mantissa is always placed to the right of the decimal point. Thus the logarithm of 7548 is 3.8779.

The power level, in decibels, of an amplifier of 3 watts undistorted output can now be found out. Reference level is .006 watts.

$$\begin{aligned} \text{Db} &= 10 \times \text{Log}_{10} \frac{w_1}{w_2} \\ &= 10 \times \text{Log}_{10} \frac{3}{.006} \\ &= 10 \times \text{Log}_{10} 500 \end{aligned}$$

To solve this equation we have to find out the logarithm of 500. As seen before, the characteristic will be 2 and mantissa will be 699 so the logarithm will be 2.699. Substituting this value the equation reduces to

$$\begin{aligned} \text{Db} &= 10 \times 2.699 \\ &= 26.99 \text{ decibels} \end{aligned}$$

LOGARITHMS

M	0	1	2	3	4	5	6	7	8	9	1	2	3	4	5	6	7	8	9
10	0000	0043	0086	0128	0170	0212	0253	0294	0334	0374	4	8	12	17	21	25	29	33	37
11	0414	0453	0492	0531	0569	0607	0645	0682	0719	0755	4	8	11	15	19	23	26	30	34
12	0792	0828	0864	0899	0934	0969	1004	1038	1072	1106	3	7	10	14	17	21	24	28	31
13	1139	1173	1206	1239	1271	1303	1335	1367	1399	1430	3	6	10	13	16	19	23	26	29
14	1461	1492	1523	1553	1584	1614	1644	1673	1703	1732	3	6	9	12	15	18	21	24	27
15	1761	1790	1818	1847	1875	1903	1931	1959	1987	2014	3	6	8	11	14	17	20	22	25
16	2041	2068	2095	2122	2148	2175	2201	2227	2253	2279	3	5	8	11	13	16	18	21	24
17	2304	2330	2355	2380	2405	2430	2455	2480	2504	2529	2	5	7	10	12	15	17	20	22
18	2553	2577	2601	2625	2648	2672	2695	2718	2742	2765	2	5	7	9	12	14	16	19	21
19	2788	2810	2833	2856	2878	2900	2923	2945	2967	2989	2	4	7	9	11	13	16	18	20
20	3010	3032	3054	3075	3096	3118	3139	3160	3181	3201	2	4	6	8	11	13	15	17	19
21	3222	3243	3263	3284	3304	3324	3345	3365	3385	3404	2	4	6	8	10	12	14	16	18
22	3424	3444	3464	3483	3504	3522	3541	3560	3579	3598	2	4	6	8	10	12	14	15	17
23	3617	3636	3655	3674	3692	3711	3729	3747	3766	3784	2	4	6	7	9	11	13	15	17
24	3802	3820	3838	3856	3874	3892	3909	3927	3945	3962	2	4	5	7	9	11	12	14	16
25	3979	3997	4014	4031	4048	4065	4082	4099	4116	4133	2	3	5	7	9	10	12	14	15
26	4150	4166	4183	4200	4216	4232	4249	4265	4281	4298	2	3	5	7	8	10	11	13	15
27	4314	4330	4346	4362	4378	4393	4409	4425	4440	4456	2	3	5	6	8	9	11	13	14
28	4472	4487	4502	4518	4533	4548	4564	4579	4594	4609	2	3	5	6	8	9	11	12	14
29	4624	4639	4654	4669	4683	4698	4713	4728	4742	4757	1	3	4	6	7	9	10	12	13
30	4771	4786	4800	4814	4829	4843	4857	4871	4886	4900	1	3	4	6	7	9	10	11	13
31	4914	4928	4942	4955	4969	4983	4997	5011	5024	5038	1	3	4	6	7	8	10	11	12
32	5051	5065	5079	5092	5105	5119	5132	5145	5159	5172	1	3	4	5	7	8	9	11	12
33	5185	5198	5211	5224	5237	5250	5263	5276	5289	5302	1	3	4	5	6	8	9	10	12
34	5315	5328	5340	5353	5366	5378	5391	5403	5416	5428	1	3	4	5	6	8	9	10	11
35	5441	5453	5465	5478	5490	5502	5514	5527	5539	5551	1	2	4	5	6	7	9	10	11
36	5563	5575	5587	5599	5611	5623	5635	5647	5658	5670	1	2	4	5	6	7	8	10	11
37	5682	5694	5705	5717	5729	5740	5752	5763	5775	5786	1	2	3	5	6	7	8	9	10
38	5798	5809	5821	5832	5843	5855	5866	5877	5888	5899	1	2	3	5	6	7	8	9	10
39	5911	5922	5933	5944	5955	5966	5977	5988	5999	6010	1	2	3	4	5	7	8	9	10
40	6021	6031	6042	6053	6064	6075	6085	6096	6107	6117	1	2	3	4	5	6	8	9	10
41	6128	6138	6149	6160	6170	6180	6191	6201	6212	6222	1	2	3	4	5	6	7	8	9
42	6232	6243	6253	6263	6274	6284	6294	6304	6314	6325	1	2	3	4	5	6	7	8	9
43	6335	6345	6355	6365	6375	6385	6395	6405	6415	6425	1	2	3	4	5	6	7	8	9
44	6435	6444	6454	6464	6474	6484	6493	6503	6513	6522	1	2	3	4	5	6	7	8	9
45	6532	6542	6551	6561	6571	6580	6590	6599	6609	6618	1	2	3	4	5	6	7	8	9
46	6628	6637	6646	6656	6665	6675	6684	6693	6702	6712	1	2	3	4	5	6	7	7	8
47	6721	6730	6739	6749	6758	6767	6776	6785	6794	6803	1	2	3	4	5	6	7	7	8
48	6812	6821	6830	6839	6848	6857	6866	6875	6884	6893	1	2	3	4	4	5	6	7	8
49	6902	6911	6920	6928	6937	6946	6955	6964	6972	6981	1	2	3	4	4	5	6	7	8
50	6990	6998	7007	7016	7024	7033	7042	7050	7059	7067	1	2	3	3	4	5	6	7	8
51	7076	7084	7093	7101	7110	7118	7126	7135	7143	7152	1	2	3	3	4	5	6	7	8
52	7160	7168	7177	7185	7193	7202	7210	7218	7226	7235	1	2	2	3	4	5	6	7	7
53	7243	7251	7259	7267	7275	7284	7292	7300	7308	7316	1	2	2	3	4	5	6	6	7
54	7324	7332	7340	7348	7356	7364	7372	7380	7388	7396	1	2	2	3	4	5	6	6	7

LOGARITHMS—continued.

M	0	1	2	3	4	5	6	7	8	9	1	2	3	4	5	6	7	8	9
55	7404	7412	7419	7427	7435	7443	7451	7459	7466	7474	1	2	2	3	4	5	5	6	7
56	7482	7490	7497	7505	7513	7520	7528	7536	7543	7551	1	2	2	3	4	5	5	6	7
57	7559	7566	7574	7582	7589	7597	7604	7612	7619	7627	1	2	2	3	4	5	5	6	7
58	7634	7642	7649	7657	7664	7672	7679	7686	7694	7701	1	1	2	3	4	4	5	6	7
59	7709	7716	7723	7731	7738	7745	7752	7760	7767	7774	1	1	2	3	4	4	5	6	7
60	7782	7789	7796	7803	7810	7818	7825	7832	7839	7846	1	1	2	3	4	4	5	6	6
61	7853	7860	7868	7875	7882	7889	7896	7903	7910	7917	1	1	2	3	4	4	5	6	6
62	7924	7931	7938	7945	7952	7959	7966	7973	7980	7987	1	1	2	3	3	4	5	6	6
63	7993	8000	8007	8014	8021	8028	8035	8041	8048	8055	1	1	2	3	3	4	5	5	6
64	8062	8069	8075	8082	8089	8096	8102	8109	8116	8122	1	1	2	3	3	4	5	5	6
65	8129	8136	8142	8149	8156	8162	8169	8176	8182	8189	1	1	2	3	3	4	5	5	6
66	8195	8202	8209	8215	8222	8228	8235	8248	8248	8254	1	1	2	3	3	4	5	5	6
67	8261	8267	8274	8280	8287	8293	8299	8306	8312	8319	1	1	2	3	3	4	5	5	6
68	8325	8331	8338	8344	8351	8357	8363	8370	8376	8382	1	1	2	3	3	4	4	5	6
69	8388	8395	8401	8407	8414	8420	8426	8432	8439	8445	1	1	2	2	3	4	4	5	6
70	8451	8457	8463	8470	8476	8482	8488	8494	8500	8506	1	1	2	2	3	4	4	5	6
71	8513	8519	8525	8531	8537	8543	8549	8555	8561	8567	1	1	2	2	3	4	4	5	5
72	8573	8579	8585	8591	8597	8603	8609	8615	8621	8627	1	1	2	2	3	4	4	5	5
73	8633	8639	8645	8651	8657	8663	8669	8675	8681	8686	1	1	2	2	3	4	4	5	5
74	8692	8698	8704	8710	8716	8722	8727	8733	8739	8745	1	1	2	2	3	4	4	5	5
75	8751	8756	8762	8768	8774	8779	8785	8791	8797	8802	1	1	2	2	3	3	4	5	5
76	8808	8814	8820	8825	8831	8837	8842	8848	8854	8859	1	1	2	2	3	3	4	5	5
77	8865	8871	8876	8882	8887	8893	8899	8904	8910	8915	1	1	2	2	3	3	4	4	5
78	8921	8927	8932	8938	8943	8949	8954	8960	8965	8971	1	1	2	2	3	3	4	4	5
79	8976	8982	8987	8993	8998	9004	9009	9015	9020	9025	1	1	2	2	3	3	4	4	5
80	9031	9036	9042	9047	9053	9058	9063	9069	9074	9079	1	1	2	2	3	3	4	4	5
81	9085	9090	9096	9101	9106	9112	9117	9122	9128	9133	1	1	2	2	3	3	4	4	5
82	9138	9143	9149	9154	9159	9165	9170	9175	9180	9186	1	1	2	2	3	3	4	4	5
83	9191	9196	9201	9206	9212	9217	9222	9227	9232	9238	1	1	2	2	3	3	4	4	5
84	9243	9248	9253	9258	9263	9269	9274	9279	9284	9289	1	1	2	2	3	3	4	4	5
85	9294	9299	9304	9309	9315	9320	9325	9330	9335	9340	1	1	2	2	3	3	4	4	5
86	9345	9350	9355	9360	9365	9370	9375	9380	9385	9390	1	1	2	2	3	3	4	4	5
87	9395	9400	9405	9410	9415	9420	9425	9430	9435	9440	0	1	1	2	2	3	3	4	4
88	9445	9450	9455	9460	9465	9469	9474	9479	9484	9489	0	1	1	2	2	3	3	4	4
89	9494	9499	9504	9509	9513	9518	9523	9528	9533	9538	0	1	1	2	2	3	3	4	4
90	9542	9547	9552	9557	9562	9566	9571	9576	9581	9586	0	1	1	2	2	3	3	4	4
91	9590	9595	9600	9605	9609	9614	9619	9624	9628	9633	0	1	1	2	2	3	3	4	4
92	9638	9643	9647	9652	9657	9661	9666	9671	9675	9680	0	1	1	2	2	3	3	4	4
93	9685	9689	9694	9699	9703	9708	9713	9717	9722	9727	0	1	1	2	2	3	3	4	4
94	9731	9736	9741	9745	9750	9754	9759	9763	9768	9773	0	1	1	2	2	3	3	4	4
95	9777	9782	9786	9791	9795	9800	9805	9809	9814	9818	0	1	1	2	2	3	3	4	4
96	9823	9827	9832	9836	9841	9845	9850	9854	9859	9863	0	1	1	2	2	3	3	4	4
97	9868	9872	9877	9881	9886	9890	9894	9899	9903	9908	0	1	1	2	2	3	3	4	4
98	9912	9917	9921	9926	9930	9934	9939	9943	9948	9952	0	1	1	2	2	3	3	4	4
99	9956	9961	9965	9969	9974	9978	9983	9987	9991	9996	0	1	1	2	2	3	3	3	4

ANTILOGARITHM

The simple definition of anti-logarithm is the number corresponding to a given logarithm.

It is shown above how with the help of logarithm, the decibel value is determined when the power level in watts is known. But when it is desired to determine the power level from given decibel value the above calculation will not do because the following formula necessary for such determination involves the use of Anti-logarithm.

$$\text{Watts} = \text{Reference level in watts} \times \text{Antilog} \frac{\text{Db}}{10}$$

Suppose the number is 3.6998. To find out anti-log of this or any number we have to proceed as follows. Look out under any column from 0 to 9 for the mantissa (6998). If correct number cannot be found look out for the next lowest figure. In this case 6998 is found out under column 1 and to the right of figure 50 in column M. The number 50 comprises the first two figures of the antilogarithm. And the third figure is 1, since the number 6998 was found under column 1. So the number found out is 501. Since the characteristic is 3, there must be four figures to the left of the decimal point. This means that a cipher has to be annexed making the number to be 5010 which is the antilogarithm of 3.6998. If the characteristic would be 2 the number would be 501. If the characteristic would be 1 the number would be 50.1. If it was -1 the number would be .501 and if it was -2 it would be .0501 and if it was -3 it would be .00501 and so on.

Besides the method described above (using logarithm tables) there is yet another method of finding out anti-

logarithm by referring the anti-logarithm tables. A specimen column from anti-logarithm tables is given below.

M	0	1	2	3	4	5	6	7	8	9	1	2	3	4	5	6	7	8	9
.45	2818	2825	2831	2838	2844	2851	2858	2864	2871	2827	1	1	2	3	3	4	5	5	6
.46	2884	2891	2897	2904	2911	2917	2924	2931	2938	2944	1	1	2	3	3	4	5	5	6
.47	2951	2958	2965	2972	2979	2985	2992	2999	3006	3013	1	1	2	3	3	4	5	5	6
.48	3020	3027	3034	3041	3048	3055	3062	3069	3076	3083	1	1	2	3	4	4	5	6	6
.49	3090	3097	3105	3112	3119	3126	3133	3141	3148	3155	1	1	2	3	4	4	5	6	6

Example :—Find out the anti-logarithm of 3.4662 using the anti-logarithm tables.

Disregard the characteristic i. e. the figure 3 before the decimal point, when referring the tables. First locate the figure 0.46 under the column M. Proceed to the right of .46 till you reach the column under 6. The figure found out is 2924. Now add to this, the figure we get under column 2 (small column to the extreme right of the tables). This figure is 1. By adding 1 to 2924 we get the final figure 2925 and since the characteristic is 3, the answer is 2925.0.

MINUS DECIBELS

There is a special procedure that is to be adopted when dealing with conversions of minus decibels to watts. In the formula on pages 66-67 of this book, sometimes it so happens, that the quantity Db. may be negative and may not be evenly divisible by 10. In such cases proper value of watts can be found only after Db. is made evenly divisible by 10. To make this -Db. evenly divisible, the following method should be employed.

Suppose the value -Db. is actually -28 with zero mantissa. To make this evenly divisible by 10, annex as many units as is necessary from the zero mantissa and add them to the quantity -28 until it becomes evenly divisible by 10. In this particular case, it is necessary to add only 2 units to bring -28 to -30 the latter figure being evenly divisible by 10. Now every unit borrowed from the zero

mantissa has got to be returned to it as a positive quantity multiplied by 10. This means that $2 \times 10 = 20$ are to be returned to mantissa and the -Db figure now becomes -30.20 which is evenly divisible by 10.

Example :— The output of a certain velocity microphone is -76 Db. Find out this rating in terms of watts.

$$\begin{aligned} \text{Watts} &= .006 \times \text{Antilog } \frac{-76}{10} \\ &= .006 \times \text{Antilog } \frac{-76}{10} \end{aligned}$$

In this case the numerator -76 is not evenly divisible by 10 (denominator). Therefore, by adding 4 units the numerator becomes -80 and because 4 units have been borrowed, $4 \times 10 = 40$ is returned to mantissa.

$$\begin{aligned} \therefore \text{Watts} &= .006 \times \text{Antilog } \frac{-80.40}{10} \\ &= .006 \times \text{Antilog } -8.4 \\ &= .006 \times .000000252 \\ &= 151.2 \text{ micromicrowatts} \end{aligned}$$

Note :—The quotient -8.4, in the above example, is arrived at by dividing the characteristic -80 and the mantissa 40 separately.

Example :—If an amplifier requires an input signal level of -27.3 Db. What is this rating expressed in watts ?

$$\text{Watts} = .006 \times \text{Antilog } \frac{-27.3}{10}$$

The numerator -27.3, being not evenly divisible by 10, is adjusted by adding 3 units to -27 and making it -30, and returning $3 \times 10 = 30$ to mantissa, making it 33.

$$\begin{aligned} \therefore \text{Watts} &= .006 \times \text{Antilog } \frac{-30.33}{10} \\ &= .006 \times \text{Antilog } -3.33 \\ &= .006 \times .00214 \\ &= .01284 \text{ milliwatts} \end{aligned}$$

**This book must be returned
within 8, 7, 14 days of its issue. A
fine of ONE ANNA per day will be
charged if the book is overdue.**

--	--

