

BIRLA CENTRAL LIBRARY

PILANI (RAJASTHAN)

Call No 621.4
P589H

Accession No 33082

THE
HEAT PUMP
Its Practical Application

THE HEAT PUMP

Its Practical Application

By

J. B. PINKERTON

M.Cons.E., M.I.Mech.E., M.I.H.V.E., M.Amer.S.H.V.E.

Consulting Engineer

PRINCES PRESS LTD.
147 VICTORIA STREET,
WESTMINSTER,
S.W.1

Copyright 1949 by Princes Press, Ltd.
All Rights Reserved

MADE AND PRINTED IN ENGLAND BY
PRINCES PRESS LTD., WESTMINSTER, S.W.1

Preface to the First Edition

This book has been prepared from a series of articles in AIR TREATMENT ENGINEER in response to many requests. Its main object is to place before the engineer a detail of the working of various Heat Pump installations. Many of the largest installations which have been working for several years, have been installed in Switzerland, and the Author is indebted to Messrs. BROWN-BOVERI & Co., LTD., ESCHER WYSS LTD., and to the SWISS FEDERAL INSTITUTE OF TECHNOLOGY, ZURICH, for invaluable help and the authority to quote freely from their records, and to many others mentioned in this work. Valuable practical information has also been had from the Heat Pump installed at Norwich, which has been in operation since 1945 and is the first large installation in England. No attempt has been made to compare the various *cycles* of operation, and the work is intended for the engineer who is concerned with the design, installation or maintenance of Heat Pump installations. Many thermodynamic theories are accepted and only where this theory touches on design has any attempt been made at elaboration. This work is intended as a practical work for the engineer who is faced with the problem of considering a Heat Pump installation either for space heating or process work where constant quantities of heat are required. Large quantities of coal have been saved by the various installations, which is of great importance at the present time. The advance made with the study of nuclear fission makes the Heat Pump of vital importance at the present time, and a section on this new development has been included in this work.

J. B. P.

Westminster, S.W.1.

June, 1949.

Contents

	PAGE
SECTION I—OUTLINE AND THEORY	9
The First Question—Recovered Heat—The Country House—The Beginning—Thermodynamics—Carnot Theory—Energy—Entropy—Temperatures—The Reversible System—Advantages—Heat Pumps—The Steam Engine—The Gas Engine—Reversed Heat—Refrigerating and Heating Machines—The Steam Heat Pump—The Thermo-compressor—The Working Medium—The Gas Heat Pump—Heat Engines—The Steam Engine—The Carnot Efficiency—Heat Pumps—The Coefficient of Performance—The Refrigerator—The Heating Machine—Efficiencies—Temperature drop in the Heat Exchanger—Effect of the Process and of the Working Medium—Effect of the Efficiencies of the Compression and Expansion—Lord Kelvin's Theory—Heat Required—Analogy of Heat Pumps and Hydraulic Machinery—Working Conditions—Application—Power Input—Output—Load Factors—Costs—Room Heating—Temperatures—Central Plants—Local Conditions—Precipitation—Sunshine—Cooling Cycle.	
SECTION II—PRACTICAL APPLICATION	89
Zurich Heat Pump—The Costs—The Weekly Load—The Layout—The Calorifiers—Heating in Winter—Cooling in Summer—Input and Output Diagrams—Daily Loads—Plans—The Setting—Load Plotted against the Days—Tables—Plan and Elevation—The Rotary Compressor—The Recordings—Results of the Heating Season—Details of the Evaporator—Steam Efficiency Chart—Yield and Storage—The Costs—Norwich Heat Pump—Limits—Advantages and Disadvantages—Thermodynamic Considerations—Kelvin's Theory—The Coefficient of Performance—History of the Experiment—Temporary Boilers—The Building and the Heating Season—Design and Construction—The First Compressor—The Second Compressor—Condenser—Evaporator—Liquid—Pipework—Valves, etc.—Choice of a Refrigerant—Results of Operation—Comparative Costs—Financial Considerations—Resumption of Tests—Summary—The Lausanne Artificial Ice Rink Heat Pump—Landquart Paper Mills Design and Layout—The Air Heat Pump—Steckborn Artificial Silk Co. Heat Pump—Design and Layout—Bell A.G. Heat Pump—Design and Layout—Viscose S.A. Heat Pump—Design and Layout—Sulzer Concentrating Plant—Lucens Heat Pump—Design and Layout—Performance of Heat Pumps with Details.	
SECTION III—ATOMIC ENERGY SURVEY	219
Elements and Compounds—Atoms and Molecules—Structure of the Atom—Chemical Combination—Protons—Neutrons and the Atomic Nucleus—Isotopes—Atomic Fuel—Necessary Precautions—Medical Applications—How it Works—Alpha Disintegration—Beta Disintegration—Nuclear Reactions—Waste Heat—The Atom "Smasher"—Chemical Engineering—Instruments—The Latest Pile—Concrete Insulation—Industrial Application of Nuclear Power—The Problem at Present—The Design—Production of Radioactive Isotopes—Packed Isotopes—Nuclear Physics—Cyclotron—Van de Graaff Generator—Radiochemical Laboratory.	
LITERATURE ON THE HEAT PUMP	245
INDEX	254

Section I

Outline and Theory

THE Heat Pump works on the same principle as the ordinary refrigerator. In the refrigerator the heat is discharged to waste. This low temperature heat is made to flow from the matter in the refrigerated space to the refrigerant and the heat is given off in the evaporator, while in the Heat Pump the reverse is the case.

The First Question

The first question that the heating engineer is likely to ask is, "why construct a machine to give heat when heat can be had by combustion?" The answer will be given later, but for the moment, it would be advisable to state that more heat can be had from a Heat Pump within limits, than would be had by consuming the fuel by other means in order to get the same quantity of heat.

This statement would seem false since it is not possible to get a greater efficiency from a machine than 100 per cent., but the Heat Pump is really a machine constructed for waste heat recovery. When this is understood, it will be seen that the Heat Pump has vast possibilities, but the design of any heating scheme which requires a Heat Pump is a matter of very great importance as the higher the upper temperature of the heat to be recovered the lower the efficiency, since a greater quantity of heat as energy has to be consumed in order to reach a higher final temperature, if the initial temperature is low.

It has been found by test on experimental plant that the greatest efficiency has been obtained when the initial temperature has been low and constant and the heating return from the central heating system is at a determined temperature. The best limits being in the range of 100° F.

To take a simple illustration of the manner in which the Heat Pump works. If you have a vast store of units of heat (unlimited supply and free) and you take or are given two units from this

store and you add only one unit which you have to pay for, then you have three units, which only cost you the price of one unit, and this is about the ratio of the Heat Pump in practice.

Recovered Heat

You have roughly two units of recovered heat ; add one unit of heat by work done, and you have three units of heat for the price of one at a high workable temperature. On this basis the Heat Pump is a most useful waste heat recovery machine. It is not a machine which by some magic *produces* more but, it is a machine which will recover heat and by adding a little more, we get heat at a higher temperature which is useful in the job of heating by convection and radiation. In this way, even if electrical energy is high in price, it compensates for its use in the Heat Pump especially with the rising costs of coal, and the high costs of labour. It is also of great use when the cost of electricity for direct heating is prohibitive, and is ideal when " off peak " electrical generation can be used as in the case of linking the Heat Pump with thermal storage.

The Heat Pump could recover waste heat say from a river during the night when there is little demand for the electricity generated, and store the high temperature heat in insulated containers to be circulated during the day-time when the Heat Pumps are shut down much in the same manner as is done at present with direct electric immersion heaters.

The Country House

On the other hand the best example of the use of a Heat Pump would be to have the low temperature heat drawn from a mill race, the evaporator being immersed in the mill-race, while the water from the race drives a water wheel or turbine which in turn drives a generator and Heat Pump. The unit could be most effective for heating and lighting a country house or property where conditions for this class of unit would be applicable. If the generation of electricity alone were attempted the heating load would be too great a load on the system, so that a small quantity of power is required for cooking and lighting, etc., and ample reserves of heat are to be had from the river mill-race for heating. It would seem therefore that the greatest use could be made of the Heat Pump where there is an abundance of hydro-electric power and little if any other fuel as in Switzerland and most of the advanced ideas on

this class of heating are to be found in Switzerland, where large Heat Pumps have been in use for over ten years, giving excellent results. There have also been several Heat Pumps in use in America, and since 1945 there has been one large Heat Pump in use in this country so that the practical application of the Heat Pump is no longer in doubt. The conditions under which these machines have worked and the results obtained will be shown later.

The Beginning

The Heat Pump is not a new discovery. It was propounded by Carnot¹ in 1824, the year Lord Kelvin was born, and carried a stage further by Kelvin² some thirty years later. The cheap supply of coal and the rapid development of the steam engine were against the development of the Heat Pump but the drive for power from nuclear fission directs attention to the possibilities of the Heat Pump at the present time.

It is claimed that in the near future, nuclear fission (commonly known as "atomic energy") will supply the electric grid and all nations are devoting large sums of money towards the harnessing of power released from an exothermic compound. The secret probed by Kelvin and Rutherford³ has been revealed. Nuclear energy can be released and all speed is being made to harness that energy so that it can be converted to useful work done.

The popular belief that nuclear fission being exothermic could generate heat in the combustion of a substance in oxygen as coal, wood, etc., can be discounted. The development must come as a chemical reaction from a substance characterised by great stability and the power released harnessed to generating stations which opens up vast possibilities for the Heat Pump, but it is not the final answer to all heating problems, and there are many pitfalls.

There are two known definitions of heat, specific and latent, and there are two common measurements of heat, Fahrenheit⁴ and Centigrade.⁵ Joseph Black⁶ in the 18th century discovered that physical changes for different materials required different quantities of heat, and the fact that when a body or liquid changed its state from solid to liquid or liquid to vapour, a considerable quantity of heat is needed to effect this change which is not measurable in temperature but can be measured as work done or energy expended

which means that heat like matter cannot be destroyed but is only convertible ; from this developed the study of thermodynamics.

Thermodynamics

The word is coined from two words, therme (heat) and dynamics (power) and the theory is the result of studies by Rumford⁷ and Davy⁸, but Joule⁹ gave the measurement of a mechanical equivalent of heat. Carnot previous to this developed a "cycle of heat," and Clausius working on this, proved the flow of heat in one direction only. Lord Kelvin working on Carnot's "Cycle of Heat" and Black's proof of latent heat at fusion or gasification showed that this could be reversed so that the latent heat in a gas or liquid could be released.

Thermodynamics is the science which explains the relation between work and heat. When Romford was boring out gun-barrels from the solid he discovered that there was an unlimited supply of heat which was generated by the work done. Davey carried out an experiment with two blocks of ice rubbing together in a sealed vacuum, causing the ice to melt. In this manner it was proved that heat had a proportional relation to work done. It was Joule however who evolved the exact relationship to work done and heat generated. Previous to this, Carnot had evolved his theory of the heat cycle which governs the principle of the Heat Pump, and upon the researches of those two early experimenters is based the two laws of thermodynamics.

Law 1.—A specific quantity of heat is absorbed for each unit of work expended and conversely each unit of work expended produces a definite quantity of heat.

Law 2.—It is impossible to transfer heat from one body to another at a higher temperature by the agency of a self-acting machine.

These two basic laws mean that heat is related to work done and that heat can only flow from a high to a lower temperature in one direction only. In other words: heat sinks constantly, or degenerates.

Carnot Theory

In 1824 Carnot published his treatise "*Reflexions sur la Puissance Motrice du Feu*," which is now a classic on heat and work done. His

work contains the first theory of the reversible heat engine. His problems were set from the studies of a steam engine at work. It was noted that the work done was supplied by heat from the boiler. In other words : the proportion of heat supplied to work done.

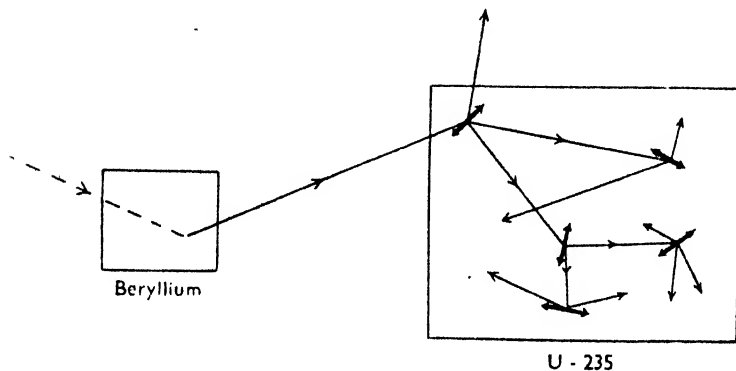

Fig. 1.—The progressive breaking up of nuclear energy

Path of Alpha particle - - - - ->
 Paths of Neutrons ————>
 Fission fragment ————>

A Heat Pump, therefore, according to Carnot, is an engine for converting heat to work or work to heat the efficiency being governed by the losses in transmission and the range in temperature. Carnot set in theory an engine in which a gas absorbed heat from a hot body, then by its expansion carried out work in its flow to a colder body. The gas then contracted and work was done against it yielding up heat to a colder body. The gas then returns to its original volume, temperature and pressure, and thus it would produce a net change of heat into mechanical work. This operation of expansion and contraction he called a " cycle " and this operation was reversible, giving up a greater output of heat from work done due to the latent heat in the liquid or gas. The efficiency of such a machine increases proportionately as the difference in temperature between the hot and the cold body which obeys the second law of thermodynamics evolved.

From this it would seem that the Carnot Cycle in reverse would give a greater heat output than input, due to the heat gain at chemical change as discovered by Joseph Black and described by

him as "latent heat," and the addition of low temperature heat added to the refrigerant.

It is well known that any chemical reaction is governed by a change in temperature whether exothermic when heat is evolved or in reverse it is endothermic when heat is absorbed, but Hess¹⁰ discovered that the amount of heat involved in a chemical change between definite amounts of different substances is always constant provided that the initial and final products are the same in each case. If a given substance is made by a series of reactions the algebraic sum of the heat absorbed or produced is the same.

Energy

Energy then cannot be created, and, as has been shown, neither can heat. This may seem a strange contradiction but we have seen that energy is directly related to heat and heat is not destructible, but flows in one direction. It flows, or sinks so that we live in a universe of thermal change. The irregular movements of a set of molecules, is energy harnessable as much as a mass moved by gravity, and bombardment of molecules by another set of molecules will set up a chemical change either exothermic or endothermic, which is not energy created but energy released, due to a chemical change, and heat can be harnessed to work done as it sinks.

Entropy

If, as we have seen, we have all energy at hand, only needing the key to release it, and all energy originates from the sun, then there must be many chemical changes as heat (or energy) sinks, and this opens up another phase known as "Entropy," derived from the Greek, meaning to "turn in," and is the quantity in a substance which increases or decreases with any heat increase or decrease in the substance. This point is very important in the study of the Heat Pump.

This change of entropy is measured by the change in the quantity of heat divided by the absolute temperature at which this change takes place. If we have a substance which is stable where neither heat flows in or out, then those conditions are said to be adiabatic and entropy is constant. Thus, if heat flows from one solid, liquid, or gas to another, as in a Heat Pump, then the loss in entropy from one agent is more than made good by the gain in the other, and

there is a net gain in entropy. If we accept this, then it could be said that as heat sinks from a hot body (the sun) to a cooler body (the earth) the entropy of the universe would continually increase and would reach a maximum entropy when all energy would pass off as heat, but heat, as it sinks, to other bodies, is converted to work done, in the motion of the universe.

Temperatures

We are often misled by temperatures. A vast quantity of low temperature heat may be useless to put to work as it sinks still further, but that quantity of low temperature heat in water or air, etc., can be recovered and added to by work done (energy converted) and the recovered heat, plus the additional heat added, can be put to useful work as it sinks from this built-up state.

If it is taken as a formula then

$$E = \frac{T_1 - T_2}{T_1}$$

where E represents the total heat available in B.Th.U.s and T_1 the low temperature heat absorbed, while T_2 represents the heat added by the energy converted by the pump. There must, of course, be an unlimited supply of heat available at T_1 , and this must remain constant, within a defined range of temperature, the lower the range, the greater the efficiency.

Entropy and Carnot Cycle—No pump working between the same temperatures of source and refrigerator can have a greater efficiency than a reversible engine.

If we examine this, it will be seen from the second Law of thermodynamics that the flow of heat must be made reversible and the refrigerant must revert to its original state of entropy, temperature and pressure.

If we examine Figure 2 we find that heat is supplied from a low temperature source T_1 which passes over an exchanger at R. The refrigerant in the exchanger at R changes its chemical state from liquid to vapour (boils) and is drawn as a vapour into the pump P where the work done by the pump is converted to heat added to

THE HEAT PUMP

the gas at B. This heat in turn is released at C through a heat exchanger and the gas reverts to liquid (chemical change). At D the liquid is stabilised by being reduced to its original pressure and the Cycle is repeated.

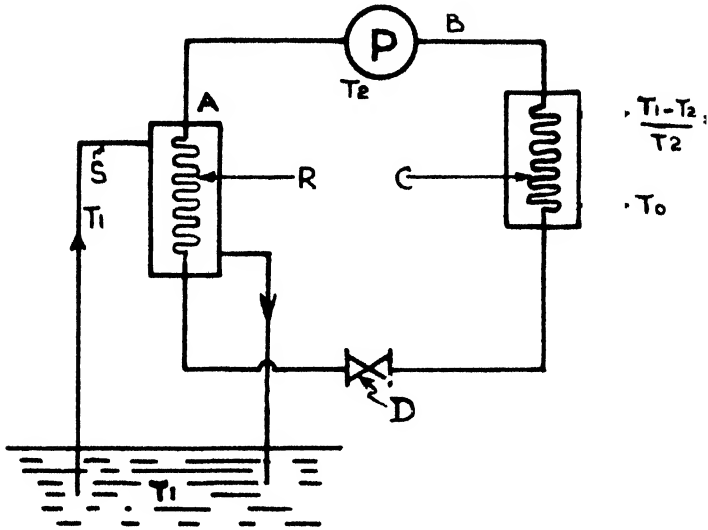

Fig. 2

It should be noted that this is the result of a perfect engine. In fact there are small losses through friction and heat losses, consequently complete conversion cannot take place but the gain in "recoverable heat" at a low temperature is about two parts gain to one part energy expended, and this has been obtained in practice. The available energy and available heat are, therefore, considerable.

If we take an example : a ball is thrown upwards for fx feet, and we ignore the frictional resistance of the air, we have an example of a reversible cycle and we get the equation $w = fx - xf$.

In other words, the mass has moved through a complete reversible cycle.

A thermodynamic illustration is much the same for a reversible cycle in the adiabatic state of a gas if we exclude friction from the

example. If we take a quantity of gas G_a in a cylinder (Fig. 3) which is fitted with a piston, and let us assume that the cylinder and piston are completely insulated. If the external pressure is less than the pressure of G_a by B , the gas will expand, and push the piston back till stability is reached, causing work to be done at W .

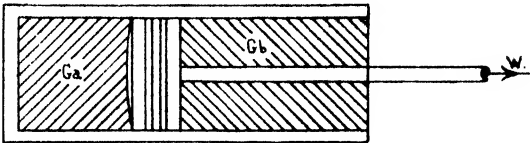

Fig. 3

On the other hand if the pressure is greater by the same amount the gas will revert to its original state at G_a , so we find that the expansion at G_a is converted to W and in its return from W to G_a we have a reversal of the process. If we add and subtract either side of the piston we have a simple practical example of a reversible system which we can apply either as heat, or as we have seen, as energy.

If we take the above example as isothermal, there (Fig. 3) can be a flow of heat to G_a from G_b which will cause the piston to move in the direction of W , owing to the expansion of G_a . If the heat then flows from G_b to G_a the piston will move in the opposite direction and thus complete the reversible cycle.

Let us now pursue the elusive dream of perpetual motion of the piston. Heat flows into a gas causing work to be done at W . If the heat is converted to energy then a fresh supply of heat has to be supplied at G_b to reverse the cycle. Excluding friction, however, if the heat were transferable from G_a to G_b alternately the piston would move backwards and forwards indefinitely. This state exists only in theory.

The Reversible System

This fact brings the Heat Pump into prominence as the nearest approach to this reversible system is the adiabatic, although we have seen that the isothermal is also reversible but its use is of slight practical value and we are concerned only with the practical applica-

tion of thermodynamics as this affects the application of the Heat Pump.

Let us then construct two Pumps, one not reversible, the other reversible. Since the reversible pump has a greater efficiency than the non-reversing pump, there should be a flow of energy from the reversible engine to drive the non-reversing engine between the same temperature limits, and in this way we would be able to extract energy and convert it to work from a low grade heat source, as outlined in T_1 for the refrigerator would act as an accumulator to store the surplus energy, but as we have seen, this would violate the second Law of thermodynamics and the work done would be held within the temperature limits, and we come back to the Carnot cycle, which gives an isothermal expansion at a temperature T_1 , as we have seen at an unlimited source, which is followed by an adiabatic expansion to a new temperature T_2 ; then follows an isothermal compression at the new temperature given at T_2 ; then follows an adiabatic compression, and the gas returns to its original state. It is acknowledged that there must be a thermal change to accommodate the isothermal or adiabatic process, whichever is taking place in the cycle.

We may then state the efficiency of this cycle as follows :—

$$\epsilon = (T_1 - T_2)/T_2$$

in which T_1 is the initial heat absorbed and T_2 is the heat yielded up to the refrigerator. We have T_1 units entering the cycle from the source and T_2 units are given up to the refrigerator, or accumulator, as outlined. If we assume the medium employed in the cycle is a perfect gas, we get the following by substituting total heat units by Q for ϵ

$$Q = \frac{T_1 - T_2}{T_1}$$

The available energy would be

$$E = T_1 \left(Q - \frac{T_2}{T_1} \right)$$

While the unavailable energy would be

$$E_2 = T_1 \left(\frac{T_2}{T_1} \right) = T_2 \left(\frac{T_1}{T_1} \right)$$

If this cycle is reversed we get an absorption of heat, then a release of heat at a greater efficiency. As we have seen, entropy is part of the cycle evolved by Carnot and gives us the state of the cycle at any given phase. This quantity is relative and its characteristics the same for all solids, liquids or gases, and the only practical result would be in a continuous gain of entropy even if two units were taken at a suitable temperature.

We have seen that when a heat conversion takes place, there are losses which cannot be put to any useful work. Meldahl¹², writing in the Brown-Boveri REVIEW, gives a simple outline in a comparison with the refrigerator, while Carrothers¹³, in a Paper to the Institution of Heating and Ventilating Engineers, gives this in diagrammatic form (Fig. 4). This he shows as a heat and work Carnot Cycle, which we have seen is the basis of design in connection with the Heat Pump. As will be seen from his diagram, the Heat Engine and the Reverse Heat Engine are in circuit as proof of the cycle. The simple statement of Meldahl that there is in fact no difference between Heat Pumps and refrigerating machines as they are both Heat Pumps is proved. It seems that the refrigerator produces "cold," in the form of ice, or it keeps food cool by extracting the heat from it. It is obvious that this type of machine is of great use in the preservation of food, while the heat units taken up have to be exhausted to waste before the refrigerant reverts to its former stability. The Heat Pump may perform the same function in reverse for the purpose of providing heat and, in many cases, despite the high capital costs, may be worth constructing in present circumstances.

Heat Pumps do in many cases, however, present important advantages, so that in spite of their high cost may be economical. A Heat Pump can, in particular, supply a much greater quantity of heat with the same consumption of energy, as would be available by direct conversion of the same energy into heat.

This fact often causes much astonishment and is frequently doubted, especially as many popular "inventors" make claims for

THE HEAT PUMP

the application of Heat Pumps without either knowing or taking into account the essential facts.

The additional output of the Heat Pump is in many cases so large that it enables the higher price of electrical energy compared with that of fuel to be more than compensated. The Heat Pump is,

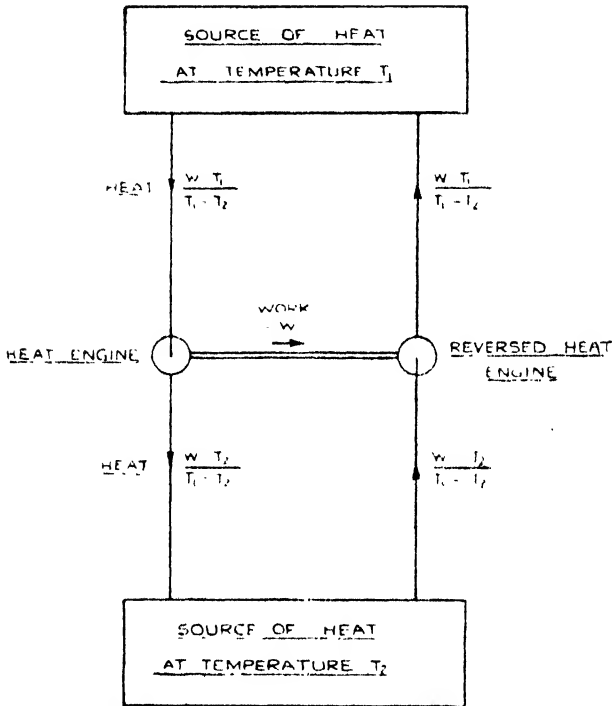

**Fig. 4.—Heat and Work Conversions.
Heat-Engine and Reversed Heat-Engine¹¹**

however, particularly valuable when, as at the present time, for instance, coal is difficult to obtain, and on the other hand the electrical energy available as a substitute is insufficient for direct heating. In such cases a Heat Pump may save the situation and prevent the output of a plant having to be reduced or the plant having to be shut down.

Advantages

A further advantage of the Heat Pump results from the fact that there is fundamentally no difference between Heat Pumps and

refrigerators. If, therefore, a Heat Pump is used for warming a building in winter, the same machine can be used in summer for cooling. In the case of large business houses, theatres, and big restaurants, this cooling in summer is so valuable that it may alone provide an economical justification of the Heat Pump.

In order to be able to judge the possibilities of a Heat Pump, a knowledge of certain thermodynamic facts is indispensable. The clearest view of the principle of the Heat Pump is obtained by comparing it with a heat engine; in the following the heat engine is discussed, and the Heat Pump later.

Heat Pumps

Heat Pumps convert mechanical work to heat. Although heat and mechanical energy are equivalent—when 1 kWh of mechanical or electrical energy disappears there invariably appears a heat quantity of 3,450 B.Th.U.s, and every time 1 kWh of mechanical or electrical energy is produced from heat, 3,450 B.Th.U.s of heat disappear—the conversion of heat into mechanical energy is subject to certain restrictions. As we have seen, mechanical or electrical energy may at any time be completely converted into heat. Experience shows, however, that it is only possible to convert heat into mechanical energy when the heat is available at a temperature higher than that of the surroundings. Even in this case, it is possible at the best to convert only a fraction of the heat into mechanical energy; the remainder must be given up to the surroundings and is definitely lost as far as further conversion into mechanical energy is concerned.

Heat Pumps may be subdivided into two main classes: steam engines and gas engines. In the case of steam engines the working medium passes through various states of aggregation (liquid—steam—liquid); this is not so in the case of gas engines.

The Steam Engine

The steam engine (Fig. 5) operates as follows:—A feed pump delivers the liquid working medium—generally water—into the boiler, where heat is supplied. The heat supplied causes the working medium to evaporate, whereby its volume considerably increases. The steam, in expanding to a lower pressure in a steam engine—reciprocating engine or turbine—does work, after which

the steam is liquefied in a condenser, whereby its latent heat of evaporation is given up to the circulating water. The condensate then returns to the feed pump.

The above-mentioned fundamental principle is evident. The steam engine can only operate when the boiler pressure is higher than the condenser pressure, that is, when the temperature of the boiler is higher than the temperature of the condenser. Secondly,

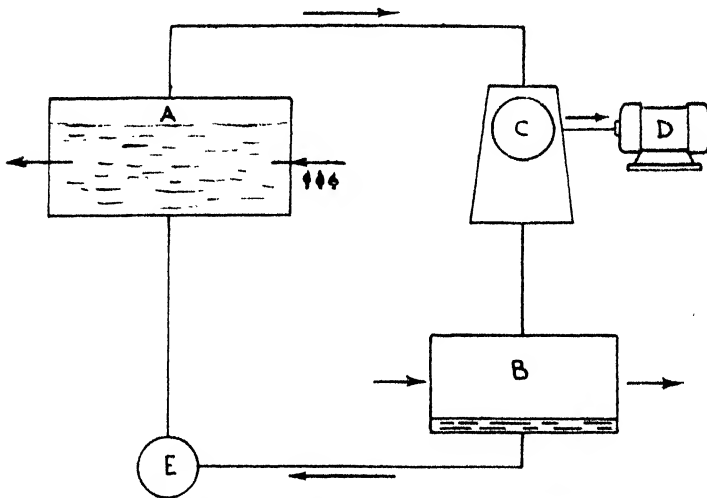

Fig. 5.—Diagram of a Steam Engine

- A. Heated boiler. B. Cooled Condenser. C. Steam engine.
D. Generator. E. Feed Pump.

in order to be able to feed the medium into the boiler, it is essential that the steam shall be condensed and, therefore, that the latent heat of evaporation of the expanded steam shall be given up to the surroundings, so that it can no longer be considered for the production of mechanical energy.

The Gas Engine

In the gas engine the working medium is similarly compressed, then heated, expands, and is finally again cooled. During the expansion of the hot gas, more energy is produced than is needed for the compression of the cold gas; the difference is the useful output.

The fundamental difference compared with the steam engine consists in the fact that the work of compression is a considerably greater fraction of the work done during expansion. The feed pump absorbs less than 1 per cent. of the output of a steam engine; in the case of the gas engine the work of compression amounts generally to more than 50 per cent. of the expansion work. In order that in practice a useful output will remain available, the efficiencies of both the power machine and of the compressor must be high. This is the reason why the gas engine appeared so very much later, as engineering practice had to attain a relatively high state of development before it was possible for the expansion machine to be able to drive even its own compressor, whereas it is hardly possible to imagine a steam engine which is not able to drive its own feed pump.

Reversed Heat

The Heat Pump is nothing other than a reversed heat engine. It is based on the fact that it is possible—apart from the losses—to reverse the thermo-dynamic process of the heat engine. In place of the rejection of heat at the lower temperature, there is the absorption of heat, the heat engine *develops* power, whereas the Heat Pump *absorbs* power, and heat is given out by the Heat Pump at the higher temperature. The heat given out is constituted by the heat equivalent of the energy supplied, whereby 3,450 B.Th.U.s appear for each kWh absorbed, and by the heat taken up at the lower temperature. In practice, both the heat absorbed and that given out may be a multiple of the heat equivalent of the energy supplied. Such a machine can, therefore, absorb heat at a lower temperature and give it out again at a higher temperature, whereas only the reverse process is observed to take place in nature. It, therefore, raises the heat to a higher temperature level—hence the name “Heat Pump.”

Refrigerating and Heating Machines

Heat Pumps can be used in two ways: as refrigerating or as heating machines. The refrigerator must absorb heat at a low temperature. This heat is abstracted from the substance to be cooled, the temperature of which is thereby reduced. The useful output of the refrigerator is, therefore, the amount of heat absorbed at the lower temperature. This heat, increased by the heat equivalent of the energy absorbed, must then be given up in some manner

or other to the surroundings. In the case of the refrigerating machine this exhaust heat is useless and generally a nuisance.

The heating machine must, on the other hand, give up heat ; the useful output is the heat given up at the higher temperature. It is constituted by the heat equivalent of the mechanical energy supplied and the heat quantity taken up at the lower temperature. The lower temperature is either the temperature of the surroundings—the air, a lake, or a river—or the temperature of some available source of exhaust heat. The heat absorbed is usually a multiple of the heat equivalent of the energy supplied. The ratio of the heat given out to the heat equivalent of the energy absorbed is known as the coefficient of performance of the heating machine ; it therefore indicates how much more heat is furnished by the heating machine than by the direct electrical heating with the same consumption of energy.

The heat taken up at the lower temperature is of great importance. If the heat has to be absorbed at the temperature of the surroundings, coefficients of performance of 3—6 can be attained, for instance, for room heating ; if exhaust heat at a more favourable temperature is available—for instance, in concentration or distillation and drying processes—the coefficient of performance may increase to 10—20.

A Heat Pump can be so built that it may be operated at will as a heating engine or as a refrigerator. The same machine may, therefore, serve for instance in a theatre or in a large restaurant for heating in winter and for cooling in summer.

The Steam Heat Pump

The steam Heat Pump (Fig. 6) and a reversed steam engine (Fig. 5). The working medium is evaporated at a low pressure in an evaporator, which takes the place of the condenser. The water circulated through the evaporator supplies the necessary latent heat of evaporation. It is no longer heated in the condenser, but cooled ; if its temperature then falls below 32° F.—as for instance in an ice plant—it is necessary to employ instead of pure water a salt solution (brine) with a sufficiently low freezing point.

The low-pressure steam so produced is continuously absorbed and compressed by the compressor. The compressor takes the place

of the turbine. The compressor absorbs power. Instead of the generator, there is the motor. The compressed steam is now condensed in the condenser, which takes the place of the former boiler. Because of the higher pressure, the steam can now be condensed at a higher temperature than in the evaporator; it can, therefore, give up its latent heat of evaporation at a temperature which is higher than that at which it was absorbed.

The latent heat of evaporation is given up to the cooling water passing through the condenser, which is thereby heated. Whereas

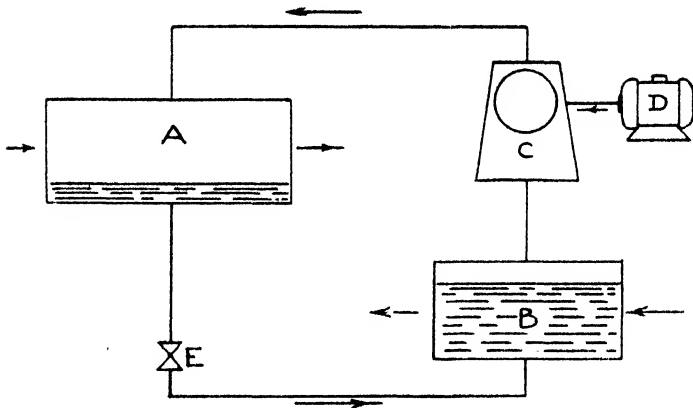

Fig. 6.—Diagram of a Heat Pump

- | | |
|--|--------------------|
| A. Cooled condenser. | C. Compressor. |
| B. Evaporator heated with waste heat
or heat from the surroundings. | D. Motor. |
| | E. Reducing valve. |

The steam heat pump is a reversed steam engine.

in the case of the steam engine the combustion gases are hotter than the cooling water, in the case of the Heat Pump the " heating water " is colder than the cooling water.

The condensed working medium must now be returned to the evaporator. Instead of the feed pump there should now be some form of motor which could deliver energy, thereby relieving the motor for driving the compressor of part of its output. This energy is, however, so small that it is not worth while to provide a special turbine for this purpose, and therefore the condensed working

medium is simply throttled down by means of a float-operated valve or an orifice plate to the evaporator pressure, and the cycle is completed. The steam Heat Pump, hence, requires only a single machine—the compressor. The plant is therefore relatively simple.

The Thermo-compressor

A very simple form of steam Heat Pump is obtained when a concentration process is operated by means of a heating machine and the steam produced is itself used as a working medium. The result is the simple plant shown in Fig. 7. The steam generated in

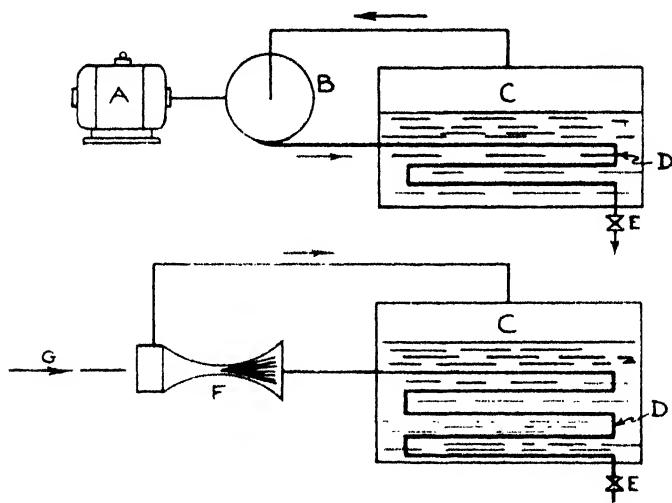

Fig. 7.--Diagram of a Thermo-Compressor

- | | |
|------------------|---------------------------|
| A. Motor. | E. Condensate outlet. |
| B. Compressor. | F. Steam heat compressor. |
| C. Cooker. | G. Live steam. |
| D. Heating coil. | |

The evaporated steam from the cooker is compressed in the compressor to a higher pressure and condensed in the heating coil. The heat of condensation thus given up maintains evaporation in the cooker.

A steam jet-injector may sometimes take the place of the compressor.

The evaporated steam leaves the thermo-compressor in the form of condensate. Its latent heat is, therefore, no longer wasted.

the concentrating pan is drawn off by a compressor, by means of which it is raised to a higher pressure and delivered into a heating coil which maintains the evaporation in the pan. Because of the higher pressure the steam may be condensed at a higher temperature;

it gives up its latent heat of evaporation again to the contents of the pan. Steam thus produced is again compressed, and so on.

In such a case the Heat Pump consists only of a compressor, which is then known as a thermo-compressor. The concentrating pan is the evaporator and the heating coil serves as condenser. The thermo-compressor makes use of the latent heat of evaporation of the steam which would otherwise be lost. This is most clearly seen from the fact that the steam does not leave the concentrating apparatus as such, but is condensed by means of the thermo-compressor and runs off in liquid state—that is without taking with it the latent heat of evaporation. Experience shows that if the evaporator is suitably insulated the mechanical energy supplied suffices to cover the heat losses of the entire concentrating plant.

The Working Medium

The working medium employed depends on the conditions. At low temperatures carbon dioxide (CO_2), ammonia (NH_3) and sulphur dioxide (SO_2) still have a relatively high vapour pressure and consequently a low specific volume. They are, hence, particularly suitable for reciprocating compressors. In the case of centrifugal compressors such media come into question only for large outputs.¹⁴

Already at an early date hydrocarbon compounds, such as ethyl chloride, ethyl bromide, and later methyl chloride (dichloromethane) were employed. Recently, various other hydro-carbon compounds with chlorine and fluorine have been used with centrifugal compressors; these media have the advantage that they are less poisonous; freons are also practically odourless. The molecular weight of these compounds makes them particularly suitable for centrifugal compressors, because the necessary pressures may be obtained with a small number of stages and moderate speeds.

The Gas Heat Pump

The gas Heat Pump is a reversed gas engine. The working medium is compressed adiabatically in the compressor and thereby heated; the heated compressed gas flows through a heat exchanger, where it gives up its heat, after which it is expanded adiabatically in an expansion machine and thereby cooled so far that it may take up heat at a lower temperature in a second heat exchanger.

Just as in the case of the gas engine the work of compression represents a considerable part of the expansion work, so in the case of the gas Heat Pump the expansion work is a considerable part of the compression work. There can, therefore, be no question of omitting the expansion machine as is usual in the case of a steam Heat Pump. That this must be so is shown by the following reasoning : When the condensate is throttled, it assumes—when necessary by partial evaporation—immediately the lower boiling temperature. If, however, gas is throttled, its temperature remains practically constant. If, therefore, the gas were to be throttled instead of expanded in an expansion machine, it simply would not assume the lower temperature which alone enables it to absorb heat at the lower temperature.

The gas Heat Pump without an expansion machine could therefore take up no heat, and hence could only give up as much heat as would correspond to the equivalent of the mechanical energy absorbed, that is, it would be no use as a Heat Pump.

The gas Heat Pump must have an expansion machine and is, therefore, more complicated than the steam Heat Pump. In spite of this, it may present advantages in certain cases. When for instance air is to be heated or cooled, the air may itself be used as working medium. In this way it is possible to avoid one heat exchanger and the temperature drop in the same. Further, it is often an advantage that no special refrigerating medium has to be used. For certain purposes, for instance where low temperatures must be attained—as in the liquefaction of gases or in high altitude test plants for aeroplane engines—gas Heat Pumps are also of advantage.

Heat Engines

As already mentioned, the Heat Pump is nothing else but a reversed heat engine. Since, however, the thermo-dynamics of heat engines are usually considerably better known, in the following the thermo-dynamics of heat engines are first discussed, and thereafter the thermo-dynamic fundamentals of Heat Pumps explained. Certain fundamental ideas must thereby be assumed to be known.

The Steam Engine

The clearest picture of the working of a steam engine is given without doubt by the so-called indicator diagram. This diagram

is obtained when the changes of state of the working medium are drawn in a pressure-volume diagram, the ordinates representing the pressure, the abscissæ the volumes. Usually, the specific volume is employed, that is, the diagram is drawn for 2.205 lb. of the

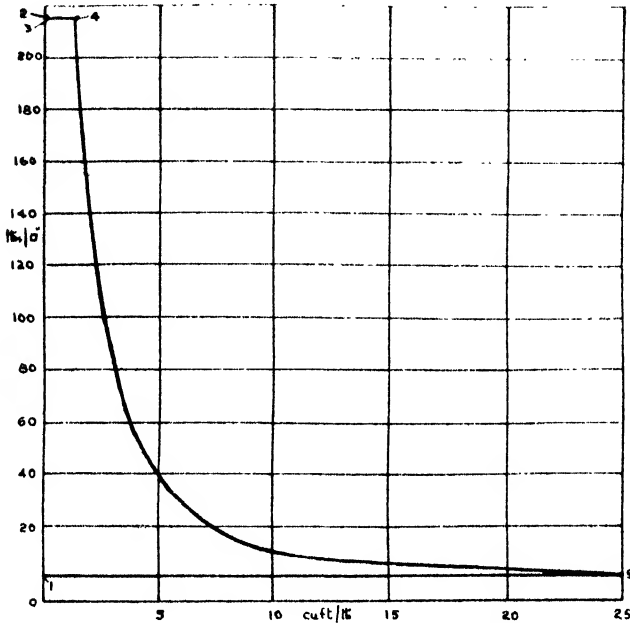

Fig. 8.—p.v. diagram of a Steam Engine

p. Pressure.

v. Specific volume.

The surfaces of the diagrams (Figs. 8 and 9) are equal; they represent the work obtained in mechanical units (Fig. 8) and in heat units (Fig. 9). The mechanical work is best illustrated in the p-v diagram; the heat quantities are best illustrated in the T-S diagram.

During evaporation and condensation heat is supplied or given out at constant temperature.

working medium. Fig. 8 shows the indicator diagram of a saturated steam engine, the working medium in this example being water.

Point 1 corresponds to water at 212° F. and a pressure of 2.205 lb. □". The water is compressed to 227.568 lb. □" abs. (point 2) and then heat supplied. The temperature rises first to 392° F. (point 3), the water thereby expanding only unnoticeably. At this

TABLE 1.—Summary of Non-Flow Processes for Gas Systems. Log.

Type of Process	Value of Exponent n	Final Pressure P_2	Final Temperature T_2	Final Volume V_2	Heat added to System Q_2	Change of internal energy of System U_2-U_1	Thermal equivalent of work performed by system $A A_1 W_2$	Change of entropy of system S_2-S_1
Constant Pressure	0	P_1	$T_1 \left(\frac{V_2}{V_1} \right)$	$V_1 \left(\frac{T_2}{T_1} \right)$	$MC_p(T_2-T_1)^*$	$MC_v(T_2-T_1)^*$ or $\frac{A(P_2V_2-P_1V_1)}{k-1}$	$AP(V_2-V_1)$	$MC_p \text{Loge} \frac{T_2}{T_1}$ or $MC_p \text{Loge} \frac{V_2}{V_1}$
Constant volume	∞	$P_1 \left(\frac{T_2}{T_1} \right)$	$T_1 \left(\frac{P_2}{P_1} \right)$	V_1	$MC_v(T_2-T_1)^*$	$MC_v(T_2-T_1)^*$ or $\frac{A(P_2V_2-P_1V_1)}{k-1}$	0	$MC_v \text{Loge} \frac{T_2}{T_1}$ or $MC_v \text{Loge} \frac{P_2}{P_1}$
Constant temperature—iso-thermal	1	$P_1 \left(\frac{V_1}{V_2} \right)$	T_1	$V_1 \left(\frac{P_1}{P_2} \right)$	$AP_1V_1 \text{Loge} \frac{V_2}{V_1}$	0	$AP_1V_1 \text{Loge} \frac{V_2}{V_1}$	$MAR \text{Loge} \frac{V_2}{V_1}$ or $MAR \text{Loge} \frac{P_1}{P_2}$

Note. MRT may be substituted for P_1V_1 or P_1P_2 for V_2/V_1 in expression above if more convenient

Note. MRT may be substituted for P_1V_1 or P_1P_2 for V_2/V_1 in expression above if more convenient

TABLE 1.—(continued)

Type of Process	Value of Exponent n	Final Pressure P_2	Final Temperature T_2	Final Volume V_2	Heat added to System $1Q_2$	Change of internal energy of System U_2-U_1	Thermal equivalent of work performed by system $A \cdot A (1W_2)$	Change of entropy of system S_2-S_1
Reversible adiabatic— isentropic	k	$P_1 \left(\frac{V_1}{V_2}\right)^k$ or $P_1 \left(\frac{T_2}{T_1}\right)^{\frac{k}{k-1}}$	$T_1 \left(\frac{V_1}{V_2}\right)^{k-1}$ or $T_1 \left(\frac{P_2}{P_1}\right)^{\frac{k-1}{k}}$	$V_1 \left(\frac{P_1}{P_2}\right)^{\frac{1}{k}}$ or $V_1 \left(\frac{T_1}{T_2}\right)^{\frac{1}{k-1}}$	0	$MC_v(T_2-T_1)^*$ or $A(P_2V_2^{\frac{k-1}{k}}-P_1V_1^{\frac{k-1}{k}})$	$MC_v(T_1-T_2)^*$ or $A(P_1V_1^{\frac{k-1}{k}}-P_2V_2^{\frac{k-1}{k}})$	0
		$P_1 \left(\frac{V_1}{V_2}\right)^{\frac{n}{n-1}}$ or $P_1 \left(\frac{T_2}{T_1}\right)^{\frac{n}{n-1}}$	$T_1 \left(\frac{V_1}{V_2}\right)^{n-1}$ or $T_1 \left(\frac{P_2}{P_1}\right)^{\frac{n-1}{n}}$	$V_1 \left(\frac{P_1}{P_2}\right)^{\frac{1}{n}}$ or $V_1 \left(\frac{T_1}{T_2}\right)^{\frac{1}{n-1}}$	$M \left(\frac{n-k}{n-1}\right)$ or $C_v(T_2-T_1)^*$	$MC_v(T_2-T_1)^*$ or $A(P_2V_2^{\frac{n-1}{n}}-P_1V_1^{\frac{n-1}{n}})$	$MAR \frac{(T_1-T_2)^*}{n-1}$ or $A(P_1V_1^{\frac{n-1}{n}}-P_2V_2^{\frac{n-1}{n}})$	$M \left(\frac{n-k}{n-1}\right) \frac{C_v}{\text{Loge}} \frac{T_2^*}{T_1}$ Note. $(V_1/V_2)^{\frac{n-1}{n}}$ or $(P_2/P_1)^{\frac{n-1}{n}}$ may be substituted for T_2/T_1 in expression above if more convenient
Polytropic	Any Constant Value	$P_1 \left(\frac{V_1}{V_2}\right)^{\frac{n}{n-1}}$ or $P_1 \left(\frac{T_2}{T_1}\right)^{\frac{n-1}{n-1}}$	$T_1 \left(\frac{V_1}{V_2}\right)^{\frac{n-1}{n}}$ or $T_1 \left(\frac{P_2}{P_1}\right)^{\frac{n-1}{n}}$	$V_1 \left(\frac{P_1}{P_2}\right)^{\frac{1}{n}}$ or $V_1 \left(\frac{T_1}{T_2}\right)^{\frac{1}{n-1}}$	$M \left(\frac{n-k}{n-1}\right)$ or $C_v(T_2-T_1)^*$	$MC_v(T_2-T_1)^*$ or $A(P_2V_2^{\frac{n-1}{n}}-P_1V_1^{\frac{n-1}{n}})$	$MAR \frac{(T_1-T_2)^*}{n-1}$ or $A(P_1V_1^{\frac{n-1}{n}}-P_2V_2^{\frac{n-1}{n}})$	$M \left(\frac{n-k}{n-1}\right) \frac{C_v}{\text{Loge}} \frac{T_2^*}{T_1}$ Note. $(V_1/V_2)^{\frac{n-1}{n}}$ or $(P_2/P_1)^{\frac{n-1}{n}}$ may be substituted for T_2/T_1 in expression above if more convenient

* Based on the assumption that specific heat is constant. From Young and Young, McGraw-Hill.

temperature the water begins to evaporate under a pressure of 227.568 lb./ \square " abs. ; further heat supply does not raise the temperature, but causes the water to evaporate instead. During this process the volume increases considerably until all water is evaporated (point 4). After all water has been converted into dry-saturated steam, the heat supply is stopped, and the steam expands adiabatically to the initial pressure (point 5). The temperature thereby sinks again to 212° F. and a small part of the steam liquefies. Heat is now abstracted from the steam at constant pressure ; the temperature then remaining constant, the steam condenses, however, and the volume decreases until all the steam is liquefied (point 1). The cycle is then closed and can be repeated as often as desired.

As during this whole process no permanent change of any substance occurs, the cycle is purely thermodynamic. The mechanical work thereby obtained is represented by the indicator diagram 1, 2, 3, 4, 5, 1.

In this diagram, the net mechanical work is the difference between the expansion work of the steam—surface between 4, 5, and the ordinate axis—and the work of the feed pump— surface between 1, 2 and the ordinate axis. In Fig. 8 this second surface is, however, practically invisible, as the feed pump absorbs only a minute fraction of the work of expansion.

The Gas Engine

Fig. 10 shows the indicator diagram of a gas engine. Air at atmospheric pressure, that is at a pressure of 14.72 lb./ \square " , and a temperature of 572° F. abs. (point 1), is compressed adiabatically to 42.669 lb./ \square " (point 2) and then heated at constant pressure to 1,472° F. abs. (point 3). The air thus heated expands adiabatically to the original pressure (point 4) and is then again cooled at atmospheric pressure to the original temperature (point 1). In practice the expanded air escapes through the chimney, and in its place fresh air is drawn in. The work done is again represented by the surface 1, 2, 3, 4, 1.

Here again the mechanical work is the difference between the expansion work—surface to the left of 3, 4—and the work of compression—surface to the left of 1, 2. The fundamental difference

compared with the steam engine consists in the fact that with a gas engine the work of compression is a substantial amount—in the example illustrated it amounts to 50 per cent. of the work of expansion. If any useful output is to be given at all, the efficiencies of both the turbine and the compressor must clearly be quite high.

The indicator diagram satisfies all requirements as long as we are interested only in mechanical energy. If, however, heat quantities are to be shown, it is more advantageous to employ a diagram with absolute temperature as ordinates and entropy as abscissæ.

The idea of entropy is somewhat abstract. For the present it is, however, sufficient to bear the following in mind :—

(a) That entropy is, just as the specific volume, the internal energy, or the heat content, a pure function of state, that is, 2.205 lb. of water or steam has in every state which is given for example by the pressure and the temperature, a certain definite entropy, the value of which may be obtained from steam tables, such as is the case for the specific volume of the heat content.*

(b) From the definition entropy s

$$d s = d Q/T \dagger$$

where $d Q$ represents the heat quantity supplied at the temperature T , it follows at once that in the temperature-entropy diagram the surface element

$$T \cdot d s = T \cdot d Q/T = d Q$$

represents directly the heat quantity supplied. In this representation, therefore, heat quantities appear as surfaces, isothermal changes of state as horizontal lines, and adiabatic changes of state—since $d Q = 0$ —as vertical lines. Herein lies the great practical value of the entropy diagram. Exactly the same cyclic process illustrated in the indicator diagram Fig. 8 can now be represented

* It would be too extended to prove this statement here. It is a consequence of the second law of thermo-dynamics. Those wishing to pursue the subject may follow it up in any text-book on thermo-dynamics.

† This definition of entropy applies strictly only to reversible processes. It can, however, by means of an artifice be applied also to irreversible changes of state, such as throttling, by taking into account the heat produced by friction.

in the entropy diagram Fig. 9. Point 1 corresponds again to boiling water at 14.72 lb./□" abs., the temperature of which is, therefore, 701.78° abs., and which has an entropy per lb. of 0.0383 B.Th.U.s/°F. Adiabatic compression of the water causes no noticeable increase of temperature, so that point 2 practically coincides

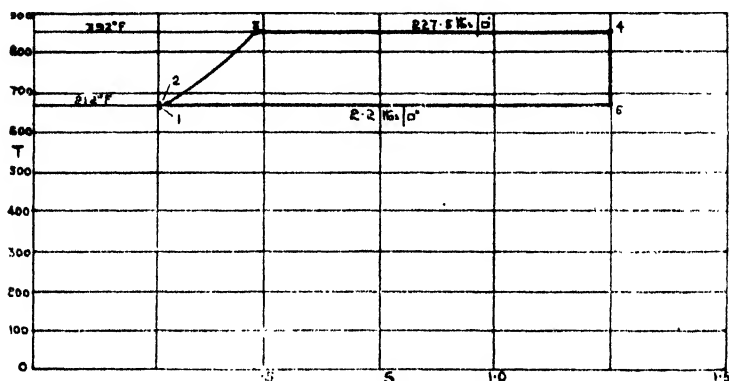

Fig. 9.—T-S diagram of Steam Engine

T. Absolute temperature. S. Entropy.

- | | |
|---|--|
| 1. State of condensate at condenser pressure. | 3. Condensate heated to boiling point. |
| 2. Condensate compressed to boiler pressure. | 4. Condensate evaporated. |
| | 5. Steam expanded to condenser pressure. |

The surface of the diagrams (Fig. 8 and 9) are equal; they represent the work obtained in mechanical units (Fig. 8) and in heat units (Fig. 9). The mechanical work is best illustrated in the p-v diagram; the heat quantities are best illustrated in the T-S diagram.

During evaporation and condensation heat is supplied or given out at constant temperature.

with point 1. During the following heating process the temperature rises first to 883.4° F. abs., i.e., the boiling temperature corresponding to 227.568 lb./□" abs. Simultaneously the entropy also increases (point 3). A further increase of the heat supply causes the water to evaporate, during which process the temperature remains constant, the entropy continuing to increase until all water is evaporated (point 4). Now the steam expands adiabatically to 14.233 lb./□", during which the temperature again falls to 703.4° F. abs. (point 5), and when the steam is again condensed by

abstraction of heat, its entropy returns to the original value and the cycle is complete.*

The total heat absorbed during this process is represented by the surface below the line 1, 2, 3, 4.

The heat given out is represented by the surface below the line 5, 1, and the difference, converted into mechanical work, is represented by the surface 1, 2, 3, 4, 5, 1, which therefore—expressed in heat units—must be equal to the area of the indicator diagram. On the other hand, it is not possible by simple means to show, in

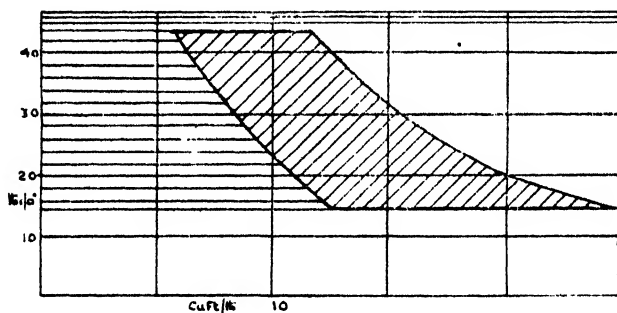

Fig. 10.—*p-v* diagram of a Gas Engine

p. Pressure.

v. Specific volume.

the entropy diagram for instance, the work of the feed pump. Figs. 10 and 11 are the corresponding *p-v* and *T-S* diagrams for a gas engine.

The Carnot Efficiency

The entropy diagram enables the substance of the famous law of Carnot to be illustrated very clearly. The entropy diagram of the saturated steam engine shown in Fig. 9—except for the left-hand

* According to Clausius' law, entropy can only increase or at the best remain constant, but never decrease. The explanation is as follows: When any body gives up heat, this heat must necessarily pass to another body. During this process the temperature of the body to be heated must be lower than that of the body supplying the heat, so that the increase of the entropy of the first is necessarily greater than the decrease of the second. The total entropy of both bodies must, therefore, increase. In the ideal case there is no difference of temperature, and the increase and decrease of entropies just balance each other. A decrease in the total entropy would mean that the colder body had given out heat, which is impossible. The entropy of any single body may, however, either increase or decrease.

upper corner below the points 2 and 3—is a rectangle. If this corner is disregarded* it is at once evident that the heat available at a certain temperature can never be completely converted into mechanical work.

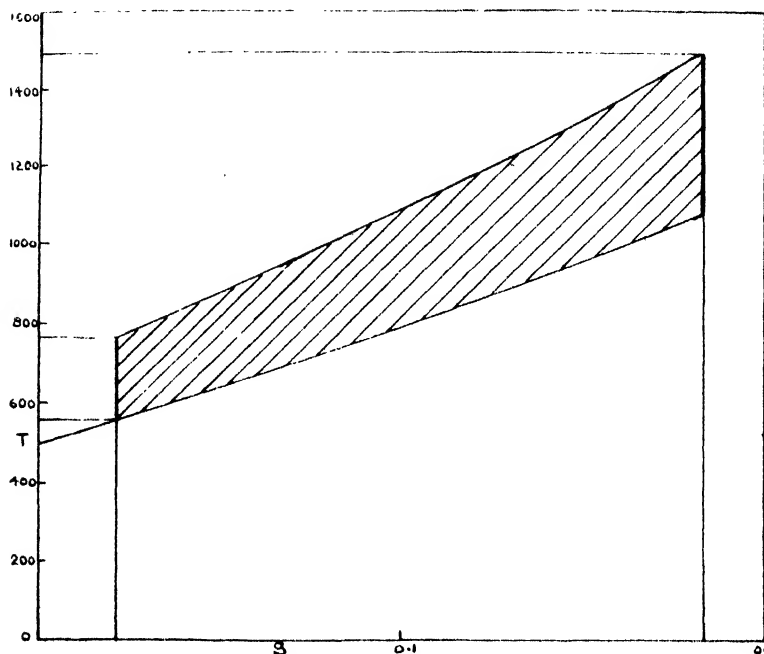

Fig. 11.—T-S diagram of a Gas Engine
 T. Absolute temperature. S. Entropy.

The surfaces of the two diagrams are equal and represent the work obtained in mechanical units (Fig. 10) and heat units (Fig. 11). The mechanical work is best represented in the p-v diagram. The heat quantities are best shown in the T-S diagram.

In the gas engine the heat must be supplied at an increasing temperature and be given out at a decreasing temperature.

If the two temperatures T_1 and T_2 are given, then of the same amount of heat Q available at the temperature T_1 , there can be converted into mechanical work at a maximum only a fraction

$$Q \cdot \frac{T_1 - T_2}{T_1}$$

* This corner is missing because the process chosen operates without feed-water heating.

whilst the remainder $Q \cdot \frac{T_2}{T_1}$ must inevitably be given out again

at the temperature T_2 if the cycle is to be completed. This is the

consequence of the law of Carnot.* The ratio $\frac{T_1 - T_2}{T_1}$ is also

the Carnot efficiency; if a heat engine works between the temperatures T_1 and T_2 , the terminal efficiency can never exceed the Carnot efficiency.

Heat Pumps

The Heat Pump is nothing other than the reversal of the heat engine, and the working process of the steam Heat Pump would be, for instance, as follows (Fig. 8): Boiling water (point 1) is converted to steam by the heat supplied (point 5). The steam is adiabatically compressed (point 4) and then again condensed by abstraction of heat (point 3). The resulting condensate is afterwards again expanded to the initial pressure.

The heat quantities may once again be read off from the entropy diagram (Fig. 9). The heat supplied is represented by the surface below the line 1, 5, the quantity of heat given off by the surface below the line 4, 3, 2, 1, and the necessary power by the surface 1, 5, 4, 3, 2, 1. By means of this process a certain amount of heat is therefore taken in at the lower temperature and increased by the heat equivalent of the mechanical work absorbed and given out again at a higher temperature.

The Coefficient of Performance

The entropy diagram enables us to see immediately the maximum efficiency of a Heat Pump. The enclosed surface represents the power consumption theoretically. The surface below the diagram is the heat absorbed, and the two together represent the maximum heat which the Heat Pump can give out. It is customary to express the performance of the Heat Pump on the ratio of the useful heat

* This is, of course, no "proof" of Carnot's law. The definite relationship between entropy and state postulated previously, without which it would be quite impossible to draw an entropy diagram, is, on the contrary, a consequence of the law of Carnot.

to the power absorbed—also expressed in heat units ; the ratio is called the coefficient of performance. The theoretical maximum value of the coefficient of performance may be deduced from Carnot's law ; it depends, however, upon which heat quantity is regarded as the useful heat, for a Heat Pump may operate either as a refrigerator, or as a heating machine, and the coefficient of performance differs accordingly.

The Refrigerator

In the case of the refrigerator the useful output is the heat absorbed at a lower temperature, for this is the heat quantity which is abstracted from the substance to be cooled and is, therefore, the amount of "cold" produced. The maximum ratio of the useful output to the power absorbed is in this case

$$\epsilon_{th\ k} = - \frac{T_2}{T_1 - T_2} *$$

as follows from Carnot's law.

The upper temperature limit T_1 in the case of the refrigerator lies in practice in the neighbourhood of 572° F. abs. It is given by the temperature of the available cooling water. The coefficient of performance is fixed by the choice of the lower temperature T_2 , and the entropy diagram shows at once how important it is not to make this temperature a single degree lower than absolutely necessary. An unnecessarily low temperature increases the amount of power required and at the same time reduces the useful output. At very low temperatures, as come into operation for the liquefaction of air or in particular of hydrogen (20° abs.)— 68° F., or Helium (39.2° F.) enormous amounts of energy have to be supplied to produce very small outputs of cold.

The Heating Machine

In the case of the heating machine the useful output is, on the other hand, the heat given out at a higher temperature. The

* The minus sign comes from the fact that the useful output is a heat quantity *taken in*.

maximum ratio of useful output to the energy absorbed is then according to Carnot's law :

$$\epsilon_{th} = 1 + \frac{T_1}{T_1 - T_2}$$

The available electrical (or mechanical) energy could also be *directly* converted into heat and used for heating purposes. The

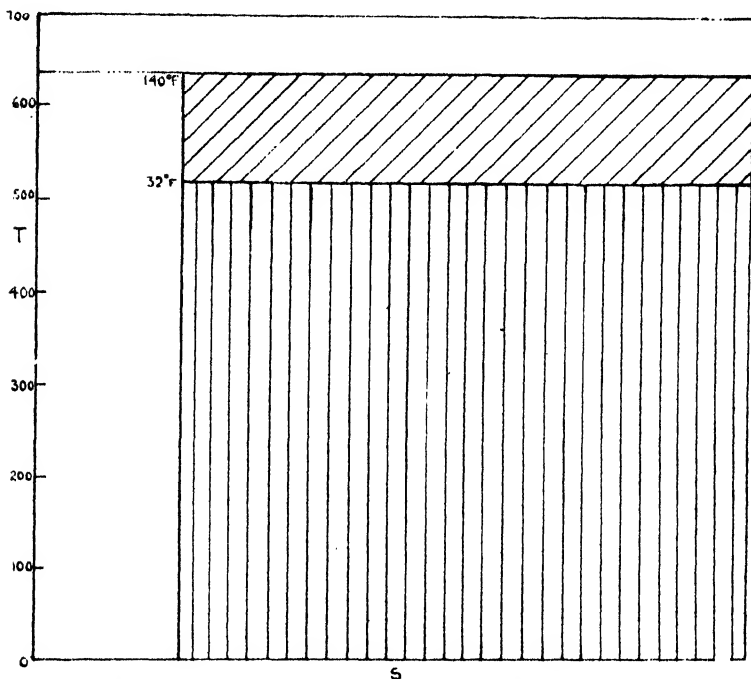

Fig. 12.—Carnot diagram of a Heating Machine

//////. Theoretically necessary energy consumption.

|||||. Heat recovered from the surroundings.

The lower the upper temperature, the smaller the energy consumption. Heating installations for operating with Heating Machines must be liberally dimensioned.

coefficient of performance indicates, therefore, in this case, how many times more heat is made available for heating purposes by the heating machine.

What values of the coefficient of performance can be attained depends on the operating conditions. In the case of heating

THE HEAT PUMP

machines which make the heat of the surroundings available for room heating, the lower temperature is fixed in the neighbourhood of 572° F. abs. (Fig. 12). The higher the upper temperature T_1 is chosen, therefore, the greater is the consumption of energy. It is,

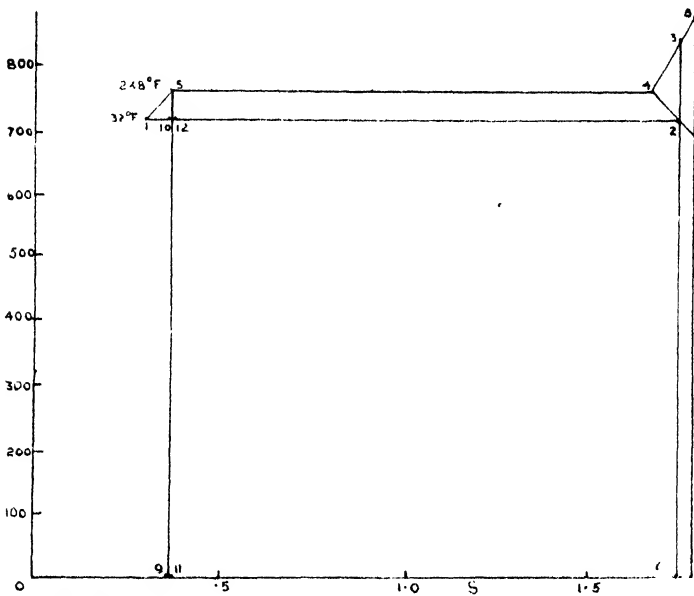

Fig. 13.—Entropy diagram of a Thermo-Compressor¹⁵

Evaporator temperature 212° F. Condenser temperature 298° F.

- 1, 2, 3, 4, 5, 1 = Theoretical compression work.
- 2, 6, 7, 8, 3, 2 = Additional work due to compressor losses.
- 2, 6, 9, 10, 2 = Theoretically recoverable latent heat of evaporation.
- 10, 9, 11, 12, 10 = Losses due to throttling and subsequent evaporation of the condensate.

The small amount of energy consumed 1, 2, 6, 7, 8, 3, 4, 5, 1 enables the large part 12, 2, 6, 11, 12 of the latent heat of evaporation to be recovered and to be returned to the evaporation process. The vapour leaves the concentrating plant as condensate and not as steam. The latent heat of evaporation is therefore not lost.

hence, futile to connect a Heat Pump to an inadequately dimensioned central heating system. With coal firing it is possible without much loss to force the temperature up to 176 or 194° F. ; such a temperature would, however, completely nullify the advantage of a

Heat Pump, and for room heating it is therefore essential to employ for the few really cold winter days additional fuel and to dimension the Heat Pump only for the average heating requirements.

There is, however, for heating machines a further particularly interesting field of application. If, for instance, both temperatures may be raised, then the useful output with constant energy consumption steadily increases (Fig. 13). Such a possibility does indeed exist in many cases when exhaust heat is available from any process, e.g., in concentrating, distilling, or drying processes, where large heat quantities are consumed, in order to convert water into steam which is not utilised. Here in many cases it is possible to recover by means of the Heat Pump the latent heat of evaporation, which would otherwise be lost, and to return it again to the process. Under favourable circumstances it is possible to achieve extraordinarily high coefficients of performance, especially when the steam produced serves at the same time as working medium for the heating machine, so that the Heat Pump can take the cheap form of a thermo-compressor.

Efficiencies

The ideal coefficient of performance (ϵ_{th}) according to Carnot cannot be achieved in practice. If (ϵ) is the coefficient of performance actually achieved, then the efficiency of the Heat Pump is

$$\eta = \epsilon / \epsilon_{th}$$

The efficiency differs according to whether the Heat Pump operates as a refrigerator or as a heating machine, as we have just seen.

The efficiency is affected mainly by :

- (a) The drop of temperature in the heat exchangers.
- (b) The working process used and by the nature of the working substance.
- (c) The efficiency of the machines used.

These influences cannot, however, be clearly separated, and in any case it is out of the question, as has already been attempted, to

show the total efficiency of a Heat Pump as the product of individual efficiencies, where the latter take into account the effect of the heat exchanger, of the process, of the working medium and of the efficiency of the machine.

It is, of course, always possible in any particular case to determine for instance the effect of the efficiency of the compressor used on the coefficient of performance of the Heat Pump and to express this effect by a numerical factor. The factor thus obtained does not, however, represent numerically the efficiency of the compressor, and for the same compressor it may assume different values, according to circumstances. The same applies to the other individual factors ; in each concrete case, numerical values may be given ; they have, however, neither practical value nor physical meaning.

Only by the aid of certain assumptions is it possible to visualise clearly the effect of the above-mentioned conditions. It must, however, always be borne in mind that the considerable simplifications as to the variations of temperature and of the process thus assumed, do not apply in reality. The art of the engineer consists in overcoming or considerably minimising the deficiencies of the simple processes by suitable measures. In the following, therefore, only the effect of the different conditions is shown in quite a general way.

(a) Temperature Drop in the Heat Exchangers

Let $T_0 =$ lower temperature.

$T_1 =$ upper temperature.

$\delta T_0 =$ temperature drop in the evaporator.

$\delta T_1 =$ temperature drop in the condenser.

$\Delta T = T_1 - T_0 =$ temperature difference to be overcome.

The theoretical coefficients of performance according to Carnot are :—

$$e_{th r} = - \frac{T_0}{\Delta T} \text{ for the refrigerator.}$$

$$e_{th h} = + \frac{T_1}{\Delta T} \text{ for the heating machine.}$$

The temperature drop at the heat exchangers causes the temperatures to be displaced; the Heat Pump must in reality work under the following conditions:—

$$T_0 - \delta T_0 = \text{lower temperature.}$$

$$T_1 + \delta T_1 = \text{upper temperature.}$$

$$\Delta T + \delta T_0 + \delta T_1 = \text{temperature difference to be overcome.}$$

and the corresponding coefficients of performance of an ideal machine are

$$\epsilon_{1k} = \frac{T_0 - \delta T_0}{\Delta T + \delta T_0 + \delta T_1} \text{ for the refrigerator.}$$

$$\epsilon_{1h} = 1 + \frac{T_1 + \delta T_1}{\Delta T + \delta T_0 + \delta T_1} \text{ for the heating machine.}$$

from which it follows:

$$\frac{\epsilon_{1k}}{\epsilon_{1h}} = \frac{\Delta T}{\Delta T + \delta T_0 + T_1} \left(1 - \frac{\delta T_0}{T_0} \right) \text{ for the refrigerator.}$$

$$\frac{\epsilon_{1h}}{\epsilon_{1k}} = \frac{\Delta T}{\Delta T + \delta T_0 + \delta T_1} \left(1 + \frac{\delta T_1}{T_1} \right) \text{ for the heating machine.}$$

A temperature drop δT_0 at the lower temperature is therefore always more harmful than a temperature drop δT_1 of the same magnitude at the higher temperature.

(b) Effect of the Process and of the Working Medium

Fundamentally, all reversible processes are equivalent, independently of the working medium, used. As soon as the cycle

becomes irreversible, the working medium has an effect on the coefficient of performance, depending on the process chosen.

1. In the case of steam Heat Pumps it is usual to base on the following simple process in order to illustrate the effect of the working medium : The working medium is completely evaporated at the lower temperature, the dry-saturated steam is compressed adiabatically to such a pressure that it condenses at the higher temperature. The boiling condensate is then throttled to the pressure of the evaporator.

This process is imperfect in two respects. During the adiabatic compression the steam is heated to a higher temperature than that at which the heat is given up and hence the work of compression is uselessly increased ; by the throttling of the boiling condensate a large amount of expansion work is lost, increasing with the degree of evaporation during the throttling. In reality the compressor, therefore, is cooled or working media are employed which have a high molecular weight and a high specific heat in the steam condition, and which therefore become less heated during compression. The condensate is, wherever possible, cooled below the boiling point and is expanded or throttled in stages. The simplified process, therefore, gives a deformed and exaggerated picture of the effect of different working media.

Let

L_v = the ideal work of compression, that is adiabatic to the higher temperature, then isothermal to the condenser pressure.

L_e = the ideal work of expansion of the boiling condensate,

Q_0 = ideal amount of heat taken up,

L_{1v} = the theoretical work of compression during adiabatic compression to condenser pressure,

a_v = $L_v/L_{1v} < 1$,

then for the ideal process

$$\epsilon_{1k} = \frac{Q_0/A}{L_v - L_e} \text{ for the refrigerator}$$

$$\epsilon_{1h} = + \frac{Q_0/A}{L_v - L_e} + 1 \text{ for the heating machine.}$$

and for the chosen comparison process

$$\epsilon_{2k} = \frac{Q_0/A - L_e}{L_{1v}} \text{ for the refrigerator.}$$

$$\epsilon_{2h} = \frac{Q_0/A - L_e}{L_{1v}} + 1 \text{ for the heating machine.}$$

and upon rearrangement

$$\epsilon_{2k} = a_v \left\{ \epsilon_{1k} - (\epsilon_{1k} - 1) \frac{L_e}{L_v} \right\}$$

$$\epsilon_{2h} = a_v \left\{ (\epsilon_{1h} - 1) - \epsilon_{1h} \frac{L_e}{L_v} \right\} + 1$$

Therefore those working media are advantageous for which the ratio L_e/L_v is small, that is, having a high latent heat of evaporation and a low specific heat in the liquid state. In the steam state a high specific heat is desirable in order that a_v may be as large as possible. These conditions are partially contradictory. In general working media with a high molecular weight are to be preferred.

As can be seen, the effect of the working medium on the coefficient of performance also depends on the level of the temperature and on the temperature difference to be overcome. A generally valid "working substance efficiency" or "process efficiency" does not exist; only for certain definite conditions is it possible to give numerical values for each individual case.

2. With gas Heat Pumps, for practical reasons, the heat is also supplied and abstracted at constant pressure. As, however, no evaporation and liquefaction takes place, the temperatures do *not* remain constant, and the heat is taken in at increasing temperature and given out at decreasing temperature. If the Carnot efficiency is calculated on the basis of the extreme temperature limits, a poor

value is obtained ; but in most cases Heat Pumps serve to cool or to heat some substance, in other words, the heat transfer is not required to take place at constant temperature. Hence, if the temperature variation of the Heat Pump is adapted to the requirements and counter-flow heat exchangers are used, gas Heat Pumps may also operate favourably, in spite of the fact that at first sight the entropy diagram appears to be less advantageous.

(c) Effect of the Efficiencies of the Compression and Expansion

Let

- L_{1v} = theoretical work of compression.
- L_{1e} = theoretical work of expansion of the chosen process.
- η_v = adiabatic efficiency of the compressor.
- η_e = adiabatic efficiency of the expansion machine.

Then the coefficient of performance becomes

$$\epsilon_{2k} = \frac{Q_0/A - (L_e - L_{1e} \cdot \eta_e)}{L_{1v}/\eta_v - L_e \cdot \eta_e} \text{ for the refrigerator}$$

$$\epsilon_{2h} = \frac{Q_0/A - (L_e - L_{1e} \cdot \eta_e)}{L_{1v}/\eta_v - L_e \cdot \eta_e} + 1 \text{ for the heating machine,}$$

from which it follows after rearrangement

$$\frac{\epsilon_{2k}}{\epsilon_{2h}} = \frac{L_{1v} - L_{1e}}{L_{1v}/\eta_v - L_{1e} \cdot \eta_e} \left\{ 1 + \frac{1 - \eta_e}{\epsilon_{2k}} \cdot \frac{L_{1e}}{L_{1v} - L_{1e}} \right\}$$

for the refrigerator.

$$\frac{\epsilon_{2h}}{\epsilon_{2h}} = \frac{L_{1v} - L_{1e}}{L_{1v}/\eta_v - L_{1e} \cdot \eta_e} \left\{ 1 + \frac{1/\eta_v - 1}{\epsilon_{2h}} \cdot \frac{L_{1v}}{L_{1v} - L_{1e}} \right\}$$

for the heating machine.

Now here :

$$(L_{1v} - L_{1e}) / (L_{1v}/\eta_v - L_{1e} \cdot \eta_e) = \eta_m$$

is directly the efficiency of the machinery installation, and after further re-arrangement we obtain

$$\epsilon_{gk} = \epsilon_m \left(\begin{array}{c} \epsilon_{2k} + (1 - \eta_c) \dots L_{1v} \\ \dots \dots \dots L_{1v} \dots L_{1v} \end{array} \right) \text{ for the refrigerator}$$

$$\epsilon_{gh} = \eta_m \left(\begin{array}{c} \epsilon_{2h} + \left(\begin{array}{c} 1 \\ \dots \dots \dots 1 \end{array} \right) \dots L_{1v} \\ \dots \dots \dots L_{1v} \dots L_{1v} \end{array} \right) \text{ for the heating machine}$$

If we take as an example the simplified process of a steam Heat Pump described previously, then for this process $\eta_m = \eta_c$ and $L_{1v} = 0$, therefore

$$\epsilon_{gk} = \eta_v \cdot \epsilon_{2k} \text{ for the refrigerator}$$

$$\epsilon_{gh} = \eta_v \cdot \epsilon_{2h} + (1 - \eta_v) \text{ for the heating machine.}$$

In the case of this simplified process it is therefore possible to introduce the adiabatic efficiency of the compressor as a simple factor in the calculation of the refrigerator. Even for the simplest of heating machines, this is, however, no longer admissible.

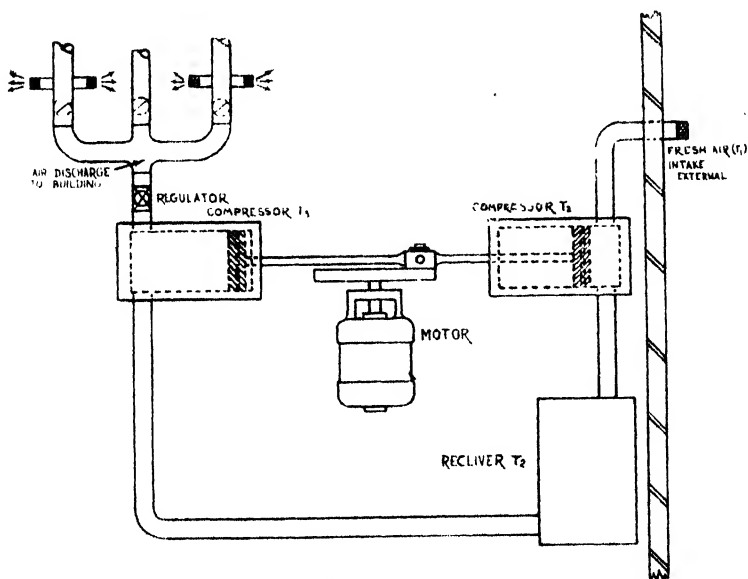

Fig. 14—Lord Kelvin's suggested lay-out for the Heat Pump

Lord Kelvin's Theory

Lord Kelvin pointed out that air could be used as a refrigerant and the T_1 and T_2 temperatures could be had by using air as the

refrigerant, then raising the temperature before discharge. In other words, air was drawn into a compressor which compressed the air to a receiver T_3 , (Fig. 14) thence passing from another compressor and discharged to the building at T_3 . It was held that if it were intended to supply warm air to a building it would be much better to use the air itself and to discharge the air to the building, using a small re-circulation.

The machine would have two cylinders, as shown in Fig. 14. The cycle of operation was as follows :--Air was drawn in from the external atmosphere to the motor cylinder on one throw of the stroke. Then the valve closed and the remainder of the stroke caused the air to expand, reducing its pressure. In this way the flow of heat was through the cylinder to the expanded air, the expanded air being at a lower temperature than the surrounding air. A large heating surface of course was necessary on the cylinder to give the transfer.

On the second return stroke, the air was then discharged in to the receiver and this, in turn, had also a large heating surface to give an easy heat transmission from the external surface exposed to the

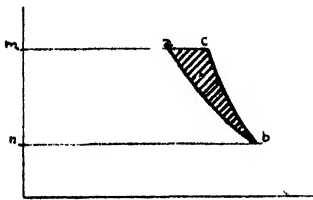

Fig. 15

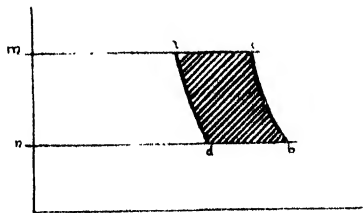

Fig. 16

The indicator diagrams for the suggested layout above

atmosphere of the building to be heated: Thus the gain, as nearly as possible, is an isothermal expansion, while the air in the receiver dropped below atmospheric.

From the low pressure cylinder and receiver, air is then compressed and the heat T_3 is transferred by work done and the desired air temperature is discharged to the room. The indicator diagram for the process is shown in Fig. 15 and also in Fig. 16.

In Fig. 15 it has been assumed that the expansion, as explained, is isothermal; the motor diagram is "MABN" while that of the compressor is "NBCM."

Fig. 16 is more likely if the expansion is isothermal and shows the flow of heat regained in the receiver, the air, in consequence, increasing its entropy from "ND" to "NB." Point B corresponds to point D in Fig. 15, while the compressor diagram "NBCM" is the same as before.

Lord Kelvin took as an example, the heating of air from atmosphere with a temperature of about 50° F., to a final temperature of 80° F., while he calculated that by means of this ideal machine, 1 lb. of air will be delivered per second with an expenditure of 0.283 H.P., this mechanical energy being converted to heat at 0.2 B.Th.U.s per second.

Heat Required

The heat required to warm 1 lb. of air from 50° F. to 80° F. is about 7 B.Th.U.s, so that the heat given to the air would be 35 times the equivalent of the work spent. In other words, the efficiency output using air heated in this way is 35 times greater than the equivalent of mechanical energy transferred thermally.

Lord Kelvin visualized a steam engine which was capable of converting into work $1/10$ th of heat diverted by the combustion of coal, so that the effect of the whole combustion would be that heat transferred to the air would be 3.5 times the calorific value of the fuel used.

Compared with modern steam plant, this seems enormous, as the overall efficiency of the steam engine has not a higher efficiency than $1/10$ th, so that allowing for loss of power and thermal losses, it would seem that by the method described a useful heating effect in the warming of the air could actually be obtained for the expenditure of less than half the fuel consumed by direct heating. As has been found in practice, the heat discharged at T_1 is two parts gain to one part fuel consumed, but the total gain of 7 B.Th.U.s could not be utilised as almost half of this input was dissipated by the vitiated air. Even with an attempt at recirculation this could not all have been retained although the vitiated air could be used thermally to

raise the temperature of the receiver, but in practice this was not effective.

It should be noted in examining this theory of Kelvin's that heat given up to the air is not all recovered from the conversion in heat of mechanical energy. The gain of course is at T_1 from the atmosphere and not from the conversion of mechanical energy which is an expenditure of energy and not an addition. Kelvin stated that about $34/35$ parts of the heat is drawn from the surrounding objects and $1/35$ part is created by the action of the agent, which in this case is air.

Air Heat Pumps have developed along these lines both on the Continent and in America, but with variations, using an indirect agent as the refrigerant, and the transfer of heat taking place from the agent through a condenser to the air to be heated. So far there is no Heat Pump in existence which works successfully using air as the "agent." As the function of the "agent" is to bring about a heat gain and absorb as much low-grade heat as possible, air would have to be handled in great quantities and the flow of heat at T_1 would have to be at a maximum and constant which is not possible with air as the agent. It has been shown that this Heat Pump which was outlined by Kelvin could not be made effective in practice. Morley¹⁶ in 1922 compared this hydraulically.

Analogy of Heat Pumps and Hydraulic Machinery

This is a useful though by no means perfect analogy and does not constitute proof of the relationship. Consider a Pelton wheel supplied with a small quantity of water at a very high head and let the Pelton wheel drive a pump lifting water through a head of a few feet only. It is obvious that in spite of inevitable losses the quantity of water pumped may be many times that supplied to the Pelton wheel since the ratio of heads is so great. The Pelton wheel is analogous with the Heat Pump supplied at high temperature and working with a large temperature drop. The pump corresponds to the reversed heat engine working with a small temperature range and discharging at moderate temperature. In the hydraulic case water falling from a high head is the means of raising a larger amount of water through a much smaller difference of head. So in the thermodynamic case, heat supplied at high temperature is the means of delivering a larger amount of heat at a low temperature.

Kelvin also pointed out that the reversed heat engine could be used to cool buildings in hot weather as well as warm them in cold. In this case, referring to Fig. 14; the air flow is altered. The compressor takes in air from the building, compresses it and delivers to the receiver which acts as a cooler. Operation in the cooler corresponds to nb, bc, cm of Fig. 15 or 16, in which, however, nb is now at atmospheric pressure. The cooled high pressure air is now admitted to the motor cylinder and expanded to atmospheric pressure again - diagram being ma, ad. The temperature falls during expansion to a minimum at d and the cooled air is now delivered into the building again. This cycle is used in the Bell-Coleman type of refrigerating plant.

Returning to Kelvin's Warming Machine, it should be noted that the cycle here described is not a Carnot cycle and that while in the example he gave, heat is imparted to the air entering the building it has 35 times the work spent, part of this could not be utilised in the building. The external air temperature being 50° F. the minimum temperature in the building might be 60° F., so that of the 7 B.Th.U.s given to each lb. of air in raising its temperature from 50° F. to 80° F., only that due to cooling at 60° F., i.e., 4.7 B.Th.U.s, could be effective in the building--the remainder being carried away by the vitiated air. The attempt might be made to induce air leaving the building at 60° F. to heat the receiver to that temperature but the impossibility of collecting all the air leaving the building as well as the difficulties involved would render this not practical.

In fact it seems clear that a completely closed cycle of operation in the warming machine and building is impracticable. A variation of Kelvin's proposal would be to take in air and compress it above atmospheric pressure so also raising its temperature and then circulate it through pipes in the building. When it dropped to the minimum temperature permissible in the pipes it would enter the motor cylinder, expand to atmospheric pressure and be discharged. The driving agent as before would have to supply the difference of the power of the compressor and the motor. Were this method adopted, air for ventilation would have to be supplied separately. It is, therefore, advisable on the whole to combine heating and ventilating as in Kelvin's proposal. Kelvin's method permits the transference of heat in the receiver being facilitated by use of a

water circulation, the heat passing from water to air rather than from air to air.

It will be seen that Morley had the germ of the present-day Heat Pump in outline, but at that time there was no defined method of heat transfer to give maximum efficiency. It should be noted that even to-day accurate information on heat transfer agents and compressor efficiencies is slight, and most of our information has been obtained from Switzerland, America and Norwich, but fuller information will be given on this matter later.

In the design of the Heat Pump it is necessary to study the maximum and minimum temperatures for the particular district in which the unit is to be installed, and also the particular type of establishment in which the Heat Pump is working. There is a new factor in heating to be taken into account and that is that it is possible to use the Heat Pump as a means of cooling which would be welcomed on very hot days. The question of complete air conditioning in this country has always been pushed aside because of the costs of refrigeration but the installation of a Heat Pump overcomes this difficulty.

Fig. 17 shows the maximum and minimum temperature as registered at Kew for the heating season 1946-47, which was the most severe winter on record in this country. It will be noted that the maximum temperature did not rise above freezing for two weeks during February, 1947, but this does not mean that a Heat Pump should be installed to cope with this unusual demand. It is best to design the Heat Pump installation to meet the average degree day demand and to use some auxiliary means of heating to overcome the severe loads. There are many variations of this method from solid fuel fired boilers to off-peak electrical thermal storage. The latter method is useful for large installations as a means of topping-up during the night. If the weather is mild then the Heat Pump can be used for filling a storage cylinder and the "low temperature" water in the storage can be used to build-up the heating when the demand on the Heat Pump is too great.

Fig. 18 shows the mean temperature and the degree days at 65° F. for the heating season 1946-47, and as has been stated, this was an exceptionally cold winter. This will give the greatest

OUTLINE AND THEORY

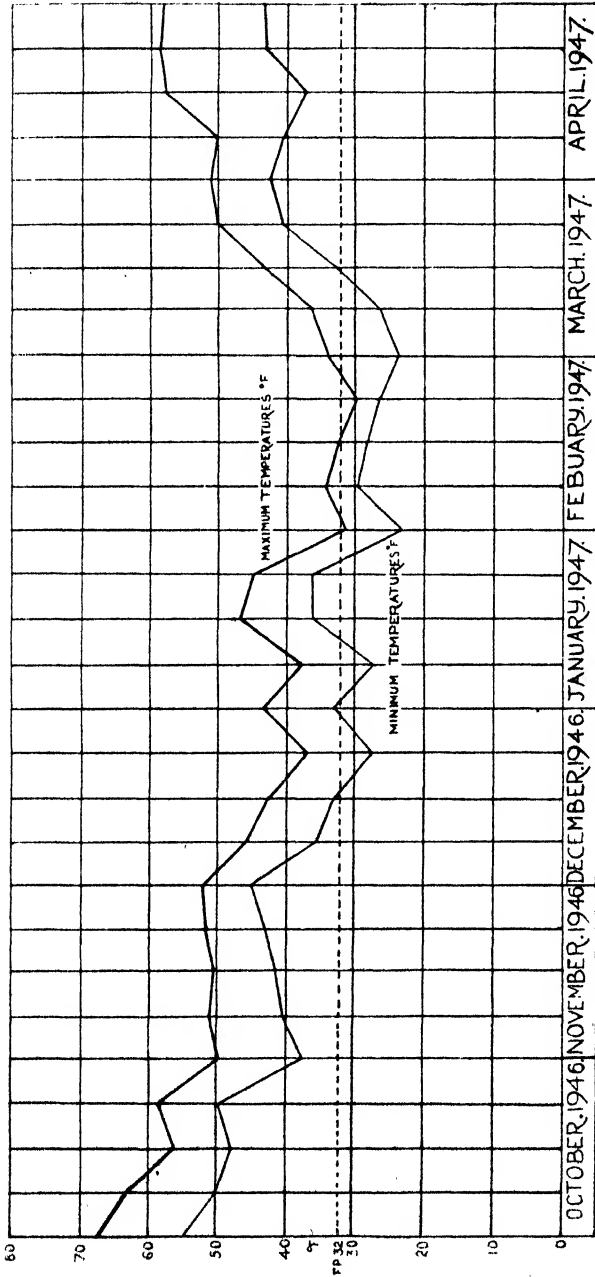

Fig. 17.—Graph showing the Maximum and Minimum Temperatures as Registered at Kew, taken from "Air Treatment Engineer"

possible maximum demand on the Heat Pump for any winter season but it is advisable to study the weather records in the particular part of the country in which the Heat Pump has to be installed as the greatest efficiency is obtained when the Heat Pump is designed within prescribed limits to meet a given load and the higher the temperature difference between T_1 and T_2 , the greater the efficiency of the unit. It will be clear then that the Heat Pump must be designed to meet a given heat load and any greater load must be taken by some other means. The Psychrometric Chart (Fig. 31) is by kind permission of Messrs. Air Control Installations Ltd., and has been especially compiled by Mr. Bernard C. Oldham for air-conditioning work.

Some interesting suggestions on the application of the Heat Pump are made by Ad. Baumann and D. Marples, writing in the BROWN-BOVERI REVIEW, in the form of questions and their answer as to the application of the Heat Pump on when can a Heat Pump come into consideration for heating? The general answer to this question is simply: whenever heat under moderate temperatures is required—not exceeding the boiling point of water under atmospheric pressure, for instance—in the form of hot water or air for heating, washing or drying in industrial plants, as well as for heating rooms and air conditioning. For all cases of this description, the advantages of the Heat Pump should be examined.

With regard to the utilisation of available energy, the practice of lowering the value of high-grade energy must be condemned. Common examples are afforded by burning fuel in a boiler at a high temperature, which has to be subsequently reduced by resistance to the transmission of heat in pipelines and by consuming electricity which represents energy in its highest form, in heating resistances. In such cases, high-grade energy should be consumed in order to raise the value, by increasing the temperature to the maximum, either of redundant heat or of heat taken from the surroundings.¹⁷ This stepping-up process is carried out by the Heat Pump, against an expenditure of high-grade energy which amounts to only a fraction of that necessary to produce the same amount of heat directly, namely, $1/3$ to $1/6$ for heating plants and $1/10$ to $1/20$ in evaporating plants. These considerations apply not only to electrically driven Heat Pumps but also to any form of drive such as steam turbines or internal combustion engines: in every case, the

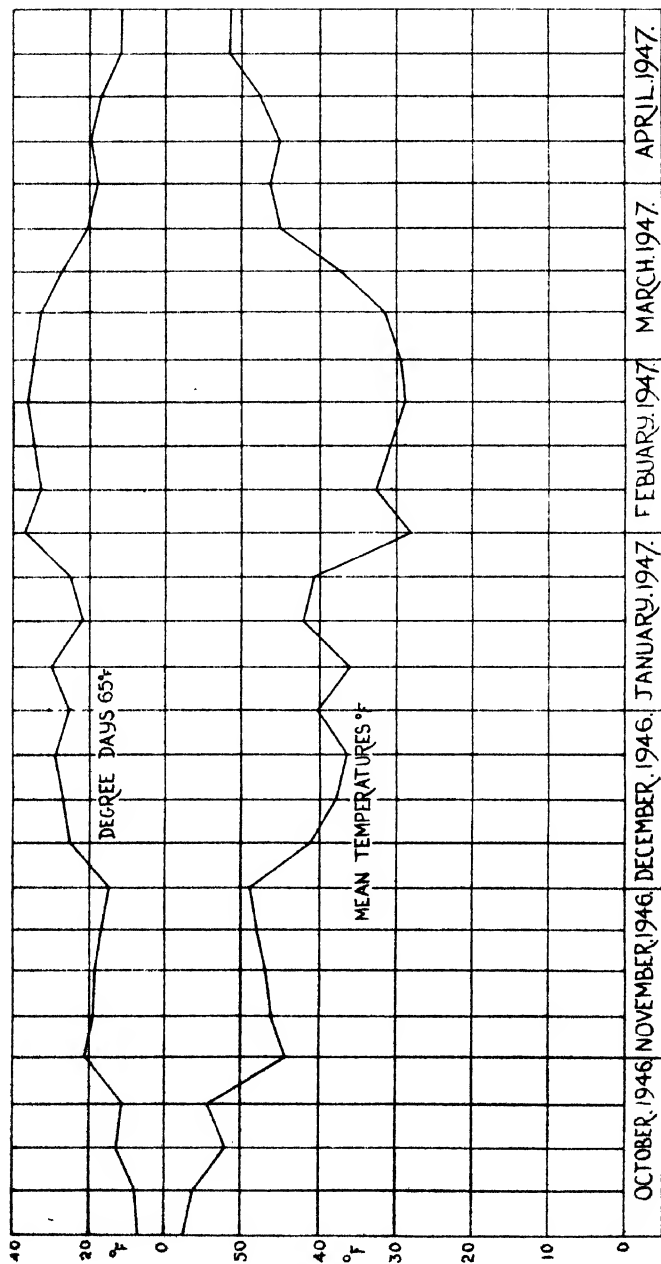

Fig. 18.—Graph showing the Mean Temperature over the 1946-47 Heating Season and the corresponding Degree Days over that period

THE HEAT PUMP

Heat Pump ensures a saving of high-grade energy (electricity, fuel) equivalent to several times the amount expended. Conservation of energy resources, no matter whether they be in the form of fuel or electricity, is no transient necessity, but one of the most urgent problems of the future.

Coal tends to become more and more a raw product rather than a fuel. Refining plants between the pit and consumer¹⁸ extract valuable base products for the ever-increasing number of synthetic substances manufactured by the chemical industry, whereas the residual coke is available as fuel.

Finally, the limited supply of energy together with the law of supply and demand render it necessary to differentiate the claims to hydro-electric energy of various classes of consumers¹⁹. Recent restrictions in winter have shown clearly the limitations of this indigenous supply of energy, particularly with regard to heating. Consequently, the need of making the most of available resources is likely to continue.

Bearing these considerations in mind, the possibilities of the Heat Pump will have to be carefully examined in the future whenever conditions are suitable and whenever heat in the form of hot water or hot air has to be produced at temperatures not exceeding 176° F. to 212° F., or the heat contained in water vapour which is given off, as is the case, for instance, in evaporating plants, can be recovered.

From the point of view of national economy, the Heat Pump is of interest inasmuch as it not only enables fuel to be replaced by inland sources of heat, but also, as has been pointed out by Professor Bauer²⁰, because it ensures a more rational consumption of electricity for producing heat, and balancing the electric load on the power stations. With the Heat Pump, as opposed to the electric boiler, the greater part of the heat consumed is available on site in the form of heat contained in the surroundings, with the result that the load on the electric plant (turbines, generators, transformers, and transmission lines) is reduced accordingly, and a greater margin of high-grade electrical energy thus becomes available.

What Conditions have to be Fulfilled by a Heat Pump for Heating

(a) Either heat from the surroundings or waste heat must be available in sufficient quantities.

(b) The temperature difference between the available source of heat and that required for heating must not be too great, if possible, not more than 112° — 176° F.

The conditions (a) and (b) are those necessary to obtain high coefficients of performance for the Heat Pump, as it is only then that it is worth while utilising heat from the surroundings or going to waste.

(c) The heating capacity must be big enough. According to the present stage of technical development, it should amount to at least 35,780--71,560 B.Th.U./hr. This applies particularly to auxiliary vapour Heat Pumps with turbo-compressors.

(d) The number of operating hours per year and the degree of utilisation of the plant should be as high as possible.

(e) If an electric drive comes into consideration--which is mostly the case--the necessary electrical energy must be available at a reasonable price.

The conditions outlined will be examined in greater detail.

Regarding (a) and (b) ; Sources of Heat and Coefficient of Performance

Practically unlimited sources of heat are available by water from rivers and lakes ; ground water, air from rooms or out of the interior of the earth, such as from deep mines, can also be considered, as well as hot air saturated with steam given off during manufacturing processes, etc. An interesting source of heat is also afforded by warm cooling water from machines, apparatus, etc., the temperature of which is not high enough to permit of direct utilisation of its heat, which would otherwise represent a more simple solution. However, it is essential if waste heat is to be considered as a source of heat that it should be available in ample quantities. Otherwise the temperature drop in the evaporator becomes so great as to impair the coefficient of performance. The influence of the magnitude of the source of heat is shown clearly by Figs. 19-22, a comparison between Figs. 21 and 22 being particularly instructive. If the same results are obtained from waste heat and river water, preference should be generally given to the former as a source of heat because as a rule its temperature is not liable to so many fluctuations

THE HEAT PUMP

throughout the year, and the intake is more simple than if water has to be drawn from lakes or rivers.

Whenever water from the surroundings is taken as a source of heat, the Heat Pump plants have to be located in the vicinity of

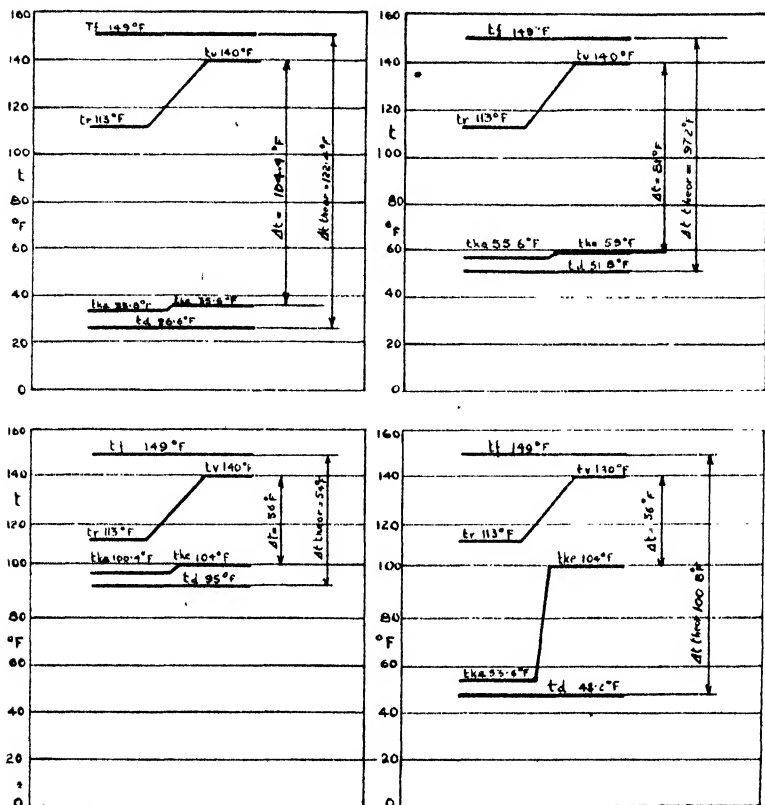

Figs. 19-22.—Temperature Diagrams for Heating Water from 113° F. to 140° F. for four different conditions of the source of Heat

Figs. 19 and 20

The source of heat consists of river water at 35.6° F. during winter (Fig. 19) and 59° F. during summer (Fig. 20). As an ample amount of river water is available, it follows that its temperature drop across the evaporator ($t_{ke} - t_{ke}$) is small, which ensures a comparatively high performance coefficient ϵ .

Figs. 21 and 22

Fig. 21 shows the conditions when waste water at 104° F. is available in ample quantity, whereas in Fig. 22 it is limited. Despite the high temperature of

OUTLINE AND THEORY

the source of heat, high performance coefficients ϵ can be obtained only if waste water is available in sufficient quantity (Fig. 21), otherwise its temperature drop across the evaporator can become so great that the performance coefficient is no higher than if the evaporator is heated with 50° F. river water (Figs. 22 and 20).

Among the conditions necessary to obtain a high performance coefficient for the Heat Pump it is necessary to ensure an ample supply for the source of heat.

- t_v . Temperature of hot water leaving condenser (140° F. for all cases).
 - t_r . Temperature of hot water returning to condenser (113° F. for all cases).
 - t_{ke} and t_{ke} . Temperatures of the source of heat when entering and leaving evaporator.
 - Δt . Temperature difference between hot water leaving condenser and source of heat entering evaporator.
 - t_f . Liquefaction temperature of auxiliary vapour in condenser.
 - t_d . Evaporation boiling temperature of auxiliary vapour in evaporator.
 - Δt_{theor} . Temperature difference ($t_f - t_d$).
 - ϵ_{theor} . Performance coefficient, defined as follows:—
- $$\epsilon_{theor} = \frac{(273 + t_f) - (273 + t_d)}{(273 + t_f) - (273 + t_b)} = \frac{\Delta t_{theor}}{\Delta t}$$

streams, rivers or lakes in order to keep down the costs of pumping. As to the quantity of water required, it can be stated that to one (m³) of water per second flowing through the evaporator corresponds to an hourly heating output of about 17.7×10^6 B.Th.U., it being assumed that the lowest temperature of the source of heat during the winter amounts to 35.6° F., and that the hot water leaves at a temperature of 140 to 158° F.

Small and medium-size plants can make use of the drinking-water supply as a source of heat, since during the winter and intermediate seasons when heating is required, the capacity of the waterworks is generally in excess of the normal demands. In this manner the load factor of the waterworks is improved and, at the same time, the Heat Pump no longer requires a special pumping station with its attendant pipelines. Furthermore, during the winter the temperature of this water is generally higher than that of fresh water from lakes or rivers, which has a favourable effect on the coefficient of performance, but a general demand if returned to the main might cause trouble.

At first sight, atmospheric air, which is available everywhere, would appear to afford a convenient source of heat. Its utilisation for this purpose, however, although possible in principle, is subject to a number of drawbacks. The temperature of the source of heat

should remain constant within fairly narrow limits, otherwise the heating output and leaving temperature are both subject to prohibitive fluctuations. Furthermore, the precipitation of water contained in the air can give rise to operating difficulties as soon as its temperature drops below freezing point, due to deposits of frost or even ice on the surfaces of the evaporator. Unless special precautions are taken, the use of atmospheric air as a source of heat is therefore not to be recommended.

The effective coefficient of performance ϵ_{ke} referred to the power input at the motor terminals can be written as follows :—

$$\epsilon_{kl} = \frac{Q}{AL} = \frac{T_v}{T_v - T_{ke}} \cdot \eta = \frac{T_v}{\Delta t} \cdot \eta \text{ where}$$

Q designates the heating output in B.Th.U./h.

AL the thermal equivalent in B.Th.U./hr. of the electrical energy expended by the driving motor.

T_v leaving temperature to heating system in °K.

T_{ke} temperature of the source of heat in °K (e.g., river water).

Δt the difference between the two aforementioned temperatures.

η The overall efficiency of the installation due to the various losses, including the irreversibility of the Heat-Pump cycle.

For auxiliary-vapour Heat Pumps with turbo-compressors, the overall efficiency varies approximately as follows :—

Heating output of the unit B.Th.U./h.	Overall efficiency η
794,000—3,970,000	0.45—0.55
3,970,000—11,910,000	0.55—0.60
over 11,910,000	0.60—0.65

From the foregoing it will be seen that—for a given temperature of the source of heat—the performance coefficient becomes higher

as the difference between the leaving temperature to the heating system and the temperature of the source of heat becomes smaller, i.e., the temperature difference which has to be surmounted by the Heat Pump becomes smaller (c.f. Figs. 19 and 20). The following performance coefficients are influenced by this temperature difference, the lower figures corresponding to small installations and low temperatures of the source of heat (river or lake water in winter), whereas the higher figures are valid for larger installations and favourable temperatures for the source of heat (river or lake water during the intermediate seasons and summer, ground and tepid waste water).

Application

	Performance coefficient referred to motor terminals
(1) Room heating with standard radiators for 104/158° F., leaving temperature from Heat Pump 149° F.	2.5—4
(2) Room heating with radiators for 113° F., leaving temperature from Heat Pump, heating by radiation or from ceiling panels	3.5—6
(3) Heating hot water to 158° F., for industrial purposes :—	
(a) with water from surroundings	2.5—4.0
(b) with warm waste water... ..	3.0—7.5
(4) Swimming Pools. Leaving temperatures from Heat Pump 104° F.	
during winter	4.0—6.0
during summer	5.0—8.0
(5) Air Heating. Leaving temperature from Heat Pump 86° F.	
(a) with closed circuit	2.5—6.0
(b) with fresh air and ground water... ..	8—12
(6) Evaporating plants with thermo-compressor	
for solutions boiling with difficulty	5—10
for solutions boiling readily... ..	11—25

Power Input

The foregoing figures enable the approximate electrical power input and motor rating to be easily determined, as can be seen from the following example :—

For a case according to (2), the heating output amounts to 11.01×10^6 B.Th.U./hr. and the coefficient of performance to 4.5. The power input at the motor terminals is therefore :—

$$L = \frac{11,010,000 \times .252}{4.5 \times 860 \times .252} = 775 \text{ kW}$$

i.e., 4.5 times smaller than with direct electric heating.

Fig. 23 shows the performance coefficients ϵ_{kl} which can be obtained with large heating units producing hot water with the temperature of the source of heat as a parameter.

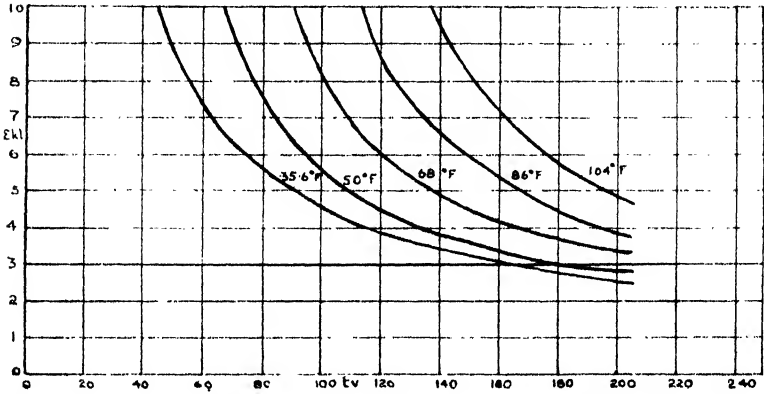

Fig. 23. Performance coefficients of Heat Pumps (auxiliary vapour Heat Pump with turbo-compressor) of large capacity for producing hot water, the source of heat being water at different temperatures taken from the surroundings

- t_v . Hot-water leaving temperature.
- t_{ke} . Temperature of source of heat.
- ϵ_{kl} . Performance coefficient of Heat Pump referred to input at motor terminals (for definition see text; overall efficiency $\eta = 60\%$).

This diagram shows the performance coefficient ϵ_{kl} for a given leaving temperature t_v of the heating system and for different temperatures t_{ke} of the source of heat. For other overall efficiencies a corresponding correction is necessary.

A performance coefficient of 6, for instance, means that with an expenditure of one kWh, it is possible to produce an amount of heat equal to six times the thermal equivalent of one kWh, viz., $6 \times 14450 = 86,700$ B.Th.U./hr.

Regarding (c); Influence of the Heating Output per Heat-Pump Unit

Increasing the output per unit ensures lower specific installation costs of the heating plant (Fig. 24), and at the same time, a more

favourable overall efficiency and performance coefficient for given operating conditions. In other words the economy is thus increased.

The lower limit of the output per Heat-Pump unit in the case of an auxiliary vapour machine with turbo-compressor lies around 1,191,000 to 595,500 B.Th.U./hr., according to the temperature of the source of heat.

According to Bauer and Peter²¹ the installed heating output for room heating amounts to 67.5 to 87.4 B.Th.U./h. per 35.35 cu. ft. of enclosed volume for climatic conditions in Northern and Eastern

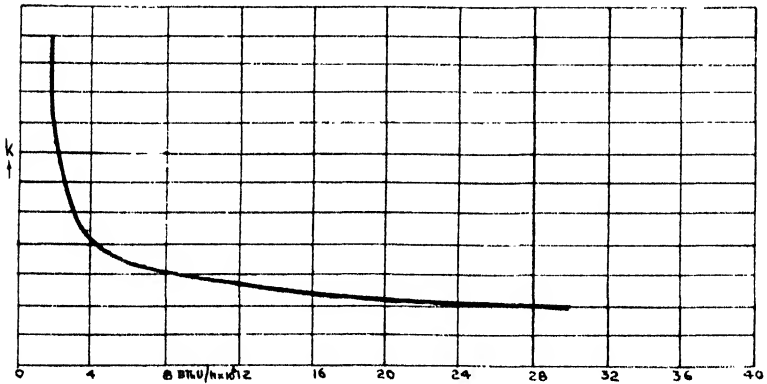

Fig. 24. Specific installation costs of Heat Pumps
(Auxiliary vapour Heat Pump with Turbo-Compressor)
k. Specific installation costs.

Q. Heating capacity in Millions B.Th.U./hr. The installation costs increase rapidly for small heating capacities. Auxiliary vapour Heat Pumps with turbo-compressors come therefore primarily into consideration for medium and large plants, having heating capacities in excess of approximately 595,000-1,191,000 B.Th.U./hr.

Switzerland, regardless of the influence of the wind and radiation, the conventional outdoor temperature being -4° F. and room temperature 62.6° F. The smallest built-in volume of buildings that can be heated by a Heat Pump amounts therefore to 247,450 to 600,950 cu. ft., according to the atmospheric and climatic conditions coming into consideration. For instance, if the minimum outdoor temperature is higher or if lower room temperatures have to be maintained—e.g., in workshops, garages, shops, etc.—or if the

Heat Pump delivers only a fraction of the total heating output, the minimum enclosed volume is increased accordingly.

Regarding (d) ; Load Factor and Number of Full-load Operating Hours

As with any other machine, these factors have in the present case an appreciable influence on the cost of the heat produced. They can be defined as follows :—

Load factor of the Heat Pump

$$a = \frac{\text{amount of heat effectively produced per year B.Th.U.}}{\text{maximum amount of heat that can be produced per year B.Th.U.}}$$

Number of full-load operating hours (degree days) :

$$h_{11} = \frac{\text{amount of heat effectively produced per year (B.Th.U.)}}{\text{hourly full load heating output (B.Th.U./hr.)}}$$

Costs and Running Loads

Industrial processes requiring large amounts of heat and operating continuously naturally give the most favourable results. The conditions for room heating are examined in Table 1.

Regarding (e) ; Cost of Electrical Energy

The supply of current for heating during peak periods generally offers little interest to the supply undertakings on account of the low tariffs based on the cost of fuel. On the other hand, with the Heat Pump which converts heat from the surroundings against an expenditure of energy which is the equivalent of only a fraction of the amount of heat produced (see performance coefficient), it is possible to pay higher prices for electrical energy. These are not proportional, however, to the performance coefficient, because the first costs of a Heat Pump installation are considerably higher than those of a corresponding installation heated by fuel. The fixed charges and interest are therefore affected accordingly, and have an appreciable influence on the cost of the heat produced. The price which can be paid for electrical energy is therefore lower than that

obtained only from comparison with the cost of fuel. As the latter increases, the conditions become rapidly more favourable for the Heat Pump. With the high cost of coal delivered to the bunkers and given favourable operating conditions, it becomes possible with new plants of large capacity to pay standard rates for electrical energy supplied. Evaporating plants can be written off within a few years, even if the number of operating hours is relatively small.

The conditions for Heat Pumps become still more favourable if they can be adapted to the load conditions on the electrical network, so as to obtain tariff concessions. For instance, contracts can be made with the power-supply undertaking without obligation to deliver energy at all times, with the implication that after previous notification, the Heat Pump has to be shut down during temporary periods of shortage of electrical energy, it being then necessary to resort to fuel for maintaining the heating. Experience shows that with hydro-electric power plants, a shortage of water necessitating a curtailment of the supply of electrical energy occurs seldom in Switzerland in normal years, as to have practically no influence on reducing the saving in fuel and load factor of the Heat Pump.

For room heating it is also possible to avoid daily load peaks (e.g., cooking peaks between 10 a.m. and noon) by shutting down the Heat Pump during these periods (on-and-off operation). Fig. 25 shows in a very simplified manner the super-imposition of a Heat Pump on the load diagram of a municipal electric system. The heat-storage capacity of the heated rooms, offices and workshops plays a very important part if the Heat Pump has to run intermittently, since on it depends the temperature drop during the shut-down periods. For instance, experience shows that a heat drop of 35.6°F. can be perfectly well allowed for domestic heating plants.

If, on the other hand, it is essential to maintain the leaving or room temperature constant—as is the case, for instance, for heating processes or heating of modern buildings which are very pervious to cold—uninterrupted heating becomes necessary. The addition of a heat accumulator enables load peaks of the electrical network to be bridged in such cases.

The consumption of energy and operating time in air-conditioning plants can be considerably increased by utilising the Heat Pump for

THE HEAT PUMP

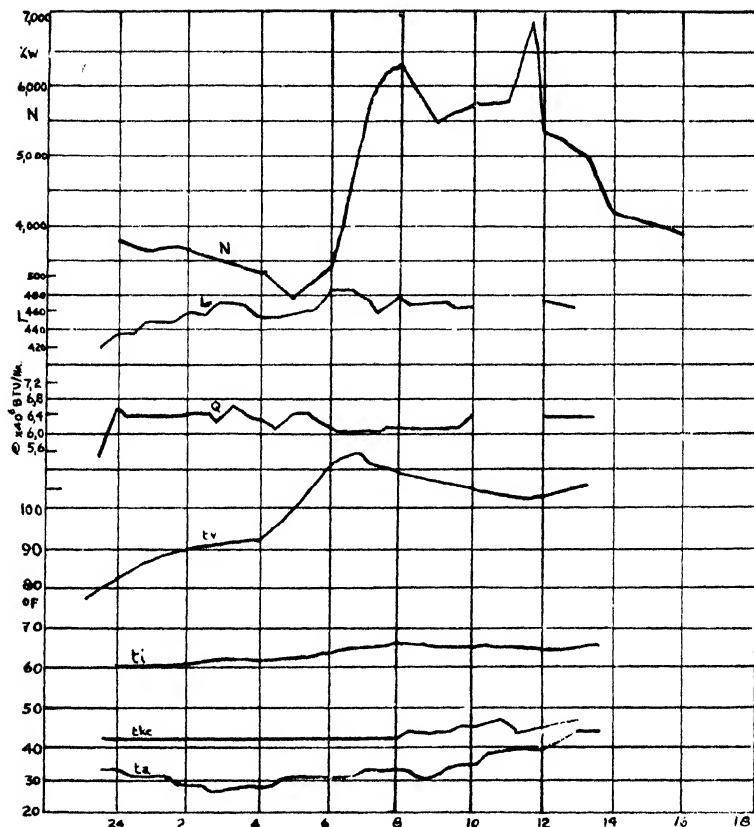

Fig. 25.—Daily load Diagram of a Heat Pump for room heating with on-and-off regulation

Abscissa: Hours of the day.

Ordinates: *N*. Load on electric network in kW.

L. Power taken by Heat Pump from electric network in kW.

Q. Heating capacity of Heat Pump in B.Th.U./hr.

t. Temperatures.

t_e. Hot water leaving temperature in °F.

t_i. Room temperature in °F.

t_a. Outdoor temperature in °F.

t_{ke}. Temperature of source of heat in °F.

Δt . Drop in room temperature, during stoppage of Heat Pump (in the present case 0.9 °F. per hour).

In order to obtain favourable load conditions for the power-supply undertaking, the warming-up of rooms (possibly a hot-water accumulator) should be carried out with fully loaded heating machine (best efficiency) during the night or off-peak periods. The Heat Pump is shut down when the maximum load on the electric network occurs or the room temperature is sufficiently high.

heating in winter and cooling in summer. For these reasons installations of this description are likely to be viewed with favour by power supply undertakings, who will be prepared to sell energy at advantageous tariff rates.

For economic reasons it is necessary to concentrate heat production in units of average or large capacity. For this reason the Heat Pump is eminently suitable for heating factories, blocks of flats, building estates, complete towns or districts, swimming pools, etc., both alone or in conjunction with district heating schemes and waste heat recovery at power stations.

Room Heating

For room heating, the amount of heat delivered is the main demand, which must be supplied at a reasonable cost, in order that a plant of this description can pay, it is therefore necessary to devote particular care to the dimensioning of the Heat Pump and heating system, both as regards heating capacity and value of the leaving temperature of the hot water. If the size of the plant and heating load have been determined—i.e., the heating capacity per hour computed from the frequency curves of the average daily temperature, the flow and return temperatures of the heating water, the temperature which has to be maintained in the heated rooms and the average outdoor temperature when the Heat Pump is stopped—and the average frequency of the mean outdoor temperatures is known, it is possible to determine how many days a given heating output is needed (surface A, Fig. 26). In this manner, the average number of days per year during which heating is required can be determined.

The base load attributed to the Heat Pump and the leaving temperature for which it should be designed depend on whether more importance is attached to reducing the fuel consumption—as is the case at the present time—or whether in normal times as an economical operation. In the latter case, the heating capacity of the Heat Pump is reduced, thus increasing its load factor and number of full-load operating hours.

Line *a* in Fig. 26 bounds the amount of heat furnished by a Heat Pump designed for 30 per cent. of the installed heating capacity. Table 2 shows the heating conditions for the same installation,

THE HEAT PUMP

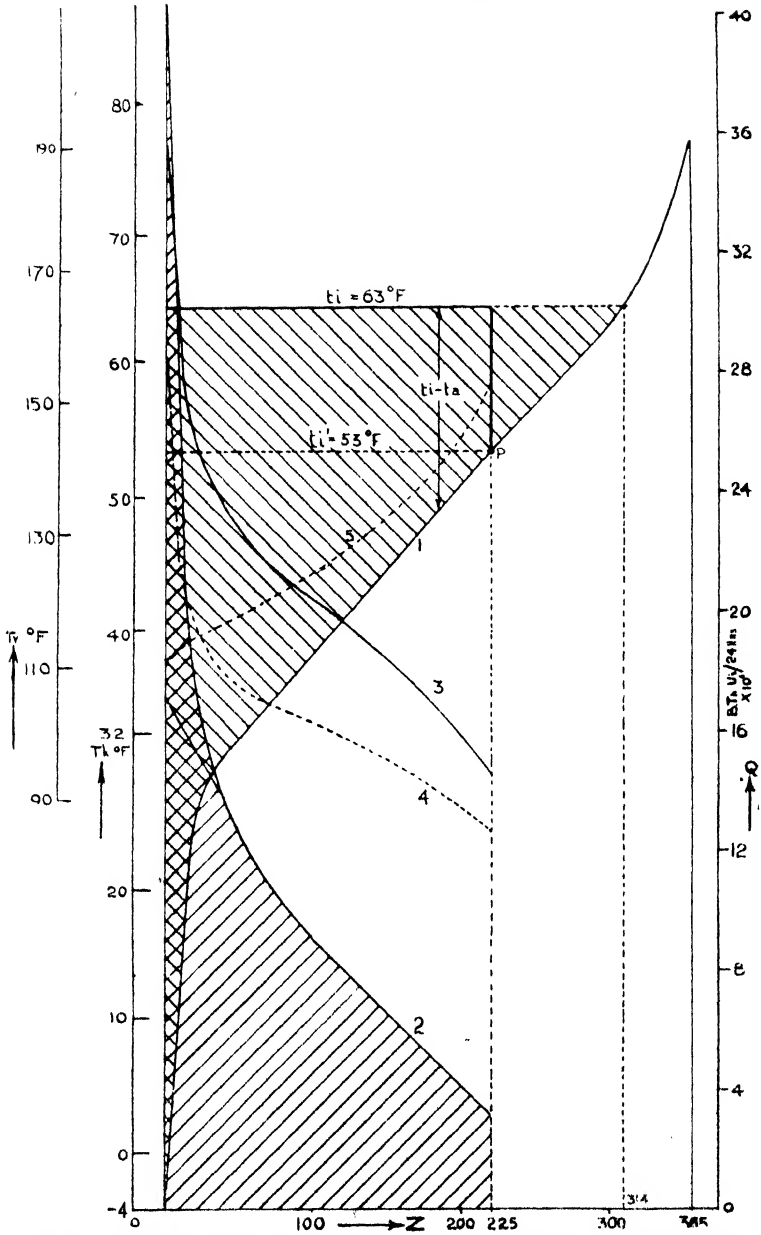

Fig. 26.—Example showing the determination of the amount of heat required for room heating and the choice of the base load for the Heat Pump (For climatic conditions at Zurich)

Fig.--26

- Abscissa: Z . Number of days per year.
 Ordinates: t_a . Mean daily outdoor temperature.
 t_k . Temperature of the source of heat (water from the River Limmat).
 t_l . Room temperature (64.4° F.) to be maintained by heating.
 t_l^1 . Heating limit (53.6° F.), i.e., mean outdoor temperature above which heating is stopped.
 t_r . Heating water leaving temperature.
 Q . Daily heat consumption in B.Th.U. deduced from frequency (curve 1) of mean outdoor temperatures.
 Q_{max} . Maximum demand for heat in B.Th.U. per 24 hours when $t_a = -4^\circ$ F.

Curve 1. Frequency curve of the main daily outdoor temperatures in the town of Zurich, according to records of the Swiss Central Meteorological Institute between 1869 and 1929. Point P, for instance, implies that in Zurich during the last 60 years, there were on the average 225 days per year with a mean daily outdoor temperature not exceeding 53.6° F.

Curve 2. Frequency curve of the daily demand for heat Q , as deduced from curve 1: $Q \sim f(t_l - t_a)$

Curve 3. Frequency curve of the leaving temperature t_r of heating water when heating up.

Curve 4. Ditto, for normal operation.

Curve 5. Frequency curve of the temperature t_k of the source of heat.

Surface A. Mean heat consumption in B.Th.U. during the entire heating period of 225 days.

Surface B. Mean degree-day surface during the heating period. Each degree Centigrade difference ($t_l - t_a$) per day, gives one degree-day. If on a given day the difference $t_l - t_a = 42.8^\circ$ F., this day reckons as six degree-days. (Cf. Hottinger, "Klima and Gradtage," publishers J. Springer, Berlin, 1938.) If the Heat Pump is dimensioned for a base load equal to 30% of the installed heating capacity, the amount of heat it produces is limited approximately by line (a) in the surface A. It can cover approximately 92% of the total yearly demand for heat, only the small amount corresponding to the peaks above line (a) having to be furnished by additional means

operating data with fuel alone having been added for the sake of comparison.

It is interesting to note that for the example considered, the Heat Pump, although dimensioned for only 30 per cent. of the installed heating capacity, can furnish roughly 92 per cent. of the total yearly demand for heat, whereas the remaining 8 per cent. has to be produced by fuel. Fig. 27 shows to what extent the total heat consumption can be covered by the Heat Pump when it is dimensioned for varying percentages of the installed heating capacity.

Final Temperature

The value of the leaving temperature is of decisive importance for the economy of the Heat Pump. The amount of energy con-

TABLE 2.—Corresponding to the example of a room-heating Heat Pump Plant

Numerical example of Combined Room Heating with a Heat Pump and Fuel, for a rated Heating Capacity of 238×10^6 B.Th.U./hr.					
(a) Heat Pump.					
Percentage of the rated heating capacity furnished by the Heat Pump	Rated heating capacity of Heat Pump Millions B.Th.U./hr.	Daily heating output of the heat Pump with -40° F. outdoor temperature Millions B.Th.U./hr.	Percentage of annual heat consumption furnished by Heat Pump	Number of operating hours of Heat Pump h approx.	Warming up Normal operation
50	11.9	286.0	99.0	2060	The Heat Pump alone is sufficient for outdoor temperatures not lower than $-F.$ approx. $-F.$ approx.
40	9.5	229.0	97.5	2520	
30	7.15	171.2	92.0	3200	
(b) Heating with Fuel alone.					
Total amount of heating necessary with outdoor temperature $t_a = -4^\circ$ F.	Total amount of heat required when $t_a = -20^\circ$ C.		Load factor referred to an operating period of 225 days	Number of full load operating hours when heating with fuel alone	
Warming up 238×10^6 B.Th.U./hr. Normal operation 159×10^6 B.Th.U./hr.	406 $\times 10^6$ B.Th.U.		28%	about 1030	

sumed and the rating of the driving motor become smaller as the performance coefficient increases, which, in turn, implies as small a temperature difference as possible between the heating system and source of heat (cf. Fig. 23). Higher leaving temperatures can also be considered if sufficient warm waste water is available as a source

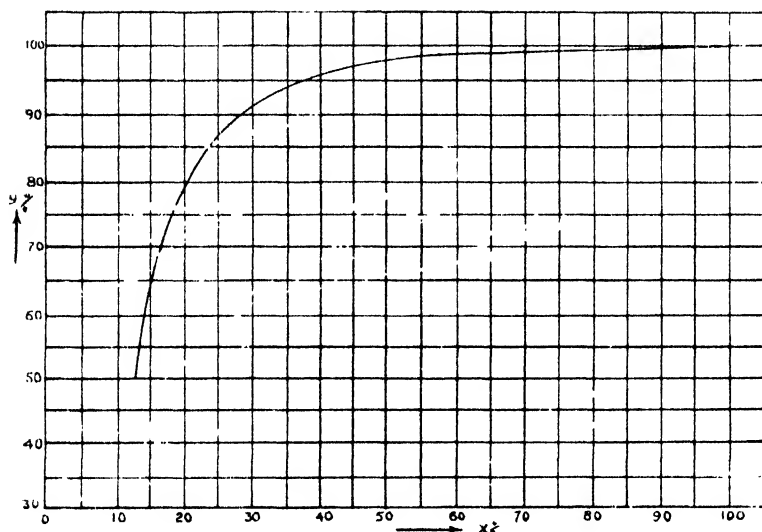

Fig. 27.—Percentage of the total amount of heat consumed per year furnished by a Heat Pump dimensioned for varying percentages of the total installed heating capacity, the heating conditions being as assumed in Table 1

Abscissæ: Heating capacity of Heat Pump X as a percentage of the maximum heating output of the installation.

Ordinates: Percentage Y of the total yearly consumption of heat furnished by the Heat Pump.

Heat Pumps for room heating have to be dimensioned for the base load. 90% of the total heat consumption can be covered by a Heat Pump dimensioned for approximately 30% of the maximum heating capacity of the plant.

of heat—e.g., cooling water from compressors or internal-combustion engines, apparatus for finishing processes or in chemical works, or hot waste air—than if relatively cold water from the surroundings (river, lake or sea water) has to be used for this purpose. In order to obtain as high a performance coefficient as possible, it is absolutely essential to choose the leaving temperature as low as can be allowed

with respect to the temperature of the water returning from the heating system. Fig. 28 shows the average outdoor temperature, the leaving and return temperatures for standard hot-water heating radiators, designed for 194° F., leaving and 158° F. return temperatures when the outdoor temperature is -4° F. and the installation is being heated up, both for normal heating and when heating up. As can be seen from Fig. 26, curve 4, for the example considered of a heating plant in Zurich, with standard $194/158^{\circ}$ F. radiators and normal heating, leaving temperatures in excess of 140° F. occur on the average during only five days per year, whereas 122° F. is exceeded only during 35 days. A maximum leaving temperature of 149° F., for example (Fig. 28, curve 6), is sufficient to enable the Heat Pump to cope with the heating requirements, including losses in the hot-water system and sudden fluctuations of the outdoor temperature, the occasional peaks due to very low outdoor temperatures being met either with additional heating or by increasing the size of the radiators. For a heating installation in a works in Baden, which is designed for leaving temperatures of only 104 to 113° F., constitutes a case in point.

Panel heating by radiation is well adapted for Heat Pumps inasmuch as the hot-water leaving temperature normally is $104-113^{\circ}$ F., and does not exceed 131° F.

Still more favourable conditions than with hot water exist when heating is carried out with hot air. In order to eliminate draughts and ensure even distribution of the heat, relatively large volumes of air have to be circulated, with the result that low leaving temperatures are sufficient. These amount to $77-86^{\circ}$ F. for normal operation, and do not exceed 95° F. These small increases in temperature imply high performance coefficients and a good overall efficiency of the heating plant. This kind of heating is particularly interesting when it can be combined with an air-conditioning installation. It should be mentioned that heating water for swimming pools is particularly suitable for Heat Pumps since leaving temperatures not exceeding 104° F. are sufficient for normal operation. This will be given later.

The initial cost is of very great importance in heating plants. The tendency to distribute the heating output over several units, as has been done in particular with reciprocating machines, is frequently

due to the desire to utilise available designs rather than to economical considerations. Limitations of this description do not apply to turbo-compressors.

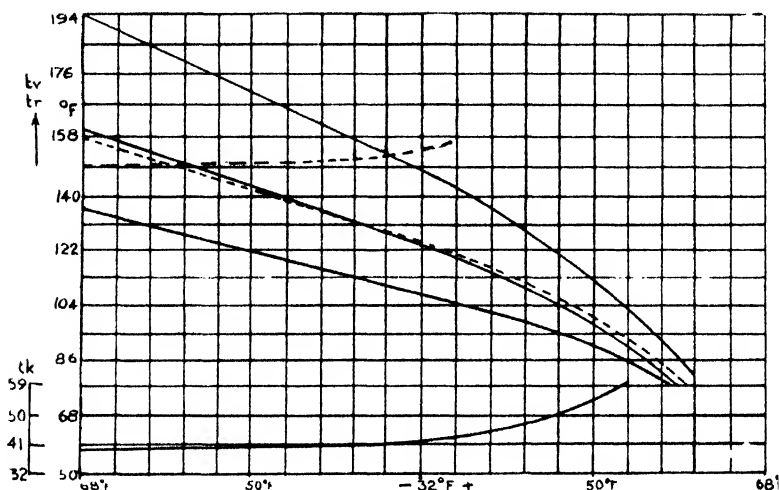

Fig. 28.—Leaving and return temperatures of hot water for standard radiators in function of the outdoor temperature, showing how they can be adapted to operation with a Heat Pump

- t_o . Outdoor temperature.
- t_k . Temperature of source of heat.
- t_v . Hot-water leaving temperature.
- t_r . Hot-water return temperature.

- 1 = t_r } Temperatures for standard radiators when heating up.
- 2 = t_r } Temperatures for normal operation.
- 3 = t_r }
- 4 = t_r }
- 5 = t_k } Temperature of the source of heat in function of the outdoor temperature.

6. Leaving temperatures which can be reached by the Heat Pump when the temperature of the source of heat t_k varies.

In order to keep the performance coefficient of the Heat Pump as high as possible and reduce the amount of energy consumed, the leaving temperature of the Heat Pump should not appreciably exceed 65° C. By reincreasing the surface of the radiators, the Heat Pump can meet the demands beyond curve 6.

The Heat Pump in Centralised Heating Plants and Heating Power Plants

Burning fuel for producing steam at relatively low pressures and temperatures for maintaining rooms at a temperature of 62.6° F., for

instance, represents unwarrantable waste from the viewpoint of efficient utilisation of energy. It is far more advantageous against a slightly higher expenditure of fuel to produce high-pressure steam which gives up high-grade energy in a back-pressure heating turbine, the expanded exhaust steam then giving up its heat to hot water in a calorifier. As the demands for heat do not generally coincide with those for electricity, it is advisable to connect the generators in the heating plant in parallel with a large electrical network, which can absorb the surplus energy and make good any deficiencies.

Local Conditions

Local climatic conditions have a greater bearing on the heating installation design with the Heat Pump than with any other form of heating. It has been shown that the scheme should be designed to take the "average" heating load, and that topping-up must be done by some additional means of heating such as thermal storage, direct electric or solid fuel heating, and that the scheme must not be designed to take the maximum heating load as is done at present with heating schemes. It is necessary to take the heating load over an average season, such as the winter of 1947-48, and the winter of 1946-47 is exceedingly useful to base your maximum load, so that by designing for the former, you can get the topping-up heating load by the difference between the two winters and the maximum winter load is shown in Fig. 17, while the readings from Kew, London, as printed in AIR TREATMENT ENGINEER for the winter of 1947/8, are given in Table 3. These tables give the maximum and minimum dry-bulb temperature during the months recorded together with the averages. Fig. 29, which is taken from the monthly weather report of the Meteorological Office, is for September, 1947, which began rather warm while Fig. 30 gives the hours of sunshine, which has a marked influence on the design of any scheme for a Heat Pump installation. If it is kept in mind that the minimum working temperature is desired, say 100° F. between T_1 and T_2 , so that the maximum efficiency can be had from the installation, it will be easily understood why it is so necessary to take note of heat losses and heat gains accurately. The Report for September, 1947, shows that the month was remarkable for unusual warmth over most of England and Wales: broadly speaking it was wet and rather dull in the north-

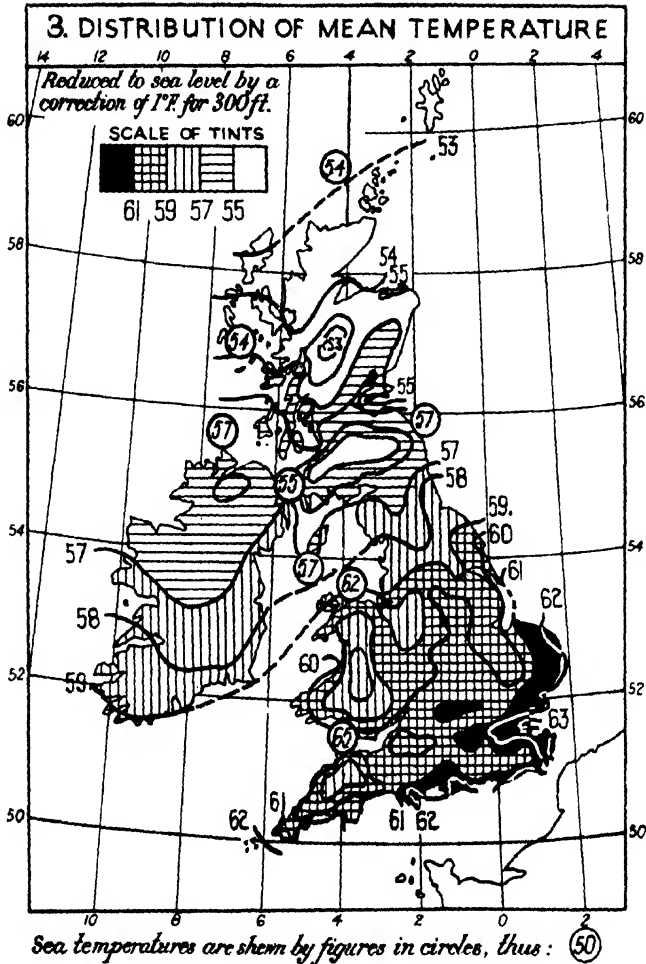

Fig. 29

west of the British Isles and dry and somewhat sunnier than usual in the south-east.

During the opening days pressure was high in a belt extending from north of the Azores across the British Isles to northern Scandinavia, while a shallow trough of low pressure approached the

THE HEAT PUMP

TABLE 3
November, 1947

October, 1947				November, 1947			
Date	Maximum Temp. deg. F.	Minimum Temp. deg. F.	Mean Temp. deg. F.	Date	Maximum Temp. deg. F.	Minimum Temp. deg. F.	Mean Temp. deg. F.
1	61.2	38.7	49.8	1	57.0	39.4	50.0
2	63.7	40.6	53.4	2	58.1	49.3	54.5
3	61.7	45.1	53.6	3	57.2	47.7	50.9
4	65.5	39.0	51.3	4	54.3	44.8	50.4
5	64.0	38.1	48.7	5	55.9	39.6	51.3
6	68.0	39.2	53.1	6	44.4	39.4	44.1
7	70.3	40.8	57.9	7	53.0	36.1	49.0
8	63.0	51.4	57.0	8	57.7	47.1	51.5
9	62.8	45.1	54.7	9	60.1	52.2	55.0
10	66.2	53.4	58.8	10	58.6	50.0	53.2
11	64.4	51.6	58.0	11	60.0	49.3	59.3
12	68.4	48.2	57.6	12	60.4	51.4	57.4
13	63.5	46.2	55.0	13	51.6	43.7	48.0
14	55.9	44.8	52.3	14	46.9	41.9	44.1
15	61.3	38.3	52.2	15	62.4	36.9	42.1
16	59.5	50.0	56.1	16	43.0	34.5	37.9
17	59.4	50.5	54.0	17	49.0	32.4	30.1
18	57.6	46.6	52.7	18	39.0	33.3	30.7
19	57.9	38.8	49.1	19	43.0	37.6	40.3
20	52.9	34.3	46.4	20	57.6	39.6	52.0
21	55.4	31.6	42.6	21	59.0	56.7	57.9
22	59.4	43.0	52.2	22	60.8	57.4	58.6
23	60.0	45.3	52.9	23	60.8	45.5	55.0
24	56.8	49.5	49.8	24	48.9	41.7	45.1
25	58.6	46.9	52.2	25	44.8	33.8	40.8
26	52.0	45.5	47.8	26	39.6	30.7	34.7
27	50.2	46.2	48.0	27	39.0	29.8	34.5
28	51.8	48.3	47.8	28	41.2	31.6	30.0
29	49.1	38.5	45.9	29	39.6	33.8	30.9
30	49.5	43.5	43.5	30	35.4	32.7	32.7
31	53.8	45.9	49.8	31	40.1	32.0	36.0
Mean	59.5	43.5	51.7	Mean	51.1	40.9	46.2
				Mean	49.0	38.4	42.8

OUTLINE AND THEORY

TABLE 3—(continued)

January, 1948				February, 1948				March, 1948			
Date	Maximum Temp. deg. F.	Minimum Temp. deg. F.	Mean Temp. deg. F.	Date	Maximum Temp. deg. F.	Minimum Temp. deg. F.	Mean Temp. deg. F.	Date	Maximum Temp. deg. F.	Minimum Temp. deg. F.	Mean Temp. deg. F.
1	55.0	40.1	48.7	1	50.5	43.0	47.3	1	54.7	35.2	43.7
2	55.9	50.2	53.1	2	54.5	48.6	51.4	2	43.0	30.7	39.0
3	55.0	50.7	52.7	3	51.6	39.7	46.0	3	48.6	36.0	39.9
4	55.8	51.4	53.2	4	48.7	39.6	43.0	4	47.1	35.8	40.5
5	51.8	37.9	45.2	5	46.9	39.9	43.7	5	41.7	33.4	37.4
6	48.9	33.6	40.6	6	48.0	39.0	43.0	6	54.7	34.7	41.2
7	51.4	41.9	47.3	7	53.1	39.0	47.8	7	53.8	33.9	46.2
8	44.4	37.6	40.5	8	54.3	50.0	52.2	8	56.3	47.7	50.5
9	47.8	33.6	41.0	9	54.3	39.0	48.0	9	70.5	43.7	54.7
10	45.9	39.7	42.6	10	52.0	38.8	47.7	10	58.1	43.0	51.4
11	49.8	45.9	48.4	11	48.0	42.3	46.6	11	61.2	39.2	48.9
12	53.4	44.1	48.2	12	49.1	41.5	45.3	12	60.6	35.2	47.7
13	55.8	49.6	53.1	13	55.6	40.8	48.0	13	63.5	37.0	48.9
14	49.6	40.6	45.5	14	50.5	45.7	48.4	14	65.8	41.5	51.4
15	44.1	37.0	40.8	15	52.3	45.0	48.7	15	55.9	45.0	50.2
16	41.5	34.2	39.2	16	45.5	38.7	42.4	16	54.7	47.7	51.6
17	50.0	32.4	41.2	17	39.0	33.3	37.2	17	53.4	43.9	49.3
18	43.2	36.9	40.3	18	37.9	31.1	34.2	18	52.5	42.4	47.3
19	40.1	32.0	36.1	19	36.0	28.0	33.3	19	55.2	43.3	49.3
20	40.8	31.3	35.4	20	28.9	22.6	25.3	20	56.7	49.6	52.0
21	41.5	35.6	39.4	21	31.3	23.0	26.2	21	54.1	46.6	50.4
22	43.3	34.5	38.3	22	34.9	22.6	29.5	22	51.0	43.2	48.6
23	41.5	34.3	37.9	23	35.4	32.4	34.0	23	51.5	37.2	45.9
24	45.0	38.3	41.4	24	37.0	32.9	34.5	24	55.6	33.1	44.1
25	45.9	33.3	41.2	25	37.0	32.2	34.7	25	59.0	38.1	47.8
26	45.7	38.5	42.6	26	37.5	32.7	35.6	26	60.3	43.2	50.4
27	47.8	40.1	42.8	27	44.2	33.6	37.8	27	54.9	41.2	48.2
28	46.9	34.5	42.3	28	54.1	33.8	43.0	28	63.0	41.2	49.8
29	48.9	37.9	44.2	29	58.3	32.0	44.8	29	54.5	43.2	50.4
30	53.6	43.0	48.4	30	48.0	48.0	48.0	30	54.7	43.2	50.2
31	52.0	45.5	48.0	31	46.0	36.7	41.4	31	50.0	36.5	45.5
Mean ...	48.1	39.2	43.9	Mean ...	46.0	36.7	41.4	Mean ...	55.6	40.4	47.5

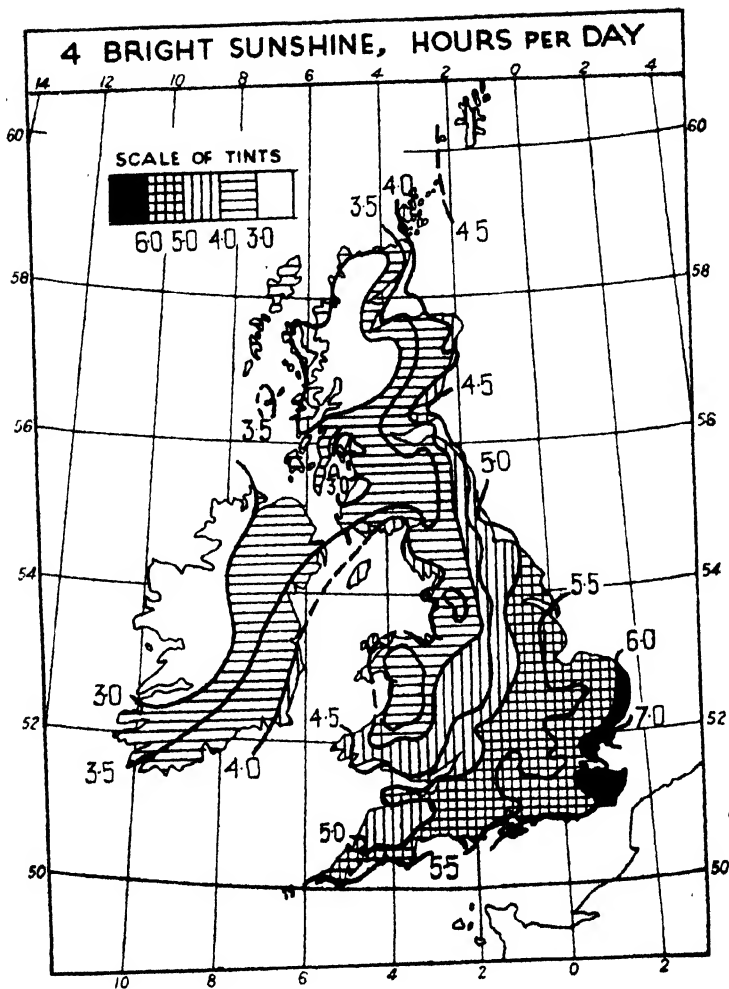

Fig. 30

west of Scotland and moved away north-east. Weather was mainly fair, apart from morning fog, in most districts, but some rain was reported in north Scotland on the 2nd, and locally in north and west Scotland and Ireland on the 3rd. In the next few days a depression off south-west Iceland moved very slowly east and decreased in intensity, while associated troughs of low pressure

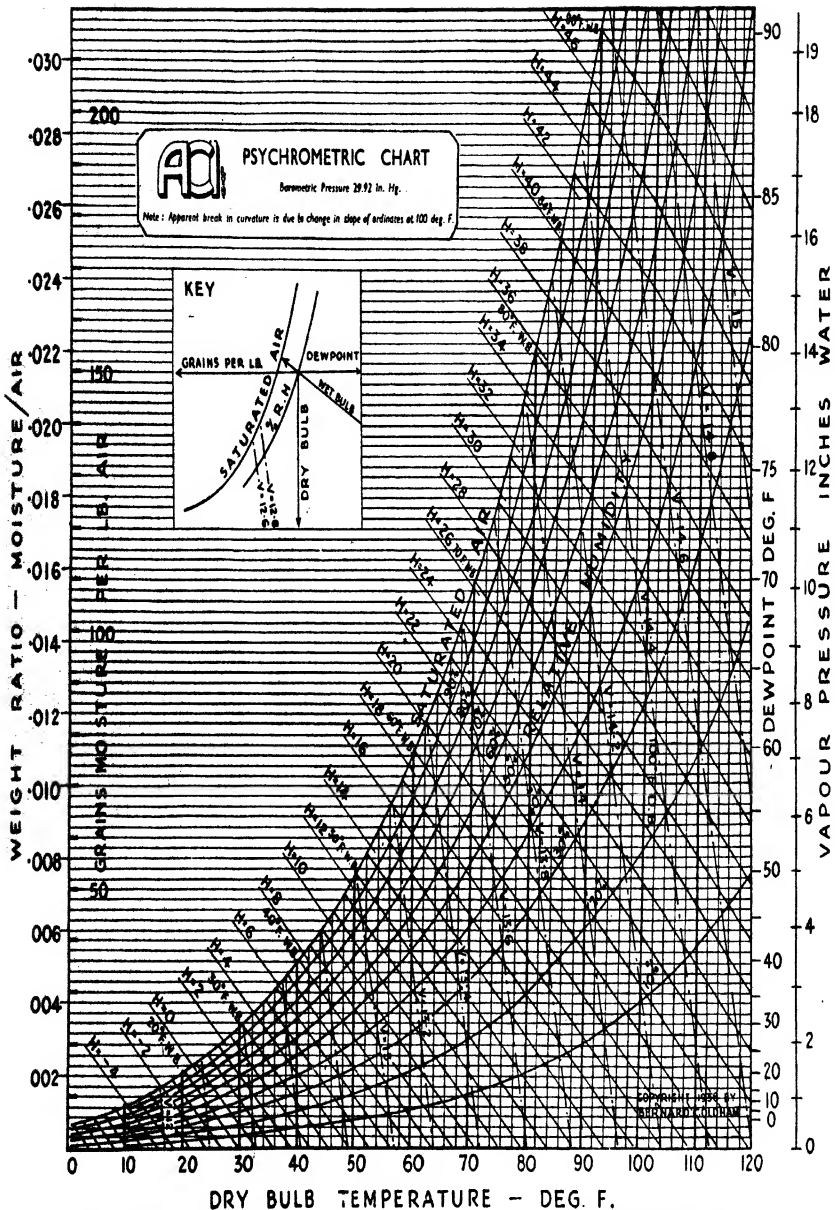

Fig. 31.—This Psychrometric Chart has been specially compiled by Bernard C. Oldham and reproduced by kind permission of Messrs. Air Control Installations, Ltd.

crossed the British Isles; rain occurred at times in the west and north but fair weather persisted in eastern and Midland districts of England. On the 7th and 8th further troughs of low pressure moved east across the country, giving rather heavy rain locally in Scotland, particularly on the 8th; slight, scattered rain occurred in England and Wales on the 7th, and heavier rain in north-west England and North Wales on the 8th. A small secondary depression over the Hebrides moved quickly east on the 9th and, on the 10th, a complex depression in mid-Atlantic approached south-west Iceland; gales were reported locally and rain occurred in the west and north but the fair weather continued over most of England. From the 11th-13th a deep depression was centred near Iceland, while troughs of low pressure moved east over the British Isles; rain occurred in most areas and the long drought was terminated at many stations in England on the 11th. On the 14th a disturbance west of Scotland moved north-east to the Faroes, where it remained almost stationary while becoming less deep. On the 16th an associated secondary depression over the Irish Sea moved quickly north-north-east. During this period gales occurred locally in the north of Scotland and rain was fairly general except in the south-east of the country; high temperatures were registered in England on the 15th and 16th. On the 17th a small depression approached western France from the Atlantic; thereafter it moved eastward, causing considerable rain in south and east England, with local thunderstorms. By the 18th a ridge of high pressure was situated over the northern districts and depression off Portugal was spreading north; rain fell in south and east England and south Scotland on the 18th and more generally on the 19th and 20th. Subsequently a ridge of high pressure moving east over the country maintained fair weather in most areas on the 21st, but further rain on the 22nd, heavy locally in Scotland, was associated with a depression, which moved rapidly east-north-east off the north of Scotland. Subsequently an anti-cyclone was situated north of the Azores, while depressions in the far north moved east and minor troughs crossed the British Isles. The weather was considerably cooler and, except in the north and west, conditions were mainly fair. On the 29th the anti-cyclone spread north-east and by the 30th was centred over south Ireland, rainfall on that day being mainly confined to the north of Scotland.

Pressure and Wind

Broadly speaking, mean pressure was somewhat below the average in the north of Scotland, and somewhat exceeded the aver-

age in England and Wales and south Scotland ; at 9h. the deviation from the average ranged from -1.7 mb. at Lerwick to $+2.0$ mb. at Plymouth. Wind from some westerly point predominated on the whole. Gales were fairly frequent in the north of Scotland, being reported on 8 days at Lerwick and 7 days at Stornoway. Among the highest speeds registered in gusts were 66 m.p.h. at Paisley and Durham on the 9th, 69 m.p.h. at St. Ann's Head on the 16th and 75 m.p.h. at Edinburgh and 76 m.p.h. at Bell Rock on the 22nd.

Temperature

Mean temperature exceeded the average, the excess being greatest in eastern districts of England and the Midlands, where it amounted to more than 3° F. The first three weeks were generally warm but the last week was cool on the whole. As far as can be estimated, mean temperature over England and Wales was, with two exceptions namely, 1929 and 1933, the highest for September since before 1901 ; in 1929 the mean temperature was higher than in 1947 but in 1933 it was about the same.

The extremes for the month were : (England and Wales) 88° F. at Norwich on the 16th, 30° F. at Santon Downham on the 25th and at Houghall on the 30th ; (Scotland) 78° F. at Glenbranter on the 2nd, 26° F. at Peebles on the 30th ; (Northern Ireland) 76° F. at Lisburn on the 2nd, 39° F. at Ballykelly on the 26th and 30th, and at Lisburn, Hillsborough, Armagh and Castle Archdale on the 30th.

Precipitation

The general precipitation expressed as a percentage of the average for the period 1881-1915 was 78 over England and Wales, 135 over Scotland, and 110 over Northern Ireland. In Scotland more than the average occurred in western, northern and central districts and less than the average over much of the eastern districts. More than twice the average occurred in part of Sutherland and at Renfrew, while totals were only about half the average on the coast of East Lothian and Berwickshire. In England and Wales more than the average was received over most of north-west England, locally in North Wales, in the Tees valley and in a mainly inland area in South Devon. On the other hand, less than 50 per cent. occurred near the Northumbrian coast, locally on the north coast of

Cornwall, locally in Worcestershire and over the eastern part of East Anglia, while less than 25 per cent. was received at Lowestoft.

In Northern Ireland percentages of the average ranged from 97 at Garvagh and Seaforde to 121 at Londonderry and Ballymena.

Measurable rain occurred very frequently in the north-west and north ; for example, on 28 days at Colonsay, and 27 days at Stornoway, Duntuilin, Cape Wrath, Benbecula, Fort William and Tiree.

Among the heavier falls in 24 hours were :—

8th, 2.11 in. at Glenquey Reservoir, Glendevon.

14th, 2.40 in. at Cwm Dyli, Snowdon.

22nd, 2.74 in. at Achfary, Sutherland.

30th, 2.52 in. at Arienskill and 2.17 in. at Inverailort, Inverness-shire.

Thunderstorms occurred fairly frequently for the time of year ; for instance, on four days at Earl's Colne and East Malling. They occurred mainly on the 8th, 16th-20th, and 23rd.

The long drought which occurred throughout the greater part of August was not terminated in parts of England until the 11th or even the 17th. At Wye, Kent, there was no measurable rainfall from July 29th—September 16th inclusive, a period of 50 days. At Oxford an absolute drought prevailed for 37 days ending on September 11th, being the longest ever recorded, that is, since 1815.

Sunshine

Sunshine exceeded the average in the Shetland Isles and in eastern and Midland districts of England but was below the average in the west of the British Isles. The percentages for the districts ranged from 78 in Northern Ireland to 113 in England, N.E. The sunniest periods on the whole were the 1st-6th and 21st-30th.

TABLE 4
 PHYSICAL PROPERTIES OF COMMON GASES AND VAPOURS BASED ON CURRENT LITERATURE^{1,2}

Substance	Formula	Specific Gravity (Air = 1)	Boiling Point (Deg. C)	Vapour Pressure (MM HG 20° C.)	Lower Limit of Inflammability (%) by Volume	Probable Safe Limits of Exposure to Man and Animals (PPM)	
1 Acetone	CH ₃ CO.CH ₃	2.0	56.5	184.8	2.2	1205-2110 (cats)	1
2 Ammonia	NH ₃	0.6	-33.4	Gas	19	85-100 (man)	2
3 Amyl acetate (n)	CH ₃ COO.C ₅ H ₁₁	4.5	142	N.D. ³	1.1	400 (man)	3
4 Amyl acetate (s)	(CH ₃ CH ₂ CH ₂) ₂ CH.COO.C ₅ H ₁₁						
5 Aniline	CH ₃ CHO.COCH ₃	4.5	133	N.D.	N.D.	<0.2 ⁴ (guinea pigs)	4
6 Benzene	C ₆ H ₆ .NH ₂	3.3	184.4	2.4	N.D.	<7 (man)	5
7 Bromine	C ₆ H ₆	2.7	80.4	34	1.4	100 (man)	6
8 Butyl acetate (n)	Br ₂	4.7	58.8	Gas	N.I. ³	0.15-0.3 (man)	7
9 Carbon dioxide	CH ₃ .COO.C ₄ H ₉	4.0	125	11	1.7	<400 (man)	8
10 Carbon disulphide	CO ₂	1.5	-78.5	Gas	N.I.	550 (man)	9
11 Carbon monoxide	CS ₂	2.6	-46.3	Gas	4.3	<20 (man)	10
12 Carbon tetrachloride	CO	0.97	-190	Gas	12.5	<100 (man)	11
13 Cellosolve (monoethyl) ether of ethylene glycol	CCl ₄	5.3	76	90	N.I.	<100 (man)	12
14 Chlorine	CH ₃ OH.CH ₂ OC ₂ H ₅	3.1	134.8	4.0	N.D.	0.05 ⁴ (guinea pigs)	13
15 Dichlorethylene (trans)	Cl ₂	2.5	-34.6	Gas	N.I.	<0.35 (man)	14
16 Dichlorethyl ether	CHCl.CHCl	3.0	59.8	260	N.I.	<3 (man)	15
17 Diethylene dioxide	(ClCH ₂ CH ₂) ₂ O	4.9	178.6	0.73	N.D.	15 (guinea pigs)	16
18 Ethanol	O(CH ₂) ₂ O	3.0	101.1	28.0	N.D.	14 (guinea pigs)	17
19 Ethyl benzene	C ₃ H ₅ OH	1.0	78.4	43.9	3.5	1000 (man)	18
20 Ethyl chloride	C ₂ H ₅ C ₂ H ₅	3.6	136.5	15.3	N.D.	<0.1 ⁴ (guinea pigs)	19
21 Ethylene dichloride	C ₂ H ₄ Cl	2.2	12.2	1100	4	14 (guinea pigs)	20
22 Ethylene oxide	C ₂ H ₄ Cl ₂	3.4	83.5	78	6.0	<100 (guinea pigs)	21
23 Formaldehyde	CH ₂ CH ₂ O	1.5	13.5	1100	3	0.025 ⁴ (guinea pigs)	22
24 Gasoline	H.CHO	1.0	-21	Gas	N.I.	<20 (man)	23
	C _n H _{2n+2}	1.7-2.0	50-144		1.1	108 (man)	24

TABLE 4.—continued

25 Hydrogen chloride	HCl	1.3	-83.7	Gas	N.I.	<10 (man)	25
26 Hydrogen cyanide	HCN	0.93	25.2	N.D.	N.D.	<18 (man)	26
27 Hydrogen fluoride	HF	0.7	19.4	N.D.	N.I.	3 (man)	27
28 Hydrogen sulphide	HS ₂	1.2	-59.6	Gas	4.3	<20 (man)	28
29 Mercury	Hg	7.0	357.0	—	N.I.	1.0 ⁷ (man)	29
30 Methanol	CH ₃ OH	1.1	66	95	7.5	100 (man)	30
31 Methyl bromide	CH ₃ Br	3.3	4.5	Gas	N.D.	0.010 ⁴ (guinea pigs)	31
32 Methyl butyl ketone (iso)	CH ₃ CO.C ₄ H ₉	3.5	107	13.0	N.D.	0.15 ⁴ (guinea pigs)	32
33 Methyl chloride	CH ₃ Cl	1.8	-24	Gas	4	<0.12 ⁴ (guinea pigs)	33
34 Methyl ethyl ketone	CH ₃ CH ₂ COCH ₃	2.5	79.0	N.D.	N.D.	0.3 ⁴ (guinea pigs)	34
35 Methyl formate	HCOOCH ₃	2.2	31.8	476.4	4.5	0.15 ⁴ (guinea pigs)	35
36 Methyl propyl ketone	CH ₃ CO.CH ₂ .C ₄ H ₉	3.0	101.7	N.D.	N.D.	0.15 ⁴ (guinea pigs)	36
37 Nitro benzene	C ₆ H ₅ .NO ₂	4.2	210	N.D.	N.D.	60 (man)	37
38 Nitrogen tetraoxide	NO ₂ or N ₂ O ₄	1.6-3.2	-21.3	Gas	N.I.	10 (as NO ₂) (man)	38
39 Ozone	O ₃	1.6	-112	Gas	N.D.	1.0 (man)	39
40 Phosgene	COCl ₂	3.4	8.2	Gas	N.I.	<1 (man)	40
41 Sulphur dioxide	SO ₂	2.3	-10	Gas	N.I.	10 (man)	41
42 Toluene	C ₆ H ₅ .CH ₃	3.2	111	N.D.	1.4	100 (man)	42
43 Tetrachlorethylene	CCl ₄ ; CCl ₂	5.7	120.8	N.D.	N.I.	<100 ⁸	43
44 Trichlorethylene	CHCl:CCl ₂	4.5	87.2	57	N.I.	<100 ⁸	44
45 Turpentine	C ₁₀ H ₁₆	4.7	146	N.D.	N.D.	<200 (man)	45
46 Vinyl chloride	CH ₂ CHCl	2.2	-13.9	N.D.	4	0.5 (guinea pigs)	46
47 Xylene (m)	C ₆ H ₄ (CH ₃) ₂	3.7	136-141	N.D.	N.D.	100 (man)	47

¹ In addition to the substances listed in this table may be mentioned chronic acid with a probable safe limit of exposure of 1 milligram per 10 cubic metres, and the chlorinated naphthalenes, less than 10 milligrams per cubic metre being safe for the trichloronaphthalene and 0.5 milligrams for naphthalenes of higher chlorination.

² Data are based chiefly on the following sources: (a) "Schadliche Gase," Ferdinand Flury and Franz Zernik, Berlin, 1931; (b) Publications of the Bureau of Mines and the Public Health Service; and (c) International Critical Tables, published by McGraw-Hill Book Company, Inc., New York; (d) "Noxious Gases," by Y. Henderson and H. W. Haggard, Amer.Chem.Soc. Monograph

No. 35, The Chem. Cat. Co., Inc., N.Y., 1927; (e) and Standards of the American Standards Association, 29, West 39th Street, New York, N.Y.

³ No data. ⁴Per cent. by volume. ⁵Non-inflammable. ⁶Milligrams per litre. ⁷Milligrams per 10 cubic metres. ⁸Assumed to be as toxic as carbon tetrachloride.

THE HEAT PUMP

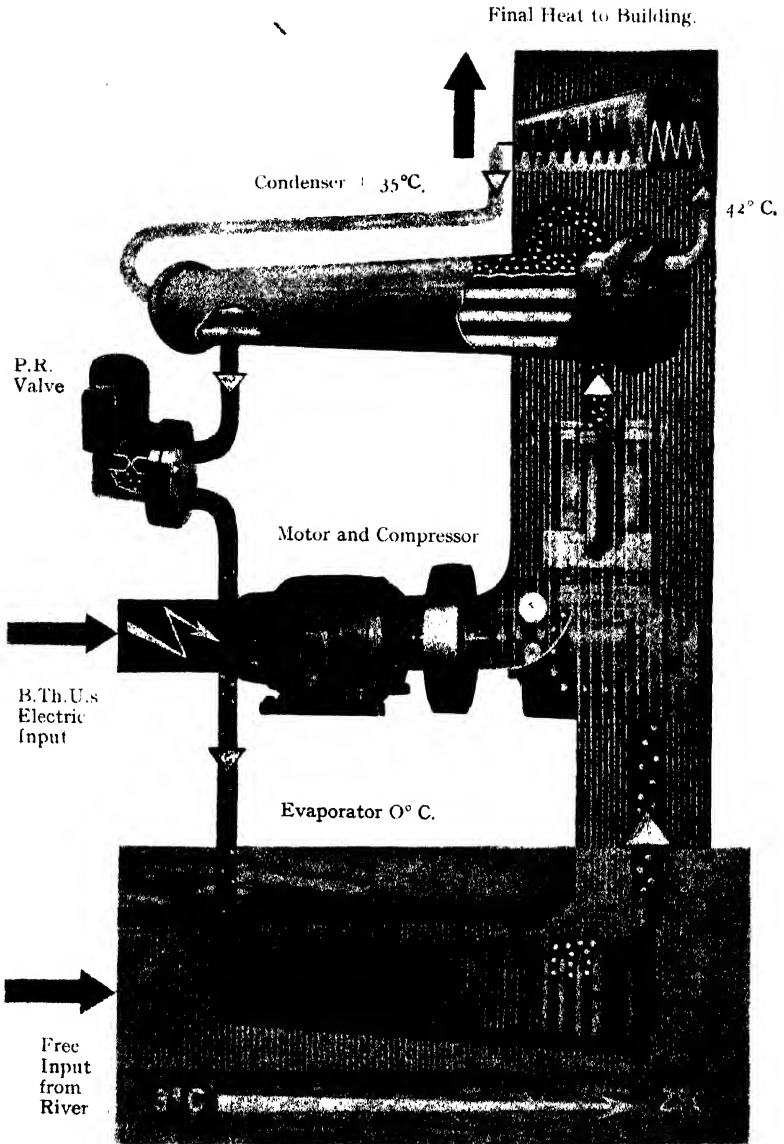

Fig. 32.—This illustration by kind permission of Escher-Wyss, of Switzerland, shows in pictorial form the cycle of the Heat Pump, with the free heat source in the river and the make-up by the motor

It will be observed that the weather conditions should be carefully studied for the district in which the Heat Pump is to operate, so that the design temperature for heating and cooling can be arrived at. If this is carefully selected, the most economical working of both the heating and the cooling cycle will be achieved, and as has been found in practice, a maximum, average or minimum temperature will not achieve very much and the location of the building, its exposure, etc., should be carefully considered in the design. Weather conditions for almost all parts of this country are available and these should be consulted, as to give a list here would take up too much space. If there is no recognised weather station in the district, the figures needed for design can be had from the nearest air port.

Cooling Cycle

For the cooling cycle, which is easily achieved with the Heat Pump, both wet and dry bulb temperatures must be taken into the design and, unfortunately, these do not occur simultaneously, but the design can be simply effected by means of the necessary valves, so that the heater battery circuits are used for heating in winter, using the "hot" side of the cycle, while the heat can be abstracted from the building and the cold water from the evaporator circulated to the batteries. A pictorial design of the principle of the Heat Pump by Escher-Wyss is shown in Fig. 32. The scheme has been explained in previous chapters but is outlined as follows. The cooling agent or refrigerant is evaporated at 0° C. by the suction effect of the compressor. The evaporation of the liquid demands heat and the river water at 3° C. drops a degree to 2° C. The vapour in passing into the compressor has the work of the compressor transferred to heat in the vapour at high pressure and temperature. This agent carries the heat to the condenser where the heat is transferred from the vapour to the water and the vapour condenses, passing as a liquid through the pressure reducing valve, returning as a liquid at its original pressure to the evaporator to begin its cycle. The temperature difference is shown in the illustration, and it has been repeatedly found in practice that the difference should be about 100° F. We shall now deal with actual installations of plant.

SECTION I BIBLIOGRAPH

¹ Nicholas Leonard Sadi Carnot (1796-1832) : " Reflections sur la Puissance Mortice du Feu," 1824. Was first to discern clearly the nature of the connection between heat and mechanical work.

² William Thomson Kelvin (1824-1907) : " The Economy of the Heating and Cooling of Buildings by Means of Currents of Air," 1852. " On Vortex Atoms," 1867.

³ Sir Ernest Rutherford : " Radio-active Substances and their Radiations " (1913). He was the first to count the alpha particles projected from radium and gave proof of the atomic theory of matter. He suggested the nucleus atom.

⁴ Gabriel Daniel Fahrenheit (1686-1736) : German physicist invented the Fahrenheit thermometer widely used by heating engineers.

⁵ Latin *centum* hundred ; *gradus* degree. The lower fixed point is 0° C., which is taken as the melting of ice and the upper limit of 100° C. is the point at which water boils. This scale was divided by Celsius into one hundred parts.

⁶ Joseph Black (1728-99) : He discovered that to produce liquelaction ice requires to absorb a large amount of heat. From this was evolved the theory of latent heat.

⁷ John Rumford discovered the relation between heat and mechanical work.

⁸ Sir Humphrey Davy evolved the same theory by melting ice in a vacuum by rubbing two pieces together by mechanical means.

⁹ James Prescott Joule (1818-1889) : The Joule, the practical unit of energy or work, is named after this British physicist.

¹⁰ Henric Hess, German physicist.

¹¹ From a Paper read before the Inst. of Mechanical Engineers, by Carrothers 1947.

¹² A. Meldahl (Hv.) : BROWN BOVERI & CO. TECHNICAL REVIEW.

¹³ Inst of Heating and Ventilating Engineers' Journal, 1947.

¹⁴ Brown-Boveri supplied in 1925 a centrifugal compressor for ammonia with a cooling output of 8×10^6 kcal/h.

¹⁵ Brown-Boveri thermo-compressor A. Meldahl (Hv.).

¹⁶ T. B. Morley. " The Reversed Heat Engine as a means of Heating Buildings." THE ENGINEER, 133 (1922) 3450. Pp. 145-146, 10/2/22.

¹⁷ See Electricite, miroir de la technique moderne a l'Exposition Nationale Suisse 1939," page 120, published by " Electrodiffusion " Societe Suisse pour la diffusion de l'energie electrique. Furthermore : " Vom Temperaturwert der Kalorie," Rundschau Deutscher Technik, February 18th, 1943, p. 4.

¹⁸ Thau : " Brennstoff and Warmewirtshchaft," Nos. 2, 26, and 29, 1942.

¹⁹ Prof. Dr. B. Bauer : " Die Warmepumpenanlage Walcheplatz in Zurich," Technical Supplement No. 406 of the NEUE ZURICHER ZEITUNG, March 10th. 1943.

²⁰ " Anpassung der Warmeversorgung der Schweizerischen Industrie an die gegenwartige und kommende Kohlenwirtshchaft," p. 12. This is the publication of a series of short Papers presented at the general meeting of the Swiss Association of Energy Consumers at Zurich, on March 24th, 1924.

²¹ B. Bauer and W. Peter : " Wasser und Energiewirtschaft," No. 7/8, 1935, p. 109.

Section II

Section II

Practical Application

ZURICH Town Hall has been heated by a Heat Pump since 1939. The Town Hall was re-constructed, and when the problem of heating was undertaken serious consideration was given to various forms of solid and liquid fuel firing. The internal design of the Town Hall is of interest. Many of the ceilings are of plaster cast or fine wood carving which called for special care in the design of the heating installation. The heating pipe work and the ventilation trunking is concealed in the false ceiling and wall air space. The rising mains were easily concealed by the upright stanchions of the main building, rising to feed the heater batteries in the roof space where the main fresh air inlet and exhaust fans are situated.

The decision to install a Heat Pump was arrived at after considering all the main difficulties. The building has no suitable basement, being built on the side of the river, as can be seen in Fig. 33, with the result that a room had to be converted, which was adjacent to the Committee Rooms. The plant had therefore to be silent in operation, and it should be noted that this plant in operation gives a reading of only 30 decibels.

This Heat Pump installation is of special interest for the heater batteries (Fig. 34) serve a double purpose. In winter the Heat Pump supplies the hot water to the batteries, while in summer the Heat Pump acts as a refrigeration unit supplying cooling water to the same batteries, while hot water storage tanks are installed for "topping up" when the peak load demand falls too heavily on the Heat Pump. The lay-out of the system is shown in Figs. 34, 42 and 43.

The decision to install a Heat Pump for this, the first large Heat Pump scheme in Europe, was arrived at after very careful study. Oil and solid fuel required the necessary bunker space, which was not available. Direct electric heating meant that the heating load would fall on the peak demand at the power-stations, and with the

difficult conditions in Europe, the Authorities decided to install a Heat Pump, but it was to prove such a success, even in its first year of operation, that a further scheme was undertaken for the Zurich Public Baths, which saves about 900 tons of coal alone per annum.

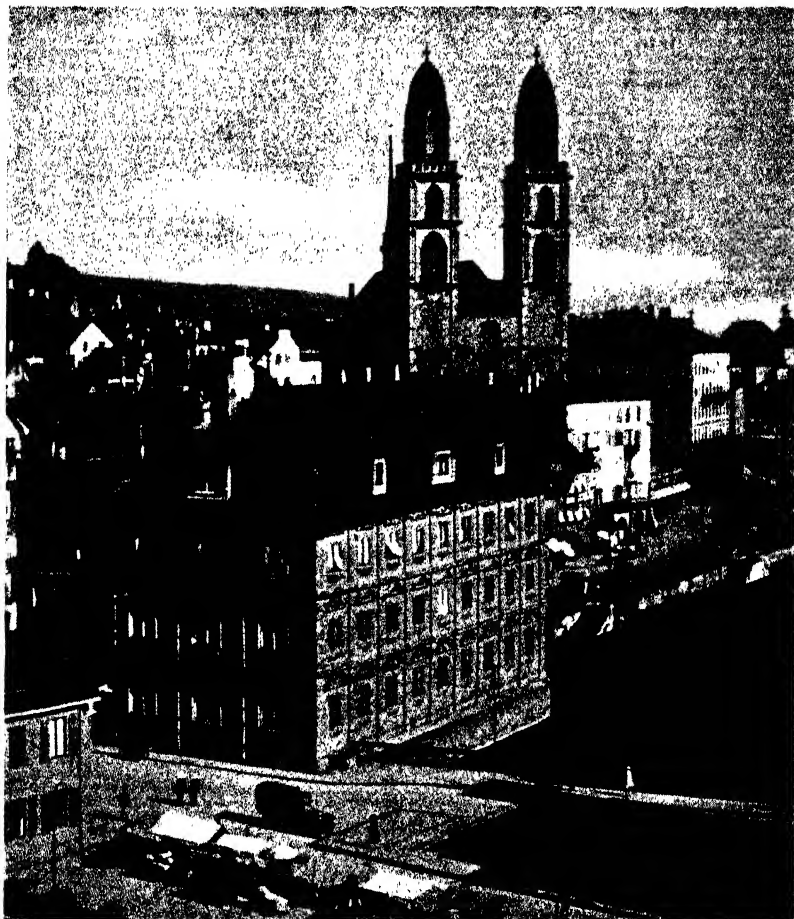

Fig. 33.—The Town Hall at Zurich. This is the first effective and efficient Heat Pump installation in Europe

The Costs

Running costs had to be studied in this installation in the Town Hall, as with all types of heating installations. Oil at that time

PRACTICAL APPLICATION

was offered at $1\frac{1}{2}$ units per kwh., whereas direct electrical heating power supplied was at the rate of $3\frac{1}{2}$ units per kwh., or more than double the cost. The fixed tariff did not help in this instance as the higher the current demand, the greater the cost.

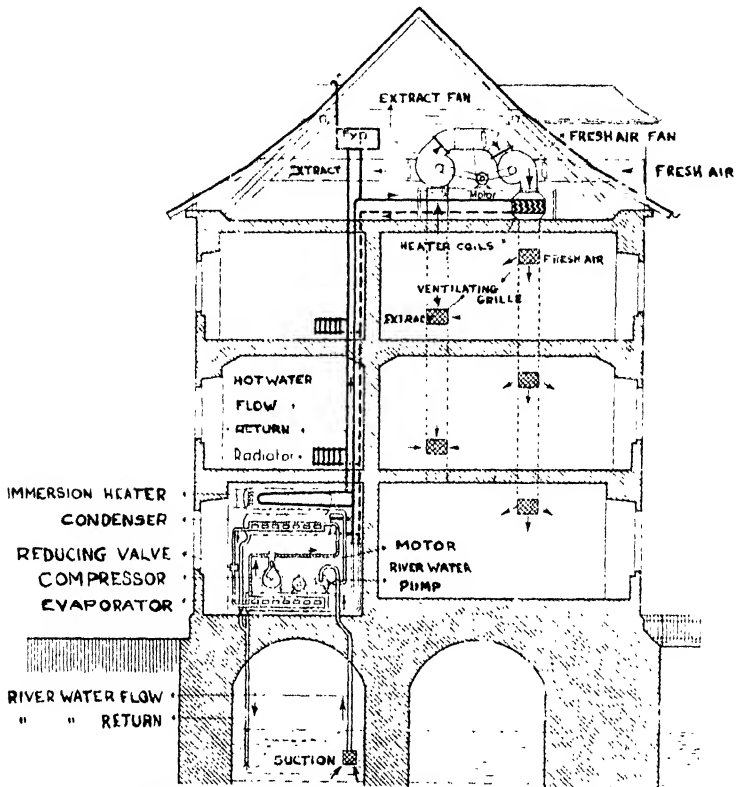

Fig. 34.—Section elevation of the Town Hall

In order to get the advantage of the "off peak" load, some form of thermal storage had to be devised, or else some source of cheap heat. If a combination could be had, then the electrical load could be taken at the peak period. It is true that the consumption of power would be at the normal tariff rate and not at "off peak" charges, but the Heat Pump has more than justified this in the Zurich Town Hall for a combination of thermal storage and immersion heating has been achieved with the hot water tanks re-

ferred to and shown in Fig. 36, while Figs. 37 and 38 show the layout of the scheme for heating and for cooling.

The Zurich Town Hall installation has had minor initial troubles, but the plant gives an efficiency of 3.5 per cent. over input, and it is estimated that even without thermal storage there would be a marked saving.

Figs. 39 and 40 show the temperature changes outside, as against the source of heat which were used as a basis in calculating the designs for this important Heat Pump installation. In the top part of Fig. 39 the variation in temperatures is given. Point F shows that there are 110 days in the heating season in Zurich on which the average day temperature falls below 39.2°F . Point G marks the heating limit, and this shows that there are 198 days with average day temperatures below 50°F . Heating is, therefore, required on those days, but on 40 days the heat output required exceeds half of the maximum output. The oblique shaded part dz and of length $t_1 - t_*$ shows the heat loss through loss of convection, and this has to be made up by heating once the temperature has been built up. The area between the frequency curve of the open-air temperature and the verticals through t_1 indicate the heat input required for each heating season, while the rectangle enclosed by the verticals at $t_* = -4^{\circ}\text{F}$., and at $t_1 = 64.4^{\circ}\text{F}$. This represents the maximum loading of the heating system when under constant operation. The proportion of the two areas for Zurich is 0.216, which indicates that when the system is designed for an outside temperature of -4°F ., the loading on the system is only 21.6 per cent.

The Weekly Load

Fig. 41 gives the weekly load on the heating installation when the outside temperature was -4°F . It will be seen that the Heat Pump carried at least 90 per cent. of the load with only three peak periods. The build-up of heat between 6 a.m. and noon on the Monday morning, a further peak period on Wednesday afternoon, and a further topping-up on Friday afternoon.

This means that on the Monday, the Canton Council Hall was in use and the supplementary rooms by members of the County Council. That on Wednesday was when a meeting of Town Coun-

PRACTICAL APPLICATION

cillors took place in the Canton Council Hall, while the Friday peak load was caused by a general meeting of all Councillors and City Administrators when all rooms of the Town Hall were in use.

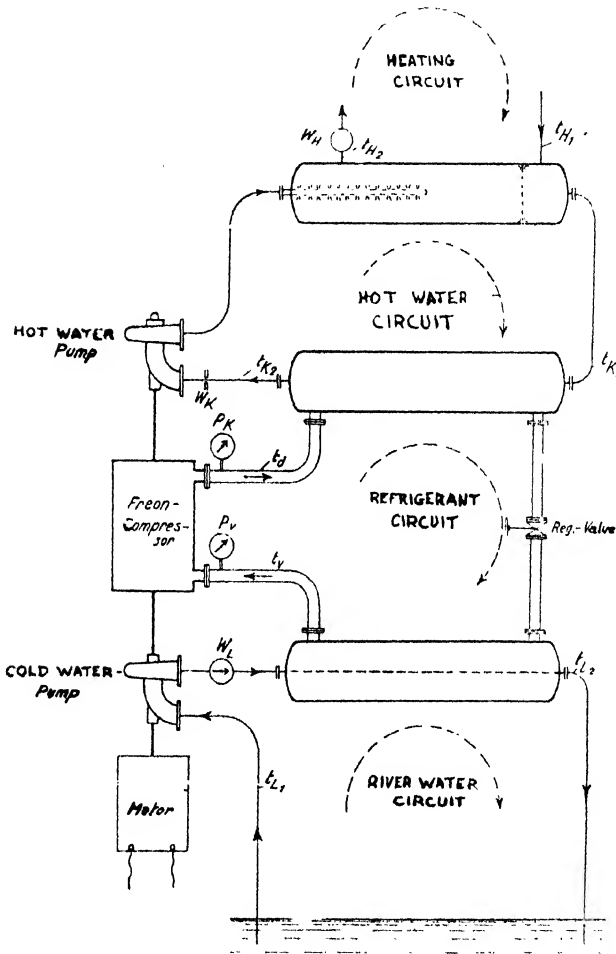

Fig. 35.—The lay-out of the Heat Pump circuit

During the night, heat has to be supplied to the caretaker's flat, and for the room used by the night watchman. The general day load is caused by the use of the offices by the Cantonal Administration.

THE HEAT PUMP

This diagram can be taken as an average with an outside temperature fluctuating.

As the Committee Rooms of the Town Hall require rapid and adequate ventilation, it was decided to use part plenum and part radiators, as shown in Figs. 34, 42 and 43. The main chambers are supplied by the plenum fans, for summer cooling and winter heating, while the offices, caretaker's flat, etc., are supplied with radiators.

The entire scheme is illustrated in Figs. 42 and 43. A standard method of concealed trunking supplies the Council Chambers while the general lay-out of the scheme, with the Heat Pump and heater and cooling batteries is shown in Fig. 34.

The water is pumped up from the River Limmat by the Pump, passes through the evaporator, giving up its heat to the refrigerant, and then returns to the river. The heat transfer is to a calorifier above, which feeds the heater batteries and the radiators. Figs. 37 and 38 show in detail the arrangement for winter heating and summer cooling which is obtained by a set of three-way cocks. The temperatures are given in the illustration in degrees centigrade.

The entire Heat Pump plant, as can be seen, is situated on the ground floor near the main Council Chambers, while the F.A.I. fans as well as the exhaust fans are situated in the roof space above the Canton Council Hall to the left.

When the scheme runs in reverse as a cooling scheme, it will be noted that heat is taken from the Council Chambers, transferred to the batteries, thence to the water in the heat exchangers, through the evaporator and back into the river.

It will be noted that the scheme was designed for an average day load of 10-12 hours per week, while the peak demand can be topped up from the thermal reserve which is made up when the Town Hall is not fully utilised, and there is a surplus of heat available from the Heat Pump.

The heat load when calculated, decided the sizing of the radiators and heater batteries. At low temperatures, it was decided to get the maximum radiation surface that the space in the windows under

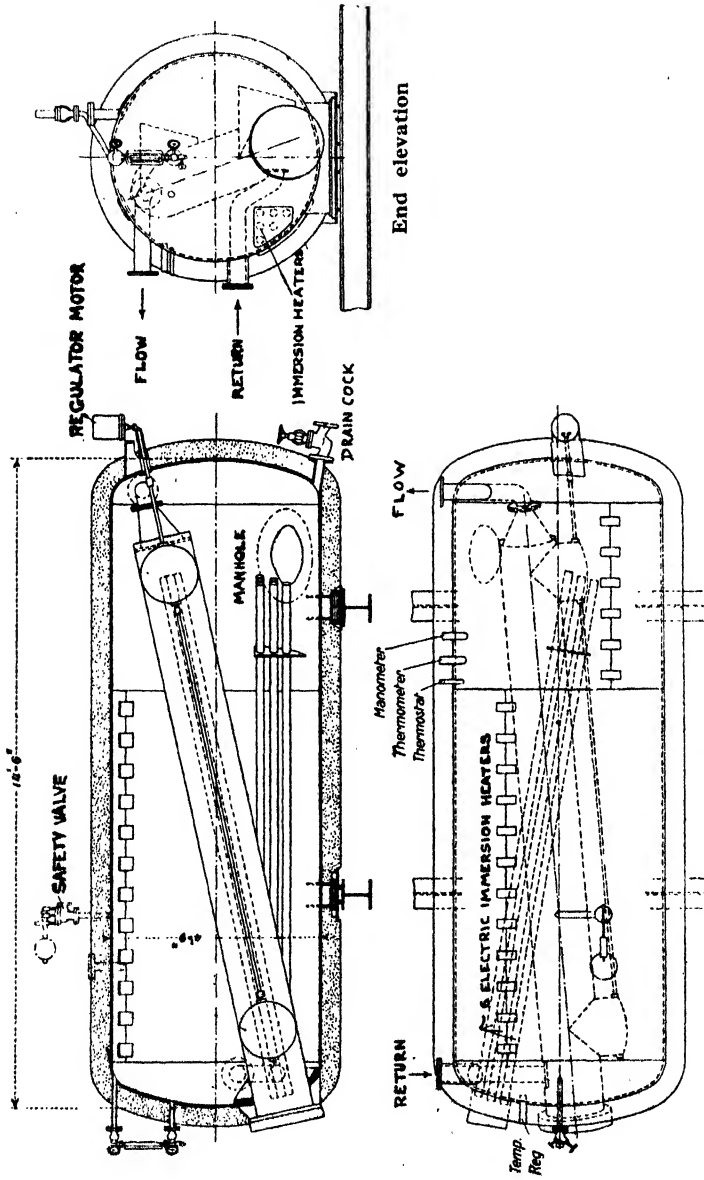

Fig. 36—The calorifier with the make-up electrode heaters

THE HEAT PUMP

the ledge would allow, while the batteries were of gilled tubes to get the maximum surface of heat transfer in the limited space. The radiators are of sheet steel and sized for a maximum heating water temperature of 140° F. Fig. 42 shows the lay-out of the pipe-work and the ducting of the plenum plant. Sizing of the scheme was achieved by working on a maximum heat carrying capacity of the water so that all other sizing was automatically determined from this maximum loading.

The scheme does not differ very much beyond this from the usual scheme of plenum heating combined with low pressure hot water, except that with a lower flow temperature. Tubes are much larger than they are in normal heating systems as well as larger

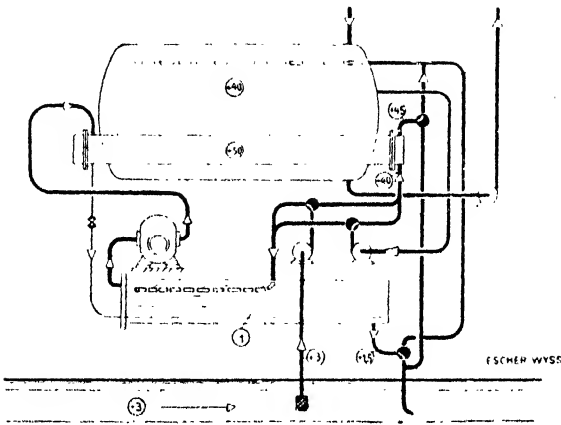

Fig. 37.-Heating in winter

radiating surfaces of the radiators. A feature of the scheme is that each room can be shut off automatically when not in use so that the maximum heat saving is achieved, and transferred to the thermal storage cylinders. The scheme is designed on the period of use of the various rooms and not as is usual on a maximum demand with an outside temperature of, say, 30° F., and a room temperature of 65° F. On the ground floor it will be noted that the Hall of Honour (9) is the only ground floor room with plenum heating which can be cooled in summer. The F.A.I. is behind the statues and at high

level, and is spread out by deflection from the grilles so that the Hall is bathed in warmth or cooled as the case may be, thus avoiding unpleasant movements of the air, either hot or cold. The exhaust outlets are hidden in special stoves which have been retained for their artistic value.

In Figs. 42 and 43 the numbers in the circles indicate the rooms. The legend is as follows: (1) Entry of fresh air; (2) Filter; (3) Pre-heater; (4) Washer; (5) F.A.I. Fan; (6) Air Heater; (7) Exhaust Fan.

A single thermostat ensures that constant indoor temperature is maintained for heating as well as for cooling purposes. In the

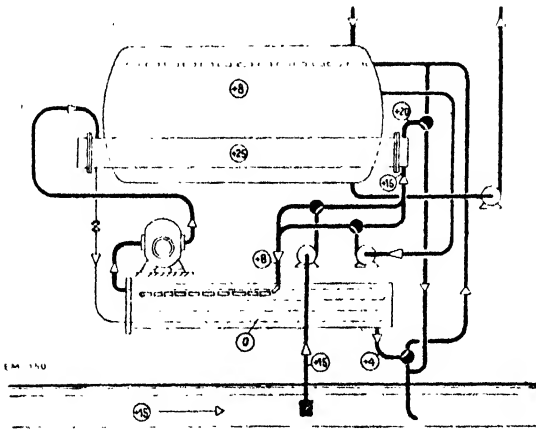

Fig. 38.—Cooling in summer

Meeting Room 12 the window bays are designed as benches where two radiators running in the same direction are hidden. The benches in the Entrance Hall are furnished each with a convector. On the first floor is the Canton Council Hall 13, the former Government Council Hall 17, now used as a meeting-room for the various political parties, and the Vestibule 14, situated between both of them. All these rooms have plenum air-heating and can, therefore, be cooled. The fresh air in the Canton Council Hall is discharged horizontally by cross-currents through a protruding ceiling frieze,

THE HEAT PUMP

whereas the outgoing air is sucked away from under the seats, which are arranged as in an amphitheatre.

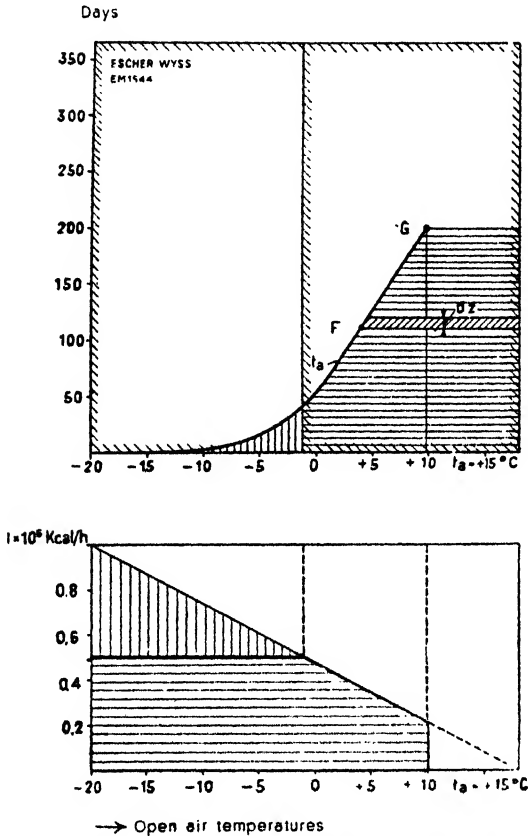

Fig. 39.—Parallel shading shows input of Heat Pump at Zurich Town Hall, vertical shading shows the topping-up heating. Top figure d.z. shaded shows the supplementary heating needed, while the bottom graph shows the distribution of the heating load

In order to reduce the cooling effect of the glass at those seats which are in the immediate vicinity of the windows, warm air is

PRACTICAL APPLICATION

blown from below towards the interior side of the windows. In the former Meeting Hall of the Government Council, due to the

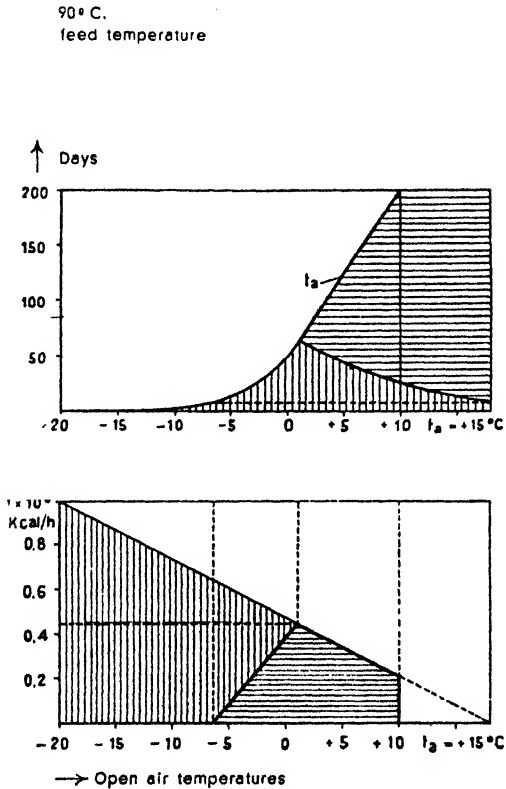

Fig. 40.—At a maximum of 90° C. feed temperature the supplementary heating system must take over the full load; during the coldest period the Heat Pump takes more than two-thirds of the load

architectural features of the room, the F.A.I.s are below the windows. In spite of this arrangement, no draught can be felt even by

those who are quite near. All ducts are placed between stanchions and the parquets of the floor and the outgoing air is extracted under the artistic stoves referred to.

On the top floor is the caretaker's flat, which is fitted throughout with radiators, while to the left of this flat is the main ventilating plant. No. 1 shows the main fresh air inlet ; 2 is a dry type throw-away filter ; 3 is the heater battery ; 4 the washer ; 5 is the main ventilation fan ; 6 is the final heater battery ; 7 is the exhaust outlet fan.

It will be noted that this plant is housed under the eaves of the roof, and the motors and fan are fitted with anti-vibration mats on joists, in suspension, throwing the main loading to the outside walls to prevent the transmission of sound to the Canton Council Hall.

A special vertical shaft carries the main service from the Heat Pump below to the ventilating plant on the roof, and the plant is so concealed that architectural features are given to the roof, as can be seen in the section, while no plant is visible.

In order to arrive at a suitable tariff for electric supply for the Heat Pump, a general day load as against kW. per B.Th.U. was evolved and this is shown in Fig. No. 45. This shows graphically the cost per day. The curve "A" represents the average day temperature. The curve "B" that of the water from the River Limmat in comparison with the number of days. The curve represents from 37.5° F. as the lowest temperature and rises to 57.5° F. as the highest temperature of the heating period.

The former was taken as a basis for calculation since no accurate records were available, while 64.5° F. was chosen as the indoor temperature "C" suitable for the whole heating period. The curve of the heating water, temperature "D" is determined by the outside temperature and heating surface.

The secondary water temperature together with the temperature of the Limmat water determines the course of the effective figure being the curve "E." This gives the quantity of the heat which is to be generated.

The area between "A" and "C" indicates the quantity of heat to be produced and the area between "F" and "C" indicates the

amount of work to be done to transfer mechanical energy to thermal energy. In multiplying the proportionate number with the corresponding degree of efficiency and the price per kW., a comparison is obtained with a corresponding heating apparatus based on solid or liquid fuel.

In the case in question the efficiency figure " E " of 7640 B.Th.U.s kWh. compares favourably with oil on a price basis. Fig. 44 shows the calculation of the price for current for the Heat Pump. The evaporation temperature is given on the upper part of the graph with the guaranteed output and the actual measured output

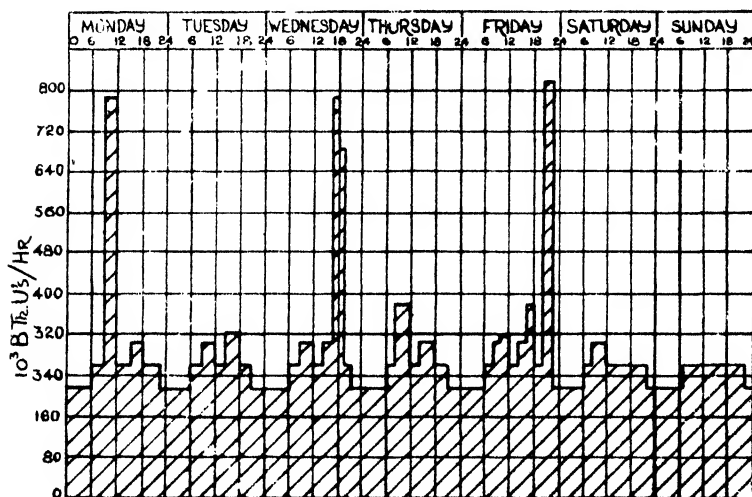

Fig. 41. The daily load of Heat Pump and make-up

of the Heat Pump. The kW. input converted to heat is given in the lower part of the diagram with the water temperature given central as a base. The points marked X in the evaporation temperature are the points at which the current consumption was measured.

The plant lay-out is shown in Fig. 46. It consists of a motor, two pumps and a rotary compressor. One pump lifts the water from the River Limmat, passing the water over the evaporator. The other pump acts as circulator for the hot water calorifier system, and is similar to that in use in an ordinary hot water heating

system. The cycle of the refrigerant is that which has been described in earlier chapters.

A special oil filter prevents the flow of lubricant away from the moving parts. Two manometers register the working conditions. One registers the conditions of the refrigerant before compression, the other after the addition of the mechanical energy. There is also a special water valve on the suction side of the pump besides a foot valve which acts as an injector and prevents air locks in the flow of water from the River Limmat, should there be any variation in the supply level.

The Heat Pump unit (Fig. 46a) is made by Escher-Wyss, and consists of (1) Compressor; (2) Condenser; (3) Evaporator; (4) Motor; (5) Flanged Coupling; (6) Water pumped from River Limmat; (7) Heating Circulator; (8) Regulation Valve; (9) Make-up Thermal Storage. The refrigerant is Dichlorodifluormethan, known generally as Freon 12, which is an oil-like liquid with a specific weight of 1.4 and a vapour pressure of 3.14 at an absolute pressure of 32° F., and latent heat at chemical change of 82 kW./lb. at 32° F.

Fig. 47 shows a section of the patent compressor while Fig. 48 gives a section of the evaporator showing the coils. Note the large heat transfer surface to get the maximum effect of the gasified refrigerant. Fig. 36 shows a section of the calorifier which is fitted with a safety valve and normal fittings resting on a cradle of two channel irons.

Freon 12 has many advantages as a refrigerant. It is odourless, non-poisonous and its chemical state is stable, and it is quite inexpensive. In a well-designed scheme it will last indefinitely.

The evaporator and condenser are so constructed that the maximum transfer is obtained. The initial heat at T_1 from the river water is forced at speed over the coils to effect rapid evaporation of the refrigerant. The water is agitated by means of a slip baffle of sheeting built in between the banks of tubes in the battery. The evaporator and condenser are insulated with cork about $\frac{1}{2}$ in. thick. The entire unit is built up compactly, as can be seen in Fig. 48. The evaporator is capable of a transfer of 280,000 B.Th.U.s/hr. at an average temperature difference of 41° F. between

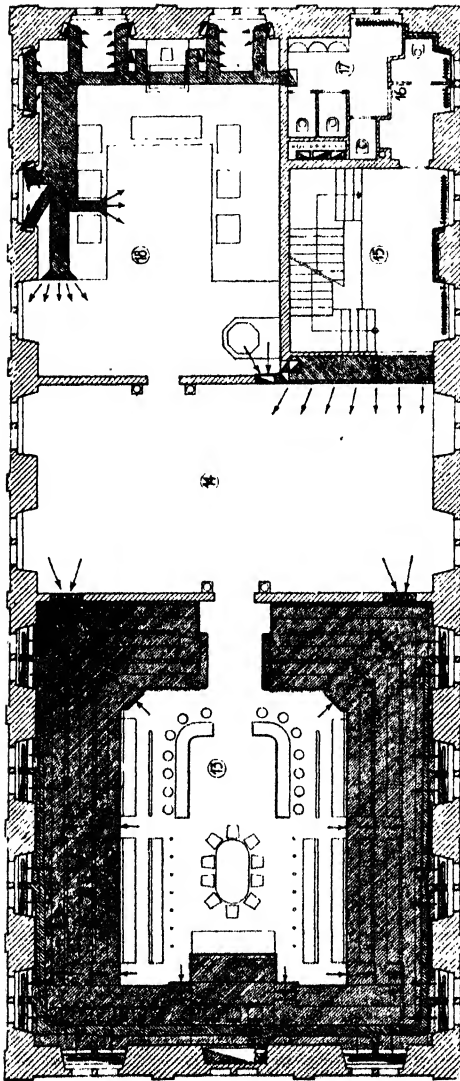

Fig. 42.—Plan showing the fresh air and exhaust ventilation

the refrigerant and the river water, while the discharge water has a temperature drop of 2.7° F.

The condenser consists of 48 tubes in parallel through which the heating water flows passing three times the length of the shell of the condenser. In the centre of the condenser is fitted a prismatic oil separator by which oil is separated from the refrigerant by means of steel sheets, then the refrigerant on liquefying passes through the pressure reducing valve to begin the cycle again.

The compressor (Fig. 47) is of special interest as it is one of the latest type made by Escher-Wyss. It is very compact, and is smooth and silent in operation. There is an outer and an inner working space. An eccentric cam (b) on rotating causes a suction and discharge alternately. The valve (d) is operated by two pawls, (c) locked by a nut (e) and the rotating of the shaft gives two chambers, one under vacuum, the other under pressure, while the spring-loaded valve (g) is set to the desired working conditions. The working of the unit is indicated by arrows. The casing, which is of stout construction, for silencing, is water-cooled.

The calorifier illustrated in Fig. 36 is made of steel 14 ft. 6 in. long, and 4 ft. 9 in. in diameter. It will be noted that 6 electric heating elements are set at an angle in the calorifier in two banks, one of 35 kW., the other of 30 kW. for topping-up, when necessary. These units are operated by means of an immersionstat set to a pre-determined temperature. The elements are set at an angle for ease of fitting and inspection. The secondary flow of the heating water is through 36 heat transfer coils of $4\frac{1}{2}$ in. diameter shown in section in Fig. 36. This acts as a reservoir of 2,400,000 B.Th.U.s/hr.

The Setting

The temperature setting of the Heat Pump is regulated automatically by means of a thermostat connected up to a motorised mixing valve with immersion bulbs in the heating water flow. If the temperature falls, the Heat Pump is automatically brought into action. If the heating load is too great for the Heat Pump the thermal storage is brought into operation by means of the mixing valve, and if after a period the load is still too great, the heating elements top up the heating load, cutting out automatically when the desired heating flow temperature is obtained. As the heat load

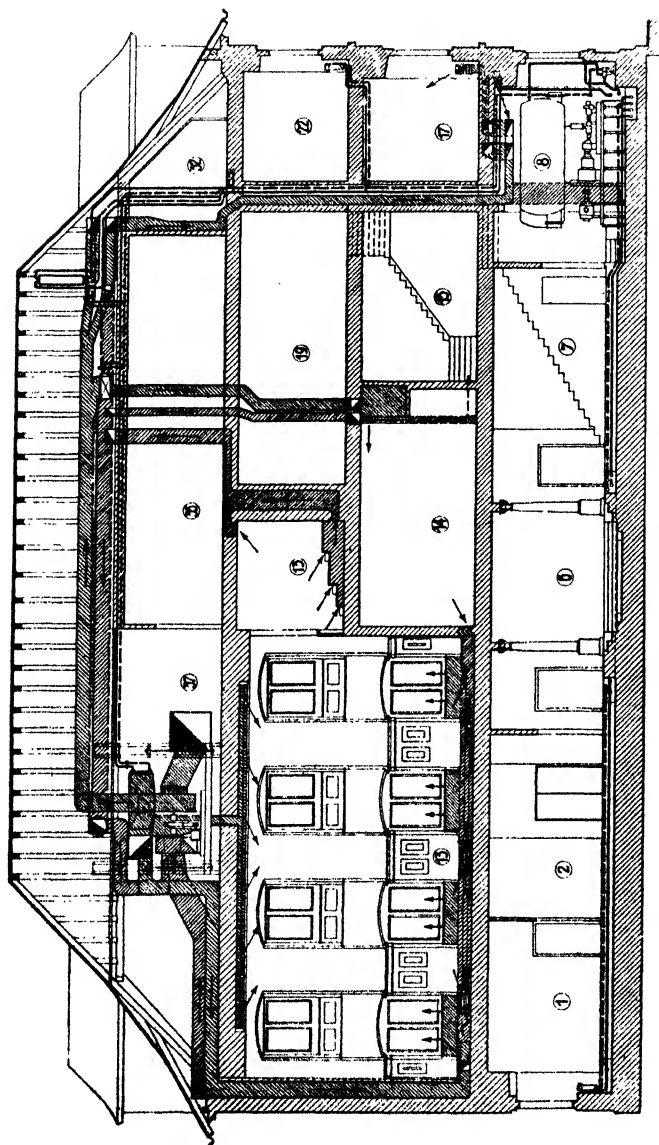

Fig. 43.—A section showing the trunking for fresh air and exhaust

THE HEAT PUMP

falls the process is reversed, when the thermal storage may be all that is necessary, or as rooms fall out of use the thermal storage can be made up by the Heat Pump.

The two heating elements act separately with the Heat Pump to prevent overloading, but as one unit, if the action of the Heat Pump

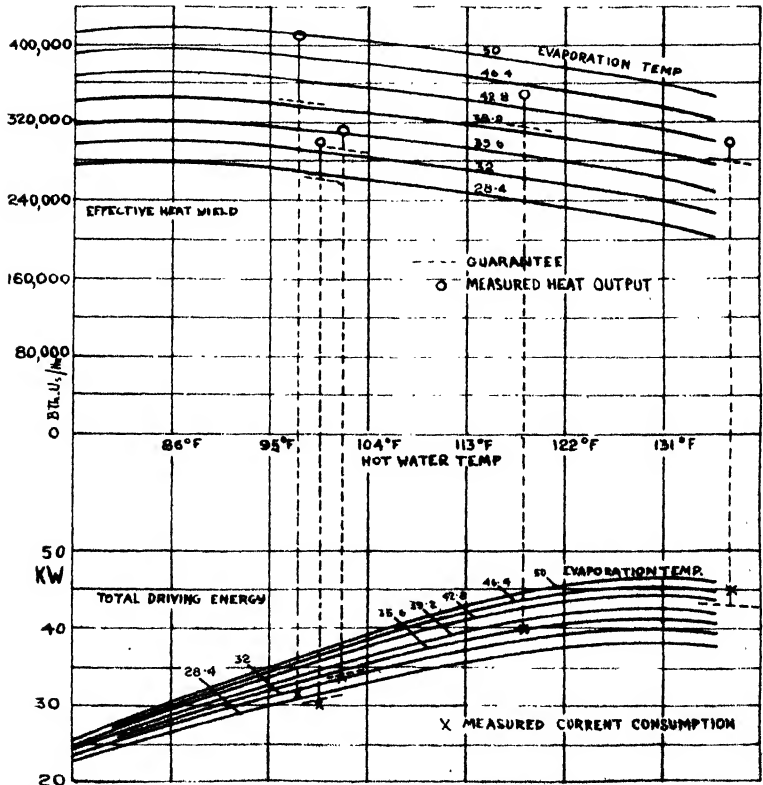

Fig. 44.—The guaranteed output and the measured output on site

and one unit cannot carry the peak heating load or if the Heat Pump is cut out, then both banks act as one heating unit.

In a unit such as this, it is important to obtain accurate working data from the plant so that errors or faults can be rectified and so

PRACTICAL APPLICATION

that comparisons of costs can be obtained. Since this was the first large Heat Pump plant in operation, it was necessary that running costs should be carefully tabulated.

The most important factor was that of efficiency ; to obtain the heat output in B.Th.U.s against the kW. consumption of mechanical energy to thermal and direct electric topping-up by means of the immersion heaters.

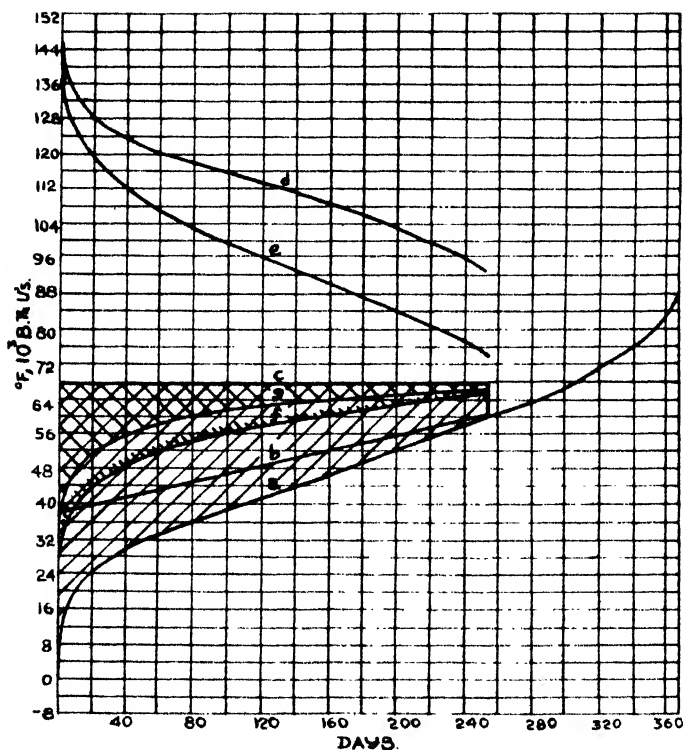

Fig. 45.—The load plotted against the days

When the plant had been in operation for a complete heating season, independent readings were taken by Dr. Eichelberger on the instructions of the Chief Engineer of the Cantonal "Hochbauamt," and the results are tabulated in Table 5. The cycle of operations is shown diagrammatically in Fig. 35. The initial cycle, that of

THE HEAT PUMP

the River Limmat water in heat quantity, is given as Q_1 , and was obtained by a temperature reading as the water passed through a water meter to the evaporator, and then on leaving the evaporator to return to the river. W_1 is the quantity of water as given by the meter reading. In the refrigerant cycle the pressure p_v and the temperature t_v on the suction side of the compressor and p_k and t_k on the discharge pressure side were taken. In the heating

TABLE 5*

		1	2	3	4	5
Limmat-water Cycle.						
Entry-temp.	tL1 °C.	9.3	9.4	9.5	9.8	9.8
Exit-temp.	tL2 °C.	7.65	7.1	6.5	6.55	6.84
Water Quantity	WL m ³ /h	22.1	22.38	22.38	14.09	12.0
Heat Quantity	QL kal/h	36600	51000	66300	46000	(36500)
Condensator-water Cycle.						
Entry-temp.	tK1 °C.	52.74	42.32	30.22	33.9	33.2
Exit-temp.	tK2 °C.	57.47	47.7	36.58	38.8	37.8
Water Quantity	WK m ³ /h	15.8	15.95	15.85	15.88	16.2
Heat Quantity	QK kal/h	74700	85700	100200	77500	74500
Heat Water Cycle.						
Entry-temp.	tH1 °C.	51.7	39.62	29.5	32.28	32.22
Exit-temp.	tH2 °C.	57.17	48.06	36.76	38.55	38.23
Water Quantity	WH m ³ /h	13.32	10.0	14.62	11.8	11.9
Heat Quantity	QH kal/h	72400	84400	106000	74000	71500
Freon-Cycle.						
Evapor. Press	p_v , atue	2.05	2.49	2.21	2.0	1,815
Evapor. Temp.	t_v , °C.	3.0	1.61	0.5	-3.2	-5.0
Condens. Press.	p_k , atue	15.70	12.73	10.0	10.19	9.9
Condens. Temp.	t_k , °C.	102.5	84.6	76	60	56.3
Working effect	L, kW	47.67	42.78	36.96	36.11	34.99
Heat-equiv.	AL, kal/h	36500	32900	28500	27800	27000
Heat-result	Q K					
	L, kWh	1570	2000	2720	2145	2130
Effect-number	Qk					
	AL	1.81	2.32	3.16	2.49	2.47

* This table is given exactly as compiled by Dr. Eichelberger.

water circuit the quantity of heat QH was determined by means of a meter on the flow WK and a temperature recording of the water T_{t_1} before and T_{t_2} after condensation of the refrigerant. The meter recording the quantity of water was a tested and sealed instrument.

The temperatures tH_1 and tH_2 (readings taken on the flow and return of the hot water calorifier) were also recorded, but the heating

water circuit meter readings were only taken for the purpose of checking the quantity of water circulated to give the necessary heat transfer. The electric consumption was taken from the electric meters installed, readings having been taken before the tests were carried out.

The Heating Season

As the heating season was well advanced when the tests were carried out, severe outdoor temperatures did not occur, but heavy loading was artificially obtained by throttling the T_1 water cycle from the River Limmat, and reducing the temperature of the T_1

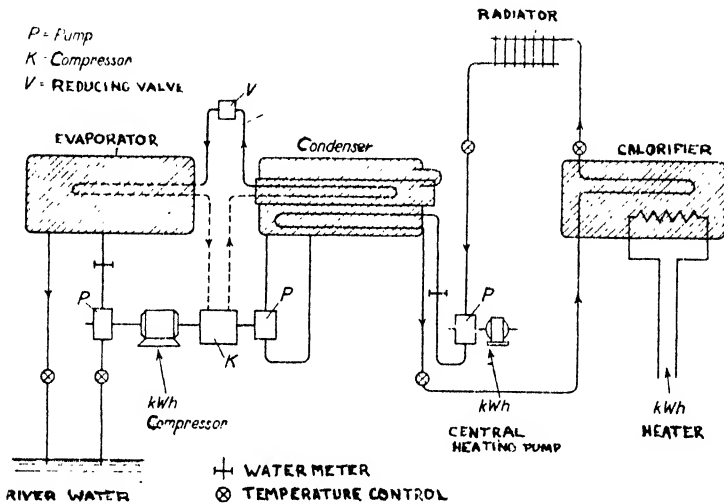

Fig. 46

water. By this means the primary water cycle from the River Limmat was reduced to 36.95° F., but at this low temperature on the discharge from the evaporator, the discharge pipe iced up. It should be noted that the River Limmat seldom drops in temperature below 37.5° F. This low temperature was obtained in the winter of 1939/40 and 1946/47, when it was found after the melting of the ice on the Lake of Zurich, the River Limmat's temperature was 35.6° F. at its lowest reading. The pump functioned at this temperature with short stops due to freezing when the Heat Pump cut out automatically and the T_1 circuit then thawed out automatically.

THE HEAT PUMP

This is carried out by means of the safety thermostat, while the heating is topped-up by means of the thermal storage, and if necessary the 65 kW. heater elements. Fig. 49 shows a steam efficiency comparison¹.

The effective working temperature of the Heat Pump can be obtained from the tables. The topping-up maximum was 6,280 B.Th.U.s/kWh., and the corresponding Heat Pump input was

TABLE 6
FEBRUARY, 1939

Day	Power consumption KWh			Heat-product × 40° B.T.U.s			Heat- yield Pump plus Reservoir B.T.U.s/kWh.	
	Heat- Pump	Reser- voir	Total	Heat- Pump	Reser- voir	Total		
Wednesday	1	695	—	695	1304	—	1304	7504
Thursday	2	528	93	621	1385	80	1465	9436
Friday	3	697	—	697	1440	—	1440	8268
Saturday	4	680	—	680	1335	—	1335	7860
Sunday	5	630	—	630	1235	—	1235	7840
Monday	6	723	—	723	1444	—	1444	7992
Tuesday	7	387	955	1342	776	821	1597	4760
Wednesday	8	325	1000	1325	315	680	1175	3548
Thursday	9	245	400	645	504	344	848	5256
Friday	10	465	—	465	987	—	987	8488
Saturday	11	365	—	365	1040	—	1040	11396
Sunday	12	575	—	575	1157	—	1157	8048
Monday	13	548	—	548	1108	—	1108	8084
Tuesday	14	383	1230	1613	729	1057	1786	4428
Wednesday	15	609	575	1184	1034	494	1528	5160
Thursday	16	230	400	630	261	344	605	3840
Friday	17	450	8	458	859	6	865	7552
Saturday	18	375	977	1352	765	840	1605	4748
Sunday	19	420	383	803	745	329	1074	5348
Monday	20	488	63	551	642	54	696	5332
Tuesday	21	582	—	582	1013	—	1013	6960
Wednesday	22	565	—	565	1046	—	1046	7404
Thursday	23	420	—	420	801	—	801	7884
Friday	24	395	—	395	732	—	732	7412
Saturday	25	510	—	510	935	—	935	7332
Sunday	26	508	532	1040	1140	457	1597	6140
Monday	27	432	7	439	753	6	759	6912
Tuesday	28	525	—	525	1028	—	1028	7832

296,000 B.Th.U.s/hr. Fig. 44 shows the tabulated results compared with the estimated output as guaranteed by the makers before the plant was installed, and the results after installation. Evaporation temperatures lie between 90° F. below the T₁ temperatures and the condensing temperature of 9° F. above the heating water temperature. The difference between the evaporator temperature

PRACTICAL APPLICATION

of the Freon and the river water varies according to results between 10.8° F. and 26.1° F. This deviation from the recorded values compared with that estimated is explained by the fact that Freon as the refrigerant was chosen after the estimates had been given. Further, an additional 10 per cent. heat load was added after the plant had been designed and manufactured.

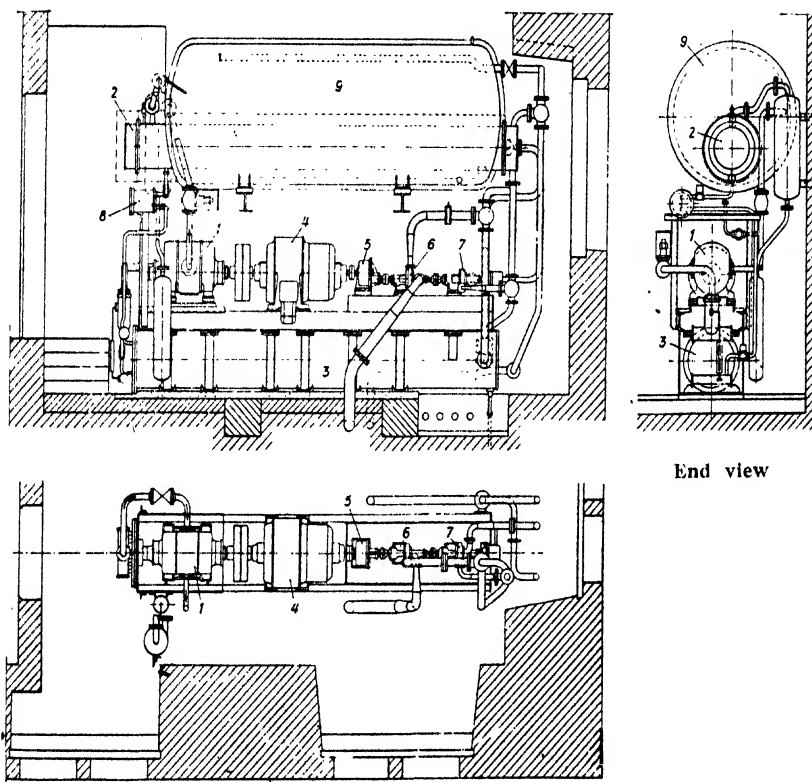

Fig. 46a. -Plan and elevation of the unit

In the lower part of the diagram recordings of the condenser are also given. The curve is drawn to a 3.5° F. difference in the evaporator. The recording in the upper part of the diagram shows that the guaranteed figures were exceeded except with an evaporator temperature of 144.5° F. (which did not occur more than once) in spite of the fact that the heat transfer surfaces in both evaporator

and condenser were not sufficient in view of the added 10 per cent heat load. This satisfactory test recording shows clearly that this Heat Pump installation was a complete success despite the initial difficulties. Fig. 46 shows diagrammatically the lay-out of the Heat Pump which has just been described and in order to get indisputable evidence of the Zurich Town Hall Heat Pump installation, the "Hochbauamt" of the Canton Zurich as the clients, the Electricity Supply Co. of Zurich as the suppliers of current, and the "Schweizerische Electrotechnische Verein," who were specially interested in this problem, agreed to set up permanent recording equipment during the entire heating season, and took steps to obtain permanent records, not only as outlined, but flow and return recordings on the Limmat water cycle, that of the refrigerant cycle, and the heating water cycle together with outside air temperatures at ground and water level.

For this purpose thermo-couples were used which could be checked on all measuring places through liquid-thermometers. As the maximum difference of the temperatures of the Limmat water was supposed to be 37.5° F. and that of central heating water 42.8° F., thermo-couples were chosen for the measure of the difference of temperature with ten copper elements connected in series whose soldered edges were placed in melting ice.

As the Venturi used for the measure of the Limmat water could, for various reasons, only be applied at an unsuitable place, little use of the results could be made because air movement reduced the transverse action. But as the quantity of the Limmat water supply was constant and without interruption, this was taken as a constant. The heating water-quantity which varied greatly and was measured by means of a Venturi and whose curve was drawn by a recording-instrument, was permanently checked by liquid-manometers. Besides the consumption of power of the driving motor in connection with the compressors, Limmat water and heating-water circulating-pump, also that of the central-heating circulating-pump, was measured, but the latter turned out to be comparatively small.

The Recordings

When the measurements were worked out, including the outdoor-air and the Limmat water temperatures, also the make-up heat

PRACTICAL APPLICATION

quantities of the thermal-storage and of the Heat Pump and the corresponding driving power were also measured, to complete the record.

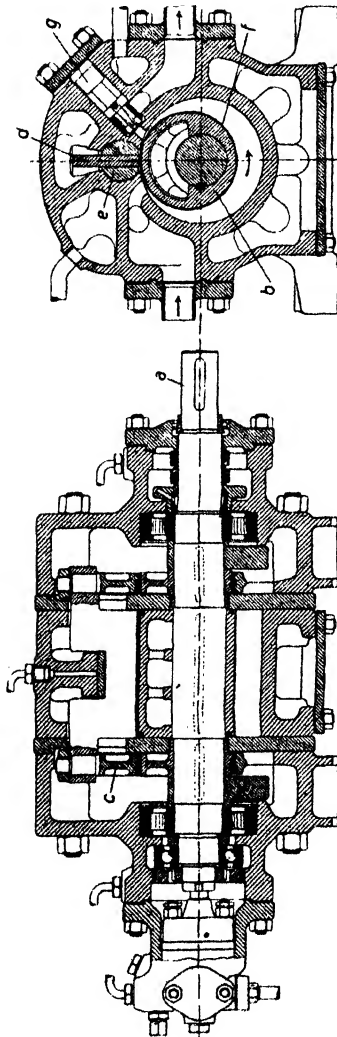

Fig. 47. Ro Compi

The figure which is generally quoted as the output of heat is the quotient between the produced heat-quantity B.Th.U.s/hr., and the work expended in kWh.

THE HEAT PUMP

Fig. 50 gives the heating diagram of the heating season 1938/39.

Table 7 gives the results of the tests for the entire heating season which add to the average value of 7360 B.Th.U.s/kWh., referred to as the efficiency of the Heat Pump is greater than the T_1 and T_2 difference, while a greater output is obtained in practice from the plant being kept in continuous service.

TABLE 7

RESULTS OF THE LOAD FOR THE HEATING SEASON 1938/39

Month Heat period 1938/39	Consumption of power		Reserv. kWh.	Revolving pump of centr. heating kWh.	Heat prod. Heat Pump × 40 B.T.U.	Heat prod. Heat Pump pro. each kWh. of compr. B.T.U.s/kWh.
	Recorded days	Com- pressor kWh.				
Oct.	8	2045	3024	26.5	4246	8260
Nov.	29	10170	7371	204	17688	6960
Dec.	30	13010	26875	211.5	21464	6600
Jan.	31	14500	14272	217	27615	7620
Feb.	28	13755	6623	193.5	26513	7712
Mar.	31	16915	1005	209	31426	7432
April	25	4900	5650	311	9050	7384
May	22	3609			7148	7920
June	2	71	0	2.5	130	7832
Total ...	206	78975	64820	1375	145289	—
Average Value	1	383	315	6.74	706	7360

The comparison with a fully-automatic oil-fired plant, as had at first been planned, would have exceeded the Heat Pump by 70 per cent. The comparative Heat Pump loading has also been tabulated in Table 6. The total heating load for the heating season was 580×10^6 B.Th.U. The electric consumption during this period was 268×10^6 B.Th.U.s, while the heat extracted from the River Limmat during this period was 376×10^6 B.Th.U.s, giving in all 644×10^6 B.Th.U.s. From these figures the efficiency of the Heat Pump is obtained.

$$\eta = \frac{580}{161} = 0.9 = 90\%$$

Therefore the heat output which determined the current supply

$$\text{charge was } 7.360 \frac{0.9}{0.7} = 9,460 \text{ B.Th.U.s/kWh.}$$

PRACTICAL APPLICATION

which compares favourably with the estimated loading of 9,440 B.Th.U.s/kWh.

In Fig. 50 is shown the output in heat of the Heat Pump together with the thermal storage make-up. Below on the same diagram

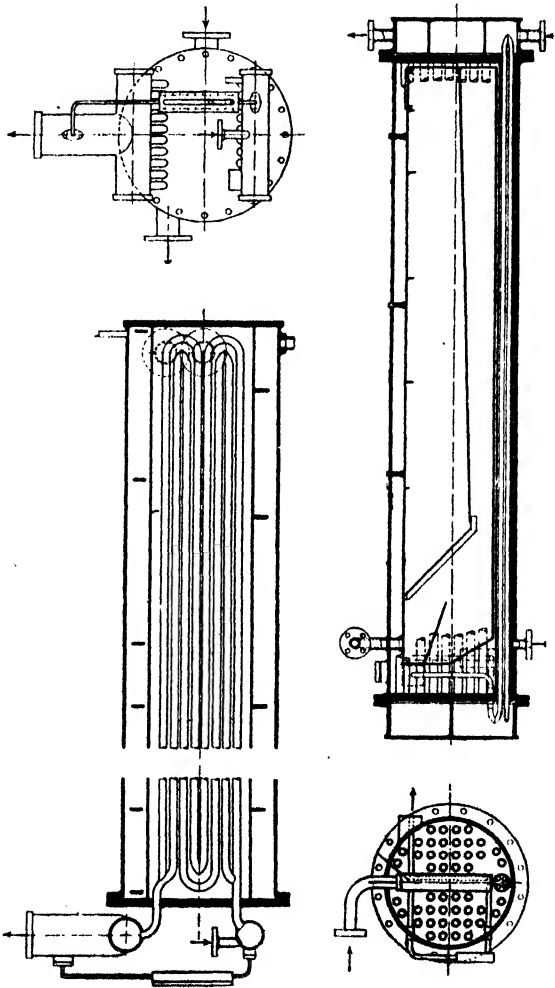

Fig. 48.—Evaporator showing tubes and shell

is given the corresponding outside temperature, together with the River Limmat temperatures during the first heating season 1938/39.

When the thermal storage reservoir make-up is in operation the Heat Pump output drops. The reason for this was due to faulty erection of the mixing make-up from the thermal storage which was rectified before the following heating season.

Small Make-up

It will be noticed that when the Heat Pump was running constantly little thermal make-up was required as was the case during the second part of the heating season. When the Heat Pump was undergoing repairs the immersion heaters and the thermal reservoir had to take the entire load for a short period during the day-time

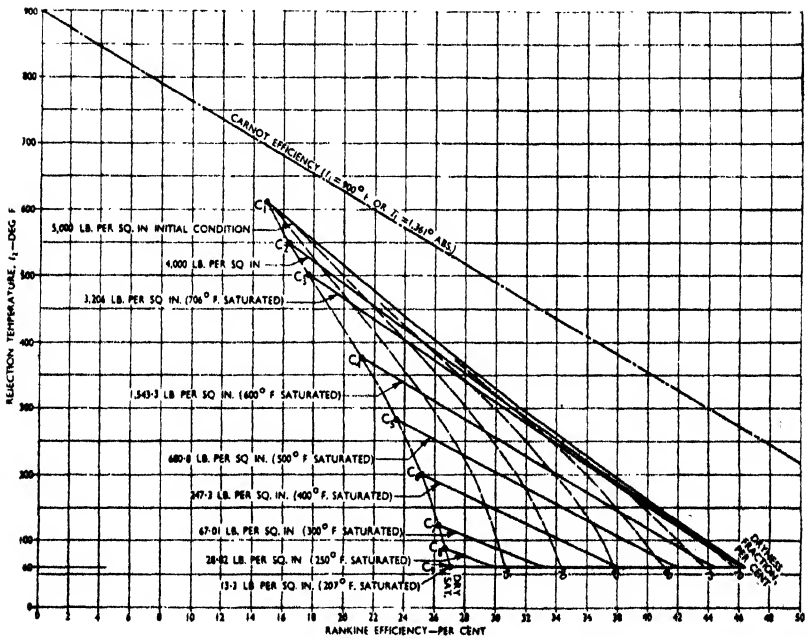

Fig. 49.—Steam efficiency chart

in April and May, but the Heat Pump was not out of service for any length of time, as can be seen from Fig. 44. The output of the Heat Pump with the thermal storage was able to take the heating load of the Police Station during the night and day when servicing of the unit was being carried out.

PRACTICAL APPLICATION

The Heat Pump installation has more than paid for the capital outlay, and has been of invaluable assistance to the Swiss during and since the second World War. The cost of coal to Switzerland pre-1939 was about 100 million francs, and, due to the post-war increase of costs is now 1½ million. The entire heating load for Switzerland is approximately 15×10^9 kWh., which is available in Switzerland if utilised by means of the Heat Pump. Capital costs,

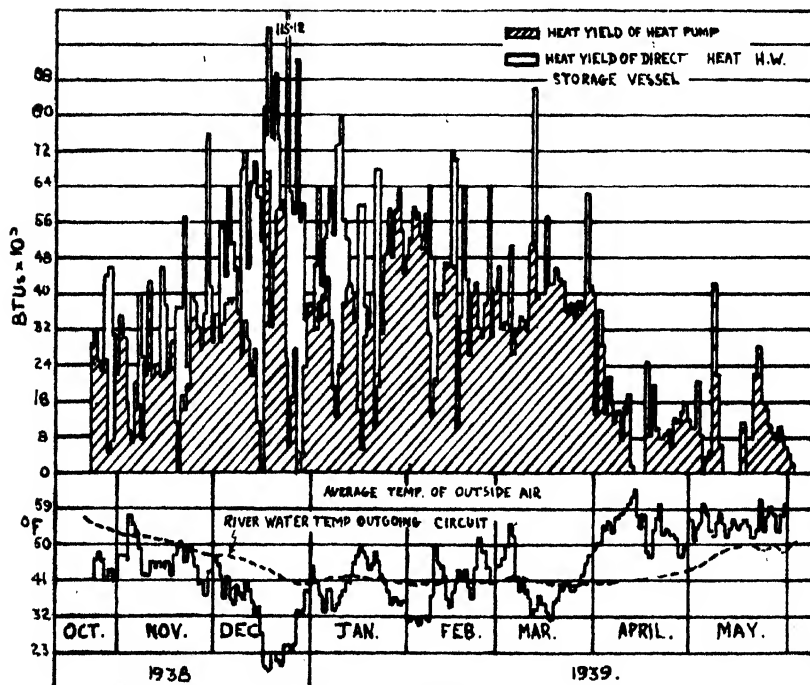

Fig. 50

if taken over a period of ten years, should write off the initial cost of the installation and the costs of servicing are infinitesimal. It should be noted that this installation has been in operation for eight years, and much valuable data has been collected, while the plant has had additions and improvements since the official tests were run, so that figures which are estimated for a Heat Pump on this design can easily be obtained in practice. The estimated figures in this case were given by the makers as 7,440 B.Th.U.s/kWh., with

a heat output of 0,460 B.Th.U.s/kWh., and these were exceeded in practice.

The possibilities of employing Heat Pumps can best be illustrated by means of a few examples (Figs. 39 and 40, and Table 8), in which the temperature changes of open air and source of heat applying in Zurich have been taken as a basis for calculation. The upper section of Fig. 39 shows the frequencies of given temperatures.

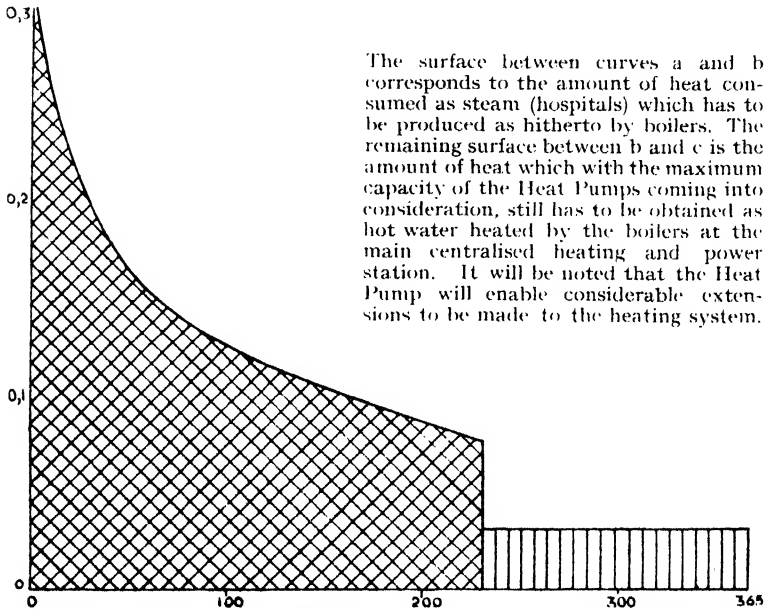

Fig. 51a.—Diagram showing heat production before setting to work the additional Heat Pump Station of the centralised heating and power plant of the Swiss Federal Institute of Technology, Zurich

Ordinates: Daily heat demand in 40° B.Th.U.s.
 Abscissa: Number of days per year.

Point F, for example, indicates that there are 110 days on which the average day temperature lies below 39.2° F. Point G, which marks the heating limit, indicates that in Zurich there are 198 days with average day temperatures below 50° F. We must thus heat on 198 days, while only on 40 days does the heat output required exceed half of the maximum heat output. The obliquely shaded strip just above point F, of height dz and of length $t_1 - t_2$, denotes the quantity of heat which, in the conditions given, flows away into the open air

during the time dz and must be replaced by heating. The whole area between the frequency curve of the open air temperatures and the verticals through t_1 , accordingly provides a measure of the warmth required for each heating season, while the rectangle enclosed by the verticals at $t_a = -4^\circ \text{F.}$ and at $t_1 = +64.4^\circ \text{F.}$ represents the quantity of heat which could be given off by the heating system working at constant full capacity. The proportion of the two heat areas in the case of Zurich, for instance, is 0.216, which means

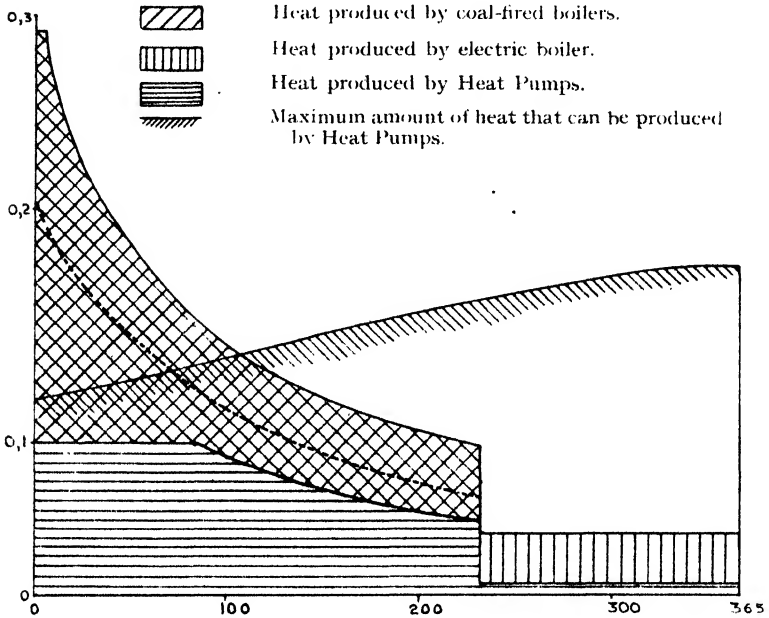

Fig. 51b.- Diagram showing heat production after setting to work the additional Heat Pump Station

Ordinates: Daily heat demand is 40^9 B.Th.U.s.

Abscisse: Number of days per year.

that when the heating system is constructed for an open air temperature of -4°F. only 21.6 per cent. of its heating power is utilised.

The Costs

In view of the high initial costs of Heat Pumps, this low degree of utilisation is unfavourable. Conditions can be very noticeably improved if the Heat Pump is constructed for about half this performance, the peak periods of heat requirement, especially on

THE HEAT PUMP

cold days, being covered by a supplementary thermal plant. In Fig. 39 the heating limit of the Heat Pump has been taken for an open air temperature of -33.8° F., i.e., midway between the room

TABLE 8
Increased Economic Efficiency of Heat Pump Heating Systems by Combination with Ordinary Heating, Air Heaters and Utilisation of Waste Water

Heating Plant	Highest Heating Water Temperature	Degree of Utilisation		Full load Figures ¹		Quantities of Heat ² produced by		Parity Price relation ³	
		Entire Heating System	Heat Pump	Heat Pump	Supp. Heating	Heat Pump	Supp. Heating	Per- form- ance	1 kg. coal
Figures 1kWh.									
Radiation Heating Heat Pump alone	50	21.7	21.7	100%	0	100%	0	4.7	0.81
Heat Pump with supplementary heating system	50	21.7	41	50%	50%	95.3%	4.7%	4.75	0.82
Central Heating usual heating water temp.	90	21.7	33.5	45%	100%	72%	28%	3.1	0.54
low heating water temp. ⁴	70	21.7	32	67%	75%	99%	1%	3.6	0.62
Factory heating peak periods covered by air heater	80	14.5	25	57%	43%	98.5%	1.5%	3.2	0.55
Hot water Supplies with Heat Pump alone	50	mostly throughout the year		100	0	100	0	4.3	0.74
with supplementary heating	80			50	50	50	50	4.3	0.74

¹ in % of the full maximum heating performance at -20° C. open-air temperature;

² in % of the total heat requirements for the year;

³ indicates price relation at which the costs of heating by coal and Heat Pump are equal;

⁴ With extensive or enlarged heating surfaces.

≡ Heat Pump.

||| Supplementary heating system.

temperature ($+64.4^{\circ}$ F.) and the lowest open air temperature (-4° F.). It can now be seen from a comparison of the areas that the degree to which the Heat Pump can be utilised for heating works out at a much more favourable figure. It is in fact about 41 per

cent. The supplementary heating system must only cover the quantity of heat represented by the small vertical hatched area, which amounts only to 4.7 per cent. of the total heat output. The supplementary heating system is thus very rarely employed and can be of very simple construction. It is not necessary here to take any need for high efficiency into account.

The predetermining of the energy requirement to a sufficient degree of accuracy now becomes a question of the greatest interest. It is not possible in doing this to limit the calculations to specific working conditions, and above all it is not possible—as has often been done—to limit them to maximum feed temperature and minimum temperature of the source of heat. The requirement is much rather a complete calculation of a whole heating period on the basis of the known range of open-air temperatures and the temperature of the source of heat. The calculations necessary are extensive, since both the temperatures of the heating water and those of the heat source are subject to considerable variations, and the simplified calculation according to temperature frequencies which is customary in technical heating questions cannot be applied here.

The Norwich Heat Pump

Few Heat Pump installations have excited as much interest as that at Norwich, which has been described in varying detail from time to time over the three years of its life, but the installation has been greatly improved during the past heating season and much of the following detail is taken from the Paper read by J. A. Sumner.¹

So far as is known, no large commercial Heat Pump designed purely for building heating and utilising low-grade heat from natural sources had been constructed in this country until 1945, when the Norwich Heat Pump described was installed. It initiated a long-term experiment which was carried out on a larger scale than the previous experiments by Haldane. The results of heating a large building by means of the Norwich experimental machine are given, together with some details of the capital and running costs incurred. For the sake of completeness, a brief account of the principle of the Heat Pump is included, and suggestions regarding the future of the Heat Pump are made.

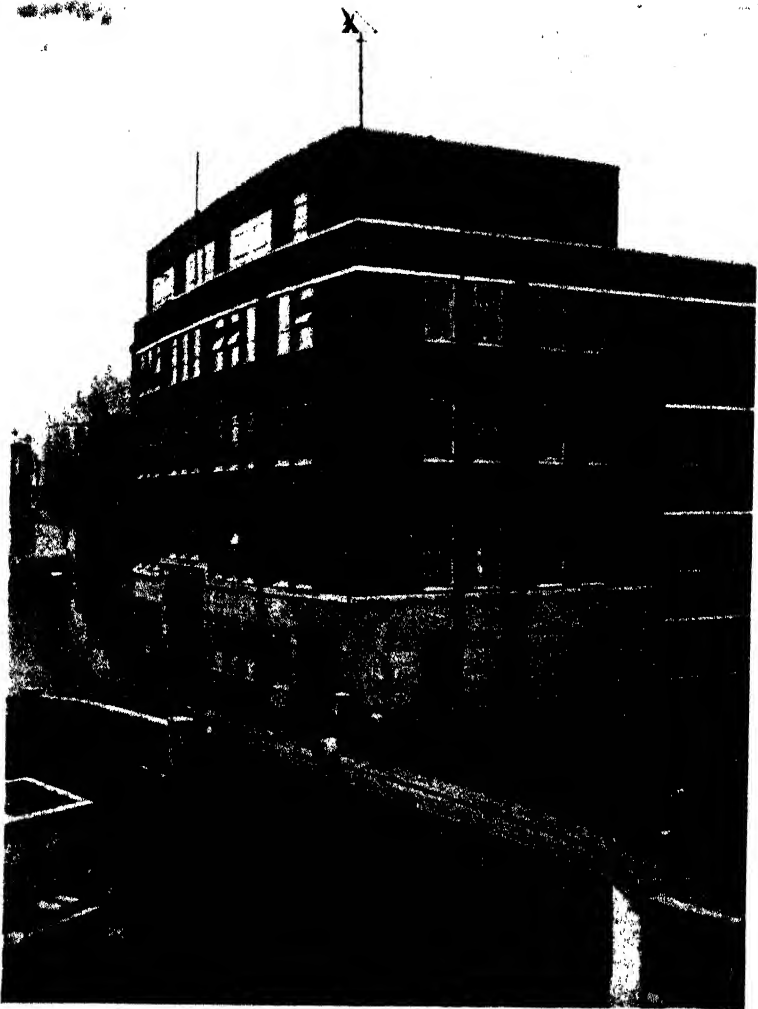

Fig. 52.—The building at Norwich, which is 250 ft. long by 90 ft. wide on four floors and a sub-basement. The River Wensum is in the foreground

It is not desired to imply that the apparatus described herein, represents an example of high efficiency—the nature of the materials and plant available preclude it from being more than a relatively inefficient pump, constructed as a pioneer effort for practical use and experimental purposes. But it is hoped that the presentation

of such factual data (probably the first of such data to be made available in respect of Heat Pump operation in Great Britain) will provide a more reliable guide to the practicability and economy of use of the Heat Pump, than the more hypothetical facts hitherto presented, which have been based upon conditions in other countries.

Limits

The Heat Pump is a refrigerating plant designed and constructed to work within limits of pressure and temperature, greater than those required for refrigerating purposes (the gas temperatures range from 30 deg. F. for T_2 to 200 deg. F. for T_1 , as compared with 85 deg. F. for T_1 in the normal refrigerator). The main difference between a refrigerator and Heat Pump is that, whereas the former is used to extract heat from a body of air, or a substance in a cold room or chamber, which heat is normally discharged to waste, the Heat Pump extracts heat either from atmospheric air or from a supply of low-temperature water, such as a river or lake, and this heat, which is normally at too low a temperature to be useful is then raised to a higher temperature by the compressor. The heat at this higher temperature is used for the purpose of heating the building.

Advantages

The advantage of the Heat Pump is that the heat put into the building may be three or more times the heat equivalent of the mechanical power required to operate the plant. The heat output really comes from two sources :--

(a) The low-grade heat supply (atmospheric air, river, well, or lake water, or mains water, or from the earth) ; and

(b) The energy supplied to drive the plant (electrical, steam, Diesel engine, or water power).

In a particular case, e.g., for every 4 units of heat given out, approximately 3 units will be picked up from source (a), where it is usually available at no cost, and rather less than 1 unit is introduced as mechanical or electrical energy from source (b), which normally must be paid for.

The ratio $\frac{\text{Heat output}}{\text{Energy input}}$, i.e., the

ratio $\frac{\text{Sources (a) plus (b)}}{\text{Source (b)}}$ is usually

described as the coefficient of performance of the plant; a more suitable term used is suggested namely, "reciprocal thermal efficiency."

Essentially, the Heat Pump comprises a cooler (evaporator) and heater (condenser), together with a compressor and an expansion valve as shown diagrammatically in Fig. 53.

In the closed circuit ACBD, a liquid "refrigerant" circulates; this may be ammonia, sulphur dioxide, or "Freon," etc. The compressor C reduces the pressure in the evaporator A to a level at which the liquid boils, the refrigerant chosen being one which will boil at a low temperature, e.g., sulphur dioxide will boil at 30 deg. F. under a pressure of 22 lb. per sq. in. abs. In boiling, the latent heat of evaporation is taken from the low-temperature river water circulating in the tubes and is transferred to the refrigerant. The resulting sulphur dioxide vapour containing the low-temperature heat thus abstracted from the river is then compressed to a higher pressure, causing its temperature to rise, i.e., the low-temperature heat abstracted from the river water is now raised to a more useful high temperature. The hot vapour passes through the tubes of the condenser, condenses to a liquid, and so gives out to the building heating water, which is circulated round the tubes, its latent heat of condensation. The resulting liquid then passes through the expansion valve D (where its pressure is reduced) into the evaporator, and the cycle of operations is repeated.

Thermodynamic Considerations

A brief outline of the thermodynamic theory of the heat engine (producing work) and of the Heat Pump is given here, in order to explain the terms used throughout.

Kelvin's Theory

In 1851, Kelvin stated that if a heat engine has an *absolute* inlet temperature T_1 and an exhaust of refrigerator *absolute* temperature T_2 , "the efficiency of a perfect heat engine is expressed by the ratio of the difference of the absolute temperatures of the source and

condenser to the absolute temperature of the source." Thus, for an ideal engine working directly so as to degrade heat and thus produce work, we have the well-known expression

Thermal efficiency

$$E = \frac{\text{Work produced}}{\text{Heat taken in at high temperature}} = \frac{T_1 - T_2}{T_1}$$

e.g., assuming working terminal temperatures $T_1 = 180$ deg. F. (640 deg. F. abs.), and $T_2 = 80$ deg. F. (540 deg. F. abs.),

$$E = \frac{640 - 540}{640} = 0.156, \text{ or } 15.6 \text{ per cent.} \quad \dots \quad (1)$$

This means that, of the total heat energy originally available, 15.6 per cent. has been converted into mechanical work, and 84.4 per cent. has been rejected.

What happens if the cycle of operations of the above heat engine is reversed, so that, instead of supplying heat at high temperature and rejecting the residue at low temperature after work has been done, we take in heat at low temperature, do work on it, and thereby complete the cycle so as to obtain heat at a higher temperature? Obviously, if such an exactly reversed cycle of operations can be performed, the reciprocal of the above expression will be obtained, i.e. (for the ideal engine)

$$\begin{aligned} \frac{1}{E} &= \frac{\text{Heat produced (at high temperature)}}{\text{Work expended}} \\ &= \frac{T_1}{T_1 - T_2} = \frac{640}{640 - 540} \\ &= 6.4 \left(\text{i.e. } \frac{1}{0.156} \right) \text{ or } 640 \text{ per cent.} \quad \dots \quad (2) \end{aligned}$$

This would mean that a quantity of heat has been taken in and raised from a low temperature so as to be delivered at a higher temperature, the heat delivered being 6.4 times greater than the heat equivalent of the mechanical or electrical energy expended to

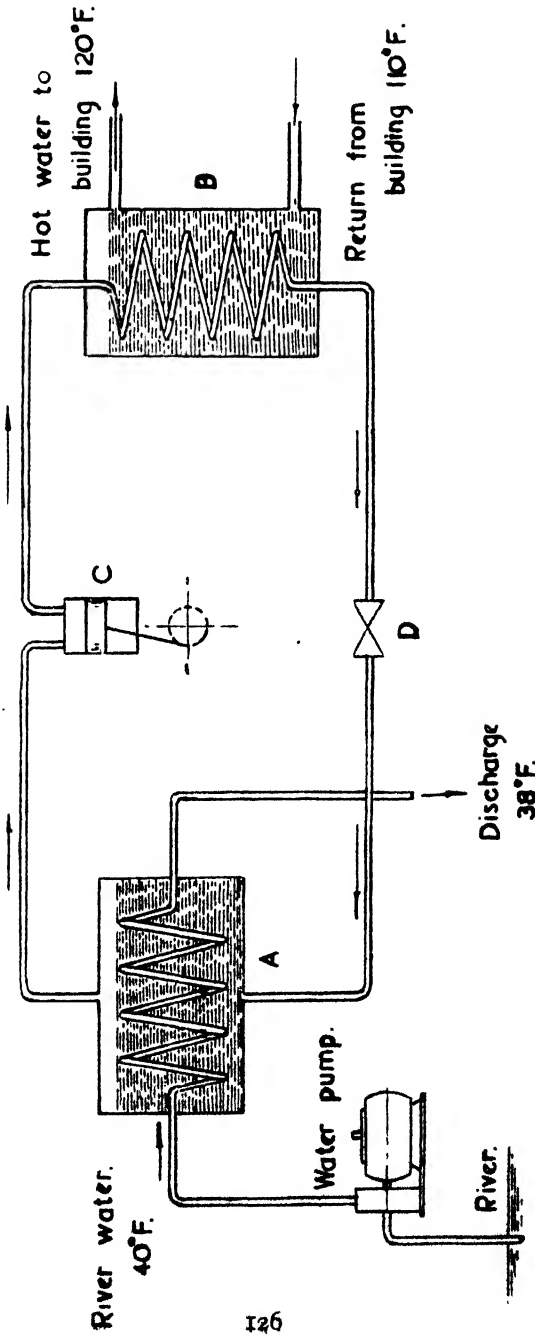

Fig. 53.—Essential elements of a Heat Pump installation shown diagrammatically

carry out the operation. It will be noted that heat has not been "created." Almost the same quantity of heat that has been delivered at a high and commercially useful temperature was available originally at a low temperature which had no commercial value. The function of the Heat Pump and of the electrical or mechanical energy used to drive it, is merely to lift the temperature of available heat from the lower to the higher temperature.

It will be seen that the coefficient adopted for the Heat Pump operation is one designed to measure the ratio of high-temperature heat delivered to the work expended to carry out the operation. The coefficient is also seen to be the reciprocal of the expression used to ascertain the thermal efficiency of the direct heat engine.

It would seem to be important to differentiate between the operation of the refrigerator and that of the Heat Pump. Whilst in each case we are considering a Heat Pump as a pump driven by mechanical means, so as to pump up heat from a low to a high temperature, in the latter case the operation has been extended to a considerable degree. For a refrigerator we are concerned with abstracting heat from a substance so as to make it cold, and the most efficient refrigerator is therefore the one which *abstracts* the greatest amount of heat from the cold body for a given expenditure of mechanical work. The standard method of defining this ratio for the refrigerator is as follows:—

$$\frac{\text{Heat abstracted}}{\text{Work expended}} = \frac{T_2}{T_1 - T_2} \quad \text{Co-efficient of performance.}$$

But the most efficient Heat Pump designed to heat a building, for instance, will be the one which *delivers* the greatest amount of heat at high temperature, and the method of defining this ratio for the Heat Pump is as follows:—

$$\frac{\text{Heat delivered}}{\text{Work expended}} = \frac{T_1}{T_1 - T_2}$$

Thus, the expressions which define the most efficient machine— for a refrigerator and Heat Pump respectively—have entirely different meanings numerically and in their connotations. The Heat Pump cycle is, literally, the reversed operation of the cycle

used in the heat engine as defined by Kelvin, and the expression for their respective efficiencies of operation are reciprocal.

The Co-efficient of Performance

It is, therefore, suggested that the term "co-efficient of performance" should be restricted to the operation of the refrigerator.

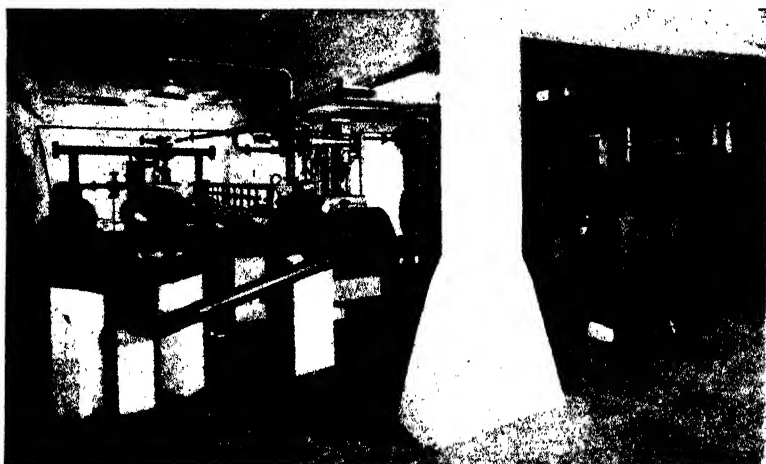

Fig. 54.— A view of the plant-room from the left of the evaporator, showing the condenser on the right of the column in the foreground

When considering the operation of the Heat Pump—which, ideally, is the reversed heat engine cycle—it is suggested that the term "Reciprocal Thermal Efficiency" should be used (see equations (1) and (2), and this term has been used throughout.

History of the Experiment

In 1940 the new workshops and offices of the Norwich Corporation Electricity Department were nearing completion, and it became necessary to decide upon the type of plant to be installed for heating the building. The central heating installation had already been erected, comprising a hot-water circulating system with radiators, panel heaters, and electric fan unit heaters. A specification for a Heat Pump was accordingly prepared and forwarded to each of the British manufacturers of refrigerating plant with a request that they should tender for the supply of a suitable Heat Pump installation.

No manufacturer was prepared to submit a tender, and the war situation undoubtedly influenced this decision.

Temporary Boilers

It was, therefore, decided temporarily to install modern coal-fired boilers, with accurate meters for measuring continuously the heat put into the building (and thereby the true combustion efficiency), next to make a long-term scientific test relating to the costs and other features associated with the coal-fired boilers, and subsequently to install a Heat Pump in place of the boilers, so that the true comparative costs of building heating by these various methods could be established. It was not until 1944-5 that the opportunity occurred of installing a Heat Pump in substitution for the boilers. Even then, it became necessary to construct this Heat Pump by using an old second-hand compressor and to manufacture the evaporator, compressor, and most of the other components from materials available in the distribution and power station stores.

The Norwich Heat Pump, therefore, has not the somewhat higher efficiency that would be associated with a specially constructed machine. It has, however, permitted accurate data to be established as to the relative costs of heating a large building by coal-fired boilers and by the Heat Pump respectively. Primarily it has been possible to demonstrate that normal British conditions are such as to permit even a relatively inefficient machine to operate satisfactorily for heating a building throughout a normal British winter, and to operate with considerable economy in fuel consumption.

The Building and the Heating System

The building is of the dimensions shown in Fig. 52. It is a steel and reinforced concrete frame building, brick filled, with very large window area. There is a hot-water central-heating system, comprising wall radiators, embedded panel heaters, and (originally) unit heaters with electric fans. The system was designed for a flow temperature of 180 deg. F. to 160 deg. F.

During the winter of 1940-1 experiments were carried out to ascertain the minimum flow temperature required to maintain a temperature of 62.5 deg. F. in the offices and 60 deg. F. in the work-

shops, on the coldest days. It was found that, provided the "unit" fan heaters were not used, the maximum flow temperature required was 130 deg. F. during the short periods of very low ambient temperatures, but that 120 deg. F. would suffice as a *maximum* flow temperature for the major part of the heating season. In view of the high maintenance costs, and the unduly high flow tempera-



Fig. 55.—The evaporator, left, with the old compressor and the condenser on the right, showing the lay-out of the plant

tures required, the unit heaters were, therefore, replaced by radiators.

From 1940 to 1945 the coal-fired boilers were used exclusively. In October, 1945, the Norwich Heat Pump was completed, and was put into use for the remainder of the heating season. The source of low-grade heat was that of the River Wensum, which is immediately adjacent to the building, and which has a minimum flow of 30,000,000 gallons per day.

Design and Construction

The design of the plant was somewhat prejudiced by the fact that at the time of its construction, materials and apparatus were

very difficult to obtain. In fact it only became possible to consider the experimental installation when a used compressor became available through the medium of a second-hand disposals list. This was purchased and put into service, although it had serious limitations for experimental purposes. In December, 1946, a new two-stage compressor was provided by the manufacturers of the less suitable second-hand machine, and showed a considerable improvement in performance. Special evaporators and condensers were also out of the question, and had to be made on site from such materials as were available. The only apparatus which was obtained from the refrigerator manufacturers was the automatic float valve and the safety valves.

First Compressor

The first compressor was second-hand, manufactured about twenty-five years ago by Messrs. Peter Brotherhood, Ltd. Single-stage double acting, bore 11 inches, stroke 9 inches, maximum speed 350 r.p.m. Designed for use with ammonia. Output when used for ice-making stated to be 16 tons per 24 hours.

Second Compressor

Single-crank, two-stage annulus compressor. Cylinder bore : first stage, 16 inches ; second stage, annulus 16 inches minus $13\frac{1}{2}$ inches. Stroke 9 inches. Speed 300 r.p.m.

Condenser

The condenser is of the shell and tube type, the shell being made of standard cast-iron water pipes of the flanged pattern. The necessary connections were made by using suitable T-pieces. There are three shells mounted one above the other, and each consists of two T-pieces with a straight section between them. At the extreme ends a tube plate is fitted, and standard brass turbine condenser tubes are jointed to the tubeplates by ferrules with metallic and fibre packings.

Since the cast-iron pipes were only safe up to pressures of 100 lb. per sq. in., it was arranged that the water from the building heating system would circulate between the shell and the tubes, whilst the gas circuit was within the brass tubes themselves. These tubes were capable of withstanding the high pressure of the compressed

vapour ; and the gas circuit at the ends of the shells was completed by fabricated boxes and bends.

Evaporator

The evaporator is of similar construction to the condenser, but the river water is arranged to circulate within the brass tubes, the refrigerant occupying the space between the tubes and the shell. This arrangement was possible since the gas pressures on the evaporator side are sufficiently low. The evaporator shells are pierced along their length to permit the insertion of spray nozzles through which the liquid refrigerant is pumped in the form of a fine atomised spray over the water tubes. The object of this was

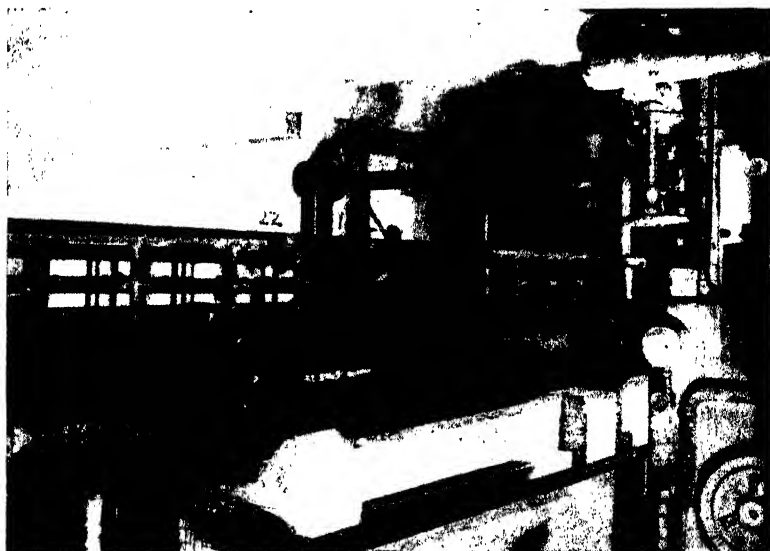

Fig. 56.- A close-up view of the evaporator. Note the sprays feeding the refrigerant over the banks of tubes through which the water circulates inside the main shell of the evaporator

chiefly to reduce the amount of refrigerant in the plant, but it was also thought that the use of sprays might assist evaporation.

Liquid Circulation Pump

Standard centrifugal type pump driven by 3 h.p. three-phase a.c. motor: This pump was fitted with a " packless " gland to make

it suitable for use with the refrigerant. The liquid receiver is of fabricated sheet steel.

Pipework and Valves

All the pipework for the refrigerant circuits was carried out in high-pressure mild steel tubing, and that for the water circuits in similar piping of suitable grade. Standard steam and water valves were used.

Automatic Float and Safety Valves

The automatic float valve is a standard ammonia type, incorporating a float chamber with a by-pass needle valve and the necessary isolating valves. The safety valves were of the spring-loaded type—commonly used on refrigerating plant.

Automatic Safety Devices

As it was intended to run the plant unattended for considerable periods, automatic safety devices arranged to trip the driving motor were devised and fitted. They gave protection against the following contingencies :—

- (1) Excessive pressure in condenser.
- (2) Displacement of belt on compressor flywheel.
- (3) Failure of river water circulating pump.
- (4) Excessively low pressure in evaporator.
- (5) Blockage of filters in river water circuit or blockage of evaporator tubes.

Choice of Refrigerant

The choice of refrigerant was largely governed by mechanical considerations and availability. The compressor bearings limited the permissible pressures to 200 lb. per sq. in.; consequently ammonia was out of the question for the output temperatures required. "Freon 12" was not obtainable, and finally it was decided to use sulphur dioxide. This refrigerant allowed the use of brass condenser tubes, which would not have been possible with ammonia.

Results of Operation

The results of operation during the winter of 1945-6 and 1946-7 are tabulated. During November, 1945, trouble developed due to

THE HEAT PUMP

solid bodies being drawn in from the river into the evaporator tubes, thus causing water restrictions and freezing within the tubes. The latter trouble was overcome by installing a gauze screen on the river water inlet pipe and by fitting a safety device which trips out the driving motor if the velocity of the river water in the tubes falls below a certain value. The cessation of operation in December, 1946, is due to the installation of the new compressor.

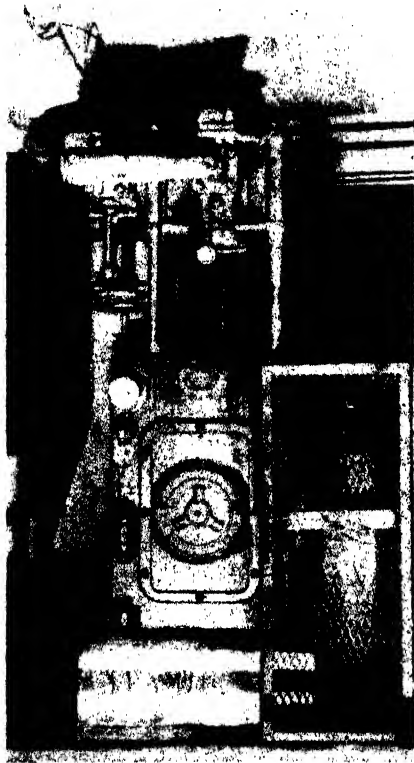

Fig. 57. The Peter Brotherhood compressor which was fitted to the plant in 1945

It will be seen, however, that the averaged seasonal efficiency obtained with the old compressor during the winter heating season 1945-6 is 3.45. The installation of the new compressor has resulted in a still greater efficiency of operation.

The results tend to show that the Heat Pump of the immediate future with design based upon experience, should be able to work in Great Britain at an average seasonal efficiency of the order of 4, with water and ambient air conditions as for the Norwich experiment.

Comparative Costs of Building Heating

It has been mentioned that the Norwich experiment embodied a careful scientific study of the costs of heating a given building (Fig. 52) by means of coal-fired boilers and a Heat Pump respectively. Expenditure to provide thermal storage can usually be fully justified when the Heat Pump is electrically driven, so as to obtain the benefit of off-peak charges. The following tables allow for the introduction of thermal storage so as to illustrate this point.

Annual Operating Data for Comparison :-

Heat supplied to building during heating season	20,000 therms
Peak heat demand	8 "
Average heating demand	5 "
Calorific value of coal ($\frac{1}{2}$ -inch washed nuts)... ..	12,000 B.Th.U.s per lb.

Price of coal per ton, 65s. 0d.

Cost of electricity :-

For loads on peak	£4 per kVA., plus 0.6d. per kW.-hour.
For loads off peak	0.6d. per kW.-hour.
Average thermal efficiency of combustion	5.5 per cent.
Average seasonal cost of attendance, removing ashes, filling hoppers, etc., on coal-fired boilers	£230
Average annual cost of maintenance and repair of coal-fired boilers	£150
Capital cost of coal-fired boilers	£1,500
Capital cost of Heat Pump	£3,000
Additional cost of Thermal storage vessel for Heat Pump	£500

THE HEAT PUMP

The comparative costs (based upon actual facts derived from a long-term experiment) of heating a building with a cubic content of 500,000 cu. ft. are shown in the first two columns of Table 9. The case relating to thermal storage is not a part of the actual experiment.

TABLE 9.—Comparative Annual Costs of Heating a Large Building

	Coal-fired Boilers	Heat Pump	
		Without Thermal Storage	With Thermal Storage
Capital cost	£1,500	£3,000	£3,500
Averaged seasonal reciprocal efficiency	—	4.00	4.00
Tariff for electrical energy ...	—	£4 per kVa. demand ; 0.6d. per kW.-hour	0.6d. per kW.-hour
Annual capital charges ...	£225 (15 per cent.)	£210 (7 per cent.)	£245 (7 per cent.)
Cost of coal (or electricity) ...	£440	£601	£367
Annual cost of attendance... (including coal and ash handling)	£230	—	—
Repairs and maintenance ...	£150	£50	£50
Replenishment of refrigerant	—	£25	£25
Total	£1,045	£978	£769
Cost per therm ,	12.5d.	11.7d.	9.2d.

Financial Consideration

On a purely financial basis the Heat Pump is shown to be the cheapest method of heating a building in England with characteristics as described. But the national consideration of the most suitable form of heating to adopt involves considerations other than those of finance, e.g., economy in the use of coal, a substance which may prove to be a rapidly wasting asset.

To drive the electric motor for the more efficient Heat Pump with a reciprocal efficiency of .4 involves the burning at the power station of 9.1 lb. of low-grade coal for each unit of heat (therm) passed into the building. To pass a unit of heat (therm) into the

building when the coal-fired boilers were used requires that 16.6 lb. of a much better quality coal should be burned. Thus, if this instance is assumed to apply to the general case, in place of each 1,000,000 tons of high-grade fuel burned annually on direct heating boilers for building heating, only 545,000 tons of much lower-grade fuel would be required at the generating stations if it were possible to replace the heating boilers by Heat Pumps. To the consequential national advantage can be added further benefits in the form of reduced smoke emission, and the reduced production and transport of ashes, etc., would be even greater. From a national standpoint the saving of coal which the Heat Pump will effect may be more important than the saving in monetary costs.

Resumption of Tests

It is suggested that the experimental Norwich Heat Pump has established certain facts relating to the heating of large buildings in England. These facts may provide a basis for serious consideration of the extended use of the Heat Pump in this country in those cases where a suitable source of low-grade heat is available. The established facts may now be summarised.

Summary

(1) Where the source of low-grade heat is a British river or lake, and the building with its heating installation is similar to that at Norwich, the heat input to the building, using a Heat Pump, over a heating season will be from 3.5 to 4 times the equivalent heat energy required to drive the machine. Future developments in compressor and Heat Pump component design indicate that the average seasonal reciprocal efficiency may rise to 4 or 4.5 for a normal British heating season.

(2) Where a building heating system is designed so that the maximum water flow temperature is less than 135 deg. F. (as for the Norwich experiment) the reciprocal efficiency will be proportionately higher. The case in which the highest reciprocal efficiency will be achieved is one in which air, rather than water, is used as the medium circulating in the building. In the latter case, when using a British river or lake as the source of low-grade heat, an actual reciprocal efficiency averaging 5.0 over the whole season may be expected. Further, the Heat Pump may then be used effectively to cool the building during the summer.

THE HEAT PUMP

(3) The Norwich experiment relates particularly to a Heat Pump designed for a maximum output of 8 therms per hour. It has been established by a long-term scientific experiment that the overall running costs, including capital charges based upon the relatively high capital cost of Heat Pump plant, are lower than the overall capital and running costs of heating the building with automatically stoked coal-fired boilers running at 55 per cent. combustion efficiency. There are reasons which may justify this lower overall running cost of the Heat Pump for any size of Heat Pump exceeding approximately 5 therms per hour.

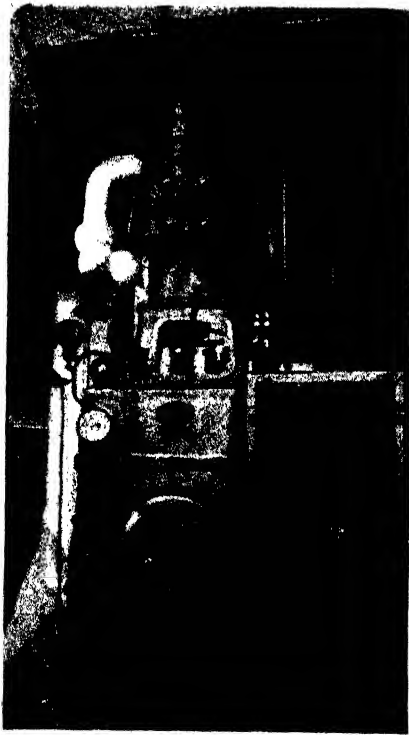

Fig. 58.—The new compressor of the same make which is giving a greater efficiency at present

(4) Apart from the direct financial and ancillary advantages, the use of the Heat Pump in place of coal-fired boilers has the effect of reducing the consumption of coal from approximately 16.6 lb. of

high-grade coal delivered to the building to 9.1 lb. of low-grade coal delivered at the central generating station, per therm of heat sent into the building.

The Lausanne Artificial Ice Rink Heat Pump

A Heat Pump with a different application is that which is installed at Lausanne, in Switzerland. It is the largest Heat Pump installation of its kind, but there is another of similar design at Neuchatel, a smaller rink, which we illustrate in Fig. 63, also in Switzerland. In the case of the Lausanne Ice Rink, the Heat Pump also acts as a heating make-up for the town district heating. The water main is 600 mm. in diameter, and it is tapped and led into the Heat Pump condensers of the ice rink compressors. This causes the temperature of the water in the mains to rise by 2.5° C. This heat recovery of the water through drawing off what would otherwise be waste heat saves approximately 350,000 kWh. per winter. The diagram and arrangement for the scheme is shown in Fig. 59.

The scheme is as follows : (1) Town water supply main ; (2) Condensers of the ice rink compressors ; (3) Auxiliary coolers ; (4) Water pump ; (5) Water meters to check the consumption of in and out supplies ; (6) Points of consumption or draw-off ; (7) Ammonia tester ; (8) Heating reservoir and storage ; (9) The snow pit.

This design is unique of its type. The waste heat from the compressors is drawn off into the town mains, which are used for the district heating scheme referred to. In this way a thermal storage is built up in the district heating mains which supply the town, while the heating of the coils under the stands are supplied from a separate heat exchanger.

Original Design

It should be pointed out that this scheme was not " adapted " to the existing Heat Pump installation, as the Heat Pump system for the whole water supply of the town was laid down and designed at the time of the erection of Lausanne Ice Rink. In this way it was possible to balance the small by-pass led from the main referred to earlier. Thus the water is circulated in a closed circuit. The water led off is raised in temperature by no less than 10° C. This is sufficient for the panels in the roof of the stand, which give radiant heating to the audience and to the coils referred to, and when

THE HEAT PUMP

returned to the main causes a temperature rise of 2.5° C. The surplus heat drawn off in the making of the ice is about 250,000 B.Th.U.s daily during the winter months, while the heat transfer is higher in summer.

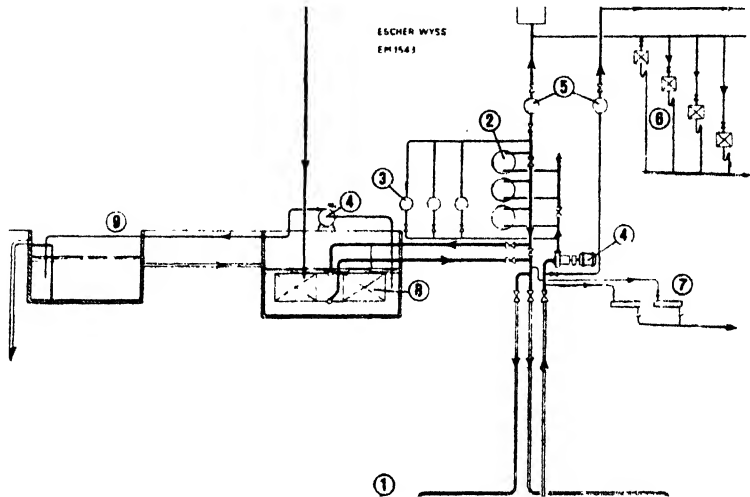

Fig. 59.—The main water conduit, 60 mm. in diameter, which conveys a smaller stream of water through the condensors to the ice rink compressors, raising the temperature by an average of 2.5° C. This corresponds to a saving of heating power of approx. 350,000 kWh. per winter

- | | |
|---------------------------------------|--------------------------|
| 1. Town water supply main | 6. Points of consumption |
| 2. Condensors of ice-rink compressors | 7. Ammonia tester |
| 3. Auxiliary coolers | 8. Heating aggregate |
| 4. Water pump | 9. Snow pit |
| 5. Water meters | |

For the purpose of cooking, heating and washing this gives a great saving in fuel, which is approximately $33\frac{1}{4}$ per cent. The saving in this direction is equally balanced in summer and winter, for it is found that the warm water consumption per head is three times as much in summer than in winter owing to the demand on the shower-baths, which are shown in the background of Fig. 63. The cubicles, too, are heated by radiators and coils, which are part of the circuit feeding the coils referred to.

Fig. 59, if followed closely, will show the ingenious method employed to prevent the overheating of drinking water, or the passage of gases into the pressure water in case of leakage. The slightest trace of such gases are audibly announced by an electrical resistance in series with a horn, and so far there has not been any sounding of the alarm since the scheme was installed and tested in 1943.

Hot Water Supply

The hot water supplying the wash-basins and baths, as well as the shower-baths and the heat exchangers, is always more than adequate. All cooking apparatus is of course fed with hot water. It should be noted that the condensate leaving the liquefier is of approximately the same temperature as the hot water supply. It consists therefore of a great quantity of heat which can be given up to cold water in any heat exchanger without the employment of any further apparatus, or it can be married up to a mixing valve with a regulator to give the quantity of blended water required. At a temperature of $+10$ to 12° C. of the cold water inflow, it is possible by this means to make available for the water heating process a supplementary quantity of heat which amounts to from 10 to 15 per cent. of the heat output given in the liquefier of the Heat Pump. In cases where the warmth of the liquid cannot be made use of, a part of it can still be regained by means of two-stage expansion.

Insulated Storage

Two insulated water containers are fitted to carry out the above scheme. One of these containers holds the day's supply of hot water at 50° F., while in the other, the pre-heated water coming from the heating system is stored. Its temperature corresponds to that of the heating system water which is about 40° C., and is thus generally lower than is needed or desired. The heat has therefore to be stepped up for re-use, and this is done by means of the Heat Pump.

The method is as follows: the pre-heated water is led into the warm water container, which has been emptied as the flow of the low temperature water takes place, and the flow of water is taken through the liquefier of the Heat Pump. This is done by means of a circulating pump, and this process can be adapted when the plant does not serve simultaneously for space-heating, but only for domestic hot-water heating.

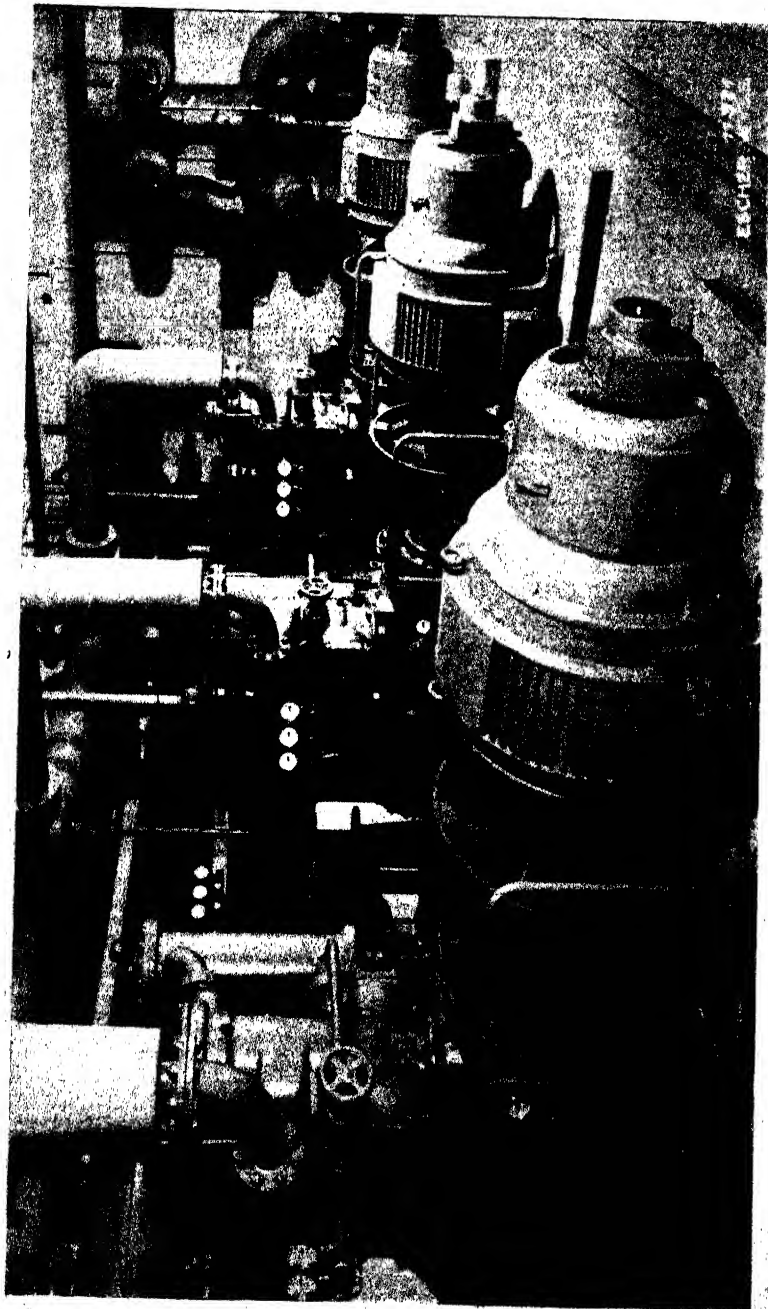

Fig. 60.—The three compressors of the Escher Wyss Heat Pump plant fitted to Lausanne Artificial Ice Rink with by-pass piping to the Town's main central heating. Note the compact arrangement of the pipework

It is of course advantageous to use some form of off peak thermal storage, but there is no waste heat with this scheme, as the overflow of heat is to the district heating mains, but it should be noted that the scheme was designed to take the circulating pressure of the district heating mains and there is no danger of reverse circulation.

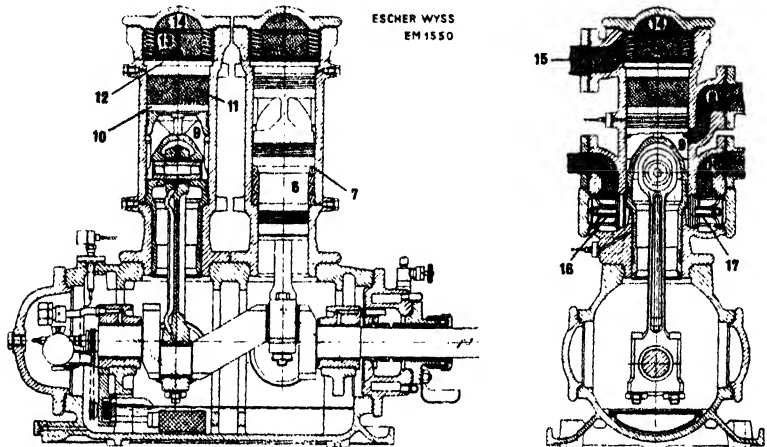

Fig. 61.—The Frigotrop Type Compressor (Escher Wyss Patent) with double action stepped suction piston works in two stages with the smallest possible clearance space, thereby suitable for high-speed working

- | | |
|--|-----------------------------|
| 6 Plunger piston | 13 1st stage pressure valve |
| 7 Ring surface on plunger piston | 14 Pressure chamber |
| 8 Suction branch | 15 To intermediate cooler |
| 9 Channel in upper section of piston | 16 2nd stage suction valve |
| 10 1st stage suction valve | 17 2nd stage pressure valve |
| 11 Compressor chamber | 18 Pressure branch |
| 12 Steel plate of 1st stage pressure valve | |

A view of the plant room is shown in Fig. 60, which is to the design of Messrs. Escher Wyss. The three compressors are of the Frigotrop Type, which is the patent of this firm, and a unit is shown in diagrammatic form in Fig. 61. This unit has a double-action stepped suction piston which works in two stages with the smallest possible clearance space, which makes it suitable for high speed working, and the numbering is as follows: (6) Plunger piston; (7) Ring surface on plunger piston; (8) Suction branch; (9) Channel in upper section of piston; (10) First stage suction valve; (11) Compression chamber; (12) Steel plate of first stage pressure valve; (13) First stage pressure valve; (14) Pressure chamber; (15) To

THE HEAT PUMP

intermediate cooler ; (16) Second stage suction valve ; (17) Second stage pressure valve ; (18) Pressure branch. This Heat Pump installation at Lausanne (Fig. 62) and Neuchatel (Fig. 63) is a remarkable adaptation of the Heat Pump to ice-making as a refrigerating machine, also as a Heat Pump for heating and for the supply of domestic hot water, and last but by no means least, a form of thermal make-up to the mains.

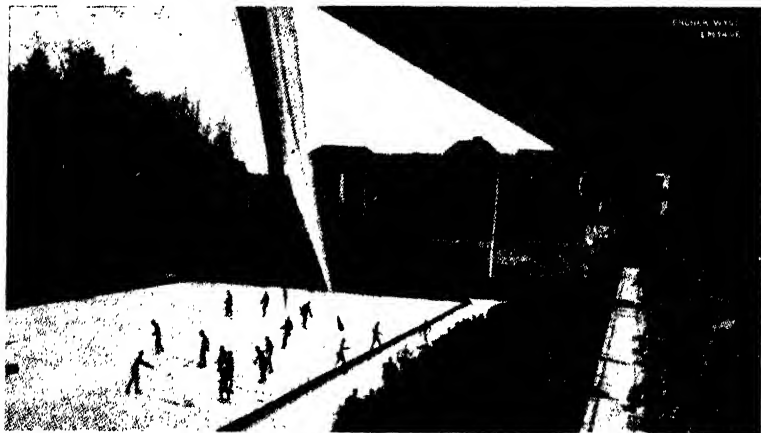

Fig. 62.—The Lausanne artificial ice rink which serves simultaneously as a Heat Pump heating system for the entire water supply of the town

Another interesting installation in Switzerland which is novel, yet has been in use for the past ten years, is a thermo-compressor installation for handling a mixture of alcohol and water vapour (Fig. 64), while another thermo-compressor used for evaporating milk products is shown in Fig. 65.

The ratio $\lambda = \frac{G}{L}$ is called the specific evaporation figure G ,

being the amount of water evaporated in lb. per hour and L the power input measured at the terminals of the motor driving the thermo-compressor.

Both performance coefficient ϵ and specific evaporation figure become higher as the temperature level—i.e., the operating pressure

—is raised and the temperature difference Δt between the saturation temperatures corresponding to the pressures at the outlet and inlet of the thermo-compressor become small.

Pressure Level

Weight of water to be evaporated 450 lb./hr. Boiling temperature of the solution of $t_0 = 113^\circ \text{F.}$, $T_0 = 318^\circ \text{K}$ and a temperature



Fig. 63.—The Neuchatel ice rink, showing the dressing-rooms in the background

difference $\Delta t = 57.2^\circ \text{F.}$, hence $t_1 = 59^\circ \text{C.}$ and $T_1 = 332^\circ \text{K.}$ With the given size of plant, an overall efficiency of $\eta = 0.55$ can be assumed.

The performance coefficient amounts to

$$\frac{332}{57.2} \times 0.55 = 3.2$$

The power input at the motor terminals can be determined from this figure as being equal to 58 kW. Hence :

$$\lambda = \frac{2205}{58} = 38.05 \text{ lb./kWh.}$$

If, on the other hand, evaporation is carried out under atmospheric pressure, i.e., $t_0 = 178.2^\circ \text{F.}$, $T_0 = 372^\circ \text{K.}$, and all other conditions remaining the same, so that $t_1 = 113^\circ$, $T_1 = 386^\circ \text{K.}$, then :

$$\epsilon = \frac{386}{57.2} \times 0.55 = 6.75 \text{ and}$$

$$\lambda = \frac{2205}{44.5} = 49.7 \text{ lb./kWh.}$$

with a power input of 44.5 kW. at the motor terminals.

Evaporation is carried out preferably, whenever possible, at atmospheric pressure, because no special sealing devices are then

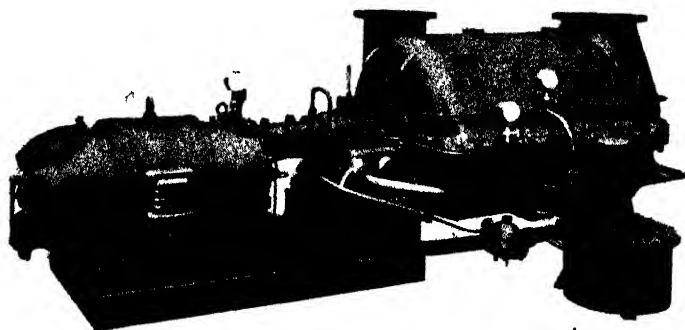

Fig. 64.—Thermo-compressor by Brown-Boveri for handling a mixture of alcohol and water vapour (vapour pressure exchanger)

Weight of vapour handled	882 lb./Hr.
Suction pressure292 lb./□"
Delivery pressure	1.45 lb./□" abs.
Intake 10,240 c.f.m.	Motor input 40 kW.
Suction temperature	60.8° F.

required for the compressor glands, nor is a special pump required for evacuating condensed water, which simplifies the operation of the plant.

Certain substances, however, are affected by the temperature, so that their concentration has to be carried out at low temperatures, under vacuum, so as to maintain their vitamin content, flavour and aroma. The treatment of milk, fruit juice and certain organic solutions calls for precautions of this description.

PRACTICAL APPLICATION

The power input of the compressor should correspond exactly to the amount of heat necessary to cover the losses of the evaporating plant, such as radiation, warming up the raw solution, heat carried away with the concentrated product and condensate, heat removed by the vacuum pump, etc. If the compressor has been correctly dimensioned, both heat and temperature balance should tally.

The difference in saturation temperatures between compressed steam and boiling solution determines the pressure ratio which has to be produced by the compressor, and consequently the number of impellers. The effective temperature difference, i.e., pressure ratio, is however considerably higher than that necessary for heat transmission across the heating surfaces alone. Account must also be taken of the pressure losses of the apparatus and pipework, air leakage and, particularly if high vacua are being worked to, of the height of the column of boiling liquid, as well as of the formation of deposits on the heating surfaces and the lag of the boiling point. This last-named factor is the difference in temperature of the boiling point of the solution and that of pure water, and generally increases as concentration progresses.

An exact knowledge of all these factors is necessary for each particular case in order to ensure satisfactory operation under all conditions occurring.

The properties of the liquid to be treated also call for particular attention when designing the compressor. Suitable separators, dryers, washers, etc., prevent incrustation of the inner surfaces, whereas corrosion of the compressor blading can be avoided by an appropriate choice of the materials used. With plants working under vacuum special arrangements for evacuating the system and preventing ingress of air are required.

Whenever different kinds of products are treated in the same plant, different temperature differences may occur. Various means exist for adapting the compressor to the changed operating conditions, among which speed regulation may be mentioned.

Some representative examples of thermo-compressors for evaporating or distilling plants are shown in Figs. 64 to 66. The installation shown in Fig. 65 is especially interesting²; it is used for preparing milk sugar (lactose), as a by-product of casein and

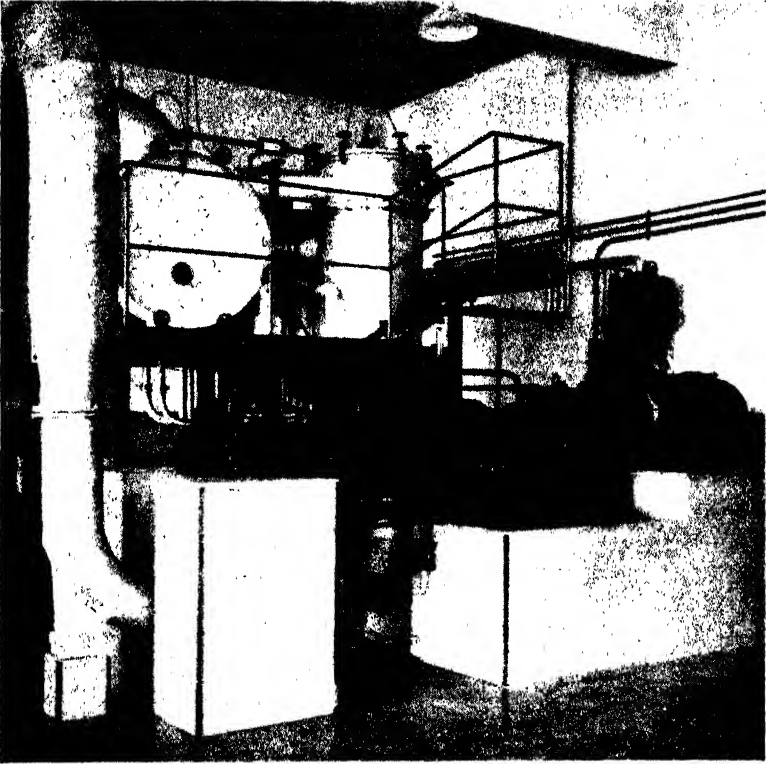

Fig. 65.—A Brown-Boveri thermo-compressor in an evaporating plant handling milk products. Control gear is mounted on the wall by the motor

Nominal evaporative capacity : 2205 lb. of water per hour.

Evaporation with thermo-compressors affords an ideal means of concentrating liquid foodstuffs. Among the many advantages they possess may be mentioned :

- (a) Concentration can be carried out at the moderate temperatures necessary for conserving vitamins, the flavour and aroma.
- (b) The various operations are carried out with maximum cleanliness and hygiene due to the use of electricity and the suppression of fuel.
- (c) Due to the high performance coefficient, the energy consumption amounts to only a small fraction of that necessary for evaporation by direct electric heating.

albumin. Full or skimmed milk can also be concentrated in the initial stages of manufacturing dried milk products, which are very stable and can be kept for a considerable time. In this manner, seasonal surpluses can be stored for times when there is a shortage

PRACTICAL APPLICATION

of milk. Such plants can operate entirely without fuel, and can be paid off within a very short time.

All kinds of products can be treated, like whey and milk sugar, as well as milk powder and dried milk in the spring, whereas various

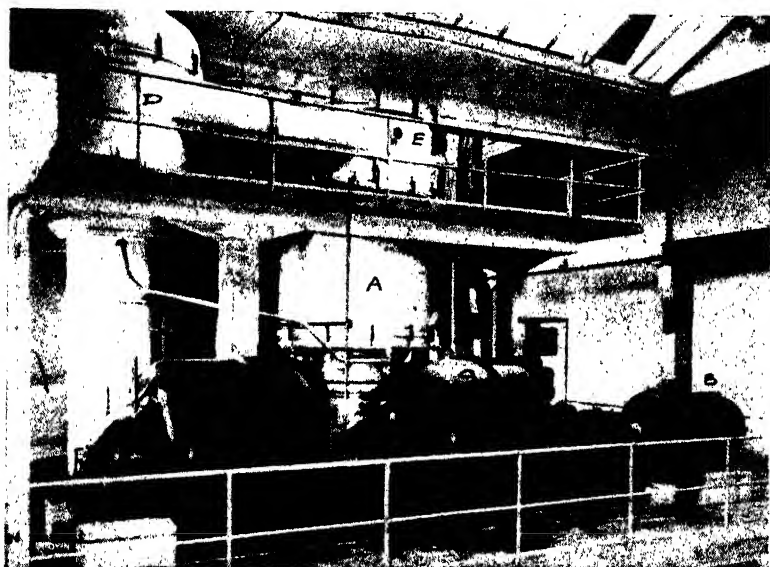

Fig. 66.—Thermo-compressor set for an evaporating plant handling milk products and unfermented fruit juice

6615 lb. of water being normally evaporated per hour. The liquid to be concentrated boils in the evaporator A. The compressor C, driven by an induction motor B over gearing, takes in the water vapour which is boiled off after it has previously traversed the steam separator D, and delivers it to the heating tubes of the evaporator A, where its latent heat is used for heating. Inspection windows E at appropriate places enable the operation to be readily checked.

The energy consumption is approximately 9 times smaller than with direct electric heating.

According to the available raw products, the installation is used variously and without any changes, for concentrating either milk products or unfermented fruit juices.

kinds of fruit juices can be concentrated later on in the year. A plant of this description was set to work in Eastern Switzerland in the autumn of 1942, for evaporating 6615 lb. of water per hour

(Fig. 66). During the autumn, up to 30,000 litres of grape juice were treated daily.

The Landquart Paper Mills

The air Heat Pump, as may be imagined, is a reversed gas engine, using the air as a refrigerant, with a separate compressor and expansion. Air is compressed adiabatically in the compressor, raising the temperature, which then passes through a heat exchanger giving up its heat; then it is expanded adiabatically and cooled and is ready to take up heat again in a secondary exchanger. The arrangement is shown in Figs. 67 and 68. An advanced arrangement proposed by Lebre and developed at the Swiss Federal Institute of Technology is shown in Figs. 69 and 70, and this is the principle on which this scheme is based. It is of the multicellular rotor type, and was developed from the Zurich Congress Building installation, which was the first of its type.

This installation at Landquart is of interest inasmuch as the Heat Pump operates with *air* and not with an auxiliary working medium. This design is specially suited for cases where air must be heated or whenever an insufficient amount of water is available. Air Heat Pumps require not only a compressor but also an expansion machine. These two machines are combined in an ingenious manner in the Lebre cellular rotor.

The Landquart Paper Mills is the first instance of an air Heat Pump with cellular rotor being installed for an industrial heating process. Various far-reaching improvements to the air-flow conditions through the cellular rotor were incorporated, with the result that a coefficient of performance of 2.78 was obtained with the operating conditions coming into consideration. Subsequent research has shown that the air Heat Pump with cellular rotor can be still further improved and cheapened. It can consequently come into consideration for a number of industrial applications for which its very simple operation—air as operating medium, no evaporator but only a heat exchanger serving as air pre-heater on the hot side in the place of a condenser—renders it eminently suitable.

The plant in Landquart is designed for a heating output of 460,000 B.Th.U.s/hr. Moist, warm air coming from a paper machine

PRACTICAL APPLICATION

serves as the source of heat, and is also utilised in waste-heat recuperators for heating the fresh air for drying the felts before it traverses the heat exchanger of the Heat Pump. The Heat Pump

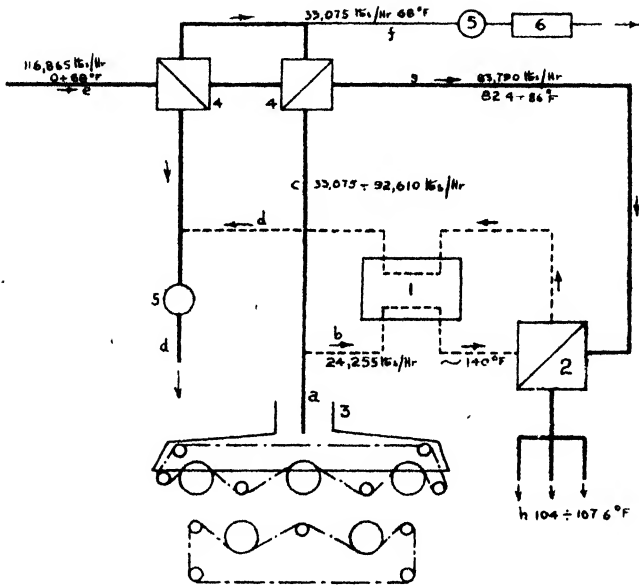

Fig. 67.-- Layout diagram of the Heat Pump plant used for drying in the Landquart Paper Mills, Landquart (Switzerland)

1. Cellular rotor
2. Heat exchanger (air heater) } of the
3. Vapour collector of the paper machine. } Brown Boveri-Lebre air Heat Pump.
4. Two-stage recuperation plant for heating fresh air from 32-36° to 86° F.
5. Fans.
6. Heater for air used for defogging.
- a. Air exhausted from paper machine (104° F. relative humidity $x = 70$ per cent.).
- b. Branch of exhaust air used in Heat Pump as source of heat.
- c. Branch of exhaust air used in recuperator 4 for heating fresh air.
- d. Cooled air to atmosphere.
- e. Fresh air.
- f. Branch of warm fresh air for heating machine room.
- g. Fresh air heated to 86° F. going to heat exchanger 2 of air Heat Pump.
- h. Warm air at 104° - 107.6° C. for drying felts.

enables approximately 180 tons of coal to be saved per year, without taking into account the pre-heating in the waste-heat recuperators. A welcome ancillary feature is the considerable lengthening of the

THE HEAT PUMP

life of the felt strips used in the paper machine due to the increased temperature of the drying air.

Fig. 67 shows diagrammatically the layout of the plant with Heat Pump and recuperators for fresh air, and Fig. 68 the Heat Pump itself.

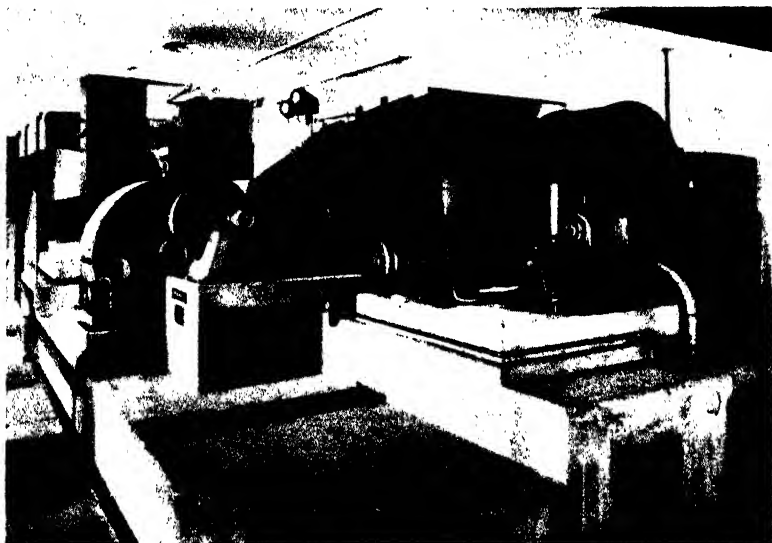

Fig. 68.—460,000 B.Th.U.s/hr. Air Heat Pump installation of the Landquart Paper Mills, Landquart (Switzerland)

In this interesting installation an air Heat Pump is used for heating, the compression and expansion being carried out by means of a cellular rotor according to the Brown Boveri-Lebre system. The source of heat consists of the moist, warm air leaving the paper machine. The Heat Pump receives air which has already been heated to 86° F. in recuperators, and raises its temperature to 104° F., before it is used for drying felts in the paper machine.

This relatively small Heat Pump alone enables approximately 180 tons of coal to be saved per year.

Sources of Heat

A suitable source of heat is essential to the operation of a Heat Pump plant. Not only must the heat source be ample, but it must also exceed certain minimum temperature limits, if the gain in heat is to be worth while. The temperature difference between the available source of heat and that required for heating must not

be too great, and if possible not more than 90-140° F. Well-water provides a constant year-round source and is the most satisfactory. Air, on the other hand, varies considerably in temperature and is usually at its lowest temperature when heat requirements are greatest, unless where exhaust waste heat is available as at Landquart Mills. Nevertheless, air offers the greatest possibility for the Heat Pump because it is universally available, and by using at low outdoor temperatures some form of storage or of auxiliary heat, it can be made to operate satisfactorily. This is particularly so in climates where the outdoor temperature seldom drops below 25° F.

Streams, rivers or lakes offer a satisfactory source of water, but where these are not available the sinking of wells would appear necessary, as it is not likely that the water companies would permit the use of their water for this purpose. It should be noted that about 45,000 gallons an hour flowing through the evaporator are required for a heating output of about a million B.Th.U.s, assuming that the lowest temperature of the source of heat is 35° F., and that the hot water leaves at a temperature of 140-160° F.³ It has been suggested that the latent heat of the water be extracted by freezing it, but it is estimated that in Washington (D.C.) the amount of ice formed during the winter in heating a 14,000 cu. ft. well-insulated house by this method would be 210 tons or 7,800 cu. ft., which would make a pile about half the size of the house. Heated circulating water from a steam condenser or other similar waste heat can be economically used and would increase the co-efficient of performance, but it must be available in quantities. Such waste heat is made use of in Switzerland in a number of industrial applications of the Heat Pump, such as at Landquart Paper Mills, and considerable saving of fuel for heating would be made in this country by waste heat recovery.

When air is used as the source of heat, the size of the machine and the energy consumed in pumping the heat are both very dependent upon the temperature difference. Three difficulties are encountered: the capacity of the machine is reduced on the days when heat is most needed; the efficiency when carrying overloads during the coldest weather is greatly reduced; when the transfer surfaces absorbing heat from out-of-doors are below the freezing point, frost will collect on them, impairing the transfer of heat, especially on foggy days and when the moisture content of the air

THE HEAT PUMP

is high. These difficulties can, however, for the most part be overcome

It will be seen, therefore, that the design of Heat Pump apparatus is very dependent upon operating conditions, and especially on the climate in which the apparatus is to be operated.

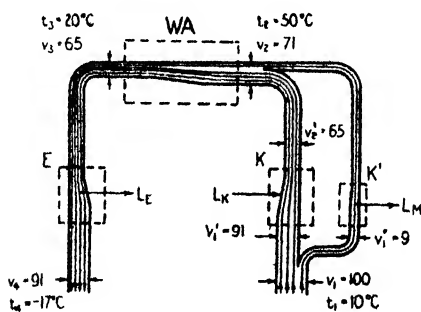
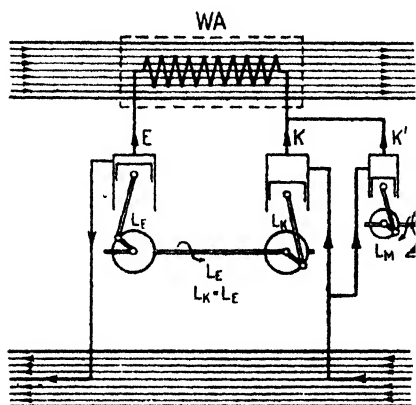

Fig. 69.—Diagram of air Heat Pump with auxiliary compressor

- | | |
|-----------------------|----------------------------|
| M = Electric Motor | K' = Auxiliary Compressor. |
| E = Expansion Machine | WA = Heat Exchanger. |
| K = Main Compressor | |

It has been suggested that a heat engine may have an advantage over the electric motor as a source of power. Modern heat engines reject two-thirds to four-fifths of the heat supplied to them as fuel. If the Heat Pump were driven with a heat engine then heat rejected

by the engine through the exhaust and water jacket, and usually wasted, could be utilised as additional heat that could not have been supplied by an electric motor. Willis shows that the fuel cost with the engine-driven Heat Pump would be about a penny for 100,000 B.Th.U.s, which would be equivalent to about 14s. per ton for 13,000 B.Th.U.s coal burned under a boiler, and equivalent to the cost of the same coal at about 89s. per ton with the electric motor-driven apparatus assuming electrical energy at $\frac{1}{2}$ d. per kWh.*

The question of availability of power is almost academic. While a power shortage exists at the present time, new generating capacity planned for installation in the next two years should adequately provide for any foreseeable increase in demand attributable to the Heat Pump. Neither is there any expected problem in respect to local distribution facilities. While a concentration of Heat Pumps in any given area may require rebuilding of circuits and increased transformer capacities, these changes are normally routine. However, in the event of the size of individual units being increased above say 5 h.p., with an accompanying change to three-phase motors, a considerable problem might arise. At present, three-phase supply is available in only a very limited percentage of residential territory and to bring such service into these areas would ordinarily be uneconomic except for a very substantial load. Presumably the best answer to this problem is the use of multiple single-phase motor-compressor units.

The really vital question in connection with power supply is price. Price in turn depends in most instances on two other major variables—the cost of coal and the load factor. However, since the cost of coal also influences to a large extent the cost of competitive heating, this factor tends to cancel. Assuming an overall thermal efficiency of the utility system of 25 per cent. from boilers to the customers' premises, and a coefficient of performance of 4 to 1 for the Heat Pump, it is obvious that the B.Th.U.s delivered by the Heat Pump would be exactly equal to the B.Th.U.s of the heat energy contained in the coal burned at the power house. But since the delivered cost of coal by the carload or shipload will ordinarily run only 30 to 40 per cent. of the cost in small lots to the householder, and since the boiler efficiency of the utility company

* For the purpose of conversion the U.S. cent has been taken as $\frac{1}{2}$ d.

is higher than that of a home furnace, the fuel component in the energy cost of operating a Heat Pump is reduced accordingly. On the other hand, operating expenses and taxes incurred by the utility at least partially offset these savings.

In an average utility steam plant system, the fuel component of the energy cost will range from about 2 mills to 6 mills per kWh.

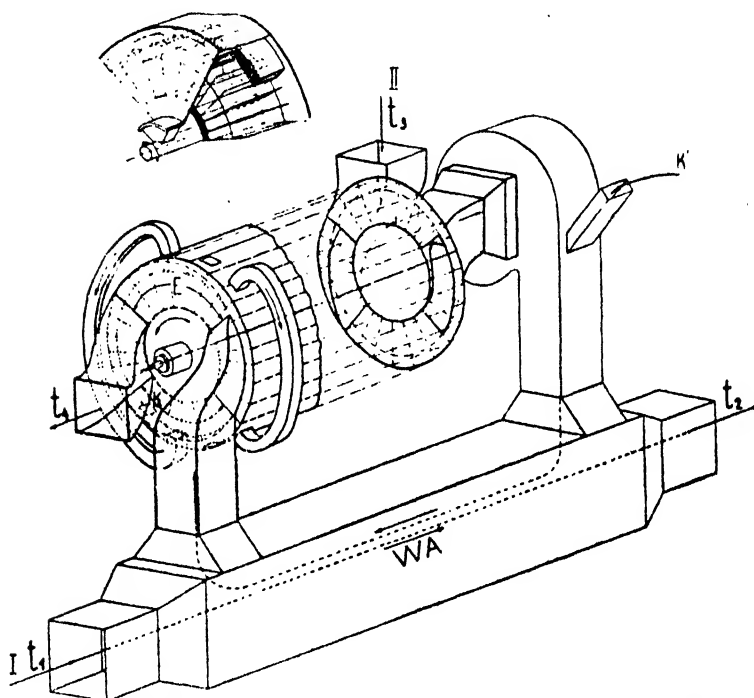

Fig. 70.—Diagram of multi-cellular motor with heat exchanger

K = Compression Zone.
E = Expansion Zone.

K¹ = Air Inlet from Auxiliary Compressor.
WA = Heat Exchanger.

If this energy is utilised in a Heat Pump with a coefficient of performance of 4 to 1, each kWh. would produce useful heat at a rate of approximately 13,000 B.Th.U.s per hour.

Load Factor a Major Element in Cost of Service

Unfortunately, a more important element in the price of electric service is the cost associated with the large investment required to

PRACTICAL APPLICATION

generate, transmit and distribute the energy. In a typical plant, this investment will now run about £100 per kilowatt of installed capacity, on which annual costs for maintenance, depreciation, interest and taxes, plus a return to the investor, will average from 12 to 15 per cent. A conservative figure would be £12 10s. per year

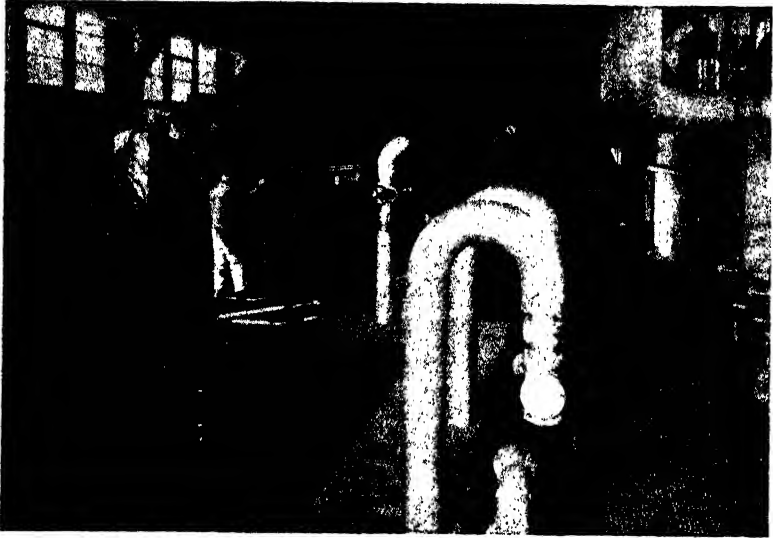

Fig. 71.—Heat Pump plant of the Steckborn Artificial Silk Co., Ltd., Steckborn (Switzerland)

Comprising two thermoblocs (heating machines), each for 4—6.8 Million B.Th.U.s/hr. With lake water at 55.4° F. each unit has a normal heating capacity of 6.04 Million B.Th.U.s/hr. when heating hot water from 136.4° F. to 158° F. About two-thirds of this amount of heat is extracted from the water of the Lake of Constance, whereas the remaining third is furnished by the electrical energy consumed.

With one unit alone in operation, roughly 2100 tons of coal per year are saved.

per kW. or about 5.7 mills per hour, assuming the consumer makes use of the service steadily for the entire 8,760 hours in the year.

The aim of the Heat Pump is to conserve fuel and indirectly to raise the efficiency of the power station. In other words, the Heat Pump is a waste heat recovery plant and considerable use has been made of this in various installations either by recovering the heat from vitiated air or water. At the Steckborn Artificial Silk

Co., Ltd., the system consists of two heating units as can be seen in Fig. 71, while the lay-out of the scheme is shown in Fig. 72.

For manufacturing rayon, a considerable amount of hot water at low and medium temperature is required for heating the spinning baths, spinning machines, drying ducts and basins as well as for the spun material itself.

The conditions at Steckborn are particularly well suited for a Heat Pump since a practically unlimited heat source is provided by the Lake of Constance ; also the demands for heat are considerable and practically constant. Moreover, the plant is in continuous operation throughout the year, thus ensuring a high load factor.

Steam was used formerly for heating and the plant was re-adapted for hot-water heating, so as to render its operation as independent as possible of fuel. At the same time, considerable advantages were secured due to the cleanliness of the Heat Pump, as well as to the elimination of steam and condensed water, with the attendant troubles.

As can be seen in Fig. 72, heat is now produced by two thermoblocs, which maintain the base load for hot-water heating, and boilers for processing steam and for covering peaks for hot-water heating. At the present time, coal-fired boilers are installed, but it is proposed to add in the future an electric boiler. Heating is effected by means of steam-water heat exchangers.

One of the two Heat Pumps (Fig. 71) is sufficient at present for normal requirements, whereas the other serves as standby and for covering requirements after contemplated extensions to the plant have been carried out. The steam produced by the boilers is first of all expanded in a back-pressure turbine, to a pressure suitable for heating apparatus requiring heat at relatively high temperatures. This low-pressure steam is also used for heating the hot-water system connected to the Heat Pumps during peak periods and whenever there is a shortage of electrical energy due to low water.

The intake of water from the Lake of Constance is at a certain distance from the shore, and is arranged so that water is always taken in at as high a temperature as possible, viz., from the surface during the summer and from a deeper level during the winter, in

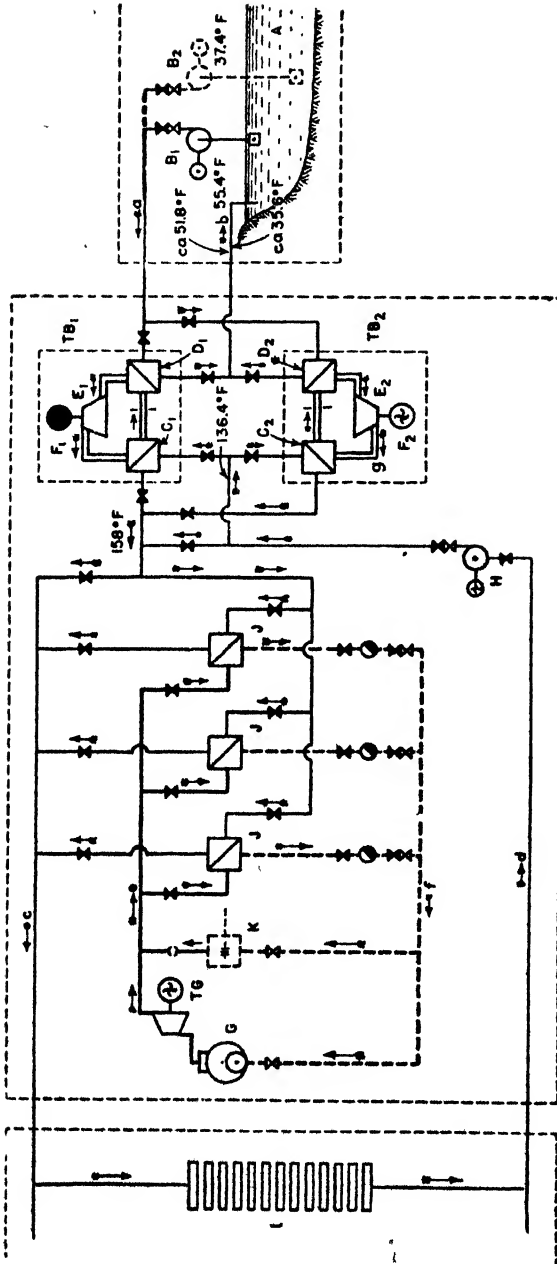

Fig. 72.—Layout diagram of the hot-water plant of the Steckborn Artificial Silk Co., Ltd., Steckborn (Switzerland) with Heat Pumps as heating machines and supplementary boilers (heated by fuel and electrically)

In order to be independent of coal supplies, heat is obtained in this plant from the Lake of Constance, the temperature of which varies between 37.4° F. in the winter and 53.4—68° F. in the summer, for producing 158° F. hot water. Two Heat Pumps (thermoblocks TB₁ and TB₂) are installed, each producing 4—6.8 Million B.Th.U.s/Hr., which correspond to the base heating load. Additional heat for covering peaks is furnished by the boilers G, and at a later date it is intended to install an electric boiler K. The steam produced is utilised in a back-pressure Turbine TG, before it gives up its heat in the heat exchangers.

THE HEAT PUMP

References to Fig. 72 :--

- A Lake of Constance.
- B₁ Pump set for summer operation (53.4—68°F.)
- B₂ Pump set for winter operation (37.4°F.)
- G Coal-fired boiler.
- H Hot-water circulating pump.
- J Steam-water heat exchanger.
- K Electric boiler (projected).
- L Hot-water consumers.
- TG Turbo-alternator set with back-pressure turbine.

- TB₁ and TB₂ Thermoblocs (Heat Pumps), each comprising :
 - C Condenser.
 - D Evaporator.
 - E Turbo-compressor.
 - F Electric motor.
- a Lake-water intake pipeline.
- b Lake-water return pipe-line.
- c Hot-water leaving main.
- d Hot-water return main.
- e Heating steam.
- f Pipeline for condensed heating steam.
- g Working-medium circuit.

order to secure the maximum performance coefficient obtainable. The pumping station comprises two vertical-shaft, bore-hole pumps located in a special building. These pumps are sized for delivery of different quantities of water, the larger pump being for winter

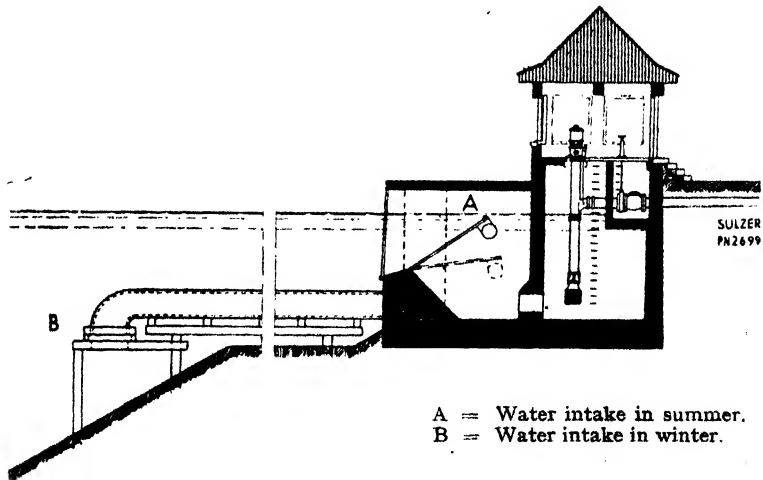

Fig. 73.—Sectional drawing of the pumping works of the Heat Pump plant installed by the Steckborn Kunstseide A.G. at Steckborn, Switzerland

conditions, when the temperature of the Lake is low, and a greater quantity of water has to be handled in order to get the same heat transfer. The smaller pump is for summer conditions when the load is smaller and the temperature differential is smaller with a lighter

PRACTICAL APPLICATION

heating load. The adoption of thermoblocs with smooth-running turbo-compressors greatly simplified the design of the foundations.

Each thermobloc consists of a turbo-compressor, driven by an 8,000 V induction motor through a reduction gearing, and evaporator with spray pump for the working medium and a condenser. Methylene chloride (CH_2CL) has been adopted as the working medium. The plant is fitted with a three-speed gear which enables the compressor speed and the heating output to be regulated according to the load on the building, which fluctuates with the seasons and the temperature of the Lake water.



Fig. 74.—Interior of the pumping works which form part of the Steckborn Heat Pump plant. Two axial deep well pumps are installed, the larger delivering 2,600 gallons per minute at 960 revs. per min., and the smaller delivering 1,750 gallons at 1,450 revs. per min. Both against a total head of 23 feet

The automatic governing devices maintain the leaving temperature of the hot water constant and ensure at the same time that as much heat as possible is always supplied by the thermoblocs, both when running alone or with the steam-water heat exchangers.

Taking the Lake water at 55.5°F ., each unit has a normal heating capacity of 4 million B.Th.U.s per hour when heating water from

THE HEAT PUMP

136.4° F. to 158° F. Almost two-thirds of the heat required is extracted from Lake Constance, and the remainder is represented by the electrical input by the motor. The intake volume is 3531 c.f.m. and the shaft input is 100 kW. This plant has been in constant operation since 1943 and has required little servicing in its five years' life.



Fig. 75.--The exterior of the pumping works shown in Fig. 74

The seriously curtailed fuel quotas of recent times have made it no simple matter for the management of Messrs. Bell A.G., of Basle, butchers, to maintain their business in its previous volume while at the same time upholding at all costs their high standard of hygiene and their up-to-date methods. To fulfil these requirements meant that, in spite of fuel restrictions, the necessary heat and, above all, the hot water needed for cleaning and scouring had to be provided as before. The rational and modern equipment already installed left little margin for additional savings or for improved methods of heat utilisation. The only solution which remained to be considered was therefore the employment of electric current for heat generation; and here the choice lay between an electric boiler and a Heat Pump plant.

After thorough study of the whole problem, the management determined to venture into new territory in the domain of heat generation and to install a Heat Pump as proposed and outlined by the Engineers. This decision was prompted above all by the desire, in the interests of national economy, to extract as much heat as possible from the none too abundant electrical energy available.

The Problem

The problem was to heat daily, from $+10^{\circ}$ C. to $+70^{\circ}$ C., about 60,000 litres of fresh water drawn from the municipal mains, i.e., to produce some 3.6 million calories per day. The hot water was to be made available in the factory, particularly for cleaning and scouring purposes.

An essential preliminary for the installation of a Heat Pump is the presence of an ample source of heat. The temperature level of this source, or the difference between the source temperature and that required for use, which the Heat Pump has to overcome, is of decisive importance for the efficiency of the plant. The smaller this temperature difference is, the less will be the power needed for pumping a definite quantity of heat, or in other words, the greater will be the useful heat output delivered per kilowatt.

In the present case a very favourable source of heat was available in the refrigerating plant which had been in use at Messrs. Bell A.G. for more than 30 years. The refrigerating plant draws a very considerable quantity of heat out of the cooling and freezing rooms both in summer and winter. Instead of letting this heat run to waste with the cooling water, as was done in the past, it can now be passed on (at least in part) to the new Heat Pump in the form of compressed ammonia gas at a temperature of $+18^{\circ}$ C. or more.

The heat supplied by the refrigerating plant is pumped up to a temperature level of about $+72^{\circ}$ C., which is required to provide a hot-water service at 70° C., in a newly installed two-stage reciprocating compressor of horizontal design. Two-stage compression was necessary both for better compressor efficiency and in order to avoid excessive final compression temperatures. The two new compression stages are lodged in two separate cylinders



Fig. 76.—General view of the factories of Messrs. Bell A.C. at Basle, Switzerland

arranged one after the other on the same piston-rod and are double-acting.

The combined refrigerating and Heat Pump plant works with three-stage compression. The service conditions allow all heat, even that normally undesirable, to be utilised by being transmitted to the water to be heated. Thus the following could be turned to useful account (see Fig. 77) :

1. The superheat of compression of the refrigerating cycle in the gas cooler *E*.
2. The superheat of the ammonia gas compressed by the first Heat Pump stage in the gas cooler *F*.
3. Part of the compression and friction heat of the two Heat Pump compression stages through the cooling jackets of the compressor *H*.
4. At least part of the superheat of the gas compressed in the second Heat Pump stage in the oil separator *I* (cooling effect desirable for purpose of better oil separation).
5. The whole condensation heat of the ammonia gases compressed by the Heat Pump compressor in the condenser *K*.
6. Part of the heat still contained in the liquid ammonia in the bottom element of the condenser *K* serving as an after-cooler.

In spite of the temperature of heat utilisation being very high for Heat Pump practice, the appropriate arrangement of the various heat-exchange apparatus, combined with other favourable factors, particularly with regard to the source of heat, resulted in a plant of exceptional economy, as the following guarantee particulars show :—

Heating output per hour	180,000 cal.
Energy required, measured at driving motor terminals	46 kWh.
Specific heating power or power factor	3915 cal/kWh
		4.55

PRACTICAL APPLICATION

The pump plant thus makes it possible to produce per kilowatt of electric energy consumed more than 4.5 times the heat which could have been obtained with an electric boiler. The practical results already available and the guarantee tests carried out have come up to expectations with regard to performance and reliability in every respect.

The flow of water through the Heat Pump plant is regulated automatically by means of a thermostat and a motorised regulating

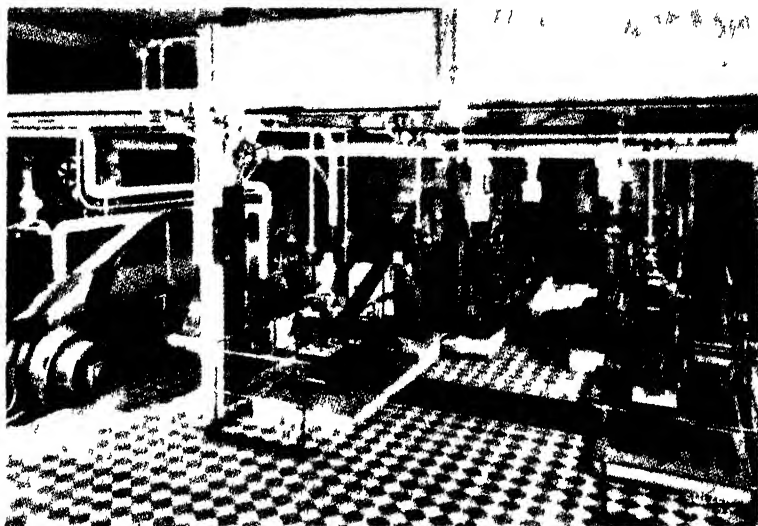

Fig. 78.—The engine room at the Bell factory, with two double ammonia compressors of 120,000 cal/h each, two ammonia compressors of 250,000 cal/h each (at -10° C. evaporating and $+25^{\circ}$ C. liquefying temperature) and a Heat Pump of 180,000 cal/h

valve in accordance with the final temperature of the water. As the water consumption is subject to pronounced fluctuation, however, an insulated hot-water storage tank with a capacity of about 50 cubic metres in an elevated position, has been erected, and from this the hot water is distributed down descending pipes to the various departments. This tank also enables the Heat Pump to be shut down during certain prescribed hours.

The plant is equipped with all the necessary protective devices, which in case of trouble stop all services or operate an alarm to warn the attendant staff.

The new Heat Pump compressor had to be housed in the existing engine-room. In spite of the limited space, it was possible to arrange it in a satisfactory position between the refrigerating compressors, where it does not disturb the layout of the machines. (Figs 78 and 79) For the sake of uniformity the new Heat Pump compressor was executed, like the existing refrigerating compressors, in horizontal design.

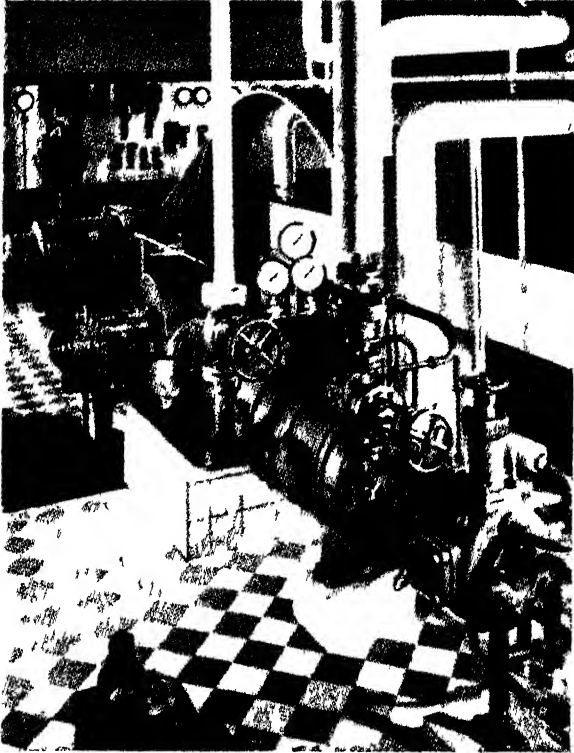

Fig. 79. A Heat Pump of 180,000 cal/h at a supply temperature of $+10^{\circ}$ C., and a delivery temperature of $+70^{\circ}$ C., serving the engine room

The Viscose Suisse S.A.

There is no fundamental difference from the thermo-dynamic point of view between a refrigerating compressor and a Heat Pump. In both cases a certain quantity of heat is withdrawn from

a source at a low level of temperature, brought to a higher level by compression, and delivered to a heat receiver at a higher temperature, the quantity delivered being equal to the original quantity drawn in plus the heat equivalent of the work done by the compressor. The refrigerating compressor and the Heat Pump are consequently machines of fundamentally similar type, the difference of names only referring to the purpose for which the machines are used.

In the case of the refrigerating compressor the main purpose is the production of cold, whilst the heat given off is generally allowed to pass away unutilised. Not so with the Heat Pump, the object of which is to supply heat that can be obtained by simultaneous but mostly useless cooling of its source. Also the temperatures and pressures of the working cycles that are adopted are different, depending on the use for which the machine is intended. Reciprocating compressors, volumetric rotary compressors, centrifugal and axial compressors, ejectors, as well as different refrigerating media and cycles can be adopted for refrigerating plant or for Heat Pump installations. In order to find the most economical solution for any particular case, it is essential to have a perfect knowledge of the particular technical branch, coupled above all with long industrial experience.

The present increasing scarcity of fuel induced the technical management of the Viscose Suisse S.A., based on considerations as outlined, to add a Heat Pump to the refrigerating installation of their Widnau works, in order not only to produce cold but also to make use of the heat which had hitherto been allowed to be wasted.

Fuel saving was the main purpose of this scheme. The following considerations will show that it has been possible to achieve the desired result and that a very interesting and economical plant has been installed.

The problems which the Viscose Suisse S.A. set were as follows :—

(a) The Frig. Side.—Cooling as, hitherto, a brine bath to a temperature of -10° C. Maximum refrigerating capacity 80,000 B.Th.U./hour.

(b) The Heating.—Increasing the outlet temperature of the cooling-water from the condensers of the refrigerating plant to 60° C. Delivering this hot cooling-water to a hot-water heating system with a prescribed return temperature of 56° C. Maximum heat requirements 460,000 cal/hour, as hitherto produced by steam heating.

General Arrangement of the Heat Pump Installation

The existing refrigerating plant included three horizontal ammonia compressors, one of the GP 220 type and the others GP 280 (Fig. 80). These compressors are used to form the first compression stage of the Heat Pump installation. The speed of the compressors could be increased without changing the existing electric motors, in order to produce the required refrigerating capacity of 80,000 B.Th.U.s/hr. This first compression stage works with a suction pressure (evaporating pressure) of 2.211 atm.abs. corresponding to -17° C., and a compression pressure of 9.314 atm.abs. corresponding to $+22^{\circ}$ C.

To form the second compression stage a WP 360 compressor had to be added to the plant. A compressor of the horizontal type was chosen in keeping with the existing units. The new compressor draws in the ammonia vapours delivered by the lower compression stage at a pressure of 9.314 atm.abs. and compresses them to 31 atm.abs., corresponding to a condensing temperature of 65° C. The suction volume of the second stage, as will be seen from the following, was made to correspond exactly to the volume of vapours delivered by the first stage, and this at full load as well as at part loads.

The heat—80,000 B.Th.U.s/hr. at full load—withdrawn from the brine cooler at a temperature of about -10° C., is "pumped up" by the two compression stages to be delivered to the hot-water circuit at a temperature of about 65° C. Thereby the heat withdrawn at the lower level of temperature is, as already mentioned, increased by the heat equivalent of the compression work done. Since the power required for all compressors, measured at the shaft, amounts to 248 h.p., the quantity of heat withdrawn from the source, amounting to 80,000 B.Th.U.s/hr., is brought up to 12,000 B.Th.U.s/hr. before being delivered into the hot-water heating system. Consequently, for each horse-power-hour expended, an amount of heat equal to 480 B.Th.U.s/hr. is obtained. Since the heat equivalent of one horse-power-hour is 148.5 B.Th.U.s, this corresponds for the whole plant to an output factor of 3.03.

PRACTICAL APPLICATION

When it is considered, however, that in the present case the power required for refrigeration would be necessary in any case, and that the heat hitherto allowed to be wasted can be made available merely by adding a second compression stage, it may be claimed that all the heat now obtained, amounting to 118,750 B.Th.U.s/hr., is the result of the extra power expended for driving the Heat Pump, i.e., 122 h.p. From this point of view, the heat obtained per horse-power-hour is as much as 1,000 B.Th.U.s corresponding to the extremely favourable output factor of 6.17.

In order to keep the final compression temperatures at the most economical figure for this particular case, the ammonia gas delivered from the first compression stage is passed through a gas cooler to lower the temperature from about 108° C. to about 70° C. before entering the second stage; the heat thus extracted is delivered to the hot-water heating system. If required, the ammonia may be cooled still further down to almost saturation point by the injection of liquid ammonia into the intermediate pressure receiver; in this case the final temperature at the outlet from the second compression stage is under 100° C.

The ammonia gases delivered from the second compression stage are liquefied in a condenser which has been added as a part of the new plant. This condenser is of the enclosed submerged type and transmits to the hot-water heating system the whole superheating and condensing heat contained in the ammonia gases issuing from the second compression stage. As already mentioned, the water returning at a temperature of 56° C. is heated to 60° C. before it leaves the condenser. The latter is subdivided into two units, of half the total capacity each, and is equipped with powerful stirring gear for circulating the hot water. The total power required for water agitation, measured at the shafts of the gears, is about 7.5 h.p.

The Heat Pump extension of the refrigerating plant consequently comprises :—

1 additional WP 360 compressor, being the second compression stage,

1 gas cooler,

1 intermediate-pressure receiver between the first and second stages,

1 condenser,

The necessary connecting piping.

THE HEAT PUMP

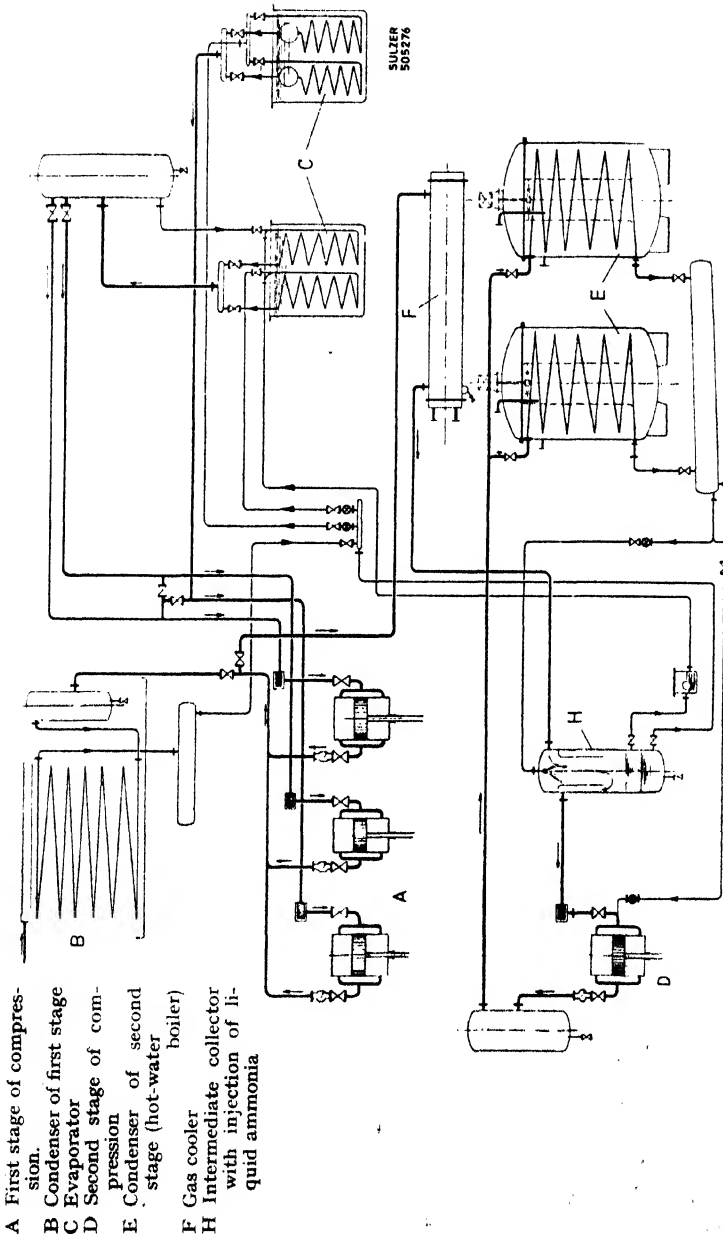

Fig. 80.—Diagram of the refrigerating installation, combined with a Heat Pump, of the Viscose Suisse S.A., Widnau

The cost of the additional plant is moderate in comparison with the quantity of heat recovered.

Power Characteristics of the Heat Pump Plant

First compression stage, after conversion, i.e., after increasing the speed of the existing three compressors :—

Evaporator pressure	2.211 atm.abs.
Evaporating temperature	-17° C.
Condenser pressure	9.314 atm.abs.
Condensing temperature	+22° C.

Refrigerating output and power required; measured at the shaft :

Compressor 1	18,000 B.Th.U.s	27 h.p.
Compressor 2	32,000	47 "
Compressor 3	35,000	52 "
Total	85,000 B.Th.U.s	126 h.p.

Second compression stage, new WP 360 compressor :—

Suction pressure	9.314 atm.abs.
Corresponding saturation temperature	+22° C.
Final compression pressure abt.	31 atm.abs.
Condensing temperature	+65° C.
Total heat output abt.	118,750 B.Th.U.s/hr.
Flow temperature of hot-water circuit	+60° C.
Return temperature of hot-water circuit	+56° C.
Power required by the compressor measured at the shaft	122 h.p.
Power required by the two stirring gears, together	7.5 h.p.
Total power for two compression stages	248 h.p.

Output Regulation of the Heat Pump Plant

The refrigerating capacity of 80,000 B.Th.U.s/hr. and also the heating output of 118,750 B.Th.U.s/hr. are to be understood as maximum values. The exact quantity of cold or heat required at any moment depends on the changing conditions in the manufacturing process; it is therefore necessary to make provision for a wide range of regulation.

THE HEAT PUMP

In a Heat Pump plant the regulation must be effected on the refrigerating side, the quantity of ammonia delivered by the first compression stage passing necessarily into the second stage. The heat output will therefore depend automatically on the refrigerating

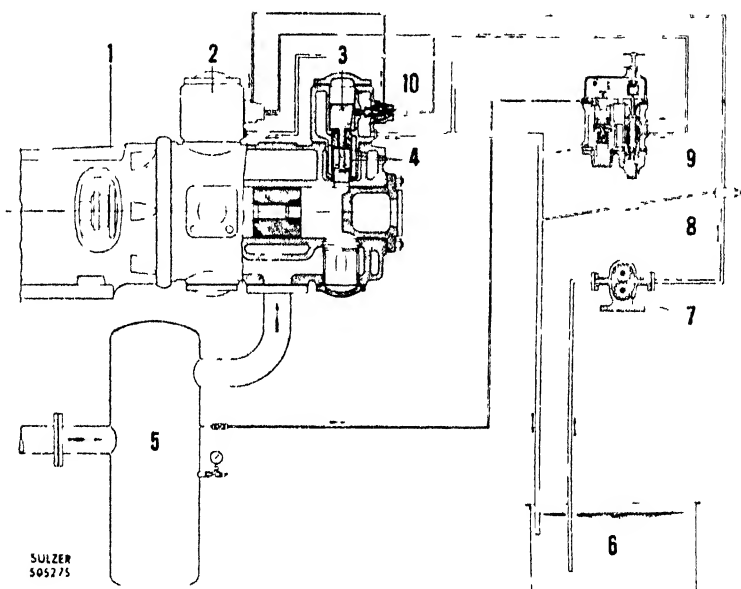

Fig. 81.— The arrangement of the regulation for the high-pressure stage of the Heat Pump plant at Widnau

- 1 Compressor frame, high pressure side
- 2 Apparatus for reducing refrigerating capacity by adding clearance spaces.
- 3 Servomotor for piston valve of the additional clearance spaces
- 4 Additional clearance spaces.
- 5 Receiver between low and high-pressure stages.
- 6 Oil container for hydraulic control.
- 7 Oil pump.
- 8 Safety valve for oil under pressure
- 9 Relay for regulating the refrigerating capacity in accordance with the evaporating pressure (suction pressure).
- 10 Equaliser.

capacity. Nevertheless, as will be shown later, it is possible to regulate the plant in a manner to comply with all requirements.

The refrigerating capacity is regulated by starting or stopping compressor units belonging to the first compression stage (Fig. 81).

The following outputs are therefore possible, according to the number of compressors in service :—

- 1.—All 3 compressors
 $Q = 80,000 \text{ B.Th.U.s/hr.} = 100\%$
- 2.—Compressors 2 and 3
 $Q = 65,700 \text{ B.Th.U.s/hr.} = 78.8\%$
- 3.—Compressors 1 and 3
 $Q = 52,500 \text{ B.Th.U.s/hr.} = 62.7\%$
- 4.—Compressors 1 and 2
 $Q = 48,700 \text{ B.Th.U.s/hr.} = 58.3\%$
- 5.—Compressor 3 alone
 $Q = 34,500 \text{ B.Th.U.s/hr.} = 41.4\%$
- 6.—Compressor 2 alone
 $Q = 31,250 \text{ B.Th.U.s/hr.} = 37.4\%$
- 7.—Compressor 1 alone
 $Q = 18,100 \text{ B.Th.U.s/hr.} = 21.4\%$

The grading is quite sufficient for regulating the refrigerating capacity. The suction volume of the second compression stage must of course be adjusted to suit the delivery from the first stage ; in the present case this is effected automatically by means of a patent capacity regulating device. For this purpose the second-stage cylinder is provided with additional clearance spaces, which can be opened up or shut off while the compressor is working. The impulses required for actuating the device are given by the delivery pressure of the first or the suction pressure of the second compression stage, which is to be maintained constant. If the pressure in the intermediate receiver rises in consequence of the gas quantity handled by the second stage being insufficient the clearance spaces of this stage are automatically reduced, to increase its intake volume. On the other hand, if the intermediate pressure falls below its proper value, more additional spaces are automatically opened, thus reducing the output of the second compression stage.

Regulation

By means of this method of regulation the output of the second compression stage can be stepped down to 78.5, 63, 58.5, 41.5 and

37 per cent., in a manner to comply accurately with the above-mentioned working conditions, 1 to 6, of the first stage.

When the refrigerating requirements are small, whilst at the same time the heat demand is greater than that which can be taken from the low-temperature source, the necessary make-up may be obtained from steam raised in an additional heating system. This latter is of such dimensions as to be capable of supplying the required maximum of 118,750 B.Th.U.s/hr. should for any reason the second compression stage, or the whole Heat Pump plant, be put out of action. For simplicity's sake this additional heating is put into service and adjusted by hand, i.e., not automatically.

Balancing Demand

If on the other hand a comparatively great demand for cold coincides with a small demand for heat, part of the ammonia vapours delivered by the first compression stage is condensed in an existing trickling condenser, the second compression stage then drawing in only enough of these vapours to cover the momentary heat requirements. Should the heat demand fall below 37 per cent. of the maximum value, part of the heat supplied by the second stage may be eliminated by the admission of cold water into the hot-water circuit, or the whole demand might be covered by the aforementioned additional steam heating plant, and the second compression stage put out of service. This regulation too is effected by hand for the sake of simplicity. Nevertheless safety members are provided, to render it impossible for abnormal conditions of service to be created owing to mistakes in regulation. Another set of safety devices is provided to put the first compression stage instantaneously out of action in case the second compression stage should fail to operate, or to stop the second compression stage if the prescribed delivery pressure is not reached by the first stage.

Any undue accumulation of heat—that is to say, a sudden reduction in the quantity of heat demanded from the Heat Pump plant—would cause a quick rise of the compression pressure of the second stage, an occurrence which must be prevented under all circumstances. For this reason, at the desire of the owners of the plant, the following safety devices have been provided.

Safety Devices

1.—An alarm device, the operating of which is made manifest optically or acoustically, should the pressure exceed a certain maximum figure ;

2.—A device by means of which cold water is automatically admitted into the hot-water circuit, in order to eliminate the surplus heat should the operating of the alarm device mentioned under (1) not be at once noticed ;

3.—A device by which the second compression stage, and thereby simultaneously the first stage, are automatically stopped should the pressure still continue to rise.

In addition to that, the plant is fitted with all the necessary safety valves, so that the ammonia gases can blow off in both stages to suction pressure, should the final pressures for some reason or other exceed the maximum permissible values.

Comparison between the Working Costs of the Heat Pump and a Coal-fired Heating Plant

Assumed working hours per annum	8,000
Heat requirements per hour	118,750 B.Th.U.s
Total heating output per annum	1000, × 10 ⁶ B.Th.U.s
Power required, measured at the terminals of the Heat Pump Motor	102 kW.
Heat pumped per kW-hour	4,657
So that the output factor of the Heat Pump side of the plant is	5.45
Electrical energy per annum, 8,000 × 102 =	816,000 kWh.
Cost of electrical energy	3.5 ct/kWh.
Annual cost of energy	£1,677

For covering these heat requirements with a coal-fired plant, the conditions would be approximately as follows :—

Calorific value of the coal	7,000 cal/kg.
Overall heat efficiency	0.88
Annual coal consumption	617 tons
Assumed coal price	100 Sw. Fr./ton
Annual expenditure for coal	61,700 Sw. Fr.
Cost of coal, per 10,000 cal/h... ..	16.25 ct.

At 17 Sw. Fr.—£ ; cost would be £3,630, so that there would be an increase for fuel of almost £2,000.

Under these circumstances the Heat Pump plant effects an annual saving of Sw. Fr. 33,300, and the expenditure entailed, including all building work, erection, etc., can thereby be paid off in about five years.

The chemical and foodstuffs industries employ concentrating plants wherever concentrates or salts have to be obtained from thin solutions. Plants of this kind differ in their manufacture according to the requirements of service. There is an essential distinction between plants in which the single evaporators are fully loaded and then emptied after the completion of the evaporating process (Fig. 82), and those for continuous operation, in which the

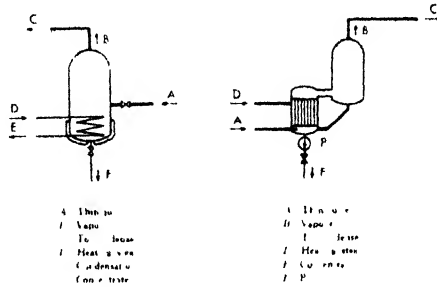

Fig. 82.—Diagrams of (left) an evaporating plant for single-load service, and (right) an evaporator for continuous service

solution flows to the evaporator without interruption and the concentrate is led off continuously (Fig. 82). In order to save heat several evaporating units can be connected in series (multi-stage evaporator, Fig. 83), in which case each stage is heated by the vapours from the preceding stage and the pressures and temperatures decrease from stage to stage. Further savings are possible when evaporating plants are provided with a vapour compressor working either as a steam-jet compressor (dynamic Heat Pump, Fig. 84), or as an electrically driven turbo-compressor (mechanical Heat Pump, Fig. 84).

It is the duty of the engineer to examine the requirements in each case and to propose the type of evaporator which is best adapted to the end in view on both technical and economic grounds. The problems which arise are so varied that they can only be satisfactorily solved with the aid of wide experience in the manufacture of evaporators and similar apparatus.

Economy of the Various Systems

Economy and reliability are the guiding thoughts in the projection of concentrating plants. For plants of small capacity and for

particular products (such as sweetened condensed milk) evaporators working on the single-charge principle are chiefly utilised (Fig. 82, left), while continuous plants are normally preferred for large quantities of material (Fig. 82, right).

The multi-stage evaporator (Fig. 83) is often advantageous when the height of the boiling temperature is of no importance, that is to say when the temperature difference necessary for evaporation

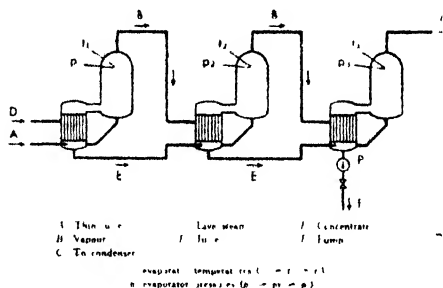

Fig. 83.—A multi-stage concentrating plant

stages can be chosen as desired. If, however, the liquids to be concentrated are sensitive to temperature, which is the case for instance with milk and fruit juices, the total temperature drop necessary for a multi-stage evaporator is no longer available, since the maximum temperature is already more or less fixed. The multi-stage evaporator is then replaced by types employing vapour compression, either with steam-jet apparatus or with electrically driven turbo-compressors.

Obviously, a multi-stage evaporator (Fig. 83) may also be combined with a steam-jet compressor (Fig. 84, left) or a turbo-compressor (Fig. 84, right).

The simple single-stage plant requires about 1.1 lb. of heating steam to evaporate 1 lb. of water. Multi-stage evaporators require only the quantity of fresh steam needed for the first stage, since the subsequent stages can be heated with the vapour from the preceding evaporator. The larger the number of stages into which the evaporating process is divided the smaller is the steam consumption. On the other hand, a larger number of stages means higher initial costs. Fig. 85 shows the course of the live steam

consumption and the quantity of vapour produced with 1 kilogram of live steam in dependence on the number of stages.

Evaporators with steam-jet compressors correspond roughly to a two-stage plant in their consumption of live steam.

The diagram in Fig. 86 gives information about the costs of steam, electric current and water under Swiss conditions for the following types of evaporator :—

- (a) concentrating plants with from 1 to 4 stages, as shown in Figs. 82 and 83 ;
- (b) evaporators with steam-jet compressors, as shown in Fig. 84 ;
- (c) concentrating plants with Heat Pumps (electrically driven turbo-compressors) as shown in Fig. 84.

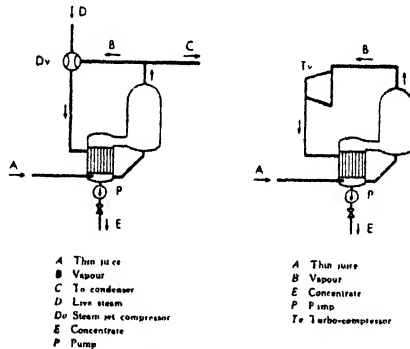

Fig. 84.—(Left) a concentrating plant with steam-jet compressor, and (right) concentrating plant with turbo-compressor

For the purposes of the diagram, fuel giving 7,200 kcal. per kg. and eight-fold evaporation in the steam boiler were assumed as a basis. If other fuels have to be considered, the cost for 7,200 kcal. should be worked out, and due account should be taken of the different evaporating figures of the boiler plant. For a concentrating plant with an evaporating capacity of say 2,000 kg. per hour, a vapour temperature of 50° C., a coal price of Sw. Fr. 120.— per ton (calorific value = 7,200 kcal. per kg.) and an annual total of 3,000 working hours, the costs for steam, electric current and water per annum, according to the diagram in Fig. 86, amount to the following figures :—

PRACTICAL APPLICATION

	Approx. Sw. Fr.
(a) For a single-stage plant	116,000.—
For a four-stage plant	30,000.—
(b) For an evaporator with steam-jet compressor ...	73,000.—
(c) For a plant with turbo-compressor at 4 cts. per kWh.	30,000.—
At 2 cts. per kWh.	20,000.—

The diagram in Fig. 86 shows further that a three-stage or four-stage concentrating plant may in some circumstances be no more expensive in service than a plant with a Heat Pump. On the other hand it is clear that when the cost of fuel is high, the conversion of

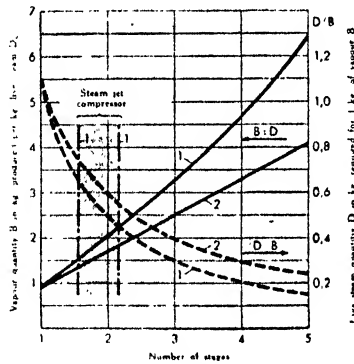

- 1 = Juice entry at boiling point
- 2 = Juice entry with preheating by stages

Fig. 85.—Steam consumption of single and multi-stage evaporators with steam-jet compressors

existing plants with high steam consumption to Heat Pump service may very well be a paying proposition, though in view of the amortisation and interest an annual total of at least 3,000 working hours must be assumed.

The equipment of a concentrating plant with a mechanical Heat Pump (turbo-compressor) is justifiable above all when cheap hydraulically generated electrical energy is available, and in particular where steam-raising costs are high. If it would in any case be necessary to erect or extend a boiler plant for the purposes of concentration, the costs of the Heat Pump and its accessories are partly compensated by the cancellation of this item.

THE HEAT PUMP

Another great advantage of a Heat Pump plant is its low cooling-water consumption, which is particularly favourable in countries with poor cooling-water conditions.

The higher the evaporation pressure and the smaller the temperature difference between heating steam and material to be concentrated, the better a Heat Pump plant will work, as can be seen from Fig. 87. While in a low-temperature plant perhaps 10-15 kg. of

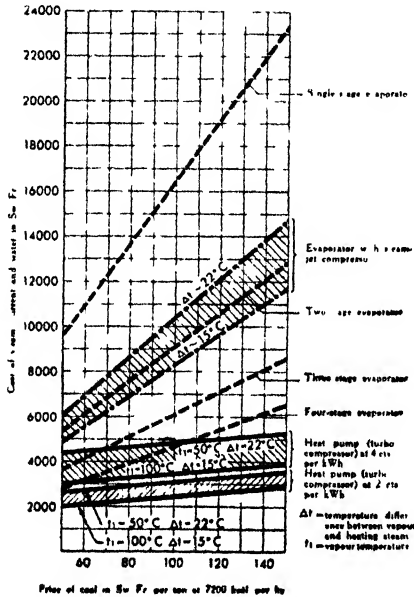

Fig. 86.—Cost of steam, electricity and water for the production of 1,000 kg. of vapour per hour for a working period of 1,000 hours

water can be evaporated per kWh., this figure will be about 20-25 kg. of water per kWh. for an evaporator with contents boiling at about 100° C. The position is very similar with the steam-jet compressor—the smaller the temperature difference, the smaller will be the quantity of live steam required.

In many cases it is worth while to consider the installation of Heat Pumps in existing plants, as notable savings of fuel may be possible with a relatively small consumption of electric energy.

Quite apart from the thermal processes involved, the material used for the plant also plays a part of considerable importance. An iron evaporator can be planned on quite different lines from evaporators of more expensive material, for instance stainless steel, which may in some cases be necessary.

Application

No generally valid rules can be laid down as to the evaporating system to be preferred, since too many factors have to be taken into

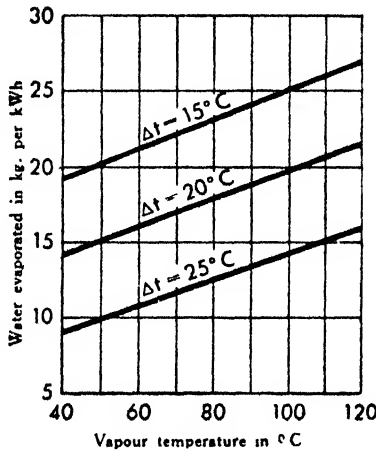

Fig. 87.—A graphical illustration of the dependence of possible evaporation with 1 kWh on the vapour temperature, and the temperature difference Δt between heating steam and vapour

consideration. The most favourable solution must be arrived at by careful investigation into the prevailing conditions in each particular case.

Low-temperature vacuum evaporators of stainless steel have proved their worth very particularly in the foodstuffs industry. Low temperatures and stainless non-corroding chromium nickel steel with 18 per cent. chromium and 8 per cent. nickel content provide a guarantee that valuable organic substances and vitamins, as well as colour and taste, are retained unimpaired. Low temperatures and high vacua, however, make heavy demands on the apparatus with regard to manufacture and machining, and only workshops with up-to-date equipment and well-trained workmen are equal to the requirements involved.

One of many evaporating plants is shown in Fig. 88. It serves for the production of concentrated fruit juices and operates with an electrically driven turbo-compressor working as a Heat Pump. All parts that come in contact with the fruit juices are of stainless non-corroding chromium nickel steel, and this fact, combined with the very low concentrating temperatures, ensures the faultless condition of the products in every respect.

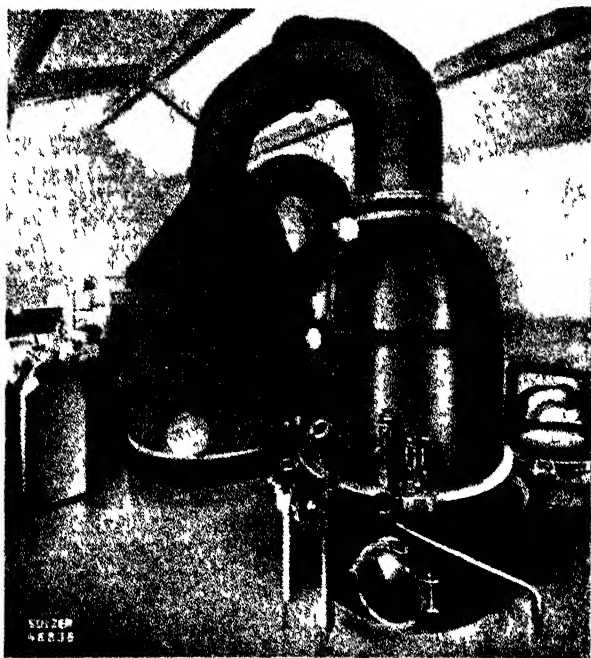

Fig. 88.—Sulzer concentrating plant for fruit juices, with Heat Pump

In the foreground of the picture is the separator, while in the right background one of the external tubular evaporators is visible. In the background to the left is the driving motor of the Heat Pump and the switchboard. Between the Heat Pump and the separator is the vapour cleaning and drying plant.

A Thermo-Compressor Installation for Concentration of Milk

Thermo-compressors for the concentration of solutions belong to the domain of Heat Pumps which have been used already for several decades for refrigerating as well as for heating purposes.

The thermo-compressor is a heating machine, the use of which is particularly advantageous for the recuperation of heat in concentrating plants. The exhaust heat contained in the steam is recuperated by compression to a higher pressure for heating the evaporator. The heat quantities involved in such concentrating installations are usually large, and by means of the apparatus described, it is possible to recuperate this heat, so that the saving in fuel thus achieved is of considerable economical importance.

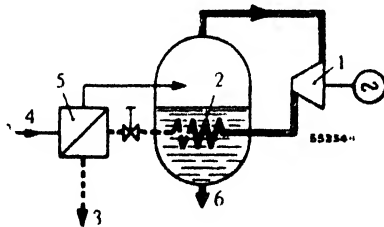

Fig. 89.—Concentrating plant with thermo-compression

- | | |
|----------------------|--------------------------|
| 1. Vapour compressor | 4. Dilute solution |
| 2. Heating coil | 5. Preheater |
| 3. Condensate | 6. Concentrated solution |

Fig. 89 shows the fundamental diagram of a Brown-Boveri thermo-compressor plant. The electrically driven vapour compressor pumps the distilled steam into the heating coil 2 of the cooker, where it is cooled and gives up its latent heat of evaporation during liquefaction. The condensate leaving at 3 can advantageously be used to preheat the dilute solution 4 in a heat exchanger 5, thereby making the heat recuperation complete. The amount of driving power required depends on the difference between the heating and the boiling temperatures, which by liberally dimensioning the heating surface 2 may be kept so small that it remains between the limits of 15–25° C. With such temperature differences the evaporation factor is of the order of 15–25, that is, the energy absorbed by the driving motor of the thermo-compressor is from 10–17 times smaller than that of an electric boiler required to achieve the same result. It is, therefore, easy to understand that the thermo-compressor is employed not only in industry for concentrating all sorts of solutions, but also that it has recently found application for the concentration of agricultural products, such as milk, fruit juices, etc.

The Lucens Installation

At the Lucens cheese factory of the Federation Laitiere Vaudoise-Fribourgoise is installed a thermo-compressor for the concentration of milk.

The installation was planned and supplied by the Aluminium Welding Works of Schlieren, as general contractors, with the collaboration of the technical office of J. Krieg, Zurich. The plant, erected in the centre of a rich milk producing region, was put into service in August, 1942.

The milk production of Switzerland of over 2½ million tons per annum is so irregularly distributed over the year, that a large part has to be converted into butter and cheese.

For the manufacture of high-quality butter, the cream is removed by means of centrifugal separators. The remaining skimmed milk was in previous years used as a dairy by-product for feeding cattle, or was even allowed to run to waste. Already at an early date attempts were made to find a technically remunerative use for the skimmed milk. This is, however, only possible if the manufacturing costs of the products obtained do not exceed the world market prices. As, however, all products necessitate the reduction of the water content, even when dried milk is not the final product, all manufacturing processes involved may be looked upon as concentration processes. By extracting the water, a dried, non-perishable and nourishing skimmed milk can be obtained, which may be used both in the foodstuffs industry and as fodder. The economics of the water extraction of the usual concentrating and drying installations depend mainly on the cost of fuel.

Milk-sugar Manufacture

The manufacture of milk-sugar, in particular, is only possible with extremely low costs of concentration. This can be achieved with the distilled vapour Heat Pump, which at Lucens is used alternately by the special technical department for pasteurising for recovering the albuminoids and the milk-sugar, and for concentrating skimmed milk. The quick circulating concentrating plant enables the milk to be concentrated into milk serum at temperatures below 60° C. and with heat application time of a maximum of 30 minutes.

The subsequent drying of the concentrated skimmed milk is then effected in a vacuum drying oven, heated by circulation of hot

PRACTICAL APPLICATION

condensate from the concentrating plant, which is further heated by live steam.

The Lucens installation is built for the following conditions :—

Hourly evaporation	1000 kg/h
Power at the motor terminals	73 kW
Evaporation factor	13.7 kg/kWh.

In practice the figures attained are :—

	Dried Milk Manufacture approx.	Milk-sugar Manufacture approx.
Quantity of skimmed milk or serum treated per hour	1500 kg.	1200 kg.
Concentration before treatment in parts by weight	9.5	4
Final concentration in parts by weight	65	72

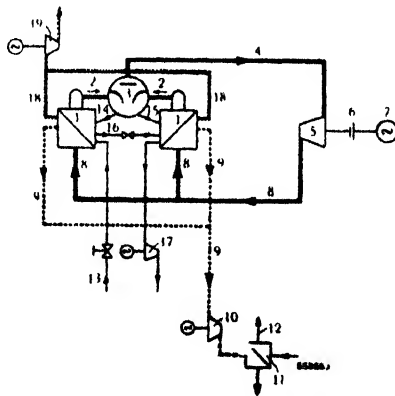

Fig. 90.—A diagram of the Lucens milk concentrating plant with thermo-compression

- | | | |
|-----------------------|-------------------------------------|-------------------------------|
| 1. Evaporator | 8. Compressed vapour | 13. Dilute milk |
| 2. Vapour | 9. Condensate | 14, 15. Return from separator |
| 3. Moisture separator | 10. Condensate pump | 16. Connecting pipe |
| 4. Vapour pipe | 11. Recuperation of condensate heat | 17. Concentrated milk pump |
| 5. Compressor | 12. Heated process water | 18. Air extraction |
| 6. Reduction gear | | 19. Air pump |
| 7. Driving motor | | |

Fig. 90 shows a diagram of the plant. The steam produced on the steam side of the two cookers 1—1 connected in parallel flows via the connection 2—2, the separator 3 and the connection 4 to the

thermo-compressor 5. The moisture carried over with the steam is removed by centrifugal action in the separator 3 and returns by gravity via 14—15 back to the evaporators 1—1. The milk to be concentrated is fed by the connection 13 to the left-hand heated space 1, the heated space on the right is fed by the connection 16, that is, by the circulation in the left-hand heated space where a certain concentration is already present. The turbo-compressor 5 forces the compressed and superheated steam to the heating coil 1—1. The condensate pump 10, in the basement, delivers the condensate to atmosphere via the pipe 9, where the heat in the condensate serves for warming process water 12 in the exchanger 11.

The water-ring vacuum pump 19 serves to remove the air leaking into the vacuum system (pipes 18—18). The condensate pump 17 delivers the concentrated milk to atmosphere for further treatment for the recovery of the milk-sugar, which is periodically also effected with the Heat Pump.

The compressor 5 is driven by a three-phase induction motor 7 of 140 kW at 380 V, 50 cycles, 2936 r.p.m.

Fig. 91 shows the installation completely erected with the thermo-compressor set in the foreground, and the two heaters and the separator in the background.

Test Results

The results of the service tests carried out on site with mercury columns and calibrated thermometers exceeded the specified performance of the set in regard to the amount of water evaporated per hour and the guaranteed concentration, as well as in regard to the specific energy consumption.

A few figures taken from these tests are given below :—

Hourly evaporation of water	1370 kg/h
Power at the motor terminals	89.8 kW.
Concentration before evaporation about	4% dry content
Concentration after evaporation	70% dry content
Evaporation figure	15.25 kg/kWh.

The adjustment of the installation was effected in a relatively short time. The method of starting and the choice of suitable pressure conditions enabled the strong tendency to foaming to be

PRACTICAL APPLICATION

overcome. An effective separator protects the compressor from entrained moisture.

In the planning of concentration installations using Heat Pumps, careful calculation of the heat and temperature balance is essential. Whereas with direct heating about 600 kcal are consumed for every kilogram of water to be extracted, a heat equivalent of only about 60 kcal/kg has to be supplied from the external source. Mistakes in the heat balance therefore show up tenfold in the latter case.

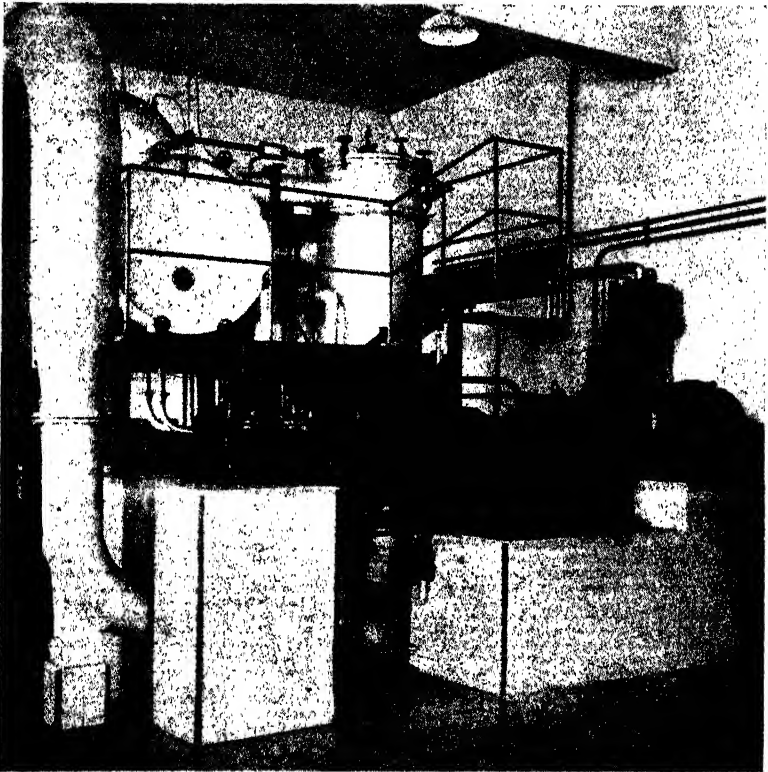

Fig. 91.—The Lucens milk concentrating plant with thermo-compression as installed

With this apparatus—evaporator and drip separator—strongly foaming solutions may be concentrated with small energy consumption without danger of fouling the thermo-compressor

A thermo-compressor installation has also been acquired by the Nordostschweizerische Milchgenossenschaft Winterthur, for concen-

trating milk, as well as fruit and grape juice, in their plant at Uster. This installation was also planned and supplied by the Aluminium Welding Works of Schlieren.

Heat Pumps for Evaporation and Distilling

An important field of application of the Heat Pump is to be found in evaporating and distilling plants which, directly or indirectly, serve the purpose of concentrating a chemical solution while recovering the solvent. This end is achieved by heating the solution so as to evaporate the solvent, which is then cooled, precipitated and recovered in a liquid form. The heat employed in evaporation is freed again in the condenser and can be utilised almost in its entirety to maintain the process. For the Heat Pump or steam compressor then required the oilfree reciprocating compressor offers a particularly appropriate design.

Simple Process

With the aid of the Heat Pump, the evaporation process becomes very simple. The vapours formed during distillation are compressed, their temperature rises and they thus become capable of giving up heat in the closed heating system of the apparatus. The output required from the compressor depends on the rise in pressure, which in its turn is dependent on the heating surface of the evaporator and on the difference between the boiling-points of the solution and the pure solvent. The equivalent in heat of the compressor output is passed on to the vaporous heating medium and is thus turned to account in the circuit. But since mechanical energy is more valuable from a thermo-dynamic point of view than heat, the aim must be to save power by keeping the difference in pressure and temperature between the heating steam and the vapours as small as possible. This difference should, in fact, only be so great as to allow the heating surfaces to be comfortably accommodated.

Carrying Medium

It appears from the above that the solvent itself acts as the heat-carrying medium. This solvent is as a rule a valuable chemical which has to be collected in its entirety after condensation for further use. It is thus a matter of the utmost importance that the substances taking part in the process should not be contaminated

in any way. One of the points, and perhaps the only one, at which foreign matter might enter the closed circuit, lies in the compressor. A lubricated machine or one subject to great internal wear would inevitably impair the quality of the solvent reclaimed. Lubricated compressors or those in which graphite piston rings or other make-

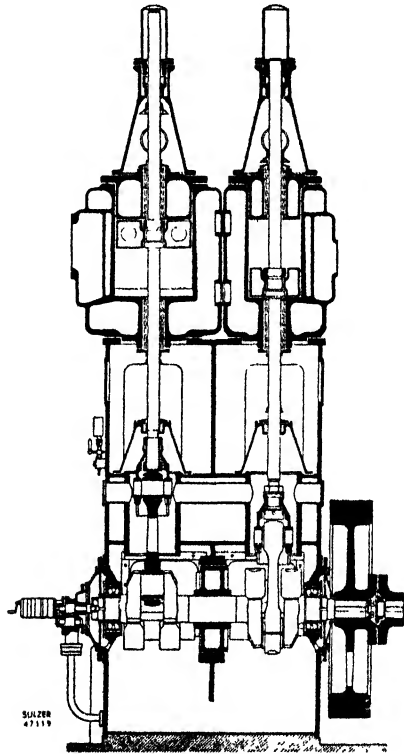

Fig. 92.—Sectional drawing, longitudinal through an oil-free oxygen compressor dealing with 840 cu. ft. per min. at 85 lb. per sq. in.

shift sealing means are employed are for this reason unsuitable for use as Heat Pumps in concentrating systems.

Extensive Plant

In extensive plants, where considerable quantities of vapour have to be dealt with, the services of the turbo-compressor or the modern axial compressor are best enlisted. The advantages of this type of machine are its economical handling of large volumes with a

comparatively small pressure difference and the fact that it requires no lubrication in the parts swept by the vapour. When, however, the ratio of volume delivered to pressure is unfavourable for the turbo-compressor, either because the quantities in question are small or because—as is often the case in the chemical industry—comparatively high compression is necessary, the requirements can be met only by a good piston-type compressor. The special designs which are occasionally recommended on the strength of price considerations are mostly unsatisfactory for technical and economic reasons. Consequently the foodstuffs and chemical industries have repeatedly expressed the wish to see a reciprocating

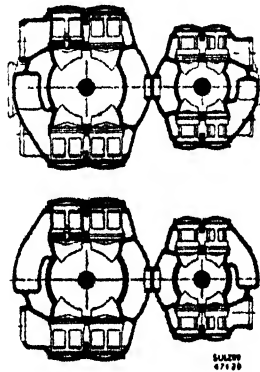

Fig. 93.—Plan of the oil-free Sulzer oxygen compressor

compressor developed which would require no cylinder lubrication and would preclude contamination of the gas or vapour during compression.

The first plants were delivered to breweries, where compressed air is required which is guaranteed free from oil and can be brought into direct contact with the beer without fear of its contamination. Since that time, the oil-free compressor has won its way into the most varied industries. It has been further developed, built to give larger outputs and higher pressures and equipped with an approved design of automatic regulation.

Two-stage Compressor

The sections through a two-stage compressor seen in Figs. 92 and 93 show the main features of the oil-free design. Sealing

between the piston, piston rod and cylinder is achieved by a labyrinth effect only, without any surface contacts; and it is done so effectively that there is scarcely any perceptible distinction between the efficiencies of the oil-free compressor and a corresponding lubricated design. An illustration of this fact is given in Fig. 94, which shows the efficiency in its dependence on the compression ratio for a compressor of medium size. The mean efficiencies shown may be exceeded in individual cases, according to the conditions of service. Not only is the cylinder kept free from the slightest trace of oil, but internal friction is also eliminated as a source of metallic contamination and losses. As there is no need to take the stability of lubricating oils into consideration and wall temperatures

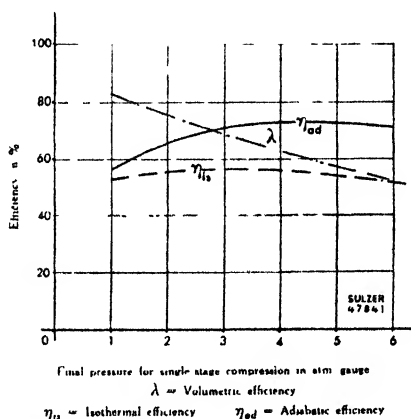

Fig. 94.—A diagram showing the efficiencies in dependence on the pressure ratio

can be left out of account, it is possible for the compression ratio to be raised to figures which would be inadmissible in lubricated machines. Compression ratios of 4 to 5, and in extreme cases of 6 to 7 per stage, have proved to be quite practicable. Thus it is often possible for a single-stage oil-free compressor to take the place of a two-stage machine of the lubricated design, which makes for considerable simplification of the plant. The expenditure for lubricating oil, itself a substantial item, is done away with, and a good margin can be saved on attendance and upkeep. Its limitation at present lies in the fact that the final compression pressure cannot be raised indefinitely. The upper limit for the single-stage com-

pressor, as stated above, lies at about 70-100 lb. per sq. in., and that for the two-stage machine at 200-280 lb. per sq. in.

Oil-free Design

On the other hand, the oil-free design can also be employed for vacuum pumps, so that it is suitable for service in all types of evaporating plant, whether these work with pressures above or below the atmospheric. There is a considerable demand for oil-free vacuum pumps in the chemical industry, as they are particularly suitable for the distillation and recovery of valuable solvents and other chemical substances. When the usual lubricated vacuum pump was the only type available, the pollution of the vapour had to be counteracted by the use of various auxiliary devices. Quite apart from their cost and space requirements, however, these were scarcely more than half-measures of very limited efficacy.

The drive of the oil-free reciprocating compressor used as a Heat Pump can also be incorporated in the general system, especially when a great deal of heat, in the form of heating steam, is required for the maintenance of the chemical process involved. In such cases it is advisable to drive the Heat Pump with steam power, for instance by means of a turbine equipped with powerful reduction gearing. The heating steam required for the process is expanded in the steam power unit and thus provides the driving power for the Heat Pump. The efficiency figure is very favourable, since the power unit only extracts from the steam the equivalent in heat of the power required for the drive and causes no waste of heat or energy apart from the insignificant radiation losses.

In former times the steam engine was the commonest form of drive for compressors. The engine could be coupled direct to the compressor ; in itself a good economic proposition, it also permitted the delivery of the compressor to be varied continuously within wide limits and practically without loss by means of a simple speed adjustment. And it is precisely this easy adjustability which is as a rule important for chemical processes.

The Steam Engine

The steam engine and the compressor have always been very closely linked in the sphere of organisation. Some important elements of the two are identical, and experience acquired with the one can often be applied to the other. When in the course of the years the popularity of the condensing engine declined in the face

of advancing electrification, it was the compressor which kept the steam engine in demand, since the leading chemical works frequently specified steam drives for their compressors. The back-pressure

TABLE 10

**8 in. × 8 in. Twin Cylinder Monobloc Methyl Chloride Machine
350 r.p.m.**

Refrigeration capacity, heat rejected to condenser and kilowatt input to compressor motor.

(a) With condenser gauge at 155° F. and the following values of evaporator gauge

(b) With evaporator gauge at 40° F. and the following values of condenser gauge.

The efficiency of compressor motor is assumed to be 90 per cent.

Evaporator Gauge °F.	B.Th.U.s/hr abstracted	B.Th.U.s/hr. rejected to Condenser	Kilowatt Input to Compressor Motor	(a)
30	323,000	452,000	50.6	Condenser Gauge 155° F.
35	366,000	501,000	53.2	
40	412,000	554,000	55.7	
45	462,000	609,000	58.0	
50	516,000	668,000	60.1	
55	576,000	734,000	61.8	
60	642,000	804,000	63.4	
70	792,000	960,000	65.7	
Condenser Gauge °F.	B.Th.U.s/hr abstracted	B.Th.U.s/hr rejected to Condenser	Kilowatt Input to Compressor Motor	(b)
115	521,000	622,000	39.5	Evaporator Gauge 40° F.
120	504,000	611,000	41.4	
125	490,000	602,000	43.6	
130	476,000	593,000	45.8	
135	462,000	585,000	48.0	
140	449,000	576,000	50.0	
145	436,000	568,000	52.0	
150	423,000	561,000	53.6	
155	411,000	554,000	55.7	
160	399,000	546,000	57.4	
165	388,000	538,000	59.2	
170	376,000	530,000	60.7	

steam engine generally used for such drives was adapted to modern conditions. Engines were developed for steam admission temperatures above 700° F. and for the highest pressures encountered.

It must be admitted, on the other hand, that the steam turbine is justified where it is not a question of obtaining a maximum output from a given quantity of steam. In such cases it offers the advantage of oil-free service, though it calls for heavy, and usually

double, speed reduction gearing. From the point of view of heat economy, the efficiency of the steam power unit in purely back-pressure service is of no great import, since it extracts only as much heat from the steam as it can convert into mechanical energy. If its efficiency is low, the amount of steam required for a given output is greater, but the heat extracted from it per unit quantity is correspondingly less, so that a greater percentage is available for heating at the outlet of the engine.

The Monobloc type of compressor as made by J. & E. Hall, Ltd., has long held the field in the refrigeration industry and offers an

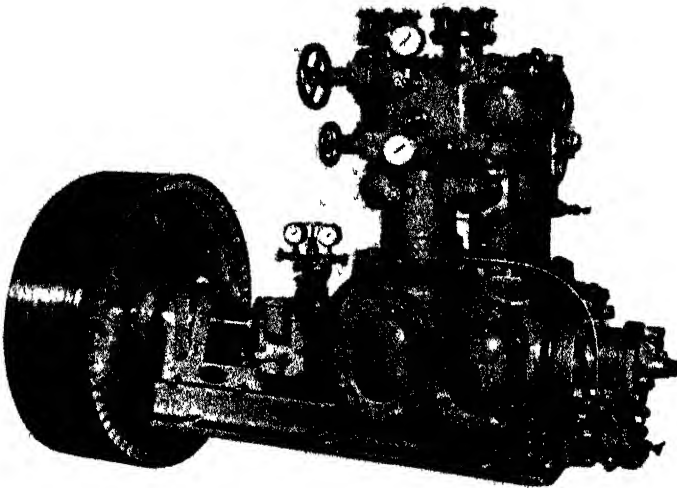

Fig. 95. J. E. Hall 8" × 8" Compressor

immediate well-tested machine for the Heat Pump. This machine (Fig. 95) is an 8 in. × 8 in. twin cylinder monobloc methyl chloride machine running at 350 r.p.m., and the table gives a useful guide in selecting a suitable compressor. The cylinders have a spring loaded safety valve to relieve any excess pressure which may be created if liquid ammonia enters the cylinder. There is also an additional safety device consisting of a metal disc which bursts under abnormally high pressure, which provides a relief from the discharge side of the suction side of the compressor. The rated

output of the machine is 42 tons refrigeration = 12,000 B.Th.U.s per hour at + 5° F. evaporation and 86° F. condensation, while for high evaporation duty 105 tons refrigeration at + 40° F. evaporation and 86° F. condensation is the rating.

The Value of the Heat Pump for Heating Installations

Although it has only attracted wide interest in the recent years of fuel shortage, the Heat Pump is not a new invention, as we have seen. It was therefore not any lack of scientific knowledge nor of machines capable of applying such knowledge which prevented the Heat Pump from being widely adopted at an earlier date. The real obstacle was the familiar fact that the impetus towards the practical employment of a superior method can only be provided by suitable economic conditions. The generation of artificial cold had long been an urgent requirement of the foodstuffs and brewing industries, and it was for this reason that the necessary machines were invented and built. Heat, however, was obtainable from other sources than the Heat Pump. The most obvious means of heat generation is combustion, and fuel-fired boilers with good efficiencies were available long before the Heat Pump was invented.

To-day, however, coal is no longer a fuel alone, but is becoming a more and more important raw material of the chemical industry, which makes fuller use of it than if it were burnt.

From the economic viewpoint, however, comparisons of heat generation by direct methods and with the Heat Pump are affected not only by fuel prices but also by the available energy supplies, as mechanical energy is needed for driving the Heat Pump. We shall therefore have to take the prices of hydraulically and thermally produced energy into account.

During the first World War the shortage of coal and the resulting rise in coal prices led to the first active development of the Heat Pump. When coal prices dropped again after 1921, however, interest in the Heat Pump practically disappeared. The hydraulic power stations then renewed their support of the Heat Pump just before the outbreak of the second World War. The idea behind this move was no doubt that, with the more complete harnessing of water power, electric current would be used on a growing scale for heat generation, and that a Heat Pump driven by an electric motor would offer more favourable current prices than, say, electrical resistance heating.

The few Heat Pump plants then in existence were not able to exert any practical influence on the new fuel shortage which came with the year 1940, especially in Switzerland. They were of course of great assistance to their owners, but represented only a very minor relief for the national heat economy. To-day, when many further plants have been installed, the position would no doubt be different. An estimate of at least 60,000 and perhaps even 100,000 tons per year as the coal saving to be ascribed to Heat Pump plants in Switzerland, for instance, cannot be far off the mark.

Electrical Supply

The supply of unlimited amounts of electrical energy, however, is also impossible, although vast schemes are being developed in Scotland. The extreme water shortage of the 1947 summer and autumn in Europe demonstrated this very clearly in countries which generate their energy mostly by hydraulic means. But even in normal years it is not possible with the existing hydro-electric plants to meet the full demand for electric energy, which is rising rapidly, particularly in winter. It is for this reason that peak-load thermal power stations are again attracting wide interest, to act as an accumulator for off-peak periods.

Since the hydro-electric power stations, despite the heavy calls on them, will nevertheless be forced by the demand to make an ever-increasing contribution to heat supplies, thereby counteracting the lack of valuable and expensive fuels, the only solution is that the electric heating processes must be made as economical as possible; and it is precisely on this account that the Heat Pump is likely to play a role of some importance, says E. Wirth, with which the author agrees.

Before the various applications of the Heat Pump are explained with practical examples, a simple pictorial presentation will be useful as an illustration of the analogy between hydraulic and thermal processes.

Water and Steam Plants

Fig. 96 shows simplified diagrams of a water-power plant on the left and a steam-power plant on the right.

The water level of the hydraulic storage lake at the top left may be assumed to lie at a height of 473 metres above sea-level, and the tail race of the water turbine at 293 metres. The water leaving the

turbine enters a river which finally flows down to the sea. The hydraulic energy supplied to the water turbine corresponds to the product of the effective head ΔH m. and the weight of water G kg. The energy balance of this hydraulic plant is shown in the middle of Fig. 96, where the weight of the water is plotted along the

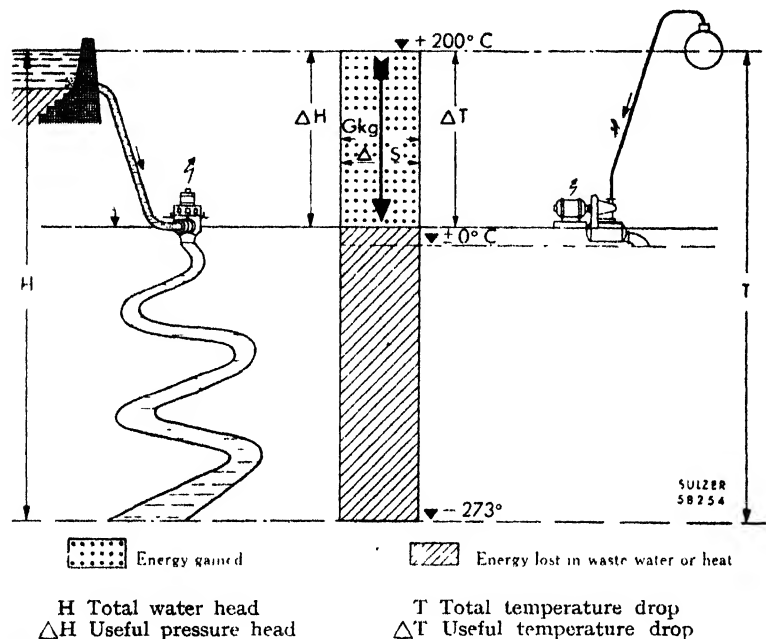

Fig. 96.—Generation of electric energy with water power (left) or heat (right) by allowing a downward flow in the direction of the black arrow

abscissæ and the head along the ordinates. The dotted area represents the work theoretically available for use, the hatched area the energy not utilised but lost through flow resistances in the river.

Boiler Steam

The steam boiler visible at the top right may be assumed to supply steam at 200° C. (or 473° C. absolute temperature), which is expanded in the condensing steam turbine below it to, say, 20° C. (or 293° C. absolute temperature). These figures are chosen to correspond to those in the hydraulic example. The work done in the turbine drives an electric generator. In this case the theoretically useful energy corresponds to the product of the available

temperature drop ΔT °C. and the entropy difference ΔS which, if not quite accurately, may for explanatory purposes also be termed the "heat weight." The entropy itself is defined by the formula

$$S = \int \frac{dQ}{T} \text{ B.Th.U.s } ^\circ\text{C.}^{-1}.$$

The energy balance can be graphically represented in this case also, and with the temperature and entropy figures chosen gives exactly the same diagram as the hydraulic power plant. The dotted area again corresponds to the theoretically useful work, while the hatched area is the energy loss inevitably involved because the heat supplied cannot be cooled down to the absolute zero of -273°C. , but leaves the steam turbine at the fairly high absolute temperature of $T = 293^\circ\text{C.}$

This presentation of the energy balance sheet is nothing else but the schematic entropy diagram of the thermal energy conversion described earlier in this work. As the entropies are plotted along the abscissæ and the absolute temperatures along the ordinates, the areas which appear as the product of these magnitudes represent heat quantities. The unit of heat, the kilogram-calorie or B.Th.U.s corresponds to 427 metre-kilograms of energy. The water and heat generate power while flowing in the direction of the black arrow from the upper to the lower altitude or temperature level. On account of its simplicity, this method is also used in the following examples.

Production Analogy

While Fig. 96 illustrates the analogy between hydraulic and thermal energy production, Fig. 97 shows the energy conversion in the pumping of water and heat. The water and the heat are raised from the lower to the higher level in the direction of the white arrow, energy being expended in the process. The pumping plant on the left raises the water from a height of 293 to 473 metres above sea-level, to retain the figures used in the first example. The theoretical energy requirements are represented by the dotted area on the left. If it were desired to represent the energy content of the water before pumping as compared with sea-level, the strip would have to be extended below the dotted area down to sea-level. This would only have a theoretical significance, however, as this energy is not practically in evidence in the present case.

In the pumping of heat a definite heat quantity, represented by the diagonally hatched area, is absorbed from the surroundings (air or water-course) at 20°C . (or 293°C . abs.) by a somewhat cooler vaporiform or gaseous working medium, after which the working medium is compressed. The work theoretically needed for this purpose in the compressor is shown in the dotted area on the right. The compression brings the working medium, with the heat absorbed by it, up to a temperature of 200°C . (or 473°C . absolute). The heat equivalent of the mechanical energy introduced and the quantity of heat pumped to a higher temperature are represented together by the squared rectangle on the right. This heat quantity, as can be seen, is considerably greater than the heat equivalent of the mechanical energy introduced. What is more, as a result of its higher temperature, it can be used, for instance, in a central heating system. The ratio of the useful heat (squared area) to the energy introduced (dotted area) is known as the coefficient of performance, or performance figure. This is a measure of the efficiency of a given Heat Pump process and plays an important part in any assessment of its economy. It is now at once clear that the performance figure will be the higher, the lower the temperature difference ΔT by which the heat from the surroundings must be raised, and in a less degree the higher the initial level, i.e., the temperature at which the heat is drawn from the surroundings by the Heat Pump.

As already mentioned, this example is based, for simplicity's sake, on the same temperature levels as in the case of power generation illustrated in Fig. 96. A temperature drop of 180°C . ($473-293$) is, however, too high for a Heat Pump, as will appear more clearly from what follows. The theoretical performance figure in the present case attains only about 2.6, which, when the inevitable losses are taken into account, gives an effective performance figure of about 1. This means that the quantity of heat supplied by such a Heat Pump would correspond approximately to the heat equivalent of the energy introduced, and would thus not represent any gain. In such a case it would be much simpler to convert the available energy into heat in an electric boiler. The economically interesting field for the Heat Pump therefore lies above all in the range of low-temperature stages, as opposed to the converse process of power generation, in which, out of regard for the thermal efficiency, the highest possible heat drop must be aimed at.

F H E H F A T P U M P

The first Heat Pump to be used on any large scale was the refrigerating machine, as we have discussed earlier. In this the interest resided only in the heat extracted from the surroundings, or in other words, in the cold generated. The heat was then raised only to the temperature required in order to give it up to the cooling water.

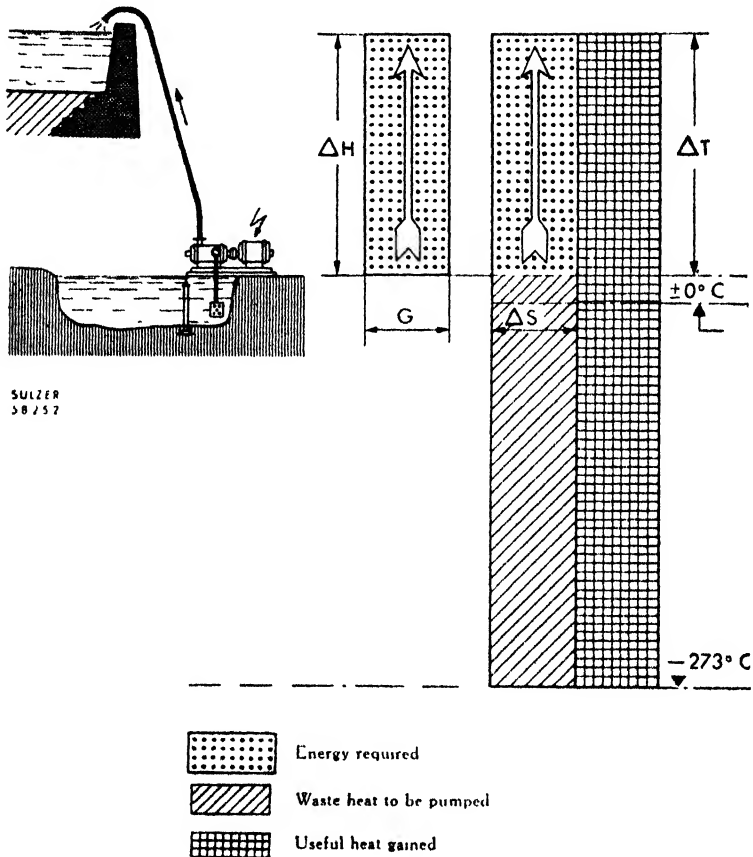

Fig. 97.—Pumping water (left) or heat (right) upwards in the direction of the white arrow

Fig. 98 shows the basic arrangement of an orthodox refrigerating plant with reciprocating ammonia compressor and its heat balance. The heat is extracted from the cellar at -15°C ., is pumped up to $+25^{\circ}\text{C}$. by the compressor and at this temperature is given up to

the water in the top right-hand corner. The quantity of heat extracted and given up and the energy supplied are again shown by the hatched, squared and dotted areas in the graphic energy balance. To the right a pump plant used for keeping down the water level in building foundations serves as a hydraulic analogue.

The heat given up at $+25^{\circ}\text{C}$. is mostly too low in temperature to be capable of practical employment. Theoretically, however, it is quite possible to raise the final pressure of the compressor and thereby to bring the heat up to a temperature level at which it can be utilised. The diagram of such a plant is given in Fig. 99, and to the right of it the corresponding hydraulic process. The heat is extracted from a watercourse at $+2^{\circ}\text{C}$., is pumped up to $+70^{\circ}\text{C}$., and is given up with the thermal equivalent of the energy introduced to the central heating systems shown schematically in the diagram. The quantities of heat and energy converted are shaded in the graph.

Performance Figures

The entropy diagrams used here to illustrate the energy balance correspond to the ideal Carnot cycle bounded by two isothermal and two adiabatic lines, which represents the highest energy utilisation theoretically attainable between two given limiting temperatures. As far as the Heat Pump is concerned, the figures practically attainable are only about 50 or 60 per cent. of the theoretical ones. Modern Heat Pump plants nevertheless give effective performance figures between 3 and 6. This means that the 3,440 B.Th.U.s, which is the heat equivalent of 1 kW-hour, together with the heat pumped from the surroundings, permits a useful heat quantity of 10,000 to 20,000 B.Th.U.s to be given off. In evaporating plants the values may be higher.⁴

Economy Factors

The economy of a Heat Pump plant naturally depends also on interest, depreciation, etc., and it is therefore desirable that the working hours per year should be as high as possible. Capital expenses per B.Th.U. converted will then be correspondingly lower.

This requirement is met in a high degree by combined plants used both for cooling and heating the heat diagram of which appears in

THE HEAT PUMP

Fig. 99. The lower compression stage brings the heat obtained at -17°C . up to $+22^{\circ}\text{C}$. (71°F). This heat quantity, to which is added the thermal equivalent of the energy introduced, is then raised in the upper stage of compression from $+22^{\circ}\text{C}$. to $+65^{\circ}\text{C}$. and, again augmented by the heat value of the energy supplied, is used for heating. An analogous two-stage pumping plant is shown on the left, one of the pumps serving chiefly for suction while the other lifts the liquid to a tank at a higher level.

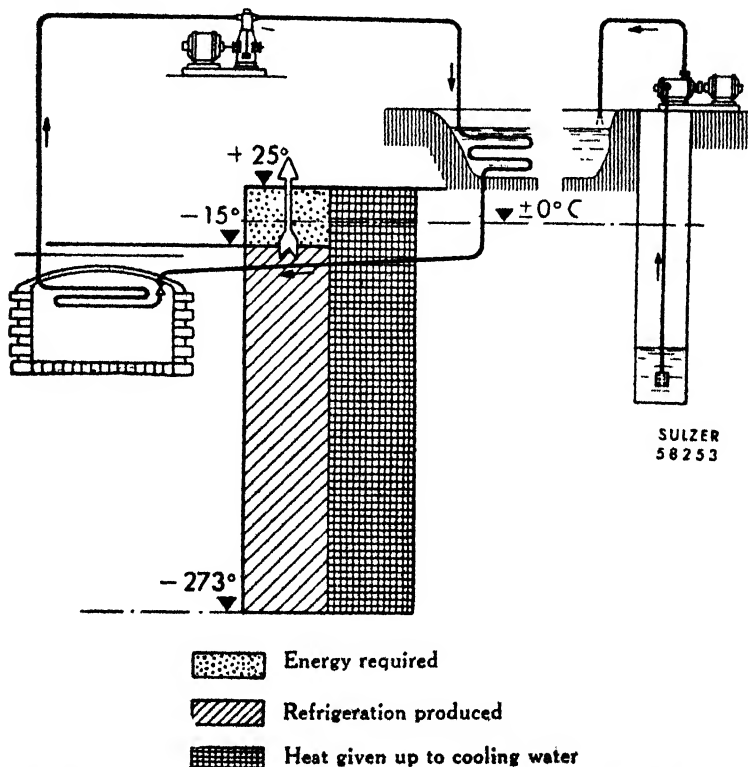

Fig. 98.—A diagrammatic illustration of a refrigerating plant with corresponding heat diagram. On the right is a pump for the purpose of hydraulic analogy

A combined plant working within these temperatures was actually installed in a large industrial undertaking in Switzerland in the period of fuel shortage during the 1939-45 war. A refrigerating plant consisting of three compressor units (Fig. 100) was already in exist-

PRACTICAL APPLICATION

ence, and to this a further compressor was added to act as an upper stage. The refrigerating stage operates between -17°C . ($+1^{\circ}\text{F}$.) and 22°C . (71°F .) at a maximum refrigerating capacity of 335,000 kcal. (1,340,000 B.Th.U.s) per hour, the heat stage operates between $+22^{\circ}\text{C}$. (71°F .) and $+65^{\circ}\text{C}$. (149°F .), the heat output being as high as 475,000 kcal. (1,900,000 B.Th.U.s) per hour. The plant can be finely regulated over a wide range and with very little loss.

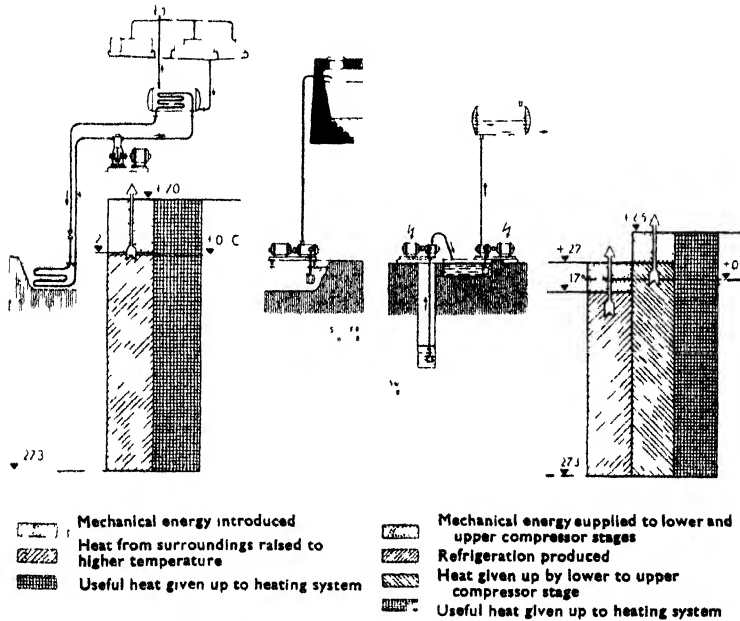

Fig. 99.—On the left is a diagram of a Heat Pump plant for central heating, with corresponding heat diagram, and a hydraulically analogous pumping plant. On the right is a diagram of a Heat Pump used simultaneously for heating and cooling, with corresponding heat diagram and a hydraulically analogous two-stage pumping plant

As refrigeration is required in any case and the utilisation of the heat is effected exclusively through the additional upper stage, the performance figure can refer to the high-pressure stage alone. The measurements made for this purpose have shown that each kilowatt-hour used for driving the upper compressor stage produces 18,800 B.Th.U.s of useful heat, which corresponds to a performance figure of 5.45.⁵

A similar combined plant was supplied to a Swiss butchering establishment, though in this case the Heat Pump has to deliver at a higher temperature level. The performance figure is approximately 4.5.

Plants of this kind are therefore indicated above all where refrigeration is also needed, as the mere addition of a further stage of compression then makes available large quantities of heat which would otherwise be disposed of. Such plants can usually be kept

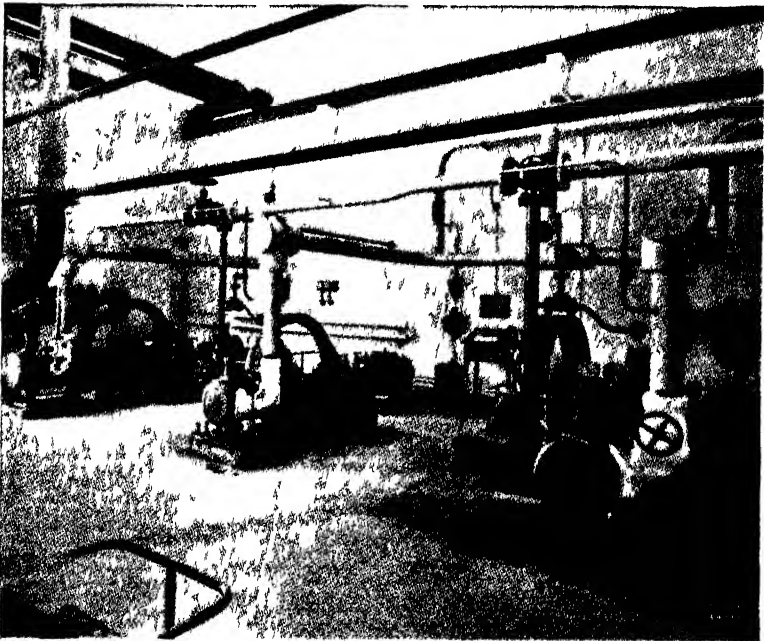

Fig. 100.—The existing refrigerating plant in a Swiss industrial establishment, comprising three ammonia compressors, with refrigerating capacity of 335,000 kcal. per hour between -17° and $+22^{\circ}$ C. (1,340,000 B.Th.U.s per hour between 1° and 72° F.)

in service throughout the year, especially for providing large quantities of domestic hot water.

Bath-Rink Conversion

Another interesting application for a combined plant is that of a swimming-bath which is converted in winter into a skating rink.

For both of these the same Heat Pump can be used, the lower temperature stage serving for the ice rink and the upper stage for the heated swimming-bath.

These combined plants can also be used alternately for heating and cooling. A specially suitable heating system is panel warming, as it requires lower initial temperatures than radiators, while the same wall or ceiling surface can be used for radiant heating in winter and for cooling in summer.

A good example of this type of plant is a Heat Pump erected in an industrial building with a volume of 350,000 cu. ft. The same radiation piping system is used for cooling and heating throughout the year. Heat is extracted from the works water supply, which is cooled by about 1° C. by the Heat Pump. A new regulating system involving only very slight losses enables the output of the Pump to be adjusted at all times so that the initial temperature in the heating system is kept constant. The transition from heating to cooling service is effected by a simple switching operation, the heating water then being conducted to the evaporator and the mains water to the condenser.

Under favourable conditions, however, the Heat Pump may also be advantageous when its only duty is the supply of heat, as the following example will show.

Subsoil Water Source

A Heat Pump plant of a capacity of 640,000 B.Th.U.s per hour is at present being built for the administrative building of a large industrial enterprise. This Heat Pump is to be used only for space heating purposes, but in view of its favourable layout and high loading at all times it can be regarded as extremely economical. The source of heat is in this case comparatively warm subsoil water which is pumped from a shaft next to the machine room and conducted to the evaporator. As there is an existing panel warming installation, the water has to be heated to $104-113^{\circ}$ F. only. In spring and autumn the heating output of the Pump exceeds the demand, and the surplus is then used for pre-heating the return water of a radiator heating system, the Heat Pump being regulated in accordance with the requirements of the latter. If the temperature of the radiator return water exceeds

40° C., the radiator heating system is again disconnected from the panel warming system and is operated with its own fuel-fired boiler. As soon as the outside temperature falls below +2° C. (+36° F.), the water of the panel warming system leaving the Heat Pump is passed on to a boiler for further heating. Regulation is automatic throughout. Under these circumstances the Heat Pump is at all times under load and is therefore able to cover 90 per cent. of the total heat requirements. Although it is restricted to winter service, the full working hours per year amount to over 3,000. The mean performance figure is about 4.

Another noteworthy Heat Pump also used for heating purposes only was recently installed in a Swiss weaving and cotton spinning mill. The heat produced is used in air-conditioning plants and for air heaters in the work-rooms. The maximum requirements are 2,200,000 B.Th.U.s per hour, half of which can be supplied by the Heat Pump plant. The remainder is provided chiefly by an oil-fired heating boiler, while peak loads are taken by the existing steam plant. Nevertheless, over 90 per cent. of the heat required annually is supplied by the Heat Pump. Its source is the water leaving the factory's turbine, this being cooled by about 1 or 2° C.

Seasonal Heating

A combined plant which works very economically owing to the high number of operating hours and favourable temperatures was supplied to a large cotton mill in Shanghai. The Heat Pump serves an air-conditioning plant and is used either for heating or cooling according to the season. The heat is drawn from the water of a nearby river, which never falls below 10° C. (50° F.) even in winter. The maximum refrigerating requirements in summer are in excess of the maximum heat requirements in winter. Skilful combination has enabled these requirements to be fulfilled on highly economical lines with the same Heat Pump, which operates for practically 24 hours per day throughout the year. The total number of operating hours per year is therefore above 7,000, while the performance figure is over 4.

Fig. 101 illustrates the employment of a Heat Pump in a drying plant. The air leaving the drying chamber carries a good deal of moisture but is warm. It is cooled in the evaporator of the Heat Pump and loses most of its water by precipitation. After being dried in this way the air is again heated in the condenser at 40° C.

(104° F.), and then returned to the drying chamber by the circulating fan.

Underground Work

Heat Pump plants of this kind have also been built for underground magazines, which have to be kept dry. The air is freed of

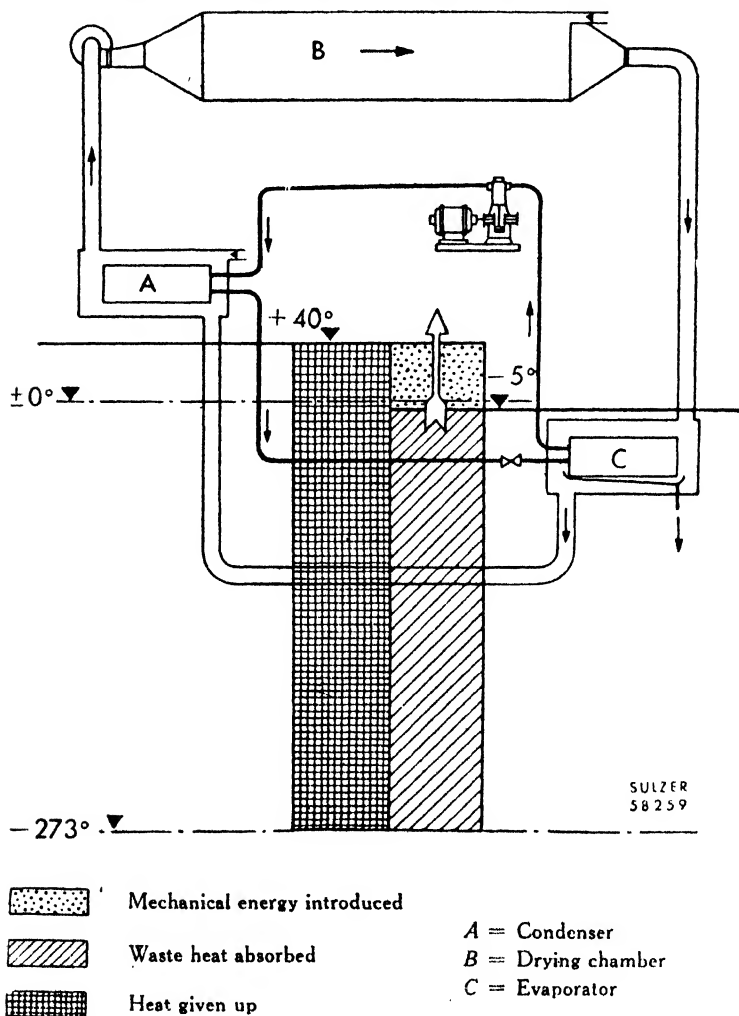

Fig. 101.—Diagram of a Heat Pump for a drying plant, with corresponding heat diagram

moisture by under-cooling and then heated by passage through the Heat Pump. This air circuit permits the moisture penetrating into the magazines through the surrounding rock to be satisfactorily eliminated.

A drying plant for the earthenware industry is at present under construction. It will be in service throughout the year, and the performance figure will in this case be approximately 5.

Other branches of the ceramics industry also have applications for the Heat Pump, which can in fact be used wherever drying has to be done at low air temperatures.

Heat-Engine Driven

Returning to the observations of Kelvin mentioned early in this book it may now be interesting to examine the diagram obtained with a Heat Pump driven by a heat engine. Actual figures for this case are available in the plant mentioned above as having been supplied by Sulzer Brothers in 1879, which in view of the topicality of this problem can fairly claim more than a mere historical interest. The heat engine consists of a drop-valve steam engine receiving its steam at 160° C. (320° F.) and giving it up after expansion as process steam at 110° C., or 230° F. (Fig. 102). The refrigerating machine driven by the steam engine raises the heat obtained at -15° C. (+5° F.) to +25° C. (77° F.) and gives it up to the cooling water. The first rectangle on the left in the heat diagram shown in Fig. 102 represents the heat introduced. The dotted upper area corresponds to the mechanical energy generated, with which the refrigerating machine is driven. The hatched area below it is the heat available for process uses. The second oblong from the left shows the mechanical energy absorbed by the refrigerating machine as a horizontally shaded area at the top and the refrigerating capacity as a hatched area below it. This is how the existing plant actually works.

Recovered Heat

If a further compression stage had later been added to the refrigerating machinery—under the influence, for instance, of rising coal prices—the heat given up by the first stage at +25° C. (77° F.) could have been raised to +65° C. (149° F.) and put to use in a heating system. An electric motor might have been used for the additional power requirements. The quantity of heat thus

PRACTICAL APPLICATION

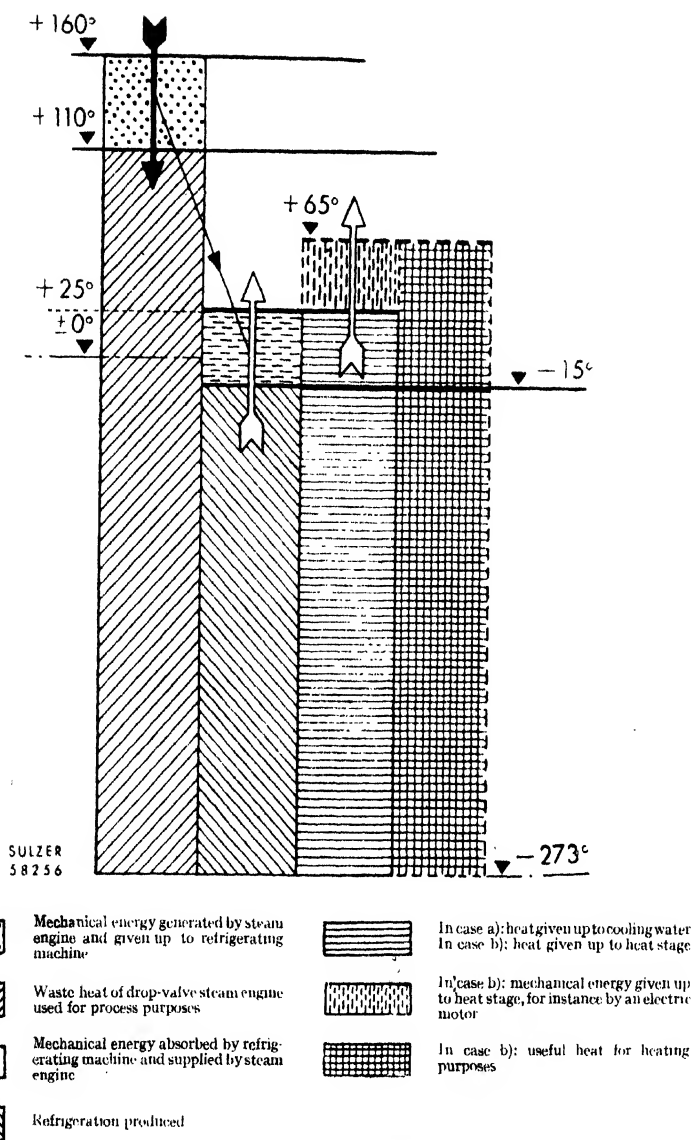

Fig. 102.—A schematic diagram of a refrigerating plant, based on existing plant with full bounding line, and on the assumption of an additional heat stage, with broken bounding line

recovered is represented by the squared area on the right enclosed by a broken line. The total amount of heat introduced (100 per cent.), which is represented by the first oblong on the left, and the 9 per cent. of additional electric energy used would in this case have supplied about 89 per cent. of useful heat for process purposes and 77 per cent. for heating, making a total of 166 per cent., to which the useful refrigeration would still have to be added. This notable

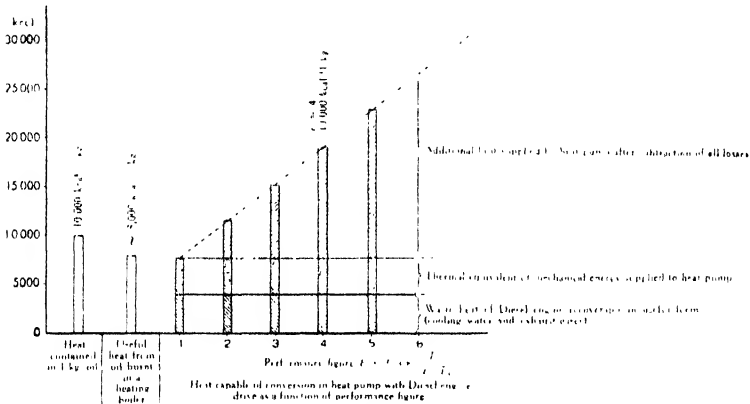

Fig. 103.—The production of useful heat by a Heat Pump with a diesel engine. Useful heat available per kilogram of oil

gain confirms the statement made by Lord Kelvin, i.e., that a Heat Pump driven by a heat engine permits of a higher heat yield than if the fuel used for the heat engine were fired in a boiler.

A modern plant of this kind is that installed in the district heating station of the Swiss Federal Institute of Technology in Zurich, referred to earlier. This is a good example of the combination of hydro-electric and thermal power and illustrates the economic benefit which such an arrangement can offer.

Obviously, a diesel engine may also be used instead of a steam power plant for driving the Heat Pump, as here too the waste heat can be utilised with very little additional trouble. It is then quite possible to obtain an upper waste heat stage which is high enough for industrial purposes and a lower stage which can be used for space heating or for the preparation of hot water. The temperature

of the waste heat does not have to be raised by artificial means, so that the normal maximum output of the diesel engine is fully available.

Fig. 103 shows the advantages secured with the combination of a diesel engine and a Heat Pump. The calorific value of 1 kg. of oil is compared with the useful heat which can be obtained by direct firing in a boiler and alternatively by employment in a diesel engine with waste heat utilisation and with Heat Pumps of various performance figures. As can be seen, the diesel engine and the Heat Pump driven by it together supply more useful heat for heating purposes than is contained in the fuel needed for the diesel engine.

For plants of this kind units of small to medium output are preferable, as large works, owing to their large quantities of waste heat, must be connected to a district heating system, which is not always justified. This fact rather favours a decentralised layout for such plants, especially as reasonable decentralisation has in times of need invariably proved superior to exaggerated centralisation. Diesel Heat Pumps are particularly economical when they can be used for the production of both heat and cold, either simultaneously or alternately.

Nowadays diesel-generator sets are being used on a growing scale for covering peak loads and for emergency current requirements. The working hours of such plants are, by their very nature, fairly low. It would be quite feasible to make use of the diesel engine in such plants for operating a Heat Pump, provided that, over and above the heat or refrigeration produced, the exhaust heat of the engine could also be made use of. The working hours of the diesel engine would in this way be increased. Experience with combined plants has shown that the time during which the diesel engine would be needed for covering peak loads or generating emergency current—and the Heat Pump would consequently have to be shut down—could be bridged in the majority of cases with the aid of suitable heat and refrigeration accumulators. This may be an advantageous scheme, for instance, in department stores, which require large quantities of heat in winter and have to be cooled as effectively as possible in summer. Under suitable conditions the

economy of peak-load and emergency diesel-generator sets can be greatly improved along these lines.

In recent times it has also become increasingly clear that the diesel engine is very often suitable for Heat Pump drive in localities where current prices are comparatively high and a Heat Pump with all its attendant advantages would not otherwise come into consideration.

There are, again, inevitably times when electricity supplies fail or have to be restricted, and this occurs chiefly in winter, precisely when the heat provided by the Heat Pump is most valuable. The solution is often the provision of a diesel engine as well as an electric motor for driving the Heat Pump. A useful arrangement is shown in Fig. 104. The electric motor-generator 1 is coupled through

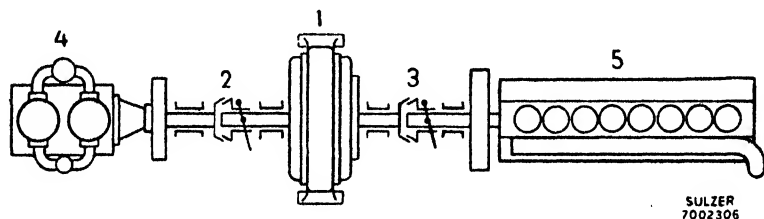

Fig. 104.—A diagram of a Heat Pump driven by electric motor and diesel engine

disconnectable clutches 2 and 3 to a Heat Pump 4 and a diesel engine 5. The Heat Pump can therefore be driven either by the electric motor or, with clutch 3 engaged, by the diesel engine. When clutch 2 is disengaged, the motor-generator is driven by the diesel engine and can then be used for generating current.

It follows from the above considerations that the gas turbine can also be used for driving a Heat Pump if equipped with a waste heat utilisation plant operating either direct or by way of the electric mains.

It may be noted in conclusion that an electrically driven Heat Pump is by no means bound to the immediate vicinity of the power station. The transmission of electric energy is much less expensive and involves far lower losses than the transmission of heat over

similar distances. A piping system of any length demands high temperatures, while the Heat Pump is preferably operated at low temperatures if high performance figures are to be attained. It is therefore obviously best to install the Heat Pump in the building to be heated or at least in its immediate proximity and to use it as far as possible where the heating system can be fed with low-temperature water, which is true above all of radiant heating installations.

In countries which obtain their electric energy chiefly from thermal sources, the utilisation of the waste heat will receive first consideration. Technically this is quite possible to-day. The difficulty lies in utilising the large quantities of heat available from the bigger thermal power stations in district or municipal heating systems which do not call for an exorbitant capital outlay. Nevertheless, Heat Pumps with high performance figures are to-day a great economic benefit even in large-scale thermal power stations, or district heating schemes.

The examples cited and the considerations here put forward all go to support the original statement: that the Heat Pump is by no means a transitory product of the boom or a symptom of an "economy of shortage," but instead, wherever it is based on careful preliminary calculation, a valuable instrument of thermal economy for the present as well as for the future.

SECTION II BIBLIOGRAPH

¹ Inst. Mech. E. 28/3/47.

² See Ad. Baumann (Dept. V): "The Thermo-compressor Installation in Lucens for the Concentration of Milk," BROWN BOVERI REVIEW, No. 5/6, 1943, page 85.

³ Baumann, A., and Marples, D. BROWN BOVERI REVIEW, July-August, 1943, pp. 467-474. "Some Applications of the Heat Pump as a Heating Machine."

⁴ SULZER TECHNICAL REVIEW, No. 2, 1945, p. 15.

⁵ SULZER TECHNICAL REVIEW, No. 2, 1944, p. 25.

Section III

Section III

Atomic Energy Survey

OWING to the rapid development of atomic energy and the interest created in the possibilities of the industrial application of this new source of power, a short outline is given as the closing section of this work. Recently, H.M. Government permitted the author to inspect the research works at Harwell, which at present is the largest research station outside America, and is developing into a considerable industrial estate. Most of the following information has been obtained from the inspection of this Research Station and only the basic developments are given to date, without any attempt being made at sensational revelations. This chapter should give the reader an indication of the development in this country.

Elements and Compounds

The science of chemistry, on which our belief in the atomic structure of matter was founded, deals with the transformation of substances into other substances. A typical example of chemical change is the burning of a piece of coal which, when raised to a high temperature in the presence of air, combines with the oxygen of the air, changes its form (being mostly transformed into invisible gases) and in so doing gives out heat. The burning of coal is not, however, a very simple process because neither air nor coal is a simple substance ; part of the coal is incapable of burning and only the oxygen in the air can combine with the combustible part of the coal. Systematic and accurate study of chemical changes can be made only by using pure substances ; that is, substances of which every particle has identical chemical properties.

Pure substances can be shown by experiment to be divisible into two classes: *elements*, which cannot by any chemical process be made into simpler substances, and *compounds*, which are formed by the union of elements in definite proportions and can be broken up again into their constituent elements. Over ninety different chemical elements exist. Some of them, such as hydrogen, oxygen and carbon, are found in great quantities in the earth's crust, in the sea

or in the atmosphere, as well as in the bodies of plants and animals ; others occur in very much smaller quantities and have been proved to exist only by the most refined methods of analysis. Although a few elements, like oxygen in the air and gold as nuggets, are found in the uncombined state, most of them occur in nature in the form of chemical compounds. Pure water, for example, is a chemical compound of the two elementary gases hydrogen and oxygen, in the proportion of almost exactly two parts by weight of hydrogen to sixteen of oxygen. Two different compounds of carbon and oxygen are well known : carbon monoxide, having twelve parts of carbon to sixteen of oxygen, and carbon dioxide, with twelve of carbon to thirty-two of oxygen. There are many different compounds of carbon and hydrogen ; for example, acetylene, with twenty-four parts of carbon to two of hydrogen, and methane, with twelve of carbon to four of hydrogen.

Atoms and Molecules

All such facts of chemical combination can be interpreted by supposing that every element consists of identical, indivisible atoms having a small but definite weight ; the weights of the hydrogen, carbon and oxygen atoms are almost exactly in the ratio of 1 : 12 : 16, and the various substances named above are formed by the union of these atoms into small groups or molecules, which are the smallest units that have the chemical nature of the compound body. Thus, the water molecule contains two atoms of hydrogen and one of oxygen ; carbon monoxide has one of carbon and one of oxygen, carbon dioxide has one of carbon combined with two oxygen atoms, and so on. The numbers 1, 12, 16 are called the *mass numbers* of the atoms in question.*

Structure of the Atom

Although in all chemical reactions the atoms of the elements behave as indivisible units, they are actually complicated structures about the make-up of which we have a good deal of knowledge. Our information has been obtained in ways most of which are too technical to discuss here, but we will mention one of them.

When electricity passes through a gas, whether as a spark at ordinary pressure or as a low discharge through a gas at reduced pressure, a stream of electrified particles travels through the gas

* Mass number is a physicist's term that corresponds roughly to the chemists' "atomic weight."

moving away from the negative terminal (the "cathode") towards the positive terminal (the "anode"). If the anode of a low discharge tube is perforated by a small hole, some of these particles will pass through the hole as a narrow beam, the properties of which can be studied. The particles turn out to be of the same nature whatever gas is contained in the discharge; they are much lighter than atoms, weighing about $1/1840$ as much as a hydrogen atom, have a definite charge of negative electricity which is the smallest electrical charge that can exist, and have been removed from the atoms in the passage of the discharge. These common constituents of all atoms are called electrons.

We now know that the different chemical properties of the ninety-odd elements arise from differences in the numbers of electrons that their atoms contain; the atom of hydrogen has only one electron; helium has two, oxygen eight, sodium eleven, and so on, while at the other end of the list is uranium, with ninety-two.

Since the electrons are so light compared with the atom as a whole, atoms must contain other things besides electrons; moreover, since the electron is negatively charged and the whole atom has no net charge, there must be positive charge elsewhere in the atom. Rutherford was able to show by experiment that the heavy, positively charged part of the atom is in fact a central nucleus very small compared with the atom as a whole. We may picture an atom as a sort of miniature solar system, the nucleus being the sun, the electrons the planets, while the force of gravitation is to be compared with the electrical force of attraction between the positive nucleus and the negative electrons, which is what maintains the coherence of the atomic structure. The analogy is rather less exact than it was once believed to be, but is still valuable.

Chemical Combination

The union of atoms into molecules is a process that involves only their outer electrons, which are the least tightly bound to the central nucleus, since the force between electric charges decreases as the distance between the charges increases. When, for example, an atom of sodium and an atom of chlorine combine to form a molecule of sodium chloride, the outermost electron of the sodium atom goes over to the chlorine atom, so that the sodium is left with a net positive charge and the chlorine with a negative one; the

molecule is kept together by the electric attraction between these charges. In many chemical compounds, such as the oxides of carbon formed when coal is burnt in air, the transfer of electrons from one atom to another is less well defined, but in all cases the outer electrons alone are concerned.

When atoms combine to form molecules, the attracting forces that pull the atoms together set up vibrations of the atoms in the



(Crown Copyright Reserved)

Fig. 105—Production of radioactive isotopes. A sample is being taken out after irradiation in Gleep. The face of the pile is in the background. The sample is in an aluminium container, which during irradiation is placed in one of the holes in the graphite blocks (bottom right) and the latter are pushed manually in and out of the pile through a hole in the concrete shield. The operator is protected from radiation from the material which has been in the pile by the lead tunnel (shown with handles), through which the samples are taken with long-handled tongs. The samples will be placed in the lead pots (centre) for transport. Cans with new samples awaiting irradiation are in the stand in the foreground. An instrument for measuring the radiation is on the left

molecule; these vibrations are passed on to neighbouring atoms and molecules, increasing their small but rapid motions that are the real microscopic essence of what appears to our senses as the

temperature of the substance. Thus the heat evolved in chemical combination comes from the forces that act between electrons and nuclei; i.e., between electrical charges separated by distances comparable with the radius of the atom. We shall see later that the energy of nuclear fission arises from the immensely stronger forces acting between electrical charges at much closer distances from one another within the nucleus.

Protons, Neutrons and the Atomic Nucleus

At the present time we have fairly detailed knowledge of the electronic structure of atoms, in the sense that we know (at least for the lighter and simpler atoms) what are the distances of the various electrons from the nucleus and roughly how this distribution of electrons explains the chemical and physical properties of different kinds of atoms. As regards the structure of the nucleus itself, we know less; we do, however, know that nuclei are built up of protons and neutrons.

The simplest nucleus, that of hydrogen, contains just one proton; the proton is, in fact, a hydrogen nucleus. Other nuclei contain both protons and neutrons, which are uncharged particles about as heavy as protons. Since the atom has no net electrical charge, and since the charges of protons and electrons are equal and opposite, the number of protons in any nucleus is equal to the number of electrons outside the nucleus.

Fig. 108 shows, in purely diagrammatic form, the make-up of a few kinds of nucleus. It must be emphasised that we do not know the detailed arrangement of protons and neutrons, but only how many of each there are and about what volume they occupy. In relation to the size of the atom, a nucleus is very small; on the scale used in the diagrams, the electrons would move within a volume several hundred yards across.

Now, two electric charges of the same sign (two positives or two negatives) repel one another with a force that varies inversely with the square of the distance between them. The electric repulsion between any two protons in the same nucleus is, therefore, huge compared with the electric attraction between the nucleus and the much more distant electrons.* In view of this strong repulsion,

* The attraction between the hydrogen nucleus and its attendant electron is, very roughly, a thousand-millionth of a pound weight; the repulsion of two neighbouring protons in a nucleus is equal to the weight of one or a few pounds.

THE HEAT PUMP

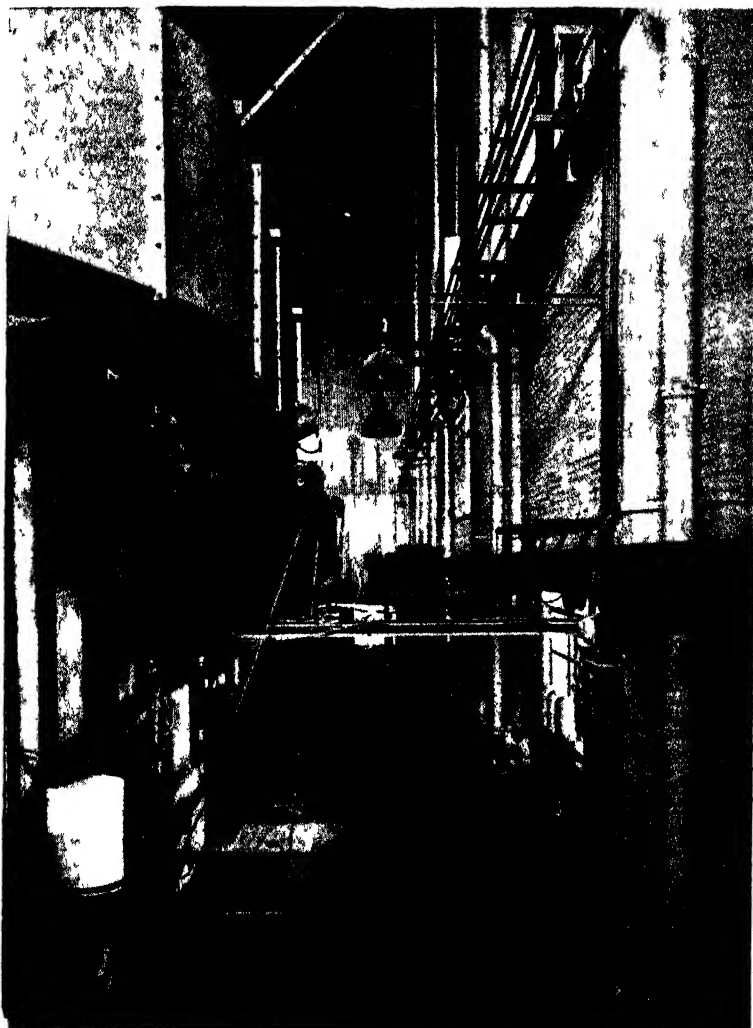

(Crown Copyright Reserved.)

Fig. 106—Gleep. The "control" face is on the left. In the bottom corner can be seen the chambers containing boron trifluoride gas which are used to measure the intensity of neutrons in the pile, and hence to control the power level at which the pile is operated. On the right are some health monitoring instruments and behind them is the control room

how does the nucleus hold together? We do not know exactly how; we do know that other attractive forces exist between the nuclear particles and overcome the repulsion of the protons, and that these somewhat mysterious forces come into play between two particles as close together as are neighbouring protons and neutrons in a nucleus.

If some of these short-range links could be broken, the repulsion of the protons would cause the nucleus to disintegrate, the fragments flying apart with energies much greater than those arising from the much weaker forces involved in chemical reactions.

Such a phenomenon actually happens in nature and is the basic fact on which the development of nuclear energy depends; although the term "atomic energy" is currently used, it is important to be clear that the energy comes from the very small but comparatively heavy nucleus, and not from the outer electronic structure of the atom.

Isotopes

Before discussing nuclear disintegration in more detail, we must mention one fact that, for simplicity, has so far been omitted. In addition to ordinary hydrogen, of which the nucleus is a single proton, there exist atoms that contain a neutron as well as a proton in the nucleus. Since they have just one electron to balance the charge of the single proton, they are chemically identical with ordinary hydrogen atoms, but are just about twice as heavy. These two kinds of hydrogen are said to be isotopes, the word being coined from the Greek to indicate that they occupy the same place in the chemists' lists of elements. Natural hydrogen contains about one part in five thousand of the heavy variety. Heavy hydrogen is often called "deuterium." Most other elements also consist of more than one isotope, but in these cases it is usual (and is much more logical) not to give a special name to each isotope, but to denote all the isotopes of a given element by that element's chemical name and symbol, and to indicate which isotope is meant by writing, as a superscript to the symbol, the total number of particles (protons and neutrons) in that particular nucleus. This number is called the mass number of the isotope. Chlorine, for example, is a mixture of two isotopes of mass numbers 35 and 37; the one nucleus contains 17 protons and 18 neutrons, the other 17 protons and 20 neutrons. They are symbolised as Cl^{35} and Cl^{37} . Uranium

exists in several isotopic forms of which U^{238} is the most abundant but, for our purpose, U^{235} is the most important.

The immediate application of atomic energy and of the new techniques that have been developed in the course of the production of atomic energy can be divided under the headings of industrial, medical and scientific applications.

Atomic Fuel

The most obvious industrial application of atomic energy is the use of uranium as a new source of fuel. Weight for weight, uranium produces about $2\frac{1}{2}$ million times as much heat as the best bituminous coal. At the present time it would still be much less economical to use uranium, however, than coal, but it appears likely that this state of affairs will be greatly modified by future developments. Nevertheless even if in actual cost uranium fuel were no more economical than coal, there would still be many advantages associated with its use. One of these is the extraordinarily small amounts of uranium fuel required to produce very large amounts of heat.

For example the total electrical power consumption in Great Britain is about 25,000,000,000 units per annum. If this could be obtained from turbines operated on steam heated by uranium power, about ten tons would be required per annum.*

The small consumption of raw material involved in the production of large amounts of power would suggest an early application of atomic power to provide electric power stations in areas devoid of coal or water power. This should make possible the opening up of large areas of countries like Australia. It should facilitate the industrialisation of backward areas of countries like India and China.

Another possible early use of uranium as a fuel could be for the propulsion of large ocean liners or battleships. For example, a giant ocean liner propelled by turbines generating 100,000 h.p., driven by atomic fuel, would probably use a few hundred-weight of uranium in a year.

Necessary Precautions

As has been pointed out, a disadvantage of the use of uranium as a fuel arises from the fact that atomic energy can only be produced

* In this and later calculations an efficiency factor of 10 per cent. is assumed in the conversion of heat into mechanical work.

in devices (piles), in which are generated simultaneously very large intensities of dangerous radiations. Great precautions have, therefore, to be taken to protect the operators of these devices, and anybody living or working in the vicinity. Very expensive and bulky screening walls have to be constructed, and highly skilled and dangerous chemical operations have to be carried out at frequent intervals in order to maintain the pile in operation.

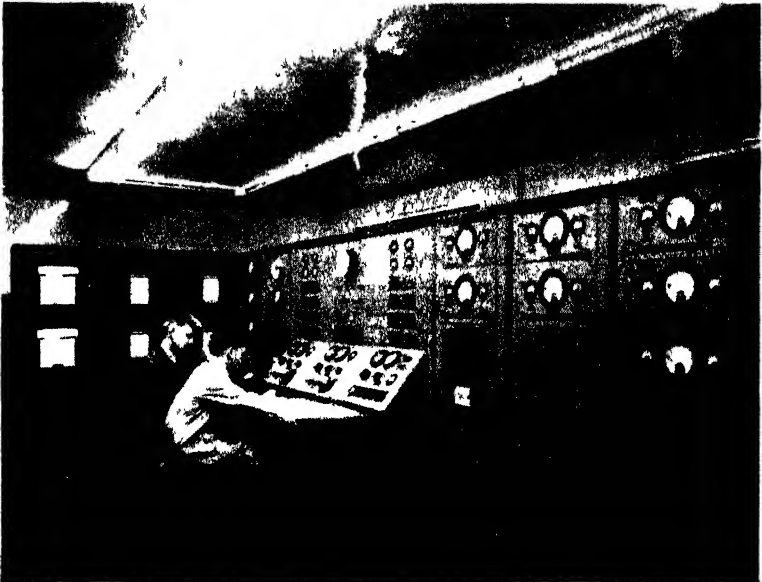

(rown Copyright Reserved)
Fig. 107—Gleep (graphite low energy experimental pile) Control Room

All these things make it appear most unlikely that atomic power will be used for small-scale power units such as motor-cars, locomotives or aeroplanes in the foreseeable future.

It is perhaps somewhat misleading to conclude that the discovery of atomic energy marks the dawn of an age of unlimited, very cheap power. In modern electrical power systems the cost of distribution is very much larger than the cost of production of power at the generating station. So that it appears likely that even if the fuel cost could be entirely eliminated the cost of electrical power at the place of consumption would only be reduced by about 20 per cent.

In other possible applications such as the supply of steam or hot water to cities and industrial plants, the cost of the service would be related much more directly to the cost of the fuel.

However, the real importance of atomic energy as a fuel is in the fact that at a time when the using up of the world's fuel resources is causing grave concern, another large source of fuel has been uncovered.

The Medical Applications

The medical applications of atomic energy, which are referred to later, arise from the fact that the pile is a very effective source of neutrons, and gamma rays and can be made to produce large quantities of radioactive isotopes of almost every element. Unstable isotopes of most elements can be produced by exposure to bombardment by slow neutrons. Such unstable isotopes decay, giving off beta and gamma rays, and can, therefore, be used in such medical applications as the treatment of malignant growths, which have until now required the use of radium.

In some ways these artificially radioactive isotopes are more useful than radium because, apart from the fact that since they are a by-product of the pile they are likely to be less expensive than radium, they can also be introduced into parts of the body that could never be reached by radium. Some of the radioactive materials also have value in the diagnosis of certain illnesses. The whole study of the medical applications of these radioactive isotopes is still in its infancy and probably holds many surprises, and of course is outside of this work.

How it Works

The nuclei of some elements are unstable (Fig. 108 and Fig. 109), spontaneously disintegrate, a small portion of the nucleus being ejected at high speed and a new and lighter nucleus being left behind. The ejected fragment is the so-called alpha particle, which is a helium nucleus and is composed of two protons and two neutrons. Typical of these unstable nuclei are the isotopes of uranium, U^{238} and U^{235} .

Alpha Disintegration

This is a purely nuclear phenomenon, quite unaffected by the state of chemical combination of the uranium or by anything else

that concerns the electronic state of the atom ; it is impossible either to influence or to predict the time at which any given uranium nucleus will disintegrate, though if we are dealing with a large number of them we can say with considerable certainty that about half of them will have disintegrated after a certain period of time,

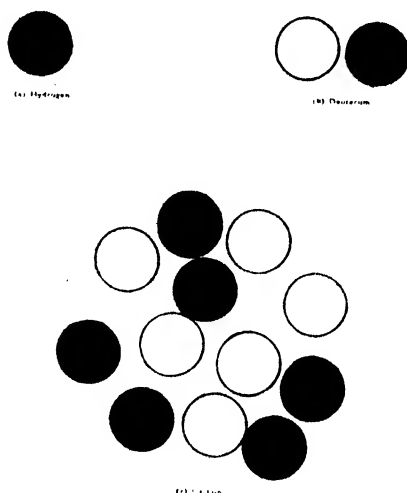

Fig. 108.—Structure of a few types of nuclei. The Proton being black and the Neutron white

called the *half-period*. At the end of two half-periods, only a quarter of the original number will be left ; after three half-periods, one-eighth, and so on.

The half-period for U^{238} is about four thousand million years ; for U^{235} , about nine hundred million years. The number of atoms in quite a small quantity of uranium is so great that, in spite of these long expectations of life, many nuclei disintegrate each second. For example, a pound of U^{238} emits something approaching a million alpha-particles per second.

Each alpha particle carries away about a million times as much energy as can be got from a uranium (or any other) atom by allowing it to combine chemically with some other kind of atom ; this energy is expended by the alpha-particle in collisions with the electrons

of whatever material it passes through,* and is ultimately converted into heat. By the time it has all disintegrated, a pound of uranium has produced several thousand times as much heat as can be got by

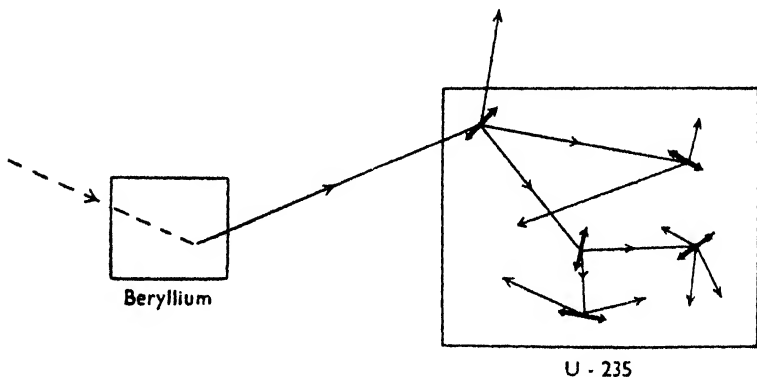

Fig. 109

Path of Alpha particle - - - - -
 Paths of Neutrons ————
 Fission fragment ————

burning a pound of coal, but this is spread over millions of years and cannot be hurried by any means at our disposal.

Beta Disintegration

As a matter of interest it may be added that the nucleus produced by the spontaneous disintegration of U^{238} is an isotope of thorium and is itself radioactive, though it does not emit alpha-particles. Its nucleus undergoes a spontaneous internal reorganisation in which a neutron changes into a proton; an electron is simultaneously created (which keeps the balance of charge right) and is ejected at high speed from the nucleus. These fast electrons are also called beta-particles. The resulting nucleus is once again unstable, and a whole series of radioactive nuclei follow one another† until finally a stable isotope of lead is formed.

Nuclear Reactions

We have said that an alpha particle emitted by a radioactive nucleus loses its energy by collisions with the outer electronic

* Alpha particles can pass through an inch or two of air before losing all their energy; correspondingly small distances in denser materials.

† Radium is one.

structure of the atoms it meets. Just occasionally, however, the particle may head straight towards the very small nucleus of a neighbouring atom. If the neighbouring nucleus is uranium, or lead, or any one of the bigger nuclei, its large positive nuclear charge will repel the positively charged alpha particle so strongly that it cannot reach the nucleus; but if the target nucleus is that of an atom with a low nuclear charge, the alpha particle may actually enter the nucleus. If it does, any one of a number of things may happen instantaneously. Very often, a proton is knocked out of the nucleus, as was found by Rutherford in 1919 to happen in the case of nitrogen. If the target element is beryllium, a neutron is ejected. Since the neutron has no charge it is quite unaffected by the electronic structure of atoms and sails right through them until it happens to hit a nucleus, and since nuclei are so small it may travel for inches through a solid material before it hits one. Only then does it make its presence known, which it can do in various ways, depending on how fast it is travelling and what kind of nucleus it happens to hit. It may, for example, bounce off the struck nucleus, giving it a bump that carries off some of the neutron's original energy; this is called *scattering*, and is the usual process when neutrons strike the nuclei of hydrogen, deuterium, and carbon. On the other hand, the neutron may simply attach itself to the target nucleus, increasing the number of neutrons by one and converting the element into the next higher isotope of itself. This process is called *capture*.

So much has been written on the theory of atomic energy that it will be best to detail to the reader what is actually taking place in practice. The first requirement for an Atomic Energy programme of this nature at Harwell is to build piles. The first pile, GLEEP (Graphite Low Energy Experimental Pile), which is referred to later, a simple unit designed to develop about 100 kilowatts of heat, was completed in August, 1947. It is being used for measurement of the properties of atomic nuclei, for testing the nuclear properties of materials used in the construction of piles and for the production of radioactive isotopes for biological, medical, scientific and industrial research.

The second pile, BEPO (British Experimental Pile), was designed to develop 6,000 kilowatts of heat in its uranium metal bars. It is a slightly larger unit than GLEEP but is a much more complex

engineering structure. Owing to its 60 times larger power, the intensity of radiations inside is correspondingly higher and greater precautions have to be taken in its operation and to prevent the escape of these radiations.

Waste Heat

The large amount of heat developed is removed by swiftly moving air which is sucked through the pile by a battery of fans and

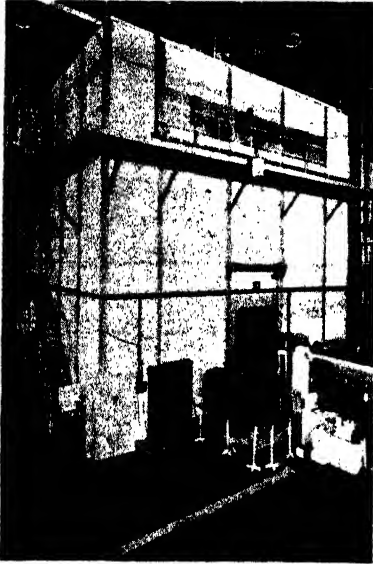

(Crown Copyright Reserved)

Fig. 110—General view of Gleep. The holes, through which samples are put into the pile for the production of radio-isotopes, are in the face on the right. In the same face a square screen of lead blocks cover the thermal column. The latter is a column of graphite used to produce slow, or "thermal" neutrons for experimental work



(Crown Copyright Reserved)

Fig. 111—A Radiochemical laboratory. Experiments are carried out behind the protective lead walls, which can be built up to any desired size with interlocking bricks. All operations are controlled remotely, and observed by means of the mirrors above the apparatus

discharged through a high chimney-stack. This pile is used for testing the effect of pile radiations on the structural and physical properties of materials which will be used in future piles. It will be the main source of radioactive isotopes for this country, and will make it possible to extend the supply of isotopes to members of the

British Commonwealth and other overseas countries. It is this waste heat which offers possibilities for the Heat Pump, but at the present stage of development this has not as yet been seriously considered by the research scientists.

The Atom "Smasher"

The work of the establishment also includes fundamental research in nuclear physics. For this work, several machines are being built for the acceleration of nuclear particles. A tower used by the R.A.F. for navigational training houses a "Van de Graaff" generator. This machine consists of a high pressure vessel housing a moving belt machine which can generate 5 million volts. Inside the vessel are vacuum tubes through which hydrogen nuclei are shot and speeded up. They emerge into a pit below, where they are used to study the properties of atomic nuclei. A cyclotron is built in one of the larger hangars.

In addition to radioactive isotopes, the Establishment will produce separated stable isotopes of many of the elements. An element such as carbon consists of two varieties having atomic weights of 12 and 13. The separate varieties or "isotopes," have different nuclear properties and it is often desirable to separate them for study. The separated isotopes are also of great use in biological and medical research since they are effectively labelled atoms and the labels enable their life history in the body to be determined. The Establishment is already producing separated isotopes of oxygen and carbon.

A small-scale electro-magnetic separator for other elements has been built and a much larger instrument, capable of separating the isotopes of any elements, has been erected in one of the hangars.

Chemical Engineering

The chemical and chemical engineering problems are amongst the most difficult in the Atomic Energy programme. When uranium metal is placed in a pile, the new element plutonium is produced together with radioactive forms of at least 30 elements, the fission products. The plutonium has to be separated from uranium and the intensely radioactive fission products.

This radioactivity, together with the toxicity of the plutonium, requires great precautions to be taken to protect the health of the

chemists. For this work, a new radiochemical laboratory, locally known as the "hot laboratory," has been built. This provides methods of shielding the chemist from radiations, as illustrated, whilst intense ventilation sweeps away any radioactive dusts, and prevents their inhalation.

Buildings are also being erected for chemical engineers who have to translate the work of the chemists into semi-scale work, leading to full-scale engineering plant. The chemical engineers have also to study methods of extraction of uranium from the many kinds of ores in which it is found in different parts of the world, and suitable equipment is being provided.

Instruments

An atomic energy project requires a great many electronic instruments. They are used for control of piles; for helping the work of radio-chemists who follow their operations by measuring the radioactivity of their samples; for experiments in nuclear physics, and for the protection of health.

A group at Malvern is directing the development of synchrotrons producing electrons of energies up to 300 million volts. It has recently completed the construction of a linear accelerator which produces electrons of 4 million volt energy by pushing them along on the crest of a travelling electron wave.

Many of the technological problems are solved by collaboration with industry, and with laboratories of Government Departments and Research Associations. The production of uranium metal, pure graphite, special metals, particle accelerators, electronic instruments are examples of work carried out by industry whilst assistance in metallurgical problems is given by the National Physical Laboratory, the British Non-Ferrous Metals Research Association, Imperial Chemical Industries and other bodies.

The Latest Pile

Future developments will depend very much on how materials stand up to the intense bombardment they would receive inside piles. To test this behaviour there had been built a more powerful pile, which would develop 6,000 kilowatts of energy and bombard 60 times as strongly as the Gleep.

Like Gleep, the Harwell Pile is a graphite moderated air-cooled pile, consisting of several hundred tons of graphite blocks in which a large number of cylindrical rods of uranium are arranged in a regular lattice. The uranium rods are enclosed in aluminium cans and these canned rods lie in channels in the graphite. Cooling air is drawn through the channels by several large electrically driven exhausters, to remove the heat released when the uranium atoms break down by fission. It is this waste heat which will interest the Heat Pump application in the future.

Concrete Insulation

The whole pile is surrounded by a concrete shield several feet thick, to protect workers from radiation, and the cooling air is discharged up a chimney-stack 200 ft. high. The protective shield is pierced by holes, which can be plugged when not wanted. There are about forty of these experimental holes and they are the means by which access is gained to the strong fluxes of neutrons in the interior of the pile. These neutron fluxes, many times more intense than can be obtained in any other way, are required for many experiments in nuclear science, both in fundamental and in applied research. Thus, for example, the applied research programme will include an investigation of the effect of irradiation by neutrons on the properties of materials, to provide information about materials used in the construction of piles. The experimental holes are also the means by which inactive elements are placed in the pile for transmutation into radioactive isotopes.

Surrounding the pile structure are the control rooms and laboratories used by the scientific and operating staff. The operation of the pile is controlled by two sets of neutron-absorbing rods which can be pushed in and out of the pile; the farther in the rods are, the slower the reaction proceeds. The first set of rods is adjusted to keep the pile operating at a constant power level.

The second set is available to shut the pile down in any emergency. This set is brought into action automatically if, for example, any part of the pile becomes over-heated, or if any one of a number of health monitors indicates an undesirable degree of radioactivity. An electric power failure, a failure in the air flow, or any one of several other contingencies, will also cause these shut-off rods to operate.

THE HEAT PUMP

The basic calculations for the Harwell Pile were begun in 1945 by a team of scientists working under Sir John Cockcroft in the laboratories of the National Research Council of Canada, and were continued when the team moved to the newly formed Atomic Energy Research Establishment at Harwell.

It was the first task of the Department of Atomic Energy at Risley under the direction of Mr. C. Hinton, to undertake the design of the pile, based on the information provided by the Harwell team. This work began in April, 1946. The pile has been built in one of the ex-R.A.F. hangars at Harwell, and first ground in the hangar was broken in June, 1946.

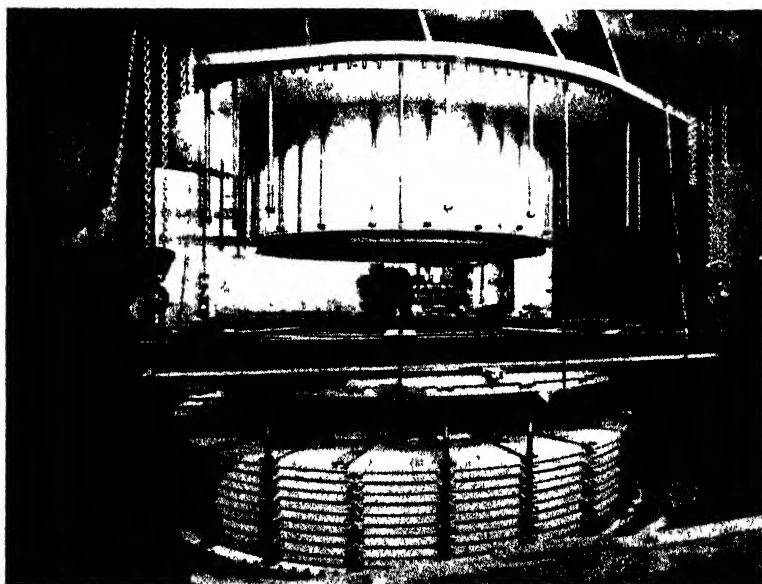

(Crown Copyright Reserved)

Fig. 112—General view of 110 in. cyclotron magnet during erection. The magnet contains 700 tons of steel. Some of the copper windings have been installed on the lower pole. There will be six pairs on each pole when the magnet is completed, containing a total of 70 tons of copper. At maximum power, a current of 600 amps at 500 volts is passed through the coils

The gap between the pole faces in the picture is 40 inches. When the magnet is completed this will be reduced to 12 inches, and it is in this gap that protons or deuterons are accelerated

The construction was greatly complicated by the necessity for raising a part of the hangar roof without interfering with the

excavation of the foundations in doing so. This was a major engineering task, but the problem was solved by erecting a Bailey bridge over the excavation, to support the roof during the operation.

Many of the components have been manufactured by Royal Ordnance Factories. The Royal Dockyard at Devonport fabricated and erected the main steel framework of the pile, to a degree of accuracy probably unique in a structure of this type. Special workshops were set up at Harwell in which the many hundred tons of very pure graphite required were machined into blocks. The uranium metal for the pile was cast at the Rocksavage factory of Imperial Chemical Industries and at the Ministry of Supply factory at Springfields.

In addition to building the first two piles there was a close collaboration with Lord Portal and his Engineering Department at Risley in preparing the design for the still higher-powered plutonium production plant which is being built near Seascale. This has required a great deal of theoretical and experimental investigations. There have also been investigations on piles in the future; piles which may generate useful energy and burn uranium efficiently instead of wastefully as at present. These studies are in an early stage, but they will show the reader that practical progress is being made.

Simultaneously with pile building and designing there has been a good deal of work on the metallurgical problems which are key problems in both existing and future piles, while it was also necessary to build up the staff and facilities for work in radiochemistry and chemical engineering. The chemists had a later start than the physicists since their laboratories take much longer to build. So until recently most of the effective chemical work was done in Canada. There are now in use three converted barrack blocks as chemistry laboratories whilst the new, so-called "hot laboratory" has been built.

This laboratory provides facilities for chemical work with the intensely radioactive materials which will come from the pile. Very efficient ventilation will sweep away any radioactive dust and prevent its being breathed by the chemists. There is provision for good shielding from radiations and for carrying out chemical

operations by remote control. The whole upper floor of this building is taken up by ventilation ducts and services.

Industrial Applications of Nuclear Power

The Establishment is working on the problem of the application of nuclear power to industrial purposes. A very minor step on the way is to extract by a heat exchanger some of the 6,000 kW. of heat developed by the Harwell pile and use it for space heating.

There have been detailed investigations on the design of natural uranium piles in which power could be generated as a by-product at a moderate efficiency. This investigation is not yet complete but it would appear that the construction of such piles is likely to be technically feasible. They would not however be worth while economically since such piles only burn up a very small proportion of the uranium. They would only be suitable as a first step to gain experience.

The Problems at Present

If Nuclear Power is to become important in the world, four major problems have to be solved. First, we must solve the so-called breeding problem—we must be able to burn up the greater part of the uranium by making the primary fuel U^{235} breed secondary fuel from U^{238} or thorium. Second, we must solve the metallurgical problem of finding materials which will stand high temperatures and be suitable for use in pile construction. Third, we must develop an efficient way of processing nuclear fuel which has been used in piles—we have to remove the intensely radioactive ash from the fuel, and do it safely and economically. Fourth, we have to be able to dispose of the large amount of radioactive ash, which would be produced by world power stations operating on nuclear fuel.

Under construction at Harwell are several particle accelerators, or "atom smashers," as they are sometimes called. There is a so-called Van de Graaff generator which speeds up atoms by 3 to 5 million volts. There is a giant cyclotron which will speed particles up to an energy of 200 million volts. These machines are required for the studies of the properties of atomic nuclei.

The Design

The Gleep pile is a simple unit designed to develop about 100 kilowatts of heat, and was completed in August, 1947. It is being used

for measurement of the properties of atomic nuclei ; for testing the nuclear properties of materials used in the construction of piles, and for the production of radioactive isotopes.

The power level at which the pile operates is controlled by means of neutron absorbing cadmium rods which hang vertically in the pile. A second set of " shut-off " rods is available to shut down the pile. The power at which the pile is operating is measured by means of chambers containing boron trifluoride gas, sunk into the

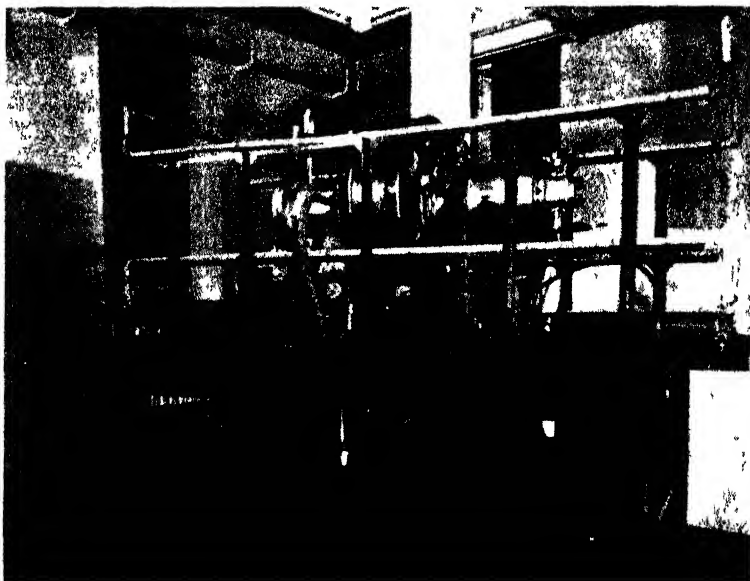

(Crown Copyright Reserved)

General view of Beta Spectrometer

pile. Neutrons falling on these chambers produce a small electric current which is recorded in the control room. From here the operating of the pile is controlled, and automatic recordings are made of the temperature and other physical constants within the pile.

The pile was designed largely by a New Zealand group of scientists working at Harwell. Many British scientists contributed to the production of the pure graphite and uranium, and designed and

produced the instruments required for the pile. Considerable assistance was also obtained from Canada, particularly in the testing of graphite.

Production of Radioactive Isotopes in Gleep

If certain elements are bombarded with the very large number of neutrons which are present in an atomic pile, they become radioactive. The radioactive elements which are formed have the same chemical properties as the ordinary inactive forms of the element, but differ in emitting radiation. The two forms of the element are called isotopes, and the radioactive form is a radio-isotope. For example, radioactive phosphorus and ordinary phosphorus are isotopes of phosphorus.

Most of the materials irradiated in Gleep are in the form of either metals or chemical salts. The procedure is very simple. The substance required is weighed out into a small aluminium can, which is placed in a graphite block. The block is then pushed into the middle of the pile. Here it stays for a suitable time until the enormous flux of neutrons has made it suitably strong in radioactivity.

Packed Isotopes

The radio isotope is now ready to be sent to the user. It is packed for transport in a lead-lined box to protect those handling it from the emitted rays. Each box is carefully labelled before despatch so as to ensure that no danger to health exists. The levels of radiation permitted are laid down and can be accurately determined.

There are uses for radio isotopes in nearly every field, including chemistry, physics, medicine, biology and agriculture. Because of the radiations which they emit they can be detected in very small quantities with comparative ease. For instance, if a drop of radioactive liquid were mixed with 100 gallons of water, the radioactivity of the 100 gallons would be clearly detectable. Thus, minute quantities of minerals taken up by animals or plants can be traced, and a new field is opened up in agriculture, biology and medicine.

Another application of radio isotopes makes use of the emitted rays themselves. For instance, cobalt metal when made radio-

active may be used as a substitute for radium, whose properties as a treatment for cancer are well established.

Following is the monthly totals of specimens of radioactive isotopes prepared at Harwell :—

September, 1947	17
October, 1947	42
November, 1947	42
December, 1947	34
January, 1948	76
February, 1948	88
March, 1948	120
April, 1948	105
May, 1948	150
June, 1948	122

Nuclear Physics

For experimental work in nuclear physics, several types of machine for the acceleration of nuclear particles are being built. Two of these, the cyclotron and Van de Graaff machine, have been mentioned. Linear accelerators and synchrotrons are being built by the AERE group working at Telecommunications Research Establishment in Malvern, another Government Research Station.

Cyclotron

The Harwell cyclotron consists of a 700-ton magnet, with poles 110 inches in diameter, between which nuclear particles (usually protons or deuterons) will be whirled round and round in a spiral path, and speeded up in successive small steps to energies of 200 million volts. The successive accelerating voltage steps are produced by a large electrical oscillator, similar to a short-wave radio transmitter. The total power consumption of the machine will be about 1,000 kilowatts.

This machine will enable the nuclei of most atoms to be broken up into fragments, and will provide nuclei of new types which even the piles cannot produce. They will also make possible experiments on the frontiers of nuclear physics which at present can only be carried out in one place in the world—the Radiation Laboratory of the University of California.

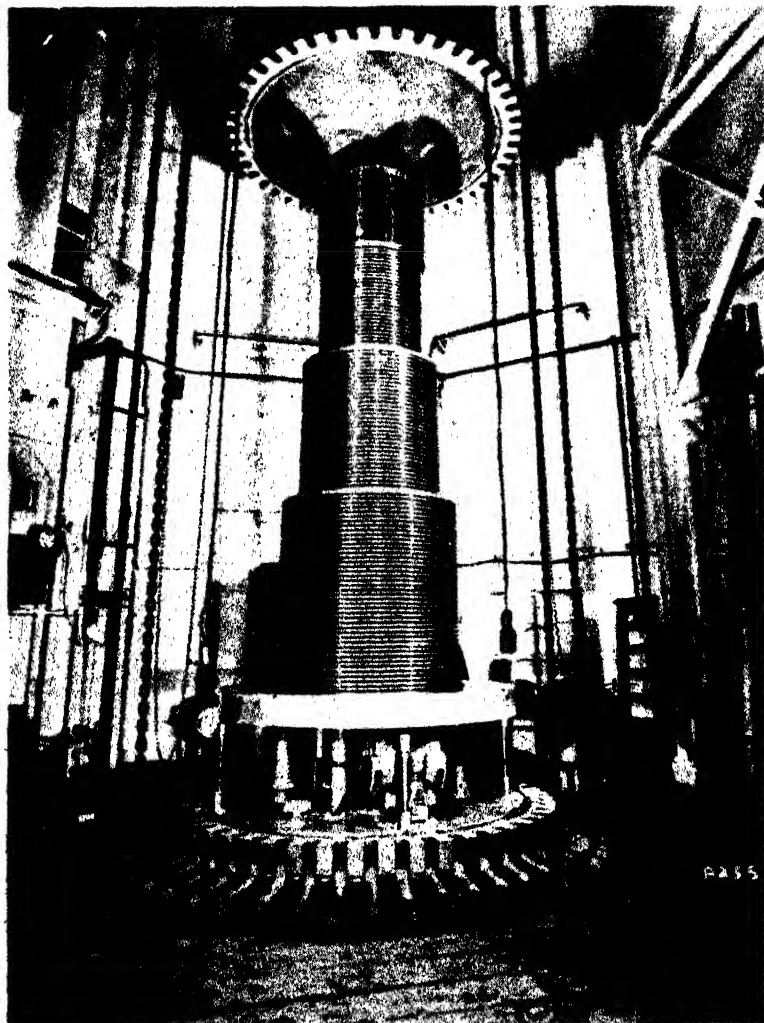

(Crown Copyright Reserved)
Van de Graaff high voltage generator. When in use the machine is enclosed by the boiler top centre, which is filled with gas under pressure

Van de Graaff Generator

The 5-million volt Van de Graaff generator is a very simple machine. A small rounded insulated terminal is enclosed in a

pressure boiler, which is filled with gas under a pressure of about 200 lb./sq. in. to prevent sparking to earth. A belt conveyor transfers electric charge from earth to the terminal. The conveyor belt, which travels at 60 m.p.h., is made of insulated rubberised material; it is "loaded" and "unloaded" with electricity by a row of points at either end, which cause a discharge to and from its surface. An auxiliary supply provides the voltage of 50,000 v. needed to make this discharge occur.

The 5 million volts produced by the machine are used to speed up hydrogen nuclei in a vacuum tube in the centre of the machine. They emerge into a pit below, where they are used to study the properties of atomic nuclei.

Most elements are mixtures of two or more components called isotopes which differ in mass but have otherwise very similar properties, so that in all ordinary physical, chemical and biological processes the isotopes go together without any change in their concentration. It is, however, possible to separate isotopes by some physical or chemical methods which make use of minute differences between their properties. The separated isotopes can be used as tracers in a similar way to radio-isotopes, but as they do not emit radiation it is more difficult to distinguish one from another, and an instrument called a mass spectrometer is required for the purpose:

There is a considerable demand for the carbon isotope of mass 13, and an experimental plant has been built in which this isotope is separated by fractional distillation. The process makes use of the small difference of about $1/10^{\circ}$ F. in the boiling point of compounds of the two isotopes. The compound used in the plant is liquid carbon-monoxide. The apparatus consists of a vertical column with a boiler at the bottom from which the liquid is distilled in a manner similar to commercial distillation processes.

Radiochemical Laboratory (or "Hot" Laboratory)

The chemical and chemical engineering problems are amongst the most difficult in any Atomic Energy programme. When uranium metal is placed in a pile, the new element plutonium is produced together with radioactive forms of at least 30 elements, the fission products. The plutonium has to be separated from uranium and the

THE HEAT PUMP

intensely radioactive fission products. This radioactivity, together with the toxicity of the plutonium, requires great precautions to be taken to protect the health of the chemists.

It will be seen that some considerable practical work has been done in the field of industrial application of atomic energy and, while the dropping of two atomic bombs galvanised the world into the reality of this atomic age, there is much that the scientists can give to the engineer, which he in turn can harness for the good of mankind.

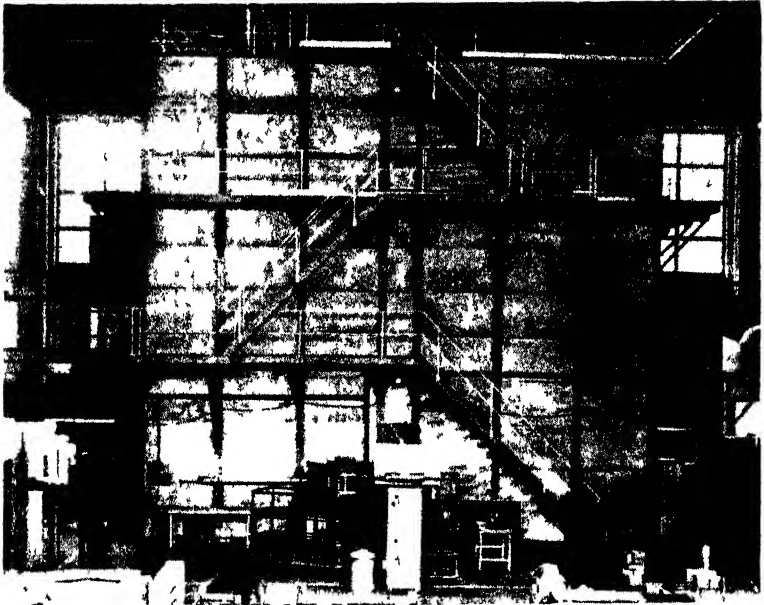

(Crown Copyright Reserved)

General view of one face of Gleep. A neutron spectrometer, in which neutrons from the Pile are diffracted by a crystal, can be seen in the foreground

It is not that atomic energy is the one means of all power, but that it opens up vast fields as by-products and the recovery of the waste heat from the pile is a field in which there may one day be a useful application of the Heat Pump, and it is to be hoped that we will develop this application at the start and not push it aside as has been done in the past with the use of coal.

LITERATURE ON THE HEAT PUMP

¹ The Reversed Heat Engine as a means of Heating Buildings. By T. B. Morley. *ENGINEER*, 133 (1922) 3450, February 10th, p. 145-146.

² The Heat Pump - an economical method of producing low-grade heat from electricity. By T. Haldane. *J. INSTN. ELECTR. ENGRS.*, 68 (1938) 402, p. 666-675.

³ Heating with Refrigerating Equipment cuts current costs. By H. L. Doolittle. *POWER*, 76 (1932), 1, p. 29-31.

⁴ Hot Water from Reversed Refrigeration. By B. J. Homkes. *ELECTR. WLD.*, 104 (1934) 5, p. 140-142.

⁵ Elektrische Raumbeheizung und ihre Wirtschaftlichkeit. Von H. Weber. *Elektrowarme*, 4 (1934) 7, s. 159.

⁶ Rapport sur les pompes de chaleur et le chauffage électrique. Par H. Melzer. *Union Intern. Product. Energ. Electr.*, 5^{eme} Congres 1934, V-7-a.

⁷ Eine vollelektrische Heiz-, Kühl- und Bewetterungsanlage mittels Wärmepumpe. Von K. Otto. *Gesundh.-Ing.* (1935), 23 November, S. 709-711.

⁸ Le chauffage thermodynamique des locaux par la vapeur a pressions sous-atmosphériques. Par Red. *Rev. gen. Electr.*, 40 (1936) 10, 5 septembre, p. 312.

⁹ Le chauffage thermodynamique et la pompe de chaleur. Par P. M. Casnault. *Electricite*, 22 (1938) 43, avril, p. 137-139.

¹⁰ Die Wärmepumpenheizung des zürcherischen Rathauses. Von M. Egli. *Bull. Schweiz. Elektrotechn. Ver.*, 29 (1938) 11, 25 Mai, S. 261-273.

¹¹ Il ciclo a pompa di calore. Di C. Corbetta. *Energia term.*, 6 (1938) 6, giugno, p. 142-148.

¹² Physikalische Grundlagen der Wärmepumpe. Von G. Eichelberg. *Schweiz. Arch. angew. Wiss. u. Techn.*, 4 (1938) 11, November, S. 297-302.

¹³ Die Anwendung der Wärmepumpe. Von R. Peter. *Schweiz. Arch. angew. Wiss. u. Techn.*, 4 (1938) 12, Dezember, S. 330-336.

¹⁴ Die Wärmepumpe. Von M. Hottinger. *Schweiz. Blatter Heizg. u. Luftg.*, 6 (1939) 1, Januar, S. 1-10.

¹⁵ Einiges über die Möglichkeit von Wärmepumpenheizungen. Von M. Egli. *Bull. Schweiz. Elektrotechn. Ver.*, 30 (1939) 2, 18 Januar, S. 42-48.

¹⁶ Betrachtungen zur Wärmepumpenheizung des zürcherischen Rathauses. Von M. Egli. *Wass. u. Energiewirtsch.*, 31 (1939) 6, Juni, S. 74-79.

¹⁷ Vers la réalisation pratique du chauffage thermodynamique. Par Red. *Electricite*, 23 (1939) 57, juin, p. 207-210.

¹⁸ Physikalische Grundlagen und Anwendungen der Wärmepumpe. Von Red. *Schweiz. Bauztg.*, 114 (1939) 1, 1 Juli, S. 11-13.

¹⁰ Sur les possibilites des pompes de chaleur. Par Red. Electricite, 23 (1939) 62, novembre, p 349-350.

²⁰ Die Entwicklungsarbeit der F T H an der Luftwärmepumpe. Von B. Bauer. Neue Zürcher Zeitung, Blatt 4, Mittagausgabe, 1 November 1939, No. 1882.

²¹ L'application des pompes a chaleur au chauffage et a la refrigeration des locaux. Par M. Chambadal Mecanique, 23 (1939) 287, novembre-decembre, p. 210-216.

²² Die elektrische Erzeugung von Wärme und Kalte in Klümaanlagen vermittels der Wärmepumpe Von B. Bauer und B. W. Bolomey. Elektr.-Verwertg., 14 (1939/40) 9/10, Dezember-Januar, S. 160-163.

²³ Von der Luftwärmepumpe. Entwicklungsarbeit der E.T.H. Von Red. Schweiz. Energiekons., 19 (1939) 12, 15 Dezember, S. 249-252.

²⁴ Elektrische Raumheizung mit Wärmepumpe. Von V. Fischmeister. Heizg. u. Luftg., 14 (1940) 4, S. 37-41.

²⁵ Gebäudeheizung mit Wärmepumpe (norweg.). Von M. Egli. Elektrotekn. T., Oslo, 53 (1940) 11, S. 125-129

²⁶ Heizung mittels Kaltemaschinen. Von G. Mark. Gesundh.-Ing., 63 (1940) 11, 16 März, S. 121-124.

²⁷ Die Wärmepump-Heizung des renovierten zürcherischen Rathauses. Von M. Egli. Schweiz Bauztg., 116 (1940) 5, 7 3.u.17. August, S. 59-64, 73-75.

²⁸ Heating by Reversed Refrigeration. By A. J. Lawless. Heat. Pip. Air. Condit., 12 (1940) 8, August, p. 473-676.

²⁹ Pumpe di calore. Di P. Vannotti. Ingegnera, 14 (1940) 8, agosto, p. 615-618.

³⁰ Die Wärmepump-Heizung des Zürcher Rathauses. Von Red. Schweiz. Bauztg., 116 (1940) 15, 12 Oktober, S. 175.

³¹ Die elektrische Erzeugung von Wärme und Kalte in Klümaanlagen vermittels der Wärmepumpe. Von B. Bauer und B. W. Bolomey. Gesundh.-Ing., 63 (1940) 42, 19 Oktober, S. 545-546.

³² Die Bestreitung von Heizungs- und Wärmeprozessen mittels der Wärmepumpe. Von P. E. Wirth. Schweiz. Bauztg., 117 (1941) 23, S. 265-270.

³³ Die Bedeutung des T.S-Schaubildes in Wärmepumpen-Anlagen. Von O. Zimmermann. Heizg. u. Luftg., 15 (1941) 7, S. 73-74.

³⁴ Neuere Anwendungen der Wärmepumpe für Gebäudeheizung. Von A. Gini. Heizg. u. Luftg., 15 (1941) 7, S. 74-78.

³⁵ Heizen mit Wärmepumpen. Von A. Ostertag. Escher-Eyss-Mitt., 14 (1941), S. 50-63.

³⁶ Die Wärmepumpe. Von H. T. Bohler. Arch. Warmewirtsch., 22 (1941) 5, Mai, S. 95-98.

³⁷ Die Wärmepumpenanlage des Zürcher Hallenbades. Von G. Eichelberg. Neue Zürcher Zeitung. —(1941) 703 (17), 7 Mai, Blatt 5.

³⁶ L'emploi de la pompe de chaleur pour la production de la chaleur et du froid dans les installations de conditionnement d'air. Par Red. *Mecanique*, 25 (1941) 293, mai-juin, p. 75-80.

³⁹ Die wirtschaftlichen Möglichkeiten der Wärmepumpe. Von P. E. Wirth. *Bull. Schweiz. Elektrotechn. Ver.*, 32 (1941) 18, 10 September, S. 435-438.

⁴⁰ Brennstoffeinsparung in der Industrie mit der Wärmepumpe. Von B. Bauer. *Neue Zürcher Zeitung, Mittagaussgabe*, --(1941) 2009, (50), Blatt 5, 10 Dezember.

⁴¹ Beitrag über die Anwendungsmöglichkeiten elektrisch angetriebener Wärmepumpen für Zentralheizungs- und Klimaanlageanlagen. Von E. Preissmann. *Diss. T. H. Wien, Wien*: 1942.

⁴² L'amélioration de rendement d'une installation frigorifique par l'adjonction d'une pompe thermique. Par Red. *Rev. tech. Sulzer*, --(1942) 2, p. 25-31.

⁴³ Brennstoffeinsparung in der Industrie mit der Wärmepumpe. Von B. Bauer. *Elektr. Verwgt.*, 17 (1942) 1, April, S. 1-10.

⁴⁴ Le chauffage industriel à l'aide de pompe thermique. Par P. Dusseiller. *Bull. tech. Suisse rom.*, 68 (1942) 8, 9, 18 avril, 2 mai, p. 85-89, 103-106.

⁴⁵ Die Wärmepumpe in der Energiewirtschaft. Von W. Wende und C. Schmittl. *Warme*, 65 (1942) 43-44, 31 Oktober, S. 376-382.

⁴⁶ Die Wärmepumpe im Dienst der Brennstoffersparnis. Zur 5. Sitzung des Elektrowärme-Ausschusses der V.d.E.W. am 2. November 1942 in Berlin. *Elekt. Wirtsch.*, 41 (1942) 22, 20 November, S. 502-505.

⁴⁷ Brennstoffsparen durch Wärmepumpen? Der Wert der Wärmepumpe im Vergleich mit der Gegendruckdampfheizung. Von H. Kahlert. *Arch. Warmew.*, 24 (1943) 10, Oktober, D. 185-189.

⁴⁸ Zur Frage der Wärmepumpe. Von K. Modrovich. *Warme*, 66 (1943) 19, Oktober, S. 232.

⁴⁹ Wirtschaftliche Grenzen verschiedener Arbeitsgebiete von Wärmepumpenanlagen. Von U.V. Buttikofer. *Elektr. Verwgt.*, 18 (1943) 7/9, Oktober-Dezember, S. 128-133.

⁵⁰ Der Kolbenkompressor als Wärmepumpe. Von R. Landolt. *Elektr. Verwgt.*, 18 (1943) 7/9, Oktober-Dezember, S. 180-181.

⁵¹ Einige Grosswärmepumpenanlagen. Von A. Baumann. *Elektr. Verwgt.*, 18 (1943) 7/9, Oktober-Dezember, S. 175-179.

⁵² Entwicklungs- und Wirtschaftlichkeitsfragen der Wärmepumpenbetriebe. Von R. Peter. *Elektr. Verwgt.*, 18 (1943) 7/9, Oktober-Dezember, S. 117-127.

⁵³ Die Schweizer Flüsse als Wärmequelle für Wärmepumpen. Von D. Mettler. *Elektr. Verwgt.*, 18 (1943) 7/9, Oktober-Dezember, S. 145-146.

⁵⁴ Die Konzessionierung von Wärmepumpenanlagen zur Gewinnung von Wärme aus Flusswasser. Von H. Kreis. *Elektr. Verwgt.*, 18 (1943) 7/9, Oktober-Dezember, S. 140-144.

⁵⁵ La pompe à chaleur, sa théorie physique et son rôle économique. Par Red. *Elektr. Verwgt.*, 18 (1943) 7/9, Octobre-décembre, p. 147-151.

- ⁵⁶ Die bestehenden Raumheiz-Wärmepumpenanlagen Zurichs. Von Red. Elektr. Verwtg., 18 (1943) 7/9, Oktober-Dezember, S. 163-172.
- ⁵⁷ Das Projekt der Wärmepumpenanlage des neuen Kantonsspitals Zurich. Von M. Egl. Elektr. Verwtg., 18 (1943) 7/9, Oktober-Dezember, S. 155-162.
- ⁵⁸ Die Schweizer Flüsse als Wärmequelle für Wärmepumpen. Von D. Mettler, Gas u. Elektrowärme, — (1944) 6, S. 120-121.
- ⁵⁹ Die Wärmepumpenanlage zur Erhaltung des Qualitäts-Standards. Von Red. Tech. Rusch Sulzer, — (1944) 3/4, S. 11-14.
- ⁶⁰ La pompe a chaleur et son role dans l'industrie alimentaire. Par Red. Rev. tech. Sulzer, — (1944) 3/4, p. 11-14.
- ⁶¹ Das Wärmepump-Ergänzungswerk des Fernheizkraftwerkes der E.T.H. Von B. Bauer. Schweiz. Bauztg., 123 (1944) 5, 29 Januar, S. 52-55.
- ⁶² Die Wärmepumpe im Rahmen der Energiewirtschaft. Von K. Linge. Z. Ver. dtsh. Ing., 88 (1944) 5/6, 5 Februar, S. 57-65.
- ⁶³ Erfahrungen aus dem Betrieb der Wärmepumpen Heizung im Rathaus von Zurich. Von M. Egl. Schweiz. Bauztg., 123 (1944) 8, 19 Februar, S. 87-91.
- ⁶⁴ Anwendungsmöglichkeiten für Wärmepumpe und Druckgasfeuerung. Von J. Kortung. Gas u. Wasserfach, 87 (1944) 3, März, S. 67-71.
- ⁶⁵ Die Rolle der Wärmepumpe in der Energiewirtschaft. Von E. Haidegger. Elektrotech. u. Maschinenbau, 62 (1944) 21/22, 26 Mai, S. 253-267.
- ⁶⁶ Les pompes a chaleur pour l'utilisation rationnelle de l'energie hydro-electrique. Par F. Personne. Electricite, 28 (1944) 111, juillet-aout, p. 121-130.
- ⁶⁷ SLM-Winterthur-Wärmepumpen. Von Red. Tech. Mitt. S.L.M., — (1944), Oktober, S. 17-20.
- ⁶⁸ Wirtschaftlichkeit der Wärmepumpe als Ergänzung industrieller Kälteanlagen. Von H. Widmer. Elektr. Verwtg., 19 (1944-45) 6/7, S. 129-136.
- ⁶⁹ La pompe thermique et ses applications pour le chauffage. Par D. Marples. Bull. tech. Suisse rom., 71 (1945) 1, 6 janvier, p. 1-8.
- ⁷⁰ Die Wärmepumpen-Heizanlage im Etzelwerk in Altendorf. Von A. Kornfehl. Bull. schweiz. elektrotech. Ver., 36 (1945) 6, 21 März, S. 157-160.
- ⁷¹ Weitere Brown Boveri Wärmepumpen helfen Kohle sparen. Von C. Krapf. Brown Boveri Mitt., 32 (1945) 4, April, S. 141-142.
- ⁷² Die mit einem * bezeichneten Zeitschriften-Artikel sind in der Bibliothek der E.T.H. vorhanden.
- ⁷³ Thompson, W.: "On the Economy of the Heating and Cooling of Buildings by Means of Currents of Air," GLASGOW PHIL. SOC. PROC., December, 1852, 3.
- ⁷⁴ Krauss, F.: "Heat Pump in Theory and Practice," POWER, February 22nd, 1921. 54, pp. 298-300.

⁷⁵ Oetken, A. : " Heat Pump in the Operation of Evaporators : Vapour Compression and Steam-Pressure Transformation," *DIE WARME*, April 28th, 1928, **51**, pp. 315-321. Abstracts : *POWER ENG.*, June, 1928, **23**, p. 243. *MECHANICAL ENG.*, August, 1938, **50**, pp. 635-636.

⁷⁶ Varinois : " Heat Pump --Its Applications," *REV. INDUSTRIELLE*, December, 1928, **58**, pp. 726-730.

⁷⁷ Haldane, T. G. N. : " The Heat Pump --An Economical Method of Producing Low-Grade Heat from Electricity," *JOURNAL I.E.E.*, June, 1930, **68**, pp. 666-675. Abstract : *ELECT. REV.*, December 27th, 1929, **105**, pp. 1161-1162.

⁷⁸ ———. " Reverse Refrigeration Process for House Heating," *ELECT. WORLD*, August 16th, 1930, **96**, pp. 315-316.

⁷⁹ Hall, C. I. : " House Heating Efficiency with Inverted Carnot Cycle," *ELECT. WORLD*, November 22nd, 1930, **96**, p. 967.

⁸⁰ Guarini, E. : " Refrigerating Machine as a Heat Pump for Warming Dwellings," *HEATING, PIPING AND AIR CONDITIONING*, February, 1931, **3**, p. 132.

⁸¹ Macintyre, H. J. : " Heat Pump--System Explained," *HEATING, PIPING AND AIR CONDITIONING*, February, 1931, **3**, pp. 133-134.

⁸² Haldane, T. G. N. : " Reversed Refrigeration Cycle for House Heating," *ELECT. WORLD*, April 25th, 1931, **97**, p. 782.

⁸³ Randal, B. F. : " Hot Water and Cold Air from a Refrigerating System," *POWER*, May 19th, 1931, **73**, pp. 779.

⁸⁴ Randal, B. F. : " A Method of Heating with Refrigeration," *HEATING AND VENTILATING*, **28**, pp. 77-79, September, 1931.

⁸⁵ Benjamin, W. M. : " Discussion of Reversed Refrigeration," *HEATING AND VENTILATING*, November, 1931, **28**, pp. 45-48.

⁸⁶ Willis, P. A. : " Heating and Refrigerating Machines and Diesel Engines," *HEATING AND VENTILATING*, January, 1932, **29**, pp. 52-53.

⁸⁷ Stevenson, A. R., Faust, F. H., and Roessler, F. W. : " Application of Refrigeration to Heating and Cooling of Homes," *REFRIGERATION ENG.*, February, 1932, **23**, pp. 83-90 ; *HEATING AND VENTILATING*, February, 1932, **29**, pp. 31-37 ; *G.E. REV.*, March, 1932, **35**, pp. 145-153.

⁸⁸ ———. " Heat Pump Shows 2.8 Coefficient of Performance. Southern California Edison Installs Complete Air Conditioning Plant in Los Angeles Office Building," *ELECT. WORLD*, March 12th, 1932, **99**, pp. 502-505.

⁸⁹ Johnson, W. C. : " Theoretical Consideration of the Value of Low Temperature Heat," *G.E. REV.*, April, 1932, **35**, pp. 227-229.

⁹⁰ Stower, H. J. : " Improved Inverted Refrigeration Cycle for Summer and Winter Air Conditioning," *HEATING, PIPING AND AIR CONDITIONING*, June, 1932, **4**, pp. 412-425.

⁹¹ Doolittle, H. L. : " Heating with Retriferation Equipment Cuts Current Costs," *POWER*, July, 1932, **76**, pp. 29-31.

⁹² Wilkes, G., and Marbury, R. E. : " House Heated by Pump with 5 to 1 Pick-up Ratio," *ELECT. WORLD*, December 17th, 1932, **100**, pp. 828-831.

THE HEAT PUMP

⁹⁸ ——— "Boilers and Heat Pumps," *ENGINEER*, December 30th, 1932, **154**, pp. 669-670. Abstract: *MECHANICAL ENG*, April, 1933, **55**, pp. 259-260.

⁹⁹ Morley, T. B.: "Steam Pressure Transformer," *STEAM ENG*, February, 1933, **11**, pp. 205-207. Abstract: *MECHANICAL ENG*, April, 1933, **55**, pp. 258-259.

¹⁰⁰ Graham, C. D., and Wilkes, G.: "Science Reverses the Refrigeration Cycle and Gives us the Heat Pump," *DOMESTIC ENG*, March, 1933, **141**, pp. 55-56 and 59.

¹⁰¹ Graham, C. D.: "Reversed Cooling for Heat, an Economical Combination." *ELECT. WORLD*, October 21st, 1933, **102**, pp. 533-537.

¹⁰² Marguere, F.: "New Heat Storage System Development in Europe," *POWER PLANT ENG*, October, 1933, **37**, pp. 426-427.

¹⁰³ Mowrey, C. F.: "Heating and Air Conditioning Buildings with Reversed Refrigeration Cycle," *HEATING, PIPING AND AIR CONDITIONING*, June and July, 1934, **6**, pp. 257-260 and 295-297.

¹⁰⁴ Homkes, B. J.: "Hot Water from Reversed Refrigeration," *ELECT WORLD*, August 4th, 1934, **104**, pp. 140-142.

¹⁰⁵ Marguere, F.: "Power Accumulation by Thermal Storage," *ELECTRICIAN*, September 7th, 1934, **113**, p. 294.

¹⁰⁶ Wilkes, G. M.: "Domestic Hot Water by Reversed Cycle," *ELECT WORLD*, November 24th, 1934, **104**, pp. 970-972.

¹⁰⁷ Marguere, F.: "Heat Temperature Storage of Power," *ENGINEERING*, December 28th, 1934, **138**, p. 721.

¹⁰⁸ ——— "Jersey Utility Building Heated and Cooled by Heat Pump Plant has New Features," *HEATING AND VENTILATING*, January, 1935, **32**, p. 58.

¹⁰⁹ Sporn, P., and McLanegan, D. W.: "All Electric Heating, Cooling and Air Conditioning System," *HEATING, PIPING AND AIR CONDITIONING*, **7**, pp. 402-409, August, 1935. Abstract: *HEATING AND VENTILATING*, July, 1935, **32**, pp. 56-57.

¹¹⁰ Askin, J.: "Unit Cooler and the Heat Pump," *REFRIGERATION ENG.*, August, 1935, **30**, pp. 72-74.

¹¹¹ Galson, H. L.: "Using the Reversed Refrigerating Cycle for a Self-Contained Heating and Cooling Unit," *HEATING, PIPING AND AIR CONDITIONING*, October, 1935, **7**, pp. 499-502.

¹¹² Wilkes, G.: "Reversed Refrigeration Water Heater—Hot Water from 6-10 kW-Hr. Daily," *ELECT. WORLD*, October 12th, 1935, **105**, p. 2476.

¹¹³ Tuckerman, G. E.: "Year Round Air Conditioning for Virginia Electric and Power," *REFRIGERATION ENG.*, January, 1936, **31**, pp. 48-49.

¹¹⁴ Chambadei, M.: "Performance and Application of Heat Pumps using Superheated Steam," *SOC. INGENIERS CIVILS MEMOIRES*, July, 1936, **89**, pp. 594-617.

¹¹⁵ Lynette, H. A.: "Central District Heating and Cooling," *REFRIGERATION ENG.*, January, 1938, **35**, pp. 7-11.

T H E H E A T P U M P

¹¹¹ Egli, M. : " The Heating of the Zurich Town Hall by the Heat Pump," S.E.V. BULL., May 27th, 1938, **29**, pp. 261-273 ; December 23rd, 1938, pp. 765-766.

¹¹² — " On the Possibilities of the Heat Pump," S.E.V. BULL., January 20th, 1939, **30**, pp. 42-48.

¹¹³ Lang, G. : " Heat Pump Applied to Railway Cars," REFRIGERATION ENG., April, 1939, **37**, pp. 240-268.

¹¹⁴ — " Heat Pump Serves New Coast Building : Cooling and Heating by Reverse Cycle Operation at Westinghouse Building, Emeryville, California," POWER, April, 1939, **83**, pp. 215-217.

¹¹⁵ Kruger, W. " Heat Pump Installation at Zurich Town Hall," V.D.I., May 27th, 1939, p. 654

¹¹⁶ — " Seattle with Low Electrical Rates Develops Its Own Heat Pump," HEATING AND VENTILATING, September, 1939, **36**, p. 61.

¹¹⁷ — " Warming the Walls by Reverse Cycle," ELECTRICAL WEST, October, 1939, **83**, p. 48.

¹¹⁸ Bauer, B., and Bolomey, B. W. : " Generation of Heat and Cold by Means of the Heat Pump," ELEKTRIZITÄTSVERWERTUNG (ELECTRICAL SERVICE), 1939-1940, No. 9/10, **14**, pp. 160-183.

¹¹⁹ Fisher, K. M. : " Heated by Reverse Cycle Refrigeration," DOMESTIC ENG., June, 1940, pp. 50-51.

¹²⁰ — " Articles on the Heat Pump, SCHWEIZERISCHE BAUZEITUNG, July 1st, 1939, p. 11 ; August 10th, 1940, p. 57 ; August 17th, 1940, p. 73.

¹²¹ Lawless, A. J. : " Heating by Reverse Refrigeration ; United Illuminating Co. Administration and Service Building, New Haven, Conn.," HEATING, PIPING AND AIR CONDITIONING, August-September, 1940, **12**, pp. 473-476, 519-521.

¹²² Ramsay, M. A. : " South American Way on this Buenos Aires Job was to Use a Heat Pump," HEATING, PIPING AND AIR CONDITIONING, March, 1941, **13**, pp. 167-170.

¹²³ Heitchue, R. D. : " Reversed Cycle Refrigeration for Air Conditioning Work," REFRIGERATION ENG., May, 1941, **41**, pp. 217-230.

¹²⁴ Hasler, O. : " Economic Basis of the Heat Pump Installation in the New Zurich Municipal Baths," S.E.V. BULL., July 30th, 1941, **32**, pp. 345-348.

¹²⁵ — " Experience with a Reversed Cycle Heating System : Administration and Service Building of the United Illuminating Co., New Haven, Conn.," POWER August, 1941, **85**, pp. 557-559.

¹²⁶ Wirth, P. E. : " Economic Possibilities of the Heat Pump," S.E.V. BULL., September 12th, 1941, **32**, pp. 435-438.

¹²⁷ — " The Heat Pump Makes Headway," S.E.V. BULL., December 19th, 1941, **32**, p. 726.

¹²⁸ — " Heat Pumps," BROWN BOVERI REV., January-March, 1942, **29**, pp. 57-58.

THE HEAT PUMP

¹³⁰ Bauer, B. : " Fuel Saving in Industry by the Heat Pump," *ELEKT. VERWTG (ELECTRICAL SERVICE)*, April, 1942, **17**, pp. 1-10.

¹³¹ Baumann, A. : " Instead of Coal," *BROWN BOVERI REV.*, April, 1942, **29**, pp. III-III2.

¹³² Dusseiller, P. : " Industrial Heating by Means of the Heat Pump," *BULL. TECH., SUISSE ROMANDE*, April 18th, 1942, **68**, pp. 85-89; May 2nd, 1942, pp. 103-106.

¹³³ ——— " Heat Pumps," *E.T.Z.*, June 18th, 1942, **63**, p. 284.

¹³⁴ ——— " Recent Applications of the Heat Pump," *BROWN BOVERI REV.*, June-July, 1942, **29**, pp. 190-191.

¹³⁵ Heitchue, R. D. : " Heating by Reversed Refrigeration," *ELECT. ENG.*, November, 1942, **61**, pp. 556-560

¹³⁶ Laudolt, R. : " Simultaneous Heating and Cooling of an Industrial Plant with Heat Pumps," *S.E.V. BULL.*, November 18th, 1942, **33**, pp. 677-678.

¹³⁷ ——— " Heat Pumps," *BROWN BOVERI REV.*, January-April, 1943, **30**, pp. 51-53.

¹³⁸ Wall, T. F. : " Heat Pump," *ENGINEERING*, March 19th, 1943, **155**, p. 221.

¹³⁹ ——— " The Heat Pump Installation of the F.K.H. in Zurich," *S.E.V.*, April 7th, 1943, **34**, pp. 174-175.

¹⁴⁰ Sewell, H. R. : " Reversed Refrigeration Cycle for Winter and Summer Air Conditioning," *REFRIGERATION ENG.*, May, 1943, **45**, pp. 328-330.

¹⁴¹ Meldahl, A. : " The Heat Pump as Refrigerating and Heating Machine," *BROWN BOVERI REV.*, May-June, 1943, **30**, pp. 75-85.

¹⁴² Baumann, A. : " The Thermo-Compressor Installation in Lucens for the Concentration of Milk," *BROWN BOVERI REV.*, May-June, 1943, **30**, pp. 85-87.

¹⁴³ Baumann, A., and Marples, D. : " Some Applications of the Heat Pump as a Heating Machine," *BROWN BOVERI REV.*, July-August, 1943, **30**, pp. 146-167.

¹⁴⁴ Paltzer, G., and Peter, R. : " Heat Pumps of the Societe des Salines Suisses du Rhin Reunies," *S.E.V. BULL.*, August 16th, 1943, **34**, pp. 467-474.

¹⁴⁵ ——— " Heat Pump Installations for Heating the Zurich Civic Buildings," *S.E.V. BULL.*, August 25th, 1943, **34**, pp. 511-512.

¹⁴⁶ Bauer, B. : " Heat Pump Systems in Switzerland," *E.T.Z.*, September 23rd, 1943, **64**, pp. 497-502.

¹⁴⁷ ——— " Energy Economy and the Thermodynamic Heat Pump," *Symposium of Articles, ELEKT. VERWTG. (ELECTRICAL SERVICE)*, 1943-1944, **18**, No. 7-9.

¹⁴⁸ Sporn, P., and Ambrose, E. R. : " The Heat Pump—An All-Electric Year Round Air Conditioning System," *HEATING AND VENTILATING*, January, 1944, **41**, pp. 68-78.

¹⁴⁹ Linge, K. : " The Heat Pump in Relation to Energy Economy," *V.D.I. ZEITS.*, February 5th, 1944, **88**, pp. 57-65.

THE HEAT PUMP.

¹⁴⁹ Egli, M. : " Experiences in the Application of the Heat Pump Method for Heating the Zurich Town Hall," SCHWEIZ BAUZEITG., February 19th, 1944, **123**, pp. 87-91.

¹⁵⁰ Sporn, P., and Ambrose, E. R. : " Description and Performance of Two Heat Pump Air Conditioning Systems," HEATING, PIPING AND AIR CONDITIONING, June, 1944, **16**, pp. 377-385.

¹⁵¹ ——— " The Heat Pump as a Load Builder," ELECT. WORLD, June 10th, 1944, **121**, pp. 99-101.

¹⁵² ——— " The Sixth Ingredient—The Heat Pump," EDISON ELECT. INST. BULL., August, 1944, **12**, pp. 240-247.

¹⁵³ Berry, R. U. : " Possibilities of Heat Pumps for Heating Homes," ELECT. ENGG., September, 1944, **63**, TRANS., pp. 610-622. Also G.E. REV., September, 1944, **47**, pp. 13-17.

¹⁵⁴ Kaufmann, P. G. : " Economics of the Heat Pump Applied to Space Heating Installations," HEATING AND VENTILATING ENGINEER, September, 1944, **18**, pp. 78-87.

¹⁵⁵ ——— " Experience with a Heat Pump System." ELECT. ENG., October, 1944, **63**, p. 361.

¹⁵⁶ Bauer, B. : " Heat Pump Extensions to the District Heating System of the Technical High School, Zurich," SCHWEIZ. BAUZEITG., 1944, **123**, p. 52.

¹⁵⁷ Faber, O. : " The Value of Heat with Special Reference to the Heat Pump," Paper read before Institution of Mechanical Engineers, April 20th, 1945. Abstract: ENGINEER, April 27th, 1945, **179**, pp. 339-340, and May 4th, 1945, pp. 358-360.

¹⁵⁸ Editorial : " The Heat Pump," ENGINEER, May 4th, 1945, **179**, pp. 352-353.

¹⁵⁹ ——— " Heating by Refrigeration," THE ELECTRICIAN, June 22nd, 1945, **134**, pp. 557-559.

¹⁶⁰ ——— " The Norwich Heat Pump," THE ENGINEER, August 31st, 1945, p. 165.

¹⁶¹ ——— " The Heat Pump," AIR TREATMENT ENGINEER, July, 1945, and November, 1946, to January, 1948.

INDEX

	PAGE
Advantages of Heat Pump	20
Air Heat Pump Diagram	154, 156
Application of the Heat Pump	61
Atomic Energy	219
— Elements and Compounds	219
— Fuel	226
Atoms and Molecules	220
Atom Smasher	223
Available Energy	19
Base Load in Designing	68
Bath and Rink	206
Beginning, The	11
Bell Factory	164
— Diagrammatic Layout	160
— Refrig. and Heating	165
— The Engine-room	167
— The General Arrangement	170
Bibliograph	86, 216, 245
Black, Joseph	11
Carnot Cycle	12
— Diagram	39
— Efficiency	35
— Theory	12
Chemical Combination of the Atom	221
— Engineering	223
Coefficient of Performance	37
Comparison of Heat by Heat Pump Temperature, etc.	117
— of Refrigeration Plant and Heat Pump	204
— of Working Costs of Heat Pump and Coal-fired Boilers... ..	177
Comparisons	19
Compressor Table of Details	195
Conditions Necessary for the Heat Pump	56
Cooling Cycle	85
Costs of Installations	63
— of Steam, Electricity and Water	182
Country House	10
Cycle of Heat Pump, Pictorial	84
Cyclotron	236
Details of Loading Costs and Performance	70
Diagram for Hot Water	58
— of a Gas Engine	35
— of a Heat Pump	25
— of a Steam Engine... ..	22, 29, 34
— of Norwich Installation	116
— showing Heat Produced Before	118
— showing Heat Produced After	119
Economy Factors	203
— of Various Systems	178
Effect of Efficiencies of the Compression and Expansion	46
— of the Process and of the Working Medium	43
Efficiencies	41
Efficiency of Carnot Cycle	18
Electric Supply	198

THE HEAT PUMP

	PAGE
Electricity Generation	199
Energy	14
Entropy	14, 33
— and Carnot Cycle	15
— Diagram	40
Evaporating Plant Diagram	179
Evaporation Comparison	183
Evaporator Section	115
Explanation of Theory	10
Frigotrop Type Compressor	143
Gas Engines	22, 32
— Heat Pump	27
Gleep	224
Hall Compressor	195
Heat Available and Reversed Heat Engine	20
— Engines	21, 28, 38
Heating Machine	38
Heat Output	62
— Pumps	21, 37
— Pumps and Hydraulic Machinery	50
— Pumps for Distilling	190
Indicator Diagram	35
— Diagram for Kelvin Layout	48
Industrial Application of Nuclear Power	238
Insulated Storage	141
Isotopes	225
Kelvin	11
— Layout for a Heat Pump	47
— Theory	49
Landquart Paper Mills	150
— Diagram of Layout	151
— Diagram of the Air Heat Pump	154
— Sources of Heat	152
— View of Plant the only large Air Heat Pump	152
Lausanne Artificial Ice Rink	139
— A View of the Ice Rink	144
— Diagram of Mains and Layout	140
— Ice-making and Hot Water Supply	140
— Insulated Storage	141
— Original Design	139
— The Compressor Room	142
Laws of Thermodynamics	12
Literature on the Heat Pump	245-253
Load Factors	64
Local Climatic Conditions	74
Lucens Installation	186
— Diagram of Layout	187
— Table of Results	188
— View of the Installation	189
Mains—a Diagrammatic Layout	140
Maximum and Minimum Tables of Temperatures as Recorded at Kew	76
— and Minimum Temperatures from October until April	53
Mean Temperature and Degree Days	55
— Temperature Distribution	75

THE HEAT PUMP

	PAGE
Medical Application of Isotopes	228
Milk and Unfermented Fruit Juice	149
— Handling	65
— -sugar Manufacture	186
Multi-stage Evaporators' Steam Consumption	181
Neuchatel Ice Rink... ..	145
Non-Flow Processes for Gas Systems	30, 31
Norwich Heat Pump	121-138
— Annual Costs	136
— Building and the Heating System	129
— Choice of a Refrigerant	133
— Comparative Costs	135
— Design and Construction	130
— Detail of the Layout	128
— History of the Experiment	128
— Summary	137
— The Compressor	134
— The Condenser	131
— The Evaporator	132
— The First Compressor	131
Nuclear Energy	13
— Physics	241
Outline and Theory	9
Percentage of Total Heat Consumed	71
Performance Figures	203
Power Input of the Heat Pump	61
Practical Application	89
Precipitation	80
Production Analogy	200
Protons, Neutrons and Nucleus	223
Psychrometric Chart	78
Properties of Common Gases	82
Recovery of Heat	10
Recoverable Heat	16
Recovered Heat	210
Refrigerating and Heating Machines	23
Refrigerant as Working Medium	27
Refrigerators	38
Refrigeration and Heating	165
Reversible Cycle	16
— System	17
Reversed Heat	23
Room Heating	67
Rotary Compressor Section	113
Rutherford	11
Seasonal Heating	208
Steam Engines	21, 28
— Efficiency Chart	116
— Heat Pump	24
Steckborn Art. Silk Co. Heat Pump	157
— Detail of Water Intake	160
— Diagram of Layout	159
— Interior of Pump Room	161
— The Problem	163
Structure of the Atom	220, 229

THE HEAT PUMP

	PAGE
Sub-soil Heat Source	207
Sulzer Compressor Section	191
Sunshine Hours	78
Table for Gas Systems	31
Temperature Limits	9
— Drop in the Heat Exchanger	42
Temperatures—Leaving and Room	73
Temperatures	15
Theory	9
Thermo-compressor	146
— Concentration Plant	184, 185
Thermo-compressors... ..	26
Thermodynamics	12
Underground Heating Work	209
Value of the Heat Pump	197
Vapour Heat Pumps with Turbo-compressors	60
Viscose Suisse S.A. Plant	168
— Arrangement of the Regulation	174
— Diagram of Layout	172
— General Arrangement	170
— Output Regulation of the Heat Pump	173
— Power Characteristics	173
Waste Heat	232
Wind Pressure	79
Zurich Town Hall Installation	89
— Calorifier Details	95, 97
— Daily Load Diagram	101
— Designed Output and Actual Output Compared	106
— Diagrams of Heat Input and Output	99
— Heat Pump Cycle	93
— Land Plotted against Days	107
— Longitudinal Section showing Trunking Installation	105
— Plan of Fresh Air Inlet	103
— Section and Detail	91

**BIRLA INSTITUTE OF TECHNOLOGY & SCIENCE
PILANI (Rajasthan)**

Call No.

Acc. No.

33082

DATE OF RETURN

--	--	--	--

