

BIRLA CENTRAL LIBRARY
PILANI (RAJASTHAN)

Class No 681

Book No G 53 C

Accession No. ~~19740~~

18840

✓

CLOCKMAKING
PAST AND PRESENT

PRACTICAL BOOKS

specially intended for

**CLOCK AND WATCH REPAIRERS
JEWELLERS AND SILVERSMITHS**

Published by

THE TECHNICAL PRESS LTD.

HOROLOGICAL HINTS AND HELPS.	F. W. Britten.
WATCH REPAIRING.	F. J. Garrard.
WATCH REPAIRER'S INSTRUCTOR	F. W. Britten.
CLOCK REPAIRING AND MAKING.	F. J. Garrard.
WATCHMAKER'S HANDBOOK.	C. Saunier.
CLOCK JOBBER'S HANDYBOOK.	F. W. Britten and P. N. Hasluck.
ELECTRICAL HOROLOGY.	H. R. Langman.
GOLDSMITH'S HANDBOOK.	G. E. Gee.
SILVERSMITH'S HANDBOOK.	G. E. Gee.
HALL-MARKING GOLD AND SILVER WARES.	J. P. de Castro.
GOLD ALLOYS.	G. E. Gee.
ENAMELLING ON METAL.	L. E. Millenet.
ENAMELLING OF PRECIOUS AND OTHER METALS.	H. de Koningh.
JEWELLERY AND ENAMELLING.	G. Pack.
ELECTRO-PLATING.	A. Watt.
MECHANIC'S WORKSHOP HANDYBOOK.	P. N. Hasluck.

The Catalogue of the Technical Press Ltd. contains books in all
branches of

SCIENCE

TECHNOLOGY

INDUSTRY

CLOCKMAKING PAST AND PRESENT)

WITH WHICH IS INCORPORATED THE MORE IMPORTANT PORTIONS OF "CLOCKS, WATCHES, AND BELLS," BY THE LATE LORD GRIMTHORPE, RELATING TO TURRET CLOCKS AND GRAVITY ESCAPEMENTS

BY

G. F. C. GORDON,
M.A., A.M.I.C.E.

SUPERINTENDENT OF THE WORKSHOPS OF THE ENGINEERING
DEPARTMENT OF CAMBRIDGE UNIVERSITY

SECOND IMPRESSION

LONDON
THE TECHNICAL PRESS LTD.
LATE OF AVE MARIA LANE, LUDGATE HILL
GLOUCESTER ROAD, KINGSTON HILL, SURREY

1946

19740
~~18840~~

✓
021
E83C

18840
~~19740~~
C/16/12

PRINTED IN GREAT BRITAIN BY THE WHITEFRIARS PRESS LTD
LONDON AND TONBRIDGE

PREFACE

It is probable that no technical subject has been so neglected by writers of books in this country as horology. In recent years, with the exception of the valuable works of the late J. F. Britten and one or two others, practically nothing has been done.

It has always appeared to me that there was room for a good deal more literature on clockmaking, but apparently those who know the subject well have not the time or inclination to record their experience for the use of others. Of course, it is a huge subject, and no single individual can be expected to cover it all; in fact, it would take many experienced men many years to do it. Again, it is very difficult to know where to start and where to stop. In this volume I have endeavoured, as far as possible, to cover ground which either has not been trodden before or which, from my own experience, I think requires more attention than it has hitherto received. It is quite impossible to leave out everything with which other writers have dealt, such as the considerations relating to the shape of wheel teeth, but in such cases I have endeavoured to emphasise the important points and add explanations which may make it easier for the younger men of the trade to understand the essentials.

I am conscious of the fact that my knowledge of the subjects with which I have dealt is very incomplete. I have used the words "probably" and "about" till I

am tired, and I am sure my book is full of errors. If my statements raise a storm of correspondence in the *Horological Journal* or elsewhere, I shall not consider that my time has been entirely wasted. Nothing helps knowledge and progress so much as healthy discussion.

Throughout this volume I have assumed the reader will own or have access to "The Watch and Clock-maker's Handbook, Dictionary and Guide," also "Old Clocks and Watches and their Makers," both by J. F. Britten.

I have to acknowledge my indebtedness to several owners of clocks who have supplied me with illustrations and information concerning them.

I append my address in the hope that I may receive some correspondence and corrections.

G. F. C. GORDON.

WHITTLESFORD,
CAMBRIDGE.

CONTENTS

	PAGE
MATERIALS	1
TOOLS	10
WHEELS AND PINIONS	20
ESCAPEMENTS	43
PENDULUMS	57
MOTIVE POWER	62
STRIKING MECHANISMS	68
LANTERN CLOCKS	83
LONG-CASE CLOCKS	89
BRACKET CLOCKS	105
THE AGE OF A MOVEMENT	108
CLOCK HANDS	115
CLOCKS FOR EXPORT	122
RESTORATION AND REPAIRS	124
CLOCK TRAINS	134
REPAIRING AMERICAN CLOCKS	139
TURRET CLOCKS AND BELLS	143
BIBLIOGRAPHY	150
APPENDIX I.	155
APPENDIX II.	156

LIST OF PLATES

(Specially Photographed and Engraved for use in this work.)

PLATE	TO FACE PAGE
I. Modified Throw with Jacot Block and Cone Plate for Drilling Arbors. Depthing Tool with Lantern Runner	12
II. Early Wheel-Cutting Machine	13
III. Lancashire Wheel-Cutting Machine	14
IV. Pinions and their Collets. (a) Eight-day Fusee of 1700. (b) Thirty-hour Fusee of 1750. (c) Eight-day Fusee of 1800	39
V. John Ebsworth in Lothbury, Londini Fecit (about 1660). Winged Lantern Clock (about 1700)	83
VI. Stuart Lantern Clock	85
VII. Late East Anglian Lantern Clock. East Anglian Sheep's Head, with 5-inch Dial	85
VIII. Friesland Clock	86

PLATE	NO	FACE	PAGE
IX.	Friesland Clock, with Dial Removed		86
X.	Small Lantern Clock, converted into a Hooded Clock, with 5-inch Dial. Lancashire (?) Hooded Clock, with 11 $\frac{1}{4}$ -inch Silvered Dial		87
XI.	Henry Hester, Westminster (about 1695)		93
XII.	Dial of Clock, by Henry Hester		93
XIII.	Eleven-inch Dial, by Edward Bird, London (about 1700). Ten-inch Dial, by Edward Cockey, Westminster (Style about 1710)		94
XIV.	Eleven-inch Dial, by Wm. Carter, Cambridge (about 1715). Twelve-inch Arched Dial, by Geo. Maynard, London (about 1715)		95
XV.	(a) 9 $\frac{1}{4}$ -inch Landscape Dial (Robert Bird, Yeldham). (b) Twelve-inch Arched Dial (Anonymous)		95
XVI.	Mahogany-cased Clock, by John Wyke, Liverpool		97
XVII.	Thirteen-inch Dial, by John Wyke, Liverpool		97
XVIII.	Lancashire Oak Case		97
XIX.	(a) Twelve-inch Frosted and Engraved Dial, by F. Knowles, Bolton. (b) Thirteen-inch Heraldic Dial (Barnish, Rochdale)		98
XX.	(a) Ten-inch "Imari" Dial (Wm. Kent, Walden). (b) Ten-inch "Nankin" Dial (Edw. Samm, Linton)		99
XXI.	Twelve-inch Dial, Frosted and Engraved Centre and Bagpipe Corners (Alex ^r . Rae, Dumfries) (about 1760)		100
XXII.	Walnut-cased Clock, by John Brown, Liverpool		101
XXIII.	Twelve-inch Dial, by John Brown, Liverpool		101
XXIV.	(a) Twelve-inch Engraved and Silvered Dial (John Holden, Lincoln (?)). (b) 8 $\frac{1}{4}$ -inch Dial, by Gibson, Thetford		102
XXV.	(a) Peter Guepin, London (about 1700). (b) Charles Gretton, London (about 1695)		105
XXVI.	(a) Back Plate, by Charles Gretton. (b) Popular Design of Back Cock		106
XXVII.	(a) Thos. Wright, London (about 1775). (b) Condliff, Liverpool (about 1820)		106
XXVIII.	Back Plate, by Thos. Wright (about 1775)		106
XXIX.	(a) Old Pin-wheel Escapement. (b) Bracket Clock, with 4-inch Silvered Dial, by Clarke, Whitechapel (about 1770)		107
XXX.	Hands of Various Periods		116
XXXI.	" " " "		116
XXXII.	" " " "		116
XXXIII.	" " " "		116
XXXIV.	" " " "		116
XXXV.	Screws of Various Periods. Attachment for Dial Movement		123

CLOCKMAKING

MATERIALS

THE chief materials the clockmaker uses are steel and brass, so a few notes on these and allied substances should prove useful.

When iron ore is smelted on the large scale the product obtained is pig-iron. This substance is really a mixture and contains only about 92 per cent. of metallic iron. It contains about $2\frac{1}{2}$ per cent. of silicon and 3 per cent. of carbon and other ingredients. It is a very cheap and readily fusible metal, but so brittle that it cannot be bent, nor can it be forged when hot. It is largely used for cast iron parts of large turret clocks, but in domestic clocks is usually confined to weights and pendulum bobs.

Wrought iron is produced from cast iron by burning out what are usually termed the "impurities" in a puddling furnace. The metal is at first quite liquid, but as the process proceeds it becomes more viscous, and finally a spongy mass of almost pure iron, with a good deal of slag entrapped in it, is extracted from the furnace, worked up under the steam hammer and passed on to the rolling mill. A great deal of the slag is expelled, but much remains in the form of ribbons or threads in the finished metal which is put on the market. A polished surface of wrought iron is frequently marred by the presence of slag marks. The carbon content of

wrought iron is about one-tenth of 1 per cent., and it cannot be hardened by heating and quenching in water.

Mild steel is a substance prepared by a process similar to that used for making wrought iron, but it is carried out at a very much higher temperature so that it remains liquid until it is poured into the ingot mould preparatory to rolling. The result is that the metal contains no slag, and in consequence is somewhat stronger.

Case Hardening.—If a piece of wrought iron or mild steel is packed in charcoal, scrap leather or pieces of horn, and heated for several hours to a good red heat, it absorbs sufficient carbon to convert the surface into a metal identical to tool steel. A piece so treated (carburised) becomes glass-hard on the surface if heated to a good red and quenched in water. Certain precautions are necessary to ensure good results, but they are so eminently satisfactory that clock factories should seriously consider the adoption of the process. Mild steel is much more easily machined than tool steel and the finished product has a really hard outside and soft and tough interior. Undoubtedly clockmakers two centuries ago used this process extensively for pinion and pallet making. A glass-hard surface on wrought iron or mild steel can be produced by heating it to a good red heat, sprinkling it with powdered potassium ferrocyanide (yellow prussiate of potash) and reheating, followed by immediate quenching in water. The case, *i.e.*, the hard surface, is not deep enough to withstand more than twenty years of wear if the ferrocyanide process is used, but it affords a ready means of rehardening an old pair of case-hardened pallets which have lost their hard surface after long service. Mr. Harry Brearley has written a small but useful book describing in detail

the process of case-hardening, pointing out the precautions necessary for getting good results.

Tool Steel.—Tool steel is essentially iron containing about 1 per cent. of carbon, and has the property of becoming intensely hard when heated to a red heat and quenched in water. With the exception of files, most articles made from tool steel are somewhat tempered, *i.e.*, partially resoftened after hardening, with a view to removing some of the brittleness. Formerly the only commercial process for producing tool steel consisted of case-hardening wrought iron strips very deeply and welding them together. The metal was anything but uniform in composition, for not only was the carbon not uniformly distributed, but the ribbons and threads of slag in the original wrought iron still remained. The clockmaker of a couple of centuries ago was therefore faced with a serious difficulty regarding suitable steel for pinions, springs, etc., and it is not to be wondered at that, at that time, the mainspring was only used as a source of driving power for the most costly movements and not used for pull string chimes and the like. The writer would not be surprised if further research led to the discovery that 80 or 90 per cent. of the mainsprings prepared a couple of centuries ago were rejected before a suitable one was made. Even to-day, with every facility for obtaining reliable material and extensive technical knowledge, mainspring making is a difficult task.

Crucible Cast Steel.—In the year 1740, Benjamin Huntsman, a clockmaker of Doncaster, introduced a process of extraordinary importance. He conceived the idea that if he melted the unhomogeneous slag-bearing tool steel in a crucible, the slag would float to

the surface, and the carbon permeate uniformly through the mass. He was so successful that he started the process on a commercial scale in Sheffield, and so revolutionised the process of tool steel making, that the crucible process is to-day worked on an enormous scale all over Europe and in America. Crucible steel is now always used for pinions, springs, pallets, etc., as well as for tools.

High-speed Steel.—The essential differences between is the modern high-speed steel and ordinary carbon steel due to the composition. Briefly, high-speed steel usually contains about 25 per cent. of such metals as chromium and tungsten. It requires a much higher temperature to harden it than ordinary tool steel, but is seldom tempered afterwards. As a rule very hard tools cannot be made of it, so it is not suitable for turning hardened pivots. It maintains its hardness for long periods under heavy cuts at high speed, in the engine lathe, but, so far as clockmakers' tools are concerned, its chief use is for taps and dies, where it exhibits a wonderful resistance to wear.

Stainless Steel.—This material, which was discovered in Sheffield, contains about 14 per cent. of the metal chromium. It is made in various grades from very mild steel up to hard steel, suitable for cutting tools and pinions. The temperature for hardening is about 150° C. higher than that necessary for hardening ordinary tool steel, and it was largely owing to cutlers not appreciating this fact which led to the early stainless knives getting a reputation for bluntness.

Invar.—Certain steels containing about 25 per cent. of nickel are remarkable from the fact that rods composed of them undergo practically no change of length with

varying temperature. A steel of this kind has been placed on the market under the name Invar, and is used for clock pendulums with satisfactory results.

Brass.—Brass is an alloy of copper and zinc, the relative proportions of each depending upon the purpose for which it is required. The average composition is copper, 65 per cent. ; zinc, 35 per cent. If a brass is required which is easily rolled or shaped cold, a 70/30 mixture is used. Another mixture, 60/40, is much used and is much stronger. Strange to say, a brass containing 60 per cent. of copper is much redder than one containing 70 per cent. Most of the light-coloured sheet brasses and soft castings used by clockmakers are of the 70/30 composition.

The strength and usefulness of a brass can be increased enormously by adding a certain amount of manganese, in the form of a manganese-copper alloy, to the metal in the crucible. The metal is rendered free from oxides by this addition, and becomes as strong as mild steel while remaining perfectly ductile. This manganese brass, when cast, may not actually contain manganese, because the latter generally accumulates in the scum on the crucible, but its physical properties show that manganese has been used to clean the metal. It is somewhat difficult to cast, but it is an ideal metal for clock plates and wheels ; far superior to common brass.

Quite recently a new brass has been discovered at the Brentford Foundry, Middlesex. It consists of copper, 80 per cent. ; zinc, 15 per cent. ; and tin, 5 per cent., and is known as "Coronium." It is stronger than steel and very easily filed and machined. If it is found to wear well and not cut the pallets, pinions and pivots, it should prove an ideal material for clockmaking.

Bronzes are usually defined as alloys of copper and tin. As the latter metal is very expensive there is no point in using bronze in preference to manganese brass which is cheaper, stronger, and easily worked. - The so-called manganese bronze is usually just manganese brass without any tin. The late Lord Grimthorpe suggested an alloy known by the trade name of "aluminium bronze" for clock work. It consists of copper, 90 per cent. ; aluminium, 10 per cent., so is not a true bronze. It is inferior in every respect to manganese brass for almost every purpose.

For such things as wheel collets a very soft brass such as 70/30 is required, whereas for wheels something much stronger is obviously desirable, or bent teeth will result, unless the wheels are made very thick and heavy.

For reproducing intricate ornamental work, gilding metal, consisting of copper, 82.25 per cent. ; zinc, 17.5 per cent. ; and tin, 0.25 per cent., is very useful. If the mould is made of graphite, extraordinary fine castings can be produced. The objection to it is that the polished metal is very dark in colour so that the ornaments require gilding or plating with brass before they are of a pleasing colour.

Brass becomes much harder when subjected to hammering, rolling or wire drawing when cold. If heated to about a red heat and then rapidly cooled, this hardness disappears. Pivot holes are much improved by burnishing them with a perfectly smooth taper broach, which hardens the surface of the metal, at the same time making the hole very smooth. The broach must be well lubricated and advanced slowly, otherwise the metal may stick to it and tear.

It is difficult to say when rolled brass became a com-

mercial product. We know that rolling mills, worked by water power, horses and man power, were in existence in the reign of George II., but whether any of them were used for finishing metal for clock dials, etc., appears doubtful. The absence of heavy engine lathes must have rendered rolling mill building very difficult, and probably the early mills were used for iron and silver only. It does not follow that even when rolled brass became plentiful many clockmakers used it. Even to this day we find some makers using thin brass castings for wheel blanks in preference to stampings from rolled plate.

Bell-metal is a hard, brittle alloy of copper with about 20 per cent. of tin. The composition varies, however, and must be adjusted according to the size and rate of cooling of the bell. Slow cooling tends to make the metal harder owing to the formation of crystals of very hard material.

Soft solder is an alloy of tin and lead, the composition varying according to the purpose for which it is used, from two parts tin to one of lead in fine solder, to two parts lead to one of tin in the solder used by plumbers for wiped joints.

Hard solder is an alloy of copper and zinc. When used for uniting brass the usual proportions are equal quantities of each metal. For metals of higher melting point, however, a solder containing more copper is better as it is stronger. The chief objection to brazing is the high temperature required, but this is got over by the addition of a good deal of silver to the brass. Silver solders vary from two parts silver to one of brass, to five parts silver to one of brass. The lower melting point of silver solders makes them easier to use.

The flux used for soft solders is usually chloride of zinc, rosin or oleic acid. The first named is the easiest to use, but is inclined to cause rusting afterwards unless the metal is thoroughly washed, preferably with ammonia.

For brazing and silver soldering, borax is used as a flux. This is made into a *clean* paste on a piece of clean glass or slate with a little water and applied to the work. If dirty, trouble will ensue.

Lacquers.—These are usually composed of shellac or other gums or resins dissolved in alcohol or other suitable solvent. Methylated spirit is unsatisfactory for the purpose. Instrument makers prefer lacquers of a deep orange colour by which means yellow brass, red brass and gun metal parts can be brought to a uniform colour. On the other hand, it is generally admitted to-day that a clear colourless lacquer which does not conceal the natural colour of brass is infinitely preferable. In fact, many people are reluctant to have dials, etc., lacquered, lest they should come back hideous. The method of applying lacquer is more or less as follows. The pieces are carefully cleaned and all traces of grease are removed. They are then heated on a thick iron plate over a bunsen flame, or in an oven, till distinctly warm, but not too hot to touch. The lacquer is placed in a small pot over the mouth of which wire is stretched. A flat camel-hair brush is dipped in the liquid and then wiped against the wire, which removes the excess and returns it to the pot. The surface of the metal then receives a very thin coating, care being taken that it is entirely covered. Time is allowed for the solvent to evaporate and the piece is again heated and treated. Some men return the dial to the oven after the second coat, with a view to producing a very bright surface. The whole operation

requires a good deal of experience, and it is better handed over to a specialist, with instructions as to colour.

Within recent years lacquers consisting of celluloid dissolved in amyl acetate have been introduced. They are extremely durable and can be obtained colourless.

For hands, etc., some men use blue lacquers, but they are a poor substitute for colouring by heat alone. The pieces are polished and care must be taken that they are not touched with the fingers before heating. They are then laid in a bed of clean sand or filings spread on a metal plate. Heat is then applied from below and the surface is watched. At first a light straw colour appears; this gradually deepens and changes from a brown to a purple and then to a blue. As soon as the blue appears, the hands should be removed from the hot plate, and receive a smear of oil. If allowed to get any hotter the blue changes to a dirty grey, in which case the hand must be repolished and the work done over again.

The silvering on dials is carried out by a chemical process. The clean surfaces are wiped over with a paste consisting of chloride of silver, salt and cream of tartar in water. They are then washed, dried, and receive a thin coat of colourless lacquer. Such a surface, if not rubbed with a cloth, will remain a good white colour for forty years in a favourable atmosphere.

TOOLS

THE tool equipment of the average clockmaker or repairer generally leaves much to be desired. A first-class man can certainly do splendid work with a somewhat crude equipment, but there is no doubt that with a really good selection he can do better work, and what is perhaps even more important, he can turn out very much more work in the day, and, therefore, make more money. As regards files, drills, cutting and burnishing broaches, the stocks should be large, so that the right tool is always at hand. Originally such tools were made by the workmen themselves, but it is now much more economical to purchase them. Before the days of a plentiful supply of tool-steel, files were frequently produced by case-hardening wrought iron, after cutting.

The flat drill has had a long life on account of the ease with which it is made, but the straight fluted drill produces a better hole. It necessitates, however, very careful use, since once it has entered a hole, it is incapable of movement to one side or the other without risk of fracture. Twist drills, *i.e.*, drills with spiral flutes, are unsatisfactory for clock work. They are too greedy when used on brass, and too soft for drilling tempered steel. For the latter purpose the drill must be nearly as hard as possible and thin at the point. It must be kept very sharp, and considerable pressure must be exerted to ensure that it cuts continuously. The speed of rotation should be very, very slow, otherwise the surface to be cut will become glazed or burnished. A hole which

has once become burnished by a drill which has ceased to cut involves a good deal of trouble before it can be made deeper.

As regards screwing tackle, the old screw plates and taps were anything but good. Male screws produced by plates of the old type are usually very variable in pitch, the thread being produced by a combination of great surface pressure, a good deal of rubbing and very little cutting. It will be found that the pitch of a screw formed on a piece of soft wire is very different from one on a piece of harder material. The tool itself suffers, and after a little time good deep threads are impossible to produce. To-day, however, very high-class dies are procurable which are designed to *cut* and are really well made; the same applies to taps. It is very false economy to purchase anything but the very best. The novice is warned against using screwing tackle upon silver steel, which, even in the soft state, is distinctly detrimental owing to its hardness. Formerly a great variety of screw sizes and pitches were in everyday use, with the result that repairers in one district could seldom obtain screws to fit clocks made in other districts. The British Association screw was designed to obviate this muddle, and now standard B.A. screws, nuts, taps and dies can be procured in every large town. By adopting a few sizes of B.A. screws such as, for example, No. 3 and No. 10, the clockmaker can usually replace a broken or lost screw with the minimum of trouble.

The clockmaker's throw is almost a necessity for many repairs, but all the writer has seen have been rather lacking in certain directions. The general usefulness of the throw could be considerably increased if it were fitted with suitable accessories for drilling arbors and

“ Jacot ” blocks for polishing pivots. Another objection to the ordinary throw is that it is so low in the centres that it will not take a long-case pallet staff with its crutch. The writer altered the heads of his throw as shown in Plate I. It will be observed that the runners can be raised for a pallet staff and an additional hole through the movable head is useful for attaching a cone-plate or Jacot block. The throw possesses certain advantages and is cheap. Being driven by a hand wheel, speed regulation is easily obtainable, and, as neither of the centres rotate, great accuracy of construction is unnecessary. But however useful the throw may be for many purposes, it is inferior for general work compared with a suitable lathe. Modern lathes are provided with a hole through the headstock and split drawn-in chucks, and as these chucks are glass-hard and dead true, they are of immense convenience for both turning and drilling operations. No one with much experience of a good clock lathe would be without it. The time saved by its use is enormous.

It is a curious thing how few men calling themselves clock repairers possess a depthing tool. Such a tool is, of course, absolutely essential to a maker, but in good repair shops it is also almost in daily use. However skilful a man may be he can always do better work in less time with a depthing tool than without one. It is a good thing to have two. The 10 cm. size is large enough for long-case chime clock work, but a smaller one is desirable for bracket clock fly pinions and French clock repairs. No tool, however, requires more careful handling than the one under consideration. It should be calipered carefully from time to time to see whether its accuracy is being maintained. If one pair of runners

PLATE I.

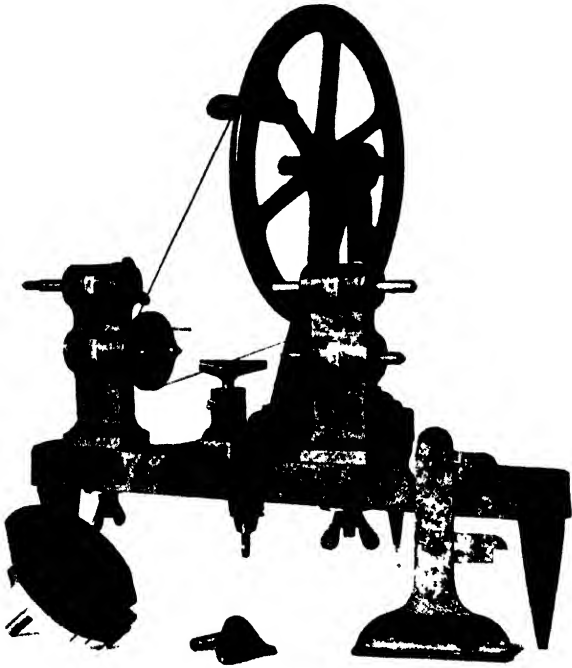

MODIFIED THROW WITH JACOBI BLOCK AND CONE PLATE FOR DRILLING ARBORS.

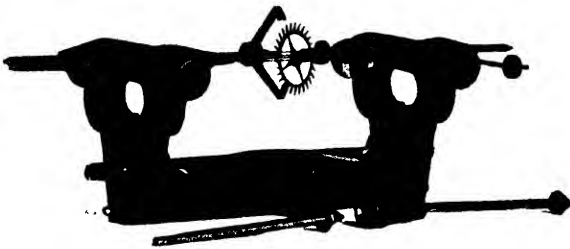

DRILLING TOOL WITH LANTERN RUNNER.

PLATE II.

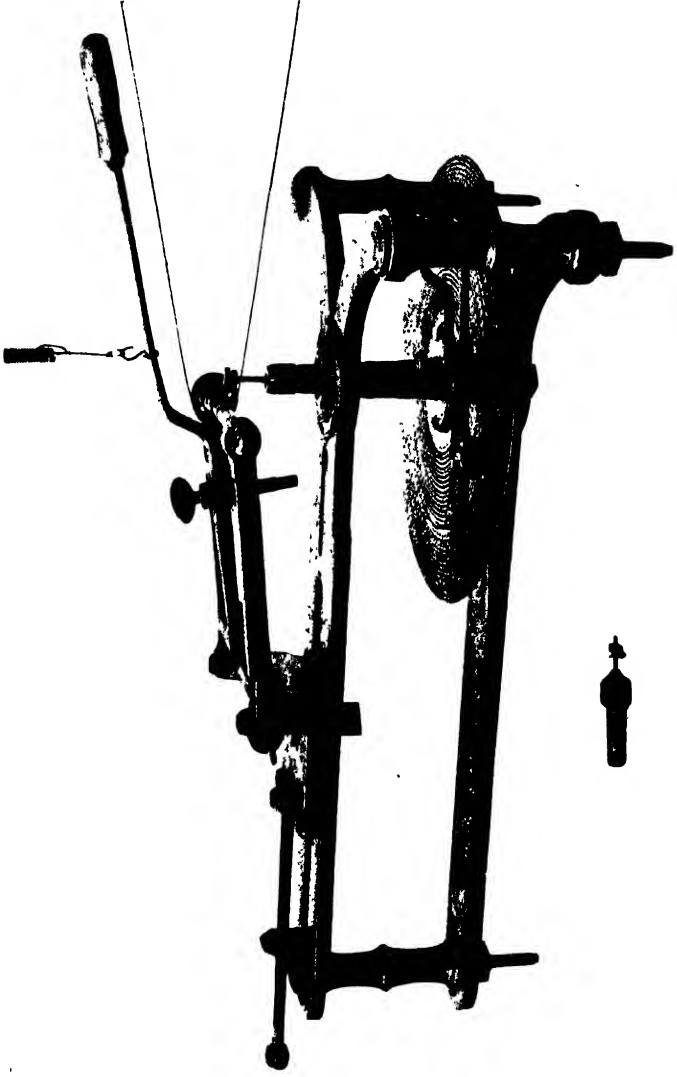

EARLY WHEEL-CUTTING MACHINE.

gets slightly out of parallel, the pinion head and wheel which are being depthed should be placed near the accurate end, and the same end, of course, should be used for scribing. It seems a pity that makers of these beautiful tools do not supply with them solid lantern runners as shown in Plate I., to enable pallets and escape wheels to be placed between the centres without removing or bending the crutch.

Few makers or repairers do their own wheel cutting, but a short description of the process may be interesting to those who have not the opportunity of witnessing the operation. In the very early clocks the teeth were all cut by hand, the wheels being of wrought iron or cast brass. Plate II. shows a machine constructed about 200 years ago. At the right hand end will be seen a vertical spindle which, down below, carries a large cast brass plate 18 inches in diameter, which is marked off with a series of concentric circles. Each circle is accurately divided according to the number of teeth it is desired to cut. An index arm and pointer can be swung over any particular circle, and the pointer is raised at intervals and the plate moved round till the next hole is ready to receive it. The top of the spindle carrying the dividing plate is bored out, and into it a number of tables, with screwed studs in the centre, can be placed for holding the wheel-blank to be cut. At the left-hand end of the machine is a pivoted frame which supports the cutter spindle. The cutter in this case describes an arc of a circle instead of moving in a straight line, so several wheels of exactly the same diameter cannot be cut at the same time. Some idea of the age of this machine may be gathered from the fact that no provision exists for cutting wheels with either sixty-three or sixty-four teeth.

Plate III. shows another type of machine much used in this country at the present time. The cutter spindle is guided by a slide, so a pile of exactly similar wheels can be cut at the same time. The great defect of this type of machine is that the arbors, upon which the wheels are held for cutting, seldom run true, with the natural result that the hole is not in the centre of the wheel. The waste of time in chucking the wheels and trueing the holes is enormous, and the day has certainly come when there is no excuse for eccentric holes in wheels. If the wheel cutter would only have his machine fitted with perfectly true draw-in chucks, and use perfectly true hardened and ground arbors, the clock finisher would get through more work in the day. The writer has adopted this plan and finds it a great relief to have every hole strictly concentric when the wheel comes from the machine. The Americans sometimes go even further ; they mount the wheel-blanks on the pinions, grip these in draw-in chucks and then cut the teeth. Whatever system is adopted, however, it is of the utmost importance that the rim of the wheel should be really well supported, so that the cutting may be clean and free from chatter.

In the earlier machines the cutter took the form either of a simple circular saw or of a single pointed cutter which cut a straight slot. The teeth were subsequently rounded up by hand. This practice survived so long that even to-day elderly men may be found who can exhibit wonderful manual skill in rounding up wheel teeth. Their skill in this respect, however, is still useful in certain repair work, though to-day it is not required in manufacturing. The single pointed cutter has now been almost entirely superseded by a multiple pointed one.

PLATE III

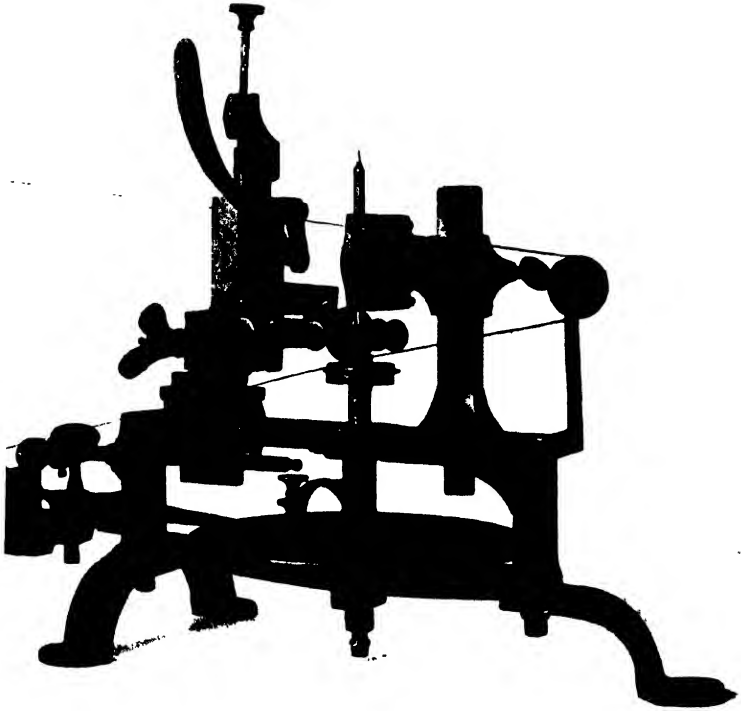

LANCASHIRE WHEEL-CUTTING MACHINE.

[To face page 14.

of the milling cutter type. Not only do these cut far more rapidly, but they are so shaped that they round up the teeth at the same time. Assuming that the machine has been set for cutting the correct size and that everything is ready, the time required to cut a sixty-four tooth wheel is about ten minutes. One direction in which our forefathers went wrong was in not having a sturdy little flywheel attached to their cutter arbors. The increased rapidity of cutting if a flywheel is fitted is surprising. The single-point cutter is still useful in certain cases where wheels with some special form of teeth are required, as in some repair jobs. A piece of steel is turned up in the lathe, so that its point exactly fits a tooth space. Half is then filed away and the piece polished, hardened and tempered. By making the tool in this way in the lathe there is no question of the two sides being in any way dissimilar, a thing which is very liable to happen if the cutter is shaped by hand. For general work, however, it will be found that a cutter about $1\frac{3}{8}$ -inch diameter, with seven cutting points and a $\frac{3}{8}$ -inch hole in the centre is as good as anything, and superior to some other types which are smaller and have a very great number of cutting points, which are liable to clog.

In clock factories now automatic wheel-cutting machines are chiefly used. These require very little attention, and, beyond placing new blanks on the arbor and removing the finished work, the girl in charge has practically nothing to do.

When wheels with narrow rims and very small holes in the centre are being made for the American type of clock, the spaces between the arms are accurately stamped out. Twenty or so of such blanks are then threaded on to a special chuck, formed like four fingers,

which pass between the arms, and the chuck is then expanded. The screw which expands the chuck also crowds the blanks together and holds them firmly between two collars. Such a chuck is very rigid and tends to keep down chatter.

Within the last few years, wheels good enough for the American type of clock have been stamped out, complete with all their teeth, from sheet brass. The dies for the purpose are, of course, expensive, but by no means prohibitive in cost. The work produced is said to be quite good enough for the 5s. type of watch.

For involute teeth used by engineers some very ingenious methods of cutting mathematically perfect curves have been developed in modern hobbing, gear-planing and gear-shaping machines, but the principles have not been applied to clock wheel production. The methods used for producing pinions are dealt with on p. 41.

A machine which is sometimes met with is known as the "rounding-up" tool. It is really a simplified wheel-cutting machine in which the dividing plate is absent, and the wheel to be operated upon is at all times free to rotate. In place of the usual milling cutter, one of a special form is provided. Half the circumference is formed like a milling cutter with a great number of cutting points. The other half is something like the blade of a propeller. Its action is as follows: after the cutting half has deepened the space between one pair of teeth, the other half engages with the next tooth space, and, during its half revolution, moves the wheel round so that the cutting half enters a second tooth space and so on. In a few seconds every tooth space right round the wheel is slightly deepened. This

tool is frequently used for slightly easing depths in common clocks, when the pivot holes are pitched too close, but the work produced by it, which the writer has examined and heard of, were far from satisfactory; in fact, quite good wheels appear to have been ruined. It may, however, be satisfactory for watch work where a ten-thousandth of an inch makes all the difference between a tight and a free depth.

A device known as the Ingold Fraise is sometimes used by watchmakers. Briefly, it consists of a cutter like a pinion, but with all the rounded portion of the leaves turned off. This, and the wheel which it is desired to reduce in size, are placed in the equivalent of a depthing tool. When they are in gear, the two are rotated by means of a bow and gradually brought nearer together. So far as the writer is aware this principle has never been applied to clock work, and it appears extremely doubtful whether the results would be satisfactory.

With regard to tools of all sorts the present-day workman is more fortunate than his predecessors, as steel is more easily procurable, and file making, etc., have been very highly developed by specialists. On the other hand, the clockmaker still finds it necessary to make a good many tools and accessories himself, such as stakes, punches for mounting wheels and other purposes, and tools for forming oil sinks. For watch work such tools are readily obtainable, but the clockmaker is expected to make his own.

A tool which is very much required is a small vertical drilling machine. It should have two spindles, one for drilling holes from, say, $\frac{1}{8}$ -inch to $\frac{3}{8}$ -inch diameter, and another very, very light spindle for use with very small

drills. If some enterprising firm would put a really good clockmaker's drilling machine, capable of rapid and accurate work, on the market at a reasonable price, it would be enthusiastically received by the more progressive members of the trade, not to mention instrument makers in addition.

As regards measuring instruments, many men still stick to the douzieme gauge, and it possesses the advantage of lightness, but there is no doubt that the ordinary micrometer is preferable partly on account of the ease with which accurate measurements are made, and partly because it is graduated in thousandths or ten-thousandths of an inch, or in equally small fractions of the centimetre. The beam compass, or sliding gauge as it is alternatively called, is of very great use to the clockmaker, not only for measuring the sizes of wheels and other parts accurately, but also for describing circles of definite radius. The writer uses one graduated both in inches and centimetres, but prefers the latter scale for most purposes. Stubb's wire gauges and sheet metal gauges are extremely useful. It is, however, much to be regretted that, when the Imperial Standard metal gauges were designed, the committee did not follow Sir Joseph Whitworth's suggestion and make the various numbers correspond with decimal fractions of an inch. As matters stand, it is frequently necessary to refer to tables.

It is difficult to speculate as to what changes will take place in the methods of manufacture of high-class clocks in the future. It all depends upon whether capital is forthcoming. Judging, however, by the methods adopted in sewing machine and motor engine factories, it appears that an enormous saving in labour might be accom-

plished if grinding machinery were installed by those who prepare the raw material for sale. For instance, in the factories mentioned, flat surfaces are trued up from the rough and polished in a remarkably short time by grinding; steel parts being simply held on magnetic tables, while the grinding is performed by the open end of a cup-shaped emery wheel. The table moves automatically to and fro under the cup wheel. Frame plates, racks, lifters, etc., could be faced and polished in such a machine for a few pence per set. Pinion arbors, etc., can be ground true and polished from the rough in a few minutes in a suitable grinding machine. Possibly the grinding machine will be used for finishing accurate pinions, just as it is used for producing screw threads of extraordinary accuracy. During the war many very, very accurate glass-hard screwed plugs were made for gauging purposes simply by grinding, the wheel being trued up at intervals and kept to form by a special attachment on the machine.

Perhaps before long it will be possible to purchase collets, pillars, hour and minute tubes, and sundries of that sort, produced in turret lathes, at a very low price just as one can purchase screws. It has been said that finished brass screws can be purchased for the same price as brass rod, the expenses and profit being made out of the turnings.

WHEELS AND PINIONS

A FULL discussion of the theory and practice relating to wheels and pinions would not only occupy much space, but involve a good deal of mathematics. The mathematical theory, moreover, cannot be very strictly adhered to for practical reasons. However, an attempt will be made to explain principles with which every clockmaker should be familiar.

If wheels and pinions were without teeth and merely consisted of two very slightly roughened rollers, the former could drive the latter provided they were pressed together. The relative speed of the wheel and pinion would then depend on their diameters. Thus, if the wheel were six times the diameter of the pinion the pinion would turn six times as fast as the wheel.

Teeth are, however, necessary, and they must be so shaped that the toothed wheel and leafed pinion gear together as smoothly as a perfectly plain wheel and pinion.

Consider the case of the wheel and pinion shown in Fig. 1. This figure also shows two dotted circles representing a toothless wheel and leafless pinion. These circles are known as the "pitch circles" or "primitive circles" of the wheel and pinion. The teeth and leaves must be so shaped that from the instant a tooth starts pressing on a leaf until it finally separates from it, the motion of the pinion will be absolutely uniform,* *i.e.*, as

* At first sight it would appear that uniformity of motion is an entirely unnecessary refinement, since every wheel in the going train moves inter-

uniform as if the larger pitch circle was driving the smaller one. Not only must this portion of the action be smooth and uniform, but the next succeeding tooth of the wheel must get into such a position that it is ready to press upon the next leaf of the pinion and

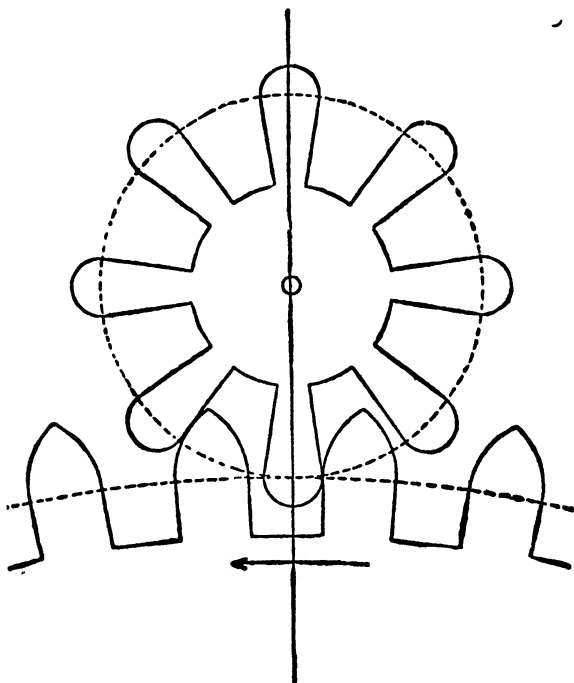

FIG. 1.—EIGHT-LEAF PINION.

not drop on to it. If drop does occur, either the pinion is too small, or the wheel and pinion too deeply in mesh, or both.

mittently, on account of the escapement. It is, however, absolutely necessary that every wheel in the clock should be *capable* of transmitting uniform motion to its pinion, *otherwise it cannot transmit uniform power*. Even a slight variation in the power transmitted through a single depth is bad, and if it occurs in several depths, in the same train, the clock is sure to stop.

There are two systems of shaping wheel-teeth and pinion-leaves, viz., the involute system and the cycloidal system. The former system is now used universally by engineers, and for their purpose possesses many advantages, not the least of which is the mathematical accuracy with which it is easily carried out. For clockwork, however, the cycloidal tooth possesses many advantages, though in some respects it is not ideal; but from the practical point of view it is quite satisfactory.

The reader who is anxious to acquire a good working knowledge of wheels and pinions should obtain a miscellaneous collection of wheels and pinions, good and bad, ancient and modern, and verify many of the statements which follow by observing the result obtained if various combinations are tested in the depthing tool and examined carefully with a glass. A few hours so spent will impress the essentials thoroughly upon his mind. The examination of a depth, *i.e.*, the action of a wheel and pinion shows that when the wheel drives the pinion the "active" part of the wheel tooth is the curved portion *outside* the pitch circle. This curved part, the addendum, acts on the flank of the pinion leaf *inside* the pitch circle. On the other hand, if the pinion drives the wheel (as in the motion work), the addendum of the pinion is the part of the leaf which does the work, and the flank of the wheel tooth *inside* the pitch circle which is acted upon. Hence we see that the shape of the tips of the wheel teeth and the flanks of the pinion leaves usually call for most attention and care in shaping. Though these statements are absolutely true with high-numbered pinions (eleven leaves or more), they are only partially true with low-numbered pinions.

If a circle rolls along a straight line a point on the

circumference of the circle will describe a curve known as a cycloid. If the rolling circle rolls upon a fixed circle then a point on the former will describe a curve known as an epicycloid. On the other hand,^c if the rolling circle rolls round the inside of a fixed circle, the curve traced is a hypocycloid. A particular case exists when the rolling circle is half the diameter of the fixed circle for then the hypocycloid becomes simply a straight line.

Now it can be shown mathematically that if the active part of the tooth of the wheel or pinion which is doing the driving is in the form of an epicycloid, and the active part of the wheel or pinion which is driven is a hypocycloid, both produced by the same size of rolling circle, then the motion of the wheel and pinion is as smooth and uniform as if two rollers represented by the pitch circles were transmitting the motion. Since it is convenient to make the pinion leaves with flat radial flanks, *i.e.*, with the hypocycloid taking the form of a straight line, it follows that the generating circle (rolling circle) for the wheel teeth must be half the diameter of the pitch circle of the pinion. Now the pitch circle of a ten-leaf pinion is larger than the pitch circle of a seven-leaf pinion, so, strictly speaking, a wheel with a given shape of tooth cannot be used for both high- and low-numbered pinions. Practically, however, there is no difference worth talking about and most practical men use the same cutter for cutting high-numbered wheels (say 100 teeth) and low-numbered wheels (say thirty teeth), and use with them high or low-numbered pinions. As a matter of fact, a portion of a circle is frequently used instead of an epicycloid for the acting portion of wheel teeth, the radius of the circle being

somewhat increased when the pinion numbers are high. The error introduced by so doing is negligible even in high-class work. It should be noticed that the mathematical theory of epicycloids and hypocycloids is strictly accurate for high-numbered gears used by engineers, but is not strictly correct in the case of clock-work owing to the relatively few leaves formed on the pinions.

We have seen that the most useful part of the driven, whether pinion or wheel, is the portion of the leaf or tooth inside the pitch circle, and that the addendum (the portion outside the pitch circle) of the driven need not be there. That is so up to a certain point. If the wheel and pinion cutting were absolutely perfect and the pivot holes and depthing were perfect too, the driven wheel or driven pinion need not have an addendum, but such perfection seldom exists in a brand new movement, and never in a clock subjected to a few years of wear. The sharp corner on the pinion leaf would cut rapidly into the wheel teeth, especially with low-numbered pinions. To minimise the tendency for this to happen an addendum of some sort is necessary. Continental makers usually give their driven pinions a semi-circular addendum. This shape has two advantages: the cutter is easy to make and the pitch diameter is easily ascertained by subtracting the thickness of the leaf (*i.e.*, twice the height of the addendum) from the full diameter of the pinion. In this country pinion makers adopt an addendum for their driven pinions very similar in shape to the epicycloidal addendum necessary for pinions which are required to drive wheels. Frequently the pinion addendum is a compromise between the two.

It is desirable in all depths that most of the action

should take place after the teeth and leaves have passed the line of centres, *i.e.*, the line joining the pivot holes. This is done because the friction is infinitely less after the line of centres than before it. The reason for this is difficult to put into words, but a simple experiment will illustrate a somewhat similar state of affairs. Hold a walking stick say 15 degrees out of the vertical; first try pushing it, point foremost, along the floor, and then pulling it in the opposite direction. In the first case we have what horologists term "engaging friction" and in the second case friction comparable with that found after the line of centres, *i.e.*, "receding friction."

By examining a number of depths with pinions of various leaf numbers we find that, in order to get all the action after the line of centres, it is necessary that the pinion should have at least ten leaves. Pinions with ten or more leaves require very high-class work or trouble will ensue. For ordinary work, therefore, the eight-leaf pinion is better, since we not only must consider ease of manufacture, but also the possibility of the movement being neglected afterwards as regards oiling and repairs. In the case of the eight-leaf pinion the action starts really so near the line of centres that the engaging friction is hardly noticeable. The action in the case of the seven-leaf pinion starts so far before the line of centres that it is unsuitable for the centre-pinion of an eight-day clock, and possibly it will be eliminated from the rest of the going train before long. Few makers now use pinions of six leaves except for motion work and repair work. The action is so much before the line of centres that however well the depthing is done great driving power is necessary, as shown by the

average old thirty-hour clock which has been carefully overhauled.

The lantern pinion is much despised in this country, and it will be a long time before its merits are sufficiently recognised to make its manufacture general. It can be made very cheaply by relatively unskilled labour, provided a good machine is installed, and a cheap lantern pinion runs with far less friction than a cheap leafed pinion. The examination of a lantern pinion depth shows that it possesses another valuable property, viz., that with even a low-numbered pinion such as a six, practically the whole of the action is after the line of centres, and therefore almost free from engaging friction. This peculiar property makes it an ideal pinion for lever or short pendulum clocks which require a comparatively rapid rotation of the escape wheel, without adding very greatly to the number of teeth in the wheels of the train.

But, just as in the case of a driven pinion all the action is after the line of centres, so in the case of a pinion used to drive a wheel all the action is before the line of centres. Hence it should not be used in the motion work. In fact, it is more suitable for a lever escapement clock than for a pendulum clock with a great deal of recoil in the escapement. Probably no greater tribute could be paid to the lantern pinion than to point out that the Ingersoll Company use it for watches, and that the Ansonia Company, after using leafed pinions, within recent years for some of their smaller time pieces, have replaced them by lanterns fitted with hardened and tempered rounds.

One might suspect that the lantern pinion would wear the wheel teeth somewhat more rapidly than a leafed pinion working *under similar conditions*, such as force

transmitted and hardness of brass, but this remains to be proved.

A few hints on the examination of wheels and pinions will help the reader to master the practical points in connection with depth.

(1) If the pinion is too large a butting action takes place, the friction is excessive and the clock will stop. If there is room to increase the depth, a pinion slightly too large does no harm, but if the wheel teeth or pinion leaves are rather thick, it will not be possible to get the depth deep enough to prevent butting of the on-coming tooth and leaf.

(2) If the pinion is too small it is not moved far enough by the outgoing tooth of the wheel, and the next tooth drops on to its pinion leaf. Wear is considerable and much power is lost. Shallow depthing helps a little, and the pitch diameter of a pinion can be slightly increased by reducing the thickness of the leaves. This is allowable in repair work, but not in new work.

(3) If the depth is too deep the outgoing tooth continues its action too long, possibly with its actual point, which is bad. It results in the succeeding tooth dropping on to its pinion leaf with a loss of power.

(4) When the depth is too shallow the action starts too soon before the line of centres; butting occurs, the point of the outgoing tooth rubs against its leaf and the clock is very liable to stop.

(5) If the wheel tooth is too pointed the depth will have to be too shallow and the characteristics of shallow depths occur.

(6) If the wheel tooth is too much rounded, the wheel and pinion must be very deep in mesh or the outgoing pinion leaf will not be moved far enough to prevent

butting taking place before the line of centres. Deep depthing prevents butting but causes a want of uniformity in the whole action.

(7) When the leaves are too thick the action starts too soon before the line of centres unless the pinion is too small, in which case all the defects of a pinion too small appear.

(8) If the wheel teeth are too thick it is impossible to get the depth deep enough. If the teeth are too thin the addendum cannot be formed properly and the whole action will be irregular and bad.

Needless to say, at all points of the action, from start to finish, there should be enough clearance between the wheel teeth and the pinion leaves to ensure sufficient freedom to permit slight back-lash.

Special attention should always be paid to the final action of the outgoing tooth, to see that its point is not used, and that the oncoming tooth takes up its job without drop, and no sooner before the line of centres than is necessitated by the number of leaves in the pinion. If, for any reason, a pinion of the right size cannot be procured, one which is driven should be slightly under size rather than over size. The reverse applies to pinions which drive the hour wheels, when one the correct size cannot be procured, and the wheel teeth are thin enough to permit deep depthing.

There is really no excuse for poor or wrongly sized pinions in high-class clocks.

With a view to making the above perfectly clear to the reader, diagrams have been prepared to illustrate some of the points mentioned. We have already seen that the theory of cycloidal teeth is not absolutely accurate when applied to pinions with very few leaves. By referring

to Figs. 1 and 2 it will be seen that with a twelve-leaf pinion the action of the oncoming tooth starts when the active face of the leaf of the pinion is on the line of centres, but in the case of pinions with fewer leaves the action starts before the line of centres. A

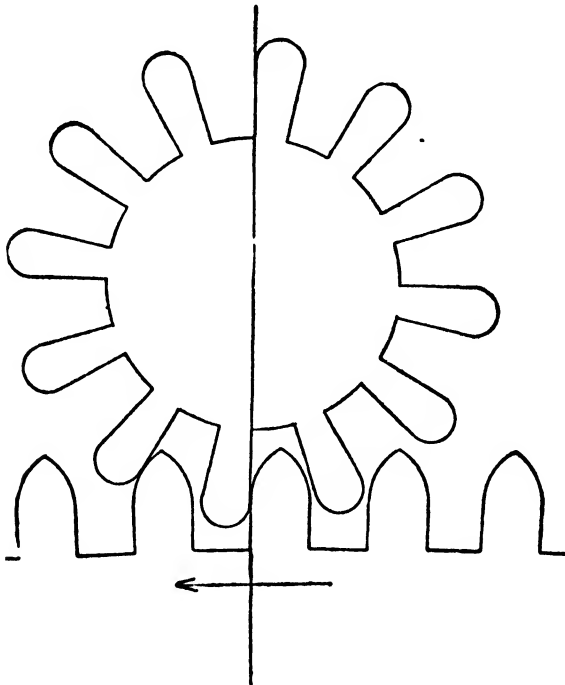

FIG. 2.—TWELVE-LEAF PINION.

careful examination of Fig. 1 shows that the action of the oncoming tooth is starting when the active face of the pinion is about half the thickness of the leaf behind the line of centres. It can also be seen that if the addenda of the teeth are slightly lengthened, or if the depth is made a little deeper, the outgoing tooth will

propel its leaf a little farther and the action of the oncoming tooth will start nearer the line of centres. This would reduce the engaging friction and a smaller weight would suffice to drive the clock; but other considerations enter into the question. If the action of the outgoing tooth is unduly prolonged, its point will come into action. Even if this does not actually occur, the leaf may yet be propelled so far that its radial flank makes a considerable angle with the line of centres, and this is objectionable since it causes the pinion to be thrust away from the wheel with considerable force, and not only are pivot friction and wear considerable, but the pinion leaf and wheel tooth will wear rapidly. It will also be found that the outgoing tooth slides rapidly across the face of the pinion leaf and the motion will become irregular. While some horologists prefer the action of the oncoming leaf with an eight-leaf pinion to start on the line of centres, others prefer that it should start when two-thirds of the thickness of the leaf has passed the line of centres. If we examine Fig. 3, which represents a six-leaf pinion, we see that the action starts considerably before the line of centres, and hence the engaging friction is very considerable. In this case also, the action may be made to commence later by increasing the length of the teeth or increasing the depth. With a six-leaf pinion, however, no manipulation can bring the action up to the line of centres because the tooth oncoming would rub the back of the leaf above it, even though extra clearance between the leaves were provided. The six-leaf pinion is always associated with a recoil escapement, and this is another factor to be considered. If the action starts very near the line of centres, the flank of the outgoing leaf makes an angle of

about 60 degrees with the line of centres, and this would suffice absolutely to prevent recoil and the escapement would work so stiffly that the clock would stop. The seven-leaf pinion has properties intermediate between the six and eight-leaf pinion, and does not require illustration. It is, of course, superior to the six and inferior to the eight, and there appears to be no justification for

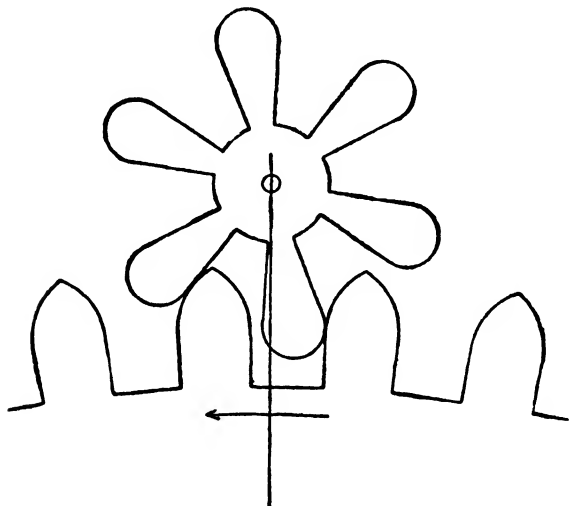

FIG. 3.—SIX-LEAF PINION.

retaining it in new work except, perhaps, in some clocks with very short pendulums.

We have already noted that with the twelve-leaf pinion, the whole of the action is after the line of centres, and hence the friction is very small. It possesses two other advantages. The outgoing leaf is propelled such a short distance that there is very little sliding of the face of the tooth over the leaf, and consequently wear is exceedingly small. It will also be observed from the diagram (Fig. 2) that only a small portion of the adden-

dum, just above the pitch line, is used, and hence there is little force tending to thrust the pinion away from the wheel, so that finer pivots can safely be used and the pivot-hole wear is exceedingly small. As already noted, the twelve-leaf pinion is far more costly and involves very accurate workmanship.

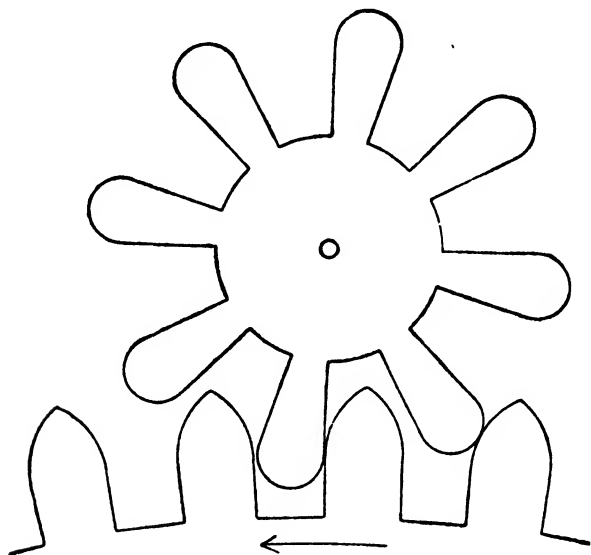

FIG. 4.—PINION TOO LARGE.

The diagrams representing defective depths are worthy of careful examination. Referring to Fig. 4, in which the pinion is too large, it will be seen that a pinion too large is equivalent to a wheel too small and consequently with the teeth too close together. The result is that the oncoming tooth butts into the end of its pinion leaf, and further motion is impossible. If there is sufficient clearance between the leaf spaces and tooth spaces a better action will be obtained by pitching deeply, in

which case the outgoing tooth will propel its leaf farther and the oncoming leaf will *tend* to get out of the way of the oncoming tooth. The action will in any case start too soon before the line of centres and be bad. A pinion too large should always be reduced or replaced.

In the case of a pinion too small (Fig. 5) we have the equivalent of a wheel too large, and hence one with the teeth too far apart. The result is that the oncoming

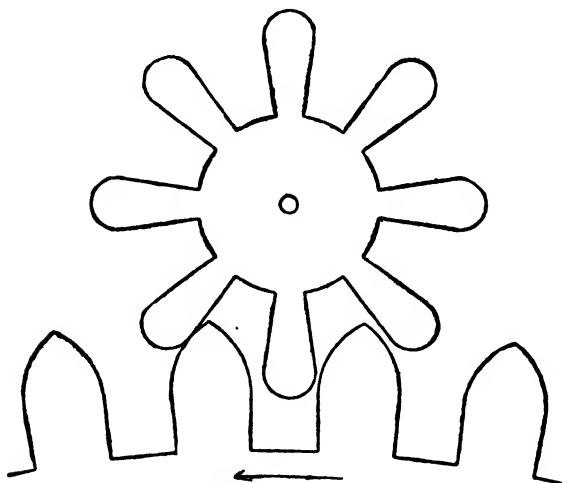

FIG. 5.—PINION TOO SMALL.

tooth, instead of being ready to commence action, is lagging behind. The outgoing tooth will then continue its action, perhaps even with its point, before the oncoming tooth reaches the leaf. If the pinion is very small the last portion of the action of the outgoing tooth may best be described by saying it slips suddenly across the end of the leaf, and the oncoming tooth may fall with a click on to its leaf.

Provided the pinion is only slightly small no harm is

done, but if it is much under size wear will be considerable, power will be lost, and the train will be noisy. On the other hand, it has been the practice of clock and watchmakers for a very long time to make their pinions a *shade* small, in order to obviate trouble which would otherwise ensue owing to inaccuracies in pinion making, wheel cutting and mounting.

A pinion too small is one of too small a pitch diameter,

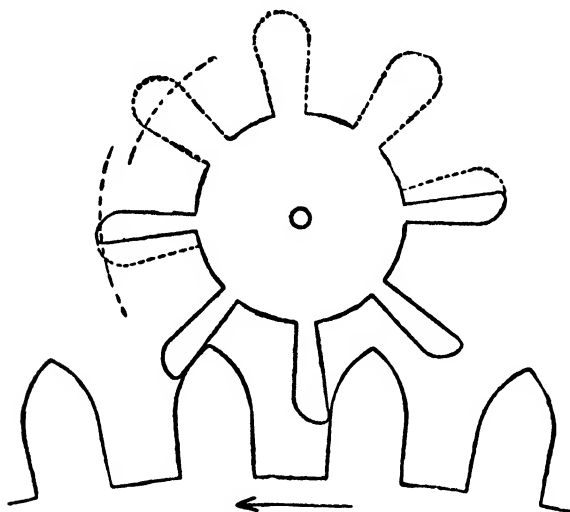

FIG. 6.—ENLARGED PINION.

and, therefore, with too short a radial flank. Inspection of Fig. 6 shows that by removing some metal from the radial flank it is possible to make it longer and, in certain cases, to increase the pitch diameter to the required extent. This improves the action a good deal, but is only resorted to when a pinion maker is asked to rectify worn pinions which the owner does not wish to have replaced by new ones of the correct size.

In the case of the pinion too deep (Fig. 7) the action of the outgoing tooth is unduly prolonged, which, as we have seen in connection with Fig. 5, is objectionable. A pinion *slightly* too deep, providing the backs of the teeth do not rub against the backs of the leaves, is less harmful

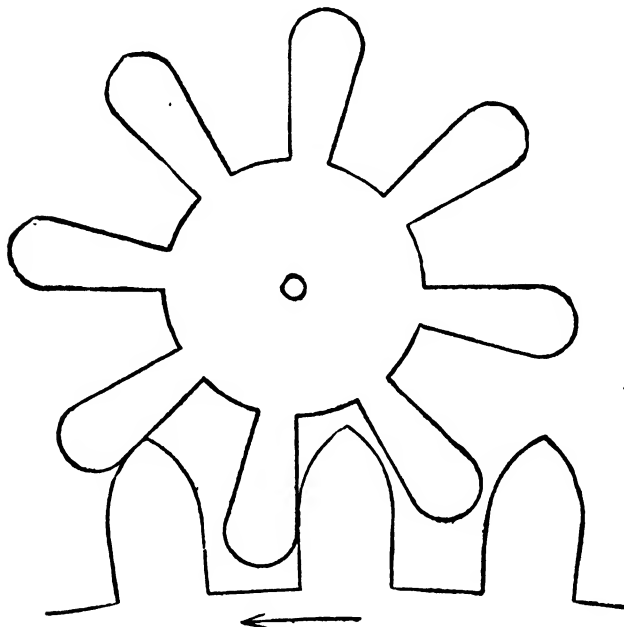

FIG. 7.—PINION TOO DEEP.

than a pinion too shallow. In the case of a pinion too shallow, as seen in Fig. 8, it will be observed that the outgoing tooth cannot propel its leaf far enough, and, in consequence, either the oncoming tooth engages with its leaf some distance before the line of centres, or, (even if the depth is very shallow,) the oncoming tooth will simply butt into the end of the leaf and the clock will stop.

Fig. 9, illustrating a badly-worn pinion, must be regarded as purely diagrammatic, since the actual amount of wear which generally takes place at every point on the acting face of a pinion has never actually been determined, so far as the author is aware, although

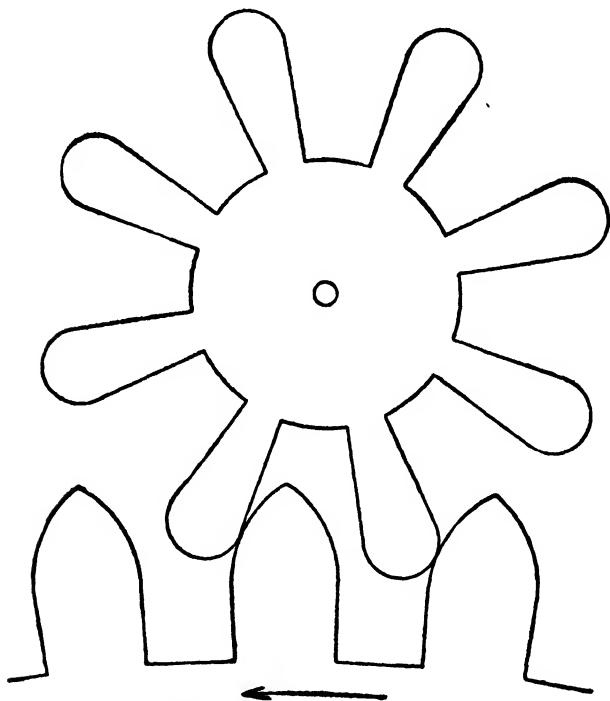

FIG. 8.—PINION TOO SHALLOW.

it could easily be ascertained if necessary. It shows quite clearly that after a certain amount of wear has taken place, the oncoming tooth will butt against the oncoming leaf, and the clock will stop.

Before leaving the subject of the size of pinions it may be well to remind the reader that the size of a pinion

depends on the diameter of the pitch circle, and that a pinion with an epicycloidal addendum has a smaller pitch circle than one of the same *full* diameter (over the tips of the leaves) with circular roundings so much favoured by the French.

There is much room for the standardisation of wheels

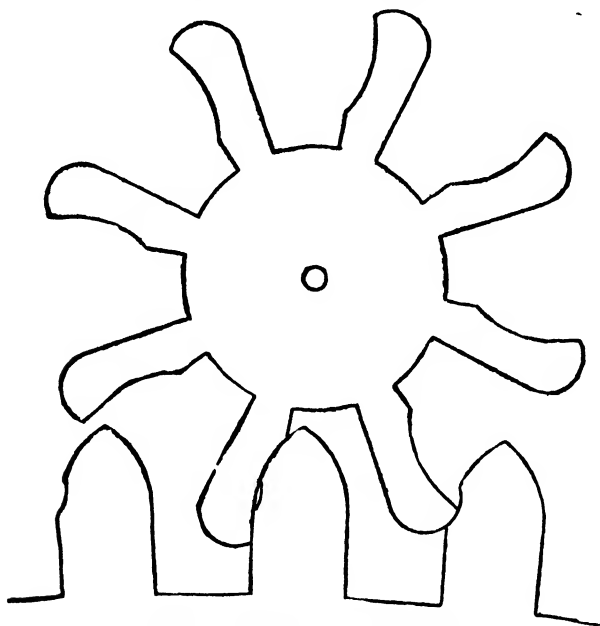

FIG. 9.—WORN CENTRE PINION.

and pinions on the lines adopted by engineers. In mechanical engineering standardisation of teeth is almost as universal as that of screw threads. A few firms making very large machinery classify their toothed wheels by the circular pitch, *i.e.*, the distance from the centre of one tooth to the centre of the next, measured round the pitch circle. Some foreign makers of clock wheel cutters have adopted this system, the “number”

of the cutter being the circular pitch in thousandths of an inch. The system chiefly used by engineers, however, is to specify the size of tooth by stating the number of teeth per inch of the diameter of the pitch circle of the wheel; thus a wheel with a pitch circle diameter of 3 inches and ninety teeth, or a wheel with a pitch circle diameter of 2 inches and sixty teeth, would be described as "thirty pitch," since each has thirty teeth per inch diameter of pitch circle. For practically all British clock work, thirty, forty, fifty and sixty pitch would suffice, *i.e.*, four sizes might be adopted, though for repair work thirty-five, forty-five and fifty-five are frequently necessary. Probably the time will come when it will be possible to go or write to any material dealer and purchase from stock both wheels and pinions of such standard sizes. The present muddle in connection with the purchase of pinions is quite unjustifiable, and some body like the British Horological Institute should make an endeavour to educate the trade and the material dealers. What a convenience it would be if the repairer could just send a postcard to any material dealer for, say, a pallet pinion of seven leaves and fifty pitch, knowing that the same would arrive by return !

Wonderfully accurate approximations to the theoretical shape of wheel teeth and pinion leaves are to be found in clocks made a century or more before the mathematical theory of the subject was worked out. Possibly many a man with some mathematical knowledge of the subject would be amazed if he was shown the enormous difference in wheel teeth of different makers who produced good work. An old clock wheel is usually readily recognised, and the somewhat unconventional shape of teeth is frequently an outstanding feature. It appears likely

that the French were among the first to adopt a very nearly correct shape of wheel tooth, and this was probably because so little power is available from the mainspring of the modern French clock.

When we examine the pinions of an old British clock we are at once struck with several points. In fact, the pinion arbors and collets are important factors in determining the age of a given movement.

Thus in a lantern clock of 1650 we usually find the pinion arbor tapered as shown in Plate IV. The arbor at the wheel end is about the same diameter as the pinion head. In this case also we find the wheel is squared and riveted on to the arbor.

The development of the fine bracket and long-case clock movement during the next twenty or thirty years saw another change, viz., the making of the pinion arbor much thinner (but still tapered) and the provision of a small brass collet, brazed on, for the reception of the wheel. These collets were conspicuous by the fact that their contact with the arbor was not more than twice the thickness of the wheel. About this time makers were undecided so far as the attachment of the wheel was concerned, for we find that some wheels were screwed on and some riveted. Now, of course, they are all riveted. The next thing we notice is that the collet became an object for ornamentation, and for a time they were somewhat elaborately shaped in the lathe as shown in Plate IV.

We then find the simple cheese-shaped collet appearing and this has survived to a certain extent down to the present day. Originally it was brazed on, but later soft solder was used except in cases where it was simply driven on to a roughened arbor. It has, of course, the

best possible shape for the latter method of fixing. The present-day collet attached with soft solder is usually accepted as combining a really good attachment for the wheel with the minimum of expense. Almost ever since eight-day clocks were made the system of riveting certain wheels to the pinion heads has been general. It possesses certain disadvantages, such as the increased difficulty in cleaning the clock, the difficulty of removing traces of wear from pinions, and the impossibility of making the pinion leaves glass-hard if they are case-hardened. Some of the Scottish makers had a mania for riveting wheels on to the pinion heads and carried the system right through the clock, much to the disgust of every one who has such a clock to clean. Moreover, if the pinion leaves require re-forming, every wheel has to be removed from its pinion, including the escape wheel!

When pinions become worn the friction of each depth increases very rapidly, and finally the train absolutely holds up. By examining a badly worn pinion with the wheel which drives it, in the depthing tool, we see the cause, viz., that a butting action finally takes place between the entering tooth and the pinion leaf. This is illustrated in Fig. 9. By slightly increasing the depth it *may* be possible to prevent butting *temporarily*, but such work is only cobbling and not repairing, and the clock will never be really satisfactory. The amount of wear which can be tolerated depends upon the position of the pinion in the train, very little wear in the case of a centre or pin wheel pinion having a great effect, but escape and fly pinions can stand a good deal of wear before the train is held up.

Generally speaking, the greater the number of teeth in the wheel compared with the number of leaves in the

PLATE IV

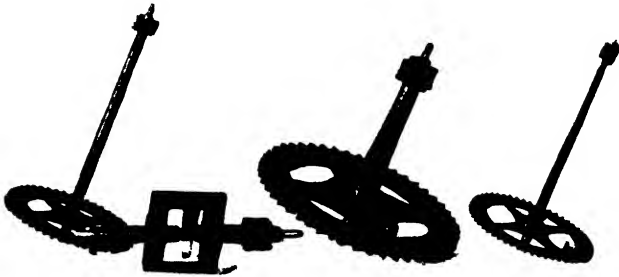
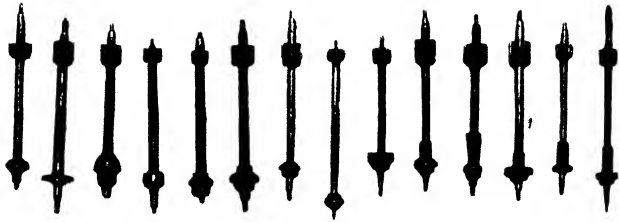

PINIENS AND THEIR COLLETS.



a

b

c

a, LIGHT-DAY FUSEE OF 1700.

b THIRTY-HOUR FUSEE OF 1750

c LIGHT-DAY FUSEE OF 1800

To face page 39.

pinion the sooner butting, resulting from wear, will take place. That is to say, a slightly worn eight-leaf pinion does not do a great deal of harm with a sixty-tooth wheel, whereas butting may take place if it is used with a ninety-tooth wheel.

The early pinions were probably all produced from the solid by means of the file. To-day two systems are in general use. Some makers use pinion wire, and others cut all their pinions in a machine very similar to that used for wheel teeth. The operation of pinion-wire making is as follows: A plate of tool steel, about a foot long, 5 inches wide and about $\frac{5}{8}$ -inch thick, has a number of holes drilled in it and countersunk. The largest hole is slightly smaller than the full diameter of the pinion, and the smallest equal to the diameter at the root of the leaves. Between these extremes the holes get gradually smaller and smaller. A punch is made like a tapered pinion, hardened and tempered, and then forced through each hole successively. The plate is then hardened and tempered. Pieces of tool-steel wire are then prepared by reducing the end sufficiently to allow them to pass and project through the smallest hole. The wire is then well greased and pulled through the largest hole. The process is repeated with the next hole, and so on until the leaves are completely formed. Messrs. Wm. Robertson, Ltd., of Warrington, have been producing pinion wire in this way for 160 years and send it all over the world. Pinion wire up to $\frac{1}{2}$ -inch in diameter and down to the smallest sizes used in watches is produced in this way, but the process requires an enormous amount of skill and experience, otherwise the draw plates will be spoilt as fast as they are made.

The chief objection to the use of pinion wire is the

labour involved in finishing the pinion. The leaves are frequently scored and always require a good deal of polishing. The labour of removing the leaves where they are not required is also considerable. For the above reasons many factories prefer to cut their pinions. The steel rod is rapidly turned down in good lathes by girls, leaving plenty of metal to form the pinion. These pieces are then transferred to automatic machines, in which the leaves are cut. These machines have attained such a high standard of perfection that the pinions which they produce require very little labour expended upon them in the way of polishing. They are, of course, hardened and tempered before they are used.

Reference has been made on p. 2 to case-hardened pinions. The material can be ordinary free cutting mild steel and has the advantages of cheapness and ease of machining. After hardening, the pinion leaves and pivots are glass-hard, but the central core is soft and ductile, thus preventing any risk of fracture.

ESCAPEMENTS

THE earliest escapement was probably of the crown wheel type. At first the crown wheel was mounted on a horizontal pinion, the verge was vertical and suspended by a string to reduce pivot friction. Sometimes the balance was in the form of a wheel, and sometimes in the form of a cross-bar with weights which could be adjusted at various distances apart for regulation. Mr. W. E. Miller, of London, has in his possession several interesting clocks of this type. They are probably German.

With slight modifications the same escapement was largely used up to about 1660 by makers in this country, who apparently did not use the cross-bar balance with adjustable weights but a balance-wheel of wrought iron with a single spoke. Additional spokes would have fouled the striking hammer. The only means of timing such clocks was by varying the driving weight (see p. 84). This escapement must not be confused with that of a verge watch. In a verge watch the balance has a natural period of oscillation brought about by the hair-spring. The escape wheel does little more than keep up the oscillations which would otherwise die down through pivot friction, air resistance, etc. On the other hand the old clocks we have been considering had no hair-springs to reverse the motion of the balances. The reversal of motion was effected entirely by the action of the wheel teeth upon the pallets. In fact, they were just pushed backwards and forwards like the hammer of an alarm clock, though their movement was much slower

Such clocks in the original state are now very rare, but one is illustrated by Cescinski and Webster. The writer has in his possession two which were originally of this type. The crown wheel and verge have been removed and an anchor escapement fitted. The short escape pinions, pivoted into cocks at one end, still remain, and the central bars have marks which show where the pottances for the bottom pivots of the verge were placed.

When the pendulum was introduced as a means of regulation it was probably at first arranged as in the Friesland clocks. The one illustrated and described on p. 87 is, of course, much later, but is probably a survival of an old system.

Very soon, however, the crown wheel pinion was placed vertical and the verge horizontal. In lantern clocks the pendulum was sometimes placed in the centre of the movement, and sometimes at the back. When placed in the centre, there was a space of about three-quarters of an inch wide between the going and striking trains (see p. 85). This type of escapement survived in bracket clocks and others requiring short pendulums until about 1815, and, when properly made, appears to be quite equal to the anchor escapement for this purpose, but it is much more costly to produce.

Most repairers to-day find great difficulty in getting good results with this type of escapement and many owners have been recommended to have it replaced. In order to obtain good reliable time-keeping with a crown escapement the following procedure should be adopted. Before the movement is taken down the clock should be tested. If the drop on each pallet is uniform throughout a complete revolution of the crown wheel, the latter is

probably in good condition. If, however, the drop is irregular for various parts of the wheel, two faults may be the cause, viz., the tops of the teeth may be of irregular height, or the teeth may not be equally spaced. The first fault is easily detected by placing the wheel in the turns or lathe, but the second fault requires more elaborate machinery than the repairer usually has at his disposal. In the writer's experience the second fault is by far the most common owing to the ease with which the first one is corrected. The accuracy of the division is exceedingly important and *must* receive attention. The defective tooth should be marked with a spot of ink and the recutting started here. In this way it is not necessary to remove more than the minimum of metal to rectify the wheel.

Having satisfied himself that the crown wheel is perfect and that the pivot holes are correct, careful attention should be paid to the verge and pallets. If the pallets are deeply pitted they should be refaced with hard steel and repolished. Verges are usually provided with knife edges at the back end and these must be examined. The knife edge usually requires either truing up or renewing. It must be in line with the centre of the verge and quite straight. If it is not straight the slightest end movement will produce a difference in depth of the escapement. This causes a variation in the arc described by the pendulum, and a slight variation in arc with this type of escapement causes grave errors in time keeping.

Having repaired the verge, attention should be paid to the front pivot hole and V-notch at the back, in which the knife edge rests. The latter must be absolutely in line with the front pivot hole and horizontal, so that

there is no chance of the depth of the escapement varying with end movement of the verge.

The repairer should also pay careful attention to the crown wheel pinion and its depth. The escapement has a big recoil, and during this recoil the pinion has to drive the contrate wheel backwards through a small angle. Small as this angle is, it is most important that the recoil can take place easily and without unnecessary friction. Unless recoil is recognised and provided for in this depth, the pendulum will have a poor action and the clock is very liable to stop.

Owners and repairers should realise that the substitution of an anchor escapement for one of the crown wheel type depreciates the value of the clock very considerably, and at the same time no advantage is gained. It may, in a few cases, cost a little less to insert the anchor escapement than to repair a crown escapement, but the saving can never compare with the great depreciation in value of the clock which such a change entails (see p. 130).

The Anchor Escapement.—This escapement, devised by Hooke about 1670, very soon superseded the crown wheel escapement for long-case clocks, but it was not until the nineteenth century that it came into general use for clocks with short pendulums, although it is much cheaper to make. The present day form of pallets differs somewhat from that found in some old long-case clocks as the entrant pallet of this escapement is now more or less horizontal and the exit pallet nearly vertical, but both are usually slightly curved, as in Fig. 10. The writer has made a practice of curving the pallets even more than shown. The effect of this extra curving is to reduce the recoil considerably and therefore give the

pendulum more freedom to swing out well. The apprentice should master the principles of adjusting this

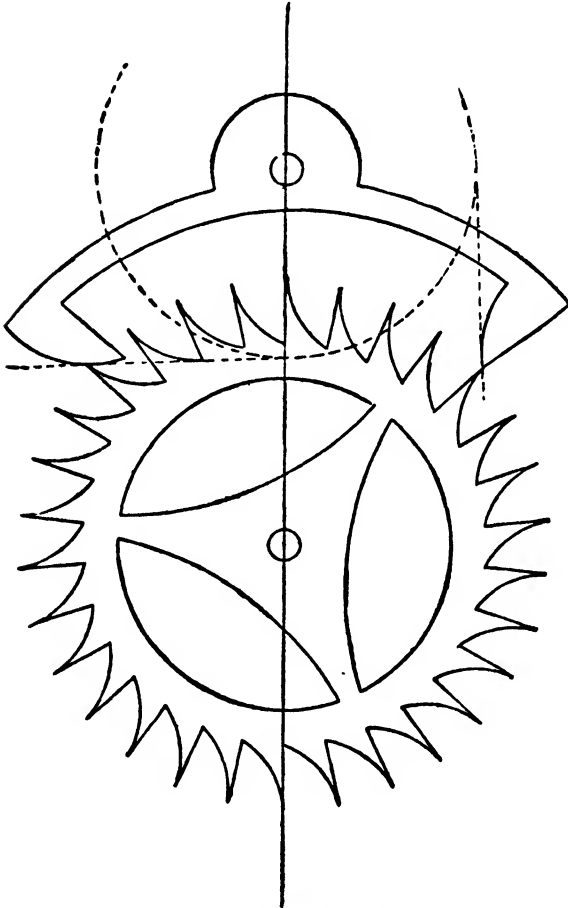

FIG. 10.—ANCHOR ESCAPEMENT.

escapement before he tampers with one. A little consideration will show that if there is too much drop onto the entrant pallet, the pallet staff must be brought nearer to

the escape wheel. If the exit pallet shows too much drop, the pallets must be gently closed after the arms have been softened. The apprentice is advised to practise pallet making at home as it will teach him a lot which will prove invaluable to him in after life. If every journeyman clockmaker had practised pallet making in his youth, the number of clocks in the country with bad escapements would be few and far between. Assuming that the escape wheel is a reasonably good one, the tick of a long-case clock should be barely audible a little distance away. The pendulum should swing out with a good healthy arc, considerably in excess of the minimum required to allow the teeth to escape. A clock with an escapement of this kind will continue to give satisfaction to its owner, and the repairer will get the name of being a good man.

Occasionally a movement is required for a case which is so narrow that the permissible arc described by the pendulum is very small. In such movements it is a good plan to shape the pallets so that the distance between the pallet staff and the escape pinion is not less than twice the radius of the escape wheel. In general, it may be said that the greater the distance between the pallet staff and the escape pinion the smaller will be the arc described by the pendulum for a given width of impulse faces of the pallets. Pallets embracing very few teeth of the escape wheel require a greater movement of the pendulum than if many teeth are embraced.

Dead Beat Escapements.—The dead beat escapement was designed by Graham. It is much used for high-class timekeepers. Each pallet consists of two distinct parts, namely, a curve struck with the pallet staff as centre known as the dead or resting face, and an impulse face

which is perfectly flat. Much has been written on the subject of this escapement, both by scientists and practical men, and there is no doubt that it gives excellent results if really well made. It appears to be generally agreed that the wheel teeth should not have to travel more than a few thousandths of an inch over the dead faces, otherwise the timekeeping is impaired. For ordinary domestic clocks of the proportions used in Britain, the dead beat escapement is not satisfactory. Owners of clocks seldom keep them clean and well oiled, and they are frequently out of beat. For such conditions of service the anchor escapement is preferable. It may be noted that Graham's dead beat escapement is really a modification of the cylinder escapement so much used in cheap watches, the difference being that in the latter the cylinder is thin and the escape-wheel teeth broad, whereas in the one we have been considering the cylinder is thick and the escape-wheel teeth narrow.

Every one familiar with clock construction knows that several varieties of dead beat escapement are used, such as the pin-wheel and pin-pallet escapements.

Plate XXIX. shows the pin-wheel and pallets from a centre seconds clock made in Scotland about 150 years ago, but perfectly circular pins are never used now for escape wheels. The D-shaped pin enables the escapement to be made with less drop. The pin-pallet escapement is much used in France. For pallets the pins are sometimes of glass-hard steel and sometimes of carnelian or other stone. When of steel and badly cut, the cheapest and best way of correcting the escapement is to make new pins. These take only a few minutes to produce in a watch- or clock-lathe with draw-in chucks. The shanks of the pins are very slightly tapered and they are lightly

pushed into the holes in the pallet arms. When in position the escapement should be tested. It will be found that, by slightly rotating the pins in their holes, the escapement can be so adjusted that the drop is reduced to a minimum, which means the maximum amount of power is available for keeping the pendulum in motion. The pins should, of course, be glass-hard. From the makers' point of view this is one of the cheapest escapements known; in fact, it is worthy of more attention than it receives in this country. The makers of time recorders for factories have adopted it on account of its cheapness and quality. It is urged that the oil tends to creep away from the pins on to the pallet arms, but this can be avoided by forming a sharp inverted V on each arm, surrounding the pins and a little distance from them. The oil does not creep over a sharp edge.

Pallet Making.—Britten's handbook gives instructions for setting out escapements, but the methods described do not ensure absolute success unless the workman has had a certain amount of practice. For the novice the following method of procedure will probably be found easier. Take a pallet forging, file both surfaces perfectly true, and drill the pallet staff hole. Remove all file scratches and rub the surface with a moistened crystal of sulphate of copper. As soon as it is coated with metallic copper, rinse it in water, and heat it gently over a lamp until the surface turns nearly black. This gives a good surface for marking out. Now take a piece of sheet metal, such as brass or zinc, and draw two lines across it at right angles. At the point of intersection drill a hole and open it out to exactly fit the escape wheel arbor. Along one of the lines select a point about 1.4 times the radius of the escape wheel away from the

hole already drilled, and form a hole a good fit for the pallet staff. Place the forging in position and lay the

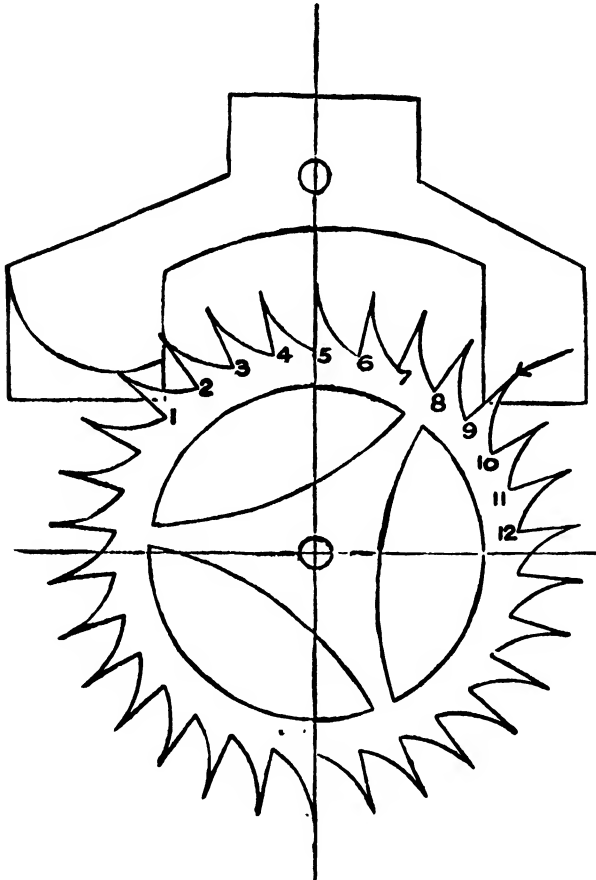

FIG. 11.

wheel on it as shown in Fig. 11. It is a good plan to place a washer (the thickness of the pallet forging) under the wheel. With a pen and ink, number twelve consecutive teeth of the wheel. In the first place see that

the radial side of tooth 5 is on the vertical line. Set a pair of fine but rigid compasses so that the distance between the points is about equal to the distance from

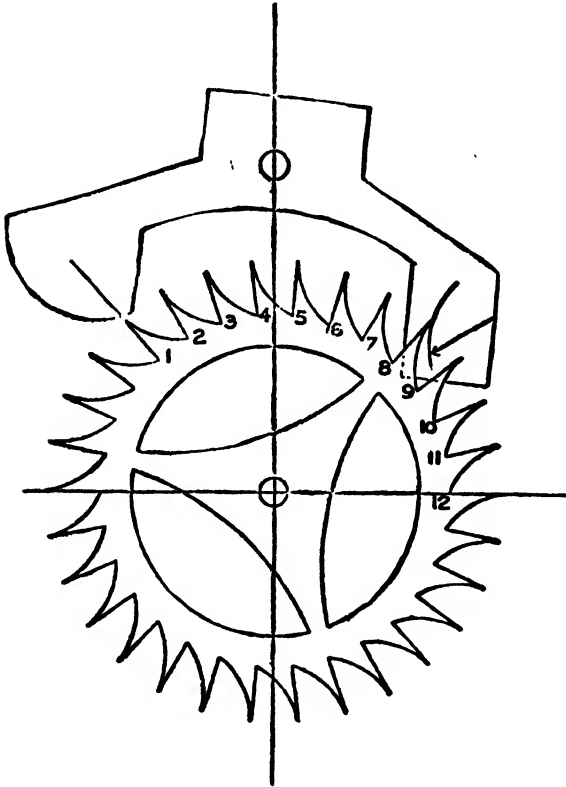

FIG. 12.

the tip of tooth 2 to the tip of tooth 4. Select as centre a point vertically above the tip of tooth 1 and draw the arc just touching it. Now file away the excess metal and remove all file scratches from the curved surface. Replace the forging and wheel as before. See that

tooth 5 is on the vertical line and move the forging round until the curved face is in contact with tooth 1. Having done this, mark the position of the tip of tooth 9 on the right hand pallet as accurately as possible. Advance the wheel half a tooth space as in Fig. 12. If the wheel has thirty teeth, tooth 12 will be on the horizontal line. See that the left-hand pallet is in contact with tooth 1, and with the compasses set as before, mark the face of the right-hand pallet. The curve should pass through the point already marked on the right-hand pallet, and just touch the tip of tooth 8. The centre of this curve will be about on an extension of a line drawn from the tip of tooth 1 to the tip of tooth 8. Form the right-hand pallet to this curve and remove all file scratches. Replace the forging and wheel with tooth 12 on the horizontal line and the right-hand pallet face touching tooth 8. Draw a radial line from the centre of the wheel along tooth 1 as shown in Fig. 12. File away the excess of metal here, taking care not to pass the line or the drop will be excessive. Now replace the wheel and forging as in Fig. 11, and again mark the position for the tip of the right-hand pallet. File away the excess of metal to this mark and the pallets will take the form shown in Fig. 13. Now file up the arms and drill the screw holes for attaching the pallets to the brass collet on the staff. It is customary for clockmakers to form sharp angles everywhere about their pallets. This is quicker and easier than forming rounded corners, but tends to cause cracking. On the whole very few crack when hardened if reasonable precautions are taken. It is easier to remove all scratches and partially polish soft metal than hard, so this should be done before hardening.

For hardening they should be coated with a thin soup

of flour and salt to prevent oxidisation. After being dried they are lowered on a wire hook into a cavity in a nice clear red fire and kept there till they are up to a good

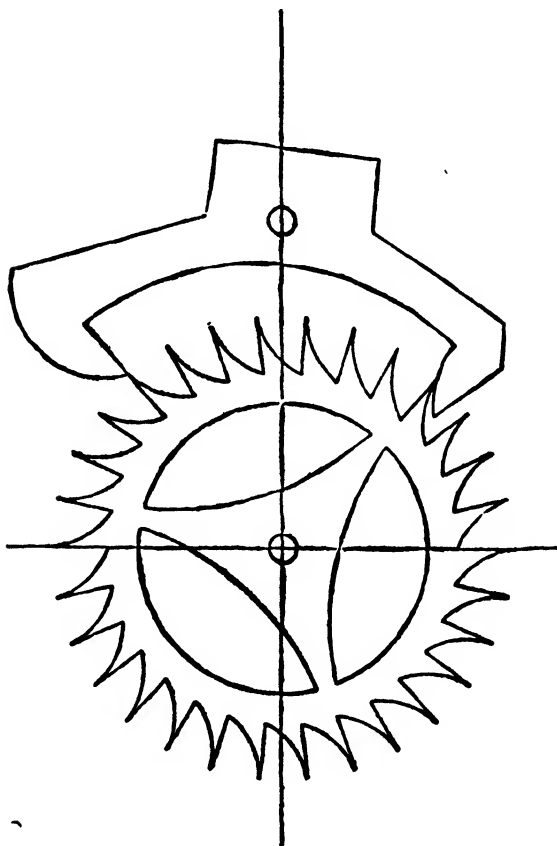

FIG. 13.

red heat. The novice is cautioned against using bellows to the fire or a gas blowpipe since either may cause sufficient overheating to produce cracking upon quenching. The water used for quenching should be slightly

tepid, and a little oil floating on the surface is also a useful precaution against cracking. No time must be lost between withdrawal from the fire and quenching. Unless too much flour and salt has been used, the pallets will be glass-hard. They are now polished and tried in the depthing tool. It will probably be found that the tip of each pallet requires a touch with the Arkansas stone to ensure just free escapement without risk of tripping. The extreme tip (*i.e.*, the last sixty-fourth of an inch) of each pallet should be in the form of a right-angle or slightly less, and not an acute angle. If the acute angle is taken to the extreme tip, very little wear on the pallet face will produce excessive drop. On the other hand, each pallet should, *as a whole*, be sufficiently acute to allow it to pass right down to the roots of the wheel teeth. This will save the tips of the teeth from injury should the pendulum receive an excessive impulse owing to careless handling. From the repairer's point of view, pallets screwed to collets are infinitely preferable to those riveted on.

Pallet faces cannot be too hard and the polishing should be as perfect as possible.

Although pallet making is such a simple operation, and a skilled man can produce them with such rapidity, almost with his eyes shut, it is useless making a new pair for an old wheel unless it is perfect. A wheel with good long teeth equally spaced can be trued up in the lathe in a few seconds, but if the division is bad, or the teeth are worn very short, it should be scrapped. A new wheel costs only a few pence, and as the pinion is frequently badly cut, it is better to insert a new pinion at the same time.

With regard to dead-beat pallets of the Graham type,

the chief difficulty is to avoid making them too thin. Many otherwise highly skilful workmen make this mistake, and consequently their escapements have too much drop. The thickness of each pallet should be as nearly as possible equal to half a tooth space, but exact equality is not possible, partly on account of the necessity for a very little drop and partly because some clearance is required between the pallet tips and the wheel-teeth. The amount of reduction of thickness on this account depends on the thickness and rake of the teeth. In view of the fact that it would be very difficult to calculate the exact thickness of pallet for a given wheel, the workman is advised to start with a rather thick pallet and work it down little by little, removing just sufficient metal from the backs of the pallets to ensure freedom of action without excessive drop.

When making verge pallets for crown wheel pendulum clocks, the simplest procedure is to start with a round bar of tool steel and turn down the verge, leaving it full size where the pallets and pendulum attachments come. These are then worked to shape with the file. For pendulum clocks the best angle between the pallets is 90 degrees or possibly slightly less, whereas in watchwork the angle is considerably larger. If the steel has been well annealed, final adjustment can be effected by twisting the verge through a very small angle.

PENDULUMS

THE time of swing of a pendulum depends mainly upon its effective length, the mass of the bob being usually only of secondary importance. The effective length depends, however, on the mass of the rod compared with the mass of the bob, and to obtain the shortest overall length of a simple pendulum for a given period of swing, it is necessary to use a small heavy bob and the lightest possible rod, suspended by the thinnest possible spring. This is practically what we find in French clocks, and the principle should be carefully noted for examples which occasionally arise where the space in a case to accommodate a pendulum is limited. Other factors which determine the time of swing are the driving action of the escapement, the arc through which the pendulum swings, and the stiffness of the suspension spring. The American thirty-hour pendulum clock (spring driven) is a good example of a *driven* pendulum, since such clocks gain about five minutes in the first twelve hours after winding, and lose an equal amount in the next twelve hours. The pendulums of crown escapement bracket clocks are to a certain extent driven, hence, to get the best performance from these, it is necessary not only to have the escapement in good condition, but the mainspring and fusee must suit one another.

In the case of a balance the period of oscillation depends on several factors. Not only is the mass of the balance of great importance, but the proportions have a very great effect also. The larger the balance of a given

mass the longer will be its period of oscillation. It is well known that the strength of the hair-spring has a great influence also, but the thickness is far more important than the width. In most timekeepers regulation is effected by altering the length of the hair-spring, but in high-class chronometers it is usual to bring them to time by varying the distribution of the mass of the rim of the balance by means of screws with relatively heavy heads.

When compensation for temperature is required, as in chronometer work, the rim of the balance is usually composed of a composite strip of brass and steel so arranged that the effect of the expansion of the balance arms is compensated by a portion of the rim, near where it is cut, being brought slightly nearer the staff. Good compensation can only be obtained by a somewhat irregular distribution of the rating screws in the rim and good results are only obtained by men of long experience.

In the case of pendulum clocks many systems of compensation have been suggested. Harrison's grid-iron pendulum, frequently referred to in elementary textbooks on physics, has almost ceased to be made.

For regulators the mercurial pendulum has long been in favour. It is simple to make and good compensation is readily effected by increasing or decreasing the length of the column of mercury in the glass cylinder. Thus, if the clock gains with a rise of temperature it is a sign that the movement of the mercury upwards is too great. Some mercury must be taken out and the rating nut adjusted so that the pendulum once more beats seconds. This is because the surface of a tall column of mercury rises more than that of a shorter one for the same increase of temperature. For turret clocks the mercurial pen-

dulum would prove too expensive and a cheaper one compensated by means of a zinc tube surrounding an iron or steel rod, is frequently adopted. The reliability of the zinc tube compensation is questioned by some authorities. For anything but the very best clocks a very satisfactory and cheap compensated seconds pendulum can be made by means of a lead cylinder about 14 inches long surrounding a rod of straight-grained varnished wood. Within the last twenty years a very satisfactory material consisting of steel containing about 25 per cent. of nickel has been used for pendulums under the name of Invar. This material is less affected by change of temperature than any other known substance. In order, however, that good compensation may be effected, the bob must be comparatively small in height unless the suspension spring is rather long. It may be remarked here that there is no object in providing a clock with a compensated pendulum unless some form of maintaining gear has previously been installed, and the movement is in first-class condition.

Our forefathers adhered to iron rods for their pendulums, but in recent years some makers have adopted brass strip for the purpose, apparently overlooking the fact that by so doing they were doubling the temperature error.

Pendulum Bobs.—It has already been remarked that the French type of small pendulum is superior to those in general use in this country for short cases. The pear-shaped bob attached to a light wire, such as was used for bracket clocks, was very satisfactory. A comparatively large hole was made in such a bob and filled with hard wood or leather before the wire was inserted, the object of this procedure being to prevent the bob gradually

unscrewing off the wire. With the abandonment of the crown escapement the lenticular bob became almost universal. It certainly has the advantage of occupying little space at the back of the case, but that is its only

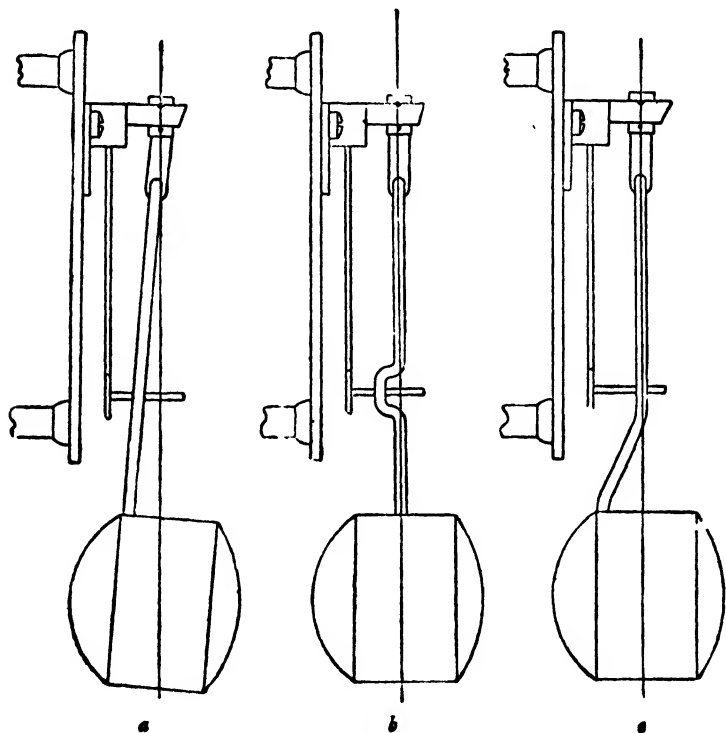

FIG. 14.

redeeming feature. It was probably introduced with the object of lessening the air resistance, but it has since been proved that a spherical bob of the same weight is less affected by the air through which it passes. The lenticular bob frequently lacks symmetry, and if this is so, it is very liable to have a rolling or wobbling motion.

Reference to Fig. 14*a* shows that a pendulum with an unsymmetrical bob does not hang vertically. The consequence is that the impulse from the crutch is not delivered in the plane joining the point of suspension to the centre of mass of the bob, *i.e.*, the impulse is received at a point outside the vertical line. This is practically equivalent to inserting a crank in the rod as shown in Fig. 14*b*. Obviously such a construction would make the bob wobble badly. By slightly bending the rod as shown in Fig. 14*c*, the wobble can usually be eliminated. It is, however, sometimes necessary to ascertain whether the plane of the suspension spring is in line with the pallet staff. If it is not so, the chops should be bent so as to secure this. Wobble is so easy to eliminate, and so detrimental to the efficiency of the clock, that it should never be tolerated.

It is sometimes found that the seconds pendulum of a weight clock is stopped on the fifth day after winding by the weight swinging, if the case is narrow. At a certain time on the fifth day, the period of swing of the weight is exactly one second and the periodic draft caused by the pendulum may be sufficient to make the weight swing so violently that finally it collides with the pendulum and stops the clock. This trouble can easily be overcome by inserting a draft screen of wood or glass between the weight and the pendulum bob.

Every clock should have a rigid support, and it is not uncommon to find a clock stopping, or behaving in an erratic manner as regards timekeeping, owing to the movement and case swinging with the pendulum, especially if the weight starts swinging also. If this occurs the case should undergo repairs or be firmly wedged.

MOTIVE POWER

FOR centuries the sole source of motive power for clocks was a weight, and it possesses the advantage of simplicity and constancy of effort. Lantern clocks were at first provided with separate weights for the going train, striking train and alarm. The weight was suspended by a plaited rope which passed over a spiked pulley. This system lasted for several centuries for thirty-hour clocks with one modification about 1670, viz., the endless rope proposed by Huygens, which provided a simple maintaining gear, since the ratchet was placed on the striking train only. The rope, however, tended to fray and fill the movement with fluff, and this led to the introduction of the chain. This necessitated a change in the form of the pulley owing to the necessity for making the chain present alternate links properly to the pins. This was usually accomplished by turning a somewhat wide and deep groove in the pulley before the pins were inserted. This groove receives about half of each intermediate link. Another method frequently used was to file away a certain amount of metal midway between each pin to make room for the intermediate links. When substituting chain for rope in old clocks it is absolutely necessary to modify the pulleys to suit, otherwise slipping and jerking will occur. Of course, care must be taken that the pulley is of the correct diameter and the pins properly spaced, or the action will be bad. If proper precautions are taken a clock chain will work quite as smoothly as a

new bicycle chain. Not only should the driving pulleys on the clocks be modified, but also the one on the weight, otherwise the chain may become twisted.

With the introduction of eight-day clocks we find the barrel for gut provided. These have undergone very little modification. The early ones were sometimes solid brass castings and very heavy. The grooving was performed by hand since nothing in the nature of a screw-cutting lathe existed 240 years ago. It will be noticed that these hand-cut grooves are very wavy in consequence. For the most part barrels were built up from castings. The front end was riveted on to the arbor, the cylindrical portion was slipped on, and then the back portion. The whole was then held together by driving tapered pins through the cylindrical portion and internal flanges on the two end plates. Some foundries produced hollow barrels cast on to the arbors, but the process is not as easy as it sounds.

With regard to the grooves some formed theirs like a right-hand screw, some left-hand, and a good many Scottish makers did no grooving at all. Unquestionably the left-hand groove is preferable, since it causes the weight to get farther and farther away from the pendulum during its descent (see p. 61), but unless the line is kept rather short it is liable, after it has stretched, to catch on the ratchet click when the clock is fully wound.

The question of grooved versus plain barrels is a matter of opinion. The writer, who has had experience of both, cannot detect any real advantage in the groove, and he is convinced that a plain barrel is quite as good. It should be noted that no attempt has been made to groove the exterior of spring barrels used in conjunction with fusees. Some makers now use fusee and barrel

arbors the front and back pivots of which are of equal diameters. This facilitates the drilling of the pivot holes in the frames and is an excellent plan. The increased thickness of the back pivot tends to cause a little extra

wheel requires a heavier weight than one with a light escape wheel. For a given movement, however, the weight depends on the quality of the wheel teeth and pinion leaves, the accuracy of the depthing, the nature of the pivots and pivot holes and the state of the oil. In the striking train the number of teeth in the warning wheel has a great influence on the weight required. A clock with low-numbered pinions requires more driving force than one in which the leaf numbers are high, for the reason given on p. 25. The average eight-day movement in fair condition will go perfectly with an 8 lbs. weight if oiled about once a year, but, as this is practically never done in practice, a 12 or 14 lbs. weight is usual, so that there may be a good margin of power. When the centre and pin-wheel pinions become worn, even comparatively little, a 50 lbs. weight will not make the clock go properly.

We are informed that the mainspring was first used as a source of motive power about 1500, but at least two centuries elapsed before the major practical difficulties in connection with its use were overcome. In fact, until about 1700, the makers of bracket clocks avoided the coiled spring for their pull-string chimes by using a form of straight cantilever spring similar to that used in locks, but acting upon a finger squared on to an arbor. Even to-day with our rolling mills, superior metals, knowledge of metallurgy and means of controlling temperatures, mainspring making is a difficult, specialised, and by no means certain job. Consequently we are bound to admire both the persistence of the old clockmakers of 230 years ago and their products. It is quite possible that for one satisfactory bracket clock spring which was made and used, ten or even fifty were tried and rejected.

The early springs were chiefly used in pocket watches fitted with verge escapements without hair-springs, *i.e.*, pendulum watches. An escapement of this type is exceedingly sensitive to variations of driving power. The "stackfreed" was designed almost immediately with a view to equalising the driving force of the spring. It consisted of a heart-shaped cam attached to an arbor rotating once in six or twelve hours. The end of a curved cantilever spring pressed on this cam and the arrangement was such that, when the mainspring was fully wound, part of its energy was expended by the cam having to force the curved spring aside. Later on, however, when the mainspring was running down, the cam was in such a position that the curved spring began to assume its original shape and give up its energy to the train by helping the cam round instead of obstructing its motion. Many watches were constructed in this way, but the stackfreed was entirely superseded by the invention of the fusee by Zech about 1525. The fusee has undergone very little modification since then, the chief changes being the application of the chain, and concealing the ratchet inside the main wheel. About the middle of the eighteenth century the attachment of the stop piece to the front plate was also changed. The contour of the fusee used for modern springs differs from those of 220 years ago in that the change of diameter at the large end is now much more rapid. The fusee was also used on thirty-hour movements, though the majority of bracket movements were constructed to run eight days. (See Plate IV.)

The old makers went to considerable trouble to proportion their fusees very accurately to their springs, a thing seldom done to-day.

On p. 130 will be found some remarks on the subject of wire lines for fusees. Present day clockmakers do not bestow sufficient care on fitting fusees and barrel arbors, with the result that both fusee and barrel frequently have so much end shake that the gut or chain is very liable to jump the groove into the next one below it. Most cases of broken chain can be traced to this cause. In the Gledhill-Brook time recorder the barrel is not cast or built up from tube, but is drawn up from sheet brass like a cup leather or cartridge case. The cover is formed in the same way, and is slipped on like the lid of a canister and held in place by three or four screws.

The going-barrel has never made any headway in this country, and this is rather a pity. Every user of high-class pendulum clocks of French manufacture is aware that they are excellent time keepers. In fact, there is not the slightest doubt that with the *right escapement* a good going-barrel is superior to a poor fusee. On the other hand, most people would admit that many French carriage clocks would be improved by fusees if there were only room for them. In France much research in connection with going-barrels has been carried out, as will be seen from Saunier's "Modern Horology."

Maintaining mechanisms of the bolt and shutter and Harrison types have been dealt with in Britten's works.

STRIKING MECHANISMS

THE earliest clocks struck the hours or had alarums, for calling the monks to their devotions, but no dials or hands. Mr. W. E. Miller, of London, is the possessor of some very early movements, some of which resemble De Vic's clock, so frequently illustrated. They were made throughout of wrought iron and are most interesting. Among other things, they demonstrate that in principle the striking train in the sixteenth century and even earlier, was almost exactly the same as to-day. They show that not only was the locking plate in use, but that the unlocking and warning arrangements were probably features of the very earliest striking clocks. In fact, with the exception of the Friesland mechanism mentioned on p. 86, and the flirt mechanism introduced about 1700, every striking clock from the very beginning seems to have "warned." In some of Mr. Miller's early examples there is one less wheel and pinion in the train. The fly and fly pinion were absent, and the warning pinion carried an arm to engage with the warning piece during the lifting period. In these very early movements not only was the fly absent but the hoop was absent also, so the train had to have a good deal of "run" at warning to prevent the detent from falling back into the notch in the locking plate.

It has already been mentioned that the earliest clocks struck the hours but had no dials. Consequently, we find striking trains in all the earliest lantern clocks. We also find that musical clocks of the lantern type

existed between 1680 and 1700 though such clocks are very rare. The striking mechanism of a clock of the seventeenth century calls for little remark beyond the fact that in lanterns the fly was frequently most inefficient, being small, heavy and by no means designed to act as a fan (see Plate IV.) They bore a great contrast to those used in eight-day movements in the reign of Queen Anne, which were light, ran at high speeds and presented a fair surface to the air. It should be noted that these improved flies were usually more or less oval in shape and not rectangular as at present. In practically all clocks of the lantern type the locking plate and hoop wheel were used, the hammer stem being a slightly tapered flat strip.

With the introduction of eight-day movements the same form of locking plate driven by a pinion on the end of the pin-wheel arbor was at first used, and this system was almost always used for four-week movements. It soon became apparent, however, that if the main wheel of an eight-day movement was made with seventy-eight teeth, the locking plate could be attached to the main wheel arbor and thus save a certain amount of wheel cutting, though it involved the division of the barrel arbor inside the barrel to permit winding. Probably this complication was less serious 230 years ago than the cutting of an extra wheel and pinion. Many clocks were made in this way, but it very soon became apparent that if the locking plate were attached to the side of the main wheel itself, the necessity for the divided barrel arbor would disappear, and this became standard practice. A few makers, however, substituted a series of pins in the side of the main wheel for the notched locking plate.

In the eighteenth century we find the hoop dispensed with by many makers, who sloped one side of the notch in the locking plate just as the French do in their locking-plate movements to-day. Some country makers substituted projections for notches in their locking plates, but this practice was usually adopted for thirty-hour movements. The notched locking plate appears to be not only easier to make, but more reliable.

The rack-striking mechanism was invented by Edward Barlow in 1675. Daniel Quare applied a similar principle a few years later to repeating watches. Since Barlow's time a good deal of modification of the original scheme has taken place. Until about 1700 the rack was placed between the frames and gathered up by a pallet or pin driven into the collet of the pallet wheel. A pin in the rim of this wheel locked the train by engaging with a projection on the side of the rack immediately after the last stroke on the bell.

At this time the teeth in the rack were usually of the ratchet type, though some makers formed them like wheel teeth.

When the rack was brought outside the movement, the first thing which was required was some modified means of locking the train after the gathering up. In some cases the final movement of the rack was utilised to move a locking piece pivoted into the frames. By far the most usual practice, however, was to give the rack hook a very big drop after the last tooth, and to take advantage of this big drop to lock the train. This principle was in use for about fifty years, and in some districts considerably longer. The next change was the introduction of a tail to the gathering pallet to do the locking. It appears strange that this was not thought of before, and even

when introduced, it took many years to spread over Britain. It is interesting to note that the French in their rack-striking movements have retained to this day the form of locking used in Britain 200 years ago.

By about 1720 we find clockmakers using a flexible rack tail, instead of a rigid one with spring-controlled hinged projection to engage with or slide over the surface of the snail. This change is much to be deplored, since the good solid rack tails of 220 years ago were unquestionably far more reliable and satisfactory.

In long-case work the snail was almost always, but not invariably, placed on the hour hand tube, and for simplicity and reliability this is the best place for it. For repeating bracket-clocks the snail was fitted on a stud with star wheel and jumper, so that it moved very quickly every hour. This practice has gone on too long. Probably the excuse was that the rack arm fouled the winding arbor, but this can be got over by cranking the former to a certain extent. The objections to a snail mounted on a star wheel are the expense involved, and the possibility of the snail getting out of step with the hour hand, especially if the minute hand of the clock is moved backwards just before the hour.

Even to-day one finds rack-striking movements which are badly designed and liable to give trouble, so a few remarks on the subject may prove useful. The rack arm is usually made about three times the length of the tail. This is a convenient proportion, since it allows of fairly coarse teeth without the snail becoming inconveniently large. The rack stud should be so placed that a square of reasonable size can be provided on which to mount the gathering pallet. This not only reduces the tendency to fracture, but allows of a pin of reasonable

size to keep the pallet in place. Probably the most frequent mistake which occurs is the planting of the rack-hook stud in the wrong position.

Referring to Figs. 15 and 16, it will readily be seen

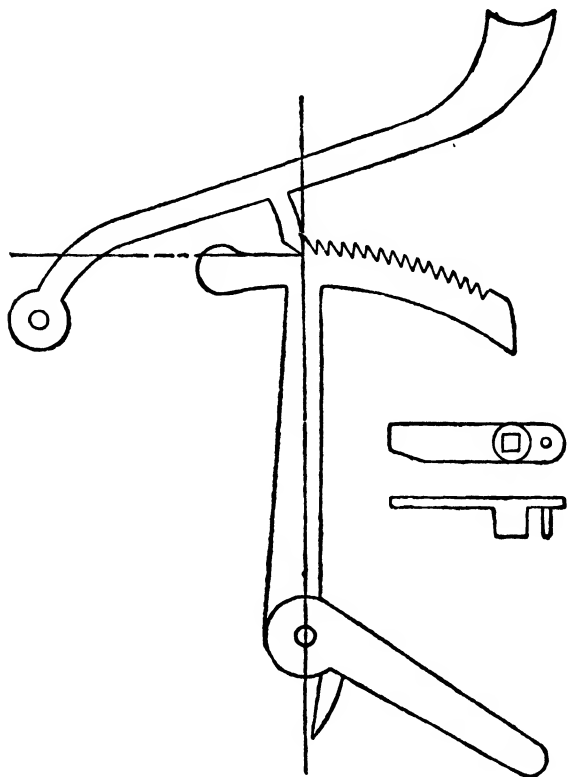

FIG. 15.

that the pressure of the rack springs is almost sufficient to make the rack hooks jump out. The blow of the tail of the gathering pallet on the stop increases this tendency. In Figs. 17 and 18, the hooks can only be raised easily if the racks are quite free to move to the right. With much slope on the gathering pallet tail, movement of the

rack to the right means pushing the train backwards about a turn or two of the fly. All this would give the lifting piece too much to do, and would be bad. To obtain the best position proceed as follows:—

Draw a line through the last tooth of the rack (in the

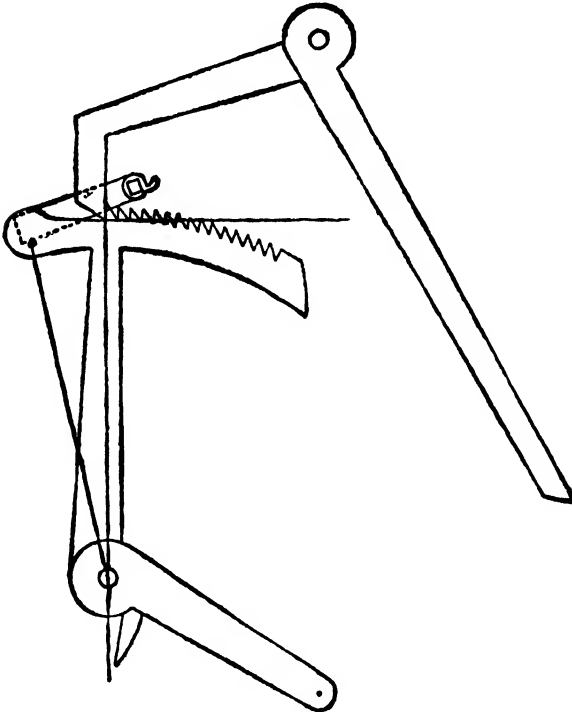

FIG. 16.

gathered up position) and the rack stud centre. Draw another line at right angles to this through the tip of the same tooth, then for rack hooks of the type shown in Fig. 19, plant the stud about one-sixteenth of an inch above this line, and for rack hook shown in Fig. 20 about a sixteenth of an inch below it. By following this plan

the locking will be quite safe, and only a small effort will be required to do the unlocking.

The formation of gathering pallets requires careful

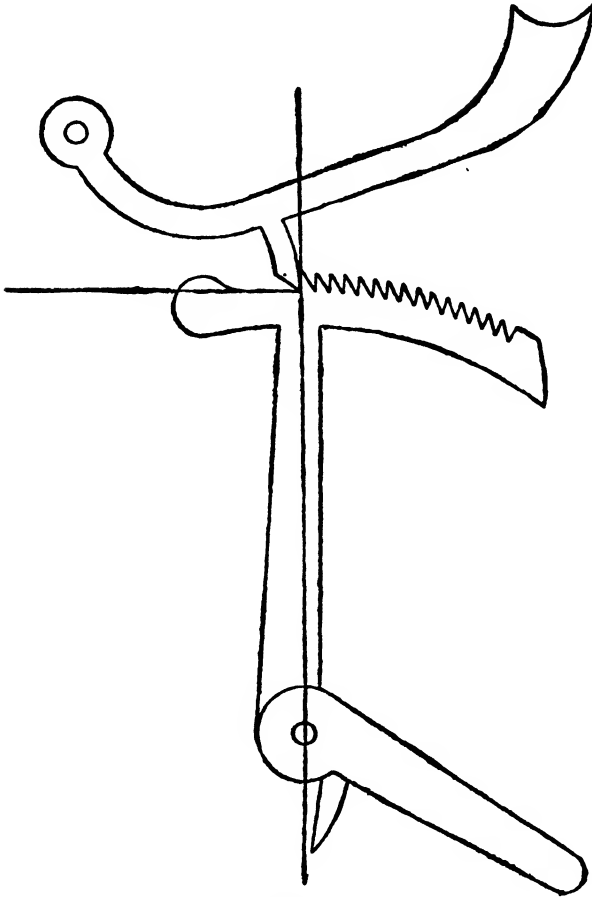

FIG. 17.

consideration. For racks with ratchet teeth the pallet is best formed like a pinion leaf, but with the flanks not radial as shown in Fig. 18. Some makers, both in this

country and abroad, use a pallet, the acting portion of which is a pin as shown in Fig. 15. They are very good since deep engagement with the rack can be obtained without risk of the succeeding tooth butting against the back of the leaf of the pallet. It may be argued that

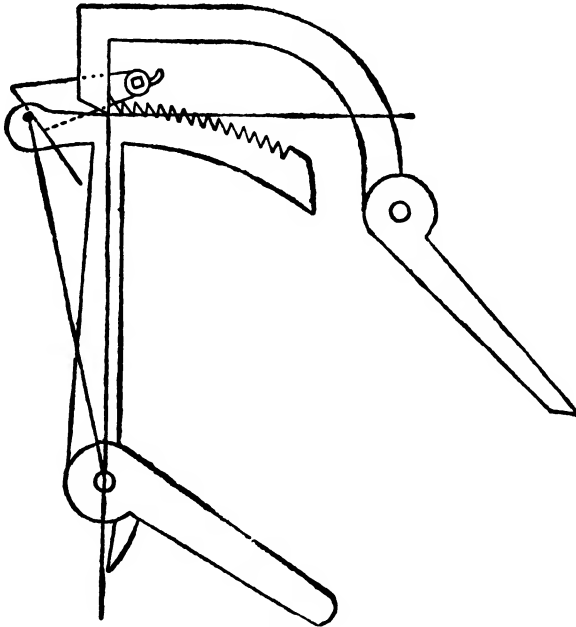

FIG. 18.

the usual form is entirely satisfactory, but the pin type is useful in cases where the rack stud has been planted a little too close to the pallet pivot.

A straight tail as shown in Fig. 16 tends to hold up the rack, especially if the stop pin is low down. A much bevelled tail as shown in Fig. 18, tends to force the rack hard to the left and makes unlocking difficult. The tails in Figs. 19 and 20 are a satisfactory compromise, since

they neither require a strong rack spring, nor do they drive the rack too hard up against the rack hook. The

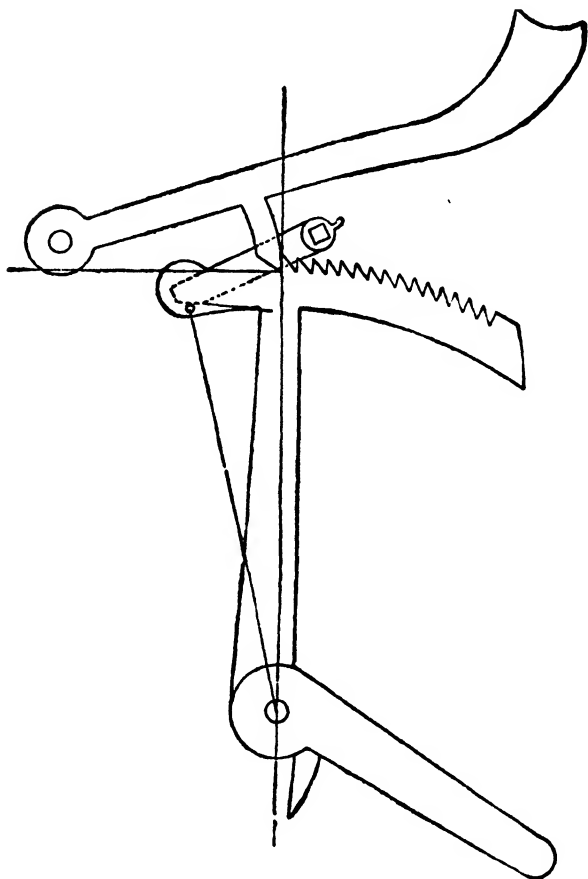

FIG. 19.

length of the pallet tail should not be less than the radius of the pallet wheel, and preferably greater. The design of the lifting piece requires much care to ensure that the going train has not to exert an undue effort.

The position of the warning piece and its angle also requires much thought. Bad design in this respect results in two things, either a great effort is required during the lifting period owing to the forcing of the warning wheel backwards, or there is a possibility of the lifting piece holding up, possibly falling when some one

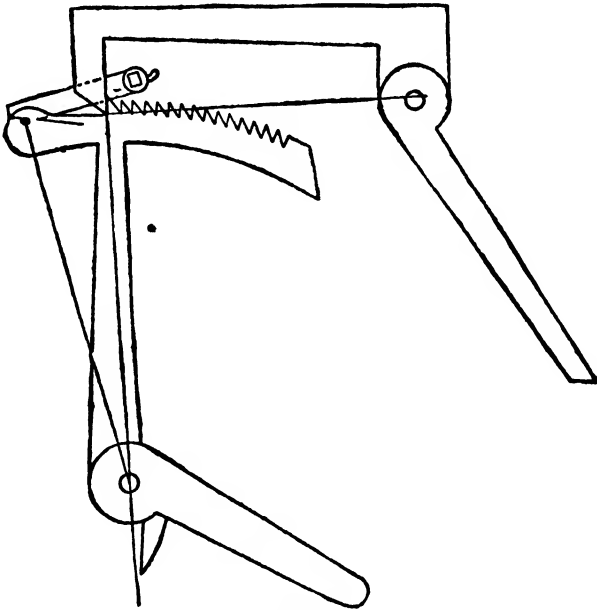

FIG. 20.

enters the room or takes the hood off the case. Some margin of safety is required, since a speck of rust or a spot of oil may just suffice to make the lifting piece hold up after the clock has been sent home to its owner. The French almost always use a weak spring to make sure the lifting piece will fall.

The rack-striking mechanism was chiefly confined to eight-day movements, but it is also found in thirty-

hour bracket-clocks, and thirty-hour long case clocks with both plate frames and bar frames.

For a long time it has been the practice of British makers to arrange for the quarter rack to knock up the hour rack hook, although Barnsdale and others have shown that it is a simple matter to provide a separate lifting piece for the hour rack hook (see Britten's Handbook). The old system was a barbarous one and should have been discarded long ago. It requires an excessively strong chime rack spring, makes an awful noise, and is very liable to get out of order. On the other hand, Barnsdale's system is barely audible even at close quarters, and is unquestionably most reliable. The Scotch method of making the quarter rack raise the hour rack hook during the gathering up period, is quieter than the English method, but quite unreliable.

Up to now we have been considering clocks provided with a warning arrangement which temporarily locks the striking train after the locking piece or rack hook has been raised, and which releases the train directly the tip of the lifting piece drops off the lifting pin.

For many years some British makers have substituted a "flirt" mechanism for warning in the case of musical and chime clocks. Briefly described, the action of the flirt is as follows. The lifting pin draws aside a relatively heavy club-shaped piece of metal controlled by a spring, which acts like a hammer when released. When released at the hour or quarter, the flirt knocks up the locking piece or rack hook, and the chime or musical train is immediately set in motion. The flirt mechanism saves very little in manufacture and is not particularly reliable. Unless the rack spring is rather strong, the rack hook may fall again before the rack has had time to

swing right back on to the snail. In the case of locking-plate musical clocks some makers provided a spring on the end of the locking piece, so arranged that when the latter is raised, the spring flicks out and rests on the hoop and so prevents the locking piece from falling into the notch again before the train has got into motion. The flirt mechanism has probably been abandoned in this country by now, but it is still found in many carriage clocks of continental manufacture. On p. 86 will be found a reference to a striking mechanism found on old Friesland clocks. It is rather troublesome to adjust, and the time of striking may vary by several minutes from hour to hour.

It is difficult to understand why British makers are so keen on retaining the bridge for the hour hand tube to ride on. The French and other continental makers rejected it long ago, and there appears to be no reason whatever for retaining it in this country. A bridge or an equivalent support for the cannon tube of a centre seconds clock is, of course, necessary, since the weight would be too great for the seconds pivot and cause the clock to stop if it were dispensed with.

From about 1690, when the eight-day long-case clock and bracket clock were well established, we find makers devoting a good deal of attention to chime and musical movements. Early musical movements are now comparatively rare, and the tunes played are generally unrecognisable by the present generation. The chief objection to musical clocks is that the owners very soon become tired of them, and this has resulted in many being converted into eight-bell chime clocks. From the earliest times the tune was changed by moving the barrel lengthways in its pivot holes, to expose a fresh

set of pins to the hammers. A musical barrel for a clock with seven tunes (one for each day of the week) and twelve or thirteen bells, requires about a thousand pins, and comparatively few men to-day have facilities for pricking and pinning such barrels at a reasonable price. The majority of the old chime clocks were rather deficient in bells, six being a common and average number. There is something deadly dull and uninteresting about a six-bell chime, so a very large number have become converted into eight-bell chimes within recent years. With eight bells it is possible to compile a pleasing selection of tunes, but the novice is warned not to use the same bell twice in quick succession unless two hammers are provided. In musical clock work the best makers provided two hammers for the majority of the bells, if not for all. This allows a good long period for the lifting of each hammer. A few isolated makers changed the tune by moving the hammer frame and bells instead of moving the barrel endways. This system involves a great deal of extra work and possesses no apparent advantage. In old work we generally find the hammer springs either horizontal or vertically below the hammers, but about the middle of the eighteenth century the present system of hammer springs became common in some districts.

Of the four-bell chimes the most popular is the one composed by Dr. Crotch in 1793 for Great St. Mary's Church, Cambridge. The same chime is frequently erroneously referred to as the Westminster chime, since it was adopted for the Houses of Parliament about sixty years later. The date 1793 is important, as it contributes to the evidence that old chime clocks have undergone alteration, if they are found to have the Cambridge chime.

On p. 128 will be found reference to the practice of

adding a chime train to an old movement which has an exceptionally good dial and case.

For chime work the nearly hemispherical bell has been almost universally used. Mr. Carpenter states that it is quite impossible to obtain bells to-day equal to some of the old ones he has had through his hands. For hour bells the shape has undergone considerable modification. It is common experience that some of the old, nearly hemispherical, hour bells of 200 years ago gave a wonderfully penetrating, pure and lasting note, with a very light hammer.

Such bells are a great contrast to more recent, somewhat angular, bells which produce a harsh note of short duration and spoilt by overtones. It would be interesting to determine whether the general design and proportions of the clear penetrating bells used on French clocks would be suitable for the larger ones used in this country. The use of coiled steel wire or tape gongs is comparatively recent. They were introduced originally by Julian Le Roy, the celebrated French horologist, for repeating watches. Very few old clocks were fitted with gongs, and probably not long before 1800. To-day gongs are being fitted in large numbers of old clocks. To make the strike slower a warning wheel, with about 20 per cent. more teeth, is substituted for the old one. Tube movements are quite recent. They cannot compare with really good bell chimes, but are made in fair numbers to meet the demand for them. One objection to them is that they require a very clumsy case. Of recent years some of the less expensive chime clocks have been provided with rods in place of gongs. The proverbial "man in the street" might not notice the difference, but the rod is unquestionably very inferior to the gong.

Hammer springs and buffers, as well as the general design of hammers, have undergone considerable modification since the introduction of the eight-day movement. Some of the early hammer springs were finely worked up and ornamented, but they very soon became very plain and purely utilitarian. The early hammers used on the very good bells were shorter and lighter than those used to-day, the flattened head on a longer and heavier stem coming into use with bells of poorer quality. The construction of hammers is dealt with on p. 112.

Prior to 1700 we find the strike-silent mechanism applied to bracket clocks. It was usually done by having a small knob at one side of the dial, so arranged that it moved the arbor of the lifting piece lengthways in its pivot holes, the position determining whether the lifting pin had any work to do or not. A more common system to-day is to actuate the mechanism from an indicator in the arch. The movement of this indicator causes the end of a lever to intercept the fall of the rack, or, if it has fallen, push it up again. For the ordinary striking clock the strike-silent mechanism is unnecessary, and very seldom, if ever, used. On the other hand, the chime-silent mechanism of a chime clock is a great convenience (to those who know how to use it without upsetting the sequence of the chimes) when the hands have to be advanced several hours. It is probably never used at all, however, and might quite well be omitted except when specially ordered. Makers probably do not realise how little the average person thinks about such details.

PLATE V.

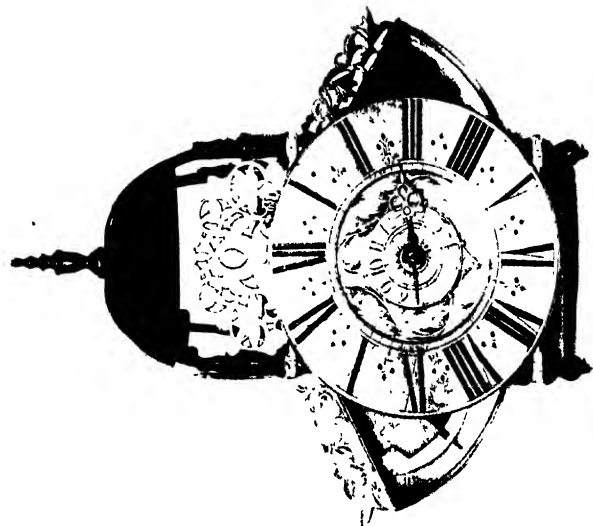

WINGED LANTERN CLOCK. ABOUT 1700.

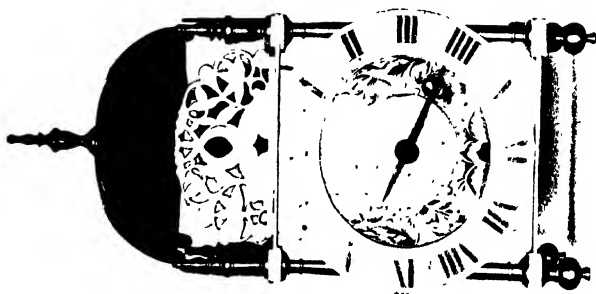

JOHN ERESWORTH
IN LOTHBURY, LONDINI FECIT.

LANTERN CLOCKS

REFERENCE to such works as Britten's "Old Clocks and Watches" shows that very choice specimens of domestic clocks were made several centuries ago, even as far back as the reign of Henry VIII. Such clocks were chiefly in use in royal palaces and the like, and it was not until about 1640 that the wealthier members of the general public became possessors of clocks. The type which was first used for general domestic purposes was the lantern clock. Naturally, it underwent certain modifications as time went on, but, for the most part, no very striking innovations were introduced during the time it survived. Plate V. illustrates a typical example dating from about 1660 and inscribed on the dial is "John Ebsworth in Lothbury Londini fecit." The movement is constructed to go for twelve hours only between windings. It was originally fitted with a vertical verge and balance wheel, but at a later date, was converted to an anchor escapement (see p. 43). Both rope wheels are provided with ratchets, and the striking train is so arranged that the weight for it hangs on the right-hand side, and hence counterbalances the tendency of the going weight to make the bracket slip out of the vertical. It will be observed that this system of ratchets on both the going and striking trains points to the movement having been made prior to the introduction of the endless rope with a single weight. Even if the endless rope had been invented, it probably could not have been used for this clock, since the balance

had fixed mass distribution and no hair-spring. Accordingly the variation of the weight of the going train was the only means of regulation, and when the clock was brought to time, the same weight might prove too great or too small for the striking train. After the introduction of the pendulum, regulation of the clock by altering the driving weight disappeared, and with a long pendulum, the weight may be doubled or halved without doing much harm. According to Mr. Miller, with the old balance, half a pound variation in the driving weight was sufficient to cause a variation of half an hour per day in time keeping. The pinions of this clock have very thick arbors, and the wheels are squared on to them without collets. The crown wheel and verge for the alarm were located outside the back plate. The dial is, of course, of cast brass, and is splendidly engraved with the lily pattern which was so popular for dials and bracket clock back-plates between 1650 and 1700. It will be observed that the alarm disc is of the Tudor rose pattern, so common for this purpose at this period. The circle is very narrow, the figures are short and thick, and the only ornamentation between them is a simple arrow head. The hand is simple and quaint in character, and very typical of clocks of this period. Surmounting the dial is a Dolphin fret, a design extremely popular for the purpose. By comparing the Ebsworth clock with the other illustrated in Plate V., we see that forty or fifty years has resulted in certain changes. The endless rope has been introduced, and the striking train rotates in the same direction as the going train. The pinion arbors are nearly parallel, and the wheels are attached to them by brass collets. The dial centre is engraved with a conventional scroll design, and the Tudor rose is no

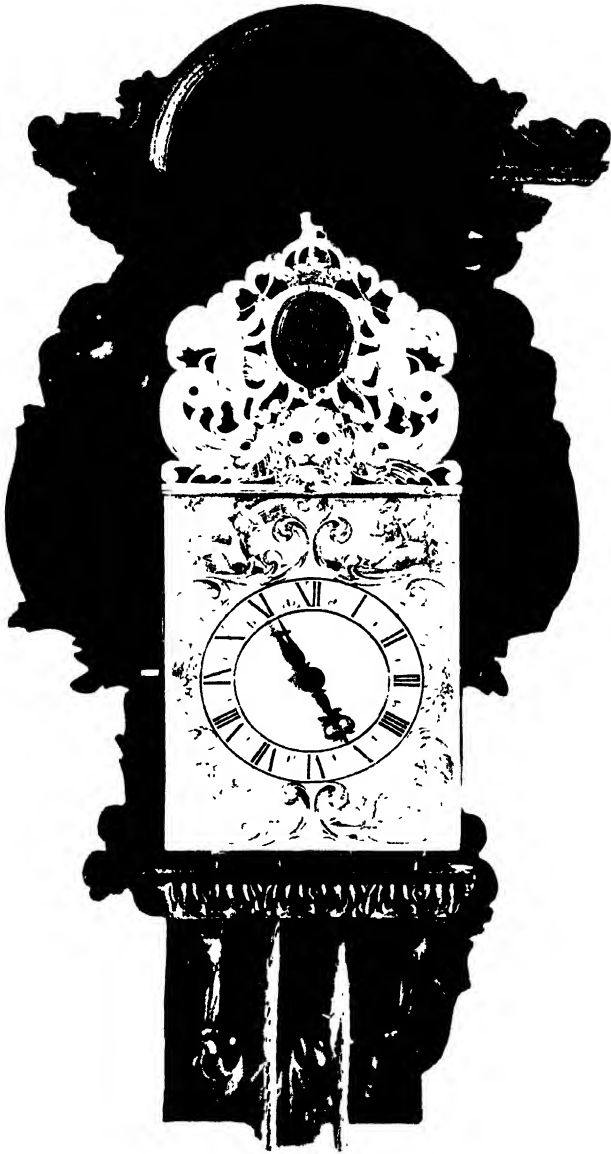

STUART LANTERN CLOCK.

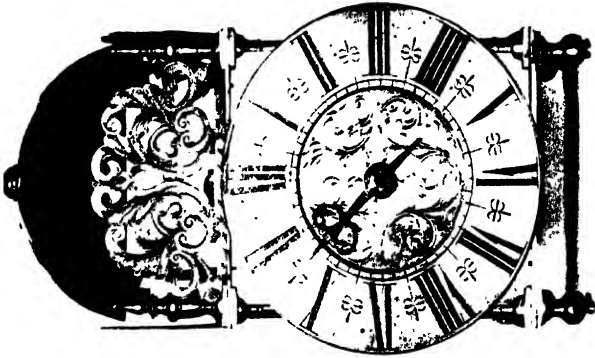

LATE EAST-ANGLIAN LANTERN CLOCK.

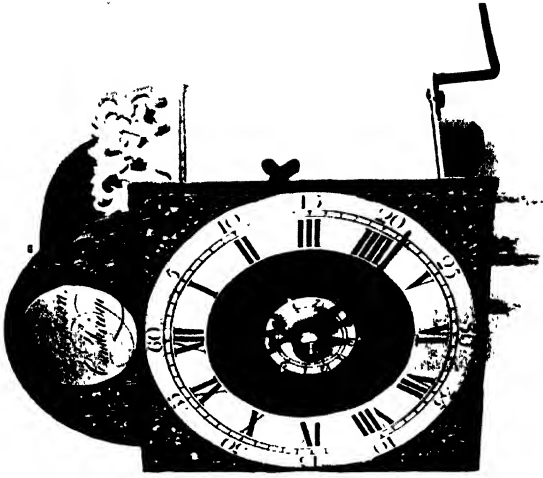

LATE-ANGLIAN SHEEP'S HEAD, WITH 5-INCH DIAL.
Ed. Slomson, Cambridge.

longer found on the alarm plate. The circle extends considerably beyond the sides of the clock and the figures are relatively long and narrow, and between them is a more or less elaborate ornamentation. The hand is more elaborately pierced, but the surface is quite flat. However, this particular clock cannot be described as typical of the period, on account of the distinctly uncommon wings on either side. The movement has a crown wheel escapement, and the pendulum bob is similar to the head of an anchor, and swings in a space between the going and striking trains. The fronts of the wings are rebated, probably with a view to closing them in with horn or possibly glass. For the most part, lantern clocks had striking movements and usually alarms in addition, but many smaller ones were made without striking trains. Occasionally they were provided with chimes, but such clocks are very rare. The lantern clock was always unsatisfactory, from the fact that the case was anything but dust-proof. This soon led to the brackets being provided with canopies as shown in Plate VI.

This particular clock is an early example which formerly hung in the Palace of Whitehall, and bears the Stuart arms in gold on the fret. The bracket does not actually belong to the clock, but is probably of approximately the same age. The canopy gradually developed in two directions. Occasionally we find lantern clocks fitted into grandfather clock cases and sometimes the movement only was cased, thus introducing the hooded clock.

The making of lantern clocks practically ceased in the large towns early in the eighteenth century, but country makers continued to make them for another thirty years or even longer. Plate VII. represents a typical East

Anglian example. It will be observed that the ornament above the bell strap has been sawn off, probably to enable a closely fitting hood to be placed over the movement to exclude dust. Such clocks were frequently of somewhat crude appearance, and lacked much of the fine engraving and finish of their predecessors. They were probably sold to well-to-do farmers and others upon whom fine detail would be lost. The lantern clock was not exclusively made in this country, but was made on the continent also. Plates VIII. and IX. show a Friesland clock and its movement. In general, its construction is somewhat similar to its British cousin, but the following differences are at once noticeable. The turned pillars of the movement are more elaborate, and the arbors in connection with the striking mechanism are elaborately turned also. The hammer-stem is vertical and connected with the pin wheel in a manner similar to that found in the wood-framed clocks of the Black Forest. Similarly, the hoop wheel is replaced by a wheel which carries a double cam and makes half a revolution for every stroke on the bell. The most peculiar feature of the striking mechanism, however, is the absence of either any warning arrangement or a flirt. The locking piece and lifting piece are rigidly connected, and the latter is provided with a peculiar hinged nose controlled by a spring. When the lifting pin presses on this nose, it merely compresses the spring for a time without unlocking the train. At approximately the hour or half-hour the pressure on the nose is so great that the lifting piece jumps up suddenly, and the clock strikes. The hinged nose flicks back into its original position, and when the lifter falls the nose is on the far side of the lifting pin. The mechanism requires careful examination before it

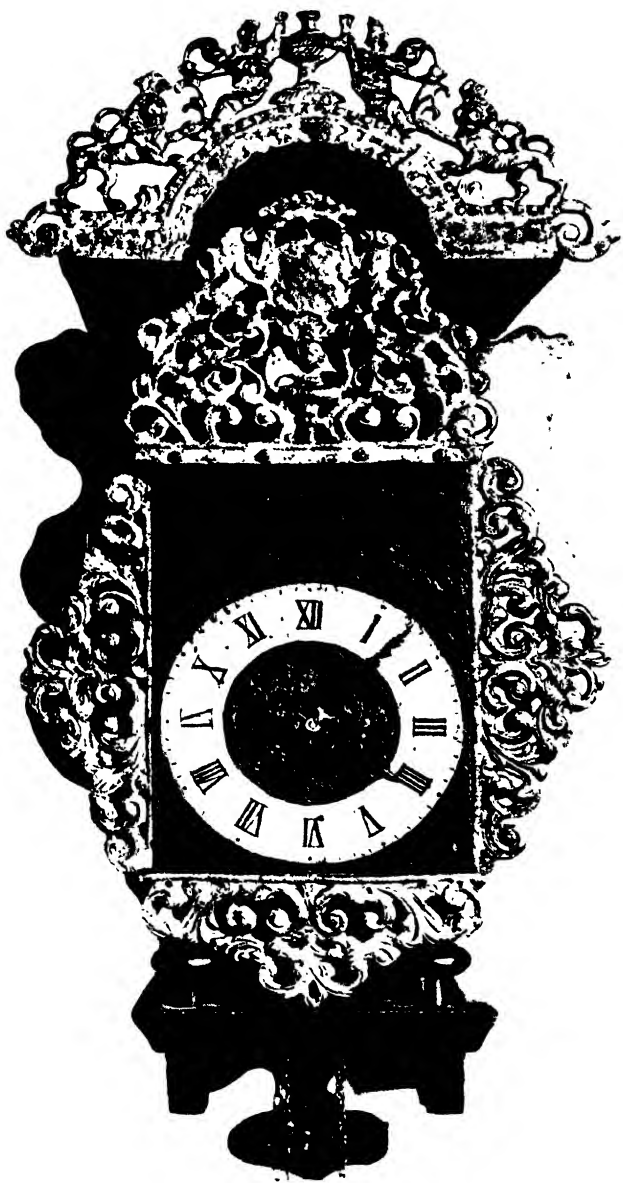

FREESTAND CLOCK

[To face page 86.]

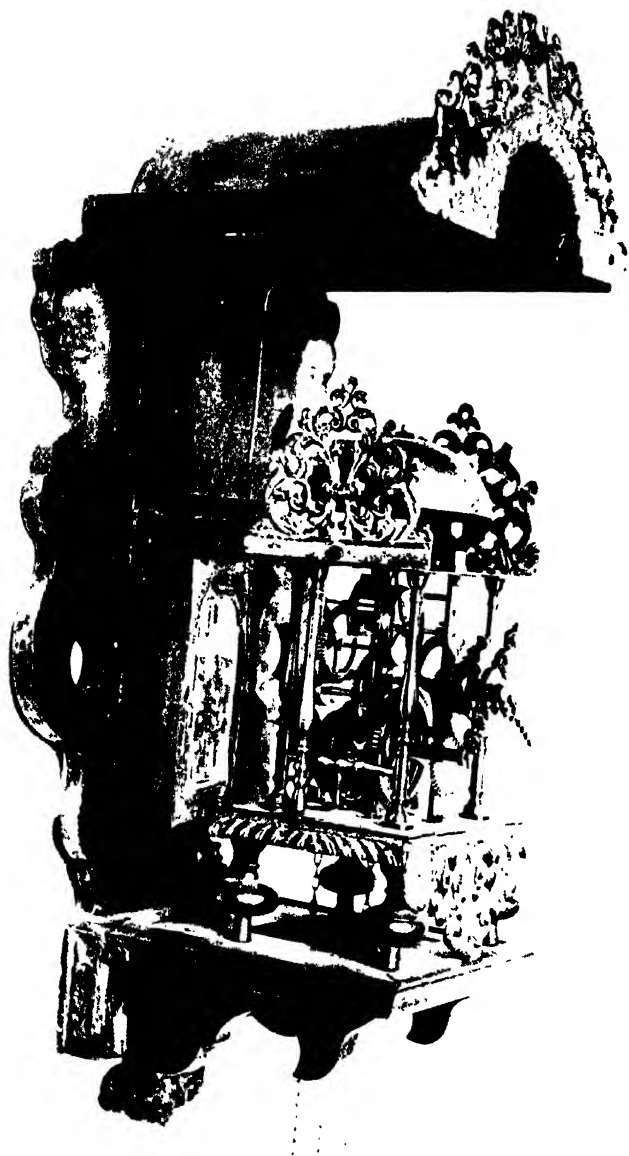

FRIESLAND CLOCK, WITH DIAL REMOVED.

PLATE X.

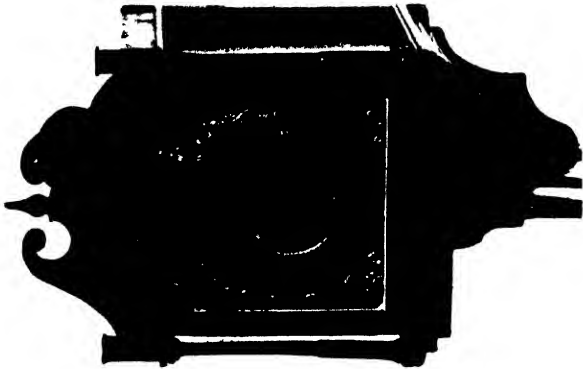

SMALL LANTERN CLOCK CONVERTED INTO A HOODED CLOCK WITH 5-INCH DIAL.

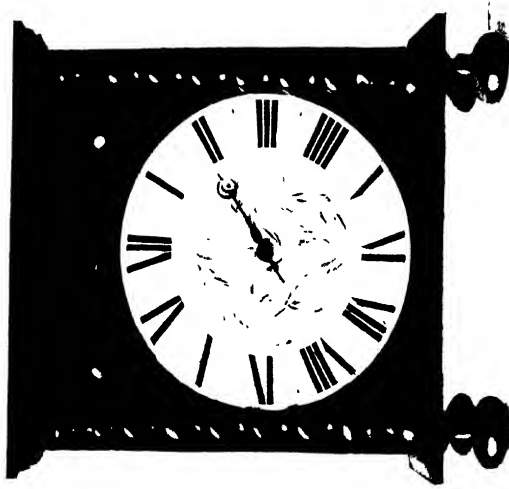

LANGASHIRE ? HOODED CLOCK WITH 11½-INCH SILVERED DIAL

can be fully understood, but, even when really well made, it is not satisfactory. The escapement is of the vertical verge crown wheel type, and the crutch engages in a relatively wide loop in the pendulum rod. A wide loop is absolutely necessary (as can be proved by slipping a piece of bouchon wire over the thin wire crutch) because otherwise, the pendulum will not swing in a plane, but tends to assume an elliptical path. The dials of these clocks are of painted sheet iron and two cast-brass hands are provided. The frets and ornamentation round the canopy and stool are of cast lead, coloured with gold paint. The side doors are of sheet iron with glass panels. The weight was carried by an endless rope. The design of the side frets much resembles some frequently found on lantern clocks made in East Anglia.

The application of wooden cases to lantern clocks resulted in further changes; dials were made still larger and the turned pillars disappeared. Not unfrequently one comes across a clock which was originally a *pure* lantern but later became a hooded clock. Plate X. shows an example of this. Holes in the plates show that this movement at one time had back and side doors and frets, but these were removed when a larger dial was fitted. Further evidence that the dial is not original is derived from the fact that no maker's name occurs on the plate in the arch. Even when this dial was fitted the clock continued for a time to have only one hand. According to Webster, lantern clocks were never made with two hands in the first instance, which seems rather remarkable in view of the fact that the minute hand was applied to long-case and bracket clocks long before the construction of lanterns ceased. Plate VII. also illustrates a curious type of clock made in large numbers

in the eastern counties of England, until quite late in the eighteenth century. It has a projecting arched dial engraved with minutes as if intended for a wooden case, but on the other hand, is fitted with back and side doors, side frets and a loop, and prongs at the back for hanging it on the wall. Many similar clocks were made with plain silvered dials and one hand only. They all had crown escapements, and were known as "Sheep's Head" clocks.

In addition to hooded clocks made from pure lanterns, many other types were constructed. Many had square dials, and not unfrequently we meet with one with a plate-frame movement, and occasionally with inside rack striking.

A somewhat peculiar hooded clock is illustrated in Plate X. It is probably of Lancashire origin, since the writer once saw one of the same type bearing the name and address of a maker in that county. The movement is of the birdcage type with crown wheel escapement. The dial is plain silvered, but there are no traces of a glass ever having been placed over it. The cornice round the top is not the original one. Over the dial is an opening to enable the sound of the bell to be heard more clearly.

LONG CASE CLOCKS

WHEN we examine the history of the long case clock we are confronted with a very big subject, and it is impossible in this volume to deal fully with the cabinet-maker's side. The evolution of cases by successive generations of London cabinet-makers, has been fully dealt with by Cescinsky and Webster in their remarkable work entitled "English Domestic Clocks," and every one who handles old clocks would do well to purchase a copy of this most interesting book. They say, however, practically nothing about North Country or Scottish styles. For the purpose, for which this volume is written, it will suffice if only brief reference is made to the more outstanding types.

We have already noted that lantern clocks were not infrequently "boxed in" with a view to rendering them more dust-proof, and the boxing-in of the weights and pendulum naturally led to the construction of long case clocks; but before entering into details a few remarks on various influences may not be out of place.

Between the years 1650 and 1750, London was the centre of the clockmaking industry in the same way that Sheffield has for a long time been the centre of the cutlery industry. This fact is chiefly attributable to London being the only large town at that time, and that it presented unequalled advantages for the sale of the clocks produced. Edinburgh, on the other hand, also proved a good centre, but to a lesser degree. Britten and Smith both mention the names of several

first-class men who migrated to London and Edinburgh for business purposes just as rising members of the legal profession not infrequently do to-day. The centering of the industry in London had a remarkably good effect on the early products. Not only were the makers situated in a good market, but they were surrounded by many great cabinet-makers of marvellous skill and excellent taste. At that time London attracted great numbers of continental workmen, and some of these must have added considerably to both the clockmakers' and the cabinet-makers' wealth of ideas, and proved of great assistance in carrying out certain designs. The trade having once been established in London and Edinburgh, makers from other parts of the country visited these towns to procure ornamental castings and other material, but by the middle of the eighteenth century we find them producing new designs of their own which are not found on London-made clocks.

There is no doubt that the early London-made clocks left nothing to be desired in workmanship and proportions. The former was due, partly to the great pride the producers took in their work, and partly because the cost was of minor importance. Another factor, however, contributed to the maintenance of a high standard of quality, and that was the powerful influence of the Clock Makers' Company. This Guild possessed very great powers, and they could not only seize and destroy any second-rate article, but could ruin any man who did not consistently turn out first-rate work.

When, however, the powers of this great Guild waned, a reaction set in and inferior goods were produced. The growing demand for clocks naturally led to another change. At first they were only purchased by the extra

wealthy, but later on other people with more slender purses required them, and the natural result was that clocks and clock cases had to be produced at a much lower figure, and many refinements had to go. It is interesting to compare the very high standard, not only of clocks, but of all sorts of beautiful old furniture in some ancient mansion with the corresponding clocks and furniture handed down from generation to generation of, say, farmers who were less prosperous. In the one case we find the choicest materials, design and workmanship, and in the other case the village craftsman's attempt to produce something of the same sort from a poor class of material, the proportions and workmanship frequently being likewise somewhat poor.

It is interesting to note that at the time the London makers were distinctly degenerating, those of Lancashire and certain other districts were producing work of great excellence. With the general slump which occurred in the clock trade owing to foreign competition, most of the provincial makers died out, and apart from movements made in factories in Birmingham, London, etc., comparatively few are made in this country at all. There still is a colony of chamber workers in London, but they are getting fewer in number every year.

Before the war the Germans were doing their utmost to stamp out the last traces of clockmaking in this country. Not many years ago the writer was shown, in a wholesale house, a sample of a finished, silvered and lacquered dial for a long case clock delivered in Glasgow for *ninepence* more than the bare cost of the brass.

The earliest long case clocks produced had certain features in common with the lantern. Many had crown escapements and short pendulums, which accounts for

the fact that the early cases were very narrow. The dials were square and not more than 9 or 10 inches across. The dial centres were frequently engraved with the lily pattern so popular at this period. The corner ornaments were simple, small and beautifully finished with the graver. The hand was of the simple double loop type, frequently bevelled on the surface. The movement was of the lantern type, and when wound with a key, the two trains were placed side by side. The hood of the case had twisted pillars on each side, and in the earliest examples the hood had to be drawn off or raised before the hand could be touched. The moulding under the hood was convex instead of concave, and the same applies to the top of the plinth. The door was long, narrow and square-topped, and the distance from the floor to the top of the plinth was frequently distinctly less than in later types. The whole design was extremely simple and dignified, the only ornamentation being a very small quantity of inlay.

The reader is cautioned against regarding any one or two of the above characteristics as pointing to an early clock. If the movement is not an old one, the style of engraving of the dial and the corner ornaments are perhaps some of the best guides, providing that the dial is a genuine old one, and not merely a reproduction. On the other hand, the size of the dial, the one hand, the thirty-hour lantern movement, the plain rectangular door, the simple case with a low plinth and several other characteristics are frequently found in clocks even as late as 1760. The matter is further complicated by dealers interchanging dials and cases so that good cases may have good dials and movements and *vice versâ*. When this is done dealers ignore, as a rule, the question of age and locality.

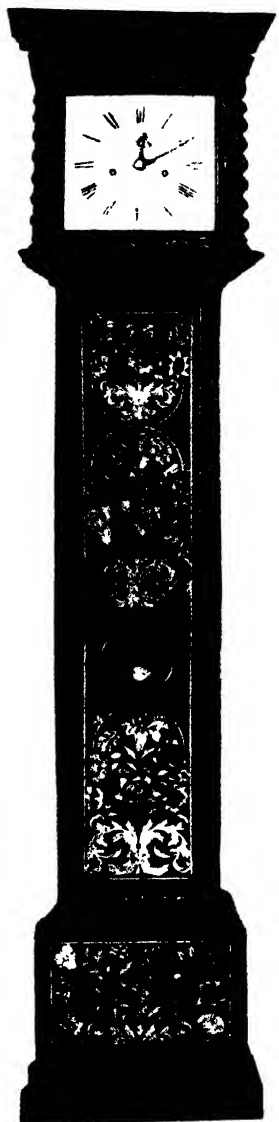
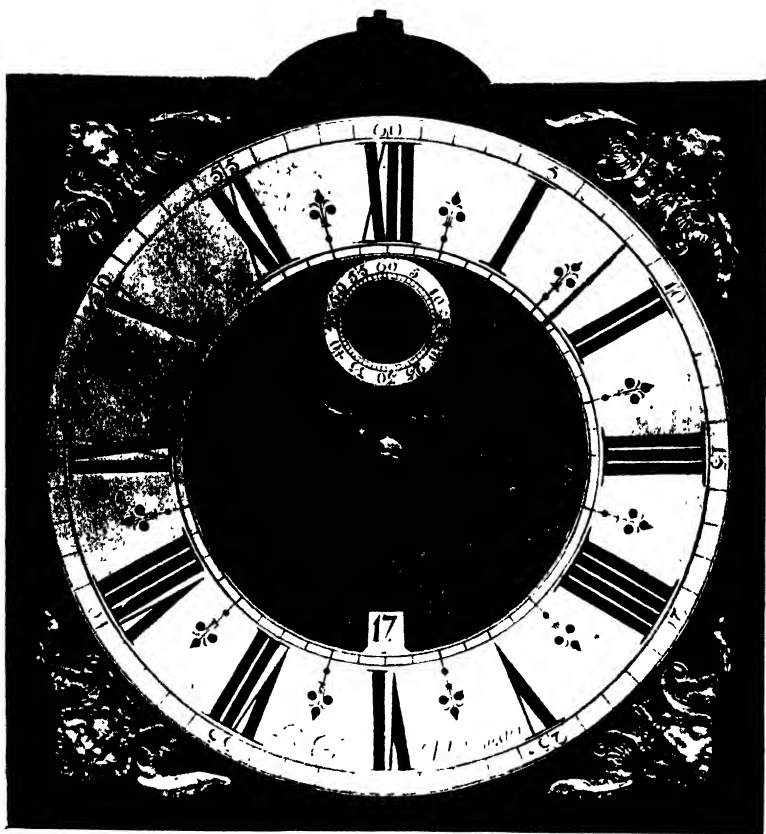

PLATE XI.

HENRY HESTER, WESTMINSTER.
ABOUT 1695

[To face page 93.]

PLATE XII.



DIAL OF CLOCK, BY HENRY HESTER.

About 1690, or perhaps even earlier, several very marked changes took place. The eight-day movement was developed ; clocks with minute hands and calendar circles were introduced, and the ornamentation of cases was further developed. This period also witnessed the introduction of frosted dial centres, which became the standard practice in London for about three-quarters of a century. The clock by Hester, shown in Plates XI. and XII., dates from about 1695.

So long as the crown escapement was used in long case clocks, the aperture for showing the day of the month was located between the centre of the dial and the figure XII., but the application of the seconds pendulum and seconds hand resulted in the aperture being placed just above the figure VI. To-day the calendar on a clock is regarded as quite unnecessary, but from about 1690 to 1790 hardly any clocks, except lanterns, were constructed without them ; in fact, the calendar was regarded as far more important than the minute hand. To-day this appears almost incredible, but it must be remembered that 200 years ago no one had a train to catch, and the general public had no printed calendars or daily newspapers to refer to when they wished to date their letters.

The introduction of the minute hand, of course, brought with it minute divisions on the dial. In some cases we find every minute separately numbered round the dial, but this soon gave way to the practice of numbering every fifth minute. Many early makers made their minutes very large and clear, as illustrated in Plate XII., but these were soon followed by the minute figures being placed outside the divisions, as shown in Plate XIII. The size of the minute figures tended to grow, as will be seen

by examining a series of dials of different ages. A few makers in the middle of the eighteenth century even went so far as to make the minute figures as large as the hour figures, as shown in Plate XXI.

About 1700-10 we find most long case clocks fitted with dials similar to those illustrated in Plate XIII. These may be regarded as characteristic of this period, and are not only found on British clocks with marquetry cases, but also on clocks of Dutch origin. It will be noticed that an early maker's name is followed by the Latin word "*fecit*" (made it), and he usually engraved his name on the base plate below the circle. The centre is frosted, with little or no ornamentation with the exception of a Tudor rose in the middle. This was probably suggested by the alarm plates of the earlier lantern clocks (see Plate V.). Surrounding the circle will be noticed the ever-popular lily design. The corner ornaments have undergone certain elaboration. About this time hour-hands became very ornate, and many of the best makers developed some extremely intricate and beautiful designs. Some were not only elaborately pierced, but the surface was carved or bevelled in addition. Further examples of the hands of this period are given on p. 117. This period witnessed the introduction of turned circles round the winding holes. It was probably done for a dual purpose, partly for ornamentation, and partly because a frosted dial is so easily marked by the winding key. The herring-bone border was introduced about this time.

The plate-frame movement was, of course, thoroughly established for eight-day work. Outside locking plates were common, but many were constructed with inside locking plates and strike main wheel of seventy-eight

PLATE XIII.

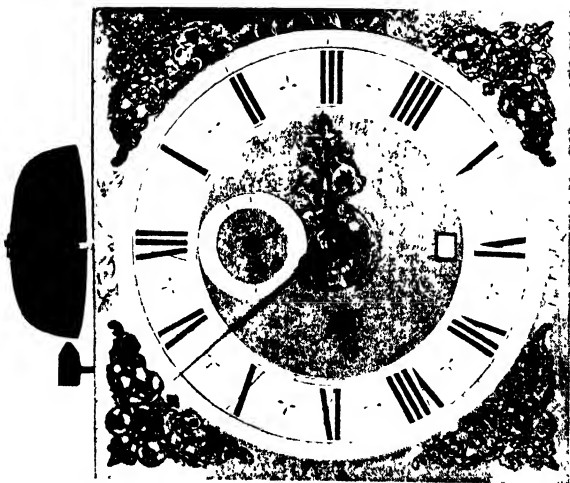

ELEVEN-INCH DIAL, BY EDWARD BIRD, LONDON,
ABOUT 1700.

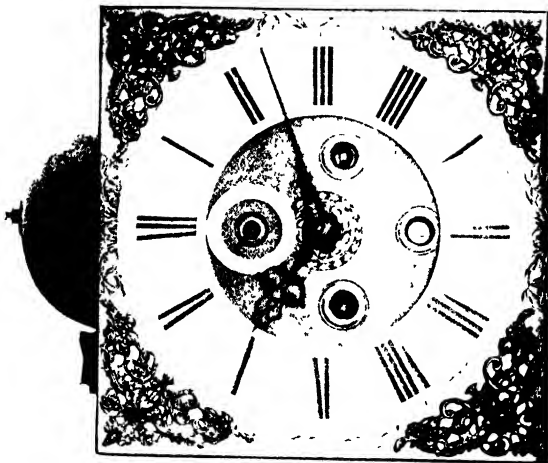

TEN-INCH DIAL, BY EDWARD COCKEY, WAR-
MINSTER. STYLE ABOUT 1710.

PLATE XIV.

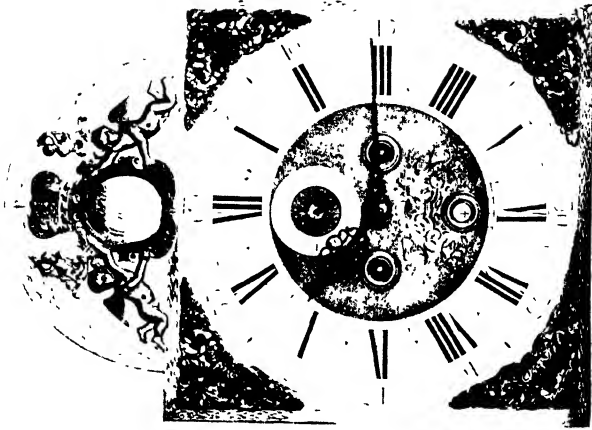

TWELVE-INCH ARCHED DIAL, BY GEO.
MAYNARD, LONDON. ABOUT 1715

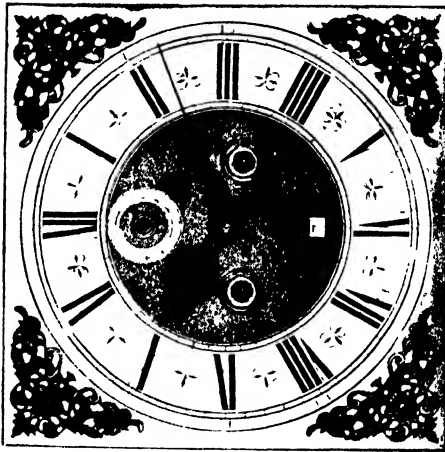

ELEVEN-INCH DIAL, BY WM. CARTER,
CAMBRIDGE. ABOUT 1715

To face page 95.

PLATE XV.

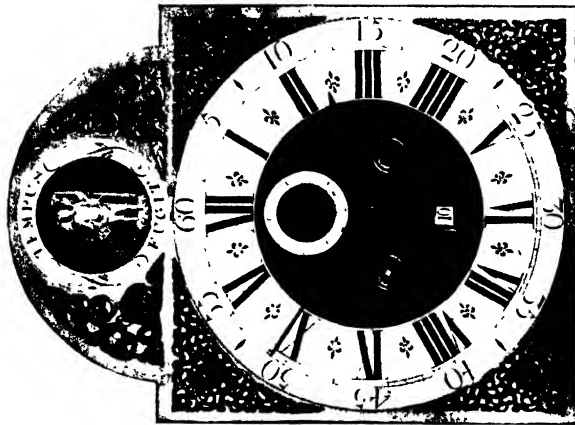

(b)
TWIV-F-INCH ARCHT'D DIAL. (ANONYMOUS.)

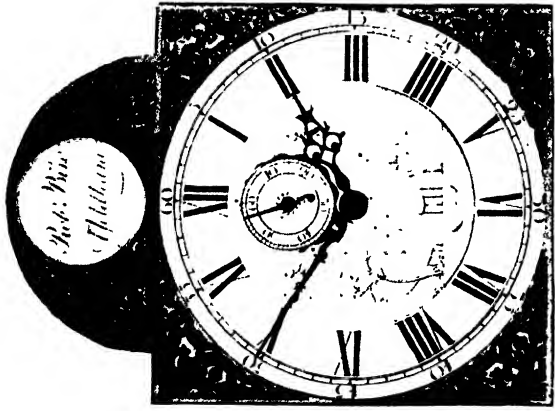

(a)
9½-INCH LANDSCAPE DIAL. ROBERT BIRD,
YFIDHAM.

[To face page 95.

teeth. The earlier clocks with rack-striking mechanism had the rack placed inside the movement. The upper pinions in the trains were made with six or seven leaves only, the fly pinions being small and light for high speeds. For train numbers, see p. 155.

About 1715 we find the arched top added to the dial. It was probably suggested by some one making a long case to accommodate a lantern clock without hiding the fret above the dial, for we meet with such clocks occasionally. For many years the arch was used merely for appearance and not put to any useful purpose. With the introduction of the arch, we find flower or scroll engraving on the dial base just outside the circle disappearing. Additional ornamentation on a very restricted scale appeared in the centre, but makers omitted the Tudor rose. Owing to the state of politics at the time, it was probably considered that the presence of a Tudor rose might seriously restrict the market for the clock. The former types of corner ornaments disappeared, and fresh designs came on the market. For the arch, the domed name-plate and dolphin ornaments shown in Plate XXI. had a very long run of popularity, but arch ornaments matching those in the corners are by no means uncommon, as shown in Plate XV. (a), which is only one of many examples.

A certain number of makers adopted the arch ornament shown in Plate XIV., using the centre space as a name-plate, or engraving a face upon it. Some of these ornaments have a smaller crown at the top.

No very striking changes in dials or movements took place between 1710 and 1730. Many new designs of corner ornaments were produced, but the dial centres remained much the same. Hands became standardised

in design, but varied in proportions, as will be noticed from Plates XXXI. and XXXII. Cases, on the other hand, underwent a good deal of change not only in material and style of finish, but also in the design of the hood. In some examples the hood followed the contour of the arch dial fairly closely, as in Plate XXII., but others carried a more or less elaborate superstructure. The latter appear to have been suggested by the tops of bracket clocks made twenty or thirty years previously and illustrated in Plates XXV. and XXVII. Such adapted designs were for the most part quite good, especially in England. By about 1730 we find the arch being used for some mechanical contrivance such as a strike silent hand; this was soon followed by various forms of automata such as a swinging figure of Father Time (Plate XV.), a ship in full sail (Plate XXIV.), or some mechanism for showing the phases of the moon (Plate XVII.). Other changes in the dial are noticeable. The corner ornaments became distinctly degenerate, not only as regards design, but also in workmanship, as will be seen from Plate XV. (b). The quarter hour divisions on the circle were omitted, the hour hand was made longer, and of less pleasing design. By 1730 most of the movements had outside racks, but the tail of the gathering pallet had not come into general use. During the period under consideration we find that clockmaking outside London and Edinburgh was becoming a very important industry, especially in Lancashire, a county which for many years held a high reputation not only for clocks but for all sorts of clockmaker's tools. Even to-day one frequently sees certain tools in catalogues described as *Lancashire pattern*. While London clocks were degenerating, the Lancashire men were rapidly improving, and so far as

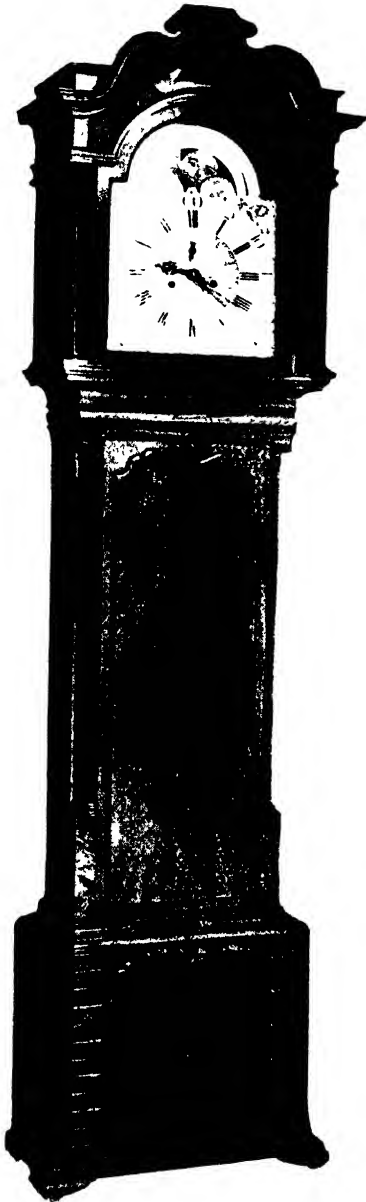
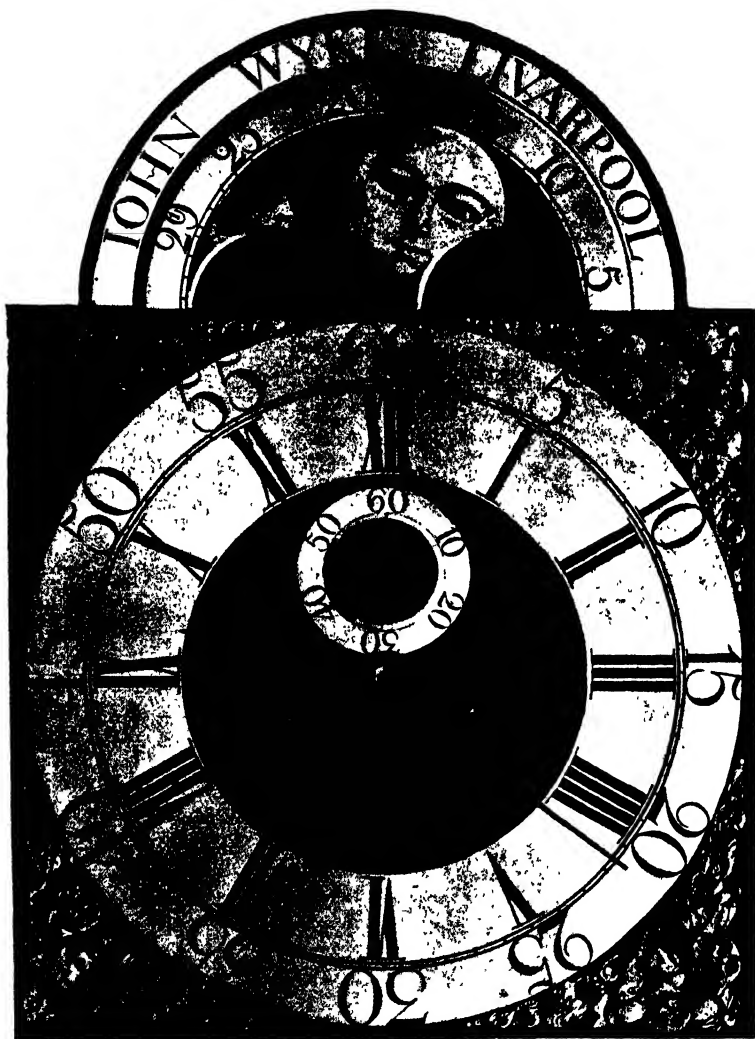

PLATE XVI.

MAHOGANY-CASED CLOCK, BY
JOHN WYKE, LIVERPOOL.

[To face page 97.]

PLATE XVII.



THIRTYEN-INCH DIAL, BY JOHN WYKE, LIVERPOOL.

{To face page 97



PLATE XVIII.
LANCASHIRE OAK CASE.

[To face page 97.]

mahogany cased clocks were concerned the north countrymen frequently excelled the Londoners in their products.

Plates XVI. and XVII. show a mahogany clock and dial by John Wyke, Liverpool. The case is one typical of the district, though many were also made with double columns at each side of the hood. The general outline of the hood is typical of the mahogany ones of the district and should be carefully noted. The base of the case is somewhat unusual, but by no means unique, since many were made so in Lancashire and Cheshire. Probably one of the most remarkable features about this case is the immense amount of detail in all the mouldings.

In the old London-made clocks we frequently find fretwork openings backed with silk to allow the sound of the bell to escape, and afford some touch of ornamentation. Some Lancashire men followed their example, and subsequently developed the practice of introducing pieces of glass into their hoods and ornamenting them with some gold design on a dark blue background. In this clock by John Wyke, the ornamental glass has been damaged and painted over. The somewhat elaborate platform between the horns of the hood is peculiar to the district. In many cases this platform was surmounted by a large fluted ball and spike of wood. The dial is a very fine example of Lancashire work, but the second hand is not original.

Probably in no district did the oak case attain such a high standard of perfection as in the north-west counties of England. A typical example is shown in Plate XVIII. Like many others made in this district, the case is provided with bands of mahogany round the door and the panel of the plinth. A certain amount is incorporated

in the hood and elsewhere. The design of the case throughout shows that the northern maker had a good eye for proportions. The lines of the hood bear a great contrast to those made in some other parts of the country at this period and which were surmounted by a somewhat heavy looking superstructure, especially in Scotland. They compare very favourably with the crudely jagged tops so frequent in other districts.

The north countryman displayed more enterprise and imagination than his London contemporary as regards dial making. While the Londoner was getting slack and disinterested in brass dials, the Lancashire men were developing new designs and turning out first-class workmanship. They frequently adopted London types of corner ornament, as will be noticed in Plate XIX. (a). In fact, this dial was probably made twenty-five years after this particular corner ornament disappeared from London workshops. Very soon they developed new designs, just as men in other districts did. After 1720 we find not only a great sameness about the centres of London dials, but many of the corner ornaments, if not actually degenerate, were poor in quality, being spoilt by fins appearing in the open work and by sand marks on the surface. On the other hand, the north countryman almost invariably filed away all rags and fins produced in casting and took care that their ornaments had good surfaces, free from sand marks, before they attached them to dials.

Some of the dial ornaments found on old clocks are illustrated by Cescinski and Webster, but a complete catalogue has never been published. In the case of the very earliest corner ornaments it is easy to arrange them in chronological order, but later on great complications

PLATE XIX.

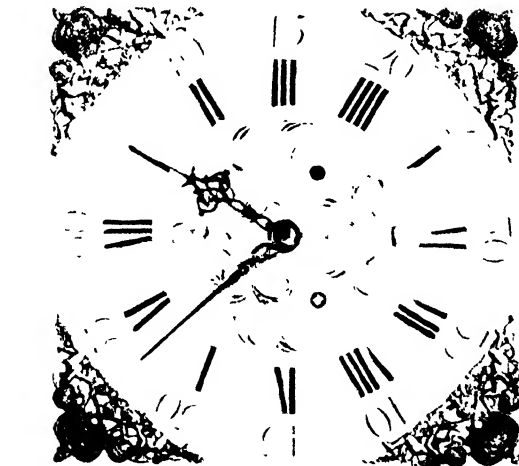

a.
TWELVE-INCH FROSTED AND ENGRAVED DIAL BY
F. KNOWLES, BOSTON.

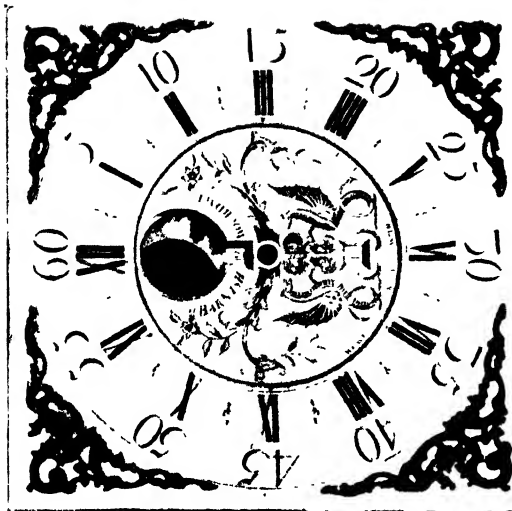

b.
THIRTEEN-INCH HERALDIC DIAL BARNISH,
ROCHDALE.

PLATE XX.

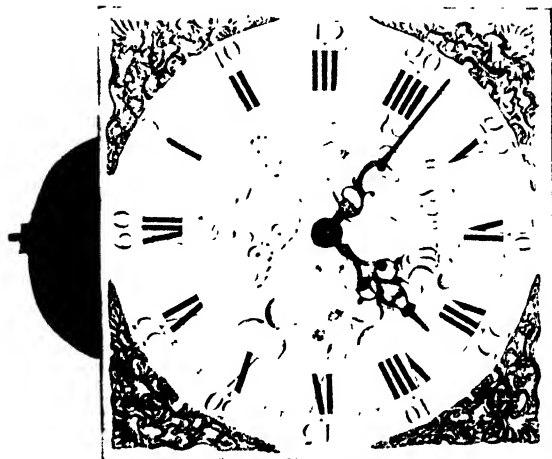

1st
TEN-INCH "IVARI" DIAL. WM KENT,
WAIDEN.

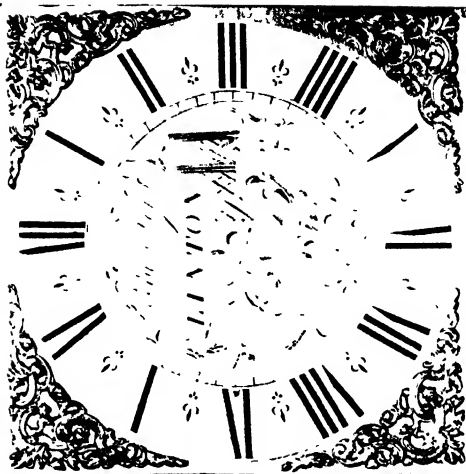

2^d
TEN-INCH "NANKIN" DIAL. EDW. SAMM,
LINTON.

arise. We have already seen that long after London makers had discarded some of the better designs, provincial makers were adopting them. The whole subject requires very careful tabulation and analysis, and perhaps some one will undertake this work. One is inclined to regard the set of cast corners representing the seasons of the year as comparatively recent, since we find it on dials from 1750 onwards. It will be observed that the engraved corners of the dial shown in Plate XXIV. (a) are of this type. On the other hand, this design is really an old one, for it is found on a sixteenth century stone dial in Exeter and on the Stuart clock illustrated in Plate VI. Sometimes makers attached engraved corner ornaments to their dials, especially in Scotland.

Provincial makers and north countrymen in particular did much to relieve the monotony of the frosted dial centre. It is probable that they did far more in this respect than the London men. In the neighbourhood of London we find that engraved centres were chiefly ornamented with rather conventional scroll designs. In fact, many engravers appear to have been incapable of producing any new ideas in this respect. Among provincial makers we find attempts to break away from standard forms. Thus, in the centre of the dial by William Kent of Walden (Saffron Walden, Essex) (Plate XX.), we find foliage, birds and butterflies. Not only this, but part of the engraving is filled with red wax, with a rather good effect. It is evident that a piece of Imari china suggested the design and red waxing. The bird and butterflies are very similar to those found on Oriental china from Japan.

The dial by Edward Samm, Linton (near Cambridge) (Plate XX.), is another example of an attempt to adapt

an Oriental design, but with a very poor result. The engraver appears to have realised that it might not be recognised as a Nankin design, so has inserted a diminutive Chinaman between the centre and "four o'clock."

The dial by Barnish of Rochdale (Plate XIX. *(b)*) has an heraldic design engraved in the centre; this was probably done to order, since it represents the arms of a Prime Bailiff of the Weaver's Company. The circle of this dial has the minutes arranged in waves, a thing frequently seen in old watches, but not very often in clocks.

The dial already referred to in Plate XIX. *(a)*, is a splendid illustration of what can be done by a combination of frosting and engraving, and the dial shown in Plate XXI. (Alex. Rae) is another good example. Both Lancashire and Scottish makers frequently used sunk seconds, as shown in the Essex landscape dial illustrated in Plate XX. *(a)*, an admirable plan, which saved all risk of the second hand catching on the hour hand. In the case of the dial shown in Plate XXI. the silvered seconds circle is "inlaid" in the base plate.

In the southern counties of England we usually find quarter-hour divisions only for one hand clocks, but makers in the north very frequently divided the space between the hours into twelve spaces (five minutes each). Sometimes these divisions were near the inner edge of the circle and sometimes near the outer edge, where the minute divisions are usually placed.

A departure from the usual practice is frequently found in Lancashire and Cheshire dials, viz., the indication of the minutes on the circle by a series of round dots, at the same time omitting the two lines one usually associates with minute divisions. London makers, apparently, only applied moon discs to arched dials, but provincial

PLATE XXI

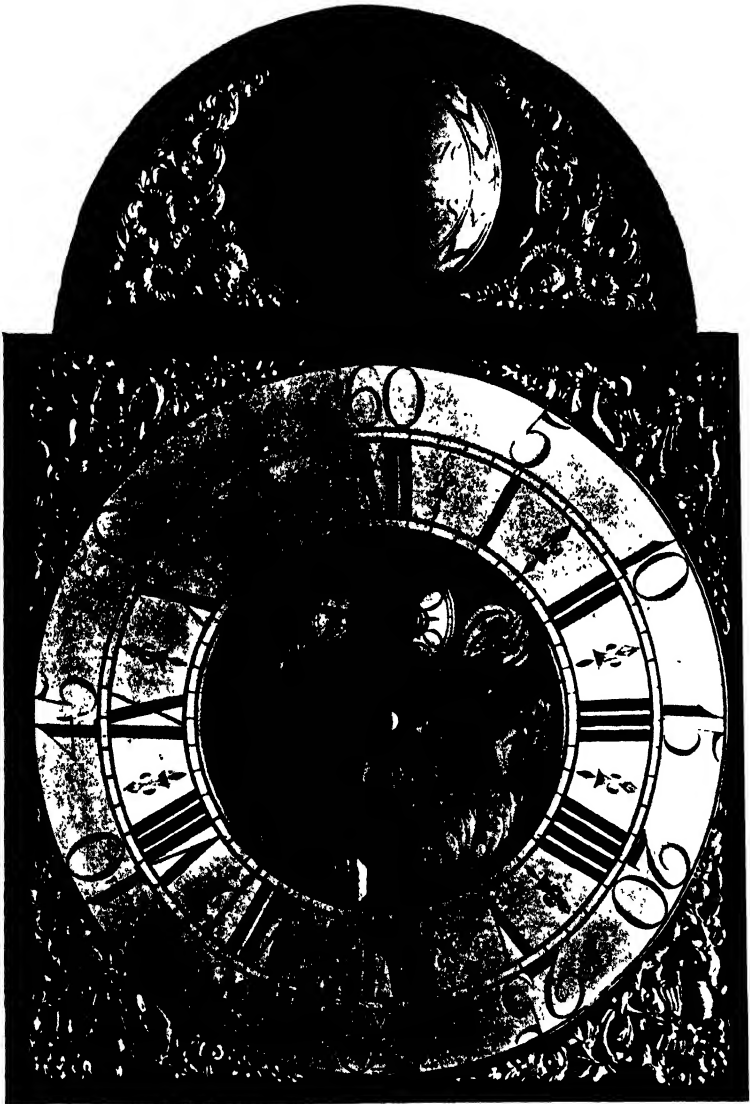

TWELVE-INCH DIAL, FROSTED AND ENGRAVED CENTRE AND BAGPIPE CORNERS. ALEX^r. RAY, DUMFRIES. ABOUT 1760.



PLATE XXII.
WALNUT-CASED CLOCK, BY
JOHN BROWN, LEVERPOOL.

PLATE XXIII.

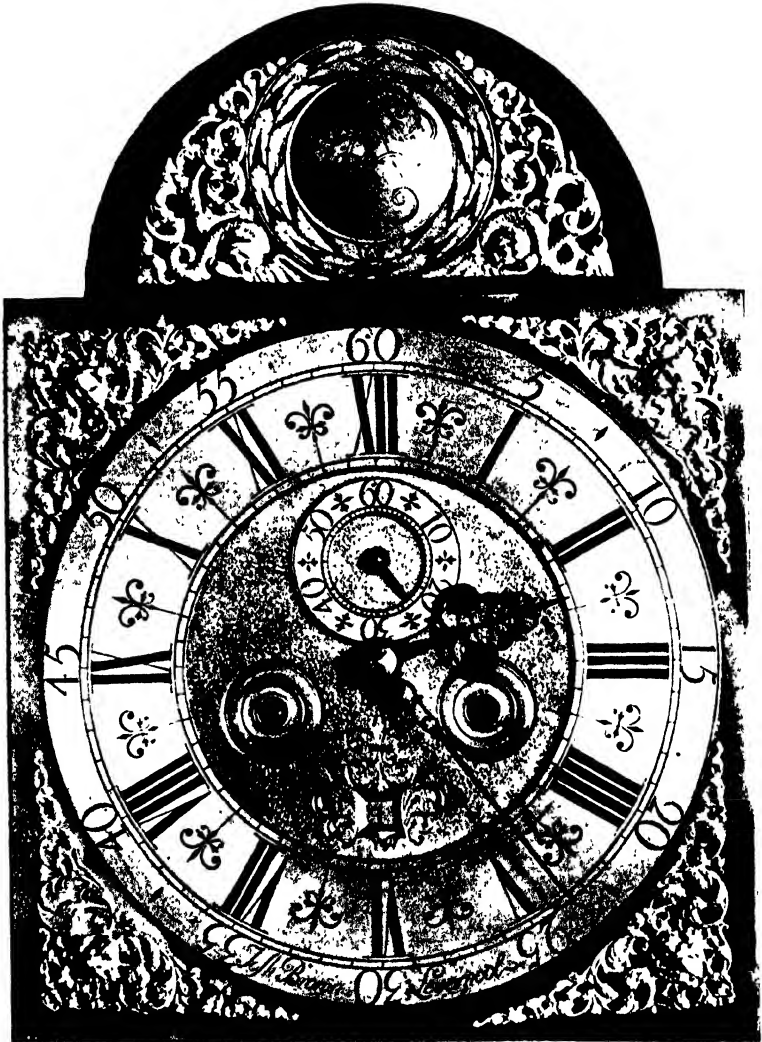

TWELVE-INCH DIAL, BY JOHN BROWN, LEVERPOOL.

{To face page 101.

makers frequently applied them to square dials. Frequently this was done by means of a circular opening as shown in Plate XIX. (*b*), but an opening of shape similar to that in the arch was also quite common.

Although two hand eight-day clocks were made in large numbers before the end of the seventeenth century, it is remarkable that the making of thirty-hour and one hand clocks should have persisted for so many years. The addition of the minute hand could not have materially added to the cost. Certainly many of the thirty-hour clocks were somewhat roughly made, but many others were of really high-class construction, showing that the maker would not have had the slightest difficulty in producing a first-class eight-day movement. At the same time they very frequently provided sham winding holes and squares. Plates XXII. and XXIII. represent a splendid example of this by John Brown of Liverpool. The case is of most exquisite walnut, and the dial and hands and movement are all of high-class workmanship, and yet it was constructed to go thirty hours only.

Returning to London-made clocks, they may be divided into several more or less definite periods, the Ebony and Walnut period, the Marquetry period, the Lacquer period and the Mahogany period. It must be distinctly understood, however, that not only did each period overlap those on either side of it, but it must be recognised that country makers were usually very slow in adopting the prevailing London fashion. This is borne out in the movements, dials and cases.

Another influence which must be considered is the facility for obtaining certain kinds of material and labour in various districts. Mahogany, being an imported wood, was more readily obtainable in towns like

London and Liverpool, and other districts relied chiefly on home-grown woods, such as oak and walnut. The first lacquer cases were coated in China, being sent out there for that purpose. London workmen copied them and after a time achieved a certain amount of success, but provincial attempts were naturally poor, owing to the absence of men who had become more or less skilled in the art through prolonged practice.

About 1750 a marked change in fashion occurred and gradually spread through the country districts, namely, the introduction of a dial composed of a single plate of brass, engraved and silvered as shown in Plate XXIV. (a). This change was probably not absolutely abrupt. From Plate XXIV. (b), which shows an $8\frac{3}{4}$ -inch square dial by G. Gibson, of Thetford,* we see that some makers were engraving the corners of their dials. Others were engraving their arches, so it is not to be wondered at that the raised circle was regarded as unnecessary. It had long been known that silver-washed surfaces form an ideal background for engraving; in fact, the Stuart clock shown in Plate VI. was silvered. These dials certainly possess one advantage, viz., the ease with which any one with poor eyesight can see the time. With the introduction of this type of dial came a very much more elaborate minute and second hand, probably with a view to making them match. In Plate XXIV. (a), it will be seen that although all three hands are comparatively simple they are of the same design. This type of dial did not persist for many years before the majority of the new clocks had painted

* It is difficult to date this dial. Edward East engraved the corners of his dials in 1665. The engraving in the centre and between the chapters suggest the reign of Queen Anne. The dial evidently had two movements before the writer bought it, without one, thirty years ago. It was apparently made in a small town in Norfolk, so is not particularly old.

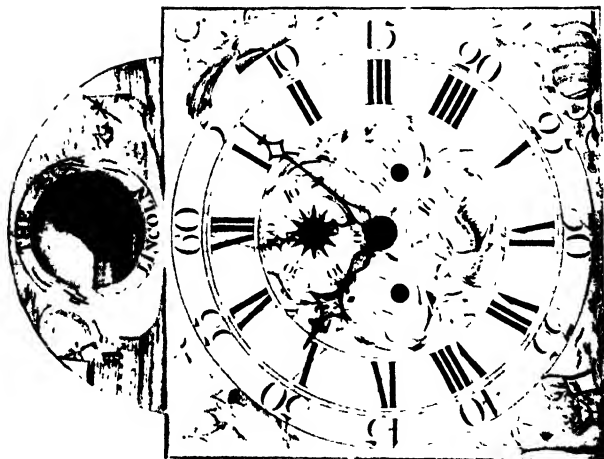

(a)

TWENTY-FIVE-INCH ENGRAVED AND SILVERED DIAL.
JOHN HOIDEN, LINCOLN (?).

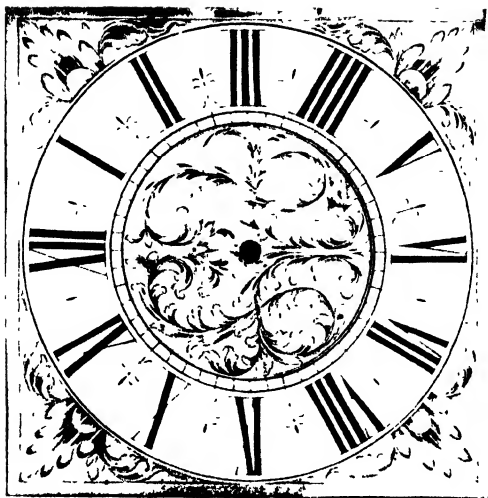

(b)

EIGHT-INCH DIAL, BY GIBSON, THETFORD.

iron dials fitted. Cheapness probably influenced makers to adopt the painted dial, but fashion also demanded it. Mr. Prichard has in his possession a fine, old chiming bracket clock with brass basket top and dating from about 1698. Until a few years ago this clock had a white painted dial and brass hands. Investigation showed that the old brass dial-base still existed behind the painted one, but the figure ring, corner ornaments, and old hands had been scrapped. Needless to say, the dial has been restored.

It very soon became apparent that the usual dial feet were unsatisfactory for painted dials, since the paint became chipped round the rivet heads if the clock received a jar in transit. This difficulty was obviated by introducing a stiff iron plate between the dial and movement, which enabled very short feet to be riveted into the former.

With the white dial followed the invariable practice of placing the figures representing the age of the moon on the dial itself instead of sometimes on the dial and sometimes on the moon disc. For the calendar the fan-shaped opening showing a portion of a circular disc, and also a calendar hand and dial as used in the later brass dials, still survived. For a time steel hands remained general, but brass hands were popular for the later movements. Some of the brass hands were extremely well designed and finished with the utmost care, but the majority were comparatively rough stampings produced in shearing dies, the sheared surfaces receiving no subsequent cleaning up or polishing.

Many of the earlier cases used for movements with white dials were of excellent design and of splendid workmanship. So good are many of these old cases that during the last twenty-five years antique furniture

dealers all over the country have been buying them and having either old or new brass dials fitted to them. Provided this change is carried out by a man who knows his job the fraud is almost impossible to detect, but in nine cases out of ten the change is plain to be seen by any one who has made a study of old clocks.

By the end of the eighteenth century or the beginning of the nineteenth century artistic clockmaking was nearly extinct in this country. Common looking dials, poor hands and appalling cases became the rule rather than the exception. Probably the worst proportioned cases came from Yorkshire, where there was a demand for something massive. Even the antique and modern furniture dealer, who will buy almost anything at a sale, is reluctant to give more than a few shillings for such atrocities.

Those with an inquiring mind will ask the reason for clocks and cases degenerating, why men departed from the beautiful and adopted the hideous. A possible explanation may be found in the last of a series of articles by Mr. E. Guy Dawber which appeared in the *Architectural Review* of June, 1899. According to Mr. Dawber architects frequently designed furniture for their clients, and he goes on to point out that some of the features of degenerate clocks which he illustrates could only come from a man with an architect's training. On the other hand the writer is informed by Dr. Cranage of Cambridge, an acknowledged authority on art and architecture, that there is not the slightest suggestion of an architect's pencil about the beautiful cases made late in the seventeenth and early in the eighteenth centuries. One very naturally concludes that architects may have been responsible for the degeneracy. If this is so, protect us from architects !

PLATE XXV.

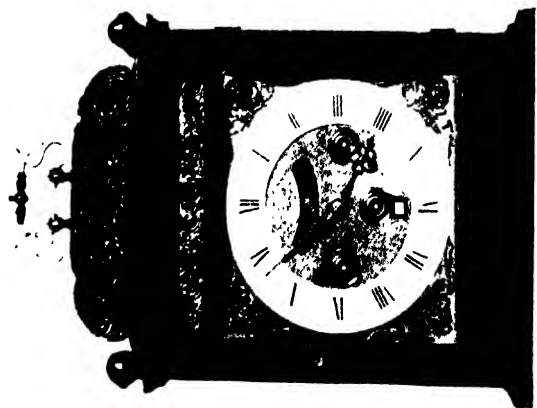

a
PETER GUPEIN, LONDON, ABOUT 1722.

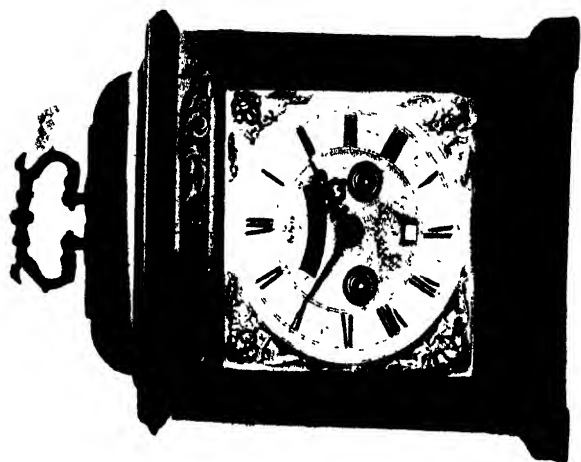

b
CHARLES GREGGION, LONDON, ABOUT 1695.

BRACKET CLOCKS

CESCINSKI and Webster, in their great work on English domestic clocks, have traced the evolution of bracket clocks in considerable detail. Without going into great detail, however, it may be said that the cases of the very earliest bracket clocks bore a close resemblance to the hoods of long case clocks. The dials were square, and at a very early stage the tops of the cases usually flat. By about 1690 we find bracket clocks being made in comparatively large numbers. The case was usually extraordinarily well proportioned and simple in character, sometimes of oak veneered with walnut, but more frequently ebonised, *i.e.*, stained jet black and then polished. It is said that pear wood is the best home-grown wood for this style of finish. Surmounting the top was either a pierced and embossed brass basket or a plain simple wooden top of the same shape. These tops are illustrated in Plate XXV. These pierced and embossed basket tops were very frequently almost identical in design, in fact, a few years ago a set of old dies for making them was sold in London. A few makers, however, departed from standard patterns. In the Wetherfield collection are some beautiful examples of bracket clocks with pierced silver tops and tortoise-shell veneer. Some of the early clocks with basket-shaped tops of wood had the latter ornamented by a pierced and engraved brass plate of splendid design. The chief characteristic of the early examples, so far as the movement is concerned, is the great amount of labour expended in making it beautiful.

The back plates were beautifully engraved by men of extraordinary skill and taste. The lily pattern was the favourite at this period, though after 1700 it practically disappeared. The characteristics of the various parts composing the movement are dealt with in another part of this volume. The introduction of the arch for dials of long case clocks naturally led to a similar change in bracket clocks. The case assumed the form shown in Plate XXVII. (a), and hundreds were made in this style up to about 1760. As time went on, the style of engraving degenerated, becoming latterly a series of more or less meaningless scrolls, before it finally disappeared in the reign of George III. It is worthy of notice, however, that about 1750 or so we find the "basket of flowers" design on back plates, on dial centres of long case clocks, and in the form of carving on furniture. A feature of the early bracket clocks was an elaborate fret attached to the back cock which supported the knife-edge pivot of the verge. This gradually degenerated, at first by making them simpler, then by using a smaller plate engraved but not pierced, and finally even engraving disappeared.

Some makers had exclusive designs of their own, but about 1700 many used the design illustrated in Plate XXVI. (b). This design was so popular that it was adapted as a fret for lantern clocks used in East Anglia (Plate VII.) during the earlier part of the eighteenth century. As a fret the design was inverted. See also the side frets of the Friesland clock (Plates VIII. and IX.).

Practically all bracket clocks with brass dials were fitted with mock pendulums which swung behind a slit in the dial. They were intended to give "life" to the clock. When an anchor escapement and a pendulum which

PLATE XXVI.

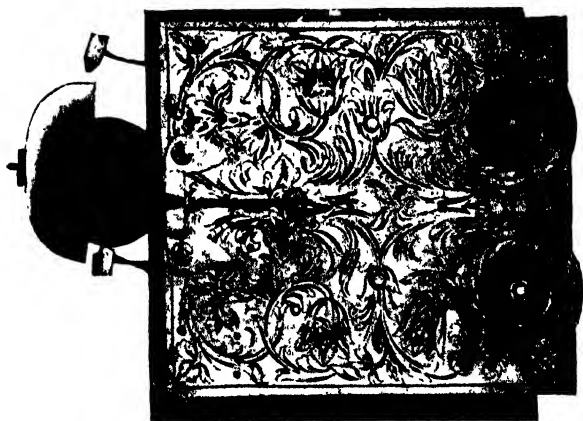

(a)
BACK PLATE, BY CHARLES GREGGON.

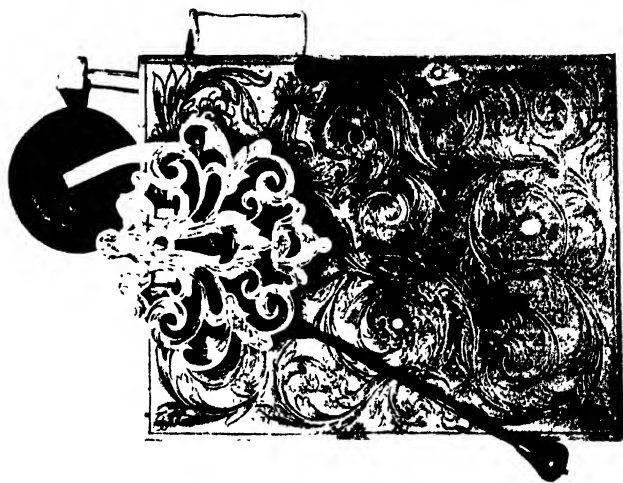

(b)
POPULAR DESIGN OF BACK COCK.

To face page 106.

PLATE XXVII.

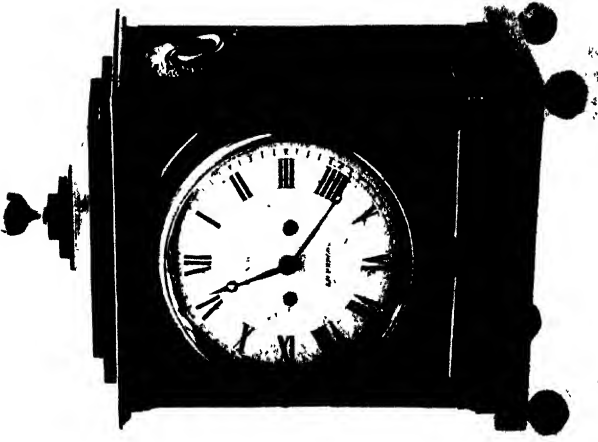

16
CONDIE, LIVERPOOL, ABOUT 1825.

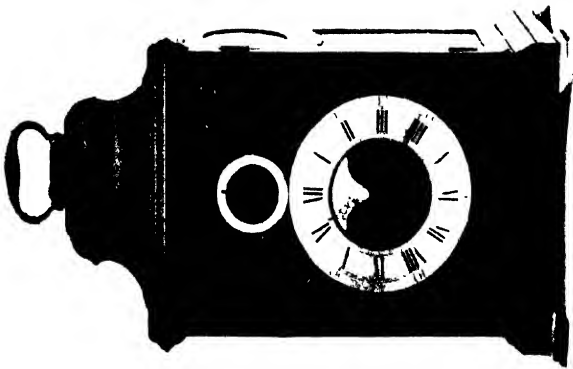

17
THOS. WRIGHT, LONDON, ABOUT 1775.

To face page 100.

PLATE XXVIII.



BACK PLATE, BY THOS. WRIGHT. ABOUT 1775.

[To face page 106.]

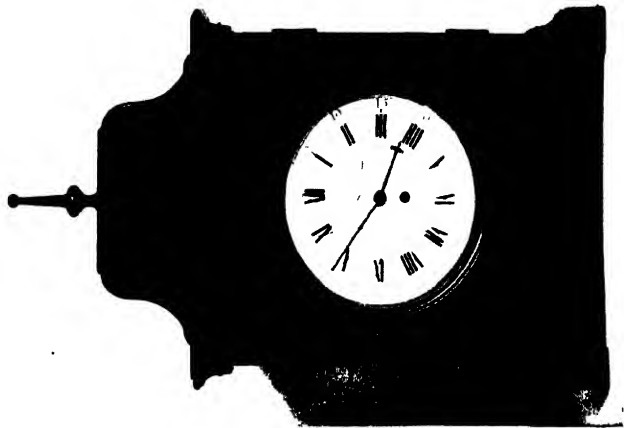

(b)

BRACKET CLOCK WITH 4-INCH SILVERED DIAL,
BY CLARKE, WHITEHALL. ABOUT 1770.

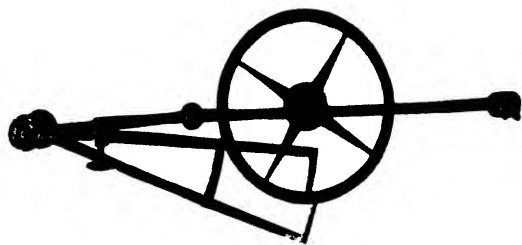

(a)

OLD PIN-WHEEL ESCAPMENT.

describes a small arc are fitted to such clocks the mock pendulum has a very poor and lifeless action, in fact it was not infrequently taken out and scrapped.

In the reign of George III., or even earlier, we find the top of the case arched to correspond with the contour of the dial, and later on, after the introduction of the round white dial, the balloon top, the lancet top, etc., were developed. Plate XXVII. (*b*) shows what might almost be described as the latest form of bracket clock made.

One cannot help admiring the early productions ; they were simple and artistic. Designers in the last 100 years have turned their attention to clock cases, but have entirely failed to equal the old work. If one examines a number of designs of modern cases in a clock shop or illustrated catalogue, one cannot help feeling that the authors of such must have been either monumental masons or cemetery keepers. The same could never be said of the old designers. On some of the cases made about the middle of the eighteenth century we find a good deal of ornamentation in the form of brass castings pinned on to the surface, and however successful such touches were in the earlier days, it will be generally admitted that it was very much overdone at one stage. The same applies to many of the elaborate chiming bracket clocks of to-day. They look overdressed, and suggest that they are designed to attract the custom of the profiteer.

Towards the end of the eighteenth century a number of small time-pieces of British make came on the market. They were chiefly fitted with verge movements arranged to go for thirty hours. Plate XXIX. shows such a clock with silvered brass dial. Many of the movements were square or rectangular.

THE AGE OF A MOVEMENT

A QUESTION one is sometimes asked is, "How is it possible to distinguish an old clock from a new one, or old parts of a movement from new parts?" No definite answer can be given. The Scotsman when asked a question frequently replies by asking another. "How does one distinguish old furniture from new, old carving from new, old printing from new, old china from new?" The only possible answer to give to such questions is, "By experience based upon close observation." Every detail, almost without exception, has undergone some modification during the past 230 years, and if one has made a careful study of the matter, one can usually tell fairly well. Of course, if any man starts out with the idea of making an exact reproduction of an old movement, true in every detail, he can do so, but it would be a very costly job. Occasionally new dial plates are cast and hammered to pass as old ones, but the usual work on movements consists of such jobs as replacing all the old pinions, a few wheels and the pallets. In such cases no attempt is made to conceal the fact. Sometimes the trains of an old eight-day movement are replanted in a pair of new plates with a view to adapting them to an old brass dial. Frequently new plates are used in order that a chime may be added to an existing clock (see p. 128). Then again there are a few clockmakers who do a fair business in making up movements out of a mixture of old and new material to suit the requirements of dealers in old clocks. When the work is well done,

such a made-up movement can readily pass as an original one unless very carefully examined. The wheels of a given clock bear a striking resemblance to one another in colour, shape of teeth, width of rim, lack of sharpness due to frequent cleaning, style of crossing out, and other minor details. When a new wheel is inserted in an old clock the workman seldom copies the collet exactly if this also requires renewing. A collet of different pattern from the rest usually points to a new pinion if the wheel is original and *vice versa*. If, however, both wheel and pinion are old and the collet is new, it may simply point to the wheel having been moved to one side or the other to make it engage in a fresh portion of the pinion it drives if the latter is much worn. Possibly a good secondhand wheel or pinion has been inserted.

An old pair of plates is fairly easy to identify. They have a somewhat distinctive colour, since most of the modern rolled brass has a reddish tinge. Cast plates are seldom of absolutely uniform thickness, and occasionally the variation is considerable. Sand and other casting marks are fairly frequent, and many old makers did not polish the face nearest the dial. The holes for the front pivots of the barrel were usually drilled small and then drifted out to the right size. This hardened the metal and raised a burr which increased the bearing surface. These burrs, though common on old work, are never seen on new. An old clock will be found to have had most of its pivot holes bushed, but an occasional bush is to be found in new work when there had been an error in depthing. When old plates have been used for a made-up movement quite a number of traces of old holes, which have been filled up, can be detected if a careful examination is made. Very frequently, when old pillars are

transferred to new plates, there is not enough metal available for riveting, in which case they are secured by a washer and screw.

When estimating the age of a movement the striking mechanism should be examined carefully. This is dealt with on p. 68, etc. There are other characteristics, however. In the older eight-day movements the main wheels are slightly larger, the barrels sometimes longer and with very little flange. The ratchets have fewer teeth and rather shallow. The upper wheels of the trains, both going and striking, are usually smaller in early movements and have teeth of fine pitch. Early movements have pinions in the upper parts of the trains with fewer leaves. Thus six and seven-leaf pinions are used in older movements where the seven and eight-leaf pinions would be used for later work (see p. 155). On the other hand, the teeth of the motion work and calendar wheel are frequently much coarser in old work, the motion wheels generally having arms instead of being solid discs. Old snails are usually scribed with concentric circles. In many early movements the centre wheel was placed near the front pivot, instead of at the back. This was a good practice from the point of view of the cleaner, and for shifting it when the second pinion is worn. It necessitates slightly longer pillars, otherwise the centre wheel fouls the pin wheel. This can be avoided, however, by placing the centre and escape pinions a little to the right, just as we find them to the left of the movement in thirty-hour work.

The bridge of an old movement frequently had pointed tips instead of rectangular, and the pendulum cock was frequently rather light and had a very small bearing surface on the back plate. It was usually slightly

ornamented. Steady pins are almost always absent in old work. Even to-day one finds workmen who do not use the best method for applying steady pins. The piece should be set in the correct position, screwed and again tested. The pin hole is then drilled through both pieces at one operation and slightly tapered by means of a broach. The parts are then separated and the steady pin hole is then countersunk on the *contact* surface. The steady pin is tapered, rounded up and driven into the part. The operation of driving in is likely to cause a burr where the projecting end comes through, but as this burr or swelling is produced in the countersink, it does not prevent the flat faces from coming together. The hole in the plate then requires opening very slightly so that the steady pin is free to slide in, but is not loose.

Centre-seconds movements for long case clocks came in about 1750, and about the same time the centre calendar hand. Some makers adopted both on the same movement. In most centre-seconds movements we find the usual centre pinion planted just above the barrel, and an extra wheel similar to the minute wheel is fixed on to the displaced centre pinion like a canon wheel, so that it can slip when the hands are moved, and this drives the minute wheel. The objection to this plan is that unless the wheel cutting and depthing are done very accurately, the minute hand has a good deal of backlash. Some Scottish makers got over this by another method. The second pinion was made so long that it could project through a hole in the front plate and be pivoted into the bridge. Assuming it was an eight-leaf pinion, it would then drive a sixty-four or sixty tooth wheel keyed on behind the canon wheel, according to the number of leaves in the escape pinion. A clock so constructed has

an imperceptible amount of backlash in the minute hand. The minute hand of a centre-seconds clock should always be about a quarter of an inch longer than the seconds hand. This enables the former to be moved round rapidly when the clock is being set to time. The seconds hand should be carefully poised even if additional metal has to be added behind the counterpoise.

A further characteristic of early work is the extent to which makers used the process of brazing when making hammers and other parts of the striking mechanism, not to mention the attachment of collets to pinions. For the latter soft solder was introduced early in the eighteenth century, and about fifty years later almost all brazed work disappeared.

The shape of screw-heads has undergone a certain amount of change, as will be noted from Plate XXXV. The top row have all square or nearly square heads and were of brass when used for attaching dial ornaments and of iron when used in lantern clocks, etc. The early long case and bracket clocks, however, were frequently furnished with screws with parabolic or conical heads, as shown at the beginning of the second line. Many makers, however, adopted the simple cheese head, especially for less well-finished movements. Some makers used another type of head shown in the second line, consisting of a sphere resting on a flat circular base. The largest of these is from a Lancashire clock made about 1760. The later movements almost always had mushroom-headed screws of varying proportions, and these were followed by cheese-headed screws with domed tops. Most of the early makers formed V-shaped slits in their screw-heads, a bad practice compared with the slit of uniform width used to-day.

It will be noted that the screws of to-day have a sharper and deeper thread (see p. 11).

Pillars have undergone some change, but for the most part are not very useful in estimating age. Early movements as a rule had more than four, some old bracket clocks had as many as seven or eight. A spherical portion in the centre was usual and reinforced the pillar where the seat-board screw passed through. The thread did not extend right through the hole, because with the screwing tackle available, the screw and tap always varied in pitch (see p. 11). Some slight grooves were turned for ornament. For about fifty years the pillars were for the most part similar in all clocks, the grooves for ornamentation often being replaced by sharp fins. These pillars were very attractive in appearance, especially when bright and clean, but involved a good deal of work. By about 1760 makers had settled down to pillars free from ornamentation. About the same time a wire hook and nut for attaching the seat board became common practice in place of the straight screw passing through the pillars. With the introduction of the arch dial into bracket-clocks, we find movements secured to the case by means of holdfasts in the form of brass brackets. These were usually engraved. They do not appear to be any improvement upon the former method of using screws passing through the base of the case and into the pillars, and they are on the whole rather unsatisfactory. If a pair rise up from the floor of the case, and another pair steady the movement near the top, the system is fairly satisfactory. It was probably introduced with a view to keeping the movement clear of the base of the case, so that the tick would be less noisy. Prior to 1700 many makers did not use pins for attaching the

front plate, but used hooks engaging in slots in the pillar ends. They were possibly a relic of the wedges used for attaching the bars in lantern clocks. The studs upon which minute wheels, etc., ride, were at first riveted into the plates. Screwing replaced riveting quite early in the work of most makers, but a good number still adhered to the older method.

CLOCK HANDS

CLOCK hands form an interesting study, and it is very important from the point of view of the collector that either the original hands, or at least hands of the same period, should be on the clock. Nothing mars the appearance of an old clock more than a pair of hands quite out of keeping with the age and style of the dial, and the restorer should bear this in mind. Hands were frequently broken when the old clock was consigned to the stables or cellar a hundred years ago, and they were usually replaced by modern stampings, or any old ones available, irrespective of style or period. It is impossible to say definitely what design of hands should be on any particular dial, but when, to the trained eye, they appear to be entirely in keeping with the dial, few would venture to assert that they were not originals, except in very exceptional cases. For instance, some makers were known to favour particular designs irrespective of fashion. Marks on the motion work sometimes show that the hands have been changed.

By comparing the hands on a large number of authentic examples it is fairly easy to follow the sequence in London-made clocks, but the same does not apply to those of provincial make. In fact, so far as provincial clocks are concerned, the subject is confusing. Lancashire makers sometimes used steel hands of a design not found in the south and they sometimes even used brass hands on brass dials. These hands were castings and frequently made by sending to the foundry London-

made hands, possibly of very intricate design and perhaps made fifty years earlier, as patterns. Nos. 23, 28, 29, 47 and 48 are cast brass hands from Lancashire clocks. We find that the comparatively crude clocks made in the country late in the eighteenth century were frequently provided with hands of a simple and early type to save labour. No. 11 is an early type found on a high-class Liverpool dial dating from about 1750. Even in London we find a certain want of sequence before 1700. Certain makers about 1670 produced beautiful hands, whereas others, the majority, contented themselves with simpler forms. Where cost was no object, some makers would probably pay special attention to hands.

The earliest hands found on British-made clocks usually consisted of a more or less simple arrow-headed index, or had loops near their extremities. No. 2 is from a lantern clock, dating from about 1650, and No. 1 is from a long-case clock of about 1670. The next definite change we find taking place was the change of shape of the loops, and the development of relatively large ears or blobs as shown in No. 4. Almost immediately we find makers adding subsidiary loops, as will be seen from the illustrations. Many of these early types had oval bosses, and their appearance was further improved by bevelling either the edges or front surfaces.

By about 1695 we find the type of hands shown in Nos. 19, 21 and 24, appearing, and many first-class makers adopted these. They are clearly elaborations of their predecessors, and are very attractive. This type was immediately followed by another of extreme intricacy. From Nos. 25, 26, 27 and 30, it will be noticed that they bear a striking similarity to one another even in detail.

PLATE XXX.

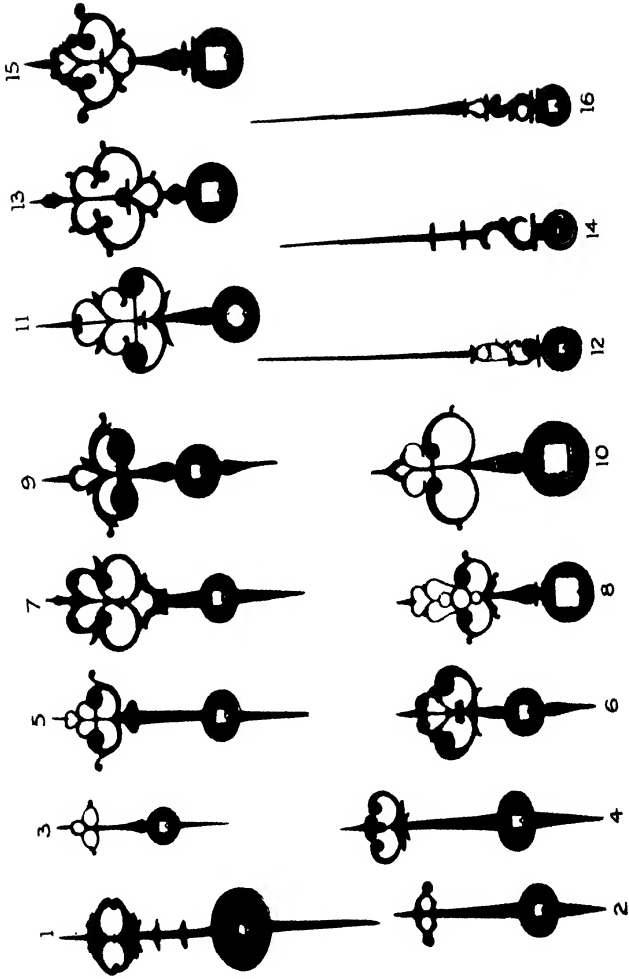

HANDS OF VARIOUS PERIODS.

[To face page 116.]

PLATE XXXI.

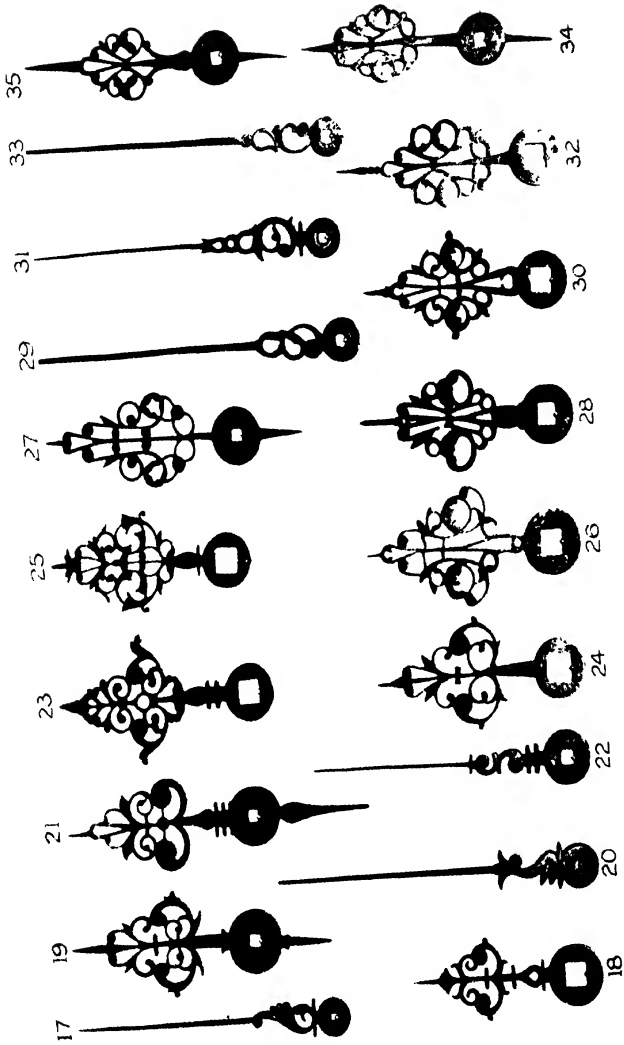

HANDS OF VARIOUS PERIODS

[To face page 110.]

PLATE XXXII

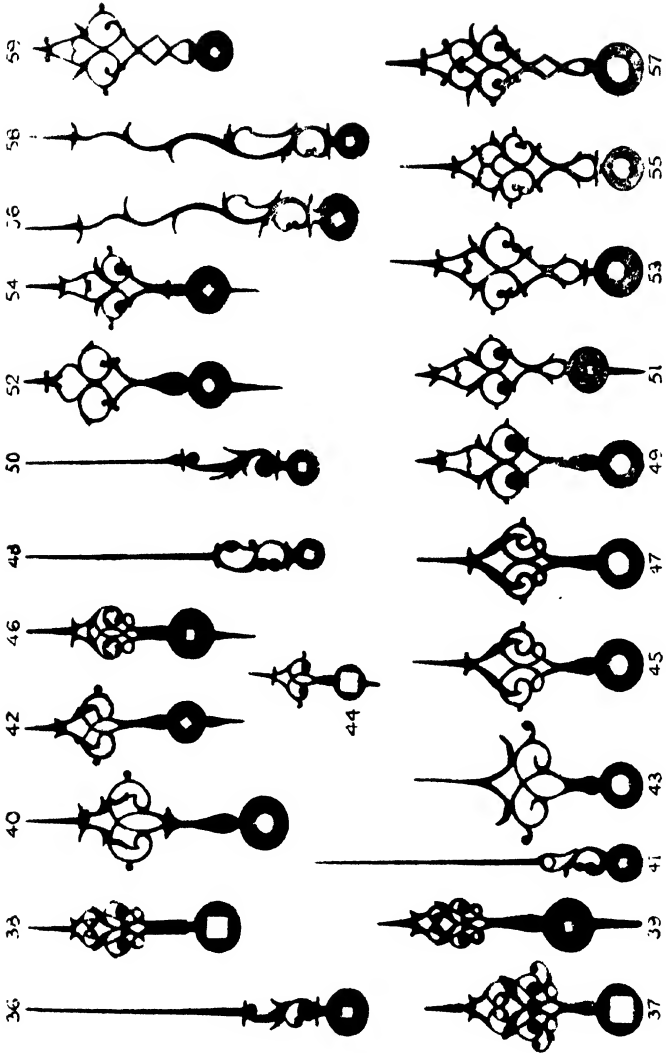

[To face page 116.]

PLATE XXXIII.

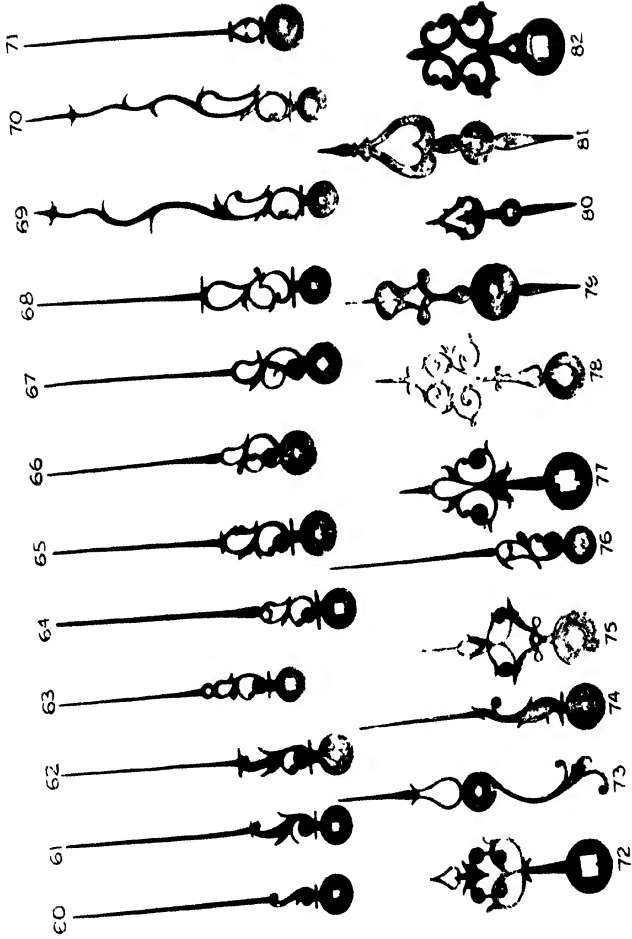

HANDS OF VARIOUS PITCHES.

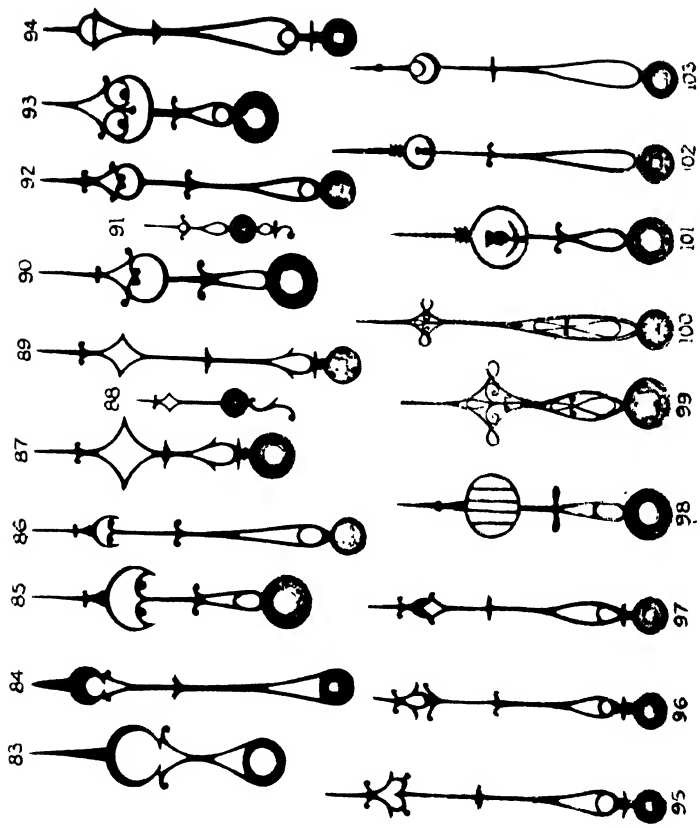

LANDS OF VARIOUS PERIODS.

[To face page 110.

A few makers enlarged the boss and also pierced it. It will be observed that when the very elaborate form was developed, the large ears or blobs were pierced in such a way as to represent incurved leaves like those found in Jacobean embroideries. These types of hand survived for about twenty years, but in the meantime other designs were introduced. At first sight Nos. 32 and 34 would appear to be new, but they are really nothing more than an oval form of their more or less heart-shaped predecessor. No. 37 is a new type, developed about the time Queen Anne came to the throne, and was almost the most popular design all over Britain for about eighty years. Unfortunately, however, many makers spoil it by making it much narrower, as shown in Nos. 38 and 39. By about 1720 we find a reaction setting in, and the disappearance of very elaborate forms. The cross-over loop type made its appearance, but some years seem to have elapsed before it took its final form. No. 43 is an early form, and Nos. 40, 42 and 44 were the standard forms which were used in large numbers all over the country till the end of the eighteenth century. Nos. 45 and 47 have not the cross-over loop, but are otherwise closely related.

In George II.'s reign we find another standard form developed. No. 49 is what might be described as the heavier type much favoured in country districts, and No. 53 the lighter type more confined to the larger centres of the industry. With the introduction of the latter type we find some makers favouring elaboration once more, as seen by Nos. 55, 57 and 59. Comparison of large numbers of hands of the type represented by Nos. 53 and 55, leads one to suppose that at this period hand making had already become a specialised trade,

since so many can be found which are exactly similar in size and form. In fact Thomas Hatton, who wrote in 1773, refers to the purchase of hands, and advocates the use of simple and cheap forms. It should be noted, however, that type No. 53 continued a favourite as long as hand-made hands were used. As a rule we find that all the earlier hour hands were "squared" on, but the later types had round holes in the boss to receive the hour-hand tube. It will be observed that for the one hand clock the spike behind the boss has been retained throughout, even though not required in conjunction with an alarm plate. The reason for this was that considerable effort was required to move the hour hand of a one hand clock, and the tip was comparatively weak and liable to hurt the finger applied to it. On the other hand the presence of the spike enables the thumb and finger to be applied in the same way that they are used to turn the key of a French clock. The later hour hands of two-hand clocks were generally of uniform thickness throughout their length. Changes have also taken place in the design of minute hands. The earliest consisted of a long fine index with a very slender S-shaped scroll near the boss, as seen in No. 60. This scroll gradually became more pronounced, and bevelling was used as a means of ornamentation as in No. 14. By 1690 we find designs of scroll as in Nos. 17 and 20. Towards the end of the reign of William III., and during the reign of Queen Anne, we find some makers using the crescent moon minute hand as seen in No. 31, but it soon went out of fashion, and the scroll became once more almost universal for more than half a century. Side shoots from the scrolls curled round in many cases to form loops, and later on the loops became much larger, as will be seen from the

series Nos. 60 to 68. Many makers, however, continued to use the comparatively simple scroll (No. 61) without loops, and, in consequence we cannot say, in most cases, whether a given clock should have a looped minute hand or not. All we can say is that makers fashioned their hands in such a way that a relatively slender hour hand was accompanied by a relatively slender minute hand, and that a heavy looking hour hand had associated with it a heavy looking minute hand.

Towards the middle of the eighteenth century, when hour hands of the No. 53 type were introduced, we find the scroll of the minute hand developed into several such large loops, that the original scroll is almost lost, as seen in No. 68. The loops then became longer, and the serpentine hand with side shoots at intervals all the way up (as in No. 69), was developed. It should be noted that original hands of this type show that considerable care was taken both in designing and finishing them.

Hands of the type numbered 40 and 53 are never found on clocks with the quarter hour divisions round the inside of the dial ring, save in very exceptional cases, and even then they were only used by makers in small towns or villages. They were then probably purchased from itinerant hand makers. The types of hand already dealt with probably include over 90 per cent. of those used up to the time when "hands to match" were introduced. It is not difficult to find exceptions, as will be seen from Nos. 72 to 82. Some are exclusive designs, and some represent local fashions. With the introduction of the plain silvered dial, and later the white painted dial, we find hands to match being introduced. The earlier examples of these were undoubtedly hand-made, and both the brass and steel ones show that considerable

pains were taken with them, as will be seen from Nos. 99 and 100. However, towards the close of the eighteenth century, we find the stamped hand coming to the fore. These were sufficiently well got up to satisfy the average person, but will not stand close inspection, since the sheared edges were never polished.

Seconds-hands have undergone very little change, and for about a century a single pointer without any counterpoise or piercing was practically universal. The counterpoise probably originated on regulators and became an absolute necessity on centre-seconds clocks. With the introduction of hands to match the seconds-hand was frequently of similar design, as shown in Nos. 88 and 91. A complete catalogue of clock hands has never been prepared, but a few examples of the hands-to-match types are given.

Repairers very frequently replace broken hands by modern stampings, overlooking the fact that they are reducing the value of the clock, in many cases enormously, by so doing. As a general rule, broken hands can be repaired quite easily by means of silver solder, the joint being both inconspicuous and very strong if the job is done properly. Soft solder is useless as it lacks strength and prevents bluing by heat. If facilities for silver soldering do not exist, the hands should be sent to a spectacle maker, who will make a good job of them. If the clock is a valuable one, and old hands of the correct style and period cannot be obtained, new ones should be made if the originals are missing. The best material for this purpose is cold-rolled mild steel. This has a bright surface and is rendered very stiff by the cold rolling, but is easily drilled and filed. Bluing by heat is preferable to blue lacquer, and by applying a little oil to the hot

surface, an excellent blue-black is obtained. The modern steel stamping is not a thing of beauty. It is easily recognised by several characteristics. It is uniform in thickness throughout its length, and is devoid of fine lines. The latter are due to the fact that the shearing dies used for stamping hands cannot be relied upon to leave very thin isthmuses of metal without producing an undue proportion of wasters. The shearing action of the dies produces a characteristic rounding of the front surface and a slight burr at the back. The edges have a sheared appearance, and the hands are usually coloured with a blue lacquer.

BRITISH CLOCKS FOR EXPORT (AND USE AT HOME)

FROM time to time good orders for clocks for use on foreign and colonial railways are placed in this country, but makers have never made serious efforts to comply with the requirements of the purchasers. It must be realised that railway clocks abroad (and at home) are almost invariably sent to headquarters for cleaning and repairs, and a thousand-mile railway journey, with much rough shunting, has to be faced every few years. One respect in which the British clock fails is the inefficient means of attaching the movement to the case. The movement should not be attached to the dial or false dial, but to a cheap iron casting such as the one illustrated in Plate XXXV. The back plate should be more than an inch wider than the front plate so that the screw heads are easily reached with a screwdriver. The casting should not be screwed to the case, but the case should be *screwed to the casting* by means of four or six countersunk 1 B.A. screws, tapped into the casting. In order that the beat of the clock may be adjusted by the native clockwinders who set them up, the impulse pins should be fixed eccentrically in small milled discs about the size of a sixpence, and these should then be attached, friction tight, to the crutches. By this means the beat is very easily adjusted without any risk of the crutch being twisted. In order to retain the market the maker, should devote his attention to reliability and avoid "eye-wash." In the past some clocks which were sent abroad never

PLATE XXXV.

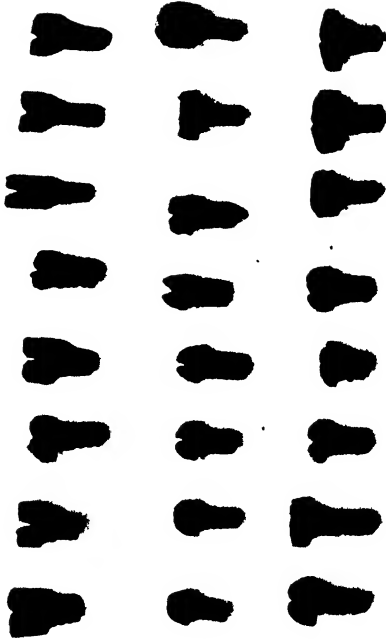
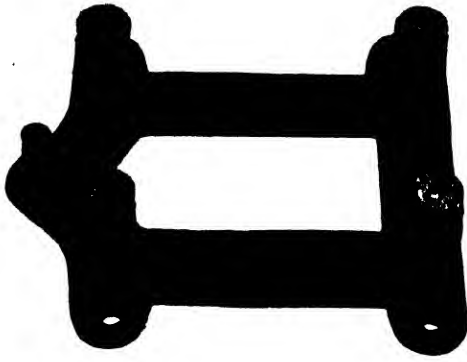

SCREWS OF VARIOUS PERIODS.

ATTACHMENT FOR DIAL MOVEMENT.

gave satisfaction. The movements became loose, the hands caught or rubbed the dials, the chains would not keep in place (see p. 67), the pinions had corded leaves, the pivots were bad, the depthing was very poor, the pallets were carelessly formed, and sometimes the pallet staff was bent. This sort of thing is not conducive to repeat orders.

The writer has some knowledge of the work done in the clock- and watch-repairing department of a large Colonial railway, and he is convinced that if the British Horological Institute were to issue designs and detailed specifications for three or four types of clock, they would confer a great benefit upon all concerned.

Watches with interchangeable parts are rapidly replacing others for railway purposes, and clocks with standardised parts would also be of immense advantage. The adoption of definite standard forms would assist the purchaser, the repairer, and the maker, and could not harm anyone.

RESTORATION AND REPAIRS

BEFORE entering into the question of restoration and repairs to clocks, a word of warning to owners may not be out of place. The best men in the trade are unanimous on one point, viz., that old British clocks, like old churches, never wear out. No expert repairer would ever suggest that an old movement is so bad that it should be replaced by a new one. Unfortunately the above statements have never reached the general public, and many fine masterpieces have been ruined by unscrupulous shopkeepers, who have recommended the replacement of original movements, subsequently selling the old one to a repairer, who makes it equal to new, and fits it into a case. Eight-day clocks are always worth repairing, but with one-hand thirty-hour clocks the circumstances are rather different. To take an extreme case let us consider a fine old lantern clock dating from, say, 1660, and therefore probably very much worn. Such a clock would probably require new pinions throughout, possibly other repairs, and what would be the result? In the writer's opinion the act of making such a clock go would result in robbing it of many of its old features and turn it into a commonplace piece of mechanism, a nuisance to wind every twelve or twenty-four hours, a noisy striker, and inconvenient for showing the time.* Many people have these beautiful old clocks gutted and cheap

* The old lantern clock reminds one of cases like Kirkstall Abbey. It is a fine old ruin, and very interesting to the antiquarian, but if roofed over the nave would be almost pitch dark in day time. This probably accounts for the fact that it has never undergone restoration.

German spring movements put in. This practice is about as reasonable as converting beautiful old historic buildings into picture palaces. The writer is of the opinion that the practice of gutting old lantern clocks and fitting eight-day movements will cease before long. In ever-increasing numbers people are realising that the genuine old lantern clock with its original movement is far more valuable than one which has had an eight-day movement fitted. The public is realising that an old clock, even hanging silent on the wall, is far preferable to a converted monstrosity placed on the mantelpiece, where it was never intended to stand. In the case of long-case clocks there is some excuse for conversion. Take, for instance, the clock illustrated in Plates XXII. and XXIII., which was originally a thirty-hour clock with sham winding squares. In this particular case, so far as the going train was concerned, a new barrel, main wheel and centre pinion sufficed to turn it into a first-class eight-day time-piece. Probably it was time the centre pinion was replaced in any case. It appears to the writer that the conversion of this clock was quite legitimate, since the general character of the clock was not impaired by the change, and the nuisance of winding every day was avoided; moreover, the movement did not possess any features of historical interest.

Regarding dials opinions differ. Many people when asked whether they want the brass dial and ornaments of their clocks cleaned say, "Oh no, we like to see it looking old." If the same people are asked whether they allow the old family silver to remain dirty or whether they have it cleaned they will say, "Of course it must be clean." The tendency to-day, however, is for the public to become more educated. They realise that

the true beauties of an old clock case and dial are only really visible if they are both freed from dirt, repaired, and intelligently polished. When the average owner feels uneasy it is probably due either to the feeling that his dial, when cleaned, will be rendered hideous by a nasty orange lacquer, or the fear that the dial may appear too bright in comparison with a somewhat dingy lacquer case. The intelligent repairer will always be able to get over these troubles. To-day very good transparent and colourless lacquers of extraordinary durability are obtainable. A good man with such a lacquer can retain all the beauties of freshly polished brass as regards colour. Then again he can control the brightness of his dial to blend well with a case which it is not possible or proper to polish to any great extent (see p. 132). Sometimes parts of dials, such as the cast ornaments, are missing and require replacement. Many men in the past seized the first set of corners they could lay their hands on and attached them without any further thought. It is obviously desirable that a dial should be restored with a set of corners similar to those the original maker put on. As a rule this is fairly easy. The general character of the dial, case and movement gives one a good idea of the type of corner to expect. It is then only necessary to try several corners of different patterns, but of about the same period, and if one is found with screw holes corresponding to those on the dial the selection is probably correct. If the dial is very dirty, this test should be carried out before it is cleaned, to ascertain whether the unevenness of the dirt or corrosion of the surface of the metal corresponds with the pattern of the corner ornaments.

As regards hands the same doctrine applies. Hands

of the correct period should be on the clock even if they have to be specially made. Not infrequently repairers replace both hands by a pair of modern stampings, in style 100 years and in workmanship 200 years later than the clock. Many delicate old hands were broken and sometimes clumsily soft soldered. It is a simple business to silver solder them, and failing the proper appliances for the work, they are best sent to a man accustomed to brazing spectacle frames. When brazed or silver soldered they should be blued by heat. It is a good plan to wipe them over with oil while still hot as the oil checks the tendency to rust and at the same time turns the blue into a good blue black (see p. 120). If the calendar circle is missing, special care should be taken that the engraving of the new one is in accordance with the style of the dial. By giving the engraver rubbings of the minute figures he ought to be able to produce a correctly engraved circle. Wheels for driving the calendar are sometimes removed, since they are suspected of causing the clock to stop. Whether this was so or not we need not consider, but obviously the calendar circle should move very easily. In fact, if the minute wheel is removed, it will be found that the weight of the hour hand alone as it falls from I to VI is more than sufficient to move the circle, if all the adjustments are correct. If the studs for the rollers are broken off or very high up, it is a good thing to plant new ones in the best possible position, viz., one at half past six, one at four o'clock, and the third at eleven o'clock. If the rollers are at half past three and half past eight, the circle wedges them tightly against their studs and they do not move freely. Some people have difficulty in detecting a new brass dial which has been fitted in place

of a white enamelled one, but as a general rule, the change is easy to detect. The base of the new dial is of rolled brass, the circle is usually attached by means of screws, the engraving in the centre usually "shouts" at one and the hands frequently afford corroborative evidence. If the white dials had a moon disc this has usually been transferred to the brass dial. In many cases it will be found that the iron false dial used with the white dial was retained when the brass one was fitted. When high-class clocks are converted into chime clocks, as a rule the dial centre is cut out and a new centre is substituted, but the change is usually so obvious, that it could not deceive a blind man. A very reprehensible and very common practice is to engrave such names as Thos. Tompion or Daniel Quare on the new centre with a view to obtaining an enhanced price for the faked-up concern. The above changes, of course, can deceive no one with the slightest technical knowledge of British clocks, but fakers to-day can defy even the most experienced. Dial plates and circles are occasionally specially cast, hammered and finished as our forefathers finished them. Movements with crown escapements are sent to the engraver and the back plates are engraved in the style common at the time engraving was about to be discontinued. If such work is really well done by men who know what they are about, the fraud is practically impossible to detect. The expert faker will go so far as to treat his brass work chemically, show the clock to a prospective purchaser, and then undertake to clean the clock, etc., before sending it home.

Faked movements are less common. Movements are, of course, frequently replaced by new or second hand ones, but so far as the writer is aware, little is done in the

way of attempting to reproduce movements. Sometimes, of course, old movements are adapted to fit particular dials, but probably very little work is done in the shape of making faithful copies of old movements from new material throughout. The public is too ignorant to justify the expense. Many owners of old clocks complain that they find the local men are unable to make them go satisfactorily, and in the provinces repairers have got rather a bad name in consequence. The trouble probably comes about through provincial men not being in touch with actual pinion makers and those who do nothing else but make and restore clocks. Assuming that the striking train is in fairly good order, and the escapement is passable, it may safely be stated that in 95 per cent. of the old clocks which give trouble the cause is a worn centre pinion. Some repairers attempt to reshape the leaves themselves, but only one in a hundred can make a really good job of it. It is very much more satisfactory to send the whole of the wheels and pinions of the train to a pinion maker, and tell him to do the best he can with them, replacing those which are so badly worn as to require renewing. It is surprising what a pinion maker can accomplish in many cases. He is frequently favoured by the fact that the original maker made his pinions a little too large or too thick in the leaf, in which case the repaired pinion is better than it ever was. Pinions cost so little to reform or replace that there is no excuse for bad ones, which not only tend to prevent the clock going or striking properly, but spoil the wheel teeth. Owners of old bracket clocks are frequently advised by ignorant shopkeepers to have the crown escapement replaced by a modern one of the anchor type. There is no excuse for

•

•

making the change. If care is taken to correct the crown wheel escapement, the clock will keep time to within half a minute a week, and as this can be depended upon, it is quite absurd to change the escapement and reduce the market value of the clock by so doing. The anchor escapement was in use in long-case clocks for 120 years before it was introduced into bracket clocks. Why did all the old makers prefer the crown-wheel escapement for bracket clocks when it is more expensive and troublesome to make? The answer is that our forefathers got better timekeeping with the crown-wheel escapement than with the anchor when the pendulum was short (see p. 46). Another thing one sometimes meets with is the recutting or the replacement of the fuseses so that chains can be introduced. This change again is costly and reduces the value of the clock without anything being gained. An equally satisfactory result can be obtained by substituting a wire line for the gut, *but* the wire line must be of the right kind. It should consist of a three-ply wire rope composed of about forty fine strands of steel wire. Each strand should withstand a good deal of bending without developing a permanent set, *i.e.*, each strand should be suitable for making a spring. Such lines are as cheap and as flexible as gut and apparently will last for ever. Other substitutes are obtainable, but they are all inferior, are really little better and frequently worse than gut. They consist either of a single steel wire with a brass wire twisted round it for ornament, or of a number of *soft* steel or brass wires not very well twisted together. A really good wire line is excellent for the heavy weights of chime clocks, but most of those in general use are of distinctly inferior quality. Before a wire line is cut, a small gas flame should be applied to the

place, to soften a length of about a quarter of an inch. After this the line should be twisted a good deal at the soft place and then cut. If this is done no trouble will be experienced with the line becoming untwisted, and the softening also saves the cutting edges of the pliers.

Regarding clock cases, the procedure is sometimes simple and sometimes difficult. If an old case requires the attention of a cabinet maker, the man employed should receive definite instructions *in writing*. If the wood contains boring insects these can be suffocated by the application of petrol, but if fungoid growth has set in, perchloride of mercury solution should be applied if the affected part cannot conveniently be cut away.

The bases of cases were frequently cut down so that they could stand in cottages with low ceilings. When restoration is carried out, care should be taken that the proportions are correct by examining *several* others of similar locality, period and material, and in the condition they left the makers.

Missing pieces of veneer, etc., should be replaced, and special attention should be paid to all the glued joints in the case. Few people realise that a case which has become rickety through the glue giving way is a fruitful cause of the clock stopping. The case tends to swing with the pendulum and bring the latter to rest (see p. 61). Even if it does not do this, the timekeeping will suffer. The hoods of long-case clocks usually require attention to render them more dust-proof. There is, of course, no such thing as an air-tight case for an ordinary clock or watch, although attempts have been made in this direction for certain chronometers

with more or less success. The gilt French clocks which stood under glass cases in every large house fifty years ago afford a good example of what can be done. In these clocks the tidal air (the air which enters or leaves the case with every change of temperature and barometric pressure) can only pass through a velvet filter *and at the bottom of the case*, so the movement never becomes smothered with dust. To attain good results with a long-case clock the case should be laid on its back on the floor and the hood put on. Strips of wood about a couple of inches wide should then be laid on the back board, pushed up to the hood and screwed to the former. The edges of these strips of wood should *not* be planed. If left rough from the saw they will prove wonderfully effective in obstructing the passage of dust and fluff through the chink. The top of the hood and cracks on the back board can be treated with glue and brown paper. Having made the hood a good dust filter, it should be ascertained whether there is a bottom to the case. If there is, it should be taken out so that the tidal air may have a free entry where it can do no harm.

It is very difficult to say what treatment the exterior of the case should have. If it appears to be in fine condition it should be left alone. An old case coated with alternate layers of smoke and beeswax in a farmhouse kitchen should be carefully cleaned, but not scraped. An old mahogany case with a rich, dark and clean oil polish should be touched up again with oil, but otherwise left in nearly the original condition, or else its market value will fall off. On the other hand, if the case is in a really bad condition owing to it being for a long period in a damp place, the polisher, and an intelligent

one at that, should be called in after the cabinetmaker has executed all repairs. A very high gloss produced by French polishing (shellac and spirit) is usually considered out of place by collectors, who prefer the old linseed oil or wax polishes of our forefathers.

CLOCK TRAINS

A FEW notes on the selection of wheel and pinion numbers may be of interest. Most mechanics know that if an eighty-tooth wheel drives a ten-leaf pinion the latter will make eight revolutions for one of the former.

We may conveniently start with the centre pinion. It usually has eight leaves. More would involve fine teeth, more accurate work, and more expense. Less would not be so good, owing to the action commencing too soon before the line of centres, and this would be accompanied by excessive friction. Very high-class regulators are usually made with twelve-leaf pinions. Having selected the centre pinion the main wheel is chosen. The barrel of a long-case clock, and the fusee of a spring clock, are usually constructed to make one turn in twelve hours (*i.e.*, sixteen turns in eight days). Hence the main wheel is provided with ninety-six teeth for an eight-leaf pinion and 144 for a twelve-leaf pinion. The escape pinion makes one revolution per minute in a long-case clock. There are two ways of doing this in general use. Some men use a centre wheel of sixty and a third wheel of fifty-six, with a second pinion of eight, and an escape pinion of seven. Others use the better plan of using a centre wheel of sixty-four, a third wheel of sixty, and pinions of eight. Escape wheels usually have thirty teeth, in which case the pendulum beats seconds. Some early makers used escape wheels of twenty and pendulums almost down to the floor. The seconds circle was then divided into forty instead of

sixty. In the case of spring clocks the numbers are rather different. The usual practice is to provide a centre wheel with eighty-four teeth, the third with seventy-eight, and the two pinions have seven leaves. By using an escape wheel of thirty teeth the pendulum is theoretically 7.9 inches long, and with a thirty-three tooth escape wheel the length is about 6.1 inches. In the striking train the same principles apply. A clock which simply strikes the hours gives seventy-eight strokes on the bell in twelve hours. Hence by giving the main wheel seventy-eight teeth and letting it drive an eight-leaf pinion carrying a pin wheel with eight pins, we obtain one revolution of the weight barrel or fusee in twelve hours. In modern rack striking movements, however, it is usual to have at least eighty-four and sometimes eighty-eight teeth in the strike main wheel. The object of this is to lessen the fall of the striking weight so that even if it is longer (and heavier) than the going weight, there is no chance of it running right down or touching the floor before the going weight has run down. This is especially important with locking-plate movements, but was not done after about 1700 (see p. 69).

Some old makers, instead of using an eight-leaf pinion for the main wheel to drive, used a nine-leaf one, in which case the pin wheel had nine pins. The number of teeth in the pin wheel depends on two factors, the number of pins and the number of leaves in the pallet pinion. The latter makes one revolution for each stroke on the bell. Assuming the pallet pinion has seven leaves and the pin wheel eight pins, the pin wheel would have $8 \times 7 = 56$ teeth. Similarly, if the pallet pinion has eight leaves the pin wheel has $8 \times 8 = 64$ teeth.

The number of teeth in the pallet wheel is an exact multiple of the leaves in the warning pinion, so that the pin in the warning wheel may always stop in the same place. By this means unnecessary "run" of the striking train at warning can be avoided, and the run can be utilised at the commencement of the striking to allow the train to gather speed before the lifting of the hammer commences. Warning pinions in the striking train usually have seven leaves, so pallet wheels usually have sixty-three or seventy teeth. In the case of the warning wheel the number of teeth depends on the rate at which the clock is to strike. A fifty-tooth wheel gives a relatively rapid strike, and a sixty-tooth wheel a relatively slow one, suitable for gongs.

The above remarks should suffice to explain the general principles, so that it is unnecessary to enter into details regarding chiming trains. The main wheel is usually provided with a hundred teeth. This ensures that the chime weight is well above the floor, in spite of its extra length, when the going train has run down. Most modern makers use the eight-leaf pinion throughout the chime train to save friction and eliminate the risk of the train failing to get into motion. Much might possibly be done to reduce the weight of the chime fly by using aluminium instead of brass for its construction.

Reference will be found elsewhere to the fact that the early makers usually employed six-leaf pinions in place of seven, and seven in place of eight. Such clocks, of course, required a good deal of driving power.

For the most part calendar work was of a simple character, the circle, disc or hand being moved forward once in every twenty-four hours. The weak point about this simple arrangement is that the owner does

not know whether the date will change in the middle of the day or the middle of the night until he tries. Then in all probability he has to stop the clock for twelve hours, or advance the hands by an equal amount to get it right. It is really no trouble to advance the calendar five times a year, after short months, provided a finger space is provided for the purpose in the seat board. In the case of some clocks with a small square aperture just above the figure VI we find a narrow slit in the dial about $\frac{1}{2}$ inch long and $\frac{1}{8}$ inch above the opening. By inserting a pin through this slit, the circle is easily advanced. This plan is very desirable in bracket clocks. Continuous calendars which compensated even for leap-year have been designed (see Grimthorpe's "Clocks, Watches and Bells"); but not one clockmaker in a hundred can reset them when wrong without expending a great deal of time on them.

For the most part the phases of the moon were shown only approximately, and for convenience, it was usually assumed that a lunation consisted of twenty-nine and a half days. Hence the moon discs in clocks such as that illustrated in Plate XVII. had $4 \times 29\frac{1}{2} = 118$ teeth round the periphery. The moon disc is then either driven by two pins projecting from the face of a wheel which revolves once in twenty-four hours, or by a bell crank with hinged tip which receives an up-and-down motion from a pin inserted into the hour wheel or snail. These arrangements are simple, cheap and quite satisfactory. Several very accurate lunation trains have been worked out. They are interesting and ingenious, but quite useless, especially as the average wheel cutter has no means of producing wheels with very out-of-the-way numbers of teeth.

From time to time we hear people talking of the Nuremberg clock and other boxes of tricks. Opinions may differ, but the average clockmaker in this country regards such productions as coming under the heading of mechanical toy making and not that of clockmaking.

REPAIRING AMERICAN CLOCKS

REPAIRERS, as a whole, dislike repairing American clocks, and, from the money point of view, there is nothing much in such work. On the other hand, the American clock which requires repairing is extremely useful for teaching apprentices and amateurs, so they would profit considerably by the experience if they spent a portion of their spare time in making such clocks go well.

The following notes will enable the novice to detect some of the chief faults. In the first place the pendulum or balance and pallets should be removed. A few drops of petrol or paraffin should then be applied to the pivots and escape wheel teeth. If the movement is then allowed to run partially down, the pivot holes will become cleared of gummy oil. Examine the pallets. If they are solid pallets of a lever clock, repolish them. If they are pin pallets, renew the pins if they are at all cut. Needles are convenient for this purpose, and the requisite lengths, slightly tapered, are easily broken off the ordinary sewing needle. In the case of pendulum clocks, broach out the pallet holes and fit a new pivot pin. Make the pin sufficiently long to carry a washer behind the pallets, and thick enough to make a new uncut part of them engage with the escape wheel. The action of the escapement requires careful examination. Drop must be reduced to a minimum with a view to conserving power. Usually the depth is adjustable, but in lever clocks with solid pallets and badly-worn

wheel teeth it may be found that, in order to get the escapement deep enough, a little of the rim of the escape wheel will have to be filed away, otherwise the locking will not be safe. Adjustments must be made so that (a) while the drop on each pallet is reduced to a minimum, there is no risk of the escapement not working smoothly; (b) while the locking is safe, it is not more than necessary.

Having adjusted the pallets, put in the balance and examine the lever. The impulse pin must have a clear run into the fork of the lever in whichever direction it is moving. After the impulse pin leaves the fork the tips of the latter must be close up to, but not rubbing, the balance staff. If the lever is long enough, it is impossible for the lever to be moved until the gap in the staff passes the tip of the fork, and the impulse pin is ready to unlock the escapement and subsequently receive its impulse. If the lever is too long, the tip of the fork rubs on the balance staff, and the friction checks the free oscillation of the balance. Assuming the balance spring has been adjusted so that the balance is in beat, try whether the clock will go with a good healthy action. Try whether the position of the movement makes any difference. It may be found that when the movement is upside down the balance oscillates well, whereas when right way up the clock is inclined to stop. This is frequently attributable to the screws which act as pivot holes for the balance. If one of the screws is taken out, cleaned and examined under an extra powerful glass, it will be found that the weight of the balance has caused the staff to wear a groove in the screw, and this groove is a source of considerable friction. By arranging the screws so that the unworn portion takes the weight of the balance and staff, a considerable improvement in the action may result.

Examine the balance pivots. If they are blunt, remove the hair-spring and grip the staff in the lathe chuck. Use a high speed, and repoint the pivots by using a well-oiled Arkansas stone slip like a file. Worn pivots usually suggest very roughly-made pivot screws. If the escapement, etc., are in perfect adjustment, and the movement lacks power, examine the teeth of the main wheel with a glass. If they are badly pitted through prolonged action with a lantern pinion, the trouble probably lies there. Slip a string round the main-spring, and, after tying it, let the movement run down and take it to pieces. Remove the main-spring and turn off the rivet which holds the main wheel on its arbor. Reverse the main wheel, and, of course, remove and re-fix the click and click-spring and spread the rivet again. This job should not take more than a quarter of an hour if the repairer has a respectable kit of tools. The effect of this reversing of the main wheel is usually very striking, and emphasises what has been written on the subject of wheel teeth and pinion leaves. Another way to attain this end is to top the wheel, re-round up the teeth, and re-depth the wheel and pinion, but this takes about twice as long and requires a certain amount of skill.

It is quite possible that some of the depths require attention, but this is not a very common fault. It is usually indicated by the fact that for a certain period the balance has a vigorous movement followed by a very poor movement, and followed again by a vigorous one. It is easy to determine from the length of the period in which depth the fault lies.

Sometimes the rounds of the escape pinion or others near it are badly worn. By gripping each one in succession with a pair of pliers and revolving it half a turn, so

that it presents a fresh surface to the wheel teeth, the action may be improved very considerably.

Needless to say, cheap foreign movements constructed with soft-brass centre pinions are not worth touching.

As regards faults in the striking train, the chief cause of the clock stopping is the great effort required to unlock the strike.

In the event of it being found that the hair-spring has been broken near the outer end and leaving it too short to permit regulation by the ordinary means, the clock can be brought to time by increasing the mass of the balance very slightly. In fact, it will probably be found that a single layer of sewing cotton wound round the rim of the balance is sufficient to make a difference of about twenty minutes a day. The advantage of this method is that it does not interfere with the poise of the balance.

As in watch work, kinks in a hair-spring are straightened out, or the curvature is varied, by means of a pair of forceps, one leg of which is formed with a concave surface like a gouge, and the other with a convex surface of about the same radius.

The amateur clock-repairer may feel disappointed that no attempt has been made in this volume to instruct him in such work as the turning and polishing of fine pivots. No one can learn such work from books. One often hears the remark that "an ounce of practice is worth a ton of theory," and if the amateur is anxious to learn pivoting and similar work, the only way of doing so is by taking lessons from an experienced practical man.

TURRET CLOCKS

UNTIL now the principal British writer on this subject has been the late Lord Grimthorpe, who took such a leading part in the design of the great Westminster clock. His book, "Clocks, Watches and Bells," first appeared in 1850, and was followed by seven subsequent editions spread over a period of about fifty years. Though the book contains much important matter, it is naturally rather out of date. Since the last edition was published enormous advances have taken place, not only in metallurgy, but also in gear-cutting, etc. Non-ferrous metals have been studied by many able scientists, and not only have many important new alloys been discovered, but investigation has shown how the older brasses and bronzes can be improved in strength, and in their capacity to withstand wear and corrosion. In ferrous metallurgy the developments have been enormous, and now the clockmaker can produce deeply case-hardened material far excelling anything which was produced formerly. Alloy steels containing nickel and chromium have shown their superiority as regards strength, toughness, and resistance to wear. By the use of steel containing a high percentage of nickel, complicated compensated pendulums are no longer necessary save in exceptional cases. Where prime cost is of secondary importance, stainless steel presents great possibilities, especially in humid or polluted atmospheres. In the hard state it appears eminently suitable for pinions, and in the soft state is being made into wire

ropes As will be seen later, the whole theory and practice of bell-founding has been revolutionised within the last few years. Lord Grimthorpe was very severe in his condemnation of the involute system of gear teeth on the grounds that the wheel thrusts the pinion away from it, thereby increasing the pivot friction and wear of the pivot hole. The cycloidal system is certainly preferable for domestic clocks where low-numbered pinions are used, but this does not apply to turret clocks, where the involute system appears preferable. In the first place it is possible, by the aid of existing machinery, to produce involute teeth with mathematical accuracy, whereas the same does not apply to cycloidal teeth. Pinions with glass-hard wearing parts can have all errors in their contour, resulting from unequal contraction on quenching, removed by modern grinding machinery. In the involute system, it is possible to vary the amount by which the wheel tooth slides over the pinion leaf. Thus, by using short much-curved addenda, the sliding or rubbing action is somewhat reduced, and the action more resembles a rolling one than a sliding one, though a certain amount of sliding or rubbing cannot be entirely avoided. Unfortunately, when this is done, it does tend to increase the pivot friction, but this disadvantage has probably been much exaggerated. If the wheels and pinions run in ball-bearings this objection (if real) disappears, since the friction in such a bearing is independent of the load it carries, throughout a very wide range. It should also be noted that, with the involute system, accuracy of depthing is of secondary importance, though of supreme importance with the cycloidal system. Another advantage lies in the fact that all involute wheels and pinions

produced with a single generating cutter run together with mathematical accuracy.

Most existing turret clocks would be greatly improved by the addition of lubricators with well-fitting lids. These would not only make lubrication simpler, but would assist and encourage the periodical washing out of the pivot holes with benzole. Simple oil holes, such as are used on common machinery, are generally ruled out on the ground that dust settles in them and is carried into the pivot holes by the oil. There is, however, no reason why they should not be covered by a strip of springy sheet metal bent to a smaller radius than the end of the bush and then sprung on. A better arrangement for most pivot holes would be the provision of a thin metal cap over the end of the bush, which would prevent dust settling on the end of the pivot or in the oil-sink. It would reduce the circulation of air in the pivot hole, and consequently retard the deterioration of the oil through dirt and oxidisation. In all probability many turret clocks will be made in future with ball-bearings instead of simple gun metal pivot holes. Few people realise how imperfect the contact between the pivot of a turret clock and its hole really is, owing to the impossibility of getting absolutely perfect uprightness in every hole. On the other hand, the use of a self-aligning ball-bearing gets over this difficulty. The average maker is doubtful of the advantage of ball-bearings as regards reduction of friction and wearing qualities, on account of experience gained with bicycles. There is, however, the greatest possible difference between the usual rubbishy bearing used in bicycles and the high-class and in expensive self-aligning bearings used for other purposes.

In view of the introduction of summer-time the best

turret clocks of the future will probably be provided with some mechanism which will enable any authorised person to advance or retard the hands by some definite amount irrespective of the operator's skill or judgment. In the case of common and erratic church clocks the practice of stopping the pendulum for an hour, or advancing the hands an hour, is quite good enough, but this is not so in the case of the principal clocks in large towns where very accurate time is necessary. Such a mechanism need not be complicated. For instance, a dog-clutch formed like two contrate wheels facing one another, and with their centres in line, could be provided at small cost. A clutch of this kind would permit the hands to be set back or be advanced by exactly an hour, and after the change the error of the clock in seconds would be precisely the same as before. At the same time the steady motion of the pendulum would not be interfered with.

The cost of winding large turret clocks has led to many enquiries as to whether electric power cannot be utilised for winding existing clocks with weights, or whether new clocks without weights are not feasible. In large public offices and hotels, synchronised electrically-operated dials are being used. They are driven by simple primary batteries like electric bells. In the case of turret clocks with large dials and heavy bell-hammers, the primary battery is out of the question, and a large set of accumulators would prove far too costly to maintain. If we utilise the current available from the electric light and power mains the question of interruption of supply owing to "blown" fuses, cable repairs, etc., has to be taken into consideration. It therefore appears that for the going train we must retain the weight clock on the grounds of reliability. For the striking and chime

trains it is possible to dispense with the weight and a good deal of the wheel work, by using electric motors and worm gears. The switch gear would, however, prove complicated and costly both in the first instance and in maintenance, and it would have to be operated by racks instead of locking plates on account of the unavoidable interruptions which occur in current supply. We are, therefore, led to the conclusion that for large turret clocks weight movements, wound electrically, will hold their own for a long time to come. The provision of electric motors for winding large turret clocks should not add materially to their initial cost, and, being automatic in their action, would save the cost of their installation in a few years. The cost of current for winding a large turret clock in Birmingham has been stated to be *2d.* per week.

For the smaller wheels of turret clocks the use of non-ferrous alloys will probably continue. Steel wheels with hard teeth, such as are used in motor cars, would not work well without a copious supply of a viscous lubricant. Moreover, steel wheels can only be produced at a reasonable price if they are forged by the thousand in extremely costly dies.

One would have thought that Lord Grimthorpe's book would have been consulted by almost everybody responsible for the installation of turret clocks, but that is not so. In consequence, we find turret clocks still being made with ordinary dead-beat escapements and located in awkward attics and towers, designed by architects who regard any place as good enough for a clock movement, providing they succeed in producing an *external* elevation which they themselves like. Owing to the extremely awkward places where turret movements are not in-

frequently located, it is of the greatest importance that the maker should take this into consideration. Those who have to take them to pieces for cleaning and repairs, frequently find the job extremely trying, since no adequate provision has been made for removing and replacing the parts one by one. The maker probably pleads that the purchaser will not pay for such facilities, and that if his movement were placed in the centre of a sensible clock-room the difficulty would not arise.

Although the quality of bells for domestic clocks has deteriorated during the last few centuries, the same does not apply to those used for turret work. Apparently the late Canon Simpson, of Fittleworth, was in a large measure responsible for improvements in the latter, as will be seen from the following extract from "Here, There, and Everywhere," by Lord Frederick Hamilton :

"Canon Simpson was an enthusiast about bells, not only about 'change ringing,' on which subject he was a recognised authority, but also about the designing and casting of bells. . . . The Canon maintained that very few bells either in England, or on the Continent, were in tune with themselves, and therefore could obviously not be in tune with the rest of the peal. Every bell gives out five tones. The note struck, or the 'tonic' (which he called the 'fundamental') the octave above it, termed the 'nominal,' and the octave below it, which he called the 'hum note.' In a perfect bell all these three octaves must be in perfect unison, but they very seldom are. The 'nominal' or upper octave is nearly always sharper than the 'fundamental' and the 'hum note' is sharper than that, thus producing an unpleasant effect. Any one listening for it can detect the upper octave or 'nominal,' even in a little hand bell. Let them listen

intently, and they will catch the sharp 'ting' of the octave above. The 'hum note' in a small bell is almost impossible to hear, but let any one listen to a big bass bell, and they cannot miss it. It is the 'hum note' which sustains the sound, and makes the air quiver and vibrate with pulsations. For many years I have lived under the very shadow of Big Ben, and I can hear its 'hum note' persisting for at least ten seconds after the bell has sounded. Big Ben is a notable instance of a bell out of tune with itself. In addition to the three octaves, every bell gives out a 'third' and a 'fifth' above the tonic, thus making a perfect chord, and for the bell to be perfect, all these five tones must be in perfect tune with each other. Space prevents my giving details as to how this result can be attained. Under the Canon's tuition I learnt to distinguish the 'third' which is at times quite strident, but the 'fifth' nearly always eludes me. During Canon Simpson's life-time, he could only get one firm of bell-founders to take his 'five tone' principle seriously. I may add that English bell-founders tune their bells to the 'nominal,' whilst Belgian and other continental founders tune them to the 'fundamental,' both according to Canon Simpson, essentially wrong in principle.

"Three days ago I read a leading article in a great morning daily, headed, 'The Renascence of Bell-founding in England,' and learnt from it that one English bell foundry was casting a great peal of bells for the War Memorial at Washington, and that another firm was carrying out an order for a peal from, wonder of wonders, Belgium itself, the very home of bells, and that both these peals were designed on the 'Simpson' five tone principle."

BIBLIOGRAPHY

OPINIONS differ as to the usefulness of a list of books on clock-making. Some enthusiasts wish to read every word which has been written on the subject. Others wish to read a few books, but do not know what has been published. Others again regard any book more than about ten years old as out of date. The man who is only interested in making a living buys a few recent books, but the man who makes clockmaking a hobby as well as a business, frequently wishes to refer to some of the older publications. The question where to stop presents some difficulty, and a line has been drawn at books in a foreign tongue. Again, many books on mechanics, astronomy, etc., contain descriptions of clocks, but since they seldom contain material which does not appear elsewhere, references to these have been almost entirely omitted. Finally we come to papers read before various societies, and articles which have appeared in various journals and magazines. These have purposely been omitted also. Some items in the list given below are pamphlets which were privately printed, and possibly should not appear in the list if the writer drew very hard and fast lines. A little confusion exists concerning the authorship of "Clocks, Watches, and Bells." All editions were by the same writer, who first appears as Edmund Beckett Denison, later as Sir Edmund Beckett, and finally as Lord Grimthorpe. Where more than one date of publication is given the years represent early and late editions, no notice having been taken of the intermediate ones.

WORKS ON HOROLOGY

ABBOT, FRANCIS. *A Treatise on the Management of Public Clocks.* Second edition. 1838.

ARNOLD, JOHN. *Certificates and Rates of Going.* 1791.

ATKINS, SAMUEL ELLIOT, and OVERALL, WILLIAM HENRY.

Some Account of the Worshipful Company of Clockmakers of the City of London. 1881.

BAIN, ALEXANDER. A Short History of Electric Clocks. 1852.

BENSON, JAMES W. Time and Time-tellers. 1875, 1902.

BOLTON, L. Time Measurement. 1924.

BOOTH, MARY LOUISE. New and complete Clock and Watchmaker's Manual. (American, translated from French.) 1877, 1882.

BOOTH, —. Clock and Watchmaking in America. 1882.

BRAY, J. Artisan's Report on Watchmaking in the Paris Exhibition, 1889.

BRITTEN, F. J. Watches and Clocks. (British Manufacturing Industries, edited by C. Philips Bevan.) 1876.

BRITTEN, F. J. Watch and Clockmaker's Handbook, Dictionary and Guide. 1884, 1922.

BRITTEN, F. J. Former Watch and Clockmakers and their Work. 1894.

BRITTEN, F. J. Springing and Adjustment of Watches. 1898.

BRITTEN, F. J. Old Clocks and Watches and their Makers. 1890, 1922.

BRITTEN, F. J. Old English Clocks. (The Weatherfield Collection.) 1907.

Catalogue of the Library of the Worshipful Company of Clockmakers of London. 1898.

CESCINSKI, HERBERT, and WEBSTER, MALCOLM. English Domestic Clocks. 1913.

CRISP, W. B. Prize Essay on the Compensation Balance. 1875.

CUMMING, ALEXANDER. The Elements of Clock and Watch Work. 1766.

CUNNINGHAM, H. H. Time and Clocks. 1906.

DENISON, SIR EDMUND BECKETT [LORD GRIMTHORPE]. A Rudimentary Treatise on Clocks, Watches and Bells. 1850, 1903.

DENT, EDWARD JOHN. Lectures on the Construction and Management of Chronometers, Watches and Clocks. 1841.

DERHAM, WILLIAM. The Artificial Clockmaker. 1696, 1750.

EARNSHAW, THOMAS, and ARNOLD, JOHN. Explanations of Timekeepers constructed by Earnshaw and Arnold. 1806.

EIFFE, H. Improvements in Chronometers. 1845.

EIFFE, JOHN SWEETMAN. Improvements in Chronometers made by J. S. Eiffe. 1842.

FERGUSON, JAMES. Select Mechanical Exercises showing how to construct different Clocks, Orreries, and Sundials on plain and easy Principles. 1773, 1778.

FRODSHAM, WM. JAMES. Experiments on the Vibration of Pendulums. 1838.

"G." (Edited by Bernard E. Jones.) Clock Cleaning and Repairing. 1917.

"G." (Edited by Bernard E. Jones.) Watch Cleaning and Repairing. 1918.

GARRARD, F. J. Watch Repairing, Cleaning and Adjusting 1903.

GARRARD, F. J. Clock Repairing and Making. 1914.

GLASGOW, DAVID. Watch and Clockmaking. 1885.

GOULD, RUPERT T. The Marine Chronometer, its History and Development. 1923.

GROSSMAN, MORITZ. Treatise on the Detached Lever Escape ment for Watches and Timepieces. 1866.

HARRISON, J. The Principles of Mr. Harrison's Timekeeper. 1767.

HARRISON, JAMES. An Introduction to a Treatise on the Proportions of Constituent Parts of Bells. 1831.

HASLUCK, PAUL N. The Clock-jobber's Handybook. 1889, 1893.

HASLUCK, PAUL N. The Watch-jobber's Handybook. 1887, 1896.

HATTON, THOMAS. An Introduction to the Mechanical Part of Clock and Watchwork. 1773.

HAYDEN, ARTHUR. Chats on old Clocks. 1917.

HENDERSON, EBENEZER. An Historical Treatise on Horology. 1836.

IMMISCH, MORITZ. Prize Essay on the Balance Spring. 1872.

KEMLO, F. Watch-repairer's Handbook. (American.) 1882.

KENDAL, JAMES FRANCIS. History of Watches and other Timekeepers. 1892.

LANGMAN and BALL. Electrical Horology. 1923.

LE ROY, JULIEN. (Translated by T. S. Evans.) A Memoir on the best Method of Measuring Time at Sea. 1806.

MANDEY, VENSTRUS, and MOXON, JAMES. Mechanic Powers. 1696.

MASKELYNE, NEVIL. An Account of the going of Mr. John Harrison's Watch from May 6th, 1766, to March 4th, 1767. 1767.

MASKELYNE, NEVIL. Answer to Pamphlet entitled "A Narrative of Facts." 1792.

MILHAM, WILLIS I. Time and Timekeepers. (American.) 1923.

MOORE, N. HUDSON. The Old Clock Book. (American.) 1912.

MORGAN, CHAS. OCTAVIUS, and SWINNERTON, M. P. Observations on the History and Progress of the Art of Watchmaking. 1849-50.

MORGAN, CHAS. OCTAVIUS, and SWINNERTON, M. P. Observations on the Classification and Arrangement of a Collection of Watches. 1875.

MUDGE, THOMAS (Senior). Thoughts on the Means of Improving Watches, particularly those for Use at Sea. 1765.

MUDGE, THOMAS (Junior). A Narrative of Facts. 1792.

MUDGE, THOMAS (Junior). Reply to Answers of Dr. Maskelyne to a Narrative of Facts relating to some Timekeepers constructed by Mr. Thomas Mudge. 1792.

MUDGE, THOMAS (Junior). A Description of the Timekeepers invented by the late Thomas Mudge. 1799.

NELTHROP, HENRY LEONARD. Catalogue of Clocks, Chronometers, etc., presented to the Worshipful Company of Clock-makers. 1895.

NELTHROP, HENRY LEONARD. Treatise on Watchwork, Past and Present. 1873.

PARR, WILLIAM. A Treatise on Pocket Watches. 1804.

PARTINGTON, CHARLES F. The Clock and Watchmaker's Complete Guide. 1826.

REID, THOMAS. *Treatise on Clock and Watchmaking.* 1822, 1826.

RIGG, EDWARD. *Compensation of Clocks, Watches and Chronometers.* 1879.

RIGG, EDWARD. *Watchmaking.* 1881.

SALOMONS, SIR DAVID. *Breguet, 1747-1823.* 1921.

SALOMONS, SIR DAVID. *Breguet, 1747-1823. Supplement.* 1921.

SAUNIER, CLAUDIUS. *Treatise on Modern Horology, translated from French by Tripplin and Rigg.* 1881.

SAUNIER, CLAUDIUS. *Watchmaker's Handbook, translated from French by Tripplin and Rigg.* 1881.

SAVIDGE, JAS. *Catalogue of the Library of the British Horological Institute.* 1908.

SCOTCHFORD, T. C. *A Treatise on the Detached Lever Escapement.* 1866.

SHADWELL, F. C. H. *Notes on the Management of Chronometers and the Measurement of Meridian Distances.* 1855.

SMITH, JOHN. *Horological Dialogues.* 1675.

SMITH, JOHN. *Horological Disquisitions.* 1694, 1708.

SMITH, JOHN. *Old Scottish Clockmakers.* 1893, 1921.

SMYTH, WM. HENRY. *Description of an Astrological Clock belonging to the Society of Antiquaries.* 1848.

THOMSON, A. *Secret of Verge Watches.* 1907.

THOMPSON, EDWARD JOHN. *Description of some Watch Movements, etc., belonging to the Company of Clockmakers.* Two parts. 1889, 1889.

THOMSON, ADAM. *Time and Timekeepers.* 1842.

TRIPPLIN, JULIEN. *Watch and Clockmaking in 1889.* 1890.

VULLIAMY, BENJAMIN LEWIS. *Some Considerations on Public Clocks.* 1828-30.

VULLIAMY, BENJAMIN LEWIS. *On the Construction and Theory of Dead-beat Escapement Clocks.* 1846.

WARNER, T. *How to keep the Clock right by Observation of the Fixed Stars.* 1876.

WOOD, EDWARD J. *Curiosities of Clocks and Watches.* 1866.

WRIGHT, D. *Notes on Technical Horology.* 1901.

APPENDIX I

COMPARISON OF CLOCK TRAINS AT VARIOUS PERIODS

EIGHT-DAY LONG-CASE CLOCKS

	1700.	1800.	1900.
<i>Going Train :</i>			
Main wheel . . .	96	96	96
Pinion . . .	8	8	8
Centre wheel . . .	60	60	64
Pinion . . .	8	8	8
Third wheel . . .	56	56	60
Escape pinion . . .	7	7	8
Escape wheel . . .	30	30	30
<i>Striking Train :</i>			
Main wheel . . .	78	84	84
Pinion . . .	9	8	8
Pin wheel . . .	54	56	64
Number of pins . . .	9	8	8
Pinion . . .	6	7	8
Pallet wheel . . .	48	49	70
Pinion . . .	6	7	7
Warning wheel . . .	48	45	63
Fly pinion . . .	6	7	7
Number of turns of fly per stroke of hammer	64	44½	90

The high-speed fly of 1700 gives slow striking and brought out the fine qualities of the bells of the period ; the nine-leaf pinion in this train is rather unusual. The train of 1900 was made for a slow strike on a gong.

APPENDIX II

IN view of the fact that Lord Grimthorpe's book "Clocks, Watches and Bells" is out of print and unlikely ever to be reprinted, the publishers have suggested that I should incorporate part of it in this volume. No other writer has ever put on record so much valuable information on turret clocks, and it would be a great pity if Lord Grimthorpe's store of information were allowed to sink into oblivion. The subject of bells I am leaving to some one, like Mr. W. W. Starmer, who can do it justice.

When a new clock-tower is being built there is usually a committee dealing with the matter, and a few suggestions to the committee are offered. In the first place they should recognise that architects are no better qualified to purchase clocks for the turrets they design, than they are to purchase the horses for stables they are commissioned to build. The committee should make careful inquiries as to the makers and performances of the principal clocks in a dozen large towns and then obtain tenders from those makers who have produced clocks of proved excellence. The same applies to the bells for the hours and quarters. This should be done before even the foundations of the turret are laid. Having selected a clockmaker and a bell-founder, these people should then instruct the architect concerning the internal design of the turret. Only by this means can really good results be obtained without rearranging the whole of the interior. In fact, the construction of the turret, before all details relating to the clock and bells are available, is

on a par with building the outside walls of a house before any thought has been given to the arrangements inside. This may sound an exaggerated statement, but it is quite true, as all turret clockmakers and bell-founders will testify.

If the clock is to keep really good time, as all public clocks should (but don't), the support for the movement must be really rigid. In fact, the rolled steel joists or ferro-concrete beams which support it will only be sufficiently free from spring if they are capable of bearing a static load equivalent to fifty, or better a hundred, times the weight of the clock.

What follows is essentially a series of verbatim extracts from Lord Grimthorpe's book, with a few slight additions. As the gravity escapement is applicable to both domestic and turret clocks, suitable designs for each are given at the end.

CHURCH OR TURRET CLOCKS

It may be supposed that as the work of these clocks only differs from that of house clocks in the size of the hands and the weight of the hammers they have to move, you have only to enlarge the machinery and the business is done. But there is a very important fact in the way of that conclusion : viz., that as you increase the strength of machinery you increase its weight in a ratio as much higher as the cube is higher than the square of any of its dimensions ; and when you increase weight you increase friction, and friction is a word which ought never to be long out of the mind of a clockmaker, or at least, of a clock designer, inasmuch as the timekeeping part of a clock is the only machine whose sole business is to overcome its own friction, resistance of the air, and variations

of heat, and to do that in a constant and uniform manner. And there is this further difference between large and small clocks : in small ones the force or weight required to work a hammer of an ounce or two is generally about the same as is required to keep the pendulum going, and so the two ' parts ' or trains are about equal in strength ; whereas in large clocks the lifting of the hammer generally requires a great deal more power than driving the hands and pendulum, and therefore ought to have much heavier and stronger machinery. Nevertheless the object of some clockmakers seems to be to make the going train of large clocks as heavy and the striking train as light as they can.

Pendulum.—Lord Grimthorpe devoted a good deal of attention to pendulums, both from mathematical and practical points of view. The conclusions he arrived at are briefly as follows :—

(a) The best form of bob is a heavy cylinder with its axis vertical, owing to the ease with which perfect symmetry is attainable (see p. 61).

(b) A lead bob is preferable to one of cast iron, since, for a given weight, it is smaller and, therefore, less affected by the atmosphere. It requires more careful handling, however.

(c) The top of the bob should be domed to prevent bits of dirt, which would accelerate the clock, resting on it.

(d) The final regulation of the clock, and slight temporary changes of rate, are best brought about by adding or removing small weights, which rest on a collar half way down the rod.

(e) The arc described by the pendulum must remain constant, otherwise the rate of the clock will vary.

(f) The cheapest and most reliable escapement, which

will maintain a constant arc, in spite of variations in the driving force in the train, is the gravity one designed by himself.

(g) The support from which the pendulum hangs must be really rigid and free from the slightest tendency to "give" or tremble.

(b) The suspension spring must be perfectly encastered (*i.e.*, gripped firmly between flat surfaces) at each end. The "pinning in" must be arranged so that the spring hangs vertically and is uniformly loaded.

(i) Provision should be made, in the design of the tower, for easy access to the rating nut, and for catching the pendulum in the event of the suspension spring breaking.

The great majority of clockmakers, till lately, set their faces against compensated pendulums, and used nothing but wooden ones. And so long as the clocks themselves are no better than they are, it would undoubtedly be a waste of money to compensate the pendulums, as the escapement errors will far exceed the temperature one. But when you have got a first-rate clock in other respects, it is absurd to prevent it from going accurately by not giving it a pendulum without which it cannot keep the same rate in hot and cold weather. It is true that a 2 seconds, or even a $1\frac{1}{2}$ seconds, compensated heavy pendulum is a rather expensive affair if well made; and with a common dead escapement probably the advantage is on the whole in favour of a 13 ft. wood pendulum of 3 cwt. over a 5 ft. compensated one of half the weight, which will enable a clock with such an escapement as I shall describe to keep within a second a week of Greenwich time. The fashion of extravagantly long pendulums has very properly gone out, as their inconvenience and

liability to be affected by the wind over-balances any advantage from them in a moderately good clock. There were several in Yorkshire until lately as long as 56 feet, or 4 seconds : 20 feet = $2\frac{1}{2}$ seconds, which old Doncaster church had, is the utmost length I should allow.

Position of Clock.—The worst of all positions for a large clock is the usual one, on a stool on the upper floor of a tower, for the reason that a clock fixed in this way is far from rigid and cannot keep accurate time. The best is on stone corbels built deep into the wall. The Westminster clock lies on independent walls, which, of course, are stronger still. Where this cannot be done, cast iron brackets bolted through the wall will do, or 18 in. \times 7 in. rolled steel joists across the room if it is not very wide. Wooden beams are not to be trusted. When the clock is fixed as firmly as this, the pendulum may be hung from the clock frame, if that is itself strong enough, and the pendulum cock properly fixed to it, or cast with it, though the wall is generally to be preferred for a long and heavy pendulum, if the clock stands near enough to it. But again it is inconvenient to have a very large clock so close to the wall that a man cannot get some access to it from behind. Therefore no general rule can be laid down for the fixing of turret clocks, except that firmness is the first consideration, to which everything else must give way according to the circumstances of the tower. Whatever increases the arc without increasing the weight is obviously a great advantage; and the principal things which do that are diminution of friction and inertia of the train, and steadiness of suspension of the pendulum. I cannot give a better proof of how much the arc depends on that, than the effect of hanging the

Westminster pendulum on its proper cock, which is a large cast iron bracket built into the wall; the arc increased full 45' over what it had been in the factory, where it was hung on what seemed a perfectly firm support, a strong timber frame built up from the ground. Even smaller pendulums generally increase their arc from about 2° in the factory to $2^\circ 30'$ as soon as they are properly fixed to a good wall on stone corbels or rolled steel joists; and as the escapement errors vary inversely as the cube of the arc, the clock should go more than twice as well with the firmer suspension; and in fact it does.

Frame.—The old-established form of clock frame was a sort of cage of vertical and horizontal bars, some of which contain the bushes for the pivots of the wheels, and have to be unscrewed from the principal bars in order to get any of the wheels out. It was a great improvement on this to fix the bushes themselves with screws instead of riveting them into the bars, as it enabled the wheels to be taken out separately, instead of all dropping loose at once and perhaps bending their back pivots as soon as the front bar was taken off. Mr. Vulliamy introduced this plan, and old Mr. Dent used it in the Exchange clock, of which a perspective view is given in Tomlinson's *Cyclopædia* under *Horology*. But he soon afterwards adopted a still better arrangement, borrowed in principle from the French, who were strangely ahead of us in this branch of clockmaking until shortly before the 1851 Exhibition.

The French clockmakers are entitled to the credit of having introduced the horizontal frame cast in one piece, with the great wheel set in bushes or cocks below it, and the smaller wheels above in separate frames of the A

shape bolted to the great one. But much more has been done since that. I will now describe a moderate-sized turret clock, suitable for a bell up to 5 or 6.cwt., and therefore only needing the striking part winding once a week, which will not do for large ones, and striking one at the ten proper half-hours as before described. This was made for a clock-tower of my house by Mr. Joyce, of Whitchurch, Salop, the maker of the great Worcester Cathedral clock, striking on a $4\frac{1}{2}$ -ton bell, and a vast number of smaller clocks. I ought to mention at the same time that Messrs. Potts, of Leeds, in 1881, put up a still larger one in the finest clock-room in the world, about 40 ft. square, in the tower of Lincoln Minster, striking on Great Tom and four new quarter bells; and Gillett and Bland, of Croydon, who made the clock for some still larger bells in the Manchester Town Hall. But all these, and a multitude of others not quite so large, by these makers, and by Smith, of Derby, belong to the class which will be described afterwards, winding every one or two days in the striking parts. Dead escapements have now become quite obsolete for all large clocks that are intended to keep time within the maximum that ought to be allowed, viz., 5 seconds a week; for I hear that some of these large clocks do not vary 5 seconds a month, except from some temporary cause. Therefore, the time is come to treat the gravity escapement as the standard one for this purpose.

Very few architects have the least idea how large a clock-tower must be to hold a clock of moderate size properly, or bells either. Their notion seems to be that it is the duty of their clients to let them build what they think pretty, and then get other people to make it useful if they can. I must inform their clients, then, that they

cannot have a clock of the best construction suitable for a bell of only 4 or 5 cwt., and one or more dials of 4 ft. diameter, unless they provide a clock-room at least 6 ft. square, and 7 is better, and at least 30 ft. fall for the weights. The frame in such a tower as that is best built into the wall about half a brick deep at each end, as mine is, and, of course, made quite level and firm. It will then be firm enough to carry the pendulum, without resorting to an independent cock built into the wall. Mine is about 3 cwt., and just 99 in. long to the bottom, being $1\frac{1}{2}$ seconds, which happened to be more convenient than a $1\frac{1}{4}$ seconds one, besides being rather better. As it is generally necessary to carry the ropes up to some place above the clock-room to get all the available fall, you have to provide space for them also, and evidently more than if they go straight down from the barrels, which is better if you have fall enough, as it saves a good deal of friction in several ways. This depends on the height of the clock-room from the ground, and the use you want to make of the lower part of the tower, which should all be considered beforehand, but never is, except by people who look after their own work, who alone get it done well.

Any one who is generally acquainted with clock-making will understand from Fig. 21 more than could be shown in it without confusion. The barrels, or great wheels of both parts, are set under the frame in bushes of the construction *a* and *d* together in Fig. 22, so that they can drive second wheels in bushes of the form *b* on the top of the frame, which top is about $1\frac{1}{2}$ in. wide, and is now always planed in a machine, to carry all the cocks and bushes quite firm and level. There are three cross bars cast in it at convenient places, which are utilised also

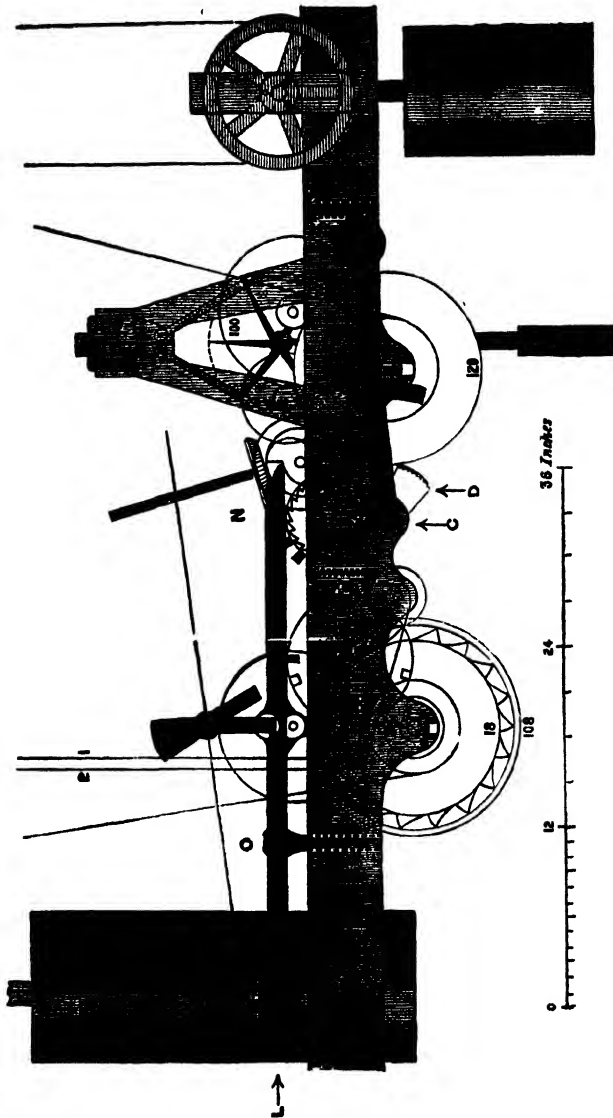

FIG. 21.

for carrying cocks for 'leading off,' for hammer-tails, winding-pinions, and anything else of that kind. The great going wheel generally has 120 teeth, and is 12 or 13 inches in diameter, and drives (first) the hour wheel with 40 teeth, on the arbor of which is the bevelled wheel driving other bevelled wheels up to the dials, both outside the tower, as usual, and in mine inside also to a dial at the end of a long passage in the house. That leading off goes downwards obliquely, and is omitted in the picture. The half-hour snails, with the main bevelled wheel, are clamped to the hour wheel by thumb-screws, to enable you to set the hands when necessary; and it drives no more wheels in the train, because it makes a better distribution of the teeth to leave it independent. The great wheel therefore drives the one marked 100 with a pinion of 10, which will turn in 15 minutes as the 40 wheel takes an hour, whatever may be the time of the great wheel, which is generally made 3 hours in these clocks. The 15 min. wheel of 100 drives another pinion of 10, \therefore in 1.5 min., and that having a wheel of 90 drives the scape-wheel pinion of 9, which, with the double three-legs and a $1\frac{1}{2}$ -sec. pendulum, turns in 9 seconds. But if the pendulum is $1\frac{1}{4}$ sec., the scape-wheel will turn in $6 \times 1\frac{1}{4}$, or $7\frac{1}{2}$ sec., and its pinion must either be 8 driven by 96 or 9 driven by 108.

In all clocks of this kind the pallet arbors are set in small cocks, on the large one which carries the pendulum, and the scape-wheel itself has only a short arbor in two cocks behind the other wheels. The pendulum swings in a long slot in the flange at the top of the frame, reaching from one cross-bar to the other; and the escapement fly also in another space, with the two three-legged wheels between the back bar and another which carries all the

wheels. There is room enough for all this, and a sufficient length of barrel, in the width of frame that the striking part requires, which is always a good deal more than the going part, on account of the greater thickness of the rope, and the cams and levers and the winding wheel. The frame is generally $4\frac{1}{2}$ in. deep, with a wide flange turned inwards all along the top, to set the various cocks on.

There is a little inconvenience in the third wheel turning in $1\frac{1}{2}$ min. instead of either 1 or 2, as you want an index of some kind to mark seconds for regulating, unless you go entirely by the striking. But this train distributes the teeth so much the best that I adhere to it, and get over the other difficulty either by a pair of small wheels in the proportion of 3 to 2, the smaller carrying a seconds hand, or else depend on an index placed over the rim of the 90 seconds wheel, which is graduated up to 30, so as to give the seconds in every half-minute, leaving you to see by the other dial, on the hour arbor, which half-minute it is. With a 2-sec. pendulum there is no such difficulty, for the scape-wheel then turns in 12 sec., and its pinion of 10 driven by a wheel of 100 lets that wheel turn in 2 minutes; and that may have a pinion of 10 driven by 100, which will turn in 20 min. instead of 15, and consequently wants a pinion of 12 to an hour wheel of 36. Several other numbers also would do; but we shall see afterwards how the second wheel may be used to obtain greater precision in the time of beginning to strike than you can get from an hour snail, a good way off the escapement too, if the second wheel turns in 15 or 20 minutes. And if you want to apply it to the half-hour striking also, which only requires two pins (T in Fig. 23, p. 177) instead of one, it must turn in

15 min. The great wheel need not turn in any particular time. Sometimes I have had them for 4 hours. In the Westminster clock it was convenient to have it turning in 3 h. 45 m. A minute-hand is, or should be, always set on the hour-wheel arbor, with a dial to set the clock by, which is best done by letting the gravity escapement run or stopping it for the necessary time, which is another advantage of these clocks.

Wire Ropes.—The introduction of wire ropes, instead of the old hemp ones of 5 or 6 times the thickness, did a great deal towards enabling the barrels and clock frames to be made smaller than the clumsy things of old times, which it is no longer necessary to describe, as wire ropes and iron barrels have become universal. But I find it is still necessary to warn people against using zinced wire ropes. I found long ago that for some reason or other zincing iron wire or sheet iron tends to make it brittle, and sometimes the zinc splits off,* while tinning it has the contrary effect; only it does very little towards preventing rust, for galvanic reasons. But the best way of preventing rust on wire ropes is to keep them well greased with a mixture of tar and grease. Paint splits off with the bending of the ropes.

Striking from the great wheel was another important improvement which followed from the use of wire ropes with many more turns of the barrel for one winding up, and especially those of steel wire, which may be thinner still. The saving in friction, and consequently in weight and the strength required, is more than any one would suppose; and that also has become universal in all clocks, except those of makers who have steadfastly set their

* This applies to coatings put on by dipping, but not to some of the more modern processes.

faces against all improvements, and consequently never dare to accept contracts guaranteeing the rate of time-keeping prescribed above, or the raising of hammers that will bring the full sound out of bells, which the old clocks never did. By using suitable cams instead of pins for working the hammers great economy in power can be effected. They are now generally cast on the great wheels, and in very large clocks are faced with steel. For an eight-day striking part I have come to the conclusion that the best arrangement is to have about 18 cams working two hammers, so that each hammer-tail and cam has the same action as if there were only half the number of cams. In some of Dent's earlier clocks the hammer-tails were on opposite sides of the wheel, with two sets of cams, each having half the number. But this is unnecessary if they are placed as in Fig. 21, keeping quite clear of each other, which is easily managed, taking care to place them so as to make the intervals between the blows exactly alike; *i.e.*, their centres must be on prolonged radii of the wheel, $1\frac{1}{2}$ cams apart. The reason for having 2 hammer-tails, instead of one shorter and working over half the space, is that the pressure of such a short lever sometimes cuts off the ends of the cams if the lever end was not blunted enough, though there are plenty of such clocks going without any such result. On the whole it is better to avoid the risk, except with small bells not above 2 cwt., which only want hammers of 4 or 5 lbs. If there are 22 or 24 cams, of course, the teeth of the great wheel, and of the small one on it, which drives the locking-plate, must be increased; and remember that when there are two hammers that 36-wheel must still be twice the number of the cams, as each cam strikes two blows. I assume the

locking-plate wheel to have one tooth for every blow struck, though you may vary the number if you keep the right proportion ; *e.g.*, you might have 30 and 66, instead of 40 and 88. Both these wheels are in front of the frame. The great wheel of 108, or 3×36 , drives a pinion of 9, which therefore goes one third round for each blow, and accordingly has 3 cams to lift the detent. The winding pinion should pump into and out of gear, as there is no use in giving the clock the friction of turning it. Its back pivot is accordingly set in a cock bolted to the cross bar in the middle of the frame, with a key that drops into a nick round the arbor to keep it in its place. In the drawing it looks as if the second hammer lever pivot was in the winding-pinion one ; it is only optically so, as they say of stars, which may either be really inside a nebula or billions of miles behind it.

Half-hour Striking.—For striking *one* no lift by the locking-plate is required, but only a long notch reaching from 12 to 2 ; and for the same reason the clock can be made to strike one at the half hours by dividing the locking-plate into 90 ($= 78 + 12$) and leaving a wide notch between every two hours, and providing a half-hour lifting pin besides the hour one. Most of the French clocks are so made ; but they have the inconvenience of striking one three times between 12 and 2 ; so that between those hours the striking tells you nothing. I once saw a turret clock made to strike one feebly on a smaller bell, from the going part, which gravity escapement clocks will bear, though not others. It was not satisfactory, and led me to devise the following plan.

To make $12\frac{1}{2}$ and $1\frac{1}{2}$ silent, with the locking plate movement, we evidently want something which will stop the lifting piece, L O N in Fig. 21 (p. 164), of a clock of

this kind, from falling after it has been lifted to give warning, until the next hour. And the way to do that is to have a 12-hour wheel (the one with 24 ratchet teeth in Fig. 21) with two steps in it, as you see, which come under the tongue of the lifting piece just over that wheel at those two half hours. The best way to drive it is by a gathering pin or single tooth, which is shown in the hour wheel marked 40, and which moves the ratchet wheel one tooth just after warning. There is also a spring click or jumper to keep it in its place, which wheels driven in that way always require, to make sure of the gathering tooth taking them up again. But another thing has to be attended to. The locking-plate, instead of having 78 teeth or spaces, as when there are no half hours, or 90, as when all the half hours strike, must have 88, and each notch must again be wide enough for striking one, only it must be divided as if there were no half-past twelve or one, for one o'clock is the same as one half hour between twelve and two. The jumper spring is on the right side of the 24 ratchet wheel with the $12\frac{1}{2}$ and $1\frac{1}{2}$ o'clock steps on it.

Maintaining Power.—The maintaining power which I always prescribe, except for very large clocks, is that known as the improved bolt and shutter. In the older form of bolt and shutter, which is now seldom used in large clocks, there is an arbor with a weighted lever at one end of it, with a click in the form of a spring bolt on another lever; when the weighted arm is lifted up the click "takes into" the teeth of some one of the train wheels, and the weight then keeps the clock going till it works itself out of gear in a few minutes and drops. The weighted lever is outside the clock and is made with a cap or shutter which shuts over the key-hole when it is

down, to make sure of your lifting it before you begin winding. With the usual ingenuity for doing things wrong, this click is very often made not as a sliding bolt, but with a hinge, so that there is one position of the lever in which it jams against the teeth and stops the clock for good, unless the winding man finds it out and releases it, which he probably will not. Sometimes too the click sticks and sometimes it slips, even if made rightly. There is another defect besides in the common bolt and shutter, viz., that it may work itself down and rest upon the winder or key before the winding is done if the man is slow about it, and then it does no good and the clock stops for the time.

Improved Bolt and Shutter.—To prevent these evils, and to simplify the construction, I introduced the plan of substituting for the 'bolt' a segment D, in Fig. 21, p. 164, of a small wheel suited to the teeth of the great wheel, and making the arbor C, which carries that and the shutter M, to pump in and out of gear, and the shutter not covering the key-hole, but made as a circular arc to the centre C, which all but touches the winder when it is on. The winder has a ring, shown by the circle at M, fixed round its end, which prevents it from being put on until you have lifted the shutter and put it into gear with the great wheel, to hold it up. As you go on winding, the clock goes on and the shutter descends, now behind the ring, which secures your pulling it out of gear again when you take off the winder, and yet it will keep in action full 10 minutes if left to work itself out. This plan is now generally used in superior large clocks. The weighted arm should be long, so as not to require a heavy weight to be lifted.

Some clockmakers found, after much trouble (of which

they were warned before), that the spring-going ratchet will not do for gravity escapement turret clocks, except very small ones. Where the dials are so large as to require more weight than can be wound up without an auxiliary pinion like the striking part, I think the Westminster maintaining power is the best (see also Fig. 23); though this one in Fig. 21 does perfectly well, and is generally used for larger clocks.

Stops for Weights.—Where the weights do not go down to solid ground there ought to be a large box full of broken stones, not gravel, for them to fall on if a rope breaks. The reason why stones are the best is that they give the weight something to do in breaking them a little more, which uses up a good deal of its force. Sawdust or chips are too elastic, and sometimes throw the weight off on to the floor, and therefore through it, as happened at St. Albans lately, from over-winding. Gravel is too hard to break, but still gravel or even sand will take off a great deal of the force of a blow in displacing it; but I am convinced that stones are the best. They may be covered with a thin board, to look tidy. Their depth should never be less than 2 ft., and more according to the bigness of the weight and the possible drop. But another kind of stop also is requisite where the weights go out of sight, to prevent over-winding, *i.e.*, winding right up to the fixed pulley. A mere straight stop to catch the top of the weight will generally do, because it gives check enough to make any man who is winding feel it, though of course there is a little risk of the jerk and strain, for which extra strength of rope must be provided; but this will not do when a great multiplying power has to be used. Nor is it at all safe to rely on human stupidity attending to any mark on the rope, which there was at

St. Albans, even if there is always light enough to see it and the real winding man is told about it, who is probably a mere blundering deputy of the one who ought to do it. At Westminster, I provided an absolute stop to the turning of the handles beyond the proper times, both when the clock is going to strike and when it is fully wound. But ropes on long ungrooved barrels do not travel uniformly enough for that method to be adopted with them; and besides that, the ropes often overlap, though they had better not. It would be easy enough to make each weight raise a lever with a sort of click to it, which would ring a bell when the weight has got to the top, in several ways. And now that electricity is coming into use for everything, the weights might make a contact to complete an electrical circuit when they reach the top, and so might make any kind of noise which the winder could not fail to hear, or drop a lever to stop him.

When the weights do not hang from the barrels, but the ropes have to be led off to a fixed pulley somewhere, it is necessary that it should be so far off and in such a position that each rope may feed straight off and on the barrel, without either separating or grinding against itself. It is so much better to let them hang down, that I would rather have them hang so by 3 lines, which requires no more pulleys, and only two-thirds of the height of 2 lines, than lead off for anything less than 15 or 20 times the length of the barrel. But more than 3 lines increase the friction enormously, and should never be used; nor should 3 together with a fixed leading-off pulley, which makes 4 lines or 3 pulleys. The weights in this clock go down within the frame, close to the walls, and are boxed all the way down. Even if they did not, the tower must not have been much smaller, on account of

the fly, in which length is of great value always for steadiness of striking, and you must have a reasonable space for the handle to turn in winding, even if it goes the right way, as it does here, not requiring the man to stand beyond it.

Four-wheeled Trains.—These horizontal frames evidently require rather more length than a well-arranged cage frame, in which the wheels stand over each other, and they would require still more to contain a four-wheeled train. Turrets are sometimes made so small that a horizontal frame clock even of 3 wheels cannot be got in. The clock can be got into less length by making the frame something like a pointed arch, which is also a strong form. Many years ago I designed some small quarter clocks with frames of this type, for a confined space, to be sent to Mexico, since such an arrangement brings the work within the smallest possible limits. I believe they were the strongest clocks of the size that had ever been made. There are no loose bars whatever to the frame, and instead of cylindrical bushes (Fig. 22 *a*) which can only be let in near the middle of the bar, the bushes are mostly of the form *c*, which admits of greater variety of position, and also enables the wheels and other pieces to be taken out singly with greater facility than the let-in bushes. Another bush, which is used in clocks with horizontal and arched frames, is that at *b*, which is the best of all for convenience of fixing, and adjusting the place of the wheels, and taking them out separately.

There is yet another kind of bush which I used first at Westminster, and it is the best for the barrel arbors of clocks with a horizontal frame. A hole of the shape *d* is cut out of the piece, which is then cast as a projection

downwards from the frame, large enough to hold a bush of the form *a*, and with a slot below just wide enough to let the arbor drop when the bushes are pulled out. Otherwise it is necessary to bolt large pieces, or cocks, on to the frame, and the back piece is sometimes difficult to get off. I shall call these 'drop-bushes' accordingly. At Westminster they are not used for the barrels, but for the third wheel arbors which drive the flies.

In connection with bushes it is necessary to warn people against making oil holes in them, which is sometimes done from overlooking the difference between the

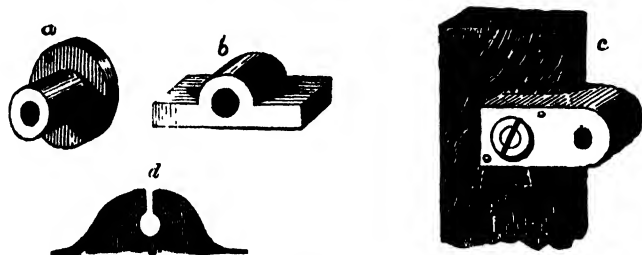

FIG. 22.

slow-going pivots of clocks which do not need oiling once a year and the quick ones in other machines which require constant feeding with oil or they will heat. Such holes in clock bushes are very soon drained of oil and become receptacles and feeders of dirt and grit. What little oil is needed easily works in from the ends of the pivots, the old oil being first wiped off.

Size of Fly.—There is no more frequent mistake in turret clocks than that of making the fly too small to preserve uniformity of time in striking, and the defect is generally incurable for want of room. When the fly of the hour striking part is too small the velocity increases after the first few blows ; and with quarters on four bells

especially, some blows come quick and others slow, according as the heavy or the light hammers are being raised. You must have a considerable superfluity of force beyond what will just raise the hammers, and the regulation of time must be done by the fly. I do not however see my way to prescribing any rule for the size in proportion to the weight of hammers or bells beyond this, that each arm of the fly of any large church clock ought to be fully 2 ft. long; and for the very large bells which have lately come into fashion again, the flies must be still longer. Length is much more effective than width. There may be from 4 to 8 turns for each blow or each quarter, according to the size of the clock. At Westminster we could get no uniformity of striking quarters with a fly going faster than 4 times to each chime; 6 or 7 is generally the best number.

When it is impossible to get room for flies of proper length and size to equalise the time, something may be done by using a three-armed fly, but that is by no means equal to one with two arms of sufficient length.

I find it necessary to add, that the flies should on no account be in front of the clock, for that involves the use of a winder with a very long pipe to clear them, which is harder to wind and strains the arbors. In very large ones, such as Westminster, a vertical rod may be carried up and the flies put quite away at the top of the room. I have seen it done also in much smaller clocks where there was no room otherwise for the flies.

LARGE CLOCKS WITH QUARTERS

Fig. 23 is a front view of a larger clock than those previously described, substantially according to the plan

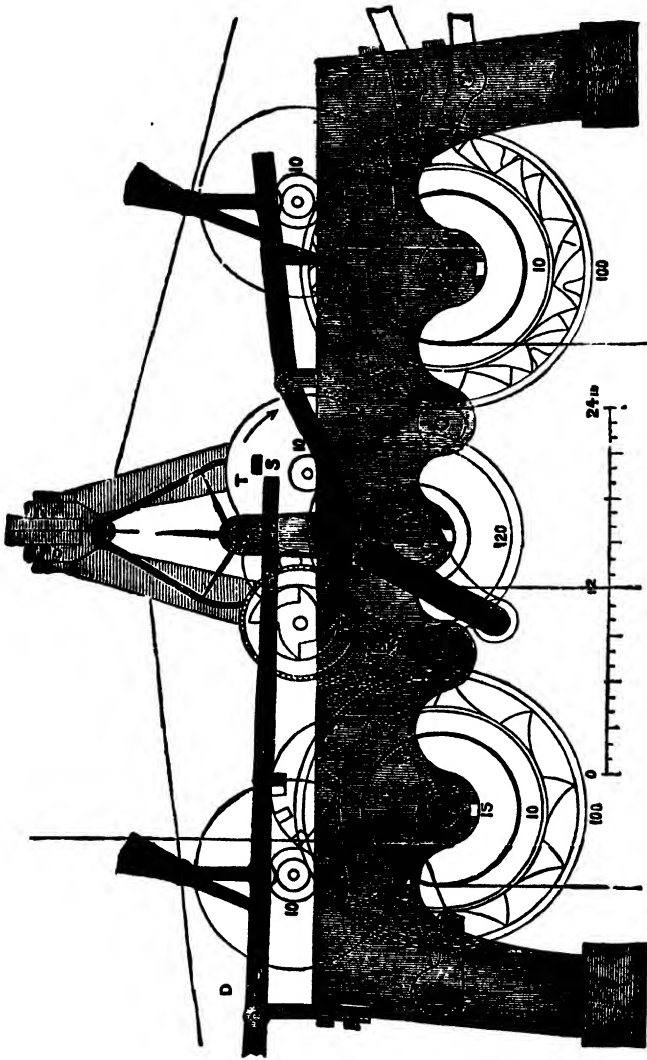

FIG. 23.

which I settled for old Mr. Dent's factory many years ago, whereby we reduced the cost of large quarter clocks to little more than a quarter of what it used to be, and at the same time greatly increased both their accuracy and strength. This only shows two quarter hammers for simplicity. Indeed four could not be shown in an elevation, as the levers must then all be on one axis or pin, and the cams come irregularly, as will be explained under quarter chimes. As Fig. 21 was of an eight-day clock, to which a quarter part might be added much like the hour part, this is of larger clocks, with heavy bells, and winding up the striking parts every day or two days, according to the available fall. It is impossible to strike heavy bells properly with an eight-day clock unless it has a very unusual fall, and even then it would want very inconveniently long barrels, and the old-fashioned clocks never did strike properly.

The hour great wheel here has only 10 cams, which I consider the best number for the arcs that have to be described by the cams and the hammer-tails or levers, when we are free to use any number, which we cannot in eight-day clocks. Therefore this requires only 16 turns of the barrel for 24 hours, or 156 blows, and 2 or 3 more for a few extra hours; or say 35 or 36 turns for winding every two days; and therefore quite short barrels will do, with wire ropes as much as $\frac{1}{4}$ in. thick, which are enough for all but very large clocks beyond the ordinary patterns.

The going part is always made to go a week, or rather 8 days and a fraction, to provide for the forgetting of a day.

It is impossible to give any rule for the size of the great wheels, as it clearly ought to depend on the work they have to do. For bells from about 30 cwt. to 53, a common

range for the tenors of large peals, an 18-in. great striking wheel is the best pattern to keep, as it is inconvenient to use many. A 24-in. wheel with only 10 cams of proper size and strength will do very well for bells up to 5 or 6 tons, or even 10 tons, if the teeth and cams are wide enough. The great going wheel may be from 13 up to 16 inches for any four dials from 7 up to 12 feet, and there are very few larger. The other wheels may be in proportion. The scape-wheel legs should be from 5 to 6 inches long, and you must allow plenty of room for a long fly, not less than 9 or 10 inches, especially for large dials, which should have a considerable superfluity of force, to drive the hands in all weathers. For that reason the scape-wheel arbor is put on a higher cock than before. The pendulum is carried in the same way by the frame. If it is a very large one it is well to put one or two brackets or struts from the wall to the back part of the frame near the pendulum, but that is not necessary generally, as this kind of frame for 18-in. great wheels is only 5 ft. 6 in. long, and forms a kind of arch when its feet are firmly bolted to the corbels, which I need not say should be a great deal deeper than there was room to show in this drawing. If they are iron brackets they should be built into the wall and wide at the top also, to prevent any risk of sideway motion under the swing of the pendulum.

For 10 cams the great wheel had better have 100 teeth, and the pinion 10; or 120 and 12 of course run rather easier, which pinion will evidently go once round for each blow. But if you want the clock to go 4 days without winding and to have only one hammer, 16 cams will be better, and 192 teeth in the great wheel, driving a pinion of 12 two-thirds round for each blow. And then you

may make the cam wheel on that pinion with 2 hollows in it one-third and two-thirds of the circumference apart, and they will always come right, because the number of the hours is odd and even alternately, if it is put in the right position ; which you will find more easily by trial than by explanation here. But this would not do when half-hours are struck by the hour part, for two odds then often come together, such as 3 and 1, 5 and 1, &c. The general calculation for all numbers is this. Let p be the leaves of the pinion, which must be a multiple of 3 if you are to use that method ; n the teeth of the great wheel, and m the cams. Then $\frac{2}{3}p$ must $= \frac{n}{m}$ or $n = \frac{2}{3}mp$: p must be taken as 12 for this purpose, and $\therefore n = 8m$. If p has 10 leaves and is only to go once round, n must evidently $= 10m$. It is not convenient to have two large hammers with a ringing peal, as it is difficult to get room for them in the frame, though it is easy enough for stationary clock bells. But it is unnecessary to consider all that if the clock winds up every day or two, which is always best for large ones. A few cocks and bushes are omitted in the drawing to avoid confusion.

In other respects this striking part is the same as in Fig. 21. But I now show the plan for letting off the striking of the hours more exactly than can be done by the slow motion of the hour wheel and its snail, especially as it is a sort of outrider to the train. This was first done in the Westminster clock, but the plan now described for the first time was not expedient there on account of the great size and weight of the discharging levers. Here you see that the long lever or detent DS is carried over to the second wheel of the going train, which has a square pin T on one of its spokes ; and there is another square

pin S on the detent, now shown below the other, the clock having just struck. But at some minutes before striking S gets raised above the circle in which T moves, which can be done, because at that time T is out of the way. Just before the detent is going to drop off the snail T has come under S, and S cannot fall again till T slips from under it, which will take place with perfect accuracy at the last beat of the pendulum for the hour, as the motion is large enough to be visible, and a very little way off the scape-wheel. This is inconsistent with altering the hands less than 15 or 20 minutes, except by running the clock, as you easily can, with a gravity escapement. In the Lincoln Minster clock Mr. Potts provided in this way for the quarters also, as did Messrs. Smith at St. Paul's and Beverley, which however are not of so much consequence as the first blow of the hour. The second wheel must in that case turn in 15 minutes ; but without the quarters it may be either 20 or 15. The pins S and T should be so placed and shaped that the pressure may not tend to stop the wheel.

As I have already shown the maintaining power which is best for clocks not requiring an auxiliary winding wheel, I show here the one which is best for those that do ; though the other, of which a piece is shown at B, may be used for them. This is the one that I designed for the Westminster clock. The winding pinion and the bars which carry it, the front one fixed and the back one hanging from the arbor, are out of the vertical, because the action of gravity is wanted to make the pinion and back bar which carries it fall on to a fixed stop, when the winding is done, or suspended for a short time. The back bar also carries the click which takes into ratchet teeth cast on the back of the great wheel. It might go

into the other teeth, but for the risk of catching only on their tops and slipping, so that ratchet teeth are safer, and practically cost nothing when once the patterns are made to cast from.

The arrangement of the quarter part for 4 bells is practically the same as for 2, except that all the levers must be on one steel pin, which should be screwed tight at its ends to help to keep it stiff. Either for 2 hammers or for 4, the best way is to cast one set of cams on one side of the great wheel and another on the other, at the proper distances to make the interval between successive chimes at least twice as great as between the blows in each chime. For 4 bells two other sets of cam rings may be cast in one, and all bolted together. Some clock-makers prefer an independent cam barrel driven by the great wheel, to which there is no objection except the extra friction, which I once found to make the difference of requiring an auxiliary winding-wheel. When steel cams are used they are all bolted to a wide ring or barrel cast with or bolted to the great wheel, the nuts being inside it. Four quarter hammer-tails cannot well be turned inwards as the hour one can, in the form which makes the pressure on the arbor only the difference instead of the sum of the two forces on the lever. But they can have their wires in the middle, instead of their fulcrum or arbor being there, as in the Westminster clock, and in that way the friction on their arbor is reduced to a minimum, the wires being put as near the cams as possible. I designed the clock at St. Paul's Cathedral to strike the hour on "Great Paul," but objection was taken to altering the striking from the very inferior old "Phelps" bell.

Two quarter hammers—or two alternate hour hammers—can also be placed as in this Fig. 24, which I designed

long ago with the same object of keeping the power and the work on the same side of the arbor, and many large clocks were so made at Dent's factory. It involves cams on both sides of the great wheel, which are as easily cast as on one side. The rope also should always pull on the same side of the barrel as the cams, in order that the pressure on the great arbor may be the difference instead of the sum of the weight and its work, and consequently the friction much less. You may fancy that these

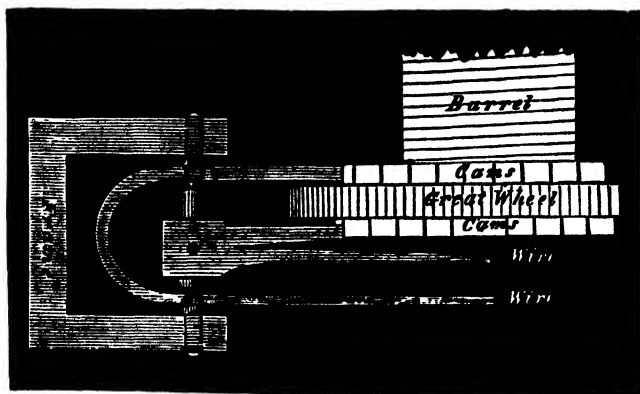

FIG. 24.

frictions of pivots, and of teeth when the cams are not on the great wheel, cannot come to much compared with a great striking weight, or a hammer of many pounds weight raised 9 in., or about 6 vertically, 156 times a day; but you will find very few clocks in which the weight \times its daily fall is not more than twice or even three times its theoretical 'duty,' or the hammer \times 78 ft., which excess is all due to these various frictions.

If no quarters are struck at the hour it is better to have 12 cams, the locking-plate being on the great wheel arbor, so that they will turn in 2 hours. In that case the pinion

may as well be of 12, driven by the great wheel of 96, and therefore turning $\frac{3}{8}$ round for each quarter chime as before described for hours in some cases.

Lifting the hammer by pins on the striking wheel, as in house clocks, is totally wrong in large ones, and it is nearly discontinued. The pins necessarily begin to act a good way from the end of the lever, and therefore at the greatest disadvantage as to leverage, and that at the very time when the hammer is rising most vertically (in the usual way of hanging) and requires the most force to lift it. The lifting should be done by cams, which begin to act on the end of the lever, and are properly shaped to act with the least possible friction throughout. Pins with rollers on them are of very little use, and do not obviate these objections, and are weaker than fixed pins : they are nearly if not quite abandoned.

Cambridge and Westminster Chimes.—Considering the thousands of men who had listened for 3 or 4 years together to the famous St. Mary's chimes at Cambridge, during three quarters of a century, it is odd that no one ever thought of copying them in any other public clock. The last but one Lord Lansdowne tried it, but his clock-maker, Mr. Vulliamy, made the mistake of ordering and hanging the bells of four successive notes before writing to ask me about them ; whereas they ought to be such notes as E, D, C, G ; or the fourth bell must be a musical 'fourth' below the third : bells are always counted from the highest note or smallest bell. At the Royal Exchange, in 1845, they did get so far as to adopt the Cambridge notes ; but the Gresham professor of music thought he could improve upon the tunes, and spoilt them. I have been told by a Cambridge man of the last century, that they were invented by the well-known Dr. Crotch, in 1780,

from an air of Handel's, who has generally had the credit of inventing them, and perhaps deserves it.

The following are several arrangements, -which are suitable for any key, and therefore I have indicated them by the bells in a peal of 6, which these quarters require, leaving the hour to be any note below the lowest quarter bell.

Cambridge and Westminster.	Doncaster and Scarborough.	Royal Exchange.
2nd { 3126 } { 3213 } { 1326 } 4th 3rd { 6213 } — { 1236 } . 1st	1st 1236 2nd { 3126 } { 3213 } { 2613 } 3rd { 6213 } { 1326 }	1st 3126 } { 6213 } 2nd } 3rd { 1326 } { 3213 } } 4th
		But this is bad.

I call the bells 1, 2, 3, 6, in all cases for more easy comparison, though they would be of various numbers according to the peal they belong to, on account of the numbers being always reckoned from the smallest, in the order in which they ring. Indeed a peal of 6 could not have these chimes at all without an odd bell, either above as at Headingley, or below as at Ossington.

You see from the table that the Cambridge chimes are repeated twice in the hour, and therefore the cams may be fixed on a barrel which turns in any multiple of the 5 chimes in that table. In some clocks the 5 sets of cams alone are put on a barrel driven by the great wheel, but with much more friction than in other clocks that I know with bells of about the same weight; one, with this second barrel, required a double multiplying power to wind it up, while another, with the cams for an hour on the great wheel itself, winds quite easily with a single pinion. At Westminster there are 3 sets of cams, or

what may be called an hour and a half's chimes, on the great wheel, *i.e.*, on a wide barrel attached to it, because it happened to be convenient with the great fall we have there. The cams may be cast in separate rings of cast steel, but it is better to have smooth-faced steel cams screwed firmly to a plain barrel, as they are at Westminster, and in all the best very large clocks now.

The interval between each chime (*i.e.*, between the chimes of each quarter) requires some attention. At Cambridge it is 3 times the interval between the blows of each chime. That appears to me decidedly too slow, and at Westminster, Doncaster, &c., I made the interval only two spaces instead of three. That again is perhaps rather too quick, and at Worcester, and all the subsequent large clocks for which I have given designs or specifications, there are $2\frac{1}{2}$ spaces, which sound the best of all. The barrel, or each portion of it which contains the 5 chimes, must then be divided into 55 spaces, of which each blow occupies 2, and the intervals between the chimes 5 spaces.

When there are two hammers for the 4th bell, as there always should be, those cams may, and should be, made longer than the others, as there is then ample room for it; which diminishes the pressure on them, and makes it more continuous, and so tends to equalise the time. This is important, because the 4th quarter bell is much the heaviest, and there is the least interval between its blows.

In all quarter clocks, striking on a peal of ringing bells, provision should be made for lifting off the hammers, or they are almost certain to be broken when the bells are rung, and perhaps the bells cracked besides. This is easily done by a lever; or, when the hammers are very heavy, it is better done, as Mr. Cattley arranged at

Worcester, by an eccentric brought down over all the levers just where they come out of the clock. The hammers must not only be lifted off the bells, but so high that the cams do not lift them at all, or all the wires will soon be broken by the jerks. And as the clock is thus relieved of its work, it is better also to make the turning of the eccentric, or pulling down the lever, let down a wooden brake on the fly arbor, to help the fly to stop the velocity and diminish the blow on the stops.

Quarters on Two Bells.—The bells must be at the musical interval called a fourth, and the higher of the two should be an octave higher than the hour bell if there are quarters at the hour; though that is not so material, and they may be the 1st and 4th of a peal of 6, or even 5, or the 4th and 7th of a peal of 8, because there should be a longish interval of time between the quarters and the hour, which saves the ear from being offended with the want of the proper musical interval. The old York Minister quarters, and a few others, were at the interval of a fifth (which in music, though not in arithmetic, is larger than a fourth), but they do not sound so well.

Time of Striking.—The quarters are generally made to let off the hour, as in house clocks. But where accuracy of time of striking is required, this plan is insufficient; for it makes the first blow of the hour depend on the time both of letting off, and of striking the quarters, both of which may easily vary several seconds. It is therefore essential to accuracy that the hour-striking should be let off by an independent snail of its own, exactly at the hour, with the quarters let off the requisite number of seconds before the hour; though the other three quarters may be allowed to strike at their proper times. Even this is not sufficient where extreme accuracy

is required, as I have already explained. The hammer should also be left 'on the lift,' or nearly ready to fall; which is in other respects also a good thing in a very large clock, because it relieves the wheels and the stopping pieces from a heavy pressure, and throws it all on the cams and hammer work, which must in any case be strong enough to bear it. In this case it is necessary to put a small click somewhere, to act on a pin in the fly arbor to prevent the train from running back when you wind up the clock: indeed it is as well to put one always, as the winding always tends to drive the train back. Where there is no special provision for accurate striking, as above, care must be taken to make the discharging snail large, and its corners sharp and hardened, and those of the discharging lever or lifting piece also. See also p. 181.

Chime Tunes.—There has been a considerable revival of the old fashion of having tunes played on bells by machinery for a few minutes at certain hours of the day. The old machinery for this purpose was extremely simple, consisting of a large barrel 2 or 3 feet in diameter, generally made of wood, with strong iron pins screwed into it like a huge musical box barrel, and pulling down levers which lifted hammers on the bells like a common striking part. If there were several tunes on the barrel, either that or the bed of levers had an endway motion, shifting at the end of each tune, or shifted once a day by the clock. The Royal Exchange chimes are of this kind, only the barrel is of cast iron, with a vast number of holes in it, in which pins or short cams are screwed to play any tunes that the bells admit of.

Some new ones of the old kind have been put up in St. Albans Cathedral by Mr. Godman, a clockmaker there, entirely from his own design. The barrel is 7 ft.

long, of wood on iron rings, and the levers are worked by cams of 'phosphor bronze' screwed on, for 8 tunes on 8 bells, which I think are quite tunes enough, and more than were generally used in old times. The tunes shift themselves. The Westminster quarters are also put there on the same plan and in connection with the chimes in a room above the clock. Notwithstanding the superiority of those I am going to describe next when constantly looked after by a competent person, which they require, and which of course costs money, I have returned to the opinion that for ordinary churches, where there are seldom any funds to spare, the old-fashioned chimes are the best.

The chimes in some foreign churches are played by hand, I understand, without anything that can be called machinery. The hammers, being light, are easily lifted a little by a man playing on keys like a piano, only with his fist instead of his fingers. I have seen tunes played on church bells here with even less machinery than that. They just tie the bell-ropes to the clappers, and the lower ends to rings on a board screwed down to the belfry floor, bringing the clappers so near to the bells that a slight pull will make them strike. The man 'operates' them (in American grammar) by pulling some of the ropes with his hands and pushing others with his arms, and so manages to play a feeble sort of tune.

NEW CHIME MACHINERY

The new kind just now referred to were introduced by Gillett and Bland, of Croydon, and by Lund and Blockley of Pall Mall, both of whom bought some patent rights of an inventor named Imhoff, and have both made improve-

ments of their own. The principle of the invention consists in this, that the hammers are raised by a long barrel full of cams which have nothing to do with dropping them, but are continually at work raising any levers that happen to be down. The levers are then caught and held by triggers, which are let off by quite small pins on a wooden barrel just like that of a common grind-organ. The barrel can also be taken out and changed, besides each barrel holding several tunes which change

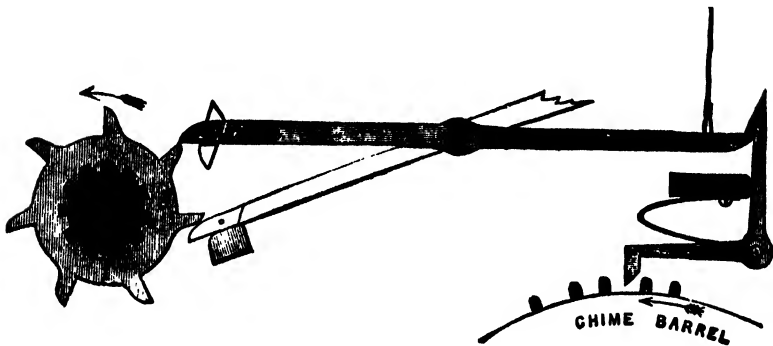

FIG. 25.

themselves by an endway motion. Fig. 25 shows Gillett and Bland's mode of lifting. Each lever has a jointed beak which is lifted by one of the 7 cams on the barrel belonging to that lever; and when it has been caught by the trigger at the other end the cam slips away, and the beak drops, so as to clear the cam next below, and gets caught again by the next to that, because it falls on to a block which stretches out the beak. This gives a greater lift for a given number of cams, and so allows more cams to be put in the barrel and more lifting to be done with a given velocity.

Lund and Blockley's lifting barrel has only 4 cams, and

they lift from 90° before the vertical up to their highest position, by means of a hinged piece dropped from each lever. They also strike the Westminster quarters by means of the same set of pins as the tunes : which I must say I disapprove of altogether compared with a proper quarter-striking part. I have seen an otherwise very satisfactory large clock of theirs, with chimes on a peal of 16 large bells for the Bombay University ; and some smaller ones. Gillett and Bland's principal chimes are at Worcester Cathedral, Boston and Croydon Churches, Bradford and Rochdale town-halls, and at Eaton Hall. The performance of both kinds is more accurate and satisfactory than in the old-fashioned machines ; but, like most superior machines, they require a great deal more care and consequent expense than the old rough ones. No chiming machinery can bring the full tone out of bells, especially the large ones : but this is stronger in lifting as well as more exact in letting off than the old kind. Every bell requires two hammers, and at Worcester some of them have three, because of the quick repetition in some of the tunes.

It is necessary to give one caution most strongly to ambitious chime-cultivators. Avoid 'chords,' or two notes sounded (professedly) at once. At Croydon they thought they knew better, and a more horrible performance I never heard from the rudest old-fashioned chime barrel of 200 years ago. I believe the chords have since been abolished.

Another caution is, not to attempt chimes on large and small bells together. For some reason, which neither I nor the bell-founders know, it is a fact well known that bells below 4 or 5 cwt. cannot be made to sound homogeneous with large ones. They attempted it at

Boston, and have got 42 bells (including the 8 of the peal), some of only a few pounds weight cast in Belgium, and chimes to play on them all together. I and other people who went specially to hear them considered them a failure. Even quarter chimes are never satisfactory when large and small bells are mixed. The same result is unpleasantly conspicuous at Eaton, though the bells

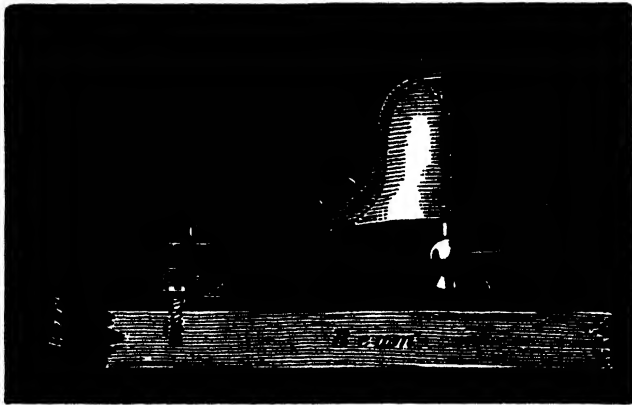

FIG. 26.

there are not so numerous, and were all cast in Belgium together.

Clock Hammers.—Turret clocks generally strike on bells of a different shape from the hemispherical house clock bells, which do not answer beyond a-very small size. Most people (except artists, who always draw them wrong) are aware that the general shape of church bells is that shown in Figs. 26, 27. The clock hammer CS is always fixed at right angles to the swing of the bell, for two very obvious reasons: first, if the bell was free to swing under the blow of the hammer, the first blow of every hour would set it swinging a little, and at every

blow after that the bell would either be out of the reach of the hammer altogether, or else jarring against it ; and

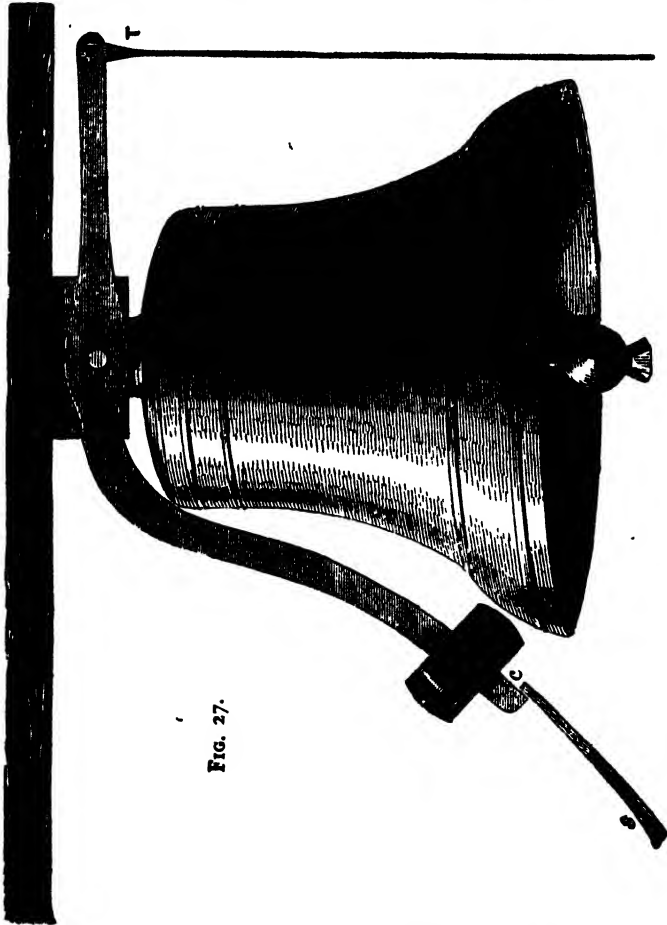

FIG. 27.

another reason (if it is worth while to talk of other reasons after this) is, that if the hammer was put in front of the bell, all its machinery would have to be moved out of the way before the bell could be rung at all.

The hammers of large clocks also differ from small ones in acting by gravity, as you see. But they equally require a check spring, or some other contrivance to keep them from jarring the bell. When a church bell is rung *up*, *i.e.*, swinging once round for each blow, and *set* mouth upwards, the clapper lies on the bell, but not so heavily as a clock hammer would, because it stands at a higher angle. The usual kind of hammer spring is shown in Fig. 26; and *s c* in Fig. 27 shows as much of the spring as there was room for. The spring is sometimes made adjustable, by having long holes for the screws to go through, so that you can bring it farther from or nearer to the bell as may be required in course of time. India-rubber buffers under the hammer shank are better in some positions, and have the advantage of never breaking and being easily replaced or altered in thickness. I used them at Westminster.

I believe it is the fashion on the Continent to fix the clock hammers with their pivots above the bell, when it has not to swing; and it has the advantage of securing a long hammer shank, and therefore less angular motion for a given lift, and moreover the effective weight of the hammer is not so much lost in the lift as it is in the common position. But on the other hand, with bells as tall as the foreign ones are, the hammer shank stands much more vertically than in the other way, and the rebound from the buffers or check spring is greater, and a greater lift (obliquely) from the bell is required to get the same momentum of the hammer; not that that imposes more work upon the clock. At Westminster we were obliged to adopt that plan, on account of the construction of the tower and bell-frame, and there it had this incidental advantage with regard to the great bell, that we

were enabled to get the hammer tail T directly over the end of the lever in the clock, by setting the hammer frame or the pivots which carry it, a little out of the cardinal position relatively to the tower, and so all cranking was avoided and a vast quantity of friction saved.

Cranks.—Nobody who has not tried it can have any idea how much of the force of a clock is wasted by having to lift the hammer through cranks. The cranks and lever arms and hammer shanks and tails should all be long. I know that in modern towers, which are nearly always built too small for properly hanging the bells, there is often great difficulty in getting room for clock hammers and cranks at all ; but wherever there is room, the action will be easier and more effective if all these arms are made long instead of short.

When the clock is above the bells, as in the Leeds town-hall, and the Royal Exchange, it is a very common mistake to put a tail to the hammer to pull down first, which of course involves the necessity for another to pull up again. It ought to be done as I designed it at Leeds (if there is room) by pulling up at once from a lever set inwards or on the same side of the arbor as the hammer itself, unless it happens from some local peculiarities that this would involve as many cranks as the other way.

In several of the former editions I gave a design for catching the hammer at its rebound without any buffer-spring ; but I have never heard of it being tried, and therefore I do not repeat it, and have modified Fig. 27 accordingly to show a common buffer-spring.

The weight of hammer and its lift can only be determined by experiments. Different thicknesses and qualities of bells require different hammers. I have generally

found that large bells whose diameter = $12 \times$ the thickness of the *sound-bow* or thickest part (which is the best proportion) require hammers of about a 50th of their weight to bring out the full tone, and small bells require heavier ones. The lift has to be less for small bells than for large: the least that is effective in bells above 3 or 4 cwt. is 6 in. (measured obliquely in the direction of the motion), and beyond 13 in. we did not find any improvement in the sound of either of the great Westminster bells. Generally they are a great deal less either in weight or lift, and often in both, and therefore you hardly ever hear a church bell sound so loud under the clock striking as in ringing with the clapper. Thinner bells, as the larger ones of peals usually are, do not require such heavy hammers as thick ones; but it must be remembered that no hammer arrangement will get as good a sound out of a thin bell as a thick one, because it is radically inferior both in quantity and quality of sound. I only add a word of warning against a piece of ignorance by which I remember a very fine old bell being cracked in a few months—viz., making the clock hammer to strike it with a sharp edge instead of a flat or slightly rounded face, as it ought to be.

The above remarks on the weight of hammers possibly require considerable revision in view of the fact that there have been great changes in bell design within the last twenty years. (See p. 149.)

DIALS

The striking of church clocks, and perhaps of public clocks in general, is of more value than their dials, except in places where the public congregate. Indeed dials a good way above the eye are of no use for indicating the

time very accurately, on account of the parallax which affects the minute hand, except when it is nearly vertical. Moreover, many church towers would be utterly defaced by dials ; and it is to be hoped that the splendid church of St. Mary's, Beverley, now that its fabric has been restored to a condition worthy of its architecture, will not long retain those abominable dials in the tower windows, which belong to the age when the inside of the church was divided into private boxes, in which people might eat their dinner or play at cards without their neighbours or the clergyman knowing anything about it.

But as dials must frequently be used, architects might as well condescend to learn something of their proper size, as they profess to provide places for them, as they do for bells, frequently in utter ignorance of what the provision ought to be. Luckily there is such a simple rule for determining it generally, which has now been long published, that they have no excuse for doing it wrong. That rule is that the diameter of the dial should not be less than a tenth of the height of its centre from the ground. If you want to verify this you have only to look at the dials of the Leeds Town Hall, planned by an architect with the usual knowledge of such things, 150 feet high and only 11 wide ; and those of the Bradford Town Hall are no better, but I do not know the exact height ; or that of St. Pancras Church, $6\frac{1}{2}$ feet wide and about 100 feet above the ground. The neighbouring railway station however has inside it a large dial 15 feet wide, at the height of 55, looking down the largest space under one roof without pillars in the world, viz., 700 feet long and 240 wide. The external dial of St. Pancras Station is rather too small, being 12 ft. 9 ins. diameter while the height is 150 ft.

But if dials are sometimes too small, the opposite mistake is often made, of figures much too large, which is not a compensation but an aggravation of the evil, for they practically contract the size of the dial, in two ways ; first by contracting the plain surface in the middle, over which the hands are most distinctly seen ; and secondly, the larger the figures are, the more they run into each other and fill up the space of the figure ring itself, and make it still more difficult to distinguish the place of the minute hand. Ignorant people fancy that you see what o'clock it is by reading the figures ; as if any single figure which you see in a clock dial indicated the figure which you read off ; except for the hour hand, and the hour also is at once recognised by the position of the hand. You see the long hand pointing to VIII, and you say, ' 20 minutes to something.' Both for the hours and the minutes everybody really judges from the position of the hands, and 12 large spots would do as well or better than figures. I have several clocks without any figures at all round the principal dial, only 12 strong marks ; and I never found anybody who even observed the fact that the figures were absent until it was pointed out to him, or complained of the want of them then. I came to the conclusion after various trials, that the figures and minutes together ought not to occupy above one-third of the radius of the dial ; the figures may be two-thirds of that one-third ; and the minutes from half to two-thirds of the remaining one-ninth of the radius, with every fifth minute strongly marked by a larger spot than the others. The Westminster dials might have been clearer, considering their great size. They are not of my design, except that I gave the architect some suggestions for them, which are partly followed and partly not followed.

They are unnecessarily confused with iron frame-work, and the clear space is unduly contracted by some broad rings supposed to be ornamental. The dials at St. Pancras Station are much better.

The only colours that seem to answer for dials and hands are black or dark blue with gilt figures and hands, or some very light coloured ground, such as white glass, with black hands and figures. Good gilding will last fifteen or sixteen years, as at the Royal Exchange, in the worst London atmosphere: bad gilding of course wants renewing much oftener, and is probably the dearest. Gilt hands on a light ground are a complete failure. The external counterpoises, if there are any, should be painted the same colour as the ground of the dial, except where they are very short in proportion to the hands, as at Westminster, in which case they cannot be mistaken at any distance for the hands themselves, and practically increase their visible length.

Dials may be made of almost anything—stone, slate, plaster, brick, iron, copper, and many old ones are of wood, which however is the worst of all, as it always shows the joints. In many cases the stone of the tower makes the best dial. Generally it requires painting, but if it is such a stone and in such a position that it will keep nearly white, it will do very well with only the black figures and minutes painted on it, and black hands, but by no means gilt ones. Dials on brick work must of course be painted. It is quite a mistake to suppose that a dial requires a very smooth surface. Some of the most distinct I have ever seen are painted on rather rough stone work; and brick will do as well, either all flat, or with the figure circle a raised ring of iron, or of any plaster that will stand. There are many dials of cast

iron ; but I should never make more than the figure ring of iron, unless there is a large hole in the wall which wants covering ; and even then it is generally better to fill it with glass, which has all the effect of a dark ground outside and is often convenient within. Slate makes a good dial, but if it is not painted it becomes a pale grey colour. I believe 6 feet diameter is the largest size that can be got in one piece, but the joints are almost invisible if well done.

Copper dials are the commonest of all, and up to a moderate size, probably the cheapest, except of course when the dial is simply painted on the wall. But they are generally made in the very worst form that could be invented, viz., convex : the effect of which is that the point of the minute hand is thrown a long way off the dial, and the parallax is so great that you cannot tell what it is pointing at, except when it is nearly vertical, when seen from below, as a public dial always is. One way to avoid this is to countersink the middle, in which the short hand travels, leaving the long hand to lie close to the raised figure ring. I have lately seen some dials made of mosaic work, like pavements, by Messrs. Rust, of 16, Albert Embankment, which look very well, and the price was not more than of copper dials ; and they can easily be made concave.

Concave Dials.—It occurred to me some years ago that all the convenience of the light copper dials might be got, with even more closeness of pointing than in a flat one, and with as much stiffness as the convexity gives, and with less distortion of appearance, simply by making them concave instead of convex. If you draw a vertical section of a convex and a concave dial, and three lines of sight, from the top, the bottom, and the middle of each,

to a spectator in the street, you will see at once that the convexity makes the upper half appear much smaller than the lower, whereas in the concave one the two halves appear even more alike in size than in a flat dial ; and the closeness of the hand pointing is evident. There are now a good many of such dials, and no one who has seen them can fail to perceive their superiority to convex ones.

Hands.—Large clock hands are so universally made of copper that it is hardly worth while to notice any other construction. There is indeed—or was, a notable exception, in Sir C. Barry's famous gun-metal hands at Westminster, which is not likely to be repeated. The length of each hand and its external counterpoise is 14 feet ; and the total weight of each hand with its external and internal counterpoises is now within 2 cwt., whereas Sir C. Barry's 4 minute hands and counterpoises weighed a ton and a quarter. His hour hands are still there ; for though very bad in construction and three times as heavy as they need be, their motion is so slow that they do not sensibly affect the clock as the minute hands did, and so they may as well stay until they become unsafe. One of them cracked and had to be taken off. The hands of the clock at old Doncaster church, which perished in the fire of 1853, were of mahogany, and stood very well ; but I should think copper ones are lighter, even including the stalk or centre piece. Where they are very large, say 5 or 6 feet long, the best form for them is that of the minute hands at Westminster, viz., a tube of thin copper, whose section is two segments of a circle, with a few diaphragms at intervals of about 2 feet to keep them stiff. The strength of this construction is enormous, and it is also good for throwing off snow, which sometimes accumulates on hands with broad edges heavily enough to

stop the clock. Smaller hands may be made quite strong enough with a convex front and a flat back, the section being an arc and its chord, or even as a single flat piece of copper with the edges turned over square. A mere rib or hollow bead raised along the middle of a hand makes it strong enough for all ordinary sizes, but it does not look well. 'Galvanised' sheet-iron hands have been tried, but the zinc peels off, and they must be pronounced a failure. The minute hand should always be straight, and plain, with a bluntish point. At the broadest part, or near the dial centre, it should be about a 13th of its length, tapering to about half as much near the point. The hour hand should be the same breadth, ending just short of the figures in a broad piece called a heart, of any shape you like.

There should always be some external counterpoises to large hands, both for wind and weight. They should not be above $\frac{1}{3}$ the length of the long hand, and should be broad, but of a shape not to be confounded with the heart of the hour hand. The advantage of counterpoising the hands to some extent for the action of the wind is evident; and the other use of an external counterpoise is to diminish the tendency of the hand either to twist the arbor, or what is more likely, to work itself loose and shake over from one side to the other every time it passes the vertical, as Reid says the old hand of St. Paul's cathedral used to do, and as Sir C. Barry's heavy hands did at Westminster to such an extent as to stop the clock. The only way to prevent this shake is to fit the hands on a tapered square or hexagon at the end of the arbor, and not a prismatic one. The latter may be called engineers' fitting, and is perfectly right for many purposes, but perfectly wrong for this, for which the old clock-

maker's taper fitting alone will answer. It is found better not to put the whole counterpoise for very long hands outside: from one-third to one-half is quite enough, leaving the remainder to be done by adjustable counterpoises inside, which should be long rather than short, as they then do the same work with less weight and friction on the arbor.

Illuminated Dials.—Occasionally it is possible, as at the Horse Guards east dial, to illuminate a common white dial by reflection from a lamp on a roof projecting below it. This answers well enough for dials to be seen a short distance only, in the few cases where it can be done. Where it cannot, the common way is to make the dial of glass, or all of it except the figures, and the rings to connect them, which form a solid framework of cast iron. The glass is ground behind, or painted, or covered with muslin stuck to it, and lamps are put behind it. But all these things have such a bad appearance by day that the advantage of illumination is dearly purchased at that cost. Now however a white glass is made by Messrs. Chance, of Birmingham, and perhaps by other makers, which forms a very good and always clean white dial by day (if left open for the rain to wash its face) and a bright one by night: the hands and figures must be black as with other white dials. It should be $\frac{3}{16}$ ths of an inch thick, or 22 oz. to the square foot; the middle of large dials has to be in two or three pieces, which must be divided by bars not radial, or they will look like hands at night; and all but the figures and minutes should be gilt.

It is now practically universal practice to use electric light for the illumination of dials. It is a simple matter to make the clock turn on the lights at night and out in

the morning. It cannot be done at all accurately by any uniform automatic motion, because the clock times of sunrise and sunset vary irregularly from the equation of time, and very slowly near the solstices, but at other times from 12 to 15 minutes a week.

It is desirable to have a wall, if possible, behind illuminated dials, instead of having them practically in the clock room; partly because the wall may be made useful as a reflector, and so save light, and also because it protects the clock itself from the variations of heat. Reflectors are a great saving of light and of cost. It must be remembered also that the counterpoises of the hands on glass dials must neither be long ones outside, nor immediately behind the glass inside, or they will cast a shadow and be confounded with the hands at night. There should always be ventilation over illuminated dials.

Dial Wheels.—The construction of the dial work of large clocks differs very little from that of small ones. The principal difference is that the numbers of the wheel teeth are differently distributed. Instead of two equal 60 min. wheels, there is a pinion on the minute-hand arbor which drives a wheel corresponding to the "minute-wheel" of a watch; and that wheel has a pinion on its arbor which drives the hour-hand wheel as in house clocks. If t t_1 are the numbers of the wheels and p p_1 of the pinions, they have only to satisfy this condition,

$\frac{t t_1}{p p_1} = 12$, bearing in mind also that, from their position, the radius of one wheel must be as much less than of the other as that of its pinion is greater. The larger wheel is generally put on the hour-hand arbor. The most convenient numbers are 90 and 100 for the wheels,

and 25, 30, for the pinions, or in smaller clocks 72, 80, and 20, 24.

The bevelled wheels leading from the clock to the dials ought to be of a good size, not less than 5 inches wide in small clocks, and 7 to 9 inches in large ones. They need not be very strong, as they have only to move the hands ; but the advantage of their being large is that any given amount of shake in the teeth allows less angular motion of the hands. In the old way of fixing clocks on a stool in the middle of the room, which I have already shown to be the worst, there was generally a vertical rod from the clock running up the middle of the room, with 2 horizontal bevelled wheels, one on the bottom worked by the clock, and the other at the top working 4 others leading to each dial ; and in that case it is necessary that the bevelled wheels on the vertical rod should be larger than all the others, both the first one in the clock, and the others leading off to the dials : otherwise the 4 leading-off wheels will take into each other as well as into the horizontal wheel. Where the vertical rod does not lead into the middle of the room this does not occur, but there must then be two nests of 3 wheels each, if there are 4 dials, besides the two wheels in the clock. I have seen several more wheels added, through a singular piece of ignorance that it is not the least necessary that the rod which leads upwards should be vertical. I was rather glad that it was necessary to put it very oblique in the Westminster clock as an example of such treatment. With bevelled wheels of the common shape, intended to lie at right angles to each other, the rod must be in a vertical plane parallel to the clock wheels, but there can seldom be any difficulty in that : if there should be, the bevelled wheels have only to be made for the proper angle.

Ventilation of Clock-room.—The clock-room at the Exchange was at first made with the object of keeping out the dust and damp in every possible way: even the slits in the floor for the ropes had sliders to them; the clock was enclosed in a glass case, the plate-glass cover originally placed over the escapement being found not enough to keep it from the damp. When the clock was repaired, and some of the brass-work replaced with iron in 1854 (for a reason which I shall mention hereafter), I suggested the removal of all this glass, and encouraging instead of preventing a draught through the room. This was done; and although the wet used to stand in drops upon the clock before in damp weather, it has been perfectly dry ever since. The same thing has been found in small clock-cases: they may easily be too air-tight. I do not mean that there is any objection to enclosing a clock in a case, and of course it is absolutely necessary where the clock-room cannot be kept locked against everybody but the man who has the care of it; only there should be a draught through the room, and the case itself not too close to let air through it. If the room can be kept warm enough to prevent the damp from condensing on the clock it is better still.

Cast-iron Wheels.—The success of the contrivances for cutting off the variations of force from the pendulum led to another alteration which helped to reduce the price of large clocks considerably; and that was the making all the wheels below the escapement, and all the dial wheels, of cast iron instead of brass or gun-metal. Mr. Vulliamy had before recommended that as a good construction for cheap clocks, but it had always been thought that they could not be also good ones on account of the greater friction of the train. I believe that apprehension was

very much exaggerated, even for clocks of the common construction, provided of course the escapement is light and well made ; but as soon as you cut off the friction of the train from affecting the escapement it is obvious that cast-iron wheels are just as good as brass or gun-metal. The clockmakers in general violently denounced it, probably for no better reason than that it lowered their prices enormously, the price being now only £200 for clocks of greater power and far greater accuracy than those for which £500 used to be charged not many years ago.

The cast-iron wheel controversy came to a head in some of the Lancashire papers soon after the making of the clock, from my design, for the Manchester Infirmary ; and the advocates of brass wheels had clearly no case whatever. Their three points against cast iron were friction, rust, and liability to break. The friction of the train is absolutely immaterial with a remontoire, or a gravity escapement, and no large clock can go with great accuracy without some such contrivance. The next objection is obvious nonsense, because all except the acting surfaces are painted, and they are of course oiled as in all other iron wheel machinery. The liability to break is a mere question of experience. Those who condemn them for clocks must be very ignorant of the extent to which cast-iron wheels finer than are ever used in church clocks are used in every factory in Yorkshire and Lancashire. I made particular inquiries once as to the sizes down to which the teeth are cast in iron wheels for spinning machinery (for that is what I mean by cast-iron wheels), and I found that they are cast with quite sufficient accuracy with teeth as small as $\frac{1}{10}$ inch thick ; which is smaller than any I have seen used in clocks, because there

is very little saving in cost in using iron wheels so small as that. The great saving of course is in the large wheels of the train, and the dial and bevelled wheels, of which a good many of the same pattern and no very fine pitch are required. Owing to the high efficiency of modern gear-cutting machinery, very accurately cut cast-iron wheels cost little more than those with moulded teeth, and they are much better.

Before I leave the cast-iron wheels I should observe that they work better with cast-iron pinions than with steel ones : indeed cast iron and steel seem never to work well together, at least in no clockwork that I am acquainted with, if there is much pressure between them. I have seen cast-iron fly ratchets used with steel clicks, by clockmakers who would not listen to the proposal of iron wheels and pinions for any but the commonest clocks, and they had to be removed, and replaced either by wrought-iron or brass ones. I have seen and heard of brass teeth worn out in an almost incredibly short time, long before iron teeth in the same clock showed any signs of wearing. Moreover, few people have any idea how rapidly brass is corroded and in fact destroyed by such an atmosphere as that of London and other large towns. I have several times seen the brass tubes which had been used in dial work, and thin pieces of brass elsewhere, brought back to be replaced with iron because they had become completely rotten. It was so at the Royal Exchange in eight years.

In this respect gun-metal is better, which is copper and tin instead of copper and zinc, but for large wheels it is no way superior to iron ; and it is generally made too soft. It is equally absurd to polish iron work, except the acting surfaces ; that rusts even sooner than brass begins to

corrode ; in fact very often in a week after the clock is put up. Then somebody who has the care of it floods it all with oil, and it is filthy ever after. The only proper rule to lay down is that *all non-acting surfaces should be painted*. In the Westminster clock even the small brass wheels in the escapement are painted like the iron ones.

The truth is that all this 'finishing' of non-acting surfaces is what old Dent used to call 'working for fools.' It has literally no other object (as plenty of clockmakers have confessed to me) than to make an impression on the 'fools' (in and out of the trade) who go to see a new clock in the first month after it is put up, and never see or want to see it again. Such people as these think it a much finer thing to have a clock look bright for a month and never keep time within a minute a week—or a day, for what they know—than 'to look like a patent mangle,' but keep time within a second a week.

I must warn people however against some altogether cast-iron clocks which got into vogue some years ago by their extreme cheapness, if they could be called cheap at any price. I heard constant complaints of them, and had to subscribe once to help a friend to get rid of one and substitute another of a proper kind. I shall give presently a form of specification showing how much of a large clock may be of cast-iron.

A few years ago I learnt when it was too late that a deputation from the corporation of a considerable town had come to London to negotiate for a first-rate town-hall clock, and after wandering about for some time they fell into the hands of 'an eminent firm' who boast of sending clocks all over the world, and engaged to pay them more than would have bought the best possible

clock for one which was warranted to keep time within 5 *minutas* (not seconds) a week ; whether it actually does perform that feat I do not know, but I heard casually of some other of its successes, which gave hopes of it breaking down altogether.

Another common cause of bad church clockmaking is the inveterate habit of jobbing for the benefit of a townsman by giving the order to a watchmaker who never made a turret clock in his life, and who immediately goes or writes to one of the few real makers for the cheapest clock that will serve his purpose, and probably charges for it as much as the people could have got a first-rate one for, if they had had a competition of the best real makers of large clocks, or even gone to one of them alone. The local watchmaker, by way of carrying out the fraud completely, generally insists on the real maker putting, not his own, but the pretender's name on the clock. If this were merely a question between the makers who consent to do so and those who will not, I should leave them to find their own remedy ; but as it affects the general credit of our public clocks, I think it right to give this warning, though it will probably not be read by one in a hundred, or attended to by one in a thousand, of those for whom it is intended. It would be far better to do the ' native talent ' job in a straight-forward way by letting the local watchmakers draw lots for a *bonus* of £20, and then advertise for tenders under proper conditions, such as I suggest below.

The practice of insisting on clockmakers tendering for bells, except quite small and common ones, is almost equally objectionable. Every now and then, one party or the other has paid dearly for it themselves, for which also I do not care ; but the more material thing is, first,

that two profits have to be got out of the transaction without any real necessity for a middle man, and that there is practically much less responsibility and control than when you deal directly with the bell-founder. You might as well insist on the clockmaker fitting up an observatory with telescopes,* or trust a builder to put in painted windows and the organ in a church.

SPECIFICATIONS FOR PUBLIC CLOCKS

Every now and then I happen to see specifications for large clocks, either prepared by somebody belonging to the office which has to order it, or in the form of a tender sent in by some advertising clockmaker, and I hardly know which are generally the worst, except that the author of the tender does know what he is about, and takes care to put in as many adjectives and as few substantives as he can, and the author of the specification never does know what he is about. An elaborate specimen of this kind was shown to me some years ago, from a Government office, which stipulated, among other remarkable things, that the pendulum was 'to vibrate 2 seconds, but to be as long as the room admitted of.' It was also to have *convex* copper dials a *quarter* of an inch thick, and a *dead* escapement, which were three specimens of the author's practical knowledge of the present state of science. The specification, though of many pages, did not contain a single thing, except the probably impossible pendulum, of the slightest value towards securing what (I suppose) was wanted, either in the way of time-keeping or striking. Sometimes the providing of a clock and bells

* There was indeed one clockmaker quite competent to do both, the late Mr. Cooke, of York; but then he made the telescopes himself, and was one of the best makers of his time.

is entrusted to the architect by people who are not aware that modern architects rather boast than are ashamed of being totally ignorant of everything of the kind. I have heard people who ought to know better say, that 'the only way is to throw all the responsibility of everything connected with the building on the architect,' and utterly puzzled when I asked them what those fine words meant, or what would they do if everything turned out wrong, as it generally does in that case. I will therefore give a specimen of the specification suitable for a large church clock, though I cannot adapt it to all possible circumstances; and a much stricter one is requisite for a general competition than for one limited to a few makers whose work I know to be of the best kind. Indeed, no specification can secure a good clock from a bad clock-maker; and it ought not to be necessary to warn people (but I find it is) that those who blow their own trumpet loudest in advertisements are very often the least to be trusted, especially in an article of which most purchasers are quite incapable of judging, until it is too late. All that a stringent specification can do is to frighten away bad makers from tendering at all; and for that purpose the first clause of the following form is useful in a general competition, provided it is certain to be enforced.

1. To make and fix a clock with m dials of n feet diameter, and striking the hours and Cambridge quarters, on bells which are or would be the 2nd, 3rd, 4th, 7th, and tenor of a peal of 8, the tenor weighing —.

2. The dials to be concave and made of copper, or painted on the wall, if smooth enough, or with the figures and minutes of cast iron, in rings. If the dials are to be illuminated they *must* be of cast iron, and should have opal glass of 22 oz. to the foot, except behind the minutes,

which may be 16 oz. to the foot. There must be no straight radiating pieces of iron in the middle. [Architects should be made to understand (if possible) that dials intended to be illuminated must have a clear opening in the wall of the full diameter of the dial.]

3. The long hands to have a short external counterpoise, painted the same colour as the dial, if not illuminated, and the hands, figures, and minutes to be gilt. If illuminated, the hands, figures, and minutes to be black, and all the rest gilt. The long hands to be straight and plain.

4. The escapement to be the double three-legged gravity, and care must be taken to leave room for the fly of sufficient length, and to make the angles such as to run no risk of tripping, and generally according to this book.

5. The pendulum to have zinc compensation with iron rod and tube, and bob not less than 2 cwt. To beat $1\frac{1}{2}$ seconds for a clock with several large dials, but may be $1\frac{1}{4}$ for a smaller clock, or if there is no room for a $1\frac{1}{2}$ second pendulum. It is to swing $2\frac{1}{2}^{\circ}$ from zero, and to have a block under it in case the spring breaks, and a degree plate.

6. The clock must lie on stone corbels or heavy rolled steel joists, or brackets bolted through the wall, and the pendulum cock either bolted to the wall, or rising from the clock-frame, which is to be generally on the plan shown in Fig. 23 of this book; but the great wheel arbors are to be in drop bushes of the form *d*, Fig. 22.

7. There is to be a minute dial, and either one for seconds or a wheel marked for that purpose, with a fixed index.

8. To have the improved bolt and shutter maintaining

power (p. 171) or the Westminster one for a very large clock. The going part to go a little over eight days.

9. The striking parts to be wound up every one or two days, except in small clocks [or they will never strike efficiently]. All the striking to be done by steel-faced cams on the great wheels. The 4th quarter bell to have two hammers (see p. 186). In smaller clocks cast-iron cams will do.

10. The hour striking to be let off independently of the quarters, and the first blow to be struck exactly at the hour, the hammer being left on the lift: the other quarters to begin exactly at 15, 30, and 45 minutes.

11. Subject to the advice of the bell-founder, the hour hammer to be not less than a 60th of the weight of the bell, and to be raised not less than 9 inches; the quarter hammers to increase in weight upwards from a 60th to a 40th of the weight of their bells, and all the hammers to be raised enough to bring the full tone out of the bells: small ones at least 6 in., and the hour one at least 9.

12. There must be either levers or eccentrics to lift the hammer levers completely off the cams, when the bells are ringing, if there is a peal.

13. The small wheels of the going part to be of manganese-brass or hard gun-metal, driving lantern pinions. All the larger wheels and the pinions driven by them may be of cast iron, and their being of brass or gun-metal will be considered no reason for a higher price. All bushes to be brass or gun-metal. The large pivots to be case-hardened, the smaller ones and their arbors to be of steel. The pulleys to be large and pivoted in brass bushes.

14. The barrels of sheet iron or steel brazed, with iron or steel wire ropes *not* coated with zinc [which makes them

crack], and the pulleys to be so placed that the ropes do not grind, or go twice over the barrel.

15. The flies not to be in front of the clock, and to be long enough to make the time of striking quite uniform, and slow enough. The fly ratchets to be either squared or keyed on, and not merely pinned. The ratchets *not* to be of cast iron, and each to have two clicks. [Many smashes have occurred for want of attention to these two conditions.]

16. All the iron-work except acting surfaces to be painted blue [black is more difficult to see if anything is wrong, and if not painted iron only gets rusty].

17. If the weights go out of sight there must be something to stop or warn against winding them too far, and also a large box with 3 feet deep of small stones, to catch the weights if they fall, unless they go down to the ground of the tower, when they can only break flags.

18. All wheels to take out separately by unscrewing the bushes ; and pulleys to be placed where they can be oiled.

19. On all points not specified, the clock is to be made according to the directions of this book, applicable to clocks of the kind now required.

20. The clockmaker to provide (or design and superintend) a strong wooden case for the clock, with glass showing the minute dial if it is in the belfry, and so arranged that the striking parts can be wound without opening the case, unless the clock is in a room always locked up, and protected from weather. In many places it is necessary to have a case for the weights, and pulleys at the top, if exposed in a bell-chamber. The pulleys must be *easily* accessible for oiling.

21. The clockmaker to provide the necessary switch-

gear for automatically turning on and off the lights according to the time of year (see p. 203). The switch to be so designed that the break is rapidly performed and free from any tendency to burn the contacts.

22. The estimate to state the cost of the clock and dials, and of the fixing, case, &c., separately.

23. Half the price to be paid on the clock being completed, to the satisfaction of such person, not objected to for good reasons assigned by the clockmaker, as the committee may appoint, and *the other half when it has gone for three calendar months continuously, without varying more than five seconds in any week*—tested by the striking of the first blow of any hour. [This is an ample margin to allow now that we know from the Westminster and other clocks that they may be made to go without much more than a second a week variation.]

In these days of wireless telegraphy every important clock-tower should be provided with a set for receiving time signals. The presence of such a ready means of verifying the accuracy of the clock is no excuse, if the maker does not provide a first class timekeeper. A log-book should be kept showing the variations from week to week, and these might with advantage be published in the local papers.

REMONTAIRE OR GRAVITY ESCAPEMENTS

These are not to be confounded with the thing called a train remontoire, a device at one time fitted to turret clocks, but now quite obsolete. A gravity or remontoire escapement is one in which the impulse is not given to the pendulum directly by the clock-train and weight, but by some other small weight lifted up, or a small spring bent up, always through the same distance, by the

clock-train at every beat of the pendulum. And the great advantage of them is that the impulse is therefore constant ; for the only consequence of a variation in the force of the clock is that the remontoire weights are lifted either faster or slower, which does not signify to the pendulum, as the lifting is always done when the pendulum is out of the way. If this can be managed with certainty, and without exposing the pendulum to some material variation of friction in the work of unlocking the escapement, which it must perform, its motion and therefore its time must be absolutely constant, since there is nothing to disturb it. It does not look a very difficult problem ; and yet it puzzled the clockmakers to solve it in a satisfactory way for about a century, in consequence of certain small difficulties which nobody would guess until he had the opportunity of seeing them in action ; and after all it was not done by the clockmakers, but by two lawyers, in different ways.*

Sir E. Beckett's Gravity Escapements.—I have now to describe the only escapements of this kind which have ever come into real use ; and that both for large and astronomical clocks, especially the former. The earliest form of them need no longer be described, as it has been superseded by two others, one with a four-legged scape-wheel for small clocks, and the other with a double three-legged wheel for large ones.

The four-legged escapement is shown in this drawing (Fig. 28) of a regulator of this kind seen from behind, half the real size. To avoid confusion, only the centres of most of the wheels are shown, and you see the train is

* Bloxam's escapement proved unreliable, and very few were made.

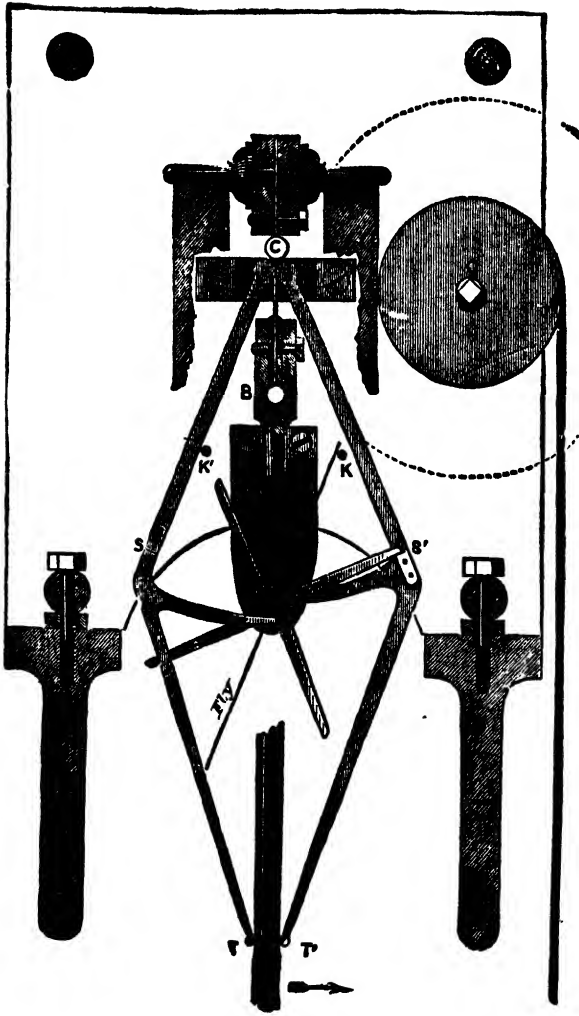

FIG. 28.

inverted, to save height in the frame and clockcase. G is the great wheel arbor, and the barrel is shaded, C the centre wheel, close to the top of pendulum and pallet arbors, B second wheel, A seconds-hand wheel, and E scapewheel. DD are the brackets which come out of a large cast-iron plate or back, from which also comes the pendulum cock, shown by partly broken lines, to leave the pallet cock visible. PP are the pillars, CST, CS'T' the pallets, and their inside pivots (the arbors being very short) run in a flat piece or cock between the centre wheel and the clock plate or frame. The scapewheel speaks for itself as to the long locking teeth ; but it has two sets of lifting pins near the centre, pointing alternately backwards and forwards, one set lifting one pallet and the other the other, the pallets being in different planes, before and behind the wheel, with one stop S pointing forwards and the other S' backwards. This cannot be done otherwise with an even-numbered wheel, and though it can with a five-legged one, that is an inferior construction in other respects, and is much more difficult to make rightly, and has not one advantage when it is made. [I say this from experience now, as I did before from theory. For with the strange propensity of mankind for taking more trouble to do wrong than it would take to do right, some persons would persist in making the escapement with five legs. I thought it might possibly save a little force or weight on the train, but it does not even do that ; nor anything else, except give more trouble to adjust : whereas the four-legged one is so easy that the very first I had made went at once perfectly without any alteration.]

The great feature of them is the regulation of the velocity and the avoidance of the banging on the pallets

and the risk of tripping, either actual or approximate, by putting a common fan-fly on the scapewheel arbor. And this becomes possible or effective only by reason of the large motion of the wheel and fly at every beat : viz., 45° in this escapement, and 60° in the three-legs. A fly would be of very little use in Bloxam's escapement, to say nothing of its other difficulties. In order to leave room for the fly the seconds wheel arbor is cut short and set in a cock within the frame, which leaves space enough for a fly above 2 in. long in each arm, from E to B.

The pallets require no beat screws, as they are only thin pieces of steel like square wires, which can easily be bent for adjustment ; and even for a 40 lbs. pendulum they have to be made very light ; they must be cut out of steel plate, and the lifting faces hardened. The pins are found to do better also of steel than of brass, and one set of them should be tapped into the wheel with left-handed screws, so that the action of lifting may not tend to loosen them. The wheel is either screwed on the arbor up to a shoulder with a left-handed screw, so that the action tends to tighten it, or is 'squared on' a hexagon and pinned. The scapewheels are also generally cut out of thin steel plate ; but some have been made of a harder kind of gun-metal or softer kind of bell-metal, ~~and I am not certain which is best.~~ But in either case the stops must be as hard as possible, either steel quite hard or jewels. I think steel hard enough, and I do not believe in leaving any place where there is friction totally dry, though the oil may be the least possible.

Another great advantage of these escapements is that the length of the teeth or legs, and the largeness of their motion, make the pressure on the stops, or the work of unlocking by the pendulum, insensible ; and therefore

also they are incapable of holding up the pallets so as to cause 'approximate tripping' by any force that you can apply to the great wheel, provided the escapement is made properly. But with that same genius for doing things wrong when it is as easy to do them right, some persons have made the angle CSE, at the stop which is struck upwards, less than 90° , and then have said the escapement failed because it sometimes tripped, as it was pretty sure to do. For safety it is as well to put the up stop a little higher and the down stop a little lower than their proper theoretical places, which are where both the angles would be exactly 90° .

That determines the theoretical distance of the pallet arbors C from E, the scapewheel centre. If its diameter is 4 in. that distance is 5.2, and that is the proper distance of the top of the pendulum spring above E. The pallet arbors must evidently be a little lower. Mr. Bloxam made them cranked in order to get their common axis in a line with the top of the spring; but that is an unnecessary refinement, at least for these escapements, and is never done. [And as no point in the pendulum really swings quite in a circle, I doubt if the friction of the pallets on it would be sensibly less for their being both made to describe the same circle by cranking their arbors: at any rate it is too insignificant to care about.]

The distance of the lifting pins from the centre should not be more than a 40th of EC, or else the angle of impulse 2γ will be larger than is found expedient. It is difficult to make the pallets light enough even with a small γ , and the larger it is the lighter they must be. The length of their tails down to the beat pins is arbitrary, but ~~I found the Westminster clock perform decidedly better with the pallet tails long than short.~~ (The length

~~here shown does very well, and it looks neat to make the two parts reciprocally parallel.~~ The pins should be placed so that the lifting may take place equally across the line of centres CE, because then it is done with the least friction. For this purpose the pins which lift the lower pallet must be set on the radii which run along the acting faces of the teeth, and the other set of pins half-way between them, with reversed screws, as I said before.

Any gravity escapement requires a heavier weight than a dead or detached one, other things being equal, because it must be strong enough to lift the pallets promptly and firmly always; but the superfluous force does not reach the pendulum, and therefore does no harm, provided the train is good enough not to waste much force generally in order to get over occasional weak places from bad wheel-cutting. Nothing tests the defects of a train like a gravity escapement. If there are bad places in a common clock train they must be very bad indeed for the teeth not to follow the pallets, though they may be giving no effective impulse for some seconds; but in a gravity clock the pallets have always to be lifted; [and I have never got a train yet in which I could not hear some weak place, recurring always at the same time of day, and requiring at least an extra pound in the weight beyond what was generally wanted. For that reason,] though a high-numbered train is not, or ought not to be, requisite for these clocks, it should be a thoroughly good one; and as defects of cutting affect low numbers more than high ones, it is better to have them rather high, though they need not be anything like what are used for first-rate dead escapements. I have the upper pinions of 10 and the centre one of 12, and if these are well cut, and still better if they are lantern pinions, they are enough; if

If they are not, you will soon hear and see it by the escapement, and the train should be rejected as a bad one.

In gravity regulators, for the same reason, the wheel must have a little run at the pallets before it begins to lift them, just as many clocks will not begin to strike if the hammer tail lies on the pins: *i.e.*, there must be banking pins K K' for the pallets to rest on just clear of the lifting pins. And in turret clocks the banking pins are useful to reduce the arc without making the pallets too thin. They may be simply a thin piece of metal adjusted for the beat pins to fall on.

It is better to have a full-sized barrel with three lines and a fixed pulley for a 'three-quarter length' clock than two lines and a smaller barrel. A clock of this kind with a 40 lbs. pendulum swinging 2° requires a weight of from 20 to 24 lbs., according to the train, to lift the pallets promptly and firmly, and loud enough for an observer.

These clocks have also been made to strike a small bell every minute by a pin on the minute wheel, which enables an observer to go on for some time without looking at the clock. Of course this requires rather more weight, and no such extra friction could be tolerated in a dead escapement. My clocks strike one at the hour on a rather large bell, but that makes no sensible difference in the weight. When there is a full striking part, the train must be arranged in the usual position, which is inverted in the mere going clocks, to save unnecessary height of the frame and the pendulum being several inches above it, on account of the extra wheel and the length of the pallets. The great wheel is also put on the left side to keep it near the side of the case and out of the way of the pendulum. When a pendulum imparts vibration to the weight, as they do sometimes, the simplest cure for it is

to put a board down the side for the weight to graze when it is near the pendulum. It has never happened in my clocks, and three lines tend to prevent it.

Unfortunately I have no daily rate of any of these clocks regularly taken in an observatory, until we come to the largest of them all; but judging of my own for long periods by the Westminster clock; which is tested daily, I have no difficulty in pronouncing it superior in steadiness of rate to any dead escapement whose rate I have ever seen. And they are made by Mr. Brock, of George Street, Portman Square, and I dare say by other makers, for half the price of the old-fashioned best dead escapement regulators with only 12 lbs. pendulums.

Some persons have taken a great deal of unnecessary trouble to modify these escapements in order to avoid the fly, as if that did any harm; and have added train remontoires, as if that did any good to any gravity escapement which really is a gravity escapement—*i.e.* which has no tendency to trip, and gives a constant impulse clear of the friction of the train. One of these attempts to get rid of the fly was exhibited by Dr. Clark, in 1862; but the wheel was stopped with a bang that thrilled all through the clock, which only tends to knock it to pieces, and keeps everything in a state of vibration. It was also a much more delicate construction, and I should prefer Bloxam's if I had to choose between them; for if you have not a fly, the less the motion is at each beat the better. Another contrivance for the same purpose, invented by a French workman here, was used by his employers in a few church clocks, and then abandoned, and my original form resumed by the makers in all their turret clocks. The fly should, of course, be as light as possible, either of thin steel or aluminium; and

the best way to put it on is with a piece of watch spring pushed in through an oblong hole so as to press always on the arbor, which should *not* be very thin. Some persons do not seem to know that a long fly is more effective than a wide one of the same area.

Another mistake made by several of these inventors, including Dr. Clark, was that of supposing it was better to let the pallets unlock the wheel in falling with the pendulum, forgetting that the pendulum is then just as much affected by the friction of unlocking as if it did it in rising, if that friction is sensible; and if it is not, still less can it signify whether it is borne directly or indirectly by the pendulum. It is still worse to keep the pallets moving in contact with the stops during each 'excursion' beyond the angle of unlocking, for that reduces it so far to a dead escapement. But the worst of all the 'improvements' was by the late Mr. Cooke, of York, the eminent telescope-maker, who also made these clocks, and rounded the stops 'to make the unlocking easy:' which degraded it to an impulse escapement, the pallets being then driven away by the teeth with a force depending on the clock weight and friction of the train.

The double three-legged escapement (Fig. 29) is so called because it has two three-legged wheels, A B C and *a b c*, in different planes, with one set of 3 lifting pins between them. Here the two wheels must be squared on the arbor, and the lifting pins need only be shouldered between them. The pallets also lie in one plane between the wheels, but one stop S points forward to receive the A B C teeth, and the other S' backward to receive the *a b c* teeth alternately. The reason for two wheels is that with one three-legged wheel you cannot have the pallets far from upright, which is evidently the

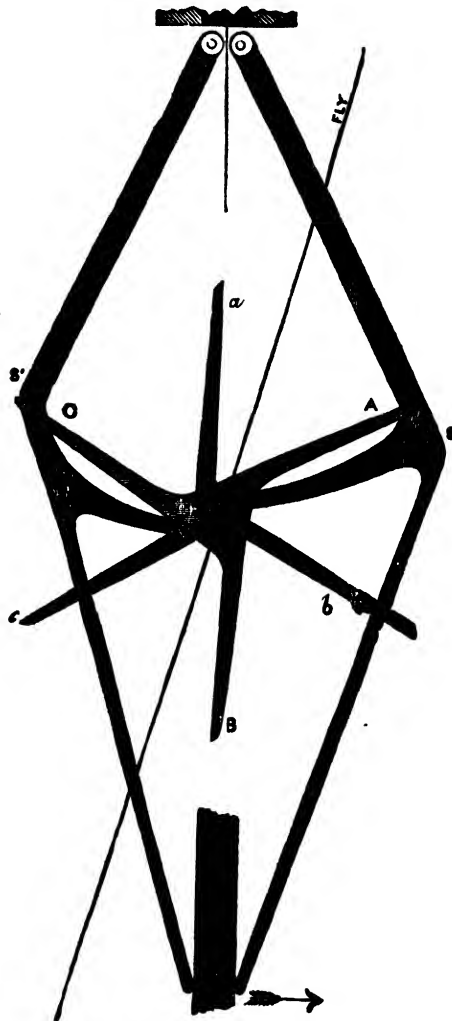

FIG. 29.

worst position for them, as it requires much more dead weight to be moved at every beat in order to have weight enough for effective impulse. It should be understood that there is no particular mechanical advantage in the two wheels being set with the alternate teeth equidistant, appearing like a six-legged wheel. They may be set with one set of legs at 90° and 30° to the other set—or at any other angles to get any greater inclination of the pallets if desired. However the equidistant arrangement is the natural one, and is generally used, though not invariably. I need hardly say that a pair of wheels of this kind are very different from a six-legged wheel, which would only move 30° at each beat, while this moves 60° , besides other differences.

In this case the distance of the pendulum top from the scape-wheel centre evidently = diameter of scape-wheel. The lifting pins should not be farther from the centre than a $\frac{1}{36}$ th of this, or the pallets have to be inconveniently light and thin: the pins and arbor may be solid as a three-leaved pinion. They should be so placed that the one which is holding up a pallet and the one which is going to lift next may be vertically over each other, the third being on a level with the centre—*i.e.*, they will stand on the radii which form the acting faces of the teeth of one wheel, as you see here.

This escapement is the best for large clocks, which must have plenty of superfluous force to drive the hands in all weathers (which superfluous force all reaches the pendulum in clocks of the old kind, varying immensely); but the fly must, on that account, be much larger in proportion than in regulators, and care must be taken in planning the clock to leave room for it. In the smallest turret clocks I have always had the fly a foot long alto-

gether and $1\frac{1}{4}$ in. wide, and in large ones considerably more. When the fly is very large, as at Westminster, the friction of a spring on the arbor is not enough, and there must be a larger 'roller' or blank-wheel pinned on the arbor for the spring to act on. At the same time it was very satisfactory to find that when the men had once forgotten to screw up the spring after doing something to the fly, the clock had never tripped in the days which had elapsed; and I have tried the same experiment elsewhere; but the four-legs will trip if the fly is loose. The greater obliquity of the pallets, 30° against $22\frac{1}{2}^\circ$, is the cause of this superiority of the three-legs; and this obliquity may be increased still more if you like by altering the relative position of the two scapewheels. But I by no means advise the omission of the fly, even then.

In very large clocks the pallet tails are too thick to bend for adjustment of the beat, and then eccentric beat pins are used, which require no description. They are usually made of brass, even in small clocks; but I think it would be better to cover them with hard wood. The finest clock of this kind I have seen was a regulator with four-legged escapement made by an amateur, Mr. George Salt, of Saltaire; and it had ivory beat pins, which certainly had less chatter than brass ones. The pendulum weighed nearly 40 lbs., and yet the clock weight was only 15 lbs., with about 4 ft. fall. This shows that a gravity escapement really requires very little more force than a dead one with as good a train as possible, though practically I should always make the weight abundant. One thing must be specially attended to, as a distinction between these and dead escapements: the beat pins must on no account be touched with oil or grease of any kind, but left absolutely dry, whatever they are made of; for

the slightest adhesion to the pendulum is fatal ; though in dead escapements the fork should always have a drop of oil, to keep it as close as possible without being tight. Moreover, care should be taken to make one pallet begin to lift simultaneously with the resting of the other, and neither before nor after.

The best evidence of the performance of these escapements is the annual report of the largest of them all at Westminster, and I have read in the *English Mechanic* that one under the charge of Professor Waldo, of Yale College Observatory, has gone for several months on a rate of only '47 sec. a week. My own have often gone for months together without any difference from Westminster for which I could venture to correct or to regulate the pendulum. I have never found on close inquiry that the rate of the very best dead escapement regulators approached that of Westminster and several other public clocks of this kind, of which I have occasionally had reports. I have had accounts of some that had been altered from other escapements to this, with the effect of reducing errors of minutes to seconds. The last was from a gentleman who said that his turret clock, made from this book by a man who had never made one before, has a better rate than any astronomical clock he had ever known.

INDEX

ADDENDUM, 22
Age of Movement, 108
Aluminium Bronze, 6
American Clocks, 15, 134
Anchor Escapement, 46

BALANCE, 57
Ball Bearings, 144, 145
B.A. Screws, 11
Barrels, 63
 Going, 67
Bell Metal, 7
Bells, 81, 148
Bibliography, 150
Blueing, 9
Bracket Clocks, 105
Brass, 4
 Rolled, 7
Brazing, 7, 112
Bridges, 79, 110

CALENDAR, 93, 127, 137
Cambridge Chime, 80, 184
Carpenter, W., 81
Case Hardening, 2
Cases,
 Airtight, 132
 Degenerate, 104
 Early, 92
 Periods, 101
 Polishing, 133
 Restoration, 131
 Unsteady, 131
Cast Iron, 1
Centre Seconds, 111
Chains, 62, 67
Chime
 Bells, 81
 Cambridge, 80, 184
 Clocks, Early, 79
 Racks, 78
Church Clocks. *See* Turret Clocks.

Clock Makers' Company, 90
Clock Trains, 131, 155
Collets, 39
Conversion
 of Bracket Clocks, 130
 of Lantern Clocks, 83, 124
 of Thirty-hour Clocks, 83, 125
Coronium, 5
Country Clocks, 91
Crown Wheel
 Escapement, 44, 130
 Pallet Making, 56
 Repairs, 45
 Replacement, 130
Crucible Steel, 3
Cycloidal Teeth, 22, 144

DEAD Beat Escapements, 49
Depthing, 27
 Tool, 12
Depths, Defective, 32
Dial,
 Arched, 95
 Cast, 84
 Cleaning, 125
 Degenerate, 96
 Enamelled, 103
 Heraldic, 100
 Lancashire, 98
 Landscape, 100
 Oriental, 99
 Ornaments, 95, 96, 98
 Replacement, 104
 Scottish, 100
 Silvering, 9, 102
 Turret Clock, 196, 203
Drilling Machine, 17
Drills, 10

ELECTRIC Turret Clocks, 146
Engaging Friction, 25

Escapements,
 Anchor, 46
 Crown, 91
 Dead Beat, 48
 Early, 43
 Gravity, 216
 Pin-pallet, 49
 Pin-wheel, 49
 Turret Clock, 225

FAKES, 104, 108, 128
 Flies, 69, 175, 224
 Flirt, 78
 Friesland Clock, 86
 Fusee, 66
 Chain, 67, 130

GATHERING Pallet, 74
 Gauge, 18
 German Dumping, 91
 Gilding Metal, 6
 Gongs, 81
 Gravity Escapement, 216
 Grinding Machines, 19

HAMMERS, 112, 192
 Hammer Springs, 82
 Hands, 115, 201
 High-speed Steel, 4
 Holdfasts, 113
 Hooded Clocks, 88
 Hoop Wheel, 70
 Huntsman, 3

ILLUMINATED Dials, 203
 Ingold Fraise, 17
 Invar, 4
 Involute Teeth, 22, 144

JACOT Block, 12

LACQUERS, 8
 Lancashire Cases, 97
 Clocks, 91

Lancashire—*continued*.
 Clockmaking, 96
 Dials, 98
 Enterprise, 98
 Hooded Clock, 88
 Screw, 112
 Wheel-cutting Machine, 14
 Lantern Clocks, 83
 East Anglian, 86
 Conversion, 87
 Pinions of, 39
 Lantern Pinion, 26
 Lifting Piece, 77
 Lily Pattern, 84, 92
 Lines, 64, 130
 Locking Plate, 69
 Long Case Clocks, 89

MAINSPRING, 3, 65
 Manganese Bronze, 5
 Mild Steel, 2
 Mock Pendulum, 106
 Movement,
 Age of, 108
 Faked, 108
 Locking Plate, 69
 Made-up, 108
 Musical Clocks, 79, 81

PALLET Making, 50, 56
 Hardening, 2, 55
 Pendulum, 57
 Brass Rod, 59
 Compensated, 58, 159
 French Type, 57, 59
 Mock, 106
 Turret, 158
 Wobbling, 61
 Pillars, 113
 Pin-pallet Escapement, 49
 Pin-wheel Escapement, 49
 Pinion, 20
 Case-hardened, 42
 Cast-iron, 208
 Collets, 39
 Cutting, 42
 Lantern, 26
 Making, 41
 Old, 39
 Repairs, 129
 Standard, 37

Pinion—continued.

Worn, 36, 40, 81

Wrong Size, 32

Pitch Circle, 20

Pivot Size, 32, 64

RACK Hook Planting, 71

Rack Striking, 70

Rack Tails, 71

Railway Clocks, 122

Repairs, 124

American Clocks, 134

Restoration, 124

Ropes, 62

Wire, 167

Rounding-up Tool, 16

SCOTTISH Barrels, 63

Centre Seconds, 111

Clockmakers', 89, 96

Dials, 95, 100

Pin-wheel Escapement, 49

Wheel Mounting, 40

Screws, 11, 112, 113

Sheep's Head Clock, 88

Silvering, 9, 102

Solder, 7

Specifications, 123, 211

Springs, 3, 65

Stackreed, 66

Stainless Steel, 4

Standardisation, 38, 123

Steady Pins, 111

Stopping, Causes of, 61, 129, 131

Strike-silent, 82

Striking Mechanism, 68

Friesland, 86

Striking Racks, 70

Stuart Clock, 85, 99, 102

Summer Time, 146

TEETH of Wheels, 20

Throw, 11

Tools, 10

Tool Steel, 3

Train Numbers, 135, 155

Tudor Rose, 84, 94, 95

Turret Clock, 143, 156

Accurate Striking, 180, 187

Bushes, 175

Chime Machinery, 189

Chimes, 184

Dials, 196, 203

Electric, 146

Frame, 161

Hammers, 192

Hands, 201

Large, for Quarters, 176

Maintaining Power, 170, 181

Metal for Wheels, 141, 206

Moderate Size, 163

Motion Work, 204

Pendulum, 158, 161

Position of, 160

Specification for, 211

Stops for Weights, 172

Wire Ropes, 167

Turret Design, 156, 159, 162

VERGE Escapement. *See* Crown wheel.

Verge Timepiece, 107

WEIGHT,

Size required, 65

Swinging, 61

Wetherfield Collection, 105

Wheel-cutting Machine, 13

Wheel Numbers, 135, 155

Wheels and Pinions, 20

Standardisation of, 38, 123

Wire Lines, 64, 130

Ropes, 167

Worn Pinions, 36, 40, 129, 208

Wrought Iron, 1

