

Birla Central Library

PILANI (Jaipur State)

Engg College Branch

Class No :- 621.384132067

Book No :- L206R

Accession No :- 39838

**RADIO-FREQUENCY
HEATING EQUIPMENT**

RADIO-FREQUENCY HEATING EQUIPMENT

WITH PARTICULAR REFERENCE
TO THE THEORY AND DESIGN
OF SELF-EXCITED POWER OSCILLATORS

BY
L. L. LANGTON
A.M.I.E.E.



LONDON
SIR ISAAC PITMAN & SONS, LTD.

First published 1949

SIR ISAAC PITMAN & SONS, LTD.
PITMAN HOUSE, PARKER STREET, KINGSWAY, LONDON, W.C.2
THE PITMAN PRESS, BATH
PITMAN HOUSE, LITTLE COLLINS STREET, MELBOURNE
27 BECKETTS BUILDINGS, PRESIDENT STREET, JOHANNESBURG

ASSOCIATED COMPANIES

PITMAN PUBLISHING CORPORATION
2 WEST 45TH STREET, NEW YORK
205 WEST MONROE STREET, CHICAGO

SIR ISAAC PITMAN & SONS (CANADA), LTD.
(INCORPORATING THE COMMERCIAL TEXT BOOK COMPANY)
PITMAN HOUSE, 381-383 CHURCH STREET, TORONTO

Preface

THE object of the author in preparing this volume is to deal mainly with the generation and transfer of Radio-frequency Power, in a manner suited to the needs of those having an interest in Radio-frequency Heating. It is not the intention that this volume should be regarded as a handbook, and the application of the technique is treated in only a broad manner in Chapters 9 and 10. Of the literature that has already been published on the subject, nearly all has been concerned with applications and this accounts for the paucity of references to other works in this volume.

Here and there in the text will be found equations of a somewhat unfamiliar nature and, at the risk of over-simplifying the mathematical treatment, the author has not, in all cases, given a full derivation of such expressions where they occur. The diligent reader should, however, have little difficulty in developing these expressions from a study of the earlier mathematics in the relevant chapters and with the assistance of Appendix 1. It is therefore advisable that the volume should at a first reading be perused throughout before returning to those chapters in which the reader may be more particularly interested.

The author's thanks are due to Professor J. Greig and Dr. N. W. McLachlan for their helpful advice, and to Mr. H. G. Atkins and Mr. H. J. Houlgate, A.M.I.E.E., for their kindness in reading the proofs.

L. L. LANGTON

LONDON, 1948

Contents

	PAGE
<i>Preface</i>	v
<i>List of Symbols</i>	ix
1. INTRODUCTORY	1
2. DIELECTRICS	6
Electrostatics — Field Distribution — Refraction — Dielectric Loss—Influence of Frequency—Heat Generated in Dielectrics—Capacitor Losses at Radio Frequencies—Power Dissipation—Thermal Consid- erations—Heat Factor—Laminated Dielectrics— Heating Non-rectangular Work	
3. EDDY-CURRENT HEATING	25
Work Materials—Curie Point—Hysteresis Loss	
4. THERMIONIC GENERATORS	33
Oscillatory Circuit—Electrical Loss—Circuit Effi- ciency—Thermionic Valve as an Amplifier—Self- excited Oscillators—Voltage and Current Character- istics (Class C)—Anode and Grid Circuit Relationships —Anode Efficiency — Outline Designs — Variable Loading—Power Oscillator Circuits—Power Control —Metering—Valve Protection—Constant Frequency Generators	
5. DIELECTRIC-HEATING WORK CIRCUITS	70
Loading—Circuit Efficiency and Power Transfer— Simple Direct Circuit—Tapped Circuits—Tuned Work Circuits—Coupled Work Circuits—Variable Matching Devices	
6. EDDY-CURRENT-HEATING WORK CIRCUITS	93
Energy Transfer—Effect of Frequency—Require- ments for High Transfer Efficiency—Overall Effi- ciency—Loading and Circuits—Direct Work Circuits —Coupled Work Coil—Tank Capacitors—Efficiency Measurements—Direct Coil Circuit—Coupled Work Coil—Effect of Temperature—Load Rematching	

	PAGE
7. THERMIONIC VALVES	107
Ionization — Triodes — Emission — Filaments — Anodes — Envelopes — External-anode Valves — Valves for High-frequency Operation—Valve Group- ing—Triode Characteristics	
8. POWER SUPPLIES	121
Valve Rectifiers—Rectifier Circuits—Smoothing— Control Circuits	
9. DIELECTRIC-HEATING APPLICATIONS	141
Compression Moulding—Bonding and Welding— Adhesive Setting—Dielectric Heating—Secondary Gluing Applications—Spot Gluing	
10. R.F. EDDY-CURRENT HEATING APPLICATIONS	166
Surface Hardening—Fool-proof Heating by R.F. Methods—Hardening Applications—Soldering—Re- mote Heating	
<i>Appendix I. L-C CIRCUITS</i>	<i>179</i>
Frequency Change on Load—Loaded Q-value— Measurement of Coupling Factor k —Optimum Coupling Factor off Resonance—Work Voltage with Coupled Circuits—Oscillator Frequency with Inductively-coupled Tuned Load—Effect of Parallel or Series Capacitance on Load imposed by Coupled Circuit	
<i>Appendix II. PROPERTIES OF DIELECTRICS</i>	<i>187</i>
<i>Appendix III. BRITISH TRIODE VALVES SUITABLE FOR R.F. HEATING EQUIPMENTS</i>	<i>190</i>
<i>Index</i>	<i>193</i>

List of Symbols

(Where a symbol is assigned more than one meaning its significance will be defined in the context.)

CAPITAL LETTERS

A	= area, cm ² .	M	= mutual inductance.
C	= capacitance, farads.	P	= power, watts.
D	= displacement.	Q	= charge, figure of merit of a tuned circuit.
E	= e.m.f.	R	= resistance.
E_b	= H.T. voltage.	S	= specific gravity.
I	= current.	T	= temperature (absolute or centigrade).
I_a	= anode current.	V	= voltage.
I_{ac}	= a.c. component of anode current.	V_{co}	= grid cut-off voltage.
I_{dc}	= d.c. component of anode current.	V_g	= applied (negative) bias voltage.
I_g	= grid current.	V_{gd}	= grid drive voltage.
I_{gdc}	= d.c. component of grid current.	X	= reactance.
L	= self inductance.	Z	= impedance.

SMALL LETTERS

c	= specific heat.	k	= coupling factor.
d	= separation, cm.	t	= thickness, time.
f	= frequency.	v	= volume.
g	= mutual conductance.	v_{amin}	= minimum anode voltage
i_{apeak}	= peak anode current.	v_{gmax}	= maximum grid voltage.
i_{gpeak}	= peak grid current.	v_{gmin}	= minimum grid voltage.
j	= mathematical operator.		

GREEK LETTERS

ϵ	= electric field strength.	ρ	= resistivity.
η	= transfer ratio.	σ	= heat factor.
λ	= wavelength.	χ	= permittivity.
μ	= permeability, amplifica- tion factor.	ω	= angular frequency.

Introductory

THE last sixty years have seen the growth of both the supply and application of electricity to industrial and domestic problems. With this growth several new methods of heating have appeared, which have been and are of great significance.

In the year 1800 Sir Humphry Davy, while experimenting with the then newly-developed voltaic battery, produced the first arc light between two carbon electrodes. The very high temperature existing in the region of the arc was soon noted and many workers, including Napier, Dupretz, and Joule, designed furnaces employing electric arcs as the source of heat. It is not surprising, when it is remembered that primary batteries were used as the source of current for the arc, that no great success attended these early efforts.

After the invention of the dynamo in 1867 the position was greatly altered. Siemens made the first practical arc furnace in 1879, following which many variations of the two main types have since been developed and find an application where very high temperatures are required. In one type, the charge to be heated is contained in a crucible of suitable refractory material and the arc is struck across one end of the crucible in the immediate vicinity of the charge; the other type employs the charge as one of the electrodes, and since this carries the arc current I^2R losses in the charge enhance the heating. The latter type of furnace is, of course, restricted to the heating of conducting materials. The arc furnace is used industrially for the production of calcium carbide (CaC_2) from lime and coke, the CaC_2 itself figuring largely in the manufacture of a type of fertilizer. Other examples of its use are the manufacture of carborundum and the oxidization of atmospheric nitrogen to form nitric acid.

Another kind of electric furnace having important applications is that in which the electrodes are in contact with the charge, and, in consequence, no arc is formed, the heating being due to I^2R losses. It is interesting to note that the world's entire supply of aluminium is manufactured in furnaces of this type. Prior to the invention of the electrical process in 1885, the total production of

2 RADIO-FREQUENCY HEATING EQUIPMENT

aluminium amounted to no more than a few hundred pounds, the chief obstacle to greater production being a suitable and economic heat-treatment for the bauxite ores.

With the early part of the twentieth century came full realization of the great advantage attending the generation and distribution of alternating currents. Nearly all supply systems laid down after 1900 were of the a.c. type, and many of the early d.c. systems were changed over to A.C. The time was thus ripe for the widespread use of induction or eddy-current furnaces for the industrial heating of metals. The charge in this type of furnace is virtually the short-circuited secondary of a transformer, the primary of which is energized by current from the supply mains or other source. With an induction furnace there are no electrodes in contact with the charge and so any risk of contamination is greatly reduced. Again, unlike the arc furnace, gaseous discharges are not inherent with this form of heating, and so there is no electrical requirement that might entail pollution of the charge. These furnaces are used extensively for the smelting of large masses of metallic material and for such purposes they are usually energized by the mains. The use of higher frequencies results in two important changes in the heating process. First, the heating tends to be confined to peripheral layers of the charge, and secondly, more energy can be induced into a charge of smaller physical size. There are many manufacturing processes in which either (or both) of these features is essential, and alternators were designed to generate power at frequencies of several kilocycles to meet such requirements. They became known as high-frequency alternators, that is high relative to mains frequencies, and the process gained the name of high-frequency induction heating.

During the last few years there has been a marked increase in the frequency used for many important metal-heating applications. The alternator, however, is not ordinarily used for the generation of large power at frequencies above about 10 kc/s. There are, nevertheless, some specialized versions such as the Alexanderson and Goldschmidt alternators, developed in the early days of radio, that work up to about 200 kc/s. Such machines are unsuitable as a source of energy for induction furnaces because they are costly and difficult to make and lack that degree of rugged simplicity so essential in industrial gear.

To generate power at frequencies above 10 kc/s the spark-gap generator with either quenched or unquenched gaps has been widely used and is fairly common to-day, because for a given power output it is somewhat cheaper in first cost than other types of generator

in this frequency range. Spark-gap generators have an upper frequency limit of about 1500 kc/s and are attended by many disadvantages such as prolific harmonic generation and the need for careful maintenance. Equipments working at several megacycles are in use to-day, although this sharp increase in frequency for industrial heating has become common only in the last year or so. At these frequencies the thermionic valve is the only type of generator having reasonable efficiency, and the development of new heating techniques brings about another extension to the already large field of application for thermionic valves in industry.

With such a wide range of frequencies as that now employed for the induction or eddy-current heating of metals it is not altogether surprising that a great deal of ambiguity exists in making reference to a particular type of equipment. The term "high-frequency induction furnace" has been used when referring to a spark-gap set working at 200 kc/s, a valve gear having a frequency of 10 Mc/s, or an alternator set operating at 1000 c/s. This ambiguity is enhanced by the fact that it has become common practice to refer to the signal-frequency amplifier of a broadcast receiver as the high-frequency amplifier, although it may in fact be operating at a frequency of many megacycles.

No definite ruling on the terminology to be used for this form of heating has yet been made by the appropriate authority—and become generally accepted—but it seems obvious that when the frequency of operation is in that spectrum normally used for purposes of radio communication, the process should be called radio-frequency eddy-current heating. The reason for the term *induction heating* not being employed in this connection is discussed in Chapter 3.

The range of the radio-frequency spectrum used for communication is by no means fixed and continues to show a steady upward extension. Two or three decades ago transmitters were erected that worked on comparatively low frequencies, for instance, Bordeaux, on 12.6 kc/s. In view of the fact that alternators are not ordinarily used above 10 kc/s it would be reasonable to make this the upper limit for high-frequency induction heating, and any equipment operating at frequencies above this value should bear the adjectival prefix "radio-frequency."

DIELECTRIC HEATING

This process can be applied to non-conducting materials only and takes place when they are situated between conducting surfaces to which an alternating potential of radio frequency is applied (*see*

4 RADIO-FREQUENCY HEATING EQUIPMENT

Fig. 1). The fact that heat is generated under these conditions has been known for many years and it has been regarded as a particular nuisance in the construction of high-powered radio transmitting stations. As the frequency employed for radio communication became higher the heating effects in dielectrics became more apparent, but no effort was made to use these effects for industrial purposes until within the last ten years or so.

The chief reason for the delay in applying dielectric heating to industry was that for almost any industrial application a temperature rise of at least 100°C must be achieved, and it seemed doubtful whether the process would prove economical despite the fact that the heating took place uniformly throughout a homogeneous

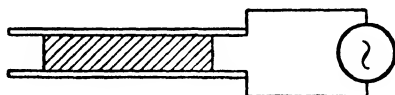

FIG. 1

dielectric. There was also the fact that the manufacture of generators having large R.F. outputs was in those days a somewhat cumbersome and costly business.

There is, however, one type of material in which a comparatively small temperature rise has very marked effects—the human body. In this case the powers necessary to bring about small increases in temperature are not large, particularly as the time taken can be fairly long. It is thus not surprising that the first application of dielectric heating was in the electro-medical field, where it has been used for more than twenty years to produce artificial fevers and similar effects in the human body. Fortunately, these effects were first tried on animals, and Schereschewsky, an early German worker, carefully plotted the relation between the frequency employed and the time it took for mice to die when held by insulated forceps between R.F. electrodes.

While dielectric heating cannot be applied to all non-conductors it is nevertheless suitable for very nearly all the thermosetting plastics, most of the thermoplastics, and a very large proportion of the solids and the more viscous liquids based on vegetable and animal matter. At the same time, the greater part of non-conducting mineral solids form suitable dielectrics for heating, and so we see that the process is very wide indeed in its scope. It is in fact likely that its industrial significance will, in the course of time, outstrip that of eddy-current heating, although there are at present many more installations and much more power devoted to the latter process.

Another significant factor is that dielectric heating makes possible a large number of applications which cannot be done by any other method. In R.F. eddy-current heating, this does not apply to anything like the same extent, and although its use will greatly simplify and cheapen a number of processes, there are few that could not be done by other methods. It must of course be realized that up to the present the use of both R.F. eddy-current and dielectric heating has been visualized largely in terms of existing applications, and the possibilities of either technique have yet to be fully developed. Nevertheless, the potential field for dielectric heating is already wider and will doubtless impinge on a greater number of industries.

Dielectrics

FROM an electrical standpoint materials are divided into two main classes, according to whether they conduct electricity or not. The division is relative, for there are some intermediate substances which may be described as either bad conductors or poor insulators. It is, however, usually possible to classify a material with certainty, and where doubt exists the classification will depend mainly on the electrical requirements of the application for which the material is to be used. When an insulating material is contained between two conducting surfaces having different potentials, it acts as a dielectric and is electrically charged.* The nature of this charge in a dielectric and also the reason for the varying degrees of conductivity possessed by metals and some other substances is determined by the atomic structure of the material.

At the present state of knowledge there are ninety-two kinds of atom, corresponding to the known natural elements. Each atom consists of a system of electric charges in which the negative electrons balance the positive protons and the resultant charge is zero. The protons are located in a central nucleus which is of much greater mass than the electrons.†

According to the Rutherford-Bohr theory, the electrons move in orbital paths round the nucleus in a manner similar to the movement of planets round the sun, but unlike planetary motion in the solar system, the electrons may change their orbital paths. Atoms may be divided into groups, according to the number of shells and sub-shells in which, in this theory, the electrons describe their orbits. The simplest and lightest atom is that of hydrogen which possesses only one extranuclear electron, and there can, of course, be only one electron shell. A heavy atom, such as that of mercury, has eighty extranuclear electrons moving in six electron shells which are themselves divided into sub-shells. For each atom there is a number of electrons which makes up a full complement of the outer

* Recent discoveries indicate that the charge resides in a surface film on the dielectric but for our treatment no error results from regarding the charge as residing *in* the dielectric.

† The nucleus, except in the case of the hydrogen atom, also contains neutrons which, while having the same mass as protons, possess no charge.

shell, and nearly all the ninety-two kinds of natural atom suffer deficiencies in this respect.*

The first electron shell, called the K shell, has a full complement of two electrons, and the hydrogen atom is thus deficient by one electron. The second, or L shell, has sub-divisions called the *s* and *p* sub-shells, which have full complements of two and six electrons respectively, making a total of eight. The M shell has a full complement of eighteen electrons in three sub-shells of two, six, and ten. Four sub-shells comprise the N shell, which has a total complement of thirty-two electrons.

The number of electrons in the outer shell of an atom governs the chemical combining power or valency of that particular element. For instance, an atom of carbon has six extranuclear electrons of which two are in the first or K shell. Instead of a full complement of eight in the L shells, there are only four electrons, and this leaves four empty places. The electrons of four hydrogen atoms could fill these places and yield the compound methane CH_4 . It can be assumed that the valency links emanate from the carbon atom in a symmetrical manner (see Fig. 2). This means that the electric field existing in a methane molecule will be symmetrical.

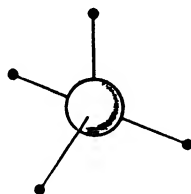

FIG. 2

While the resultant charge on any atom is zero, the electrostatic field in its immediate neighbourhood depends on whether there are any gaps in the peripheral shell. If gaps exist, there will be an attraction for the electrons in the outer shell of another atom that also has a deficiency. In this way we see that chemical valency is of an electrical nature, and when an atom has a full complement of outer-shell electrons it has no tendency to combine with other atoms. The inert elements, argon, neon, etc., have such atoms.

There is another type of combination possible between atoms apart from that exemplified by the CH_4 combination. It occurs with atoms of a certain type, and as an example we will consider the elements sodium and chlorine which combine to produce common salt (NaCl). Molecules of this kind are of particular interest. An atom of sodium possesses eleven extranuclear electrons, has the K and L shells complete, and one electron left over for the first M sub-shell. Chlorine, on the other hand, has seventeen extranuclear electrons which fill the K and L shells and the first M sub-shell. In the second M sub-shell there are only five electrons,

* In addition to the ninety-two naturally-occurring elements there are some, such as plutonium, that have been prepared artificially.

8 RADIO-FREQUENCY HEATING EQUIPMENT

and the one M-shell electron of the sodium atom is able to bring this up to the full sub-shell complement of six. We now have sodium and chlorine *ions*, the one being positively charged with ten extranuclear electrons, and the other being negatively charged, with eighteen extranuclear electrons, united by an electrostatic bond (see Fig. 3). The two ions both have their outer shells complete and are equivalent in this respect to atoms of neon and argon. Materials composed of molecules having a structure of the type just outlined

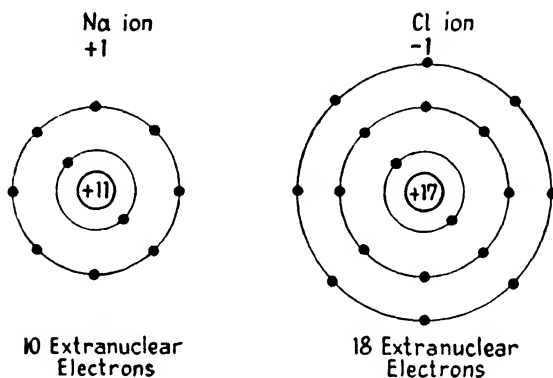

FIG. 3

are called ionic or *electrovalent* compounds, while materials like methane are called *covalent* compounds.

The significant fact about molecules of the electrovalent kind is that the centres of positive and negative charge do not coincide, and such molecules form dipoles, having an electrical moment equivalent to an electron charge multiplied by the distance between the centres of the two charges. They are called *polar* molecules. In a block of material composed of polar molecules there is, however, no resultant charge because of the random dipole orientation due to thermal agitation. Under the influence of an electric field, however, all the molecules will tend to turn in the direction of the field.

Electrovalent atomic combinations give rise to permanently polarized molecules, but it does not happen that all covalent combinations result in molecules that are not permanently polarized. To illustrate this point, let us consider water, which has two monovalent hydrogen atoms combined with a divalent oxygen atom. There are eight extranuclear electrons in the oxygen atom, the K and first L sub-shells having a full complement. The second L sub-shell is deficient by two electrons, but these gaps are not

diametrically opposite. They occur in adjacent places on one side of the shell, and Fig. 4 illustrates the asymmetrical distribution of the charge in the resulting molecule.

Electrovalent compounds are materials which in general are of salt-like character and form electrically-conducting aqueous solutions. Covalent compounds on the other hand are characterized by their un-salt-like nature and their extremely low electrical conductivity.

Materials such as copper, silver, aluminium, and most of the metals which have very good electrical conductivity possess the property by virtue of a particular type of atomic structure. They are all relatively heavy materials with a large number of extranuclear electrons of which all but one or two are in shells or sub-shells having a full complement. From a chemical standpoint, metals having one electron in the outermost orbit behave very much like hydrogen, and they allow this electron either to be shared or taken by another atom. The outermost electron is loosely held to the rest of the atomic structure, and since metals are dense the atoms are in very close proximity, thus the outer electrons become shared. This permits a movement of electrons from one atom to another and when an electrical potential is applied to a metal the free electrons move up the potential gradient and constitute a flow of current.

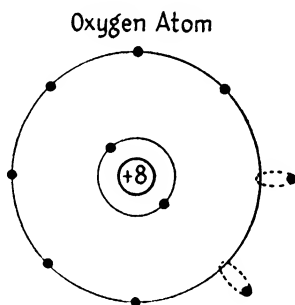

FIG. 4

Insulating materials must, of course, have no free electrons, and a study of their behaviour when a potential is applied across them is of particular importance in considering dielectric heating. First, consider a covalent compound in which the molecular charges are symmetrical. When material of this kind is placed in an electric field the extranuclear electrons are attracted up the potential gradient towards the positive electrode. The nucleus, on the other hand, is subjected to a force in the opposite direction with the result that the molecule becomes strained. Deformation due to this strain upsets the electrical balance within the molecule and it assumes polar properties having a preponderance of positive or negative charge towards one side. Molecules of the electrovalent type that are already polar will suffer deformation, in addition to orientation, when situated in an electrostatic field.

All dielectric-heating applications depend on the fact that the

10 RADIO-FREQUENCY HEATING EQUIPMENT

“work” is contained either between or in close proximity to conducting surfaces between which a rapidly alternating potential exists. The subject is, however, best approached by first considering the “work” or dielectric to be situated in a static field. All the laws governing electrostatics apply to dielectric heating, and we will begin by considering a few of the salient aspects.

ELECTROSTATICS

Two metallic plates separated by an insulating material form a capacitor. The insulating material may be air, glass, paraffin, etc., or it may be a non-material medium, i.e. a vacuum. The behaviour of the capacitor depends very largely on the nature of the insulator forming the dielectric and it is a fortunate occurrence, from an experimental point of view, that dry air and a vacuum possess many almost identical electrostatic properties.

When two parallel metallic plates are situated in air, the air that lies between them is not a dielectric until a potential difference exists between the plates. If the opposite terminals of a battery are applied to the plates, a large current flows initially, but it rapidly falls to zero as the plates acquire the battery potential. In theory the current would never fall absolutely to zero, but it rapidly becomes so small that it may be considered to do so. The two plates are now charged and the quantity of electricity situated in the electrostatic field that has been set up between them is proportional to the applied voltage and plate area, and inversely proportional to the distance separating the plates. The area and separation of the plates determines the electrical capacitance, and so, calling the quantity of electricity stored Q , we have—

$$Q = CE \text{ coulombs}$$

where C = capacitance in farads and E = applied voltage. Since no current flows in the circuit after the capacitor has been charged the battery may be removed without altering any of the conditions.

If, instead of air, a block of material such as mica had been used as the dielectric, the quantity of electricity stored would be considerably greater. The voltage being the same, it follows that the capacitance must have increased, and the amount of this increase is equal to the value of a characteristic which may be variously termed the dielectric constant, specific inductive capacitance, or *permittivity* of the material forming the dielectric. If, on the other hand, the mica had been inserted between the plates after the battery had been removed, the total charge would remain

unaltered and the voltage between the plates would be reduced in the same ratio as the increase in capacitance.

The field strength ε at any point between the plates is defined as the force that would be exerted on a unit positive charge situated at that point. Possessing both magnitude and direction, it is a vector quantity. After the inclusion of mica between the plates the field strength suffers a reduction, but the amount of charge per unit area, called the displacement, D , remains unaltered because the total charge before and after the insertion of the mica is the same. Calling the permittivity of air χ_0 and that of the material inserted χ_m , we have—

$$D = \chi_0 \varepsilon = \chi_0 \chi_m \varepsilon_1 \quad . \quad . \quad . \quad 2.1$$

where ε and ε_1 represent the field strengths in air and the material. The dielectric constant or permittivity of a vacuum is unity while for any material medium it is greater. For pure dry air, however, the value of χ is no more than 1.00083 and it may be taken in this respect as being electrically equivalent to a vacuum.

The polar properties of the molecules forming the material of which a dielectric is composed govern the value of permittivity that it will possess. Each molecule forms a dipole, which may be defined as a pair of charges separated by a distance which is small in relation to the extent of the field in which they exist. It can be shown that the dipole moment of a conducting sphere in a uniform field ε is equal to $4\pi r^3 \chi \varepsilon$, where r is the radius of the sphere, and it follows that the molecular dipoles can be likened to metallic spheres scattered throughout the dielectric. The effect of the presence of these spheres is as though the plates of a capacitor were closer than they actually are, and the capacitance is thereby increased. For a constant charge the potential between the plates would be reduced after the inclusion of the dielectric material, while for a constant applied voltage the charge would increase.

FIELD DISTRIBUTION

It is instructive to consider two charged plates supported in air by some perfect means and see what occurs when a block of insulating material is lowered half-way between them with a small gap on either side (*see* Fig. 5). Before the insertion of the block, the plates are charged to a given potential and the battery removed. The potential gradient or field strength between plates will be uniform everywhere, or, in other words, the line integral along the lines of force existing between the plates will be the same and will in fact be equal to the applied voltage. After the insertion of the block the

12 RADIO-FREQUENCY HEATING EQUIPMENT

total charge remains the same and so the displacement in both the gap x and the material will also be the same. The normal component of D (the component at right angles to the boundary surface between gap and block) remains unaltered and we may write—

$$D_{gn} = D_{mn} \quad . \quad . \quad . \quad . \quad 2.2$$

where D_{gn} refers to normal component of displacement in gap and D_{mn} refers to normal component of displacement in material. The magnitude of normal component of field strength changes at the boundary surface, it being greater in the gap, thus—

$$\frac{\epsilon_{gn}}{\epsilon_{mn}} = \frac{1}{\chi_m} \quad . \quad . \quad . \quad 2.3$$

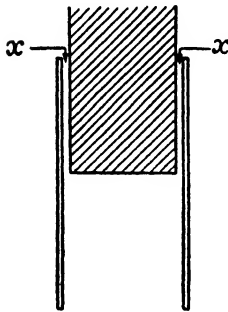

FIG. 5

where χ_m = permittivity of the material.

It is interesting to note that in the interior of a metallic conductor the field strength is zero, and in considering the boundary surface between a conductor and the dielectric, we have

$$\frac{\epsilon_{gn}}{0} = \frac{\chi_{\text{conductor}}}{\chi_m} \quad . \quad . \quad . \quad 2.4$$

from which it follows that a conductor behaves in an electrostatic field as though its permittivity were infinitely great.

Since the capacitor plates are metallic, the potential difference between them must be the same in the upper and lower halves (see Fig. 5), and there is equality between the tangential components (parallel with the boundary surface) of the field strength in the gap and in the material

$$\epsilon_{gt} = \epsilon_{mt} \quad . \quad . \quad . \quad . \quad 2.5$$

Now, since ϵ_{metal} equals 0 we have

$$\epsilon_{\text{metal } t} = \epsilon_{mt} = 0 \quad . \quad . \quad . \quad . \quad 2.6$$

From this it follows that the lines of electrical force stand at right angles to a conductor.

REFRACTION

When the electric field contains more than one dielectric material, the lines of force are refracted in crossing the interface. For two materials of which one has a large permittivity χ_1 , and the other a small value χ_2 (see Fig. 6), a line of force passing into the material

of lower permittivity is bent towards the normal. The law governing refraction is

$$\frac{\tan \theta_1}{\tan \theta_2} = \frac{\chi_1}{\chi_2} \quad \dots \quad 2.7$$

It should be noted that the effect is opposite to that occurring with light rays. In passing into a material of higher refractive index light rays are bent towards the normal.

Another, and very instructive way of looking at the question of the refraction of electric field lines in dielectrics of different χ , is given by considering energy values. It is well known that the

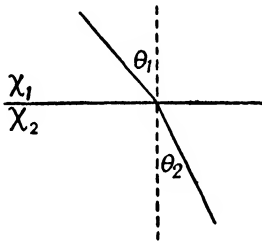

FIG. 6

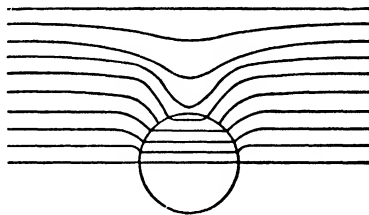

FIG. 7

energy possessed by a charged capacitor = $\frac{1}{2} CE^2$. Now, if material dielectric is inserted between two charged plates, the voltage between them drops, although the total charge remains the same. This means that the potential energy per unit volume of the dielectric is reduced in the dielectric of larger χ . The energy in an electric field always tends to a minimum and in consequence the lines of force will as far as possible pass through media of greatest permittivity. Refraction is, in consequence, governed by the fact that each line of force will take the path of minimum potential energy possible for it.

Fig. 7 shows the type of field distribution that occurs when a sphere of material having high permittivity is situated in an initially uniform field between two charged plates in air. The lines of force are refracted into the sphere because each seeks a path of less energy than it initially possessed in air. Not all the lines will pass through the sphere because, for those which are distant, the increase in air path would involve greater increase in energy than would be compensated for by the easier path through the sphere. When the material of which the sphere is made is of lower permittivity than the surrounding medium, the field distribution is of a type illustrated in Fig. 8. No line of force will pass through the sphere unless the

14 RADIO-FREQUENCY HEATING EQUIPMENT

line integral of the shorter, high-energy, path, is less than that of the longer, low-energy path which it must take in avoiding passage through the sphere.

The outline of factors governing field distribution should be borne in mind when reading the chapter dealing with dielectric applications. In these, it is usually the aim to achieve a uniform field of known strength in the work and it follows that the work must be chosen with care. When the work is non-homogeneous and of only vaguely known dimensions and dielectric properties, it is impossible to predict a rate of heating in any given region. Difficulties of this kind abound in R.F. therapy applications where the organ to be treated is often of vaguely known shape, mass, thermal and

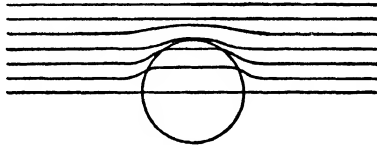

FIG. 8

dielectric properties, and is usually surrounded by layers of fats and tissue of varying thickness. Fortunately, industrial applications are relatively simple, but, even so, consistent results can be obtained on repetition work only when the material forming the work is consistent.

DIELECTRIC LOSS

So far we have considered dielectrics only when they have been situated in a static electric field. In dielectric heating, the field is of course alternating at radio frequency and new conceptions must be introduced to explain the behaviour that results. Polar molecules are subjected to an alternating force and according to Debye the dipoles will, under some circumstances, be capable of rotation. Various aspects of his theory have now been discredited but, without going too deeply into the question, a picture of what occurs, according to current theories, can be outlined as follows.

In the first place, a dipole must be accredited with two equilibrium positions that occur when it lies in opposite directions, and the energy level corresponding to each position is different. When moving from a position of low energy to one of higher energy value, energy is absorbed, but, in the converse case, it is emitted. In an alternating field, the dipoles emit more energy than they absorb, and most of this is radiated in the heat spectrum. Here we have the basis of an explanation of the losses that occur in polar

dielectrics, but in order to appreciate the effects of frequency we must reconsider the polar molecules in their influence on permittivity.

INFLUENCE OF FREQUENCY

As long as the dipoles are able to move in time with the alternations of the field, their contribution to the permittivity will be independent of frequency. When the frequency becomes very high, the dipole movements will tend to lag and the permittivity becomes reduced.

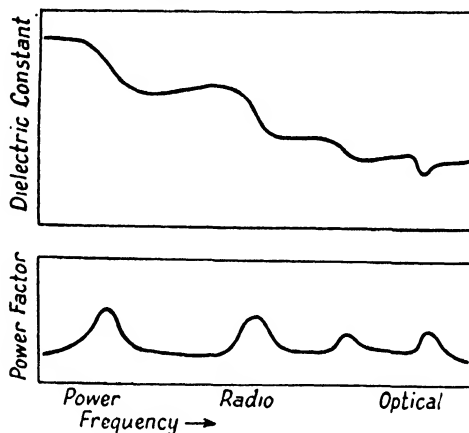

FIG. 9

If the frequencies used were so high that neither the dipoles nor any of their constituent atoms or electrons were able to move in sympathy, the permittivity would be reduced to unity or, in other words, to that existing in vacuo. Now dipoles which are under the influence of an alternating field are credited with an oscillatory movement, and possessing mass they have a dipole moment and will resonate at a particular frequency f . The time corresponding to the frequency f is known as the relaxation time of the dipole, and at the corresponding frequency the permittivity suffers a sharp reduction. At this point, losses will peak as illustrated in Fig. 9 which shows loss and permittivity plotted against frequency.

It will be noticed that there is more than one sharp depression in permittivity with rising frequency, and these depressions occur at frequencies corresponding to the relaxation time of the atomic and electronic structures. We thus have both electronic and atomic polarization due to the displacement of charges within the structure. These are not permanent dipoles and form in times generally less than 10^{-10} sec, corresponding to a frequency of 10^4 Mc/s, and so in

16 RADIO-FREQUENCY HEATING EQUIPMENT

the frequency band with which we are concerned in dielectric heating they contribute a constant part to the permittivity and consequently zero loss. In this way, we can regard the losses that occur in a practical case as being concerned almost wholly with molecular dipoles. It usually happens that the permittivity and loss are very nearly constant over the range of frequencies that are likely to be used commercially for dielectric heating.*

HEAT GENERATED IN DIELECTRICS

When the electrodes of a capacitor are subjected to an alternating potential, the displacement current that flows is due to successive

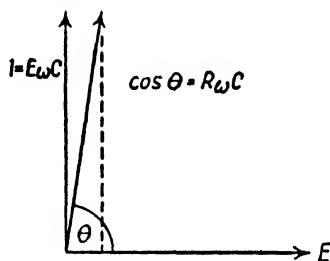

FIG. 10

charging of the capacitor with each reversal of the applied potential. If the capacitor were perfect, all the energy of one charge would become discharged on a reversal of the potential. Under these conditions, the displacement current would be in phase quadrature with the applied voltage and would lead by 90° . When there are losses due to the dielectric or any other cause, the current will lead by an angle less than 90° , there will be an in-phase or true power component, and the power factor of the capacitor will be greater than zero (see Fig. 10).

For a given applied voltage, the displacement current will be proportional to the permittivity of the material forming the dielectric. That fraction of the total current that is in phase with the voltage and represents loss, will be proportional to the power factor ($\cos \theta$) of the dielectric. The product $\chi \cos \theta$ is termed the *loss factor* of the material and may be taken as indicating the heating propensities of a homogeneous dielectric situated between conductors.

* Another type of polarization is due to ions at the interface of dielectric media and is hence called ionic or interfacial polarization. In dielectric heating it may be neglected since it is significant at only relatively low frequencies.

CAPACITOR LOSSES AT RADIO FREQUENCIES

When a dielectric is being heated between two metallic electrodes, not all the energy dissipated in the capacitor so formed will appear as heat in the dielectric. There are a number of sources of loss and the object is, of course, to minimize all but those that actually contribute useful heat. The capacitor can be represented by the circuit shown in Fig. 11, in which C is considered a perfect capacitor having series and parallel resistors which represent losses due to the causes enumerated below—

- (i) Conductor resistance;
- (ii) Radiation resistance;
- (iii) Corona loss;
- (iv) Support loss;
- (v) Conductance loss;
- (vi) Dielectric loss.

Of these, only the dielectric loss contributes useful heat although there will be a very small and in most cases almost negligible contribution due to the conductance loss in the dielectric. Items (i) to (iv) all represent wasteful loss and with good design can be kept down to about 5 to 10 per cent of the total. Conductor resistance loss will, owing to skin effect, increase with rising frequency and the increase in power factor due to this cause makes no direct contribution to the useful dissipation. Radiation resistance is determined by the distance between electrodes, and with deep work such as occurs for instance in plywood manufacture, it can cause considerable loss. Corona discharge becomes significant when the voltage applied to the electrodes exceeds about 15 kV, and this again is more troublesome with deep work because relatively high applied voltages are needed to ensure a reasonable rate of heating. Losses to the electrode supports should always be kept low by a careful selection of the constructional materials.

While the sources of loss have been shown in Fig. 11 as both series and parallel resistance, they may all be lumped together and expressed as either an effective series or an effective parallel resistance. They all contribute towards the power factor of the capacitor at a given frequency and where the resistance is considered as being in series it becomes

$$\cos \theta = \omega CR_s \quad . \quad . \quad . \quad . \quad . \quad 2.8$$

where $\omega = 2\pi f$.

For a parallel resistance

$$\cos \theta = \frac{1}{\omega CR_p} \quad . \quad . \quad . \quad . \quad . \quad 2.9$$

18 RADIO-FREQUENCY HEATING EQUIPMENT

Series or parallel resistances may be expressed in terms of each other by combining equations 2.8 and 2.9. It is usually found convenient to consider capacitor loss as being entirely due to series resistance. The power factor is reasonably accurate when expressed in the form $\cos \theta = \omega CR_s$, provided that R_s is small compared with ωC . The error is less than 1 per cent for all values of $\cos \theta$ below 0.1, and there are very few dielectrics likely to be considered industrially which have a higher power factor.

POWER DISSIPATION

The amount of energy stored in a capacitor is given by the product of its capacitance and the square of the applied voltage (i.e. the square of the root mean square value of the applied alternating voltage). The energy rating per second is equal to the square of the applied voltage E , and inversely proportional to the reactance of the capacitor.

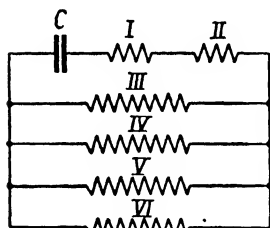

FIG. 11

$$\text{Energy per sec} = \frac{E^2}{\frac{1}{\omega C}} \quad . \quad 2.10$$

A portion of the energy proportional to the power factor of the capacitor will be dissipated as heat.

$$\text{Power loss per sec} = E^2 \omega C \cos \theta \quad . \quad . \quad 2.11$$

To adapt this expression for convenient use in dielectric heating problems it is necessary to state the capacitance in terms of the physical dimensions, and χ , of the dielectric. The capacitance of a parallel-plate capacitor is given by the fundamental expression

$$C = \frac{\chi A}{4\pi d} \text{ centimetres} \quad . \quad . \quad 2.12$$

where A = area of plates (cm^2) and d = distance between plates (cm). This may be rewritten

$$C = \frac{2.54}{4\pi \times 9 \times 10^{11}} \times \frac{\chi A_i}{d_i} \text{ farads} \quad . \quad . \quad 2.13$$

where A_i = area of plates, measured in square inches and d_i = distance between plates, measured in inches.

The power dissipated as heat per second is thus

$$P = \frac{0.225}{10^{12}} \cdot \omega E^2 \cdot \frac{\chi A_i}{d_i} \cdot \cos \theta \text{ watts} \quad . \quad . \quad 2.14$$

$$\therefore P = \frac{0.225}{10^{12}} \cdot \omega \left(\frac{E}{d_i} \right)^2 v_i \cdot \chi \cos \theta \text{ watts} \quad . \quad 2.15$$

where v_i is the volume of the work, in cubic inches.

We now see that the heating loss is proportional to the frequency, volume, loss factor, and square of the potential gradient $\frac{E}{d}$ through the dielectric.

There will be slight variations of both χ and $\cos \theta$ with frequency, but for practical purposes these may be neglected because they are unimportant over the range of frequencies covered in practical dielectric heating applications. On the other hand, both temperature and humidity have a relatively large effect on the loss factor of the dielectric. We must, nevertheless, ascribe a value to both χ and $\cos \theta$ to serve as a basis for calculations.

THERMAL CONSIDERATIONS

To discover the temperature rise that results from the inclusion of given work in an R.F. field, the electrical loss must be equated to the thermal gain of the work. The amount of heat utilized in raising the temperature of the work is equal to the product of its mass, specific heat and temperature rise. The electrical equivalent of heat is

$$1 \text{ calorie} = 4.18 \text{ joules or watt-seconds} \quad . \quad . \quad 2.16$$

If the dimensions of the work are stated in inches, the number of calories required to bring about an increase of 1°C is

$$2.54^3 \times A_i \times d_i \times c \times S \quad . \quad . \quad . \quad 2.17$$

where c = specific heat of work and S = specific gravity of work. The amount of electrical power needed to bring about a temperature rise in a given volume of material is thus

$$16.4 A_i d_i c S \times 4.18 \Delta T \text{ watt-seconds.} \quad . \quad 2.18$$

where ΔT = temperature rise

and the power for a given rate of heating

$$= 16.4 A_i d_i c S \times 4.18 \frac{\Delta T}{t} \text{ watts.} \quad . \quad . \quad 2.19$$

where $\frac{\Delta T}{t}$ = rate of heating in $^\circ \text{C}$ per second.

Thermal Losses. The expression given in equation 2.19 for the power necessary to raise the temperature of work at a given rate must be modified to suit the particular application. There will always be loss of heat from the work due to radiation convection or

20 RADIO-FREQUENCY HEATING EQUIPMENT

conduction. Radiation losses will be relatively low because in few dielectric heating applications does the work attain a temperature of more than about 150° C. Convection and conduction losses on the other hand can assume large proportions when the rate of heating is slow and when there is a considerable surface exposed to the atmosphere or to metallic electrodes of high thermal conductivity. Although the dielectric is heated uniformly, there will be a temperature gradient due to the cooling of the peripheral layers, and since all electrical insulators are poor conductors of heat the gradient tends to become steep towards the periphery and results in a relatively cool outer skin.

With applications of the type in which fairly large masses are to be heated, such as occurs with the pre-heating of moulding powders, the ratio of surface area to volume is relatively small. If the rate of heating is fairly fast, there will not be sufficient time for much heat to escape through the relatively small surface area and the temperature gradient through the material can be kept very shallow. It will of course depend on whether air gaps are included or whether the material is in contact with highly conducting electrodes. For some applications, particularly where heating times are long, it is helpful to maintain these electrodes by steam or electrical heating at the final temperature of the material in order to reduce temperature gradient.

Where very thin pieces of material are to be heated, as occurs in welding sheet polyvinyl chloride, the thermal losses tend to become significant. Surface area is then relatively large compared with the volume, and the polyvinyl chloride is in contact with highly conducting electrodes. These conditions are, however, somewhat mitigated by the very fast rate of heating common in applications of this kind. For large mass applications having fairly short heating times equation 2.19 yields a reasonably accurate result, but for other applications the value obtained must be increased in a ratio depending upon the type of application.

HEAT FACTOR

In all dielectric-heating problems the two major factors a designer wishes to know are the voltage and frequency that must be applied to give the expected rate of heating. For instance, once it has been established that the desired heating could be achieved at say 30 Mc/s with an applied voltage of 1000, the design problem is well on the way to solution. Again, a knowledge of the voltage and frequency needed for a given application will indicate whether an existing dielectric heating equipment could be used.

It is of course, possible, but somewhat tedious, to find the required voltage and frequency from the electrical and thermal expressions. This usually involves a considerable amount of arithmetic and as a result it often happens that users of dielectric heating equipment have only vague notions of the voltage and frequency required for any new application; usually they are content to base their estimates on one or two known performances. The object here is so to relate the electrical and thermal expressions that a generally applicable and simple formula will result. We have gone a long way towards achieving this object by dimensioning the electrical and thermal expressions as in equations 2.15 and 2.19. We may now write

$$\frac{0.225}{10^{12}} \cdot \left(\frac{E}{d_i}\right)^2 \cdot \omega v_i \cdot \chi \cos \theta = 16.4 A_i d_i cS \cdot 4.18 \frac{\Delta T}{t} \quad 2.20$$

Rewriting in terms of frequency (f) and potential gradient

$$f \cdot (\text{V.P.M.})^2 = \frac{4.18 \times 16.4}{2\pi \times 0.225} \cdot \frac{\Delta T}{t} \cdot \frac{cS}{\chi \cos \theta}$$

this reduces to

$$f(\text{V.P.M.})^2 = \frac{48.7}{\left(\frac{\chi \cos \theta}{cS}\right) t} \cdot \Delta T \quad 2.22$$

where f is in megacycles per second and V.P.M. is the applied voltage *per thousandth of an inch*.

The expression in parentheses on the right of equation 2.22 is of particular interest. It is exclusively concerned with the properties of the material forming the work, and we will term it the *heat factor*, σ , and by its use equation 2.22 becomes

$$f(\text{V.P.M.})^2 = \frac{48.7}{\sigma} \frac{\Delta T}{t} \quad 2.23$$

$$\therefore \frac{\Delta T}{t} = f \frac{(\text{V.P.M.})^2 \sigma}{48.7} \quad 2.24$$

Because of the variables associated with $\chi \cos \theta$ no large error is introduced by calling the numerical factor 50 instead of 48.7 and when this is done the calculation of frequency and voltage becomes almost a matter of mental arithmetic. For instance, the heat factor of polyvinyl chloride is 0.25 and if it is required to raise its temperature by 100° C in one second on an equipment working at 50 Mc/s, one can see quickly that 20 V.P.M. must be applied. It should, however,

22 RADIO-FREQUENCY HEATING EQUIPMENT

be particularly noted that it is the r.m.s. voltage that is concerned. If the material were heated between electrodes connected directly across the tank coil of a generator (see Chapter 5), the peak voltage or anode voltage swing would require to be $\sqrt{2} \times 20 = 28.3$ V.P.M.

LAMINATED DIELECTRICS

When a homogeneous material is contained between parallel electrodes, the voltage gradient is obtained simply by dividing the r.m.s. voltage by the depth of the material. Where an air gap is present or where parallel layers of different material constitute the work, the voltage gradient in each material becomes inversely proportional to its permittivity. Under these conditions the

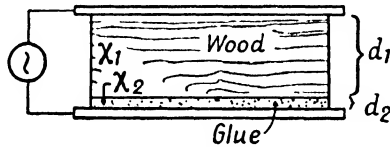

FIG. 12

gradient remains dependent upon χ values for all orientations of the interface except when it is normal to the electrodes. One practical application in which a problem of this type arises is the bonding of wood laminations by a thermosetting glue line. The R.F. energy may be applied by one of two main methods and the relative efficiency of each depends upon the electrical properties of the materials forming the work.

In one method, the glue lines are parallel to the electrodes and this is illustrated in Fig. 12 in which the glue lines are shown as a fairly thick slab for convenience. As stated above, the voltage gradients in the glue lines and the wood will be inversely proportional to the value of χ in each, and when the actual gradient in one is known that in the other is easily found. The voltage gradient in the wood is given by

$$(\text{V.P.M.})_1 = \frac{E \times 10^{-3}}{d_1 + d_2 \frac{\chi_1}{\chi_2}} \quad \dots \quad 2.25$$

where E = r.m.s. applied voltage.

It is of interest to note that where there are n layers of dielectric

$$(\text{V.P.M.})_1 = \frac{E \times 10^{-3}}{d_1 + d_2 \frac{\chi_1}{\chi_2} + \dots + d_n \frac{\chi_1}{\chi_n}} \quad \dots \quad 2.26$$

where d_n = thickness of the n th dielectric and χ_n = permittivity of n th dielectric.

The thickness of glue lines in plywood is relatively small, or in other words, $d_1 \gg d_2$ and no great error is introduced by rewriting equation 2.25

$$(V.P.M.)_1 = \frac{E \times 10^{-3}}{d_1} \quad . \quad . \quad . \quad 2.27$$

in which case the gradient in the glue line becomes

$$(V.P.M.)_2 = \frac{E \times 10^{-3}}{d_1 \frac{\chi_2}{\chi_1}} \quad . \quad . \quad . \quad 2.28$$



FIG. 13

When the χ of the wood is less than that of the glue line there will be a smaller voltage gradient in the glue line. This does not always mean that the rate of heating in the glue line will be slower because, if its heat factor in relation to that of the wood exceeds the square of the ratio of the voltage gradient, it will heat faster than the wood. Usually, however, the wood is of much lower χ and it often happens that a more effective heating of the glue line occurs when the work is set up as in Fig. 13. Here we have the same voltage gradient in the wood and the glue line, and since the heat factor of the latter is greater a much faster rate of heating occurs in the glue.

HEATING NON-RECTANGULAR WORK

To obtain a consistent rate of heating in a block of homogeneous material shaped as in Fig. 14, it is necessary to maintain the same voltage gradient at A and B, and this is achieved by having a gapped electrode as shown.

$$(V.P.M.)_A = \frac{E \times 10^{-3}}{D} \quad . \quad . \quad . \quad 2.29$$

$$(V.P.M.)_B = \frac{E \times 10^{-3}}{d_1 + d_2 \frac{\chi_m}{\chi_a}} \quad . \quad . \quad . \quad 2.30$$

For consistent heating the top electrode must be positioned such that

$$D = d_1 + d_2 \frac{\chi_m}{\chi_a} \quad . \quad . \quad . \quad 2.31$$

24 RADIO-FREQUENCY HEATING EQUIPMENT

$$\therefore d_2 = \frac{\chi_a (D - d_1)}{\chi_m} \quad . \quad . \quad . \quad 2.32$$

This treatment neglects the effect of refraction at the interface but when θ is less than 45° this will not be serious particularly if χ_m is small. A point to note is that d_2 is dependent upon the difference between D and d_1 , and if this difference is maintained, a block could be either short or tall without affecting d_2 , or in other words, the angle between the electrode and face of the work remains the same.

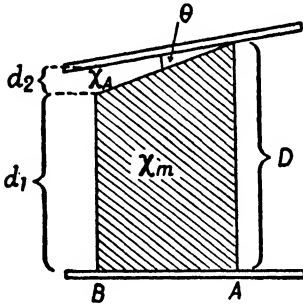

FIG. 14

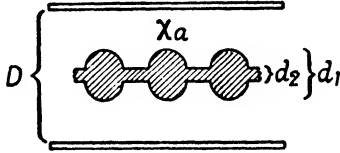

FIG. 15

A useful way of obtaining a fairly uniform heating in work of irregular but small cross-section is to use the levelling effect of large air-gaps. Fig. 15 shows electrodes with separation D between which is "work" having maximum and minimum depth of d_1 and d_2 . The heating of the work becomes more uniform as the ratio of electrode separation to maximum depth of the work increases, and as the ratio of maximum to minimum depth of the work decreases. A low value of permittivity (χ_m) for the material forming the work also tends to make heating more uniform. The ratio of the rate of heating in the shallow section d_2 to that in the deep section d_1 of the work is

$$\frac{\Delta T d_2}{\Delta T d_1} = \left\{ \frac{d_1 + (D - d_1) \frac{\chi_m}{\chi_a}}{d_2 + (D - d_2) \frac{\chi_m}{\chi_a}} \right\}^2 \quad . \quad . \quad . \quad 2.33$$

From this it is seen that a fairly uniform rate of heating can be obtained over a wide range of conditions.

Eddy-current Heating

THE heating, by the induction of electric currents, of metallic charges, when these act virtually as the short-circuited secondary of a transformer (Fig. 16) is usually called eddy-current heating, although doubts have been expressed recently as to the accuracy of this name. When the charge consists of a ferromagnetic metal a proportion of the heating will be due to hysteresis loss, but this fact was usually neglected in the early treatments of eddy-current heating. The extent to which such an omission may be justified in a practical case will, however, be considered later.

Rapidly changing flux linked with the charge induces e.m.f.s which drive currents round the charge, and in considering the distribution of these currents it is helpful to consider first the reasons underlying the well-known skin effect exhibited in conductors carrying alternating currents of high and particularly radio frequencies.

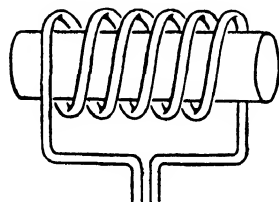

FIG. 16

Current flowing in a conductor of circular cross-section sets up a concentric magnetic field if there are no adjacent current-carrying conductors or magnetized bodies sufficiently near to distort the field. A portion of the magnetic flux exists within the conductor, as well as exterior to it, as shown in Fig. 17, and the flux lines existing within the conductor encircle and thus link with current flowing at or near the centre, without linking with that flowing near the surface. The full significance of the relative distribution of magnetic flux and current is appreciated when the flow of the current is interrupted: the collapsing magnetic field will induce an e.m.f. in the conductor in such a direction as to oppose the decay of the current which created it: the magnitude of the back-e.m.f. depending on the rate of change of flux linkage. At the centre of the conductor the back-e.m.f. will be greater because this region is linked with more flux. Since the back-e.m.f. induced in a circuit is a measure of its inductance it follows that the central region is more inductive than are the outer layers of a conductor.

26 RADIO-FREQUENCY HEATING EQUIPMENT

The resistance offered by a conductor to the passage of direct current depends on its cross-sectional area and the specific resistance of the material forming the conductor. The current density throughout the cross-section will be uniform if the material is homogeneous. For alternating currents the effect of the decreasing inductance possessed by concentric layers of increasing radius becomes significant as the frequency is raised, and the current density will become uneven because the reactance of the outer-layer paths will be relatively small. At low frequencies the difference in reactance of the outer and inner paths is unimportant because both are small and are swamped by the purely resistive component of the path impedances.

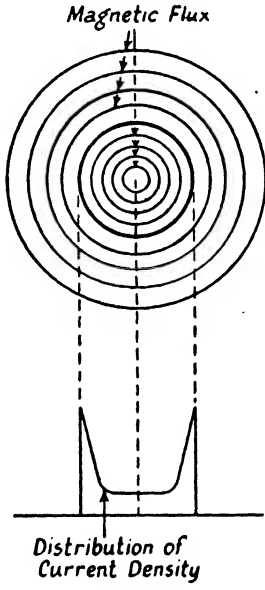

FIG. 17

The impedance offered to the passage of an alternating current by inner and outer layers of a conductor may be represented by the circuit shown in Fig. 18. If the cross-sectional areas of the inner and outer layers are the same, the resistive component of the path impedances will be identical. The reactive component of the inner path (ωL_i) will, however, be greater than that of the outer path (ωL_o). With a conductor made of a material such as copper, which has relatively low value of specific resistance, the value of R_o and R_i will be small and if

the frequency is such that the reactive values differ by a given amount, a certain current distribution will exist. For a conductor of equivalent dimensions but made of a material having higher specific resistance, say brass, the value of R_o and R_i will be greater. To obtain a more or less similar current distribution as before, the reactive components of the path impedances must be increased in proportion and this necessitates the use of a higher frequency. When the conductor material is ferromagnetic its high value of permeability enhances the reactive component of the path impedances and thus produces a distribution of the current similar to that caused by an increase in frequency with a non-ferromagnetic material. Skin effect is seen to depend upon conductor diameter, specific resistance, permeability, and frequency. The effect will be more pronounced—

- (i) at high frequencies ;
- (ii) with conductors of large diameter ;
- (iii) for materials having high values of permeability ;
- (iv) for materials of low specific resistance.

Another and perhaps more satisfactory way of explaining skin effect is to regard it as a phenomenon entirely due to eddy currents. A current flowing in the outer layer of the conductor will set up magnetic flux which induces currents in the inner layer. These currents will by Lenz's law be in opposition to the main current, and a complete phase reversal can occur for current flowing beneath the surface. Specific resistance, permeability, and frequency are easily taken into account in this view of skin effect. Material having high specific resistance will limit both the outer path main current and the inner path eddy current, and so reduce skin effect.

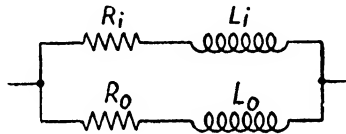

FIG. 18

For materials of high permeability the impedance of the eddy-current path is increased, and at high frequencies there will be a greater rate of change of flux linkage inducing eddy currents. With eddy-current heating, the main current in the work is not due to an applied oscillatory potential as is normally the case when considering skin effect. All currents within the work are induced by the magnetic flux associated with the work coil which is itself energized by a suitable generator.

The heating due to eddy currents may be treated mathematically, but to render the analysis tractable it is expedient to make certain simplifying assumptions as follows—

- (i) The ratio (length/mean radius) of the work having n uniformly spaced turns is large enough for the magnetic field to be considered parallel to the axis over the work length.
- (ii) The work is a circular cylinder of radius a , permeability μ , and specific resistance ρ , placed coaxially in the solenoid.
- (iii) The magnetic permeability is independent of magnetizing force and temperature,* while the specific resistance ρ is independent of temperature, i.e. μ and ρ are constant.

* This is substantially true for non-magnetic materials like brass, copper.

(iv) The sinusoidal magnetizing current ($I_{r.m.s.}$) is in phase throughout the solenoid.

The mathematical analysis, being rather intricate, is beyond our present purview, but has been given by McLachlan.* He finds that the power loss per cubic centimetre of charge at pulsance ω is represented by

$$P = \frac{4\pi n^2 \mu \omega}{l^2} \cdot I_{r.m.s.}^2 W_{(ma)} \times 10^{-9} \text{ watts} \quad . \quad 3.1$$

where $m = \left(\frac{4\pi \mu \omega}{\rho} \right)^{\frac{1}{2}}$, and all quantities are expressed in absolute units (c.g.s.).

McLachlan designates $W_{(ma)}$ to be the "loss function," which is plotted in Fig. 19. When $ma = 2.5$, the function has a maximum value, but from a practical viewpoint its variation is inappreciable over the range $ma = 2$ to 3. Thus to obtain the maximum heating effect, a very critical adjustment of frequency is unnecessary. For a given charge, however, the optimum condition can be obtained by an approximate adjustment of the frequency. From above,

$ma = \left[\left(\frac{4\pi \mu}{\rho} \right)^{\frac{1}{2}} a \right] \omega^{\frac{1}{2}}$, and since by hypothesis the quantity in [] is constant, ma may be arranged to have the value 2.5 by altering ω , i.e. by variation in frequency.

In practice the permeability increases with rise in temperature until the Curie point is reached, when the permeability suddenly falls to unity. The specific resistance also increases with rise in temperature, and may attain a value of the order twenty times that at room temperature. By virtue of these variations in permeability and specific resistance, there is an appreciable discrepancy between the results deducible from the mathematical analysis and those which obtain in practice. Nevertheless, the analysis is useful because it indicates the general trend of events (especially in the case of non-magnetic materials like brass, copper, etc.) which may be summarized as follows—

(i) There is no clearly defined optimum frequency.

(ii) At a given frequency the loss in ferromagnetic material exceeds appreciably that in non-ferromagnetic material. For a given loss, the frequency needed for the former is less than that for the latter.

(iii) The smaller the diameter, the higher must be the frequency for a given loss.

* McLACHLAN, *Bessel Functions for Engineers*, Oxford (1941), pp. 133-148.

(iv) The greater the specific resistance, the higher must be the frequency for a given loss.

WORK MATERIALS

Most materials have a permeability that departs from unity in only the fifth or sixth decimal place, but there are a few materials having permeability values incomparably greater. These are the ferromagnetic metals which possess powers of attraction when magnetized.

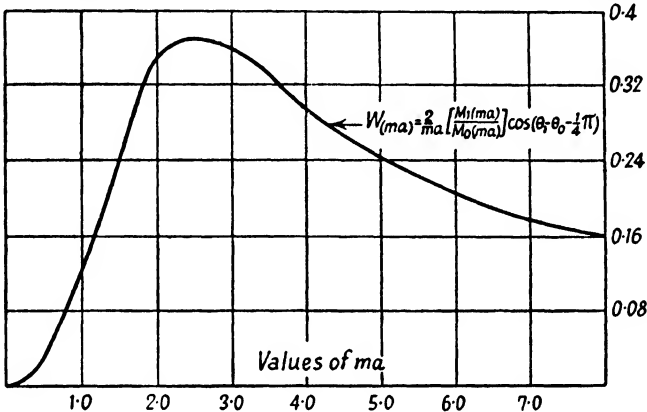

FIG. 19

Iron is the most important substance in this class, although both nickel and cobalt possess the property. Recently, however, special alloys have been developed possessing ferromagnetic properties, but which are actually composed of non-ferromagnetic material.

The value of permeability possessed by any of the ferromagnetic metals depends upon their previous treatment, and upon the strength of the magnetic field in which they are situated. Typical values are

Material	Permeability
Swedish iron	5000
Electrolytic iron	9000
Mild steel (black)	2500
Cobalt	60
Nickel	800

CURIE POINT

It has been known since the time of Gilbert that iron loses its magnetic properties when raised to red heat, and regains them on cooling. While many early workers had established the critical temperatures at which the ferromagnetic properties possessed by

30 RADIO-FREQUENCY HEATING EQUIPMENT

various metals disappeared, it was Pierre Curie who enunciated a law covering the influence of temperature on the magnetic properties of materials. The critical temperature has thus become known as the Curie point and is listed for a number of materials.

Material	Curie Point
Iron	770° C
Cobalt	1150° C
Nickel	360° C
Nickel iron Fe 70 per cent, Ni 30 per cent	70° C
Permalloy Fe 22 per cent, Ni 78 per cent	550° C
Nickel copper	10–70° C

The loss of permeability at the Curie point is sharply defined and takes place in the range of a very few degrees centigrade. This is one of the most important factors to be considered in eddy-current heating applications because the work will usually consist of iron or steel. From equation 3.1 it is seen that the power that can be dissipated in the work becomes very low when the permeability falls to unity. For this reason, it is usual to design equipment for conditions that prevail after the Curie point has been attained. Up to the Curie point heating will be satisfactory under almost any circumstances since the permeability will be high, but once the Curie point has been passed a further increase in temperature is more difficult to attain.

Depth of Penetration. The relatively low impedance path presented by the peripheral layers of the work means that 90 per cent of the power will be dissipated in a layer having a thickness

$$t = \frac{1}{2\pi\sqrt{\mu f}} \sqrt{\frac{\rho}{\mu f}} \text{ mm} \tag{3.2}$$

where ρ is expressed in c.g.s. units, i.e. ohms per cm cube $\times 10^9$ and f is the frequency in cycles per second.

For carbon steel at 20 per cent*

$$t = \frac{20}{\sqrt{f}} \text{ mm} \tag{3.3}$$

When the Curie point has been reached the thickness increases to

$$t = \frac{500}{\sqrt{f}} \text{ mm} \tag{3.4}$$

After the outer layer has reached Curie point it is no longer closely coupled to the generator, and most of the inductive transfer of energy then takes place to the next layer. Should the outer layer

* BABAT AND LOSINSKY, *J.I.E.E.*, Vol. 86 (February, 1940).

not receive enough energy to maintain its temperature, it will of course cool, but in so doing the layer again becomes ferromagnetic and efficient heating conditions once more prevail. After the whole body has attained a temperature equivalent to the Curie point, any further increase is difficult to achieve, coupling to the work becomes poor, and the power factor of the whole circuit low. The actual power needed to produce an incremental heating above the Curie point will not be much in excess of that needed below it. Thermal losses will, of course, be greater but their influence will not be unduly large. Owing to poor power factor, however, the kVA rating of

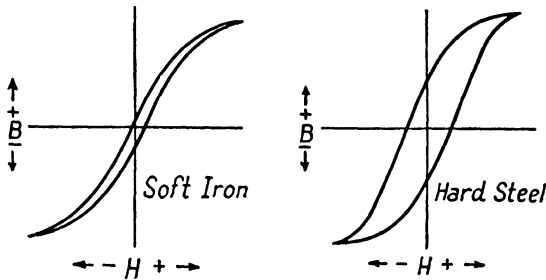

FIG. 20

the generator will need to be far greater in order to transfer the required energy to the work, and this means that a much more powerful equipment must be used.

HYSTERESIS LOSS

It is well known that when a sample of ferromagnetic material is taken through a cycle of magnetization, the loss will be proportional to the area of the hysteresis loop. For soft iron the loop area is small while for hard steels it is large, as shown in Fig. 20. It will be noted that hysteresis is due to the fact that permeability is not proportional to magneto-motive force, and with rising frequency it would appear that the heat generated by hysteresis loss increases. At radio frequencies, the heat generated by this means would apparently become more significant than that due to eddy currents, but actually at frequencies above about 100 kc/s the permeability approaches a constant value with changes in H .

Since R.F. eddy-current heating is concerned with frequencies ranging from 100 kc/s to many megacycles we see that hysteresis effects may be neglected without introducing any grave error. But when low frequencies are used, as with alternator equipment

32 RADIO-FREQUENCY HEATING EQUIPMENT

which does not usually operate at frequencies above 10 kc/s, the heating due to hysteresis must be taken into account.

At very high frequencies the power factor of the magnetizing current should not exceed 0.707 if hysteresis is ignored, but in practice it is found that it may easily reach 0.85 or more. Dannatt* suggests that the extra loss is due to eddy currents set up by fluxes transverse to the applied magneto-motive force rather than to hysteresis. Whatever the cause may be, we are led to the conclusion that in the present state of knowledge, the theory of eddy-current heating is not sufficiently complete to enable a rigorous analysis to be made. In the chapter dealing with eddy-current heating work circuits, we shall nevertheless see that the performance of R.F. eddy-current heating equipment may be predicted with reasonable accuracy from data gained by a few simple circuit measurements.

* DANNATT, *J.I.E.E.* (Dec., 1936), 667-681.

Thermionic Generators

THE power required for radio-frequency heating is usually obtained from a thermionic generator, although at frequencies suitable for some eddy-current heating applications it is possible to obtain power from other sources. For dielectric heating, however, the valve is the only suitable device for generating power at the frequencies that must be used if efficient heating is to result. The circuit, in which oscillatory energy of the required frequency is maintained and from which power is available for heating, consists of a parallel combination of coil and capacitor known as the tank circuit. This name is most apt, for the circuit may in fact be regarded as a reservoir containing the total R.F. energy generated.

OSCILLATORY CIRCUIT

The behaviour of a parallel resonant circuit is closely analogous to that of a pendulum. When no current flows in the circuit conditions are similar to a pendulum at rest. Both systems, when once energized, would be capable of sustaining oscillations for a period of time, although with a pendulum the time would ordinarily be very much longer. If the capacitor is taken by itself and charged to a given voltage from a d.c. source the energy possessed by the electrostatic field existing between the plates of the capacitor is $\frac{1}{2}CE^2$, where C is the capacitance in farads and E is the applied voltage. Conditions are now similar to displacing a pendulum from vertical and supporting the bob in a given position. Both the charged capacitor and the supported weight possess potential energy.

Connecting the coil across the capacitor is similar to releasing the pendulum bob. The potential difference existing between the terminals of the capacitor sends a current through the coil and this current gives rise to a magnetic field linked with the turns of the coil. When the capacitor is completely discharged the total energy which was in the electrostatic field is transferred to the magnetic field linked with the coil. There will now be no potential difference existing between the terminals of the capacitor or across the coil and the magnetic field will start to collapse. In so doing it

34 RADIO-FREQUENCY HEATING EQUIPMENT

induces a back-e.m.f. in the coil and charges the capacitor in the opposite direction. When the capacitor has reached its maximum charge in the opposite direction conditions are similar to those for a pendulum when the bob has swung to its limit on the other side of vertical.

A perfect pendulum, once displaced and released, would swing for ever, and similarly, a perfect parallel-resonant circuit when once energized would maintain a constant oscillatory current. Perfection however is not possible; in both the pendulum and parallel-resonant circuit the energy will die away at a rate dependent upon the frictional resistance in the one and the electrical resistance in the other.

If the frictional resistance in a pendulum were comparatively large, it would affect the time taken for a complete swing. Not all the potential energy possessed by the system at the beginning of a swing would appear as kinetic energy when the bob was travelling at its maximum velocity, and still less as potential energy at the completion of the swing. With a perfect pendulum the time taken for a swing is determined solely by its length, but if considerable resistance is present the time taken for a swing will be longer and the bob will travel a shorter distance with each swing. The rate at which the amplitude of the pendulum would decrease depends on the ratio of the mass of the bob to the resistance. It is easy to appreciate that if the resistance exceeds a certain value the pendulum will be incapable of oscillatory movement.

ELECTRICAL LOSS

An oscillatory electrical circuit possesses resistance due to the conducting material of which the coil and capacitor are made. Another point is that owing to imperfections in the dielectric, the capacitor will not become completely discharged at any time during the oscillatory process. Again, if the physical dimensions of the circuit approach or exceed $\frac{\lambda}{4}$ where λ is the wavelength of oscillation, a considerable amount of energy will be lost by radiation. Losses due to conductor resistance, dielectric imperfections, radiation, or any other cause may however be represented by an equivalent resistance in series with the circuit.

The passage of an oscillatory current through the resistance representing the total loss of the circuit, is accompanied by radiation and the generation of heat and there is a continuous reduction in the amount of energy oscillating between the magnetic and electric fields. The rate at which this reduction occurs will depend on the

ratio of the amount of energy stored in the magnetic or electric fields to that dissipated in the resistance. The ratio is called the decay factor of the circuit and is equivalent to $\frac{R}{2L}$, where R is the resistance and L is the inductance of the circuit.

It will be noted that inductance in a parallel-resonant circuit is equivalent to mass in a pendulum. Oscillations of a pendulum having a heavy bob would persist for a longer time than would be the case if the bob mass were small. Similarly, if the ratio of $\frac{L}{R}$ is large, the decay of oscillatory energy will be less.

The frequency at which a parallel-resonant circuit oscillates when it has been excited and then left for oscillations to decay at a rate depending on $\frac{R}{2L}$ is called the natural frequency and is given by the expression—

$$f = \frac{1}{2\pi} \sqrt{\frac{1}{LC} - \frac{R^2}{4L^2}} \text{ cycles per second 4.1}$$

From this it is seen that if $\frac{R^2}{4L^2} > \frac{1}{LC}$ the circuit cannot be oscillatory.

With a driven pendulum, energy is available from a spring or weights and is imparted via the escapement device to maintain the amplitude of swing constant. Under these conditions the time taken for a swing depends solely on the length of the pendulum and is not influenced by frictional resistance because extra energy is available to make up for this loss. Similarly with the parallel-resonant circuit, if sufficient energy is imparted to maintain the amplitude of the oscillatory current constant, then

$$f = \frac{1}{2\pi\sqrt{LC}} \text{ 4.2}$$

where f is termed the resonant frequency of the circuit.

The energy for maintaining a constant oscillatory current in a parallel-resonant circuit is available from the H.T. source and is transferred to the circuit via a valve which may, in effect, be regarded as an escapement device. It is essential, however, that the energy is imparted to the circuit in the right direction at the right time. If, for instance, it were made available as a pulse of current flowing in such direction as to oppose a growing electrostatic field, then it would have the effect of stopping the oscillations rather than maintaining them.

CIRCUIT EFFICIENCY

The efficiency of a circuit will determine the amount of energy that must be imparted to maintain the oscillatory current and a figure of merit for the tuned circuit would obviously be the ratio of energy stored to that dissipated at the frequency of operation. This ratio is denoted by the letter Q , and is equal to the ratio of the reactance of the coil or capacitor to the resistance in the circuit. At resonance

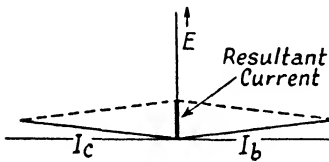

FIG. 21

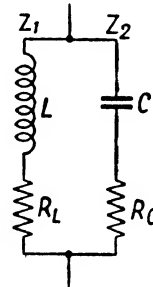

FIG. 22

the reactances are equal and it is usual to express Q as the ratio of inductive reactance to resistance.

$$Q = \frac{\omega L}{R} \dots \dots \dots 4.3$$

where $\omega = 2\pi f$.

In a parallel-resonant circuit, the *currents* flowing in coil and capacitor are very nearly 180° out of phase and the resultant current is consequently small. (See Fig. 21.) The impedance of the circuit, which is the ratio of voltage to current, is, under these conditions, high.

If the coil and capacitor are in series, conditions at resonance are very different. It is the *voltage* across each that is out of phase and the resultant voltage consequently small. The current is high and the impedance low, it being in fact equal to the d.c. resistance of the circuit. Calling the impedance of each branch of a parallel-resonant circuit Z_1 and Z_2 (see Fig. 22) where $Z_1 = R_L + j\omega L$, and $Z_2 = R_C - j/\omega C$, the impedance of the combination will be

$$Z = \frac{Z_1 \cdot Z_2}{Z_1 + Z_2} \dots \dots \dots 4.4$$

At resonance $Z_1 + Z_2$ is equivalent to $R_L + R_C$ and calling the sum of these resistances R we have

$$Z = \frac{Z_1 \cdot Z_2}{R} \dots \dots \dots 4.5$$

but since Z_1 may be assumed equal to Z_2

$$Z = \frac{Z_1^2}{R} \quad \dots \quad 4.6$$

Now in all practical cases Z_1 is very nearly equal to ωL because the resistive component is relatively small so we have

$$Z = Q\omega L \quad \dots \quad 4.7$$

Again,
$$Z_1 \cdot Z_2 = \frac{\omega L}{\omega C} \quad \dots \quad 4.8$$

so that
$$Z = \frac{L}{CR} \quad \dots \quad 4.9$$

The impedance presented by a parallel-resonant circuit can be expressed as either $Q\omega L$ or $\frac{L}{CR}$ at resonance.

For currents of non-resonant frequency, the parallel circuit presents very much lower impedance. ωL and $\frac{1}{\omega C}$ are no longer equal, and at frequencies higher than resonance $\frac{1}{\omega C}$ will be smaller and most of the current will flow through the capacitor. At frequencies below resonance ωL will be smaller and most of the current will flow through the coil. The reactive components of the coil and capacitor currents thus no longer cancel out, and the impedance of the circuit is consequently reduced. The reduction will, of course, depend on how far off resonance the applied current is, and for circuits of high Q the fall is very steep at frequencies only 1 or 2 per cent removed from resonance.

THERMIONIC VALVE AS AN AMPLIFIER

With a self-excited oscillator it is the valve's ability to amplify which permits it to act as an escapement device between the H.T. source and a parallel-resonant circuit. There are three main sets of conditions under which a valve can operate as an amplifier, and they are known as Class A, Class B, and Class C conditions of operation. It is with Class C operation that we are concerned when dealing with self-excited oscillators, but we will begin by outlining the requirements and conditions for Class A and Class B operation.

Class A Conditions. The object of this class of amplification is to obtain an output containing no distortion. Usually, the requirements are level amplification over a wide frequency range, and the load

38 RADIO-FREQUENCY HEATING EQUIPMENT

into which the valve works must in such cases be virtually non-resonant and often takes the form of a resistor. The grid of the valve is biased to a position approximately half-way down the straight part of the $I_a - V_g$ characteristic (Fig. 23). The amplitude of the oscillatory voltage applied to the grid is limited to such a value that during the positive half-cycle the grid is not driven positive with respect to the filament, and during the negative half-cycle it does not approach cut-off, in which region the $I_a - V_g$ characteristic is curved.

The advantage of distortionless amplification is gained at the expense of efficiency of conversion of d.c. energy from the H.T.

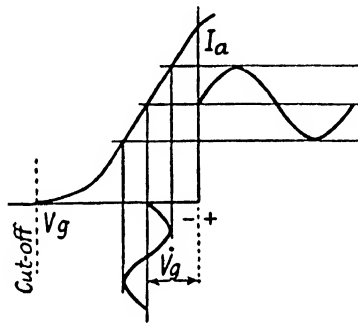

FIG. 23

source into a.c. energy in the anode circuit. The theoretical maximum for the efficiency occurs when, at the peak negative input, the grid is driven to cut-off. I_a would then be zero and the anode voltage would equal the H.T. voltage E_b (see Fig. 24) because there would be no voltage dropped across R_a . At peak positive input the value of I_a would have to be such that $I_a \times R_a = E_b$. The anode voltage would then be zero. Since anode current flows during the whole input cycle, the total swing of anode voltage is equal to E_b . The peak output voltage will thus be $\frac{E_b}{2}$ and, since the same current flows in load and valve, the theoretical maximum for the conversion efficiency is 50 per cent.

In order to obtain this efficiency the grid reaches cut-off, and distortionless amplification would not be obtained. Again, when the instantaneous anode voltage is zero, there would be no anode current. Efficiencies of this order are thus impossible to achieve under Class A conditions. In practice it is usual for the efficiency to be no higher than 20 to 30 per cent if distortionless output is required into a non-resonant load.

If the anode load is a parallel-resonant circuit, efficiencies may be higher without introducing distortion. The resonant properties of the circuit, besides being analogous to a pendulum, can also be likened to a flywheel. Any irregularities in the oscillatory current tend to be ironed out by this flywheel effect, and the current in the resonant circuit will closely approach sinusoidal wave form. Returning to the pendulum analogy, Class A conditions do not represent an escapement drive. Anode current flows during the whole cycle and it is as though the pendulum were coupled to a device which drives it throughout its swing in both directions.

Class B Conditions. The purpose of Class B operation is to obtain a fairly distortionless output at higher efficiencies than can be obtained under Class A conditions. The grid is biased to cut-off, and anode current flows during half the grid input cycle. For most of the time when anode current is flowing the $I_a - V_a$ characteristic is straight and it becomes curved only as cut-off is approached. In order that the wave form of the output voltage should be similar to that of the input voltage it is necessary to operate two valves in push-pull. One valve by itself would reproduce only a half of the grid input cycle in a non-resonant load. With resonant loads, however, the pendulum or flywheel action would permit one valve to be used. Conditions would then be similar to driving a pendulum during the whole time that it is one side of vertical. It will be seen later that the theoretical maximum for conversion efficiency in Class B conditions is 78.5 per cent, although in a practical case it is not likely to exceed 50 per cent.

Class C Conditions. The purpose of Class C operation is to obtain even higher efficiencies of conversion of d.c. into a.c. energy. The grid is biased to well beyond cut-off and the exciting voltage applied to the grid is sufficiently large to drive it well positive with respect to the cathode during the positive half of the grid input cycle. Under these conditions anode current flows for less than a half of the cycle and even if two valves were used in push-pull the output into a non-resonant load would be very distorted. When output that approximates to a sine wave is wanted it is essential to employ resonant loads and with one valve conditions are similar to driving a pendulum for part of the time that it is one side of the vertical. The theoretical maximum for the conversion efficiency will be seen

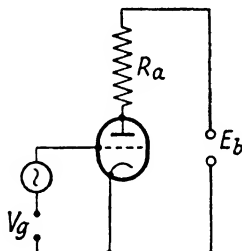

FIG. 24

40 RADIO-FREQUENCY HEATING EQUIPMENT

later to be 100 per cent, although a figure of 70 to 80 per cent is the most that can ordinarily be obtained with amplifiers in practice, and 60 to 70 per cent with self-excited power oscillators. Before dealing with Class C conditions of operation in more detail, we will consider the valve as a self-excited oscillator, when it is in fact acting as an amplifier that supplies its own grid excitation.

SELF-EXCITED OSCILLATORS

The value of bias applied to the grid of a self-excited power oscillator considerably exceeds cut-off and it therefore works under Class C conditions. The bias voltage is developed across a resistor in series with the grid. The current flowing through this resistor

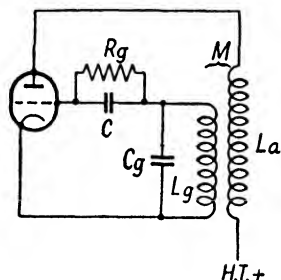

FIG. 25

will be in the form of a series of rectified pulses occurring when the grid swings positive with respect to the cathode, and the bias voltage will be equal to the average value of the rectified pulses multiplied by the value of the resistor. A capacitor shunts this resistor and its value is chosen to be such that the time constant of the RC circuit so formed is large compared with the time taken for one cycle of the radio-frequency energy. The presence of such a capacitor maintains the voltage across the resistor fairly constant since before the capacitor can become appreciably discharged another pulse of rectified current occurs to maintain the charge. The value of the capacitor is not very critical, but should be such that its reactance at the frequency of operation is low compared with the resistor. This will ensure that R.F. energy in the circuit will have a low impedance path to the grid of the valve.

An oscillatory circuit in which energy from the anode coil is fed back to the grid by the mutual coupling M between the coils L_a and L_g is shown in Fig. 25. When the H.T. is switched on there will be no bias applied to the grid, and as a result anode current will increase rapidly. This changing current flows through L_a and induces a voltage equal to $M \frac{di}{dt}$ in L_g . The sign of the mutual inductance between the two coils is arranged such that an increasing current in L_a induces a positive potential on the grid. This positive potential will bring about a further increase in anode current until saturation conditions are reached and the total emission from the filament is utilized. The $I_a - V_g$ characteristic flattens as this

condition is approached and $\frac{di}{dt}$ becomes less and finally zero. While the grid is positive with respect to the filament grid current flows and develops a voltage across R_g , and the grid capacitor C_g becomes charged in such a direction as to apply negative bias to the grid. When the value of $\frac{di}{dt}$ falls the negative bias predominates and induces a further negative potential on the grid until cut-off is reached. The pendulum or flywheel action of the circuit $L_g C_g$ has been started by this initial pulse of anode current. During the next cycle the grid will again swing positive and another pulse of grid current occurs.

It should be noted that the circuit arrangement must be such that an increase in anode current causes the grid to become more positive. As anode current increases, the instantaneous anode voltage will decrease due to the voltage drop across L_a so we see that for a valve to act as a self-excited oscillator anode and grid voltages must be out of phase. If the direction of L_a or L_g were reversed the anode and grid voltages would be in phase and the system could not oscillate.

If the bias for the valve were supplied by a battery or some other external source, no anode current would flow at the moment of switching on as the grid would be biased beyond cut-off. Under these conditions it would be impossible for oscillations to start.

VOLTAGE AND CURRENT CHARACTERISTICS (CLASS C)

Voltage and current relations in a valve operating under Class C conditions are shown in Fig. 26. Anode current flows through the tank circuit which at its resonant frequency may be represented by a resistance having the value of $Q\omega L$. The voltage drop across the circuit will be a maximum when the grid potential is $v_{g\max}$ and anode voltage at this instant will be a minimum ($v_{a\min}$). The value of $v_{a\min}$ must never be less than $v_{g\max}$ for were this to happen the grid would become the most positive electrode with respect to the filament. Current collected at the grid would increase rapidly and besides robbing the anode of current the bombardment of electrons from the filament might give rise to considerable secondary emission from the grid. At the same time the grid may run so hot that thermionic emission occurs and this together with the secondary emission can cause the grid current to reverse. As a result of the reversed grid current flowing through R_g , the bias applied to the grid becomes positive. Normal operating conditions cannot be regained because the positive bias brings about an increase in the

42 RADIO-FREQUENCY HEATING EQUIPMENT

number of electrons bombarding the grid and this in turn results in a further increase of primary and secondary grid emission. Over-driving of the grid would thus encompass the destruction of the valve in a very short time. The effect is called *blocking*, the name

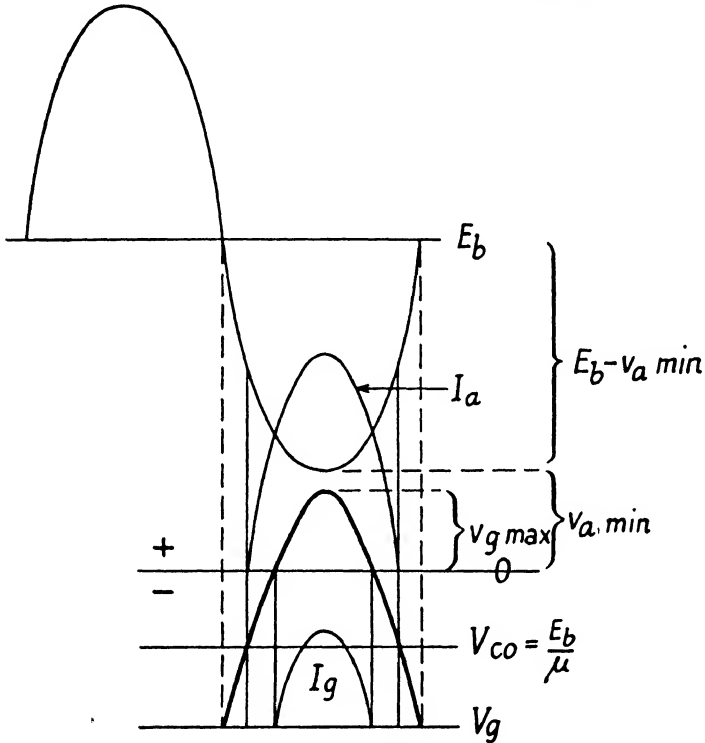

FIG. 26*

being derived from the fact that a set of conditions is created which precludes the grid from regaining a negative potential.

Anode Current. The anode current is somewhat distorted because the valve works over curved parts of its characteristic as saturation and cut-off conditions are approached. The current will consist of a d.c. component (I_{ac}) and an a.c. component at the resonant frequency of the tank circuit (I_{ac}) plus a prolific harmonic content. The voltage drop across the tuned circuit will be $I_{ac}Q\omega L$ because at harmonic frequencies the impedance presented by the tuned circuit will be relatively small and the harmonic voltages developed across the circuit will not be appreciable. Since I_{ac} is the peak

* The I_a and I_g curves are not to scale and do not represent the pulse shapes accurately.

value of the fundamental component of anode current and $E_b - v_{a\min}$ is the peak voltage, the power output is

$$\frac{(E_b - v_{a\min})I_{ac}}{2} = \frac{(I_{ac})^2 \cdot Q\omega L}{2}$$

It should be noted that I_{ac} is the vector difference between the currents flowing in the coil and capacitor (see Fig. 21). These are very large and for practical purposes are assumed equal and referred to as a tank circulating current I_t .

$$I_t = \frac{E_b - v_{a\min}}{\omega L} \quad \dots \quad 4.10$$

but
$$I_{ac} = \frac{E_b - v_{a\min}}{Q\omega L} \quad \dots \quad 4.11$$

\therefore
$$I_t = Q \cdot I_{ac} \quad \dots \quad 4.12$$

A d.c. meter in the anode circuit of a valve operating under Class C conditions would indicate the average current flowing over the whole cycle (I_{dc}). During more than half of a cycle no current will flow, while for the remaining period there will be an approximately sinusoidal pulse of current. Power input to the oscillator will be

$$E_b I_{dc} = \text{watts input} \quad \dots \quad 4.13$$

Power dissipated at the anode of the valve is the difference between input and output, i.e.

$$E_b I_{dc} - \frac{(E_b - v_{a\min})I_{ac}}{2} = \text{watts dissipated at anode} \quad \dots \quad 4.14$$

The values of both I_{dc} and I_{ac} in a given valve depend on the duration of anode-current flow.

ANODE AND GRID CIRCUIT RELATIONSHIPS

The duration of both anode and grid current flow is governed by the value of negative bias applied to the grid (V_g), the grid excitation voltage (V_{gd}), and the cut-off bias $\left(\frac{E_b}{\mu}\right)$ for the valve in question.

Anode current flows when the grid is less negative than cut-off and grid current flows when the grid is positive with respect to the filament. In the anode circuit the current is a more or less sinusoidal pulse. In the grid circuit, however, the pulse of current is by comparison very peaked and approximates in shape to a "sine-squared" waveform.

If the value of bias were equal to cut-off, the duration of anode current flow would be half the grid input cycle or 180 electrical

44 RADIO-FREQUENCY HEATING EQUIPMENT

degrees. This would be so no matter how large or small the value of grid excitation voltage. If now the bias were increased to say twice cut-off, the grid excitation voltage would need to exceed the value of $\frac{2E_b}{\mu}$ before grid current could flow and no matter how large the value of excitation voltage, anode current could not flow for as long as 180° .

It will be seen later that for normal operation the duration of anode current flow is chosen to lie between 120° and 150° . Also, one

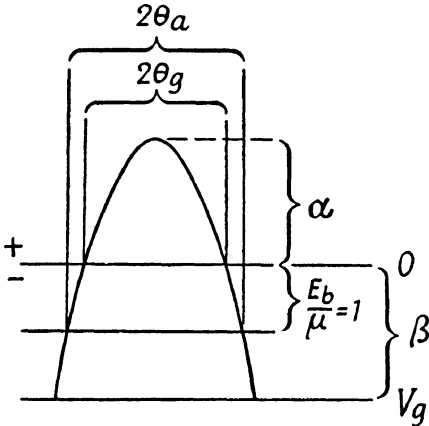

FIG. 27

of the first steps in design is to select from valve data a value for $v_{g,max}$ which, incidentally, lies between approximately 5 and 10 per cent of E_b . Knowing $v_{g,max}$ it remains to find the value of bias that must be applied in order to obtain the required duration of anode current flow. The bias voltage may be found conveniently by using a graph that is prepared in the following manner.

For a given valve the critical factor in determining length of current flow is the cut-off bias $\frac{E_b}{\mu}$. This we will take as our unit.

Let the ratio of maximum grid volts to cut-off bias, or $\frac{\mu v_{g,max}}{E_b}$, be α , and the ratio of bias volts to cut-off bias, or $\frac{\mu V_g}{E_b}$, be β . Calling the duration of anode current flow $2\theta_a$ electrical degrees, we see from Fig. 27 that since the wave form of the grid voltage fed back from the tank circuit is very nearly sinusoidal

$$\cos \theta_a = \frac{\beta - 1}{\alpha + \beta} \quad \cdot \quad \cdot \quad \cdot \quad \cdot \quad 4.15$$

The graph shown in Fig. 28 has been prepared from the above expression and enables the grid bias and drive voltages to be read off when θ_a has a value of 60° , 65° , 70° , or 75° . With a given value of θ_a α is known and β may be read off for the chosen duration of anode current flow. The necessary bias is $V_g = \beta \frac{E_b}{\mu}$ volts while

the grid drive is $V_{gd} = (\alpha + \beta) \frac{E_b}{\mu}$ volts. It will be noted from Fig. 27 that if the duration of grid current flow is $2\theta_g$ then $\cos \theta_g = \frac{\beta}{\alpha + \beta}$ and as a point of interest the duration of grid flow has been plotted in Fig. 28.

Values of θ_a between 90° and 40° are shown in Fig. 28 although the design is based only on those lying between 60° and 75° . The other values are included because they serve to illustrate some of the more interesting aspects of operation. When θ_a is 90° , the duration of anode current flow is independent of α , and Class B conditions prevail. On the other hand, for short duration currents θ_a is very dependent on α . A comparatively large value of β is required for short duration currents and the grid driving-power becomes excessive because the grid excitation voltage (V_{gd}) must, under these conditions, be very large. In practice, the values of α and β that will be encountered vary with the type of valve. High impedance valves possess a large value of μ and for these α may be as high as 4 or 5 and β 3 or 4. For low impedance valves, however, the value of α may range from about 0.5 to 2 and β from 1.5 to 2.5.

Grid Driving Power. Unlike the anode circuit, for which power is provided from a d.c. source, the grid circuit is energized by A.C. at the fundamental frequency fed back from the tank circuit. This energy is dissipated in two ways, part in the grid resistor, and part at the grid electrode of the valve.

The d.c. current flowing through the resistor (I_{gdc}) can be measured easily and the voltage drop across the resistor provides bias. Since the grid current is peaked and approximates to a sine-squared function the d.c. component is approximately half the fundamental a.c. component, and the total power dissipated in the grid circuit is thus $2V_g I_{gdc}$, half in the resistor and half at the grid electrode.

ANODE EFFICIENCY

If with a given valve θ_a is shortened by an increase in both V_g and V_{gd} leaving v_{gmax} approximately the same, then the peak anode

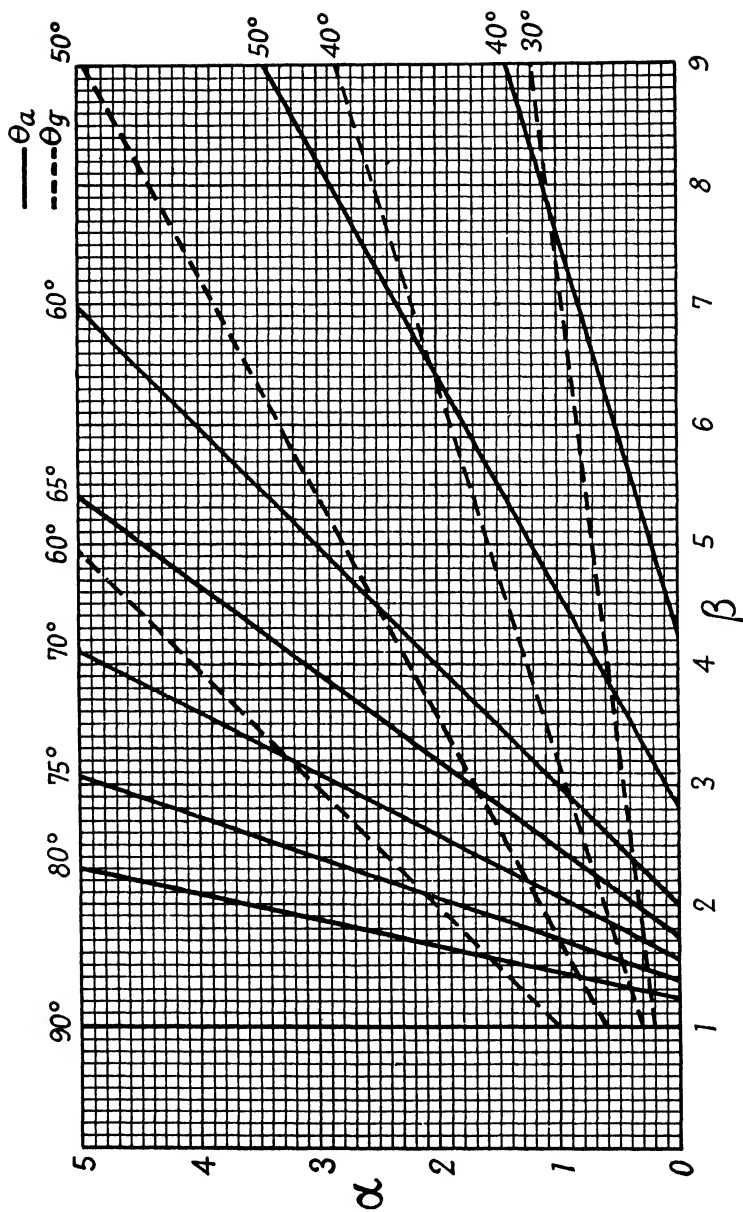

FIG. 28

current will remain almost unaltered. The current indicated on a d.c. meter in the anode circuit would, however, decrease because the duration of current flow becomes less. A substantial decrease in θ_a is accomplished by increasing the value of $Q\omega L$. In other words, the load becomes lighter, and in order to maintain $v_{a\text{min}}$ at approximately its former value I_{ac} becomes reduced. Although $v_{a\text{min}}$ remains approximately the same, the reduction in I_{dc} and I_{ac} involves a decrease in both input and output power and this is a point of great importance which we will consider later when dealing with variable loading.

For a valve operating under Class C conditions there are, among others, the following interdependent variables—

- (i) H.T. voltage;
- (ii) grid bias voltage;
- (iii) instantaneous anode voltage;
- (iv) maximum grid voltage;
- (v) d.c. anode current;
- (vi) a.c. anode current;
- (vii) grid current;
- (viii) duration of anode and grid current flow.

To make a thorough examination of the behaviour of the valve and its associated circuit is a formidable task because the influence of a small change in one variable upon the others must, with a given anode load, be plotted or calculated, and many hundreds of observations or calculations must be made before the examination is complete. Fortunately such a thoroughgoing investigation is not normally needed in designing equipment for Class C operation. There are many approximations which have been found in practice to yield results sufficiently accurate for most design work. Particularly does this apply in the case of R.F. heating because the load itself is a variable.

Calling the voltage by which the bias exceeds cut-off V_x we have

$$V_x = (\beta - 1) \frac{E_b}{\mu} \quad . \quad . \quad . \quad 4.16$$

While for the grid drive voltage we have

$$V_{gd} = (\beta + \alpha) \frac{E_b}{\mu} \quad . \quad . \quad . \quad 4.17$$

$$\therefore \cos \theta_a = \frac{V_x}{V_{gd}} = \frac{(\beta - 1)}{(\alpha + \beta)} \quad . \quad . \quad . \quad 4.18$$

The peak current that will be drawn by the anode is

$$i_{a\text{peak}} = g_m(V_{gd} - V_x) \quad . \quad . \quad . \quad 4.19$$

$$= V_{gd}g_m(1 - \cos \theta_a) \quad . \quad . \quad . \quad 4.20$$

where g_m is the mutual conductance of the valve.

For the d.c. component that would be indicated on a meter in the anode circuit we have

$$I_{dc} = \frac{g_m}{\pi} \int_0^{\theta_a} (V_{gd} \cos \theta - V_x) d\theta \quad . \quad . \quad . \quad 4.21$$

$$= \frac{V_{gd}g_m}{\pi} (\sin \theta_a - \theta_a \cos \theta_a) \quad . \quad . \quad . \quad 4.22$$

Dividing equation 4.20 by 4.22 we obtain the ratio of peak anode current to the d.c. component for any value of θ_a

$$\frac{i_{a\text{peak}}}{I_{dc}} = \frac{\pi(1 - \cos \theta_a)}{\sin \theta_a - \theta_a \cos \theta_a} \quad . \quad . \quad . \quad 4.23$$

The alternating component of the anode current is found from the fundamental Fourier coefficient

$$I_{ac} = \frac{2g_m}{\pi} \int_0^{\theta_a} \cos \theta (V_{gd} \cos \theta - V_x) d\theta \quad . \quad . \quad . \quad 4.24$$

Integrating and substituting from equation 4.18

$$I_{ac} = \frac{V_{gd}g_m}{\pi} \left(\theta_a - \frac{\sin 2\theta_a}{2} \right) \quad . \quad . \quad . \quad 4.25$$

$$= \frac{V_{gd}g_m}{\pi} (\theta_a - \sin \theta_a \cos \theta_a) \quad . \quad . \quad . \quad 4.26$$

Dividing equation 4.26 by equation 4.22 we obtain the ratio of the fundamental frequency component to the d.c. component

$$\frac{I_{ac}}{I_{dc}} = \frac{\theta_a - \sin \theta_a \cos \theta_a}{\sin \theta_a - \theta_a \cos \theta_a} \quad . \quad . \quad . \quad 4.27$$

TABLE I

θ_a	90	80	70	60	50	40	30	20	10	0
$\frac{I_{ac}}{I_{dc}}$	1.571	1.651	1.725	1.794	1.854	1.905	1.946	1.976	1.996	2.000

As the duration of anode current flow is reduced the d.c. component of the anode current decreases more rapidly than does the a.c. component. This means that the ratio of output to input or in other

words the anode efficiency is improved. The figures listed in Table I have been prepared from equation 4.27 and among other things they indicate the asymptotic value of efficiency for various values of θ_a . The condition $\theta_a = 0$ is a theoretical one and occurs when the $v_{a\min} = 0$, and although it can be closely approached in amplifiers having bias voltage provided by a separate source, such is not so with self-excited oscillators having grid-leak bias, because in these the grid losses become significant when the duration of anode current is short. In the hypothetical case of $\theta_a = 0$ the ratio $\frac{I_{ac}}{I_{dc}}$ becomes 2 and the efficiency of energy conversion is 100 per cent. For Class B conditions when $\theta_a = 90^\circ$ the ratio $\frac{I_{ac}}{I_{dc}}$ is 1.571 and the efficiency 78.5 per cent. The powers involved when $\theta_a = 0$ and the theoretical limits of efficiency are reached become vanishingly small and in order to compromise between power and efficiency it is customary to operate Class C equipment with durations of anode current flow between 120° and 150° in which case θ_a is 60° and 75° respectively.

TABLE II

θ_a	60	65	70	75
$\frac{i_{a\text{peak}}}{I_{dc}}$	4.6	4.2	3.9	3.6
$\frac{i_{a\text{peak}}}{I_{ac}}$	2.56	2.4	2.3	2.2

The upper full line curve shown in Fig. 29 is prepared from equation 4.23 and indicates the ratio of peak to d.c. anode currents for values of θ_a between 30° and 90° . The lower full curve indicates the ratio of peak to alternating current component of anode current for similar values of θ_a and is based on equation 4.27. Since it is usual to operate with a duration of anode current flow between 120° and 150° the values of $\frac{i_{a\text{peak}}}{I_{dc}}$ and $\frac{i_{a\text{peak}}}{I_{ac}}$ have been tabulated for values of θ_a between 60° and 75° in Table II. The dotted curve indicates the ratio of peak grid current to the d.c. component that would be shown on a meter in the grid circuit and is based on an expression derived from the sin-squared function.

To carry out a rapid design for a Class C oscillator, it is necessary to have valve curves extending well into the positive grid region.

50 RADIO-FREQUENCY HEATING EQUIPMENT

Characteristics of the type shown in Fig. 59 are suitable for indicating the peak currents that will flow in the anode and grid circuits at the selected values of $v_{a\min}$ and $v_{o\max}$. The maximum value of

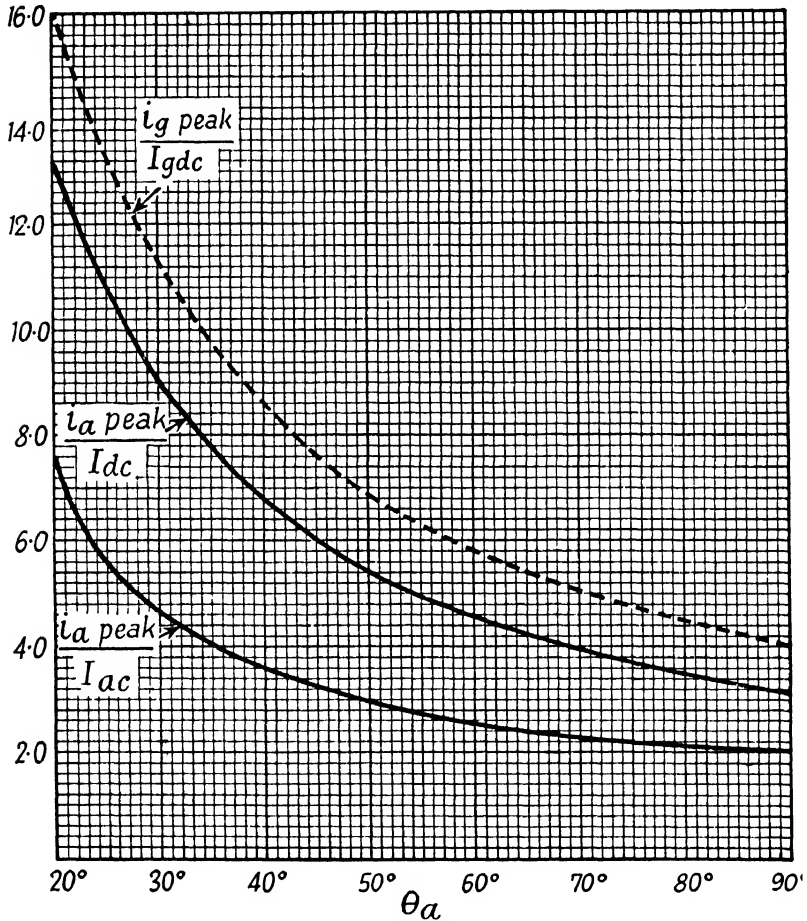

FIG. 29

d.c. anode current (I_{dc}) and the H.T. voltage (E_b) is stated by the valve manufacturer, and basing the design on a duration of anode current flow of say 140° ($\theta_a = 70^\circ$), the first step is to ascertain the peak anode current that will flow. From Table II it is seen to be $3.9 I_{dc}$. Valve curves are consulted to find the values of anode and grid potential that are required to draw the peak anode current. These will be $v_{a\min}$ and $v_{o\max}$ respectively. At the same time the

peak grid current is noted, and the sum of these currents must not exceed the total emission of which the filament is capable. We now know v_{amin} and consequently the peak oscillatory voltage ($E_b - v_{amin}$) across the tank circuit.

For $\theta_a = 70^\circ$, $\frac{I_{apeak}}{I_{ac}} = 2.3$ and so the peak value of the fundamental component of plate current is

$$\frac{3.9}{2.3} I_{dc} = I_{ac} \quad \dots \quad 4.28$$

The impedance which the tank circuit must present to satisfy the voltage and current requirements is

$$R_L = Q\omega L = \frac{E_b - v_{amin}}{I_{ac}} \quad \dots \quad 4.29$$

and from this it follows that the optimum tank inductance will be

$$L = \frac{R_L}{Q\omega} \quad \dots \quad 4.30$$

where Q is the loaded value for the circuit. However, Q must not possess a value lower than about 12 or the tank circuit will present appreciable impedance at harmonic frequencies. Besides increasing radiation, this will produce a form of instability, because the frequencies at which maximum voltage and unity power factor occur, will not be the same.*

OUTLINE DESIGNS

Taking the valve for which curves are shown in Fig. 59 a design for an oscillator having a duration of anode current of 140° can be summarized in the following stages.

- (i) $i_{apeak} = 3.9 \times 140 = 546 \text{ mA}$ (from Fig. 29).
- (ii) Choose values of v_{gmax} and v_{amin} to draw total filament emission of 800 mA $v_{gmax} = 80, v_{amin} = 200 \text{ V}$
- (iii) $I_{ac} = \frac{i_{apeak}}{2.3} = 237 \text{ mA}$ (from Fig. 29).
- (iv) $Q\omega L = \frac{E_b - v_{amin}}{I_{ac}} = 5450\Omega$
- (v) $i_{gpeak} = 190 \text{ mA}$ (from valve curves)
- (vi) $I_{gdc} = \frac{190}{5} = 38 \text{ mA}$ (from Fig. 29)

* See Appendix 1.

$$(vii) \alpha = \frac{\mu v_{g \max}}{E_b} = 1.17$$

$$(viii) \beta = 2.15 \text{ (from Fig. 28)}$$

$$(ix) V_g = \beta \frac{E_b}{\mu} = 146 \text{ V}$$

$$(x) R_g = \frac{V_g}{I_{gdc}} = 3900 \Omega$$

$$(xi) \text{ Grid power} = 2V_g I_{gdc} = 14 \text{ W}$$

$$(xii) \text{ Grid drive voltage} = \frac{E_b}{\mu} (\alpha + \beta) = 226 \text{ V}$$

$$(xiii) \text{ Output} = \frac{(E_b \cdot v_{a \min}) I_{ac}}{2} = 154 - 14 = 140 \text{ W}$$

$$(xiv) \text{ Input} = I_{ac} E_b = 210 \text{ W}$$

$$(xv) \text{ Anode dissipation} = 210 - 154 = 56 \text{ W}$$

$$(xvi) \text{ Efficiency} = \frac{154 - 14}{210} \times \frac{100}{1} = 67 \text{ per cent}$$

In the above sixteen steps the salient features of the oscillator have been outlined and form the basis for the design. The method by which power will be fed back to the grid circuit will depend on factors to be discussed later in a more detailed treatment of oscillatory

circuits, but the feed-back voltage V_{ga} or $\frac{E_b}{\mu} (\alpha + \beta)$ has been found.

The frequency at which oscillations are to occur will depend on the type of application for which the oscillator is required and also in some instances upon limitations imposed by the valve. When a frequency has been selected the optimum value of tank inductance can be found for a given loaded Q value. Let these, as an example, be 40 Mc/s and 20 respectively.

$$\text{Tank inductance} = \frac{Q\omega L}{Q\omega} = 1.08 \mu\text{H} \quad . \quad . \quad 4.31$$

For tuning to 40 Mc/s, the LC product required is $16 \mu\text{H} p\text{F}$, so the total capacitance across the tank coil must be $14.8 p\text{F}$. This capacitance will be made up of the valve inter-electrode, stray and work capacitances and the manner in which they will be proportioned is treated in the chapters dealing with work circuits.

VARIABLE LOADING

The usual procedure in power oscillator design is to establish the optimum value of anode load for a chosen duration of anode current.

A balance is then made between tank inductance, total tuning capacitance, and the expected Q -value of the loaded circuit in order that $Q\omega L$ may have a value equal to that established. Valve characteristics furnish details of the instantaneous potentials on the electrodes and also the bias and excitation voltage that must prevail in order that a given valve shall furnish the expected power in a load presenting optimum impedance.

Unfortunately, the load imposed on an R.F. heating generator is not fixed and can in fact vary between wide limits even on equipment which has been designed for a single application. With equipment of a more versatile nature, which must supply power for a range of applications, the variations in load imposed on the oscillator are considerable, and it would appear at first sight that anything approaching a design for the circuit would be virtually impossible. This is a case in which considerable judgment must be used in basing an average value for the anode load upon the range of applications, variations of circuit parameters during the heating cycle, and the particular application for which the equipment is likely to be most used. Scope for much ingenuity is possible by arranging for the load imposed to suit automatically the thermal requirements of a range of work.

It must be fully realized that the generator will deliver full "designed" power to the work circuit only when this presents optimum load, and for heavier or lighter loads there will be a reduction in power. Since the optimum load will be presented during only part of the heating cycle for perhaps one of a range of applications, it is seen that the generator must have a considerable reserve of power in order to give a reasonably good performance over the whole range. Some types of equipment may be fitted with a variable device by which a degree of matching can be achieved for different applications but even when this is done there will be a change of load during the heating cycle.

The noticeable effects of a variation in loading are changes in grid and anode current. With light loading the grid current rises and the anode current falls while the converse occurs with heavy loading. These are effects that may be readily observed, but another that is not so obvious is a considerable change in the duration of anode current flow. For light loads this becomes extremely short, and while the peak currents drawn by the grid and anode remain of the same order, both the power input and output are reduced. For loads heavier than optimum, power input increases but power output is reduced owing to a fall in the oscillatory voltage across the tank circuit due to its reduced impedance. This overloading cannot

be pushed far in equipment of good design before oscillations cease because the reduced oscillatory voltage brings about a reduction in the grid drive voltage and prevents the valve from imparting enough energy to the tank circuit to overcome the resistive loss. The effects of variable loading are worthy of a more detailed consideration than that given in the above outline because they enable a more complete picture of Class C operation conditions to be visualized.

Starting with an oscillator designed to deliver maximum power into the optimum load, we shall have obtained, among others, the following values. Anode current duration (chosen), minimum anode voltage ($v_{a\min}$), and maximum grid voltage ($v_{g\max}$). The values of $v_{a\min}$ will lie between about 4 per cent and 12 per cent of E_b , and for $v_{g\max}$ between about 2 per cent and 10 per cent of E_b according to the type of valve. Now if the load is made lighter it is interesting to trace the chain of events that results.

The fundamental component of the anode current (I_{ac}) flowing through the tank circuit of increased $Q\omega L$ produces a larger voltage drop across it. This in turn depresses $v_{a\min}$ to a lower value and makes $v_{g\max}$ relatively more positive with respect to the filament and causes grid current to increase. The increased current flowing through the grid resistor brings about an increase in the bias and although the larger value of $(E_b - v_{a\min})$ prevailing will cause a slight increase in grid drive, the value of $v_{g\max}$ will be less than with optimum loading. Bias is increased and $v_{g\max}$ reduced and from equation 4.18 it is seen that a reduction in θ_a is brought about.

An interesting point to note is that the value of $v_{a\min}$ can never reach zero or no anode current could flow, and it must in fact always remain larger than $v_{g\max}$ or blocking of the valve is liable to occur. This means that if the oscillatory voltage across the tank circuit was, say, 93 per cent of E_b under full load conditions, it cannot possibly rise to more than about 97 per cent E_b under no load conditions. Thus, between full and no load we have virtually a constant voltage circuit.

Normally, a valve operates with a value of $v_{g\max}$ as great or greater than that of the bias (V_g) under optimum loading conditions, but a reduction of load may cause the bias to become several times greater than $v_{g\max}$. The minimum anode voltage will in the meantime be reduced to a value approximately the same as $v_{g\max}$ and it is unfortunate that valve characteristics in this region are not usually obtainable. It is therefore difficult to predict the values of grid and anode current that will flow with light loading, and in practice cut and try methods must be used for obtaining them. The reduction

in θ_a that occurs on light loading is very considerable and it is interesting to make a numerical assessment of the reduction.

To simplify the calculations we will assume that the work constitutes the total loss in the circuit, that the frequency is fixed, and that the unloaded Q value for the tank circuit is very high, say 500. Under these conditions the power dissipated in the work between full and no load conditions will be very nearly inversely proportional to the loaded Q of the tank circuit. This follows from the fact that the voltage across the tank remains practically constant and the effective series resistance of the circuit is nearly inversely proportional to Q . If a tank circuit is so designed that it presents an optimum load with a Q -value of 12 let us see what occurs when Q is increased to 36.

In the first place, only one-third of the original power will be dissipated in the work, and this means that the value of I_{ac} will be reduced to one-third of its former value because the oscillatory voltage may be taken as constant. The peak anode current $i_{a\text{peak}}$ remains of the same order, and consulting the curves of Fig. 29 it will be noted that if the duration of anode current flow is 140° with an optimum load, it will be shortened to 42° when I_{ac} is a third of its former value. Fig. 29 also indicates that the d.c. component of the anode current (I_{ac}) suffers a reduction to $\frac{1}{3.3}$ of its former value,

and so the reduction in input power will be greater than that in output power, and the anode efficiency consequently higher. It will be noted that the variations in power output for even small increases in the loaded value of $Q\omega L$ are considerable but the variation becomes less marked when the circuit is badly mismatched. This accounts for the sharpness of operation of impedance matching devices when these are fitted to R.F. heating equipment, and it is also an indication of the limits imposed when such devices are not included in equipment intended for versatile application.

POWER OSCILLATOR CIRCUITS

Any circuit arrangement by which oscillatory energy in the anode may be fed back to the grid in such a manner that the anode and grid voltages are in phase opposition will function as a self-excited power oscillator. There are many such circuits, but they all depend upon an inductive or capacitive coupling between anode and grid. Those circuits that are oscillatory by virtue of the negative resistance characteristic possessed under certain conditions by a valve, are not suitable for R.F. heating because of very limited power capabilities. Similarly, the electron-coupled type of circuit, so popular where a high degree of frequency stability is wanted, is not used for

56 RADIO-FREQUENCY HEATING EQUIPMENT

power generation. The feed-back type of circuit must therefore be employed for R.F. heating applications and we have already seen such a circuit in Fig. 25, which was used to illustrate the operation of a feed-back oscillator. This arrangement, commonly known as the tickler circuit, is not suitable for R.F. heating because the anode circuit is non-resonant and there is consequently no large oscillatory current circulating.

A modification of the inductively coupled circuit is shown in Fig. 30 and is called the reversed feed-back circuit. Here we have a resonant tank circuit in the anode from which power to supply

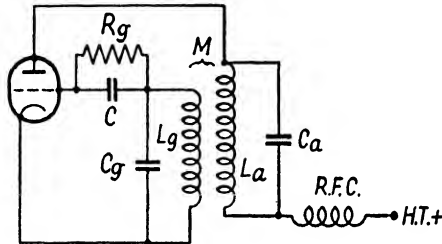

FIG. 30

the load may be taken. The circuit is sometimes used in generators for R.F. heating equipment when the frequency does not exceed about 10 Mc/s, and a feature of the arrangement is that by moving the coil L_g , relative to L_a , the mutual coupling and thus grid excitation voltage can be varied. Within limits, this can be used as a power control which operates in the following manner.

A tightening of the coupling between L_g and L_a induces a bigger voltage in L_g and tends to make the grid run more positive with respect to the filament. The increase in grid current that results brings about an increase in the bias voltage dropped across R_g , and so the larger drive voltage is compensated by a larger bias. Now, for large values of bias and drive voltage the operating arc θ_a is shortened. This shortening means a reduction in the d.c. and a.c. components of the peak anode current, and in this manner power is reduced. The anode efficiency for small values of θ_a is higher but the increase in grid driving power necessitated by the larger bias voltage may actually reduce the overall efficiency. When the coupling between L_g and L_a is loosened, excitation drops and the resulting fall in grid current causes the bias to become less, and the operating arc θ_a lengthens. Anode current and power output increase to a point where there is no longer sufficient coupling to provide power to drive the grid, and oscillations cease. While very

convenient and cheap, the use of variable grid coupling as a power control is limited on the one hand by risk of blocking when the coupling is too tight, and on the other by failure to oscillate. Either condition may effect destruction of the valve, and the intervening range of control is not wide and inclines to be very critical at each end. It follows that the ability to vary grid excitation is not a desirable feature in equipment for industrial use.

The Hartley Circuit. Many variations of the Hartley type of circuit are possible, but they all consist essentially of a coil joined between the grid and anode with a connection from an intermediate

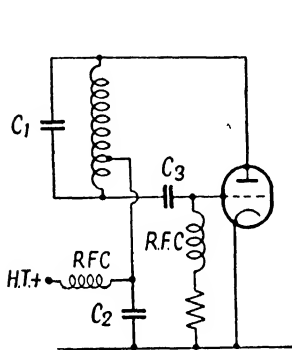

FIG. 31

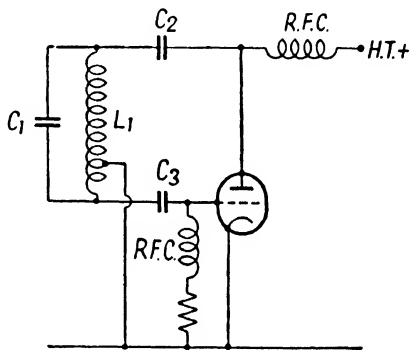

FIG. 32

tap to the filament. The position of this tap relative to the grid end of the coil determines the amount of drive voltage. Series and shunt feed arrangements are shown in Figs. 31 and 32. With the series feed arrangement the tank coil is at H.T. potential above earth. In Fig. 31 C_2 should not be the smoothing capacitor of the H.T. supply unit because owing to large self-inductance this would not possess a sufficiently low impedance path for R.F. currents. It should actually consist of an R.F. type capacitor of sufficient size to present negligible reactance at the operating frequency.

The shunt-fed arrangement shown in Fig. 32 enables the tank circuit to be at earthy potential and is thus much more convenient in use. The R.F. choke is in parallel with the tank circuit and can cause significant loss unless its impedance is relatively high at the operating frequency. It is possible to gain the advantage of having the tank coil at earthy potential with the series-fed circuit if arrangements are made to earth the H.T. positive line. When this is done, the filament becomes at H.T. potential above earth and the insulation on the filament transformer must be adequate. A disadvantage is that any control gear such as relays that may be

included in the grid-filament circuit will also be at H.T. potential above earth and this may introduce considerable constructional difficulty. The Hartley circuit works well at frequencies ranging up to about 30 Mc/s and so covers all the eddy-current and most of the dielectric-heating applications.

Colpitts Circuits. In this circuit, the connection to the filament instead of being from a tap on the tank coil is from a tap on the tank capacitor which must be in two sections as shown in Fig. 33. The grid drive voltage is determined by the relative capacitance of C_1 and C_2 . C_2 should be four to eight times larger than C_1 to prevent

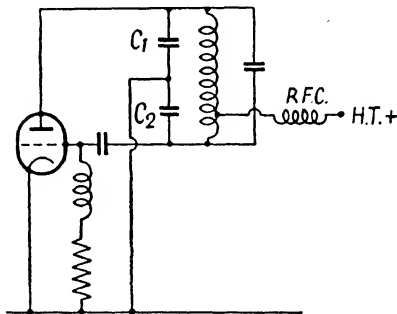

FIG. 33

too much drive voltage from being applied to the grid. The circuit is not much used for eddy-current heating purposes because the necessity for two tank capacitors makes it more expensive and the circuit does not find its most useful field of application until the frequency is above about 15 to 20 Mc/s. In this region, the inter-electrode capacitances of the valve become significant and the anode-filament and grid-filament capacitances provide the feed-back circuit and yield for practical purposes a two-terminal oscillator (Fig. 34). C_{af} is in all valves much larger than C_{ag} and an appropriate drive voltage is provided by this arrangement.

There is, however, the danger that when the work capacitance becomes relatively large, the circuit may fail to oscillate. This comes about by the fact that most of the oscillatory current will flow through C_w and the energy in C_{af} will become insufficient to provide enough power for driving the grid. On the other hand, when C_w is very small most of the oscillatory current will flow through the valve, and in particular through C_{ag} , and the electrode leads and general design of the valve must be suitable to accommodate large R.F. currents. The advantage of an earthed tank coil can be gained by shunt feed in the same manner as with the Hartley circuit or it

can of course be obtained on a series-fed circuit by arranging to earth the H.T. positive line. A slight advantage possessed by the Colpitts oscillator is that the grid and anode voltage are in exact phase opposition unless the frequency is sufficiently high for lead inductance to become significant.

The three circuits described cover nearly all the R.F. heating applications employing single-ended oscillator circuits. Magnetic coupling and the Hartley circuits are used extensively for eddy-current heating equipment while the Colpitts and Hartley cover most of the dielectric-heating applications. Two or more valves

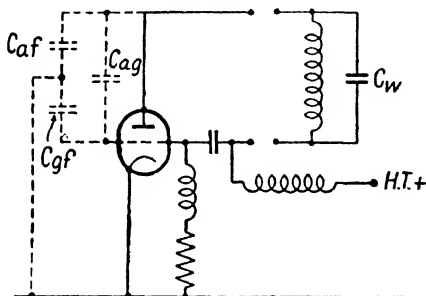

FIG. 34

may be used in parallel in any of these circuits when the application merits it. Briefly, the effect of using parallel valves is that while the oscillatory anode voltage $E_b - v_{a\min}$ remains unaltered, the oscillatory anode current I_{ac} is increased and the optimum load resistance reduced. It would be used for instance in cases where the directly-connected type of work coil is used in eddy-current heating applications particularly if the only valves available are of high impedance. Also, parallel operation often permits oscillation at higher frequencies to be obtained for dielectric-heating applications.* The lower optimum load resistance means that a tank coil of smaller inductance will impose an optimum load at a given loaded Q -value, and if stray capacitance due to the valves is significantly large, the total LC product will be less than for two valves in push-pull.

Push-pull Oscillators. With two valves operating in push-pull the oscillatory voltage across the whole tank coil is twice that across either valve. At the instant when one valve is taking peak anode current, its anode voltage will be reduced to $v_{a\min}$, and since the H.T. connection is to the mid-point of the tank coil, an auto-transformer effect increases the potential of the anode of the other valve by an equivalent amount. The oscillatory tank voltage is

* See *Wireless World*, Vol. 51, January (1945), pp. 17-18.

60 RADIO FREQUENCY-HEATING EQUIPMENT

thus $2(E_b - v_{amin})$ but since only one valve takes current at a given time the optimum load resistance is double that for either valve.

In cases where a large oscillatory voltage is required, the push-pull circuit is advantageous and a typical application is to the heating of a thick section of dielectric material. Another advantage in such an application is that it often happens that the power factor of the dielectric being heated is too small to reduce Q to the optimum value in a single-ended circuit. Since the optimum load resistance is doubled with a push-pull arrangement, its use will sometimes permit

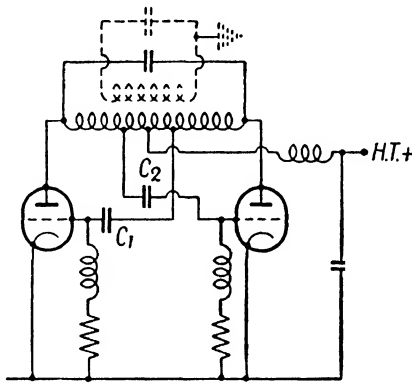

FIG. 35

a dielectric load the oscillator adequately, while with a single-ended circuit the tank coil needed to impose an optimum load would be inconveniently small. A disadvantage of the arrangement for dielectric heating is that both electrodes containing the work will be "hot" unless they are coupled inductively to the tank circuit, in which case it is permissible to earth one side, shown dotted in Fig. 35.* If inductive coupling is used it becomes necessary for reasons of efficiency to tune the coupled circuit (Chapter 5). For eddy-current heating equipment a push-pull circuit is hardly justified because the object is to achieve large work-coil currents rather than high voltages, or in other words the output circuit is required to be of low impedance. A typical push-pull oscillator circuit is shown in Fig. 35 and it will be seen to be of the Hartley type. The positions of the grid taps relative to the centre point of the coil determine the amount of grid drive voltage, and the capacitors C_1 and C_2 act as both feed-back and grid capacitors. In the circuit shown, each valve is biased separately and this arrangement has the advantage of assisting in obtaining an equalization of load between valves

* An electrostatic screen between tank coil and coupled circuit will prevent capacitive coupling.

which are not too well matched. The Hartley type of push-pull circuit is limited in frequency, and stray capacitances form a number of parasitic oscillatory circuits.

When push-pull oscillators are used for the generation of power at frequencies above about 20 Mc/s, the circuit shown in Fig. 36 may be used. Here, the feed-back is via the grid-anode capacitance of the valve, and at high frequencies a considerable power transfer occurs and enables an adequate grid-drive voltage to be built up across the aperiodic circuit between *a* and *b*. At lower frequencies

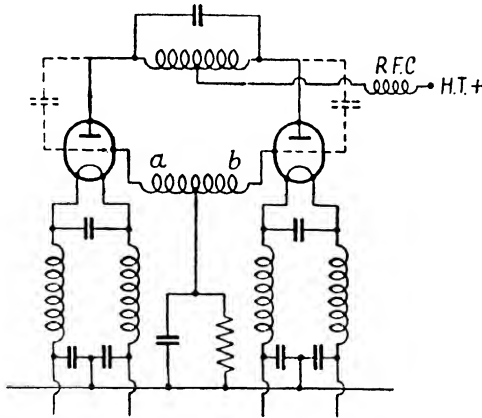

FIG. 36

the drive voltage would not be adequate unless the grid were brought near to resonance by a shunt capacitance, and we would then have the conventional tuned-anode tuned-grid type of circuit. The amount of energy fed back into the aperiodic circuit is proportional to frequency and at the higher frequencies for which this circuit can be used (80 to 90 Mc/s) there tends to be an increase in drive and bias voltage and a shortening of the operating arc θ_a which brings about a reduction in output power. With valves capable of operating at higher frequencies, the upper-frequency limit of an oscillator of this type is governed by the factors common to any lumped LC circuit. The lumped LC impedance $Q\omega L$ becomes low compared with that of say circuit wiring inductance and valve strays, and parasitic oscillations result. For generation at higher frequencies it becomes necessary to use resonant lines having distributed L and C , for these possess Q -values very many times greater than lumped circuits at frequencies above 100 Mc/s.

Resonant Line Oscillators. When two parallel conductors are shorted at one end and are an odd number of quarter wavelengths

62 RADIO-FREQUENCY HEATING EQUIPMENT

long, their behaviour at radio frequencies is similar to that possessed by a parallel-resonant circuit. Fig. 37 shows voltage and current distribution in such a resonant line and it will be seen that at the open end the current is a minimum and the voltage a maximum. At the frequency for which the length of the line is an odd multiple of $\frac{\lambda}{4}$ the open end will therefore present a very high impedance, while for other frequencies it will be less. It is easy to establish how much less when it is remembered that the standing waves of current and voltage are sinusoidal in shape. If the line is shorter than $\frac{\lambda}{4}$ its

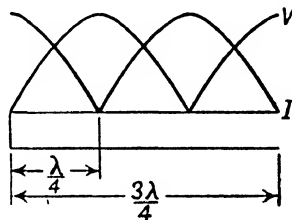

FIG. 37

properties are inductive, while if it is between $\frac{\lambda}{4}$ and $\frac{\lambda}{2}$ in length it will be capacitive, and so, if a quarter wave line is loaded with a capacitor at its open end, its length must be shortened for it to be resonant at the original frequency.*

A resonant line oscillator is shown in Fig. 38 and in order to fulfil the requirements for efficient power generation, the valve must be tapped in at a position on the line corresponding to its optimum load. The work must also be tapped in at a position on the line corresponding to its impedance at the frequency of operation and the $\frac{\lambda}{4}$ resonant line besides being a resonant tank circuit also serves as a matching device. Work capacitance modifies the resonant frequency and the extent to which this happens depends on how far down the line it is tapped in. A high capacitance tapped adjacent to the shorting bar would obviously have little or no effect on frequency.

The oscillator shown is of the Colpitts type with feed-back via

* In open-ended lines, such as are simulated by the work contained between electrodes, the properties are capacitive for lengths up to $\frac{\lambda}{4}$ and inductive between $\frac{\lambda}{4}$ and $\frac{\lambda}{2}$.

the inter-electrode capacitance. As a result, the filament is not at earthy potential, whereas the H.T. positive input to the shorting bar is. Thus without filament chokes a portion of the R.F. energy will be by-passed to earth. With a lumped LC Colpitts oscillator this difficulty is overcome by feeding the H.T. into a point a little way up the coil corresponding to the filament R.F. potential.

In the lumped LC push-pull generator (Fig. 36) filament chokes should be used because the H.T. feed is to the centre of the coil. The

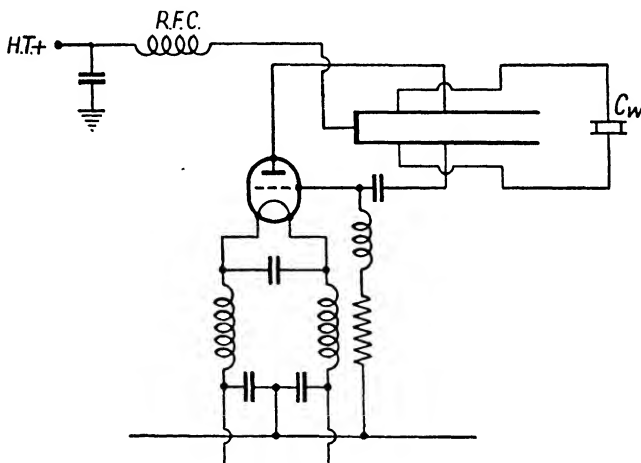

FIG. 38

choke in each filament lead should correspond to a quarter wavelength in order to bring the filament to earth potential. Stout gauge wire must be used for these chokes to avoid too great a drop in filament voltage. While for communication work the filament chokes are sometimes tuned by a capacitor, this practice is not justified in dielectric-heating equipment because the load and frequency continually vary.

In resonant line oscillators it is normal to make provision for moving the position of the shorting bar, and with work of given capacitance tapped in at a given point a movement of the bar has the effect of achieving a degree of impedance match by alteration of frequency. To obtain the maximum rate of heating in given work it is necessary to move two of the three points on the line. Owing, however, to the variations in work parameters during the heating cycle, critical adjustment is not warranted but it is more desirable when there is an air-gap between the electrodes and the work. The very high frequencies possible with line oscillators enable

64 RADIO-FREQUENCY HEATING EQUIPMENT

reasonably fast rates of heating to be achieved with a relatively low potential gradient through the work, and this facilitates the use of an air-gap.

POWER CONTROL

There are four main methods by which the R.F. output from a generator may be varied and these are—

- (i) variation in grid drive;
- (ii) „ „ load matching;
- (iii) „ „ filament emission;
- (iv) „ „ H.T. voltage.

Of these (i) has already been discussed and it has been found that as a means of varying the output from R.F. generators it is beset with severe limitations. Load matching on the other hand is much more satisfactory and various methods are treated in the chapters on work circuits. It must be remembered, however, that since matching relies upon resonance effects in tuned circuits it is inclined to be critical of adjustment and can easily permit overload conditions to prevail. This can frequently occur in practice when the rating of the generator is not large for the work that it is called upon to undertake. In these cases the anode current will not necessarily exceed a safe value but it will be noticed that the anode glows red and dissipates an altogether disproportionate amount of power for that appearing in the work.

Where valves having a filament of pure tungsten are used, it has become a not uncommon method to control power output by varying the voltage applied to the filament. While this may appear attractive in that the filament power is relatively small and a comparatively small voltage regulating device can be used, it will on fuller consideration be seen that the method is not altogether satisfactory.

Starting with a condition in which the anode load is optimum for extracting the full “design” power when the filament is at normal temperature the alterations in operating conditions that accompany a reduction in filament voltage are as follows: The reduced emission results in a lower anode current and since the H.T. voltage is the same, the effective resistance of the valve is increased. The voltage dropped across the anode load will be less and in this way output power is reduced. Owing to the reduction in oscillatory voltage, however, the anode will always be more positive in relation to the filament and the dissipation at the anode increases. In fact the load which was formerly optimum now constitutes an overload and while

the anode current will drop with a reduction in filament voltage, a bigger proportion of the input power is dissipated at the anode.

Variations in the H.T. voltage offer the most ideal method of power control from an electrical point of view but unfortunately the method is liable to become very costly and perhaps even cumbersome on equipment of large power rating. To a first approximation the oscillatory anode voltage of a generator will be proportional to the H.T. voltage and so the power output will be proportional to the square of the H.T. voltage.

METERING

It is a maxim in experimental electronic engineering that one cannot have too many meters, but for industrial equipment the number used must obviously be reduced to the essential minimum; in fact, when possible, they should be dispensed with entirely. The circuit in Fig. 39 indicates the positions in which it is desirable to have meters in order to assess the performance of equipment, but for the routine operator they would serve no useful purpose. Only where some form of tuning or impedance matching is provided should an indicating meter be fitted as an integral part of the equipment. For test purposes meter sockets can be included to enable portable meters to be plugged into circuit.

Anode current meters are most conveniently incorporated in the cathode circuit of equipment because this normally is at low potential but it must be remembered that when in this position the meter indicates the sum of anode and grid currents. Where H.T. positive is earthed, the meter can be in the H.T. positive supply lead and will indicate anode current only. The grid current meter is included in series with the grid resistor, but in both grid and anode current meters there is an essential precaution to be observed. In spite of the inclusion of R.F. chokes, some R.F. current is apt to flow in the meter and this has the effect of heating and thus spoiling the temper of the meter hairspring. To avoid destruction of the meter it is therefore necessary to include a shunt capacitance of low reactance to by-pass the R.F. currents. Any meter having a restoring torque provided by a steel hairspring must be protected in this manner, and in cases where protection cannot be provided, meters of such type should not be used. A case in point is the measurement of tank circuit r.m.s. oscillatory voltage by an electrostatic meter having steel hairspring restoring torque.

Apart from grid and anode-current metering, it is also possible for experimental purposes to have a meter indicating tank-circulating current. It may take the form of a hot wire meter for these can now

66 RADIO-FREQUENCY HEATING EQUIPMENT

be made to indicate currents with a fair accuracy up to 30–40 Mc/s. They contain no hairspring that can be impaired by the passage of R.F. currents, but when a thermo-couple and d.c. millimeter are used for tank current indication a capacitor shunt on the meter is essential. The current capacity of easily obtainable thermo-couples is not sufficient for the tank circuits on any but the very smallest equipments and a shunt must ordinarily be fitted. These should, however, be ordered with the meter and it is not recommended that an experimenter make his own shunts, as, unless he has access to

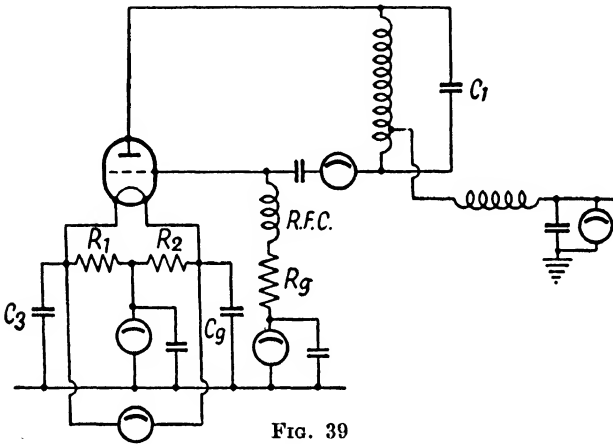

FIG. 39

standardizing equipment, they are difficult to calibrate, particularly over a range of frequencies.

The ability to measure tank-circulating current is of use only during the initial stages of design and development, and serves no useful purpose during the routine operation of equipment. Its chief purpose is to indicate r.m.s. oscillatory voltage, but this can only be found when the frequency and reactance of the tuning elements are known. In any case, with properly designed equipment the oscillatory voltage will be virtually constant between no load and full load, and tank-current measurements are useful only in checking design prediction. The measurement of r.m.s. current in the work circuit is, however, justified in equipment having an inductively coupled load and is very useful, for example, when eddy-current heating equipment is to be employed for a wide range of applications such as occur in a tool-room. Owing to the heavy work-coil currents involved in eddy-current heating, the indicator should be of the current transformer type.

In spite of the desirability of excluding the meters from industrial

gear it is sometimes advantageous to have an indication of mains input voltage. This arises when valves having pure tungsten filaments are used because such valves are somewhat sensitive to variations in filament voltage. It is again particularly desirable to have a mains voltage indicator when the equipment is supplied by a power line which feeds other heavy current loads. A filament voltage control and meter will then enable an operator to compensate for variations in voltage. This could of course be done automatically by using a constant-voltage filament transformer, but for large valves this is likely to become a costly and cumbersome item. The best remedy is to ensure that the mains voltage does not vary from a mean value by more than about 2 or 3 per cent under any conditions.

VALVE PROTECTION

There are three conditions under which a valve is liable to damage. First, on no-load the grid current tends to become excessive. Secondly, on overload the anode current will exceed the safe limit and thirdly, should the valve cease to oscillate the anode dissipation increases to a dangerous extent. To limit grid current on no-load to a reasonable value, the grid resistor fitted can be made somewhat large but when this is done the duration of anode current flow on full load is shortened and the power capabilities of the generator cannot be fully developed. One method of gaining a degree of automatic adjustment is to employ a lamp or barretter for the grid resistor as this tends to produce a constant grid current. It is also possible to achieve a limitation of grid current on no-load by including a relay which on heavy currents opens a shorting circuit across part of the grid resistor. Another and more elaborate method is to employ the constant current properties of a pentode in the grid circuit. This can be arranged to give a sensibly constant grid current over a very wide range of loading, and is to be recommended on eddy-current heating equipment having a direct work coil, where, in the absence of work, the loading is very light but where, with large diameter iron or steel work, it can become very heavy. Bias compensation using a pentode is shown in Fig. 40, and the arrangement has the added advantage that if the voltage dropped across R_1 is adjusted so that the rectified current exceeds the

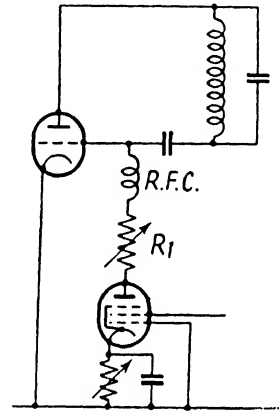

FIG. 40

68 RADIO-FREQUENCY HEATING EQUIPMENT

maximum reverse grid current that might flow due to over-drive, it is not possible for blocking to occur. A separate d.c. source must, however, be available to supply the pentode screen.

Overload protection can be provided by a fuse or overload cut-out in the earthy side of the H.T. supply or in the H.T. transformer primary. Unfortunately this fuse or cut-out offers no protection for low-impedance valves if they should cease to oscillate. The anode current taken under full load and non-oscillatory conditions may be very little different, but in the latter case the entire H.T. consumption will be dissipated at the anode with fatal results. For high-impedance valves, however, the non-oscillatory anode current will be higher than that occurring on full load and a sensitive cut-out will offer protection. One way of safeguarding low-impedance valves is to mount a thermo-couple in such a position that an undue increase in anode temperature causes it to operate a relay opening the H.T. contactor control-circuit. A more direct method, however, would be to utilize the fact that grid current ceases when oscillations stop. For low-powered equipments, the difficulty can be overcome by using the zero grid type of valve which can safely dissipate the anode power occurring with full H.T. voltage and no bias.

A simple method of guarding against valve damage due to stoppage of oscillations is to arrange for part of the bias to be provided by the voltage dropped across a resistor in the cathode lead. With many valves, a relatively low bias voltage will prevent the maximum safe anode dissipation from being exceeded, and although cathode bias is wasteful of power and reduces efficiency, it is often worth while incorporating where there is a risk of failure to oscillate. A by-pass capacitor of relatively low reactance must shunt the cathode bias resistor to obviate the application of negative feed-back.

CONSTANT FREQUENCY GENERATORS

There is a possibility that legislation may be introduced for the purpose of confining to very narrow limits the frequency at which R.F. heating may operate. In the event of such legislation being passed the self-excited type of oscillator will become practically obsolete. Whether such legislation will be passed, and enforced, is somewhat problematical, for if users can restrict radiation sufficiently, the necessity for fixed frequency operation is overcome to a large extent. There are, however, certain applications in which satisfactory screening becomes very difficult to achieve, owing to the large physical size of the work, and it may well happen that for these a fixed frequency will become a legal although not technical necessity.

An obvious solution is to apply a technique similar to that used in communication engineering in which a master oscillator of small power but of high frequency-stability drives a chain of amplifiers through a buffer stage. For R.F. heating, this introduces some difficulty, because the nature of the load even with repetition work is far from constant and when work of varying type is to be accommodated the difficulties are increased. Some form of tuning must be applied to the work circuit, and since in all but the very smallest equipments this is of very high kVA rating, the tuning component must be of large dimensions. Manual control is out of the question because for routine production work it would introduce almost catastrophic variations. Apart from the necessity for vigilant operators with some electronic knowledge, any delay on their part in keeping the output circuit in tune would result in varying times of heating for repetition work and any process time control would become invalid.

Some form of automatic control is essential, and while this should preferably be almost inertia-less, the use of direct electronic control is very difficult owing to the limitations that attach to reactance valves. The change in reactance that is possible with control valves of this type is equivalent to no more than a few picofarads, and when the change of capacitance in the work circuit can be many hundreds or even thousands of picofarads, the range of control is wholly inadequate. In any case the rating of the reactance valve would require to be comparable with or greater than that of the output valves. We are thus left with an electro-mechanical system of which the inertia is unavoidably high and therefore must usually employ a motor as the prime mover for a variable reactor element.

Another arrangement is that in which a master oscillator is used in conjunction with a self-excited power oscillator. The output from each is mixed, and the beat frequency amplified and fed to a discriminator of the type commonly used for A.F.C. in superhet receivers. The output from the discriminator is arranged to be zero for one particular frequency, but provides a positive or negative d.c. potential when the beat frequency is above or below the chosen value. These d.c. potentials are used to operate relays which energize a reversible control motor coupled to an adjustable tuning element. A feature of this system is that it does not provide for power generated at one frequency only because there is a period of hunting in which power is generated at other frequencies and for this reason it may not fulfil prospective legal requirements.

Dielectric-heating Work Circuits

THE choice of an arrangement by which power is transferred to the "work" poses one of the most important problems that must be faced in the design of dielectric-heating equipment. Due to the many factors that must be taken into account, the problem is tedious of solution rather than difficult and failure to assess these factors correctly can mar the performance of costly equipment. We shall attempt to show that, by a system of orderly grouping, the treatment of power generation and transfer may be simplified.

The problem may at the outset be considered under two separate heads. First, there is the aspect concerned with the load imposed on the generator, and secondly, the aspect concerned with the localization of the power generated in the work. Loading will determine how much R.F. power is actually generated with a given valve while circuit efficiency decides what proportion of that power is usefully dissipated in the work. These two aspects are very closely related, but it will enable a clearer understanding to be gained if they are treated separately before combining the results.

LOADING

In designing equipment, we establish for a given valve the optimum value of anode load into which it must work in order that full power may be generated.

$$\frac{E_b - v_{a\min}}{I_{ac}} = Q_L \omega L = \text{optimum load} \quad . \quad . \quad 5.1$$

where $E_b - v_{a\min}$ = anode voltage swing

I_{ac} = peak value of a.c. component of anode current

Q_L = Q -value of loaded tank circuit

ω = $2\pi f$

L = tank coil inductance.

Usually L is fixed and Q depends largely upon the nature of the work and the manner in which it is connected to the tank circuit. When Q_L possesses a value other than the optimum indicated in equation 5.1 the valve will either be working on light load or be overloaded.

Our problem is considerably simplified because ordinarily overload conditions may be neglected. This arises from the fact that when Q_L has a value lower than optimum, the voltage dropped across it by the passage of I_{ac} is reduced. In consequence, the oscillatory anode voltage is less and the anode will always be relatively more positive with respect to the filament than it is with optimum or light loads. As a result the d.c. component of the anode current and hence anode dissipation is greater. Now with good design the anode dissipation that occurs when working into an optimum load is very nearly as much as the valve will safely stand, and any considerable overload would, unless it is of a temporary nature, destroy the valve. In practice overload relays operated by devices of various types are installed to switch off the equipment should any undue overload occur.

Under conditions of light load it has been shown in the section dealing with variable loading that the value of $E_b - v_{amin}$ remains substantially constant from no load to optimum or full load. It follows that the power dissipated will be inversely proportional to the Q of the loaded circuit and if we call the optimum value Q_{LO} and the actual value under light load conditions Q_{LA} we have

$$\frac{\text{Power dissipated in circuit}}{\text{Optimum power}} = \frac{Q_{LO}}{Q_{LA}} \quad . \quad . \quad . \quad 5.2$$

Here we neglect the power lost in the tank coil and leads and this simple expression does not hold when Q_{LA} has a high value, approaching that which the circuit would have if there were no load present (Q_0). A more general expression is

$$\frac{\text{Power dissipated in circuit}}{\text{Optimum power available}} = \frac{Q_{LO}(Q_0 - Q_{LA})}{Q_{LA}(Q_0 - Q_{LO})} \quad . \quad . \quad . \quad 5.3$$

Here we see that $\frac{Q_0}{Q_{LO}}$ should have as high a value as possible and

we will call this the transfer ratio. $\frac{Q_{LO}}{Q_{LA}}$ we will call the match ratio

and its value should be as near unity as possible, it being obvious that actual and optimum loads should coincide for efficient operation. In practice, Q_0 should be as high as limitations imposed by the tank circuit dimensions permit, and Q_{LO} should have the lowest possible value above 10-12. It has already been mentioned in the chapter dealing with generators that the loaded Q value must not be lower or harmonic generation becomes prodigious.

To impose an optimum load, the expression $Q_{LO}\omega L$ fixes the size

72 RADIO-FREQUENCY HEATING EQUIPMENT

of tank coil and tuning capacitance for work having a certain effective power factor. If the effective power factor should vary with different charges of work to be heated, it is easily possible for the value of Q_{LA} to become as much as four or five times Q_{LO} . Under these circumstances the power generated will be less than $\frac{1}{4}$ or $\frac{1}{5}$ of that occurring with an optimum load. This is a very important point for if with a generator nominally rated at 2 kW there is found to be only 300 W appearing in the work, one may wonder where the rest has gone, but in actual fact it is not generated. The nominal rating of equipment is invariably quoted as the output occurring into an ideal load, and this is unfortunate because it frequently leads to confusion on the part of users. Very often the load imposed is in practice anything but optimum.

CIRCUIT EFFICIENCY AND POWER TRANSFER

Generally speaking, R.F. power may be dissipated in only two ways. It may be radiated, or it may be dissipated in the form of heat. The amount of energy radiated is dependent on the radiation resistance of the circuit and in radio-frequency heating equipment this is kept low by avoiding too great a distance between current-carrying conductors. It is further reduced by the presence of the earthed screen within which the equipment is contained. The effective height of the antenna formed by the circuit is reduced by the proximity of the screen, and power lost due to currents induced in the screen must for our purpose be lumped with that actually radiated. Radiation losses increase with frequency, but in equipment of reasonably good design they are not likely to exceed 2 per cent of the total power generated. In view of this we will neglect radiation losses in our treatment of work circuits, but it must be remembered that account of them must be taken when conditions are such that they become appreciable.

The remaining power is dissipated in the form of heat and this can occur only in the circuit. It is the object in dielectric heating to localize as much of the loss as possible in the work and while this is actually a part of the circuit we will for convenience refer to the circuit and work separately in considering circuit efficiency. The amount of heat dissipated in each depends upon their resistive components at the frequency of operation.

In the circuit, we have first the tank coil which will have an inherently low resistance and consequently high Q . Values of 200 to 300 and more are common. Associated with the coil are leads to the work and the work electrodes themselves, and the added resistance due to these together with the losses in supports, etc.,

depresses the Q of the coil to a lower value which we will call the unloaded Q -value (Q_0). In the work, the resistive component depends at a given frequency upon the shape and power factor of the material being heated.

$$R_{wk} = \frac{\cos \theta}{\omega C} \quad . \quad . \quad . \quad . \quad . \quad 5.4$$

- where R_{wk} = resistive component of work
- $\cos \theta$ = power factor of work material
- C = capacitance of work.

By re-arrangement a Q -value may be ascribed to the work :

$$Q_{wk} = \frac{1}{\cos \theta} \quad . \quad . \quad . \quad . \quad . \quad 5.5$$

the Q -value of the total load imposed on the generator by the circuit and work is thus

$$Q_{LA} = \frac{Q_0 Q_{wk}}{Q_0 + Q_{wk}} \quad . \quad . \quad . \quad . \quad . \quad 5.6$$

We may thus write

$$\frac{\text{Power in work}}{\text{Power in circuit}} = \frac{Q_0 - Q_{LA}}{Q_0} \quad . \quad . \quad . \quad . \quad . \quad 5.7$$

Combining the expressions for loading and power transfer, we obtain an overall expression that will indicate the proportion of the power appearing in the work to that generated under ideal conditions

$$\frac{\text{Power in work}}{(E_b - v_{amin})I_{ac}} = \left[\left\{ \frac{Q_{LO}}{Q_{LA}} \left(\frac{Q_0 - Q_{LA}}{Q_0 - Q_{LO}} \right) \right\} \frac{Q_0 - Q_{LA}}{Q_0} \right] \quad . \quad 5.8$$

The power factor of material forming the work in dielectric heating is rarely high enough for the Q of the loaded circuit to be as low as the ideal value of 10 to 12. In simple work circuits the power factor of the material being heated largely determines the loaded Q -value which may often be as high as 50 or even 100. When equipment is required for the specific purpose of heating material of low power factor, a relatively high loaded Q -value is imposed. This must be taken as the optimum value (Q_{LO}) and the tank inductance under such conditions will need to be small in order to impose anything like a heavy load. Now the unloaded Q -value of the circuit is limited by factors concerned with coil design, length of leads, electrode design and any losses due to the supports for same.

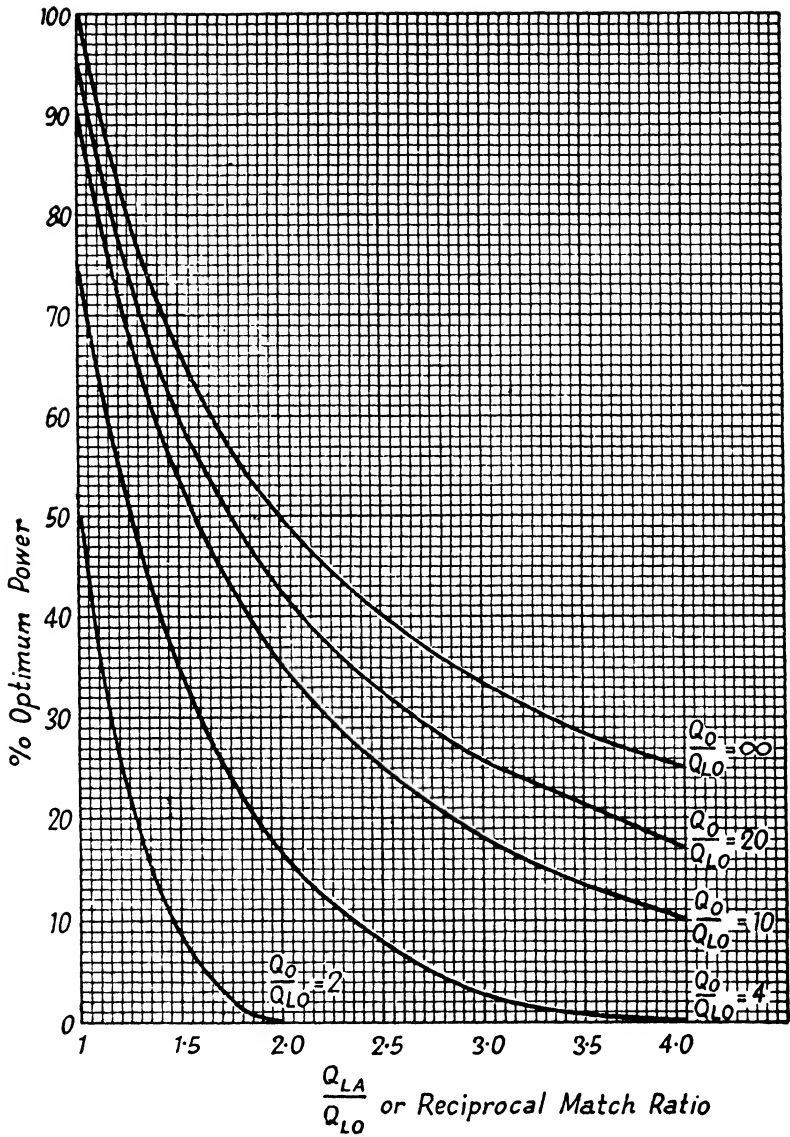

FIG. 41

Ordinary values range from 150 to 350 and more and if the Q_{LO} value is high the transfer ratio $\frac{Q_O}{Q_{LO}}$ may become as low as 3 or 4. On the other hand, it is possible when heating relatively lossy material to have a transfer ratio as high as 25. The importance of this will be seen in Fig. 41, which shows curves prepared from equation 5.8. Match ratios are dependent on the value of $\frac{Q_{LO}}{Q_{LA}}$ and as this will normally be less than unity we have, for convenience, taken the reciprocal match ratio $\frac{Q_{LA}}{Q_{LO}}$ as the abscissa in Fig. 41.

The curves illustrate the effect of mismatching and the importance of working with efficient circuits having high $\frac{Q_O}{Q_{LO}}$ or transfer ratio. Should this ratio be low, any degree of mismatch would be accompanied by a sharp fall in useful power. On the other hand it is pointless to waste too much effort in striving for the superlative in circuit design because the useful power approaches its asymptotic

value when $\frac{Q_O}{Q_{LO}} > 20$. These general considerations on work circuit conditions outline the requirements that must be fulfilled for efficient operation and should be borne in mind when examining the various types of circuit that may be used.

SIMPLE DIRECT CIRCUIT

Fig. 42 shows a simple arrangement that may be used for heating a dielectric, but like most simple arrangements it has shortcomings. It is chiefly inflexibility that mars an otherwise satisfactory arrangement. It is seen that the full oscillatory voltage $E_b - v_{a\min}$ is applied to the work and in consequence the depth and nature of the work must be such as to withstand the applied voltage without breakdown. If, on the other hand, work is so proportioned that it could withstand a far greater voltage, it is obvious that it could be heated more rapidly by a different arrangement. Practical considerations may, however, require the work to be very shallow and when this circuit is used it often happens that the H.T. applied

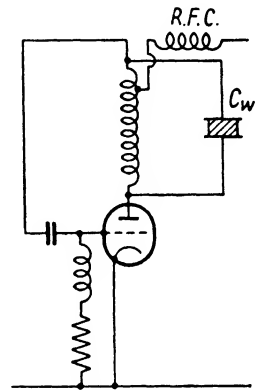

FIG. 42

76 RADIO-FREQUENCY HEATING EQUIPMENT

to the oscillator must be reduced to avoid flash-over. As a result, the power generated will suffer a sharp decline, for it is roughly proportional to the square of the H.T. voltage.

With this simple arrangement the frequency of operation is governed largely by the work capacitance, particularly when it is large in comparison with the strays. As the frequency is reduced by increasing work capacitance, the loading on the valve becomes heavier due to the reduction that occurs in ωL . Normally the Q -value for the loaded circuit will not be as low as 12 because very few dielectrics that are likely to be heated have a sufficiently high power factor. Furthermore, the effective power factor of the work is reduced by the presence of stray capacitances, and in practice it is not uncommon to have a loaded Q -value of two or three times

$\frac{1}{\cos \theta}$. Two results follow from this: first, the tank coil must be relatively small in order that $Q_{LO}\omega L$ may have the appropriate value; secondly, the transfer ratio $\frac{Q_O}{Q_{LO}}$ will incline to be small and any departure from optimum loading will bring about a sharp reduction in useful power (Fig. 41).

Effect of Strays. We can, without introducing any great error, regard the strays existing across the work as perfect capacitors. This is not strictly true, because in the case of, say, the valve inter-electrode capacitance there will be a slight loss due to the conductor-resistance of connections, and another due to dielectric loss in the envelope material surrounding the seals. Again, the electrode supports will introduce some loss, but these are or should be relatively small and may be neglected. We now have a lossy capacitor represented by the work, in parallel with perfect capacitors representing strays (Fig. 43). Calling the effective power factor of the combination $\cos \theta_1$ we have

$$\cos \theta_1 = \frac{\cos \theta C_w}{C_w + C_{ps}} \quad \dots \quad 5.9$$

where $\cos \theta$ = power factor of the work material

C_w = work capacitance and

C_{ps} = parallel stray capacitance.

A capacitance shunting the work which must be taken into account is that due to those parts of the electrodes not covered by the work. This may assume large proportions and the inactive peripheral parts of the electrodes may thus possess a capacitance of the same order as the work itself, particularly when this is of low

χ and also when it is widely spaced as occurs in the heating of circular moulding pellets.

The total value of parallel strays may be assessed quite easily because the valve inter-electrode capacitances are usually stated by the maker. Capacitance due to uncovered parts of the electrodes

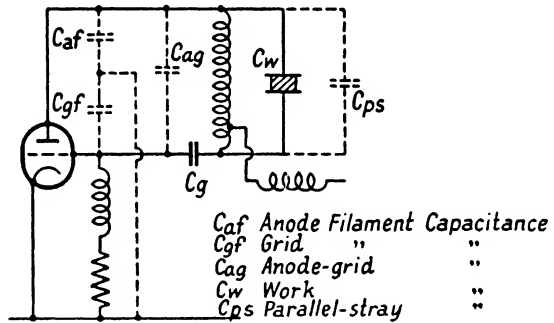

FIG. 43

and also that existing between the electrodes and screen can be found by the use of the simple approximate expression

$$C = \frac{2}{9} \frac{\chi A}{d} \text{ pF.} \quad . \quad . \quad . \quad 5.10$$

- where χ = permittivity of material
- A = area in square inches
- d = separation in inches.

In connection with the strays due to the capacitance between the electrodes and screen, it should be noted that if one of the electrodes is earthy, only the capacitance between the hot electrode and screen is significant.

Information is usually available on the power factor of the material to be heated, and knowing the capacitance due to the work and strays an effective value of power factor ($\cos \theta_1$) under the conditions of working may be obtained. The Q -value for the loaded circuit now becomes

$$Q_{LA} = \frac{Q_0 \frac{1}{\cos \theta_1}}{Q_0 + \frac{1}{\cos \theta_1}} \quad . \quad . \quad . \quad 5.11$$

At first sight it may appear that the limitations imposed by inflexibility and the inherently low transfer value $\frac{Q_0}{Q_{LO}}$ make this

simple circuit unusable. This is not wholly true, for when equipment of the single-application type is required, this circuit may be used. The ideal would be where work of high power factor having a thickness just sufficient to withstand a voltage equal to $E_b - v_{amin}$ is to be heated.

Before passing on to consider more complicated arrangements, it will be of interest to note a simple circuit that may sometimes be used (Fig. 44). Here, the work is used as the grid capacitor and the conditions under which this may be done may be described thus.

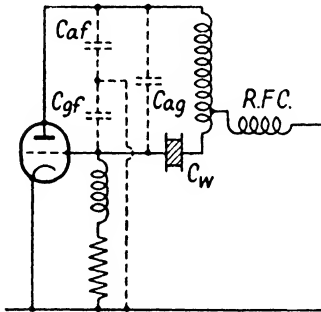

FIG. 44

The work should be shallow and of relatively large area in order to give a capacitance having low reactance at the operating frequency. The frequency will be high because the tuning capacitance is determined by the valve which must, of course, be of suitable design to accommodate the total tank circulating current. This current will flow through the work, and although the voltage drop across it will be low, the work is shallow and the voltage gradient may be adequate for reasonable heating. Shallow work

of large area cannot be accommodated easily across the tank coil and the grid work capacitor method is a way out of the difficulty. A failing with this circuit as drawn in Fig. 44 is, that should the work be liable to break down at any time the valve is exposed to great danger. This difficulty may be overcome by inserting a capacitor of relatively large value in series with the work.

TAPPED CIRCUITS

Many materials likely to be heated by dielectric heating have a very low effective power factor when included in the work circuit with its unavoidable shunt capacitances, and if the valve is connected across the whole coil, the $Q_{LA}\omega L$ value is apt to be very high. There is a limit below which L cannot be reduced in an effort to minimize $Q_{LA}\omega L$, because the tank coil would in many cases become impossibly small. With coils of a reasonable size the valve must, as a result, work into light loads and the power generated will be small, due to the mismatch conditions existing. A means of overcoming this difficulty would be to tap the valve down the coil and thus increase the load into which it works.

While the tap ratio reduces $Q_{LA}\omega L$ it will also automatically

bring about a similar reduction in $Q_o\omega L$, and the transfer ratio will not be improved. Due to the heavier loading, however, more power will be generated and although losses due to dissipation in the circuit increase, so does the useful dissipation in the work. The valve will, at a suitable tap position, work into an optimum load, and in spite of poor transfer ratio the power dissipated in the work can reach 75 to 85 per cent of the theoretical maximum. A circuit in which the valve is tapped down the coil can thus be a great benefit and is worth closer examination.

From Fig. 45 it will be seen that the valve inter-electrode capacitance is not directly across the work and this will modify

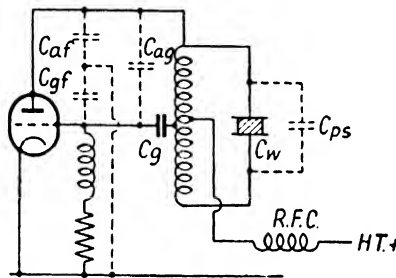

FIG. 45

the effective power factor of the material being heated. The new value will be

$$\cos \theta_1 = \cos \theta \frac{C_w}{C_w + C_v \left(\frac{T_{tap}}{T_{tot}} \right)^2 + C_{ps}} \quad \dots \quad 5.12$$

where T_{tot} = No. of turns in whole coil

T_{tap} = No. of turns from anode to tap position

$$C_v = C_{av} + \frac{C_{af} C_{gf}}{C_{af} + C_{gf}}$$

This means that the value of Q will be a little lower than when the valve was across the whole coil and some slight improvement in transfer ratio results. The peak voltage applied to the work is increased to

$$E_b - v_{amin} \cdot \frac{T_{tot}}{T_{tap}} \quad \dots \quad 5.13$$

but in deep work this is an advantage. When the work is not deep, there will be a risk of breakdown due to the steep voltage gradient,

and in order to reduce the voltage applied, a capacitor may be included in series with the work or an air-gap provided between the work and electrodes. Where a series capacitor is used, it must be of high kVA rating because the energy rating of the work circuit is itself usually very high. If, for instance, the effective power factor of the circuit is 0.01 and 1 kW of useful power is to be dissipated in the work, the energy in the circuit would need to be 100 kVA.

Fig. 46 shows a circuit which includes an air-gap or capacitor in series with the work, and in which the valve is tapped down the tank coil. It will be interesting to study the effect of stray capacitances

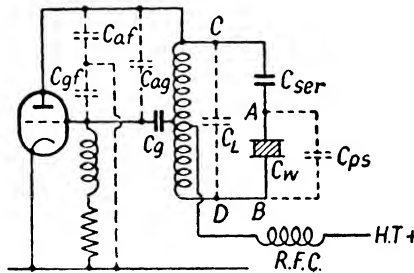

FIG. 46

in detail because this circuit has a wide range of application. The sole purpose in examining the strays is to arrive at an effective value for the power factor of the material being heated and the problem will be simplified by dealing with the circuit in stages. Between A-B we have the work capacitance. Shunting this is a capacitance due to the uncovered parts of the electrodes and that existing between the work electrodes and screen, (C_p). We have, so far, an effective power factor of

$$\cos \theta_I = \cos \theta \frac{C_w}{C_w + C_{ps}} \quad \dots \quad 5.14$$

This is in series with C_{ser} and the power factor becomes modified to

$$\cos \theta_{II} = \cos \theta_I \frac{C_{ser}}{C_{ser} + (C_w + C_{ps})} \quad \dots \quad 5.15$$

Across this combination, we have the effective capacitance existing between CD and this comprises that due to the tapped down valve $C_V \left(\frac{T_{tap}}{T_{tot}} \right)^2$ and the lead capacitance C_L which together we will call C_{VL} . The final effective value of power factor of the work becomes

$$\cos \theta_{III} = \cos \theta_{II} \frac{C_{ser}(C_w + C_{ps})}{C_{ser} + (C_w + C_{ps})} \left\{ \frac{C_{ser}(C_w + C_{ps})}{C_{ser} + (C_w + C_{ps})} + C_{VL} \right\} \quad 5.16$$

Tackling the problem in the stages outlined makes it easy, with a little practice, to arrive quickly at an effective power factor for the work in any dielectric-heating design problem. It will be noted that every stage reduces the effective power factor. Starting with a material having $\cos \theta = 0.04$ we may easily end up with $\cos \theta_{III} = 0.008$ and instead of having a work Q of 25 it will be 125, and if the unloaded Q were 300, we should have a loaded Q of nearly 90 instead of 23.

Including an air-gap or series capacitor may in some cases increase Q_L by such a large amount that the step would hardly seem prudent. If the valve were tapped down the coil sufficiently far to impose optimum load, the voltage developed across the coil could even on medium-powered equipment exceed the safe corona discharge limit of 15 to 16 kV. Discretion must, of course, be used in employing air-gaps or series capacitors for otherwise the design soon gets out of hand. But it must at the same time be realized that there are many practical advantages to be gained from the arrangement.

When an air-gap is used we have a very flexible circuit easily capable of adjustment over a considerable range. Not only may the air-gap be altered at will on well-designed equipment, but it can also be arranged to preset the tap position and thus provide additional control over operating conditions. The voltage applied to the work may be nicely controlled by the series capacitor formed by the air-gap.

$$\text{Peak work voltage} = \frac{(E_b - v_{a\min}) C_{ser}}{C_{ser} + C_w + C_{ps}} \cdot \frac{T_{tot}}{T_{tap}} \quad 5.17$$

For general purposes it is often possible by adjusting the applied voltage at a value just below the breakdown voltage to heat the work as fast as the operating frequency will permit. The mass and shape of the work must then of course be well within the capabilities of the equipment.

In the example dealt with above, the valve was tapped down the coil in order to reduce the resistance into which the valve was working, or in other words to increase the load. Summarizing the benefits that accrue from this form of circuit, we may state that work of low effective power factor for which the loaded Q will be high can be made to impose an adequate load on the valve. The

82 RADIO-FREQUENCY HEATING EQUIPMENT

transfer ratio is not substantially improved, but the power that may be extracted from a given valve is considerably increased owing to better matching.

Tapped Down Work. Having seen what occurs when the valve is tapped down it will for the sake of completeness be interesting to note what happens when the work is tapped down while the valve remains across the whole coil. A circuit of this type is shown in Fig. 47, and it will be seen that across the whole coil there is only the valve inter-electrode capacitance together with that due to the leads associated with this part of the circuit. The work capacitance plus the strays due to the uncovered part of the electrodes is tapped

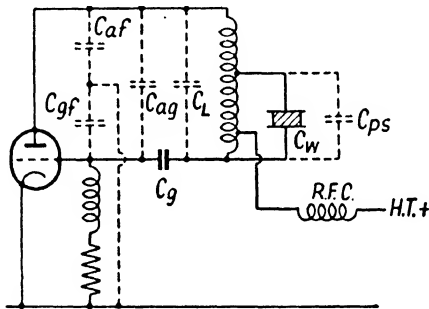

FIG. 47

down the coil. The total of the tapped down capacitance is likely in practice to exceed by a large amount that across the whole coil, and the frequency of operation will be higher because the LC product becomes

$$LC = L \left[C_{VL} + \left\{ (C_w + C_{ps}) \left(\frac{T_{tap}}{T_{tot}} \right)^2 \right\} \right] \quad . \quad 5.18$$

where C_{VL} = valve capacitance and lead strays.

The loaded Q of the circuit will also incline to be high, particularly when the tap ratio is large, because the effective power factor of the work is reduced. Considering this in two stages we have first, the reduction due to the uncovered parts of the electrode and strays to screen

$$\cos \theta_I = \cos \theta \frac{C_w}{C_w + C_{ps}} \quad . \quad . \quad . \quad 5.19$$

This effective power factor is further reduced to

$$\cos \theta_{II} = \cos \theta_I \frac{\left\{ (C_w + C_{ps}) \left(\frac{T_{tap}}{T_{tot}} \right)^2 \right\}}{\left[\left\{ (C_w + C_{ps}) \left(\frac{T_{tap}}{T_{tot}} \right)^2 \right\} + C_{VL} \right]} \quad . \quad 5.20$$

In order that $Q_L\omega L$ may have the optimum value for extracting maximum power from a given valve, L would, in spite of the low effective tuning capacitance, need to be so small that the tank coil would become impractical. Actually, we would have to work with a higher value of L and it would not be possible to load the valve adequately. Another effect would be that the applied voltage is reduced to $\frac{T_{tap}}{T_{tot}}(E_b - r_{amin})$. To summarize, we see that this

circuit is not useful owing to the tendency of both the transfer ratio to be low and the match ratio far from unity. The work would need to be very shallow, due to the reduced applied voltage, and it is in fact a circuit that is not likely to be used in well-designed equipment. One exception is the case where low efficiency can be tolerated but where something approaching a constant heating time is needed for various areas of work having the same depth.

This comes about because between a given pair of electrodes there will be, up to full load, a virtually constant voltage for any area of work that can be accommodated. Variations in the frequency of operation with work of small or large area will be masked by the tap ratio on the coil, and so we have an arrangement in which both frequency and applied voltage remain fairly constant for large alterations in work mass. When the area of the work is great, the parallel capacitance due to unused parts of the electrode is reduced and the effective power factor increased. This imposes a heavier load on the valve and yields enough energy to heat the larger mass of work in time similar to that taken for a small area. The result is that it becomes possible with a variation in heating time of 1.2 to 1 to accommodate work mass ratios of 5 to 1. An equipment that automatically gives reasonably constant heating time would perhaps be needed in certain specialized applications, but the advantage is gained only by considerable sacrifice in efficiency and restriction in the shape of work that may be heated.

TUNED WORK CIRCUITS

A major difficulty that arises in dielectric heating has been seen to be the low effective power factor possessed by work in circuits of the type so far discussed. Loaded Q -values tend to be high and in order to achieve an adequate match ratio, the valve must be tapped down the coil. This is no unmixed blessing since the high voltage developed often necessitates the use of series capacitance in order to limit the voltage applied to the work. This series capacitance has the effect of reducing the effective power factor still further and calls for an even larger tap ratio. A way out of the difficulty would be

gained if the effective work power factor could be increased without incurring any particular disadvantage, and the nearest approach is obtained by tuning the work circuit. Tuning is of itself a disadvantage in dielectric heating, for unless it can be made fully automatic it means a sacrifice of the rugged features possessed by the direct type of work circuit.

A tuned work circuit is shown in Fig. 48. Inductance is included in series with the work capacitance in order that its reactive component may be reduced. Were the circuit between *AB* resonant at the frequency of oscillation it would be resistive in character and under these conditions the work current flowing would be a maximum. The *Q* of this isolated resonant circuit (Q_T) would be governed mainly by the effective power factor of the work in conjunction with its strays because the resistive component due to the series coil would be relatively small. For normal types of work Q_T would thus range between about 25 and 60 and the voltage developed across the work would be

$$Q_T \left(E_b - v_{amin} \right) \frac{T_{tap}}{T_{tot}} \quad . \quad . \quad . \quad 5.21$$

The load imposed on the valve when the work circuit is resonant would depend mainly upon how far down the tank coil the circuit was tapped, although, of course, the power factor and work capacitance would also have a bearing.

When a perfect coil is shunted by a resistance (R_p) we have

$$Q = \frac{R_p}{\omega L} \quad . \quad . \quad . \quad 5.22$$

For a resistance tapped down the coil this becomes

$$Q = \frac{R_p}{\omega L} \left(\frac{T_{tot}}{T_{tap}} \right)^2 \quad . \quad . \quad . \quad 5.23$$

The resistance of the series work reflected across the whole tank coil gives an effective work *Q* of

$$Q_{wk} = \frac{\cos \theta \left\{ \left(\frac{C_w}{C_w + C_{ps}} \right) \left(\frac{T_{tot}}{T_{tap}} \right)^2 \right\}}{\omega^2 (C_w + C_{ps}) L} \quad . \quad . \quad 5.24$$

where *L* = tank coil inductance.

$$\text{The loaded } Q = \frac{Q_{wk} Q_O}{Q_{wk} + Q_O} \quad . \quad . \quad . \quad 5.25$$

If the work circuit is resonant we see from equation 5.24 that it would have to be tapped across a very small part of the tank coil in order to avoid overloading the valve. To do this is not usually practicable, and in any event very small variations in the work capacitance during the heating cycle would throw the circuit out of tune. Normally, the work circuit is not tuned to resonance, but has sufficient inductance included to overcome a considerable part of the work reactance in order to improve its effective power factor. At the same time, operation is on a skirt of the resonance curve so

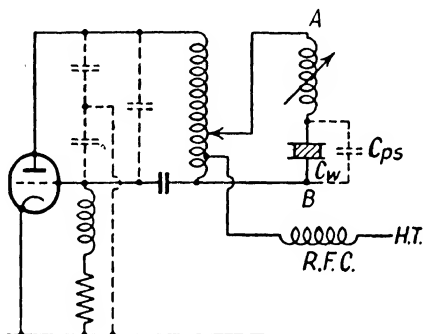

FIG. 48

that variations in work capacitance do not unduly affect rates of heating.

COUPLED WORK CIRCUITS

In the field of R.F. engineering, a common method for transferring energy from one circuit to another is via an inductive coupling. The method is extensively used for such purposes as energizing the aerial in transmitting equipment, in which case, it possesses definite advantages. First, it enables the coupled circuit to be isolated from any direct current that may flow in the energizing circuit, and, secondly, it is very selective in its transfer of R.F. energy when both the primary and secondary circuits are tuned. For communication, the selective features of inductive coupling make it invaluable for suppressing harmonics, but for R.F. heating the selective features are inclined to be a handicap.

An antenna constitutes a fixed load, because under normal circumstances its inductive, capacitive and resistive components do not alter appreciably. On the other hand, with R.F. heating various charges of work will possess different capacitances, and quite apart from this the work parameters will change during the heating cycle.

86 RADIO-FREQUENCY HEATING EQUIPMENT

Should the resonant frequency of the secondary containing the work differ from that of the tank circuit from which it is energized, the transfer of energy will be limited. Tuning must, therefore, be used in order to adjust the resonant frequency of the secondary circuit, and the advantage of an automatic change in frequency to compensate for change in work capacitance which is common to the directly-connected type of work circuit is not always retained.

The complete isolation of the work made possible by inductive couplings is in some applications advantageous, and any part of the

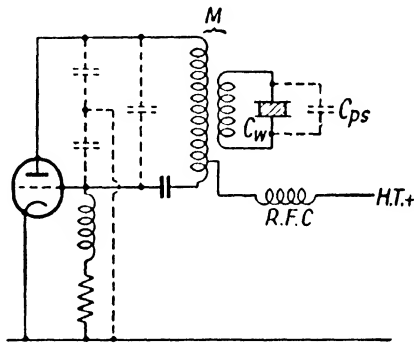

FIG. 49

secondary circuit may be earthed without harmful effect. It is, of course, the cheapest method of obtaining isolated work since it dispenses with the necessity for blocking capacitors. Whether this advantage will compensate for the drawback of selectivity that ordinarily accompanies the use of coupled tuned circuits depends largely on the type of application for which the equipment is designed. If it is intended to be foolproof in operation and yet cover a fairly wide range of application, inductive coupling will be a disadvantage, for unless tuning adjustments are made the efficiency will incline to be poor.

INDUCTIVELY-COUPLED WORK CIRCUITS

The study of inductively-coupled work circuits is a little more complex than the directly-connected variety. For instance, from Fig. 49 which shows an inductively-coupled work circuit, it may seem at first sight that the behaviour of the two resonant circuits coupled by a mutual inductance (M) could be solved by ordinary textbook treatment for such a circuit. After outlining the salient features of such a treatment of inductively-coupled resonant circuits, it will be seen, however, that this is not altogether the case,

because the ordinary treatment does not usually embrace the case of a primary energized from, and forming the controlling circuit of a self-excited oscillator.

The secondary reflects an impedance which may be regarded as being in series with the primary (Fig. 50), and the resistive and reactive components of the reflected impedance may be written

$$\Delta R_1 = \frac{\omega^2 M^2}{Z_2^2} R_2 \quad . \quad . \quad . \quad 5.26$$

$$\Delta X_1 = \frac{\omega^2 M^2}{Z_2^2} X_2 \quad . \quad . \quad . \quad 5.27$$

Primary resistance is always increased by the presence of the secondary, but the reflected reactance may be of opposite sign to

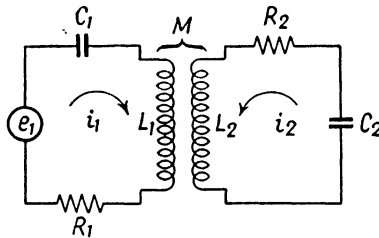

FIG. 50

the primary reactance which will thus be either reduced or increased according to whether the secondary reactance is inductive or capacitive at the frequency of operation. The voltage induced in the secondary is dependent upon the mutual inductance (M):

$$e_2 = -j\omega M i_1 \quad . \quad . \quad . \quad 5.28$$

Secondary current is governed by the induced voltage and impedance of the secondary

$$i_2 = \frac{-j\omega M e_1}{Z_1 Z_2 + \omega^2 M^2} \quad . \quad . \quad . \quad 5.29$$

At resonance the reactive components disappear:

$$i_2 = \frac{-j\omega M e_1}{R_1 R_2 + \omega^2 M^2} \quad . \quad . \quad . \quad 5.30$$

Differentiation shows that the expression has a maximum value when $R_1 R_2 = \omega^2 M^2$. Since $M = k\sqrt{L_1 L_2}$ where k is the coupling factor, we may write for the critical value at which i_2 is a maximum

$$k = \frac{1}{\sqrt{Q_1 Q_2}} \quad . \quad . \quad . \quad 5.31$$

When k exceeds the critical value, the behaviour of the circuit is such that it possesses two resonance points. This arises from the fact that at resonance the primary current is not a maximum owing to the large resistive components reflected into the primary. If the frequency changes, the primary becomes reactive, but so does the secondary and the reflected reactance is of opposite sign to that of the primary. At certain departures from the resonant frequency it is possible for the reflected reactance to reduce the primary reactance to zero again, and at the same time the reflected resistance will be less owing to the increase in secondary impedance at the new frequency. Primary current will rise and this effect gives the two tuning points commonly called the double-hump effect. The width of the hump depends on the amount by which the factor k exceeds the critical value.

With inductively-coupled work in dielectric heating it is not possible for double-humping to occur, and k is not critical in the sense referred to above. It will, however, possess a value which should not be exceeded, but this is governed by different circumstances and will be treated later. For double-humping to occur it is necessary for the primary current to pass through two maxima in the region of resonance, but when the primary consists of the tank circuit of a self-excited oscillator it is not possible for this behaviour to occur (because the grid excitation frequency is itself controlled by the tank circuit). We have seen that up to the overload point the oscillatory voltage $E_b - v_{amin}$ remains fairly constant and the primary current will thus change in a smooth manner with changes in frequency. There will, however, be a small but sudden change in primary current occasioned by a frequency jump when k exceeds a certain value.*

A feature of critical coupling is that it occurs when the reflected resistance is equal to the primary resistance, in other words the Q of the primary circuit is halved. Now, were this to apply in coupled work circuits the transfer ratio would be 2, and only 50 per cent of the generated power could be usefully dissipated even under ideal conditions.

The value of k that must not be exceeded in dielectric-heating applications is bound up with the question of valve loading. It must be arranged that when both circuits are resonant at the same frequency the resistance reflected into the primary does not depress the primary Q to a lower value than that needed to make the circuit present an optimum load to the valve. The reflected resistance may be regarded as a reflected Q , the value of which will be

* See Appendix I.

90 RADIO-FREQUENCY HEATING EQUIPMENT

optimum, and, where this is done, the equipment has of course a somewhat wider range of application. Optimum loading need not, however, always be the object, because the control could in some applications be used to mis-match deliberately. Typical examples are when there is a risk of flash-over, or when a slow rate of heating is required. By this means it serves as a power control and is likely to prove cheaper than one of the type that varies the H.T. voltage applied to the generator. In operation, it would not usually be as smooth and continuous and this accounts for the use of variable H.T. power control on many equipments.

A common type of matching device is a continuously variable tap on the inductor which serves as the tank coil. Mechanically, the arrangement is simple and similar in principle to the variable inductors that have been used for many years in transmitting equipment. It is preferable that the tap is in the valve circuit rather than the work circuit because the current then carried by the contact is considerably less.

With many dielectric-heating applications, the effective power factor of the work is so low that it is the anode that must be tapped down the tank coil in an effort to impose an adequate load on the valve. This brings about an increase in the voltage applied to the work, and unless it is of sufficient thickness to withstand this voltage or unless some limiting device is included, the variable anode tap circuit suffers limitations. The effect of variations in the tap position will be understood by reference to the section dealing with tapped direct circuits.

In practice, some form of indicator must be included in the equipment to show the effect of tap variation, and this usually takes the form of anode and/or grid current meters. On light load, anode current will be low and grid current high, and, as loading is increased, anode current rises and grid current falls. When optimum load is exceeded, the anode current rises still further and the effective Q of the tank circuit becomes so low that oscillations cease. This is an unfortunate aspect of variable matching devices and unless automatically-operated relays are included to switch off when overload occurs, the valve will be liable to damage from excessive anode dissipation.

Where variable-tap control is used on push-pull circuits conditions are rather awkward. On operating, controls of this type are required to move in opposite directions and this presents considerable mechanical difficulties. A solution is to wind the tank coil in two halves and reverse one of them so that a movement of the two taps in the same physical direction would be electrically equivalent to

moving them in opposite directions. When this is done the two halves of the coil must be mounted a little distance apart because they are connected series-opposing, and the inductance would otherwise be greatly reduced. As it is, the unloaded Q -value for the coil will be relatively low, due to an unavoidably large resistive component, and in this manner a low transfer ratio with its attendant disadvantages is unavoidable. Any degree of mis-match will be accompanied by a steep fall in useful power (Fig. 41), and the control will hence be critical of adjustment.

For many types of work the voltage developed across the tank circuit when push-pull valves are tapped down the coil would be too high for application direct to the work. In such, it is the work that must be tapped down the coil, and this means that when the power factor of the work is low, adequate loading cannot be imposed because tapping the work down has the effect of reducing its effective power factor still further. A practical point of some importance is that when the full work current is carried by the sliding or wiping taps, any high-resistance contact that may occur will produce so much local heat that the slider or wiper will be damaged.

Air-Gaps. If arrangements are made to include a variable air-gap between the electrodes and the work, it may be used as a matching device. The two main effects are that it reduces both the effective power factor of, and the voltage applied to, the work. Preferably, it is used with push-pull circuits, because the voltage across the tank coil is twice that which occurs with a single-ended circuit and the optimum load value $Q_{LO}\omega L$ is double. Work having a power factor approximately half that needed to load a single-ended oscillator would thus impose adequate loading on a push-pull generator. Summarizing, we may say that if the electrodes are in contact with the work it is generally necessary to tap the work down the tank coil, and for many materials the loading under these conditions will be light. On the other hand, if a variable air-gap is included the valves may be tapped down the coil, and with these two variables a more flexible arrangement is obtained.

Series Coil. A flexible arrangement occurs when a variable inductor is provided in series with work having a variable air-gap (Fig. 51). A further control is provided by connecting the work circuit to a variable tap on the tank coil. The full work current flows through both the tank-coil tap and the variable inductor and these must thus be of excellent design and workmanship. The method by which matching is achieved will be understood by reference to the section dealing with tuned work circuits.

92 RADIO-FREQUENCY HEATING EQUIPMENT

Inductive Coupling. Inductive coupling gives a flexible type of variable-loading control, but unfortunately two separate factors are involved. In the first place, the secondary circuit containing the work should be capable of being tuned, and this will involve one control. Secondly, a control is needed to vary the coupling between the circuits. Tuning the work circuit must ordinarily be achieved by using for the secondary coil a tapped inductor, but at the same time the whole coil must be movable in relation to the tank coil in

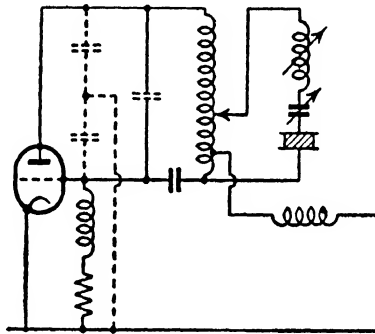

FIG. 51

order to vary the coupling. Mechanical difficulties arise in having a moving coil on which a continuously variable tap is provided, and for this reason the arrangement is not much used. A method of easing these troubles would be to employ a variable capacitor in parallel with the work, but such a solution is not practical on any but the smallest equipment. The expense and physical size of transmitting-type variable capacitors of high kVA rating makes them unsuitable for installation in dielectric-heating equipment.

Any of the devices employed for matching may be driven by a motor, automatically controlled, and thus yield an automatic rematching of the load between given limits. Systems of this type are controlled by current-sensitive relays contained in the anode and/or grid circuit of the generator and for certain types of application they greatly increase the industrial acceptability of R.F. heating equipment.

Eddy-current-heating Work Circuits

THE heating of metallic work by the induction of eddy currents takes place when it is situated in the alternating magnetic field associated with a conductor carrying R.F. currents. For most applications the work is placed inside a coil through which the R.F. current flows, because usually it is the peripheral layer of the work that must be heated. This is, however, not always so for it sometimes happens that the inner surface of holes bored in metal or limited areas on a metal surface are to be treated. The current-carrying conductor may thus take one of many possible shapes. We will, however, refer to it as the work coil whatever its actual shape may be. The purpose of the work coil is to create a preferably uniform alternating magnetic field at the surface of the work, and the heating is proportional among other things to the rate of change of flux linked with the work. This will in turn depend upon the frequency and magnitude of current flowing in the work coil, and it follows that at higher frequencies the current required for a given rate of change of flux will be less.

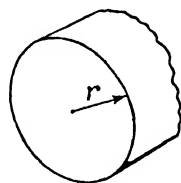

FIG. 52

Due to its physical dimensions and the nature of the material of which it is composed, the work possesses inductive and resistive components. If we consider cylindrical work (Fig. 52), the resistive component is proportional to the resistivity of the material and the radius of the work because eddy currents will flow only in the peripheral layers. On the other hand, the inductive component is proportional to the area or in other words to the square of the radius of the work. It will also be proportional to the effective permeability of the material and so ferromagnetic work of large diameter will have a comparatively large inductive component.

ENERGY TRANSFER

The work coil and work are equivalent to a transformer having a shorted secondary and may be represented by the circuit shown in Fig. 53. R_1 and L_1 are the resistive and inductive components of the work coil and L_2 and R_2 that of the work, while M represents

the mutual inductive coupling between them. Considering the circuit as a whole, some heat will be generated in the work coil due to its resistance, and this of course represents wasted power. The ratio of work coil to work current depends largely on the mutual coupling and from ordinary coupled-circuit theory we may write

$$i_1(R_1 + j\omega L_1) + j\omega M i_2 = e \quad . \quad . \quad 6.1$$

$$j\omega M i_1 + i_2(R_2 + j\omega L_2) = 0 \quad . \quad . \quad 6.2$$

The effective impedance of the work coil taking account of the presence of the work is

$$Z' = R_1 + j\omega L_1 + \left(\frac{M^2 \omega^2}{R_2^2 + \omega^2 L_2^2} \right) (R_2 - j\omega L_2) \quad . \quad 6.3$$

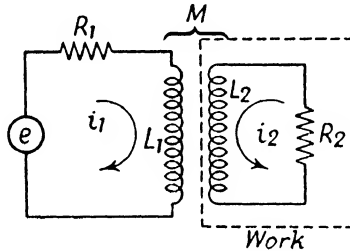

FIG. 53

Separating resistive and reactive components

$$R_1' = R_1 + \frac{(\omega^2 M^2) R_2}{R_2^2 + \omega^2 L_2^2} \quad . \quad . \quad 6.4$$

$$X_1' = X_1 - \frac{(\omega^2 M^2) \omega L_2}{R_2^2 + \omega^2 L_2^2} \quad . \quad . \quad 6.5$$

The resistance of the work coil is increased by the presence of the work while its inductance would appear to be reduced. The latter statement, however, needs qualification, and we will consider reactive changes later. In any event from an efficiency point of view, we are concerned mainly with the resistive components of the work and coil.* Putting

$$\frac{\omega L_2}{R_2} = Q_w \quad . \quad . \quad 6.6$$

the resistance reflected into the primary becomes

$$\Delta R_1 = \frac{M^2}{L_2^2} R_2 \left(\frac{Q_w^2}{Q_w^2 + 1} \right) \quad . \quad . \quad 6.7$$

* See Appendix I.

The factor in parenthesis closely approaches unity when Q_w is larger than 3, and since this will be true for large diameter work, particularly if ferromagnetic, we may write

$$\Delta R_1 = \frac{M^2}{L_2^2} R_2 \quad . \quad . \quad . \quad . \quad 6.8$$

The transfer efficiency or ratio of the useful power in the work to that wastefully dissipated in the work coil is

$$\eta = \frac{\Delta R_1}{R_1 + \Delta R_1} \quad . \quad . \quad . \quad . \quad 6.9$$

This may be rewritten

$$\eta = \frac{\frac{M^2 R_2}{L_2^2 R_1}}{\frac{M^2 R_2}{L_2^2 R_1} + 1} \quad . \quad . \quad . \quad . \quad 6.10$$

EFFECT OF FREQUENCY

Due to skin effect, R.F. currents are confined to the peripheral layers of a conductor, and the thickness of the current-carrying layer is proportional to the square root of the frequency. The R.F. resistance of the work coil is thus proportional to \sqrt{f} , but this also applies to the work. From equation 6.10 it is seen that if $R_1 = R_2$ the efficiency of energy transfer becomes independent of frequency, but when R_2 is larger than R_1 , which it usually is with ferromagnetic work, there tends to be a slight increase in transfer efficiency with rising frequency. This presupposes that Q_w is sufficiently large for $\frac{Q_w^2}{Q_w^2 + 1}$ to be taken as equal to unity, but when Q_w has a value less than 3 at a given frequency, there will be a marked increase in transfer efficiency with rising frequency. The increase in the latter case is due to the fact that Q_w increases with frequency because the inductive reactance of the work is proportional to the first power while the resistive component is proportional to the square root of frequency.

REQUIREMENTS FOR HIGH TRANSFER EFFICIENCY

For high efficiency of energy transfer, we may now tabulate the following requirements and examine how they are to be met in practice.

- (i) Work coil resistance must be low.
To satisfy this the material of which the work coil is made

must be of low specific resistance, e.g. copper, and its cross-sectional area made as large as possible. Two factors limit the diameter of the work-coil conductor. First, the radius of the coil, and second, the fact that for a given coil length it should possess a high inductance and thus a maximum number of turns. Coils are usually made of tubing because the current flows in the outer layers only, and it becomes easy to arrange for the passage of cooling water to prevent increased resistance with temperature rise.

(ii) Work resistance must be high.

This is governed largely by the nature of the work and requires that the dimensions should be large and that the material should be of high specific resistance. It is worth while noting that ferromagnetic metals satisfy the latter requirement better than other metals.

(iii) Q of the work should exceed 3.

This again is governed largely by the nature of the work because Q will be proportional to the effective permeability of the material and square root of the radius of the work. It is also proportional to the square root of frequency and so for small diameter work a high frequency is preferable for good transfer efficiency.

(iv) $\frac{M^2}{L_1^2}$ should be large.

M and L_2 are closely related because the mutual inductance existing between the circuits shown in Fig. 53 is given by

$$M = k\sqrt{L_1L_2} \quad . \quad . \quad . \quad . \quad 6.11$$

The two requirements are that L_1 should be greater than L_2 and that k should be as near unity as possible. To make L_1 large, the work coil should be of large radius and many turns. The radius is, however, actually determined by that of the work and if many turns are used its resistance becomes large. Actually, the problem is to obtain the greatest inductance for a given length of conductor, and this is facilitated by flattening the circular tubing so that a greater number of turns can be wound in a given coil length. The spacing between adjacent turns must, however, be commensurate with the peak voltage across the coil otherwise flash-over is likely to occur. To assist in obtaining a better space factor and thus more inductance for a given length, strips of mica may be inserted between turns and held in position by a suitable refractory material.

The coupling factor k is dependent on the number of flux linkages

between the coil and the work. For this to have a high value the spacing between coil and work should be kept to a minimum consistent with voltage breakdown requirements. Again, a thin layer of mica or other refractory material having high dielectric strength may be inserted between the coil and the work to enable the gap to be reduced. It also serves a useful purpose in preventing shorts occurring between turns during insertion of the work.

OVERALL EFFICIENCY

Up to now we have dealt with the efficiency of energy transfer from the work coil to the work, but in considering the overall efficiency the process must be reversed and looked at from the view-point of the capability of given work to load the generator adequately. We have seen that the transfer of energy to the work depends largely on the work parameters Q_w and R_2 which are in turn dependent on the specific resistance, permeability and dimensions of the material forming the work. Where the transfer efficiency is high, adequate loading will usually be imposed, but for many important applications transfer efficiency is unavoidably low and we must examine methods that can be adopted to improve the loading imposed by such work. Where the load imposed is very poor only a small fraction of the total power of which a generator is capable becomes usefully dissipated in the work. Besides running costs becoming relatively high, the capital cost of equipment needed for inefficient applications can become prohibitive unless efforts are made to improve the load imposed.

LOADING AND CIRCUITS

With a given valve or valves, the power that a generator is capable of developing is known with fair accuracy, and from valve characteristics the anode oscillatory voltage and current can be readily computed (*see* Chapter 4). The power that is available for useful dissipation depends on the unloaded Q -value of the tank coil (Q_O) and the optimum loaded value (Q_{LO}) which should be as little above 10 as possible. For useful power we now have

$$\frac{(E_b - v_{amin})I_{ac}}{2} \frac{Q_O - Q_{LO}}{Q_O} = \text{useful power} . \quad . 6.12$$

while the power not usefully employed is proportional to $\frac{Q_{LO}}{Q_O}$.

There are two main methods of energizing the work coil in eddy-current-heating generators and each has its particular range of application. In one, the work coil is part of the tank coil, while in

98 RADIO-FREQUENCY HEATING EQUIPMENT

the other it is coupled inductively to the tank coil. These arrangements are shown in Figs. 54 and 55 and will be referred to as the direct and coupled work circuits. It can be stated at the outset that the direct work circuit is preferable where the work is of an efficient type, and that the coupled circuit should be used with work having poor transfer efficiency.

DIRECT WORK CIRCUITS

The work coil in any eddy-current heating gear is mounted exterior to the main equipment and may for some applications be several

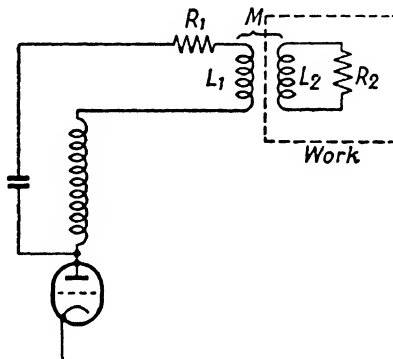

FIG. 54

feet from it. No appreciable mutual coupling exists between the tank and work coils, so that to know the total inductance tuning the tank capacitance the inductances of the coils may be added. With this circuit the work coil must be considered an integral part of the tank coil, and the unloaded Q -value of the circuit is somewhat less than would occur with a compact coil. This arises from the fact that the leads out to the work contribute resistance, but negligible inductance, and what is more important, the resistance of the work coil itself will be relatively high because for practical reasons it is usually wound with a smaller-gauge copper conductor than other parts of the circuit. While the Q of a compact coil of comparable dimensions may be 300 or more, the unloaded tank coil in circuits of this type may be a 100 or less due to the absence of mutual coupling between inductive parts of the circuit, and to unavoidably large resistive components. Even so, 90 per cent of the generated power will be available for useful work where $Q_0 = 100$ and Q_{LO} has the optimum value of 10. The resistance that must be reflected into the work coil to produce full loading is

$$\Delta R_1 \simeq \frac{Q_O}{Q_{LO}} R_1 \text{ (since } \Delta R_1 > R_1) \quad . \quad . \quad 6.13$$

but from equation 6.8

$$\Delta R_1 = \frac{M^2}{L_2^2} \cdot R_2 \text{ when } Q_w > 3 \quad . \quad . \quad 6.14$$

$$\therefore \frac{Q_O}{Q_{LO}} = \frac{M^2}{L_2^2} \frac{R_2}{R_1} \quad . \quad . \quad . \quad 6.15$$

but
$$M = k\sqrt{L_1 L_2} \quad . \quad . \quad . \quad 6.16$$

$$\therefore \frac{Q_O}{Q_{LO}} = \frac{k^2 L_1 R_2}{L_2 R_1} \quad . \quad . \quad . \quad 6.17$$

Here we see that while the work resistance R_2 should be large, its inductance L_2 is required to be small. The work must, however, possess a Q -value exceeding 3 in order to provide good inductive coupling, and so its impedance will be relatively high. It should, in fact, be comparable with that of the whole tank circuit, and a fair proportion of the tank coil (from a fifth to a half) should be localized in the work coil L_1 .

Iron or steel work, unless of very small diameter, will have a coupling factor to the work coil of 0.5 to 0.7, and will be capable of reflecting a sufficiently large resistive component to reduce Q_L to 10 or 12. It can easily happen with large diameter work that it will reduce Q_L to below 10 and impose an overload on the oscillator, and for such applications a relatively inefficient work coil should be used. This does not mean a work coil of high resistance, for it would then overheat, but one having a larger clearance to the work and thus a poorer coupling.

COUPLED WORK COIL

The overall arrangement, Fig. 55, can be regarded as two transformers in series and the main object of its use is to obtain a degree of impedance-match between the work and loaded tank circuit. When the work is not present, there is already a load imposed on the tank circuit by the closed circuit inductively coupled to it. The tank-circuit current will dissipate heat in R_1 while the current flowing in the $L_2 L_3$ circuit dissipates heat in R_2 . These both represent wasteful loss, and the object is to minimize both R_1 and R_2 . To achieve this, the tank coil considered on its own, is designed to have as high a Q -value as space limitations permit. The coupling coil L_2 which consists of one or a small number of turns is wound with large section rectangular bar or, in the case of a single-turn coil, it may consist of a sheet of copper bent into a cylinder. To

100 RADIO-FREQUENCY HEATING EQUIPMENT

obtain a high coupling coefficient k_1 , the space between the tank and coupling coils should be a minimum consistent with voltage requirements. The coupling coil should be mounted inside the tank coil, because the shorter length of coupling-coil conductor made possible by this arrangement gives reduced resistance. Most of the coupling-circuit resistance will actually be located in the work coil owing to its unavoidably small conductor cross-section, but even so the Q of the isolated coupling circuit will, in all reasonably good designs, greatly exceed 3.

The ratio of the turns on the tank coil to those on the coupling coil may be between 10 to 1 and 100 to 1 in equipment of normal

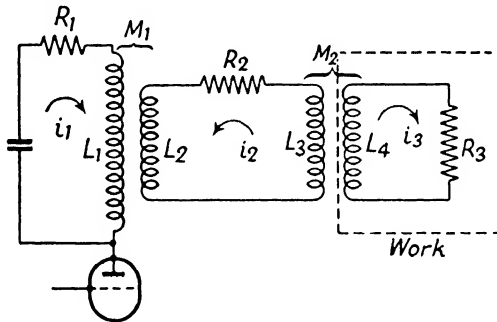

FIG. 55

design operating at frequencies between about 200 kc/s and 4 or 5 Mc/s. It follows that L_1 is very much greater than L_2 and since the coupling factor between them is usually of the order of 0.7, the mutual inductance M_1 will be much larger than L_2 . It will in fact be larger than the total inductance of the coupling circuit or, in other words, than L_2 plus L_3 . Coupling-circuit current is

$$i_2 = \frac{-j\omega M_1 i_1}{R_2 + j\omega(L_2 + L_3)} \quad \dots \quad 6.18$$

Since M_1 is greater than L_2 plus L_3 , the work coil current, which is also the coupling-circuit current, will be greater than the tank-coil current. This advantage has been gained at the expense of a reduced value of tank circuit Q before the work is included, and this reduced value must now be taken as our unloaded Q -value.

$$Q \text{ of tank circuit alone} = \frac{\omega L_1}{R_1} \quad \dots \quad 6.19$$

$$Q \text{ of tank + coupling circuit} = \frac{\omega L_1}{R_1 + \frac{M_1^2}{L_2^2} R_2} \quad \dots \quad 6.20$$

Because of the large value possessed by R_2 the effective tank-coil resistance will be larger than with a direct work-coil circuit of average good design, and less useful power is available from a given generator. The advantage of the arrangement, however, is that poor work can be made to load the generator more effectively. Poor work will usually have a Q -value lower than 3, and the coupling between the work coil and the work may be as low as 0.1. The resistance reflected by the work into the coupling-coil circuit is given by

$$\Delta R_2 = \frac{M_2^2}{L_4^2} R_3 \frac{Q_w^2}{Q_w^2 + 1} \quad . \quad . \quad . \quad 6.21$$

For very poor work ΔR_2 may be less than R_3 , but the effect of ΔR_2 on the tank circuit becomes

$$\Delta R_1 = \frac{M_1^2}{(L_2 + L_3)^2} \cdot \Delta R_2 \quad . \quad . \quad . \quad 6.22$$

Now $\frac{M_1^2}{(L_2 + L_3)^2}$ is much greater than unity, and so we have an enhanced reflected resistance, and thus loading, as compared with that prevailing in a direct work circuit.

TANK CAPACITORS

In considering the tank circuit we have neglected any losses that may be due to the capacitor used for tuning the coil to the required frequency. This is justified because the capacitors used for this purpose are of a kind having a low power factor. For equipments of large kVA rating, they are usually of the mica transmitting type immersed in oil, while more recently, ceramic pot capacitors used in series-parallel banks have gained favour. These may be either air-cooled or they may be oil-immersed when the air-cooled rating is exceeded, and they offer a saving in cost. Even so, when equipment is designed to work on a relatively low frequency of a few hundred kc/s the tank capacitor becomes a major item in the total cost of equipment. In an effort to keep costs down there has been a tendency to work at frequencies far higher than can be justified by theoretical considerations of eddy-current heating. Most of the ordinary run of oscillator valves work with full efficiency up to about 15 or 20 Mc/s, and there has recently become available a number of eddy-current heating equipments designed to work in this frequency range.

As a result of the very much lower LC product needed at these high frequencies a considerable saving in tank-circuit costs is

102 RADIO-FREQUENCY HEATING EQUIPMENT

effected. Further, the overall performance of the equipment does not suffer unduly from the increase in frequency. If anything there is a reduction in efficiency with large diameter work, in which case it can be afforded, and an increased efficiency where it is needed with poor work of small diameter. So, for general-purpose equipment, a high frequency is inclined to be an advantage. Radiation problems are of course increased, but in general there is no particular difficulty encountered in designing equipment for operation at frequencies in the megacycle range. There is, however, one very important aspect which must be taken into account. This is due to the fact that capacitive couplings become more significant as frequency is raised, and they cannot be neglected at frequencies in the megacycle range. Generally speaking, the effect of capacitive coupling will be to improve transfer efficiency, particularly with very small diameter work, but it is fortunate that a simple method of investigation about to be described applies equally at the higher frequencies, provided care is taken in making the measurements.

EFFICIENCY MEASUREMENTS

We have already seen that the power generated by an oscillator is inversely proportional to the Q of the tank circuit, and this fact can be used to gain a fairly accurate idea of the performance to be expected on given applications. The only apparatus needed is a Q -meter of good design, and all the information needed can be obtained by two or three measurements on the tank circuit. It does not matter whether the resistive load is reflected into the tank circuit by inductive or capacitive coupling, because the resultant reduction in Q is measured. The point arises, however, that the accuracy of Q measurements is apt to decrease as the frequency is raised unless precautions are taken, and for this reason more care must be observed in making measurements in the higher range of frequencies that are likely to be used for eddy-current heating. On a direct work-coil circuit, the procedure is as follows—

DIRECT COIL CIRCUIT

(i) Measure Q of unloaded tank circuit (Q_0).

If the Q -meter is of a type having built-in capacitance, no large error is introduced at the lower frequencies (0.4 to 1 Mc/s) by reducing the internal capacitor to a minimum. At higher frequencies, however, it must be remembered that the internal capacitor is in parallel with the tank circuit, and will reduce the resonant frequency unless an appropriate amount of the tank capacitor is removed. Since both the tank and Q -meter capacitor

EDDY-CURRENT-HEATING WORK CIRCUITS 103

can be considered as perfect, it is of course possible to work with the tank coil only and use the Q -meter capacitor for tuning.

(ii) Measure Q of tank circuit with work in position (Q_{LA}).

There will be a very slight change in frequency with non-ferromagnetic work, but a somewhat larger change with iron or steel. Q_{LA} should of course have a value of between 10 and 12, but this is not likely to be reached with non-ferromagnetic work although with large diameter iron and steel it may be less.

Having obtained values for Q_O and Q_{LA} , we have sufficient information to assess the overall performance at the start of the heating cycle (the effect of temperature rise will be considered later). Knowing the inductance of the tank coil and the frequency of operation, the optimum value of loaded Q is

$$Q_{LO} = \frac{E_b - v_{a\min}}{\omega L I_{ac}} \quad . \quad . \quad . \quad 6.23$$

The value of Q_{LA} is determined early in the design, and is chosen to be equal to 10 to 12, but with some equipments it may, through bad design, have a higher or more rarely, a lower value. If screening is adequate, a slightly lower value is not a serious fault because radiation due to harmonics will be suppressed. A higher value will mean a sacrifice in power and this becomes considerable if Q_O has a relatively low value. We now have

$$\text{Total power generated} = \frac{(E_b - v_{a\min})I_{ac}}{2} \quad . \quad . \quad . \quad 6.24$$

$$\% \text{ wastefully dissipated} = \frac{Q_{LO}}{Q_O} \times \frac{100}{1} \quad . \quad . \quad . \quad 6.25$$

$$\% \text{ usefully dissipated} = \left(1 - \frac{Q_{LO}}{Q_O}\right) \frac{Q_{LO}}{Q_{LA}} \left(\frac{Q_O - Q_{LA}}{Q_O - Q_{LO}}\right) \times \frac{100}{1} \quad 6.26$$

$$\text{When } Q_{LA} = Q_{LO} \text{ this becomes} = \left(1 - \frac{Q_{LO}}{Q_O}\right) \times \frac{100}{1} \quad . \quad . \quad . \quad 6.27$$

COUPLED WORK COIL

- (i) Measure Q of tank coil with work and work coil removed (Q_t).
- (ii) Measure Q of tank circuit with work coil in circuit (Q_O).
- (iii) Measure Q of tank circuit with work coil and work in circuit (Q_{LA}).

$$\text{Percentage wastefully dissipated in tank coil} = \frac{Q_{LA}}{Q_t} \times \frac{100}{1} \quad . \quad 6.28$$

104 RADIO-FREQUENCY HEATING EQUIPMENT

Percentage wastefully dissipated
in tank coil + work coil = $\frac{Q_{LA}}{Q_0} \times \frac{100}{1}$. 6.29

Whatever the type of application may be, the Q -measurement method of assessing performance can be applied. It does not matter whether the work coil is a cylindrical solenoid containing efficient work in the shape of a cylinder of iron or steel, or whether it is a pancake coil for heating flat surfaces. It may even be applied when the work coil is of hairpin type for insertion into small holes, but in such instances the measurements must be particularly accurate because the changes in Q will be small.

Reactive Changes. The effect on the frequency of oscillation of including work in the circuit is dependent on whether the work is ferromagnetic or not, and also on the type of work circuit used. If in a directly-connected circuit a material like brass is included the effect will be an increase in frequency. This results because the brass work is equivalent to a shorted coil and is inductive in character. The reflected reactance will be of opposite sign and will bring about a reduction in the effective tank inductance and thus an increase in frequency. On the other hand, ferromagnetic work will reduce operating frequency with a directly-connected circuit because of the increase in work-coil inductance due to the presence of work having permeability in excess of unity. With coupled circuits the effect on frequency will be the reverse of that prevailing with direct circuits because there are two mutual couplings to be considered. With brass this makes the reflected reactance inductive (and increases frequency) while with ferromagnetic work the increase in work-coil, and thus coupling-circuit inductance, makes the reflected reactance less inductive and reduces frequency.

EFFECT OF TEMPERATURE

It may be thought that since the work parameters change with a rising temperature, the measurements of Q with cold work will not be particularly helpful. This is definitely not so, for unless measurements are taken at one stage or another there will be no basis on which to predict performance. It is, of course, necessary to have an idea of the way in which increasing temperature will modify Q -values and thus loading, but in practice this may be readily seen by observing changes in anode and grid current. For surface heating the work should, on cold measurements, be made to impose a lighter load than optimum, and with iron or steel the loaded Q -value should be about twice optimum while with large diameter

non-ferromagnetic work it should be about three times optimum. During the heating cycle, the work-coil and tank-coil resistances increase and reduce Q_0 , while hot work depresses Q_{LA} to a value nearer optimum. Once iron or steel work attains the Curie point the power absorbed will fall sharply, but with non-ferromagnetic work it tends to increase with rising temperature.

The intelligent use of the Q -meter yields much more information than the cut-and-try methods which are so commonly employed, and it is to be recommended to anyone seriously engaged in work

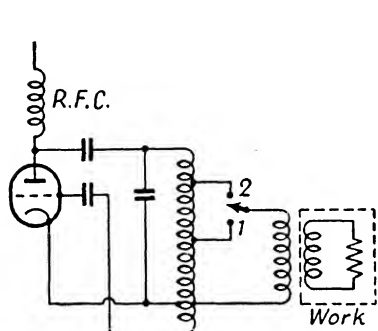

FIG. 56

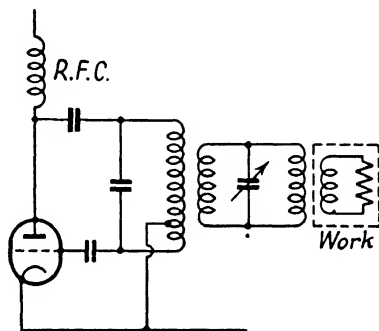

FIG. 57

on R.F. eddy-current heating equipment. An attractive feature of the method is that it can be applied before the equipment is built, if the tank and work coils, and (where needed) coupling coils are available.

LOAD RE-MATCHING

With the heating of irons and steels the load imposed on the generator changes abruptly when the Curie point is reached, and if higher temperatures are to be achieved it is preferable to re-match the work circuit. Above the Curie point the work impedance is reduced and re-match may be effected by changing the work-coil connection to position 2 shown in Fig. 56. This results in a reduction in the effective inductance of the tank coil, and work-coil current is increased. A current-sensitive relay in the anode circuit can be made to operate the contactor mechanism for effecting the change-over. Other relays should, however, be employed to apply a large bias voltage in order to suppress oscillation during the changeover.

Where low-powered eddy-current heating is used for a range of applications, it is possible to tune the work circuit to resonance as shown in Fig. 57. The kVA rating of capacitors used for tuning in

106 *RADIO-FREQUENCY HEATING EQUIPMENT*

equipments of less than about 1.0 kW rating is not unduly large, and banks of relatively inexpensive capacitors may be switched in and out to suit various applications. In cases where the frequency is of the order of many megacycles, a continuously variable capacitor may be conveniently used on equipment of low power rating.

Thermionic Valves

THE thermionic valve is the most efficient device for the generation of power at frequencies higher than a few kilocycles. Large valves used for the purpose are basically similar to the smaller types met with in broadcast receivers, but they possess features which are necessary for meeting the requirements of high-power high-frequency generation. To understand the reasons for these features we will consider the elements of valve theory in relation to the practical methods adopted to fulfil high-power high-frequency requirements.

As the name implies, the thermionic valve is a device which permits the passage of current in one direction only, and, in its simplest form, it consists of a cathode which when maintained at a high temperature emits electrons (negatively-charged particles of small mass) and these are attracted to a surrounding anode which is maintained at a high positive potential with respect to the cathode and the passage of electrons constitutes a flow of current.

IONIZATION

The cathode and anode are contained within an evacuated envelope in order that the electrons may have an unobstructed path. If, however, gas is present in the envelope, the fast moving electrons are impeded by the gas molecules and the resultant collisions may be sufficiently intense to knock one or more electrons out of the gas molecule. This leaves an ionized molecule with a positive charge and produces one or more free electrons. The ionized gas molecules are attracted to, and bombard the filament, and if the bombardment is sufficiently severe they may destroy the emitting surface. Another effect accompanying ionization is that by virtue of the free electrons produced, the gas becomes conducting.

Even with valves having the most suitable type of structure and with which every known manufacturing precaution has been adopted it is not possible to obtain a perfect vacuum, and slight traces of gas remain. Now the velocity acquired by electrons in their passage to the anode is governed by the potential gradient existing between the cathode and anode. We see, therefore, that while the risk of ionization is always present it increases with an increase of the anode

108 RADIO-FREQUENCY HEATING EQUIPMENT

voltage at which a valve is designed to operate. The power rating of a valve is, broadly speaking, dependent upon the square of the rated anode voltage, and so with high-power valves the question of ionization is an important one.

TRIODES

If an open mesh of wire is interposed between the cathode and anode and is charged to any potential with respect to the cathode it will effectively control the passage of electrons to the anode. When the grid is sufficiently negative with respect to the cathode it makes the potential gradient at the surface of the cathode negative and prevents any electrons reaching the anode. On the other hand, if the grid is positive with respect to the cathode the flow of electrons to the anode is increased until at suitable grid and anode potentials the entire cathode emission is drawn off. Most of it goes to the anode while a lesser amount flows to the grid and gives rise to grid current. The inclusion of a grid to form the three-electrode valve or triode endows a particularly significant property—the valve becomes capable of *amplifying*, because the power used at the grid is very much less than the anode power which it controls.

EMISSION

In all but very small valves, the cathode is a filament of metallic wire heated by the passage of a current. As is well known, the passage of an electric current in a conductor is due to a movement of free electrons momentarily unattached to any particular atom or molecule. The velocity of these electrons increases with rising temperature and if their kinetic energy exceeds that necessary to overcome the restricting forces at the surface of the conductor the electrons escape. This loss of electrons leaves the filament with a slight positive charge, and if there is no other positively-charged surface sufficiently near to overcome the attraction of the filament, there will be a continual return of electrons to it. The cloud of electrons existing round the filament under these conditions is known as the *space charge*.

The velocity that an electron must acquire to break free from a filament is not reached at ordinary temperatures and the work to be done in breaking free is different for each material. The temperature that must be reached for emission to occur is determined by a factor known as the *work function* of the material. For a material to be suitable for use as an emitting filament it is necessary for its work function to be such that satisfactory emission occurs at temperatures below the melting-point of the material.

FILAMENTS

The high temperatures that must be reached for satisfactory thermionic emission limit the choice of filament materials to pure tungsten, thoriated tungsten and barium or strontium oxide coatings. Large valves having anode dissipation in excess of 2 kW usually have filaments of pure tungsten because the emitting surface

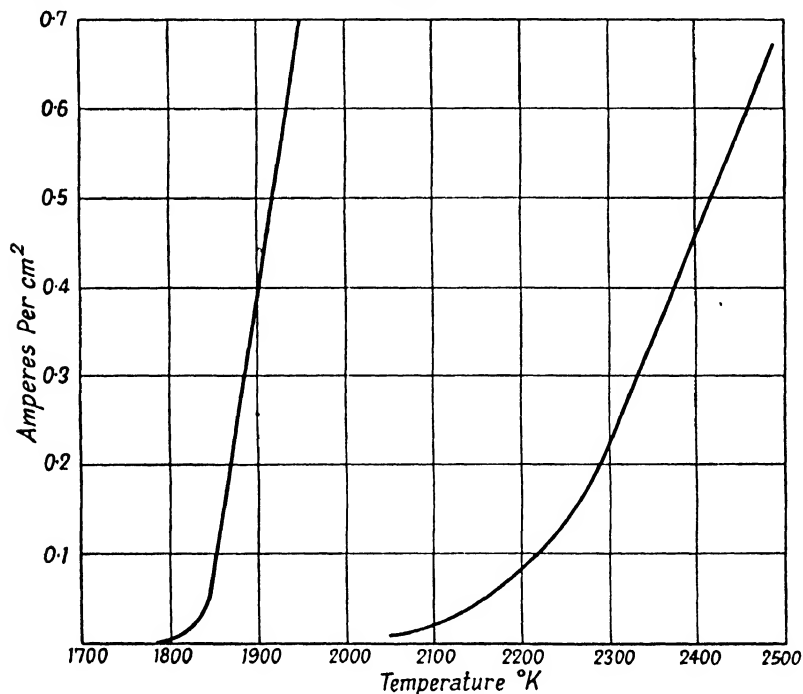

FIG. 58

is relatively robust and not easily damaged by ionic bombardment. Tungsten has a melting point of 3500° K which is much higher than that of any other common metal, but in valves its normal operating temperature is limited to 2500° K. It is interesting to note that filament temperatures are considered in the absolute temperature scale (K) for which zero is -273° C. The reason is that electronic movement at absolute zero is completely free, or inertialess, and it provides, therefore, a reference point at which specific conditions exist, irrespective of the conducting material under consideration.

For medium-impedance valves of about 2 kW anode rating, the filament emission required is about 4 to 5 A and this must of course

110 RADIO-FREQUENCY HEATING EQUIPMENT

be increased for valves of higher power. The emission per square centimetre of tungsten surface over a range of temperatures is shown in Fig. 58, which also indicates the emission of thoriated tungsten surfaces. The work function of pure tungsten is relatively high, and although it must be operated at high temperatures and consequently requires considerable heating power, it is essential to use pure tungsten when the anode voltage exceeds 5000. The power required to heat tungsten filaments ranges from 100 W, in the smaller valves, up to about 8.0 kW in the largest and the filament voltages range from 10 to 30 V.

Thoriated Tungsten Filaments. If about 1 per cent of thorium oxide is included in the tungsten wire material during manufacture, the temperature at which adequate emission can be obtained is much reduced. Thorium was first used in trying to overcome difficulties experienced in the early days of tungsten-filament electric lamps. These filaments were prone to sudden fracture and it was found that thoriated type were more robust, physically. When filaments of this type were tried in valves, it was noticed that copious emission occurred at a temperature well below that needed with pure tungsten filaments. The increased emission is due to a surface layer of thorium, which has the effect of greatly reducing the kinetic energy that an electron must acquire in order to break through the surface.

In manufacture, a reducing agent is included with the thorium oxide and the filament is flashed or maintained at a temperature of about 2600° K for a minute or so to bring about the reduction of thorium oxide to metallic thorium. Subsequent operation for a few minutes at 2100° K causes the thorium to diffuse through to the surface, where it forms a layer one molecule thick. The normal operating temperature for thoriated tungsten filament is approximately 1900° K or some 600° below that of pure tungsten and this results in a considerable saving in the power required for filament heating.

A disadvantage of this type of filament is that the emitting layer of thorium is more prone to damage by ionic bombardment than is the case with pure tungsten. This is because in valves of normal construction having anode voltages higher than 5 kV, the potential gradient is steep enough to accelerate the electrons to a velocity at which considerable ionization of the residual gas occurs. While tungsten filaments are able to withstand the resulting ionic bombardment, the emitting surface of a thoriated filament would rapidly be destroyed if employed under such conditions.

Oxide-coated Filaments. The third type of emitting surface

commonly used is not ordinarily fitted in valves of the type suitable for R.F. heating equipment. The oxide coatings are much too prone to damage by ionic bombardment and this severely limits the maximum permissible anode voltage, and consequently the power rating. They are, however, used in equipment for applications that do not call for powers much in excess of 100 W. Copious emission occurs at a temperature of 1150° K and the power needed for filament heating is comparatively low.

General Considerations. It will be noted that the emitting surface of the two main types of filament used in R.F. heating possess different degrees of stability. Tungsten filaments can be regarded as comparatively rugged, because they are not greatly affected by ionic bombardment. On the other hand, the work function of tungsten is large and considerable heating power is needed to produce the required emission. With thoriated tungsten filaments the surface is being constantly evaporated and replaced by diffusion of thorium from the interior of the filament wire. Any large degree of ionic bombardment will produce temporary or lasting loss of emission.

In view of the unstable nature of the emitting surface, thoriated tungsten filaments are usually designed to have a fairly high safety factor. If, for example, a valve draws a peak emission of 2 A, the tungsten filament would have a peak emission capability of the same order with perhaps 10 per cent in hand. With a thoriated tungsten filament, however, a safety factor of 4 or 5 is commonly used and a peak emission of 8 or 10 A would be available in such a valve when the emitting surface is in prime condition.

Filament Heating Power. The power supplied to the filament is expended mainly in the form of heat radiated into the evacuated envelope, but there is also an almost negligible proportion lost by conduction through the filament supports. Now when a body is maintained at a temperature greatly in excess of its surroundings, the energy radiated is proportional to the fourth power of its absolute temperature. It follows that the power required to maintain a tungsten filament at its operating temperature of 2500° K will be approximately three times that needed to maintain a thoriated tungsten filament at 1900° K.

Life. The life of a tungsten filament is governed by the temperature at which it is normally operated, and in practice the working point is chosen so that reasonably long life is obtained together with adequate emission. The usual life is between two and three thousand hours, and is determined by the rate and evenness at which tungsten is evaporated from the surface. Failure occurs through an actual break in the filament caused by a reduction in diameter giving rise

to an increase in resistance sufficient to raise the temperature in this region to the melting point of tungsten. With valves having thick filaments the life inclines to be longer, or alternatively, the filament may be operated at a slightly higher temperature, in which case greater emission will be obtained.

Thoriated tungsten filaments have, by virtue of their lower operating temperature, an inherently longer life. In practice, the life is usually determined by the amount of thorium available in the tungsten. Reference to Fig. 58 shows that if the filament is operated at a temperature higher than normal, the emission increases rapidly, but under such conditions the thoriated layer becomes evaporated faster than it can be replaced by diffusion from the interior of the filament. When the layer has been evaporated the emission drops to that of pure tungsten operating at the same temperature. The emission can be renewed by applying a reduced voltage to the filament for a period, a new emitting layer being formed by diffusion of thorium from the interior.

Voltage Variations. The effect of variations in voltage applied to a filament is of more than academic interest because it is possible in some circumstances for supply-mains voltages to fluctuate by ± 10 per cent, or even more. With thoriated tungsten filaments an appreciable rise or fall in the supply voltage will have a serious adverse effect on the valve. There is, of course, a degree of flexibility due to the large safety factor with which these filaments are designed, but the emission-temperature characteristic is steep and if the emission becomes inadequate it has the effect of increasing the internal resistance of the valve and hence the voltage drop across it. Ions will then have greater acceleration towards the filament, and the bombardment will be more severe with a resultant shortening of valve life.

The emission-temperature characteristic of tungsten is much less steep and this fact is often utilized for providing a very simple control of the R.F. power generated. A variable resistance or other device is fitted to control the filament voltage and thus the power generated. Reduced-power operation does not have an adverse effect upon tungsten because it can withstand heavy ionic bombardment. There is, however, a serious shortcoming with this type of power control which is treated in Chapter 4, under the sub-heading of power controls.

ANODES

Radio-frequency heating applications require powers ranging from 100 W or so up to many kilowatts, and since the self-excited type of generator commonly used has an anode efficiency of 66 per cent,

a power equivalent to about half that generated must be dissipated at the anode. We see, therefore, that in small valves the anode must dissipate about 50 W while in large ones the dissipation ranges up to 20 kW or more. There have been valves made in which the anode dissipation is as high as 150 kW but these are of a specialized nature and outside the range of normal commercial production.

The methods employed to dissipate large quantities of heat from the anode govern the design of high-power valves and they can be roughly grouped into two main classes. One is the internal-anode class which has an evacuated envelope surrounding the anode, and the other the external-anode class in which the vacuum is contained within the walls of the anode itself. There are many types of valve in each class, each type being designed to dissipate a given power at the anode.

Internal-anode Types. Valves dissipating up to 1.5 kW at the anode can be built into a glass envelope, cooled by radiation, and by convection air currents. For the larger valves in this range a fan is sometimes used. Even in the largest glass envelope valves, the dimensions of the anode rarely exceed about 3 in. in length and 1½ in. in diameter and the total radiating surface is limited. Consequently, for a dissipation of 1.5 kW, the plate runs very hot and often attains red-heat. This restricts the number of materials that may be used because they must be able to operate at high temperatures, they must be easy to machine and they must not be excessively expensive. Molybdenum and tantalum are commonly used, and in recent years carbon anodes have been fitted to valves of small power rating.

Carbon Anodes. An advantage of carbon is that, being black, it is a good radiator of heat and consequently operates at a lower temperature than metallic plates of the same dimensions dissipating equivalent power. A disadvantage of carbon, however, is that the valve cannot be so effectively evacuated as with other types of anode material, the porous nature of the carbon making the removal of occluded gas a difficult process. In consequence, valves of this type are relatively soft. The maximum H.T. voltage that can be safely applied, is therefore limited, and this in turn limits the power rating. Carbon anode valves of small power rating are usually fitted with thoriated tungsten or even oxide-coated filaments in order that the filament power shall not be disproportionately large compared with the anode rating. They are widely used in low-powered equipment because they are easily mass produced, and as a result are relatively cheap. Such valves have anode dissipations ranging from 40 to 200 W at H.T. voltages ranging up to 2 kV.

114 RADIO-FREQUENCY HEATING EQUIPMENT

Metal Anodes. For larger anode dissipations in the glass envelope class, molybdenum and tantalum are used. Tantalum possesses the valuable property of absorbing gas at high temperatures, and so it has a cleaning effect on the vacuum, enabling anodes of this type to be operated at cherry red-heat. Molybdenum anodes may also be operated at red-heat but they possess no cleaning action. Recently, it has become the practice to coat molybdenum anodes with zirconium, a material that effects a great improvement on the radiating properties of the surface.

Full anode dissipation can thus be achieved at well below red-heat and such valves may be recognized by the dull black colour of the anodes. It is interesting to note that zirconium-covered grids are becoming increasingly common, the object in this case being to reduce grid temperature and limit primary emission. Another useful property of zirconium is that it gives very little secondary emission and it can be expected that it will, in future, be much more widely used. (It is, of course, not usual practice to coat tantalum anodes or the cleaning effect of this metal would be impaired.)

Due to the higher degree of vacuum that can be achieved with molybdenum and tantalum anodes, the maximum H.T. voltage is much greater than with carbon anode valves; the main limiting factor is the nature of the filament material. With thoriated tungsten filaments it is not usual to exceed 5000 V for H.T. because of the sensitive nature of the emitting surface. When pure tungsten is used for the filament the H.T. voltage may be as high as 20 kV although it must be remembered that for valves having an anode dissipation of 1.5 kW, 10 kV is about the maximum that would ordinarily be used. Even at this figure the ratio of voltage to current, and hence the impedance of the valve, would be higher than is convenient in most circuit arrangements.

ENVELOPES

With further developments of the kind typified by zirconium coating the maximum anode rating of the commercial range of glass envelope valves may in future reach values of 3 or 4 kW. It is, however, very improbable that these figures will ever be exceeded because of the restriction imposed by the use of glass as an envelope material. It melts at about 450° C and the envelopes have consequently to be of considerable size to present an adequate cooling area. The physical size of glass envelopes cannot be increased beyond that used at present as the internal leads to the electrodes would become much too long for high-frequency operation.

The seals through which leads are brought out of the envelope

constitute one of the most important details in a valve. Since these seals run hot it is essential that the metal and glass used shall have compatible coefficients of expansion. Although copper welds to glass in a satisfactory manner it cannot be used because its coefficient of expansion is too great. Originally, platinum wire was used in the seal because this material possesses the same coefficient of expansion as glass and can be securely welded to it. Nowadays a nickel alloy wire coated with copper is commonly used, but research in the art of glass-metal seals has not ceased. It is a point of interest that when the vacuum of a valve fails completely the trouble is usually due to the seal.

There is one point in connection with lost vacuums which the users of glass envelope valves should note. If a grid or anode lead is left in contact with the envelope, R.F. discharges are liable to puncture the envelope at the point of contact and the valve will, in the course of minutes or hours, fill with air. It is rare that the puncture is visible to the naked eye. In properly-built apparatus failures of this type should not occur, but the danger is very real in lash-up arrangements.

Silica Envelope Valves. The need for higher powers than could be generated with glass envelope valves was felt towards the close of World War I. Silica envelopes provided a solution because this material has an extremely small coefficient of expansion and does not crack as a result of thermal shocks. Its melting point of 1500°C is extremely high and silica envelopes can be made smaller and can run much hotter than those of glass. These valves have, for nearly thirty years, been used extensively by the British Admiralty, and because of this lengthy period of service, it has been a common failing to regard silica valves as somewhat old-fashioned. In actual fact modern versions of silica valves are in some respects in advance of other types.

Using the latest methods available for increasing the heat radiation from metal parts, it has been possible to make valves of very small physical size for a given anode dissipation. This is a great advantage where the overall dimensions of radio-frequency heating apparatus have to be kept small. The operating temperature of electrodes is not so severely hampered by envelope limitations as when glass is used and the electrodes can be physically small. Very-high-frequency operation is possible with valves of this construction. Again the loss factor of the material is low, and so heating of the seals due to this cause is minimized.

Silica is relatively costly and difficult to work and the envelope is frequently the most expensive part of the valve. It is not unusual

116 RADIO-FREQUENCY HEATING EQUIPMENT

for manufacturers to replace at small cost valves which have failed, provided the envelope is undamaged. The frequency at which full power may be generated with the smaller valves is of the order of 150 Mc/s coming down to 10 Mc/s for larger valves having anode dissipations of up to 10 kW. The degree to which the thermal properties of silica can be utilized is indicated by some of the older types of valve which had anode dissipations of 25 kW at an H.T. voltage of 20 kV (using, of course, pure tungsten filaments).

EXTERNAL-ANODE VALVES

For very-high-power working, silica has for many years been out-moded by copper-anode, water-cooled valves, and a great deal of development effort has been expended on valves of this type. In such valves the anode is a copper cylinder having a glass seal at one end through which the filament and grid leads are brought out. The copper cylinder is evacuated and so no external envelope is required for containing the vacuum. A jacket surrounds the anode and cooling water flows in sufficient quantity to limit the temperature rise of the anode to 20° or 30° C.

The high thermal capacity of water makes it an ideal cooling medium and the dissipation of heat from an anode is most effectively ensured by this method. Power ratings of hundreds of kW are possible with this class of valve, but the more common types range in size from 4 to 30 kW anode dissipation. They are fitted with pure tungsten filaments in order that the permissible H.T. voltage, and hence the power rating, is not unduly limited by ionization difficulties. Although the anode is effectively cooled by water, the grid of such a valve may dissipate enough energy to attain a temperature sufficiently high for thermionic emission to occur. The risk of blocking must, therefore, be guarded against when using valves of this type.

Another kind of external-anode valve is the air-cooled version. Several types are made and in all of them the object is to present the maximum area of highly-conducting anode material to an air current or blast. One type is somewhat similar to a water-cooled valve save that the water-jacket is replaced by large metal fins which greatly increase the cooling area. In another type the anode cavity within which the grid and filament are contained is bored from a solid block and holes are drilled through the surrounding material to conduct the passage of an air blast.

VALVES FOR HIGH-FREQUENCY OPERATION

As the frequency of power generation is increased, the valve

requirements become more and more exacting. Many factors contribute to the difficulties that must be overcome to ensure satisfactory operation at higher frequencies, and it is not surprising to find that the cost of suitable valves is somewhat greater than that of the lower-frequency types of equivalent power rating.

No definite line of demarcation can be chosen as the frequency above which the difficulties become significant for it varies with the type and power rating of the valve. The commonplace types, having anode dissipation up to about 150 W, should be satisfactory for power generation up to 30 or 40 Mc/s. In the range 0.5 to 2 kW anode dissipation the ordinary type of valve operates fairly well up to 12 or 15 Mc/s, and valves of much greater anode dissipation up to 4 or 5 Mc/s. At higher frequencies in each power range the valves must be of a specialized type to give adequate performance. In general, however, the maximum rating of even very specialized valves is low; for instance, it is difficult to find valves capable of generating a power of say 10 kW at a frequency of 100 Mc/s.

One inherent limitation to high-frequency operation is due to the inter-electrode capacitance, and another to the inductance of anode and grid leads. The capacitance adds to the total LC product of the whole circuit while the inductance, being effectively in series with the inter-electrode capacitance, will add to the loading on the valve. The significance of each depends on the ratio of its value to that of the external tuning capacitance in one case, and external inductance in the other. At very high frequencies the inter-electrode capacitance forms a major part of the total tuning capacitance, and so a considerable proportion of the tank-circulating current will flow in the valve. This means that grid and anode leads must be of very low R.F. resistance to avoid loss, and they should in consequence be of large cross-section.

The speed with which electrons travel to the anode is not infinite and at frequencies in excess of about 100 Mc/s the transit time of an electron becomes an appreciable fraction of an R.F. cycle. When this happens the power expended at the grid increases considerably and besides reducing overall efficiency, it rapidly comes about that circuit arrangements are incapable of providing the requisite grid-driving power. Furthermore, the grid voltage and anode current are no longer 180° out of phase, and special circuit arrangements are required to bring about the phase relationships necessary in self-exciting oscillators. To minimize transit time the electrodes should of course be closely spaced and the anode voltage high, but the inter-electrode capacitance will then become very large and there will also be a risk of flash-over attendant upon close spacing. The

118 RADIO-FREQUENCY HEATING EQUIPMENT

generation of large powers calls for electrodes having large areas, but this again means added capacitance and so we see that power generation at very high frequencies presents conflicting requirements.

VALVE GROUPING

We have so far considered valves as being divided into two main classes—the internal- and external-anode types. It is, however, perhaps preferable to classify valves under headings decided by the method of cooling rather than the method of construction. We then have—

- (i) Valves cooled by direct radiation.
- (ii) Valves cooled by forced air.
- (iii) Valves cooled by water.

Valves cooled by radiation include all the internal-anode types together with those external-anode valves having large cooling fins surrounding the anode. This latter type is nowadays becoming somewhat outmoded because it serves to bridge no gap that cannot be covered by other types. Forced-air cooling applied to valves with relatively massive external anodes is very efficient, and enables valves of this type to be of comparatively small physical size. This is of great benefit for power generation at very high frequencies, but necessitates fairly expensive auxiliary gear. As a result, it is usually preferable to use radiation-cooled valves if the frequency required is not excessively high. Water-cooled valves must, of course, be used where very high power is to be generated, and in many districts the use of ordinary mains water is unwise owing to problems of scaling and electrolysis. In such cases a circulating water system must be installed.

TRIODE CHARACTERISTICS

For radio-frequency heating application, it is preferable to have complete characteristics of the type of valve which it is proposed to use. Peak anode and grid currents should be known for a range of anode and grid voltages, especially in the region where the grid runs positive to the filament by an amount ranging up to 5–10 per cent of the normal H.T. voltage. Such curves are shown in Fig. 59 and it will be noted that the control-grid current increases rapidly when its potential approaches that of the anode. The sum of the currents drawn by anode and grid at selected values of $v_{o\max}$ and $v_{o\min}$ indicate the peak emission current that must be provided by the filament. In the case of valves having tungsten filaments the peak emission figure is usually stated by the manufacturer.

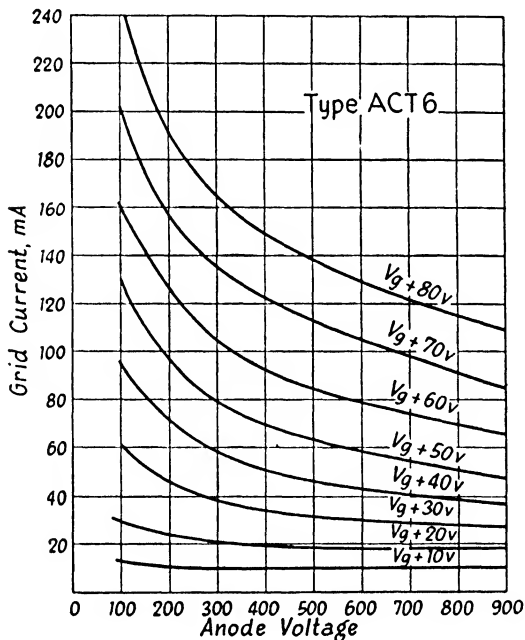
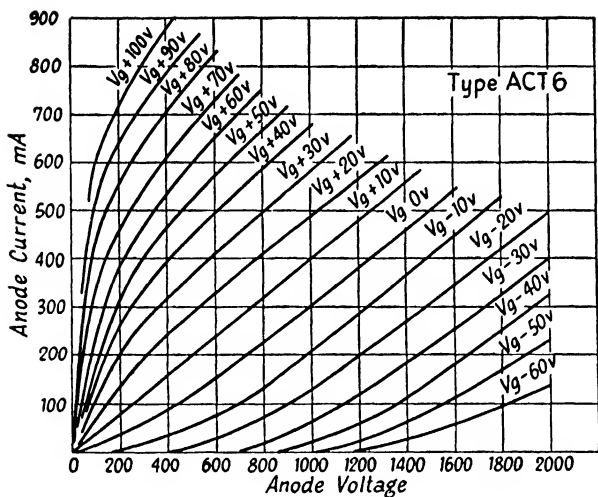

FIG. 59. CHARACTERISTICS OF THE OSRAM TYPE ACT6 TRIODE

Filament Voltage	10.0
Filament Current	1.6 A
Anode Voltage D.C.	1800
Continuous Anode Dissipation	75 W max.
Peak Space Current	800 mA
Amplification Factor	22
Max. Safe Anode Current (Class C)	140 mA

120 *RADIO-FREQUENCY HEATING EQUIPMENT*

With thoriated tungsten filaments the peak emission is not often given, but the large safety factor used in the design of filaments of this type removes the necessity for an accurate knowledge of the figure. Manufacturers however, usually state a maximum H.T. current and by applying the expressions developed in Chapter 4 for the a.c. and d.c. components of anode current, it is possible to arrive at a figure of peak emission for design purposes.

Power Supplies

THE equipment needed to supply high-tension power for the generator forms a major part of any radio-frequency heating equipment. The actual power required varies with the type of equipment. This may have an R.F. output ranging from about 100 W for small dielectric-heating applications up to 150 kW and more for large induction-heating installations and some of the very large-mass dielectric-heating applications. Although the maximum anode efficiency of the generator may exceed 66 per cent, it is safer when dealing with power supplies to work on a figure of 50 per cent which means that H.T. powers of from 200 W up to 300 kW and more are needed. For the smaller generators H.T. potentials may well be as low as 1000 V although this will, of course, depend upon whether the valves are of high- or low-impedance type. At the other end of the power range the H.T. potential will not exceed 18 to 20 kV since no normal valves are made requiring a greater voltage.

For generators having an output less than about 2 kW power is normally obtained from single-phase mains on which a load up to about 4 kW is imposed. When dealing with larger powers, three-phase mains are used. There are, however, instances in which generators having R.F. outputs up to 5 kW and more have been supplied from single-phase mains. Apart from the inconvenience of rectifying large powers obtained from single-phase supplies, considerable unbalance is imposed on the mains when this is done. Mains distribution networks are of the three-phase type, and supply authorities are liable to raise objections if the loading on one phase is excessive. To provide d.c. power for the generator any device which permits the passage of a current in one direction only will serve as a rectifier and such devices may be grouped under three heads, electro-mechanical, electro-chemical, and thermionic. It is with the thermionic type that we shall be mainly concerned under the generic name of valve rectifiers.

VALVE RECTIFIERS

The valve rectifier is essentially a two-electrode or diode arrangement that permits the passage of current when the anode is positive with

122 RADIO-FREQUENCY HEATING EQUIPMENT

respect to the cathode. Four types of rectifier valve are commonly used and in practice each covers a more or less well-defined power range.

- (i) High-vacuum or hard rectifier;
- (ii) Hot-cathode, mercury-vapour rectifier;
- (iii) Thyatron (as (ii) but with addition of grid);
- (iv) Ignitron (mercury-pool grid rectifier).

The purpose of the thyatron and ignitron is to permit the control of rectified voltage, but we shall see later that the grid does not function in quite the same way as in a triode or high-vacuum, three-electrode valve.

Hard Rectifiers. These are constructed on much the same pattern as the valves used for R.F. generation, save that the grid is omitted. Emission from the filament is attracted to the anode when this is positive, but during the succeeding half-cycle no current flows and it follows that the average current cannot exceed half the peak current and is, in fact, likely to be less. The filament must be capable of emission current exceeding twice the required rectified current or inefficient conditions will prevail. Once the anode reaches a sufficient potential to draw the peak emission, there will be no increase in current for a further increase in voltage. If, however, adequate emission is available, the anode current will follow the three-halves power law or, in other words, it will be proportional to (anode voltage)¹.

The peak permissible anode current is determined by the maximum emission that the filament can supply when operating at such a temperature as to ensure reasonably long life. The anode would, of course, have to be of sufficient area to accommodate this current without over-heating and the largest type of hard rectifying valves are water-cooled. During the inoperative half-cycle when the anode is negative with respect to the filament, the anode-filament voltage may reach a value as much as π times the rectified voltage, according to the type of circuit used. The valve must be constructed to withstand this high value of peak reverse voltage which in turn places a limit on the d.c. voltage that may be obtained with a given valve in a given circuit.

Compared with mercury rectifiers, a failing of the hard rectifier is that the voltage drop across it is relatively large and it is thus not so efficient particularly in low-voltage circuits. For normal types of hard rectifier the anode voltage required to produce a given value of rectified current is so high that the valve is equivalent to including a resistance of anything between about 300 and 800 Ω

in the circuit. It has, nevertheless, many characteristics which make it altogether more robust and less sensitive to operating conditions. For this reason it is used extensively in broadcast receivers and may sometimes be advantageously employed in low-power radio-frequency heating equipment. This would occur where the powers are sufficiently small to be provided by the mass-produced type of hard valve. While there may be perhaps no great saving in valve cost, their use obviates the necessity of observing many precautions that apply to mercury-vapour valves and affords an economy in auxiliary equipment.

Mercury-vapour Rectifiers. This type of rectifying valve contains mercury vapour at low pressure in equilibrium with liquid mercury. Electrons from the filament are accelerated towards the anode at quite low potentials, but their passage is impeded by mercury molecules. Some of the resulting collisions will be sufficiently severe to knock electrons out of the mercury-vapour molecules and thus produce positive ions and free electrons. The ionization potential of mercury is 10·4 volts, but when the anode is about 20 volts positive with respect to the filament the collisions become very numerous. The number of free electrons produced at these voltages is small compared with the number emitted by the filament, and so they have no appreciable effect upon anode current. The positive ions are attracted to the filament, but because of their large mass they move at a relatively low speed and, although they are less in number than the electrons emitted by the filament, there are sufficient present in the inter-electrode space at any time to neutralize the electronic space charge.

The negative space charge surrounding the filament repels electrons as they are emitted, but when the charge is neutralized the electrons have an unobstructed path to the anode which will then draw the total filament emission. Complete neutralization occurs when the anode voltage is between 15 and 20 volts and the steep anode characteristic of the mercury-vapour valve is contrasted with that of the hard rectifier in Fig. 60. Because of the low-voltage drop across a mercury-vapour valve its effective resistance is only a few ohms and the efficiency is consequently very good.

The most important condition to be observed in operating a mercury-vapour rectifier is that the voltage across it does not at any time exceed 22 volts. Were it to do so, the heavy ions which are attracted to the filament would attain a higher velocity than the emitting surface could safely withstand and the filament would be rapidly destroyed. To prevent this happening, three precautions must be taken.

124 RADIO-FREQUENCY HEATING EQUIPMENT

In the first place the filaments must be switched on for 30 sec or more to attain full operating temperature before the application of anode voltage. If the emission were insufficient to produce enough ions to cause complete space-charge neutralization when the anode voltage is applied, the electron path to the anode would not be unimpeded, and the voltage drop across the valve would be relatively high. The few ions produced would thus be accelerated

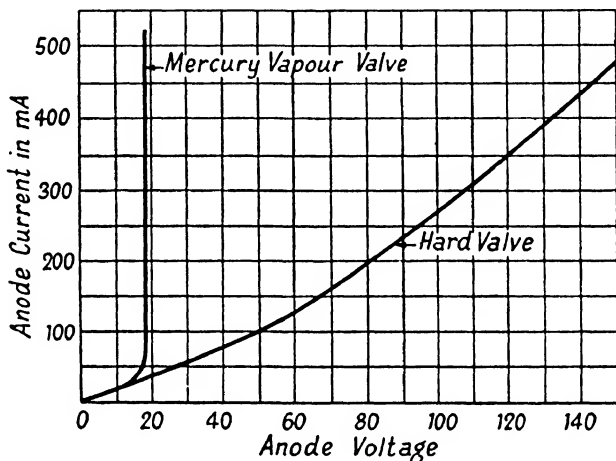

FIG. 60

by a steep potential gradient towards the filament. Secondly, it is essential that no large overload is imposed on the rectifier such as would be caused by shorting the output or by charging a large capacitor. The heavy initial charging current taken by the capacitor would represent a very heavy load and the voltage drop across the rectifier would, under these conditions, exceed the safe value. For this reason, it is essential to use a series choke between the rectifier and load, because this has the effect of limiting current surges besides providing a degree of smoothing. The third precaution is concerned with the ambient temperature as this temperature affects the vapour pressure within the bulb. If the temperature is too low, the vapour pressure is reduced to a point where insufficient ions are produced to cause space-charge neutralization at anode potentials less than 22 V. On the other hand, if the temperature were too high the mercury-vapour pressure would increase and reduce the flash-over voltage between the anode and filament and thus reduce the safe peak inverse voltage that the valve could withstand.

The low voltage drop occurring across mercury-vapour rectifiers endows them with peculiar features. For instance, the filament must be designed so that the working voltage does not exceed 5 V, otherwise the voltage drop between its ends and the anode is liable to be greater than the safe maximum of 22 V. An oxide coating is used in order that adequate emission can be obtained from filaments of normal dimensions at such low voltages. Power loss in the valve is small and permits the anodes to be of relatively small size. In practice it is common to use hot-cathode, mercury-vapour rectifiers for powers up to 40 to 50 kW and they are thus included in most radio-frequency heating equipment. For higher powers the mercury-arc rectifier is normally used, although in recent years there has been a tendency to use it on lower powers as the result of recent developments in the arc-type of rectifier.

Thyratrons. The thyatron used for power rectification is similar in many respects to the hot-cathode mercury-vapour valve, but a grid is fitted for control purposes. This grid surrounds the anode and, when a sufficiently negative potential is applied to it, electrons are prevented from travelling to the anode and attaining sufficient velocity to ionize the mercury vapour. When the grid is less negative, the electron velocity becomes high enough for ionization of the gas to occur in the region between grid and anode and the valve becomes conducting. Because of the absence of a space charge the grid no longer affects control *once ionization occurs*, and irrespective of the potential applied to the grid ionization will persist until the anode voltage drops to a value lower than the ionization potential of mercury.

For radio-frequency heating thyratrons are usually fitted only on equipment having outputs in excess of about 20 kW, and so would be used in polyphase rectifier circuits. The phasing of the grids determines the voltage output, and they may by this means be made to initiate ionization at any required part of the positive half-cycle of anode voltage. Thyratrons possess two voltage limitations because not only will the maximum safe peak reverse voltage limit the d.c. output voltage that may be obtained, but there is also a maximum above which the grid cannot suppress ionization. This will, of course, be governed largely by the geometry of the valve and is called the peak forward voltage.

Ignitrons. These are essentially arc rectifiers containing low-pressure mercury vapour and having a pool of mercury as the cathode. Rectifiers of this kind are suitable for supplying very heavy currents and are made in two types. One has the electrodes contained within an evacuated glass envelope; in the other they

126 RADIO-FREQUENCY HEATING EQUIPMENT

are mounted in a steel box which is continuously evacuated by a pump. The latter type is used for exceptionally heavy loads such as occur in traction and so does not find a place in radio-frequency heating equipment. The ignitron is a cold-cathode or mercury-pool rectifier provided with a grid or other means of initiating ionization at the required point on the anode voltage cycle.

Pool rectifiers normally have a starting electrode which, after a momentary contact with the mercury pool, sets up an arc that terminates at a hot spot created on the cathode surface. This arc must not be extinguished while the rectifier is in use and special electrodes are fitted to maintain the arc while the anode or anodes are negative with respect to the cathode. In recent years, however, a type of ignitron has been developed in which the arc is started at the beginning of each conducting period and permitted to go out at the end. The starter is a pencil of resistance material immersed in the mercury pool, and when a sufficient potential is applied to it, sparking occurs between the pencil and the mercury. This causes a hot spot in a matter of a few micro-seconds and initiates the arc which permits current to pass to the anode. The starting potential may be applied at any period during the anode voltage cycle and in this way the effect is similar to that obtained with a grid. Ignitrons of the pencil type do not need maintaining arcs or mechanical starting arrangements, and are not limited by a peak forward as well as reverse voltage.

Pool-type rectifiers permit the passage of extremely heavy currents without damage and may be started almost instantly. It is not, however, easy to design them for very high voltage working and they do require auxiliary control relays and equipment. Compared with mercury-vapour valves they are more expensive and the voltage dropped across them inclines to be somewhat greater. They do not, on the other hand, require replacement as frequently as the hot-cathode valves.

RECTIFIER CIRCUITS

A practice which has been used for some years in R.F. therapy generators is to feed the anode of the oscillator valve with raw A.C. Owing to the marked similarity between R.F. therapy and R.F. heating equipment it is not surprising to find that A.C. has in some cases been used as an H.T. source for the latter. At first sight it seems an easy solution to the difficulty of rectification, but many factors are involved. Apart from considerations of cost and simplicity, a detailed analysis of a given heating problem must be made before deciding to use such a method.

A.C. Operation. When an oscillating valve is provided with high-tension current from an a.c. source the valve generates power only when the anode is positive with respect to the filament. This is so during a half-cycle of the a.c. input and for the remaining half-cycle the filament is positive with respect to the anode. Unless considerable inductance is included in the a.c. source, the H.T. current taken by the valve will be a sinusoidal pulse at mains frequency. With considerable inductance present, however, the H.T. current pulse tends to be squared off, but under these conditions the regulation of the supply, i.e. the drop in H.T. voltage with increased loading, becomes worse. The squaring of the H.T. pulse enables somewhat more R.F. power to be obtained from a given valve since conditions then approximate to supplying the H.T. from an interrupted d.c. source. But the current squaring is accompanied by disadvantages from an R.F. point of view.

The leading edge of the current pulse is remarkably steep and the effect on the oscillator valve is something like that of shock excitation. As a result, the harmonic components of the anode current are very prolific, and this has three unfortunate effects. In the first place, the fundamental frequency current is limited because the total current contains such large harmonic components. Secondly, the Q of the loaded tank circuit must be relatively high to reject the harmonic currents from the work circuit, and this in itself restricts the amount of power available for heating the work by reducing the transfer ratio (see Fig. 41). Thirdly, and perhaps most important, the presence of prolific harmonic components greatly increases the radiating propensity of the equipment and screening is consequently more difficult. In spite of these shortcomings it has been argued that if the anode of a valve operated on A.C. can be made to dissipate up to its full rating, an R.F. output equal to that obtained with D.C. can be made available for heating the work. Apart from the necessity for higher loaded Q -values which in itself invalidates the argument, many interesting facts are brought out in considering the matter further.

To achieve full anode dissipation on A.C., it is essential to effect a considerable increase in the H.T. voltage. The anode is heated during the positive half-cycle only, and has the remaining half-cycle to cool, so that if the H.T. current were perfectly squared by series inductance, the voltage would need to be $\sqrt{2}$ times that used with D.C., but since perfect squaring is not possible the peak a.c. voltage would actually be somewhat more. The very high peak H.T. voltage during the operative half-cycle calls for considerable

128 RADIO-FREQUENCY HEATING EQUIPMENT

emission from the filament, and this consequently needs to be larger than it would be for equivalent anode dissipation on a d.c. supply. If the peak H.T. voltage with an a.c. supply exceeds 5 kV, the use of thoriated tungsten filaments is ruled out because of their liability to damage by ionic bombardment. Pure tungsten filaments must thus be used for the generation of powers over about 0.5 kW from a single valve, and as a result the filament heating power necessary is apt to be disproportionately large. Valves having anodes made of carbon are also unsuitable because they cannot be effectively evacuated. It is not wise to use them when the peak H.T. voltage exceeds 2 kV, and so for a.c. operation they are limited to output powers of 200 W or so.

For the generation of more than about 0.5 kW of R.F. power from an a.c. supply, we are thus left with a tungsten filament valve having a molybdenum anode, preferably zirconium coated. Valves of this type can, with an a.c. source, be made to operate at full-rated anode dissipation if the insulation is sufficient to withstand the high peak forward and reverse voltages. But the conditions prevailing if such a valve were pushed to its limits on A.C. would probably encompass its destruction for the following reason. Not only would the anode run hot, but the grid also would be likely to attain a temperature at which primary emission occurs, and, during the inoperative half-cycle, this emission would be accelerated by a steep potential gradient to the filament and produce bombardment which would impair even a filament of pure tungsten.

Operation of an oscillator from an a.c. source is seen to be impracticable if large R.F. powers are to be generated, but for a few small power applications its simplicity and cheapness are perhaps warranted, although anode dissipations approaching those possible on D.C. cannot be safely attained. There is, however, one aspect which must be appreciated, and which limits the use of an a.c. source for even small power applications. This concerns the rapid heating of small volumes of material and it applies even when the R.F. power required is small. Rate of heating is the important thing in applications of this type and this in turn will depend upon the frequency and the square of voltage gradient through the material. Frequency is limited by such factors as the type of valve used, work capacitance, etc., and the applied voltage must be high in order to achieve the required rate of heating. It is, in fact, usually necessary to work with a voltage gradient through the material closely approaching the rupture voltage, and with an a.c. source the maximum rate of heating that can safely be attained is reduced. The rupture voltage cannot possibly be exceeded, and since the

material cools during the inoperative half-cycle thermal radiation losses are greater. Such applications as the continuous seam welding of thermoplastics can, as a result, be more satisfactorily carried out with a d.c. source of high-tension.

So far, we have considered the use of a single oscillator valve operated from an a.c. source, and although this is not an uncommon arrangement it is one that is to be strongly deprecated. The oscillator valve also serves as a half-wave rectifier, and this entails a considerable d.c. component through the secondary of the transformer supplying H.T. The d.c. component tends to saturate the iron, and to overcome this difficulty a somewhat larger and more costly transformer is required. Normally an a.c. source of H.T. should be used only when *two* valves are employed, as it then becomes possible to have full-wave rectification and the d.c. magnetizing currents balance out in the transformer secondary. A full-wave self-rectifying oscillator also overcomes to a large extent the difficulty caused by the work cooling for half the time. Troubles due to harmonic generation and necessity for high peak reversed voltages remain, but oscillators of the type can nevertheless be usefully employed for a restricted range of applications. Circuits using two valves for operation on A.C. are shown in Figs. 61 and 62. In one case, the valves operate in push-pull from an R.F. point of view, and in the other they are in parallel. Inductance is included in series with the H.T. source to limit changes in the current supplied by the transformer, and with a sufficiently large value of inductance it is possible for the supply current and the amplitude of the oscillatory voltage to remain nearly constant.

Single-phase Rectifier Circuits. When considering the use of A.C. as a source of supply, we have seen that half-wave rectification imposes losses on the mains transformer and these become serious when the currents are large. For this reason alone, single-phase half-wave rectification arrangements are not used as power rectifiers. There are other drawbacks, such as the necessity for comprehensive smoothing if a reasonably constant D.C. is required. As a result full-wave and bridge-type rectifiers are most often used with single-phase supply.

The full-wave rectifier (Fig. 63) employs two valves operating with a centre-tapped transformer in such a way that the two valves alternately supply rectified current to the load. The rectified voltage wave is sinusoidal in shape and hence the ratio of the r.m.s. voltage between the centre-tap and one end of the winding compared to the rectified d.c. voltage is equivalent to the sinusoidal form factor. During the period when a given valve is non-conducting

130 RADIO-FREQUENCY HEATING EQUIPMENT

there will be a voltage applied in the opposite direction. Neglecting the voltage drop across the conducting valve this will be equal to the peak voltage across the whole transformer winding, or π times the d.c. voltage. The valves must be capable of withstanding this peak inverse voltage.

In the bridge rectifier (Fig. 64) two of the four valves are conducting

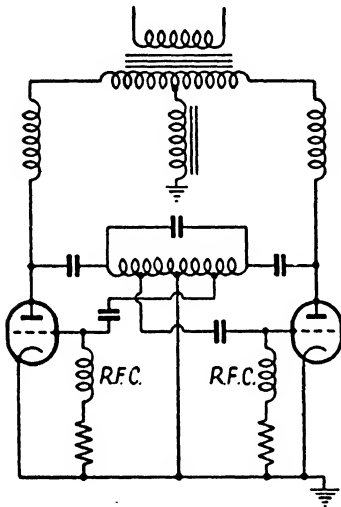

FIG. 61. SELF-RECTIFYING OSCILLATOR WITH VALVES IN PUSH-PULL

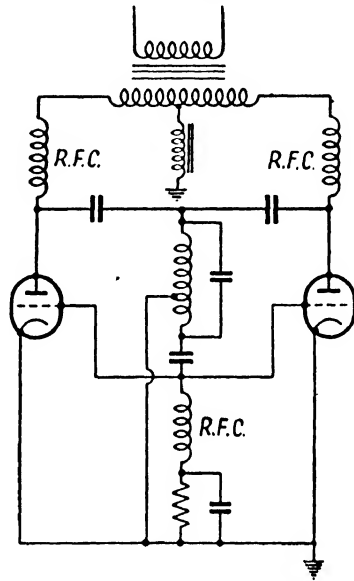

FIG. 62. SELF-RECTIFYING OSCILLATOR WITH VALVES IN PARALLEL

at one time, and because the transformer is not centre-tapped the peak inverse voltage is reduced to $\frac{\pi}{2}$ or 1.57 times the d.c. voltage.

This means that with valves capable of withstanding a certain peak inverse voltage, twice the d.c. potential can be developed with a bridge than with a full-wave circuit. A disadvantage lies in the fact that the filaments of the four valves used in a bridge circuit are not at the same potential, and three separate windings must be employed on the filament transformer. It is of interest to note that the bridge rectifier is a true full-wave arrangement, while the circuit shown in Fig. 63 should strictly be called bi-phase half-wave since current flows in only half the secondary at a time. By common usage however, the method has become generally known as single-phase full-wave rectification.

Polyphase Rectifiers. When a d.c. power exceeding 3 to 4 kW is required for a generator, rectifiers working from three-phase mains offer many advantages. Not only is a balanced load imposed on the mains but each valve is, in some circuits, called upon to handle only a small fraction of the power, and this permits large power rectifiers to be built with valves of medium rating. A large number of rectifier circuits is possible with three-phase currents, but in practice only about half a dozen are used, each of which has advantages for certain types of equipment. A general feature of three-phase rectifiers is that the ripple voltage may be three, six or, in some circuits, twelve times the supply frequency so permitting relatively small series inductance to effect good smoothing.

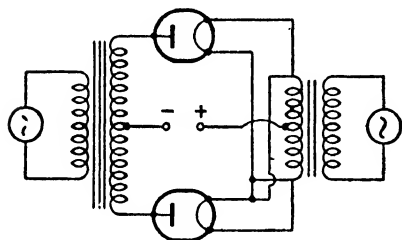

FIG. 63. SINGLE-PHASE FULL-WAVE RECTIFIER

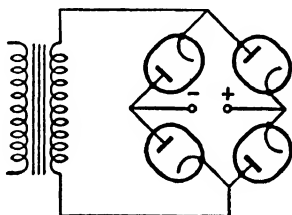

FIG. 64. SINGLE-PHASE BRIDGE RECTIFIER

Four rectifying circuits are shown in Figs. 65–68 and comprise the three-phase half-wave, full-wave, half-wave double-delta and six-phase half-wave circuits. For very large rectifiers a twelve-phase arrangement is often used but this ordinarily comes outside the scope of radio-frequency heating equipment. With the circuits shown in Figs. 65–68 it should be noted that instead of using a three-phase transformer it is possible to use three single-phase transformers with their secondaries star connected, but if this is done a larger mass of iron is required for a given kVA rating, and furthermore, d.c. saturation difficulties arise in the half-wave rectifiers. With the full-wave circuit, three single-phase transformers sometimes offer advantages, for although the total mass and cost will be greater than that of a three-phase transformer they may be physically disposed to permit a reduction in overall dimensions of the equipment.

The filament transformers used in a three-phase rectifier must be insulated to withstand the d.c. output voltage. All the half-wave rectifying arrangements require only one filament winding. This is, however, no unmixed blessing, for when six valves are to be supplied, the current is liable to be so large that the transformer becomes of

132 RADIO-FREQUENCY HEATING EQUIPMENT

awkward proportions. On the other hand, full-wave rectifiers call for four filament windings of which one must be capable of heating three filaments. Usually, filament windings are centre-tapped to equalize the anode current in each leg of the filament.

Current and voltage relations and other important data for the

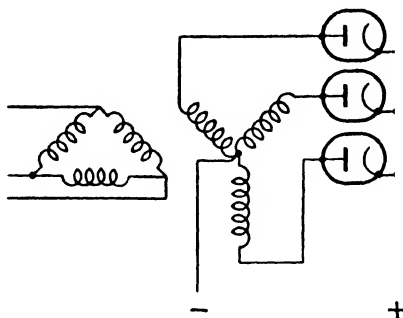

FIG. 65. THREE-PHASE HALF-WAVE RECTIFIER

single and polyphase circuits already discussed are given in Table III. Peak r.m.s. and transformer voltages are stated in terms of the d.c. output voltage, and r.m.s. currents in terms of the d.c. load current. The figures in the Table assume a load input inductance

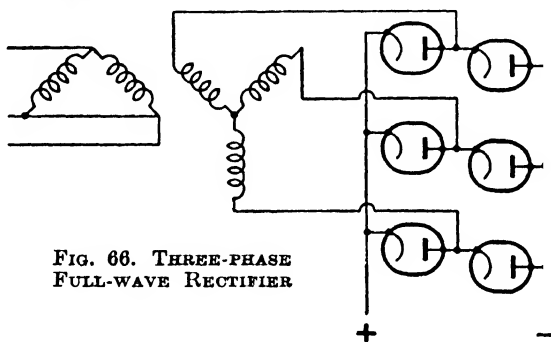

FIG. 66. THREE-PHASE FULL-WAVE RECTIFIER

large enough to maintain a continuous current in the rectifier, and they neglect the voltage dropped in the valve and circuit. These assumptions introduce no large error and the figures given in the Table greatly simplify rectifier design.

The design is of course largely governed by the required d.c. power, but often the choice of circuit is bound up with the rating and price of available rectifying valves. With six given valves for use on a three-phase supply, the low peak inverse voltage of the

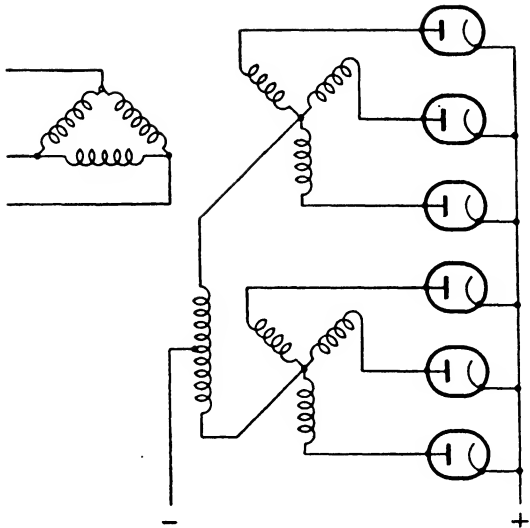

FIG. 67. THREE-PHASE DOUBLE-DELTA RECTIFIER

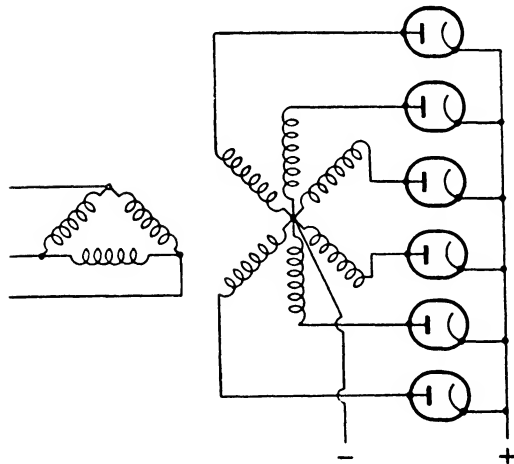

FIG. 68. SIX-PHASE HALF-WAVE RECTIFIER

TABLE III

RATIO	SINGLE-PHASE FULL-WAVE RECTIFIER	SINGLE-PHASE BRIDGE RECTIFIER	THREE-PHASE HALF-WAVE RECTIFIER	THREE-PHASE DOUBLE-DELTA RECTIFIER	THREE-PHASE FULL-WAVE RECTIFIER	SIX-PHASE HALF-WAVE RECTIFIER
<u>R.m.s. voltage per leg</u>	1.11	1.11	0.855	0.855	0.428	0.741
<u>D.c. voltage</u>	3.14	1.57	2.09	2.09	1.045	2.09
<u>Peak inverse voltage</u>	0.707	1.0	0.577	0.289	0.816	0.289
<u>R.m.s. transformer secondary current</u>						
<u>Direct current</u>	1.57	1.11	1.48	1.48	1.05	1.814
<u>Secondary kVA</u>	1.1	1.11	1.21	1.05	1.05	1.28
<u>D.c. load kW</u>	0.637	0.900	0.675	0.675	0.955	0.075
<u>Secondary utilization factor</u>	0.900	0.900	0.827	0.955	0.955	0.955
<u>Primary utilization factor</u>	0.500	0.500	0.333	0.333	0.333	0.167
<u>Average current per anode</u>	0.500	0.500	0.333	0.333	0.333	0.167
<u>Peak anode current</u>	1.00	1.00	1.000	1.500	1.00	1.00
<u>Average current per anode</u>	2	2	3	6	6	6
<u>Direct current</u>	0.483	0.483	0.183	0.042	0.042	0.042
<u>Peak anode current</u>						
<u>Direct current</u>	1.00	1.00	1.000	1.500	1.00	1.00
<u>Fundamental ripple frequency</u>						
<u>Main frequency</u>	2	2	3	6	6	6
<u>R.m.s. ripple voltage</u>						
<u>D.c. voltage</u>	0.483	0.483	0.183	0.042	0.042	0.042
<u>Peak ripple voltage</u>						
<u>D.c. voltage</u>	+0.363 -0.639	+0.363 -0.639	+0.363 -0.209	+0.0472 -0.093	+0.0472 -0.093	+0.0472 -0.093

full-wave circuit enables a much greater d.c. voltage to be obtained. On the other hand, the double-delta and six-phase circuits will provide more current at a lower voltage. Other factors to be considered are the ripple frequency, which should be high in order to give more steady d.c. and the transformer utilization factor, which has a bearing on capital costs. Another point sometimes of importance is the peak line voltage of the transformer secondary. With half-wave rectifiers this may be high enough to increase the difficulties of transformer and design the transformer cost, particularly if the voltage is in the region at which corona discharge becomes troublesome.

Utilization Factor. The rating of a transformer is governed by its losses and the manufacturers quote a rating at which the maximum safe temperature-rise occurs. This is based on the power delivered into a resistive load, but when the transformer supplies a rectifier, the losses will be higher because of the irregular wave-shape of the current drawn by the rectifier. The ratio of the d.c. power developed by the rectifier to the a.c. power which the transformer would dissipate in a resistance for the same transformer losses is called the utilization factor and its value depends on the type of rectifier circuit used. With full-wave rectifiers the primary and secondary of a transformer have the same value of utilization factor, but with half-wave circuits D.C. flows in the secondary and increases its losses, and in this way the utilization factor of the secondary is made less than that of the primary. To avoid overheating it is necessary to use relatively large transformers when the utilization factor is low.

SMOOTHING

Most of the rectifiers used for supplying H.T. power to R.F. heating equipment are the mercury-vapour or pool rectifier type. Inductance in series with the load is a necessity in the former, and advantageous with the latter type. A smoothing capacitor may or may not be included, and we thus have circuits between the rectifier and load of the types shown in Figs. 69 and 70. To limit the peak current drawn by the valve it is necessary to ensure a continuous flow of current from the rectifier, and this entails a certain minimum value for the series inductance. The problem is considerably simplified by assuming that the reactance of the inductance at the fundamental frequency of the ripple voltage is large compared with the load resistance. We then have a simple approximate relation stating that a continuous current flow from the rectifiers will occur when the ratio of inductive reactance to load resistance equals or exceeds the ratio of rectifier ripple voltage to the d.c. output voltage:

$$\frac{\omega L}{R_L} > \frac{\text{ripple voltage}}{\text{d.c. voltage}} \quad . \quad . \quad . \quad 8.1$$

where $\omega = 2\pi f$,

L = inductance of series choke,

R_L = load resistance.

The main ripple voltage will be at the fundamental frequency f or $2f$ in single-phase, or $3f$ or $6f$ in three-phase rectifiers, but there will also be components at harmonics of these frequencies. The percentage of ripple voltage from the rectifier to that appearing across the load will be approximately $\frac{R_L}{\omega L}$ in Fig. 69 and $\frac{1}{2\omega LC}$ in Fig. 70, because the capacitive reactance will be considerably less

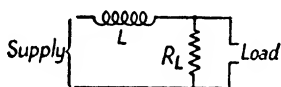

FIG. 69

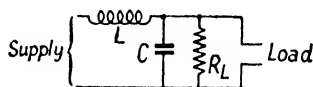

FIG. 70

than the load resistance. Harmonic voltages will be suppressed to a greater extent and since they are in any case smaller in the first place their effect may be neglected.

From equation 8.1 the minimum value of inductance that should be employed with various rectifier arrangements operating from a 50 c/s supply is as shown below.

Single-phase, full-wave and bridge $L = \frac{R_L}{980} \quad . \quad 8.2$

Three-phase half-wave $L = \frac{R_L}{1500} \quad . \quad 8.3$

Three-phase full-wave
 Three-phase double-delta
 Six-phase half-wave $L = \frac{R_L}{3000} \quad . \quad 8.4$

With single-phase rectifiers a capacitor must be employed to reduce the ripple voltage to a reasonably low value. When three-phase supply is used it is not necessary to include a smoothing capacitor if the fundamental frequency of the ripple voltage is $6f$, but it may be required in half-wave rectification when the ripple voltage is $3f$.

CONTROL CIRCUITS

The powers employed in all but the smallest R.F. heating equipments are of such magnitude as to require special switching arrangements,

and the potentials applied to the anode circuit of the generator are so high that operational safety becomes of prime importance. At the same time the generator valves must be protected against damage due to overload, failure to oscillate, or stoppage in the water- or air-cooling systems, and the potential drop across the mercury-vapour rectifier valves must be prevented from exceeding the safe value. Common practice in the power engineering field solves most of the difficulties associated with the large mains current rating of equipments and leaves the problem of generator and rectifier valve protection to be solved by more specialized methods.

Magnetic Contactors. The current flowing in the primary circuit of the H.T. transformer on medium- or high-powered equipments is normally too large to be controlled by manually-operated switches of reasonable dimensions, and this also applies to the primary current of the filament transformer on high-powered equipments. Another important aspect is that a manually-operated switch is dependent on the human factor and this introduces an element of unreliability. It follows that automatic devices are often included in the filament circuit of medium- and low-powered equipments, not because of any particularly heavy current, but because of the protection they afford. For automatic switching, resort is made to the push-button-operated magnetic contactor commonly used in motor-control circuits.

The magnetic contactor is essentially a switch operated by a solenoid energized from the mains. The switch contacts are normally open, and when in this position the magnetic reluctance of the iron circuit associated with the solenoid is high. This means that the solenoid current necessary to operate the contactor is relatively great, but once it has closed the current drops to a fraction of the closing value. Consequently the contactor maintaining current contributes a negligible amount to the total load on the mains, a typical example being that of a maintained contactor rating of 0.3 kVA for a switched power of 12 kW in a three-phase contactor. Furthermore, the contactor circuit is highly inductive and the actual power absorbed is thus lower than the volt-ampere product.

The circuit arrangement for a contactor necessitates a pair of contacts in addition to those required for switching the mains power, thus, for a single-phase contactor there would be three pairs of contacts and for a three-phase circuit, there would be four. On pressing the start button the contactor operates, and the additional pair of contacts serve to maintain the start button circuit after the finger has been removed. This is illustrated in Fig. 71 which shows a control circuit for a three-phase rectifier system, in which

138 RADIO-FREQUENCY HEATING EQUIPMENT

contactors are used for switching both H.T. and filament circuits. A particular requirement in such a circuit is that the H.T. contactor must not be capable of operating until a period of about a minute has elapsed after the rectifier filament circuit has been energized. This is to ensure that the filament temperature of the rectifier valves is high enough to provide full emission before the H.T. is switched on.

A delay switch, ordinarily of the thermal type, is used to provide this safeguard. In switches of this type the heat generated by the passage of a current through a wire is made to deflect a bi-metallic strip or other temperature-sensitive device. They have, however, a serious disadvantage, in that, should the interval of time between successive operations be short, the temperature-sensitive device will not be cool and will operate in a shorter time than that for which it has been designed. To assist in overcoming this disadvantage it is usual to arrange for the current-carrying conductor in a thermal relay switch to be disconnected once the switch has operated in order that it may cool before the next operation. Such an arrangement is shown in Fig. 71 where the thermal relay switch energizes a bridge-rectifier which operates relay 1. This has two contacts, one of which is normally open and the other closed. When relay 1 operates, the normally-closed contact opens, and disconnects the thermal coil, while the other contact closes and maintains the supply to the rectifier. Another normally-open relay is energized by the rectifier, and when this closes it completes the H.T. contactor circuit so that it becomes capable of operation on pressing the H.T. start button. There have recently been developed thermal-delay switches of the two-position or changeover type. When these are used it is possible to delay the application of H.T. until after the thermal coil has cooled and thus ensure a constant delay time on successive operations.

The contacts associated with various protective devices are included in the contactor-control circuits, and those of a more important nature such as water- or air-flow switch contacts, are usually wired in the filament contactor circuit. Should this circuit be opened, the supply to relay 2, via T_1 , will be cut off, and the H.T. contactor also opens. A useful feature of contactor-operated equipment is that the controls may be placed in any convenient position and a number of stop buttons can be included in this circuit. The contactor currents are small and can be conveniently carried by trailing cables of small cross-section.

Fig. 71 shows contactors wired into a typical three-phase full-wave rectifier circuit in which the oscillator filament is switched on

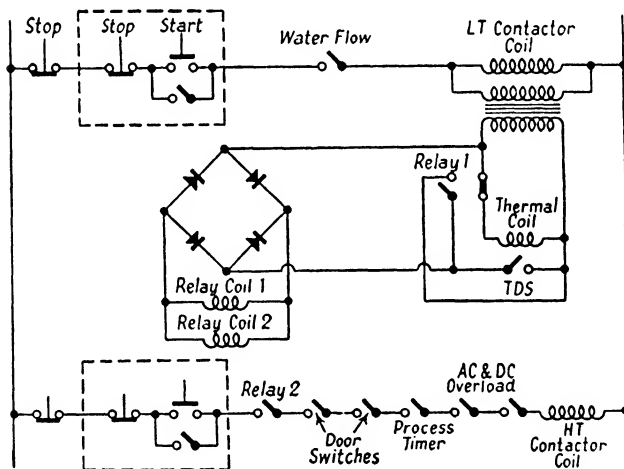
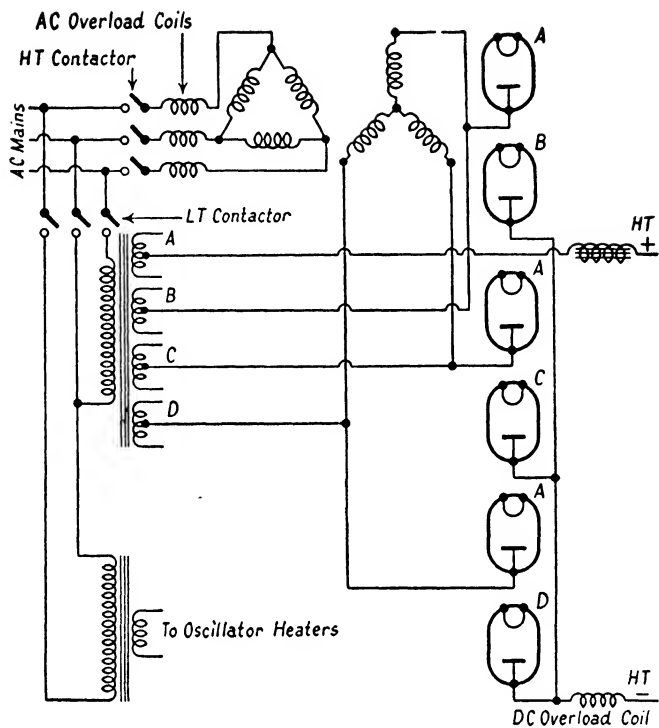

FIG. 71

140 *RADIO-FREQUENCY HEATING EQUIPMENT*

simultaneously with the rectifier filaments. In actual practice an R.F. filter must be included in the mains input to the rectifier transformers to keep R.F. currents out of the mains. The filter should be mounted inside the screen within which the equipment is housed at the position where the mains leads enter. There should, of course, be no appreciable R.F. energy in the rectifier, because R.F. chokes are included in the H.T. supply to the generator, and any large smoothing capacitors are, or should be, shunted with physically small, low-value capacitors to ensure an effective R.F. by-pass. If for any reason there is an appreciable leakage into the rectifier system, it may make its presence apparent by burning out the insulation on the end secondary turns of the mains transformers. Although leakage from the generator should be fairly small, there is a risk with mercury-vapour valves that they will burst into parasitic oscillations at very high frequencies, and for this reason it is preferable to include small R.F. chokes in the anode leads.

Dielectric Heating Applications

THE industrial use of R.F. power for the heating of insulation material is not based on a historical development extending over several decades, as has been the case with R.F. eddy-current heating. Dielectric heating was first suggested as a possibility for industrial use a little over a decade ago and was applied at that time on a very restricted scale. Only during the last four or five years has it impinged upon a range of industries concerned with the fabrication of goods from non-metallic substances, and it is safe to say that we are now witnessing the early development of an industrial process that will prove revolutionary in many fields of application.

Heat treatments of non-conducting materials have as an object the accomplishment of one, or occasionally two, of three processes which taken together, have an enormously wide field of application. These objects can be stated as—

- (i) the promotion of temperature-sensitive chemical reactions or changes in molecular structure;
- (ii) the softening of plastics;
- (iii) the removal of water or volatile constituents.

The scope of the applications has hitherto been restricted because of the unavoidably steep temperature gradients common to normal methods of heating. This follows from the fact that in all of these methods heat reaches the central part of the body by conduction, and the thermal conductivity of the materials concerned is low. It is possible with normal methods by employing very long heating times to avoid too steep a temperature gradient, but time factor has technical importance in many applications while in others the economic aspect is of major consideration. Thus many much-needed heating applications that cannot be carried out by ordinary methods can be accomplished by the rapid and uniform heating which dielectric heating offers. At the same time many applications possible by present heating methods can be greatly improved if dielectric heating is employed.

142 RADIO-FREQUENCY HEATING EQUIPMENT

COMPRESSION MOULDING

Thermosetting powders used in the compression moulding of a wide range of goods are usually based on either a phenolic or urea resin to which an appropriate filler has been added. When heated to about 100°–120° C, these powders tend to coagulate into a spongy mass which can then be pressed into the desired shape. After shaping, the hot mould causes a further temperature increase of 15°–20° C and this brings about a non-reversible process known as polymerization. The article is now rigidly set in the desired shape and can be removed after the mould is opened. This, in brief, is an outline of the moulding process which, because of the poor thermal conductivity of the powder, spongy mass and finished article, is beset with limitations.

Originally, it was the practice to place weighed quantities of cold powder into the hot mould to which pressure was then applied. After the powder reached the plastic stage the mould closed for such time as was required for polymerization, or curing, as it is commonly called, to take place throughout the article. The cure is dependent upon temperature and time, and at very high temperatures can take place in a matter of seconds. It follows that the mould must not be too hot, otherwise curing of the surface layers may be effected before the mould is closed. With the relatively low mould temperature imposed by this limitation the curing time for articles having a thick section must be long and in some cases extends up to 15 min and more. For this reason, one rarely sees mouldings with a thicker section than 0.5 in., and in the usual run of moulded articles no section is more than about 0.25 in., and in many cases less.

Apart from the limitations in thickness there are other aspects of the process which are far from satisfactory. Abrasion between the mould and cold powder causes erosion of the mould surfaces, and this point must be carefully watched when the moulded article needs to have a high finish or when there are tight dimensional limits. The problem is aggravated in such cases as heat-resistant and very high grade electrical mouldings which are made from powders having a coarse-grained mineral filler. Another drawback occurs when the mould has delicate inserts, because these are prone to break, should the mould close before the powder has become plasticized.

The difficulties result entirely from the inability to achieve a rapid and controlled through-heating of the powder, and in an effort to surmount this obstacle it has become common practice in mouldings thicker than about 0.25 in. to pre-heat the powder before it is placed in the mould. Although easing the position somewhat,

pre-heating has by no means offered a solution. To achieve the best results the degree of pre-heating should be very nearly to the curing temperature of the powder, but this cannot be achieved with ovens or any other method which relies primarily on the transfer of heat to the centre of the mass by conduction. The oven temperature must not be too high or surface pre-curing occurs and so the process will, as a result, be lengthy. This in itself places a limit to the temperature that can be reached because pre-cure will take place at relatively low temperatures when they are maintained for a long time.

If any really worth while advantage is to be gained from pre-heating, the powder should become plastic throughout during the process and while oven pre-heating does not achieve this state it is, nevertheless, found that after heating in shallow trays, the powder becomes somewhat awkward to handle and sub-divide. Pelletting is commonly used to overcome this difficulty and at the same time to yield pellets of known and constant mass. It is achieved by compressing the cold powder into a shape which usually takes the form of a thick disc. There are some powders, such as those having a rag filler, that are not well adapted to pelletting and for these pre-heating is usually carried out in a tray or container into which a predetermined amount of powder is placed.

Advantages of Dielectric Heating. For the pre-heating of pellets or powders, dielectric heating offers outstanding advantages, and it also happens that it is an application to which the process is easily adapted. The uniform heating that takes place permits pellets to be of much thicker section than could otherwise be handled, and the fast rate of heating that is easily possible permits a higher temperature to be achieved without risk of pre-cure. It is, in fact, very tempting to pre-heat to a temperature at which a cure could be accomplished in as short a time as say 20 to 30 sec, but if this is done, the operation of transferring the powder or pre-forms to the mould becomes one of such precision that the human factor is usually not able to cope with it. Provided the unique advantages of dielectric heating are not pushed too far in pre-heating thermo-setting materials, the benefits resulting from its use are so great as to make it a virtually indispensable process in any moulding shop.

With dielectric heating, mould closure can take place almost at once, because the material is already hot enough to flow and there are no regions of relatively cold and abrasive powder. Mould-wear is thus reduced to a minimum and any delicate inserts are not so prone to break. The limitation of thickness hitherto common to the compression-moulding industry is greatly reduced if not entirely removed with dielectric heating. This comes about because with the

144 RADIO-FREQUENCY HEATING EQUIPMENT

uniform heating of a pellet or powder to a high temperature, the mould is not called upon to increase, but merely to maintain the temperature in order to provide the cure.

The speed with which a thorough cure takes place is greatly reduced on any thickness of section, but the saving is increasingly significant for thicknesses greater than 0.25 in. Because of the ready flow of the pre-heated powder or pre-form, less pressure is

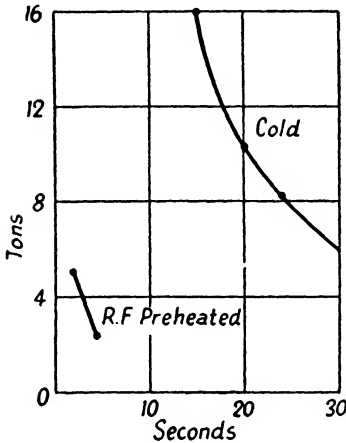

FIG. 72. PRESS CLOSING-TIME FOR A TEST-CUP MOULDING WITH COLD AND PRE-HEATED PELLETS

required for moulding and a press of given size is able to accommodate more work (see Fig. 72). A very much better quality of moulding can be attained much more rapidly and the compression-moulding technique can be extended to include much thicker work than could otherwise be accommodated. At the same time it becomes possible to mould in much more intricate patterns. In fairness, however, it must be stated that for mouldings of small dimensions and thickness, such as buttons or toothpaste tube caps, the application of dielectric heating is not likely to prove economical unless the whole installation is suitably adapted.

Power Requirements. To bring about a temperature increase of 100°C in one pound of wood-filled phenolic powder in a period of one minute, the power that must be usefully dissipated is approx. 1.100 kW. A generous rating for a dielectric-heating equipment needed to bring about this rate of heating in a pound of material should, however, be about twice as great, or in other words 2 kW per pound per 100°C .* Where the material is of an awkward shape, the efficiency of heating may be less than 50 per cent, owing to bad matching and an equipment of even higher power would be needed. This point is fully discussed in Chapter 5 and the curves shown in Fig. 41 indicate the results when matching is bad. It is, however, reasonable to assume a heating efficiency of 50 per cent for

* With equipment of single-application type or those in which impedance matching arrangements are good, the efficiency of heating can be as high as 80 or 90 per cent giving a figure in the region of 1.2 kW rating per kW usefully dissipated.

most applications, and since the efficiency of energy conversion from mains frequency to radio frequency is again about 50 per cent, the mains input needed to bring about a temperature rise of 100° C per pound per minute would be approximately 4 kW.

Frequency. The rate at which powders or pre-forms must be heated is governed largely by other operations in the moulding process, and a heating time ranging from one to three minutes is usual. To attain a temperature rise of 120° C in one minute means a heating rate of 2° C per second, and since any powder or pre-form will withstand an applied r.m.s. voltage of 5000 V/in., we find the minimum frequency from

$$f = \frac{48.7}{\sigma(\text{VPM})^2} \frac{\Delta T}{t} \text{ megacycles} \quad . \quad . \quad 9.1$$

where

σ = heat factor of material

VPM = applied r.m.s. voltage per 0.001 in.

$\frac{\Delta T}{t}$ = rate of heating—° C per sec.

Powders and Pellets. It will be noticed in the table of constants in Appendix 2, dealing with thermosetting materials, that the heat factor of powders is considerably lower than that of pellets. The applied voltage at a given frequency must be greater with a powder to obtain an equivalent rate of heating. This means that generally speaking the use of an air-gap is not to be recommended when heating powders. The density of powder in relation to that of pellets also means that when an equipment is fitted with electrodes that accommodate a charge of pre-forms sufficient to load the generator fully, the substitution of powder for pellets will mean a falling off in efficiency. Without a substantial increase in the applied voltage, there would be a slower rate of heating (approximately half) in a smaller mass (approximately half) of material, and so the useful power dissipation would be in the region of only a quarter of that occurring with pre-forms. General-purpose equipment likely to be wanted for both powders and pre-forms should, therefore, be capable of adjustment between wide limits in order that a reasonable degree of matching can be achieved.

An interesting feature of the heating of powder is that it is not subject to such a large temperature gradient as exists with pre-forms because the container in which it is held serves as a thermal insulator. The container may conveniently be made of such material as well-dried white wood, because this possesses a fairly low heat factor. It will, however, char with repeated heating and for production use

146 RADIO-FREQUENCY HEATING EQUIPMENT

a material like mycalex should be employed. A difference between powders and pellets is that in general a given depth of the former is not able to withstand the voltage that could be withstood by pellets. This makes it possible to attain a much faster rate of heating with pellets, especially in view of the increased heat factor. The safe voltage is modified in practice, however, by the air path between electrodes because of the very humid condition of such air due to the moisture evaporated from the hot pellets or powder. To remove this water vapour and also to prevent its deposition on the relatively cold electrodes it is usual to arrange for the blowing of hot air through the electrode chamber.

Mould Loading. Those single-impression applications in which large masses of powder are pre-heated by R.F. present no particular difficulty from a mould-loading aspect. The material coagulates into an easily-handled mass that can be quickly transferred to the mould. On the other hand, multi-impression moulds present difficulty because of the time taken to load a large number of moulds. If this time exceeds about 30 sec, the temperature to which the powder or pellets are heated must be reduced to avoid pre-cure, and the benefits of R.F. heating become somewhat impaired. In practice, it is easy to load consistently and in reasonably short time a dozen impression moulds each with two pellets, but when the number of impressions reaches eighteen or more it is usually necessary to employ a loading tray. The pre-forms are actually heated while in the tray which is then transferred to the mould, and by manipulation of a slide each impression is simultaneously filled. A drawback to heating pre-forms in a multi-impression tray is that the area of the tray is normally very large in relation to that of the pre-forms and from an R.F. standpoint the efficiency of heating is apt to be low (*see* Chapter 5).

Multi-impression loading is more beneficial in the case of powders because the loading tray serves as a measure for the charges. The transfer of the heated powder from the tray cavity to the mould cavity is, however, fraught with mechanical difficulties because the hot powder will not flow down into the mould cavity with the same ease as a cold powder.

Timing. The rate at which a powder or pellet heats in a given R.F. field is dependent upon the homogeneity of the powder and the consistency of packing. Fortunately the powders now supplied conform to a reasonably tight specification, and their physical and electrical properties do not vary between batches by more than a tolerable amount. Pellets are also of a consistent nature because the process is performed in a fully-automatic pelleting machine.

Unless powder has been abused by, say, storage in a humid atmosphere, we may reasonably expect fairly consistent repetition heating of powders or pre-forms.

Now, in spite of the dependence of polymerization on temperature and time, the process is not over-critical and the quality of a moulded product is not greatly affected if the temperature of the hot pre-forms or powders has a tolerance of as much as $\pm 10^\circ\text{C}$. This pre-supposes that the final temperature is not so high as to produce risk of pre-cure during normal handling times. Because of this flexibility, we may gauge final temperatures purely on a time basis, and after a trial heating of given work the time switch may be pre-set, ensuring a reasonably uniform temperature for repetition work.

It is often conjectured whether dielectric heating can be applied to the moulded article while it is actually in the press. Although in one or two isolated instances it is possible, it is not altogether prudent and cannot be done as a rule. Variations in thickness between different parts of the article produce very different rates of heating because at a given applied voltage the heating is inversely proportional to the square of the thickness. Thinner parts of the article would plasticize and cure while thicker parts were still in powder form. The thicker parts would, of course, eventually cure with the continued application of R.F. energy, but for satisfactory moulding a fairly uniform degree of powder turbulence is necessary as the mould closes, and this essential feature would be entirely absent. Even where the article to be moulded is a flat disc, it is doubtful whether the modifications to the press necessitated by electrical requirements would be altogether justified. There is, however, the possibility that R.F. heating may be satisfactorily applied to heating the charges in transfer-moulding processes (see Fig. 73). Very rapid heating of the charge would be synchronized with movements of the ram and many of the difficulties that at present handicap transfer moulding could be overcome.

Heat Treatment of Thermoplastics. When cold, thermoplastic materials solidify, but at more elevated temperatures ranging from about 70°C upwards* according to the type of material, they soften and become plastic. This is a reversible process, and no molecular change occurs at high temperatures as it does with thermosetting materials. It follows that the rapid and controlled degree of heating that can be achieved by dielectric heating is not particularly beneficial for the moulding of thermoplastic articles. Injection moulding is commonly used, the material being maintained at a plastic temperature within a cylinder and then forced through a

* This figure applies to what we may term commercial thermoplastics.

148 RADIO-FREQUENCY HEATING EQUIPMENT

nozzle into a mould which, on cooling, is opened to produce the article. It also happens that some of the thermoplastics from which the articles are fabricated possess a poor heat factor and application of dielectric heating would be difficult, if not impossible, on a commercial basis. We thus see that for moulding thermoplastics the ordinary methods of conduction heating are, in the main, satisfactory, particularly in view of their relatively low cost. There is, however, a range of applications for which dielectric heating can be most

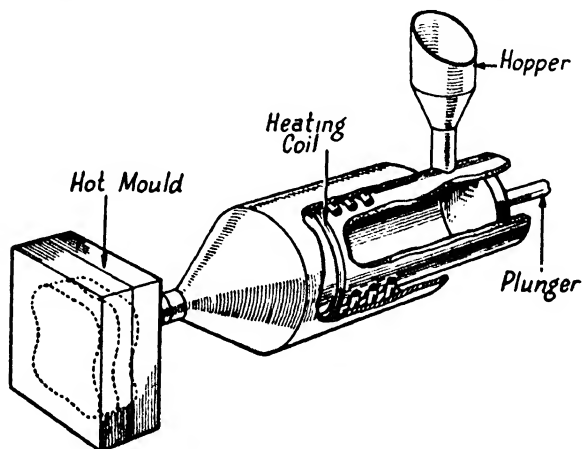

FIG. 73. DIAGRAMMATIC REPRESENTATION OF TRANSFER MouldING

beneficially employed in the thermoplastic field and that is the bonding or welding of sheets. Again, batch, or even continuous pre-heating prior to such operations as callendering or extruding may in some cases be beneficial.

BONDING AND WELDING

For some thermoplastics there is no really satisfactory adhesive and one very important material of this type is polyvinyl chloride (P.V.C.) and no matter what plasticizer is used with the resin it cannot be "glued" in a really satisfactory manner. The widespread use of P.V.C. as a substitute for rubber in many industries has made this shortcoming acutely felt and it is particularly important in the case of the water-proof, decorative clothing and fancy goods industries. Stitching offers no solution because the relatively soft material yields to the pressure applied by threads especially when the material is stretched. Here then we have an application to which dielectric heating is well suited since the material can be rapidly brought to a plastic stage and the hot P.V.C. may then be welded by

pressure. There are two main methods by which this is done: in one a long weld is made by a single impression; in the other the process is continuous, the objects being to imitate the sewing machine in its ability to negotiate corners and the joining of curves of different radii.

Impression Welding. Single-impression equipment can be made to accommodate long lengths of weld, either straight or shaped to some desired pattern according to the arrangement of the electrodes. A difficulty that arises is due to the fact that the thickness of the material may be no more than a few thousandths of an inch and the alignment of electrodes must thus be accurate. For long welds this means that the mechanical construction must be to close limits and the whole electrode assembly very massive in order to avoid warpage. A satisfactory weld occurs with P.V.C. at a temperature of about 150°C and the dielectric strength of the material is so high that this temperature can easily be reached in one second with a moderately high frequency. The heat factor of P.V.C. is 0.25, and it will easily withstand an applied voltage of more than 100 V per 0.001 in. and so we see that a temperature increase of 150°C per second may be achieved at a frequency of about 30 Mc/s with a relatively low applied voltage. Applications of this type are fairly simple from an electrical view-point because no particular difficulty is encountered in the efficient production of relatively small powers in the 30 to 50 Mc/s range. The useful power that must be dissipated for this rate of heating to occur in a weld 12 in. long, $\frac{1}{8}$ in. wide and $\frac{1}{16}$ in. deep is not more than 65 W, although an extra 40 to 100 per cent should be allowed for heat dissipated in the electrodes and losses by thermal conduction and radiation.

Continuous Welding. For continuous welding the material is passed between electrodes which are in the form of discs to which a motor drive is applied to feed the material at a predetermined rate (Fig. 74). The whole arrangement should, in theory, be very similar in operation to a power-operated sewing machine, but its performance in practice falls very far short of this standard. The chief reasons for the shortcomings are bound up with the fast rate of heating that is necessary with equipment of this type. We saw that with a single-impression machine it is easily possible to weld 12 in. in one second, but to give the continuous welding machine a fair chance we will credit it with a speed no greater than 2 in./sec or 10 ft/min. This incidentally is a speed which an ordinary power-operated sewing machine can better by more than 300 per cent. Now the effective length of electrode with discs of reasonable dimensions is about an eighth of an inch and at 2 in./sec the material must be heated to

150 RADIO-FREQUENCY HEATING EQUIPMENT

150° C in a sixteenth of a second. In other words, the rate of heating must be 2400° C/sec.

To achieve such rates of heating, even at frequencies in the region of 100 Mc/s, the voltage that must be applied has to approach very closely that which will break down the P.V.C. This, in itself, is a bad feature in equipment intended for industrial use, but when it is remembered that the commercial tolerance on the thickness of thin sheets can be as much as ± 20 per cent, the position is greatly aggravated. Where the material thins there will almost certainly be a breakdown, and where it thickens to its upper limit it may not

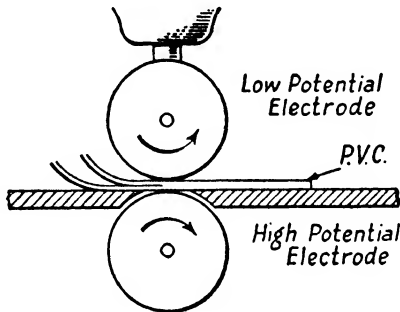

FIG. 74

reach a temperature high enough to weld. Again, any lack of co-ordination between the rate of feed and the applied voltage will produce the same effects even when the material is absolutely uniform. The only way to ease the situation is to reduce the speed to 1 in./sec or less, but when this is done the operation tends to become slower than can be economically warranted. Another unfortunate tendency exhibited by this type of equipment is for the two sheets of material to stick to the electrodes rather than to each other. This comes about because after continued operation the electrode discs become very hot and, in fact, attain weld temperature. The material, on the other hand, does not become securely welded until it has cooled to below the softening temperature, and immediately it has left the electrodes there is no appreciable adhesive force between the two sheets. It is possible that an R.F. welder for continuous seams will be produced, but it will doubtless have to go through an incubation period as did the sewing machine in its early stages. Even so, it is doubtful whether a continuous welder, made at an economic price, could possess anything like the same degree of flexibility.

A more practical approach to an R.F. operated welder of the

sewing-machine type would be to arrange for the material to be heated in sets of about $\frac{1}{2}$ in. A reciprocating device, having intermittent operation, would be required for moving the material forward. The heating for a $\frac{1}{2}$ in. weld could be as short as a quarter-second without calling for dangerously-high applied voltage or a frequency above that which could be conveniently generated and applied to the work.

While the discussion on welding has so far been confined to P.V.C. it must be appreciated that many thermoplastic materials may be welded in this manner. The requirements are that its heat factor should exceed about 0.08 in order that the electrical aspect should not become too difficult, and it is preferable for the material to be capable of being callendered into sheets. The type of plasticizer used with the resin is of primary importance, and can considerably modify the R.F. welding properties of the material. This applies to any thermoplastic material, and it will be found that with different plasticizers the ratio of time to rate of heating and applied pressure will vary considerably. In some cases, the use of an unsuitable plasticizer will make the R.F. welding of the material an impracticable proposition.

Impression welding is inherently more suitable for welding a range of materials than is the continuous process because it is easy to arrange for the peculiar requirements of a given material to be accommodated. Thus, it is possible to apply considerable pressure before heating or to terminate the heating cycle before pressure is removed. Again, a wide range in the rate of heating can be achieved, and with these adjustments, it is possible to weld any thermoplastic material that is capable of being welded by heat and pressure.

ADHESIVE SETTING

It is only recently that the manufacture and development of adhesives have been tackled along scientific lines and right up to the beginning of the twentieth century animal glues, of a type that had been used since prehistoric times, formed almost the only adhesives commercially available. Vegetable or starch glues began to acquire some importance in the early part of the century and are now used extensively in the plywood industry. Neither the common-place animal nor vegetable glues are particularly water resistant and the requirements of aircraft construction in the first world war led to the development of casein glues. These are prepared from milk from which the cream has been separated and which is then soured into curds and whey. The curds, after washing and drying, constitute raw casein, which is then mixed with an alkaline salt or solvent to

152 RADIO-FREQUENCY HEATING EQUIPMENT

provide the glue, usually in the form of a powder, which the user mixes with an appropriate amount of water.

Synthetic Resins. During the early 1930's a phenol-formaldehyde resin film called Tego was introduced in Europe for plywood manufacture and was found to possess a durability that surpassed any other type of glue. It is, however, rather expensive and has led to the development of urea-formaldehyde glues which, while not possessing the outstanding serviceability of the phenols, are in this respect somewhat better than casein glues and are cheaper to make than the phenols. A major cause in reducing the cost of these urea glues is that they are compatible with cheap extenders such as wheat, rye, and tapioca flour. Both phenol and urea glues can now be obtained in powder form which may be suspended in water, but the phenol glues are not compatible with cheap extenders although limited quantities of walnut-shell flour may be used to add bulk.

Phenolic and urea glues are of the thermosetting variety and when heated they go through a plastic stage before polymerization occurs in a manner similar to the powders used in compression moulding. A feature of the urea glues is that the cure takes place at a lower temperature than with the phenols, although accelerators may be used with either to produce a lower cure temperature than is possessed by the straight resin. The chemical catalysts used with ureas for this purpose are generally acidic although this is not always so with phenols. It is now possible to produce accelerators which will bring about a cure within a reasonable time at a temperature as low as 40° C. Before such rapid accelerators were developed it was essential to use hot presses for the manufacture of plywoods having thermosetting adhesive glue lines, but the major part of the plywood industry is not so equipped. The hot press technique was first applied to plywood manufacture in Europe and it is interesting to note that in America there were only ten such presses prior to 1935, while by 1942 there were 200. If glues having rapid accelerators are used for the cold press manufacture of plywood, it is necessary to maintain the temperature of the press shop at an uncomfortably high level to achieve a cure, and the time involved is very much longer than would be taken in hot presses where a temperature of 100° to 120° C can easily be attained.

Hot presses for plywood manufacture are of the multi-daylight type in order that a minimum number of glue lines may be contained between hot surfaces. Each sheet of plywood is placed between platens which are either steam or electrical-resistance heated, and in the case of $\frac{1}{8}$ in. three-ply having two glue lines a cure can be

achieved in 3 to 4 min. Thicker plys up to $\frac{1}{2}$ in. can be cured in times ranging up to 20 min and these figures represent a great advance over the long periods extending from many hours up to days that are needed for cold pressing. Another important point is that the cold-pressed plywood requires extended kilning to reduce moisture content to a value where risk of warpage in a normal atmosphere is minimized. On the other hand, hot-pressed plywood having synthetic resin glue lines, will often have a moisture content below normal equilibrium at the conclusion of the press heating cycle.

Primary and Secondary Gluing. Owing to the importance of the plywood industry the process has become referred to as a primary gluing operation and this name also applies to the manufacture of laminated woods. These are not to be confused with plywoods because the grains of the fibres in adjacent layers are parallel, while in plywoods they are transverse. Operations in which ply or laminated woods are combined or assembled with each other or with solid woods are called secondary gluing operations. The amount of glue used in primary gluing far exceeds that used for secondary gluing, although the number of plants engaged on ply or laminated wood manufacture is relatively small. The distinction is useful in differentiating between the two gluing operations as there are some glues common to both. These are, particularly, casein and resin adhesives, but for secondary operations animal glues remain the outstanding all-round adhesives. On the other hand, silicate of soda, soyabean, cavassa, and albumen (dried blood) glues are rarely used outside the primary field. It is interesting to note that the setting time for some of the primary glues, namely casein and soyabean, besides, of course, the synthetic resins, is improved by hot pressing, while for albumen glues the process is essential.

Before considering the applications of dielectric heating to the process of setting adhesives, it will be advisable to inquire a little more closely into the mechanism of the adhesive process. In the above outline it was seen that only in the last two or three decades has the subject of glues received any serious attention, and even to-day the treatment is too empirical to yield much useful data from a scientific standpoint.

Adhesion. There are at present three main mechanisms by which adhesion is credited to occur and the oldest and most widely accepted concept is that of mechanical adhesion. This postulates that the glue, while fluid, gains access to the cavities of the wood structure and subsequently solidifies. The second is concerned with specific adhesion and does not rely on any degree of porosity in the

154 RADIO-FREQUENCY HEATING EQUIPMENT

material. It depends mainly on intimacy of contact and is concerned with the surface forces that exist on solid bodies. It has, for instance, been found that two freshly cleaved surfaces of mica require a force of 550 lb/in.² to separate them, although no adhesive in the ordinary sense of the word is present. The third mechanism is concerned with the electrical forces associated with molecular structure (*see* Chapter 2).

Such structures can be either polar or non-polar and it is postulated that an affinity exists between materials of similar structures. For instance, a polar liquid like water will mix with another polar liquid such as glycerine, but will not mix with a non-polar liquid like benzene. Wood is normally polar and it follows that wood adhesives should likewise be polar, thus it is found that those which are, namely phenol and urea resins, casein and the like, form satisfactory wood adhesives.

DIELECTRIC HEATING

The outstanding property possessed by dielectric heating, namely, that it causes a uniform temperature rise in bodies of poor thermal conductivity, has a most useful field of application in setting those adhesives that are temperature sensitive. The electrical properties possessed by such adhesives are usually much different from those of the materials to which they are to be made to adhere and with the glues at present available this is often a handicap, although there are some secondary-gluing applications in which this can be turned to advantage. Generally speaking dielectric heating is applied only to the synthetic resin glues and these adhesives when combined with sufficient liquid (usually water) to ensure adequate spreading, possess very high values of permittivity. This means that when the glue lines are parallel to the electrodes, Fig. 75, the voltage gradient through the glue lines is much less than through the wood (*see* Chapter 2). Now the rate of heating is proportional to the power factor of and the square of the voltage gradient through the material being heated, so we see that unless the power factor of the glue line is very high it will heat more slowly than the wood. There will, of course, be a transfer of heat by conduction under these conditions from the wood to the glue line, but to achieve a cure in this way is very wasteful because a relatively large mass of wood must be heated to bring it about. Fortunately, the power factor possessed by synthetic resin glues is comparatively high and eases the position.

Although the permittivity of a wood may be one-tenth that of a synthetic resin glue, the power factor of the latter may be up to twenty-five times that of the wood. Even so, with most combinations

156 RADIO-FREQUENCY HEATING EQUIPMENT

of plywoods of normal size, it follows that the glue lines must be parallel to the electrodes and with the adhesives at present available this is inclined to be wasteful since so much energy is expended in the wood.

Up to now no successful efforts have been made to produce a synthetic resin compatible with the requirements of primary gluing

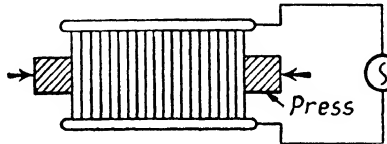

FIG. 76

by dielectric heating. The electrical properties of such a glue may be simply stated as one having a much lower permittivity than that of present glues, and the power factor, while needing to be high, could reasonably be less than that of the present glues. Until such adhesives are produced the advantages of dielectric heating cannot be fully realized by that section of the industry concerned with primary gluing.

A normal type of hot press can produce $\frac{1}{8}$ in. plywoods with

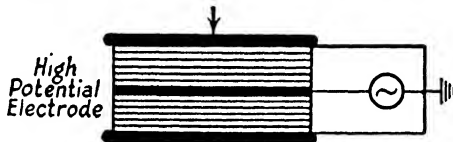

FIG. 77

synthetic resin glue lines at a rate which makes it certain that to replace it by a dielectric-heating equipment would be uneconomic. On $\frac{1}{8}$ in. plywoods the question may be a little in doubt, but for thicker boards it is certain that dielectric heating is the only economic process. For a manufacturer who has not installed hot presses the position is altogether different and for any thickness of ply or laminated board it would pay him to install R.F. heating, particularly as it is reasonably certain that more suitable glues are likely to become available in the not too distant future. Normal types of cold press having a large daylight can be adapted to dielectric heating and the platens of the press may be used as the earthy electrodes while the hot electrode is centrally placed between equal stacks of similar plywood Fig. 77. When this is done it is usually preferable to provide short flexible conductors between the platens

because the inductive loop formed by the press is in some cases sufficiently large to become significant.

Power Requirements. As a basis for the approximate calculation of power requirements we may take spruce wood, having a nominal water content of 6 per cent. This weighs $\frac{1}{2}$ lb/ft³ and it requires a dissipation of very nearly $\frac{1}{2}$ kW to bring about a temperature rise of 120° C during three minutes. If this mass of wood were in the form of $\frac{1}{8}$ in. three-ply, it would constitute about 4 ft² of plyboard and would thus have 8 ft² of glued surface. Now a normal phenol glue spread is 30 lb per 1000 ft² of single glued surface, and so there would be approximately 0.24 lb of glue spread in our 4 ft² of plyboard. The mix of this spread is about 40 per cent solid to 60 per cent water which means that about 0.14 lb of water is to be heated and evaporated, and in view of the latent heat of vaporization of water, this requires a dissipation of about 1 kW for a period of three minutes.

To dissipate $1\frac{1}{2}$ kW of power, the rating of the equipment should reasonably be twice as great, and so a 3 kW generator would be needed for the production of 4 ft² of plyboard in a period of 3 min. It is not essential for the board to be in the form of $\frac{1}{8}$ in. ply, and it could, of course, be 1 ft² of 24-ply, 1 in. thick, and having twenty-three glue lines. Even so, the capital and operating costs of R.F. equipment to produce such a small amount of ply are somewhat large for commonplace manufacture. There is, however, the possibility of limiting power requirements by employing a process of hot stacking for the boards after they leave the press.

It will be seen in the above example that the trouble is concerned almost wholly with the amount of water in the phenol mix and while there are other mixes such as 60 per cent solid, 20 per cent water and 20 per cent alcohol, the trouble would still be present although not to such a serious extent. In any case, the use of alcohols in the mix is not generally favoured because of short mixer and spreader life possessed by the glue. Also, machine cleaning and maintenance becomes more difficult and costly. Once resin glues possessing little or no water content and long mixer life have been developed, together with low permittivity and high power factor, we shall see revolutionary developments in the manufacture of large-area plyboards.

SECONDARY GLUING APPLICATIONS

A very useful application for dielectric heating in the timber industry is the edge-gluing of boards (Fig. 78). Much waste timber can be salvaged in this fashion and, after it has been veneered, it can be used in place of new timber. The relative mass of glue to timber

158 RADIO-FREQUENCY HEATING EQUIPMENT

in operations of this type is very much less than in plywoods, and dielectric heating proves advantageous. The cost of numerous clamps for cold-setting the glue is avoided, and a large area of shop space is made available for other operations.

In all edge-gluing applications, the glue lines can conveniently be normal to the electrodes, and the rate of heating in the glue line much faster than in the wood. The distance separating electrodes is normally small, and rarely exceeds 2 in., with the result that rapid heating is easily possible at frequencies as low as 4 or 5 Mc/s without the application of very high voltage. The electrodes need not be in the form of continuous flat plates, but may be made as strips, arranged to coincide with the glue lines. Where a great quantity of one size of scrap is to be bonded, this is a good plan, because it avoids an unnecessary amount of wood being heated, but it is, of course, essential that the strip electrodes should be rigidly backed by a mechanically strong insulating material of low dielectric loss, such as micalex.

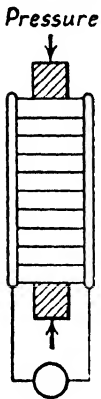

FIG. 78

Cabinet Making. For the mass production of small cabinets such as those used for radio sets, dielectric heating may become of great importance. The three to five hour cold-glue set time is eliminated, and when outputs run into hundreds a day, the saving in clamps and shop space will be considerable. Clean production planning becomes possible, and the bottlenecks, hitherto common, can be eliminated. An R.F. generator of 3 kW output is capable of setting simultaneously all the glue lines in two cabinets of 16 in. \times 10 in. \times 9 in. in a little over a minute, and one such generator could thus cope with the output of a fairly large plant.

Many electrode arrangements are possible for secondary gluing applications, and the high permittivity of the present range of resin glue mixes is an advantage in these applications. This is because the field lines between electrodes will concentrate in media of high permittivity, and for this reason a fair degree of latitude in electrode placement becomes possible. Electrodes arranged as in Fig. 79 can be mounted in a jig into which the whole cabinet is assembled. The entire assembly may be run down a shallow chute into the heating chamber in which the electrodes automatically connect with the R.F. supply from the generator. An arrangement of this type makes for clean and rhythmic production, and at the same time only three or four electrode jigs are needed for a very large output of cabinets.

Where runners are to be fixed to flat boards, an electrode arrangement similar to that shown in Fig. 80 will be effective. The high permittivity glue lines absorb nearly all the energy, and produce a satisfactory joint in an extremely short time. Even where a joint is recessed as in Fig. 81, the glue line will absorb more energy than the intervening wood. It is preferable to remember the basic reason

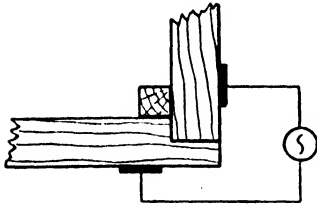

FIG. 79

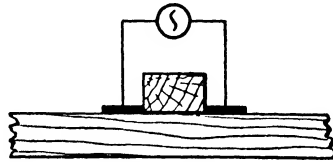

FIG. 80

for this rather than a number of given electrode arrangements, and it can be stated quite simply

$$\frac{\Delta T_g}{\Delta T_w} = \left(\frac{L_w}{L_g}\right)^2 \frac{\sigma_g}{\sigma_w} \quad . \quad . \quad . \quad 9.3$$

where ΔT = temperature rise
 L = length of path
 σ = heat factor
 and $_w$ & $_g$ refer to wood and glue.

If for instance, the permittivity of the glue were ten times that of the wood, as it often is, the length of the glue line between electrodes

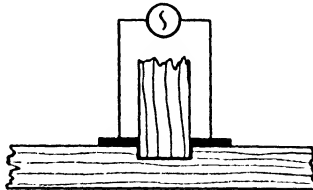

FIG. 81

must be over ten times that of the wood before more energy flows in the wood. Even if more energy did flow in the wood the amount that is dissipated as heat would not necessarily exceed that in the glue, because the power factor of the latter is greater.* In this way

* Remembering that in this example the volume of the glue line is over ten times that of similar cross-section of wood.

There is a sinusoidal distribution of voltage along the electrodes so if the voltage antinode is E_{\max} , that at a point distant x metres from it becomes

$$\frac{E_x}{E_{\max}} = \cos\left(\frac{360x}{\lambda}\right) \quad . \quad . \quad . \quad 9.5$$

Now in applications concerned with the primary and secondary glueing of timber, the electrodes may well be up to 6 m in length, and since it is not advisable to have a variation in voltage of more than 10 per cent along the electrodes, the frequency used in such applications should be low. When electrodes are fed at the centre point, their effective lengths are halved so far as voltage variations are concerned, and so we may tabulate the following maximum frequencies that may be employed for centrally-fed electrodes for a 10 per cent voltage change.

TABLE IV

Length of Electrode	$\chi = 2$	$\chi = 4$
3 ft	33.4 Mc/s	23.6 Mc/s
6 ft	16.8 Mc/s	11.9 Mc/s
10 ft	10.0 Mc/s	7.1 Mc/s
15 ft	6.7 Mc/s	4.7 Mc/s
20 ft	5.0 Mc/s	3.5 Mc/s
30 ft	3.3 Mc/s	2.4 Mc/s

It should be noted that with centrally fed electrodes the voltage will rise towards each end.

Since the rate of heating is proportional to the square of the applied voltage, we see that with a 10 per cent variation in voltage the variation in rate of heating will be 1 to 0.81, and this may be more than can be tolerated in some applications.

Tuning Stubs. It is possible to bring about a considerable modification in the voltage distribution along electrodes, and by so doing to employ a relatively high frequency without introducing large variations in voltage. This is done by attaching tuning stubs at equidistant intervals along the electrodes. The stubs consist of inductors slung between the electrodes and their total effective inductance must be such as to tune the work capacitance to resonance. Consider for instance two narrow electrodes, 3 m in length, centrally fed from a generator operating at 20 Mc/s. Taking the permittivity of the adjacent medium as 2.5, the wavelength of propagation is 9.5 m. and the voltage difference along half the

162 RADIO-FREQUENCY HEATING EQUIPMENT

electrode length will be 1 to 0.820. Now if six tuning stubs were attached there would be three operating in each half of the electrode. Their effect would be to equalize the voltage along the electrode and the total voltage change would be similar to that existing on an electrode having a length of only $\frac{x}{2N}$ where x is the electrode length and N the number of tuning stubs.

$$\frac{Er}{E_{\max}} = \cos\left(\frac{360x}{2N\lambda}\right) \quad . \quad . \quad . \quad 9.6$$

In our example the effective length of the electrodes is 1.5 m, and this will be concerned with three tuning stubs so that the voltage variation will be no greater than if the electrode were $\frac{1}{2}$ m in length.

The value of inductance for each stub depends on the work capacitance and frequency of operation.

$$L = \frac{N}{\omega^2 C} = \frac{10^6 N}{4\pi^2 f^2 C} \text{ microhenries} \quad . \quad . \quad 9.7$$

Assuming a capacitance of 1000 pF for our 6 m electrodes loaded with work, the inductance of each stub becomes

$$\frac{6 \times 10^6}{4\pi^2 \times 400 \times 1000} = 0.38 \mu\text{H} \quad . \quad . \quad 9.8$$

The load imposed by work tuned to resonance with inductive stubs is equivalent to a resistance having a value equal to the dynamic resistance of the circuit so formed.

$$\frac{L}{CR} = Q\omega L = \frac{10^6}{2\pi f C \cos \theta} \text{ ohms} \quad . \quad . \quad 9.9$$

where f is in Mc/s
and c is in pF.

If the work in our example has a power factor of 0.03 it represents a resistive load of approximately 260 Ω .

An important aspect of stub tuning is that it can only be applied to long narrow electrodes. If, for example, square electrodes of large area were to be used, as is often the case in plywood manufacture, it would not be possible to bring about a degree of voltage equalization over the whole electrode surface. Stubs could be employed along a given edge to equalize the voltage along that edge, but for central parts of the electrodes no equalization is possible owing to the impossibility of bridging them by inductors of sufficiently low value. Another aspect is that, even if large area electrodes could be satisfactorily stub-tuned, the capacitance of such electrodes would be very high indeed, and the resistive load

that they would impose at frequencies between 25 and 35 Mc/s would for most material impose a load of much less than 100 Ω .

Co-axial cables may be conveniently designed to have a characteristic impedance of between 40 and 80 Ω , and it may appear that such would form a convenient link with the generator in cases where the load imposed by the work is between these limits. This is, however, erroneous, because the voltage step-down attendant upon matching a generator into a co-axial cable precludes an adequate voltage across the work. For these reasons, stub-tuning is impracticable with large area electrodes which must, therefore, be energized

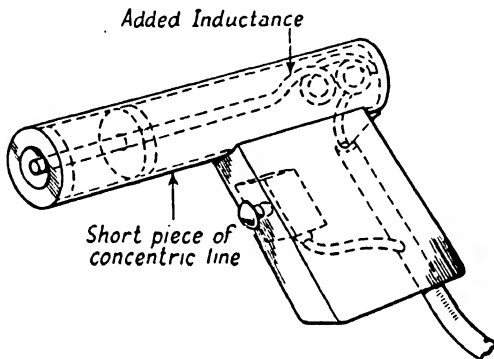

FIG. 83

by power at a frequency low enough to prevent unduly large voltage gradients. Even with long narrow electrodes used in secondary glueing applications, the decision to stub-tune needs very careful consideration because it converts the equipment into the single-application type, and introduces resonance effects which will enhance any inconsistency in the properties of repetition work.

SPOT GLUING

In the manufacture of wooden structures such as the fuselage of an aircraft, three or four layers of thin veneer are laid on an appropriate former with a resin glue between the veneers. Normally, the ply so formed is either tacked or bound with wire to hold it in shape during the curing process. Both methods of securing the ply leave much to be desired, and a specialized type of R.F. equipment has been developed; it is the radio-frequency pistol, shaped as shown in Fig. 83, and consists essentially of a closed-end quarter-wave transmission line. The frequency employed in equipment of this type is of the order of 200 Mc/s so that the length of the pistol would require to be about 37.5 cm. This is too long for convenient

164 RADIO-FREQUENCY HEATING EQUIPMENT

use, and the electrical length of the line may be shortened to more reasonable dimensions by inserting an inductor in the closed end of the line. Power is fed via a co-axial cable of approximately 80Ω impedance, and this is connected in at an appropriate point on the inductor to provide a satisfactory match.

The end of the pistol is placed against the unbonded ply and is energized by pressing the trigger which controls the power supply to the generator. The open end of the line is of high impedance, and at this position a voltage antinode exists and results in a maximum electric field. Normally, very little electric flux would exist external to the end of the pistol, but when this is up against a ply having glue lines of high permittivity, the energy involved in a passage through the wood and glue is less than through air, and so the flux is able to concentrate to some extent in the glue lines. In this way, the ply becomes effectively secured at the points where the pistol is held in a matter of a second or so. There are, of course, many applications in which this type of equipment would be beneficial in the furniture industry.

The useful power involved is very small, since the mass of the glue line to be heated is almost insignificant. Normally, it requires an equipment having a nominal rating of many times the useful dissipation, and the overall efficiency is low. Since the total power required in the glue line does not exceed about 10 W the generator comes within a range that can be conveniently made from standard radio components. This application is interesting because it affords an example in which the unique advantages afforded by dielectric heating become very much worth while although conversion efficiency is extremely poor. It is only in very small mass applications, of which this is one example and continuous seam welding another, that low efficiencies can be tolerated. Where large masses are to be heated, the efficiency must be fairly high or the capital cost of equipment becomes prohibitive.

The applications already mentioned cover those which are, up to the present, the most commonly used. There are, however, many other industrial processes to which dielectric heating could be profitably applied and there are in fact not a few in which it has already been used with marked success, if only on a limited commercial scale. One aspect which offers great scope is the promotion of chemical and bacteriological processes. For instance, dielectric heating offers unique advantages in the sterilization of medicants. These can at the same time be packed in hermetically-sealed containers of cellulose acetate or similar material and thus greatly increase the useful life and reliability of such products.

Dehydration is another process where dielectric heating offers perhaps the only really satisfactory solution. While it is relatively easy to reduce the water content of substances to a fairly low percentage, the removal of the remaining traces of water is very difficult by any other method. It would, of course, be very uneconomic to use dielectric heating for the removal of all the water, but when other methods have reduced water content to a fairly low level it can be used for the *final* drying. In this connection it is interesting to note that for a given expenditure of power much more water can be removed in the initial stages by centrifusion. When this is done there is no absorption of power such as is occasioned by the latent heat of vaporization of water in a heating process.

The earliest industrial application of dielectric heating, namely to the vulcanization and processing of rubber, has not yet achieved a marked degree of success. This is due to the fact that, of the world's output of rubber, by far the larger part is used in tyre manufacture and in order to give it the required tensile strength and resistance to abrasion, it is necessary to add a considerable amount of material such as carbon black. When this is present in sufficient quantities the rubber becomes partially conducting and tyres fitted to aircraft were, during the war, made from conducting rubber to neutralize the static charge on aircraft when landing. The dispersion of carbon in ordinary-type mixes is too irregular to permit of consistent dielectric heating, but much research is now being carried out by rubber technologists to produce a mix having the necessary mechanical properties while at the same time being sufficiently uniform to permit the use of dielectric heating. Vulcanization times for ordinary car tyres are nowadays about 30–40 min, while for giant tyres they can range up to $1\frac{1}{2}$ –2 hr, but when dielectric heating is applied only a fraction of these times will be required.

R.F. Eddy-current Heating Applications

EDDY-CURRENT or induction heating, as it is also called, has been used industrially for many years, but the recent widespread use of R.F. eddy currents for heating purposes has greatly extended the range of applications. It must not be imagined, however, that R.F. generators have replaced the earlier alternators working at frequencies from 500 c/s to 10 kc/s. The range of useful application for each is different. Mains-frequency current, besides that generated by motor alternators was, and is, used for large-mass melting of metals. Of recent years there has been a tendency to employ the higher-frequency alternators (5 to 10 kc/s) for the selective heating of large masses of metals. In these instances use is made of the fact that, because of skin effect, eddy currents are localized in and heat the outer layers of the work, the thickness of the layer heated being, among other things, inversely proportional to the square-root of the frequency. The upper frequency limit for efficient power generation with commercial rotating machinery has hitherto been about 10 kc/s, with a result that there is a limitation to the range of usefulness for alternators in applications which require selective heating. R.F. eddy-current heating, on the other hand, has a much wider range of application for the selective heating of metals, particularly iron and steel.

Power Concentration at R.F. The power dissipated in given work is proportional to the frequency and to the square of the current in the work coil. If an alternator equipment operating at 5 kc/s had a work coil of 1000 A.T. per cm, it would dissipate the same power in the work as an R.F. equipment of equivalent power generating at 500 kc/s but having a work-coil of only 100 A.T. per cm. A difference however, is that the diameter of the work would have to be much greater at 5 kc/s to load the alternator adequately. We see that with an R.F. current of only a fraction of the former value, an equivalent power will be dissipated in a thinner skin on a smaller diameter. The volume of material heated is thus very much less and so enormous concentrations of power are obtainable. This is exemplified by the fact that it is possible, easily, with R.F. eddy-current heating, to achieve a temperature rise in the peripheral skin at the rate of

I.F. EDDY-CURRENT HEATING APPLICATIONS 167

1000° C/sec. The great concentration of power in a thin layer of metal is the most significant property of R.F. eddy-current heating and the one that makes possible revolutionary applications in the hardening and annealing fields.

Higher Radio Frequencies. There has been a tendency to use relatively high radio frequencies for eddy-current heating in the last year or two, and whereas a range of 200 to 500 kc/s was initially common, many equipments now installed work at frequencies up to 15 Mc/s and more. The work-coil current required for a given power dissipation is consequently much less and the cross-sectional area of the work-coil conductor can be reduced. This permits a smaller work coil radius, which, of course, suits work of small dimensions. It also happens that as the frequency is increased, the efficiency of heating for small diameter work improves. One drawback to operating at higher frequencies is that radiation difficulties increase, and another is that the leads from the generator to the work coil must be kept relatively short otherwise the overall efficiency becomes poor. If, however, the work circuit is tuned it becomes possible to employ the leads feeding it as untuned transmission lines, in which case, they may be long without serious detriment.

Low-frequency Limitations. We have already seen that when frequencies of the order of 5–10 kc/s are used for surface heating the volume of metal treated is unavoidably large, and the rate of heating possible at these frequencies cannot approach that which obtains at radio frequencies for the following reasons: The work-coil current necessary for a great concentration of power at a frequency of a few kc/s would be uneconomically large, because of the difficulty and cost of making an alternator of sufficiently low impedance. Even if such heavy current were available, the cross-sectional area of the work-coil conductor would need to be so large that it would impose limitations on the coil design. Furthermore, the heavy current would set up considerable mechanical forces between the work coil and work, and these could become dangerously large. For the reasons outlined, alternator equipment is largely confined to melting operations and to the through heating of large cross-sectional work prior to forging and neither of these operations requires a particularly fast rate of heating. The only surface heating applications for which alternators are used are where large diameter surfaces are to be hardened, as, for instance, occurs with tractor gear wheels.

A characteristic of alternators is that their overall efficiency falls when they are designed and made for low output powers. The overall efficiency of valve generators, on the other hand, tends to

168 RADIO-FREQUENCY HEATING EQUIPMENT

remain constant for any power rating and will, if anything, be slightly lower on big equipments because of the power taken by ancillary gear such as water pumps, etc. The major difference between alternator and valve equipment is that the former must be regarded as fixed heavy capital plant having a limited range of application. In some large installations this may also apply to valve generators, but they can also be relatively low-powered and portable with versatile uses in say a tool room.

SURFACE HARDENING

To emphasize the benefits obtained by the use of R.F. eddy-current heating for case-hardening, we will briefly review the normal methods. Carbon is the chief hardening element in steels, and parts are usually manufactured from steel having a carbon content of 0.1 to 0.2 per cent. This is insufficient to produce a hard surface after treatment and the first requirement is to increase the carbon content of those surfaces which are to be hardened to a value exceeding 0.4 per cent. This is done by packing the part in a carbonaceous material and heating to about 800° C for periods up to several hours. Gas-charged ovens may also be used for this purpose. It is, of course, necessary to prevent an increase in carbon content in those regions of the part not requiring to be hardened and one method of achieving this is first to copper-plate the whole part and remove the plating in those regions to be hardened. After the required regions have been carbonized, the part is allowed to cool slowly and is then reheated to hardening temperature and quenched. The rapidity and the length of the quench affects the degree of hardness. Water, brine, certain oils or an air blast, may be used as the quench medium, and each has its particular range of application.

The procedure outlined above is of a type requiring some skill, particularly as it often happens in practice that such things as the optimum hardening temperature are judged purely by eye, an accomplishment that takes a long time to acquire. There has been a tendency in recent years to employ pyrometric methods for temperature assessment in hardening processes and this tends to minimize the operational skill necessary. The greatest drawback to the usual methods, however, is that the part being treated is very likely to distort after successive heating and cooling and any accurate machining required must be done after hardening and may involve lengthy and costly grinding operations.

The carbon contained in cold steel is called pearlite carbon and as the temperature of the steel is raised a sudden change takes place at the decalesence point, the carbon becoming martensite or hardening

carbon. If allowed to cool slowly, the martensite changes back to pearlite carbon at the recalescence point, which may be 50 to 100° C lower than the decalescence point. With sudden cooling, however, the martensite carbon hardens the steel. It is fortunate that for carbon steels having a content not greater than about 1 per cent the decalescence point coincides very nearly with the Curie point at which the steel loses its ferromagnetic properties. It is, for instance, possible to ascertain when decalescence occurs by noting when the heated steel no longer affects a magnetic compass needle and this type of indication has, in fact, been used in some hardening shops.

FOOL-PROOF HEATING BY R.F. METHODS

By using radio frequencies, many kW/in.² of surface may be dissipated in a depth of no more than $\frac{3}{8}$ in. and a temperature rise to the Curie or decalescence point can be attained in less than one second although times of 2 to 5 sec are more common in practice. A feature of this rapid surface heating is that the production of scale is almost entirely eliminated and the work remains clean. On switching off the power, it is possible for the heat to be transferred to the body of the part so rapidly by conduction as to be equivalent to a quenching operation. This would, of course, apply particularly in large diameter work on which a very thin skin was rapidly heated. For most applications, however, this self-quench would be too slow and a normal type of liquid quench is applied before appreciable conduction losses occur. For this reason it is usually preferable to incorporate quenching facilities as a part of the work-coil assembly, and to arrange for the quench to be operated automatically at the conclusion of the heating cycle.

Accurate Control of Depth. Where generators operating at many megacycles per second are used, the thickness of the layer initially heated is likely to be less than that finally required. The initial layer, being thin, will heat very rapidly, and once it attains the Curie point the R.F. power becomes transferred to the next inner layer which will be heated by both eddy currents and conduction. The result is that the thickness of the Curie-point layer increases much more rapidly than the temperature of the peripheral layer and by timing the heat cycle the required depth of hardening may be obtained without overheating the peripheral layer. This is fortunate, for should the decalescent point be exceeded by more than about 50° C, the hardening qualities of the steel would be impaired. All equipments are fitted with automatic timing devices and these may be pre-set for any desired heating time. If arrangements are made

170 RADIO-FREQUENCY HEATING EQUIPMENT

to apply quench automatically at the end of the heat cycle, the whole process becomes absolutely fool-proof besides being extremely rapid. The result is that on repetition work, hardening of tool-room precision is obtained and at the same time rejects are minimized.

Most of the benefits gained from hardening by R.F. eddy-current heating would be lost if the part had first to be carbonized in a muffling oven, for this is, perhaps, the most inconvenient part of normal hardening operations. The necessity is avoided by making the part from steel having a carbon content of 0.4 to 0.6 per cent. Only those regions of the part that are to be hardened are raised to a high temperature, and the main body remains tough steel. If now a part made of steel of this carbon content was treated in the ordinary way, the whole of the surface, if not the whole part would become hardened. The elimination of the carbonizing operation made possible by R.F. eddy-current heating causes the whole hardening process to become one of innate simplicity and results in a great reduction in hardening costs. Also, as only limited volumes of steel are heated, the power costs are reduced and, further, installation of R.F. eddy-current heating enables a hardening shop to become one of the cleanest instead of one of the dirtiest in a factory. It is, in fact, no longer necessary to localize hardening operations in one shop because R.F. equipments can be installed conveniently at any point in a production line.

HARDENING APPLICATIONS

This book is largely concerned with the efficient design and operation of R.F. generators, but it must be remembered that some applications are inherently inefficient. Their industrial usefulness, however, combined with the fact that in many instances they give results not easily obtained by any other method, more than justifies the application. An aspect which must nevertheless be borne in mind is that with inefficient applications the capital cost of equipment can become very large. Only a small fraction of the available power is usefully dissipated and to dissipate this relatively small amount of power the rating of the equipment must be large. Where the application is inherently inefficient it is more important than ever for the equipment to be well designed or capital costs may get out of hand.

Cylindrical Surfaces. Where the surface of an iron or steel cylinder or rod is to be hardened, the efficiency of heating is reasonably good when the diameter exceeds about $\frac{3}{8}$ in. From 50 to 80 per cent of the rated output of the generator may then be dissipated in the heated layer provided the work radius and the generator output

are compatible. To heat a $\frac{3}{8}$ in. rod on a generator of say 20 kW rating would be inefficient because the diameter of the work-coil conductor that could be bent on a sufficiently short radius would be very small in relation to the rest of the circuit conductors, and losses in the work coil relatively high.

Generally speaking, the length of the work should not be more than six diameters or the energy transfer becomes inefficient. Where long cylindrical surfaces are to be treated it is preferable to feed the work through the coil and apply a continuous quench behind the work coil as shown in Fig. 84. The work coil may be of one, or a very small number of turns, and the feed rate is adjusted to suit the heating time and width of the coil. For a given rate of

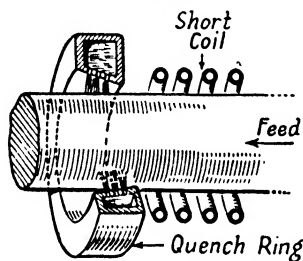

FIG. 84

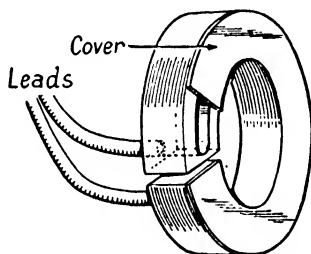

FIG. 85

feed the position of the quench ring relative to the work coil will, of course, determine the quench delay which in turn affects the hardening. Quench jets should, of course, be directed away from that part of the work being heated. It is necessary with this arrangement to have a sink for disposing of the quench liquid and the whole set-up must be securely carried on rigid fixtures.

Gear Teeth. The hardening of teeth on gear wheels is an important application of R.F. eddy-current heating because it avoids distortion which would ordinarily result if the whole wheel were heated in an oven or gas-charged furnace. The density of eddy currents flowing in the teeth contours is, however, not constant, there being a tendency for lower density in the concave curves at the point of the teeth. These are, however, more closely coupled to the work coil and conduction losses will in any case be less than in the tooth spaces. The net result is that the tooth contours tend to heat in a fairly even manner unless the tooth pitch is very small, when there will be a consistent heating of the whole tooth. Where the width of the teeth is small compared to the wheel diameter, single-turn work coils are more efficient and these may be fabricated from copper sheet as shown in Fig. 85.

172 RADIO-FREQUENCY HEATING EQUIPMENT

Bevel gears may be treated by having a conical work coil as shown in Fig. 86, and this again may be of single-turn type, Fig. 87. It should be noted that the separation between the narrow part of the gear and the work coil should be larger or more rapid heating in this area is apt to result, particularly with single-turn coils. Cluster gears may be treated in one operation by having work coils in series.

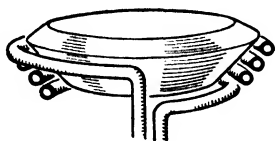

FIG. 86

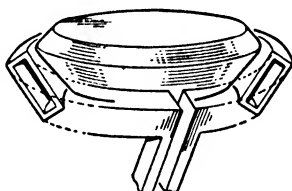

FIG. 87

The spacing between work coil and work can be adjusted to ensure consistent heating of each gear.

Internal Heating. Another important application is the heat treatment of cylinder bores or liners. Any distortion of the bore or inner would be most unwelcome and costly to rectify. By normal

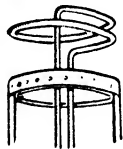
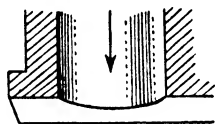

FIG. 88

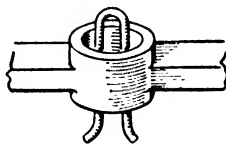

FIG. 89

methods the whole mass must be heated and risk of distortion is great. It is in applications of this kind that the localized and rapid heating made possible by R.F. eddy currents is particularly beneficial. Heating must usually be of the progressive type with the work rigidly held and fed over the coil. Quench arrangements must, of course, be included as shown in Fig. 88.

Where the surface of small diameter bores is to be hardened the work coil can be in the shape of a hairpin as shown in Fig. 89. To heat the whole surface it is necessary for the hairpin to be rotated in the bore or for the work to rotate round the hairpin. Work coils

R.F. EDDY-CURRENT HEATING APPLICATIONS 173

of this type are, however, very inefficient because of their high ratio of resistance to inductance.

Flat Surfaces. Where limited areas on a flat surface are to be heated, a pancake type of work coil can be used, Fig. 90. It may also take the form of a fabricated single-turn work coil. There is a tendency when the coil is parallel to the work surface for the heating

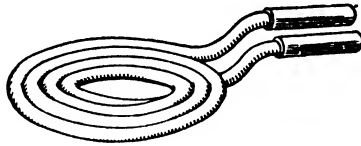

FIG. 90

to be more rapid in the central region and the coil should, therefore, be slightly conical. (Again, this effect is more pronounced in the case of single-turn fabricated coils.) Two flat surfaces in different planes may be hardened by having a specially-shaped work coil as shown in Fig. 91. It is possible to harden almost any irregular surface by having work coils of an appropriate shape, but it must be

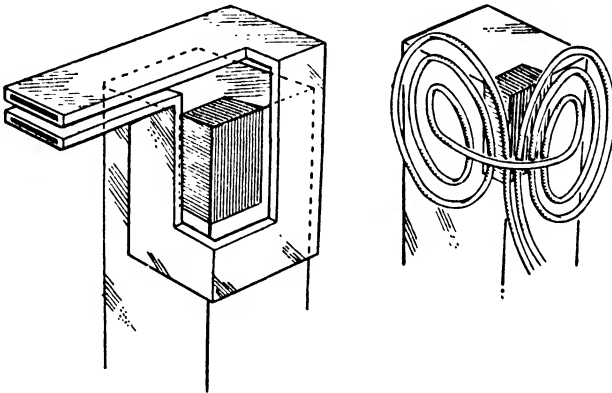

FIG. 91

remembered that for applications of this kind the overall efficiency will usually be low.

Alloy Steels. The surface hardening of high-speed tool steels by R.F. eddy currents cannot be accomplished so readily as with ordinary carbon steels. This is because the decalescence point in high-speed steels occurs at relatively high temperature, in the region of 1000° to 1200° C, while the Curie point is no higher than

with ordinary carbon steel namely 840° C. R.F. eddy currents will quickly heat the peripheral layer, but as soon as this reaches the Curie point most of the energy is transferred to deeper layers. It is thus not possible to attain a hardening temperature rapidly in the outer skin, and there will be very deep, if not through heating, of the work before a high enough surface temperature is reached. The thickness of the layer that reaches the decalescence point cannot be adjusted accurately as with ordinary carbon steels and, in fact, the thickness of the hardened layer is best controlled by the carbonization depth. Thus the awkward carbonizing process must be retained even if R.F. eddy-current heating were applied.

The inward creep of the applied power could, of course, be arrested to some extent by a sudden change to a higher frequency once the required depth had reached the Curie point. Even so, it would not be possible for the peripheral layer to reach 1000° to 1200° C before considerable inward creep had occurred. The precise control which is such an attractive feature of R.F. eddy-current hardening of carbon steels would be lost and, in any case, the equipment would become complicated by arranging for an automatic jump to a higher frequency. Although R.F. eddy-current heating is not practicable for hardening applications on high-speed steels,* it is used for melting small charges of such steel. The inherent cleanliness of the method makes it attractive when dealing with these relatively costly alloys.

Apart from high-speed steels, R.F. eddy-current heating can be applied beneficially to almost every type of hardening operation. There are many instances in which whole crankshaft assemblies have been treated and smaller parts of engines, such as gudgeon pins, etc., can be handled easily without massive installations. Tool hardening is another popular application, and the time is not far distant when every tool room will have its own low-powered, but versatile, eddy-current heating equipment. For tool-room use it is unnecessary to have built-in quenching arrangements associated with the work coil, because the requirements are different with almost every application. Automatic quenching in the tool-room, can, however, be extemporized by placing the work and work coil in an oil bath. On application of power the hot work sets up a layer of oil vapour which holds off the liquid, but on switching off, the vapour layer collapses and quenching is automatically applied. This method of applying a quench may prove useful for some production applications. Precautions are necessary when water is used as the quench liquid, because it often happens that about 3 per cent of

* The application of R.F. eddy-current heating to tool tips is satisfactory because in this case a through, and not surface, hardening is usually required.

sulphuric acid is added to give a bright and clean finish to the hardened part. The water is then partially conducting, and the work coil must be insulated with an acid- and heat-resistant covering before immersion in the water.

Power Requirements. It is not possible to assess with any accuracy the generator power needed for an inefficient application. Where the whole periphery of large diameter iron or steel work is being treated, conditions are efficient, and a knowledge of the necessary generator power is easy to gain. It is safe to say that with an application of this type, 50–60 per cent of the rated power will appear in the work. For a given depth of heating to the Curie point on given diameter work, the volume of metal concerned is known. The rated output of a generator needed to heat a given volume of iron or steel is

$$\text{watt seconds} = v \times 110,000 \quad . \quad . \quad 10.1$$

where v = volume in cubic inches.

This is a very approximate expression which may be applied where the thickness of the required layer is greater than the depth of eddy-current penetration, and where the heating time is less than about 10 sec. It indicates that to be of use for even small tool-room applications, an equipment should have a rated power preferably not lower than about 2.0 kW.

SOLDERING

The soft soldering of repetition articles such as the cans in which paper-foil capacitors are housed, has long presented a difficulty in mass-production plants. The problem has assumed an even greater importance in recent years, when the call for tropicalized finish meant that joints in such cans had to be absolutely air-tight. It is for repetition soldering operations such as these that the use of R.F. heating means a great speed-up in production, while at the same time yielding extremely good joints. Furthermore, its use results in the cleaning-up of a hitherto untidy process in the manufacturing schedule.

Soldering processes of this type can be made fully automatic by using a pre-formed ring, rectangle, or other required shape of solder, and placing it in position on the job to be soldered. The bottom of a rectangular-shaped capacitor can will serve as a typical example. The pre-formed solder is dropped into the can and rests in position over the joint to be soldered as shown in Fig. 92. If a single-turn work coil surrounds the can in this position, the tinned steel of which the can is made becomes heated to a temperature sufficient to melt the solder in a matter of two or three seconds. The solder

176 RADIO-FREQUENCY HEATING EQUIPMENT

flows readily into the hot work and ensures an effective joint, provided, of course, the work is clean. Here, it is the work that melts the solder, and the risk of the work being insufficiently hot, so prevalent with the soldering iron method, is eliminated. The need for training operatives to that degree of manipulative skill which soldering ordinarily requires is also eliminated.

In the example given, the work coil was placed round a can, but this is not essential. If conductors carrying currents in opposite directions were placed adjacent to opposite faces of the can, the potential difference set up along the faces would cause eddy currents to flow right round the can. This makes it possible for the soldering

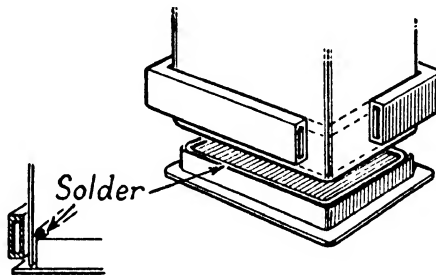

FIG. 92

to be done on a conveyor belt. Long conductors forming the work coil can be shaped as shown in Fig. 93, with the conveyor belt running between them. The length of the conductors and the R.F. current they carry must, of course, be commensurate with the speed of the conveyor belt and size of the cans on it. The seam down the side of the can may be soldered by placing a length of solder in the groove and arranging for it to pass under either a single or a long hairpin work conductor.

When the bottom of the can is being soldered the load imposed on the generator is of an efficient nature, because the work approximates to a bar of ferromagnetic material of cross-section equivalent to that of the can. The thickness of the material forming the can is, however, likely to be rather less than the eddy-current penetration depth, and this reduces efficiency. If a high radio frequency is employed, the penetration depth is reduced, and by this means the efficiency can be increased somewhat, but R.F. radiation difficulties become more pronounced under these conditions.

Where the cross-section of the work is very small, and a soldered joint is to be effected between two non-ferromagnetic materials, an extreme instance being the soldering of a fine-gauge copper wire into a cylindrical brass soldering tag, the use of R.F. heating would

be ineffective unless a small piece of iron or steel could be temporarily introduced.

Brazing. The normal methods of brazing or silver soldering are to employ an iron or torch flame to heat the work to the melting point of the brazing alloy used, and the temperature may be between two or three times that needed for soft solders. Because of this comparatively high temperature, it is easy for distortion of the work to occur when using a flame, while with an iron, the time factor assumes importance. In either case, much skill on the part of the operator is needed to produce satisfactory work. When R.F. eddy-current heating is applied to brazing, the technique employed is broadly similar to that used for soft soldering, namely, a rod of

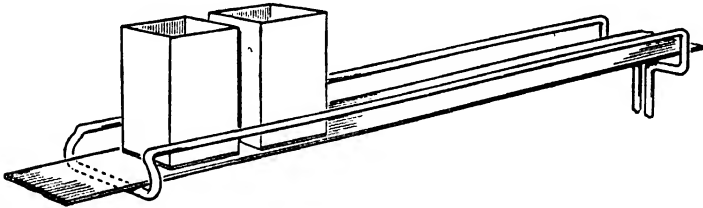

FIG. 93

brazing alloy is pre-formed into the appropriate shape and is placed over the area to be jointed which is then heated by a work coil and in turn melts the brazing alloy.

Many types of brazed joints can be economically effected by R.F. heating, and the speed with which such joints are achieved far exceeds that possible by other methods. Silver brazing alloys are particularly suitable, and have a remarkable degree of penetration into the hot work, so much so that the strength of the R.F. heated silver-alloy joint may exceed that of the main body of the work. An attractive feature in applications of this kind, is that not only does it ensure a most effective heating of the work in the region of the joint but the R.F. current from the generator can, if it is sufficiently powerful, be passed through a series of work-coils used to perform other brazing or perhaps hardening operations on the same piece of work. In this manner, a number of operations may be combined to enable a fairly complicated part to be fabricated in one operation.

As with soft soldering, brazing and silver soldering is more easily carried out by R.F. heating when the work is of ferromagnetic material, although with non-ferromagnetic work the operation is somewhat more satisfactory than soft soldering, the resistive component of the work reaching higher values because of the

178 *RADIO-FREQUENCY HEATING EQUIPMENT*

increased temperature. Even so, there is a marked improvement when the work is of iron or steel.

REMOTE HEATING

The oldest application of R.F. eddy-current heating is in the radio valve industry, where it has been used for more than twenty years. The requirement is to heat metallic anodes contained within evacuated glass envelopes. Now the magnetic field due to a coil carrying a current is undisturbed by the presence of insulating material because, in the first place its permeability is unity, and being non-conducting, it is not possible for the field to be distorted due to the induction of eddy currents. This fundamental fact has been known for a century, and when the industrial necessity became sufficiently great, it was applied in the valve industry. The object is to heat the anode to a temperature higher than that which it is likely to attain in use, for the purpose of driving-off occluded gas during the pumping operation. Spark-gap generators were originally used for this purpose, and while many still exist they are being replaced by valve generators in order to reduce radiation.

The efficiency of heating in applications of this kind is fairly low, because of the unavoidably large separation that must exist between the work coil and the work, but it is obvious that when no other method is satisfactory, the efficiency of R.F. heating does not really matter. It is rather surprising that the remote-heating possibilities of R.F. eddy-current heating have not been utilized to a much greater extent, but we shall doubtless see many such applications of diverse nature developed in future years.

180 RADIO-FREQUENCY HEATING EQUIPMENT

energy is at that instant stored in the capacitor and is CE^2 joules. The r.m.s. current flowing through the capacitor is $2\pi fCE$. If the energy dissipated in the circuit is W watts, that dissipated per cycle is $\frac{W}{f}$ joules.

$$\frac{\text{Energy stored}}{\text{Energy dissipated}} = \frac{CE^2}{\frac{W}{f}} = \frac{fCE^2}{W} = \frac{2\pi fCE^2}{2\pi W} = \frac{EI}{2\pi W} \quad \text{A.2}$$

The ratio of stored to dissipated energy is therefore $\frac{1}{2\pi}$ times the ratio of volt-amperes to watts or in other words to the Q of the circuit. To avoid erratic operation it is necessary that the stored energy is greater than approximately twice that dissipated and the minimum desirable loaded Q -value is thus 10–12.

The condition of unity power factor at which equality exists between the reactance of the inductive and capacitive components, determines the frequency of oscillation.

$$X = j\omega \frac{L - C(R^2 + \omega^2 L^2)}{\omega^2 C^2 R^2 + (\omega^2 LC - 1)^2} \quad \text{A.3}$$

When X is zero, the numerator is equal to zero, and solving for C

$$C = \frac{L}{\omega^2 L^2 + R^2} \quad \text{A.4}$$

If C is the variable reactive element in the circuit

$$Z = \frac{Z_L}{\sqrt{\omega^2 C^2 R^2 + (\omega^2 LC - 1)^2}} \quad \text{A.5}$$

where Z is the circuit impedance and Z_L the coil impedance.

Differentiation gives

$$C = \frac{L}{\omega^2 L^2 + R^2} \quad \text{A.6}$$

If on the other hand L is the variable reactive element

$$L = \frac{1 + \sqrt{1 + 4\omega^2 C^2 R^2}}{2\omega^2 C} \quad \text{A.7}$$

Solving for C

$$C = \frac{L}{\omega^2 L^2 - R^2} \quad \text{A.8}$$

Here we see that when C is a variable the conditions of unity power factor and maximum impedance coincide. When L is the variable,

such is no longer the case and the discrepancy is accentuated in circuits of low Q .

Measurement of Coupling Factor k

It is not ordinarily easy to measure the effective coupling between coils at radio frequencies particularly when one of them is the tank coil of a self-excited power oscillator. Again, a considerable portion of the coupling may be capacitive and this will either add to or subtract from the mutual inductive coupling according to the directions in which the two coils are wound. Once an effective value has been found for k at the frequency of operation it may be used in the ordinary way for calculating circuit parameters whether the coupling is either predominantly inductive or capacitive.

A simple and closely approximate method of finding the effective k of coupled circuits at R.F. is to measure the frequency at which the generator oscillates first with the coupling coil open-circuited and then with it shorted. In the first case the

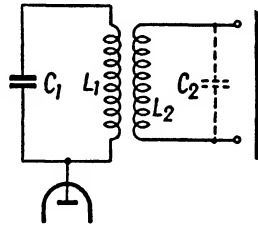

FIG. 94

coupling coil is tuned by its self-capacitance only (Fig. 94), and this being relatively small compared with the coupling-coil inductance makes the secondary capacitive in character and so reflects inductance into the primary. The frequency of oscillation (ω_o) is now

$$\omega_o = \frac{1}{\sqrt{C_1 \left(L_1 + \frac{1}{\omega^2 C_2} \right)}} \quad \text{A.9}$$

Since $\frac{1}{\omega C_2}$ is very large, owing to the small value of the self-capacitance, we will assume the frequency to be the same whether the open secondary coil is present or not. In this case

$$\omega_o = \frac{1}{\sqrt{L_1 C_1}} \quad \text{A.10}$$

When the secondary is shorted* it is inductive and reflects negative

* At high frequencies it is not possible to short out the secondary by a conductor of zero impedance but in most cases the additional Z introduces no large error. If the shorting impedance is not inconsiderable it must be accommodated in the above expression. Similarly, accommodation must be made where the open-circuit frequency changes on removing the secondary coil.

inductance into the primary. The new frequency of oscillation (ω_s) is

$$\omega_s = \frac{1}{\sqrt{C_1 \left(L_1 - \frac{\omega_s^2 M^2}{\omega_s^2 L_2} \right)}} = \frac{1}{\sqrt{C_1 \left(L_1 - \frac{\omega_s^2 k^2 L_1 L_2}{\omega_s^2 L_2} \right)}} \\ = \frac{1}{\sqrt{C_1 (L_1 - k^2 L_1)}} \quad . \quad . \quad \text{A.11}$$

and

$$\frac{\omega_s}{\omega_o} = \sqrt{\frac{L_1 C_1}{C_1 (L_1 - k^2 L_1)}} \quad . \quad . \quad \text{A.12}$$

$$\therefore \frac{\omega_o}{\omega_s} = \sqrt{1 - k^2} \quad . \quad . \quad \text{A.13}$$

$$\therefore k = \sqrt{1 - (f_o/f_s)^2} \quad . \quad . \quad \text{A.14}$$

Thus by two measurements of frequency which can, with a relatively simple absorption wavemeter, be determined to better than 0.5 per cent, a close approximation of the effective coupling factor may be found.

Optimum Coupling Factor Off Resonance

In the section of Chapter 5 that deals with inductively-coupled dielectric-heating work circuits it is shown that with resonant work the value of coupling factor that must not be exceeded if overload is to be avoided is given by

$$k_{opt} = \frac{1}{\sqrt{Q_r + Q_2}} \quad . \quad . \quad \text{A.15}$$

Assume the secondary to be off resonance and that the resistive component of secondary impedance is then negligible compared with the reactive component. Let the off-resonant work capacitance be C_2' and the resonant capacitance C_2 and let the secondary Q at resonance be Q_2 . Off resonance we have for the resistance reflected into the tank circuit

$$\Delta R_1 = \frac{\omega^2 M^2 R_2}{\left(\omega L_2 \sim \frac{1}{\omega C_2'} \right)^2} \quad . \quad . \quad \text{A.16}$$

At resonance $\omega L_2 = Q_2 R_2$. Therefore to a first approximation

$$\omega L_2 \sim \frac{1}{\omega C_2'} = R_2 Q_2 \left(1 \sim \frac{C_2}{C_2'} \right) \quad \dots \quad \text{A.17}$$

$$\therefore Q_r = \frac{\omega L_1}{\Delta R_1} = \frac{\frac{\omega L_1}{\omega^2 M^2 R_2}}{R_2^2 Q_2^2 \left(1 - \frac{C_2}{C_2'} \right)^2} = \frac{\omega L_1 R_2^2 Q_2^2 \left(1 - \frac{C_2}{C_2'} \right)^2}{\omega^2 k^2 L_1 L_2 R_2} \quad \text{A.18}$$

$$= \frac{Q_2 \left(1 \sim \frac{C_2}{C_2'} \right)^2}{k^2} \quad \dots \quad \text{A.19}$$

$$\therefore k_{opt} = \sqrt{\frac{Q_2 \left(1 \sim \frac{C_2}{C_2'} \right)^2}{Q_r}} \text{ for non-resonant condition.} \quad \text{A.20}$$

Work Voltage with Coupled Circuits

Where the secondary circuit is tuned, as in dielectric-heating applications, let the voltage appearing across the work be e_{wk}

$$e_{wk} = \frac{\omega M i_1 X_c}{Z_2} = \frac{\omega M i_1 \frac{1}{\omega C_2}}{\sqrt{R_2^2 + \left(\omega L_2 \sim \frac{1}{\omega C_2} \right)^2}} \quad \text{A.21}$$

At resonance $\omega L_2 = \frac{1}{\omega C_2}$ and since $Q_2 = \frac{\omega L_2}{R_2}$, $e_{wk} = \omega M i_1 Q_2$.

Let the work be altered to some new capacitance C_2' but assume that the ratio of stray to work capacitance remains the same, in which case the effective power factor of the circuit remains unaltered and $Q_2 = Q_2'$. If the secondary were resonant at the frequency of the generator when the work capacitance was C_2 , we may write, when work capacitance is altered to some other value C_2' ,

$$e_{wk} = \frac{\omega M i_1 Q_2' \frac{C_2}{C_2'}}{\sqrt{1 + \left(Q_2 \sim Q_2' \frac{C_2}{C_2'} \right)^2}} \quad \dots \quad \text{A.22}$$

Since the secondary is no longer resonant, e_{wk} is reduced and an examination of equation A.22 indicates that when $C_2 > C_2'$ or in other words when $\frac{1}{\omega C_2'} > \omega L_2$ it is not possible for e_{wk} to be less than $\omega M i_1$, no matter how far the circuit may be off resonance.

reflects negative inductance into the primary which raises the frequency of oscillation. The increased frequency makes the secondary reactance more inductive and so, by reflected negative inductance, further increases the frequency. These increases make

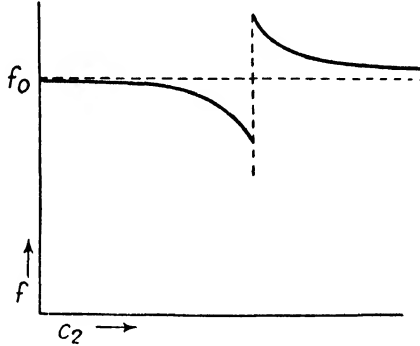

FIG. 95

the primary reactance inductive and stable conditions are reached when equality again exists between reflected negative inductance and primary inductive reactance. There are thus two stable frequencies of oscillation and with increasing C_2 the frequency will jump from the lower to the higher and with decreasing C_2 from the higher to the lower value. (See Fig. 95.)

Calling the frequency on load f_L and the unloaded frequency f_o we have for the maximum value by which f_L can depart from f_o

$$\text{max. value* of } (\omega_L L_1 \sim \omega_o L_1) = \frac{\omega_o L_1}{2Q_L} - \frac{\omega_o L_1}{2Q_o} \quad \text{A.28}$$

$$\therefore f_L = f_o \pm \left\{ \frac{f_o}{2Q_L} - \frac{f_o}{2Q_o} \right\} \quad \text{A.29}$$

Knowing f_o, f_L and Q_o we may find Q_L from

$$Q_L = \frac{f_o}{2 \left\{ (f_o \sim f_L) + \frac{f_o}{2Q_o} \right\}} \quad \text{A.30}$$

The condition under which frequency jump occurs is when the secondary kVA rating exceeds that of the primary. Equality of kVA rating is similar to the condition of critical coupling when considering the response curves of tuned coupled circuits.†

* Since ΔR_{1max} refers to resonant conditions, angular frequency ω_o may be used for both parts of the right-hand side of equation A.28.

† Double humping in coupled circuits normally treats of modulated carriers where the circuit forms a band-pass filter. With R.F. heating there is no modulation and we are concerned with power at one frequency only.

186 RADIO-FREQUENCY HEATING EQUIPMENT

Effect of Parallel or Series Capacitance on Load imposed by Coupled Circuit

We will deal with the resonant case because the parallel or series capacitance is usually present to achieve this condition.

The load imposed is proportional to the reflected resistance ΔR_1 .

(1) Parallel case

When work (C_W) having a power factor ($\cos \theta$) is in the secondary circuit and has a parallel capacitor of very low power factor (C_{PS}) we have

$$\cos \theta_1 = \frac{\cos \theta C_W}{C_W + C_{PS}} = \omega(C_W + C_{PS})R_2$$

where R_2 is the equivalent series resistance.

$$R_2 = \frac{\cos \theta C_W}{\omega(C_W + C_{PS})^2}$$

$$\Delta R_1 = \frac{\omega^2 M^2}{R_2} = \frac{\omega^3 M^2 (C_W + C_{PS})^2}{\cos \theta C_W}$$

Here we see that loading is proportional to the third power of frequency and will also reach high values when $C_{PS} > C_W$.

(2) Series case

Where series capacitance (C_S) of very low power factor is included in the secondary, we have

$$\cos \theta_1 = \frac{\cos \theta C_S}{C_S + C_W} = \omega \frac{C_S C_W}{C_S + C_W} R_2$$

$$R_2 = \frac{\cos \theta C_S}{\omega C_S C_W}$$

$$\Delta R_1 = \frac{\omega^2 M^2}{R_2} = \frac{\omega^3 M^2 C_W}{\cos \theta}$$

Here again loading is proportional to the third power of frequency and in this case directly proportional to work capacitance. The above treatment may be most easily extended to embrace the non-resonant case by applying the device utilized on pp. 181-3.

Note. When the secondary coil resistance (R_{2c}) is of significant size, it must be added to R_2 .

Appendix II

PROPERTIES OF DIELECTRICS

THE figures given below for the physical and electrical properties of dielectrics are intended as a useful guide. Owing to the discrepancies occurring between samples due to variations in either conditions of manufacture or previous treatment, no hard and fast figures can be given unless these conditions are fully specified together with the conditions of measurement. The figures will, however, serve to give a relative indication and may, in fact, be used as a basis for approximate design.

PHENOL FORMALDEHYDE MOULDING POWDERS

	FORM	SPECIFIC GRAVITY <i>S</i>	SPECIFIC HEAT <i>c</i>	PERMITTIVITY χ	POWER FACTOR $\cos \theta$	HEAT FACTOR σ	BULK FACTOR
General-purpose Wood-flour filled	Powder	0.54	0.35	1.7	0.016	0.144	2.5
	Pellet	0.80	0.35	3.7	0.028	0.29	
	Moulding	1.35	0.35	5.5	0.035	0.40	
Heat-resisting asbestos filled	Powder	0.92	0.35	2.3	0.018	0.128	2.0
	Pellet	1.50	0.35	5.0	0.040	0.38	
	Moulding	1.85	0.35	6.5	0.065	0.65	
Medium shock	Powder	0.39	0.35	1.5	0.015	0.158	3.5
	Pellet	0.90	0.35	3.9	0.030	0.37	
	Moulding	1.38	0.35	5.2	0.040	0.43	
Med-high shock	Powder	0.28	0.35	1.4	0.015	0.142	5.0
	Pellet	0.85	0.35	3.9	0.027	0.35	
	Moulding	1.39	0.35	5.5	0.040	0.45	
High shock	Powder	0.158	0.35	1.3	0.008	0.19	9.0
	Pellet	0.80	0.35	4.3	0.030	0.475	
	Moulding	1.38	0.35	6.0	0.045	0.57	
Electrical grade low-loss mica filled	Powder	0.85	0.35	1.9	0.008	0.051	2.0
	Pellet	1.38	0.35	4.2	0.013	0.113	
	Moulding	1.70	0.35	5.8	0.015	0.146	

PHENOL FURFURAL MOULDINGS

Wood-flour filled	Moulding	1.4	0.35	6.0	0.04	0.435	2.7
Fabric filled	Moulding	1.38	0.35	6.0	0.45	0.54	10.0
Mineral filled	Moulding	1.00	0.35	7.0	0.06	0.64	2.0

UREA MOULDINGS

Cellulose filled	Moulding	1.5	0.35	5.5	0.04	0.42	2.4
Fabric filled	Moulding	1.39	0.35	6.0	0.05	0.62	12.0
Asbestos filled	Moulding	1.8	0.35	5.5	0.06	0.62	2.0

188 RADIO-FREQUENCY HEATING EQUIPMENT

The pellets just referred to in connection with phenol formaldehydes were cold pressed at approx. 4000 lb/in.² Medium shock fillers are of short fibre length while high shock fillers are of long fibre length such as fabric cuttings and string. The temperature to which Urea powders and pellets must be preheated prior to moulding is somewhat more critical than is the case with phenols and a tolerance of $\pm 5^{\circ}\text{C}$ should not be exceeded. R.F. pre-heating is particularly advantageous in the case of melamines because this material is very sensitive to flow markings.

MELAMINE MOULDINGS

	FORM	SPECIFIC GRAVITY S	SPECIFIC HEAT c	PERMITTIVITY ϵ	POWER FACTOR $\cos \theta$	HEAT FACTOR σ	BULK FACTOR
Paper filled	pellet	1.2	0.35	3.3	0.04	0.31	2.0

GLASS

Crown	2.5	0.161	6.6	0.007	0.114
Flint	3.5	0.117	7.0	0.004	0.068
Pyrex	2.2	0.200	4.5	0.002	0.022
Window	2.4	0.120	7.5	0.015	0.370
Plate	2.5	0.150	6.5	0.008	0.138
Photographic	2.5	0.115	7.0	0.010	0.244
Cobalt	2.4	0.120	7.0	0.006	0.146
Bottle	2.4	0.120	6.5	0.005	0.113

WOODS

Sprucewood 0% moisture	0.37	0.34	2.2	0.052	0.9
Sprucewood 6% moisture	0.40	0.39	2.5	0.070	1.12
Sprucewood 10% moisture	0.42	0.42	3.2	0.090	1.63
Beechwood 0% moisture	0.56	0.35	2.0	0.070	0.72
Beechwood 6% moisture	0.61	0.40	3.0	0.110	1.35
Beechwood 10% moisture	0.63	0.44	4.4	0.180	2.8
Walnut 0% moisture .	0.38	0.58	2.1	0.035	0.33
Walnut 6% moisture .	0.42	0.64	3.0	0.060	0.67
Walnut 15% moisture .	0.52	0.70	5.5	0.120	1.8
Fir 4% moisture	0.37	0.39	2.7	0.052	1.0
Whitewood 0% moisture .	0.38	0.39	1.6	0.022	0.24
Oak 8% moisture	0.60	0.52	3.7	0.045	0.68
Maple 8% moisture	0.47	0.53	4.2	0.043	0.72
Birch 10% moisture	0.59	0.48	5.2	0.065	1.15

SYNTHETIC RESIN GLUE MIXES

Phenolic	1.20	0.9	15	0.80	11.0
Urea	1.22	0.9	21	0.75	14.3

THERMOPLASTICS

Methyl methacrylate compound	1.18	0.35	3.2	0.025	0.20
Styrene resin	1.06	0.37	2.6	0.0001	0.0006
Shellac moulding compound	1.7	0.33	3.0	0.02	0.16
Casein resin	1.35	0.40	6.4	0.052	0.62
Ethyl cellulose compound .	1.14	0.38	2.5	0.015	0.09
Cellulose acetate sheet .	1.31	0.45	4.0	0.065	0.44
Cellulose acetobutyrate .	1.21	0.35	3.6	0.018	0.15
Cellulose nitrate	1.45	0.36	6.15	0.085	1.00
Methacrylic resin	1.19	0.41	2.8	0.020	0.12
Vinyl resin	1.85	0.28	4.0	0.017	0.20
Polyvinyl chloride (plasticised)	1.35	0.35	4.0	0.028	0.25

MISCELLANEOUS

	FORM	SPECIFIC GRAVITY δ	SPECIFIC HEAT c	PERMITTIVITY χ	POWER FACTOR $\cos \theta$	HEAT FACTOR σ	BULK FACTOR
Fibre		1.3	0.35	5.0	0.05	0.55	
Porcelain wet process		2.4	0.25	6.0	0.006	0.06	
Porcelain dry process		2.3	0.26	5.0	0.006	0.05	
Finid quartz		2.2	0.20	4.0	0.0003	0.003	
Rubber (hard)		1.15	0.30	2.8	0.01	0.08	
Slate		2.4	0.25	6.0	0.025	0.25	
*Mycalex		3.5	0.22	7.0	0.003	0.027	

* Mycalex is a useful constructional material for R.F. heating equipment and can be machined, preferably with tungsten carbide tools. It is composed of mica powder and lead borate or other glass-type bond, has a maximum safe temperature of 400° C, is self healing after arcing and has negligible water absorption.

Appendix 3

BRITISH TRIODE VALVES SUITABLE FOR R.F. HEATING EQUIPMENTS (at time of publication)

MANUFACTURER	TYPE NUMBER	FILAMENT VOLTAGE	FILAMENT CURRENT (amps)	FLUORESCENT MATERIAL	PEAK EMISSION (amps)	MAX. ANODE VOLTAGE	MAX. ANODE CURRENT (mA)	ANODE DISSIPATION (watts)	AMP'N FACTOR	V _g max (volts)	MAX. FREQ. FOR FULL H.T. VOLTAGE (Mc/s)	DIMENSIONS	
												LENGTH	DIAM.
GLASS-ENVELOPE RADIATION COOLED													
Ostram	DET 12	7.5	3.15	Thoriated Tungsten		1 250		60	10.3		75	167 mm	67 mm
Mullard	TY 2-125	6.3	5.4	"		2 500	240*	135	26		60	42 mm	65 mm
STC	4304 CB	7.5	3.3	"	1.0	1 250	100	50	10.5		100	163 mm	64 mm
Ediswan	EHF 100	6.0	5.0	"		1 250		100	13.5		150	145 mm	58 mm
Ostram	DET 17	10.0	5.0	"		2 000	250	125	36.0		25	225 mm	64 mm
STC	4357 A	10.0	10.0	"	4.0	4 000	500	350	32.0		100	206 mm	130 mm
Ediswan	RHZ 350	23.0	16.0	Pure Tungsten	2.5	4 000		750	43.0		60	14 in.	5 in.
STC	30/10 A	10.0	21.0	Thoriated Tungsten	8.0	3 000	1 000	1 200	22.0		20	246 mm	75 mm
SILICA-ENVELOPE RADIATION COOLED													
Mullard	TYSS-250	6.5	11.5	Thoriated Tungsten		2 000	400	250	21.5	200	75	178 mm	64 mm
"	TY84-500	10.0	10.0	"		4 000	660	500	26.0	300	50	290 mm	94 mm
"	TY85-2000	14.5	26.5	"		5 000	1 400	2 000	31.0	450	30	408 mm	108 mm
"	TY85-3000	20.5	26.0	"		5 000	2 250	3 500	32.0	500	30	550 mm	110 mm
"	TY85-3600	21.5	20.0	"		5 000	2 000	3 500	47.0		15	470 mm	101 mm
"	TX10-4000	23.0	47.0	Pure Tungsten	6.0	12 000	1 200	4 000	55.0	800	2	515 mm	103 mm
EXTERNAL-ANODE RADIATION COOLED													
Ostram	ACT 6	10	1.6	Oxide	0.8	1 500	140	75	22.0		30	225 mm	54 mm
Ostram	ACT 9	16.0	22.0	Pure Tungsten	2.0	10 000	400	800	40.0		15	470 mm	186 mm

*Maximum Cathode Current.

EXTERNAL-ANODE FORCED-AIR COOLED

Osrain . . .	ACT 19	8-25	7-0	Thoriated Tungsten	2-0	2 500	200	150	15-5		100	190 mm	39 mm
Osrain . . .	ACT 9	16-0	22-0	Pure Tungsten	2-0	10 000	400	1 100	40-0		15	470 mm	196 mm
Osrain . . .	ACT 24	6-0	17-0	Oxide	6-0	1 500		1 500	35-0		85	13 in.	3½ in.
Ediswan . . .	EHA 2500	8-0	80-0	Pure Tungsten	4-5	7 500		2 500	55-0		50	9 in.	6½ in.
Ediswan . . .	EHA 5000	11-0	125-0	"	11-0	8 500		5 000	20-0		25	11½ in.	8½ in.
STC . . .	3J 170 E	10-0	22-0	Thoriated Tungsten	7-5	6 000	1 250	3 500	17-0		50	225 mm	155 mm
STC . . .	3J 192 E	5-0	66-0	"	10-0	7 000	2 000	4 500	18-0			242 mm	153 mm
STC . . .	3J 191 E	10-0	33-0	"	12-0	10 000	2 000	5 000	26-0			362 mm	150 mm
STC . . .	3J 221 S	22-0	70-0	Pure Tungsten	12-0	17 500	2 500	10 000	26-0			506 mm	172 mm
Osrain . . .	ACT 14	18-0-20-0	75-0	"	10-0	12 000	2 000	8 000	45-0		10		
Osrain . . .	ACT 21	13-0	320-0	"	25-0	10 000			20-0		50	16 in.	17 in.
Osrain . . .	ACT 16	18-0-20-0	100-0	"	12-0	15 000	2 000	12 000	45-0		20		
Mullard . . .	12X-20A	18-5	85-0	"	11-0	12 000	3 000*	18 000	40-0	900	20	741 mm	102 mm

EXTERNAL-ANODE WATER COOLED

Ediswan . . .	EHW 3000	8-0	80-0	Pure Tungsten	4-5	7 500		3 000	55		50	260 mm	70 mm
STC . . .	4225 A	22-0	41-0	"	6-0	6 000	1 500	5 000	18		3	18 in.	3½ in.
Osrain . . .	CAT 6	18-0-20-0	75-0	"	10-0	12 000	2 000	12 000	45		10	714 mm	164 mm
Osrain . . .	CAT 9	18-0-20-0	100-0	"	12-0	15 000	2 000	18 000	45		20	808 mm	238 mm
Mullard . . .	TX12-20W	18-5	85-0	"	11-0	12 000	3 000*	18 000	40	900	20	741 mm	102 mm
STC . . .	3 Q221 E	25-0	70-0	"	12-0	17 500	2 500	20 000	26			506 mm	172 mm
Osrain . . .	CAT 21	13-0	320-0	"	25-0	10 000		20 000	20		50	16 in.	6 in.
Osrain . . .	CAT 11 C	31-5	230-0	"	50-0	18 000	10 000	75 000	35		2	1113 mm	305 mm
STC . . .	4030 C	25-0	250-0	"	45-0	17 500	17 500	80 000	36		2	52 in.	6 in.

* See previous methods circuit

Index

- A.C. HIGH tension, 127-9
Actual load, 71
Adhesion, 153
Adhesives, 151
Aircraft fuselage, 163
Air gaps, 91
Alloy steel, eddy-current heating of, 174
Alternator, H.F., 2
Amplification—
 Class A, 37
 Class B, 39
 Class C, 39
Anode—
 carbon, 113
 current, 42
 current duration, 44
 dissipation, 43
 efficiency, 45-6
 molybdenum, 114
 tantalum, 114
 zirconium, 114
Arc furnace, 1
Automatic rematch—
 dielectric heating, 92
 eddy-current heating, 105

BACK e.m.f., 25
Barium oxide, 109
Bias—
 compensation, 67-8
 separate, 41
Blocking, 42
Bonding, 148-9
Brazing, 177
Bridge rectifier, 130

CABINET making, 158
Capacitance—
 coupling, 102
 of parallel plates, 18
 (stray), 76 *et seq.*
Capacitor—
 grid, 66
 losses, 17-18
Carbon anode, 113
Casein glue, 151
Centre-fed electrodes, 161
Circuit efficiency, 72
Class—
 A amplification, 37
 B amplification, 39
 C amplification, 39

Co-axial cable, 163
Colpitts oscillator, 58
Compression moulding, 142-7
Corona discharge, 17 *et seq.*
Coupled circuit—
 coupling factor, 87 *et seq.*
 coupling factor measurement, 181-2
 secondary isolation, 85-6
 secondary earthing, 86
Coupled circuit (tuned)—
 double-hump effect, 88 *et seq.*
 frequency jump, 88, 184-5
 optimum coupling at resonance, 89
 optimum coupling off resonance, 182-3
 reflected resistance, 87
 reflected reactance, 87
 reflected Q, 88-9
 voltage step-up, 89
Coupled circuit (untuned)—
 effective primary impedance, 94
 effective primary reactance, 94
 effective primary resistance, 94
 reflected resistance, 94-5
 reflected resistance with double coupling, 101
Coupled work coil, 99
 measurement, 103
Curie point, 28-9
Curing, 142
Cut-off bias, 38, 43 *et seq.*
Cylinders, eddy-current heating of, 170, 172

DANNAT, 32
Decalescence, 168
Decay factor, 35
Delay switch, 138
Depth of penetration, 30
"Designed" power, 53-4 *et seq.*
Dielectric constant, 10
Dielectric heating applications—
 bonding, 148-9
 compression moulding, 142-7
 continuous welding, 149-51
 dehydration, 151-65
 furniture, 158
 impression welding, 149
 melamine, 188
 pellets, 145
 phenol, 142
 plywood, 151-7
 powder, 145

194 RADIO-FREQUENCY HEATING EQUIPMENT

- Dielectric heating applications—
 (contd.)
 spot-glueing, 163-4
 sterilization, 164
 urea, 188
 vulcanization, 165
- Dielectric heating work circuits—
 coupled, 86
 direct, 75
 for deep work, 79, 89
 for shallow work, 78, 82, 183
 grid capacitor, 78
 series, 80
 tapped down, 82
 tapped up, 79
 tuned, 84
- Dielectric loss, 14
 Dipole moment, 11
 Displacement, 11
 Dissipation, anode, 43
 Driven amplifier, 69
- EDDY-CURRENT heating applica-
 tions—
 alloy steel, 174
 brazing, 177
 cylinder surface, 170
 cylinder bore, 172
 flat surfaces, 173
 remote heating, 178
 soldering, 175
 surface hardening, 168 *et seq.*
- Eddy-current heating work circuits—
 coupled, 99
 coupled measurement, 103-4
 direct, 98
 direct measurement, 102-3
 for efficient work, 98
 for inefficient work, 99
 switched tap, 105
 tuned secondary, 105-6
- Electrical adhesion, 154
 Electron, 6
 Electron-coupled oscillator, 55
 Electronic sewing machine, 149-50
 Electrovalency, 8
 Energy level, 14
- FEEDBACK oscillator, 56
- Field—
 distribution, 12-13 *et seq.*
 strength, 11
- Filament—
 chokes, 63
 failure, 111-12
 heating power, 111
 life, 111
 oxide, 110
 thick, 112
- Filament—(contd.)
 tungsten, 111-12
 tungsten, thoriated, 112
- Flat surfaces, eddy-current heating
 of, 173
- Flux linkage, 25
 Flywheel effect, 39
 Form factor, 129
 Free electrons, 9
 Frequency jump, 88
 Ferromagnetic materials, 29
 Furniture manufacture, dielectric
 heating in, 158
- GAPPED electrodes, 23
 Gas ionization, 107
 Generator spark gap, 2
- Grid—
 bias voltage, 45
 capacitor, 40
 cut-off, 38, 43 *et seq.*
 drive voltage, 45
 driving power, 45
 phasing, 125
 resistor, 40
 zirconium, 114
- Glue—
 line, 23 *et seq.*
 mixes, 157
- HALF-WAVE rectifier, 129
 Hard rectifier, 122
 Hardening, 168-75
 Harmonics, 42
 Hartley oscillator, 57
 Heat factor, 21 *et seq.*
 Heated electrodes, 20
 Hysteresis loss, 31
- IGNITRON, 125
 Inductance of tuning stubs, 162
- Induction—
 furnace, 2
 heating, 3
- Input power, 43
 Ion, 8
 Ionic bombardment, 107 *et seq.*
 Ionic polarization, 16
 Ionization potential of mercury, 123
- JOULE, 16
- LAMINATED—
 dielectric, 22
 wood, 153
- Line—
 open, 62
 shorted, 62
 resonant oscillation, 62-3
- Loading, effect of strays, 76 *et seq.*

- Long electrodes, 160
 centre-fed, 161
 Loss—
 factor, 16
 function, 20
 MAGNETIC contactor, 137
 Martensite carbon, 168
 Match ratio, 71 *et seq.*
 Matching, 53 *et seq.*
 McLachlan, 28
 Mechanical adhesion, 153
 Melamine, 188
 Mercury vapour rectifier—
 filament, 125
 filament warming, 124
 limitation, 124
 vapour pressure, 124
 Meter—
 electrostatic, 65
 hot-wire, 65
 moving-coil, 65
 protection, 65
 Metering, 65
 Molecular dipole, 11
 Molybdenum anode, 114
 Moulding—
 pellets, 143-5
 powders, 142-5
 Mutual conductance, 48
 Mutual inductance, 86 *et seq.*
 NATURAL frequency, 35
 Negative resistance characteristic, 55
 Nucleus, 6
 Neutron, 6
 Non-conducting materials, 3
 Non-rectangular work, 23
 OPTIMUM—
 coupling at resonance, 89
 coupling off resonance, 182
 load, 70
 loading, 53 *et seq.*
 Oscillator—
 Colpitts, 58
 electron coupled, 55
 feedback, 55
 Hartley, 57
 line, 61-3
 negative resistance, 55
 push-pull, 59-61
 reversed feed-back, 56
 tickler, 56
 tuned anode-tuned grid, 61
 Outline design, 51
 Output power, 43
 Overload, 53-4
 protection, 68
 Oxide filament, 111
 PARALLEL—
 glue lines, 154
 glue lines, rate of heating, 155
 plate capacitor, 18
 resonant impedance, 37
 Peak forward voltage, 125
 Peak reverse voltage, 122
 Pearlite carbon, 168
 Pellets, 145
 Permeability, 26
 Permittivity, 10
 Perpendicular glue line, 155
 Pendulum, 33
 Pentode, 67
 Phenol, 142
 Plywood—
 hot press, 152
 heating, 154-7
 Polar molecule, 8
 Polymerization, 142
 Polyphase rectifier, 131
 Potential gradient, 19
 in laminated dielectrics, 24 *et seq.*
 Power—
 control, 64-5
 factor, 16
 factor when $\omega C \gg R$, 18
 requirements, dielectric heating, 144
 requirements, eddy-current heating, 175
 Pre-cure, 143
 Proton, 6
 Pulsatance, 29
 Push-pull oscillator, 59-61
 P.V.C., 143
 Q—
 loaded optimum, 71
 loaded actual, 71
 lower-limit loaded, 179-80
 measurement, 102-3
 of capacitor, 36
 of coil, 36
 of work, 73
 of work, effect of strays, 76 *et seq.*
 reflected at resonance, 88-9
 reflected off resonance, 183
 value, 36
 Quantity of charge, 10
 Quench, 168
 RADIANT energy, 111
 Radiation—
 losses, 72
 resistance, 17, 72
 Recalescence, 169
 Reflected Q, 88-9, 183
 Reflected—
 reactance, 87
 resistance, 87

196 RADIO-FREQUENCY HEATING EQUIPMENT

- Refraction, 12
- Relaxation time, 15
- Remote heating, 178
- Resistance—
 - equivalent series, 17
 - equivalent parallel, 17-18
- Resonant frequency, 35
- Rubber, vulcanization of, 165
- Rutherford-Bohr theory, 6

- SCREEN, electrostatic, 60
- Series feed, 57
- Shunt feed, 57
- S.I.C., 10
- Single-ended oscillator, 60
- Single-phase rectifier, 129
- Skin effect, 25-7
- Smoothing, 135
- Soldering, 175
- Space charge, 108
- Specific—
 - adhesion, 153-4
 - gravity, 19
 - heat, 19
- Spot-gluing, 163-4
- Standing waves, 62
- Steel, carbon content, 168
- Sterilization, 164
- Strontium oxide, 169
- Synthetic resin glue, 152
 - mixes, 152
- Surface hardening, 168

- TANK capacitors—
 - ceramic, 101
 - mica, 101
 - costs, 101
- Tank circuit, 43 *et seq.*
- Tank current, 38
 - measurement, 65-6
- Temperature absolute, 109
- Tantalum anode, 114
- Thermal losses, dielectric heating, 19
- Thoriated tungsten, 109
 - working temperature, 109

- Thyratron, 125
- Tickler circuit, 56
- Transfer ratio, 71 *et seq.*
- Transfer moulding, 147
- Transit time, 117
- Tungsten—
 - melting temperature, 109
 - working temperature, 109

- UNITY power factor, 180
- Useful power, 74 *et seq.*
- Utilization factor, 135

- VALENCY, 7
- Valve—
 - envelope, 115
 - envelope puncture, 115
 - external anode, 116
 - glass envelope, 114
 - protection, 67
 - seals, 114-5
- Variable loading, 52 *et seq.*
- Variable matching—
 - air gaps, 91
 - inductance, 92
 - series coil, 91
 - taps, 89-90
- Velocity of electromagnetic propagation, 162
- Voltage distribution with tuning stubs, 162
- Vulcanization, dielectric heating in, 165

- WORK-COIL—
 - inductance, 96
 - resistance, 96
 - turn spacing, 96
- Work coils, 171-3
- Work—
 - ferromagnetic, 99
 - Q, 94-6
 - resistance, 96

ELECTRONICS

By F. G. SPREADBURY, A.M.Inst.B.E.

An authoritative and up-to-date book dealing with the science and applications of the electron. The author explains the facts in a most logical manner. The first part of the book deals with pure electronics, and the second part with the principal applications. The book is of essential value and importance to all radio and electrical engineers and technicians. **55s.** net.

ELECTRONICS IN THE FACTORY

By PROFESSOR H. F. TREFWMAN, M.A., M.I.E.E.,
M.I.Mech.E., M.Brit.I.R.E.

A lucid description of the latest applications of electronics to industrial production of every kind. **20s.** net.

THE ELECTRONIC MUSICAL INSTRUMENT MANUAL

By ALAN DOUGLAS

This comprehensive handbook explains the relationship between electrical tone colours and their acoustic counterparts, and describes the most modern circuits for achieving satisfactory results. The latest instruments are described and illustrated in detail.

ELECTRONIC DEVICES

By HENRY A. MILLER, A.M.I.E.E., M.I.E.S., F.R.S.A.

A summary of the most important devices available at the present time. These devices are indispensable, particularly in electrical, radio, and illuminating engineering, as well as in the home. They are simply and authoritatively explained in this interesting and topical work. **12s. 6d.** net.

MEET THE ELECTRON

By DAVID GRIMES

This important American book gives a clear and extremely readable introduction to electricity and magnetism with special reference to elementary electronics. The book is well illustrated with numerous drawings and examples taken from everyday experience. **7s. 6d.** net.

PITMAN BOOKS

PHOTOELECTRIC CELLS IN INDUSTRY

By R. C. WALKER, B.Sc., A.M.I.Mech.E.
A.M.I.E.E.

This book presents a representative selection of the industrial uses of light-sensitive cells of the emission and rectifier types. It gives a lucid explanation of the theory of operation of these devices. All those described are being or have been employed in industry. The book is recommended to electrical engineers, and to all concerned with the industrial use of the photoelectric cell. **40s. net.**

PERMANENT MAGNETS

By F. G. SPREADBURY, A.M.Inst.B.E.

Gives a comprehensive account of the subject. The book deals with practically all magnet materials in current use in this country, as well as with carbon steel. Other chapters deal with magnet design, magnetic measurements and measuring instruments, magnetization and magnetizers, demagnetization and demagnetizers. **35s. net.**

CATHODE-RAY OSCILLOGRAPHS

By J. H. REYNER, B.Sc., A.C.G.I., D.I.C.
M.I.E.E.

A guide to the practical application of cathode-ray tubes to the examination of oscillations or wave-forms and to numerous other purposes. Covers types of oscillograph tube, the oscillograph in use, wave-form examination, and special applications. **8s. 6d. net.**

DICTIONARY OF ELECTRICAL TERMS

Including Electrical Communication

By S. R. ROGET, M.A., A.M.Inst.C.E.

Covers electric light, power, and traction, telegraphy and telephony, radio, and the general science of electricity and magnetism. **12s. 6d. net.**

PITMAN BOOKS

DATE OF ISSUE

This book must be returned
within 3, 7, 14 days of its issue. A
fine of ONE ANNA per day will
be charged if the book is overdue.

