

Birla Central Library

PILANI (Rajasthan)

Class No. 517.3806213

Book No. F81D

Accession No. 40276

**DIFFERENTIAL EQUATIONS
FOR ELECTRICAL ENGINEERS**

DIFFERENTIAL EQUATIONS
FOR
ELECTRICAL ENGINEERS

BY
PHILIP FRANKLIN
*Professor of Mathematics
Massachusetts Institute of Technology*

SIXTH PRINTING

NEW YORK
JOHN WILEY & SONS, INC.
LONDON: CHAPMAN & HALL, LIMITED

COPYRIGHT, 1933
BY PHILIP FRANKLIN

All Rights Reserved

*This book or any part thereof must not
be reproduced in any form without
the written permission of the publisher.*

SIXTH PRINTING, OCTOBER, 1947

Printed in U. S. A.

PREFACE

This text is the outgrowth of a course given for over ten years to electrical engineering students in their junior year at the Massachusetts Institute of Technology. At present the course is one of thirty lectures, and covers a large part of the material of the first six chapters.

While the course follows one in ordinary differential equations, no greater knowledge of this subject is assumed in the text than that frequently included in a first course in the calculus.

The first three chapters are concerned with the ordinary differential equations which arise in the problem of determining the flow of current in a network with lumped constants, and such formal knowledge of complex numbers and Fourier series as is useful for their convenient solution.

The object of the next three chapters is to give the reader an elementary working knowledge of partial derivatives and partial differential equations, including their mathematical origin, geometric and physical meaning, and solution for assigned boundary values.

The last two chapters are of a more theoretical nature, containing demonstrations which justify the earlier calculations with power series and Fourier series. The majority of students, owing to limitations of time and interest, will be content with the initial statement of the results. For the abler students, these chapters will both satisfy their immediate curiosity and skepticism, and enable them to consult more detailed works on analysis.

A short bibliography, arranged by chapters, giving some suggestions for further study, will be found at the end of the book.

In writing this text, I have been helped by mimeographed notes, originally written by Professor H. B. Phillips in collaboration with the late Professor C. L. E. Moore, and subsequently revised by Professor K. L. Wildes. I have also profited by numerous suggestions from colleagues and students.

PHILIP FRANKLIN

CAMBRIDGE, MASS.
January 1, 1933

CONTENTS

CHAPTER I

COMPLEX NUMBERS

	PAGE
1. Real Numbers	1
2. Complex Numbers	3
3. Vectors, Polar Form	7
4. Multiplication and Division in Polar Form	9
5. Powers and Roots	10
6. Complex Variables, Power Series, Analytic Functions	13
7. Exponential and Trigonometric Functions	15
8. Hyperbolic Functions	21
9. Conformal Mapping	25
10. Fundamental Regions	34

CHAPTER II

AVERAGE VALUES AND FOURIER SERIES

11. Average Values	42
12. Root Mean Square Values	45
13. An Inequality for Averages	46
14. Odd and Even Functions	48
15. Periodic Functions	53
16. Trigonometric Integrals	56
17. Finite Trigonometric Sums	61
18. Fourier Series for Arbitrary Periodic Functions	69
19. Fourier Series, Sine Series, Cosine Series, for Arbitrary Functions	75

CHAPTER III

LINEAR DIFFERENTIAL EQUATIONS WITH CONSTANT COEFFICIENTS

20. Linear Equations	80
21. The Complementary Function	83
22. The Particular Integral	86
23. Systems of Equations	90
24. The Differential Equations for a Single Electric Circuit	95
25. The System of Differential Equations for an Electric Network	97
26. Solution of the Circuit and Network Equations	99
27. Method of Variation of Constants	105

CHAPTER IV

PARTIAL DERIVATIVES AND PARTIAL DIFFERENTIAL EQUATIONS

	PAGE
28. Derivatives and Differentials	114
29. Total Differentials	116
30. Change of Variables	117
31. Equation of the Tangent Plane, and a Related Partial Differential Equation	125
32. Formation of Partial Differential Equations by the Elimination of Arbitrary Functions	128
33. Partial Differential Equations solvable by Direct Integration	133
34. First Order Equations, Linear in the Derivatives	137
35. Linear Homogeneous Equations with Constant Coefficients	142
36. Particular Solutions	148

CHAPTER V

THE PHYSICAL MEANING OF CERTAIN PARTIAL DIFFERENTIAL EQUATIONS

37. Flow of Electricity in a Cable	156
38. One Dimensional Heat Flow	162
39. Steady, Irrotational Motion of an Incompressible Fluid in Two Dimensions	166
40. Vibration Problems	172
41. Heat Flow in Space, Curvilinear Co-ordinates	175

CHAPTER VI

SOLUTIONS OF PARTIAL DIFFERENTIAL EQUATIONS SATISFYING GIVEN BOUNDARY VALUES

42. The Steady-state Temperature of a Plate, Two Dimensional Potential Functions	182
43. The Potential Function for a Long Rectangle	183
44. Variable Flow of Heat in a Rod with ends kept at Temperature Zero	188
45. Variable Flow of Heat in a Rod with ends kept at any Constant Temperature	190
46. The Telegraph Equations	196
47. The Wave Equation	199
48. The Radio Equations	202
49. Problems solved by using the General Solution	204
50. Closed Form for the Fourier Series Solution	208

CHAPTER VII

ANALYTIC FUNCTIONS

51. Limits	211
52. Steadily Increasing Real Variables	212
53. Functions, Continuity	213

CONTENTS

vii

	PAGE
54. Series	213
55. Absolute Convergence	215
56. Operations on Series	216
57. Uniformity	220
58. Continuous Limiting Function	221
59. A Test for Uniform Convergence	222
60. Power Series	224
61. Operations on Power Series	225
62. Derivatives	228
63. Integrals	231
64. Integral of a Polynomial	233
65. Integral of a Series	235
66. Cauchy-Riemann Differential Equations	237
67. Cauchy's Integral Theorem	239
68. Taylor's Series	242
69. Alternative Definitions of Analytic Functions	245

CHAPTER VIII

CONVERGENCE OF FOURIER SERIES

70. Statement of the Theorem	249
71. A Change of Scale	251
72. The Partial Sums	251
73. The Trigonometric Sum	252
74. Transformation of the Limit	253
75. Proof of the Limit	255
76. Uniformity of the Convergence	258
77. Functions Smooth near One Value	259
78. Rearrangement of the Terms	261
79. Integration of Fourier Series	262
80. Differentiation of Fourier Series	264
81. Least Square Error	266
82. A Particular Approximation	267
83. Convergence in the Mean	269
84. Averages of Series, Convergent in the Mean	270
85. Multiplication of Fourier Series	271
86. Division of a Finite Trigonometric Sum by a Sum of the First Order	272
87. Abel's Theorem	276
88. Series of Damped Harmonics	277

DIFFERENTIAL EQUATIONS

CHAPTER I

COMPLEX NUMBERS

The solution of certain ordinary differential equations which arise in electrical circuit theory is materially simplified by the use of complex numbers. Furthermore, many problems of mathematical physics, including the determination of lines of flow of electricity or magnetic lines of force in a steady, two-dimensional field, lead to a partial differential equation which has an intimate connection with analytic functions of a complex variable. Accordingly, we devote this chapter to a study of complex quantities.

1. Real Numbers. The need for complex numbers arises in algebra from the impossibility of finding, among the real numbers, square roots of negative quantities. As the extension of the concept "number" from the real to the complex domain is analogous to its previous extensions within the real domain, we briefly recapitulate the definitions of fractions and negative numbers.

The first numbers met with are the **positive integers**, 1, 2, 3, . . . used in counting. For applications of numbers to the measurement of length it is convenient to introduce the **fractions**. When directed scales are used, as temperatures above and below zero, or distances north and south, we require the **negative** numbers. From the original point of view of counting, neither fractions nor negative numbers have any meaning. Having the positive integers, and the rules for their composition by addition (+) and multiplication (\times), we may always find a new positive integer x from two given positive integers a and b such that

$$a + b = x, \tag{1}$$

or

$$ab = x. \tag{2}$$

Sometimes, if $a > b$, we may find an x such that

$$b + x = a. \tag{3}$$

We also write this as

$$a - b = x, \quad (4)$$

defining subtraction ($-$) by the equivalence in meaning of these equations. Similarly, if a is an integral multiple of b , we may find an x such that

$$bx = a, \quad (5)$$

or

$$\frac{a}{b} = x. \quad (6)$$

Division (\div) is *defined* by the equivalence of these equations. From the standpoint of abstract mathematics, zero and the negative numbers are introduced as those symbols satisfying (3) when $a \leq b$. Similarly, the positive fractions are introduced as symbols satisfying (5) when a and b are both positive integers. When a is a positive integer, and b is a negative integer, we introduce a negative fraction. We do not define fractions with zero denominators. A consistent set of laws for operating with these negative and fractional quantities, including the rule of signs for multiplication, may be set up, as the reader knows. We note that our definitions make

$$\frac{a}{1} = a. \quad (7)$$

so that any integer may be represented as a fraction. The totality of fractions make up the system of **rational** numbers. Any rational number may be specified in terms of zero and the positive integers by means of a pair of such numbers, in a given order, together with a sign.

Irrational numbers are introduced by limiting processes. For example, we may use the unending decimal expressions, as:

$$\begin{aligned} \sqrt{2} &= 1.41421 \cdot \cdot \cdot, \\ \pi &= 3.14159 \cdot \cdot \cdot, \end{aligned}$$

which define the irrational numbers on the left as limits of the rational numbers made up of their digits taken to 1, 2, 3, etc. decimal places. We observe that rational numbers give either finite or repeating decimals, while irrational numbers give non-repeating decimals. The rational and irrational numbers together

make up the system of real numbers. Any real number may be specified by an infinite sequence of digits, each selected from the set 0, 1, 2, . . . 9, together with the position of the decimal point and the sign.

In practical applications, we are never able to distinguish between an irrational number, and a rational approximation to a sufficient number of decimal places. In most engineering work three or four places suffice and six or seven places are usually adequate for precise scientific applications. Consequently, while the distinction between rational and irrational numbers is of great theoretical importance, practically we never use irrational numbers, but only rational approximations to them.

Every first degree equation

$$ax + b = 0, \quad a \neq 0, \quad (8)$$

in the rational number system, has a root. That is, for any two rational numbers $a \neq 0$, and b , we may find a rational number x which satisfies (8). Similarly this equation is always solvable in the real number system. The equation:

$$x^2 = a, \quad (9)$$

has roots in the rational number system only for special values of a . It has real roots when a is any positive real number, but no real root when a is negative.

2. Complex Numbers. To construct a number system in which (9) will always have roots, we begin by defining the **imaginary unit**¹ i as a new type of number whose law of multiplication will make

$$i^2 = -1. \quad (10)$$

We then define a **complex number** as a combination

$$a + bi, \quad (11)$$

formed from two real numbers, a and b , and the imaginary unit i . We often omit terms with zero coefficients. Also, coefficients which are unity are not written explicitly.

Thus we write:

$$a + 0i = a, \quad 0 + bi = bi, \quad (12)$$

¹ Electrical engineers frequently use j as the symbol for the imaginary unit, to avoid confusion with the symbol for current intensity.

as well as

$$a + 1i = a + i, \quad a + (-1)i = a - i. \quad (13)$$

In consequence of these conventions, the system of complex numbers includes the real number system, as well as the pure imaginaries of the form bi , and, in particular, the imaginary unit i itself.

The laws of operation for complex numbers are taken as the ordinary laws of algebra for real quantities, with equation (10) added. This leads us to define addition by

$$(a + bi) + (c + di) = (a + c) + (b + d)i. \quad (14)$$

In order to have subtraction the inverse of addition, we must then define

$$(a + bi) - (c + di) = (a - c) + (b - d)i. \quad (15)$$

For multiplication we write

$$(a + bi)(c + di) = (ac - bd) + (ad + bc)i, \quad (16)$$

and for the inverse operation, division,

$$\frac{a + bi}{c + di} = \frac{ac + bd}{c^2 + d^2} + \frac{-ad + bc}{c^2 + d^2}i. \quad (17)$$

In our definition of a complex number in terms of two real numbers, we assumed that each distinct pair of real numbers gives a different complex number. Consequently, if we write

$$a + bi = c + di, \quad (18)$$

where a, b, c, d are all real numbers, we must have:²

$$a = c \quad \text{and} \quad b = d. \quad (19)$$

In consequence of (14) every complex number may be looked on as the sum of a real number a , and a pure imaginary number bi . The equivalence of (18) and (19) is expressed by saying:

When two complex numbers are equal, their real parts are equal and also their imaginary parts are equal.

In particular, a complex number is zero only if its real and imaginary parts are each separately zero.

² This is different from the corresponding relation for fractions or decimals, since:

$$\frac{1}{2} = \frac{2}{4} \quad \text{and} \quad .2 = .199999 \dots$$

Logically, we should carry out operations on complex numbers by using the equations which define these operations. However, owing to our familiarity with the rules of ordinary real algebra, it is practically simpler to proceed as if i were real, merely remembering that a real and a pure imaginary term never combine, and that $i^2 = -1$. For example, in practice, we divide complex numbers by writing:

$$\frac{a + bi}{c + di} = \frac{(a + bi)(c - di)}{(c + di)(c - di)} = \frac{(ac + bd) + (-ad + bc)i}{c^2 + d^2}. \quad (20)$$

EXERCISES I

1. Given $z_1 = 1 - 2i$, $z_2 = -2 + i$, $z_3 = -4i$, find:

(a) $z_1 + z_3$, (b) $z_3 - z_1$, (c) $z_2 + z_3$, (d) $z_2 - z_1$, (e) $z_1 z_2$, (f) z_3 / z_2 , (g) $z_1 z_3$, (h) z_2 / z_1 .

2. The impedance of an electric circuit element to an impressed sinusoidal electromotive force of a particular frequency is conveniently represented by a complex quantity, $z = r + ix$, whose real part, the resistance r , is always positive, but whose reactance, x , may be positive or negative. See p. 102. The formulas for the impedance equivalent to two impedances in series or parallel are the same as those for combining resistances to constant electromotive forces, if the operations are taken in the complex sense. Namely, for series connection,

$$z = z_1 + z_2,$$

and for parallel connection,

$$\frac{1}{z} = \frac{1}{z_1} + \frac{1}{z_2}.$$

Three circuit elements have their impedances to a 60-cycle e.m.f. given by $z_1 = 7 + 650i$, $z_2 = 5 - 10i$, $z_3 = 8 + 3000i$. Find the impedances equivalent to:

(a) z_1 and z_2 in series, (b) z_1 and z_2 in parallel, (c) z_1 , z_2 and z_3 all in series, (d) z_1 , z_2 and z_3 all in parallel, (e) z_1 in series with the combination of z_2 and z_3 in parallel, (f) z_1 in parallel with the combination of z_2 and z_3 in series.

3. Verify that $(1 + i)^2 = 2i$.

4. Solve the equation $z^2 - 4z + 7 = 0$, and check by a direct calculation of the left member for each root.

5. (a) Prove that every complex number has two complex square roots, by finding x and y in terms of a and b such that

$$(x + iy)^2 = a + bi.$$

(b) Show that every quadratic equation has a root, the coefficients being any complex numbers with the leading one different from zero.

6. Solve the equation

$$(x + iy) + (c + di) = a + bi$$

for x and y and compare the result with (15) of the text.

7. Solve the equation

$$(x + iy)(c + di) = a + bi$$

for x and y , and compare the result with (17) of the text.

8. The number $\bar{z} = a - bi$ is called the conjugate of the number $z = a + bi$. Prove:

(a) $z + \bar{z}$ and $z\bar{z}$ are both real numbers.

(b) If $z + z_1$ and zz_1 are both real, $z_1 = \bar{z}$, or z_1 and z_2 are both real.

(c) Prove that the conjugates of $z_1 + z_2$, z_1z_2 and z_1/z_2 are respectively $\bar{z}_1 + \bar{z}_2$, $\bar{z}_1\bar{z}_2$, \bar{z}_1/\bar{z}_2 .

(d) If $P(z)$ is a polynomial with real coefficients, then the conjugate of $P(z)$ is $P(\bar{z})$.

(e) $a = \frac{z + \bar{z}}{2}$, $b = \frac{z - \bar{z}}{2}$.

9. Compute

$$\frac{1}{2} \left(\frac{3i}{2 - 3i} + \frac{-3i}{2 + 3i} \right),$$

and also the real part of $3i/(2 - 3i)$. This illustrates part (e) of the preceding problem.

10. Prove that, if

$$(x + iy)(a + bi) = 0, \quad \text{and} \quad a + bi \neq 0,$$

where x, y, a, b are all real, then $x = y = 0$.

11. The absolute value of the complex number $z = a + bi$ is defined by

$$|z| = \sqrt{a^2 + b^2},$$

where the arithmetic, or positive, square root is meant. This definition makes the absolute value of a real positive number equal to itself, and of a real negative number equal to its negative.

Using the fact that, when A and B are real,

$$(A - B)^2 \geq 0,$$

prove that

$$|z_1 + z_2| \leq |z_1| + |z_2|,$$

and

$$|z_1 + z_2| \geq |z_1| - |z_2|.$$

12. By the method of problem 11, show that

$$\frac{|a| + |b|}{\sqrt{2}} \leq |z| \leq |a| + |b|.$$

13. Prove that, if $z_1z_2 = z_3$, then

$$|z_1| \cdot |z_2| = |z_3|.$$

This equation, squared, gives:

$$(a_1^2 + b_1^2)(a_2^2 + b_2^2) = a_3^2 + b_3^2.$$

Noting that, if a_1, b_1, a_2, b_2 are integers, then a_3, b_3 will also be integers, show from this that the product of two integers, each the sum of two squares, is

again the sum of two squares. Illustrate by expressing

$$2929 = (2^2 + 5^2)(1^2 + 10^2)$$

as the sum of two squares.

3. Vectors, Polar Form. We often represent the real numbers by the points on an indefinite straight line, for example, an axis of co-ordinates. Similarly, we may represent complex numbers geometrically. Here we require two dimensions. In an infinite plane, we draw two axes at right angles, and by selecting a unit of length, obtain a pair of co-ordinates (x, y) for each point in the plane. Conversely, there is just one point for each pair of co-ordinates. By making the complex number $a + bi$ correspond to the point (a, b) we obtain a method of representing complex numbers graphically. Instead of considering, Fig. 1, the point $P = (a, b)$ as the representation, we may equally well consider the directed segment, or vector OP , extending from the origin $O = (0, 0)$ to P as the representative of the complex number. In this case, any parallel segment of the same length and direction is taken as corresponding to the same complex number.

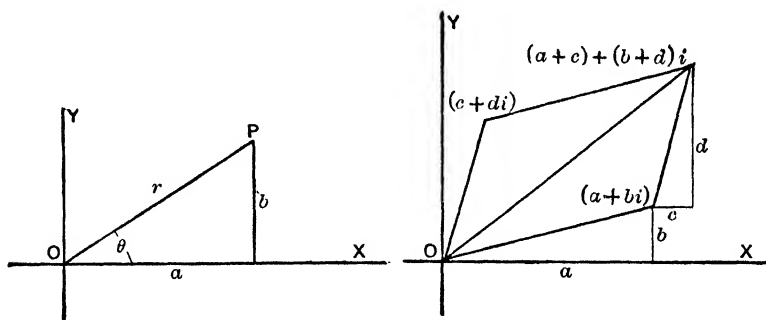

FIG. 1

FIG. 2

If two complex numbers are given graphically, their sum or difference may be directly obtained by adding or subtracting their representative vectors according to the parallelogram law. (See Fig. 2.) This follows from equations (14) and (15).

Before interpreting multiplication and division, it is advisable to introduce polar co-ordinates. If r, θ are the polar co-ordinates of (a, b) , Fig. 1, defined in the usual way as the length of OP (radius r , or absolute value of z , $|z|$) and the angle which rotates

OX into OP (angle or amplitude), measured in the direction which takes OX into OY , we have:

$$\begin{aligned} a &= r \cos \theta, \\ b &= r \sin \theta, \end{aligned} \quad (21)$$

and

$$\begin{aligned} r &= \sqrt{a^2 + b^2}, \\ \theta &= \tan^{-1} \frac{b}{a}. \end{aligned} \quad (22)$$

We restrict r to be positive. Hence, in the equations just written, we take the positive square root, and then take a value of the inverse tangent for which equations (21) are satisfied. Thus the angle θ is determined numerically to within an integral multiple of 360° , or 2π radians. All these values correspond to the same position of the radius vector on the diagram.

In view of equations (21), we may write

$$\begin{aligned} z &= a + bi \\ &= r \cos \theta + i r \sin \theta \\ &= r(\cos \theta + i \sin \theta). \end{aligned} \quad (23)$$

We introduce a special notation for this last expression,

$$r \underline{\theta} = r(\cos \theta + i \sin \theta). \quad (24)$$

The notation

$$r \bar{\theta} = r \underline{-\theta} = r(\cos \theta - i \sin \theta) \quad (25)$$

is also used. We distinguish them verbally by reading $r \underline{\theta}$ as r , lead angle θ , and $r \bar{\theta}$ as r , lag angle θ . The angle θ may be expressed either in degrees or radians, depending on the units used in the trigonometric functions of equations (24) and (25).³

The transformation from polar to rectangular components of a complex vector, or number, is easily accomplished by the use of (21) or (22). Or we may make a direct use of the right triangle in Fig. 1. For example, by either method we note that:

$$a = a \underline{0^\circ \pm k360^\circ}, \quad bi = b \underline{90^\circ \pm k360^\circ},$$

where k is zero or any positive integer, $a > 0$ and $b > 0$.

³ The notation $\sin x$ is used in two senses. In elementary trigonometry, or in computational work, "sin 1" means $\sin 1^\circ = .0175$, while in advanced mathematics it means $\sin 57.3^\circ = .842$. In this text, all angles given numerically are in radians, unless the degree sign ($^\circ$) is added. We may combine angles in degrees and radians, just as we may combine a length of 2 ft. with one of 3 in. to get a length of 2.25 ft. or 27 in. Thus, it is occasionally convenient to write $\sin (1 + 2^\circ)$ to mean $\sin 1.035$ or $\sin 59.3^\circ$.

4. Multiplication and Division in Polar Form. We next consider the product of two complex numbers:

$$\begin{aligned} z_1 &= r_1 \sqrt[\theta_1]{} = r_1(\cos \theta_1 + i \sin \theta_1), \\ z_2 &= r_2 \sqrt[\theta_2]{} = r_2(\cos \theta_2 + i \sin \theta_2). \end{aligned} \quad (26)$$

We note that

$$\begin{aligned} &(\cos \theta_1 + i \sin \theta_1)(\cos \theta_2 + i \sin \theta_2) \\ &= (\cos \theta_1 \cos \theta_2 - \sin \theta_1 \sin \theta_2) + i(\sin \theta_1 \cos \theta_2 + \cos \theta_1 \sin \theta_2) \\ &= \cos (\theta_1 + \theta_2) + i \sin (\theta_1 + \theta_2). \end{aligned}$$

After multiplying in $r_1 r_2$, we deduce from this:

$$z_1 \cdot z_2 = (r_1 \sqrt[\theta_1]{})(r_2 \sqrt[\theta_2]{}) = r_1 r_2 \sqrt[\theta_1 + \theta_2]{}. \quad (27)$$

This shows that when two complex numbers in polar form are multiplied together, the radius of the product is the product of the radii of the factors, while the angle of the product is the sum of the angles of the factors. If, Fig. 3, A and B are the points representing the factors, while C represents the product and U represents the real unit ($1 = 1\sqrt[0^\circ]{} = 1 + 0i$), the triangles UOA and BOC are similar. For, they have an angle of one equal to an angle of the other,

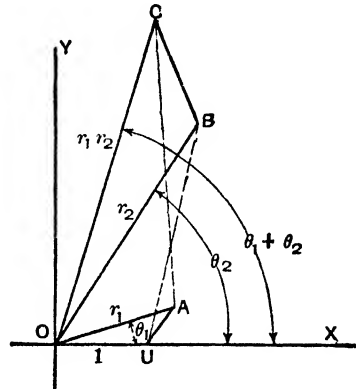

FIG. 3

$$\angle UOA = \theta_1 = \angle BOC,$$

and the sides including the equal angles proportional,

$$\frac{OC}{OB} = \frac{r_1 r_2}{r_2} = \frac{r_1}{1} = \frac{OA}{OU}.$$

Consequently, if we start with A and B , Fig. 3, we may obtain the product C graphically by drawing in triangle OUA , and then constructing a triangle OBC on OB similar to it. When the angles involved are not in the first quadrant, we may avoid confusion by noting that the triangle OBC may be obtained from OUA by first rotating this triangle in the positive direction about O until OU

falls on OU' along OB , and then scaling the triangle up or down, keeping O fixed, until U' reaches B .

Since the order of the factors is immaterial, the rôles of A and B may be interchanged in the construction. The construction shows that the length of the product will be changed if we use the same vectors OA and OB , but alter the length of the unit vector OU . Similarly the direction of the product will be changed if we alter the direction of OU . In this respect multiplication differs from addition, since the construction for the sum of two vectors made no use of the unit vector. In vector analysis, where methods for dealing with vectors without employing co-ordinate axes are developed, the law of addition of vectors is the same as that here used, but the laws for multiplication are different from that discussed here.

Since division is the inverse of multiplication, if

$$\frac{r_1|\theta_1}{r_2|\theta_2} = r|\theta, \quad (28)$$

we must have:

$$r_1|\theta_1 = (r_2|\theta_2)(r|\theta) = r_2r|\theta_2 + \theta. \quad (29)$$

This shows that:

$$r_1 = r_2r, \quad \text{and} \quad \theta_1 = \theta_2 + \theta \pm k360^\circ.$$

Since the solution of these is

$$r = \frac{r_1}{r_2}, \quad \theta = \theta_1 - \theta_2 \mp k360^\circ,$$

we obtain the same complex number for all values of the integer k , and in particular may take $k = 0$. That is,

$$\frac{z_1}{z_2} = \frac{r_1|\theta_1}{r_2|\theta_2} = \frac{r_1}{r_2}|\theta_1 - \theta_2, \quad (30)$$

so that, when two complex numbers in polar form are divided, **the radius of the quotient is the quotient of the radii, and the angle of the quotient is the difference of the angles.**

5. Powers and Roots. By using (27) to multiply a complex number by itself n times, we find that, for any positive integral value of n :

$$(r_1|\theta_1)^n = r_1^n|n\theta_1. \quad (31)$$

That the same formula holds for negative powers is seen from:

$$(r_1|\underline{\theta}_1)^{-n} = \frac{1}{(r_1|\underline{\theta}_1)^n} = \frac{1|0}{r_1^n|\underline{n\theta}_1} = r_1^{-n}|\underline{-n\theta}_1.$$

For a root, or power of the form $1/q$, where q is an integer, we note that, if

$$(r_1|\underline{\theta}_1)^{1/q} = r|\underline{\theta},$$

then,

$$r_1|\underline{\theta}_1 = (r|\underline{\theta})^q = r^q|\underline{q\theta}.$$

Consequently,

$$r_1 = r^q, \quad \text{and} \quad \theta_1 = q\theta \pm k360^\circ.$$

The solution of these equations for r and θ gives:

$$r = r_1^{1/q} \quad \text{and} \quad \theta = \frac{\theta_1 \mp k360^\circ}{q}.$$

Since the radii r and r_1 are positive, r is the arithmetic q th root of r_1 . In the second expression, if we take the plus sign and give q consecutive integral values to k , the corresponding q values of θ will lead to q distinct complex numbers. Any other value of k will lead to a complex number equal to one of the q just referred to, since its angle will differ from one of them by an integral multiple of 360° . Thus a complex number has exactly q distinct q th roots, given by

$$(r_1|\underline{\theta}_1)^{1/q} = r_1^{1/q} \left| \frac{\theta_1 + k360^\circ}{q} \right., \tag{32}$$

$$k = 0, 1, 2, \dots, q - 1.$$

This only differs from (31) in having n replaced by $1/q$, and the added multiples of 360° , which may be omitted if we only seek one q th root, but must be used, with different k , if we wish all possible q th roots. If θ_1 is in radians, it is more convenient to write the angle as $(\theta_1 + k2\pi)/q$, though this is not necessary by the convention stated in the footnote³ on p. 8.

By raising both sides of equation (32) to the p th power, and simplifying by (31), where p is a positive or negative integer, we find:

$$(r_1|\underline{\theta}_1)^{p/q} = r_1^{p/q} \left| \frac{p}{q} (\theta_1 + k360^\circ) \right., \tag{33}$$

$$k = 0, 1, 2, \dots, q - 1.$$

This will give q distinct values, if the fraction p/q is in its lowest terms so that p and q have no common factors. Thus equation (31) applies for all rational values of n . When we define irrational powers of a complex number, problem 15, p. 20, we shall find that these also are given by (31). The result expressed in equation (31) is often referred to as De Moivre's theorem.

Let us apply the result to the problem of finding the three cube roots of -8 . We have:

$$-8 = -8 + 0i = 8\sqrt[3]{180^\circ}.$$

Hence by (32),

$$\begin{aligned} (8\sqrt[3]{180^\circ})^{1/3} &= 8^{1/3} \sqrt[3]{\frac{180^\circ + k360^\circ}{3}}, \\ k &= 0, 1, 2; \end{aligned}$$

and the three cube roots of -8 are:

$$\begin{aligned} 2\sqrt[3]{60^\circ} &= 1 + \sqrt{3}i, \\ 2\sqrt[3]{180^\circ} &= -2, \\ 2\sqrt[3]{300^\circ} &= 1 - \sqrt{3}i. \end{aligned}$$

We have just seen that the equation

$$z^n = a + bi$$

has n roots, and, in fact, have computed them. In general, in the complex number system, every algebraic equation of the n th degree with complex numbers as coefficients, which may, in particular, be real, has roots. Thus the construction and solution of algebraic equations never leads us beyond the complex number system.

EXERCISES II

- Given $z_1 = -2 + 5i$, $z_2 = -3 - 7i$, $z_3 = 2 + 3i$, $z_4 = 4\sqrt[3]{225^\circ}$, $z_5 = 6\sqrt[3]{45^\circ}$, $z_6 = 3\sqrt[3]{\pi/4}$, compute algebraically, and check graphically: (a) $z_1 + z_2$, (b) $z_1 - z_2$, (c) $z_3 - z_2$, (d) $z_3 - z_1$, (e) $z_4 \cdot z_5$, (f) z_5/z_6 , (g) $z_5 \cdot z_6$, (h) z_6/z_4 , (i) $z_1 + z_4$, (j) z_1/z_2 , (k) $z_5 + z_6$, (l) $z_1 \cdot z_5$.
- Find the two square roots of $-1.23 + 3.72i$ and plot them.
- Find the three cube roots of $-3 + 4i$ and plot them.
- Compute and plot the four fourth roots of i .
- In transmission line calculations, we require the values of \sqrt{ZY} and $\sqrt{Z/Y}$, where Z is the series impedance of the line, and Y is the admittance to ground. See problem 4, p. 160. For a certain line, subject to a 60-cycle impressed e.m.f., we have $Z = 0.135 + 0.63i$ and $Y = 1.43 \times 10^{-3} + 4.66 \times 10^{-4}i$.

Compute the values of the two quantities \sqrt{ZY} and $\sqrt{Z/Y}$ for this case.

6. Compute $(2 - 2i)^{10}$.

7. The distance from A to B is 6 miles, and AB bears 30° east of north, while the line BC is 8 miles long and bears 40° west of north.

(a) Represent each of these lines as a complex number, taking the unit vector OU a line one mile long, due east. Find the sum of these two complex numbers, express it in polar co-ordinates, and hence find the length and direction of AC .

(b) Solve the problem as stated in (a), when OU is a line 2 miles long in a north-easterly direction.

(c) Compare the geometric representation of the product of the complex numbers corresponding to AB and BC in parts (a) and (b).

8. Describe geometrically the location of $(z_1 + z_2)/2$ with respect to z_1 and z_2 . Do the same for $(z_1 + 2z_2)/3$. Hence show that $(z_1 + z_2 + z_3)/3$ is the center of gravity of the triangle with vertices at z_1, z_2, z_3 .

9. Prove that the points representing the n th roots of any complex number are the vertices of a regular polygon of n sides.

10. Show that when the roots of the quadratic equation

$$az^2 + bz + c = 0,$$

where a, b, c , are real, are complex, they may be expressed in polar form as

$$\sqrt{\frac{c}{a}} \left| \cos^{-1} \frac{-b}{2\sqrt{ac}} \right|.$$

11. Prove that if a, b, c are any three real numbers, either (a) the circle with i and $-b/a + ci/a$ as the extremities of a diameter cuts the real axis (locus of points with zero imaginary component) or (b) the circle with 0 and $-2c/b$ as the extremities of a diameter cuts the line which is the locus of points whose real part is equal to $-b/2a$. Prove that the points found in (a) are the real roots, if any, and the points found in (b) are the complex roots, if any, of the quadratic equation

$$az^2 + bz + c = 0.$$

12. If $z_1 = r_1\theta_1, z_2 = r_2\theta_2, z_3 = r_3\theta_3$, and $z_3 = z_1 + z_2$, show geometrically that

$$r_1 - r_2 \leq r_3 \leq r_1 + r_2.$$

Compare this result with that of problem 11 on p. 6.

13. Given any two points A and B , neither of which is at O , the origin, prove that by a proper choice of the unit point U , the product of the complex numbers represented by OA and OB may be made equal to any complex number different from zero, but the quotient of the two numbers is independent of the choice of U .

6. Complex Variables, Power Series, Analytic Functions. We say that a real variable y is a function of a real variable x for a certain range of values of x if, for each value of x in this range, there is determined one or more values of y . When there is just one y for each x , the function is said to be single-valued.

The range of a complex variable is usually taken to be two dimensional, e.g., if z takes on all values with absolute value (radius) less than 2, its range on the vector diagram is the interior of a circle of radius 2 drawn about the origin as center. Similarly if the real part of z is between 1 and 3, while the coefficient of i in the imaginary part is between 2 and 4, the range is the interior of a square.

Since we have defined addition and multiplication for complex numbers, it is at once seen that such equations as

$$w = 2 + 5iz,$$

or

$$w = 4z^2,$$

define w as a single-valued function of z for all values of z . More generally, any polynomial in z with real or complex coefficients, is a single-valued function of z . After the polynomials, it is natural to consider expressions obtained from polynomials by limiting processes, for example by adding on more and more terms, as:

$$A_0 + A_1z + A_2z^2 + \cdots + A_nz^n + \cdots, \quad (34)$$

which is called a **power series in z** , or

$$A_0 + A_1(z - C) + A_2(z - C)^2 + \cdots + A_n(z - C)^n + \cdots \quad (35)$$

which is a power series in $(z - C)$. Here C and A_0, A_1 , etc., are in general all complex numbers.

For the power series which we shall use in this chapter, the coefficients will be such that when z , or $(z - C)$ is small enough in absolute value, the series will converge to a finite sum. That is, inside some circle of the z plane, with center C , each series defines a function of z . This function is said to be **analytic** at these points, or for the values of z corresponding to them. In Chapter VII the properties of such power series are discussed in detail, and in particular, it is proved that they may be multiplied, differentiated, and integrated in the same way as the polynomials of which they are the limits. It is also shown that any point at which a function is analytic may be taken as the center C of a power series which converges to the function in some circle with this point as center.

Of course, the series may not be the simplest way to deal with the function practically. Thus,

$$\frac{1}{1 - z} = \frac{1}{1 - C} + \frac{(z - C)}{(1 - C)^2} + \frac{(z - C)^2}{(1 - C)^3} + \cdots$$

if

$$|z - C| < |1 - C|, \quad C \neq 1,$$

so that the function $1/(1 - z)$ is analytic at all points except the point $z = 1$. However, for most purposes it would be simpler to use the form $1/(1 - z)$ than any of the series. This example is an illustration of the class of analytic functions met in algebra, i.e., the class of functions obtained from the complex variable z , and complex constants by addition, subtraction, multiplication, division, and extraction of roots. These functions are all analytic except at points which make a denominator or a quantity whose root is taken zero.

7. Exponential and Trigonometric Functions. We shall now define the exponential and trigonometric functions for complex values of the variable. For real values of x we have the following series⁴:

$$\begin{aligned} e^x &= 1 + \frac{x}{1!} + \frac{x^2}{2!} + \frac{x^3}{3!} + \dots, \\ \sin x &= x - \frac{x^3}{3!} + \frac{x^5}{5!} - \frac{x^7}{7!} + \dots, \\ \cos x &= 1 - \frac{x^2}{2!} + \frac{x^4}{4!} - \frac{x^6}{6!} + \dots. \end{aligned}$$

These give one way of calculating the three functions for all real values of x .

The first of these suggests a function of the complex variable z , namely:

$$e^z = 1 + \frac{z}{1!} + \frac{z^2}{2!} + \frac{z^3}{3!} + \dots \tag{36}$$

Although we have written the left member e^z , and continue to call the function defined by the series the exponential function, it is no longer capable of interpretation as a power when z is not real.

The fundamental property of the exponential function for real values is

$$e^{x_1} \cdot e^{x_2} = e^{x_1 + x_2}.$$

To see if this property continues to hold, we multiply the series

$$e^{z_1} = 1 + z_1 + \frac{z_1^2}{2!} + \dots + \frac{z_1^n}{n!} + \dots,$$

⁴ The quantity $e = 2.71828 \dots$, the base to which natural logarithms are taken, is occasionally denoted by ϵ in works on electricity to avoid confusion with the symbol for instantaneous electromotive force.

by

$$e^{z_1} = 1 + z_1 + \frac{z_1^2}{2!} + \cdots + \frac{z_1^n}{n!} + \cdots,$$

and find:

$$e^{z_1} \cdot e^{z_2} = 1 + (z_1 + z_2) + \frac{(z_1 + z_2)^2}{2!} + \cdots + \frac{(z_1 + z_2)^n}{n!} + \cdots,$$

since the n th term of the product

$$\frac{z_1^n}{n!} + \frac{z_2 z_1^{n-1}}{1!(n-1)!} + \cdots + \frac{z_2^r z_1^{n-r}}{r!(n-r)!} + \cdots + \frac{z_2^n}{n!} = \frac{(z_1 + z_2)^n}{n!}$$

by the binomial theorem. On comparing our product series with the defining equation (36), we see that

$$e^{z_1} \cdot e^{z_2} = e^{z_1+z_2}. \quad (37)$$

As all the laws of exponents were derived from this relation, they hold for complex values of the exponent. For example

$$(e^z)^m = e^{mz}. \quad (38)$$

When complex values are considered, the exponential and trigonometric functions are intimately related. Accordingly, before studying the exponential functions further, we define the sine and cosine of a complex quantity by means of the series

$$\sin z = z - \frac{z^3}{3!} + \frac{z^5}{5!} - \frac{z^7}{7!} + \cdots \quad (39)$$

and

$$\cos z = 1 - \frac{z^2}{2!} + \frac{z^4}{4!} - \frac{z^6}{6!} + \cdots \quad (40)$$

The relation between the exponential function and these two functions may be found as follows. Replace z in (36) by iz , and break up the series into two series:

$$\begin{aligned} e^{iz} &= 1 + (iz) + \frac{(iz)^2}{2!} + \frac{(iz)^3}{3!} + \cdots \\ &= \left(1 - \frac{z^2}{2!} + \frac{z^4}{4!} - \cdots\right) + i \left(z - \frac{z^3}{3!} + \frac{z^5}{5!} - \cdots\right). \end{aligned}$$

By comparing this with (39) and (40), we find Euler's equation:

$$e^{iz} = \cos z + i \sin z. \quad (41)$$

Since (39) contains only odd powers of z , the sine is an odd function of z , that is, it reverses sign when the sign of z is changed. Similarly from (40), which contains only even powers of z , we see that the cosine is an even function of z , being unchanged when the sign of z is changed. Applying these facts, and putting $-z$ in place of z in (41), we find:

$$e^{-iz} = \cos z - i \sin z. \quad (42)$$

The equations (41) and (42) may be solved for the sine and cosine, in the form:

$$\sin z = \frac{e^{iz} - e^{-iz}}{2i}, \quad (43)$$

$$\cos z = \frac{e^{iz} + e^{-iz}}{2}. \quad (44)$$

This pair of equations may be used to reduce any trigonometric identity to an algebraic identity, which may be proved by using (37) and (38). For example, the addition theorem:

$$\sin(A + B) = \sin A \cos B + \cos A \sin B$$

reduces, in view of (43) and (44) to

$$\begin{aligned} \frac{e^{i(A+B)} - e^{-i(A+B)}}{2i} &= \frac{e^{iA} - e^{-iA}}{2i} \cdot \frac{e^{iB} + e^{-iB}}{2} \\ &+ \frac{e^{iA} + e^{-iA}}{2} \cdot \frac{e^{iB} - e^{-iB}}{2i}. \end{aligned}$$

This is seen to be an identity when we multiply out and apply the laws of exponents. Conversely, trigonometric identities may be obtained by starting with exponential identities. By these methods we may show that all the formulas and identities of the trigonometric functions obtained for real numbers continue to hold when the arguments are complex. For complex, as for real quantities, we define the tangent, cotangent, secant and cosecant in terms of the sine and cosine. We note that the relations (43) and (44) might have been taken as the definition of $\sin z$ and $\cos z$, and then the series (39) and (40) could have been deduced from them.

The exponential and trigonometric functions are easily computed for complex values of the argument, if tables giving their values for real arguments are available. We begin with the ex-

ponential function. We have from (37) and (41)

$$\begin{aligned} e^{a+ib} &= e^a \cdot e^{ib} \\ &= e^a(\cos b + i \sin b) \\ &= e^a \cos b + ie^a \sin b. \end{aligned} \tag{45}$$

In this formula, as in all formulas derived from (39) and (40), the argument of the trigonometric functions is to be taken in radians.

Formula (45) gives us a means of writing any number as an exponential, since⁵

$$\begin{aligned} r|_{\theta} &= r(\cos \theta + i \sin \theta) \\ &= e^{\ln r} (\cos \theta + i \sin \theta) \\ &= e^{\ln r + i\theta}. \end{aligned} \tag{46}$$

Thus, if the logarithm be defined as the inverse of the exponential function, we have:

$$\log_e z = \ln r + i\theta. \tag{47}$$

Since θ is only determined to within a multiple of 2π , a complex number has an infinite number of logarithms.

From (46) we note that

$$r|_{\theta} = re^{i\theta}, \tag{48}$$

which gives an alternative way of writing complex numbers in polar form. This explains why, in sections 4 and 5, we found the laws for θ similar to the laws for exponents. It is occasionally convenient to use degrees in the right, as well as in the left member of (48), so that we write:

$$r|\underline{A}^\circ = re^{iA^\circ},$$

the right member being defined by this relation, or by the convention (see footnote ³ on p. 8) that A° means the number $A\pi/180$.

The sine, or cosine of a complex number may now be computed by using (43) or (44) together with (45). Thus we have

$$\sin(a + bi) = \frac{e^{i(a+bi)} - e^{-i(a+bi)}}{2i} = \frac{e^{-b+ai} - e^{b-ai}}{2i}$$

⁵ $\ln r$ means natural logarithm of r , often written $\log_e r$ or in advanced mathematical texts simply $\log r$.

$$\begin{aligned}
 &= \frac{e^{-b}(\cos a + i \sin a) - e^b(\cos a - i \sin a)}{2i} \\
 &= \frac{(e^b + e^{-b})}{2} \sin a + i \frac{(e^b - e^{-b})}{2} \cos a. \quad (49)
 \end{aligned}$$

EXERCISES III

- Write each of the following in the form rei^{θ} , and also in the form re^{iA° :
 (a) $3 + 5i$, (b) $3 - 5i$, (c) $5(\cos 60^\circ + i \sin 60^\circ)$ (d) $5|30^\circ$, (e) $4|\pi/4$.
- Express each of the following in the form $a + bi$:
 (a) $e^{i\pi/2}$, (b) $e^{i\pi}$, (c) $e^{i3\pi/2}$, (d) $e^{i2\pi}$, (e) $e^{-8i\pi}$.
- Express in the form $a + bi$:
 (a) $3e^{i20^\circ}$, (b) $-2e^{i\pi/3}$, (c) $\log_e(2 + 2i)$, (d) $\log_e(-1)$, (e) $\log_e i$.
- Compute the value of $e^{.02 - .03i}$ to three decimal places, (a) by using (45) of the text and (b) by a direct use of the series (36) of the text.
- Prove that, for z complex:
 (a) $\sin^2 z + \cos^2 z = 1$, (b) $\cos 2z = \cos^2 z - \sin^2 z$, (c) $\sin 2z = 2 \sin z \cos z$.
- (a) Show that any polynomial in $\sin x$ and $\cos x$ may be reduced, by means of (43) and (44) to a first degree expression in terms of the form e^{inx} and e^{-inx} , where n is an integer, and then further reduced to a sum of terms each of the form $a \sin nx$ and $b \cos nx$ by means of (41) and (42). (b) Illustrate part (a) for $\sin^4 x$, $\sin^2 x \cos^2 x$. (c) From the result of part (b) find $\int \sin^4 x \, dx$ and $\int \sin^2 x \cos^2 x \, dx$.

7. If $w = \sin^{-1} z$ is a quantity for which $z = \sin w$, prove that

$$\begin{aligned}
 \sin^{-1} z &= \frac{1}{i} \log_e (iz \pm \sqrt{1 - z^2}) \\
 &= i \log_e (\pm \sqrt{1 - z^2} - iz).
 \end{aligned}$$

8. If $\tan z = \frac{\sin z}{\cos z}$, prove that, for z complex,

$$(a) \quad \tan z = \frac{e^{iz} - e^{-iz}}{i(e^{iz} + e^{-iz})}.$$

$$(b) \quad \tan 2z = \frac{2 \tan z}{1 - \tan^2 z}.$$

9. If $\tan^{-1} z = w$ means $z = \tan w$, prove that

$$\tan^{-1} z = \frac{i}{2} \log_e \frac{i + z}{i - z}.$$

10. (a) If z is a complex function of a real variable t , $z = x(t) + iy(t)$, prove that

$$\frac{dz}{dt} = \lim_{\Delta t \rightarrow 0} \frac{\Delta z}{\Delta t} = \frac{dx}{dt} + i \frac{dy}{dt}.$$

(b) Similarly to (a) show that

$$\frac{de^z}{dt} = e^z \frac{dz}{dt}.$$

(c) Apply (b) to find a complex function of t whose derivative is $e^{(a+bt)t}$.

(d) Separate the solution of (c) into real and imaginary components, and so find the value of $\int e^{at} \cos bt \, dt$.

11. If A , and a are constants, but t is a variable, which we may think of as the time, the complex number

$$A \underline{\omega t + a} = A e^{i(\omega t + a)}$$

is called a **rotating vector**.

(a) Justify this terminology by showing that the vector representing this number in the complex plane is of constant length, and rotates uniformly with frequency $\omega/2\pi$.

(b) Prove that the product of any two rotating vectors is a rotating vector whose frequency is the sum of the frequencies of the two vectors.

(c) Prove that the quotient of any two rotating vectors is a rotating vector whose frequency is the difference of the frequencies of the two vectors.

(d) State the special form of (b) and (c) which applies when one of the vectors is of frequency zero, i.e., a constant vector. Similarly the form which applies when the two vectors are of the same frequency.

(e) Show that the sum or difference of two rotating vectors of the *same* frequency, is a rotating vector of the same frequency, either from the geometric interpretation, or by using the identity

$$A e^{i(\omega t + a)} \pm B e^{i(\omega t + b)} = e^{i\omega t} (A e^{ia} \pm B e^{ib}).$$

Note that the sum or difference of two rotating vectors of different frequencies is in general *not* a rotating vector.

12. Show that each of the three rotating vectors $z_1 = 15 \underline{377t - 45^\circ}$, $z_2 = 5 \underline{377t}$, $z_3 = 12 \underline{377t + 30^\circ}$ rotates sixty times per second, and find in the form of a rotating (possibly stationary) vector each of the following:

(a) $z_1 + z_2$, (b) $z_2 - z_3$, (c) $z_1 + z_3$, (d) $z_1 \cdot z_2$, (e) z_2/z_1 , (f) $z_2 \cdot z_3$, (g) z_2/z_3 .

13. Noting that $E_m \sin(\omega t + a)$ is the imaginary component of the rotating vector $E_m \underline{\omega t + a}$, and the real component of the rotating vector $E_m \underline{\omega t + a - 90^\circ}$, determine the rotating vector

- (a) whose real component is $6 \sin(85t - 20^\circ)$,
 (b) whose imaginary component is $5 \sin(63t - 35^\circ)$,
 (c) whose imaginary component is $7 \cos 54t + 6 \sin 54t$,
 (d) whose imaginary component is $3 \cos(45t + 125^\circ)$.

14. Prove that

$$\cos(a + bi) = \frac{(e^b + e^{-b})}{2} \cos a - i \frac{(e^b - e^{-b})}{2} \sin a.$$

15. If $z^m = e^{m \log_e z}$, where

$$\log_e z = \ln r + i(\theta \pm 2k\pi), \quad k \text{ integral,}$$

(a) Prove that, if m is an integer, this leads to just one value for all k , the ordinary m th power of z .

(b) If m is a rational number, in its lowest terms p/q , this leads, for different values of k , to one of the q values of this power as found in section 5.

(c) If this is taken as the definition of z^m , there are an infinite number of m th powers when m is irrational, or complex.

16. Using the definition given in 12, (c), compute one value of each of the following in the form $a + bi$.

(a) $3\sqrt{2}$, (b) $23i$, (c) $(4 - 4i)\sqrt{3}$, (d) $(1 + \sqrt{3}i)^i$, (e) $(\sqrt{3} - i)^{(2+2i)}$.

17. (a) Prove that, if z be changed by $2\pi i$, e^z is unchanged. Hence, if k is an integer,

$$e^{z \pm 2k\pi i} = e^z.$$

(b) For this reason e^z is said to be periodic, and to have the periods $2k\pi i$. Prove that $2\pi i$ is, numerically, the smallest period.

18. (a) Verify that the sum of the geometric progression

$$e^{iz} + e^{2iz} + \dots + e^{niz} \text{ is } \frac{e^{(n+1)iz} - e^{iz}}{e^{iz} - 1} = \frac{e^{(n+1)iz} - e^{\frac{iz}{2}}}{e^{\frac{iz}{2}} - e^{-\frac{iz}{2}}}.$$

(b) From this, and the result obtained when z is replaced by $-z$, deduce that:

$$\sin z + \sin 2z + \dots + \sin nz = \frac{\cos \frac{z}{2} - \cos \left(n + \frac{1}{2}\right)z}{2 \sin \frac{z}{2}},$$

and

$$\cos z + \cos 2z + \dots + \cos nz = \frac{\sin \left(n + \frac{1}{2}\right)z - \sin \frac{z}{2}}{2 \sin \frac{z}{2}}.$$

19. Prove that, if $z = a + bi$,

- (a) $|e^z| = e^a$, (b) $|e^{-z}| = e^{-a}$,
 (c) $\frac{|e^b - e^{-b}|}{2} \leq |\sin z| \leq \frac{e^b + e^{-b}}{2}$,
 (d) $\frac{|e^b - e^{-b}|}{2} \leq |\cos z| \leq \frac{e^b + e^{-b}}{2}$.

8. Hyperbolic Functions. If we omit the i from the right members of equations (43) and (44), or leave out the minus signs in the series (39) and (40), we obtain the **hyperbolic functions**.⁶ Using the customary abbreviations \sinh , read hyperbolic sine, and \cosh , read hyperbolic cosine, we have:

$$\sinh z = \frac{e^z - e^{-z}}{2}, \tag{50}$$

$$\cosh z = \frac{e^z + e^{-z}}{2}, \tag{51}$$

* For the origin of the name, see problem 3, p. 23.

$$\sinh z = z + \frac{z^3}{3!} + \frac{z^5}{5!} + \frac{z^7}{7!} + \dots, \quad (52)$$

$$\cosh z = 1 + \frac{z^2}{2!} + \frac{z^4}{4!} + \frac{z^6}{6!} + \dots \quad (53)$$

Either the first two, or the last two, may be taken as definitions, and the other two then deduced from them, by means of (36). The hyperbolic functions for real values of the argument are tabulated in most collections of mathematical tables. The direct functions are easily found from tables of exponential functions, but for finding inverse functions, tables of the functions themselves are desirable. Analogously to the corresponding trigonometric functions, we define \tanh (hyperbolic tangent), \coth (hyperbolic cotangent), sech (hyperbolic secant) and cosech (hyperbolic cosecant) by the relations:

$$\begin{aligned} \tanh z &= \frac{\sinh z}{\cosh z}, & \coth z &= \frac{\cosh z}{\sinh z}, \\ \operatorname{sech} z &= \frac{1}{\cosh z}, & \operatorname{cosech} z &= \frac{1}{\sinh z}. \end{aligned} \quad (54)$$

The hyperbolic functions enable us to simplify the expression for the sine or cosine of a complex number. Thus, from (49), combined with (50) and (51) we deduce

$$\sin(a + bi) = \cosh b \sin a + i \sinh b \cos a. \quad (55)$$

By comparing (43) and (44) with (50) and (51), we find the following relations between the trigonometric and hyperbolic functions:

$$\begin{aligned} \sin iz &= i \sinh z, & \cos iz &= \cosh z, \\ \sinh iz &= i \sin z, & \cosh iz &= \cos z. \end{aligned} \quad (56)$$

From these equations we may deduce relations involving hyperbolic functions from those involving trigonometric functions by replacing the arguments by i times new arguments. Thus, in (55) we may put $a = ia'$, $b = ib'$, and find, after making use of (56):

$$i \sinh(a' + ib') = \cos b' i \sinh a' + i^2 \sin b' \cosh a'.$$

On dividing this by i , and dropping primes, we have:

$$\sinh(a + bi) = \cos b \sinh a + i \sin b \cosh a. \quad (57)$$

By this method, we find for hyperbolic functions:

$$\cosh^2 z - \sinh^2 z = 1, \quad (58)$$

$$\cosh (A + B) = \cosh A \cosh B + \sinh A \sinh B, \quad (59)$$

$$\sinh (A + B) = \sinh A \cosh B + \cosh A \sinh B, \quad (60)$$

from the corresponding formulas for trigonometric functions.

EXERCISES IV

1. Prove that

$$\cos (a + bi) = \cos a \cosh b - i \sin a \sinh b.$$

2. Prove that

$$\cosh (a + bi) = \cosh a \cos b + i \sinh a \sin b,$$

(a) By using problem 1 and (56),

(b) By putting $A = a$, $B = bi$ in (59),

(c) By a direct application of (50) and (51), combined with (43) and (44).

3. In Fig. 4, CD is an arc of the circle $x^2 + y^2 = 1$ with center at the origin A . If the shaded sector ACD has an area equal to $u/2$, we have $BD = \sin u$, $AB = \cos u$, $CE = \tan u$. For Fig. 5, if CD is an arc of the hyperbola

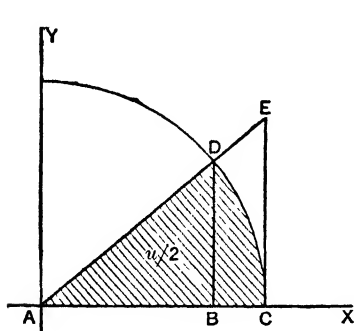

FIG. 4

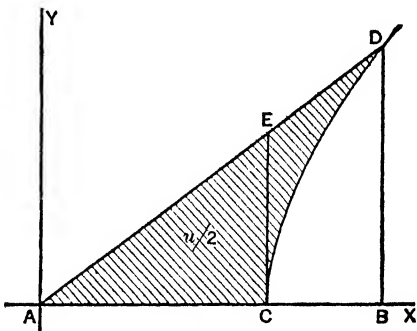

FIG. 5

$x^2 - y^2 = 1$, and the shaded sector is $u/2$ in area, prove that $BD = \sinh u$, $AB = \cosh u$, $CE = \tanh u$. This analogous set of relations of hyperbolic functions to a rectangular hyperbola to those of circular functions to the unit circle is the origin of the terminology.

4. If the first formula defines ϕ , $-\frac{\pi}{2} < \phi < \frac{\pi}{2}$, the Gudermannian of u , $gd u$, prove that:

$$\begin{aligned} \sinh u &= \tan \phi, & \cosh u &= \sec \phi, \\ \tanh u &= \sin \phi, & \coth u &= \operatorname{cosec} \phi, \\ \operatorname{sech} u &= \cos \phi, & \operatorname{cosech} u &= \cot \phi, \end{aligned}$$

also

$$u = \ln \tan (\pi/4 + \phi/2), \quad \phi = 2 \tan^{-1} e^u - \pi/2.$$

5. If $u = 1$, compute ϕ from the last formula in problem 4, and verify the first two relations of that problem for the values taken from the tables.

6. If $\sinh^{-1} z = w$ means $z = \sinh w$, prove that

$$\sinh^{-1} z = \log_e (z \pm \sqrt{1 + z^2}).$$

7. If $\tanh^{-1} z = w$ means $z = \tanh w$, prove that

$$\tanh^{-1} z = \frac{1}{2} \log_e \frac{1+z}{1-z}.$$

8. In the calculus we found

$$\int \frac{dx}{1+x^2} = \tan^{-1} x, \quad \int \frac{dx}{1-x^2} = \frac{1}{2} \ln \frac{1+x}{1-x}.$$

Using problem 9, p. 19, express the first integral in a form analogous to that written for the second one. Then, using problem 7 above, express the second integral in a form analogous to that written for the first.

9. Using problem 7, p. 19 and problem 6 above, express each of the integrals

$$\int \frac{dx}{\sqrt{1-x^2}} = \sin^{-1} x, \quad \text{and} \quad \int \frac{dx}{\sqrt{1+x^2}} = \ln(x + \sqrt{1+x^2})$$

in another form, similar to that written for the other integral.

10. Prove that, if $z = a + bi$,

$$\begin{aligned} |\sinh b| &\leq |\sin z| \leq \cosh b, \\ |\sinh b| &\leq |\cos z| \leq \cosh b, \\ |\sinh a| &\leq |\sinh z| \leq \cosh a, \\ |\sinh a| &\leq |\cosh z| \leq \cosh a. \end{aligned}$$

11. The Bessel function of order n ,

$$J_n(z) = \sum_{k=0}^{\infty} \frac{(-1)^k z^{n+2k}}{2^{n+2k} k! (n+k)!}, \quad \text{where } 0! = 1 \text{ in the first term, is one solution}$$

of the differential equation

$$\frac{d^2 w}{dz^2} + \frac{1}{z} \frac{dw}{dz} + \left(1 - \frac{n^2}{z^2}\right) w = 0,$$

as will be shown in problem 10, p. 230.

(a) Assuming this fact, verify that the modified Bessel function of order n , $I_n(z) = i^{-n} J_n(iz)$ is one solution of

$$\frac{d^2 w}{dz^2} + \frac{1}{z} \frac{dw}{dz} - \left(1 + \frac{n^2}{z^2}\right) w = 0,$$

and that, as thus defined,

$$I_n(z) = \sum_{k=0}^{\infty} \frac{z^{n+2k}}{2^{n+2k} k! (n+k)!}.$$

(b) Show that, if

$$\text{ber } z = \sum_{k=0}^{\infty} \frac{(-1)^k z^{4k}}{2^{4k} (2k!)^2}, \quad \text{bei } z = \sum_{k=0}^{\infty} \frac{(-1)^k z^{2+4k}}{2^{2+4k} [(2k+1)!]^2},$$

then

$$I_0(\sqrt{iz}) = \text{ber } z + i \text{bei } z,$$

and that this last function is a solution of the differential equation

$$\frac{d^2w}{dz^2} + \frac{1}{z} \frac{dw}{dz} - iw = 0.$$

(c) Show that, if z is a real quantity, then $J_n(z)$ and $I_n(z)$ are real, while in general $I_0(\sqrt{iz})$ will be complex, having the real quantities $\text{ber } z$ and $\text{bei } z$ as its real and imaginary components, respectively.

9. Conformal Mapping. Since all the possible values of a real variable may be represented by the points on a line, when we have two real variables, one of which depends on another, we may represent the relation between them graphically by taking two lines, one for each of the variables, as the X and Y axes of co-ordinate geometry, and indicate that a value y corresponds to a value x by plotting the point (x, y) . A less convenient, though possible way of indicating the correspondence is to merely take the two lines, and indicate by some symbol, say the same letter, corresponding values. Thus, in this sense the C scale of a slide rule, together with the L scale graphically depict the logarithmic function, the distance from 1 to, e.g., 3 on the C scale being a constant times the logarithm of the distance from 0 to 3 on the L scale, since the first is proportional to $\log 3$, and the second to 3.

For the complex variable, we must use the latter method, since a single complex variable has a real and an imaginary component, so that the first type of graph for a complex variable would require four dimensions. Accordingly we take two planes, one for the independent complex variable, usually denoted by $z = x + iy$, and one for the dependent variable, which is a function of z , $w = u + iv$. Here x, y, u and v are all real quantities. The functional relation between w and z will determine, at least for some region of the z plane, a value of w for every value of z . If a sufficient number of corresponding points are marked, a fair notion of the relation is given. We may regard this correspondence of the points in the z and w planes as giving a map of one plane on the other. If we think of the planes as superimposed, we have a transformation of the plane into itself, and we sometimes speak of the function $w = f(z)$ as a transformation of the plane.

As a first example, consider the function:

$$w = (2 + 2i)z + (-3 - 5i). \quad (61)$$

We begin by separating the real and imaginary parts, writing

$$\begin{aligned} u + iv &= (2 + 2i)(x + iy) - 3 - 5i \\ &= 2x - 2y - 3 + (2x + 2y - 5)i. \end{aligned}$$

By equating real and imaginary parts, we find from this

$$\begin{aligned} u &= 2x - 2y - 3, \\ v &= 2x + 2y - 5. \end{aligned} \tag{62}$$

These equations, which give u and v in terms of x and y enable us to find the image of any given point in the z plane. For example, we find as the points corresponding to

$$\begin{aligned} z = x + iy &= 0, & 2, & 2 + 2i, & 2i, \\ w = u + iv &= -3 - 5i, & 1 - i, & -3 + 3i, & -7 - i, \end{aligned}$$

respectively. These values could, of course, have been obtained directly from (61), but if more than one is wanted it is worth while carrying out the simplifications which lead to (62) once for all.

If a curve in the z plane is given, we may construct its image approximately by taking a sufficient number of points on it, and joining their images by a smooth curve. If the equations of the transformation are complicated, this is the only practicable method. In simple cases, like the present one, we may transform the equation of the curve, given in the form⁷ $y = f(x)$, or $F(x, y) = 0$, by finding x and y in terms of u and v . We solve equations (62) as simultaneous in x and y , and find:

$$\begin{aligned} x &= \frac{u}{4} + \frac{v}{4} + 2, \\ y &= -\frac{u}{4} + \frac{v}{4} + \frac{1}{2}. \end{aligned} \tag{63}$$

From these equations, we see for example that the circle

$$x^2 + y^2 = 1 \tag{64}$$

in the z plane, has as its image in the w plane the curve whose equation is

⁷ We recall that $f(x)$ means any function of x , and $F(x, y)$ any function of x and y , that is, any quantity which is determined by the values of the independent variables, x in the first case and x and y in the second. The function does not need to change with these quantities, though it usually does. Thus 3 is a function of x , or a function of x and y . When several different functions occur in the same problem, we use other letters, as $g(x)$, $H(x, y)$ for them.

$$\left(\frac{u}{4} + \frac{v}{4} + 2\right)^2 + \left(-\frac{u}{4} + \frac{v}{4} + \frac{1}{2}\right)^2 = 1.$$

This may be simplified to

$$u^2 + v^2 + 6u + 10v + 26 = 0,$$

or

$$(u + 3)^2 + (v + 5)^2 = 8, \tag{65}$$

which shows that it is also a circle.

As an additional example, we shall find the images of the lines through the points previously used,

$$x = 0, \quad x = 2, \quad y = 0, \quad y = 2.$$

The images are

$$u + v + 8 = 0, \quad u + v = 0, \quad -u + v + 2 = 0, \quad -u + v - 6 = 0,$$

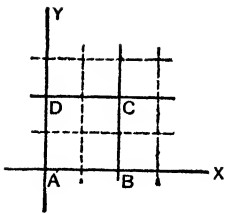

FIG. 6

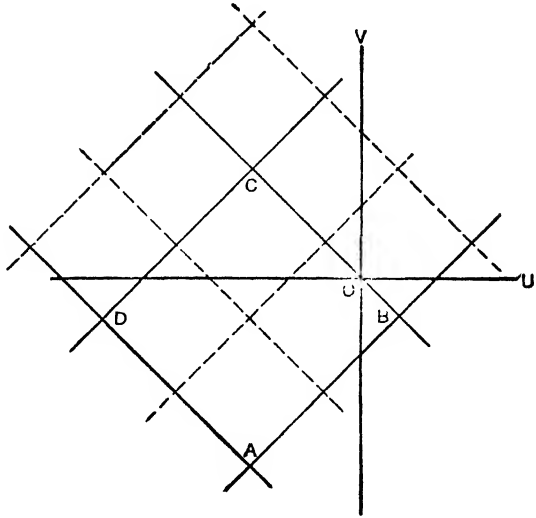

FIG. 7

respectively. We indicate the points and straight lines in Fig. 6, and their images in Fig. 7.

We have computed the images of both the vertices and the sides. Logically, it was unnecessary to calculate the vertices separately, since they are located as the intersections of the sides. Practically, their values serve to check the computation. In this transformation, because the equations (63) are of the first degree in u and v ,

straight lines go into straight lines. This fact would give the sides from the vertices. However, for general transformations, straight lines do not go over into straight lines, but into curved lines, as we shall see in the next illustration.

If a single curve only were to be transformed, instead of deriving (63) from (62), it would be simpler to derive (63) directly by solving (61) for z in terms of w :

$$\begin{aligned} z &= \frac{w + 3 + 5i}{2 + 2i}, \\ x + iy &= \frac{u + iv + 3 + 5i}{2 + 2i} \cdot \frac{2 - 2i}{2 - 2i} \\ &= \left(\frac{u}{4} + \frac{v}{4} + 2\right) + i\left(-\frac{u}{4} + \frac{v}{4} + \frac{1}{2}\right). \end{aligned} \quad (66)$$

A continuation of the process used for the full lines in Fig. 6, shows that the dotted lines are transformed as indicated in Fig. 7. The effect of the transformation (61) on the square network is to scale it up in the ratio 1 to $2\sqrt{2}$, to rotate it about the origin through 45° , and then to slide it parallel to itself, or to translate it by the vector OA or $-3 - 5i$. Further calculation would show the same effect on any square network, however fine. Moreover, from the nature of the transformation, the points inside a small square bounded by four lines of the network in the z plane go over into points bounded by the images of these lines. Consequently, we suspect that any figure in the z plane is changed into its image in the w plane by the combination of scaling up, rotating, and translating described above. We verify this conjecture by writing (61) in the form

$$\begin{aligned} w &= 2\sqrt{2} \left[\frac{45^\circ}{r|\theta} \cdot r|\theta - 3 - 5i \right] \\ &= 2\sqrt{2} \left[r|\theta + \frac{45^\circ}{r|\theta} - 3 - 5i \right]. \end{aligned} \quad (67)$$

This shows that if any point $z = r|\theta$ be selected, its image w is found by scaling up the vector joining it to the origin in the ratio $2\sqrt{2}$, rotating it through 45° , and finally adding the vector $-3 - 5i$, or translating it by this amount. Consequently, any figure formed of a collection of points is imaged by the same process. From this point of view, we could write down (65) at once as the image of (64). For the latter is the equation of a circle of radius one, with center at the origin. The scaling up changes the radius to $2\sqrt{2}$,

or $\sqrt{8}$, the rotation leaves it unchanged, and the translation takes the center from $(0, 0)$ to $(-3, -5)$.

It is not hard to see that the reasoning just used applies to any first degree expression in z , and shows that the mapping defined by it consists of a combination of scaling up or down, rotation through an angle, and a translation.

As a second example, consider the function

$$w = \frac{12}{z - 3}, \quad (68)$$

and let us find out its effect on the lines

$$\begin{aligned} x &= 1, 2, 3, \dots \\ y &= 1, 2, 3, \dots \end{aligned}$$

of Fig. 6. As we wish to transform lines, we require x and y in terms of u and v . We apply the method used to obtain (66). We begin by solving (68) for z :

$$z = \frac{3w + 12}{w},$$

or

$$\begin{aligned} x + iy &= 3 + \frac{12}{u + iv} \\ &= 3 + \frac{12u - 12iv}{u^2 + v^2}. \end{aligned}$$

On equating real and imaginary parts, we obtain from this

$$\begin{aligned} x &= 3 + \frac{12u}{u^2 + v^2}, \\ y &= \frac{-12v}{u^2 + v^2}. \end{aligned} \quad (69)$$

These equations show that the images of the lines

$$x = 0, \quad x = 1, \quad y = 0, \quad y = 1;$$

are the curves:

$$\begin{aligned} 3(u^2 + v^2) + 12u &= 0, & 2(u^2 + v^2) + 12u &= 0, \\ v &= 0, & u^2 + v^2 + 12v &= 0, \end{aligned}$$

respectively. Similarly we may apply the equations (69) to the other lines of Fig. 6, and find as the image of the network of squares

there shown, the curvilinear network shown in Fig. 8. The square having one vertex at $z = 3$ has as its image in the w plane an infinite region. In fact, the equation (68) shows that, as z approaches 3, the numerical value of the corresponding w becomes infinite. On the other hand, equations (69) show that, as w

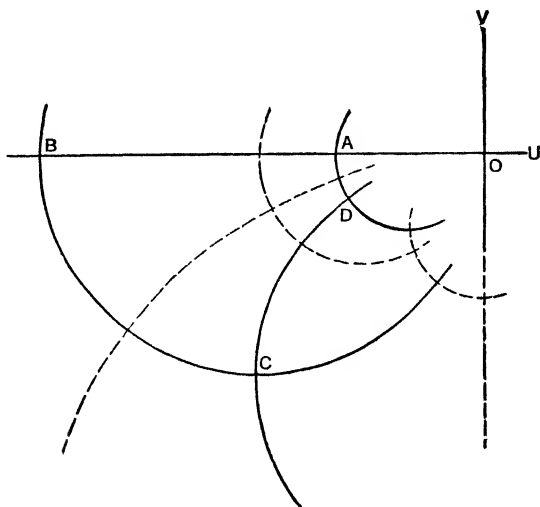

FIG. 8

recedes from the origin in any way whatever, as long as its distance from the origin becomes infinite, the corresponding value of z will approach 3. We express this situation briefly by saying "the point at infinity" in the w plane is the image of the point $z = 3$.

It will be noted that the transformation just discussed takes straight lines into curves. As the lines parallel to the x -axis go into circles tangent to the u -axis, while lines parallel to the y -axis go into circles tangent to the v -axis, the square network is transformed into a network formed of two series of curves, here circles (or in two cases the axes themselves), intersecting at right angles. Further, if the network were taken very fine, the curvilinear meshes would have sides nearly straight, and for any one mesh nearly equal. Thus, for a small portion of the plane, the map takes squares approximately into squares. This is a characteristic property of all maps obtained from analytic functions. It may

be made plausible as follows. For a function of a real variable, which is differentiable so that its graph has a tangent at every point a small portion of the graph may be considered as straight and replaced by a small part of the tangent. This is done whenever we interpolate in a mathematical table by using proportional parts. But, at a point C where a function of a complex variable is analytic it is differentiable.⁸ For a small region surrounding the point C , the transformation will, approximately, have the same effect as the first two terms of the Taylor's series in powers of $z - C$:

$$w = w(C) + w'(C)(z - C) + w''(C) \frac{(z - C)^2}{2!} + \dots, \quad (70)$$

and these two terms, except when the derivative $w'(C)$, i.e., dw/dz evaluated for $z = C$, is zero, give a linear transformation, which takes figures into similar figures, and in particular squares into squares. The transformations which preserve shape for small figures, and hence preserve angles are said to be **conformal**, so that the mappings obtained from analytic functions in general are conformal. Even for fairly simple functions, there may be isolated points at which the functions have zero derivatives, or fail to be analytic, and consequently at which the preservation of angle property breaks down.

EXERCISES V

1. Sketch the image in the w plane of the square in the z plane bounded by the lines $x = 0, x = 1, y = 0, y = 1$, for each of the following transformations:

- (a) $w = 5z + 2$, (b) $w = -2iz + 5$, (c) $w = -4z - 6$, (d) $w = iz$,
 (e) $w = (3 + 4i)z$, (f) $w = 3iz + 5 + 2i$, (g) $w = (5 + 5i)z + 2 + 3i$,
 (h) $w = (1 + \sqrt{3}i)z - 2i$, (i) $w = 2 \angle 40^\circ \cdot z - 4 \angle 125^\circ$,
 (j) $w = a \angle A^\circ \cdot z + b \angle B^\circ$.

2. (a) Deduce the equations for changing the co-ordinates of a point to those of the point when referred to parallel axes through the point x_0, y_0 by using the transformation

$$w = z - x_0 - iy_0.$$

(b) Deduce the equations for changing the co-ordinates of a point to those of the point when referred to new axes through the same origin making an angle a with the old axes by using the transformation

$$w = \angle -a \cdot z.$$

⁸ In Chapter VII we shall show that, conversely, if a function of a complex variable has a continuous derivative in some two-dimensional region containing a point C inside it, the function is analytic at C .

3. Find the image of the curve $2x^2 - 3xy + 2y^2 = 6$ under the transformation $w = |45^\circ \cdot z$.

4. Find the image of the co-ordinate axes for each of the following transformations:

$$(a) w = \frac{1}{z}, \quad (b) w = \frac{2i}{z}, \quad (c) w = \frac{-3 + 5z}{z}, \quad (d) w = \frac{iz}{4 + 5z},$$

$$(e) w = \frac{1 + 2z}{3 - 4z}, \quad (f) w = \frac{2i - 3z}{3z + 2i}.$$

5. Sketch the image of the square bounded by the lines $x = 10$, $x = 10.1$, $y = 10$, $y = 10.1$ for each of the transformations of problem 4.

6. For each of the transformations of problem 4, find which point in the z plane has as its image the "point at infinity" in the w plane. What is the image in the w plane of the "point at infinity" in the z plane?

7. Find the equation of the image of the circle $x^2 + y^2 = 1$ under the transformations:

$$(a) w = \frac{1 - z}{2 + 2z}, \quad (b) w = \frac{z + i}{2z - 2i}.$$

8. (a) If, as in problem 8 on p. 6, we denote the conjugate of w by \bar{w} , show that, if its locus has more than one real point, the equation

$$s w \bar{w} + S w + \bar{S} \bar{w} + t = 0,$$

where s and t are real and S may be complex, always represents a circle, unless $s = 0$, when it represents a straight line unless $S = t = 0$ as well. Show also that, by suitably choosing the constants, this equation may be made to represent any given circle or straight line.

$$(b) \text{ Observing that if } w = \frac{Az + B}{Cz + D}, (AD - BC \neq 0), \text{ then } \bar{w} = \frac{\bar{A}\bar{z} + \bar{B}}{\bar{C}\bar{z} + \bar{D}},$$

and using the result of (a), show that under this transformation all the circles and straight lines of the w plane are the transforms of circles or straight lines of the z plane. Problems 4 and 7 illustrate this fact.

(c) Solve the equation given in (b) for z in terms of w . Since it is of the same form as the original expression, the result of (b) shows that all the circles and straight lines of the z plane transform into circles or straight lines of the w plane.

9. (a) Using the identity:

$$\frac{Az + B}{Cz + D} = \frac{A}{C} + \frac{1}{\frac{BC - AD}{C^2} \left(z + \frac{D}{C} \right)},$$

show that every transformation of the type

$$w = \frac{Az + B}{Cz + D}, \quad AD - BC \neq 0,$$

can be looked upon as a combination of a translation, a rotation and scaling up or down, a transformation of the type $1/z$, and a second translation, unless $C = 0$, when only the first two transformations need be used.

(b) Show directly that the transformation $w = 1/z$ takes each equation of the form $a(x^2 + y^2) + bx + cy + d = 0$, where the coefficients are all real,

into an equation of similar type in u and v , and conversely that an equation of this type in u and v is taken into a similar equation in x and y .

(c) From (a) and (b) prove that every transformation of the type mentioned in (a) takes all the straight lines and circles of the z plane into straight lines or circles in the w plane, and conversely.

10. (a) If $w = \frac{Az + B}{Cz + D}$, $AD - BC \neq 0$, and w_1, w_2 are the images under this transformation of z_1 and z_2 , deduce the relation:

$$\frac{w - w_1}{w - w_2} = \left(\frac{Cz_2 + D}{Cz_1 + D} \right) \frac{z - z_1}{z - z_2}.$$

(b) Show from the property of an angle inscribed in a circular segment, that the locus of a point z such that the angle of the complex number $(z - z_1)/(z - z_2)$ is k or $\pi + k$ is a circle through the points z_1 and z_2 .

(c) By combining the results of parts (a) and (b), prove that the transformation of (a) takes all the straight lines and circles of the z plane into straight lines or circles of the w plane, and conversely.

11. Find the image of the line $x = 3$ under the transformation $w = z^2$.

12. Using polar co-ordinates in both planes, find the images of the lines $\theta = 0^\circ, 45^\circ, 90^\circ$, and 135° as well as the images of the circles $r = 1, 2$, and 3 for each of the following transformations:

$$(a) w = z^2, \quad (b) w = z^3, \quad (c) w = \sqrt{z}, \quad (d) w = z^n.$$

13. Recalling that the angle of intersection of two curves is defined as the angle between their tangents at the point of intersection, and that the transformations here considered take tangent curves into tangent curves, prove that, if two curves intersect at the origin in the z plane at an angle A , their images in the w plane intersect at an angle $2A$, under the transformation of 12 (a); $3A$ under that of 12 (b); $A/2$ under that of 12 (c) and nA under that of 12 (d). Note that this does not contradict the statements made at the end of section 9, since the functions defining the first two transformations have a zero derivative at the origin, that defining the third fails to be analytic at the origin, since its derivative becomes infinite, and the last function has a zero derivative if n is greater than unity, and fails to be analytic if n is less than unity.

14. Find the images of the straight lines through the point C of the z plane under the transformations:

$$(a) w = B + D(z - C)^2, \quad (b) w = B + D(z - C)^n.$$

15. (a) If, at a point C , the first derivative of a function is zero, but the second is not zero, the function may be approximated, near C , by the first two non-zero terms of its Taylor's series in powers of $(z - C)$:

$$w = w(C) + w''(C) \frac{(z - C)^2}{2!}, \text{ approximately.}$$

From this and 14 (a) show that the transformation defined by the function doubles angles at the point $z = C$, $w = w(C)$.

(b) When the first, second, etc., up the two $(n - 1)$ st derivatives are zero, at

C , the first two non-zero terms of the Taylor's series are:

$$w = w(C) + w^{(n)}(C) \frac{(z - C)^n}{n!}, \text{ approximately.}$$

From this and 14 (b) show that the transformation defined by the function gives angles at the point $w = w(C)$ which are n times the corresponding angles at the point $z = C$.

10. Fundamental Regions. In most of the cases so far considered, z occurred to the first degree only, so that there was just one z for each w . For more complicated functions there may be several different values of z which give the same w . Thus, consider

$$w = z^n, \quad n \text{ a positive integer.} \quad (71)$$

We introduce polar co-ordinates, putting

$$w = r_1 \underline{\theta}_1, \quad z = r \underline{\theta}.$$

Then

$$r_1 = r^n, \quad \theta_1 = n\theta.$$

This shows that the circles $r = 1, 2, 3, \dots$ in the z plane are transformed into the circles $r_1 = 1, 2^n, 3^n, \dots$ in the w plane.

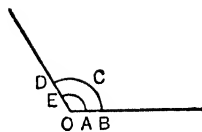

FIG. 9

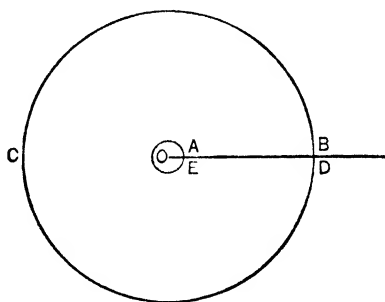

FIG. 10

For $n = 3$, the first two of each set are shown in Figs. 9 and 10 respectively. The straight lines $\theta = k$ in the z plane are transformed into the straight lines $\theta = nk$ in the w plane. Thus the points of the z plane in the sector between the lines $\theta = 0$ and $\theta = 360^\circ/n$, together with those on the first line, give rise to values of w which fill the entire w plane, and give each value just once. If we consider z to be restricted to this sector, BOD in Fig. 9, while w is unrestricted, there is one z for each w and one w for each z .

A region of the z plane which is mapped by a given function into the entire w plane, such that each point of the w plane is the image of just one point of the region, is called a **fundamental region** for the function. Evidently, for $w = z^n$, the sector between the lines $\theta = a$, $\theta = a + 360^\circ/n$, together with the points on one of these lines, gives rise to a fundamental region. Thus, in the present example, we may regard the z plane as made up of n fundamental regions, and if we map a set of co-ordinate lines in one of them, on the entire w plane, we will have at the same time mapped the corresponding lines for the other regions.

If we required the images of the lines $x = \text{constant}$, $y = \text{constant}$, our problem would be more difficult. We illustrate for the case $n = 3$, so that the transformation is

$$w = z^3.$$

This leads to:

$$\begin{aligned} u + iv &= (x + iy)^3 \\ &= x^3 - 3xy^2 + i(3x^2y - y^3). \end{aligned}$$

Consequently,

$$u = x^3 - 3xy^2, \quad v = 3x^2y - y^3. \tag{72}$$

By solving the first equation for y , and inserting its value in the second equation, we find:

$$27x^3v^2 = (8x^3 + u)^2(x^3 - u).$$

which gives the image of the lines $x = \text{constant}$. For example, for $x = 1$, we have

$$27v^2 = (8 + u)^2(1 - u). \tag{73}$$

Similarly, by solving the second equation of (72) for x and inserting the result in the first, we have:

$$27y^3u^2 = (v - 8y^3)^2(v + y^3),$$

which gives the image of the lines $y = \text{constant}$.

Even in this case it might be simpler to plot the image curves directly point by point. For example, when $x = 1$, equations (72) become:

$$u = 1 - 3y^2, \quad v = 3y - y^3,$$

which give the co-ordinates of the curve (73) expressed parametrically in terms of the variable y .

As a problem of different character, we consider the mapping defined by the function

$$w = \sin z.$$

We deduce from this equation:

$$\begin{aligned} u + iv &= \sin(x + iy) \\ &= \sin x \cosh y + i \cos x \sinh y \end{aligned}$$

by applying equation (55), p. 22. On equating real and imaginary components, we find

$$\begin{aligned} u &= \sin x \cosh y, \\ v &= \cos x \sinh y. \end{aligned} \tag{74}$$

From these we may plot the curves which are the images of the straight lines $x = \text{constant}$, $y = \text{constant}$, point by point. However, we may carry out the elimination of x and y respectively, by using the relations:

$$\sin^2 x + \cos^2 x = 1, \tag{75}$$

and

$$\cosh^2 y - \sinh^2 y = 1, \tag{76}$$

this last being equation (58), p. 23. From (74) we have:

$$\sin x = \frac{u}{\cosh y}, \quad \cos x = \frac{v}{\sinh y},$$

and if these be squared and added, we have in view of (75):

$$\frac{u^2}{\cosh^2 y} + \frac{v^2}{\sinh^2 y} = 1. \tag{77}$$

Similarly we may write

$$\cosh y = \frac{u}{\sin x}, \quad \sinh y = \frac{v}{\cos x},$$

square these, subtract, and use (76) to get:

$$\frac{u^2}{\sin^2 x} - \frac{v^2}{\cos^2 x} = 1. \tag{78}$$

Equation (77) shows that the lines $y = \text{constant}$ go into ellipses, except when $y = 0$. When $y = 0$, we see from (74) that $v = 0$, and $-1 \leq u \leq 1$. Similarly it follows from equation (78)

that the lines $x = \text{constant}$ go into hyperbolas, except when $\sin x = 0$, or $\cos x = 0$. When $\sin x = 0$, we see from (74) that $u = 0$. When $\cos x = 0$, we see from (74) that $v = 0$ and $u \leq -1$ or $u \geq 1$.

For this function $\sin z$ we may take, as a fundamental region in the z plane, the part of the plane above the x -axis and between the lines $x = 0$ and $x = 2\pi$, together with the boundary points lying in the first quadrant. For, as y increases from zero to infinity, the ellipses (77) start with the portion of the x -axis between -1 and $+1$, and gradually expand to fill up the plane. On the other hand, for any one ellipse, y is constant, and as x increases from 0 to $\pi/2$, equations (74) show that the point moves in the negative direction along this ellipse in the first quadrant around from the y -axis to the x -axis. Similarly we see that increasing x to π , $3\pi/2$ and 2π , moves the point around the ellipse through the fourth, third and second quadrants back to the starting point on the positive y -axis.

In Fig. 11 we have drawn the ellipses for $y = 1, 2$ as well as those portions of the hyperbolas which correspond to the parts of the lines $x = 1, 2$ for which y is positive, i.e. in the fundamental region described above. The image of the square $ABCD$ of Fig. 6 is the line $AFBCD$ of Fig. 11, the side AB being mapped on the line AF together

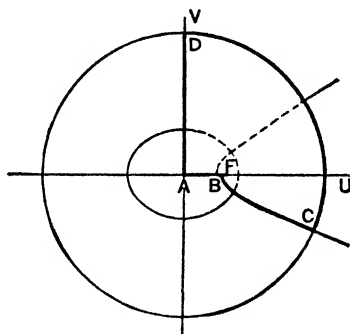

FIG. 11

with the part folded back on itself FB . F is the representation of the point $z = \pi/2$, and at this point angles are doubled⁹ so that a straight angle of 180° goes into a re-entrant angle of 360° . At all points except F , $w = 1$ and F' , $w = -1$, angles are preserved. The ellipses and hyperbolas all have their foci at these points, and hence cut each other at right angles from the relation of the tangent to an ellipse or hyperbola to the focal radii.

⁹ As $w = \sin z$, $w' = \cos z = 0$ when $z = \pi/2$, while $w'' \neq 0$, so that this is in accordance with problem 15, p. 33.

EXERCISES VI

1. Find the image of the lines $x = 1$ and $y = 1$ under the transformation $w = \sqrt{z}$, by solving the equation for z in terms of w . The images of the lines $x = \text{constant}$ under this transformation give the lines of flow for an incompressible fluid moving between two perpendicular walls in a steady, irrotational manner.

2. Find the image of the line $x = 2$ under the transformation $w = \sqrt[3]{z}$, by the method used in problem 1. The lines $x = \text{constant}$ for this transformation give the lines of flow of a fluid moving between two walls making an angle of 60° .

3. Show that the portion of the z plane between the lines $y = 0$ and $y = 2\pi$, together with points on the former line, may be taken as a fundamental region for the transformation $w = e^z$. Find the images of the lines $x = \text{constant}$, $y = \text{constant}$.

4. If $w = z + e^z$, one possible fundamental region is the part of the z plane between the lines $y = -\pi$ and $y = \pi$, together with the points on these lines for which $x \geq 0$. Find the images of these lines, and also the image of the line $y = 0$. Also plot by points the images of the lines $x = 1$ and $y = \pi/2$. The images of the lines $y = \text{constant}$ for this transformation give the lines of flow of a fluid flowing from a channel bounded by two parallel walls out and back around these walls. Or they give equipotential lines between the plates of a condenser, near the edge of the plates.

5. The transformation $w = z + 1/z$ takes the part of the z plane inside — or outside — the circle of radius one with center at the origin, into the entire w plane. Taking the outside of the circle as the fundamental region, plot the curve in this region whose image under the transformation is the line $v = 1$. The curves in this region whose images are the lines $v = \text{constant}$ are the lines of flow for a fluid flowing past a cylinder.

6. (a) Plot the curves in the z plane whose images under the transformation $w = i \log_e z$ are the lines $u = \text{constant}$, $v = \text{constant}$. The curves whose images are the lines $v = \text{constant}$ give the lines of flow about a rotating cylinder.

(b) Plot the curve whose image under the transformation $w = z + 1/z + i \log_e z$ is the line $v = 1$. This is one of the lines of flow for a fluid moving past a rotating cylinder.

7. (a) Show that the transformation $w = z + 1/z$ may be written

$$\frac{w - 2}{w + 2} = \frac{(z - 1)^2}{(z + 1)^2}.$$

(b) Show from (a) that the angle of $\frac{w - 2}{w + 2}$ is twice the angle of $\frac{z - 1}{z + 1}$. Use

this fact to plot the image of the curve $\tan \text{angle of } \frac{z - 1}{z + 1} = 4$.

(c) Plot, by points, the curve in the w plane which is the image of the circle $(x - .2)^2 + (y - .3)^2 = 1.53$. This curve is an example of the Joukowski aerofoil. It is possible to find the stream lines for flow past it by first finding them for the circle of which it is the transform as in problem 5, and finding their transforms.

8. (a) If the point on the surface of the earth with latitude ϕ and longitude θ is plotted in a plane in accordance with the equations

$$r_1 = \tan\left(\frac{\phi}{2} + 45^\circ\right), \quad \theta_1 = \theta,$$

r_1 and θ_1 being polar co-ordinates, we obtain a stereographic map. If we use the equations

$$\begin{aligned} x &= \ln \tan\left(\frac{\phi}{2} + 45^\circ\right), \\ y &= \theta, \end{aligned}$$

we obtain Mercator's projection of the sphere. Show that if $z = x + iy$ on the Mercator map, and $w = r_1 \theta_1$ for the stereographic map, the maps are related by the transformation

$$w = e^z.$$

(b) On the sphere a differential displacement along a meridian is proportional to $d\phi$, while that along a parallel is proportional to $d\theta \cos \phi$, so that the angle A made by a differential element of a curve on the sphere with a meridian $\theta = \text{constant}$ is such that $\tan A = \cos \phi d\theta/d\phi$. Find dr_1 and $d\theta_1$ for the stereographic projection, and hence the tangent of the angle made by an element with the image of a meridian, a radius vector. Also find dx and dy , and hence the tangent of the angle made with the image of a meridian, a parallel to the x -axis, for the Mercator projection. The fact that the three angles are equal shows that the two types of maps each preserve angles. That one would do this if the other did follows from the conformal character of the transformation $w = e^z$.

9. Find a fundamental region for the transformation $w = \cos z$, and the equation of the images of the lines $x = \text{constant}$, $y = \text{constant}$.

10. Find the image of the square $ABCD$ of Fig. 6 under the transformation $w = \cosh z$.

11. Plot the images of the lines $x = 1$, $y = 1$ when $w = \sinh z$.

12. Find the curves whose images are the lines $u = \text{constant}$, $v = \text{constant}$, when $w = \log \frac{z-1}{z+1}$. The curves whose images are $u = \text{constant}$ give the lines of force for the magnetic field or the right sections of the cylindrical equipotential surfaces for the electric field due to two parallel wires, carrying currents of equal intensity and opposite directions. Or they give the equipotential lines for a conducting plate of material with very great resistance connected with the two poles of a battery.

13. Plot by points the curve whose image is the line $u = 1$ under the transformation $w = \log(z-1)(z+1)$. This is one line of force for the magnetic field, or right section of one cylindrical equipotential surface for the electric field due to two parallel wires carrying equal currents in the same direction (returning at infinity), or an equipotential line for a conducting plate of material with very great resistance connected with two like poles at the points $1, -1$, the corresponding unlike poles being connected to the plate at infinity. This and the preceding problem illustrate three interpretations of the curves whose images are the lines $u = \text{constant}$ when $w = \log[(z-a_1)^{k_1} \cdots (z-a_n)^{k_n}]$.

The first two are the magnetic lines of force or right sections of the cylindrical equipotential surfaces for the electric field due to a set of parallel wires at the points a_1, \dots, a_n , carrying currents of strength k_1, \dots, k_n , the direction being given by the signs. If the sum of the k 's is not zero, we must think of a return wire at infinity. The other interpretation is the equipotential lines in a conducting plate of material with very great resistance, due to contact with potentials k_1, \dots, k_n , at the points a_1, \dots, a_n respectively. In this case, also we must think of an additional contact at infinity if the sum of the k 's is not zero.

14. If $w = f(z)$ is a single-valued function of z , i.e., a function such that there is just one w for each z , and a fundamental region is selected for z , there is just one z in this region for each w . If the z plane may be divided into several fundamental regions, the inverse function $z = F(w)$ has, in general, as many values as there are fundamental regions. Each set of values for a region gives rise to a **branch** of the function. A value of w is said to be a **branch-point** of the function $F(w)$ if, when w describes a small closed curve about this point, and we allow a corresponding value of z to vary continuously, the final value belongs to a different branch from the initial value. Since the closed circuit corresponds to a change of angle of 360° , while the z path corresponding to it must be open and hence correspond to a different change of angle, angles are not preserved at a branch-point. Hence no point at which a function has a finite derivative different from zero can be a branch-point. In general, at the branch-points, the derivative is zero or becomes infinite, which gives a simple way to practically locate them. For each of the following functions find those finite values of w which are branch-points of the function:

$$(a) z = w^{\frac{1}{2}}, \quad (b) z = w^{\frac{1}{3}}, \quad (c) z = \log w, \quad (d) z = \sin^{-1} w.$$

15. In the discussion of problem 14 the rôles of w and z may be interchanged. Find those finite values of z which are branch-points of each of the following functions:

$$(a) w = z^{\frac{1}{2}}, \quad (b) w = \log(z - a), \quad (c) w = \cosh^{-1} z.$$

16. If $w = f(z)$ is a function such that there are several values of w for each value of z , in a region containing the point $z = C$, this point is said to be a **branch-point** of the function if, when z describes a small, closed circuit about the point C , and the corresponding value of w varies continuously, the final value of w differs from the initial value. We may test a point C by putting $z = C + re^{i\theta}$, where r is small, letting θ change from 0 to 360° , and finding the effect on w . Show that each of the following functions have branch-points at a and b :

$$(a) w = \sqrt{(z-a)(z-b)}, \quad (b) w = \sqrt{z-a} + \sqrt{z-b},$$

$$(c) w = \frac{1}{\sqrt{z-a}} + \frac{1}{\sqrt{z-b}}.$$

17. If, when the closed circuit about C of problem 16 is traversed a second time, we obtain a third value of w , and so on, there being in all k different values before we return to the original value of w , the branch-point is said to be of **order k** . (a) Show that the origin is a branch-point of the third order for

the function $w = z^{\frac{1}{2}}$, and one of the second order for the inverse function $z = w^2$. (b) Find the order of the branch-point a for the function $w = b + (z - a)^{\frac{1}{2}}$, and that of the branch-point b for the inverse function $z = a + (w - b)^2$.

18. For each of the following functions, find possible branch-points by examining the derivative, as in problem 14, test them by the method of problem 16, and find their order as defined in problem 17.

$$(a) w = \sqrt{\frac{z-a}{z-b}}, \quad (b) w = \sqrt{z-a}.$$

19. Show that a is a branch-point of the third order for the function $w = 2z + (z - a)^{\frac{1}{2}}$. This is not indicated by the derivative, as the inverse function is not single-valued.

CHAPTER II

AVERAGE VALUES AND FOURIER SERIES

For oscillating quantities, like alternating currents and the electromotive forces which cause them, it is frequently the average effect, rather than the instantaneous effects, which are of interest. The average effects find mathematical expression in average and root mean square values, which we proceed to discuss.

As the mathematical expressions for alternating currents as functions of the time are periodic functions, we deduce some of the properties of such functions and define an expansion in sine and cosine terms, the Fourier series, appropriate for them. These Fourier series facilitate the calculation of average and root mean square values as well as other calculations involving the functions. The expansions also have applications to certain problems in partial differential equations.

11. Average Values. If x is a real variable, and y is a function of x , the **average value of y with respect to x** , for a given interval $a < x < b$ is, by definition:

$$\bar{y} = \text{average } y = \frac{1}{b-a} \int_a^b y \, dx. \quad (1)$$

For a finite number of values of y , the ordinary meaning of average is the sum of the values divided by their number. The connection between this meaning, and the definition (1) may be seen by dividing the interval from a to b into n equal parts, and averaging the corresponding ordinates in the usual sense. We have

$$Y_n = \frac{y_0 + y_1 + \cdots + y_n}{n + 1}.$$

which may be written:

$$Y_n = \frac{(y_0 \Delta x + y_1 \Delta x + \cdots + y_{n-1} \Delta x) + y_n \Delta x}{(n \Delta x) + \Delta x},$$

by multiplying $\Delta x = \frac{b-a}{n}$, the distance between two consecutive

ordinates, into numerator and denominator. If we now let n become infinite, we observe that the parenthesis in the numerator is an expression for a series of rectangles approximating the area bounded by the curve $y = f(x)$, the axis of x and the ordinates $x = a$, $x = b$, and hence approaches $\int_a^b y \, dx$. But the term in the denominator $n\Delta x = b - a$, and the extra terms in numerator and denominator, $y_n\Delta x$ and Δx each approach zero, so that we conclude:

$$\lim_{n=\infty} Y_n = \bar{y}.$$

Suppose we let the variable x measure time, and the variable y be the instantaneous value of some physical quantity at time x . If F is any effect of y whose rate of change is proportional to y , we will have:

$$\frac{dF}{dx} = ky, \quad \text{or} \quad dF = ky \, dx.$$

The total effect for the time interval $a < x < b$ will be:

$$F = \int_a^b ky \, dx.$$

If the variable were constant and equal to y_0 throughout this interval, the effect would be:

$$\int_a^b ky_0 \, dx = k(b - a)y_0.$$

These two effects will be equal if $y_0 = \bar{y}$, as defined by (1), so that the definition of average implies that the average of a variable quantity is the constant quantity which, acting in place of it, would give the same total effect F .

Geometrically, the average of y from a to b is the height of a rectangle of the same width equivalent in area to that bounded by the curve, the x -axis and the lines $x = a$, $x = b$. This furnishes a simple method of remembering (1) and also gives a fairly accurate graphical method of estimating averages. From this interpretation it is clear that the average of a continuous function lies between its greatest and least values. For particular functions it may be arbitrarily near either value. If we are dealing with a physical quantity, rather than a mathematical function, for different choices of the independent variable averages may be obtained

equal to any value between the greatest and least value of the quantity. For example, if the physical quantity changes uniformly from 0 to 1 in 100 seconds, and we average with respect to a variable which changes from 0 to 0.99 in the first second, and from 0.99 to 1.00 in the remaining time, the average will be nearly zero. On the other hand, if the independent variable runs from 0 to 0.01 in the first 99 seconds, and then changes from 0.01 to 1.00 in the last second, the average will be nearly 1. It is usually clear from physical considerations which independent variables give averages of practical use. For our purposes, the preferred variable will generally be the time.

We note that the average is unchanged by a change of units in the independent variable, x , which is merely a change of scale. For, in (1), the unit of x appears both in dx and in $b - a$, and so divides out. However, the average changes in the same way as y for a change of scale in the units of the dependent variable, y .

In evaluating the average of a function defined by separate analytic definitions in different parts of the interval, we must break up the integral in a corresponding way. As an example, we consider the function defined in the interval $0 < x < 4$ by the relations:

$$\begin{aligned} y &= \sqrt{3}x, & 0 \leq x \leq 1, \\ y &= \sqrt{3}, & 1 < x \leq 3, \\ y &= 4\sqrt{3} - \sqrt{3}x, & 3 < x \leq 4. \end{aligned} \quad (2)$$

The graph of this function is one half of a regular hexagon.

To find the average for the interval $0 < x < 4$, we first compute the integral:

$$\begin{aligned} \int_0^4 y \, dx &= \int_0^1 y \, dx + \int_1^3 y \, dx + \int_3^4 y \, dx \\ &= \int_0^1 \sqrt{3}x \, dx + \int_1^3 \sqrt{3} \, dx + \int_3^4 \sqrt{3}(4 - x) \, dx \\ &= \sqrt{3} \frac{x^2}{2} \Big|_0^1 + \sqrt{3}x \Big|_1^3 - \sqrt{3} \frac{(4 - x)^2}{2} \Big|_3^4 \\ &= 3\sqrt{3}. \end{aligned}$$

Then the average is:

$$\bar{y} = \frac{\int_0^4 y \, dx}{4 - 0} = \frac{3\sqrt{3}}{4} = 1.30.$$

12. Root Mean Square Values. To treat effects whose rates are not proportional to the first power of the quantities which cause them, we require other types of averages.¹ In particular, let us consider an effect H whose rate of change is proportional to y^2 , so that:

$$\frac{dH}{dx} = ky^2, \quad \text{or} \quad dH = ky^2 dx.$$

The total effect for the interval $a < x < b$ will be:

$$H = \int_a^b ky^2 dx.$$

If y were constant, equal to y_0 , the effect would be

$$\int_a^b ky_0^2 dx = k(b - a)y_0^2.$$

These effects will be equal provided that y_0 is the **root mean square** value of y for the interval $a < x < b$, defined by:

$$\bar{y} = \text{r.m.s. } y = \sqrt{\frac{\int_a^b y^2 dx}{b - a}}. \quad (3)$$

The root mean square value of a quantity is the square root of the average of the square of the quantity, and is the constant to be put in place of a variable quantity when calculating effects whose rates of change are proportional to the square of the quantity. Since a current i (amperes), produced by an electromotive force, abbreviated e.m.f., of e (volts) across a resistance R (ohms), generates heat at a rate dH/dt (cal./sec.) given by:

$$\frac{dH}{dt} = 0.24i^2R = 0.24 \frac{e^2}{R}, \quad (4)$$

the number of calories generated in any time interval $t_1 < t < t_2$, may be expressed in terms of the root mean square values for that interval as:

$$H = 0.24\bar{i}^2R(t_2 - t_1) = 0.24 \frac{\bar{e}^2}{R} (t_2 - t_1). \quad (5)$$

Just as for averages, if the analytic definition of a function differs in different parts of the interval considered, we must compute the

¹ See problem 18, p. 51 for geometric mean distance.

integral for each of these parts separately. Thus, to compute the root mean square value of the function defined by (2), for the interval $0 < x < 4$, we first evaluate the integral:

$$\begin{aligned} \int_0^4 y^2 dx &= \int_0^1 y^2 dx + \int_1^3 y^2 dx + \int_3^4 y^2 dx \\ &= \int_0^1 3x^2 dx + \int_1^3 3 dx + \int_3^4 3(4-x)^2 dx \\ &= x^3 \Big|_0^1 + 3x \Big|_1^3 - (4-x)^3 \Big|_3^4 \\ &= 8. \end{aligned}$$

We then have for the root mean square value:

$$\bar{y} = \sqrt{\frac{\int_0^4 y^2 dx}{4 - 0}} = \sqrt{\frac{8}{4}} = \sqrt{2} = 1.41.$$

13. An Inequality for Averages. For the particular function defined by (2), and the interval considered, we found the root mean square value numerically greater than the average value. We proceed to prove that this is true in general.

Let $f(x)$ and $g(x)$ be two functions, each made up of a finite number of continuous pieces in the interval $a \leq x \leq b$. Unless the ratio of the two functions is constant for the entire interval, for any constant X we shall have:

$$[Xf(x) + g(x)]^2 > 0, \quad (6)$$

and consequently for the average of this expression:

$$\frac{1}{b-a} \int_a^b [Xf(x) + g(x)]^2 dx > 0. \quad (7)$$

This expands into:

$$\frac{\int_a^b f^2 dx}{b-a} X^2 + \frac{2 \int_a^b fg dx}{b-a} X + \frac{\int_a^b g^2 dx}{b-a} > 0. \quad (8)$$

As the quadratic expression in X which forms the left member of this inequality is never zero, when equated to zero it must give a quadratic equation with no real roots. Hence its discriminant ($B^2 - 4AC$ for the equation $AX^2 + BX + C = 0$) must be nega-

tive, so that

$$\left[\frac{2 \int_a^b fg \, dx}{b-a} \right]^2 - 4 \frac{\int_a^b f^2 \, dx}{b-a} \cdot \frac{\int_a^b g^2 \, dx}{b-a} < 0.$$

After transposing, dividing by 4, and taking the positive square root, we have:

$$\left| \frac{\int_a^b fg \, dx}{b-a} \right| < \sqrt{\frac{\int_a^b f^2 \, dx}{b-a}} \cdot \sqrt{\frac{\int_a^b g^2 \, dx}{b-a}}. \quad (9)$$

We notice that this becomes an equality if the functions are in a constant ratio, which checks with our argument, since in this case $-g(x)/f(x)$ is a constant, and when we take this value for X , (6) and hence (7) or (8) reduce to equalities. But this is the only value of X for which the left member of (8) is zero, so that the quadratic equation has equal roots, and its discriminant is zero.

In view of the definitions (1) and (3), we may express our result in the form: **The average value of the product of two functions is numerically less than the product of their root mean square values for the same interval, unless the ratio of the functions is constant throughout the interval, in which case we have equality.**

When $g(x) = 1$ throughout the interval, (9) reduces to

$$\frac{\int_a^b f \, dx}{b-a} < \sqrt{\frac{\int_a^b f^2 \, dx}{b-a}}. \quad (10)$$

This establishes the result we set out to prove: **The average value of a function is numerically less than its root mean square value for the same interval, unless the function is constant throughout the interval, when we have equality.**

If in the first result we let x be the time, $f(x)$ the instantaneous e.m.f., e , and $g(x)$ the instantaneous current, i , we find that the average power is numerically less than the product of r.m.s. e by r.m.s. i , or

$$\bar{p} < \bar{e} \cdot \bar{i},$$

unless the ratio of e to i is constant, that is, the impedance is a pure resistance, when we have equality. The ratio $\bar{p}/(\bar{e} \cdot \bar{i})$ which we have just proved to be numerically less than or equal to unity is

the power factor, so that this result is consistent with its interpretation as efficiency.

14. Odd and Even Functions. An even function is one for which

$$f(-x) = f(x). \quad (11)$$

Geometrically, an even function is characterized by the property that its graph to the left of the Y -axis is a mirror image of that to the right of the Y -axis. Thus Fig. 12 is the graph of an even function. Or we may obtain the graph to the left of the Y -axis from that on the right by a rotation of 180° about the Y -axis. Even powers of x , and polynomials or power series in x containing even powers are illustrations.

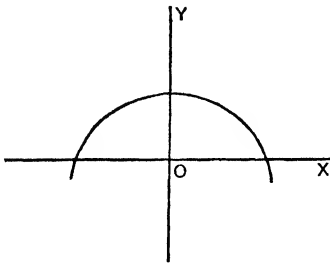

FIG. 12

If we average an even function over the interval $-a < x < a$, we get the same result that we obtain for the interval $-a < x < 0$, or for the interval $0 < x < a$. For, by putting $x = -u$, $dx = -du$, and using (11), we find:

$$\int_{-a}^0 f(x) dx = - \int_a^0 f(u) du.$$

Since interchanging the limits changes the sign of an integral and we may use any letter for the variable of integration, we have further:

$$\int_{-a}^0 f(x) dx = \int_0^a f(x) dx.$$

Consequently,

$$\begin{aligned} \frac{1}{2a} \int_{-a}^a f(x) dx &= \frac{1}{2a} \left[\int_{-a}^0 f(x) dx + \int_0^a f(x) dx \right] \\ &= \frac{1}{a} \int_{-a}^0 f(x) dx \\ &= \frac{1}{a} \int_0^a f(x) dx, \end{aligned} \quad (12)$$

and the three averages are all equal, as stated. This result is also evident from the geometric interpretation of an average.

An **odd function** is one for which

$$f(-x) = -f(x). \tag{13}$$

For any such function the graph to the left of the Y -axis may be obtained from that to the right of the Y -axis by taking two mirror images, the first in the Y -axis and the second in the X -axis. Or we may obtain either half from the other by a single rotation of 180° about an axis through the origin perpendicular to the XY plane. One such function is shown in Fig. 13. Odd powers of x , and polynomials or power series in x containing only odd powers are illustrations.

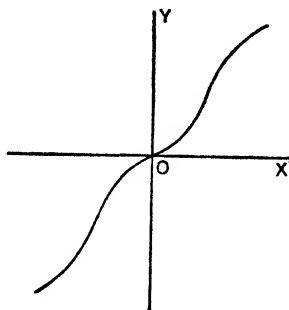

FIG. 13

If we average an odd function over the interval $-a < x < 0$, we get the negative of the average for the interval $0 < x < a$, and the average for the interval $-a < x < a$ is zero. For, by putting $x = -u$, $dx = -du$, and using (13), we find:

$$\int_{-a}^0 f(x) dx = \int_a^0 f(u) du.$$

Then, by interchanging the limits, reversing the sign, and taking x as the variable of integration, we deduce:

$$\int_{-a}^0 f(x) dx = - \int_0^a f(x) dx.$$

By dividing both sides of this equation by a , we verify our first statement. The second statement follows from:

$$\frac{1}{2a} \int_{-a}^a f(x) dx = \frac{1}{2a} \left[\int_{-a}^0 f(x) dx + \int_0^a f(x) dx \right] = 0. \tag{14}$$

From (11) and (13) we see that if we multiply several functions together, each of which is either odd or even, the product will be an odd function if the number of odd functions is odd, and the product will be an even function if the number of odd functions is zero or an even number. In particular the square of an even function is an even function, and the square of an odd function is an even

function. Hence for any even function, or any odd function, the root mean square value is the same for each of the intervals $-a < x < 0$, $0 < x < a$, $-a < x < a$.

EXERCISES VII

1. Find the average value of each of the following functions for the interval $-2 < x < 2$:

(a) 3, (b) x^2 , (c) $\cos \frac{x}{2}$, (d) $\cosh x = \frac{e^x + e^{-x}}{2}$, (e) $2x$, (f) x^3 ,

(g) $\sin \frac{x}{2}$, (h) $\sinh x = \frac{e^x - e^{-x}}{2}$.

2. Find the average value of each function of problem 1 for the interval $0 < x < 2$, and also for the interval $-2 < x < 0$.

3. Which of the functions of problem 1 are even functions, and which of them are odd functions? Compare the answers to problems 1 and 2 with the results of section 14.

4. Find the root mean square value of each of the functions of problem 1 for the interval there given, and deduce the values for the intervals of problem 2.

5. Find the r.m.s. value of each of the following functions for the interval indicated:

(a) $\cos t$, $0 < t < \pi/4$, (b) $1/t$, $2 < t < 5$, (c) t^2 , $0 < t < 5$.

6. Find the r.m.s. value of the function $\sin t$ for each of the following intervals: (a) $0 < t < \pi/4$, (b) $0 < t < \pi/2$, (c) $0 < t < \pi$.

7. Find the average and r.m.s. value of the function $\sin x \cos x$ for the three intervals: (a) $0 < x < \pi/2$, (b) $-\pi/2 < x < 0$, (c) $-\pi/2 < x < \pi/2$. Compare your answers with the results of sections 13 and 14.

8. Find the average and r.m.s. value of a function which is x for $0 < x < 2$ and $4 - x$ for $2 < x < 4$, for the interval $0 < x < 4$. Draw the graph.

9. Find the average and r.m.s. value, over the interval $0 < x < 2\pi$, of a function which is $\cos x$ for $0 < x < \pi/2$, and 0 for $\pi/2 < x < 2\pi$.

10. Find the average and r.m.s. value of a function which is $2x$ for $0 < x < 1$, and $3 - x$ for $1 < x < 3$, over the interval $0 < x < 3$.

11. If a given function $F(x)$ can be written as the sum of an even function and an odd function, then

$$F(x) = f(x) + g(x),$$

and

$$F(-x) = f(x) - g(x).$$

By solving these equations prove that any function can be written in the way indicated.

12. Illustrate problem 11 by decomposing each of the following functions into the sum of an even and an odd function: (a) e^x , (b) $x^3 - 2x^2 + 4x - 3$, (c) xe^{-x} .

13. Find by inspection the average value over the interval $-3 < x < 3$ of each of the following functions:

(a) $\sin^3 x$, (b) $\sin 2x \cos^3 x + 2$, (c) $\sin 3x \cos^2 x - 3$.

14. Given that

$$F(x) = c_1 f_1(x) + c_2 f_2(x) + c_3 f_3(x).$$

(a) Express the average value of F in terms of the average values of f_1, f_2, f_3 for the same interval.

(b) Express the r.m.s. value of F in terms of the r.m.s. values of f_1, f_2, f_3 , and the averages of their products, taken two at a time.

15. (a) Express the average of a function y for the interval $a < x < c$, \bar{y}_{ac} , in terms of the average of the same function for the intervals $a < x < b$, and $b < x < c$, \bar{y}_{ab} and \bar{y}_{bc} , and the lengths of these intervals.

(b) Using the result of (a), express the r.m.s. value \bar{y}_{ac} in terms of \bar{y}_{ab} , \bar{y}_{bc} and the lengths $(b - a)$ and $(c - b)$.

16. For a certain distribution of masses along the x -axis, let $m = m(u)$ be the total amount of mass in the interval $0 < x < u$. If the inverse function is $u(m)$, show that the average of this function for the interval $0 < m < M$, where M is the total mass, is the distance of the center of gravity from the origin.

17. For a distribution of masses in a plane, let $m = m(u)$ be the total amount of mass inside a circle of radius u about the origin, $0 < x^2 + y^2 < u^2$. If the inverse function is $u(m)$, show that the root mean square of this function for the interval $0 < m < M$, where M is the total mass, is the radius of gyration of the system of masses, about an axis through the origin perpendicular to the plane.

18. The geometric mean of two quantities is the square root of their product, but may also be considered the exponential of the average of the logarithms, since

$$e^{\frac{\ln a + \ln b}{2}} = \sqrt{ab}.$$

This leads us to define the **geometric mean** of a function as the exponential of the average of the logarithm of the function.

(a) For example, consider a circle of radius a , and a point, P , whose distance from the center, O , is b . By the law of cosines, the distance from the point to the extremity of a radius making an angle θ with OP is:

$$\hat{\rho}_{P, \theta} = \sqrt{a^2 + b^2 - 2ab \cos \theta}.$$

If we regard this as a function of the arc length on the circle, and take the **geometric mean distance**, D , from the point to the circumference. Since the average is unchanged by a change in scale, we may average with respect to θ , and since we have to deal with an even function, may average from 0 to π . Thus

$$\ln D = \frac{1}{\pi} \int_0^\pi \frac{1}{2} \ln (a^2 + b^2 - 2ab \cos \theta) d\theta.$$

This integral is a continuous function of a for all values, and except when $a = b$, we may differentiate with respect to a under the integral sign, and so find:

$$\begin{aligned} \frac{d(\ln D)}{da} &= \frac{1}{\pi} \int_0^\pi \frac{a - b \cos \theta}{a^2 + b^2 - 2ab \cos \theta} d\theta \\ &= \frac{1}{\pi} \int_0^\pi \left[\frac{1}{2a} + \frac{1}{2a} \frac{a^2 - b^2}{a^2 + b^2 - 2ab \cos \theta} \right] d\theta. \end{aligned}$$

But:

$$\begin{aligned} a^2 + b^2 - 2ab \cos \theta &= (a^2 + b^2) \left(\sin^2 \frac{\theta}{2} + \cos^2 \frac{\theta}{2} \right) \\ &\quad - 2ab \left(\cos^2 \frac{\theta}{2} - \sin^2 \frac{\theta}{2} \right) \\ &= (a + b)^2 \sin^2 \frac{\theta}{2} + (a - b)^2 \cos^2 \frac{\theta}{2}, \end{aligned}$$

so that

$$\begin{aligned} \int_0^\pi \frac{1}{a^2 + b^2 - 2ab \cos \theta} d\theta &= \int_0^\pi \frac{\sec^2 \frac{\theta}{2} d\theta}{(a + b)^2 \tan^2 \frac{\theta}{2} + (a - b)^2} \\ &= \frac{2}{|a^2 - b^2|} \tan^{-1} \left[\left| \frac{a + b}{a - b} \right| \tan \frac{\theta}{2} \right]_0^\pi \\ &= \frac{\pi}{|a^2 - b^2|}. \end{aligned}$$

Thus we have:

$$\frac{d(\ln D)}{da} = \frac{1}{2a} + \frac{1}{2a} \frac{a^2 - b^2}{|a^2 - b^2|} = \frac{1}{a} \quad \text{or} \quad 0,$$

according as a is greater or less than b .

From the original integral for $\ln D$, we see that when a is zero, $\ln D = \ln b$, and since the derivative is zero for a less than b , we have:

$$\ln D = \ln b, \quad D = b, \quad \text{if } a < b.$$

The integral is continuous, so that when $a = b$, $\ln D = \ln b = \ln a$, and by integrating $1/a$, and using this to determine the constant of integration, we find

$$\ln D = \ln a, \quad D = a, \quad \text{if } b < a.$$

These results are consistent with the fact that the integral is symmetrical in a and b .

Thus, the geometric mean distance from a point to a circumference is equal to its distance from the center, if the point is outside the circle, and equal to the radius, if the point is inside the circle, or on the circumference.

(b) By the geometric mean distance from a curve to a curve, is meant the average of the distance from a point on the first curve to a point on the second, obtained by taking the geometric mean with respect to one arc length, and then the geometric mean of this with respect to the second. Thus

$$\ln D = \frac{1}{s} \frac{1}{s'} \int_0^s \int_0^{s'} \ln \delta_{ss'} ds ds'.$$

When the two curves are circles, deduce from the result of part (a) that this geometric mean distance is the radius of the larger circle, if one circle encloses the other, or the common radius, if they coincide and the distance between the centers, if the circles are outside one another. Note that in the last case, the first average has the effect of replacing one circle by its center, a point outside the other circle.

(c) The geometric mean distance from an area to an area is defined by

$$\ln D = \frac{1}{A} \frac{1}{A'} \int_A \int_{A'} \ln \delta_{AA'} \, dA \, dA'$$

the integrals being here double integrals, taken over the areas indicated. When the areas are circles, which are outside one another, by taking as the elements of area in each case concentric rings, and noting that from part (b), the geometric mean distance from one such ring to a ring of the other circle is the distance between centers, we see that in this case the value of D is the distance between centers for the two areas.

To treat the case of concentric circles, we first note that for a point P inside a circle of radius a , at distance b from the center, the geometric mean distance to the concentric rings which include the point will be the radius of these rings, while to those which do not include the point it will be the distance of the point from the center. Thus, if D_b is the geometric mean distance from the point P to the entire circular area:

$$\begin{aligned} \ln D_b &= \frac{\int_0^b \ln b \cdot 2\pi r \, dr + \int_b^a \ln r \cdot 2\pi r \, dr}{\pi a^2} \\ &= \frac{1}{a^2} \left\{ \ln b \cdot r^2 \Big|_0^b + r^2 \left(\ln r - \frac{1}{2} \right) \Big|_b^a \right\} \\ &= \ln a - \frac{1}{2} + \frac{b^2}{2a^2}. \end{aligned}$$

If now, we let P range over the area of a concentric circle of radius c ,

$$\ln D = \frac{\int_0^c \ln D_b \, 2\pi b \, db}{\pi c^2} = \ln a - \frac{1}{2} + \frac{c^2}{4a^2}.$$

Thus

$$D = ac - \frac{1}{2} + \frac{c^2}{4a^2},$$

where c is the radius of the smaller, and a that of the larger circle. In particular, the geometric mean distance from a circular area to itself is

$$D = ac - \frac{1}{2}.$$

The results of this problem are of use in the calculation of inductance for circular wires.

15. Periodic Functions. A function $f(x)$ is said to be **periodic**, of period T , if

$$f(x + T) = f(x). \tag{15}$$

It follows that, if n is any integer,

$$f(x + nT) = f(x), \tag{16}$$

so that any integral multiple of T , nT , is also a period.

The integral of a periodic function taken over any interval of

length T , the smallest period, is the same as that for the interval $0 < x < T$. For, if the interval is that from a to $a + T$, we may put $a = nT + b$, where n is an integer, positive, zero, or negative, and b is a positive number less than T . In Fig. 14, $n = 1$. We then have

$$\begin{aligned} \int_a^{a+T} f(x) dx &= \int_{nT+b}^{(n+1)T} f(x) dx + \int_{(n+1)T}^{(n+1)T+b} f(x) dx \\ &= \int_b^T f(u) du + \int_0^b f(u) du, \end{aligned}$$

where in the first integral, $x = u + nT$, and in the second integral, $x = u + (n + 1)T$, and we have used the relation

$$f(u + nT) = f(u + [n + 1]T) = f(u),$$

which follows from (16). But the last two integrals written may be combined into

$$\int_0^T f(u) du, \quad \text{or} \quad \int_0^T f(x) dx.$$

Hence we have:

$$\int_a^{a+T} f(x) dx = \int_0^T f(x) dx. \quad (17)$$

As Fig. 14 shows, our transformations may be interpreted geometrically as a dissection of the area representing the first integral

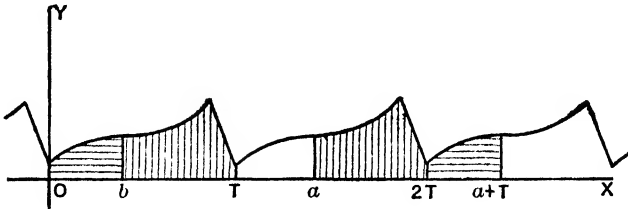

FIG. 14

into two pieces, which may be rearranged to give an area congruent to that which represents the first integral.

By dividing each side of equation (17) by T , we obtain the result: **The average of a periodic function is the same for all intervals of length equal to the smallest period.**

If we use an interval of length equal to any period, nT , we will

get the same average. For, let A denote the value of either member of (17). Then the integral over any interval of length T is A , and the integral over any interval of length nT is nA , so that the average for this interval is $\frac{nA}{nT} = \frac{A}{T}$.

We shall show that we get nearly this same value if we average over any interval which is very large as compared with the smallest period. If this large interval is that from a to $a + C$, we may write

$$C = NT + b,$$

where N is a large positive integer, and b is a positive number less than T . We then have:

$$\frac{1}{C} \int_a^{a+C} f(x) dx = \frac{NA + B}{NT + b}, \tag{18}$$

where

$$B = \int_{a+NT}^{a+C} f(x) dx.$$

If the function is always positive, B will be less than A , and in any case B will be numerically less than T times F , the numerically largest value of $f(x)$.

But we may rewrite (18) as

$$\frac{1}{C} \int_a^{a+C} f(x) dx = \frac{\frac{A}{T} + \frac{B}{NT}}{1 + \frac{b}{NT}}.$$

Since b/T is less than unity, the denominator is practically unity if N is large compared with 1. Similarly the numerator differs from A/T by a small quantity when N is large compared with F . Thus the fraction differs but little from A/T when N is large.

As an illustration of the ideas just discussed, we note that the average value of a sixty-cycle alternating current of maximum value I_m for a time interval as large as one hour will differ from the average for 1/60th of a second, the smallest period by at most I_m divided by 2×10^5 , and even for an interval of about two minutes the difference will be less than 1/7000th of I_m . This explains why,

in most applications to alternating currents, we only require average and root mean square values for intervals of length equal to one period, or for the interval from 0 to T .

16. Trigonometric Integrals. Alternating currents and e.m.f.'s may often be represented with sufficient accuracy by single sine or cosine terms. In all cases they may be regarded as made up of a sum of such terms. Consequently, the averages of sine terms and cosine terms are of frequent occurrence in practice. In calculating the root mean square value of sums of sine and cosine terms, we square before taking the average, so that we are here concerned with the averages of squares and products of sine and cosine terms. For these reasons, it will be worth while for us to solve these important special average problems once for all. We proceed to deduce a few rules which apply to them.

We begin with a single sine function, $\sin(\omega t + s)$ where ω and s are constants, and t is the variable time. The smallest period is

$$T = \frac{2\pi}{\omega}. \quad (19)$$

We have for the average over the fundamental interval:

$$\begin{aligned} \frac{1}{T} \int_0^T \sin(\omega t + s) dt &= - \left. \frac{\cos(\omega t + s)}{\omega T} \right|_0^T \\ &= - \frac{\cos(2\pi + s) - \cos s}{2\pi} \\ &= 0. \end{aligned} \quad (20)$$

For, by (19) ωT may be replaced by 2π , and the two cosine terms cancel since the trigonometric functions are all unchanged when the angle is altered by 2π .

A single cosine function, $\cos(\omega t + c)$, may be treated similarly, or reduced to the case of the sine by the relation:

$$\cos(\omega t + c) = \sin\left(\omega t + c + \frac{\pi}{2}\right). \quad (21)$$

Thus we have proved:

I. The average of a single sine, or of a single cosine term, is zero when taken over any complete period.

Let us next consider the product of two sine functions, $\sin(\omega t + s)$ and $\sin(\omega' t + s')$, whose frequencies $\omega/2\pi$ and $\omega'/2\pi$ are commensurable, that is, have a rational ratio. We write this

as the ratio of two integers, p and p' , with no common factors:

$$\frac{\frac{\omega}{2\pi}}{\frac{\omega'}{2\pi}} = \frac{\omega}{\omega'} = \frac{p}{p'}, \quad \text{or} \quad \frac{p}{\omega} = \frac{p'}{\omega'}. \quad (22)$$

Hence, if we put

$$T = \frac{2\pi p}{\omega} = \frac{2\pi p'}{\omega'}, \quad (23)$$

T will be a period of each of the sine terms, being p fundamental periods ($2\pi/\omega$) of the first, and p' fundamental periods ($2\pi/\omega'$) of the second term. In fact T is the smallest common period of the two terms.

Hence T is a period of the product, and its average for this period is:

$$\frac{1}{T} \int_0^T \sin(\omega t + s) \sin(\omega' t + s') dt.$$

By making use of the trigonometric identity,

$$\sin A \sin B = \frac{1}{2} [\cos(A - B) - \cos(A + B)],$$

we may replace the expression for the average by

$$\frac{1}{2} \left\{ \frac{1}{T} \int_0^T \cos[(\omega - \omega')t + s - s'] dt - \frac{1}{T} \int_0^T \cos[(\omega + \omega')t + s + s'] dt \right\}. \quad (24)$$

When neither $\omega - \omega'$ nor $\omega + \omega'$ is zero, each of the two terms in the brace is the average of a cosine term over the interval from 0 to T . But T is a period for each of these cosine terms, since

$$T = \frac{2\pi(p - p')}{\omega - \omega'} = \frac{2\pi(p + p')}{\omega + \omega'},$$

by (23), so that T is $(p - p')$ fundamental periods of the first, and $(p + p')$ fundamental periods of the second cosine terms. Hence, by principle I above, the value of each of the averages in (24) is zero.

The product of two cosine functions, or of a sine function and a cosine function, may be reduced to the product of two sines with the same frequencies, by the relation (21), so that we have proved:

II. The average of the product of two sines, of two cosines, or of a sine and a cosine, of commensurable but numerically unequal frequencies, taken over any complete period of the product, is zero.

Practically, we always reduce negative frequencies to positive ones by the relations:

$$A \sin(-\omega t + s) = -A \sin(\omega t - s)$$

and

$$A \cos(-\omega t + c) = A \cos(\omega t - c),$$

so that the only remaining case which need be treated is that for which $\omega - \omega'$ is zero. Here, the second average in (24) is zero as before, while the first is the average of a constant,

$$\cos[(\omega - \omega')t + s - s'] = \cos(s - s'),$$

which is the constant itself. Thus the average of the product is one half of this, and we have:

$$\frac{1}{T} \int_0^T \sin(\omega t + s) \sin(\omega t + s') dt = \frac{\cos(s - s')}{2}. \quad (25)$$

By making use of (21), we find from this that

$$\frac{1}{T} \int_0^T \cos(\omega t + c) \cos(\omega t + c') dt = \frac{\cos(c - c')}{2}, \quad (26)$$

and also that

$$\frac{1}{T} \int_0^T \sin(\omega t + s) \cos(\omega t + c) dt = \frac{\sin(s - c)}{2}, \quad (27)$$

since this last average is:

$$\begin{aligned} \frac{1}{T} \int_0^T \sin(\omega t + s) \sin\left(\omega t + c + \frac{\pi}{2}\right) dt &= \frac{\cos\left(s - c - \frac{\pi}{2}\right)}{2} \\ &= \frac{\sin(s - c)}{2}. \end{aligned}$$

The order of the difference $s - s'$ in (25) is unimportant, since $\cos(s - s') = \cos(s' - s)$. This checks with the fact that there is nothing to distinguish s from s' in the original product, since they are each the phase of one sine factor. Similar remarks apply to (26). In (27), however, we must take the order as indicated, the phase of the sine factor minus that of the cosine factor, since $\sin(s - c) = -\sin(c - s)$.

We formulate the results for equal frequencies in:

III. The average of the product of two sines or of two cosines of the same frequency taken over any complete period is one half the cosine of the difference between the phases of the factors. For the product of a sine and a cosine, the average is one half the sine of the angle by which the sine term leads the cosine term.

We notice, in particular, that if we are dealing with sines and cosines all in the same phase, which may be made zero by a proper choice of the initial time, then the average becomes zero for a sine times a cosine term, and is one-half for a sine or cosine term times one of the same frequency, that is, the square of such a term.

As an application of these principles, let us compute the r.m.s. value over a period for

$$i = 6 \cos(\omega t + 60^\circ) + 6 \sin(\omega t + 30^\circ) - 2 \sin 3 \omega t.$$

The square of i will contain three squares, and three products. By the remark just made, the average will be $\frac{1}{2}$ for each of the squares of trigonometric functions. By principle III the product $\cos(\omega t + 60^\circ) \sin(\omega t + 30^\circ)$ will have as its average

$$\frac{\sin(30^\circ - 60^\circ)}{2} = \frac{\sin(-30^\circ)}{2} = -\frac{1}{4}.$$

By principle II, the remaining products will have their averages equal to zero, so that the average of i^2 is:

$$\begin{aligned} \bar{i^2} &= 6^2 \cdot \frac{1}{2} + 6^2 \cdot \frac{1}{2} + 2^2 \cdot \frac{1}{2} - 2 \cdot 6 \cdot 6 \cdot \frac{1}{4} \\ &= 20. \end{aligned}$$

Hence the r.m.s. value of i is

$$\bar{i} = \sqrt{20} = 4.47.$$

By expanding the terms, we may write the given i in the alternative form:

$$i = 6 \cos \omega t - 2 \sin 3 \omega t,$$

where all the terms have zero phase. From this form, by principle III and the remarks made in connection with it, we see that the average of i^2 is:

$$\begin{aligned} \bar{i^2} &= 6^2 \cdot \frac{1}{2} + 2^2 \cdot \frac{1}{2} \\ &= 20, \end{aligned}$$

which checks the preceding calculation.

The second method is frequently the most expeditious way of making the calculation, since when the phases are all made zero, and we average the square, all the cross product terms have a zero average, and we need merely take account of the squared terms, for each of which their trigonometric part gives an average of $\frac{1}{2}$.

From the results of section 15, we see that values here found for averages over a complete period are approximately equivalent to those taken over any long interval.

EXERCISES VIII

1. Find the r.m.s. value of each of the following e.m.f.'s, for an interval large compared with the period:

$$(a) e = 400 \cos (120\pi t + 50^\circ) - 70 \sin (360\pi t + 42^\circ),$$

$$(b) e = 100 \sin 50\pi t + 200 \cos 50\pi t + 14 \sin 150\pi t + 10 \cos 150\pi t,$$

$$(c) e = 160 \cos 60\pi t + 32 \cos (180\pi t + 72^\circ),$$

$$(d) e = 234 \sin (50\pi t + 78^\circ 40') + 47 \sin (150\pi t - 2^\circ 50'),$$

$$(e) e = 15 \sin \left(\frac{\pi t}{30} + 75^\circ \right) + 3 \sin \left(\frac{\pi t}{10} - 75^\circ \right).$$

2. Find the r.m.s. value of each of the following currents, for an interval large compared with the period:

$$(a) i = 2.56 \sin (120\pi t + 88^\circ 50') - .187 \sin (360\pi t - 33^\circ 30'),$$

$$(b) i = 50 \sin 50\pi t + 100 \cos 50\pi t + 7 \sin 150\pi t + 5 \cos 150\pi t,$$

$$(c) i = 1.37 \cos (60\pi t - 31^\circ) + .21 \cos (180\pi t + 11^\circ),$$

$$(d) i = 2 \sin 50\pi t + .3 \cos 150\pi t,$$

$$(e) i = 15 \sin \left(\frac{\pi t}{30} + 73^\circ 10' \right) + 3 \sin \left(\frac{\pi t}{10} - 80^\circ 40' \right).$$

3. The currents of problem 2 arise when the corresponding e.m.f.'s of problem 1 are impressed on circuits of suitable impedances. Find the average power, $p = ei$, over a complete period, for each of these five cases.

4. Check formulas (26) and (27) of the text by direct integration.

5. If

$$i = I_1 \sin (\omega t + a_1) + I_3 \sin (3\omega t + a_3) + I_5 \sin (5\omega t + a_5) + \dots,$$

$$e = E_1 \sin (\omega t + b_1) + E_3 \sin (3\omega t + b_3) + E_5 \sin (5\omega t + b_5) + \dots,$$

show that, for a complete cycle, the r.m.s. values are:

$$\bar{i} = \sqrt{\frac{I_1^2 + I_3^2 + I_5^2 + \dots}{2}},$$

$$\bar{e} = \sqrt{\frac{E_1^2 + E_3^2 + E_5^2 + \dots}{2}},$$

and the average power, $p = ei$, is:

$$p = \frac{E_1 I_1 \cos (a_1 - b_1) + E_3 I_3 \cos (a_3 - b_3) + E_5 I_5 \cos (a_5 - b_5) + \dots}{2}.$$

6. Show that the results of problem 5 are unchanged if all the sines are replaced by cosines.

7. Prove that, if

$$\begin{aligned} i &= I_1 \cos \omega t + H_1 \sin \omega t + I_3 \cos 3\omega t + H_3 \sin 3\omega t + \dots, \\ e &= E_1 \cos \omega t + F_1 \sin \omega t + E_3 \cos 3\omega t + F_3 \sin 3\omega t + \dots, \end{aligned}$$

then, for any complete cycle,

$$\begin{aligned} \bar{i} &= \sqrt{\frac{I_1^2 + H_1^2 + I_3^2 + H_3^2 + \dots}{2}}, \\ \bar{e} &= \sqrt{\frac{E_1^2 + F_1^2 + E_3^2 + F_3^2 + \dots}{2}}, \\ \bar{p} &= \frac{E_1 I_1 + F_1 H_1 + E_3 I_3 + F_3 H_3 + \dots}{2}. \end{aligned}$$

8. Let

$$\begin{aligned} e &= A \cos(\omega t + a) = A \sin\left(\omega t + a + \frac{\pi}{2}\right) = A \cos a \cos \omega t - A \sin a \sin \omega t, \\ i &= B \cos(\omega t + b) = B \sin\left(\omega t + b + \frac{\pi}{2}\right) = B \cos b \cos \omega t - B \sin b \sin \omega t. \end{aligned}$$

Compute the r.m.s. values, using each of the three forms, also the average power, using each of the nine combinations.

9. (a) Calculate the smallest possible period for each of the c.m.f.'s of problem 1, or the currents of problem 2.

(b) Show that 1 second is a period for each of the first four parts of problems 1 and 2, and calculate the number of cycles per second in each case.

10. Prove that, if either p or p' in equation (22) is an even number, the T defined by equation (23) is the smallest period for the product $\sin(\omega t + s) \sin(\omega t + s')$, but if p and p' are both odd, $T/2$ is the smallest period of this expression.

11. Prove that the average value of the product of two sines of incommensurable frequencies, e.g. $\sin 3x \sin \sqrt{5}x$, taken over a time interval large compared with the reciprocal of the difference of the frequencies, is small, and that the average value approaches zero when the interval is increased indefinitely.

12. (a) Find the average value of $\sin 3x \sin 2\sqrt{2}x$ over the interval

$$0 < x < 2.9.$$

(b) Find the average for the interval $0 < x < 1000$, and compare the result with problem 11.

13. Using the principles of section 16, verify the conclusions of section 13 for the special case when $f(x)$ and $g(x)$ are single sine or cosine terms, and the interval is a complete period of both of them.

17. Finite Trigonometric Sums. We have defined a function as periodic, of period T , if equation (15) is satisfied. The functions $\sin x$ and $\cos x$ are each of period 2π , while $\sin nx$ and $\cos nx$ are each of period $2\pi/n$. Consequently, if n is restricted to integral values, 2π is an integral multiple of a period, and hence also

a period, for all these functions. Now consider a sum:

$$f(x) = A + A_1 \cos x + B_1 \sin x + A_2 \cos 2x + B_2 \sin 2x + \dots + A_N \cos Nx + B_N \sin Nx. \quad (28)$$

Since each term of the sum is unchanged when x changes by 2π , the same is true of the sum, and the function just written is periodic with 2π as a period.

If we change the scale on the x -axis in the ratio $2\pi/T$, we shall have a function of period T :

$$\begin{aligned} F(x) &= A + A_1 \cos \left(\frac{2\pi}{T} \right) x + B_1 \sin \left(\frac{2\pi}{T} \right) x \\ &\quad + A_2 \cos 2 \left(\frac{2\pi}{T} \right) x + B_2 \sin 2 \left(\frac{2\pi}{T} \right) x + \dots \\ &\quad + A_N \cos N \left(\frac{2\pi}{T} \right) x + B_N \sin N \left(\frac{2\pi}{T} \right) x. \end{aligned} \quad (29)$$

Suppose that a function has been constructed in this way, and we are given the function, either graphically or otherwise, together with the information that no terms have been used in constructing it beyond $\cos N \left(\frac{2\pi}{T} \right) x$ and $\sin N \left(\frac{2\pi}{T} \right) x$. We may find the coefficients by taking the proper averages, as follows.

We begin by taking the average of each side of (29) over any interval of length T , say $a < x < a + T$. By principle I, of section 16, all the terms on the right have a zero average for this interval, except the first term. This term is constant, and so has its average equal to itself. Thus we have:

$$\frac{1}{T} \int_a^{a+T} F(x) dx = A. \quad (30)$$

Next, we multiply both members of (29) by $\cos n \left(\frac{2\pi}{T} \right) x$, where n is one of the integers $1, 2, \dots, N$. This gives

$$\begin{aligned} F(x) \cos n \left(\frac{2\pi}{T} \right) x &= A \cos n \left(\frac{2\pi}{T} \right) x + A_1 \cos \left(\frac{2\pi}{T} \right) x \cos n \left(\frac{2\pi}{T} \right) x \\ &\quad + B_1 \sin \left(\frac{2\pi}{T} \right) x \cos n \left(\frac{2\pi}{T} \right) x + \dots + A_n \cos^2 n \left(\frac{2\pi}{T} \right) x \\ &\quad + B_n \sin n \left(\frac{2\pi}{T} \right) x \cos n \left(\frac{2\pi}{T} \right) x + \dots + A_N \cos N \left(\frac{2\pi}{T} \right) x \cos n \left(\frac{2\pi}{T} \right) x \\ &\quad + B_N \sin N \left(\frac{2\pi}{T} \right) x \cos n \left(\frac{2\pi}{T} \right) x. \end{aligned}$$

Now average both sides of this equation over the interval $a < x < a + T$. The first term has a zero average by principle I, and the terms corresponding to indices different from n have a zero average by principle II of section 16. Finally, by principle III the average of $\cos^2 n \left(\frac{2\pi}{T} \right) x$ is $\frac{1}{2}$, while the average of $\sin n \left(\frac{2\pi}{T} \right) x \cos n \left(\frac{2\pi}{T} \right) x$ is zero, so that we have:

$$\frac{1}{T} \int_a^{a+T} F(x) \cos n \left(\frac{2\pi}{T} \right) x dx = \frac{A_n}{2}. \quad (31)$$

In a similar way, we may multiply both members of (29) by $\sin n \left(\frac{2\pi}{T} \right) x$, and average over the interval $a < x < a + T$. The result is:

$$\frac{1}{T} \int_a^{a+T} F(x) \sin n \left(\frac{2\pi}{T} \right) x dx = \frac{B_n}{2}. \quad (32)$$

From the formulas (30), (31) and (32) we may write:

$$\begin{aligned} A &= \frac{1}{T} \int_a^{a+T} F(x) dx = \text{average of } F(x), \\ A_n &= \frac{2}{T} \int_a^{a+T} F(x) \cos n \left(\frac{2\pi}{T} \right) x dx \\ &= \text{twice the average of } F(x) \cos n \left(\frac{2\pi}{T} \right) x, \\ B_n &= \frac{2}{T} \int_a^{a+T} F(x) \sin n \left(\frac{2\pi}{T} \right) x dx \\ &= \text{twice the average of } F(x) \sin n \left(\frac{2\pi}{T} \right) x. \end{aligned} \quad (33)$$

In all of these the averages are to be taken over some interval of length T , as indicated. The most convenient interval is usually that for $a = 0$, $0 < x < T$, or that for $a = -T/2$, $-T/2 < x < T/2$. The difference between the expression for A and those for A_n is due to the fact that the average of the square of a cosine is $\frac{1}{2}$, except when it is the cosine of zero, when the average is 1. We write the first coefficient A rather than A_0 to call attention to this fact.

If the function $F(x)$, the left member of (29), is given graphically, we may evaluate the integrals of (33) by graphical, mechanical

or numerical methods.² If $F(x)$ is given analytically, we may evaluate the integrals in certain simple cases by the methods of the integral calculus.

For functions built up of trigonometric sums, certain peculiarities of the sums lead to properties of the functions, and conversely, if the functions have these properties we can draw conclusions about the sums from which they were constructed.

For example, since a constant, and the cosine terms of such a series are all even functions, a sum containing no sine terms will necessarily produce an even function. Conversely, if the function is even, no sine terms can have been used in forming it. For, since the function is even, and any sine by itself is odd, the product of the function by a sine term will be odd, and if the averages in (33) are taken from $-T/2$ to $T/2$, they will be zero for all the B_n . We note, incidentally, that for an even function, $F(x)$, we may take the averages for the constant term, A , and the cosine terms, A_n , from 0 to $T/2$, since the integrands are here even functions, being the product of two even functions.

Similarly, since the sines are all odd functions, a sum built up of sines alone will produce an odd function. Conversely, if the function is odd, only sine terms can have been used in forming it. For, since the function is odd, and any cosine by itself is even, the product of the function by a cosine term will be odd, and if the averages in (33) are taken from $-T/2$ to $T/2$, they will be zero for A and all the A_n . We note that for an odd function, $F(x)$, we may take the averages for the sine terms, B_n , from 0 to $T/2$, since

² One possible graphical method of finding an integral is to represent it as an area and approximate this area by a sum of rectangles or trapezoids. The approximate area may be computed, and the difference between the true and approximate areas may be estimated by counting the squares of the graph paper included in it. The numerical method consists in reading off a series of equally spaced ordinates, y_1, y_2, \dots , and h , the distance between two consecutive ordinates, and taking the area as

$$A = h \left(\frac{y_1}{2} + y_2 + \dots + y_{n-1} + \frac{y_n}{2} \right),$$

the trapezoidal rule, or as

$$A = \frac{h}{3} (y_1 + 4y_2 + 2y_3 + 4y_4 + 2y_5 + \dots + 4y_{2m} + y_{2m+1}),$$

Simpson's rule. In this the number of ordinates must be odd, and the coefficients are alternately 4 and 2, except the first and last.

the integrands are here even, being the product of two odd functions.

A property of a function of importance in applications to alternating currents is that defined by the equation:

$$F\left(x + \frac{T}{2}\right) = -F(x). \quad (34)$$

Any function satisfying this relation will necessarily be periodic, and of period T , since:

$$F(x + T) = -F\left(x + \frac{T}{2}\right) = F(x).$$

We call such a function an **odd-harmonic** function. As Fig. 15 illustrates, the graph of an odd-harmonic function consists of a

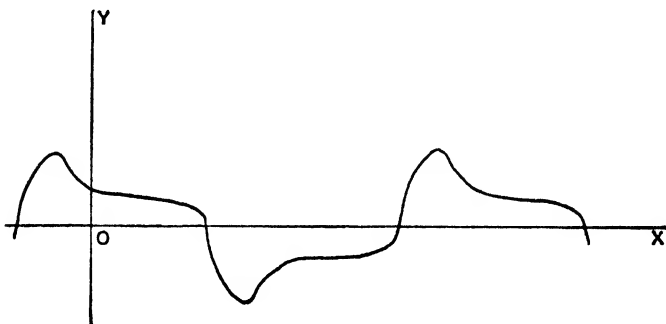

FIG. 15

wave, followed by a numerically equal but negative wave. The e.m.f.'s generated in practice, and hence the corresponding currents, have this property. We sometimes refer to the terms of the series in (29) as **harmonics**,³ the constant being the zero th harmonic, and the terms $A_n \cos n\left(\frac{2\pi}{T}\right)x + B_n \sin n\left(\frac{2\pi}{T}\right)x$ together making up the n th harmonic. The reason for calling a function which satisfies (34) an odd-harmonic function is that such a function will arise whenever we build up our series of terms (29), using only odd values of n , or odd harmonics. Conversely, if any function built up of sine and cosine terms has this property, no constant term, or terms with even values of n can have been used

³ Compare problem 6, p. 202.

in forming it. These statements are proved by observing how $\cos n\left(\frac{2\pi}{T}\right)x$ and $\sin n\left(\frac{2\pi}{T}\right)x$ change when x is increased by $\frac{T}{2}$. We have:

$$\cos \left[n \left(\frac{2\pi}{T} \right) \left(x + \frac{T}{2} \right) \right] = \cos \left[n \left(\frac{2\pi}{T} \right) x + n\pi \right]$$

and

$$\sin \left[n \left(\frac{2\pi}{T} \right) \left(x + \frac{T}{2} \right) \right] = \sin \left[n \left(\frac{2\pi}{T} \right) x + n\pi \right]$$

Since both the sine and cosine are unchanged when the angle is changed by 2π , or an even multiple of π , we see that the even harmonics are unchanged when x is increased by $T/2$. However, as the sine and cosine change their sign when the angle is changed by π or an odd multiple of π , we see that the odd harmonics change sign, when x is increased by $T/2$. Thus the odd harmonics all satisfy (34), and hence a sum of odd harmonics also satisfies (34). On the other hand, if a function $F(x)$ satisfies (34) and we calculate the coefficient of an even harmonic by means of (33), we multiply the function by an even harmonic, and the product is a function satisfying (34), so that its average is zero, since:

$$\int_0^T F(x) dx = \int_0^{T/2} F(x) dx + \int_{T/2}^T F(x) dx,$$

and the second integral is

$$- \int_0^{T/2} F(u) du,$$

when we put $x = u + T/2$, $dx = du$, and make use of (34), so that the second integral is the negative of the first integral.

We shall illustrate the formulas (33), and the last few observations, by considering the function

$$F(x) = \cos^3 x.$$

We assume that it is also known that $N \leq 4$ for this function. We may then put

$$\begin{aligned} \cos^3 x &= A + A_1 \cos x + B_1 \sin x + A_2 \cos 2x + B_2 \sin 2x \\ &\quad + A_3 \cos 3x + B_3 \sin 3x + A_4 \cos 4x + B_4 \sin 4x, \end{aligned}$$

since the period of the function is $T = 2\pi$, and $2\pi/T = 1$.

It is not necessary to calculate all these coefficients by (33), for we have:

$$\cos(-x) = \cos x,$$

and

$$\cos(x + \pi) = -\cos x.$$

As $\cos^3 x$ also satisfies these relations, the function with which we are dealing is an even function, and also an odd-harmonic function. From the first property, all the coefficients of the sine terms are zero, and from the second property, the constant, A , and all the coefficients with even subscripts are zero. Thus our expansion simplifies to

$$\cos^3 x = A_1 \cos x + A_3 \cos 3x.$$

From (33) we have.

$$A_1 = \frac{2}{2\pi} \int_{-\pi}^{\pi} \cos^3 x \cos x \, dx,$$

$$A_3 = \frac{2}{2\pi} \int_{-\pi}^{\pi} \cos^3 x \cos 3x \, dx.$$

But, by section 7, we have

$$\begin{aligned} \cos^4 x &= \left(\frac{e^{ix} + e^{-ix}}{2} \right)^4 \\ &= \frac{e^{4ix} + 4e^{2ix} + 6 + 4e^{-2ix} + e^{-4ix}}{16} \\ &= \frac{\cos 4x}{8} + \frac{\cos 2x}{2} + \frac{3}{8}, \end{aligned} \tag{35}$$

and

$$\begin{aligned} \cos^3 x \cos 3x &= \left(\frac{e^{ix} + e^{-ix}}{2} \right)^3 \left(\frac{e^{3ix} + e^{-3ix}}{2} \right) \\ &= \frac{e^{6ix} + 3e^{4ix} + 3e^{2ix} + 2 + 3e^{-2ix} + 3e^{-4ix} + e^{-6ix}}{16} \\ &= \frac{\cos 6x}{8} + \frac{3 \cos 4x}{8} + \frac{3 \cos 2x}{8} + \frac{1}{8}. \end{aligned}$$

As the average of the cosines of multiples of x from $-\pi$ to π , is zero, we need only use the constant terms, and have:

$$A_1 = \frac{1}{\pi} \int_{-\pi}^{\pi} \cos^4 x \, dx = \frac{1}{\pi} \int_{-\pi}^{\pi} \frac{3}{8} \, dx = \frac{3}{4},$$

and

$$A_3 = \frac{1}{\pi} \int_{-\pi}^{\pi} \cos^3 x \cos 3x \, dx = \frac{1}{\pi} \int_{-\pi}^{\pi} \frac{1}{8} \, dx = \frac{1}{4}.$$

Hence we have:

$$\cos^3 x = \frac{3}{4} \cos x + \frac{1}{4} \cos 3x.$$

Our computation has illustrated the theory, although it can hardly be said to give a practical application of it, since, by the method used to derive (35), we have:

$$\begin{aligned} \cos^3 x &= \left(\frac{e^{ix} + e^{-ix}}{2} \right)^3 \\ &= \frac{e^{3ix} + 3e^{ix} + 3e^{-ix} + e^{-3ix}}{8} \\ &= \frac{\cos 3x}{4} + \frac{3 \cos x}{4}. \end{aligned}$$

EXERCISES IX

1. Which of the following are odd functions, which are even functions, and which are odd-harmonic functions?

(a) $F(x) = 5 \sin \frac{x}{6} + 2 \sin \frac{7x}{6},$

(b) $F(x) = 5 - 6 \cos \frac{x}{3} + 8 \cos \frac{4x}{3},$

(c) $F(x) = 65 \cos 11x + 5 \cos 33x - \cos 99x,$

(d) $F(x) = 5 \sin 4x - 4 \sin 12x + 3 \sin 20x,$

(e) $F(x) = 0.$

2. Prove that if a function has only even harmonics, when considered to be of period T , it may be considered to be of period $T/2$.

3. If $F(x) = 2x^2 - 2x^3, 0 \leq x \leq 1$, sketch the graph for $-3 < x < 3$ if:

(a) $F(x)$ is an even function, and of period 2,

(b) $F(x)$ is an odd function, and of period 2,

(c) $F(x)$ is of period 1,

(d) $F(x)$ is an odd-harmonic function, and of period 2.

4. Show that the expression on the right side of (29) is equivalent to:

$$A + a_1 \sin \left(\frac{2\pi x}{T} + s_1 \right) + \cdots + a_N \sin \left(\frac{2N\pi x}{T} + s_N \right),$$

or to:

$$A + a_1 \cos \left(\frac{2\pi x}{T} + c_1 \right) + \cdots + a_N \cos \left(\frac{2N\pi x}{T} + c_N \right),$$

and express the function:

$$2 + 5 \sin 4\pi x + 6 \cos 4\pi x + 5 \sin 8\pi x + 2 \cos 8\pi x$$

in both ways.

5. Assuming that N is limited as stated, illustrate the use of (33) to determine the coefficients not known to be zero from other considerations for each of the following functions:

$$(a) \sin^2 x, N \leq 2, \quad (b) \cos^2 x, N \leq 2, \quad (c) \sin^3 x, N \leq 3.$$

6. (a) By taking the proper averages of the expression

$$\cos(x + a) = A + A_1 \cos x + B_1 \sin x,$$

determine the values of the coefficients.

(b) Do the same for:

$$\sin(x + a) = A + A_1 \cos x + B_1 \sin x.$$

7. Prove that in finding the coefficients with odd subscripts for an odd-harmonic function, we may take the averages in (33) from 0 to $T/2$.

8. (a) Prove that if a function is both an even function, and an odd-harmonic function, in determining the coefficients of the odd cosine terms, we may take the averages from 0 to $T/4$.

(b) Prove that for a function which is both an odd function, and an odd-harmonic function, in determining the coefficients of the odd sine terms, we may take the averages from 0 to $T/4$.

18. Fourier Series for Arbitrary Periodic Functions. If we take any periodic function, $F(x)$, which has the period T , we may calculate constants for it by the formulas found in the preceding section for finite trigonometric sums, namely:

$$\begin{aligned} A &= \text{average of } F(x) = \frac{1}{T} \int_a^{a+T} F(x) dx, \\ A_n &= \text{twice the average of } F(x) \cos n \left(\frac{2\pi}{T} \right) x \\ &= \frac{2}{T} \int_a^{a+T} F(x) \cos n \left(\frac{2\pi}{T} \right) x dx, \\ B_n &= \text{twice the average of } F(x) \sin n \left(\frac{2\pi}{T} \right) x \\ &= \frac{2}{T} \int_a^{a+T} F(x) \sin n \left(\frac{2\pi}{T} \right) x dx. \end{aligned} \tag{36}$$

These constants, of which there are generally an infinite number different from zero, are called the **Fourier coefficients** of the function. Since, when the function was composed of a finite number

of trigonometric terms, they had these numbers as coefficients, we are led to write down the infinite series of terms:

$$\begin{aligned} & A + A_1 \cos \left(\frac{2\pi}{T} \right) x + B_1 \sin \left(\frac{2\pi}{T} \right) x + A_2 \cos 2 \left(\frac{2\pi}{T} \right) x \\ & + B_2 \sin 2 \left(\frac{2\pi}{T} \right) x + \cdots + A_n \cos n \left(\frac{2\pi}{T} \right) x \\ & + B_n \sin n \left(\frac{2\pi}{T} \right) x + \cdots, \end{aligned} \quad (37)$$

which is called the **Fourier series** of the function $F(x)$.

For example, consider the function of period 12 defined by the following equations in the interval $-6 \leq x \leq 6$:

$$\begin{aligned} F(x) &= 0, & -6 \leq x \leq -3, \\ F(x) &= x + 3, & -3 < x \leq 0, \\ F(x) &= 3 - x, & 0 < x \leq 3, \\ F(x) &= 0, & 3 < x \leq 6. \end{aligned} \quad (38)$$

The graph of this function is shown in Fig. 16. The function may be verbally defined as "three diminished by the numerical

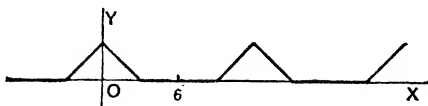

FIG. 16

difference between x and the nearest multiple of twelve, if this difference is less than three, and zero, if the difference is greater than three."

Since for this function, $T = 12$, we may put $a = -6$, and compute the averages of (38) from -6 to 6 . These averages will come out zero for the B_n , since $F(x) \sin n \left(\frac{2\pi}{12} \right) x$ is an odd function, owing to the even character of $F(x)$. Moreover, as $F(x)$ and hence $F(x) \cos n \left(\frac{2\pi}{12} \right) x$ are even functions, the averages for A and the A_n may be taken from 0 to 6 . Thus we write:

$$A = \frac{1}{6} \int_0^6 F(x) dx, \quad A_n = \frac{2}{6} \int_0^6 F(x) \cos n \left(\frac{2\pi}{12} \right) x dx.$$

But:

$$\int_0^6 F(x) dx = \int_0^3 (3-x) dx + \int_3^6 0 \cdot dx = -\frac{(3-x)^2}{2} \Big|_0^3 = \frac{9}{2},$$

as is also obvious from the figure. Hence

$$A = \frac{1}{6} \cdot \frac{9}{4} = \frac{3}{4}.$$

Again:

$$\begin{aligned} \int_0^6 F(x) \cos n \left(\frac{\pi}{6} \right) x dx &= \int_0^3 (3-x) \cos \frac{n\pi x}{6} dx + \int_3^6 0 \cdot dx \\ &= \left[\frac{6}{n\pi} \sin \frac{n\pi x}{6} (3-x) - \frac{6^2}{n^2\pi^2} \cos \frac{n\pi x}{6} \right]_0^3, \\ &= \frac{36}{n^2\pi^2} \left(-\cos \frac{n\pi}{2} + 1 \right), \end{aligned}$$

so that

$$A_n = \frac{1}{3} \frac{36}{n^2\pi^2} \left(-\cos \frac{n\pi}{2} + 1 \right) = \frac{12}{n^2\pi^2} \left(1 - \cos \frac{n\pi}{2} \right).$$

The cosine term, and hence the parenthesis, assumes different values, depending on the remainder of n when divided by 4. Thus:

$$n = 1, 5, 9, \dots, \quad \cos \frac{n\pi}{2} = \cos \frac{\pi}{2} = 0; \quad (1 - 0) = 1;$$

$$n = 2, 6, 10, \dots, \quad \cos \frac{n\pi}{2} = \cos \pi = -1; \quad (1 - [-1]) = 2;$$

$$n = 3, 7, 11, \dots, \quad \cos \frac{n\pi}{2} = \cos \frac{3\pi}{2} = 0; \quad (1 - 0) = 1;$$

$$n = 4, 8, 12, \dots, \quad \cos \frac{n\pi}{2} = \cos 2\pi = 1; \quad (1 - 1) = 0;$$

consequently,

$$A_1 = \frac{12}{\pi^2}, \quad A_2 = \frac{24}{2^2\pi^2}, \quad A_3 = \frac{12}{3^2\pi^2}, \quad A_4 = 0, \dots,$$

and the Fourier series for the function (38) is

$$\begin{aligned} \frac{3}{4} + \frac{12}{\pi^2} \left(\cos \frac{\pi x}{6} + \frac{2}{2^2} \cos \frac{2\pi x}{6} + \frac{1}{3^2} \cos \frac{3\pi x}{6} \right. \\ \left. + \frac{1}{5^2} \cos \frac{5\pi x}{6} + \dots \right). \end{aligned} \quad (39)$$

In Chapter VIII we shall prove that the Fourier series for any function which, like the function (38), is periodic and in any interval of length one period is made up of a finite number of smooth pieces which join together continuously, represents the function for all values of x . That is, for any fixed value of x , the series converges to the value of the function for the particular x considered. In Fig. 17 the full curve is the graph of the first three

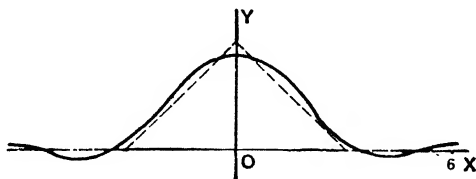

Fig. 17

terms of (39), while the dotted line is the graph of (38). This illustrates how the partial sums of the series approximate the function.

If a periodic function is made up of smooth pieces which do not join together continuously, the values obtained from the two pieces which abut at a point of discontinuity will not agree. For such a function, the Fourier series will converge for all values of x . The sum of the series will equal the value of the function for any x not corresponding to a point of discontinuity, and will equal one-half the sum of the two values associated with the point for an x corresponding to a point of discontinuity. Giving arbitrary values to the function at the points of discontinuity in advance will not affect the coefficients of the Fourier series. For these are given by integrals, or areas under curves, and are not changed by changes in the ordinates at isolated points. In general, we shall regard our functions as undefined at the points of discontinuity, although the sum of the Fourier series gives a definite value for these points.

The function of period 16 defined in the interval $-8 < x < 8$ by the equations:

$$\begin{aligned} F(x) &= 0, & -8 < x < 0, \\ F(x) &= 4, & 0 < x < 4, \\ F(x) &= 0, & 4 < x < 8, \end{aligned} \tag{40}$$

has discontinuities at the points for $x = 0, 4$ or any value differing from one of these by an integral multiple of 16. Its graph is shown

in Fig. 18. We proceed to compute its Fourier coefficients as defined by (36). We have:

$$A = \frac{1}{16} \int_{-8}^8 F(x) dx, \quad A_n = \frac{2}{16} \int_{-8}^8 F(x) \cos n \left(\frac{2\pi x}{16} \right) dx,$$

$$B_n = \frac{2}{16} \int_{-8}^8 F(x) \sin n \left(\frac{2\pi x}{16} \right) dx.$$

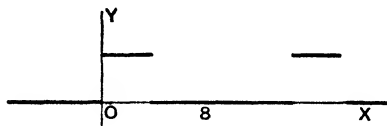

FIG. 18

But:

$$\int_{-8}^8 F(x) dx = \int_{-8}^0 0 dx + \int_0^4 4 dx + \int_4^8 0 dx = 4x \Big|_0^4 = 16,$$

as is also obvious from the figure, so that

$$A = \frac{16}{16} = 1.$$

Again,

$$\int_{-8}^8 F(x) \cos \frac{n\pi x}{8} dx = \int_{-8}^0 0 dx + \int_0^4 4 \cos \frac{n\pi x}{8} dx + \int_4^8 0 dx$$

$$= \frac{32}{n\pi} \sin \frac{n\pi x}{8} \Big|_0^4 = \frac{32}{n\pi} \sin \frac{n\pi}{2},$$

so that:

$$A_n = \frac{1}{8} \cdot \frac{32}{n\pi} \sin \frac{n\pi}{2} = \frac{4}{n\pi} \sin \frac{n\pi}{2}.$$

And:

$$\int_{-8}^8 F(x) \sin \frac{n\pi x}{8} dx = \int_{-8}^0 0 dx + \int_0^4 4 \sin \frac{n\pi x}{8} dx + \int_4^8 0 dx$$

$$= -\frac{32}{n\pi} \cos \frac{n\pi x}{8} \Big|_0^4 = \frac{32}{n\pi} \left(1 - \cos \frac{n\pi}{2} \right),$$

so that:

$$B_n = \frac{1}{8} \cdot \frac{32}{n\pi} \left(1 - \cos \frac{n\pi}{2} \right) = \frac{4}{n\pi} \left(1 - \cos \frac{n\pi}{2} \right).$$

From these expressions, in which we put n successively equal to 1, 2, 3, etc., we find for the Fourier series:

$$1 + \frac{4}{\pi} \left(\cos \frac{\pi x}{8} - \frac{1}{3} \cos \frac{3\pi x}{8} + \frac{1}{5} \cos \frac{5\pi x}{8} - \dots \right) + \frac{4}{\pi} \left(\sin \frac{\pi x}{8} + \frac{2}{2} \sin \frac{2\pi x}{8} + \frac{1}{3} \sin \frac{3\pi x}{8} + \frac{1}{5} \sin \frac{5\pi x}{8} + \dots \right). \quad (41)$$

The full curve of Fig. 19 is the graph of the sum of the terms of (41), up to and including those involving $\frac{7\pi x}{8}$. The dotted curve is the graph of the function defined by the sum of the series.

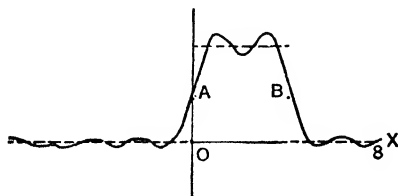

FIG. 19

A and B correspond to the points of discontinuity. Not all rearrangements of the terms of a Fourier series will give a convergent series, but it is always allowable to group the sine terms together, and the cosine terms together into two separate series as is done in (41).

EXERCISES X

1. Find the Fourier series for a function which is of period 10, is zero in the interval $-5 < x < 0$, and in the interval $0 < x < 5$ is equal to:

(a) x , (b) x^2 , (c) 10, (d) $\sin x$, (e) e^x .

2. A function is of period 16, and is defined in the interval $-8 < x < 8$ by the equations:

$$F(x) = 0, \quad -8 < x < -4; \quad F(x) = -2, \quad -4 < x < 0; \\ F(x) = 1, \quad 0 < x < 4; \quad F(x) = 0, \quad 4 < x < 8.$$

Find the Fourier series which represents it.

3. Find the Fourier series for a function which is of period 40, and in the interval $-20 < x < 20$ is defined by:

$$F(x) = -10, \quad -20 < x < 0; \quad F(x) = 0, \quad 0 < x < 10, \\ F(x) = 20, \quad 10 < x < 20.$$

4. In looking up the number whose logarithm is x , we seek, in the tables, a number y which is the excess of x over the greatest integer less than x . Draw

the graph of y as a function of x , and find the Fourier series which represents this function.

5. In finding the values of the trigonometric functions of an angle of x radians, we make use of the angle of y degrees, in the first quadrant, $0 \leq y \leq 90$, which, except for sign, has the same trigonometric functions as x . Draw the graph of y as a function of x , and find the Fourier series which represents this function.

6. Prove that the numerical value of $\sin x$, $|\sin x|$, is an even function of period π , and find the Fourier series which represents it.

7. Find the Fourier series which represents $|\cos x|$.

8. Find the Fourier series for a function which is of period 6, and in the interval $-3 < x < 3$ equals x^2 .

9. A function is periodic, of period 8. Find the Fourier series which represents it, if it is defined in the interval $0 < x < 8$ by

$$\begin{aligned} F(x) &= 5, & 0 < x < 2; & & F(x) &= 2, & 2 < x < 4; \\ F(x) &= -5, & 4 < x < 6; & & F(x) &= -2, & 6 < x < 8. \end{aligned}$$

10. Find the Fourier series which represents the function of period 2π , defined in the interval $-\pi < x < \pi$ as equal to

(a) e^x , (b) $x \sin x$, (c) $x \cos x$.

19. Fourier Series, Sine Series, Cosine Series, for Arbitrary Functions. For many purposes it is convenient to represent a function by a Fourier series, even when the function is not periodic. This may be done by the formulas (36) of the last paragraph, provided we take the averages over the interval a to $a + T$ in which we wish to represent the function. For example, suppose we wish to represent the function x by a Fourier series, of period 2, in the interval $a < x < a + 2$. We have:

$$\begin{aligned} A &= \frac{1}{2} \int_a^{a+2} x \, dx = \frac{x^2}{4} \Big|_a^{a+2} = a + 1; \\ A_n &= \frac{2}{2} \int_a^{a+2} x \cos n \left(\frac{2\pi}{2} \right) x \, dx = \left[\frac{x \sin n\pi x}{n\pi} + \frac{\cos n\pi x}{n^2\pi^2} \right]_a^{a+2} \\ &= \frac{2 \sin n\pi a}{n\pi}; \\ B_n &= \frac{2}{2} \int_a^{a+2} x \sin n \left(\frac{2\pi}{2} \right) x \, dx = \left[-\frac{x \cos n\pi x}{n\pi} + \frac{\sin n\pi x}{n^2\pi^2} \right]_a^{a+2} \\ &= -\frac{2 \cos n\pi a}{n\pi}. \end{aligned}$$

For $a = 0$, the series is:

$$y = 1 - \frac{2}{\pi} \left(\sin \pi x + \frac{\sin 2\pi x}{2} + \frac{\sin 3\pi x}{3} + \dots \right), \quad (42)$$

whose graph is shown in Fig. 20. It agrees with the function $y = x$ in the interval $0 < x < 2$. For any value of a , we have:

$$y = a + 1 + \frac{2}{\pi} \left(\sin \pi a \cos \pi x - \cos \pi a \sin \pi x + \frac{\sin 2\pi a}{2} \cos 2\pi x - \frac{\cos 2\pi a}{2} \sin 2\pi x + \dots \right), \quad (43)$$

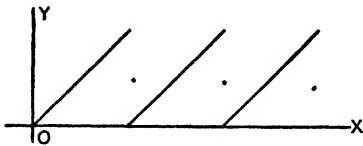

FIG. 20

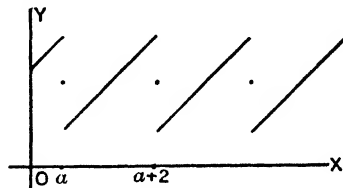

FIG. 21

whose graph is shown in Fig. 21. It agrees with the function $y = x$ in the interval $a < x < a + 2$. The relation of these series may be seen by writing (43) in the form:

$$y - a = 1 - \frac{2}{\pi} \left\{ \sin \pi (x - a) + \frac{\sin 2\pi (x - a)}{2} + \frac{\sin 3\pi (x - a)}{3} + \dots \right\},$$

which shows that its graph is that of (42) moved a units up and a units to the right. This takes the part of the graph $y = x$ for $0 < x < 2$ into the part for $a < x < a + 2$.

We may represent a function in the interval $0 < x < T/2$ by a Fourier series of period T involving sine terms only, called a **sine series**. We use formulas analogous to (36) of the preceding paragraph for the sine coefficients, taking the averages over the interval in question, and put the cosine coefficients and constant term equal to zero. For, the Fourier series found in this way will represent the odd, periodic function, of period T agreeing with the given function in the interval $0 < x < T/2$.

For, example, the sine series of period $T = 2p$ which represents the function 1 in the interval $0 < x < p$ has coefficients:

$$\begin{aligned} B_n &= \frac{2}{p} \int_0^p 1 \cdot \sin n \left(\frac{2\pi x}{2p} \right) dx = -\frac{2}{p} \frac{\cos \frac{n\pi x}{p}}{\frac{n\pi}{p}} \Bigg|_0^p \\ &= \frac{2}{n\pi} (1 - \cos n\pi), \end{aligned}$$

and the required series is:

$$\frac{4}{\pi} \left(\sin \frac{\pi x}{p} + \frac{1}{3} \sin \frac{3\pi x}{p} + \frac{1}{5} \sin \frac{5\pi x}{p} + \dots \right). \quad (44)$$

The function which is odd, of period $2p$, and equal to 1 in the interval $0 < x < p$ is an odd-harmonic function, which explains why the coefficients of the even terms are zero.

In a similar way, we may represent a function in the interval $0 < x < T/2$ by a Fourier series of period T involving cosine terms only, called a **cosine series**. As before, we use formulas analogous to (36) for the cosine coefficients and constant term, taking the averages over the interval in question, and put the sine coefficients equal to zero. For, the Fourier series found in this way will represent the even, periodic function of period T , agreeing with the given function in the interval $0 < x < T/2$.

As an example of this, let us find a cosine series of period $T = 2p$ which represents the function x in the interval $0 < x < p$. We have:

$$\begin{aligned} A &= \frac{1}{p} \int_0^p x \, dx = \frac{1}{p} \cdot \frac{x^2}{2} \Big|_0^p = \frac{p}{2}, \\ A_n &= \frac{2}{p} \int_0^p x \cos n \left(\frac{2\pi}{2p} \right) x \, dx = \frac{2}{p} \left[\frac{x \sin \frac{n\pi x}{p}}{\frac{n\pi}{p}} + \frac{\cos \frac{n\pi x}{p}}{\frac{n^2\pi^2}{p^2}} \right]_0^p \\ &= \frac{2p}{n^2\pi^2} (\cos n\pi - 1), \end{aligned}$$

and the required series is:

$$\frac{p}{2} - \frac{4p}{\pi^2} \left(\cos \frac{\pi x}{p} + \frac{1}{3^2} \cos \frac{3\pi x}{p} + \frac{1}{5^2} \cos \frac{5\pi x}{p} + \dots \right). \quad (45)$$

The function which is even, of period $2p$, and equal to x in the interval $0 < x < p$ becomes odd harmonic if $p/2$ is subtracted from it, which explains the absence of the even terms.

EXERCISES XI

1. Verify that the sine series of period $2p$ which represents the function x in the interval $0 < x < p$ is:

$$\frac{2p}{\pi} \left(\sin \frac{\pi x}{p} - \frac{1}{2} \sin \frac{2\pi x}{p} + \frac{1}{3} \sin \frac{3\pi x}{p} + \dots \right).$$

2. Using the sine series for 1 given in (44) of the text, and the result of problem 1, show that the sine series of period $2p$ which represents the function $Ax + B$ in the interval $0 < x < p$ is:

$$\frac{1}{\pi} \left\{ (4B + 2pA) \sin \frac{\pi x}{p} - \frac{2pA}{2} \sin \frac{2\pi x}{p} + \frac{(4B + 2pA)}{3} \sin \frac{3\pi x}{p} - \frac{2pA}{4} \sin \frac{4\pi x}{p} + \dots \right\}.$$

3. Using the cosine series for x given in (45) of the text, show that the cosine series of period $2p$ which represents the function $Ax + B$ in the interval $0 < x < p$ is:

$$B + \frac{Ap}{2} - \frac{4Ap}{\pi^2} \left(\cos \frac{\pi x}{p} + \frac{1}{3^2} \cos \frac{3\pi x}{p} + \frac{1}{5^2} \cos \frac{5\pi x}{p} + \dots \right).$$

4. Find the sine series of period 4 which represents the function $2x + 3$ in the interval $0 < x < 2$,

- (a) By direct calculation of the coefficients.
 (b) By using the result of problem 2.

5. Find the cosine series of period 4 which represents the function $2x + 3$ in the interval $0 < x < 2$,

- (a) By direct calculation of the coefficients.
 (b) By using the result of problem 3.

6. If $F(x) = x$, $0 < x < 3$; and $F(x) = 3$, $3 < x < 6$;

- (a) Expand in a sine series of period 12,
 (b) Expand in a cosine series of period 12.

7. If $F(x) = 0$, $0 < x < 3$; $F(x) = 3$, $3 < x < 6$;

- (a) Expand in a sine series of period 12,
 (b) Expand in a cosine series of period 12.

8. (a) Find the sine series, $S(x)$, of period 4 which represents the function $F(x) = 2x$, $0 < x < 1$; $F(x) = 4 - 2x$, $1 < x < 2$;

(b) Find the cosine series, $C(x)$, of period 4 which represents the same function in the interval $0 < x < 2$.

(c) Show that $C(x) = \frac{1}{2} \left\{ 2 + S(2x - 1) \right\}$, both from an examination of the graphs of the functions, and from the series.

9. (a) Assuming a result, proved in Chapter VIII, that the r.m.s. value of a function equals the limit of the r.m.s. value of its Fourier series taken to n terms, as n increases indefinitely, prove from the series in problem 1 that:

$$\frac{\pi^2}{6} = \frac{1}{1^2} + \frac{1}{2^2} + \frac{1}{3^2} + \dots$$

(b) As in (a), prove from the expansion (45) of the text, that

$$\frac{\pi^4}{96} = \frac{1}{1^4} + \frac{1}{3^4} + \frac{1}{5^4} + \frac{1}{7^4} + \dots$$

This converges fairly rapidly, so that the first 5 terms will give π correct to three decimal places.

10. (a) Taking r.m.s. values as in (a) of the preceding problem, deduce from the expansion (44) of the text that

$$\frac{\pi^2}{8} = \frac{1}{1^2} + \frac{1}{3^2} + \frac{1}{5^2} + \dots$$

(b) Put $x = 0$, and $x = p$ in the expansion (45) of the text, sum the resulting series by means of (a) of this problem, and so verify that the series has the same value as the function it represents at these points.

11. (a) If a function is expanded in a sine series $S(x)$ of period $2p$ which represents it in the interval 0 to p , and a cosine series $C(x)$ of period $2p$ which represents it in this same interval, show that $\frac{1}{2}\{S(x) + C(x)\}$ is a Fourier series for the function which is zero in the interval $-p < x < 0$, and equal to $F(x)$ in the interval $0 < x < p$.

(b) Illustrate the result of (a) for the function of problem 1 (a), p. 74.

(c) Use part (a) to find sine and cosine expansions, of period 10 , representing the functions of parts (b), (c), (d), (e) of problem 1, p. 74, from the results of that problem.

12. If a function is periodic of period $4p$, is odd, and also an odd-harmonic function, show that its Fourier coefficients are given by:

$$A = A_n = B_{2n} = 0, \quad B_{2n+1} = \frac{2}{p} \int_0^p F(x) \sin(2n+1) \left(\frac{2\pi}{4p}\right) x dx.$$

Deduce from this a method of representing any function in the interval $0 < x < T/4$ by a sine series of period T , containing only odd harmonic terms.

13. If a function is periodic of period $4p$, is even, and also an odd-harmonic function, show that its Fourier coefficients are given by:

$$A = A_{2n} = B_n = 0, \quad A_{2n+1} = \frac{2}{p} \int_0^p F(x) \cos(2n+1) \left(\frac{2\pi}{4p}\right) x dx.$$

Deduce from this a method of representing any function in the interval $0 < x < T/4$ by a cosine series of period T , containing only odd harmonic terms.

14. (a) Taking $T = 4p$, illustrate the expansions of problems 12 and 13 for the function $F(x) = x$, $0 < x < p$.

(b) Similarly for $F(x) = 1$, $0 < x < p$.

CHAPTER III

LINEAR DIFFERENTIAL EQUATIONS WITH CONSTANT COEFFICIENTS

This chapter is devoted to methods of solving one, or a system of several, ordinary linear differential equations with constant coefficients. The determination of the flow of current in an electric network¹ due to prescribed electromotive forces leads to a system of equations of this type, and we emphasize particularly the devices best suited to this application.

20. Linear Equations. An expression is said to be **linear** in a set of variables if it is a sum of terms each of which contains just one of these variables raised to the first power as a factor. Thus²

$$L(y) = A_3 \frac{d^3y}{dx^3} + A_2 \frac{d^2y}{dx^2} + A_1 \frac{dy}{dx} + A_0y \quad (1)$$

is linear in the four variables $\frac{d^3y}{dx^3}$, $\frac{d^2y}{dx^2}$, $\frac{dy}{dx}$, y , if the coefficients A_0 , A_1 , A_2 , A_3 do not depend on these variables. These coefficients may be functions of x , although in most of the applications of such expressions we shall make in the following sections the coefficients will be constants.

A **linear differential equation** is formed by equating a linear expression in y and some of its derivatives to a given function of x . If the highest derivative which occurs in the linear expression is $\frac{d^ny}{dx^n}$, the equation is said to be of the **n th order**. Thus, if A_3 is

¹ Under the assumption that the resistances, inductances and capacities are "lumped," i.e. each act at a single place in the network, and are constant. See sections 24 and 25.

² If y is a known function of x , the three derivatives may be found, so that the expression depends on the function y and hence is abbreviated by $L(y)$. Thus $L(x^3)$ means that

$$y = x^3, \quad \frac{dy}{dx} = 3x^2, \quad \frac{d^2y}{dx^2} = 6x, \quad \text{and} \quad \frac{d^3y}{dx^3} = 6,$$

and hence

$$L(x^3) = 6A_3 + 6A_2x + 3A_1x^2 + A_0x^3.$$

not zero,

$$A_3 \frac{d^3 y}{dx^3} + A_2 \frac{d^2 y}{dx^2} + A_1 \frac{dy}{dx} + A_0 = A(x) \quad (2)$$

is a linear differential equation of the third order.

If an expression, $L(y)$, is linear in y and some of its derivatives, and we replace y by the sum of two functions, $u_1 + u_2$, we obtain the sum of the results of replacing y by each of the functions u_1, u_2 in turn. That is:

$$L(u_1 + u_2) = L(u_1) + L(u_2). \quad (3)$$

Similarly, if y is replaced by a constant times a function, cu , the result is the constant, c , times the result for the function u , i.e.

$$L(cu) = cL(u). \quad (4)$$

From these results it follows that if we know n linearly independent³ solutions u_1, u_2, \dots, u_n of the equation with right member zero,

$$L(y) = 0,$$

and one solution u of the equation

$$L(y) = A(x), \quad (5)$$

the complete solution of the latter equation will be

$$y = c_1 u_1 + c_2 u_2 + \dots + c_n u_n + u, \quad (6)$$

where the c_1, c_2, \dots, c_n are the n arbitrary constants. For, by the principles expressed in (3) and (4), we will have

$$\begin{aligned} L(y) &= c_1 L(u_1) + c_2 L(u_2) + \dots + c_n L(u_n) + L(u) \\ &= A(x), \end{aligned}$$

since $L(u_k) = 0$, and $L(u) = A(x)$. Thus (6) gives a solution of (5), and as the u_k are linearly independent, it contains n constants and so is the complete solution.

³ Such that no constants a_1, a_2, \dots, a_n not all zero, can be found for which $a_1 u_1 + a_2 u_2 + \dots + a_n u_n = 0$. For example $2, x$, and $3x + 4$ are *not* linearly independent, since $2(2) + 3(x) - 1(3x + 4) = 0$, while $2, x$, and e^x are linearly independent. A method of establishing linear independence is indicated in problems 5 and 6, p. 82. It may be noted that $2c_1 + c_2 x + c_3 e^x$ contains three constants, but $2c_1 + c_2 x + c_3(3x + 4) = 2(c_1 + 2c_3) + (c_2 + 3c_3)x$ contains really only two constants, $(c_1 + 2c_3)$ and $(c_2 + 3c_3)$.

The part of the solution of a linear differential equation involving the constants is called the **complementary function**. The term u is called a **particular integral**. The discussion just given shows that any function which satisfies the differential equation may be used as a particular integral, and that the complementary function, which by itself is the complete solution of the corresponding equation with right member zero, is formed in a simple way from any n linearly independent functions which satisfy the equation with right member zero.

EXERCISES XII

1. By differentiating and eliminating the constants, find the differential equation with right member zero whose solution is:

(a) $c_1 + c_2x$, (b) $c_1e^x + c_2e^{2x}$, (c) $c_1 \sin x + c_2 \cos x$, (d) $c_1e^{-x} + c_2xe^{-x}$, (e) $c_1e^{2x} \cos 2x + c_2e^{3x} \sin 2x$.

2. For each part of problem 1, find the differential equation whose complementary function is the expression there given, and admitting as a particular integral the expression given in the corresponding part of this problem.

(a) x^2 , (b) $2e^x + 3$, (c) $\sin 2x$, (d) e^x , (e) $2x + 1$.

3. Find the differential equation with right member zero whose solution is:

(a) $c_1x^2 + c_2x^3$, (b) $c_1x + c_2e^x$, (c) $c_1 \sin x + c_2e^x$, (d) $c_1 \sin x + c_2 \sin 2x$, (e) $c_1f(x) + c_2g(x)$.

4. Find the differential equation whose complete solution is:

(a) $x^2 + c_1 + c_2x^4$, (b) $\sin 2x + c_1 + c_2 \cos 2x$, (c) $1 + c_1x^2 + c_2x^4$.

5. (a) Prove that if $a_1u_1 + a_2u_2 = 0$ (a_1, a_2 constants not both zero), then

$$a_1 \frac{du_1}{dx} + a_2 \frac{du_2}{dx} = 0,$$

and the determinant

$$\begin{vmatrix} u_1 & u_2 \\ \frac{du_1}{dx} & \frac{du_2}{dx} \end{vmatrix} = u_1 \frac{du_2}{dx} - u_2 \frac{du_1}{dx} = 0.$$

This shows that if the expression just written is not zero, the two functions are linearly independent.

(b) Similarly, if the condition

$$a_1u_1 + a_2u_2 + \cdots + a_nu_n = 0,$$

all the derivatives of the functions u_k will satisfy equations of this form, and the determinant

$$\begin{vmatrix} u_1 & u_2 & \cdots & u_n \\ \frac{du_1}{dx} & \frac{du_2}{dx} & \cdots & \frac{du_n}{dx} \\ \cdot & \cdot & \cdot & \cdot \\ \cdot & \cdot & \cdot & \cdot \\ \frac{du_1}{dx^n} & \frac{du_2}{dx^n} & \cdots & \frac{du_n}{dx^n} \end{vmatrix} = 0.$$

Thus if the determinant just written is not zero, the n functions are linearly independent.

6. Apply the result of problem 5 (a) to prove that each expression in problem 1 is made up of a pair of linearly independent functions.

21. The Complementary Function. The solution of the linear differential equation of the first order with constant coefficients and right member zero,

$$\frac{dy}{dx} - ry = 0, \quad (7)$$

is

$$y = ce^{rx}. \quad (8)$$

The solution of a linear differential equation of any order with constant coefficients and right member zero may be reduced to the solution of first order equations of the same type, by a process of factoring the differential operator. We illustrate by some examples. The equation

$$3 \frac{d^2y}{dx^2} + 2 \frac{dy}{dx} - y = 0 \quad (9)$$

suggests the algebraic expression⁴

$$3X^2 + 2X - 1 = 3(X - \frac{1}{3})(X + 1). \quad (10)$$

Since it is immaterial whether we first multiply by a constant, and then differentiate, or perform these operations in the reverse order, linear differential operators with *constant* coefficients combine like algebraic expressions.⁵ Thus the algebraic relation (10)

⁴ Since $ax^2 + bx + c = a(x - r_1)(x - r_2)$, where r_1 and r_2 are the roots of the quadratic equation $ax^2 + bx + c = 0$, the factors may be found from the quadratic formula, $x = \frac{-b \pm \sqrt{b^2 - 4ac}}{2a}$, if not immediately obvious. For

equations of higher degree than the second the factors would still be found from the roots of an algebraic equation, but this would usually have to be solved by some method of trial and error.

⁵ This no longer holds if the coefficients are not constant. For example:

$$(xX)(X + x) = (X + x)(xX) = xX^2 + x^2X,$$

but
$$\left(x \frac{d}{dx}\right) \left(\frac{d}{dx} + x\right) y = x \frac{d^2y}{dx^2} + x^2 \frac{dy}{dx} + xy,$$

and
$$\left(\frac{d}{dx} + x\right) \left(x \frac{d}{dx}\right) y = x \frac{d^2y}{dx^2} + (1 + x^2) \frac{dy}{dx}.$$

shows that the differential equation (9) is equivalent to

$$\left(\frac{d}{dx} - \frac{1}{3}\right)\left(\frac{d}{dx} + 1\right)y = 0, \quad (11)$$

where the parentheses indicate that we are to first compute

$$y_1 = \frac{dy}{dx} + y,$$

and then set

$$\frac{dy_1}{dx} - \frac{1}{3}y_1 = 0.$$

Equation (11) shows that the solution of the first order equation

$$\frac{dy}{dx} + y = 0,$$

namely, c_1e^{-x} , is a solution of equation (9). For, when this expression is subjected to the operator $\left(\frac{d}{dx} + 1\right)$, the result is zero, and the second operator leaves it zero. Or, in other words, from our method of getting this expression, when y_1 is computed it comes out zero, and this obviously satisfies the differential equation written for y_1 .

But the order of the parentheses in (11) may be changed, just as they may be changed in the algebraic expression (10). Consequently, a similar argument shows that the solution of

$$\frac{dy}{dx} - \frac{1}{3}y = 0,$$

namely, $c_2e^{x/3}$, is also a solution of equation (9). Thus, by the preceding section,

$$y = c_1e^{-x} + c_2e^{x/3} \quad (12)$$

is the complete solution of (9).

As a second example, consider

$$\frac{d^2y}{dx^2} + 4\frac{dy}{dx} + 6y = 0. \quad (13)$$

The corresponding algebraic expression is here

$$X^2 + 4X + 6 = (X + 2 - i\sqrt{2})(X + 2 + i\sqrt{2}),$$

and the argument previously used would indicate as the solution⁶ of (13)

$$y = C_1 e^{(-2+i\sqrt{2})x} + C_2 e^{(-2-i\sqrt{2})x}. \quad (14)$$

But, from equation (45) on p. 18,

$$e^{(-2+i\sqrt{2})x} = e^{-2x} \cos \sqrt{2}x + i e^{-2x} \sin \sqrt{2}x,$$

and

$$e^{(-2-i\sqrt{2})x} = e^{-2x} \cos \sqrt{2}x - i e^{-2x} \sin \sqrt{2}x,$$

so that this expression may be rewritten as

$$y = c_1 e^{-2x} \cos \sqrt{2}x + c_2 e^{-2x} \sin \sqrt{2}x, \quad (15)$$

where

$$c_1 = C_1 + C_2, \quad c_2 = iC_1 - iC_2.$$

The value given in (15) will be a real number provided x , c_1 , and c_2 are real, so that it is a more useful form of the solution than (14) for most purposes.

We finally consider the example

$$\frac{d^2 y}{dx^2} + 6 \frac{dy}{dx} + 9y = 0, \quad (16)$$

for which the corresponding algebraic expression is

$$X^2 + 6X + 9 = (X + 3)^2,$$

so that the differential equation may be written

$$\left(\frac{d}{dx} + 3 \right) \left(\frac{d}{dx} + 3 \right) y = 0. \quad (17)$$

The previous argument shows that $c_1 e^{-3x}$ is one solution, but fails to give a second, since the two factors are alike. To find a second solution, we note that

$$\left(\frac{d}{dx} + 3 \right) x e^{-3x} = e^{-3x},$$

so that if we replace y by $c_2 x e^{-3x}$ in (17), the result of the first operator will be to remove the x , and the second will then give zero.

⁶ Each of these terms is a function, assuming complex values, of the real variable x . For the meaning of, and rules for differentiation of such a function, see problem 10, p. 19.

Thus the solution of (16) is

$$y = c_1 e^{-3x} + c_2 x e^{-3x}. \quad (18)$$

In general, the solution of any linear differential equation with constant coefficients and right member zero may be obtained by finding the roots of the analogous algebraic equation. A real root, r , leads to a term $c e^{rx}$, a pair of conjugate complex roots, $a + bi$ and $a - bi$ leads to two terms $c_1 e^{ax} \cos bx$ and $c_2 e^{ax} \sin bx$, if these are simple roots. When the equation has several, say q , roots equal, so that there are q equal first or second degree factors, the proper number of terms are obtained by multiplying the term, or pair of terms for a single factor by $1, x, x^2, \dots, x^{q-1}$. This follows from the fact that

$$\left(\frac{d}{dx} - r \right) x^m e^{rx} = m x^{m-1} e^{rx}, \quad (19)$$

so that, when the operators corresponding to the equal factors are applied in succession, each reduces the power of x by unity, until the $(m + 1)$ st factor gives zero.

22. The Particular Integral. When the differential equation has a right member consisting of one or more exponential terms added together, the particular integral is readily found. Consider, for example, the equation

$$3 \frac{d^2 y}{dx^2} + 2 \frac{dy}{dx} - y = 4e^{2x} + 2e^x. \quad (20)$$

To get the first term on the right, we substitute Ae^{2x} for y in the left member, and equate the result to the first term:

$$12Ae^{2x} + 4Ae^{2x} - Ae^{2x} = 4e^{2x},$$

which will be true if

$$15A = 4. \quad A = \frac{4}{15}.$$

Similarly, the second term on the right may be obtained from Be^x , and we find $B = \frac{1}{2}$. Thus, finally, from the discussion given in section 20, and the solution of (9) found in (12), we may write as the complete solution of (20):

$$y = \frac{4}{15} e^{2x} + \frac{1}{2} e^x + c_1 e^{-x} + c_2 e^{x/3}. \quad (21)$$

We note that if the exponential occurred in the complementary function, the particular solution would have the form Axe^{rx} if r were a simple root, and Ax^qe^{rx} , if r were a root corresponding to q equal factors. This follows from (19), and in such a case the actual computation is often best made by using (19) and the factored form of the differential operator.

In equations arising from practical problems, we more often meet right members formed from sines and cosines than from exponential functions. These are most simply treated by regarding them as the real, or imaginary, components of complex exponentials. For example, to solve the equation

$$\frac{d^2y}{dx^2} + 4 \frac{dy}{dx} + 3y = 3 \sin 3x, \quad (22)$$

we consider instead the equation:

$$\frac{d^2Y}{dx^2} + 4 \frac{dY}{dx} + 3Y = 3e^{3ix} = 3 \cos 3x + 3i \sin 3x. \quad (23)$$

In this equation x is still a real number, but Y is a complex⁷ number, say $u + iv$. The result of substituting $Y = u + iv$ in the left member of (23), $L(Y)$ is:

$$L(Y) = L(u + iv) = L(u) + iL(v).$$

Hence, if $Y = u + iv$ solves (23), we must have:

$$L(u) = 3 \cos 3x, \quad L(v) = 3 \sin 3x,$$

and the **imaginary component** of Y , v , is a solution of (22).

A particular solution of (23) of the form Ae^{3ix} is found to be

$$Y = \frac{3e^{3ix}}{-6 + 12i}. \quad (24)$$

But

$$\begin{aligned} \frac{3e^{3ix}}{-6 + 12i} &= \frac{3(\cos 3x + i \sin 3x)}{6(-1 + 2i)} \cdot \frac{(-1 - 2i)}{(-1 - 2i)} \\ &= (-.1 \cos 3x + .2 \sin 3x) + i(-.2 \cos 3x - .1 \sin 3x). \end{aligned}$$

Hence

$$v = -.2 \cos 3x - .1 \sin 3x \quad (25)$$

⁷ Compare footnote ⁶, p. 85.

is a particular integral of (22), and the complete solution is

$$y = -.2 \cos 3x - .1 \sin 3x + c_1 e^{-x} + c_2 e^{-3x}. \quad (26)$$

An alternative method of determining v from (24) is to introduce the polar form of the complex numbers. We have

$$\begin{aligned} -6 + 12i &= 6\sqrt{5} \sqrt{180^\circ - \tan^{-1} 2} \\ &= 13.4 \sqrt{116^\circ 30'}, \end{aligned}$$

so that

$$\begin{aligned} \frac{3e^{3ix}}{-6 + 12i} &= \frac{3\sqrt{3x}}{13.4 \sqrt{116^\circ 30'}} = .224 \sqrt{3x - 116^\circ 30'} \\ &= .224 \cos(3x - 116^\circ 30') + i .224 \sin(3x - 116^\circ 30'), \end{aligned}$$

and

$$v = .224 \sin(3x - 116^\circ 30'). \quad (27)$$

This is in agreement with (25).

Since a right member of a differential equation which is not a sum of sines and cosines may be replaced, over any limited range, by a Fourier series, most problems of practical importance come under the type just treated. Some indications as to the method for a right member which is a polynomial, or the product of a polynomial and an exponential (which may be real or complex) are given in problems 7 and 8, p. 89. A general method, theoretically applicable to any right hand member is given in section 27.

EXERCISES XIII

1. Solve the following differential equations:

$$(a) \frac{d^2y}{dx^2} - 4y = 0, \quad (b) \frac{d^2y}{dx^2} - 6 \frac{dy}{dx} + 8y = 0, \quad (c) \frac{d^2y}{dx^2} + 9y = 0,$$

$$(d) \frac{d^2y}{dx^2} + 5 \frac{dy}{dx} + 8y = 0, \quad (e) \frac{d^2y}{dx^2} + 7 \frac{dy}{dx} + 18y = 0.$$

$$2. \text{ Solve: } (a) \frac{d^2y}{dx^2} = 0, \quad (b) \frac{d^2y}{dx^2} + 4 \frac{dy}{dx} + 4y = 0, \quad (c) \frac{d^3y}{dx^3} = 0,$$

$$(d) \frac{d^4y}{dx^4} + 6 \frac{d^2y}{dx^2} + 9y = 0, \quad (e) \frac{d^4y}{dx^4} - 8 \frac{d^2y}{dx^2} + 16y = 0.$$

3. Find the complete solution of each of the following differential equations:

$$(a) \frac{d^2y}{dx^2} + 25y = 13e^x + 25e^{5x}, \quad (b) \frac{d^2y}{dx^2} - 6 \frac{dy}{dx} + 5y = 2e^{2x} + 3e^{-4x},$$

$$(c) \frac{d^2y}{dx^2} + 3 \frac{dy}{dx} + 4y = 5e^{4x}, \quad (d) \frac{d^2y}{dx^2} - 25y = 2e^{5x}, \quad (e) \frac{d^2y}{dx^2} + 3 \frac{dy}{dx} = e^{-2x}.$$

4. Solve the differential equation

$$\frac{d^2y}{dx^2} + 6\frac{dy}{dx} + 10y = 3\cos 4x + 3\sin 4x,$$

obtaining the particular integral by considering the right member (a) as the real component of $3\sqrt{2}e^{i4x}$ plus the imaginary component of $3\sqrt{2}e^{-i4x}$; (b) as the imaginary component of $3\sqrt{2}e^{i4x + 45^\circ}$; (c) as the real component of $3\sqrt{2}e^{-i4x - 45^\circ}$; (d) as the imaginary component of $3\sqrt{2}e^{i4x + 90^\circ} + 3\sqrt{2}e^{-i4x - 90^\circ}$; (e) as the real component of $3\sqrt{2}e^{i4x} + 3\sqrt{2}e^{-i4x}$.

5. Solve each of the following, obtaining the particular integral from the relation of the right member to one or more complex exponential functions.

$$(a) \frac{d^2y}{dx^2} - 7\frac{dy}{dx} + 10y = 2\sin 2x,$$

$$(b) \frac{d^2y}{dx^2} + 5\frac{dy}{dx} + 7y = 5\sin 3x + 4\sin 9x,$$

$$(c) \frac{d^2y}{dx^2} + 2\frac{dy}{dx} + 2y = 4\cos(x - 30^\circ),$$

$$(d) \frac{d^2y}{dx^2} + y = 5\cos 2x + 3\sin 2x + 2\cos 6x - \sin 6x.$$

$$(e) \frac{d^2y}{dx^2} + 4y = 5\sin 2x.$$

$$6. \text{ Solve: } (a) \frac{d^2y}{dx^2} - 6\frac{dy}{dx} - 7y = 5, \text{ noting that } 5 = 5e^{0x};$$

$$(b) \frac{d^2y}{dx^2} = 4; \quad (c) \frac{d^4y}{dx^4} - 18\frac{d^2y}{dx^2} + 81y = e^{3x};$$

(d) $\frac{d^4y}{dx^4} + 8\frac{d^2y}{dx^2} + 16y = e^{2x} + \sin 2x$; (e) $\frac{dy}{dx} + 3y = 4e^{2x} \sin 5x$, noting that the right member is the imaginary component of $4e^{(2+5i)x}$.

7. (a) Find a particular integral of the equation

$$\frac{d^2y}{dx^2} - 4y = 3x^2,$$

of the form $Ax^2 + Bx + C$.

(b) Find a particular integral of the equation

$$\frac{d^2y}{dx^2} + 16y = xe^{2x},$$

of the form $Ae^{2x} + Bxe^{2x} = (A + Bx)e^{2x}$.

(c) Find a particular integral of the equation

$$\frac{d^2y}{dx^2} - 10\frac{dy}{dx} + 25y = xe^{5x},$$

of the form $Ax^2e^{5x} + Bx^3e^{5x} = x^2(A + Bx)e^{5x}$.

(d) Find a particular integral of the equation

$$\frac{d^2y}{dx^2} + 10y = x\sin 2x,$$

as the imaginary component of the particular integral of

$$\frac{d^2Y}{dx^2} + 10Y = xe^{2ix},$$

of the form $Ae^{2ix} + Bxe^{2ix} = (A + Bx)e^{2ix}$.

8. The parts of problem 7 illustrate that if the right hand member of the differential equation contains the product of an exponential and a polynomial (which may consist of only one term) the corresponding particular integral in general will be a polynomial of the same degree multiplied by the exponential, and the coefficients may be found by substitution. When any of the terms of the form of the particular integral just mentioned are in the complementary function, the form just mentioned must be multiplied by x raised to a power equal to the number of terms in the complementary function.

Prove that this rule will always lead to as many first degree equations to determine the unknown coefficients, as there are unknown coefficients to be found.

The exponential may be $e^{ax} = 1$, as in 6 (a), 6 (b) and 7 (a). Polynomials multiplied by trigonometric functions, or by trigonometric and exponential functions may be reduced to complex exponentials as in 6 (e), 7 (d).

9. (a) Find a particular integral of the differential equation

$$\frac{d^2y}{dx^2} = 4$$

using the rule in problem 8. Use this to find a solution of the differential equation which is zero when $x = 0$, and also when $x = 2$.

(b) Expand 4 in a Fourier sine series of period 4, and find a particular integral of the differential equation

$$\frac{d^2y}{dx^2} = \frac{16}{\pi} \left(\sin \frac{\pi x}{2} + \frac{1}{3} \sin \frac{3\pi x}{2} + \frac{1}{5} \sin \frac{5\pi x}{2} + \dots \right)$$

by treating the terms separately.

(c) Show that the Fourier sine series for the solution found in (a) is the particular integral found in (b).

10. The right member of a differential equation is the odd function of period 12 defined by

$$\begin{aligned} A(x) &= 3x, & 0 < x < 3, \\ A(x) &= 18 - 3x, & 3 < x < 6. \end{aligned}$$

Find the solution of the differential equation

$$\frac{dy}{dx} + 2y = A(x),$$

which is zero when x is zero, for $0 < x < 12$.

(a) By fitting together the solutions for the four intervals $0 < x < 3$, $3 < x < 6$, $6 < x < 9$, $9 < x < 12$.

(b) By expanding the right member in a Fourier sine series, of period 12.

23. Systems of Equations. The solution of a system of linear differential equations, with constant coefficients, to be solved as

simultaneous, may be reduced to the solution of one or more separate equations. We shall illustrate this method, as it will enable us to anticipate the form of the solution. Practically, we need not perform the eliminations but merely substitute expressions of the correct form, with unknown coefficients, into the system as given.

Consider the system of two equations:

$$\begin{aligned} 2 \frac{dx}{dt} + \frac{dy}{dt} + 5x + y &= e^{3t}, \\ 3 \frac{dx}{dt} + 2 \frac{dy}{dt} + 9x + y &= -2e^{3t}. \end{aligned} \quad (28)$$

These may be written in the form

$$\begin{aligned} \left(2 \frac{d}{dt} + 5\right)x + \left(\frac{d}{dt} + 1\right)y &= e^{3t}, \\ \left(3 \frac{d}{dt} + 9\right)x + \left(2 \frac{d}{dt} + 1\right)y &= -2e^{3t}. \end{aligned}$$

We eliminate as we would for simultaneous algebraic equations. We operate on the first equation with $\left(2 \frac{d}{dt} + 1\right)$, the operator on y in the second equation, and on the second equation with $\left(\frac{d}{dt} + 1\right)$, the operator on y in the first equation. The result is

$$\begin{aligned} \left(2 \frac{d}{dt} + 1\right)\left(2 \frac{d}{dt} + 5\right)x + \left(2 \frac{d}{dt} + 1\right)\left(\frac{d}{dt} + 1\right)y &= \left(2 \frac{d}{dt} + 1\right)e^{3t}, \\ \left(\frac{d}{dt} + 1\right)\left(3 \frac{d}{dt} + 9\right)x + \left(\frac{d}{dt} + 1\right)\left(2 \frac{d}{dt} + 1\right)y &= \left(\frac{d}{dt} + 1\right)(-2e^{3t}), \end{aligned}$$

or

$$\begin{aligned} 4 \frac{d^2x}{dt^2} + 12 \frac{dx}{dt} + 5x + 2 \frac{d^2y}{dt^2} + 3 \frac{dy}{dt} + y &= 7e^{3t}, \\ 3 \frac{d^2x}{dt^2} + 12 \frac{dx}{dt} + 9x + 2 \frac{d^2y}{dt^2} + 3 \frac{dy}{dt} + y &= -8e^{3t}, \end{aligned}$$

whose terms in y are identical, so that on subtracting we have the equation in x :

$$\frac{d^2x}{dt^2} - 4x = 15e^{3t}.$$

The complementary function of this equation is found from

$$X^2 - 4 = 0,$$

and the particular solution is found by trying Ae^{3t} in the equation. The result is

$$x = 3e^{3t} + c_1e^{2t} + c_2e^{-2t}. \quad (29)$$

If y were now found by a similar process, two new constants would appear. These would have to be properly related to c_1 and c_2 in order that the value of y combined with that just found for x should solve the system. The relations might be found by actually substituting the values of x and y in the system. If we substituted the value of x given in (29) in one of the equations of the system, and solved for y , one new constant would appear. That there are no additional constants in the solution for y corresponding to (29) may be seen by multiplying the first of equations (28) by 2 and subtracting the second. The result is

$$\frac{dx}{dt} + x + y = 4e^{3t},$$

or

$$y = 4e^{3t} - \frac{dx}{dt} - x.$$

When the value of x given in (29) is substituted in this, we find:

$$y = -8e^{3t} - 3c_1e^{2t} + c_2e^{-2t}. \quad (30)$$

The process of elimination used to get x from the system (28), may be applied to any system of linear equations with constant coefficients to get a differential equation satisfied by any one of the variables. This will be linear with constant coefficients, and will have as a right member terms appearing in the right members of the equations of the system, or terms arising from them by differentiation. Hence the solution for each variable will consist of a complementary function, composed, in general, of exponential functions, and a particular integral. When the equations of the original system have right members which are sums of exponentials, the particular integral for each of the variables will in general be a sum of all the exponentials which occur in any of the equations, with suitable numerical coefficients.

The exceptional cases, which arise when there are multiple factors in the expression which gives the complementary function, or when some of the exponential terms in the right members are in the complementary function seldom occur in practice. Accord-

ingly we shall give no detailed discussion of the form in this case, although it could be predicted as indicated in problem 2, p. 94.

If we assume that the form of solution of any given system is known to start with, the actual calculation may be somewhat simplified. Let us illustrate this method by the system of equations (28). For the complementary function, we try to satisfy the corresponding system with right members zero by

$$x = ae^r, \quad y = be^r.$$

On substituting these values in (28), with right member omitted, we find:

$$\begin{aligned} 2ar + br + 5a + b &= 0, \\ 3ar + 2br + 9a + b &= 0. \end{aligned}$$

These equations may each be solved for the ratio $\frac{a}{b}$, giving:

$$\frac{a}{b} = -\frac{r+1}{2r+5} = -\frac{2r+1}{3r+9}. \quad (31)$$

From the equality of the last two fractions,

$$(r+1)(3r+9) - (2r+1)(2r+5) = 0, \quad (32)$$

and⁸

$$r = 2, \quad \text{or} \quad -2.$$

These values, inserted in (31), give

$$\frac{a}{b} = -\frac{1}{3} \quad \text{or} \quad 1. \quad b = -3a, \quad \text{or} \quad b = a.$$

Hence, if $x = c_1e^{2t}$, the corresponding term in y is $-3c_1e^{2t}$ and if $x = c_2e^{-2t}$, the corresponding term in y is c_2e^{-2t} .

For the particular integrals, we put $x = Ae^{3t}$, $y = Be^{3t}$ directly into the equations (28), retaining in the right members all terms in e^{3t} , here all the terms. The result is

$$\begin{aligned} (11A + 4B)e^{3t} &= e^{3t}, \\ (18A + 7B)e^{3t} &= -2e^{3t}, \end{aligned}$$

⁸ When the number of equations is large, the coefficients are more easily eliminated by the method of determinants. Thus, here (32) is equivalent to

$$\begin{vmatrix} 2r+5 & r+1 \\ 3r+9 & 2r+1 \end{vmatrix} = (2r+5)(2r+1) - (r+1)(3r+9) = 0.$$

and when e^{3t} is divided out, and the equations solved for A and B , we find $A = 3$, $B = -8$. Hence the solution of (28) is

$$\begin{aligned}x &= 3e^{3t} + c_1e^{2t} + c_2e^{-2t}, \\y &= -8e^{3t} - 3c_1e^{2t} + c_2e^{-2t},\end{aligned}$$

which agrees with (29) and (30).

EXERCISES XIV

1. Solve each of the following systems by both methods:

(a) $\frac{dx}{dt} + \frac{dy}{dt} - 3x + y = e^{2t}$, $\frac{dx}{dt} - y = 0$;

(b) $2\frac{dx}{dt} + 4\frac{dy}{dt} + 3x + y = e^{4t}$, $\frac{dx}{dt} + 2\frac{dy}{dt} + 2x = 0$;

(c) $\frac{dx}{dt} + y = e^{2t}$, $\frac{dx}{dt} + 2x + y = 0$.

The parts of this problem illustrate that the number of independent constants in the complete solution of a system is at most equal to the sum of the orders of the separate equations (here $1 + 1 = 2$), but may be any number less than this (as here, 2 in (a), 1 in (b) and 0 in (c)).

2. Solve by the method of elimination:

(a) $5\frac{dx}{dt} + 2\frac{dy}{dt} + 6x + y = 0$, $4\frac{dx}{dt} + 3\frac{dy}{dt} + 5x + 2y = 0$;

(b) $2\frac{dx}{dt} + \frac{dy}{dt} + 2x + y = 0$, $\frac{dx}{dt} - \frac{dy}{dt} + x - y = 0$;

(c) $\frac{dx}{dt} + 2\frac{dy}{dt} - 4x - 2y = e^{2t}$, $\frac{dx}{dt} + \frac{dy}{dt} - 3x - y = 0$;

(d) $4\frac{dx}{dt} + 2\frac{dy}{dt} - 7x - 3y = e^{2t}$, $3\frac{dx}{dt} + \frac{dy}{dt} - 5x - y = 0$;

(e) $3\frac{dx}{dt} - \frac{dy}{dt} - 6x + 2y = e^{2t}$, $\frac{dx}{dt} + 5\frac{dy}{dt} - 2x - 10y = 0$.

These systems illustrate the exceptional cases. If the second method were used, for the complementary function in parts (a) and (d), the two equal roots in the equation for r , and the fact that the corresponding coefficients were related, would lead us to expect an exponential multiplied by t in the complementary function. In parts (b) and (e), although there are two equal values of r , the corresponding coefficients in x and y are not related, and no additional terms appear in the complementary function. Parts (c), (d) and (e) show that the particular integral, for an exponential on the right which appears in the complementary function, is an exponential times a polynomial in t of degree one greater than the power appearing in a similar term of the complementary function. The second method can lead to no error in the particular solution, since the process there is self verifying, but it may lead to some of the terms in the complementary function being omitted, unless it is carefully used.

3. Solve the following systems of equations:

$$(a) \frac{dx}{dt} - 4y = e^{-t}, \quad \frac{dy}{dt} + z = 0, \quad \frac{dz}{dt} - 2x = 0;$$

$$(b) \frac{dx}{dt} + 2y - 3z = e^{2t}, \quad \frac{dy}{dt} + x + 3z = 0, \quad \frac{dz}{dt} - x - 2y = 0;$$

$$(c) \frac{dx}{dt} + 2y + 2z = e^t, \quad \frac{dy}{dt} - 2x + z = 0, \quad \frac{dz}{dt} + y - 2x = 0.$$

4. Solve: (a) $\frac{dx}{dt} - 3x - y = 3e^{2t}$, $\frac{dy}{dt} - 2x - 2y = 0$;

$$(b) \frac{d^2x}{dt^2} + \frac{dy}{dt} - 2y = \sin t, \quad \frac{dx}{dt} + x - 3y = 0;$$

$$(c) \frac{d^2x}{dt^2} - 4y = \cos 3t, \quad \frac{d^2y}{dt^2} + x = 0.$$

5. Solve each of the following systems:

$$(a) \frac{d^2y}{dt^2} - x - 4y = 0, \quad 5 \frac{d^2y}{dt^2} + x = e^{2t};$$

$$(b) \frac{d^2y}{dt^2} - 28 \frac{dx}{dt} - 8y = 0, \quad \frac{d^2y}{dt^2} + 4x = 0;$$

$$(c) \frac{d^2x}{dt^2} + \frac{d^2y}{dt^2} - 2 \frac{dx}{dt} + 6 \frac{dy}{dt} + x + 9y = 0,$$

$$\frac{d^2x}{dt^2} + \frac{d^2y}{dt^2} + 8 \frac{dx}{dt} + 4 \frac{dy}{dt} + 16x + 4y = 0;$$

$$(d) \frac{d^2y}{dt^2} - 5x - 4y = 0, \quad \frac{d^2x}{dt^2} - 4x - 5y = 0;$$

$$(e) \frac{d^2x}{dt^2} + \frac{d^2y}{dt^2} - 3 \frac{dx}{dt} - 4 \frac{dy}{dt} + 2x + 3y = 0, \quad 3 \frac{dx}{dt} + \frac{dy}{dt} - 6x - 3y = 0.$$

24. The Differential Equation for a Single Electric Circuit.

Consider an electric current flowing through an element, Fig. 22, containing resistance, inductance, and capacity. We arbitrarily

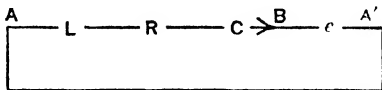

FIG. 22

select one direction, say that from A to B as the positive direction for the element. If q (coulombs) is the quantity of electricity which has passed a given point in the element in the positive direction, at time t (seconds), the current⁹ i (amperes), where

$$i = \frac{dq}{dt},$$

⁹ Whenever we use i for the current intensity, and e for the electromotive force, we put $j = \sqrt{-1}$, and $\epsilon = 2.71828 \dots$, in place of the symbols i and e previously used.

will be the same at all points of the element, but will in general vary with the time. The potential, or electromotive force, abbreviated e.m.f., will be different at the points A and B . The total drop will be the sum of three drops in e.m.f., e_L , e_R , e_C (volts), where we regard a difference of potential as positive when the potential increases as we move in the positive direction. The first of the three drops is

$$e_L = -L \frac{di}{dt}.$$

It is proportional to the rate of change of the current and the positive constant of proportionality, L (henries) is the **inductance** of the element. The second drop,

$$e_R = -Ri,$$

is proportional to the current itself and the positive constant of proportionality, R (ohms) is the **resistance** of the element. The third drop is proportional to the quantity of electricity accumulated since the condensers were discharged, so that

$$e_C = -\frac{q}{C} = -\frac{1}{C} \int_0^t i dt.$$

The reciprocal of the positive constant of proportionality, C (farads) is the **capacity** of the element.

If the element AB is connected in series with a source of e.m.f., e , the total difference of potential between the points A and A' will be

$$e' = e + e_L + e_R + e_C. \quad (33)$$

In view of the relations given above, this may also be written

$$e' = e - L \frac{di}{dt} - Ri - \frac{1}{C} \int_0^t i dt, \quad (34)$$

or, in terms of quantity of electricity, q ,

$$e' = e - L \frac{d^2q}{dt^2} - R \frac{dq}{dt} - \frac{q}{C}.$$

Finally, if the points A and A' are in contact, so that the current through the element AB is caused by the e.m.f. in BA' , the difference of potential e' will be zero, and from equation (34)

$$0 = e - L \frac{di}{dt} - Ri - \frac{1}{C} \int_0^t i dt. \quad (35)$$

We may obtain a differential equation for the current from this by differentiating each term. The result is:

$$L \frac{d^2i}{dt^2} + R \frac{di}{dt} + \frac{i}{C} = \frac{de}{dt}. \quad (36)$$

Of course, when there is no term involving capacity, this differentiation is unnecessary. A differential equation for q would follow directly from (35).

25. The System of Differential Equations for an Electric Network. When electric currents flow through a network of elements which form several circuits, the total e.m.f. across each element may be expressed in terms of the current through that element, the constants for the element, and the sources of e.m.f. in the element. The currents in the various elements are related by Kirchhoff's first law, which states that:

I. For all the elements which meet at any junction point, the algebraic sum of the currents, taken positive when toward the point, negative otherwise, is zero.

The e.m.f.'s in the various elements are related by the second law of Kirchhoff, namely:

II. For all the elements which make up any closed circuit, the algebraic sum of all the e.m.f.'s, taken positive when in one direction around the circuit, e.g. clockwise for a plane network, negative otherwise, is zero.

We shall illustrate the application of these laws to the network shown in Fig. 23. We assign numbers to the elements, and arbitrary directions to be taken as positive indicated by the arrows in the figure. If i_1 is the current, and e_1 the source of e.m.f. in the first element, reckoned positive when in the direction of the arrow, i.e.

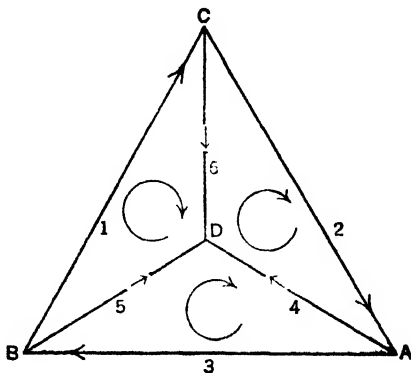

FIG. 23

from B to C , and this element contains inductance L_1 , resistance R_1 , and capacity C_1 , we have as in (34) for the total difference

of potential between the points B and C :

$$e_1' = e_1 - L_1 \frac{di_1}{dt} + R_1 i_1 + \frac{1}{C_1} \int_{t_0}^t i_1 dt. \quad (37)$$

We may write five additional equations of this form for the remaining five elements.

By applying the first law to the points A, B, C , we find:

$$\begin{aligned} i_2 - i_4 - i_3 &= 0, \\ i_3 - i_5 - i_1 &= 0, \\ i_1 - i_6 - i_2 &= 0. \end{aligned} \quad (38)$$

By applying the second law to the three fundamental¹⁰ circuits indicated by the curved arrows in the figure, we find:

$$\begin{aligned} e_2' + e_1' - e_6' &= 0, \\ e_3' + e_5' - e_4' &= 0, \\ e_1' + e_6' - e_6' &= 0. \end{aligned} \quad (39)$$

In the next section we shall show how to obtain the permanent state of the currents directly from equations (38) and (39), but we shall reduce these equations further, in order to see their real nature.

We first solve equations (38) for the three currents i_4, i_5, i_6 in terms of the other three. The result is:

$$\begin{aligned} i_4 &= i_2 - i_3, \\ i_5 &= i_3 - i_1, \\ i_6 &= i_1 - i_2. \end{aligned} \quad (40)$$

If, now, the six e_k' in (39) are replaced by their values as given by (37) and the analogous equations, and i_4, i_5 and i_6 are eliminated by means of (40), there results:

$$\begin{aligned} (L_2 + L_4 + L_6) \frac{di_2}{dt} + (R_2 + R_4 + R_6) i_2 + \left(\frac{1}{C_2} + \frac{1}{C_4} + \frac{1}{C_6} \right) \int_{t_0}^t i_2 dt \\ - L_4 \frac{di_3}{dt} - R_4 i_3 - \frac{1}{C_4} \int_{t_0}^t i_3 dt - L_6 \frac{di_1}{dt} - R_6 i_1 - \frac{1}{C_6} \int_{t_0}^t i_1 dt \\ = e_2 + e_3 - e_6. \end{aligned} \quad (41)$$

¹⁰ In the sense that the equation for any other circuit in the figure is a consequence of the equations for these three. Just as, in writing (38) we omitted the equation for the point D , since this would merely be the sum of the other equations.

and two other equations, similar in form. By differentiating these equations, we obtain a system of three second order differential equations in the currents i_1, i_2, i_3 . After these are solved for i_1, i_2, i_3 , the remaining three currents may be found from (40).

The process is typical of that for any network. We apply the first law to all but one of the points of junction, and solve for as many of the currents as we can, in terms of the rest. We then apply the second law to a fundamental set of circuits, and eliminate the currents for which we solved the first set of equations. The result is equivalent to a system of linear differential equations with constant coefficients, each of at most the second order, with as many equations as there are currents to be determined.

26. Solution of the Circuit and Network Equations. The differential equation satisfied by the current, in a circuit containing resistance R , inductance L , and capacity C , caused by an impressed e.m.f. e , was found in (36) to be

$$L \frac{d^2i}{dt^2} + R \frac{di}{dt} + \frac{i}{C} = \frac{de}{dt}. \quad (36)$$

The e.m.f. is frequently a single sine term:

$$e = E_m \sin(\omega t + \alpha). \quad (42)$$

In the case of any periodic e.m.f., the equivalent Fourier series is a sum (or infinite series) of terms of this form, and the solution for the sum will be the sum of the solutions for the separate terms. Thus we are led to consider the differential equation:

$$L \frac{d^2i}{dt^2} + R \frac{di}{dt} + \frac{i}{C} = \omega E_m \cos(\omega t + \alpha). \quad (43)$$

The complementary function is found from the roots of

$$LX^2 + RX + \frac{1}{C} = 0,$$

or

$$X = -\frac{R}{2L} \pm \sqrt{\frac{R^2}{4L^2} - \frac{1}{LC}}.$$

The quantities R , L and C are all positive. Consequently, the expression under the radical is either a positive number less than $\left(\frac{R}{2L}\right)^2$, zero, or a negative number. In the first case we abbreviate

the roots by $-a_1, -a_2$, since they are both real and negative. In the second case, we put $\frac{R}{2L} = a$, so that the roots are both $-a$. In the third case, we define a as before, and write¹¹

$$\sqrt{\frac{R^2}{4L^2} - \frac{1}{LC}} = b \sqrt{-1} = bj,$$

so that the complementary function has one of the forms:¹¹

$$\begin{aligned} c_1 e^{-at} + c_2 e^{-at}, \\ c_1 e^{-at} + c_2 t e^{-at}, \\ c_1 e^{-at} \sin bt + c_2 e^{-at} \cos bt. \end{aligned} \quad (44)$$

The particular integral is found by regarding the equation (43) as the real component of the equation:¹¹

$$L \frac{d^2 I}{dt^2} + R \frac{dI}{dt} + \frac{I}{C} = \omega E_m e^{j(\omega t + \alpha)} = \omega E_m e^{j\alpha} e^{j\omega t}. \quad (45)$$

A particular solution of (45) is

$$\begin{aligned} \frac{\omega E_m e^{j\alpha} e^{j\omega t}}{-L\omega^2 + Rj\omega + \frac{1}{C}} &= \frac{E_m e^{j\alpha} e^{j\omega t}}{j \left[R + j \left(L\omega - \frac{1}{\omega C} \right) \right]} \\ &= \frac{1}{j} \cdot \frac{E_m |\omega t + \alpha|}{\sqrt{R^2 + \left(L\omega - \frac{1}{\omega C} \right)^2} \left| \tan^{-1} \left(\frac{L\omega}{R} - \frac{1}{\omega RC} \right) \right|}. \end{aligned}$$

The real component of this is the imaginary component of the fraction which multiplies $\frac{1}{j}$, or

$$\frac{E_m}{\sqrt{R^2 + \left(L\omega - \frac{1}{\omega C} \right)^2}} \sin \left(\omega t + \alpha - \tan^{-1} \left[\frac{L\omega}{R} - \frac{1}{\omega RC} \right] \right). \quad (46)$$

Thus (46) is a particular solution of (43), and the complete solution of (43) is obtained by adding to (46), the appropriate one of the complementary functions given in (44).

In a specific application, the values of c_1 and c_2 could be determined from the knowledge of two facts about the circuit, e.g. the current at some one time, and the charge on the condenser at some

¹¹ See footnote ⁹, p. 95 for the notation j and ϵ .

one time. One condition on c_1 and c_2 would arise when the value of the current, and corresponding time were substituted in the complete solution. The second condition would arise when the current was eliminated, by use of the complete solution, from the equation

$$L \frac{di}{dt} + Ri + \frac{1}{C} \left(q_1 + \int_{t_0}^t i dt \right) = E_m \sin(\omega t + \alpha), \quad (47)$$

as the terms involving t would cancel out because this is an integral of (43). The physical significance of (47) is the same as

$$L \frac{di}{dt} + Ri + \frac{1}{C} \int_{t_0}^t i dt = E_m \sin(\omega t + \alpha), \quad (48)$$

which results from putting the value of the e.m.f. of (42) in (35).

The particular integral given in (46) is a periodic function, while the terms of the complementary function given in (44) all approach zero when t becomes infinite.¹² Hence, theoretically when t is very large, and in most practical applications even after a fairly short time, the terms of the solution arising from the complementary function become negligible, and the important part of the solution is that given by the particular integral. Thus (44) defines the **transient** current, and (46) gives the permanent, or **steady-state** current, regardless of the values of the constants in (44). Since the steady-state current is the only part of interest for many applications, it is worth while to introduce certain definitions and abbreviations which simplify its calculation.

We begin by noting that (46) may be obtained¹³ from (48), if we ignore the terms arising from the constant t_0 . In fact, (48), with lower limit omitted, is the imaginary component of

$$L \frac{dI}{dt} + RI + \frac{1}{C} \int I dt = E_m \epsilon^{j(\omega t + \alpha)} = E_m \epsilon^{j\alpha} \epsilon^{j\omega t},$$

¹² Since $e^{-at} = \frac{1}{e^{at}} < \frac{1}{1+at}$; $te^{-at} < \frac{t}{1+at + \frac{a^2 t^2}{2}}$.

¹³ The expression (46) is a particular solution of (45), and hence actually solves this equation. It is not a solution of (48) for an arbitrary value of t_0 . It may be obtained from (48) in the way indicated, and is the **steady-state** solution of (48) in the sense that the difference between it and the solution of (48) approaches zero when the time becomes infinite.

and we find that $Ae^{j\omega t}$ is a solution of this, if

$$A = \frac{E_m \epsilon^{j\alpha}}{R + j \left(L\omega - \frac{1}{\omega C} \right)}.$$

Thus

$$I = \frac{E_m \epsilon^{j\alpha} \epsilon^{j\omega t}}{R + j \left(L\omega - \frac{1}{\omega C} \right)}, \quad (49)$$

and the imaginary component of this is (46).

We next define the **impedance**, Z , of an element containing resistance R , inductance L and capacity C , to a simple harmonic e.m.f. of frequency ω as:

$$Z = R + j \left(L\omega - \frac{1}{\omega C} \right). \quad (50)$$

Thus impedance is a complex function of a real variable, the frequency, and for any given frequency reduces to a complex number. If, then, we define¹⁴ **complex current**, I , as the complex exponential term whose imaginary component is the actual simple harmonic steady-state current, and similarly the **complex e.m.f.**, E , as the complex exponential term whose imaginary component is the actual applied simple harmonic e.m.f., the relation (49) becomes

$$I = \frac{E}{Z}. \quad (51)$$

This reduces the determination of the steady-state current in a single circuit to a problem in the algebra of complex numbers.

The methods just given for the single circuit require but slight modification when we consider the system of equations for an electric network. The complementary function may be found as in section 23, and will always consist of terms containing as one factor an exponential whose exponent is a negative number multiplied by the time. Thus these terms will approach zero as the time increases indefinitely, and will correspond to transient currents.

The periodic particular integrals will give the steady-state cur-

¹⁴ Thus the complex current and complex e.m.f. are "rotating vectors" in the sense of problem 11, p. 20, and the results are often stated in terms of vectors rotating in the (complex) plane.

rents. The terms for a particular frequency present in the applied e.m.f.'s may be obtained by omitting all terms not of this frequency, and substituting complex exponentials of this frequency in the system of differential equations of which the set just mentioned is the real part. The introduction of the terms impedance, complex current, and complex e.m.f. defined for each element of the network, reduces the calculation to the solution of a set of algebraic equations.

For example, if in the network of section 25, there is a term in one of the e.m.f.'s of frequency ω , say

$$E_{m_1} \sin(\omega t + \alpha_1)$$

in e_1 , we define the complex e.m.f., E_1 (for ω) as

$$E_1 = E_{m_1} e^{j\alpha_1} e^{j\omega t}.$$

In the same way we define complex e.m.f.'s for ω for each of the elements, putting them zero for any element not containing in its e.m.f. a term of frequency ω . We define the complex currents for ω , I_1 , I_2 , etc., as the complex exponentials whose imaginary components give the steady-state currents of frequency ω . We define impedances for the elements by (50), so that, for example,

$$Z_1 = R_1 + j \left(L_1 \omega - \frac{1}{\omega C_1} \right).$$

Then it follows from equation (41), and the two similar equations that:

$$\begin{aligned} (Z_2 + Z_4 + Z_6)I_2 - Z_4I_3 - Z_6I_1 &= E_2 + E_4 - E_6, \\ (Z_3 + Z_5 + Z_4)I_3 - Z_5I_1 - Z_4I_2 &= E_3 + E_5 - E_4, \\ (Z_1 + Z_6 + Z_5)I_1 - Z_6I_2 - Z_5I_3 &= E_1 + E_6 - E_5. \end{aligned} \quad (52)$$

It may be noted that the equations just written may be found directly from Kirchhoff's laws. Thus from (37), we have

$$E_1' = E_1 - Z_1 \cdot I_1, \text{ etc.}$$

so that (39) becomes:

$$\begin{aligned} E_2 - Z_2 \cdot I_2 + E_4 - Z_4 \cdot I_4 - E_6 + Z_6 \cdot I_6 &= 0, \\ E_3 - Z_3 \cdot I_3 + E_5 - Z_5 \cdot I_5 - E_4 + Z_4 \cdot I_4 &= 0, \\ E_1 - Z_1 \cdot I_1 + E_6 - Z_6 \cdot I_6 - E_5 + Z_5 \cdot I_5 &= 0. \end{aligned} \quad (53)$$

Applied to the complex currents, we have in place of (38):

$$\begin{aligned} I_2 - I_4 - I_3 &= 0, \\ I_3 - I_5 - I_1 &= 0, \\ I_1 - I_6 - I_2 &= 0. \end{aligned} \tag{54}$$

The set of equations (52) follows when I_4 , I_5 and I_6 are eliminated from (53) by means of (54).

The set (52) may be solved for any of the currents. Thus

$$I_1 = \frac{\begin{vmatrix} E_2 + E_4 - E_6, & Z_2 + Z_4 + Z_6, & -Z_4 \\ E_3 + E_5 - E_4, & -Z_4, & Z_3 + Z_5 + Z_4 \\ E_1 + E_6 - E_5, & -Z_1, & -Z_5 \end{vmatrix}}{\begin{vmatrix} -Z_6, & Z_2 + Z_4 + Z_6, & -Z_4 \\ -Z_5, & -Z_4, & Z_3 + Z_5 + Z_4 \\ Z_1 + Z_6 + Z_5, & -Z_6, & -Z_5 \end{vmatrix}}.$$

If the constants were all given numerically, this could be reduced to a complex constant times an exponential in the time, and its imaginary component would give the term in i_1 of frequency ω .

EXERCISES XV

1. Find the steady-state current in a single circuit containing resistance R , inductance L and capacity C if the impressed e.m.f. is (a) $e = E_m \sin \omega t$, (b) $e = E_m \cos \omega t$, (c) $e = E_m \cos (\omega t + \alpha)$, (d) $e = E_m \sin \omega t + F_m \cos \omega t$.

2. Find the steady-state current in a single circuit containing a resistance of 60 ohms, an inductance of 8 henries, and a capacity of 3 microfarads = 3×10^{-6} farads, when the impressed e.m.f. is

$$e = 100 \sin (120\pi t) + 25 \sin (360\pi t + 25^\circ) + 3 \sin (600\pi t - 10^\circ).$$

3. Find the transient current when a condenser of capacity 5 microfarads = 5×10^{-6} farads charged with .004 coulombs is discharged through a circuit containing a resistance of 2 ohms and an inductance of 14 henries.

4. Assuming that, for a given frequency, each of the three elements of the network of Fig. 24 contains impedances Z_1 , etc. and sources of e.m.f. giving rise to complex e.m.f.'s E_1 , etc., set up the equations which determine the complex currents.

5. Assuming that, for a given frequency, the elements 1 and 2 of the network of Fig. 24 contain impedances Z_1 and Z_2 and no sources of e.m.f., but the element 3 contains a source of e.m.f. giving rise to the complex e.m.f. E_3 , and no impedance solve for I_3 and interpret your result to give the law for finding the single impedance equivalent to two impedances in parallel.

6. Assuming that the elements of the network of Fig. 25 have, for a given frequency, impedances Z_1, Z_2, \dots, Z_6 , and that the element 6 has an impressed

e.m.f. of this frequency giving rise to a complex e.m.f. E_s , set up the equations which determine the complex currents.

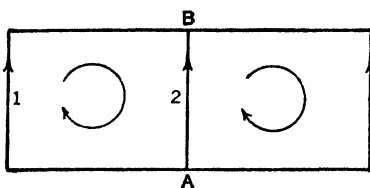

FIG. 24

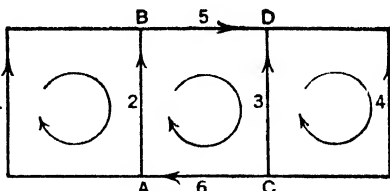

FIG. 25

7. (a) If the element 1, in the network of Fig. 24 contains e.m.f. e_1 , resistance R_1 , and inductance $L_1 - M$, the element 2 contains inductance M , and the element 3 contains e.m.f. e_3 , resistance R_3 and inductance $L_3 - M$, show that the equations for the currents i_1 and i_3 are:

$$e_1 = R_1 i_1 + L_1 \frac{di_1}{dt} + M \frac{di_3}{dt},$$

$$e_3 = R_3 i_3 + L_3 \frac{di_3}{dt} + M \frac{di_1}{dt}.$$

These are the equations for two circuits with mutual inductance M , and the result shows that the presence of mutual inductances in a network does not change the type of the equations. In fact, a network with mutual inductances can always be replaced by one without them, but with some added elements and changed inductances (in some cases to negative values).

(b) If, in the equations of part (a) of this problem,

$$e_1 = E_m \sin(\omega t + \alpha),$$

$$e_3 = F_m \sin(\omega t + \beta),$$

find the steady-state solution for i_1 and i_3 .

8. If a mass $m = \frac{w}{g}$ is vibrating on a straight line, under the influence of an external force F , a restitutive force proportional to the displacement, and a friction force proportional to the velocity, the equation of motion is

$$m \frac{d^2 x}{dt^2} = -ax - k \frac{dx}{dt} + F.$$

(a) By comparison with equation (36) of the text, justify the analogy of the effects of inductance, resistance and capacity to those of inertia (mass), friction, and of a restitutive force. Note that it is rate of change of e.m.f. which corresponds to external force.

(b) If $w = 8$ lb., $g = 32 \frac{\text{ft.}}{\text{sec.}^2}$, $a = 5 \frac{\text{lb.}}{\text{ft.}}$, $k = 1 \frac{\text{lb. sec.}}{\text{ft.}}$, $F = 10 \sin 4t$ lb., find the steady-state forced oscillations.

27. Method of Variation of Constants. Whenever we know the complementary function for a linear differential equation of

any order, with constant or variable coefficients, we may determine a particular integral by solving a set of linear algebraic equations, and then performing certain integrations.

We shall illustrate the method for the general third order equation:

$$L(y) = A_3 \frac{d^3 y}{dx^3} + A_2 \frac{d^2 y}{dx^2} + A_1 \frac{dy}{dx} + A_0 y = A. \quad (55)$$

We assume that the complementary function of this equation is known. By section 20 it has the form:

$$c_1 u_1 + c_2 u_2 + c_3 u_3,$$

where each of the three functions u_1, u_2, u_3 is a solution of the differential equation with right member zero,

$$L(u_1) = L(u_2) = L(u_3) = 0. \quad (56)$$

We now attempt to find a solution of the equation (55) in the form of the complementary function, but with the constants, c_1, c_2, c_3 , replaced by variable functions of x, v_1, v_2, v_3 , so that

$$y = v_1 u_1 + v_2 u_2 + v_3 u_3. \quad (57)$$

Since there are three functions, v_1, v_2, v_3 , we may impose two conditions on them in addition to requiring that (57) be a solution of the differential equation (55). We impose as one condition the relation:

$$\frac{dv_1}{dx} u_1 + \frac{dv_2}{dx} u_2 + \frac{dv_3}{dx} u_3 = 0, \quad (58)$$

and as the second condition:

$$\frac{dv_1}{dx} \cdot \frac{du_1}{dx} + \frac{dv_2}{dx} \cdot \frac{du_2}{dx} + \frac{dv_3}{dx} \cdot \frac{du_3}{dx} = 0. \quad (59)$$

We then have, on differentiating equation (57)

$$\frac{dy}{dx} = v_1 \frac{du_1}{dx} + v_2 \frac{du_2}{dx} + v_3 \frac{du_3}{dx} + u_1 \frac{dv_1}{dx} + u_2 \frac{dv_2}{dx} + u_3 \frac{dv_3}{dx}.$$

In view of the condition (58), this reduces to:

$$\frac{dy}{dx} = v_1 \frac{du_1}{dx} + v_2 \frac{du_2}{dx} + v_3 \frac{du_3}{dx}. \quad (60)$$

Again, on differentiating (60), we have:

$$\frac{d^2y}{dx^2} = v_1 \frac{d^2u_1}{dx^2} + v_2 \frac{d^2u_2}{dx^2} + v_3 \frac{d^2u_3}{dx^2} + \frac{dv_1}{dx} \frac{du_1}{dx} + \frac{dv_2}{dx} \frac{du_2}{dx} + \frac{dv_3}{dx} \frac{du_3}{dx}.$$

In view of the conditions (59), this reduces to:

$$\frac{d^2y}{dx^2} = v_1 \frac{d^2u_1}{dx^2} + v_2 \frac{d^2u_2}{dx^2} + v_3 \frac{d^2u_3}{dx^2}. \quad (61)$$

Finally, we differentiate (61), to obtain:

$$\begin{aligned} \frac{d^3y}{dx^3} &= v_1 \frac{d^3u_1}{dx^3} + v_2 \frac{d^3u_2}{dx^3} + v_3 \frac{d^3u_3}{dx^3} \\ &+ \frac{dv_1}{dx} \frac{d^2u_1}{dx^2} + \frac{dv_2}{dx} \frac{d^2u_2}{dx^2} + \frac{dv_3}{dx} \frac{d^2u_3}{dx^2}. \end{aligned} \quad (62)$$

We have next to impose the condition that the expression (57), subject to the added restrictions (58) and (59) should be a solution of the differential equation (55). On substituting the expressions (57), (60), (61) and (62) in the left member of (55), we find:

$$\begin{aligned} L(y) &= v_1 L(u_1) + v_2 L(u_2) + v_3 L(u_3) \\ &+ A_3 \left(\frac{dv_1}{dx} \frac{d^2u_1}{dx^2} + \frac{dv_2}{dx} \frac{d^2u_2}{dx^2} + \frac{dv_3}{dx} \frac{d^2u_3}{dx^2} \right). \end{aligned}$$

But, by (56), the first three terms in the equation just written are zero, and (55) will be satisfied if

$$A_3 \left(\frac{dv_1}{dx} \frac{d^2u_1}{dx^2} + \frac{dv_2}{dx} \frac{d^2u_2}{dx^2} + \frac{dv_3}{dx} \frac{d^2u_3}{dx^2} \right) = A. \quad (63)$$

The equations (58), (59) and (63) give three simultaneous equations of the first degree in $\frac{dv_1}{dx}$, $\frac{dv_2}{dx}$, $\frac{dv_3}{dx}$ which may be solved for these quantities. The variables v_1 , v_2 , v_3 may then be determined by integration. If we only wish a particular integral, we need not keep the arbitrary constants in these integrals; if we retain the constants and substitute in (57), the result is the complete solution of the differential equation (55).

The method applies to equations of any order, there being in general $(n - 1)$ conditions imposed, which together with the condition that the differential equation be satisfied determine the n derivatives of the variable coefficients.

As a more concrete example, let us apply the method to the second order equation

$$(1 - x^2) \frac{d^2y}{dx^2} + 2x \frac{dy}{dx} - 2y = 6(1 - x^2)^2. \quad (64)$$

We assume that the complementary function is known to be

$$c_1x + c_2(1 + x^2).$$

That this is a solution of the equation with right member zero is easily proved by direct substitution. The assumed form of the solution is in this case, accordingly,

$$y = v_1x + v_2(1 + x^2), \quad (65)$$

and the imposed condition, analogous to (58), is

$$\frac{dv_1}{dx} x + \frac{dv_2}{dx} (1 + x^2) = 0, \quad (66)$$

in view of which

$$\frac{dy}{dx} = v_1 + 2xv_2, \quad (67)$$

and

$$\frac{d^2y}{dx^2} = \frac{dv_1}{dx} + 2x \frac{dv_2}{dx} + 2v_2. \quad (68)$$

When the values given in (65), (67) and (68) are substituted in the differential equation (64), there results

$$(1 - x^2) \left(\frac{dv_1}{dx} + 2x \frac{dv_2}{dx} \right) = 6(1 - x^2)^2, \quad (69)$$

which is analogous to (63).

We now solve the equations (66) and (69) as simultaneous equations in $\frac{dv_1}{dx}$, $\frac{dv_2}{dx}$. We thus find

$$\frac{dv_1}{dx} = 6(1 + x^2), \quad \frac{dv_2}{dx} = -6x.$$

Integration of these expressions gives:

$$v_1 = 6x + 2x^3 + c_1, \quad v_2 = -3x^2 + c_2.$$

By inserting these values in (65), the complete solution of the differential equation (64) is found to be

$$y = 3x^2 - x^4 + c_1x + c_2(1 + x^2). \quad (70)$$

An interesting relation between the choice of constants in the variable coefficients, and a special set of initial conditions of the differential equation is discussed in problem 7, p. 110. The application of the method to equations with constant coefficients is indicated in problem 9, p. 110 and those which follow.

EXERCISES XVI

1. Verify that $c_1x^2 + c_2(1 + x)$ is the complementary function for the differential equation

$$(x^2 + 2x) \frac{d^2y}{dx^2} + (-2 - 2x) \frac{dy}{dx} + 2y = (x^2 + 2x)^2,$$

and from this find the complete solution of the equation.

2. Find the complementary function of the differential equation

$$\frac{d^2y}{dx^2} - y = \frac{1}{e^x + e^{-x}},$$

by the method of section 21, and then find a particular integral by the method of variation of constants.

3. Find values of m which make x^m a solution of the equation with right member zero derived from

$$x^2 \frac{d^2y}{dx^2} - 4x \frac{dy}{dx} + 6y = x^4 \sin x,$$

and then solve the equation.

4. Solve the equation

$$\frac{dy}{dx} + P(x)y = Q(x),$$

where $P(x)$ and $Q(x)$ are any functions of x , by the method of variation of constants, noting that the equation with right member zero may be solved by separating the variables.

5. In a linear differential equation of the second order, if one integral u of the equation with right member zero is known, and we put $y = vu$ in the equation, we are led to an equation of the form solved in problem 4 if dv/dx is taken as a new variable. Illustrate this method for equation (64) of the text, taking $u = x$.

6. For each of the following equations, verify that the function u satisfies the equation with right member zero, and then solve by the method indicated in problem 5.

$$(a) \quad u = 1, \quad \cos x \frac{d^2y}{dx^2} + \sin x \frac{dy}{dx} = 12;$$

$$(b) u = e^{2x}, \quad (1 - 2x) \frac{d^2y}{dx^2} + 4x \frac{dy}{dx} - 4y = x^2 - x;$$

$$(c) u = x^2 - 1, \quad (1 + x)^2 \frac{d^2y}{dx^2} - 2(1 + x) \frac{dy}{dx} + 2y = (1 + x)^4.$$

7. (a) By considering the equations (57), (60) and (61) of the text, and the analogous equations for an n th order equation, prove that the special solution of an n th order linear differential equation, which is zero together with all its derivatives up to and including the $(n - 1)$ st when $x = x_0$, may be found by choosing the constants in the variable coefficients so that they are all zero for $x = x_0$.

(b) Show that the solution described in (a) may be written

$$y = u_1 \int_{x_0}^x \frac{dv_1}{dx} dx + u_2 \int_{x_0}^x \frac{dv_2}{dx} dx + u_3 \int_{x_0}^x \frac{dv_3}{dx} dx,$$

in the third order case, and in general,

$$y = \sum_{k=1}^n u_k \int_{x_0}^x \frac{dv_k}{dx} dx.$$

8. Apply the results of problem 7 to find the solution of equation (64) of the text which is zero and has a zero first derivative when $x = 2$.

9. (a) The linear differential equation with constant coefficients,

$$a_3 \frac{d^3y}{dx^3} + a_2 \frac{d^2y}{dx^2} + a_1 \frac{dy}{dx} + a_0 y = A(x),$$

has the complementary solution

$$c_1 e^{m_1 x} + c_2 e^{m_2 x} + c_3 e^{m_3 x},$$

provided the equation

$$P(m) = a_3 m^3 + a_2 m^2 + a_1 m + a_0 = 0,$$

has three distinct roots m_1, m_2, m_3 . Show that the complete solution is

$$y = v_1 e^{m_1 x} + v_2 e^{m_2 x} + v_3 e^{m_3 x},$$

where the derivatives of v_1, v_2 and v_3 satisfy the equations:

$$\begin{aligned} \frac{dv_1}{dx} e^{m_1 x} + \frac{dv_2}{dx} e^{m_2 x} + \frac{dv_3}{dx} e^{m_3 x} &= 0, \\ m_1 \frac{dv_1}{dx} e^{m_1 x} + m_2 \frac{dv_2}{dx} e^{m_2 x} + m_3 \frac{dv_3}{dx} e^{m_3 x} &= 0, \\ a_3 \left(m_1^2 \frac{dv_1}{dx} e^{m_1 x} + m_2^2 \frac{dv_2}{dx} e^{m_2 x} + m_3^2 \frac{dv_3}{dx} e^{m_3 x} \right) &= A(x). \end{aligned}$$

(b) Show that, if b_1, b_2, b_3 are three constants satisfying the equations:

$$\begin{aligned} b_1 + b_2 + b_3 &= 0, \\ m_1 b_1 + m_2 b_2 + m_3 b_3 &= 0, \\ a_3 (m_1^2 b_1 + m_2^2 b_2 + m_3^2 b_3) &= 1, \end{aligned}$$

the complete solution found in part (a) may be written:

$$y = b_1 e^{m_1 x} \int_{x_1}^x e^{-m_1 x} A(x) dx + b_2 e^{m_2 x} \int_{x_2}^x e^{-m_2 x} A(x) dx \\ + b_3 e^{m_3 x} \int_{x_3}^x e^{-m_3 x} A(x) dx,$$

where x_1, x_2, x_3 give rise to the three arbitrary constants.

10. If the polynomial

$$P(m) = a_3 m^3 + a_2 m^2 + a_1 m + a_0 \\ = a_3 (m - m_1)(m - m_2)(m - m_3),$$

and the fraction with this denominator is expanded into partial fractions,

$$\frac{1}{P(m)} = \frac{b_1}{m - m_1} + \frac{b_2}{m - m_2} + \frac{b_3}{m - m_3}, \quad (I)$$

(a) Verify that

$$\frac{b_1}{m - m_1} = \frac{b_1}{m} \cdot \frac{1}{1 - \frac{m_1}{m}} = \frac{b_1}{m} + \frac{b_1 m_1}{m^2} + \frac{b_1 m_1^2}{m^3} + \dots,$$

and

$$\frac{1}{P(m)} = \frac{1}{a_3 m^3} \frac{1}{1 + \frac{a_2}{a_3 m} + \frac{a_1}{a_3 m^2} + \frac{a_0}{a_3 m^3}} = \frac{1}{a_3 m^3} + \dots,$$

the omitted terms in each case containing powers of $\frac{1}{m}$ higher than the third.

Use these expansions, and the two obtained from the first by changing the subscripts, to expand both sides of equation (I) in descending powers of m , and by equating corresponding coefficients, derive the relations:

$$0 = b_1 + b_2 + b_3, \\ 0 = m_1 b_1 + m_2 b_2 + m_3 b_3, \\ \frac{1}{a_3} = m_1^2 b_1 + m_2^2 b_2 + m_3^2 b_3.$$

(b) Since $P(m_1) = 0$, we have

$$\lim_{m \rightarrow m_1} \frac{P(m)}{m - m_1} = \lim_{m \rightarrow m_1} \frac{P(m) - P(m_1)}{m - m_1} \\ = \lim_{\Delta m_1 \rightarrow 0} \frac{P(m_1 + \Delta m_1) - P(m_1)}{\Delta m_1},$$

when we write

$$m = m_1 + \Delta m_1, \text{ or } \Delta m_1 = m - m_1, \\ = \frac{dP(m_1)}{dm_1} = P'(m_1),$$

by the definition of a derivative. Consequently,

$$\lim_{m \rightarrow m_1} \frac{m - m_1}{P(m)} = \frac{1}{P'(m_1)}.$$

Use this result, after multiplying both sides of equation (I) by $m - m_1$, and taking the limit as m approaches m_1 , to prove that $b_1 = \frac{1}{P'(m_1)}$. In a similar way evaluate b_2 and b_3 .

(c) By identifying the equations of problem 9 (b) with those found in (a) of this problem, show that the b_1, b_2, b_3 of 9 (b) have the values found in (c) of this problem, namely

$$b_1 = \frac{1}{P'(m_1)}, \quad b_2 = \frac{1}{P'(m_2)}, \quad b_3 = \frac{1}{P'(m_3)}.$$

11. Let the right member of the differential equation with constant coefficients of problem 9 be $Re^{rx} = A(x)$.

(a) Verify that

$$\begin{aligned} e^{m_1 x} \int_{x_1}^x e^{-m_1 x} A(x) \\ = \frac{R}{r - m_1} [e^{rx} - e^{m_1 x + (r - m_1)x_1}], \end{aligned}$$

unless $r = m_1$. In this case, it is $R(xe^{m_1 x} - x_1 e^{m_1 x})$, which is the limit of the former expression when r approaches m_1 .

(b) By combining problem 9 (b), problem 10 (c) and (a) of this problem, show that the complete solution may be written

$$\begin{aligned} y &= \sum_{k=1}^3 \frac{R}{(r - m_k)P'(m_k)} [e^{rx} - e^{m_k x + (r - m_k)x_k}] \\ &= \frac{Rer^x}{P(r)} - \sum_{k=1}^3 \frac{R}{(r - m_k)P'(m_k)} [e^{m_k x + (r - m_k)x_k}], \end{aligned}$$

where the second form comes from the expansion (I) of problem 10, with m replaced by r .

12. Apply the result of problem 7 to show that, if we put $x_1 = x_2 = x_3 = x_0$ in the solution written in problem 11 (b), the solution is that which vanishes, together with its first and second derivatives at $x = x_0$. In particular, if $x_0 = 0$, the solution is:

$$\frac{Rer^x}{P(r)} - \sum_{k=1}^3 \frac{Rem_k x}{(r - m_k)P'(m_k)}.$$

This is a special case of the Heaviside expansion. A similar formula for an n th order equation, with the summation running from 1 to n gives the solution whose derivatives vanish up to those of the $(n - 1)$ st order.

13. (a) Consider the set of algebraic equations

$$\begin{aligned} L_{11}x_1 + L_{12}x_2 + L_{13}x_3 &= f_1, \\ L_{21}x_1 + L_{22}x_2 + L_{23}x_3 &= f_2, \\ L_{31}x_1 + L_{32}x_2 + L_{33}x_3 &= f_3. \end{aligned} \tag{I}$$

Let us abbreviate by D the determinant of the nine L_{st} ,

$$D = \begin{vmatrix} L_{11} & L_{12} & L_{13} \\ L_{21} & L_{22} & L_{23} \\ L_{31} & L_{32} & L_{33} \end{vmatrix}$$

and by M_{st} the co-factor of the element L_{st} in this determinant. Then, if

$$Du_1 = f_1, \quad Du_2 = f_2, \quad Du_3 = f_3, \quad (II)$$

and

$$\begin{aligned} x_1 &= M_{11}u_1 + M_{21}u_2 + M_{31}u_3, \\ x_2 &= M_{12}u_1 + M_{22}u_2 + M_{32}u_3, \\ x_3 &= M_{13}u_1 + M_{23}u_2 + M_{33}u_3, \end{aligned} \quad (III)$$

equations (I) will be satisfied. Show that (I) is a consequence of (II) and (III) and that the verification requires only multiplications and additions, when the equations are written in the form here given.

(b) If now, the set (I) in part (a) are a system of differential equations with constant coefficients, of the sort discussed in section 23, f_1, f_2, f_3 will be functions of t , and the L_{st} will be of the form:

$$L_{st} = a_{st} + b_{st} \frac{d}{dt} + c_{st} \frac{d^2}{dt^2} + \dots$$

The determinant D , and the co-factors M_{st} will also be of this form, so that the set of equations (II) become a set of linear differential equations, each in a single variable, u_k , and the set (III) become a set of formulas for determining the x_k from the u_k by differentiation, multiplication, and addition. The verification is precisely the same as that for the algebraic case, since linear operators with constant coefficients combine under multiplication like algebraic quantities.

(c) Suppose that D is an operator of the n th order, and M_{11}, M_{21}, M_{31} are all of at most the m th order. Show that if we take, as solutions of (II) those of the type mentioned in problem 7, which vanish, together with their derivatives up to and including the $(n-1)st$, when $t = t_0$ the x_1 obtained from them will vanish together with its derivatives up to and including the $(n-m-1)st$ when $t = t_0$. The formula obtained when the right members are all exponentials, by applying the result of problem 12 to the equations (II), and substituting in (III) is known as the generalized Heaviside expansion.

(d) In general, when the L_{st} are all of the first order, the M_{st} are of the second order, and D is of the third order. Thus the solution of part (c) is such that all the variables vanish when $t = t_0$. Apply this method to find the solution of parts (a) and (b) of problem 3, p. 95 which makes all the variables vanish when $t = 0$.

(e) All the considerations of this problem apply, with slight modification, to systems containing any number of equations. Apply the considerations of part (c) to solve each of the systems of problem 1, p. 94, taking $t = 0$ as the value for which the u_k , and when possible their derivatives, vanish and state exactly what conditions the solution for x and y may be expected to satisfy.

CHAPTER IV

PARTIAL DERIVATIVES AND PARTIAL DIFFERENTIAL EQUATIONS

When dealing with physical quantities and their dependence on more than one independent variable, we encounter relations between functions and their partial derivatives, that is partial differential equations. In this chapter we shall discuss the mathematical origin and nature of the solution of some simple partial differential equations. We begin by recalling the definition of an ordinary, and of a partial derivative.

28. Derivatives and Differentials. If y is a function of a single variable x , $y = f(x)$, the derivative of y with respect to x is defined by

$$\begin{aligned} f'(x) &= \frac{dy}{dx} = \lim_{\Delta x \rightarrow 0} \frac{\Delta y}{\Delta x} \\ &= \lim_{\Delta x \rightarrow 0} \frac{f(x + \Delta x) - f(x)}{\Delta x}. \end{aligned} \quad (1)$$

We may illustrate this definition geometrically, by considering the curve which is the graph of the equation $y = f(x)$. In Fig. 26,

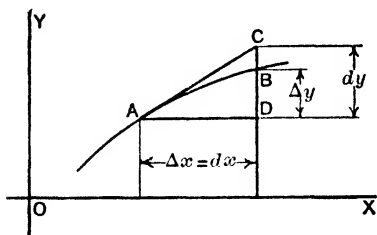

FIG. 26

the point A has co-ordinates (x, y) and B has co-ordinates $(x + \Delta x, y + \Delta y)$. Here Δx is an arbitrary increment in x , and Δy the corresponding increment in y . The derivative dy/dx , the slope of the tangent to the curve at A

may be thought of as the ratio of two differentials, one of which, dx , is taken arbitrarily and the other of which is then determined by

$$dy = \left(\frac{dy}{dx} \right) dx.$$

If, in particular, we take $dx = \Delta x = AD$ in Fig. 26, DC , the increment of y when we move along the tangent line will represent dy while DB , the increment of y when we move along the curve will represent Δy .

If z is a function of several variables, and we hold all the variables except x fixed, z becomes a function of the single variable x . Accordingly we may carry out the process indicated in (1). The result is the **partial derivative** of z with respect to x , written $\frac{\partial z}{\partial x}$, or z_x . Thus when $z = f(x, y)$ is a function of the two variables x and y ,

$$f_x = z_x = \frac{\partial z}{\partial x} = \lim_{\Delta x \rightarrow 0} \frac{f(x + \Delta x, y) - f(x, y)}{\Delta x}. \quad (2)$$

The partial derivative of z with respect to y , $\frac{\partial z}{\partial y}$ is defined similarly.

We may define each of these partial derivatives as the quotient of two differentials by taking an arbitrary dx and then, independently, an arbitrary dy and writing

$$d_x z = \left(\frac{\partial z}{\partial x} \right) dx, \quad d_y z = \left(\frac{\partial z}{\partial y} \right) dy.$$

These partial differentials will generally be quite different. Thus, while the partial derivatives of a function may be written as quotients, or fractions, the numerators of these fractions will *not* be the same for different partial derivatives. The curved delta notation is used for partial derivatives to remind one of this point. For example, while

$$\frac{dz}{dy} \cdot \frac{dy}{dx} = 1,$$

we have:

$$\frac{\partial z}{\partial y} \cdot \frac{dy}{dx} = \frac{d_y z}{d_x z},$$

in general *not* equal to one.

29. Total Differentials. The partial differentials $d_x z$ and $d_y z$ by themselves are of relatively little use, but the **total differential**,

$$dz = d_x z + d_y z, \quad (3)$$

obtained from them is of great importance. From the definition of $d_x z$ and $d_y z$, we have:

$$dz = \frac{\partial z}{\partial x} dx + \frac{\partial z}{\partial y} dy. \quad (4)$$

We may interpret this equation geometrically by considering the surface in space whose equation is $z = f(x, y)$. In Fig. 27,

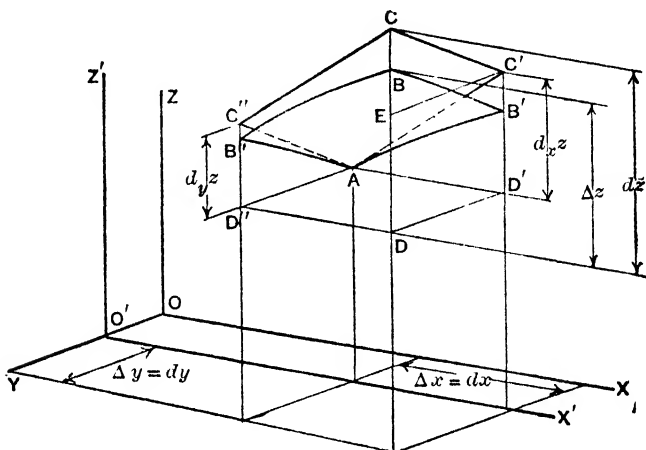

FIG. 27

$AB'BB''$ is a small portion of this surface, and $AC'CC''$ is a portion of the plane¹ tangent to the surface at A . The point A has co-ordinates (x_0, y_0, z_0) . The point B' is obtained by giving x the increment Δx , the point B'' by giving y the increment Δy , and the point B by giving these increments to x and y , in each case remaining in the surface. The points C' , C'' , C are the corresponding points in the tangent plane. Since the straight line AC' is the intersection of the plane tangent to the surface at A , and the plane $y = y_0$ through A , while the curve AB' is the intersection of the surface with the plane $y = y_0$, the line AC' is tangent¹ to the curve

¹ For a smooth surface, the tangent lines at any point A to all the plane curves on the surface drawn through the point A lie in a plane called the plane tangent to the surface at A . See problem 6, p. 128.

AB' at A . If we refer to the axes $O'X'$ and $O'Z'$ in the plane $y = y_0$, the equation of the curve AB' is $z = f(x, y_0)$, and the slope of the tangent to it at the point A is $\left. \frac{\partial z}{\partial x} \right|_0$. The subscript indicates that after the derivative is computed, x and y are to be replaced by x_0 and y_0 . It follows from this that

$$D'C' = \left. \frac{\partial z}{\partial x} \right|_0 AD' = \left. \frac{\partial z}{\partial x} \right|_0 dx = d_x z.$$

By applying similar considerations to the plane $x = x_0$, we find that

$$D''C'' = \left. \frac{\partial z}{\partial y} \right|_0 AD'' = \left. \frac{\partial z}{\partial y} \right|_0 dy = d_y z.$$

But, since $AC'CC''$ is a parallelogram,

$$\begin{aligned} DC &= DE + EC \\ &= D'C' + D''C'' \\ &= d_x z + d_y z \\ &= dz. \end{aligned}$$

Thus the total differential as defined by (3), or (4) is the increment experienced by the ordinate in the tangent plane, when x and y are given their increments.

We see from the figure² that when AD' and AD'' are small, the ratio of BC to DB is small, and the ratio of DB to DC is nearly one. That is, in general,

$$\lim_{\Delta x, \Delta y \rightarrow 0} \frac{\Delta z}{dz} = 1, \text{ if } dx = \Delta x, dy = \Delta y \text{ in } dz. \quad (5)$$

This property enables us to use the expression for the total differential given in (4) to change from the partial derivatives with respect to one set of variables, to those with respect to new variables related to them.

30. Change of Variables. Suppose that x and y are functions of a single variable t . Then $z = f(x, y)$ becomes a function of t , and we have:

$$\frac{\Delta z}{\Delta t} = \frac{\Delta z}{dz} \cdot \frac{dz}{\Delta t} = \frac{\Delta z}{dz} \cdot \left[\frac{\partial z}{\partial x} \frac{\Delta x}{\Delta t} + \frac{\partial z}{\partial y} \frac{\Delta y}{\Delta t} \right],$$

² Or as in problem 8, p. 121.

by (4), where we take $dx = \Delta x$, and $dy = \Delta y$. When Δt approaches zero, so do Δx and Δy , so that we may apply (5), and from

$$\lim_{\Delta t=0} \frac{\Delta z}{\Delta t} = \lim_{\Delta t=0} \frac{\Delta z}{\Delta x} \left[\frac{\partial z}{\partial x} \lim_{\Delta t=0} \frac{\Delta x}{\Delta t} + \frac{\partial z}{\partial y} \lim_{\Delta t=0} \frac{\Delta y}{\Delta t} \right],$$

deduce

$$\frac{dz}{dt} = \frac{\partial z}{\partial x} \frac{dx}{dt} + \frac{\partial z}{\partial y} \frac{dy}{dt}. \quad (6)$$

If, instead of being functions of a single variable t , x and y were each themselves functions of two other variables, s and t , we could proceed as before, keeping s constant during the process, and obtain the partial derivative of z with respect to t as:

$$\frac{\partial z}{\partial t} = \frac{\partial z}{\partial x} \frac{\partial x}{\partial t} + \frac{\partial z}{\partial y} \frac{\partial y}{\partial t}. \quad (7)$$

In this equation, when differentiating with respect to x , y is held constant, when differentiating with respect to y , x is held constant, and when differentiating with respect to t , s is held constant. In case any confusion on this point is likely to occur, we indicate the variables held fast by subscripts, writing the equation (7) as

$$\frac{\partial z}{\partial t} \Big|_s = \frac{\partial z}{\partial x} \Big|_y \frac{\partial x}{\partial t} \Big|_s + \frac{\partial z}{\partial y} \Big|_x \frac{\partial y}{\partial t} \Big|_s. \quad (8)$$

For example, if u were a function of T , the temperature of a gas, and p the pressure, so that $u = u(T, p)$, by means of the relation between the temperature, pressure and volume of a gas, $F(T, p, v) = 0$ or $T = T(p, v)$, we could eliminate T and regard u as a function of p and v . The application of (8) to this case gives:

$$\begin{aligned} \frac{\partial u}{\partial v} \Big|_p &= \frac{\partial u}{\partial T} \Big|_p \frac{\partial T}{\partial v} \Big|_p + \frac{\partial u}{\partial p} \Big|_T \frac{\partial p}{\partial v} \Big|_p, \\ \frac{\partial u}{\partial p} \Big|_v &= \frac{\partial u}{\partial T} \Big|_p \frac{\partial T}{\partial p} \Big|_v + \frac{\partial u}{\partial p} \Big|_T \frac{\partial p}{\partial p} \Big|_v. \end{aligned}$$

When p is constant, p does not change, so that

$$\frac{\partial p}{\partial v} \Big|_p = 0,$$

and

$$\frac{\partial p}{\partial p} \Big|_v = 1,$$

so that the relations simplify to

$$\left. \frac{\partial u}{\partial v} \right|_p = \left. \frac{\partial u}{\partial \bar{T}} \right|_p \left. \frac{\partial \bar{T}}{\partial v} \right|_p,$$

and

$$\left. \frac{\partial u}{\partial p} \right|_v = \left. \frac{\partial u}{\partial \bar{T}} \right|_p \left. \frac{\partial \bar{T}}{\partial p} \right|_v + \left. \frac{\partial u}{\partial p} \right|_T.$$

Note that, if the subscripts were omitted in the second equation, we should have the *same* symbol, in the *same* equation with *two* meanings!

Let us apply the formulas just developed to transform the partial derivatives with respect to x and y into combinations of those with respect to u and v where

$$u = ax + by, \quad v = cx + dy. \quad (8)$$

We have from equation (7)

$$\begin{aligned} \frac{\partial z}{\partial x} &= \frac{\partial z}{\partial u} \frac{\partial u}{\partial x} + \frac{\partial z}{\partial v} \frac{\partial v}{\partial x} \\ &= a \frac{\partial z}{\partial u} + c \frac{\partial z}{\partial v}. \end{aligned} \quad (9)$$

For the second derivative, we have:

$$\frac{\partial^2 z}{\partial x^2} = \frac{\partial}{\partial x} \left(\frac{\partial z}{\partial x} \right) = \frac{\partial}{\partial u} \left(\frac{\partial z}{\partial x} \right) \frac{\partial u}{\partial x} + \frac{\partial}{\partial v} \left(\frac{\partial z}{\partial x} \right) \frac{\partial v}{\partial x},$$

and, on making use of the expression (9), this reduces to

$$\begin{aligned} \frac{\partial^2 z}{\partial x^2} &= a \left(a \frac{\partial^2 z}{\partial u^2} + c \frac{\partial^2 z}{\partial u \partial v} \right) + c \left(a \frac{\partial^2 z}{\partial v \partial u} + c \frac{\partial^2 z}{\partial v^2} \right), \\ &= a^2 \frac{\partial^2 z}{\partial u^2} + 2ac \frac{\partial^2 z}{\partial u \partial v} + c^2 \frac{\partial^2 z}{\partial v^2}. \end{aligned} \quad (10)$$

The reader will recall that the order of differentiation³ is immaterial, which justifies our putting

$$\frac{\partial^2 z}{\partial u \partial v} = \frac{\partial^2 z}{\partial v \partial u}.$$

By a calculation similar to those just made, we find also

$$\frac{\partial z}{\partial y} = b \frac{\partial z}{\partial u} + d \frac{\partial z}{\partial v}, \quad (11)$$

³ See problem 11, p. 123.

and

$$\begin{aligned}\frac{\partial^2 z}{\partial y^2} &= b^2 \frac{\partial^2 z}{\partial u^2} + 2bd \frac{\partial^2 z}{\partial u \partial v} + d^2 \frac{\partial^2 z}{\partial v^2}, \\ \frac{\partial^2 z}{\partial x \partial y} &= ab \frac{\partial^2 z}{\partial u^2} + (ad + bc) \frac{\partial^2 z}{\partial u \partial v} + cd \frac{\partial^2 z}{\partial v^2}.\end{aligned}\quad (12)$$

As a second illustration, consider the relations

$$\begin{aligned}x &= \sin(2u + 3v) + u, \\ y &= u^2 + 3v^2,\end{aligned}\quad (13)$$

and let us determine the partial derivatives of u and v with respect to x and y . Theoretically, this could be done by solving the equations (13) for u and v in terms of x and y , and then differentiating partially. Practically, it is simpler to use (7), which tells us that:

$$\begin{aligned}1 &= \frac{\partial x}{\partial x} = \frac{\partial x}{\partial u} \frac{\partial u}{\partial x} + \frac{\partial x}{\partial v} \frac{\partial v}{\partial x}, \\ 0 &= \frac{\partial y}{\partial x} = \frac{\partial y}{\partial u} \frac{\partial u}{\partial x} + \frac{\partial y}{\partial v} \frac{\partial v}{\partial x}.\end{aligned}$$

On replacing the derivatives of x and y by their values as computed from (13), these equations become

$$\begin{aligned}1 &= \frac{\partial u}{\partial x} [2 \cos(2u + 3v) + 1] + \frac{\partial v}{\partial x} 3 \cos(2u + 3v), \\ 0 &= \frac{\partial u}{\partial x} 2u + \frac{\partial v}{\partial x} 6v,\end{aligned}$$

These may be solved to give:

$$\begin{aligned}\frac{\partial u}{\partial x} &= \frac{v}{(2v - u) \cos(2u + 3v) + v}, \\ \frac{\partial v}{\partial x} &= \frac{-u}{(6v - 3u) \cos(2u + 3v) + 3v}.\end{aligned}\quad (14)$$

The derivatives of u and v with respect to y may be calculated in a similar manner, from

$$\frac{\partial x}{\partial y} = 0, \quad \frac{\partial y}{\partial y} = 1,$$

and shown to be:

$$\begin{aligned}\frac{\partial u}{\partial y} &= \frac{-\cos(2u + 3v)}{(4v - 2u) \cos(2u + 3v) + 2v}, \\ \frac{\partial v}{\partial y} &= \frac{2 \cos(2u + 3v) + 1}{(12v - 6u) \cos(2u + 3v) + 6v}.\end{aligned}\quad (15)$$

EXERCISES XVII

1. If $x = u^2$, $y = 4u + 5v$, (a) Compute the partial derivatives of x and y with respect to u and v . (b) Hence find the partial derivatives of u and v with respect to x and y by the method used in the text to derive (14). (c) Check these values by solving the equations given for u and v in terms of x and y , and differentiating directly.

2. For the transformation to polar co-ordinates, $x = r \cos \theta$, $y = r \sin \theta$, carry out parts (a), (b) and (c) as for problem 1, where r , θ take the place of u and v .

3. If $f(x, y)$ is a function of x, y and hence of the u, v of problem 1, compute (a) $\partial f / \partial u$ and $\partial f / \partial v$ in terms of $\partial f / \partial x$ and $\partial f / \partial y$, (b) the second derivatives of f with respect to u and v in terms of the first and second derivatives of f with respect to x and y .

4. Using the results of problem 2, show that, on transforming to polar co-ordinates, we have:

$$\frac{\partial^2 f}{\partial x^2} + \frac{\partial^2 f}{\partial y^2} = \frac{\partial^2 f}{\partial r^2} + \frac{1}{r} \frac{\partial f}{\partial r} + \frac{1}{r^2} \frac{\partial^2 f}{\partial \theta^2}.$$

5. Prove that, if u is a function of x and y , and z is a function of u , $z = f(u)$.

$$\frac{\partial z}{\partial x} = \frac{dz}{du} \frac{\partial u}{\partial x} = f'(u) \frac{\partial u}{\partial x}.$$

6. (a) Prove that, if u is a function of x and y , and z is a function of u and x ,

$$\frac{\partial z}{\partial x} \Big|_y = \frac{\partial z}{\partial u} \Big|_x \frac{\partial u}{\partial x} \Big|_y + \frac{\partial z}{\partial x} \Big|_u,$$

where, as in the text, the subscripts indicate the variables held fast.

(b) Illustrate the relation in (a) for $u = x^2 + 3xy$, $z = 3x + 2u$, and check by direct differentiation after replacing u by its value.

7. (a) If u and v are functions of x and y , and $u = f(v)$, show that

$$\left| \begin{array}{c} \frac{\partial u}{\partial x} \frac{\partial v}{\partial x} \\ \frac{\partial u}{\partial y} \frac{\partial v}{\partial y} \end{array} \right| = \frac{\partial u}{\partial x} \frac{\partial v}{\partial y} - \frac{\partial u}{\partial y} \frac{\partial v}{\partial x} = 0.$$

(b) Verify that the hypothesis of (a) is satisfied for

$$u = \sin(2x + y^2), \quad v = 4x^2 + 4xy^2 + y^4,$$

and also verify the conclusion directly.

8. The law of the mean for a function of a single variable, $y = f(x)$, whose graph is a smooth curve, states that

$$f(x_2) - f(x_1) = (x_2 - x_1) f'(x_3),$$

for some value x_3 between x_1 and x_2 : $x_1 < x_3 < x_2$.

(a) Show that this expresses the geometrical fact that on any arc of a smooth plane curve, there is always some intermediate point at which the tangent is parallel to the chord.

(b) Apply the law of the mean to prove, for a function of more than one variable, there is an x_3 , $x_1 < x_3 < x_2$, for which:

$$f(x_2, y) - f(x_1, y) = (x_2 - x_1) f_x(x_3, y),$$

where

$$f_x(x, y) = \frac{\partial f}{\partial x}.$$

(c) Assuming that the partial derivatives of the function $z = f(x, y)$ are continuous, i.e., that

$$\lim_{\substack{x=x_0 \\ y=y_0}} f_x(x, y) = f_x(x_0, y_0) \quad \text{and} \quad \lim_{\substack{x=x_0 \\ y=y_0}} f_y(x, y) = f_y(x_0, y_0),$$

and the result of (b), complete the proof of (5) sketched in the following:

$$\begin{aligned} \Delta z &= f(x + \Delta x, y + \Delta y) - f(x, y) \\ &= f(x + \Delta x, y + \Delta y) - f(x, y + \Delta y) + f(x, y + \Delta y) - f(x, y) \\ &= \Delta x f_x(x_3, y + \Delta y) + \Delta y f_y(x, y_3). \end{aligned}$$

Hence, if $\Delta s^2 = \Delta x^2 + \Delta y^2$,

$$\begin{aligned} \frac{\Delta z}{\Delta s} &= \frac{\Delta x}{\Delta s} f_x(x_3, y + \Delta y) + \frac{\Delta y}{\Delta s} f_y(x, y_3), \\ &= \frac{dz}{\Delta s} + \frac{\Delta x}{\Delta s} \left[f_x(x_3, y + \Delta y) - f_x(x, y) \right] \\ &\quad + \frac{\Delta y}{\Delta s} \left[f_y(x, y_3) - f_y(x, y) \right], \end{aligned}$$

on taking the limit as Δx and Δy , and hence Δs approach zero,

$$\lim_{\substack{\Delta x=0 \\ \Delta y=0}} \frac{\Delta z}{\Delta s} = \lim_{\substack{\Delta x=0 \\ \Delta y=0}} \frac{dz}{\Delta s},$$

and, unless the common value is zero,

$$\lim_{\substack{\Delta x=0 \\ \Delta y=0}} \frac{\Delta z}{dz} = \lim_{\substack{\Delta x=0 \\ \Delta y=0}} \frac{\frac{\Delta z}{\Delta s}}{\frac{dz}{\Delta s}} = 1.$$

(d) Extend the proof of (c) to a function of more than two variables, $z = f(x_1, x_2, \dots, x_n)$ where in this case:

$$dz = \frac{\partial z}{\partial x_1} dx_1 + \frac{\partial z}{\partial x_2} dx_2 + \dots + \frac{\partial z}{\partial x_n} dx_n,$$

and derive from this formulas for $\frac{dz}{dt}$ and $\frac{\partial z}{\partial y_1}$ analogous to (6) and (7) of the text, namely:

$$\frac{dz}{dt} = \frac{\partial z}{\partial x_1} \frac{dx_1}{dt} + \frac{\partial z}{\partial x_2} \frac{dx_2}{dt} + \dots + \frac{\partial z}{\partial x_n} \frac{dx_n}{dt},$$

and

$$\frac{\partial z}{\partial y_1} = \frac{\partial z}{\partial x_1} \frac{\partial x_1}{\partial y_1} + \frac{\partial z}{\partial x_2} \frac{\partial x_2}{\partial y_1} + \dots + \frac{\partial z}{\partial x_n} \frac{\partial x_n}{\partial y_1}.$$

9 (a) If x , y , and z are connected by the equations:

$$f(x, y, z) = 0, \quad \text{and} \quad \phi(x, y) = 0,$$

and y is eliminated, z becomes a function of x . Find $\frac{dz}{dx}$, in terms of the partial derivatives of f and ϕ . Hint: Use the relations $f_x dx + f_y dy + f_z dz = 0$, and $\phi_x dx + \phi_y dy = 0$, and eliminate dy .

(b) If $f(x, y, z) = 0$ determines z as a function of x and y , find $\frac{\partial z}{\partial x}$, either by the method of (a), or the result of (a) when $\phi(x, y) = 0$ is $y - y_0 = 0$.

10. If x , y , u , and v are connected by the equations $f(x, y, u, v) = 0$ and $g(x, y, u, v) = 0$, we may think of x and y as functions of u and v , or u and v as functions of x and y . Find the values of $\frac{\partial x}{\partial u}$, and $\frac{\partial u}{\partial x}$, by the method of problem 9.

11. Using some of the results and definitions of problem 8, complete the following sketch of a proof that, when all the partial derivatives f_x , f_y and f_{xy} are continuous, $f_{xy} = f_{yx}$. Put

$$F(x, y) = f(x + \Delta x, y) - f(x, y).$$

Then

$$\begin{aligned} f(x + \Delta x, y + \Delta y) - f(x, y + \Delta y) - f(x + \Delta x, y) + f(x, y) \\ &= F(x, y + \Delta y) - F(x, y) \\ &= \Delta y F_y(x, y_3) = \Delta y [f_y(x + \Delta x, y_3) - f_y(x, y_3)] \\ &= \Delta y \Delta x f_{xy}(x_3, y_3). \end{aligned}$$

Then put

$$G(x, y) = f(x, y + \Delta y) - f(x, y),$$

and show that the same expression equals

$$G(x + \Delta x, y) - G(x, y) = \Delta x \Delta y f_{yx}(x_4, y_4).$$

Thus $f_{xy}(x_3, y_3) = f_{yx}(x_4, y_4)$, and on taking the limit as Δx and Δy approach zero, $f_{xy}(x, y) = f_{yx}(x, y)$.

12. (a) If $M(x, y) dx + N(x, y) dy$ is the total differential of a function $f(x, y)$, it is said to be exact. By identifying the expression with the total differential of $f(x, y)$, and using the result of problem 11, show that for an exact expression, it is always true that

$$\frac{\partial M}{\partial y} = \frac{\partial N}{\partial x}.$$

(b) Complete the proof sketched that if the condition of (a) holds, the expression $M dx + N dy$ is exact. Put $u(x, y) = \int M dx$, the integration being carried out with y fixed. Then if $f(x, y) = u(x, y) + v(y)$, $\frac{\partial f}{\partial x} = M$. Thus we will have $M dx + N dy = df$ if

$$N = \frac{\partial f}{\partial y} = \frac{\partial}{\partial y} \int M dx + v'(y),$$

or

$$v'(y) = N - \frac{\partial}{\partial y} \int M dx.$$

But $v(y)$ can be found to satisfy this provided the right member is a function of y only, i.e., has a partial derivative with respect to x which is zero, or

$$\frac{\partial N}{\partial x} - \frac{\partial}{\partial x} \frac{\partial}{\partial y} \int M dx = 0,$$

which is the condition given, in view of the result of problem 11, if the continuity requirements of that problem are met.

13. If C is a curve given by $x = x(t)$, $y = y(t)$, joining the points $x_1 = x(t_1)$, $y_1 = y(t_1)$ and $x_2 = x(t_2)$, $y_2 = y(t_2)$, the equation:

$$\int_C M(x, y) dx + N(x, y) dy = \int_{t_1}^{t_2} \{M[x(t), y(t)]x'(t) + N[x(t), y(t)]y'(t)\} dt$$

defines the meaning of the left member, called a **line integral**. (a) Show that, if $M dx + N dy$ is the exact differential of $f(x, y)$, the value of the integral is

$$f[x(t_2), y(t_2)] - f[x(t_1), y(t_1)].$$

(b) Show that if we traverse the curve in the opposite direction, the line integral changes sign.

(c) Suppose we have two curves joining the points $P_1 = (x_1, y_1)$ and $P_2 = (x_2, y_2)$, and in the region included by these curves the functions M and N have continuous first partial derivatives, such that $\frac{\partial M}{\partial y} = \frac{\partial N}{\partial x}$. We may draw a continuous series of curves joining the two points between the first and the second curve. Along each of these curves we may find a function $f(x, y)$, by problem 12, and hence find $f(x_2, y_2)$ corresponding to a given $f(x_1, y_1)$ the same for all the curves. Since $f(x_2, y_2)$ can not vary from curve to curve for the continuous series, it must be the same for the first and last curve. Show from this, and (b) that the line integral of a differential $M dx + N dy$ is zero about any closed curve, such that M and N have continuous first partial derivatives and $\frac{\partial M}{\partial y} = \frac{\partial N}{\partial x}$ throughout the region bounded by the curve.

(d) Illustrate (c) for the closed curve $x = \cos t$, $y = \sin t$, $t_1 = 0$, $t_2 = 2\pi$, and the differential

$$(2x + 3y) dx + (2y + 3x) dy.$$

Why does the result not apply to the differential

$$\frac{-y}{x^2 + y^2} dx + \frac{x}{x^2 + y^2} dy$$

for the same path ϵ

14. If $X(x, y)$ and $Y(x, y)$ are the components of force acting on a particle at any point (x, y) of the plane, a plane force field is defined. The work done by the field on the particle in any motion is the line integral $\int X dx + Y dy$.

If the amount of work done is the same for any two paths, joining the same end points, the field is said to be conservative. If $\frac{\partial X}{\partial y} = \frac{\partial Y}{\partial x}$, and suitable continuity requirements are met, (a) Show that the field is conservative. (b) Show that a function $U(x, y)$, called a force potential, can be found such that

$$X = \frac{\partial U}{\partial x}, \quad Y = \frac{\partial U}{\partial y}.$$

15. Let $u(x, y)$ and $v(x, y)$ be two functions, and suppose $\frac{\partial u}{\partial x} \frac{\partial v}{\partial y} - \frac{\partial u}{\partial y} \frac{\partial v}{\partial x} = 0$. Let x vary, but y be so chosen that $u(x, y) = c_1$. Show that if $\frac{\partial u}{\partial y} \neq 0$, under these conditions, $\frac{dv}{dx} = 0$, so that v is constant if u is constant, i.e., there is a functional relation between u and v . If $\frac{\partial u}{\partial y} = 0$, but $\frac{\partial u}{\partial x} \neq 0$, we could interchange the rôles of x and y , while if both were zero under the usual condition of continuous derivatives, this would be true either at isolated points or throughout a region. In the latter case u would be constant, and hence a function of v .

31. Equation of the Tangent Plane, and a Related Partial Differential Equation. The equation of the tangent plane to a surface at a given point is readily obtained from Fig. 27. For, the tangent plane to the surface

$$z = f(x, y) \tag{16}$$

at the point

$$A = (x_0, y_0, z_0)$$

on the surface, passes through the points

$$C' = \left(x_0 + \Delta x, y_0, z_0 + \frac{\partial z}{\partial x} \Big|_0 \Delta x \right)$$

and

$$C'' = \left(x_0, y_0 + \Delta y, z_0 + \frac{\partial z}{\partial y} \Big|_0 \Delta y \right).$$

But the equation

$$z - z_0 = (x - x_0) \frac{\partial z}{\partial x} \Big|_0 + (y - y_0) \frac{\partial z}{\partial y} \Big|_0 \tag{17}$$

is evidently satisfied when, in it, (x, y, z) are replaced by any one of the three sets of co-ordinates just written. Since equation (17) is of the first degree in x, y , and z it is the equation of a plane, and

since it is satisfied by the co-ordinates of A , C' and C'' , the plane passes through these three points, and accordingly is the tangent plane to the surface at A .

Suppose we have an assigned direction at each point of space. Let the direction at the point (x, y, z) be that parallel to the line joining the origin and the point

$$x = A(x, y, z), \quad y = B(x, y, z), \quad z = C(x, y, z).$$

We shall refer to this last line, or any line segment equal and parallel to it as the vector with components A , B , C . Similarly we shall refer to the direction as the direction A , B , C . If we have a surface (16) such that the tangent plane to it at any point $P_0 = (x_0, y_0, z_0)$ on the surface is parallel to the direction for that point, i.e., A_0 , B_0 , C_0 , where

$$A_0 = A(x_0, y_0, z_0), \quad B_0 = B(x_0, y_0, z_0), \quad C_0 = C(x_0, y_0, z_0),$$

we will have:

$$C_0 = A_0 \frac{\partial z}{\partial x} \Big|_0 + B_0 \frac{\partial z}{\partial y} \Big|_0. \quad (18)$$

For, the point

$$Q = (x_0 + A_0, y_0 + B_0, z_0 + C_0),$$

is such that the segment P_0Q is a vector with components A_0 , B_0 , C_0 . Hence Q is a point on the line through P_0 , parallel to the direction A_0 , B_0 , C_0 , and the tangent plane will be parallel to this direction if it contains the point Q , and hence the segment P_0Q . But, since the result of replacing x, y, z in equation (17) by the co-ordinates of Q is (18), we see that if the tangent plane is parallel to the direction A_0 , B_0 , C_0 , then (18) will hold. The same argument shows that, conversely, if (18) holds the tangent plane is parallel to the direction A_0 , B_0 , C_0 .

As the equation (18) does not contain x, y , or z , but only x_0, y_0, z_0 , we may drop all subscripts, and write

$$A(x, y, z) \frac{\partial z}{\partial x} + B(x, y, z) \frac{\partial z}{\partial y} = C(x, y, z). \quad (19)$$

This is a partial differential equation since it expresses a relation between x, y, z and the partial derivatives of z with respect to x and y . The discussion just given shows that we may expect

it to be satisfied by those equations which represent surfaces such that at each point of the surface, the tangent plane is parallel to the corresponding direction A, B, C .

EXERCISES XVIII

1. Find the equation of the tangent plane to the surface $z = \sqrt{a^2 - x^2 - y^2}$, at the point on it with $x = x_0, y = y_0$, and in particular the equation when $x_0 = y_0 = \frac{a}{2}$.

2. (a) If the equation of a surface is given in the form $U(x, y, z) = 0$, show that

$$\frac{\partial z}{\partial x} = -\frac{U_x}{U_z}, \quad \frac{\partial z}{\partial y} = -\frac{U_y}{U_z}.$$

(b) Hence show that the equation of the tangent plane at the point x_0, y_0, z_0 may be written:

$$U_{x_0}(x - x_0) + U_{y_0}(y - y_0) + U_{z_0}(z - z_0) = 0.$$

(c) Interpret the partial differential equation

$$A(x, y, z) U_x + B(x, y, z) U_y + C(x, y, z) U_z = 0$$

geometrically.

3. Show that all the results of problem 2 are unchanged if the original equation is $U(x, y, z) = k$, where k is a constant.

4. Write the equation of the sphere whose upper half is the surface of problem 1 in the form

$$x^2 + y^2 + z^2 = a^2,$$

and solve problem 1 by applying the results of problem 2 to this form.

5. By considering the geometric meaning of the equation, show that the solutions of:

(a) $\frac{\partial z}{\partial x} = 0$ represent surfaces whose tangent planes contain parallels to the x -axis, i.e., cylindrical surfaces with elements parallel to the x -axis.

(b) $a \frac{\partial z}{\partial x} + b \frac{\partial z}{\partial y} = 0$ represent cylindrical surfaces with elements parallel to the direction $a, b, 0$.

(c) $a \frac{\partial z}{\partial x} + b \frac{\partial z}{\partial y} = c$ represent cylindrical surfaces with elements parallel to the direction a, b, c .

(d) $x \frac{\partial z}{\partial x} + y \frac{\partial z}{\partial y} = z$ represent surfaces whose tangent planes contain the vector joining the origin to the point of contact, i.e., conical surfaces with vertex at the origin.

(e) $y \frac{\partial z}{\partial x} - x \frac{\partial z}{\partial y} = 0$ represent surfaces of revolution, with the z -axis as axis of revolution.

6. (a) If $x(t)$, $y(t)$, $z(t)$ are the equations of a curve in space, and the tangent line is defined as the limiting position of a secant, show that the direction of the tangent at any point is the direction $x'(t)$, $y'(t)$, $z'(t)$.

(b) If the curve in (a) lies on the surface $F(x, y, z) = 0$, we have $F[x(t), y(t), z(t)] = 0$, identically in t . Assuming that $F(x, y, z)$ has continuous partial derivatives, apply the result of problem 8 (d), p. 122, to prove:

$$0 = \frac{dF}{dt} = F_x x' + F_y y' + F_z z'.$$

(c) From (a) and (b), show that if $F(x_0, y_0, z_0) = 0$, the equation

$$F_{x_0}(x - x_0) + F_{y_0}(y - y_0) + F_{z_0}(z - z_0) = 0,$$

represents a plane through (x_0, y_0, z_0) containing all the straight lines tangent at (x_0, y_0, z_0) to curves on the surface drawn through this point.

7. Derive equation (17) of the text from problem 6 (c), by putting

$$F(x, y, z) = z - f(x, y).$$

8. Prove that the orthogonal projection of the direction F_{x_0} , F_{y_0} , F_{z_0} of problem 6 (c) on each of the co-ordinate planes is perpendicular to the intersection of the tangent plane with that co-ordinate plane. Hence, by the methods of descriptive or elementary solid geometry, show that the direction F_{x_0} , F_{y_0} , F_{z_0} is perpendicular to the tangent plane.

32. Formation of Partial Differential Equations by the Elimination of Arbitrary Functions. If we differentiate an equation involving two variables, x and y , and n arbitrary constants, n times, the constants may be eliminated. The result is an ordinary differential equation which is satisfied by the original relation for all values of the constants. In general it will be of the n th order, and the original relation will be its complete solution.

If we have a single relation containing more than two variables, e.g. x , y and z , we may differentiate partially, thinking of z as a function of x and y . In this way we obtain relations from which we may eliminate arbitrary functions which occur in the original relation.

We begin with an equation with one arbitrary function:

$$z = f(2x - 3y) + 4x + 6y. \quad (20)$$

We find from this, where as usual $f'(u)$ denotes $\frac{df}{du}$:

$$\frac{\partial z}{\partial x} = 2f'(2x - 3y) + 4$$

$$\frac{\partial z}{\partial y} = -3f'(2x - 3y) + 6.$$

We have now three equations, and two quantities connected with the function to be eliminated, namely $f(2x - 3y)$ and $f'(2x - 3y)$. Accordingly we need not differentiate further. We eliminate $f(2x - 3y)$ by omitting the first equation, and on eliminating $f'(2x - 3y)$ from the other two equations, find:

$$3 \frac{\partial z}{\partial x} + 2 \frac{\partial z}{\partial y} = 24. \quad (21)$$

As a second illustration, consider

$$z = f(x^2 + y^2 + z^2). \quad (22)$$

In differentiating this, we must remember that z is a function of x and y . We find:

$$\begin{aligned} \frac{\partial z}{\partial x} &= f'(x^2 + y^2 + z^2) \left(2x + 2z \frac{\partial z}{\partial x} \right), \\ \frac{\partial z}{\partial y} &= f'(x^2 + y^2 + z^2) \left(2y + 2z \frac{\partial z}{\partial y} \right). \end{aligned}$$

We eliminate $f'(x^2 + y^2 + z^2)$ from these equations, obtaining

$$y \frac{\partial z}{\partial x} - x \frac{\partial z}{\partial y} = 0. \quad (23)$$

We may proceed similarly with any equation involving a single function. If we solve for this function, the equation takes the form:

$$U(x, y, z) = f[V(x, y, z)]. \quad (24)$$

Here f is the arbitrary function to be eliminated, while U and V are functions of x, y, z known for any particular example. Thus, if $U = z$, $V = x^2 + y^2 + z^2$, the equation (24) reduces to (22). On differentiating the equation (24), and using the subscript notation for the partial derivatives, we have:

$$\begin{aligned} U_x + U_z \frac{\partial z}{\partial x} &= f'(V) \left(V_x + V_z \frac{\partial z}{\partial x} \right), \\ U_y + U_z \frac{\partial z}{\partial y} &= f'(V) \left(V_y + V_z \frac{\partial z}{\partial y} \right). \end{aligned}$$

When the elimination of $f'(V)$ is carried out, there results:

$$(U_x V_y - U_y V_x) \frac{\partial z}{\partial x} + (U_x V_z - U_z V_x) \frac{\partial z}{\partial y} = U_y V_x - U_x V_y. \quad (25)$$

We may interpret these results geometrically. We have two families of surfaces, obtained by putting U equal to a series of constants, or V equal to a series of constants. A particular function f in (24) pairs up these constants, and hence two surfaces, one from each family. We conclude from this that the surface (24) is generated by *curves of intersection of some U surface with some V surface*, as follows. Let $P_0 = (x_0, y_0, z_0)$ be a point on the surface (24). Define k_0 and k_0' by

$$U(x_0, y_0, z_0) = k_0, \quad V(x_0, y_0, z_0) = k_0'.$$

Then, since P_0 is on the surface (24), we have:

$$k_0 = f(k_0').$$

Consequently, for any point (x, y, z) on both the surfaces

$$U(x, y, z) = k_0, \quad V(x, y, z) = k_0', \quad (26)$$

equation (24) is satisfied. Hence it contains all the points on these two surfaces, i.e., their entire curve of intersection. If the direction A, B, C is the direction of the tangent to this curve of intersection at any point, it will lie in the tangent plane to either surface and hence by problem 2, p. 127, we will have:

$$A U_x + B U_y + C U_z = 0, \quad A V_x + B V_y + C V_z = 0. \quad (27)$$

By solving these equations for the ratios $A/C, B/C$, we find:

$$\frac{A}{U_x V_y - U_y V_x} = \frac{B}{U_x V_z - U_z V_x} = \frac{C}{U_y V_z - U_z V_y}. \quad (28)$$

This shows that the solutions of (25) represent surfaces whose tangent planes contain the directions A, B, C , as was to be expected from our interpretation of (24). We may summarize the situation by noting that:

1. Through each point of space we have a particular U surface, a particular V surface and a particular curve of intersection.
2. The tangent to the curve of intersection at the point is the intersection of the tangent planes to the U and V surfaces at the point.
3. The partial differential equation (25) expresses the fact that its solution represents a surface tangent to the curve of intersection.

4. The equation (24) represents a surface built up from curves of intersection.

As illustrations, we note that for (20), the U and V surfaces are families of parallel planes, given by:

$$z - 4x - 6y = k, \quad 2x - 3y = k'.$$

Thus the surfaces here coincide with their tangent planes. The curves of intersection coincide with their tangent lines, and are the lines in the direction 3, 2, 24 which are the coefficients of (21). Again, for (22), the U surfaces are the planes

$$z = k,$$

parallel to the XY plane, while the V surfaces are the spheres

$$x^2 + y^2 + z^2 = k',$$

with center at the origin. The curves of intersection are circles parallel to the XY plane, with centers on the z -axis, which explains why equation (23) is that of problem 5(e), p. 127, whose solutions are surfaces of revolution.

As an example of elimination leading to an equation of higher order than the first, consider

$$z = f(y - 3x) + g(y - 2x) + e^{2x+3y}, \quad (29)$$

which contains two arbitrary functions. On taking first derivatives, we find:

$$\begin{aligned} \frac{\partial z}{\partial x} &= -3f'(y - 3x) - 2g'(y - 2x) + 2e^{2x+3y}, \\ \frac{\partial z}{\partial y} &= f'(y - 3x) + g'(y - 2x) + 3e^{2x+3y}; \end{aligned} \quad (30)$$

while the second derivatives are:

$$\begin{aligned} \frac{\partial^2 z}{\partial x^2} &= 9f''(y - 3x) + 4g''(y - 2x) + 4e^{2x+3y}, \\ \frac{\partial^2 z}{\partial x \partial y} &= -3f''(y - 3x) - 2g''(y - 2x) + 6e^{2x+3y}, \\ \frac{\partial^2 z}{\partial y^2} &= f''(y - 3x) + g''(y - 2x) + 9e^{2x+3y}. \end{aligned} \quad (31)$$

We have altogether six equations, and six quantities, namely the two functions and the four derivatives. Consequently, we would

not expect to be able to eliminate them at this stage. However, the functions only occur in the first equation, (29), so that if this is left out, we have five equations in four quantities, and may eliminate them by omitting the two equations (30), solving two of the equations (31) for the two second derivatives, and inserting their values in the third of equations (31). The result is:

$$\frac{\partial^2 z}{\partial x^2} + 5 \frac{\partial^2 z}{\partial x \partial y} + 6 \frac{\partial^2 z}{\partial y^2} = 88e^{2x+3y}. \quad (32)$$

In any case where z is given as a sum of n arbitrary functions of x and y , plus a known function of x and y , the n th derivatives of these functions will only occur in the partial derivatives of the n th order. Accordingly, we have merely to differentiate n times in all possible ways, and omit all except the $n + 1$ equations which give the n th partial derivatives. The n , n th ordinary derivatives of the arbitrary functions may then be eliminated from these last. The result will be an equation of essentially the type here found, a homogeneous linear partial differential equation of the n th order, with non-zero right member.

If the functions enter in a more complicated way, it will be necessary to differentiate more times, and there may be several different equations of lowest order, as in problem 7, p. 133.

EXERCISES XIX

1. Eliminate the arbitrary function from

(a) $z = f(3x + 4y) + 8y$, (b) $z = f(3x + 4y) - 6x$, (c) $z = f(z + 6x) + 8y$.
 (d) Interpret geometrically, and explain why the result is the same for parts (a), (b) and (c).

2. Eliminate the arbitrary function in each case. Also interpret geometrically, and compare with problem 5, p. 127.

(a) $z = f(y)$, (b) $z = f(bx - ay)$, (c) $az = cx + f(bx - ay)$, (d) $z = xf(y/x)$,
 (e) $z = f(x^2 + y^2)$.

3. Eliminate the two arbitrary functions in each case.

(a) $z = f(y) + g(x) + ye^{2x}$, (b) $z = f(y) + xg(y) + x^2$,
 (c) $z = f(4x + 5y) + g(2x - 3y)$, (d) $z = f(x) + g(3x + 5y) + 4y^2$.

4. Eliminate the arbitrary function from

$$z = e^{ax}f(x - y).$$

5. Find the partial differential equation whose complete solution is

$$z = f(x - vt) + g(x + vt)$$

where v is a constant, and f and g are arbitrary functions.

6. Prove that the arbitrary functions may be eliminated from $z = f(x) \cdot g(y)$ to give the differential equation of the second order $z \frac{\partial^2 z}{\partial x \partial y} = \frac{\partial z}{\partial x} \frac{\partial z}{\partial y}$.

7. (a) From $z = xg(y) + yf(x)$, the arbitrary functions can not be eliminated to give a second order equation. Show that the function satisfies both of the following third order equations:

$$y \frac{\partial^3 z}{\partial x^2 \partial y} = \frac{\partial^2 z}{\partial x^2} \quad \text{and} \quad x \frac{\partial^3 z}{\partial x \partial y^2} = \frac{\partial^2 z}{\partial y^2}.$$

Thus the given relation can not be the complete solution of any single partial differential equation, but is the complete solution of the system formed of the two equations just written. This may be seen from the result of part (b) of this problem.

(b) Eliminate the three functions from $z = yf(x) + xg(y) + h(y)$, and thus show that this is the complete solution of the first of the partial differential equations written in part (a). Similarly the complete solution of the second equation is $z = yf(x) + xg(y) + k(x)$.

33. Partial Differential Equations Solvable by Direct Integration. If a partial differential equation contains just one partial derivative and does not contain the dependent variable except in this derivative, it may be solved by successive integration. Since in partial differentiation, we hold some of the variables constant, in the integration which is the reverse process we also regard these variables as constant. Consequently, in place of the customary "constants" of integration, we must use arbitrary functions of the variables held fast.

For example, the equation

$$\frac{\partial^3 z}{\partial x^3} = 6x + y + 12x^2y^2 \quad (33)$$

gives on successive integration with respect to x :

$$\frac{\partial^2 z}{\partial x^2} = 3x^2 + xy + 4x^3y^2 + f(y),$$

$$\frac{\partial z}{\partial x} = x^3 + \frac{x^2y}{2} + x^4y^2 + xf(y) + g(y),$$

$$z = \frac{x^4}{4} + \frac{x^3y}{6} + \frac{x^5y^2}{5} + \frac{x^2}{2}f(y) + xg(y) + h(y).$$

Here all the integrations are with respect to x , so that y is treated as constant during each integration, and the arbitrary constant is put equal to a function of y . We may simplify the result slightly,

by putting $\frac{f(y)}{2} = k(y)$, which makes

$$z = \frac{x^4}{4} + \frac{x^3y}{6} + \frac{x^5y^2}{5} + x^2k(y) + xg(y) + h(y). \quad (34)$$

As a second example, consider

$$\frac{\partial^2 z}{\partial x \partial y} = 12x \sin(3xy). \quad (35)$$

If we integrate with respect to y , we find:

$$\frac{\partial z}{\partial x} = -4 \cos(3xy) + f(x),$$

and we may integrate this with respect to x to give:

$$z = \frac{-4 \sin(3xy)}{3y} + \int_a^x f(x) dx + g(y).$$

Thus, if we put

$$\int_a^x f(x) dx = h(x),$$

a new arbitrary function, we have as the solution of (35):

$$z = \frac{-4 \sin(3xy)}{3y} + h(x) + g(y). \quad (36)$$

If we have a system of several equations of this type, we may solve the first, and then find the restrictions on the arbitrary functions by substituting the solution in the other equations. If any inconsistent conditions arise, the system has no solution. For example, if we have

$$\frac{\partial^2 z}{\partial x^2} = 0, \quad \frac{\partial^2 z}{\partial y^2} = 0, \quad (37)$$

holding simultaneously, we find by integrating the first equation twice with respect to x ,

$$z = xf(y) + g(y),$$

and on substituting this result in the second equation,

$$xf''(y) + g''(y) = 0.$$

Since this must be true for all values of x and y , we must have

$$f''(y) = \frac{d^2 f}{dy^2} = 0 \quad \text{and} \quad g''(y) = \frac{d^2 g}{dy^2} = 0,$$

two ordinary differential equations whose solutions are

$$f(y) = ay + b, \quad g(y) = cy + d,$$

respectively, so that the solution of the system is

$$z = axy + bx + cy + d. \quad (38)$$

Note that the solution of the system (37) involves no arbitrary functions, but only arbitrary constants. If the second equation had been $\frac{\partial^2 z}{\partial y^2} = x^2$, the system would not have had any solution.

EXERCISES XX

1. Solve the following differential equations:

(a) $\frac{\partial z}{\partial x} = 0$, (b) $\frac{\partial z}{\partial y} = 0$, (c) $\frac{\partial z}{\partial x} = x^2$, (d) $\frac{\partial z}{\partial x} = xy$, (e) $\frac{\partial z}{\partial x} = \frac{x}{y}$,

(f) $\frac{\partial z}{\partial x} = 2 + \frac{x}{y}$.

2. Integrate each of the following equations:

(a) $\frac{\partial^2 z}{\partial x \partial y} = \frac{x}{y} + 6$, (b) $\frac{\partial^2 z}{\partial x^2} = 2xy - 3x$, (c) $\frac{\partial^2 z}{\partial x \partial y} = x^2 + y^2$,

(d) $\frac{\partial^2 u}{\partial x \partial t} - x^3 = e^t$, (e) $\frac{\partial^2 u}{\partial x \partial t} - x - t = 0$, (f) $\frac{\partial^3 u}{\partial x^2 \partial t} = \sin(2x + 3t)$.

3. (a) Show that the system of equations:

$$\frac{\partial z}{\partial x} = 2x + 3y, \quad \frac{\partial z}{\partial y} = 3x - 6y,$$

has as its solution $z = x^2 + 3xy - 3y^2 + c$.

(b) Show that the system

$$\frac{\partial z}{\partial x} = 3y, \quad \frac{\partial z}{\partial y} = 2x$$

has no solution.

4. Show that the solution of the system of equations

$$\frac{\partial^2 z}{\partial x^2} = 4e^{2x-y}, \quad \frac{\partial^2 z}{\partial x \partial y} = -2e^{2x-y}, \quad \frac{\partial^2 z}{\partial y^2} = e^{2x-y},$$

is $z = e^{2x-y} + ax + by + c$.

5. Solve the following equations by introducing new variables suggested by the second form in which they are written:

(a) $\frac{\partial z}{\partial x} = xyz$ or $\frac{\partial(\ln z)}{\partial x} = xy$,

$$(b) \quad z \frac{\partial z}{\partial x} = 2x - 2y \quad \text{or} \quad \frac{\partial(z^2)}{\partial x} = 4x - 4y,$$

$$(c) \quad \frac{\partial z}{\partial x} = ye^z \quad \text{or} \quad \frac{\partial(e^{-z})}{\partial x} = -y.$$

6. Solve the equation

$$y \frac{\partial^2 z}{\partial x \partial y} - 2 \frac{\partial z}{\partial x} - 18y^4 x^2 = 0,$$

by putting $\frac{\partial z}{\partial x} = p$, and regarding

$$y \frac{\partial p}{\partial y} - 2p - 18y^4 x^2 = 0$$

as an ordinary differential equation in p and y , in which x is constant.

7. (a) Show that the solution of the system:

$$Pv = \frac{\partial u}{\partial y}, \quad -Pu = \frac{\partial v}{\partial y}, \quad Qv = \frac{\partial u}{\partial x}, \quad -Qu = \frac{\partial v}{\partial x},$$

satisfies

$$\frac{\partial(u^2 + v^2)}{\partial x} = 0 \quad \text{and} \quad \frac{\partial(u^2 + v^2)}{\partial y} = 0,$$

so that $u^2 + v^2$ is constant. This suggests that we put

$$u = c \sin z, \quad v = c \cos z,$$

where c is constant, and z is a new function of x and y .

(b) Show that the expressions just written will solve all four equations of the system if

$$\frac{\partial z}{\partial x} = Q, \quad \frac{\partial z}{\partial y} = P,$$

so that $z = Qx + Py + a$, and the solution of the system is given by

$$u = c \sin(Qx + Py + a), \quad v = c \cos(Qx + Py + a).$$

8. Show that the system

$$\frac{\partial z}{\partial x} = M(x, y), \quad \frac{\partial z}{\partial y} = N(x, y),$$

has no solution unless $\frac{\partial M}{\partial y} = \frac{\partial N}{\partial x}$, and that in this case the solution is

$$z = \int_{x_0, y_0}^{x, y} M dx + N dy + c.$$

Compare problems 12, 13, pp. 123-4.

(9.) (a) If $\frac{\partial w}{\partial y} - \frac{\partial v}{\partial z} = a$, $\frac{\partial u}{\partial z} - \frac{\partial w}{\partial x} = b$, and $\frac{\partial v}{\partial x} - \frac{\partial u}{\partial y} = c$, where a, b, c

are constants, hold simultaneously, show that the solutions may be written:

$$u = f(x, y, z), \quad v = \int^x \frac{\partial f}{\partial y} dx + cx + g(y, z),$$

$$w = \int^{x, y} \left\{ \frac{\partial f}{\partial z} dx + \left[\int^x \frac{\partial^2 f}{\partial y \partial z} dx \right] dy \right\} + \int^y \frac{\partial g}{\partial z} dy - bx + ay + h(z),$$

where f , g and h are arbitrary functions of three, two, and one variable as indicated and the integrals are to be taken with only those quantities indicated in the limits treated as variable.

(b) If the right members are replaced by three functions of x , y , and z , namely $A(x, y, z)$, $B(x, y, z)$, $C(x, y, z)$, show that there are no solutions unless

$$\frac{\partial A}{\partial x} + \frac{\partial B}{\partial y} + \frac{\partial C}{\partial z} = 0,$$

and in this case the solutions may be found by a method similar to that indicated in (a).

34. First Order Equations, Linear in the Derivatives. A partial differential equation of the first order, i.e., containing no derivatives other than $\frac{\partial z}{\partial x}$ and $\frac{\partial z}{\partial y}$, and linear in these derivatives, is necessarily of the type

$$A \frac{\partial z}{\partial x} + B \frac{\partial z}{\partial y} = C, \quad (39)$$

whose interpretation was given in section 31. The solution of any such equation may be reduced to the solution of a system of ordinary differential equations by a reversal of the process used in section 32 to derive (25) from (24). In fact, the discussion there given shows that the solution is built up of surfaces made up of curves tangent to the directions A , B , C . The system of ordinary differential equations of these curves is

$$\frac{dx}{A} = \frac{dy}{B} = \frac{dz}{C}, \quad (40)$$

and if we find two first integrals of this system, in the form

$$U(x, y, z) = c_1, \quad V(x, y, z) = c_2, \quad (41)$$

they will represent two families of surfaces through the directions A , B , C . Hence

$$U(x, y, z) = f[V(x, y, z)] \quad (42)$$

or either of the equivalent forms

$$V = g(U), \quad h(U, V) = 0, \quad (43)$$

for any particular choice of the function represents a surface formed of curves of intersection of the surfaces (41). Consequently its tangent plane at any point contains the direction

A, B, C for that point, and accordingly (42) gives the solution of (39).

Independently of geometric arguments, this last fact may be checked by a direct calculation. For, to say that (41) is a pair of first integrals of (40), means that the corresponding differential relations,

$$U_x dx + U_y dy + U_z dz = 0, \quad V_x dx + V_y dy + V_z dz = 0$$

are satisfied in virtue of (40), i.e.

$$AU_x + BU_y + CU_z = 0, \quad AV_x + BV_y + CV_z = 0.$$

As these equations are identical with (27), we may deduce from them (28), which shows that (39) is essentially (25), the equation obtained by eliminating the arbitrary function from (24), or (42).

As a first illustration of the method, let us take

$$3 \frac{\partial z}{\partial x} + 2 \frac{\partial z}{\partial y} = 24. \quad (44)$$

For this equation, the system (40) becomes

$$\frac{dx}{3} = \frac{dy}{2} = \frac{dz}{24}.$$

From the first two equations, we have

$$2 dx = 3 dy, \quad 2x - 3y = c_1,$$

while from the last two, we have

$$dz = 12 dy, \quad z - 12y = c_2.$$

On identifying these with (41), we have by (42), as the solution of (44):

$$z - 12y = F(2x - 3y). \quad (45)$$

As this may be written

$$z = F(2x - 3y) - 2(2x - 3y) + 4x + 6y,$$

it becomes identical with (20) if $F(u) = f(u) + 2u$. Thus we have here reversed the process of deriving (21) from (20).

As another illustration of the method, we shall solve

$$x \frac{\partial z}{\partial x} + (3x - 2y) \frac{\partial z}{\partial y} = 0, \quad (46)$$

for which the system (40) is⁴

$$\frac{dx}{x} = \frac{dy}{3x - 2y} = \frac{dz}{0}. \quad (47)$$

It follows that

$$dz = 0, \quad z = c_1,$$

and

$$(3x - 2y) dx = x dy, \quad x^2y - x^3 = c_2,$$

where the last differential equation may be solved either as a linear equation, or as a homogeneous equation.⁵

Thus the solution of (46) may be written:

$$z = f(x^2y - x^3).$$

As a slightly more complicated example, consider

$$2y \frac{\partial z}{\partial x} - 3x \frac{\partial z}{\partial y} = 12x - 6y. \quad (48)$$

For this case, the system of ordinary differential equations is

$$\frac{dx}{2y} = \frac{dy}{-3x} = \frac{dz}{12x - 6y}. \quad (49)$$

The first pair of equations may be solved at once, and gives

$$-3x dx = 2y dy, \quad 3x^2 + 2y^2 = c_2.$$

This equation may be used to eliminate the variable y from (49). In fact, we have

$$y = \frac{\sqrt{2c_2 - 6x^2}}{2},$$

⁴ When none of the denominators are zero, the relation $\frac{a}{b} = \frac{c}{d}$ implies $ad = bc$.

When either b or d is zero, we use the second equation to define the meaning of the first. Thus, if d is known to be zero, either b or c is zero. In (47), since $3x - 2y$ is not identically zero, it follows that $dz = 0$.

⁵ $\frac{dy}{dx} + \frac{2}{x}y = 3$ admits the integrating factor $e^{\int \frac{2}{x} dx} = e^{2 \ln x} = x^2$, and the integral of $x^2 dy + 2xy dx = 3x^2$ is $x^2y = x^3 + c_2$; or after putting $y = vx$, the equation becomes $(3 - 2v) dx = v dx + x dv$, or $-3 \frac{dx}{x} = \frac{dv}{v-1}$, from which

$-3 \ln x + \ln c_2 = \ln(v-1)$, or $c_2 x^{-3} = \frac{y}{x} - 1$.

and by means of this the relation

$$y dz = (6x - 3y) dx,$$

obtained from the first and third members of (49), may be reduced to the form:

$$dz = \frac{12x dx}{\sqrt{2c_2 - 6x^2}} - 3 dx,$$

which integrates into

$$z = -2\sqrt{2c_2 - 6x^2} - 3x + c_1.$$

To find the solution from our integrals, we may either eliminate c_2 from the equation just written by using

$$c_2 = 3x^2 + 2y^2,$$

and then eliminate the constants by an assumed arbitrary relation

$$c_1 = f(c_2),$$

or regard the solution as given by these last three equations, all holding simultaneously. The result, in either case, may be reduced to the form

$$z = -4y - 3x + f(3x^2 + 2y^2) \quad (50)$$

A quicker, but less straightforward process of finding the second integral depends on the algebraic principle that, if several fractions are equal, any linear combination of the numerators divided by the same combination of the denominators yields an equal fraction.⁶ On applying this principle to (49), with multipliers 3, 4, and 1, we find:

$$\begin{aligned} \frac{dx}{2y} &= \frac{dy}{-3x} = \frac{dz}{12x - 6y} = \frac{3(dx) + 4(dy) + 1(dz)}{3(2y) + 4(-3x) + 1(12x - 6y)} \\ &= \frac{3 dx + 4 dy + dz}{0}. \end{aligned}$$

⁶ In symbols, for three fractions, if $\frac{a}{a'} = \frac{b}{b'} = \frac{c}{c'}$, then each of these $= \frac{pa + qb + rc}{pa' + qb' + rc'}$. For, putting each of the three fractions equal to k , we have $a = ka'$, $b = kb'$, $c = kc'$ and hence $pa + qb + rc = k(pa' + qb' + rc')$. This establishes the relation, including the case in which some of the denominators are zero in view of footnote ⁴ on p. 139. In this argument all the quantities may be constants or variables.

That is

$$3 dx + 4 dy + dz = 0,$$

which is an exact differential and leads to

$$3x + 4y + z = c_1.$$

This is essentially the same as the second integral found above, and when combined with the first integral gives (50). This method is only applicable when we can find by inspection a set of factors, in general functions of x, y, z but here the constants 3, 4, 1, and such that the corresponding linear combination of the denominators is zero, while that of the numerators is an exact differential expression.

EXERCISES XXI

1. Solve the differential equations:

$$(a) \frac{\partial z}{\partial x} - \frac{\partial z}{\partial y} = 0, \quad (b) x \frac{\partial z}{\partial x} - y \frac{\partial z}{\partial y} = 0, \quad (c) y \frac{\partial z}{\partial x} + x \frac{\partial z}{\partial y} = 0,$$

$$(d) ax \frac{\partial z}{\partial x} + by \frac{\partial z}{\partial y} = 0, \quad (e) ay \frac{\partial z}{\partial x} + bx \frac{\partial z}{\partial y} = 0.$$

2. Solve the differential equations of problem 5, p. 127 by the method of section 34.

3. Prove that each of the functions U and V of (41) when set equal to zero gives a solution of equation (39). Conversely, show that if two particular solutions of (39) are known, they may be used in place of the U and V of (41), and hence may be used to find the solution (42).

4. (a) Prove that if $z = U(x, y)$ is any particular solution of the differential equation $A(x, y) \frac{\partial z}{\partial x} + B(x, y) \frac{\partial z}{\partial y} = 0$, where, as indicated, the first two coefficients are functions of x and y only, and the third is zero, the general solution may be written $z = f(U)$. (b) Illustrate for the equations of problem 1.

5. Either by applying the result of 4 (a), or otherwise, verify that the solution of $a \frac{\partial z}{\partial x} + b \frac{\partial z}{\partial y} = 0$, may be written $z = f(bx - ay)$.

6. (a) Prove that if $z = V(x, y)$ is a particular solution of the differential equation $A(x, y) \frac{\partial z}{\partial x} + B(x, y) \frac{\partial z}{\partial y} = C(x, y)$, where as indicated the coefficients are functions of x and y only, and $z = U(x, y)$ is a particular solution of the corresponding equation with right member zero, as in problem 4 (a), the general solution may be written $z = f(U) + V$. (b) Show that, if the right member is a sum of several functions, as $C_1(x, y) + C_2(x, y)$, and the particular solutions obtained by considering them separately are $z = V_1(x, y)$, $z = V_2(x, y)$, then $z = V_1 + V_2$ is a particular solution corresponding to the sum, and hence the general solution may be written $z = f(U) + V_1 + V_2$.

7. (a) Find values of the constants p and q which make $z = px + qy$ a particular solution of the equation

$$5 \frac{\partial z}{\partial x} + 7 \frac{\partial z}{\partial y} = 0.$$

(b) Find a function of x alone, $X(x)$, such that $z = X(x)$ is a particular solution of the equation

$$5 \frac{\partial z}{\partial x} + 7 \frac{\partial z}{\partial y} = 15x^2.$$

(c) Find a function of y alone, $Y(y)$, such that $z = Y(y)$ is a particular solution of the equation

$$5 \frac{\partial z}{\partial x} + 7 \frac{\partial z}{\partial y} = 42y^2.$$

(d) By using parts (a), (b) and (c) of this problem, and applying the result of problem 6, find the general solution of the equation

$$5 \frac{\partial z}{\partial x} + 7 \frac{\partial z}{\partial y} = 15x^2 + 42y^2.$$

8. Solve the differential equation

$$3 \frac{\partial z}{\partial x} + 5 \frac{\partial z}{\partial y} = 9x + 10y + 4e^{3x},$$

by the method indicated in problem 7.

9. Solve the differential equations:

$$(a) \quad ax \frac{\partial z}{\partial x} + by \frac{\partial z}{\partial y} = 2ax + 3by. \quad (b) \quad ay \frac{\partial z}{\partial x} + bx \frac{\partial z}{\partial y} = 3bx + 4ay.$$

10. Solve the differential equations:

$$(a) \quad \cos y \frac{\partial z}{\partial x} + \sin x \frac{\partial z}{\partial y} = 2 \cos y, \quad (b) \quad 2x \frac{\partial z}{\partial x} + (x + 3y) \frac{\partial z}{\partial y} = x^2 + 2x^2.$$

$$11. \text{ Solve: } (a) \quad \frac{\partial z}{\partial x} + \frac{\partial z}{\partial y} = az, \quad (b) \quad e^y \frac{\partial z}{\partial x} + e^x \frac{\partial z}{\partial y} = e^x.$$

12. Solve the equation $a \frac{\partial z}{\partial x} + b \frac{\partial z}{\partial y} = ax + by + c$ by the method indicated in problem 7, and also by the general method.

13. Solve the equation $ax \frac{\partial z}{\partial x} + by \frac{\partial z}{\partial y} = axz + byz + cz$ by the general method. Why is the method of problem 7 not applicable in this case?

$$14. \text{ Solve: } (a) \quad x^2 \frac{\partial z}{\partial x} + y^2 \frac{\partial z}{\partial y} = z^2, \quad (b) \quad yz \frac{\partial z}{\partial x} + xz \frac{\partial z}{\partial y} = xy.$$

35. Linear Homogeneous Equations with Constant Coefficients.
An equation such as

$$8 \frac{\partial^2 z}{\partial x^2} + 2 \frac{\partial^2 z}{\partial x \partial y} - 15 \frac{\partial^2 z}{\partial y^2} = 0, \quad (51)$$

each of whose terms contains the independent variable just once, either itself or in a derivative, is said to be **linear**. The left member of such an expression, $L(z)$, is accordingly linear in z and its partial derivatives in the sense of section 20, and has the same characteristic property as ordinary linear differential expressions, namely:

$$L(c_1z_1 + c_2z_2) = c_1L(z_1) + c_2L(z_2). \quad (52)$$

Any properties of ordinary linear differential equations which were derived from (52) also hold for linear partial differential equations. Thus, if as in (51) the right member of the equation is zero, and $z = z_1$, $z = z_2$ are particular solutions, then $z = z_1 + z_2$ will also be a solution. Again, if the right member is not zero, and $z = z_0$ is a particular solution, the sum $z = z_0 + z_1$, where $z = z_1$ is the general solution of the equation with right member zero, will be a solution and in fact the general solution.

When, as in (51), z itself is absent and all the derivatives are of the same order, the equation is said to be **homogeneous**. For simplicity, we restrict ourselves to this case, and also require the coefficients to be constants. The solutions of equations of this type may be reduced to the solution of first order equations by a process of factoring the differential operator, analogous to that used in section 21. Thus equation (51) suggests the algebraic expression:

$$8X^2 + 2X - 15 = (2X + 3)(4X - 5). \quad (53)$$

Since it is immaterial whether we first multiply by a *constant*⁷ and then differentiate partially, or perform these operations in the reverse order, partial differential operators with constant coefficients combine like algebraic quantities. Thus (53) shows that equation (51) is equivalent to:

$$\left(2 \frac{\partial}{\partial x} + 3 \frac{\partial}{\partial y}\right) \left(4 \frac{\partial}{\partial x} - 5 \frac{\partial}{\partial y}\right) z = 0. \quad (54)$$

By problem 5, p. 141, the solution of the equation

$$\left(4 \frac{\partial}{\partial x} - 5 \frac{\partial}{\partial y}\right) z = 4 \frac{\partial z}{\partial x} - 5 \frac{\partial z}{\partial y} = 0$$

is

$$z = z_1 = f(5x + 4y).$$

⁷ Compare the statement in footnote ⁵, p. 83 and problem 8, p. 147.

This is a solution of (54), since on applying the first operator we get zero, and the second operator leaves it zero. But, as the factors of (53) could be written in reverse order, we see similarly that the solution of

$$\left(2 \frac{\partial}{\partial x} + 3 \frac{\partial}{\partial y}\right) z = 2 \frac{\partial z}{\partial x} + 3 \frac{\partial z}{\partial y} = 0,$$

or

$$z = z_2 = g(3x - 2y)$$

is also a solution of (54).

Consequently,

$$z = f(5x + 4y) + g(3x - 2y) \quad (55)$$

is a solution of (54), or (51). We suspect it to be the general solution, since it contains two arbitrary functions, and in section 32 we found that the elimination of two functions from expressions similar to (55), gave equations similar to (51).

We may verify that it actually is the general solution by effecting the transformation of variables

$$u = 5x + 4y, \quad v = 3x - 2y \quad (56)$$

suggested by the form of our tentative solution, (55). For this transformation, we have, analogous to (10) and (12),

$$\begin{aligned} \frac{\partial^2 z}{\partial x^2} &= 25 \frac{\partial^2 z}{\partial u^2} + 30 \frac{\partial^2 z}{\partial u \partial v} + 9 \frac{\partial^2 z}{\partial v^2}, \\ \frac{\partial^2 z}{\partial x \partial y} &= 20 \frac{\partial^2 z}{\partial u^2} + 2 \frac{\partial^2 z}{\partial u \partial v} - 6 \frac{\partial^2 z}{\partial v^2}, \\ \frac{\partial^2 z}{\partial y^2} &= 16 \frac{\partial^2 z}{\partial u^2} - 16 \frac{\partial^2 z}{\partial u \partial v} + 4 \frac{\partial^2 z}{\partial v^2}. \end{aligned}$$

In consequence of this,

$$8 \frac{\partial^2 z}{\partial x^2} + 2 \frac{\partial^2 z}{\partial x \partial y} - 15 \frac{\partial^2 z}{\partial y^2} = 484 \frac{\partial^2 z}{\partial u \partial v}, \quad (57)$$

and in terms of u and v , equation (51) is

$$\frac{\partial^2 z}{\partial u \partial v} = 0,$$

which may be solved by successive integration, as described in section 33. The solution is

$$z = f(u) + g(v),$$

which checks with (55) when u and v are replaced by their values in terms of x and y given in (56).

If, instead of (51), we were required to solve

$$8 \frac{\partial^2 z}{\partial x^2} + 2 \frac{\partial^2 z}{\partial x \partial y} - 15 \frac{\partial^2 z}{\partial y^2} = 96x, \quad (58)$$

we should need a particular solution, in addition to the solution of the equation with right member zero. As the right member, $96x$, involves x only, we seek a particular solution $z = X(x)$, which involves x alone. This will satisfy (58), provided:

$$8 \frac{d^2 X}{dx^2} = 96x, \quad \text{or} \quad \frac{d^2 X}{dx^2} = 12x.$$

A particular⁸ solution of this ordinary differential equation is

$$X(x) = 2x^3,$$

so that

$$z = z_0 = 2x^3$$

is a particular solution of (58). As the equation with right member zero is (51), whose solution has been found to be (55), it follows that the general solution of equation (58) is:

$$z = 2x^3 + f(5x + 4y) + g(3x - 2y). \quad (59)$$

Equation (58) might also have been solved by the transformation (56). For, this gives (57), and hence reduces equation (58) to the form

$$484 \frac{\partial^2 z}{\partial u \partial v} = \frac{96}{11} (u + 2v).$$

The solution of this equation is found by successive integration to be

$$z = 2 \left(\frac{u + 2v}{11} \right)^3 + f(u) + g(v),$$

which checks with (59), in view of (56).

⁸ Corresponding to taking the constants of integration zero in $X = 2x^3 + c_1x + c_2$. Any other choice would do as well.

To illustrate the procedure when the algebraic expression has multiple factors, we consider the equation

$$\frac{\partial^2 z}{\partial x^2} + 6 \frac{\partial^2 z}{\partial x \partial y} + 9 \frac{\partial^2 z}{\partial y^2} = 0. \quad (60)$$

This may be written

$$\left(\frac{\partial}{\partial x} + 3 \frac{\partial}{\partial y} \right) \left(\frac{\partial}{\partial x} + 3 \frac{\partial}{\partial y} \right) z = 0.$$

As the two first order operators are the same, we apparently get but one solution,

$$z = z_1 = f(3x - y).$$

However, a second solution is

$$z = z_2 = xg(3x - y),$$

since if this is operated on with

$$\frac{\partial}{\partial x} + 3 \frac{\partial}{\partial y},$$

when the operator acts on $g(3x - y)$ it gives zero, and when it acts on x , it gives a constant. Thus the result of applying the operator once is a constant times $g(3x - y)$. If, now, the operator is applied a second time, we get zero, so that $z = z_2$ is a solution of (60). This leads us to guess as the general solution of (60),

$$z = f(3x - y) + xg(3x - y). \quad (61)$$

This may be verified by effecting the transformation of variables

$$u = x, \quad v = 3x - y.$$

When the order of the derivatives is greater than the second, more than two factors may be equal. The procedure here is indicated in problem 10, p. 148.

EXERCISES XXII

1. Solve the differential equations:

$$(a) \frac{\partial^2 z}{\partial x^2} - 6 \frac{\partial^2 z}{\partial x \partial y} + 8 \frac{\partial^2 z}{\partial y^2} = 0, \quad (b) \frac{\partial^2 z}{\partial x \partial y} + 13 \frac{\partial^2 z}{\partial y^2} = 0,$$

$$(c) 4 \frac{\partial^2 z}{\partial x^2} + 7 \frac{\partial^2 z}{\partial x \partial y} + 3 \frac{\partial^2 z}{\partial y^2} = 12, \quad (d) 16 \frac{\partial^2 z}{\partial x^2} - 24 \frac{\partial^2 z}{\partial x \partial y} + 9 \frac{\partial^2 z}{\partial y^2} = 0.$$

2. (a) Show that the general solution of the equation

$$\frac{\partial^2 U}{\partial x^2} + \frac{\partial^2 U}{\partial y^2} = 0$$

is $U = f(x + iy) + g(x - iy)$.

(b) Let $w(z) = u(x, y) + iv(x, y)$, as in section 9, where w is an analytic function of $z = x + iy$. Show that, if we take $f(x + iy) = \frac{1}{2}w(x + iy)$ and $g(x - iy) = \frac{1}{2}\bar{w}(x - iy)$, the solution of part (a) reduces to $U = u(x, y)$. Similarly, if we take $f(x + iy) = -\frac{1}{2}iw(x + iy)$, and $g(x - iy) = \frac{1}{2}i\bar{w}(x - iy)$, the solution of part (a) reduces to $U = v(x, y)$, where $\bar{w}(\bar{z})$ is conjugate to $w(z)$.

3. Apply the process of problem 2 (b) to find two particular solutions of the differential equation of problem 2 (a), from each of the following analytic functions, and verify by direct differentiation.

(a) $e^z = e^x \cos y + ie^x \sin y$, (b) $z^2 = x^2 - y^2 + 2ixy$,

(c) $\log z = \frac{1}{2} \ln(x^2 + y^2) + i \tan^{-1} y/x$,

(d) $\sin z = \sin x \cosh y + i \cos x \sinh y$.

4. Show that the general solution of the wave equation

$$v^2 \frac{\partial^2 z}{\partial x^2} - \frac{\partial^2 z}{\partial t^2} = 0,$$

is $z = f(x + vt) + g(x - vt)$.

5. Solve the differential equation

$$\frac{\partial^2 z}{\partial x^2} - \frac{\partial^2 z}{\partial y^2} = 2 + 3x + 5y - x^2,$$

(a) by the tentative method, (b) by transforming to new variables.

6. Solve the equation

$$\frac{\partial^2 z}{\partial x^2} - 2 \frac{\partial^2 z}{\partial x \partial y} + \frac{\partial^2 z}{\partial y^2} = 5e^{xy} + \sin x.$$

7. Show that the system of equations:

$$Pv = \frac{\partial u}{\partial y}, \quad -Pu = \frac{\partial v}{\partial y}, \quad Qv = \frac{\partial u}{\partial x}, \quad -Qu = \frac{\partial v}{\partial x},$$

implies

$$P \frac{\partial v}{\partial x} - Q \frac{\partial v}{\partial y} = 0, \quad \text{and} \quad P \frac{\partial u}{\partial x} - Q \frac{\partial u}{\partial y} = 0,$$

so that we must have $u = f(Qx + Py)$ and $v = g(Qx + Py)$. Determine the form of f and g by substituting back in the original equations. Compare problem 7, p. 136.

8. Verify that

$$\left(x \frac{\partial}{\partial x} + \frac{\partial}{\partial y}\right) \left(\frac{\partial}{\partial x} + y \frac{\partial}{\partial y}\right) z \quad \text{and} \quad \left(\frac{\partial}{\partial x} + y \frac{\partial}{\partial y}\right) \left(x \frac{\partial}{\partial x} + \frac{\partial}{\partial y}\right) z$$

only give the same result if $z = f(x + y)$.

9. (a) Show that if p and q are constants, and h is an arbitrary function $z = (px + qy) h(3x - y)$ is a solution of equation (60) of the text, by considering the effect of the operator $\partial/\partial x + 3 \partial/\partial y$ on the two factors.

(b) Noting that

$$(px + qy)h(3x - y) = -q(3x - y)h(3x - y) + (p + 3q)xh(3x - y),$$

show that the solution of part (a) is included in the general solution (61) of the text, and express $f(u)$ and $g(u)$ in terms of $h(u)$. Illustrate for $h(u) = u^2$.

10. (a) Show that the equation

$$\left(a \frac{\partial}{\partial x} + b \frac{\partial}{\partial y}\right)^n z = 0$$

is satisfied by $x^k f(ay - bx)$ for $k = 0, 1, \dots, n - 1$. These give n distinct solutions, unless $a = 0$, in which case we may use $y^k f(ay - bx)$.

(b) Solve $\left(\frac{\partial}{\partial x}\right)^3 \left(\frac{\partial}{\partial y}\right)^3 \left(\frac{\partial}{\partial x} - \frac{\partial}{\partial y}\right) z = \frac{\partial^2 z}{\partial x^4 \partial y^3} - \frac{\partial^2 z}{\partial x^3 \partial y^4} = 0$.

36. Particular Solutions. The solution of a physical problem can not contain any constants or functions which may be given arbitrary values. When some of the conditions in the mathematical formulation of the problem take the form of differential equations, there are always enough auxiliary relations at hand to determine the arbitrary elements in the solution of these differential equations. When dealing with ordinary differential equations, where arbitrary constants appear, we usually obtain the specific solution by first finding the general solution including the arbitrary constants, and then determining these constants from the initial conditions, or boundary values. For partial differential equations, where arbitrary functions appear, the analogous process is rarely applicable, and the general solution is of little help in finding the particular solution desired. We may often succeed by first finding particular solutions of the partial differential equation which satisfy the boundary conditions, or some of them, and suitably combining these particular solutions to give the solution of the physical problem. Solutions which break up into a product of functions, each of which involves only one of the variables, are useful in this connection. We proceed to explain a method of obtaining such particular solutions for certain simple types of equations.

We begin with the equation

$$\frac{\partial^2 z}{\partial x^2} + \frac{\partial^2 z}{\partial y^2} = 0, \tag{62}$$

and seek a solution of the form

$$z = X(x) \cdot Y(y), \quad \text{or} \quad z = X \cdot Y. \tag{63}$$

We frequently omit the independent variables, and write X and Y for $X(x)$, $Y(y)$, as the notation reminds us that X is a function of x alone, and Y is a function of Y alone. We also use the primed notation for derivatives, so that

$$X' = X'(x) = \frac{dX}{dx}, \quad X'' = X''(x) = \frac{d^2X}{dx^2},$$

with similar relations for Y . With this notation, we have on differentiating (63):

$$\begin{aligned} \frac{\partial z}{\partial x} &= X' \cdot Y, & \frac{\partial^2 z}{\partial x^2} &= X'' \cdot Y, \\ \frac{\partial z}{\partial y} &= X \cdot Y', & \frac{\partial^2 z}{\partial y^2} &= X \cdot Y''. \end{aligned}$$

On inserting these values in (62), we have as a condition that z be a solution of the partial differential equation:

$$X'' \cdot Y + X \cdot Y'' = 0.$$

We may separate the variables in this equation, and write it

$$\frac{X''}{X} = -\frac{Y''}{Y}. \quad (64)$$

This separation of the variables is not always possible; our method only applies to equations capable of such separation.

We now observe that the left member of (64) does not involve y , and hence can not change when y changes. Similarly the right member does not involve x , and hence can not change when x changes. As the two members are equal, their common value can not change when either variable changes and hence must be a constant, k . Thus we may write

$$\frac{X''}{X} = k, \quad -\frac{Y''}{Y} = k,$$

two ordinary differential equations to determine X and Y . In the ordinary notation, we may write the first

$$\frac{d^2X}{dx^2} - kX = 0,$$

whose solution is found by the method of section 21 to be

$$\begin{aligned}
 X &= c_1 e^{\sqrt{k}x} + c_2 e^{-\sqrt{k}x}, \quad \text{if } k > 0, \\
 X &= c_3 \sin \sqrt{-k}x + c_4 \cos \sqrt{-k}x, \quad \text{if } k < 0, \\
 X &= c_5 x + c_6, \quad \text{if } k = 0.
 \end{aligned} \tag{65}$$

Similarly, we may solve the equation for Y , and find from

$$\frac{d^2 Y}{dy^2} + kY = 0,$$

that

$$\begin{aligned}
 Y &= c_7 \sin \sqrt{-k}y + c_8 \cos \sqrt{-k}y, \quad \text{if } k > 0, \\
 Y &= c_9 e^{\sqrt{k}y} + c_{10} e^{-\sqrt{k}y}, \quad \text{if } k < 0, \\
 Y &= c_{11}y + c_{12}, \quad \text{if } k = 0.
 \end{aligned} \tag{66}$$

The solutions of (62) required are found by combining (65) and (66) with (63). We simplify the notation by putting

$$\begin{aligned}
 \sqrt{k} &= a, \quad \text{if } k > 0 \\
 \sqrt{-k} &= b, \quad \text{if } k < 0.
 \end{aligned}$$

We then have, as the particular solutions sought:

$$\begin{aligned}
 z &= (c_1 e^{ax} + c_2 e^{-ax})(c_7 \sin ay + c_8 \cos ay), \\
 z &= (c_3 \sin bx + c_4 \cos bx)(c_9 e^{by} + c_{10} e^{-by}), \\
 z &= (c_5 x + c_6)(c_{11}y + c_{12}).
 \end{aligned} \tag{67}$$

Each of these solutions apparently contains four constants c , but really contains only three independent ones, since one of them may be divided out. For example, in the first form, if $c_1 \neq 0$, we may write

$$\begin{aligned}
 z &= (c_1 e^{ax} + c_2 e^{-ax})(c_7 \sin ay + c_8 \cos ay) \\
 &= \left(e^{ax} + \frac{c_2}{c_1} e^{-ax} \right) (c_1 c_7 \sin ay + c_1 c_8 \cos ay) \\
 &= (e^{ax} + c_2' e^{-ax})(c_7' \sin ay + c_8' \cos ay).
 \end{aligned}$$

The advantage of not replacing one of the constants c by unity is that we do not exclude the possibility of any of them being zero.

Since the equation (62) is linear, the sum of any number of solutions is again a solution. Thus if we take any number of solutions of one or more of the forms given in (67), obtained by giving different values to a , b and the constants c , their sum will be a solution of (62). We may even take an infinite number of terms,

provided the series converges in such a way that it may be differentiated termwise.

Let us next consider the simpler equation

$$2x \frac{\partial z}{\partial x} - 3y \frac{\partial z}{\partial y} = 0. \quad (68)$$

This will have a solution of the form (63),

$$z = X \cdot Y,$$

provided

$$2xX' \cdot Y - 3yX \cdot Y' = 0.$$

The variables may be separated, by writing the equation

$$2x \frac{X'}{X} = 3y \frac{Y'}{Y},$$

and the reasoning used for (64) shows that each member is a constant, k . That is,

$$2x \frac{X'}{X} = k, \quad 3y \frac{Y'}{Y} = k.$$

The first equation, in other notation, is

$$2x \frac{dX}{dx} - kX = 0,$$

which leads to

$$\frac{dX}{X} = \frac{k}{2} \frac{dx}{x}, \quad \ln X = \frac{k}{2} \ln x + c_1, \quad X = e^{c_1} x^{k/2}.$$

Similarly the second equation may be written

$$3y \frac{dY}{dy} - kY = 0,$$

and solved in the form:

$$Y = e^{c_2} y^{k/3}.$$

Thus the solution of (68) of the form sought is

$$z = X \cdot Y = e^{c_1} e^{c_2} x^{k/2} y^{k/3}$$

or

$$z = cx^{3a}y^{2a}, \quad (69)$$

where we have simplified the writing by putting $e^{c_1}e^{c_2}$ equal to a new constant c , and $k = 6a$ to avoid fractions.

To appreciate the generality of solutions built up of particular solutions, let us note that the general solution of (68) may be found by the method of section 34 to be

$$z = f(x^3y^2).$$

If $f(u)$ is an analytic function, it may be expanded in a Maclaurin series,

$$\left\{ \begin{array}{l} f(u) = A_0 + A_1u + A_2u^2 + \cdots + A_nu^n + \cdots, \\ \text{and} \\ z = A_0 + A_1x^3y^2 + A_2(x^3y^2)^2 + \cdots + A_n(x^3y^2)^n + \cdots \end{array} \right.$$

which is a series of terms of the form (69), with a taking on integral values.

We conclude our discussion with an application to a more complicated equation, namely:

$$\frac{\partial^2 u}{\partial x^2} = a \frac{\partial^2 u}{\partial t^2} + 2b \frac{\partial u}{\partial t} + cu, \quad (70)$$

where a, b, c are given real constants. Here u is a real⁹ function of x and t , so that we put for the particular solution:

$$u = X(x) \cdot T(t) = X \cdot T. \quad (71)$$

When we calculate the derivatives, we find that (70) will be satisfied provided

$$X'' \cdot T = aX \cdot T'' + 2bX \cdot T' + cX \cdot T.$$

In separating the variables, the term $cX \cdot T$ could be put on either side. If we leave it where it is, we have as the separated form:

$$\frac{X''}{X} = \frac{aT'' + 2bT' + cT}{T}.$$

As before, each side must be a constant, k , and the ordinary differential equations for X and T are

$$\frac{X''}{X} = k, \quad \frac{aT'' + 2bT' + cT}{T} = k.$$

⁹ When u is complex, the constant k in (72) may be complex, and the discussion here given of (72) requires modification. Compare problem 4, p. 160.

The first equation has been found to have the solutions given in (65). The second equation in ordinary notation is

$$a \frac{d^2 T}{dt^2} + 2b \frac{dT}{dt} + (c - k)T = 0.$$

Thus the roots of the quadratic algebraic equation associated with it are

$$\frac{-b \pm \sqrt{b^2 - ac + ak}}{a}, \quad (72)$$

which are real and different, conjugate imaginary, or real and equal, according as

$$b^2 - ac + ak >, <, \text{ or } = 0. \quad (73)$$

We abbreviate the roots in these three cases by

$$p, q; \quad s + iv, \quad s - iv; \quad r, r$$

respectively. The corresponding solutions for T may then be written:

$$\begin{aligned} T &= c_7 e^{pt} + c_8 e^{qt}, \\ T &= c_9 e^{st} \sin vt + c_{10} e^{st} \cos vt, \\ T &= c_{11} e^{rt} + c_{12} t e^{rt}. \end{aligned} \quad (74)$$

In general, the value of k for which

$$ak = ac - b^2$$

is not zero, so that one of the cases (73) will be satisfied by values of k which are positive, as well as by values which are negative and the value zero. For the other two cases (73), the sign of k will be fixed, and hence the type of solution for X given by (65) which goes with it is determined. Thus there are in general five types of solution. As an example, suppose $a = 1$, $b = 2$, $c = 12$, and let us find the form of solution for certain values of k . Here (72) reduces to

$$-2 \pm \sqrt{-8 + k}.$$

As typical values of k we take $-1, 0, 4, 8, 17$, and find for the corresponding solutions, from (71), (65) and (74):

$$\begin{aligned} u &= (c_3 \sin x + c_4 \cos x)(c_9 e^{-2t} \sin 3t + c_{10} e^{-2t} \cos 3t), \\ u &= (c_6 x + c_8)(c_9 e^{-2t} \sin 2\sqrt{2}t + c_{10} e^{-2t} \cos 2\sqrt{2}t), \end{aligned}$$

$$\begin{aligned}
 u &= (c_1 e^{2x} + c_2 e^{-2x})(c_9 e^{-2t} \sin 2t + c_{10} e^{-2t} \cos 2t), \\
 u &= (c_1 e^{2\sqrt{2}x} + c_2 e^{-2\sqrt{2}x})(c_{11} e^{-2t} + c_{12} t e^{-2t}), \\
 u &= (c_1 e^{\sqrt{17}x} + c_2 e^{-\sqrt{17}x})(c_7 e^t + c_8 e^{-5t}).
 \end{aligned}$$

EXERCISES XXIII

1. Show that the particular solutions of the equation

$$\frac{\partial^2 u}{\partial x^2} = h^2 \frac{\partial u}{\partial t},$$

of the special form $u = X(x) \cdot T(t)$ are of one of the three forms:

$$\begin{aligned}
 u &= (c_1 e^{ax} + c_2 e^{-ax})e^{a^2 t/h^2}, \\
 u &= (c_3 \sin bx + c_4 \cos bx)e^{-b^2 t/h^2}, \\
 u &= c_5 x + c_6.
 \end{aligned}$$

2. Find the particular solutions of the form $z = X(x) \cdot Y(y)$ for each of the equations:

$$\begin{aligned}
 (a) \quad \frac{\partial z}{\partial x} - \frac{\partial z}{\partial y} &= 0, & (b) \quad x \frac{\partial z}{\partial x} - y \frac{\partial z}{\partial y} &= 0, & (c) \quad 2y \frac{\partial z}{\partial x} - 5x \frac{\partial z}{\partial y} &= 0, \\
 (d) \quad e^y \frac{\partial z}{\partial x} + e^x \frac{\partial z}{\partial y} &= 0, & (e) \quad \frac{\partial z}{\partial x} + \frac{\partial z}{\partial y} &= az, & (f) \quad y^2 \frac{\partial z}{\partial x} + x^3 \frac{\partial z}{\partial y} &= 0.
 \end{aligned}$$

3. Use the method of section 36 to find particular solutions of the following equations:

$$(a) \quad \frac{\partial^2 z}{\partial x^2} - h^2 \frac{\partial^2 z}{\partial t^2} = 0, \quad (b) \quad \frac{\partial^2 z}{\partial x \partial y} - 2 \frac{\partial^2 z}{\partial y^2} = 0, \quad (c) \quad \frac{\partial^2 z}{\partial x^2} + h^2 \frac{\partial^2 z}{\partial t^2} = 0.$$

4. (a) Show that the equation

$$\frac{\partial^2 z}{\partial x^2} = 2 \frac{\partial^2 z}{\partial y^2} - 12 \frac{\partial z}{\partial y} + 4z,$$

admits five types of particular solution.

- (b) Show that the equation

$$\frac{\partial^2 z}{\partial x^2} = 2 \frac{\partial^2 z}{\partial y^2} - 12 \frac{\partial z}{\partial y} + 18z$$

admits only three types of particular solution.

5. Show that the particular solutions of the equation

$$r^2 \frac{\partial^2 u}{\partial r^2} + r \frac{\partial u}{\partial r} + \frac{\partial^2 u}{\partial \theta^2} = 0,$$

which factor into two functions, each of one variable, are

$$\begin{aligned}
 u &= (c_1 r^a + c_2 r^{-a})(c_7 \sin a\theta + c_8 \cos a\theta), \\
 u &= (c_3 \sin [b \ln r] + c_4 \cos [b \ln r])(c_9 e^{b\theta} + c_{10} e^{-b\theta}) \\
 u &= (c_4 \ln r + c_6)(c_{11} \theta + c_{12}).
 \end{aligned}$$

6. Show that the differential equation

$$\frac{\partial^2 u}{\partial r^2} + \frac{1}{r^2} \frac{\partial^2 u}{\partial \theta^2} + \frac{1}{r} \frac{\partial u}{\partial r} + a^2 u = 0,$$

has particular solutions of the form:

$$u = [c_1 J_n(ar) + c_2 Y_n(ar)] (c_3 \sin n\theta + c_4 \cos n\theta),$$

where $J_n(x)$ and $Y_n(x)$ are two independent solutions of the ordinary differential equation:

$$\frac{d^2 X}{dx^2} + \frac{1}{x} \frac{dX}{dx} + \left(1 - \frac{n^2}{x^2}\right) X = 0.$$

This is called Bessel's equation. See problem 10, p. 230, for $J_n(x)$.

7. Show that the differential equation

$$r \frac{\partial^2(ur)}{\partial r^2} + \frac{\partial}{\partial z} \left[(1 - z^2) \frac{\partial u}{\partial z} \right] = 0,$$

has particular solutions of the form:

$$u = (c_1 r^n + c_2 r^{-n-1}) [c_3 P_n(z) + c_4 Q_n(z)],$$

where $P_n(z)$ and $Q_n(z)$ are two independent solutions of the ordinary differential equation:

$$(1 - z^2) \frac{d^2 Z}{dz^2} - 2z \frac{dZ}{dz} + n(n+1)Z = 0.$$

This is known as Legendre's equation. See problem 11, p. 231 for $P_n(z)$.

CHAPTER V

THE PHYSICAL MEANING OF CERTAIN PARTIAL DIFFERENTIAL EQUATIONS

In this chapter we shall discuss some of the partial differential equations which have their origin in engineering or physical problems. We shall outline the derivation of the equations from physical principles, explaining the significance of the quantities which occur in the equations, and stating the physical laws of which the equations are the mathematical interpretation.

37. Flow of Electricity in a Cable. Consider a long, insulated cable carrying an electric current. The circuit is schematically represented in Fig. 28, where AB is the cable, and the current flows

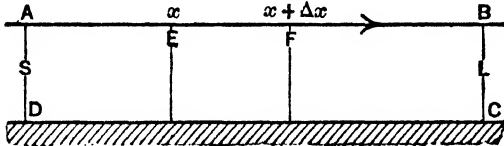

FIG. 28

through AB , then through the load L , returning through the ground CD to the element DA containing S , the source of e.m.f. causing the current to flow. The arrow indicates the direction considered as positive in measuring current and difference of potential, as in section 24. Since we are not justified in considering the insulation as perfect for a long line, we must regard the current as varying with the position of the point considered on the line, as well as with the time, t (seconds). The electromotive force will also vary with position as well as with the time. Accordingly if e (volts) is the e.m.f., and i (amperes) the current, at a point x (units of length, e.g. miles) from one end of the cable, as A , we will have:

$$e = e(x, t), \quad i = i(x, t).$$

Let the series resistance of the cable per unit of length be R (ohms/mile), and the inductance per unit of length be L (henries/mile). The loss of current due to imperfection of the insulation

is governed by the capacitance to ground per unit of length C (farads/mile) and the conductance to ground per unit of length G (mhos/mile or 1/ohm mile). While e and i change continuously with x , we may compute their rates of change by considering the action in a segment of the cable of length Δx , as EF in Fig. 28, and then letting Δx approach zero for the limiting relation.

For the segment of the cable of length Δx , considered at any time t , the drop in e.m.f., $-\Delta e$ is equal to that due to the resistance of the segment considered plus that due to its inductance. The resistance of the segment is $R \Delta x$, which causes a drop in e.m.f. $R \Delta xi$, while the inductance of the segment is $L \Delta x$, which causes a drop in e.m.f. $L \Delta x \frac{\partial i}{\partial t}$, so that we may write

$$-\Delta e = R \Delta xi \Big|_{x'} + L \Delta x \frac{\partial i}{\partial t} \Big|_{x''}. \quad (1)$$

Here x' and x'' represent intermediate points of the segment at which we evaluate i and $\frac{\partial i}{\partial t}$. While the equation (1) would only be true for a random choice of x' and x'' if the current were constant throughout the segment EF , the equation will be correct if the proper average values of i and $\frac{\partial i}{\partial t}$ are used, that is, if the intermediate points x' and x'' are properly selected. If, now, we divide both sides of equation (1) by Δx , and let Δx approach zero, since x' and x'' both lie between x and $x + \Delta x$, they will approach x , and we will have in the limit:

$$-\frac{\partial e}{\partial x} = Ri + L \frac{\partial i}{\partial t}. \quad (2)$$

This is our first relation connecting v , i , x and t .

The change in current for the segment of length Δx must be found from its action as a condenser. We recall, p. 96, that for the e.m.f. across a condenser

$$e = -\frac{1}{C} \int_a^i i dt, \quad \text{or} \quad -i = C \frac{de}{dt}.$$

Accordingly, the drop in current for the segment of length Δx , due to its capacity to ground, $C \Delta x$, is $C \Delta x \frac{\partial e}{\partial t}$. Similarly the drop in

current due to its leakage $G \Delta x$ is $G \Delta x e$. Hence we may write

$$-\Delta i = G \Delta x e \Big|_{x'''} + C \Delta x \frac{\partial e}{\partial t} \Big|_{x^{iv}}. \quad (3)$$

Here x''' and x^{iv} indicate the points at which we evaluate e and $\frac{\partial e}{\partial t}$, and the equation is correct if these points are properly selected. We note that the action of the segment as a condenser is equivalent to two elements in parallel with it, one containing capacity $C \Delta x$, small to the first order, and the other containing resistance $\frac{1}{G \Delta x}$, large to the first order. Thus the effect of either on the e.m.f. is small to the second order, which explains why we did not have to consider them in setting up (1). When we divide both sides of (3) by Δx , and take the limit as Δx approaches zero, we find:

$$-\frac{\partial i}{\partial x} = Ge + C \frac{\partial e}{\partial t}, \quad (4)$$

which is our second relation connecting v , i , x and t .

The two equations (2) and (4), together, determine v and i in terms of x and t . We may eliminate i from these equations by differentiating the equation (2) with respect to x , and eliminating $\frac{\partial i}{\partial x}$ by means of (4) as it stands, and $\frac{\partial^2 i}{\partial x \partial t}$ by means of the equation obtained from (4) by differentiation with respect to t . The resulting equation is:

$$\frac{\partial^2 e}{\partial x^2} = LC \frac{\partial^2 e}{\partial t^2} + (RC + LG) \frac{\partial e}{\partial t} + RGe, \quad (5)$$

which is a relation e must satisfy. A similar process may be used to eliminate e and its derivatives from (2) and (4), and leads to the equation:

$$\frac{\partial^2 i}{\partial x^2} = LC \frac{\partial^2 i}{\partial t^2} + (RC + LG) \frac{\partial i}{\partial t} + RGi, \quad (6)$$

which is a relation i must satisfy.

The equations (5) and (6) are identical except for the difference in meaning of the dependent variable. They are of the same type

as equation (70), p. 152, for which we determined some particular solutions.

If e is determined as the solution of (5) for given boundary or initial conditions, it is not necessary to solve (6) for i , since i may be found from (4) to within a function of t , and this function will be determined by (2) to within a constant, in general. Similar remarks apply when the rôles of e and i are interchanged. The equations (2), (4), (5) and (6) are sometimes known as the **telephone equations**, since they are used in discussing telephonic transmission.

In many applications to telegraph signaling, the leakage is small, and the term for the effect of inductance is negligible, so that we may put $G = L = 0$, and the equations take the simplified form:

$$\begin{aligned} -\frac{\partial e}{\partial x} &= Ri, \\ -\frac{\partial i}{\partial x} &= C \frac{\partial e}{\partial t}, \\ \frac{\partial^2 e}{\partial x^2} &= RC \frac{\partial e}{\partial t}, \\ \frac{\partial^2 i}{\partial x^2} &= RC \frac{\partial i}{\partial t}. \end{aligned} \tag{7}$$

These are known as the **telegraph equations**. If e is determined from the third equation and the additional conditions, i is definitely determined from the first. On the other hand, if i is determined from the fourth equation, the first two equations merely determine e to within an arbitrary constant, which must be found from the additional conditions.

For high frequencies, the terms in the time derivatives are large, and some qualitative properties of the solution may be found by neglecting the terms for the effect of leakage and resistance in comparison with them. On putting $G = R = 0$, the equations become:

$$\begin{aligned} -\frac{\partial e}{\partial x} &= L \frac{\partial i}{\partial t}, \\ -\frac{\partial i}{\partial x} &= C \frac{\partial e}{\partial t}, \\ \frac{\partial^2 e}{\partial x^2} &= LC \frac{\partial^2 e}{\partial t^2}, \\ \frac{\partial^2 i}{\partial x^2} &= LC \frac{\partial^2 i}{\partial t^2}. \end{aligned} \tag{8}$$

These are known as the **radio equations**. Here if either quantity is found from the last two equations and the additional conditions, the first two only determine the remaining quantity to within an arbitrary constant.

EXERCISES XXIV

1. Show that the general solution of the radio equations (8) may be written

$$e = f\left(x - \frac{t}{\sqrt{LC}}\right) + g\left(x + \frac{t}{\sqrt{LC}}\right),$$

$$i = \sqrt{\frac{C}{L}} f\left(x - \frac{t}{\sqrt{LC}}\right) - \sqrt{\frac{C}{L}} g\left(x + \frac{t}{\sqrt{LC}}\right),$$

by finding the general solution of the third equation, and then determining i from the first two. The additive constant which apparently comes in may be omitted since if the same constant be added to the function f , and subtracted from the function g , the value of e is unchanged, while that of i is changed by a related constant. These solutions may be interpreted as a combination of two waves, one moving to the left, and the other to the right, each with velocity $\frac{1}{\sqrt{LC}}$.

2. The so-called "distortionless line" is one for which the relation $LG = RC$ holds. (a) Show that in this case the transformation of variables

$$e = e_1 e^{-kt}, \quad i = i_1 e^{-kt}, \quad \text{where } k = \frac{R}{L} = \frac{G}{C},$$

reduces the equations (2), (4), (5), (6) to the form (8).

(b) Using part (a), and the result of problem 1, find the general solution for the distortionless line. Interpret it as a combination of waves which preserve their shape, but die down exponentially.

3. Prove that, if we make the transformation of variables $e = e_1 e^{-kt}$, $i = i_1 e^{-kt}$ equations (2) and (4) will become two new equations of essentially the same form. In particular, if $k = R/L$, the term corresponding to Ri in the new equations will be missing, while if $k = G/C$, the term corresponding to Ge in the new equations will be missing.

4. If we are dealing with a transmission line, and the impressed e.m.f. is a single sine term, after the steady state has been reached, the current and e.m.f. will involve t through a factor of this same frequency. Thus we may write

$$e = E_m(x) \sin [\omega t + \alpha(x)],$$

$$i = I_m(x) \sin [\omega t + \beta(x)].$$

We now proceed as in section 26, regarding these as the imaginary components of

$$E = F(x)e^{j\omega t}, \quad I = H(x)e^{j\omega t},$$

where the complex functions $F(x)$ and $H(x)$ are defined by

$$F(x) = E_m(x)e^{j\alpha(x)}, \quad H(x) = I_m(x)e^{j\beta(x)},$$

and E and I satisfy

$$-\frac{\partial E}{\partial x} = RI + L \frac{\partial I}{\partial t}, \quad -\frac{\partial I}{\partial x} = GE + C \frac{\partial E}{\partial t}.$$

(a) Show that these last equations will be satisfied provided that $F(x)$ and $H(x)$ satisfy:

$$-F' = (R + j\omega L)H, \quad -H' = (G + j\omega C)F.$$

(b) If we define the impedance Z and admittance to ground Y by the equations

$$Z = R + j\omega L, \quad Y = G + j\omega C,$$

and eliminate H , the result is

$$F'' = Z \cdot YF.$$

From this, and the other equations, show that the required values of E and I may be written:

$$E = K_1 \epsilon^{\sqrt{ZY}x + j\omega t} + K_2 \epsilon^{-\sqrt{ZY}x + j\omega t},$$

and

$$I = \sqrt{\frac{Y}{Z}} \left\{ -K_1 \epsilon^{\sqrt{ZY}x + j\omega t} + K_2 \epsilon^{-\sqrt{ZY}x + j\omega t} \right\},$$

where the coefficients K_1 and K_2 are suitable complex constants.

(c) Put $\sqrt{ZY} = p + jq$, $\sqrt{\frac{Y}{Z}} = P\epsilon^{j\phi}$, $K_1 = A\epsilon^{ja}$, $K_2 = B\epsilon^{jb}$ in the result of part (b), and by finding the imaginary components, show that

$$e = A\epsilon^{px} \sin(qx + \omega t + a) + B\epsilon^{-px} \sin(-qx + \omega t + b),$$

and

$$i = -PA\epsilon^{px} \sin(qx + \omega t + a + \phi) + PB\epsilon^{-px} \sin(-qx + \omega t + b + \phi).$$

5. Show that, if the value of $e = E_m(x) \sin[\omega t + \alpha(x)]$ is given for two different values of x , all the constants in the solution of problem 4 (c) will be determined. In particular, show that if $e = 0$, when $x = x_1$, and $e = E_m(0) \sin[\omega t + \alpha(0)]$ when $x = 0$, the solution for e is

$$e = D \{ \sinh p(x - x_1) \sin(\omega t + \beta) \cos q(x - x_1) \\ + \cosh p(x - x_1) \cos(\omega t + \beta) \sin q(x - x_1) \},$$

where

$$D = \frac{E_m(0)}{\sqrt{\sinh^2 px_1 + \sin^2 qx_1}}, \\ \beta = \alpha(0) - \tan^{-1}(\tan qx_1 \coth px_1).$$

In this case the solution for i is given by

$$i = -PD \{ \cosh p(x - x_1) \sin(\omega t + \beta + \phi) \cos q(x - x_1) \\ + \sinh p(x - x_1) \cos(\omega t + \beta + \phi) \sin q(x - x_1) \}.$$

6. Show that, when $R = G = 0$, the particular solutions found in problems 4 and 5 are special cases of the general solution of the radio equations found in problem 1.

7. Show that, when $LG = RC$ the particular solutions of problems 4 and 5 are special cases of the general solution for the distortionless line found in problem 2.

38. One Dimensional Heat Flow. Let us consider a long, thin rod surrounded, except at the ends with material impervious to heat. Unless all the points of the rod are at the same temperature, heat will flow along the rod. If the rod is homogeneous, and of the same cross section throughout, we may schematically regard the rod as a line, since the temperature of all the points of any one cross section will be sensibly the same.

When heat is flowing uniformly, it is found from experiment that the amount of heat flowing past any portion of the rod is proportional to the difference of temperature of the end points of the portion, to the area of the cross section and to the time of flow, and inversely proportional to the length of the portion considered. In symbols,

$$-\Delta H = \frac{KA(U_2 - U_1) \Delta t}{x_2 - x_1}, \quad (9)$$

the notation being as follows: $x(\text{cm.})$ is the distance along the rod measured from some fixed point, $U(^\circ\text{C.})$ is the temperature at any point, i.e., cross section, and the subscripts 1 and 2 refer to the end points of the portion considered. $\Delta H(\text{cal.})$ is the amount of heat flowing in the positive direction in time $\Delta t(\text{sec.})$. $A(\text{cm.}^2)$ is the area of a cross section, and $K\left(\frac{\text{cal.}}{\text{cm. sec. }^\circ\text{C.}}\right)$ is a physical constant for the material, the specific conductivity. From the way in which temperature is defined, heat flows from a higher to a lower temperature, e.g., if $x_2 > x_1$, and $U_2 > U_1$, the flow will be in the negative x direction. Thus the minus sign is necessary to keep K positive when the differences are written as in (9). We have given the units in the C.G.S. system. In the English system we should have K as $\left(\frac{\text{B.T.U.}}{\text{ft. sec. }^\circ\text{F.}}\right)$. For non-uniform flow, for a small portion of the rod, x to $x + \Delta x$, as in Fig. 29, and a small time interval the flow is approximately uniform, so that we are led to assume the limiting form of

$$\frac{\Delta H}{\Delta t} = -KA \frac{\Delta U}{\Delta x},$$

or

$$\frac{\partial H}{\partial t} = -KA \frac{\partial U}{\partial x}, \quad (10)$$

as the exact law for the rate of flow past any section, when the flow varies both with the time and the distance along the rod.

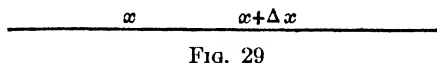

FIG. 29

We recall a second law concerning heat. When a homogeneous substance of density D $\left(\frac{\text{gm.}}{\text{cm.}^3}\right)$ and volume V (cm.^3) and hence of mass DV (gm.) has its temperature raised ΔU ($^{\circ}\text{C.}$), the amount of heat absorbed ΔH (cal.) is proportional to the mass and to the increase in temperature, so that

$$\Delta H = c DV \Delta U, \quad (11)$$

where c $\left(\frac{\text{cal.}}{\text{gm.}^{\circ}\text{C.}}\right)$ is a physical constant for the material, the specific heat. On dividing both terms of this equation by Δt , and taking the limit for Δt approaching zero, we have the corresponding law for rates:

$$\frac{\partial H}{\partial t} = c DV \frac{\partial U}{\partial t}. \quad (12)$$

Let us now consider any variable flow of heat along the rod. We consider the piece of length Δx shown in Fig. 29. The rate of flow into this segment across the section at x is, by (10)

$$-KA \left. \frac{\partial U}{\partial x} \right|_x,$$

and similarly the rate of flow out of the segment at $x + \Delta x$ is

$$-KA \left. \frac{\partial U}{\partial x} \right|_{x+\Delta x}.$$

Since the sides of the rod are insulated, the total rate of flow into the segment is

$$\frac{\partial H}{\partial t} = KA \left\{ \left. \frac{\partial U}{\partial x} \right|_{x+\Delta x} - \left. \frac{\partial U}{\partial x} \right|_x \right\}. \quad (13)$$

But, by (12) this rate may also be expressed as

$$\frac{\partial H}{\partial t} = c DA \Delta x \left. \frac{\partial U}{\partial t} \right|_{x'}, \quad (14)$$

where we have replaced V by $A \Delta x$, another expression for the volume of the piece of the rod. As the points of our segment are not all at the same temperature, (14) will only apply when an appropriate average rate of change of temperature is used. This is accounted for by taking x' a proper value of x between x and $x + \Delta x$. On equating the two expressions for the rate of gain of heat given in (13) and (14), and dividing through by $KA \Delta x$, we find:

$$\frac{cD}{K} \left. \frac{\partial U}{\partial t} \right|_{x'} = \frac{\left. \frac{\partial U}{\partial x} \right|_{x+\Delta x} - \left. \frac{\partial U}{\partial x} \right|_x}{\Delta x}.$$

On taking the limits of both sides as Δx approaches zero,¹ we find:

$$\frac{cD}{K} \frac{\partial U}{\partial t} = \frac{\partial^2 U}{\partial x^2}.$$

Here all the derivatives are evaluated at x , since $x + \Delta x$, and hence x' approaches x , so that we need no subscripts. We replace $\frac{cD}{K}$ by a new constant $h^2 \left(\frac{\text{sec.}}{\text{cm.}^2} \right)$ and write the equation for one dimensional heat flow as:

$$h^2 \frac{\partial U}{\partial t} = \frac{\partial^2 U}{\partial x^2}. \quad (15)$$

By a similar analysis (p. 178) when we have flow in three dimensions, the equation is found to be

$$h^2 \frac{\partial U}{\partial t} = \frac{\partial^2 U}{\partial x^2} + \frac{\partial^2 U}{\partial y^2} + \frac{\partial^2 U}{\partial z^2}. \quad (16)$$

Consequently, in particular, if we have steady flow in which the temperature does not vary with the time, we have:

$$\frac{\partial^2 U}{\partial x^2} + \frac{\partial^2 U}{\partial y^2} + \frac{\partial^2 U}{\partial z^2} = 0. \quad (17)$$

¹ Compare equation (2), p. 115, with $f(x, y)$ replaced by $F(x, t) = \frac{\partial U}{\partial x}$.

EXERCISES XXV

1. Using (9), compute the heat loss per day through 200 square meters of brick wall ($K = .0020$), if the wall is 30 cm. thick, the inner face is at 20°C . and the outer face at 0°C . If the heat of combustion of coal is 7000 cal./gm., and the efficiency of the furnace is 60%, how much coal must be consumed daily to compensate for this loss? Note that if a differential equation is used, its solution under the condition of the problem is one of the laws from which we derived the differential equation.

2. A refrigerator with walls 8 cm. thick has as its outside dimensions 108 cm. by 108 cm. by 58 cm. The temperature inside the box is 10°C ., and that outside the box is 25°C ., while $K = .0002$ is an average value for the walls of the box. Assuming that there is uniform flow, and neglecting the effects at the edges and corners, i.e., regarding the heat gain as that for a single wall equal in area to the surface half way between the inner and outer surfaces, of a box 100 cm. by 100 cm. by 50 cm., find the heat gain per day. If ice is used, find the number of kilograms required per day, recalling that a gram of ice, in melting, absorbs 80 calories and the specific heat of water is 1, and assuming that the water from the ice is at 5°C . when it leaves the box. If a mechanical refrigerating unit is used which pumps 50% as much heat outside the refrigerator as the same electrical energy would generate in a heating coil, in accordance with the law given in equation (4), p. 45, find the number of kilowatt hours used per day.

3. Carry out the analysis of the text for flow in a rod for which c , D , K and A though constant for each cross section, vary with x , and derive the equation for this case:

$$c(x) D(x) A(x) \frac{\partial U}{\partial t} = \frac{\partial}{\partial x} \left[K(x) A(x) \frac{\partial U}{\partial x} \right].$$

4. If a long hollow cylindrical pipe has its inner and outer surfaces each kept at temperatures constant for the surface, though varying with the time, the heat will flow along the radii, and the temperature for any cylindrical surface, concentric with the outer surface of the pipe, will be constant. For a homogeneous pipe, c , D and K are constant, while $A = 2\pi rL$, r being the radius and L the length of pipe considered. For this case derive the equation

$$(a) \quad h^2 \frac{\partial U}{\partial t} = \frac{1}{r} \frac{\partial}{\partial r} \left[r \frac{\partial U}{\partial r} \right],$$

either from first principles, or the result of problem 3. Also show that the rate of flow across any concentric cylindrical section is

$$(b) \quad \frac{\partial H}{\partial t} = -K 2\pi rL \frac{\partial U}{\partial r},$$

and hence, when the inner and outer surfaces have their temperatures fixed, so that the flow is steady, this quantity is constant.

5. For a homogeneous spherical shell, whose outer and inner surfaces are each kept at a temperature constant for the surface, though varying with the time, we have radial flow. For this case derive the equation

$$(a) \quad h^2 \frac{\partial U}{\partial t} = \frac{1}{r^2} \frac{\partial}{\partial r} \left[r^2 \frac{\partial U}{\partial r} \right],$$

for the temperature, and

$$(b) \quad \frac{\partial H}{\partial t} = -K 4\pi r^2 \frac{\partial U}{\partial r},$$

for the flow across any concentric spherical surface.

6. A steam pipe 30 cm. in diameter is insulated by a layer of concrete ($K = .0025$) 10 cm. thick. If the outer surface is at 25°C. , and the inner one at 155°C. , compute the heat loss in calories per day for 40 meters of pipe. Hint: Use problem 4 (b) to obtain an ordinary differential equation in U and r .

7. A hollow lead sphere whose inner and outer diameters are 2 cm. and 8 cm., respectively is heated electrically by a resistance coil of 10 ohms placed inside. At what rate must heat be supplied to keep the inner surface at a temperature 15°C. higher than that of the outside, if K is .0827 for lead? Recalling the law given in equation (4), p. 45, compute the e.m.f. necessary to maintain the given temperature difference. Hint: Use problem 5 (b) to obtain an ordinary differential equation in U and r .

8. A wire of resistance .1 ohm per centimeter length is embedded along the axis of a cylindrical cement tube of radii .05 and 1.0 cm. respectively. An electric current of 5 amperes is found to keep a steady difference of temperature of 124°C. between the inner and outer surfaces of the tube. What is K for cement? See problems 4 (b), 6 and 7.

9. A spherical shell for which $K = .0025$ of inner radius 24 cm. and outer radius 26 cm. has its inner surface 40°C. higher than its outer one. Compute the rate in calories per second at which heat must be supplied: (a) By using problem 5 (b) to obtain an ordinary differential equation in U and r . (b) By considering the loss as equal to that for a single wall equal in area to the mid-surface of the shell, a sphere of radius 25 cm.

10. A long cylindrical shell of material for which $K = .003$ of inner radius 50 cm. and outer radius 52 cm. has its inner surface 50°C. higher than its outer one. Compute the rate in calories per second, per meter length of the shell, (a) by using problem 4 (b) to obtain an ordinary differential equation and (b) by considering the loss as equal to that for a single wall equal in area to the mid-surface of the shell, a cylinder of radius 51 cm.

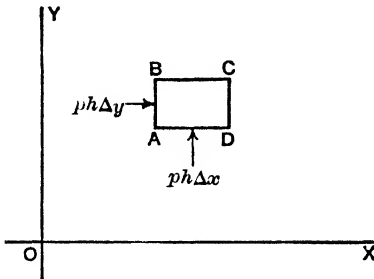

FIG. 30

39. Steady, Irrotational Motion of an Incompressible Fluid in Two Dimensions.

Consider a layer of fluid, moving between two planes distant h (ft.) apart, in such a way that every particle moves in a plane parallel to the bounding planes, and the motion is the same in each of these parallel planes. We may

then restrict our attention to any one plane, and use x and y coordinates in this plane, as in Fig. 30.

We consider the motion to be caused by external forces, proportional to the mass considered, like the force of gravitation, and the internal pressure. Let the fluid have density D $\left(\frac{\text{lbs.}}{\text{ft.}^3}\right)$, let the pressure at any point on a surface perpendicular to the xy plane be p $\left(\frac{\text{lbs.}}{\text{ft.}^2}\right)$, and let the forces, per unit mass, have components X and Y $\left(\frac{\text{ft.}}{\text{sec.}^2}\right)$. Thus X and Y are the components of the acceleration that would be caused by the external forces, for a unit mass. Let u and v $\left(\frac{\text{ft.}}{\text{sec.}}\right)$ be the components of the velocity. These quantities D , p , X , Y , u and v will in general all be functions of x , y (ft.) and t (sec.), the time.

Now consider a small rectangle, with sides parallel to the axes of length Δx and Δy respectively. The volume of fluid on this rectangle is $h \Delta x \Delta y$, and its mass is $\frac{D}{g} h \Delta x \Delta y$. The external force on this mass in the x direction is $\frac{XD}{g} h \Delta x \Delta y$. The pressure on the face AB is $ph \Delta y$, where p is evaluated at a suitable point in the face, and similarly that on CD is $-ph \Delta y$, where p is evaluated at a suitable point in that face. These are the only forces in the x direction, so that on expressing that mass times acceleration equals force, we have

$$\left[\frac{D}{g} h \Delta x \Delta y \frac{du}{dt}\right]_{x', y'} = \left[\frac{XD}{g} h \Delta x \Delta y\right]_{x'', y''} + [ph \Delta y]_{x, y'''} - [ph \Delta y]_{x+\Delta x, y^{iv}}.$$

In this equation, x' , y' and x'' , y'' must be properly selected intermediate points, to give the correct average value of $\left(D \frac{du}{dt}\right)$ and (XD) , which actually vary throughout the rectangle. If y''' and y^{iv} are each taken as $y + \frac{\Delta y}{2}$, the error will be of higher order than the terms written, and we shall use these values in obtaining the limiting relations. If we divide both sides of the equation just written by $\left[\frac{Dh \Delta x \Delta y}{g}\right]_{x, y}$, and then take the limit as Δx and Δy

each approach zero, the result is:

$$\frac{du}{dt} = X - \frac{g}{D} \frac{\partial p}{\partial x}. \quad (18)$$

The last term results from the fact that

$$\lim_{\Delta x=0} \frac{p\left(x + \Delta x, y + \frac{\Delta y}{2}\right) - p\left(x, y + \frac{\Delta y}{2}\right)}{\Delta x} = \left[\frac{\partial p}{\partial x}\right]_{x, y + \frac{\Delta y}{2}},$$

by equation (2), p. 115.

In an entirely similar manner, we find the equation

$$\frac{dv}{dt} = Y - \frac{g}{D} \frac{\partial p}{\partial y}. \quad (19)$$

In computing the time derivatives of the velocities in the left members of (18) and (19), we must compute u and v for a particular particle, and follow this particle in its motion. Since, in this motion, the time rate of change of x and y are, respectively u and v , by definition, we have²

$$\begin{aligned} \frac{du}{dt} &= \frac{\partial u}{\partial x} u + \frac{\partial u}{\partial y} v + \frac{\partial u}{\partial t}, \\ \frac{dv}{dt} &= \frac{\partial v}{\partial x} u + \frac{\partial v}{\partial y} v + \frac{\partial v}{\partial t}. \end{aligned} \quad (20)$$

A third equation involving our variables results from the conservation of matter. The rate at which fluid enters the face AB is $[Duh \Delta y]_{x, y'}$, and the rate at which fluid enters the face CD is $[-Duh \Delta y]_{x+\Delta x, y''}$. Similar expressions hold for the other two faces. Thus the total rate for the rectangle is:

$$-h \Delta x \Delta y \left[\frac{[Du]_{x+\Delta x, y''} - [Du]_{x, y'}}{\Delta x} + \frac{[Dv]_{x'', y+\Delta y} - [Dv]_{x', y}}{\Delta y} \right].$$

This rate may also be measured from the change in density, as

$$\frac{\partial D}{\partial t} h \Delta x \Delta y.$$

² By (7) p. 118 extended to three variables, or problem 8 (d), p. 122, we have $\frac{dz}{dt} = \frac{\partial z}{\partial x} \frac{dx}{dt} + \frac{\partial z}{\partial y} \frac{dy}{dt} + \frac{\partial z}{\partial t}$. Here z is a function of x , y and t , and the derivatives $\frac{dx}{dt}$ and $\frac{dy}{dt}$ are computed on the same basis that made x and y functions of t , in computing $\frac{dz}{dt}$, in this case the assumption that we move with the particle.

If we equate these two expressions for the rate at which fluid is entering the volume over the rectangle, divide by $h \Delta x \Delta y$, and let Δx and Δy approach zero we find:

$$\frac{\partial D}{\partial t} = - \frac{\partial(Du)}{\partial x} - \frac{\partial(Dv)}{\partial y}, \quad (21)$$

where we have taken $y' = y'' = y + \frac{\Delta y}{2}$, $x' = x'' = x + \frac{\Delta x}{2}$, which does not affect the limiting relation.

If the relation between p and D were known, e.g., for a perfect gas, by Boyle's law $p = kD$, one of these quantities could be eliminated, and equations (18) and (19), simplified by (20), together with (21) would give three equations for the determination of the three functions p or D , u and v .

Let us simplify the situation by considering an incompressible fluid, so that D is constant, in steady motion, so that none of the quantities depend on the time, and the partial time derivatives are all zero. We also assume that the external force field is conservative, so that, by problem 14, p. 124, we may write

$$X = \frac{\partial U}{\partial x}, \quad Y = \frac{\partial U}{\partial y}. \quad (22)$$

Then, using (20) and (22), and omitting the t partial derivatives, we may write (18) and (19) in the form:

$$\begin{aligned} u \frac{\partial u}{\partial x} + v \frac{\partial u}{\partial y} &= \frac{\partial U}{\partial x} - \frac{g}{D} \frac{\partial p}{\partial x}, \\ u \frac{\partial v}{\partial x} + v \frac{\partial v}{\partial y} &= \frac{\partial U}{\partial y} - \frac{g}{D} \frac{\partial p}{\partial y}. \end{aligned} \quad (23)$$

For this case, equation (21) takes the form:

$$\frac{\partial u}{\partial x} + \frac{\partial v}{\partial y} = 0. \quad (24)$$

The quantity

$$\omega = \frac{1}{2} \left(\frac{\partial v}{\partial x} - \frac{\partial u}{\partial y} \right), \quad (25)$$

is called the **rotation** of the fluid.³ In the case of steady motion of an incompressible fluid under conservative forces, i.e., when equa-

³ See problem 3, p. 171 for the physical interpretation of this quantity, and problem 4, p. 171 for a proof of the statement which follows.

tions (23) and (24) hold, the rotation is constant along each stream line. The **stream lines** are the curves whose tangent direction at any point is the same as the velocity of the fluid at the point, and for steady motion they coincide with the paths of the individual particles. In consequence of this, if the rotation is constant along any curve crossing all the stream lines, it will be constant everywhere in the region considered. In particular, if it is zero along any such curve, it will be zero everywhere, and the motion is said to be **irrotational**. In this case, we have

$$\frac{\partial v}{\partial x} = \frac{\partial u}{\partial y}, \quad (26)$$

so that, by problem 12, p. 123,

$$u \, dx + v \, dy$$

is the exact differential of a function ϕ , and

$$u = \frac{\partial \phi}{\partial x}, \quad v = \frac{\partial \phi}{\partial y}. \quad (27)$$

This function ϕ is called the **velocity potential**. It follows from equation (24) that the velocity potential ϕ satisfies the equation

$$\frac{\partial^2 \phi}{\partial x^2} + \frac{\partial^2 \phi}{\partial y^2} = 0. \quad (28)$$

In problem 2, p. 147 it was shown that this equation may be satisfied by taking for ϕ the real (or imaginary) component of any analytic function of the complex variable $z = x + iy$.

EXERCISES XXVI

1. Show that, when the motion is irrotational, so that (26) holds, equations (23) are equivalent to:

$$\begin{aligned} \frac{\partial}{\partial x} \left(\frac{u^2 + v^2}{2} + \frac{gp}{D} - U \right) &= 0, \\ \frac{\partial}{\partial y} \left(\frac{u^2 + v^2}{2} + \frac{gp}{D} - U \right) &= 0, \end{aligned}$$

and from these deduce the integral

$$\frac{u^2 + v^2}{2} + \frac{gp}{D} - U = c.$$

2. If $\phi(x, y)$ is the velocity potential, satisfying equations (27), show that the curves $\phi(x, y) = \text{constant}$ intersect the stream lines at right angles. From

this fact, and the discussion of section 9, show that, if the analytic function $w(z) = \phi(x, y) + i\psi(x, y)$, the curves $\psi(x, y) = \text{constant}$ are the stream lines for the motion.

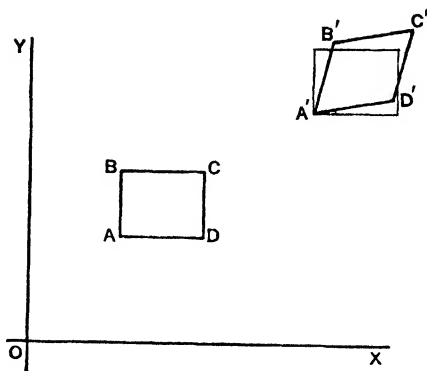

FIG. 31

3. Consider the rectangle with sides Δx and Δy of Fig. 31. The co-ordinates of its vertices A, D, C, B are, respectively:

$$x, y; \quad x + \Delta x, y; \quad x + \Delta x, y + \Delta y; \quad x, y + \Delta y.$$

After an interval Δt , its vertices are at the points whose co-ordinates are

$$\begin{aligned} &x + u \Delta t, y + v \Delta t; \quad x + \Delta x + (u + \Delta_x u) \Delta t, y + (v + \Delta_x v) \Delta t; \\ &x + \Delta x + (u + \Delta_x u + \Delta_y u) \Delta t, y + \Delta y + (v + \Delta_x v + \Delta_y v) \Delta t; \\ &x + (u + \Delta_y u) \Delta t, y + \Delta y + (v + \Delta_y v) \Delta t. \end{aligned}$$

Find the angle between the old and new positions of the sides AD and AB , and the quotient of these angles by Δt . Show that the limiting values, or angular velocities of these sides are, respectively, $\frac{\partial v}{\partial x}$ and $-\frac{\partial u}{\partial y}$, so that the average

$$\text{of these is } = \frac{1}{2} \left(\frac{\partial v}{\partial x} - \frac{\partial u}{\partial y} \right).$$

4. We may eliminate p from equations (23) by differentiating the first with respect to y , the second with respect to x , and subtracting. Show that, in view of (24) and (25), the resulting relation may be written

$$u \frac{\partial \omega}{\partial x} + v \frac{\partial \omega}{\partial y} = 0.$$

Since, as in (20), when we move along a stream line,

$$\frac{d\omega}{dt} = \frac{\partial \omega}{\partial x} u + \frac{\partial \omega}{\partial y} v,$$

with no partial derivative with respect to the time since we have steady motion, the equation just written expresses the fact that ω does not change for motion along a stream line, i.e., is constant.

5. Show that equations (23) and (24) may be satisfied by taking $u = -\alpha y$, $v = \alpha x$, $p = \frac{D\alpha^2}{2g}(x^2 + y^2)$, if $U = 0$. In this case the velocities are like those of a rigid body rotating with angular velocity α . Calculate the rotation, and show that it is equal to α at all points.

6. When there is no external force acting, we may take U equal to zero, and the integral of problem 1 is

$$\frac{u^2 + v^2}{2} + \frac{gp}{D} = c.$$

Show that, if $w(z) = w(x + iy) = \phi(x, y) + i\psi(x, y)$ as in problem 2, this integral may be written

$$p = -\frac{D}{2g} \left| \frac{dw}{dz} \right|^2 - \frac{cD}{g}.$$

7. If the function $w(z)$ of problem 6 is $\alpha \log_e z$, and the pressure is zero at infinity, find the pressure as a function of x and y .

8. Compute the pressure when the function of problem 6 is (a) $w = z^{1/2}$, (b) $w = z^{2/3}$, (c) $w = z + e^z$, (d) $w = z + 1/z$, (e) $w = z + 1/z + i \log_e z$. For the type of fluid motion in each case, compare problems 1, 2, 4, 5, 6, p. 38.

40. Vibration Problems. Consider a tightly stretched string, vibrating in a horizontal plane.⁴ Let its weight per unit of length be $D \left(\frac{\text{lbs.}}{\text{ft.}} \right)$, and let it be subjected to a tension, T (lbs.). Let x (ft.) be the co-ordinate along the equilibrium position of the string, the x -axis in Fig. 32, and let y (ft.) be the distance from a

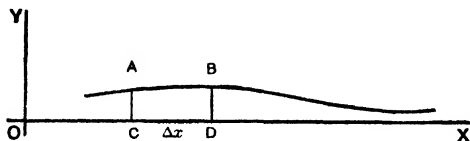

FIG. 32

point on the string to its corresponding equilibrium position. As we are only considering small vibrations, we may neglect the motion parallel to the x -axis, caused by the new position not being a straight line, and consider the mass of the segment of the string AB as equal to that of CD , namely $\frac{D}{g} \Delta x$. Thus, for the segment, the product of mass times acceleration parallel to the y -axis is:

$$\frac{D}{g} \Delta x \left. \frac{\partial^2 y}{\partial t^2} \right|_x. \quad (29)$$

⁴ The plane need not be horizontal, if the tension is so great compared with the weight that the effect of gravity is negligible.

The forces on the segment are due to the tension at the ends. These are along the tangent to the curve giving the position of the string, whose inclination to the x -axis has a tangent $\frac{\partial y}{\partial x}$. As this inclination is small, we may neglect the difference between the sine and the tangent, and regard the sine as $\frac{\partial y}{\partial x}$. Then the y components of tension at A and B are, respectively,

$$-T \left. \frac{\partial y}{\partial x} \right|_x \quad \text{and} \quad T \left. \frac{\partial y}{\partial x} \right|_{x+\Delta x},$$

so that the resultant force parallel to the y -axis is:

$$T \left(\left. \frac{\partial y}{\partial x} \right|_{x+\Delta x} - \left. \frac{\partial y}{\partial x} \right|_x \right). \quad (30)$$

Since the y components of force and of mass times acceleration are equal, we may equate (29) and (30). If we divide through by Δx , and take the limit as Δx approaches zero, $x + \Delta x$, and the intermediate point x' will both approach x , and we have in the limit:

$$\frac{D}{g} \frac{\partial^2 y}{\partial t^2} = T \frac{\partial^2 y}{\partial x^2}. \quad (31)$$

This is the equation for a vibrating string, when $\left(\frac{\partial y}{\partial x}\right)^2$ is small compared with unity, since our various approximations amount to a replacement of the factor $\sqrt{1 + \left(\frac{\partial y}{\partial x}\right)^2}$, the cosine of the slope angle, by unity in certain places.

EXERCISES XXVII

1. Show that the general solution of equation (31) may be written

$$y = f\left(x + \sqrt{\frac{Tg}{D}} t\right) + g\left(x - \sqrt{\frac{Tg}{D}} t\right),$$

and interpret this as two wave motions, travelling in opposite directions, with velocity $\sqrt{\frac{Tg}{D}}$.

2. When the string is fixed at both ends, the fundamental vibration is given by the solution

$$y = \sin \frac{\pi x}{a} \sin \left[\sqrt{\frac{Tg}{D}} \frac{\pi t}{a} \right],$$

where a (ft.) is the length of the string. Verify that this is a solution of the equation (31). Show that the frequency is $\frac{1}{2a} \sqrt{\frac{Tg}{D}}$, so that the pitch of the fundamental note for the string of a musical instrument is proportional to the square root of the tension, and inversely as the length and the square root of the density.

3. Show that, if the density and tension vary with the position along the string, the equation is

$$\frac{D(x)}{g} \frac{\partial^2 y}{\partial t^2} = \frac{\partial}{\partial x} \left[T(x) \frac{\partial y}{\partial x} \right].$$

4. Consider a vibrating, stretched membrane such as a drumhead, subject to a tension T $\left(\frac{\text{lbs.}}{\text{ft.}}\right)$ assumed to be the same in all directions, and at all points of the membrane. Let D $\left(\frac{\text{lbs.}}{\text{ft.}^2}\right)$ be the weight per unit area. By considering the forces and accelerations on a small rectangle of the membrane, parallel to the z -axis, drawn perpendicular to the equilibrium position of the membrane, deduce the equation:

$$T \left(\frac{\partial^2 z}{\partial x^2} + \frac{\partial^2 z}{\partial y^2} \right) = \frac{D}{g} \frac{\partial^2 z}{\partial t^2}.$$

5. When a long, elastic rod is vibrating longitudinally⁵ we have to deal with

⁵ An entirely different type of equation results from transverse vibrations. Here, for equilibrium under small deflections, the equation is $EI \frac{d^2 y}{dx^2} = M$, where E $\left(\frac{\text{lbs.}}{\text{ft.}^2}\right)$ is the modulus of elasticity in force per unit area per percentage extension, I (ft.⁴) is the moment of inertia of the area of cross section about a horizontal transverse axis through the center of gravity, and M is the bending moment about a horizontal transverse axis in the section x due to the load beyond x . When the load per unit length is F $\left(\frac{\text{lbs.}}{\text{ft.}}\right)$,

$$M = \int_x^a (u - x) F(u) du, \quad \frac{dM}{dx} = - \int_x^a F(u) du, \quad \frac{d^2 M}{dx^2} = F(x),$$

so that the equation in terms of the load is $EI \frac{d^4 y}{dx^4} = F(x)$. For small vibrations, the effect of angular acceleration is negligible, and the equation is obtained from the static one by deducting from the load per unit length that part which overcomes mass times acceleration per unit length, or $\frac{DA}{g} \frac{\partial^2 y}{\partial t^2}$, where D $\left(\frac{\text{lbs.}}{\text{ft.}^3}\right)$ is weight per unit volume, and A (ft.²) is area of cross section. Thus the equation is

$$EI \frac{\partial^4 y}{\partial x^4} = F(x) - \frac{DA}{g} \frac{\partial^2 y}{\partial t^2},$$

or the corresponding equation without the term $F(x)$, for deviations from the equilibrium position.

the displacement u (ft.) of an element originally at distance x (ft.) from one end of the rod. If $D \left(\frac{\text{lbs.}}{\text{ft.}^3} \right)$ is the weight per unit volume, A (ft.²) is the area of cross section of the rod, the mass times acceleration for a small segment is $\frac{DA}{g} \Delta x \frac{\partial^2 u}{\partial t^2} \Big|_x$. The forces on the segment are the elastic forces on the cross sections which bound it. But, the force on any cross section is $EA \frac{\partial u}{\partial x} \Big|_x$, where $E \left(\frac{\text{lbs.}}{\text{ft.}^2} \right)$ is the modulus of elasticity in force per unit area per percentage of extension, and $\frac{\partial u}{\partial x}$ is the percentage extension at the point. This is the force in the positive x direction on the part to the left of the section since the derivative is positive when the rod is under tension. By equating the forces to the mass times the acceleration, and taking the limit, deduce the equation

$$E \frac{\partial^2 u}{\partial x^2} = \frac{D}{g} \frac{\partial^2 u}{\partial t^2}.$$

41. Heat Flow in Space, Curvilinear Co-ordinates. For problems in three space, it is often desirable to introduce other types of co-ordinates than the Cartesian co-ordinates x, y, z based on three sets of parallel planes. We may use any three systems of surfaces

$$\alpha(x, y, z) = c_1, \quad \beta(x, y, z) = c_2, \quad \gamma(x, y, z) = c_3, \quad (32)$$

such that, in the part of space in which we are interested, just one surface of each type passes through each point, and three surfaces, one of each type, intersect in just one point in the part of space in question.

In the usual applications, we take a **triple orthogonal system** of surfaces, that is, surfaces such that any surface of one of the families cuts those surfaces of the other two families which intersect it at right angles. In that case, if several surfaces are drawn for each family corresponding to values of the constants which differ by small amounts, the portion of space under consideration will be divided into a network of small "curvilinear cubes," similar to the "curvilinear square" networks for the plane found in section 9.

A typical such "curvilinear cube" is shown in Fig. 33. It is bounded by the surfaces $c_1 = \alpha, \alpha + \Delta\alpha, c_2 = \beta, \beta + \Delta\beta, c_3 = \gamma, \gamma + \Delta\gamma$, so that the curvilinear co-ordinates of A are (α, β, γ) and of E are $(\alpha + \Delta\alpha, \beta + \Delta\beta, \gamma + \Delta\gamma)$. To the first order the edges of this cube will be $h_1 \Delta\alpha, h_2 \Delta\beta$ and $h_3 \Delta\gamma$ where $h_1(\alpha, \beta, \gamma), h_2(\alpha, \beta, \gamma), h_3(\alpha, \beta, \gamma)$ are three functions of position. These func-

tions, which give the relation between differentials of distance, and differentials of the curvilinear co-ordinates could be changed without changing the three families of surfaces, by replacing the functions of (32) by constants times these functions, or in fact replacing each by any function of itself.

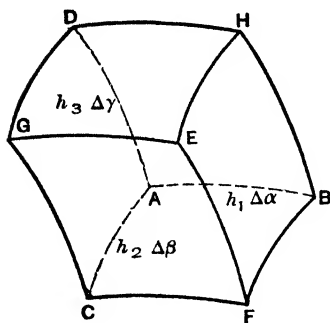

FIG. 33

Let us now apply the argument of section 38 to derive the equation governing the flow of heat in three dimensions, when we use orthogonal, curvilinear co-ordinates. We assume that the temperature $U(\alpha, \beta, \gamma, t)$ is a function of the three co-ordinates of position and of the time, and shall compute the rate of flow of heat into the cube in terms

of the temperature. We may compute the flow into the cube through the face $ACGD$, by equation (10), and will only make an error of higher order than the terms written, if we regard the area of the face as the same as that of a rectangle with sides $h_2 \Delta\beta$ and $h_3 \Delta\gamma$, and calculate the rate of change of temperature, as well as h_2 and h_3 for the values $\alpha, \beta' = \beta + \frac{\Delta\beta}{2}, \gamma' = \gamma + \frac{\Delta\gamma}{2}$. Thus the rate is

$$-K \left(h_2 h_3 \Delta\beta \Delta\gamma \frac{1}{h_1} \frac{\partial U}{\partial \alpha} \right)_{\alpha, \beta', \gamma'}$$

The term $\frac{1}{h_1} \frac{\partial U}{\partial \alpha}$ is the limit of $\frac{\Delta U}{h_1 \Delta\alpha}$, or the rate of change of temperature with respect to distance perpendicular to the surface, required in the equation (10). Similarly, the rate of flow out through the opposite face $BFEH$ is:

$$-K \left(h_2 h_3 \Delta\beta \Delta\gamma \frac{1}{h_1} \frac{\partial U}{\partial \alpha} \right)_{\alpha + \Delta\alpha, \beta', \gamma'}$$

to within a term of higher order than that written. Thus the rate of gain of heat due to these two faces may be written:

$$K \Delta\alpha \Delta\beta \Delta\gamma \frac{\left[\frac{h_2 h_3}{h_1} \frac{\partial U}{\partial \alpha} \right]_{\alpha + \Delta\alpha, \beta', \gamma'} - \left[\frac{h_2 h_3}{h_1} \frac{\partial U}{\partial \alpha} \right]_{\alpha, \beta', \gamma'}}{\Delta\alpha}, \quad (33)$$

where we have inserted the factor $\Delta\alpha$ in both numerator and denominator.

In a similar manner, we may find two analogous expressions for the rate of gain of heat due to the other two pairs of opposite faces, namely

$$K \Delta\alpha \Delta\beta \Delta\gamma \frac{\left[\frac{h_3 h_1}{h_2} \frac{\partial U}{\partial \beta} \right]_{\alpha', \beta + \Delta\beta, \gamma'} - \left[\frac{h_3 h_1}{h_2} \frac{\partial U}{\partial \beta} \right]_{\alpha', \beta, \gamma'}}{\Delta\beta}, \quad (34)$$

and

$$K \Delta\alpha \Delta\beta \Delta\gamma \frac{\left[\frac{h_1 h_2}{h_3} \frac{\partial U}{\partial \gamma} \right]_{\alpha', \beta', \gamma + \Delta\gamma} - \left[\frac{h_1 h_2}{h_3} \frac{\partial U}{\partial \gamma} \right]_{\alpha', \beta', \gamma}}{\Delta\gamma}. \quad (35)$$

But we may also measure the rate of gain of heat for the cube by (12). Since the volume is, to within a term of higher order than that written, equivalent to that of a rectangular parallelepiped with edges $h_1 \Delta\alpha$, $h_2 \Delta\beta$ and $h_3 \Delta\gamma$, we have for the rate of gain, by (12)

$$cD \left[h_1 h_2 h_3 \Delta\alpha \Delta\beta \Delta\gamma \frac{\partial U}{\partial t} \right]_{\alpha'', \beta'', \gamma''}. \quad (36)$$

If, now, we equate (36) to the sum of (33), (34) and (35), divide through by $K \Delta\alpha \Delta\beta \Delta\gamma$, and take the limit as $\Delta\alpha$, $\Delta\beta$, and $\Delta\gamma$ all approach zero, we find:

$$\frac{cD}{K} h_1 h_2 h_3 \frac{\partial U}{\partial t} = \frac{\partial}{\partial \alpha} \left(\frac{h_2 h_3}{h_1} \frac{\partial U}{\partial \alpha} \right) + \frac{\partial}{\partial \beta} \left(\frac{h_3 h_1}{h_2} \frac{\partial U}{\partial \beta} \right) + \frac{\partial}{\partial \gamma} \left(\frac{h_1 h_2}{h_3} \frac{\partial U}{\partial \gamma} \right). \quad (37)$$

If we divide through by $h_1 h_2 h_3$, and replace $\frac{cD}{K}$ by h^2 , the equation takes the form:

$$h^2 \frac{\partial U}{\partial t} = \frac{1}{h_1 h_2 h_3} \left\{ \frac{\partial}{\partial \alpha} \left(\frac{h_2 h_3}{h_1} \frac{\partial U}{\partial \alpha} \right) + \frac{\partial}{\partial \beta} \left(\frac{h_3 h_1}{h_2} \frac{\partial U}{\partial \beta} \right) + \frac{\partial}{\partial \gamma} \left(\frac{h_1 h_2}{h_3} \frac{\partial U}{\partial \gamma} \right) \right\}. \quad (38)$$

In order to apply this equation to any particular system, we must know the functions h_1 , h_2 , h_3 for the particular system of co-ordinates used. They can usually be seen from geometrical considerations in the simpler cases, and may always be found analytically from the formula for arc length. For, in orthogonal curvilinear co-ordinates, the expression for the differential of arc length takes the form

$$ds^2 = h_1^2 d\alpha^2 + h_2^2 d\beta^2 + h_3^2 d\gamma^2. \quad (39)$$

This may be verified from Fig. 33, since the distance Δs is that between the point A with co-ordinates α, β, γ , and the point E , with co-ordinates $\alpha + \Delta\alpha, \beta + \Delta\beta, \gamma + \Delta\gamma$, which is to the order considered the diagonal of a rectangular parallelepiped with edges $h_1 \Delta\alpha, h_2 \Delta\beta, h_3 \Delta\gamma$.

For ordinary rectangular co-ordinates, we have $h_1 = 1, h_2 = 1, h_3 = 1$, either from a glance at Fig. 34, or from the relation

$$ds^2 = dx^2 + dy^2 + dz^2. \quad (40)$$

Thus, for this case, the equation (38) reduces to:

$$h^2 \frac{\partial U}{\partial t} = \frac{\partial^2 U}{\partial x^2} + \frac{\partial^2 U}{\partial y^2} + \frac{\partial^2 U}{\partial z^2}. \quad (41)$$

Cylindrical co-ordinates in space are formed by using plane polar co-ordinates, r, θ in place of x and y , and retaining z . The arc element is here

$$ds^2 = dr^2 + r^2 d\theta^2 + dz^2, \quad (42)$$

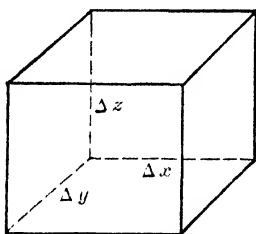

FIG. 34

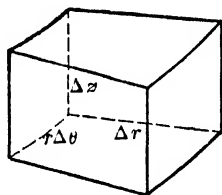

FIG. 35

and either from this or Fig. 35 we have $h_1 = 1, h_2 = r, h_3 = 1$. Thus the equation (38) becomes:

$$h^2 \frac{\partial U}{\partial t} = \frac{1}{r} \frac{\partial}{\partial r} \left(r \frac{\partial U}{\partial r} \right) + \frac{1}{r^2} \frac{\partial^2 U}{\partial \theta^2} + \frac{\partial^2 U}{\partial z^2}. \quad (43)$$

or

$$h^2 \frac{\partial U}{\partial t} = \frac{\partial^2 U}{\partial r^2} + \frac{1}{r} \frac{\partial U}{\partial r} + \frac{1}{r^2} \frac{\partial^2 U}{\partial \theta^2} + \frac{\partial^2 U}{\partial z^2}. \quad (44)$$

A system of spherical co-ordinates (Fig. 36) is formed by a radial co-ordinate r giving the distance from the origin, an angular co-ordinate of longitude θ , as for cylindrical co-ordinates, and a co-ordinate of co-latitude (i.e. measured down from the pole) ϕ . The

surfaces $r = c_1$, $\theta = c_2$, $\phi = c_3$ are accordingly spheres, planes and cones respectively. The arc element is here

$$ds^2 = dr^2 + r^2 \sin^2 \phi d\theta^2 + r^2 d\phi^2, \quad (45)$$

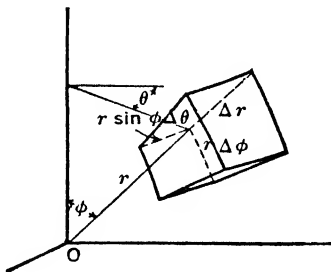

FIG. 36

so that for spherical co-ordinates we have $h_1 = 1$, $h_2 = r \sin \phi$, $h_3 = r$. The equation (38), for spherical co-ordinates, is accordingly:

$$h^2 \frac{\partial U}{\partial t} = \frac{1}{r^2} \frac{\partial}{\partial r} \left(r^2 \frac{\partial U}{\partial r} \right) + \frac{1}{r^2 \sin^2 \phi} \frac{\partial^2 U}{\partial \theta^2} + \frac{1}{r^2 \sin \phi} \frac{\partial}{\partial \phi} \left(\sin \phi \frac{\partial U}{\partial \phi} \right), \quad (46)$$

or

$$h^2 \frac{\partial U}{\partial t} = \frac{\partial^2 U}{\partial r^2} + \frac{2}{r} \frac{\partial U}{\partial r} + \frac{1}{r^2 \sin^2 \phi} \frac{\partial^2 U}{\partial \theta^2} + \frac{1}{r^2} \frac{\partial^2 U}{\partial \phi^2} + \frac{\cot \phi}{r^2} \frac{\partial U}{\partial \phi}. \quad (47)$$

EXERCISES XXVIII

1. Show analytically that if $x = r \cos \theta$, $y = r \sin \theta$, $z = z$, the formula for ds^2 given in (40) becomes that of (42).

2. Show that if $x = r \sin \phi \cos \theta$, $y = r \sin \phi \sin \theta$, $z = r \cos \phi$, then equation (45) is a consequence of (40).

3. By regarding one dimensional flow of heat as a special case of three dimensional flow, with the temperature unchanged by changes in two of the co-ordinates,

- Deduce equation (15) from equation (41),
- Deduce equation (a), problem 4 p. 165 from equation (43),
- Deduce equation (a), problem 5, p. 165 from equation (46).

4. Extend the argument used to obtain (21) for the two dimensional flow of a liquid, to establish the "equation of continuity,"

$$\frac{\partial(Du)}{\partial x} + \frac{\partial(Dv)}{\partial y} + \frac{\partial(Dw)}{\partial z} + \frac{\partial D}{\partial t} = 0,$$

for three dimensional flow, where u, v, w are the components of velocity parallel to x, y, z respectively.

5. The motion of a fluid in three dimensions is irrotational when a function ϕ can be found such that

$$\frac{\partial\phi}{\partial x} = u, \quad \frac{\partial\phi}{\partial y} = v, \quad \frac{\partial\phi}{\partial z} = w.$$

This function ϕ is called the velocity potential. Show that, for the irrotational motion of an incompressible fluid (D constant) the velocity potential satisfies Laplace's equation:

$$\frac{\partial^2\phi}{\partial x^2} + \frac{\partial^2\phi}{\partial y^2} + \frac{\partial^2\phi}{\partial z^2} = 0.$$

6. Since the left member of the condition of problem 5 is essentially the right member of (41) of the text, the form for cylindrical or spherical co-ordinates follows at once from equations (43) and (46). Use this fact to show that

$$\phi = k \ln \sqrt{(x-x_0)^2 + (y-y_0)^2}, \quad \text{and} \quad \phi = \frac{k}{\sqrt{(x-x_0)^2 + (y-y_0)^2 + (z-z_0)^2}}$$

are each solutions of Laplace's equation:

$$\frac{\partial^2\phi}{\partial x^2} + \frac{\partial^2\phi}{\partial y^2} + \frac{\partial^2\phi}{\partial z^2} = 0,$$

except for those values of x which make them infinite. Take the origin of the spherical co-ordinates at x_0, y_0, z_0 .

7. A particle of unit mass at (x, y, z) is attracted to a particle of mass m at x_0, y_0, z_0 by a gravitational force with components:

$$X = \frac{km(x_0 - x)}{R^3}, \quad Y = \frac{km(y_0 - y)}{R^3}, \quad Z = \frac{km(z_0 - z)}{R^3},$$

where

$$R = \sqrt{(x - x_0)^2 + (y - y_0)^2 + (z - z_0)^2},$$

in accordance with the inverse square law. Show that these components may be derived from a potential, as in problem 14, p. 124,

$$X = \frac{\partial U}{\partial x}, \quad Y = \frac{\partial U}{\partial y}, \quad Z = \frac{\partial U}{\partial z},$$

if

$$U = \frac{km}{R}.$$

The result of problem 6 shows that this gravitational potential for a single particle satisfies Laplace's equation except at the particle. By a limiting argument which starts with this fact, it is shown that the gravitational potential giving rise to the forces of attraction for any distribution of matter satisfy Laplace's equation at points where there is no matter. Owing to the fact that the inverse square law holds for the attraction and repulsions of electric charges and magnetic poles, a similar result holds for the potentials for the forces in an electrostatic, or magnetostatic field.

8. Let s_1, s_2, s_3 be the components of electric current in a three dimensional medium, and ρ the charge density at any point. Using the fact that the current may be interpreted as density of charge times velocity, and that charge is conserved, deduce the equation:

$$\frac{\partial s_1}{\partial x} + \frac{\partial s_2}{\partial y} + \frac{\partial s_3}{\partial z} = - \frac{\partial \rho}{\partial t}.$$

CHAPTER VI

SOLUTIONS OF PARTIAL DIFFERENTIAL EQUATIONS SATISFYING GIVEN BOUNDARY VALUES

In the preceding chapter we have discussed the partial differential equations which arise in certain physical situations. Here we shall consider some specific problems in which, in addition to the partial differential equation, there are enough boundary values or initial conditions to completely determine the solution.

42. The Steady-state Temperature of a Plate, Two Dimensional Potential Functions. Suppose a thin plane plate of uniform thickness and of the same material throughout has its faces insulated, and its edges kept at prescribed temperatures. These may differ from point to point, but do not change with the time. It is clear from physical considerations that the temperatures at the interior points of the plate will approach determinate values, and if the temperatures had these values to begin with, they would be maintained under the conditions stated.

If these steady-state temperatures are given by a function $U(x, y)$, this function must satisfy equation (17), p. 164, or

$$\frac{\partial^2 U}{\partial x^2} + \frac{\partial^2 U}{\partial y^2} = 0, \quad (1)$$

since the function does not contain z . Thus from a mathematical point of view, the problem amounts to finding a function $U(x, y)$ which satisfies (1) inside the region of the xy plane corresponding to the plate, and takes pre-assigned values on the boundary.

The problem of finding a potential function in a two dimensional region which takes on given boundary values has the same mathematical formulation, whether we are dealing with the potential for the forces in an electrostatic field, the potential for the forces in a magnetostatic field, the potential for the forces in a gravitational field, or the potential for the velocities in irrotational, steady fluid motion.¹ Consequently, if the mathematical problem is solved

¹ Compare problem 7, p. 180 and equation (28), p. 170.

analytically for a particular region and a given set of boundary values, the solution is applicable to a physical problem of each type. Also, if the value of the solution at a particular point were determined experimentally for any one of these physical problems, it would lead to an approximate numerical value for each of the others.

43. The Potential Function for a Long Rectangle. Suppose the region is a rectangle, $ABCD$, with the sides AD and BC so long compared with AB and CD that we may consider them infinite without sensibly disturbing the solution of the problem for the points in the actual finite rectangle. Let the prescribed boundary values be 0° for AD , DC and BC and 50° along AB , and assume $AB = 20$ cm.

The method used to solve this problem does not depend on the temperature along AB being constant, but would apply if this temperature were any function of the distance along AB . The success of the method does depend on the given temperatures being zero on the other three sides of the rectangle. The modification of the method to give the solution for a rectangle, not necessarily elongated, with the values on all four sides arbitrary functions of the distances, is indicated in problem 4, p. 187.

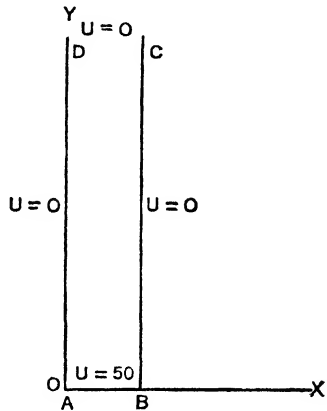

FIG. 37

The boundary values given do not join smoothly together, since if we approach A along DA , the values are zero, while if we approach A along BA they are 50. There are two reasons for considering values of this type. In the first place, we may regard the given boundary conditions as a simple approximation to the problem in which the temperatures along AB are 50° C. with the exceptions of two small portions at the ends, say 10^{-6} cm. each, and change continuously from 50 to 0 in each of these small portions. A second justification for considering discontinuous boundary conditions is the type of auxiliary problems which arise when the method of problem 4, p. 187 is applied. This reduces the problem for a rectangle with temperatures given arbitrarily, and different

from zero on all four sides to that of four problems, in each of which the temperature is zero on three of the sides, and the given values on the fourth side. Thus, even when the original problem has boundary values which join up smoothly, these auxiliary problems may have values which do not join up smoothly.

We take AB and AD as axes of x and y respectively, as indicated in Fig. 37. Then the conditions for the boundary may be written:

$$U(0, y) = 0; \quad U(20, y) = 0; \quad U(x, \infty) = 0; \quad U(x, 0) = 50. \quad (2)$$

Since the problem has only one solution, if we can find, by guesswork or otherwise, an expression satisfying equation (1), and the conditions (2), it will necessarily be the solution required. We build up such an expression by noting in the first place that equation (1) is linear, so that the sum of any number of particular solutions of this equation, each multiplied by any constant, will also be a solution of the equation. Again, as the first three of the conditions (2) require the function to be zero, they will also hold for the combination of solutions just mentioned, if they hold for the separate solutions, since a sum of zeros, each multiplied by a constant is still zero. Thus we begin by finding terms satisfying the equation (1), and also the first three conditions (2). Finally, we shall satisfy the last condition by a suitable infinite series of such terms.

As a basis for forming particular solutions of (1), we recall the solutions of the form $X(x) \cdot Y(y)$ of equation (62), p. 148 given in (67) p. 150. They are

$$\begin{aligned} U &= (c_1 e^{ax} + c_2 e^{-ax})(c_7 \sin ay + c_8 \cos ay), \\ U &= (c_3 \sin bx + c_4 \cos bx)(c_9 e^{by} + c_{10} e^{-by}), \\ U &= (c_5 x + c_6)(c_{11} y + c_{12}), \end{aligned} \quad (3)$$

with the present notation. Since all of these satisfy (1), we next try to specialize the constants in one of the three forms in such a way that the first three conditions of (2) will be met. Since the third condition requires U to be zero when y is infinite, regardless of the value of x , we are led to try the second expression, with b positive and $c_9 = 0$. The first condition that U be zero when x is zero regardless of the value of y is met by taking $c_4 = 0$. Thus the expression reduces to

$$c_3 c_{10} \sin bx e^{-by},$$

and the second condition, that U be zero when $x = 20$, regardless of the value of y may be met by taking b properly, namely so that

$$\sin 20 b = 0.$$

This requires that

$$20 b = n\pi, \quad b = \frac{n\pi}{20},$$

where n is an integer, and positive since b is positive. We now write A_n for the value of c_3c_{10} selected to go with a particular n , and have

$$A_n e^{-\frac{n\pi y}{20}} \sin \frac{n\pi x}{20}, \quad n = 1, 2, 3, \dots \quad (4)$$

as a set of terms, each of which satisfies the equation (1) and the first three conditions (2).

The same will be true of a sum, or infinite series² of such terms, and to solve our problem we have merely to determine the coefficients of a series:

$$U(x, y) = \sum_{n=1}^{\infty} A_n e^{-\frac{n\pi y}{20}} \sin \frac{n\pi x}{20}, \quad (5)$$

so that the fourth condition (2) will be satisfied. This requires that

$$50 = U(x, 0) = \sum_{n=1}^{\infty} A_n \sin \frac{n\pi x}{20}. \quad (6)$$

Accordingly the A_n are the coefficients of the expansion of 50 in a Fourier sine series of period 40, i.e., the B_n of section 19. From equation (44), p. 77 or problem 2, p. 78 we find that

$$A_n = \frac{200}{n\pi}, \quad n \text{ odd and } A_n = 0, \quad n \text{ even,}$$

so that

$$U(x, y) = \frac{200}{\pi} \sum_{n=1}^{\infty} \frac{1 - (-1)^n}{2n} e^{-\frac{n\pi y}{20}} \sin \frac{n\pi x}{20}, \quad (7)$$

² On p. 278 it is proved that the series for $U(x, y)$ of (5) with the A_n Fourier constants for any piecewise smooth function, satisfies the differential equation (1) for all values of x, y , corresponding to points inside the rectangle, and takes on the correct boundary values at all points where these values are continuous.

or, written out,

$$U(x, y) = \frac{200}{\pi} \left(e^{-\frac{\pi y}{20}} \sin \frac{\pi x}{20} + \frac{1}{3} e^{-\frac{3\pi y}{20}} \sin \frac{3\pi x}{20} + \frac{1}{5} e^{-\frac{5\pi y}{20}} \sin \frac{5\pi x}{20} + \dots \right).$$

This gives the solution of the problem. The series may be used for practical computation when y is not too small compared with 20, since the first few terms will then give a good approximation. For example, when $x = 10$, $y = 10$, we find:

$$\begin{aligned} u(10, 10) &= \frac{200}{\pi} \left(e^{-\frac{\pi}{2}} - \frac{e^{-\frac{3\pi}{2}}}{3} + \frac{e^{-\frac{5\pi}{2}}}{5} - \dots \right) \\ &= \frac{200}{\pi} (.2079 - .0030 + .0001 - \dots) \\ &= 13.1. \end{aligned}$$

We note that if the given temperature for the side AB had been a less simple function of x than the constant value 50 for this case, its Fourier series could have been obtained by the methods described in section 19. If it were given as one or more terms of a Fourier sine series of the appropriate period, we could solve the problem directly. For example, if we wished to have $U(x, 0) = 100 \sin \frac{\pi x}{20} + 50 \sin \frac{\pi x}{4}$, in place of the last condition (2), the other conditions remaining unchanged, we should again use (5), and have:

$$100 \sin \frac{\pi x}{20} + 50 \sin \frac{\pi x}{4} = U(x, 0) = \sum_{n=1}^{\infty} A_n \sin \frac{n\pi x}{20},$$

so that all the A_n are zero except A_1 and A_5 , and these are 100 and 50, respectively. The solution for this case is accordingly:

$$U(x, y) = 100 e^{-\frac{\pi y}{20}} \sin \frac{\pi x}{20} + 50 e^{-\frac{5\pi y}{20}} \sin \frac{5\pi x}{20}. \quad (8)$$

EXERCISES XXIX

1. A long rectangular plate has its surfaces insulated, and the two long sides, as well as one of the short sides maintained at 0° C. Find an expression $U(x, y)$ for the temperature in the steady state if

- (a) The other short side, $y = 0$, is kept at 40° C. and is 30 cm. long;
- (b) $U(x, 0) = 8x$, and the short side is 6 cm. long;

- (c) $U(x, 0) = 2x - 4$, and the short side is 4 cm. long;
 (d) $U(x, 0) = 10$, $0 < x < 4$, $U(x, 0) = 0$, $4 < x < 8$ and the short side is 8 cm. long;
 (e) $U(x, 0) = 2 \sin \pi x/10$ and the short side is 10 cm. long;
 (f) $U(x, 0) = 5 \sin \pi x/3 + 3 \sin \pi x/4$ and the short side is 12 cm. long.

2. A long rectangular plate of width a cm. with insulated surfaces has its temperature 0° C. on both of the long sides and one of the short sides, so that $U(0, y) = 0$, $U(a, y) = 0$, $U(x, \infty) = 0$. Show that

(a) If $U(x, 0) = c$, the steady-state temperature is

$$U(x, y) = \frac{4c}{\pi} \sum_{n=1}^{\infty} \frac{1 - (-1)^n}{2n} e^{-\frac{n\pi y}{a}} \sin \frac{n\pi x}{a},$$

(b) If $U(x, 0) = px$, the steady-state temperature is

$$U(x, y) = \frac{2ap}{\pi} \sum_{n=1}^{\infty} \frac{(-1)^n}{n} e^{-\frac{n\pi y}{a}} \sin \frac{n\pi x}{a}.$$

3. A rectangular plate is bounded by the lines $x = 0$, $x = a$, $y = 0$, $y = a'$. Its surfaces are insulated, and the temperatures along the edges are given by $U(0, y) = 0$, $U(a, y) = 0$, $U(x, a') = 0$, $U(x, 0) = 100^\circ$ C.

(a) By suitably restricting the constants in the second expression in (3) of the text, deduce the particular solution which satisfies the first three conditions:

$$A_n \sin \frac{n\pi x}{a} \left[e^{\frac{n\pi(y-a')}{a}} - e^{-\frac{n\pi(y-a')}{a}} \right],$$

or

$$2A_n \sin \frac{n\pi x}{a} \sinh \frac{n\pi(y-a')}{a}.$$

(b) Using a series of such solutions, show that

$$U(x, y) = \frac{400}{\pi} \sum_{n=1}^{\infty} \frac{[1 - (-1)^n] \sin \frac{n\pi x}{a} \sinh \frac{n\pi(a'-y)}{a}}{2n \sinh \frac{n\pi a'}{a}}.$$

4. The method used in problem 3 enables us to find a potential function which is zero on three sides of a rectangle, and equals any given function of the distance on the fourth side. Show that the potential function whose boundary values are

$$U(0, y) = f_1(y), \quad U(a, y) = f_2(y), \quad U(x, 0) = f_3(x), \quad U(x, a') = f_4(x),$$

may be found by adding together four potential functions,

$$U(x, y) = U_1(x, y) + U_2(x, y) + U_3(x, y) + U_4(x, y),$$

given by the respective boundary conditions:

$$\begin{array}{llll} U_1(0, y) = f_1(y), & U_1(a, y) = 0, & U_1(x, 0) = 0, & U_1(x, a') = 0; \\ U_2(0, y) = 0, & U_2(a, y) = f_2(y), & U_2(x, 0) = 0, & U_2(x, a') = 0; \\ U_3(0, y) = 0, & U_3(a, y) = 0, & U_3(x, 0) = f_3(x), & U_3(x, a') = 0; \\ U_4(0, y) = 0, & U_4(a, y) = 0, & U_4(x, 0) = 0, & U_4(x, a') = f_4(x). \end{array}$$

5. A circular plate of radius 10 cm. has its surfaces insulated, and one half of its circumference kept at 0° C. and the other half at 100° C. Using the suggestions which follow, find the temperature $U(r, \theta)$ as a function of the polar co-ordinates r, θ in the steady state. Note that by (44) p. 178, the differential equation is

$$\frac{\partial^2 U}{\partial r^2} + \frac{1}{r} \frac{\partial U}{\partial r} + \frac{1}{r^2} \frac{\partial^2 U}{\partial \theta^2} = 0,$$

one of whose particular solutions was found in problem 5, p. 154 to be $(c_1 r^a + c_2 r^{-a})(c_3 \sin a\theta + c_4 \cos a\theta)$. To avoid infinite values at the origin, we take $c_2 = 0$, and a positive. The fact that θ is an angular co-ordinate only determined to within multiples of 2 leads to the condition $U(r, \theta + 2\pi) = U(r, \theta)$, which is satisfied by taking $a = n$, an integer. Thus the series assumed for the solution is

$$U(r, \theta) = A + A_1 r \cos \theta + B_1 r \sin \theta + A_2 r^2 \cos 2\theta + B_2 r^2 \sin 2\theta + \dots$$

6. Show that when the values of a potential function on the boundary of a circle of radius R are given by

$$U(R, \theta) = f(\theta),$$

the steady-state temperature at an interior point is found by the method outlined in the preceding problem to be

$$U(r, \theta) = \frac{1}{\pi} \int_{-\pi}^{\pi} \left[\frac{1}{2} + \sum_{n=1}^{\infty} \left(\frac{r}{R} \right)^n \cos n(\theta - t) \right] f(t) dt.$$

44. Variable Flow of Heat in a Rod with ends kept at Temperature Zero. The temperatures in a homogeneous rod, in which heat flows parallel to the axis of the rod, satisfy the equation

$$\frac{\partial^2 U}{\partial x^2} = h^2 \frac{\partial U}{\partial t}, \quad (9)$$

as was shown in section 38. If we consider a rod of finite length, whose sides are insulated, with a given initial distribution of temperatures, and suddenly change the temperature of the end points to 0° C., and keep them at this temperature,³ the temperature of any section of the rod will be determined by these conditions for all later times.

For example, let the rod be 10 cm. long, of material for which $h^2 = .6$, and assume that the temperature was initially $2x$, where x (cm.) is measured from one end of the rod. Then we have the initial condition:

$$U(x, 0) = 2x, \quad (10)$$

³ The modification for other fixed temperatures is indicated in the next section, and in problem 11, p. 196 a method applicable to variable end temperatures is sketched.

and since the ends are kept at temperature zero, we have the boundary conditions:

$$U(0, t) = 0, \quad U(10, t) = 0. \tag{11}$$

The physical interpretation indicates that there is just one function determined by the conditions (10), (11) and the differential equation (9). Consequently, if we can build up by tentative means an expression which satisfies all these conditions, it will be the desired solution.

We begin by recalling the particular solutions of (9) found in problem 1, p. 154, namely

$$\begin{aligned} U &= (c_1 e^{ax} + c_2 e^{-ax}) e^{-\frac{a^2 t}{h^2}}, \\ U &= (c_3 \sin bx + c_4 \cos bx) e^{-\frac{b^2 t}{h^2}}, \\ U &= c_5 x + c_6. \end{aligned} \tag{12}$$

The conditions (11) may be met by taking the second expression, with $c_4 = 0$, and such a value of b that

$$\sin 10b = 0.$$

It follows from this that:

$$10b = n\pi, \quad b = \frac{n\pi}{10},$$

where n is an integer, which may be considered to be positive.⁴ Thus, on replacing b by its value just found, and writing A_n in place of c_3 for the coefficient for a particular choice of n , we have:

$$A_n \sin \frac{n\pi x}{10} e^{-\frac{n^2 \pi^2 t}{100 h^2}}, \quad n = 1, 2, 3, \dots \tag{13}$$

as a set of terms, each of which satisfies the differential equation (9), as well as the conditions (11). The same will be true of a sum or infinite series⁵ of such terms and hence we have merely to determine the coefficients of such an infinite series,

$$U(x, t) = \sum_{n=1}^{\infty} A_n \sin \frac{n\pi x}{10} e^{-\frac{n^2 \pi^2 t}{100 h^2}}, \tag{14}$$

⁴ Nothing is gained by taking both positive and negative values, since

$$A_n \sin \frac{n\pi x}{10} + A_{-n} \sin \frac{-n\pi x}{10} = (A_n - A_{-n}) \sin \frac{n\pi x}{10}.$$

⁵ Compare footnote ² on p. 185, and p. 278.

to satisfy the remaining condition, (10). That is:

$$2x = U(x, 0) = \sum_{n=1}^{\infty} A_n \sin \frac{n\pi x}{10},$$

and the A_n are the coefficients of the expansion of $2x$ in a Fourier sine series of period 20. From the result of problem 1, p. 77 or problem 2, p. 78, the value of A_n is found to be

$$A_n = \frac{(-1)^{n+1} 40}{n\pi}.$$

Thus the solution of the problem is obtained by putting these values in (14), and putting $h^2 = .6$. The result is

$$U(x, t) = \frac{40}{\pi} \sum_{n=1}^{\infty} \frac{(-1)^{n+1}}{n} \sin \frac{n\pi x}{10} e^{-\frac{n^2\pi^2 t}{60}}, \quad (15)$$

or, written out

$$\frac{40}{\pi} \left\{ \frac{\sin .1\pi x}{1} e^{-\frac{\pi^2 t}{60}} - \frac{\sin .2\pi x}{2} e^{-\frac{4\pi^2 t}{60}} + \frac{\sin .3\pi x}{3} e^{-\frac{9\pi^2 t}{60}} - \dots \right\}.$$

This series converges very rapidly, owing to the exponential terms, and except for small values of t (less than 4 seconds) the first two terms give a good numerical approximation to the value of $U(x, t)$.

45. Variable Flow of Heat in a Rod with ends kept at any Constant Temperatures. If the ends of the rod considered in the preceding section were suddenly changed to temperatures different from zero, and kept at these temperatures, the method previously used would not be directly applicable, since a particular solution with the correct non-zero values at the ends would no longer have these values if it were multiplied by a constant, or added to a second such solution. However, the procedure may be modified to suit the present situation, as we shall now show.

As a specific example, let us consider a rod 4 cm. in length, of material for which $h^2 = 5$. Let one end of the rod be kept at 20°C. , and the other at 60°C. until temperatures indistinguishable from those of the steady state are reached. At some time thereafter, let us suddenly lower the temperature of the cooler end to 10° , and raise that of the warmer end to 70° , and from then on maintain these temperatures. Thus the boundary conditions are here:

$$U(0, t) = 10, \quad U(4, t) = 70, \quad (16)$$

and the initial condition is

$$U(x, 0) = 10x + 20, \quad (17)$$

the steady-state temperature for the end values 20 and 60. It may be found by recalling from the discussion of section 38 that, in the steady state, the temperature gradient is constant, so that

$$\frac{U_2 - U_1}{x_2 - x_1} = \frac{U - 20}{x - 0} = \frac{60 - 20}{4 - 0}, \quad (18)$$

or

$$U - 20 = 10x, \quad U = 10x + 20.$$

Thus we have to satisfy the differential equation (9), subject to the conditions (16) and (17). To transform this problem into one of the type treated in the preceding section, we put

$$U = U_S + U_T, \quad (19)$$

where U_S is a solution of the differential equation, involving x only, satisfying the given boundary conditions (16). We may put $U_S = ax + b$, since this satisfies the differential equation, being essentially the third expression in (12), and determine the constants to satisfy the end conditions, (16). These give:

$$a \cdot 0 + b = 10, \quad a \cdot 4 + b = 70,$$

from which

$$b = 10, \quad a = \frac{70 - b}{4} = 15,$$

so that ⁶

$$U_S = 15x + 10. \quad (20)$$

Since, from (19),

$$U_T = U - U_S = U - 15x - 10, \quad (21)$$

it is the difference of two solutions of the differential equation (9), which is linear in U , and so is again a solution. For the boundary

⁶ Physically, the process amounts to determining the steady-state temperatures for the permanent end temperatures, U_S , and subtracting it off to leave U_T , the transient part of the solution. Thus, analogously to (18), we might have determined U_S from:

$$\frac{U_S - 10}{x - 0} = \frac{70 - 10}{4 - 0}, \quad U_S - 10 = 15x.$$

conditions,⁷ we have from (21) and (16):

$$\begin{aligned} U_T(0, t) &= U(0, t) - 10 = 10 - 10 = 0, \\ U_T(4, t) &= U(4, t) - 15 \times 4 - 10 = 70 - 70 = 0. \end{aligned} \quad (22)$$

For the initial condition, we have from (21) and (17):

$$\begin{aligned} U_T(x, 0) &= U(x, 0) - 15x - 10 = 10x + 20 - 15x - 10 \\ &= -5x + 10. \end{aligned} \quad (23)$$

Hence the problem of determining the function $U_T(x, t)$ which satisfies the equation (9), the boundary conditions (22), and the initial conditions (23) is of exactly the same type as that solved in the preceding section, and we may put

$$U_T(x, t) = \sum_{n=1}^{\infty} A_n \sin \frac{n\pi x}{4} e^{-\frac{n^2\pi^2 t}{16h^2}}, \quad (24)$$

which satisfies the differential equation (9), and the conditions (22), and determine the coefficients to satisfy the condition (23). This last condition requires that

$$-5x + 10 = U_T(x, 0) = \sum_{n=1}^{\infty} A_n \sin \frac{n\pi x}{4}.$$

By using the result of problem 2, p. 78, we find that

$$A_n = 0, \quad n \text{ odd}, \quad \text{and} \quad A_n = \frac{40}{n\pi}, \quad n \text{ even}.$$

Accordingly we put $n = 2m$, $h^2 = 5$, and have for $U_T(x, t)$:

$$U_T(x, t) = \frac{20}{\pi} \sum_{m=1}^{\infty} \frac{1}{m} \sin \frac{m\pi x}{2} e^{-\frac{m^2\pi^2 t}{20}}. \quad (25)$$

From (19), (20) and (25) the solution of the original problem is:

$$U(x, t) = 15x + 10 + \frac{20}{\pi} \sum_{m=1}^{\infty} \frac{1}{m} \sin \frac{m\pi x}{2} e^{-\frac{m^2\pi^2 t}{20}}. \quad (26)$$

Written out, this is

$$15x + 10 + \frac{20}{\pi} \left\{ \frac{\sin \frac{\pi x}{2}}{1} e^{-\frac{\pi^2 t}{20}} + \frac{\sin \frac{2\pi x}{2}}{2} e^{-\frac{4\pi^2 t}{20}} \right.$$

⁷ The details are merely a check on our work, since U_S was formed in such a way that the boundary values of U_T would be zero. However, to obtain the new initial condition, (23), we must carry out the subtraction.

$$\left. + \frac{\sin \frac{3\pi x}{2}}{3} e^{-\frac{9\pi^2 t}{20}} + \dots \right\}.$$

We note that, when t is very large, the exponential terms of the series are small, so that, when t becomes infinite, the solution reduces to the first two terms. This is in agreement with the remark in footnote ⁶, p. 191, that (20) is the steady-state solution for the given terminal conditions.

EXERCISES XXX

1. The ends A and B of a rod 50 cm. long have their temperatures kept at 0° and 100° C. respectively until the temperatures are indistinguishable from those for the steady state. At some time after this, there is a sudden change in the end temperatures. Find the temperature of any point in the rod, $U(x, t)$, as a function of x (cm.), the distance from one end A , and t (sec.) the time elapsed after the sudden change for each of the following cases.

(a) The temperature of B is suddenly reduced to 0° C., and kept so, while that of A is kept at 0° C.;

(b) The temperature of B is kept at 100° C., while that of A is suddenly increased to 100° C., and maintained at this point;

(c) The temperature of B is suddenly reduced to 50° C., and kept at this point, while that of A is kept at 0° C.;

(d) The temperature of A is suddenly raised to 25° C. while that of B is suddenly reduced to 75° C., and then these temperatures are maintained;

(e) The temperature of A is suddenly raised to 50° C., while that of B is suddenly raised to 150° C., and then these temperatures are maintained.

2. If the rod of problem 1 (a) is of silver, for which $h^2 = .576$, compute the temperature of the midpoint of the rod 2 minutes after the change in temperature.

3. Compute the temperature of a point 5 cm. from the end A , 3 hours after the sudden change for the rod of problem 1 (b), and also for that of problem 1 (e), if the rod is of glass, for which $h^2 = 175.0$.

4. Show that the temperature of the midpoint of the rod of problem 1 (d) does not change with the time, and does not depend on the value of h^2 . Compute it.

5. Find the temperature of a point 12.5 cm. from the end A of the rod of problem 1 (d), 5 minutes after the sudden change

(a) If the rod is of silver, for which $h^2 = .576$;

(b) If the rod is of wrought iron, for which $h^2 = 5.78$;

(c) If the rod is of glass, for which $h^2 = 175.0$.

6. (a) A wrought iron rod 80 cm. long has one half its length at 0° C., and the other half at 50° C. If the sides are suddenly insulated, the temperature of the hot end reduced to 0° C., and thereafter the two ends kept at 0° C., find

194 SOLUTIONS SATISFYING GIVEN BOUNDARY VALUES

the temperature of the rod, $U(x, t)$ as a function of the distance from the end originally at 0° , and the time after the sudden change.

(b) Assuming $h^2 = 5.78$, compute the temperature for a point 20 cm. from the end originally at 0° C., 12 minutes after the change.

7. The ends of a rod 60 cm. long have their temperatures kept at 0° C. and 180° C. until the steady state is approximated. The ends are then suddenly insulated, so that thereafter no heat flows at the ends, and hence by (10) on p. 163,

$$\frac{\partial U}{\partial x} = 0, \quad x = 0 \quad \text{and} \quad \frac{\partial U}{\partial x} = 0, \quad x = 60.$$

(a) Show that for any integral value of n ,

$$A_n \cos \frac{n\pi x}{60} e^{-\frac{n^2\pi^2 t}{3600h^2}},$$

is a particular solution of the differential equation which satisfies the end conditions.

(b) Using a series of such solutions, find an expression for $U(x, t)$, which for $t = 0$ gives the initial distribution of temperatures and hence represents the temperature of a point in the rod at distance x from the cooler end, t seconds after the sudden change in conditions.

8. A rod 40 cm. long has its midpoint raised to 100° C. while the ends are at 0° C., until each half approximates the steady state. The source of heat is then removed from the midpoint, and this is insulated. Find the temperature $U(x, t)$.

9. (a) A rod 20 cm. long has its ends kept at 0° and 100° C. respectively until the steady state is reached. The end at 0° is kept at this temperature, while the other end is suddenly insulated so that, as in problem 7, $\frac{\partial U}{\partial x} = 0$ there. Using particular solutions of the form

$$A_n \sin \frac{(2n+1)\pi x}{40} e^{-\frac{(2n+1)^2\pi^2 t}{1600h^2}},$$

find the temperature as a function of x and t . See problem 12, p. 79 for this type of expansion in odd harmonic terms.

(b) From physical considerations, deduce the relation of this problem to problem 8, and verify by comparing the two results.

10. The parts of this problem outline a method of finding the temperature of a rod of length a , initially at 0° C. throughout, and having the end $x = 0$ kept at 0° C., and the end $x = a$ held at temperature $f(t)$, at time t .

(a) Show that, if $f(t)$ is constant,

$$f(t) = 1,$$

the solution of the problem will be

$$U_1(x, t) = \frac{x}{a} + \frac{2}{\pi} \sum_{n=1}^{\infty} \frac{(-1)^n \sin \frac{n\pi x}{a}}{n} e^{-\frac{n^2\pi^2 t}{a^2h^2}}.$$

(b) Thus the function

$$\begin{aligned} V(x, t) &= U_1(x, t), \quad \text{when } t > 0, \\ V(x, t) &= 0, \quad \text{when } t \leq 0, \end{aligned}$$

gives the temperature of a rod zero throughout before $t = 0$, and having the end $x = a$ at temperature 1 after this time. The two definitions join together, except for $x = a$, when $t = 0$. Show that, if the interval 0 to t be divided into N equal parts $\Delta t = t/N$, and we put

$$t_0 = 0, \quad t_1 = \Delta t, \quad t_2 = 2\Delta t, \quad t_3 = 3\Delta t, \quad \dots \quad t_N = N\Delta t,$$

if the function $f(t)$ is constant in each interval,

$$0 < t \leq t_1, \quad t_1 < t \leq t_2, \quad \dots \quad t_{N-1} < t \leq t_N,$$

the solution of the problem may be written

$$U_2(x, t) = \sum_{n=1}^N f(t_n) \frac{-V(x, t - t_n) + V(x, t - t_{n-1})}{\Delta t} \Delta t,$$

since this satisfies the differential equation, and takes the proper values at the point $x = a$ for all values of t except the values t_1, t_2, \dots where there are sudden changes.

(c) The solution $U_2(x, t)$ of (b) suggests that, if $f(t)$ is a continuous function, and we approximate it by a function constant in N intervals, the approximation will be better as we increase N , and the actual solution will be the limit of $U_2(x, t)$ for n infinite, namely:

$$U(x, t) = \int_0^t f(u) \frac{\partial V(x, t - u)}{\partial t} du.$$

In this integral the derivative is not defined for $u = t$, since $V(x, t)$ has no partial t derivative when $t = 0$, but the integral may be calculated without using this isolated value. The direct justification of the derivation is difficult, but it is possible to verify that the integral does solve the problem. That it satisfies the differential equation follows from the fact that $V(x, t)$ satisfies the equation, by differentiating under the integral sign. $U(x, 0)$ is obviously zero, since the limits are then both zero. Again, $U(0, t)$ is zero, since the integrand is zero, and it may be shown that

$$\lim_{x=0} U(x, t) = U(0, t).$$

To investigate $\lim_{x=a} U(x, t)$, we note that for a value x_1 near a , and an interval $t + \epsilon$ to $t - \epsilon$ with midpoint at t , the contribution to the integral outside this t interval will be small, and if the t interval is small, the factor $f(u)$ will be nearly $f(t)$. Thus the integral will be nearly

$$f(t) \int_{t-\epsilon}^{t+\epsilon} \frac{\partial V(x_1, t - u)}{\partial t} du = f(t) [V(x_1, \epsilon) - V(x_1, -\epsilon)]$$

or since $V(a, \epsilon) - V(a, -\epsilon)$ is nearly 1 when ϵ is small, and x_1 is near a , the value of the integral is nearly $f(t)$. This discussion is in no sense a proof, but is merely intended to give some idea of the nature of the proof.

11. Show that the temperature of a rod of length a initially at temperature $f(x)$, whose ends are kept at temperatures $g_1(t)$ and $g_2(t)$ may be expressed as the sum of three functions,

$$U(x, t) = U_0(x, t) + U_1(x, t) + U_2(x, t),$$

each of which satisfies equation (9), and whose respective boundary conditions are

$$\begin{aligned} U_0(0, t) &= 0, & U_0(a, t) &= 0, & U_0(x, 0) &= f(x); \\ U_1(0, t) &= g_1(t), & U_1(a, t) &= 0, & U_1(x, 0) &= 0; \\ U_2(0, t) &= 0, & U_2(a, t) &= g_2(t), & U_2(x, 0) &= 0. \end{aligned}$$

The determination of $U_0(x, t)$ has been discussed in the text, while $U_1(x, t)$ and $U_2(x, t)$ may be found by the method sketched in problem 10.

46. **The Telegraph Equations.** We have seen, equations (7), p. 159, that when current is flowing in a long line, and the influence of all factors except resistance and capacitance to ground is neglected, the equations satisfied by the voltage and current are

$$-\frac{\partial e}{\partial x} = Ri, \quad -\frac{\partial i}{\partial x} = C \frac{\partial e}{\partial t}. \quad (27)$$

The equation obtained by eliminating the current is

$$\frac{\partial^2 e}{\partial x^2} = RC \frac{\partial e}{\partial t}. \quad (28)$$

As this equation is identical in form with equation (9), for one dimensional heat flow, the methods given in the two preceding sections may be applied to it.

As an example, suppose one end of a line 100 miles long is kept at 2 volts as compared with 6 volts for the other extremity, until a steady state is reached. The first end is then grounded, so that its potential is suddenly reduced to 0 volts, while the other end has its potential maintained. Let $R = .12$ ohms per mile and $C = 2$ microfarads per mile. Then $C = 2 \times 10^{-6}$ farads per mile, and in equation (28) the coefficient $RC = 2.4 \times 10^{-7}$.

The steady-state solution of the differential equation (28) is a first degree expression in x , and by a process analogous to that used to obtain (17) or (20), we find the initial condition

$$e(x, 0) = 2 + \frac{x}{25}, \quad (29)$$

the steady-state solution equal to 2 when x is 0, and equal to 6 when $x = 100$.

The permanent end conditions require that

$$e(0, t) = 0, \quad e(100, t) = 6. \quad (30)$$

Thus the problem is to find a solution of the differential equation (28), which also satisfies (29) and (30). We solve this problem by writing

$$e = e_s + e_T, \quad (31)$$

where e_s is the steady-state solution for the permanent end conditions, (30), so that

$$e_s = \frac{3x}{50}. \quad (32)$$

The conditions to be satisfied by the transient part of the solution,

$$e_T = e - \frac{3x}{50},$$

in addition to the differential equation, are then

$$e_T(0, t) = 0, \quad e_T(100, t) = 0, \quad (33)$$

from (30), and

$$e_T(x, 0) = 2 + \frac{x}{25} - \frac{3x}{50} = 2 - \frac{x}{50}. \quad (34)$$

By analogy with (13), we write

$$A_n \sin \frac{n\pi x}{100} \epsilon^{-\frac{n^2\pi^2 t}{100^2 RC}}, \quad (35)$$

as particular solutions of (28) which satisfy the boundary conditions (33), and put

$$e_T(x, t) = \sum_{n=1}^{\infty} A_n \sin \frac{n\pi x}{100} \epsilon^{-\frac{n^2\pi^2 t}{100^2 RC}}. \quad (36)$$

The initial condition (34) will be met, provided that

$$2 - \frac{x}{50} = e_T(x, 0) = \sum_{n=1}^{\infty} A_n \sin \frac{n\pi x}{100}.$$

From problem 2, p. 78, we have

$$2 - \frac{x}{50} = \frac{4}{\pi} \sum_{n=1}^{\infty} \frac{\sin \frac{n\pi x}{100}}{n},$$

so that

$$e_T(x, t) = \frac{4}{\pi} \sum_{n=1}^{\infty} \frac{\sin \frac{n\pi x}{100}}{n} \epsilon^{-\frac{n^2\pi^2 t}{100^2 RC}}. \quad (37)$$

From (31), (32), (37) and the fact that $RC = 2.4 \times 10^{-7}$, we have, finally

$$e(x, t) = \frac{3x}{50} + \frac{4}{\pi} \sum_{n=1}^{\infty} \frac{1}{n} \sin \frac{n\pi x}{100} \epsilon^{-\frac{n^2\pi^2 t}{.0024}}. \quad (38)$$

The current may be found from the first of equations (27), which may be written

$$i = -\frac{1}{R} \frac{\partial e}{\partial x} = -\frac{1}{.12} \frac{\partial e}{\partial x}.$$

From this and (38), we obtain:

$$i(x, t) = -\frac{1}{2} - \frac{1}{3} \sum_{n=1}^{\infty} \cos \frac{n\pi x}{100} \epsilon^{-\frac{n^2\pi^2 t}{.0024}}. \quad (39)$$

This series converges for $t > 0$, because of the presence of the exponential terms. For $t = 0$, the series oscillates. This indetermination of i for $t = 0$ is due to the discontinuity in our conditions.

EXERCISES XXXI

1. The length of an ocean cable is $3142 = 1000\pi$ miles. The resistance is 3 ohms per mile, and the capacitance to ground is $\frac{1}{3}$ microfarad per mile, or $\frac{1}{3} \times 10^{-6}$ farads per mile. Find the e.m.f., $e(x, t)$ and the current, $i(x, t)$ at any point as a function of the distance from one end, x (miles), and the time t (seconds) after the two ends are grounded, if initially the e.m.f. was

$$(a) \quad e(x, 0) = E_1 \sin \frac{x}{1000} + E_2 \sin \frac{x}{200};$$

(b) $e(x, 0) = \frac{Ex}{1000\pi}$, the steady-state condition due to one end being grounded, and the other at the constant e.m.f. E .

2. A cable is a miles long. Initially the line is uncharged, so that $e(x, 0) = 0$. If, at $t = 0$ the end $x = a$ is connected to a constant e.m.f. E , find $e(x, t)$ and hence $i(x, t)$. In particular, show that the current at the receiving end, $x = 0$, is given by

$$-\frac{E}{Ra} \left[1 - 2 \left(\epsilon^{-\frac{\pi^2 t}{a^2 RC}} - \epsilon^{-\frac{4\pi^2 t}{a^2 RC}} + \epsilon^{-\frac{9\pi^2 t}{a^2 RC}} - \dots \right) \right].$$

3. Using the data of problem 1, and the result of problem 2, show that the current received $\frac{1}{3}$ second after a signal is sent is less than .0004 of the maximum

value,* but has risen to 30%, 73%, and 90% of the maximum at the end of 1, 2 and 3 seconds respectively.

4. Using problem 2, show that for a line 100 miles long, with resistance 170 ohms per mile and capacitance to ground .07 microfarads per mile, or 7×10^{-8} farads per mile, the current received is over 96% of the maximum at the end of $\frac{1}{10}$ of a second.

47. The Wave Equation. In section 40 we derived the equation satisfied by the small displacements of a tightly stretched, vibrating string. If we write $s = \sqrt{Tg/D}$, the equation is

$$\frac{\partial^2 y}{\partial x^2} = \frac{1}{s^2} \frac{\partial^2 y}{\partial t^2}. \quad (40)$$

By problem 1, p. 173, s is the velocity of propagation of the wave motion along the string. For the units of section 40, s was in ft./sec., while x and y were in ft. If we convert s to cm./sec., we may measure x and y in cm.

As a specific example, consider a string 100 cm. in length, with fixed end points, so that

$$y(0, t) = 0 \quad \text{and} \quad y(100, t) = 0. \quad (41)$$

If the string is initially displaced in a sinusoidal arch, of height 2 cm.,

$$y(x, 0) = 2 \sin \frac{\pi x}{100}, \quad (42)$$

and if it is at rest in this position, we also have:

$$\frac{\partial y}{\partial t} = 0, \quad \text{for } t = 0. \quad (43)$$

To find the displacement at any other time, we must find the function $y(x, t)$ which satisfies the differential equation (40), takes on the boundary values (41), and also satisfies the initial conditions (42) and (43).

We begin by writing down the particular solutions of equation (40) found by the method of section 36. They are:

$$\begin{aligned} y &= (c_1 e^{ax} + c_2 e^{-ax})(c_7 e^{ast} + c_8 e^{-ast}), \\ y &= (c_3 \sin bx + c_4 \cos bx)(c_9 \sin bst + c_{10} \cos bst), \\ y &= (c_5 x + c_6)(c_{11} t + c_{12}). \end{aligned} \quad (44)$$

* See footnote*, p. 210.

The conditions (41) will be met by taking the second form, with $c_4 = 0$, and a value of b such that

$$\sin 100b = 0,$$

which requires that

$$100b = n\pi, \quad b = \frac{n\pi}{20},$$

where n may be taken as a positive integer.⁸ The condition (43) will be met if we take $c_3 = 0$. Thus, on writing A_n as the value of c_3c_{10} that goes with a particular n , we have

$$A_n \sin \frac{n\pi x}{100} \cos \frac{n\pi st}{100}, \quad (45)$$

as a term satisfying the differential equation (40), as well as the additional conditions (41) and (43). To satisfy the remaining condition, (42), we take an infinite series of such terms, and write

$$y(x, t) = \sum_{n=1}^{\infty} A_n \sin \frac{n\pi x}{100} \cos \frac{n\pi st}{100}. \quad (46)$$

The condition (42) requires that

$$2 \sin \frac{\pi x}{100} = y(x, 0) = \sum_{n=1}^{\infty} A_n \sin \frac{n\pi x}{100}.$$

Since the left member is, as it stands, a Fourier series of the required form with all the coefficients zero except A_1 , which is 2, we have from (46) without further calculation:

$$y(x, t) = 2 \sin \frac{\pi x}{100} \cos \frac{\pi st}{100}. \quad (47)$$

Owing to the simple form of our conditions, this result could have been found by inspection from a comparison of the conditions with (44). However, the method is applicable even when the initial conditions are not so specialized.

EXERCISES XXXII

1. A tightly stretched string of length a cm. is drawn aside at its midpoint a distance p cm., so that its initial position is given by

$$y(x, 0) = \frac{2px}{a}, \quad 0 \leq x \leq \frac{a}{2},$$

⁸ See footnote 4, p. 189.

$$y(x, 0) = 2p - \frac{2px}{a}, \quad \frac{a}{2} \leq x \leq a.$$

It is initially at rest, so that

$$\frac{\partial y}{\partial t} = 0, \quad t = 0,$$

and is suddenly released from this position. If its end points are kept fixed throughout, so that $y(0, t) = y(a, t) = 0$, find an expression for $y(x, t)$.

2. Find $y(x, t)$ for the string of problem 1 if the remaining conditions are unchanged, but the initial position, instead of being the one there given is:

$$(a) \quad y(x, 0) = p \sin \frac{n\pi x}{a}, \quad \text{where } n \text{ is any integer;}$$

$$(b) \quad y(x, 0) = p \sin^3 \frac{\pi x}{a};$$

$$(c) \quad y(x, 0) = apx - px^2.$$

3. If the string is of length a , and fixed at the end points, but not at rest when $t = 0$, we will have initial conditions of the form:

$$y(0, t) = y(a, t) = 0,$$

$$y(x, 0) = f(x),$$

$$\frac{\partial y}{\partial t} = g(x) \quad \text{when } t = 0.$$

Show that in this case

$$y(x, t) = \sum_{n=1}^{\infty} \sin \frac{n\pi x}{a} \left(A_n \sin \frac{n\pi t}{a} + B_n \cos \frac{n\pi t}{a} \right)$$

where the B_n are the coefficients of the expansion of $f(x)$ in a sine series, so that

$$f(x) = \sum_{n=1}^{\infty} B_n \sin \frac{n\pi x}{a},$$

and the A_n are related to the coefficients of the expansion of $g(x)$ in a sine series, so that

$$g(x) = \sum_{n=1}^{\infty} \frac{n\pi s}{a} A_n \sin \frac{n\pi x}{a}.$$

4. Apply the result of problem 3 to find the displacement $y(x, t)$ of a tightly stretched string of length a , if the ends are fixed, $y(0, t) = y(a, t) = 0$, and the string is initially in the equilibrium position, $y(x, 0) = 0$, but for $t = 0$ the velocities, $\partial y / \partial t$ are given by:

$$(a) \quad \frac{\partial y(x, 0)}{\partial t} = p \sin \frac{n\pi x}{a}, \quad n \text{ being an integer;}$$

$$(b) \quad \frac{\partial y(x, 0)}{\partial t} = p \sin^3 \frac{\pi x}{a};$$

$$(c) \quad \frac{\partial y(x, 0)}{\partial t} = apx - px^2.$$

5. Show that, if $y(x, 0)$ has the value given in one of the parts of problem 2, and $\partial y(x, 0)/\partial t$ the value given in this, or some other, part of problem 4, the end points being fixed, the solution of the problem may be found by adding the results for the two separate cases.

6. If the displacement of the point x_0 of the string be found for problem 3, we have:

$$y(x_0, t) = \sum_{n=1}^{\infty} \sin \frac{n\pi x_0}{a} \left\{ A_n \sin \frac{n\pi st}{a} + B_n \cos \frac{n\pi st}{a} \right\}.$$

The terms involving A_n and B_n together determine the n th overtone, or n th harmonic. If x_0/a is irrational and the displacement of the point x_0 is any given periodic function of the time, of period $2a/s$, show how to find an initial velocity and displacement that will give rise to it. What types of initial conditions will make this function odd, even, or odd-harmonic?

48. **The Radio Equations.** In section 37, we saw that for certain high frequency circuits, the equations governing the current and voltage could be roughly approximated by

$$-\frac{\partial e}{\partial x} = L \frac{\partial i}{\partial t}, \quad -\frac{\partial i}{\partial x} = C \frac{\partial e}{\partial t}. \quad (48)$$

As the equation obtained from these by eliminating i , namely

$$\frac{\partial^2 e}{\partial x^2} = LC \frac{\partial^2 e}{\partial t^2}, \quad (49)$$

is of the same type as equation (40), it may be treated in a similar manner to that used in the preceding section.

For example, suppose the e.m.f. of a line 200 miles long was initially given by

$$e(x, 0) = E \sin \frac{\pi x}{200}, \quad (50)$$

and the initial current were constant,

$$i(x, 0) = I_0. \quad (51)$$

These values imply nothing about the partial derivatives with respect to t , for $t = 0$, but do determine the partial derivatives with respect to x when $t = 0$, namely:

$$\frac{\partial e(x, 0)}{\partial x} = \frac{\pi E}{200} \cos \frac{\pi x}{200}, \quad \frac{\partial i(x, 0)}{\partial x} = 0.$$

If, as we shall assume, the initial state was the result of a physical situation determined by equations (48), the second equation shows

that

$$\frac{\partial e(x, 0)}{\partial t} = 0. \quad (52)$$

Suppose further that, at $t = 0$, the ends of the line were suddenly grounded. Then we have as additional boundary conditions:

$$e(0, t) = 0, \quad e(200, t) = 0. \quad (53)$$

The equation (49), together with the conditions (50), (52) and (53) completely determine $e(x, t)$. By a process entirely analogous to that used to obtain (47) in the last section, we find that

$$e(x, t) = E \sin \frac{\pi x}{200} \cos \frac{\pi t}{200\sqrt{LC}}. \quad (54)$$

To find the current, $i(x, t)$ we must use both of the equations (48). The first gives:

$$\frac{\partial i}{\partial t} = -\frac{1}{L} \frac{\partial e}{\partial x} = -\frac{E\pi}{200L} \cos \frac{\pi x}{200} \cos \frac{\pi t}{200\sqrt{LC}}, \quad (55)$$

while from the second we find:

$$\frac{\partial i}{\partial x} = -C \frac{\partial e}{\partial t} = \frac{EC}{200\sqrt{LC}} \sin \frac{\pi x}{200} \sin \frac{\pi t}{200\sqrt{LC}}. \quad (56)$$

The result of integrating equation (55) with respect to t is:

$$i(x, t) = -E \sqrt{\frac{C}{L}} \cos \frac{\pi x}{200} \sin \frac{\pi t}{200\sqrt{LC}} + f(x),$$

where $f(x)$ is an arbitrary function of x . This value will only satisfy equation (56) if $f(x)$ is a constant, and from equation (51), its value is I_0 . Thus the solution for i is:

$$i(x, t) = -E \sqrt{\frac{C}{L}} \cos \frac{\pi x}{200} \sin \frac{\pi t}{200\sqrt{LC}} + I_0. \quad (57)$$

EXERCISES XXXIII

1. Neglecting R and G , find the current $i(x, t)$ and the e.m.f. $e(x, t)$ in a line a miles long, t seconds after the ends were suddenly grounded, if initially

$$i(x, 0) = I_0, \quad \text{so that} \quad \frac{\partial e(x, 0)}{\partial t} = 0,$$

and (a) $e(x, 0) = E_1 \sin \frac{\pi x}{a} + E_7 \sin \frac{7\pi x}{a}$; (b) $e(x, 0) = \frac{Ex}{a}$, the steady-state condition due to one end being grounded, and the other at potential E .

2. A line of length a is initially uncharged, so that $i(x, 0) = 0$, $e(x, 0) = 0$, $\frac{\partial e(x, 0)}{\partial t} = 0$. At $t = 0$, one end $x = a$ is suddenly connected with a constant potential E while the other end is grounded. Neglecting R and G , find $e(x, t)$ and hence $i(x, t)$. Hint: Put $e = e_S + e_T$, where e_S is the steady-state solution for the permanent end conditions, as in section 45.

3. A line of length a is initially uncharged, so that $i(x, 0) = 0$, $e(x, 0) = 0$, $\frac{\partial e(x, 0)}{\partial t} = 0$. At $t = 0$, one end $x = 0$ is suddenly connected with a constant potential E , while the other end $x = a$ is left open, so that $i(a, t) = 0$ and hence $\frac{\partial e(a, t)}{\partial x} = -L \frac{\partial i(a, t)}{\partial t} = 0$. Neglecting R and G , find $e(x, t)$ and hence $i(x, t)$. Here it is necessary to put $e = e_S + e_T$, as in problem 2, and in finding e_T to use particular solutions of the type

$$A_n \sin \frac{(2n+1)\pi x}{2a} \cos \frac{(2n+1)\pi t}{2a\sqrt{LC}},$$

and a series expansion of the type described in problem 12, p. 79. Compare problem 9 (a), p. 194.

4. A line is 50 miles long, and has resistance $R = .12$ ohms per mile, inductance $L = 2 \times 10^{-8}$ henries per mile, leakage $G = \frac{1}{3} \times 10^{-8}$ mhos per mile, capacity to ground $C = 1.2 \times 10^{-8}$ farads per mile. (a) Show that $i = I_0 e^{.00004x}$, $e = 3000 I_0 e^{.00004x}$ are possible steady-state values for the line. (b) If the initial values, $i(x, 0)$ and $e(x, 0)$ are those given in (a), so that $\frac{\partial e(x, 0)}{\partial t} = 0$, and the ends are suddenly grounded, find the e.m.f. $e(x, t)$ for the line. For the particular solutions of equation (5) on p. 158, see equation (70) on p. 152.

5. If the line of problem 4 is initially uncharged, so that $e(x, 0) = i(x, 0) = \frac{\partial e(x, 0)}{\partial t} = \frac{\partial i(x, 0)}{\partial t} = 0$, and at $t = 0$ the end $x = 50$ has a constant e.m.f., E , suddenly impressed on it and the other end is grounded, find $e(x, t)$. Hint: Put $e = e_S + e_T$, where e_S is the steady-state solution for the permanent end conditions, i.e., the solution of the form $A e^{\sqrt{RG}x} + B e^{-\sqrt{RG}x}$ which takes on the proper end values, so that in this case

$$e_S = E \frac{e^{.00004x} - e^{-.00004x}}{e^{.002} - e^{-.002}} = \frac{E \sinh .00004x}{\sinh .002}.$$

49. Problems solved by using the General Solution. Sometimes a problem involving the solution of a partial differential equation determined by given boundary or initial conditions may be solved by specializing the arbitrary functions which appear in the general solution.

As a first example, consider the equation of the vibrating string discussed in section 47, namely

$$\frac{\partial^2 y}{\partial x^2} = \frac{1}{s^2} \frac{\partial^2 y}{\partial t^2}. \quad (58)$$

Let the end points be fixed, so that if the length is a ,

$$y(0, t) = 0, \quad y(a, t) = 0. \quad (59)$$

Let the string be initially at rest, so that

$$\frac{\partial y(x, 0)}{\partial t} = 0, \quad (60)$$

and let the initial position be given,

$$y(x, 0) = F(x). \quad (61)$$

It is to be noted that in (59) t may have any value, but as the only values of x corresponding to points on the string are such that $0 < x < a$, in (60) and (61) x must be restricted to these values. Thus $F(x)$ is only defined for these values.

We have determined the solution of (58) which satisfies conditions of the above form in section 47, by using Fourier series. We may also determine the solution as follows. The general solution of (58) has been found in problem 4, p. 147 to be

$$y(x, t) = f(x + st) + g(x - st). \quad (62)$$

The condition (59), applied to this, shows that

$$f(st) + g(-st) = 0, \quad f(a + st) + g(a - st) = 0.$$

If we put $-st = u$, the first of these equations may be written:

$$g(u) = -f(-u), \quad (63)$$

and this may be used to eliminate g from the second equation. The result is

$$f(a + st) - f(-a + st) = 0.$$

By putting $-a + st = u$, we may write this as

$$f(u + 2a) = f(u). \quad (64)$$

The equations (63) and (64) hold for *all* values of u . The first defines g in terms of f , and the second shows that f is periodic, of period $2a$.

In view of (63), we may write (62) as

$$y(x, t) = f(x + st) - f(-x + st). \quad (65)$$

Let us next apply the conditions (60) and (61), which only hold for $0 < x < a$ to this last relation. They give the conditions:

$$\begin{aligned} sf'(x) - sf'(-x) &= 0, & 0 < x < a, \\ f(x) - f(-x) &= F(x), & 0 < x < a. \end{aligned}$$

The first of these may be integrated, giving

$$f(x) + f(-x) = c, \quad 0 < x < a.$$

As the value of $y(x, t)$ in (65) is obtained by subtracting two values of the function f , this value will not be changed if f is modified by an additive constant. By a proper choice of this constant, we may make $c = 0$ in the last equation, since if c is not zero, we need merely subtract $c/2$ from f . Thus the last condition may be taken as

$$f(x) + f(-x) = 0, \quad \text{or} \quad f(x) = -f(-x), \quad (66)$$

and this may be used to reduce the preceding condition to

$$2f(x) = F(x), \quad \text{or} \quad f(x) = \frac{1}{2}F(x), \quad 0 < x < a. \quad (67)$$

We need not restrict the value of x in (66), since by (64) f is of period $2a$, and by (66) for $0 < x < a$, it is odd in the first period, and hence it is odd throughout.

The equations (64), (66) and (67) show that if $G(u)$ is an odd, periodic function of period $2a$ which agrees with $F(u)$ for $0 < u < a$, f will be $\frac{1}{2}G$, and by (65) the solution of our problem will be:

$$y(x, t) = \frac{1}{2}\{G(x + st) + G(x - st)\}. \quad (68)$$

The equation (49) for the e.m.f. of a line when resistance and leakage are neglected, or

$$\frac{\partial^2 e}{\partial x^2} = LC \frac{\partial^2 e}{\partial t^2}, \quad (69)$$

may be treated similarly. If both ends of the line are grounded, we have two conditions analogous to (59). If the ends are kept at constant potential E_0 and E_a , we solve by subtracting off the particular solution of (69) for the steady state, and put:

$$e = e_S + e_T, \quad e_S = E_0 + \frac{(E_a - E_0)x}{a}, \quad (70)$$

so that

$$e_T(0, t) = 0, \quad e_T(a, t) = 0. \quad (71)$$

For example, if the line were originally uncharged,

$$e(x, 0) = 0, \quad \frac{\partial e(x, 0)}{\partial t} = 0, \quad i(x, 0) = 0, \quad (72)$$

and at $t = 0$ the end $x = a$ were raised to a potential E , while the other end $x = 0$ were left at 0 potential, we should have

$$e(x, t) = \frac{Ex}{a} + e_T(x, t), \quad (73)$$

and e_T would satisfy the differential equation (69), the boundary conditions (71), and the initial conditions:

$$e_T(x, 0) = -\frac{Ex}{a}, \quad \frac{\partial e_T(x, 0)}{\partial t} = 0. \quad (74)$$

By comparing these conditions with those which led to (68), we see that

$$e_T(x, t) = \frac{1}{2} \left\{ G\left(x + \frac{t}{\sqrt{LC}}\right) + G\left(x - \frac{t}{\sqrt{LC}}\right) \right\}, \quad (75)$$

where $G(u)$ is an odd, periodic function of period $2a$ which agrees with $-Eu/a$ for $0 < u < a$, i.e., a periodic function of period $2a$ which agrees with $-Eu/a$ for $-a < u < a$.

EXERCISES XXXIV

1. Derive equations (47) and (54) by the method of section 49.
2. Solve problems 1 and 2, p. 200-01 by using the general solution.
3. Find $e(x, t)$ in problem 1, p. 203 by using the general solution.
4. If the initial velocity of a vibrating string of length a with fixed end points is given by

$$\frac{\partial y(x, 0)}{\partial t} = H(x),$$

and the string is initially in the equilibrium position,

$$y(x, 0) = 0,$$

show that

$$y(x, t) = \frac{1}{2s} \int_{x-st}^{x+st} K(u) du,$$

where $K(u)$ is an odd, periodic function of period $2a$, agreeing with $H(u)$ for $0 < u < a$.

5. Use the result in problem 4, to solve problem 4, p. 201.

6. By using the results of problem 5 on p. 202, and problem 4 above, show that if the end points of the string are fixed, the initial position $y(x, 0) = F(x)$ and the initial velocity $\frac{\partial y(x, 0)}{\partial t} = H(x)$, $0 < x < a$, the solution may be

written:

$$y(x, t) = \frac{1}{2s} \int_{x-st}^{x+st} K(u) du + \frac{1}{2} \{G(x+st) + G(x-st)\},$$

where, as in (68) of the text and problem 4 above, $G(u)$ and $K(u)$ are odd periodic functions of period $2a$, agreeing with $F(u)$ and $H(u)$ respectively for $0 < u < a$.

7. The e.m.f. for a line of length a satisfies the initial conditions $e(x, 0) = F(x)$, $\frac{\partial e(x, 0)}{\partial t} = H(x)$, $0 < x < a$. Neglecting R and G , and using the general solution, find $e(x, t)$, t seconds after the sudden change if

(a) both ends are suddenly grounded at $t = 0$;

(b) the end $x = 0$ is grounded, and the end $x = a$ is connected to a constant potential E ;

(c) the end $x = 0$ is grounded, and the end $x = a$ is left open $\frac{\partial e(a, t)}{\partial x} = 0$, as in problem 3, p. 204.

8. Solve problem 7 if we take account of R and G , but the values are such that the line is distortionless, $LG = RC$. See problem 2, p. 160.

50. **Closed form for the Fourier Series Solutions.** The general solution of the equation

$$\frac{\partial^2 U}{\partial x^2} + \frac{\partial^2 U}{\partial y^2} = 0, \quad (76)$$

has been found in problem 2, p. 147 to be

$$U = f(x + iy) + g(x - iy). \quad (77)$$

While it is difficult to find directly two functions f and g to give required boundary values, like those treated in section 43, we may sometimes work back from the Fourier series solution to the functions f and g , and so simplify the solution.

For example, in problem 2, p. 187 the solution of (76) which reduced to zero on both long sides and one of the short sides of a long rectangle a cm. wide, and was c on the other short side was found to be

$$U(x, y) = \frac{4c}{\pi} \sum_{n=1}^{\infty} \frac{1 - (-1)^n}{2n} e^{-\frac{n\pi y}{a}} \sin \frac{n\pi x}{a}. \quad (78)$$

By (45), p. 18, we have:

$$\left[e^{\frac{\pi i(x+iy)}{a}} \right]^n = e^{-\frac{n\pi y}{a} + \frac{i n \pi x}{a}} = \left(\cos \frac{n\pi x}{a} + i \sin \frac{n\pi x}{a} \right) e^{-\frac{n\pi y}{a}}.$$

Consequently, if we put

$$e^{\frac{i(x+iy)}{a}} = Z, \tag{79}$$

the summation in (78) is the imaginary component of

$$S(Z) = Z + \frac{Z^3}{3} + \frac{Z^5}{5} + \dots$$

To sum this series, we differentiate, and find

$$S'(Z) = 1 + Z^2 + Z^4 + \dots,$$

a geometric progression with sum

$$\frac{1}{1 - Z^2} = \frac{1}{2(1 - Z)} + \frac{1}{2(1 + Z)}.$$

Thus,

$$S(Z) = \int_0^Z S'(Z) dZ = \frac{1}{2} \log_e \frac{1 + Z}{1 - Z}. \tag{80}$$

A comparison of this last result with (77) and (79) shows that if we put

$$f(u) = -\frac{ic}{\pi} \log_e \frac{1 + e^{\frac{\pi i u}{a}}}{1 - e^{\frac{\pi i u}{a}}}, \quad g(u) = \frac{ic}{\pi} \log_e \frac{1 + e^{-\frac{\pi i u}{a}}}{1 - e^{-\frac{\pi i u}{a}}}, \tag{81}$$

in equation (77), it will give the solution (78). In fact, since the variables in f and g in (77) are conjugate complex quantities, as defined in problem 8, p. 6, the values of f and g when (81) are used will be conjugate, and U will be twice the real component of f , or owing to the factor $-i$, and the $\frac{1}{2}$ in (80), $4c/\pi$ times the imaginary component of (80).

By using equations (45) and (47), p. 18, we may reduce the solution (78) to the form

$$U(x, y) = \frac{2c}{\pi} \left[\tan^{-1} \left\{ \frac{\sin \frac{\pi x}{a} e^{-\frac{\pi y}{a}}}{1 + \cos \frac{\pi x}{a} e^{-\frac{\pi y}{a}}} \right\} + \tan^{-1} \left\{ \frac{\sin \frac{\pi x}{a} e^{-\frac{\pi y}{a}}}{1 - \cos \frac{\pi x}{a} e^{-\frac{\pi y}{a}}} \right\} \right]. \tag{82}$$

We may readily check directly that this satisfies the given boundary conditions. For example for $y = 0$, the two quantities whose inverse tangents are taken are reciprocal, so the inverse tangents give complementary angles, and the value of U is $2c/\pi \cdot \pi/2 = c$.

EXERCISES XXXV

1. Find the functions in (77) which give the series solution of problem 2 (b), p. 187, and hence show that the series there given is equivalent to

$$U(x, y) = \frac{2ap}{\pi} \tan^{-1} \left\{ \frac{\sin \frac{\pi x}{a} e^{-\frac{\pi y}{a}}}{1 + \cos \frac{\pi x}{a} e^{-\frac{\pi y}{a}}} \right\}.$$

2. Show that the solution of problem 6, p. 188 is the real component of

$$\frac{1}{\pi} \int_{-\pi}^{\pi} \left[\frac{1}{2} + \sum_{n=1}^{\infty} \frac{z^n}{Z^n} \right] f(t) dt,$$

where $z = re^{i\theta}$, $Z = Re^{it}$. By summing the geometric progression, reduce the expression to the form

$$\frac{1}{2\pi} \int_{-\pi}^{\pi} \frac{Z+z}{Z-z} f(t) dt,$$

and hence reduce the solution of the problem to the form

$$U(r, \theta) = \frac{1}{2\pi} \int_{-\pi}^{\pi} \frac{R^2 - r^2}{R^2 - 2Rr \cos(t - \theta) + r^2} f(t) dt.$$

This expression for a solution of the steady-state temperature, or potential function, in terms of prescribed boundary values on the circumference of a circle is known as Poisson's integral.

* The identity

$$1 - 2(\epsilon^{-t} - \epsilon^{-4t} + \epsilon^{-9t} - \dots) = 2\sqrt{\frac{\pi}{t}} \left(\epsilon^{-\frac{\pi^2}{4t}} + \epsilon^{-\frac{9\pi^2}{4t}} + \epsilon^{-\frac{25\pi^2}{4t}} + \dots \right)$$

from the theory of theta functions is useful here.

CHAPTER VII

ANALYTIC FUNCTIONS

This chapter is devoted to a discussion of the elementary properties of analytic functions of a complex variable. We begin by recalling certain definitions, fundamental in the calculus, and extending them so as to apply to complex variables.

51. Limits. Let a_t be a real variable, whose value is determined for an infinite number of values of the quantity t , which we may consider successively. The quantity t may change abruptly, for example, taking on in succession the values

$$1, 2, 3, \dots$$

or

$$1, \frac{1}{10}, \frac{1}{100}, \dots$$

Or it may vary continuously, like the time variable in physical problems, for example, changing steadily from 0 to 1, or increasing indefinitely from 0 through all positive real values. We thus have an isolated, or continuous, succession of values of the variable a_t . We say that:

The real variable a_t approaches a finite limit A , if, beyond a certain point in its succession of values, the numerical value of the difference a_t and A becomes, and stays, smaller than any fixed positive quantity.

If the variable a_t be represented geometrically by a variable point a_t on a representative scale, the definition requires that, as the point takes on its succession of positions, the distance from it to the fixed point A ultimately becomes and remains as small as we please. This suggests the alternative procedure of first stating that:

The positive real variable p_t approaches zero as a limit if, beyond a certain value in its succession of values, it becomes and stays smaller than any fixed positive quantity; and then stating that:

The real variable a_i approaches a limit A , if the numerical value of the difference between a_i and A , $|a_i - A|$, approaches zero as a limit.

From two real variables, a_i and b_i , we may form a complex variable, $a_i = a_i + ib_i$. If a_i is approaching A as a limit, and b_i is approaching B as a limit, we say that the complex variable a_i is approaching $A = A + iB$ as a limit.

Let us consider the representation in the complex plane. The distance from the variable point a_i to the fixed point A , $|a_i - A|$, is the hypotenuse of a right triangle whose sides are $a_i - A$ and $b_i - B$. If these two sides are each approaching zero, so is the hypotenuse, and conversely if the hypotenuse is approaching zero, so are each of the sides. Thus we have the equivalent definition:

The complex variable a_i approaches a finite limit A if the absolute value of the difference between a_i and A approaches zero as a limit.

It is clear from geometric considerations that the absolute value of the variable approaches the absolute value of the limit, and, except when the limit is zero, a suitable determination of the angle of the variable approaches one value of the angle of the limit.

52. Steadily Increasing Real Variables. We shall frequently make use of the principle that:

If a real variable is constantly increasing, but always less than a fixed quantity, it must approach a finite limit.

To see this, consider the variable point on the number scale, and mark all the integral points between its initial position and the bounding fixed quantity. A certain number of these, from the left on, will ultimately be passed or reached by the variable, while the rest will not be. Thus, from a certain value on, the variable point is located in a particular unit. Divide this unit into tenths, and by the same reasoning we see that ultimately the variable will be in a particular tenth. Continuing in this way, we find a succession of intervals of width $1/10^n$. The readings of the left-hand boundary points of these intervals give an infinite decimal, which is the limit of the variable since the difference between this infinite decimal and the variable is ultimately less than $1/10^N$, for any fixed N .

The argument applies if the variable is sometimes stationary, so long as it never decreases.

A similar result applies to variables which are steadily decreasing, since these may be thought of as a constant, minus a steadily increasing variable.

If a variable steadily increases, but does not remain less than any fixed quantity, so that it ultimately exceeds every fixed quantity, it is said to become infinite. We write in this case

$$\lim a_t = \infty. \quad (1)$$

Even if we regard ∞ as a number subject to some of the arithmetic operations, the definition of approach to a limit does not apply. In fact, since a_t is finite, if we assigned any value to $|\infty - a_t|$, it would be ∞ , which does not approach zero. Many writers reserve the term limit for finite limit, and write (1), but read it " a_t becomes infinite." If a_t is complex, and its absolute value becomes infinite, we again write (1). In all cases, (1) is equivalent to

$$\lim 1/a_t = 0.$$

53. Function, Continuity. We say that y is a function of x , for a certain range of value of x , if for each x in this range, one or more values of y are determined. This definition is applicable to the case where x and y are real, and also to the case when either or both are complex. We are usually concerned with the case where there is just one value of x for each y , in which case we have a single valued function.

We say that $y = f(x)$ is a continuous function of x , at $x = x_0$, if, whenever x approaches x_0 , $f(x)$ approaches a limit, and this limit is $f(x_0)$.

We say that a function is continuous throughout a range, which is usually an interval for one real variable, and a two dimensional region for a complex variable, if it is continuous for all points of the range.

The definitions of function and continuity require only slight modification to apply to the case of more than one independent variable x . For example, $z = f(x, y)$ is a continuous function of x and y , at $x = x_0$, $y = y_0$, if whenever x approaches x_0 and y approaches y_0 , $f(x, y)$ approaches $f(x_0, y_0)$.

54. Series. An unending sum of real or complex constants,

$$u_1 + u_2 + u_3 + \dots \quad (2)$$

or, as it is often abbreviated,

$$\sum_{n=1}^{\infty} u_n, \quad (3)$$

is called an **infinite series**. For any finite number of terms, we may form the sum in the usual way, and thus define the **partial sums**,

$$\begin{aligned} s_1 &= u_1, \\ s_2 &= u_1 + u_2, \\ &\quad \cdot \quad \cdot \\ s_n &= \sum_{k=1}^n u_k = u_1 + u_2 + u_3 + \cdots + u_n. \end{aligned} \quad (4)$$

The values of s_t , $t = 1, 2, 3, \cdots$ define a variable which may approach a limit S , in accordance with the definition given in section 51. If this is the case, so that

$$\lim_{t \rightarrow \infty} s_t = S, \quad t = 1, 2, 3, \cdots \quad (5)$$

we say that the series (2), or (3) is **convergent**, and has the sum S . We indicate this by writing:

$$S = \sum_{n=1}^{\infty} u_n = u_1 + u_2 + u_3 + \cdots, \quad (6)$$

which is to be thought of as an abbreviation for (4) and (5).

We note that when a series converges, the individual terms must approach zero. In fact:

$$\begin{aligned} \lim u_n &= \lim (s_n - s_{n-1}) \\ &= \lim s_n - \lim s_{n-1} \\ &= S - S = 0. \end{aligned} \quad (7)$$

Consequently, there is an upper bound to all the terms, since from a certain term on, the terms will be numerically less than any fixed positive quantity, say 1. Suppose this is true after N terms. Any positive number bigger in absolute value than 1 and each of these N terms is numerically bigger than any term of the series.

If the variable s_t does not approach a finite limit, the series is **divergent**. It is evident that the series obtained from a given series by changing a *finite* number of its terms, is convergent or not according as the original series was convergent or not.

55. Absolute Convergence. We shall now prove that if an infinite series of complex terms has each term less in absolute value than the corresponding term of a convergent series of positive real numbers, the first series converges, and the absolute value of its sum, is less than the sum of the second.

Let the series of complex terms be

$$u_1 + u_2 + u_3 + \cdots, \quad (8)$$

and the series of positive terms be

$$T = M_1 + M_2 + M_3 + \cdots, \quad (9)$$

so that

$$|u_1| \leq M_1, \quad |u_2| \leq M_2, \quad \cdots, \quad |u_n| \leq M_n, \quad \cdots. \quad (10)$$

We separate u_n into its real and imaginary components, and put

$$u_n = a_n + ib_n = a_n' - a_n'' + ib_n' - ib_n'', \quad (11)$$

where when a_n is positive,

$$a_n = a_n', \quad a_n'' = 0,$$

but when a_n is negative,

$$a_n' = 0, \quad a_n'' = -a_n.$$

Similarly b_n' is b_n or 0, and b_n'' is 0 or $-b_n$, according as b_n is positive or negative. Thus each of the quantities a_n', a_n'', b_n', b_n'' is positive or zero, and if we write the sum to n terms

$$s_n = s_n' - s_n'' + it_n' - it_n'', \quad (12)$$

each of the four variables s_n', s_n'', t_n', t_n'' will be steadily increasing in the sense of section 52. But, from (10), and the fact that the absolute value of a sum is less than or equal to the sum of the absolute values, we have each of these variables always less than $\sum_{k=1}^n |u_k|$ and hence less than the corresponding partial sum of (9), and hence less than T . Thus, by section 52, each of the four quantities on the right of (12) approaches a limit, so that the left member s_n approaches a limit S and the series (8) converges.

Moreover, since

$$\left| \sum_{k=1}^n u_k \right| \leq \sum_{k=1}^n |u_k| \leq \sum_{k=1}^n M_k, \quad (13)$$

on taking the limits we find:

$$S \leq T. \quad (14)$$

If the series of positive terms, obtained from a series of complex terms by taking the absolute value of each of its terms, converges, the original series is said to be **absolutely convergent**. In this case, we may take $M_n = |u_n|$ in the above discussion, and we see that if a series is absolutely convergent, it is convergent, and the absolute value of its sum is less than or equal to the sum of the series of absolute values.

The inequality (13) shows that any series (8), related to a convergent series (9) by (10), is absolutely convergent.

56. Operations on Series. By using the fact that, if a variable approaches zero, any constant times this also approaches zero, and the sum or difference of two variables each of which approaches zero is a new variable approaching zero, where the variables are $|S - s_n|$ for two convergent series, we see that:

The result of multiplying each term of a convergent series by a constant is a convergent series, whose sum is the constant times the sum of the original series.

If two convergent series be added together, or subtracted, term by term, the result is a convergent series whose sum is the sum or difference of the sums of the original series.

For some convergent series, rearrangements of the terms may yield divergent series, or convergent series with different sums.¹ For an **absolutely convergent series, however, any rearrangement of the terms such that no terms are added or omitted yields a convergent series with the same sum.**

To prove this, let s_n' be the partial sum to n terms of the rearranged series, and s_N be the first partial sum of the original series which includes all the terms in s_n' , while s_M is the last partial sum all of whose terms are included in s_n' . Since no terms are added or omitted, we have M and N both becoming infinite when n becomes infinite. Let t_n be the partial sum to n terms of the series obtained from the original series by taking absolute values. Then we have $s_N - s_n'$ with fewer terms than $s_N - s_M$, and each of these last equal in absolute value to a term in $t_N - t_M$, so that

$$|s_N - s_n'| \leq |t_N - t_M|.$$

¹ See problem 12, p. 219.

But, from the absolute convergence, when n and hence N and M become infinite, t_N and t_M each approach the same limit, T , so that the right member approaches zero, and s_n' must approach the same limit as s_n .

The result just proved may be applied to the multiplication of absolutely convergent series. Let their terms be u_n and \bar{u}_n , their sums be S and \bar{S} , and their partial sums s_n and \bar{s}_n , while T and \bar{T} are the sums, and t_n and \bar{t}_n are the partial sums of the series obtained from them by taking absolute values. Then since

$$\lim s_n = S, \quad \lim \bar{s}_n = \bar{S},$$

we have:

$$\lim s_n \bar{s}_n = S\bar{S}, \quad (15)$$

and the series whose partial sum is $s_n \bar{s}_n$ converges. This is a particular set of partial sums, with a particular arrangement, of the series:

$$u_1 \bar{u}_1 + u_1 \bar{u}_2 + u_2 \bar{u}_1 + u_2 \bar{u}_2 + \dots \quad (16)$$

obtained by multiplying each term of one of the series by each term of the second.

The series (16) converges absolutely, since on taking absolute values of the terms, we have a series of positive terms whose partial sums are all less than certain partial sums $t_n \bar{t}_n$, and hence less than $T\bar{T}$. Thus, as these partial sums steadily increase, by section 52, they approach a limit. Since (16) converges absolutely, and for one rearrangement gives certain partial sums which approach the product $S\bar{S}$, by (15), any rearrangement of (16) which adds or omits no terms will give the correct product.

One arrangement which is frequently convenient is to take first all those terms whose subscripts add up to 2, then 3, then 4 etc., namely:

$$u_1 \bar{u}_1 + u_1 \bar{u}_2 + u_2 \bar{u}_1 + u_1 \bar{u}_3 + u_2 \bar{u}_2 + u_3 \bar{u}_1 + \dots \quad (17)$$

EXERCISES XXXVI

1. Prove that $\lim 1/n = 0$, and $\lim 1/2^n = 0$, where $n = 1, 2, 3, \dots$ and in each case find out a value of N , such that when n is greater than N the variable is within .001 of its limit.

2. Prove that

$$\lim_{t=1} \frac{t^2 - 1}{t - 1} = 2, \quad \text{and} \quad \lim_{t=4} \frac{t - 4}{t^3 - 64} = \frac{1}{48}.$$

3. Show that $\lim (r|\theta|)^n$, as $n = 1, 2, 3, \dots$, (a) $= 0$, if $r < 1$; (b) $= \infty$, if $r > 1$; (c) $= 1$, if $r = 1$, $\theta = 0$ or $2k\pi$; but (d) no limit is approached if $r = 1$, $\theta \neq 0$ or $2k\pi$.

4. Prove that, as $n = 1, 2, 3, \dots$

$$\lim \frac{2n + 3 + i(4 - 3n)}{n - 3} = 2 - 3i.$$

5. Using the result of problem 3, show that, as $n = 1, 2, 3, \dots$, $\lim \frac{1 - c^n}{1 - c}$, where c is a complex constant, (a) $= \frac{1}{1 - c}$, if $|c| < 1$; (b) $= \infty$, if $|c| > 1$; but (c) the quantity approaches no limit if $|c| = 1$, $c \neq 1$.

6. Prove that, if $\lim_{n \rightarrow \infty} a_n = A$, the series with

$$u_1 = a_1, u_2 = a_2 - a_1, \dots, u_n = a_n - a_{n-1}$$

converges, and has the sum A .

7. By combining the results of problem 6 and 5 (a), show that, if $|c| < 1$, the geometrical progression

$$1 + c + c^2 + \dots + c^n + \dots$$

converges, and has the sum $1/(1 - c)$.

8. (a) Prove that

$$\lim_{n \rightarrow \infty} \frac{n - 1}{n} = 1;$$

(b) Using problem 6, and part (a) of this problem, show that the series

$$\frac{1}{1 \cdot 2} + \frac{1}{2 \cdot 3} + \frac{1}{3 \cdot 4} + \dots + \frac{1}{n(n-1)} + \dots$$

converges, and has the sum unity.

9. We illustrate a method of comparing a series with an integral, as applied to the series

$$\frac{1}{1^p} + \frac{1}{2^p} + \frac{1}{3^p} + \dots + \frac{1}{n^p} + \dots, \quad p \text{ any real number,}$$

in the following parts of this problem.

(a) Show that $\frac{1}{(n+1)^p} < \int_n^{n+1} \frac{1}{x^p} dx < \frac{1}{n^p}$;

(b) By summing inequalities of the type given in part (a), deduce that

$$\int_1^{N+1} \frac{1}{x^p} dx < \sum_{n=1}^N \frac{1}{n^p} < 1 + \int_1^N \frac{1}{x^p} dx;$$

(c) From the result of (b), show that the series converges if $p > 1$, and diverges if $p \leq 1$.

10. For the case $p = 1$, the inequality of 9 (b) becomes

$$\int_1^{N+1} \frac{1}{x} dx < \sum_{n=1}^N \frac{1}{n} < 1 + \int_1^N \frac{1}{x} dx,$$

or, writing s_N for the sum of the first N terms of the series

$$\frac{1}{1} + \frac{1}{2} + \frac{1}{3} + \cdots + \frac{1}{n} + \cdots,$$

$$\ln(N+1) < s_N < 1 + \ln N.$$

Show from this that, although the partial sums ultimately become infinite, they do not exceed 1000 until N exceeds $e^{999} > 10^{433}$, a number considerably greater than the estimated number of electrons in all the bodies of the solar system!

11. Noting that the odd partial sums of the series

$$1 - \frac{1}{2} + \frac{1}{3} - \cdots + \frac{1}{2n-1} - \frac{1}{2n} + \frac{1}{2n+1} - \cdots$$

may be written in either of the forms

$$1 - \left(\frac{1}{2} - \frac{1}{3}\right) - \left(\frac{1}{4} - \frac{1}{5}\right) - \cdots - \left(\frac{1}{2n} - \frac{1}{2n+1}\right),$$

or

$$\left(1 - \frac{1}{2}\right) + \left(\frac{1}{3} - \frac{1}{4}\right) + \cdots + \left(\frac{1}{2n-1} - \frac{1}{2n}\right) + \frac{1}{2n+1},$$

(a) Show from the first form that the odd sums steadily decrease, and from the second that they are always greater than zero, so that by section 52 they approach a limit.

(b) Combine part (a) with the fact that the separate terms of the series approach zero to show that the even sums, $s_{2n} = s_{2n-1} - 1/2n$, approach the same limit, so that the series converges.

12. By problems 9 or 10 the partial sums of the series

$$1 + \frac{1}{2} + \frac{1}{3} + \cdots$$

become infinite. Consequently, the partial sums of the series

$$\frac{1}{2} + \frac{1}{4} + \frac{1}{6} + \cdots,$$

which are just half as big, also become infinite, and so do those of the series

$$1 + \frac{1}{3} + \frac{1}{5} + \cdots,$$

which are greater than those of the second series. No matter how many terms are removed from the beginning of these series, the remaining series will have partial sums which become infinite.

These facts enable us to find a rearrangement of the terms of the convergent, but not absolutely convergent, series of problem 11, having any given number, say one, as limit. For, we have merely to start with enough positive terms to get a sum greater than or equal to one, then enough negative terms to get a sum less than or equal to one, and so on, each time beginning with the first term not already used, the first few terms being:

$$1 - \frac{1}{2} + \frac{1}{3} + \frac{1}{5} - \frac{1}{4} + \frac{1}{7} + \frac{1}{9} \cdots$$

Show that, by making the partial sums approximate an indefinitely increasing variable, like 2^n , we may find a rearrangement which gives a series diverging to infinity.

13. (a) If $P(n)$ is a polynomial, of degree p , whose leading term has a numerical value an^p , prove that

$$\lim_{n \rightarrow \infty} \frac{an^p}{|P(n)|} = 1.$$

(b) From part (a), and the definition of limit, show that for sufficiently large n , $n > N_1$,

$$\frac{1}{2an^p} < \frac{1}{P(n)} < \frac{2}{an^p}.$$

(c) From part (b), and problem 9, and section 55, show that the series

$$\frac{1}{P(1)} + \frac{1}{P(2)} + \frac{1}{P(3)} + \cdots + \frac{1}{P(n)} + \cdots$$

is absolutely convergent, if $p \geq 2$.

(d) Use the same method to show that if the general term of a series is the quotient of two polynomials, with that in the numerator of degree at least two less than that in the denominator, the series is absolutely convergent.

14. If the terms of an infinite series, u_n , are such that

$$\lim_{n \rightarrow \infty} \left| \frac{u_n}{u_{n-1}} \right| = C, \quad \text{and} \quad C < 1,$$

show that the series is absolutely convergent, by taking as the comparison series of section 55,

$$A(1 + c + c^2 + c^3 + \cdots)$$

and starting with the $(N + 1)$ st term of the given series, where

$$C < c < 1, \quad A = |u_{N+1}|$$

and N is so large that, for n greater than N , the ratio $\left| \frac{u_n}{u_{n-1}} \right|$ differs from its limit, C by less than $c - C$.

57. Uniformity. Consider a variable function, $f_t(x)$, defined over some range of the variable x for an infinite succession of values of t . As in section 51, t may either vary continuously or change abruptly. An example of the latter situation is obtained by considering the partial sum to n terms of a series, each of whose terms is a function of x ,

$$s_n(x) = u_1(x) + u_2(x) + \cdots + u_n(x). \quad (18)$$

The variable x may be real, in which case we shall be concerned with an interval, or the variable may be complex, in which case the range will be a two dimensional region.

Suppose, for each value of x considered, as x_0 , the succession of constants, $f_i(x_0)$ approaches a limit, $F(x_0)$, in the sense defined in section 51. Thus, for this value of x , $x = x_0$, and any fixed small positive quantity, say η , when we go sufficiently far out in the succession, say t beyond T_{η, x_0} , the numerical value of the difference between $F(x_0)$ and $f_t(x_0)$ will be less than the fixed small quantity, or

$$|f_t(x_0) - F(x_0)| < \eta, \text{ beyond } t = T_{\eta, x_0}. \quad (19)$$

As the notation indicates, if we take a smaller quantity η , or a different x_0 , we may have to go further out in the succession, and take a new T_{η, x_0} . If, when the small positive quantity is fixed, it is possible to find some point in the succession, i.e., a T_η , which will serve for all values of x in the range considered, we say that $f_i(x)$ approaches $F(x)$ **uniformly** in x , for the range considered.

In particular, if the function is the partial sum of an infinite series of functions, as the $s_n(x)$ of (18), and $s_n(x)$ approaches $S(x)$ uniformly in x , for any given range, we say that the series converges, to the sum $S(x)$, **uniformly** in x , for the given range.

58. Continuous Limiting Function. Suppose that each of the functions $f_i(x)$ is continuous at $x = x_0$, as defined in section 53, so that

$$\lim_{x=x_0} f_i(x) = f_i(x_0). \quad (20)$$

for each value of t . Then, if x is inside a range in which $f_i(x)$ converges uniformly in x to $F(x)$, $F(x)$ is continuous at x_0 . For, by the uniformity, there is some point in the succession, T_η , such that thereafter, for any value of x , x_1 , in the range, the values of $f_t(x)$ and $F(x)$ are arbitrarily near together, i.e.

$$|f_{t'}(x_1) - F(x_1)| < \eta, \text{ } t' \text{ beyond } t = T_\eta. \quad (21)$$

In particular, if we consider x_0 ,

$$|f_{t'}(x_0) - F(x_0)| < \eta, \text{ } t' \text{ beyond } t = T_\eta. \quad (22)$$

But, for any fixed t' beyond T_η , $f_{t'}(x)$ is continuous, so that (20) holds, and in particular for all x_1 in the range, sufficiently close to x_0 we will have

$$|f_{t'}(x_1) - f_{t'}(x_0)| < \eta. \quad (23)$$

With this choice of t' , and any such x_1 , equations (21), (22) and (23) all hold, and hence,

$$|F(x_1) - F(x_0)| < 3\eta. \quad (24)$$

Since η is an arbitrarily small fixed positive quantity, so is 3η , and (24) shows that when x_1 is sufficiently close to x_0 , $F(x_1)$ is arbitrarily close to $F(x_0)$, i.e.

$$\lim_{x=x_0} F(x) = F(x_0), \quad (25)$$

so that $F(x)$ is continuous at x_0 .

In particular, if each of the terms in an infinite series is a function of x , continuous at x_0 , the same is true of the sum of any finite number. Thus, if in (18) the $u_n(x)$ are all continuous at x_0 , $s_n(x)$ will be continuous at x_0 . Hence, by the result just proved, if the series converges to $S(x)$ uniformly, $S(x)$ will be continuous at x_0 .

59. A Test for Uniform Convergence. The following theorem gives a useful test for uniform convergence. **If for some range of x , each term of the series of functions**

$$u_1(x) + u_2(x) + u_3(x) + \dots \quad (26)$$

is numerically less than the corresponding term of the convergent series of positive constants.

$$T = M_1 + M_2 + M_3 + \dots, \quad (27)$$

so that

$$|u_n(x)| \leq M_n, \quad (28)$$

then the series of functions (26) converges uniformly in x for this range. The series is absolutely convergent for all such values of x .

For any fixed value of x in the range, x_0 , the series (26) converges by the theorem of section 55. Let its sum be $S(x)$, and its partial sum to N terms be s_N . Then we have

$$\begin{aligned} S(x) - s_N(x) &= \lim_{n=\infty} [s_n(x) - s_N(x)] \\ &= \lim_{n=\infty} [u_{N+1}(x) + u_{N+2}(x) + \dots + u_n(x)] \quad (29) \\ &= u_{N+1}(x) + u_{N+2}(x) + u_{N+3}(x) + \dots \end{aligned}$$

By similar reasoning, if t_N is the partial sum to N terms of the series (27) we have:

$$T - t_N = M_{N+1} + M_{N+2} + M_{N+3} + \dots \quad (30)$$

Since the infinite series on the right of (29) is term for term numerically less than that on the right of (30), by the theorem of section 55, its sum is numerically less, and hence

$$|S(x) - s_N(x)| \leq |T - t_N|, \quad (31)$$

for all values of x in the range. Thus we may make the left member numerically small, for all x , by selecting an N which makes the right member small, and we have uniform convergence.

The absolute convergence follows from the remark at the end of Section 55.

EXERCISES XXXVII

1. Using the test of section 59, with

$$1 + a + a^2 + \dots$$

as the series of positive constants, show that the series

$$1 + x + x^2 + x^3 + \dots$$

converges uniformly in x , for the range defined by any fixed a ,

$$a < 1, \text{ and } |x| < a.$$

(2) (a) Show that the difference between the sum of the series in problem 1, and the partial sum to n terms is $\frac{x^{n+1}}{1-x}$, which is numerically less than $\frac{a^{n+1}}{1-a}$, and prove the uniform convergence directly from this.

(b) By considering the behavior of the expression in part (a) for values of x near 1, show that while the series converges for all values of x such that $|x| < 1$, it does not converge uniformly in x for this range.

3. Noting that the n th term of the series

$$\frac{x}{(1+x)(1+2x)} + \frac{x}{(1+2x)(1+3x)} + \frac{x}{(1+3x)(1+4x)} + \dots$$

may be written $\frac{1}{1+nx} - \frac{1}{1+(n+1)x}$, show that for $0 < |x| < 1$, the partial sum to n terms of the series is $\frac{1}{1+x} - \frac{1}{1+(n+1)x}$, so that the sum of the series is $\frac{1}{1+x}$. Hence show that, if $S(x)$ be the sum of the series, $S(0) = 0$, but $\lim_{x=0} S(x) = 1$. It follows from the theorem of section 59, that the series can not converge uniformly in x in any region containing the origin. Verify this by a direct examination of the difference between $S(x)$ and $s_n(x)$ for values of x near zero.

4. Show that, for all values of x , the partial sum to n terms of the series

$$\frac{|x|}{1+|x|} + \frac{|x|}{(1+|x|)^2} + \frac{|x|}{(1+|x|)^3} + \dots$$

is $1 - \frac{1}{(1 + |x|)^n}$, and discuss the non-uniformity of the convergence for a region including the origin, along the lines indicated in problem 3.

5. If $F(x) = \lim_{t=\infty} f_t(x)$, and $f_t(x) = \frac{a + bt^2}{1 + tx^2}$, show that we have non-uniform convergence in any region including the origin, and that $F(0) = a$, but $F(x) = b$, $x \neq 0$. Thus $F(x)$ is not continuous for $x = 0$, if $b \neq a$, but is continuous if $b = a$.

6. If the n th term of a series of functions, $u_n(x)$ is defined to be 1 for values of x such that n is the biggest integer less than or equal to $1/|x|$, and otherwise zero, show that the series converges for all values of x , having a sum 1 when $x \neq 0$, and $|x| < 1$, and a sum 0, when x is zero. The convergence is non-uniform in any region including the origin.

7. Using the fact that the integral of a real function over an interval is numerically at most the product of the length of the interval times the greatest numerical value of the integrand, prove that if $f_t(x)$ converges to $F(x)$ uniformly in x , for the range $a \leq x \leq b$, then $\int_a^x f_t(x) dx$ converges to $\int_a^x F(x) dx$, for all values of x in the given range. Applied to series, this shows that a uniformly convergent series of real functions may be integrated termwise, and the new series is uniformly convergent.

8. Except for $x = 0$, the limit, $F(x)$, of the function $f_t(x) = \frac{t}{1 + t^2x^2}$ as $t = \infty$, is 0, so that $\int_0^1 F(x) dx = 0$. However, $\lim_{t=\infty} \int_0^1 f_t(x) dx = \lim_{t=\infty} \tan^{-1} t = \pi/2$. Thus, by problem 7 the convergence can not be uniform. Show this directly.

9. If $f_t(x) = t \sin tx$, when $0 < x < \pi/t$, but $f_t(x) = 0$, when $\pi/t < x < \pi$, show that $\lim_{t=\infty} f_t(x) = F(x) = 0$, and $\int_0^\pi F(x) dx = 0$, while $\lim_{t=\infty} \int_0^\pi f_t(x) dx = 2$. Discuss the non-uniformity as suggested in problem 8.

60. Power Series. In section 6 we defined a power series in the complex variable $z - C$, as a series of the form

$$A_0 + A_1(z - C) + A_2(z - C)^2 + A_3(z - C)^3 + \dots, \quad (32)$$

in which C and the coefficients A_0, A_1, A_2 , etc. are complex constants. When $C = 0$, we have the power series in z ,

$$A_0 + A_1z + A_2z^2 + A_3z^3 + \dots \quad (33)$$

To save writing, we shall for the most part discuss this last form. Most of the results may be carried over to the more general form, by taking $z - C$ as a new variable, which amounts to moving the origin to the point C

We first prove that, if the series (33) is convergent for any value $z = z_1 \neq 0$, it converges uniformly in z for the range $|z| \leq r$, where r is any positive number less than $|z_1|$. It is also absolutely convergent for these values of z . For, by the remark at the end of section 54, since the series converges for $z = z_1$, there will be some number, say B , numerically larger than all the terms of the series, so that

$$|A_n z_1^n| < B. \quad (34)$$

It follows from this that, for all values of z such that

$$|z| \leq r < |z_1|, \quad (35)$$

if

$$\frac{r}{|z_1|} = c, \quad \text{then } c < 1,$$

and

$$|A_n z^n| = \left| A_n z_1^n \left(\frac{z}{z_1} \right)^n \right| < B c^n.$$

Thus for these values of z , the series (33) is term by term numerically less than the series of positive terms

$$B + Bc + Bc^2 + Bc^3 + \dots$$

This last series is a geometric progression with ratio less than one, and therefore converges. Thus, by the test for uniform convergence in section 59, the series (33) converges uniformly in z for the range given by (35), that is, the region consisting of all the points inside and on the boundary of a circle of radius r with center at the origin, and is absolutely convergent for these values.

We shall refer to such a circle as a **circle of uniform convergence**, and the result just proved shows that, if a power series for any value of z besides $z = 0$, there are such circles.

Since the powers of z are all continuous functions, by section 58 we see that the sum of a power series, $f(z)$, is a continuous function of z at all points inside and on any circle of uniform convergence.

61. Operations on Power Series. If we have two power series,

$$\begin{aligned} f(z) &= A_0 + A_1 z + A_2 z^2 + A_3 z^3 + \dots \\ g(z) &= B_0 + B_1 z + B_2 z^2 + B_3 z^3 + \dots, \end{aligned} \quad (36)$$

it follows from section 56 that

$$f(z) + g(z) = (A_0 + B_0) + (A_1 + B_1)z + (A_2 + B_2)z^2 + \dots \quad (37)$$

and

$$f(z) \cdot g(z) = A_0B_0 + (A_0B_1 + A_1B_0)z + (A_0B_2 + A_1B_1 + A_2B_0)z^2 + \dots, \quad (38)$$

for values of z in any circle with center at the origin, or radius $r < |z_1|$, where z_1 is any value of z for which both the series of (36) converge.

By repeated application of (38), we may find the series for the successive powers of a given series. For example, the powers of a function given by a series with first term zero,

$$h(z) = C_1z + C_2z^2 + C_3z^3 + \dots \quad (39)$$

are

$$\begin{aligned} h^2 &= C_1^2z^2 + 2C_1C_2z^3 + (C_2^2 + 2C_1C_3)z^4 + \dots, \\ h^3 &= C_1^3z^3 + 3C_1^2C_2z^4 + (3C_1^2C_3 + 3C_1C_2^2)z^5 + \dots, \\ &\dots \end{aligned} \quad (40)$$

These suggest a method of finding a power series for a function of a function of this type. Thus, from

$$f(h) = A_0 + A_1h + A_2h^2 + A_3h^3 + \dots, \quad (41)$$

(39) and (40), we find the series

$$\begin{aligned} A_0 + (A_1C_1)z + (A_1C_2 + A_2C_1^2)z^2 + \\ (A_1C_3 + 2A_2C_1C_2 + A_3C_1^3)z^3 + \dots \end{aligned} \quad (42)$$

To prove that, for sufficiently small z , this series actually converges to $f[h(z)]$, we first consider the case in which all the coefficients C_1, C_2, \dots as well as A_0, A_1, A_2, \dots are positive or zero, and a positive value of z such that the series 41 converges for the corresponding positive value of h . Then, since the sums of the series (40) and (41) are greater than any of their partial sums, which increase with the number of terms, for any two integers M and N , $M > N$ the difference between the sum of (41), and the sum to M terms of (42) will be less than the difference between the sum of (41), and its sum to N terms, plus the difference between the sum, and sum to M terms for each of the series for the first N powers of h , multiplied by the corresponding coefficient A_1 ,

A_2, \dots, A_N . However, for any N large enough to make the first difference small, there are larger numbers M such that the other N differences, multiplied by the coefficients and added together, are small. Thus when M becomes infinite, the sum of (42) to M terms approaches the sum of (41) for the case considered.

For the general case, we apply the argument just given to the numerical values, and find the differences for this case numerically less than those for the numerical values. Thus, at least for values of z such that the sum

$$|C_1| |z| + |C_2| |z|^2 + |C_3| |z|^3 + \dots \quad (43)$$

converges to a value h_1 for which

$$|A_0| + |A_1| h_1 + |A_2| h_1^2 + |A_3| h_1^3 + \dots \quad (44)$$

converges, the series (42) converges to $f[h(z)]$.

We next consider the problem of expressing the quotient of two power series in a power series as an application of these processes. We first note that if $A_0 \neq 0$,

$$\begin{aligned} \frac{1}{A_0 - z} &= \frac{1}{A_0 \left(1 - \frac{z}{A_0}\right)} = \frac{1}{A_0} \left(1 + \frac{z}{A_0} + \frac{z^2}{A_0^2} + \dots\right) \\ &= \frac{1}{A_0} + \frac{z}{A_0^2} + \frac{z^2}{A_0^3} + \dots, \end{aligned} \quad (45)$$

for values of z such that $|z| < |A_0|$, by problem 7, p. 218.

By replacing z in this series by

$$h(z) = -A_1 z - A_2 z^2 - A_3 z^3 - \dots, \quad (46)$$

we obtain a power series for $1/f(z)$, where $f(z)$ is the power series of (36). Then, by applying (38), to this series and $g(z)$, we obtain a power series which converges to the quotient $g(z)/f(z)$ for sufficiently small values of z

EXERCISES XXXVIII

1. (a) Prove that the series

$$1 + r + \frac{r^2}{2!} + \frac{r^3}{3!} + \dots$$

converges for all real values of r , by comparing the terms after the N th with a geometric progression with ratio r/N , where N is any integer greater than r .

(b) From the result of part (a), prove that the series for e^z , $\sin z$, $\cos z$, $\sinh z$, $\cosh z$ converge for all complex values of z , and hence that any circle with center at the origin is a circle of uniform convergence for these series.

2. (a) By comparing the terms after the N th, where N is so large that $\left| \frac{m-N}{N+1} r \right| < c < 1$, with a geometric progression, prove that the series

$$1 + mr + \frac{m(m-1)}{1 \cdot 2} r^2 + \frac{m(m-1)(m-2)}{1 \cdot 2 \cdot 3} r^3 + \dots$$

converges for all real values of m , and all real values of r , numerically less than 1.

(b) Use part (a) to prove that the series

$$f(z, m) = 1 + mz + \frac{m(m-1)}{2!} z^2 + \frac{m(m-1)(m-2)}{3!} z^3 + \dots$$

for any one real value of m , is uniformly convergent in z , in any circle with center at the origin, and radius less than 1.

(c) Prove that, for any one value of z , and $|m| < M$, the series converges uniformly in m .

3. (a) Prove that the function of problem 2 (b), defined for z less than unity, satisfies the relation $(1+z)f(z, m) = f(z, m+1)$.

(b) From part (a), and the fact that $f(z, 1) = 1+z$, prove that when m is a positive integer, zero, or a negative integer, $f(z, m) = (1+z)^m$.

4. (a) Prove that, by problem 3 (b),

$$f(z, m) \cdot f(z, n) = f(z, m+n)$$

for integral values of m and n , and hence the coefficients must be related as required by (38), and the relation is true, for all real values of m and n . Verify for the first few coefficients.

(b) From part (a), deduce that $f(z, m) = (1+z)^m$ for all rational values of m .

(c) From problem 2 (c), prove that for a fixed z , $f(z, m)$ is a continuous function of m , and hence by part (b) of this problem equals $(1+z)^m$ for irrational values of m , as these powers are ordinarily defined.

5. A power series in z may be written as a power series in $z-C$, by writing $z = (z-C) + C$, and using this to express the powers of z as polynomials in $(z-C)$. Noting that, if $|C| < r$, and $|(z-C)| < r - |C|$, then $|(z-C)| + |C| < r$, show that if the original series converges for z_1 , and $|z_1| = r$, the new series converges for $|z-C| < r$, and has the same sum as the original series. The coefficients of the new series are themselves infinite series, which must first be shown to converge.

62. Derivatives. If $y = f(x)$ is a real function of the real variable x , and

$$\lim_{h \rightarrow 0} \frac{f(x+h) - f(x)}{h} = f'(x), \quad (47)$$

regardless of how h approaches zero through real values, we define $f'(x)$ as the derivative of y with respect to x , dy/dx .

Similarly, if $w = f(z)$ is a complex function of the complex variable z , and

$$\lim_{h \rightarrow 0} \frac{f(z+h) - f(z)}{h} = f'(z), \quad (48)$$

regardless of how h approaches zero through complex values, we define $f'(z)$ as the derivative of w with respect to z , dw/dz .

We shall now prove that, if $f(z)$ is given by a power series, for all values of z inside a circle of uniform convergence, there is a derivative as defined by (48), and it may be expressed as a power series by differentiating each term by the familiar rule for real functions.

Let the series

$$f(z) = A_0 + A_1z + A_2z^2 + A_3z^3 + \dots, \quad (49)$$

be convergent for $z = z_1$, and therefore absolutely convergent for any value numerically less than this.

Let $|z| = r$, at the point where we are investigating the derivative, so that $r < |z_1|$. We take p any positive number such that $r + p < |z_1|$. Then

$$|A_0| + |A_1|r + |A_2|r^2 + |A_3|r^3 + \dots$$

and

$$|A_0| + |A_1|(r + p) + |A_2|(r + p)^2 + |A_3|(r + p)^3 + \dots$$

each converge, in consequence of the absolute convergence of (49). Hence the series obtained by subtracting these termwise, and dividing by p will converge. Its general term is

$$|A_n| \frac{(r + p)^n - r^n}{p} = |A_n| \left(nr^{n-1} + \frac{n(n-1)}{1 \cdot 2} r^{n-2}p + \dots \right). \quad (50)$$

The second form shows that it is positive, and decreases if p is replaced by any smaller number.

Now let h be any complex number numerically less than p , and form the series for the difference quotient

$$\frac{f(z + h) - f(z)}{h},$$

which has the general term

$$A_n \frac{(z + h)^n - z^n}{h} = A_n \left(nz^{n-1} + \frac{n(n-1)}{1 \cdot 2} z^{n-2}h + \dots \right). \quad (51)$$

Since the numerical value of this is less than that found from the second form by taking the numerical values of the terms separately, it is less than the term (50), which came from a convergent series of positive terms. Hence, by the test of section 59, the series with terms given by (51) converges uniformly in h , for $|h| < p$. Thus,

by section 58, it converges to a continuous function of h , and the difference quotient approaches a limit, for $h = 0$, given by putting $h = 0$ in the separate terms, so that, finally:

$$f'(z) = A_1 + 2A_2z + 3A_3z^2 + 4A_4z^3 + \dots \quad (52)$$

On p. 14, we defined an **analytic function** of a complex variable as a function with a power series representation. Thus the result just proved shows that, **if a function is analytic at a point, it has a derivative at the point, and the derived function is analytic at the point.** The process may be repeated, so that there are derivatives of all orders.

EXERCISES XXXIX

1. Prove that if $f(z) = A_0 + A_1z + A_2z^2 + A_3z^3 + \dots$, then $A_0 = f(0)$, $A_1 = f'(0)$, $A_2 = f''(0)/2!$, etc. This shows that if two power series in z represent the same function, they must have the same coefficients.

2. Show that the series obtained for the quotient of two power series in section 61 must agree with that found by the usual long division process.

3. Find dw/dz if $w = 1/(1 - z)$, and $|z| < 1$, both by a direct application of the definition, and by using the power series.

4. Find dw/dz if $w = (1 + z)^{1/2}$, $|z| < 1$, by two methods, as in problem 3.

5. Show that, for complex functions of complex variables,

$$\frac{dw}{dz} = \frac{dw}{ds} \cdot \frac{ds}{dz}$$

6. Show that the rules for differentiating products, quotients, and integral powers are the same for complex functions as for reals. Thus rational functions may be differentiated without recourse to the series.

7. Use the series to prove that the rules for differentiating e^z , $\sin z$, $\cos z$, $\sinh z$ and $\cosh z$ are the same as those for the corresponding real functions.

8. Prove that, if $f(z)$ is expanded in powers of $z - C$,

$$f(z) = B_0 + B_1(z - C) + B_2(z - C)^2 + B_3(z - C)^3 + \dots,$$

by the method of problem 5, p. 228, or otherwise, then

$$B_0 = f(C), \quad B_1 = f'(C), \quad B_2 = \frac{1}{2!} f''(C), \text{ etc.}$$

9. If the solution to a differential equation be assumed in the form of a power series, and the coefficients are determined so that the equation is satisfied, show that if the series giving the solution converges for $z = z_1$, it represents a solution of the equation for $|z| < |z_1|$. Use this method to solve the equations

$$(a) \frac{dw}{dz} + z = 0, \quad (b) \frac{d^2w}{dz^2} + z = 0, \quad (c) \frac{dw}{dz} = z^2 + w^2.$$

10. Prove that Bessel's function of order n ,

$$J_n(z) = \sum_{k=0}^{\infty} \frac{(-1)^k z^{n+2k}}{2^{n+2k} k! (n+k)!} \text{ with } 0! = 1 \text{ in the first term,}$$

is a solution of the differential equation $\frac{d^2w}{dz^2} + \frac{1}{z} \frac{dw}{dz} + \left(1 - \frac{n^2}{z^2}\right)w = 0$.

11. Prove that Legendre's polynomial of order n , n an integer,

$$P_n(z) = \sum_{k=0}^n (-1)^k \frac{(2n - 2k)!}{2^k k! (n - k)! (n - 2k)!} z^{n-2k}, \text{ with } 0! = 1 \text{ in the first term,}$$

is a solution of the differential equation

$$(1 - z^2) \frac{d^2w}{dz^2} - 2z \frac{dw}{dz} + n(n + 1)w = 0.$$

12. Prove that the hypergeometric function

$$F(a, b; c; z) = 1 + \frac{a \cdot b}{1 \cdot c} z + \frac{a(a + 1)b(b + 1)}{1 \cdot 2 \cdot c(c + 1)} z^2 + \dots$$

is a solution of the differential equation

$$z(1 - z) \frac{d^2w}{dz^2} + [c - (a + b + 1)z] \frac{dw}{dz} - abw = 0.$$

63. Integrals. For real variables, the indefinite integral of a function, $f(x)$,

$$\int f(x) dx = F(x) \tag{53}$$

is defined as a function whose derivative $F'(x) = f(x)$. The definite integral,

$$\int_a^b f(x) dx = \lim_{\max |\Delta x_k| \rightarrow 0} \sum_{k=1}^n f(x_k) \Delta x_k, \tag{54}$$

where x_k is some point in the interval of length $|\Delta x_k|$, and the n intervals just fill up the interval from a to b .

These two definitions are related by the fundamental theorem of the integral calculus, which states that

$$\int_a^b f(x) dx = F(b) - F(a). \tag{55}$$

For complex variables, the definition of the indefinite integral carries over without change. In fact, if

$$f(z) = A_0 + A_1 z + A_2 z^2 + \dots, \tag{56}$$

then

$$F(z) = A_{-1} + A_0 z + \frac{A_1}{2} z^2 + \frac{A_2}{3} z^3 + \dots, \tag{57}$$

where A_{-1} is any complex constant, is a function having $f(z)$ as its derivative for any z such that $|z| < |z_1|$, where z_1 is a point at which (56) converges. For, since the terms of (57) are numerically less than those of the series obtained by multiplying the series (56) by z , and this last series converges absolutely for any z_2 such that $|z_2| < |z_1|$, the series (57) converges uniformly for $|z| < |z_2|$, and hence, by the result of section 62, it has the series (56) as its derivative for all $|z| < |z_2| < |z_1|$, i.e. since z_2 may be arbitrarily close to z_1 , for all $|z| < |z_1|$.

The definition of a definite integral must be modified when the variable is complex. For, when x is real, there is only one set of values it can pass through in going from a to b . A complex variable, on the other hand, can vary continuously between two points in the complex plane along any curve joining them. Let, then, C be a curve starting at A and ending at B , two complex values. Then the definite integral of $f(z)$ along C is defined by

$$\int_C f(z) dz = \lim_{\max|\Delta z_k| \rightarrow 0} \sum_{k=1}^n f(z_k) \Delta z_k, \quad (58)$$

where the curved arc AB is divided into n parts, z_k being any point on the k th part, and Δz_k being the difference obtained by subtracting the complex number giving the first end point from that giving the second end point of the k th part.

To study this further, we break up the functions into their real and imaginary components, writing $z = x + iy$, and

$$f(z) = u(x, y) + iv(x, y), \quad \text{and} \quad \Delta z = \Delta x + i \Delta y. \quad (59)$$

Also we may express x and y in terms of a single parameter t for the curve C , so that:

$$x = x(t), \quad y = y(t). \quad (60)$$

The sum in (58) may then be written

$$\sum_{k=1}^n (u_k + iv_k)(\Delta x_k + i \Delta y_k),$$

or

$$\sum_{k=1}^n u_k \Delta x_k - \sum_{k=1}^n v_k \Delta y_k + i \sum_{k=1}^n u_k \Delta y_k + i \sum_{k=1}^n v_k \Delta x_k,$$

where Δx_k and Δy_k are the differences for two consecutive values of t_k , and u_k and v_k are evaluated for values of x and y for some

value of t intermediate between these. When $\max |\Delta z|$ approaches zero, so do Δx and Δy , and the sums approach integrals. When the curve C is smooth, or at any rate made up of a number of smooth pieces, the limit of each of the sums may be written as an integral in t , giving

$$\int_{t_0}^t u x'(t) dt - \int_{t_0}^t v y'(t) dt + i \int_{t_0}^t u y'(t) dt + i \int_{t_0}^t v x'(t) dt.$$

Thus, using the notation of *line integrals*, defined in problem 13, p. 124, we have:

$$\int_C f(z) dz = \int_C (u dx - v dy) + i \int_C (u dy + v dx). \quad (61)$$

The evaluation is thus reduced to two integrals in a real parameter t , the first of which is

$$\int_{t_0}^t \{u[x(t), y(t)]x'(t) - v[x(t), y(t)]y'(t)\} dt.$$

The parameter may be x , unless the curve C has a part consisting of a straight line segment parallel to the y -axis. In particular, when the limits are both real, and the path is the segment of the real axis joining them, the integral (61) reduces to

$$\int_a^b f(x) dx = \int_a^b u(x, 0) dx + i \int_a^b v(x, 0) dx.$$

This is the special type we have used in simplifying the evaluation of real integrals in Chapter III.

We note that if the curve for which a complex integral is taken is traversed in the reverse direction, we shall have the same ordinary integrals, but with limits interchanged, so that the value of the integral will be the negative of its original value.

64. Integral of a Polynomial. Let us apply the definition (61) to the evaluation of the definite integral

$$\int_C z^n dz, \quad (62)$$

where n is a positive integer. Since it will appear later that the value only depends on the initial point, z_0 and final point z_1 of the path C , we shall not specify the path beyond this.

We note that the two integrands on the right in (61) are the real and imaginary components of

$$f(z) dz = (u + iv)(dx + i dy), \quad (63)$$

which gives a simple way of remembering or calculating them.

Let us introduce polar co-ordinates. Then

$$\begin{aligned} z &= r|_{\theta} = r \cos \theta + ir \sin \theta, \\ f(z) &= z^n = r^n |_{n\theta} = r^n \cos n\theta + ir^n \sin n\theta. \end{aligned}$$

For the total differential of z , we have

$$\begin{aligned} dz &= dr \cos \theta + i dr \sin \theta - r \sin \theta d\theta + ir \cos \theta d\theta, \\ &= dr|_{\theta} + r d\theta|_{\theta + \frac{\pi}{2}}. \end{aligned}$$

It follows from these results that

$$\begin{aligned} z^n dz &= r^n |_{n\theta} \left[dr|_{\theta} + r d\theta|_{\theta + \frac{\pi}{2}} \right] \\ &= r^n dr |_{(n+1)\theta} + r^{n+1} d\theta |_{(n+1)\theta + \frac{\pi}{2}}. \end{aligned}$$

Thus the integral (62) is equal to

$$\begin{aligned} \int_C r^n dr \cos (n+1)\theta - r^{n+1} d\theta \sin (n+1)\theta \\ + i \int_C r^n dr \sin (n+1)\theta + r^{n+1} d\theta \cos (n+1)\theta. \end{aligned}$$

But each of these integrands is an exact expression, being the total differentials of

$$\frac{r^{n+1} \cos (n+1)\theta}{n+1} \quad \text{and} \quad \frac{r^{n+1} \sin (n+1)\theta}{n+1},$$

respectively. Hence, by problem 13, p. 124, the line integrals may be calculated by using these expressions and the value of r and θ at z_0 and z_1 . Since we have

$$\frac{r^{n+1} \cos (n+1)\theta}{n+1} + i \frac{r^{n+1} \sin (n+1)\theta}{n+1} = \frac{z^{n+1}}{n+1},$$

it follows that, for any path going from z_0 to z_1 ,

$$\int_C z^n dz = \frac{z_1^{n+1} - z_0^{n+1}}{n + 1}, \tag{64}$$

so that the rule for evaluating the definite integral of an integral power of a real variable applies equally well to such a power of a complex variable.

From the original definition of a complex integral as the limit of a sum, (58), it follows that if the integrand is multiplied by any complex constant, the only effect will be to multiply the integral by the same constant. Also, the integral of a sum will be the sum of the integrals.

Thus, from (64) it follows that the definite integral of any polynomial in z depends only on the end points of the path of integration, and may be found by the same procedure used for real polynomials.

65. Integral of a Series. We may derive a bound for the numerical value of a complex integral from (58). For, since Δz_k has as absolute value the length of the chord joining two points of subdivision of the path C , if $f(z)$ is in absolute value less than or equal to M for all points of the path, it follows that

$$\begin{aligned} \left| \sum_{k=1}^n f(z_k) \Delta z_k \right| &\leq \sum_{k=1}^n |f(z_k) \Delta z_k| \\ &\leq M \sum_{k=1}^n |\Delta z_k| \\ &\leq M \cdot L, \end{aligned}$$

where L is the length of the path, since the sum of the chords is less than the sum of the arcs themselves. Hence, on taking the limit, we have

$$\left| \int_C f(z) dz \right| \leq M \cdot L. \tag{65}$$

Now consider a succession of functions, $f_i(z)$, approaching a limit function $f(z)$, **uniformly** in z along a curve C . To compare the integral of the function with that of the limit, we note that

$$\left| \int_C f(z) dz - \int_C f_i(z) dz \right| = \left| \int_C [f(z) - f_i(z)] dz \right| \leq M_i \cdot L,$$

where M_i may be taken as the greatest value of $|f(z) - f_i(z)|$ on the curve C , and L is the length of C . Since the limit $f(z)$ is ap-

proached uniformly, M_t approaches zero, and hence $M_t \cdot L$, since L is fixed. Thus the left member also approaches zero, and

$$\lim \int_C f_t(z) dz = \int_C f(z) dz. \quad (66)$$

In particular, the function $f_t(z)$ may be the partial sum of an infinite series, in which case the result shows that **a series of functions which converges uniformly in z for a region including the path of integration, may be integrated termwise along this path.**

Since a power series converges uniformly in z in any circle of radius r , less than z_1 , where z_1 is a point at which it converges, it follows that we may integrate termwise along any path entirely inside such a circle. Since the partial sums are here polynomials in z , they may be integrated by the elementary rule, as shown in section 64.

Comparing this result with the indefinite integral as defined by (56) and (57), we see that, for any path entirely inside a circle of uniform convergence, the integral of a power series depends only on the end points, and is given by the formula, analogous to (55),

$$\int_{z_0}^{z_1} f(z) dz = F(z_1) - F(z_0).$$

In particular, for any closed path entirely inside a circle of uniform convergence, $z_1 = z_0$, and the integral is zero.

EXERCISES XL

1. Evaluate the integral $\int_C z dz$, (a) where C is any path joining 0 and $1 + i$, by using the indefinite integral; (b) where C is the path $x = t^2$, $y = t^3$, t varying from 0 to 1, by using the line integrals.

2. Evaluate the line integrals which give $\int z^2 dz$ over the path $x = 3t$, $y = 3t$, and also over the path $x = 3t$, $y = 3t^2$, t varying from 0 to 1 in each case. Check by using the indefinite integral.

3. Evaluate the integral of e^z over the path $x = 2$, $y = t$, where t varies from -1 to 1 , and check by using the indefinite integral, and problem 7, p. 230.

4. Prove that if the origin is not on the path the argument by which (64) was derived applies equally well if n is any negative integer, different from -1 , and hence find the integral of z^{-2} over any path joining -1 and 1 which does not go through the origin.

5. Prove that

$$\int_{z_1}^{z_2} \frac{dz}{z} = (\ln r + i\theta) \Big|_{z_1}^{z_2} = \log_e z_2 - \log_e z_1,$$

provided that the origin is not on the path, and the angle of $\log_e z_2$ is obtained from that of $\log_e z_1$ by continuous variation along the path.

6. By taking a new origin at a , any complex number, and applying problems 4 and 5, show that if the path C is a circle of radius R and center at a , traversed in the positive direction,

$$\int_C \frac{dz}{z-a} = 2\pi i, \quad \int_C \frac{dz}{(z-a)^n} = 0, \quad n > 1.$$

66. Cauchy-Riemann Differential Equations. In section 62 it was proved that if z is any point inside a circle of convergence of a power series for $f(z)$,

$$\lim_{h \rightarrow 0} \frac{f(z+h) - f(z)}{h} = f'(z), \tag{67}$$

regardless of how h approached zero through complex values.

This puts certain restrictions on the real and imaginary components of $f(z)$. To investigate them, we put

$$z = x + iy, \quad h = \Delta z = \Delta x + i\Delta y,$$

and

$$f(z) = f(x + iy) = u(x, y) + iv(x, y),$$

$$f(z+h) - f(z) = \Delta f = \Delta u + i\Delta v.$$

With this notation, (67) becomes

$$\lim_{\Delta x, \Delta y \rightarrow 0} \frac{\Delta u + i\Delta v}{\Delta x + i\Delta y} = f'(z). \tag{68}$$

In particular, we may let Δz approach zero through real values, in which case, $\Delta y = 0$, and $\Delta z = \Delta x$. The equation (68) then shows that:

$$\frac{\partial u}{\partial x} + i\frac{\partial v}{\partial x} = f'(z). \tag{69}$$

Similarly, we may let $\Delta x = 0$, and $\Delta z = i\Delta y$. In this case we find from (68)

$$-i\frac{\partial u}{\partial y} + \frac{\partial v}{\partial y} = f'(z). \tag{70}$$

Since the right members of (69) and (70) are equal, so are the left members, and on equating real and imaginary components, we obtain

$$\frac{\partial u}{\partial x} = \frac{\partial v}{\partial y}, \quad \frac{\partial v}{\partial x} = -\frac{\partial u}{\partial y}. \tag{71}$$

These are known as the Cauchy-Riemann equations.

As $f'(z)$ is again a power series, it has a derivative $f''(z)$, and on using $f'(z)$ in place of $f(z)$ in (69), we find

$$\frac{\partial^2 u}{\partial x^2} + i \frac{\partial^2 v}{\partial x^2} = f''(z). \quad (72)$$

If we apply this process to (70), we find

$$-i \frac{\partial^2 v}{\partial y^2} - \frac{\partial^2 u}{\partial y^2} = f''(z). \quad (73)$$

As the real and imaginary components of these expressions must agree, we have

$$\frac{\partial^2 u}{\partial x^2} = -\frac{\partial^2 u}{\partial y^2}, \quad \frac{\partial^2 v}{\partial x^2} = -\frac{\partial^2 v}{\partial y^2}.$$

Thus both u and v satisfy Laplace's equation,

$$\frac{\partial^2 \phi}{\partial x^2} + \frac{\partial^2 \phi}{\partial y^2} = 0. \quad (74)$$

This last fact is the basis of many of the applications of analytic functions of a complex variable to physical problems which lead to Laplace's equation.

EXERCISES XLI

1. By using the equations (71), find out which of the following expressions are surely not analytic functions of $z = x + iy$.

- $x^2 - y^2 - 1 + 2x + 2ixy + 2iy$,
- $x^2 + y^2 + y + 2x + 2ixy + 2iy$,
- $(a + bi)(x + c + di) + (-b + ai)(y + e + fi)$,
- $e^{-y} \cos x + ie^{-y} \sin x$.

2. Prove that in each part of problem 1 where the equations (71) are satisfied, the expression is equal to the analytic function obtained by replacing y by zero, and x by z .

3. (a) If z is expressed in terms of r and θ , apply the argument of the text to derive the two expressions for the derivative:

$$f'(z) = \left(\frac{\partial u}{\partial r} + i \frac{\partial v}{\partial r} \right) (\cos \theta - i \sin \theta),$$

and

$$f'(z) = -\frac{1}{r} \left(\frac{\partial u}{\partial \theta} + i \frac{\partial v}{\partial \theta} \right) (\sin \theta + i \cos \theta);$$

(b) From part (a), derive the equations

$$\frac{\partial u}{\partial r} = \frac{1}{r} \frac{\partial v}{\partial \theta}, \quad \frac{\partial v}{\partial r} = -\frac{1}{r} \frac{\partial u}{\partial \theta}.$$

4. Express z^n in polar co-ordinates, and by means of problem 3 (a), show that its derivative is nz^{n-1} .

5. By using equations (69), prove that the rules for differentiating e^z , $\sin z$, $\cos z$, $\sinh z$ and $\cosh z$ are the same as those for the corresponding real functions.

6. Verify that the equations (71) are satisfied for each of the functions of problem 5.

67. Cauchy's Integral Theorem. This theorem states that, if C is the complete boundary of a region R , such that the single-valued function $f(z)$ is analytic at all points in R and on C ,

$$\int_C f(z) dz = 0. \quad (75)$$

When R lies entirely inside a circle of convergence of a single power series representation, the theorem reduces to a result mentioned in section 65. For the general case, we recall a result of problem 13, p. 124, to the effect that the line integral of $M dx + N dy$ is zero about any closed curve, such that at all points on the curve and in the region bounded by it,

$$\frac{\partial M}{\partial y} = \frac{\partial N}{\partial x}, \quad (76)$$

and these partial derivatives are continuous at these points.

But, by (61), the left member of (75) is expressible in terms of two line integrals,

$$\int_C f(z) dz = \int_C (u dx - v dy) + i \int_C (u dy + v dx), \quad (77)$$

and the argument of the last section shows that the partial derivatives of u and v are continuous, by (69) and (70), since $f'(z)$ is continuous, and satisfy (71), which may be written

$$\frac{\partial u}{\partial y} = -\frac{\partial v}{\partial x}, \quad \frac{\partial u}{\partial x} = \frac{\partial v}{\partial y}, \quad (78)$$

at all points where $f(z)$ is analytic. But as the condition (76), applied to the two integrands of (77), is precisely the condition (78), Cauchy's theorem is proved for the case in which the region R is bounded by a single closed curve. In this case R is said to be simply connected.

When the region R is multiply-connected, so that its complete boundary consists of several closed curves, like that of Fig. 38, it

may be divided into a number of simply connected pieces, like R_1 and R_2 by the "cuts" AB and CD . The curves bounding R_1 and R_2 , together make up the boundary of the original region together with AB and CD taken twice in opposite directions. Thus, since the integral is zero for the boundary of R_1 and R_2 taken separately, and the integral over AB is the negative² of that over

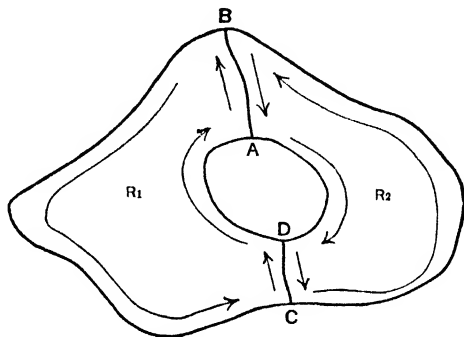

FIG. 38

BA , the integral is zero for the boundary of the original region. It is to be noted that the two curves are traversed in opposite directions, the general rule being to take such a direction that the bounded region is always on the same side, in this case the left, as we go round.

EXERCISES XLII

1. Prove that, if the multiply-connected region R is bounded by two closed curves, C_1 and C_2 , and $f(z)$ is analytic in the region R as well as on C_1 and C_2 , then

$$\int_{C_1} f(z) dz = \int_{C_2} f(z) dz,$$

if we traverse both curves in the same direction.

2. Using problem 1, show that the result of problem 6, p. 237 is unchanged if the circle is replaced by any closed curve which does not cut itself, and has the origin inside the region bounded by it.

3. Using problems 1 and 2, show that, if $f(z)$ is analytic at all points of a simply connected region R , its boundary C , except the point a in R , and for $0 < |z - a| < |z_1 - a|$,

$$f(z) = \frac{A_{-m}}{(z-a)^m} + \cdots + \frac{A_{-1}}{z-a} + A_0 + A_1(z-a) + A_2(z-a)^2 + \cdots,$$

² The condition that $f(z)$ is single-valued insures that the same values are used on the two sides of AB and CD .

then

$$\int_C f(z) dz = 2\pi i A_{-1},$$

where the integral is taken about C in the positive direction.

4. The coefficient A_{-1} in the expansion of problem 3 is called the **residue** of the function $f(z)$ at the point a . (a) Prove that, if $f(z)$ and $g(z)$ are two polynomials with $g(z)$ divisible by $z - a$, but not by $(z - a)^2$, then the residue of $f(z)/g(z)$ at a is $f(a)/g'(a)$. Compare problem 10 (b), p. 111.

(b) Prove that, if a function is analytic at all points of a simply connected region R and its boundary C except a finite number of points in R , the integral of the function, taken about C in the positive direction, is $2\pi i$ times the sum of the residues at these points.

(c) Apply the results of (a) and (b) to find the integral of $4/(z^2 - 4)$ taken positively around a circle of radius 3, with center at the origin.

5. Let $f(z)/g(z)$ be a rational function in its lowest terms. Let the equation $g(z) = 0$ have no real roots, and the degree of $f(z)$ be at most 2 less than the degree of $g(z)$. Let the roots of $g(z)$ with positive imaginary component, i.e. in the upper half plane, be a_1, a_2, \dots, a_k , and draw a semicircle with center at the origin of radius R , so large that all these roots are inside the semicircle. (a) If S denotes the semicircle traversed negatively, show from problem 4 that

$$\int_{-R}^R \frac{f(z)}{g(z)} dz + \int_S \frac{f(z)}{g(z)} dz = 2\pi i \text{ (sum of residues at points } a);$$

the first integral being taken along the real axis.

(b) Since $\left| z^2 \frac{f(z)}{g(z)} \right|$ approaches a finite limit when $|z|$ becomes infinite, when R is large enough we must have $\left| \frac{f(z)}{g(z)} \right| < \frac{K}{|z|^2}$, so that, by (65), the integral over S in (a) is less than $K/R^2 \cdot \pi R$, which approaches zero when R becomes infinite. From this and (a) deduce that

$$\int_{-\infty}^{\infty} \frac{f(z)}{g(z)} dz = 2\pi i \text{ (sum of residues at points } a).$$

6. Evaluate $\int_{-\infty}^{\infty} \frac{1}{x^2 + 1} dx$ by using problem 5(b), and check by elementary methods.

7. Use the method of residues of problem 5 (b) to evaluate

$$(a) \int_{-\infty}^{\infty} \frac{1}{x^4 + 1} dx, \quad (b) \int_{-\infty}^{\infty} \frac{x^2}{x^6 + 1} dx,$$

$$(c) \int_{-\infty}^{\infty} \frac{dx}{(x^2 + a)^2 + b^2}, \quad (d) \int_{-\infty}^{\infty} \frac{dx}{(x^2 + a^2)(x^2 + b^2)};$$

8. (a) Prove that, if a polynomial of the n th degree $f(z)$ is divisible by $(z - a)^p$, but not by $(z - a)^{p+1}$, the residue of $f'(z)/f(z)$ at a is p .

(b) From (a) and problem 4 (b), prove that

$$\frac{1}{2\pi i} \int_C \frac{f'(z)}{f(z)} dz$$

is always an integer, or zero, and gives the number of roots of $f(z)$ taking account of their multiplicity in the region bounded by C , provided no root lies on C .

(c) Since $\frac{f'(z)}{f(z)} - \frac{n}{z}$ has a numerator of degree at most $n - 2$, and denominator of degree n , we may show by the reasoning of problem 5 (b), that, if C is a circle of radius R with center at the origin,

$$\lim_{R \rightarrow \infty} \int_C \left[\frac{f'(z)}{f(z)} - \frac{n}{z} \right] dz = 0.$$

Show from this that

$$\lim_{R \rightarrow \infty} \int_C \frac{f'(z)}{f(z)} dz = \lim_{R \rightarrow \infty} \int_C \frac{n}{z} dz = 2\pi in.$$

That is, by (b), when the circle is large enough it will contain n roots, so that every algebraic equation of the n th degree has n roots in the complex plane.

68. Taylor's Series. We may derive some information about the size of the circle of convergence of the power series about any point in a region throughout which the function is analytic, by the use of the Cauchy integral theorem. We first notice that if the

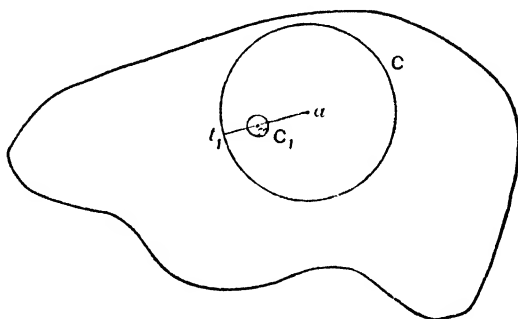

FIG. 39

function $f(z)$ is analytic at all points of the region R , it has a continuous derivative throughout this region. Let a be any point in the region R and C a fixed circle with center a and radius r , lying entirely in the region as in Fig. 39. Select z , any fixed point inside C , and let C_1 be a variable circle with center z and radius r_1 , with r_1 so small that C_1 lies entirely inside of C . Then, in the region between C and C_1 the function $f(t)/(t - z)$ considered as a function of t , has a continuous derivative, by problem 6, p. 230, since it is the quotient of two functions, each of which has a continuous derivative

Consequently, by the reasoning of the last two sections, its integral about the curves C and C_1 , taken in opposite directions and added together, is zero. Or, taking them in the same direction, say the positive one, which reverses a sign, we have:

$$\int_C \frac{f(t)}{t-z} dt = \int_{C_1} \frac{f(t)}{t-z} dt = \int_{C_1} \frac{f(z)}{t-z} dt + \int_{C_1} \frac{f(t) - f(z)}{t-z} dt \quad (79)$$

By problem 6, p. 237, the first integral is $2\pi i f(z)$. Again, by applying (65) to the second integral, we find that it is numerically at most

$$\frac{|f(t) - f(z)|}{r_1} 2\pi r_1 = |f(t) - f(z)| 2\pi.$$

But, since $f(z)$ is continuous, this last expression approaches zero when t approaches z , that is, when r_1 approaches zero. Consequently, if we let r_1 approach zero, the last integral in (79) approaches zero, and the equation becomes

$$\int_C \frac{f(t)}{t-z} dt = 2\pi i f(z). \quad (80)$$

Let us next expand $1/(t-z)$ in powers of $z-a$. We have

$$t-z = t-a - (z-a) = (t-a) \left(1 - \frac{z-a}{t-a} \right),$$

so that

$$\begin{aligned} \frac{1}{t-z} &= \frac{1}{t-a} \left[1 + \frac{z-a}{t-a} + \frac{(z-a)^2}{(t-a)^2} + \dots \right. \\ &\quad \left. + \frac{(z-a)^{n-1}}{(t-a)^{n-1}} + \frac{(z-a)^n}{(t-a)^n \left(1 - \frac{z-a}{t-a} \right)} \right], \end{aligned} \quad (81)$$

since

$$\frac{1}{1-u} = 1 + u + u^2 + \dots + u^{n-1} + \frac{u^n}{1-u}.$$

We may express the integrand in (80) in a series in powers of $z-a$ by multiplying each term in (81) by $f(t)$. The difference between the sum of the series to the term in $(z-a)^{n-1}$ and the integrand in (80) will be

$$\frac{(z-a)^n f(t)}{(t-a)^{n+1} \left(1 - \frac{z-a}{t-a} \right)},$$

whose numerical value,

$$\left| \left(\frac{z-a}{t-a} \right)^n \frac{f(t)}{t-z} \right| \leq \frac{\max |f(t)|}{|t_1-z|} \left(\frac{|z-a|}{r} \right)^n,$$

where $\max |f(t)|$ is the biggest value on C , and t_1 is the point on C nearest to z . If z is inside any circle C' with center a and radius less than r , say $r-d$, the last quantity is at most

$$\frac{\max |f(t)|}{d} \left(1 - \frac{d}{r} \right)^n,$$

which approaches zero when n becomes infinite. Thus, inside any circle C' , i.e., any circle with center a lying entirely in R , the infinite geometric series

$$\frac{f(t)}{t-z} = \frac{f(t)}{t-a} + \frac{f(t)}{(t-a)^2} (z-a) + \frac{f(t)}{(t-a)^3} (z-a)^2 + \dots$$

converges uniformly to its sum on the left. Hence, it may be integrated termwise to give a series, which when divided by $2\pi i$, converges to $f(z)$ by (80). Indicating the coefficients, which are independent of z , by our usual notation, we obtain finally a series

$$f(z) = A_0 + A_1(z-a) + A_2(z-a)^2 + A_3(z-a)^3 + \dots, \quad (82)$$

where

$$A_n = \frac{1}{2\pi i} \int_C \frac{f(t)}{(t-a)^{n+1}} dt. \quad (83)$$

This proves that, if a function is analytic at all points of a region R , the power series expansion about any point in R will converge uniformly in any circle with this point as center, lying entirely in R .

The argument of section 62 shows that the function $f(z)$ given by the series (82) has derivatives of all orders, which may be found by termwise differentiation, at all points inside a circle of uniform convergence, and in particular at $z = a$. This shows that

$$f(a) = A_0, \quad f'(a) = A_1, \quad f''(a) = 2A_2, \quad \dots, \quad f^{(n)}(a) = n! A_n, \quad (84)$$

so that the series (82) has the same form as the Taylor's series defined in the calculus. Thus the above result shows that the Taylor's series of a function about any real or complex point a , will converge to the function for all values inside any circle, with center a , provided that the function is analytic at all the points inside this circle.

EXERCISES XLIII

1. Show that the formula (83) still holds if the curve C is any closed curve, with the point a in its interior, lying entirely in R .

2. Show that if $f(z)$ is analytic at all points of a region R , C is any closed curve lying entirely in R , and a any point inside C , then

$$f(a) = \frac{1}{2\pi i} \int_C \frac{f(t)}{t-a} dt \quad \text{and} \quad f^{(n)}(a) = \frac{n!}{2\pi i} \int_C \frac{f(t)}{(t-a)^{n+1}} dt.$$

The first of these is known as **Cauchy's integral formula**.

3. Taking the curve of problem 2 as a circle of radius r , with center at a , and using (65), show that

$$|f(a)| \leq M, \quad |f^{(n)}(a)| \leq \frac{n!M}{r^n},$$

where M is the maximum value of $|f(t)|$ on the circle.

4. Find the radius of the largest circle inside which the convergence of the Taylor's series is guaranteed by the theorem of section 68, about the origin, about the point 2 and about the point $-2i$, for each of the following functions:

$$(a) \frac{1}{1+z}, \quad (b) \frac{1}{1+z^2}, \quad (c) \frac{1}{1-z^2}, \quad (d) \frac{1}{z^2+6z+10}.$$

69. Alternative Definitions of Analytic Functions. We have defined a single-valued function as analytic at a point, provided this point is inside a circle of convergence of some power series representation of the function. We have seen that in this case the Taylor's series about this point will represent the function, at least for all values inside any circle inside the region in which the function is analytic. Thus the definition

I. A function is analytic in a region, if each point of the region is inside a circle of convergence of some power series representation of the function, may be replaced by

II. A function is analytic in a region, if the function may be expanded in a Taylor's series about each point of the region.

Another possible definition is

III. A function is analytic in a region, if the function has a derivative at each point of the region, which is continuous at the point.

That the functions defined by I, (a) are included in III follows from section 62. On the other hand, if a function satisfies III, the argument of section 68, which merely depended on the function $f(t)$ having a continuous derivative, shows that the function satisfies II. Thus III is equivalent to the other definitions.

We may use the property established in section 67 as the basis for a fourth definition, namely

IV. A function is analytic in a region, if it is continuous in this region and its integral over any closed curve lying entirely inside it, is zero.

It follows from sections 60, and 67 that the functions defined by I are included in IV. To prove the converse, let $f(z)$ be a function satisfying IV, in the region R , and define a new function

$$F(z) = \int_{z_0}^z f(t) dt, \quad (85)$$

where z_0 is a fixed point, and z a variable point in R , and the integral is taken over a path entirely in R . Just what path is taken is immaterial, since the difference for two paths is the same as the sum for the first from z_0 to z , and the second from z to z_0 . But this is the integral of the function over a closed path in R , which is zero. Thus (85) defines a single-valued function.

Let us next compute $F(z + \Delta z)$, taking the path from z_0 to z used in (85), together with the straight line segment joining z and $z + \Delta z$, which will lie in the region R when $|\Delta z|$ is small enough. Then:

$$\begin{aligned} F(z + \Delta z) - F(z) &= \int_{z_0}^{z+\Delta z} f(t) dt - \int_{z_0}^z f(t) dt \\ &= \int_z^{z+\Delta z} f(t) dt. \end{aligned} \quad (86)$$

Combining the identity,

$$\int_z^{z+\Delta z} f(z) dz = f(z)\Delta z,$$

with (86), we may deduce that

$$\frac{F(z + \Delta z) - F(z)}{\Delta z} = \frac{1}{\Delta z} \int_z^{z+\Delta z} [f(t) - f(z)] dz + f(z). \quad (87)$$

The first term on the right, by (65) is numerically at most

$$\frac{1}{|\Delta z|} \max |f(t) - f(z)| \cdot |\Delta z| = \max |f(t) - f(z)|,$$

which approaches zero when Δz approaches zero since $f(z)$ is continuous in R . Thus, by taking the limit of (87) when Δz approaches zero, we find:

$$F'(z) = \lim_{\Delta z \rightarrow 0} \frac{F(z + \Delta z) - F(z)}{\Delta z} = f(z) \quad (88)$$

Thus $F(z)$ has a derivative, $f(z)$ which is continuous in R , so that $F(z)$ is analytic in the sense of III, which is equivalent to the other definitions. But, in section 62, we showed that the derivative of an analytic function was analytic, so that $f(z)$ is analytic in the sense of I.

Another possible definition is

V. If a function has real and imaginary components u and v , $f(z) = u + iv$, which have continuous first partial derivatives at all points of a region, satisfying the Cauchy-Riemann equations:

$$\frac{\partial u}{\partial x} = \frac{\partial v}{\partial y}, \quad \frac{\partial v}{\partial x} = -\frac{\partial u}{\partial y}, \quad (89)$$

then the function is analytic in the region.

For, by section 66, V includes all functions satisfying I, and the reasoning of section 67 shows that IV includes all functions satisfying V.

We conclude with a somewhat more general property, which leads to a method of showing that a function is analytic.

VI. The limit of any succession of analytic functions which approach the limiting function uniformly in a region, is an analytic function in the region.

This follows from the fact that owing to the *uniformity*, the integral of the limit is the limit of the integral, by (66), and the limit is continuous by section 58. Thus, as each approximating function satisfies IV, so does the limiting function.

The approximating functions may be the partial sums of a series. The power series of I is a special case of this.

Since all of the definitions given are equivalent, any one might be used as the fundamental definition. In particular, many authors base a systematic treatment on the definitions III or V.

EXERCISES XLIV

1. If w is an analytic function of s , for s in R_1 , and s is an analytic function of z , for z in R_2 taking on only values in R_1 for z in R_2 , then w is an analytic function of z in R_2 . Prove this by using problem 5, p. 230, and definition III. Also by using problem 5, p. 228, section 61 and definition I.

2. In section 61, using definition I, it was shown that the sum, difference, and product of two functions analytic at a point was analytic at the point.

A similar result held for the quotient if the denominator was not zero at the point. Prove these results on the basis of definition III.

3. Prove that, if $z = g(w)$ is the inverse function to $w = f(z)$, then

$$\frac{dz}{dw} = g'(w) = \frac{1}{f'(z)} = \frac{1}{f'[g(w)]},$$

if $f'(z) \neq 0$, and $z = g(w)$ has no derivative if $f'(z) = 0$, so that if $f(z)$ is analytic in some region containing z_0 , $g(w)$ is analytic in some region containing the corresponding value of w , w_0 in the first case, but not in the second.

4. From problem 3, and the definition of a branch-point given in problem 14, p. 40, show that a function is not analytic at a branch-point. Use this fact to determine in what circles the Taylor's series for the function $w = \sqrt{z+1}$, about the origin, will converge.

5. Show that the quotient of two analytic functions has no finite derivative at a point where the numerator is not zero, but the denominator is zero, and use this fact to determine in what circles the Taylor's series for the function $w = \sec z$, about the origin, will converge.

6. Use definition V to show that, if $u(x, y)$ satisfies Laplace's equation, (74), then

$$f(x + iy) = u + i \int_{a, b}^{x, y} -\frac{\partial u}{\partial y} dx + \frac{\partial u}{\partial x} dy,$$

where a, b is any fixed point, and x, y is any variable point in a simply connected region in which u satisfies (74), and the line integral is taken over a path lying entirely in this region, defines an analytic function in the region. Illustrate if $u = x^2 - y^2$.

7. Write down the formula analogous to that in problem 6, which determines an analytic function when v is given, and illustrate when $v = 2x$.

8. Prove that each of the following series defines a function which is analytic in any finite region.

$$(a) 1 + \frac{e^z}{1!} + \frac{e^{2z}}{2!} + \frac{e^{3z}}{3!} + \dots$$

$$(b) \sin z + \frac{\sin 2z}{2!} + \frac{\sin 3z}{3!} + \dots$$

9. (a) Prove that the series

$$f(z) = \frac{1+z}{1 \cdot 2} + \frac{1+z+z^2}{2 \cdot 3} + \frac{1+z+z^2+z^3}{3 \cdot 4} + \dots$$

defines a function which is analytic inside a circle with radius one and center at the origin.

(b) Using the fact that

$$\sum_{k=n}^{\infty} \frac{1}{k(k+1)} = \sum_{k=n}^{\infty} \frac{1}{k} - \frac{1}{k+1} = \frac{1}{n},$$

show that the power series for the function of part (a) is:

$$f(z) = 1 + z + \frac{z^2}{2} + \frac{z^3}{3} + \dots$$

CHAPTER VIII

CONVERGENCE OF FOURIER SERIES

In this chapter we shall establish certain results on Fourier series, as defined in section 18. In particular, we shall prove the theorem on convergence, stated in that section.

70. Statement of the Theorem. If $f(x)$ is a periodic function, of period T , the Fourier series for $f(x)$ is defined as the series

$$A + \sum_{n=1}^{\infty} \left[A_n \cos n\left(\frac{2\pi}{T}\right)x + B_n \sin n\left(\frac{2\pi}{T}\right)x \right], \quad (1)$$

where

$$\begin{aligned} A &= \text{average of } f(x), \\ A_n &= \text{twice the average of } f(x) \cos n\left(\frac{2\pi}{T}\right)x, \\ B_n &= \text{twice the average of } f(x) \sin n\left(\frac{2\pi}{T}\right)x, \end{aligned} \quad (2)$$

each average being taken over an interval of length T . By section 15, it is immaterial which interval we take.

Since the function $f(x)$ is of period T , it is determined for all values of x when its values for any interval of length equal to the period T , say that from 0 to T , are known. We shall restrict our attention for the present to functions which are **piecewise smooth**, that is, functions made up in the interval from 0 to T of a finite number of pieces, each of which has a continuous derivative. More precisely, let the interval from 0 to T be broken up into k intervals:

$$\begin{aligned} P_0 \text{ to } P_1, \quad P_1 \text{ to } P_2, \quad P_2 \text{ to } P_3, \quad \dots \\ P_{s-1} \text{ to } P_s, \quad \dots \quad P_{k-1} \text{ to } P_k, \end{aligned}$$

where

$$P_0 = 0, \quad P_k = T \quad \text{and} \quad P_0 < P_1 < \dots < P_{k-1} < P_k.$$

Then we assume it is possible to so select the number k , and the values P_s , that there are k functions, $\phi_s(x)$, such that

$$f(x) = \phi_s(x), \quad P_{s-1} < x < P_s, \quad s = 1, 2, 3, \dots, k,$$

and each function $\phi_s(x)$ has a continuous derivative at all points of the s th interval, including the end points:

$$\frac{d\phi}{dx} = \phi'(x), \quad P_{s-1} \leq x \leq P_s.$$

The graph of one such function is shown in Fig. 40. It illustrates the fact that in each interval, the graph has a continuously turning tangent, which is never vertical.

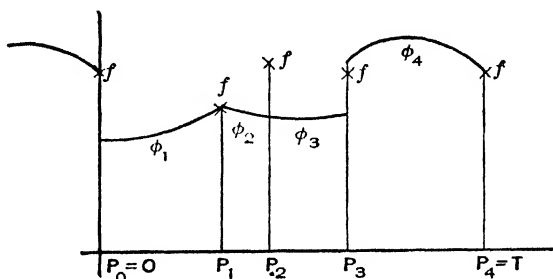

FIG. 40

For the values P_s , the functions $\phi_s(x)$ and $\phi_{s+1}(x)$ need not be equal, and $f(x)$ need not be equal to either of them. The value of $f(x)$ itself at these points has no relation to the Fourier series, since the ordinates P_s , k in number, can not affect the averages in (2) which determine the coefficients. In fact, these averages may be computed from the integrals for each interval, with $f(x)$ replaced by the appropriate $\phi_s(x)$.

We notice that if x approaches a value P_s , through smaller values, $f(x)$ approaches $\phi_s(P_s)$, while if x approaches P_s through greater values, $f(x)$ approaches $\phi_{s+1}(P_s)$. We indicate this by writing

$$f(P_s +) = \phi_{s+1}(P_s); \quad f(P_s -) = \phi_s(P_s). \quad (3)$$

For a value of x not equal to one of the P_s , i.e. inside one of the intervals, the value approached is the same on both sides, and equals the value of the function at the point. We indicate this by writing

$$f(x +) = f(x -) = f(x), \quad x \neq P_s. \quad (4)$$

In accordance with section 53, the function is continuous at all points for which (4) is satisfied, and discontinuous at those points

P_1 , for which it is not satisfied. Thus, the function whose graph is given in Fig. 40, is discontinuous at P_0, P_2, P_3 and P_4 , but continuous at all other points, including P_1 , between 0 and T .

We now wish to prove that

If $f(x)$ is a piecewise smooth, periodic function, its Fourier series converges for all values of x . The sum of the series equals $f(x)$, if $f(x)$ is continuous at x , and equals $\frac{1}{2}[f(x+) + f(x-)]$ if $f(x)$ is discontinuous at x .

Since the proof consists in a number of results, the reader is advised to go over the next five sections hastily, to get the main trend of the argument, before studying them in detail.

71. A Change of Scale. When T , the period of the function is equal to 2π , the Fourier series (1) is simply

$$A + \sum_{n=1}^{\infty} (A_n \cos nx + B_n \sin nx). \quad (5)$$

We may reduce the general case to this by changing the scale on the x -axis, replacing the original unit by a new one $2\pi/T$ times the old unit.

This is effected analytically by introducing a new variable

$$X = \frac{2\pi}{T} x, \quad (6)$$

which takes the piecewise smooth function $f(x)$, of period T into a new function $F(X) = f(TX/2\pi)$, of period 2π . For any particular value of x , the values of $F(X)$, $F(X+)$ and $F(X-)$ for the corresponding X are equal, respectively, to those of $f(x)$, $f(x+)$ and $f(x-)$. Moreover, the sum of the series is unchanged, since the multiples of $2\pi/Tx$ in the first series are equal to the multiples of X in the new series, and the coefficients, being averages, are unchanged by a change of scale in the independent variable.

We imagine the change of scale made, but revert to the earlier notation, so that from now on we regard $f(x)$ as a piecewise smooth function of period 2π , and the Fourier series is (5).

72. The Partial Sums. The partial sum of the series (5) to N terms is:

$$S_N = A + \sum_{n=1}^N (A_n \cos nx + B_n \sin nx). \quad (7)$$

We may write the coefficients as

$$\begin{aligned} A &= \frac{1}{2\pi} \int_{-\pi+x}^{\pi+x} f(t) dt, \\ A_n &= \frac{1}{\pi} \int_{-\pi+x}^{\pi+x} f(t) \cos nt dt, \\ B_n &= \frac{1}{\pi} \int_{-\pi+x}^{\pi+x} f(t) \sin nt dt. \end{aligned} \quad (8)$$

We have used t for the variable of integration to avoid confusion with the fixed x for which we are considering the sum of the series, and have taken the interval over which we average, which may be any interval of length 2π , as that from $-\pi + x$ to $\pi + x$ to simplify a later reduction.

Since x is constant, we may take terms in x inside the integral sign, and write the general term of (7):

$$\begin{aligned} &A_n \cos nx + B_n \sin nx \\ &= \frac{1}{\pi} \int_{-\pi+x}^{\pi+x} f(t) (\cos nx \cos nt + \sin nx \sin nt) dt \\ &= \frac{1}{\pi} \int_{-\pi+x}^{\pi+x} f(t) \cos n(t-x) dt. \end{aligned}$$

Thus we have:

$$S_N = \frac{1}{\pi} \int_{-\pi+x}^{\pi+x} \left[\frac{1}{2} + \sum_{n=1}^N \cos n(t-x) \right] f(t) dt.$$

We now change to a new variable of integration,

$$t = x + u, \quad dt = du,$$

and have

$$\begin{aligned} S_N &= \frac{1}{\pi} \int_{-\pi}^{\pi} \left[\frac{1}{2} + \sum_{n=1}^N \cos nu \right] f(x+u) du \\ &= \frac{1}{\pi} \int_{-\pi}^{\pi} s_N f(x+u) du, \end{aligned} \quad (9)$$

if the trigonometric sum s_N is defined by

$$s_N = \frac{1}{2} + \sum_{n=1}^N \cos nu. \quad (10)$$

73. The Trigonometric Sum. We may find a simpler expression for s_N by multiplying both sides of (10) by $2 \sin u/2$. We have:

$$\begin{aligned} 2 \sin \frac{u}{2} s_N &= \sin \frac{u}{2} + \sum_{n=1}^N 2 \cos nu \sin \frac{u}{2} \\ &= \sin \frac{u}{2} + \sum_{n=1}^N [\sin (n + \frac{1}{2})u - \sin (n - \frac{1}{2})u], \end{aligned}$$

since this agrees with the above form when the terms in brackets are expanded by the addition theorem for the sine. But, when this last expression is written out:

$$\begin{aligned} \sin \frac{u}{2} + \sin \frac{3u}{2} - \sin \frac{u}{2} + \sin \frac{5u}{2} - \sin \frac{3u}{2} + \dots \\ + \sin (N + \frac{1}{2})u - \sin (N - \frac{1}{2})u, \end{aligned}$$

all the terms except the one before the last appear twice, with opposite signs, and so cancel out. Thus we have:

$$2 \sin \frac{u}{2} s_N = \sin (N + \frac{1}{2})u,$$

and¹

$$s_N = \frac{\sin (N + \frac{1}{2})u}{2 \sin \frac{u}{2}}. \quad (11)$$

We note that

$$\frac{1}{\pi} \int_0^\pi s_N du = \frac{1}{2}, \quad (12)$$

as may be seen from (10), since the integral is zero for all the cosine terms.

74. Transformation of the Limit. The theorem stated at the end of section 70, for the function of period 2π , will be established if we show that

$$\frac{1}{2}[f(x+) + f(x-)] = \lim_{N \rightarrow \infty} \frac{1}{\pi} \int_{-x}^x s_N f(x+u) du. \quad (13)$$

For, by (9) the right member is the limit of the partial sum to N terms, or the sum of the series as defined in section 54. At points of discontinuity, the left member has the stated form, and at points of continuity, where (4) is satisfied, it reduces to $f(x)$.

Again (13) will follow as a consequence of the two equations

$$\frac{1}{2}f(x+) = \lim_{N \rightarrow \infty} \frac{1}{\pi} \int_0^\pi f(x+u) s_N du, \quad (14)$$

¹This result is in agreement with problem 18 (b), p. 21.

and

$$\frac{1}{2}f(x-) = \lim_{N=\infty} \frac{1}{\pi} \int_{-\pi}^0 f(x+u) s_N du. \quad (15)$$

We need only prove the first of these, since the second may be proved by entirely similar reasoning.²

To further transform (14), we notice that, from (12)

$$\frac{1}{2}f(x+) = \frac{1}{\pi} \int_0^{\pi} f(x+) s_N du, \quad (16)$$

since $f(x+)$ is constant during the integration. Taking the limit as N becomes infinite, we deduce

$$\frac{1}{2}f(x+) = \lim_{N=\infty} \frac{1}{\pi} \int_0^{\pi} f(x+) s_N du. \quad (17)$$

This last equation shows that (14) is equivalent to

$$\lim_{N=\infty} \frac{1}{\pi} \int_0^{\pi} f(x+) s_N du = \lim_{N=\infty} \frac{1}{\pi} \int_0^{\pi} f(x+u) s_N du,$$

which will follow if the difference of the two expressions whose limits are taken approaches zero, or

$$\lim_{N=\infty} \frac{1}{\pi} \int_0^{\pi} [f(x+u) - f(x+)] s_N du = 0. \quad (18)$$

The factor π may be omitted, since the right member is zero, and we may replace s_N by its value as given in (11) to obtain:

$$\lim_{N=\infty} \int_0^{\pi} [f(x+u) - f(x+)] \frac{\sin(N + \frac{1}{2})u}{2 \sin \frac{u}{2}} du = 0, \quad (19)$$

as a relation from which the theorem will follow.

² Or, the second may be looked on as a consequence of the first, since if the first is true for the function $F(y) = f(2x - y)$, then

$$F(x+u) = f(2x - [x+u]) = f(x-u), \quad \text{and} \quad F(x+) = f(x-).$$

Also

$$\int_0^{\pi} F(x+u) s_N du = \int_0^{\pi} f(x-u) s_N du = \int_{-\pi}^0 f(x+u) s_N du,$$

on replacing u by $-u$, and recalling that s_N is an even function. Thus (14) applied to $F(x)$ gives (15) applied to $f(x)$.

75. Proof of the Limit. To prove the relation (19), we shall break up the interval of integration into $m + 1$ intervals, namely those from

$$0 \text{ to } p_0, \quad p_0 \text{ to } p_1, \quad p_1 \text{ to } p_2, \quad \dots \quad p_{s-1} \text{ to } p_s, \quad \dots$$

$$p_{m-1} \text{ to } p_m = \pi,$$

where p_1, p_2, \dots, p_{m-1} are so chosen that the function $f(x + u)$, regarded as a function of u , is smooth in the interval 0 to p_1 , and each of the intervals mentioned above, and p_0 is a value less than $\pi/2$ between 0 and p_1 to be specified presently. It will be noticed that with the exception of p_0 , and possibly of 0 and p_m , the p_s here used correspond to some of the P_s of section 70, with different subscripts.

For the first interval, the integral in (19) may be written

$$I_0 = \int_0^{p_0} \frac{f(x + u) - f(x)}{u} \cdot \frac{\frac{u}{2}}{\sin \frac{u}{2}} \cdot \sin (N + \frac{1}{2})u \cdot du, \quad (20)$$

by inserting the factor u in numerator and denominator.

Each of the three factors of the integrand of (20) lies between definite bounds, which we proceed to calculate.

For the first factor we have:

$$\left| \frac{f(x + u) - f(x)}{u} \right| = |f'(X)| < D, \quad (21)$$

since for any smooth function³ there is a value X , between x and $x + u$ for which the tangent to the graph is parallel to the chord joining the points with these x -co-ordinates. Since the tangent to each smooth piece of our graph turns continuously and is never vertical, there is some maximum value D_s for each piece which the slope never exceeds numerically. We may pick D from the function as any number bigger than the k numbers D_s , for the k smooth pieces of our function.

To estimate the size of the second factor, we note that since p_0 is less than $\pi/2$, $u/2$ is less than $\pi/4$. Thus, since the arc is less than the tangent in the first quadrant,

³ Compare problem 8, p. 121.

$$\left| \frac{u}{2} \right| < \left| \tan \frac{u}{2} \right| \leq \frac{\left| \sin \frac{u}{2} \right|}{\left| \cos \frac{u}{2} \right|}; \quad (22)$$

and since the cosine decreases as the arc increases,

$$\left| \cos \frac{u}{2} \right| > \left| \cos \frac{\pi}{4} \right| > \frac{1}{2}. \quad (23)$$

In consequence of (22) and (23):

$$\left| \frac{\frac{u}{2}}{\sin \frac{u}{2}} \right| < \frac{1}{\left| \cos \frac{u}{2} \right|} < 2. \quad (24)$$

Finally, the third factor of the integrand, being a sine, is numerically less than unity.

Combining this fact with (21) and (24), we have the integrand of I_0 , in (20) less than $2D$, so that

$$|I_0| < p_0 2D. \quad (25)$$

This may be made small, say less than a given small positive quantity, η , by taking

$$p_0 < \frac{\eta}{2D}. \quad (26)$$

The integrals for the remaining intervals,

$$I_s = \int_{p_{s-1}}^{p_s} \frac{f(x+u) - f(x+)}{2 \sin \frac{u}{2}} \sin (N + \frac{1}{2})u \, du, \quad (27)$$

$$s = 1, 2, \dots, m,$$

may be treated by integrating by parts. In fact, integrating the factor $\sin (N + \frac{1}{2})u$ and taking the other factor as the one differentiated, we find:

$$I_s = - \frac{f(x+u) - f(x+)}{2 \sin \frac{u}{2}} \frac{\cos (N + \frac{1}{2})u}{N + \frac{1}{2}} \Big|_{p_{s-1}}^{p_s} +$$

$$\int_{p_{s-1}}^{p_s} \left\{ \frac{f'(x+u)}{2 \sin \frac{u}{2}} - \frac{[f(x+u) - f(x+)] \cos \frac{u}{2}}{4 \sin^2 \frac{u}{2}} \right\} \frac{\cos (N + \frac{1}{2})u}{N + \frac{1}{2}} \, du. \quad (28)$$

It must be remembered that all these operations are with respect to u , x being held constant. To estimate the size of this, we note that if F is numerically larger than the biggest numerical value assumed by the function in any of the k smooth pieces, we shall have:

$$|f(x + u) - f(x)| < 2F. \tag{29}$$

Again, if D is larger numerically than the slope of any of the smooth pieces at any point, as in (21), then

$$|f'(x + u)| < D. \tag{30}$$

Moreover, since u lies between p_0 and π for each of the intervals of integration in (27), $u/2$ lies between $p_0/2$ and $\pi/2$, i.e. in the first quadrant, so that

$$\left| \sin \frac{u}{2} \right| \geq \left| \sin \frac{p_0}{2} \right|, \quad \text{or} \quad \frac{1}{\left| \sin \frac{u}{2} \right|} \leq \frac{1}{\left| \sin \frac{p_0}{2} \right|}. \tag{31}$$

From (28), the fact that a cosine is at most unity, and the inequalities (29), (30) and (31), we may conclude that:

$$|I_s| < \frac{1}{N + \frac{1}{2}} \left\{ \frac{2F}{\sin \frac{p_0}{2}} + (p_s - p_{s-1}) \left(\frac{D}{2 \sin \frac{p_0}{2}} + \frac{F}{2 \sin^2 \frac{p_0}{2}} \right) \right\}. \tag{32}$$

As the quantity inside the braces is independent of N , the sum of all the m integrals I_s will be numerically less than some expression independent of N (although depending on η through p_0 by (26)) divided by $N + \frac{1}{2}$. Consequently, by taking N sufficiently large, say bigger than N_1 , the sum can be made small, say less than η .

Thus, for any given η and any x , we may first select p_0 to satisfy (26) and the condition that the function be smooth between x and p_0 , and then N_1 as just described. Then for all $N > N_1$, we shall have:

$$|I| = |I_0 + I_1 + I_2 + \dots + I_m| < 2\eta,$$

where I is the integral of (19). But as η and hence 2η is arbitrarily small, this is precisely the meaning of the statement that the integral I approaches zero, as defined in section 51.

Since the discussion of sections 71 through 74 showed that the theorem of section 70 would follow as a consequence of (19), which

we have just proved, we have finally established the theorem in question.

76. Uniformity of the Convergence. As the sines and cosines in (1), or (5) are continuous functions of x , the sum of the series will be a continuous function in any interval in which the series converges uniformly. Thus the series can not converge uniformly for an interval as large as a period of $f(x)$, if $f(x)$ has any points of discontinuity. The proof would lead us to expect this, since the number of terms N_1 which we must take to be sure that the partial sum is near the limit, or that the integral (19) is near zero, is determined by the m relations (32). These show that the smaller we take p_0 , the larger the term in the braces will be, owing to the $\sin(p_0/2)$ in the denominator, and hence the larger N_1 must be to make the bounds for the integrals small. But, as p_0 is always between x and the nearest point of discontinuity, to the right for the integral discussed, and to the left for the corresponding one derived from (15), we shall have to take a larger N_1 the nearer x is to a point of discontinuity.

However, if the function consists of a single smooth piece, since there are no points p_s except $p_1 = p_m = \pi$, the quantity p_0 may be selected for all values of x as a value less than $\pi/2$ which satisfies (26), and then N_1 determined so that in this case we have uniform convergence.

This result still holds, even if there is a discontinuity in the derivative, like the point P_1 in Fig. 40, provided the function is continuous. For, suppose the interval from $u = 0$ to $u = p_0$ is allowed to contain one such point $u = q$, and let us attempt to estimate a bound for

$$\left| \frac{f(x+u) - f(x+)}{u} \right|.$$

As the function is smooth in each of the intervals 0 to q , and q to p_0 , we have for these intervals, as in (21),

$$\left| \frac{f(x+u) - f(x+q)}{u-q} \right| < D, \quad \left| \frac{f(x+q) - f(x+)}{q} \right| < D,$$

which may be written:

$$|f(x+u) - f(x+q)| < D(u-q), \quad |f(x+q) - f(x+)| < Dq,$$

if u is in the second interval, so that $u - q$ is positive. By adding these last, we deduce

$$|f(x+u) - f(x)| < Du,$$

or

$$\left| \frac{f(x+u) - f(x)}{u} \right| < D, \quad (33)$$

for u in the second interval. But this holds for u in the first interval, by the argument for (21), so that (33) may be used in place of (21), and the argument completed as before. We may extend this to include a finite number of such points. This proves that:

If a piecewise smooth, periodic function is continuous for all values of x , its Fourier series converges uniformly in x for all values of x .

Note that a periodic function defined as equal to a continuous function $g(x)$ in an interval of length T , say $0 \leq x \leq T$, will only be a continuous periodic function if $g(0) = g(T)$.

77. Functions Smooth near One Value. We shall now prove that, if a periodic function $F(x)$ is smooth in some interval containing x_0 , and may be approximated to any degree by a piecewise smooth function, uniformly for all x , then the Fourier series for it converges for $x = x_0$, to $F(x_0)$.

Let the function be $F(x)$, smooth in the interval $x_0 - h$ to $x_0 + h$. By section 71 we may assume it of period 2π . Let $f(x)$ be of the same period, equal to $F(x)$ in this interval and those differing by $2n\pi$, and otherwise equal to a piecewise smooth approximating function. Then, for all x :

$$|F(x) - f(x)| < \eta. \quad (34)$$

But, by (13) and (11) the partial sum to N terms of the series for $F(x)$ and $f(x)$, at x_0 , will differ by

$$\frac{1}{\pi} \int_{-\pi}^{\pi} \frac{F(x_0+u) - f(x_0+u)}{2 \sin \frac{u}{2}} \sin (N + \frac{1}{2})u \, du. \quad (35)$$

But, for u between $-h$ and h , the difference in the numerator is zero, while for other values between $-\pi$ and π , we have

$$\left| \sin \frac{u}{2} \right| > \left| \sin \frac{h}{2} \right|, \quad (36)$$

and (34), so that the expression in (35) is numerically at most

$$\frac{1}{\pi} \cdot 2\pi \cdot \frac{\eta}{2 \sin \frac{h}{2}} = \frac{\eta}{\sin \frac{h}{2}}. \quad (37)$$

But, as $f(x)$ is periodic and piecewise smooth, by the theorem of section 70, for $N > N_1$, the difference between the sum to N terms for $f(x)$ and $f(x_0) = F(x_0)$ can be made small, say less than η . Thus, by combining this with (37), we see that for $N > N_1$, the sum to N terms of the series for $F(x)$ will differ from $F(x_0)$ by less than

$$\left(1 + \frac{1}{\sin \frac{h}{2}}\right)\eta,$$

which can be made arbitrarily small, by taking η small. This proves the theorem.

EXERCISES XLV

1. If the function of period 2π which equals x for $-\pi < x < \pi$, is expanded in a Fourier series, apply the analysis of the text to find an N_1 , such that, for $x = \pi/2$, the sum of the series to more than N_1 terms will differ from x by less than .1.

2. Prove that the Fourier series for a piecewise smooth function converges uniformly in any interval, provided that the function is continuous at all points of the interval, including the two end points.

3. If a function of period 2π becomes infinite at one, or a finite number of points, in such a way that $\int_{-\pi}^{\pi} |f(x)| dx$ is finite, the coefficients of the Fourier series will all be finite. In this case each of these points may be enclosed in an interval so small that the integral of $|f(x)|$ over these intervals is arbitrarily small. Show that, if the function is piecewise smooth except for these points at which it becomes infinite, they may be enclosed in intervals in such a way that the contribution to (19) from them is small, if $f(x+)$ is finite, and hence show that for such a function the theorem of section 70 applies to all values of x for which $f(x+) + f(x-)$ is finite. Periodic functions, equal to $\ln|x|$ or $|x|^{-\frac{1}{2}}$ between $-\pi$ and π are illustrations. Their Fourier series will converge to them, except for $x = 0$.

4. If a function fails to have a derivative at the point x , but is piecewise smooth in any interval not containing x , and in some interval containing x satisfies an inequality of the form

$$|f(x+u) - f(x+)| < Du^r, \quad r > 0,$$

show that the integral (20) is in this case subject to

$$|I_0| < \int_0^{p_0} 2Du^{r-1} du \leq \frac{2Dp_0^r}{r},$$

and that the argument of section 75 may be carried out, using this in place of (25). A periodic function equal to $x^{\frac{1}{2}}$ from $-\pi$ to π is an example. Its Fourier series will converge to it for all values of x .

5. By taking a suitable inscribed polygon, which is piecewise smooth, a piecewise continuous function may be approximated uniformly to any degree. Combine this fact with the argument in section 77, and the results of problems 3, and 4 to show that if a periodic function is piecewise continuous, except for a finite number of points where it becomes infinite in the way described in problem 3, its Fourier series converges to it for any value of x , such that near this value:

$$|f(x + u) - f(x)| < Du^r, \quad r > 0.$$

Note that, if $f(x)$ has a derivative at x , the above condition holds with $r = 1$. This result covers nearly all Fourier series met in practical applications.

78. Rearrangement of the Terms. If the Fourier series for a function is absolutely convergent, we may rearrange the terms in any way that does not add or omit any, without disturbing the sum, by section 56. An example is the function of period 2π , equal to x^2 from $-\pi$ to π , for which the series is

$$\frac{\pi^2}{3} - \frac{4}{1^2} \cos x + \frac{4}{2^2} \cos 2x - \frac{4}{3^2} \cos 3x + \dots \quad (38)$$

This is seen to be absolutely convergent, by the test of section 55, and problem 9, p. 218.

While we have shown that the Fourier series for a piecewise smooth function always converges, in general it will not converge absolutely, so that a random rearrangement of the terms will make the series diverge, or converge to a different sum. An example is the function of period 2π , equal to x from $-\pi$ to π , for which the series is

$$\frac{2}{1} \sin x - \frac{2}{2} \sin 2x + \frac{2}{3} \sin 3x - \frac{2}{4} \sin 4x + \dots \quad (39)$$

This series is only absolutely convergent for $x = 0$, or π , since for other values of x , the series contains terms numerically near $(\sin x)/n$ fairly regularly distributed, and the series of numerical values diverges like

$$A \left(1 + \frac{1}{1+k} + \frac{1}{1+2k} + \frac{1}{1+3k} + \dots \right).$$

For the series obtained from a piecewise smooth function, the sine terms will converge by themselves, and the cosine terms will converge by themselves. For these are the series for $\frac{f(x) - f(-x)}{2}$

and $\frac{f(x) + f(-x)}{2}$, the odd and even function equal to $f(x)$ in half a period. Since the sum of these two functions is $f(x)$, by section 56, we see that we may always sum the sine and cosine terms separately, and then add the results.

Similarly, if

$$f(x) = c_1 f_1(x) + c_2 f_2(x) + \cdots + c_k f_k(x), \quad (40)$$

where all the functions are piecewise smooth, the coefficients for $f(x)$ will be the corresponding combination of the coefficients for the other functions, and we may sum the series either in the usual way, or by summing those terms which correspond to each of the component functions separately.

79. Integration of Fourier Series. In problem 7, p. 224, we saw that a uniformly convergent series could be integrated termwise. We shall now show that, regardless of the non-uniformity, we may always integrate the Fourier series of a piecewise smooth function termwise. Let the series for $f(x)$ be

$$A + \sum_{n=1}^{\infty} \left[A_n \cos n \left(\frac{2\pi}{T} \right) x + B_n \sin n \left(\frac{2\pi}{T} \right) x \right]. \quad (41)$$

By integrating termwise from a to x , we obtain the series

$$A(x - a) + \sum_{n=1}^{\infty} \left[A_n \frac{\sin n \left(\frac{2\pi}{T} \right) x - \sin n \left(\frac{2\pi}{T} \right) a}{n \left(\frac{2\pi}{T} \right)} + B_n \frac{-\cos n \left(\frac{2\pi}{T} \right) x + \cos n \left(\frac{2\pi}{T} \right) a}{n \left(\frac{2\pi}{T} \right)} \right] \quad (42)$$

which we should expect to converge to $\int_a^x f(x) dx$.

To prove this, we investigate the Fourier series for the function

$$g(x) = \int_a^x f(u) du - Ax. \quad (43)$$

This function is of period T , since:

$$g(x + T) - g(x) = \int_x^{x+T} f(u) du - AT = 0, \quad (44)$$

since A , the constant term in the series for $f(x)$, may be found from

$$A = \frac{1}{T} \int_x^{x+T} f(u) du.$$

As $g(x)$ is defined in terms of an integral, it is continuous for all values of x , and is piecewise smooth, since $f(x)$ was. We note that, interior to any piece where $f(x)$ is smooth,

$$g'(x) = f(x) - A. \tag{45}$$

From the character of $g(x)$, its Fourier series will converge to it for all x , so that:

$$g(x) = A' + \sum_{n=1}^{\infty} \left[A_n' \cos n\left(\frac{2\pi}{T}\right)x + B_n' \sin n\left(\frac{2\pi}{T}\right)x \right], \tag{46}$$

where

$$\begin{aligned} A' &= \frac{1}{T} \int_0^T g(x) dx, & A_n' &= \frac{2}{T} \int_0^T g(x) \cos n\left(\frac{2\pi}{T}\right)x dx, \\ B_n' &= \frac{2}{T} \int_0^T g(x) \sin n\left(\frac{2\pi}{T}\right)x dx. \end{aligned} \tag{47}$$

We may transform these last integrals by integrating by parts, and we need not divide up the interval at points where $g'(x)$ is discontinuous, since $g(x)$ is everywhere continuous.⁴ We find as the result:

$$\begin{aligned} A_n' &= \frac{g(x)}{n\pi} \sin n\left(\frac{2\pi}{T}\right)x \Big|_0^T - \frac{1}{n\pi} \int_0^T \sin n\left(\frac{2\pi}{T}\right)x g'(x) dx, \\ B_n' &= -\frac{g(x)}{n\pi} \cos n\left(\frac{2\pi}{T}\right)x \Big|_0^T + \frac{1}{n\pi} \int_0^T \cos n\left(\frac{2\pi}{T}\right)x g'(x) dx. \end{aligned} \tag{48}$$

The integrated part vanishes, since $g(x)$ as well as the sines and cosines appearing therein are of period T . Thus the values for 0 and T are the same, and cancel out when subtracted. For the integrals, we replace $g'(x)$ by its value as given in (45), and note

⁴ If u and v have continuous derivatives in the intervals a to b , and b to c ,

$$\begin{aligned} \int_a^c u dv &= \int_a^b u dv + \int_b^c u dv = uv \Big|_a^b - \int_a^b v du + uv \Big|_b^c - \int_b^c v du \\ &= uv \Big|_a^c - \int_a^c v du + uv \Big|_{b+}^{b-}, \end{aligned}$$

and the last term is zero if u and v are continuous at b , so we need not take account of b in the integration by parts.

that the terms in A may be omitted, since the average of a sine or a cosine over a period is zero. Thus the expressions reduce to:

$$\begin{aligned} A_n' &= -\frac{1}{n\pi} \int_0^T \sin n\left(\frac{2\pi}{T}\right) x f(x) dx = -\frac{B_n}{n\left(\frac{2\pi}{T}\right)}, \\ B_n' &= \frac{1}{n\pi} \int_0^T \cos n\left(\frac{2\pi}{T}\right) x f(x) dx = \frac{A_n}{n\left(\frac{2\pi}{T}\right)}. \end{aligned} \quad (49)$$

These equations enable us to write in place of (46):

$$g(x) = A' + \sum_{n=1}^{\infty} \frac{-B_n \cos n\left(\frac{2\pi}{T}\right)x + A_n \sin n\left(\frac{2\pi}{T}\right)x}{\frac{2\pi}{T}}. \quad (50)$$

This converges for all values, so that in particular when $x = a$, we have:

$$g(a) = A' + \sum_{n=1}^{\infty} \frac{-B_n \cos n\left(\frac{2\pi}{T}\right)a + A_n \sin n\left(\frac{2\pi}{T}\right)a}{\frac{2\pi}{T}}. \quad (51)$$

By subtracting the two convergent series (50) and (51) term by term, and comparing with (42), we see that the series part of (42) is $g(x) - g(a)$. But, on evaluating these functions by means of (43), we find for the expression (42):

$$\begin{aligned} A(x - a) + g(x) - g(a) &= A(x - a) + \int_a^x f(u) du - Ax + Aa \\ &= \int_a^x f(u) du, \end{aligned} \quad (52)$$

as we expected.

This proves that if we integrate the Fourier series for a piecewise smooth, periodic function, omitting the constants of integration, so as to obtain a multiple of x plus a new Fourier series, this expression converges to the indefinite integral of the original function.

80. Differentiation of Fourier Series. If a periodic function, $g(x)$, is the integral of a piecewise smooth function, $f(x)$, so that for all values of x

$$g(x) = \int_a^x f(u) du, \quad (53)$$

then for values of x inside an interval in which $f(x)$ is smooth,

$$f(x) = g'(x),$$

so that $f(x)$ is also periodic. From the result of the preceding section, it follows that the Fourier series obtained from that for $f(x)$ by termwise integration only differs from that for $g(x)$ by a constant. Consequently if the Fourier series for $g(x)$ be differentiated termwise, it will converge for all values, and equal the derivative of $g(x)$ for values of x inside an interval in which this derivative is smooth.

The process of termwise differentiation is not applicable, in general, to Fourier series for functions which can not be obtained by integrating other functions. Since integrals are always continuous functions of their upper limits, this excludes functions with discontinuities.

To illustrate some of the possibilities, consider the function of period 2 which equals x^2 for $-\pi < x < \pi$:

$$g(x) = \frac{\pi^2}{3} - \frac{4}{1^2} \cos x + \frac{4}{2^2} \cos 2x - \frac{4}{3^2} \cos 3x + \dots \quad (54)$$

Since this is the integral of the function of period 2 which equals $2x$ for $-\pi < x < \pi$, it may be differentiated termwise to give:

$$f(x) = \frac{4}{1} \sin x - \frac{4}{2} \sin 2x + \frac{4}{3} \sin 3x - \dots, \quad (55)$$

which converges for all values, and equals the derivative of $f(x)$ except for x an integral multiple of π .

However, since $f(x)$ has points of discontinuity, we should not expect the series obtained from (55) by termwise differentiation to represent its derivative. In fact, the series is

$$4 \cos x - 4 \cos 2x + 4 \cos 3x - 4 \cos 4x + \dots \quad (56)$$

This series diverges for all values of x , since it always contains an infinite number of terms numerically greater than 2. Note that the derivative of $f(x)$ is 2, except for x a multiple of π , and this has a Fourier series consisting of the constant term only. However, $f(x)$ is not the integral of this function from a to x if this interval includes a multiple of π .

81. Least Square Error. We have seen that for piecewise smooth functions, the Fourier series converges, though not, in general, uniformly. Thus from the mere convergence, we could deduce nothing about the relation of averages, or root mean square values for the function, and the partial sums of the series.

There is another sense in which the Fourier series converges, of importance for averaging processes, which we proceed to discuss in this and the next three sections.

Consider a piecewise continuous periodic function, $f(x)$, of period T . Let us try to approximate this function by a sum having the same form as the partial sum of a Fourier series,

$$T_N = a + \sum_{n=1}^{\infty} \left[a_n \cos n \left(\frac{2\pi}{T} \right) x + b_n \sin n \left(\frac{2\pi}{T} \right) x \right] \quad (57)$$

in such a way that the root mean square value of the error:

$$f(x) - T_N \quad (58)$$

will be as small as possible. We shall call any sum T_N a **trigonometric sum of order N and period T** . If the root mean square error is R , then R will be least when R^2 is least. But

$$\begin{aligned} R^2 &= \frac{1}{T} \int_0^T [f(x) - T_N]^2 dx \\ &= \frac{1}{T} \int_0^T \left\{ f(x) - a - \sum_{n=1}^N \left[a_n \cos n \left(\frac{2\pi}{T} \right) x + b_n \sin n \left(\frac{2\pi}{T} \right) x \right] \right\}^2 dx, \end{aligned} \quad (59)$$

by (57), and by expanding the square we find

$$\begin{aligned} R^2 &= \frac{1}{T} \int_0^T \left\{ [f(x)]^2 - 2f(x) \left(a + \sum_{n=1}^N \left[a_n \cos n \left(\frac{2\pi}{T} \right) x + b_n \sin n \left(\frac{2\pi}{T} \right) x \right] \right) \right. \\ &\quad \left. + \left(a + \sum_{n=1}^N \left[a_n \cos n \left(\frac{2\pi}{T} \right) x + b_n \sin n \left(\frac{2\pi}{T} \right) x \right] \right)^2 \right\} dx. \end{aligned} \quad (60)$$

We recall that the Fourier coefficients of $f(x)$ are given by:

$$\begin{aligned} A &= \frac{1}{T} \int_0^T f(x) dx, & A_n &= \frac{2}{T} \int_0^T f(x) \cos n \left(\frac{2\pi}{T} \right) x dx, \\ & & B_n &= \frac{2}{T} \int_0^T f(x) \sin n \left(\frac{2\pi}{T} \right) x dx. \end{aligned} \quad (61)$$

We also note that the cross product terms from the last square in (60) may be omitted, since their average is zero, while the average

values of $\sin^2 n(2\pi/T)x$ and of $\cos^2 n(2\pi/T)x$ will each be $\frac{1}{2}$, by section 16. Using these facts, we may simplify (60) to:

$$R^2 = \frac{1}{T} \int_0^T [f(x)]^2 dx - 2aA - \sum_{n=1}^N (a_n A_n + b_n B_n) + a^2 + \sum_{n=1}^N \left(\frac{a_n^2}{2} + \frac{b_n^2}{2} \right). \quad (62)$$

By adding and subtracting the quantities which complete the square, this may be replaced by:

$$R^2 = \frac{1}{T} \int_0^T [f(x)]^2 dx + (a - A)^2 + \sum_{n=1}^N \left[\frac{(a_n - A_n)^2}{2} + \frac{(b_n - B_n)^2}{2} \right] - A^2 - \sum_{n=1}^N \left[\frac{A_n^2}{2} + \frac{B_n^2}{2} \right]. \quad (63)$$

Since the coefficients of the trigonometric sum, a , a_n , b_n , only appear in terms which are squares, with positive coefficients, R^2 will be least when these squares are zero. That is, when

$$a = A, \quad a_n = A_n, \quad b_n = B_n, \quad n = 1, 2, 3, \dots, N, \quad (64)$$

in which case the trigonometric sum of order N , T_N , is simply the partial sum of the Fourier series to N terms. This proves the theorem:

Of all trigonometric sums of given order N and the same period approximating a piecewise continuous periodic function, the root mean square value of the error is least when the trigonometric sum is composed of the first N terms of the Fourier series for the function.

82. A Particular Approximation. For any piecewise continuous periodic function, there are trigonometric sums for which the root mean square error, R , is less than any fixed, small positive quantity η_1 .

We may show this as follows. We first surround each of the values of x for which the function is discontinuous by an interval of length η . We then replace the graph of the function inside these intervals I by a single chord, and in the other intervals, I' , where the function is continuous, we replace it by a series of chords, such that the function never differs by more than η from them. The process is illustrated in Fig. 41. Then, if $f(x)$ is the original func-

tion, and $g(x)$ the function whose graph is the broken line made up of the chords, we have:

$$|f(x) - g(x)| \leq \eta, \quad \text{in } I'. \quad (65)$$

Also, if F is the largest numerical value of $f(x)$ assumed in any of the continuous pieces, the ordinates of the polygonal line are also numerically at most this value, and we have:

$$|f(x) - g(x)| \leq 2F, \quad \text{in } I. \quad (66)$$

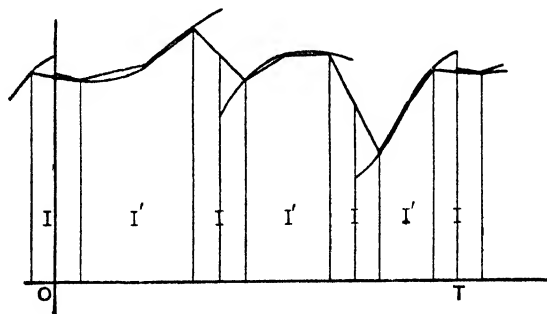

FIG. 41

In any one period interval, as from 0 to T , the combined length of the intervals I' is at most T , while if there are k points of discontinuity, the combined length of the intervals I is at most $2k\eta$.

We now observe that the function $g(x)$ is periodic, piecewise smooth, and everywhere continuous. Therefore by the theorem proved in section 76, its Fourier series converges uniformly. Thus, by taking N_1 sufficiently large, we may make

$$|g(x) - T_{N_1}| < \eta, \quad (67)$$

for all x , where T_{N_1} is the partial sum to N_1 terms of the Fourier series for $g(x)$, that is, a trigonometric sum of order N_1 , of period T .

For the error made by replacing $f(x)$ by T_{N_1} we have, in view of (65), (66) and (67):

$$|f(x) - T_{N_1}| < 2\eta, \quad \text{in } I', \quad (68)$$

$$|f(x) - T_{N_1}| < 2F + \eta, \quad \text{in } I. \quad (69)$$

Thus, when we integrate the square of this, we have at most

$$4\eta^2 \cdot T$$

as the contribution from the intervals I' , and at most

$$(2F + \eta)^2 \cdot 2k\eta$$

as the contribution from the intervals I .

This shows that for R^2 , the square of the integral divided by T , we have:

$$R^2 < 4\eta^2 + (2F + \eta)^2 \cdot 2k\eta. \tag{70}$$

If we take η less than unity, we have

$$R^2 < [4 + 2k(2F + 1)^2]\eta. \tag{71}$$

Since k and F are determined by $f(x)$, the factor which is multiplied by η in this expression is fixed, and we may make R^2 less than η_1^2 by taking η small enough. The T_{N_1} found as above is then a trigonometric sum approximating $f(x)$ with root mean square error less than η_1 .

83. Convergence in the Mean. When an infinite series of functions, which may or may not converge, is related to a given function in such a way that the root mean square error made by replacing the function by the N th partial sum of the series, or its square:

$$R^2 = \frac{1}{T} \int_0^T [f(x) - s_N]^2 dx, \tag{72}$$

approaches zero as N becomes infinite, we say that the partial sum s_n , or the series **converges in the mean** to the function for the interval $0 < x < T$. Since the integrand in (72) is a square, it is positive, and the same result holds for any other interval inside this one.

If the function is periodic and piecewise continuous, and the series is its Fourier series, we have from (63) and (64):

$$R^2 = \frac{1}{T} \int_0^T [f(x)]^2 dx - A^2 - \sum_{n=1}^N \left[\frac{A_n^2}{2} + \frac{B_n^2}{2} \right]. \tag{73}$$

The form of this shows that as we increase N , R^2 either decreases or stays the same, since we subtract more squared terms on the right. But in section 81 we saw that there were trigonometric sums of order N_1 which made R^2 less than η_1^2 , while in section 80 we saw that R^2 for the partial sum of the Fourier series is smaller than that for any other sum of the same order.

Thus, for N greater than N_1 in (73), R^2 is less than η_1^2 , and since η_1^2 is arbitrarily small, it follows that as N increases indefi-

nately, the limit of R^2 is zero. In accordance with the definition just given, this proves:

The Fourier series for a piecewise continuous, periodic function converges in the mean to this function, for any interval.

84. Averages of Series, Convergent in the Mean. If s_n converges in the mean to a function $f(x)$, and S_n converges in the mean to a function $F(x)$, for the same interval, all the functions being piecewise continuous, then **when n becomes infinite the average of the product $s_n S_n$ approaches as a limit the average of the product of the functions, $f(x) F(x)$ taken over this interval.** That is, we wish to prove:

$$\lim_{n \rightarrow \infty} \text{average } s_n S_n = \text{average } fF, \quad (74)$$

or

$$\lim_{n \rightarrow \infty} \text{average } (fF - s_n S_n) = 0. \quad (75)$$

We may write:

$$fF - s_n S_n = f(F - S_n) + S_n(f - s_n). \quad (76)$$

Now recall the result of section 13, that the average of a product is numerically at most the product of the root mean square values of the factors. This shows that

$$|\text{average } f(F - S_n)| \leq \text{r.m.s. } f \cdot \text{r.m.s. } (F - S_n), \quad (77)$$

and also

$$|\text{average } S_n(f - s_n)| \leq \text{r.m.s. } S_n \cdot \text{r.m.s. } (f - s_n). \quad (78)$$

But

$$S_n^2 = [F - (F - S_n)]^2, \quad 0 \leq [F + (F - S_n)]^2$$

so that, by addition,

$$S_n^2 \leq 2F^2 + 2(F - S_n)^2.$$

Consequently, for the averages,

$$\text{average } S_n^2 \leq 2 \text{average } F^2 + 2 \text{average } (F - S_n)^2,$$

which is equivalent to

$$(\text{r.m.s. } S_n)^2 \leq 2(\text{r.m.s. } F)^2 + 2(\text{r.m.s. } [F - S_n])^2. \quad (79)$$

If we indicate r.m.s. values of f and F by \bar{f} and \bar{F} , and the r.m.s. errors $F - S_n$ and $f - s_n$ by R and r respectively, we may combine equations (76), (77), (78) and (79) to give:

$$|\text{average } (fF - s_n S_n)| \leq \bar{f} \cdot R + r \sqrt{2\bar{F}^2 + 2R^2}. \quad (80)$$

Since s_n and S_n converge in the mean to f and F respectively, when n becomes infinite, r and R approach zero, so that the right member of (80) approaches zero. Hence the left does also, which establishes (75).

Several special cases of this result are of interest. For example, we may put $F = f$, and $S_n = s_n$ in (74), and take the square root of both sides, which proves that

When s_n converges in the mean to $f(x)$, the root mean square value of s_n approaches the root mean square value of $f(x)$.

For Fourier series this follows directly from the fact that the left and hence the right member of (73) approached zero.

Again, we may put $S_n = F$, in which case we find:

The average of the product of s_n by a function F approaches the average of f times F , provided s_n converges in the mean to f .

Thus the average of Ff may be calculated termwise from the series for f . For the Fourier series, if F is the constant 1, or any of the sines and cosines, this is in accord with the definition of the Fourier coefficients.

85. Multiplication of Fourier Series. If two trigonometric sums of the same period of order N , T_N and t_N are given, they may be multiplied and their product expressed as a new trigonometric sum of order $2N$, by means of the relations

$$\begin{aligned} 2 \sin px \sin qx &= \cos (p - q)x - \cos (p + q)x, \\ 2 \cos px \cos qx &= \cos (p - q)x + \cos (p + q)x, \\ 2 \sin px \cos qx &= \sin (p - q)x + \sin (p + q)x. \end{aligned} \tag{81}$$

The transformation is often most conveniently performed by means of equations (43) and (44), p. 17 before multiplication, and then these or equation (41), p. 16.

We shall now prove that if T_N and t_N are the N th partial sums of the Fourier series for $F(x)$ and $f(x)$, respectively, then the m th Fourier sine or cosine coefficient of the trigonometric sum $T_N t_N$ approaches the corresponding coefficient of $F(x)f(x)$, when N becomes infinite.

For, since T_N converges in the mean to F , and

$$\frac{1}{T} \int_0^T (\cos mx^F - \cos mxT_N)^2 dx \leq \frac{1}{T} \int_0^T (F - T_N)^2 dx$$

it follows that $\cos mxT_N$ converges in the mean to $\cos mx^F$. As

we also have t_N converges in the mean to f , by the theorem at the beginning of section 84, i.e. (74),

$$\lim_{N \rightarrow \infty} \text{average} \cos mx T_N t_N = \text{average} \cos mx f. \quad (82)$$

This is the result to be proved, since when $m = 0$, each side is the constant term, and when $m = 2n\pi/T$, each side is one half the n th cosine coefficient. The result for the sine coefficients is proved in precisely the same way.

When one of the series is a finite sum, this result may be used practically to find the series for the product. As an example, from

$$x = 2 \left(\frac{\sin x}{1} - \frac{\sin 2x}{2} + \frac{\sin 3x}{3} - \dots \right)$$

we may deduce, on multiplying by $\sin x$,

$$\begin{aligned} x \sin x &= 1 - \frac{\cos x}{2} - \frac{2 \cos 2x}{1 \cdot 3} + \frac{2 \cos 3x}{2 \cdot 4} \\ &\quad - \frac{2 \cos 4x}{3 \cdot 5} + \dots \end{aligned}$$

86. Division of a Finite Trigonometric Sum by a Sum of the First Order. The quotient of a finite trigonometric sum by an expression of the form $A + B \sin x + C \cos x$, where we take the period as 2π to simplify the writing, may sometimes be conveniently expressed in a Fourier series as follows. By the method of the last section, the series may be obtained from that for

$$\frac{D}{A + B \sin x + C \cos x} = \frac{D'}{1 + C' \cos(x - a)}.$$

If this is never infinite, C' will be less than 1, and we can find a real number b such that

$$\frac{-2b}{1 + b^2} = C'.$$

We take the value of b numerically less than unity.

We may change D' by multiplying all the terms by a constant, and to simplify what follows shall assume

$$D' = \frac{1 - b^2}{1 + b^2}.$$

We also put $a = 0$, since the series for other a may be obtained

from that found by replacing x by $x + a$. Thus the problem is reduced to the expansion of

$$\frac{1 - b^2}{1 + b^2 - 2b \cos x}, \quad b^2 < 1. \quad (83)$$

For this we have

$$\frac{1 - b^2}{1 + b^2 - be^{ix} - be^{-ix}} = -1 + \frac{1}{1 - be^{ix}} + \frac{1}{1 - be^{-ix}},$$

as may be verified by adding the fractions on the right.

We may then divide out to get:

$$\begin{aligned} & -1 + (1 + be^{ix} + b^2e^{2ix} + b^3e^{3ix} + \dots) \\ & + (1 + be^{-ix} + b^2e^{-2ix} + b^3e^{-3ix} + \dots), \end{aligned}$$

as these geometric progressions converge to the fractions when x is real, since in that case:

$$|be^{ix}| = |b| < 1.$$

If we now add the series termwise, the result is

$$1 + 2b \cos x + 2b^2 \cos 2x + 2b^3 \cos 3x + \dots, \quad (84)$$

which is the desired series.

If the divisor were a trigonometric sum of the N th order, it could be factored into N real factors, each of the first order, so that the series could theoretically be found by multiplying together N series, each obtained from (84). However, as these are infinite series, the details become too complicated to be practical.

Similar considerations apply to the division of an infinite Fourier series by a trigonometric sum of the first order.

EXERCISES XLVI

1. From the relation

$$\frac{\pi}{4} = \sin x + \frac{\sin 3x}{3} + \frac{\sin 5x}{5} + \frac{\sin 7x}{7} + \dots,$$

valid for $0 < x < \pi$, derive by successive integration the series

$$-\frac{\pi x}{4} + \frac{\pi^2}{8} = \cos x + \frac{\cos 3x}{3^2} + \frac{\cos 5x}{5^2} + \frac{\cos 7x}{7^2} + \dots,$$

and

$$-\frac{\pi x^2}{8} + \frac{\pi^2 x}{8} = \sin x + \frac{\sin 3x}{3^3} + \frac{\sin 5x}{5^3} + \frac{\sin 7x}{7^3} + \dots$$

2. From the series, valid for $0 < x < \pi$;

$$-\frac{x}{2} + \frac{\pi}{4} = \frac{\sin 2x}{2} + \frac{\sin 4x}{4} + \frac{\sin 6x}{6} + \dots,$$

derive by successive integration the series:

$$\frac{x^2}{4} - \frac{\pi x}{4} + \frac{\pi^2}{24} = \frac{\cos 2x}{2^2} + \frac{\cos 4x}{4^2} + \frac{\cos 6x}{6^2} + \dots,$$

and

$$\frac{x^3}{12} - \frac{\pi x^2}{8} + \frac{\pi^2 x}{24} = \frac{\sin 2x}{2^3} + \frac{\sin 4x}{4^3} + \frac{\sin 6x}{6^3} + \dots.$$

3. Assuming that $\sin ax$ is expanded in a sine series,

$$\sin ax = B_1 \sin x + B_2 \sin 2x + \dots + B_n \sin nx + \dots.$$

Derive by integration the series:

$$\frac{\cos ax}{a} - \frac{\sin a\pi}{a^2\pi} = \frac{B_1}{1} \cos x + \frac{B_2}{2} \cos 2x + \dots + \frac{B_n}{n} \cos nx + \dots$$

and

$$\frac{\sin ax}{a^2} - \frac{\sin a\pi}{a^2\pi} x = \frac{B_1}{1^2} \sin x + \frac{B_2}{2^2} \sin 2x + \dots + \frac{B_n}{n^2} \sin nx + \dots.$$

By combining the last relation with

$$x = 2 \left(\frac{\sin x}{1} - \frac{\sin 2x}{2} + \frac{\sin 3x}{3} - \dots \right),$$

and comparing with the original expression, determine the B_n and thus show that:

$$\sin ax = \frac{2 \sin a\pi}{\pi} \left(\frac{\sin x}{1^2 - a^2} - \frac{2 \sin 2x}{2^2 - a^2} + \frac{3 \sin 3x}{3^2 - a^2} - \dots \right),$$

and

$$\cos ax = \frac{2a \sin a\pi}{\pi} \left(\frac{1}{2a^2} + \frac{\cos x}{1^2 - a^2} - \frac{\cos 2x}{2^2 - a^2} + \frac{\cos 3x}{3^2 - a^2} - \dots \right).$$

4. By an argument similar to that used in problem 3, show that

$$\sinh ax = \frac{2 \sinh a\pi}{\pi} \left(\frac{\sin x}{1^2 + a^2} - \frac{2 \sin 2x}{2^2 + a^2} + \frac{3 \sin 3x}{3^2 + a^2} - \dots \right),$$

and

$$\cosh ax = \frac{2a \sinh a\pi}{\pi} \left(\frac{1}{2a^2} - \frac{\cos x}{1^2 + a^2} + \frac{\cos 2x}{2^2 + a^2} - \frac{\cos 3x}{3^2 + a^2} + \dots \right).$$

5. By using equation (12), and the relation

$$s_N = \frac{\sin(N + \frac{1}{2})u}{2 \sin \frac{u}{2}} = \frac{1}{2} \sin Nu \cot \frac{u}{2} + \frac{1}{2} \cos Nu,$$

prove that

$$\frac{1}{\pi} \int_0^\pi \sin Nu \cot \frac{u}{2} du = 1,$$

and deduce from this by integrating by parts

$$\frac{1}{\pi} \int_0^\pi \ln \sin \frac{u}{2} \cos Nu du = -\frac{1}{N}.$$

By problem 3, p. 260, we may expand $\ln \left| \sin \frac{x}{2} \right|$ in a Fourier series, and the result just found shows that

$$\ln \left| \sin \frac{x}{2} \right| = A - \frac{\cos x}{1} - \frac{\cos 2x}{2} - \frac{\cos 3x}{3} - \dots$$

As this is valid for all values of x except multiples of 2π , we may put $(\pi - x)$ in place of x , and so find

$$\ln \left| \cos \frac{x}{2} \right| = A + \frac{\cos x}{1} - \frac{\cos 2x}{2} + \frac{\cos 3x}{3} - \dots$$

Finally, we may determine the constant A by replacing x by $2x$, and noting that

$$\ln |\sin x| = \ln 2 + \ln \left| \sin \frac{x}{2} \right| + \ln \left| \cos \frac{x}{2} \right|,$$

so that

$$A = \ln 2 + 2A, \quad \text{and} \quad A = -\ln 2.$$

6. Using the expansions found in problem 5, deduce

$$\begin{aligned} \ln \left| \tan \frac{x}{2} \right| &= -2 \left(\frac{\cos x}{1} + \frac{\cos 3x}{3} + \frac{\cos 5x}{5} + \dots \right), \\ \int_0^x \ln \left| \tan \frac{u}{2} \right| du &= -2 \left(\frac{\sin x}{1^2} + \frac{\sin 3x}{3^2} + \frac{\sin 5x}{5^2} + \dots \right), \\ \int_0^x \left[\int_0^v \ln \left| \tan \frac{u}{2} \right| du \right] dv &= \frac{1}{\pi} \int_0^\pi \left[\int_0^v \ln \left| \tan \frac{u}{2} \right| du \right] dv \\ &= 2 \left(\frac{\cos x}{1^3} + \frac{\cos 3x}{3^3} + \frac{\cos 5x}{5^3} + \dots \right). \end{aligned}$$

7. If P and Q are any real numbers, we have

$$(P + Q)^2 \leq (P + Q)^2 + (P - Q)^2 \leq 2P^2 + 2Q^2.$$

Deduce from this that, if f_n , g_n and F are any three real functions, defined for any interval, we have over this interval:

$$[\text{r.m.s. } (F - g_n)]^2 \leq 2[\text{r.m.s. } (F - f_n)]^2 + 2[\text{r.m.s. } (f_n - g_n)]^2.$$

This shows that, if two variable functions f_n and g_n are such that, as n becomes infinite, r.m.s. $(f_n - g_n)$ approaches zero, then if f_n converges in the mean to F , g_n also converges in the mean to F .

8. Let the function $F(x)$ be periodic of period T , and piecewise continuous except for a finite number of points in each period interval at which it becomes infinite, but in such a way that $\int_0^T F(x)^2 dx$ is finite. Show that if we surround the exceptional points by small intervals, and form the function $G(x)$ equal to $F(x)$ outside these intervals, and to zero inside these intervals, we may make r.m.s. $(F - G)$ less than any fixed positive quantity, η , by making the intervals small enough. Using this fact, and the inequality of problem 7, modify the argument of section 82 so as to prove that the Fourier series for $F(x)$ converges in the mean to this function for any interval. The functions in problem 5 are of this character.

87. Abel's Theorem. In the applications of Fourier series in Chapter VI, we frequently found the solution of our problem in the form of a Fourier series with certain exponential damping factors multiplied into the terms. For any fixed value of the variable (t or y) these factors were positive, and, except for the value zero, decreased as we went out in the series. To discuss such damped series, we shall need the following theorem:

If a_1, a_2, a_3, \dots are a steadily decreasing set of positive numbers, and we multiply them into the terms of a convergent series

$$s = u_1 + u_2 + u_3 + \dots, \quad (85)$$

to form a new series

$$a_1u_1 + a_2u_2 + a_3u_3 + \dots, \quad (86)$$

this second series converges.

Since the series (85) converges, when n is sufficiently large, say greater than N , the partial sums to n terms, s_n , will all be within unity of their limit, and therefore less than $|s| + 1$. Thus any number T , bigger than this last number, and also numerically larger than the first N partial sums, will be numerically larger than all the partial sums. We may now state an additional part of the theorem:

If T is any number numerically larger than all the partial sums s_n , the sum of the series (86) is less than a_1T .

To prove the theorem, we begin by noting that from the definition of the partial sum to k terms, $s_1 = u_1$ and

$$s_k - s_{k-1} = \sum_{n=1}^k u_n - \sum_{n=1}^{k-1} u_n = u_k, \quad k > 1.$$

We may use these relations to write the partial sum to n terms, S_n , for the series (86) in terms of the s_n , namely:

$$\begin{aligned} S_n &= a_1u_1 + a_2u_2 + a_3u_3 + \dots + a_nu_n \\ &= a_1s_1 + a_2(s_2 - s_1) + a_3(s_3 - s_2) + \dots + a_n(s_n - s_{n-1}). \end{aligned} \quad (87)$$

By transposing one term, and regrouping, we find from this

$$S_n - a_n s_n = s_1(a_1 - a_2) + s_2(a_2 - a_3) + \dots + s_{n-1}(a_{n-1} - a_n). \quad (88)$$

If we regard the right member of (88) as the sum to $n - 1$ terms of an infinite series, whose n th term is $s_n(a_n - a_{n+1})$, this series

converges absolutely. For, as the a_n steadily decrease when n increases, $(a_n - a_{n+1})$ is positive or zero, so that

$$|s_n(a_n - a_{n+1})| < T(a_n - a_{n+1}). \tag{89}$$

Thus the series whose terms are $|s_n(a_n - a_{n+1})|$, is a series of positive terms, and its partial sum to $n - 1$ terms is less than

$$\begin{aligned} T(a_1 - a_2) + T(a_2 - a_3) + T(a_3 - a_4) + \dots + T(a_{n-1} - a_n) \\ = Ta_1 - Ta_n < Ta_1. \end{aligned} \tag{90}$$

Hence, since its partial sums are all less than a fixed number, by section 52, the series with terms $|s_n(a_n - a_{n+1})|$ converges, so that the series with terms $s_n(a_n - a_{n+1})$ converges absolutely.

This shows that the right member of (88) approaches a limit as n becomes infinite, and since the a_n are positive and steadily decreasing, by section 52, they approach a limit a , while s_n approaches the limit s . Thus $a_n s_n$ approaches a limit, as , and so S_n must approach a limit, S . This proves the first part of the theorem, and the series (86) converges to the sum S .

For the second part, we take the limit of both sides of (88), after making use of (89) and (90), to obtain:

$$|S - as| < Ta_1 - Ta.$$

But since $|s| < T$, this implies:

$$S < Ta_1 - Ta + a|s| < Ta_1, \tag{91}$$

which proves the second part of the theorem.

88. Series of Damped Harmonics. Consider a series of continuous functions like (5) p. 185, or (14) p. 189, or in general

$$\sum_{n=1}^{\infty} u_n(x)a_n(y), \tag{92}$$

where the functions $a_n(y)$ are all unity for $y = 0$, decrease as y increases, and for any fixed $y > 0$, for sufficiently large n , form a set of positive quantities decreasing to zero as n increases indefinitely.

Then, if the series $u_n(x)$ converges for a certain range, by the first result of section 87, the series (92) converges for all values of y , and x in this range. Thus it defines a function, $U(x, y)$.

Let us now fix $x = x_0$, and denote by S_n the partial sum to n terms of the series:

$$S = U(x_0, y) = \sum_{n=1}^{\infty} u_n(x_0)a_n(y). \quad (93)$$

Then, since the series with general term $u_n(x_0)$ converges, we may find an N such that the difference between its sum, and partial sum to n terms is numerically less than any fixed small positive quantity, η , provided $n \geq N$. That is, if s is the sum, and s_n the partial sum to n terms,

$$|s - s_N| < \eta, \quad \text{and} \quad |s - s_{N+m}| < \eta, \quad m > 0. \quad (94)$$

It follows from this that

$$\left| \sum_{n=1}^m u_{N+n}(x_0) \right| = |s_{N+m} - s_N| < 2\eta. \quad (95)$$

If we select the N just mentioned so large that, for $n > N$, the $a_n(y)$ are positive and decreasing and $a_{N+1}(y) < 1$ for any fixed y , we may apply the second result of section 87 to the series:

$$S - S_N = \sum_{n=1}^{\infty} u_{N+n}(x_0)a_{N+n}(y), \quad (96)$$

and, as we may use 2η in place of the T of (91), we find:

$$|S - S_N| < 2\eta a_{N+1}(y) < 2\eta, \quad y > 0, \quad (97)$$

since $a_{N+1}(y) < 1$. This also holds for $y = 0$, by (94) since the left member is then $|s - s_N|$. Thus, in the interval $0 \leq y \leq y_0$, by taking a sufficiently large N , we may make $|S - S_N|$ less than any fixed 2η , for all y . Thus, by section 57, the series (93) converges uniformly in y , and therefore by section 58 represents a continuous function of y in this interval. Hence in particular:

$$\lim_{y=0} U(x_0, y) = U(x_0, 0). \quad (98)$$

If x_0 is interior to an interval, $x_0 - h < x < x_0 + h$, in which the series with general term $u_n(x)$ converges uniformly in x , we may determine the N used in the above so that (94) and hence (97) holds for this whole interval. Thus the series (93) here converges uniformly in x and y , for $x_0 - h < x < x_0 + h$, and $0 < y < y_0$, so that by section 58 the sum is a continuous function of x and y , and in particular:

$$\lim_{\substack{x=x_0 \\ y=0}} U(x, y) = U(x_0, 0). \quad (99)$$

In the case of (5) p. 185 and (14) p. 189, where the $u_n(x)$ are the terms of the Fourier series for a piecewise smooth function, for values inside an interval in which the function is continuous, we may apply (99) to show that the correct boundary values are taken on. At a value for which the function is discontinuous, (98) shows that, for a special approach, the boundary value taken on by $U(x, y)$ is the sum of the Fourier series, i.e., the average of the two limits approached by the function.

We shall only discuss differentiation in detail for the specific series:

$$U(x, y) = \sum_{n=1}^{\infty} A_n \sin knx e^{-kny}, \quad (100)$$

as the reasoning is similar for most of the other series used in Chapter VI. If we differentiate the general term of this one or more times with respect to either of the variables, we shall have a power of k times a power of n times the sine or cosine of knx :

$$\pm k^p n^p A_n \left\{ \begin{array}{l} \sin \\ \cos \end{array} \right\} knx e^{-kny}. \quad (101)$$

While this series may diverge for $y = 0$, as long as all the A_n are numerically less than some fixed positive quantity F , the series just written will converge for any $y > 0$. We note that, by (73), we may take $\sqrt{2}$ r.m.s. $f(x)$ as F , if the A_n are the Fourier coefficients for a piecewise continuous function. To prove the statement about convergence, consider the series for $y \geq h$. Then, for such values, the terms of the series are numerically at most

$$k^p n^p F e^{-knh}. \quad (102)$$

But, the ratio of the n th to the $(n - 1)$ st term is

$$\frac{k^p n^p F e^{-knh}}{k^p (n - 1)^p F e^{-k(n-1)h}} = \frac{1}{\left(1 - \frac{1}{n}\right)^p} e^{-kh}.$$

As n becomes infinite, this approaches the limit

$$e^{-kh} < 1,$$

since k and h are positive. Thus, by problem 14 on p. 220, the series with general term (102) converges.

Consequently, by section 59, the series with general term (101) converges uniformly for all x and $y \geq h$. Thus by problem 7,

p. 224 the series may be integrated termwise with respect to either variable, any number of times. By carrying out the integrations which lead us back to the series (100), we see that the series (101) converges to that p th derivative which, applied to the terms of (100) gives the terms of (101).

Since h is any positive quantity, it follows that, for any positive value of y , any derivative of $U(x, y)$ may be obtained by differentiating the series (100) termwise. Thus $U(x, y)$ will satisfy any linear partial differential equation with constant coefficients, satisfied by its terms separately, for y greater than zero.

BIBLIOGRAPHY

CHAPTER I

1. Curtiss, D. R. Analytic Functions of a Complex Variable. Chicago, 1926.
2. Fine, H. B. College Algebra. Boston, 1905.
3. Townsend, E. J. Functions of a Complex Variable. New York, 1915.

CHAPTER II

4. Byerly, W. E. Fourier Series and Spherical Harmonics. Boston, 1893.
5. Lipka, J. Graphical and Mechanical Computation. New York, 1918.

CHAPTER III

6. Fry, T. C. Elementary Differential Equations. New York, 1929.
7. Guillemin, E. A. Communication Networks. Vol. I. New York, 1931.

CHAPTER IV

8. Woods, F. S. Advanced Calculus. Boston, 1932.

CHAPTER V

9. Carslaw, H. S. The Mathematical Theory of the Conduction of Heat in Solids. London, 1921.
10. Mason, M. and Weaver, W. The Electromagnetic Field. Chicago, 1932.
11. Phillips, H. B. Vector Analysis. New York, 1933.
12. Ramsey, A. S. Hydromechanics. Vol. II. London, 1929.
13. Timoshenko, S. Vibration Problems in Engineering. New York, 1928.
14. Woodruff, L. F. Principles of Electric Power Transmission and Distribution. New York, 1928.

CHAPTER VI

15. Bateman, H. Partial Differential Equations of Mathematical Physics. Cambridge, 1932.

See references under Chapter V:

CHAPTER VII

16. Titchmarsh, E. C. *The Theory of Functions*. London, 1932.
 17. Whittaker, E. T. and Watson, G. N. *Modern Analysis*. Cambridge, 1927.
- See references 1 and 3 under Chapter I.

CHAPTER VIII

18. Carslaw, H. S. *The Theory of Fourier Series and Integrals*. London, 1930.
- See references 16 and 17 under Chapter VII.
19. R. Rothe, F. Ollendorf and K. Pohlhausen. *Theory of Functions as Applied to Engineering Problems*. Cambridge, Mass., 1934.
 20. E. Jahnke and F. Emde. *Tables of Functions with Formulae and Curves*. Leipzig, 1933.

ANSWERS

EXERCISES I (Page 5)

1. (a) $1 - 6i$, (b) $-1 - 2i$, (c) $-2 - 3i$, (d) $-3 + 3i$, (e) $5i$, (f) $-.8 + 1.6i$, (g) $-8 - 4i$, (h) $-.8 - .6i$.
2. (a) $12 + 640i$, (b) $5.16 - 10.1i$, (c) $20 + 3640i$, (d) $5.18 - 10.1i$, (e) $13.3 + 637i$, (f) $5.8 + 568i$.
4. $2 \pm \sqrt{3}i$.
5. (a) $x + iy = \pm \left(\sqrt{\frac{a + \sqrt{a^2 + b^2}}{2}} + i \sqrt{\frac{-a + \sqrt{a^2 + b^2}}{2}} \right)$.
9. $-9/13$.
13. $48^2 + 25^2$ or $15^2 + 52^2$.

EXERCISES II (Page 12)

1. (a) $-5 - 2i$, (b) $1 + 12i$, (c) $5 + 10i$, (d) $4 - 2i$, (e) -24 , (f) $-2i$, (g) 18 , (h) $-.75$, (i) $-4.83 + 2.17i$, (j) $.847 + 1.26i$, (k) $6.36 - 3.18i$, (l) $12.7 + 29.7i$.
2. $1.16 + 1.61i$, $-1.16 - 1.61i$.
3. $1.26 + 1.15i$, $-1.63 + .520i$, $.364 - 1.67i$.
4. $.924 + .383i$, $-.383 + .924i$, $-.924 - .383i$, $.383 - .924i$.
5. $\sqrt{ZY} = 1.73 \times 10^{-3} \sqrt{83^{\circ}52'} = 1.85 \times 10^{-4} + 1.72 \times 10^{-4}i$, $\sqrt{Z/Y} = 372 \sqrt{-5^{\circ}57'} = 370 - 38.5i$.
6. $-32768i$.
7. (a) 11.6 mi., $10^{\circ}47'$ West of North.

EXERCISES III (Page 19)

1. (a) $5.83e^{i1.030} = 5.83e^{i59^{\circ}2'}$, (b) $5.83e^{-i1.030} = 5.83e^{-i59^{\circ}2'}$, (c) $5e^{i1.047} = 5e^{i60^{\circ}}$, (d) $5e^{i.524} = 5e^{i30^{\circ}}$, (e) $4e^{i.785} = e^{i45^{\circ}}$.
2. (a) i , (b) $-i$, (c) 1 , (d) 1 .
3. (a) $2.82 + 1.03i$, (b) $-1 - 1.73i$, (c) $1.04 + (.785 \pm 2k\pi)i$, (d) $(1 \pm 2k)\pi i$, (e) $(.5 \pm 2k)\pi i$.
4. $1.020 - .0306i$.
6. (b) $1/8 (\cos 4x - 4 \cos 2x + 3)$, $1/8 (-\cos 4x + 1)$, (c) $1/32 (\sin 4x - 8 \sin 2x + 12x) + C$, $1/32 (-\sin 4x + 4x) + C$.
10. (c) $e^{(a+bi)t}/(a + bi)$, (d) $e^{at} (a \cos bt + b \sin bt)/(a^2 + b^2)$.
12. (a) $18.8 \sqrt{377t - 34^{\circ}10'}$, (b) $8.1 \sqrt{377t + 228^{\circ}}$, (c) $22.5 \sqrt{377t - 12^{\circ}20'}$, (d) $75 \sqrt{754t - 45^{\circ}}$, (e) $.333 \sqrt{45^{\circ}}$, (f) $60 \sqrt{754t + 30^{\circ}}$, (g) $.417 \sqrt{-30^{\circ}}$.
13. (a) $6 \sqrt{85t - 110^{\circ}}$, (b) $5 \sqrt{63t - 35^{\circ}}$, (c) $9.23 \sqrt{54t + 49^{\circ}25'}$, (d) $3 \sqrt{45t + 215^{\circ}}$.
16. (a) 4.72 , (b) $-.487 + .873i$, (c) $4.18 - 19.6i$, (d) $.269 + .224i$, (e) $10.7 + 3.78i$.

EXERCISES IV (Page 23)

5. $49^{\circ}36'$.

EXERCISES V (Page 31)

2. (a) $u = x - x_0$, $v = y - y_0$, (b) $u = x \cos a + y \sin a$, $v = -x \sin a + y \cos a$.3. $7u^2 + v^2 = 12$.4. (a) $u = 0$, $v = 0$, (b) $v = 0$, $u = 0$, (c) $u = 5$, $v = 0$, (d) $5u^2 + 5v^2 = v$, $u = 0$, (e) $6u^2 + 6v^2 + u = 1$, $v = 0$, (f) $v = 0$, $u^2 + v^2 = 1$.6. (a) 0, 0, (b) 0, 0, (c) 0, 5, (d) $-.8$, $.2i$, (e) $.75$, $-.5$, (f) $-2i$, -1 .7. (a) $u = 0$, (b) $u = 0$.11. $v^2 + 36u = 324$.12. (a) $\theta = 0, 90^{\circ}, 180^{\circ}, 270^{\circ}$; $r = 1, 4, 9$, (b) $\theta = 0, 135^{\circ}, 270^{\circ}, 45^{\circ}$; $r = 1, 8, 27$, (c) $\theta = 0, 22^{\circ}30', 45^{\circ}, 67^{\circ}30'$; $r = 1, 1.41, 1.73$, (d) $\theta = 0, n45^{\circ}, n90^{\circ}, n135^{\circ}$; $r = 1, 2^n, 3^n$.14. Slope angle A into $2A$ for (a) and nA for (b).

EXERCISES VI (Page 38)

1. $u^2 - v^2 = 1$, $2uv = 1$.2. $u^3 - 3uv^2 = 2$.3. $u^2 + v^2 = e^{2x}$, $v = u \tan y$.4. $y = \pi$, $x \leq -1$; $y = -\pi$, $x \leq -1$; $y = 0$.9. $0 < x \leq \pi$; $(u/\cosh y)^2 + (v/\sinh y)^2 = 1$, $(u/\cos x)^2 = (v/\sin x)^2 = 1$.10. Area in 1st and 2nd quadrants bounded by $(u/3.76)^2 + (v/3.63)^2 = 1$, left branch of $(u/.416)^2 - (v/.909)^2 = 1$, and $v = 0$. The image of $A = (0, 0)$ is $(1, 0)$.11. $(u/1.17)^2 + (v/1.54)^2 = 1$, $-(u/.540)^2 + (v/.841)^2 = 1$.12. $(x-1)^2 + y^2 = e^{2u}[(x+1)^2 + y^2]$, $x^2 + y^2 - 1 = 2y \cot v$ 13. $e^2 = (x^2 + y^2 - 1)^2 + 4x^2y^2$.14. (a) 0, (b) 0, (c) 0, (d) 1, -1 .15. (a) 0, (b) a , (c) 1, -1 .

17. (b) fourth, third.

18. (a) a, b , second, (b) a , second.

EXERCISES VII (Page 50)

1. (a) 3, (b) $4/3$, (c) $.841$, (d) 1.82 , (e) 0, (f) 0, (g) 0, (h) 0.2. (a) 3, (b) $4/3$, (c) $.841$, (d) 1.82 , (e) 2, -2 , (f) 2, -2 , (g) $.460$, $-.460$, (h) 1.38 , -1.38 .4. (a) 3, (b) 1.79 , (c) $.853$, (d) 1.98 , (e) 2.31 , (f) 3.02 , (g) $.521$, (h) 1.71 .5. (a) $.905$, (b) $.316$, (c) 11.2 .6. (a) $.425$, (b) $.707$, (c) $.707$.7. (a) $.319$, $.354$, (b) $-.319$, $.354$, (c) 0, $.354$.8. $1, 1.15$.9. $.159$, $.354$.10. 1, 1.15 .

14. (a) $\bar{F} = c_1\bar{f}_1 + c_2\bar{f}_2 + c_3\bar{f}_3$, (b) $\bar{F}^2 = c_1^2\bar{f}_1^2 + c_2^2\bar{f}_2^2 + c_3^2\bar{f}_3^2 + 2c_1c_2\bar{f}_1\bar{f}_2 + 2c_1c_3\bar{f}_1\bar{f}_3 + 2c_2c_3\bar{f}_2\bar{f}_3$.

15. $\bar{y}_{ac} = [(b-a)\bar{y}_{ab} + (c-b)\bar{y}_{bc}]/(c-a)$, $\bar{y}_{ac}^2 = [(b-a)\bar{y}_{ab}^2 + (c-b)\bar{y}_{bc}^2]/(c-a)$.

EXERCISES VIII (Page 60)

- (a) 286, (b) 159, (c) 115, (d) 169, (e) 10.8.
- (a) 1.82, (b) 79, (c) .98, (d) 1.43, (e) 10.8.
- (a) 323, (b) 12,600, (c) 95.5, (d) 45.6, (e) 117.
- .707A, .707B, $1/2 AB \cos(a-b)$.
- $1/60, 1/25, 1/30, 1/25, 60$, (b) 60, 25, 30, 25.
- (a) .507, (b) .0028.

EXERCISES IX (Page 68)

- odd (a), (d), (f); even (b), (c), (f); odd harmonic (a), (c), (d), (f).
- $2 + 7.82 \sin(4\pi x + 50^\circ 10') + 5.38 \sin(8\pi x + 21^\circ 50')$, $2 + 7.82 \cos(4\pi x - 39^\circ 50') + 5.38 \cos(8\pi x - 68^\circ 10')$.
- (a) $1/2 - 1/2 \cos 2x$, (b) $1/2 + 1/2 \cos 2x$, (c) $3/4 \sin x - 1/4 \sin 3x$.
- (a) $\cos a \cos x - \sin a \sin x$, (b) $\sin a \cos x + \cos a \sin x$.

EXERCISES X (Page 74)

- (a) $\frac{5}{4} + \sum_{n=1}^{\infty} \left\{ \frac{5[(-1)^n - 1]}{n^2\pi^2} \cos \frac{n\pi x}{5} + \frac{5(-1)^{n+1}}{n\pi} \sin \frac{n\pi x}{5} \right\}$,

(b) $\frac{25}{6} + \sum_{n=1}^{\infty} \left\{ \frac{50(-1)^n}{n^2\pi^2} \cos \frac{n\pi x}{5} + \left[\frac{25(-1)^{n+1}}{n\pi} + \frac{50[(-1)^n - 1]}{n^3\pi^3} \right] \sin \frac{n\pi x}{5} \right\}$,

(c) $\frac{e^5 - 1}{10} + \sum_{n=1}^{\infty} \left\{ \frac{5[(-1)^n e^5 - 1]}{5^2 + n^2\pi^2} \cos \frac{n\pi x}{5} + \frac{n\pi[(-1)^{n+1} e^5 + 1]}{5^2 + n^2\pi^2} \sin \frac{n\pi x}{5} \right\}$.
- $-\frac{1}{4} + \sum_{n=1}^{\infty} \left\{ -\frac{1}{n\pi} \sin \frac{n\pi}{2} \cos \frac{n\pi x}{8} + \frac{3}{n\pi} \left(1 - \cos \frac{n\pi}{2} \right) \sin \frac{n\pi x}{8} \right\}$.
- $\sum_{n=1}^{\infty} \left\{ -\frac{20}{n\pi} \sin \frac{n\pi}{2} \cos \frac{n\pi x}{20} + \frac{10}{n\pi} \left(1 - 3 \cos n\pi + 2 \cos \frac{n\pi}{2} \right) \sin \frac{n\pi x}{20} \right\}$.
- $\frac{1}{2} - \sum_{n=1}^{\infty} \frac{1}{n\pi} \sin 2n\pi x$.
- $45 - \sum_{n=1}^{\infty} \frac{360}{(2n-1)^2\pi^2} \cos(4n-2)x$.
- $\frac{2}{\pi} - \sum_{n=1}^{\infty} \frac{4}{\pi(4n^2-1)} \cos 2nx$.

7. $\frac{2}{\pi} + \sum_{n=1}^{\infty} \frac{4(-1)^{n+1}}{\pi(4n^2 - 1)} \cos 2nx.$
8. $3 + \sum_{n=1}^{\infty} \frac{36(-1)^n}{n^2\pi^2} \cos \frac{n\pi x}{3}.$
9. $\sum_{n=1}^{\infty} \left\{ \frac{6}{n\pi} \sin \frac{n\pi}{2} \cos \frac{n\pi x}{4} + \frac{7[(-1)^{n+1} + 1]}{n\pi} \sin \frac{n\pi x}{4} \right\}.$
10. (a) $\frac{e^{\pi} - e^{-\pi}}{2\pi} + \sum_{n=1}^{\infty} \frac{(-1)^n(e^{\pi} - e^{-\pi})}{\pi(1 + n^2)} (\cos nx - n \sin nx),$
- (b) $1 - \frac{1}{2} \cos x + \sum_{n=1}^{\infty} \frac{2(-1)^n}{n^2 + 2n} \cos (n + 1)x,$
- (c) $-\frac{1}{2} \sin x + \sum_{n=1}^{\infty} \frac{(-1)^{n+1}(2n + 1)}{n^2 + 2n} \sin (n + 1)x.$

EXERCISES XI (Page 77)

4. $\sum_{n=1}^{\infty} \frac{6 + 14(-1)^{n+1}}{n\pi} \sin \frac{n\pi x}{2}.$
5. $5 - \sum_{n=1}^{\infty} \frac{16}{\pi^2(2n - 1)^2} \cos \frac{(2n - 1)\pi x}{2}.$
6. (a) $\sum_{n=1}^{\infty} \left\{ \frac{12}{n^2\pi^2} \sin \frac{n\pi}{2} - \frac{6}{n\pi} \cos n\pi \right\} \sin \frac{n\pi x}{6},$
- (b) $\frac{9}{4} + \sum_{n=1}^{\infty} \frac{12}{n^2\pi^2} \left(\cos \frac{n\pi}{2} - 1 \right) \cos \frac{n\pi x}{6}.$
7. (a) $\sum_{n=1}^{\infty} \frac{6}{n\pi} \left(\cos \frac{n\pi}{2} - \cos n\pi \right) \sin \frac{n\pi x}{6},$
- (b) $\frac{3}{2} - \sum_{n=1}^{\infty} \frac{6}{n\pi} \sin \frac{n\pi}{2} \cos \frac{n\pi x}{6}.$
8. (a) $\sum_{n=1}^{\infty} \frac{16}{n^2\pi^2} \sin \frac{n\pi}{2} \sin \frac{n\pi x}{2},$
- (b) $1 - \sum_{n=1}^{\infty} \frac{8}{(2n - 1)^2\pi^2} \cos (2n - 1)\pi x.$
14. (a) $\sum_{n=1}^{\infty} \frac{8p(-1)^{n+1}}{\pi^2(2n - 1)^2} \sin \frac{(2n - 1)\pi x}{2p},$
- $\sum_{n=1}^{\infty} \left\{ \frac{4p(-1)^{n+1}}{\pi(2n - 1)} - \frac{8p}{\pi^2(2n - 1)^2} \right\} \cos \frac{(2n - 1)\pi x}{2p};$
- (b) $\sum_{n=1}^{\infty} \frac{4}{(2n - 1)\pi} \sin \frac{(2n - 1)\pi x}{2p}, \quad \frac{4(-1)^{n+1}}{(2n - 1)\pi} \cos \frac{(2n - 1)\pi x}{2p}.$

EXERCISES XII (Page 82)

1. (a) $y'' = 0$, (b) $y'' - 3y' + 2y = 0$, (c) $y'' + y = 0$, (d) $y'' + 2y' + y = 0$, (e) $y'' - 6y' + 13y = 0$.

2. (a) $y'' = 2$, (b) $y'' - 3y' + 2y = 6$, (c) $y'' + y = -3 \sin 2x$, (d) $y'' + 2y' + y = 4e^x$, (e) $y'' - 6y' + 13y = 26x + 1$.

3. (a) $x^2y'' - 4xy' + 6y = 0$, (b) $(x - 1)y'' - xy' + y = 0$, (c) $(1 - \cot x)y'' - 2y' + (1 + \cot x)y = 0$, (d) $(\cot x - 2 \cot 2x)y'' - 3y' + (4 \cot x - 2 \cot 2x)y = 0$, (e) $(f'g - g'f)y'' + (fg'' - gf'')y' + (f''g' - g''f')y = 0$.

4. (a) $xy'' - 3y' = -4x$, (b) $\sin 2x y'' - 2 \cos 2x y' = -4$, (c) $x^2y'' - 5xy' + 8y = 8$.

EXERCISES XIII (Page 86)

1. (a) $y = c_1e^{2x} + c_2e^{-2x}$, (b) $y = c_1e^{2x} + c_2e^{4x}$, (c) $y = c_1 \cos 3x + c_2 \sin 3x$, (d) $y = (c_1 \cos 1.32x + c_2 \sin 1.32x)e^{-2.6x}$, (e) $y = (c_1 \cos 2.45x + c_2 \sin 2.45x)e^{-3.6x}$.

2. (a) $y = c_1 + c_2x$, (b) $y = (c_1 + c_2x)e^{-2x}$, (c) $y = c_1 + c_2x + c_3x^2$, (d) $y = (c_1 + c_2x) \cos 1.73x + (c_3 + c_4x) \sin 1.73x$, (e) $y = (c_1 + c_2x)e^{2x} + (c_3 + c_4x)e^{-2x}$.

3. (a) $y = .5e^x + .5e^{5x} + c_1 \cos 5x + c_2 \sin 5x$, (b) $y = .05e^{-5x} + c_1e^x + (c_2 + .25x)e^{5x}$, (c) $y = .156e^{4x} + (c_1 \cos 1.32x + c_2 \sin 1.32x)e^{-1.6x}$, (d) $y = c_1e^{-5x} + (c_2 + .1x)e^{6x}$, (e) $y = c_1 + (c_2 - x/3)e^{-3x}$.

4. $y = -.147 \cos 4x + .88 \sin 4x + (c_1 \cos x + c_2 \sin x)e^{-3x}$ or $y = .172 \sin (4x - 59^\circ) + Ae^{-3x} \sin (x + a)$.

5. (a) $y = .131 \sin (2x + 66^\circ 50') + c_1e^{2x} + c_2e^{6x}$, (b) $y = .33 \sin (3x - 97^\circ 35') + .046 \sin (9x - 148^\circ 40') + (c_1 \cos .866x + c_2 \sin .866x)e^{-2.6x}$, (c) $y = 1.79 \sin (x - 3^\circ 30') + (c_1 \cos x + c_2 \sin x)e^{-x}$, (d) $y = -1.67 \cos 2x - \sin 2x - .571 \cos 6x + .286 \sin 6x + c_1 \cos x + c_2 \sin x$, (e) $y = (c_1 - 1.25x) \cos 2x + c_2 \sin 2x$.

6. (a) $y = -.714 + c_1e^{7x} + c_2e^{-x}$, (b) $y = .67x^3 + c_1 + c_2x + c_3x^2$, (c) $y = (.139x^2 + c_1x + c_2)e^{3x} + (c_3 + c_4x)e^{-3x}$, (d) $y = .156e^{2x} + (c_1 + c_2x - .312x^2) \sin 2x + (c_3 + c_4x) \cos 2x$, (e) $y = c_1e^{-3x} + .566e^{2x} \sin (5x - 45^\circ)$.

7. (a) $-.75x^2 - .375$, (b) $(-.01 + .05x)e^{2x}$, (c) $.167x^2e^{6x}$, (d) $-.111 \cos 2x + .167x \sin 2x$.

$$9. y = 2x^2 - 4x = \sum_{n=1}^{\infty} \frac{-64}{\pi^3(2n-1)^3} \sin \frac{(2n-1)\pi x}{2}$$

10. (a) $y = 1.5x + .75e^{-2x} - .75$, $0 < x < 3$, $y = (.75 - 1.5e^6)e^{-2x} - 1.5x + 9.75$, $3 < x < 9$, $y = (.75 - 1.5e^6 + 1.5e^{18})e^{-2x} + 1.5x - 18.75$, $9 < x < 12$.

$$(b) y = \sum_{n=1}^{\infty} \frac{(-1)^n 432 \left\{ (2n-1)\pi \left[\frac{\cos(2n-1)\pi x}{6} - e^{-2x} \right] - 12 \sin \frac{(2n-1)\pi x}{6} \right\}}{(2n-1)^2 \pi^2 [144 + (2n-1)^2 \pi^2]}$$

EXERCISES XIV (Page 94)

1. (a) $x = .2e^{2t} + c_1e^t + c_2e^{-2t}$, $y = 4e^{2t} + c_1e^t - 3c_2e^{-2t}$, (b) $x = -.57e^{4t} + c_1e^{-57t}$, $y = .43e^{4t} + c_1e^{-57t}$, (c) $x = -.5e^{2t}$, $y = 2e^{2t}$.

2. (a) $x = c_1e^{-t} + c_2te^{-t}$, $y = (c_1 + 7c_2)e^{-t} + c_2te^{-t}$, (b) $x = c_1e^{-t}$, $y = c_2e^{-t}$, (c) $x = c_1e^{2t} - te^{2t}$, $y = c_2e^t + (2 + c_2)e^{2t} - te^{2t}$, (d) $x = c_1e^{2t} + c_2te^{2t} - .25t^2e^{2t}$, $y = (-c_1 - 2c_2 - 1)e^{2t} + (-c_2 + 1)te^{2t} + .25t^2e^{2t}$, (e) $x = c_1e^{2t} + .312te^{2t}$, $y = c_2e^{2t} - .062te^{2t}$.

3. (a) $x = .143e^{-t} + 2c_1e^{-2t} + [4c_2 \cos 1.73t + 4c_3 \sin 1.73t]e^t$, $y = -.286e^{-t} - c_1e^{-2t} + [(c_2 + 1.73c_3) \cos 1.73t + (-1.73c_2 + c_3) \sin 1.73t]e^t$, $z = -.286e^{-t} - 2c_1e^{-2t} + [(2c_2 - 3.46c_3) \cos 1.73t + (3.46c_2 + 2c_3) \sin 1.73t]e^t$, (b) $x = .5e^{3t} + 6c_1 + 5c_2 \cos t + 5c_3 \sin t$, $y = -.2e^{3t} - 3c_1 + (-3c_2 - c_3) \cos t + (c_2 - 3c_3) \sin t$, $z = .033e^{3t} - 2c_1 + (-2c_2 + c_3) \cos t + (-c_2 - 2c_3) \sin t$, (c) $x = .2e^t + [(c_2 + 5.57c_3) \cos 2.78t + (-5.57c_2 + c_3) \sin 2.78t]e^{-.5t}$, $y = (.2 - c_1)e^t + [4c_2 \cos 2.78t + 4c_3 \sin 2.78t]e^{-.5t}$, $z = (.2 + c_1)e^t + [4c_2 \cos 2.78t + 4c_3 \sin 2.78t]e^{-.5t}$.

4. (a) $x = 2.25e^{5t} + c_1e^t + c_2e^{4t}$, $y = 1.5e^{5t} - 2c_1e^t + c_2e^{4t}$, (b) $x = .081 \cos t - .487 \sin t + c_1e^{.844t} + c_2e^{-.583t}$, $y = -.135 \cos t - .189 \sin t + .615c_1e^{.844t} + .135c_2e^{-.583t}$, (c) $x = -.106 \cos 3t + (2c_1 \cos t + 2c_2 \sin t)e^t + (2c_3 \cos t + 2c_4 \sin t)e^{-t}$, $y = -.012 \cos 3t + (c_2 \cos t - c_1 \sin t)e^t + (-c_4 \cos t + c_3 \sin t)e^{-t}$.

5. (a) $x = .1e^{3t} + c_1e^{.816t} + c_2e^{-.816t}$, $y = .02e^{3t} - .3c_1e^{.816t} - .3c_2e^{-.816t}$, (b) $x = c_1e^t + c_2e^{-2t} + [c_3 \cos .866t + c_4 \sin .866t]e^{-.5t} + [2c_5 \cos 1.73t + 2c_6 \sin 1.73t]e^t$, $y = -4c_1e^t - c_2e^{-2t} + [(2c_3 - 3.46c_4) \cos .866t + (3.46c_3 + 2c_4) \sin .866t]e^{-.5t} + [(c_5 + 1.73c_6) \cos 1.73t + (-1.73c_5 + c_6) \sin 1.73t]e^t$, (c) $x = c_1e^{-2.33t} + [c_2 \cos t + c_3 \sin t]e^{-2t}$, $y = -25c_1e^{-2.33t} + [(3c_2 + 4c_3) \cos t + (-4c_3 + 3c_2) \sin t]e^{-2t}$, (d) $x = c_1e^{3t} + c_2e^{-3t} + c_3 \cos t + c_4 \sin t$, $y = c_1e^{3t} + c_2e^{-3t} - c_3 \cos t - c_4 \sin t$, (e) $x = 2c_1e^t + c_2e^{2t}$, $y = -3c_1e^t + c_2e^{2t}$.

EXERCISES XV (Page 104)

2. $i = .0457 \sin (120\pi t - 88^\circ 25') + .0028 \sin (360\pi t - 64^\circ 35') + .0002 \sin (600\pi t - 99^\circ 45')$.

3. $t = -2.5 \times 10^{-6} e^{-.0714t} \sin 119.4 t$.

4. $I_1 + I_2 + I_3 = 0$, $Z_1I_1 - Z_2I_2 = E_1 - E_2$, $Z_2I_2 - Z_3I_3 = E_2 - E_3$.

5. $I_3 = E_3(Z_1 + Z_2)/(Z_1Z_2)$.

6. $I_1 + I_2 - I_5 = 0$, $I_5 + I_3 + I_4 = 0$, $-I_1 - I_2 + I_6 = 0$, $I_1Z_1 - I_2Z_2 = 0$, $I_2Z_2 + I_5Z_5 - I_3Z_3 + I_6Z_6 = E_6$, $I_3Z_3 - I_4Z_4 = 0$.

7. (b) $i_1 = P/Q \sin (\omega t + \alpha + p - q)$, where $P|p = R_3E_m + (L_3E_m - MF_m)\omega j$, and $Q|q = M^2\omega^2 + R_1R_3 - L_1L_3\omega^2 + (L_1R_3 + L_2R_1)\omega j$.

8. (b) $x = 1.32 \sin (4t - 76^\circ)$:

EXERCISES XVI (Page 109)

1. $y = x^4 + 4x^3 + c_1x^2 + c_2(1 + x)$.

2. $y = -.25(e^x + e^{-x}) \ln (e^x + e^{-x}) + (c_1 + .25x)e^x + (c_2 - .25x)e^{-x}$.

3. $y = -x^2 \sin x + c_1x^3 + c_2x^2$.

4. $uy = \int_{x_0}^x uQ(x) dx + c$, where $\ln u = \int_{x_1}^x P(x) dx$.
6. (a) $y = -12 \cos x + c_1 + c_2 \sin x$, (b) $y = x^2/4 + 1/8 + c_1 e^{2x} + c_2 x$,
(c) $y = (x^4 + 4x^3 + 3x^2)/6 + c_1(x^2 - 1) + c_2(x + 1)$.
8. $y = 12 - 28x + 15x^2 - x^4$.
13. (da) $x = 1/7e^{-t} - 1/3e^{-2t} + 1/21(4 \cos \sqrt{3}t + 2\sqrt{3} \sin \sqrt{3}t)e^t$, $y = -2/7e^{-t} + 1/6e^{-2t} + 1/42(5 \cos \sqrt{3}t - \sqrt{3} \sin \sqrt{3}t)e^t$, $z = -2/7e^{-t} + 1/3e^{-2t} + 1/21(-\cos \sqrt{3}t + 3\sqrt{3} \sin \sqrt{3}t)e^t$, (db) $x = .5e^{3t} - 2 + 1.5 \cos t - .5 \sin t$,
 $y = -.2e^{3t} + 1 - .8 \cos t + .6 \sin t$, $z = .033e^{3t} + .667 - .7 \cos t - .1 \sin t$,
(ea) $x = .2e^{2t} - .25e^t + .05e^{-3t}$, $y = .4e^{2t} - .25e^t - .15e^{-3t}$, $x = dx/dt = y = 0$
for $t = 0$, (eb) $x = -4/7e^{4t} - 2/21e^{-2t/3}$, $y = 3/7e^{4t} - 2/21e^{-2t/3}$, no conditions,
(ec) $x = -.5e^{-2t}$, $y = 2e^{2t}$, no conditions.

EXERCISES XVII (Page 121)

1. (a) $x_u = 2u$, $x_v = 0$, $y_u = 4$, $y_v = 5$, (b) $u_x = 1/(2u)$, $u_y = 0$, $v_x = -2/(5u)$,
 $v_y = 1/5$, (c) $u = \sqrt{x}$, $v = y/5 - 4\sqrt{x}/5$.
2. (a) $x_r = \cos \theta$, $x_\theta = -r \sin \theta$, $y_r = \sin \theta$, $y_\theta = r \cos \theta$, (b) $r_x = \cos \theta$, $r_y = \sin \theta$,
 $\theta_x = (-\sin \theta)/r$, $\theta_y = (\cos \theta)/r$, (c) $r = \sqrt{x^2 + y^2}$, $\theta = \tan^{-1}(y/x)$.
3. (a) $f_u = 2uf_x + 4f_y$, $f_v = 5f_y$, (b) $f_{uu} = 4u^2f_{xx} + 16uf_{xy} + 16f_{yy} + 2f_{\theta\theta}$,
 $f_{uv} = 10uf_{xy} + 20f_{yy}$, $f_{vv} = 25f_{yy}$.
9. (a) $\frac{dz}{dx} = \frac{\phi_x f_y - \phi_y f_x}{\phi_y f_z}$, (b) $\frac{\partial z}{\partial x} = -\frac{f_x}{f_z}$.
10. (a) $\frac{\partial x}{\partial u} = -\frac{f_u g_y - f_y g_u}{f_x g_y - f_y g_x}$, $\frac{\partial u}{\partial x} = -\frac{f_x g_v - f_v g_x}{f_u g_v - f_v g_u}$.

EXERCISES XVIII (Page 127)

1. $z \sqrt{a^2 - x_0^2 - y_0^2} + xx_0 + yy_0 = a^2$, $\sqrt{2}z + x + y = 2a$.
4. $zz_0 + xx_0 + yy_0 = a^2$.

EXERCISES XIX (Page 132)

1. $4z_x - 3z_y = -24$.
2. (a) $z_x = 0$, (b) $az_x + bz_y = 0$, (c) $az_x + bz_y = c$, (d) $xz_x + yz_y = z$,
(e) $yz_x - xz_y = 0$.
3. (a) $z_{xy} = 2e^{2x}$, (b) $z_{xx} = 2$, (c) $15z_{xx} - 2z_{xy} - 8z_{yy} = 0$, (d) $5z_{xy} - 3z_{yy} = -24$.
4. $z_x + z_y = az$.
5. $v^2 z_{xx} - z_{tt} = 0$.

EXERCISES XX (Page 135)

1. (a) $z = f(y)$, (b) $z = f(x)$, (c) $z = x^3/3 + f(y)$, (d) $z = x^2y/2 + f(y)$,
(e) $z = x^3/(2y) + f(y)$, (f) $z = 2x + x^2/(2y) + f(y)$.
2. (a) $z = 1/2 x^2 \ln y + 6xy + f(x) + g(y)$, (b) $z = x^3y/3 - x^2/2 + xf(y) + g(y)$,
(c) $z = x^2y/3 + xy^3/3 + f(x) + g(y)$, (d) $u = xe^t + tx^4/4 + f(x) + g(t)$,

(e) $u = x^2t/2 + xt^2/2 + f(x) + g(t)$, (f) $u = 1/12 \cos(2x + 3t) + f(x) + g(t) + xh(t)$.

5. (a) $z = e^{xy/2}f(y)$, (b) $z^2 = 2x^2 - 4xy + f(y)$, (c) $z = -\ln[f(y) - xy]$.

6. $z = 3x^2y^4 + y^2f(x) + g(y)$.

EXERCISES XXI (Page 141)

1. (a) $z = f(x + y)$, (b) $z = f(xy)$, (c) $z = f(x^2 - y^2)$, (d) $z = f(x^by^{-a})$, (e) $z = f(bx^2 - ay^2)$.

2. (a) $z = f(y)$, (b) $z = f(bx - ay)$, (c) $az = cx + f(bx - ay)$, (d) $z = xf(y/x)$, (e) $z = f(x^2 + y^2)$.

7. $z = x^3 + 2y^3 + f(7x - 5y)$.

8. $z = 3x^2/2 + y^2 + 4e^{3x}/9 + f(5x - 3y)$.

9. (a) $z = 2x + 3y + f(x^by^{-a})$, (b) $z = 4x + 3y + f(bx^2 - ay^2)$.

10. (a) $z = 2x + f(\cos x + \sin y)$, (b) $z = \frac{x^3}{3} + \frac{x^2}{2} + f\left(\frac{x+y}{x\sqrt{x}}\right)$.

11. (a) $z = e^{ax}f(y - x)$, (b) $x - y - e^{x-z} + e^{y-z} = f(e^x - e^y)$.

12. $z = cx/a + x^2/2 + y^2/2 + f(bx - ay)$.

13. $z = x^c/a e^{x+y}f(x^by^{-a})$.

14. (a) $1/z - 1/x = f(1/y - 1/x)$, (b) $z^2 - x^2 = f(y^2 - x^2)$.

EXERCISES XXII (Page 146)

1. (a) $z = f(2x + y) + g(4x + y)$, (b) $z = f(x) + g(13x - y)$, (c) $z = 1.5x^2 + f(x - y) + g(3x - 4y)$, (d) $z = f(3x + 4y) + xg(3x + 4y)$.

5. $z = x^2 + x^3/2 - 5y^2/6 - x^4/12 + f(x + y) + g(x - y)$.

6. $z = 5e^{8y}/36 - \sin x + f(x + y) + xg(x + y)$.

7. $u = c \sin(Qx + Py + a)$, $v = c \cos(Qx + Py + a)$:

9. (b) $f(u) = -quh(u) = -qu^3$, $g(u) = (p + 3q)h(u) = (p + 3q)u^2$.

10. (b) $z = f(x + y) + g(x) + yh(x) + y^2k(x) + p(y) + xq(y) + x^2r(y)$.

EXERCISES XXIII (Page 154)

2. (a) $z = ce^{ax}e^{ay}$, (b) $z = cx^ay^a$, (c) $z = ce^{1ax^2}e^{2ay^3}$, (d) $z = ce^{ae^x}e^{-ae^y}$, (e) $z = ce^{(a+b)x}e^{-by}$, (f) $z = ce^{3ax^2}e^{-4ay^2}$.

3. (a) $z = (c_1e^{ahx} + c_2e^{-ahx})(c_7e^{at} + c_8e^{-at})$, $z = (c_3 \cos bhx + c_4 \sin bhx)(c_9 \cos bt + c_{10} \sin bt)$, $z = (c_5 + c_6x)(c_{11} + c_{12}t)$, (b) $z = (c_1 + c_2e^{ay})e^{2ax}$, $z = (c_1 + c_2y)$, (c) $z = (c_1e^{ahx} + c_2e^{-ahx})(c_7 \cos at + c_8 \sin at)$, $z = (c_3 \cos bhx + c_4 \sin bhx)(c_9e^{bt} + c_{10}e^{-bt})$, $z = (c_5 + c_6x)(c_{11} + c_{12}t)$.

EXERCISES XXIV (Page 160)

2. (b) $e = e^{-kt} \left[f\left(x - \frac{t}{\sqrt{LC}}\right) + g\left(x + \frac{t}{\sqrt{LC}}\right) \right]$,
 $t_i = e^{-kt} \sqrt{\frac{C}{L}} \left[f\left(x - \frac{t}{\sqrt{LC}}\right) - g\left(x + \frac{t}{\sqrt{LC}}\right) \right]$.

EXERCISES XXV (Page 165)

1. 2.3×10^8 cal./day, 55 kg./day.
2. 1.3×10^6 cal./day, 15.3 kg./day, 3 kwh./day.
6. 1.38×10^9 cal./day.
7. 23.7 cal./sec., 31.4 volts.
8. .0023.
9. (a) 392 cal./sec., (b) 393 cal./sec.
10. 2404 cal./sec.

EXERCISES XXVI (Page 170)

7. $p = -\frac{Da^2}{2g(x^2 + y^2)}$.
8. (a) $p_\infty = \frac{D}{8g(x^2 + y^2)^{1/2}}$, (b) $p_\infty = \frac{2D}{9g(x^2 + y^2)^{1/3}}$,
 (c) $p_0 = \frac{D}{2g}(3 - 2e^x \cos y - e^{2x})$, (d) $p_\infty = \frac{D(2x^2 - 2y^2 - 1)}{2g(x^2 + y^2)^2}$,
 (e) $p_\infty = \frac{D(-2x^2y - 2y^3 + x^2 - 3y^2 - 2y - 1)}{2g(x^2 + y^2)^2}$.

EXERCISES XXIX (Page 186)

1. (a) $\sum_{n=1}^{\infty} \frac{160}{(2n-1)\pi} \sin \frac{(2n-1)\pi x}{30} e^{-\frac{(2n-1)\pi y}{30}}$,
 (b) $\sum_{n=1}^{\infty} \frac{96(-1)^{n+1}}{n\pi} \sin \frac{n\pi x}{6} e^{-\frac{n\pi y}{6}}$,
 (c) $\sum_{n=1}^{\infty} \frac{-8}{n\pi} \sin \frac{n\pi x}{2} e^{-\frac{n\pi y}{2}}$,
 (d) $\sum_{n=1}^{\infty} \frac{20}{n\pi} \left(1 - \cos \frac{n\pi}{2}\right) \sin \frac{n\pi x}{8} e^{-\frac{n\pi y}{8}}$,
 (e) $2 \sin \frac{\pi x}{10} e^{-\frac{\pi y}{10}}$,
 (f) $5 \sin \frac{\pi x}{3} e^{-\frac{\pi y}{3}} + 3 \sin \frac{\pi x}{4} e^{-\frac{\pi y}{4}}$.
5. $50 + \sum_{n=1}^{\infty} \frac{200}{(2n-1)\pi} \left(\frac{r}{10}\right)^{2n-1} \sin(2n-1)\theta$.

EXERCISES XXX (Page 193)

1. (a) $\sum_{n=1}^{\infty} \frac{200(-1)^{n+1}}{n\pi} \sin \frac{n\pi x}{50} e^{-\frac{n^2\pi^2 t}{2500k^2}}$,
 (b) $100 - \sum_{n=1}^{\infty} \frac{200}{n\pi} \sin \frac{n\pi x}{50} e^{-\frac{n^2\pi^2 t}{2500k^2}}$,

$$(c) x + \sum_{n=1}^{\infty} \frac{100(-1)^{n+1}}{n\pi} \sin \frac{n\pi x}{50} e^{\frac{-n^2\pi^2}{2500k^2}},$$

$$(d) 25 + x - \sum_{n=1}^{\infty} \frac{50}{n\pi} \sin \frac{n\pi x}{25} e^{\frac{-n^2\pi^2}{625k^2}},$$

$$(e) 50 + 2x - \sum_{n=1}^{\infty} \frac{200}{(2n-1)\pi} \sin \frac{(2n-1)\pi x}{50} e^{\frac{-(2n-1)^2\pi^2}{2500k^2}},$$

2. 27.9°.

3. 74.9°, 42.7°.

4. 50°.

5. (a) 37.5°, (b) 30.5°, (c) 25°.

$$6. (a) \sum_{n=1}^{\infty} \frac{100}{n\pi} \left(\cos \frac{n\pi}{2} - \cos n\pi \right) \sin \frac{n\pi x}{80} e^{\frac{-n^2\pi^2}{6400k^2}}, \quad (b) 5.1^\circ.$$

$$7. (b) 90 - \sum_{n=1}^{\infty} \frac{720}{(2n-1)^2\pi^2} \cos \frac{(2n-1)\pi x}{60} e^{\frac{-(2n-1)^2\pi^2}{3600k^2}};$$

$$8 \text{ and } 9. \sum_{n=1}^{\infty} \frac{800(-1)^{n+1}}{(2n-1)^2\pi^2} \sin \frac{(2n-1)\pi x}{40} e^{\frac{-(2n-1)^2\pi^2}{1600k^2}};$$

EXERCISES XXXI (Page 198)

$$1: (a) e = E_1 \sin \frac{x}{1000} \epsilon^{-t} + E_2 \sin \frac{x}{200} \epsilon^{-2t},$$

$$i = -\frac{E_1}{3000} \cos \frac{x}{1000} \epsilon^{-t} - \frac{E_2}{600} \cos \frac{x}{200} \epsilon^{-2t},$$

$$(b) e = \sum_{n=1}^{\infty} \frac{2E(-1)^{n+1}}{n\pi} \sin \frac{nx}{1000} \epsilon^{-n^2},$$

$$i = \sum_{n=1}^{\infty} \frac{2E(-1)^n}{3000\pi} \cos \frac{nx}{1000} \epsilon^{-n^2}.$$

$$2. e = \frac{Ex}{a} + \sum_{n=1}^{\infty} \frac{2E(-1)^n}{n\pi} \sin \frac{n\pi x}{a} \epsilon^{\frac{-n^2\pi^2}{a^2RC}},$$

$$i = -\frac{E}{Ra} + \sum_{n=1}^{\infty} \frac{2E(-1)^{n+1}}{Ra} \cos \frac{n\pi x}{a} \epsilon^{\frac{-n^2\pi^2}{a^2RC}}.$$

EXERCISES XXXII (Page 200)

$$1. \sum_{n=1}^{\infty} \frac{8p(-1)^{n+1}}{(2n-1)^2\pi^2} \sin \frac{(2n-1)\pi x}{a} \cos \frac{(2n-1)\pi st}{a},$$

$$2. (a) p \sin \frac{n\pi x}{a} \cos \frac{n\pi st}{a},$$

$$(b) \frac{p}{4} \left(3 \sin \frac{\pi x}{a} \cos \frac{\pi st}{a} - \sin \frac{3\pi x}{a} \cos \frac{3\pi st}{a} \right),$$

$$(c) \sum_{n=1}^{\infty} \frac{8pa^2}{(2n-1)^2\pi^2} \sin \frac{(2n-1)\pi x}{a} \cos \frac{(2n-1)\pi st}{a};$$

4. (a) $\frac{pa}{n\pi s} \sin \frac{n\pi x}{a} \sin \frac{n\pi st}{a}$,
 (b) $\frac{pa}{12\pi s} \left(9 \sin \frac{\pi x}{a} \sin \frac{\pi st}{a} - \sin \frac{3\pi x}{a} \sin \frac{3\pi st}{a} \right)$,
 (c) $\sum_{n=1}^{\infty} \frac{8pa^3}{(2n-1)^4 \pi^4 s} \sin \frac{(2n-1)\pi x}{a} \sin \frac{(2n-1)\pi st}{a}$.

EXERCISES XXXIII (Page 203)

1. (a) $e = E_1 \sin \frac{\pi x}{a} \cos \frac{\pi t}{a \sqrt{LC}} + E_7 \sin \frac{7\pi x}{a} \cos \frac{7\pi t}{a \sqrt{LC}}$,
 $i = I_0 - \sqrt{\frac{C}{L}} \left(E_1 \cos \frac{\pi x}{a} \sin \frac{\pi t}{a \sqrt{LC}} + E_7 \cos \frac{7\pi x}{a} \sin \frac{7\pi t}{a \sqrt{LC}} \right)$,
 (b) $e = \sum_{n=1}^{\infty} \frac{2E(-1)^{n+1}}{n\pi} \sin \frac{n\pi x}{a} \cos \frac{n\pi t}{a \sqrt{LC}}$,
 $i = I_0 + \sqrt{\frac{C}{L}} \sum_{n=1}^{\infty} \frac{2E(-1)^n}{n\pi} \cos \frac{n\pi x}{a} \sin \frac{n\pi t}{a \sqrt{LC}}$,
 2. $e = \frac{Ex}{a} + \sum_{n=1}^{\infty} \frac{2E(-1)^n}{n\pi} \sin \frac{n\pi x}{a} \cos \frac{n\pi t}{a \sqrt{LC}}$,
 $i = -\frac{Et}{La} - \sqrt{\frac{C}{L}} \sum_{n=1}^{\infty} \frac{2E(-1)^n}{n\pi} \cos \frac{n\pi x}{a} \sin \frac{n\pi t}{a \sqrt{LC}}$,
 3. $e = E - \sum_{n=1}^{\infty} \frac{4E}{(2n-1)\pi} \sin \frac{(2n-1)\pi x}{2a} \cos \frac{(2n-1)\pi t}{2a \sqrt{LC}}$,
 $i = \sqrt{\frac{C}{L}} \sum_{n=1}^{\infty} \frac{4E}{(2n-1)\pi} \cos \frac{(2n-1)\pi x}{2a} \sin \frac{(2n-1)\pi t}{2a \sqrt{LC}}$,
 4. (b) If $\beta_n = \frac{n^2 \pi^2}{6} \times 10^8 - 851$,
 $e = \sum_{n=1}^{\infty} \frac{6000n\pi I_0 [1 - (-1)^n e^{-0.02}] \sin \frac{n\pi x}{50} e^{-30.3t} \left(\frac{30.3}{\beta_n} \sin \beta_n t + \cos \beta_n t \right)}$,
 5. With β_n as in 4(b) above, $e = \frac{E \sinh .00004x}{\sinh .002}$
 $+ \sum_{n=1}^{\infty} \frac{2En\pi(-1)^n}{n^2 \pi^2 + 4 \times 10^{-8}} \sin \frac{n\pi x}{50} e^{-30.3t} \left(\frac{30.3}{\beta_n} \sin \beta_n t + \cos \beta_n t \right)$.

EXERCISES XXXIV (Page 207)

2. $y(x, t) = 1/2[G(x + st) + G(x - st)]$, where
 (1) $G(u) = (-1)^m \frac{2pv}{a}$, if $u = ma + v$, m integral and $|v| \leq \frac{a}{2}$,
 (2a) $G(u) = p \sin \frac{n\pi u}{a}$, (2b) $G(u) = p \sin^2 \frac{\pi u}{a}$,
 (2c) $G(u) = (-1)^m (apv - pv^2)$, if $u = ma + v$, m integral, $0 \leq v \leq a$.

3. $e(x, t) = 1/2[G(x + t/\sqrt{LC}) + G(x - t/\sqrt{LC})]$, where

$$(1a) G(u) = E_1 \sin \frac{\pi u}{a} + E_7 \sin \frac{7\pi u}{a},$$

$$(1b) G(u) = \frac{Ev}{a}, \text{ if } u = 2ma + v, m \text{ integral, } |v| < a.$$

5. $y(x, t) = \frac{1}{2s} \int_{x-st}^{x+st} K(u) du$, where

$$(4a) K(u) = p \sin \frac{n\pi u}{a}, \quad (4b) K(u) = p \sin^2 \frac{\pi u}{a},$$

$$(4c) K(u) = (-1)^m (apv - pv^2), \text{ if } u = ma + v, m \text{ integral, } 0 \leq v \leq a.$$

7. Put $\phi = \frac{\sqrt{LC}}{2} \int_{x-t/\sqrt{LC}}^{x+t/\sqrt{LC}} K(u) du + 1/2 \left[G\left(x + \frac{t}{LC}\right) - G\left(x - \frac{t}{LC}\right) \right]$, where $K(u)$ and $G(u)$ are odd, periodic functions. Then

(a) $e(x, t) = \phi$, $G(u)$ and $K(u)$ of period $2a$ agreeing with $F(u)$ and $H(u)$ respectively for $0 < u < a$,

(b) $e(x, t) = \frac{Ex}{a} + \phi$, $G(u)$ and $K(u)$ of period $2a$ agreeing with $\left[F(u) - \frac{Eu}{a}\right]$ and $H(u)$ respectively for $0 < u < a$,

(c) $e(x, t) = \phi$, $G(u)$ and $K(u)$ odd harmonic of period $4a$, agreeing with $F(u)$ and $H(u)$ respectively for $0 < u < a$.

8. Put $k = \frac{R}{L} = \frac{G}{C}$, and ϕ as in 7 above. Then

(a) $e(x, t) = e^{-kt}\phi$, $G(u)$ and $K(u)$ of period $2a$ agreeing with $F(u)$ and $[H(u) + kF(u)]$ respectively for $0 < u < a$,

(b) $e(x, t) = \frac{\sinh \sqrt{RG}x}{\sinh \sqrt{RG}a} + e^{-kt}\phi$, $G(u)$ and $K(u)$ of period $2a$ agreeing with $\left[F(u) - \frac{\sinh \sqrt{RG}u}{\sinh \sqrt{RG}a}\right]$ and $[H(u) + kF(u)]$ respectively for $0 < u < a$,

(c) $e(x, t) = e^{-kt}\phi$, $G(u)$ and $K(u)$ odd harmonic of period $4a$ agreeing with $F(u)$ and $[H(u) + kF(u)]$ respectively for $0 < u < a$.

EXERCISES XXXVI (Page 217)

1. $N \geq 1000$, $N \geq 10$.

EXERCISES XXXIX (Page 230)

$$3. (1 - z)^{-1} = \sum_{n=1}^{\infty} n z^{n-1}.$$

$$4. 1/2(1 + z)^{-1/2} = 1 - \sum_{n=1}^{\infty} \frac{1 \cdot 3 \cdot 5 \cdots (2n-1)}{(-2)^{n+1} n!} z^n.$$

$$9. (a) c \left(1 + \sum_{n=1}^{\infty} \frac{z^n}{n!}\right), \quad (b) c_1 \left(1 + \sum_{n=1}^{\infty} \frac{(-z^2)^n}{2n!}\right) + c_2 \sum_{n=1}^{\infty} \frac{(-1)^{n+1} z^{2n-1}}{(2n-1)!},$$

$$(c) c + c^2 z + c^2 z^2 + (1/3 + c^4) z^3 + (c/6 + c^4) z^4 + \cdots$$

EXERCISES XL (Page 236)

1. t .
2. $-18 + 18t$.
3. $2ie^2 \sin 1 = 12.9t$.
4. $-2/3$.

EXERCISES XLI (Page 238)

2. (a) $z^2 + 2z - 1$, (c) $(a + bi)(z + c - f + [d + e]i)$, (d) e^{ia} .

EXERCISES XLII (Page 240)

4. (c) 0.
6. π .
7. (a) $-\pi/\sqrt{2}$, (b) $\pi/3$, (c) $\pi/\sqrt{2(a^2 + b^2)(a + \sqrt{a^2 + b^2})}$,
(d) $\pi/(ab[a + b])$.

EXERCISES XLIII (Page 245)

4. (a) 1, 3, $\sqrt{5}$, (b) 1, $\sqrt{5}$, 1, (c) 1, 1, 1, (d) $\sqrt{10}$, $\sqrt{26}$, $\sqrt{10}$.

EXERCISES XLIV (Page 247)

4. $|z| < 1$.
5. $|z| < \pi/2$.
6. $z^2 - 2abi$.
7. $\int_{a,b}^{x,y} \frac{\partial v}{\partial y} dx - \frac{\partial v}{\partial x} dy + iv, \quad 2iz + 2b$.

EXERCISES XLV (Page 260)

1. Equation (32) gives $N_1 = 165,000$, but inspection of the series shows that any $N_1 > 20$ will suffice.

INDEX

A

Abel's theorem, 276
 Absolute convergence, 215
 Absolute value, 6, 7
 Analytic function, 14, 211, 245
 Average, 42
 product of two sines, 56

B

Bessel's function, 24, 155, 230
 Branch-point, 40

C

Cauchy-Riemann equations, 237
 Cauchy's integral formula, 245
 Cauchy's integral theorem, 239
 Circle of uniform convergence, 225
 Closed form of solution, 208
 Complementary function, 82
 Complex current, 102
 Complex e.m.f., 102
 Complex number, 3
 Conformal mapping, 25
 Conjugate complex number, 6
 Continuity, 122, 213
 Convergence in the mean, 269, 275
 Convergent series, 214
 Cosine series, 77
 Curvilinear co-ordinates, 175

D

De Moivre's theorem, 12
 Derivatives of complex functions, 228
 Differentials, 114
 Distortionless line, 160, 208
 Divergent series, 214

E

e, ϵ , 15, 95
 Electric circuit, 95, 99
 Electric flow in a long line, 156, 196,
 202, 206
 Electric network, 97, 102
 Elimination of functions, 128
 Euler's equation, 16
 Even function, 48, 64
 Exact differential, 123
 Exponential function, 15

F

Fluid motion, 166
 Force potential, 125, 180, 182
 Fourier coefficients, 69
 Fourier series, 70, 75, 249
 for piecewise continuous functions,
 261, 266, 270, 275
 for piecewise smooth functions,
 249, 251, 259
 Function, 13, 213
 Fundamental region, 34

G

Geometric mean distance, 51
 Gravitational potential, 180, 182
 Gudermannian, 23

H

Harmonic, 65, 202
 Heat flow, 162, 176, 182
 in a rod, 188
 Heaviside expansion, 112, 113
 Hyperbolic functions, 21
 Hypergeometric function, 231

I

i , 3, 95
 Imaginary component, 20, 87
 Imaginary unit, 3
 Impedance, 5, 102, 161
 Inequality for averages, 46
 Infinite series, 214
 Infinity, 30, 213
 Integrals of complex functions, 231
 Integration of Fourier series, 262
 Integration of uniformly convergent series, 235
 Inverse hyperbolic functions, 24
 Inverse trigonometric functions, 19

J

j , 3, 95
 Joukowski aerofoil, 38

K

Kirchhoff's laws, 97

L

Laplace's equation, 180, 182, 238
 Law of the mean, 121
 Least square error for trigonometric sums, 267
 Legendre's polynomials, 155, 231
 Limits, 211
 Linear, 80, 143
 Linearly independent functions, 81, 82
 Linear ordinary differential equations, 80, 105
 Linear partial differential equations, 137, 142
 Line integral, 124
 \ln , 18
 Logarithm, 18

M

Mercator's projection, 39

O

Odd function, 49, 64
 Odd harmonic function, 65
 Odd harmonic series, 79
 Operations on Fourier series, 261, 271
 Operations on power series, 225
 Operations on series, 216
 Ordinary differential equations, linear, 80, 105

P

Partial derivative, 115
 Partial differential, 115
 Partial differential equations, linear, 137, 142
 Particular integral, 82
 Particular solutions, 148
 Period, 53
 Periodic function, 53
 Piecewise continuous, 261, 266, 270, 275
 Piecewise smooth, 249, 251, 259
 Poisson's integral, 210
 Polar co-ordinates, 7
 in space, 178
 Potential for a circle, 188, 210
 Potential for a rectangle, 183, 208
 Power series, 14, 224
 Powers of complex numbers, 10, 20

R

Radio equations, 160, 202, 206
 Real number, 1
 Residue, 241
 r.m.s., 45
 Root mean square, 45
 Roots of an algebraic equation, 12, 242
 Rotating vector, 20
 Rotation, 169

S

Series, 213
 Sine series, 76
 Smooth, 249

Steady-state current, 101
Steady-state solution, 191, 197
Steady-state temperature, 164, 182
Stereographic projection, 39
Systems of differential equations, 90,
134

T

Tangent plane, 125
Taylor's series, 31, 242
Telegraph equations, 159, 196
Telephone equations, 159
Total differential, 116
Transformation of the plane, 25
Transient current, 101
Transient solution, 191, 197
Trigonometric functions, 15
Trigonometric series, 69, 75, 249
Trigonometric sum, 62, 266
Triply orthogonal system, 175

U

Uniform approach to a limit, 221
Uniformly convergent Fourier series,
258
Uniformly convergent series, 221

V

Variation of constants, 105
Vector, 7, 126
rotating, 20
Velocity potential, 170, 180, 182
Vibrating string, 172, 199, 204

W

Wave equation, 173, 199, 204

CENTRAL LIBRARY
BIRLA INSTITUTE OF TECHNOLOGY & SCIENCE
PILANI (Rajasthan)

Call No.

Acc. No. 40276

DATE OF RETURN

DATE OF RETURN			

