

BIRLA CENTRAL LIBRARY
PILANI [RAJASTHAN]

Class No. 629.133

Book No. J89 A V.2

Accession No. 59504

AIRCRAFT ENGINES

AIRCRAFT ENGINES

BY

A. W. JUDGE

*Associate of the Royal College of Science, London; Diplomat of Imperial College of Science and Technology (Petrol Engine Research); Whitworth Scholar; Tyndall Prize-man; Associate Member of the Institution of Automobile Engineers; Associate Fellow of the Royal Aeronautical Society
late Senior Technical Assistant, Air Ministry*

VOLUME TWO

SECOND IMPRESSION



LONDON

CHAPMAN & HALL LTD

11 HENRIETTA STREET, W.C.2

1942

First published 1941
Second impression, April 1942

Printed in Great Britain by The Whitefriars Press Ltd.,
London and Tonbridge. Bound by G. & J. Kitcat Ltd.,
London. Flexiback Binding Patent No. 441294.

PREFACE TO VOLUME TWO

WHILST the first volume of this work, which was published several months ago, was concerned mainly with the theoretical and experimental aspects of aircraft engines, the present one is devoted principally to the descriptive side and to a lesser extent to certain design and theoretical considerations not previously dealt with.

The descriptive sections include accounts of some typical British aircraft engines which were in production prior to and in the earlier stages of the present war, together with certain more recent engines which are fitted to American aircraft purchased by this country. It has not been possible, for obvious reasons, to include accounts of some of the latest British engines coming into service at the time of going to press with this book. This omission is not, however, so unfortunate as may at first appear, since the predictions of possible new types of high output engines to meet the demands for improved performances of military aircraft—which will be found in the earlier sections of this volume—will enable the reader to anticipate many of the later developments. In this connection it may be mentioned that the recent disclosures in the American technical press concerning the Rolls Royce 2,000 h.p. "Vulture" 24-cylinder X-type engine, the Rolls Royce 1,600 h.p. "Griffin" and the Napier 24-cylinder "Sabre" engine appear to bear out the conjectures advanced in Chapters I and III.

The preparation of this book has been carried out under difficult circumstances not unconnected with existing war conditions and disturbances; the indulgence of the reader is therefore sought for any seeming omissions or curtailments, which would not be evident under peace-time conditions. In conclusion, acknowledgment is here gratefully accorded to the firms, institutions, individuals and publications which have assisted in the matter of information and illustrations. In this connection our special appreciation is made to Messrs. Rolls Royce Ltd., The Bristol Aeroplane Co. Ltd., Messrs. Armstrong-

Siddeley Ltd., the de Havilland Aircraft Co. Ltd., the American aircraft firms whose products are mentioned, and to *The Aeroplane, The Automobile Engineer, Aircraft Production and Automotive Industries.*

A. W. JUDGE.

FARNHAM, SURREY. 1941.

CONTENTS

CHAPTER	PAGE
I. GENERAL DESIGN CONSIDERATIONS	I
II. TORQUE AND BALANCE CONSIDERATIONS	31
III. TYPES OF AIRCRAFT ENGINES	61
IV. THE RADIAL AIR-COOLED ENGINE	116
V. SLEEVE VALVE AIRCRAFT ENGINES	146
VI. SOME OTHER AIRCRAFT ENGINE TYPES	177
VII. AIRCRAFT ENGINE COMPONENTS	228
VIII. THE LUBRICATION OF AIRCRAFT ENGINES	282
IX. THE IGNITION SYSTEM	323
X. THE EXHAUST SYSTEM	368
XI. ACCESSORIES, ENGINE STARTING, ETC.	388
XII. THE TESTING OF AIRCRAFT ENGINES	416
APPENDIX	
I. AIR MINISTRY SPECIFICATION FOR MINERAL LUBRICATING OILS	428
II. COMPARISON OF VARIOUS ALTERNATIVE AUXILIARY POWER SYSTEMS	429
KEY TO TEXT REFERENCES	430
INDEX	435

CHAPTER I

GENERAL DESIGN CONSIDERATIONS

THERE is a wide range of aircraft engines in present use, each particular class or type having been designed to meet certain special requirements in connection with the size and purpose of the aircraft, its performance, operating conditions, etc.

In general, these engines may be classified conveniently into a limited number of power output groups, each of which is applicable to definite types of aircraft, as follows:—

(1) 50 to 100 B.H.P. Light aircraft, two-seater club machines, etc.

(2) 100 to 250 B.H.P. Civil training machines, first stage military tuition aircraft, light touring machines.

(3) 250 to 700 B.H.P. More advanced military training machines (single and twin engine), commercial medium speed aircraft, higher performance single engine civil aircraft.

(4) 700 to 1,200 B.H.P. Larger commercial multi-engine machines, flying boats, single engine military fighters, multi-engine bombers, twin-engine long distance fighters.

(5) 1,000 to 2,000 B.H.P. High performance commercial multi-engine aircraft, high performance military single engine fighter machines, twin-engine bombers, heavy load carrying long distance machines.

Engine Types. The selection of the particular type of engine, that is to say, the number and arrangement of the cylinders, depends upon a number of factors, each of which has to be taken into consideration. In general, the number of cylinders depends principally upon the maximum power output required, but there are certain exceptions to this rule, since in certain circumstances, notably where maximum machine performance is concerned, it is preferable to have a larger number of smaller cylinders than a smaller number of larger cylinders; this subject is dealt with more fully later in this chapter.

The popular types of engine for Class 1 aircraft are the two-

and four-cylinder opposed ones for the lowest powers, and the four- and six-cylinder "in-line" or vertical (inverted) types. Each of these designs gives a relatively small frontal area of engine, combined with good torque and engine balance qualities, satisfactorily cooling arrangements, reliability and general accessibility. All of these engines are of the air-cooled variety.

The smaller air-cooled radial engines of the seven-cylinder type and the larger air-cooled six-cylinder inverted "in-line" engines are employed for engines in Class 2 aircraft. Typical examples are the Armstrong Siddeley seven-cylinder radial Lynx IVc (180 B.H.P. at 2,700 R.P.M.) and the De Havilland Gipsy Six II six-cylinder "in-line" (200 B.H.P. at 2,350 R.P.M.).

The engines for Class 3 aircraft are all air-cooled in this country and the U.S.A. They include the seven- and smaller nine-cylinder radials, the twelve-cylinder vee type (Gipsy Twelve) and a sixteen-cylinder H-type (Napier Rapier VI). In this country the water-cooled engines are represented only in the 700 to 1,100 B.H.P. class, namely, by the Rolls Royce twelve-cylinder vee-type engines, *e.g.*, Kestrel and Merlin models; larger models are, however, now in production.

The larger nine- and fourteen-cylinder air-cooled radial engines comprise engines ranging from about 800 to 1,500 B.H.P. In addition there are eighteen-cylinder radials of 1,800 to 2,000 h.p.

Another notable type of air-cooled engine in the 1,000 B.H.P. class is the Napier Dagger VIII which has twenty-four cylinders arranged in two sets of twelve-cylinder opposed placed side-by-side and geared together; this is known as the H-type engine. A larger model of this engine has been announced.

Having made a general survey of the available types it is proposed to consider the principal factors concerned with or governing the selection of the particular type of engine for an aeroplane.

These factors include (1) Power output. (2) Total power plant "drag" or head resistance. (3) Weight per horse power. (4) Air or water cooling. (5) Engine speed. (6) Fuel consumption. (7) Accessibility. (8) Reliability. (9) Maintenance attention. (10) Engine form and pilot's field of vision. (11) Engine torque and balance.*

Power Output. As previously mentioned the type of engine to be selected depends largely upon the required maximum

* This subject is dealt with in Chapter II.

output, since this usually determines the number of cylinders.

If, however, the power obtainable with a given fuel, mixture strength, engine speed and other "constant" factors was strictly proportional to the cubical capacity, *i.e.*, the bore and stroke, of the cylinder then, from the point of view of simplicity of design and minimum manufacturing cost, it would be better to employ the smallest number of cylinders that would give satisfactory engine torque and balance conditions. For limited power outputs of 100 h.p. up to about 200 B.H.P. in the case of engines used for lighter civil and commercial aircraft this principle is generally followed and the six-cylinder "in-line" and seven-cylinder radial engines are adopted in preference to engines with more cylinders of smaller dimensions.

At the other extreme, however, where the maximum power output is required with the minimum frontal area of engine, it is usual to employ a larger number of cylinders than the minimum that would be required to give good engine balance and torque qualities and lower cost of manufacture or minimum maintenance attention; in the latter respect, the smaller the number of cylinders the lower will be the maintenance costs.

This preferential selection of a greater number of cylinders, with their various components, such as pistons, valves and connecting-rods, is based upon two main considerations, namely, (1) Increased power from the smaller cylinders, and (2) Better grouping of the smaller cylinders to reduce head resistance in the aircraft.

Effect of Cylinder Bore on Output. It is a well-known fact, supported by both theoretical and experimental results, that as the diameter of a petrol-type engine cylinder is reduced, the compression ratio can be increased for a given fuel and mixture strength,* progressively, before detonation—or incipient knock—occurs. This means that the output per unit volume, *e.g.*, per litre of cylinder capacity, can be increased as the cylinder bore is reduced.

An example of the possible power increase is given in a graph † relating to the effects of cylinder bore on aircraft engine performance, in which the output per litre for a cylinder of 4 in. bore is shown to be no less than 40 per cent. greater than one of $5\frac{1}{2}$ in. bore and about 65 per cent. more than one of $6\frac{1}{2}$ in. bore.

In regard to the effect of cylinder bore upon compression

* *Video* pages 65 to 68, Volume I.

† Fig. 42, Volume I.

ratio, cylinders of different bores but with the same 5 in. stroke were tested for power output.¹ The bores ranged between $2\frac{3}{4}$ in. and $3\frac{3}{4}$ in. and it was found that the compression ratio at which detonation was just evident, with a given fuel of 80 octane rating and air-fuel adjusted for maximum knock, with the ignition advanced to give maximum power, was 6.4 to 1 for the smaller cylinder and 5.5 to 1 for the larger one. The corresponding values of the I.M.E.P. were 130 and 120 lb. per sq. in., respectively. Another factor contributing to the greater power output from smaller cylinders is the reduction of the reciprocating weights per cylinder which in turn enable higher operating speeds to be employed. Thus, in the previously mentioned example of aircraft engine cylinders ranging from 4 to $6\frac{1}{2}$ in. bore, if the weights of the piston assembly in the case of the $5\frac{1}{2}$ in. bore be represented by 100 per cent., then the values for the 4 and $6\frac{1}{2}$ in. bore would be about 46 and 152 per cent., respectively. The maximum or "take-off" engine speeds in these two cases would be 140 and 85 per cent. of the speed, expressed in R.P.M., of the $5\frac{1}{2}$ in. bore cylinder engine.

Another factor in connection with the use of smaller cylinders is the improved air-cooling which can be obtained owing to the reduction of the heat flow paths; an indirect result of this is the ability to employ greater "boost" pressures and therefore to obtain higher maximum power outputs.

It should be mentioned that the results given are comparative only for the particular design of air-cooled cylinders tested and are therefore not necessarily applicable, in a quantitative sense, to those of different design or bore and stroke ratio.

The selection of the size of cylinder in the case of engines of higher outputs, namely, 500 to 1,500 B.H.P., is to some extent a matter of compromise between output, cost, maintenance and other governing factors.

For the larger output engines the present tendency appears to be to limit the size of cylinder to 5 to $5\frac{1}{2}$ in. bore, which would give about 100 B.H.P. per cylinder, on the assumption of an output of 47 B.H.P. per litre—a value which is higher than the commercial engines available at the outbreak of the War in 1939. The outputs of the larger air- and water-cooled British engines (850 to 1,100 H.P.) ranged from 34 to 40 B.H.P. per litre. The general tendency, following engine design improvements and the use of higher octane value fuels, is for a pro-

gressive increase in the horse power per litre of more recent engines.

Cylinder Size and Overall Dimensions. The fact that it is possible to employ smaller cylinders of increased output, for a given rated output, enables the frontal area of the engine to be reduced, since the cylinder projected areas are smaller and, for a given stroke-bore ratio the crankshaft is of smaller throw and a smaller section crankcase is possible on this account.

An interesting comparison² between two engines of different cylinder size of approximately the same output, can be made by considering the case of a nine-cylinder single-row radial engine having cylinders of 6.25 in. bore and stroke, with a

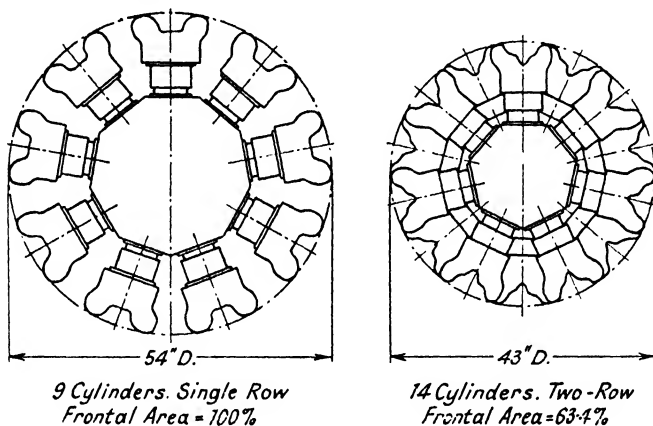

FIG. 1. Comparison of radial engines of equal power.

fourteen-cylinder two-row radial employing cylinders of 5 in. bore and stroke (Fig. 1). The former engine has a cylinder capacity of 1,726 cu. in. and the latter 1,375 cu. in. On account of the higher M.E.P. and rotational speed, the fourteen-cylinder engine gives about the same output but, owing to the arrangement of the smaller cylinders in two rows, the overall diameter of the engine is reduced by 11 in. or 6.05 per cent. and the frontal area by 36.6 per cent.; the head resistance is reduced by a like amount. Similarly, in the case of a six-cylinder "in-line" engine having larger cylinders a reduction of cross-section or frontal area can usually be effected by employing twelve smaller cylinders arranged in two banks of six cylinders inclined to one another as in the Vee-twelve type

engine. If it were not for crankshaft torsional vibration difficulties the eight-cylinder "in-line" engine would offer an advantage in reduced frontal area. Another benefit in employing a greater number of smaller cylinders suitably arranged is associated with the improvement in the torque of the engine.

In the case of the nine- and fourteen-cylinder engines of equal output previously considered, the maximum values of the torques work out at about 46,000 and 31,000 lbs. in., respectively, and the ratios of maximum to mean torque values at 92 and 36 per cent., respectively. Some further information on frontal areas is given at the end of this chapter.

Weight Per Horse Power. From the point of view of aircraft performance the ratio of the maximum output of an engine to its weight is of primary importance. Assuming equally favourable conditions of reliability, fuel consumption per h.p., overall dimensions, long life between overhauls, engine balance and torque, etc., the engine giving the lowest weight per B.H.P. at full load will give the best performance, *e.g.*, maximum climbing rate and level speed at a given altitude or pay load.

The development of the aircraft engine has largely been one of progressive reduction of weight per h.p., improved reliability and longer life. This statement is borne out by the fact that, whereas, in 1915 the weights per h.p. of existing British engines³ varied between about 3.0 and 4.75 lbs., in 1933 these weights ranged from about 1.25 to 2.25 lbs.; in 1939-40 the production engines gave dry weights per h.p. lying between 1.20 and 2.0 lbs.

The apparently slower rate of decrease of engine weights in recent years is explained by the fact that more engine parts are included in the later engines; typical examples of these are the propeller reduction and supercharger drive gears, superchargers, accessory drives, starter units, etc. The modern requirement of longer periods of operation between overhauls is another factor that has tended to limit weight reduction.

The lowest weights per h.p. are associated with the higher horse power engines, namely, of 1,000 to 2,000 B.H.P. and the highest ones with the smaller engines down to about 200 B.H.P. Certain of the four- and six-cylinder "in-line" engines used for light aeroplanes such as club machines give weights per h.p. lying between about 2.0 and 2.7 lbs.; these designs, however, have been in production for several years with little major alterations,

In regard to *water-cooled high power engines*, the 1939-40 Rolls Royce series of Kestrel and Merlin engines gave dry weights of 1.30 to 1.42 lbs. per take-off B.H.P.

The higher power *air-cooled radial engines* of the 1,000 to 1,400 h.p. class had rather lower values, namely, from 1.00 to 1.29 lbs. per take-off B.H.P.

It is interesting to note that the 1931 Schneider Trophy Rolls Royce twelve-cylinder vee-type engine, supercharged to about 18 lbs. per sq. in. gave 2,350 B.H.P. at 3,200 R.P.M. for a total weight of 1,630 lbs. ; this works out at 0.695 lb. per h.p.

The *aircraft compression-ignition engine* is heavier than its high octane petrol engine counterpart, but as evidence of what has already been accomplished in regard to the careful design of such engines, it may be mentioned that the earlier Packard nine-cylinder air-cooled radial engine of 225 h.p. gave 2.26 lbs. per h.p. The Bristol "Phoenix" nine-cylinder air-cooled radial (1934) engine of 470 B.H.P. gave 2.62 lbs. per h.p. The Junkers "Jumo" 204 (1937) "double-six" two-cycle engine of 750 B.H.P. had a weight of 2.09 lbs. per h.p., whilst the later Jumo 206 gave 1.39 lbs. per h.p. The 1940 nine-cylinder air-cooled radial Guiberson A-1020 C.I. engine (U.S.A.) of 340 B.H.P. (take-off) weighs 620 lbs., *i.e.*, 1.94 lbs. per h.p.

In connection with *two-cycle engines*, although none of these has reached the production stage for modern aircraft purposes, they offer certain advantages in the matter of low weight per horse power, since from about 30 to 60 per cent. more power is attainable for a given cylinder size, although allowance must be made for the additional weight of the cooling system, air scavenging and compressing equipment, etc.

Engine Dry Weights. When comparisons are made of various designs of aircraft engines on the weight per horse power basis it is necessary to define the various items which are included in the weight ; otherwise false conclusions are liable to be drawn from the results.

Thus when making comparisons of air- and water-cooled engines the total weights of the air-cooling cowls and ducts should be included in the former case and those of the radiator, cooling water, piping and other parts of the water-cooling system in the latter instance.

In order to afford a more accurate basis for such comparisons it is usual in the case of engines manufactured in this country to define the *Net Dry Weight* as including the carburettor(s),

TABLE I. BRITISH AIRCRAFT ENGINES

Maker's Name and Engine Type	No. and Arrangement of Cyls.	Cooling	Bore and Stroke	Capacity	Reduction Gear Ratio	Compression Ratio	International Rating			Maximum Altitude Rating			Take-off Power	Dry Weight	
							Altitude (Super-charging)	Engine Speed	Power	Altitude	Engine Speed	Power			
ARRO ENGINES															
Pirie	4 I.L.	A.	80.77 x 100	Litres 2.048	D.	5.58	ft. S.L.	R.P.M. 2,350	B.H.P. 45	ft. S.L.	R.P.M. 2,624	B.H.P. 50	B.H.P.	lb. 129½	
ALVIS															
Leonides	9 R.	A.	122 x 112	11.78	0.5:1 0.63:1	6.3	8,250	3,000	435	9,000	3,100	440	450	708	
Pelides	14 R.	A.	146 x 165	38.67	—	6	5,000	2,150	1,065	7,500	2,150	975	1,060	1,475	
ARMSTRONG SIDDELEY															
Genet Major IA	7 R.	A.	108 x 114.35	7.32	D.	5	S.L.	2,200	150	S.L.	2,425	165	—	327	
Genet Major IV	7 R.	A.	108 x 114.5	7.32	0.663:1	5.25	S.L.	2,400	160	S.L.	2,700	180	—	367	
Lynx IVC	7 R.	A.	127 x 139.7	12.4	D.	5	S.L.	1,900	215	S.L.	2,090	240	—	515	
Cheetah VA	7 R.	A.	133.3 x 139.7	13.65	D.	5.2	S.L.	2,100	285	S.L.	2,400	326	—	596	
Cheetah IX	7 R.	A.	133.3 x 139.7	13.65	D.	6.35	6,000	2,100	310	7,300	2,425	350	—	635	
Cheetah X	7 R.	A.	133.3 x 139.7	13.65	D.	6.35	6,750	2,300	325/340	7,000	2,425	355	360/375	694	
Tiger VIII	14 2-R.	A.	139.7 x 152.4	32.7	0.394:1	6.2	6,200 } 2-S. 12,800	2,375 } 2,200	840 } 756	6,600 } 15,000	2,450 } 2,450	782 } 810	918 } 845/880	1,590 } 1,260	
Tiger IX	14 2-R.	A.	139.7 x 152.4	32.7	0.394:1	6.2	6,250	2,375	775/805	6,500	2,450	810	—	—	
BRISTOL															
Mercury VIII, IX	9 R.	A.	146 x 165	24.8	0.372:1 } 0.50:1	—	13,000	2,400	795/825	14,000	2,650	840	775	1,005 (+5)	
Mercury XI, XII	9 R.	A.	146 x 165	24.8	0.50:1	—	3,500	2,400	780/820	6,000	2,750	890	830	1,005 (+5)	
Pegasus XC	9 R.	A.	146 x 190.5	28.7	0.50:1	—	3,500	2,475	710/740	5,250	2,600	830	920	1,030	
Pegasus XXII, XXIII	9 R.	A.	146 x 190.5	28.7	0.50:1 } 0.572:1	—	4,000	2,250	800/840	6,500	2,600	890	1,010	1,030 (+5)	
Pegasus XVII, XVIII	9 R.	A.	146 x 190.5	28.7	0.372:1 } 0.50:1	—	4,750 } 2-S. 14,750	2,250 } 2,250	780/815 } 720/750	3,000 } 15,500	2,600 } 2,600	1,000 } 885	965 } 835	1,130 (+5) } 1,130 (+5)	
Pegasus XIX, XX	9 R.	A.	146 x 190.5	28.7	0.572:1 } 0.50:1	—	8,500	2,250	800/835	10,000	2,600	925	835	1,130 (+5)	
Pegasus XXV, XXVII	9 R.	A.	146 x 190.5	28.7	0.50:1 } 0.372:1	—	11,000	—	795/830	9,500	—	915	830	1,035 (+5)	

GENERAL DESIGN CONSIDERATIONS

Hercules II	14 R.	A.	146 x 165	38.7	0.444:1	—	5,000	2,400	1,100/1,150	4,000	2,750	1,375	1,300	1,680	
Hercules IV	14 R.	A.	146 x 165	38.7	0.444:1	—	4,500	—	1,010/1,050	5,500	—	1,220	1,380	1,680	
Taurus II	14 R.	A.	127 x 137	25.4	0.444:1	—	5,000	—	860/900	5,000	—	1,065	1,010	1,300	
Perseus X	9 R.	A.	146 x 165	24.9	0.50:1	—	14,500	2,400	700/730	15,500	2,750	880	750	1,110	
Perseus XI, XII	9 R.	A.	146 x 165	24.9	0.572:1	—	6,500	2,400	715/745	6,500	2,750	905	830	1,105 (+5)	
Perseus XIII, XIV	9 R.	A.	146 x 165	24.9	0.50:1	—	4,000	2,250	680/710	6,000	2,600	815	890	1,100(+10)	
Aquila IV	9 R.	A.	127 x 137	15.6	0.666:1	—	4,500	2,600	450/470	6,000	3,000	540	600	830	
Cirrus (Blackburn)	4 I.L.	A.	95 x 127	3.605	D.	5.8	S.L.	2,300	82	S.L.	2,600	90	82	227	
Major 150	4 I.L.	A.	120 x 140	6.33	D.	5.8	S.L.	2,000	138	S.L.	2,450	150	132	325	
DE HAVILLAND															
Gipsy Minor	4 I.L.	A.	102 x 115	3.759	D.	6	S.L.	2,250	80	S.L.	2,600	90	80	210 (±5)	
Gipsy Major I	4 I.L.	A.	118 x 140	6.124	D.	5.25	S.L.	2,700	120	S.L.	2,350	130	130	300	
Gipsy Major II	4 I.L.	A.	118 x 140	6.124	D.	5.25	S.L.	2,400	140	S.L.	2,400	140	—	310 (±5)	
Gipsy Six I	6 I.L.	A.	118 x 140	9.186	D.	5.25	S.L.	2,100	185	S.L.	2,350	200	200	450 (±7)	
Gipsy Six II	6 I.L.	A.	118 x 140	9.186	D.	6	S.L.	2,400	205	S.L.	2,400	205	205	469 (±7)	
Gipsy Twelve	12 I.V.	A.	118 x 140	18.372	0.667:1	6	7,500	2,400	405/420	7,750	2,450	110/425	525	1,058	
NAPER															
Rapier VI	16 H.	A.	89 x 89	8.830	0.390:1	7	4,750	3,650	355/370	6,000	4,000	380/395	365	713	
Dagger VII	24 H.	A.	97 x 95	16.8	1:2.69	7.75	3,500	3,500	700/725	5,000	4,000	780/805	760	1,305	
Dagger VIII	24 H.	A.	97 x 95	16.8	0.308:1	7.5	9,000	4,000	925	8,750	4,200	1,000	955	1,390	
POISJOY															
Niagara III	7 R.	A.	77 x 87	2.835	0.468:1	6	S.L.	3,300	88	S.L.	3,650	95	95	116	
Niagara V	7 R.	A.	81 x 87	3.130	0.4375:1	—	S.L.	4,000	125	S.L.	4,600	137	119	185	
ROLLS-ROYCE															
Kestrel XIV, XV, XVI	12 V.	C.W.	127 x 140	21.3	0.632:1	6	11,000	2,600	690	14,500	3,000	745	670	955	
Kestrel XIV, XV, XVI (v.p.)	12 V.	C.W.	127 x 140	21.3	0.477:1	6	12,250	2,750	715	14,500	3,000	745	745	985	
Kestrel XXX	12 V.	C.W.	137 x 140	21.3	—	—	11,750	2,400	550	14,250	2,750	600	720	967	
Merlin II, III	12 V.	E.G.	137.2 x 152.4	27	0.477:1	6	2,600	2,600	900	16,250	3,000	1,030	890	1,335	
Merlin X	12 V.	E.G.	137.2 x 152.4	27	0.477:1	—	2,500 } 2-S. 13,250 }	2,600 }	1,400 }	5,250 }	3,000 }	1,145 }	1,065 }	1,394 }	

A. = Air. W. = Water. C.W. = Composite water. E.G. = Ethylene Glycol. R. = Radial. 2-R. = Two-row Radial. H. = "H" formation. V = "V" formation. L. = In Line. I. = Inverted. H.O. = Horizontally opposed. D. = Direct Drive. S.L. = Sea Level. 2-S. = Two-speed Supercharger.

induction system, ignition system with its bonding and screening, fuel pump, water outlet collector pipes, engine starting gear, carburettor and magneto coupling mechanism, supercharger and its piping system and accessory drives in the engine unit.

The *Gross Dry Weight* is defined as the net dry weight plus the following items, namely, the airscrew hub, exhaust branch pipes and manifolds, or stub pipes, air intakes, starting units, accessories and controls, claws or couplings, primers, oil and petrol filters on engine, and relief valve for fuel pump when separate from the engine.

The Weight in Running Order is the gross dry weight as defined above, plus the weight of the radiator and water, the connecting pipes and controls and the internal parts in their normal oily condition.

It should be noted that this weight does not include the tanks, petrol, oil, reserve water, engine instruments or exhaust tail pipes. The particulars of British aircraft engines in production in December, 1939,⁴ are given in Table I.

Air and Water Cooling. The aircraft engine designer has the option of either air- or water-cooling systems and in deciding which to use he must take into account a number of considerations. As this subject has been dealt with at some length in Volume I of this work it will be sufficient for present purposes to give a brief summary of the advantages and disadvantages of each system.

Water cooling * gives more uniform cooling of the cylinder and enables compact designs of engines of smaller frontal area per h.p., since banks of cylinders "in-line" can be cooled with practically the same efficiency as single cylinders.

It has been shown⁵ that for similar engines of equal stroke-bore ratios the frontal area of a water-cooled twelve-cylinder vee-type engine is considerably less than that of a radial air-cooled one; this subject is dealt with more fully, later in this chapter.

It is thus possible to reduce the head resistance of engine nacelles or fuselages of high speed military machines on this account. The effect of the radiator form resistance must, however, be taken into account, but when this unit can be made part of the wing surface there is practically no additional resistance; duct cooling, however, reduces the drag appreciably.

* This term here includes "liquid-cooled" engines using other cooling solutions.

The maximum power outputs of aircraft engines per litre cylinder capacity have, hitherto, always been obtained from water-cooled engines owing to the more uniform cooling and better regulation of maximum cylinder temperatures; higher compression ratios for a given octane value fuel can be employed before detonation commences.

The principal disadvantage of the water-cooled engine lies in the necessity for a radiator, water-piping and other items, each of which is a possible source of trouble. For military machine purposes the water-cooling system is more vulnerable. Another drawback lies in the risk of the water in the system freezing when standing on the ground when the machine is used in high latitude countries or under wintry conditions in this country; with certain liquid-cooled systems this does not occur.

The *air-cooled engine* is a more compact unit compared with the complete water-cooled engine system and it is definitely lighter for a given power output than the water-cooled one if overall weights are considered.

It is unaffected by low temperature operating conditions and with modern oil heating systems can be started more readily and takes less time to attain its normal working temperatures.

The fact of its being self-contained enables air-cooled engine units to be installed more conveniently in multi-engine machines, since there are no radiators, water-piping, etc., to consider. For this reason the radial air-cooled engine is almost universally adopted for aircraft of the multi-engine type; moreover, the installation of the radial-type engine is usually simpler and engines can be replaced more readily.

Although the frontal area of an air-cooled radial engine is, as previously stated, appreciably greater than for "in-line" water-cooled engines of equal output, the cylinder cowling can be made a surface of revolution and, by careful design in relation to the rest of the engine cowling, the resistance of the whole unit can be minimised by approximating to the ideal streamline form in multi-engine machines.

With the exception of the inverted "in-line" engines the water-cooled vee-type gives a much better view ahead and on either side, forwards, than the radial engine in single-engine machines. For military purposes this is a distinct advantage and, in addition, it enables a central synchronized machine-gun or cannon to be arranged more conveniently.

A general survey of the various types of British makes of

aircraft engines available in 1940 showed that the radial air-cooled type was fitted to four makes, the air-cooled "in-line," vee- and H-type engines to four other makes and the water- or liquid-cooled vee-type to only one make of engine.

Of the various American makes of engines,* the majority were of the air-cooled radial seven, nine- and fourteen-cylinder types, with two or three of the smaller models as air-cooled four-cylinder "in-line" or opposed. The only water- or liquid-cooled engines were high-powered models made by the Wright, Allison and Lycoming firms.

Engine Speeds. The principal lines of improvement of the power output from an aircraft engine of given dimensions, *i.e.*, of its h.p. per litre, have been associated on the one hand with attempts to increase the B.M.E.P. by the adoption of better combustion chamber designs, improved cylinder cooling, the use of higher compression ratios as a result of the previous two items and the availability of fuels of higher octane value ; and by the use of supercharging. On the other hand, since the power output of an engine of given dimensions varies as the product of the B.M.E.P. and the engine speed the output can also be increased by arranging for the engine to run reliably at higher speeds, whilst maintaining a high B.M.E.P. value.

Much of the progress in recent years in connection with increased horse power per litre of aircraft engines has been due to the employment of higher operating speeds. This has been brought about mainly by the improvement in engine materials, lubrication systems, valve port design, greater attention to engine balance problems and other contributory factors.

It is significant that, whereas in 1927 the average aircraft engine rated speeds were of the order of 1,800 to 1,900 R.P.M., in 1939 these had risen to 2,400 to 2,800 R.P.M. for engines of 750 to 1,000 B.H.P.

Piston Speed. The engine speed when expressed in terms of revolutions per minute must also take into account the piston stroke of the engine, so that comparison of engine R.P.M.'s alone may be misleading.

The factor that determines the maximum engine speed for an engine of given stroke is the maximum value of *mean piston velocity* or rubbing speed. This speed is related to the maximum velocity of the piston, which occurs a little before the piston is halfway down its stroke, being dependent upon the ratio of the connecting-rod to crank lengths.

* See Table No. 2.

Thus for a ratio of 3 : 1 the maximum piston velocity occurs at about 16·8 degrees before the mid-position of the crank, *i.e.*, before the 90 degrees crank position from top dead centre.

For ratios of 4 : 1 and 5 : 1 the values of the crank angles are 13·3 and 10·9 degrees before the mid crank position, respectively. Thus the shorter the connecting-rod in relation to the crank throw, the earlier in the stroke will the maximum velocity of the piston occur. The actual value of this maximum velocity is rather greater than the peripheral velocity of the crank-pin, but approaches the velocity of the latter as the ratio of connecting-rod to crank throw increases; for an infinite length of rod the maximum velocity would be equal to the crank pin velocity.

The mean piston velocity is given by the following relation (Fig. 2) :—

$$V = 2SN$$

where V = mean piston velocity in feet per minute, S = piston stroke in feet and N = revolutions per minute.

From this relation it follows that for a given (maximum allowable) piston velocity, the engine R.P.M. will vary inversely as the piston stroke.

The mean piston speeds at normal R.P.M. of modern British aircraft engines vary from about 2,000 to 2,800 ft. per min. (for certain Bristol engines), the average value being about 2,400 ft. per min.

Taking the latter value of the piston speed, an engine of 6 in. stroke will run at a corresponding speed of 2,400 R.P.M., whilst one of 3 in. will operate at 4,800 R.P.M.

The maximum allowable piston speed is usually determined by considerations of engine materials, lubricating oil pressure and temperature and the actual design of the piston, its rings and the cylinder unit. The engine speed is also to some extent governed by the main and crank-pin loadings and rubbing velocities, so that in fixing the upper speed limit a number of factors must be taken into account.

As previously stated, the selection of the most suitable number of cylinders in the case of an engine of given power

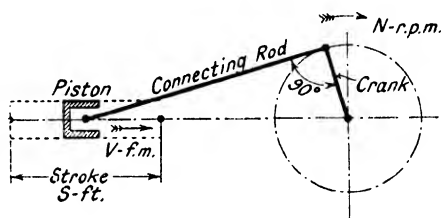

FIG. 2.

TABLE 2. AMERICAN AIRCRAFT ENGINES *

ENGINE MAKE AND MODEL	CYLINDER DATA										RATINGS						Weight (Lb.)	
	Arrangement	Cooling Medium	Number of Cylinders	Bore and Stroke (In.)	Total Piston Displacement (Cu. In.)	Compression Ratio	B.M.E.P. at Cruising (Lb. per Sq. In.)	Maximum (Except Take-off)		Take-off		Cruising		Engine—Dry without Hub or Starter	Per Cruising H.p.			
								Horsepower	R.P.M.	Altitude (Ft.) or At Sea Level	Horsepower	R.P.M.	Horsepower			R.P.M.		
Akron (r)-Funk	IV-L	W	4-3 $\frac{1}{2}$ X 4 $\frac{1}{2}$	200.5	6.25	117 $\frac{1}{2}$	63	2,125	—	—	—	—	255	4,081				
Allison	V-60	Liq.	12-7 $\frac{1}{2}$ X 6	1,710.0	6.65	146	960	2,600	1,090	3,000	—	—	1,340	1,861				
Continental	Series 7, 8, 9-A-30	Hor.	4-3 $\frac{1}{2}$ X 3 $\frac{1}{2}$	171.0	5.40	122 $\frac{1}{2}$	50	1,900	50	1,900	—	—	160	3,204				
Continental	W670-Mr	Rad.	7-3 $\frac{1}{2}$ X 4 $\frac{1}{2}$	668.0	6.10	133 $\frac{1}{2}$	250	2,200	250	2,200	—	—	460	1,874				
Continental	A-40-4	Hor.	4-3 $\frac{1}{2}$ X 3 $\frac{1}{2}$	115.0	5.14	90	42	2,700	40	2,575	30	2,300	145	4,831				
Franklin	44C150	Hor.	4-3 $\frac{1}{2}$ X 3 $\frac{1}{2}$	150.0	5.50	94	50	2,300	—	—	37 $\frac{1}{2}$	2,100	172	4,601				
Franklin	44C171	Hor.	4-3 $\frac{1}{2}$ X 3 $\frac{1}{2}$	171.0	6.25	97	60	2,350	—	—	45	2,150	172	4,601				
Jacobs	L-5MA7	Rad.	7-3 $\frac{1}{2}$ X 5	831.0	6.00	105	285	2,000	300	2,125	210	1,900	510	2,431				
Jacobs	L-6M	Rad.	7-3 $\frac{1}{2}$ X 5 $\frac{1}{2}$	914.0	6.00	96	300	2,100	330	2,200	210	1,900	550	2,621				
Jacobs	L-4MA7	Rad.	7-3 $\frac{1}{2}$ X 5	757.0	5.38	97	225	2,000	370	2,200	175	1,900	476	2,721				
Kinner	K-5	Rad.	5-7 $\frac{1}{2}$ X 5 $\frac{1}{2}$	372.0	5.00	90	100	1,810	—	—	70	1,650	275	3,931				
Kinner	K-5	Rad.	5-7 $\frac{1}{2}$ X 5 $\frac{1}{2}$	715.0	5.20	98	210	1,900	—	—	150	1,700	450	2,801				
Kinner	SC-7	Rad.	7-3 $\frac{1}{2}$ X 6	1,044	5.50	111	350	1,900	350	1,900	250	1,700	650	2,601				
Lambert (2)	R-266	Rad.	5-4 $\frac{1}{2}$ X 3 $\frac{1}{2}$	1,044	5.55	113 $\frac{1}{2}$	90	2,375	—	—	63	—	224	3,561				
Lambert (2)	R-266	Rad.	5-4 $\frac{1}{2}$ X 3 $\frac{1}{2}$	1,044	5.55	111	90	2,375	72	—	—	—	224	3,561				
Lenape-Palooze	LM-365	Rad.	3-7 $\frac{1}{2}$ X 4	160.4	5.80	132 $\frac{1}{2}$	65	2,350	—	—	—	—	190	2,151				
Lenape-Brave	LM-5	Rad.	5-4 $\frac{1}{2}$ X 4	267.0	5.00	128 $\frac{1}{2}$	95	2,200	—	—	—	—	192	2,021				
Lycorning (4)	O-145-A1	Hor.	4-3 $\frac{1}{2}$ X 3 $\frac{1}{2}$	144.5	5.65	99	50	2,300	50	2,300	38	2,100	152	4,001				
Lycorning	O-145-A3	Hor.	4-3 $\frac{1}{2}$ X 3 $\frac{1}{2}$	144.5	5.65	110	55	2,300	55	2,300	42	2,100	164	3,911				
Lycorning	O-145-B3	Hor.	4-3 $\frac{1}{2}$ X 3 $\frac{1}{2}$	144.5	5.65	112	65	2,550	65	2,550	47	2,300	167	3,551				
Lycorning	GO-145-C3	Hor.	4-3 $\frac{1}{2}$ X 3 $\frac{1}{2}$	144.5	6.50	106	75	3,200	75	3,200	56	2,900	193	3,741				
Lycorning	R-530-D1	Rad.	7-7 $\frac{1}{2}$ X 4 $\frac{1}{2}$	529.2	6.50	124	210	2,200	220	2,300	165 (a)	2,000	430	2,611				
Lycorning	R-680-D5	Rad.	9-7 $\frac{1}{2}$ X 4 $\frac{1}{2}$	680.4	6.50	122	245	2,100	260	2,300	210 (a)	2,000	505	2,740				
Lycorning	R-680-E3	Rad.	9-7 $\frac{1}{2}$ X 4 $\frac{1}{2}$	680.4	7.00	129	285	2,200	300	2,300	222 (a)	2,000	514	2,311				

GENERAL DESIGN CONSIDERATIONS 15

Menasco Pirate C4S	IV-L	Air	4-11 X 5 1/2	363.0	5.50	121	150	2,260	3,000	158	2,260	112	2,025	299	7.67
Menasco-Buccaneer B6	IV-L	Air	6-4 1/2 X 5 1/2	489.0	5.50	108	160	1,975	SL	160	1,975	120	1,800	332	
Menasco-Buccaneer B6S	IV-L	Air	6-4 1/2 X 5 1/2	489.0	5.50	121	200	2,250	4,500	212	2,250	150	2,025	423	2.82
Menasco-Unitwin 2-544	IV-1 1/2	Air	12-4 1/2 X 5 1/2	1,085.0	6.00	147	600	2,400	5,400	660	2,480	450	2,230	1,350	3.00
Pratt & Whitney-Wasp Jr. TB2	Rad.	Air	9-5 1/2 X 5 1/2	985.0	6.00	121	420	2,200	SL	440	2,300	300	2,000	690	2.30
Pratt & Whitney-Wasp SiH1	Rad.	Air	9-5 1/2 X 5 1/2	1,344.0	6.00	118	550	2,200	8,000	600	2,230	400	2,000	864	2.16
Pratt & Whitney-Hornet SiE	Rad.	Air	9-6 1/2 X 6 1/2	1,590.0	6.50	123	750	2,250	7,000	875	2,300	525	2,000	975	1.86
Pratt & Whitney-Twin Wasp Jr. SB4-C	Rad.	Air	14-5 1/2 X 5 1/2	1,535.0	6.75	120	750	2,550	9,500	825	2,625	525	2,250	1,133	2.16
Pratt & Whitney-Twin Wasp S3C4-G	Rad.	Air	14-5 1/2 X 5 1/2	1,830.0	6.70	139	1,100	2,550	6,200	1,200	2,700	700	2,175	1,490	2.13
Pratt & Whitney-Twin Wasp S4C4-G	Rad.	Air	14-5 1/2 X 5 1/2	1,830.0	6.70	139	1,050	2,550	7,500	1,200	2,700	700	2,175	1,490	2.13
Ranger 6-440C-2	IV-L	Air	6-4 1/2 X 5 1/2	441.0	6.00	102	175	2,450	SL	—	—	650	2,250	—	2.29
Ranger V-770B-4	IV-V	Air	12-4 X 5 1/2	773.0	6.50	110	305	2,300	SL	315	2,400	230	2,150	565	2.46
Ranger SGV-770B-6	IV-V	Air	12-4 X 5 1/2	773.0	6.00	123	420	2,350	5,700	500	2,950	300	2,500	640	2.13
Rover L-267	IV-L	Air	4-4 1/2 X 5	267.2	5.10	113 1/2	75	1,975	SL	—	—	—	—	225	3.00 1/2
Sky (5) 70	IV-L	Air	4-3 1/2 X 4 1/2	200.0	6.25	94	60	2,050	SL	—	—	45	1,900	178	3.96
Warner-Scarab Jr. 50	Rad.	Air	5-4 1/2 X 4 1/2	301.0	5.20	117 1/2	90	2,025	SL	90	2,025	(f)	—	230	2.56 1/2
Warner-Super Scarab 165	Rad.	Air	7-4 1/2 X 4 1/2	500.0	6.30	144	165	2,100	SL	175	2,250	(f)	—	332	2.01 1/2
Wright Cyclone GR-2600-A5B	Rad.	Air	14-6 1/2 X 6 1/2	2,603.0	6.40	144	1,350	2,300	5,000	1,600	2,400	900	1,900	1,950	2.17
Wright Cyclone GR-1820-G205A	Rad.	Air	9-6 1/2 X 6 1/2	1,823.0	6.70	141	1,000	2,300	4,500	1,200	2,500	650	2,000	1,302	2.00
Wright Cyclone GR-1820-G105A	Rad.	Air	9-6 1/2 X 6 1/2	1,823.0	6.30	143	900	2,300	6,700	1,100	2,350	625	1,900	1,272	2.04
Wright Cyclone R-1820-G3B	Rad.	Air	9-6 1/2 X 6 1/2	1,823.0	6.20	137	820	2,100	8,800	900	2,350	600	1,900	1,103	1.84
Wright Cyclone R-1820-F52	Rad.	Air	9-6 1/2 X 6 1/2	1,823.0	6.40	126	775	2,100	5,800	890	2,200	550	1,900	1,000	1.82
Wright Whittwind R-975-E3	Rad.	Air	9-5 X 5 1/2	973.0	6.30	132	420	2,200	1,400	400	2,250	325	2,000	675	2.08
Wright Whittwind R-760 E2	Rad.	Air	7-5 X 5 1/2	756.0	6.30	118	320	2,200	SL	300	2,400	225	2,000	570	2.53

March, 1940. See also later data given in Chapter 4.
 * * 87-octane rating for take-off.
 (a) Rate with controllable propeller at 2,000 ft.
 (c) Obtainable also for 87-octane fuel with slightly lower ratings.
 (d) Obtainable also for 95-octane fuel with slightly lower ratings.
 (f) 75 per cent. power allowable.

† Based on maximum h.p.
 ‡ Applies to motor with 0.5625 propeller gear ratio.
 (a) Rate with controllable propeller at 2,000 ft.
 (c) Obtainable also for 87-octane fuel with slightly lower ratings.
 (d) Obtainable also for 95-octane fuel with slightly lower ratings.
 (f) 75 per cent. power allowable.

SL—Sea level
 Rad.—Radial.
 Hor.—Horizontal opposed.
 IV-L—Inverted-In-Line.
 IV-V—Inverted-V type.

Cylinder Arrangement
 Hor.—Horizontal opposed.
 IV-L—Inverted-In-Line.
 IV-V—Inverted-V type.
 Rad.—Radial.

output involves considerations of bore, stroke and engine speed, cylinder arrangement, weight and cost. In this connection it is of interest to consider the results of an investigation into the possible alternative numbers of cylinders for an engine of 2,000 B.H.P., B.M.E.P. of 115 lbs. per sq. in. (applicable to compression-ignition engines), mean piston speed of 2,500 ft. per min. and stroke/bore ratio of 1.2.

Fig. 3⁹ illustrates the results of such an investigation and shows the relation between the various quantities concerned. It will be noted that for a given engine speed the capacity, bore

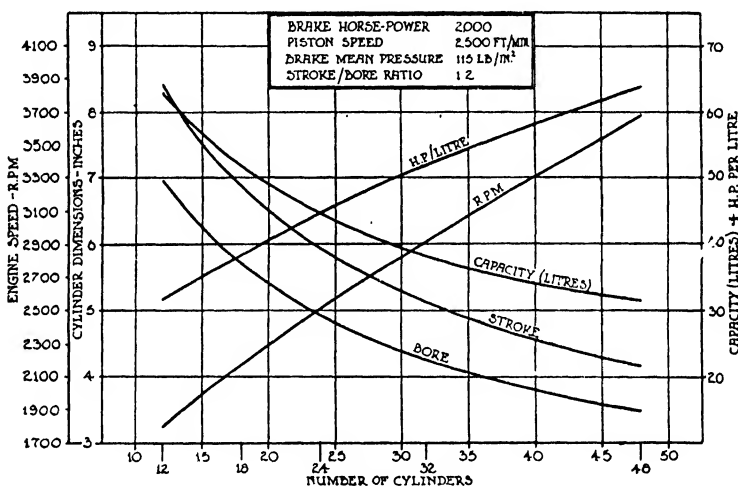

FIG. 3. Alternative cylinder choice for 2,000 B.H.P. engine.

and stroke diminish with increase in the number of cylinders, whilst the specific output and R.P.M. increase under the same conditions. An examination of the results indicates that an eighteen-cylinder (two bank radial) or twenty-four-cylinder (four banks of six-cylinders each) would appear to be the most suitable arrangements for the 2,000 h.p. engine in question.

The engine speeds of British aircraft engines at International and maximum altitude power ratings are given in Table 1 and some corresponding data for American aircraft engines is given in Table 2. In connection with the weights per h.p. in the latter table it should be noted that these are reckoned on the lower cruising h.p. values. The weights per "take-off" h.p. are from 55 to 75 per cent. of the cruising h.p. values.

Fuel Consumption. The amount of fuel used by an engine is usually expressed in terms of the weight of fuel per B.H.P. per hour. This quantity is dependent upon several factors, of which the chief ones are the calorific value of the fuel and the brake thermal efficiency. The higher the values of these two items the lower will be the fuel consumption per B.H.P. hour.

As the theoretical and experimental aspects of fuel consumption are dealt with at some length in the first volume of this work, it will here suffice to state the conclusions arrived at, namely, that the minimum fuel consumptions are associated with (1) The use of high calorific value fuels. (2) Mixture strengths rather weaker in petrol than that giving complete combustion. (3) The largest size of cylinder practically convenient. (4) The highest compressions without detonation ; in this respect the use of high octane fuels is important. (5) The most suitable design of combustion chamber, namely, that giving the highest thermal efficiency. (6) The throttle-opening, which for minimum consumption should be from three-quarters to full opening. (7) The most appropriate valve timing.

Engine speed, also, has an influence upon the fuel consumption per h.p. hour, since within certain limits the thermal efficiency rises with speed increase ; at the highest engine speeds, however, the thermal efficiency tends to become constant.

In regard to the effect of compression ratio upon fuel consumption, it may be of interest to quote the results of some single cylinder engine tests made with a normal grade of petrol of 0.76 specific gravity and a calorific value of 18,900 B.T.U.'s per lb. The values of the fuel consumptions for the different compression ratios were as follows :—

TABLE 3. FUEL CONSUMPTION AND COMPRESSION RATIO

Compression ratio	4.0	4.5	5.0	5.5	6.0	6.5	7.0
Fuel consumption (lb. per B.H.P. hour)	0.55	0.515	0.485	0.465	0.445	0.435	0.420

The fuel consumptions of modern aircraft engines lies between about 0.37 and 0.55 lbs. per B.H.P. hour according to the design, grade of fuel and other influencing factors. The lowest values correspond to high compression engines using 100-octane fuel and economical mixture strengths. The higher

values are associated with lower octane number fuels and the use of gear-driven superchargers.

In regard to *supercharged engines* in which the supercharger is driven by means of gearing from the engine, the power absorbed in driving the supercharger must be debited from the total power output, the result being to reduce the thermal efficiency and therefore to increase the fuel consumption per h.p. as compared with the same engine running under normal aspiration, or unsupercharged conditions.

If, however, the supercharger is driven by the exhaust gases of the engine as in the exhaust turbo-blower system, then additional power is obtained for the same fuel consumption and therefore the fuel consumption per B.H.P. hour will be less than for the similar engine unsupercharged.

In regard to the *effect of altitude upon fuel consumption* it has been shown⁶ that under conditions of correct mixture strength a normally aspirated nine-cylinder engine consuming air at the rate corresponding to 10.3 I.H.P. per lb. of air per min. would give comparative fuel consumptions, in lbs. per B.H.P. hour, of 0.491 at ground level; 0.489 at 5,000 ft. and 0.482 at 15,000 ft. The difference between ground level and 15,000 ft. in the fuel consumption is therefore small, namely, about 1.8 per cent.

In the case of *supercharged engines* it can be shown that the fuel consumption per B.H.P. hour tends to become less as the altitude increases under constant conditions of mixture strength and torque, to the extent of 3 to 4 per cent. between ground level and 15,000 ft.

The compression-ignition (C.I.) engine which operates with compression ratios between about 13 : 1 and 18 : 1 is characterized by its relatively low fuel consumption; this is due primarily to the higher thermal efficiency resulting from the employment of high compression ratios. Thus, for high speed automobile designs the minimum fuel consumptions lie between 0.37 and 0.42 lb. of Diesel oil per B.H.P. hour; values as low as 0.34 lb. have, however, been obtained from certain engines.

A single sleeve-valve C.I. engine, tested by Ricardo,⁷ of 5½ in. bore and 7½ in. stroke, operating at 1,300 R.P.M. with a compression ratio of 15 : 1 developed a maximum B.M.E.P. of 120 lbs. per sq. in. Over a range of loads represented by B.M.E.P. values of 60 to 100 lbs. per sq. in. the fuel consumption was practically constant at its minimum value of

0.355 lb. per B.H.P. hour, thereafter increasing to 0.43 lb. per B.H.P. hour at full load.

This wide range of loads with minimum fuel consumption is a characteristic feature of C.I. engines. The petrol engine, on the other hand, provides a relatively small range of loads for

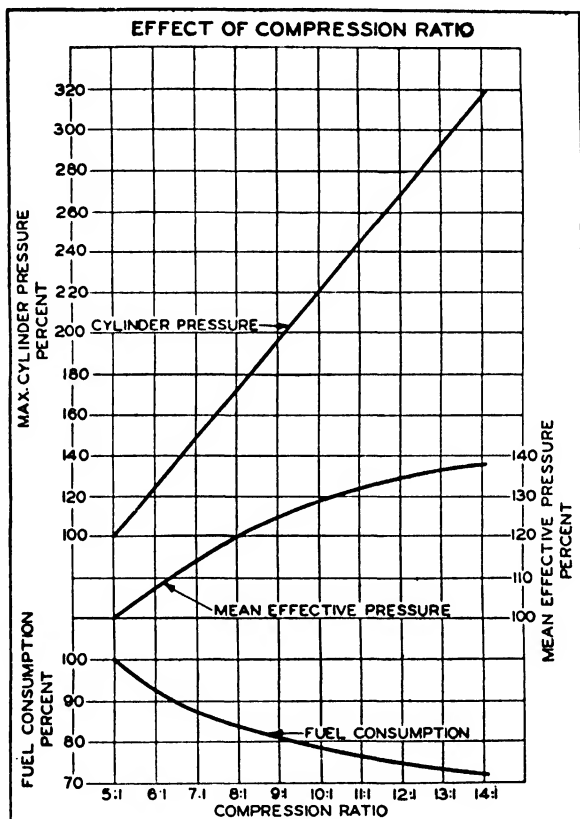

FIG. 4. Compression ratio effect on maximum and mean cylinder pressures and upon fuel consumption.

minimum fuel consumption; usually from about 75 to 90 per cent. of full load.

Two-cycle engines, for various practical reasons which are dealt with later in this work, invariably show appreciably higher fuel consumptions per B.H.P. than four-cycle engines operating under similar speed, mixture strength and fuel

grade conditions. In this connection an interesting comparison may be made from the results of power and fuel consumption tests, by Ricardo, upon engines of the two- and four-cycle types of sleeve valve engine, each of which had a bore and stroke of $5\frac{1}{2}$ and 7 in., respectively. The combustion chamber design was identical and the same degree of turbulence occurred in each case. The two-cycle engine gave a minimum value of fuel consumption of 0.435 lb. per B.H.P. hour, whilst the four-cycle gave 0.36 lb. The engines were both of the C.I. type and ran at 1,200 and 1,400 R.P.M., respectively.

The lowest published fuel consumption figure obtained for a two-cycle C.I. engine of the aircraft pattern, appears to be that of the Junker's opposed piston Jumo V engine, namely, 0.38 lb. per B.H.P. hour.

The effect of *using fuels of high octane number* in suitably designed engines enables higher compressions to be employed, with corresponding reductions in fuel consumption. The actual amount of saving in fuel depends upon a number of factors, but it has been shown⁸ that there is a practically linear relation between the specific fuel consumption and the octane number of the fuel when used under conditions of maximum compression ratio without detonation occurring. The specific fuel consumption of an engine operating under these conditions on 90-octane fuel is 15 per cent. less than when using 73-octane fuel. A change from 87-octane to 100-octane fuel would give a saving of about 13 per cent. in fuel consumption.

With the use of high octane fuels of 100, and above, the fuel consumptions begin to approach those attained by compression-ignition engines, whilst the power-to-weight values are considerably higher in the petrol-type aircraft engine. *Many recent engines use 100-octane fuel for take-off purposes and then switch over to 87-octane fuel.*

The effect of increase in compression ratio not only reduces the fuel consumption, but gives increased B.M.E.P. and maximum cylinder pressures as shown in Fig. 4.²

The compression ratios used with 87-octane fuel are from 6:1 to 7:1, so that with 100-octane fuel appreciably higher compression ratios of 7.5:1 to 8.0:1 are possible.

It is significant, however, that as the maximum cylinder pressures increase at a higher rate than the B.M.E.P.'s a compromise must be made between maximum power output and maximum allowable cylinder pressures in order to avoid

increases in the weight per B.H.P. of the engine, since the greater part of the engine's weight is dependent upon the value of the maximum cylinder pressure. In this connection the weight of the four-cycle C.I. engine must necessarily be higher, always, than that of the corresponding four-cycle petrol engine of similar output.

An important point in connection with *methods of increasing the power of an engine* is that since the maximum cylinder pressures increase at a higher rate with increase of compression ratio it is better to obtain increased power by supercharging rather than by raising the compression, since the maximum cylinder pressures will be lower in the former instance.

Engine Reliability. Although during the earlier period of development of the aircraft engine a relatively high percentage of engine failures occurred under flying conditions, the modern engines are notable for their extreme reliability. Just as with the automobile engine, the causes of the various failures in the past have been investigated and improvements made in design and materials, followed by further periods of work's laboratory testing, until each source of engine trouble has been overcome successfully. Since this method of development has been followed intensively over a period of at least twenty-five years and aircraft engine types have tended to become standardised, the reliability of the modern engine has been established on a sound basis.

The earlier troubles experienced included exhaust valve failures, lubrication system breakdowns, fractured crankshafts, valve spring breakages, piston and piston ring failures due to temperature and lubrication difficulties, sparking plug failures, ignition system defects, troubles due to faulty carburation under aircraft manœuvring conditions, bearing failures, etc., etc.

Many of the improvements which have contributed to the reliability of the modern engine have been associated with the use of better engine materials. Thus, in the instance of the exhaust valve—a component which is called upon to operate at temperatures of 700° to 800° C. and is subjected not only to the corrosive influence of the hot burnt gases, but also to high periodicity impact stresses—the use of high grade alloy steels, stellite valve faces and internal cooling by metallic salts has overcome the main difficulties experienced.

Similarly developments in sparking plug design and materials, together with the duplication of both the plugs themselves

and the ignition units, *e.g.*, the magnetos, have eliminated an earlier possible source of engine failure.

Troubles due to cylinder overheating, resulting in detonation or pre-ignition have been dealt with by the adoption of light alloy pistons, cylinders and heads and by improved cooling methods.

When it is considered that not only have these various sources of unreliability been investigated and eliminated, in the past, but at the same time the performances of aircraft engines have been improved progressively, much credit is due to the design and research staffs of the firms concerned.

Another contributory factor to engine reliability is the endurance or "type" and acceptance tests which engines are required to pass before being accepted for adoption in aircraft. These tests involve endurance tests of fifty hours, measurements of the power output, tests under overload conditions, *i.e.*, at slightly higher speeds than the maximum permissible ones, followed by a stripping down of the engine for examination, reassembly and further short period tests. Fuller particulars of the type and acceptance tests are given in Chapter XII.

The question of engine reliability is also one concerned with the number of the component parts, since the greater the number of components in any engine the greater will be the sources of potential trouble. From this point of view an engine of given output with the minimum number of cylinders has the advantage over those with a greater number, but as previously mentioned the selection of the number of cylinders and their arrangement involves other important considerations so that a compromise must be made if all desirable conditions are to be fulfilled or approximated to.

The sleeve valve engine, with its relatively small number of component parts, must always be more reliable, *a priori*, than the poppet valve engine, assuming similar conditions of material, design and workmanship, etc. It should not, however, be concluded from these considerations that poppet valve engines are in any way unreliable, since as previously pointed out, their associated earlier troubles have been investigated and overcome satisfactorily.

In regard to the relative merits of air- and liquid-cooled engines from the viewpoint of reliability, the latter type of power unit with its liquid circulating pumps, piping, cylinder and pipe, joints, radiator and other associated equipment must necessarily have a greater number of possible sources of

trouble than the more compact self-contained air-cooled engine with a similar number of cylinders.

Accessibility and Maintenance. Good accessibility to all parts of an engine likely to require regular or longer interval periods of attention is a desirable feature. Parts such as valve stem clearance adjusters, sparking plugs, contact-breakers of ignition apparatus, fuel and oil filters, etc., should be located so as to be readily accessible, so that ordinary tools can be employed for their adjustment or removal when "top" overhauls are necessary. These remarks apply also to the engine accessories described in Chapter XI.

Similarly, other items requiring dismantling for complete overhaul purposes should also have their holding down nuts, etc., arranged conveniently for access by suitably-designed spanners. In this way a good deal of time can be saved and maintenance costs minimised.

In connection with the maintenance of well-designed aircraft engines, it is evident that those engines having the fewest component parts will be the cheapest to maintain. For this reason the sleeve-valve and compression-ignition engines are generally associated with low maintenance costs.

Engine Form and Pilot's Field of Vision. In the case of single-engined aircraft of the tractor type the field of vision of the pilot, both ahead and on the sides of the fuselage, is largely determined by the size and type of the engine. Since it is desirable, from both the military and civil aircraft point of view, for the pilot to obtain the best possible view ahead and to the sides the choice of engines is limited to those having the smallest frontal areas above the airscrew axis. For minimum fuselage drag the total frontal area must be a minimum.

In connection with the smaller civil type single- and two-seater aircraft employing engines up to about 200 h.p., the inverted four- and six-cylinder "in-line" engines have been adopted largely on account of the small frontal area above the airscrew axis; also, on account of their smaller total frontal area and for certain other advantageous features which are referred to in Chapter III.

From the purely high speed aircraft viewpoint the most suitable engine is that having both minimum frontal area above the airscrew axis and also minimum total area. For this reason the vee-type liquid-cooled engine with two banks of six-cylinders each has proved most satisfactory in British fighter aircraft.

The big advantage of this type over the radial engine of equal power output from considerations of the pilot's field of view is well illustrated by the outline diagrams reproduced in Fig. 5,¹⁰ showing the pilot's view for a liquid-cooled vee-type and a nine-cylinder air-cooled radial engine of equal power output. In the latter case—as was the practice a few years

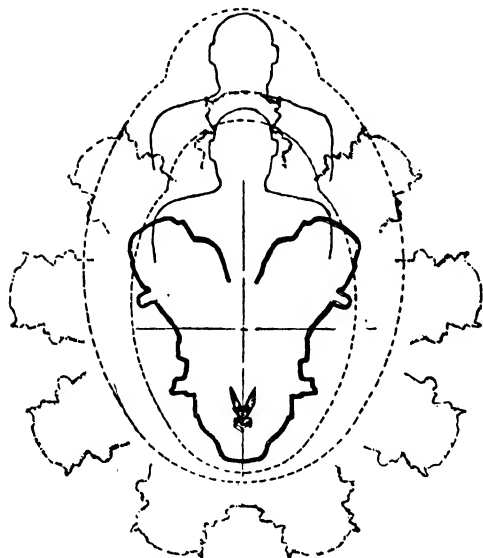

FIG. 5. Comparison of twelve-cylinder vee and nine-cylinder radial type engines of similar output.

ago—the cylinder heads protruded from the front sides of the fuselage, thus giving a smaller section fuselage. The head resistance of this combination was, however, relatively high as compared with the same engine provided with a circular type of cowling of the Townend, N.A.C.A. and similar designs.* The comparison should therefore be made between the two sections of fuselage represented by the pilot's outline and vee-type engine and the pilot's outline

and a circle enclosing the radial engine; under these conditions the marked superiority of the vee-type engine is obvious. An alternative arrangement giving an excellent field of vision for the pilot is that of the inverted vee-type engine, since in this instance there is a smaller frontal area above the airscrew axis.

The pilot's field of vision is not affected appreciably by the size and type of engine employed in the case of multi-engined aircraft, so that here the air-cooled engine, with its inherent merits, can be adopted with advantage.

Engine Frontal Areas. It should here be pointed out that although for purely maximum performance it is desirable for the fuselage maximum cross-sectional area to be kept as low as

* Vide Chapter VIII, Volume I of this Work.

possible, this area is not always governed by the frontal area of the engine, since other items—such as retractable undercarriages, military equipment, gun turrets, etc.—have also to be taken into account; in all cases, however, the engine of minimum frontal area per h.p. is preferable.

In this connection it is of interest to note that the Rolls Royce "Kestrel XVI" 1,000 h.p. engine has a frontal area of 4.40 sq. ft., thus giving a specific potential power of 227 h.p. per sq. ft. of frontal area, whilst the corresponding figure for

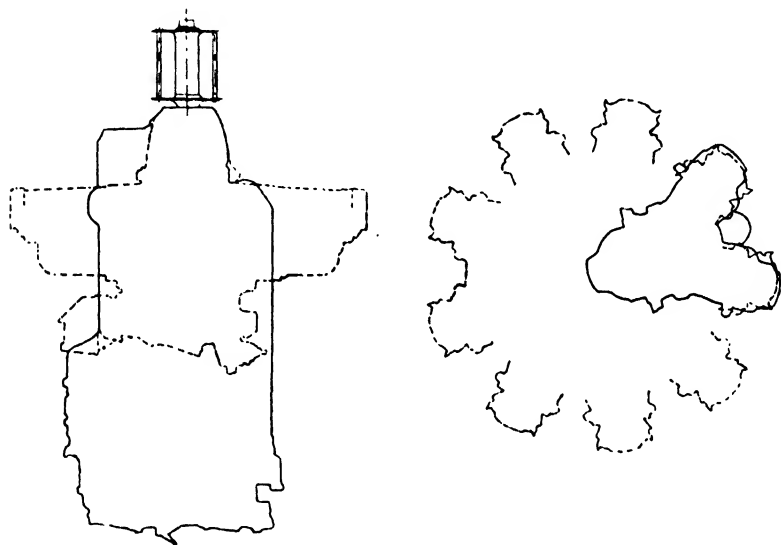

FIG. 6. Plan and frontal areas of twelve-cylinder vee and nine-cylinder radial engines of similar outputs.

the "Merlin" engine is 256. If the maximum potential power value be taken, however, the latter engine gives the exceptional figure of 308 h.p. per sq. ft. of frontal area. In the case of the nine-cylinder air-cooled radial Bristol "Pegasus XVIII" engine of 1,000 h.p. (maximum) the overall diameter is 55.3 in., which is equivalent to a potential power of about 60 h.p. per sq. ft. of frontal area.

The Bristol "Hercules II" fourteen-cylinder two-bank air-cooled radial sleeve-valve engine develops a maximum output of 1,375 h.p. and has an overall diameter of 52.0 in. This gives about 93 h.p. per sq. ft. of frontal area; the advantage of

using two banks of smaller cylinders in place of a single bank of larger cylinders is here well illustrated.

The Wright Double-Row Cyclone engine of 1939 is a fourteen-cylinder two-row radial air-cooled engine of 1,600 B.H.P. (maximum take-off) and has an overall diameter of 55 in. This is equivalent to 97 h.p. per sq. ft. of frontal area. The later eighteen-cylinder two-row 2,000 h.p. Wright radial gives an appreciably higher value than this, namely, by about 25 per cent.

The more recent Pratt and Whitney "Double Wasp" two-

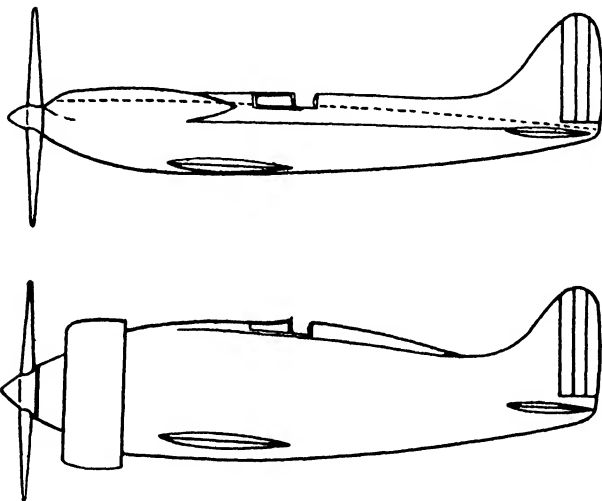

FIG. 7. Illustrating the dimensions of fuselages of the twelve-cylinder vee and nine-cylinder radial engines of similar outputs.

row eighteen-cylinder air-cooled radial has a diameter of $51\frac{1}{2}$ in. and, as supercharged, develops 1,600 B.H.P. at an altitude of 20,000 ft., which it is claimed by the makers would be equivalent to about 3,000 B.H.P. at ground level if it were possible to open the engine out. Accepting the latter figure, the results show an equivalent of 207 h.p. per sq. ft. of frontal area.

When making comparisons of the drags of air- and liquid-cooled engines it is, of course, necessary to take into account the drag of the radiator in the latter type of engine, so that unless the radiators form part of the wing or fuselage surface, the engine frontal areas alone are not the correct figures for

comparison. In this connection the liquid-cooled engine aircraft still possesses a marked advantage in the matter of low drag.

Fig. 8² illustrates eight alternative arrangements of cylinders and their frontal areas in comparison with that of the nine-cylinder radial engine which is taken as 100 per cent. The engines have the same size of cylinder and the frontal areas given are those of the circumscribing dotted lines, representing the corresponding fuselage or engine nacelle cross-sections.

It will be observed that the frontal areas and therefore the form drag of the radial engines are dependent principally upon the cylinder size, whereas those of the lower "in-line" engines depend upon the number of cylinder banks as well as the cylinder size. As the power outputs of the engines illustrated, for the same size of cylinder, are nearly proportional to the total number of cylinders the ratio of the number of cylinders to the corresponding frontal areas affords a figure of comparison of the power output per unit frontal area. The following are comparative results for the types of equal cylinder dimension engines indicated.

TABLE 4. COMPARATIVE POWER OUTPUTS PER UNIT FRONTAL AREA

Type of Engine	No. of Cylinders N	Frontal Areas Per cent. of 9-Cylinder A	Power Output per Unit Frontal Area $\frac{N}{A} \times 100$
Radial	5	90	5.55
Radial	7	92	7.61
Radial	9	100	9.00
Radial	11	120	9.17
Radial	14—Two-bank	92	15.22
Radial	18—Two-bank	100	18.00
Two-bank (opposed)	12	39	30.75
Two-bank Vee	12	39	30.75
Four-bank H-type	24	71	33.80
Four-bank X-type 60 degrees	24	84	28.55
Four-bank X-type 90 degrees	24	96	25.00

The results given in Table 4 show that the higher horse power engines give the greater outputs per unit frontal area, or the smallest form drag per h.p. The two- and four-bank engines are superior to the radial type engines of smaller power in

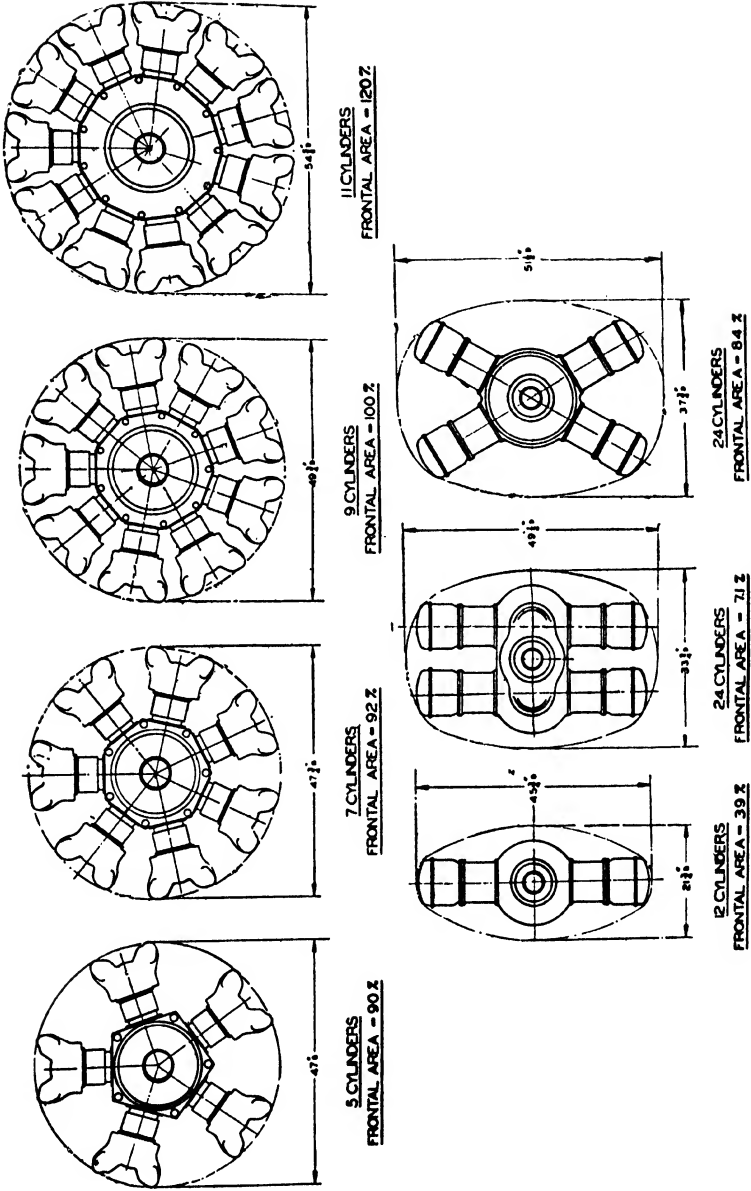

Fig. 8. Frontal areas of different types of engines.

output per unit frontal area, although the four-bank, twenty-four-cylinder 90° X-type engine is less efficient than the two other twenty-four-cylinder types.

The eighteen-cylinder two-bank radial engine is the best of the radial combinations considered and is the nearest to the four-bank 90° X-type in power output per unit frontal area.

The two-bank or horizontally opposed twelve-cylinder engine, whilst unsuitable for single fuselage aircraft lends itself to designs of machines in which the engines can be mounted within the wings, if the latter are of suitable depth. In this arrangement the form drag of the engine would be negligible. In larger machines the H- and X-type engines would also be suitable for mounting flatwise within deep-section wings.

Limits of Engine Size. There is a practical limit to the size of an aircraft engine, from the point of view of the maximum number of cylinders. Apart from considerations of increased bulk and localized weight the increase of power by multiplying the number of cylinders is obtained at the expense of an increase in the number of working components and therefore of increased liability of breakdown. Moreover, with a large number of cylinders the problem of the distribution of the mixture equally to all cylinders whilst maintaining correct mixture strength in each cylinder becomes more difficult to solve unless the petrol-injection system is adopted.

The present maximum number of cylinders for radial air-cooled engines is eighteen, but it is understood that experimental engines with a greater number of cylinders have been made. In this connection the logical method of increasing the output would be to use additional banks of seven or nine cylinders each, so that the total number of cylinders would be multiples of these numbers, *e.g.*, 21, 27, 28, 35, 36, 42, 45, etc.

Increasing the number of cylinder banks in a radial engine will introduce special problems in connection with efficient cooling of the cylinders, inlet and exhaust manifolding, engine mounting, etc.

At present the limit of engine power per unit appears to be about 2,000 to 2,500 h.p. and the maximum number of cylinders hitherto used in production aircraft is twenty-four. It is considered better to multiply the number of engine units, for higher total power requirements, rather than to increase the single engine outputs beyond about 2,000 h.p. Thus large aircraft requiring powers for propulsion in excess of about 2,000 favour the use of two, four or six engines of 1,000 to

2,000 h.p. mounted along the wings. These arrangements give an added measure of safety in the event of one of the engines breaking down and also enable a much better distribution of engine load and wing stress to be obtained. Moreover, there is an improvement in the take-off conditions since more of the wing surface is covered by the slip streams.

CHAPTER II

TORQUE AND BALANCE CONSIDERATIONS

DURING the period which has elapsed since the first power-driven aeroplane made its successful flights a wide variety of aircraft engines has been employed. The earliest of these were based upon the existing designs of motor car and motor cycle engines which were lightened as much as possible in order to give improved power to weight ratios. Subsequently to this initial phase the development of aircraft engines has included periods during which certain types of air-cooled or water-cooled engines have become popular for a time and have afterwards been superseded by new designs. Many of the latter have been abandoned, whilst others have persisted throughout practically the whole phase of development; in this respect the static radial engine is an outstanding example.

In general the line of progress has been one of constant increase in the power developed per unit of piston area, reduction of weight per h.p., greater reliability and longer engine life between overhauls.

The modern types of aircraft engines appear to have settled down to certain definite arrangements of cylinders in the lower and medium power classes, just as the motor car engine has tended to become standardised, but in the higher power class there is more scope for the adoption of alternative cylinder arrangements—or engine types—so that development is proceeding in several different directions.

Engine Torque. Before proceeding to a consideration of aircraft engine types it will be necessary to discuss, in brief, the subject of engine torque and balance in so far as it affects the adoption or selection of different designs.

Commencing with the simplest case of the single-cylinder petrol engine operating upon the four-cycle principle, the piston is subjected to gas pressures which vary from the maximum value due to combustion of the fuel and air charge, down to negative values during the induction stroke in the case of a normally aspirated engine. The manner in which

the pressures on the piston vary during a working cycle is clearly shown by the indicator diagram (Fig. 10).

In addition to the effects of gas pressure the piston is also subjected to certain forces, known as *inertia forces* due to its having to be accelerated during the earlier part of its movement towards the crankshaft and retarded towards the latter end of the same stroke. The actual value of the inertia force on the piston is dependent upon the weight of the piston and a part of the connecting-rod connected to it; to the ratio of the connecting-rod to crank length and the engine R.P.M. The actual expression for the piston inertia force at the ends of the stroke is as follows:—

$$\begin{aligned} \text{Piston inertia force} &= \frac{M}{g} \cdot \frac{4\pi^2 N^2}{3,600} \cdot r \left(1 \pm \frac{1}{n} \right) \text{lbs.} \\ &= 0.000343 M N^2 r \left(1 \pm \frac{1}{n} \right) \text{lbs.} \end{aligned}$$

where M = weight of piston in lbs.; N = R.P.M.; g = acceleration due to gravity ($= 32.12$ ft.-sec.²); r = crank radius in ft. and n = ratio of connecting-rod to crank length.

If the crank makes an angle θ with the cylinder axis produced to the crank centre, then the inertia force F is given approximately by the following relation:—

$$F = 0.000343 M N^2 r \left(\cos \theta + \frac{r}{l} \cos 2\theta \right) \text{lbs.}$$

[The positive sign in the formula relates to the inertia force at the beginning of the inward stroke, whilst the negative sign corresponds to the value at the end of the stroke.

The manner in which the inertia force on the piston varies throughout a complete stroke is shown in Fig. 9. The dotted line in this diagram gives the inertia force values for a connecting-rod of infinite length, *i.e.*, for a piston having a simple harmonic motion. It will be observed that the inertia force is positive in value for rather less than one-half of the inward stroke and negative for the remaining portion.

It is important to note that during the first part of the firing stroke of the engine the inertia force opposes the gas pressure force, whilst it augments the latter during the remainder of the stroke. In certain cases the inertia forces at very high engine speeds may equal or exceed those due to the gas pressure, since the magnitude of the former forces varies as the square of the speed.

During the former part of the compression stroke the inertia and gas pressure forces act in the same direction, but are opposed towards the end of the stroke.

It will thus be apparent that the pressures given by the indicator diagram are modified to an appreciable extent—more especially at high engine speeds—by the effects of the inertia forces on the piston assembly.

Fig. 10 illustrates the manner in which the indicator diagram may be modified by the inertia forces in the case of a single-cylinder engine of 5-in. bore and 6-in. stroke with a piston and

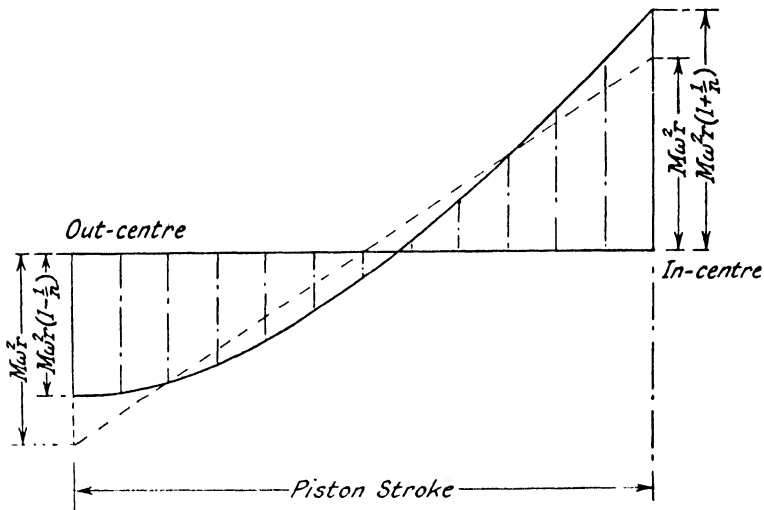

FIG. 9. Inertia forces on piston.

small-end connecting-rod assembly weighing $2\frac{1}{2}$ lbs. and engine speed of 2,400 R.P.M. The full line diagram shows the resultant piston pressures in lbs. per sq. in. after allowing for the inertia pressures.

In this example there is a negative pressure on the piston during the first two-thirds of the compression stroke, followed by a reversal to positive pressure for the last third of the stroke. At the commencement of the firing stroke the inertia pressure is actually greater than the gas pressure, so that there is a momentary reversal of the resultant pressure to a negative value approaching the maximum initial value of the inertia force; this cannot, however, be shown clearly on the diagram. During the firing stroke the effect of the inertia

forces is to reduce the gas pressures during the first part of the stroke and to augment them appreciably during the latter part, as shown by the full-line diagram for the firing stroke.

As the engine speed is increased still further, the resultant pressures during the first portion of the firing stroke are reduced progressively, whilst those of the latter part are increased continuously; during the induction and exhaust strokes the resultant pressure diagram approximates closely to that of the inertia pressures.

From the preceding considerations it is apparent that, in order to prevent the occurrence of excessive inertia pressures it is necessary to keep the weight of the reciprocating parts,

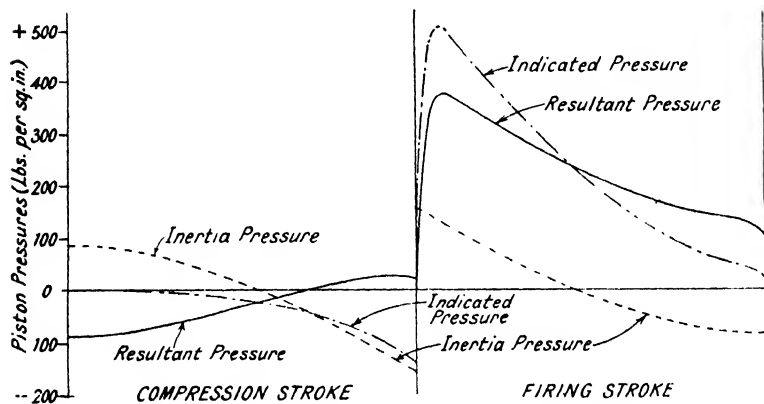

FIG. 10. Modification of gas pressures by inertia effects.

i.e., the piston, rings and the small end portion of the connecting rod down to a minimum and, further, to avoid excessive engine speeds. In the former connection the adoption of aluminium alloy pistons in place of steel or cast-iron ones practically halves the value of the reciprocating weight and therefore of the maximum inertia pressures. The substitution of a lighter alloy, such as one of magnesium for aluminium would reduce the piston weight still further by 30 to 40 per cent.

The importance in aircraft engine design of reducing the inertia forces to a minimum is emphasized by the fact that these forces not only increase the loading on the bearings during the idle strokes of the engine, but introduce reversals of loadings which otherwise would not occur during these strokes. Since friction is an irreversible process the loss of power is continuous

during both the acceleration and retardation periods of the piston, so that the frictional losses of power during the idle strokes will increase with the value of the inertia forces.

Reversal of loadings on the small and big end connecting-rod bearings tends to promote vibration and knocking effects, which can only be minimized by keeping the inertia forces as small as possible.

The example of piston pressures shown in Fig. 10 represents only one case of inertia effects. The indicator diagram will be modified to a lesser extent as the engine speed is reduced by inertia force effects.

On the other hand, if an engine is run at high speeds without external load, *i.e.*, if it is allowed to *race under its own power* without an airscrew or engine brake, the inertia pressures may not only exceed the gas pressures, but attain a much higher value than the engine components are designed to withstand with the usual factors of safety, so that there is a definite risk of mechanical failure.

In regard to multi-cylinder engines it is necessary, in order to obtain a complete record of the resultant piston pressures, to superpose the pressure diagrams of the individual cylinders, each in their correct phases. If this is done it will be found that with the increase in the number of cylinders of an engine, having equal firing intervals, the inequalities of piston pressure—similar to those shown in Fig. 10—tend to become reduced or smoothed out.

In these considerations it has been possible only to give a bare outline of the principles concerned; for a fuller account the reader is referred to the index references given at the end of this work.

Engine Torque. The manner in which the actual turning movement or torque of an engine is estimated for any given piston position is illustrated by the diagram given in Fig. 11 in which A denotes the piston, B the crank pin and C the axis of the crankshaft; and $AB = l$ and $CB = r$.

The total pressure P on the small end of the connecting-rod is obtained from the diagram of resultant piston pressures (similar to that shown in Fig. 10) for any

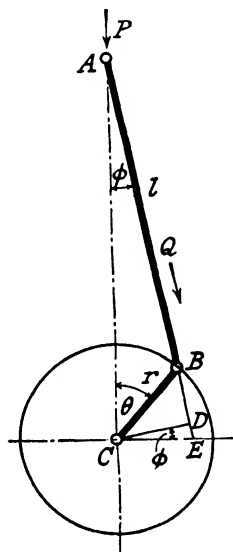

FIG. 11.

position of the crank BC; this pressure, multiplied by the piston area gives the pressure P.

If the thrust, due to P, in the connecting-rod AB be denoted by Q, then the following relation is obtained:—

Torque = Q.CD, where CD is perpendicular to AB produced.

$$\text{Now } P = Q \cos \phi = Q \cdot \frac{AC}{AE} = Q \cdot \frac{CD}{CE}.$$

$$\text{Thus, torque} = Q.CD = P.CE = Pr \sin \theta \left(1 + \frac{r \cos \theta}{\sqrt{l^2 - r^2 \sin^2 \theta}} \right)$$

where l = length of connecting-rod and r = crank radius.

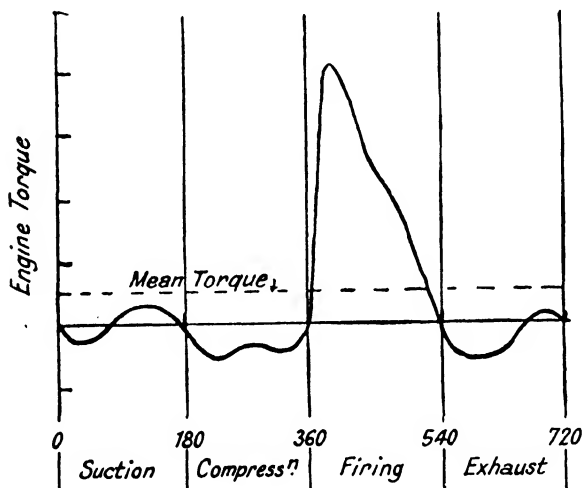

FIG. 12. Single-cylinder engine torque diagram.

Similarly, it can be shown that the torque may be expressed as follows:—

$$\text{Torque} = Pr \frac{\sin (\theta + \phi)}{\cos \phi}.$$

The torque diagram may be constructed either by plotting values of torque as ordinates on a piston stroke or a crank-angle base.

A simple graphical method is to construct to a suitable scale a diagram similar to that of Fig. 11 and to measure off the distances CE (in feet) for the different crank-angle positions

and then to multiply these by the corresponding values of the resultant piston load P lbs. ; the result is the engine torque for the crank-angle θ in lbs. ft.

The Torque Diagram. If the torque values be plotted on a crank-angle base for a complete cycle of operations the result will be a curve of fluctuating torques on the general lines shown in Fig. 12 for a single-cylinder engine. The actual shape of the torque curve will be governed by the dimensions of the connecting rod and crank, the indicator diagram and engine speed and must therefore be constructed for any particular design of engine.

It will be observed that the torque curve has a pronounced peak during the firing stroke period and smaller positive and negative fluctuations during the idle strokes.

The value of the maximum torque corresponding to this peak is usually several times that of the average or mean torque, namely, from seven to ten times in actual examples from practice. This result indicates that it is necessary in crankshaft strength calculations to take the value of the maximum torque obtained from the torque curve.

For the purposes of computing engine outputs and for air-screw calculations the mean torque values are taken. These are conveniently obtained from the following relation :—

$$\text{Mean torque} = 5,252 \times \frac{\text{B.H.P.}}{\text{R.P.M.}}$$

Since the B.H.P. of an engine is proportional to the product of the B.M.E.P. and R.P.M. it follows that the mean torque is directly proportional to the B.M.E.P. of the engine. Thus a curve showing values of B.M.E.P. as ordinates on a speed base will also be one of mean torque values, but to another scale, for the actual torque values.

In the case of multi-cylinder engines the torque variation curves are obtained by superposing the torque curves of individual cylinders in their correct firing orders or phases, and adding or subtracting the ordinates of the positive and negative portions, respectively.

The torque diagram obtained from a four-cylinder vertical engine of the usual crank arrangement employed in motor car engines, namely, the two outer cranks in the same plane and position with the two inner cranks at 180 degrees to them is indicated by the dotted lines in Fig. 13 (A) and for a six-cylinder vertical engine with cranks at 120 degrees in Fig.

13 (B) by the dotted lines. In each instance the mean torque value is shown by the horizontal dotted line.

These diagrams show that the effect of increasing the number

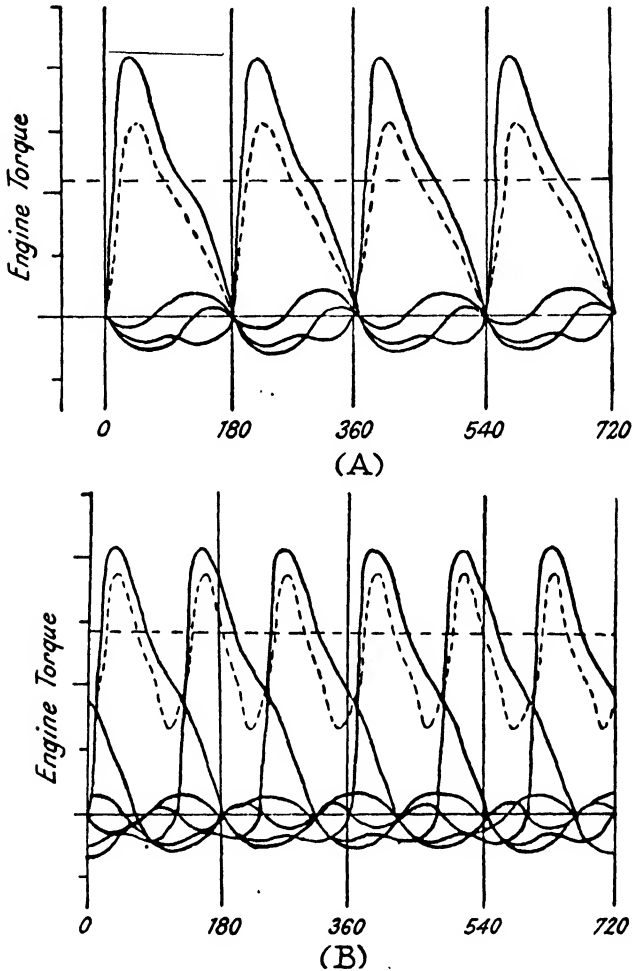

FIG. 13. Four- and six-cylinder in-line engine torque diagrams

of cylinders is to reduce the values of the maximum torques as shown by the peaks of the curve, whilst increasing the mean torque, so that the ratio of maximum to the mean torque is reduced progressively nearer to unity.

In this connection the comparative results for single- and multiple-cylinder engines ¹¹ given in Table 5 are of interest.

TABLE 5. TORQUE RELATIONS FOR DIFFERENT ENGINES

Type of Engine	Load	Connect- ing-rod to Crank Ratios	Max. Torque Variation = Max. - Min. Torque lbs. ft.	Mean Torque lbs. ft.	Max. Torque Variation Mean Torque
Single-cylinder	Full	4	750	79.6	9.3
Four-cylinder vertical	Full	4	526.6	318.6	1.65
Six-cylinder vertical	Full	4	475.6	474	0.99
Six-cylinder vertical	$\frac{1}{2}$	4	359.9	239	1.50
Six-cylinder vertical	$\frac{1}{4}$	4	398.1	119.5	3.33
Six-cylinder vertical	0	4	576.2	0	Infinity
Eight-cylinder Vee	Full	4	583.7	637.2	0.916
(2 banks of 4 cylinders)	Full	3	584	637	0.916
Twelve-cylinder Broad Arrow (3 banks of 4 cylinders)	Full	4	398	956	0.407
Twelve-cylinder Vee (2 banks of 6 cylinders)	Full	4	398	956	0.407

It will be observed from these results that the torque fluctuations as given by the values in the third column from the right diminish progressively with the increase in the number of cylinders and the ratio of the maximum torque variation to mean torque also diminishes with the increase in the number of cylinders.

Another interesting point shown by the results given for the six-cylinder engine is that the ratio of the maximum torque variation to the mean torque increases as the load is reduced from a value of 1.5 at full load to infinity at zero load, *i.e.*, the positive and negative torque variations cancel each other and so give a mean torque of zero.

From the point of view of smooth running the smaller the value given in the last column of Table 5 the better will be the engine's performance, assuming that the engine balance conditions are the same in each case. The advantage of the twelve-cylinder over the eight-cylinder vee-type engine is shown by the value of 0.407 in comparison with 0.916 for the latter engine. The six-cylinder vertical engine, with cranks at 120 degrees, is practically as good as the eight-cylinder vee-type, the relative values for the ratio of maximum torque variation to mean torque being 0.99 and 0.916, respectively.

From these results it can be inferred that the larger the

number of cylinders of a given size in an engine of good balance conditions the smaller will be the torque fluctuations in relation to the mean torque and the smoother the running. The frequency of these fluctuations at any given engine speed will be directly proportional to the number of cylinders.

In regard to the torque values for the twelve-cylinder vee-type engine with two rows of six cylinders each, the curves reproduced in Fig. 14 show by the dotted lines the separate

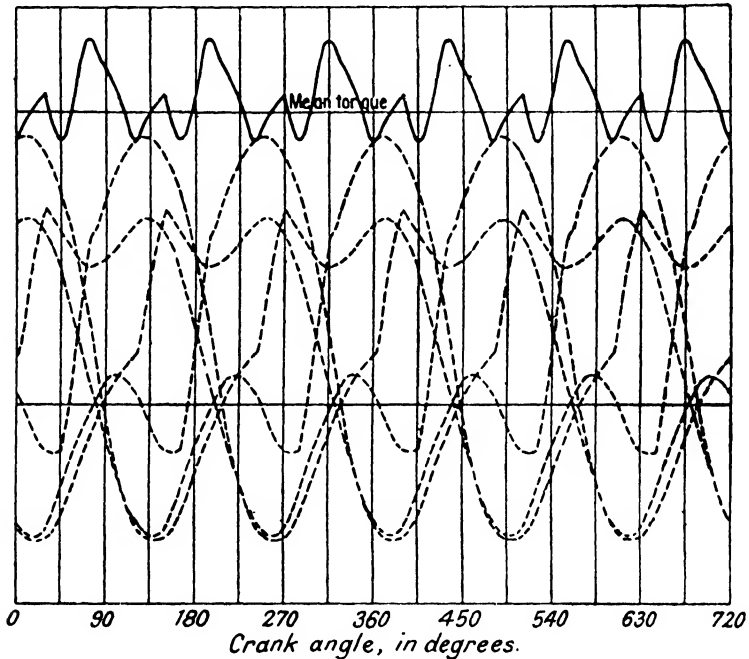

FIG. 14. Torque curves of 400 h.p. twelve-cylinder vee-type engine.

torque curves for each of the six pairs of cylinders, whilst the full line represents the resultant torque curve for the complete engine as given by the algebraic addition of the six ordinates of the dotted curves. The engine in question was of 400 B.H.P. with a bore and stroke of 5 and 7 in. respectively. The connecting-rod to crank ratio was 3.43. The maximum value of the engine torque in this case was 1,345 lbs. ft. and the ratio of maximum to mean torques was 1.25. The ratio of the maximum torque variation to mean torque was 0.35.

In regard to the *torque variations of engines of similar total*

cylinder capacities, but with different numbers of cylinders, it will be evident that as the number of cylinders is increased owing to the smaller sizes of the individual cylinders and their greater number, both the torque fluctuations and the ratio of maximum to mean torque will be reduced. Thus in the case of a six-cylinder engine the variation of torque from the mean value in one instance was 45 per cent., whilst for a twelve-cylinder engine of the same capacity it was only 10 per cent.

The improved torque qualities of the engine with the greater number of smaller cylinders is thus another argument in favour of this type.

Effect of Engine Speed on Torque. Hitherto the subject of engine torque has been discussed without regard to the engine speed. It can be shown, however, that as the engine speed is increased the ratio of the maximum to the mean torque also increases, the maximum value corresponding to the highest engine speed of operation. In this connection it may be of interest to give the results of an investigation¹² made on a four-cylinder vertical engine of 3 in. bore and 5 in. stroke into the effect of engine speed on torque.

TABLE 6. SPEED EFFECT ON TORQUE VARIATIONS

Engine speed in R.P.M.	2,000	2,500	3,000	3,500
Max. torque in lbs. ft.	230	355	516	712
Min. torque in lbs. ft.	0	— 119	— 273	— 466
Mean torque in lbs. ft.	103·7	103·7	103·7	103·7
Ratio $\frac{\text{Max. torque}}{\text{Mean torque}}$	2·23	3·44	5·01	6·29

In general the principal dimensions of the crankshaft are determined from the maximum torque value, but it is necessary also to take the range of torque variation into account and the effect, of torsional vibrations.

Torsional Vibrations of Crankshafts. If the engine torque were perfectly uniform then, when the engine was running at a constant speed, the crankshaft would experience a small amount of twist due to the applied torque, but would otherwise be unaffected. On the other hand, if the torque applied to the crankshaft is of a fluctuating nature—as in the case of all types of petrol engines—the crankshaft, which is assumed to be operating under load conditions, will tend to vibrate about

its axis of rotation at a certain frequency depending upon its dimensions, couplings, type of steel and nature of the torque variations, etc.

The manner in which the crankshaft vibrates may be better understood if one considers the example of a helical spring fixed at its upper end to a horizontal member and allowed to hang down under its own weight and an additional load at the end. If the load is pushed upwards periodically the spring with its load will tend to vibrate in a vertical direction, and if the time interval between the "pushes" happens to coincide with, or be a multiple of the natural time of the spring and its load the amplitude of the vibrations will increase considerably; in other words, if the frequency of the impressed vibrations is the same or a multiple of the natural frequency a resonance effect results, causing an appreciable increase in the amplitude of the vibrations.

If, instead of vibrating the spring vertically, it is twisted through a small angle about its axis and then released, the spring and its load will commence to untwist and twist again, *i.e.*, to vibrate about the axis, and if the frequency of the impressed vibrations is equal to, or a multiple of, the natural frequency of vibration of the spring about its axis the amplitude of the vibrations will be accentuated. These vibrations are known as torsional ones and are similar to those which occur in the case of a loaded shaft or crankshaft transmitting torque of a periodically fluctuating nature, although the problem of ascertaining the nature and amount of these vibrations is much more complicated. Thus instead of a plain shaft—for which the natural period of vibration is readily calculable—there is a shaft with crank webs, fillets, couplings, flywheel or airscrew hub and airscrew, etc., with no part held rigidly as in the case of the spring previously considered.

Another factor that must be considered is the damping effect of the crankshaft parts and attachments in modifying the nature of the vibrations.

It is not possible to devote the necessary space in this volume to the analytical or experimental aspects of torsional vibrations and crankshaft design and the reader is therefore referred to the fuller account given in the author's book¹³ and the other sources of information¹⁴ given in the list of references at the end of this volume.

The general deductions which can be made from these results are that each aircraft engine crankshaft system, complete with

its airscrew unit, has its own natural periods of torsional vibrations and if the frequency of the torque variations approaches that of the natural vibrations the crankshaft will experience "resonance" effects which result in increased amplitudes of vibration and therefore of increased "twisting" stresses. Thus when an engine is accelerated gradually from a low speed to its maximum working speed there will be certain "critical speeds" in the range at which the torsional vibrations attain their maximum amplitudes; these are usually evident as tremors or vibrations associated with certain engine speeds. As the engine speed is increased above or reduced below the critical speed, the vibrations die down.

In aircraft engine design it is necessary to arrange for the normal and maximum working speeds to be well removed from any critical speed. Unless this is done there is a risk of crankshaft failure by fracturing under the increased torsional stresses; several instances of such failures have occurred in earlier aircraft engines.

Certain types of engines, notably those with the longer crankshafts, are more prone to excessive torsional vibrations than others; thus the straight-eight engine is an example of a difficult type for which to design a sufficiently stiff crankshaft to withstand torsional vibrational effects.

It can be demonstrated theoretically and confirmed by actual torsion vibration records, *i.e.*, torsionographs, that apart from the principal critical speed other secondary speeds or harmonics can also occur; in general these are not serious unless near to the engine operating speeds.

It is possible to estimate the torsional stiffness of a crankshaft of given design and material, by means of formulæ based partly upon rational assumptions and partly on experimental results so that the critical speeds can be determined in the design stage of an engine.

Damping Effects. From the preceding considerations it will be evident that whilst it is not possible to avoid critical speed or resonance effects in any engine, these may be arranged so as to occur away from the normal and maximum engine speeds. There is, however, another method of minimising torsional vibration effects, namely, by the provision of a torsional damping device. In its elementary form this consists of a series of thin circular discs bolted to one end of the crankshaft and another series of similar discs attached to another member on similar lines to the plates of a metal plate clutch.

The second set of plates is held in a cylindrical unit having a free bearing upon the crankshaft unit, as shown in Fig. 15 in which the end of the crankshaft *E* has a member *B* provided with a series of steel plates attached to it. The plates are arranged to lie between another series of similar plates attached to the drum unit *A*, but not actually touching the plates of *B*. The drum unit *A* is provided with a bearing at *C* on the crankshaft member *B*. The whole of the interior of the drum *A* is filled with oil of suitable viscosity. Thus when the crankshaft experiences torsional vibrations the plates attached to *B* also oscillate about the axis of the crankshaft, these vibrations being damped down in amplitude by the fluid resistance of the oil between the two sets of plates. The damping unit rotates with the crankshaft, but owing to the inertia of the member *A*, relative movement

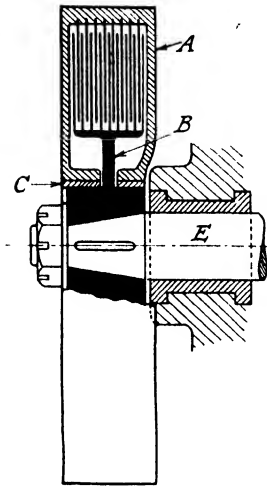

FIG. 15. Torsional vibration damper.

occurs between the two sets of plates during periods of vibrations and the latter are therefore effectively damped down.

The Pendulum Type Damper. A torsional vibration damper employed for the crankshafts of radial engines and known as the "dynamic damper" utilizes the principle that a vibration of given frequency can be damped out by attaching to the vibrating member a pendulum of similar frequency so as to counteract the original vibration by oscillating out of phase with it. This principle is illustrated in Fig. 16 in which diagram *A* shows a simple pendulum subjected to regular impulses at its natural frequency; these impulses cause the pendulum to commence swinging and, in time, to build up a big amplitude of swing. These conditions are analogous to those of the torsional impulses occurring at

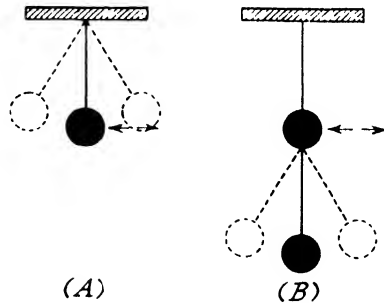

FIG. 16. Principle of pendulum-type damper.

the natural torsional vibration frequency of the crankshaft thus causing a relatively large amplitude of vibration and increased stresses.

Diagram B (Fig. 16) shows how the vibration of the pendulum can be brought to a standstill by providing a second pendulum of equal weight and length, *i.e.*, of equal vibration frequency.

The dynamic damper shown diagrammatically in Fig. 17 is a short pendulum hung on to the crankshaft and tuned to the frequency of the normal speed power impulses so as to absorb the vibrations in a similar manner to that shown in diagram B, Fig. 16.

In the case of the nine-cylinder radial engine torsional vibration is set up by the firing impulses four and a half times each revolution. To damp out these vibrations in the Wright engines the rear crankshaft counterweight is suspended on the crank cheek in such a manner that it forms a free swinging pendulum oscillating in the plane of the crankshaft rotation and of such short radius that its frequency corresponds to that of the power impulses. The restoring force of this pendulum is the centrifugal force due to crankshaft rotation. Since this centrifugal force increases with the engine speed the frequency of the pendulum bears a fixed ratio to the crankshaft speed and hence to the power impulses. The action of the pendulum always therefore opposes the crankshaft torsional vibrations.

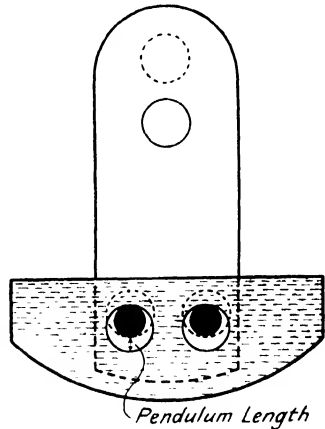

FIG. 17. Application of pendulum-type damper to crankshaft.

The arrangement of the dynamic damper consists in movably suspending the slotted steel counterweight from the crank cheek which extends down into the slot by means of two spool-shaped pins passing through oversized holes in both the weight and crank cheek. The difference in diameter between the pins and the holes determines the pendulum length and the two-point suspension causes the entire mass of the weight to swing through the same degree of arc without rotation about its centre of gravity. This method has the advantage

of balancing the torsional oscillations without the use of any weight over that of the usual counterbalance weight on the crankshaft; further, it is practically frictionless so that no frictional energy is dissipated as with the friction type of damper; as the motion of the weight is extremely slight there is no appreciable wear.

Fig. 18 illustrates the Wright "G" Cyclone engine damper which is fitted as standard on all radial engines of this type.

Other types of pendulum damper that have been fitted to aircraft engines, include the "Sarazin" and "Redynam," the former being used on Hispano Suiza engines; the latter is made under the same licence as the Wright device.

Notes on Vibration Dampers. The fitting of a properly designed vibration damper to an engine which is known to have torsional resonance in the region of its normal speed will lower the speed of synchronism to an extent depending upon the movement of inertia of the damper and the damping action or coefficient.

In regard to the effect of a fluid friction type of damper upon the performance of an engine it has been shown¹⁵ that a certain proportion of the horse power, namely of the order of 5 per cent., is absorbed by the damper, so that the latter must be designed to dissipate the equivalent heat; otherwise there is a risk of overheating and seizure of the plates.

Another method of altering the major critical speed is to fit a spring coupling between the engine and airscrew; by a suitable selection of such a coupling the critical speed in question can be adjusted to practically any desired value; the stiffness of the spring in the coupling can be made variable for this purpose.

In regard to the allowable limits of crankshaft torsional oscillations a tentative standard of 0.5 degree in either direction has been suggested² as reasonable for single and double row radial engines; such oscillations are measured by torsigraph instruments such as the R.A.E., Prescott, Draper, etc.

It may be mentioned, as a point of interest, that the critical speed of any engine can be varied by the addition of a flywheel; this increases the inertia and reduces the natural vibration frequency.

In the case of geared engines a limit to the permissible vibration frequency is set by the permissible clearance between the gear teeth in order to avoid hammering action upon both the faces of each of the teeth, which in time would result in excessive wear and fatigue effects.

Engine Balance. Apart from the vibrational effects caused

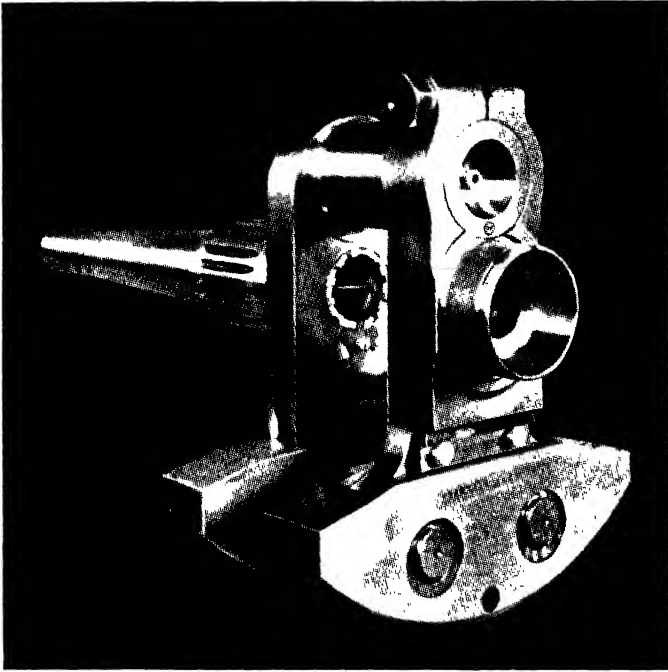

FIG. 18. The Wright radial engine pendulum damper.

by torque variations, an engine may be subjected to other vibrations and rocking actions due to lack of proper balance of the reciprocating members, namely, the pistons and the small end portions of the connecting rods; further, if the rotating masses are unbalanced vibrations or couples will also occur on this account.

These vibrations or rocking couples are transmitted to the engine supports and thence to the aircraft structural members.

In regard to the centrifugal effects of rotating members such as crank pins and their webs, it is possible to balance these by means of counter balance weights (Fig. 19 (A)), and if suitably located the latter can be arranged to obviate any rocking couples due to the planes of action of the centrifugal forces being different (Fig. 19 (B)).

In connection with the balancing of the reciprocating forces, this is a more difficult problem, but in the case of multi-cylindered engines it is often possible to arrange for the reciprocating forces of pairs of cylinders to operate in opposite directions and thus to cancel out. It is necessary, however, for the cylinder axes to coincide, otherwise there will be a rocking couple due to the reciprocating forces acting at some distance apart (Fig. 19 (D)).

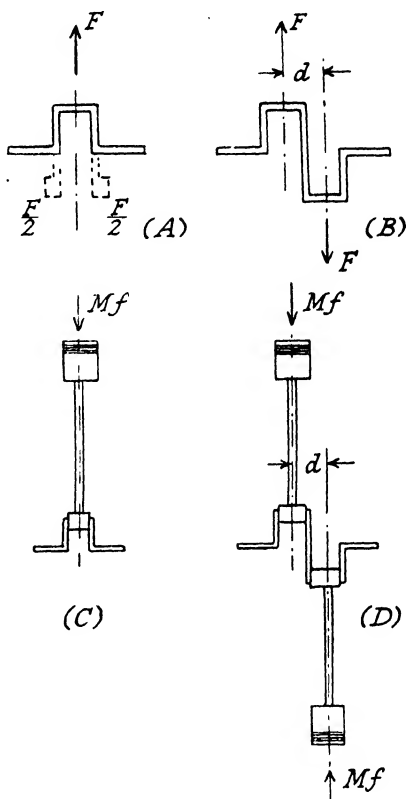

FIG. 19.

- A.—Balancing crank centrifugal force by a pair of weights $\frac{F}{2}$.
- B.—Example of unbalanced centrifugal force couple Fd , due to non-alignment of cranks.
- C.—Unbalanced inertia force of single-cylinder engine.
- D.—Balanced inertia forces of twin engine, but introduction of unbalanced couple, Mfd .

The single-cylinder engine (Fig. 19 (C)) is the most difficult of any to balance since it is necessary to introduce an equal and opposite reciprocating force for this purpose. This can only be effected approximately by means of a pair of counter weights rotating in opposite directions at engine speed. The effect is equivalent to that of a single reciprocating mass of twice the weight of the individual ones, having a simple harmonic motion opposed to the reciprocating movement of the piston assembly. The latter, however, does not have a true simple harmonic motion owing to the limited length of connecting rod in relation to the crank length, since an infinite connecting-rod length would be necessary for this motion. The arrangement shown therefore gives only an approximate balance.

In order to study the balance of any particular engine having more than one cylinder it is usual to consider the results of an analysis of a single-cylinder unbalanced engine and to apply these to all of the cylinders of the engine so that the resultant forces and couples can then be estimated.

It is not possible here, owing to space limitations, to give more than a bare outline of the method so the reader is referred to the reference works¹⁶ given at the end of this volume for fuller information.

A mathematical analysis of the motion of the piston assembly of a single-cylinder engine indicates that the piston acceleration, on account of the limited connecting-rod to crank ratio or connecting-rod obliquity, is made up of a number of component accelerations which would be given by the following individual accelerations, namely :—

(1) A crank of given radius $R = w^2r$, where w is the angular velocity of the main engine crank and r its radius, rotating at engine speed, but out of phase with the main crank by 180 degrees.

(2) A crank of smaller radius aR (where $a =$ a constant) rotating at twice crankshaft speed and 90 degrees in advance of the main crank.

(3) A crank of still smaller radius bR (where $b =$ a constant) rotating at four times engine speed and 90 degrees in advance of the main crank.

(4) A crank of even smaller radius cR (where $c =$ a constant) rotating at six times engine speed and 90 degrees in advance of the main crank.

There are other even smaller harmonics corresponding to

rotating cranks at higher speeds, but their magnitudes are negligible in practice.

These acceleration components are illustrated graphically in Fig. 20 for the first, second, fourth and sixth harmonics in the case of the main crank AB. The resultant acceleration is obtained by the graphical method of finding the resultant of the vectors shown by the arrows.

The actual value of the force causing the acceleration is obtained by multiplying the resultant acceleration by the mass of the reciprocating parts.

If θ = main crank-angle with the axis of the cylinder, M = mass of reciprocating parts, and w = angular velocity of the main crank, and r = radius of main crank, then the following is the general expression for the force F corresponding to the acceleration in the case of a single-cylinder petrol engine :—

$$F = Mw^2r \left\{ \sin(\theta + \pi) + \frac{1}{n} \sin\left(2\theta + \frac{\pi}{2}\right) + \frac{1}{4n^3} \sin\left(4\theta + \frac{\pi}{2}\right) + \frac{1}{16n^5} \sin\left(6\theta + \frac{\pi}{2}\right) + \dots \right\}$$

where n = connecting-rod to crank ratio.

The resultant force of acceleration or reciprocating force is therefore made up (1) of a primary force Mw^2r represented by a mass M at crank radius, 180 degrees out of phase with the main crank, at radius r rotating at engine speed ; (2) a secondary force or harmonic represented by a mass $\frac{M}{4n}$ at crank radius, 90 degrees out of phase, rotating at twice engine speed ; (3) a third harmonic represented by a mass $\frac{M}{64n^3}$, 90 degrees out of phase, rotating at four times engine speed, and so on.

If N = R.P.M. of crankshaft then $w = \frac{2\pi N}{60}$ radians per sec.

From this analysis it is evident that the balancing of the various harmonic forces in the case of a single-cylinder engine, by means of counterbalance weights alone, presents considerable difficulty.

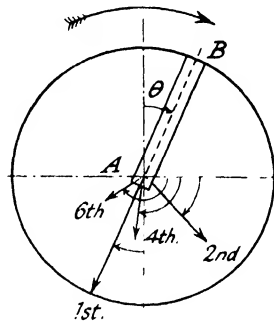

FIG. 20. Vector components of piston acceleration.

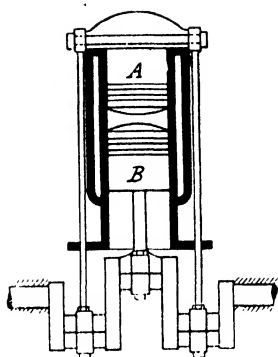

FIG. 21. Example of opposed piston balanced engine.

In applying these results to multi-cylinder engine arrangements it is usual to consider only the first and second harmonics since the magnitudes of the other higher harmonics are generally so small as to be negligible.

In regard to the allocation of the weight of the connecting-rod it is usual to consider the big end portion as rotating and to allow for this in the crank counterbalance, whilst the small end is regarded as forming part of the piston reciprocating weight. The actual proportions of the connecting-rod's weight are usually taken as being

inversely proportional to the distances between the end centres and the centre of gravity of the rod.

The Opposed Piston Single-Cylinder Engine. There is one particular arrangement of single-cylinder engine, namely, the opposed piston type in which the reciprocating forces due to the pistons balance very nearly and thus give a practically vibrationless engine. An early example of this type was the Gobron Brille employed on car engines (Fig. 21). In this case the lower piston B and its connecting-rod and crank followed the usual single-cylinder engine practice. The upper piston A was connected to a cross-head from either side of which was hinged a long connecting-rod coupled to a crank arranged at 180 degrees to that of piston B. The two pistons thus operated in opposite directions and their reciprocating forces were in balance; those of the small ends of the connecting-rods were arranged so as to be approximately in balance.

The same general scheme is adopted in the recent Junkers high-speed aircraft C.I. engine (Fig. 22) in which the two opposing pistons A and B work in a common

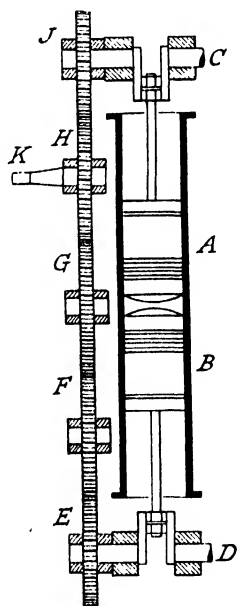

FIG. 22. The Junkers opposed piston engine principle.

cylinder, the space between the pistons in their innermost positions forming the combustion chamber. These pistons are coupled by connecting-rods to separate crankshafts C and D which are connected together by means of a train of gear wheels J, H, G, F and E, of which the second one H carries the airscrew hub shaft K.

This type of engine, whilst giving excellent balance of both the reciprocating and rotating forces, has the disadvantage of excessive height, but it provides an interesting alternative of a

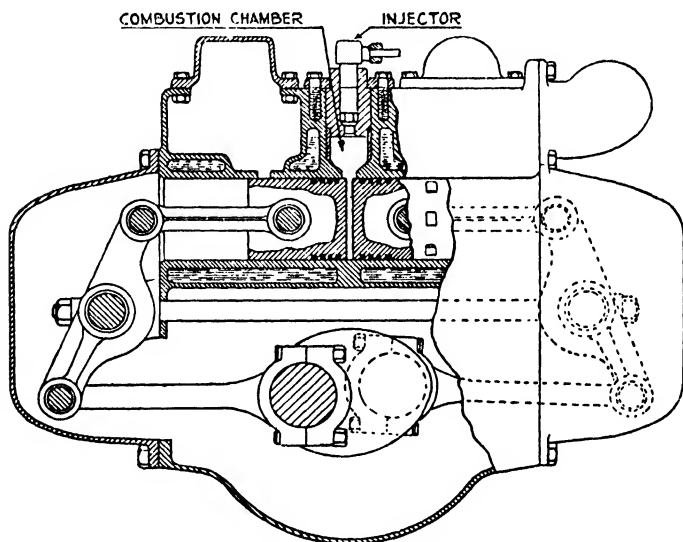

FIG. 23. Balanced piston two-cycle C.I. engine.

“ flat ” engine for installation in the wings where two or four engines are to be employed.

Another alternative arrangement for the opposed piston engine is that shown in Fig. 23, where a single crankshaft is employed; the coupling of the piston, in each case, being by means of two connecting-rods and a rocking lever. The particular engine in question is the Hill two-cycle high-speed C.I. one.

Typical Examples of Engine Balance. The inertia or reciprocating forces in the case of various arrangements of four-cycle engines are given in convenient tabular form* in the

* Courtesy Society of Automotive Engineers.

following pages. These arrangements have been grouped into six representative classes, as follows, namely, (1) *In-line Engines*; (2) *Opposed Engines*; (3) *Vee-type Engines*; (4) *Radial Engines without Link Rods*; (5) *Radial Engines with Link Rods*; and (6) *W-type Engines*.





In each case the primary and secondary "shaking" forces and rocking couples are given, whilst in the last column the firing intervals are given in degrees of crank angle.

In regard to the notation employed the following are the symbols and their interpretations:—

- C = Centrifugal force, in lbs., that would be obtained by rotating the reciprocating weight of one cylinder with crank speed at crank radius.
- W = Value of the centrifugal force produced by the counterweight necessary to cancel all or part of the inertia forces. The primary weight is supposed to run with the same speed and in the same direction as the crankshaft. The secondary weight runs twice as fast and in the same direction, unless otherwise noted. The angular position of the weights with respect to the crankpin is indicated in the diagram by P and by S , respectively.
- H = The horizontal unbalanced inertia resultant after the counterweight indicated has been incorporated.
- V = The vertical unbalanced inertia resultant after the counterweight indicated has been incorporated.
- θ = Crank angle, measured from the crank position as shown, in a clockwise direction.
- a = Distance in inches as shown.
- b = Distance in inches as shown.
- c = Distance in inches as shown.
- M_v = Rocking couple, in lb.-ins., in the vertical plane. A positive couple turns clockwise in the top view or the side view, as shown.
- M_h = Rocking couple, in lb.-ins., in the horizontal plane. A positive couple turns clockwise in the top view or the side view, as shown.
- λ = Ratio of crank radius divided by connecting-rod length.

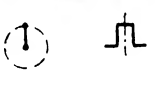
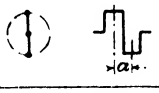
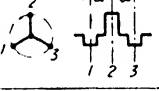
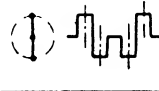
Balance of In-line Engines. The four- and six-cylinder engines of this type are employed in the smaller class of aircraft, so that it is proposed to consider briefly the engine balance of these two types.

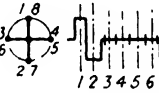
TABLE 7 (A)

INERTIA BALANCE AND FIRING INTERVALS						
ARRANGEMENT OF CRANKSHAFT AND CYLINDERS	NO. OF CYL.	PRIMARY		SECONDARY		FIRING INTERVAL DEG.
		SHAKING FORCE	ROCKING COUPLE	SHAKING FORCE	ROCKING COUPLE	
FOUR-CYCLE IN-LINE ENGINES						
	1	$W=0$ $V=C\cos\theta$ $H=0$	$M=0$	$W=0$ $V=2\lambda C\cos 2\theta$ $H=0$	$M=0$	720
	2	$W=0$ $V=0$ $H=0$	$M_V = \alpha C\cos\theta$	$W=0$ $V=2\lambda C\cos 2\theta$ $H=0$	$M=0$	180 540
	3	$W=0$ $V=0$ $H=0$	$M_V = \alpha\sqrt{3}C\sin\theta$	$W=0$ $V=0$ $H=0$	$M_V = \alpha\sqrt{3}\lambda C\sin 2\theta$	240
	4	$W=0$ $V=0$ $H=0$	$M=0$	$W=0$ $V=4\lambda C\cos 2\theta$ $H=0$	$M=0$	180
	6	$W=0$ $V=0$ $H=0$	$M=0$	$W=0$ $V=0$ $H=0$	$M=0$	120
	8	$W=0$ $V=0$ $H=0$	$M=0$	$W=0$ $V=0$ $H=0$	$M=0$	90
	8	$W=0$ $V=0$ $H=0$	$M=0$	$W=0$ $V=0$ $H=0$	$M_V = 4\lambda C\cos 2\theta$	90

In regard to the four-cylinder engine, the usual arrangement of the cranks for equal firing intervals of 180 degrees is that shown in Table 7 (A). As the two outside pistons are always moving in the opposite direction to the two inside ones the reciprocating forces tend to balance, but owing to the obliquity of the connecting rod, it is shown by an analysis that there is an unbalanced secondary inertia or shaking force in the vertical direction of magnitude $4\lambda \cos 2\theta$, where λ is the ratio of crank to connecting rod, *i.e.*, the reciprocal of the ratio n used in

TABLE 7 (B)

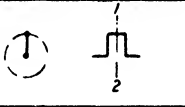
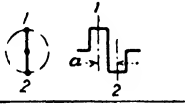
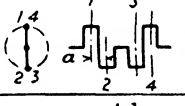
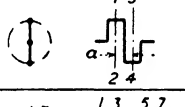
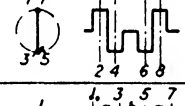
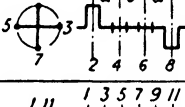
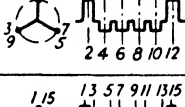
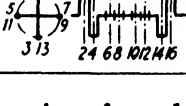
INERTIA BALANCE AND FIRING INTERVALS						
ARRANGEMENT OF CRANKSHAFT AND CYLINDERS	NO. OF CYL.	PRIMARY		SECONDARY		FIRING INTERVAL, DEG.
		SHAKING FORCE	ROCKING COUPLE	SHAKING FORCE	ROCKING COUPLE	
FOUR-CYCLE OPPOSED ENGINES						
	2	$W=0$ $V=2C\cos\theta$ $H=0$	$M=0$	$W=0$ $V=0$ $H=0$	$M=0$	180 540
	2	$W=0$ $V=0$ $H=0$	$M_V = \alpha C\cos\theta$	$W=0$ $V=0$ $H=0$	$M_V = \alpha\lambda C\cos 2\theta$	360
	4	$W=0$ $V=0$ $H=0$	$M=0$	$W=0$ $V=0$ $H=0$	$M_V = 2\alpha\lambda C\cos 2\theta$	180
	4	$W=0$ $V=0$ $H=0$	$M_V = 2\alpha C\cos\theta$	$W=0$ $V=0$ $H=0$	$M=0$	180
	8	$W=0$ $V=0$ $H=0$	$M=0$	$W=0$ $V=0$ $H=0$	$M=0$	180 2 CYLS. SIMULT
	8	$W=0$ $V=0$ $H=0$	$M_V = 2b(a+b) \times C\cos\theta$ $- 2bC\sin\theta$	$W=0$ $V=0$ $H=0$	$M=0$	90
	12	$W=0$ $V=0$ $H=0$	$M=0$	$W=0$ $V=0$ $H=0$	$M=0$	60
	16	$W=0$ $V=0$ $H=0$	$M=0$	$W=0$ $V=0$ $H=0$	$M=0$	90 2 CYLS. SIMULT.

the previous formulæ. In consequence the engine will experience a vibration of twice engine speed frequency. This effect can be neutralized by rotating a pair of equal weights of suitable value, in opposite directions at twice engine speed, and an early example of this method was the Lanchester "Anti-Vibrator" fitted to motor-car engines.¹⁶

TABLE 7 (C)



INERTIA BALANCE AND FIRING INTERVALS						
ARRANGEMENT OF CRANKSHAFT AND CYLINDERS	NO. OF CYL.	PRIMARY		SECONDARY		FIRING INTERVAL DEG.
		SHAKING FORCE	ROCKING COUPLE	SHAKING FORCE	ROCKING COUPLE	
FOUR-CYCLE V-TYPE ENGINES						
	2	$W=0$ $V=2C\cos\theta$ $\times\cos^2\frac{\alpha}{2}$ $H=2C\sin\theta$ $\times\sin^2\frac{\alpha}{2}$	$M=0$	$W=0$ $V=2\lambda C\cos 2\theta$ $\times\cos^2\frac{\alpha}{2}$ $H=2\lambda C\sin 2\theta$ $\times\sin^2\frac{\alpha}{2}$	$M=0$	
	2	$W=C$ $V=0$ $H=0$	$M=0$	$W=0$ $V=0$ $H=\sqrt{2}\lambda C$ $\times\cos 2\theta$	$M=0$	450 270
	2	$W=\frac{1}{2}C$ $V=C\cos\theta$ $H=0$	$M=0$	$W=\frac{1}{2}\sqrt{3}\lambda C$ $V=0$ $H=0$	$M=0$	420 300
	2	$W=0.293C$ $V=\sqrt{2}C$ $\times\cos\theta$ $H=0$	$M=0$	$W=0.541\lambda C$ $H=0$ $V=0.765\lambda C$ $\times\cos 2\theta$	$M=0$	405 315
	6	$W=0$ $V=0$ $H=0$	$M_V=\frac{1}{2}a\sqrt{3}$ $\times C\sin\theta$ $M_H=\frac{3}{2}a\sqrt{3}$ $\times C\cos\theta$	$W=0$ $V=0$ $H=0$	$M_V=\frac{1}{2}a\sqrt{3}$ $\times \lambda C\sin 2\theta$ $M_H=\frac{3}{2}a\sqrt{3}$ $\times \lambda C\cos 2\theta$	120
	8	$W=C*$ $V=0$ $H=0$	$M=0$	$W=0$ $V=0$ $H=4\sqrt{2}\lambda C$ $\times\cos 2\theta$	$M=0$	90
	8	$W=C*$ $V=0$ $H=0$	$M=0$	$W=0$ $V=0$ $H=0$	$M=0$	90
	8	$W=0$ $V=0$ $H=0$	$M=0$	$W=2\sqrt{3}\lambda C$ $V=0$ $H=0$	$M=0$	60 120 60 120 ETC.
	12	$W=0$ $V=0$ $H=0$	$M=0$	$W=0$ $V=0$ $H=0$	$M=0$	60
	12	$W=0$ $V=0$ $H=0$	$M=0$	$W=0$ $V=0$ $H=0$	$M=0$	45 75 45 75 ETC.
	16	$W=0$ $V=0$ $H=0$	$M=0$	$W=0$ $V=0$ $H=0$	$M=0$	45
	16	$W=0$ $V=0$	$M=0$	$W=0$ $V=0$	$M=0$	45

TABLE 7 (D)

INERTIA BALANCE AND FIRING INTERVALS						
ARRANGEMENT OF CRANKSHAFT AND CYLINDERS	NO OF CYL.	PRIMARY		SECONDARY		FIRING INTERVAL DEG.
		SHAKING FORCE	ROCKING COUPLE	SHAKING FORCE	ROCKING COUPLE	
FOUR-CYCLE RADIAL ENGINES; NO LINK RODS						
	3	$W = \frac{1}{2}C$ $V = 0$ $H = 0$	$M = 0$	$W = \frac{1}{2}AC$ <i>REVERSE ROTATION</i> $V = 0$ $H = 0$	$M = 0$	240
n CYLINDER RADIAL SINGLE ROW $n = \text{ODD}$ $n > 3$	n	$W = \frac{n}{2}C$ $V = 0$ $H = 0$	$M = 0$	$W = 0$ $V = 0$ $H = 0$	$M = 0$	$\frac{720}{n}$
DOUBLE ROW RADIAL n CYLINDERS PER ROW $n = \text{ODD OR EVEN}$ 180-DEG CRANK PHASE ANGLE BETWEEN ROWS = $\frac{360}{2n}$	$2n$	$W = \frac{n}{2}C$ <i>EACH ROW</i> $V = 0$ $H = 0$	$M = 0$	$W = 0$ $V = 0$ $H = 0$	$M = 0$	$\frac{720}{n}$
FOUR-CYCLE RADIAL ENGINES; WITH LINK RODS						
SINGLE ROW SINGLE CRANK n CYLINDERS $n > 3$ r = DISTANCE CRANKPIN TO KNUCKLE PIN L = LENGTH OF LINKROD L = LENGTH OF MASTER ROD CONDITIONS: 1. r = CONSTANT 2. $L = r + L$ 3. ANGLE BETWEEN KNUCKLE PINS IS SAME AS ANGLE BETWEEN CYLINDERS	n	$W = \frac{n}{2}C$ $V = 0$ $H = 0$	$M = 0$	$W = n \frac{r}{L} AC$ <i>SAME SIDE AS CRANKPIN WHEN MASTER ROD IS IN TOP DEAD CENTER</i> $V = 0$ $H = 0$	$M = 0$	$\frac{720}{n}$

It should be noted that there are no unbalanced rocking couples in the four-cylinder engine.

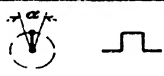
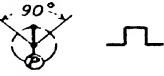
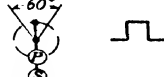
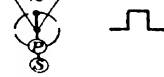
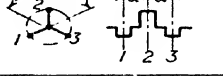
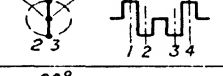
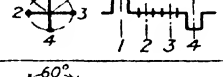
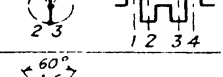
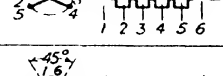
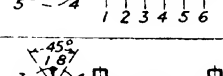
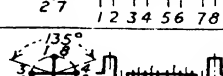
The balance of the six-cylinder engine with cranks at 180 degrees, as shown in Table 7 (A), is perfect as regards the primary and secondary inertia forces and rocking couples. The results of analysis of the engine balance by the method previously outlined, however, shows that whilst the primary, second and fourth harmonics are in perfect balance there is a sixth harmonic present, due to the synchronization of all six piston sixth harmonics, which give rise to an unbalanced reciprocating force of maximum value $\frac{27}{64} \frac{Mw^2r}{n^5}$, causing a vibration of

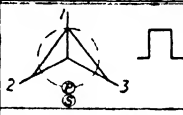
TABLE 7 (E)

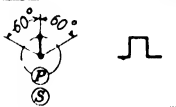
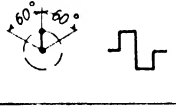
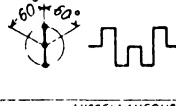
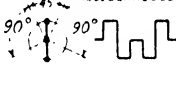
INERTIA BALANCE AND FIRING INTERVALS						
ARRANGEMENT OF CRANKSHAFT AND CYLINDERS	NO OF CYL	PRIMARY		SECONDARY		FIRING INTERVAL DEG.
		SHAKING FORCE	ROCKING COUPLE	SHAKING FORCE	ROCKING COUPLE	
FOUR-CYCLE W-TYPE ENGINES						
	3	$W = \frac{1}{2}C$ $V = 0$ $H = 0$	$M = 0$	$W = \frac{1}{2}\lambda C$ $V = 0$ $H = \lambda C \sin 2\theta$	$M = 0$	120 300 300
	6	$W = \frac{1}{2}C^*$ $V = 0$ $H = 0$	$M = 0$	$W = \lambda C$ $V = 0$ $H = 2\lambda C \times \sin 2\theta$	$M = 0$	120
	12	$W = 0$ $V = 0$ $H = 0$	$M = 0$	$W = 2\lambda C$ $V = 0$ $H = 4\lambda C \times \cos 2\theta$	$M = 0$	60
	16	$W = 0$ $V = 0$ $H = 0$	$M = 0$	$W = 0$ $V = 0$ $H = 0$	$M = 0$	45

* OPPOSITE EACH CRANK

frequency equal to six times engine speed. In practice, however, the magnitude of this is so small as to be negligible.

The Straight Eight Engine. The eight-cylinder "in-line" engine with cranks arranged as shown in the upper of the two eight-cylinder diagrams in Table 7 (A) is perfect as regards both the primary and secondary effects, and this engine gives equal firing intervals of 90 degrees.

The lower crank arrangement shown in Table 7 (A) is balanced in all respects, with the exception of a secondary rocking couple of magnitude $4\lambda C \cos 2\theta$; it occurs in the vertical plane. Although the balance of the straight eight engine may be made perfectly satisfactory and the torque is better than other "in-line" engines of fewer cylinders, this type is more prone to torsional vibration effects due to the long crankshaft. In order to compensate for this the stiffness of the latter must be increased, and this involves an increase in diameter of the crank-pins and main journals. The rubbing velocity of these bearing surfaces and also the weight of the crankshaft are increased on this account, so that part of the other benefits of this type are offset by these two disadvantages. Another drawback is the undue length of the engine; the more difficult

inlet manifolding to ensure even distribution of the mixture to the cylinders is yet another disadvantage.

The Multi-cylinder Opposed Engine. The two-cylinder opposed engine of the 180 degrees crank type shown in Table 7 (B) gives perfect balance of the primary and secondary inertia forces, but there exists a primary rocking couple of magnitude, $aC \cos \theta$, and a secondary one of amount, $a\lambda C \cos 2\theta$, which cannot conveniently be balanced.

The four-cylinder opposed engine shown in the third column down in Table 7 (B) is balanced except for a secondary rocking couple of magnitude, $2a\lambda C \cos 2\theta$, but this arrangement involves the use of four separate cranks instead of the two shown in the fourth column; the balance of the latter is not so good, however, since there exists a primary rocking couple of amount, $2aC \cos \theta$. In general, where a small number of cylinders is employed the opposed engine gives better balance than the corresponding "in-line" type.

The balance of the eight-cylinder opposed or "flat" engine is not so good as that of the "in-line" one of similar number of cylinders, except with the upper of the two crank arrangements shown in Table 7 (B); this type, however, has the disadvantage of two cylinders firing simultaneously, thus effecting the torque of the engine seriously.

In the other arrangement shown, whilst the firing intervals are equal, there is an unbalanced primary rocking couple of magnitude, $2(2a + b)C \cos \theta - 2bC \sin \theta$.

In order to obtain perfect balance of both primary and secondary forces and couples the minimum number of cylinders required is twelve; this gives equal firing intervals of 60 degrees with the crank arrangement shown in Table 7 (B). The opposed twelve-cylinder engine may be considered as consisting of two inherently balanced six-cylinder units, and it has therefore all of the merits of the twelve-Vee type, with the additional advantage of enabling the engine to be mounted within the wings in the case of large multi-engined aircraft.

In regard to the opposed sixteen-cylinder engine, this gives the same excellent balance qualities as the sixteen-Vee type, but has the undesirable feature of simultaneous firing in two cylinders.

Radial Engines. Omitting the example of the three-cylinder radial engine with its connecting rods all driving on to the same single crank-pin, the balance of all radial engines with five or more cylinders can be made practically perfect in the

master connecting-rod type by suitable design of the link and master rods and proper counterweight apportioning. The results given in Table 7 (D) for the directly coupled connecting-rod type (no link rods) show that, theoretically, there is perfect balance of primary and secondary forces and couples. Actually there must exist a rocking effect due to the fact that it is not possible to ensure that the lines of action of all the connecting rods lie in the same plane, since the connecting rods are arranged side by side. In the master-and-link rod method, however, these conditions do not exist, and it is principally on this account that the arrangement in question has been adopted generally in modern aircraft radial engines. The conditions necessary to ensure perfect engine balance are set forth in the second radial engine Table 7 (D), in the first column, for engines with any number of cylinders of five and over, viz. :—

(1) The distance from the crank-pin to knuckle-pin must be constant.

(2) The length of master rod must be equal to the length of the link rod plus the distance from crank-pin to knuckle-pin.

(3) The angle between the knuckle-pins is the same as that between the cylinder axes.

The values of the counterbalance weights necessary to ensure proper balance are given in the third and fifth vertical columns.

Firing Intervals of Radial Engines. If the number of cylinders is *even*, it is not possible in the case of a single crank engine to obtain equal firing intervals. Thus, for example, a six-cylinder radial engine with firing order 1, 3, 5, 2, 4, 6 will have firing intervals of 120, 120, 180, 120, 120 and 60 degrees respectively.

In general, if there are n cylinders, where n is even, there will be three different firing intervals of $\frac{720}{n}$, $\frac{1,080}{n}$ and $\frac{360}{n}$ degrees, of which the first will occur $(n - 2)$ times during a complete cycle and the second and third once each.

If, however, there is an *odd* number of cylinders the firing intervals must all be equal. Thus for n odd cylinders the firing intervals for a four-cycle engine will always be $\frac{720}{n}$ degrees and the firing order for cylinders numbered consecutively from 1 to n will be 1, 3, 5, 7 . . . n for one revolution of the crankshaft and 2, 4, 6, 8 . . . to $(n - 1)$ for the second revolution, and so on.

Thus in the case of a nine-cylinder radial engine the firing

order will be as follows, namely, 1, 3, 5, 7, 9, 2, 4, 6, 8. It should be pointed out that it is possible in the case of a *six-cylinder radial engine* consisting of three equally spaced (120 degrees) cylinders working on one crank and the other three equally spaced cylinders working on a second crank at 180 degrees to the first to obtain equal firing intervals. Whilst this arrangement gives perfect balance of the primary and secondary inertia forces it introduces primary and secondary rocking couples on account of the two sets of cylinder axes being in parallel planes.

The W-type Engine. An examination of the results given in Table 7 (E) indicates that for engines with the cylinder axes at 60 degrees it is possible to balance the primary forces and the primary and secondary couples, but there is an unbalanced horizontal secondary force in each case. The sixteen-cylinder engine with four lines of four cylinders at angles of 90, 45 and 90 degrees gives perfect balance, but has no apparent practical advantage over the opposed or Vee-types considered.

The Vee-type Engine. The balance of this type of engine is generally satisfactory in the case of the eight- and twelve-cylinder models.

Considering the two-cylinder Vee-type driving on to a single crank, the degree of balance depends upon the included angle between the cylinder axis. The best balance is obtained when this angle is 90 degrees, the balance becoming progressively worse for the 60 and 45 degree angle cylinder arrangements. In the case of the 90-degree twin engine the primary inertia force and rocking couples are zero, as is the secondary vertical inertia force; there is, however, an unbalanced horizontal force, but no secondary rocking couple.

An eight-cylinder engine built up of four pairs of 90-degree twin-cylinder engines can be balanced perfectly and also gives equal firing intervals of 90 degrees each.

Similarly the twelve-cylinder 60-degree Vee-type engine with cranks at 120 degrees, as shown in Table 7 (C), is balanced for both primary and secondary disturbing factors and gives equal firing intervals of 60 degrees. The 45-degree twelve-cylinder Vee-type whilst in perfect balance gives unequal firing intervals, but if the sixteen-cylinder arrangements of 45 and 135 degrees shown in Table 7 (C) are employed perfect balance is obtained with equal firing intervals of 45 degrees,

CHAPTER III

TYPES OF AIRCRAFT ENGINES

A Brief Historical Survey. Interest in power-driven aircraft dates back to the days before the introduction of the petrol type of engine ; thus as long ago as 1848 John Stringfellow built a model aeroplane which made a successful flight with the aid of a small steam engine. Later, in 1890, Sir Hiram Maxim constructed a large machine which was fitted with two steam engines and a boiler of light design—for the period in question—giving a total dry weight of just under 5 lbs. per h.p. The machine was tested with a system of guard-rails to prevent it from lifting more than a few inches, as it was desired to solve the problem of stability before attempting actual flights, but the lift of the machine was such that it broke the rails and wrecked itself.

The other historic example of a steam-driven aeroplane was that of Laurence Hargrave, who in 1890 carried out satisfactory trials with models fitted with a steam engine developing 0.75 h.p. for a weight of 7 lbs.

Although the petrol engine has proved itself considerably lighter than the steam engine of orthodox design, yet there are many advantages connected with the use of steam, such as the maintenance of power at all altitudes, absence of complicated carburettor, the use of lower engine speeds to suit propeller characteristics, etc. If a satisfactory steam engine, operating on a fuel-fired steam-producing plant could be made within the weight and bulk limits of existing petrol engines used on aircraft it would prove a serious rival to the latter.

The first successful attempt at constructing a light petrol engine for aircraft use appears to be that of Charles Manly, the assistant to Langley of America, who built a power-driven aeroplane which apparently failed owing to some defect in the launching rail. The Manly engines were of the radial pattern, and one of these which was employed in a scale model Langley aeroplane gave 26 B.H.P. for a weight of 200 lbs. ; a later model full-size engine is stated to have given 52 B.H.P. for 187 lbs. weight.

It is of interest to note that the Manly five-cylinder radial was the first of its kind and possessed several advanced features for the period in question. Thus the cylinders were water-cooled with brazed jackets and the engine was fitted with a master connecting rod with four link rods hinged to it—as in modern practice. The exhaust valves were of the overhead type, operated by push-rods and rocker arms. Ignition was provided by accumulator and coil to the high-tension sparking plugs.

The Wright Bros. at Kitty Hawk, America, were able to make the first successful power flight of their previously tested "glider" with the aid of a four-cylinder "in-line" vertical water-cooled engine of exceptional design for the period in question. The engine's cylinders were of 4.42 in. bore and 3.94 in. stroke, and each was made from a separate steel casting and fitted with an aluminium water-jacket around the barrel; no special cooling means appear to have been provided for the cylinder heads; a gear-type water pump was used for circulating the cooling water. Surface carburation was employed.

The principal features of this engine included suction-operated inlet and mechanically-operated exhaust valves, cast-iron pistons and piston rings, steel-tubular type connecting rods, a light flywheel and low-tension ignition system with make-and-break igniters in the cylinders provided with electric current from a dynamo driven by friction from the flywheel rim. The engine ran at a normal speed of 1,300 R.P.M. and developed from 12 to 15 h.p. for an engine weight of 240 lbs., corresponding to 20 to 16 lbs. per h.p.

Among the engine types used on aeroplanes prior to 1912 were the low-powered Anzani air-cooled vee-twin, three-cylinder arrow and static radial engines, the Simms and Antoinette water-cooled eight-cylinder vee-types, the Green four-cylinder water-cooled vertical, certain J.A.P. motor-cycle type vee-twin air-cooled engines, the Gnome air-cooled rotary engines with fixed crankshafts and rotating cylinders weighing about 3 to 4 lbs. per h.p. The Renault and R.A.F. eight-cylinder air-cooled vee-type engines, the twelve-cylinder vee-type and the six-cylinder vertical water-cooled engines (favoured by German designers) and the larger single and double-row Gnome, Le Rhone, B.R.1 and B.R.2 rotary engines were the successors of these earlier engines during the period of the war of 1914 to 1918.

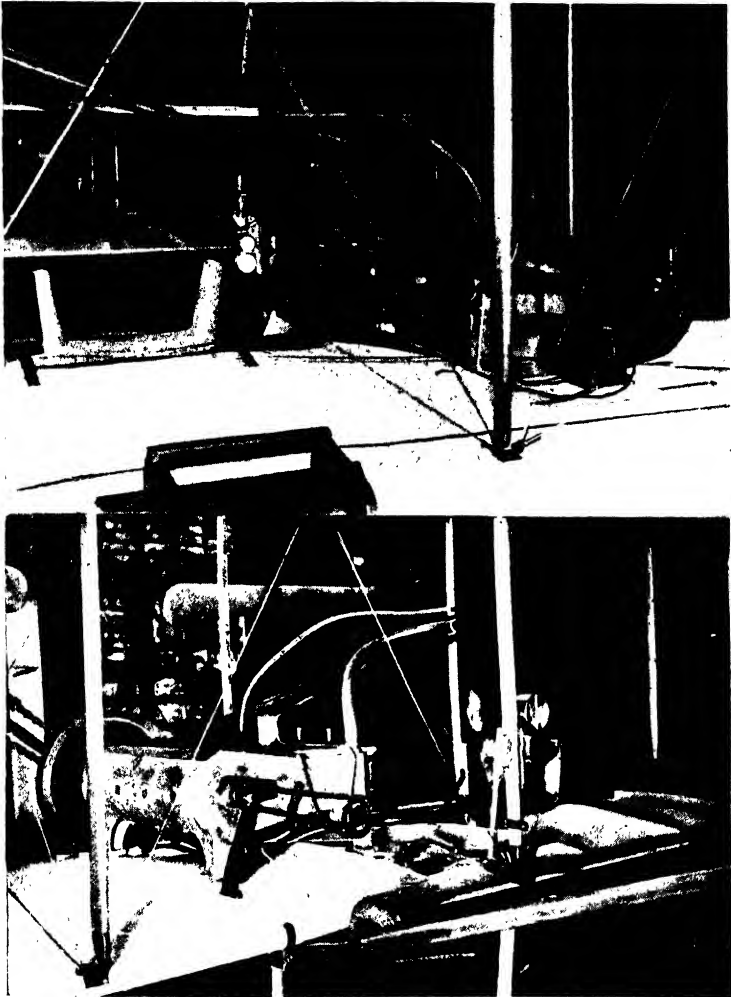

FIG. 24. The original Wright engine fitted to biplane machine. Note the flywheel magneto and chain drives to the pair of oppositely-rotating airscrews. The engine was mounted with its cylinders horizontal.

(Courtesy of The Science Museum, London.)

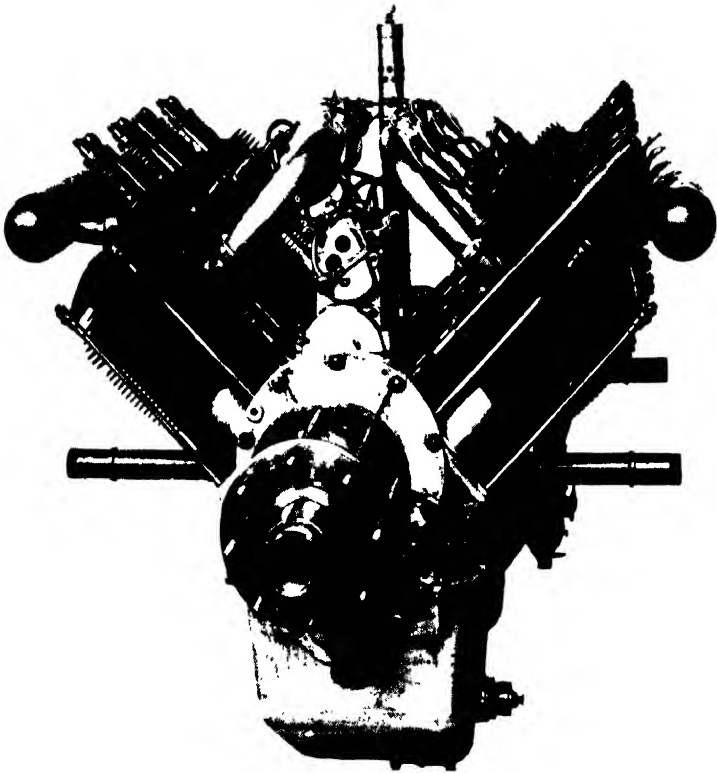

FIG. 25. The 80 h.p. air-cooled eight-cylinder Vee-type Renault engine used during 1914-18.

(Courtesy of The Science Museum, London.)

Mention should also be made of certain engines of outstanding merit used during the latter part of the war period in question. These included the 160 h.p. Siddeley-Deasy and Beardmore six-cylinder "in-line" vertical water-cooled engines; the eight-cylinder water-cooled vee-type Wolsley Viper and Hispano-Suiza engines, the Rolls Royce 250-h.p. Falcon and 360-h.p. Eagle and the 400-h.p. American Liberty twelve-cylinder water-cooled vee-types.

Subsequent to 1918 the rotary type of engine lost favour, whilst the air-cooled opposed-cylinder, vertical and static radial types increased in popularity. Similarly, the twelve-cylinder water-cooled vee-type engines were developed in this country and abroad. Another successful post-war engine was the twelve-cylinder Napier Lion of 450 h.p. with three banks of four cylinders each arranged arrow-wise.

Types of Modern Engines. Modern aircraft engines appear to have settled down to certain definite types, or arrangements of cylinders and crankshafts, each type or design being associated with a certain range of power outputs for specific aircraft purposes; in addition, there is a number of non-standard and experimental models which are being investigated for possible future development.

The power output is generally fixed by the number of cylinders of a size ranging from about 4 to 6 in. diameter, and the actual grouping of the cylinders is determined from considerations of frontal area, cooling method (air or liquid), engine torque and balance to give the best performance combined with minimum weight per h.p. and reasonably low fuel consumption per h.p. hour.

The modern types to be described have been evolved in this manner and each is considered to represent about the best compromise between all of the factors involved. The performance and reliability of these engines over appreciable periods of service afford ample proof of their suitability.

The outline drawings given in Fig. 26 show the more popular present and possible future types of modern engine; they do not necessarily include every pattern of aircraft engine in use at present.

(A) The Inverted "In-line" Engine. The proved advantages of the four- and six-cylinder "in-line" automobile engines in the matter of convenient cylinder and crankshaft arrangement giving good torque and balance qualities has led to the adoption of these two designs, but on a larger scale, for

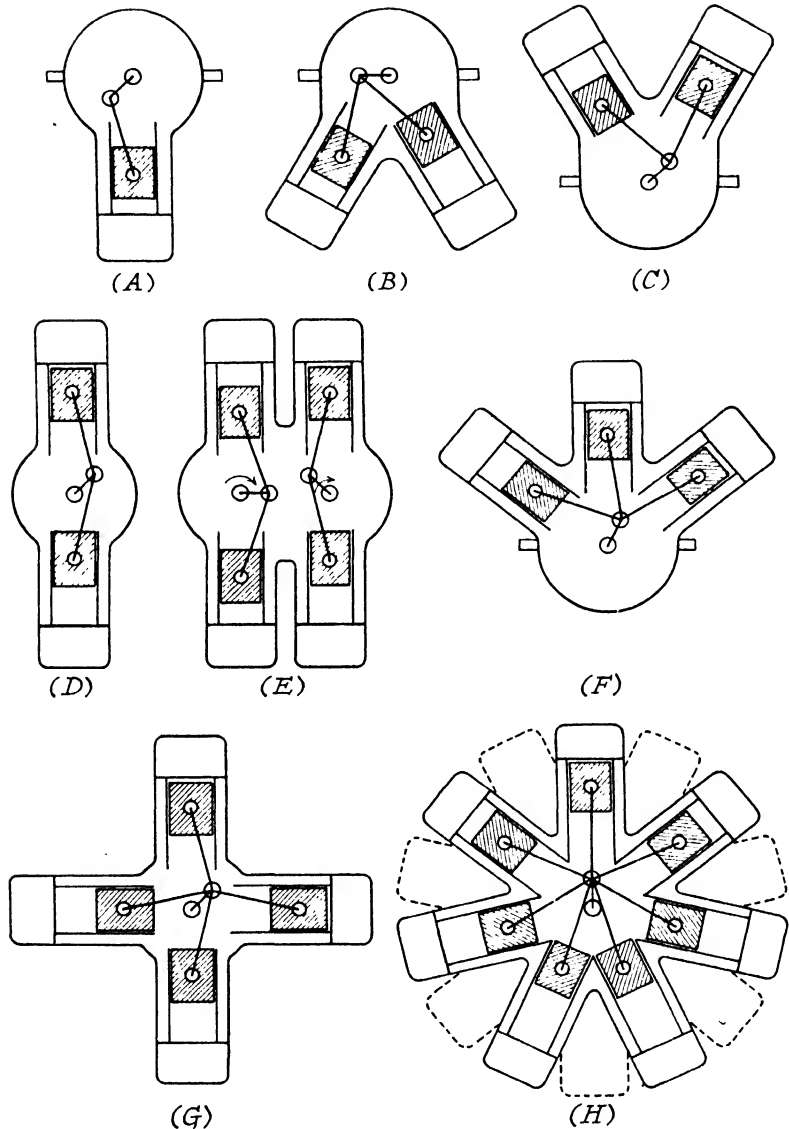

FIG. 26. Types of Aircraft Engine. A—Inverted "In-line" 4 and 6-cylinder. B—Inverted Vee-type, 8 and 12-cylinder. C—Vee-type, 8, 12 and 16-cylinder. D—Opposed type, 2, 4, 8 and 12-cylinder. E—H-type, 16 and 24-cylinder. F—Arrow-type, 12 and 16-cylinder. G—X-type, 16 and 24-cylinder. H—Radial type, 7 to 18 cylinders (single or double bank).

modern aircraft engines of low and medium power. The excellent balance of the six-cylinder engine with pairs of cranks at 120 degrees, as used in automobiles, had resulted in this type being adopted previously for aircraft purposes ; to the examples of the Beardmore and Siddeley-Deasy water-cooled engines previously mentioned may be added the German engines of the 1914-1918 war, namely, the Mercedes, Benz, Austro-Daimler and Opel, all noted for their reliability, good shape for the existing designs of aircraft and even running. The disadvantages of these engines included the necessity for relatively deep-sectioned fuselages, greater weight per h.p. and somewhat excessive moments of inertia about the machine's centre of gravity ; the latter factor resulted in poor manœuvrability as compared with the rotary and Vee-types.

The modern air-cooled six-cylinder " in-line " engines are of the inverted pattern, an arrangement which gives an excellent forward field of vision for the pilot and enables the cooling of the cylinders to be effected satisfactorily. Similarly, the four-cylinder " in-line " engines are also of the inverted pattern ; in each case the greater bulk of the engine, that is, the cylinders and lower half of the crankcase is located below the airscrew axis ; there is thus very little of the engine, namely, the crankcase cover part, above this axis.

Difficulties in regard to engine lubrication with the inverted arrangement of the cylinders have been overcome satisfactorily by the careful design of the lubrication system, which is of the dry sump type.

An additional advantage of the inverted cylinder arrangement is that of accessibility to the items requiring maintenance attention in service on aircraft, namely, the ignition unit, sparking plugs and valve clearances.

The arrangement of the cylinders in line results in a low frontal area and enables the cooling of the cylinders to be effected satisfactorily with the minimum of drag. The crankcase can be made as stiff as desired without excessive weight, whilst the inverted arrangement enables installation to be effected in a simple manner ; similarly, engine removal is a matter of general ease and convenience. In regard to the four-cylinder type air-cooled engines, these usually develop between 100 and 150 B.H.P. at their normal engine speeds of 2,000 to 2,500 R.P.M. The drive to the propeller is direct.

The dry weight per maximum (take-off) h.p. of modern engines lies between 2.1 and 2.6 lbs. for unsupercharged engines

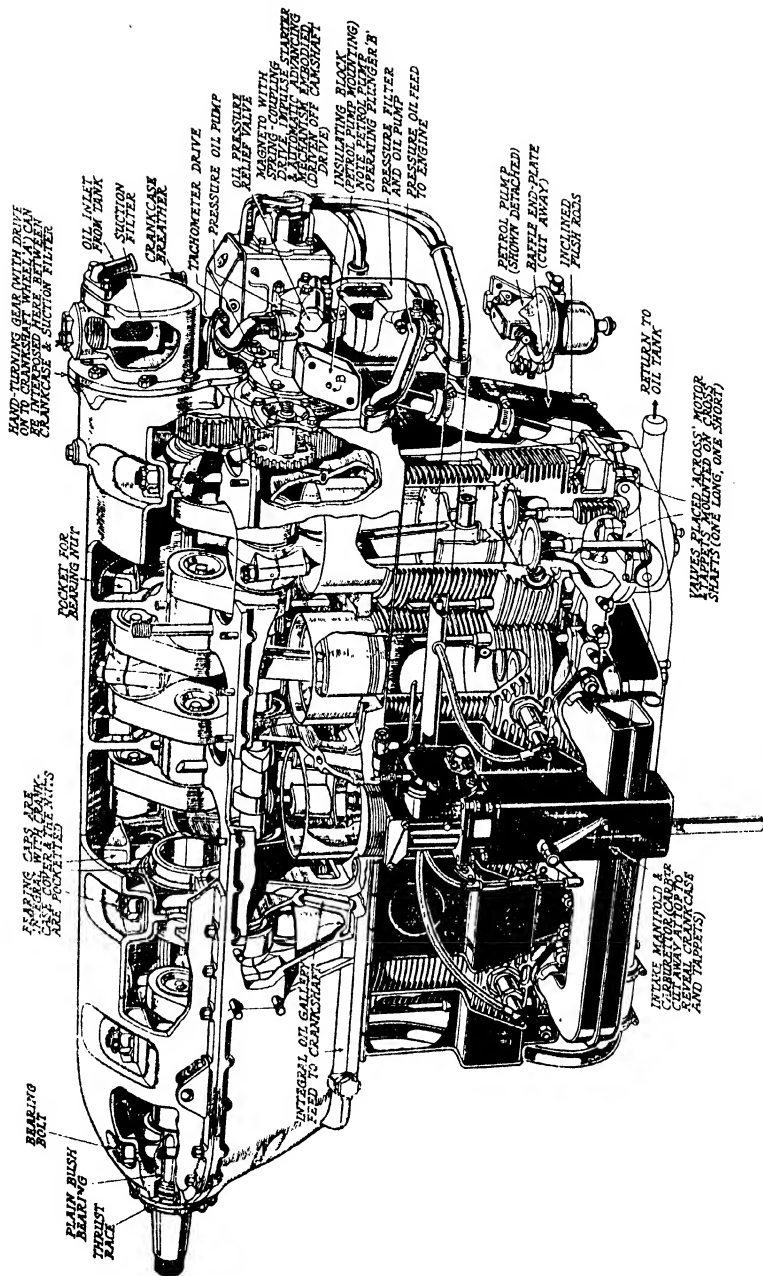

Fig. 27. The Gipsy Minor four-cylinder inverted air cooled engine.
 (Courtesy, "The Aeroplane.")

using 80-octane fuel; the smaller engines are relatively heavier than the larger ones. The compression ratios, dependent upon the octane rating of the fuels for which the engines are designed, lie between about 5.50 : 1 for 75 octane to 6.5 : 1 for 80 octane fuel. Fuel consumptions range from 0.50 to 0.60 lb. per B.H.P. hour and oil consumptions from 0.010 to 0.015 lb. per B.H.P. hour.

Typical Four-cylinder Inverted Engines. The Gipsy series of four-cylinder engines includes the Gipsy Minor, developed from the original Gipsy 100/120 h.p. unit of 1927 and the larger Gipsy Major, Series I and II, engines.

The Gipsy Minor (Fig. 27) has a bore and stroke of 4.016 in. (102 mm.) and 4.528 in. (115 mm.), giving a cylinder capacity of 229.29 cu. in. (3.76 litres). It has a compression ratio of 6 : 1 and weight, less the airscrew boss, of 205 to 215 lbs. The take-off power is 80 B.H.P. at 2,250 R.P.M. and normal cruising power 60 B.H.P. (66.6 per cent.) at 2,250 at sea level. Fig. 28 shows the full throttle and throttled power and consumption curves obtained during official type tests with a fuel not inferior to 70-octane. The normal compression ratio is 6 : 1. The fuel consumption under the previously stated cruising conditions is 0.5 pints per B.H.P. hour; for fuel of 0.75 S.G. this is equivalent to 0.375 lb. per B.H.P. hour.

The engine cylinders are machined from a carbon steel forging to form the external cooling fins and ground internally. After machining a special treatment is applied to all exposed surfaces of the barrels for corrosion protection. One end of the barrel is spigoted into the cylinder head, the joint being sealed by a copper-asbestos washer. The other end projects into the interior of the crankcase to the extent of a flange on the barrel, an oil-tight joint being made by means of a Dermatine ring.

Other features of this engine include separate aluminium alloy heads provided with flanged bronze valve guides and high-expansion steel seatings for the overhead pattern valves, which are operated by push rods and rockers from the five-bearing camshaft located on the exhaust side.

The pistons are of the full-skirt type machined from cast and heat-treated aluminium alloy; two compression and one oil-control ring are fitted. The connecting rod is of H-section, machined from heat-treated aluminium alloy. The big-end is fitted with a steel-backed white metal bearing and is clamped together with two high-tensile steel bolts. Drillings in the big

end allow oil to lubricate the cylinder wall and small-end bearing by splash. The crankcase and top cover are cast in magnesium alloy; the main bearing studs extend through the top cover on either side of the crankshaft centre line. The

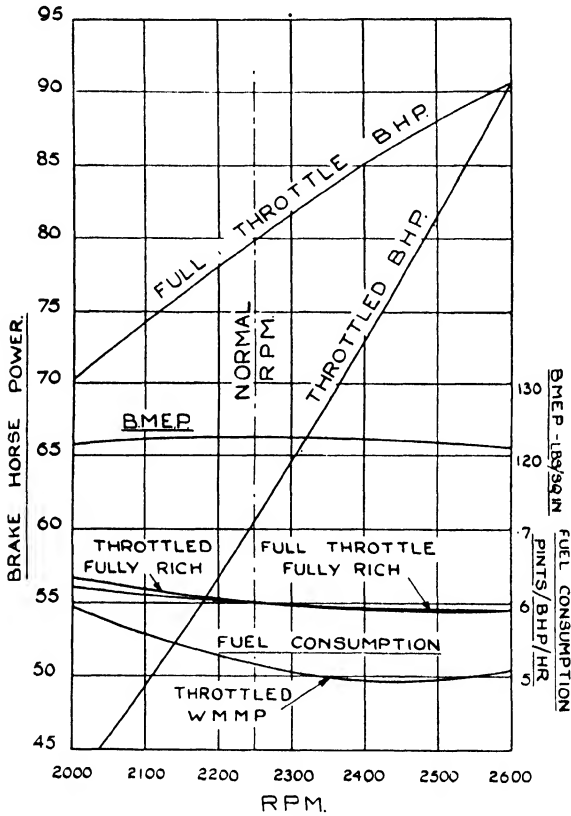

FIG. 28. Performance curves for the Gipsy Minor engine.

crankshaft is made from a nickel-chrome steel forging and rotates in six white-metalled steel-backed main bearings. A ball-thrust bearing is provided at the front end to locate the shaft and take the fore-and-aft airscrew loads.

A Zenith 40 F.A.I.H. downdraught carburettor is fitted on the port side of the engine. The induction pipe riser is jacketed and exhaust-heated. An Amal fuel pump feeds the carburettor

with fuel. Mixture control is provided on the carburettor by an "air-bleed" valve, hand-operated from the cockpit.

Ignition is by B.T.H. magneto of the Duplex type, providing dual ignition for the two sets of 14 mm. sparking plugs per cylinder. The magneto drive is taken through a spring coupling incorporating a vernier device for adjusting the engine timing. An impulse starter is also incorporated in the magneto drive to facilitate starting and an automatic timing device obviates the use of a hand ignition "advance" control.

The dry sump method of lubrication, regulated to 40-45 lbs. per sq. in. pressure, is used.

The engine has an overall length of about 48 in., depth 24 in., and width $12\frac{1}{2}$ in. The height above the crankshaft axis is 5.8 in.

The Gipsy Major, Series I and II, four-cylinder engines are of larger capacity designed for higher outputs and the latter for use with higher octane or "leaded" fuels. The former model is intended for use with fixed-pitch and the latter for variable-pitch airscrews; the cylinder capacities are each just over 6 litres. These engines have a bore and stroke of 4.646 in. (118 mm.) and 5.512 in. (140 mm.) respectively, giving a capacity of 373.7 cu. in. (6.124 litres). The Series I, with compression ratio of 5.25 : 1, weighs 305 lbs. complete with airscrew boss and cylinder baffles and develops a maximum output of 130 B.H.P. at 2,350 R.P.M.; the normal output is 120 B.H.P. at 2,100 R.P.M. The Series II engine, with compression ratio of 6.0 : 1, weighs 310 lbs. complete for receiving controllable pitch airscrew and including cylinder baffles. It develops a maximum output of 140 B.H.P. at 2,400 R.P.M. and has a normal output of 125 B.H.P. at 2,100 R.P.M.

In general, these engines resemble the Gipsy Minor, but differ in many of the actual design details and in regard to certain materials employed in their construction. Thus, the detachable cylinder heads of the Series I engine are of aluminium bronze, whilst the exhaust valves of the Series II engine are "stellited" to resist corrosion by the leaded fuels. The Series II engine is not an adaptation of the Series I engine but has been redesigned to give increased power and improved accessibility with long periods between overhaul.

In this connection the Gipsy Major engines are approved for operating periods of no less than 1,000 hours between complete overhaul, intermediate overhauls being considered unnecessary. Further, the earlier twenty-five-hour schedule

of cleaning and adjustment to the ignition and valve gear, fuel and oil systems has been increased to fifty-hour intervals. In connection with the dimensions of the more recent Series II engine the overall length, height and width are 50.5 in., 29.5 in. and 20 in., respectively.

The frontal area is 550 sq. in., so that assuming a take-off output of 137 B.H.P. this gives the relatively low figure of about 4 sq. in. of frontal area per horse power.

The Gipsy Major engines are fitted with Claudel Hobson AI-48 down-draught carburettors, mixture being controlled by "air bleed" valve operated from the pilot's cockpit. Hot and cold air intakes either interconnected with the throttle to give cold air for full throttle and warm air (drawn through a flame trap) for part throttle cruising conditions, or independently operated are provided. An exhaust-heated jacket is provided in the vertical branch of the manifold from the carburettor. Provision is made for the fitting of dual fuel pumps driven by eccentrics on the camshaft. The camshaft,

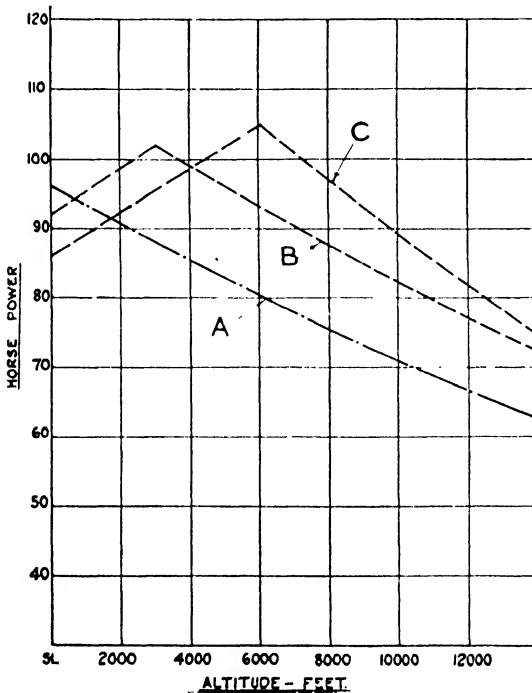

Fig. 29. Performance curves for Gipsy Major Series II engine.

oil pumps and dual tachometer drives are driven by spur gears from a pinion on the rear end of the crankshaft. A spiral gear train from the intermediate shaft of the camshaft driving train drives the magneto cross-shaft. A drive for a vacuum pump for navigation instruments is provided by a second cross-shaft which itself is driven from the crankshaft by a spur and a level train. The starter drive is transmitted through a dog mounted on the rear end of the crankshaft. All of these drives and auxiliaries are housed in or mounted on a magnesium alloy timing cover at the back of the engine.

In regard to the performance of the Series II engine at altitudes, the results shown in Fig. 29 illustrate how the available outputs are affected by the altitude and type of airscrew employed.

Curve A relates to the performance with fixed-pitch airscrew

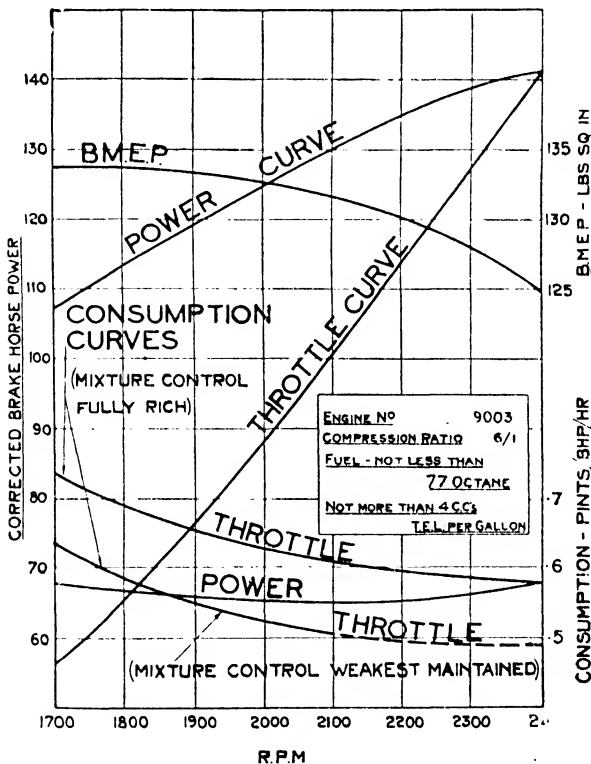

FIG. 30. Power and throttle curves for Gipsy Major Series II engine.

and shows how the output falls continuously as the altitude increases.

Curve B gives the available output for a two-pitch controllable airscrew intended for effective operation at relatively low altitudes; it is designed to absorb, when in the coarse pitch position, the power developed at 2,100 R.P.M. at 3,000 ft. when throttled until the induction pipe pressure is reduced to 11.7 lbs. per sq. in. Above 3,000 ft. the limitation is that imposed by throttling to the maximum cruising speed of 2,100 R.P.M.

Curve C relates to a two-pitch controllable airscrew intended for effective operation at altitudes in excess of 5,000 ft. It is designed to absorb, when in the coarse pitch position, the power developed by the engine at 2,100 R.P.M. at 6,000 ft. with induction pressure of 11.7 lbs. per sq. in.; this is approximately full-throttle.

Two other interesting examples of air-cooled, inverted four-cylinder "in-line" engines are the Cirrus Minor and Major engines. The former has a bore and stroke of 3.74 in. (95 mm.) and 5.00 in. (127 mm.) giving a cubical capacity of 220 cu. in. (3.605 litres). It has a compression ratio of 5.8 : 1 and gives a maximum output of 90 B.H.P. at 2,600 R.P.M., with a cruising output of 82 B.H.P. at 2,300 R.P.M.

The Cirrus Major engine has a bore and stroke of 4.72 in. (120 mm.) and 5.5 in. (140 mm.) giving a cubical capacity of 386 cu. in. (6.33 litres). The compression ratio is 5.8 : 1 and maximum output, 150 B.H.P. at 2,450 R.P.M., with cruising output at 138 B.H.P. at 2,200 R.P.M. The constructional features of both types of engines are similar in most respects, but there are certain design differences. For the Cirrus Major engine these features include steel cylinders machined from forgings located in the crankcase by spigots and secured at their base by four bolts so that no cylinder head distortion can occur by this clamping-down method. The cylinder heads are made from Y-alloy castings, spigoted and clamped by eight studs to the cylinder flange. The cylinder head forms one-half of the valve gear box and has an Elektron (magnesium alloy) cover which acts as an oil bath for the valve mechanism. Y-alloy pistons of the slipper type with fully-floating gudgeon pins, located by circlips, and fitted with two compression and one scraper ring are employed. The connecting rods are made from the light aluminium alloy, Hiduminium, and the big ends have white-metal bearings in steel shells. The crank-

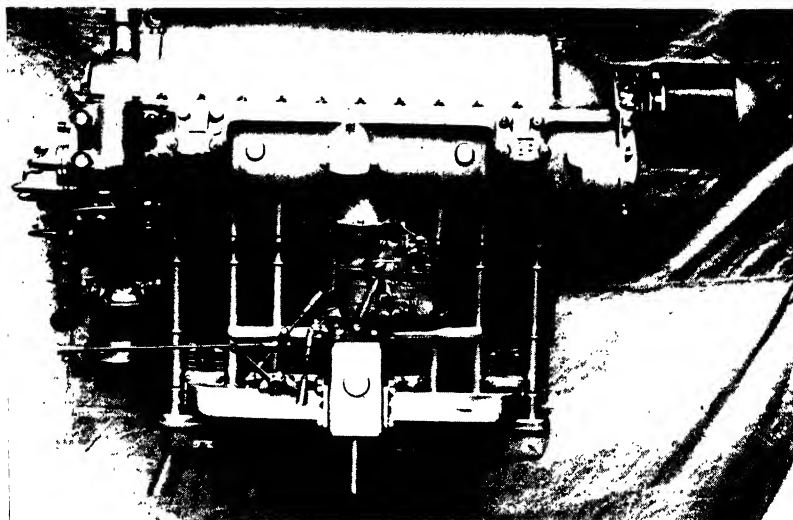

FIG. 31. The "Cirrus Minor" four-cylinder inverted engine.

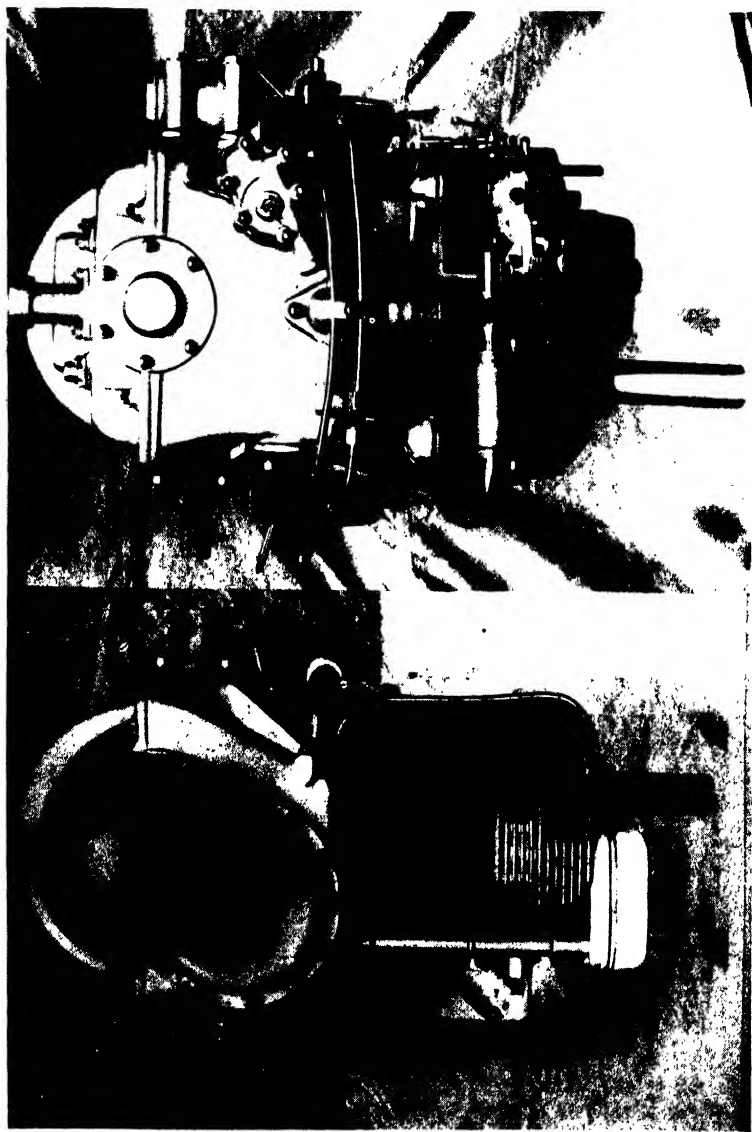

FIG. 32. End views of the "Cirrus Minor" four-cylinder inverted air-cooled engine.

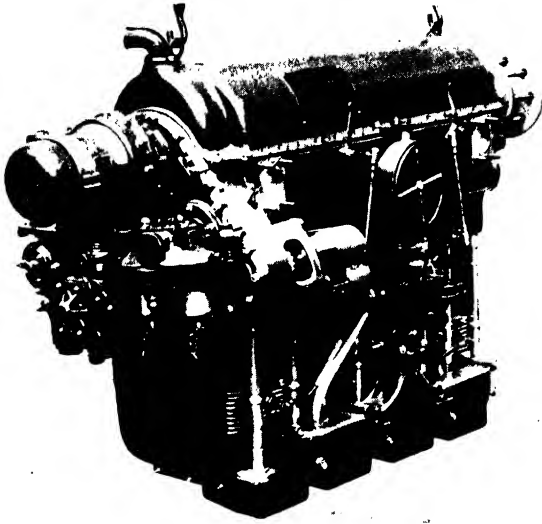

FIG. 33 The "Cirrus Major" engine showing carburettor and rear-end accessories.

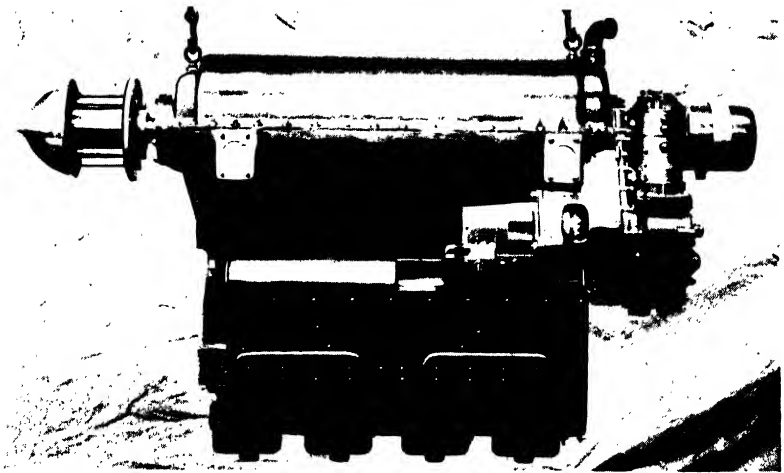

FIG. 34. The "Cirrus Major" four-cylinder inverted air-cooled engine.

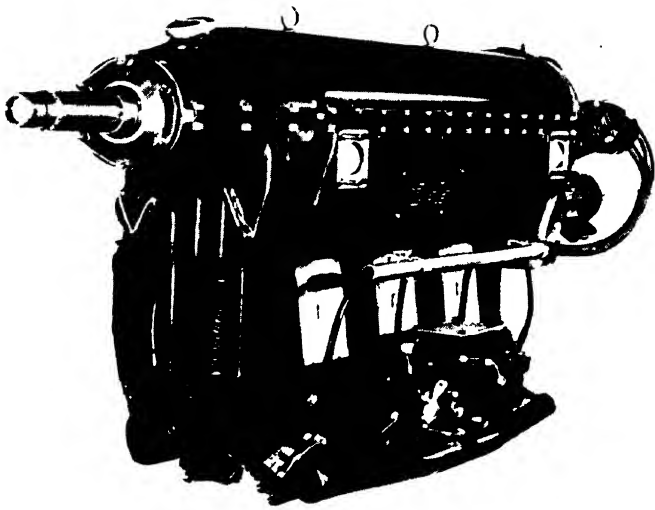

FIG. 37. The Menasco "Pirate" C.4 four-cylinder air-cooled engine (125 h.p.).

shaft is of the five-bearing pattern with ball-thrust bearing at the front end. A spinner is fitted and the airscrew boss is of a pattern made to simplify removal of the airscrew. The

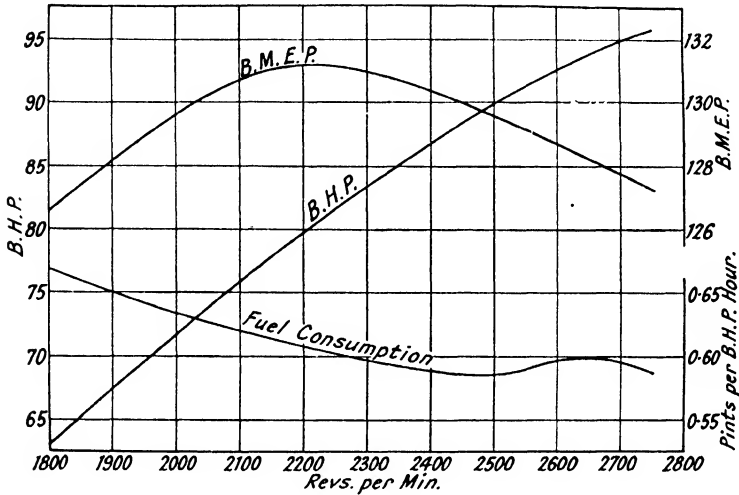

FIG. 35. Performance curves for the Cirrus Minor engine.

rear end is fitted with a gear for operating the magneto vertical driving shafts; a dog can be fitted to the crankshaft for an inertia starter. The camshaft is carried in five plain bearings

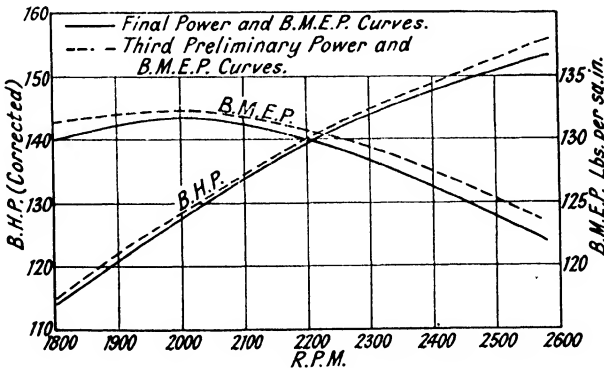

FIG. 36. Power curves for the Cirrus Major engine.

and is driven from the front end of the engine through a train of gears.

Overhead type push-rod and rocker valves are employed ; double ball-ended push rods are used and the tappets are cup-ended and in one piece, passing through duralumin guides.

The whole of the valve rocker mechanism is enclosed. The valve clearances are easily set by means of an adjustable ball cup in the rocker with lock-nut and tab washer. Instead of a hardened pad on the rocker a ball is fitted in the cup ended rocker and a flat on the ball makes contact with the valve stem. The ball being free to turn in its housing offers a constant large wearing surface, whilst the flat maintains correct relative position on the valve stem and eliminates all wear.

The crankcase is made in the form of an Elektron casting with all the pressure oilways embodied. Two Amal fuel pumps can be fitted to it, the usual arrangement being one on either side at the rear operated by cams on the separate magneto vertical driving shafts. Hand-priming levers are fitted to these pumps for starting purposes. The rear end of the crankcase has a breather located centrally, whilst on one side the tachometer drive is taken off and provision is made on the opposite side for any similar drive that may be required. The cover to the timing gears at the front end is split on the crankshaft line and can be removed with the crankcase cover, but acts merely as a cover to the gears.

Pressure-fed lubrication is provided ; this embodies an oscillating piston type of pump instead of the usual gear wheel one ; this is an advantage where the oil tank is placed at some distance below the engine. A suction filter is fitted in the pump body. A pressure oil filter is provided as a separate unit and is attached to the crankcase on the right-hand side. This filter consists of a number of conical filters with a common outlet. The oil pressure is 25 to 35 lbs. per sq. in. and the amount of oil in circulation is $\frac{1}{2}$ gallon. The oil consumption is 1 to $1\frac{1}{2}$ pints per hour. The engine is fitted with a Claudel Hobson down-draught carburettor with an independent altitude control. The inlet manifold is of special design and is in three pieces. The central portion is the heater muff and is an Alpac casting ; the two steel branch pipes are bolted to this muff.

Ignition is by two B.T.H. S.G.4 magnetos of the spigot-mounted type, one having an impulse starting device ; the distributors face upwards, for easy access ; two 14 mm. sparking plugs are fitted to each cylinder.

The engine cylinder cowling has detachable inspection panels to facilitate removal of the sparking plugs for cleaning.

The engine is provided with special resilient bearer feet having rubber bushes.

In connection with the *maintenance of this engine*, the oil is changed, the oil and petrol filters cleaned, jets cleaned, sparking plugs inspected and magneto contact breaker and valve clearances are checked every fifty hours. A top overhaul is recommended every

300 hours and a complete overhaul after 600 hours of normal running. The Cirrus Minor and Major engines complete weigh 227 lbs. and 325 lbs., respectively.

The Menasco air-cooled four-cylinder "in line" engines* are made in several models, viz., the Pirate C.4, D.4, C.4S, and D.4S. ones. The two former engines are of the 125 h.p. unsupercharged rated type and the latter, 150 h.p. rating, supercharged type.

All of these engines have cylinders of $4\frac{3}{4}$ in. bore and $5\frac{1}{8}$ in. stroke giving a

cylinder capacity of 363 cu. in. (6 litres) The compression ratios, in the case of the C.4 and C.4S engines are 5.5 : 1.

The dry weights of the two 125 h.p. models are 300 lbs. each and of the supercharged ones, 320 and 314.5 lbs., respectively. The best engine from the power-to-weight viewpoint is the D.4S. supercharged engine, which has a take-off output rating of 165 h.p., giving a weight of 1.9 lbs. per h.p.

The Menasco C.4 engine is fitted with two Scintilla magnetos and a Stromberg NA-R.4D carburettor. It will develop just over 130 B.H.P. at 2,400 R.P.M. and has a minimum fuel

* Menasco Manufacturing Co., Los Angeles, California, U.S.A.

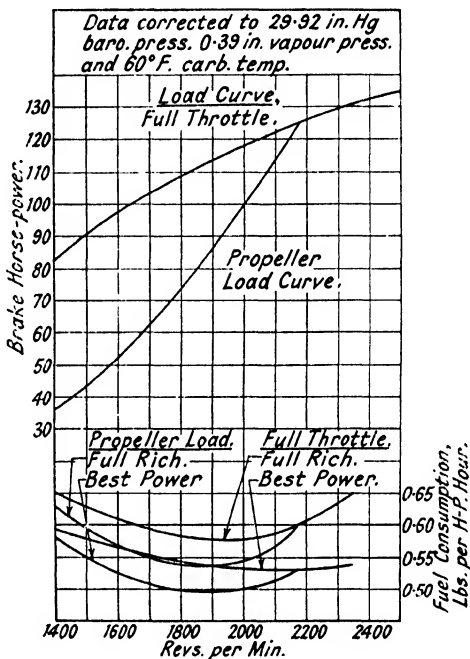

FIG. 38. Performance curves for the Menasco "Pirate" C.4 engine.

consumption of 0.50 lb. per B.H.P. hour. A power curve for this engine is reproduced in Fig. 38.

The supercharged C.4S. model employs a gear-driven blower with a gear-ratio of 9.6 to 1. It has a fuel consumption (minimum) of 0.55 lb. per B.H.P. hour at the rated horsepower and oil consumption of 0.025 lb. per B.H.P. hour.

The Menasco D.4S. engine, shown in Fig. 37, is similar to the C.4S. model in all its main features but embodies certain later design improvements. This is shown with the engine-cooling cowling in position.

Typical Inverted Air-cooled Six-cylinder Engines. These engines, in general resemble the inverted four-cylinder ones

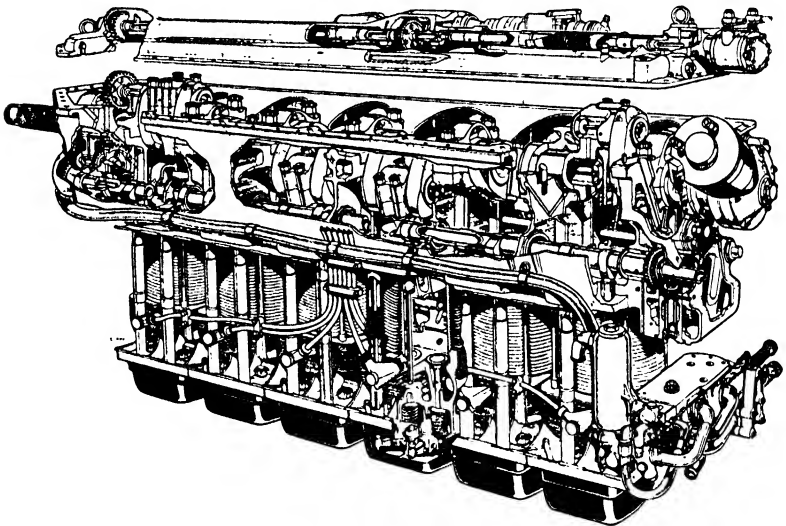

FIG. 40. The Gipsy Six Series II six-cylinder inverted air-cooled engine.
(Courtesy "The Aeroplane.")

and usually represent developments of the latter type for higher power outputs. With the two additional cylinders greater attention must be paid to the subject of efficient cooling of the two rear cylinders, whilst the longer crankshaft must be sufficiently stiff to avoid resonant torsional vibration effects.

Typical examples of air-cooled engines of this class are the Gipsy Six Series I and II ones. Both engines have the same bore and stroke, namely, 4.646 in. (118 mm.) and 5.512 in.

(140 mm.), corresponding to a cylinder capacity of 560.6 cu. in. (9.186 litres).

The Series I engine has a compression ratio of 5.25 : 1 and is designed for use with fuels of minimum octane value of 70. It is suitable for fixed pitch airscrew machines. The engine

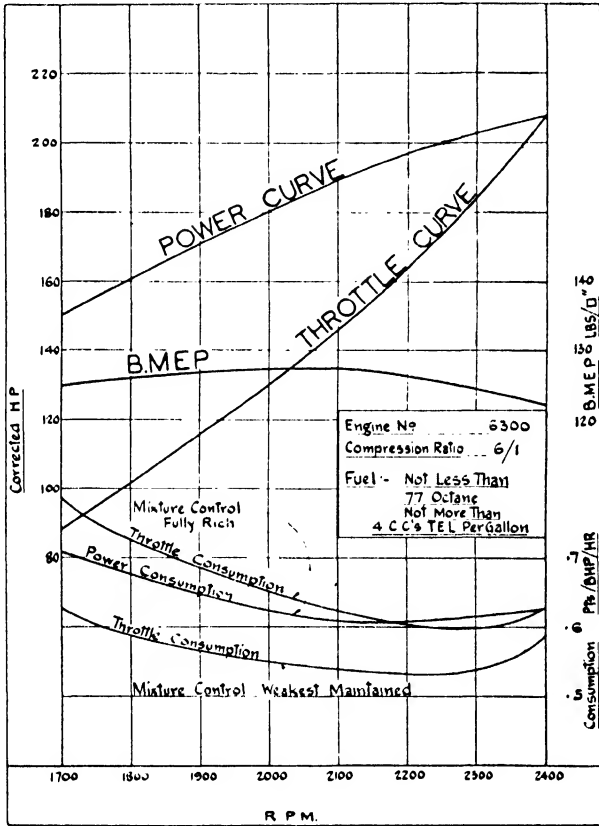

FIG. 41. Performance curves for the Gipsy Series II engine.

has a maximum output of 200 B.H.P. at 2,350 R.P.M. and a normal output of 185 B.H.P. at 2,100 R.P.M. It has a dry weight of 486 lbs., i.e., 2.43 lbs. per h.p. The minimum fuel consumption for cruising near ground level on the weakest mixture; corresponding to 145 B.H.P. at 2,100 R.P.M. is about 0.50 lb. per h.p. hour. The Series II engine has a com-

pression ratio of 6.0 : 1 and is suitable for fuel of 77 octane value and above. It therefore gives a greater output and has a lower specific fuel consumption per h.p. hour.

The engine is suitable for use with controllable pitch airscrews and it will give about 153 B.H.P. at 6,000 ft. altitude with such airscrews used in conjunction with the de Havilland constant speed governor ; as the altitude increases to 14,000 ft. the power falls progressively to 112 B.H.P. The maximum ground level output is 205 B.H.P. at 2,400 R.P.M. The minimum fuel consumption for low level weak mixture conditions is about 0.47 lb. per h.p. hour ; for all-out level flight at full throttle with mixture control in the fully rich position this figure is increased to about 0.49 lb. per h.p. hour.

The dry weight of this engine is 470 lbs., corresponding to 2.3 lbs. per h.p.

Special features of the Series II engine include the use of steel cylinders machined all over and the treatment of exposed surfaces to prevent corrosion ; aluminium alloy cylinder heads ; slipper-type pistons of aluminium alloy (D.T.D. 132), with fully floating gudgeon pins and two compression and one scraper ring below the gudgeon pin ; aluminium alloy (D.T.D. 130) connecting rods with four bolts to each big-end and white-metal lined split steel shells ; eight-bearing crankshaft with white-metal main bearings and ball-thrust bearing at the front end ; Elektron crankcase ; fully-enclosed overhead valve gear with one inlet and one stellited exhaust valve per cylinder ; high expansion steel valve seat inserts ; light alloy tubular push rods and steel tappets operated off seven-bearing camshaft ; twin Claudel Hobson AI 48 down-draught carburettors, each supplying three cylinders ; lubrication at 40 to 45 lbs. per sq. in. pressure ; dual ignition by two B.T.H. magnetos and Rotax electrical engine starter.

In regard to the carburation system the carburettors, up to the highest cruising speed draw warm air from around the cylinders through a flame trap. When the throttle is fully opened a change-over flap is moved and air is taken from outside the engine cowling ; thus freezing is prevented at cruising R.P.M., with no loss of performance at full throttle. When, however, a controllable-pitch airscrew is fitted and operational conditions may require full open throttle settings on the carburettor under cruising conditions, a separately operated flame-trap control to be used in conjunction with an air intake thermometer is fitted, so that induction temperatures may

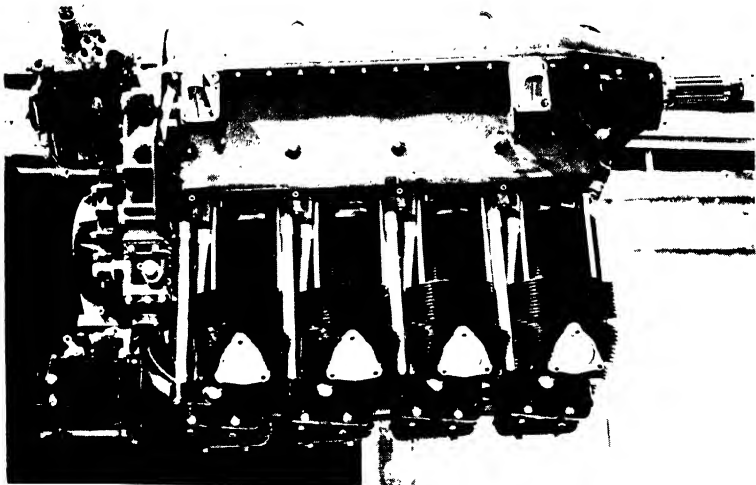
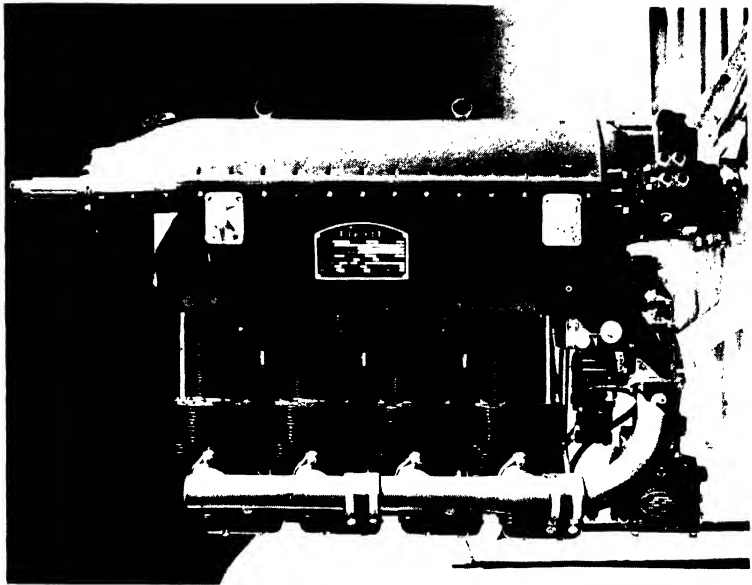

FIG. 30. The Menasco "Pirate" D.S.4 supercharged four-cylinder engine (150 h.p.).

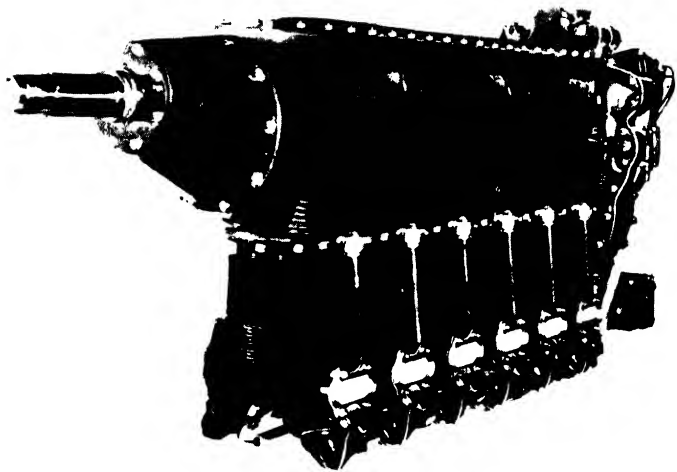

FIG. 42. The Menasco inverted six-cylinder air-cooled engine.

be regulated from the aircraft cockpit. Altitude control is normally by an air valve in the carburettor, operated from the cockpit, but when a constant-speed airscrew is employed it is recommended that the engine be fitted with the Claudel Hobson automatic mixture control unit.

In connection with the auxiliary drives the camshaft and all auxiliaries are driven off the gear wheel on the front end of crankshaft between the ball thrust-bearing and the first crank-throw. A train of hardened gears with profile-ground teeth drives the camshaft; also the shaft in top cover which runs at 1.5 times crankshaft speed to drive the magnetos. An extension of this shaft will rotate the constant-speed airscrew governor, when fitted, and a vacuum pump for the operation of flying instruments. There is an alternative type of crankcase top cover which incorporates a drive for an electric generator of (up to) 500 watts output. Accommodation has also been made for an oil pressure increasing valve and hand-control, for use when 2-position controllable airscrews are fitted. Fuel and oil pumps are driven off the vertical shaft at the back of camshaft. Tachometer drives and starter are fitted at the back of crankcase.

The fuel feed supply to the carburettors is by an Amal Duplex engine-driven diaphragm type fuel pump.

Fig. 41 shows the B.H.P., B.M.E.P. and fuel consumption curves for this engine.

The overall length, height and width of the Gipsy Six Series II engine are $63\frac{1}{2}$ in., $31\frac{3}{4}$ in. and 19 in., respectively.

A typical American engine, namely, the Menasco Super-Buccaneer inverted six-cylinder engine, is illustrated in Fig. 42. This has a bore and stroke of $4\frac{3}{4}$ in. (120.7 mm.) and $5\frac{1}{8}$ in. (130.1 mm.) respectively, giving a cubical capacity of 544.9 cu. in. (8.93 litres). It has a compression ratio of 5.5 : 1 and is supercharged by means of a centrifugal blower geared up with 10.9 : 1 drive ratio.

The engine develops a maximum output of 290 B.H.P. at 2,400 R.P.M. and an upper cruising output of 260 B.H.P. at 2,300 R.P.M., although it is recommended to cruise at a lower output, namely, 180 B.H.P. at 2,000 R.P.M.

The inlet manifold pressure is 44.0 in. of mercury (abs.) at sea level and 39.5 in. at 7,500 ft.

The dry weight of the engine is 550 lbs., *i.e.*, 1.9 lbs. per h.p.

The engine has a frontal area of 3.625 sq. ft., which gives an area of about 1.8 sq. in. per maximum B.H.P.; this low

value is obtained by careful attention to the cylinder and crankcase design.

The fuel recommended is of 80-octane rating and the specific fuel consumption is given at 0.55 lb. per h.p. hour.

The oil pressure for lubrication is 50 to 60 lbs. per sq. in. and the circulation at 2,300 R.P.M. at 175° F. (79.4° C.) is 22.6 lbs. per min. The rate of heat transfer to the oil is 390 B.T.U. per min.

The oil consumption is 0.87 galls. per hour at full power.

In connection with the *cylinder temperatures* of this engine the maximum permissible value (sparking plug washer thermocouple method) is 230° C. for continuous operation; 290° C. for take-off (5 mins. maximum period) and 290° C. for climb (15 mins. maximum period). The maximum permissible cylinder barrel temperature is 150° C.

Opposed Cylinder Engines. In this class of engine the cylinders are arranged in opposing pairs on opposite sides of the crankshaft, the total number of cylinders ranging from two to twelve.

The advantage of this arrangement is that it gives excellent

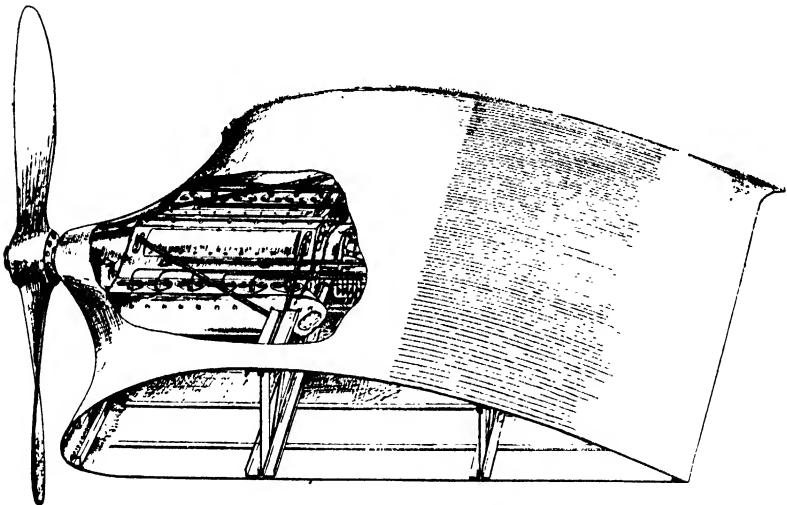

FIG. 43. Illustrating method of housing large opposed cylinder engine in wing of aircraft.

engine balance with good torque and even firing intervals and permits of a shape of engine, in the larger sizes, which can be

housed within the wing section in the case of large multiple engine aircraft. A typical engine of the two-cylinder opposed class developed from motor-cycle practice for so-called power-driven gliders was the ABC model of 1917. This engine, of 28 to 30 B.H.P. was fitted with part of the cylinder barrels and the heads protruding from the sides of the fuselage nose in order to obtain the necessary cooling effect. This engine had steel cylinder barrels machined from forgings and overhead push-rod and rocker arm-operated inlet and exhaust valves.

The lowest powered engines of more recent date develop about 40 B.H.P. and employ two sets of opposed pairs of cylinders. An example of an engine of this type was the Coventry Victor one of 1937, illustrated in Fig. 44. It had a cylinder capacity of $1\frac{1}{2}$ litres and developed 40 B.H.P. at 3,000 R.P.M. for a total weight of 142 lbs. An interesting feature was the induction system by which the fresh charge was taken through the crankcase, thus warming it to some extent and serving to keep the oil cool. The engine in question was about 2 ft. long and wide and about $1\frac{1}{2}$ ft. axial length.

A more recent four-cylinder opposed engine is the Continental one made by Continental Motors, Michigan, U.S.A., and marketed here by Messrs. Coventry Victor Motors Ltd. Known as the model A-50 (Fig. 45) it has a bore and stroke of 3.875 in. and 3.625 in., giving a cubical capacity of 171 cu. in. (2.8 litres). The compression ratio is 5.4 : 1 and the rated h.p. is 50 at 1,900 R.P.M. on 73-octane fuel.

The finned cylinders are made from steel forgings shrunk and screwed into Alcoa heat-treated aluminium heads. The pistons are also of Alcoa alloy cast in permanent moulds. Each is fitted with two compression and one scraper ring. The H-section connecting-rod has a bronze bush at the small end, while the big-end bearing is a copper-lead bearing of the replaceable thin steel shell backed type. The forged four-throw crankshaft has also steel backed copper-lead bearings. Plain thrust faces are formed on the propeller end throw, and on a shoulder near the airscrew enabling the unit to be used as either a pusher or tractor.

A Proferall cast camshaft with six hardened cams and three journals is employed. At the airscrew shaft end the shaft is extended to carry an eccentric which drives the fuel pump. The overhead valves are driven through rockers and tappet rods fitted with Wilcox-Rice hydraulic tappets operated by engine oil pressure, thus eliminating valve tappet adjustments.

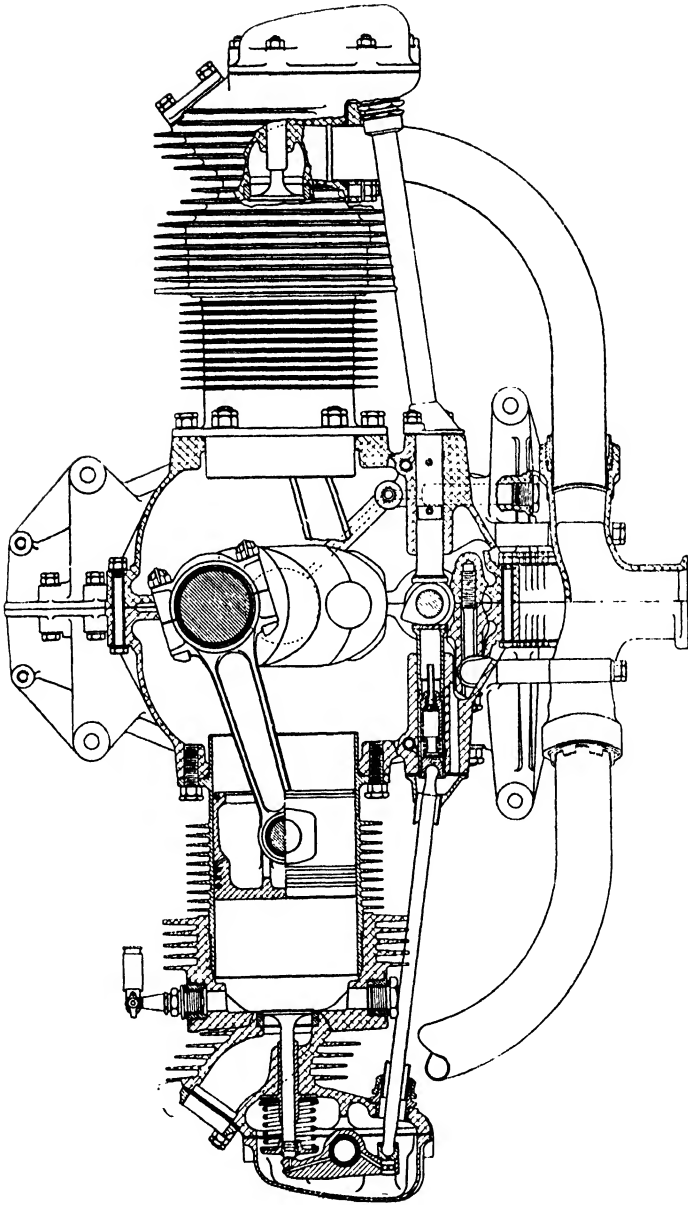

FIG 45. The Continental four-cylinder opposed engine in sectional view.

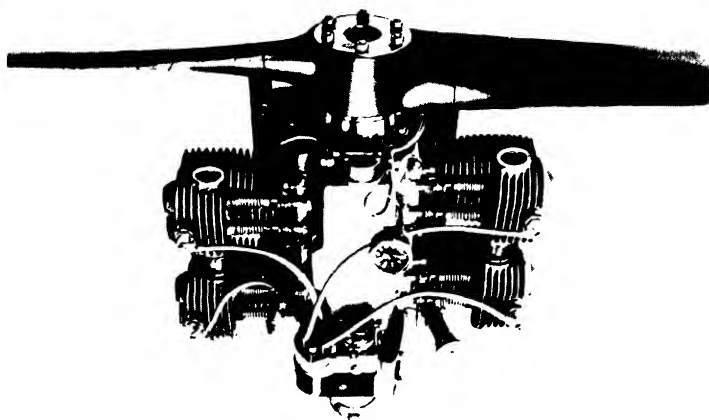

FIG. 44. The Coventry Victor four-cylinder opposed engine (40 h.p.).

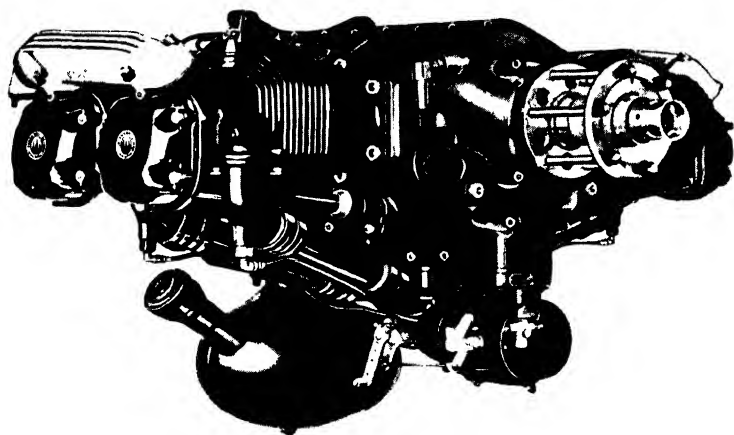

FIG. 46. The Continental four-cylinder opposed engine.

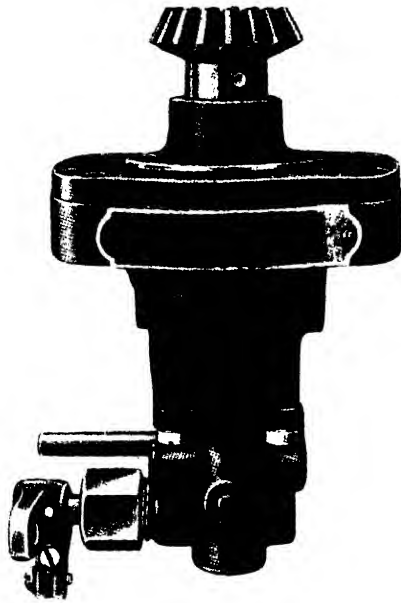

FIG. 48. The Continental fuel injector having cylindrical plungers which reciprocate for pumping and rotate for positive valving.

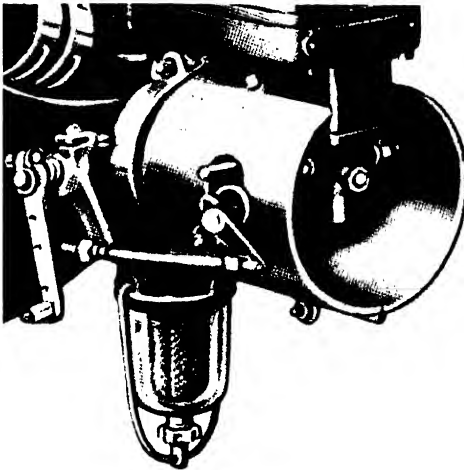

FIG. 49. The Continental fuel injection system showing injector enclosed in air scoop which conducts air blast to air intake unit.

The entire rocker box mechanism is lubricated automatically. Aluminium-bronze valve seat inserts and sparking plug bushes are fitted. The crankcase is of Alcoa aluminium alloy cast in two pieces and bolted together. It is reinforced with a central web supporting the central crankshaft and camshaft bearings. The timing gears are at the opposite end to the propeller shaft, the casing forming the support for the dual ignition units, oil pump, tachometer drive, starter and generator. A Stromberg NA-S3AI updraught carburettor is fitted to an aluminium manifold with exhaust hot-spot. Steel inlet pipes connect this manifold to all the four inlet ports. To obtain uniform fuel distribution to the four cylinders, an air-intake scoop with "egg-crate"-type straightener vanes is required.

The engine has built-in rubber mountings for insulating it from the fuselage mounting as far as possible.

The weight of the engine is 150 lbs., while the overall dimensions are: length $30\frac{3}{8}$ in.; width $31\frac{1}{8}$ in. and height 23 in.

An alternative to the standard carburettor is the fuel injection system, described later.

The same manufacturers also produce four other similar types of engine rated at 50, 65, 75 and 85 h.p., respectively, embodying certain improved design features and relatively better performances.

The 75-h.p. engine has the same bore and stroke as the 50-h.p. model, but has been designed to operate with a compression ratio of 6.3 : 1, on fuel of 73-octane rating (minimum). It develops 75 B.H.P. at 2,600 R.P.M. for a dry weight of 176 lbs. (fuel injection model). The power and fuel consumption curves for this engine are given in Fig. 47. This series of engines is of the direct airscrew drive type, *i.e.*, the airscrew is

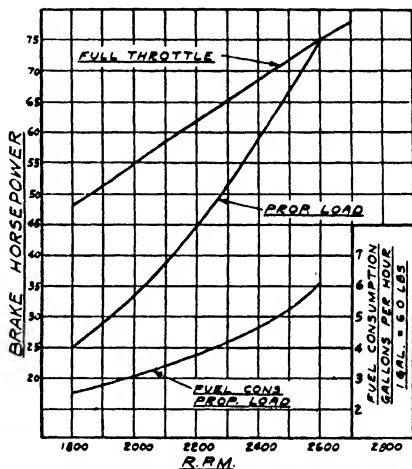

FIG. 47. Performance curves for the Continental 75 h.p. four-cylinder opposed engine.

attached to the front end of the crankshaft, without step-down gearing.

Fuel Injection System. The Continental low pressure fuel injection system employed as an alternative to the standard carburettor consists of a fuel injector unit with cylindrical plungers which reciprocate for pumping and rotate for distributing the fuel positively to pairs of cylinders. The two plungers rotate at one-half the injector speed each plunger serving two cylinders by alternatively discharging first to one and then to the other. The plungers have return springs to keep them in contact with the operating cams.

A refinement of design provides for two grooves on the plungers, the one nearest the tip to arrest all fuel which works down the plunger and, through passages and a tube vent, into the intake piping. The lower of the two grooves is connected through drilled passages and ducts to the pressure side of the engine-oiling system. The cam drive and gearing is also lubricated from the overflow of the pressure oil system of the engine. The surplus oil is returned to the engine crankcase to be circulated again.

Each plunger is of constant stroke and the fuel is metered on its intake side into 18 to 20 in. of vacuum produced by the plungers; the latter force the metered quantity of fuel to the engine. As the air throttle on the intake side of the engine and the fuel metering valve are both linked together, if the load is reduced and the speed increases, substantially the same amount of fuel and air is divided among more cylinder inductions and each individual charge is correspondingly smaller. Inversely, if the speed is pulled down with load, again substantially the same amount of fuel and air is divided among less cylinder inductions and each charge is correspondingly larger. This is important, for an injector engine must be capable of both a power dive and also must function perfectly when the speed is reduced by the extra load of a climb. The use of a variable pitch airscrew is also made possible by the ability to compensate for load, which is inherent in this injection system.

The system, it is claimed, also compensates for varying atmospheric pressure, or altitude effect; this is done by restricting the fuel in the injector to the maximum required by the engine, as is the maximum quantity of air drawn in by the engine.

The fuel is injected into the air through spray jets mounted

at the intake ports of the engine. The spray jets impart a rotary movement or swirl, to the atomized fuel, thus ensuring uniform admixture with the air drawn into the engine. Light, hydraulically-operated valves in each spray jet seal the fuel in the discharge lines against the intake manifold depression and maintain the fuel lines filled with fuel between each spray discharge.

The advantages claimed for this fuel injection system include those of uniform mixture distribution, higher volu-

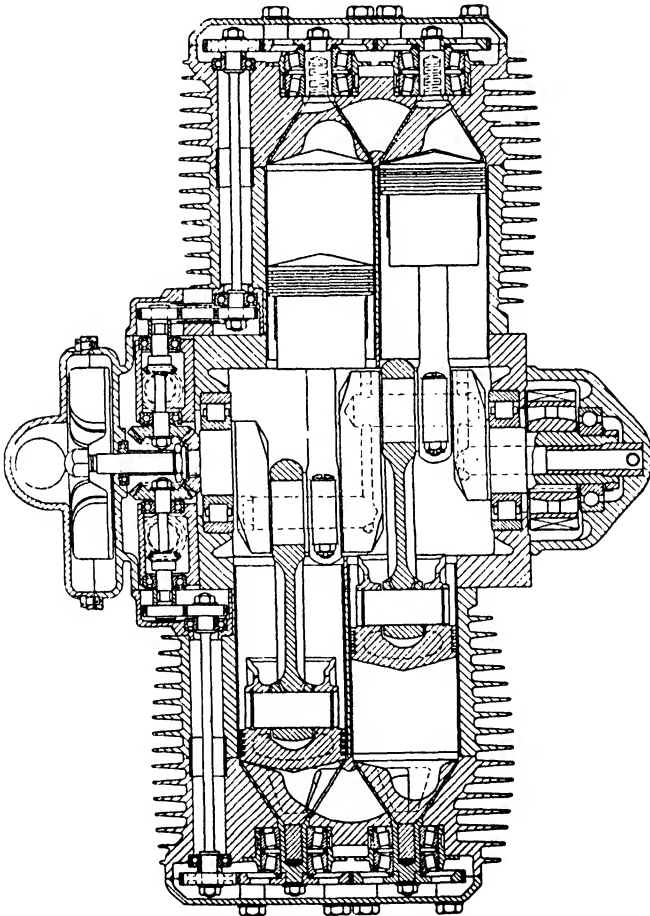

FIG. 50. The Aspin rotary valve opposed cylinder engine.

metric efficiency, freedom from ice formation, reduced fire hazard, and no necessity for the application of heat to the mixture as with carburetors.

The Aspin Engine. An engine of the opposed-cylinder type having several novel features which has been developed experimentally is the Aspin, shown in Fig. 50¹⁸, of 3.27 in. (83 mm.) bore and 3.15 in. (80 mm.) stroke giving a capacity of 106 cu. in. (1,731 c.c.). This engine developed 80 to 90 B.H.P. at 4,500 R.P.M. with a compression ratio of 10.2 : 1.

The special feature of the Aspin engine is the cylinder head valve assembly consisting of a conical head with a rotary valve

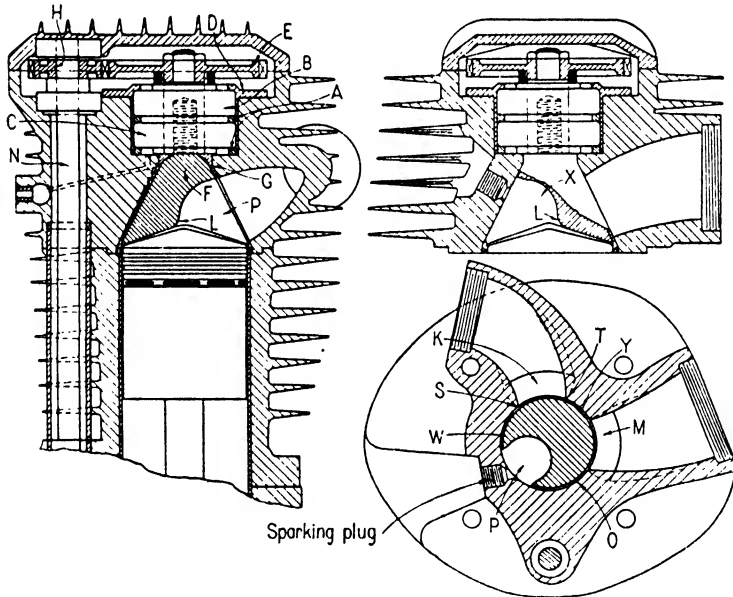

FIG. 51. Cylinder head showing rotary valve and piston of the Aspin engine.

of similar conical shape containing a port for the inlet and exhaust operations. Details of the head assembly are shown in Fig. 51.* The rotary valve unit F, in the experimental engine, is a nitralloy shell filled with light alloy and externally coned to 60 degrees. Attached to this is a cylindrical member B carried on the Timken bearings at A and C. Above these is the half-speed sprocket E engaging at the left with the smaller

* *Automobile Engineer.*

one H driven by the vertical shaft N. Referring, again, to the left-hand sectional view the cavity in the rotating valve F constitutes the compression space, the piston crown at top dead centre coming close to the lower conical surface of the rotary valve; the contour of the port at L is stated to be an important item in the valve design.

The valve F rotates anti-clockwise and, as shown, is approximately in the charge ignition position and remote from any hot area. After ignition the port P rotates past the plain surface at O, during the firing stroke and thence reaches the angular position opposite M, the exhaust port, when the exhaust operation occurs. After this the inlet port K is uncovered and overlaps M to a degree which is determined by the length of the section Y and by the location of the point T, which represents the start of the induction stroke. The point S determines the valve closing lag, after which the port P passes over the blank surface W to give the compression operation and thence to the ignition position near the end of the compression stroke shown in the left-hand illustration.

Owing to the shape of the combustion chamber formed in the rotating valve and to the absence of the hot-spots associated with poppet valve engines, *e.g.*, the exhaust valve heads the combustion process, it is possible, in the Aspin engine, to employ higher compression ratios without detonation effects. It is believed that after ignition there is an initial flame-front movement only, the whole of the remaining charge being then simultaneously projected radially from three sides and at varying but very high velocities upon the flame nucleus as the piston reaches its top dead centre, thus prohibiting any specifically directional movement since all avenues of frontal movement are then closed and complete combustion occurs very quickly, but progressively.

An experimental single-cylinder air-cooled engine, of 2.64 in. (67 mm.) bore and 2.78 in. (70.5 mm.) stroke, giving a capacity of 15.2 cu. in. (249 c.c.) developed 5 B.H.P. at 1,800 R.P.M., 25 B.H.P. at 7,000 R.P.M. and 32 B.H.P. at 11,000 R.P.M. It was found possible to employ a compression ratio of 14.1 : 1 with an ordinary fuel of 0.74 S.G. and heating value 18,810 B.T.U.'s per lb. It is stated that low octane fuels, such as paraffin oil, can be used at this high compression ratio without detonation and that the engine, which was not supercharged, could be operated at a speed of 14,850 R.P.M. without failure.

The results obtained from the experimental engine indicate that a maximum output of about 130 B.H.P. per litre was obtained; the indicated thermal efficiency¹⁸ was claimed to be as high as 50 to 60 per cent., according to the output and engine speed.

In general design the rest of the engine shown in Fig. 50 follows orthodox practice. The piston is of the solid trunk type, of Y-alloy with a gudgeon pin of exceptionally large diameter. The connecting rod is of an aluminium alloy, known as Ceralumin, of 31 tons per sq. in. tensile strength. It runs directly on the nitrided crank-pin journal.

The "Flat" Engine. As previously mentioned the opposed-cylinder engine flat shape arrangement lends itself very satisfactorily to stowage in deep-section aircraft wings, in the case of multi-engine machines. Although at the time of writing, with the exception of the Lycoming engine, the larger type of "flat" engine is still in the experimental stage, the opposed-piston engine—of which the Junker's compression ignition engine is an outstanding example—has the same general form as the opposed-cylinder engine and would appear to offer possibilities for wing stowage.

It may be of interest to note that many years ago Messrs. Beardmore Company evolved a design¹⁹ for a 12-cylinder "flat" engine, based upon the successful Beardmore "Tornado" compression-ignition engines used on the R101 airship. The former engine had a bore and stroke of 6 and 6½ in. respectively, and was designed to develop 500 B.H.P. at 1,750 R.P.M. for a weight of just under 3 lbs. per h.p. Fig. 43, on page 80, illustrates the neat method of engine mounting within the wing which is possible with the type of engine in question.

The Lycoming Flat Engine. An interesting example of a modern "flat" engine is that of the 12-cylinder horizontally opposed Lycoming engine, built by the Lycoming Division of the Aviation Manufacturing Co., of Williamsport, Pa., U.S.A. This liquid-cooled engine is designed for installation in the wings of large aircraft. It has a bore of 5.25 in. (133.2 mm.) and stroke of 4.75 in. (120.7 mm.) and corresponding cylinder capacity of 1,234 cu. in. (20.6 litres). The compression ratio is 6.5 : 1. The engine is supercharged by means of an exhaust-driven turbo-supercharger, using a 10-in. diameter impeller geared to a ratio of 6.55 : 1. The engine is rated at 1,000 B.H.P. at 3,100 R.P.M. at sea-level and it has a take-off rating of 1,200 B.H.P. at 3,400 R.P.M. The rated overspeed

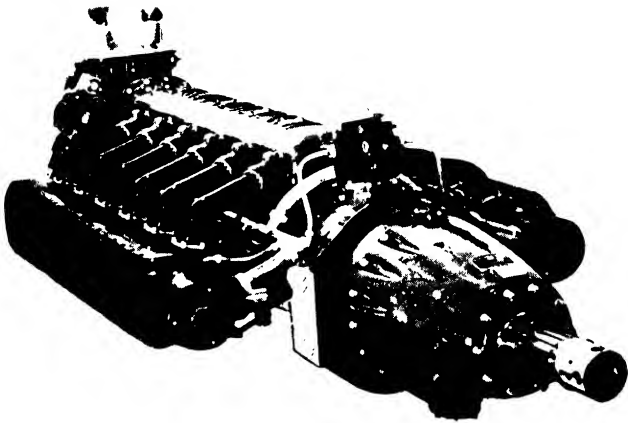

FIG. 52. The Lycoming 1,000-h.p. twelve-cylinder opposed liquid-cooled engine.

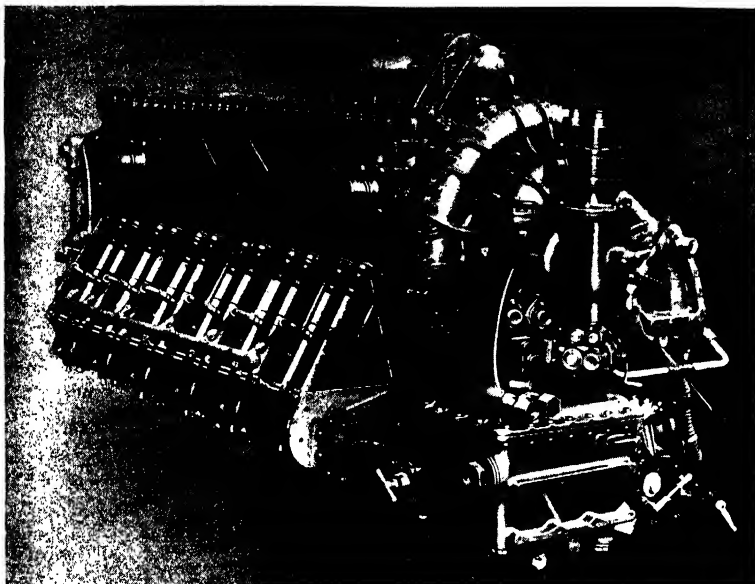

FIG. 53. Rear end view of "Gipsy Twelve" inverted twelve-cylinder Vee engine (400 h.p.).

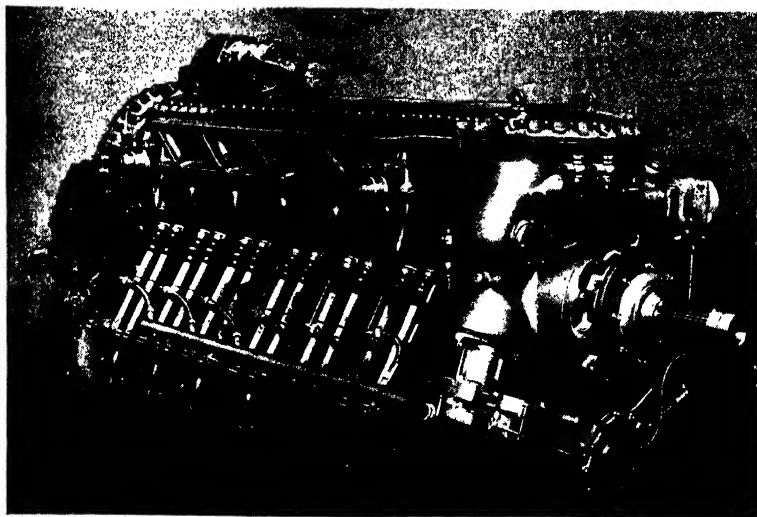

FIG. 54. Front end view of "Gipsy Twelve" engine.

dive R.P.M. is 3,720. The power falls progressively with altitude in the usual manner until at 25,000 ft. the engine develops 570 B.H.P. at 3,400 R.P.M.

The dry weight is 1,325 lbs., *i.e.*, 1.325 lbs. per h.p. on the 1,000 h.p. rating.

The engine has a low frontal area, namely, about 7 sq. ft., which is equivalent to about 143 B.H.P. per sq. ft. When installed in the wing of an aircraft the elimination of engine drag should result in an appreciable gain in the top speed and cruising range of the aircraft.

The engine is 106.66 in. long, 44.13 in. wide and 37.92 in. high.

The fuel consumption, using 100-octane fuel, is 0.5 lb. per B.H.P. hour at normal rating; the oil consumption is 0.025 lb. per B.H.P. hour.

The engine is designed to operate a Hamilton standard hydraulically controlled constant speed airscrew, or a Curtiss electrically-controlled airscrew geared at 0.4 times engine speed. Provision is made for three-point engine suspension.

The Inverted Vee-type Engine. The inverted twelve-cylinder Vee-type engine, whilst not offering any smaller frontal area per h.p. than the usual Vee-type has advantages in regard to improved field of vision, in the case of single engine aircraft, owing to the relatively small amount of space occupied by the engine above the airscrew or crankshaft; as will be shown later, however, this is not an outstanding advantage in modern high-powered fighter aircraft.

Typical examples of this class of engine are the Gipsy Twelve, the German Junkers Juno 211, 1,200 h.p. petrol injection, 1,000 h.p. Mercédés-Benz, and the American Ranger, 420-h.p. air-cooled ones. These are all of the 12-cylinder type, the German engines being liquid cooled.

The Gipsy Twelve (Figs. 53 and 54) is of particular interest on account of its low cooling losses and the fact that it has a frontal area of only 1.75 sq. in. per h.p., *i.e.*, 82.3 h.p. per sq. ft. of frontal area. This supercharged engine, of 4.646 in. bore (118 mm.) and 5.512 in. (140 mm.) stroke has a cylinder capacity of 1,121.2 cu. in. (18.372 litres). The compression ratio is 6:1 and the fuel used, namely, D.T.D. 230, has an octane value of 87. The maximum power rating is 410/425 B.H.P. at 2,450 R.P.M. at 7,750 ft. with zero boost; the International rating is 405/420 at 2,400 R.P.M., at 7,500 ft. with zero boost. The maximum take-off power is 505/525

B.H.P. at 2,600 R.P.M. at sea level, at + 3½ lb. per sq. in. boost pressure.

The performance of this engine at altitude is shown by the graphs in Fig. 55. The engine employs a gear-driven centrifugal supercharger, with a gear-ratio of 7·14 to 1, giving supercharger rotor speeds of 17,000 to 18,500 R.P.M. The

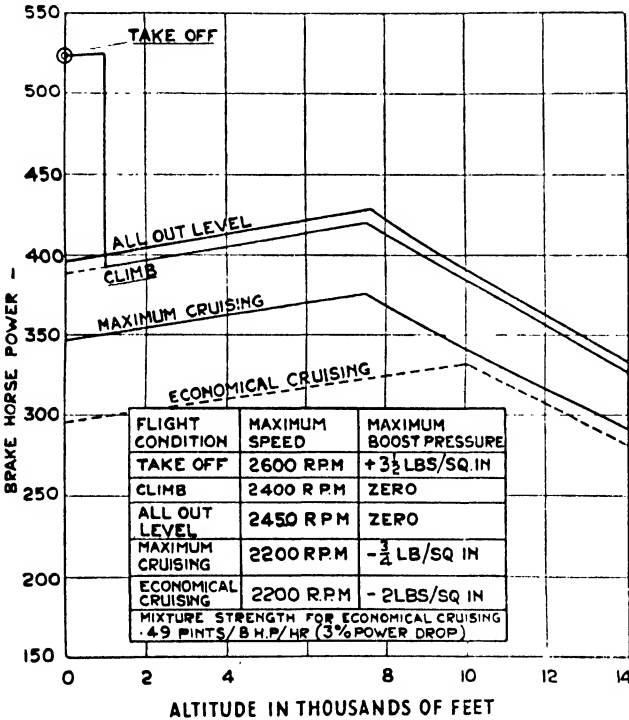

FIG. 55. Performance curves for Gipsy Twelve engine.

airscrew is geared down, the gear ratio being 0·667 to 1. The dry engine weight is 1,058 lbs., *i.e.*, about 2 lbs. per h.p.

The cylinder arrangement enables a cowling of circular cross-section to be used, the diameter being relatively small in proportion to the power delivered ; in a typical case the ratio of engine diameter to airscrew diameter is 0·30. The total engine frontal area is 6·4 sq. ft.

It should be noted that the cylinder dimensions are the same as for the Gipsy Six II engine, there being several interchange-

able components in these two engines. In general construction and materials the Gipsy Twelve engine resembles the latter engine. The nickel chrome H-section connecting rods are machined all over from forgings.

The master rod is forked at its big end to receive the plain connecting rod. Both rods are bronze-bushed at their small ends. The big end of the forked rod is fitted with a steel-backed lead bronze split bearing, which bears directly on the crankshaft. The bearing is made with an outside surface of white metal to provide a bearing for the plain rod. Oil holes are drilled through the bearing to provide lubrication for the big-end of the plain rod.

The crankshaft is a nickel-chrome forging machined all over ; it has eight main bearings.

Journals and crankpins are hollow, capped at both ends and drilled to afford pressure lubrication for the big ends. The front of the crankshaft is machined to form driving dogs for the vacuum pump and airscrew governor, tapered and keyed for the reception of the airscrew reduction gear and machined to carry the driving gear for the camshafts and auxiliaries.

The crankcase is of a deep section Elektron casting, with seven massive cross webs which carry the main bearings low down in the crankcase. The top cover is also of Elektron and has a housing at the rear which carries the starter gear and electric starter ; the booster coil is also mounted on this cover. Inside, on the left-hand side, a hole is cast from front to rear to serve as a main oil gallery.

In regard to the valve operating gear the tappets are squared-ended at the cam end to prevent rotation and are fitted with ball ends to engage the tappet rods. The closing of the valve and the return stroke of each tappet is done by the action of the valve springs. The tappet rod has a cup at the upper end and a ball end at the bottom. At the tappet rod end of the rocker arm the rocker is tapped to receive a hardened steel screw cup-end and lock-nut for adjusting the valve stem clearance. A telescopic cover encloses the tappet rod and seats outwardly under the action of an enclosed central spring against a Dermatine ring in the tappet guide flange at the crankcase and a similar ring in a recess on the top side of the cylinder head ; a cast Elektron cover encloses the valve gear. The exhaust valve face is stellited as are the ends of both exhaust and inlet valve stems. Double concentric valve springs are

fitted and the valve stem collar is held in position on the valve with split taper collets.

The camshafts and all auxiliaries other than the supercharger, vacuum pump, and airscrew governor are driven from a gear wheel mounted directly behind the reduction gear on the front end of the crankshaft. This is the steadiest part of the crankshaft and provides the smoothest drive for the accessories. From the crankshaft gear the drive is taken through double idler gears situated one on each side of the crankshaft to the two camshafts. Bevel gears integral with the front camshaft gears drive the two magnetos. The rear of the (L.H.) camshaft is splined externally and engages a horizontal coupling shaft which drives the "Dowty" pump, generator and metering pump at its rear end. It also drives by means of bevel gears the vertical shaft from the lower end of which the oil pump is operated. Machined integrally with the vertical oil pump drive shaft are two worm gears which drive the dual revolution indicator and the fuel pump.

The supercharger is bolted to the rear end of the crankcase and is driven by means of a long driving shaft splined at its front end into a coupling in the rear of the airscrew shaft, and at its rear end into another coupling which drives through a layshaft, the impeller of the supercharger. The impeller is machined all over from a forging and is dynamically balanced to enable it to run in ball bearings at a maximum speed of approximately 20,000 R.P.M. The impeller draws the mixture from an S.U. carburettor fitted low down on right-hand side of the supercharger casing and compresses it to a pressure controlled by the cam on the automatic boost control to a maximum of $3\frac{1}{2}$ lbs. per sq. in. under take-off conditions. On leaving the impeller the kinetic energy of the mixture is converted into pressure by diffuser blades, which pass the mixture into the delivery volute casing. From the delivery volute the mixture passes into a large main manifold between the banks of the cylinders. Four branch manifolds carry the mixture to the inlet ports on the cylinder heads. Directly above the carburettor the mixture passes through a section of casing which is jacketed and through which return oil from the engine is constantly fed. Hot oil is also fed to the two hollow butterfly valves on the carburettor itself so that with the heater jacket, ice formation is obviated.

The lubrication system, which is of the dry sump kind, employs a gear-type pressure pump, drawing its oil from a

separate tank and two gear-type scavenge pumps which collect the used oil from the crankcase and base of the supercharger casing and return it to the oil tank. Two scavenge filters and also pressure and suction filters are employed.

The Engine Cooling System. This is of the pressure-duct class and has been adopted as the result of much research work with the object of providing minimum cooling loss. The engine has a circular cowling which terminates at the front in an airscrew spinner, without break of line so as to give an efficient profile or clean entry. The cooling air entry for the

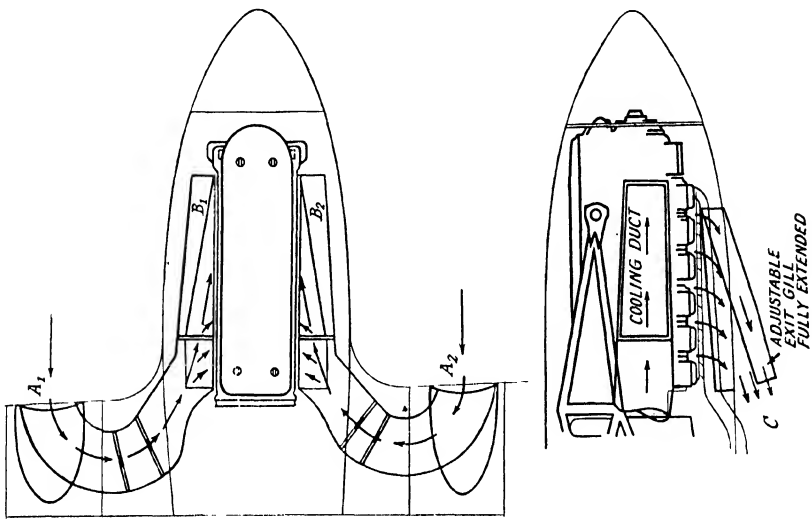

FIG. 56. The air-cooling system used on the Gipsy Twelve engine.

engine is located about three-quarters of the radius of the airscrew from the centre, *i.e.*, in the most intense part of the slip-stream, by means of orifices made in the leading edge of the wing; this arrangement is equally suitable for fuselage and wing-mounted engines. Wind-tunnel tests have shown that correctly designed orifices in this position do not materially affect the lift of the wing.

The air is forced at pressure to galleries outside the banks of six cylinders through ducts which follow an easy sweep and are unobstructed by auxiliary units. Thence it flows over the fins of the cylinders and cylinder heads to the space between the banks and is exhausted downwards and rearwards. In air-

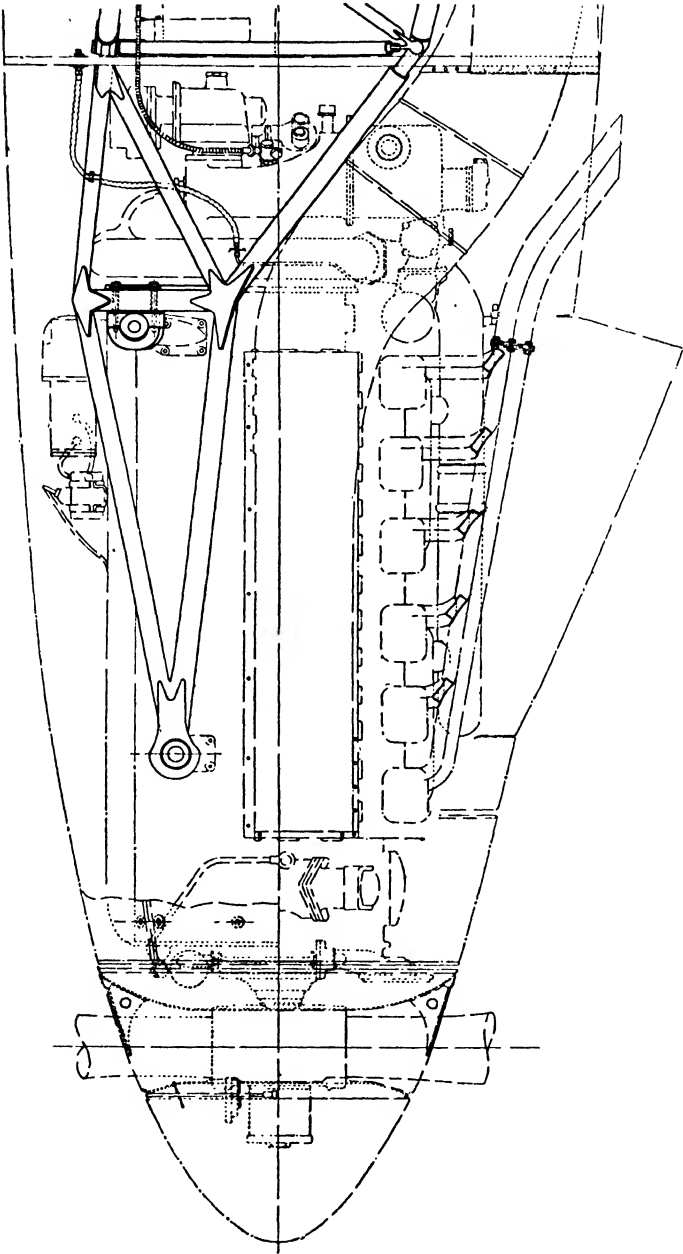

FIG. 57. Side view showing typical installation of Gipsy Twelve engine in aircraft.

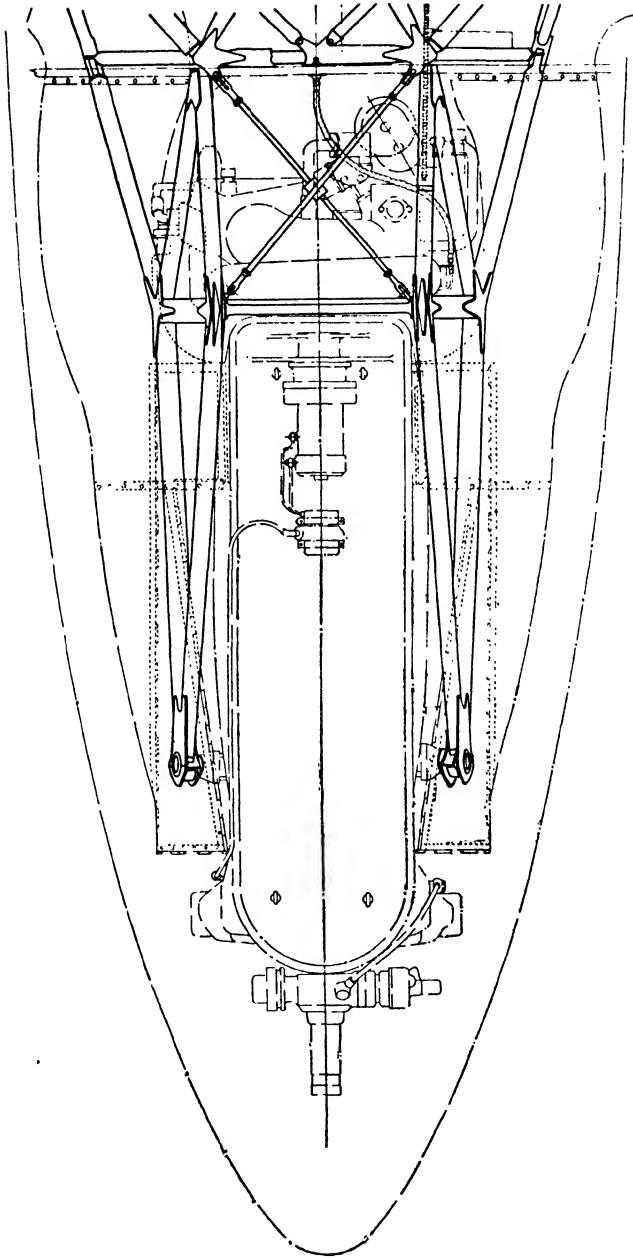

FIG. 58. Plan view of Gipsy Twelve installation in aircraft.

craft of high-speed range the air flow must naturally be controlled, for if the cooling is effective when climbing at, say, 100 M.P.H., it will be excessive when cruising at more than 200 M.P.H. and will create unnecessary drag and reduction of speed. Material economy of power is achieved by limiting the air flow to the cooling requirements. Control of the air flow is effected by an air-exit gill located in the most efficient position for minimum interference and drag, namely, on the underside of the engine nacelle. In the fully-open position for take-off this gill induces a suction which assists the slipstream pressure in forcing the air over the engine. In cruising conditions the gill is nearly closed to restrict the airflow to the desired rate, at the same time greatly reducing the drag.

Fig. 56 illustrates the general layout of the Gipsy Twelve cooling system in diagrammatic form. Air enters the openings A1 and A2 in the leading edge of the wing, and from there is led through fixed ducts to scoops or galleries B1 and B2, one on the outside of each bank of cylinders.

These scoops or galleries, which are designed to be removable in the airframe for access to the sparking plugs, are joined to the fixed ducts in such a way that movement of the engine in the airframe cannot impose any load on the fixed ducts or on themselves. The joint is made airtight to avoid putting the air in the engine bay under pressure.

After passing between the cylinder and head cooling fins, the air escapes at C, and it is recommended that this opening should be controlled in area to meet variable conditions.

The Gipsy Twelve engine has been fitted to commercial and also military aircraft and has justified the claims of its makers for performance, reliability and economy.

Liquid-cooled Inverted Vee-twelve Engine. As an example of this type of engine the Junkers Ju. 211A has been selected. This is a 1,200 h.p. model with cylinders at 60 degrees using fuel injection and having a two-speed supercharger. It has a bore of 5.91 in. (150 mm.) and stroke of 6.50 in. (165 mm.), giving a cylinder capacity of 2,135 cu. in. (35 litres), and develops a maximum output for take-off of 1,200 B.H.P. at 2,300 R.P.M. The compression ratio is 6.7 : 1 and maximum piston speed 41.5 feet per sec.

The general construction and materials of this engine follow accepted practice, but there is one novel feature which characterizes the Ju. 211A engine, namely, the fuel injection system in place of the usual carburettor. The fuel injection

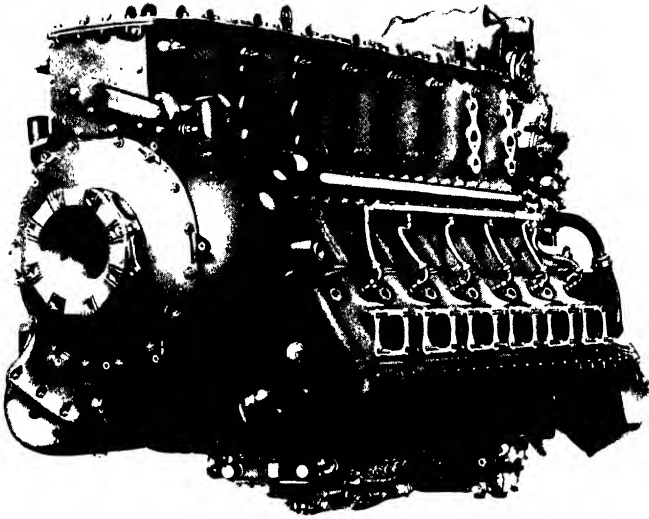

FIG. 50. The Junkers "Juno 211A" inverted twelve-cylinder liquid-cooled engine (1,200 h.p.). (Courtesy "The Aeroplane.")

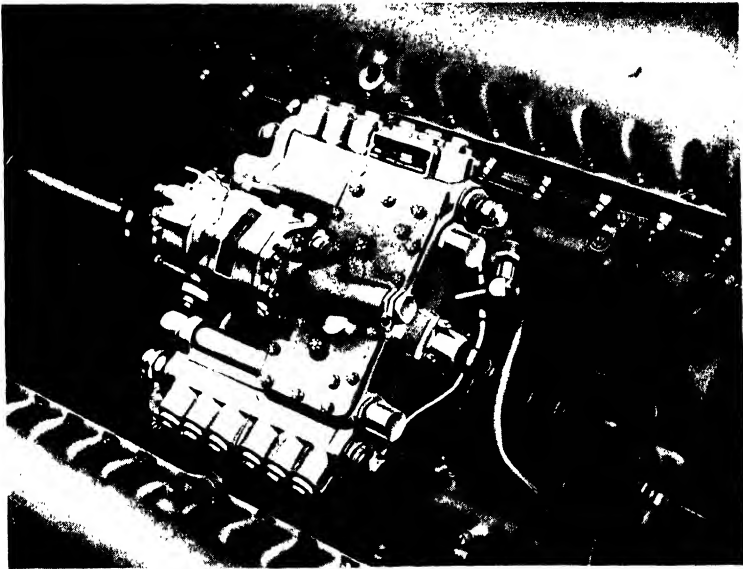

FIG. 60. The fuel-injection system unit of the Junkers "Juno 211A" engine. (Courtesy "The Aeroplane.")

pump unit is situated below, between the cylinders (Fig. 60).²⁰ It consists of twelve separate barrels and plungers arranged in Vee formation similar to that of the engine itself. The individual pumps supply the metered fuel to injectors screwed into the cylinder heads; these have three hole orifices for producing a conical spray of fuel across the cylinder head, as shown in Fig. 61.²¹ It will be observed that the fuel is sprayed from between the two inlet valves to the exhaust valve opposite; the sparking plugs are arranged on the opposite side of the cylinder.

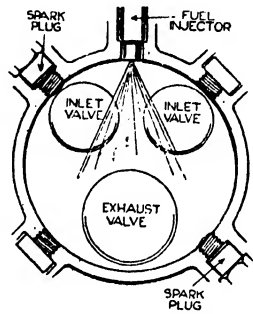

FIG. 61. Method of injecting the fuel in Junkers engine.

The fuel is injected under a pressure of about 73 lbs. per sq. in. during the suction stroke, namely, at 104 degrees before bottom dead centre. The plunger bore is 9 mm. and its stroke, 8 mm.

Details of the injector nozzle and pump * are reproduced in Figs. 62 and 63. The individual pump unit has a central plunger which is operated by a cam, giving a sharp outward movement but a relatively slow return, under the influence of a coil spring. When the cam is moved inward by the spring, fuel is forced through a valve into the pipe leading to the injection nozzle. A slot in the side of the plunger is arranged to register with a spill port, allowing the fuel to return to the suction side of the pump. It is only when the plunger moves forward sufficiently for the groove to cease to register with the spill port that fuel is pumped to the injector. The plunger can be rotated by means of a gear on its periphery and a control rack in order to vary the amount of fuel which can escape through the spill port as the plunger moves, so as to meter the fuel to suit the engine's requirements. In order to prevent backlash

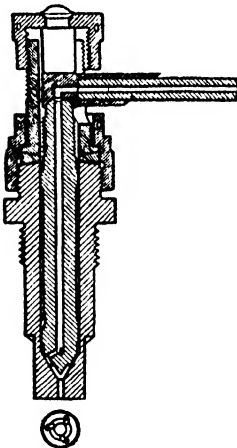

FIG. 62. One of the fuel-injection nozzle units.

* *The Autocar.*

between the gear and rack another spring-loaded rack engages with the same gear (Fig. 64). The plunger racks controlling the amount of fuel delivered by the pumps are themselves operated by a series of racks and pinions from a

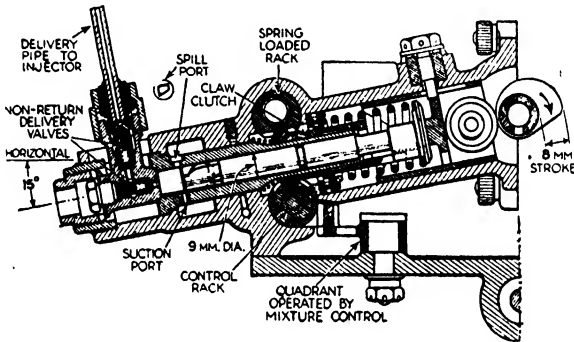

FIG. 63. The cam-operated fuel injection pump; twelve separate pumps of this type are employed.

hydraulic relay actuated by the engine. This provides a system of altitude and boost control. The relay is supplied with oil under pressure by an engine-driven pump as it varies the plunger position with the air pressure in the inlet pipe. Air from this pipe is taken to a capsule chamber, where the

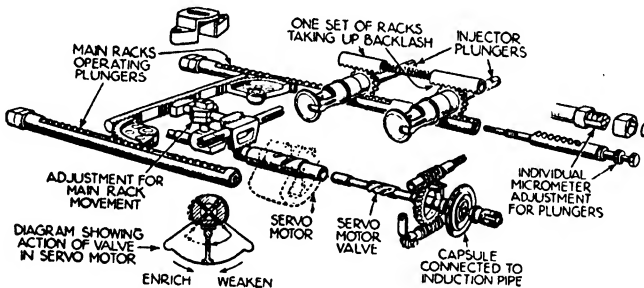

FIG. 64. The fuel pump delivery control system mechanism.

expansion and contraction of the aneroid unit is arranged to operate a rod carrying the valve of the relay thus controlling the relay and therefore the amount of fuel that the plunger pumps supply. Manual control is also provided and each plunger rack has an individual adjustment for the amount of fuel delivered to its cylinder. The hydraulic relay system, it

will be observed, is somewhat similar to that employed on British carburettors used with supercharged engines, as described in the first volume of this book.

Another inverted twelve-cylinder Vee-type engine is the Mercedes-Benz D.B. 601 used on the Messerschmidt 109 and 110 machines. This engine, with a bore of 150 mm. (5.9 in.) and stroke of 160 mm. (6.3 in.), giving a total capacity of 33.9 litres (2,069 cu. in.) develops 1,150 B.H.P. for take-off at 2,500 R.P.M. with a boost pressure of 5.2 lbs. per sq. in. ; the compression ratio is 6.9 : 1.

The cylinders are set at 60 degrees with one another ; the cylinder blocks are light alloy castings, in one piece, with screwed-in steel liners.

The cylinders are liquid-cooled with a 50 per cent. water-glycol solution. Petrol injection is employed as with the Junkers Ju. 211A engine, previously described, using the Bosch injection unit with a de-aerator interposed between the fuel pump and injection pump.

The engine is of the geared supercharged type, using a centrifugal compressor driven through an hydraulic coupling with a step-up ratio of 10.39 : 1 ; variable filling of the coupling to obtain variation in speed of the supercharger impeller with height is effected by means of a two-stage gear pump receiving lubricating oil from the main oil filter.

The engine, complete with oil pump, fuel pump, generator, hydraulic pump, starter, airscrew control gear, piping and wiring to bulkhead, weighs 1,610 lbs.

The Vee-type Engine. From the earliest days in the development of aircraft engines this type of engine has been popular and it has passed through various stages, from the early two-cylinder Anzani and J.A.P. engines, the eight-cylinder Antoinette, Simms and Curtiss and the air-cooled R.A.F., Hispano-Suiza, Wolsley Viper and Renault engines of the early part of the 1914-18 war period to the later war period Rolls Royce Falcon and Eagle water-cooled engines and the Liberty Twelve. The water-cooled twelve-cylinder Vee types have been popular in this country, France and Italy, but only to a limited extent in America since the mass production period of the Liberty engine. In America to-day, the liquid-cooled 1,000 h.p. type Allison appears to be the only production model at the time of writing.

The reasons for the popularity of the Vee-type engine are concerned with its excellent combination of good balance and

torque, with compactness of design and low frontal area. This type of engine, in the higher power class (1,000 to 1,600 h.p.) is ideal for single seater fighter aircraft; it also gives the lowest frontal area per h.p. of existing engines, for multi-engined aircraft. Moreover, the power plant drag loss, with properly located radiators, ducted and housed in the wings, can be kept down to a very low percentage of the total power output. A further advantage of liquid-cooled engines of this arrangement is its ability to operate under super-normal boosts for emergency requirements, since the cooling system is adequate, in modern designs, to take care of the surplus heat. The engine can therefore operate at excess outputs, involving higher cylinder temperatures over relatively much longer periods than air-

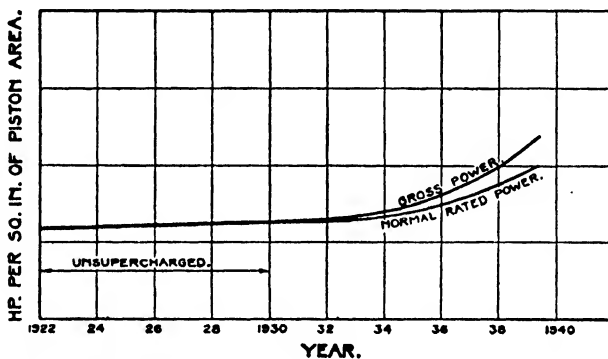

FIG. 65. Illustrating progress in liquid-cooled Vee-type engines.

cooled engines, without ill-effect. In regard to the performance of British liquid-cooled engines (Rolls Royce) and those of foreign manufacture the policy in this country has been to employ higher degrees of supercharging or boosts, and thus to obtain lighter and more compact designs, whereas abroad, the tendency has been towards lower boosts, and therefore larger engine capacities for the same outputs; this has meant heavier engines per h.p. and greater bulk—and therefore frontal area per h.p.

The manner in which the liquid-cooled Vee-type engine has been developed here is illustrated by the results²² given in Figs. 65 and 66. The former diagram shows the increase of h.p. in terms of piston area which has occurred over a period of years. The h.p. in this instance is that of the normal rated power as distinct from the potential h.p. that would be deve-

loped at sea-level. It is believed, however, that the method of comparing power outputs at rated altitudes affords a better basis than that of sea-level outputs. The upper curve marked "gross power" relates to the total power developed, whereas the lower curve of "normal rated power" takes account of the power absorbed in driving the supercharger.

Fig. 66 illustrates how the engine dry weight per h.p. has been reduced, progressively, over the period indicated ; in this

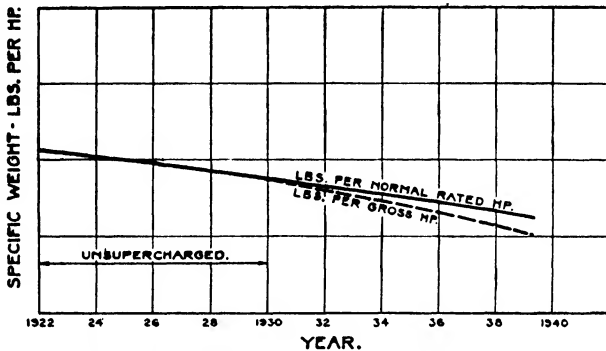

Fig. 66. Showing weight reduction in liquid-cooled Vee-type engines.

respect, the reduction in engine weight during more recent years has been very marked.

The Rolls Royce Vee-type Engines. The engines produced by Messrs. Rolls Royce Ltd. since the 1914-18 war period have all been of the twelve-cylinder Vee type, and these have established a world-wide reputation for low weight per h.p., extreme reliability and long life between overhauls. Even in the more recent Merlin engines the normal Vee-arrangement is preferred to the inverted Vee-one used in certain foreign engines. The latter arrangement imposes certain restrictions on the layout of the power plant due to the necessity of leaving the whole of the underneath unmasked by any other features of the installation except the cowling. The accessibility of the inverted arrangement is not considered to be as good as for the normal one, although the removal of the complete engine from the aircraft is easier.

In regard to the subject of frontal area, it can be stated that in the case of modern fighter aircraft the cross-section of the fuselage in the engine cowling portion is such that, even with a liquid-cooled Vee-type engine of 1,000 h.p. rating there is

still a good deal of room available so that an appreciably larger h.p. engine can be installed without impairing the pilot's field of vision—since it is the usual practice to arrange for the pilot's head to be above the top of the fuselage in a suitably designed compartment protected by transparent panels.

A further advantage of low total frontal area, in the case of fighter aircraft, is the smaller weight of armour-plate required to protect the engine against machine-gun bullets.²³ Owing to the inclination of the cowling to the line of flight a somewhat thinner plate—probably of $\frac{1}{4}$ in. armoured sheet, as against $\frac{1}{2}$ in. for normal impact—can be used as a protection against large bore steel-cored machine-gun bullets. The radiators can also be protected, unless concealed in the fuselage.

The development of the Rolls Royce engines since about 1920 has been in connection, not only with the total power output, but also in the general improvement of the output per litre, or what is a more rational basis of comparison, in the h.p. per unit of piston area.

The performances of the various model Rolls Royce engines available up to the time of writing are given in Table No. 8 ; the outputs are given both in terms of the rated values at the specified altitudes and also the approximate ground or potential outputs. The results given show in a somewhat striking manner the marked improvement in the specific potential power (h.p. per litre) and in weight reduction per potential h.p.

In regard to the frontal areas, these are 4.40 and 5.85 sq. ft. for the Kestrel XVI and Merlin engines, respectively, giving the comparative values of 227 and 256 h.p. per sq. ft. of frontal area, respectively. Taking *maximum potential power*, the Merlin engine in question gives no less than 308 h.p. per sq. ft. of frontal area instead of the normal value of 256. In this connection it should be mentioned that the maximum potential h.p. on 87-octane fuel of the Merlin II engine, fully supercharged, at ground level is 1,805. A still further improvement in the Merlin engine is the Merlin RM2SM, which on 100-octane fuel with its two-speed supercharger in high gear has an international rated h.p. of 1,135 at 15,500 ft. and a maximum output of 1,145 h.p. at 16,750 ft. The approximate (potential) ground h.p. (normal) is 1,930 and (maximum), 2,040, the latter corresponding to an output of 78.5 h.p. per litre.

Since it is only possible to describe a single typical modern liquid-cooled Vee-type engine, the Rolls Royce Merlin II engine

TABLE 8. PERFORMANCES OF VARIOUS ROLLS ROYCE ENGINES

TYPE.	Bore x Stroke, inches.	Swept vol., litres.	Normal r.p.m.	Normal power, h.p.	Rated altitude ft.	Approx. ground power (potential) h.p.	Dry weight, lb.	Specif. (potential) power, h.p./litre.	Specific weight, (potential) lb./h.p.
EAGLE IX .	4.5 x 6.5	20.2	1,800	360	0	360	965	17.8	2.68
CONDOR IIIB .	5.5 x 7.7	35.3	1,900	665	0	665	1,364	18.8	2.05
(2) BUZZARD .	6.0 x 6.6	36.6	2,000	825	0	825	1,510	22.5	1.83
(1) KESTREL IIS .	5.0 x 5.5	21.2	2,250	480	10,000	(670)	910	(31.6)	(1.36)
(1) KESTREL V .	5.0 x 5.5	21.2	2,500	600	11,000	(870)	945	(41.0)	(1.08)
(1) KESTREL XVI .	5.0 x 5.5	21.2	2,600	690	11,000	(1,000)	970	(47.1)	(0.97)
(1) MERLIN II .	5.4 x 5.0	27.0	2,600	990	12,250	(1,500)	1,335	(55.5)	(0.89)
(3) MERLIN X .	5.4 x 6.0	27.0	2,600	960	13,000	(1,500)	1,394	(55.5)	(0.93)
(1) PEREGRINE .	5.0 x 5.5	21.2	2,850	860	13,500	(1,365)	1,106	(64.4)	(0.81)

(1) Fully supercharged. (2) Moderate supercharger. (3) With two-speed supercharger in high gear.

has been selected for this purpose. It should, however, be noted that this engine is also available as a two-speed supercharger model, designated the Merlin X.

The Rolls Royce Merlin Engine. This is a geared twelve-cylinder Vee-type engine of 5.4 in. (137 mm.) bore and 6.0 in. (152.4 mm.) stroke, giving a cylinder capacity of 1,650 cu. in. (27 litres). The engine in question is illustrated in Figs. 67, 68 and 69.

In general construction it follows closely the well-tried principles of the previous engines made by the firm but incorporates the various improvements resulting from research and development work. The engine is of particularly compact design and of special note is the neat and convenient grouping of the auxiliary equipment.

The cylinder blocks of six cylinders each are arranged at 60 degrees to each other. Each block (Fig. 72) consists of an aluminium alloy casting with integral cylinder heads and water-jackets. Wet-type steel liners are fitted to the cylinders. Each cylinder has two inlet and two exhaust valves operated by overhead camshafts by means of rocker arms. The valves, camshaft and rocker gear are housed in the cylinder head. The cylinder liners have soft aluminium alloy joint rings, for gas-tightness, at the tops and rubber joint rings for the coolant joint below. The lower end of the liner is flanged and seats on the crankcase. In order to allow for relative movement between the cylinder skirts and liners, spring-loaded glands are employed. Flexibility to a limited degree is provided between each combustion head by means of lateral saw-cuts. The cylinder block is secured to the crankcase by means of fourteen long studs extending from the top of the block casting into the crankcase; these studs pass through tubes in the block casting, the tubes being expanded in position. The cylinder liners are thus put in compression and the studs take the reactions to the firing stroke forces.

The exhaust valves are sodium-cooled and work in phosphor bronze guides; cast-iron guides are used for the inlet valves. The valve seatings are of aluminium bronze for the inlets and high silicon chromium (heat resisting) steel for the exhausts; the seatings are screwed into the heads of the cylinder block castings. The exhaust valve heads and seatings are coated with an extremely hard, hot corrosion-resisting alloy known as "Brightray." The stem ends of these valves have caps made of nickel case-hardening steel; those of the inlet valves

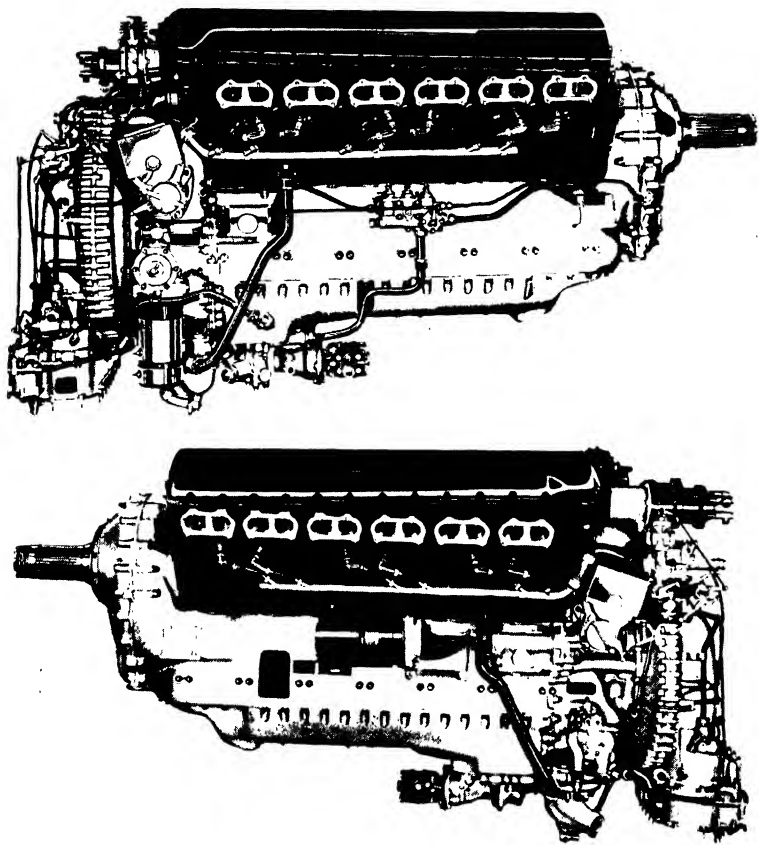

FIG. 67. The Rolls Royce "Merlin" engine.

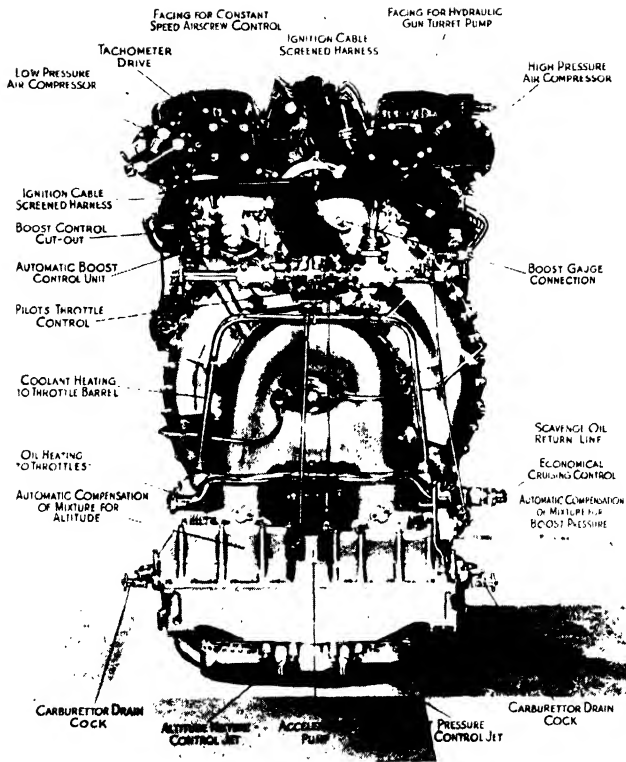

Fig. 68. Rear end view of Rolls Royce "Merlin" engine showing principal components.

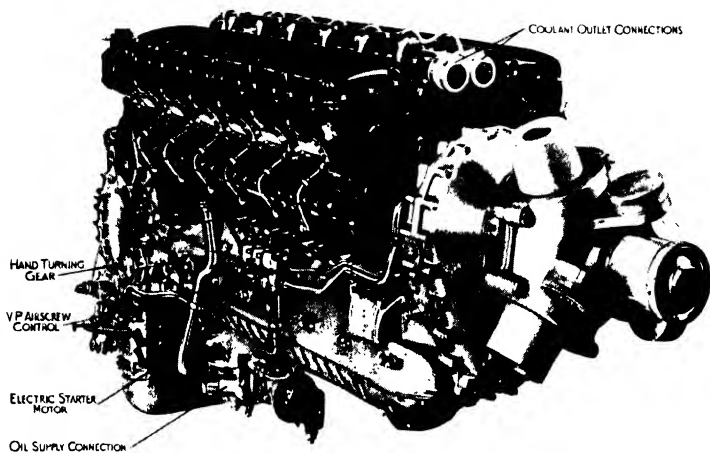

FIG. 69. Three-quarters front end view of "Merlin" engine, showing starting gear, variable pitch airscrew and other details.

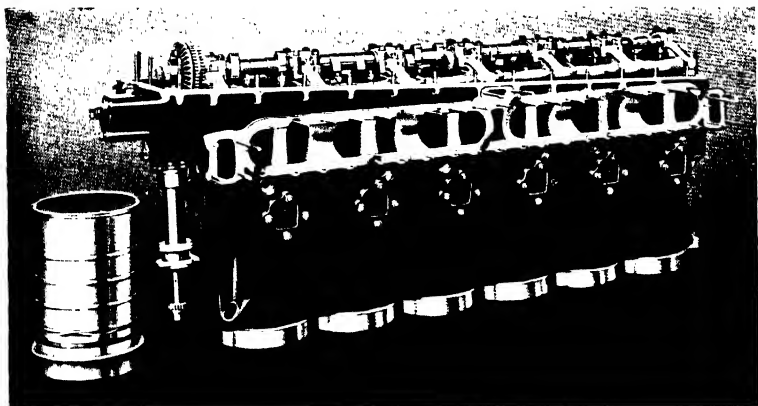

FIG. 72. Cylinder block and one cylinder barrel of "Merlin" engine.

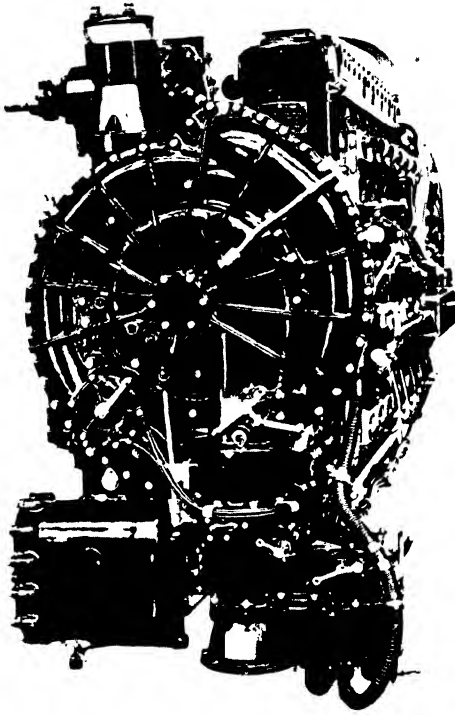

FIG. 73. The Napier "Dagger VIII" twenty-four-cylinder air-cooled engine.

are coated with Stellite. Each valve has two concentric coil return-springs retained by a collar and split wedge ; a spring circlip at the upper end retains the valve in its guide in the event of valve spring failure.

The engine is fitted with forged aluminium alloy pistons, marine type nickel steel connecting rods and crankshaft made of V.C.M. steel, running in seven lead bronze bearings ; fuller details of these components are given in a later chapter.

The crankcase is an aluminium casting, in two halves bolted together. The upper half, with which is cast integral the rear half of the reduction gear casing, carries the cylinder blocks, and, in addition, incorporates the seven main bearings and caps, the engine mounting feet, slinging points, etc. The lower half carries the oil pumps and filters, and drives for a hydraulic undercarriage pump or low pressure air compressor. A vertical facing is formed at the rear end of both halves for mounting the wheelcase which houses the auxiliary drives.

The main bearings are split mild steel shells lined with lead bronze and fitted into recesses machined in the crankcase. The bearings are held in position by caps and bolts which pass through the caps and across the whole width of the crankcase, a design giving the rigidity of an integrally cast bearing cap whilst allowing the withdrawal of the lower half of the crankcase without disturbing the bearings.

The camshafts are of nickel steel forgings machined all over and case-hardened and ground on the cam and bearing surfaces. Seven brackets, centrally disposed along the top of the cylinder block (Fig. 72) and secured to it by studs, carry the camshaft and rocker mechanism, the rocker spindles being located one on each side of and parallel to the camshaft. The camshafts are driven through the spring drive by an inclined shaft and bevel gears from the wheelcase at the rear end of the engine. Each valve is operated by a separate steel rocker having a spherical-headed tappet screw and lock nut at the valve end for tappet adjustment. The camshaft operates above, and acts directly on, a hardened rocker pad in the centre of the rocker shaft.

In order to damp out irregularities in angular velocity and torque, the drive from the crankshaft to the supercharger, timing gears, and auxiliary components, is taken through a torsionally flexible shaft which provides a spring drive. The twisting of this shaft is limited by a hollow sleeve connected

to its outer end by means of a damper clutch, the drive then being taken up by the sleeve (Fig. 71).

The wheelcase is an aluminium alloy casting, secured by studs to the rear face of the crankcase and having the supercharger unit mounted on its rear face.

It houses also the drives to the camshafts, magnetos, water and oil pumps, fuel pumps, supercharger, hand and electric starters and the electrical generator.

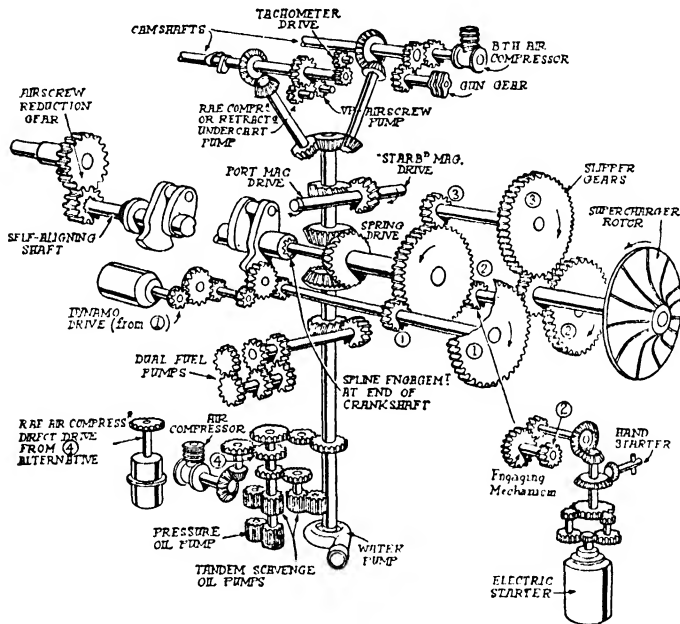

FIG. 71. Schematic view of the various drives taken off the Merlin engine crankshaft. (Courtesy "The Aeroplane.")

In order to reduce the engine revolutions, which at full output are about 2,600 R.P.M., down to the most suitable airscrew speed, a *single spur reduction gear* (Fig. 70) is fitted at the front end of the crankcase. The cast aluminium reduction gear casing houses the forward roller bearings and is secured by bolts to the crankcase—which houses the rear roller bearings on the airscrew and pinion shafts. The pinion is hollow and is carried in two roller bearings; it is coaxial with and driven from the crankshaft by means of the short hollow shaft shown in Fig. 71. This shaft is serrated at both

ends and engages the crankshaft flange and the forward end of the pinion, internally. The pinion engages with a toothed ring bolted to a flange formed integral with the hollow airscrew shaft, the latter being supported on roller bearings and fitted with a ball thrust bearing taking axial loads in either direction. The hollow drive shaft isolates the pinion bearings from the crankshaft loading.

The engine cooling liquid is circulated through the cooling system by a large capacity centrifugal-vane pattern pump located on the base of the wheelcase and driven at $1\frac{1}{2}$ times engine speed by means of a vertical shaft from the main bevel wheel driving the auxiliaries. Two bends on the pump casing, fitted with gland type connections, deliver the coolant through pipes into the rear lower end of each cylinder block. The coolant circulates through the jackets and cylinder heads, finally leaving through three outlets along the upper side of the cylinder block, inside the Vee, which connect with a main outlet pipe discharging either forwards or rearwards, depending on the method of installation of the engine.

In regard to the *airscrew shaft*, this is splined to take a standard variable pitch airscrew. In the case of the de Havilland design the piston of this unit is operated from the high pressure oil system through the medium of a central tube secured to and rotating with the shaft, fed from a spherically-seated oil connection located in a housing in the rear half of the reduction gear casing. The airscrew hub is centralized upon cones at either extremity.

Lubrication of the gears is effected by two jets fed from the low pressure system and directed on the teeth at their engaging surfaces, the bearings being lubricated by splash and drainage down the casing walls. An oil sealing ring of special design is retained in the forward housing of the airscrew shaft by a spring circlip located inside the serrated ring nut which retains the outer races of the roller and thrust bearings.

The supercharger is of the high speed centrifugal type mounted coaxially with the crankshaft and driven from it by means of a speed multiplying gear. A description and illustrations of this unit are given in Volume I of this book.

The Merlin engine can be supplied with either a single or two-speed supercharger drive, the latter giving improved take-off, low altitude performance in climbing or level flight and fuel economy under cruising conditions.

The supercharger delivery pressure is controlled by an

automatic servo mechanism working through a differential linkage so as to limit the throttle opening and thus to protect the engine from any damage resulting from over-boosting. The carburettor and boost control system of the Merlin engine are described and illustrated in Volume I of this book; the carburettor in question is a twin-choke updraught model of Rolls Royce S.U. design.

The fuel pumps for supplying the carburettor are of the dual gear pattern operating in parallel and having one inlet and one outlet connection. Each pump has a sufficient capacity to meet the maximum engine demand; excess fuel delivery is returned *via* a disc type of relief valve to the suction side of the pump. The pumps are driven by independent quill shafts.

The ignition system consists of two twelve-cylinder magnetos spigot-mounted on opposite sides of the wheelcase, and driven by a skew gear from the upper vertical drive shaft through serrated couplings which allow a vernier adjustment for timing purposes, and cater also for slight errors in alignment. Each magneto fires one plug in each of the twelve cylinders.

The wiring system is completely screened for use in aircraft fitted with radio equipment, and comprises three metal conduits coupled by metal braiding with the two covers housing the high tension magneto leads, and twenty-four sparking plug adaptors with short metal braided connections to the wires in the conduits. The screening is virtually earthed by being secured to the engine with clips and studs. Special heat resisting adaptors are fitted to the exhaust plugs.

The lubrication system, which is described in detail in Chapter VIII, operates on the dry sump principle.

Provision is made for *starting the engine* either by a hand-turning gear or electric starter motor. Details of these methods are given in Chapter XI; the principle is shown in Fig. 71.

In regard to the *auxiliary drives and accessories* of the Merlin engine the manner in which the various drives are arranged is shown diagrammatically in Fig. 71. An engine-driven 12 volt 500 watt electrical generator is mounted on the left-hand side of the upper half crankcase, and runs at 1.914 times engine speed by a gear train from one of the supercharger planet wheels. Spider couplings connect the drive and dynamo armature shafts through the medium of fabric discs.

A revolution counter drive connection is mounted at the rear end of the camshaft on the left-hand bank of cylinders, the counter being driven at one-quarter engine speed.

Drives are fitted also on the left- and right-hand cylinder heads respectively for one low pressure and one high pressure air compressor. The former is of the R.A.E. twin-rotor type B, and is driven from the left-hand camshaft at 0.793 times engine speed; the latter is of the B.T.H. A.V.A. piston type and is driven from the right-hand camshaft at 0.5 engine speed.

In addition, a special drive for a Lockheed undercarriage pump, Mark IV type I.F., is provided in the crankcase lower half, this drive being taken from the gear driving the main oil pumps through a bevel train. Also a gun turret pump may be driven, if required, from the right-hand camshaft.

A drive is arranged from the reduction gear pinion for the constant speed unit for the airscrew and for the Pesco, Romec, or Eclipse B.3 type vacuum pump for operation of the blind flying panel and automatic pilot or de-icing equipment.

The production engine performance figures for the Merlin II and X engines at the rated boost pressures of $6\frac{1}{4}$ and $5\frac{3}{4}$ lbs. per sq. in., respectively, are given in the table on p. 110, supplied by the manufacturers.

The Allison Liquid-cooled Engine. The twelve-cylinder Vee-type engine made by the Allison Engineering Co., of Indianapolis, is, at the time of writing, the only one of its class made in the U.S.A. It has a bore of 5.5 in. (139.7 mm.) and stroke of 6.0 in. (152.4 mm.), giving a cylinder capacity of 1,710 cu. in. (28 litres). The engine has a compression ratio of 6.65 : 1 and operates on fuel of 90 to 100 octane number. The V-1710-C15 model is rated at 1,060 B.H.P. at 3,000 R.P.M. for take-off and 960 B.H.P. at 2,600 R.P.M. at 12,000 ft. An output of 1,090 B.H.P. for five minutes is developed at 13,200 ft. The fuel consumption on 100-octane fuel is 0.6 lb. per B.H.P. hour. The dry weight of 1,325 lbs. gives a specific weight of 1.25 lbs. per h.p., reckoned on the take-off rated power.

The engine is supercharged, a geared centrifugal blower with step-up gear ratio of 8.77 : 1 being used for this purpose. The output per litre works out at 38.90. The maximum B.M.E.P. is 169 lbs. per sq. in. and maximum piston speed 3,000 ft. per min.

The engine is 98.53 in. long, 29.28 in. wide and 41.875 in. in height; in this connection it is interesting to note that the Rolls Royce Merlin X engine of 1,145 B.H.P. maximum output has a length of 76 in. and an output at 3,000 R.P.M. of 42.5 B.H.P. per litre.

TABLE 9. MERLIN ENGINE PERFORMANCE

Engine Type	Series Number	Reduction Gear Ratio	International Rating			Maximum Power Rating			Rated Boost lbs./sq. in.	Take-off			Nett Dry Weight lbs.	Min. Octane Value Fuel
			Alt. ft.	R.P.M.	B.H.P.	Alt. ft.	R.P.M.	B.H.P.		Max. R.P.M.	Min. R.P.M.	Boost lbs./sq. in.		
Merlin fully Supercharged	Merlin II	.477	12,250	2,600	990	16,250	3,000	1,030	+ 6½	3,000	2,090	+ 6½	1,335	87
			2,500 13,250	2,600	1,040 965	5,250 17,750	3,000	1,145 1,025	+ 5½	1,025/1,065 B.H.P. at 2,850 R.P.M. in M.S. gear				1,394

The H-type Engine. By arranging for a relatively large number of small-sized cylinders in four banks, as shown at E in Fig. 26, it is possible to obtain a power unit of high output with a comparatively small frontal area. There is also the further advantage of the greater output per unit capacity by the use of the smaller cylinders. The torque qualities of such an engine are also better than for an engine of similar output with a smaller number of cylinders.

The H-type of engine requires two crankshafts geared together and this in turn necessitates a relatively greater number of component parts than for an engine having fewer cylinders for the same output.

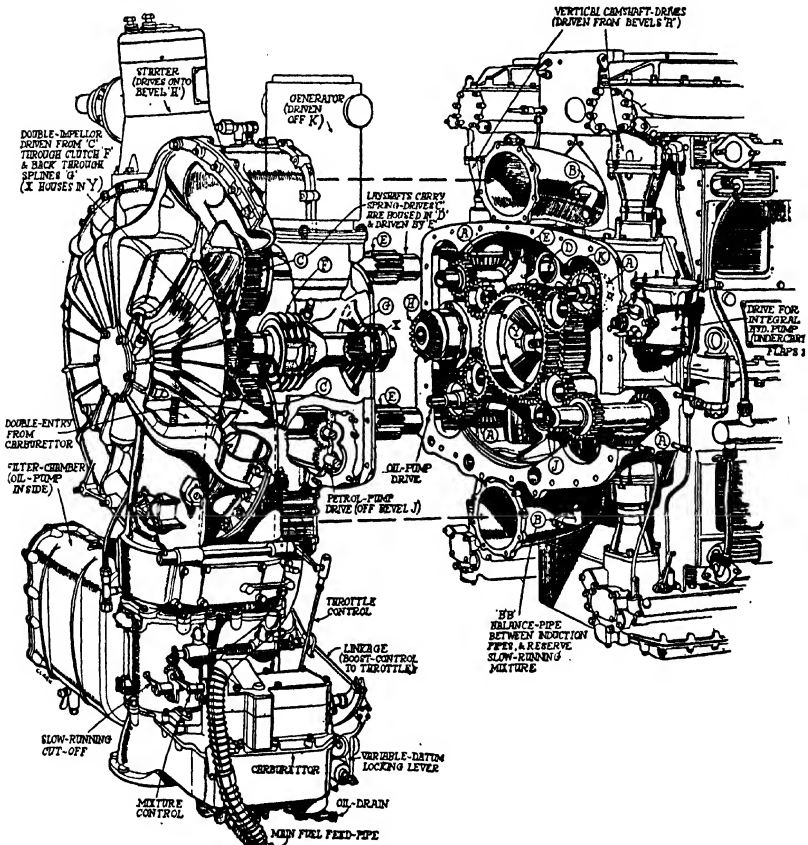

FIG. 75. Details of supercharger and other engine drive units, etc. Napier "Dagger VIII" engine. (Courtesy "The Aeroplane.")

An example of an aircraft engine of this type was the Napier "Rapiere" engine, having four banks of four cylinders each. The bore and stroke were each $3\frac{1}{2}$ in. (89 mm.), giving a cylinder capacity of 538.8 cu. in. (8.83 litres). The engine, which was air-cooled, had a compression ratio of 7 : 1. It had a normal rating of 355 to 370 h.p. at 3,650 R.P.M. at 4,750 ft. altitude and a maximum one of 380 to 395 h.p. at 4,000 R.P.M. at 6,000 ft. The maximum take-off power was 365 at 3,500

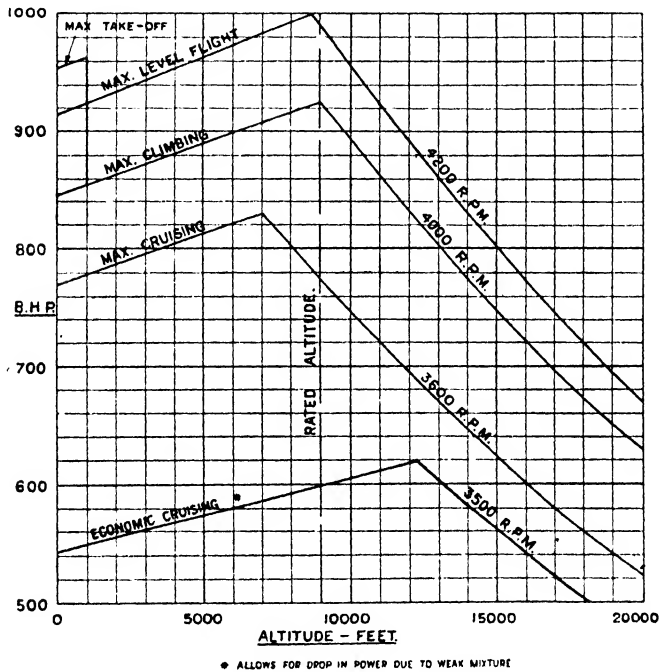

FIG. 76. Performance curves of Napier "Dagger VIII" engine.

R.P.M. The dry weight was 713 lbs., giving about 2.0 lbs. per h.p. at normal rating.

A later development of this engine is the Napier "Dagger VIII" air-cooled model, which has twenty-four cylinders arranged in four banks of six cylinders each. The cylinder bore and stroke are 3.81 in. (97 mm.) and 3.75 in. (95 mm.), giving a cylinder capacity of 1,027 cu. in. (16.85 litres).

The compression ratio is 7.5 : 1 and on 87-octane fuel the engine has an International rated power maximum for climb

of 925 h.p. at 4,000 R.P.M. at + 4 lbs. per sq. in. boost. The maximum level h.p. is 1,000 at 4,200 R.P.M. at 8,750 ft. at + 5 lbs. per sq. in. boost (Fig. 76). The maximum take-off output is 955 h.p. at 4,200 R.P.M. at sea-level at + 6 lbs. per sq. in. boost. The fuel consumption under economic cruising conditions works out at 0.46 lb. per B.H.P. hour.

The engine on its maximum rating gives 189 h.p. per sq. ft. of frontal area and an output of 59.5 h.p. per litre.

The dry weight of this engine is 1,390 lbs., which is equivalent to about 1.4 lbs. per h.p.

The general layout of the engine is illustrated in Figs. 74 and 75. There are two vertical and two inverted blocks of cylinders arranged symmetrically. The crankshafts of each set of twelve cylinders (six above and six below) are arranged as to mesh with the airscrew reduction gear, which has a reduction ratio of 0.308 to 1; the airscrew shaft is above the centres of the two crankshafts. The well-finned steel cylinders have aluminium alloy heads, machined all over; these contain the inlet and exhaust valves and their ports and passages. The cylinders are cooled by means of air-scoops mounted above and below the upper and lower groups of cylinders, the cooling air passing over the cylinder heads down between the cylinder barrels and out through ports left in the sides of the cowling, as shown in Fig. 74.

The engine is provided with a double-entry centrifugal supercharger driven by spur gears through layshafts (Fig. 75) which carry spring drives to relieve overloads and absorb shocks. A special S.U. carburettor mounted below the supercharger has twin choke tubes, fully automatic control, with a two-position mixture control and four-stage boost control. Provision is made for warm and cold air intakes, a flame trap being fitted over the former intake; the choke and throttle are heated by the warm engine oil in order to prevent ice formation.

The engine constructional features, such as the pistons, connecting-rods, crankshafts, etc., follow accepted high grade practice. The connecting-rod assembly for each crank is made up of a forked rod in which a steel bearing-shell lined with lead-bronze is fixed and a plain rod which oscillates on the outside of the bearing shell. The hollow gudgeon pins rock in phosphor bronze bushes, and the main crankshaft bearings are of the lead-bronze variety.

The crankcase is of aluminium alloy and is made in halves

joined along the horizontal centre line of the engine. The detachable nose piece forms the cover for the main reduction gears and houses the drives for the magnetos, distributors and control unit for the airscrew; these components are arranged in X-formation, so as to give a clear entry for the cowling (see Fig. 331).

In regard to the valves there is one plain inlet and one sodium-cooled exhaust valve per cylinder. A special feature of the valves is the self-adjusting hydraulic tappet on each, operated off the low pressure oil system; this method, adopted from car engine practice, obviates the necessity for valve stem clearance adjustment. The valve-operating mechanism is wholly enclosed and lubricated automatically. Ignition is by two magnetos with separate 24-point distributors mounted on the front cover, as previously mentioned; they are driven from an extension of the starboard crankshaft through gearing. An automatic advance and retard unit is fitted.

Lubrication is on the dry-sump principle. The crankshaft journal and big-end bearings are lubricated by oil at 50 lbs. per sq. in. pressure. The reduction gears are lubricated by means of two high pressure supply oil jets. Oil from the high pressure system is passed through a reducing valve to supply the low pressure system at 10 lbs. per sq. in. and this low pressure oil lubricates the rest of the engine's moving components. The single pressure and two scavenge pumps are of the gear type; small vane-type pumps at each end of the camshaft casing return the surplus oil to the crankcase. The oil sump on the under side of the timing case contains the pressure oil pump, two main scavenge pumps, oil relief valve and the filters. The latter are of the Tecalemit pattern arranged in tandem between the pressure pump and the engine; there are two gauze filters for the scavenged oil. Provision is made for a Rotax hand or electric starter.

The Arrow-type Engine. In this arrangement of the cylinders, illustrated diagrammatically at F in Fig. 26, there are three banks of cylinders set in broad arrow or "double-Vee" formation. The principal advantage of this type over the ordinary Vee pattern is the shorter fore-and-aft dimension and stiffer crankshaft that can be employed. From the aspects of frontal view and accessibility it is inferior to the Vee-type of equal output, but its lower moment of inertia about the C.G. of the aircraft is a point in its favour where manœuvrability is concerned. A typical engine of this class

was the Napier Lion, which was produced in 1918 and established an excellent reputation in both military and commercial aircraft. It has since fallen out of favour and its place taken largely by the Vee-type.

The 1924, Series V, model Napier Lion engine was a development of their earlier one and had three banks of four cylinders each; each outer block was set at 60 degrees to the centre block. The bore and stroke were 5.5 in. (139.7 mm.) and 5.125 in. (130 mm.), giving a cylinder capacity of 1,460 cu. in. (23.9 litres). The engine had a compression ratio of 5.8 : 1 and developed 460 B.H.P. at 2,000 R.P.M. for a dry weight of 900 lbs., thus giving 1.95 lbs. per h.p. The airscrew was geared down to run at 1,320 R.P.M.

The output of 19.2 h.p. per litre, whilst characteristic of engines of its date, is considerably lower than that of modern engines, but no doubt if this engine had received the same development attention it would have been increased to present-day values.

The X-type Engine. The logical development of the liquid-cooled twelve-cylinder type of engine, where appreciably greater outputs are concerned, appears to be the X-type having twenty-four cylinders. The end-view of such an arrangement would be similar to that shown in Diagram G, Fig. 26, but the cylinder axes need not necessarily be vertical and horizontal, respectively, as shown. This arrangement gives a relatively low frontal area combined with the fore and aft compactness of the twelve-cylinder Vee-type engine.

Engines of this class, already in the production stage, have estimated outputs of 2,000 to 3,000 B.H.P. at ground level.

The Mercedes-Benz DB-605, twenty-four cylinder X-type engine, is rated at 2,000 h.p. It represents a development of the existing twelve-cylinder Vee-type DB-601 engine of the same make.

Another modern example of an engine of the X-type is the Allison one made by the Allison Engineering Co., of Indianapolis, Indiana, U.S.A. This is equivalent to two Allison twelve-cylinder Vee-type engines arranged with one in the normal and the other in the inverted position geared together to a common airscrew, but retaining their separate crankshafts. The engine has a maximum output of about 2,400 B.H.P.

CHAPTER IV

THE RADIAL AIR-COOLED ENGINE

THE radial air-cooled engine with fixed cylinders and crankcase—as distinct from the earlier rotary radial engines which were popular during the Great War of 1914-18—is now more widely employed than any other design of aircraft engine. Although the advantages of the radial engine have been dealt with elsewhere in this volume and in Volume No. 1, it may be of interest, before proceeding to describe some typical engines, to summarize these advantages and also to mention one or two of its demerits. The modern engine of this cylinder arrangement gives a small bulk and the lowest weight per unit output. In the latter connection, although the dry weight does not differ appreciably from that of the liquid-cooled engine of similar output, the fact that it requires no radiator, cooling medium pipes, controls, etc., renders the complete unit lighter per h.p. than the corresponding liquid-cooled engine.

The radial engine, since it requires no separate cooling system, is entirely self-contained and is ideal for rapid production in the works. It is insensitive to climatic extremes and therefore does not require the same precautions as liquid-cooled engines in extreme winter conditions. Another important factor is the comparative rapidity with which it gives its full power after starting from the cold, as compared with liquid-cooled engines.

The radial engine has excellent engine balance qualities, and with its short crankshaft is much less prone to torsional vibration effects than engines with long crankshafts, *e.g.*, the “in-line” and Vee-type ones. Many of the design features of the radial engine are simpler than the corresponding ones of the other engines mentioned; in particular, the crankcase, cylinders, crankshaft, main bearings (which are relatively few in number), connecting-rod assembly and valve operating gear. The engine is easy to install, maintain and overhaul; moreover, injury to any particular cylinder does not necessitate the replacement of a cylinder block. A further advantage is

that all of the cylinders can be made to similar design, so that replacement is an easy and relatively inexpensive matter.

Although the symmetrical arrangement of the cylinders, crankcase and supercharger—when fitted—enables an engine cowling in the form of a surface of revolution to be used and, further, since there are now efficient drag-reducing cowling designs available and in use, it must be admitted that the frontal areas and total form drags of radial engines, in general, are relatively higher than those of liquid-cooled engines of similar outputs. Here it may be of interest to mention that the frontal areas of a nine-cylinder radial engine of 1,750 cu. in. and a twelve-cylinder Vee-type liquid-cooled one of 1,645 cu. in. displacement were 1,780 and 842 sq. in. respectively. After due allowance is made for the ducted radiator of the latter engine there is still a fairly marked advantage in low total power unit drag.

The two-bank radial engine with fourteen or eighteen cylinders gives a lower form drag per unit cylinder displacement and thus tends to bridge the gap between the two engine types discussed; the three bank arrangement is still better.

The liquid-cooled engine, on account of the more uniform cooling of the cylinders and the avoidance of excessive temperature regions, can employ higher compression ratios for a given octane value fuel and cylinder size, so that the output per cylinder can be made higher—a fact which, taken in conjunction with the lower form drag, explains the reason why the highest aircraft speeds have been achieved with liquid-cooled engines.

Radial Engine Types. The current designs of air-cooled radial engines include those ranging from the small five-cylinder engines of 80 to 100 h.p. employed in light American aircraft to engines of 2,000 h.p. and above having two banks of nine cylinders each.

The single row radial engines have five, seven and nine cylinders and the two row ones, fourteen and eighteen cylinders.

Particulars of production type radial engines are given in Tables 1 and 2 on pages 8 and 9.

Since it is not possible, owing to space considerations, nor is it desirable, to describe each and every type of radial engine in present production, a few representative engines only will be referred to in this chapter, commencing with the lower output models and dealing with those of the higher powers later.

The Pobjoy Engines. These engines, of which the "Cataract" and "Niagara" are typical examples, are of the seven-cylinder pattern. The Niagara III, now replaced by the later Niagara V, had a bore and stroke of 3.03 in. (77 mm.) and 3.43 in. (87 mm.), respectively, giving a cylinder capacity of 173 cu. in. (2.835 litres). It was rated at 88 h.p. at 3,300 R.P.M. and had a maximum output of 95 B.H.P. at 3,650 R.P.M. for a dry weight of 156 lbs., *i.e.*, 1.64 lbs. per h.p. The airscrew was geared down to give a ratio of 0.468 : 1, so that for an engine speed of 3,300 R.P.M. the airscrew rotated at 1,545 R.P.M.

The general layout of the engine is illustrated in Fig. 77.

Special features include the neat housing of the engine within its cowling, aluminized exhaust collector rings of compact design, totally enclosed, fully lubricated overhead valve gear, rubber-damped sub-mounting, the use of an N.A.C.A., low drag cowling, Claudel AV40E/1 carburettor with automatic hot and cold air intake and auxiliary starting device, Tecalemit fuel pump, two Rotax N.A.E. magnetos of the four-spark polar inductor stationary contact breaker pattern, with 14 mm. sparking plugs, Rotax 150 watt generator and electric starter.

The later Niagara V seven-cylinder radial engine is designed for 87-octane fuel and has a higher compression ratio. It has a maximum output of 137 B.H.P. for a dry weight of 185 lbs., *i.e.*, 1.35 lbs. per h.p.; at the time of writing fuller particulars of this engine had not been released for publication.

Armstrong Siddeley Engines. Several different sizes of seven-cylinder radial engines, including the Genet Major, Lynx and Cheetah models are produced by the firm in question. In addition there is the Tiger fourteen-cylinder, two bank radial of higher output.

The Genet Major engine is made in two models, namely, the IA and the IV; the latter having the same bore, but slightly longer stroke, is a development of the former type and will therefore be considered here.

The Genet Major IV engine has a bore and stroke of 4.25 in. (108 mm.) and 4.5 in. (114.5 mm.); giving a cylinder capacity of 446.9 cu. in. (7.32 litres). The compression ratio is 5.25 : 1 and the engine is rated at 160 h.p. at 2,400 R.P.M. (sea level), with a maximum output of 180 B.H.P. at 2,700 R.P.M. (sea level) on 77-octane fuel. It is not supercharged.

The airscrew is geared down, the ratio being 0.663 : 1. The

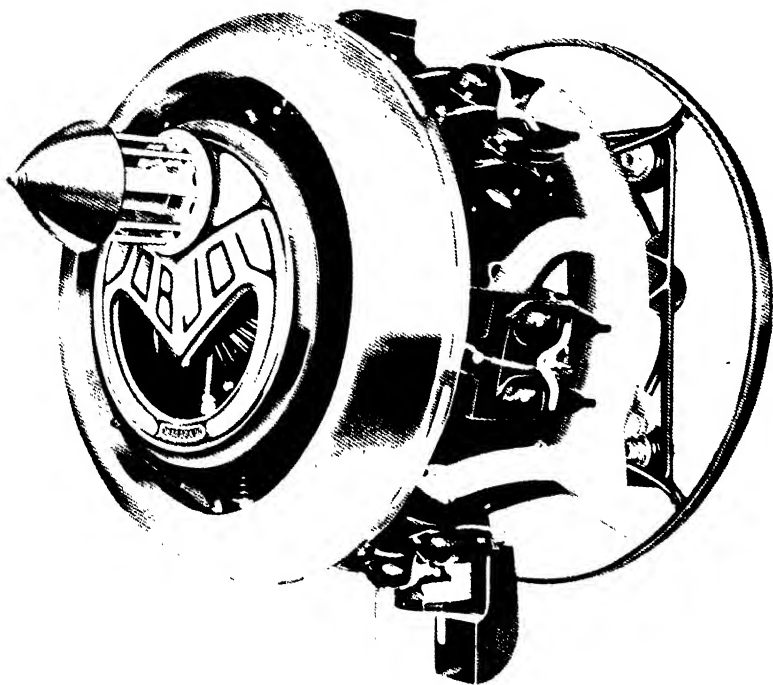

FIG. 77. The Pobjoy "Niagara" radial engine.

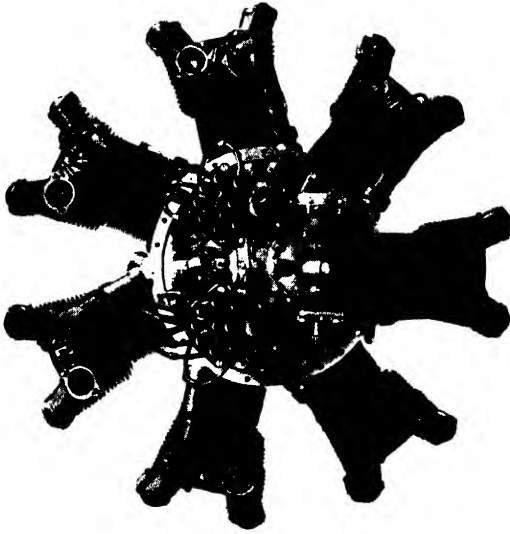
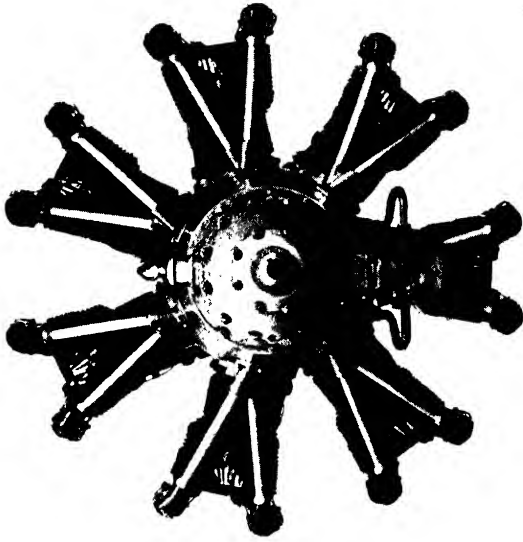

FIG. 78. The Armstrong Siddeley "Genet Major IV" engine (180 h.p.).

dry weight is 367 lbs., thus giving about 2.04 lbs. per h.p. (maximum output). The fuel consumption, under cruising conditions, is 0.51 lb. per h.p. hour. The engine has an overall diameter of 38.6 in. and length (from engine bearer face to rear of airscrew hub) of 17.15 in.

The general design and materials of this engine follow accepted practice and need not therefore be described here. The general layout of the engine and its components are clearly illustrated in Figs. 78 and 79, from which the clean design and open spacing of the cylinders and cooling fins will be evident; the enclosed valve-operating push rods, the inlet pipes and the accessories at the rear are well arranged and do not obstruct the cooling air flow.

A range of seven-cylinder radial engines, developing greater outputs than the Genet model described, includes the Lynx and Cheetah engines employed for civil aircraft and military trainers. The Lynx IVC and Cheetah VA are unsupercharged, the former having a cylinder capacity of 12.4 litres and a maximum output, at sea level, of 240 B.H.P., at 2,090 R.P.M. for a dry weight of 515 lbs. The latter model, of 13.65 litres capacity, gives a maximum of 326 B.H.P. at 2,400 R.P.M. at sea level for a dry weight of 596 lbs. Both engines are of fairly low compression, namely, 5.0 : 1 and 5.2 : 1, respectively, and are of the direct airscrew drive pattern.

The other Cheetah engines, namely, the IX, X and XI, are of the supercharged type with higher outputs. Thus, the X model, of 13.65 litres, develops 355 B.H.P. at 2,425 R.P.M. at 7,000 ft. altitude and has a take-off output of 360 to 375 B.H.P. for a dry weight of 694 lbs.

The Cheetah XI engine is of smaller capacity, namely, 12.4 litres and employs a compression ratio of 6.35 : 1. The bore and stroke are, respectively, 5.25 in. (133.3 mm.) and 5.0 in. (127 mm.), giving a cylinder capacity of 759 cu. in. (12.4 litres). This engine, which is shown in Fig. 80, has an International rating of 415 B.H.P. at 2,650 R.P.M. at 7,500 ft.; maximum power rating of 435 B.H.P. at 2,825 R.P.M. at 8,750 ft. and maximum take-off output of 460 B.H.P. at 2,825 R.P.M. at sea level with a (maximum) boost of 4 lbs. per sq. in. The dry weight is 760 lbs., corresponding to 1.75 lbs. per h.p. (maximum power rating).

The centrifugal supercharger is driven at 6.52 times crankshaft speed and the airscrew hub at 0.594 times engine speed; an epicyclic reduction gear is employed for this purpose. The

engine is designed to operate upon fuel of not less than 87-octane value.

The accessories, such as the two magnetos, 500-watt generator, hydraulic, vacuum pumps and air compressor are arranged at the rear end of the engine; the Rotax electric starter is also at this end. The overhead valves are operated by push rods of the enclosed automatically lubricated type arranged in front of the cylinders. The mixture intakes are at the rear of the latter and are masked by them so as not to interfere with the air-cooling arrangements.

The design of this engine permits of a particularly neat form of mounting of the circular tube pattern (as shown in Fig. 80). A variable pitch airscrew of the de Havilland or Fairey type is fitted.

The Tiger class engines are of the fourteen-cylinder two-row radial type, in two banks of seven cylinders each, supercharged and with geared-down airscrew.

Fig. 81 illustrates the Tiger IX engine of 5.5 in. (139.7 mm.) bore and 6 in. (152.4 mm.) stroke, giving a cylinder capacity of 1,996 cu. in. (32.7 litres). It has a compression ratio of 6.25 : 1 and is designed for a fuel of not less than 87-octane value.

The International rated power is 775/805 B.H.P. at 2,375 R.P.M. at 6,250 ft. The maximum power rating is 810 B.H.P. at 2,450 R.P.M. at 6,500 ft. and the maximum take-off power is 845/880 B.H.P. at 2,375 R.P.M. at sea level. The engine has a dry weight of 1,260 lbs., corresponding at maximum power rating to 1.5 lbs. per h.p. or for maximum take-off power to 1.43 lbs. per h.p. The supercharger is driven at 5.4 times crankshaft speed and gives a maximum boost pressure of $2\frac{1}{2}$ lbs. per sq. in., corresponding to the take-off power at maximum engine speed. The airscrew runs at 0.594 times the crankshaft speed and employs an epicyclic reduction gear. The supercharger, which is of the centrifugal pattern, is located at the rear between the cylinder unit and the accessories—which are mounted on the rear cover unit. The compressed mixture of air and fuel is distributed to the cylinders by means of seven two-branched intake pipes. Provision is made for hand or electric or gas starting of the engine, and other accessories that may be fitted as required include hydraulic and vacuum pumps, high and low pressure air compressors. The engine has a Rotax 500 water generator, a two-diaphragm type fuel pump and hot and cold air intakes. The lubricating oil is cooled by means of a Gallay dual-stage cooler.

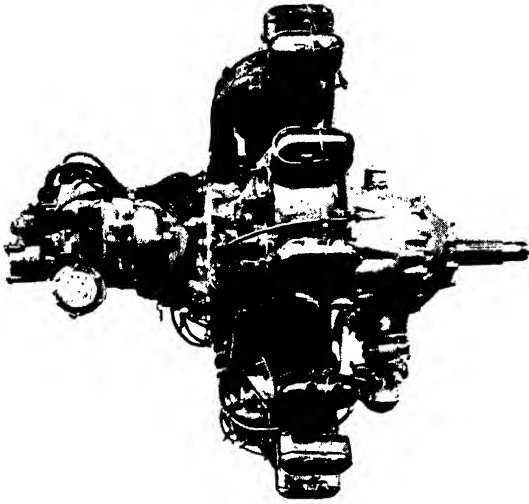

FIG. 79. Side view of "Genet Major IV" seven-cylinder radial engine.

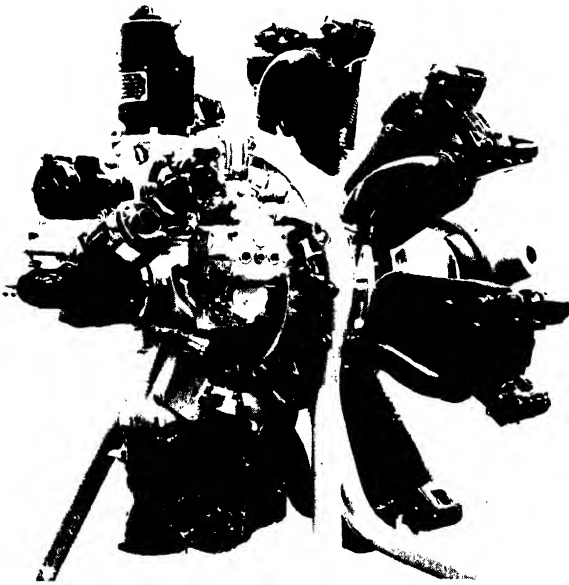

FIG. 80. The Armstrong Siddeley "Cheetah XI" (415 h.p.) engine, showing accessories and engine mounting.

[To face p. 120.

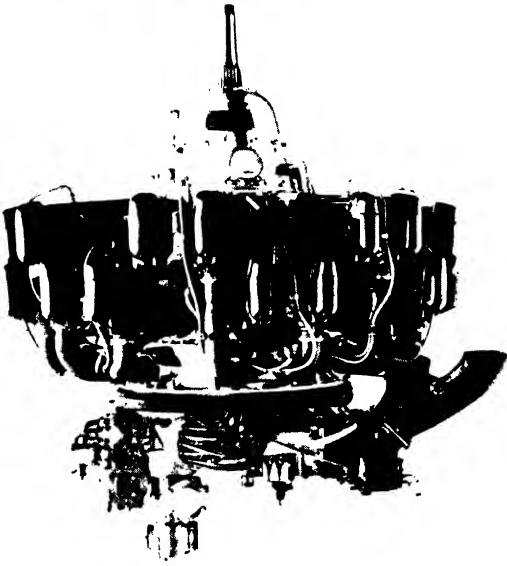
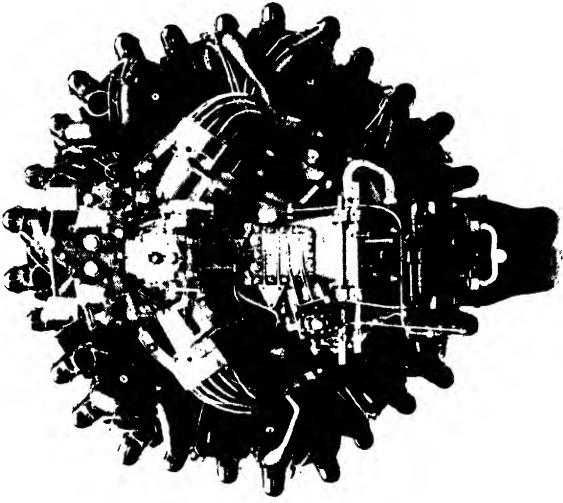

FIG. 81. The Armstrong Siddeley "Tiger IX" engine (850 h.p.).

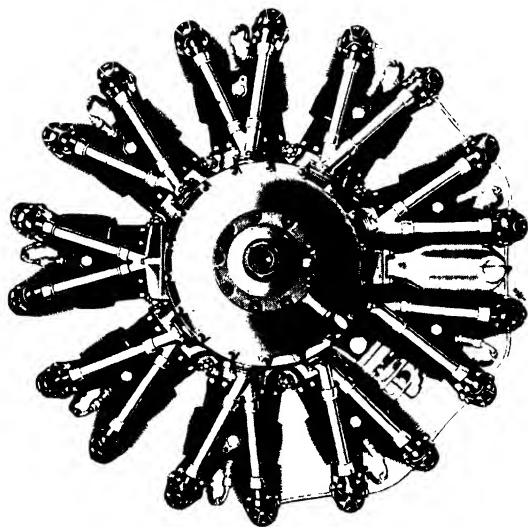
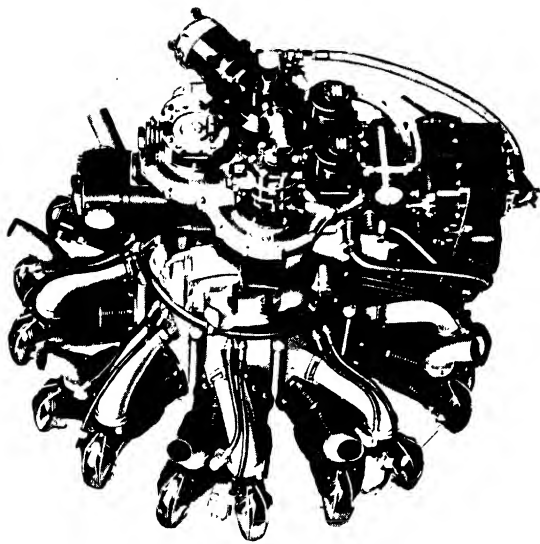

FIG. 82. The Alvis nine-cylinder radial "Leonides" engine (430 h.p.).

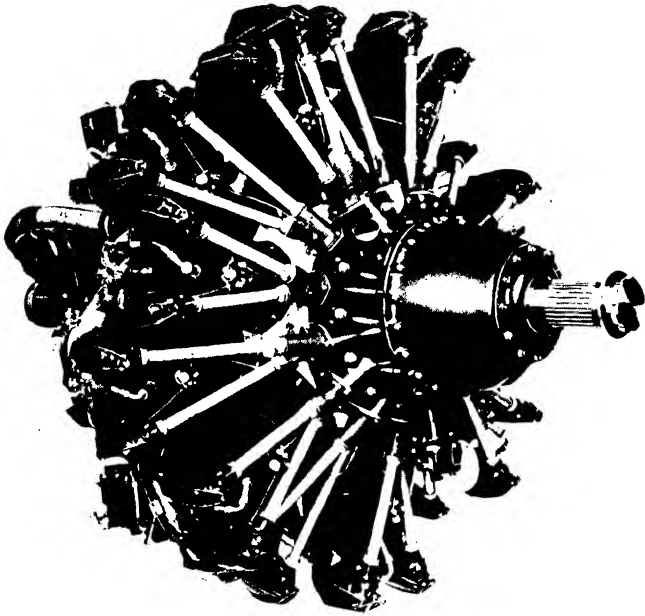

FIG. 83. The Alvis fourteen-cylinder twin row radial "Pelides Major" engine (1,000 h.p.).

Comparative Outputs and Frontal Areas. The two bank arrangement of the Tiger IX engine gives an appreciably lower head resistance than for the single row Cheetah XI engine, for the overall diameter is 50.8 in. for a maximum output of 810 B.H.P., corresponding to 57.5 h.p. per sq. ft. of frontal area. The overall diameter of the Cheetah XI engine is 43.75 in., which for the maximum output of 435 B.H.P. gives 42.5 h.p. per sq. ft. of frontal area.

The Alvis Engines. Two different models are made by the firm in question, namely, a nine-cylinder single row radial, known as the "Leonides" and a fourteen-cylinder two row radial, known as the "Pelides." The former is supercharged and has a bore and stroke of 4.80 in. (122 mm.) and 4.41 in. (112 mm.), respectively, giving a cylinder capacity of 718.5 cu. in. (11.78 litres). The compression ratio is 6.3 : 1 and fuel of 87-octane is used. The engine has an International rating of 415/435 B.H.P. at 3,000 R.P.M. at 8,250 ft. with a boost pressure of 3 lbs. per sq. in. The maximum power rating is 445 B.H.P. at 3,100 R.P.M. at 8,750 ft. The maximum take-off power is 430/450 B.H.P. at 3,000 R.P.M. with a boost pressure of 5 lbs. per sq. in.

The supercharger ratio is 6.5 : 1 and the airscrew reduction ratio is 0.5 : 1 or, alternatively, 0.63 : 1.

The dry weight is 708 lbs.; this corresponds to about 1.6 lbs. per h.p. for the maximum power rating value.

The engine has a relatively low frontal area for its output, so far as radial engines are concerned; the overall diameter is 41.5 in.

The cylinder barrels are of nitrided steel and the heads are made of Y-alloy shrunk on to the barrels. The barrel is finned over its whole exposed length and the heads are also well finned. The pistons are of forged aluminium alloy with cooling and stiffening ribs below the crown. Overhead valves with enclosed push rods and rocker arms, automatically lubricated, are employed. Both valves are of high heat resistance austenitic steel; the exhaust valve is sodium filled and its seating is Stellited. Ignition is by dual compensated cam-type magnetos, fully screened to prevent radio interference. Lubrication is on the dry sump principle, there being one pressure and two scavenging pumps (in tandem). All of the accessory drives are taken from the gearbox fitted to the rear cover of the engine.

The "Pelides" engine has cylinders of 5.75 in. (146 mm.)

bore and 6.5 in. (165 mm.) stroke, giving a capacity of 2,365 cu. in. (38.67 litres). It employs a compression ratio of 6 : 1. The International rated power is 1,065 B.H.P. at 2,150 R.P.M. at 5,000 ft. The maximum rating is 975 B.H.P. at 2,150 R.P.M. at 7,500 ft., whilst the maximum take-off power is 1,060 B.H.P. The dry weight is 1,475 lbs., which for the maximum rated output gives 1.39 lbs. per h.p.

The Bristol Engines. A wide-range of air-cooled radial engines has been produced by The Bristol Aeroplane Company over a relatively long period of years, during which a considerable amount of research and development work has been carried out upon both the poppet and sleeve valve designs ; the latter are dealt with in the chapter which follows. The Bristol engines are widely employed in both civil and military aircraft and have established a high standard of reliability, performance and long working life between overhauls.

As a result of single-cylinder engine research work considerable improvement has been made in regard to the output per unit cylinder capacity. Thus, over a period of eighteen years, up to 1940, the output per litre has been increased by 150 per cent. and the gross B.M.E.P. from 112 to 188 lbs. per sq. in. During this period the crankshaft speeds have risen from 1,625 R.P.M. (for the original Jupiter engine) to 2,925 R.P.M. for the more recent Pegasus engine. Despite the addition of gearing, supercharger, and a fairly extensive range of modern accessories, the specific weight per h.p. has been reduced by 43 per cent. At the same time, a saving of fuel per B.H.P. hour amounting to no less than 25 per cent. has also been effected.

The improved power output per litre has been due primarily to more efficient cylinder finning, to the adoption of supercharging, higher engine speeds ; to the employment of higher compression ratios in consequence of improved cylinder head and valve design and to the use of fuels of higher octane value. In this connection reference should be made to the graph shown in Fig. 40 on p. 64, Volume I of this work.

In regard to the more recent types of Bristol engines, these include different models of the single row nine-cylinder Mercury and Pegasus engine series of which leading particulars and performance figures are given in Table No. 10.

The engines referred to in Table 10 are designed for fuel to Specification D.T.D. 230 (octane value, 87), and for oils conforming to Specification D.T.D. 109.

TABLE 10. BRISTOL 9-CYLINDER RADIAL ENGINES

Engine Type	Bore	Stroke	Cubic Capacity	Overall Diameter	Airscrew Reduction Gear Ratio	Maximum Take-off Power B.H.P.	International Rated Power B.H.P.	Maximum Power for All-out Level Flight (5 min.) B.H.P.	Bare Dry Weight to A.M. Schedule E.124/3
MERCURY VIII and IX Fully Supercharged	5.75 in. (146 mm.)	6.5 in. (165 mm.)	1,520 cu. in. (24.9 litres)	51.5 in. (1,307 mm.)	VIII 0.572 IX 0.500	725	795/825 at 3,500 ft. (3,900 m.)	840 at 14,000 ft. (4,265 m.)	VIII 1,010 lbs. (458 kgs.) IX 1,005 lbs. (456 kgs.)
MERCURY XI and XII Medium Supercharged	5.75 in. (146 mm.)	6.5 in. (165 mm.)	1,520 cu. in. (24.9 litres)	51.5 in. (1,307 mm.)	XI 0.572 XII 0.500	830	780/820 at 3,500 ft. (1,070 m.)	890 at 6,000 ft. (1,830 m.)	XI 1,010 lbs. (458 kgs.) XII 1,005 lbs. (456 kgs.)
PEGASUS Xc Civil Rated	5.75 in. (146 mm.)	7.5 in. (190.5 mm.)	1,753 cu. in. (28.7 litres)	55.3 in. (1,405 mm.)	0.500	920	710/740 at 3,500 ft. (1,070 m.)	830 at 5,250 ft. (1,600 m.)	1,030 lbs. (467 kgs.)
PEGASUS XXII and XXIII Medium Supercharged	5.75 in. (146 mm.)	7.5 in. (190.5 mm.)	1,753 cu. in. (28.7 litres)	55.3 in. (1,405 mm.)	XXII 0.500 XXIII 0.572	1,010	800/840 at 4,000 ft. (1,220 m.)	890 at 6,500 ft. (1,980 m.)	XXII 1,090 lbs. (497 kgs.) XXIII 1,035 lbs. (469 kgs.)
PEGASUS XVII and XVIII Two-Speed Supercharger	5.75 in. (146 mm.)	7.5 in. (190.5 mm.)	1,753 cu. in. (28.7 litres)	55.3 in. (1,405 mm.)	XVII 0.572 XVIII 0.500	965	780/815 at 4,750 ft. (1,450 m.) 720/750 at 14,750 ft. (4,500 m.)	1,000 at 3,000 ft. (915 m.) 885 at 15,500 ft. (4,730 m.)	XVII 1,135 lbs. (515 kgs.) XVIII 1,130 lbs. (513 kgs.)
PEGASUS XIX and XX Fully Supercharged	5.75 in. (146 mm.)	7.5 in. (190.5 mm.)	1,753 cu. in. (28.7 litres)	55.3 in. (1,405 mm.)	XIX 0.572 XX 0.500	835	800/835 at 2,600 m.	925 at 10,000 ft. (3,050 m.)	XIX 1,035 lbs. (469 kgs.) XX 1,030 lbs. (467 kgs.)
PEGASUS XXV and XXVII Fully Supercharged	5.75 in. (146 mm.)	7.5 in. (190.5 mm.)	1,753 cu. in. (28.7 litres)	55.3 in. (1,405 mm.)	XXV 0.500 XXVII 0.572	830	795/830 at 11,000 ft. (3,360 m.)	915 at 9,500 ft. (2,900 m.)	XXV 1,035 lbs. (469 kgs.) XXVII 1,040 lbs. (471 kgs.)

The performance graphs of the Mercury XI and XII engines are given in Fig. 84. In this connection the results for the maximum take-off power and International rating correspond to a boost pressure of $3\frac{1}{2}$ lbs. per sq. in.; similarly for the "all-out level flight" results.

The performance graphs for the Pegasus XVII and XVIII engines, which are fitted with two-speed superchargers, are

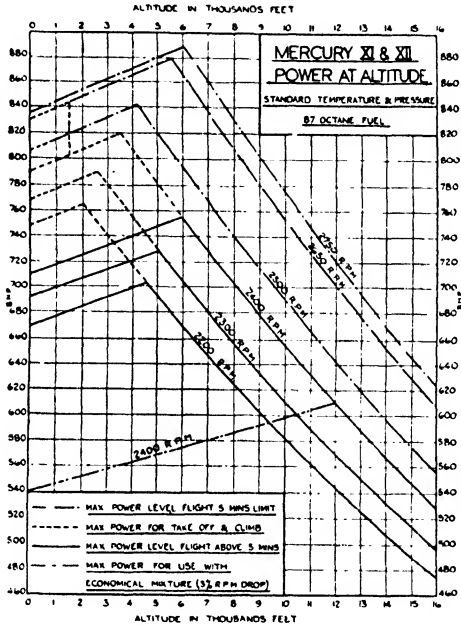

FIG. 84.

reproduced in Fig. 85. In these, the maximum take-off power corresponds to a boost pressure of $5\frac{1}{2}$ lbs. per sq. in.; the International Rating to $2\frac{1}{2}$ lbs. per sq. in. and the "all-out level flight" to $5\frac{1}{2}$ lbs. per sq. in.

Features of Mercury and Pegasus Engines. The design of the various components of these engines is based upon the results of intensive experimental work and flight trials totalling some hundreds of thousands of hours during which any weak points have been disclosed and subsequently rectified; as a result each detail has been developed to a high standard of performance and reliability.

It is only possible, here, to give a brief outline of some of the leading features of these engines, but in the case of certain components, notably the pistons, valves and valve gear, crankshaft and connecting-rods, and engine mounting, fuller accounts will be found in Chapter VII.

The Bristol cylinders (see Figs. 170, 172 and 173, Vol. I.) are among the special features that have received considerable

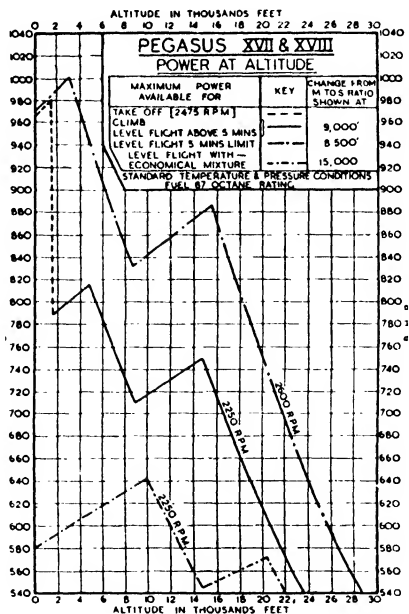

FIG. 85.

development attention and they have been designed to operate reliably at extremely high power outputs in conjunction with modern close-fitting low drag cowlings and to withstand satisfactorily the effects of leaded fuels.

The pitch, depth and shapes of the cooling fins have been developed for maximum efficiency. The total cooling area is relatively large, ranging from 150 to 180 sq. ft., according to the engine type. Some technical details regarding these cylinders and their heads are given in Volume No. I of this work. A thermo-couple location is provided in each cylinder head for temperature measurement purposes. The cylinders are machined all over from hollow forgings of special alloy

nitriding steel and the cylinder bore is finished by grinding, followed by the nitrogen hardening process—which results in a long life without regrinding, so that the use of oversize pistons is unnecessary.

The cylinder heads are machined from aluminium alloy forgings. The various stages in the production of a typical cylinder head are shown from left to right in Fig. 87; the complete cylinder with its head is depicted in the extreme right-hand illustration. The head is screwed, shrunk and locked into position on the cylinder barrel. The valve seats in the cylinder head are of austenitic nickel-manganese-chrome steel, having a high coefficient of expansion similar to that of the aluminium alloy used for the head, into which the seats are screwed and shrunk; there is no tendency, therefore, for the seats to become loose under operating conditions. The exhaust valve seats are Stellite. *The valves* themselves are of relatively large diameter, the exhaust valve being of the sodium-filled type with Stellite face. An interesting feature of the valves is the nitrogen-hardened portions of the stems, which operate in the valve guides. A hardened steel button is pressed into the end of each stem to provide a durable wearing surface for the rocker actuation.

The valve-operating gear incorporates automatic clearance compensation and also automatic lubrication.

The pistons are of forged aluminium alloy, full-skirted and fitted with four rings, two of which are gas or compression ones.

The crankcase is made in two halves, from aluminium alloy forgings suitably heat-treated and machined.

The crankshaft and connecting-rod assembly are of the one-piece master rod and coupled crankshaft pattern, with heavy duty big-end bearing incorporating a floating bush.

The engines are provided with airscrew reduction gears with alternative ratios and provision is made for operation of the controllable pitch or constant speed airscrews.

The high-speed *centrifugal supercharger* has a spring drive and centrifugal clutch to ensure smooth running and freedom from shock loads. On the Pegasus XVII and XVIII engines a two-speed supercharger is fitted. These superchargers are illustrated and described in Volume I of this work.

An interesting feature of the lubrication system is the use of a high initial oil-pressure system enabling the engine to be opened up to full power directly after starting; this is described on page 311.

The two magnetos fitted to each engine have automatic advance and retard mechanism and the double contact breakers are interconnected with the throttle in order to provide an additional advance for maximum fuel economy when cruising. The ignition system is fully shielded for radio screening and is neatly harnessed as a complete unit.

The engines are fitted with *Claudel Hobson carburettors* of the type described more fully in Volume I of this work. This design incorporates automatic variable datum servo control units for both boost pressure and mixture strength. The engine is thus protected from excess induction pipe pressure under all conditions, and the pilot is not obliged to watch his boost gauge. Increased power for take-off is available without any possibility of damaging the engine. The pilot's throttle lever has the same progressive control of engine power as with an unsupercharged engine. The automatic mixture control makes it impossible to run the engine on mixture strengths that would be either dangerously weak or wastefully rich. The pilot need not alter his mixture control lever position with changes of altitude.

The carburettor is fitted with a delayed action pump giving positive and rapid acceleration without detriment to cruising economy. Hot oil is circulated round the chokes to ensure thorough vaporisation. A controllable air intake is standardized.

A natural flow of gas to the two inlet valves of each cylinder is ensured by nine pairs of large section induction pipes, connected to nine tangentially arranged Y branches from the supercharger.

In regard to the *accessory drives* the rear cover has been laid out to provide the most accessible and compact arrangement for the wide range of accessories required in the equipment of modern aircraft. Provision is made for single or dual fuel pump; high and low pressure air compressors; shaft driven electric generator; combined hand and electric starter; vacuum pump; high pressure oil pump; and constant speed airscrew governor.

Besides the above-mentioned accessories, the rear cover carries the engine oil pump, oil gauge connection, auxiliary oil feed filter, tachometer drive, magnetos and (if required) the control valve for a controllable pitch airscrew.

As a result of extensive research and flight testing, an *inter-cylinder baffle system* has been evolved which is not only very

efficient from the standpoints of good cylinder temperature distribution and cooling air flow economy, but also has constructional advantages. Each complete baffle is divided vertically into two symmetrical halves. Each half is fixed to its cylinder at the head by a quick-release attachment of the "skewer" type, and is located at the bottom by two pins which rest in rubber bushes carried by a base plate fixed between the pairs of cylinders. This construction greatly facilitates the rapid removal and re-fitting of the baffles, as there are no nuts or bolts to deal with. The baffles are made from fully-tooled aluminium pressings, with duralumin fittings, and are anodically treated to prevent corrosion. Their outer ends have leather air seals bearing against the engine cowl. The sparking plugs and leads are accessible without disturbing the baffles. Provision is included for the accommodation of accessory cooling air ducts.

The single outlet exhaust manifold is mounted on the front of the engine by simple three-point attachments which incorporate flexible joints to allow for expansion; this is illustrated in Fig. 328, p. 378.

The manifold has a large internal volume, which ensures efficient flame damping and quiet operation. The design also reduces the general temperature of the exhaust system, avoids hot spots, and thus minimises the risk of fire. The contour and position of the manifold provide an entry of good aerodynamic form for the engine cowling.

The mounting arrangements permit the standard manifold to be used unaltered with the single outlet pipe between any pair of cylinders, except between Nos. 5 and 6 where the carburettor intervenes. Twin outlet pipes can be provided in the Mercury type manifold.

The manifold is manufactured from one-piece steel pressings. All joints are riveted, thus avoiding the incipient faults which are liable to occur in a welded manifold. The whole unit is nickle-plated both inside and out as a protection against corrosion. Fully machined fittings are employed in the mountings assemblies, thus ensuring interchangeability of manifolds of the same type.

The Bristol engines have simple light alloy cone plates for mounting purposes, but an alternative flexible mounting is also available; these items are described later in this volume.

Long and short cowlings of low drag combined with efficient cylinder cooling are designed for the engines. The long cowl

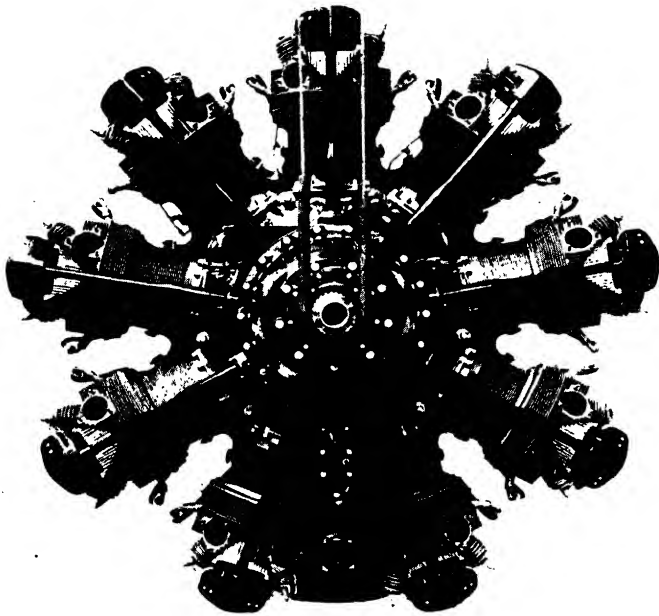

FIG. 86. The Bristol "Mercury" nine-cylinder air-cooled radial engine (840/890 h.p.).

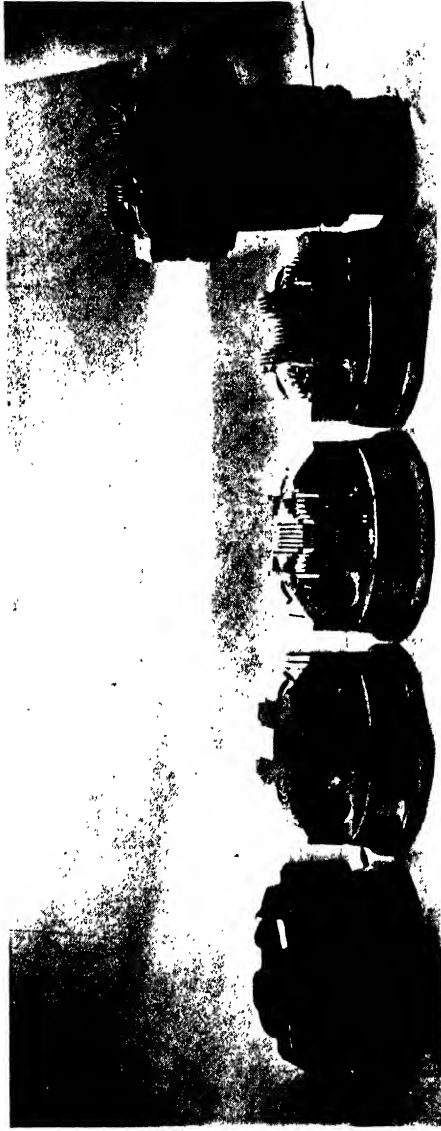

FIG. 87. Showing various stages in the manufacture of a Bristol aluminium alloy cylinder head from the forging shown on the left.



FIG. 88. The carburetor and induction system of the Bristol "Mercury" and "Pegasus" engines, showing also the twin inlet and exhaust valve gear, shielded ignition cables, sparking plugs, etc.

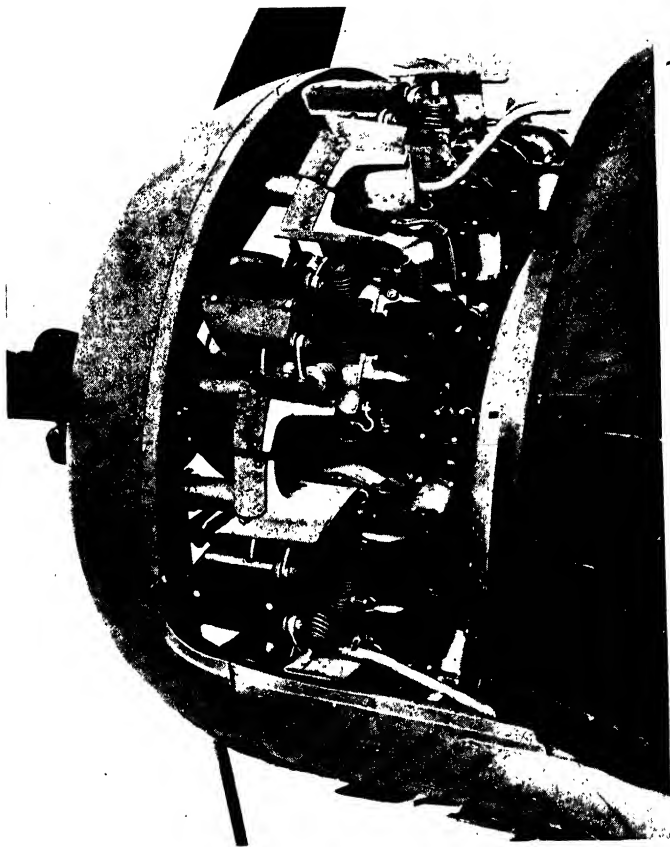

FIG. 89. The inter-cylinder baffles on the Bristol "Mercury" engine as installed in an aircraft.

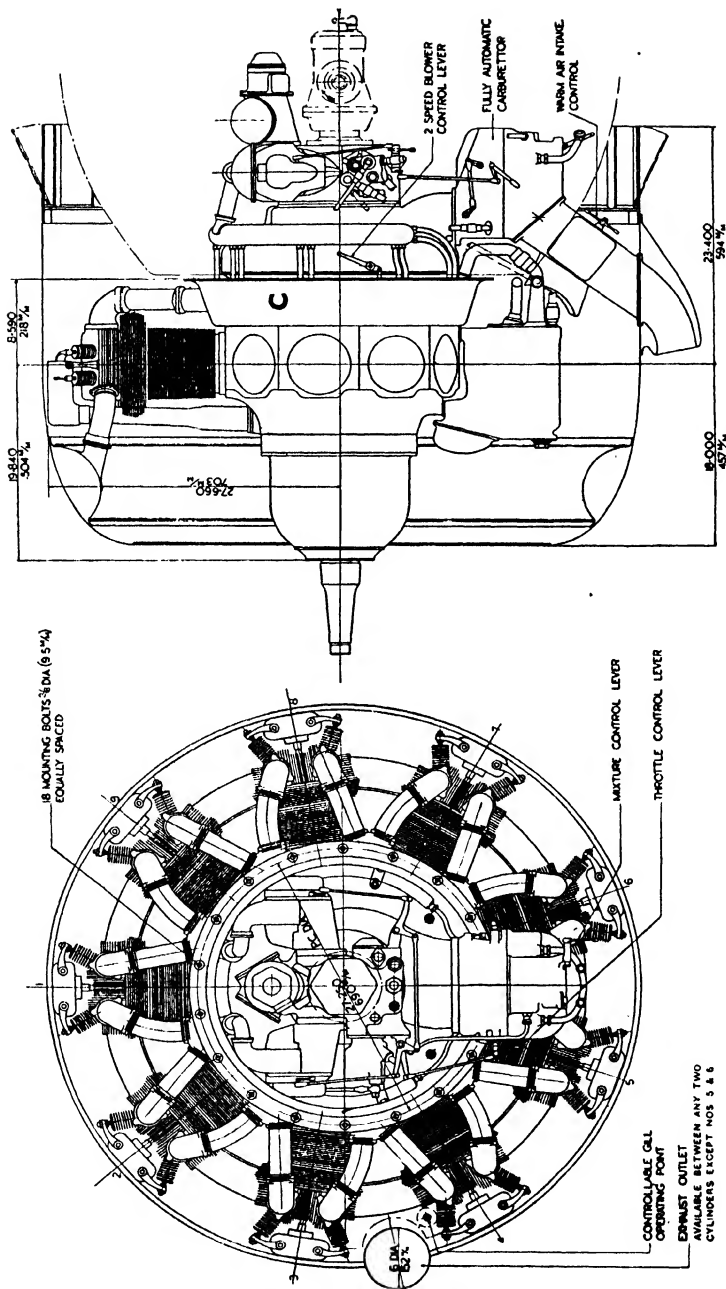

FIG. 90. Installation diagram of the Bristol "Pegasus" two-speed supercharger radial engine. (The mounting unit is shown at C in the R.H. illustration.)

is provided with a controllable gill assembly having some interesting features.

The panels are neat and quickly detachable, providing easy accessibility. There is no overlapping, so that minimum drag is ensured. The method of actuation is by an endless roller chain, running round the inside of the rear cowl support ring. Through sprocket wheels, this chain operates a screw mechanism which controls the hinging movement of each gill panel lever. The support ring is interrupted and the chain diverted between certain cylinders to allow for the exhaust pipe or pipes. Advantage is taken of this to provide an adjustable jockey sprocket for maintaining correct chain tension, and a splined main driving sprocket. The gear is irreversible, so that flight loads cannot react upon the operating mechanism. The final drive is suitable for either manual, hydraulic or electric operation.

Pratt and Whitney Engines. All of the engines made by the Pratt and Whitney Division of the United Aircraft Corporation, East Hartford, Connecticut U.S.A., are of the high-powered air-cooled radial type, and the firm in question has specialized in such engines since its foundation in 1925. The first production engine was the 400 h.p. nine-cylinder "Wasp," which established an excellent reputation. This was followed by the higher-powered "Hornet" and the smaller "Wasp Junior"; all of these engines were nine-cylinder radial ones. Later, the twin-row fourteen-cylinder engines known, respectively, as the "Twin Wasp," "Twin Wasp Junior" and "Twin Hornet," were introduced. The modern products of this firm include the "Wasp Junior," "Wasp" and "Hornet" nine-cylinder radials of the supercharged type, and the twin versions of these engines with fourteen cylinders. There are alternative models of the "Twin Wasp" fitted with single and two-speed superchargers.

The largest engine for which particulars are available is the "Twin Hornet" with single-speed supercharger. This has a bore of 5.75 in. (146 mm.) and stroke of 6.00 in. (152.4 mm.) and a cylinder capacity of 2,180 cu. in. (35.75 litres). The engine, designed for fuel of 100-octane value, has a compression ratio of 6.66 : 1 and centrifugal supercharger ratio of 7.56 : 1. Two alternative airscrew gear ratios, namely, 0.500 : 1 and 0.5625 : 1 are available. The engine has a normal rating of 1,100 B.H.P. at 2,550 R.P.M. to 6,200 ft. and 1,000 B.H.P. at 2,700 R.P.M. at 14,500 ft.

It has a maximum take-off output of 1,400 B.H.P. at

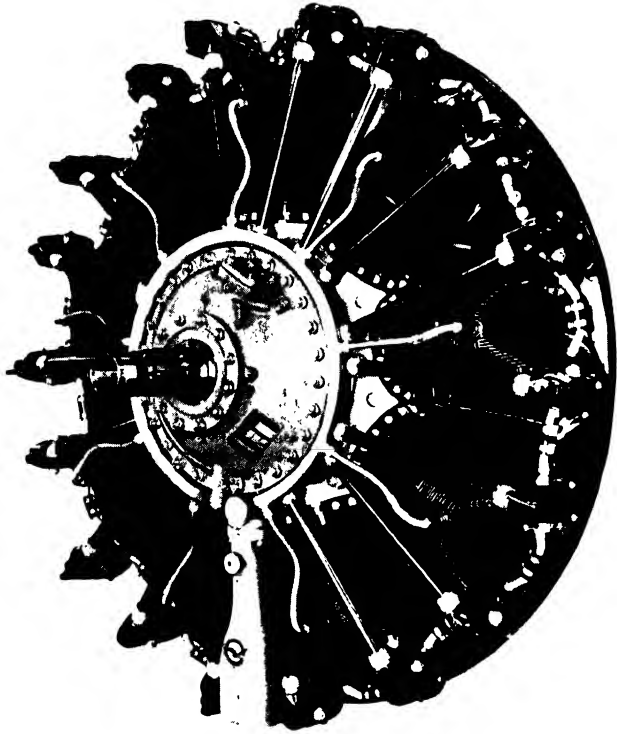

FIG. 91. Pratt and Whitney H.I. "Wasp" engine (550 h.p.).

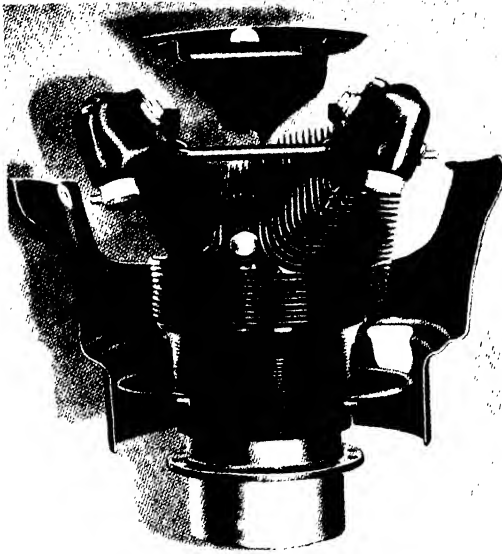

FIG 92. Cylinder and baffles of "Wasp" engine.

2,500 R.P.M. The dry weight is 1,635 lbs. for the 0.500 air-screw ratio model, which corresponds to about 1.49 lbs. per h.p. for the normal rated power at 6,200 ft., or 1.17 lbs. per h.p. for the maximum take-off output.

The overall diameter of this engine is 51.63 in., which gives an output on the normal rating of 76 B.H.P. per sq. ft. of frontal area.

The "Wasp" engine has nine cylinders each of 5.75 in. (146 mm.) bore and stroke, giving a cylinder capacity of 1,344 cu. in. (22.03 litres). It is designed to operate on fuel of 87-octane rating and has a compression ratio of 6.5 : 1. The engine speeds for full power under different altitude conditions range from about 2,000 to 2,250 R.P.M., and the corresponding supercharger rotor speeds are 24,000 to 27,000 R.P.M. The airscrew is direct driven in one model and at 0.666 times engine speed in the alternative one.

The engine has a normal rated output of 550 B.H.P. at 2,200 R.P.M. to 8,000 ft., and a military five-minute one of 600 h.p. at 2,250 R.P.M. to 6,200 ft. The dry weight is 864 lbs. for the direct drive model; this corresponds to about 1.57 lbs. per h.p. for the normal rated output.

The overall diameter is 51.44 in., so that the engine develops, on its normal rated output, about 38 B.H.P. per sq. ft. of frontal area. It will be noted that this is just one-half of the value for the "Twin Hornet" engine previously mentioned; the advantage of the latter two-row radial in the matter of lower drag is thus clearly shown.

In regard to the constructional details of the "Wasp Junior," "Wasp" and "Hornet," single-row radial engines, the cylinders (Fig. 92) are built up with cast aluminium heads containing the valve mechanism housings, screwed and shrunk on to the forged steel barrels having integral cooling fins; certain models have nitrided cylinder bores. The inlet valve seatings are of aluminium bronze and the exhaust valve seating, alloy steel. The exhaust ports have shrunk-in stainless-steel liners which provide a slip joint for the exhaust pipes. The combustion chamber is of hemispherical shape with the valves situated in a plane at right angles to the crankshaft. The pistons are machined from aluminium alloy forgings. The underside of the piston is ribbed for strength and increased cooling area. Three compression and two dual oil-control rings are employed.

The big-end bearing of the master-rod has a lead-silver

bearing ; that used for the " Wasp Junior " engine is of lead-bronze. Each rod is bronze-bushed for both the piston and knuckle-pin. The crankshaft is of the single-throw two-piece pattern ; it has three main bearings ; one roller bearing on each side of the crank with a ball thrust bearing in the nose portion. The geared airscrew drive models have also a roller bearing supporting the front end of the shaft in an anchor plate. The crankshaft has steel counterweights riveted to its cheeks, and it is also fitted with a fly-weight type of vibration damper.

The crankcase is machined from a hemispherical aluminium alloy forging on some models, whilst on the " B " Wasp Junior a magnesium alloy casting is employed. It is in two similar sections machined together, divided on the centre line of the cylinders and bolted together. The blower section contains the centrifugal supercharger and mounting lugs for installing the engine. The accessory section at the rear carries all the accessories and has integrally cast vanes as well as blades in the carburettor intake elbow for balanced diffusion of the compressed mixture.

The cam drum rotates clockwise at one-eighth engine speed and operates the overhead valves through push-rods and rocker arms. The accessory drives are at the rear, driven by three layshafts extending right through the blower and rear sections. Each shaft carries a spur gear at its forward end which engages with a drive gear attached to the rear end of the crankshaft. An upper shaft provides the drive for the starter and generator. Each of the two lower shafts drives one magneto through an adjustable coupling. Four vertical drives are provided by means of a bevel gear on each lower shaft. The lower shafts drive the oil and fuel pumps ; there is also provision for an angle-drive on the lower left-hand side.

Ignition is by means of two Scintilla magnetos, whilst the carburation requirements are provided by a double self-priming Stromberg carburettor on all models except the " Wasp Junior," which employs a single barrel model. The mixture, which can be controlled automatically, is fed through the blades in the carburettor intake elbow to the supercharger through the diffuser vanes and annular space in the blower section ; thence to the cylinders by tangential intake pipes. A hot-spot or mixture heater is provided. The exhaust gases are ejected through a stainless-steel manifold cast in an alu-

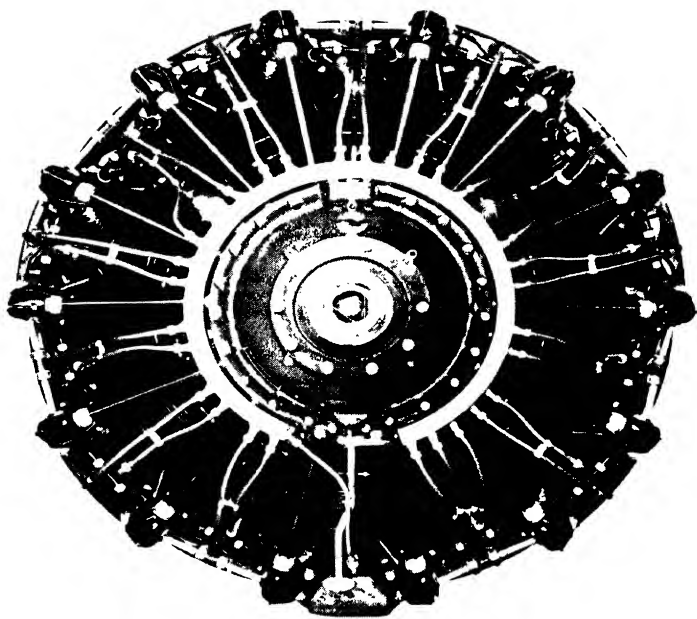

FIG. 93. Pratt and Whitney Twin "Wasp" fourteen-cylinder twin-row engine. S₃C₃-G (1,100 h.p.).

roller bearings in the crankcase sections. The airscrew shaft is supported within the crankshaft by a bronze-lined bearing and in the nose section by a deep-groove ball thrust bearing. The counterbalance weights are riveted to the crank webs.

The engine is fitted with a double barrel pattern down-draught self-priming Stromberg or Chandler-Evans non-icing and compensating carburettor; this is attached to the rear section of the crankcase unit.

The ignition is by means of two Scintilla magnetos, each operating its own independent set of sparking plugs through manifolds providing short leads. The centrifugal supercharger has a relatively large diameter impeller mounted on ball-bearings and driven by dual intermediate gears with a spring coupling to absorb driving shocks and to equalize the driving loads. The impeller drive ratios are 7.15 : 1 for the single-speed supercharger and 7.15 : 1 and 8.47 : 1 for the two-speed model.

The supercharger section of the engine (Fig. 96) is machined and finished from a magnesium alloy casting. Its impeller runs on the axis of the crankshaft and is geared to the latter. The kinetic energy of the mixture emerging at high speed from the impeller tips is transformed into pressure energy in the annulus feeding the intake pipes, by means of an interposed diffuser. Steel vanes in the carburettor elbow provide uniform diffusion of the compressed mixture to the cylinders.

The accessory or rear section of the engine is housed in a magnesium alloy casing which contains the drives for the engine starter, electric generator, two magnetos, fuel and oil pumps, two tachometers, a vacuum pump and two auxiliaries; the latter can be used for two gun-synchronizers. The shafts run in bronze bearings.

In regard to the carburettor a special Pratt and Whitney *automatic mixture control* is employed to ensure positive control of the fuel mixture and power output for three operating conditions, under the control of the pilot. For emergency it provides for full throttle and "full" rich mixture, whilst for take-off and climb it provides rated power and moderately rich mixture; for cruising purposes the power is limited automatically to a predetermined amount whilst the mixture is regulated to give economical running. When set to cruising conditions no further attention to mixture control is required until the completion of the flight. The automatic control utilizes the aneroid bellows method of intake pressure regulation.

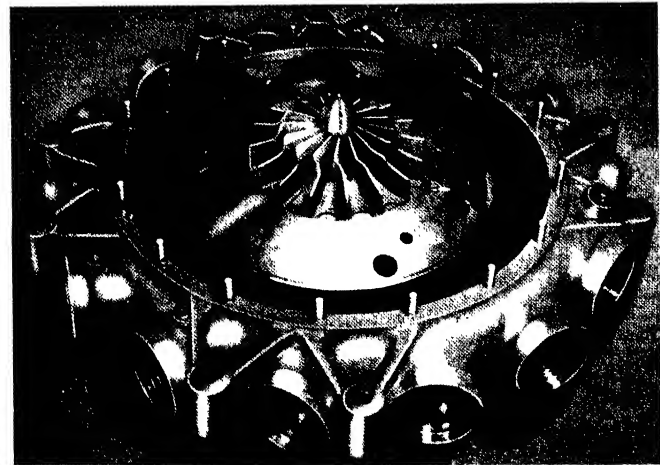

Fig. 96. Supercharger unit of Twin "Wasp" engine.

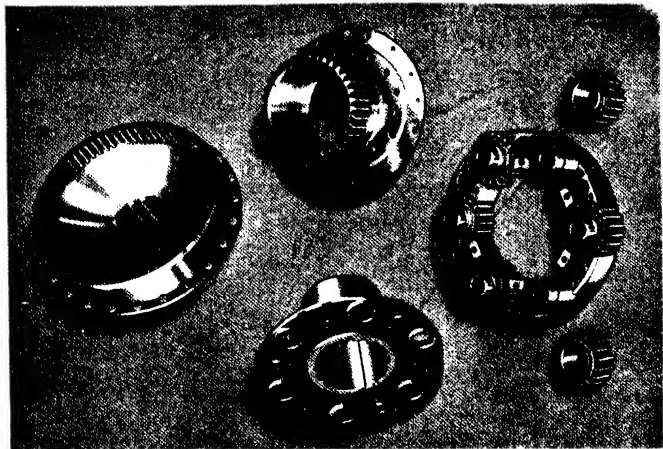

Fig. 97. Details of the airscrew reduction gear for Twin "Wasp" engine.

[To face p. 134.]

The *airscrew reduction gear* (Fig. 97) consists of a fixed gear bolted to the crankcase housing which engages six pinion gears carried in a cage which is splined to the airscrew shaft. These pinions are mounted on concentric shafts and float between the fixed and drive gears; the latter is splined to the crankshaft. Lead bronze bearings are used for the pinions and the pinion shafts are heat-treated. The complete airscrew drive unit can be removed in one section from the engine.

The Wright Air-cooled Radial Engines. The engines built by the Curtiss-Wright Corporation, New York, have all been

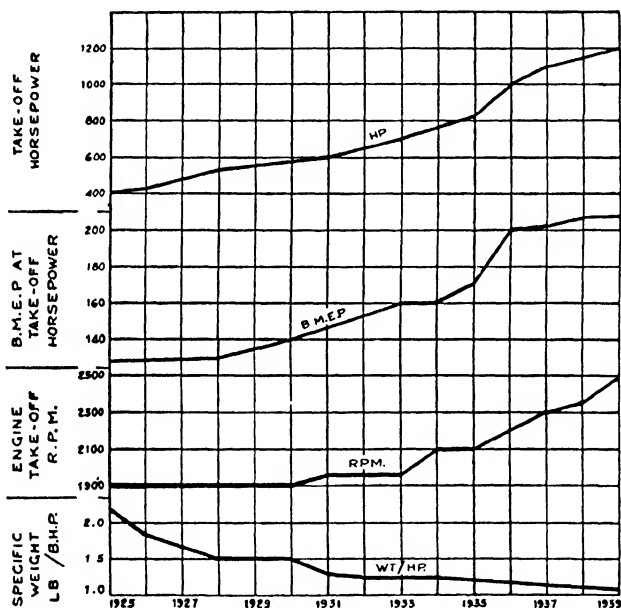

FIG. 98. Illustrating development of the Wright Cyclone nine-cylinder radial engine.

radial ones since the commercial production of the Cyclone engine in 1925. The more recent engines, which are extensively employed in civil and military aircraft, range from the smaller "Whirlwind" ones of 230 to 412 B.H.P. (sea level) to the larger 2,000 h.p. "Duplex Cyclone" type.

A considerable amount of research and development work has been carried out in connection with engine design, cooling and supercharging of the Wright engines, with the result that

the modern version of the Cyclone nine-cylinder radial engine develops about three times the power output of the 1925 version. The improvement in the performance of this engine is illustrated by the graphs²⁴ given in Fig. 98 which cover a period of fourteen years. It will be observed that the take-off

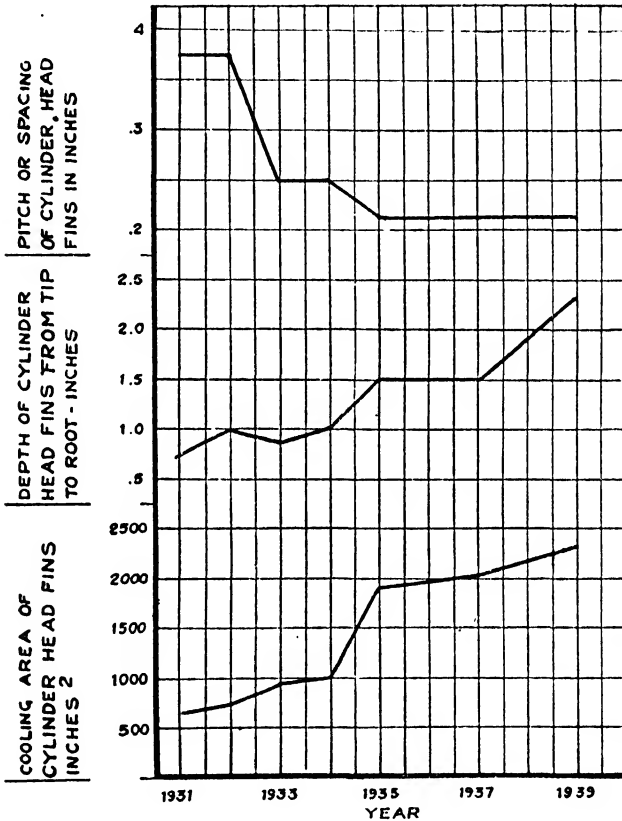

FIG. 99. Illustrating improvement in engine cooling for the Wright Cyclone engine.

power B.M.E.P., during this period, has increased from about 128 to 208 lbs. per sq. in. and the engine speed from 1,900 to 2,500 R.P.M., whilst the specific weight has been reduced from 2.2 to 1.1 lb. per h.p. The contributing factors to these improvements include more efficient cooling, super-charging,

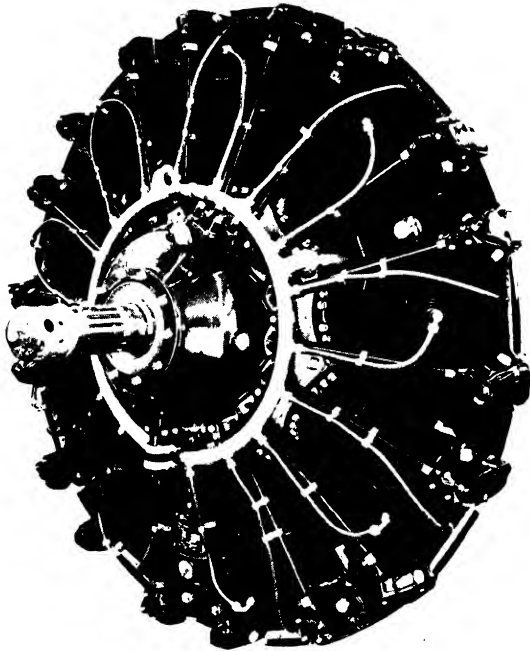

FIG. 100. Wright "Cyclone" G-100, nine-cylinder single-row radial engine (1,100 h.p.)



FIG. 101. Sectional view of Wright "Cyclone" G-200 cylinder, showing cooling fins and valves.

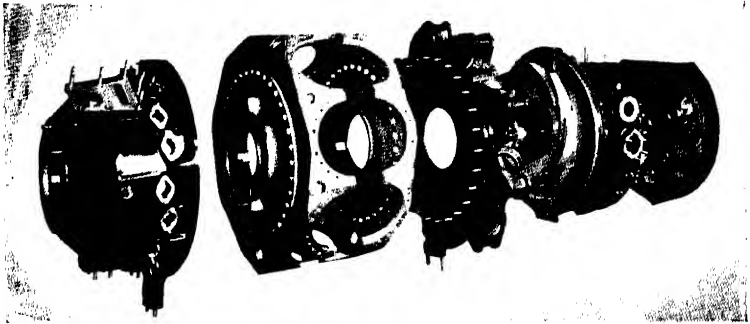

FIG. 102. The Wright "Cyclone" engine crankcase components.

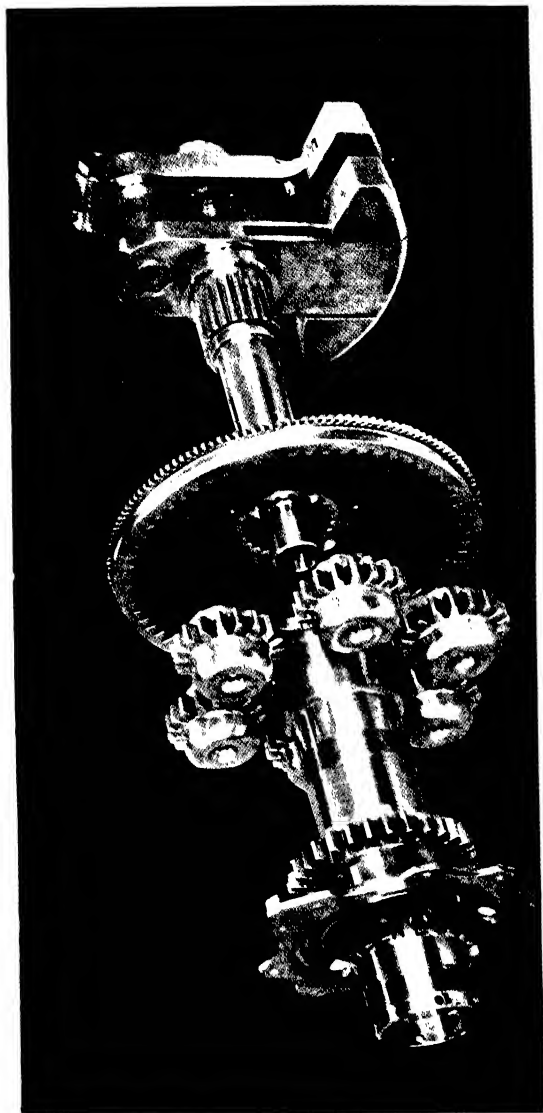

Fig. 103. The Wright "Cyclone" G.100 crankshaft and reduction gear for airscrew drive.

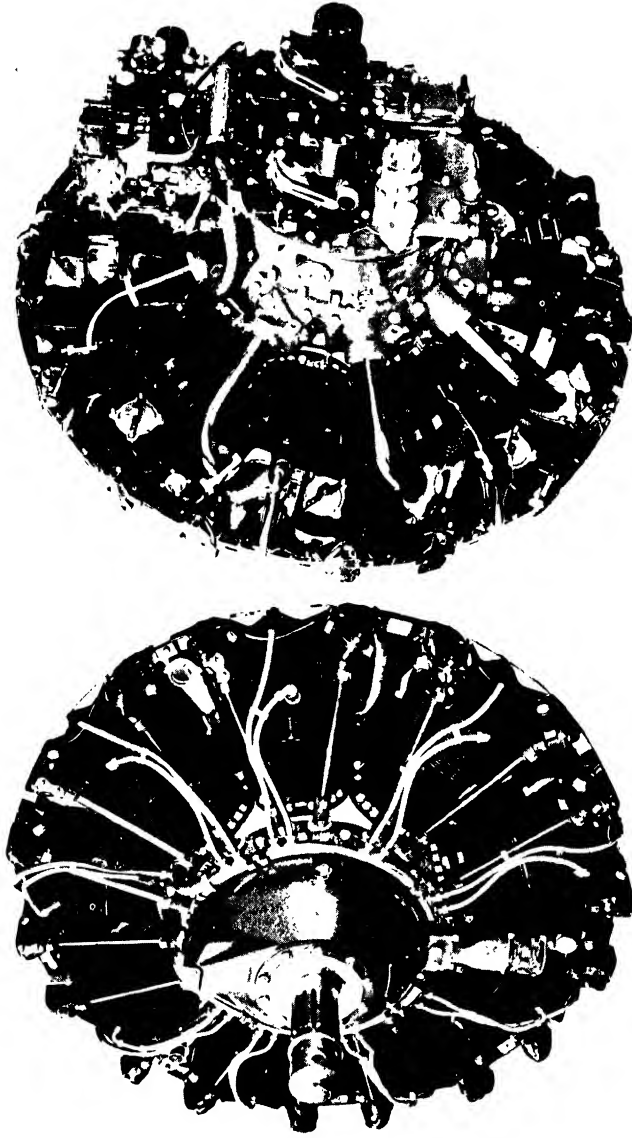

FIG. 104. Wright "Cyclone" G.200 nine-cylinder radial engine (1,200 h.p.).

damping of vibration, improvements in sparking plugs, fuels, oils, dynamic suspension and engine materials.

In regard to the progress made in *engine cooling* this is due to reducing the pitch of the fins and increasing the fin depth and area of the cylinder head fins. The manner in which these changes have been effected is illustrated in Fig. 99, from which it will be seen that the cooling area has been increased from about 600 sq. in. to 2,300 sq. in., and the depth of the fins by three times, whilst the pitch of the fins has been reduced progressively from 0.375 in. to 0.21 in.—the latter figure representing about the smallest practical fin pitch for efficient cooling under modern cowled conditions.

An important factor in the improved output of these engines has been the employment of higher octane value fuels. Thus, in 1925 the fuel used had an octane value of about 73, whereas in 1940 the octane value was 95 in certain models and 90 and 87 in others.

As it is not possible here to describe all of the various Wright engines now in use, four representative engines will be considered, namely, the G.100 and G.200 Cyclone series, the Double-Row Cyclone 14 and the Duplex Cyclone 18 engines.

The G.100 Cyclone engine shown in Fig. 100 is a nine-cylinder single-row radial model of 6.125 in. (155.6 mm.) bore and 6.875 in. (174.6 mm.) stroke, giving a cylinder capacity of 1,823 cu. in. (29.88 litres). It is designed, in different models, for fuels of 87- and 90-octane value and has corresponding compression ratios of 6.0 : 1 and 6.3 : 1. The engine is made in both the single and two-speed centrifugal supercharger patterns; in the latter design the two supercharger gear ratios are 7.14 : 1 and 10.0 : 1. The airscrew is geared down, the ratio being, alternatively, 0.6875 : 1 or 0.666 : 1.

The two-speed supercharger engine (model G105A) has a maximum take-off power of 1,100 B.H.P. at 2,350 R.P.M. (with the lower supercharger gear ratio), a maximum output at 2,350 R.P.M. (with the lower supercharger gear ratio) and a maximum output for protracted periods, on the lower gear of 900 B.H.P. at 2,300 R.P.M. for altitudes up to 6,700 ft. With the higher supercharger gear ratio the engine develops 775 B.H.P. at 2,300 R.P.M. at 17,300 ft. altitude corresponding to an inlet manifold pressure of 33.6 in. of mercury (sea level value is taken as 43.5 in.). The fuel used for these performances is of 90-octane value. The dry weight is 1,287 lbs., corresponding to a maximum take off value of 1.17 lb. per h.p.

In regard to the *cylinder cooling* the maximum cylinder head temperature (sparking plug washer thermo-couple) permissible for continuous operation is 205° C., but for take-off (five minutes' duration) and climb (fifteen minutes' duration) this is increased to 260° C. The maximum permissible cylinder barrel temperature (embedded couple) is 149° C.

The cylinder of the G.100 "Cyclone" engine has a cooling area of 2,800 sq. in. corresponding to a total cooling area for all nine cylinders of 175 sq. ft. This liberal cooling area is obtained by careful attention to the design and dispositions of the cooling fins. The latter average over 1½ in. deep and are spaced at $\frac{7}{32}$ in. (0.219 in.) apart. The finning is carried well up on the integral rocker-boxes in such a manner as to equalize the cooling of the intake side and the hotter exhaust side. It is also distributed around the sparking plug bosses so as to permit a free flow of air across the finned type of plug used in this engine. Air deflectors, or baffles, direct the flow of air through the cooling fins of the cylinder head and barrel; the design of these close-fitting baffles is the result of much experimental work.

The cylinder head is an aluminium alloy casting, heat-treated to a Brinell hardness of 70 to 90. The cylinder barrel is made from a nitralloy steel forging of about 60 lbs. weight, which is subsequently machined inside and the fins cut on the outside to a final weight of about 12 lbs. The inside of the barrel is nitrogen-hardened to give a glass hard surface of Rockwell Superficial 80 min. and depth of 0.022 in. The surface finish of the cylinder bores is such that no point of roughness greater than three-millionths of an inch is left. The cylinder heads are screwed and shrunk on to the barrels. For this purpose the head is heated in an electric furnace to 315° C. and then screwed tightly on to the cold barrel. The inlet valve seating inserts in the cylinder head are of a special nickel aluminium bronze; the exhaust seatings are of a nickel-chromium-molybdenum steel containing also manganese and tungsten, of the stainless steel class.

The exhaust valves are of the hollow sodium-filled type, made from heat-resisting steel with Stellite faces. The overhead valves are actuated by a cam housed in the nose section of the crankcase. Hardened steel cam follower rollers, running on the cam ring, operate the rocker arms by means of fully enclosed tubular push rods. The rocker arms are carried on Timken tapered roller bearings. Aluminium

alloy pistons with three compression and three oil control rings are employed ; these are illustrated in Chapter VII.

The forged alloy steel connecting-rod assembly comprises the master rod and eight articulated or link rods ; all of these rods are hand-polished to a mirror surface. The crank pin hole of the master rod is also polished to form a high grade bearing surface between the rod and the steel shell of the high lead-bronze crank-pin bearing. Both the knuckle and gudgeon pin bearings of the link rods and the gudgeon pin bushing of the master rod are of rolled bronze spun into position ; the spinning process eliminates rivet holes and thus increases the strength at the ends of the rods.

The crankcase is made in five separate sections, namely, the *nose, power, mounting, supercharger* and *accessory sections*. The *nose section* is of forged aluminium alloy, encloses the cam mechanism and houses the valve tappets and guides ; it also provides for a constant speed and hydromatic airscrew governor drive. Drilled oil passages in the forging supply the internal automatic valve gear lubrication ; an oval drain tube from the nose section provides improved oil scavenging. The *power section* is machined from two symmetrical steel forgings in order to provide the necessary strength for the unit in question ; previously, an aluminium alloy forging for the lower-powered engine was employed. This section contains no studs but is held in position by means of nine through-bolts. The *mounting section* which is located immediately behind the power section has nine equally spaced mounting lugs to provide for the attachment of the engine to the aircraft engine mounting ring. This section forms the front wall of the supercharger diffuser and distribution chamber ; it also carries the tangential ports for the curved individual induction pipes leading to the nine cylinders. The *supercharger section*, also of cast aluminium alloy, carries the supercharger diffuser plate, the carburettor, the mounting pads for the tachometer and fuel pump, left and right gun synchronizers and the oil filter. It acts as a housing for the accessory drive gears the bearings for which are carried in the *accessory section*. The latter is practically a flat plate of magnesium alloy and forms the rear crankcase cover. On it are mounted the oil pump, two magnetos and a spur gear accessory drive box which provides power for various flight equipment or instruments. Raised starter and generator mounting pads are provided for these accessories and provision can be made for

either a three- or twelve-jaw starter; the two-speed supercharger control valve is also mounted in this section.

The engine has a planetary system of reduction gears for the airscrew shaft (Fig. 103), consisting of a large driving ring gear, with nitrided internal teeth; this is splined to the crankshaft. This ring gear drives pinions of heat-treated alloy steel around a stationary nitrided "sun" gear which is bolted to the nose section. The pinions run on spindles on the spider at the rear of the airscrew shaft; they are bell-shaped to permit them to compensate for the deflection of the spindles under load thus always presenting their full tooth surface to the mating gears. Spur gears are used exclusively in the accessory drive gear mechanism. The accessory gears are driven through a single extension shaft splined to the rear end of the crankshaft; this extension shaft is coupled to the main accessory drive gear through a special spring coupling.

Ignition is by two Scintilla magnetos operating two independent sets of sparking plugs; the entire ignition system is shielded to prevent radio interference.

The engine employs a Chandler-Groves down-draught carburettor of the non-icing type. Instead of the conventional float chamber the fuel flow is controlled by a chamber walled by two diaphragms. The fact that this chamber is always full ensures positive action irrespective of the attitude of the machine during manœuvring or aerobatics. The fuel-air mixture is inherently compensated for changes in altitude, without the attention of the pilot. For commercial transport operation there is also a manually controlled mixture device to enable maximum fuel economy to be obtained. The two-speed supercharger unit contains a small set of planetary speed reduction gears and two hydraulically-operated clutches for putting these gears into or out of operation. For take-off and low altitude flight the supercharger is driven at reduced speed through these gears. At the critical altitude the mechanism is locked so as to provide a solid drive for the high gear ratio. The two-speed gear unit is controlled by means of a two-way valve, from the pilot's cockpit, which directs oil pressure to one or other of the pistons which engage the two clutches for the high and low speed operation.

The Wright Cyclone G.200 engine represents a development of the G.100 engine previously described, and it has a higher take-off output rating, namely, 1,200 B.H.P. Although

basically of the same design as the latter engine it incorporates several improvements including more efficient combustion and cooling, longer life and reduced maintenance costs. The engine has the same bore and stroke as the G.100 model, but employs a compression ratio of 6.7 : 1 instead of 6.3 : 1 ; it is designed for fuel of 90-octane value. A two-speed supercharger of the same ratios as for the G.100 engine is fitted, but other models have single-speed superchargers of 7.0 : 1 and 8.3 : 1 blower drive ratio.

The engine has a take-off power rating of 1,200 B.H.P. at 2,500 R.P.M. and 1,000 B.H.P. at 2,300 R.P.M. at 4,500 ft. with the lower blower ratio (7.14 : 1). With the higher blower ratio (10.0 : 1) the engine develops 900 B.H.P. at 2,300 R.P.M. at 14,000 ft. for a dry weight of 1,302 lbs.

Fig. 101 shows the general shape of the cylinder in sectional view. In order to cope with the higher output it has been necessary to increase the cooling fin area, partly by employing deeper bead fins on a thicker dome section. These fins are 2.25 in. deep on top of the head and give an increased head cooling area of 8 per cent., making 2,200 sq. in. in all. The greater proportionate increase occurs on the cylinder barrels where the fin area has been increased by 60 per cent. to 1,300 sq. in. The total cooling area is 3,510 sq. in., or 24.4 sq. ft. per cylinder ; this is about 24 per cent. more than that of the G.100 engine.

In regard to the valve mechanism a bronze bushing is inserted in the rocker arm bolt bosses to increase the life of the contact surfaces of the aluminium alloy bosses. The valves have 45 degrees angle seatings.

The exhaust valve head of this engine is more conical in shape than that of the G.100 engine, in order to give a larger sodium chamber. The cylinder head is screwed with a new form-fit type of ground buttress thread and has no tapering run-out ; it is shrunk on to the cylinder barrel. The inside walls of the latter receive a micro-finish after nitriding, guaranteed to be accurate within 2 micro-inches (0.000002 in.) longitudinally ; this corresponds to the surface finish of Johansson gauge blocks. There are twenty equally spaced cylinder holding down studs.

To ensure maximum volumetric efficiency the exhaust valve guides are streamlined and the area of the exhaust port increased by 20 per cent. over that of the G.100 engine, to $2\frac{3}{4}$ in. diameter. The intake pipes from the diffuser section

have also been increased to $2\frac{3}{4}$ in. diameter ; stainless steel inlet valves are employed.

Particulars of the pistons, connecting-rods and crankshafts of this engine are given in Chapter VII.

The steel crankcase power section which has been stiffened to take the heavier loads due to the increased power output is machined from steel forgings. The two halves are joined at the centre line by means of flanges and short bolts and nuts

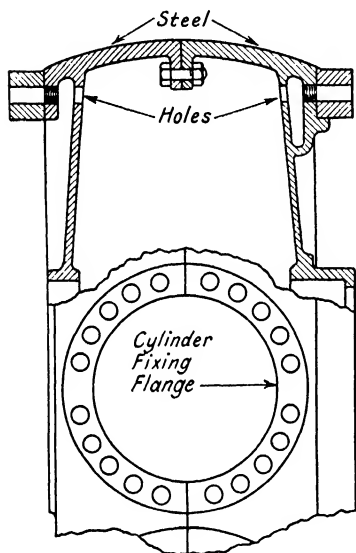

FIG. 105. The steel crankcase power section of the Wright G.200 Cyclone engine.

instead of the much longer through bolts of the G.100 engine. Fig. 105 illustrates the principle of the method employed. The side walls are inclined inwardly for stiffness. The use of cap screws for the cylinder attachment, in this engine, obviates the possibility of stripped threads. The crankcase design makes provision for a *new oil scavenging system*, the engine being treated as a pump with the oil thrown by centrifugal action from metering jets in the tops of the crank cheeks. An immediate outlet outside the cylinder skirts is provided for this oil to escape from the crankcase through eighteen holes around the outer edge of each wall. On the outside it is collected in annular channels formed by the attachment flanges. The nose section of the crankcase is machined from a magnesium alloy casting ; it houses the 3:2 (or 16:9) airscrew reduction gear which employs twenty pinions. The induction system gives a greater flow velocity for the mixture than in the G.100 engine. It employs the same diameter of impeller for the centrifugal supercharger, namely, 11 in., but of more efficient design ; the diffuser section has twelve instead of the previously used nine blades.

The crankshaft is fitted with a double vibration damper instead of the single one used on the G.100 engine.

In most other respects the general design and arrangement

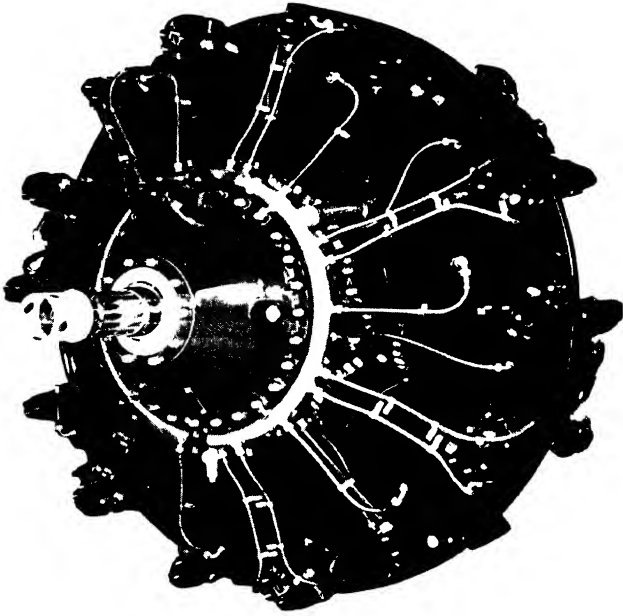

FIG. 106. Wright Double Row "Cyclone 14" fourteen-cylinder radial engine (1,600 h.p.).

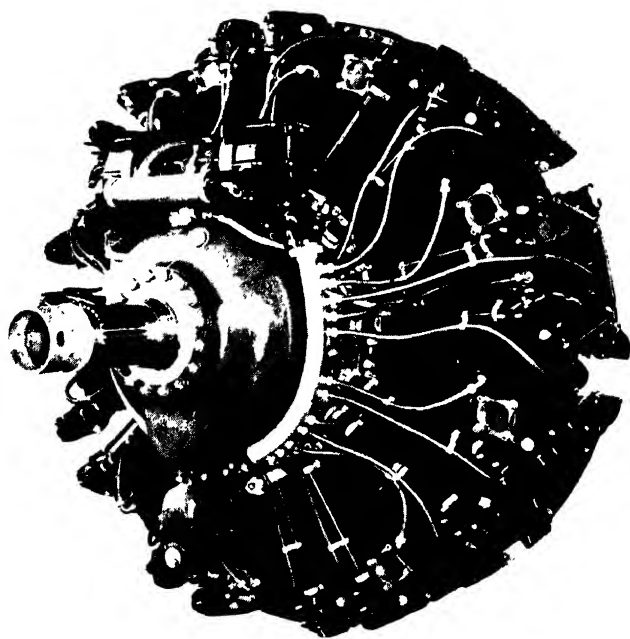

FIG. 108. Wright "Duplex-Cyclone," eighteen-cylinder two-row radial engine (2,000 h.p.).

of the G.200 engine and its accessories and their drives resembles those of the G.100 model.

The engine employs a different design of carburettor, however; this is the Stromberg injection type which introduces fuel below the throttle, thus eliminating the possibility of ice formation. It embodies an automatic mixture control which is not affected by altitude or the use of the two-speed supercharger. If inadvertently set to "weak" for take-off the mixture is corrected automatically to "full rich" and does not return to "weak" until properly throttled. An automatic load compensation device causes the mixture to remain constant for the same power at different engine speeds. The Scintilla magnetos used on this engine have a compensated spark timing device providing an equal advance on all cylinders.

A novel feature of the engine is the utilizing of engine oil pressure to turn the oil strainer at equal intervals, thus obviating a ground maintenance operation.

The Wright Double-Row Cyclone engine is an air-cooled radial one with two banks of seven cylinders each. The cylinders have a bore of 6.125 in. (155.5 mm.) and stroke of 6.312 in. (160.2 mm.) giving a cylinder capacity of 2,603 cu. in. (42.6 litres). The engine is made in several models, all of the same cylinder dimensions but with compression ratios varying from 6.3 : 1 (for 87-octane fuel) to 6.85 : 1 (for 95-octane fuel) and with single and two-speed superchargers.

The model GR2600-A5A has a take-off output of 1,600 B.H.P. at 2,400 R.P.M. and develops 1,350 B.H.P. at 2,300 R.P.M. at 5,000 ft. with the low-speed blower and 1,275 B.H.P. at 2,300 R.P.M. at 12,000 ft. with the high-speed blower.

The supercharger gear ratios are 7.14 : 1 and 10.0 : 1 and the airscrew reduction gear ratio is 0.5625 : 1; alternative ratios of 0.4375 : 1 and 0.500 : 1 are provided.

Fig. 107 illustrates the performance curves of the various models; the dotted lines give the (American) military rating outputs at different altitudes.

The overall diameter of the engine is 55 in. This gives an area of 16.5 sq. ft. and an equivalent output (take-off) of 97.0 B.H.P. per sq. ft. of frontal area. As the G.200 engine nine-cylinder radial has about the same external diameter, this result represents a considerable increase in output per sq. ft. of frontal area.

The main design features and materials of this engine are similar to those of the other more recent Wright Cyclone

engines, but the cylinder head finning is relatively deeper whilst the intake and exhaust ports are at the rear on all cylinders.

The two bronze sparking plug bushings, just above the

horizontal cooling fins of the cylinder head are located symmetrically at 90 degrees to each other, and are surrounded by deep vertical cooling fins to give a free flow of cooling air over the finned sparking plug.

The crankcase is generally similar to that of the other Cyclone engines described, except that the main or power section consists of three aluminium forgings divided at places through the centre of the cylinder locations of each bank of cylinders. They are bolted together between the cylinders of each bank. These combined main sections contain all three main crankshaft roller bearings and support the front and rear cam-gear drive assemblies, the cams and the tappet and guide assemblies. The crankshaft is of three-piece construction, and is fitted with Wright dynamic dampers on each of the two crank counterbalance weights. The crankshaft construction permits of

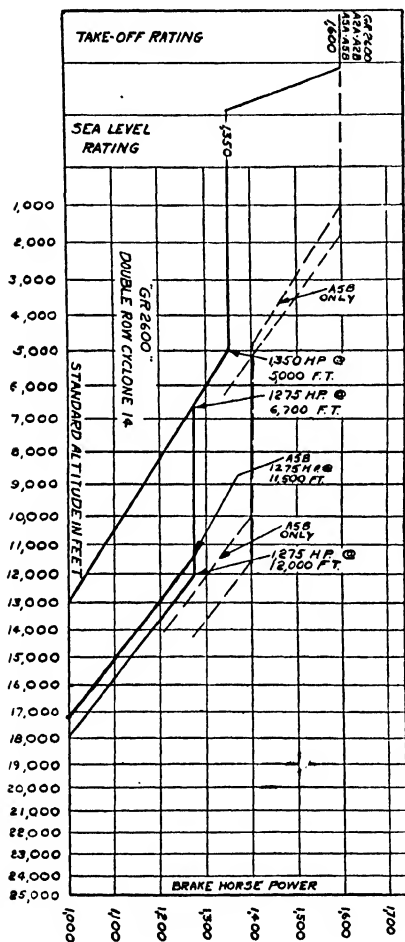

FIG. 107. Performance curves for the Wright Double Cyclone 14 engine.

the use of a single-piece master connecting rod for each bank of cylinders. Two valve operating cam-rings are employed,

each of which is supported on journals mounted on the front and rear of the main crankcase. Each cam is an alloy steel forging having two sets of cam lobes. The cams are driven through intermediate gears from two other gears, one integral with the airscrew reduction drive gear and the other attached to the rear end of the crankshaft. Both cams rotate at one-sixth crankshaft speed in a counter-crankshaft direction.

The engine employs a non-icing Chandler Groves carburettor similar to that used on the G.100 engines. Two Scintilla magnetos are provided for ignition purposes.

The more recent Wright Duplex Cyclone engine (Fig. 108) has two banks of nine cylinders each, and is rated at 2,000 h.p. It is the most powerful American air-cooled radial engine at the time of writing, and was designed for use in large passenger aircraft such as the Boeing Clipper seventy-four-passenger machine used for trans-oceanic purposes, and the U.S. Army Douglas B-19, 20-ton bomber. Detailed particulars of this engine were not available at the time of going to press with this book.

It is of interest to mention that experimental and development work is proceeding on multi-bank radial engines with take-off power outputs up to 3000 H.P.

CHAPTER V

SLEEVE VALVE AIRCRAFT ENGINES

SEVERAL alternative types of petrol engine to the poppet valve one have been constructed and tested during the past thirty to forty years. These include the rotary-valve, slide valve, cuff-valve, swash-plate, single and double-sleeve valve engines. Of all these alternatives the only ones that have survived in recent years are the sleeve and rotary valve designs.

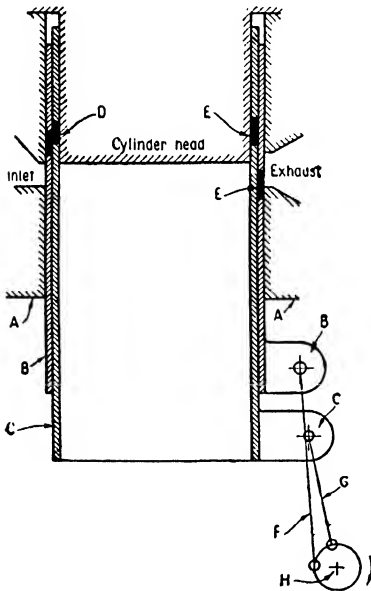

FIG. 109. Principle of the double-sleeve valve engine.

The Double-Sleeve Valve Engine. The first satisfactory sleeve-valve engine was that invented by C. Y. Knight, of Chicago, U.S.A., and constructed about 1905. This was taken up commercially in this country by the Daimler Company in 1909 and developed to a high degree so that it was able to undergo an endurance test of 137 hours, followed by a track run in a car of 2,000 miles at an average speed of 43 miles an hour. Other tests with the Knight engine were those of 337 hours in 1913 and 300 hours in 1914, thus placing the endurance and reliability of this type of engine beyond

doubt. The Knight engine was adopted as a standard car engine by the Daimler Company from 1909 until a few years ago, when the poppet valve type was reverted to.

The Knight engine employed a pair of concentric sliding sleeves between the cylinder barrel and the piston. Each sleeve was given a small up-and-down motion by means of a

crank, driven at one-half engine speed and a short connecting-rod. The upper ends of these sleeves were arranged to slide between the cylinder barrel and cylinder head, and were provided with ports to register at the appropriate moments in the cycle of operations, with the fixed inlet and exhaust valve ports in the cylinder block, as indicated diagrammatically in Fig. 109.²⁵ In this diagram A represents the cylinder and B and C the two thin sleeves for valve opening and closing purposes. These sleeves have inlet ports D, and exhaust ports E, such that by a pre-determined arrangement or timing of the movements of the sleeves, the inlet ports and exhaust ports of each sleeve respectively coincide at specified times with the fixed inlet and exhaust ports. The sleeves are operated by connecting-rods F and G, which are actuated by two cranks arranged at different phase-angles from the secondary shaft H running at half engine speed.

The sleeves therefore have an up-and-down motion, giving zero velocity at the two ends and a maximum velocity at about mid-stroke. With this arrangement the valve-ports could be given quick opening and closing operations.

The advantages of this type of engine over the poppet valve one were that it ran much quieter—since there were no valve cams, tappets, valves or other impact members—and, on account of its pocketless combustion chamber, gave a higher thermal efficiency; moreover, by suitably designing and apportioning the sleeve and cylinder ports higher volumetric efficiencies could be obtained than with the poppet valve type. Another advantage is the ability of this type of engine to stand up to long periods of operation without maintenance attention, other than replenishing the oil for lubrication. From the servicing point of view the double-sleeve valve engine requires only the substitution of the inner sleeve by a new one, without the necessity of fitting new pistons, whereas the poppet valve cylinder, if not fitted with a liner, needs re-boring and the fitting of an over-size piston.

Finally, the number of component parts of the engine is smaller than for a poppet valve engine—with its tappets, rocker arms, collars, cotters, valves and valve-springs, valve-seatings, etc.

The double-sleeve valve engine, however, had certain drawbacks which rendered it unsuitable for high performance aircraft engine purposes. The principal drawback lay in providing for the adequate lubrication of the sleeves, for there are

three separate sliding surfaces ; further, in order to ensure satisfactory lubrication the oil consumption must be increased over that of normal engines. The maximum speed of the engine was limited by problems of sleeve distortion and sleeve balance, so that it was not possible to obtain such high outputs per given cylinder volume, as with the poppet valve engine.

Other disadvantages include those of greater engine weight, higher mechanical losses (or lower mechanical efficiencies), rather higher manufacturing cost and greater difficulty in cranking over or starting under cold weather conditions, due to the frictional resistance of the sleeves.

The double-sleeve valve system was applied by M. Gabriel Voisin,²⁶ a French automobile manufacturer, in 1935, to an air-cooled seven-cylinder radial engine of 3.34 in. bore and 4.13 in. stroke, designed to develop 120 B.H.P. at 3,000 R.P.M. for a weight of 460 lbs., complete with carburettor and ignition equipment. The engine is shown in side-sectional and front views in Fig. 110,² the following being a key to the lettering on the illustrations :—

A, inlet piping cast integral with the front cover ; B, cylinders in two parts assembled by means of bolts ; C, sparking plug and mounting for same ; D, magnesium alloy piston with three compression rings and one oil-control ring ; E, master-rod with roller bearing, pressure-lubricated ; F, roller bearing of master-rod ; G, short connecting-rods for the valve sleeves ; H, eccentrics operating the short connecting-rods of the sleeves ; I, planetary pinions operating the connecting-rods of the valve gear ; J, two-piece crankshaft ; K, counterweight on crank arms ; L, pinion and gear of pump drive ; M, cast-iron valve sleeves ; N, guides for valve sleeves which obviate the risk of breaking of the sleeves ; O, starting crank coupling ; P, point of entry of oil under pressure into the crankshaft ; Q, link rods ; R, exhaust ; S, flywheel enclosing the clutch comprising a torus dragged along by oil and held in the end position by an electro-magnetic plate ; T, oil-pump driving shaft ; U, oil pump ; V, aluminium cylinder head in which are chill-cast two steel parts, for supporting the spark plug and the junk ring respectively ; X, cross-bar of valve gear assuring the proper spacing of the planetaries operating the eccentrics.

Various improvements were made to the Daimler Knight engine during the relatively long period in which it was employed for automobiles. The later engines had steel in place

of the earlier cast-iron sleeves and were fitted with aluminium alloy pistons. In regard to their performances, B.M.E.P. values up to about 122 lbs. per sq. in. were obtained from a

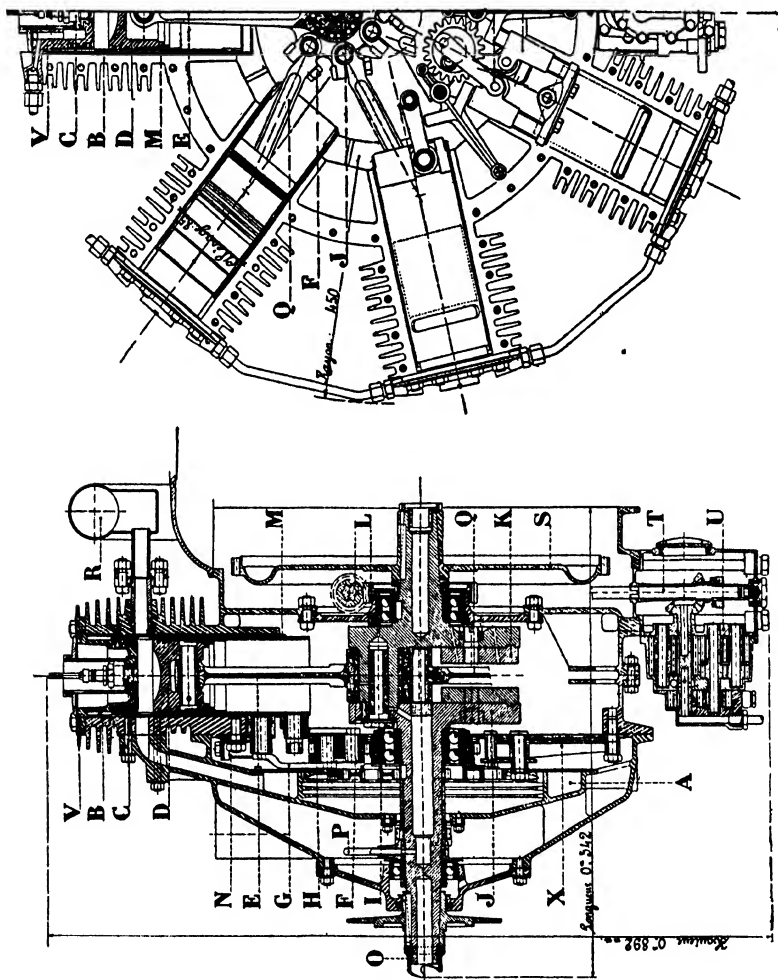

FIG. 110. The Voisin double-sleeve valve seven-cylinder radial engine.

97 mm. bore engine at 1,500 R.P.M., the lowest petrol consumption being 0.60 pint per B.H.P. hour, corresponding to 23.7 per cent. brake thermal efficiency for a compression ratio of 5 : 1. The mechanical efficiency was 81 per cent., and oil consumption 0.04 pint per B.H.P. hour.

It is not proposed to consider the double-sleeve valve engine more fully in view of the fact that it has not proved suitable for aircraft purposes, but the information previously given should serve to indicate the advantages of this type and to emphasize the value of the improved single-sleeve valve engine now to be considered.

The Single-Sleeve Valve Engine. The principal disadvantages of the double-sleeve valve type, namely, in regard to weight, mechanical efficiency and lubrication, have been largely overcome in the case of the single-sleeve valve type—sometimes referred to as the “mono-sleeve” valve engine.

In this design, which was invented jointly by P. Burt, of the Argyll Company, and a Canadian engineer, J. McCollum, in 1909, the two sleeves of the former type are replaced by a single sleeve which is given a combined vertical and peripheral movement in order to obtain the proper valve opening and closing sequences. Incidentally, this combined movement of the sleeve greatly simplifies the lubrication of the outer surface of the latter and that of the cylinder wall by distributing the oil more uniformly.

The Burt McCollum engine has been built commercially for cars by the Argyll Company and the Vauxhall Motor Company (1925); motor cycle single-sleeve valve engines were made by the Barr and Stroude Company for several years.

In 1914 a single-sleeve valve aircraft engine made by the Argyll Company was entered for the Naval and Military Aeroplane Engine Competition initiated by the Government, and was awarded a prize of £100. This engine was a water-cooled six-cylinder vertical model of 785 cu. in., and developed 130 B.H.P. This engine demonstrated the sleeve valve principle very favourably, but unfortunately experienced constant trouble with its crankshaft.

Progress with the sleeve valve engine was revived after the War of 1914–1918, and a considerable amount of pioneer work was carried out by H. Ricardo; this was referred to in promising terms in the Aeronautical Research Committee's Report for 1925–1926. In the latter year this type of engine was taken up, experimentally, by the Bristol Aeroplane Company Ltd., and has subsequently been developed until, to-day, it has not only proved a commercial success, but is threatening seriously to replace the air-cooled radial poppet valve engine. It should be mentioned that in 1927 the Continental Motors Corporation of America produced a single-sleeve valve engine

of the nine-cylinder type. It had a cylinder capacity of 787 cu. in. and developed 220 B.H.P.

The Working Principle. The principle of operation of the single-sleeve valve engine is illustrated in Fig. III.²⁵ This diagram shows only the single sleeve or working liner and the part of the cylinder containing the valve ports. The piston is arranged to reciprocate in this sleeve, and the latter is constrained to move both up and down and sideways, so that any point on it describes an ellipse. One method of obtaining this motion is that shown, whereby the gear-shaft A, driven at one-half engine speed by chain or gear-wheels from the crankshaft, engages with the sleeve-operating crank gear B, through spiral gearing, for the axes of A and B are at right angles. The gear B carries a Tee-headed type of crankpin C, which is attached to the sleeve valve D by a pin E and held between suitable lugs on the sleeve. The crankpin C is free to rotate, and can also slide endwise in a bearing contained in the gear B; it can also swing sidewise about the pin E anchored in the sleeve lugs. This mechanism causes the sleeve to have the desired "elliptical" motion for the valve port events. The sleeve near its upper end is provided with ports of special shape, usually varying from four to six in number.

The general arrangement of these valve ports is such that one-half of them form the inlet ports on one side, and the other half the exhaust ports on the other side of the sleeve. There are, however, several alternative arrangements for the ports, some of which are illustrated in Fig. 112. In the lower arrangement the sleeve ports are all double-acting, *i.e.*, they are alternatively inlets and exhausts; this gives a larger valve

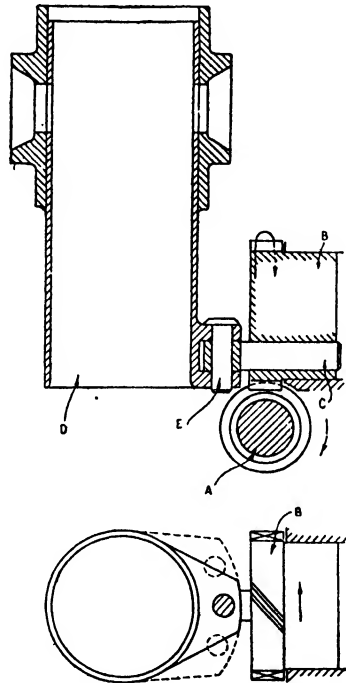

FIG. III. Principle of the single sleeve-valve engine.

of the latter cases the cylinder ports are sealed by the plain parts of the sleeve. (5) Towards end of firing stroke, exhaust ports about to open ; and finally, (6) Exhaust ports fully open —as shown by the white spaces on the left.

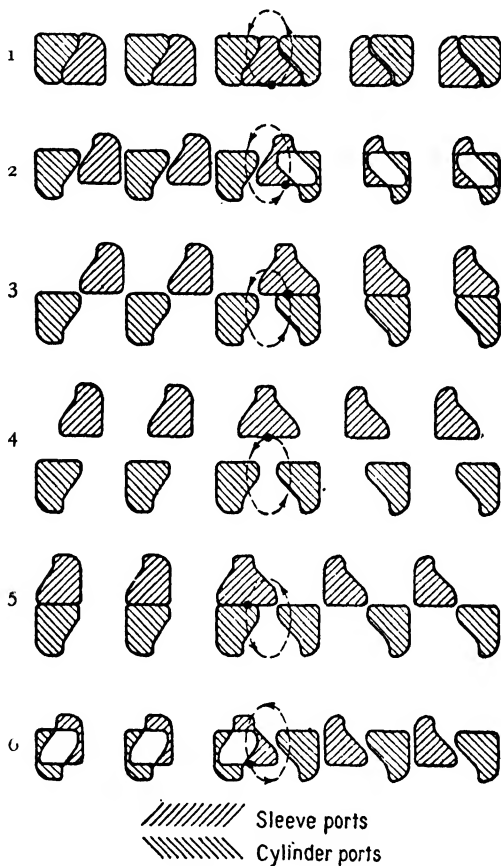

FIG. 113. Sequence of valve port openings and closing in five-port engine.

By suitably shaping and positioning the sleeve and valve ports the valve timing can be varied to any desired extent ; the valve port areas can also be designed, within practical constructional limits, to give the maximum volumetric efficiency.

Further, it has been shown possible to shape the inlet sleeve and valve ports so as to obtain rotational movement of the fresh

charge in order to promote a higher degree of turbulence. This method has been used by Ricardo in connection with his "rotational swirl" system for the air charge of a single-sleeve valve compression-ignition engine.²⁷ It may also be mentioned that the single-sleeve valve engine can readily be arranged to operate on the two-cycle principle.

The Argyll Aircraft Engine.

This engine (Fig. 114) built for the 1914 Naval and Military Aeroplane Competition, was the first aircraft model using the single-sleeve valve principle.

It was a six-cylinder in-line engine of 125 mm. bore and 175 mm. stroke, giving a swept volume of 12.885 litres (about 785 cu. in.). It had a compression ratio of 4.5 : 1, and on the test bench gave a maximum B.H.P. of 131 at 1,300 R.P.M. The maximum value of the B.M.E.P. was 110 lbs. per sq. in. at 1,000 R.P.M.

The mechanical efficiency varied from about 89 per cent. at 600 R.P.M. to 85 per cent. at 1,200 R.P.M.

The petrol consumption in the competition was 0.63 pints per B.H.P. hour, and the corresponding brake thermal efficiency 23.6 per cent. The oil consumption was 0.067

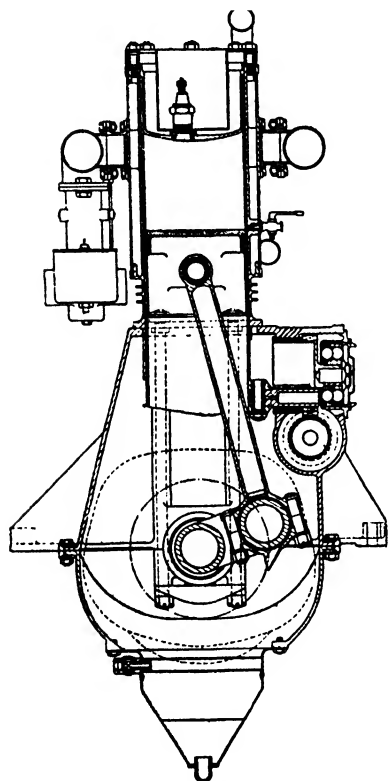

FIG. 114. The Argyll single-sleeve valve aircraft engine.

pints per B.H.P. hour over a ten-hour run. The engine had a dry weight of 5.4 lbs. per B.H.P.

The upper ends of the sleeves were located between the steel cylinder heads and the steel cylinder barrels, no sealing or junk rings being employed. The sleeves were made of cast iron, whilst the pistons and connecting rods were of steel. Pressure-fed oil at 25 lbs. per sq. in. provided for the lubrication

of the working parts, the dry-sump principle being employed. The crankcase top and bottom halves, were aluminium castings, with a sheet metal oil sump which carried the connecting-rod troughs.

It may be of interest to mention here that an Argyll racing-car engine using single-sleeve valves broke a number of world's records at Brooklands in 1913. Rated at 17.3 h.p. it had four cylinders each of 83.5 mm. bore and 130 mm. stroke; the stroke of the sleeves was 1.5 in. The compression ratio used was 5.6 : 1. The engine gave 75 B.H.P. at 3,200 R.P.M. and a B.M.E.P. of 115 lbs. per sq. in. at 2,400 R.P.M. The inlet valve ports opened on top dead centre, and closed 30 degrees after bottom dead centre. The exhaust ports opened at 60 degrees before bottom dead centre, and closed 15 degrees after top dead centre.

In concluding this brief historical survey it may be mentioned that Messrs. Panhard and Levassor some sixteen years since constructed a twelve-cylinder Vee-type double-sleeve valve aircraft engine with steel cylinders and welded on jackets, aluminium pistons and hollow circular section connecting-rods. The engine gave 450 B.H.P. at 1,500 R.P.M. and 550 B.H.P. at 1,800 R.P.M. for a weight of 1,160 lbs., *i.e.*, about 2 lbs. per h.p. The B.M.E.P. at 1,800 R.P.M. was 126 lbs. per sq. in. with a compression ratio of 5 : 1; the maximum output mentioned is equivalent to 17.5 B.H.P. per litre.

Development of Sleeve Valve Engines. Whilst the design and performances of the earlier single-sleeve valve engines were meritorious, it was evident that a considerable amount of development was necessary if these engines were to compete with the poppet valve type. In particular the problems of cylinder cooling, lubrication, engine materials, the drive for the sleeve, combustion chamber and valve port design had to be considered and research work undertaken to overcome some of the earlier difficulties experienced.

The Bristol Aeroplane Company in 1927 constructed the first single-sleeve valve engine²⁸ in the form of a Vee-twin-engine of 5½ in. bore and 6 in. stroke; this developed a B.M.E.P. of 135 lbs. per sq. in. at 2,000 R.P.M. Certain practical difficulties were, however, experienced in connection with the material of the sleeves. The original nickel cast-iron ones were found to crack and puncture. Ordinary steel and soft steel sleeves were then tried, but without satisfactory results. Finally, it was found that nitrided steel sleeves with aluminium

alloy barrels and cylinder heads, suitable finned, gave very promising results. In this way it was found possible to reduce cylinder head temperatures by 50° C. and at the same time to obtain a B.M.E.P. of 145 lbs. per sq. in. at 2,000 R.P.M. After a further period of research with single-cylinder units, it was

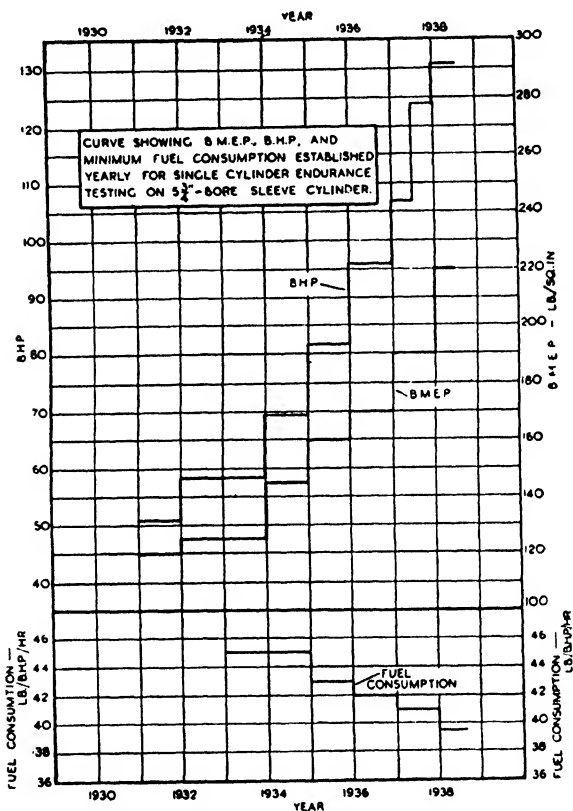

FIG. 115. Illustrating progress in the development of the Bristol sleeve-valve engine.

found that endurance runs of 100 hours could be made without adjustment, at 2,000 R.P.M. and 120 lbs. per sq. in. B.M.E.P.

Since 1930 a progressive development has occurred in Bristol sleeve valve engines, whereby the B.H.P. and B.M.E.P. have been increased and the fuel consumption reduced, whilst the cylinder and cylinder head cooling difficulties have been overcome satisfactorily.

Fig. 115 illustrates the advances in power output, B.M.E.P. and fuel consumption made on Bristol $5\frac{3}{4}$ in. diameter single-cylinder units, over a period of years. It will be observed that the B.H.P. has been increased by about 180 per cent. and the B.M.E.P. by about 83 per cent., whilst the fuel consumption per B.H.P. hour has been reduced by about 13 per cent.

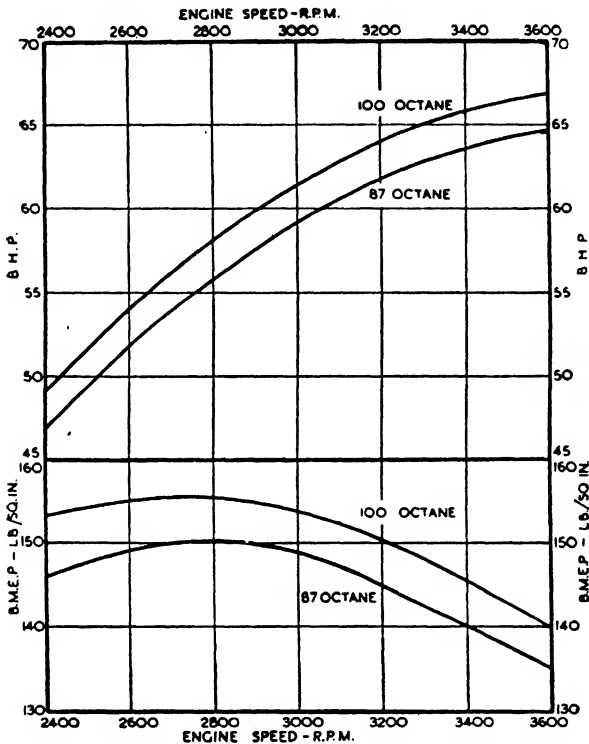

FIG. 116. Performance curves for Bristol "Aquila" size single-sleeve valve cylinder.

The results of most of this research and development work on $5\frac{3}{4}$ in. bore and other sizes of cylinder have been applied to the radial air-cooled engines now in regular production, but it is of interest to note that in 1931 the development of a high-speed twelve-cylinder Vee-type engine was considered, and an experimental six-cylinder vertical engine of $4\frac{1}{2}$ -in. bore by $4\frac{1}{2}$ -in. stroke was actually built by the Bristol Aeroplane Company.

The first complete Bristol sleeve valve engine was the nine-cylinder air-cooled radial of $5\frac{3}{4}$ in. bore and $6\frac{1}{2}$ in. stroke, giving 24.9 litres cylinder capacity, known as the "Perseus"; this engine completed its official trials with marked success. A

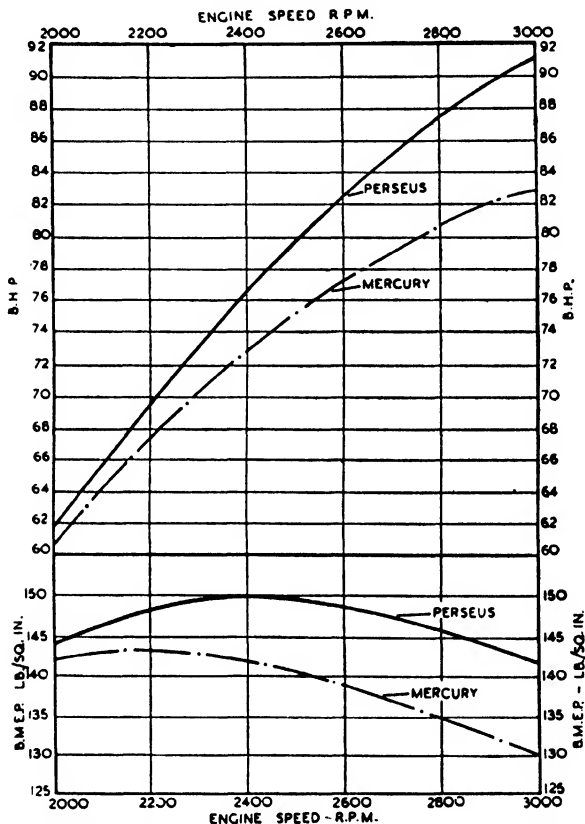

FIG. 117. Comparison power curves for "Perseus" sleeve valve and "Mercury" poppet valve units. Compression ratio was adjusted to give similar detonation characteristics. 87-octane fuel. Full throttle. Normal aspiration.

similar engine, but with a 5-in. bore and $5\frac{3}{8}$ -in. stroke, giving 15.6 litres, known as the "Aquila," completed its type trials in 1934 and has since been actively developed for medium-sized commercial aircraft.

The power curves for the "Aquila" size cylinder are given in Fig. 116 for both 87- and 100-octane fuels and without super-

charging. In each instance the compression ratio was adjusted in order to give similar detonation characteristics for main engine operating conditions at appropriate ratings. These results also illustrate the marked improvement made possible by the adoption of 100-octane fuel.

TABLE II. COMPARISON OF SLEEVE AND POPPET VALVE ENGINES

Cylinder type	Perseus	Mercury	
Valving	Sleeve	4 poppet push rod	
Bore and stroke in.	5½ × 6½	5½ × 6½	
Displacement cu. in.	168.8	168.8	
Cylinder assembly weight lbs.	42.1	46	
Cooling fin area sq. in.	2,970	2,364	
Peak power naturally aspirated	{ B.M.E.P. . . lbs./sq. in.	138	130
	{ R.P.M.	3,200	3,000
	{ B.H.P. per sq. in. piston area	3.62	3.20
	{ Mean piston speed ft./min.	3,460	3,250
Sustained power for 100 hours 87-octane fuel	{ B.M.E.P. . . lbs./sq. in.	190	165
	{ R.P.M.	2,800	2,650
	{ B.H.P. per sq. in. piston area	4.37	3.59
	{ Mean piston speed ft./min.	3,040	2,870
Sustained power for 100 hours 100-octane fuel	{ B.M.E.P. . . lbs./sq. in.	220	185
	{ R.P.M.	2,800	2,750
	{ B.H.P. per sq. in. piston area	5.05	4.18
	{ Mean piston speed ft./min.	3,040	2,980

The success experienced with the single-row radial sleeve valve engines has been followed by the development of a double-row fourteen-cylinder radial, known as the "Hercules" of 38.7 litres (2,360 cu. in.) capacity.

Sleeve and Poppet Valve Comparative Results. Some interesting results concerning the relative performances of similar dimension sleeve and poppet valve engines have been given by A. H. R. Fedden,²⁸ and are here reproduced in both tabular and graph form. The "Perseus" and "Mercury" engine cylinders were each of 5½ in. bore and 6½ in. stroke, the former

having a single-sleeve valve and the latter two inlet and two exhaust valves of the overhead type. Table II refers to single cylinder engine units capable of maintaining their power for at least 100 hours without maintenance attention.

The results given in Table II show that for equal cylinder displacements the sleeve valve unit is about 9 per cent. lighter

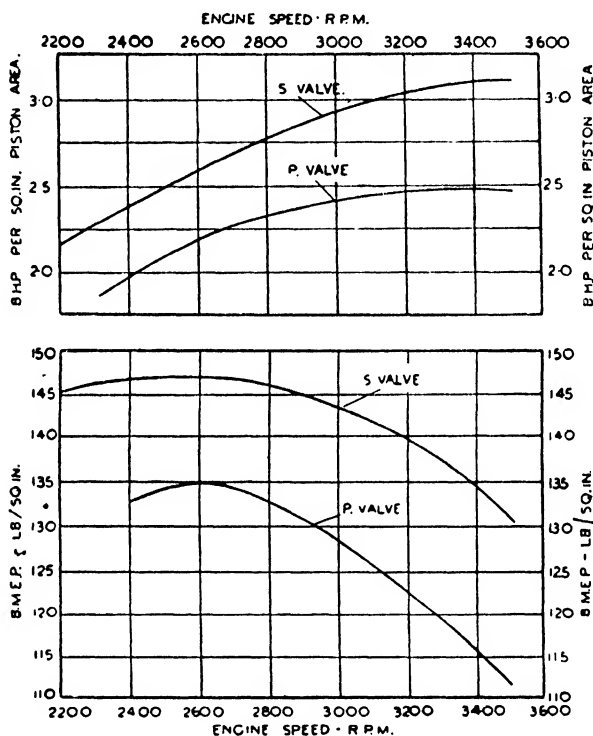

FIG. 118. Comparative power curves for 98.2 cu. in. poppet valve unit and 105.6 cu. in. sleeve valve one. Compression ratio was adjusted to give equal detonation characteristics. 87-octane fuel. Fuel consumption, Aquila 0.48 lb. per B.H.P. hour.

in weight, despite the greater fin area and under similar fuel conditions gives appreciably more power at a slightly higher mean piston speed. With the 100-octane fuel the power per sq. in. of piston area is about 20 per cent. greater than that of the four-valve poppet engine.

The comparative results for a sleeve valve engine of 5 in. bore and $5\frac{3}{8}$ in. stroke and a two-valve poppet engine of 5 in.

bore and 5 in. stroke, are even more striking. Although the cylinder displacement of the former is only about 7.5 per cent. greater, the B.H.P. per sq. in. of piston area at 3,600 R.P.M. was 3.37 with 87-octane fuel as against 2.525 at 3,300 R.P.M. for the poppet engine—an increase of about 33.5 per cent.

With 100-octane fuel the sleeve valve engine gave 5.36 B.H.P. per sq. in. of piston area at 3,300 R.P.M. ; unfortunately no results were available for the poppet valve engine operating on this fuel.

Fig. 118 shows the comparative power curves for these two engines under ordinary aspiration conditions and for the compression ratios adjusted in each case to give similar detonation conditions when running on 87-octane fuel ; the fuel consumption for the sleeve valve engine was 0.48 lb. per B.H.P. hour. The cylinder displacements of the sleeve and poppet valve engines were 105.6 and 98.2 cu. in., respectively. The marked superiority of the sleeve valve engine is due mainly to its better "breathing capacity," *i.e.*, its high volumetric and combustion efficiencies.

Fuel Consumption Loop. The method of plotting fuel consumptions per B.H.P. hour against corresponding values of B.M.E.P. affords a valuable indication of studying the effects of mixture variation upon power output, as explained on p. 140, Volume I of this work.

Fig. 119 shows the fuel consumption loop for the Bristol "Perseus" sleeve valve engine and also includes information on the ignition timing and cylinder head temperatures. The portion of the lower curve between B.M.E.P. values of 125 and 145 is almost flat, thus indicating the marked fuel economy over this range of powers, *viz.*, about 0.40 lb. per B.H.P. hour. The maximum B.M.E.P. of about 148 lbs. per sq. in. corresponds to a fuel consumption of 0.46 lb. per B.H.P. hour and a cylinder head temperature of about 217° C.—which is appreciably lower than the maximum of 225° C.

The results expressed by the fuel consumption loop emphasize the smoothness of running under extreme fuel economy conditions, and the stable character of the curve in question.

Future Developments of the Sleeve Valve Engine. Although the single-sleeve valve engine has only received a relatively limited amount of research attention in comparison with the poppet valve aircraft engine, there are definite indications that it has a most promising field of development. In this connection mention may be made of some research results obtained

by the Bristol Aeroplane Company,²⁷ in which an endeavour was made to discover the limit of power output from a sleeve valve engine. The test was not conclusive, however, as the limit proved to be unattainable with the supercharger available.

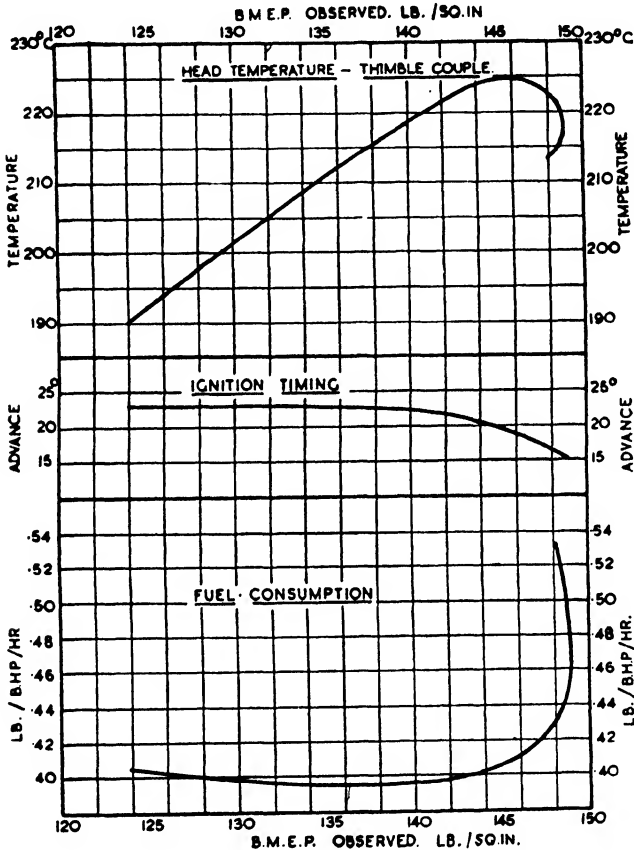

FIG. 119. Fuel consumptions and cylinder head temperatures of "Perseus" engine unit.

The results are, nevertheless, considered to be outstanding, and it is believed that the powers obtained could not be approached with a poppet valve unit under similar conditions. With a boost of 14 lbs. per sq. in. and a cylinder of 168.8 cu. in. capacity, the B.M.E.P.'s obtained were 305 lbs. per sq. in. at 2,400 R.P.M. and 272 lbs. per sq. in. at 3,000 R.P.M. The

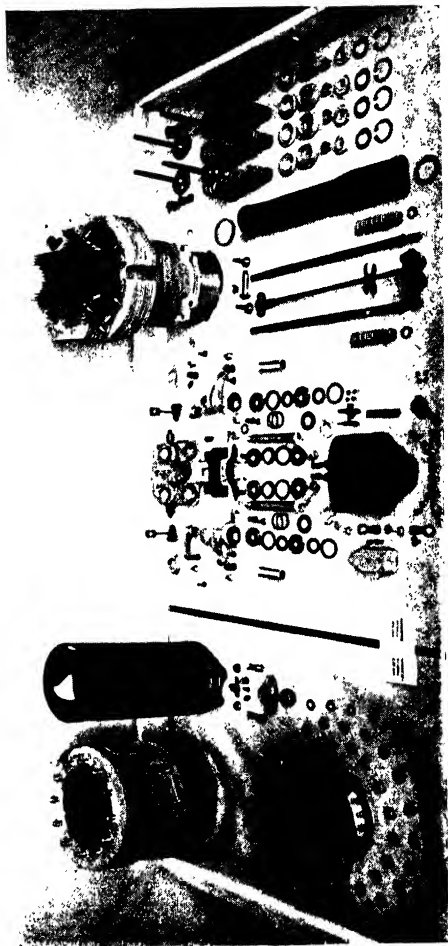

FIG. 120. Illustrating the relatively small number of cylinder unit parts of the sleeve valve engine (L. H. side) as compared with poppet valve engine (R. H. side).

corresponding powers per unit piston area are 6.0 B.H.P. per sq. in. and 6.7 B.H.P. per sq. in. If the above figures are corrected for the power absorbed by the separately driven blower, the B.M.E.P.'s are 276 lbs. per sq. in. at 2,400 R.P.M. and 245 lbs. per sq. in. at 3,000 R.P.M., whilst the powers are 5.4 B.H.P. per sq. in. and 6.0 B.H.P. per sq. in. The conditions of the test, it was stated, were in no way arranged to be unusually favourable for the production of a high output. Thus, the intake temperature was high, namely, 95° to 100° C. and the fuel was a commonly-used mixture of about 100-octane rating. The fuel consumption was 0.63 lb. per B.H.P. hour.

Mention may also be made of some exceptionally good results obtained by Ricardo from a small sleeve valve engine²⁹ as long ago as 1930, when an experimental engine ran heavily supercharged for several hundred hours on ordinary aviation spirit at a B.M.E.P. of over 400 lbs. per sq. in. and gave a specific output at least three times as great as that of existing poppet-valve aircraft engines, without any signs of distress, or overheating of the engine. With a special high octane fuel the engine would maintain a B.M.E.P. of 550 lbs. per sq. in. With these high degrees of supercharging the exhaust is discharged from the cylinder at pressures of 300 lbs. per sq. in. and above so that the question arises as to whether it would not be feasible to utilize some of this pressure energy by arranging for the exhaust to operate in a low-pressure cylinder. In this connection, the compounding of the engine is possible since the same sleeve valve can be arranged to operate as both inlet and exhaust valve to the high-pressure and as the inlet valve to the low-pressure cylinder. In this way, greater fuel economy could be obtained and a high power-to-weight ratio. The Ricardo engine, with a bore of 2½ in. and stroke of 3½ in. ran at speeds of 5,000 to 6,000 R.P.M. and gave well over 100 B.H.P. per litre. Owing to its relatively small size it was possible to employ a high compression ratio, namely, of 6.8 to 1.

Some Inherent Advantages. The comparatively high performances of recent single sleeve valve engines are due to certain inherent advantages over the poppet valve engine, which may conveniently be summarized as follows:—

(1) *Absence of Exhaust Valve.* It is a well-known fact that one of the power limiting factors in the poppet valve engine is the working temperature of the exhaust valve and its mechanical strength at this temperature. The exhaust valve is the hottest part of the combustion chamber system, and its temperature

limits the power output, since the detonation tendency for any fuel is governed by the maximum cylinder temperature ; moreover, the volumetric efficiency is reduced progressively as the temperature of the cylinder increases. The effect upon the power output of exhaust valve temperature has been investigated by Dr. Gibson ³⁰ in the case of air-cooled cylinders fitted alternately with ordinary exhaust valves and specially designed exhaust valves of the internal liquid cooled type, fitted with radiating surfaces on the stems.

In one set of tests made at a speed of 1,800 R.P.M. and compression ratio of 5.5 to 1, the exhaust valve working temperature was 750° C., and the maximum B.M.E.P. 127.5. When fitted with the cooled exhaust valve, the temperature was found to be 300° C. and the value of the maximum B.M.E.P. was increased to 133 lbs. per sq. in. The petrol consumption was reduced from 0.615 to 0.59 pints per B.H.P. hour with the substitution of the cooled valve. It was also found that the average temperature of the cylinder head was reduced by 26° C. and of the piston, at its hottest part, by 25° C. In general, as a result of numerous tests made upon different cylinders it was concluded that on the average from 2 to 3 per cent. more power was obtainable on account of the cooler exhaust valve.

(2) *Greater Volumetric Efficiency.* Apart from the improved charge efficiency due to the absence of a hot exhaust valve, the sleeve valve engine, owing to its relatively greater inlet port areas enables an increased weight of charge to be taken into the cylinder. Similarly, during the exhaust event, owing to the freer flow through the ports of the burnt gases, the residuals in the cylinder at the end of the exhaust stroke are at a lower pressure, thus assisting also in obtaining a higher charge efficiency.

(3) *Better Combustion Chamber Shape.* Although it is possible with the poppet valve engine to approximate to the ideal combustion chamber shape, this necessitates the use of inclined valves and a more complicated valve mechanism. The sleeve valve engine combustion chamber, on the other hand, can be made to any approved symmetrical form with the sparking plug central and with a complete absence of pockets, and valve heads ; moreover, the cylinder head can also be made to a more simple design since there are no valve seatings or special cooling areas, other than that of the sparking plug housings. In aircraft engines two sparking plugs must be

fitted per cylinder ; in the single-sleeve valve engine these are arranged side-by-side in the cylinder head, with relatively long stems, since the head is of the sunk pattern.

(4) *Higher Compression Ratios.* For the same cylinder dimensions it is possible, for the reasons given, to employ higher compression ratios—and also boost pressures—than for a poppet valve engine. In practice the compression ratio may be raised from about 8 to 15 per cent. over that of the poppet valve engine of similar dimensions, etc. Further, it has been shown that if, owing to unsuitable fuel or too high a compression, detonation does occur, this is invariably less violent in its effects than in the poppet valve engine. Another important point is that the sleeve valve engine will operate more smoothly on weaker mixtures—a fact which is borne out by the fuel consumption loop curves previously mentioned.

(5) *Reduced Maintenance Attention.* Owing to the absence of valve gear the maintenance attention is markedly less than for the poppet valve engine.

(6) *Greater Simplicity and Fewer Parts.* With the elimination of valve cams, tappets, push-rods, valve units, etc. (Fig. 120) the general design of the engine is simplified and, owing to the symmetry of the cylinder units, a better external design of engine results. Further, there is a complete enclosure of all working parts and absence of external oil leads—generally necessary for overhead poppet valve engines.

(7) *More Silent Operation.* The substitution of a single sleeve operating in a well-lubricated cylinder barrel, for the usual valve-operating mechanism, results in the elimination of the noise associated with the latter ; sleeve valve engines are noticeably quieter in their operation on this account.

Other advantages include the relative simplicity of the major parts which enables accurate repetition machining to be done ; reduced production cost ; good accessibility ; cooler exhaust ; freedom from lead and also cold corrosion and, in general, smoother running—more particularly under weaker mixture conditions.

It is possible, as stated previously, to obtain any desired degree of charge turbulence by means of the port design ; this is a useful factor in petrol-injection and compression-ignition engines. In regard to reliability, from the earliest tests upon sleeve valve engines it has been shown that they can be made to operate over comparatively long periods without maintenance attention or loss of power. Although the modern aircraft

poppet valve engine has attained a high standard of reliability, the single-sleeve valve has achieved this same standard with less development work, owing to its inherent simplicity of design and absence of the usual valve mechanism.

Some Practical Difficulties. The development of the single-sleeve valve engine has been associated with the solving of certain practical difficulties including those of maintaining satisfactory gas tightness of the sleeve and cylinder head joint ; the lubrication of the sleeve ; the selection of the most suitable metals for the cylinder, sleeve and piston from the point of view of correct expansions and maximum wear period ; the adequate cooling of the cylinder head and the satisfactory design of the sleeve-operating gear in order to avoid premature wear effects. Another important item is in connection with the cold starting of the engine in view of the relatively large viscous film area between the sleeve and the cylinder barrel and the usual piston and cylinder barrel. In the case of air-cooled engines the cylinder, sleeve and head cooling problems have been more difficult than for the poppet valve engine. Yet another drawback to many designs of sleeve valve engine has been that of excessive oil consumption ; this was more particularly the case with the double-sleeve valve engine.

That these difficulties have been satisfactorily overcome, as a result of careful research and development work on the part of the engineer and metallurgist is evident from the performance results previously given and from the fact that air-cooled radial sleeve valve engines have been in commercial production and in use on both civil and military aircraft in this country for some appreciable time.

The use of an aluminium alloy cylinder and piston necessitates the employment of a sleeve material of ample strength and with a thermal coefficient of expansion approximating to that of the aluminium alloy. In this connection it has been found that there is a nickel-chrome-iron alloy of practically the same expansion as the aluminium alloys used for the cylinder and piston. It has been the experience of the Bristol Aeroplane Company that nitrided KE965 steel sleeves give satisfactory results with aluminium alloys. It may also be mentioned that, with the aid of suitable alloying elements, steels with high expansion coefficients are now a commercial proposition.

The difficulties associated with the carbonizing of the junk

rings on the cylinder head—which ensure gas-tightness of the sleeve—have been overcome by improved cylinder head design and special finning. Lubrication troubles associated with the double-sleeve valve engine are not experienced with the modern single-sleeve one, owing to the spreading action of the oil between the sleeve and cylinder barrel due to the elliptical motion of the sleeve. The fact that there is a very little wear between the sleeve and cylinder barrel, even after thousands of hours running, is evidence of the satisfactory lubrication of the surfaces in question.

The Sleeve Drive. The sleeve-operating mechanism troubles of earlier engines have been overcome and the somewhat excessive wear reduced down to about the same proportions as the other wearing parts of the engine. The Bristol sleeve drive employs a spherically seated bearing for the sleeve (Fig. 121), which can swivel so as to remain in line with the operating pin of the crank; the latter is driven by a train of gears inside the front cover of the engine.

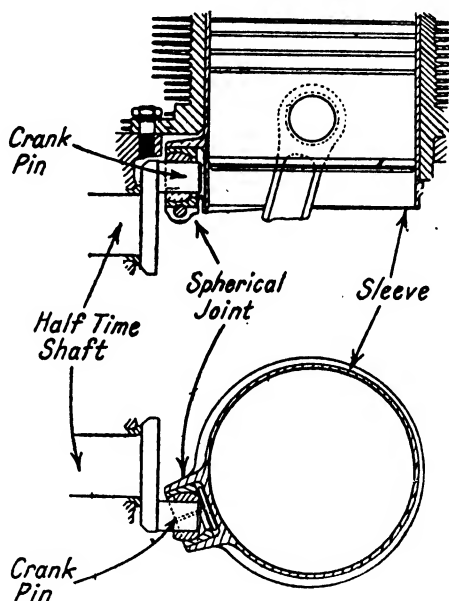

FIG. 121. Method of operating the sleeve.

is driven by a train of gears inside the front cover of the engine.

The spherical bearing arrangement appears to have overcome satisfactorily the earlier troubles experienced with the sleeve drive. The motion provided by this drive is an elliptical one in which the vertical motion is approximately 50 per cent. greater than the horizontal one.

Lubricating Oil Consumption. The earlier double sleeve valve engines were somewhat notorious in the matter of oil consumption on account of the relatively large sleeve areas to be lubricated. In the case of the single sleeve, however, the

satisfactory distribution of the oil produced by the oval motion results in oil economy, although it must be remembered that the area of the sleeve oil film is about twice that of the poppet-valve engine cylinder wall; further, the upper part of the sleeve, on both sides, is exposed to relatively high temperatures during combustion. Another factor is the necessary transmission of heat from the cylinder, through an oil film, the sleeve and another oil film to the cylinder wall but, as there is no hot exhaust valve to radiate heat to the piston, the temperature of the latter is generally lower than in the poppet engine of similar compression ratio and fuel conditions.

From these considerations one would anticipate that the oil consumption must be greater than in the corresponding size of poppet valve engine. On the other hand, the absence of valve tappets, rocker-arm bearings and valve guides—all of which must be properly lubricated—effects a certain saving of oil.

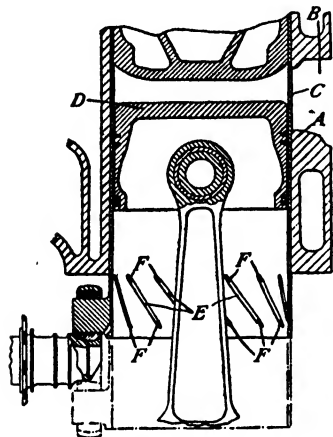

FIG. 122.

The Bristol sleeve valve engines claim low oil consumptions, due to special attention having been given to the subject, and it is stated that the oil consumptions are approximately the same in similar sizes of their poppet and sleeve valve engines. Thus, in both the "Perseus" and "Mercury" engines the con-

sumption lies between 6 and 12 pints per hour.

A method of minimising lubricating oil consumption in sleeve valve engines³¹ is illustrated in Fig. 122. It has been found that in some instances oil on the wall of the cylinder, passing by the scraper rings and reaching the combustion space results in excessive oil consumption. To prevent this it has been customary to provide holes through the piston placing the scraper ring groove in communication with the interior of the piston. In some instances, however, more especially in the case of engines having horizontal cylinders, this has not always been found satisfactory. The engine shown in Fig. 122 comprises a water-cooled cylinder A having inlet and exhaust ports, one of which is shown at B, controlled

by a sleeve valve C. Arranged to reciprocate within the bore of the sleeve valve is a piston D having two pressure sealing rings and two scraper rings. Formed in the bore of the sleeve valve C adjacent to its lower end is a series of inclined grooves E, the inclination of these grooves being approximately 45 degrees to the cylinder axis and their disposition being such that at the lowest position of the piston relatively to the sleeve the scraper rings lie adjacent to or below the lower ends of the grooves while the pressure sealing rings lie above the grooves. The upper end of each groove overlaps in a circumferential direction the lower end of the adjacent groove and each groove is provided adjacent to its ends with holes F which pass through the wall of the sleeve into the crankcase. The motion of the sleeve in relation to the disposition of the grooves that during the initial part of its movement the rotational movement is such that the upper end of each groove lies circumferentially in advance of the lower end of the groove. Rotational motion in this direction continues throughout approximately half the downward movement of the sleeve, with the result that the grooves tend to have a pumping action, so to speak, scraping oil from the surface of the piston and drawing this oil downwards and delivering it through the holes directly from the grooves into the crankcase.

Some General Considerations. In regard to the *mechanical efficiency* of the single-sleeve valve engine there is little publicly available data, but it is known that in the case of two similar air-cooled radial engines, namely, the sleeve valve "Perseus" and the poppet valve "Mercury" engines there is no measurable difference in mechanical efficiency up to the highest speeds at which the engines can be motored.

Concerning the *cold starting* of single-sleeve valve engines, it is a fact that there is a much greater area of viscous oil film and that this must offer a higher resistance to engine cranking. Cold tests made upon a "Perseus" and also a poppet valve "Pegasus" engine at various engine temperatures ranging from -15°C. to $+15^{\circ}\text{C.}$ indicate that the additional starting load is not more than about 10 per cent. at -15°C. and 14 per cent. at $+15^{\circ}\text{C.}$ The results of these tests are shown graphically in Fig. 123.

Tests that have been carried out under winter conditions, in Canada, indicated that no starting difficulties were experienced even at temperatures of -20°C. without external heating.

The question of *oil cooling* is one requiring special attention in sleeve valve engine design since the oil films must transmit an appreciable proportion of the combustion heat to the cylinder walls and cooling fins. Some figures given by Fedden ⁴ indicate that the percentage of h.p. to the oil in the case of

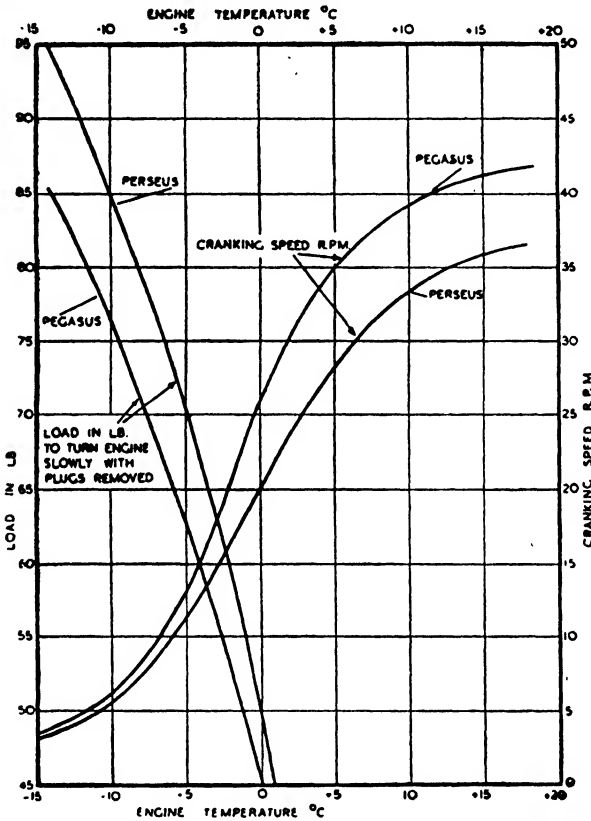

FIG. 123. Cranking test results for "Perseus" sleeve valve and "Pegasus" poppet valve engine.

the poppet valve "Mercury" engine was 3.9, whereas in the sleeve valve "Perseus" it was 5.5. The oil return in gallons per B.H.P. hour was 0.33 for the "Mercury" and 0.37 for the "Perseus." The excess heat in the lubricating oil can be dissipated by employing a suitable design of oil cooler, so that no difficulty need be experienced on this account.

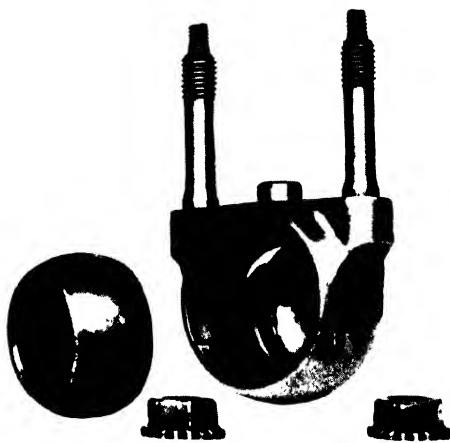

FIG. 124. Spherical joint of the sleeve valve drive unit

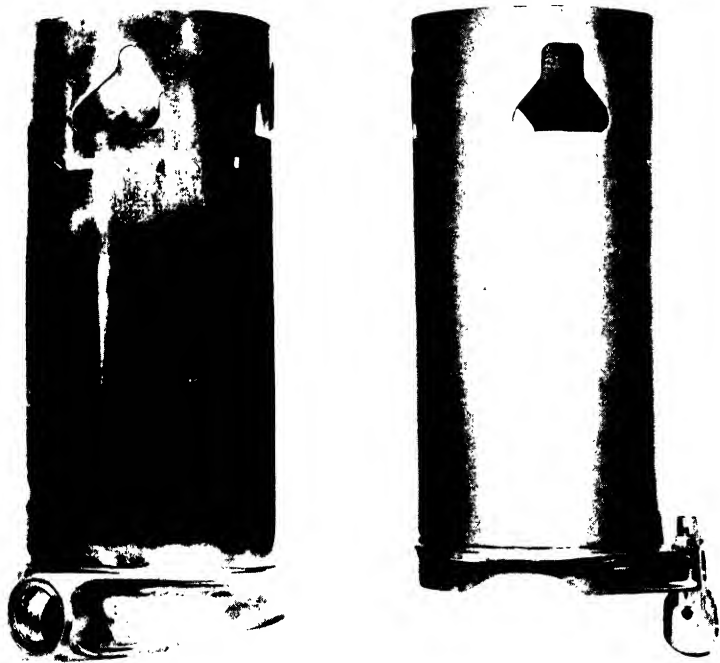
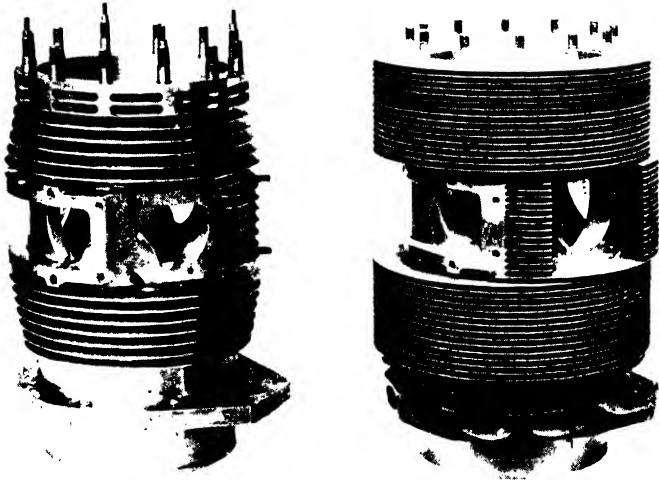

FIG. 125. The earlier (*left*) and more recent (*right*) types of Bristol sleeve units.



8339

FIG. 126. The original "Perseus" cylinder (*left*) and that of the latest production type (*right*).

In regard to the *dimensions* of single-sleeve valve radial engines, owing to the absence of overhead valve mechanism it is possible to effect a reduction in overall diameter of these engines, and thus to reduce the frontal areas.

The *maintenance and servicing* of single-sleeve valve engines is appreciably less since there are no valve clearances to be adjusted or valves and seatings to grind. The only attention necessary with sleeve valve engines is in connection with the sparking plugs and magnetos. The man-power required to service sleeve valve engines is therefore considerably less than that for similar types of poppet valve engine. In the later sleeve valve engines the sparking plug overhaul periods have been increased to 100 hours under service conditions.

From the military point of view the sleeve valve radial engine is considered *much less vulnerable* than a similar output poppet valve radial engine. The outside design is cleaner and more free from vital operating parts and the valve gear within is robust and well protected; similarly the sparking plugs are protected by the cylinder or junk heads.

The *exhaust gas temperatures* are generally lower, on account of the higher compression ratios employed, than for similar size poppet valve engines.

Constructional Details. In most essentials, other than the cylinder and valve units the sleeve valve engine resembles closely the poppet valve type of aircraft engine, so that it is here necessary only to consider the cylinder and valve design.

The Bristol sleeve valve engine cylinder has two exhaust ports in front and three inlet ports at the rear, while the sleeve has only four ports, one of which uncovers alternately an inlet and an exhaust port in the cylinder.

The sleeve drive has already been referred to and this is shown in outline in Fig. 121 and in photographic detail in Fig. 124.

The principal features of the cylinder and valve design are shown in Fig. 127 for the "Perseus" engine units.

The Cylinder Head. For the purpose of cooling the cylinder head the cooling air must be taken down inside the wall of the head to the crown; in this connection, the original design employed plain fins and a simple deflector.

The first main improvement was to provide the cylinder head with a fin arrangement incorporating a baffle, directing the cooling air over the crown of the head thus producing turbulent circulation around the sparking plugs. This general

layout has since been followed ; radial finning giving circulation under running conditions provides all the cooling required for maximum power output.

It is of interest to note that the cylinder head utilizes the principle of complete pressure baffling since the whole layout is based on attaining a velocity head at the upper front section and allowing air to leak through finned cells to the lower pressure air at the rear.

The cylinder head is provided with two piston-type or junk rings for sealing the sleeve against loss of pressure from within the cylinder ; it has also a number of oil grooves.

During the high cylinder pressure periods of the working cycle the sleeve is at the top of its path and its ports have reached the highest positions above the sealing rings. The two sparking plugs are fitted in the centre of the smooth slightly convex face of the head, forming the top of the combustion chamber.

The modern cylinder head is in the form of a die casting in Y-alloy. The sleeve, of nitrided steel, is shown in Fig. 127 and in its development increased port area and control of turbulence or swirl have been the principal considerations.

The pistons are made of comparatively short length, in the form of light alloy drop forgings ; each is provided with two compression and two scraper rings, as in the case of the Pegasus engine.

Bristol Engine Equipment Features. The Bristol sleeve valve engines are fitted with high-speed superchargers similar to those described in the first volume of this work. In each case the supercharger is associated with a carburettor of the fully automatic type, incorporating variable-datum servo devices for controlling the boost pressure and mixture ratio.

Dual ignition is provided by two transversely-mounted magnetos. The magneto drive incorporates a variable timing device, interconnected with the carburettor in such a way that the best ignition setting is obtained automatically for every throttle position, including the extra advance necessary for economical cruising. The whole ignition system is completely shielded for radio screening, the cable harness being of particularly neat and light design.

Airscrew reduction-gears of the normal Bristol-Farman bevel epicyclic type are fitted to all these engines. In each case the airscrew shaft is of robust construction, and the assembly includes a special high-duty oil-seal, through which oil at pressures up to 200 lbs. per sq. in. can be conveyed to the

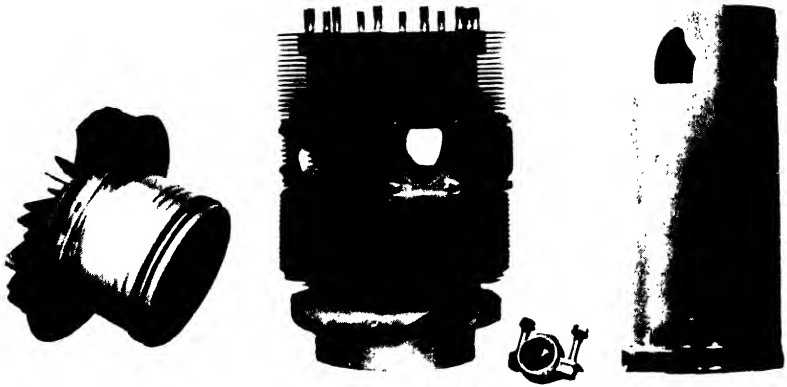

FIG. 127. The cylinder head, cylinder, spherical joint member and sleeve of Bristol sleeve valve engine.

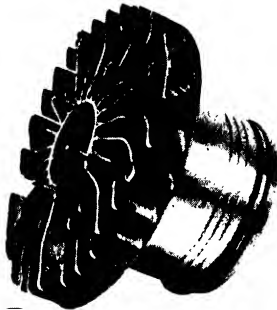

FIG. 128. Bristol sleeve valve engine cylinder head, showing junk rings.

The largest engine is the "Hercules" IV, which is a fourteen-cylinder double bank engine of 38.7 litres capacity, corresponding to a bore and stroke of $5\frac{1}{4}$ in. (146 mm.) and $6\frac{1}{2}$ in. (165 mm.) respectively; the cylinders have the same dimensions as the "Perseus" engines. The overall diameter is 52 in. and the maximum take-off power of 1,380 B.H.P. at 2,800 R.P.M. This is equivalent to 97 h.p. per sq. ft. of frontal area.

The "Perseus" engine has the same bore and stroke as the "Hercules" and has nine cylinders, giving a capacity of 24.9 litres and overall diameter of 52 in. It is made in a range of models for various civil and military purposes, giving maximum take-off powers of 750 to 890 B.H.P.

The table on page 175 gives the principal particulars of the various types of Bristol engines.

Constructional Details. The exhaust manifold is of the Bristol large-volume single-outlet type, made from one-piece steel pressings riveted together, there being no welded joints. The manifold affords a good leading-edge contour for the close-fitting low-drag cowl which is provided with controllable outlet gills. The exhaust outlet is below (Fig. 133).

Inter-cylinder baffles are fitted to ensure optimum cooling characteristics under all flight conditions. These baffles are of very simple yet efficient design, due to the symmetrical shape of the sleeve valve cylinder and the infrequency of maintenance attention required; and each is made from a single aluminium pressing.

The carburettor cold air intake, extending down behind the rear support-ring of the engine cowl, is of one-piece construction and is easily faired-off into the nacelle, or fuselage. Warm air can be supplied to the carburettor, when required, through a pair of collectors attached to the main intake body. These project forward inside the cowl towards the two lower cylinders, and have spring-loaded shutters controlled by the pilot. As an additional precaution against the carburettor freezing under adverse climatic conditions, an exhaust-heated induction elbow can be fitted, and is standardized on the "Perseus" XIIc civil-rated engine.

The Bristol "Hercules" Engine. The crankcase of this engine is formed of three rings, machined from light alloy forgings, which have their joint faces on the cylinder centre lines. They are held together by two sets of through bolts, the rear set of which is extended back for the attachment of the supercharger. The latter is of the gear-driven centrifugal

TABLE 12. PARTICULARS OF BRISTOL AIR-COOLED RADIAL SLEEVE VALVE ENGINES

Engine Type	Maximum Take-off Power B.H.P.	International Rated Power B.H.P.	Maximum Power for All-out Level Flight (5 mins.) B.H.P.	Cubic Capacity	Overall Diameter	Airscrew Reduction Gear Ratio	Bare Dry Weight
HERCULES II Medium Supercharged	1,300	1,100/1,150 at 5,000 ft. (1,520 m.)	1,375 at 4,000 ft. (1,220 m.)	2,360 cu. ins. (38.7 litres)	52.0 ins. (1.32 m.)	0.444	1,680 lbs. (762 kgs.)
HERCULES IV Civil Rated	1,380	1,010/1,050 at 4,500 ft. (1,370 m.)	1,220 at 5,500 ft. (1,680 m.)	2,360 cu. ins. (38.7 litres)	52.0 ins. (1.32 m.)	0.444	1,680 lbs. (762 kgs.)
TAURUS II Medium Supercharged	1,010	860/900 at 5,000 ft. (1,520 m.)	1,065 at 5,000 ft. (1,520 m.)	1,550 cu. ins. (25.4 litres)	46.25 ins. (1.175 m.)	0.444	1,300 lbs. (590 kgs.)
PERSEUS X Fully Supercharged	750	700/730 at 14,500 ft. (4,420 m.)	880 at 15,500 ft. (4,730 m.)	1,520 cu. ins. (24.9 litres)	52.0 ins. (1.32 m.)	0.500	1,110 lbs. (504 kgs.)
PERSEUS XI and XII Medium Supercharged	830	715/745 at 6,500 ft. (1,980 m.)	905 at 6,500 ft. (1,980 m.)	1,520 cu. ins. (24.9 litres)	52.0 ins. (1.32 m.)	XI 0.572 XII 0.500	1,110 lbs. (504 kgs.) 1,105 lbs. (502 kgs.)
PERSEUS XIIIc and XIVc	890	680/710 at 4,000 ft. (1,220 m.)	815 at 6,000 ft. (1,830 m.)	1,520 cu. ins. (24.9 litres)	52.0 ins. (1.32 m.)	XIIIc 0.500 XIVc 0.666	1,110 lbs. (504 kgs.) 1,120 lbs. (508 kgs.)
AQUILA IV Civil Rated	600	450/470 at 4,500 ft. (1,370 m.)	540 at 6,000 ft. (1,830 m.)	950 cu. ins. (15.6 litres)	46.0 ins. (1.168 m.)	0.500	830 lbs. (376 kgs.)

type. The fully-automatic carburettor is of the down-draught type, and is mounted on the top face of the volute casing. It is fitted with a one-piece air intake having two chutes; one protruding above the cowl line for the intake of cold air; and the other facing the rear upper cylinder to collect warm air, the supply of which is regulated by a spring-loaded shutter, under the pilot's control. The air intake is clear of the rear engine-cowl support-ring, and is easily faired-off into the nacelle.

The "Hercules" is mounted in the airframe by means of the seven rearward-extended crankcase bolts, to which either flexible- or rigid-type mounting brackets may be attached. The arrangement of the single-outlet, pressed-steel exhaust manifold and the close, low-drag cowl with controllable gills, is very similar to that of the "Perseus." The amount of extra length involved is very moderate, due to the compact construction of the engine.

In regard to future developments of this type it is understood that an eighteen cylinder two-row radial has already passed its acceptance tests.

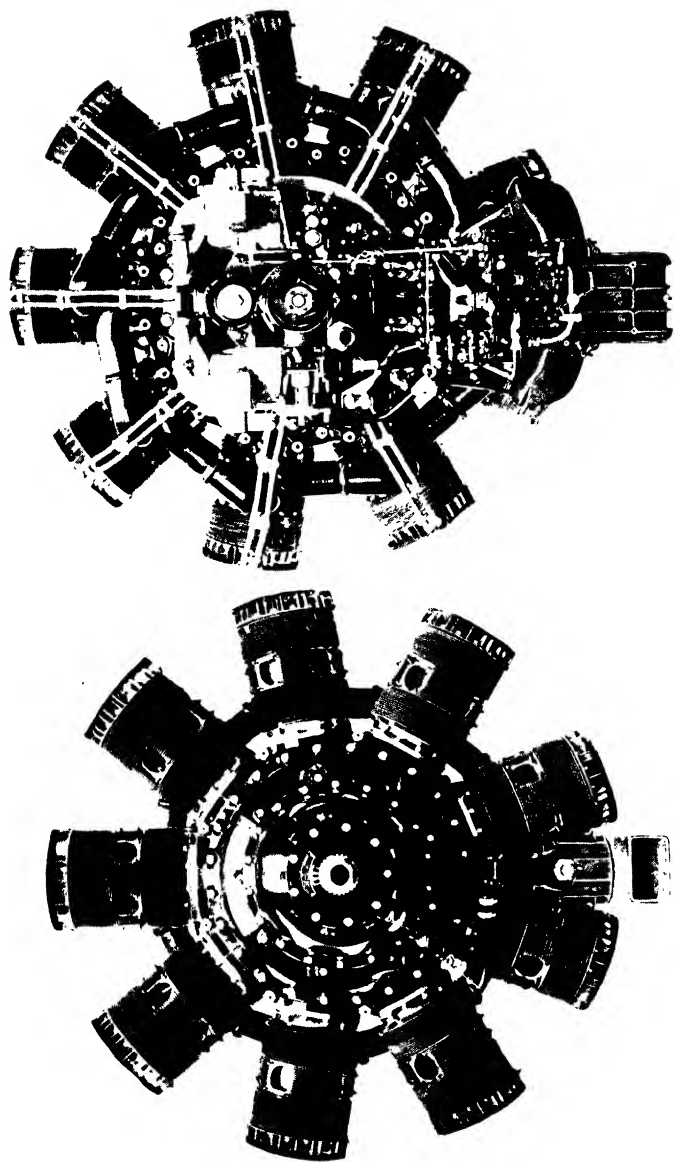

FIG. 130. Front and rear views of Bristol "Perseus XII" sleeve valve engine.

[To face p. 176.

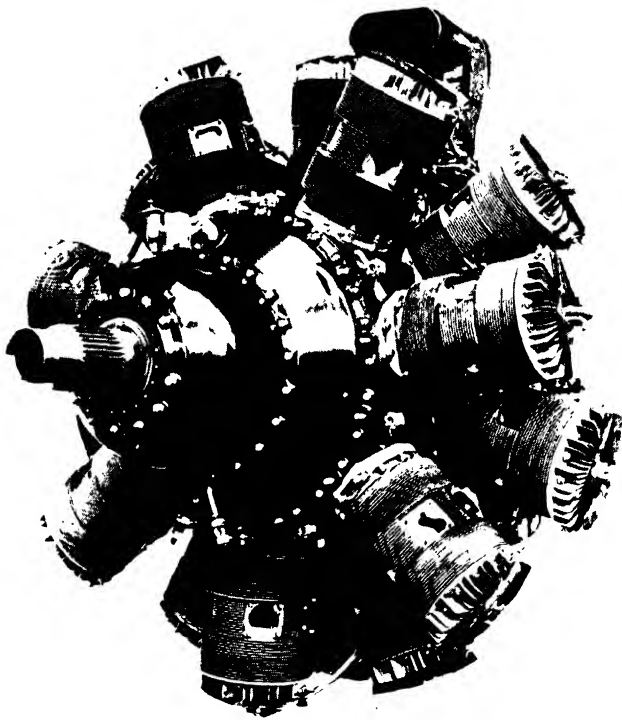

FIG. 131. Bristol "Taurus II" medium supercharged sleeve valve engine.

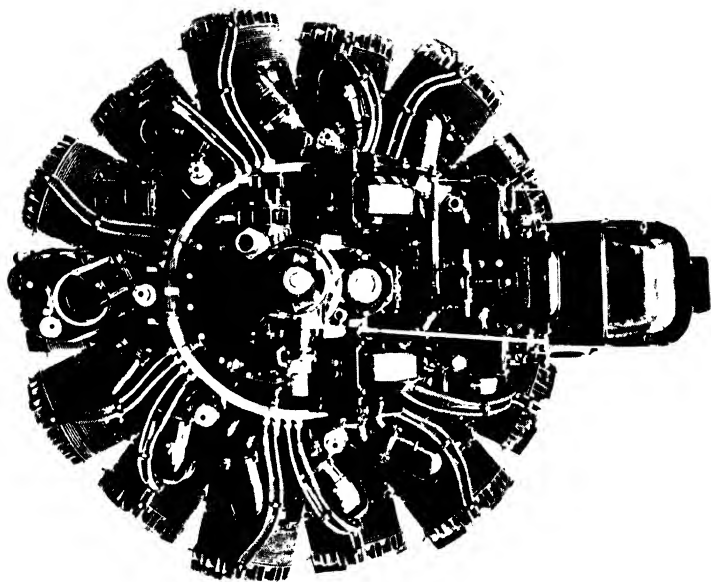

FIG. 132. The Bristol "Hercules" fourteen-cylinder twin row sleeve valve engine.

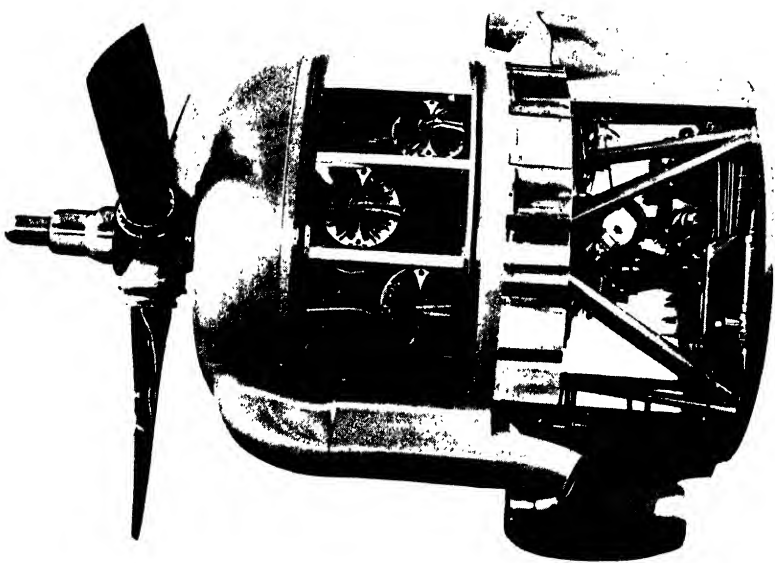

FIG. 133. Installation of Bristol "Hercules" engine complete with cowling and cooling gills.

CHAPTER VI

SOME OTHER AIRCRAFT ENGINE TYPES

WHILST it is a fact that the large majority of aircraft engines in the experimental and production stages belong to the four-cycle poppet and sleeve valve class it should not be overlooked that certain other designs of engines have been or are being considered for aircraft purposes. Among these are engines operating upon the two-cycle principle using air-petrol mixtures and the compression-ignition or Diesel type employing heavier fuels than petrol engines; other engines that have been proposed or built for experimental purposes include the barrel-type or swash-plate, steam and combustion-turbine engines.

The Two-cycle Engine.

Although a considerable amount of research has been carried out on engines employing the two-cycle principle for aircraft purposes, with the exception of the compression-ignition type, there has been no important practical

development of the petrol-type of engine; the principal reasons for this are considered later in this section.

In order to illustrate the theoretical and practical aspects of the two-cycle engine it will be necessary to give a brief outline of the principle of this class of engine, taking for this purpose the simplest example, namely, that shown in Fig. 134.

The cylinder of this engine is longer than that of the normal four-cycle engine and it is provided with two ports, T and E,

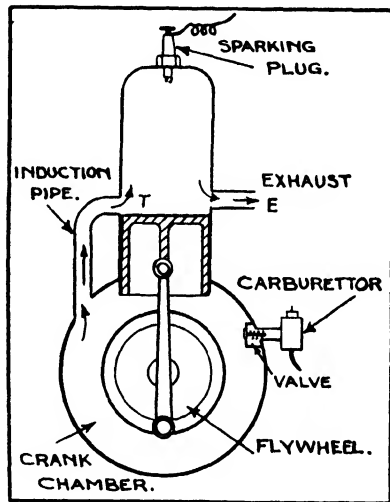

FIG. 134. Principle of the two-cycle engine.

near its lower end, of which E is situated slightly above T. In this engine the upper edge of the piston controls the exhaust and induction timing operations. The air-petrol mixture is drawn into the crank chamber when the piston ascends and is there compressed during the descent of the piston. When the piston descends in its firing and expansion stroke it eventually reaches the position, near the end of its expansion stroke, where the upper edge begins to uncover the port E, thus releasing the pressure and allowing most of the exhaust to escape through this port. The cylinder is then left filled with exhaust gas

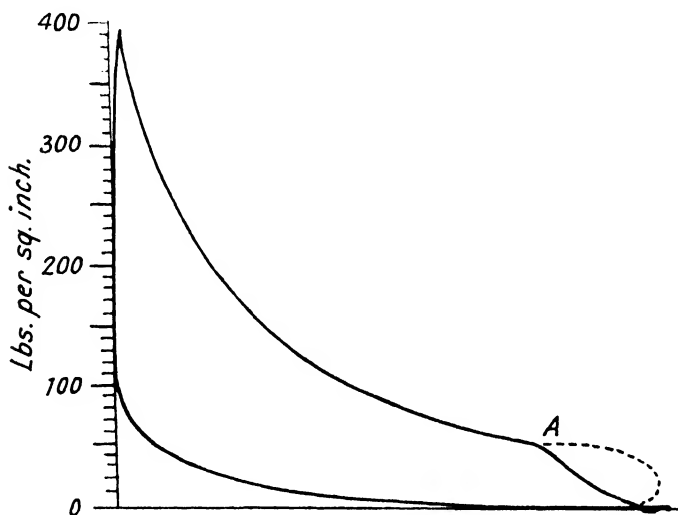

FIG. 135. Two-cycle engine indicator diagram. Dotted line shows four-cycle engine exhaust process, for comparison purposes.

at about atmospheric pressure. As the piston descends still further it uncovers the transfer port T, communicating with the crankcase, thus allowing the compressed air-petrol mixture to enter the cylinder. As both the ports T and E are open at the same time the mixture tends to sweep the residual exhaust gases out through the port E, *i.e.*, to scavenge the cylinder.

Fig. 135 illustrates a typical indicator diagram for this kind of engine; the exhaust port opening position is shown at A. Theoretically, the two-cycle engine should give twice the power output of that from a four-cycle engine of similar bore and stroke at the same engine speed, since it has twice the number of power strokes. In practice, the type described gives only

about 40 to 50 per cent. more power owing principally to its lower volumetric efficiency. In this connection it must be remembered that whereas a four-cycle engine has a period for induction or charging of 200 to 250 degrees of crank angle, the two-cycle one has a much shorter period, namely, from 50 to 80 degrees of crank angle; on this account there must inevitably be a loss of volumetric efficiency. Further, whilst the exhaust period of the high-speed four-cycle engine is usually about 220 to 250 degrees, that of the two-cycle engine is only about 80 to 120 degrees, so that unless an appreciable amount of fresh mixture is lost in scavenging the exhaust gases, there will be a higher proportion of residual gases left in the cylinder at the commencement of the compression stroke. For these reasons the B.M.E.P. of this type of two-cycle engine is appreciably lower than that of a four-cycle engine of similar dimensions, compression ratio and mixture strength running at the same speed.

The fuel consumption per h.p. will also be higher, since, apart from the lower thermal efficiency there is generally a direct loss of fuel to the exhaust during the scavenging process. Another disadvantage is the increased difficulty—in the case of aircraft engines—of providing for the additional cylinder cooling, since there is about 50 per cent. more waste heat to be dealt with.

In order to improve the performance of the two-cycle engine various schemes have been employed, including the use of air compressors or blowers for introducing the mixture, separate scavenging devices, the use of opposed pistons in long cylinders, stepped pistons, etc. Whilst some of these methods have proved satisfactory in the case of slow-speed engines they have not always given the desired results in high-speed ones. It is true that the power output per unit volume has been increased in the more advanced designs of two-cycle engines but the fuel consumption per h.p. is invariably greater than for the corresponding four-cycle engine.

It has usually been found that the additional power necessary to drive the scavenge blower, and the limited expansion due to the early opening of the exhaust port have to some extent offset the other beneficial factors so that the thermal efficiency has suffered, despite the fact that there is a lower heat loss to the cylinder walls than in the case of the four-cycle engine. The use of a supercharger to supply mixture through a port near the bottom of the cylinder, or a valve port near the top,

whilst improving the volumetric efficiency and consequent power output of a two-cycle engine, will usually only do so at the expense of greater fuel consumption, since it is difficult to prevent the loss of some of the mixture through the exhaust port.

The logical solution of this problem of fuel loss appears to be that of introducing air under pressure to scavenge and charge the cylinder whilst the fuel is injected after the exhaust and induction ports are closed, *i.e.*, during the compression stroke, by means of a fuel injection pump. This method was actually employed by the late Professor W. Watson as long ago as 1911 in the case of an experimental engine.

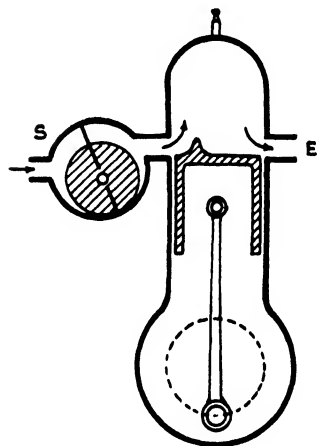

FIG. 136. Compressor-charged two-cycle engine. S, compressor; E, exhaust port. Fuel is injected after cylinder ports are closed.

It should be pointed out that even if the fuel wastage problem is solved there still remains the increased difficulty of cooling a high-speed two-cycle engine using air-petrol mixture, from the aircraft viewpoint; in addition the question of increased fuel consumption per h.p., on account of the lower thermal efficiency, must be considered.

A further factor is that of *engine weight*, for the two-cycle engine with its longer cylinders and relatively large compressor—and this component must be larger than a supercharger for the corresponding type of four-cycle engine—will necessarily be heavier for a given bore and stroke than a four-cycle engine. Thus, if the output per litre of a two-cycle engine is, for example, 50 to 60 per cent. greater than for the corresponding four-cycle engine, the weight per h.p. will not be reduced by a similar percentage.

Although, in modern four-cycle aircraft engines it is necessary to incorporate a supercharger, it should be pointed out that *the air compressor* necessary for a two-cycle petrol injection engine of similar bore and stroke would have to be at least twice the capacity for the same engine speed. The scavenging operation would also entail the loss of some of the scavenging air so that the capacity of the compressor would have to be

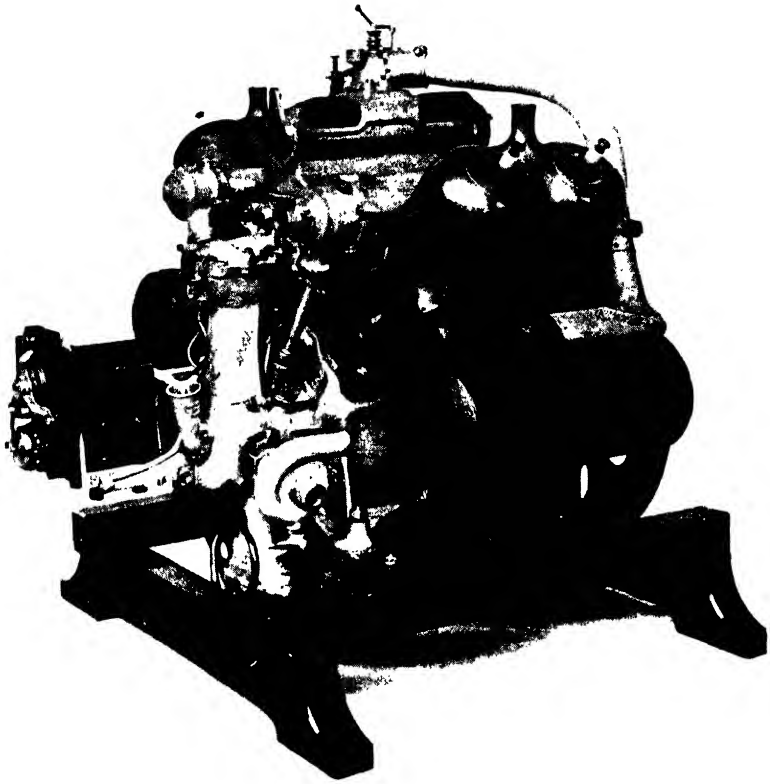

FIG. 137. The N.E.C. four-cylinder two-cycle aircraft engine.
(*Courtesy The Science Museum, London.*)

still greater on this account. Moreover, it would be a difficult matter to maintain the ground power output of a two-cycle engine by means of its charging and scavenging compressor alone.

In the case of compression-ignition engines the two-cycle principle offers certain advantages in the matter of increased thermal efficiency, due to the higher compression ratios used, and the embodiment of the fuel injection principle.

An early example of a two-cycle aircraft engine was the N.E.C. four-cylinder Vee-type (Fig. 137) having its cylinders cast in pairs with electrolytically deposited copper water jackets. The exhaust and inlet ports were on opposite sides of the cylinder, the former port being the first uncovered. A Roots blower divided into three parts was used for scavenging and supercharging. The two outer parts were for the former and the inner part for the latter purposes. Between the central portion and each pair of cylinders a rotary valve was fitted to admit the mixture at the correct time; the admission of the charge was delayed until a considerable volume of air had been forced into the cylinder. The engine had a bore of 3.69 in. (93.5 mm.) and stroke of 4.5 in. (114 mm.), and it developed 50 B.H.P. at 1,250 R.P.M. for a dry weight of 150 lbs. The engine, of which an example is shown in the Science Museum, South Kensington, was fitted to Colonel A. Ogilvie's Wright biplane in use from 1911 to 1914.

The Compression-Ignition Engine. This type of engine employs a heavier grade of fuel, known as Diesel oil and utilizes the heat due to the compression of the air charge to ignite the fuel injected into the combustion chamber. For this purpose high compression ratios, namely, from about 14:1 to 18:1 are employed. The modern compression-ignition (C.I.) engine in general design and construction is on similar lines to the automobile engine and runs at similar speeds.

The principle of this engine is illustrated in Fig. 138. During the induction stroke A, pure air is taken into the cylinder through an overhead type inlet valve. It is next compressed, as shown in diagram B, and its temperature increases progressively until near the end of the compression stroke the temperature exceeds the self-ignition temperature of the fuel, so that when the fuel is injected it burns in the air charge (diagram C). The compression pressures employed in C.I. engines usually range from 450 to 650 lbs. per sq. in., whilst

the maximum temperature of compression lies between 350° and 450° C. The fuel injection generally commences some 15 to 10 degrees before the end of the compression stroke and

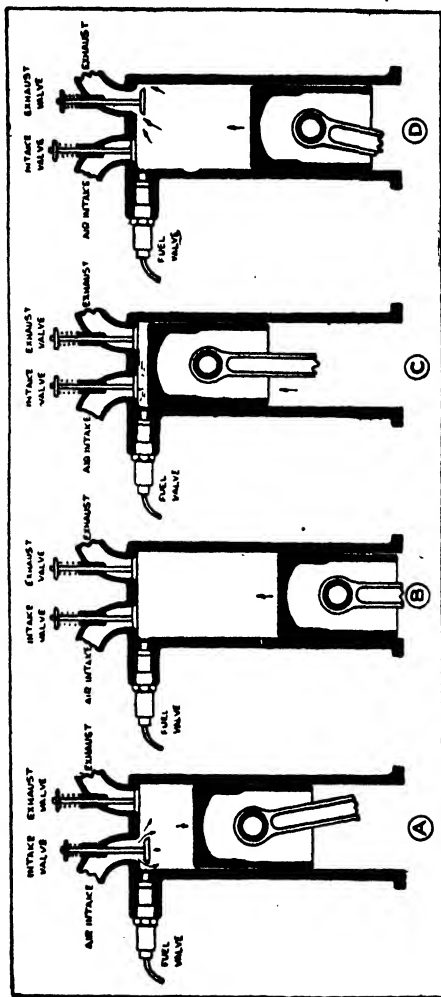

FIG. 138. Illustrating principle of the four-cycle compression-ignition engine.

continues for a definite period of 10 to 45 degrees of crank angle, according to the load. It should here be explained that the output of the engine is controlled by the amount of fuel injected, so that load regulation is a matter of varying the

period of fuel injection; in all cases the engine takes in the maximum quantity of air in order to obtain the proper temperature for ignition of the injected fuel.

Immediately injection ceases the burnt gases expand and eventually they are exhausted similarly to the petrol engine expansion and exhaust processes, for the four-cycle type of engine (Diagram D, Fig. 138).

The manner in which the cylinder pressures of a high-speed C.I. engine may vary during the compression and expansion strokes is illustrated in Fig. 139; the corresponding air

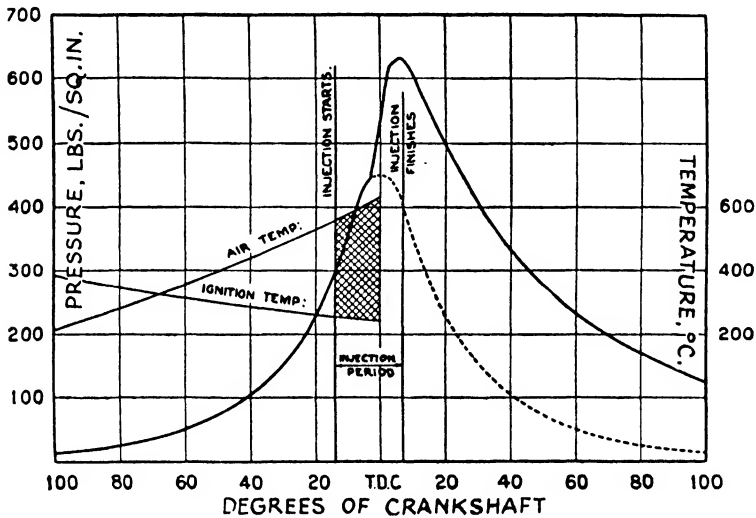

FIG. 139. Cylinder pressure, air and ignition temperature diagrams for C.I. engine.

temperatures during compression and the fuel ignition temperatures are also shown. It will be observed that the latter temperatures decrease gradually with increase of compression, but at the start of injection the air-charge temperature is about 570°C. , whereas the ignition temperature is well below this value, namely, at about 260°C. , so that the fuel commences to burn practically as soon as it is injected. Actually there is an initial lag or delay period, as explained in Vol. I of this work.

The injection in this case occurs at about 15 degrees before top dead centre and continues for a crank angle period of about 20 degrees. The cylinder pressure during combustion rises

from the maximum compression value of about 450 lbs. per sq. in. to about 630 lbs. per sq. in., corresponding to the end of the injection; thereafter the hot combustion products expand continuously, doing useful work on the piston until the exhaust valve opens.

Effect of Injection Advance. It has been shown in volume I that the C.I. engine operates upon a kind of modified constant pressure cycle, dependent upon the amount of injection advance, *i.e.*, upon how early the fuel is injected before top dead centre of the compression stroke. Thus, if the injection

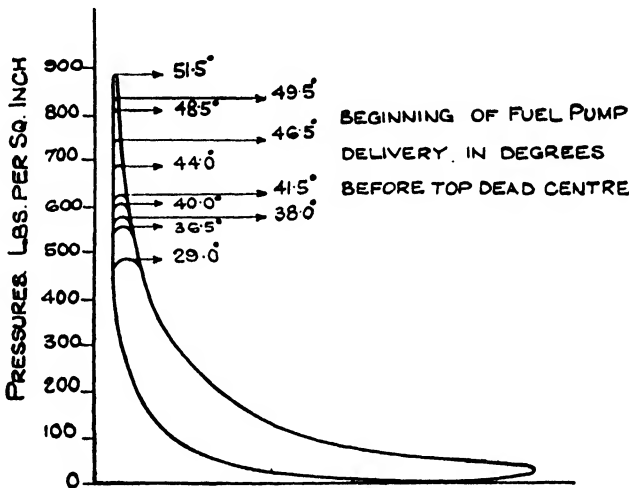

FIG. 140. Effects of injection advance upon the indicator diagram.

is timed to commence at 50 to 40 degrees before top dead centre the cycle of operations approximates closely to the constant volume or Otto cycle of the petrol engine. On the other hand, if the timing is retarded sufficiently the combustion can be arranged to occur almost at constant pressure. These results are illustrated by the indicator diagrams³² given in Fig. 140, obtained with injection timings ranging from 29 to 51.5 degrees before top dead centre. It will be observed that as the timing is advanced the shape of the diagram approaches that typical of petrol engines and the maximum pressure increases progressively from the maximum compression value of about 480 lbs. per sq. in. to nearly 900 lbs. per sq. in. for the greatest

advance, namely, 51.5 degrees. With the 29 degrees injection advance there is very little increase in the maximum pressure above the compression pressure and constant pressure cycle conditions are approached.

In practice a certain amount of injection advance before that corresponding to the constant pressure type of diagram is desirable, since a higher B.M.E.P. and a more rapid combustion process suitable for the higher engine speeds are obtained. The limit to the amount of injection advance is fixed from considerations of maximum permissible cylinder pressures and therefore of engine weight ; this is an important factor in aircraft engine design. In connection with the amount of injection advance for a given engine it can be shown that *better fuel economy* occurs, within certain limits, as the injection is advanced. The principal reason for this is the greater expansion of the burnt gases, which results in a higher B.M.E.P. for a given quantity of fuel injected.

Efficiency of the C.I. Engine. The thermal efficiency of the C.I. engine is appreciably higher than that of the petrol engine, owing to the higher compression ratios employed. In this connection, if the injection advance be adjusted so as to give approximately constant volume combustion conditions similar to those occurring in high-speed petrol engines, the theoretical air standard efficiencies of the two types may be compared directly from the following relation ³² :—

$$\text{Air Standard Efficiency} = 1 - \left(\frac{1}{r}\right)^{0.396} .$$

Taking the examples of a petrol engine of 6 : 1 compression ratio, the corresponding efficiency works out at 0.51, whilst that of a C.I. engine of 15 : 1 compression ratio is 0.66, *i.e.*, about 30 per cent. greater than for the petrol engine.

In actual practice there is a notable increase in the thermal efficiency of the C.I. engine over that of the petrol engine. The actual value of this efficiency, however, depends upon the amount of fuel injected, *i.e.*, upon the ratio of air-to-fuel. The higher efficiencies appear to be obtained when the quantity of fuel injected is sufficient to combine chemically, or burn, with about 75 to 80 per cent. of the air charge in the cylinder. Greater quantities of fuel than this amount whilst giving more power result in lower efficiencies. Smaller amounts of fuel give lower outputs and efficiencies.

The indicated thermal efficiency values obtained from C.I.

engines having compression ratios of 14 : 1 to 18 : 1 are usually found to lie between the limits of 0.40 and 0.50, although higher values have occasionally been obtained. Thus, in the case of a sleeve valve engine of 15 : 1 compression ratio, running at 1,300 R.P.M. indicated efficiencies up to 0.53 have been measured.

A formula for the indicated thermal efficiency of high speed C.I. engines based upon a somewhat limited amount of experimental evidence given in a Report of the Aeronautical Research Committee³³ is as follows :—

$$\text{Indicated thermal efficiency} = 1 - \left(\frac{1}{r}\right)^{0.236}.$$

This formula gives values of 0.4 for a compression ratio of 8.6 : 1 and 0.485 for one of 17 : 1.

Fuel Consumption. The C.I. engine, on account of its high thermal efficiency, has a correspondingly low fuel consumption per B.H.P. The actual value of this fuel consumption is dependent upon the air-fuel ratio, engine speed, type of combustion head, amount of injection advance, etc., but under favourable operating conditions values of 0.35 to 0.38 lb. per B.H.P. per hour have been obtained in production engines. The corresponding fuel consumptions under cruising conditions of aircraft petrol engines operating on fuel of 87-octane rating are usually from 0.45 to 0.48 lb. per B.H.P. hour ; with higher octane fuels and suitably designed engines the fuel consumption is appreciably lower.³³

Weights of C.I. Engines. The C.I. engine is invariably heavier per h.p. than the petrol engine of similar output, whether for automobile or aircraft purposes. The principal reason for this is that the maximum cylinder pressures are higher and the B.M.E.P. values are lower than for the modern petrol engine.

In regard to engine weight, the weights of the parts having to withstand the gas pressures, namely, the cylinders, pistons, connecting rods, crankshaft and crankcase are dependent upon the maximum cylinder pressure values, whilst the power output is a linear function of the B.M.E.P.

The ratio of the maximum to mean cylinder pressure, under full output conditions, is therefore a measure of the weight-to-power ratio of an internal combustion engine.

Thus in the case of a well-designed petrol engine the corresponding values of the maximum and mean (B.M.E.P.) pres-

tures may be 140 and 600 lbs. per sq. in., giving a maximum to mean pressure value of 4.28. A typical high speed C.I. will develop a B.M.E.P. of 100 lbs. per sq. in. for a maximum cylinder pressure of 750 lbs. per sq. in., giving a ratio of maximum to mean pressure of 7.5 : 1.

Thus the relative weights of the petrol and C.I. engines will be as 4.28 : 7.5, *i.e.*, as 1.00 : 1.75, so that the C.I. engine would be 75 per cent. heavier. In practice it is found that under similar conditions of speed, output and main engine design features and materials of construction, the C.I. four-cycle engine is from 30 to 50 per cent. heavier than the corresponding petrol engine. The two-cycle C.I. engine, however, is relatively, much lighter and approximates to within 20 to 30 per cent. of the corresponding petrol engine's weight.

Thus the Junker Jumo two-cycle C.I. engine of recent design weighs under 2 lbs. per B.H.P. The earlier Packard and nine-cylinder radial C.I. engine of the four-cycle pattern had a weight of 2.12 lbs. per B.H.P., and the Bristol nine-cylinder Phoenix 2.62 lbs. per B.H.P.

From these and earlier considerations it is seen that the high performance aircraft petrol engine using fuel of 80- to 100-octane rating will always be appreciably lighter than the best existing C.I. engines, so that for military purposes, where engine power-to-weight is the ruling factor, the petrol engine should always be superior.

The C.I. Engine for Long Range Flights. The lower fuel consumption of the C.I. engine will enable it to show to advantage in the case of long range aircraft, provided the length of flight exceeds a certain minimum value ; below this latter range the petrol engine is superior. In this connection it is the total weight of the engine and its fuel which affords the standard of comparison, so that although the C.I. engine may be from 30 to 50 per cent. heavier, it consumes only about 65 to 75 per cent. of the fuel for the same engine output under cruising conditions of flight, and therefore if the flight is of sufficient length the C.I. engine machine will prove the more economical, irrespective of any question of cheaper fuel.

The flying range at which equality of engine, tanks and fuel is reached in the case of petrol and C.I. engines of equal output is expressed by the following relation ³⁴ :—

$$T = \frac{W_1 - W_2}{0.693 (C_2 - C_1)}$$

where T = range in hours.

W_1 = weight of the C.I. engine in lbs. per B.H.P.

W_2 = weight of petrol engine in lbs. per B.H.P.

C_1 = fuel consumption of C.I. engine in lbs. per B.H.P. hour.

C_2 = fuel consumption of petrol engines in lbs. per B.H.P. hour.

As an example, if the weights of the C.I. and petrol engines are 2.2 and 1.50 lbs. per B.H.P., and the fuel consumptions are 0.35 and 0.45 lb. per B.H.P. hour respectively, the formula

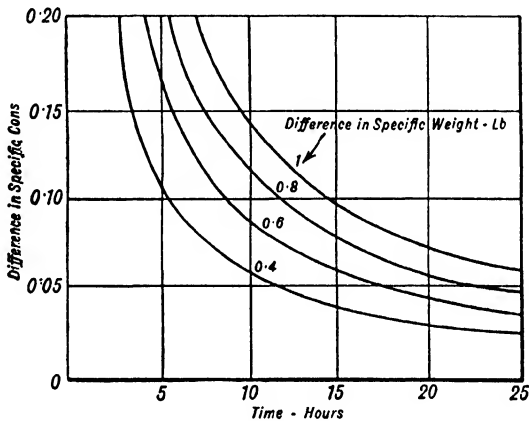

FIG. 141. Curves showing flying time necessary for equal total weight of engine, fuel and fuel tanks of engines of different specific weight and consumption.

shows that the equality range will be 10.1 hours; beyond this range the C.I. engine and its fuel and tanks will become increasingly lighter in comparison with the petrol engine.

In these considerations the load factor is assumed to be 0.63 of the take-off power and the tank weight 0.10 the weight of fuel.

Fig. 141 shows the flying times necessary for equal weight (total) of engine, fuel and fuel tanks of engines of different specific weight and consumption. The following results have been calculated to show the relative values of the fuel for C.I. engines and that for 87- and 100- octane value fuels for petrol engines.

TABLE 13. COMPARISON OF PETROL AND C.I. ENGINES

Engine	87 octane	100 octane	Com- pression ignition
Specific weight of engine, on take-off power, lb. per h.p.	1.15	1.05	1.50
Specific cruising consumption, lb. per B.H.P. hour	0.460	0.420	0.355
Weight of fuel tanks and lubricating oil and tanks, per cent. of fuel . . .	9.4	9.7	10.5
Specific gravity of fuel	0.750	0.715	0.850

The following table gives some comparative data, supplied by the Bristol Aeroplane Company, concerning the Bristol Phoenix C.I. engine of 1934 and the best corresponding Bristol radial engine of the same date. In this connection, whilst the performance of the latter type of engine has since been improved considerably by design features and the use of high octane fuels, the C.I. engine has not been developed to the same extent, so that the comparison is at present more favourable to the petrol engine than the tabular results indicate :—

TABLE 14. RELATIVE PERFORMANCES OF AIRCRAFT C.I. AND PETROL ENGINE MACHINES

Engine Type	Relative Maximum Output per Litre		Cruising Fuel Consumption Lbs./ B.H.P./hr	Weight per Cruising B.H.P. Engine Gross plus Fuel and Oil			
	Take-off	Flight		4 hrs.	6 hrs.	8 hrs.	10 hrs.
Compression-ignition engine	100	100	0.390	5.05	5.95	6.84	7.73
Petrol engine	163	174	0.490	4.99	6.10	7.21	8.32

These results show that for flights up to slightly over six hours the petrol engine machine is lighter, but for longer flights the C.I. engine machine becomes increasingly lighter.

Advantages of the C.I. Engine. The main advantages of the C.I. engine for aircraft purposes may be summarized briefly as follows :—

- (1) Comparative freedom from fire risk due to the use of high flash point fuel and the absence of electrical ignition apparatus.
- (2) Greater fuel economy, with the use of less expensive fuel ; therefore lower fuel cost.
- (3) High standard of reliability due to absence of sparking plugs, magnetos and complicated aircraft carburettor.
- (4) Possibility of increased range of flight, due to lower fuel consumption.
- (5) More uniform distribution of fuel and air to the cylinders, due to direct injection of the fuel and absence of induction manifolds ; this advantage does not, however, hold with petrol-injection and some supercharged petrol engines.
- (6) Absence of sources of wireless interference, viz., sparking plugs and magneto contact breakers and brushes.
- (7) Elimination of difficulties experienced with petrol engine carburettors in connection with altitude control devices, variable temperature and icing effects.
- (8) Lower cooling losses, due to higher thermal efficiency, and consequent reduction in sizes of radiator or cooling fins.
- (9) Easier starting in cold weather and much quicker full power operation after starting.
- (10) Less difficulty in keeping the exhaust valves and pistons cool than in the petrol engine, owing to the waste heat being a lower proportion of the total heat of combustion.

Fuel Consumption Range. A notable feature of the modern C.I. engine is its relatively wide range of mean pressures over which the fuel consumption remains fairly constant as compared with the considerably smaller range in the case of the petrol engine. The results of some tests (Fig. 142) made by Dr. S. J. Davies³⁸ on a car petrol engine at 1,500 R.P.M. (Curve A) and a C.I. engine at 1,600 R.P.M. (Curve B) clearly illustrate this point. Not only is the fuel consumption per I.H.P. hour much smaller for the latter engine, but the values of 0.40 lb. and below is maintained from 40 to 110 lbs. per sq. in. (I.M.E.P.) ; in the case of the petrol engine the economic fuel consumption range is about 5 lbs. per sq. in. ; further, at the maximum I.M.E.P. the fuel consumption increases rapidly. It should, however, be pointed out that most aircraft petrol engines show a wider economic fuel consumption range than the example given.³⁹

The present principal disadvantages of the aircraft C.I. engine are its greater weight per h.p., its greater bulk and the impossibility, so far, of utilizing more than 75 to 80 per cent.

of the oxygen of the air charge so that the maximum power per unit volume is not yet attainable. To some extent this latter drawback appears to be an actual advantage for altitude operation, since it is found that as the air density is reduced, progressively more and more of the air charge can be utilized and the performance at altitude thereby improved.

The Two-cycle C.I. Engine. The principal disadvantage of the petrol type two-cycle engine, namely, wastage of fuel, is avoided in the C.I. engine, which compresses air only and does not admit the fuel until the compression of the air is practically complete. The higher thermal efficiency of the C.I. engine on account of its greater compression ratio results in a smaller proportion of waste heat, so that the cylinder temperatures are

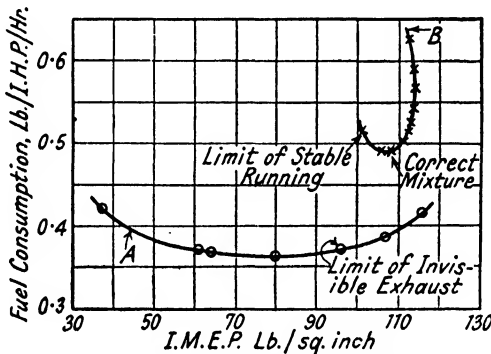

FIG. 142. Fuel consumption ranges of C.I. and petrol engines.

not normally so high as in the petrol engine; for this reason the design of the two-cycle engine is, to some extent, simplified.

In view of the importance of reducing the weight per h.p. of the C.I. engine in order that it may come within the allowable limit for aircraft purposes the two-cycle engine offers the greatest possibilities, although there are several practical difficulties in applying this principle.

Air Scavenging Considerations. The most important of these difficulties is that of scavenging the cylinders properly, at the end of the expansion stroke, so that the bulk of the residual gases are swept out and at the same time a certain degree of cylinder and piston cooling is achieved. The scavenging operation is rendered more difficult on account of the very limited period available for this purpose. Thus, in the case of an engine running at 1,800 R.P.M., with a scavenging period of,

say, 100° of crank angle—and this is a liberal allowance—the whole process of scavenging must be completed within a period of 0.009 sec. Unless the residuals are effectively scavenged the fresh air charge will be reduced in amount and the engine will not develop its full power.

It is not possible to scavenge efficiently engines of the type shown in Fig. 136, the only satisfactory method being to arrange for the air scavenge (or charging) and the exhaust

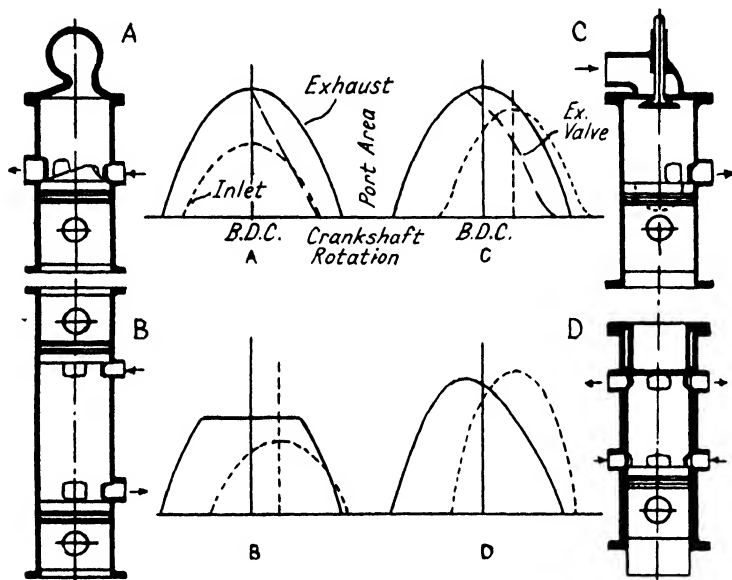

FIG. 143. Scavenging of typical two-cycle engines, showing port opening diagrams.

ports to be at opposite ends of the cylinder, so that uniflow scavenging is obtained.

Referring to Fig. 143,³⁵ the arrangement shown at A is equivalent to that previously given in Fig. 136 for exhaust and scavenge ports near the bottom of the cylinder. The corresponding air inlet and exhaust port opening diagrams are shown to the right of the cylinder diagram. Although cheaper to manufacture than other designs, this type of engine suffers from the disadvantages of low volumetric efficiency and higher fuel consumption previously explained.

The most promising alternative designs are those illustrated in diagrams B, C and D, Fig. 143; in each of these uniflow

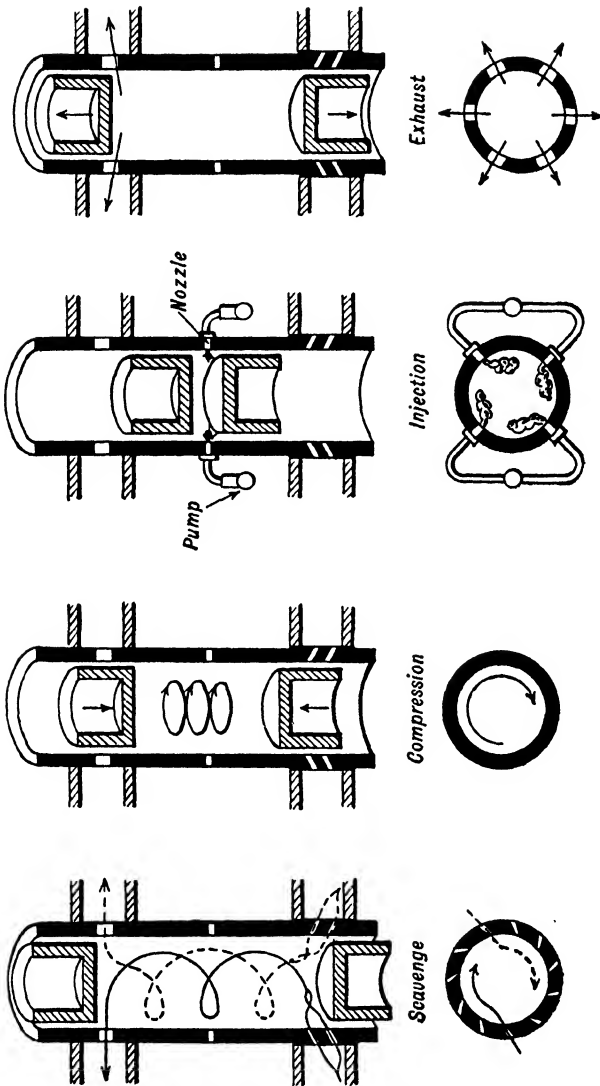

FIG. 144. Showing sequence of operations in Junkers two-cycle C.I. engine of opposed piston type.

scavenging is provided for. The arrangement shown in diagram B employs two opposed pistons in the same cylinder. One piston controls the exhaust ports at its end of the cylinder, whilst the other piston controls the air inlet ports at its end.

This arrangement, which is used on the Junkers' aircraft two-cycle C.I. engine, permits of efficient uniflow scavenging and avoids excessive loss of scavenging air since the exhaust port controlling piston is given a lead over the inlet port and closes just before the latter—as shown by the port opening diagram ; the residual exhaust gases are thus reduced to a minimum. In order to ensure the most efficient scavenging the air ports of the Junkers engine are arranged in a tangential manner so that the air supplied by the blower is given a spiral motion as it enters, as indicated in Fig. 144. In this engine the combustion chamber is the space left between the two pistons when these are on or near their top dead centres.

The arrangement shown in diagram C (Fig. 143) has the air inlet ports at the lower part of the cylinder and a poppet type exhaust valve in the cylinder head ; as in the case of the opposed piston engine, the exhaust valve opens well before the inlet ports—which are, of course, piston-controlled—and it closes in advance of the inlet ports. This system provides for much better piston and exhaust port cooling than would be possible if the upper valve were the air inlet and the lower ports the exhaust ones.

The engine shown, diagrammatically, at D (Fig. 143) represents a single-sleeve valve engine, with the exhaust ports near the top of the cylinder controlled positively by the sleeve valve ; the inlet ports near the lower end of the cylinder are also controlled positively by the sleeve valve. The exhaust has a lead over the inlet, as shown by the port opening diagram to the left, in Fig. 143, and it is possible with this controlled exhaust and inlet port to obtain the most efficient scavenging action.

In a typical instance of a single sleeve valve C.I. engine of bore and stroke $5\frac{1}{2}$ in. and 7 in. respectively, tested by Ricardo, the exhaust ports were arranged to commence opening at 75 degrees before bottom dead centre and to attain their maximum opening at about 25 degrees before this centre. The air inlet ports commenced to open at 47 degrees before and closed at 55 degrees after bottom dead centre ; the exhaust port closed at the same moment. Thus the exhaust and air inlet periods were 130 degrees and 102 degrees of crank angle, respectively. In this engine the air inlet ports were of appreciably greater maximum area than the exhaust and attained their maximum opening at about 15 degrees after bottom dead centre. With these port openings and timings it was possible

to obtain a supercharge of 3 lbs. per sq. in., corresponding to the air pressure within the cylinder at the moment the inlet and exhaust ports closed together, *i.e.*, at 55 degrees after bottom dead centre.

The single-cylinder engine in question employed a scavenge air pressure of 4.8 lbs. per sq. in. and gave a B.M.E.P. of 98.5 lbs. per sq. in. at 1,200 R.P.M.

An important item in connection with the air scavenging of two-cycle engines of the types shown in diagrams B, C and D (Fig. 143) is that the power output of the engine increases as the pressure of the scavenging air is increased, *i.e.*, as the quantity of air supplied per revolution. In the case of the 5½ in. by 7 in. Ricardo single-sleeve engine unit, previously mentioned, the following results³⁶ were obtained at 800 R.P.M. :—

TABLE 15. B.M.E.P. AND SCAVENGING AIR SUPPLY

Scavenge air, per cent. of swept volume of cylinder	60	80	100	120	130
B.M.E.P. (lb. per sq. in.) [approximate]	47	70	88	102	107

Four Cycle Engine Comparison. It is of interest to note that an engine of similar dimensions operating on the four-cycle principle at the same speed, with normal aspiration, gave a B.M.E.P. of 125 lbs. per sq. in. as compared with 88 lbs. per sq. in. for the two-cycle engine with 100 per cent. scavenge air.

The ratio of the B.H.P.'s of the two- and four-cycle engines at 800 R.P.M. is therefore $\frac{2 \times 88}{125} = 1.408$. Actually the two-cycle engine's net output would be somewhat less, owing to the power absorbed in driving the air compressor.

Power Employed for Scavenging. It has been shown that the B.M.E.P. of a two-cycle engine is dependent upon the amount of scavenging air supplied at any given speed, the mean pressure increasing progressively with the quantity of air supplied. In aircraft engine practice there is a limit to the amount of air that can efficiently be employed ; this is governed by the size of the compressor and the power required to drive it. It is found that the quantity of air supplied by the compressor

should be equivalent to 150 to 200 per cent. of the piston swept volume for end to end scavenging, as in the opposed piston type engine; in this connection the Junkers engines generally arrange for 160 per cent. of the piston swept volume. The corresponding air pressure usually lies between 4 and 6 lbs. per sq. in. and seldom exceeds 7 lbs. per sq. in. for engine speeds up to 1,500 R.P.M.

The power required to supply air to the cylinders under these conditions, allowing for the unavoidable wastage of 25 to 30 per cent. through the exhaust ports, is of the order of 10 to 15 per cent. of the total or gross output of the engine. In general,³⁵ for a direct-driven air compressor, about 1/60th of the gross output will be absorbed for each lb. per sq. in. of scavenging air pressure. The weight of the air compressor, using modern light alloys and alloy steels, would be about 0.1 to 0.25 lb. per B.H.P.

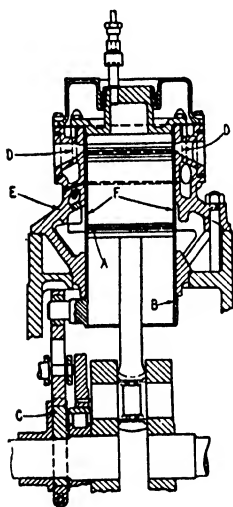

FIG. 145. Single-sleeve valve two-cycle C.I. engine.

Ricardo Two-cycle Engine. A typical two-cycle single sleeve valve engine is shown diagrammatically in Fig. 145. The exhaust ports D, near the top of the cylinder, are controlled by the sleeve which has corresponding ports in its upper end. The part of the sleeve over the exhaust ports is protected by the piston A during the firing stroke. The cylinder is of slightly reduced diameter at its upper end, namely, about 1/2750 of the bore diameter; this, in conjunction with the tapered end of the sleeve,

makes a gas-tight joint. When the cylinder and sleeve are made of aluminium alloy and alloy steel respectively this arrangement appears to be quite satisfactory and enables a construction to be used which facilitates cooling of the combustion chamber.

The air inlet ports E are controlled by ports F in the sleeve B. As the piston moves downwards on its firing stroke the sleeve B also moves downwards, but at a slower rate, so that its tapered upper edge commences to uncover the exhaust ports D before the piston top uncovers the scavenging air ports F in the sleeve.

In regard to the performance of single sleeve two-cycle engines, an earlier single-cylinder unit of $5\frac{1}{2}$ in. bore and 7 in. stroke tested by Ricardo gave a B.M.E.P. of 124 lb. per sq. in. at 900 R.P.M. ; 120 at 1,000 R.P.M. and 86 at 1,400 R.P.M. As the scavenging and charging air for this engine was provided by a separate compressor it is necessary to make a suitable allowance for the power absorbed in driving the compressor. This correction reduces the mean pressure values by 10 per cent. at 900 R.P.M. and 14 per cent. at 1,400 R.P.M.

The fuel consumption was found to remain fairly constant at 0.40 lb. per B.H.P. hour over a B.M.E.P. range of 50 to 90 lbs. per sq. in. At the maximum value of the B.M.E.P., namely, 111 lbs. per sq. in. (net), the fuel consumption was 0.475 lb. per sq. in. This value is from 12 to 15 per cent. higher than for a four-cycle C.I. sleeve valve engine of similar dimensions giving the same B.M.E.P. and employing the same compression ratio.

The results of later tests upon a two-cycle sleeve valve engine⁴¹ indicated that a B.M.E.P. of 80 lbs. per sq. in. (uncorrected for power absorbed by the blower) could be maintained over a 50-hour endurance test for a maximum cylinder pressure of 910 lbs. per sq. in.

In the case of the $5\frac{1}{2}$ in. by 7 in. single-sleeve two-cycle engine it was shown that at 1,200 R.P.M. a B.M.E.P. of 98.5 lbs. per sq. in. and maximum cylinder pressure of 800 lbs. per sq. in. were obtained for a scavenge pressure of 4.8 lbs. per sq. in.

Supercharging C.I. Engines. The output per litre of a C.I. engine depends upon the amount of oxygen* of the charge that can usefully be employed in the combustion of the fuel. For normally aspirated engines about 75 to 80 per cent. of the air charge is concerned in the combustion process. It is possible, however, to increase the available amount of air by admitting it under compression, and if the amount of fuel injected is increased appropriately more power will be developed per litre. In this connection the C.I. engine combustion process is not limited by detonation factors as in the case of the petrol engine, although the temperature conditions must be taken into account, at the higher supercharging pressures.

In general, the charge temperatures will be higher than those of supercharged petrol engines owing to the absence of cooling effects due to the evaporation of the fuel.

* See also p. 227.

Maximum cylinder pressure is usually the limiting factor in the supercharging of aircraft C.I. engines, since the engine weight is a function of this pressure. It is therefore usual to specify a certain upper limit to the maximum pressure, when deciding upon the supercharge pressures and to adjust the timing of the injection so that under all operating conditions of power output this maximum pressure is not exceeded; this is known as "constant maximum pressure supercharging."

As the pressure of the air charge is increased it is necessary to retard the injection timing in order to limit the maximum pressure. Fig. 146 illustrates the results of some tests made by Ricardo upon a supercharged C.I. single-sleeve valve engine of $5\frac{1}{2}$ in. bore and 7 in. stroke. The compression pressure of the normally aspirated engine was 460 lbs. per sq. in. and the

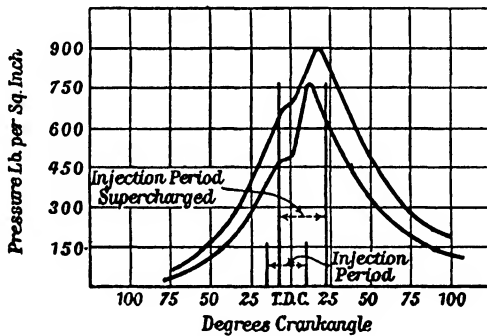

FIG. 146. Supercharging of C.I. engine.

I.M.E.P. 141 lbs. per sq. in. at 1,300 R.P.M. The pressure diagram under these conditions is that given in the lower curve of Fig. 146. When the engine is supercharged to $1\frac{1}{2}$ atmospheres (abs.) the compression pressure was increased to 700 lbs. per sq. in. (upper diagram, Fig. 146), and the I.M.E.P. was raised to 192 lbs. per sq. in. The maximum cylinder pressures were 750 and 900 lbs. per sq. in. respectively.

The results of similar tests upon other designs of C.I. engines show that in general the increase in output of supercharged engines is approximately proportional to the induction pressure, although if the injection advance is adjusted to give constant maximum pressure conditions the output will usually increase at a rather lower rate.

The effect of supercharging upon the combustion charac-

teristics is to reduce the delay period, the latter being *very nearly inversely proportional to the absolute induction pressure*.³⁷

Fig. 147 illustrates the results of some tests³⁷ made upon a C.I. engine with induction pressures up to 3 atmospheres (abs.). The engine in question was of the Ricardo compression swirl type, namely, the Comet Mark III. cylinder head, and the graphs show clearly the linear relation between the gross power output and the induction pressure. In regard to the fuel consumption of supercharged engines, the tests in question showed that in the case of a separately driven blower the fuel consumption at loads below the smoky exhaust limit is reduced by

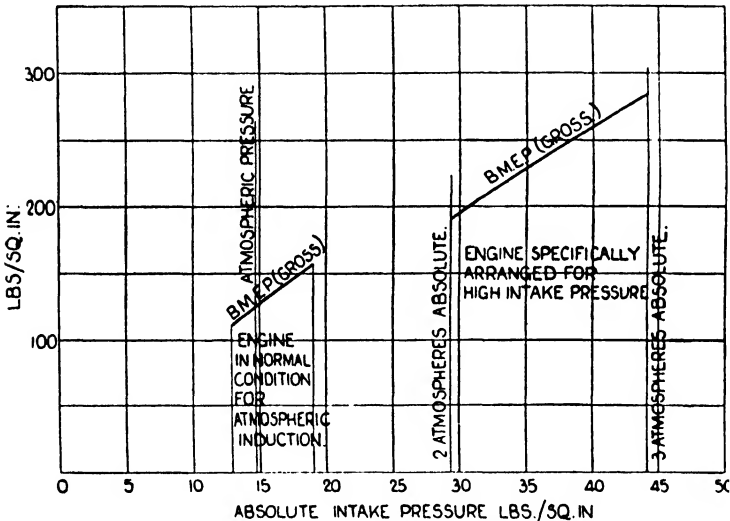

FIG. 147. Brake mean effective pressures with different degrees of supercharging C.I. engine.

supercharging by an amount corresponding very closely to the work done by the supercharger on the engine piston during the suction stroke, so that when the engine is driving its own supercharger the fuel consumption will be increased only by the equivalent amount of the net loss in the blower, *i.e.*, the sum of the mechanical and pumping losses. These losses can be avoided to a large extent when the engine is operating at reduced loads by the method of by-passing from the intake to the delivery; a further reduction is possible with a variable speed drive between the engine and blower.

The limit to the specific output of supercharged C.I. engines

at present appears to be that of piston temperature, and in this connection the use of cylinders of smaller size is advocated, since the heat flow conditions improve as the cylinder bore is reduced.

The greatest outputs per litre of C.I. engines of the supercharged type have always been obtained from the smaller sizes, a fact which supports the above contention.

The temperature of the cylinder head does not increase at the same rate as the B.M.E.P., however, and a relatively large improvement in output can usually be obtained before the temperature limiting conditions occur. In this connection the

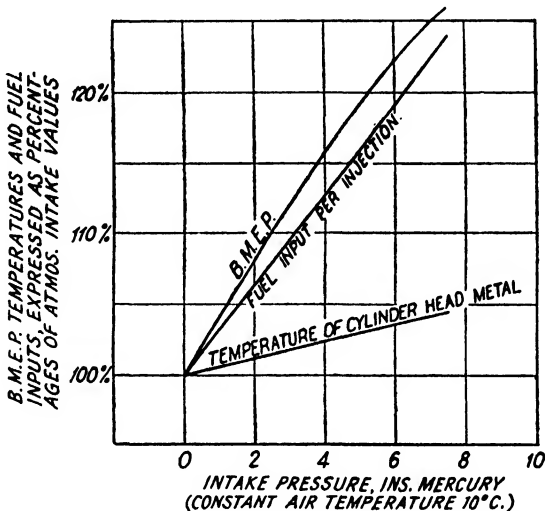

FIG. 148. Effect of supercharging C.I. engine upon B.M.E.P. and cylinder head temperature.

results of some tests made upon a standard six-cylinder automobile C.I. engine operating at 1,500 R.P.M., without any alterations of valve timing and compression ratio, are shown in Fig. 148, from which it is seen that a 25 per cent. increase in the B.M.E.P. is obtained with an induction pressure, above atmospheric,* of 7 ins. mercury, *i.e.*, a 23.4 per cent. supercharge. The corresponding increase in the cylinder head temperature amounts only to about 4.5 per cent.

Some experimental work carried out on the Bristol "Phoenix" air-cooled radial engine in 1934-5, by the Research Department of the manufacturers, showed that for the normally aspirated

* 29.92 in. mercury.

engine operating with a fuel consumption of 0.4 lb. per B.H.P. hour the B.M.E.P. was 94 lbs. per sq. in. When supercharged to 4 lbs. per sq. in. (boost pressure) the B.M.E.P. was raised to 125 lbs. per sq. in. for the same fuel consumption. When, however, the maximum fuel injection quantities were employed the respective values of the B.M.E.P. were 123 and 152 lbs. per sq. in. It will therefore be seen that all of the experimental evidence given indicates the important results that are possible with the supercharging of C.I. engines.

Altitude Effect on Performance. The effect of altitude upon the performance of C.I. engines has been studied to some extent both in the altitude test laboratory and during actual test flights. One of the earliest investigations was that made by G. F. Mucklow⁴² on a Crossley C.I. engine which was run at reduced intake pressures at different loads. The trials were made by throttling the air intake, the degree of such throttling being measured by the pressure at the end of the induction stroke from light spring indicator diagrams. The range of intake pressures employed was 2 lbs. to 6 lbs. per sq. in. below atmospheric pressure. The general deductions made from the results of these tests were as follows :—

When running at constant speed and developing a constant brake horse power, a reduction of suction pressure appears to lengthen the time interval between injection of the fuel and the start of combustion. The rate of pressure rise after combustion has started appears to be unaltered by a reduction of suction pressure, whilst at any given load the magnitude of this pressure rise remains approximately the same at all suction pressures. The maximum pressure is decreased as the suction pressure is reduced, whilst more heat is evolved by combustion during expansion. The temperature of the exhaust gases is increased, as also are the heat losses to the jackets. These effects become more pronounced as the load on the engine is increased.

In consequence of the above effects, the brake thermal efficiency is decreased by a reduction of suction pressure, whilst the fuel consumption is increased, these effects becoming relatively greater with increase in the load on the engine. Thus at 68.1 B.H.P. a reduction of 2 lbs. per sq. in. in the suction pressure results in the brake thermal efficiency being reduced by some 17 per cent. of the efficiency under normal conditions, whilst at 24.1 B.H.P. the corresponding reduction in efficiency is 4.4 per cent. of the normal value appropriate to this load.

Subject to certain corrections, a reduction in suction pressure by throttling the air intake causes the same effects on the engine as are produced by altitude conditions.

As a result of comparative flying tests made with the Packard C.I. engine, described later in this chapter, and a petrol engine developing the same ground horse-power (225 h.p.) fitted to two aeroplanes of similar design, the performance figures illustrated in the graphs reproduced in Fig. 149 were obtained ; the results for a 350 h.p. petrol engine developing the same power (about 130 h.p.) at 20,000 ft. are also included.

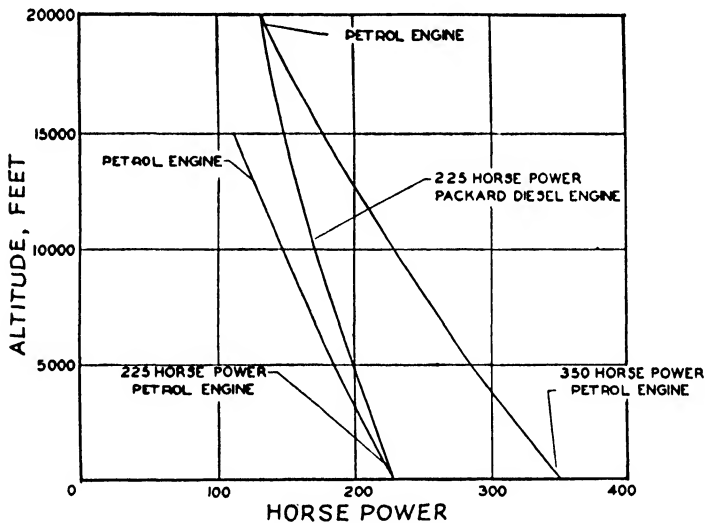

FIG. 149. Flight test results with aircraft C.I. and petrol engines.

These values indicate the ability of the C.I. engine to maintain its power much better than the unsupercharged petrol engine of equal ground horse power, and to give a similar performance at 20,000 ft. to a petrol engine (unsupercharged) of about 55 per cent. greater ground horse power.

The results of level speed flying tests made with the 225 h.p. engines at 10,000 ft. and 19,250 ft. showed maximum speeds of 118 and 92.6 M.P.H. for the C.I. engine and 91.3 M.P.H. at 10,000 ft. for the petrol engine ; the ceiling of the machine in the latter case was 14,270 ft. at which the level speed was 64 M.P.H. At the ceiling of the C.I. engine machine, namely, 20,000 ft., the level speed was 82 M.P.H.

The rates of climb at sea level of the C.I. and petrol engine machines were 730 and 635 ft. per min. respectively ; at 10,000 ft. the rates were 567 and 190 ft. per min. respectively.

The climbing speed of the C.I. engine machine increased from 77 M.P.H. at sea level to 82.3 M.P.H. at 19,250 ft. altitude ; corresponding values for the petrol engine machine were 61.2 M.P.H. at sea level and 65 M.P.H. at 12,000 ft. The improved performance of the C.I. engine is due principally to the fact that for normal flying the amount of fuel injected into the cylinders is smaller by about 75 to 80 per cent. than that necessary to combine with all of the oxygen. As the altitude increases, the air density falls and more and more of the total oxygen is utilized, so that a stage is reached when all of the oxygen of the air charge is taken up in the combustion of the fuel.

During 1936-7 a series of laboratory tests was made by the American National Advisory Committee for Aeronautics ⁴⁸ upon a single-cylinder displacer-type C.I. engine of 5 in. bore and 7 in. stroke under simulated altitude conditions, during which the air-inlet temperature and pressure and the exhaust back pressures were varied for a wide range of fuel quantities, and, from part to full load. As the changes in altitude are fundamentally changes in air density as a result of variations of air pressure and temperature, irrespective of supercharging, the scope of the tests was arranged to include the effect of a wide range of temperatures and pressures of the inlet air.

An analysis of the test results under varying conditions of inlet-air temperature, inlet-air pressure and inlet and exhaust pressures indicated that engine performance cannot be reliably corrected on the basis of either inlet-air density or weight of air charge. It was found that the engine power increased with the inlet-air pressure and decreased with increase in temperature in very nearly straight line relations over a wide range of air-fuel ratios.

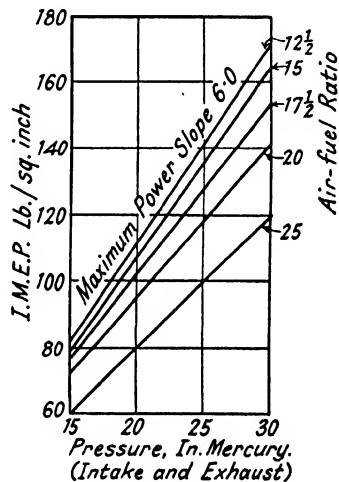

FIG. 150.

The results of some of these tests are given in Figs. 150 and 151. Fig. 150 shows the effect of both inlet and exhaust pressure on the I.M.E.P. over a range of air-fuel ratios from 12.5 : 1 to 25 : 1 for an air-inlet temperature of 82° F., whilst Fig. 151 illustrates the effect of inlet-air temperature variation on sea-level performance for different air-fuel ratios.

It is noted by the authors of this report that the impression that the C.I. engine loses power with increasing altitude less rapidly than the petrol engine may be due to the fact that the former type is operated with excess air at sea level in order to give a clear exhaust, but as the altitude increases the air-fuel ratio diminishes and maximum power is obtained at the expense of a smoky exhaust. *Under similar conditions of air-*

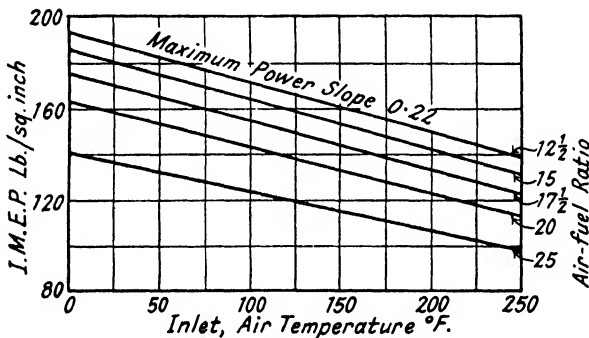

FIG. 151.

fuel proportions the performances of the C.I. and petrol engines are stated to be approximately the same.

Owing to the decrease in the air charge with increase in altitude, the compression pressure and the friction M.E.P. decrease. The mechanical efficiency also decreases, because the B.M.E.P. decreases much faster than the friction M.E.P. A low compression pressure of 290 lb. per sq. in. at 14,000 ft. resulted in an increase in the ignition lag from 11 to 21 degrees, the rates of pressure rise became extremely high, and engine operation became rough.

In the case of a supercharged engine, full blower pressure can be used at sea level and for any length of time, as no limitations are imposed by detonation or pre-ignition characteristics of the fuel. With sea-level exhaust conditions and with constant inlet air temperatures of 87° F., the power increases quite uniformly

with boost pressures, but with the pressure-rise type of combustion used in the test engine it was necessary to increase the maximum cylinder pressures in order to obtain maximum power from the higher boost pressures. The fuel consumption per horse power hour was found to decrease for practically all fuel quantities with increase of boost pressure.

The following general conclusions can be drawn from the test results :—

(1) The altitude performance of an unsupercharged C.I. engine compared favourably with that of a carburettor type petrol engine.

(2) The sea-level performance of the unsupercharged C.I. engine could not be accurately corrected on the basis of air density for differences of air temperatures and pressure. Maximum performance varied differently from part load performance with air pressure and temperature changes.

(3) Maximum sea-level performance (unsupercharged) could be connected when maximum cylinder pressure did not limit output as follows :—

(a) For each inch of mercury increase in inlet air pressure with constant sea-level exhaust pressure add 7·4 lbs. per sq. in. I.M.E.P. or B.M.E.P.

(b) For each inch of mercury increase in inlet and exhaust pressure add 6·0 lbs. per sq. in. I.M.E.P. or B.M.E.P.

(c) For each degree F. increase in inlet air temperature, subtract 0·22 lb. per sq. in. I.M.E.P. or B.M.E.P.

(4) Maximum sea-level boosted performance can be corrected as follows :—

For each inch of mercury increase in inlet-air pressure with conservative maximum cylinder pressures, add 4·0 lbs. per sq. in. indicated or brake mean effective pressure.

For each inch of mercury increase in inlet-air pressure with unlimited maximum cylinder pressure, add 5·0 lbs. per sq. in. indicated or brake mean effective pressure.

(5) Reduced exhaust back pressure increased the engine power slightly, while increased exhaust back pressure decreased engine power at an increasing rate.

Fuel Injection and Combustion. When the fuel is injected into the highly compressed air charge it is necessary to ensure intimate admixture of the fuel spray particles with the air during the very limited period of the fuel injection, to obtain efficient combustion. In this connection the C.I. engine is at a disadvantage compared with the petrol engine which uses a

more volatile fuel and provides a period of about 360 degrees of crank angle for the fuel vaporization and mixing with the air, whereas a period of only about 15 to 30 degrees is available in the case of the C.I. engine, *i.e.*, only $\frac{1}{2}$ to $\frac{3}{4}$ of the petrol engine's period.

The fuel atomizing and air mixing system must therefore be very efficient, more particularly at the higher engine speeds now employed for C.I. engines.

The various designs of combustion chambers and fuel injectors of modern engines are the result of careful consideration of this problem; in this connection it may be mentioned that there are several alternative methods of achieving this result.

The diagrams given in Fig. 152 illustrate the principles of some of the combustion systems employed in modern C.I. engines designed to run at petrol engine speeds. In each instance the position of the fuel injector is denoted by the letter E.

The system indicated in diagram A is that of the "rotational swirl" method employed by Ricardo. In this example the cylinder proper has a combustion chamber of cylindrical form and of about one-half of the cylinder diameter. The air-inlet ports are arranged to admit the air in a tangential manner, thus promoting a rotational swirl which persists during the compression stroke. Additional turbulence is given to the air during the final part of the compression stroke when the piston—which approaches very closely towards the flat portion of the cylinder head—traps some of the air charge and forces it laterally inwards into the combustion chamber. The air charge is in a state of rotation when the fuel is injected through the offset injector in a direction vertically downwards, and therefore at right angles to the swirling mass of air. The fuel particles are thus mixed thoroughly with the air during combustion. Owing to the turbulence of the air charge—which has a rotational speed of nine to ten times the engine crankshaft speed—it is found sufficient to use a plain hole injector nozzle of comparatively simple design. A relatively low fuel injection pressure, namely, of 1,500 to 3,000 lbs. per sq. in. is used in this system. It is possible to obtain B.M.E.P.'s of 100 to 120 lbs. per sq. in., with clean exhausts with this combustion method.

Diagram B shows a combustion head, also due to Ricardo, known as the "Comet," which is based upon the same prin-

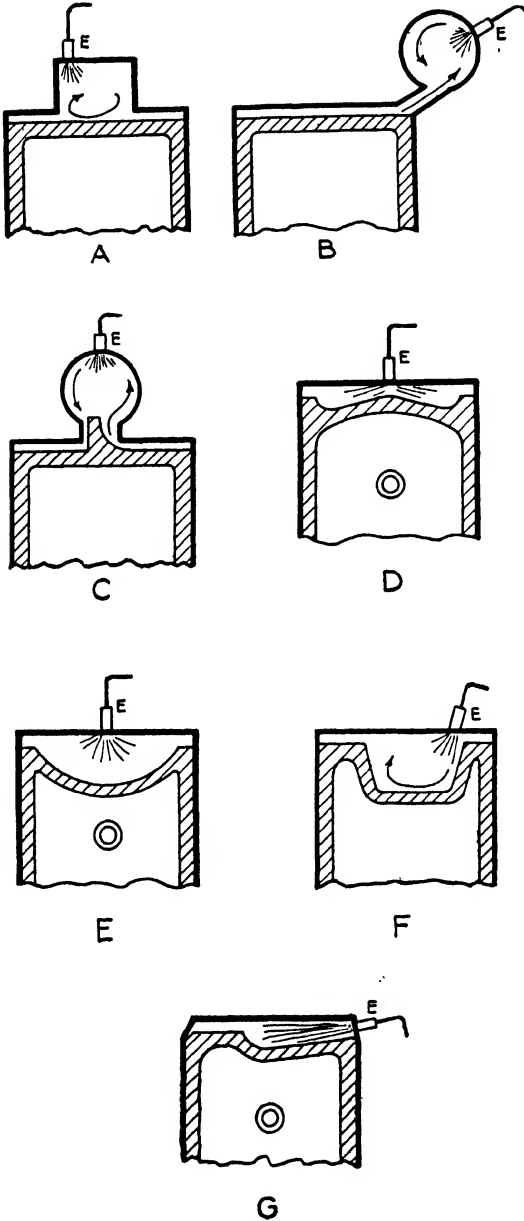

FIG. 152. Compression ignition engine combustion systems.

ciple of rotational turbulence. In this example the piston comes very close to the cylinder head at the top of its compression stroke and the air charge is forced through a narrow throat and thence tangentially into the spherical chamber shown. The fuel injector is arranged to spray its fuel radially inwards, *i.e.*, normal to the direction of swirl of the air charge. This type of combustion head has been widely used on automobile and stationary C.I. engines. It gives efficient combustion with freedom from "Diesel knock" and owing to the flat cylinder head enables relatively large valves to be employed. There is, however, a certain loss of energy owing to the high velocity of the charge through the narrow throat and it is necessary to use an electric heater plug in the spherical chamber wall for starting from the cold. The arrangement shown in diagram C is somewhat similar in principle. It is known as the *Clerestory* head and has a relatively larger communicating passage between the cylinder and combustion chamber above. The piston crown has a projection of special shape for promoting turbulence.

The combustion system illustrated in the examples shown in diagrams D, E, F and G is known as the *Direct Injection* or *Open Combustion Chamber* one; it is the method most favoured for aircraft C.I. engines. There is no auxiliary combustion chamber, with its additional cooling surface, as in the other methods mentioned. Instead, the combustion of the fuel takes place in the region formed between the piston crown and cylinder head, near the end of the compression stroke. In this system there is usually a comparatively low degree of turbulence, so that to ensure the desired admixture of the fuel and air it is necessary to use injection nozzles of the multiple hole pattern—for the purpose of spraying the fuel evenly into the air charge—and a relatively high fuel injection pressure is employed to force the fuel particles right across the air spaces.

The arrangement shown at F is the *Leyland* one and it provides for a certain degree of turbulence within the hollow piston crown, by the use of a masked inlet valve.

The fuel injection pressures employed with direct injection systems usually range from 1,500 to 4,000 lbs. per sq. in., according to the design of combustion chamber, maximum engine speed and other ruling factors.

The direct injection type C.I. engine has the advantage of a lighter cylinder head, owing to the absence of external auxiliary chambers. In general, this type is more efficient,

thermally, since the heat loss during compression and combustion is lower than for the higher turbulence types of engine. Another advantage lies in its better cold starting characteristics; no heater plugs are necessary, as with most ante-chamber engines. This type of C.I. engine will run efficiently on a wider range of fuel grades than most others.

There is another combustion system that has been somewhat widely used in the past on C.I. engines, namely, that known as the *Pre-combustion Chamber* system, in which fuel is injected into an auxiliary chamber which communicates with the cylinder through a throat or perforated plate. The fuel is injected into the ante-chamber and commences to burn; in so doing it projects a mixture of burning and unburnt fuel through the throat into the cylinder, where combustion proceeds. This method requires a high compression pressure, is less efficient, thermally, than the direct injection process and introduces cold starting difficulties; it has more recently been supplanted by the direct injection and other methods.

In this brief outline of the existing combustion systems it has not been possible to include certain variants of the principal methods described; neither has it been possible, owing to space limitations, to deal with the subjects of fuel pumps and injection nozzles. The reader seeking fuller information on the theoretical and practical aspects of modern high-speed C.I. engines is recommended to consult Reference No. 27, given at the end of this volume, which includes the subject of aircraft C.I. engines.

It is now proposed to refer to some typical C.I. engines which have been built for aircraft purposes.

Typical Aircraft C.I. Engines. The various advantages of the C.I. engine render it an attractive proposition for aircraft purposes. Although a limited amount of development work has been carried out in Europe and the U.S.A., the introduction of high octane fuels has given the petrol engine another step forward in its path of progress so that not only is it lighter than the corresponding C.I. engine, but its fuel consumption has been reduced to a certain extent. Except for its greater weight and bulk per h.p. the C.I. engine still possesses the desirable attributes of low fuel consumption, greater simplicity and safety so that in the long-range commercial aircraft field it has attractive possibilities. For most military aircraft purposes, however, its use is ruled out on account of its greater weight and bulk for a given power output.

The first successful aircraft C.I. engine in this country was the eight-cylinder Beardmore "Tornado" one of $8\frac{1}{4}$ -in. bore and 12-in. stroke built for the R101 airship. The engine used the direct injection combustion system with a compression ratio of 12.25 : 1 and developed 650 B.H.P. at 1,000 R.P.M. for a weight of 6.9 lbs. per B.H.P. The B.M.E.P. and maximum cylinder pressures were 100 and 850 lbs. per sq. in., respectively, and the fuel consumption 0.35 to 0.40 lb. per B.H.P., according to the load.

Another interesting design of aircraft engine having several unique features was the American Packard nine-cylinder air-cooled radial one, shown in Fig. 153.²⁷ This engine was built in 1930 and carried out its ground and air tests satisfactorily, although it was not subsequently developed. The engine had a bore of $4\frac{1}{8}$ in. (122.5 mm.) and stroke of 6 in. (152.4 mm.), giving a cylinder capacity of 980 cu. in. (16.2 litres). It was designed for a speed of 1,950 R.P.M., but would run at higher speeds satisfactorily. The compression ratio was 16 : 1, the compression pressure being about 500 lbs. per sq. in. and temperature 538° C. The maximum cylinder pressures, with the rather large injection advance of 45 degrees employed, was 1,200 lbs. per sq. in. Despite the heavier weight requirements associated with this high pressure it was found possible to design the engine to a weight limit of 2.12 lbs. per B.H.P. The engine developed 240 B.H.P. at 2,050 R.P.M. and had a cruising load fuel consumption of 0.40 lb. per B.H.P. hour. A special feature of this engine was the use of a single valve in the cylinder head to act alternatively as air inlet and exhaust valve. The engine employed the direct injection system with air turbulence; the air charge was arranged to circulate once around the cylinder during the injection period. The pistons were of the side cavity type, the spaces thus formed acting as the combustion chambers. The crankshaft, which was of the usual radial engine single-throw pattern, had a torsional damping device, employing strong compression springs in the counterbalance weight units.

Another promising example of air-cooled radial C.I. is the Bristol "Phoenix," to which reference has previously been given in this chapter. This engine is of the nine-cylinder type with a bore of 5.75 in. (146 mm.) and stroke of 7.5 in. (190.5 mm.), giving a cylinder capacity of 1,753 cu. in. (28.7 litres). The normal and maximum speeds are 1,900 and 2,000 R.P.M., respectively, and the rated and maximum powers, 415 and

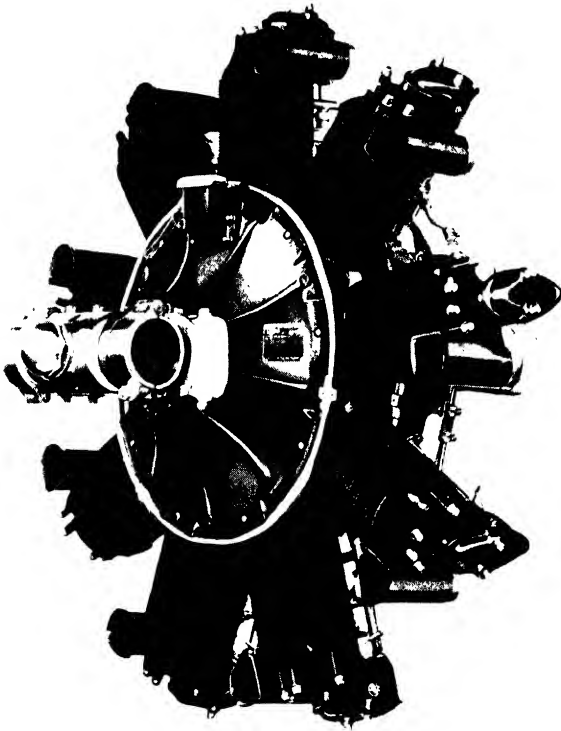

FIG. 153. The Packard compression ignition engine.

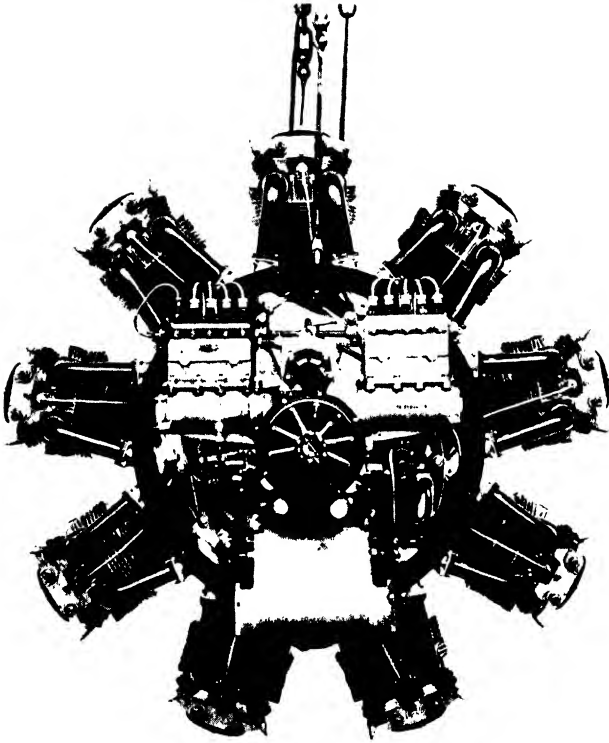

FIG. 154. Bristol "Phoenix" compression ignition engine.

470 B.H.P., respectively. The engine weighs 2.62 lbs. per B.H.P. on the rated output.

In regard to the performance of this engine, which was built in 1934, the graphs given in Fig. 156 show some comparative test results with those of a Bristol "Jupiter" engine of the same date; the latter nine-cylinder radial engine had a slightly higher rated output. The tests were carried out successively in a Westland "Wapiti" aircraft.

The test results indicated that the C.I. engine power output

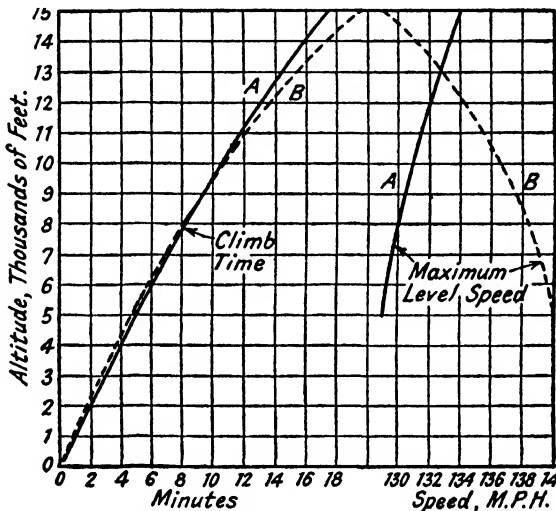

FIG. 156. Comparative flight trials. Bristol "Phoenix" and "Jupiter VIII" in "Wapiti" aircraft.

- (A) "Phoenix" results; total weight 4,896 lbs.
- (B) "Jupiter VIII" results; total weight 4,810 lbs.

at altitudes was maintained much better than for the petrol engine. Thus, compared with the latter engine, the maximum speed at 1,500 ft. was increased by 5 M.P.H. and the time of climb to this height was improved by 13 per cent. The take-off was also better, requiring 13 secs. for a 500-ft. run with the maximum total weight of 5,300 lbs. These results confirm similar general comparative test deductions made with the Packard C.I. engine. In regard to fuel consumption, the "Phoenix" engine showed a 35 per cent. improvement under similar cruising speed conditions to the "Jupiter" engine; the actual fuel consumption was 0.390 lb. per B.H.P. hour.

It was stated, at the time, that during its trials the "Phoenix" engine behaved perfectly satisfactorily from all aspects of operation of an aircraft engine and in addition possessed certain advantages. The engine could be started with a hand

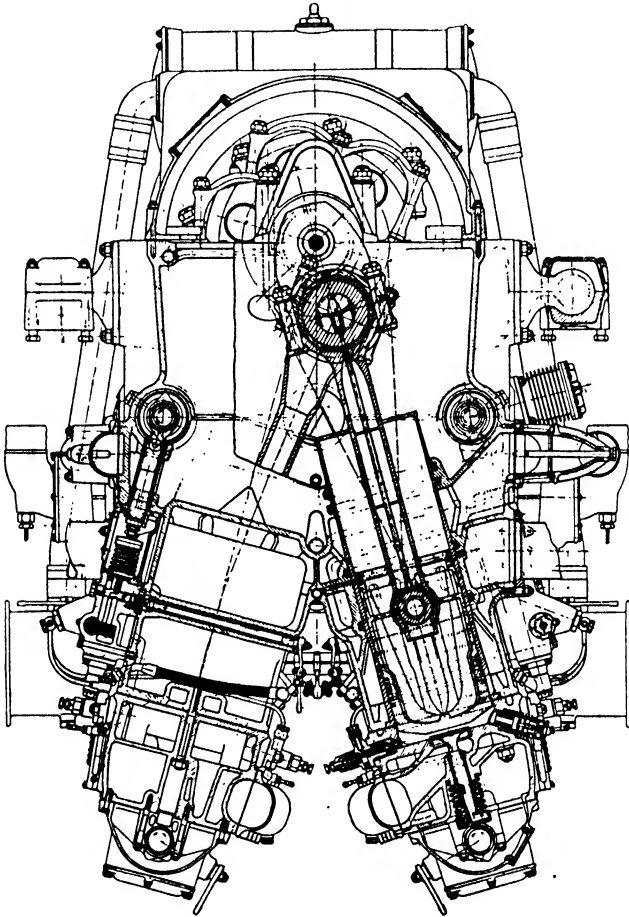

FIG. 158. Sectional view of Deschamps engine.

or electric "inertia" starter without difficulty. Regular slow running, though a little faster than with a petrol engine, and excellent acceleration were notable qualities of the engine. The engine was found to operate at temperatures down to -40°C . satisfactorily.

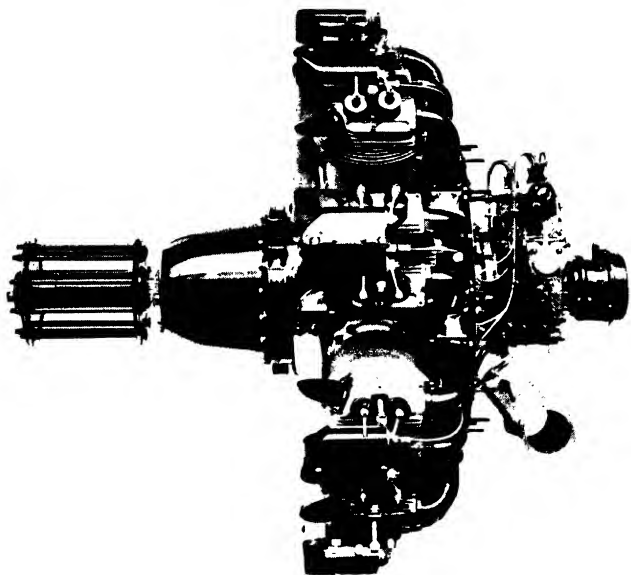

FIG. 155. Bristol "Phoenix" compression ignition engine, in side view.

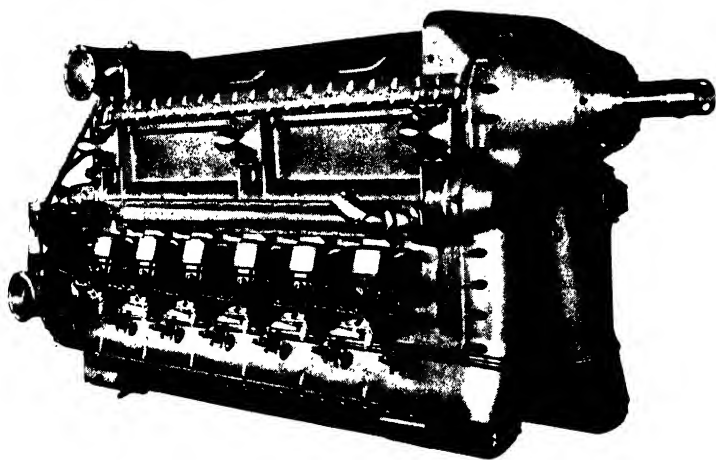

FIG. 157. The Deschamps inverted twelve-cylinder Vee-type two-cycle compression ignition engine.

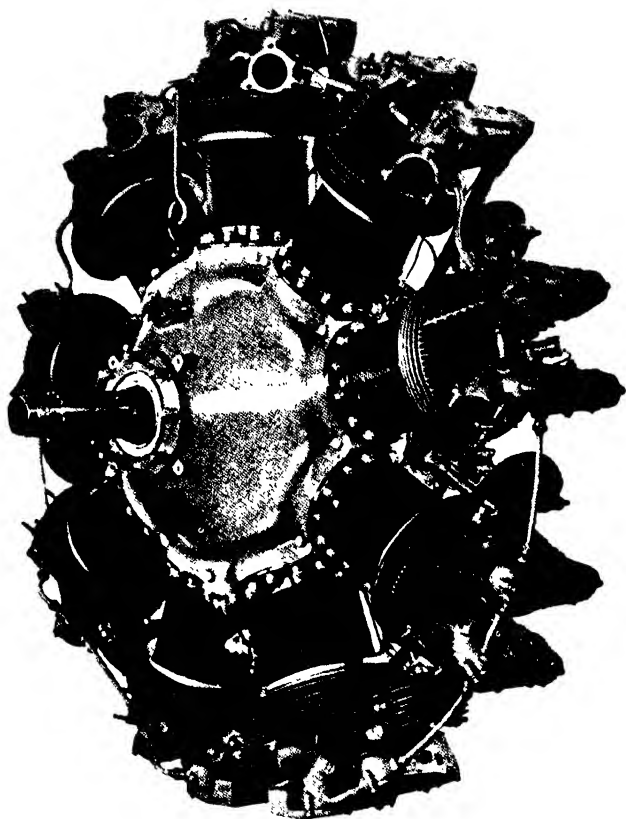

FIG. 159. The Guiberson compression ignition engine.

Another interesting design of C.I. engine is the Deschamps 1,200 h.p. inverted twelve-cylinder Vee-type one, operating on the two-cycle principle. It developed 1,200 B.H.P. at 1,600 R.P.M. and had a bore and stroke of 6 in. (152.5 mm.) and 9 in. (228.5 mm.), respectively, and a cylinder capacity of 3,052 cu. in. (50 litres). The engine was scavenged at a pressure of 12 lbs. per sq. in. by means of a centrifugal compressor run at 13.5 times crankshaft speed. The air delivery was arranged to be 25 per cent. greater than the piston swept volume. The terminal air pressure when the exhaust port and air valves were closed was about 4 lbs. per sq. in. above atmospheric. The air admission poppet valves were situated at the tops of the cylinders and the twelve exhaust ports per cylinder were at the lower ends and piston controlled. The compression ratio used was 16 : 1, the fuel injection pressure to the two fuel injectors per cylinder being 3,500 lbs. per sq. in. These injectors were located opposite to one another to provide tangential sprays; the pistons were domed and the cylinder heads flat. The direct injection system was employed in this engine. The engine had a weight of 2 lbs. per B.H.P.; this weight included the compressor, fuel booster pumps, and injection equipment. The fuel consumption was 0.410 lb. per B.H.P. hour and the maximum value of the B.M.E.P. was stated by the manufacturers to be 98 lbs. per sq. in. The engine in question was built for D. J. Deschamps by the Lambert Engine and Machine Co., of Illinois, U.S.A.

It is not possible, owing to space limitations, to describe several other types of aircraft C.I. engine which have been built, but not so far put into production, so that the rest of the descriptive part of this section will be devoted to accounts of two or three modern types of engines which have actually been employed in commercial aircraft; these include the 1940-41 American Guiberson A-1020 engine and the German Junkers Jumo engine; the latter engine has also been made in this country by Messrs. Napier Ltd., as the Culverin engine. In France it is made as the C.L.M. engine.

The Guiberson engine belongs to the nine-cylinder air-cooled radial class, operating on the four-cycle principle. It is illustrated in external view in Fig. 159 and sectionally in Fig. 160. The direct injection combustion method is employed, the combustion chamber being formed by the dome of the cylinder head and the concave piston crown (Fig. 161). It belongs to the quiescent combustion chamber type in which

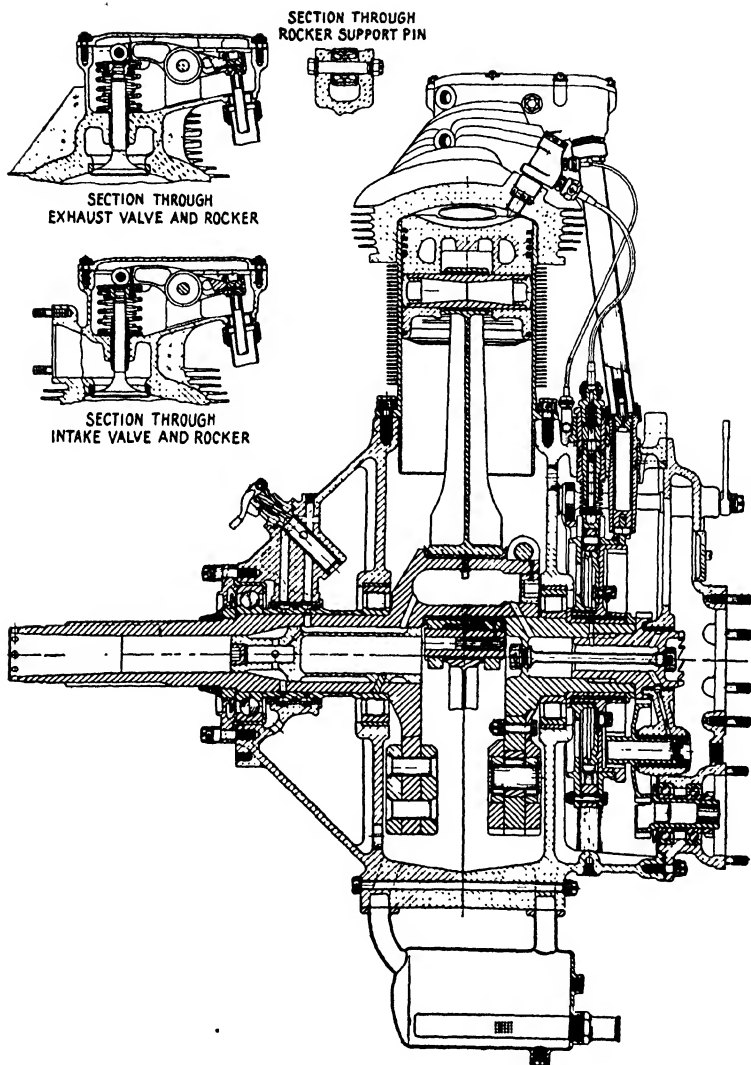

FIG. 160. Sectional view of the Guiberson compression ignition engine.

no special means are used to promote turbulence, the chief end sought being maximum volumetric efficiency and B.M.E.P. This type of combustion chamber affords easy starting from the cold without heater plugs.

The engine has a bore and stroke of 5.125 in. (130 mm.) and 5.50 in. (140 mm.), respectively, with a corresponding cylinder capacity of 1.021 cu. in. (16.7 litres). It employs a compression ratio of 15 : 1 and has a rated output of 320 B.H.P. at 2,200 R.P.M. with 340 B.H.P. at 2,250 R.P.M. for take-off purposes. The B.M.E.P. value is 113 lbs. per sq. in. at the rated h.p. The fuel consumption is quite low, being 0.38 lb. per B.H.P. hour at the full rated power. When at cruising power, namely, 190 B.H.P., the fuel consumption drops to 0.34 lb. per B.H.P. hour.

The engine has a diameter, overall, of 47 in. and weighs 620 lbs., *i.e.*, 1.94 lbs. per rated h.p.

In regard to the constructional features, an aluminium alloy crankcase made in two halves, bolted together along the centre line, is used. The crankshaft runs in roller bearings, with a ball thrust for the airscrew loads. The rear part of the crankcase contains the valve tappet guides and fuel injection pumps, the latter being connected with a fuel duct bored in the rear part of the crankcase. The cylinders have forged steel barrels and short cooling fins, with aluminium alloy heads screwed and shrunk into place. The valve seats are of silchrome for the exhaust and aluminium bronze for the intake valves, respectively, and are shrunk into the cylinder heads.

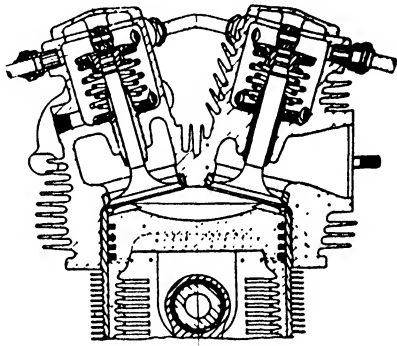

FIG. 161. Cylinder head, showing valves and piston of Guiberson engine.

The heat-treated aluminium alloy pistons each have three compression and one oil-control ring above and one oil-control ring below the gudgeon pins; the latter is of the full floating type, positioned by aluminium alloy plugs at each end. The master and link rods follow the usual radial engine practice, the crankpin bearing of the master rod being of the steel-backed, lead-bronze bushing pattern. The crankshaft is of the two-piece type and (as will be seen from Fig. 160) is well lightened by drilling, and plugged to form oil passages. The valve cam ring is of forged steel and the inlet and exhaust

cams are unified in one lobe for the valve action; this is known as the "monorail" cam with four lobes on the cam ring. The latter is carried on a Duro-bronze bushing, having the cam drive integral with the cam ring, which turns at one-eighth engine speed in the opposite direction to the crankshaft.

The fuel cam ring is secured to the valve cam by four mounting bolts with slots for adjustment. A fuel cam adjust-

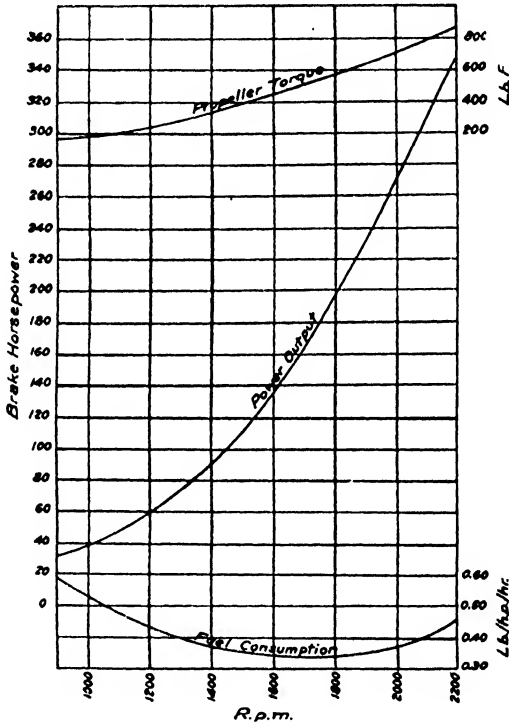

FIG. 162. Performance curves for Guiberson engine.

ment eccentric extends through the valve cam for adjusting the fuel cam ring. Incidentally, the valve rocker arms are mounted on Timken roller bearings and the whole of the push-rod and rocker-arm gear is enclosed and lubricated at its essential places, automatically.

The fuel injection system comprises nine individual fuel pumps of the Guiberson vacuum type, designed to obviate the use of a governor. When the fuel plunger is at the bottom of its

stroke, the inlet port in the pump housing is uncovered and fuel flows into the barrel above the plunger aided by a partial vacuum created during the down stroke of the plunger. On its upward stroke, the plunger forces the surplus fuel out through the inlet port until it reaches its cut-off position, when it covers the port. Fuel compression and injection then take place while the plunger moves upward until the latter reaches its release position, when the fuel can by-pass through a hole in the upper portion of the plunger *via* an annular groove around the latter into the inlet port. This releases the pressure and injection ends, while the plunger continues ineffectively to the end of its stroke. Such is the operation of the pump at full throttle.

With the throttle set in any intermediate position, the operation is the same except for the lowest plunger position. As the fuel inlet port is then only partially opened, it governs the amount of fuel admitted to the barrel above the plunger. This is particularly effective, since the time is limited in which the fuel can flow through the restricted inlet port. If the engine speed decreases at any particular throttle setting, the time that the fuel inlet port remains open is increased and, consequently, more fuel is admitted and the speed of the engine increases. When the engine speed increases unduly, this action is reversed. When the throttle is closed the plunger does not uncover the inlet hole at all and as no fuel is injected the engine stops. The spring-loaded fuel injectors have triple orifice nozzles and spray the fuel fanwise across the clearance space through three holes, each of 0.014 in. diameter radially disposed at 55 degrees. The fuel is injected at a pressure of 2,200 to 2,500 lbs. per sq. in. The cartridge method of starting is provided for in the design of this engine.

Another model, known as the T-1020 engine, made by the same firm, has a rated output of 250 B.H.P. and overall diameter of 44.875 in. ; its construction is identical with that of the engine described. The manufacturers are the Guiberson Diesel Engine Co., Dallas, Texas, U.S.A.

Apart from the Junkers two-cycle engines described later, other C.I. aircraft engines of German origin include the Maybach and Mercedes-Benz ones. The former is a twelve-cylinder Vee model of 5 $\frac{7}{8}$ in. (150 mm.) bore and 7 $\frac{7}{8}$ in. (200 mm.) stroke, developing 410 B.H.P. at 1,400 R.P.M., although later models are known to have higher outputs per litre. The combustion system employs the direct injection principle,

using cut-away piston heads and side injectors; this arrangement is similar to that shown in diagram G, Fig. 152.

The Mercedes-Benz engines are made in the twelve-cylinder Vee (700/750 h.p.) and the sixteen cylinder Vee (900/1,200 h.p.) sizes; these engines have been fitted to German airships; the larger model was used in the Hindenburg LZ129 airship, destroyed by fire at Lakehurst, U.S.A., in 1937.

The engines employed the pre-combustion chamber system. The larger engine had a bore of 6.89 in. (175 mm.) and stroke of 9.05 in. (230 mm.),

giving a cylinder capacity of 5,401 cu. in. (88.5 litres). It had an output of 1,200 B.H.P. at 1,600 R.P.M. for a B.M.E.P. of 107 lbs. per sq. in. and a weight of 4,320 lbs., *i.e.*, about 3.6 lbs. per B.H.P. The smaller engine of 53.88 litres developed 720 B.H.P. at 1,720 R.P.M. for a dry weight of 2,060 lbs., *i.e.*, about 2.86 lbs. per B.H.P. The fuel consumption under cruising conditions was 0.405 lb. per B.H.P. hour.

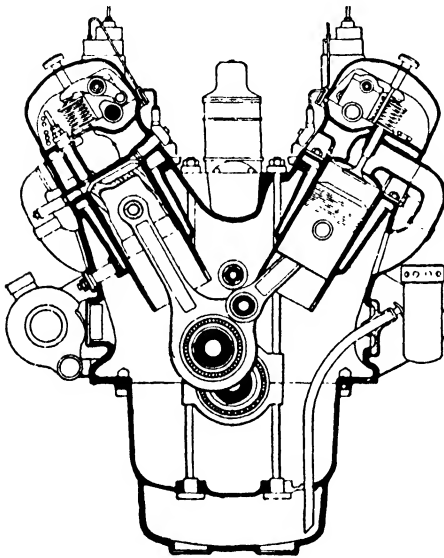

FIG. 163. The Maybach twelve-cylinder Vee-type compression ignition engine.

The Junkers C.I. engines of the "Jumo" class belong to the

opposed-piston vertical cylinder two-cycle liquid-cooled pattern of which the Jumo 204 (750 h.p.), 205-C (550 h.p.) and 206 (1,050 h.p.) are typical examples.

The Jumo 205-C engine has a bore of 105 mm. and stroke of 2×160 mm., with corresponding cylinder capacity of 16.62 litres. It employs a compression ratio of 17 : 1 and develops a maximum B.M.E.P. of 102 lbs. per sq. in. The maximum output is 610 B.H.P. at 2,200 R.P.M. for an engine weight of 1,124 lbs., giving 2.04 lbs. per rated h.p. (550), or 1.11 lbs. per cu. in. of cylinder capacity. The engine has a frontal area of 6.5 sq. ft. so that at the rated h.p. this is equivalent to about

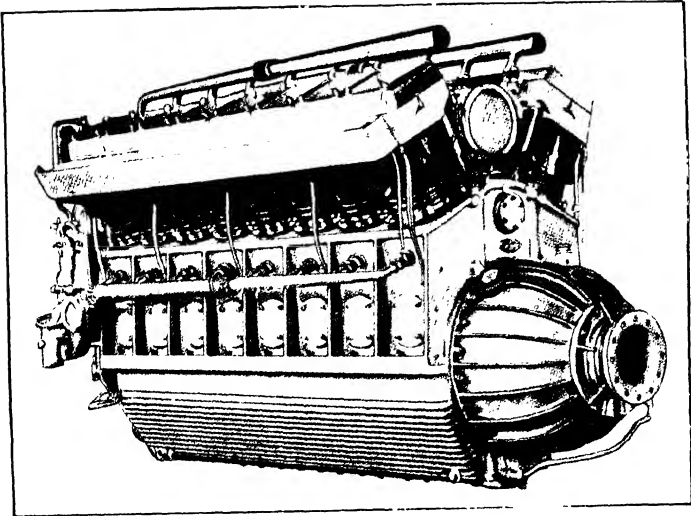

FIG. 104. The sixteen-cylinder 1,200-h.p. Mercedes-Benz compression ignition engine, used on the LZ129 Zeppelin airship.

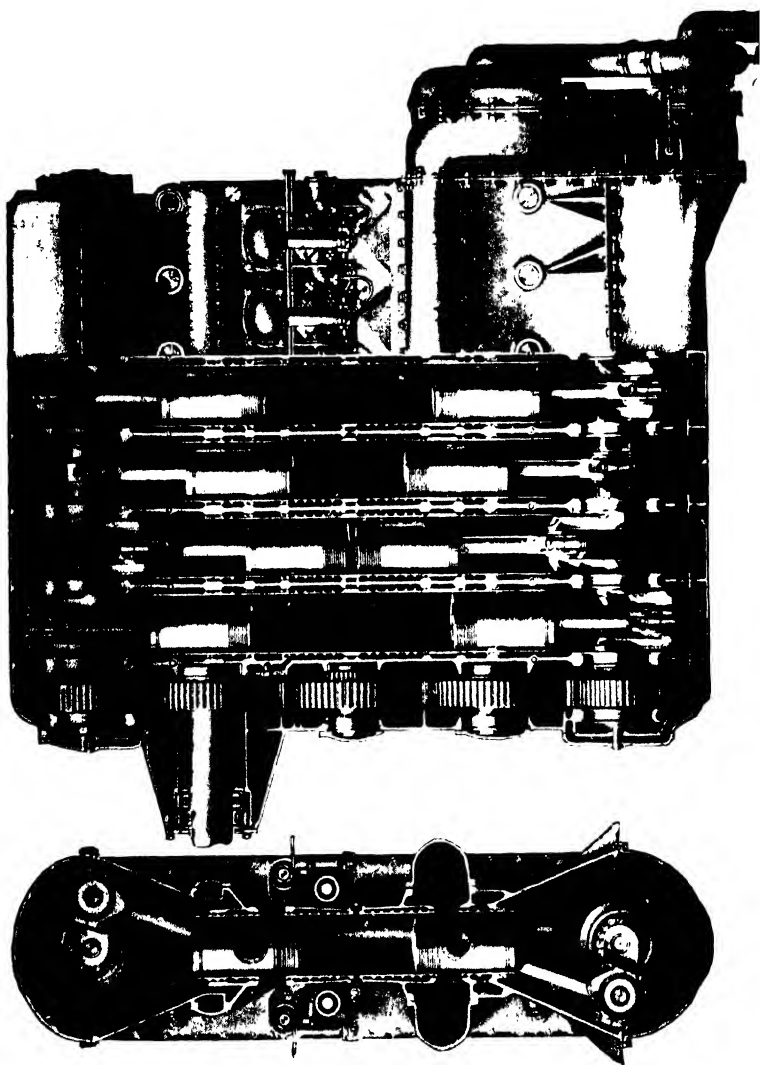

FIG. 166. Pictorial part-sectional view of the Junkers "Jumo" engine.

85 h.p. per sq. ft. The fuel consumption is stated to be 0.35 lb. per B.H.P. hour and the oil consumption 0.018 lb. per B.H.P. hour.

The Jumo 204 engine is rated at 750 h.p. at 1,720 R.P.M. It has a bore and stroke of 120 mm. and 2×210 mm., respectively, with a cylinder capacity of 28.60 litres. The maximum output is 800 B.H.P. at 1,850 R.P.M. and the lowest fuel consumption, 0.34 lb. per B.H.P. hour. The engine weighs, complete, 1,650 lbs., which is equivalent to 2.20 lbs. per B.H.P. The frontal area is 8.3 sq. ft., giving about 90 h.p. per sq. ft. of frontal area for the rated output.

The engine is 5 ft. 9½ in. in length. It employs a compression

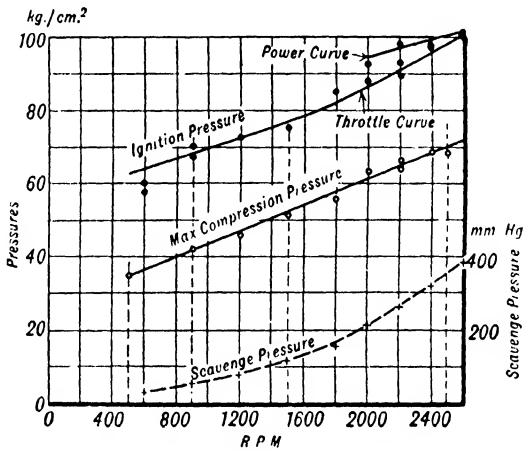

FIG. 165. Pressure values for the Jumo 205 engine at various speeds.

ratio of 17 : 1 and develops a maximum B.M.E.P. of 96 lbs. per sq. in.

The Jumo 206 engine has a cylinder capacity of 25 litres and has an output of about 40 B.H.P. per litre with corresponding weight of 1.39 lbs. per h.p.⁴⁰

The cycle of operations in these engines is illustrated by the four diagrams reproduced in Fig. 144 ; reference has been made earlier in this chapter to the air scavenge system, shown more fully in the left-hand diagram. The exhaust ports above are uncovered before the air scavenge ports below and the air is admitted through tangential ports, so as to produce a spiral motion which results in more efficient scavenging of the burnt gases. The volume of the scavenging air is about 1.6 times the cylinder capacity in the Jumo 204 and 205 engines and 1.3

times in the Jumo 206 engine. Fig. 165 shows the air scavenge, compression and maximum (ignition) pressure values for the Jumo 205 engine at various speeds, expressed in kg. per sq. cm.; in this connection 1 lb. per sq. in. equals 0.0703 kg. per sq. cm. At 2,000 R.P.M. the corresponding values of the scavenge, compression and maximum pressures are 3.9, 868 and 1,230 lbs. per sq. in., respectively. During the compression stroke the spiral motion, or turbulence, persists until at the moment of injection—when the two pistons are almost at their inner dead centres—the air is still in motion and the fuel, which is injected through four equally spaced nozzles, mixes efficiently with the air charge.

Fig. 167 shows the Jumo 205 engine piston, cylinder and crankshaft arrangements. It will be observed that the upper crankshaft is geared direct to the airscrew shaft, whilst the lower crankshaft is connected through a train of three gears to this shaft which runs at less than crankshaft speed. There is a vibration damper in the airscrew shaft drive:

The air compressor employed for scavenging is of the centrifugal type driven by step-up gears from the lower crankshaft (Fig. 167).

Experimental work has been carried out with an exhaust-gas driven supercharger, which, for the Jumo 205 engine, weighs about 66 lbs. and develops 160 h.p. at 19,700 ft. altitude. With this type of supercharger it has been found possible to maintain ground-level power with approximately the same fuel consumption, namely 0.352 lb. per B.H.P. hour, to 19,700 ft.

In regard to the fuel injection system there are two injection pumps to each cylinder unit, namely, one on each side. Thus, for a six-cylinder (double) engine there are six fuel injection pumps on each side of the cylinder block, each set (Fig. 168), being operated by a common camshaft. An illustration of one of these fuel injection pumps will be found in Reference 27. Each injection pump is connected by short lines to pairs of fuel injectors. Two fuel transfer pumps, driven from the rear end of each camshaft, supply fuel to the injection pumps. The fuel injection pressure employed varies from 7,350 to 8,820 lbs. per sq. in. and the injection nozzles are of the open pattern, each injector having two small holes at the end, arranged to give a fan-shaped spray with an apex angle of about 120 degrees.

It is interesting to note that since this engine works on the two-cycle principle the complete operation of injection and

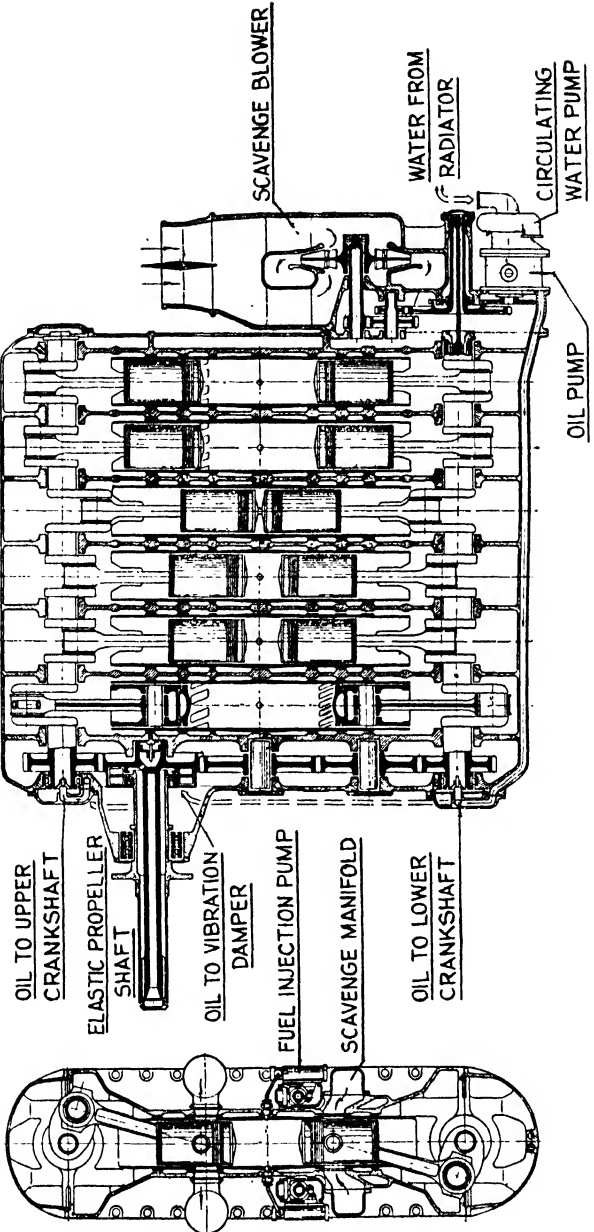

FIG. 167. The six (double) cylinder Junkers Jumo two-cycle compression-ignition engine.

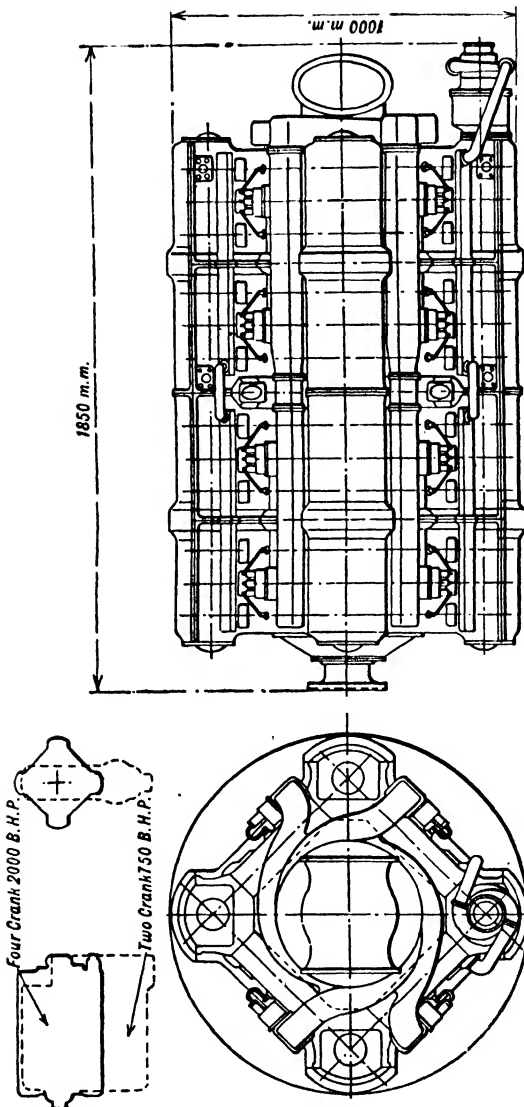

Fig. 168. Schematic arrangement for sixteen-cylinder opposed piston engine (2,000 h.p.).

atomization occurs 25 times a second in each cylinder, each period being of the order of 0.001 sec.

In regard to possible developments of this type of engine which, owing to its somewhat excessive cylinder axis dimensions, is more suitable for wing installation than in the nose of a

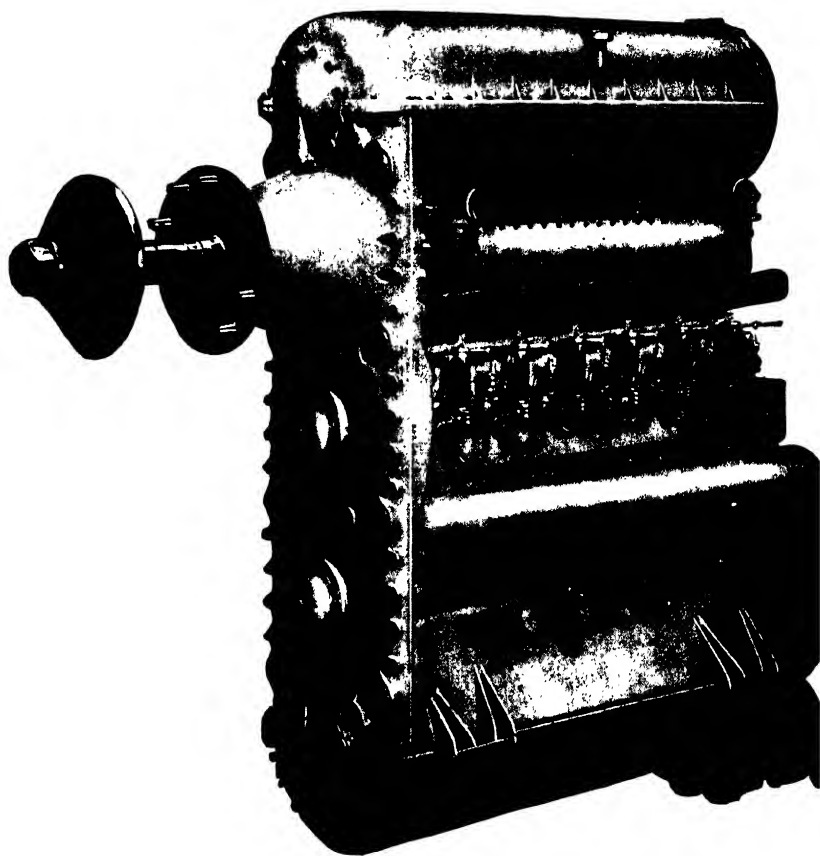

FIG. 169. Outside view of the Junker's "Jumo" six (double) cylinder engine, showing aircrew shaft.

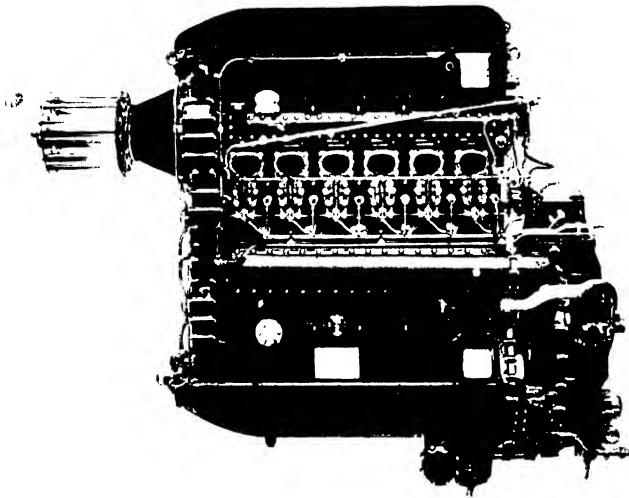

FIG. 170. The Napier "Culverin" six (double) cylinder aircraft engine (720 h.p. at 1,700 R.P.M.) built under the Junkers patents.

fuselage, a four-crankshaft engine of 2,000 h.p. having sixteen double cylinders has been planned by the manufacturers. This engine arrangement, shown in Fig. 168, would have an overall length of 1,850 mm. (6 ft. 1 in.) and diameter of 1,000 mm. (3 ft. 3.4 in.), giving a rated output of about 237 h.p. per sq. ft. of frontal area.

The specific weight of such an engine would be about 1.1 lb. per h.p. In connection with the Junker's Jumo engines, although there is an absence of inlet and exhaust valves of the poppet or sleeve types, and in consequence no valve operating mechanism, this advantage is to some extent offset by the duplication of pistons, connecting rods and crankshafts, and also the necessity for a train of gearing which must be so designed that each gear transmits most of the power output of its bank of cylinders; further, the bearings for these gears must also be dimensioned for these relatively high power transmissions. In addition, there are two fuel injection pump camshafts, pumps and drives. The mechanical efficiency of this type of engine may therefore reasonably be expected to be lower than for the single piston per cylinder design of C.I. engine.

Comparative Power Outputs of C.I. Engines. A useful method of comparing the power outputs of aircraft C.I. engines is in respect to the horse power per square inch of piston area; another method is that of the horse power per unit piston swept volume.

If the value of the B.M.E.P. is known, at normal rated output and the mean piston velocity V ft. per min., then the following relation holds:—

$$\text{B.H.P. per sq. in. of piston area} = \frac{\text{B.M.E.P.} \times V}{K \times 33,000}$$

where $K = 2$ for a two-cycle and 4 for a four-cycle engine.

The following table gives some relative values for the normal rated outputs of some typical engines:—

Quantity	Bristol Phoenix 4-Cycle Radial	Packard 4-Cycle Radial	Guiberson 4-Cycle Radial	Ricardo Sleeve-valve* 4-Cycle	Ricardo Sleeve-valve 2-Cycle*	Junkers Jumo V 2-Cycle
B.M.E.P.	83.5	95	113	100	88	97
Mean piston velocity	2,380	1,950	2,017	2,100	1,600	2,160
H.P./sq. in. of piston area	1.50	1.40	1.72	1.59	2.13	3.10
H.P./100 cu. in. of piston swept volume	20.0	23.6	31.3	22.7	29.0	49.0

* Water cooled 5½ in. bore by 7 in. stroke.

Other C.I. Aircraft Engines. Apart from the selected engines mentioned in the previous pages of this chapter, there are several other designs or adaptations which have been built and tested in this country and abroad. Thus, an experimental Rolls-Royce "Condor" engine of the 12-cylinder Vee-type was adapted to C.I. engine requirements and tested by the Air Ministry. It was designed to give 500 B.H.P. at 2,000 R.P.M. and weighed 1,500 lbs. The maximum cylinder pressure was 800 lbs. per sq. in. and the B.M.E.P. 97 lbs. per sq. in. at 1,900 R.P.M., giving an equivalent output of 1.75 B.H.P. per sq. in. of piston area, or 23.4 B.H.P. per 100 cu. in. of cylinder capacity. The fuel consumption given under cruising conditions was 0.37 to 0.38 lb. per B.H.P. hour.

Other C.I. aircraft engines that have been built include the

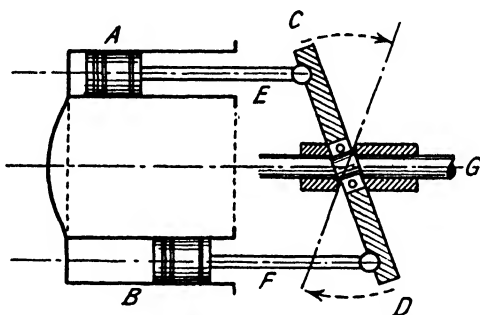

FIG. 171. Principle of barrel type engine.

Clerget 14-cylinder air-cooled radial of 600 B.H.P., the Coatalen 12-cylinder Vee water-cooled 550 H.P. ones, etc.

The Axial or Barrel-Type Engine. Among the alternative types of engine proposed for use in aircraft is that in which the cylinders are arranged with their axes parallel to the main shaft's axis, the drive to the latter being by means of ball-ended piston rods and socket-bearings for these, mounted on an inclined disc or plate known as a "wobble" or "swash plate," according to whether the engine cylinder unit is fixed and the main shaft rotates or the shaft is fixed and the cylinder unit with its pistons, etc., revolve bodily around the shaft and inclined disc attached to it.

The principle of the former type engine is illustrated diagrammatically in Fig. 171, which shows only two of the cylinders, A and B, with their unit pistons and rods E and F respectively. The latter have ball and socket joints in the

inclined plate CD which is mounted on ball bearings on the inclined portion of the main driving shaft G.

As the pistons reciprocate within their cylinders on the two- or four-cycle principle of operations the inclined plate is forced to rotate the main shaft, whilst it wobbles to and fro as indicated by the dotted lines in Fig. 171. It will be observed that any convenient number of cylinders may be arranged around the shaft axis. If the shaft is fixed the cylinder unit will rotate bodily about it, in a similar manner to the Gnome rotary engine, which was popular until about 1918.

Various designs of engines, including the Macomber, Helm, Bristol and the Mitchell swash plate type, with Mitchell thrust-

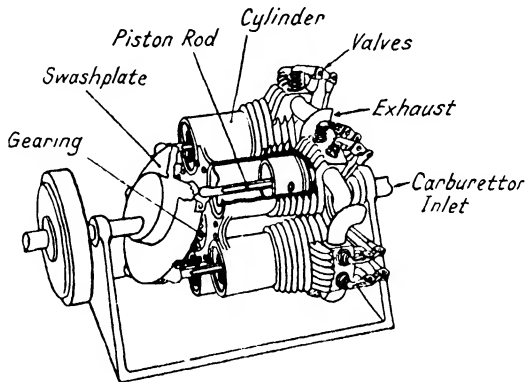

FIG. 172. Barrel-type rotary engine.

socket bearings, have been made to operate on this principle. More recently the American Herrmann and Hall barrel engines have been put forward for aircraft. The advantages claimed for the barrel-type engine are that it gives a smaller frontal area per h.p. than any other engine and can be made lighter per horse power. Further, since the pistons can be given a true harmonic motion, the engine's speeds can be increased by about 12 per cent. without increasing the maximum inertia forces. The principal disadvantage of the barrel-type engine lies in the relatively high frictional losses between the piston rod and inclined plate bearings owing to the heavy thrust pressures; attempts to reduce these losses usually result in appreciable increase in the weight of the engine.

Fig. 173⁴⁴ illustrates the frontal areas of four different types

of aircraft engines of 2,000 H.P. at 400 M.P.H., and serves to emphasize the theoretical advantage, at least, of the barrel-type engine in the matter of low frontal area and power unit drag.

The principal field of application of the barrel-type engine

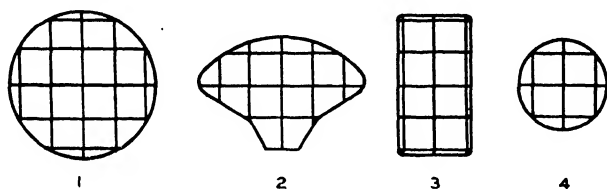

Type of Engine	No. of Cyls.	Frontal Area Sq. Ft.	Engine Drag (Hp.) At 20,000 Ft.	At Sea Level
1 Two-Row Radial	18	16	373	700
2. Double Allison	24	12	289	542
3. H-Type	24	10	233	436
4. Barrel Type	18	6	144	270

FIG. 173. Comparison of frontal areas of typical aircraft engines.

would appear to be in connection with the two-cycle C.I. engine, since pairs of cylinders can be placed in line with each other and the two cylinders contain a single piston unit which is subjected to a firing impulse at the beginning of each stroke ;

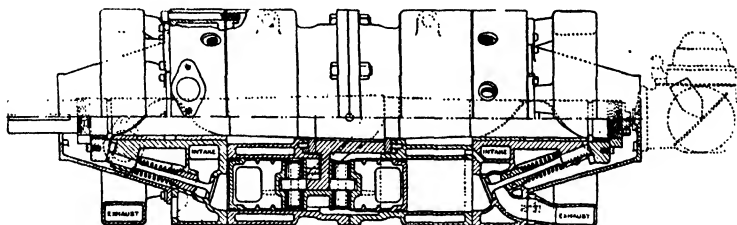

FIG. 174. The Herrmann barrel engine with twelve cylinders (140 h.p.).

the firing pressure can be balanced to a large extent by the piston inertia so that the bearing loads are not excessive. In the paper mentioned in Reference 44 the author gives a specification for an 18-cylinder 7 in. bore by 8 in. stroke two-cycle engine, with wobble plate mechanism, which he considers can be built with a frontal area of not more than 7 sq. ft., to

deliver 5,000 B.H.P. at 3,000 R.P.M. for a weight of about 3,000 lbs. Many practical difficulties would have to be overcome in such a design, whilst the lower mechanical efficiency inherent in most engines of this type would no doubt prove a drawback.

Fig. 174 shows the general arrangement of the Herrmann barrel-type 12-cylinder engine built during 1938 for experimental purposes. It had a bore and stroke of $3\frac{1}{8}$ in. (77.6 mm.) and $3\frac{3}{4}$ in. (95.3 mm.), giving a cylinder capacity of 330 cu. in. (5.407 litres); it developed 140 to 150 B.H.P. at 1,900 R.P.M.

In this design two cylinder blocks are employed, each having six parallel cylinder bores. They are joined together by flanges and bolts. The pistons are cast in pairs connected by a solid web carrying two rollers. These are in contact with the cam plate which forms two sine waves (Fig. 175). One revolution of the engine shaft corresponds to four strokes of each piston or to a complete cycle of a four-cylinder unit. All valves are located in the cylinder heads, being slightly inclined to the cylinder axes so that the stems converge towards and are in contact with bevelled cam faces on a plate mounted on the mainshaft. Each plate has two cam lobes, the inner for the exhaust and the outer for the inlet valves. An annular induction manifold is formed round the main bearing having radial passages to the valve pockets, the combustion chambers being shaped to produce an anti-detonating effect.

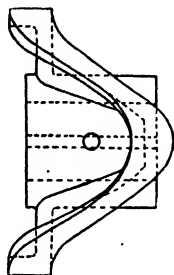

FIG. 175. The sine wave-shaped cam plate.

The dry weight of the engine, with cast iron cylinder blocks, without its carburettor was 384 lbs. It is estimated that with aluminium blocks and liners the engine weight could be reduced to 216 lbs., *i.e.*, about $1\frac{1}{2}$ lb. per B.H.P.

Oxygen Boosting of C.I. Engines. Experiments have been carried out on a C.I. engine by Dr. P. H. Schweitzer,⁸⁴ of Pennsylvania State College, using liquid oxygen which was injected into the air inlet. It was found that if the oxygen concentration was increased from the normal 21 per cent. to 45 per cent., the B.H.P. was increased by 60 per cent. The suggestion has therefore been made to increase the take-off power of aircraft C.I. engines by using liquid oxygen.

CHAPTER VII

AIRCRAFT ENGINE COMPONENTS

ALTHOUGH a certain amount of information relating to aircraft components has already been given in connection with the descriptions of typical engines, it is proposed, in this section, to give some further notes on this subject and to include some details not hitherto mentioned.

Engine Cylinders. The modern practice in regard to air-cooled cylinders is to employ alloy steel barrels and aluminium alloy heads. The barrels are usually machined from hollow forgings, the cooling fins being turned from the solid exterior portion of these by means of a series of form turning tools, also with multiple tools, after preliminary rough turning operations, in a turret lathe.

The steel employed for the Bristol "Pegasus" and "Mercury" engines is of the nickel-chrome-molybdenum grade

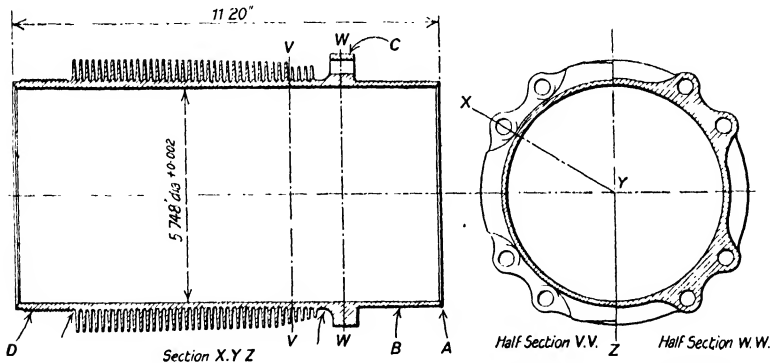

FIG. 176. Sectional views of Bristol air-cooled cylinder. (*Machinery.*)

suitable for hardening by the nitrogen process; it is made to D.T.D. Specification No. 228. The maximum tensile stress is from 55 to 65 tons per sq. in. with a minimum elongation of 18 per cent. and Izod impact test figure of not less than 35 ft.-lb. The hardness of the cylinder before nitriding

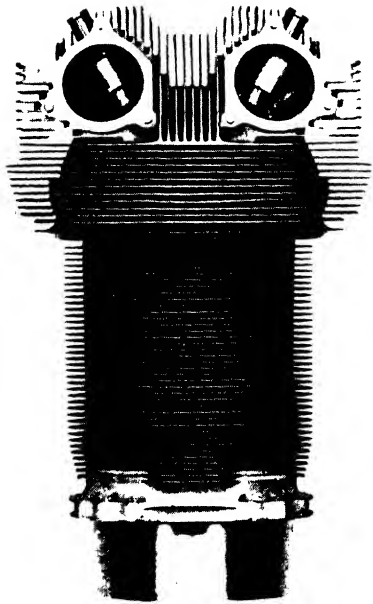

FIG. 177. The complete cylinder and head of Bristol "Mercury"
and "Pegasus" engines.

is 250 to 290 Brinell; after nitriding it must have a minimum value of 600 on the Vicker's diamond hardness scale.

Fig. 176 ⁴⁵ illustrates the finished cylinder of a Bristol engine and shows the screwed portion on the left for the cylinder head attachment, the finning and the holding down flange at C. The plain portion B fits into the crankcase and the end A is bevelled. The fins have a 4-degree taper from the head portion inwards towards the base and the fin thickness varies from 0.015 in. at the tip to 0.062 in. at the root.

The whole cylinder as machined is tinned in order to protect the areas not required to be hardened. The tin deposit is

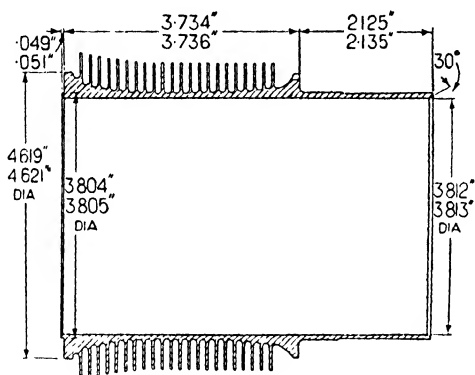

FIG. 178. Section through cylinder barrel of Napier "Dagger" engine.
(*Aircraft Production.*)

ground from the bore so as to expose the steel which is afterwards hardened by the nitriding method, *i.e.*, exposing it to a stream of ammonia gas for seventy-two hours at a temperature (for the metal) of 485° C.

Other steels employed for air-cooled cylinder barrels are medium carbon steel with 0.5 to 0.6 per cent. carbon, with a tensile strength of 45 tons per sq. in., and nickel steel with 0.35 to 0.45 per cent. carbon and about 1 per cent. nickel, having a tensile strength of 35 to 45 tons per sq. in.

The **cylinder heads** of modern air-cooled engines are subjected to severe temperature conditions so that, apart from the necessity of adequate finning, it is necessary to employ metals which will give a high rate of heat conduction, combined with the necessary mechanical strength conditions at the operating temperatures. Some idea of the heat distribution in the cylinder

head region of an air-cooled aircraft cylinder may be gathered from the approximate temperature values, under normal operating conditions shown in Fig. 179. In this connection the exhaust valve seating region is the hottest part of the internal surface and the inlet valve—due to the cooling effect of the incoming charge—the coolest part. The extreme tips of the fins are, of course, the coldest parts of the cylinder head.

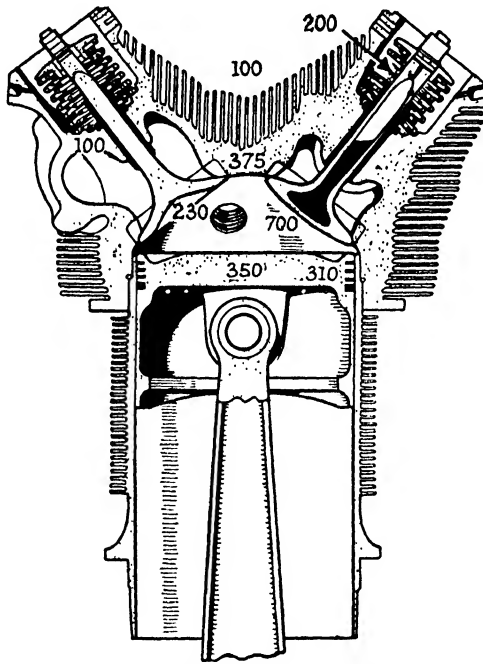

FIG. 179. Air-cooled cylinder temperatures.

The necessity for high strength is on account not only of the maximum combustion pressures, which are about 600 to 700 lbs. per sq. in., but also because of the internal stresses caused by the differences of temperature within the metal, previously noted.

The metals which give the best combination of good heat conductivity, combined with lightness and satisfactory mechanical strength properties at working temperatures, are certain light aluminium alloys. Hitherto, the high copper, and the zinc and silicon alloys of aluminium have been employed, but more recently the Hiduminium and Y-alloys have taken their

place. If the cylinder heads are sand cast to final exterior form the most suitable aluminium alloys are the Hiduminium R.R. 50 and R.R. 53 ones. Another alloy possessing good ductility in addition to maximum strength is Hiduminium R.R. 53 C. ; it is used for cast cylinder heads for C.I. engines. The light alloys used when cylinder heads are machined

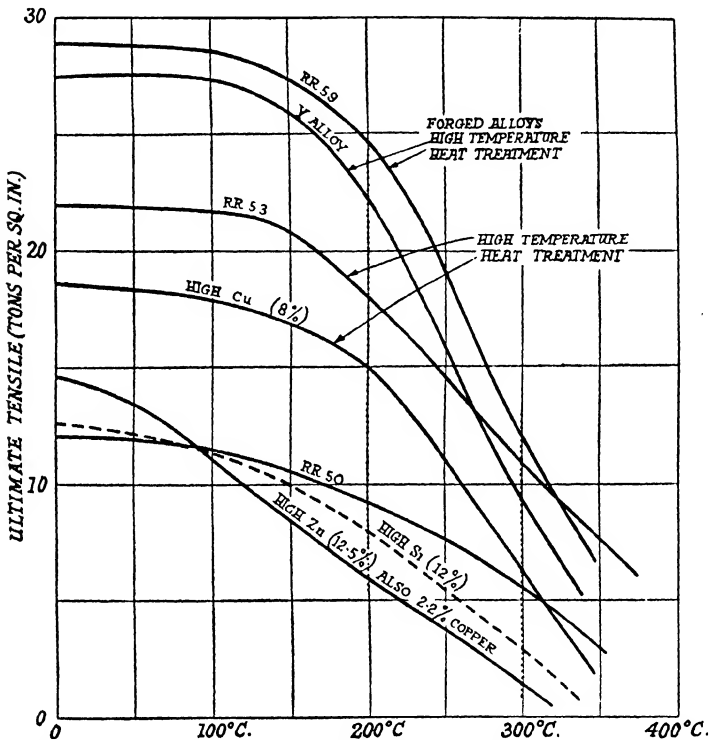

FIG. 180. Curves showing the strengths at elevated temperatures of various aluminium alloys after being maintained for thirty minutes at these temperatures.

from solid forgings are Hiduminium 59 and Y-alloy. In this case the heads are made with more accurate finning and cleaner surfaces than are possible by the sand casting process. The compositions and hardnesses of the five aluminium alloys previously mentioned are given in Table 16, whilst their mechanical strength properties at elevated temperatures are shown in Fig. 180.⁴⁶

An important requirement of cylinder head alloys is their resistance to both the corrosive and erosive attack of fuels containing tetra-ethyl lead; the high magnesium alloys are not so resistant as the aluminium ones mentioned previously.

The heat conductivities of the alloys given in Table 16 lie between 0.41 and 0.43 (up to 200° C. in C.G.S. units). The thermal expansion coefficients range from 23×10^{-6} to 24×10^{-6} (up to 200° C. per °C.).

TABLE 16. COMPOSITIONS AND HARDNESSES OF ALUMINIUM CYLINDER HEAD ALLOYS

	Cu	Mg	Si	Ni	Fe	Ti	Zn	Notes	Brinell Hardness
R.R.50 .	1.4	0.12	2.2	1.1	1.1	0.23	—	Normal condition for use Aged 160° C.	76
R.R.53 .	2.0	1.6	0.9	1.3	1.3	0.10	—	Solution treated and aged	135
Y alloy .	4.0	1.5	0.5	2.0	0.4	—	—	Solution treated	110
R.R.59 .	2.0	1.7	0.3	1.3	1.3	0.05	—	Solution treated and aged	130
R.R.53c	{ 0.8 to 2.0	{ 0.3 to 0.8	{ 2.0 to 3.0	{ 0.5 to 1.5/	{ 0.8 to 1.4	{ 0.3 —	—	Fully heat treated	100/115*

* Sand cast.

The specific gravities of these alloys lies between 2.65 and 3 compared with mild steel, 7.8.

Fig. 181 is a sectional view of a Bristol cylinder head in Y-alloy; the two half-sections are taken through the inlet and exhaust valve ports—which lie in different planes. There are two inlet and two exhaust valves per cylinder.

When aluminium alloy cylinder heads are used it is necessary to employ much harder metals for the valve seatings and sparking plug holes. In the example shown in Fig. 181 the valve seatings are of nickel chrome manganese high expansion steel; the exhaust valve seating faces are given a deposit of Stellite—a hard synthetic cutting alloy used for high speed tools. The valve seats are screwed and shrunk into the cylinder head; the sparking plug adapter is also shrunk into place in a similar manner, namely, by heating the head in a gas muffle to about 400° C. and screwing the cold adapter into position.

Bronze valve seatings are also used in some cases, but this metal cannot be Stellite and has not therefore the same wearing qualities of the alloy steel seatings treated in this manner.

The cylinder head stamping or forging usually requires about 80 machining operations to complete the final component, during which—in the case of the head shown in Fig. 181—the weight of the forging is reduced by machining from 49 lbs. to

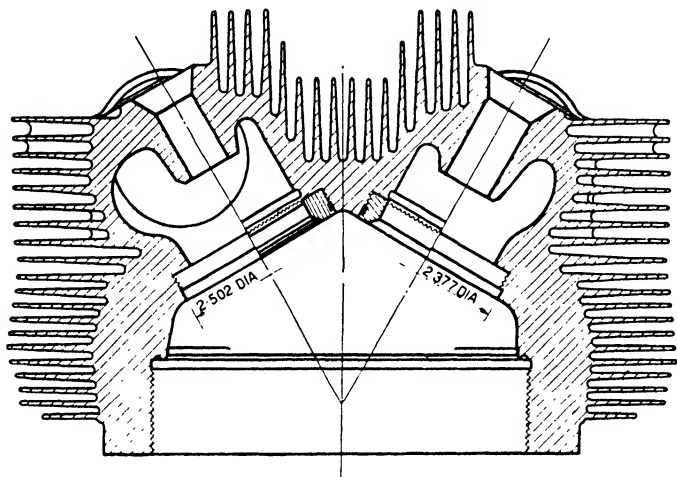

FIG. 181. Sectional view of Bristol aluminium alloy cylinder head.

only 15 lbs. Most of the fin machining is done with gang mills and the circular fins are turned with multi-cut tools.

The lower part of the interior of the head is cylindrical in shape and this portion is screwed to suit the thread on the upper part of the steel cylinder barrel. Afterwards the head is shrunk on to the barrel by heating the head to about 400° C. and screwing it on to the cold cylinder barrel.

An important item in connection with each cylinder and head assembly is the *correct adjustment of the compression ratio* so that this is the same for each cylinder unit. For this purpose about 0.060 in. is left on the face of the flange C (Fig. 176). The cylinder is fitted with a plug which fills the bore to a certain depth. Water is poured into the cylinder through the sparking-plug hole—the valves being in position—and the volume of the water required to fill the cylinder gives the clearance volume. This is invariably greater than the correct value, so that with the aid of a simple conversion table it is possible to ascertain

just how much metal to remove from the flange C to give the correct compression ratio.

The cylinder bore of Bristol engines is finished by honing, followed by a lapping operation, using centrifugally-cast iron lapping stick members; a mixture of lard oil and paraffin is used for both operations.

The aluminium alloy cylinder head of the Wright Cyclone Model G-100 engine is sand cast to a high degree of accuracy; the fins average $1\frac{1}{2}$ in. in depth and are spaced only $\frac{7}{32}$ in. apart. When the aluminium alloy casting for the head has cooled sufficiently to permit its being cleaned and prepared for machining the mould is separated and the baked sand broken away and destroyed.

The excellence of the casting process may be appreciated when it is mentioned that the cooling fins taper from 0.090 in. to 0.060 in., and in order to prevent distortion or fracture of these fins special finishing nails are fixed within the moulding sand; about 1,000 of these nails are used in each half head. The cylinder barrels are machined from nitriding steel forgings, each of about 60 lbs. weight; during the machining operation a considerable amount of metal is removed so that the final weight is only about 12 lbs. The annealed metal has a Brinell hardness of about 240, and the surface hardness of the barrel after the nitriding process is 80 C. on the Rockwell superficial scale. The cylinder head is screwed on to the barrel, the threads on the latter being first rough milled on a thread milling machine and then final ground to a tolerance of 0.001 in.; the thread employed is a special type of buttress shape. The cylinder head is fitted to the barrel by heating the former to about 315° C. and screwing it on to the cold barrel. Whilst the head is still heated the valve seats and guides are first cooled in a mixture of dry ice (solid CO₂) and alcohol and then inserted into position in the head. The inlet valve seating insert is of nickel aluminium bronze and the exhaust valve one of a special nickel chrome molybdenum steel.

In some cases the aluminium alloy head is made as a removable unit and is then held on to the cylinder barrel by means of four or more high tensile steel studs screwed at their upper ends to the crankcase. It is necessary in this method to use a copper-asbestos washer to make the joint between the head and barrel. This is the method employed for the Gipsy "Minor," "Major" and "Twelve" engines (Fig. 183).

The cylinder head of the Napier "Dagger" engine (Fig. 184)

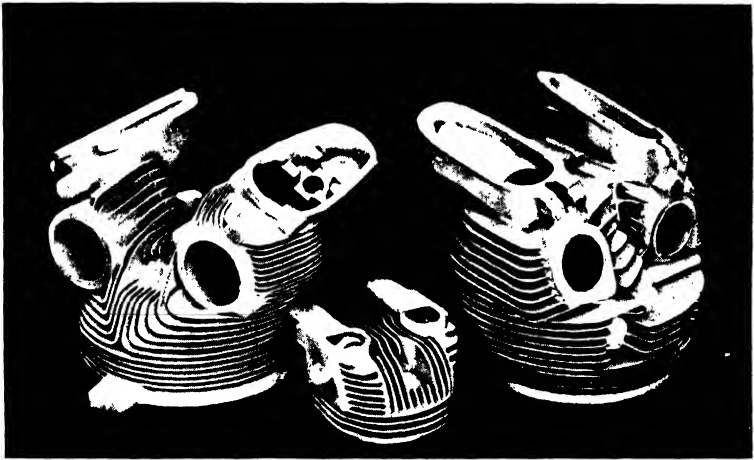
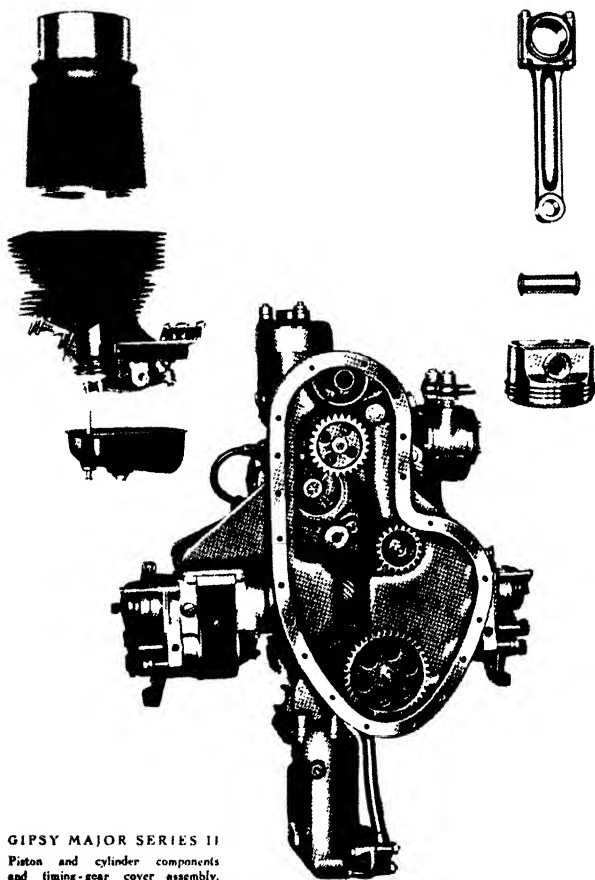

FIG. 182. Some typical cylinder head castings in Hiduminium alloy. (*High Duty Alloys Ltd.*)



GIpsy MAJOR SERIES II
Piston and cylinder components
and timing-gear cover assembly.

FIG. 183. Piston and cylinder components and timing gear cover of "Gipsy Major" Series II engine.

is of light aluminium alloy and has a register engaging a ground spigot on the top of the cylinder barrel (Fig. 178). Another spigot at the bottom of the barrel registers with a corresponding hole in the crankcase, and the head and barrel are held down to the crankcase by four studs screwed into the latter. The

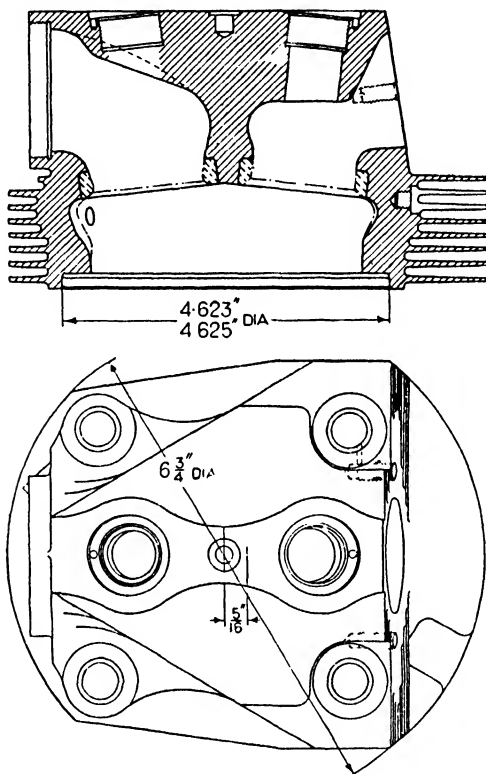

FIG. 184. Cylinder head of Napier "Dagger" engine. (*Aircraft Production.*)

barrel is made from a stamping in nitriding steel (D.T.D. Specification No. 317) by the process of turning and grinding.

Cylinder Weights. In regard to the weights of air-cooled cylinders for radial engines, the Bristol Mercury engine of $5\frac{3}{4}$ in. bore and $6\frac{1}{2}$ in. stroke, giving a displacement of 169 cu. in. with four poppet valves, weighs 46 lbs. The Bristol Perseus sleeve valve cylinder weighs 42.1 lbs. and it has the same bore and stroke as the Mercury engine.

of an air-cooled engine; this is because the hotter regions can be cooled more effectively with the cooling liquid than by means of fins. The exhaust valve, which is shown as a solid alloy steel type, is the hottest item, but by using the hollow sodium-cooled pattern the temperature is reduced appreciably. It will be observed that the aluminium alloy head is shown with hard metal inserts for the valve seatings and the sparking plug threaded portion.

The earlier Rolls-Royce aircraft engines, such as the "F" type 60 degree 12-cylinder Vee-type engine employed alu-

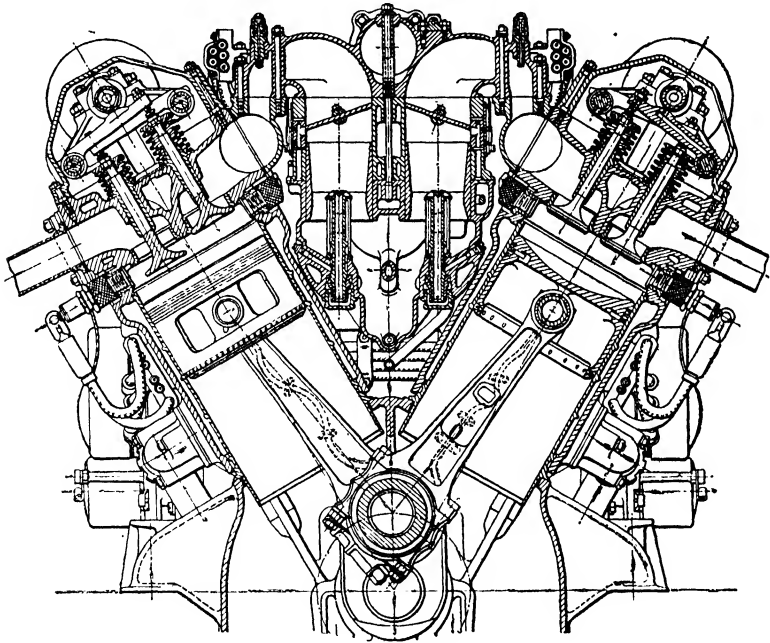

FIG. 186. Cylinders, pistons and connecting rods of Rolls Royce F-type engine.

minium alloy cylinder blocks (Fig. 186) ⁴⁷ and heads, with the inlet and exhaust passages cast integrally with the walls forming the water jackets. Renewable valve seating rings screwed into the heads and renewable cast iron valve guide sleeves were used. Carbon steel cylinder liners having flanged joints between the upper ends and the cylinder heads were fitted into the cylinder blocks. The upper joint was made gas-tight by

means of a soft aluminium ring, while near the lower end of each liner a sliding water-tight joint was formed by means of a rubber ring fitted into a groove in the liner. Immediately below this joint a flange formed on the liner had its bearing on the crankcase, the whole assembly being held in position by means of long bolts. The end ones were fitted outside the block and the others passed down through the water spaces between the liners, the bolts being enclosed in aluminium tubes swaged out at the ends to form a water-tight joint with the jacket casting. With this method there were no aluminium walls in the water spaces between the liners, so that both the weight and length of the engine was reduced appreciably. The liners (Fig. 186) each had three intermediate external stiffening projection rings. The cylinders each had two inlet and two exhaust valves.

The cylinder blocks of the Rolls-Royce Merlin engine are machined from R.R. 50 aluminium alloy castings (D.T.D. Specification No. 133B). This alloy, after heat treatment, has a minimum tensile strength of 11 tons per sq. in., elongation of $2\frac{1}{2}$ per cent. (minimum) and hardness of 60 to 80 Brinell. The cylinder castings are given a water or glycol test of 30 lbs. per

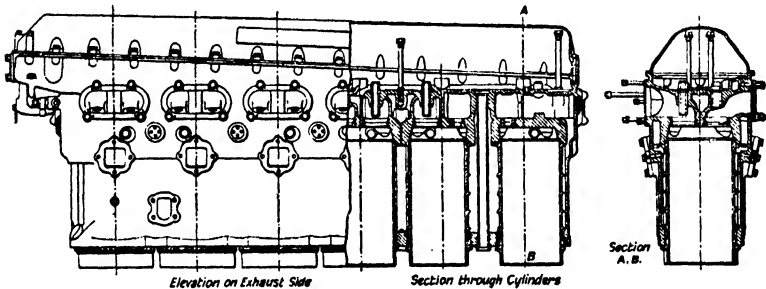

FIG. 187. Cylinder block of Rolls Royce "Merlin" engine. (*Machinery.*)

sq. in. before machining. The sparking plug screwed adapters and locking rings are shrunk into place, the cylinder block being heated to 320° F. for this purpose. These have an interference fit of 0.002 in. which ensures a permanent fit of the adapters and locking rings after the cylinder blocks have cooled.

The inlet valve seating ring is of aluminium bronze and the exhaust ring of Silchrome alloy steel; these insert rings are shrunk into position in a similar manner to the sparking plug

adapters. The inlet and exhaust valve guides are of cast iron and phosphor bronze respectively, shrunk into place. The inlet valve guides are burnished internally by forcing hardened steel balls through them. As this method cannot be used for the cast iron guides without risk of splitting them the holes are finished by a fine reaming process.

The method of securing the wet type high carbon steel liners is somewhat similar to that previously described for the "F" type engine. It uses a spring-loaded rubber ring in an external groove in the liner for the lower (water) joint and a soft aluminium ring for the gas joint above. Relative movement between the cylinder skirts and the liners is provided for by the spring-loaded glands, whilst at the same time ensuring cooling liquid-tight joints. An illustrated account of the cylinder construction is given in Vol. I of this work.

A particularly interesting example of an aircraft cylinder block casting is that of the Napier "Culverin" C.I engine—which is the English built version of the Junkers Jumo engine. This monobloc casting is made in Hiduminium alloy R.R. 50 and it embodies the twelve cylinder bores, cylinder cover flanges, the air and exhaust port openings timing gear half casing, engine bearers, etc.

Crankcases. In most instances the crankcase not only serves to enclose the whole of the main power transmitting working members, such as the connecting rods and crankshaft—and thus to provide an oil-tight chamber, but part of the crankcase forms the supports between the cylinder units and the main bearings, so that it must be made strong enough to take the maximum gas pressure loads under repeated impact conditions. In radial engines the whole of the crankcase is thus concerned, but in the case of "in-line" and vee-type engines it is only the cylinder-to-main bearing portions of the crankcase.

The crankcases of aircraft engines are sometimes made in aluminium casting alloys such as R.R. 50 or R.R. 53 or alternatively in a high strength magnesium alloy such as Elektron and Magnuminium. The advantage of magnesium alloys for this purpose lies in their high strength-to-weight ratio, but it is not generally advisable to employ these alloys for components exposed to relatively high temperatures since their tensile strengths diminish quickly with temperature elevation as will be seen from the following tabular results due to L. Aitcheson.

TABLE 17. TENSILE STRENGTHS AT ELEVATED TEMPERATURES OF WROUGHT ALLOYS OF ALUMINIUM AND MAGNESIUM¹

Temperature of Test °C.	Elektron AZ855	Duralumin Maximum Stress.	Y Alloy	RR56
20	20.0	26.5	25.0	27.0
100	16.5	25.5	23.5	24.0
150	13.7	22.5	22.5	22.5
200	12.0	20.0	21.5	21.0
250	6.0	18.5	21.0	20.5
300	—	13.0	16.5	15.0
350	—	8.0	13.0	10.0

¹ Values given are in tons per sq. in.

The alloys shown in the preceding table are wrought and heat-treated ones and it will be noted that whilst at 200° C. the tensile strengths of the aluminium alloys are 20 tons per sq. in. or above, that of the magnesium alloy (Elektron AZ855) is 12 tons per sq. in. The falling off in strength is even more marked at 250° C. Special alloys of magnesium, such as the cerium-cobalt class, give rather higher strengths than the figures given in Table 17. Thus an alloy containing 10 per cent. cerium, 1.5 per cent. cobalt, 1.5 per cent. manganese and the rest magnesium has a tensile strength of 18.6 tons per sq. in. at 20° C., 13.2 tons per sq. in. at 200° C. and 7.4 tons per sq. in. at 300° C.

The cast magnesium alloys used for aircraft engines show a somewhat similar rate of decrease of strength with temperature increase, but have lower initial strength values at air temperatures. Thus, Elektron AZG and A8 sand cast alloys have yield points of 6 to 7 tons per sq. in. and tensile strengths of 10 to 12 tons per sq. in.* with 5 to 3 per cent elongation and 45 to 55 Brinell hardness values.

The specific gravities of these alloys is about 1.82 so that the ratio of tensile strength to specific gravity is from $\frac{10}{1.82}$ to $\frac{12}{1.82}$, *i.e.*, from 5.5 to 6.6. The corresponding values for R.R. 53-casting alloy are $\frac{21}{2.75}$ to $\frac{23}{2.75}$, *i.e.*, from 7.6 to 8.35. The solution treated cast magnesium alloys give values of 8.2 to 11.0.

* Solution treated alloys give maximum values of 15 to 20 tons per sq. in.

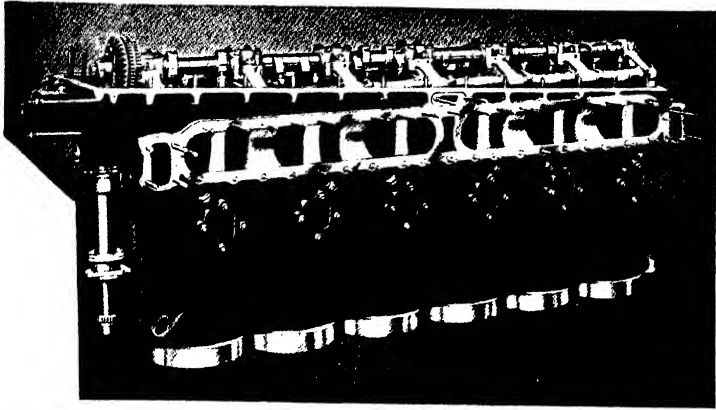

FIG. 188. Rolls Royce "Merlin" engine cylinder block.

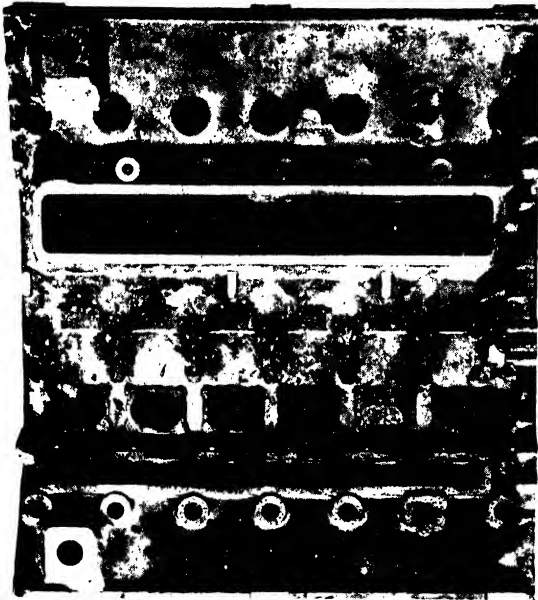

FIG. 189. Aluminium alloy cylinder block and crankcase unit of Napier "Culverin" engine.

[To face p. 240.

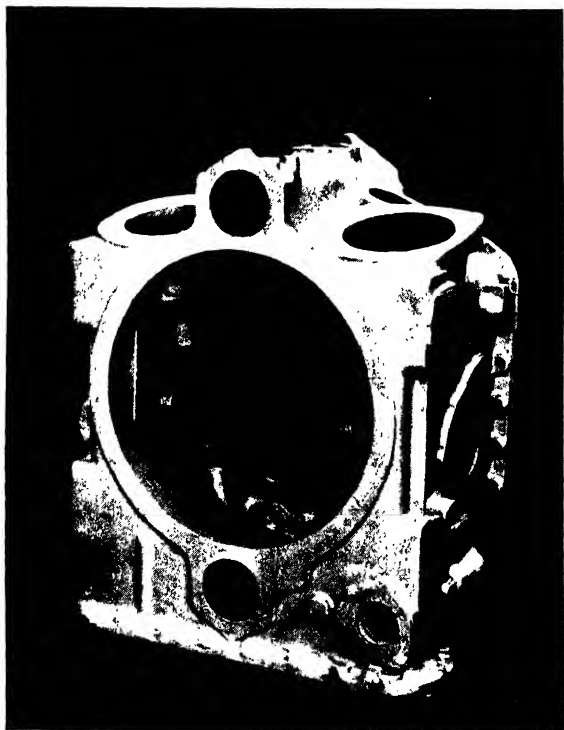

FIG. 190. Aircraft engine timing gear case cast in magnesium alloy. (*Magnesium Castings Product Co.*)

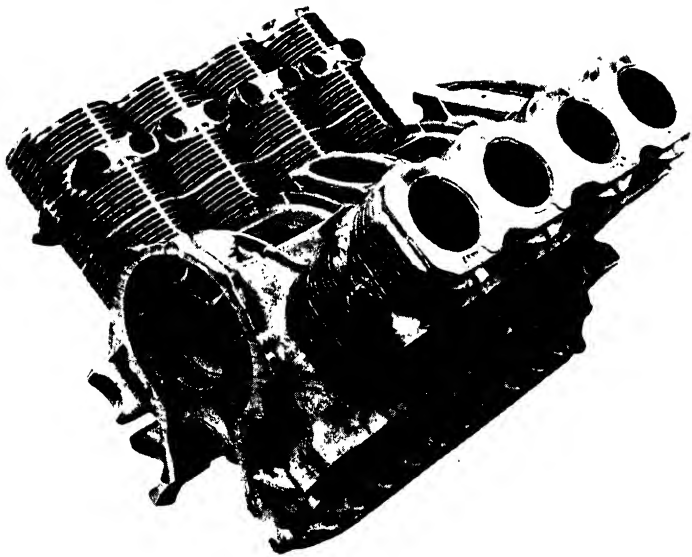
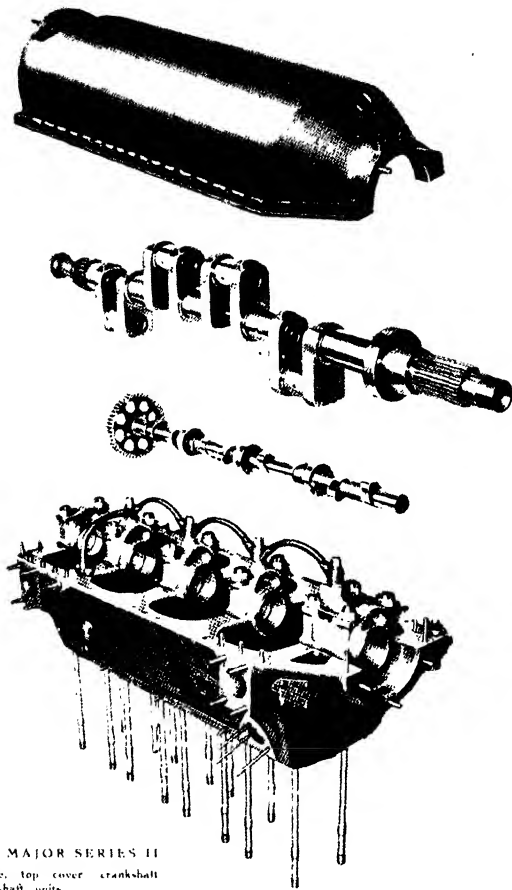

FIG. 191. Cylinder block and crankcase unit for aircraft engine cast in High Aluminium alloy. (*High Duty Alloys Ltd.*)



GIPSY MAJOR SERIES II
Crankcase, top cover, crankshaft
and camshaft units.

FIG. 192. Crankcase, top cover, crankshaft, and camshaft of
"Gipsy Major" engine (inverted four-cylinder type).

Magnesium alloys, on account of their light weight are also particularly suited to other aircraft engine castings, where strength alone is not the ruling factor; typical examples of such applications are supercharger casings, valve covers, induction casings, carburettor castings, timing gear covers, crankcase bottom halves, push rod covers, reduction gear casings, lubrication system components, ignition system parts, etc.

In regard to aircraft engine crankcases a certain amount of information has been given in the preceding descriptive sections, so that it is here necessary to illustrate only one further example, namely, that of the Bristol radial engine crankcase shown in Fig. 194. This is made in two halves from aluminium alloy forgings; the latter have special advantages over castings for this purpose both in load-carrying capacity and fatigue resistance. In this connection it must be remembered that the crankcase of a radial engine is somewhat heavily loaded.

Pistons. The chief considerations in the design of pistons are strength between crown and gudgeon pin section to resist gas pressure loads, good thermal conductivity and wearing properties. The maximum gas pressure loads usually lie between 450 and 550 lbs. per sq. in. in petrol engines so that the total loads in the case of a piston of $5\frac{1}{2}$ in. diameter will range from 4.8 to 5.8 tons.

In order to maintain the piston at a sufficiently low temperature to prevent excessive heating of the fresh charge of mixture during the induction stroke, excessive expansion and detrimental effects upon the lubricating oil on the piston skirt and under the crown it is necessary to employ aluminium alloys and to design the piston suitably, so as to conduct the surplus heat to the cylinder walls and lubricating oil within.

Experience has shown that aluminium alloys such as Y-alloy, R.R. 53 and R.R. 59 are fully satisfactory for aircraft engine pistons, since these alloys combine excellent thermal conductivity with good strength and wear-resistance properties.

Taking the R.R. 59 forged alloy as an example, this alloy (which is used for pistons) under engine temperature conditions has a tensile strength of about 19.5 tons per sq. in. (at 250° C.) with a Brinell hardness, at 250° C. of 87 falling to 125 after cooling. The specific gravity is 2.75, so that it has the same strength-to-weight properties as an alloy steel of 55 tons per sq. in. tensile strength at 250° C. The coefficient of linear expansion from

20° to 300° C. is 24.0×10^{-6} (for steel the corresponding value is 10.8×10^{-6}).

The thermal conductivity from 0° to 100° C. is 0.428 * (steel, 0.114), so that this alloy is a considerably better heat conductor than steel.

A particularly suitable aluminium alloy of the sand and die casting class employed for aircraft engine pistons is R.R. 53 (corresponding to specifications D.T.D. 238 and D.T.D. 131A). It has good strength properties at elevated temperatures, excellent bearing properties and gives sharp clean impressions when sand or die cast so that the minimum machining is required. The specific gravity is 2.75. The coefficient of linear expansion from 20° to 300° C. is 23.8×10^{-6} and thermal conductivity from 0° to 100° C., 0.43.

The strength properties at elevated temperatures are given in the following table.

TABLE 18. PROPERTIES OF R.R. 53 ALLOY

Temperature	Tensile Strength Tons per sq. in.		Brinell Hardness	
	Sand Cast	Die Cast	Sand Cast	Die Cast
20° C.	18.5	24.0	129	138
200° C.	16.0	22.0	101	115
250° C.	14.0	19.5	78	80
300° C.	13.0	15.5	50	55
350° C.	8.8	9.0	27	30

The endurance limit at 40×10^6 cycles is ± 5.5 tons per sq. in. for the sand cast metal and ± 6.9 for the die cast metal.

In regard to the general design of pistons it is usual to employ shorter ones than for automobile engine purposes. The depths of aircraft engine pistons usually range between 0.66 and 0.75 of the piston diameter.

English practice favours the rib-less type of piston design whilst the American engines employ pistons having internal cooling ribs for the underneath of the crown and sometimes for the skirt portions. The outer portions of the pistons in the region of the gudgeon pin bosses are arranged well below the

* C.G.S. units.

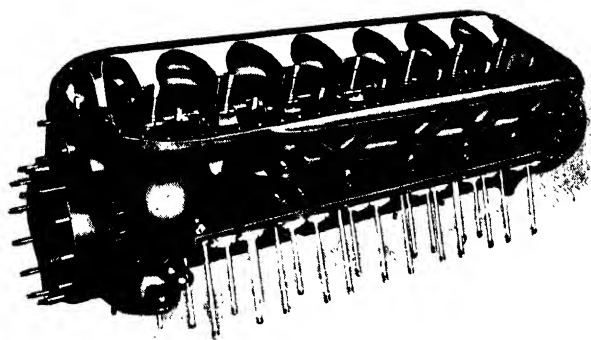

FIG. 193. Crankcase unit of the "Gipsy Twelve" inverted Vee-type engine. Showing cover and cylinder joints, etc.

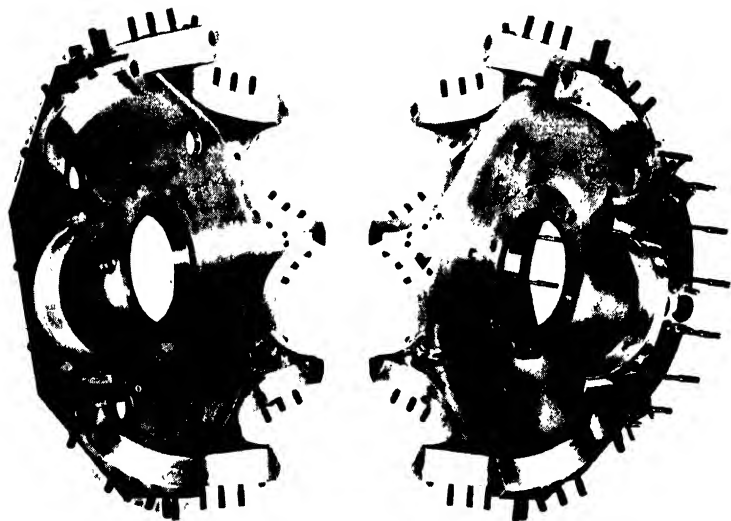

FIG. 194. Crankcase components of Bristol radial nine-cylinder engine.

skirt diameter as shown in Fig. 195 (upper illustration) ; the gudgeon pins are thus of appreciably shorter lengths than the piston diameters.

It is usual to employ two (or three) gas pressure rings and one oil-control ring above the gudgeon pin and one oil-control

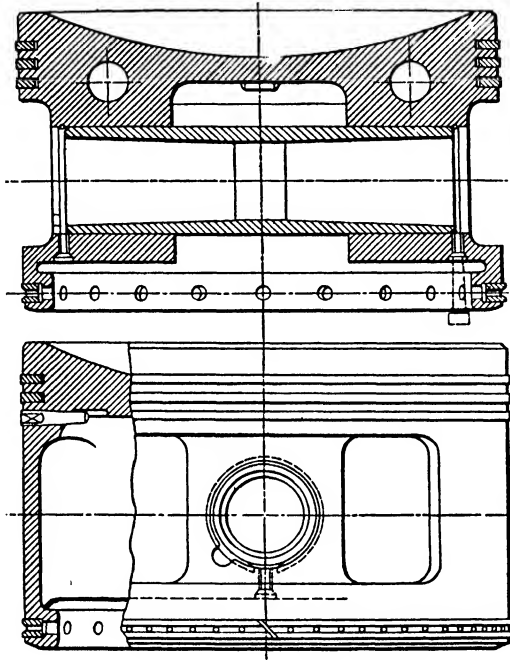

FIG. 195. Typical aircraft engine piston. (*Rolls Royce.*)

ring below the latter, usually at the bottom of the skirt ; oil drainage holes are arranged through the skirt for this purpose.

The usual allowance for clearance between pistons of RR and Y alloys and the steel cylinder walls is 0.006 in. per in. diameter at the top land of the piston diminishing to 0.004 in. for the bottom land above the gudgeon pin. At the top of the skirt the clearance is 0.0025 in. to 0.003 in. and at the bottom 0.0015 to 0.0020 in. This tapering of the piston is to allow for the piston head temperature being higher than for the skirt portion.

In regard to the *thickness of the piston crown* the following formulæ⁵⁰ are generally employed.

$$\begin{aligned} \text{Centre thickness for mechanical stress} &= 0.11 \times \text{diameter.} \\ \text{" " " thermal " "} &= 0.015 \times \text{B.H.P.} \\ &\text{per cylinder.} \end{aligned}$$

The two thicknesses given by these formulæ are worked out and the greater value is taken.

The *gudgeon pin* is made of nickel case-hardening steel, hardened and ground so as to be a good push or floating fit in the piston bosses.

The gudgeon pin is retained in position by spring clips, such as circlips at each end, which engage in grooves machined near the ends of the gudgeon pin holes in the piston. In some cases (Fig. 196) retaining washers as well as spring clips are employed to hold the pin in position.

The diameter of the gudgeon pin is about 0.20 to 0.25 times the piston diameter and its length 0.80 times the piston diameter.

Fig. 196 illustrates the Bristol radial engine type of piston and its component parts. Four rings are fitted above the gudgeon pin, namely, two gas rings and, in the third groove from the top, a double oil-control ring. A single oil-control ring is located below the gudgeon pin and oil return holes are drilled through the skirt portion for this ring.

The pistons used on the Pratt and Whitney "Twin Wasp" engines (Fig. 197) are machined from aluminium alloy forgings. They have flat heads which are provided with recesses to allow clearance for both the inlet and exhaust valves when the piston is on its top dead centre. The underside of the crown is ribbed for stiffening and also cooling purposes. Ribs are also machined in the inner wall of the piston between the gudgeon pin holes, in order to provide additional strength and to improve the cooling of the piston. The piston has five high tension piston rings, including three compression and one dual oil-control rings above the gudgeon pin and one oil-control ring below, near the bottom end of the piston skirt.

A sectional view of the Wright Cyclone 200 series 1,200 h.p. radial engine piston is given in Fig. 198. It is known as the "Uniflow" design because of the uniform oil flow over the surface provided by the special piston ring arrangement. The piston has six rings in all. The bottom ring, ordinarily an oil-control ring, is inverted to act as a pump. The five upper rings all act as scrapers, the two lower ones being located in

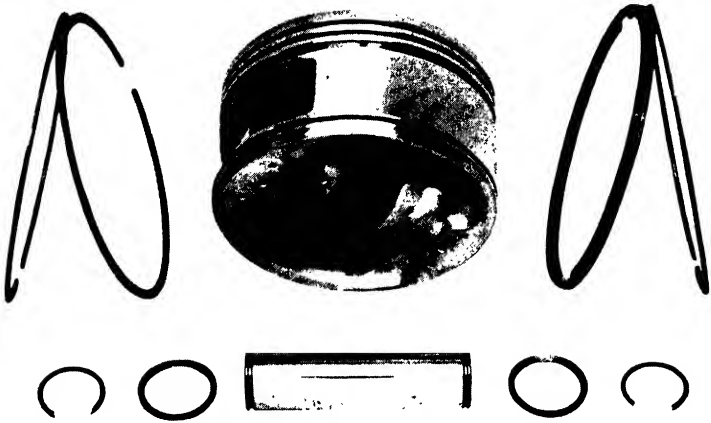

FIG. 196. The Bristol piston and its components.



FIG. 197. Piston of Pratt and Whitney Twin "Wasp" engine.

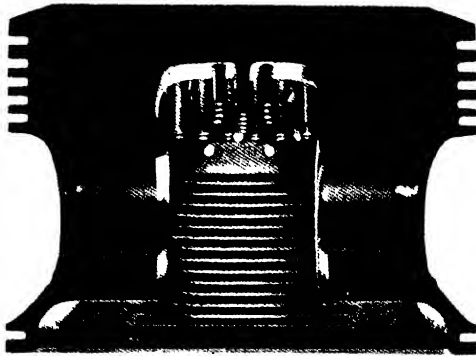

FIG. 198. Wright "Cyclone" engine piston, showing cooling studs.

separate grooves of extra width to allow the oil pumped by the bottom ring to drain into the interior of the piston through drainage holes; in this way, it is claimed, a constant film of oil is maintained on the thrust faces, providing a medium of heat conduction between the skirt of the piston and the cylinder wall. The oil consumption is reduced below that previously obtained with the ordinary design of piston. The inside of the piston crown has a series of cooling spikes of "stalactites" which are actually formed in the piston during the forging process; this provides more cooling area than with plain ribs. The inside portions of the thrust face regions of the piston are also ribbed for cooling purposes.

The gudgeon pin is retained in position by means of a spiral coil spring which is snapped into grooves in the gudgeon pin hole at either end of the pin. The latter is sharply bevelled

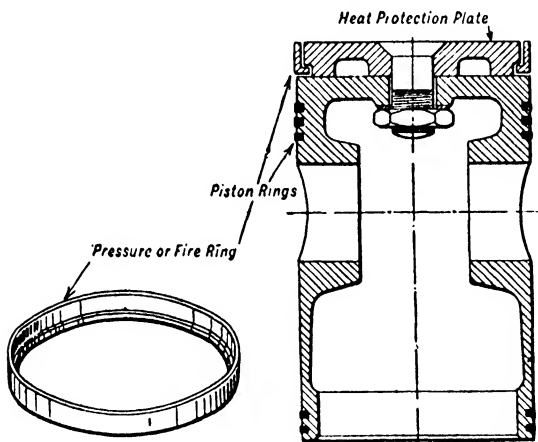

FIG. 199. Junkers "Jumo" engine piston.

at each end so that any lateral motion tends to expand the coiled spring more tightly in its groove. This spring ring is removed by means of a special "button hook" type of tool. The piston crown has a pair of bevelled edges, arranged on a diameter perpendicular to the gudgeon pin axis, for valve head clearance purposes.

The pistons for C.I. engines are relatively longer than for normal petrol type engines, and greater consideration is given to the maintenance of the higher compression and gas pressures; usually by the provision of an additional gas ring. Fig. 199

shows the piston arrangement of the Junkers "Jumo" engine, which is of relatively long proportions and is fitted with six rings. It was found necessary in order to meet the prevailing temperature and pressure conditions in this opposed-piston type of engine to fit a heat-protection plate to the piston crown and to provide a continuous section, *i.e.*, uncut, thin piston ring at the crown end of the piston. Under pressure from the air charge or gases the ring is pressed against the piston and the sides of the cylinder so as to form an effective seal. It is closely fitted so that there is just room at normal working temperatures for a thin film of oil between the piston crown and cylinder walls. The thickness of the upper ring is an important factor in its design, and it is made sufficiently thick to prevent seizure under working conditions.

Piston rings are made to standard specifications in hammered cast iron of stated composition having widths ranging from 0.09 in. for pistons of 4 in. to $5\frac{1}{2}$ in. diameter; 0.12 in. for diameters of $5\frac{3}{4}$ in. to 7 in. and 0.15 in., from $7\frac{1}{4}$ to 8 in. The rings are diagonally cut and the gaps after hammering vary progressively from 0.25 in. for 4-in. pistons to 0.53 in. for 8-in. ones. The radial depths also increase progressively from 0.134 in. to 0.230 in. for pistons ranging from 4 to 8-in. diameter. Radial pressures of the rings are greatest for the smaller diameter pistons; thus, for 4-in. pistons the specified pressure is 7.2 lbs. per sq. in. and this pressure is reduced uniformly with increase in piston diameter to 4.95 lbs. per sq. in. for pistons of 8-in. diameter. The side clearances of the rings in their piston grooves is from 0.004 in. to 0.006 in.

Connecting Rods. These rods are subjected to compression as well as to side bending effects and may be regarded as pin-jointed struts under side loads. In considering the end loads the gas pressure and inertia loadings, as well as the angularity of the rod must be considered. Full accounts of the analytical methods of estimating the stresses in connecting rods will be found in References Nos. 13 and 50 given at the end of this volume. It has been shown that the I-section connecting rod is the lightest for its strength than other alternative sections; practically all connecting rods of aircraft engines are of this section. In some cases oil pipes are attached to the webs by clips and screws (Fig. 201) to lead the oil to the gudgeon pin bearing; in other instances the centre portion of the web is enlarged and made hollow to form an oil lead (Fig. 200).

In order to give high strength properties for minimum weight, but at the same time to avoid brittleness, connecting rods are made as drop forgings or stampings from high tensile alloy steels. A typical steel for this purpose is a $4\frac{1}{4}$ per cent. nickel chromium steel of the air-hardening class, with a minimum tensile strength of 100 tons per sq. in. Another steel is the $4\frac{1}{4}$ per cent. nickel chromium molybdenum one of 100 tons per sq. in. tensile strength and 8 to 12 per cent. elongation. These steels contain from 0.5 to 1.5 per cent. chromium and the latter steel 0.5 per cent. molybdenum in addition.

It is important in manufacturing the connecting rod stamping to ensure the correct direction of grain flow along the rod and into the bosses. A poor grain flow in the event of machining across the flow will reduce the strength of the rod to some extent.

The connecting-rod stampings, after inspection and the making of sample rod tests for tensile strength and hardness are machined by turning, milling and profiling all over to remove the scale and thus to enable the rod to be normalised under the best conditions. The rods are then final machined and tested by the acid or Magnaflux methods for minute cracks or other surface defects. The gudgeon pin bush is then shrunk into place by heating the rod to about 360° C. and pressing in the cold bush.

The connecting-rods of "in-line" engines are similar in general design to those of automobile engines, but are usually lighter for their strength due to the use of steels of higher

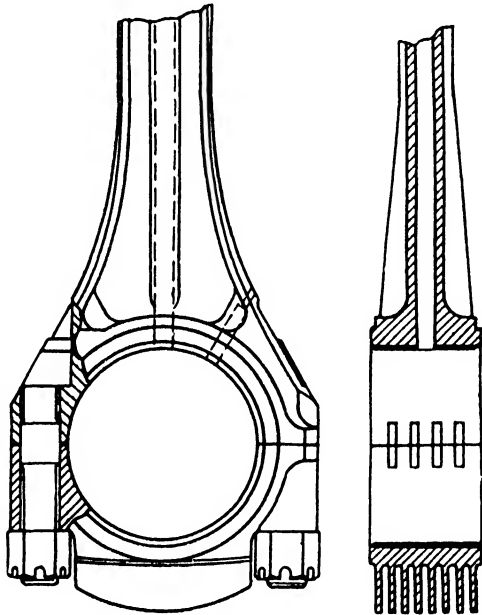

FIG. 200. Big end portion of typical light design of connecting rod.

tensile strength. Fig. 200 illustrates a design of connecting-rod big end having integral cooling fins in the cap and bevelled headed cap bolts. The rod is of the hollow I-beam section previously referred to. It will be noted that the cap bolts are lightened by turning them down to the diameter of the base of the screw thread, with the exception of a central portion on either side of the bearing split.

The connecting rods of the Gipsy Six series engines are machined from forgings of D.T.D. 130 aluminium alloy, and the big end caps are each secured by four high tensile steel bolts. The big end bearing is a steel shell lined with white metal. Drilled holes in the big end allow oil to escape under pressure from the bearing and to lubricate the cylinder wall by splash.

In the case of *Vee-type engines* it is usual to provide for facing pairs of cylinders, connecting rods which operate on the same crank-pin, viz., a plain rod on one side and a forked big end one on the other side. Fig. 201 illustrates the connecting-rod arrangement of a Rolls Royce twelve-cylinder Vee-type engine,⁴⁷ showing how the forked rod works on the crank-pin, while the other plain rod works on the big end of the forked rod ; in each case the same bearing area is provided. The rods are of I-section and are made of $3\frac{1}{2}$ per cent. nickel steel, machined all over and heat-treated. The forked rod big end bearing consists of a steel block split longitudinally and lined with white metal internally and also externally over the central portion ; the big end of the plain rod works on this part. The small end phosphor bronze bushes are of the floating type lubricated from the big end bearings by pipe feeds.

The Rolls Royce "Merlin" engine connecting rods are similar in design to the ones just described and belong to the marine type. They are machined from nickel steel forgings and the forked rod carries a nickel steel bearing block lined inside and out with a special lead-bronze alloy. The bearing block which is divided across its bore bears directly on the crank-pin and is secured to the forked rod by four bolts, whilst the outer lining of the block forms the bearing for the plain rod. The floating phosphor bronze small end bush, in this design, is lubricated by oil mist from the crankcase ; not by oil pipe feed, as in the earlier model.

The connecting rod arrangement for the *radial type of engine* consists of a main or master connecting rod having a bearing

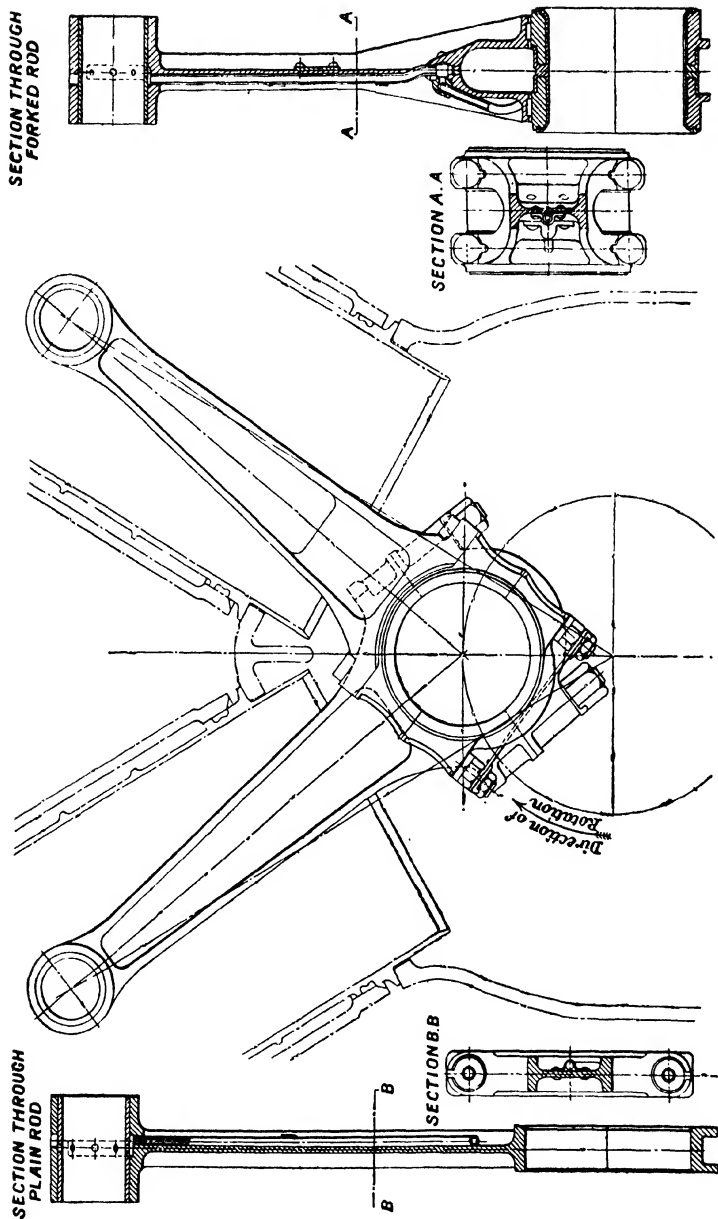

FIG. 201. Connecting-rod system of Vee-type engine. (Engineering.)

on the crank-pin. This rod has a number of uniformly spaced pins mounted between its big end flanges and upon these pins the big end portions of the other smaller connecting, articulated or link rods work. The master rod must be made considerably stronger than the link rods, since it has to take, in addition to its own gas, inertia and bending loads, the bending effects due to the forces transmitted by the link rods.

Fig. 203 shows the connecting-rod system of the Bristol "Mercury" and "Pegasus" radial engines. As the crankshafts of these engines are of the two-piece pattern the master rod big end portion is made solid and the main bearing for this rod consists of a phosphor bronze bush of the drilled floating type having bearings internally on the crank-pin and externally in the master rod big end portion. The link rod (or wrist) pins are rigidly secured between the flanges of the master rod and the link rods have phosphor bronze bearings on these pins. These bearings are pressure lubricated, oil being collected from the front of the big end bearing of the master rod, by means of a specially shaped oil retainer and passed through channels cut in the retainer to the front end of the link rod pins. Holes drilled in the latter convey the oil to their outer surfaces. Leakage of oil from the rear of the big end bearing is prevented by means of a spring-loaded thrust ring. The gudgeon pin bearings are of phosphor bronze with suitably drilled holes for lubrication purposes. In connection with the master rod this is machined from a stamping of nickel chrome steel (100 tons per sq. in. tensile strength) which weighs about 42 lbs. initially, but when machined and finished is only 9 lbs. 5½ ozs., including the gudgeon pin bush. In the case of the link rods these are of nickel chrome steel (65 to 70 tons per sq. in. tensile strength) stampings. The weight of the rough stamping is 9½ lbs., but after machining the finished rod weighs only 2 lbs. 2 ozs.

The master rod used on the Armstrong Siddeley "Cheetah" radial engine⁵¹ (Fig. 204) is of the split variety, made from an air-hardening nickel chrome steel stamping weighing 53 lbs. It requires eighty-seven machining operations and when finished the rod and its cap weigh 13½ lbs. Split type big end bearings consisting of two steel shells lined with lead-bronze are employed. The link rods are bronze bushed and each rod is checked for weight within plus or minus 2 drams.

Fig. 205 illustrates the master rod arrangement employed in the Wright "Cyclone" 1,200 h.p. engine (G.200 series). The master rod bearing is end-sealed—a development that makes

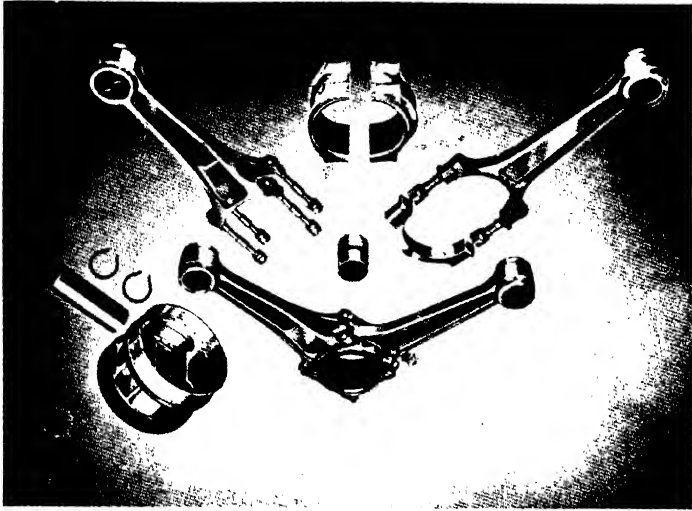

FIG. 202. The Rolls Royce "Merlin" engine connecting rods and piston.

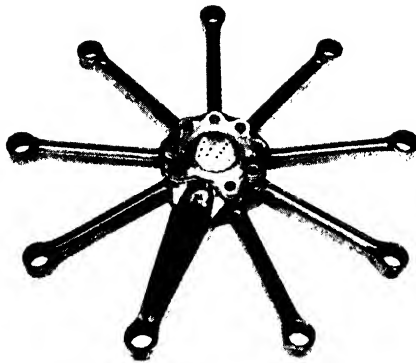

FIG. 203. Connecting-rod system of British "Mercury" and "Pegasus" engines.

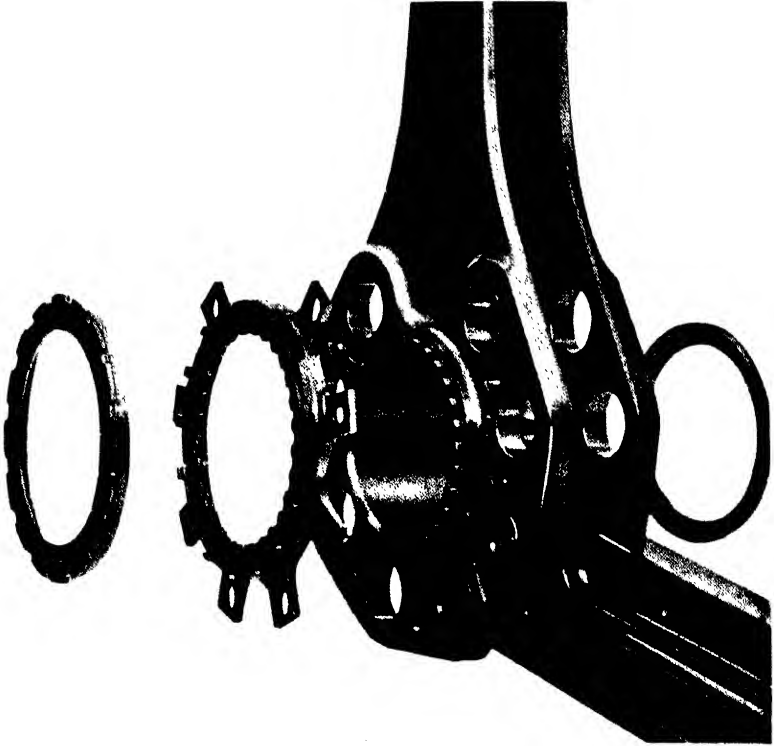

FIG. 205. Wright "Cyclone" master rod and link rod arrangement.

possible a novel method of lubricating the link pins and avoids the necessity of holes drilled in the master rod.

End-sealing of the bearing is accomplished by the rings shown in Fig. 205. At the right is a light, self-lubricating aluminium alloy ring with a rim which prevents the centrifugal loss of oil from that end of the bearing. The bearing itself is a copper-lead alloy with a steel backing which incorporates

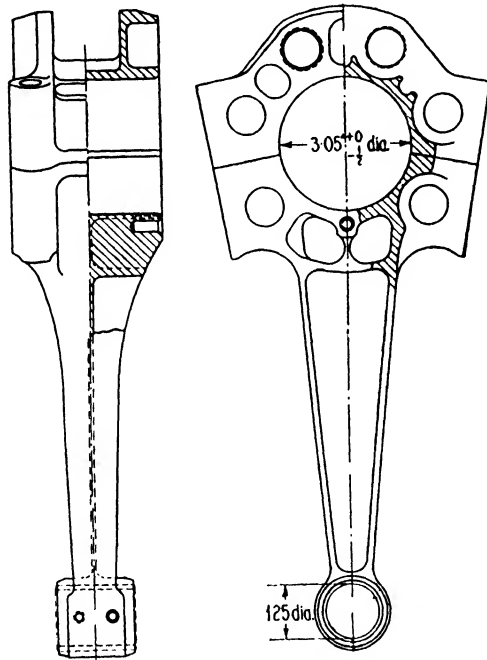

FIG. 204. Master rod for the Armstrong Siddeley "Cheetah" radial engine.

externally projecting splines, shown on the left side of the master rod. The bearing is pressed into the mirror-finished bearing hole in the master rod and its splined portion is then engaged by the locking ring which prevents the bearing from turning or moving laterally. None of the bearing surface is sacrificed for oil holes or grooves, and it is unnecessary to spin over the ends or pin the bearing to secure it.

It will be seen that the steel locking ring, besides being splined internally, also has eight lugs extending spider-wise which reach out over the ends of the wrist pins. Cap

screws through these lugs into the wrist pins not only hold the latter fast but also form the anchorage for securing the bearing. The aluminium ring at the extreme left prevents loss of oil in the same manner as the one at the right and is telescoped with the locking ring to prevent leakage between the two. These rings are held apart by a circling spring which forces the aluminium rings snugly against the crank cheeks

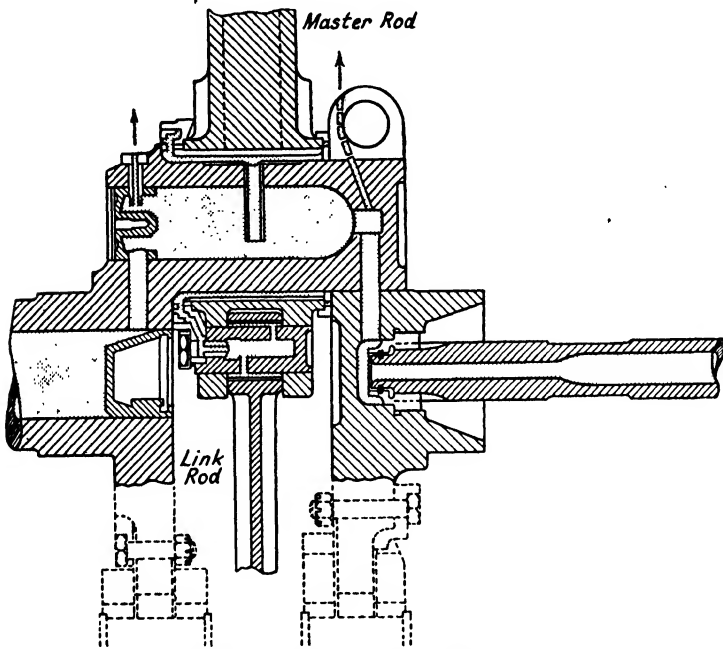

Fig. 206. Wright "Cyclone" connecting rods and crank-pin, showing also lubrication system.

on either side. The passage formed between the telescoping rings fills with oil and drilled passages in the locking ring conduct this oil into the hollow wrist pins from whence two holes meter it to the articulated rod bearings.

This method of end-sealing it is claimed assures a constant oil film on the entire working surface as the loads advance around it. Oil needed for the lubrication of the cylinder walls is accurately metered through jets provided in both front and rear crank cheeks.

The oil circulation may be traced, in Fig. 206, from the rear

end of the crankshaft up to the hollow crankpin, where there is a sludge eliminating centrifuge tube. A small flat of 0.025 in. on the crank-pin distributes oil for the master rod bearing.

Bearing Metals. The metals employed for lining big end and main bearings include white metals, lead-bronzes, cadmium base-bearing metals, aluminium base-bearing metals, cadmium-silver-copper alloys, etc.

White metal lined bearings are employed in several of the smaller types of aircraft engine—usually with steel shells. The white metals used have a high tin content and also contain the hardening element, antimony. Typical compositions of white metals are given in Table 19.

The white metals, whilst possessing low frictional qualities, are relatively weak and soft. The tensile strength is about 4 tons per sq. in. and the Brinell hardness at 30° C. is about 15.

Lead-bronzes are stronger and harder than white metals and are able to withstand much higher bearing loads, whilst possessing good anti-friction properties. Typical compositions of lead-bronzes are given in Table 19. The Brinell hardnesses at 20° C. range from 30 to 45. The bearing pressures for white metals should not exceed 1,400 to 1,800 lbs. per sq. in. for big end and main bearings, whereas for steel-backed lead-bronze bearings with a hardness of 30 to 38 the maximum pressures allowable are about 2,600 to 2,900 lbs. per sq. in.

A cadmium-copper-silver bearing metal is employed in the U.S.A. for high bearing pressures and it retains its hardness better at elevated temperatures than most other alloys; a typical composition is given in Table 19.

The Air Ministry D.T.D. 224 white metal specification stipulates 5.5 to 7.5 per cent. copper; 6 to 7 per cent. antimony; 0.6 per cent. nickel and the remainder, tin.

Crankshafts. The crankshaft of an aircraft engine is designed primarily from considerations of the provision of suitable bearing areas for the crank-pins and main journals and the possession of sufficient crankshaft rigidity. The deflection of the crankshaft under loads must not exceed the limit necessary to maintain an even pressure distribution on the bearings, so that the design and material must be such as to ensure sufficient rigidity for this purpose. In certain designs, notably, the "in-line" engine crankshafts, the dimensions are governed by the necessity of providing sufficient stiffness to avoid torsional vibration difficulties, so that whilst a crankshaft may be designed so as to be strong enough for its working stresses,

TABLE 19. COMPOSITIONS AND HARDNESSES OF BEARING METALS

Group	Composition, per cent.											Brinell Hardness		
	Sn	Pb	Cu	Sb	As	Fe	Ni	Cd	Misc.	20°	100°	400°		
Tin-base white metals	92.9	—	3.4	3.6	—	0.05	0.08	—	—	13	6	2.5		
	87.2	0.2	5.7	6.9	0.02	0.03	—	—	—	22	8	3		
	80.4	0.7	7.4	11.4	0.02	0.04	—	—	—	27	10	3		
Lead-base white metal	10.7	70.4	1.7	15.3	0.15	0.06	0.01	1.83	—	22	9	4		
Cadmium-base bearing metals	—	—	1.9	—	—	—	—	97.6 96.9	0.48 Ag	38 35	19 16	6 5.5		
Aluminium-base bearing metals	Al with additions principally of metals of the iron group. Composition not specified.											42 49	40 45	30 33
Lead bronzes	— 2	30 28	70 70	— —	— —	— —	— —	— —	Nominal composition	30 45	23 41	17.5 38		

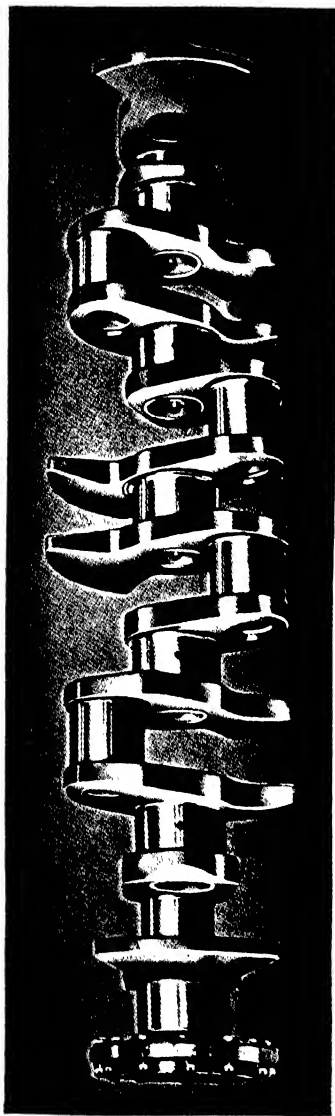

FIG. 207. The Rolls Royce "Merlin" engine six-throw crankshaft, showing balance weights, etc.
[To face p. 254.]

it is not always sufficiently stiff against torsional vibration effects causing excessive amplitudes or undesirable critical speeds. In order to economise in weight crankshafts are made with hollow journals and pins ; this does not materially affect the stiffness if otherwise suitably designed.

Crankshafts are made as drop forgings with the correct grain flow to ensure maximum strength properties ; they are afterwards machined all over and balanced both statically and dynamically. The machined surfaces are checked for minute cracks or surface defects by the Magnaflux and similar methods.

Crankshafts are often made of 56 to 65 tons per sq. in. tensile strength, nickel chrome steel, and the main journal and crank-pin bearing surface metal, after machining, is hardened by the Shorter flame or induction heating hardening processes.

Modern aircraft engine crankshafts in this country are now made of nickel-chromium-molybdenum steel of the nitriding class. A typical composition is : carbon, 0.35 to 0.50 ; nickel, 1 per cent. ; chromium, 0.5 to 1.5 per cent. ; molybdenum, 0.9 to 1.5 per cent., with silicon and manganese in addition. Such a steel when suitably heat-treated gives from 55 to 65 tons per sq. in. tensile strength.

A somewhat stronger crankshaft steel, also of the nitriding class, is the high chromium-molybdenum one containing 2.5 to 3.5 per cent. chromium and 0.3 to 0.7 per cent. molybdenum. It has a tensile strength of 60 to 70 tons per sq. in. and when nitrided provides excellent bearing surfaces for the lead-bronze bearings employed. It is usual to nitride the surfaces all over, as this gives increased fatigue strength, more especially in regions of stress concentration such as keyways, oil-holes, screw-threads, etc. The diamond hardness of the nitrided surface is between 800 and 850 and the depth of the hardened case is usually about 0.020 to 0.030 in.

The standard practice in regard to main bearings is to provide a main journal bearing on either side of each crank, so that the total number of main bearings is one more than the number of cranks.

Fig. 207 illustrates the Rolls Royce "Merlin" engine crankshaft, with its balance weights and flanged coupling, on the left, to the airscrew reduction gear and timing ring. It is machined from a one-piece forging in V.C.M. chrome-molybdenum steel (D.T.D. Specification No. 228). The composition is as follows : carbon, 0.3 to 0.35 per cent. ; silicon, 0.35 per cent. (max.) ; manganese, 0.5 to 0.7 per cent. ; nickel, 0.75 per cent. (max.) ;

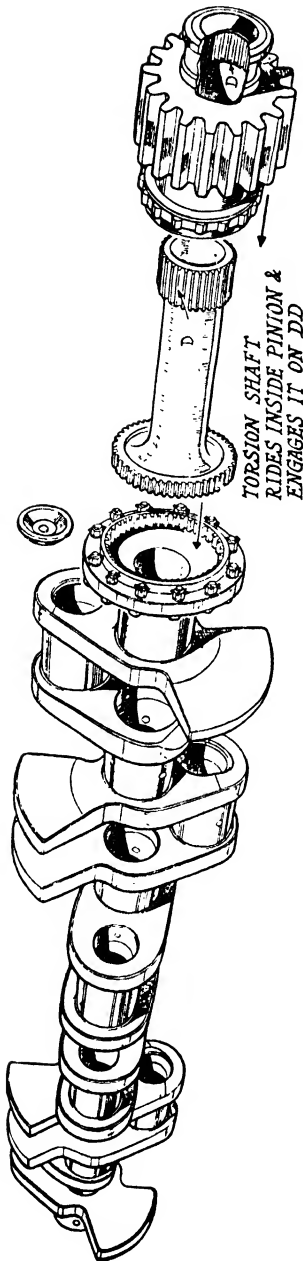

FIG. 208. Rolls Royce "Merlin" crankshaft showing torsion shaft drive for camshaft, supercharger and auxiliaries. ("The Aeroplane.")

chromium, 0.7 to 1.5 per cent.; molybdenum, 1.0 to 1.5 per cent. When oil treated, by hardening at 870° C. and tempering at 650° to 700° C., the tensile strength lies between 55 and 65 tons per sq. in.; with 18 per cent. (min.) elongation; 50 per cent. (min.), reduction of area; 40 ft. lb. Izod impact value and 255 to 293 Brinell hardness. The crankshaft is carried in seven lead-bronze bearings. It is nitrided after machining. The crankpins and journals are bored and fitted with oil-retaining covers, drilled passages being provided for the oil supply to the crank-pins. The drive to the airscrew reduction gear is taken from a flange bolted to the front end, and there is a spring drive to the camshaft, supercharger and all of the auxiliaries from the rear end.

The arrangement of the crankshaft, camshaft, main bearings, airscrew reduction gears and centrifugal supercharger of the American twelve-cylinder inverted Vee-type air-cooled Ranger 420 H.P. engine⁵² is shown in Fig. 209. The sectional view of the crankshaft illustrates how the hollow bores of the crank journals and pins are fitted with covers for the purpose of enclosing the oiling system shown.

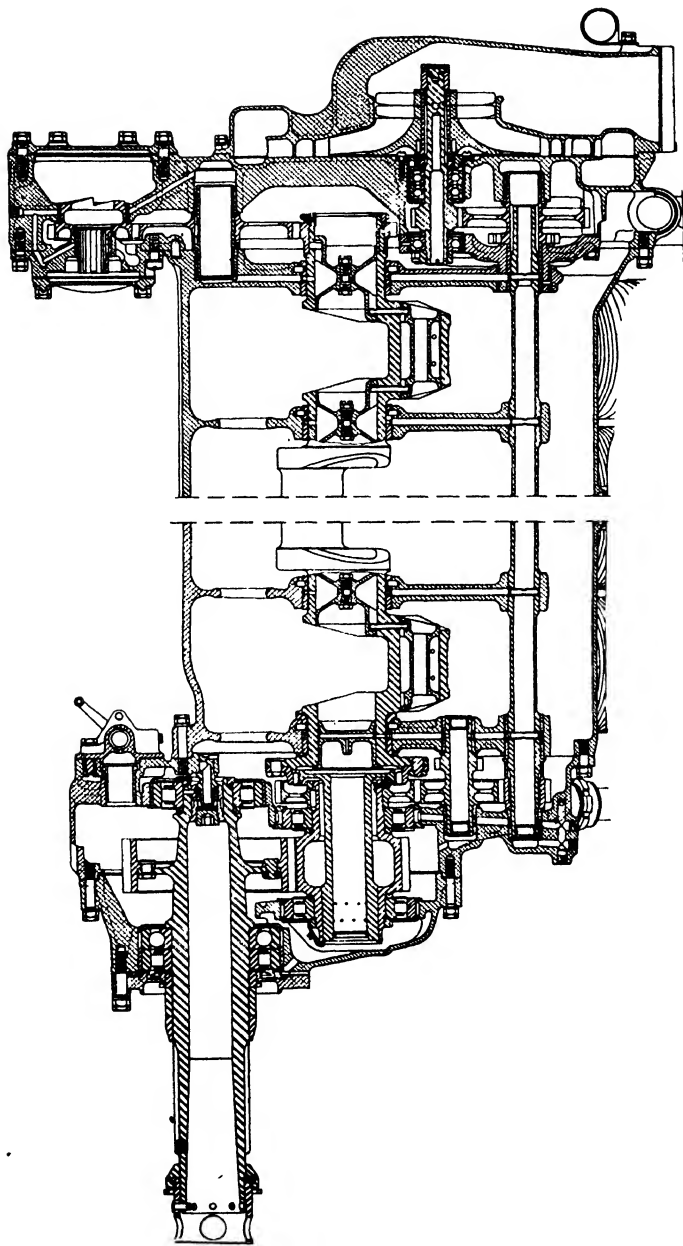

FIG. 209. The crankshaft, supercharger, airscrew reduction gear, etc., of twelve-cylinder inverted Vee-type "Ranger" engine.

The lubrication arrangement for the camshaft end bearings, whereby oil under pressure is taken from the end main bearings through the vertical passages is also indicated. The airscrew reduction gears have a ratio of 2 : 3 and the airscrew shaft is mounted on roller and deep-groove (thrust-taking) bearings. There are two camshafts, one for each bank of six cylinders. The supercharger is geared up from the rear end of the crankshaft, to run at 8.84 times engine speed. The oil pump drive is shown in the upper right-hand side of the crankcase.

The crankshafts of single row radial engines are usually of the two-piece type, consisting of one main journal member with its crank web, counterweight and crank pin and the other main journal member with its crank web and counterweight; the crank is bored to receive the end of the crank-pin, the latter being clamped by a pinch bolt and nut. Fig. 211 shows the Bristol single row radial type of crankshaft employed on the "Mercury" and "Pegasus" engines, which is based on this principle of construction. The method in question enables a solid big end to be used for the master rod, and the floating bearing bush arrangement previously described.

Both members of the crankshaft are machined from forgings in nitriding alloy steel, the whole of the surfaces being nitrided. The crankshaft is bored for lightness and drilled for lubricating oil passages. It is carried on one ball bearing and two roller bearings. The tailshaft (shown on the right), through which the accessories are driven is a separate member splined to the crankshaft and given a small degree of universal movement to relieve the crankcase rear cover of all crankshaft loads.

The crankshafts of the Wright "Cyclone" engines are constructed in a somewhat similar manner, from two machined nickel chrome steel forgings clamped rigidly together at the rear crank cheek and supported by three bearings in the direct drive model and two in the geared one. The counterweights embody the Wright torsional vibration damper previously referred to.

A method of making aircraft engine crankshafts of the built-up hollow type due to F. H. Royce, of Rolls-Royce Ltd., is shown in Fig. 213. It is designed to provide the maximum stiffness and rigidity with minimum weight. The webs shown at A have internally threaded holes B and are split at C. The ends of the web are cut away towards the centre to reduce weight. The hollow pin D is threaded at each end and the

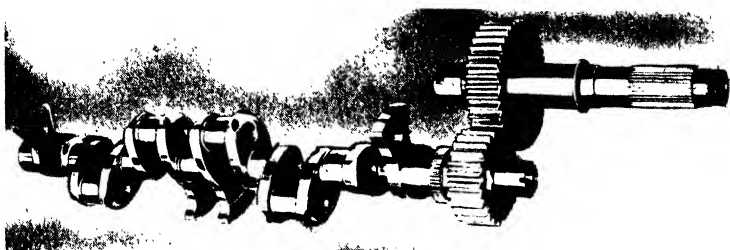

FIG. 210. Crankshaft and airscrew drive of the "Gipsy Twelve" inverted Vee-type engine.

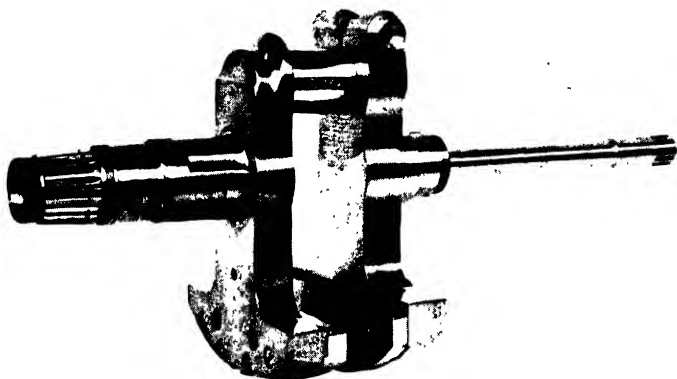

FIG. 211. The Bristol single-row radial engine crankshaft.

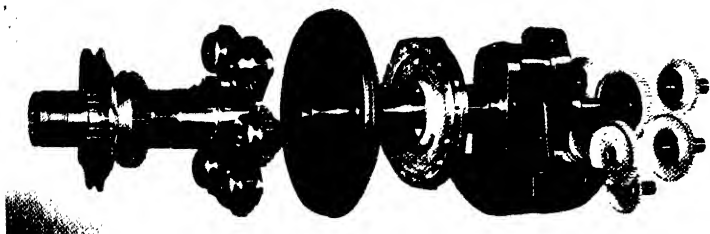

FIG. 212. The Wright "Cyclone" (G.100) crankshaft arrangement showing concentric airscrew reduction gear on left and accessory drive gears on right. The components are shown separated for clearness.

threads engage with those of the webs. The bolts E, with their part spherical washers, pass through the webs and the latter are clamped tightly round the pins D by means of nuts fitted with locking means.

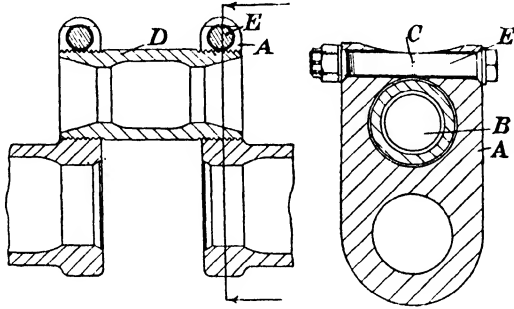

FIG. 213.

A crankshaft design⁵³ for the geared-type light aircraft Lycoming four-cylinder opposed engine is shown in Fig. 214. The engine develops 75 B.H.P. at 3,200 R.P.M. and, by means of the reduction gearing shown, giving a ratio of 1.588 : 1, the airscrew rotates at 2,015 R.P.M. ; the axis of the airscrew is kept fairly close to that of the crankshaft by this means.

The earlier difficulties experienced from torsional vibration were overcome in the manner indicated. It was found that

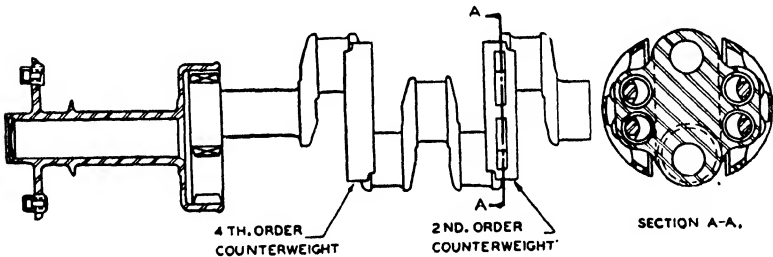

FIG. 214. Lycoming four-cylinder opposed engine crankshaft.

there were two pronounced critical speeds, due to harmonics of twice and four times the frequency of rotation, respectively, and it was found that a Lanchester-type damper could not be made to give relief from both. It was therefore decided to use the pendulum-type of dynamic damper which has proved so successful in large aircraft engines. Fig. 214 shows the crank-

shaft and a section through the dampers. Dampers are made in pairs to simplify the crankshaft balancing problem. A pair of fourth-order dampers is attached to the second crank arm, and a pair of second-order dampers to the fifth arm. It was found that switching the two dampers around did not materially alter their effectiveness. Without dampers the reduction gear was extremely noisy and there was even a case of pinion failure, but with the dampers the torsional amplitudes are small, gear stresses, propeller stresses and bearing loads are reduced, and lighter gears can be used.

The Valves and Valve Operating Gear. The valves of most modern engines are of the overhead push-rod and rocker arm, or overhead camshaft-operated patterns. They have to withstand repeated hammering action whilst being subject to relatively high operating temperatures; they are also pre-loaded by the valve springs to an appreciable degree of tensile stress. In addition, the exhaust valve is exposed to the corrosive effects of the hot exhaust gases under its head and around part of the stem in the vicinity of the head. The stems of the valves have to withstand the abrasive action due to the sliding movements in the valve guides. Further, the ends of the valve stems transmit the operating forces and, on account of the clearances necessary to ensure proper seating of the valves under cold and hot working conditions, are subjected to appreciable local impact effects.

It will thus be realised that the duties of the aircraft engine valve are severe ones, so that careful design and selection of material are necessary.

The use of leaded fuels in engines is associated with corrosive action on the valves so that the steel selected must be able to withstand this corrosive effect.

Various kinds of alloy steels have been employed in the history of aircraft engine development. These have included nickel chrome high tensile steels, stainless steels, silicon chrome steel, cobalt chrome steel, high speed steel, high nickel chrome and tungsten steels. Of these steels those possessing the necessary tensile strengths and hardnesses at the operating temperatures are the cobalt chrome, silicon chrome and the high nickel chrome austenitic ones. A typical cobalt chrome steel has a tensile strength of 45 tons per sq. in. cold, and 25 tons per sq. in. at 700° C. Similar properties are given by certain silicon chrome steels. The high nickel chrome steel, having 0.40 to 0.45 per cent. carbon; 1.5 to 1.8 per cent.

silicon ; 0.6 to 1.5 per cent. manganese ; 12 to 13 per cent. chromium and 18 to 22 per cent. nickel with tungsten up to 3 per cent. gives a cold tensile strength of about 43 tons per sq. in. ; 34 tons per sq. in. at 700° C. and 24 tons per sq. in. at 800° C. The cold hardnesses of the three valve steels mentioned lie between 250 and 300 Brinell. All of these steels possess good anti-scaling properties.

A group of valve steels, often used for aircraft engines, is the "Silchrome" one, having from 1 to 4 per cent. silicon and 8 to 24 per cent. chromium, with 1 to 4 per cent. nickel and sometimes up to 3 per cent. molybdenum.

The Silchrome, cobalt chrome and tungsten steels are not so good in their corrosion resistance properties to the action of leaded fuels as the high nickel chromium austenitic steels. The latter however, have a higher thermal expansion coefficient, so that a greater allowance must be made in the valve clearances when such steels are employed ; their thermal conductivities are lower than for the Silchrome and cobalt chrome steels.

A typical modern valve steel, conforming to the D.T.D. No. 49B Specification, has the following composition : Carbon, 0.35 to 0.45 per cent. ; chromium, 12.5 to 14.5 per cent. ; nickel, 12.5 to 14.5 per cent. ; manganese, 0.5 to 1.0 per cent. ; silicon, 1.00 to 1.75 per cent. ; tungsten, 2.0 to 3.0 per cent.

With austenitic steels it is necessary to provide the valve stem with a hardened tip to resist impact effects ; it is now usual to provide a welded button of Stellite on the valve stem end for this purpose.

The inlet valve operates at a much lower mean temperature than the exhaust valve, due to the cooling action of the inflowing air-fuel mixture. Thus, as previously mentioned, whilst the inlet valves of a well-designed engine seldom exceed a mean temperature of 250° C., the exhaust valves normally operate at temperatures of 600° C. to 750° C.

Exhaust Valve Cooling. Apart from strength and non-corrosive properties which are essential to modern exhaust valves, the question of adequate cooling of the heads and stems is of high importance, since the volumetric efficiency and the maximum useful compression ratio that can be used (for the given grade of fuel employed) are largely governed by the value of the exhaust valve temperature.

In order to improve the heat conduction properties of exhaust valves it is now customary to make the heads and stems hollow and to partially fill this space with sodium.

Examples of typical hollow sodium enclosed exhaust valves are shown in Fig. 215; a fuller account of these valves is given in

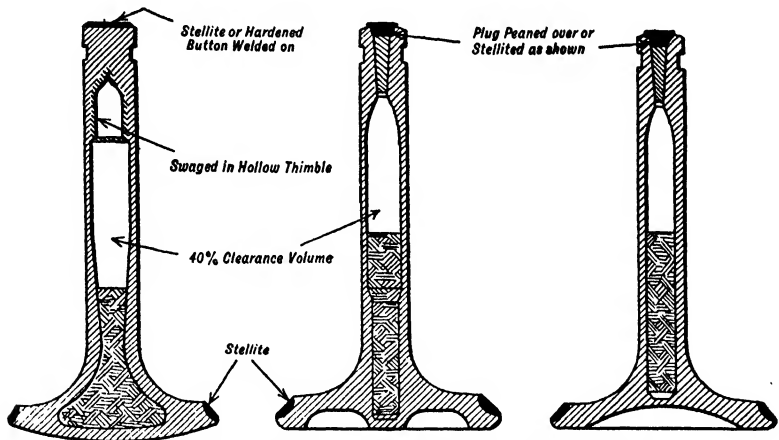

FIG. 215. Types of sodium-filled exhaust valves.

Volume I. of this work. In some cases, *e.g.*, the Napier "Dagger" engine, the inlet valve also is made hollow. Both valves are Stellite on the ends of their stems and the working parts of the stems in the valve guides are nitrided to increase the wear resistance. The valves (Fig. 215)⁵⁴ are made of D.T.D. Specification No. 49 steel from stampings.

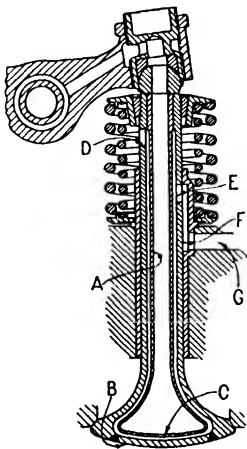

FIG. 216. Air- or liquid-cooling systems for exhaust valves.

A method of continuously cooling exhaust valves emanating from Germany is shown in Fig. 216. This uses a hollow member A shaped to the interior contour and enclosed by means of a plate welded in the head of the main valve. Lubricating oil or air can be used as the cooling medium; it is led to the interior of the inserted member by way of drillings in the valve rocker and ball-shaped adjuster. It then leaves through a central aperture C in the head to the annular space between the member and the body of the valve. From this region of highest temperature the coolant rises up the valve stem and

escapes through the hole D in the valve stem. Alternatively, the discharge from the valve stem can be arranged through a hole E to a passage F in the valve guide from which it escapes by the discharge passage G.

The seating faces of exhaust valves are usually coated with Stellite to increase their wear resistance and at the same time to protect the faces against the scouring and hot corrosive effects of the exhaust gases. In some instances an alloy known as "Brightray," consisting of 80 per cent. nickel and 20 per cent. chromium, is used to coat the valve faces.

Valve Inserts. In regard to *valve inserts* in aluminium alloy cylinder heads, the high tensile aluminium bronze rings are now being replaced with valve steel metals and these are often

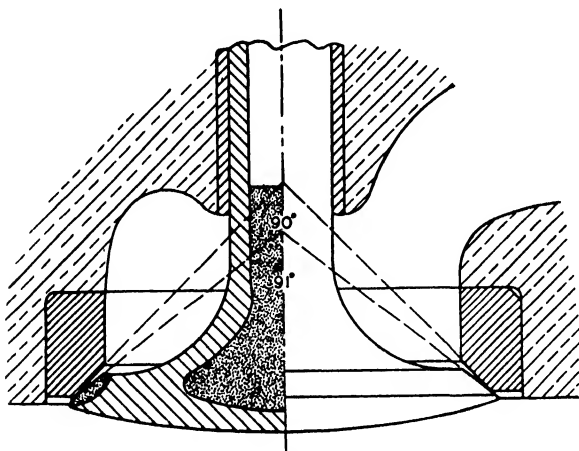

FIG. 217. Valve seat angles.

coated with Stellite or Brightray. In one or two designs, however, Monel metal seatings have been employed with satisfactory results.

In some air-cooled engines a valve sealing insert steel of nickel-chromium-manganese, having a high coefficient of linear expansion (0.000022) is employed, since this coefficient is approximately the same as that of the aluminium alloy used for the cylinder head.

A typical valve insert material of this class, known as N.M.C., is sometimes used. This contains 12 per cent. nickel, 5 per cent. manganese, 3.5 per cent. chromium, 0.5 to 0.6 per cent. carbon and 0.5 per cent. silicon. The valve seating face is generally

Stellited, but this is not absolutely essential. Silchrome No. 1 alloy steel is also used for valve inserts.

An important point in regard to valve seat angles is illustrated in Fig. 217, which shows a sodium-cooled valve with Stellited face having an included angle of 91° , whilst the insert ring valve seating face has an angle of 90 degrees. The *differential seat angles* are so arranged that the valve rests on the insert with the large diameter of its head when cold and over the whole face under normal working temperature conditions.

The method of manufacturing the valve blank should give the correct grain flow in order to develop the full mechanical properties of the material. In this connection the extrusion

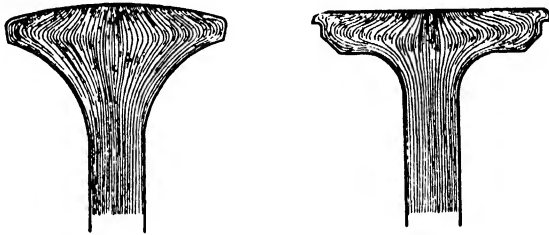

FIG. 218. Grain flow in valve blanks.

process, whereby a cylindrical slug is heated and inserted in a die and is then subjected to pressure to force the metal through this die so as to form the stem, gives satisfactory grain flow. Fig. 218 illustrates two types of valve head made by the extrusion process; in each case the correct grain flow has been obtained.

Valve Dimensions. The diameter of each valve is determined from considerations of the maximum permissible gas velocity, in each case, at the normal working speed of the engine. The mean piston speed is readily found from the engine R.P.M., and the ratio of the mean gas velocity to this piston speed is the same as the ratio of the piston area to the valve area, *i.e.*, at the ratios of the squares of the piston and valve port diameters.

The gas velocities in aircraft engines, at normal engine speeds usually range from 200 to 260 ft. per sec. The inlet gas velocity, owing to the slightly larger diameter or area of valve is generally about 10 to 15 per cent. less than the exhaust gas velocity; in some designs, however, these velocities are equal.

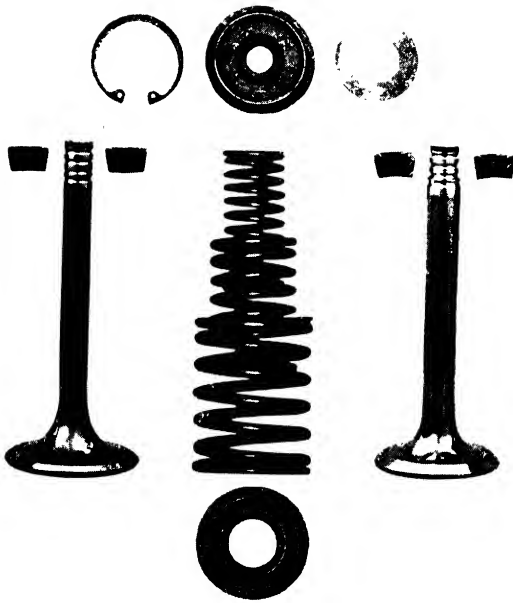

FIG. 219. The Bristol valves and their components.

The lift of the valve, to ensure no wire-drawing of the gases should not be less than one quarter of its diameter.

The valves and components used in the Bristol "Mercury" air-cooled radial engines are illustrated in Fig. 219. The stems are drilled hollow, and in the case of the exhaust valve it is partly filled with sodium; an austenitic nickel chrome steel is used for the valves. The exhaust valve seating face is Stellite and the valve stems are nitrided. A hardened button is pressed into the end of each stem to provide a durable wearing surface. The valve seats are made of austenitic

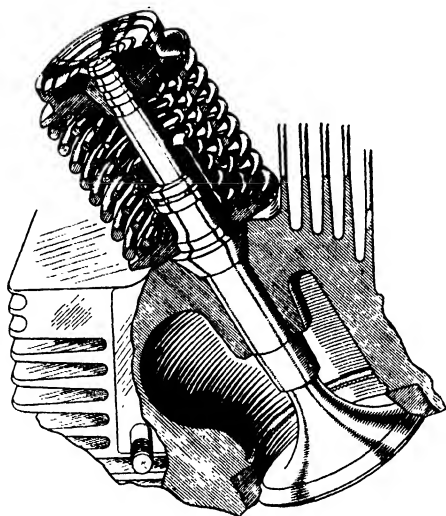

FIG. 220. The assembled Bristol valve in its working position.

nickel-manganese-chrome steel having an expansion coefficient similar to that of the aluminium alloy cylinder head. Triple valve springs are used for the valve. The exhaust valve seating is Stellite.

The assembled Bristol valve is shown in Fig. 220; this illustration also shows the felt pad incorporated in the upper spring washer for lubricating the valve stems.

Valve Stem Clearance Compensation. The Bristol engines employ a novel method of compensating for the effects upon valve stem clearance of cylinder expansion. This arrangement is illustrated in Fig. 221. It will be seen that as the cylinder expands when hot, the rear rocker bracket pivots rise with it,

whilst the position of the front pivot in relation to the crankcase is maintained practically constant by means of a tie rod. The pivots are so disposed in relation to the push rods and rockers that the displacements at either end of the rocker assembly cancel each other out, and the total valve clearances remain virtually unaffected.

In order to maintain the valve stem clearance constant under all operating conditions certain makes of aircraft engine

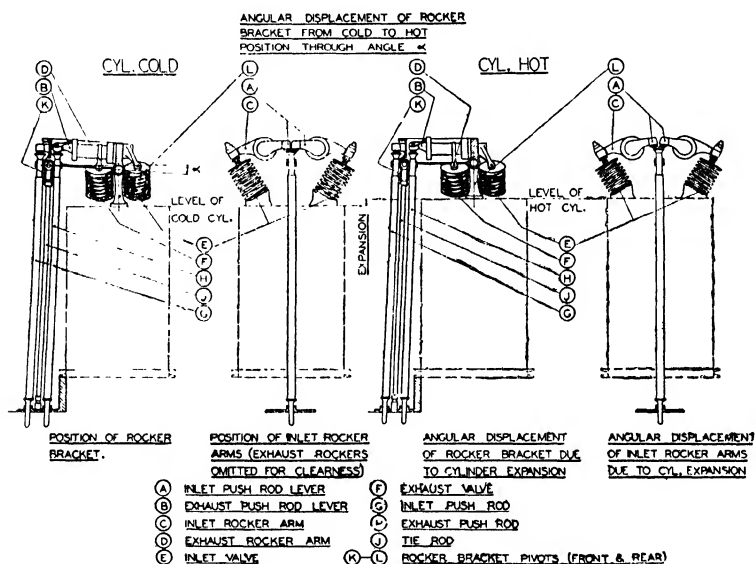

FIG. 221. The Bristol valve stem clearance compensation device.

employ the hydraulic self-adjusting device shown in Fig. 222 ; this method was previously used on Packard car engines. Referring to the diagram (Fig. 222) it will be observed that the valve tappet which is operated by the valve cam is of hollow design and has a plunger member which abuts against the end of the valve stem. Oil under pressure, from the lubricating system, is delivered to the reservoir R, whence it passes through a hole H into the hollow tappet, up the central tube and past a non-return ball valve into the adjusting chamber below the end of the plunger. Oil also passes from the reservoir through a hole in the upper end to lubricate the tappet guide and to assist in eliminating any air in the hydraulic system, since this is

essential to the satisfactory working of the device. The pressure of the oil on the plunger maintains the latter against the valve stem end and gives the equivalent to zero valve stem clearance.

Another type of automatic tappet clearance device used on

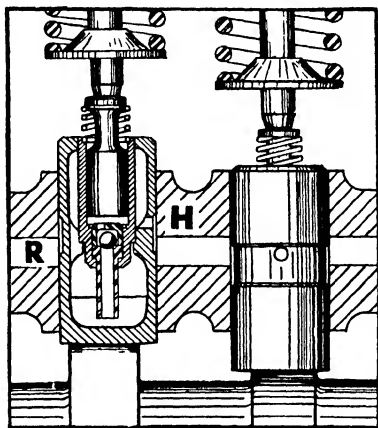

FIG. 222. Hydraulic valve stem clearance automatic adjusting device.

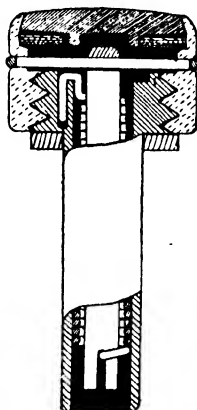

FIG. 223. Automatic valve-stem clearance adjuster.

petrol engines is shown in Fig. 223 ; this employs a mechanical method of adjustment.

The spindle of the tappet is drilled throughout its length to accommodate a coil spring and is threaded externally at the top. On to this threaded section screws a phosphor bronze nut drilled to accommodate a cross pin which is held in position by a spring circlip. The steel mandrel in the centre of the coil spring is slotted at each end, the lower slot engaging the crossbar at the bottom of the spring and the top slot engaging the cross pin. It will thus be seen that the phosphor bronze nut is spring loaded, the action of the spring tending to unscrew the nut in an upward direction. In the top of the nut is located the hardened steel tappet head resting on a number of spring steel discs which deflect to a pre-determined amount in accordance with the recommended tappet clearance, which is governed by the degree of chamfer of the underside of the tappet head. This forms the complete assembly for "located" tappets, but for spinning tappets a flat spring clip is placed in position over the tappet head.

In practice the action of the coil spring keeps the tappet in contact with the tip of the valve stem, the deflection of the internal steel discs allowing for the normal clearance.

Valve Springs. In the past trouble has been experienced with valve springs by failure through fatigue and surging effects through the coils at certain speeds within the necessarily wide speed range of engine speeds. These troubles have now been overcome largely by the adoption of better spring materials, methods of manufacture and testing; the surging effects have been cured by the use of closed end springs or the adoption of double and triple concentric springs.

Owing to the liability of springs to fail through initial surface defects it is now the practice to employ ground steel wire for making springs or to shot-blast the surfaces after coiling so as to give a work-hardening effect.

The steels employed for valve springs include a hard drawn carbon steel with 0.7 to 0.8 per cent. carbon and 1.0 per cent. manganese (maximum). Pure Swedish iron is often used in the manufacture of carbon steel springs. Another spring material is a steel having 0.4 to 0.5 per cent. carbon and 1.0 to 1.5 per cent. chromium with 0.15 per cent. of vanadium; when suitably heat-treated it has a tensile strength of 90 to 115 tons per sq. in. The carbon spring steels when oil hardened and tempered give 80 to 90 tons per sq. in. tensile strength.

The magnetic method of testing valve springs for cracks and surface defects has resulted in a big reduction in the number of valve spring failures in practice.

Valve Operation Gear. In general the valve operating mechanism of aircraft engines is similar to that of motor vehicle ones, although it is of lighter design and more attention is paid to the matter of lubrication.

In most instances the push rod and rocker arm method is used for operating the valves, but in certain cases the overhead camshaft is employed; notably for 12-cylinder Vee-engines.

The push rods are generally made hollow, for lightness and provision is made at one end of the rocker arm, by means of a screw device provided with locking means, for adjusting the valve stem clearances. The rocker arms are bushed and work on hardened steel pins; alternatively, ball or roller bearings are employed.

The whole of the valve-operating mechanism is enclosed in an oil- and dust-tight built-up casing; the push rods

have a concentric cylindrical casing, usually of telescopic design, and the rocker gear has a fairly close fitting casing integral with the push rod one. Sometimes a light alloy, *e.g.* Elektron, cover is provided to this casing for ready access to the valve adjustment device.

The Rolls Royce "Merlin" engine employs overhead camshafts of nickel steel, namely one camshaft per bank of

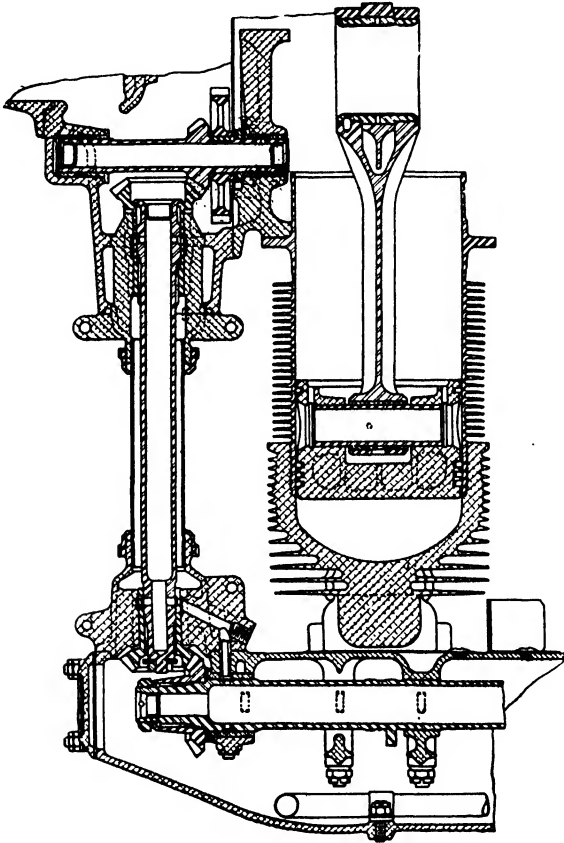

FIG. 224. Camshaft and drive of the "Ranger" inverted type engine.

six cylinders. These are made from forgings machined all over, case-hardened and ground on the cam and bearing surfaces. The camshaft and rocker mechanism (Fig. 188) are carried by means of seven brackets arranged centrally along

the top of the cylinder block and secured to it by studs. The rocker spindles are located one on each side of and parallel to the camshaft. The latter is driven through a spring drive by an inclined shaft and bevel gears from the rear of engine. Each valve is operated by a separate steel rocker arm having a spherically-headed tappet screw and lock nut at the valve end for valve stem clearance adjustment. The camshaft operates

above, and acts directly on a hardened rocker pad in the centre of the rocker shaft.

Four valves, two inlet and two exhaust, are provided for each cylinder, all working parallel to the axis of the cylinder. All valves are produced in K.E.965 steel, the inlet valves being on the inside of the Vee. The exhaust valves have sodium filled stems, and are treated over the crown and seat engaging surfaces with "Brightray," whilst the ends of the stems are fitted with hardened caps of nickel steel. The tips of the inlet valve stems are deposited with Stellite.

Each valve is fitted with two concentric coil springs retained by a collar and split wedge, and a spring circlip at the upper end retains

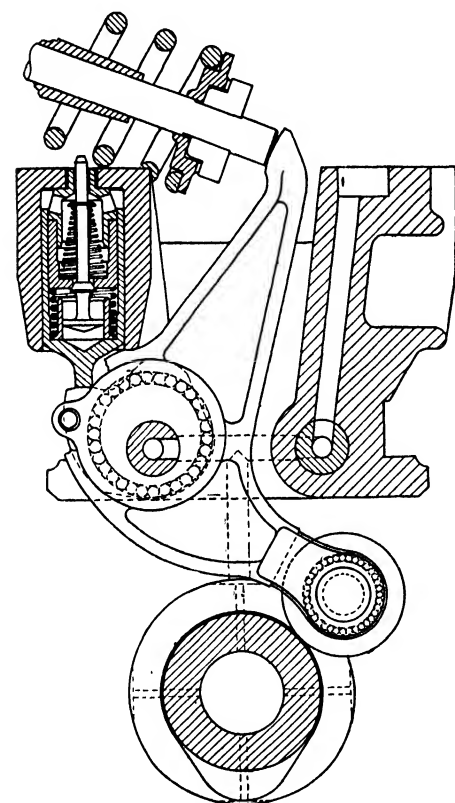

FIG. 225. Hydraulic automatic adjustment device applied to rocker arm.

the valve in its guide *in the event of valve spring failure.*

Fig. 224 shows how the overhead camshaft of the 12-cylinder inverted Vee-type air-cooled "Ranger" engine is operated from the lower horizontal shaft, driven at one-half engine speed, by means of two pairs of bevel gear drives. The camshaft is

hollow and its bearings are lubricated automatically. Oil from the crankcase is led down to the vertical shaft bearings and the bevel gears and thence by means of the drilled passages shown, to the camshaft bearings below.

The overhead camshaft may be arranged to operate the valves by means of a rocker arm of the pattern illustrated in Fig. 225. The rocker roller which is operated by the cam has needle bearings, and the rocker itself is also mounted on needle bearings. The axis of the main bearing of the rocker is arranged on an eccentric shaft such that a hydraulic device, similar in principle to that of the automatic valve tappet adjuster (Fig. 222), takes up any backlash between the rocker arm end and the valve stem; this hydraulic adjusting device is operated from the oil pressure system.

The valve-actuating mechanism of the Franklin AC-150 four-cylinder opposed aircraft engine is shown in Fig. 226. This employs a hollow push rod operated, from the central camshaft, and a rocker arm having its central bearing member housed on a cylinder head bracket. Provision is made at the push rod end of the rocker arm for adjusting

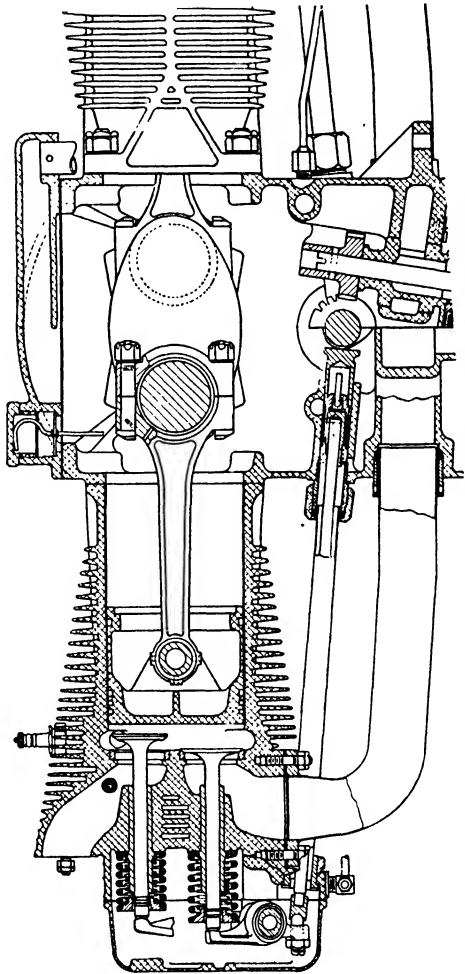

FIG. 226. The valve mechanism of the Franklin four-cylinder opposed engine.

the valve stem clearance. The rocker arms operate on bronze bushings mounted on hollow pins through which oil passes to lubricate the entire valve mechanism.

Pratt and Whitney Valve Gear. The two-row radial air-cooled engines such as the "Twin Wasp" have overhead valves operated by push rods and rocker arms, as shown in Fig. 227, totally enclosed and lubricated automatically. The rocker arm has a ball bearing. A special feature is the automatic lubrication system in which engine oil under pressure is circulated continuously through the valve tappets and hollow push rods to the various working surfaces. The return oil drains through the push rod cover tubes or through scavenging pipes to a rubber-mounted cylinder head oil sump from which it is returned to the oil tank by means of a special suction, or scavenging, stage of the main oil-pump; it is therefore impossible for oil to collect in the rocker boxes at any time.

The exhaust valve (Fig. 227) is sodium-cooled and is faced with Stellite. The rocker arms and push rods are of heat-treated aluminium alloy, with hardened ball ends. The valve stem clearance adjustment is by means of a fine-pitch screw in the rocker arm; a locking nut is fitted to secure the adjusting screw.

The plan view of the cylinder head of the Bristol "Mercury" engine reproduced in Fig. 228 shows the neat arrangement of the rocker arms and push rods operating the four valves. The push rods are operated by case-hardened valve tappets working in phosphor bronze guides mounted radially around the cam chamber at the front of the crankcase. The hollow tappets have case-hardened rollers which bear on the cam. The rollers are bushed with phosphor bronze and rotate on hardened pins. The tappet guides are located at their inner ends in a ring fixed to the crankcase wall. The outer ends are flanged and are secured to the crankcase by studs which serve also for the lower attachment of the push rod casings. During operation all the components are completely exposed to oil spray. To prevent oil leakage past the tappets of the lower four cylinders these are shrouded by brass sleeves and their guides are specially drilled for oil drainage. The crankcase itself has suitable oil passages to return the oil to the sump. The whole tappet assembly is robust and reliable and of minimum weight.

Cam Gear for Radial Engines. The usual cam arrangement for radial engines is a cam ring having cam lobes for operating

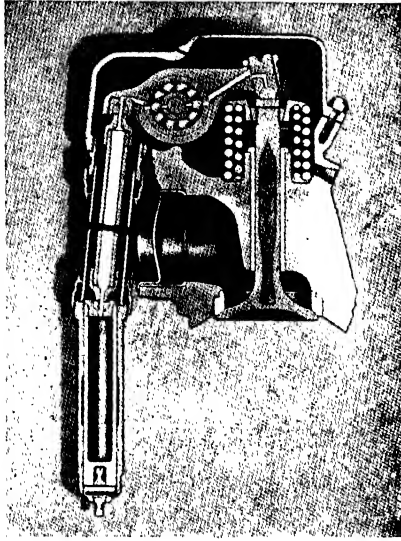

FIG. 227. Pratt and Whitney radial engine valve gear.

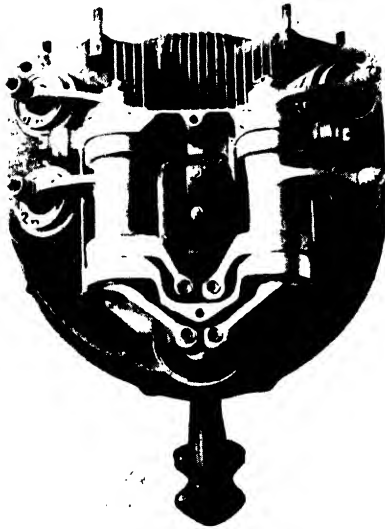

FIG. 228. Cylinder head of the Bristol "Mercury" engine showing valve gear.

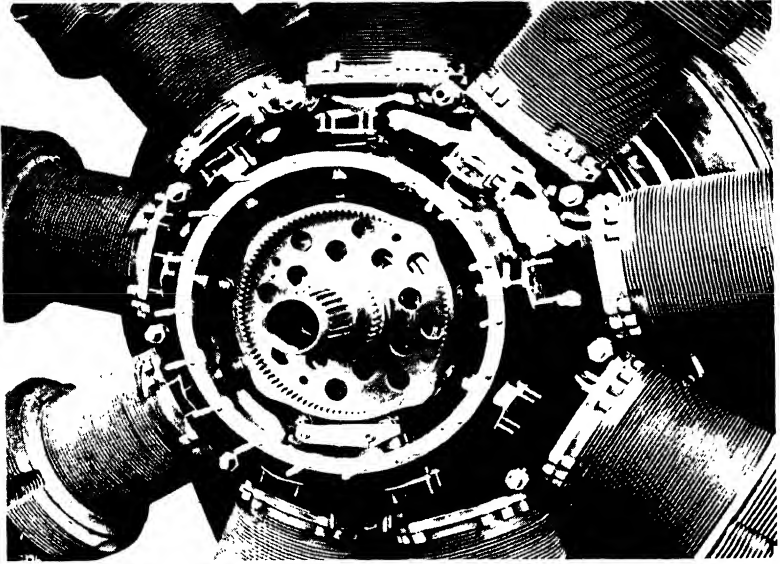

FIG. 229. The Bristol valve tappet and cam ring assembly.

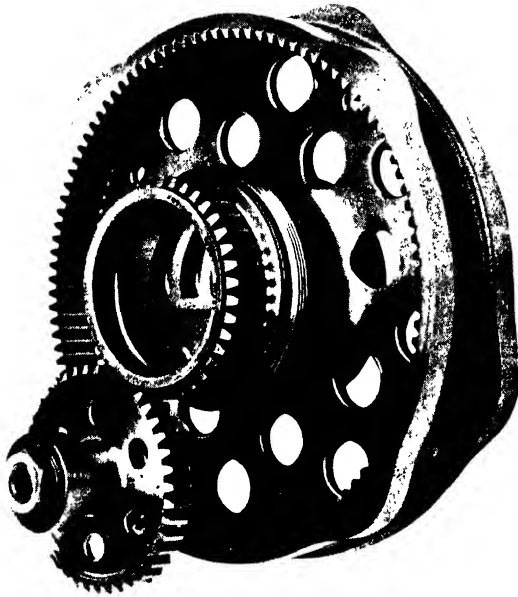

FIG. 230. Bristol "Mercury" engine cam rings and gear drive.

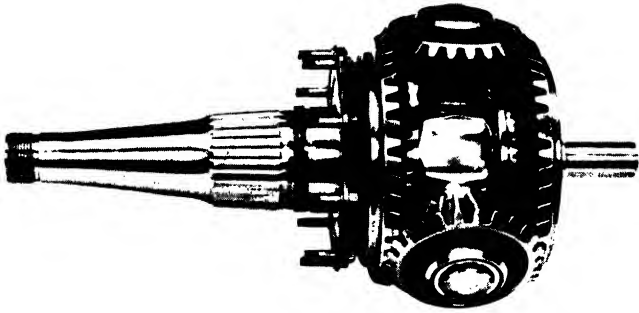

FIG. 231. Airscrew reduction gear of Bristol "Mercury" engine.

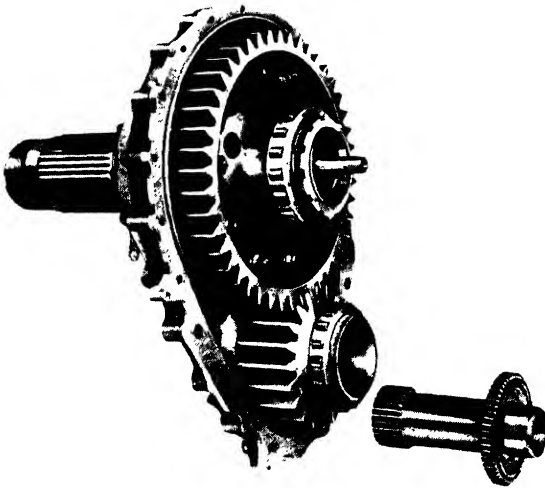

FIG. 232. The Rolls Royce "Merlin" engine airscrew reduction gear, which is similar in principle to that shown in Fig. 233.

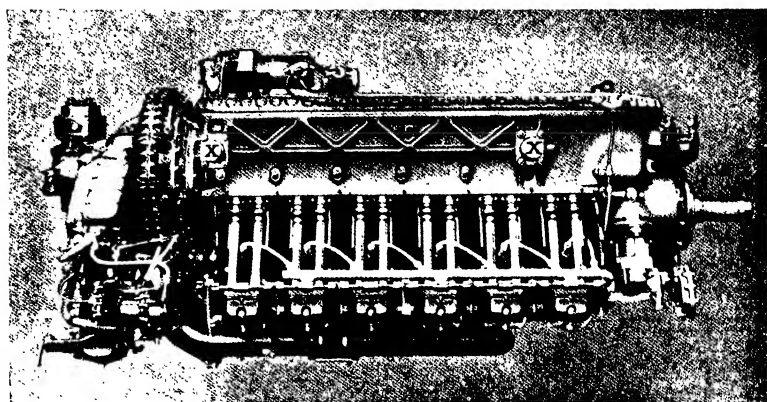

FIG. 236. The "Gipsy Twelve" engine showing trunnion mountings at X, X.

the inlet valves, and a somewhat similar cam ring parallel with the former for the exhaust valves. The cam rings are arranged concentrically with the crankshaft axis and they are gear-driven at an appropriate lower speed in order to give the correct number of valve operations per crankshaft revolution.

In the simplest case of a three-cylinder radial engine giving three firing strokes every two revolutions of the crankshaft, if the cam ring rotates at one-half engine speed in the opposite direction to the crankshaft it will require only one valve-operating lobe; there will of course be two such cam rings mounted solid with one another for the inlet and exhaust valves, respectively.

A five-cylinder radial engine will require a two-lobe cam ring geared to run at one-quarter engine speed. A seven cylinder engine will need a three-lobe cam running at one-sixth engine speed, whilst a nine-cylinder engine will require a four-lobe cam running at one-eighth engine speed; and so on. In each case the cam ring is assumed to run in the opposite direction to the crankshaft and there is a separate cam ring or circle for the inlet and exhaust valves.

In general, if there are n cylinders in a single row radial engine and the cam ring rotates in the opposite direction to

the crankshaft there will be $\frac{n-1}{2}$ lobes on the cam ring and

the latter will rotate at $\frac{1}{n-1}$ times engine speed.

If, however, the cam ring rotates in the same direction as the crankshaft it will require one more lobe per cam ring but will rotate at a lower speed. Thus, in the case of a nine-cylinder engine five lobes will be required and the cam ring will rotate at one-tenth engine speed. This arrangement gives a heavier cam ring and a bigger cam ring gear reduction ratio so that it is seldom used. In connection with the cam shape, hollow-faced cams are generally employed on radial engines whilst tangent cams are used for Vee-type and "in-line" ones; other designs of cams are sometimes used however, namely, the generated and constant acceleration ones.

Fig. 230 shows the cam rings and the gear drive for same in the case of Bristol "Mercury" engine. It will be observed that the cam sleeve embodies inlet and exhaust cam tracts, each having four cams. It rotates concentrically with the crankshaft, but in the opposite direction, at one-eighth engine

speed. The cam driving gear is located directly on the crankshaft, and engages with a large gear splined to the lay shaft. The smaller lay shaft pinion meshes with the teeth formed in the internal periphery of the cam sleeve. The lay shaft is carried in two roller bearings, one of which is mounted directly on the aluminium alloy front cover, and the other in a high expansion steel housing bolted on to the inside of the cover. The roller bearings are of special design, and permit a small angular movement of the lay shaft to prevent any overloading of the pinion teeth due to slight flexure of the cam sleeve. The cam driving gear is coupled to the crankshaft by means of serrations, thus facilitating accurate valve timing adjustment. The cam sleeve is short and stiff, and the cam tracts are located centrally over the pressure lubricated bearing of the sleeve. The cams are designed with low acceleration characteristics, which are permissible because of the automatic valve clearance compensation provided.

The Airscrew Drive. In order to obtain the increased outputs per litre of modern engines it has been necessary to employ higher crankshaft speeds and these are well above the maximum efficient speeds of airscrews; the shafts of the latter have, therefore, to be geared down from the crankshaft. A certain amount of information on engine and airscrew speeds and gear reduction ratios has already been given in the previous descriptive sections of this book.

Aircraft reduction and timing gears are usually made from an air-hardening alloy steel, such as the $4\frac{1}{4}$ per cent. nickel chromium steel or nickel chromium molybdenum with 1.3 to 1.8 per cent. nickel, 1.2 to 1.6 per cent. chromium, 0.2 to 0.4 per cent. molybdenum, 0.3 to 0.4 per cent. carbon and low silicon and manganese content. Such steels give tensile strengths in the heat treated condition of at least 100 tons per sq. in. and, owing to the air-hardening method employed, experience a minimum amount of distortion and risk of cracking during the hardening process.

The two gear arrangements favoured for this purpose are the epicyclic and direct spur gear drive ones. The former method employs either straight tooth spur type gears or bevel gears and has the advantage of giving a symmetrical layout whereby the axis of the airscrew is in line with that of the crankshaft; it necessitates a rather greater overhang of the airscrew shaft, however than of the simple spur reduction gear method. The airscrew shaft is usually mounted on roller bearings and pro-

vided with a suitable thrust race or bearing. Fig. 231 illustrates the airscrew shaft and reduction gear of the Bristol "Mercury" engine; this design is suitable for use with controllable-pitch or constant-speed airscrews.

The engine torque is transmitted to the airscrew hub by taper splines, on which the hub is retained securely in position by a special bronze nut, which also acts as an efficient hub extractor when unscrewed. Pressure oil for airscrew pitch control can be conveyed to the bore of the air screw shaft through an oil seal attached to the front of the reduction gear case.

The reduction gear is of the Farman bevel epicyclic type, which has been used and developed in "Bristol" engines for many years. It is light and compact, yet highly reliable. The design is also well adapted to provide alternative gear ratios. Both bevel wheels are mounted on spherical thrust rings which permit them a slight amount of universal movement. This ensures an equal distribution of load between the three bevel pinions. High individual tooth loading is thus avoided, and weight is saved without risk of failure.

The assembly is enclosed within a compact forged aluminium alloy casing, and is easily withdrawn as a unit after removing the nuts securing it to the crankcase. Following the usual practice the airscrew shaft is splined to take the airscrew and thus to provide a positive drive to this member.

The airscrew drive reduction epicyclic gears of the Wright "Cyclone" engine are shown in Fig. 212; the gears have been displaced to reveal the details of the drive. The reduction ratio obtained is 11:16. The reduction gear unit is encased in the nose section of the crankcase and the serrated inner shaft shown on the extreme left-hand side is the shaft to which the airscrew is attached.

A typical example of a speed reduction airscrew shaft drive is the Rolls Royce one illustrated, sectionally, in Fig. 233.⁴⁷ The front end of the crankshaft is provided with a flange on which is bolted an internally-toothed ring, the teeth of which engage with similar teeth on the end of a short hollow shaft. The opposite end of the latter is provided with splines which transmit the torque to a hollow pinion mounted in roller bearings and located endwise by a light ball bearing. This prevents any transverse loads from being transmitted to the crankshaft from the gearing. The pinion engages with a toothed ring bolted to a flange formed on the airscrew shaft,

which is supported on roller bearings and has a ball thrust bearing to take the airscrew thrust. The gearing is enclosed in a cast aluminium casing, made in two parts bolted together and also to the crankcase. The gear teeth are lubricated at the point of engagement by oil delivered through two oil jets.

Engine Mountings. The method of mounting an engine to the fuselage nose or wing structure is governed by the type

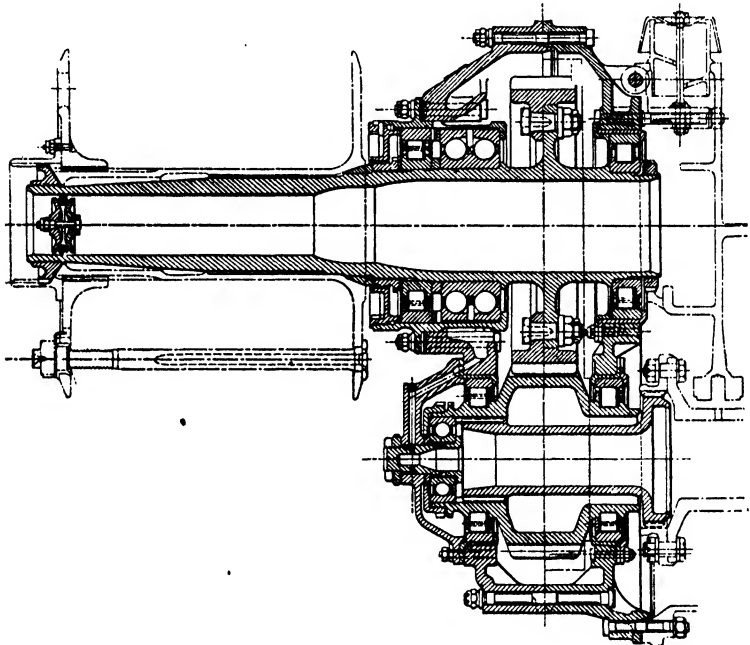

FIG. 233. Airscrew reduction gear unit, showing gears and bearings, etc.

and size of engine, but in general all mountings must be designed with a sufficient margin of safety to withstand (1) the weight of the engine, (2) the engine torque reaction, (3) the airscrew thrust, and (4) the torque due to airscrew gyroscopic effects during turning and similar evolutions. The maximum value of the resultant force due to the worst combination of these loadings governs the strength of the mounting.

In the case of the horizontally opposed engine a relatively light and simple mounting can be employed. Usually the engine is provided with four mounting lugs on the crankcase

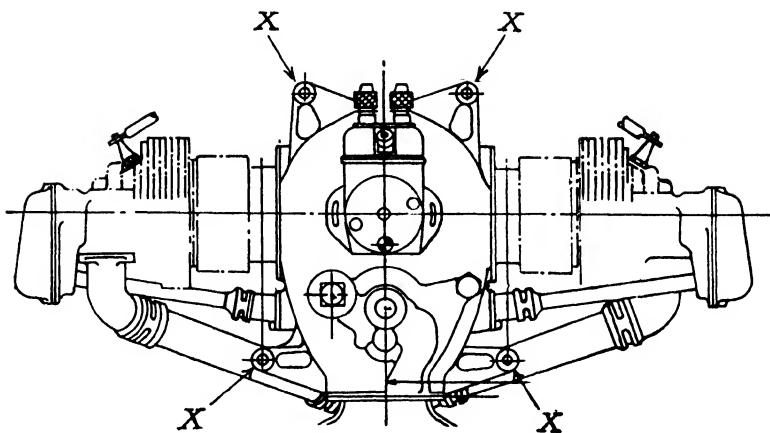

FIG. 234. Mounting of opposed-cylinder engine.

casting, as shown at X in Fig. 234, so that four suitably braced longitudinal fuselage members can be used for holding the engine and taking the various possible combinations of loads.

The Vee-type engine is usually provided with four lugs or engine bearers on the upper part of the crankcase, immediately below the cylinder bases, namely, two on either side at the

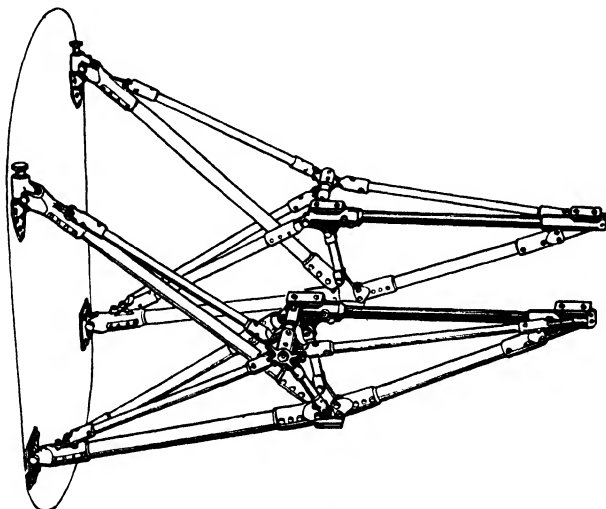

FIG. 235. Mounting for Vee-type engine. (*The Aeroplane.*)

front and rear ends, respectively. These bearers are secured to corresponding brackets on the fuselage or nacelle framework. The framework in question is generally of tubular construction built up on the triangulated principle to provide the maximum rigidity at all points.

Fig. 235 shows a typical tubular engine mounting for a Rolls Royce twelve-cylinder Vee-engine; four mounting points are provided. The left hand parts of the tubular mounting are attached to the fuselage bulkhead frame member at the four places shown. The steel tubes used for the engine mounting have steel forgings at the joints and the bulkhead attachment members are bolted to corresponding brackets on the bulkhead, so that the complete engine and mounting can readily be removed.

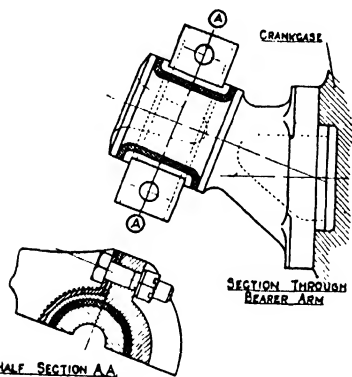

FIG. 237. Trunnion pin mounting of Gipsy Twelve engine.

The method of mounting the Gipsy Twelve inverted twelve-cylinder Vee-engine is illustrated in Fig. 236.* The upper part of the crankcase has four engine mounting machined faces, namely, two on either side arranged at the front and rear ends, respectively. Trunnion pin members are bolted to these faces, the front inclined pin and bearing being shown enlarged in Fig. 237. The

section of the Elektron crankcase between the two mounting lugs is made of girder design, with external inclined struts between the equivalent top and bottom flanges of the girder (Fig. 236). The engine mounting is of the overhung triangulated tubular pattern with bearings at the four engine mounting points. The engine itself forms a rigid bracing member between the two side tubular mountings; diagonal bracing is employed for the rear panel of the framework as seen in plan view and the attachment tubes for the bulkhead member are splayed outwards for greater lateral rigidity.†

It is possible to replace the steel tube engine mounting assembly by two light alloy engine bearer members of the type

* Facing page 273.

† Vide Figs. 57 and 58, pages 94 and 95.

illustrated in Fig. 238. The front and rear trunnion attachments of the engine are made at F and R, respectively. A strong tubular strut inclined member is attached between the

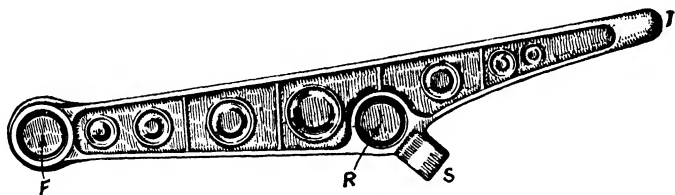

FIG. 238. Light alloy engine bearers used on certain German aircraft.

lug S and the bulkhead framework, whilst the end T is secured direct to a fitting at the upper end of the bulkhead. The engine bearer shown in Fig. 238 is made in Elektron and its weight, for supporting a 1,000 h.p. engine is only 26 lbs. It

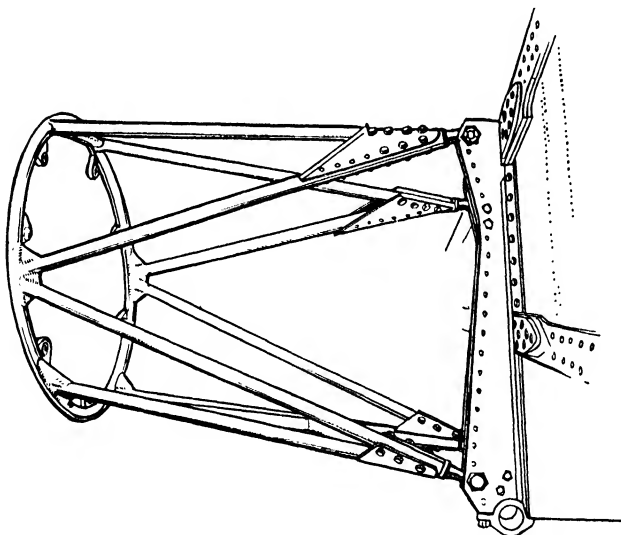

FIG. 239. Framework on aircraft for radial engine mounting.
(*Aircraft Production.*)

is made as a one-piece forging from Elektron magnesium alloy of 20.5 tons per sq. in. tensile strength (proof stress, 12 tons per sq. in.) and 13 per cent. elongation. This type of mounting has been used for German engines in aircraft.

The method of mounting radial engines is generally much simpler than for the other types of engine referred to. Owing to the circular form of the crankcase the engine can be bolted to a circular ring type of mounting on the aircraft. This mounting is supported by triangulated tubular members to the rest of the fuselage or wing framework so as to take all the loads occurring under the most severe conditions. A typical welded framework mounting for a radial engine is shown in Fig. 239; the engine is bolted to the ring unit on the left.

The core mounting plate employed for Bristol radial engines, shown in Fig. 240, is located on a spigot between the crankcase and supercharger; it has a flange drilled with eighteen holes to accommodate mounting bolts.

Flexible Mountings. As in the case of motor car engines which are flexibly mounted on suitably located rubber block

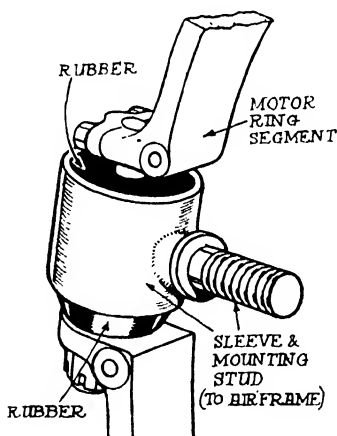

FIG. 243. Detail of one of the Bristol flexible engine mounting members.

members, aircraft engines are now frequently mounted in the same manner. This form of mounting serves to damp out engine vibrations and to prevent their transmission to the rest of the framework of the aircraft. Usually the flexible mounting takes the form of a central bolt member enclosed within an outer metal cylindrical member, the space between the two being filled with a special kind of rubber either solidly or in the form of a series of blocks. One member is secured to the engine and the other to the machine mounting plate or frame so that the rubber provides an insulating medium against vibration effects; incidentally, it is necessary with such mountings to ensure electrical connection between the engine metal and the metal framework of the aircraft in the case of earth return electrical systems by means of a flexible metal conductor.

Two types of aircraft engine suspension units, known as the "Metalastik" are illustrated in Fig. 241.* These are for use

* Facing page 281.

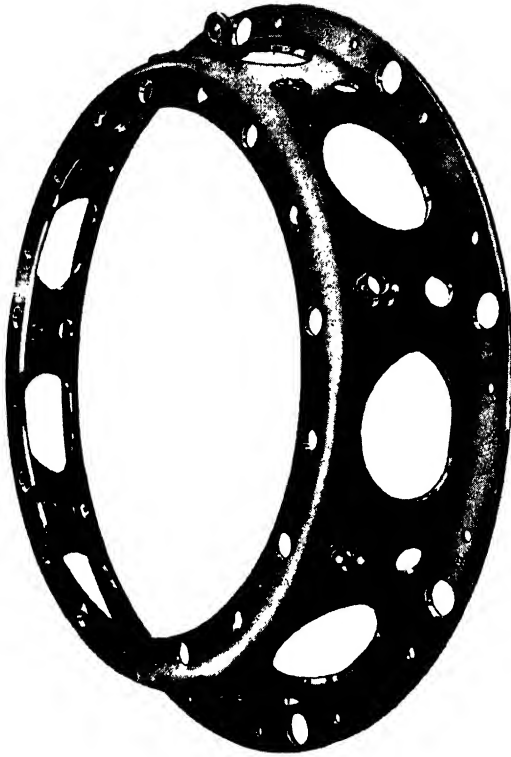

FIG. 240. Bristol radial engine mounting plate.

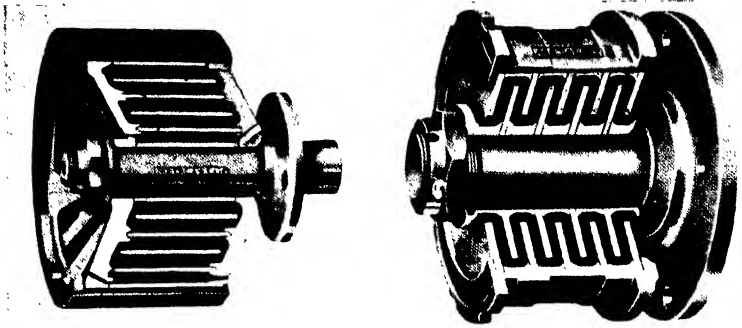

FIG. 241. "Metallastik" rubber-steel engine mountings.

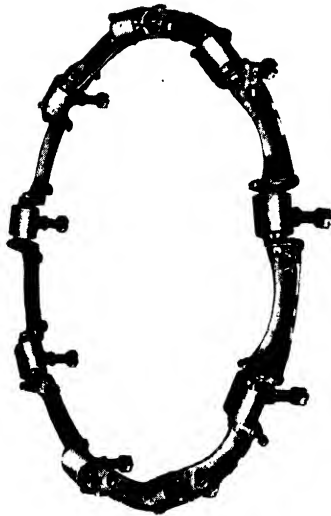

FIG. 242. Flexible mounting for Bristol radial engines.

with "in-line" and vee-type engines, there being one of these units at each engine mounting point.

Bristol radial engines are also provided when required with the flexible mounting method illustrated in Fig. 242. A detail drawing of one of the mountings is given in Fig. 243. This mounting consists of a ring made up of nine rubber buffer mounting units spaced equidistantly between light alloy support brackets of wide channel section. The ring is attached to the front face of the cone mounting flange, utilising the existing drilled holes. The nine mounting bolts, one from each rubber buffer unit, protrude rearwards through clearance holes already provided in the cone mounting flange. The rubber buffers effectively damp out engine torque fluctuations and airscrew vibration, but fully adequate stiffness is provided against the direct engine weight loads. The mounting there-

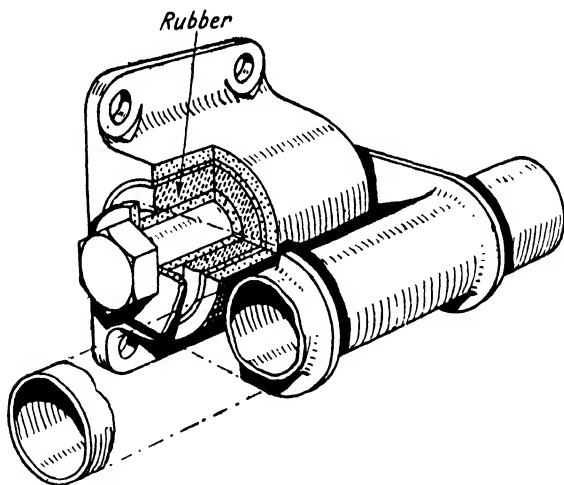

FIG. 244. Silentbloc rubber-type flexible aircraft engine mounting.

fore has no tendency to droop. It is not affected adversely by gyroscopic torque.

The use of this flexible type mounting is recommended as a means of prolonging airframe life and improving the comfort of flight. It is available in different grades of flexibility, so as to enable a suitable selection to be made according to the degree of stiffness provided in the individual airframe.

CHAPTER VIII

THE LUBRICATION OF AIRCRAFT ENGINES

THE problem of lubricating satisfactorily under all operating conditions the bearing surfaces of the various moving components of an aircraft engine is a very important one, involving not only the selection of the correct grade of lubricant, but also the design of the distributing system. The latter involves considerations of quantity, pressure, cooling and filtering of the lubricant.

Before proceeding to discuss the matter of suitable lubricating oils for aircraft engines, it may be helpful to mention a few facts on the general subject of lubrication, having a direct bearing upon petrol- and C.I.-type engines.

Lubrication Principles. When two components of a bearing, such as the shaft and its bearing, are adequately lubricated with a suitable oil the two metallic surfaces are not in metallic contact, but are separated by an oil film, and the resistance to relative motion between the shaft and its bearing therefore depends largely upon the physical properties of the oil, namely, its viscosity; it is independent of the frictional coefficients of the bearing metals. This type of lubrication is termed the "fluid" one. There is, however, another form of lubrication liable to occur in the case of bearings and sliding surfaces under inadequate lubrication conditions, or in instances where appreciable surface roughness of the components prevents the maintenance of "fluid" lubrication. In such cases the oil film is insufficient in thickness to prevent occasional contact of the bearing surfaces, with the result that the frictional resistance is increased appreciably; usually the frictional coefficients under these "boundary" lubrication conditions are from ten to twenty-five times greater than for fluid lubrication, but are less than the "dry" coefficients. It should here be explained that if the bearing surfaces were perfectly, or chemically, clean the coefficient of friction would be much higher, but a trace of oil on the surfaces reduces this value appreciably. Thus, under the conditions of boundary lubrication the film of oil is infinitely thin, but the actual value of the

frictional coefficient will depend not only upon the nature of the oil, but upon the metals used for the shaft and bearing. The friction effect in this case is proportional to the load on the bearing, so that the coefficient of friction is actually independent of the load.

There is a certain property associated with lubricating oils, which, for want of a better name, is termed "oiliness." It is difficult to define, but it can be stated that it is a surface effect produced by the lubricant upon the metallic surface with which it is in contact. In this connection fatty oils, *i.e.*, oils saponifiable or those containing "fatty" ingredients, such as castor, rape or olive oil, exhibit a greater degree of "oiliness" than purely mineral oils, so that the frictional coefficient at any given temperature is lower under severe conditions of loading and slow speeds. Under extreme conditions of loading and high rubbing speeds, seizure between the shaft and its bearing would be less likely to occur with the lubricant of greater "oiliness." It is mainly for this reason that *compound oils*, *i.e.*, mineral oils blended with a proportion of fatty oil are preferred by many engine users. In this connection it has been found that when pure hydrocarbon (mineral) oils are blended with fatty oil, the former constituent appears to eliminate the normal tendency of the fatty oil to oxidise and thicken under engine operating temperatures.

Castor oil alone was used in many of the earlier aircraft engines. This oil possessed good lubricating properties at engine temperatures and enabled high bearing pressures to be employed; moreover, as it did not mix appreciably with the petrol used in these engines the crankcase oil was not thereby diluted. Its chief drawback—and one that has since caused its abandonment for normal aircraft engine purposes—was its gumming tendency, which resulted in the sticking of piston rings in their slots and the valves in their guides; it also caused a higher rate of formation of carbon deposits in the piston head and combustion chamber walls.

Castor oil, on account of its excellent "oiliness" is still employed for the purpose of running in new engines for the first few hours of their operation; thereafter special mineral or compound oils are employed. The excellent "oiliness" property of castor oil is such that whilst the bearing thus lubricated may be operating under "boundary" lubrication conditions, with a film only a few molecules thick, the coefficient of friction is still reasonably low. The film adheres very

strongly to the surface of the metal and it is extremely difficult to remove. It is largely on this account that when a new engine is run in with castor oil as a lubricant, the bearing metals retain some of this oil in their surface layers, and the beneficial effects thus persist for appreciable periods after the change over to mineral oil has been made. In this connection it must be emphasised that the "oiliness" property of castor oil is not due to its viscosity.

Lubrication Conditions in Petrol Engines. All of the rotary motion components of the engine, of which the main, big end and camshaft bearings are examples, operate under conditions of fluid lubrication. Since the bearing pressures vary with the different components it is usual in higher powered engines at least to supply the lubricating oil at higher pressures to the more heavily loaded bearings, notably the main journals and big ends, than to the more lightly loaded ones, such as the camshaft, rocker and reduction gear bearings and moving surfaces. Thus, whilst it is usual to supply oil at a pressure of 50 to 80 lbs. per sq. in. to the former bearings, it is only necessary to employ a pressure of 4 to 8 lbs. per sq. in. for those of the latter components.

In the case of the pistons and cylinder walls it is considered highly probable that *boundary lubrication conditions exist* between the piston rings and the cylinder wall. The most favourable periods during the cycle of operations for these conditions are during the maximum cylinder pressure and early expansion stages and also to a lesser extent at the ends of the strokes. It is considered that during the intermediate part of the stroke fluid lubrication exists.

The results of some tests made by Dr. Stanton⁵⁶ on the friction of pistons and their rings in an aircraft engine cylinder confirmed this conclusion that the friction of the rings was of the boundary lubrication type, *i.e.*, the friction was independent of the speed and proportional to the normal pressure between the rings and cylinder wall. The normal pressure due to the elasticity of the rings was found to be augmented by the gas pressure at the back of the rings, in their slots, due to the leakage of gas from the combustion chamber through the slits in the rings. Thus it was found that as a result of this leakage the friction of the rings with a gas pressure of 80 lbs. per sq. in. was double that when the pressure was 14.7 lbs. per sq. in.

Taking *the engine as a complete unit*, the results of motoring

and deceleration tests made with the engine hot indicate that the friction of the engine is almost entirely of the "fluid" lubrication character, since the power absorbed by this friction varies as the square of the speed. Further, it is generally known from engine tests that the frictional losses depend upon the viscosity of the engine lubricant so that the conditions are those of "fluid" lubrication. In view of the relatively high proportion of the bearing surfaces known to operate under finite oil film lubrication conditions in an engine, as compared with the small proportion of boundary lubrication conditions of the piston rings and part of the piston, *i.e.*, on the thrust face, these results appear as logical conclusions.

Cooling due to Lubricant. Apart from its primary function as a bearing surface lubricant, the engine oil, in the case of an aircraft engine, also plays an important part in *cooling the big end bearings*. For this reason, in high duty engines a greater quantity of oil is usually circulated than is necessary for actual lubrication purposes and to avoid excessive lubrication of the cylinder walls by oil-jets or splash from this supply special oil control rings are often fitted to scrape off the surplus oil; in other instances the oil thrown off on to the cylinder walls by the big end is limited by the size and location of the hole in the upper or connecting rod half of the bearing.

An interesting point noticed in oil consumption tests of high speed engines is that there is a more or less sudden increase in the oil consumption at high speeds; this is considered to be due to a change from boundary to "fluid" lubrication conditions at these speeds.

Cylinder Wear. The question of *cylinder wear* is to a large extent concerned with the adequacy, or otherwise, of cylinder lubrication. Although there is no general agreement as to whether the cylinder bore wear is due to the corrosive effect of the products of combustion—more particularly under warming-up conditions—or to abrasive wear, it must be evident that under starting conditions when there is very little lubricant on the cylinder walls, the result of the relatively high thrust pressures between the piston and cylinder wall will tend to promote "boundary" lubrication or abrasive conditions. As the oil circulates the walls become lubricated and the initially severe conditions cease. The fact that the greater wear occurs near the top of the cylinder in the region opposite the upper piston ring when the piston is on its top dead centre, combined with that of the difficulty of lubricating the upper part of the

cylinder barrel—even under normal operating conditions—tends to support the view of inadequate lubrication as the primary cause of upper cylinder wear. Taub and Young⁵⁷ have put forward the suggestion that the main cause of wear is the result of blow-by of the gases—which would be accentuated by lack of lubrication—and suggest the fitting of improved piston rings and at the same time the delivery of a plentiful supply of oil to the cylinder walls, the surplus being removed by suitable oil scraper rings.

Breaking Down of the Oil. When an engine is working under normal conditions and the piston is on its top dead centre oil from the big end jets, from the oil mist in the crankcase or that splashed up from the rotating members finds its way on to the cylinder walls. As the piston descends part of this oil film is scraped away by the oil control rings, but a film is left on the rest of the cylinder walls. During the firing stroke this oil film is exposed to the action of the combustion products, consisting of carbon monoxide or carbon dioxide, and oxygen—in the case of the weaker mixtures—at a temperature varying from about 2,000° C. down to 700° or 800° C. The oil under these severe temperature conditions tends to crack or break down into unsaturated hydrocarbons and gummy constituents, whilst a certain amount of oxidation occurs due to the free oxygen in the combustion products. During the next strokes of the piston this altered oil mixes with fresh lubricant, whilst some of it enters the ring groove spaces. As a result, there is a gradual admixture of cracked and oxidised oil with the original unused oil. Further, the altered oil tends to accumulate behind the piston rings and in the ring gaps, and in time to form gummy deposits which fill these spaces and eventually prevent the rings from performing their proper duties; these gummy products resulting from cracking and oxidation are insoluble in the original lubricant so that they are not diluted or removed by the latter.

It is extremely difficult to simulate actual engine conditions in laboratory tests of oils so that, in general, laboratory tests are not always safe guides as to the behaviour of the oil in the engine. For this reason the only satisfactory or final test of an aircraft engine lubricant is that of an extended endurance run on the particular type of engine concerned; at least 100 hours' endurance test is necessary.

Engine Oil Properties. Aircraft engine oils are now largely

of the mineral type derived from the higher boiling constituents of petroleum by distillation processes. The actual properties of these mineral oils are to some extent governed by the origin or character of the crude petroleums from which they are derived. Thus, oils obtained from Russian crudes are usually naphthenic; from Texas and other sources, asphaltic and from Pennsylvanian sources, paraffinic. The latter have the lowest densities and are less liable to oxidation; the asphaltic oils are the heaviest and more readily oxidised.

Compound oils consisting of mineral and vegetable oils, *e.g.*, castor oil, are also employed, but with modern high piston temperatures and speeds the gumming effects on piston rings is a serious drawback, since it reduces the periods between engine overhaul.

The more modern mineral oils, produced by special processes of refining and blending have proved fully satisfactory for aircraft engines of high performance, there being no difference in wear or lubrication as compared with castor base oils.⁶⁸

More recently, special oils, including the doped, hydrogenated, volatilized, etc., varieties, produced by new processes have appeared and important claims in regard to non-oxidising, gumming and sludging tendencies have been made for such oils.

The subject of engine lubricating oils, their chemical and physical properties is an extensive one and for reasons of space limitation cannot be dealt with more fully in these considerations, but a brief outline will now be given of some of the desirable properties of aircraft engine oils and their tests.

Viscosity of Oils. As previously mentioned, viscosity of a lubricant is an important property concerning the maintenance of the oil film under "fluid" lubrication conditions. In general, the more viscous the oil the greater the bearing load pressures that can be employed. On the other hand, if the oil is too viscous at low temperatures, engine friction will be increased and cold starting made more difficult.

Since the viscosity of an oil diminishes with increase in temperature it is necessary to select an oil which will possess a sufficient viscosity at the normal working temperatures of the main and big end bearings to prevent the oil film from breaking down; the same applies, but to a lesser extent, to the oil film on the cylinder walls. The temperature of the latter usually averages about 150° to 200° C. and of the big end bearings, 80° to 100° C.

The effect of temperature in reducing the viscosity of a good quality engine lubricating oil is shown by the following results :—

Temperature ° F.	0	70	140	200	400
Redwood viscosity (seconds) .	40,000	1,800	170	57	30

It follows, from these considerations, that it is desirable to employ a lubricating oil having the least possible change of viscosity between cold starting temperatures and the normal engine temperatures ; at the same time the viscosity must not be excessive, otherwise friction and heating will result.

In this connection the use of a low viscosity oil is not desirable since this involves a higher pumping capacity, increased oil consumption and a greater risk of break-down of the " fluid " lubrication conditions.

In this connection it is usual to blend mineral oils from various crude oil sources so as to obtain the best viscosity temperature curve.

The viscosity of aircraft engine oils is generally determined at two temperatures, namely, 100° F. and 200° F. and, when expressed in absolute units, or " poises," is specified to be not greater than 2.9 poises for the summer grade, and 1.75 poises for the winter grade at 100° F. At 200° F. the corresponding values are 0.183 and 0.133 poises.

When the Redwood viscosity scale is used, the viscosities of aircraft engine oils of summer grade are 90 to 100 seconds, and for winter grades 70 to 80 seconds at 150° F.

The *Viscosity Index* method of comparing lubricating oils depends upon measurements of the rate of change of viscosity with temperature and is usually specified for viscosities between 100° F. and 210° F. The standard scale employed is 0-100, the former value corresponding to an oil having a very great change of viscosity with temperature and the latter to one exhibiting a small change. In general, a medium to high viscosity index corresponds to a lubricating oil possessing good lubricating properties at engine temperatures, *i.e.*, a good " body," combined with low oxidation tendencies.

The *Flash Point* of lubricating oil should not be too low, from the point of view of the possibility of a fire ensuing in the event of an aeroplane crash, due to the splashing of oil over hot exhaust pipes ; also, from considerations of ignition within the combustion chamber. If the flash point is too low the oil will burn, depositing carbon around the piston rings.

The open flash points of aircraft engine lubricating oils are specified to be not less than 200° C. (390° F.).

Carbonisation of engine oils is an important factor in their selection. Although no oil is free from oxidation or carbon forming, it is desirable that this should be a minimum. It has already been mentioned that the exposure of the oil film to the action of the high temperature combustion products results in cracking and oxidation and the eventual formation of insoluble asphalts; the latter, in contact with the hot surfaces of the piston heads, rings and combustion chamber walls, form carbon deposits. The nature of these deposits varies with the grade of oil used. The most satisfactory oils, in this respect, are those causing the minimum amount of deposit; the latter should be of a soft and flaky nature such that the greater part is blown through the exhaust.

The darkening of engine lubricating oil in service is due largely to oxidation attributable to the cause stated and also to the churning up of the oil in the crankcase, in the presence of moisture and air at fairly high temperatures; excessive oxidation causes the oil to thicken and promotes the formation of carbonaceous deposits. Further, an oxidised oil is more readily broken down by the hotter surfaces of the engine, to form carbon deposits thereon.

The carbonizing property of an engine oil is determined in the laboratory by the *Coke Test*. This consists in introducing about 4 grams of the oil into a weighed glass bulb placed in an iron sheath, the latter being immersed in a bath of molten metal at 550° C. Ten minutes after all fuming has ceased the bulb is removed, allowed to cool and re-weighed and the increase in weight expressed as a percentage of the original weight is taken as the coke number.

More recently, however, the coke test as a means of determining the carbon forming property of an oil has been considered to be less important than the *Oxidation Test*, whereby the tendency to form carbon after the oil has become oxidized is assessed. In this test 40 c.c. of the oil is maintained at 200° C. in a boiling-tube and air is blown through the oil at the rate of 15 litres per hour for a period of six hours on consecutive days. The viscosity of the "blown" oil is determined at 100° F. and the ratio of this viscosity to that of the original oil at the same temperature is taken as a measure of the oxidation tendency. This ratio for aircraft engine oils is about 2 : 1; in specifications the viscosity increase is stipulated not to

exceed 100 per cent. A *Coke Number* of the "blown" oil is also determined and compared with the value before blowing. For aircraft engine oils typical values are 0.65 and 1.65 respectively. In this connection the Air Ministry Specification D.T.D. No. 109, states that the coke number should not be greater than 0.70 and not increased to more than 1.70 by the oxidation test.

Engine oils are also given a *Cold Test* to ensure their suitability for use in engines operating at the lower temperatures experienced at the higher flying altitudes; in this respect temperatures down to -45°C . are occasionally experienced at the high altitudes reached by fighter machines. The cold test for mineral oils is a viscosity test. The oil which has previously been kept at room temperature for twelve hours is placed in a U-tube of 6 to 7 mm. diameter, with limbs 15 mm. apart and to a depth of 10 cm. in each limb. The tube is then heated to 80°C . in a water bath for five minutes, after which it is placed in a freezing mixture at the specified temperature. After twenty minutes air, at a pressure of 12 in. of water, is applied to one limb of the tube without removing the tube from the freezing mixture. It is specified that the rate of flow of the oil under this pressure shall not exceed 1 cm. during the first minute. The temperatures for the summer and winter grades of oil are -8°C . and -10°C ., according to the D.T.D. Specification No. 109.

Another test which is specified for aircraft engine oils is the *Acid Test* to ensure that mineral acids are absent from such oils, on account of their corrosive actions on the engine metals. The organic acidity of these oils is checked; this is usually low for mineral oils but greater for fatty oils.

In the case of *castor oils* used for aircraft engines these have a tendency to deposit solids known as "foots" if exposed to low temperatures for any length of time; such deposits may cause trouble by blocking the oil passages and filters. The method adopted in the case of castor oils for determining the cold test is to first warm a sample of the oil to 30°C . and allow it to cool to ordinary room temperature. It is then placed in a glass tube, 18 mm. in diameter, filled to a height of about 30 mm. The tube is sealed to exclude moisture and exposed to a temperature of -10°C . The oil (pharmaceutical quality) must remain quite clear for a period of four days and in the case of "treated" castor oil, for ten days.

Fuel Dilution of Engine Oil. Dilution of the engine oil by

the fuel occurs to a greater or lesser extent in petrol engines, depending upon the lubrication system employed and certain other factors. Among the latter are included the use of over-rich mixtures for starting and occasionally for normal running, the quality of the fuel and the mechanical state of the engine. Thus, with worn pistons or rings, mixture will leak past into the crankcase during the compression stroke and the fuel content thus dilutes the engine oil. Engines used for short periods of running are more prone to crankcase dilution

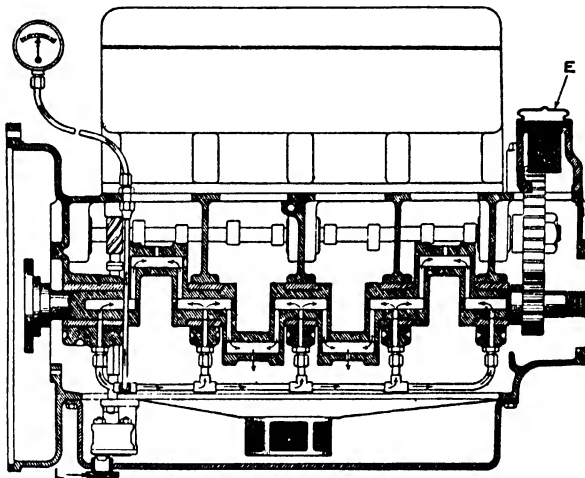

FIG. 245. The pressure-splash lubrication system. E denotes the oil filler with strainer. The pressure gauge is on the delivery side of the oil pump.

than otherwise; dilution is also worse under cold weather conditions.

Engines which employ the " splash " or " assisted-splash " method of lubrication are apt to suffer much more from the effects of fuel dilution than those operating upon the dry sump principle in which the oil is drained continuously from the crank-chamber.

In regard to the effects of fuel dilution, tests ⁵⁹ have shown that in the case of a medium heavy oil the viscosity of the oil is reduced by 10.7 per cent. for a 1 per cent. dilution with petrol; 27 per cent. for 2½ per cent. dilution; 64 per cent. by 10 per cent. dilution and 75 per cent. for 15 per cent. dilution.

In practice, however, a balancing point occurs at which the dilution is kept constant by evaporation of the petrol ; this very probably happens at low dilutions.

Lubrication Systems. Except in the cases of a few low-powered aircraft engines, the dry sump method of lubrication is now employed. In the former instances, which to some extent follow car engine practice, oil is supplied to the main and big end bearings at a pressure of 40 to 60 lbs. per sq. in. from an oil supply contained in a sump (Fig. 245). The cylinders and other working surfaces are lubricated by oil mist or spray from the oil escaping from the big end bearings. In

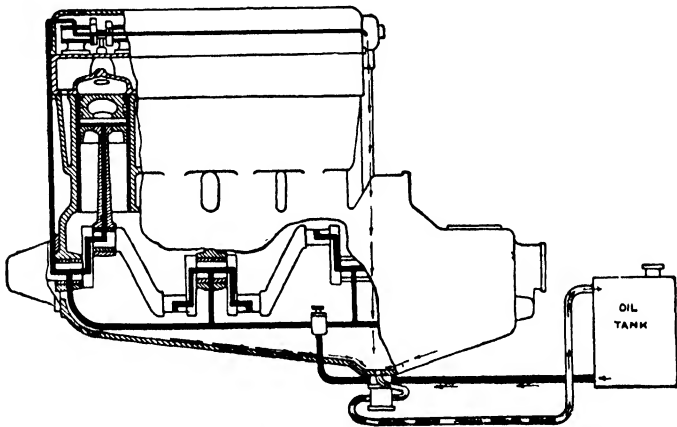

FIG. 246. The dry sump method of lubrication.

most cases a positive oil supply is provided for the overhead valve rocker mechanism.

The principle of the dry sump method is illustrated diagrammatically in Fig. 246. The oil for lubricating the engine is contained in an oil tank situated some way from the engine—behind the fireproof bulkhead as a rule—and is drawn from this tank by means of a single pressure pump, which delivers the oil under a pressure of 50 to 80 lbs. per sq. in. (according to the type of engine) to the hollow crankshaft, whence the oil escapes through suitably located holes, drilled through the main and big end journals to the bearings of these parts. It is usually arranged for the cylinder walls to be lubricated by jets of oil directed through holes in the lower ends of the connecting rods and upper bearing shells ; these holes coincide

with other holes drilled through the crank-pin such that once per revolution the oil under pressure escapes in the form of jets directed on to the lower parts of the cylinder barrels.

The escaping oil from the various bearings and other working surfaces drains down into a suitably located sump, whence it is constantly removed by means of one or more larger capacity low pressure pumps, termed *Scavenging Pumps*, and returned through an oil-cooling device to the oil tank. In this way no oil is allowed to remain in the engine crankcase, so that there is no possibility of lubrication difficulties occurring during evolutions of the aircraft. Apart from this advantage, the oil consumption is reduced to a minimum and the various working surfaces are lubricated efficiently. As mentioned previously, it is only the heavily loaded main and big end bearings which are lubricated at the higher pressures of 50 to 80 lbs. per sq. in. In some cases, however, oil pressures up to about 120 lbs. per sq. in. are employed in aircraft engines with heavily loaded bearings. The other more lightly loaded bearings are fed positively with oil at a low pressure, namely, about 4 to 8 lbs. per sq. in. A suitably arranged pressure reducing valve is usually employed for this purpose. With the dry sump method it is not necessary to carry such a big supply of oil as in the wet sump system. The space thus saved enables the crankcase to be made of smaller dimensions. In regard to the pumps employed for aircraft engines in this country, these are invariably of the meshed gear pattern employed on automobile engines.

The total pumping capacity of the scavenge pump or pumps is usually about 30 to 50 per cent. greater than that of the pressure pump. In some engine types, notably the "in-line" ones, two sumps are sometimes employed, in which case two scavenge pumps—driven off the same shaft—are fitted. Since the *temperature* of the lubricating oil within the engine must be kept down to a certain limiting value in order to maintain the viscosity sufficiently high to ensure fluid lubrication under all working conditions, the oil-cooling system is designed to ensure these results. In this connection it is usual to limit the outlet (or scavenge pump suction) temperature to 95° to 100° C. The return oil temperature should not be more than 70° C. for maximum power and 60° to 65° C. for normal power outputs. Apart from the necessity of maintaining a sufficiently high viscosity in the engine lubricant, there is also the question of

cooling the big end bearings so that a low oil temperature is essential.

In connection with the subject of *oil pressures*, these should be no higher than is necessary to ensure fluid lubrication of the bearings under maximum power conditions. Excessive oil pressures are not only a source of additional power loss in the pump, but introduce difficulties in regard to oil leakages in the high pressure system.

Similarly, in regard to *oil quantity*, high rates of oil circulation signify loss of power in the pump operation and unnecessary cooling of surfaces within the engine which are relatively

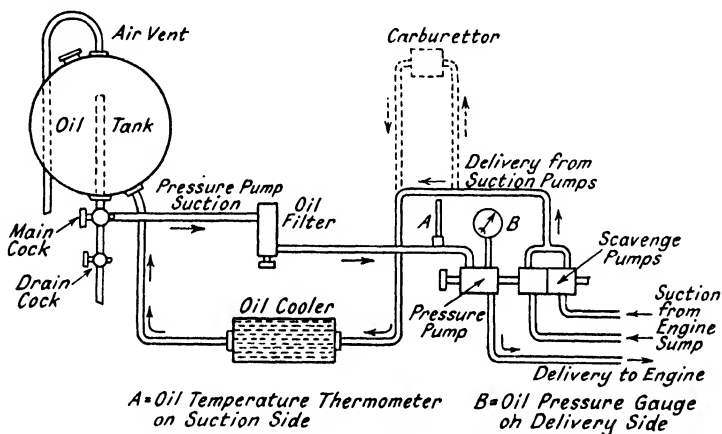

FIG. 247. Typical lay-out of aircraft engine dry sump lubrication system.

unimportant; the oil may thus become overheated and necessitate larger oil coolers.

The rates of oil circulation vary appreciably according to the type and power output of the engine. An average value for a 500 B.H.P. engine is 70 to 100 gallons per hour, but the pressure pump usually provides for a greater rate. With wet sump lubrication a higher rate of oil circulation is usual than for the dry sump method.

In regard to *oil consumption*, with a well-designed dry sump system a high-powered liquid-cooled engine should use only about 0.01 to 0.02 lb. per B.H.P. hour, the higher value corresponding to full power output; air-cooled engines usually show somewhat higher outputs.*

* Vide page 423 for test consumptions.

The oil pumps used for the high pressure supply are fitted with relief valves to ensure that the maximum oil pressures decided upon are not exceeded; without these valves there would be a risk of burst oil pipes and galleries and unnecessary power absorption in the pump.

Oil Filters. The used engine oil which drains into the crankcase sump contains fine carbon and metallic particles, which, if left in the oil, would cause a relatively rapid wear of the bearings, so that it is essential to remove this solid matter from the oil before it enters the engine again. In addition to the fine and coarse filters of the metallic wire gauze variety used on the suction sides of the pumps, it is necessary to fit a special filter in the oil system to deal with the finer particles which pass through the gauze filters. These oil filters or cleaners are often of the felt element type, consisting of a cylindrical container with a hollow star-section felt filter inside. The dirty oil passes through the felt from the outside to the inside depositing its solid content in the felt; the cleaned oil is taken away from the upper end of the central hollow felt element part. It is necessary to clean the felt element at regular intervals, in a petrol bath, but in most instances it is considered advisable to renew the felt element after a certain period of engine operation.

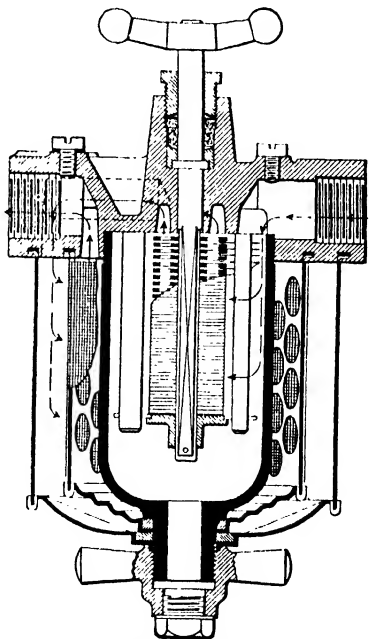

FIG. 248. The Autoclean type of filter.

Another type of oil filter used on aircraft engines is the Autoclean self-cleaning one (Fig. 248). The dirty oil is led to the annular space between the inside surface of the outer vertical cylindrical container and the Monel metal fine mesh gauze cloth cylinder within, which is carried in a perforated metal cage. This gauze element removes the larger dirt particles. The oil then passes between a series of thin metal

discs arranged axially one above the other. The clearances between these discs are very small, but the total surface of entry for the oil is sufficiently great to prevent appreciable resistance to the oil flow. The finer particles are trapped between the plates and the cleaned oil passes upwards through holes in the plates to the oil outlet above. The plates are cleaned by rotating the handle seen above the filter in Fig. 248, and the solid matter then falls to the bottom of the central chamber, whence it is removed periodically through an orifice having a handle operated plug. The filter will also deal with any water in the oil. The Monel metal gauze filter will operate for at least 2,000 hours before it is necessary to remove it for cleaning.

An improved pattern filter working on the Autoklean principle, known as the Cuno filter (Fig. 249), is now used as standard on Wright "Cyclone" and other radial engines of the same manufacturers. Any lint, carbon or gummy residue is retained by the edges of the discs. Coupled with the filtration discs is a series of cleaner discs which exercise a combing action when rotated, thus cleaning each individual filter disc. Instead of turning the cleaner disc unit by hand at regular intervals, as in the ordinary plate type of filter, this operation is performed automatically by means of a compact oil-driven motor which rotates the cleaning disc assembly slowly but continuously whilst the engine is running. The Cuno filter is about 9 in. high and the upper hexagonal casing containing the actuating oil motor is 3 in. across and 2 in. deep. The driving pressure for this motor is obtained from the differential pressure between the discharge and suction sides of the pressure pump; the reciprocating motion of a piston in the motor cylinder is converted to rotary motion for turning the cleaner element. The piston gives a rocking movement to a simple bell-crank which, in turn, oscillates a clutch ring having a one-way roller ratchet-and-pawl action which causes movement of the cleaner element in one direction only. The filter has a capacity of 1 quart and requires a pressure difference of 25 lbs. per sq. in. to operate its oil motor. With this type it is only necessary to remove the sediment plug below after relatively long intervals.

Sludge Traps. Apart from the use of oil filters of the cotton, felt or multiple disc pattern for removing the sludge from lubricating oil, use is sometimes made of the centrifugal principle whereby the dirty oil is swirled within the crankshaft

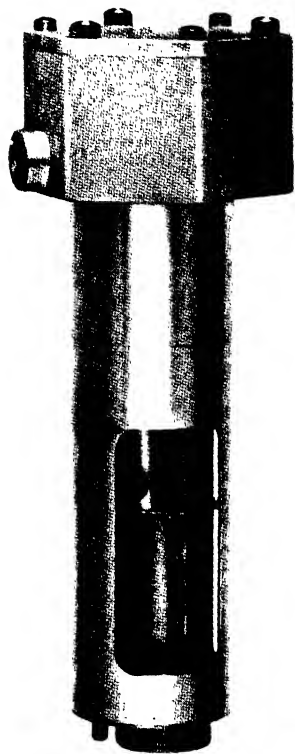

FIG. 249. The Cuno self-cleaning oil filter used in Wright engines

or inside the recessed flywheel rim, so that the heavier solid matter forming the sludge is centrifuged outwards into suitable recesses or "traps"; when the engine is given a complete overhaul this sludge can readily be removed.

Fig. 250 illustrates a typical example of a sludge trap in the case of a master connecting rod bearing of a radial engine. It consists of a tube extending from the centre of the crankpin to the surface of the latter where the oil is discharged. The solid matter in the oil is thus thrown outwards by centrifugal action, and this sludge collects on the inside of the hollow crankpin; it cannot reach the bearing of the latter since the oil supply for this is taken through the central tube shown. The collected sludge is removed from the inside of crankpin when the engine is overhauled.

Mention should here be made of a combined oil cleaner and cooler for aircraft engines devised by B. C. Carter,⁶⁰ in which the used engine oil is led to a rotor within the cooler casing, thereby causing the rotor to turn at a high speed by the reaction of the issuing oil and air from jets situated in the rotor. The solid matter is centrifuged and collects in a series

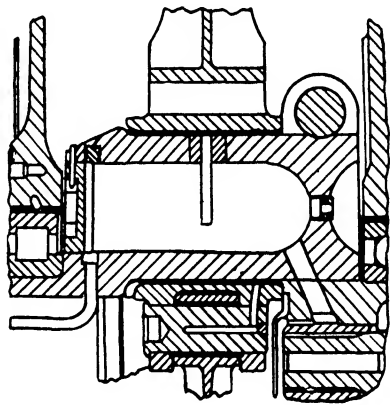

FIG. 250. Sludge trap in crankpin master rod bearing of radial engine.

of annular trays within the rotor, where it can readily be extracted by a special device provided for the purpose. The oil passing through the rotor issues in jets and is sprayed upon the inner surface of a large domed cooling element, the outer surface of which is placed in the airscrew slipstream.

Oil Coolers. The oil after passage through the engine is cooled by passing it through a special design of cooler, based upon the same principle as the engine cooling fluid radiator. This is placed in the relative air stream or in a special cooling duct and the surplus heat is extracted from the oil outside the radiator tubes—in the honeycomb type of cooler—by the air flowing through the inside of these tubes.

Although it is possible to compute the capacity or size of an

oil cooler for any given engine and type of aircraft, there are several factors of uncertainty, which generally necessitate the final fixing of sizes by experimental methods.

It has been shown that the heat transmitted to the lubricating oil is equivalent to 2 to 5 per cent. of the engine B.H.P., and on this basis, knowing the aircraft's climbing and maximum speeds and the permissible temperature rise and rate of circulation of the oil some idea of the approximate size of oil cooler can be obtained. The unknown factors in such an estimate include the cooling effect of the engine crankcase and other surfaces with which the oil is in contact before draining to the sump; the situation of the crankcase relatively to the cooling air stream; whether the cooler is in or out of the airscrew's slipstream; whether ducted or whether the engine is geared down at the airscrew—in which case a somewhat larger oil cooler will be required. Similarly, if the engine has a close cowling this will result in less internal cooling and therefore a larger capacity external oil cooler.

The rate of heat dissipated, expressed in horse power, for oil of specific heat k , a mass flow of W lbs. per hour and with inlet and outlet temperatures of T_1 and T_2 °C., respectively, is given by the following relation:—

$$\text{H.P.} = \frac{kW(T_1 - T_2)}{1410}$$

If the oil has a density s , then if the mass flow in gallons per hour, G , be considered.

$$\text{H.P.} = \frac{ksG(T_1 - T_2)}{141}$$

An average value for $ks = 0.475$. It is convenient to remember that at 300 galls. per hour, each degree Centigrade change of temperature represents 1 h.p. dissipated.

The subject of oil cooling for aircraft is dealt with in an Aeronautical Research Committee publication,⁶⁰ which gives the results of an investigation and a certain amount of experimental data obtained from typical oil coolers.

The publication in question contains a quantitative analysis of the rate of transference of heat from the oil to metal and metal to air and gives a graph showing the characteristics of oil coolers as regards heat transference, together with estimates of the thickness of virtual laminar layers of oil, in contact with the metal surfaces of coolers, through which the heat passes by conduction alone; the transference of heat from a

fluid in laminar motion is also dealt with in an appendix. The general conclusions of these investigations are summarized as follows :—

To predict the performance of a cooler proposed for any given conditions it is necessary to estimate the values of the heat transfer coefficients that will obtain for oil to metal and for metal to air. Much of the relevant information is given in the Report's figures and tables. Particular reference is made to a series of graphs given in the Report, which reveal how the cooling per square foot and the efficiency of the coolers depend upon the heat transfer coefficients. The type of oil cooler most suitable for any particular application depends

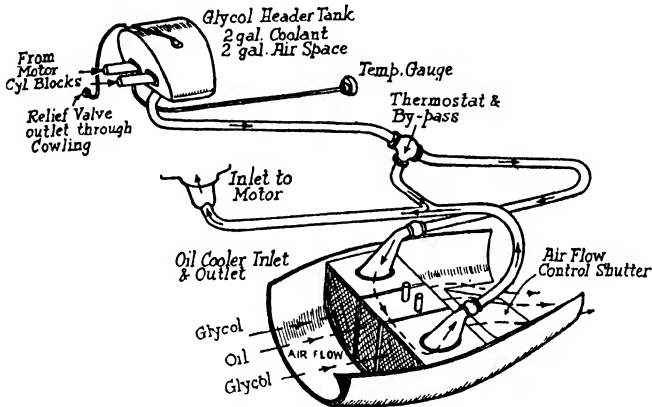

FIG. 251. Oil- and liquid-cooling system of Hawker "Hurricane" (The Aeroplane).

upon many considerations. It is stated that quantities are involved, however, which often cannot be predicted with precision, and fundamental information is lacking, more particularly in respect of drag and heat transfer coefficients for oil coolers which project into the relative wind.

In general, *lubricating oils are much more difficult to cool than water*, and one problem of oil coolers is that of the cold oil when the engine is first started up. Thus, if small tubes are used these may become blocked with the viscous cold oil and unless pressure relief valves are fitted the cooler may fracture. On the other hand, if the tubes are too large, the central portions of the oil stream will not be able to cool down. To overcome this difficulty it is desirable to provide

some means of regulating the cooling and to ensure, by means of baffles that they come into contact with the cooling surface ; these baffles, for tubular coolers of the inside oil flow pattern, take the form of thin strips of metal twisted spirally. For the outside oil flow type of cooling tube the baffles are usually arranged as intermediate tube plates.

In regard to *the performance of oil coolers*, it should be remembered that if designed for clean oil circulation, the cooler will lose part of its cooling efficiency when the oil becomes oxidized and any deposition of fine sludge will cause a reduction of the cooling effect, so that the capacity of the cooler should

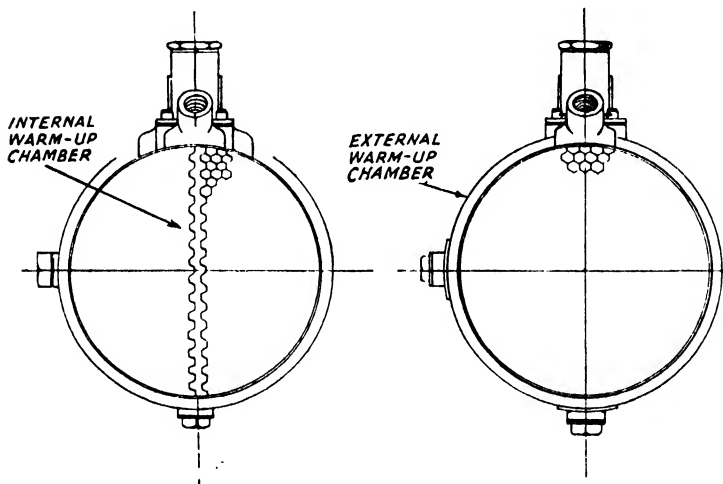

FIG. 252. Oil temperature regulation schemes.

be about 30 to 40 per cent. greater than for new oil alone. In the construction of oil coolers of the soldered joint patterns, the use of ordinary solders is not always advisable on account of the high temperatures which may occur ; for this reason silver-soldered joints are frequently used.

In connection with *the design of oil coolers* it is necessary to make provision against the oil becoming too cool, or even frozen. Various methods have been employed for this purpose. One such method, incorporated in oil coolers used on certain British aircraft, contains a self-regulating unit whereby when the oil temperature falls below a certain value the oil is by-passed round the jacket of the cooler so as to keep the core at

a higher temperature. The control can be effected by the pressure, temperature or viscosity of the oil.

Fig. 252 (*right*)⁶¹ shows this method of regulating the oil temperature, whilst an alternative scheme for an internal warm-up chamber is shown in the left-hand diagram. In each case the core is arranged in sections so that the oil traverses it several times.

An important item in regard to the design and operation of oil coolers is the *effect of entrapped air* in the system due principally to the action of the oil scavenge pump taking in air with the crankcase oil. This results in emulsification and

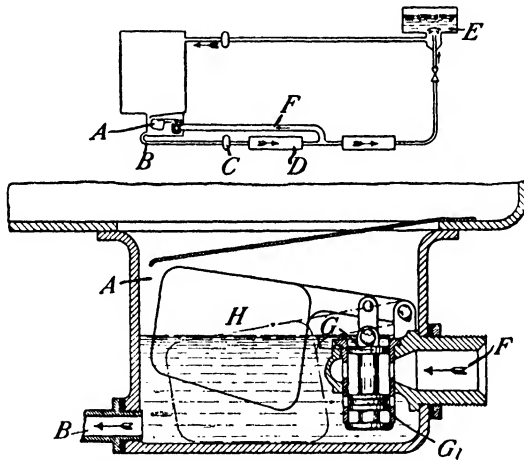

FIG. 253. Method of preventing frothing of the engine oil.

consequent increase in volume of the product so that the oil tank may overflow, with the result that oil will be lost. Means should therefore be provided to prevent excessive back pressure which may retard the escape of the air.

A method of preventing aeration and associated frothing of the oil in an aircraft engine lubrication system, due to B. C. Carter,⁶² is illustrated in Fig. 253. In this system the oil level in the sump is kept sufficiently low to obviate over-lubrication of the engine. A main oil sump is provided with a small auxiliary oil sump A having an outlet B to a scavenge pump C. Oil is drawn by the scavenge pump from the sump and passes through a filter D, after which it is passed through a cooler and into a reservoir tank E, from which it is pumped into the

engine. Oil is by-passed through a pipe F from the delivery side of the scavenge pump to the sump. The rate of flow through the by-pass pipe is controlled by the oil level in the sump by a float-controlled piston valve to maintain the oil level in the sump sufficiently above the level of the outlet pipe B to exclude air being taken in by the scavenge pump. The valve consists of two parts, G and G_1 in a ported cylinder. The piston G_1 acts as the movable valve member to cover and uncover outlet ports in the cylinder, while G serves as the balancing piston. The incoming oil flows through an annular duct and inlet ports into the body of the valve and through the outlet ports into the sump when the ports are uncovered by the piston G_1 . Upward movement of the valve is limited by a stop. The upper end of the valve stem is extended to a link which is coupled to a lever connected at one end to a float H. The other end of the lever is pivoted to a fulcrum. Any slight deviation in the oil level in the sump from a mean position causes the piston valve under the action of the float to regulate the amount of opening of the outlet ports and thereby modifies the rate of flow of the by-pass oil to the sump until the mean oil level has been restored.

The group of oil coolers in which the oil is not sprayed includes a relatively large number of examples, typical instances of which are the Gloster, Supermarine, Boulton and Paul (Sidstrand), Stanton "Vortex," Vickers-Potts and Bristol. It is not possible, under present space limitation conditions to describe all of these, so that only certain typical ones will be considered. For information concerning the other types and performance data relative to some of these the reader is referred to the publication given in Reference No. 60.

Fig. 254 illustrates the Vickers-Potts oil cooler, which consists of hollow fins threaded in two tubes, in which the oil flows through each fin or element in turn, *i.e.*, in series; in this design any number of cooling elements can be added as required. A by-pass valve, normally set at about 15 lbs. per sq. in., is fitted between the inlet and outlet pipes to provide an alternate path and thus prevent excessive pressure during cold starting conditions. In this arrangement the oil is exposed in thin layers to the cooled walls of the fins; the oil flow is given a certain amount of turbulence by means of the stays through the fins. It will be noted that the space between the fins is increased by local flattening to give increased freedom for the air flow and at the same time to reduce the wind resist-

ance. Each fin element provides about one square foot and the usual number of elements are 5, 7, 9 and 14; the 5-element cooler is satisfactory for an engine of 450 B.H.P. and it weighs about 10 lbs. empty.

An 11-element cooler, weighing 17.6 lbs. empty and 24.5 lbs. full, was tested in flight on a 684 B.H.P. Rolls Royce "Condor" engine, with an oil flow of 460 galls. per hour. At 15,000 ft.

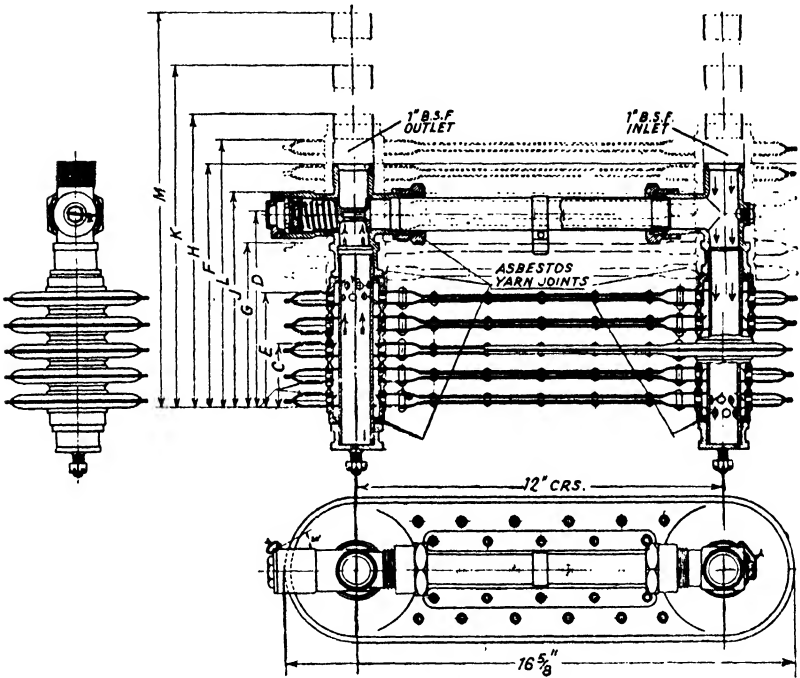

FIG. 254. The Vickers-Potts oil cooler.
 [R. and M. Report No. 1486. Courtesy Air Ministry.]

with 80° C. mean temperature difference between the oil and the atmospheric air the rate of heat dissipation was 14.4 h.p., corresponding to about 2.1 per cent. of the engine output for a climbing speed of 67 M.P.H.

The Bristol type of oil cooler illustrated in Fig. 255 consists of a cylindrical container through which the air tubes pass longitudinally. The number and size of the tubes can be varied to suit the engine output, cooling air speed and other governing factors. The type illustrated is for fast aircraft and

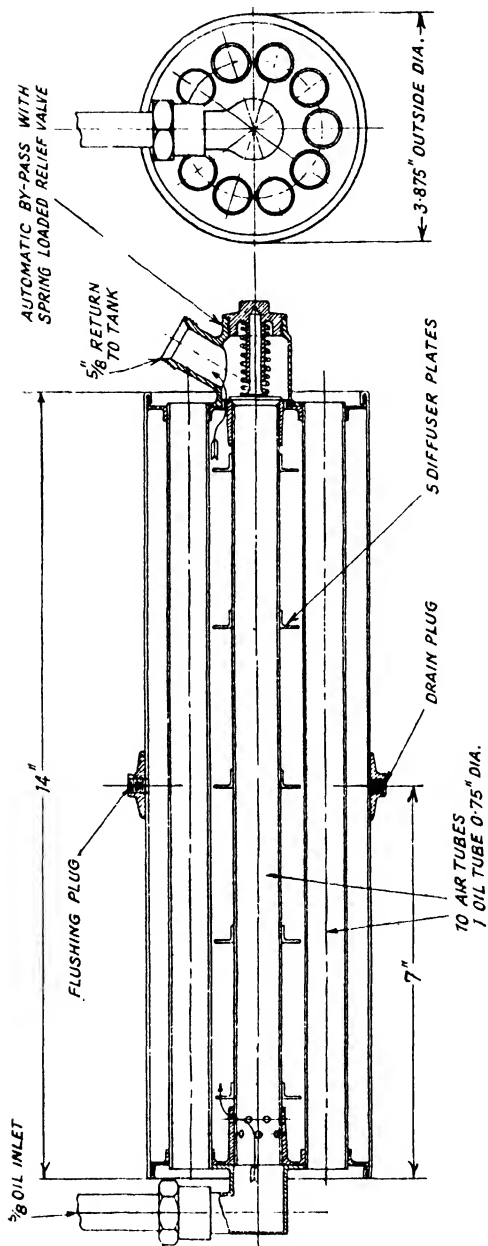

FIG. 255. The Bristol oil cooler. [R. and M. No. 1486. Courtesy the Air Ministry.]

has ten tubes of 28 S.W.G. copper and weighs 3 lbs. empty and 6 lbs. full. It is designed for a temperature drop of about 30° C. across the cooler. The cooler is self-regulating by means of a by-pass valve, which serves also as a safety valve.

The Robertson oil cooler shown in Fig. 256 has flattened aluminium tube elements, usually of 0.015 in. thickness. It

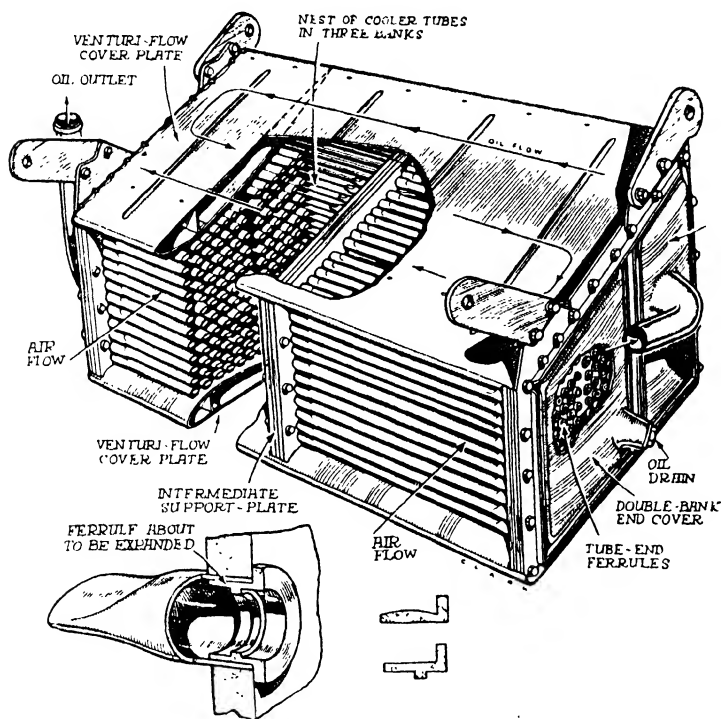

FIG. 256. The Robertson oil cooler, showing below (left) details of ferrule joint for the tubes.

[The Aeroplane.

has particularly free air passages and is provided with a by pass valve for cold starting. This type, which has been used in British machines, can be arranged in an air duct for low velocity flow, so that the drag can be reduced to small proportions. As shown in Fig. 256, the tubes are secured to the tube plates by special ferrules. The oil flows through the cooler several times, the actual number of such flows being

selected to suit the required cooling results. The weight of cooler for a 550-h.p. engine is about 10 lbs.

This type of cooler may be used for the dual purpose of oil cooling and air heating—for warming the carburettor intake supply or the cabin of an aircraft.

The Serck and John Marston (R.A.E. single and double cooler element) types of oil cooler are of the honeycomb pattern and are well adapted to the requirements of modern fast aircraft ; more particularly to the duct method of cooling.

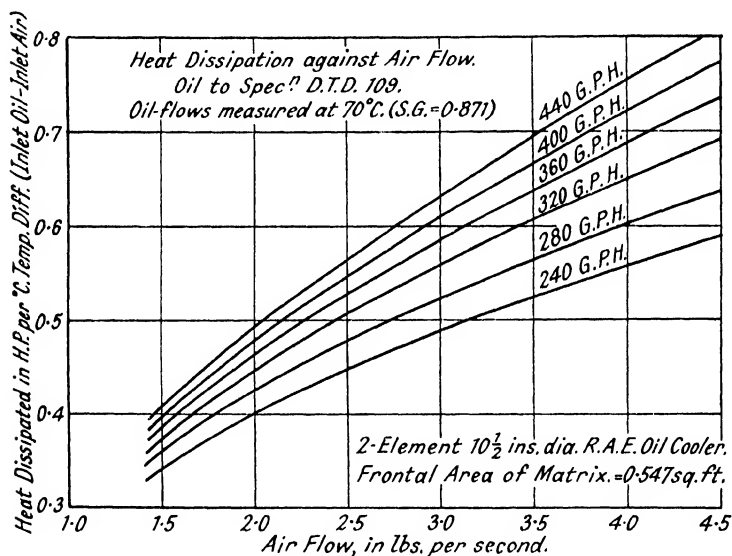

FIG. 257. Performance graphs for R.A.E. oil cooler. (J. Marston Ltd.).

The R.A.E. Oil Cooler. This cooler has been designed for use in a ducted system and it is intended to operate on small air flow ; efficient cooling is thus obtained for a small power consumption. The extraction of large quantities of heat by small air flow gives considerable rise in air temperature, and thus provides a supply of hot air suitable for cabin heating or similar purposes. The cooler consists of two or more elements arranged in line so that the hot oil enters the rear element and the cooled oil is delivered by the front element. The valve setting in the front element is relatively heavy, so that this element is normally in full action : the valve on the rear

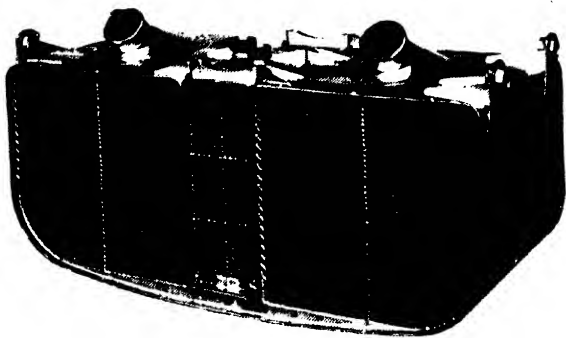

FIG. 258. The Serck combined radiator and oil cooler, incorporating also carburettor warm air intake.

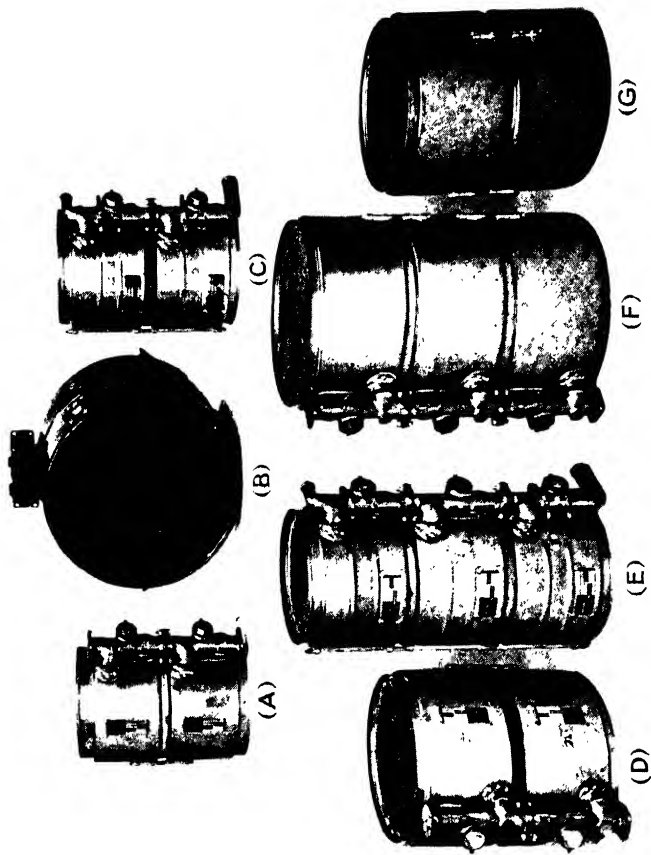

FIG. 260. R.A.E. oil coolers (made by John Marston Ltd., Wolverhampton). A, two element, 8 in. diam.; B, two element, 14 in. diam.; C, two element, $8\frac{1}{2}$ in. diam.; D, two element, $10\frac{1}{2}$ in. diam.; E, three element, $8\frac{1}{2}$ in. diam.; F, three element, 12 in. diam.; G, two element, $10\frac{1}{2}$ in. diam. *Note.* All of the coolers shown are fitted with 1.40 x 5 mm. tubes.

[To face p. 307.

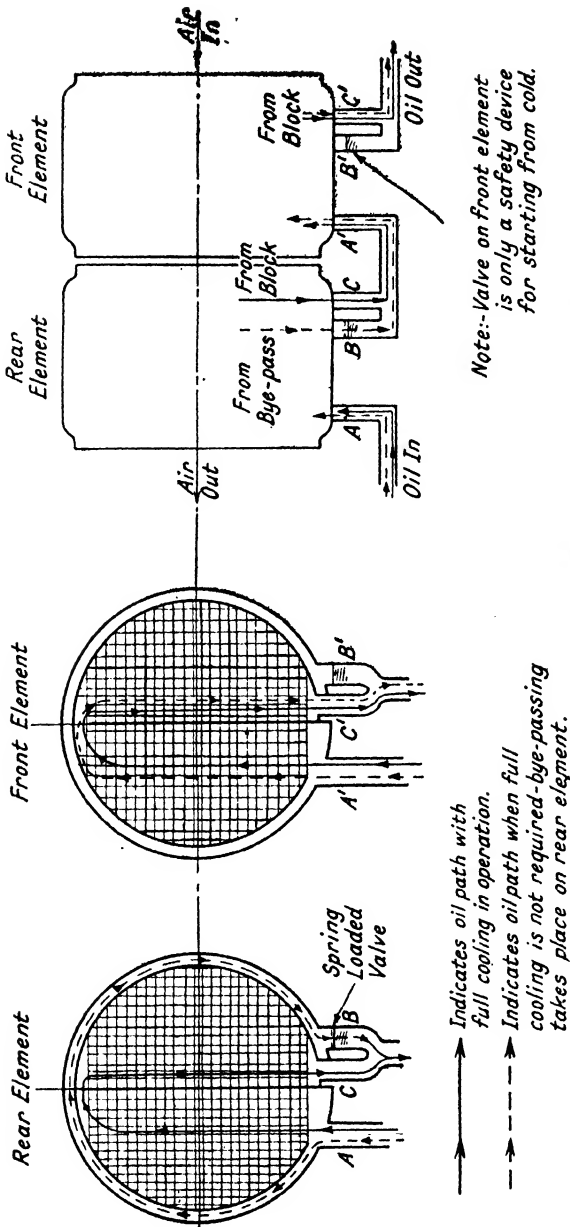

FIG. 259. Diagrams showing operation of Marston R.A.E. type oil cooler.

element is closed by a lighter spring. The combination of cross flow in the component elements with contra flow of the air and oil in the assembled cooler promotes the efficiency of the cooling and enables close regulation of oil temperature to be obtained with a minimum loss of oil pressure.

An important feature of this cooler is the dual provision against freezing or choking: this is given by the jackets around the honeycomb block, and by the pre-heated air employed in the second element.

The jacket ensures circulation in a portion of the honeycomb tube block under all conditions, while the construction of the honeycomb promotes rapid growth of the oil stream width, as the by-pass valves close when more cooling is required and the pre-heated air prevents undue chilling of the oil in the relatively inactive portion of the rear tube block. By these means the changes of air speed as between climbing and level flight conditions result in rapid and positive response of the cooler to the requirements of the engine; thus ample cooling is given at full throttle and overcooling is avoided in cruising flight or diving.

Special attention is given to the construction of the coolers. The materials used are not subject to corrosion under the most severe conditions. The coolers are tested to a pressure of 150 lbs. per sq. in. and a temperature of 150° C.

Where cabin heating is required the heater can be made in three elements.

The Gally dual stage oil cooler also employs an improved honeycomb type of radiator block, combining the advantages of the film and tubular patterns; it gives maximum cooling capacity, low air resistance and is of light weight per h.p. The method of construction of these coolers, and of liquid-cooled engine radiators is illustrated in Figs. 261 and 262. The cooler or radiator may be built of double or triple tube units with two and three orifices, respectively.

In the case of the dual cooler the oil can circulate continuously through the larger diameter tubes of the front portion, constituting the *first stage*; the heated air passing through the first stage maintains the temperature of the *second stage* sufficiently to prevent over-cooling. Immediately the oil temperature rises both stages of the cooler are in operation. With this design of cooler the difficulties associated in regard to over-cooling and congealing during diving or gliding operations from high altitudes—and consequent low temperature conditions—have been overcome. A special

feature of this cooler is its relatively high strength which enables pressures up to 500 lbs. per sq. in. to be employed if necessary. In regard to the construction of the cooler, copper, steel or cupro-nickel can be employed as desired.

In connection with the more recent tendency in high speed aircraft engines to combine the liquid cooling radiator with the oil cooler as a single unit, relatively long cooling tubes are used; the ratio of length to diameter of tube in such cases ranges from about 44 : 1 to 50 : 1.

The Oil Tank. This should be of light alloy sheet construction and have a rather greater capacity than that equivalent to the full endurance capacity, namely, about two to four hours more. It should also allow an air space above the oil

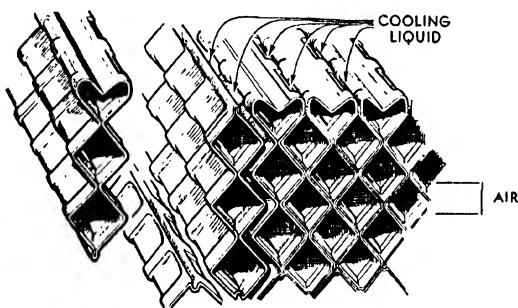

FIG. 261. Illustrating method of construction of Galley radiator for liquid-cooled engines and oil coolers.

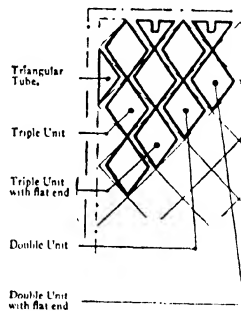

FIG. 262. Detail of Galley radiator illustrating method of construction.

with a vent pipe open to the external air to obviate any pressure effects within the tank. The latter should be located at a height not less than 18 in. above the suction position of the pressure pump. Arrangements should be provided to shut off the oil supply to this pump, namely, by means of a cock and a suitable device provided for shutting this tap when the engine stops working; this is usually accomplished by inter-connecting the main oil cock with the petrol tank cock, or the magneto earthing switch. Alternatively, a non-return valve of the lightly-loaded spring type may be fitted on the pressure pump delivery side and the spring tension adjusted so that the head of oil in the tank is just unable to open the valve. The annealed copper oil piping used should be of wide bore and able to withstand an internal pressure, continuously, 50 per cent. higher than the maximum oil pressure.

Lubrication of the Valve Mechanism. The valve-operating mechanism of most of the four-cycle and C.I. engines employed on aircraft is of the overhead pattern employing either push-rods and rocker arms, or overhead camshafts—in the case of Vee-type engines.

In the earlier designs of aircraft engines of the radial and opposed-cylinder types the ball ends of the push rods, in contact with the cup fittings on the rocker arms were lubricated by

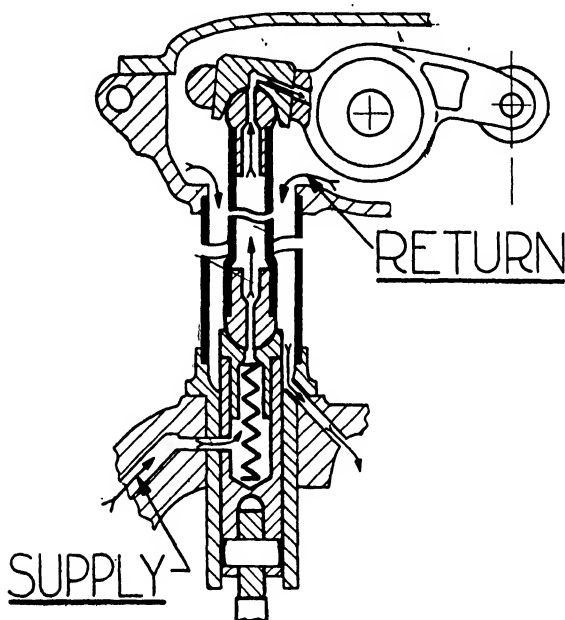

FIG. 263. Valve gear lubrication method used on Wright "Cyclone" engines.

grease gun application but in modern engines the valve-operating gear is enclosed and lubricated automatically from low pressure oil supply.

A common arrangement is to enclose the hollow push-rod in a tubular casing made with an oil-tight joint at the tappet end; the upper end of this casing makes another oil-tight joint with the rocker gear enclosing casing. Oil from the low-pressure supply enters from an oil gallery through a hole drilled in the side of the hollow tappet and flows through the hollow push-rod to the ball-end joint at the top, whence it is

led by means of an oil passage drilled through the rocker arm to the bearing of the latter. The oil after leaving the bearing is returned through the passage formed between the outside of the push-rod and inside of the tubular casing to a sump which is drained by the scavenge pump. In radial engines this sump is located between the bottom cylinders, *i.e.*, at the lowest part of the engine.

Fig. 263 illustrates the method of valve lubrication of the

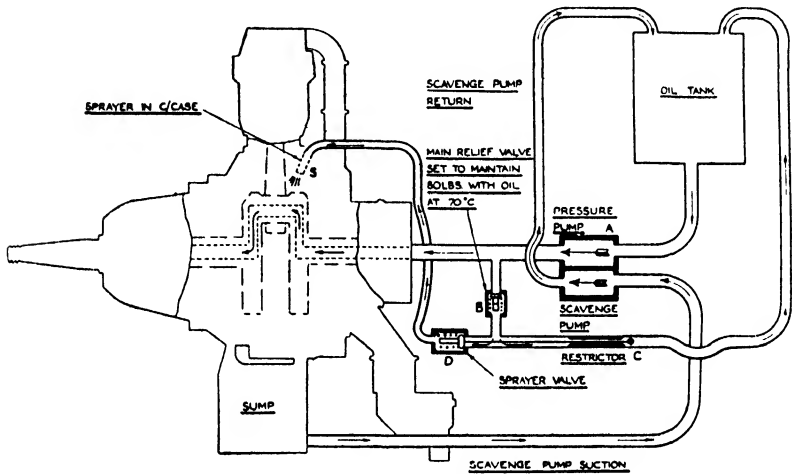

FIG. 264. The Bristol high initial oil pressure system.

Wright "Cyclone" engine, which is based upon the principle just described.

Other methods of valve mechanism lubrication have been described in Chapters III and IV.

High Initial Oil Pressure System. It is well known that air-cooled engines require much less time to warm up than liquid-cooled ones, so that such engines will develop their full power more quickly. In order to reduce still further this warming-up period the Bristol radial engines now employ a high initial oil pressure system such that they can develop almost full power as soon as they are started from the cold; this system is standardized on the "Mercury" and "Pegasus" engines.

Referring to Fig. 264, which shows the principle, under normal conditions the oil enters the engine from the pressure pump (A) through the tail end of the crankshaft. The main relief valve

(B) is set to maintain the oil pressure at 80 lbs./sq. in. (5.62 kgs./sq. cm.) with the oil at 70° C. The by-passed oil from this valve is returned under its own pressure to the oil tank, together with the oil from the scavenge pump.

A restrictor (C) of suitable size is fitted between the main relief valve (B) and the return pipe line to the oil tank. This restrictor is so constructed that it will allow normal circulation of by-passed oil at a reasonable pressure. When the oil is cold, however, the increased viscosity and quantity of the oil by-passed by the relief valve cause the restrictor to create a higher pressure. The resulting high oil pressure in the tail end of the crankshaft ensures an adequate supply of oil to all bearings, especially the big end bearing, which under normal pressure and high viscosity would not receive a sufficient flow. The increased pressure created by the restrictor also opens valve (D) which is connected to a sprayer (S) fitted in the top of the crankcase. This sprayer supplies splash oil abundantly to the pistons as long as the flow of cold oil from the big end is insufficient to lubricate them under full power conditions.

Immediately the oil becomes warm and its viscosity decreases, the pressure created by the restrictor is automatically reduced, the sprayer valve shuts and the auxiliary supply is cut off.

In actual practice the sprayer valve and restrictor are combined in the form of a sleeve valve which permits the quantity of oil circulated through the sprayer to be governed; also the temperature at which the sprayer is cut out automatically.

The system described is entirely automatic in operation.

Oil Dilution by Fuel for Starting. A method which has been employed in Canada and the U.S.A. for starting engines under low temperature conditions consists in reducing the viscosity of the oil by the addition of petrol or fuel. This oil dilution has been effected in the case of certain American Army aircraft engines prior to stopping the engines and has been found to be a satisfactory method, enabling the engines to be cranked over freely when exposed to sub-zero temperatures for long periods. Moreover, it is claimed that the system provides proper lubrication immediately after cold starting and greatly reduces the warming-up period.

The Worth oil dilution system, now used on some Canadian aircraft, is shown schematically in Fig. 265, and has been tested thoroughly under various climatic lower temperature conditions with satisfactory results. It includes an oil tank having

another tank or hopper of about $1\frac{1}{2}$ galls. capacity inside. The oil circulating through the engine is kept from the main supply which surrounds the hopper; as the oil in the latter is used up it is replenished from the main supply through orifices in the bottom of the hopper. The upper end of the latter is open and in communication with the expansion space of the main tank. The return oil from the engine goes either through or by-passes an oil cooler, after which it enters the upper end of the hopper in a downward spiral path; this helps to separate air from the scavenged oil. From the lower end of the hopper oil is led by piping through a special cock to the engine. This

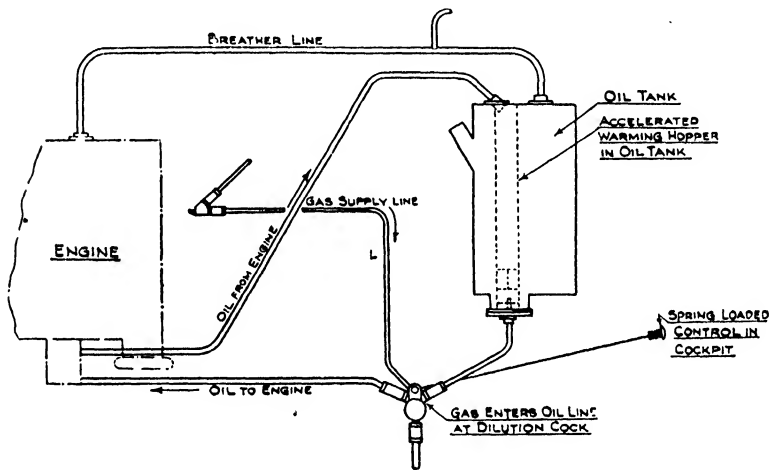

FIG 265. Oil dilution by fuel for starting purposes.

cock is so arranged that when it is turned into one position petrol will flow from the main supply or a separate tank so as to dilute the oil entering the engine. A shut-off valve, operated by the pilot, enables the latter to hold the petrol metering valve in the special cock open for the necessary period to dilute the oil; when this valve is released by the pilot it is shut off automatically. In ordinary circumstances about four minutes is required to effect the proper degree of oil dilution. As the heat from the engine distils the petrol from the oil as it circulates, it is necessary to extend the engine breather beyond the engine cowl line and away from the exhaust manifold; the distillation is largely completed within ten minutes of starting. Tests⁴³ carried out on engines

installed in aircraft of Canadian Airways throughout a whole winter, when temperatures of -44°F . were experienced are stated to have proved thoroughly the claims of this oil dilution system for easy cold starting and efficient lubrication.

In connection with this system a special solenoid-operated oil dilution valve has been developed by the Aeronautical Manufacturing Co., of Buffalo, N.Y., to enable the operator to dilute the oil by closing an electric switch which causes the current to energize a solenoid which then opens the fuel valve; when the current is switched off a spring returns the valve on to its seating.

Typical Lubricating Systems. The principle of a simple pressure lubricating system, whereby the main and big end bearings are lubricated by high-pressure oil, whilst the camshaft and timing gears, the cylinder walls and pistons are lubricated by oil mist or splash, is illustrated in Fig. 245. In this method which has been employed on low-powered aircraft engines the oil, after lubricating the engine parts, drains back into an inclined chamber below the camshaft, whence it passes through a large wire gauze filter into the lower sump. The oil pump driven by helical gearing through a vertical shaft (shown on the left-hand side) is of the submerged pattern and draws its oil supply from the sump. A pressure gauge and an oil pressure relief valve are situated on the delivery side of the pump. The oil filler, with gauze filter, is shown at E. Whilst of relatively simple layout this system makes no provision for oil cooling; further, it is not suitable for the engines of aircraft designed for steep dives, banks or aerobatics.

The Gipsy Inverted Six engine uses the dry sump method in which one pressure pump supplies oil at 40 to 45 lbs. per sq. in. to the main and big end bearings by way of a cast-in passage, in the top cover, which leads to the main bearings. The oil is drawn from a separate tank through a coarse gauze filter and delivers the pressure supply by adjustable pressure relief valve to an Autoklean filter. The oil leaves the big end bearings and caps through holes drilled in these components so as to splash lubricate the cylinder walls; the cams and tappets are lubricated by splash, also. Another supply of oil at a pressure adjusted by a balanced piston valve to 15 lbs. per sq. in. lubricates the camshaft bearings and accessory drives. Two scavenge pumps, each with a detachable fine-mesh gauze filter on its suction side draw the used oil from each end of the crankcase; there are no external oil pipes.

The *Gipsy Inverted Twelve* engine utilizes the same method of lubrication, the following being a detailed description of the system. The main oil sump carries the pressure and two scavenge pumps and the two scavenge oil filters; also one pressure and one suction filter. A long auxiliary felt pressure filter in which is incorporated a pressure relief valve is bolted on to the oil sump. The filters are accessible for cleaning by removing hexagonal caps; the cleaning periods are 250 hours. The main pressure filter is of the Auto-klean pattern, and is cleaned by turning a tommy bar fitted for this purpose.

The oil delivered by the pressure pump, after passing through the Auto-klean filter then passes through the auxiliary filter, and thence to the engine as follows: By means of a relief valve and with the aid of shims the main oil pressure is adjusted to 60 lbs. per sq. in. After passing through the pressure filter the oil divides into two streams. The main

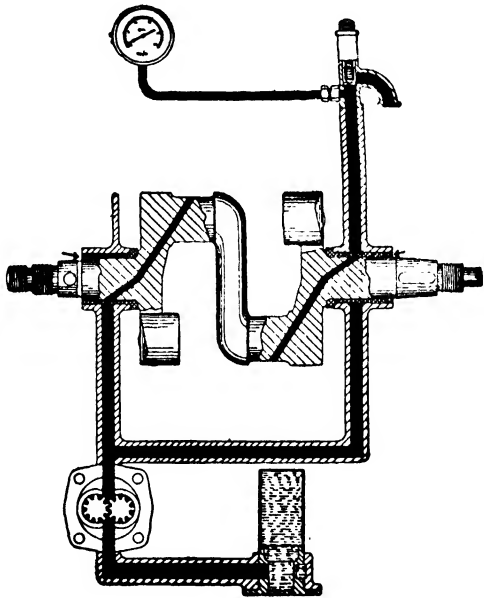

FIG. 266. Simple pressure lubrication system for small aircraft engines.

stream flows upwards to the top cover and along a cast-in gallery connected by drillings to the crankshaft main bearings. The oil passes into the crankshaft through the hollow journals and crank-pins to the big ends. This stream also lubricates the airscrew shaft bearing, the rear main bearing, the camshaft idler spindles and also supplies oil to the reduction gear oil jet. The second stream passes through a balanced piston mechanism which automatically reduces the pressure to approximately 20 lbs. per sq. in. The oil at this reduced pressure lubricates the hollow camshafts, the magneto drives, and the accessory drives. The pistons, cams and tappets are

lubricated by the oil splash from the main bearings, big ends and camshafts. A drilling is provided in the R.H. camshaft rear bearing which connects with a hole in the supercharger carrier case and serves to lubricate the supercharger layshaft. Holes in the layshaft gear assist in maintaining an oil mist which lubricates the gears. Oil is sucked from the crankcase by the depression existing in the supercharger casing and lubricates the front impeller bearing. The Tecalemit metering pump at the rear of the engine delivers oil to the rear impeller bearing. Oil for the airscrew governor is fed at engine pressure from the top cover to a drilling in the top facing (L.H. side of the crankcase). This drilling connects with the oil hole for the front main bearing. The oil flows to the drive housing and thence to the airscrew governor. The action of the governor increases the pressure to approximately 180 lbs. per sq. in. The oil is then fed to the rear airscrew shaft bearing along the hollow shaft to the airscrew.

Oil collected in the crankcase and the base of the supercharger casing is scavenged by two gear-type pumps, through two scavenge filters and delivered by means of an external pipe to the *hollow spindles of the butterfly valves on the carburettor* (to prevent ice formation), thence to the oil jacket on the supercharger casing. The oil return pipe to the tank is connected to a union on the cover of the oil jacket. To avoid excessive pressure in the spindles of the butterfly valves, a by-pass valve is provided in the supercharger casing which delivers return oil direct to the jacket. A centre screw type of fixing holds the valve gear cover in place and the joint is sealed by a Hallite ring. Attached to each of these covers is a vent stand pipe to allow for the escape of excess oil and fumes. A plug is provided for filling and also determines the level of the oil in the cover. The movement of the rockers splashes oil over all the moving parts of the rocker gear to effect lubrication.

The earlier Bristol Jupiter VIII lubrication system, before the adoption of the high initial pressure oil method, is shown in Fig. 267; it is of the usual dry sump arrangement, the oil under pressure being supplied through the end of the hollow crankshaft to the floating bush big end bearing of the master rod. The engine shown is a nine-cylinder radial one of 440 B.H.P. with an oil pressure of 60 lbs. per sq. in., oil circulation rate of 70 to 80 galls. per hour and an oil consumption of 2 to 2½ galls. per hour. The actual capacity of the pressure pump is 200 galls. per hour, that of the scavenge pump being

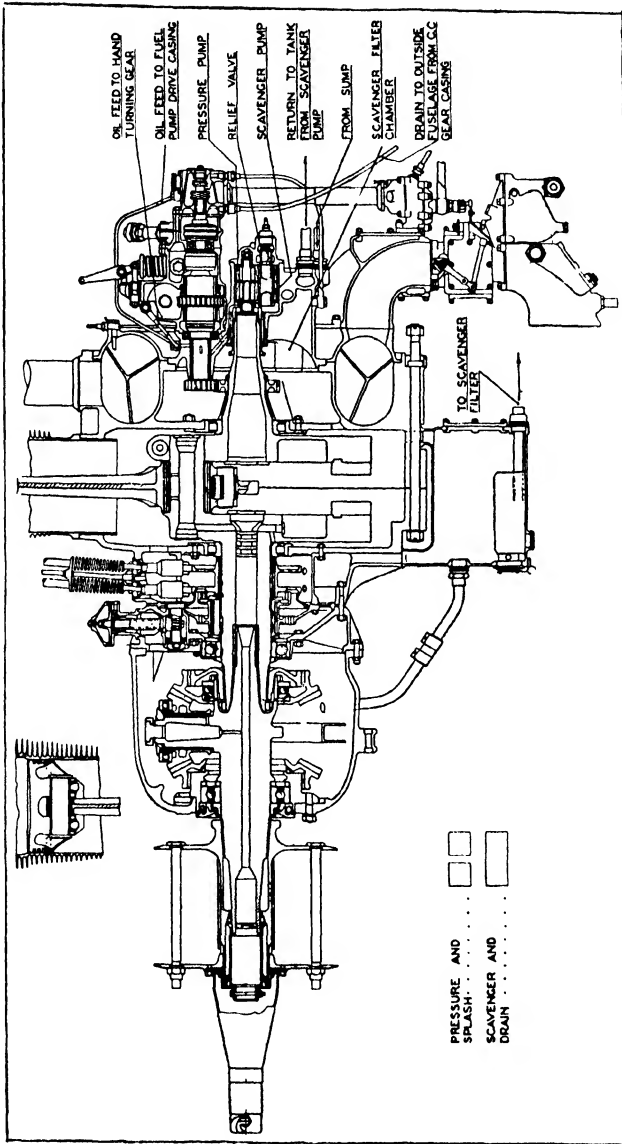

Fig. 267. Lubrication system of radial engine.

25 per cent. greater ; both pumps are of the spur gear pattern, embodied in one unit, which is fitted on to the back of the engine with a drive for the pumps off the rear end of the crankshaft. There is a relief valve on the pressure pump delivery side, the surplus oil being by-passed to the suction side.

The later "Mercury" and "Pegasus" engines employ the dry sump method oil drawn from the tank through filters entering the hollow crankshaft at a normal pressure of 80 lbs. per sq. in. The used oil is returned by the scavenge pump from the engine sump, through a filter to the tank. The oil pump (Fig. 268) is a compact unit designed for easy removal and operates on the meshed gear principle ; both the pressure and scavenge pumps, it will be observed, are housed in the same unit. The latter pump has 30 per cent. greater capacity than the pressure pump ; a spring-loaded relief valve in the pressure delivery side maintains the correct pressure. Independent oil filters are provided in both the pressure and scavenge lines ; they are quickly removable for cleaning without breaking the oil pipe lines. An additional renewable felt filter is incorporated in the oil return line ; this filter is mounted on the bulkhead.

In regard to representative American radial engines, apart from the information previously given in Chapter 4, the following are additional particulars relating to the Pratt and Whitney "Twin Wasp" engine lubricating system. In this engine the high pressure oil is led from the oil pressure pump through pipes in the rear and blower sections of the crankcase unit and thence through oil seal rings into the crankshaft. Oil mist lubrication is arranged for the cam and cam gear train, impeller gear train, accessory drives, master rod bearing and knuckle pins ; this is provided from the pressure lubricated items.

For the valve gear lubrication oil is led to a manifold within the front main crankcase section, thence through the drilled tappets and push rods to the valve gear. Inter-rocker-box and inter-cylinder drain pipes are provided, from which the return oil is scavenged by a third stage on the oil pump through a separate sump. A thermostatic oil-temperature control is provided in the lubrication system. Oil returning from the engine below the minimum operating temperature is by-passed automatically round the oil cooler and directed to the oil tank immediately adjacent to the suction line, when it

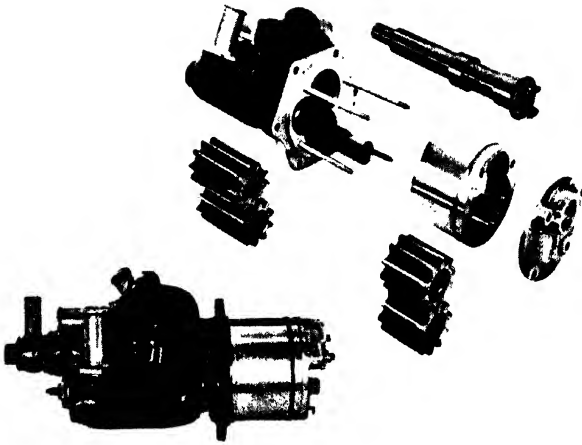

FIG. 268. The Bristol oil pump and its components.

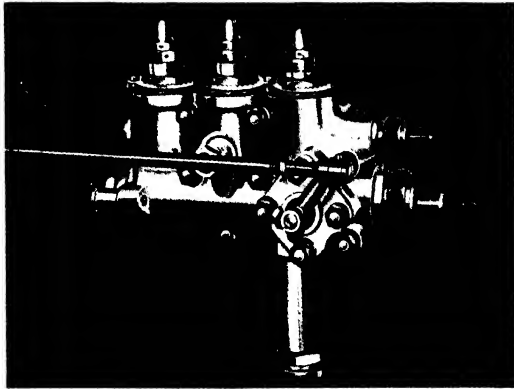

FIG. 272. The Rolls Royce triple oil pressure relief valve unit.

[To face p. 318.

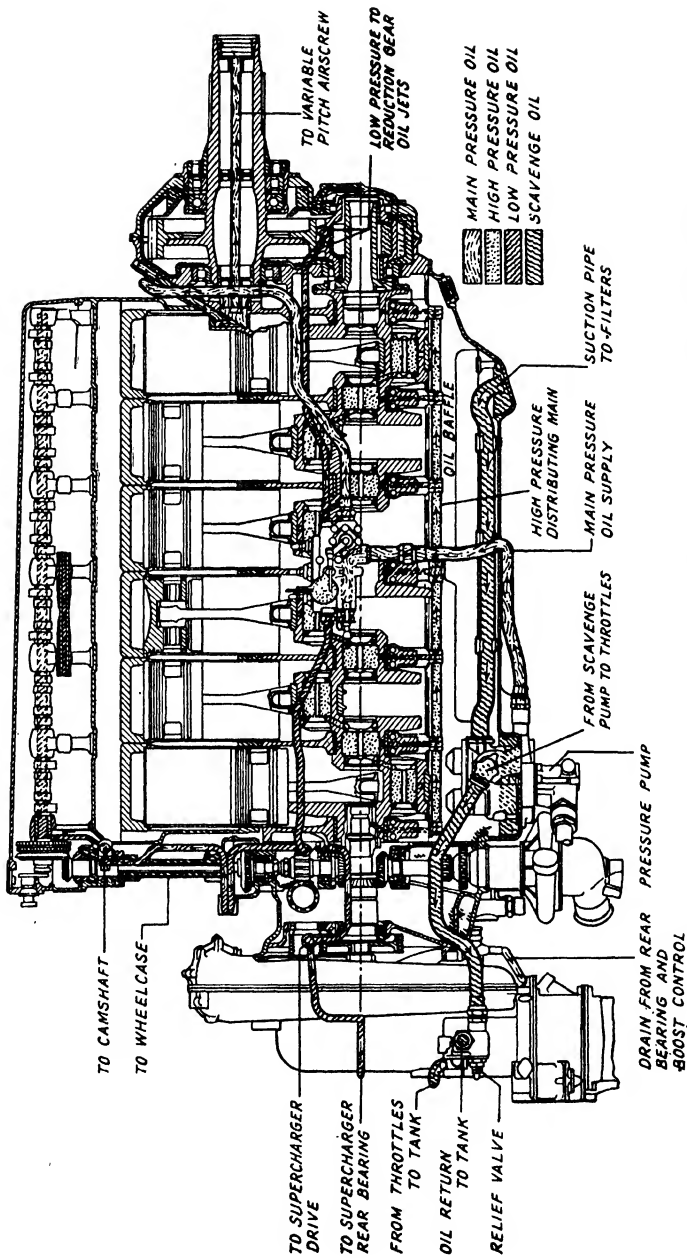

FIG. 269. The Rolls Royce "Merlin" engine lubrication system, in side sectional view.

returns to the engine. Oil above the maximum temperature is made to pass through the cooler. The control is equipped with a check valve to prevent accumulation of oil when the engine stops. With this arrangement the oil is brought to the correct operating temperature very quickly and is then main-

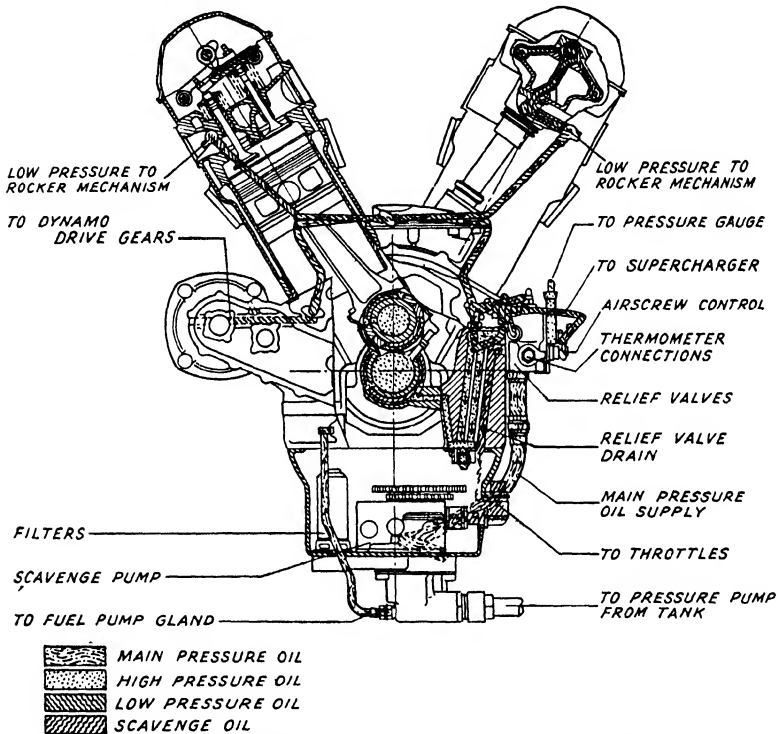

FIG. 270. The Rolls Royce "Merlin" engine lubrication system in front sectional view.

tained at this temperature automatically, under all weather conditions.

As a final example of a modern high output aircraft engine lubrication system, that of the Rolls Royce "Merlin" engine will now be considered. The dry sump lubrication system in question is illustrated in Figs. 269, 270 and 271. It employs one pressure and two scavenge pumps, the latter working in parallel to drain, independently, the front and rear sumps in the lower half crankcase. All the pumps are of the gear type

and are driven from the wheelcase through an idler gear from the lower vertical drive shaft to the water pump.

The pressure pump delivers oil to a triple relief valve unit, on the right hand side of the upper half crankcase, which regulates the oil pressures, firstly for operation of the variable

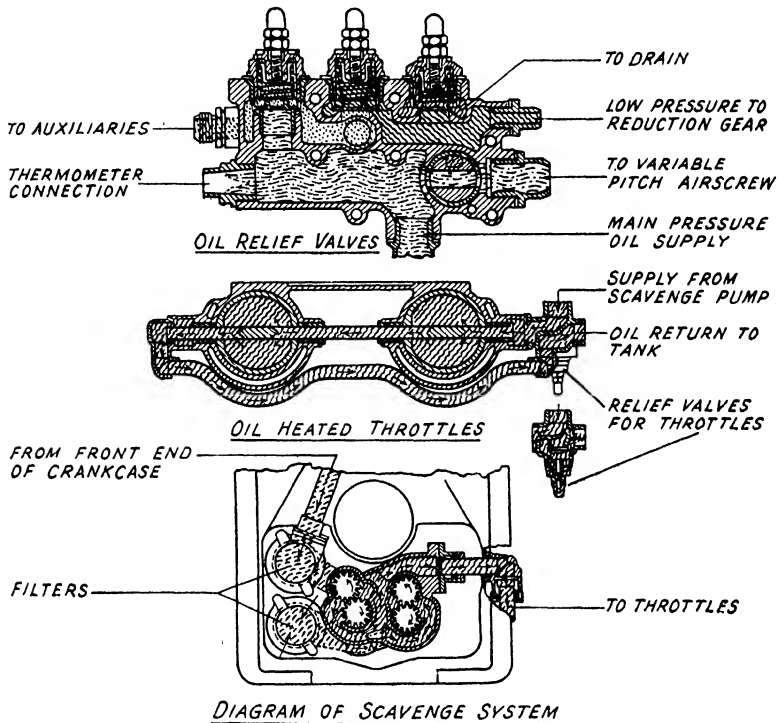

FIG. 271. The Rolls Royce "Merlin" engine lubrication system, oil pumps, relief valves, etc.

pitch airscrew (150 lbs./sq. in.) and fuel pump bushes, secondly for the main high pressure feed (70 lbs./sq. in.) to the crankshaft and bearings, and finally, for low pressure feed to the auxiliaries. The relief valve body contains also a pressure gauge connection, a thermometer pocket for measurement of the oil inlet temperature and a change-over valve, for airscrew pitch

control, which allows the high pressure stage to be connected with or shut off from the airscrew hub by movement of a control lever operated from the pilot's compartment.

Fig. 272 * shows the triple relief valve unit, which is mounted on the right hand side of the crankcase; the control rod and lever for the variable pitch airscrew are also shown in this illustration.

The oil from the second stage (engine main oil pressure) is fed into drilled passages in the crankcase, and thence, to a main gallery pipe supplying each of the seven main bearings. The big end bearings are fed *viâ* oil passages in the crank webs and holes drilled in the crank-pins.

The pistons, gudgeon pins and connecting rod small ends are lubricated by splash, a baffle being provided in the crankcase lower half to prevent an excess of oil being thrown into the cylinders.

The third stage is regulated between 4 and 8 lbs./sq. in. and supplies the various auxiliaries such as camshaft, rockers, reduction gear, generator and supercharger drive gears and tail bearing. Oil draining back to the crankcase through the camshaft drive housings is used for the lubrication of the inclined camshaft drives and the wheelcase gears. Drainage of the oil from the valve mechanism into the crankcase is effected *viâ* tubes through which pass the cylinder holding down studs.

The scavenge pumps drain the front and rear of the crankcase independently, one drawing oil through a pipe along the bottom of the crankcase from the forward end and the other from the rear sump, both delivering into a common duct leading to the oil tank return. Separate gauze filters are arranged on the suction side of each scavenge pump, both filters being easily detachable downwards for cleaning.

Connecting Rod Small Ends. In regard to the lubrication of the *small end connecting rods* of aircraft engines, whilst some types rely on splash lubrication, others prefer to ensure positive lubrication by taking a small supply of oil from the big end bearing either through a copper pipe secured to the web of the connecting rod—when the H-section rod is employed, or through a rifle-drilled hole in the web itself. As the bearing in question is of the rocking type it is usually found that splash lubrication, or oil drainage from the cylinder walls through the hollow gudgeon pin and a suitable hole leading to the small end bush is satisfactory.

* Facing p. 318.

CHAPTER IX

THE IGNITION SYSTEM

THE ignition systems of aircraft engines, whilst having certain common features with those of automobile engines, have been developed to solve various difficulties peculiar to their use on aircraft and not met with on engines designed for ground operation only. In consequence, modern ignition equipment for aircraft engines has attained a higher standard of development than any other type. In regard to the kinds of ignition apparatus employed the magneto is almost universal, but development work has been proceeding with coil ignition systems, as these possess certain advantages, to overcome problems associated with their use on aircraft engines ; these are referred to later.

It is now standard practice to provide a duplicated ignition system including magneto, H.T. cables and sparking plugs in order to obviate any risk of ignition failure. Although the two ignition systems concerned must be independent of each other electrically, the actual mechanical drive and certain other items may be common to each system.

Some General Considerations. The aircraft engine ignition system is required to provide a rapid and regular series of sparks of sufficient intensity to ignite the weakest fuel-air mixtures normally used, over a range of engine speeds from the slow starting to the maximum output speeds. Provision must also be made for manual or automatic advance and retard of the ignition to suit various operating conditions.

In general, the magneto and coil ignition systems provide considerably more electrical energy at the sparking plug points than is really necessary to ignite the mixture. Thus, it has been shown⁶⁴ that with sparking plug voltages of 4,500 to 6,000, the energy required to unite a weak mixture of petrol and air was about 0.007 joule per spark, and for a rich mixture, 0.004 joule ; as the voltage is increased above about 6,000, the required energy falls rapidly.

The energy of the spark obtained with modern ignition systems is of the order of 0.03 to 0.06 joules, *i.e.*, about

ten times the required minimum amount to ignite the mixture.

The voltages across the sparking plug points, with the usual gaps of 0.012 to 0.015 in., given by the ignition apparatus generally lie between 5,000 and 8,000. In practice, the gap between the plug points increases gradually in service, owing to erosion, so that a higher voltage is required for the ignition sparks. Thus, whilst a sparking voltage of about 4,700 to 5,000 would be needed in a modern aircraft engine for plugs with gaps of 0.012 in., if the latter were increased to 0.24 in., the voltages required would be about 6,000 to 8,000, according to the design of plug.

A higher voltage is necessary for starting purposes, with a given plug gap, than for normal running conditions.

Altitude Effects. The effect of altitude upon the performance of the ignition system is to create more severe conditions than ground level ones.

In general, as the altitude increases, the air density is reduced. Thus at 20,000, 30,000 and 40,000 ft. the air densities are 53, 36 and 23 per cent., respectively, of the ground level densities.

It is well known that as the air density diminishes, so does the voltage necessary to break down the air gap between two conductors at a fixed distance apart.

Thus, according to Paschen's law, the product of the breakdown voltage and the air pressure is constant, *i.e.*, the breakdown voltage varies directly as the air density, according to the following relation, for a pair of parallel plates with rounded edges.

$$\text{Breakdown voltage } E = \delta \cdot E_0$$

where δ = air density and E_0 = breakdown voltage at ground-level air density, *i.e.*, 27,000 volts per cm.

This formula requires modification for the shape and nature of the sparking electrode surfaces, *i.e.*, for non-uniform electrical fields. If this effect be considered in regard to the aircraft magneto it will be found that there is a risk of electrical insulation breakdown, or sparking across air gaps between near conductors, so that in magnetos designed for altitude conditions it is necessary to increase the air spaces between the high tension members and the earthed portions in order to avoid misfiring at the sparking plugs at the higher flying altitudes. The results of some tests mentioned by G. E. Bairsto,⁶⁵ in connection with an aircraft engine which was

misfiring at high altitudes, showed that the sparking plug voltage required from the magneto to give regular sparking diminished with increase in altitude for plugs of 0.013 and 0.023 in. gaps, respectively. It was found that for the plug gap of 0.023 in., the original magneto voltage was only just equal to the required sparking plug voltage at 23,000 ft. and for the plug gap of 0.013 in. at 36,000 ft. Above these respective heights misfiring would occur. With a modified magneto, in which the surface and air space insulations were increased, the altitude at which misfiring occurred with a normal plug gap of 0.013 in. was raised to 40,000 ft., and for eroded points giving a gap of 0.023 in., to 35,000 ft.

In this connection it may be mentioned that the standard test for British aircraft magnetos, under reduced air density conditions, is that regular sparking across standard test gaps set at 6,000 volts shall be obtained from all high tension leads when the magneto is operated under air density conditions equivalent to 45,000 ft., *i.e.*, at about one-fifth of ground air density.

In the design of magnetos for high altitude operation every possible parallel path between the various H.T. conductors and earth must be considered and steps taken to make such space or surface safety factors sufficiently large. In this connection tests have shown that the possible leakage paths between H.T. conductors and earth, with air insulation should be at least 20 mm., and where there is nearby insulating material to the air leakage path, the latter should be not less than 25 mm.

Corona Effects. Another electrical characteristic of low air density operating conditions is the "corona," or brush discharge through air, without complete breakdown. This may occur in the windings of the H.T. coil and may cause deterioration of the surface resistance of the moulded insulation due to the formation of nitrous and nitric acids; the eventual effect of the latter is to cause parts of the surface to become partial conductors. The ozone and acids formed during corona discharge have also a detrimental effect upon the lubricant of the magneto bearings.

Arcing at Contact Breaker. Another effect of altitude pointed out by Bairsto⁶⁵ is in connection with the formation of a spark or arc at the contact-breaker points, which limits the maximum voltage available from the magneto; this arcing becomes more pronounced with reduction of air density,

so that a magneto or coil system which is operating satisfactorily at ground level, with about the maximum permissible current carried at the contact-breaker points at the "break," may become unreliable at high altitude.

The effect of *arcing at the contact breaker* is usually shown by tests made of the secondary circuit peak voltages at air densities corresponding to different altitudes. It is then found that the secondary voltage gradually falls with altitude increase until a certain altitude is attained, when a fairly sudden drop of voltage occurs, accompanied by more or less severe arcing at the contact breaker. This effect is more noticeable and the voltage drop greater at low magneto speeds than at higher ones.

Temperature Effects. Aircraft ignition apparatus, notably the magnetos, have to operate at higher temperatures than those of the outside atmosphere, since they are enclosed in engine cowlings and are usually located in positions where they are shielded from the cooling air currents. In high duty engines the magneto temperatures may reach 70° to 80° C., whilst cables near exhaust systems may be, and often are, exposed to much higher temperatures. The principal detrimental effect of increased temperature is upon the insulation of the magneto, *e.g.*, the moulded insulation parts of the distributor and rotor and the armature winding insulation.

The standard tests for British aircraft magnetos for temperature effects is made with the magneto placed in a closed box containing dry air at 65° C. with the base or flange of the magneto raised to 85° C. Under these conditions the magneto must undergo an endurance test for twenty-four hours and during this period voltage characteristics and shunt resistance tests are made. The reduction in the spark voltage at any point in the speed range must not exceed 10 per cent. of the previous normal air temperature value. Further, the spark voltage at the established slow speed test must not be less than 5,000 volts when the H.T. circuit is shunted with a resistance of 200,000 ohms.

In connection with the selection of insulating material for moulded parts of magnetos the class known as "stabilites," of which the loaded hard rubbers are typical, are generally preferable to the synthetic resins, since they are immune from electrical "tracking," *i.e.*, surface leakage paths of carbonized material of relatively low electrical resistance. The loaded rubber parts, whilst possessing better electrical qualities, are

liable to softening effects at the higher temperatures and tend to contract after exposure for long periods to engine cowling temperatures and vibration effects. When synthetic resin parts are used for ignition apparatus ample electrical factors of safety are employed ; in this connection synthetic resins of the urea group offer certain advantages.

Radio Interference and Screening. Another important requirement of ignition systems is *non-interference with the radio receiver system* on aircraft. To fulfil this condition it is necessary to screen, effectively, the sparking plugs, H.T. cables and the magneto, and to earth these metal screens. The effect of such screening is to give the ignition generator an additional capacity load of about 150 to 250 micro-microfarads and therefore to reduce its voltage output. It is chiefly for this reason that standard acceptance tests on aircraft magnetos at both slow and maximum speeds are required to be carried out and a capacity load of 250 m.mfds. shunted across each spark gap ; under these conditions regular sparking must be obtained at 9,000 volts.

Another standard test, to take into account the unfavourable working conditions of a *sparking plug partly carbonized across its electrodes* and equivalent, therefore to a shunt resistance, is to stipulate that regular sparking should be obtained with a capacity load of 250 m.mfds. and a shunt resistance of 200,000 ohms across each spark gap.

In connection with the effect of the ignition system screening upon the performance, the regular sparking voltages of a typical magneto without screening was 12,600 in the retarded position at 500 R.P.M. With screening equivalent to a shunt capacity of 200 m.mfds., the regular sparking voltages obtained in the fully advanced and retarded positions were 13,000 and 9,500, respectively. For a shunt capacity of 600 m.mfds. the output voltages were 9,600 and 7,200, whilst for 800 m.mfds. the corresponding values were 8,700 and 6,400 volts, respectively.

It will be deduced from these results that the output voltage is lowered progressively, with increase in shunt capacity, so that it is important to reduce the amount of screening to the minimum by employing the shortest possible lengths of H.T. cable, and by other means. Another point which is shown from these results is that an appreciably high voltage is obtained with the magneto control in the *fully advanced position*.

The Safety Gap. The safety gap in magnetos is an air gap arranged between a selected point in the H.T. supply from the secondary coil to the distributor rotor and the "earthed" metal part of the magneto to afford a leakage path should the output voltage exceed a certain pre-arranged maximum value ; in this way excessive voltage effects on the coil windings are avoided. The safety gap therefore determines the altitude voltage performance of a magneto, since the reduced air density gives a lower breakdown voltage across this gap. In some instances magnetos are made without safety gaps, special consideration then being given in the design of the H.T. section to the provision of sufficiently long high tension leakage paths. When safety gaps are fitted these are about 8 mm. to 10 mm. across, and to avoid corona effects the spark gap is often arranged to rotate ; in one such method the earthed electrode member is the larger gear wheel for driving the distributor rotor arm.

Other Ignition System Requirements. The aircraft ignition system, in addition to fulfilling the conditions previously outlined, must also be capable of operating over relatively long periods without attention or overhaul ; in this respect, apart from occasional plug inspection or cleaning, the ignition system should be able to operate without attention for the same period as that between major overhauls of the engine, namely, about 400 to 600 hours.

The effect of increasing outputs from modern aircraft engines has introduced certain problems in the design of the ignition system, concerning higher operating temperatures and maximum speeds of magnetos ; when power dive requirements are considered, these speeds are of a higher order than usual. Further, with the tendency to reduce the overall dimensions of modern engines, in order to obtain maximum power outputs per unit frontal area, it has become more necessary than ever to reduce the size or bulk of the ignition apparatus.

The employment of high-octane leaded fuels has brought two further ignition system problems, namely (1) the increased erosive action of the fuel on the sparking plug electrodes, and (2) the increased compression and boost pressures employed, which enhance the misfiring tendencies at the higher altitudes, namely, of 30,000 ft. and above, since the H.T. discharge becomes relatively easier within the magneto itself on account of reduced air density conditions.

It should be mentioned, in concluding these considerations of the conditions to be fulfilled by modern aircraft ignition equipment that the latter *must be fireproof*—otherwise there would be serious risk of igniting any petrol vapour that might be around it.

Aircraft Magnets. There are three available types of magneto, namely, as follows: (1) *The rotating armature*, (2) *the polar inductor* and (3) *the rotating magnet* ones.

The rotating armature magneto has the primary and secondary coils wound on a soft-iron laminated armature which is arranged to rotate between the poles of a permanent horseshoe magnet. Fig. 274 illustrates the changes of flux between the two magnet poles and the armature as the latter makes a revolution; the primary and secondary windings are denoted by the letters P and S. The induced voltage in the primary coil is a maximum for Position 4 and a minimum, or zero, in Position 2; it will be observed that there are two maximum positions per revolution. The primary circuit of the armature has a contact breaker connected in series with it and the circuit is completed through a switch and the "earth" of the magneto metal frame and the engine. The secondary circuit is wound around the primary one and consists of a large number of fine insulated wire windings, whereas the primary coil contains only a few turns of relatively thick insulated wire windings. The sparking plugs are connected, in turn, with the secondary or H.T. circuit by means of a rotary arm type of distributor, and both the sparking plugs and secondary coil have "earth" returns through the magneto metal and engine.

When the armature coil is in one of the Positions 4 (Fig. 274), the circuit of the primary coil is broken by the mechanical opening, by means of a cam, of the contact-breaker points and the sudden collapse of the magnetic flux then induces a high voltage in the secondary circuit, roughly in proportion to the ratio of secondary to primary coil windings. Fig. 275 illustrates the principle upon which the layout of this type of

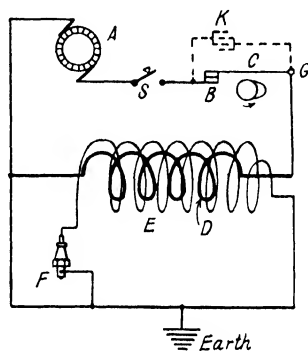

FIG. 273. Principal of rotating armature magneto.

magneto is arranged and it shows, for simplicity of explanation, a four-cylinder magneto supplying the sparking plugs 1, 2, 3 and 4 from the distributor segments similarly numbered.

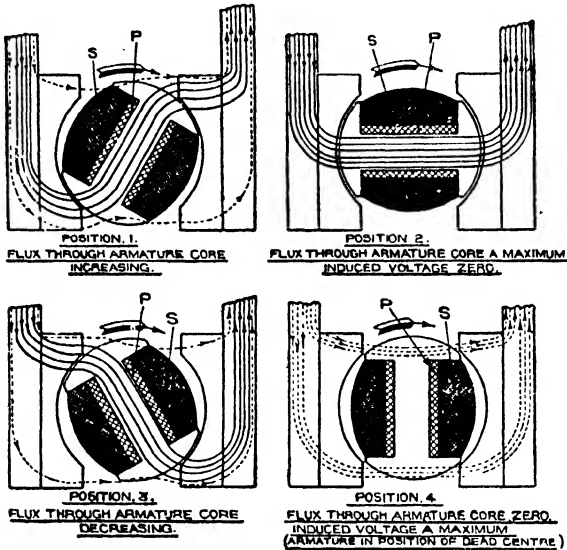

FIG. 274. Illustrating the flux changes in the rotating armature magneto.

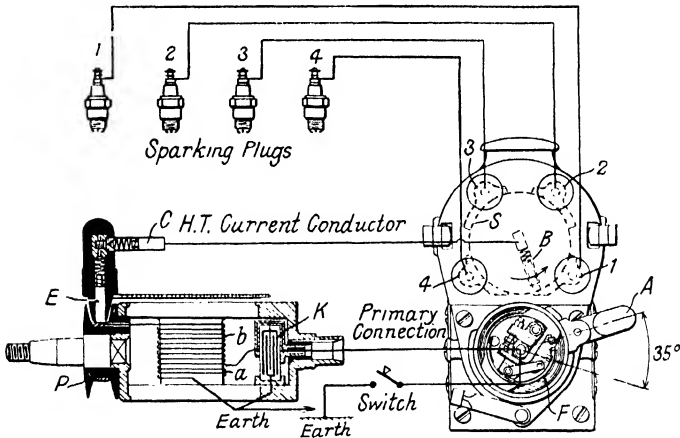

FIG. 275. Rotating armature magneto for four cylinder engine.

The cam F for operating the contact breaker is of the annular type, there being two such cams. The primary coil is not shown, but the secondary coil at *a, b* has one end "earthed" and the other taken through light spring-loaded brushes E and C to a rotating conductor B having a carbon brush which makes contact, in turn, with each of the four numbered metal segments similar to S, so that the high tension current is led in turn through the H.T. cables to the sparking plugs.

In order to alter the timing of the sparks in relation to the piston position, *i.e.*, to advance or retard the ignition, the ring containing the two fixed cams is arranged to rotate through a small angle by means of the manually-operated lever shown at A; usually an angle of 30 to 35 degrees is provided. To prevent arcing across the contact-breaker points when the latter break the primary circuit a *fixed condenser* is connected in shunt with the two contacts. This condenser becomes charged during the "break" and discharged when the contacts close together again. By this means the contacts are prevented from becoming pitted. Further, by suppressing the discharge across the contacts at the "break" and sending a reverse current through the closed contacts the condenser causes a more complete and rapid suppression of the magnetic flux and therefore produces a higher and more regular voltage in the secondary circuit.

The *fixed condenser* in parallel with the contact-breaker points is a common feature of both magneto and coil ignition systems.

The condenser is generally made of tinfoil and mica laminae, but in certain magnetos rolled tissue paper is employed between the tinfoil plates, so as to give a cylindrical form of condenser. The condenser, after thorough drying, is coated with paraffin wax and housed in a metal container. The overhanging tinfoils on either side of the paper insulation are arranged to form the two separate insulated plates of the condenser. The capacity of the condenser usually lies between 0.1 and 0.3 mfd. and it should have an insulation resistance of at least 10 megohms between the plates and be capable of withstanding, continuously, an applied voltage of 1,000.

In regard to the method of *cutting-off the ignition* in order to stop an engine, this is done by breaking the primary circuit by means of a switch; this switch can be seen in the lower centre of Fig. 275 and it is connected between the primary

connection at the centre of the contact-breaker screw and the metal of the engine, or "earth."

Although, for simplicity of explanation the high tension distributor in Fig. 275 is depicted as being of the rubbing carbon-brush type, in all modern ignition systems this arrangement is replaced by a rotating arm with a metallic end which passes very close to the distributor metal members, so that the H.T. current passes through a small air gap of the order of 0.01 to 0.015 in. wide; this is known as the *jump spark* or *gap-type* distributor.

With this form of distributor, ventilation of the interior is necessary as, otherwise, the products of the ionization caused

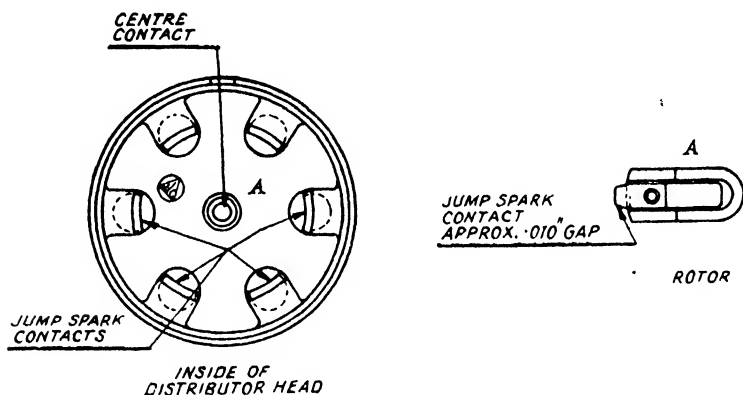

FIG. 276. The "jump spark" type of distributor. The rotor on right is attached to shaft at A (left).

by the jump sparks, *i.e.*, nitric acid, nitrous acid and ozone will accumulate, with detrimental results.

Speed of Magneto. In regard to the speeds of rotating armature magnetos, with two cams for operating the contact breaker, there will be two sparks produced per revolution of the armature. Thus, for a four-cylinder engine, working on the four-cycle principle, two sparks per armature revolution will be required and the armature must run at engine speed. A six-cylinder engine will need three sparks per revolution so that the armature must run at $1\frac{1}{2}$ times engine speed.

In general, for an engine of n cylinders working on the four-cycle principle, the magneto armature must run at $\frac{n}{2}$ times engine speed.

The number of segments of the distributor is made equal to the number of cylinders, so that *the distributor arm must always run at one-half engine speed*. It is necessary, therefore, to gear down the arm in question. The ratio of the gearing between the armature and distributor shaft is $1 : \frac{n}{2}$ for an engine having n cylinders. Thus, for a six-cylinder engine the gear ratio is $1 : 3$, *i.e.*, the distributor arm rotates at one-third of the armature speed. The gearing in question is integral with the magneto in all cases.

Contact Breakers. The contact breaker is an important item in magnetos and much attention has been given to its design

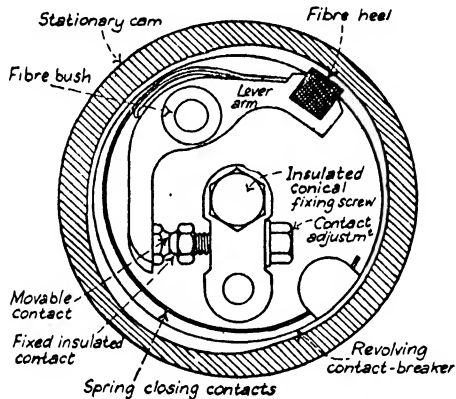

FIG. 277. Contact breaker of rotating armature magnetos.

and materials. Most rotating armature patterns have the internal fixed cams and rotating contact-breaker arrangement shown in Fig. 277. The movable contact arm is relatively heavy and therefore subject to centrifugal and inertia effects at high engine speeds with the necessity of providing a strong spring control; this in turn leads to increased wear between the cams and the heel of the contact-breaker arm. The original steel contact breaker shown in Fig. 277 was subsequently replaced by one of aluminium alloy or laminated Bakelite, to reduce the inertia effects. More recently, magnetos have been made with fixed contact breaker units and revolving cams of the coil ignition type shown in Fig. 278. The rocking member of the contact breaker is made extremely light so that a much lower spring pressure can be employed to close

the contacts. Further, instead of being limited to two cams it is possible to employ four- or six-lobed cams, thus reducing the speed of the armature shaft. Thus, in the case of a six-cylinder engine a six-lobed cam would be employed and this would rotate at one-half engine speed. The advantage of this arrangement is that, since the distributor arm has to run at one-half engine speed the armature shaft can be arranged

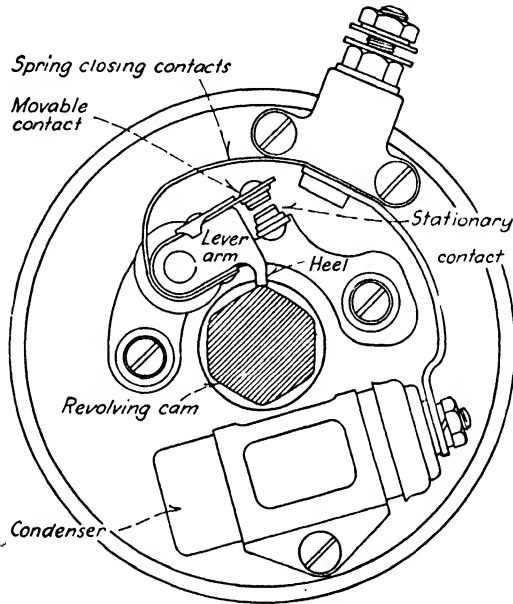

FIG. 278. Improved contact breaker unit.

to drive the distributor arm directly by means of an axial extension member.

In the case of eight-cylinder engines, instead of using an eight-lobed cam, a four-lobed one and two contact breakers is employed as shown in Fig. 279; this illustration depicts a typical automobile type contact breaker. For radial engines the cam, in some magnetos, has the same number of lobes as the number of cylinders and it is integral with the distributor gear spindle. In order to provide for compensation on account of the link rods about the master connecting rod, the cam profile is made to give the corresponding unequal angular

intervals between the consecutive sparks; in this way the correct spark timing for each individual cylinder is procured.

The contacts of magneto and coil ignition system contact breakers were formerly made of an alloy of platinum and iridium for automobile ignition units. Later the contacts were made of, or tipped with, tungsten in order to obtain greater resistance to wear and impact effects. It is necessary, however, to limit the maximum current at "break" to a value

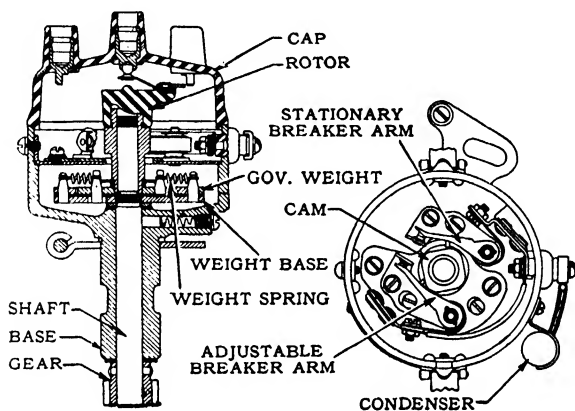

FIG. 279. Four-lobed contact breaker unit with two contact breakers, for eight-cylinder engine.

below 3.5 amperes and the maximum voltage to 300 in order to avoid appreciable "pitting" of the contact surfaces; if unchecked, this will cause misfiring.

An alloy consisting of 3 parts platinum and 1 part iridium is now often used for aircraft magneto contacts and with these the limiting current at "break" is about 5 amperes.

It should be mentioned that in coil ignition systems the current flow—from battery source—is unidirectional so that contacts of tungsten are used instead of platinum-iridium, since with the latter material the crater forming tendency is appreciably greater and more rapid in its cumulative effects.

Magnet Materials. The permanent magnets of all types of magneto are now made of alloy steels or nickel-aluminium-iron alloy, such as Alnico and Alni.

The earlier high-carbon steels used for magnets were subsequently replaced by tungsten steels containing 5 to 6 per cent. tungsten, having superior magnetic properties. Later,

the cobalt steels with 35 per cent. cobalt were introduced and more recently the nickel-aluminium-iron alloy. The latter material has considerably better magnetic properties and, being considerably lighter than ordinary alloy steels enables a marked saving in weight and space to be effected.

In regard to the desirable magnetic properties of permanent magnets it is necessary for the magnet material to possess *high remanence* and *coercive force* in order to obtain the maximum permanent magnetism; in this connection a high coercive force indicates high resistance to demagnetization by vibration or opposing demagnetomotive force.

The other important property associated with permanent magnets is the magnetic field density B (lines per sq. cm.) produced by a magnetizing force H (1.26 magnetizing current in amperes \times turns per cm. length of magnetizing coil). The maximum value of the product B and H or $(BH)_{MAX}$ denoting the maximum value of the field density and demagnetizing force during demagnetization gives a useful indication of the suitability of magnet materials; the higher the value, the better is the material for this purpose. Thus, it can be stated, that the best magnet material is that possessing the highest coercive force and $(BH)_{MAX}$ value and the lowest density.

From the values given in the following table it will be observed that nickel-aluminium-iron is superior to the other magnet materials. A typical composition for this alloy is 60 per cent. iron, 27 per cent. nickel and 13 per cent. aluminium. The metal is used in the form of castings and is extremely hard to machine; as a rule metal can be removed only by grinding.

TABLE 20. PROPERTIES OF PERMANENT MAGNET MATERIALS

Magnet Material	Coercive Force	Remanence (Flux Density)	BH_{max} .	Relative Weight for given Application
2 per cent. chromium steel.	60	9,000-10,000	{ 240,000 } { 250,000 }	300
6 per cent. tungsten steel.	65-70	10,000	{ 270,000 } { 290,000 }	300
35 per cent. cobalt steel.	240-250	8,500-9,000	{ 850,000 } { 900,000 }	100
Nickel-aluminium-iron alloy.	400-450	6,500-7,000	{ 1,250,000 } { 1,300,000 }	50-60

When 6 per cent. tungsten steel is replaced by 35 per cent. cobalt steel, the magnet is reduced to one-quarter the length but the area of the cross-section must be increased by 10 per cent. for the same flux.

If, on the other hand, nickel-aluminium-iron alloy is substituted for tungsten steel the length of the magnet is reduced to one-eighth, but the area must be increased by 40 per cent. From these values the marked saving in size and weight with the two latter materials will be evident.

Disadvantages of Rotating Armature Magneto. With this type it is possible only to obtain two sparks per revolution, so that for aircraft engines of more than six cylinders the magneto armature speeds would become excessive. Another

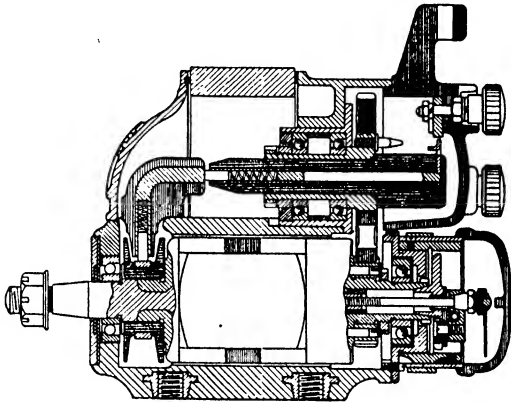

FIG. 280. The B.T.H. rotating armature aircraft type magneto.

disadvantage is due to the fact that the more delicate parts of the magneto, namely, the primary and secondary coils and condenser form the revolving members and are therefore more liable to breakdown, in particular under high speed and vibration effects. The disadvantage of having a revolving contact breaker has already been referred to.

For these reasons this type of magneto, although used on certain light aircraft engines, has more recently been replaced by the two other types described later.

Fig. 280 illustrates the B.T.H. rotating armature magneto used on certain de Havilland "Gipsy" in-line engines. The magneto is of the base-mounted pattern, with die-cast housing having the distributor end-plate and driving end-plate as

integral parts. The primary and secondary windings are wound on the usual H-section armature. The beginning of the primary winding is connected to the core, while the end is joined to the insulated side of the condenser and to the beginning of the secondary winding; the other side of the condenser is connected to the core. The insulated side of the condenser is connected to the insulated platinum-iridium contact of the contact breaker, and the insulated end of the secondary winding to the brass insert in the slip-ring. The contact breaker is of the usual pattern. The timing lever has an advance and retard range of 25 degrees. The safety spark gaps are fitted on the brush holder and operate between the distributor brush and the slow speed wheel. The distributor brush, connected to the end of the secondary winding, is mounted on the gear wheel, which rotates at one-half armature speed. The distributor gear wheel is made of a synthetic material, known as Textolite, and meshes with a steel gear on the armature shaft; this ensures quiet operation. The magneto is arranged for one direction of rotation, an arrow being stamped on it to indicate this direction. The armature shaft rotates on two ball bearings which are initially grease packed, so as to require no further lubrication; the only part requiring lubrication is the distributor gear wheel, which is given eight drops of light machine oil through the oil well at the distributor end of the magneto at twenty-five hours' running intervals. The distributor rotor arm is of the "jump-spark" type.

The Stationary Armature Magneto. There are two main types of magneto in which the primary and secondary coils are stationary, namely, (1) the *polar inductor*, and (2) the *rotating magnet* ones.

The *polar inductor magneto* has stationary magnets as well as coils, and the changes of magnetic flux are obtained by rotating soft-iron inductors between the poles of the magnets.

The principle of this magneto is illustrated in Fig. 281; the three diagrams show the manner in which flux reversal in the armature core occurs. Four small air gaps are interposed in the complete magnetic circuit, one being arranged between the annular end of each inductor and the ring magnet pole which surrounds it, and also a gap between the end of the inductor finger and its corresponding armature pole. During each revolution of the rotor shaft there are four complete reversals of flux, so that for the type illustrated there are four sparks

per revolution. When the inductor rotates an alternating current is generated which reaches a maximum four times per revolution. The inductor fingers become alternately N and S poles, which move past the poles of the laminated cir-

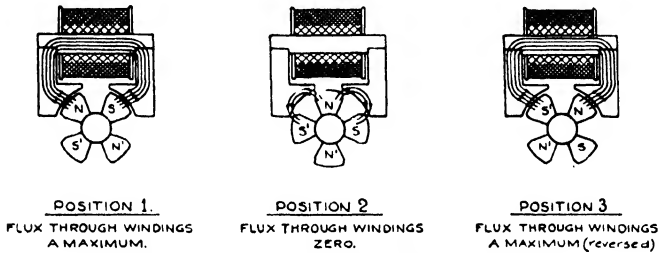

FIG. 281. Principle of polar inductor magneto.

cuit carrying the armature windings, and as each pair of fingers is followed by a second pair the flux in the laminated circuit is reversed. The primary winding is broken at the correct moment by means of a contact breaker, thus causing a high voltage spark to occur in the secondary circuit, in a

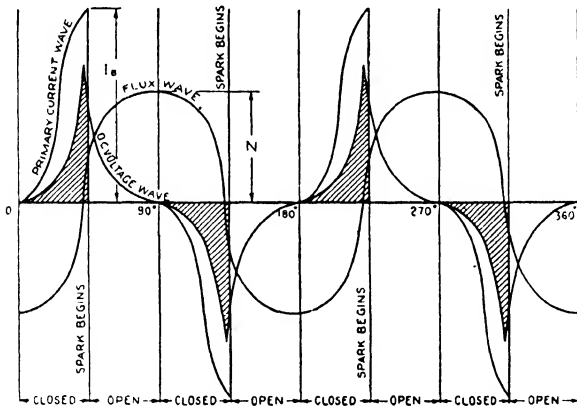

FIG. 282. Flux and voltage curves for polar inductor magneto.

similar manner to the rotating armature magneto previously described.

Fig. 282 illustrates the manner in which the flux and voltage vary during four cycles, corresponding to one revolution of the inductor shaft.

This type of magneto is applicable to multi-cylinder engines, including the eight- and twelve-cylinder Vee-types, and seven-, nine- and fourteen-cylinder radial engines. The advantages of this design of magneto include low operating speed, the use of a straight-through driving shaft, stationary coils with laminated iron core and fixed magnets, absence of brushes, ample leakage surfaces, rotating safety-spark gap and ease of dismantling.

Fig. 283 illustrates the B.T.H. polar inductor magneto layout for an eight-cylinder engine, the contact breaker being shown on the left, the inductor and coil in the centre and the jump spark distributor on the right.

In this magneto the beginning of the primary winding is

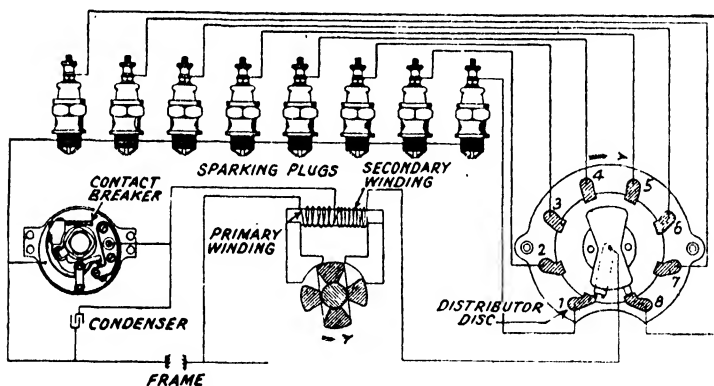

FIG. 283. Lay-out for eight cylinder polar inductor magneto circuit.

connected to the armature core or earth, and the end is connected to the beginning of the secondary winding and to the contact breaker. The cam operates the rocker arm separating the contacts four times per revolution of the shaft. When the contacts are closed the primary winding is short-circuited, and as the inductor rotates, the current induced in the primary winding builds up until the cam separates the contacts at the instant when this current is at a maximum. The instantaneous collapse and reversal of the flux at the moment of "break" produces the high voltage in the secondary winding which causes the spark.

As previously mentioned, the beginning of the secondary winding is connected to the end of the primary winding, and the end of the secondary winding is connected to the small

brass insert in the armature coil moulding. This insert makes contact with the collector brush which is in turn connected to the rotating metal brush. The spark leaps from the rotating brush to the various segments as the brush rotates, and thus the ignition sparks are distributed to the various plugs on the engine. These connections will be understood on reference to Fig. 283. It should be particularly noted, however, that the order of the plugs as shown in the diagram, does not necessarily agree with the numbering of the cylinders commonly adopted.

A special type of distributor is provided for operating with a small spark gap between the rotating metal brush and the segments, the latter being arranged to protrude well beyond the surface of the material. With distributors of this design "tracking" cannot occur.

The distributor used on the B.T.H. Types AC and SC magnetos is fastened to the magneto by means of two set screws which are screwed into bronze inserts located in the aluminium end casting. In addition these machines have a metal shield which completely screens the distributor and contact breaker in order to prevent interference with wireless apparatus installed on the aeroplane.

The safety spark gap is one of the special features in the design of this type of magneto. Should any connecting lead become disconnected from its plug, undue rise of voltage which might damage the insulation of the magneto, is guarded against by the provision of the safety gap across which the spark may discharge when there is no alternative gap between the spark plug electrodes. A brass point protrudes from the distributing brush box towards the slow speed gear wheel, and a serrated stud, screwed into the gear wheel, constitutes the other pole of the gap. Owing to the fact that this gap is always rotating, the air between the electrodes is in a constant state of commotion, and thus ionization is reduced to a minimum. Furthermore, the machines are provided with suitable means of ventilation so that the air in the machines is constantly being changed.

In regard to the contact breaker, it is necessary to close and open the primary circuit four times during each revolution of the rotor shaft, and this is effected by means of a four-point cam which is mounted on the end of the shaft. This cam operates a bell-crank lever, the end of which carries the movable contact. When the lever is deflected by the cam the

distance between the platinum points is no greater than 0.012 in.

The usual fibre brush is replaced by a bronze bush lubricated by means of a small oil wick fitted inside the bearing

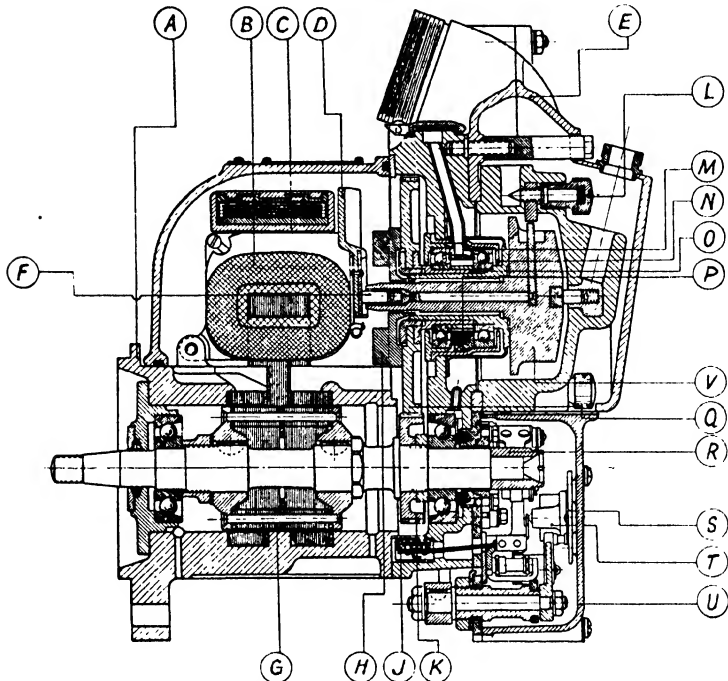

FIG. 284. Sectional view of Rotax "Watford" Nine-cylinder Magneto (Type S.P. 9-6).

A—Poles shoes tunnel. B—Coil. C—Condenser. D—H.T. pick-up plate. E—Screen. F—Distributor arm carbon to pick-up. G—Rotor unit. H—Fan. J—L.T. spring and block. K—Pinion wheel. L—Terminal knob. M—Lubrication feeder. N—Distributor bearing housing. O—Distributor bearing sleeve. P—Distributor bearing gas excluder. Q—Distributor wheel. R—Contact breaker operating cam. S—Earthing block insulator. T—Earthing block insulator. U—Contact breaker cover. V—Distributor rotor arm.

pin. There is a radial hole in the pin so that oil from the wick can flow outwards and lubricate the bearing surface.

Fig. 284 illustrates the Rotax "Watford" polar inductor magneto of the nine-cylinder screened ignition pattern giving four sparks per revolution of the inductor spindle.

The inductor consists of two cheeks which are assemblies of laminæ mounted concentrically on a hollow spindle made of high tensile steel. The inductor runs in a tunnel on ball bearings. The bore of this tunnel presents six poles to the inductor, four of which are connected to the extremities of four permanent bar magnets, and the other two forming part of the armature core. The laminated pole shoes, which are made of a special high permeability steel, are cast in a casing of aluminium ensuring a solid construction; the pole shoes present cylindrical faces to the inductor.

The entire magnetic flux system is laminated, and this, in conjunction with the design of the tunnel and inductors, gives a strong magnetic flux alteration through the armature core. The speeds at which the magneto will run efficiently are very much in excess of those obtainable by any other system. The magneto will function perfectly at 8,000 R.P.M., the number of sparks then being 32,000 per minute.

The usual test voltage under fully screened conditions, that is, with 6 ft. of braided cable on each lead, is 9,000 volts.

The double contact breaker mechanism of the magneto provides a means of increasing the ignition advance on the engine at predetermined positions of the throttle, *i.e.*, coinciding with normal cruising position, in excess of that normally obtained through the action of the automatic timing device.

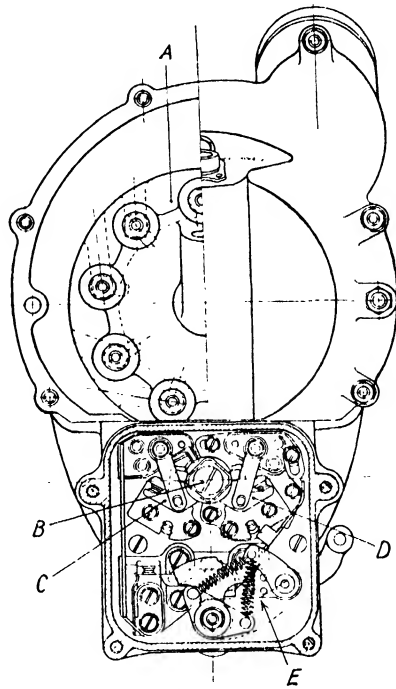

FIG. 285. End View of Rotax "Watford."

Nine-cylinder magneto, showing nine contact distributor at A; four-lobe cam at B; fixed contact breaker at C and moveable contact breaker at D. The quick-action switch mechanism is shown at E.

The mechanism is operated through a lever, at the rear of the contact-breaker base, inter-connected with the engine throttle control. Reference to Fig. 286 will indicate the relative positions of two contact breakers. X is a fixed position contact breaker and Y an adjustable position contact breaker functioning through the switch Z.

The lever of the adjustable position contact breaker Y is angularly positioned to the lever of the fixed contact breaker X and is operated by the common four-lobe cam prior to the latter lever. The angular positioning is obtained by bodily movement of the adjustable contact breaker assembly round the cam, moving up for maximum advance and down for minimum advance, location and locking being by means of four screws, D, E, F, G.

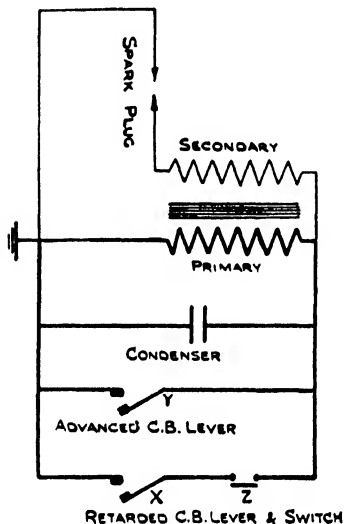

FIG. 286. Circuit diagram for Rotax "Watford" nine-cylinder magneto with double contact breaker.

Speed of Rotation of Polar Inductor Magnetos.

As this type of magneto gives four sparks per revolution, a four-cylinder magneto will run at one-half crankshaft speed; a six-cylinder one at three-quarters and an eight-cylinder one at crankshaft speed. For an engine having n cylinders

the magneto will operate at $\frac{n}{8}$ times engine speed for four-cycle engines and $\frac{n}{4}$ times engine speed for two-cycle ones.

Two-Lobe Contact Breaker Type Magneto. It is sometimes an advantage to operate polar inductor magnetos at twice the normal speeds by employing a two-lobe cam to operate the contact breaker instead of the four-lobe one shown in Fig. 281. The higher inductor speed results in a better spark at lower speeds, for slow running and starting purposes; it also supplies all of the sparking plugs with the same polarity spark as in the coil ignition system.

The Rotating Magnet Magneto. In this design the coil, contact-breaker unit and condenser are stationary and the magnet, which is of special shape, rotates. The primary and secondary coils are wound around a laminated iron core of the special shape shown in Fig. 287. The two-pole magnet during

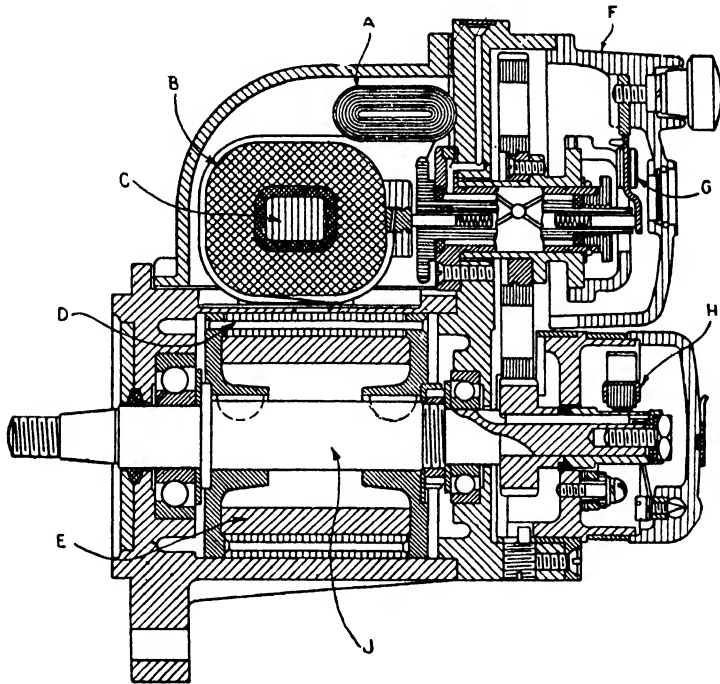

FIG. 287. Six-cylinder rotating magnet type magneto.

A—Condenser. B—Windings. C—Laminated armature core. D—Laminated magnet pole. E—Ring magnet. F—Distributor. G—Distributing brush holder. H—Contact-breaker. J—Straight through shaft.

one complete revolution gives two complete flux reversals and therefore two sparks per revolution. The four-pole magnet, for similar reasons, gives four sparks per revolution. It is possible, within certain limits, to employ a larger number of poles so that if these are equal to the number of cylinders of the engine the magnet shaft can be rotated at the same speed as the engine's camshaft; this type of magneto is termed a *camshaft-speed* one.

The magnet is usually of the cobalt steel type, but by using nickel-aluminium-iron a marked saving in weight may be effected. In this type of magneto the contact breaker unit is stationary and is operated by a cam on the magnet shaft, having a number of lobes equal to the number of sparks per revolution, *i.e.*, to the number of magnet poles. Alternatively, by using two contact breakers the magnet shaft cam can be made with half the number of lobes.

Fig. 287⁶⁶ shows a sectional view of a six-cylinder rotating magnet magneto, the various parts lettered being described in the caption below.

Camshaft Speed Magnetos. The polar inductor and rotating magnet magnetos, by suitable selection of the inductor projectors, or fingers, or of the magnet poles in the latter

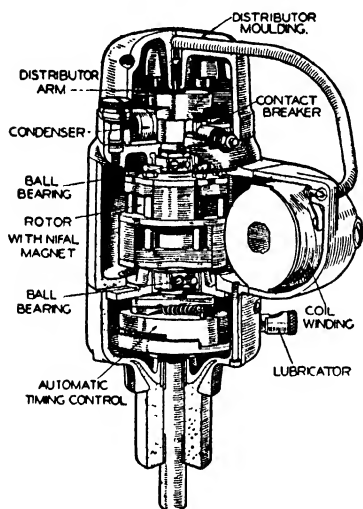

FIG. 288. Automobile type of camshaft speed magneto. (Lucas).

type, can be designed to operate at the same speed as the camshaft. This arrangement gives higher voltages at lower engine speeds and permits the cam for actuating the contact breaker and also the distributor arm to be run at the same speed, *i.e.*, that of the camshaft. In this way gearing between the inductor or magnet and the contact breaker cam and also the distributor arm can be avoided and all of these components driven off a single shaft connected directly to the camshaft of the engine. A further advantage is that the casing containing the fixed contact-breaker unit can be arranged to rotate about the driving shaft axis through a small angle, relatively to the operating lobed cam, so as to provide advance or retard of the spark; this movement may be either manual or automatic, *i.e.*, by a governor mechanism or pneumatic means.

General Characteristics of Aircraft Magnetos. The voltage curves for a typical magneto having cobalt steel magnets are

operate at the same speed as the camshaft. This arrangement gives higher voltages at lower engine speeds and permits the cam for actuating the contact breaker and also the distributor arm to be run at the same speed, *i.e.*, that of the camshaft. In this way gearing between the inductor or magnet and the contact breaker cam and also the distributor arm can be avoided and all of these components driven off a single shaft connected directly to the camshaft of

shown in Fig. 289, for the fully advanced, half-retarded and fully retarded positions. The curves show the manner in which the voltage increases with the armature speed and also indicate the minimum speeds at which the voltage is sufficient for starting an engine. With the standard sparking plug gaps, a minimum voltage of about 5,000 is required to provide a satisfactory spark, namely, of 0.02 joule per spark. If, however, the plug points are eroded and the gap is greater, a higher voltage is necessary. Thus, if a minimum of 6,000 volts is

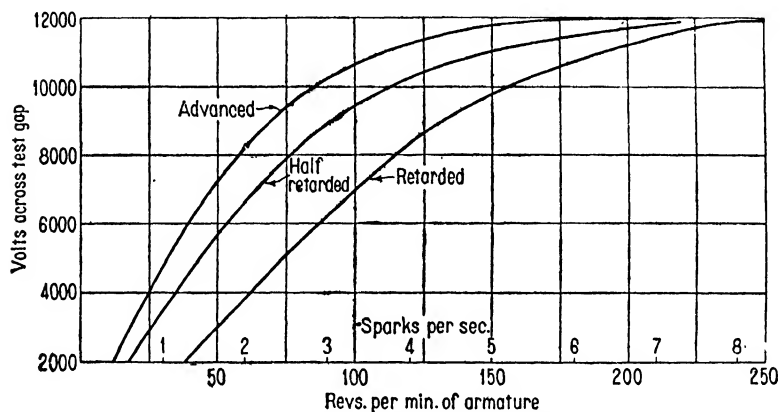

FIG. 289. Voltage curves for cobalt steel magneto.

assumed, then in the fully advanced, half-retarded and fully retarded positions of the timing lever, the minimum armature speeds will be about 37, 51 and 87 R.P.M., respectively; these results indicate the importance of employing *advanced spark timing for starting purposes*.

A number of aircraft magneto voltage speed characteristic curves under various conditions of load, given by G. E. Bairsto, are reproduced in Fig. 290. The magneto A was a British twelve-cylinder rotating magnet one giving four sparks per revolution. B was a German sixteen-cylinder magneto giving eight sparks per revolution and having rotating inductors and doubled magnetic and electric circuits and double contact breakers. C was a Continental nine-cylinder magneto of the rotating magnet type giving four sparks per revolution. D was an R.A.E. design of magneto of the polar-induction pattern giving six sparks per revolution.

The three sets of curves were obtained with (1) no shunt

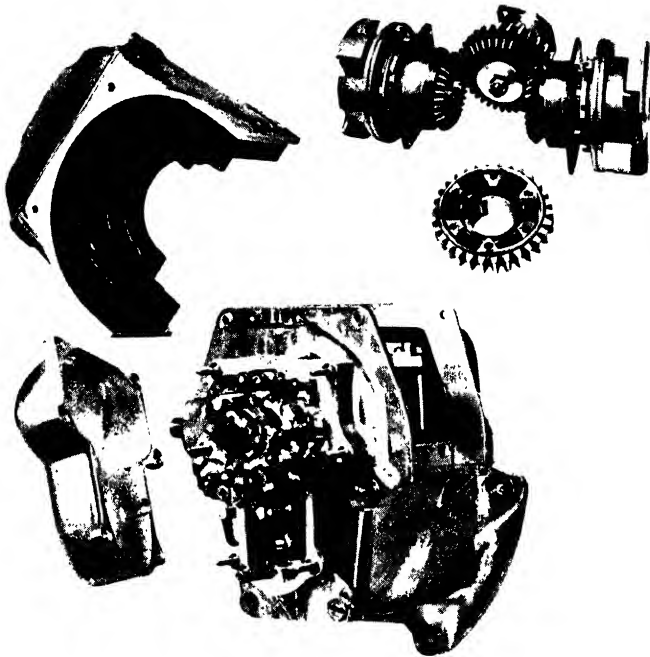

FIG. 291. One of the Bristol shielded magnetos and details of the engine drive.

Magneto Mountings, Drives, Timing, etc. There are two principal methods employed for mounting magnetos on aircraft engines, namely, the *flange* and *base*, or *engine bracket* ones; particulars of the standard dimensions for each type of mounting are given in a British Standard Specification.

In regard to the method of driving the magneto by gearing from one of the engine drive shafts, this varies considerably according to the design of engine; in this connection it is desirable to employ the minimum number of meshing gears, since the effects of any backlash are accumulative.

The magneto drive in most British engines is through a vernier coupling which enables fine adjustments of the ignition timing to be made and at the same time allows for slight errors in alignment.

The method of controlling the ignition timing may be either manual or automatic. In the former case provision is made for moving the contact-breaker unit relatively to its operating cam. If moved in the same direction as the cam rotates the ignition is retarded; if in the opposite direction it is advanced.

Automatic control is often arranged by interconnecting the carburettor throttle and spark advance lever so that as the throttle is opened the ignition is advanced; in some instances the ignition is slightly retarded again at full throttle opening. Another method, similar to that used on automobile engines is to operate the contact-breaker unit by means of a small centrifugal governor device (see Fig. 279) whereby, as the engine speed increases the weights move outwards, and in doing so cause the contact-breaker unit to move towards the approaching cam lobe, *i.e.*, in the opposite direction of rotation to the cam.

Another method of ignition timing control, used on Bristol engines is based on an electrical principle. The magnetos are each fitted with double contact breakers (B.T.H. or Rotax* design), controlled by a selective switch or toggle interconnected with the throttle lever. When the latter is moved into the cruising position one contact breaker is held out of action; the timing is then at maximum advance for best cruising fuel economy. At all other throttle positions the second contact breaker is switched into operation. This gives a reduced amount of ignition advance. The further retardation necessary for starting and slow running is obtained by a

* See p. 343.

centrifugal device incorporated in each magneto drive coupling (Fig. 291); the latter also incorporate vernier adjustments for the timing setting and enable the magnetos to be removed and replaced without altering the timing.

Referring, again, to Fig. 291, the upper right-hand illustration shows how the two magnetos are driven from a single bevel wheel on the engine drive shaft; the spring and vernier couplings are also shown.

The range of ignition timing provided on magnetos for different aircraft engines varies appreciably, namely, from 15 to 45 degrees; in a few instances the timing is fixed. For rotating armature magnetos the range of ignition timing is 25 to 30 degrees; for polar-inductor type, 15 to 30 degrees, and for rotating magnet types 15 to 25 degrees, as a rule.

Magneto weights usually range from about 0.6 to 0.8 lb. per cylinder for engines of four and six cylinders; from 1.0 to 1.5 lbs. per cylinder for engines of nine to twelve cylinders, and 0.8 to 1.2 lbs. for larger units. In this respect it should be remembered that for the two magnetos, these figures should be doubled.

Reducing the Size of Magnetos. The necessity of keeping the sizes of modern aircraft engines of given output down to a minimum has introduced certain difficulties in regard to the reduction of size of the ignition system components, notably the dual magneto units. Not only must the weight be kept down as much as possible but the shape and size must be considered also.

The introduction of the newer alloys for the magnets of magnetos, such as Alni and Alnico (nickel-aluminium-copper-cobalt) has enabled a big reduction in size to be made to the magnet systems.

Another method of reducing the size of the ignition unit is to combine the two dual ignition units so that a single driving shaft only is needed. The L.T. generator units can then have the same common magnet system but with two entirely independent L.T. and H.T. systems as officially laid down. Further, it is possible to make the distributor as a separate unit, driven from the engine's camshaft so that it can be placed in a different position to the magneto generator unit in a similar manner to the distributor unit and the H.T. coil of ordinary coil ignition systems. In this way a certain amount of space can often be saved, but usually at the expense of increased weight.

The Coil Ignition System. Although for automobile engine purposes the battery and high tension coil has replaced the magneto almost exclusively, it has not as yet threatened seriously the aircraft engine magneto, but a good deal of experimental work has been done and is still in progress, to overcome certain disadvantages associated with the coil ignition system. The practical solution of these drawbacks would no doubt give the lead to the system in question on account of its other advantages.

In general, the coil ignition system, the principle of which is shown in Fig. 292, consists of a primary circuit taking its L.T. supply from a battery which is maintained by an engine-driven generator, with a secondary coil as in magneto systems. The contact breaker in the L.T. system, condenser across the contacts, rotor arm and distributor are common to both systems. The main difference between the two systems is the substitution of a battery supply of L.T. current at constant voltage for the magneto L.T. generator supply, thereby simplifying the ignition system by dispensing with the generator unit.

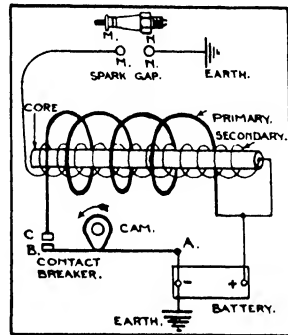

FIG. 292. Illustrating principle of the coil ignition system.

The principal advantages of the coil ignition system over the magneto one are as follows :—

(1) Greater simplicity and reduced bulk, since the contact breaker and distributor rotor single-drive unit can be made lighter ; the H.T. coil can be located in any convenient place away from the driven unit.

(2) A stronger spark at low engine speeds which obviates the necessity of using a hand-starter magneto, impulse starter or booster coil.

(3) Better electrical performance over a wider range of advance and retard.

The coil ignition system is cheaper to manufacture.

The principal disadvantages of the system in question may be summarized, briefly, as follows :—

(1) Where the L.T. supply is taken from the aircraft electrical system battery a serious source of electrical interference

with the radio receiver is introduced. This is due to the fact that the high frequency effects due to the sparks are also

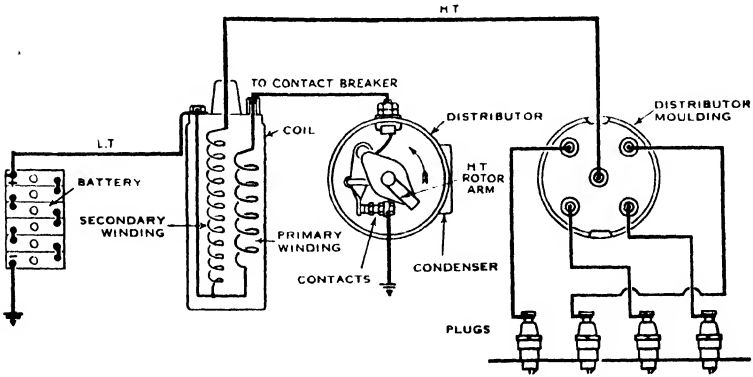

FIG. 293. General lay-out scheme for four-cylinder engine coil ignition system.

transmitted from the primary windings of the coil and thence to the other aircraft electrical circuits, from which they are

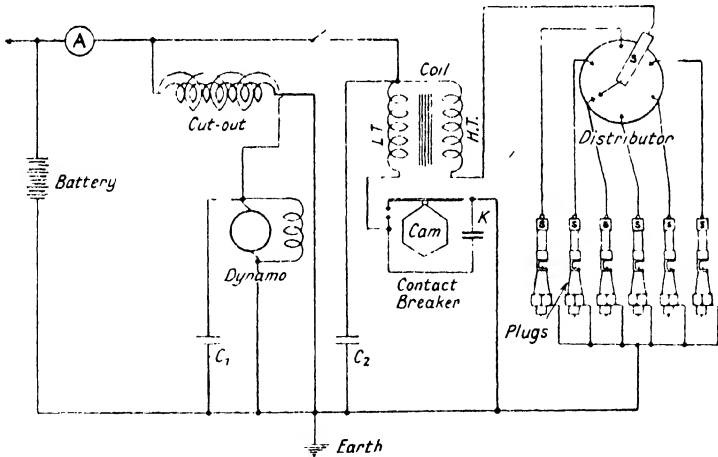

FIG. 294. A typical screened coil ignition system for six-cylinder engine.

radiated. To overcome this important drawback a separate battery and generator can be employed, but the question of

increased weight and bulk then place the coil ignition system in an inferior position to the magneto.

(2) The coil ignition system when used on aircraft under the prevailing conditions of shunt resistance and capacity loads is not so good as the aircraft magneto.

(3) The magneto enables higher sparking rates to be attained than with the coil ignition system.

(4) Greater risk of fuel ignition in a crash with the coil ignition system.

In regard to reliability there is nothing to choose between

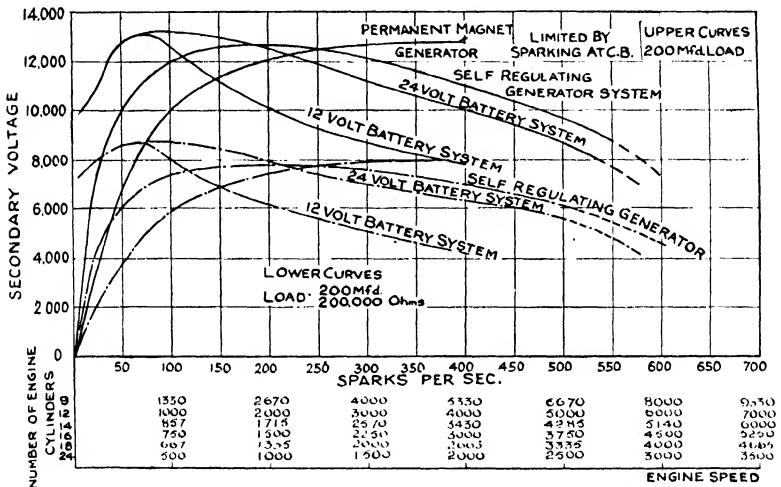

FIG. 295. Voltage-speed characteristics of coil ignition systems under various conditions of load.

the two systems, as the wide experience of automobile engine users has established.

Fig. 295⁶⁵ illustrates the voltage speed characteristics of coil ignition systems under different conditions of load ; these curves should be compared with those shown in Fig. 295 for magnetos.

The coil ignition system operates best at the lower engine speeds and, as previously stated, gives much better voltage performance at very low speeds, as the curves of Fig. 295 show. On the other hand, the performance of the 12-volt system shown in Fig. 295 is poor at high speeds and even

when designed for 24 volts is not comparable with the results given by a modern high-grade magneto.

One method which has been considered and upon which much experimental work ⁶⁵ has been carried out in this country consists in supplying current to the coil from the aircraft battery whilst the engine is being started and as soon as the latter is operating satisfactorily to switch over from the battery L.T. supply to that provided by an engine-driven generator. A special form of relay was devised for this purpose to function at a minimum (engine) speed of 800 R.P.M. The generator used was designed for the extreme speed range from idling to power-dive engine speeds without causing electrical interference with the aircraft radio installation. It was necessary to screen, effectively, the generator, coil and wiring system and to introduce choke-capacity interference suppressors.

Tests made with a coil ignition system and R.A.E. self-regulating generator without a battery and with the secondary shunted capacity of 200 m.mfds. showed that the maximum generator volts was 35 at 4,750 R.P.M. The secondary voltage was 10,000 at 500 R.P.M., rising to a maximum of nearly 13,000 at 1,700 R.P.M. and falling gradually to about 9,200 at 5,000 R.P.M. The generator weighed 10 lbs., and as will be seen from the performance curves given with those of battery coil ignition systems, in Fig. 295, the lower and upper limits of speed for a load of 200 m.mfds. and 200,000 ohms were 30 and 500 sparks, respectively.

It should be mentioned that apart from the ignition systems dealt with in this chapter, other types now in the test stage have been designed to provide better voltage characteristics and a magneto discharge of shorter duration in order to overcome sparking plug erosion difficulties and the high altitude ignition troubles hitherto experienced.

Sparking Plugs. These important components of the ignition system must fulfil a number of exacting requirements, which may be summarized, briefly, as follows:—

(1) They must operate satisfactorily under all the conditions of engine speed, mixture strength and compression ratios of modern high output aircraft engines.

(2) They must possess a high heat resistance so that the electrodes do not become sufficiently hot to cause any pre-ignition effects. This requirement necessitates good heat conduction from the interior members and satisfactory dissipation of the heat from the exposed portions of the plugs on the

cylinder heads, under modern engine cowling and cooling conditions.

(3) They must offer the maximum resistance to erosion, or burning away of the spark points whatever type of fuel is employed.

(4) The insulating material must withstand satisfactorily the chemical action effects of the fuel and hot products of combustion ; it must be strong mechanically and have excellent electrical insulating properties and good thermal conductivity.

(5) The electrical contacts and insulation must be hermetically sealed in a water-tight casing.

(6) Gas-tight joints between the insulator and metal parts are essential under all operating conditions.

(7) Complete electrical screening to prevent electrical interference with the radio apparatus on aircraft.

(8) Ease of dismantling for cleaning and inspection purposes.

A considerable amount of research work has been carried out on sparking plugs in connection with the design of the body, electrodes, connections, the most suitable materials for the electrodes and the insulators, etc.

The sparking plug voltage necessary to produce a satisfactory spark for ignition purposes, namely, from 0.03 to 0.06 joules per spark, depends upon the width of the gap between the electrodes and the density of the gases between the gap ; the wider the gap and the higher the density, the greater is the voltage required for the spark. Apart from these factors, there is also the possibility of deposits of carbon or of the fuel combustion products forming on the insulating surfaces of the plug and introducing a shunt-resistance effect in the secondary circuit, thereby reducing the ignition voltage ; this effect, together with the shunt capacity of the ignition system screening has already been referred to. This deposit may become sufficient, after certain periods of engine running, to provide an alternative path to earth for the high voltage discharge without bridging the sparking plug points. Under these conditions the insulator having the longest leakage path between the electrode and the outer metal shell is the best.

Sparking Plug Insulators. Owing to the exacting demands of aircraft engines the normal types of automobile plugs are not suitable from the point of view of insulating materials and electrode metals.

Mica insulated plugs have been widely used in aircraft

engines on account of their good electrical insulation properties under working temperature conditions. The mica used for the exposed part of the insulator near the central electrode is of the clear ruby or muscovite grade, in the form of washers over the electrode. The rest of the insulator is usually of mica wrappings—since washers would provide potential leakage paths between the layers, from electrode to shell—and the dark amber (phlogophite variety) is generally preferred for this purpose. This material has an upper working temperature limit of about 850° C.

The Lodge mica type plugs have a similar quality of wrapped

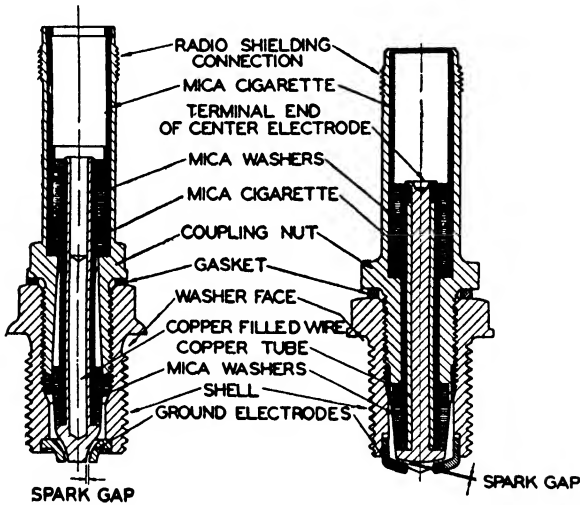

FIG. 296. Typical American mica insulated sparking plugs.

mica treated by a special process, such that they are able to withstand overheating for a brief period without ill effect.

These plugs are made gas-tight, permanently, so that they are unaffected by expansion and contraction of the central electrode under temperature changes, by shrinking the steel collar (which forms the shoulder between the upper and lower sets of mica washers) directly on to the mica wrapping of the central electrode.

Fig. 296 illustrates two typical mica insulated plugs, used on American aircraft engines, having mica washers at the two ends of the central electrode and mica wrapped in "cigarette" form for the central portion.

Mica, apart from its good high temperature insulation properties has certain disadvantages, namely : (1) It is a poor heat conductor so that cooling of the plug is more difficult. (2) In consequence of its low heat conductivity oil, fuel, moisture and current conducting deposits may accumulate on the insulator during " idling " running, and thus short-circuit the plug ; under full load conditions these deposits would be burnt off. (3) If overheated the water contained in chemical combination is driven off so that the mica becomes hydrated with consequent expansion, brittleness and transition to a white and powdery material. (4) In order to improve the heat flow through the main insulation the manufacturers usually reduce the thickness of the mica tube or wrapping, which not only renders the latter more fragile but increases the capacity of the secondary circuit. (5) The thermal expansion of mica is about half that of the steel of the central electrode unit so that it is more difficult to maintain a gas-tight joint under varying temperature conditions. (6) The affinity of mica for moisture is another disadvantage, so that this type of plug should be stored in heated cabinets. (7) Perhaps the greatest drawback to the use of mica in aircraft engine plugs is its liability to attack by the lead products of the " leaded " fuels now used in high output engines.

Mica is a silicate and tends to react vigorously with litharge (lead oxide), which may be formed on the exposed surface of the mica insulator by the oxidation of lead bromide from the " leaded " fuel ; such deposits seriously affect the thermal and electrical properties of the plug. The practical effects of lead attack on mica are those of partial disintegration by pinholes punctured right through to the electrode inside.

Although the mica plug has been widely used it is generally considered to have reached the limit of its development for aircraft engines and for this reason new materials have been sought for the more recent engines.

Ceramic Insulators. Ceramic materials, the earlier ones of which were the porcelains and steatite, are among the alternatives. The ceramic insulators used on certain American aircraft engine plugs represent a marked advance on the earlier materials for this class. The quartz and feldspar constituents which have been shown to cause volume changes and reduced insulation efficiency at high temperatures have been replaced by inert components such as *sillimanite* ; further improvements have been effected by finer grinding and the employment of

higher production temperatures so that the recent ceramic insulators are greatly superior to previous ones in mechanical strength, thermal properties and glaze fit. One advantage put forward for modern ceramic insulator plugs is the reduction of weight possible in making such plugs. Thus, for an eighteen-cylinder engine the mica plugs previously used for the dual ignition system weighed 4.8 lbs., whereas with 10 mm. ceramic insulator plugs the weight was only 1.26 lbs. for the same

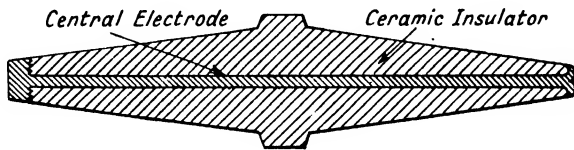

FIG. 297. Shape of ceramic insulator.

engine. Fig. 297 illustrates the shape of the ceramic insulator on an aircraft plug, with the central electrode moulded *in situ*. A shoulder below the maximum diameter seats directly on the shell or the internal gasket.

Sintered Aluminium Oxide Insulators. The most recent insulator material is aluminium oxide sintered into a hard uniform substance, known by the commercial names of Sintox and Sinterkorund. It is twice as strong as porcelain, has five times as great a heat conductivity, is immune from the attack of "leaded" fuel products and possesses a thermal expansion nearer to that of nickel than other ceramic materials hitherto employed, so that it is easier to seal the central electrode. Another advantage is that the cleaning of the insulator surface is a simple matter, for even sand blasting does not spoil the surface. Plugs having this type of insulator are shown in Fig. 299.⁶⁵ Certain difficulties which have been associated with plugs of this pattern are concerned with the design of a suitable joint between the insulator and the metal body of the plug; it has not been found easy to make a gas-tight joint without a certain amount of risk of cracking the insulator, more particularly at places where sectional changes occur. In this connection the use of spring washers instead of copper and asbestos washers is an improvement. Another trouble experienced has been that of misfiring due to low insulation resistance caused by carbon deposits, owing to the operating temperature being too low to

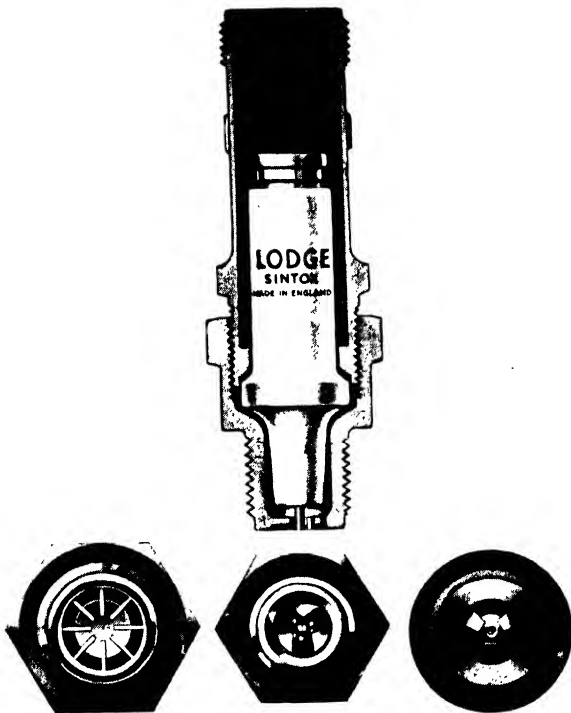

FIG. 298. The Lodge Sintox insulator sparking plug. (Below) Three alternative electrode arrangements, showing on left platinum-iridium electrode model.



FIG. 301. The K.L.G. sparking-plug with six platinum-iridium electrodes.

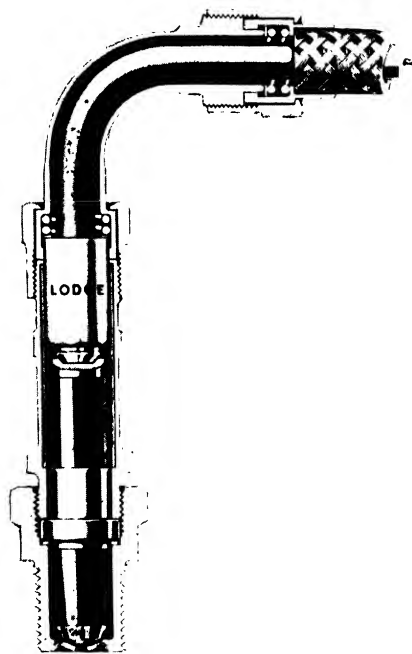

FIG. 303. The Lodge screened aircraft engine sparking plug.

[To face p. 359.]

burn off the deposits. These difficulties have now been overcome largely by design changes, including better joint methods

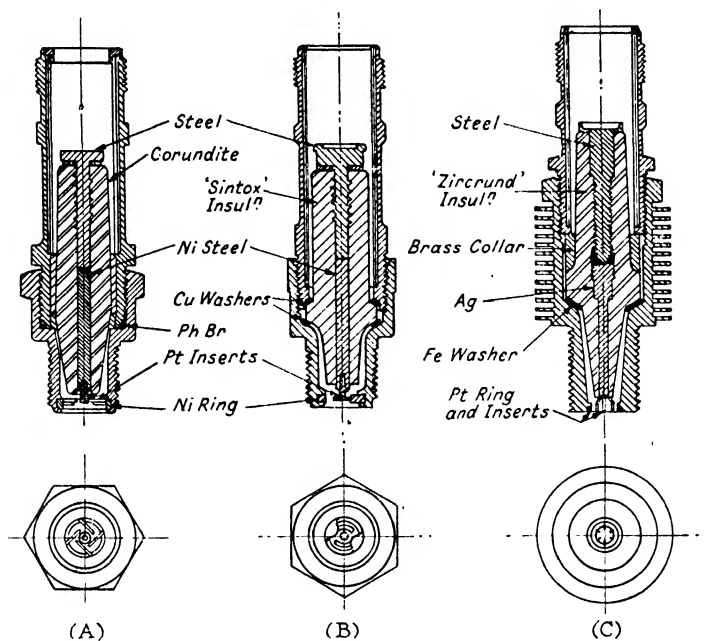

FIG. 299. Typical sparking plugs with sintered aluminum insulators. A—K.L.G., R-C.I; B—Lodge R.S.I; C—Sphinx Mk.I.Y.

and the provision of longer surface insulation for about the same gas space inside the plug body.

Electrode Materials. The chief trouble experienced with sparking plugs is that associated with the erosion of the electrodes, more particularly when "leaded" fuels are employed. This eating away of the electrodes results in a progressive increase of the sparking gap which necessitates the frequent removal of the plugs for resetting the gaps. It also requires a higher secondary voltage to bridge the increased gap and therefore adds to the difficulty of satisfactory high altitude operation. Tests made with modern sparking plugs on an air-cooled engine of 7.3 : 1 compression ratio and 100-octane fuel, with B.M.E.P.'s of the order of 220 lbs. per sq. in. indicate that it requires about 100 hours of running to increase the gap from its initial setting of 0.015 to 0.020 in.; it is the principal

object of electrical ignition research to extend this period considerably, namely, to at least 400 hours.

In regard to the most suitable metals for the plug electrodes various metals and alloys have been examined and in this connection it is of interest to refer to some of the results of investigations on erosion carried out by W. R. Debenham and F. G. Haydon⁶⁷ on a number of metals, including ferrous alloys, nickel-chromium alloys, tungsten, Stellite and alloys with a nickel content exceeding 95 per cent. The metals were tested in an engine running on 87-octane fuel. The general results of these tests indicated that tungsten showed the least erosion, pure nickel being second to it; all of the nickel alloys showed less erosion than the other alloys tested. None of the materials showed any signs of chemical attack and the erosion was confined to a small area.

Tungsten, despite its excellent erosion resistance is not suitable for plug electrodes since it requires a high sparking voltage and is difficult to apply on account of its brittleness, so that plug "points" cannot satisfactorily be adjusted by bending when made of this material.

High nickel alloys have generally proved the most suitable for aircraft plug electrodes since their erosion and sparking voltage are low and they can be used for the construction of adjustable electrodes in the form of inserts in a steel centre and the plug shell; moreover, these alloys or the pure nickel—which is the best electrode material of the nickel series—can readily be worked and bent for adjustment.

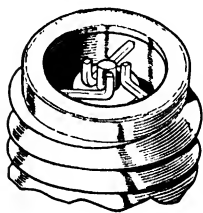

FIG. 300. Lodge plug electrodes consisting of three square sectioned platinum wires.

More recently platinum and platinum-iridium have been used in place of nickel, since the erosion resistances of these metals is only one-fourth to one-fifth of that of nickel. The platinum-iridium alloy, containing about 20 per cent. of iridium is preferable to platinum alone, since the latter is much softer and is more difficult to secure into the plug metal. The alloy is not, however, ideal, since it is liable to globular formations and transverse fissures

after appreciable periods of service.

Fig. 300 shows a Lodge aircraft plug having a Sintox insulator and a central electrode of platinum-iridium alloy wire of 0.047 in. (1.19 mm.) diameter. The metal shell or "earth"

electrodes consist of three square platinum wires brazed, by the hydrogen process, into a nickel ring in the plug shell. This design presents a minimum surface to the effect of erosion by hot gases and gives maximum life before gap adjustment becomes necessary. The tangential arrangement of the earth electrodes makes the setting of the electrodes a simple matter.

The K.L.G. plug shown in Fig. 302 is used on Bristol air-cooled radial engines and has given satisfactory results. It has a central steel electrode encircled by a copper sleeve and a mica wrapping, with mica washers at either end. The cadmium-plated steel screening sleeve is formed integral with the gland nut. This whole plug centre assembly is

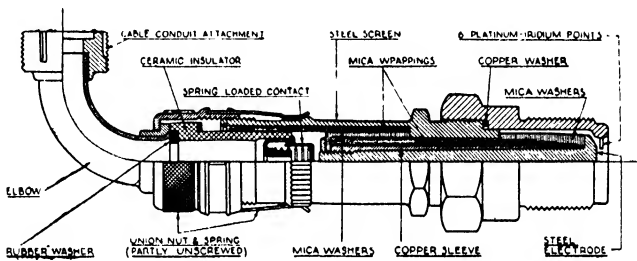

FIG. 302. K.L.G. sparking plug as used on Bristol aircraft engines.

screwed into the plug body which carries at its inner end the six platinum-iridium wire earthing points. These have been found to be much less prone to erosion than the previously used nickel points; the voltage required to produce the spark is also reduced considerably.

The flexible cable conduit is connected to the plug screen by a union nut attachment, with a pair of spring clips to lock the nut when screwed home. Between the nut and the end of the plug is gripped the shoulder of a ceramic insulator, into which seats a spring-loaded contact device. The bared cable end is nipped into the latter, so that whilst efficient contact is maintained with the plug electrode under all conditions of running, the one operation of unscrewing the union nut disconnects both conduit and cable from the plug. The whole assembly is watertight.

The Lodge screened terminal fittings (Fig. 303) give efficient radio interference-free couplings of cables to sparking plugs with conduit screening harness or metal braided cable. It is

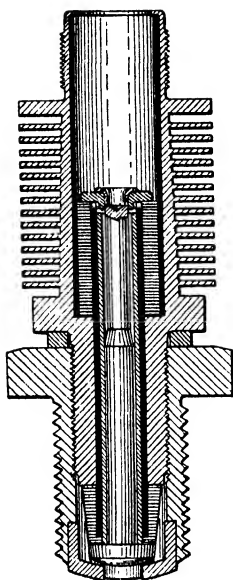

FIG. 304. Bendix aircraft engine sparking plug.

used also for couplings between the flexible branch and the main circuit; embodies a patent spring ferrule which provides a coupling with a butted metal joint which is quite free from radio interference, rain and spray proof and spring locked against the effects of vibration. All exposed metal surfaces are rendered resistant to rusting and sea-air corrosion by cadmium plating.

A typical American aircraft plug, known as the Bendix, made by the Scintilla Magneto Co., is illustrated in Fig. 304; it was designed as the result of extensive research on plugs. The plug has mica insulation and pure nickel electrodes, but investigations on an improved alloy, namely, that shown at D in the results of electrode erosion rates, in Fig. 305, indicate the possibility of using this better alloy. The earth electrode is of the adjustable four-prong type, using wide flat prongs extending over the blunt nose of the core, the sparks passing between the inner prong surfaces and the flat surface of the core electrode; this arrangement, it is claimed, gives a baffle action which prevents the accumulation of lead and other

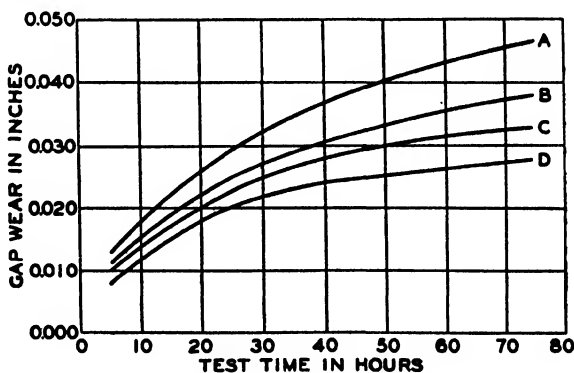

FIG. 305. Bendix aircraft sparking plug electrode erosion tests results.

deposits on the nose of the core. The centre electrode is of one-piece design, cold worked. A large copper tube, which surrounds the spindle of the central electrode and rests on the inner surface of the electrode nose assists in dissipating the heat from the nose.

Referring to Fig. 305⁶⁸ curve A was obtained from a special alloy recommended for plug electrodes; curve B, for the metal previously used in standard Bendix plugs; curve C, for pure nickel, and curve D for the other special alloy previously mentioned.

Fig. 306 shows the sparking voltages required for Bendix plugs, measured on a liquid-cooled engine operated at 3,100 R.P.M., with 30 degrees spark advance. The tests were made

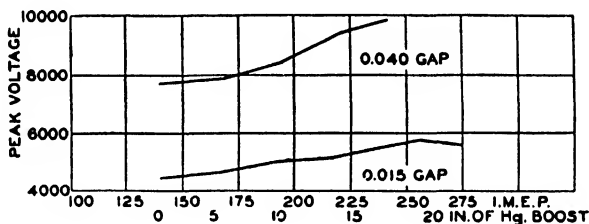

FIG. 306 Showing relation between breakdown voltage and I.M.E.P. in actual engine.

with gaps of 0.015 and 0.040 in. The results show the marked increase in sparking voltage as the gap is increased and the smaller increase with the increase of mean pressure. It was also found that the breakdown voltage of these plugs increased according to a linear law with the gaseous pressure, using CO_2 in a test bomb. Thus, for a plug with 0.015 in. spark gap the breakdown voltage was 7,600 for zero pressure; 8,000 volts for 12 lbs. per sq. in.; 10,000 volts for 68 lbs. per sq. in. and 14,000 volts for 180 lbs. per sq. in. pressure.

The rate of erosion of sparking-plug electrodes does not appear to be affected by the initial gap and increase of voltage does not increase the rate of increase of gap. Erosion is, however, increased by increase of the electrical capacity of the screening cables for preventing radio interference; the usual capacity addition from this cause is 100 to 200 m. mfd.

Fig. 308 illustrates the results of some tests on the effect of screening, using different lengths of screening cables, upon the erosion of the plug electrodes; it will be observed that there

is practically a linear increase of spark gap with length of screened cable.

Other factors affecting plug erosion include the effect of the distributed nature of the capacity, the shapes and sizes of the electrodes, type of engine in which the plugs are used and whether coil or magneto ignition is employed. Mention should

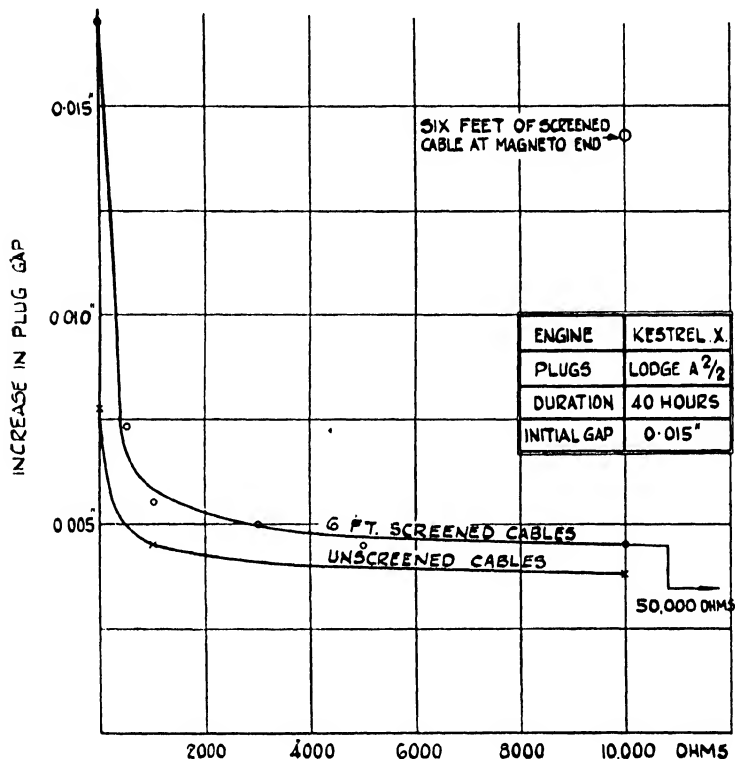

FIG. 307. Graphs showing effect upon erosion of sparking plug electrodes of resistances in series with the plugs.

here be made of the use of a series resistance in the plug cables, as a means of reducing electrode erosion by damping the spark. Tests were made at the R.A.E.,⁶⁵ using various resistance values; the results are shown in Fig. 307. It will be seen that the erosion is reduced by about 70 per cent. when a resistance of 1,000 to 2,000 ohms is inserted in the plug end, but that

the addition of further resistance up to 50,000 ohms does not effect any further marked improvement ; moreover, there is

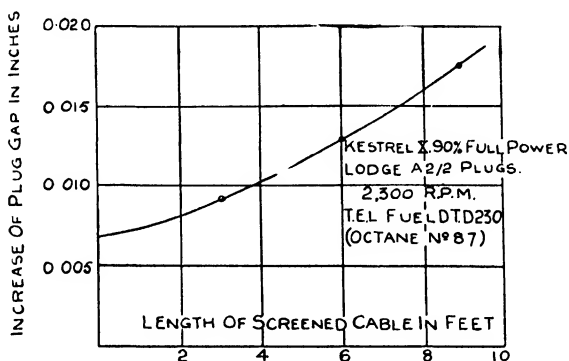

FIG. 308. Variation of erosion of sparking plug electrodes with length of screened cable.

little difference between the erosion effects with the un-screened cable and 6 ft. of braided cable, with resistances greater than 2,000 ohms.

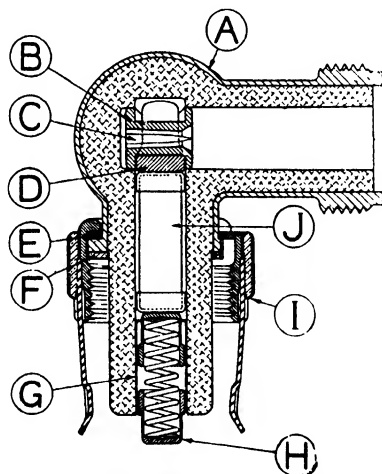

FIG. 309. The K.L.G. elbow resistor for screened sparking plugs.

A—Steel shell. B—Cable nipple. C—Cable-securing needle. D—Locking stump. E—Interlocking washer. F—Seating washer. G—Contact housing. H—Spring-loaded contact. I—Cable nut. J—1,000 ohm resistance.

(The Aeroplane)

An interesting resistance attachment to the screen of sparking plugs, designed by Messrs. K.L.G. Ltd., is illustrated in Fig. 309. The resistor is held in position between the cable end fitting and central electrode by means of a spring. It is stated that the use of this resistance unit has increased the period between plug maintenance attention by about three times, so that plugs thus fitted can be operated for 80 to 100 hours without adjustment of the gap.

Sparking Plug Specifications. The standard sizes of sparking plugs used for aircraft engines are the 12 mm., 14 mm. and 18 mm. ones; these sizes refer to the diameters over the plug threads. The pitches of the screw threads, which are of 60 degrees angle are 1.25 mm., 1.25 mm. and 1.5 mm., respectively. The standard plugs used for aircraft engines are specified in the British Standard Specification No. 2.E.9; this Specification also gives the dimensions for the tapped holes in the cylinder. In connection with the shape of the plug thread, this is radiused at the core and has a flat top similar to that of the Standard U.S. threads. The sparking plug washers are also standardized.

In regard to the screening requirements these are described in detail in the Air Ministry D.T.D. Specification No. E and I, 442, containing the Instructions for Screening and Bonding the Ignition System of Aero-Engines.

H.T. Cables for Sparking Plugs. The high-tension braided and harness cables for aircraft engines must be able to withstand somewhat severe conditions, including those of relatively high temperatures and exposure to the effects of engine lubricating oil, fuel and ozone.

The cables near the sparking plugs are often exposed to temperatures of the order of 140° to 160° C. and the insulating material must be able to withstand such temperatures continuously. The best quality rubber, of natural origin, used for H.T. cables will not stand up to such temperatures for long, as softening and oxidation effects occur. The latter may to a large extent be prevented by coating the rubber with cellulose lacquer so as to protect it against oxidation. The use of cotton-braided covers with cellulose lacquer coatings has also proved satisfactory.

More recently synthetic rubbers, including Neoprene, Buna and Thiokol have been applied to H.T. cable construction, since they will withstand the action of oil and petrol, and can be used at temperatures up to about 150° C. without protective

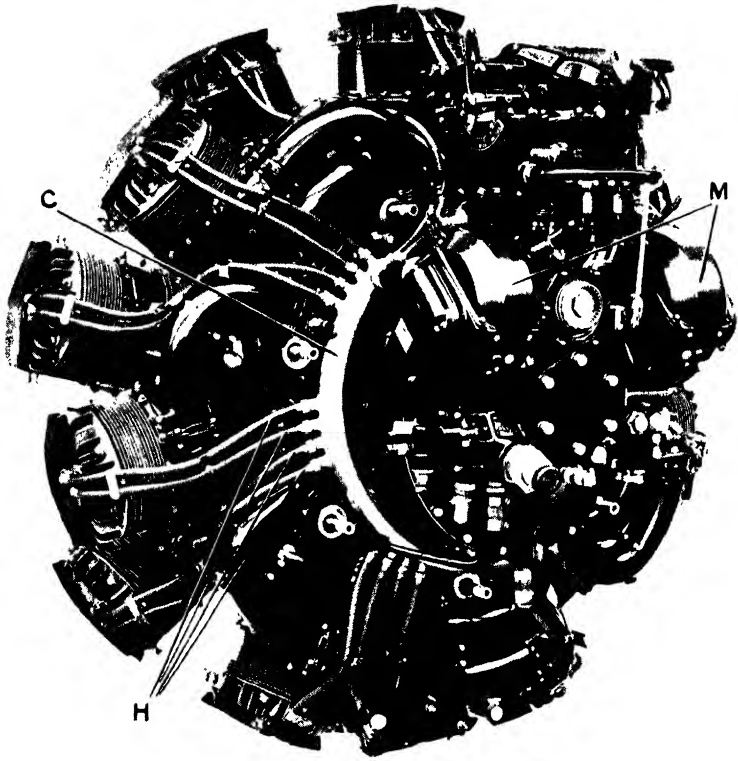

FIG. 310. The Bristol sleeve valve engine ignition harness.
C—Ignition harness. H—Sparking plug screened cables. M—Dual magnetos.

coatings or braiding. A promising material for H.T. cables is a composite material having a high-grade rubber core, an outer sheath of synthetic rubber and a treated braiding enclosing the latter ; the braiding is treated with an oil varnish or cellulose to protect it against oxidation effects.

Fig. 310 shows the ignition harness for the Bristol nine-cylinder radial engine ; this is a particularly neat arrangement and occupies the minimum of space whilst giving easy access to the plugs. The harness consists of a horseshoe-shaped main conduit connected through flexibly jointed elbow pieces to the metal casings which surround the magneto distributors and contact breakers. The screwed unions around the main conduit are attached to smaller conduits of flexible metallic tubing leading to the sparking plugs. Through this system of conduits passes each continuous length of H.T. cable from distributor to plug. It is possible to detach and replace each cable without disturbing the others ; the cables themselves incorporate synthetic rubber compounds rendering them highly resistant to the effects of heat, oxidation, petrol and oil ; moreover, the complete ignition system is waterproof.

CHAPTER X

THE EXHAUST SYSTEM

The Exhaust System. The principal requirements of an efficient exhaust system for an aircraft engine may be stated, briefly, as follows: (1) It should discharge the exhaust gases clear of the aircraft with an exit temperature as low as possible, namely, well below the visible flame temperature; this is important for night flying military aircraft. (2) It should give the minimum back pressure (mean) in the exhaust system. (3) It should silence the exhaust noises down to a reasonable limit.

Whilst it is possible with ground installations to silence efficiently a high-powered engine, the weight of the exhaust pipe, silencer and other items would be prohibitive on aircraft, so that a compromise must be made, such that the maximum degree of silencing, combined with a relatively low back pressure and exit temperature are obtained for an exhaust pipe and silencer combination which shall not exceed 0.05 to 0.10 lb. per maximum B.H.P. of engine.

Apart from these main essentials the exhaust system must fulfil a number of important practical requirements; these are considered later.

Some General Considerations. When a single-cylinder petrol engine is operating steadily at a given speed, with a "straight through" or open pipe type of silencer, *i.e.*, a tube of constant diameter, the pressure at any position in the exhaust pipe is not uniform but fluctuates between certain maximum and minimum values.

The nature of the pressure variations, it has been found, depends upon a number of factors including the ratio of length-to-diameter of pipe, the engine speed and inlet and exhaust valve timing.

These pressure waves are actually sound waves of definite frequencies which can be calculated approximately for the cylinder and exhaust pipe combination regarded as an acoustical resonator from the following relation ⁷² :—

$$\text{Frequency} = \frac{V_s}{2\pi} \sqrt{\frac{A}{V(l + 0.89\sqrt{A})}}$$

Where V = cylinder volume. V_s = velocity of sound. A = cross-sectional area of pipe. l = length of pipe (foot-second units).

The frequencies in question correspond to those for an organ pipe of the exhaust pipe dimensions, closed at one end and open at the other. The frequency of the fundamental wave

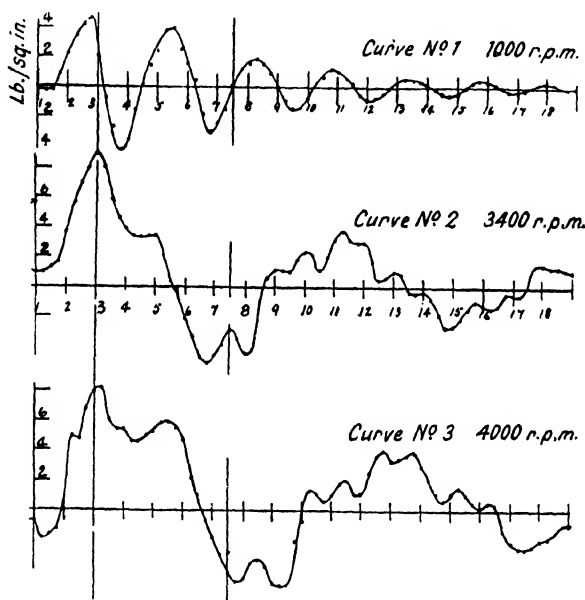

FIG. 311. Exhaust pressure curves for single cylinder engine.

is not affected by the speed of the engine, but as the speed increases there is not sufficient time for the wave to become damped out, so that the succeeding exhaust discharge wave is interfered with by the residual wave in the pipe and therefore the character or shape of the pressure wave, *i.e.* pressure fluctuations on a crank-angle or time base, is changed.

Fig. 311 illustrates the results of some tests made by Dr. J. C. Morrison⁷³ on a single-cylinder petrol engine of 85.7-mm. bore and 84-mm. stroke, with a compression ratio of 5.25 : 1 and valve passages of 39.7 mm. (1 $\frac{9}{16}$ in.) diameter, in which pressure

diagrams were taken from the exhaust pipe near the valve by means of a special indicator. The three curves correspond to diagrams obtained at 1,000, 3,400 and 4,000 R.P.M. respectively. The base line scale is such that the 18 divisions equal 600 degrees, *i.e.* rather less than two complete revolutions for the four-cycle engine. The maximum valve lift was 8.1 mm.

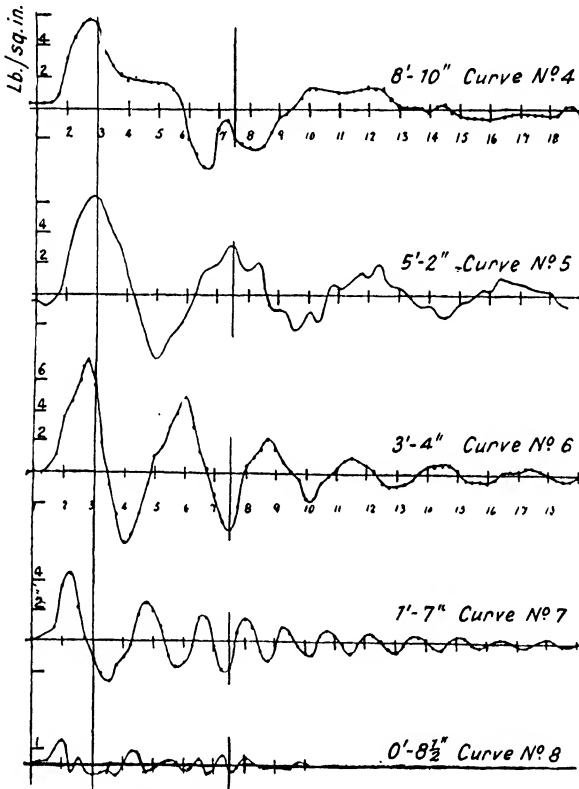

FIG. 312. Effect of exhaust pipe length on pressure valves.

($\frac{5}{16}$ in.). At the lowest speed the pressure waves are roughly of the damped sine wave form and practically die out before the exhaust valve again opens. As the speed is increased the pressure fluctuations are of greater amplitude and of a different character, and the mean value of the pressure—taking the positive and negative parts of the curves—increases with the speed.

As the speed increases the harmonics of the fundamental wave are seen to become more pronounced, the combination of waves tending to lower the pressure rather than to form higher pressure peaks or nodes.

The maximum pressure occurs just before the bottom dead centre for low speeds and a little after for the highest speeds; the exhaust valve of the engine in question opened at about 60 degrees before bottom dead centre.

The effect of exhaust pipe length upon the pressure fluctuations for smooth pipes of 8½ in. to 8 ft. 10 in. is shown by the curves 4 to 8 in Fig. 312 for an engine speed of 2,000 R.P.M. These results indicate that the pressure at bottom dead centre increases with length of pipe to a maximum of about 7½ lbs. per sq. in. for a length of 3 ft. 4 in., there being no further increase for greater lengths; the addition of a silencer did not increase this pressure.

The length of pipe beyond which any further lengthening does not increase the maximum pressure has been termed the *critical length*. This length was found to diminish as the engine speed was increased, in

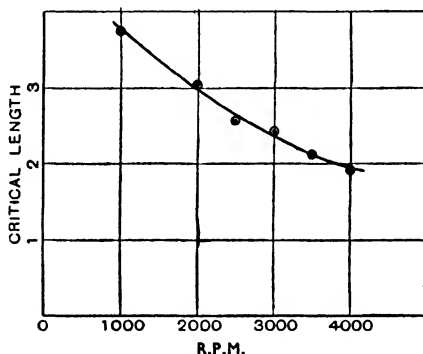

FIG. 313. Critical length of exhaust pipe for different speeds.

the manner shown in Fig. 313; thus at 4,000 R.P.M. the critical length was a little more than one-half the length at 1,000 R.P.M. Actually it is the ratio of pipe length to diameter which is concerned with the results mentioned, so that the lengths given should be divided by the internal diameter of the pipe, namely 1½ in. The absolute values of critical length-to-diameters is dependent upon the valve lift, valve timing, exhaust port and manifold design and certain other factors, so that experimental determination is necessary for any particular design of engine.

The nature of the pressure variations in the exhaust pipe is such that the first pressure rise occurring at about bottom dead centre just after the exhaust valve has commenced to open is followed by a negative or minimum pressure wave which,

in turn, is succeeded by another pressure wave of smaller intensity than the first.

Utilising Exhaust to improve Charge Efficiency. By suitably selecting the size of the exhaust pipe it is possible to arrange for the negative pressure just near to the exhaust valve to occur at the same time as the inlet valve is opening so that there is actually an increased suction effect in the cylinder which tends to *improve the volumetric efficiency*. This effect has been utilised in certain designs of engines in order to obtain better charging of the cylinders; a typical example is that

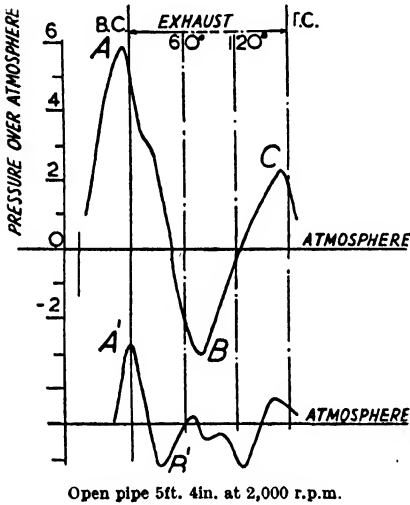

Open pipe 5ft. 4in. at 2,000 r.p.m.

FIG. 314.

of the two cycle engines using the Kadency system.⁷⁴ It should be pointed out that since the pressure wave characteristics change with increase or decrease of engine speed, this method of increasing the charge efficiency is applicable over a limited range of speeds; in practice this range would correspond with speeds in the vicinity of the maximum output speed.

Fig. 314 illustrates two typical exhaust pressure curves taken near the exhaust manifold and near the open end of the exhaust pipe, namely, at 4

in. from the end, in the case of a 5 ft. 4 in. pipe and engine speed of 2,000 R.P.M. The results show how the exhaust pressure is reduced considerably towards the open end of the pipe.

Multi-cylinder Engines. Hitherto, the exhaust system of a single-cylinder engine only has been considered, in order to illustrate certain fundamental facts. When the multiple-cylinder engine with a common exhaust system to each bank of cylinders is studied experimentally, it is found that there are certain differences from the single-cylinder exhaust pressure characteristics.

On the other hand, if each of the cylinders has its own

separate short exhaust pipe the results previously given for single cylinders are applicable.

As far back as 1911 indicator diagrams were obtained by the author from single- and four-cylinder petrol engines, using the Watson optical indicator. Fig. 315 illustrates the results of one series of tests upon a four-cylinder engine having a 9-ft. exhaust pipe and two plain expansion chambers each of about 1 cu. ft. capacity, arranged in series. Curve A corresponds to a speed of 600 R.P.M. and Curve B to 1,240 R.P.M. It will be observed that at each speed there is the characteristic

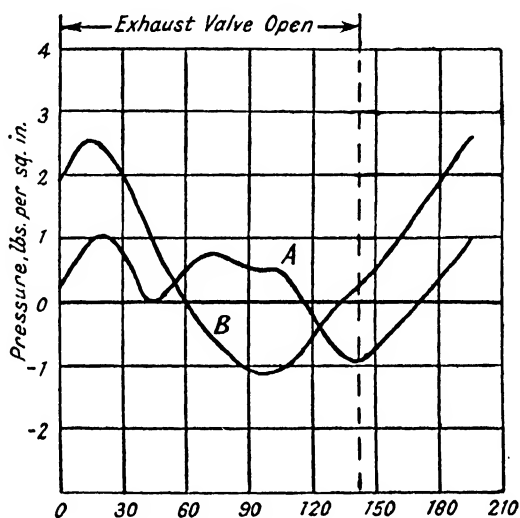

FIG. 315.

maximum pressure peak soon after the exhaust valve opens, followed by a negative pressure one just before the valve closes. Curve B shows a marked resonance effect due to the exhaust frequency corresponding to the natural frequency of the exhaust pipe system.

The results of some tests made by Dr. J. C. Morrison⁷² on a 2-litre, six-cylinder engine, fitted with four short curved exhaust pipes leading into a common pipe followed by a 6-ft. pipe and an absorption type of silencer, are reproduced in Fig. 316 for speeds of 1,500 to 4,000 R.P.M. The diagram of exhaust pressures obtained at 1,500 R.P.M. is given for two complete revolutions, to show the degree of variation between

the different pulses. The differences in the pulses are due to the fact that there were four offtakes from the six cylinders at different parts of the manifold. The first pressure peak at A, just before the bottom dead centre is followed by a quick fall to a point B below atmospheric; this part of the curve would probably continue as in the dotted line if it were not for the next pulse. The pressure was below atmospheric at top dead centre—a condition favourable to the induction process. It was found that as the engine speed increased beyond 2,000 R.P.M. the peak pressures and also the mean exhaust pressure rose appreciably. The nature of the exhaust pressure curve is influenced by *the shape of the exhaust cam* and the *exhaust valve timing*, so that by studying the exhaust curve at the normal operating speed of any engine it may be possible to effect beneficial results in the power output by experimental

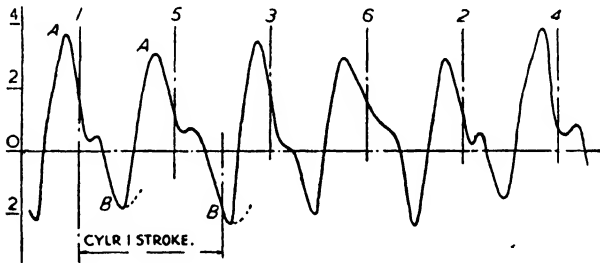

FIG. 316. Exhaust pressure curves for six-cylinder engine.

variations of cam shape and valve timing. Thus, the maximum peak pressures can be kept down and the minimum or negative pressures arranged to occur when the inlet valve is about to open. Other variables that can be investigated experimentally include the exhaust manifold size and shape, the exhaust pipe dimensions and the silencer.

Exhaust Mean Pressure and Output. The effect of exhaust or back pressure is to increase the area of the exhaust-suction loop of the indicator diagram; as this area represents negative work the result will be to reduce the net area of the complete diagram. Thus as the exhaust pressure increases so the power output is reduced. Another effect of back pressure in the exhaust system is to increase the temperature of the exhaust valve and also of the residual exhaust gases left in the cylinder just before the inlet valve opens. The former effect may eventually give rise to detonation of the charge whilst both of

these tend to reduce the charge or volumetric efficiency. It is for these reasons that aircraft engine silencing systems aim at reducing the exhaust mean pressure to the minimum value, namely, below about 1 lb. per sq. in.

It is important to remember that whilst in many instances the value of the exhaust mean pressure gives a measure of the power lost in the exhaust system this is not true in general, since *it is the value of the pressure in the vicinity of the exhaust manifold at the top dead centre, and at the moment of opening of the inlet valve that determines the effect of the exhaust system upon the power output.* Thus, whilst the exhaust mean pressure may be from 1 to 4 lbs. per sq. in. above atmospheric, the pressure near the exhaust valve at the moment of opening of the inlet valve may actually be below atmospheric pressure; this is also a measure of the residual gas pressure.

Tests made upon a Curtiss eight-cylinder aircraft engine ⁷⁵ which was run at a given speed, with various back pressures and power measurements made, indicated that for exhaust mean pressures up to about 7 in. of mercury (3.4 lbs. per sq. in.) the power loss was directly proportional to the exhaust pressure, but for higher values of the pressure the rate of loss of power increased more rapidly, due no doubt to the effect of increasing exhaust temperature upon the volumetric efficiency.

Further data on this subject are given in Chapter VIII, Vol. I. of this work, where a number of different test results are shown indicating how the increase or reduction of the exhaust pressure affects the power output, both qualitatively and quantitatively. It is also shown that the effect of exhaust pressure is more serious at higher altitudes than at ground level.

In regard to the type and acceptance tests of supercharged aircraft engines in this country it is usual to apply a correction to the measured B.H.P. for exhaust or back pressure, the power output being altered by $1\frac{1}{2}$ per cent. for each 1 lb. per sq. in. of back pressure. Thus, if the B.H.P. of an engine is measured on a dynamometer and its value is P for an exhaust pressure of p lbs. per sq. in., then the B.H.P. P_0 of the same engine using an exhaust system giving a mean pressure of p_0 lbs. per sq. in. will be given by

$$P_0 = P \cdot \left(\frac{1 + 0.015p}{1 + 0.015p_0} \right).$$

This correction can, however, only be regarded as approximate, for reasons given earlier in this section.

Exhaust Silencers. When an aircraft engine is allowed to exhaust its burnt gases straight into the atmosphere, although the power output is generally a maximum, as compared with exhaust pipe and silencer systems, the resultant noise is intolerable and—apart from any considerations of open-flame effects—quite unacceptable for aircraft operating conditions.

It is therefore necessary to employ a suitable exhaust silencing system such that whilst it will reduce the exhaust noise down to the desired limits of intensity will not reduce appreciably the power output at take-off, climb, cruising and full power outputs; moreover, the exhaust system must be as light as possible in weight and of minimum bulk. A further requirement for aircraft purposes is that the shape of the exposed part of the exhaust system should be such as to give the minimum drag effect, in conjunction with the engine nacelle or fuselage, as the case may be.

The exhaust noise, which is the result of the fluctuating pressures at exit from the system, is due to a combination of notes of various frequencies, *i.e.* the sound wave is of complicated form made up of fundamental notes and overtones, etc. For practical purposes the exhaust noise may conveniently be regarded as consisting of two main parts, namely, a *low-to-medium frequency band* of about 50 to 600 cycles per second and, disregarding an intermediate frequency band from 600 to about 3,500 cycles per second, of little noise, a *high-frequency band* of about 3,000 to 10,000 cycles per second.

The lower frequency part appears to be due to a resonance effect between the varying capacity of the cylinder and exhaust system as the piston moves in the exhaust stroke and the area through the exhaust valve as it opens and closes. This conjecture has actually been confirmed by tests⁷⁶ made upon a petrol engine driven by an electric motor at the same speeds as when running under its own power, when the low-pitch noises were shown to be almost as great as when the engine was working normally.

The high pitch part of the noise is due primarily to the release of high-pressure gas—at pressures of 50 to 70 lbs. per sq. in.—through the exhaust ports and silencing system. Alterations of engine speed whilst affecting the intensity of the total noise do not materially influence the pitches of the two parts of the noise.

In studying the problem of effectively silencing the exhaust noise it is necessary to consider the means to deal with each

of the two main frequency bands. Unfortunately any silencing system designed to suppress or damp down the high-frequency band will not reduce the low-frequency notes appreciably.

Thus it has been ascertained that a silencer of the *absorption type* consisting of a straight-through perforated tube in an outer casing filled with absorbent material, such as glass, silk or bundled fine wires, will damp down and absorb most of the high-frequency notes; in this case the peaks of the high-frequency pressure waves pass out through the perforations into the absorbent material and are thereby reduced in magnitude, but may return after some delay out of phase with other peaks; in effect, these waves are smoothed down so as to give a more or less continuous pressure condition associated with low intensity noise at exit.

This type of silencer is, however, ineffective for dealing with the lower frequency band, for which the best type of silencer is the *capacity type*, i.e. a plain silencer of relatively large capacity and big changes of sections; its action is based upon the absorption of sound waves in the turbulent areas of each change of section.

By combining the two types of silencer it is possible to deal with both the higher and lower frequency bands and thus to obtain the best silencing of the complete exhaust noise. Fig. 317* illustrates, diagrammatically, how this can be effected, whilst the practical interpretation of these principles to composite silencers is indicated below in Fig. 317.

Absorption Silencers. In consideration of this type of silencer, which is one of the most effective of any, at present, it may be pointed out that the human ear is more sensitive to notes of higher than of lower frequency. Thus, at about 40 cycles per sec. the ear is just sensitive to noise and as the frequency increases the audibility also increases rapidly, reaching a maximum between about 1,000 and 3,000 cycles per sec. Of the various absorption silencers available, special

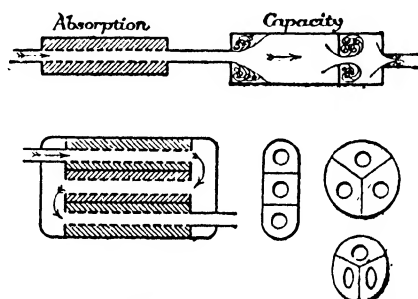

FIG. 317. (Above) Absorption and capacity type silencer. (Below) Examples of absorption silencers.

* Courtesy "Engineering."

mention should be made of the Burgess, Servais and Willman silencers illustrated in Figs. 318, 319 and 320. The former type, in its simplest form, consists of an inner perforated pipe D of the "straight-through" type, located in an outer cylindrical chamber F enclosing the sound-absorbing material E. The exhaust gases pass straight through the pipe D, the higher

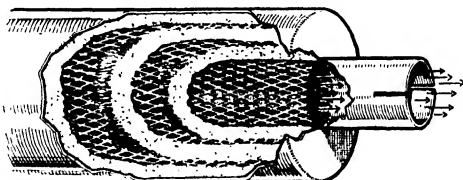

FIG. 319. The Servais absorption type silencer.

frequency pressure waves being absorbed or damped through the perforations and absorbent material.

The Servais silencer, shown in Fig. 319, consists of a sandwich roll arrangement of expanded metal netting with absorbent material, such as steel wool, asbestos fibre or spun glass wool between. The central perforated or "net" tube has a straight-through passage for the exhaust gases. This type of silencer has also proved effective for silencing machine guns and pistols ; it is designed primarily for aircraft, automobile and

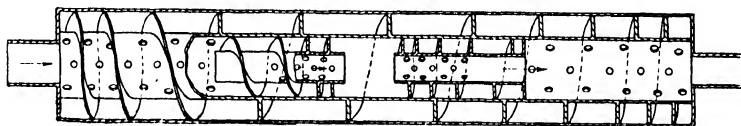

FIG. 320. The Willman silencer.

marine engines. The Willman silencer, shown in Fig. 320, aims at absorbing the higher frequency notes by the provision of chambers of calculated capacities each of which deals with one of the harmonics from the first to the eleventh ; the high-frequency harmonics are damped by interference and resonance of the helicoidal chambers ; the latter act as resonators responding to a scale of multiple frequencies.

In connection with the absorption type of silencer it is not absolutely essential to have an absorbent material between the perforated exhaust pipe and the outer cylindrical container as the Willman design of silencer indicates.

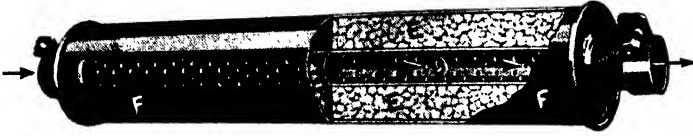

FIG. 318. The Burgess silencer.

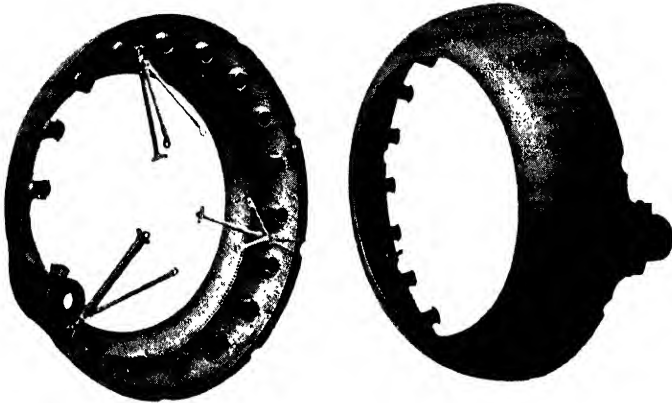

FIG. 328. Bristol exhaust manifold (shrouded type).

The results of some tests ⁷⁶ made with motor-cycle type silencers on a two-cycle engine with two similar silencers, one having plain perforations in the exhaust pipe with glass silk in the outer container and the other outward perforations of the nutmeg grater pattern and without absorbent material in the outer container are shown in Fig. 321. The nutmeg-grater

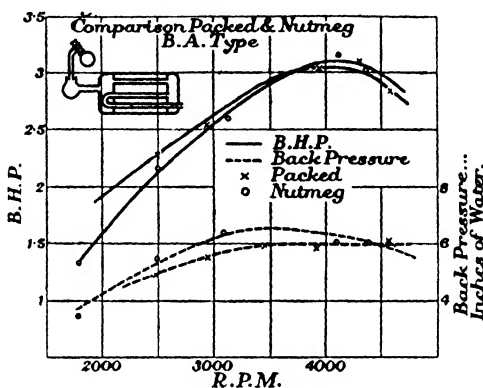

FIG. 321. Absorption silencer test results.

type was inferior at lower outputs but gave a slightly greater maximum output, although it was slightly more noisy.

These results are of practical interest since there is always a possibility of the absorbent material becoming impregnated with carbon or oily deposits from the exhaust after prolonged periods of running.

The Vokes Aircraft Engine Silencer. The design of this

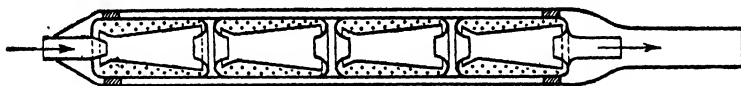

FIG. 322. The Vokes aircraft engine silencer.

silencer with its separate expansion reservoirs and perforated containers is shown in Fig. 322. The outer cylindrical container is of relatively small diameter, namely, about twice the exhaust pipe diameter, so that its drag is comparatively low.

Tests made at the R.A.E. on a Vokes silencer fitted to a Rolls Royce "Kestrel" engine developing 450 B.H.P. showed a noise reduction of 26 B.S. phons and a back pressure of 1.9 to 3.2 lbs. per sq. in. The weight of the silencer was 39 lbs.

The Burgess Aircraft Engine Silencer. After an extended series of experiments in conjunction with the Burgess Products Co. Ltd., this type (Fig. 323) was developed at the R.A.E. to provide a light, durable and effective silencer of low back pressure for use on aircraft.

The design is based on scientific principles and the noise reduction and back pressure can be very closely predicted, so much so that, experimentally, the agreement with the calculated values were within the limits of observation.

Essentially this silencer is a full resonator consisting of two resonator chambers, the first, at the inlet end having re-entry to the exhaust passage and the second one an outlet to atmosphere. Surrounding the exhaust pipe and within these chambers are acoustic filters communicating through properly proportioned and located holes with the exhaust pipe and with the exterior surrounding chamber.

The acoustic principle so successfully employed in this silencer is known as "reflection," due to the sound waves

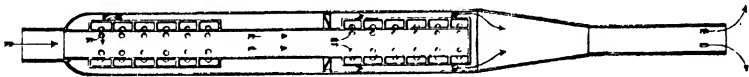

FIG. 323. The Burgess-Farnborough silencer.

being reflected out of phase. If the pressure peaks can be reflected so as to coincide with the hollows or troughs of the following wave, they cancel each other out and the sound waves are neutralized.

Carefully observed tests have proved that the passage of the exhaust gases through the secondary acoustic filters causes a suction on the primary series. This explains the extremely low back pressure readings obtained from the complete system, tests on experimental silencers consisting of a primary system alone having given much higher back pressure.

This silencer is not a standard production article but is individually designed for each application and full particulars of the aircraft engine for which it is required—bore, stroke, R.P.M., diameter of exhaust at manifold or collector ring and temperature of exhaust gas must be known before a design can be prepared.

Tests made at the R.A.E. with the Burgess types J. and K. (Farnborough modified) aircraft silencers for a Rolls Royce "Kestrel" engine at 450 B.H.P. output showed that the noise

reduction in B.S. phons was 26 and 23 respectively, whilst the back pressures were 1.5 and 0.3 lb. per sq. in. respectively. The two silencers weighed 39 and 44 lbs. respectively.

Exhaust Noise Intensity. In connection with the noise reduction of the Burgess Type K silencer it should be explained that the 23 phons reduction was sufficient to reduce the engine exhaust noise below that of the airscrew noise. The open exhaust noise of an aircraft engine at full power is about 110 decibels at 15 ft. and a reduction of 25 to 30 decibels corresponds to a fairly satisfactory degree of noise reduction below the threshold of feeling. The noise of the airscrew is well above that of an engine fitted with an efficient silencer ;

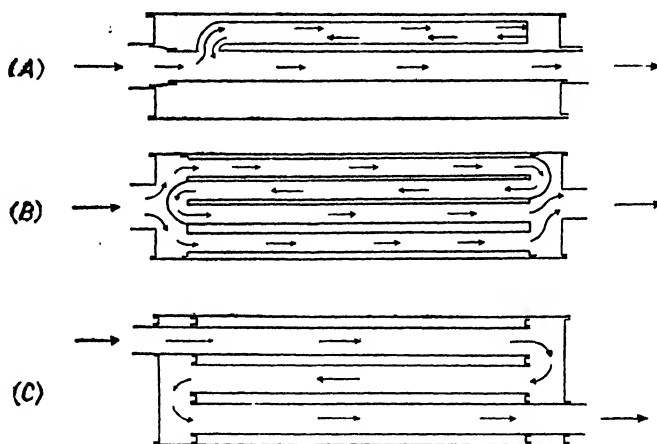

FIG. 324. Interference type silencers.

thus for a typical airscrew with a tip speed of 750 ft. per sec. the noise at a distance of 15 ft. is about 105 decibels, and this is reduced to about 92 decibels for a tip speed of 550 ft. per sec.

Interference Type Silencers. The principle employed in this type of silencer is somewhat similar to the reflection type mentioned previously and consists in the cancellation of the sound waves causing most of the noise by interference between the constituent waves, whereby the pressure peaks are made to coincide with the negative or minimum pressure ones so as to cancel out.

Typical examples of such silencers ⁷⁸ are shown in Fig. 324. Diagram A illustrates the principle of the Quincke silencer, in which a closed end tube of length equal to one-quarter of the

wavelength of the sound wave to be cancelled is employed. The wave enters the smaller tube, is reflected from the closed end and returns out of phase to cancel out the direct wave. Diagram B refers to the Herschell pattern silencer which provides a divided path for the sound waves, one path being one-half of the wavelength to be cancelled longer than the short wave path. When the waves re-unite at the exit side they are out of phase by one-half wavelength and therefore cancel out.

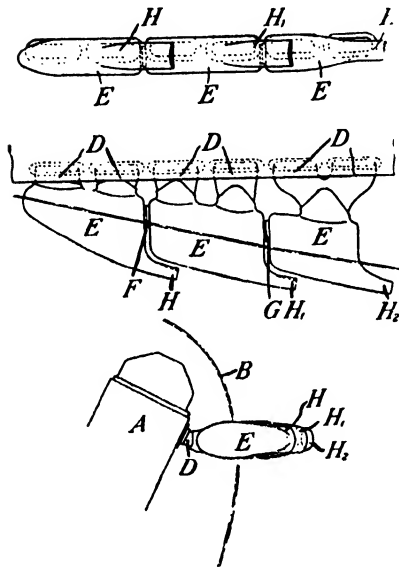

FIG. 325. Rolls Royce ejector type silencer.

Diagram C shows another type of silencer in which the gas travels through perforated tubes or pipes alternatively from one end of the silencer to the other. This type is usually made with three pipes, the gas first flowing from the front to the rear through one pipe, then through another pipe to the front, and thence to the rear and into the tail pipe. At any transverse section of the silencer a wave in one pipe is out of phase with the wave in another pipe and can short-circuit across the surrounding chamber and cancel out.

The Ejector Type Manifold. This design of exhaust manifold which is used on Rolls Royce "Merlin" engines possesses the advantages of minimum bulk, low head resistance, minimum disturbance of the discharged gases to the external airstream and the beneficial effect of the kinetic energy of the gases discharged from the nozzles in creating a forward thrust on the aircraft.

Fig. 325 is a reproduction of the original patent specification drawings⁷⁹ which illustrate an exhaust system which serves an engine having two banks of cylinders arranged in a Vee, one of the banks being shown at A. The engine is contained in a cowling B. Each bank has six cylinders, the exhaust gases

from which pass into short pipes D. Three expansion boxes E are connected together by short lengths of piping F and G, and each of these collects the gases from two of the pipes D. Each box has rearwardly projecting nozzles H, H₁, and H₂ with orifices shaped as shown in Fig. 325, those of nozzles H, H₁ being crescent shaped and that of H₂ being oval. These nozzles are tapered and restricted and operate to increase the kinetic energy of the gases at the point of discharge. The group of boxes together forms a member of flattened streamline shape except for the necessary departure therefrom due to accommodating the discharge orifices. In the example shown only a part of the streamline member lies outside the cowling. It

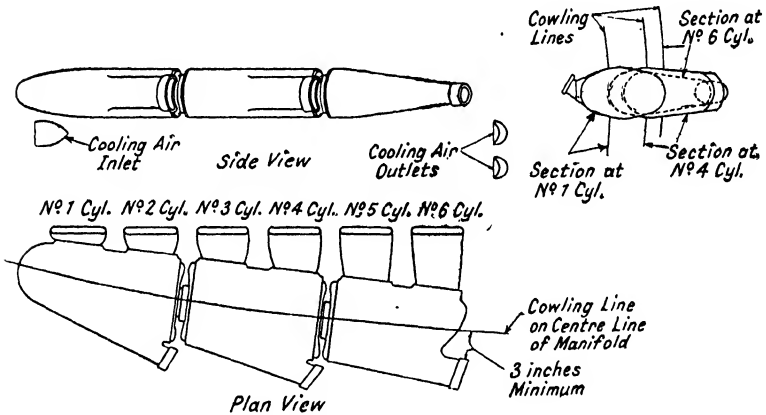

FIG. 326. Rolls Royce ejector type silencer.

may, however, be wholly outside. The rearwardly projecting nozzles have two advantages. Firstly, less disturbance to the external air stream is caused by the discharge of the gases; and secondly, the kinetic energy of the gases discharged from the nozzles may create a forward thrust on the aircraft.

Fig. 326 shows the ejector manifold, with the principal items lettered for easier identification, the type in question being the later development of the earlier slotted, streamlined blister-type exhaust system used on Rolls Royce engines, in which the exhaust gas expansion took place in one lobe or blister coupled to each pair of cylinders, the discharge being through a slot in the outer face of each lobe; this arrangement had the advantage of preventing flames at the outlets.

The back pressure with the type of exhaust system shown in Fig. 326 can be kept down below 1 lb. per sq. in. and the performance of the aircraft is not affected ; at very high speeds, namely 350 M.P.H. and above, the system actually gives an increase in the speed of the machine. The ejector system has good silencing and also flame-damping properties.

The system in question showed a noise reduction of 6 decibels as compared with short stub pipes for the exhaust gases, whilst the weight is only about 60 per cent. of the long exhaust pipe system. *Cooling of the ejector manifolds* is assisted by a

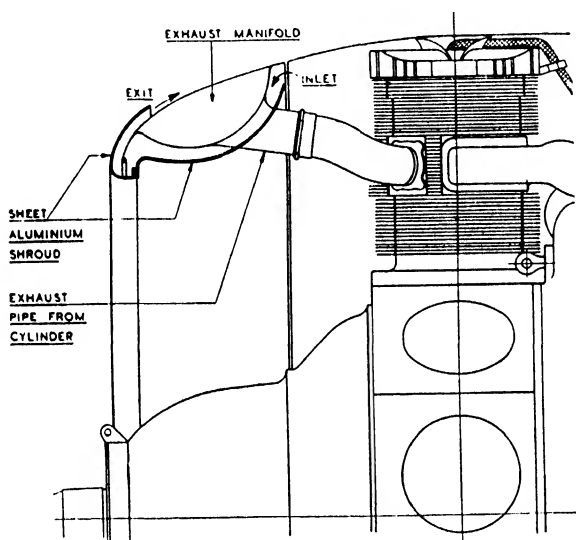

FIG. 327. Bristol shrouded exhaust manifold.

small scoop in the engine cowling which directs air on to the short pipes between the cylinder and lobe and also on to the sparking plugs and ignition leads.

In regard to the weight of the ejector type of silencer, a finished pair for the 12-cylinder Vee engine each measure 37 in. long by 4 in. wide at the maximum section and they together weigh 35 lbs.

Radial Engine Exhaust System. The most efficient type of exhaust system appears to be the annular one, such as that used on Bristol radial engines, located at the front of the engine. It is characterized by the use of a large volume manifold forming a properly streamlined leading edge for a close-fitting low-drag

engine cowl unit. The shrouded exhaust manifold shown in Fig. 327 represents a marked improvement on the previous design; it embodies the principle of reverse flow cooling. The manifold in question consists of a shield or shroud fitted around the nose and inner surface of the exhaust manifold. The annular outlet aperture between the shroud and the manifold is located near the nose in a region of relatively low air pressure, whilst the inlet aperture is at the rear of the shroud, in the high pressure region which exists immediately in front of the cylinders. A proportion of the air flowing through the cowl therefore diverges from the main stream and flows forward through the channel between the shroud and the manifold, rejoining the outer air stream at the nose aperture. With this arrangement it has been shown that the cooling power loss, based on the product of the volume flow and pressure drop, is reduced, whilst the capacity for adequate cooling of higher powered engines inside a given diameter cowl is increased.

The collector ring volume is usually made about one-half the total cylinder capacity, in radial engines.

Fig. 328* illustrates the exhaust manifold of the Bristol "Mercury" and "Pegasus" radial engines. This is of unit construction and mounted on the front of the engine by simple three-point attachments having flexible joints to allow for expansion effects. The manifold is of relatively large internal volume, giving adequate flame-damping combined with satisfactory silencing properties. The mounting arrangements enable the standard manifold to be used without alteration with the single outlet pipe between any pair of cylinders, except where the carburettor intervenes below.

The manifold is made from one-piece steel pressings with riveted joints instead of welded ones. The whole unit is nickel-plated both inside and out in order to protect the steel against corrosion.

Materials for Exhaust Systems. Originally, exhaust manifolds were made from Swedish iron sheet, but later were of mild steel sheet. In such cases it was necessary to protect the interior and exterior surfaces against corrosion by nickel plating, spraying with aluminium or by the Fescolizing process.

The heat-resisting nickel chromium steels and special stainless steels are also used for aircraft exhaust manifolds.

More recently the "Merlin" engine manifolds have been

* Facing p, 378.

made from Inconel nickel alloy consisting of 80 per cent. nickel, 14 per cent. chromium and the balance mainly of iron. This alloy, although about 7 per cent. heavier than steel, has excellent heat- and corrosion-resistance properties and can readily be worked as it has a good ductility. It has satisfactory mechanical strength properties and a high fatigue strength combined with toughness. It retains a large proportion of its initial strength at the maximum manifold temperatures. Inconel can also be welded satisfactorily; the welds produced are ductile and possess similar corrosion resistance to that of the base metal itself.

When stainless steel is used for exhaust systems it is usual to specify the sheet material to the D.T.D. Specification No. 171.

The thickness of the sheet steel employed is 18 S.W.G. to 20 S.W.G.; Inconel sheet for exhaust manifolds is used in similar thicknesses.

Practical Notes on Aircraft Exhaust Systems. In the installation of aircraft exhaust systems the efficiency can be improved in so far as reduction of horse power loss of the engine is concerned by exposing the greater part of the exhaust system to the slipstream; this reduces the manifold and outlet pipe temperatures and therefore the volume of the exhaust gases at exit. It should not, however, be allowed to add to the drag of the machine by more than a slight amount.

In general, irrespective of the type of manifold employed, the silencing system should aim at reducing as much as possible the exit pressure variations. If the gases could be ejected as a continuous stream instead of a pulsating one the silencing would approach the ideal.

The exhaust gases should be diverted at exit from the pilot's or passengers' cabins in order to avoid the unpleasant physical effects associated with their constituents, more especially the poisonous carbon monoxide gas associated with the exhaust of richer fuel-air mixtures. The metal parts of the exhaust system should be kept well clear of the aeroplane structure or any struts or wires. Where structural supports are necessary adequate heat insulation between the hot pipes and the structure should be provided.

In order to allow for expansion effects between the hotter exhaust system and the cooler engine, expansion joints should be fitted between the two; these joints should be carefully designed to avoid any possible gas leakages or flame effects.

The exhaust gas outlets should not be allowed to impinge

upon any part of the aircraft surfaces, structure, rods, wires, etc.

In order to ensure adequate mechanical strength of the exhaust system it should be capable of withstanding a hydraulic pressure test of 50 to 70 lbs. per sq. in. without signs of leakage at the joints or defects in the material.

In locating the exhaust connections within the fuselage engine bay, or engine nacelle, care should be taken to avoid proximity to electric cables, fuel or oil pipes; the latter should be kept at least 4 in. away from the metal parts of the exhaust system.

The parts of the exhaust system within the cowling should be kept as cool as possible by arranging for a cooling air-stream to flow over them; this is readily effected by suitable forward ducts or air inlets and guide cowling. The exhaust system cooling arrangements should be designed to keep the temperatures of the metal surfaces, cooled by the air-stream, down sufficiently to reduce to a minimum the risk of fire, should an oil or petrol pipe fracture during a crash.

In order to reduce the power losses due to friction, bends and sudden changes of section in the exhaust system the internal pipes should be of sufficient diameter, namely at least the exhaust port diameter, and be smooth internally. The number of bends should be a minimum in the exhaust system, and where such bends occur they should each have a radius of at least three times the diameter of the pipe or manifold section.

Where a long exhaust pipe is employed it should be supported at least 3 in. away from the fuselage. The best silencing effect from such a pipe is obtained by closing the exit end with a streamlined metal piece and perforating the last 10 ft. or so of the pipe on the side remote from the fuselage with a large number of holes of $\frac{1}{8}$ in. to $\frac{3}{16}$ in. diameter. The total area of these holes should be about 50 per cent. greater than the internal cross-sectional area of the pipe.

CHAPTER XI

ACCESSORIES, ENGINE STARTING, ETC.

THE modern aircraft engine, apart from its main purpose of providing the power for rotating the airscrew, is called upon to drive a number of accessories, some of which are concerned with the engine operation whilst others are for external purposes, *i.e.*, in the aircraft itself.

The accessories fitted in connection with the engine's own requirements include the detachable magnetos, oil and fuel pumps, liquid cooling pumps, tachometer, etc.

Those fitted for external purposes include the air compressors, vacuum pump, hydraulic (oil) pumps, electric generator for battery charging, etc.

The power required for driving the various accessories of a modern aircraft is now appreciable for a relatively large number of ancillary power services have to be provided for. It is estimated that in the case of a twin-engined bomber, weighing 8 or 9 tons, about 12 h.p. is required, whilst for a machine of 20 to 25 tons about 30 h.p. would be needed.

Fig. 329 illustrates the rear cover of the Bristol Pegasus XVIII radial engine, and shows the various accessory drives and accessories required for the equipment of a modern aircraft. In this layout provision is made for single or dual fuel pump; high and low pressure air compressor; shaft-driven electric generator; combined hand and electric starter; vacuum pump; high-pressure oil pump and constant speed airscrew governor. Besides these accessories the rear cover carries the engine lubrication system oil pump, oil gauge connection, auxiliary oil feed filter, tachometer drive magnetos and (if required) the control valve for a controllable pitch airscrew. The components shown in Fig. 329 have been neatly located in positions providing good accessibility to those items that may require attention.

The disposition of the accessories of certain other engines are shown on some of the illustrations in Chapters III, IV and V.

In connection with the auxiliary equipment of the Rolls

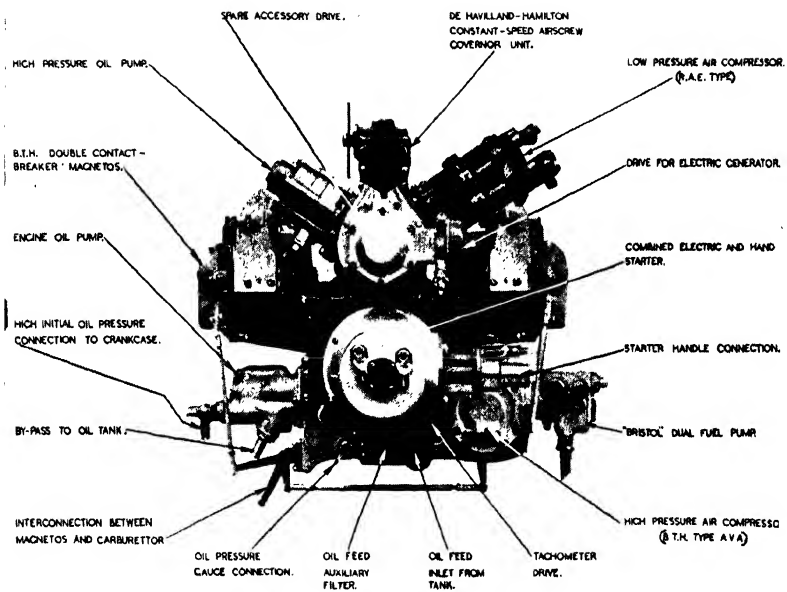

7750

FIG. 329. The Bristol "Pegasus" engine accessory arrangement.

[To face p]

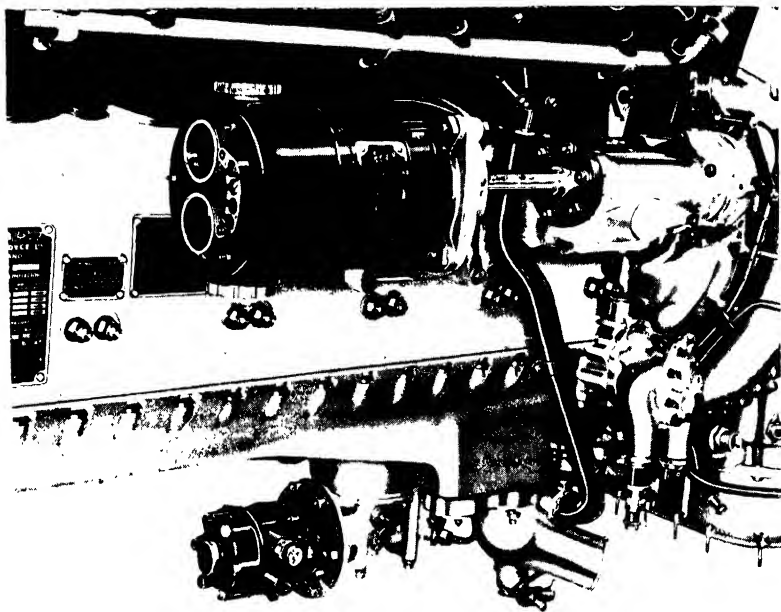

FIG. 330. Some of the Rolls Royce "Merlin" engine auxiliary equipment.

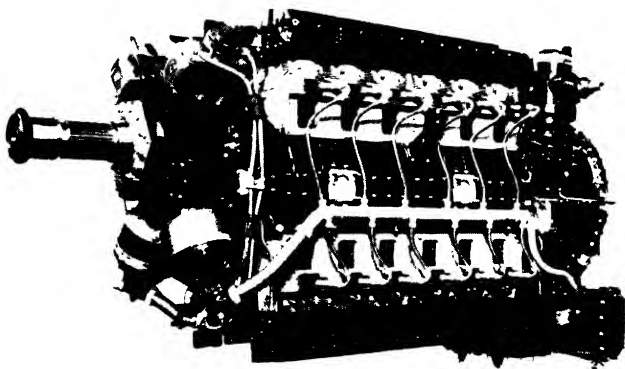

FIG. 331. The Napier "Dagger VIII" engine showing detachable nose piece containing the drives for the two magnetos, distributors and control unit for airscrew; the latter are arranged in X-formation.

Royce "Merlin" engine an engine-driven 12-volt, 500-watt generator is mounted on the left-hand side of the upper half crankcase (Fig. 330) and is driven at 1.914 times engine speed by a gear train from one of the supercharger planet wheels. Spider couplings connect the drive and dynamo armature shafts through the medium of fabric discs. A revolution indicator (tachometer) drive connection is mounted at the rear end of the camshaft on the left-hand bank of cylinders; this runs at one-quarter engine speed. Drives are also fitted on the left- and right-hand cylinder heads, respectively, for one low-pressure and one high-pressure air compressor. The former is of the R.A.E. twin-rotor pattern and is driven from the left-hand camshaft at 0.793 times engine speed, whilst the latter is of the B.T.H. A.V.A. piston type shown in Fig. 349; it is driven from the right-hand camshaft at one-half engine speed. In addition a special drive for a Lockheed undercarriage oil pump is provided in the crankcase lower half (Fig. 330), the drive being taken from the gear driving the main oil pumps through a bevel train. Further, an oil pump for providing the pressure to operate a gun turret may

TABLE 21. BARE AND DRY ENGINE WEIGHTS

Part	Four-cylinder Air-cooled 150 h.p.	Twelve-cylinder Liquid-cooled, 1,200 h.p.
	lbs.	lbs.
Carburettor	7.75	39.75
Carburettor screen and gaskets	0.25	0.45
Magnetos	16.00	26.50
Ignition cable assembly	3.25	16.00
Sparking plugs	1.75	4.50
Priming system on engine	—	1.00
Exhaust flanges and gasket	0.75	2.00
Accessory drive covers	0.25	1.75
Cooling baffles	4.00	—
Oil screen	0.25	—
Bare engine weight	265.25*	1242.00†
Engine dry weight	299.5	1333.95
Percentage weight of components	12.9	7.4

* Including engine lubrication system, tachometer drive, fuel pump drive and all piping and controls between the engine parts.

† Including integral supercharger and its drive, airscrew reduction gears, coolant pumps, lubrication system on engine details, starter connection, and drives for various accessories, *e.g.*, gun synchronizers, generator, power-take-off, vacuum pump, etc., and all piping and controls between engine parts.

be driven from the right-hand side camshaft. In addition, a drive is arranged from the reduction gear pinion of the constant speed unit for the airscrew and for the Pesco, Romec or Eclipse B.3 type vacuum pump for operation of the blind flying panel and "automatic pilot" navigation device, or for de-icing equipment.

Component and Accessory Weights. As previously mentioned in this volume, the *net dry weight* of an engine includes certain components, such as the carburation and ignition system items, so that the weight of the bare engine is increased appreciably. Thus, in the cases of two representative aircraft engines Table 21 is an analysis of the detail weights.

From these results it is shown that the percentage component weight is smaller for the larger output engine.

In regard to the accessories and other parts which make up the difference between the *dry and gross engine weights* these differ considerably according to the engine type and output. Thus, for a high-power engine fitted to service aircraft, a number of accessories including air compressors, vacuum pump, oil pressure pump for undercarriage and gun turret operation, etc., would be included, whereas in the case of lower power engines for light aircraft these would not be required.

TABLE 22. GIPSY TWELVE ENGINE ACCESSORY WEIGHTS

Part	Weight in lb.
Electric starter motor (B.T.H.)	15.5
Electric booster coil (B.T.H.)	2.0
Hydraulic pumps (Dowty)	11.5
Air compressor (B.T.H.)	4.5
Vacuum pump (Rotax Eclipse)	4.0
Generator (B.T.H. 24 volt-500 watt)	13.5
Air intake (less extension pipes)	3.0
Exhaust manifolds (long side)	14.5
Exhaust manifolds (short side)	9.0
Constant speed airscrew governor	3.25
Hydraulic jack (for cooling gill operation)	16.75
Total weight of accessories	97.5
Dry engine weight	1058.0
Gross dry engine weight	1155.5
Percentage weight, accessories to dry engine weight	9.2

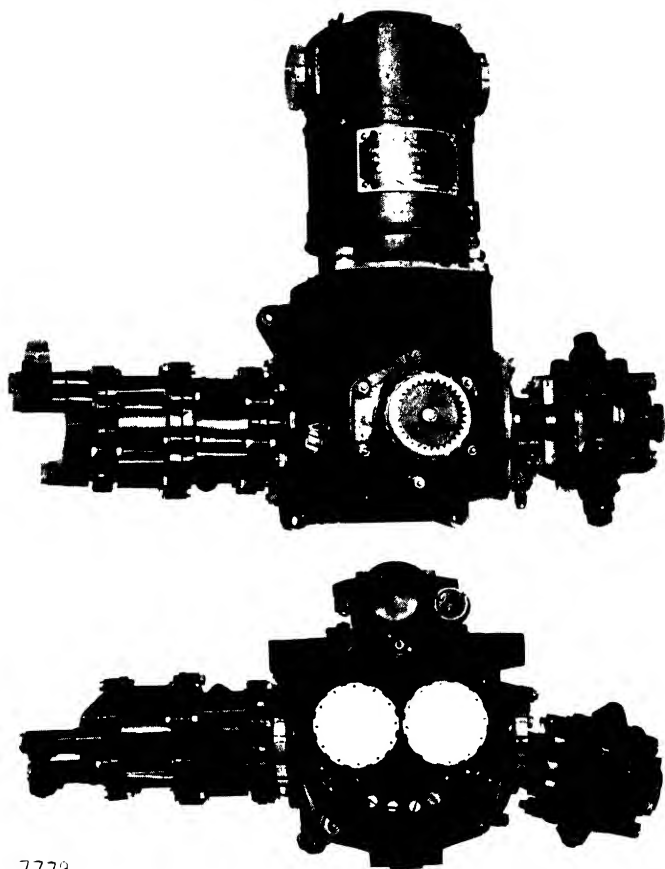

7779

FIG. 331A. The Bristol auxiliary gear box.

As an indication of the manner in which these accessories increase the engine weight, the Gipsy Twelve 405/420 B.H.P. (International Rating) air-cooled inverted Vee-type engine will be taken as an example. The detail weights of the components not included in the dry engine weight are given in Table 22.

The airscrew, which is of the de Havilland controllable pitch, constant speed pattern adds 187 lbs. to the gross engine weight as given in Table 22, so that the weight of the components then represents about 27 per cent. of the engine dry weight.

When it is considered that the total power plant weight includes, in addition to the gross dry engine weight items, the radiator or cooling baffle system, fuel and oil tanks and piping, controls and other necessary fitments, the exhaust tail pipes, engine instruments, etc., it will be apparent that the net dry weight does not afford a reliable indication of the actual dead weight of the power unit, exclusive of fuel, oil and coolant liquid weights.

Auxiliary Gear Boxes. In view of the relatively large number of accessories that is now required on modern aircraft engines the fitting of these accessories on the engine unit itself introduces difficulties in regard to the driving means, *i.e.* the gear drives and different gear ratios required within the engine ; it also tends to render certain of the accessories difficult of access for adjustment and maintenance purposes when the engine is installed in an aircraft.

In order to overcome these objections a scheme has been evolved for providing a separate remote type of accessory gearbox which is mounted on the bulkhead and driven by means of a single extension type of shaft from the rear end of the engine. The gearbox provides suitable gear ratios for obtaining the different speeds required by the accessories mounted on it. This system, although not yet adopted generally, is probably the most satisfactory solution of the accessory drive and location problem. It has more recently been developed by the Bristol Aeroplane Company in connection with their radial engines, with promising results. Fig. 331A illustrates a separate bulkhead type of gearbox. The serrated member seen in the centre is the drive connection to the engine. Above, in the upper illustration, is the vertical generator, whilst on the left in both illustrations, is the low pressure air compressor. The high pressure air compressor is above the

generator in the lower view, whilst the high-pressure oil pump is on the right in both illustrations. The unit is mounted on the bulkhead by means of the flange shown near the top of the lower illustration and centre of the upper one.

Another advantage of the auxiliary gearbox unit is that the pipe lines and cables from the aircraft can be shortened; further, the engine can be removed bodily for overhaul without disturbing the auxiliaries or their pipe lines and cables. It is necessary to employ a cardan shaft type of drive between the engine and gearbox in order to allow for differences in alignment between the two.

Auxiliary Power Unit. In the case of the larger types of modern aircraft requiring a relatively large number of accessories and including electric heating, lighting, cooking and other services, it is probable that the present method of locating the accessories on or near to the main engines will be replaced by that in which a separate petrol or Diesel engine drives the generator, compressor, hydraulic pumps, etc. This method has the advantages of enabling the accessory power unit to be installed in the most convenient part of the aircraft, whilst giving a constant driving speed with good accessibility, during flight, to the accessories.

It is, however, open to the criticism of being more bulky and heavier than the present engine-mounted accessory arrangement. Minor objections to be overcome are those of noise of operation within the aircraft, fire hazards and auxiliary engine cooling.

A small auxiliary power unit used on flying boats is the A.B.C. one comprising a horizontally-opposed air-cooled engine of 54 mm. bore and 38 mm. stroke developing a maximum output of 5 B.H.P. It drives, either simultaneously, or individually—by means of clutch engagements—a 350-watt generator, a fuel pump capable of lifting 2,250 gallons an hour with a 16 ft. lift, a bilge pump delivering 500 gallons an hour with 16 ft. lift and two air compressors giving pressures of 200 lbs. per sq. in.

The "Eclipse" auxiliary unit used on the large Douglas DC4 aircraft has a four-cylinder opposed type engine of 2 $\frac{3}{4}$ -in. bore and 3 in. stroke, developing 30 B.H.P. at 4,000 R.P.M., with centrifugal-hydraulic governor. The engine has Prestone liquid-cooled cylinders and is constructed with cylinders and crankcase of aluminium alloy and nickel-iron cylinder liners. Overhead valves are employed, the exhaust valves having copper inserts and Stellite seats. The coolant passes through

a radiator which is air-cooled by means of a fan. The engine is started by means of a gear pump and high-pressure oil stored in a reservoir.

The engine, which weighs 230 lbs. complete, drives a $6\frac{1}{2}$ kW. alternator supplying 120-volt, 800-cycle current. The alternator weighs 62 lbs. The total weight of engine, alternator and its accessories is about 320 lbs., *i.e.* about 50 lbs. per kW.

The adoption of the auxiliary power unit is only possible in the case of large multi-engine aircraft, but it offers scope for improving and at the same time simplifying the main engine design.

Electric and Hydraulic Power Alternatives. The problem of providing power for driving the various auxiliaries and other power-operated items of an aircraft, *e.g.* the retractable undercarriage, wing flaps, bomb doors, gun and turrets, involves a consideration of the various alternatives, including pneumatic, hydraulic and electric systems with their engine-driven sources of supply and operating motors.

The use of compressed air, whilst convenient for such purposes as machine-gun operation, automatic gyroscope-controlled "pilot," wheel brakes and pneumatic de-icing wing equipment, involves the use of air bottles, a compressor for high pressure air and pipe lines, which are vulnerable in military aircraft. This method does not offer a complete solution of the ancillary power requirements.

The hydraulic power system, using hydraulic pumps for supplying oil under a pressure of 300 to 400 lbs. per sq. in. for use in pipe lines leading to the various items to be operated hydraulically, offers certain advantages. The whole system, including the pumps and motors—which can now be made as light as 2 lbs. per h.p.—can readily be applied and high operating loads obtained with light fittings. Hydraulic power is particularly suited to the operation of retractable undercarriages, wing flaps, bomb doors and gun turrets. It cannot, however, provide the power for all the accessories of an aircraft, *e.g.*, the lighting and heating generator, and is therefore adopted mostly for the applications mentioned.

The hydraulic system requires the use of oil pipes leading to the various components. These are vulnerable items and potential sources of trouble, by leakages. Moreover, the fracture of one of the pipes would put the whole of the system out of use. To obviate this risk the pipes would be duplicated and separated in the aircraft. It may, however, be pointed

out that the hydraulic braking systems of automobiles have proved as reliable as the mechanical systems.

The weight of the hydraulic system can be reduced appreciably if the oil pressure is increased ; thus a doubling of the pressure will give a saving of about 20 per cent. in the weight.

The electric power system, consisting of a generator, battery and motor units offers perhaps the best possibilities for the majority of aircraft ancillary power services, and since it is essential for lighting, heating—and in many cases for engine-starting purposes—its use for other purposes can readily be extended without a marked increase in weight of the parts. The cables employed are convenient and relatively light for conveying the current to any part of the aircraft, whilst the use of a parallel wiring system obviates any general risk of electrical failure, due to one of the electrical circuits or components going out of action ; the fitting of suitable fuses also, tends to localize failures.

The present electric supply for civil and military aircraft in this country is either 12 or 24 volt D.C. Other alternatives proposed are the 24 volt A.C. and 110 volt A.C. ; the adoption of the latter supply would enable a substantial reduction in the weight of the electrical system to be effected.

In regard to the relative merits of each of the power supply systems mentioned, at present no one system will fulfil all of the demands of modern aircraft and it has been found necessary to make provision for all three methods. In this connection the reader is referred to a good general outline of the problem of ancillary power services on aircraft in Reference No. 71, from which Appendix II at the end of this volume has been reproduced.

Starting Aircraft Engines. The method of starting aircraft engines, before the advent of automatic starting devices was as follows: the ignition was switched off, the carburettor controls set to give a rich mixture and the throttle partly opened. The engine crankshaft was then given a few revolutions by swinging the airscrew, finally leaving one blade of the latter in a convenient position for obtaining a good pull. The ignition was switched on and the airscrew was given a sharp pull by hand, over the compression of one or more cylinders, to start the engine.

In the case of larger engines of over 400 H.P., two or three mechanics would link hands and give a united pull to start the engine. The use of a hand starter magneto was of much

assistance and in many instances, if the engine had been properly primed with mixture it was possible to start it by means of the starter magneto alone; one has seen Bristol Fighter Rolls Royce engines of the last war started in this manner.

Hand Starter Magnetos. These are still used for starting aircraft engines. The starter magneto resembles the standard rotating armature type, but the shaft of the slow speed wheel is extended to take a handle or sprocket for hand rotation; the magneto has no mechanical connection with the engine. The usual gear ratio between the starting handle and armature shaft is 5:1 so that for an average hand turning speed of 70 to 80 R.P.M., the armature speed is 350 to

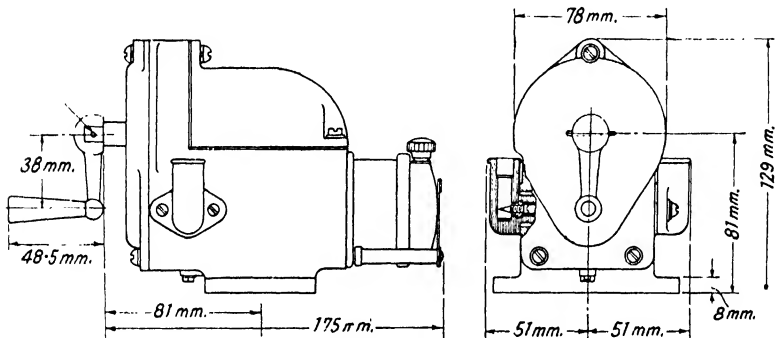

FIG. 332. B.T.H. hand starting magneto.

400 R.P.M., at which speed a series of very good sparks is obtained. The H.T. cable from the hand starter magneto is connected to the distributor rotor of the main ignition magnetos, special "starter" terminals being fitted on the latter for this purpose. Hand starter magnetos (B.T.H.) are also available with two terminals for H.T. connections to each of the two dual running ignition magnetos. When the handle of the starter magneto is rotated a stream of intense sparks passes through the distributor of the running magneto to the appropriate cylinders of the engine, so that good sparks occur at each of the plugs in turn as the engine is cranked over by hand or automatically. As soon as the engine "fires" it picks up speed on its own magnetos. It should be mentioned that no timing device is necessary on the hand-starter magneto since correct timing is ensured by the distributor system of

the main magnetos. Each starter magneto is provided with a short-circuiting terminal on the contact breaker cover so that it can be cut out by means of a separate switch, thus obviating any accidental sparking effects when the engine is stationary.

Fig. 332 shows, in outline, the B.T.H. hand starter magneto (Type AS) of the base-mounted pattern, with one H.T. cable connection socket in section; flange-mounted hand starter magnetos are also available.

Mechanical Starter. The first improvement upon the air-screw hand-swinging method of starting engines was due to the introduction of the Hucks mechanical starter, consisting of an

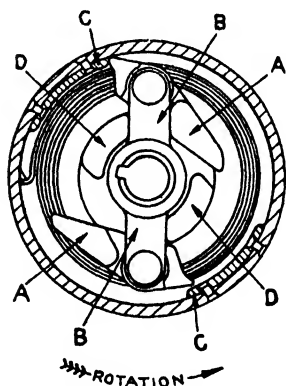

FIG. 333. Section through B.T.H. type Z impulse starter. A, pawls; B, hub member arms; C, stops on magneto end plate; D, arms on driving member.

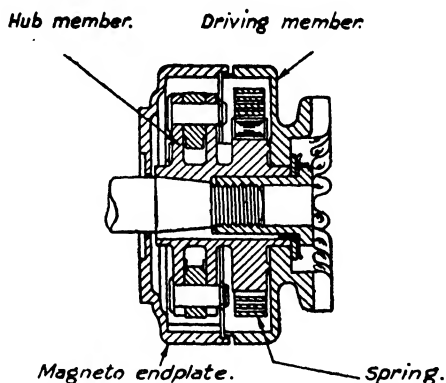

FIG. 334. Sectional view of B.T.H. Type Z impulse starter.

automobile chassis, which could be driven up to the aircraft, having a power take-off device in the form of a roller chain driven shaft with dogs which could be engaged with corresponding ones on the airscrew boss. When the dog was thus engaged a clutch on the chassis was employed to transmit the engine power to the airscrew shaft for starting purposes. This method, whilst being satisfactory on aerodromes, does not solve the problem of starting engines after forced landings in inaccessible places, or of restarting engines in the air.

Impulse Starters. Instead of using a hand starter magneto, the main ignition magnetos may be fitted with a device between the engine drive and armature shaft to give the latter a rapid "flick over" when the contact breaker is about to open or

"break," and the engine drive is operating at a low speed. The result is to give an intense spark at a low engine speed. The B.T.H. impulse starter utilizes a driving and hub member linked by a stout flat helical spring which is alternately wound up and released by means of pawls and trip devices so as to allow the spring to give a sudden impulse to the armature over part of its revolution. When the engine is working the pawls are thrown out of action by centrifugal force and the whole unit rotates solidly.

Hand Starting of Engines. A safer and more convenient method of starting engines on the ground, used on Rolls Royce "Eagle" engines was to provide a hand-turning gear, with a large step-down gear ratio, to rotate the crankshaft at a sufficient speed for starting. Used in conjunction with a petrol priming device and a hand-starting magneto this method proved satisfactory; one man could normally provide enough energy for engine cranking purposes. The usual ratio of the hand-turning gear was 15:1 to 18:1. The starting handle was provided with a safety engagement device for disconnecting it as soon as the engine "fired"; in one or two instances a free-wheel device was employed.

The hand-starting method is still employed on certain modern engines, but is fitted as an alternative means to electric motor starters in the event of the latter failing to operate. For this reason the hand and electric starter are combined as a single unit; reference is made to this type of starter later in this chapter.

Compressed Air Starting. In this method compressed air from an air bottle is admitted to a distributing valve unit operated by one of the half-engine speed shafts of the engine, so that the air is admitted into the appropriate cylinders at the proper moment, namely, at the beginning of the expansion stroke of the cycle. After the engine has been set into rotation the cylinders become charged with mixture and, with the aid of a hand-starter magneto the engine can then be started. A later improvement on this method is the use of carburetted air by passing the compressed air through an auxiliary carburettor device so that it picks up a certain amount of fuel; in this way the engine will commence to "fire" earlier than if compressed air alone is used.

The compressed air method was used as long ago as 1916 for starting the 250-h.p. Rolls Royce and R.A.F. 3A engines.⁶⁹ When used on the former engine it was found that the (cold)

engine crankshaft could just be turned with air at 100 lbs. per sq. in., whilst with a pressure of 200 lbs. per sq. in. the crankshaft speed was 60 R.P.M. The weight of the starting equipment for a 300-h.p. engine, exclusive of the air bottle and compressor was about 10 lbs.; the air bottle of capacity suitable for starting the engine at least twice (once from the cold) was about 25 lbs. in weight.

A later scheme, known as the Air Ministry Type "A" system, used an air bottle kept charged by an air compressor, a petrol-priming device for the compressed air and an engine-operated carburetted compressed air distributor. The system also included a starting button operated by the pilot's heel for connecting the air bottle with the air distributor, an auxiliary air bottle charging device for use on the ground from an

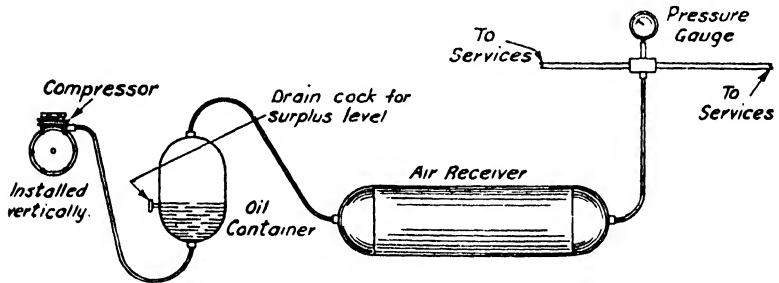

FIG. 335. Compressed air engine starting equipment.

external source; a gauge to show the pilot the pressure of the compressed air in the air bottle and a master cock for controlling the air supply to the starting button. It is necessary with this system to fit non-return valves to the engine cylinders, so that the working pressure effects cannot be communicated to the compressed air system. The non-return valves are usually made with sparking plug threads. This method of engine starting has been used to some extent on Continental aircraft engines.

A variation of this starting method, employed on certain Bristol engines, and known as the "gas-starter" system, used a petrol-air mixture which was compressed by a small electric motor-driven compressor and then supplied to the cylinders through an engine-driven distributor. A hand-starter magneto was used to provide the starting ignition sparks.

Cartridge Starters. These devices utilize the pressure of the

gases generated by the explosion of a special cartridge, or cartridges, to provide the turning effort *via* the engine pistons and crankshaft. It is necessary to prime the cylinders beforehand and to arrange for the crankshaft (or airscrew) to be set in one selected position before the cartridge is fired. The principle of this method is an old one, for the use of cartridges for starting engines was applied to Wolseley car engines in 1905.

The cartridge is fired by a special pistol device fitted either to the cylinder head or connected by metal tubing to the cylinder head or to an engine-driven gas-distributor as in the compressed-air starting system; the distributor method is not so good as the direct-cylinder connection one, as the gas is cooled in transit and the high explosion pressure much reduced.

When the cartridge is fired direct the piston of the cylinder in question is arranged to be some 10 to 20 degrees down on its firing stroke, in order to take full advantage of the high-pressure gases.

The Farman cartridge starter operates upon this principle and its percussion pin is actuated by means of a cable control placed in the cockpit.

The Coffman starter, developed by the Federal Laboratories, Pittsburg, U.S.A., utilizes the high-pressure gases, at 2,000 to 2,500 lbs. per sq. in., from a cartridge weighing about 1 oz., ignited by a small dry battery, to operate a piston in the starter cylinder unit. The piston unit operates a worm screw which transmits the power necessary to turn the engine crankshaft at a maximum speed up to 200 R.P.M. for a period of five or six revolutions. This starter, complete with its connections, weighs about 25 lbs. for a 500-h.p. engine; it does not require a booster magneto.

The Bristol combustion starting system illustrated, diagrammatically, in Fig. 337, utilizes the Coffman cartridge unit, shown on the upper right-hand side. The breech unit is connected to the starter on the engine by a pipe of reasonable but limited length; in most instances this pipe is long enough to permit mounting the breech on the instrument panel. For multi-engined installations a magazine breech mechanism has been evolved, taking enough cartridges at one loading to suffice for all the starts likely to be required during the day's flight operations. In either case, the cartridge is fired on each occasion by an electric current through a switch in the cockpit.

The current can be provided by any available source, but one cell of a flashlight battery has sufficient energy for this purpose. The starter unit itself is mounted in the usual position on the rear cover of the engine. It has a multi-toothed driving dog which, in the first stage of the application of the combustion gas-pressure to a piston inside the unit, moves forward into engagement with a corresponding jaw on the tail-shaft of the engine. As the gas-pressure further increases with the burning of the charge in the cartridge, the continued forward movement of the piston is transformed by an arrangement of helical splines into a turning movement of the driving-dog, and therefore of the engine. The travel of the piston is resisted by a spring, and as soon as the full travel has been used up, a port is uncovered automatically, through which the residue of the gas

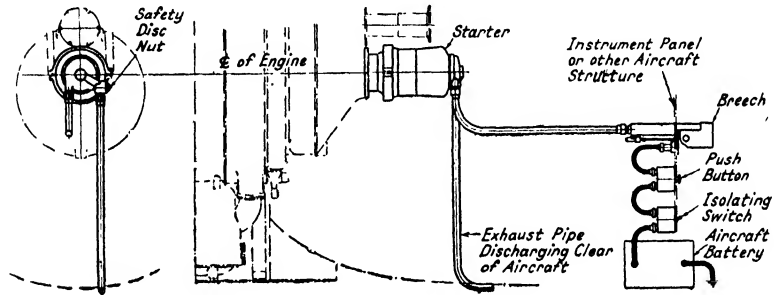

FIG. 337. Bristol cartridge starting system.

escapes from the pressure chamber to an exhaust pipe and the spring returns the piston to its initial position, ready for another start. The safety device in the pressure chamber usually consists of a metal disc of accurately specified thickness, which shears should the pressure exceed that which gives the maximum desired torque at the starter jaw, and releases the gas at once to the exhaust pipe.

Another scheme for starting aircraft engines with an explosive cartridge patented by Messrs. B.T.H. Ltd. is shown in Fig. 338. Gases under pressure are supplied by the cartridge to the valve chamber 2 which communicates with the turbine inlet and exhaust chambers. The valves, which are rigidly connected, are shown in the position at start. From the inlet chamber the gases expand through the nozzle 8 and pass through the runner blades 9 to the exhaust. The torque is transmitted through teeth on the runner shaft to the gear

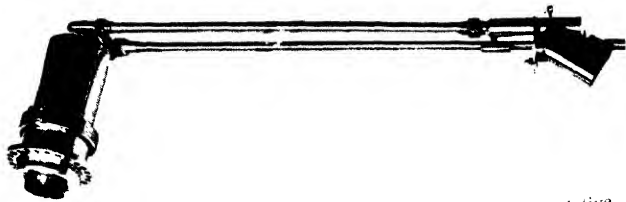

FIG. 336. Coffman cartridge starter unit, showing (below) relative size of cartridges.

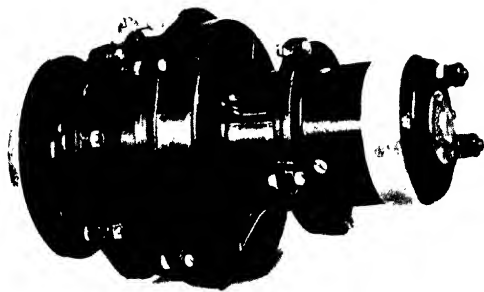

FIG. 341. Rotax-Eclipse combined hand and electric inertia starter. This operates off a 12 v. accumulator and weighs $30\frac{1}{2}$ lb.

wheel 16 keyed to the shaft 17, which is splined to take the driving clutch half 21. This is provided with dogs to engage dogs on the driven clutch half, which is keyed to the engine shaft. A solenoid 30, mounted round the clutch, engages the halves and is connected in circuit with the heater plug which fires the cartridge. To prevent overspeeding of the turbine, in case the engine fires before all the energy in the cartridge has been expended, a trip is operated by the clutch half 21. A trigger 36 is held against part 21 by a leaf spring and engages the end of lever 41. A spring 43 holds washer 44 against the other end of the lever 41. The washer is threaded on the spindle carrying the inlet and exhaust valves, so that its position can be adjusted. When the solenoid circuit is closed and clutch half 21 is pulled into engagement, trigger 36 is pushed back by the spring. When the engine fires and clutch half 21 is pushed out of engagement, trigger 36 is hit and frees lever 41. Spring 43 then closes the inlet valve and opens the exhaust valve, so that the gases from the cartridge are diverted from the turbine to the exhaust.

Inertia Starters. The power for cranking the engine in this type of starter is derived from the energy stored in a relatively small flywheel rotating at a high speed. The latter result is obtained by means of hand- or electric-motor operated gearing of high step-up ratio. When the flywheel unit is running at a sufficiently high speed, and the engine has been primed beforehand, the flywheel starting jaw is slid along to engage with a similar jaw on the engine crankshaft, so as to rotate the latter. It is necessary to use a torque overload device of the spring-loaded clutch pattern in the starter drive to the crankshaft. It is also necessary to use a hand-starter magneto or an electric booster coil for starting. This type of starter, on account of its high maximum torque, may increase, appreciably, the stress range on the engine components so that special consideration should be given to this matter in the design of the components; in this connection the stress range may be increased as much as 200- to 300 per cent.

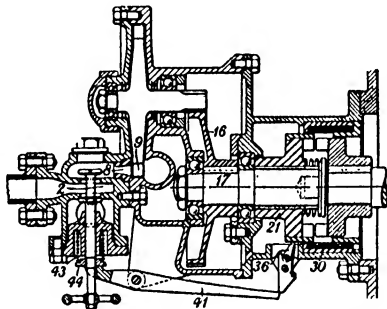

FIG. 338. Explosive cartridge engine starting scheme.

The Bristol Aeroplane Company have applied this type of inertia starter to their "Mercury" engines, using a suitably

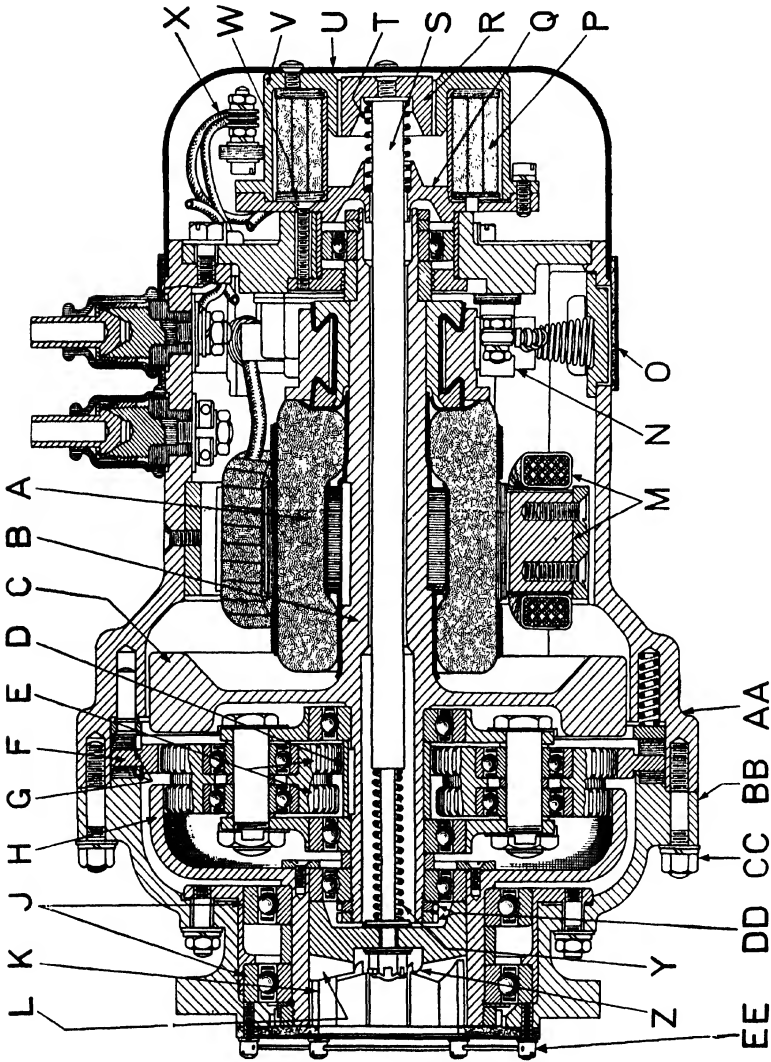

Fig. 339. The B.T.H. electric inertia starter with horizontal motor.

modified design of rear cover and rear end of the crankshaft, with entirely satisfactory results. The hand inertia starter

weighs 33 lbs. and is operated by means of a hand crank for 30 to 45 seconds, when the flywheel speed is sufficient to provide energy for turning the crankshaft for several revolutions at a high momentary speed.

As an alternative an electric inertia starter has been fitted to Bristol engines. It employs an electric motor bolted on to the starter flywheel housing. The starter weighs 35 lbs. and derives its current supply from a 12-volt battery. The time taken to speed up the starter flywheel is 5 to 10 seconds. To avoid the risk of short-circuiting the battery in the event of a crash a double-pole cut-out switch is provided in the starter motor circuit.

The B.T.H. electric inertia starter is shown in Fig. 339; it is designed for either horizontal or vertical motor position. For an engine of 200 h.p. rating this type of starter requires a 12-volt, 25-amp. hour battery, and it weighs 22 lbs.

Referring to Fig. 339, the armature A of the D.C. series motor is built up on a hollow shaft B which is integral with the flywheel C. Keyed to the shaft is a sun pinion D which engages with a double planetary gear system E. The planet gears also engage with an internal gear F—normally held stationary between the “Ferobestos” plates G—and also with an internal gear cut on the inside of a bell casting H. This bell casting therefore is driven at a reduced speed, the overall speed reduction being 200·7 to 1. The nominal speed of the armature and flywheel at the time of engagement is approximately 15,000 R.P.M., thus the speed of the bell casting is 75 R.P.M. The bell casting is carried on two ball-bearings J, and is splined at K to drive the engaging dog L.

The motor field system is indicated at M and the brush-gear at N.

The engagement of the starter dog with the engine dog is effected by means of a solenoid mounted at the back of the starter. The solenoid consists of a winding P, a pole piece Q, and a plunger R, to which is attached the operating rod S carrying the starter dog L.

The starter motor is energized by pushing and holding in the starter switch knob for 30 seconds during which time the motor speeds up the flywheel to 15,000 R.P.M. When the starter switch is released, the bell-gear and dog are running at 75 R.P.M. The solenoid switch knob is then pulled out, energizing the solenoid P, Fig. 339, causing the pole-piece Q to attract the plunger R. The operating rod S thus moves

towards the engine, engaging the starter dog L with the engine dog. The solenoid switch should be released as soon as the engine fires. Should the jaws of the dogs clash at the moment of engagement, the spring Y will be momentarily compressed

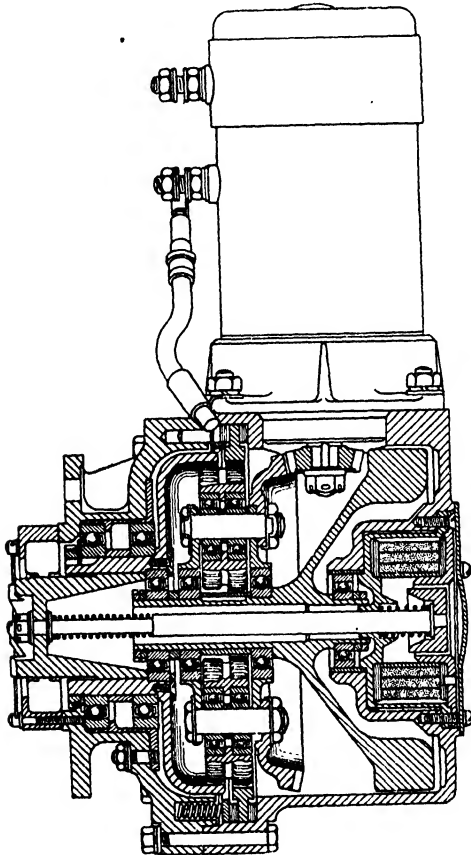

FIG. 340. The B.T.H. electric inertia starter with vertical motor.

until the starter dog turns to such a position that it will engage properly with the engine dog. The spring T returns the plunger and starter dog to the normal position when the solenoid is de-energized.

In the event of a back-fire, as soon as the load reaches the pre-determined value of the torque overload release (clutch)

setting, the internal gear F slips round, relieving the starter and the engine crankshaft of undue stress. When the engine is warm it will be found that the starter motor need not be energized for as long as 30 seconds.

The Rotax "Eclipse" inertia starter is of the hand-operated pattern. The kinetic energy of the rotating flywheel is transmitted to the engine by means of a multiple gear reduction adjustable torque overload release, an engaging mechanism and driving jaw. The flywheel requires about 15 to 25 seconds to crank it to its correct speed of 12,000 R.P.M.; the speed of turning the hand crank is about 80 R.P.M. When the flywheel speed mentioned has been attained the hand crank is removed and the starter jaw is engaged with the engine crankshaft jaw by means of an operating clevis; the initial cranking speed upon engagement is about 80 R.P.M., which is usually ample for a prompt start. When the engine "fires" the starter jaw is disengaged automatically.

The Rotax "Eclipse" electric inertia starter has a similar mechanism but the hand-operated drive is supplemented by a high-speed electric motor one (Fig. 341); its substitution reduces the flywheel speeding-up time to 5 or 10 seconds.

Direct Cranking Motor Starters. As an alternative to the electric inertia starter an electric motor operated from a standard aircraft accumulator can be employed to rotate the engine crankshaft through suitable reduction gearing operating an automatic meshing and demeshing mechanism through an adjustable torque overload release. Fig. 342 shows the Rotax "Eclipse" electric starter which is suitable for cranking engines up to 200 h.p. from a 12-volt battery supply with a current consumption of approximately 150 amps. The motor shaft has a pinion attached which drives a crown wheel gear. This is integral with a spur pinion which meshes with three planetary gears which are mounted on a barrel and run in a stationary gear fastened to the housing. These gears drive the barrel containing the torque overload release, namely, a spring-adjusted clutch. The externally-splined clutch discs are driven by the barrel and the internally splined discs drive the spline nut. Threaded within this is a screw shaft which is caused to advance at the first rotation until the stop nut rests against the back end of the threads. The starter jaw advances with the screw shaft and meshes with the engine jaw. A friction brake is used to make the jaw advance into mesh before rotating; this consists of a three-piece friction ring

having tips which fit into corresponding slots in the jaw. It is held in position on the barrel plate by a spring of given tension. The rear faces of the starter teeth are sloped so that when the engine starts the jaw is thrown out of mesh. The clutch has a safety device to permit only the proper amount of torque to be used for engine turning purposes; it also protects the starter from possible damage in the event of an engine back-fire.

Another pattern of electric starter is the *combined direct cranking, hand or electric one* (Fig. 343). The electric motor is designed to crank the engine for which it is selected, through a reduction gear ratio of 90 : 1, continuously, from a 12- or 24-volt battery. It has also a hand-turning gear shaft coupling with a gear reduction ratio of 18 : 1. Both methods of starting employ the same automatic meshing and demeshing mechanism with an adjustable torque overload release. The armature drives through an intermediate gear, a sun gear which is integral with a spur pinion meshing with three planetary gears. The hand-turning gear operates a bevel gear which meshes with another on the shaft of the intermediate gear, the pinion of which drives the sun gear and thus the spur pinion meshes with the three planetary gears. The latter drive the barrel containing the torque overload device consisting of a spring-adjusted multiple plate clutch; in its other respects the engine cranking unit is similar to that previously described. The starter, which is suitable for engines up to 800 h.p., weighs 36 lbs. In regard to the performance of this type of engine starter, the following particulars show the torque available and the electrical consumptions of the starters with 12- and 24-volt batteries:—

TABLE 23. PERFORMANCES OF COMBINED HAND AND ELECTRIC STARTERS

Torque Obtained lbs. ft.	Revolutions per minute		Current Consumption (amps.)	
	12 volt	24 volt	12 volt	24 volt
200	40	45	210	125
250	35	41	250	145
300	30	37	300	165

It may be noted that a starter of the type described, with electric-drive gear reduction of 122 : 1 and hand-gear ratio of

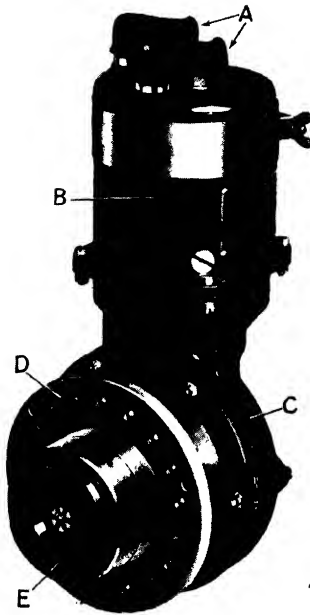

FIG. 342. Direct cranking electric starter for engines up to 200 h.p.
 A—Battery cable connections. B—Electric motor. C—Gear housing. D—Mounting flange. E—Engine engagement dogs.

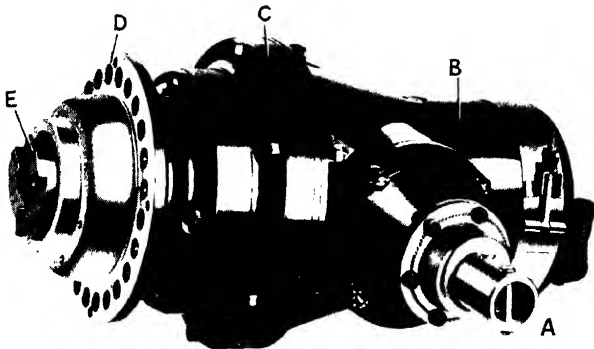

FIG. 343. The Rotax-Eclipse direct cranking electric starter.
 A—Hand starting connection. B—Electric motor. C—Gear wheel housing. D—Mounting flange. E—Engine engagement dogs.

18 : 1, designed for starting 350-h.p. engines gives a cranking speed of 35 to 45 R.P.M. for a current consumption of 120 amps. at 12 volts, *i.e.*, about 1.9 h.p. input to the motor.

Starting Torques of Engines. The turning moment necessary to turn the crankshaft of an aircraft engine depends upon a number of factors, the most important of which are (1) the power rating of the engine ; (2) the cranking speed ; and (3) the temperature of the engine ; (4) the throttle opening.

In general, the starting torque increases with the horse power of the engine, the cranking speed and throttle opening and with

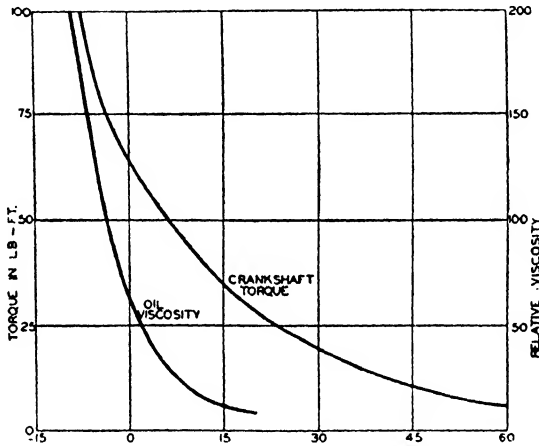

FIG. 344. Effect of temperature on the cranking torque and oil viscosity.

decrease in the temperature, since the viscosity of the oil increases with fall of temperature.

The torque required to just rotate the crankshaft from rest with the throttle nearly closed varies from about 40 lbs. ft. for engines of 200 to 300 h.p. to 120 lbs. ft. for those of 600 to 700 h.p. for an air temperature of 15° C.

The starting torque increases considerably as the engine temperature falls from the normal air value of 15° C. to 20° C. down to freezing point. The manner in which the torque increases with temperature fall is illustrated in Fig. 344,⁷⁰ which shows also the variation in oil viscosity with temperature ; the general resemblance of these curves indicates that it is mainly on account of viscosity increase that greater starting torque is required as the temperature falls.

Starting Motor Arrangements. The starting motors used for aircraft engines have similar characteristics to those of auto-

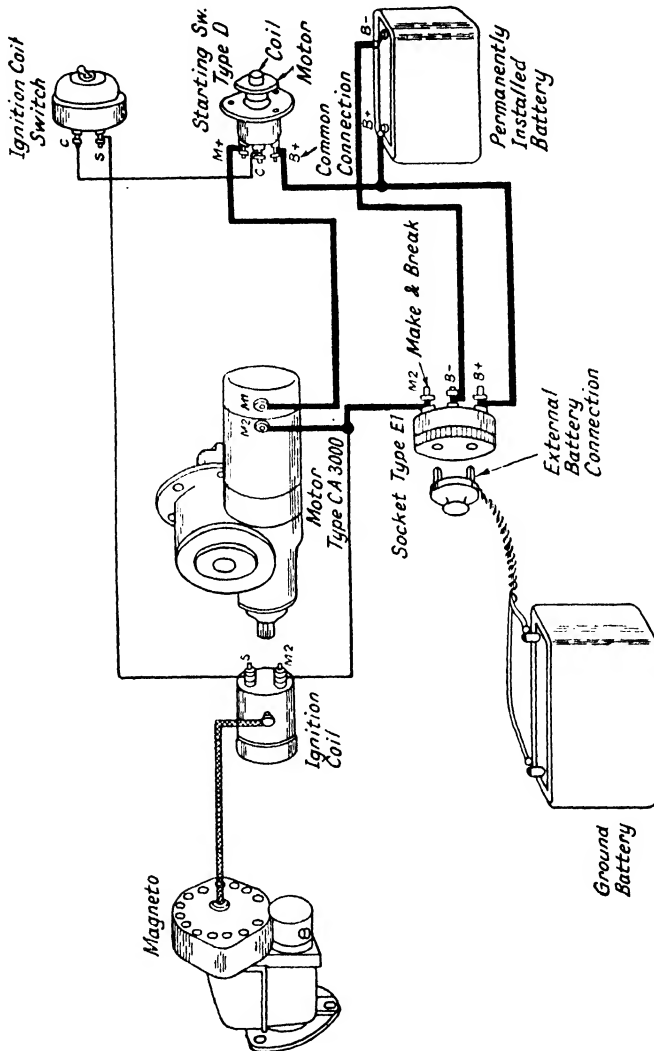

FIG. 345. B. T. H. starting equipment, showing arrangement of the wiring. The ignition coil is used as a booster coil.

mobile engines, but are of course designed for greater outputs. The starting motor is usually of the four-pole series wound type and is used in conjunction with a solenoid-operated switch

on the motor itself, controlled by a simple push-button type of switch placed in the cockpit of the aircraft. This latter switch when depressed closes the circuit of the solenoid. Usually a direct-cranking electric motor is employed in conjunction with a *booster coil*. The latter coil is connected in parallel across the starter so that as soon as the solenoid switch is closed the coil is brought into action. The H.T. lead from the booster coil is connected to the magneto H.T. distributor, *i.e.*, to the same connection as for the hand-starter magneto, when the latter is fitted as an alternative. The booster coil is in effect a trembler coil having a primary winding fed from the same

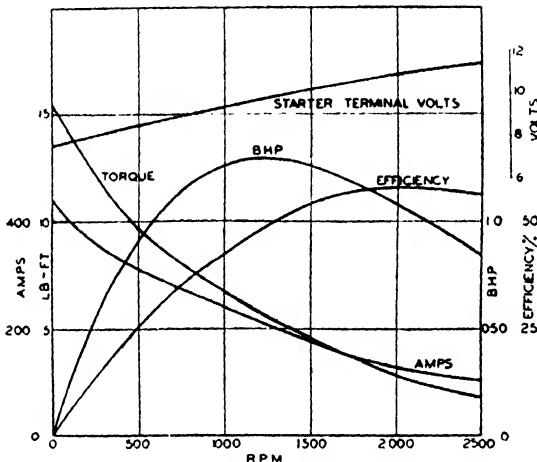

FIG. 346. Starting motor characteristics.

battery supply as the starting motor. The secondary winding gives the H.T. supply which is taken to the distributor rotor arm.

In regard to the starting motor's electrical characteristics, these are illustrated, in the case of a 12-volt, four-pole series-wound automobile size of motor in Fig. 346. It will be observed that the maximum torque occurs at zero speed; this is the "breakaway" torque value when the switch is just closed. This breakaway torque is usually about twice the resisting torque of the engine when the latter is only just turning. As soon as the engine commences to turn it will continue to accelerate so long as the motor torque exceeds the resisting torque. When the two torques are equal the maximum

engine cranking speed of the motor is attained. In this connection it will be noted that the B.H.P. of the starting motor increases with its speed of rotation; the maximum value, in Fig. 346, occurs at about 1,200 R.P.M., corresponding to the normal engine cranking speed given by the motor reduction gearing.

Rolls Royce "Merlin" Engine Starter. The Merlin engine employs a 12-volt starting motor mounted vertically on the lower right-hand side of the wheel case (Fig. 347). The starting motor A has also a hand-starting connection; this is shown at B in Fig. 347. The motor armature shaft drives through a train of reduction gears and a jaw clutch to one of the planet wheels of the supercharger unit. The drive is transmitted from here to the main shaft by means of a screw engagement device. The engine drive includes a safety type of slipping clutch. The gear reduction ratio of the electric starter is 393 : 1; that of the hand starter is about 14 : 1. The hand starter is provided with a free-wheel unit and its drive to the engine is taken through the slipping clutch unit previously mentioned.

Combined Electric Inertia and Direct Starter. A more recent development in electric motor starting devices for aircraft engines consists of a combination hand and electric inertia starter provided with an additional feature for continuing the cranking of the engine by means of the electric motor after the kinetic energy of the starter flywheel has been dissipated. A typical example is the American "Eclipse" combination starter, series 41, for engines of 1,500 to 1,800 h.p. rating.

In another model of B.T.H. electric inertia starter the engagement of the dogs is effected automatically by means of a special solenoid circuit arrangement whereby the solenoid operates at a predetermined voltage value and engages the starter with the engine. The energy stored in the flywheel commences to turn the engine after which the starter acts as electrical turning gear, the motor being energized until the engine fires; the switch is then released.

The chief advantage of this method is that the energy stored in the flywheel furnishes the heavier "breakaway" torque and the electric motor has only to carry the lighter load of continuous cranking; this arrangement reduces the drain on the battery.

Another combination by the former firm is a direct cranking electric starter and integrally mounted hydraulic feathering

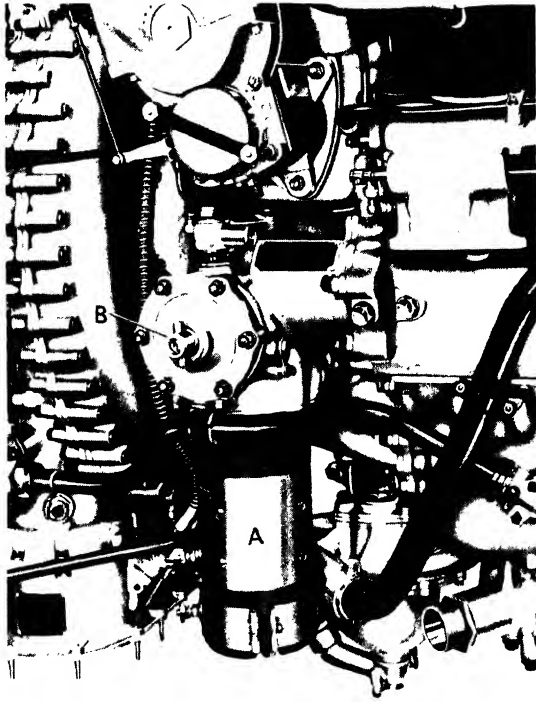

FIG. 317. Rolls Royce "Merlin" engine starting unit.

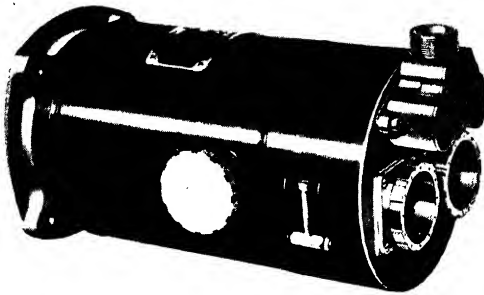

FIG. 318. The Rotax 24-volt, 1,000 watt generator.

[To face p. 410.

pump for hydromatic airscrews. The combined unit weighs appreciably less than the separate components and some line tubing is saved.

Other Engine Accessories. Among the other engine accessories which cannot, however, be described in detail here, are the oil pressure gauges, engine and radiator thermometers, revolution indicators, fuel tank contents gauges (direct and distant reading), boost pressure gauges, etc. Particulars of these instruments and accessories are given in Reference 80 at the end of this book.

Engine-driven Generators. The electric generator, or dynamo, is provided for the purpose of keeping the aircraft batteries charged, so as to give a constant voltage source of direct current supply for the various purposes required in the operation of the aircraft. Both the 12- and 24-volt pattern generators are used. Typical standard models are the 12 volt, 150 watt; 12 volt, 500 watt and 24 volt, 1,000 watt ones.

The generators are of the compensated voltage or automatic output regulated types of the Air Ministry 5C/561 and 5C/562 specified patterns. The former type is based on a similar principle to the automobile dynamo whereby the charging current from the generator is adjusted automatically so as to give a large value when the battery is partly discharged and a low or trickle charge when the battery is charged.

The Air Ministry pattern 12-volt, 500-watt generator has a special regulating system giving a constant output over a speed range of 4,000 to 6,000 R.P.M. To avoid overcharging on long runs when the battery is not being used a resistance is provided which is switched into the shunt field of the generator to cut down the charging current. A "two-charge" switch and automatic cut-out are employed in the generator-battery circuit. The generator in question is of the flange-mounted pattern measuring about $5\frac{1}{2}$ in. diameter by $9\frac{1}{2}$ in. long and weighing 22 lbs. The Rotax 24-volt, 1,000-watt generator, shown in Fig. 348, is of the compensated voltage type, giving its maximum output at 4,000 to 6,000 R.P.M. It is driven at $2\frac{1}{2}$ times engine speed. It is $5\frac{3}{4}$ in. in diameter by about $12\frac{1}{4}$ in. long and weighs 35 lbs.; the voltage control box weighs 7 lbs. 6 ozs. The generator is fully screened to prevent radio interference and has a cooling jacket through which slip stream air is circulated through the ringed openings shown in Fig. 348,

Air Compressors. In order to supply the compressed air needed for purposes such as engine starting (in some cases only), operation of the air-brakes, gyroscopic "automatic pilot," pneumatic wing de-icer, sirens, etc., it is usual to include an engine or electric motor-driven air compressor of light design. Typical examples are the B.T.H. single- and double-cylinder compressors of the positive action, silent operation, low power consumption pattern. The complete compressor installation includes the compressor, pipe lines, oil container,

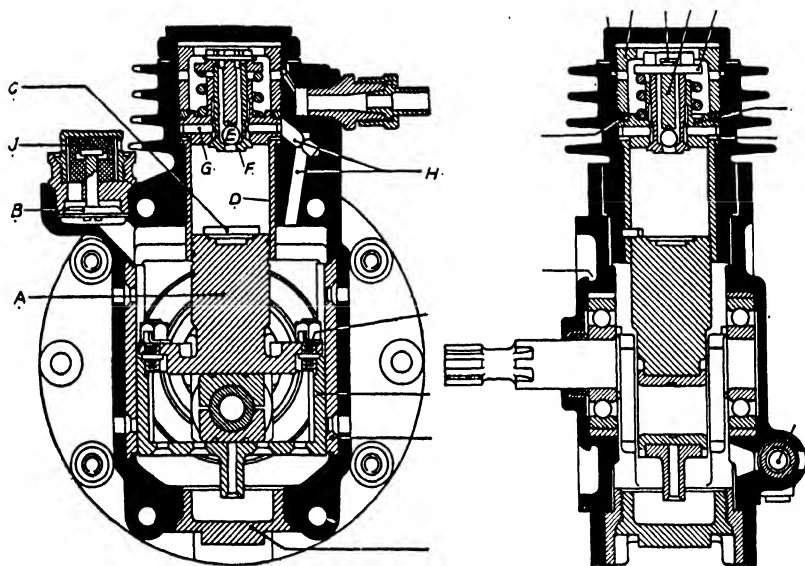

FIG. 349. The B.T.H. air compressor.

reservoir for storing the compressed air, pressure gauge and control cocks ; a normal installation is shown in Fig. 335.

The compressor cylinder is finned for cooling purposes, and is mounted in a suitable position on the engine or bulkhead in the cooling air stream so that its temperature does not exceed 70°C .

The action of the B.T.H. air compressor is illustrated in Fig. 349. By the upward stroke of the piston A, Fig. 349, air is drawn by way of an automatic inlet valve B, into the crankcase. Then the downward stroke of the piston compresses the air, and on reaching the bottom of its stroke, a transfer port C in

the cylinder D is opened, allowing the air to be transferred from the crankcase into the cylinder D. The air is now further compressed and passes through a delivery ball-type valve E of the main valve unit into the air receiver by the next upward stroke of the piston. When the receiver reaches the pressure for which the spring-loaded relief valve F is adjusted, the back pressure from the air receiver acting upon this valve causes it to open and enables the air to by-pass through the holes G in the valve body and holes H in the compressor body into the crankcase. Under these conditions the compressor cannot generate any pressure, because the air in the crankcase and cylinder is circulated through the circuit described. A separate oil container holds a proportionate quantity of oil through which air is pumped, so that upon the valve cutting out the back pressure on the oil forces some of it along the delivery pipe to the compressor head, thus sealing the ball-valve E.

The single-cylinder, single-stage compressor weighs $4\frac{1}{2}$ lbs., has a piston displacement of 0.368 cu. ft. of free air per minute at 1,200 R.P.M. and will give a reservoir pressure of 200 lbs. per sq. in. ; it requires 10 minutes to raise this pressure in a 400 cu. in. capacity reservoir. The power consumption is 0.175 h.p. at 200 lbs. per sq. in. The compressor cuts out automatically when the reservoir reaches its pre-arranged pressure ; the compressor then runs idly.

The double-cylinder compressor has twice the free air pumping capacity for the same pressure and it weighs 9 lbs.

Engine Heating for Starting Purposes. For many civil and military aircraft operating conditions it is important to be able to start the engines easily under all existing atmospheric temperatures on the ground. To do this it is necessary to heat the engines and the lubricating oil to a certain minimum temperature in each case ; with liquid-cooled engines the coolant is warmed beforehand and maintained in this condition ready for quick starting.

In the case of air-cooled engines the use of a heater cover, consisting of a lined canvas hood to enclose all of the engine, and a heater of the Davy lamp or catalytic type—using petrol or paraffin—is satisfactory for the purpose. The hot combustion products from the lamp below are guided upwards by a suitable canvas funnel so as to circulate around the engine. Heater lamps of the previously mentioned types are quite safe

even in the presence of petrol vapour and a lamp of about 1 gallon capacity will maintain an engine at a sufficiently warm temperature for easy starting purposes for about a day and a half. The advantage of the oil lamp heating system is that for normal air temperatures it will also heat the lubricating oil if the tank is under the engine heater cover; moreover, the method is an independent one applicable to any aerodrome or landing ground. Where external electric power is available a more convenient method is to use the engine heater cover and to employ electric resistance heaters for the coolant and oil systems. In the case of the coolant system an immersion heater or a separate water tank with its immersed heater may be employed; in the latter method the auxiliary water tank is connected by two water cock fittings to the bottom part of the radiator, so that a natural circulation of the heated water occurs. In another method a small water heater unit is provided with a small motor-driven circulating pump and the water which has been heated by an electric resistance wound around the cylindrical water tank, is pumped through rubber hose of $\frac{1}{4}$ in. to $\frac{3}{8}$ in. bore to the header tank of the engine cooling system, so that the hot water delivery is to the pipe leading from the header tank to the tops of the engine water jackets. A return hose pipe is taken from the radiator pipe connection to the header tank, to the suction side of the heater circulating pump. In this way a constant circulation of heated water is maintained in the engine cooling system. The same unit can also have an electric connection for attaching the cable of another immersion heater for the oil tank. The complete unit is designed for easy attachment and withdrawal.

In a typical application of the electric method of heating the oil and water of a 500 h.p. engine, with air temperature at 15° C., the oil tank capacity was 7 gallons and a 360-watt heater in the sump raised the average oil temperature to 65° C. in a period of 4 hours and to 78° C. in 8 hours. The water temperature was increased from 15° C. to 40° C. by means of a 1,700-watt heater in a period of 4 hours; the water-cooling system capacity was 13 gallons. The air temperature within the engine cover was raised from 15° C. to 25° C. in 6 hours.

Of the other alternative methods of engine heating that of steam heating has certain advantages, when a hangar installation is available. The steam can be led direct to the base of the radiator and allowed to flow through or into the water, the

surplus condensation water being allowed to flow out of the overflow pipe. Another method which is sometimes used is to remove the cold oil from the oil reservoir tank and replace it by heated oil, and to replace the cold cooling system water by hot water.

The method of facilitating engine starting by diluting the lubricating oil with petrol and the Bristol high initial oil pressure system, described in Chapter VIII, should also be mentioned in connection with these remarks on engine starting.

CHAPTER XII

THE TESTING OF AIRCRAFT ENGINES

AIRCRAFT engines intended for installation in aircraft as distinct from experimental or development models, are required to undergo a number of searching tests before they are accepted for installation in the aircraft. These tests are designed to show the general reliability, endurance qualities and standard of performance of the engines ; they include in general tests for endurance over a stipulated period of time, measurements of output, speed, fuel and oil consumption under part and full throttle conditions, starting, slow-running and acceleration tests, etc.

Each country has its standard tests in connection with the International Air Navigation Regulations. In this country the requirements for engines intended for use in civil aircraft are set forth in the Air Ministry Publications No. 840, with subsequent addenda, and No. 1208, Design Leaflets C₁, C₂ and C₃.

As all of these tests involve the running of the engine under load a special form of power absorption or transmission brake (or dynamometer) provided with means for measuring the engine's power output at various speeds, is employed in the test house. Formerly, it was not uncommon to fit the engine with a calibrated airscrew or paddle-type dynamometer and to test it for output, reliability and endurance. The principal dynamometers used for high-power aircraft engines are the hydraulic absorption and the electric generator types. In the former pattern dynamometer the whole of the engine power is absorbed in churning and heating the water within the casing of the machine, whereas in the latter type the engine drives an electrical generator, the current from which can be employed for charging batteries or any other useful purpose in the works ; both types of dynamometer operate on the same principle, namely, that of measuring the torque reaction of the machine casing.

The principle of the hydraulic dynamometer is illustrated

in Fig. 350, which shows the rotor member, connected to the engine shaft, rotating inside a casing filled with water. The casing has a number of projections to assist in increasing the resistance to rotation of the rotor and it is mounted on anti-friction bearings concentric with the rotor shaft axis so that if there were no constraint on it, it would be free to rotate about the rotor shaft. When the latter is rotating, the effect of the rotor is to churn up the water thus causing it to exert a drag or torque effect upon the casing, equal to the

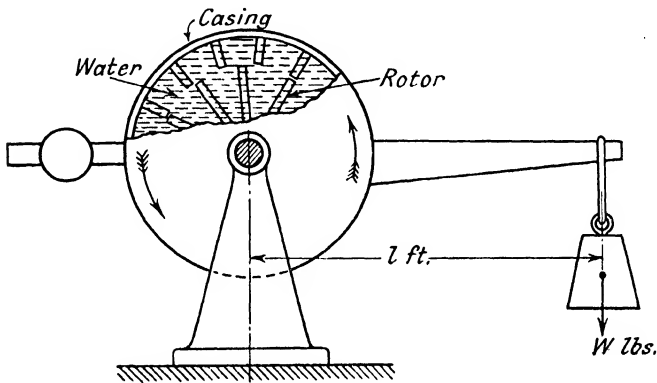

FIG. 350.

torque transmitted by the rotor from the engine. The casing is prevented from rotating, *i.e.*, is balanced, by means of weights at the end of the casing arm; the product of the total weight by the length of the arm is equal to the torque of the engine shaft, assuming the arm itself is balanced.

The horse power of the engine can then be estimated from the following simple relation

$$\text{B.H.P.} = \frac{2 \pi \cdot W \cdot l \cdot N}{33,000}$$

where W = weight in lbs. on torque arm, l = length of torque arm in ft., N = R.P.M.

For any particular machine this expression may be written as follows:—

$$\text{B.H.P.} = k \cdot W \cdot N.$$

where $k = \frac{2 \pi l}{33,000}$.

It is therefore necessary only to balance the torque by means of the weight W and to measure the speed of the crankshaft with a tachometer. For convenience, however, a spring balance is attached to the end of the torque arm so that it is necessary only to read off the pull on the balance instead of having to adjust weights when the engine output is to be measured.

The Heenan and Froude dynamometer, which works on the principle outlined, has a number of refinements to enable horse

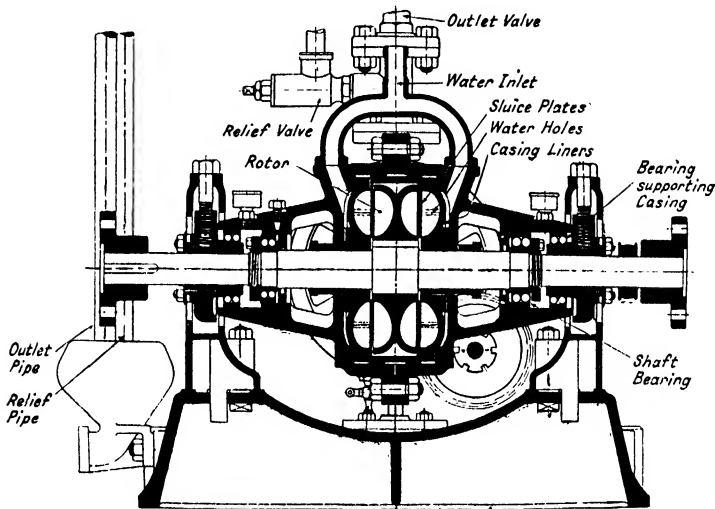

FIG. 351. Heenan and Froude hydraulic dynamometer.

power measurements to be made quickly and easily. Fig. 351 shows a sectional view of this dynamometer, with the principal parts annotated.

In this design the crude paddle and vane arrangement of Fig. 350 is replaced by cups of semi-elliptic cross section on both the rotor and inner sides of the rotor casing; this gives much better power absorption and enables the overall diameters of the rotor and casing to be reduced considerably. The brake has a constant flow of water through it, since the water is heated by the churning action; in other words, the engine power absorbed is converted into heat energy. When in action, the water is supplied to the pockets by means of holes drilled in the vanes. The water is then discharged by the revolution

of the rotor into the pockets formed in the casing and a vortex action is set up, the water being circulated constantly around each elliptical space formed by the coming together of pockets in the rotor and casing. The resistance offered by the water to the action of the rotor reacts upon the casing which tries to turn in its anti-friction roller supports. This tendency is opposed by the torque arm on the casing and a spring balance device.

It should be noted that the three forces resisting rotation, namely (1) the hydraulic resistance of the rotor, (2) the friction of the shaft bearings, and (3) the friction of the glands all react on the casing, which being free to swivel upon its anti-friction bearings transmits the whole of these forces to the torque arm weighing device.

The horse power absorbed by the dynamometer is calculated from a similar formula to that previously given, namely:—

$$\text{B.H.P.} = \frac{W \times N}{K}, \text{ where } W = \text{weight on torque arm in lbs.,}$$

$N = \text{R.P.M.}$ and $K = \text{a constant for the dynamometer.}$

Thus, in the case of a machine having an arm 5 ft. $3\frac{1}{10}$ in. long, $K = 1,000$, whilst for a metric machine with a 1,432.4 mm. arm $K = 500$.

In the case of the model shown in Fig. 351 the load is regulated by means of sluice plates, consisting of thin metal plates between the rotor and casing flat surfaces. These plates can be advanced or withdrawn by means of a mechanism operated by an external handwheel. If moved towards the main shaft they cut off communication between the rotor and a number of the cups and so diminish the effective resistance of the dynamometer and therefore the load. This method of adjusting the load to suit the capacity of the engine can be employed whilst the engine is running, so that a power curve can readily be taken over a wide range of speed.

The water supply, if from the town mains, is at a pressure of 10 to 30 lbs. per sq. in., and an allowance of about 3 to 4 gallons per B.H.P. per hour is made; the water can leave the machine at any temperature up to about 140° F. The dynamometer described is widely used in this country, many different models being available. It possesses the advantages of having a very low starting resistance, wide range of load adjustment, absence of any load on the engine's bearings, suitability for long endurance tests and silence in operation.

In the case of the electrical torque-arm type of dynamometer the load is varied electrically by altering the field coil current with the aid of variable resistances ; the field current is supplied from a separate source for this purpose.

An advantage of the electric dynamometer is that it can be arranged, by a suitable change of connections, to act as a motor for running in the engine and for starting the latter.

It is not possible, in this brief account, to describe the various alternative kinds of dynamometer of the hydraulic, electrical and air brake types ; the reader desiring fuller information is referred to Reference No. 81 given at the end of this book.

General Testing Procedure. When the new engine has passed inspection it is mounted on a suitable engine stand and given a *running-in operation* for the purpose of bedding down the main, big-end, camshaft and other bearings, the pistons and cylinder walls, etc.

For this test the engine is motored electrically with the ignition and fuel supply to the carburettor switched off. The running-in speed is usually from 500 to 600 R.P.M. and occupies about five hours. During this operation the engine is liberally lubricated with a special low viscosity oil which, during its circulation, is passed through a centrifuger of the de Laval pattern to remove any solid deposits. After the running-in process the engine is transferred to the dynamometer engine stand and connected to the dynamometer by means of a flexible coupling. The subsequent test procedure can best be described by referring to the general practice adopted for Bristol air-cooled radial engines. The testing arrangements are necessarily somewhat elaborate in view of the number and importance of the exacting test standards adopted for these engines.

Fig. 352 illustrates one of the Bristol engine test rooms, and shows the large cooling air duct surrounding the engine seen under test. The fan chamber for this duct is beyond the partition on the left. On the right can be seen the large triple-glass window separating the test room from the control room in which the test operators work. Fig. 353 shows the Heenan and Froude hydraulic dynamometer, and, on the right, the honeycomb entry to the sound-absorbing exhaust tunnel.

The large air ducts enable cooling air speeds up to 180 M.P.H. to be employed, although normally a speed of 100 to 120 M.P.H. is used ; in order to obtain the required volume of air and cooling speeds a 500-h.p. electric motor is used to drive the fan.

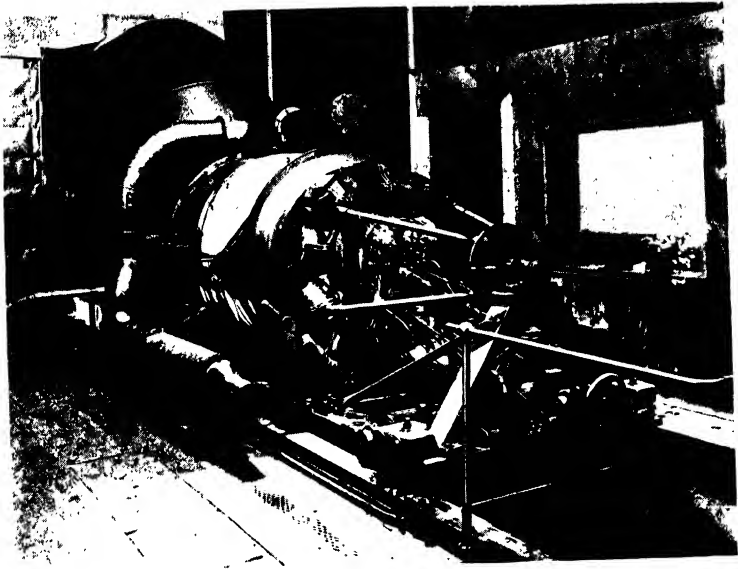

FIG. 352. Bristol radial engine on test bed, showing air-cooling duct.

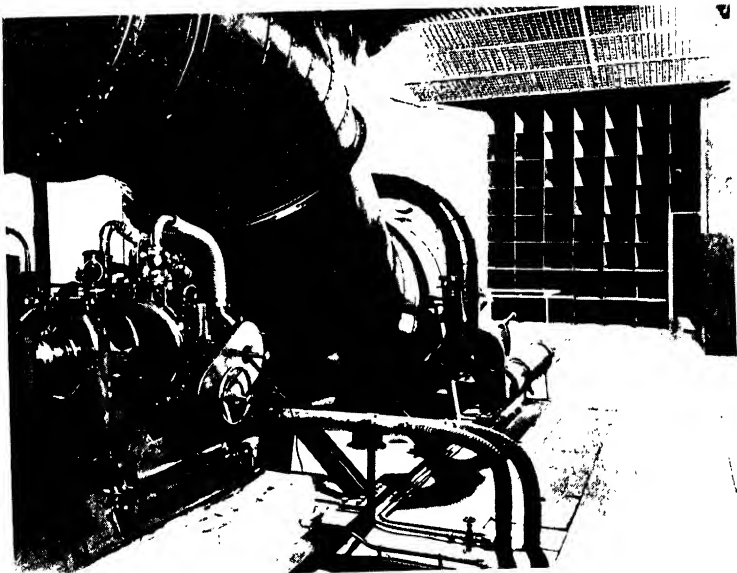

FIG. 353. Bristol test house, showing hydraulic brake, air-cooling duct, etc.

The engine is mounted on a movable cradle for facility of coupling up with the dynamometer; the latter—as shown in Fig. 353—is situated at the rear of the air duct; at the back of the dynamometer there is a 100-h.p. electric motor for the purpose of motoring and starting the engine under test.

The Oil Supply System. The test stand has a *duplicate oil supply system* to enable either castor-blend or mineral oils to be used during the tests. As mentioned earlier in this volume, the former grade of oil is employed for initial running of the engine under its own power, after which the normal mineral oil is used. The oil supply tanks are provided with electric heating elements and water-cooling coils to vary the oil temperature as required; usually this is held at about 70° C.

The fuel supply is connected to three flowmeters for measuring the fuel consumption, and thence to the carburettor on the engine. The flowmeters are also used in connection with the adjustment of the carburettor jets.

Other Test Equipment. In addition to the usual carburettor controls the equipment of the test stand includes twin ignition switches, two tachometers and a means of checking the speed with a hand rev-counter, oil pressure and temperature gauges, air speed indicator, thermocouples for measuring the cylinder and other temperatures, boost pressure gauge, U-tubes and depression chambers for the testing of supercharged engines.

Preliminary Running Under Power. When the various pipes and controls have been connected to the engine the latter is motored around and the cooling fan started. If everything is in order the ignition is switched on and the engine is allowed to run light at about 800 R.P.M. for a period of half an hour. The load is then applied gradually and the throttle opened until by the end of a further half-hour the engine is developing its proper test load. In the case of *supercharged engines* the load is 90 per cent. of the ground level power at normal R.P.M. and with the rated boost pressure in the induction system. For *non-supercharged* engines of the high compression type the load is 90 per cent. of the rated ground power level.

During the tests flowmeter readings are checked and any necessary adjustments are made to the carburettor to give the correct fuel consumption and power. Afterwards the engine is run for one and a half hours at 90 per cent. load and at normal speed.

Up to this stage of the test the vegetable base lubricating oil

has been used. This is now drained out, the filters examined and the oil system changed over to the officially specified mineral oil, *e.g.*, D.T.D.109, and the engine is opened up for a further hour at 90 per cent. load.

During the last five minutes of this hour unsupercharged engines are opened up to full throttle, using a leaded fuel in the case of high compression engines or up to normal ground level power for supercharged engines.

Type Tests for New Designs of Engines. The first engine of a new design or type before being accepted as "airworthy" by the Air Ministry, has to undergo an official type test before which the manufacturers must declare its proposed power rating.

The following is an extract from Air Ministry Publication 840, hitherto used for type tests for new designs of engines :—

Preliminary. Before an engine is submitted for type test, the maker must have declared the rated full power, normal and maximum permissible R.P.M., etc. In addition, the engine should have satisfactorily completed the standard two hours' endurance test ; have been stripped for examination, measurement and recording of engine data such as bore, stroke, compression ratio, weight, etc., and finally re-assembled and tuned up on the test bench. The type test should be started with the taking of a power curve.

Endurance Test. An endurance test of 100 hours' duration at normal speed at 90 per cent. full power (unless otherwise specified) is to be taken. This endurance test will comprise ten non-stop runs of ten hours' duration: Fifty hours of this test will be carried out with the engine fitted with an airscrew, such airscrew being suitable for the thrust test. The last ten hours' run must be carried out on an approved form of brake, and at the commencement of the one-hundredth hour of the endurance test the load will be increased so that the engine is running at full power at normal R.P.M. until within five minutes of the completion of the test, when the engine will be opened out to full throttle.

Civil Aircraft. For engines intended for civil aircraft the duration of the endurance test shall be fifty hours, to comprise five non-stop runs of ten hours' duration. Twenty hours of this test will be carried out with an airscrew. The load will be increased to full power on the fiftieth hour, otherwise the conditions will be the same as laid down in the preceding paragraph.

Slow Running and Acceleration. The engine must be run as described on p. 424. The duration of the slow running is to be ten minutes.

High Speed. The engine to be run for one hour continuously at 5 per cent. in excess of the established maximum permissible speed, and under load conditions at the option of the manufacturer.

High Power. The engine is to be run for one hour continuously at the established maximum permissible speed and at full throttle.

Power Curve. Another power curve to be taken.

Dismantling. On completion of the above tests the engine is to be completely dismantled for inspection by the A.I.D. inspector. On completion of inspection, any defective or unduly worn parts that have been rejected must be renewed and the engine re-assembled for test.

Final Test. If the condition of the engine has been satisfactory, it will be required to be submitted to a final test of thirty minutes under the same conditions as the endurance test.

During the preceding tests the consumptions of fuel and oil are measured on any non-stop run of ten hours' running of the fifty hours' duration test, and these consumptions, in the case of civil aircraft engines, must be within 20 per cent. of the makers' rating. The actual fuel consumptions laid down depend upon the compression ratio and grade of fuel employed; the consumptions are usually specified for the type of engine in the official specifications. In regard to the *oil consumption*, this should not exceed 0.025 pints per B.H.P. hour for water-cooled engines and 0.045 pints for air-cooled ones.

The *water pump delivery* is also required to fulfil certain conditions: At normal R.P.M. the engine water pump will be required to deliver at least 15 gallons per minute per 100 B.H.P. (normal) against a circuit resistance or head of 2 lbs. per sq. in. in excess of that required to overcome the hydraulic resistance of the engine, while the water just before the pump inlet branch is maintained at a temperature of not less than 75° C., and its pressure at least 4 lbs. per sq. in. below atmospheric. This test will be carried out with the engine developing the rated full power at normal R.P.M. for at least thirty minutes. At the slowest speed at which the engine will run fitted with the airscrew used during the thrust test, the pump must be capable of circulating water through the engine with a resistance at the water outlet branch equivalent of 2 ft. head of water.

In connection with the *maximum speed tests*, Bristol engines are tested by the makers at 15 per cent. over the normal speed instead of the usual 10 per cent. ; and at 5 per cent. in excess of the maximum rated speed on a moderate load.

The Engine Accessories. In regard to the *endurance test*, this is arranged to cover not only the performance of the engine itself, but also of all of its auxiliary parts such as the fuel pumps, carburettors, magnetos and other standard accessories supplied with the engine.

Final Inspection. As previously noted, after the type tests have been completed the engine is stripped for inspection by the A.I.D. representative, the parts having first been washed and cleaned. Any corrections or replacements necessary are made and the engine is then re-assembled and taken to the test house, where it is mounted on a dynamometer stand and run with mineral oil lubricant for half an hour, the load being increased gradually to the 90 per cent. figure as in the case of the endurance test ; this load is held for one hour, the last five minutes as before being at full throttle or rated boost.

The final test employed for Bristol engines, in addition to the running already described, includes a power curve, a throttle curve and, in the case of supercharged and altitude-rated engines an *altitude curve* and a *constant boost curve*.

In connection with the *slow running and acceleration tests*, the engine, after its endurance tests, is generally taken to an open hangar and mounted on its test stand. The power is absorbed by a four-bladed test airscrew which provides also the necessary cooling air stream. Each stand is operated from a cabin and the equipment as regards controls, fuel and oil circulation, instruments, etc., is similar to that of the dynamometer test house. To satisfy the official requirements engines should run reasonably slowly and be able to open up to the normal R.P.M. within five seconds without any excessive "popping" or rough periods of running ; they should run reasonably well at 80 per cent. reduction from normal R.P.M. when the dynamometer has been adjusted for 90 per cent. power at normal R.P.M.

Thrust Tests. In order to test the thrust bearings of the engine it is usual to submit these bearings to a thrust of 6 lbs. per B.H.P. on the airscrew shaft during tests made under the same conditions as the endurance tests ; if, however, a suitable

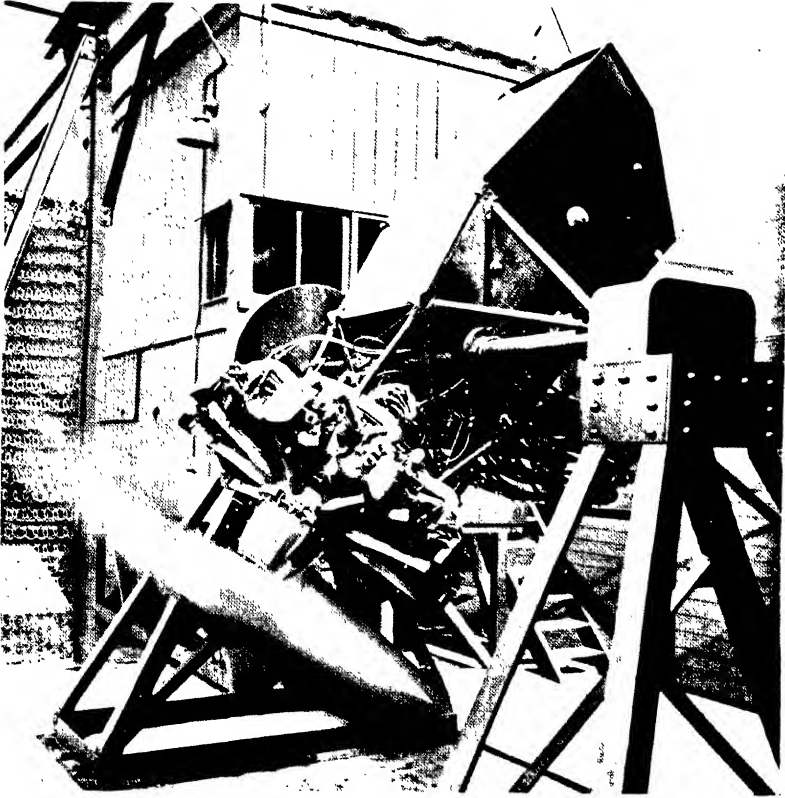

FIG. 351. The Bristol tilting test engine stand.

airscrew is fitted the thrust test can be made with this. The direction of the thrust should be the same as that of the airscrew normally fitted in the aircraft in which the engine is to be installed, *i.e.*, tractor or pusher.

Tilting Tests. Engines intended for military and similar purposes where severe climbing, banking and diving conditions have to be provided for are usually given independent tests on a tilting test bed capable of holding the engine rigidly at any given angle to the horizontal, up to the vertical diving attitude. In this way the fuel and oil systems can be tested and the other components likely to be affected by the inclination of the machine—as, for example, the controls and cables—checked.

Fig. 354 shows one of the tilting test stands used by the Bristol Company, with a "Pegasus" engine undergoing a 70-degree tilting test. In this type of test stand all controls and feed lines with the exception of the lubrication system—which is mounted on the trunnion arm and moves with the engine—are flexible in order that movement of the engine is unrestricted; the controls are actuated by means of Arens cables.

Other Tests. In the preceding outline of the usual test procedure and requirements for aircraft engines it has not been possible to include mention of any other special tests specified for military aircraft engines of recent design. Although these engines, in general, have to fulfil the test requirements previously described, other conditions may be specified by the Air Ministry and special instructions in regard to these issued to the manufacturers; under peace time circumstances these instructions are available to the public in the appropriate Air Ministry Publications.

Measuring Engine Power in Flight. Special types of transmission dynamometers are now available for use on aircraft to measure the engine output under flight conditions. A typical one is that developed at the R.A.E. on the basic principle of Ford's torsionmeter.⁸² It measures the torque transmitted to the airscrew from the engine by means of a spring element inserted in the drive. The deflections of the spring, which are proportional to the transmitted torque, are measured by an electrical method whereby the voltage is proportional to the air gap which in turn is proportional to the spring deflection. In order to deal with large torsional oscillation effects a damping device is embodied in the drive. With this type of hub dynamo-

meter power curves under climbing altitude and other flight conditions can be obtained and corresponding fuel consumptions measured by means of a suitable flowmeter.

The Bendemann hub dynamometer⁸³ is another device for measuring the engine power during flight. It consists of a system of hydraulic pistons and cylinders interposed between the engine shaft and airscrew in such a manner that the hydraulic pressure generated in the cylinders is proportional to the torque. This pressure is transmitted through small tubes to an instrument in the pilot's cockpit, which records the values.

Aircraft Engine Test Houses. Modern aircraft engine works are equipped with special test houses designed not only to carry out all of the officially specified engine tests, but also to reduce considerably the engine noises in their immediate vicinity. Not only is it necessary for the operators to work under the best conditions, but it is also desirable that the engine and exhaust noise should not be a nuisance to the occupants of other buildings in the district.

Modern test houses are designed on scientific principles involving investigations of the acoustical frequencies and intensities of the noises emitted by engines under full power tests; these frequencies generally range from about 40 to 9,000 cycles per second. The test houses are provided with sound-absorption devices to deal with the more objectionable frequencies. The test house is usually made with double walls, each entirely independent of the other. Thus, the more recent Bristol test house has two sets of walls, each of the air cavity type, so that there are four thicknesses of brickwork with three air spaces between the inside and outside. The reinforced concrete roof is carried by the inner walls and does not make contact with the outer ones. The inner walls have sound-absorbing panels and the engine test bed is insulated acoustically from the floor; the latter is in its turn insulated from the walls. The entry to the sound-absorbing exhaust tunnel is shown in Fig. 353.

The design of this test house is so satisfactory that in the control room between two test houses with two 1,000 h.p. engines only a few feet away conversations can be carried out as comfortably as in any normal works; there is also a complete absence of the usual air pulsations. In addition, immediately outside the test house with the two engines running at full power only a very subdued drone can be heard; a

few yards away from the building this drone becomes inaudible above the sounds which are normal in any industrial locality.

In this connection the usual engine test bed noise of about 138 phons equivalent loudness is reduced by nearly 50 per cent. in the adjoining control room and in the zone immediately outside the building.

APPENDIX I

AIR MINISTRY SPECIFICATION D.T.D. No. 109 FOR MINERAL LUBRICATING OILS (ABRIDGED)

(1) **Definition.** The term "Mineral Lubricating Oils" shall denote pure highly refined petroleum oils free from adulterants.

(2) **Appearance.** The oil shall be clear and free from dirt, suspended matter and other impurities.

(3) **Viscosity.** The absolute viscosity shall be :—

Summer Grade	Winter Grade
At 100° F. not more than 2.9 poise.	At 100° F. not more than 1.75 poise.
At 200° F. not less than 0.183 poise.	At 200° F. not less than 0.133 poise.

(4) **Flash Point.** The "open" flash point shall not be less than 390° F. (199° C.) when determined by the method described in Appendix I.*

(5) **Free Acid.** The oil shall contain not more than a trace of mineral acid, and not more organic acid than corresponds to 0.01 gm. KOH per 100 gm. of oil when tested by the methods described in Appendix II.*

(6) **Ash.** The ash content shall not exceed 0.01 per cent. by weight when tested as described in Appendix III.*

(7) **Oxidation Test.** After blowing for twelve hours as described in Appendix IV* the viscosity at 100° F. shall not be greater than 2.0 times the original viscosity at the same temperature.

(8) **Coke Number.** (a) The coke number shall not exceed 0.70 when determined by the method specified in Appendix V.*

(b) The coke number of the oil after twelve hours' blowing (in accordance with the method described in Appendix IV) * shall not exceed the original coke number plus 1.

(9) **Cold Test.** The oil shall not cease to flow when exposed for one hour to the following temperatures :—

For Summer Oil	— 8° C. (18° F.)
For Winter Oil	— 10° C. (14° F.)

The test shall be carried out by the method described in Appendix VI.*

* These Appendices are given in the full specification.

A P P E N D I X I I
COMPARISON OF VARIOUS ALTERNATIVE AUXILIARY POWER SYSTEMS *

Factor	MAIN ENGINE DRIVE		AUXILIARY POWER UNIT
	Direct	Accessory Gear Box	
1. Reliability	Good.	Good.	Good.
2. Weight	Light.	Fairly simple, except in small machines.	Heavy. Central, but requires silent chamber. Impossible for small machines.
3. Installation	Complicates power unit.	Moderately simple.	Simple.
4. Maintenance on ground	Troublesome. Interferes with engine servicing.	Inherently simple.	Possible. Very heavy. Always available.
5. Maintenance in flight	Impossible.	Only with batteries, or compressed air.	Necessitates supercharged or oversize unit.
6. Duplication of services	Only with batteries, or compressed air.	Inherent.	Considerable, chamber requires protection.
7. Availability on ground	Inherent.	Small.	Requires silencing. Straightforward.
8. Compensation for altitude	Small.	Not increased.	
9. Fire risk	Small.	Requires constant speed drive.	
10. Noise	Not increased.		
11. Generation of alternating current	Requires constant speed drive.		

OTHER FORMS OF ANCILLARY POWER

Factor	OTHER FORMS OF ANCILLARY POWER		
	Pneumatic	Hydraulic	Electric
1. Reliability	Poor.	Good.	Good.
2. Weight	Light.	Light.	Lighter than D.C.
3. Installation	Simple. No return pipe required.	Simple, but two pipe lines required.	Simple.
4. Control	Cocks and valves.	Cocks and valves.	Switches and solenoids
5. Maintenance	By bottle.	By compressed air.	Requires skilled personnel.
6. Duplication (a) of source of energy	By bottle.	By compressed air.	Heavy.
(b) of transmission	Difficult.	Difficult.	Easy.
(c) of receiver	Difficult.	Difficult.	Possible but heavy.
7. Applicability to undercarriage, flaps, etc.	Not feasible with present pressures.	Ideal.	Reasonably good.
8. Applicability to gun turrets	Not feasible.	Broken pipe involves complete shut down.	Not feasible except through hydraulic gearing.
9. Vulnerability	Pressure bottle dangerous.	By compressed air accumulator.	Low.
10. Availability on ground	By compressed air bottle.	Rapid.	By battery. Requires auxiliary power unit.
11. Response	Slow.		Instantaneous.

* The Diagram of Auxiliary Power Services on Aircraft. R. H. Chaplin and F. Nixon. Journ. Roy. Aeron. Soc., March 30th. 1939

KEY TO TEXT REFERENCES

1. C. D. Hawley and E. Bartholemew. Ethyl Gasoline Corporation, U.S.A.
2. *Power Plant Trends*. G. J. Mead. Royal Aeron. Soc. Journal, November, 1937.
3. *Aero Engine Design*. G. S. Wilkinson. Proc. Inst. Autom. Engrs., February, 1934.
4. *British Aero Engines*. Flight, December 7th, 1939.
5. *Liquid-cooled Aero Engines*. H. Wood. Journ. Soc. Automotive Engrs., July, 1936.
6. *The Internal Combustion Engine*. Pye. Volume II. Oxford University Press.
7. Proc. Diesel Engine Users Association, March, 1930.
8. *Fuels for Aircraft Engines*. E. L. Bass. Royal Aeron. Soc. Journal, March, 1935.
9. *The Oil Engine*. [Temple Press Ltd., London.] May, 1938.
10. *Liquid Cooled Engines*. A. Graham Forsyth. Royal Aeron. Soc. Journal, November 29th, 1934.
11. *Unbalanced Forces in Reciprocating Engines*. J. L. Napier. Automobile Engineer, February, March, 1920.
12. *Torque Calculations*. H. A. Golding. Proc. Inst. Autom. Engrs. (1924-25).
13. *Mechanics of High Speed Engines. Automobile and Aircraft Engines*. A. W. Judge. Sir I. Pitman Ltd., London. 3rd Edition.
14. *On the Stiffness of Crankshafts*. H. Constant. Aeron. Research Committee, R. and M. No. 1201 (1929).
The Effective Torsional Rigidity of a Crank. R. V. Southwell. Aeron. Research Committee, R. and M. No. 1211 (July, 1927).
Inertia Torque in Crankshafts. F. A. Stepney Acres. Proc. Inst. Autom. Engrs. (1919-20).
Torsional Vibration in Crankshaft-Aircrew Systems. B. C. Carter and A. Swan. The Automobile Engineer (March, 1926).
Dynamic Forces in Aircraft Engines. B. C. Carter. Journ. Roy. Aero. Soc., Vol. XXXI.
On the Equivalence between the Dynamical System of a Multi-crank Flywheel System and a Certain Electrical Circuit. E. B. Moullin. Aeron. Research Committee, R. and M. 1045.
Bending and Torsional Strains and Stresses in Loaded Crankshaft. H. Carrington. The Engineer (May 21st, 1926).
Torsional Vibration in the Diesel Engine. F. M. Lewis. Soc. of N.A. and M.E. (New York, 1925).
Torsional Vibrations in Reciprocating Engine Shafts. G. R. Goldsbrough. Proc. Roy. Soc. of A., Vol. CIX, p. 99.
Zur Berechnung der Verdrehungsschwingungen von Wellenleitungen. J. Geiger. Z.d.V.D.I. (1921).

14. *Torsion of Crankshafts*. S. Timoshenko. Trans. Amer. Soc. Mech. Engrs., Vol. XLIV, p. 653 (1922).
Engineering (July 13th, 1928).
15. *Torsional Vibration in Engines. Effects of Fitting a Damper, a Flywheel or a Crankshaft-driven Supercharger*. B. C. Carter. Aeron. Research Committee, R. and M. No. 1053. February, 1926.
16. *Engine Balance. Automobile and Aircraft Engines*. A. W. Judge. Sir I. Pitman Ltd., London. 3rd Edition.
Engine Balancing. F. W. Lancaster. Proc. Inst. Autom. Engrs., 1913-14.
Engine Balancing Calculations. M. Platt. Proc. Inst. Autom. Engrs., 1923-24.
Balancing of Automobile Engines. H. S. Rowell. Proc. Inst. Autom. Engrs., 1923-24.
Balancing of Engines. A. Sharp. Longmans, Green & Co. Ltd., London.
17. *Engine Types and Design Trends*. L. P. Kabb. S. A. E. Journal, October, 1934.
18. *The Aspin Engine*. The Automobile Engineer, January, 1938.
19. *High Speed Diesel Engines*. 3rd Edition. A. W. Judge (Chapman and Hall Ltd.).
20. The Aeroplane, January 5th, 1940.
21. The Autocar, February, 1940.
22. *Liquid Cooled Engines*. A. G. Elliott. Flight, December 7th, 1939.
23. *Aviation de Bombardement*. C. Rougeron (Berger-Levrault, Paris).
24. *Aero Motors and Their Development*. A. Nutt. World Automotive Engineering Congress of the Society of Automotive Engineers, San Francisco, June 7th, 1940.
25. *Sleeve Valve Engine Development*. W. Ferrier Brown. Proc. Inst. Autom. Engrs., Vol. 20, 1925-26.
26. *Automotive Industries*, March 23rd, 1935.
27. *High Speed Diesel Engines*. 3rd Edition. A. W. Judge. Chapter VI. (Chapman and Hall Ltd.).
28. *The Development of the Mono-sleeve Valve for Aero Engines*. A. H. R. Fedden. Proc. Inst. Autom. Engrs., Vol. 33, 1939.
29. *The Development and Progress of the Aero Engine*. H. R. Ricardo. Journal Royal Aeron. Soc., May 30th, 1930.
30. Proc. Inst. Mech. Engrs., December, 1923.
31. D. Napier Ltd. and H. C. Tryon. Pat. No. 519,116. March, 1940.
32. *The Work of Ackroyd-Stuart and Development of the Oil Engine*. A. E. L. Chorlton. Proc. Inst. Marine Engrs., November, 1931.
32. *Aircraft Engines*. Vol. I, p. 9. A. W. Judge (Chapman and Hall Ltd.).
33. *Aircraft Engines*. Vol. I, p. 117. A. W. Judge (Chapman and Hall Ltd.).
34. E. L. Bass. The Engineer, April 2nd, 1937.
35. *High Speed Two-stroke Oil Engines*. P. E. Biggar. The Automobile Engineer, April, 1930.
36. *The Internal Combustion Engine*. Vol. II. D. R. Pye (Oxford University Press).

37. *The Supercharging of Compression Ignition Engines.* J. H. Pitchford. Proc. Inst. Autom. Engrs., December, 1938.
38. *Some Characteristics of High Speed Oil Engines.* S. J. Davies. Proc. Inst. Mech. Engrs., December, 1931.
39. *Aircraft Engines.* Fig. 85, p. 142. Vol. 1. A. W. Judge.
40. *Junkers Heavy-oil Aero Engines.* Dr. Ing J. Gasterstaedt. The Engineer, February 5th, 1937.
41. Report of Aeronautical Research Committee, 1933-34.
42. *The Effect of Reduced Air Pressure, etc., on the Performance of a Solid-injection Oil Engine.* G. F. Mucklow. Proc. Inst. Autom. Engrs., 1926-27.
43. *Compression Ignition Engine Performance at Altitude.* C. S. Moore and J. H. Collins. N.A.C.A. Technical Note No. 619.
44. E. S. Hall. Proc. S.A.E. National Aeronautical Meeting, Washington, March, 1940.
45. *The Production of Bristol Engines.* Machinery. September 17th, 1936.
46. *Nickel Alloys in Aeronautical Engineering.* H. C. Hall. The Bureau of Information on Nickel, London.
47. *The Rolls Royce "F" Type Aero Engine.* Engineering, December 28th, 1928.
48. *The "Dagger" in Production.* Aircraft Production. July, 1940.
49. *Light Alloys for Aeronautical Purposes.* L. Aitchison. Journal Royal Aeron. Soc., December 14th, 1933.
50. *Handbook of Aeronautics.* Vol. II. A. Swan (Pitman Ltd., London).
51. *Building the Cheetah Engine.* Aircraft Production, August, 1939.
52. Automotive Industries, April 15th, 1939.
53. C. H. Wiegman. Automotive Industries, April 1st, 1940.
54. *Aero Engine Valve Manufacture.* Machinery, April 22nd, 1937.
55. *Valve Manufacture.* Machinery, July 4th, 1940.
56. *The Friction of Pistons and Piston Rings.* T. E. Stanton. Aeron. Research Committee, R. and M. No. 931.
57. *Internal Combustion Engine Lubrication.* Symposium of Papers read before the Institution of Mechanical Engineers, 1939.
58. *The Lubrication of Aircraft Engines.* F. A. Foord. Journal Royal Aeron. Soc., May 23rd, 1929.
59. *Lubricating Oil Tests.* J. E. Southcombe. Germ Lubricants Ltd., London, E.C.2.
60. *Oil Cooling for Aircraft.* B. C. Carter. R. and M. No. 1486.
61. *The Automobile Radiator (and Oil Coolers).* J. Coltman. Proc. Inst. Autom. Engrs., April, 1940.
62. *Improvements in Lubrication Systems of Engines.* B. C. Carter. Patent No. 512,991, March 25th, 1939.
63. Canadian Aviation, March, 1940.
64. *The Characteristics of the Spark Discharge and its Effect in Igniting Explosive Mixtures.* N. Campbell and C. C. Paterson. Advis. Committee for Aeronautics. Report E.S.C. No. 23.
65. *Some Factors Controlling the Development of Electrical Ignition of Aero Engines.* G. E. Bairsto. Journal Royal Aeron. Soc., February 16th, 1939.
66. *The High Tension Magneto.* A. P. Young and L. Griffiths. Proc. Inst. Autom. Engrs., 1927-28.

67. *On the Erosion of Sparking Plug Electrode Materials, etc.* W. R. Debenham and F. G. Haydon. Aeron. Research Committee, R. and M. No. 1744.
68. *Spark Plug Endurance Tests.* T. Tognola and A. W. De-Chard. Journ. Soc. Automotive Engrs. U.S.A. 1938-39.
69. *Starting of Engines in Aircraft.* Aeron. Research Committee. I.C.E. Sub-committee Report No. 3, April, 1917.
70. *Electrical Equipment for Automobiles.* E. A. Watson. Proc. Inst. Autom. Engrs., 1932-33. Vol. 27.
71. *The Problem of Ancillary Power Services on Aircraft.* R. H. Chaplin and F. Nixon. Journal Royal Aeron. Soc., March 30th, 1939.
72. *Exhaust Systems for Four and Six Cylinder Engines.* J. C. Morrison. Proc. Inst. Autom. Engrs., February, 1940. Vol. 8, No. 5.
73. *The Problem of Exhaust Silencing and Engine Efficiency.* J. C. Morrison. Proc. Inst. Autom. Engrs., March, 1933. Vol. 27.
74. *A New Two Stroke Engine.* English Mechanics, February 2nd, 1940.
75. American National Advisory Committee Report, No. 55, 1919.
76. *Exhaust Noise and Other Noises of Motor Transport.* T. R. Cave-Brown-Cave. Journ. Roy. Soc. of Arts, June 28th, 1935.
77. *Experiments in Aero-engine Exhaust Silencing.* A. W. Morley. Aeron. Research Committee, R. and M. No. 1760.
78. *Causes of Noises in Exhaust System.* E. G. Gunn. Automotive Industries, January 27th, 1934.
79. *Exhaust Pipes for Internal Combustion Engines of Aircraft.* J. E. Ellor and Rolls Royce Ltd. Patent No. 506,333, September 24th, 1937.
80. *Handbook of Aeronautics.* (Sir. I. Pitman Ltd.)
Aircraft Instruments. Stewart (Chapman and Hall Ltd.).
81. *Testing of High Speed Internal Combustion Engines.* A. W. Judge (Chapman and Hall Ltd.).
82. *Dynamometry with Particular Reference to the Measurement of Engine Power in Flight.* N. S. Muir. Journ. Roy. Aeron. Soc., February 25th, 1937.
83. *The Direct Measurement of Engine Power on an Airplane in Flight with a Hub Dynamometer.* W. D. Gove and M. W. Green. N.A.C.A. Report, No. 252.
84. Mech. Eng., U.S.A. Vol. 62, No. 10, October, 1940.

Official Aircraft Publications

The Directorate of Technical Development, Air Ministry, issues a large number of D.T.D. Specifications for aircraft material, electrical, engine and other components. A full list of these specifications can be obtained from H.M. Stationery Office, York House, Kingsway, London, W.C.2.

The British Standards Institution, 28 Victoria Street, London, S.W.1, publishes a relatively large number of British Standard Specifications for Aircraft Materials and Components under the following sections: A, bolts, etc.; B, brass, copper, etc.; D, dope and ingredients; E, electrical; F, fabric, transparent sheets, rubber hose, etc.; K, cast-iron for piston rings, etc.; L, aluminium and light alloys; S, steels, carbon and alloy; T, tubes; V, timber, glues, etc.; W, wire, wire

ropes, etc. ; X, paints and varnishes ; S.P., standard details (shackles, turnbuckles, fork joints, etc.). A full list of these Specifications can be obtained from the address given. The British Standards Institution also publish a special Sectional List of British Standards on Aircraft Materials and Components relating to dope and protective covering, magnetos, airscrew hubs, benzole, glossary of aeronautical terms, nomenclature for timber for aircraft purposes, land aerodrome and airway lighting and calibration of carburettor jets for petrol engines.

Aircraft General Standards (A.G.S.) may be obtained from The Secretary, Air Ministry (R.T.P.), Kingsway, London, W.C.2.

Standard Specifications (S.A.E.) relating to the United States of America for materials, engines, components, tests, etc. are issued by the Society of Automotive Engineers, 29 West 39th Street, New York, N.Y. and the American Society for Testing Materials (A.S.T.M.) for material specifications.

INDEX

- A** B.C. auxiliary power unit, 392
 A.B.C. engine, 81
 Absorption type silencer, 377
 Acceleration of piston, 48, 49
 Accessibility of engine, 23
 Accessories, engine, 173, 388 *et seq.*,
 411
 weights of, 389, 390
 engine, tests, 424
 Accessory drives, 127, 132, 134, 140,
 173
 section, crankcase, 139
 Acid test for lubricating oils, 290
 Advance of injection, 184
 Advantages of C.I. engines, 190
 of sleeve valve engines, 163, 164
 Aeronautical Manufacturing Com-
 pany, 314
 Research Committee, 186, 298
 Air compressor, 109, 179, 180, 398,
 399, 412, 413
 cooled engines, 2, 7, 8, 9, 10, 11,
 14, 15, 24, 25, 26, 27, 28, 61 *et seq.*
 cooling advantages, 11
 cylinder data, 136, 141
 Gipsy Twelve system, 93
 variable control, 130
 density and sparking voltage, 324,
 325
 exhaust valve, 262
 inlet temperature, 204, 205
 Ministry lubricating oil specifica-
 tion, 428
 type generator, 411
 quantity and B.M.E.D., 195
 used in C.I. engine, 185, 219
 radial engines, 116 *et seq.*, 130
 scavenging, 7, 179, 180, 191, 192,
 193, 194, 195, 219
 power required, 195, 196
 Aircraft engine, test procedure, 416,
 422, 423
 magneto characteristics, 346, 347,
 348
 types, 1, 2
 Airscrew, controllable pitch, 69, 70,
 72, 78, 120, 391
 gear drives, 79, 89, 90, 106, 126,
 135, 140, 172, 274 *et seq.*
 ratios, 89, 106, 113, 118, 119, 120,
 123, 130, 133, 134, 143
 Airscrew, shaft, 107
 Aitcheson, L., 239
 Alcoa alloy, 81, 83
 Allison liquid-cooled engine, 12, 14,
 99, 109
 X-type engine, 115
 Alni magnets, 335, 350
 Alnico magnets, 335, 336, 350
 Alpac casting, 74
 Aluminium alloys, 230 *et seq.*
 bronze, 69, 83, 131, 215
 Altitude effect on fuel consumption,
 18
 on performance, 201, 202, 211
 effects on ignition, 324, 325
 performance of engines, 70, 90, 103,
 110, 112, 124, 125
 Alvis engines, 121, 122
 Amal fuel pump, 74, 78
 American aircraft engine data, 14, 15,
 135, 136
 engines, 2, 14, 15, 26, 63, 75, 109,
 115, 130 *et seq.*, 210, 213, 214,
 225, 226
 National Advisory Committee for
 Aeronautics, 203
 Amplitude, torsional vibrations, 42,
 43, 46
 Analysis of engine balance, 52 *et seq.*
 of piston's motion, 48, 49
 Ancillary power alternatives, 429
 Angle of injection, 182, 183
 of valve seating, 264
 Antoinette engines, 62, 99
 Anzani engines, 62, 99
 "Aquila" engine, 157, 158, 173, 175
 Arcing at contact breaker, 325
 Argyll Company, 150
 engine, 154
 Armour plate for aircraft, 102
 Armstrong Siddeley, 2, 118, 250
 radial engines, 118, 119, 120
 Arrow-type engines, 39, 64, 114, 115
 Ash test, lubricating oil, 289
 Aspen engine, 85, 86, 87
 Austenitic steel, 126, 260, 261, 265
 Austro-Daimler engine, 65
 Autoclean oil filter, 295, 315
 Automatic mixture control, 134, 140,
 143
 valve clearance adjuster, 81, 114,
 265, 266, 267
 variable datum servo control, 127

- Auxiliary drives, 71, 79, 92, 105, 106, 108, 120, 127, 132, 134, 139, 173, 391
 gear boxes, 391, 392
 power units, 392, 393, 429
 Axial engine, 224, 225, 226
- B**ACK pressure in exhaust systems, 368, 374, 375, 379, 380
- Bairdo, G. E., 324, 325, 347
- Balance of engines. *See* Engine balance.
 weights, 44, 45, 46, 47, 52 *et seq.*
- Barrel-type engine, 224, 225, 226
- Beardmore engine, 63, 65
 compression ignition engine, 88, 210
- Bearing materials, 67, 68, 72, 78, 81, 105, 131, 132, 133, 135, 248, 250, 253
 metals, properties of, 253, 254
- Bearings, load reversals in, 34, 35
- Bendemann dynamometer, 426
- Benz engine, 65
- B.H.P., 1, 2, 6, 7, 14, 21, 37, 67 *et seq.*, 122, 133, 156, 157, 159 *et seq.*
 and exhaust pressure, 374, 375
 dynamometer calculation, 419
 measurements, 418 *et seq.*
 per unit piston area. *See* Horse power.
- B.M.E.P., 12, 16, 18, 20, 37, 109, 122, 135, 136, 156, 157, 158, 162, 163, 164, 185, 186, 187, 195, 197, 199, 200, 359
 and scavenging air supply, 195
 and speed curve, 37
 of C.I. engines, 223
- Boeing Clipper, 145
- Boost pressure, 4, 90, 109, 110, 121
- Booster coil for starting, 409
- Bores of aircraft engines, 8, 9, 14, 15
- Bosch fuel injection, 99
- Boundary lubrication, 282, 283, 284
- B.R. rotary engines, 62
- Brake, testing. *See* Dynamometer.
- Breakaway torque, 409, 410
- Breakdown voltages, 324, 363
- Breaking current for contact breaker, 335
- Brightray, 104, 263
- Bristol accessories, 388, 391
 airscrew drive, 275
 Aquila engine, 157, 158, 173, 175
 cam ring, 273, 274
 connecting rod design, 250
- Bristol crankshaft, 258
 cylinder construction, 228, 233
 engine development, 122, 123
 mounting, 280, 281
 starting system, 399
 tests, 420, 425, 426
 exhaust system, 384
 -Farman airscrew gear, 172
 "Hercules" development, 25, 174, 175, 176
 high initial oil system, 311
 ignition harness, 367
 "Jupiter" engine, 211, 316
 "Mercury," 123, 124, 168, 228, 235, 250, 258, 273, 311, 385
 "Pegasus," 25, 123, 124, 125, 129, 169, 170, 228, 250, 258, 311, 385, 388
 "Perseus," 159, 161, 162, 168, 169, 170, 174, 175, 235
 "Phoenix," 7, 189, 200, 210, 211
 oil cooler, 302, 303, 304
 piston design, 244
 sleeve valve engines, 150, 155 *et seq.*
 swash-plate engine, 225
 Taurus engine, 175
 valve assembly, 265, 272
- British aircraft engine data, 8, 9
- B.T.H. air compressor, 412
 electric inertia starter, 402, 403, 404, 410
 hand-starter magneto, 395
 magneto, 69, 74, 341, 349
 starting system, 400, 401
- Buna, rubber, 366
- Burgess silencer, 378, 380
- Burt, J., 150
- C**ABLES, H.T., for sparking plugs, 366, 367
- Calorific value of fuel, 17
- Cam plate for barrel engine, 227
 rings, 132, 144, 145, 272, 273, 274
 speed of rotation, 272, 273
- Camshaft speed magneto, 345, 346
- Camshafts, 81, 92, 105, 132
- Capacity-type silencer, 377
- Carbonization of lubricating oils, 289
- Carburettor, Chandler-Evans, 134
- Chandler-Groves, 140, 145
 Claudel-Hobson, 70, 74, 78, 118, 127
 Stromberg, 75, 83, 133, 134
 S.U., 108, 113
 Zenith, 68
- Cartridge method of engine starting, 217, 398, 399, 400, 401

- Carburettor air intake, 174
 Carter, B. C., 297, 301
 Castor oil, 283, 290
 Catalytic lamp, 413
 Centrifugal force, 52
 on crankshafts, 47
 type supercharger, 90
 Ceralumin, 88
 Ceramic insulators, sparking plugs
 357, 358
 Chandler-Evans carburettor, 134
 Chandler-Groves carburettor, 140,
 145
 Charge efficiency, exhaust improve-
 ment of, 372
 "Cheetah" engine, 118, 119, 250
 Chrome molybdenum steel, 255
 Claudel Hobson, 70, 74, 78, 79, 118,
 127
 Clerestory combustion chamber, 207,
 208
 Clerget C.I. engine, 224
 Coatalen C.I. engine, 224
 Cobalt chrome steel, 260
 magnet steels, 336, 346, 347
 Coercive force, 336
 Coffman engine starter, 399
 Coke test for lubricating oils, 289,
 290, 428
 Coil ignition system, 351 *et seq.*
 Cold starting, sleeve valve engines,
 169, 170
 Cold test for lubricating oils, 290, 428
 Combined electric starters, 410, 411
 Combustion chamber, sleeve valve
 engine, 164
 systems of C.I. engines, 206, 207
 Comet combustion chamber, 206, 207
 Mark III combustion head, 199
 Comparative performances, C.I. and
 petrol engines, 189
 Compensation method for valve
 clearances, Bristol, 266
 Components, sleeve valve engine, 165
 Compositions of light alloys, 232, 240
 Compound lubricating oils, 283, 287
 Compressed air engine starting, 397,
 398
 Compression-ignition engine, 7, 18,
 19, 181 *et seq.*
 altitude effects, 201, 202
 efficiency, 185, 186
 supercharging, 197 *et seq.*, 213
 weight, 186
 engines, types, 209 *et seq.*
 Compression pressures, C.I. engines,
 181, 183, 210
 ratio and cylinder bore, 3, 4
 and fuel consumption, 17, 19
 Compression ratio and cylinder pres-
 sures, 19
 checking method, 233
 ratios of engines, 8, 9, 14, 15, 67,
 75, 77, 79, 81, 86, 87, 89, 96,
 109, 112, 119, 121, 130, 131,
 210, 213
 of sleeve valve engines, 196
 Condenser, ignition, 331
 Conductivities of metals. *See*
 Thermal conductivities.
 Connecting rod design, 139, 246 *et seq.*
 lubrication, 250, 252, 314 *et seq.*,
 322
 master. *See* Master connecting
 rod.
 materials, 91, 105, 139, 247
 to crank ratio, 32
 rods for Vee engines, 248, 249, 250
 Contact breaker design, 333, 334, 335
 contact materials, 335
 sparking, 325
 Continental engine, 81
 Motors engine, 150
 Cooling action of lubricant, 285
 air. *See* Air cooling.
 drag, engines. *See* Power plant
 drag.
 liquid system, Merlin, 107
 Corona effects, 325
 Coventry Victor engine, 81
 Cowlings, low drag, 128
 Cracking of lubricating oils, 286
 Crankcase design, 68, 114, 126, 132,
 134, 139, 144, 214, 215, 239 *et seq.*
 dilution. *See* Fuel dilution.
 materials, 68, 74, 78, 91, 105, 113,
 126, 132, 134, 139, 144, 215, 239,
 240
 Crankshaft, 132, 133, 139, 144, 212,
 214, 215, 221, 253 *et seq.*
 design, 255
 materials, 68, 91, 255, 256
 Critical length of exhaust pipe,
 371
 speeds of crankshafts, 42, 43, 46
 "Culverin" engine, 213, 239
 Cuno oil filter, 296
 Curtiss engine, 99, 375
 Curtiss-Wright, 135
 "Cyclone" connecting rods, 250, 251
 cylinder construction, 234
 engines, 15, 26, 46, 135 *et seq.*, 296
 oil filter, 296
 pistons, 244
 valve mechanism lubrication, 310,
 311
 Cylinder, Bristol, 228
 "Napier Dagger," 229

Cylinder baffle cooling system, 127, 133, 172
 bore, effect on power, 3, 16
 on compression, 3
 machining accuracy, 138, 141
 construction methods, 81, 86, 104, 121, 125, 131, 138, 141, 171, 215, 220, 229 *et seq.*
 cooling fins, 126, 136, 137, 141, 171, 228, 229
 heads, 126, 131, 138, 141, 171, 215, 229, 232 *et seq.*
 head temperature, C.I. engine, 200, 230, 236
 materials, 67, 72, 78, 81, 121, 125, 138, 141, 166, 215, 228 *et seq.*
 number for given output, 16
 pressures, 4, 11, 20, 21
 stroke, effect on power, 16
 temperatures, 80, 138, 162, 230, 236
 wear, 285, 286
 weights, 235

DAMPERS, torsional vibration, 43, 44, 45, 46

Davies, S. J., 190
 Davy lamp engine heater, 413
 Debenham, W. R., 360
 Decibels, sound measurement, 381
 De Havilland, 2, 120
 Delay period in C.I. engines, 183, 199
 Deschamps C.I. engine, 212, 213
 Deschamps, D. J., 213
 Diesel knock, 208
 Direct cranking engine starter, 405, 410
 injection C.I. engine, 207, 208
 Distributor arm, 331, 332, 333
 ignition, 332, 341
 Double sleeve valve engine, 146 *et seq.*
 Douglas aircraft, 145
 Dowty pump, 92
 Drag of power plant. *See* Power plant drag.
 Draper torsigraph, 46
 Dry sump lubrication, 292 *et seq.*
 weight of engine, 7, 8, 9, 10, 14, 15, 65, 75, 77, 89, 90, 109, 111, 118, 119, 389, 390
 D.T.D. fuel specification, 122
 metal specifications, 228, 235, 238, 242, 248, 253, 255, 386
 oil specification, 290, Appendix I
 spark plug specifications, 366
 Duct cooling, 10
 "Duplex Cyclone" engine, 26, 135, 143
 Dynamometers, 418, 419, 430

ECLIPSE auxiliary power unit, 392
 Efficiency, air standard, 185
 mechanical. *See* Mechanical efficiency.
 thermal, C.I. engines, 186
 volumetric. *See* Volumetric efficiency.
 Eight-cylinder engines, 39, 43, 53, 54, 55, 58, 60
 magneto, 340
 Eighteen-cylinder engines, 2, 16, 26, 27, 29, 145
 Ejector-type silencer, 382, 383, 384
 Electric generators, 411
 heater, engine, 414
 power for engine auxiliaries, 393, 394
 starting motors, 402, 403 *et seq.*
 Electrode, sparking plug, materials, 359
 Elektron, 72, 74, 78, 91, 240
 Endurance tests, 22, 422
 Engine accessories. *See* Accessories.
 air cooling. *See* Air cooling.
 balance, 46 *et seq.*
 design tendencies, 27, 28, 29, 59, 60, 63, 64
 development, performance data, 122, 135, 136
 -driven electric generators, 411, 412
 frontal areas. *See* Frontal areas.
 heating for starting, 413, 414, 415
 historic types, 61, 62
 maintenance. *See* Maintenance.
 mountings, 75, 176, 276, 277, 278, 279
 performance values. *See* Performances.
 reliability, 21
 shape and field of vision, 23
 size, limits of, 29
 speeds, 2, 12, 13, 16, 67 *et seq.*, 122, 123, 135
 starting systems, 78
 temperatures, 21
 testing methods, 416 *et seq.*
 torque, 6, 32 *et seq.*
 vibrations. *See* Vibrations.
 Epicyclic reduction gear, 120, 141
 Erosion of sparking plugs, 328, 355, 357, 358, 362, 363
 Exhaust gas-driven supercharger, 220
 pipe length effects, 369, 370, 371
 pressure effect on power, 203, 374, 375, 376
 silencers. *See* Silencers.
 system metals, 385, 386
 practical notes on, 386, 387

Exhaust systems, 368 *et seq.*
 temperature, 171
 valve, 104, 126, 138, 141
 cooling, 261, 262, 263
 design, 141
 manifolds, 128, 130
 materials, 21, 104, 126, 138
 port liners, 131
 seatings, 138, 232, 233, 234, 235
 temperature, 21, 163, 164

Expansion coefficients. *See* Thermal expansion.

FAIREY, 120
 Farman airscrew drive, 275
 cartridge starter, 399
 Fescolizing exhaust systems, 385
 Filters, oil. *See* Oil filters.
 Final engine test, 423
 Firing intervals, radial engines, 59, 60
 Flashpoint of lubricating oils, 288, 428
 Flat-type engine, 80, 88 *et seq.*
 Flexible engine mountings, 280, 281
 Flight range and fuel consumptions, 187, 188, 189
 tests, C.I. and petrol engines, 202, 211, 425, 426
 Flowmeter, 421
 Fluid friction, 282 *et seq.*
 Flux changes in magneto, 330, 339
 density in magnets, 336
 Foets of castor oils, 290
 Ford torsionmeter, 425
 Four-cylinder engines, 2, 8, 9, 14, 15, 37, 38, 39, 53, 54, 69 *et seq.*
 Fourteen-cylinder engines, 2, 5, 8, 9, 12, 15, 25, 26, 27, 28, 117, 118, 119, 130, 132, 133, 143, 174, 224
 Franklin air-cooled engine, 271, 272
 Free acid test, 290, 428
 Frequencies of engine noises, test houses, 426
 Frequency of exhaust waves, 368, 369, 376, 377
 Frontal areas, comparative values, 27, 226
 and outputs, 25, 27, 121, 143, 219
 of engines, 2, 5, 11, 23, 24, 25, 26, 27, 28, 29, 70, 79, 89, 101, 102, 117, 143, 219, 226
 Froude dynamometer, 417, 418, 419, 420, 421
 Fuel consumption and altitude effect, 18
 and compression ratio, 18, 19, 20
 curves, 68, 71, 73, 77, 156
 loop, 161, 162

Fuel consumption of sleeve valve engine, 18
 of two-cycle engine, 19
 range, 190
 two-cycle engines, 179, 180
 consumptions, C.I. engines, 18, 186, 187, 189, 190, 191, 213, 215, 218, 219
 of engines, 17, 18, 67, 75, 77, 80, 109, 156, 179, 186, 190
 dilution of engine oil, 290, 291, 292
 economy in C.I. engines, 185, 186, 189, 197
 injection and combustion, 205
 -electric ignition systems, 83, 84
 pressures, 206, 208, 213, 217, 220
 systems, 205, 206, 207, 213, 216, 217, 220
 pumps, 108, 217
 Fuselage dimensions, 26

GALLEY oil cooler, 120, 308, 309
 Gaps of sparking plugs, 324, 325, 355, 359, 360, 362, 363, 364, 365
 Gas pressure forces in engine, 32, 33
 velocities, 264
 Generators, electric, 411, 412
 "Genet Major" engine, 118
 German engine mounting, 278, 279
 engines, 88, 89, 96, 97, 115, 193, 194, 217 *et seq.*
 Gibson, 164
 "Gipsy" engine lubrication systems, 314, 315, 316
 "Major" engine, 67, 69, 70, 71, 72, 234
 "Minor" engine, 66, 67, 68, 69, 234
 "Six" engine, 2, 76 *et seq.*, 234, 248, 314
 "Twelve" engine, 2, 89 *et seq.*, 234, 278, 315, 390, 391
 Gnome engines, 62
 Gobron Brille engine, 50
 Grain flow in valve blanks, 264
 Green engine, 62
 Gross dry weight, 10
 Ground power, potential, 102, 103
 Gudgeon pin, 243, 244, 245
 Guiberson C.I. engines, 7, 213

HAND - CRANKING engine
 starters, 401, 405, 406
 Hand starter magnetos, 395
 Hardness of cylinder barrels, 234
 of crankshafts, 255
 Hardness of light alloys, 232, 240, 241

Hargrave, Laurence, 61
 Harmonics of piston motion, 48, 49
 Haydon, F. G., 360
 Heat dissipated to lubricating oil, 298
 Heat-resisting steels, 385
 Heating engines for starting, 413, 414, 415
 Helm swash plate engine, 225
 "Hercules" engine. *See* Bristol Hercules engine.
 Herrmann and Hall barrel engine, 225
 Herschell silencer, 382
 Hiduminium, 72, 230, 231, 236
 High initial oil pressure system, 126, 311, 312
 octane fuels, 4, 11, 15, 17, 20, 328
 power engines, 2, 4, 8, 9, 16, 27, 28, 29
 Highest output engines, 16, 25, 26, 27, 28, 29, 30, 115, 145, 222
 Hindenburg airship engines, 218
 H-type engines, 2, 9, 12, 16, 27, 28, 29, 64, 111 *et seq.*
 Hiram Maxim's engine, 61
 Hispano-Suiza engine, 46, 63, 99
 "Hornet" engines, 130, 131, 132
 Horse power measurement, 418 *et seq.*
 per litre, 3, 4, 16, 88, 103, 109, 113, 122, 163, 197, 200, 219
 per unit frontal area. *See* Frontal area.
 per unit piston area, 100, 223
 per unit volume, 223
 powers of engines, 2, 8, 9, 14, 15, 135
 Hub dynamometer, 425, 426
 Hucks engine starter, 396
 "Hurricane" liquid- and oil-cooling system, 299
 Hydraulic dynamometers, 418, 419, 430
 power for auxiliaries, 393, 394
 pump, 109
 valve stem clearance device, 267
 vibration damper, 44

IGNITION advance, 331, 350
 and throttle control, 343, 344, 349
 system, Pratt and Whitney engines, 132
 requirements, 323 *et seq.*
 systems, alternative, 350
 of engines, 69, 74, 108, 114, 132, 134, 172, 322 *et seq.*
 switch, 331
 temperature in C.I. engines, 182, 183
 timing and B.M.E.P., 162

I.M.E.P., 4, 190, 191, 198, 203, 204, 205
 and breakdown voltage, 363
 Impulse starter magneto, 396
 In line engines, 2, 8, 9, 11, 14, 15, 39, 52, 53, 63, 64, 65
 Inconel metal, 386
 Indicated thermal efficiency, 186
 Indicator diagram, 33, 34, 178, 183, 184, 198
 Induction pressure and power output, 203, 204, 205
 and supercharging, 198, 199
 Inertia engine starters, 401 *et seq.*
 forces, 32
 Injection, fuel pump, 84, 98
 lag, 183
 nozzles, 97
 period, 182, 183, 184
 timing effects, 184
 Inlet valve, 143, 260, 261 *et seq.*
 Inspection, after tests, 424
 Insulating materials, ignition system, 326, 327
 sparkling plugs, 355
 International rated power, 103, 112, 119, 120, 121, 123
 Interference suppressors, 352, 354
 Inverted engines, 2, 8, 9, 11, 14, 15, 63 *et seq.*
 Vee-type engine, 89 *et seq.*

J.A.P. engines, 62, 99
 Johansson gauge, 141
 Jump spark distributor, 332, 341
 Junkers engine balance, 50
 Ju. 211 engine, 89, 96, 97, 98
 "Jumo" engine, 7, 20, 187, 193, 218 *et seq.*
 piston, 245
 "Jupiter" engine. *See* Bristol Jupiter engine.

KADENCY system, 372
 "Kestrel" engine, 2, 7, 25, 102, 103, 379, 380
 K.L.G. elbow resistor fitting, 365
 sparkling plug, 359, 361, 365
 Knight sleeve valve engine, 146

LANCHESTER engine balancer, 54
 Langley power-driven aircraft, 61
 Lead bronze, 253, 254
 Leaded fuel and sparking plugs, 356, 358
 "Leonides" engine, 121
 Le Rhone engines, 62
 Leyland combustion chamber, 207, 208

"Liberty" engine, 63, 99
 Lift of valve, 265
 Light alloy pistons, 34
 Limits of engine size, 29
 Liners, cylinder, 234, 237, 238
 Liquid-cooled valve, 262
 cooling, 96, 99, 101, 102, 107
 Lobes, number on cam ring, 272, 273
 Lodge screened terminal fittings, 367
 sparking plugs, 356, 359, 360
 Lubricating oil consumption, 74, 80, 89, 167, 294
 disintegration, 286
 pressures. *See* Oil pressures.
 properties, 286 *et seq.*
 quantity, 294
 rate of circulation, 294
 specification, Appendix I.
 systems, 74, 92, 93, 114, 126, 142, 143, 252, 292 *et seq.*, 315 *et seq.*
 Lubrication of valve mechanism, 310, 318
 of Wright Cyclone crankshaft, etc., 251, 252
 principles, 282 *et seq.*
 "Lycoming" engine, 12, 88
 crankshaft, 259
 "Lynx" engine, 2, 118, 119

MACHINING cylinders, 228, 229, 233, 234, 238
 Macomber engine, 225
 Magnesium alloys, 240, 241
 Magneto, Bristol, 127
 "B.T.H." *See* B.T.H.
 "Gipsy" engine type, 337, 338
 hand starter, 395, 397
 ignition advance range, 350
 impulse starter, 396, 397
 materials, 335, 336, 337
 polar inductor type, 339 *et seq.*
 rotating armature type, 329, 330, 332, 337
 magnet type, 345, 346
 Scintilla. *See* Scintilla magneto.
 speeds of rotation, 332, 344, 345
 standard performance requirements, 325, 326
 stationary armature type, 338, 339
 voltages, 347, 348
 weights, 350
 Magnetos, aircraft, 329 *et seq.*
 Maintenance of engine, 23, 75, 171
 periods of engines, 69, 75
 sleeve valve engines, 171
 Manly radial engine, 61
 Marston, J., 306, 307
 Master rod, 91, 126, 133, 139, 214, 215, 250, 251

Maximum engine sizes, 29
 pressures, C.I. engines, 183, 184, 198
 Maybach engine, 217, 218
 McCollum, J., 150
 Mean piston speed, 12, 13, 14
 Mechanical efficiency, sleeve valve engine, 169
 engine starter, 396
 Menasco engines, 75, 76, 79
 Mercédès, 65
 Benz engine, 89, 99, 115, 217
 "Mercury" engine. *See* Bristol Mercury engine.
 "Merlin" connecting rods, 248, 250
 crankshaft, 255, 256
 cylinder design, 238, 239
 engine accessories, 389, 390
 performances, 103, 110
 silencer, 382, 383
 starting system, 410
 engines, 2, 7, 25, 101 *et seq.*, 238, 239, 382
 lubrication system, 319, 320, 321, 322
 valve operating gear, 269, 270
 Messerschmitt aircraft, 99
 Metalastik engine mounting, 280
 Mica insulation, sparking plugs, 355, 356, 357
 Mitchell swash plate engine, 225
 Monel metal valve seating, 263
 Morrison, J. C., 369, 373
 Motors, electric starting, 408, 409, 410
 Mounting section, crankcase, 139
 Mountings, engine, 276, 277, 278, 279
 Mountings for magnetos, 349
 Mucklow, G. F., 201
 Multi-cylinder engines, 29, 30, 52 *et seq.*
 opposed engines, 54, 58

NAPIER "Culverin" engine, 213, 239
 "Dagger" engine, 2, 111, 112, 113, 114, 229, 235, 263
 "Lion" engine, 63, 115
 "Rapier" engine, 2, 112
 N.E.C. two-cycle engine, 181
 Needle bearings for rocker arm, 270, 271
 Neoprene rubber, 366
 Net dry weight, 7, 8
 "Niagara" engine, 118
 Nickel aluminium bronze, 234
 iron magnetos, 336
 chrome manganese alloy valve seating, 232, 263
 molybdenum steel, 234, 274
 steel, 274
 valve steels, 260

- Nickel, chromium electrodes, 360
electrodes, 360
- Nine-cylinder engine, 2, 5, 7, 8, 9, 12, 14, 15, 24, 25, 26, 27, 28, 117, 121, 122 *et seq.*, 210, 213
- Nitralloy, 86, 126, 133, 138, 228, 234
- Nitrided steel cylinder sleeves, 131, 138, 166, 172
- Nose section, crankcase, 139, 142
- Number of cylinders for given output, 16
- O**CTANE value, 4, 17, 20, 67
- Oil consumption, 74, 80, 89, 167, 294
- Oil coolers, 120, 297 *et seq.*
cooling in sleeve valve engines, 170
of bearings, 285
dilution by fuel, 290, 291, 292, 312, 313
for starting, 312, 313
economy device, sleeve valve, 168
filters, 295, 296
frothing prevention, 301
pressure, 69, 74, 80, 292, 293, 314, 315, 316, 321, 322
pump, 292, 293, 312, 314, 315 *et seq.*
quantities, 294
scavenging system, Wright, 142
specification, Appendix I
supply for testing, 421
tank, 309
- Oiliness, 283
- Opel engine, 65
- Open combustion chamber, 208
- Opposed-cylinder engine mounting, 277
engines, 2, 50, 51, 54, 58, 80 *et seq.*, 271, 392
- Opposed-piston balanced engines, 50, 51, 218 *et seq.*
- Overall dimensions of engines, 5, 24, 25, 26, 27, 28, 69, 79, 83, 89, 109, 121, 123, 131, 143, 173, 175, 215
- Oxidation test, 289
- P**ACKARD C.I. engine, 202, 210
- Panhard and Levassor, 155
- Paschen's law, 324
- "Pegasus" engine. *See* Bristol Pegasus engine.
- "Pelides" engine, 121
- Pendulum-type vibration damper, 44, 45, 46
- Performance curves for coil ignition systems, 353
for magnetos, 348
for oil coolers, 306
- Performance curves of engines, 68, 70, 71, 73, 75, 77, 83, 90, 112, 124, 125, 144, 156, 157, 158, 160, 216, 219
- Performances of engines, 67, 69, 72, 75, 77, 79, 83, 87, 88, 89, 99, 103, 109, 112, 113, 118 *et seq.*, 130, 131, 136, 137, 154, 157, 159, 209 *et seq.*
of engine starters, 406, 407, 409
"Perseus" engine. *See* Bristol Perseus engine.
- Petrol injection system, 84, 96, 97, 98
- "Phoenix" engine. *See* Bristol Phoenix engine.
- Phons, degree of silencing, 379, 380
- Pilot's field of vision, 23
- Piston clearances, 243
design, 126, 242, 243, 244
friction, 284
inertia forces, 32
loads, 241
materials, 67, 81, 105, 126, 215, 241, 242
rings, 243, 245, 246
speed, 12, 13, 109, 159
- Platinum sparking plug electrodes, 360
- Platinum-iridium contacts, 335
electrodes, 360
- "Pobjoy" engines, 118
- Poises, 288
- Polar inductor magneto, 338
- Poppet and sleeve valve engine comparison, 159, 160
- Port diagrams, sleeve valve engine, 152
opening angles, two-cycle, 179, 192, 193
- Power curve test, 423
curves. *See* Performance curves.
maximum potential, 102
measurement. *See* Engine testing methods.
in flight, 425, 426
output, 2
and compression ratio, 4
and cylinder bore, 3, 4
and engine speed, 135, 157, 158, 159
and frontal area, 24 *et seq.*, 102
plant drag, 2, 5, 23, 24, 25, 26, 27, 28, 93, 100, 117
required for scavenging, 195, 196
section, crankcase, 139
- Pratt and Whitney "Double Wasp" engine, 26
engines, 130, 131, 132, 133, 134
"Hornet" engine, 130

- Pratt and Whitney lubricating system, 318
 pistons, 244
 "Twin Hornet," 130
 "Twin Wasp," 130
 "Wasp" engine, 130, 131
 Pre-combustion chamber, 209, 218
 Prescott vibration damper, 46
 Pressure of injection, 206, 208, 213
 variations in exhaust, 368 *et seq.*
 Pressure-fed lubrication. *See* Lubricating systems.
 Pressure-splash lubrication system, 291, 292
 Pressures, compression. *See* Compression pressures.
 maximum. *See* Maximum pressures.
 of compressed air systems, 392, 413
 Proferall cast camshaft, 81
 Propeller. *See* Airscrew.
 torque curve, 216
 Properties of magnesium alloys, 241
 of metals at elevated temperatures, 231, 241
 Pump fuel. *See* Fuel pump.
 oil. *See* Oil pump.
- Q**UINCKE, silencer, 381
- R**ACING effect on engine, 35
 Radial engine balance, 56, 58, 59
 contact breaker, 334
 exhaust system, 384
 firing intervals, 59
 lubrication systems, 316, 317, 318
 magneto, 342, 343
 vibration damper, 44, 45, 46
 engines, 2, 5, 7, 11, 24, 25, 26, 27, 28, 45, 56, 58, 59, 61, 116 *et seq.*
 Radio interference of ignition system, 327
 R.A.E. magneto, 347, 348
 oil cooler, 306, 307
 sparking plug tests, 364
 torsigraph, 46
 transmission dynamometer, 425
 R.A.F. engine, 62, 99
 Ranger engine camshaft, 269, 270
 crankshaft, 255
 inverted Vee engine, 89, 256
 Rate of heat transfer to oil, 80
 Redwood viscosity, 288
 Redynam damper, 46
 Reliability of engine, 21, 22, 75
 Relief valve, oil, 293, 295, 302, 303, 305, 311, 312, 315, 316, 318, 320, 321, 322
 Remanence, 336
 Renault engine, 62, 99
 Resonance effects, crankshaft. *See* Torsional vibrations.
 in exhaust systems, 372, 373, 374
 Ricardo, 18, 20, 150, 163, 194, 196, 199, 206
 compression swirl engine, 199, 206
 two-cycle engine, 194, 196
 Rice Wilcox valve tappet adjuster, 81
 Robertson oil cooler, 305
 Rocker arm, automatic adjustment, 270
 Rocking couples, 47, 52 *et seq.*
 Rolls Royce airscrew drive, 275, 276
 "Condor" C.I. engine, 224
 crankshaft, 255, 258, 259
 cylinder design, 237, 238, 239
 "Eagle" engine, 63, 397
 ejector silencer, 382, 383
 engine mounting, 277, 278
 starting, 397
 "Falcon" engine, 63, 99
 "F"-type engine, 237
 "Kestrel" engine. *See* Kestrel engine.
 "Merlin" engine. *See* Merlin engine.
 Vee-type engines, 101 *et seq.*
 R.R. aluminium alloys, 231, 232, 236, 239, 240, 241, 242, 243
 Rotary engines, 62
 swirl combustion chamber, 206, 207
 valve engine, 85, 86, 87
 Rotax Eclipse direct cranking starter, 405
 inertia starters, 405
 electrical generator, 120, 411
 engine starters, 78, 114, 120
 Watford magneto, 342, 343, 349
 Rubber engine mountings, 280, 281
 Running-in of engines, 283, 420
- S**AFETY gap, ignition system, 328, 341
 Sarazin damper, 46
 Scavenge pumps, 293, 314, 315, 316, 318, 320, 321
 Schneider Trophy engine, 7
 Scintilla magneto, 75, 133, 134, 140
 sparking plug, 362
 Screening effect and erosion, 363
 of ignition system, 327, 352
 of sparking plugs, 352, 361, 364, 365, 366
 Self-adjusting valve clearance devices, 81, 114, 266, 267

- Self-cleaning oil filter, 296
 Self-ignition temperature, 181, 183
 Servack oil cooler, 306
 Servais silencer, 378
 Seven-cylinder radial engine, 118, 119
 Shrinking cylinder barrels in position, 234
 valve inserts in position, 232, 234, 239
 Siddeley Deasy engine, 65
 Silchrome, 215, 261
 Silencers, absorption type, 377, 378, 379
 capacity type, 377
 interference type, 381
 principles of, 376 *et seq.*
 types of, 377 *et seq.*
 Silencing in engine test houses, 426, 427
 Silentbloc engine mounting, 281
 Silicon chrome steel, 104, 260, 261
 Sillimanite, 357
 Single-cylinder engine, 35, 36, 37, 39, 47, 48, 50, 53
 research, 122, 135, 136, 156, 157
 Sintered aluminium oxide insulators, 358, 359
 Sinterkorund, 358
 Sintox, 358
 Six-cylinder engine, 2, 37, 38, 76 *et seq.*
 magneto, 345
 Sixteen-cylinder C.I. engine, 222, 223
 engine, 2, 54, 55, 57, 58, 60, 222
 Sleeve valve C. I. engines, 192, 194, 195
 double, 146, 147, 148, 149
 drive, 109, 151, 154, 167, 168
 engine advantages, 163, 164
 disadvantages, 166, 167
 engines, 18, 22, 146 *et seq.*
 ports, 147, 151, 152, 153
 single, 146, 150 *et seq.*
 single-engine performances, 156
 Voisin, 148, 149
 Sleeves. *See* Cylinder construction and materials.
 Sludge traps, 296, 297
 Sluice gate dynamometer, 419, 420
 Sodium-filled valves, 262, 263
 Solder for oil coolers, 300
 Sound intensities, exhaust, 380, 381
 Sparking plug, Bendix, 362, 363
 bronze bushings, 144
 cable connectors, 361, 364, 365
 electrical energy for spark, 323
 electrode materials, 359, 360
 erosion, 328, 355, 357, 358, 359, 360, 361
 gap. *See* Gaps of sparking plugs.
 Spark plug H.T. cables, 366
 insulators, 355 *et seq.*
 K.L.G., 359, 361, 365
 Lodge, 356, 359, 360
 screening, 352, 361, 364, 365, 366
 Specifications, 366
 Sphinx, 359
 voltages, 323, 324, 325, 327, 343, 355
 plugs, 21, 354 *et seq.*
 Specific gravities of light alloys, 232, 240
 output of C.I. engines, 199, 200
 power, potential, 102, 103
 weight of C.I. engine, 223
 Speed, piston, 12, 13
 of cam ring, 272, 273
 of magneto, 332, 344, 345
 Speeds, engine. *See* Engine speeds.
 Sphinx sparking plug, 359
 Splash lubrication system, 290, 291
 Stabilities, 326, 327
 Stainless steel exhaust liners, 131
 manifolds, 385, 386
 for valves, 142, 260
 Stanton, 284
 Starting aircraft engines, 169, 170, 311, 312, 313, 394 *et seq.*
 torques, 170, 406, 407
 Steam heating for engine starting, 414, 415
 Steel crankcase construction, 142
 Steels for crankshafts, 255
 for cylinder barrels, 228, 229, 234, 239
 Stellite sparking plug electrodes, 360
 Stellited valve seatings, 69, 78, 105, 138, 232, 261, 263, 264, 265, 270
 Straight-eight engine, 43, 57, 58
 Stringfellow model aircraft, 61
 Strokes of aircraft engines, 8, 9, 14, 15
 Stromberg carburettor, 75, 83, 133
 injection carburettor, 143
 Supercharged engine, fuel consumption, 18
 systems, 76, 79, 88, 90, 92, 96, 107, 109, 113, 119, 126, 134, 137, 139
 sleeve valve engine, 156, 163
 Supercharger, exhaust turbine type, 88
 gear ratios, 76, 79, 88, 90, 109, 119, 121, 134, 137, 143
 "Merlin," 107
 "Napier Dagger," 111, 113
 "Pratt and Whitney," 134
 section, crankcase, 132, 139
 Wright, 137, 139

- Supercharging C.I. engines, 197, 213, 219 *et seq.*
- S.U. carburettor, 108, 113
- Swash-plate engine, 224
- Synthetic rubber insulators, 366, 367
- T**AUB and Young, 286
- "Taurus" engine. *See* Bristol Taurus engine.
- Tecalemit filter, 114
- Temperature, air inlet and power, 204, 205
- effects on ignition apparatus, 326
- of exhaust valves. *See* Exhaust valve temperature.
- oil-regulating systems, 298 *et seq.*
- Temperatures and metal strength properties, 231
- cold starting, 169, 170
- cylinder. *See* Cylinder temperature.
- head, 80, 138, 230, 236
- of bearings, 287
- of compression, C.I. engines, 182, 183
- Tensile strengths of light alloys, 231, 240
- Testing aircraft engines, 416
- house, engine, 426, 427
- procedure, 420
- Texolite, 338
- Thermal conductivities of light alloys, 232, 242
- expansion coefficients, 232, 241, 242
- Thiokol rubber, 366
- Throttle curves, 68, 71, 77
- Thrust tests, engine, 424
- "Tiger" engine, 118, 120
- Tilting tests, engine, 425
- Timing of fuel injection, 184, 185
- of sleeve valve C.I. engine, 192, 194
- Timken, 138
- Tinning of cylinders, 229
- Torque arm, 419
- breakaway, 409, 411
- calculations, 35, 36, 419
- instantaneous, 36
- maximum, 36, 37, 38, 39, 40
- mean, 37
- of engines, 31 *et seq.*
- reaction, 276, 419
- starting, 170, 406, 407
- variation, 36, 37, 38, 40
- Torsiographs, 43
- Torsiometer, 425
- Torsional vibration dampers, 43, 44, 45, 46
- vibrations, 41, 42, 43, 116
- Transmission dynamometers, 416, 417, 418, 425
- Tungsten contacts, 335
- sparkling plug electrodes, 360
- steel magnets, 335, 336
- valve steels, 260, 261
- Twelve-cylinder engines, 2, 7, 9, 15, 24, 25, 27, 38, 39, 54, 55, 57, 60, 88, 89 *et seq.*, 101, 213, 217, 218, 220, 226
- Twenty-four cylinder engines, 2, 16, 27, 28, 29, 115
- "Twin Hornet" engine, 130
- "Twin Wasp" engine, 130, 133
- Two-cycle C.I. engines, 187, 191 *et seq.*, 212, 213, 218 *et seq.*
- engines, 7, 19, 117 *et seq.*
- Two-cylinder engine, 2, 53, 54, 55, 60
- Type tests of engines, 22
- U**NIFLOW" design of piston, 244
- V**ACUUM pump, 109
- Valve, exhaust. *See* Exhaust valve.
- guides, 234, 237, 238
- inlet. *See* Inlet valve.
- materials, 69, 86, 104, 121, 141, 260, 261
- mechanism lubrication, 310, 318
- operating mechanism, 74, 91, 114, 141, 260, 268 *et seq.*
- proportions, 264
- rotary, 85, 86, 87
- seating inserts, 69, 83, 104, 232, 233, 234, 237, 238, 262, 263
- springs, 106, 265, 268
- stem clearance, automatic adjusters, 81, 114, 266, 267
- Vee-type engine advantages, 99, 100
- mounting, 277, 278
- progress curves, 99, 100
- engines, 2, 7, 8, 9, 10, 11, 14, 15, 23, 24, 25, 27, 55, 60, 89 *et seq.*, 99 *et seq.*
- Vibration dampers, 43, 44, 45, 46, 258, 259
- Vibrations, due to inertia effect, 35
- due to unbalance, 46, 47, 53 *et seq.*
- torsional, 41 *et seq.*
- Vickers-Potts oil cooler, 302, 303
- "Viper," Wolseley, engine, 99
- Viscosity effect on starting engines, 407
- index, 288
- of lubricating oils, 287, Appendix I

- Voltage curves of coil ignition systems, 353
of magnetos, 347
- Voltages, magnetos. *See* Magneto voltages.
- sparkling plug. *See* Sparking plug voltages.
- Volumetric efficiency, 164, 180, 372
- Vokes silencer, 379
- Vortex oil cooler, 302
- W**ASP" engines, 130, 131, 132
Water-cooled cylinders, 236,
et seq.
- Water cooling advantages, 10
pump delivery data, 423
supply, hydraulic dynamometer,
419
- Watson indicator, 373
- Wear, cylinder. *See* Cylinder wear.
of sparking plug electrodes, 360,
362
- Weight, dry. *See* Dry weight of
engine.
engine, and flight range, 187, 188,
189
gross. *See* Gross dry weight.
in running order, 10
of accessories, 389, 390
of armour plating, 102
of exhaust systems, 368, 379, 380,
384
of magnetos, 350
- Weight per H.P., 2, 6, 7, 16, 65, 75,
77, 88, 101, 113, 118, 119, 130,
131, 135, 137
reduction of Vee-engines, 101
specific, 101, 103
- Weights of air-cooled cylinders, 253
of C.I. engines, 186, 187, 210
et seq.
of engines, 8, 9, 14, 15, 65, 67, 69,
75, 77, 79, 81, 83, 88, 89, 90, 109,
110, 112, 123, 130, 131, 175, 186
- "Whirlwind" engine, 135
- Willman silencer, 378
- Wing located engines, 80
- Wobble plate engine, 224
- Worth oil dilution system, 312, 313
- Wright, 12, 62, 135
"Cyclone" engine. *See* Cyclone.
"Double-row Cyclone" engine.
See Duplex Cyclone.
dynamic balancer, 44, 46, 144
early aircraft engine, 62
vibration damper, 45, 46
- W-type engines, 57, 60
- X**-TYPE engine, 27, 28, 29, 54, 55
64, 115, 116
- Y**-ALLOY, 72, 172, 230, 231, 232
- Z**ENITH carburettor, 68

DATE OF ISSUE

This book must be returned within 3/7/14 days of its issue. A fine of ONE ANNA per day will be charged if the book is overdue.

--	--	--	--	--	--

