

**Birla Central Library**

**PILANI (Rajasthan)**

Class No :- 620.1123

Book No :- B861E

Accession No :- 41796

**CENTRAL LIBRARY**

**B. I. T. S.**

**PILANI**

---

Acc. No.....

**ISSUE LABEL**

**Not later than the latest date stamped below.**

--	--	--



**ELASTIC ENERGY  
THEORY**



# ELASTIC ENERGY THEORY

BY

J. A. VAN DEN BROEK, PH.D.

*Professor of Engineering Mechanics,  
University of Michigan*

*SECOND EDITION*

NEW YORK

JOHN WILEY AND SONS, INC.

LONDON: CHAPMAN & HALL, LIMITED

COPYRIGHT, 1931, 1942, BY  
JOHN A. VAN DEN BROEK

---

*All Rights Reserved*

*This book or any part thereof must not  
be reproduced in any form without  
the written permission of the publisher.*

SECOND EDITION

*Fifth printing, September, 1950*

PRINTED IN THE UNITED STATES OF AMERICA

DEDICATED TO  
WILLIAM CHRISTIAN HOAD  
*Professor of Civil Engineering  
University of Michigan*





## PREFACE TO SECOND EDITION

The most important change in the second edition of *Elastic Energy Theory* is the revision of the notation. In the preface to the first edition the author acknowledged his indebtedness to August Föppl, from whom he obtained the formula  $P\Delta = \Sigma CFS$  for the elastic deformation of trusses. The formula  $P\Delta = \int \frac{M_p M_q ds}{EI}$ , for the elastic deformation of beams, the author developed independently by a process rigorously analogous to the development of the formula for trusses. He was unaware at the time that this formula already existed.

Notation is a serious problem in scientific writing. Viewing the matter in retrospect, the author deemed it worth while to simplify the original notation and bring it into closer agreement with notations found elsewhere. In this second edition, then, what was originally written as  $P\Delta = \int \frac{M_p M_q ds}{EI}$  is now written as  $F\Delta = \int \frac{mM ds}{EI}$ .

The subject matter and its arrangement are substantially maintained. Some new material, however, has been added, notably on signs, page 60; symmetry and anti-symmetry, page 95; piston rings, page 104; pipe problems, etc., page 126; spiral springs, page 185; and columns, page 226.

The author wants to express his indebtedness to Mr. P. C. Hu for the very effective assistance which he has rendered.

J. A. VAN DEN BROEK

ANN ARBOR, MICHIGAN  
January, 1942



## PREFACE TO FIRST EDITION

The theory of strength of materials, assuming elasticity, gives rise to two further theories and offers various methods for the analysis of statically indeterminate structures. While in the Teutonic countries the "Formänderungs Arbeit," energy of deformation, generally receives preferred consideration, in most American and English textbooks on strength of materials the elastic energy theory is either entirely omitted or else very inadequately treated. American textbooks on strength of materials generally stress the theory of the elastic curve. They conveniently neglect to discuss such problems as require the theory of elastic energy for their solution, and so place the burden of developing that theory upon the authors of books on design.

Thus it happens that the student is likely to have the theory of elastic energy brought to him piecemeal. One part, as it applies to redundant frames, will come to him from one author, and other parts applying to arches, bents, or resilience, will come from others. The student thereby may be compelled to adjust himself to a varying terminology. He finds after much confusion that the phrase "kinetic theory of structures" has reference to structures that are at all times in a state of static equilibrium; that "virtual velocities" means imaginary displacements; and that "equivalent loads" signifies bending-moment areas. Further, he meets with the theory of least work, which tells only a small part of the story of elastic energy and tells even that very inadequately. One of the purposes of this book is to eliminate this confusion.

In connection with the elastic energy theory, the author advances two claims: First, that the theory of elastic energy may be developed inductively from the principles of conservation of energy equally as well as it may be developed deductively from Castigliano's partial differential equation; second, that the theory of elastic energy is a general one, that it is alike applicable to trusses, straight beams, bents, and curved beams.

The theory of elastic energy, within the assumption of elastic behavior of material and the principle of superposition, will accomplish all that any other theory or method will do. Furthermore, in the author's

opinion, it is not only the most general theory available, but it is also the simplest and easiest to grasp.

The basic philosophy given in Chapter II along with the principle of conservation of energy underlies every argument and every analysis of the problems either discussed in the text or listed in the back of the book.

During the past ten years the subject matter of this book has been given from mimeographed notes to seniors and advanced engineering students at the University of Michigan. The analytic integration method was used while the possibilities of the graphical summation method were merely pointed out. When, in the fall of 1929, the author's colleagues decided to teach the elastic energy theory in the elementary course in strength of materials, the graphic summation method was adopted as the most general and the one most easily applied. A similar procedure has been followed in this book.

The question of what class of readers to keep in mind while writing this book, what previous training to presuppose, has been somewhat of a problem. The author's own classes of college students have already been mentioned. Although they have training in calculus, he not only prefers to present to them the graphic summation method because of its simplicity but also feels justified in doing so. Another type of men who may conceivably be interested was suggested by a group of practicing engineers, to whom the material of this book was presented in evening classes in Detroit, Michigan. It is among men with college training and several years of practical experience that the author has met with the greatest response and the most sincere appreciation for his efforts in expounding one general philosophy, applicable to the largest possible range of problems in structural design. Readers with previous experience in the analysis of statically indeterminate structures are referred to the last chapter in this book, "Estimate of Elastic Energy Theory."

The book is not a handbook, and browsing therein is likely to lead to disappointment and to an incorrect estimate of its contents. Great pains have been taken to anticipate queries and to treat matters in the greatest detail.

The majority of examples and problems are original. For the solution of the problems on combined beam and truss action listed in the back of the book, the author is indebted to Mr. H. J. Kist of New York City. August Föppl's "Vorlesungen über technische Mechanik" has for years been the author's inspiration. Some problems are taken from Föppl. The author favors what the Germans call "Vorlesungen," lectures, as a

method of procedure in either classroom or textbooks. The material in this book, therefore, is presented in the same order and sequence that he employed in presenting it to his classes.

J. A. VAN DEN BROEK

ANN ARBOR, MICHIGAN  
February, 1931



## NOTATION AND TYPOGRAPHICAL CONVENTIONS



FOR

### *ELASTIC ENERGY THEORY*

<i>A</i>	area (in. <sup>2</sup> ).
<i>a</i>	linear acceleration (ft./sec. <sup>2</sup> ).
<i>b</i>	width (in.).
<i>C</i>	constant; specifically ( $C = L/AE$ ) (in./lb.).
<i>c</i>	distance from neutral axis to outer surface of beam.
<i>D</i>	diameter, as of spiral spring coil or spiral stairway (in. or ft.).
<i>d</i>	diameter, as of spiral spring wire (in. or ft.).
<i>d</i>	depth (in.).
<i>E</i>	modulus of elasticity in tension or compression, $E = s/e$ (lb./in. <sup>2</sup> ).
<i>e</i>	linear strain ( $\Delta/l$ ), abstract number.
<i>e</i>	eccentricity (in.).
<i>e<sub>s</sub></i>	shear strain ( $\Delta_s/l$ ), abstract number.
Elasticity	linear relationship between stress and strain. A material is elastic when $E$ is constant in the equation $s = Ee$ .
<i>F</i>	auxiliary force (lb.).
<i>f</i>	tensile or compressive forces in members of trusses caused by the application of an auxiliary load of magnitude $F$ (lb.).
<i>f</i>	coefficient of sliding friction, abstract number.
<i>G</i>	modulus of elasticity in shear, $G = s_s/e_s$ (lb./in. <sup>2</sup> ).
<i>g</i>	acceleration of gravity (32.2 ft./sec. <sup>2</sup> ).
<i>H</i>	horizontal reaction (lb.).
<i>h</i>	depth (inches), $I = bh^3/12$ .
<i>h</i>	height (in. or ft.).
h.p.	horsepower (ft-lb./min.).
<i>I</i>	moment of inertia of an area about a line (in. <sup>4</sup> ).
<i>i</i>	radius of gyration (in.) $I = A\bar{i}^2$ .
<i>J</i>	moment of inertia of an area about a point (polar moment of inertia) (in. <sup>4</sup> ).
<i>j</i>	radius of gyration (in.) $J = Aj^2$ .
<i>k</i>	constant.
<i>L</i>	length (in. or ft.).
<i>l</i>	length (in. or ft.).
<i>M</i>	bending moments in beams due to actual loading (in-lb. or ft-lb.).
<i>M'</i>	auxiliary couple (in-lb.).
<i>m</i>	bending moment at any section in a beam due to an auxiliary force $F$ , couple $M'$ , or torque $T'$ (in-lb.).

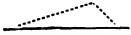
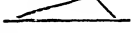

$N$	constant.
$n$	constant.
$n$	number of revolutions per minute (r.p.m.).
$P$	concentrated load (lb.).
$p$	pressure per unit area (lb./in. <sup>2</sup> ).
$Q$	concentrated load.
$R$	radius, as of curved beam (in. or ft.).
$R$	radius of curvature (in.).
$R_1, R_2, \text{ etc.}$	reactions (lb.).
$r$	radius, as of spiral spring wire (in. or ft.).
$S$	tensile or compressive forces in members of trusses caused by the application of the actual loading (lb.).
$s$	tensile or compressive stress (force intensity) (lb./in. <sup>2</sup> ) $s = Mc/I$ .
$s$	distance along an arc (in.) $s = \phi R$ or distance.
$s_1$	elastic limit stress.
$s_s$	shear stress $s_s = V\bar{y}A/bI$ .
Strain	deformation per unit length (abstract number).
Stress	load intensity (lb./in. <sup>2</sup> ).
$T$	torque in beams or shafts due to actual loading (in-lb. or ft-lb.).
$T$	forces in members of redundant trusses caused by the actual loading after all redundants have been removed (lb.).
$T$	tangential forces in rings.
$T''$	auxiliary torque (in-lb.).
$t$	torque at any section in a beam due to an auxiliary force $F$ , couple $M'$ , or torque $T''$ (in-lb.).
$t$	thickness (in.).
$t$	temperature (degrees).
$U$	tensile or compressive forces in members of trusses caused by the application of an auxiliary load of unit magnitude (lb.).
$u$	weight per unit volume (in case of hydrostatic pressure $p = uy$ , $w = uyt$ ) (lb./in. <sup>3</sup> ).
$V$	volume.
$V$	shear (lb.).
$v$	linear velocity (ft./sec.).
$v$	variable distance from neutral axis.
$W$	energy or work (in-lb. or ft-lb.).
$W$	total distributed load (lb.).
$w$	load per unit distance (lb./in. or lb./ft.).
$x$ or $y$	linear displacements, ordinates of elastic curves (in.).
$\bar{X}$	distance to centroid measured from $y$ axis.
$\bar{Y}$	distance to centroid measured from $x$ axis.
$z$	variable radius.
$\Delta$	deformation (in.) $\Delta = el$ or $\Delta = e_s l$ .
$\Delta$	linear displacement as of a panel point on a truss or of a point on the elastic curve of a beam (in.).
$\alpha, \beta, \theta, \text{ and } \phi$	angles (radians or degrees).

$\lambda$	coefficient of thermal expansion.
$\alpha$	angular acceleration (radians/sec. <sup>2</sup> ).
$\omega$	angular velocity (radians/sec.).
$\mu$	poisson's ratio.
	force vector (lb.).
	torque vector (in-lb.).
	<i>m</i> bending-moment diagram.
	<i>M</i> bending-moment diagram.
$\Sigma$	summation (tabular addition).
$\int$	summation (integration, either analytical or semi-graphical). Limits may be indicated as follows: $\int_A^B$ , $\int_{x_1}^{x_2}$ , $\int_0^\phi$ or $\int_A^A$ . It is entirely immaterial whether the integration proceeds from left to right or from right to left. $\int_A^A$ means integration from a point <i>A</i> on a closed structure, such as a culvert or a ring, entirely around the structure back to the starting point <i>A</i> .

If, for purposes of cross reference, equations are labeled, they are marked (a), (b), (c), etc. Formulas are designated as (1), (2), (3).



# CONTENTS

CHAPTER	PAGE
I. STATICALLY DETERMINATE VERSUS STATICALLY INDETERMINATE STRUCTURES . . . . .	1
II. ELASTIC ENERGY . . . . .	6
III. ANALYSIS OF FRAMES . . . . .	8
IV. REDUNDANT FRAMES . . . . .	14
V. ANALYSIS OF BEAMS . . . . .	41
VI. REDUNDANT BEAMS . . . . .	64
VII. COMBINED BENDING AND DIRECT STRESS . . . . .	138
VIII. COMBINED BENDING AND TORSION . . . . .	166
IX. ELASTIC ENERGY AND DEFORMATIONS DUE TO SHEAR . . . . .	171
X. RESILIENCE . . . . .	176
XI. ELASTIC CURVES AS INFLUENCE LINES . . . . .	198
XII. THE THEORY OF LEAST WORK . . . . .	221
XIII. COLUMNS . . . . .	226
XIV. ESTIMATE OF ELASTIC ENERGY THEORY . . . . .	261
APPENDIX I . . . . .	269
APPENDIX II . . . . .	271
PROBLEMS . . . . .	273
INDEX . . . . .	295



## CHAPTER I

### STATICALLY DETERMINATE VERSUS STATICALLY INDETERMINATE STRUCTURES

In the analysis of a large group of engineering structures the equations of static equilibrium (for coplanar structures  $\Sigma F_x = 0$ ,  $\Sigma F_y = 0$ , and  $M = 0$ ) are sufficient to enable us to solve for unknown reactions, shears, and bending moments, and for unknown forces in various members in structures. The frame shown in Fig. 1 and the beam shown in Fig. 2 represent two such structures. The forces in the members of the frame, the reactions, shears, and bending moments at various points in the beam, may be completely determined by the foregoing

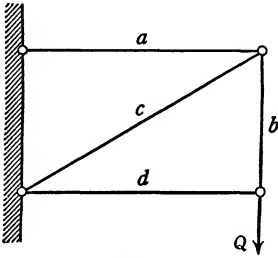

FIG. 1.

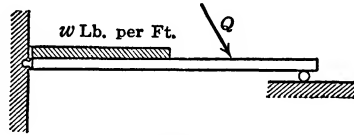

FIG. 2.

equations. Structural types that lend themselves to this method of analysis are designated by the term “statically determinate structures.”

In other types of engineering structures the conditions of static equilibrium do not provide sufficient equations to solve for all the unknowns. If, for example, an additional bar were introduced in Fig. 1, or if the beam in Fig. 2 were built into a wall instead of being hinged at the left support (see Figs. 3 and 4), one additional unknown would be introduced in each case. (In the former a new force would appear in bar  $e$  [Fig. 3], and in the latter an additional bending moment would occur at the left end of the beam [Fig. 4].) Since we need as many equations as we have unknowns, the introduction of an additional unknown would call for an additional equation. If the equations of static equilibrium are just sufficient for the analysis of problems represented by Figs. 1 and 2, they would obviously not be adequate for the analysis of

## 2 DETERMINATE VERSUS INDETERMINATE STRUCTURES

those given in Figs. 3 and 4. Structures of this type are designated by the term "statically indeterminate structures."

This distinction between the two types of structures is essentially a mathematical one. It explains and justifies the terminology by which the two main types of engineering structures are differentiated with regard to stress and strain analysis. Nevertheless, it is important also to realize clearly the physical distinction which exists between the two types.

**Physical Distinction between Statically Determinate and Statically Indeterminate Structures.** In the analysis of structures such as those of Fig. 1 and Fig. 2 we assume: *first*, that the structure and its individual members shall be strong enough to resist whatever forces may be brought to bear upon them; *second*, that it shall not deform to the

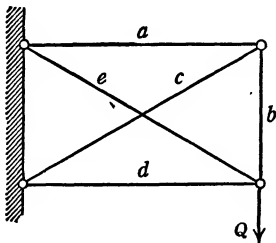

FIG. 3.

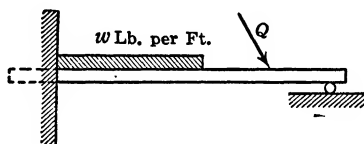

FIG. 4.

extent of disturbing materially the geometric relation between its various parts.

In Fig. 1 we find not only that every bar has to carry a definite force, but also that all the bars are necessary to the proper functioning of the structure. In Fig. 2 the left support must supply a horizontal as well as a vertical reaction. If it were changed into a sliding support, such as the right one, the structure would not be stable. If in Fig. 2 the right support were removed, the structure would likewise become unstable.

*As a characteristic physical feature of statically determinate structures it may be said, then, that every member, every support, every part, has a definite function to perform.*

Since Fig. 3 was obtained by the introduction of an extra member into Fig. 1, it may be said that Fig. 3 contains more members than are absolutely necessary for purposes of equilibrium. Not only bar *e*, but also any other bar, may be regarded as superfluous. In fact, Fig. 3 may be looked upon as representing two trusses, as illustrated by Figs. 5 and 6, both functioning to the same end, namely, that of carrying the load *Q* as shown in Fig. 3. The main difficulty in the analysis of Fig. 3 lies in

determining the value of  $Q_1$ , that portion of  $Q$  carried by the truss shown in Fig. 5, and the value of  $Q_2$ , the portion of the load  $Q$  carried by the truss as shown in Fig. 6. In Fig. 2 the function of the right reaction is to hold up the right end of the beam. If, however, the beam is built into a wall at the left end (Fig. 4), the beam might conceivably function as a cantilever beam without aid of a reaction at the right end. It follows, then, that the bending moment supplied by the wall and the right reaction in Fig. 4 function to the same end.

*A characteristic physical feature of statically indeterminate structures, therefore, is that two or more members, two or more supports, two or more parts, function to one and the same purpose.*

In determining the reactions, forces in members, etc., of statically determinate structures, the sizes of various members and the elastic

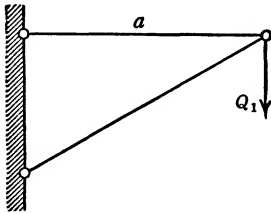

FIG. 5.

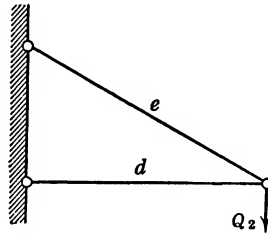

FIG. 6.

behavior of the structure are immaterial, provided that the structure is strong enough to carry the superimposed loads, and provided that the deformations are not sufficient to affect materially the geometric relations of its various parts.

This is not true in the analysis of statically indeterminate structures. In Fig. 3, for example, if we assume all bars to be of equal size, bars  $a$ ,  $e$ ,  $c$ , and  $d$  to be of steel and bar  $b$  to be of rubber, it would seem that the truss as shown in Fig. 6 will have to carry the major part of the load. This is true simply because bar  $b$  is not capable of transferring any large portion of the load to the truss shown in Fig. 5. Similarly, in Fig. 4 the magnitude of the right reaction depends very largely on whether or not the reaction itself will yield, or whether or not the left support is completely rigid. If the right support (Fig. 4) should settle slightly when the loads are placed upon the beam, less reaction would result than there would be if the support permitted no such settling. Since the elastic properties of various members so materially influence the magnitude of the stresses and forces set up in statically indeterminate structures, it would seem that we must take into account the elastic behavior of these structures if we are to make an analysis of the stresses



and strains involved therein. We have stated before that, for the analysis of statically indeterminate structures, the equations of static equilibrium are insufficient. These equations, for reasons just given, must be supplemented by others involving the elastic behavior of structures.

The theory of elasticity gives us a choice of two philosophies, two methods of attack, which may lead to identical mathematical expressions, but which differ fundamentally in underlying physical concepts. The one method is based upon the consideration and the analysis of the elastic curve; the other rests upon the principle of the conservation of energy. The first method is found in nearly all English textbooks on strength of materials, and it may be studied by consulting any one of the numerous textbooks on the subject. Although effective in certain instances, it is limited, because curvature is very much of an abstraction and in complicated problems becomes greatly involved. Furthermore, the theory of curvature is limited to beams and is inapplicable to trusses.

In these pages it is proposed to base our arguments upon the principle of conservation of energy, which, we believe, makes a direct and strong appeal and which is applicable to trusses and beams alike.

Deflections and displacements of engineering structures are rarely important for their own sake. As a key to the analysis of statically indeterminate structures, however, they are of the greatest significance. In Fig. 4, for example, we may have little interest in the extent to which the beam may sag in the middle. However, if the displacement of the right end of the beam can be expressed in terms of the load on the beam and of its right reaction, if we know in advance that this displacement is a certain amount, zero for instance, such an expression will produce the needed additional equation. *The expression "statically indeterminate" does not mean that the equations of static equilibrium do not apply. These equations are always essential for a complete analysis. It means that the equations of static equilibrium must be supplemented.*

**Limitations of the Theory of Elasticity.** The foregoing arguments will form the basis of our present analysis of statically indeterminate structures. Large and impressive books based upon the theory of elasticity and full of mathematical arguments might be written. In common parlance the terms "theoretical" and "mathematical" are not infrequently used as synonymous terms. It must be clearly recognized, however, that the science of mathematics, as far as engineering is concerned, is merely a tool, a means to an end. A theory is not correct unless it takes into account all the facts bearing upon the subject at hand. If it does this accurately, it will be correct, independently of the amount or kind of mathematical reasoning involved in the

development of the theory. If in our theory relating to engineering structures we assume perfect homogeneity and perfect elastic behavior, our conclusions will be correct only so far as these structures actually are homogeneous and elastic. Steel is almost perfectly elastic within a certain range; concrete and wood are neither so elastic nor so homogeneous. Therefore, the results of our theory as applied to structures made of concrete and wood will be in error to the extent that these materials fail to behave in accordance with our assumptions.

Mathematical developments may be impressive because of their intricacy and the amount of work often involved. Assumptions, on the other hand, are difficult to emphasize because once they are stated one can do little more than repeat them. Nevertheless, the importance of the assumptions upon which a theory is based is at least equal to that of the rest of the theory, mathematical or otherwise. In our treatment of the elastic energy theory we assume:

First, that the structures to be analyzed shall behave as perfectly homogeneous and elastic bodies.

Second, that the deformations of the structure are not sufficient to alter materially the geometric relation of its various parts to one another.

Third, that the law of superposition holds.

It should constantly be kept in mind that, whenever we violate any one of the assumptions upon which a theory is based, the conclusions reached by the theory will be in error. Furthermore, it should be remembered that the possibility remains for the development of other theories, taking other factors into account. (See footnotes, page 267.)

## CHAPTER II

### ELASTIC ENERGY

**Work** is defined as the product of force and distance. For a constant force  $F$  acting over a finite distance  $\Delta$ , the work done is given by the expression  $W = F\Delta$ . When we have a variable force, acting over an infinitesimal distance  $d\Delta$ , the work done is expressed as  $dW = Fd\Delta$ . The total amount of work over a finite distance may be obtained by means of the summing process called integral calculus, thus:

$$W = \int dW = \int Fd\Delta.$$

Force being expressed in pounds and distance in feet or inches, work is expressed as foot-pounds or inch-pounds. By plotting force  $F$  as ordinate and distance  $\Delta$  as abscissa, work  $W$  may be represented graphically as an area.

If, for example, a weight  $Q$  fastened to a rubber bar is placed upon one's hand and the hand is lowered, the load on the bar will uniformly increase from zero to  $Q$ , and the load on the hand will gradually decrease from  $Q$  to zero. The total work done by  $Q$  will be its change of potential energy. Work equals the weight  $Q$  times the distance  $\Delta$  and is represented by the rectangular area  $Q\Delta$  (Fig. 7). The weight acts partly against the rubber bar and partly against the hand. The work expended in stretching the rubber bar is represented by the left triangular area  $\frac{Q\Delta}{2}$  (Fig. 7), whereas the work done against the hand is shown by the right

triangular area and is represented by the same expression  $\frac{Q\Delta}{2}$ . If the weight on the rubber bar at some intermediate position is called  $F'$ , the differential quantity of work done on it while stretched a differential distance  $d\Delta$  will be  $dW = F'd\Delta$ . This differential work  $dW$  is represented by the small rectangle within the first triangle (Fig. 7). If the bar is perfectly elastic, the force applied to it is directly proportional to its elongation. The total work done on it will be stored within it in the form of elastic energy, to be given up when the load is removed (Fig. 7).

If we assume that a load  $F$  is suspended from the rubber bar and subsequently a load  $Q$  is added (Fig. 8), then the total energy stored in the bar will be equal to the large triangle  $\frac{(F + Q)(\Delta_1 + \Delta_2)}{2}$ . This large triangle may be divided into two small triangles  $o$  and  $n$  and a rectangle

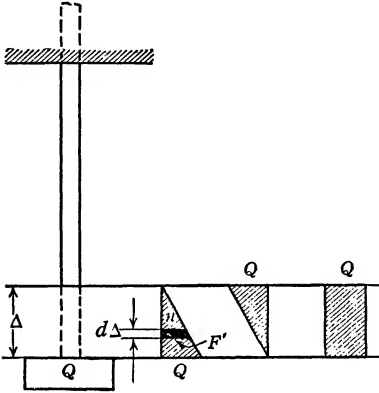

FIG. 7.

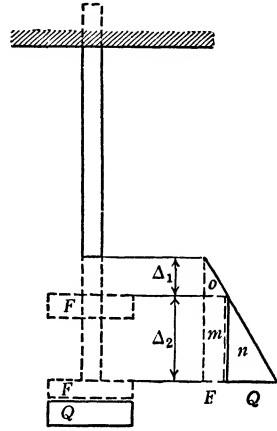

FIG. 8.

triangle  $m$ . Triangle  $o$  represents the energy stored in the rubber bar as  $F$  is gradually applied, the force increasing from zero to  $F$ . Triangle  $n$  represents the energy that would be stored in the bar if  $Q$  were gradually applied, the force increasing from zero to  $Q$ . As  $Q$  is applied, however,  $F$  is in full action. During the application of  $Q$ ,  $F$  is displaced over the distance  $\Delta_2$ . The work done on the rubber bar by  $F$  during the application of the load  $Q$  is represented by the rectangle  $m$  and is equal to  $F\Delta_2$ .

CHAPTER III  
ANALYSIS OF FRAMES

DISPLACEMENT OF ANY JOINT IN A FRAME IN ANY DIRECTION

We assume a frame to be loaded with any system of loads  $Q$ , and propose to find the displacement of point  $A$  in the direction  $\theta_1$  (Fig. 9a).

As the loads are placed upon the structure, each member will behave like the rubber bar shown in Figs. 7 and 8. The elongations and contractions of the various bars may be small, but if the structure is elastic

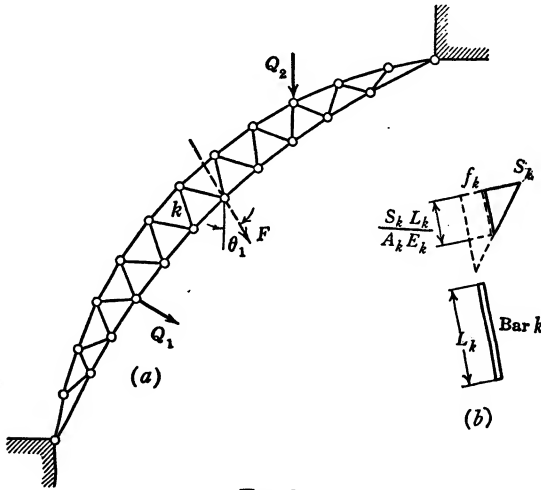

FIG. 9.

and if, for the purpose of stress computation, it may be assumed to maintain its original shape, such decrease or increase of length will be proportional to the stresses in the bars. These stresses in turn are proportional to the loads placed upon the structure.

For purposes of analysis let us assume an auxiliary load  $F$  to be applied at point  $A$  in the direction  $\theta_1$ . The load  $F$  causes a displacement of point  $A$ . The dead load likewise causes such displacement. We are, however, in no way concerned with these displacements. Our sole interest is in the displacement of  $A$  in the direction  $\theta_1$  as caused by the actual loads  $Q_1$  and  $Q_2$ , etc.

Let us direct our attention to what takes place in any one member, say bar  $k$ . As the auxiliary load  $F$  is applied, bar  $k$  will be loaded with a force  $f_k$  (Fig. 9b). If subsequently the actual loads  $Q_1, Q_2$ , etc., are applied and the principle of superposition is assumed to hold, another force will be superimposed upon the already existing force. This force is designated  $S_k$ . Corresponding to the increment of force  $S_k$ , the bar will change in length  $\frac{S_k L_k}{A_k E_k}$ , in which  $L_k$  stands for length

of bar,  $A_k$  for area of bar, and  $E_k$  for its modulus of elasticity. A part of the total elastic energy stored in bar  $k$  is due to the auxiliary force  $F$  acting on the truss while the actual loads  $Q$  are being applied, or to a force  $f_k$  acting on bar  $k$  while force  $S_k$  is being superimposed. *This elastic energy is graphically represented by the small rectangle in Fig.*

9b, and its value is expressed by the term  $\frac{f_k S_k L_k}{A_k E_k}$ . We may represent the

term  $\frac{L_k}{A_k E_k}$  by the constant  $C_k$ , called the elastic coefficient of bar  $k$ .

Thus  $\frac{f_k S_k L_k}{A_k E_k} = C_k f_k S_k$ .

What is true for bar  $k$  is true for any bar in the structure. The total energy stored in the structure, stored because the auxiliary load  $F$  is assumed to be acting on the structure before loads  $Q_1, Q_2$ , etc., are applied, is therefore the sum of expressions of the form  $CfS$  for all bars. If the structure is perfectly elastic, if the principle of superposition is applicable, and if the principle of conservation of energy is assumed to hold, then this stored internal elastic energy must equal the work done by  $F$ .  $F$  does no work in a direction at right angles to its line of action. Therefore we may say

$$F\Delta = \Sigma C f S. \quad \text{Formula (1)}$$

Here  $F$  = an auxiliary load applied at a certain point in the frame acting in the direction  $\theta_1$ .

$\Delta$  = displacement of this point in direction  $\theta_1$ .

$\Sigma$  = summing over all bars in the frame.

$f$  = forces in bars due to auxiliary load. (First applied.)

$S$  = forces in bars due to actual loads. (Subsequently applied.)

$C$  = elasticity coefficient for bars.

The auxiliary load  $F$  may be assumed to be of any value. In the development of formula (1) it is shown that the  $f$  forces are proportional to  $F$ , and so  $F$  may be canceled if desired, or  $F$  may at the outset be selected as unity.

Formula (1) is sometimes written  $\Delta = \Sigma Cfs$ . This, however, is to be avoided. Formula (1) purports to equate elastic energy against external work. As written in the modified form it would appear as if inches were equated against energy, thus obscuring the most essential attribute of the formula.

## EXAMPLE 1

To find the horizontal displacement  $\Delta_x$  of point  $B$  (Fig. 10a) under the action of vertical load  $Q$ , we introduce an auxiliary load  $F$  (Fig. 10b) which stresses all the bars with forces  $f$  proportional to the stress dia-

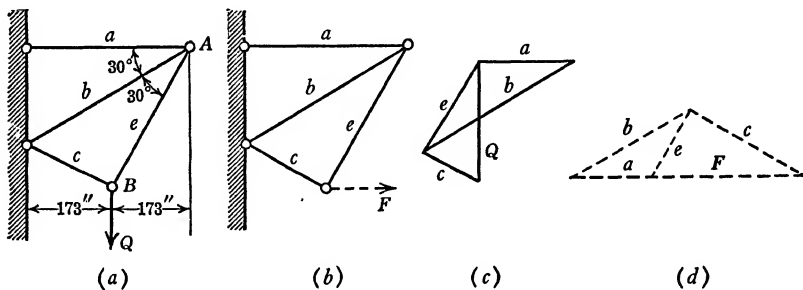

FIG. 10.

gram (Fig. 10d). The values of  $f$ , letting  $F = 10,000$  lb., are given in the table. The forces  $S$ , shown in Fig. 10c, are caused by the actual load  $Q$ . The values of  $S$  for the various bars, letting  $Q = 10,000$  lb., are also shown in the table.

Bar	Length	Area	$C = \frac{L}{AE}$	$S$	$f$	$CfS$	$S^2$	$CS^2$
$a$	346	2	0.00000577	+ 8,667	-5000	-250.0	+ 75,000,000	433
$b$	400	2	0.00000667	-15,000	+8667	-867.0	+225,000,000	1500
$c$	200	3	0.00000222	+ 5,000	+8667	+ 96.5	+ 25,000,000	55
$e$	346	3	0.00000384	+ 8,667	-5000	-166.5	+ 75,000,000	288
						$\Sigma CfS =$ -1187.0		2276

$$\Delta_x = \frac{\Sigma CfS}{F} = \frac{-1187}{10,000} = -0.119 \text{ in.}$$

The minus sign indicates that the displacement of point  $B$  is in opposition to the sense of the assumed load  $F$ , that is, to the left.

EXAMPLE 2

To find the vertical displacement  $\Delta_y$  of point  $B$  (Fig. 10a) under the action of a vertical load  $Q$ , we assume an auxiliary load  $F$  to be acting at point  $B$  in a vertical direction before load  $Q$  is applied. Since we already have a stress diagram  $S$  and since we are at liberty to assume  $F$  to be of any value, we may assume  $F$  to be equal to  $Q$ , in which case the  $f$  forces will be equal to the  $S$  forces and formula (1) becomes

$$\Delta_y = \frac{\Sigma C f S}{F} = \frac{\Sigma C S^2}{F} = \frac{+2276}{10,000} = + 0.228 \text{ in.}$$

The plus sign in this answer indicates that the displacement of point  $B$  has the same direction and sense as the auxiliary load  $F$ , which in this case is the same as the actual load  $Q$ .

EXAMPLE 3

Formula (1), as it stands, provides a means for the solution of certain types of statically indeterminate trusses. For example, let Fig. 11 represent a five-panel truss over three supports. For the sake of sim-

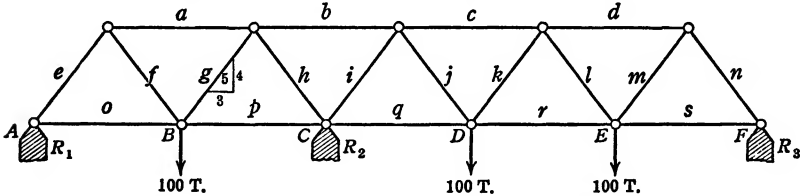

FIG. 11.

plicity the slope of all inclined members is assumed to be a 3 : 4 : 5 relationship; furthermore, the areas of all bars are assumed to be equal.

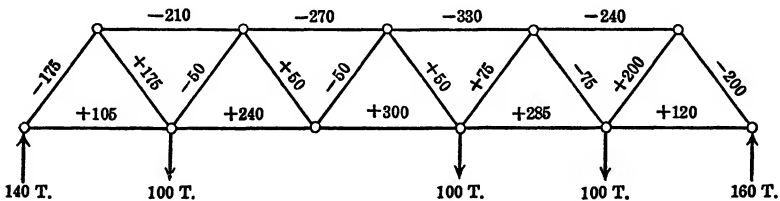

FIG. 12.

The supports at points  $A$ ,  $C$ , and  $F$  are assumed to be unyielding, and the vertical loads applied at points  $B$ ,  $D$ , and  $E$  are assumed to be 100 tons each. The truss is once redundant, that is, it contains one



more member, or one more reaction, than is absolutely necessary for stability. Let us select  $R_2$ , the reaction at  $C$ , as the redundant one.  $R_2$  having been obtained, the other two reactions and the forces in all the members may be obtained by means of the equations of statics.

With  $R_2$  removed (Fig. 12) the truss is statically determinate. The forces in the members under this condition of loading are indicated on the respective members for convenient reference.

With the loads at  $B$ ,  $D$ , and  $E$  removed and  $R_2$  replaced by a concentrated load  $F$ , say of 100 tons (Fig. 13), the truss is statically deter-

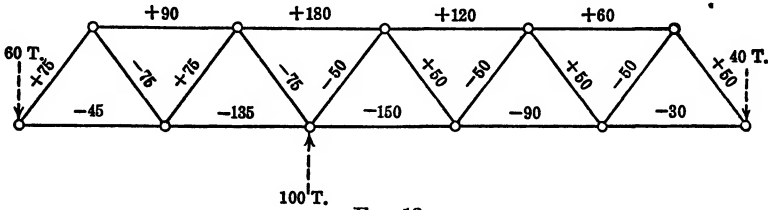

FIG. 13.

minate and the forces in members for this condition of loading are recorded on Fig. 13.

Under the condition of loading represented by Fig. 12 the vertical displacement of  $C$  may be found as  $\Delta_1 = \frac{\Sigma CfT}{F} = \frac{\Sigma LfT}{100AE}$ . Under the application of a single load of 100 tons at  $C$  (Fig. 13), the vertical displacement of  $C$  may be found as

$$\Delta_2 = \frac{\Sigma CfT}{F} = \frac{\Sigma Cf^2}{F} = \frac{\Sigma Lf^2}{100AE}.$$

$R_2$  may be regarded as the force necessary to return point  $C$  to its original position after having been displaced a distance  $\Delta_1$  under the action of the external loads (Fig. 12). If a force of 100 tons displaces point  $C$  a distance  $\Delta_2$ , then  $R_2$ , the force necessary to reduce the displacement  $\Delta_1$  to zero, is

$$\begin{aligned} R_2 &= -\frac{\Delta_1}{\Delta_2} \times 100 \text{ tons} = \frac{-\Sigma LfT}{100AE} \times \frac{100AE}{\Sigma Lf^2} \times 100 \\ &= \frac{-\Sigma LfT}{\Sigma Lf^2} \times 100 \text{ tons} = \frac{167,850,000}{849,000} = 198 \text{ tons.} \end{aligned}$$

In order to reduce to a minimum the numerical work in this example, the simplest possible truss was assumed, and the moduli of elasticity and areas of all bars were assumed to be equal. The factors  $A$  and  $E$  therefore cancel. In any practical example, however, they would not

cancel, and where our table shows columns for the values  $L$ ,  $LfT$ , and  $Lf^2$ , columns for the values  $C$ ,  $CfT$  and  $Cf^2$  would have to be substituted.

Bar	$L$	$T$	$f$	$LfT$	$Lf^2$
$a$	6	-210	+ 90	- 113,400	48,600
$b$	6	-270	+180	- 291,600	194,400
$c$	6	-330	+120	- 237,600	86,400
$d$	6	-240	+ 60	- 86,400	21,600
$e$	5	-175	+ 75		28,125
$f$	5	+175	- 75	- 131,250	28,125
$g$	5	- 50	+ 75		28,125
$h$	5	+ 50	- 75	- 37,500	28,125
$i$	5	- 50	- 50		
$j$	5	+ 50	+ 50	+ 25,000	
$k$	5	+ 75	- 50		
$l$	5	- 75	+ 50	- 37,500	
$m$	5	+200	- 50		
$n$	5	-200	+ 50	- 100,000	75,000
$o$	6	+105	- 45	- 28,350	12,150
$p$	6	+240	-135	- 194,400	109,350
$q$	6	+300	-150	- 270,000	135,000
$r$	6	+285	- 90	- 153,900	48,600
$s$	6	+120	- 30	- 21,600	5,400
				-1,678,500	849,000

In adding the  $LfT$  column it is essential that strict attention be paid to signs. Signs frequently prove the largest source of errors in the application of our theory. The minus sign under the  $LfT$  column means that the displacement of  $C$  (Fig. 12), due to the loads at points  $B$ ,  $D$ , and  $E$ , is of opposite sense to the auxiliary load as shown in Fig. 13.

If we assume the areas of all bars equal to 20 sq. in., their lengths either 24 or 20 ft., and  $E$  equal to 15,000 tons per sq. in., then

$$\Delta_2 = \frac{\sum Lf^2}{100AE} = \frac{849,000 \times 12 \times 4}{100 \times 20 \times 15,000} = 1.36 \text{ in.}$$

(The lengths of bars in the  $L$  column are to be expressed in inches. To modify the lengths as given in the table requires a multiplication factor 4, changing the units 5 and 6 to 20 and 24, respectively, and the factor 12 to reduce the feet units to inch units.) A change of 1 in. in the elevation of point  $C$ , therefore, would change the value of  $R_2$  by

$$\frac{100}{1.36}, \text{ or } 73.8 \text{ tons.}$$

## CHAPTER IV

### REDUNDANT FRAMES

The last example given on the foregoing pages constitutes a special case of a frame with one redundant member. In this frame any one of the reactions whose displacement is known to be zero may be selected as the superfluous or redundant one. This procedure, however, is not always practicable or desirable. Our analysis should be as general as possible and independent of the condition of zero displacement. Such an analysis may be made by assuming any one or more bars in a statically indeterminate frame as redundant, and by a reasoning analogous to that followed in the development of formula (1).

#### FRAME WITH ONE REDUNDANT MEMBER

Let Fig. 14*a* represent a frame with one redundant member.

Let  $S_a, S_b$ , etc., represent the forces in bars  $a, b$ , etc., caused by the actual loading  $Q_1, Q_2$ , etc. (In our example [Fig. 14*a*] we have assumed the actual loading to consist of but a single concentrated load  $Q$ .)

Let bar  $e$  be regarded as the redundant member.

Let  $T_a, T_b, T_c$ , etc., be the forces in bars  $a, b, c$ , etc., caused by the actual loading  $Q_1, Q_2$ , etc., when the redundant bar  $e$  is removed (Fig. 14*b* and 14*f*).

Let  $U_a, U_b, U_c$ , etc., be the forces in bars  $a, b, c$ , etc., caused by a tensile force unity acting in the place of the redundant bar  $e$  (Fig. 14*c* and 14*g*).

Let  $R$  be an initial auxiliary force acting in the redundant bar  $e$  (Fig. 14*e*).

In the development of formula (1) we introduced an auxiliary force  $F$  merely for purposes of analysis. In the analysis of redundant frames a similar procedure is advantageous, but instead of an external force  $F$  we assume an auxiliary internal force  $R$ , acting in the redundant bar  $e$ .

We are familiar with the procedure of computing live-load forces in structures independently of dead-load forces. Similarly in our example, if the principle of superposition is to apply, the forces  $S_a, S_b, S_c,$  etc.,

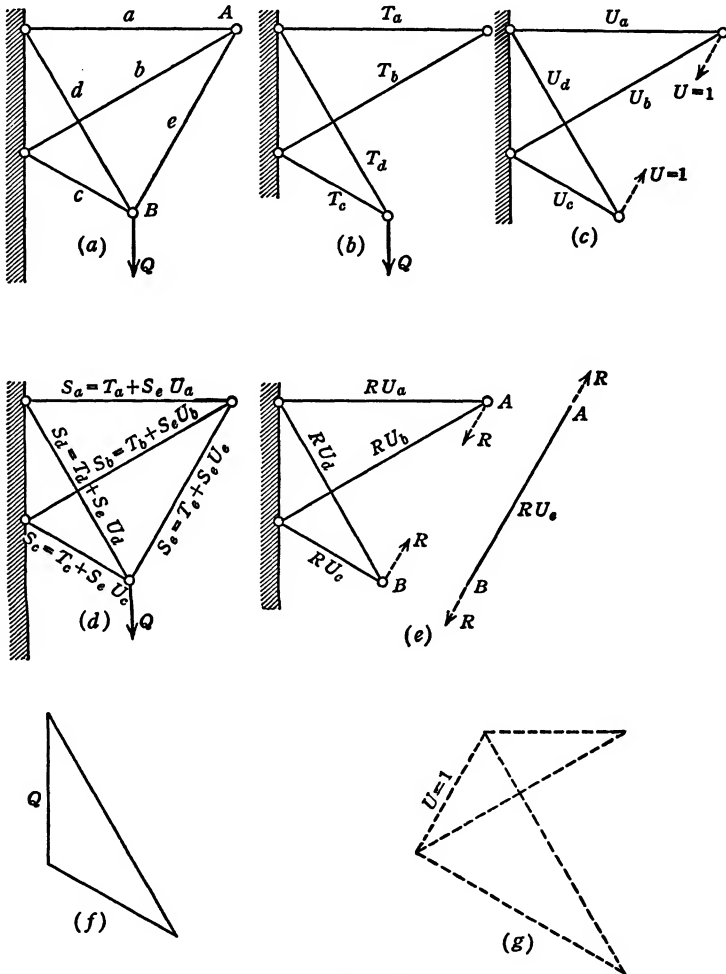

FIG. 14.

caused by actual loads  $Q_1, Q_2,$  etc., will be independent of dead-load forces, erection forces, and temperature forces that may be within the frame before the application of load  $Q_1, Q_2,$  etc. To gain a physical picture of the idea, let us assume a turnbuckle to be built into the redundant bar  $e$ , and let this turnbuckle be turned so as to cause a force  $R$  to be set up within bar  $e$ . Previously, with bar  $e$  removed and

tensile forces of magnitude unity assumed acting in its place (Fig. 14c), we designated the resulting forces in the remaining bars as  $U_a$ ,  $U_b$ , etc. The forces caused by the auxiliary force  $R$  acting in bar  $e$  may then be designated as  $RU_a$ ,  $RU_b$ ,  $RU_e$ , etc. (Fig. 14e).

Let the forces produced in the various bars, under the action of the load  $Q_1$ ,  $Q_2$ , etc., with bar  $e$  removed, be designated as  $T_a$ ,  $T_b$ ,  $T_e$ , etc. The fact that in our example  $T_a$ ,  $T_b$ , and  $T_e$  have the value zero (Fig. 14b) does not preclude our representing such forces by the symbol  $T$ .

In accordance with the definition at the beginning of this chapter, the actual force in the redundant bar  $e$  may be represented by  $S_e$ , or  $T_e + S_e U_e$  if we so choose, since, for bar  $e$ ,  $T_e = 0$  and  $U_e = 1$ .

The actual force in any bar caused by the loading  $Q_1$ ,  $Q_2$ , etc., with bar  $e$  in place, will therefore be given by the expressions  $T_a + S_e U_a$ ,  $T_b + S_e U_b$ , etc. (Fig. 14d). If we assume the auxiliary load  $R$  to be acting before the actual loads  $Q_1$ ,  $Q_2$ , etc., are applied, the elastic energy stored in the frame because of this assumed condition may be computed from formula (1),  $F\Delta = \Sigma CfS$ .

Here, however, the auxiliary force is called  $R$  instead of  $F$ . The auxiliary forces within the bars, instead of being called  $f$ , are designated by  $RU_a$ ,  $RU_b$ , etc., and the actual forces within the bars are not labeled as  $S$  but are represented by the expressions  $T_a + S_e U_a$ ,  $T_b + S_e U_b$ , etc. The auxiliary force  $R$ , assumed to be acting in bar  $e$  before the application of load  $Q$ , gives rise to stored elastic energy in the structure. This stored energy, in accordance with formula (1), is given as  $\Sigma CRU(T + S_e U)$ . This energy must equal the external work done by the auxiliary force  $R$ .  $R$ , however, is an internal force and its external work is zero. Therefore,  $\Sigma CRU(T + S_e U) = 0$ . In this expression  $R$  is a constant and may be canceled, or, in other words,  $R$  might have been assumed as unity at the outset.  $C$ ,  $U$ , and  $T$  differ for different bars.  $S_e$  is the unknown for which we must solve.

$$\Sigma CRU(T + S_e U) = 0 = \Sigma CTU + S_e \Sigma CU^2.$$

Therefore

$$S_e = \frac{-\Sigma CTU}{\Sigma CU^2}. \quad \text{Formula (2)}$$

Note the minus sign in the numerator, and also note the fact that the force unity assumed to be acting in the place of the redundant bar (Fig. 14c) is a tensile force.

EXAMPLE 4

Compute the forces in the redundant frame represented by Fig. 14a. Let  $Q = 10,000$  lb. and  $E = 30,000,000$  lb. per sq. in. The lengths and areas of the various bars are listed in the accompanying table, as are also the values of the various factors needed in the solution of the problem. The  $U$  loading is shown by Fig. 14c, and the corresponding  $U$  forces are shown by the force diagram of Fig. 14g. The  $T$  loading is represented by Fig. 14b, and the corresponding  $T$  force diagram by Fig. 14f.

Bar	Length	Area	$C = \frac{L}{AE}$	$U$	$T$	$CUT$	$CU^2$
<i>a</i>	346	2	0.0000577	+1	0	0	0.0000577
<i>b</i>	400	2	0.0000667	-1.73	0	0	0.0002000
<i>c</i>	200	3	0.0000222	+1.73	-10,000	-0.0384	0.0000666
<i>d</i>	346	2	0.0000577	-2	+17,330	-0.2000	0.0002308
<i>e</i>	346	3	0.0000385	+1	0	0	0.0000385
						-0.2384	0.0005936

Therefore

$$S_e = \frac{-\Sigma CUT}{\Sigma CU^2} = \frac{-(-0.2384)}{0.0005936} = + 4000 \text{ lb.}$$

The force in bar *a* is

$$S_a = T_a + S_e U_a = 0 + 4000(+1) = + 4000 \text{ lb.}$$

The force in bar *b* is

$$S_b = T_b + S_e U_b = 0 + 4000(-1.73) = - 6920 \text{ lb.}$$

The force in bar *c* is

$$S_c = T_c + S_e U_c = - 10,000 + 4000(+1.73) = - 3080 \text{ lb.}$$

The force in bar *d* is

$$S_d = T_d + S_e U_d = + 17,330 + 4000(-2) = + 9330 \text{ lb.}$$

In this problem the plus sign means tension and the minus sign means compression.

EXAMPLE 5

Our problem in example 3 (page 11, Fig. 11) involved essentially the same analysis as that used in the development of formula (2). We computed  $\Sigma CfS$  and  $\Sigma Cf^2$  and found  $R_2$  to be equal to the ratio of  $-\Sigma CfS : \Sigma Cf^2$ . If one of the bars, instead of one of the reactions, is taken as the redundant member, formula (2) should be applied.

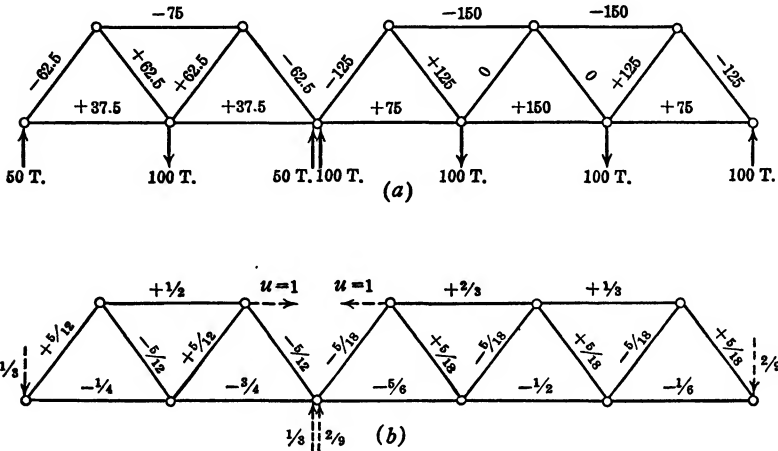

FIG. 15.

If we assume the top chord  $b$  (Fig. 11, page 11) as the redundant bar, then the respective  $T$  and  $U$  forces in the various bars are as indicated on Figs. 15a and 15b.

$$S_b = \frac{-\Sigma CUT}{\Sigma CU^2} = \frac{-AE\sum LUT}{AE\sum LU^2} = \frac{-(-2250)}{26.21} = + 85.8 \text{ tons.}$$

Taking moments about point  $C$  (Fig. 11) we have

$$12R_1 + 4 \times 85.8 - 6 \times 100 = 0.$$

Therefore

$$R_1 = 21.4 \text{ tons,}$$

$$18R_3 + 4 \times 85.8 - 6 \times 100 - 12 \times 100 = 0.$$

Therefore

$$R_3 = 80.8 \text{ tons,}$$

$$R_1 + R_2 + R_3 = 300.$$

Therefore

$$R_2 = 198 \text{ tons.}$$

Bar	$L$	$U$	$T$	$LUT$	$U^2$	$LU^2$
$a$	6	+0.500	- 75.0	-225.0	0.25	1.500
$b$	6	+1.000	0.0	0.0	1.00	6.000
$c$	6	+0.667	-150.0	-600.0	0.444	2.667
$d$	6	+0.333	-150.0	-300.0	0.111	0.667
$e$	5	+0.417	- 62.5	-130.0	0.173	0.865
$f$	5	-0.417	+ 62.5	-130.0	0.173	0.865
$g$	5	+0.417	+ 62.5	+130.0	0.173	0.865
$h$	5	-0.417	- 62.5	+130.0	0.173	0.865
$i$	5	-0.278	-125.0	+174.0	0.077	0.385
$j$	5	+0.278	+125.0	+174.0	0.077	0.385
$k$	5	-0.278	0.0	0.0	0.077	0.385
$l$	5	+0.278	0.0	0.0	0.077	0.385
$m$	5	-0.278	+125.0	-174.0	0.077	0.385
$n$	5	+0.278	-125.0	-174.0	0.077	0.385
$o$	6	-0.250	+ 37.5	- 56.25	0.062	0.375
$p$	6	-0.750	+ 37.5	-168.75	0.563	3.375
$q$	6	-0.833	+ 75.0	-375.0	0.695	4.167
$r$	6	-0.500	+150.0	-450.0	0.250	1.500
$s$	6	-0.167	+ 75.0	- 75.0	0.028	0.167
				-2250.0		26.208

EXAMPLE 6

Airplane Fuselage

*Given.* An airplane fuselage, constructed of welded tubes and eccentrically loaded by air loading applied to fin and rudder (Fig. 16a).

*To find.* The stresses in the fuselage as a function of the loading.

A welded fuselage is a highly redundant structure. Every weld represents a condition of redundancy and would require an extra simultaneous equation in order to permit a rigorous solution. Such a solution would be prohibitively lengthy and involved. By making certain reasonable assumptions, however, the degree of redundancy may be reduced to one. The magnitude and location of the resultant air pressure on fin and rudder are questions of aerodynamics and will not be discussed here. Let the resultant air pressure equal  $Q$  and let its application be at point  $\times$  (Fig. 16a).

Elementary mechanics teaches that a single force  $Q$  is equal to another and parallel force  $Q$  plus a torque equal to the product of  $Q$  and the distance between the forces. The effect of the eccentrically applied force may thus be translated in terms of a side thrust  $Q$  and



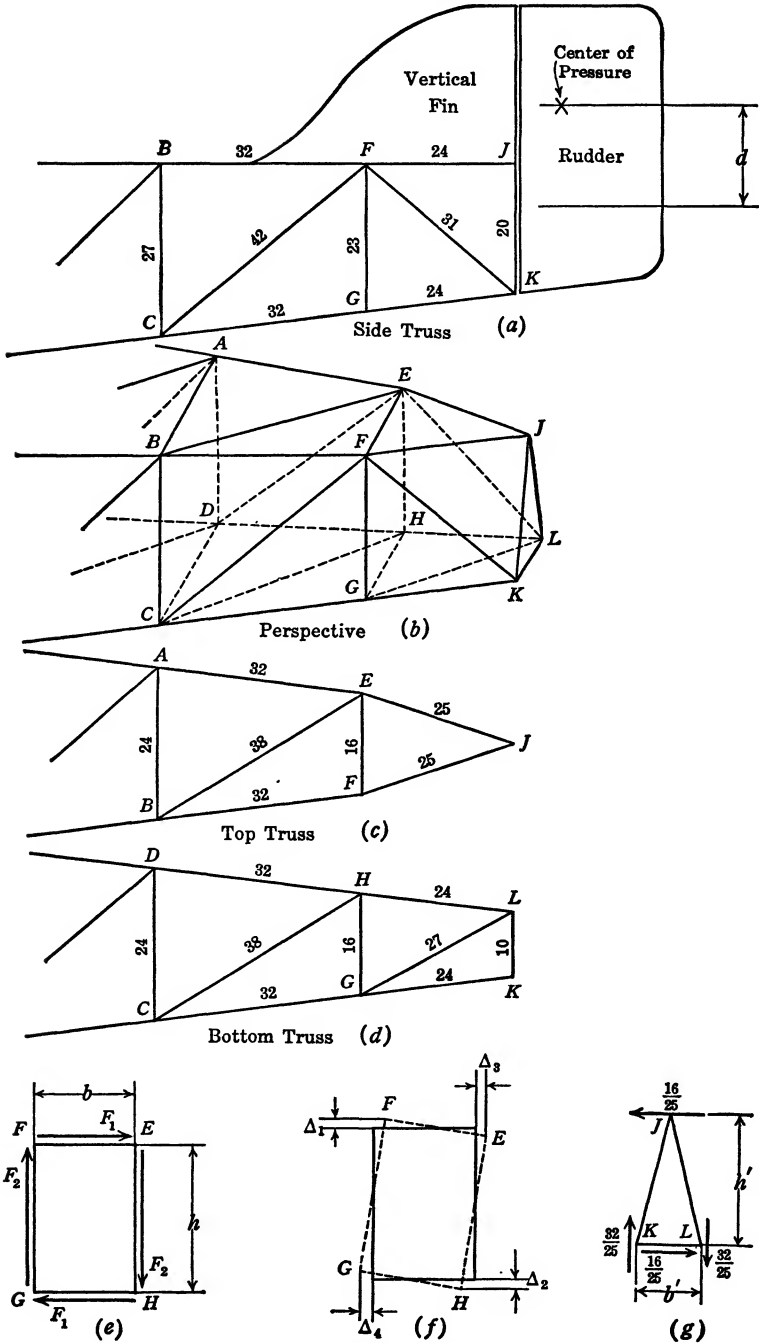

FIG. 16. Airplane Fuselage.

a torque  $Qd$ . The principle of superposition being assumed, two distinct stress analyses may be made, one for the effect of the side thrust and another for the effect of the torque. The resultant stresses are then to be added algebraically. One of the assumptions we propose to make is that the side thrust is carried exclusively by the top and bottom trusses. The resistance of the two vertical trusses against any horizontal side thrust is of negligible magnitude.

The manner in which the horizontal side thrust  $Q$  distributes itself between the bottom and the top trusses is important on two counts: first, because the stresses due to the side-thrust loading are affected by it; and second, because the value  $d$  (Fig. 16a) and thus the torque  $Qd$  are affected by it. The manner in which the side thrust is distributed between the top and the bottom trusses depends on the stiffness coefficient of the two trusses. A few extreme examples will illustrate this point.

Let us suppose that a diagonal in the bottom truss were cut, and thus the effectiveness of the truss completely destroyed. The side thrust  $Q$  would then be carried entirely by the top truss and  $d$  (Fig. 16a) would be measured down to point  $J$ .

If, on the other hand, the bottom truss were intact and the resistance of the top truss were assumed reduced to zero, then  $Q$  would be carried by the bottom truss and  $d$  (Fig. 16a) would be measured down to line  $GK$ .

With both top and bottom trusses identical, or, more correctly speaking, if both top and bottom trusses have the same stiffness coefficient—require the same load to produce the same deflection—then the side thrust  $Q$  distributes itself equally between top and bottom trusses and  $d$  (Fig. 16a) would be measured to the halfway point between  $J$  and  $K$ .

The point to which  $d$  is to be measured may be located by considering the top and the bottom trusses separately. Determine in each case the force necessary to produce a unit displacement. The force  $Q$  will then distribute itself between the top and the bottom trusses in direct ratio to these forces. The line of action of the transverse force  $Q$  is then the centroid of the forces producing unit displacement in top and bottom trusses.

The most important consideration in the analysis of air loading in a fuselage is the effect of the torque  $Qd$  upon the stresses in the fuselage.

Let us concentrate our attention on the second bay from the end. As a torque is applied to the fuselage, point  $F$  moves vertically relative to point  $B$  and point  $E$  moves horizontally relative to point  $A$  (Fig. 16a).

These relative motions are resisted by the front and top trusses respectively. The fact that the tubes are welded induces bending as well as direct stresses in the members. The bending of the members of the truss is relatively far less effective in resisting distortion of the truss than are the direct stresses in the members. By ignoring the effects of the welds, in other words, by assuming the trusses as pin-connected, we materially simplify our problem without seriously affecting the accuracy of our analysis. In the analysis of riveted bridge trusses a similar assumption is made. The trusses are analyzed as if they were pin-connected and later corrections are made for the stiffening effect of the rivet connections, if such are desired.

Assuming the fuselage pin-connected and a wire strung diagonally across the bulkhead from  $C$  to  $A$ , then a very small force in the wire would readily distort the bulkhead and cause it to assume a diamond shape without materially affecting the stresses in longerons or truss diagonals. In other words, two diagonals from  $C$  to  $A$  and from  $B$  to  $D$  would, with very little force, keep the bulkhead from being distorted.

For this reason, although all bulkheads should be braced, the stresses in the bracing tubes or bracing wires need not be considered as materially affecting the stresses in the top, bottom, or side trusses. It is thus quite reasonable to ignore the stresses in the bulkhead braces.

If we are satisfied that the fuselage may be regarded as pin-connected and that the stresses in the bulkhead wires or tubes may be ignored, we may proceed with the analysis.

It is best to analyze as a unit a segment of the fuselage consisting of several bays, the ends of which may be regarded as rigid and the sides as essentially continuous planes.

For the purpose of illustration, we analyze a segment consisting of one bay only, bay  $BCGF$  (Fig. 16*b*). (It should be realized that a segment of a fuselage consisting of several bays may advantageously be analyzed as a unit, provided that the foregoing conditions are satisfied.)

The torque  $Qd$  is to be transmitted through the bay. The primary forces which the trusses of the fuselage are able to transmit are forces lying in the different planes of the fuselage. Since the sum of the horizontal and vertical forces must in each case equal zero, the forces in the different planes of the fuselage appear as represented in Fig. 16*e*.

The forces  $F_1$  in top and bottom trusses must necessarily be the same, as must the forces  $F_2$  in the two side trusses. Letting torque  $T_1 = F_1h$  and torque  $T_2 = F_2b$ , then one of our conditions is

$$T_1 + T_2 = F_1h + F_2b = Qd \text{ (Fig. 16e).} \quad (a)$$

Suppose that a diagonal in the bottom truss is cut and the effectiveness of the truss destroyed; then the truss is statically determinate.  $F_1$  then equals zero; therefore  $T_1 = 0$  and  $F_2 = \frac{Qd}{b}$ . Furthermore, the transverse force  $Q$  would be carried exclusively by the top truss. With all trusses effective we have one condition of redundancy. The two horizontal trusses together carry one torque  $T_1 = F_1h$ ; the two vertical trusses carry another torque  $T_2 = F_2b$ . The two torques  $T_1$  and  $T_2$  equal the total applied torque  $Qd$ . The problem is to find the magnitudes of torques  $T_1$  and  $T_2$ .

If the bulkheads are completely rigid then one bulkhead will rotate relative to the other through an angle  $\theta$  (Fig. 16f).

$$\theta = \frac{\Delta_1 + \Delta_2}{b} = \frac{\Delta_3 + \Delta_4}{h} \quad (\text{Fig. 16e and 16f}). \quad (b)$$

$\Delta_1$  and  $\Delta_4$  may be expressed by means of formula (1) as a function of  $F_2$  and  $F_1$  respectively, while  $\Delta_2$  and  $\Delta_3$  may also be expressed as a function of  $F_2$  and  $F_1$ , thus establishing the second of the required equations necessary for the determination of  $F_1$  and  $F_2$ .

The magnitudes of  $\Delta_1, \Delta_2, \Delta_3,$  and  $\Delta_4$  are evaluated in the tables below.

NOTE. The auxiliary load  $F$  is applied in the direction of the displacement  $\Delta$ . Although in the front side truss the actual stress in bar  $BF$  is a function only of the actual force  $F_2$ , in the rear side truss the actual stress in bar  $AE$  is a function of the actual force  $F_1$  in the top truss as well as of the actual force  $F_2$  in the side truss. If, however, the diagonal  $DE$  were replaced by a diagonal  $AH$ , this would not be true. Although, in the latter case, there appears to be less geometric symmetry, there is actually more elastic symmetry.

Bar	$L$	$A$	$CE = \frac{L}{A}$	$f$	$S$	$CEfS$
$BF$	32	0.10	320	$-1.185F$	$-1.185F_2$	$+449.6FF_2$
$CF$	42	0.10	420	$+1.555F$	$+1.555F_2$	$+1016.4FF_2$
						$+1466FF_2$

$$\Delta_1 = \frac{\Sigma CfS}{F} = \frac{1466FF_2}{FE} = \frac{+1466F_2}{E}$$

Bar	$L$	$A$	$CE = \frac{L}{A}$	$f$	$S$	$CEfS$	
$AE$	32	0.10	320	$+1.185F$	$+1.185F_2 - 1.333F_1$	$+449.6FF_2 - 505.6FF_1$	
$DE$	42	0.10	420	$-1.555F$			$+1016.4FF_2$

$$\Delta_2 = \frac{\Sigma Cfs}{F} = \frac{1466F_2}{E} - \frac{505.6F_1}{E}.$$

Bar	$L$	$A$	$CE = \frac{L}{A}$	$f$	$S$	$CEfS$	
$AE$	32	0.10	320	$-1.33F$	$-1.33F_1 + 1.185F_2$	$+566.4FF_1 - 505.6FF_2$	
$BE$	38	0.065	584	$+1.58F$			$+1460FF_1$

$$\Delta_3 = \frac{\Sigma Cfs}{P} = \frac{+2026F_1}{E} - \frac{505.6F_2}{E}.$$

Bar	$L$	$A$	$CE = \frac{L}{A}$	$f$	$S$	$Cfs$	
$DH$	32	0.10	320	$+1.33F$	$+1.33F_1$	$+566.4FF_1$	
$CH$	38	0.065	584	$-1.58F$			$-1.58F_1$
						$+2026.4FF_1$	

$$\Delta_4 = \frac{+2026F_1}{E}.$$

Substituting these values in equation (b) we obtain

$$(2932F_2 - 505.6F_1)h = (4052F_1 - 505.6F_2)b.$$

Since  $h = 23$  and  $b = 16$

$$2932F_2 - 505.6F_1 = 2819F_1 - 351.7F_2,$$

$$3284F_2 - 3325F_1 = 0, \quad (b)$$

$$16F_2 + 23F_1 = Qd. \quad (a)$$

Solving equations (a) and (b) simultaneously we obtain

$$F_1 = 0.0255Qd; \quad F_2 = 0.0258Qd.$$

NOTE. Since both bulkheads were assumed as completely rigid, bars  $AB$ ,  $BC$ ,  $CD$ , and  $DA$  did not enter into our computations. The procedure in analyzing a segment of a fuselage composed of several bays is similar. The top, bottom, and side trusses are analyzed separately, and bulkhead bars, such as bars  $AB$ ,  $BC$ ,  $CD$ , and  $DE$ , would appear in the computations as members of side or horizontal trusses.

The foregoing example might have been analyzed by means of formula (2). If the cross section of the fuselage were other than rectangular, this procedure would be the simpler one.

**Analysis of Stresses in Bay  $FGKJ$  as a Function of the Torque  $Qd$ .** The last bay of the fuselage, bay  $FGKJ$ , is once redundant. Any one of the bars may be regarded as redundant. Let  $FJ$  be the redundant bar. Then, according to formula (2),

$$S_{FJ} = \frac{-\Sigma CTU}{\Sigma CU^2}.$$

Let us further assume bulkheads  $JKL$  as completely rigid. The  $U$  and  $T$  forces are listed in the table below. They are evaluated in the following manner. The  $U$  forces are those induced in the frame by the application of a unit force in the direction of bar  $FJ$ . A unit tensile force in the direction of  $FJ$  induces a unit compressive force in bar  $EJ$ . These two forces in turn induce a force through  $J$ , in the plane of the bulkhead, having a magnitude  $\frac{1}{2}\frac{6}{5}$  (Fig. 16*g*).

This force is resisted by another force of magnitude  $\frac{1}{2}\frac{6}{5}$  in the plane  $HGKL$  (Fig. 16*b*) and by two equal and opposite parallel forces in the planes of the side trusses, of magnitude  $\frac{h'}{b'} \times \frac{16}{25}$ . Since  $h' = 20$  and  $b' = 10$ , these forces are  $\frac{3}{2}\frac{2}{5}$  (Fig. 16*g*).

The force  $\frac{3}{2}\frac{2}{5}$  induces in bar  $FK$  a tensile force  $\frac{3}{2}\frac{1}{3} \times \frac{3}{2}\frac{2}{5} = + 1.725$ , and in bar  $EL$  a compressive force of the same magnitude. Bar  $HL$  is simultaneously stressed  $\frac{2}{2}\frac{4}{3} \times \frac{3}{2}\frac{2}{5} = + 1.336$  by the force in the vertical plane and  $\frac{2}{1}\frac{4}{6} \times \frac{1}{2}\frac{6}{5} = + 0.96$  by the force in the horizontal plane, or a total of 2.296 unit forces.

The  $T$  forces are those that are induced in the frame by the application of torque  $Qd$  with the bar  $FJ$  removed. With  $FJ$  removed the two side trusses are the only ones able to resist the torque  $Qd$ . The  $T$  forces carried by the side trusses then are  $\frac{Qd}{b'}$  or  $\frac{Qd}{10}$ .

Bar  $FK$  is stressed by a compressive force,

$$-\frac{31}{23} \times \frac{Qd}{10} = -0.135Qd;$$

bar  $GK$  is stressed with a tensile force,

$$+\frac{24}{23} \frac{Qd}{10} = +0.104Qd.$$

Bar	$L$	$A$	$CE = \frac{L}{A}$	$U$	$T$	$U^2$	$CTU$	$CEU^2$
$FJ$	25	0.10	250	+1.0	0.0	1.0	0.0	250
$EJ$	25	0.10	250	-1.0	0.0	1.0	0.0	250
$FK$	31	0.10	310	+1.725	-0.135Qd	2.975	-72.3Qd	923
$EL$	31	0.10	310	-1.725	+0.135Qd	2.975	-72.3Qd	923
$GK$	24	0.10	240	-0.336	0.104Qd	1.785	-33.3Qd	429
$HL$	24	0.10	240	+2.296	-0.104Qd	5.270	-57.3Qd	1266
$GL$	27	0.65	415	-1.08	0.0	1.17	0.0	486
							-235.2Qd	+4527

$$S_{FJ} = \frac{-\Sigma CTU}{\Sigma CU^2} = \frac{-\Sigma CETU}{\Sigma CEU^2} = \frac{-(-235.2Qd)}{+4527} = +0.0519Qd.$$

### FRAMES WITH TWO OR MORE REDUNDANT MEMBERS

In the analysis of frames with two or more redundant members the work is somewhat more lengthy and the resulting formulas are somewhat more involved, but the argument and the underlying reasoning are the same as those applied to frames with one redundant member.

Figure 17a, for example, has two bars more than are absolutely necessary to insure stability, and therefore has two statically indeterminate unknowns. (Compare problem 5, page 274, which is statically determinate.) Any two of the bars may be regarded as redundant. In this example let us regard the bars  $m$  and  $n$ , marked  $\times$  (Fig. 17a), as the two redundant bars.

The forces  $S_m$  and  $S_n$ , which these two bars ultimately carry under the action of the external loading, are the two unknowns for which we must solve. With  $S_m$  and  $S_n$  once determined we may readily proceed to find the forces in the other bars by analyzing the remaining frame as a statically determinate one.

Following the logic employed in the proof for formula (2) we may imagine bars  $m$  and  $n$  removed and compute, in the remaining bars, the forces resulting from the external loads only. These forces for the

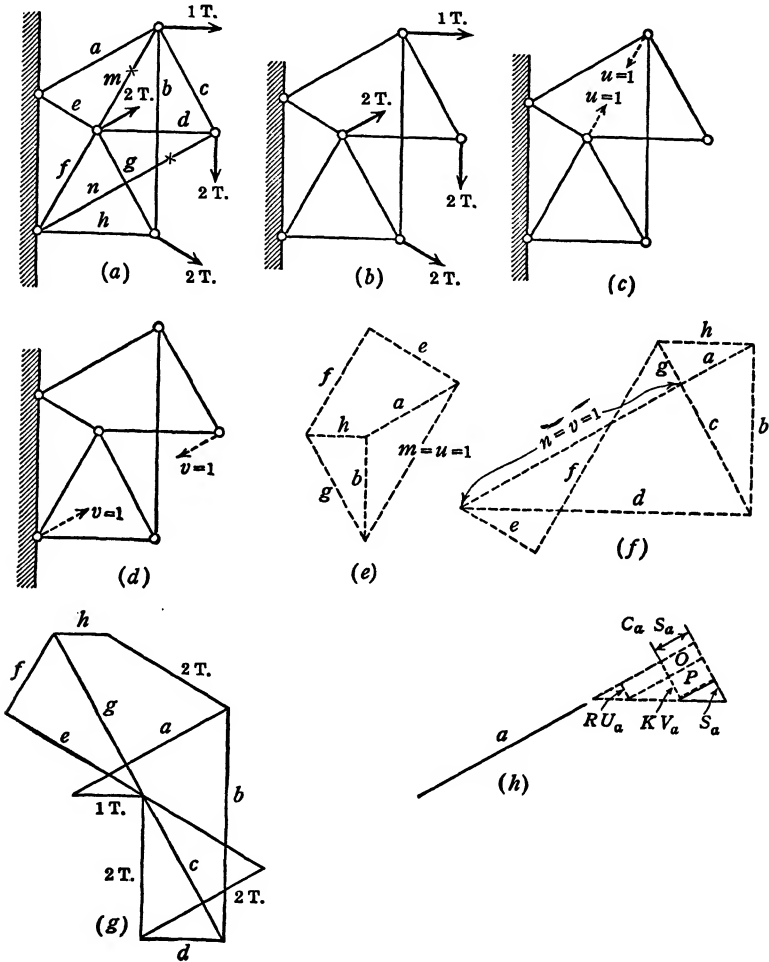

FIG. 17. Analysis of Truss with Two Redundants.

different bars  $a$ ,  $b$ , etc., we designate as  $T_a$ ,  $T_b$ , etc. (see Figs. 17b and 17g).

Let us assume a tensile force unity, represented by the symbol  $u$ , acting in place of bar  $m$ , and a tensile force unity, represented by  $v$ , acting in the place of bar  $n$  (see Figs. 17c and 17d). The forces in the different bars caused by these two unity forces may then be separately



computed and represented by  $U_a, U_b$ , etc., and  $V_a, V_b$ , etc. (see Figs. 17e and 17f).

The true final forces in any bar may then be represented by the expressions:

$$S_a = (T_a + S_m U_a + S_n V_a);$$

$$S_b = (T_b + S_m U_b + S_n V_b);$$

$$S_m = (T_m + S_m U_m + S_n V_m); \text{ etc.}$$

The last expression will also serve to represent the final force in bars  $m$  and  $n$ , if we keep in mind that, for bar  $m$ ,  $T_m = 0$ ,  $U_m = 1$ , and  $V_m = 0$ , whereas, for bar  $n$ ,  $T_n = 0$ ,  $U_n = 0$ , and  $V_n = 1$ .

If next we assume an auxiliary internal force  $R$  acting in bar  $m$  and an auxiliary internal force  $K$  acting in bar  $n$  before the external loads are applied, then we may apply the same argument we used in the proof of formula (2). The deformations of the truss caused by the applications of the actual loads will be independent of the presence of the auxiliary forces  $R$  and  $K$ , provided that the elastic limit is not exceeded, that the deformations are of a relatively small order of magnitude, and that the principle of superposition holds.

Bar  $a$  (Fig. 17h) may be regarded as representative of all the bars in the frame.  $RU_a$  is the auxiliary force with which bar  $a$  is loaded because of the presence of the auxiliary force  $R$  acting in member  $m$ .  $KV_a$  is the auxiliary force with which bar  $a$  is loaded because of the presence of the auxiliary force  $K$  acting in member  $n$ .  $S_a = T_a + S_m U_a + S_n V_a$  is the force in the bar produced by the actual loading. The rectangles  $O = C_a S_a R U_a$  and  $P = C_a S_a K V_a$  (Fig. 17h) represent the elastic energy stored in bar  $a$  because the auxiliary forces  $R$  and  $K$  are present in bars  $m$  and  $n$ , respectively, while the actual loads are applied.  $\Sigma C S R U$  and  $\Sigma C S K V$  represent the elastic energy stored in the entire frame because the auxiliary forces  $R$  and  $K$  are present while the actual loads are applied. This elastic energy must equal the external work done by  $R$  and  $K$ . Since  $R$  and  $K$  are both internal forces, the external work done by each will necessarily be zero. Therefore

$$\Sigma C S R U = R \Sigma C U (T + S_m U + S_n V) = 0$$

and

$$\Sigma C S K V = K \Sigma C V (T + S_m U + S_n V) = 0.$$

$K$  and  $R$ , being constants, may be canceled. Then we obtain

$$\Sigma C U T + S_m \Sigma C U^2 + S_n \Sigma C U V = 0,$$

$$\Sigma C V T + S_m \Sigma C V U + S_n \Sigma C V^2 = 0.$$

All factors are known except  $S_m$  and  $S_n$ . Solving for  $S_m$  and  $S_n$  we obtain

$$S_m = \frac{(\Sigma CUT)(\Sigma CV^2) - (\Sigma CVT)(\Sigma CVU)}{(\Sigma CUV)^2 - (\Sigma CU^2)(\Sigma CV^2)},$$

$$S_n = \frac{(\Sigma CVT)(\Sigma CU^2) - (\Sigma CUT)(\Sigma CUV)}{(\Sigma CUV)^2 - (\Sigma CU^2)(\Sigma CV^2)}.$$

Here  $S_m$  = force in redundant bar  $m$  due to external loading.

$S_n$  = force in redundant bar  $n$  due to external loading.

$T$  = force in any bar caused by external loads when both redundant bars are removed.

$U$  = force in any bar caused by a tensile force unity in the direction of the redundant bar  $m$  (with bar  $n$  out).

$V$  = force in any bar caused by a tensile force unity in the direction of the redundant bar  $n$  (with bar  $m$  out).

NOTE.  $T$  for redundant bars,  $U$  for bar  $n$ , and  $V$  for bar  $m$  are zero.  $U$  for bar  $m$  and  $V$  for bar  $n$  are unity.

The analysis of frames with two redundant members is rare enough, and it is not likely that the analysis of three redundant members in one frame is called for. However, if such an analysis is desired, the proof for formulas (1) and (2) and example 7 point the way. The numerical work may become more involved, but the logic and the method of procedure are the same.

#### EXAMPLE 7

Compute the forces in bars  $m$  and  $n$  in the frame shown in Fig. 17a, page 27.

Figures 17e and 17f give the stress diagrams for the  $u$  and  $v$  forces acting in place of the  $m$  and  $n$  bars, respectively. The table gives the areas and lengths of the different bars, also the different factors needed in the solution. If we assume all the bars to be of the same material, the modulus of elasticity  $E$  for all bars would be the same. Therefore  $C$  would have to be multiplied by the same factor  $L/E$  throughout. It is readily seen that, as long as we are not concerned with actual displacements,  $E$  cancels, and we are therefore justified in using a simpler factor for  $C$ , namely,  $C = \frac{L}{A}$ . The angles which the different bars in Fig. 17a make with one another are  $30^\circ$ ,  $60^\circ$ , or  $90^\circ$  throughout.

Bar	Length	Area	$C = \frac{L}{A}$	$T$	$U$	$V$	$CUT$	$CVT$	$CUV$	$CU^2$	$CV^2$
<i>a</i>	115.5	2	57.7	+2.487	-0.577	+0.333	- 83.0	+ 47.8	-11.1	19.2	6.4
<i>b</i>	173.3	3	57.7	-3.243	-0.577	-0.667	+108.0	+125.0	+22.2	19.2	25.6
<i>c</i>	100	2	50	+2.308	0.0	+0.577	0.0	+ 66.6	0.0	0.0	16.6
<i>d</i>	100	2	50	-1.154	0.0	-1.155	0.0	+ 66.7	0.0	0.0	66.7
<i>e</i>	57.7	3	19.2	+4.23	+0.577	-0.333	+ 46.8	- 27.6	3.7	6.4	2.1
<i>f</i>	100	4	25	-1.285	+0.667	-0.962	- 21.4	+ 30.8	-16.0	11.1	23.2
<i>g</i>	100	2	50	+4.89	+0.667	+0.77	+163.0	+188.0	+25.6	22.2	29.6
<i>h</i>	100	2	50	-0.70	-0.333	-0.385	+ 11.6	+ 13.5	+ 6.4	5.5	7.4
<i>m</i>	100	2	50	0.0	+1.0	0.0	0.0	0.0	0.0	50.0	0.0
<i>n</i>	173.3	3	57.7	0.0	0.0	+1.0	0.0	0.0	0.0	0.0	57.7
							+225.0	+510.8	+23.4	133.6	235.3

$$S_m = \frac{(+225.0)(235.3) - (+510.8)(+23.4)}{(23.4)^2 - (133.6)(235.3)} = \frac{52,900 - 11,950}{548 - 31,400}$$

$$= \frac{40,950}{-30,852} = -1.33 \text{ tons.}$$

$$S_n = \frac{(+510.8)(133.6) - (+225.0)(+23.4)}{-30,852} = \frac{68,200 - 5260}{-30,852}$$

$$= -2.04 \text{ tons.}$$

The stress in bar *m* therefore is a compressive stress of  $\frac{1.33}{2} = 0.66$  tons per sq. in.

With the forces in bars *m* and *n* computed, the forces in the remaining bars in the frame can now easily be calculated. The values of the forces for the different bars as recorded in stress diagrams *U* and *V* (Figs. 17*e* and 17*f*) need only be multiplied by (-1.33) and (-2.04), respectively, and subsequently added to values of the forces as recorded in stress diagram *T* (Fig. 17*g*), to obtain the desired end.

### TEMPERATURE STRESSES

In a statically determinate structure changes in the temperature of its parts, or of the entire structure, do not affect the forces in the members. The structure readily deforms to allow for such changes in length as are produced by temperature changes. In a statically determinate truss, for example, one of the supports moves slightly in or out with the seasonal changes in temperature. In a statically indeterminate structure, however, the situation is very different. In a two-hinged arch, for example, the fact that the supports are unable to move laterally with respect to each other constitutes the reason for the statically indeter-

minate nature of the structure. Temperature changes may produce very high stresses, and it is important that we be able to compute them.

Two conditions may be considered. The first occurs when the redundant member itself is not changed in length or location. For example, in a two-hinged arch (see problem 12, page 277) we may assume one support changed into a sliding support. When the temperature is changed to the amount  $t$ , this sliding support changes its location relative to the other by the amount  $\Delta_1 = \lambda tl$  ( $\lambda$  is the coefficient of expansion,  $l$  is the linear distance between supports). If next we introduce a force unity acting at the sliding support and in the direction

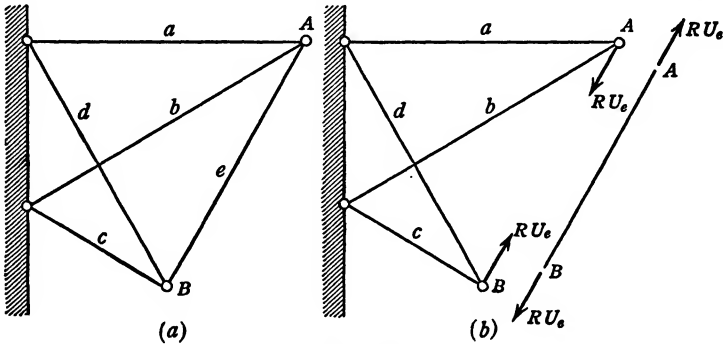

FIG. 18.

of the line connecting the two supports, then, by formula (1), ( $F\Delta_2 = \Sigma CfS$ ). The displacement due to this force unity is  $\Delta_2 = \Sigma CU^2$ . (See example 2.) The force  $H$  necessary to keep the arch supports fixed in position is equal to a force necessary to return the sliding support to its original position.  $H = \frac{-\Delta_1}{\Delta_2} = \frac{-\lambda tl}{\Sigma CU^2}$ . When  $t$  is positive,  $H$  is always negative.

For the second condition let us assume bar  $e$  (Fig. 18a) to have its temperature changed to the extent of  $t$  degrees. The force to solve for is  $S_e$ , the force in bar  $e$  due to its change in temperature. Let us assume a force  $R$  to be initially acting in bar  $e$  (Fig. 18b) before the change in temperature. If  $U$  represents the forces in the members due to a tensile force unity acting in bar  $e$ , then the forces in the members induced by the auxiliary force  $R$  will be  $RU_a, RU_b$ , etc. The forces in the members due to the actual loading  $S_e$  will be  $S_e U_a, S_e U_b$ , etc.

The relative change of position of points  $A$  and  $B$  at the extremities of the two trusses (Fig. 18b) may be expressed as

$$\Delta_{AB} = \frac{\Sigma_a^d CfS}{R} = \frac{\Sigma_a^d CRUS_e U}{R} = S_e \Sigma_a^d CU^2.$$

(Note that the summations proceed only up to and including bar  $d$ .)

The change of length of bar  $e$  is influenced by two factors,  $S_e$  and  $\lambda$ . Numerically, also, this change is equal to  $\Delta_{AB}$ .  $U$  for bar  $e$  is 1. Therefore

$$\Delta_{AB} = + C_e S_e + \lambda L_e = C_e S_e U_e^2 + \lambda L_e.$$

The two expressions for  $\Delta_{AB}$  are numerically equal but necessarily opposite in sign, for if, in the first case, points  $A$  and  $B$  come closer together, moving in the direction and sense of  $R$ ,  $\Sigma_a^d C U^2$  would be positive. By the same token the points  $A$  and  $B$ , considered as the extremities of bar  $e$ , would move in sense opposite to  $R$ , which was assumed to be a pull, and therefore  $C_e S_e U_e^2 + \lambda L_e$  would be negative.

$$\Sigma_a^d C U^2 S_e = - \lambda L_e t - C_e U_e^2 S_e.$$

$$\Sigma_a^d C U^2 S_e + C_e U_e^2 S_e = \Sigma_a^e C U^2 S_e = - \lambda L_e t.$$

$$S_e = \frac{-\lambda L_e t}{\Sigma C U^2}. \quad \text{Formula (3)}$$

#### EXAMPLE 8

Assume bar  $e$  (Fig. 14a) to be heated  $100^\circ \text{C}$ .

Assume size and length of bars the same as in example 4, page 17.

$\lambda = 0.000013$  per centigrade degree.

$\lambda L_e t$  is therefore  $0.000013 \times 346 \text{ in.} \times 100 = 0.450 \text{ in.}$

From the table in example 4, page 17, we have  $\Sigma C U^2 = 0.00005936$ ;

therefore  $S_e = \frac{-0.450}{0.00005936} = -7580 \text{ lb.}$

The stress in bar  $e$ , therefore, due to a rise in temperature of  $100^\circ \text{C}$ . in bar  $e$  only, is a compressive stress of  $\frac{7580}{3} = 2530 \text{ lb. per sq. in.}$

$$S_a = S_e U_a = -7580 \times (+1) = -7580 \text{ lb. (compression).}$$

$$S_b = S_e U_b = -7580 \times (-1.73) = +13,100 \text{ lb. (tension).}$$

#### CHECK ON COMPUTED STRESSES IN FRAMES

Figure 19a represents the familiar example of a frame. The forces in the members of this frame are found in example 4 (page 17). Though we have taken an indeterminate frame with one redundant member for our example, it is well to keep in mind that the arguments apply with equal force to any other frame, statically determinate or indeterminate, having any number of redundant members.

Regarding the frame as a free body and ignoring its dead weight it will be in equilibrium under the action of the external loads and the reactions. In fact, from the point of view of equilibrium, no essential distinction can be made between loads and reactions. It is immaterial whether the reactions are shown as resultant single forces, as resultant vertical and horizontal components, or as forces equal to those acting in members  $a, d, b,$  and  $c$  shown in Fig. 19a.

Not only is the truss as a whole in equilibrium, but also all the joints individually (Fig. 19b) are in equilibrium.

Let us select as origin an arbitrary point  $O$  anywhere in the plane of the frame. Now draw lines from  $O$  to the various points  $A, B,$  etc.

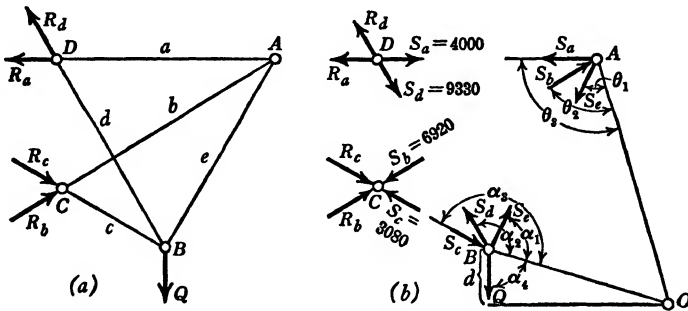

FIG. 19.

The angles made at the joint  $A$  by the forces  $S_e, S_b, S_a,$  are designated by  $\theta_1, \theta_2, \theta_3,$  etc., and the line connecting the joint  $A$  and point  $O$  (Fig. 19b) is designated by  $AO$ . For point  $B$  the angles which the forces make with the line  $BO$  are shown as  $\alpha_1, \alpha_2, \alpha_3,$  and  $\alpha_4$ . If we resolve the forces at each joint into components parallel to the line connecting the joint with  $O$ , we obtain equations of equilibrium for each joint.

For joint  $A$ , for example, we have

$$+ S_e \cos \theta_1 - S_b \cos \theta_2 + S_a \cos \theta_3 = 0.$$

For joint  $B$ , we have

$$+ S_e \cos \alpha_1 + S_d \cos \alpha_2 - S_c \cos \alpha_3 + Q \cos \alpha_4 = 0.$$

If we write an equation for each joint we will find, when considering all such equations as a group, that each internal force  $S$  occurs twice and each external load occurs once.

Let us multiply each equation thus obtained by the length of the line connecting the joint with  $O$ :

$$OA(S_e \cos \theta_1 - S_b \cos \theta_2 + S_a \cos \theta_3) = 0;$$

$$OB(S_e \cos \alpha_1 + S_d \cos \alpha_2 - S_c \cos \alpha_3 + Q \cos \alpha_4) = 0; \text{ etc.}$$

Since the equation of each joint equals zero, their sum must equal zero. Because of such addition the internal forces within the members of the frame, represented by  $S$  in Fig. 19*b*, will group themselves in such expressions as  $S_e(OA \cos \theta_1 + OB \cos \alpha_1)$ , etc., while the external forces (including reactions) will appear as  $Q(OB) \cos \alpha_4$ .

$$OA \cos \theta_1 + OB \cos \alpha_1 = AB = \text{length of member } e = L_e.$$

$OB \cos \alpha_4$  is the distance from a joint to the point at which a perpendicular dropped from  $O$  cuts the line of action of an external force acting at this joint—the projection of  $OB$  on the line of action of  $Q$ . We may designate this expression  $OB \cos \alpha_4$  by  $d$  as shown in Fig. 19*b*.

The sum of all the equilibrium equations for the various joints, resolved in the direction of the lines connecting the joints and the origin  $O$ , may then be written as follows:

$$\Sigma SL + \Sigma Qd = 0 \quad \text{or} \quad \Sigma SL = - \Sigma Qd.$$

The  $S$  forces are positive in sign (+) when they are tension, and negative (−) when compression, and  $d$  is positive when the distance is measured from the joint (in the sense of the force) to the point of intersection between the line of action of the force and the perpendicular on this line dropped from  $O$ .

We may eliminate the negative sign in our equation simply by reversing the definition of sign for  $d$ ; thus:

$$\Sigma SL = \Sigma Qd. \qquad \text{Formula (4)}$$

Here  $S$  = force in a member (+ for tension and − for compression).

$L$  = length of member.

$Q$  = external force (including reactions).

$d$  = distance from point of application of force  $Q$  to point where line of action of force is intersected by perpendicular dropped from  $O$  ( $d$  is positive when  $Q$  points away from this point of intersection, negative when it points towards this point of intersection).

The proof of this formula being general, it is applicable to both statically determinate and indeterminate frames. Furthermore, our point of origin  $O$  was arbitrarily chosen. By selecting  $O$  judiciously we may simplify the evaluation of  $\Sigma Qd$ . Proof of formula (4) involves the equilibrium equations written for all the joints in a truss. We may write equations of equilibrium for all joints, and satisfy ourselves that each joint is in equilibrium. In doing so we would accomplish exactly what

we aim to do by formula (4). The advantage of formula (4) is that it offers a simple means for accomplishing this result. It will check for possible errors in sign, length of bars, or forces  $T$ ,  $U$ , or  $V$  involved in our stress analysis. Stress and strain, relationships underlying the elastic behavior of our structure, did not enter into the development of formula (4). Therefore we cannot expect to detect errors in the elastic coefficient  $C = \frac{L}{AE}$ , particularly errors in the values for area  $A$  and modulus of elasticity  $E$  of the bars, by the use of formula (4).

## EXAMPLE 9

Let us check the values of the stresses in the frame shown in Fig. 19a as obtained in example 4 (page 17). If we select the origin  $O$  at point  $C$  (Fig. 19a), the value of  $d$  for  $R_b$ ,  $R_c$ , and  $R_a$  will be zero. The other factors  $S$ ,  $L$ ,  $Q$ , and  $d$ , also  $\Sigma SL$  and  $\Sigma Qd$ , are shown in the accompanying

Bar	$L$	$S$	$SL$	Force $Q$	$d$	$Qd$
$a$	346	+4000	+1,384,000	$Q = 10,000$	$d_1 = +100$	+1,000,000
$b$	400	-6920	-2,768,000	$R_b = -6,920$	0.0	
$c$	200	-3080	-616,000	$R_c = -3,080$	0.0	
$d$	346	+9330	+3,228,000	$R_a = +4,000$	0.0	
$e$	346	+4000	+1,384,000	$R_d = +9,330$	$d_2 = +173$	+1,614,000
			+2,612,000			+2,614,000

table. The fact that  $\Sigma SL = +2,612,000$  is, to all intents and purposes, equivalent to  $\Sigma Qd = +2,614,000$  is a check on the values of the forces in the members of the truss as computed in example 4 (page 17).

## EXAMPLE 10

In example 3 (page 11), involving a five-panel truss with three supports,  $R_2$  was computed to be 198 tons. The actual forces in the members are the  $T$  forces, due to the external loads in the absence of  $R_2$ , plus the forces caused by  $R_2$ . The  $f$  forces, as shown in the table on page 13, are caused by a 100-ton load acting in the place of  $R_2$ . The actual forces, then, are  $T + \frac{R_2 f}{100}$ . If we place the origin  $O$  on a horizontal line passing through the points of application of the loads and



reactions, then for each load and reaction  $d$  would be zero. Therefore  $\Sigma Qd$ , in this example, is zero.  $\Sigma SL$  is the sum of the values tabulated in the last column of the table. The actual forces, in accordance with the notation of example 3, are represented by  $\left(T + \frac{R_2f}{100}\right)$ . The sum of the values in the last column of the table is  $+1638 - 1632 = 6$ , practically zero, which checks the results of example 3 (page 11).

Bar	$L$	$T$ Forces	$\frac{R_2f}{100}$ Forces	$T + \frac{R_2f}{100}$	$L\left(T + \frac{R_2f}{100}\right)$
<i>a</i>	6	-210	+178	- 32	-192
<i>b</i>	6	-270	+356	+ 86	+516
<i>c</i>	6	-330	+238	- 92	-552
<i>d</i>	6	-240	+119	-121	-726
<i>e</i>	5	-175	+149	- 26	-130
<i>f</i>	5	+175	-149	+ 26	+130
<i>g</i>	5	- 50	+149	+ 99	+495
<i>h</i>	5	+ 50	-149	- 99	-495
<i>i</i>	5	- 50	- 99	-149	-745
<i>j</i>	5	+ 50	+ 99	+149	+745
<i>k</i>	5	+ 75	- 99	- 24	-120
<i>l</i>	5	- 75	+ 99	+ 24	+120
<i>m</i>	5	+200	- 99	+101	+505
<i>n</i>	5	-200	+ 99	-101	-505
<i>o</i>	6	+105	- 89	+ 16	+ 96
<i>p</i>	6	+240	-267	- 27	-162
<i>q</i>	6	+300	-297	+ 3	+ 18
<i>r</i>	6	+285	-178	+107	+642
<i>s</i>	6	+120	- 59	+ 61	+366

#### MAXWELL'S LAW OF RECIPROCITY OF DISPLACEMENT

Let us consider the displacement of point  $B$  (Fig. 20*a*) in the direction  $\theta_2$ , and under the action of load  $Q$  applied at point  $A$  in direction  $\theta_1$ . To evaluate this displacement we apply formula (1),  $F\Delta = \Sigma Cfs$ . In connection with this formula we introduce an auxiliary force  $F$  at  $B$ , which may be of any magnitude and operates in the direction  $\theta_2$ . Since  $F$  may be chosen to be of any value, let it be equal to  $Q$  (Fig. 20*b*). The displacement of point  $B$  in direction  $\theta_2$  under action of load  $Q$  at  $A$  would then be

$$\Delta_b = \frac{\Sigma Cfs}{Q}$$

Next, let us consider the truss loaded with a force  $Q$  at  $B$  in direction  $\theta_2$  (Fig. 21a) and find the displacement  $\Delta_a$  of point  $A$ , in direction  $\theta_1$ . For purposes of analysis we introduce an auxiliary force  $F$  at point  $A$

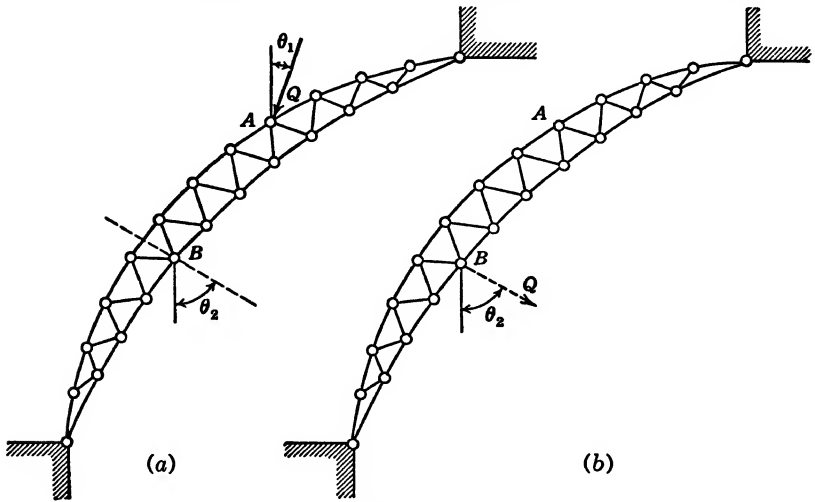

FIG. 20.

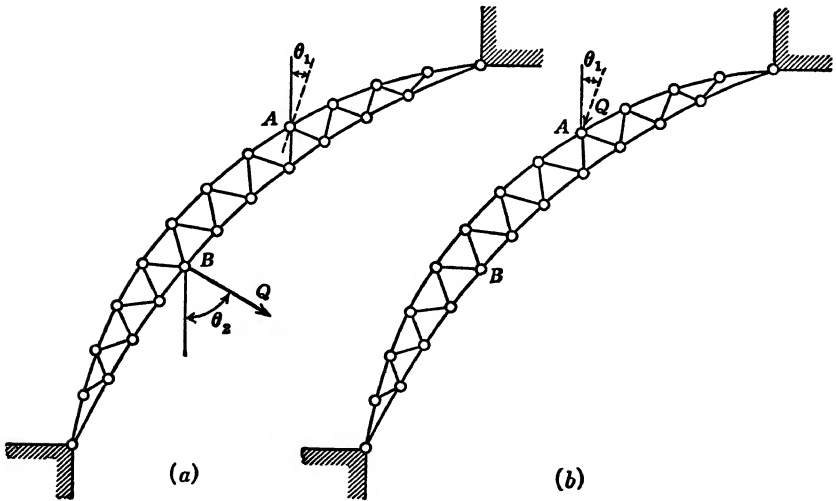

FIG. 21.

in direction  $\theta_1$ . Let  $F$  in this case also be equal to  $Q$  (Fig. 21b). Formula (1) gives us

$$\frac{\sum C f S}{Q} = \Delta_a,$$

in which  $f$  represents the forces induced by the loading as shown in Fig. 21b and  $S$  represents the forces induced by the loading as shown in

Fig. 21a. By comparing the figures it may be seen that the  $f$  forces of Fig. 21b are identical with the  $S$  forces of Fig. 20a and that the  $S$  forces of Fig. 21a are identical with the  $f$  forces of Fig. 20b.

$$\text{Since } \Delta_b = \frac{\sum Cfs}{Q} = \Delta_a, \text{ it follows that } \Delta_b = \Delta_a.$$

If a force  $Q$ , applied at point  $A$  in direction  $\theta_1$ , causes a displacement  $\Delta$  at point  $B$  in direction  $\theta_2$ , then the same force  $Q$  applied at  $B$  in direction  $\theta_2$  would cause the same displacement  $\Delta$  at point  $A$  in direction  $\theta_1$ .

This rule states a part of *Maxwell's Law of Reciprocity of Displacement* as applied to frames. (For proof of Maxwell's law as applied to beams, see page 198.) Note that the proof is equally valid for both statically indeterminate and statically determinate frames.

INFLUENCE LINES

In example 3 (page 11) we computed the displacement  $\Delta_c$  of point  $C$  under the sole action of a 100-ton load applied at  $C$  (Fig. 13). By means

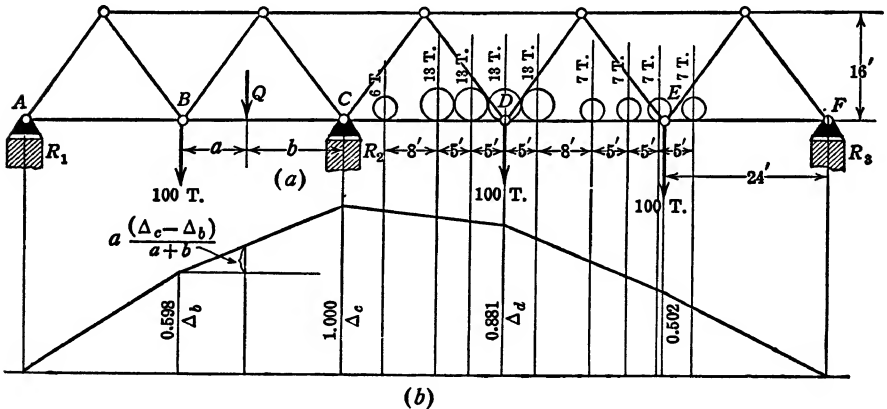

FIG. 22. Influence Line for  $R_2$ .

of formula (1) we may compute the displacements of points  $B$ ,  $D$ , and  $E$  under the action of a single 100-ton load applied at  $C$ , and construct a diagram as shown in Fig. 22b. If a 100-ton load applied at  $C$  causes a displacement  $\Delta_d$  at  $D$ , then, according to Maxwell's law, a 100-ton load applied at  $D$  would cause this same displacement  $\Delta_d$  at  $C$ . If there is a reaction  $R_2$  at point  $C$  to prevent this displacement, this reaction would be  $R_2 = \frac{\Delta_d}{\Delta_c} \times 100$  tons. Figure 22b is the influence diagram for the reaction  $R_2$ , and  $\Delta_d$  is a measure of the influence of a load, applied

at  $D$ , upon the reaction  $R_2$ . (For definition and examples of influence lines see page 200.)

The load need not have been exactly 100 tons. It might have been of any value, represented by  $Q$ , as long as we understand  $\Delta_c$  and  $\Delta_d$  to be the displacements at  $C$  and  $D$  under the sole influence of  $Q$  applied at  $C$ . With  $\Delta_c$  and  $\Delta_d$  thus interpreted,  $R_2 = \frac{\Delta_d}{\Delta_c} Q$ . We know that

$\Delta_d$ ,  $\Delta_c$ , and  $Q$  will always be in a fixed ratio. If  $\Delta_c = 1$ , then  $R_2 = \Delta_d Q$ . In other words, if the influence diagram is constructed with  $\Delta_c = 1$ , the effect of a load  $Q$  at  $D$  upon the reaction at  $C$  is represented by  $\Delta_d \times Q$  when  $\Delta_d$  is measured by the same scale as  $\Delta_c$ . Any panel load between panel points, say load  $Q$  (Fig. 22a), would distribute itself as follows:  $\frac{Qb}{a+b}$  to point  $B$ , and  $\frac{Qa}{a+b}$  to point  $C$ . The effect of  $Q$  upon

$R_2$ , therefore, would be equal to the effect of  $\frac{Qa}{a+b}$  at  $C$  plus  $\frac{Qb}{a+b}$  at point  $B$ , which would be shown graphically on the influence diagram by

$$\begin{aligned} Q \left( \frac{a}{a+b} \times \Delta_c + \frac{b}{a+b} \Delta_b \right) &= \frac{Q(a\Delta_c + b\Delta_b)}{a+b} \\ &= \frac{Q(a\Delta_b + b\Delta_b + a\Delta_c - a\Delta_b)}{a+b} \\ &= Q \left( \Delta_b + \frac{a(\Delta_c - \Delta_b)}{a+b} \right). \end{aligned}$$

This is  $Q$  multiplied by the ordinate under the load  $Q$ .

The effect of the 100 tons suspended from points  $B$ ,  $D$ , and  $E$  upon the reaction  $R_2$  would be  $R_2 = 100(0.598 + 0.881 + 0.502) = 198$  tons. The influence upon  $R_2$  of the concentrated locomotive wheel loads, shown in Fig. 22a, would be the value of each load multiplied by its corresponding ordinate on the influence diagram, and summed for all the wheel loads.

If we had a model of our truss, we might pin it at its extremities and give it unit displacement at point  $C$ . Then we would have a mechanical device which in one operation would give us our influence diagram, and we might measure the values of  $\Delta_b$ ,  $\Delta_d$ , and  $\Delta_c$  instead of computing them.

We may then express our conclusions as follows: All mathematical theory of elasticity is for the purpose of expressing the elastic behavior of structures. We may obtain the elastic behavior of structures from

models, and *Maxwell's Law of Reciprocity of Displacements* provides the key to the interpretation of such elastic behavior.

Maxwell's law, as may be seen from the foregoing proof and, in fact, from its strict adherence to the logic presented in all the preceding pages, is the embodiment of the soundest theories of elasticity we have, mathematical or otherwise. The success of its application is contingent only upon the quality of workmanship in the model. The application of Maxwell's law has one striking advantage. When a mathematical analysis becomes disproportionately difficult with more than one statically indeterminate unknown, Maxwell's law holds true regardless of the degree of indeterminateness of the structure. Therefore, the influence diagram of a structure having many redundant members may be obtained with little or no more effort than that of a structure having only one redundant member.

The construction of models for trusses may be too difficult for practical purposes. Maxwell's law, however, is equally applicable to beams, and a more detailed discussion of its use in connection with influence lines will be presented in the chapter on beams. (See page 198.)

The arguments we have just advanced in the construction of an influence line for  $R_2$  (Fig. 22*b*) are equally applicable to  $R_1$  and  $R_3$ . To obtain the influence line for  $R_1$ , give the point of application of  $R_1$  a unit displacement, then measure or compute the displacements at the remaining panel points and connect such displacements by straight lines. (See problem 13, page 277, for influence lines, or elastic curves, for a truss with two redundant members.)

## CHAPTER V

### ANALYSIS OF BEAMS

In the analysis of structures composed of beams our logic is identical with the reasoning involved in our analysis of frames. Our first consideration is the law of conservation of energy. We assume the condition of elastic behavior, Hooke's law, and of the principle of superposition. We further assume that the deformations are of a magnitude so small as not materially to affect the geometric relations of various parts of the structure to one another. And finally we presuppose the absence of abrupt changes in either modulus of elasticity or cross section of members.

In the analysis of frames we proceeded as follows:

1. Introduced, solely for the sake of analysis, an auxiliary load  $F$  at a certain point and operating in the direction in which we wanted to find the displacement of the point.

2. Found the forces  $f$  (first applied) produced in members by the auxiliary load  $F$ .

3. Found the forces  $S$  (subsequently applied) produced in members by the actual loading  $Q$ .

4. Used the expression  $CfS$  to represent the elastic energy stored in a member because the force  $f$  is present during the application of the force  $S$ .

5. Summed the expression  $CfS$  over all the bars in the frame, and equated  $\Sigma CfS$  to the external work done by  $F$ , namely,

$$\Sigma CfS = F\Delta$$

### DEFORMATION OF BEAMS

In the analysis of beams our procedure will be similar to that followed in the analysis of frames. Such differences as may appear will be differences in the mechanism used for evaluation purposes rather than differences in reasoning. In the analysis of a frame we based our reasoning upon the elastic behavior of a single member as a representative unit. In the analysis of beams we shall base our

reasoning upon the elastic behavior of an element of infinitely small dimensions.

Length is represented by the symbol  $ds$ ,  $dx$ , or  $dy$ , and cross-section area by the symbol  $da$ .

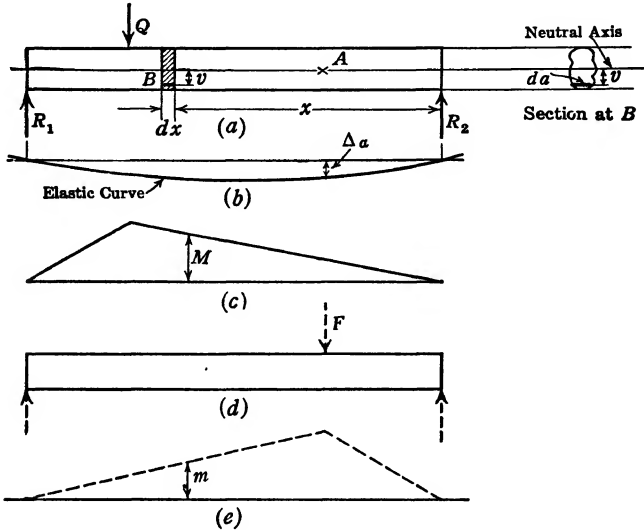

FIG. 23.

Let  $Q$  (Fig. 23a) represent the actual loading on a beam. ( $Q$  may be any loading, either several concentrated loads or distributed loads or both.)

Let  $\Delta_a$  (Fig. 23b) represent the vertical displacement of the point  $A$  under the action of load  $Q$ .

Let  $F$  represent an auxiliary force, introduced merely for the sake of analysis, applied at point  $A$  in the direction of  $\Delta_a$  (Fig. 23d).

Let  $M$  (Fig. 23c) represent the bending moment caused by the actual load  $Q$ .

Let  $m$  (Fig. 23e) represent the bending moment caused by the auxiliary force  $F$ .

Let  $v$  represent the distance from the neutral axis\* of any point in a beam, as point  $B$ .

Let  $f_b$  represent the stress (unit force) on a particle at point  $B$  caused by the auxiliary load  $F$ .

Let  $s_b$  represent the stress at point  $B$  caused by the actual load  $Q$ .

\* The "neutral axis of a beam" passes through the center of gravity of the cross-sectional area of the beam. (See section at  $B$  [Fig. 23a]. See also any textbook on elementary strength of materials.)

Let  $ds$ ,  $dx$ , or  $dy$  represent differential distance.

Let  $da$  represent differential area.

In the analysis of a frame we select any one bar as a representative unit, ignore the weight of the bar itself, and assume the  $S$  and  $f$  forces be constant throughout the length of the bar.

In a beam the stresses vary continuously from left to right and from top to bottom. If we take an element (Fig. 24), say of length  $n$  at point  $B$ , the stresses at the ends,  $s_1$  and  $s_2$ , will be of different magnitude. The difference between  $s_1$  and  $s_2$  will depend, among other things, on the length  $n$  of the element. The smaller the distance  $n$  becomes, the less will be the difference between  $s_1$  and  $s_2$  at the two extremities. If  $n$  becomes infinitely small, if it approaches zero as a limit, then the

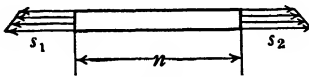

FIG. 24.

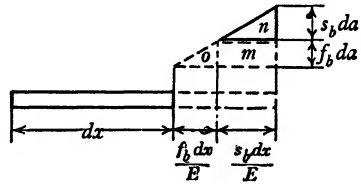

FIG. 25.

quantity  $s_1 - s_2$  will likewise approach zero as a limit. In other words the element (Fig. 24) will be subjected to a constant stress throughout its infinitely small length.

The same reasoning may be applied to the vertical variation of stress. In a beam loaded as in Fig. 23a the bottom fibers would be stressed in tension, the top fibers in compression, and at the neutral axis the fibers would not be stressed at all.

If the element (Fig. 24) is of finite dimension, the stress cannot be considered as uniformly distributed over its cross-sectional area. The smaller we assume the cross-sectional area of the element to be, the more nearly uniform would be the distribution of the stresses over its entire cross-sectional area. If the area is assumed to be approaching zero as its limit, then the stress would be uniformly distributed.

This is not, as might seem, indulging in inaccuracies. No extremely small quantities are being disregarded. In terms of calculus, differential quantities of a higher order may be ignored without causing any error. In this process, if we assume the dimensions of our element (Fig. 24) to be approaching zero as a limit, the stresses at its extremities are uniformly distributed over the cross-sectional area. Further, the difference between  $s_1$  and  $s_2$  vanishes, and the element is stressed with a constant stress over its entire length. For such an element the conditions of loading are identical with those we assumed for bars in a



truss (see page 9), and we may proceed to develop our beam formula as we developed formula (1).

In Fig. 25 is shown the infinitesimally small particle of the beam (Fig. 23a) at point  $B$  of length  $dx$  and cross-sectional area  $da$ , and located a distance  $v$  from the neutral axis. The auxiliary load  $F$  at point  $A$  (Fig. 23d) will cause a bending moment  $m$  to act at point  $B$ , and a corresponding stress,  $f_b = \frac{mv^*}{I}$  to be set up in the particle. The load on the particle will be

$$\text{Stress} \times \text{area} = f_b da = \frac{mvda}{I}.$$

If the actual loading  $Q$  is applied after  $F$  is in full operation, a bending moment  $M$  will be superimposed upon the moment  $m$  already acting. The particle at  $B$  (Fig. 25) will have a stress  $s_b = \frac{Mv}{I}$  superimposed upon the stress  $f_b$  already there. This stress  $s_b$  will, according to Hooke's law, cause the particle at  $B$  to elongate.

$$E = \frac{\text{stress}}{\text{strain}}; \text{strain} = \frac{\text{stress}}{E}.$$

$$\begin{aligned} \text{Total elongation} &= \text{strain} \times \text{length} \\ &= \frac{\text{stress} \times \text{length}}{E} = \frac{s_b dx}{E} = \frac{Mvdx}{EI}. \end{aligned}$$

The energy stored in the particle at  $B$  because  $F$  is fully acting while  $Q$  is applied is shown by the rectangle  $m$  (Fig. 25), and is represented by the expression:

$$f_b da \times \frac{s_b dx}{E} = \frac{mvda}{I} \times \frac{Mvdx}{EI} = \frac{mMv^2 dadx}{EI^2}.$$

The energy stored in the shaded block (Fig. 23a) is

$$\frac{mMdx}{EI^2} \int_A v^2 da.$$

As long as we limit our attention to the shaded block,  $dx$  will be constant and  $da$  the only variable. The summation of  $v^2 da$  over the entire cross-sectional area of the beam,  $v$  being measured to the neutral axis (center of gravity axis of the cross-sectional area), is the moment of

\* See any elementary textbook on strength of materials.

inertia of the cross-sectional area of the beam about its center of gravity axis. Therefore, the energy stored in the shaded block (Fig. 23a) is

$$\frac{mMdxI}{EI^2} = \frac{mMdx}{EI}.$$

The energy stored in the entire beam then is  $\int_L \frac{mMdx}{EI}$ , summed over the entire length of the beam. This energy, if we assume the law of conservation of energy to hold, must equal the external work done by  $F$ , which is  $F\Delta$ . Therefore,

$$F\Delta = \int \frac{mMdx}{EI}. \quad \text{Formula (5) }^*$$

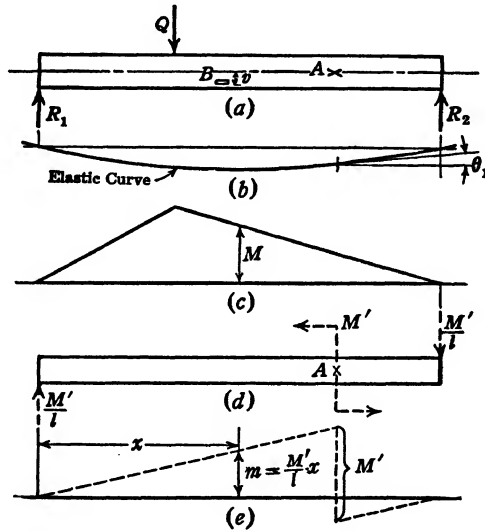

FIG. 26.

If the displacement sought were that of the point at which load  $Q$  is applied, then the auxiliary force  $F$  might be taken equal to  $Q$ , and then  $m$  at every point would be equal to  $M$ , and formula (5) would appear as  $Q\Delta = \int \frac{M^2dx}{EI}$ .

If we wanted to find the angular displacement of the beam at a point  $A$  (Fig. 23a), we would apply an auxiliary moment  $M'$  (Fig. 26d) at that point instead of an auxiliary force  $F$ .

\* We have here considered only the elastic energy due to bending. The particle of the beam represented by Fig. 24 is subject to shear stresses on the end planes, and some elastic energy due to shear is stored in the particle. However, the shear elastic energy in beams of ordinary proportions is negligible. See page 173.

Figure 25, which has reference to Fig. 23*a*, is equally applicable to Fig. 26*a*, and the arguments introduced to find the linear displacement of *A* fully apply to the problem of finding the angular displacement of the tangent to the elastic curve at *A*.

Thus the work done by  $M'$ , rotating while the loading represented by  $Q$  is being applied, is equal to  $M'\theta_1$ . The elastic energy stored in the beam, because  $M'$  was fully acting while  $Q$  was applied, is

$$\int \frac{mMdx}{EI}.$$

Therefore

$$M'\theta_1 = \int \frac{mMdx}{EI}. \quad \text{Formula (6)}$$

Note that  $m$  is a linear function of  $M'$  and is proportional, but not always equal, to  $M'$ .

A comparison between formulas (1), (5), and (6),

$$F\Delta = \Sigma CfS,$$

$$F\Delta = \int \frac{mMdx}{EI},$$

$$M'\theta_1 = \int \frac{mMdx}{EI},$$

will reveal that all give expression to the same philosophy, the same physical phenomena. The left side of each equation represents mechanical work done by an auxiliary force or moment, expressed in inch-pounds; the right side of the equation expresses elastic energy stored because an auxiliary force or moment is acting during the application of the actual loading. Qualitatively,  $m$  and  $M$  in formulas (5) and (6)

are of the same nature as  $f$  and  $S$  in formula (1); and  $\frac{dx}{EI}$  in formulas (5)

and (6) qualitatively takes the place of the elastic coefficient  $C = \frac{L}{AE}$  in formula (1).

#### TOTAL ELASTIC ENERGY DUE TO BENDING

Let us consider an infinitesimal element in the beam, length  $dx$ , cross-sectional area  $dA$ , and situated a distance  $x$  from the right end and a distance  $v$  from the neutral axis (Figs. 23*a*, 27*a*, and 27*c*). This element is

loaded with a force  $\frac{Mv}{I} dA$  and is deformed a distance  $\Delta = \text{strain} \times \text{length} = \frac{\text{stress}}{E} \times \text{length} = \frac{Mvdx}{EI}$  (Fig. 27c).

The total elastic energy stored in the element is represented by the triangular area  $DEF$  (Fig. 27c) and is equal to

$$\frac{1}{2} \times \frac{MvdA}{I} \times \frac{Mvdx}{EI} = \frac{M^2v^2dA dx}{2EI^2}.$$

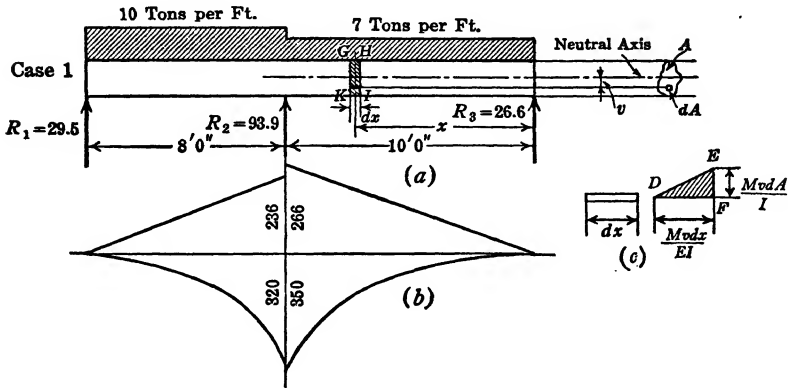

FIG. 27.

At any cross section  $x$  only  $v$  is variable. The energy stored in the shaded block  $GHIK$  (Fig. 27a) may be written

$$\frac{M^2 dx}{2EI^2} \int_A v^2 dA.$$

Since  $\int v^2 dA$  over the cross-sectional area  $A$  of the beam is the moment of inertia of this area, we have

$$\frac{M^2 dx}{2EI^2} \int_A v^2 dA = \frac{M^2 dx}{2EI}.$$

The energy stored in the entire beam, then, is

$$W = \int \frac{M^2 dx}{2EI}. \tag{Formula (7)}$$

EXAMPLE 11

Find the displacement of point  $A$ , distance  $a$  from the wall, in a cantilever beam loaded with a concentrated load  $Q$  at its free end.  $E$  and  $I$  are assumed constant (Figs. 28a and 28b). The bending

moment  $m$  for the auxiliary load is shown by a dotted line (Fig. 28e). The bending moment  $M$  for the actual load is shown by the solid line (Fig. 28c).

According to formula (5),

$$\Delta_a = \int \frac{mMdx}{FEI}$$

Note that the product  $mM$  has significance only between points  $A$  and  $B$ ; as between points  $A$  and  $C$  its value is zero. In other words,  $F$  produces no bending moment in the beam and therefore creates no stresses between  $A$  and  $C$ . It follows, then, that no elastic energy can be stored within that portion of the beam in which  $F$  fails to make itself felt.

$$\Delta_a = \int_0^a \frac{mMdx}{FEI} = \int_B^A \frac{FxMdx}{FEI} = \frac{1}{EI} \int_B^A xMdx.$$

Here  $\frac{1}{EI}$ , as a constant, may be written outside of the summation sign. The subscripts 0 and  $a$ , or  $B$  and  $A$ , at the top and bottom of the summation sign, namely,  $\int_B^A$ , signify that the summation applies only to that portion of the beam lying between points  $B$  and  $A$ . We may conceive the area under the bending moment curve  $M$  to be divided into an infinitely large number of small rectangles. One of these rectangles  $Mdx$  is shown on the sketch (Fig. 28c). Then  $xMdx$  would represent the moment of the small rectangle about the point  $A$ . Further,  $\int_B^A xMdx$  would be the sum of all the moments of the infinite number of rectangles within the trapezoidal area between  $A$  and  $B$  about the point  $A$ . This sum is equivalent to the trapezoidal area between points  $A$  and  $B$  multiplied by its  $\bar{X}$ , the distance from  $A$  to its centroid.

To evaluate this Area  $\bar{X}$  it is convenient to divide the trapezoidal area into a rectangle and a triangle and take the sum of the moments of both, thus:

$$\begin{aligned} \Delta_a &= \frac{1}{EI} \int_B^A xMdx = \frac{\text{Area } \bar{X}}{EI} = \frac{A_1\bar{X}_1 + A_2\bar{X}_2}{EI} \\ &= \frac{1}{EI} \left[ Q(l-a) \times a \times \frac{a}{2} + Qa \times \frac{a}{2} \times \frac{2}{3}a \right] \\ &= \frac{Q}{EI} \left( \frac{a^2l}{2} - \frac{a^3}{2} + \frac{a^3}{3} \right) = \frac{Qa^2}{6EI} (3l-a). \end{aligned}$$

To obtain the same result by means of integral calculus we write

$$\begin{aligned} \Delta_a &= \frac{1}{EI} \int_0^a \frac{mMdx}{F} = \frac{1}{EI} \int_0^a \frac{FxQ(x+l-a)dx}{F} \\ &= \frac{Q}{EI} \left( \frac{x^3}{3} + \frac{lx^2}{2} - \frac{ax^2}{2} \right)_0^a = \frac{Qa^2}{6EI} (3l-a). \end{aligned}$$

The point *A* in the beam was arbitrarily chosen. It was taken to represent any point at a distance *a* from the left end. Let us now substitute *y* for  $\Delta_a$  and *x* for *a* (that is, the distance out from the left support and not the *x* shown in the sketch). We then obtain

$$y = \frac{Qx^2}{6EI} (3l-x),$$

which is the equation of the elastic curve expressed in the conventional manner, namely in *x* and *y* coordinates with the origin at point *B*.

**EXAMPLE 12**

Find  $\theta_1$ , the rotation of the tangent to the elastic curve at point *A* in a cantilever beam, under the action of a concentrated load *Q* at its free end. *E* and *I* are assumed constant (Fig. 28*b*).

For purposes of analysis we introduce an auxiliary moment *M'* at point *A* (Fig. 28*f*). The bending moment *m*, caused by this auxiliary moment *M'*, will be a constant moment  $m = M'$ , extending only over the length *a* of the beam from *A* to *B* (Fig. 28*g*). According to formula (6) the elastic energy stored in the beam because *M'* is present before the application of the load *Q* is given by the expression

$$M'\theta_1 = \int_A^B \frac{mMdx}{EI} = \int_A^B \frac{M'Mdx}{EI},$$

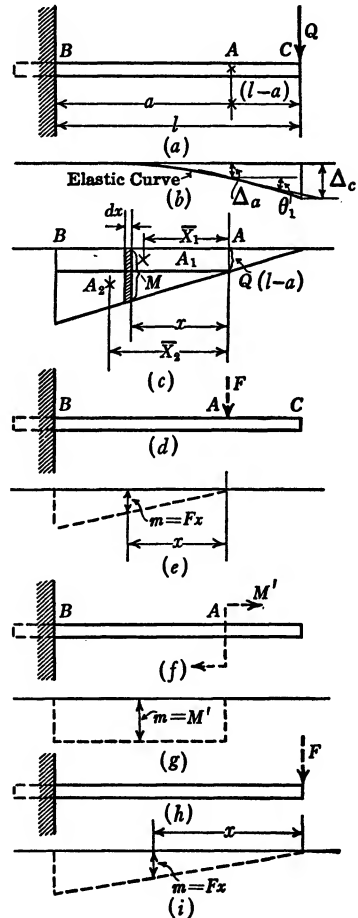

FIG. 28.

from which we derive

$$\theta_1 = \frac{1}{EI} \int_A^B M dx.$$

$M dx$  is the small rectangle, with altitude  $M$  and base  $dx$ , shown cross-hatched in Fig. 28c.  $\int_A^B M dx$  is the sum of an infinite series of such small rectangles, all within the bending-moment diagram  $M$  summed between the limits of  $A$  and  $B$ .  $\int_A^B M dx$ , therefore, is the area under the bending-moment diagram  $M$  between points  $A$  and  $B$ . Therefore

$$\theta_1 = \int_A^B \frac{M dx}{EI} = \frac{\text{Area} \int_A^B}{EI} = \frac{Q}{EI} \frac{\{(l-a) + l\}a}{2} = \frac{Q(2la - a^2)}{2EI}.$$

$$\text{When } a = l, \theta_1 = \frac{Ql^2}{2EI}.$$

### EXAMPLE 13

Find the displacement  $\Delta_c$  of the free end of a cantilever beam under the action of a concentrated load at its extremity.  $E$  and  $I$  are assumed constant (Fig. 28b).

Introduce an auxiliary load  $F$  at point  $C$  in the direction of  $\Delta_c$  (Fig. 28h). The bending moment  $m$ , caused by the auxiliary load  $F$ , is  $m = Fx$  (Fig. 28i). The actual bending moment,  $x$  being measured from point  $C$ , is  $M = Qx$ . From formula (5) we have

$$\Delta_c = \int_0^l \frac{mM dx}{FEI} = \int_0^l \frac{FxM dx}{FEI} = \int_0^l \frac{xM dx}{EI} = \frac{\text{Area } \bar{X}}{EI}$$

By "Area" is meant the area under the bending-moment curve  $M$ . In examples 11 and 12 only the area under the  $M$  curve between points  $A$  and  $B$  is considered. In this instance, since  $m$  extends over the entire length of the beam, the entire area under the  $M$  curve is meant (Figs. 28c and 28i).  $\bar{X}$  is the distance to the centroid of the  $M$  bending-moment area measured from point  $C$ . Therefore

$$\Delta_c = \frac{Ql \times \frac{l}{2} \times \frac{2}{3}l}{EI} = \frac{Ql^3}{3EI}.$$

This value might also have been obtained from example 11 by substituting  $l$  for  $a$ .

**THE TOOLS OF ENGINEERING MECHANICS**

In the development of the science of strength of materials we employ three different means for the expression of thought, all of which are intimately related. These are:

1. Symbolic logic (mathematics).
2. Free-body sketches (graphs and diagrams).
3. Language.

**FREE-BODY SKETCHES**

As formulated by Sir Isaac Newton, every action has an equal and opposite reaction. The distinction, therefore, between external and internal forces is an artificial one. In nature external forces are non-existent. The truss represented by Fig. 12, page 11, for example, in reality forms part of the earth. What are commonly called external reactions are in reality internal forces; the abutments act upon the truss and the truss in turn acts upon the abutments with equal intensity, but with opposite sense. What may appear to be external loads at the panel points are in reality internal forces acting between floor beam and truss. The principal value of the free-body sketch lies in the fact that it permits internal forces and moments to be represented by vectors as external forces. There are no restrictions as to size, or dimensions, in the representation of free bodies. An entire locomotive, an entire bridge, in fact anything varying in size from an infinitesimal particle to the entire solar system, may be represented as a free body. In Fig. 19a the truss is shown as a free body separated from the earth as well as from the loads. The effects of the earth and the load on the truss are the forces shown as arrows. Though many textbooks make the attempt, the forces in the members, Fig. 19a, cannot be effectively shown by arrows. Such forces occur in pairs, equal and opposite, and their resultant is zero. If it is desired to show the forces in the members themselves as external forces acting on the joints, then the joints themselves must be represented as free bodies.

The free-body sketch principle is one of the most effective tools in mechanics. The use of the free-body sketch may well be made fool proof if a few simple propositions are observed. The reason they are here especially emphasized is that, simple as these propositions are, they are yet frequently violated, causing errors which might easily have been avoided.

*Proposition 1.* A free-body sketch must account for all forces, known and unknown, no more and no less. If one chooses to show components



of a force rather than the force itself, then the force itself should be eliminated.

*Proposition 2.* All bodies with which the engineer is concerned are part of the earth. Any part of the earth under special investigation—a bridge, a locomotive, a crankpin, or an infinitesimal particle—is separated from the earth by passing imaginary planes along boundaries of our own choice. At any point where such an imaginary plane cuts the body, if the body be three-dimensional and of finite dimensions, there are six unknowns to be accounted for, three unknown forces parallel to the  $x$ ,  $y$ , and  $z$  axes of a coordinate system and three unknown moments, one about each of these three axes of the coordinate system. If the body is two-dimensional and of finite dimensions, then the unknowns are reduced to only three in number, namely, two component unknown forces and one unknown moment. In Fig. 26, page 45, for example, the structure is two-dimensional. The unknown reactions at each end are in fact three in number. However, the beam is supposed to rest on rollers, which means that both the horizontal and the moment reaction are zero. They are, therefore, not shown. In Fig. 40b, page 78, the horizontal reaction is assumed to be zero and is therefore not shown. The remaining two reactions, the linear one,  $V_a$ , as well as the moment reaction,  $M_a$ , are both shown.

One pitfall must be guarded against, namely, the error of allowing our wish to become the father of our thought. Whenever we decide not to show a possible unknown force acting on a free body, we must be certain that our reasons for assuming it to be zero are incontestably valid.

*Proposition 3.* Forces are represented by vectors. The inclination of the line designates the direction of the force. The magnitude of the force may be shown by the length of the line, if drawn to scale. More commonly the magnitude of a force is indicated by writing on the sketch a number designating the magnitude. The arrow on the vector represents the sense of the force. We differ here, possibly, with definitions of direction and sense found in other textbooks. A person sitting in a chair, for example, exerts a force on the chair, while the chair exerts a force on the person. Both forces have the same direction, which is vertical. They differ, however, in sense, the one being downward while the other is upward.

As we stipulated at the outset, the three media for the expression of logic are interrelated. It is important to realize that the arrowheads on the force vectors have exactly the same significance as the plus or minus signs in algebraic equations. Many times the direction and sense of an unknown force are known and the magnitude only remains

to be found. At other times both magnitude and sense of the unknown forces are unknown (see Fig. 44c, page 88).

It is entirely immaterial how we show the arrows of any unknown force acting on a free-body sketch provided that we rigidly observe two rules. One is that the plus and minus signs in any algebraic equation are strictly in harmony with the arrowheads on the vectors in the free-body sketch. The other is Newton's third law of motion, which says that for any action there is an equal and opposite reaction. In Fig. 44c (page 88) it is entirely immaterial how the arrows in the free bodies appear. If at point  $A$ , at the top of the vertical leg,  $V_1$  is shown pointing downward,  $H_1$  pointing to the left, and  $M_a$  acting clockwise, then at the same point,  $A$ , the left end of the horizontal beam  $AB$ ,  $V_1$  *must* be shown pointing upward,  $H_1$  *must* point to the right, and  $M_a$  *must* act counter-clockwise.

### SEMI-GRAPHIC INTEGRATION

The method of semi-graphic integration as a means of solving certain differential equations was first proposed by Mohr in Germany, and by Greene in Michigan. At the time, especially in the United States, the differential equation  $\frac{d^2y}{dx^2} = \frac{1}{R} = \frac{M}{EI}$  was stressed almost to the exclusion of any other. If we multiply the foregoing expression by  $dx$  and integrate, we obtain

$$\int \frac{d^2y}{dx^2} dx = \frac{dy}{dx} = \tan \theta = \theta = \int \frac{M dx}{EI} = \frac{\text{Area}}{EI}$$

(when the deflections are small,  $\tan \theta = \theta$ ). The conventional procedure was to write  $M$  as a function of  $x$  and integrate analytically. Mohr's and Greene's suggestion was to the effect that the integration, instead of being accomplished by analytical means, might be effected by evaluating the area, or the moment of the area, under the bending-moment curve. Greene called his suggestion the method of area moments. When first meeting with it the present author regarded the area-moment method of analyzing redundant problems in structural engineering as one of the outstanding advances in the science of strength of materials of his generation. He continues so to regard it until this day. In this book the method of semi-graphical integration is also stressed wherever feasible. No special name is offered for it, however. The two procedures are identical in that they are both methods of semi-graphical integration. The student who is familiar with the method of area moments, however, must realize that, beyond this one

identity (and an identity in appearance of resulting expressions,  $\frac{\text{Area}}{EI}$  and  $\frac{\text{Area } \bar{x}}{EI}$ ), all similarity between the two procedures ends.

Any writing down of an equation in connection with the analysis of an engineering structure must of necessity be based upon some appreciation of how this structure behaves physically. The method of area moments, being predicated on the differential equation for curvature, requires that the structure be studied from the point of view of curvature. The equation  $\theta = \frac{\text{Area}}{EI}$  is defined as the deflection of a tangent at one point on the structure relative to a tangent at some other point, and  $\Delta = \frac{\text{Area } \bar{x}}{EI}$  is defined as the linear displacement of a point on a structure relative to a tangent at some other point.

Here we are interested in evaluating formula (5),  $\Delta = \int \frac{mMdx}{FEI}$ ; or formula (6),  $\theta = \int \frac{mMdx}{M'EI}$ . In these expressions both  $\Delta$  and  $\theta$  signify not relative but absolute displacements. Furthermore, the consideration of the elastic curve plays no part whatsoever in our analysis. Instead, our analysis is predicated on the principle of conservation of energy.

The advantage of the semi-graphical integration procedure arises from the fact that the kinds of loading most commonly encountered in engineering practice are of only four types. The bending moments of these four types of loading, when applied to straight beams, may, with a little practice, be represented by four stereotyped simple bending-moment curves, the areas and moment areas of which may be evaluated and subsequently utilized without requiring re-evaluation (see Appendix I).

Figures 29 to 32 represent bending-moment diagrams for the four basic types of loading applied to straight beams.

#### RULES FOR GRAPHIC INTEGRATION

1. For a concentrated load  $Q$  the bending-moment diagram may always be represented as a straight line. The area under the bending-moment curve will always be a triangle (Fig. 29a), a rectangle (Fig. 29b), or a trapezoid (Fig. 29e), a combination of the first two. If the area under the bending-moment curve is a triangle, the equation of this curve will be  $M = KQx$ , provided that we measure  $x$  from the vertex of

the triangle. In the accompanying sketches the constant  $K$  will be unity as shown in Fig. 29a, and  $\frac{4}{9}$  and  $\frac{5}{9}$  in Fig. 29c.

2. For a uniformly distributed load the bending-moment diagram

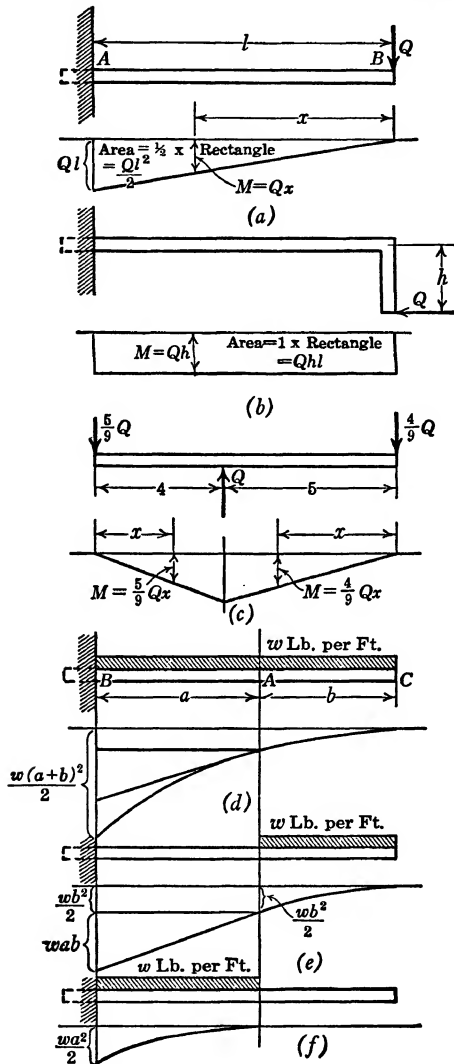

FIG. 29.

will always be some form of parabola. For the simple beam, carrying a uniformly distributed load, the bending moments of the reaction and load may be combined and represented graphically by a single curve (Fig. 30a); or they may be shown separately (Fig. 30b). No hard and fast rule about the drawing of bending-moment diagrams can be given.

It may be said, however, that, if graphic integration is to be resorted to, it is advantageous to draw the bending-moment diagrams in as simple a form as possible. This is generally best accomplished by drawing the component parts; that is, the bending moment of each reaction, each force, and each loading is pictured separately.

If a cantilever beam is uniformly loaded throughout its entire length (Fig. 29*d*), the bending-moment area between points *A* and *B* presents a truncated parabolic area. The loading, however, may be regarded as two loadings, one extending from *B* to *A* (Fig. 29*f*) and one

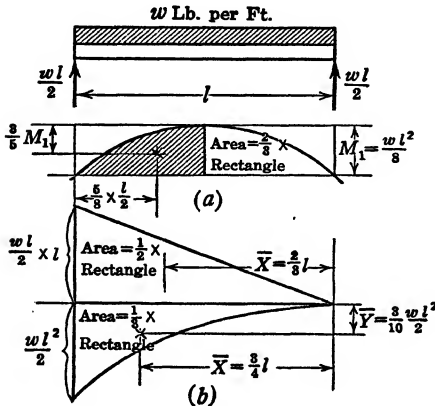

FIG. 30.

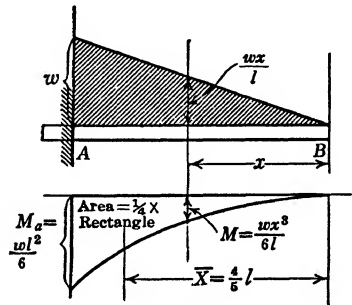

FIG. 31.

from *A* to *C* (Fig. 29*e*). This arrangement divides the bending-moment area between *A* and *B* into a trapezoidal area (Fig. 29*e*) and a simple parabolic area (Fig. 29*f*). Together they are equivalent to the truncated parabolic area (Fig. 29*d*).

3. For a uniformly varying load (Fig. 31), if the load intensity is directly proportional to the distance (being *w* at *A*), the load intensity at distance *x* is  $\frac{wx}{l}$ ; the maximum load intensity is *w*; the total load on the beam is  $\frac{wl}{2}$ ; and the equation of the bending-moment curve is a cubic equation,  $M = \frac{wx^3}{6l}$ . The area under the bending-moment curve is one-fourth of its circumscribed rectangle,

$$\frac{M_a l}{4} = \frac{wl^3}{24},$$

and the distance  $\bar{X}$  from the vertex to the centroid of the area under the bending-moment curve is  $\bar{X} = \frac{4}{5}l$ .

4. For a beam loaded with a couple (Figs. 26*d*, 28*f*, and 29*b*) the bending-moment curve will always be a straight line, and the area under the bending-moment curve will always be either a rectangle or a triangle.

For the properties of the areas under the bending-moment curves for varying conditions of loading see Appendix I.

A bending-moment diagram may usually be drawn in many different ways. The facility and success of graphic integration are somewhat dependent on the manner in which the bending-moment diagram is represented. Figure 32*a* represents a built-in beam loaded with a concentrated load. Figure 32*b* represents a free-body sketch of this beam. Figure 32*c* shows the resultant bending moment. Figure 32*d* graphically shows the bending moment at any section in the beam in terms of all the forces to the right of the section. Figure 32*e* shows the bending moment at any section of the beam in terms of all the forces to the left of the section.

The fact that each of the graphs of Figs. 32*c*, *d*, and *e* accurately represents the bending moment at any point in the beam should be self-evident. Figure 32*f* is constructed by first drawing the bending moment of the beam in the manner of a simply supported beam (the triangle above the  $x$  axis), then laying off the bending moments  $M_a$  and  $M_b$  at each end and connecting the ordinates  $M_a$  and  $M_b$  by a straight line (the trapezoid below the  $x$  axis).

That Fig. 32*f* accurately represents the bending moment of the beam as loaded in Fig. 32*a* may be proved as follows:

The equation for the bending moment shown in Fig. 32*a* is

$$M = R_b x - M_b \text{ (see Fig. 32*d*);}$$

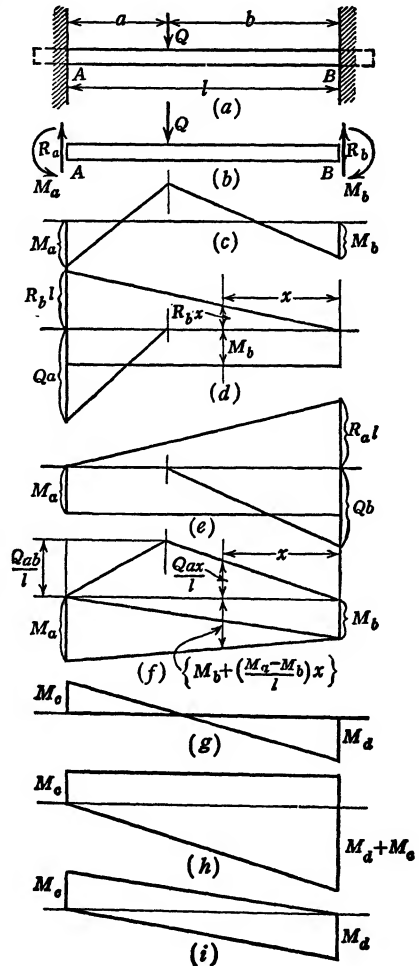

FIG. 32.

for the bending moment shown in Fig. 32*f* it is

$$M = \frac{Qax}{l} - \left\{ M_b + \frac{(M_a - M_b)x}{l} \right\}.$$

If we can show the two expressions to be identical, the legitimacy of drawing the bending-moment curves in the manner of Fig. 32*f* will be established.

Taking the moments about the point *A* (Fig. 32*b*) we have the following equations, the third of which is the identity desired:

$$M_a + R_b l - M_b - Qa = 0,$$

$$R_b = \frac{Qa}{l} - \frac{(M_a - M_b)}{l},$$

$$R_b x - M_b = \frac{Qax}{l} - \left\{ \frac{(M_a - M_b)x}{l} + M_b \right\}.$$

The composite bending-moment diagram of Fig. 32*c* gives us the best picture of the manner in which the bending moment varies along the beam. However, it will be of little use in the graphic integration process as long as the quantities involved in the drawing, such as the values of  $M_a$  and  $M_b$  and the location of the points of intersection of the curve with the  $x$  axis, are unknown. Graphic integration means the evaluation of areas under the bending-moment diagram and of the moments of such areas about certain points. For purposes of graphic integration, then, the bending-moment diagrams are drawn in the manner shown by either Fig. 32*d*, 32*e*, or 32*f*, presenting in each case simple rectangles, triangles, or trapezoids. The trapezoid of Fig. 32*f* may be divided by one of its diagonals as shown in the sketch and considered as two triangles. In connection with the analysis of continuous beams or built-in beams, and particularly in connection with the analysis of bents and culverts, the representation of bending-moment diagrams in the manner of Fig. 32*f* will prove advantageous.

The bending-moment diagram for a beam with a positive bending moment at one end, a negative moment at the other, and no loading between the ends is shown as in Fig. 32*g*. By adding a constant positive and negative moment of the same magnitude, Fig. 32*g* may be changed into Fig. 32*h* without changing its meaning. By adding and subtracting the same positive and negative triangular bending-moment area, Fig. 32*h* may be changed into an equivalent bending-moment diagram as shown in Fig. 32*i*.

In the application of formulas (5) and (6),  $\Delta = \int \frac{mMdx}{FEI}$  and  $\theta_1 = \int \frac{mMdx}{M'EI}$ ,  $F$  and  $M'$ , representing the auxiliary force or moment, will always cancel. ( $F$  or  $M'$ , being of any arbitrary magnitude, might have been selected as unity, in which event they would not have appeared in formulas (5) and (6).) In the analysis of straight beams and combinations of straight beams, such as bents and culverts, the foregoing expressions which are to be summed will invariably reduce to the form

$$\int Mdx, \text{ or } \int xMdx.$$

If  $M$  is the ordinate at any point in the  $M$  bending-moment curve, and  $dx$  is an infinitesimally small length at the same point,  $Mdx$  will be an infinitely small rectangle and  $\int_a^b Mdx$  will represent the summing of such small rectangles over the entire range from  $a$  to  $b$ . This represents the area under the bending-moment curve shown cross-hatched in Fig. 33. If  $x$  is always measured from the same point, then  $xMdx$  represents the moment of the small rectangle  $Mdx$  about that point, and  $\int_a^b xMdx$  represents the sum of all such moments for an infinite series of consecutive small rectangles. The student must keep in mind that  $dx$  is an infinitely small distance, or, to be more exact, a distance approaching zero as its limit. Therefore, no error is caused by measuring  $x$  to the edge of the small rectangle  $Mdx$  instead of measuring it to its centroid.

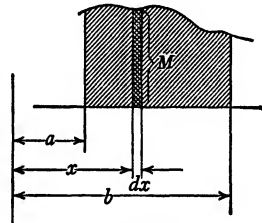

FIG. 33.

This summation, by principles of elementary mechanics, is defined as the moment of the entire area about the point, and may be represented as Area  $\bar{X}$ . (Area refers to a portion under the bending-moment diagram between definite limits, and  $\bar{X}$  represents the distance to the centroid of such area measured from the point from which  $x$  was measured.)

In evaluating the expressions  $\int Mdx$  and  $\int xMdx$  by graphic means, it is important that both the  $m$  and the  $M$  diagram shall be drawn, so that the areas under the  $M$  curve and their moments may be easily visualized. Furthermore, to distinguish clearly between the effect of the auxiliary loading and the actual loading, it is of great



importance to emphasize the inherent distinction between  $m$  and  $M$ . This may be shown by representing  $m$  as a dotted graph and  $M$  as a solid graph.

The principle of conservation of energy underlies this entire treatise. Where the graph shows that either  $m$  or  $M$  is zero there can be no energy involved, and the expression for energy must thus be zero.

The  $m$  diagram, caused by an auxiliary concentrated load  $F$ , or an auxiliary couple  $M'$ , will always be one of two things, a rectangle or a triangle. If  $m$  is represented in the graph by a rectangle, its equation will be  $m = KM'$ , and the expression  $\int mMdx$  takes the form  $K \int M'Mdx$ . Since  $M'$  cancels,  $K \int M'Mdx$  will be merely a constant times the area under the  $M$  diagram. (The constant  $K$  will generally be unity.) If  $m$  is represented in the graph by a triangle, its value will be expressed as  $CxF$ , and  $\int mMdx$  will appear as  $C \int xFMdx$ . Since  $F$  always cancels,  $C \int xMdx$  will always be a constant multiplied by the moment of the area under the  $M$  curve, *the moment to be taken about the vertex of the  $m$  diagram.*

### SIGNS

The determination and interpretation of signs, in problems of strength analysis, frequently constitute a major difficulty. The magnitude determination of an unknown amounts to one half of the answer. The correct interpretation of the sign is the other half. One may, for example, determine the magnitude of the moment which a reinforced-concrete beam must carry, and proportion the beam accordingly. The interpretation of the sign will determine whether the reinforcing steel is to be placed in the top or in the bottom of the beam. The author recalls arguments about the meaning of signs which continued for weeks. In one instance which he recalls the checker and the designer compromised by specifying that reinforcing steel be placed in both bottom and top of the beam.

Any confusion about the meaning of signs, the author feels, is generally due to the influence of tradition, to the attempt to apply archaic definitions which are basically illogical. Engineering may be defined as applied science, but engineers are human, and, in common with the rest of the race, they attempt at times to substitute rule for logic.

The meaning of signs is essentially relative. One of the important rules of mathematics is that an equation may be multiplied by  $-1$ , changing the signs of all the terms in the equation, without in any way changing its meaning. A plus or a minus sign by itself has no meaning. It assumes significance only in its relationship to other signs.

One definition of sign, which has given rise to a great deal of confusion, is the one applied to bending moments. In his youth the author learned that when a beam bends so as to "hold water" the bending moment is positive; when it bends so as to "shed water" it is negative. The second edition of the supposedly up-to-date textbook from which he teaches his elementary students still offers this definition. This definition is archaic, unscientific, and in violation of one of the first rules of logic. This is not advanced as a personal opinion, but as a statement of fact.

In a beam of uniform cross section, built in at both ends and loaded with a uniformly distributed load, the bending moment at the wall is of a sign opposite to that in the middle of the beam. If one is designated as positive, the other is marked negative. No issue is taken with that procedure. It is only when we say that the moment at the wall *is* negative, and that the one in the middle of the beam *is* positive that we violate the rules of logic. Consider a long and slender piece of spring steel. If it is long enough and slender enough and loaded with equal and opposite couples at each end, it will assume the shape of a complete circle. According to the aforementioned definition the moment at the top would be negative, at the bottom it would be positive, but those at the sides the rule ignores. The structural engineering profession offers to provide a rule for the moments at the sides of a long, slender spring-steel beam curved in the shape of a complete circle. The beam, or the drawing, is to be turned clockwise through  $90^\circ$ , and the rule of signs is then to be applied as before. This is merely adding an arbitrary convention to a supremely illogical rule. Should we wonder that confusion often reigns in matters of signs when the analysis of complicated structures is encumbered with such rules and conventions?

One other source of confusion about signs arises from the fact that in a single analysis several different rules of signs may be applied to one equation. The final sign in the answer then presents a problem analogous to that of unscrambling the egg. It is to be remembered that, in the analysis of redundant structures, the theory of elasticity is but a supplementary theory, and that the theory of static equilibrium is primary. A complete solution will always require one or more equations of static equilibrium. These equations, however, are quite distinct, and

any rule of sign applying to them need in no way affect rules for signs applying to the elasticity equations.

As to the elasticity equations, we may have one rule of sign for bending moments, and another for curvature, or elastic energy, depending on which theory is used. Still another rule of sign may assert itself, namely, the rule derived from the mathematical traditions associated with the cartesian, or some other coordinate, system. One advantage in the application of the theory of elastic energy lies in the fact that only one rule of signs applies. We are completely indifferent to all rules of signs as applying to bending moments; and distances  $x$ , measured either to the left or to the right, have no sign associated with them. Any attempt to apply the rules associated with the cartesian coordinate system, to attach minus signs to distances measured to the left and plus signs to distances measured to the right, cannot possibly make any contribution, since these definitions are completely foreign to the philosophy of elastic energy.

In applying the theory of elastic energy we are primarily concerned with the evaluation of the integral  $\int \frac{mMdx}{EI}$ . In the proof of our formulas we represented by an area that quantity of elastic energy in which we are interested, a small rectangle, the product of two sides. In our formula it is well to regard the product  $mM$  also as the essential quantity. It is thus immaterial what individual sign is associated with either  $m$  or  $M$ . The product of two minus quantities is a plus quantity, as is the product of two positive quantities. The only rule of sign (by this we mean to exclude all arbitrary rules of signs relative to bending moments as well as the rules of signs associated with the cartesian coordinate system) involved in the application of the theory of elastic energy is the one which is initiated when we begin writing an equation, and whose function terminates when the equation is completed.

Whether we evaluate  $\int mMdx$  analytically or graphically, the only thing we must make sure of is that the same rule of sign is applied to the auxiliary moment  $m$  as to the actual moment  $M$ .

In example 11 (pages 47 and 49)  $Q$  is shown acting downward (Fig. 28a), and the  $M$  bending moment was drawn below the  $x$  axis (Fig. 28c). The auxiliary force  $F$  in Fig. 28d is also shown as acting downward. If the  $M$  bending moment is negative, surely the  $m$  bending moment is of the same sign. Since both bending moments  $m$  and  $M$  have the same sign, the product  $mM$  is positive. A positive answer for

$\Delta_a = \int \frac{mMdx}{FEI}$  is interpreted in relation to the assumed auxiliary load  $F$

(Fig. 28*d*). Since this  $F$  (Fig. 28*d*) is acting downward, the displacement  $\Delta_a$  is a downward displacement.

Regardless of any rules concerning bending-moment diagrams advocated by others, we might with full justification have shown the  $M$  bending-moment diagram as positive. However, if we had done so, we should also have shown the  $m$  bending-moment diagram as positive and our answer would have been in no way affected thereby.

The application of the auxiliary load  $F$ , or auxiliary couple  $M'$ , is specified to be at the point where, and in the direction in which, we seek the displacement. The sense of neither  $F$  nor  $M'$  is specified. We might, therefore, have shown  $F$  in Fig. 28*d* as acting upward instead of downward. If we had done so, the  $m$  and  $M$  bending moments would have been of opposite sign and the product  $mM$  would have been negative. A negative value for  $\Delta_a$ , interpreted in relation to the sense of the auxiliary load  $F$ , would mean that it would be in a sense opposite to the upward pointing force  $F$ , or downward. The answers thus are identical no matter what procedure is followed.

No matter how complicated the problem, the rule regarding signs here promulgated and illustrated by our discussion of example 11 is absolutely the only valid rule of signs involved in any elastic-energy equation. Any other rules relative to signs are only too apt to confuse matters.

It is possible that bending moments which are positive in one of a series of simultaneous equations must be regarded as negative in another equation of the same series (see page 87).

## CHAPTER VI

### REDUNDANT BEAMS

The description of the elastic behavior of beams given in Chapter V is important, not so much for its own sake as for the sake of providing means of analyzing redundant structures. It is rarely that we are interested in the deflection of a beam as such. Once this deflection is known, however, this knowledge may well serve as a means of analyzing statically indeterminate structures.

The following examples cover

- Rectilinear beams,
- Bents, and
- Curved beams.

#### RECTILINEAR BEAMS

##### EXAMPLE 14

*Given:* A beam built in at the left end, freely resting upon an unyielding support at its right end, and loaded with a uniformly distributed load  $w$  pounds per foot.  $E$  and  $I$  are assumed constant (Fig. 34a).

*To find:* The reaction  $R_2$  at the right end.

The vertical displacement of any point in the beam is given by formula (5):

$$\Delta = \frac{\int mMdx}{FEI}.$$

The vertical displacement of the end of the beam is represented by

$$\Delta_b = 0 = \frac{\int mMdx}{FEI}.$$

The auxiliary force  $F$  applied at point  $B$  may be of any value.

Then,  $m = Fx$  (Fig. 34c) and

$$\int \frac{mMdx}{FEI} = \frac{F \int xMdx}{FEI} = 0.$$

Therefore  $\int xMdx = 0$ . As previously shown (pp. 59 and 60),  $\int xMdx$  is equal to Area  $\bar{X}$ , which is the moment of the area under the  $M$  bending-moment diagram about the point of vertex of the triangular bending-moment diagram  $m$ . Thus

$$\int xMdx = \text{Area } \bar{X} = A_1\bar{X}_1 - A_2\bar{X}_2 = 0$$

or

$$\left(R_2l \times \frac{l}{2}\right) \frac{2}{3}l - \left(\frac{wl^2}{2} \times \frac{l}{3}\right) \frac{3}{4}l = 0.$$

From this last equation we obtain

$$R_2 = \frac{3}{8}wl.$$

To obtain this solution analytically we substitute the bending-moment equation for  $M$  and integrate:

$$\int xMdx = \int_0^l x \left(R_2x - \frac{wx^2}{2}\right) dx = \left(\frac{R_2x^3}{3} - \frac{wx^4}{8}\right)_0^l = 0.$$

Therefore

$$R_2 = \frac{3}{8}wl.$$

### EXAMPLE 15

#### General Rule Concerning Application of Auxiliary Load $F$ or $M'$

*Given:* A beam built in at the left end, freely resting upon an unyielding support at the right end and loaded with a uniformly distributed load  $w$  pounds per foot.  $E$  and  $I$  are assumed constant.

*To find:* The displacement  $\Delta_a$  at any point  $A$  in the beam any distance  $a$  from the left end. (Figs. 35a and 35b.)

Formula (5) again applies. An auxiliary load  $F$  is applied at  $A$  and its corresponding bending moment sketched and algebraically expressed. As we apply  $F$ , however, the question arises whether we shall consider the beam a cantilever (Fig. 35d), a simply supported beam (Fig. 35f), or the original statically indeterminate beam (Fig. 35i).

If we apply formula (5),  $F\Delta = \int \frac{mMdx}{EI}$ , we shall see that it is immaterial which of the three alternatives is taken. The left side of the equation represents work done by the auxiliary force  $F$ ; the right

side expresses the elastic energy stored because  $F$  is present before the application of the actual loads  $w$ . Whether the structure is redundant or not when the auxiliary load  $F$  is applied has no bearing on either the theory or the development of formula (5).

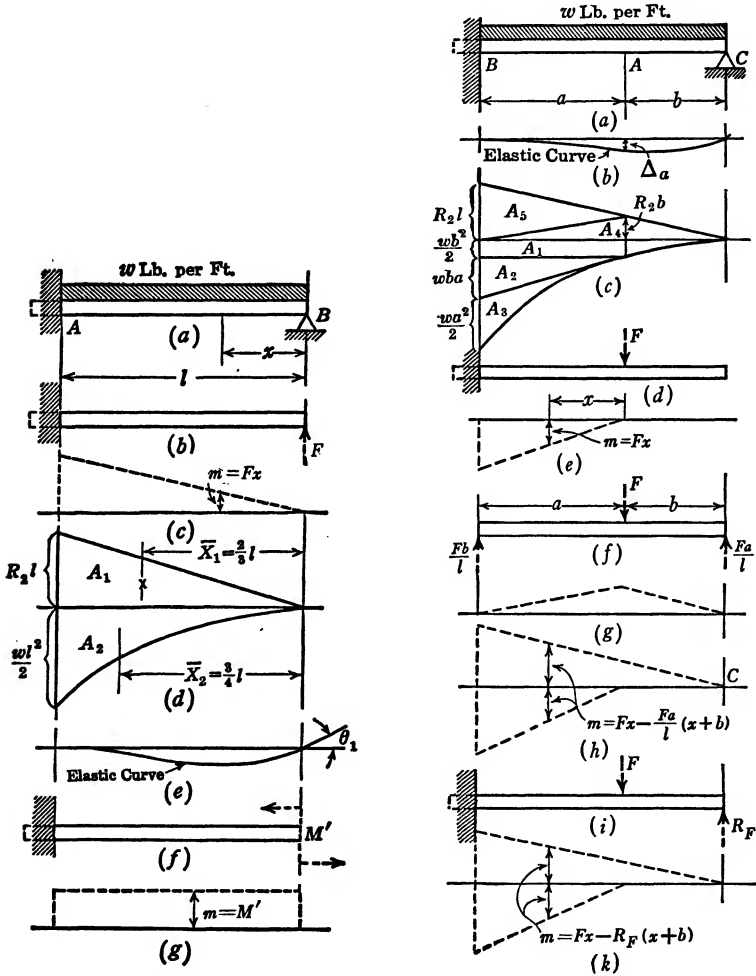

FIG. 34.

FIG. 35.

This problem is analogous to that of stress analysis in a redundant truss, in which it is assumed that the redundant restraints are removed before the auxiliary loads  $R$  and  $K$  are applied, and in which the stresses caused by the actual loads are assumed superimposed upon those caused by the auxiliary loads.

The  $m$  bending-moment diagrams which we would obtain in these cases are shown in Figs. 35e, 35g, and 35k. The  $m$  bending-moment diagram of Fig. 35g may also be shown as in Fig. 35h. In all three figures, 35e, 35h, and 35k, the  $m$  bending-moment diagrams have in common the curve below the  $x$  axis, expressed by the equation  $m = Fx$ . But the last two figures, 35h and 35k, in addition to a curve below the  $x$  axis, show another straight line curve above the  $x$  axis. This second curve cuts the  $x$  axis at  $C$ . It is similar to the  $m$  bending moment in example 14 (Fig. 34c), differing only in that it contains a constant, that is, the curves above the  $x$  axis are all straight lines in Figs. 34c, 35h, and 35k. Only the slopes of the lines differ. The  $M$  bending-moment diagram is identical with that in example 14.

In example 14 we have seen that  $\int_0^l mMdx$  is zero. Therefore, if we choose to express  $m$  as shown in Figs. 35h and 35k, it may be said to consist of two parts:  $m_1$ , the curve above the  $x$  axis, and  $m_2$ , the curve below the  $x$  axis. Thus considered,  $\int_0^l mMdx$  would be equal to

$$\int_0^l m_1 M dx + \int_0^l m_2 M dx.$$

The value of  $\int_0^l m_1 M dx$  is 0 because it is identical, except for the presence of a constant, with the expression  $\int_0^l mMdx$  of example 14.

We may therefore generalize as follows:

*In applying an auxiliary load  $F$  or  $M'$  to a redundant structure it is theoretically immaterial how we imagine the beam supported as long as it is stable, and as long as no supports or restraints are introduced other than those originally there. However, it is always permissible and generally advantageous to remove sufficient restraints from the structure to make it statically determinate before the auxiliary load  $F$  or couple  $M'$  is applied.*

Having satisfied ourselves that the load  $F$  as applied in Fig. 35d gives the simplest  $m$  bending-moment diagram with its vertex at point  $A$  and  $x$  measured from point  $A$  to the left, we may proceed with the evaluation of  $\Delta_a$ .

Letting  $m$  and  $M$  be represented as shown in Figs. 35e and 35c,

$$\Delta_a = \int \frac{mMdx}{FEI}$$

becomes

$$\int \frac{FxMdx}{FEI} = \int \frac{xMdx}{EI} = \frac{\text{Area } \bar{X}}{EI}.$$



The  $\bar{X}$  is defined by  $x$ , and since  $x$  is measured from the vertex of the  $m$  diagram (from point  $A$ ) therefore  $\bar{X}$  is measured from the same point.

Since  $m$  (between points  $A$  and  $C$ ) is zero,  $mMdx$  between these points is likewise zero.

The only Area  $\bar{X}$  that comes under consideration, therefore, is the moment of the  $M$  bending-moment area lying between points  $A$  and  $B$  about the point  $A$ .

$$\begin{aligned} \frac{\text{Area } \bar{X}}{EI} &= \frac{+A_1\bar{X}_1 + A_2\bar{X}_2 + A_3\bar{X}_3 - A_4\bar{X}_4 - A_5\bar{X}_5}{EI} \\ &= \left( \frac{wb^2a}{2} \times \frac{a}{2} + \frac{wba^2}{2} \times \frac{2a}{3} + \frac{wa^3}{6} \times \frac{3a}{4} - \frac{R_2ba}{2} \times \frac{a}{3} - \frac{R_2la}{2} \times \frac{2a}{3} \right) \times \frac{1}{EI}. \end{aligned}$$

Substituting  $(l - a)$  for  $b$ , and  $\frac{3}{8}lw$  for  $R_2$  (example 14), we have

$$\Delta_a = \frac{wa^2}{48EI} (2a^2 - 5la + 3l^2).$$

Note that the signs are to be interpreted by checking back to the auxiliary loading of Fig. 35*d*, in which  $F$  is vertical in a downward sense. The plus sign in the above expression, therefore, means a displacement in the direction and sense of  $F$ , namely, downward.

Adopting the symbolism of analytical geometry, that is, expressing  $\Delta_a$  as  $y$ ,  $a$  as  $x$ , and changing signs in order that downward displacements may be negative instead of positive, we obtain

$$y = \frac{wx^2}{48EI} (5lx - 2x^2 - 3l^2),$$

which is the equation of the elastic curve.

#### EXAMPLE 16

*Given:* A beam built in at the left end, freely resting upon an unyielding support at its right end, and loaded with a uniformly distributed load  $w$  pounds per foot.  $E$  and  $I$  are assumed constant.

*To find:* The angular displacement  $\theta_1$  of the tangent to the elastic curve at point  $B$  (Figs. 34*a* and 34*e*).

Formula (6) gives

$$M'\theta_1 = \int \frac{mMdx}{EI}.$$

If we apply an auxiliary couple at  $B$ , the beam being regarded as a simple cantilever beam (see rule, page 67), the auxiliary bending moment  $m$  will at all points be a constant and equal to  $M'$  (Figs. 34f and 34g).

$$\theta_1 = \frac{\int_A^B m M dx}{M' EI} = \frac{\int_A^B M' M dx}{M' EI} = \frac{\int_A^B M dx}{EI}$$

$\int_A^B M dx$  is the area under the  $M$  diagram between points  $A$  and  $B$ .

Therefore, from Fig. 34d,

$$\theta_1 = \frac{\int_A^B M dx}{EI} = \frac{\text{Area} \int_A^B}{EI} = \frac{+A_1 - A_2}{EI} = \left( \frac{R_2 l^2}{2} - \frac{wl^3}{6} \right) \frac{1}{EI}$$

Substituting the value for  $R_2$  which was found in example 14, namely,  $R_2 = \frac{3}{8}wl$ , we obtain

$$\theta_1 = \left( \frac{3}{16} wl^3 - \frac{wl^3}{6} \right) \frac{1}{EI} = + \frac{wl^3}{48EI}$$

(The plus sign indicates that  $\theta_1$  is to be regarded in the same sense as  $M'$  in Fig. 34f, that is, as counterclockwise.)

EXAMPLE 17

*Given:* A simply supported beam loaded with a uniformly distributed load  $w$  pounds per foot over its entire length.  $E$  and  $I$  are assumed constant.

*To find:* The angular displacement  $\theta_1$ , at point  $A$ , a certain distance,  $a$ , from the left end (Figs. 36a and 36b).

Formula (6) gives

$$\theta_1 = \frac{\int m M dx}{M' EI}$$

If we apply an auxiliary moment  $M'$  at point  $A$  (Fig. 36c), the  $m$  moment diagram will be as shown in Fig. 36d (see also Figs. 26d and 26e, page 45).

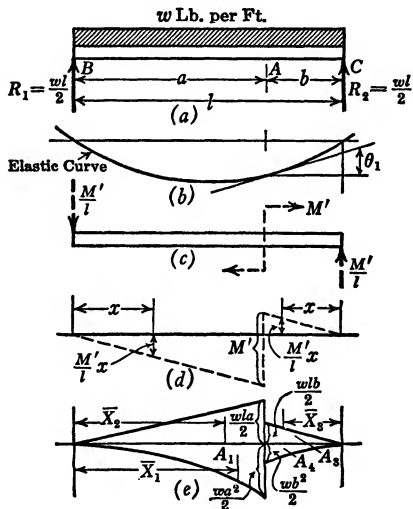

FIG. 36.

The  $M$  bending-moment diagram, due to the actual loading, is shown in Fig. 36e (see also Figs. 30a and 30b, page 56).

The expression  $\theta_1 = \frac{\int mMdx}{M'EI}$  must be summed over the entire length of the beam. This cannot be done in one operation but may be done in two steps: first, from  $B$  to  $A$ , and then from  $C$  to  $A$ .

$$\begin{aligned}\theta_1 &= \int_B^C \frac{mMdx}{M'EI} = \int_B^A \frac{mMdx}{M'EI} + \int_C^A \frac{mMdx}{M'EI} \\ &= \int_B^A \frac{\frac{M'}{l}xMdx}{M'EI} + \int_C^A \frac{\frac{M'}{l}xMdx}{M'EI} \\ &= \frac{\text{Area } \bar{X}]^A}{lEI} \Big|_B + \frac{\text{Area } \bar{X}]^A}{lEI} \Big|_C \\ &= \frac{A_1\bar{X}_1 - A_2\bar{X}_2 + A_3\bar{X}_3 - A_4\bar{X}_4}{lEI}.\end{aligned}$$

(See page 59 for proof of  $\int xMdx = \text{Area } \bar{X}$ .)

Note that in Fig. 36d, for both portions of the beam,  $x$  is measured from the free end. In evaluating Area  $\bar{X}$ , the  $\bar{X}_1$  and  $\bar{X}_2$  are measured from point  $B$ , whereas  $\bar{X}_3$  and  $\bar{X}_4$  are measured from point  $C$ .

When the  $m$  and  $M$  diagrams are shown on the same side of the  $x$  axis, they are of the same sign, and the product  $mM$  will therefore be positive. When they are shown on opposite sides of the axis their product is negative.  $A_1\bar{X}_1$  and  $A_3\bar{X}_3$  will thus be positive, but  $A_2\bar{X}_2$  and  $A_4\bar{X}_4$  will be negative.

Evaluating  $\sum \frac{A\bar{X}}{EI}$ , we obtain

$$\begin{aligned}& \begin{matrix} A_1 & \bar{X}_1 & A_2 & \bar{X}_2 & A_3 & \bar{X}_3 & A_4 & \bar{X}_4 \end{matrix} \\ & \frac{wa^2}{2} \times \frac{a}{3} \times \frac{3}{4}a - \frac{wla}{2} \times \frac{a}{2} \times \frac{2}{3}a + \frac{wlb}{2} \times \frac{b}{2} \times \frac{2}{3}b - \frac{wb^2}{2} \times \frac{b}{3} \times \frac{3}{4}b = \theta_1 lEI \\ & \frac{wa^4}{8} - \frac{wla^3}{6} + \frac{wlb^3}{6} - \frac{wb^4}{8} = \theta_1 lEI.\end{aligned}$$

Substituting  $(l - a)$  for  $b$ , we obtain

$$\theta_1 = \frac{w}{24EI} (l^3 - 6a^2l + 4a^3).$$

When  $a = 0$ ,  $\theta_1 = +\frac{wl^3}{24EI}$ ; when  $a = l$ ,  $\theta_1 = \frac{-wl^3}{24EI}$ ; when  $a = \frac{l}{2}$ ,  $\theta_1 = 0$ .

The plus sign signifies rotation in the sense of  $M'$ ; the minus sign signifies rotation in the sense opposite to  $M'$ .

Suppose that we allow the  $F$  loading to correspond to Fig. 28f (page 49) and the  $m$  bending-moment diagram to be that shown in Fig. 28g. This is the wrong procedure because it violates the rule given on page 67. This rule says that we may remove as many redundants as we like, so long as equilibrium is maintained and no reactions or restraints are added to help support the auxiliary load  $M'$ . If the beam were supported in the manner shown in Fig. 28f, then we would have a moment reaction  $M'$  at the left end. If a beam is supported in this manner by an auxiliary loading  $M'$  at point  $B$  as well as at point  $A$ , and subsequently loaded in the manner shown in Fig. 36a, the expression  $\int \frac{mMdx}{EI}$  would equal the total work done by the entire auxiliary loading. That is,  $M'\theta_1 + M'\theta_2 = \int \frac{mMdx}{EI}$ , where  $\theta_2$  is the rotation of the tangent to the elastic curve at  $B$ .

#### EXAMPLE 18

*Given:* A continuous beam 18 ft. long, resting on three unyielding supports, and loaded with 10 tons per foot over the first span and with 7 tons per foot over the second span (Fig. 37a).  $E$  and  $I$  are assumed constant.

*To find:* The reactions.

In this example we have three unknowns:  $R_1$ ,  $R_2$ , and  $R_3$ . However, we have two independent equations from statics,  $\Sigma F_y = 0$  and  $\Sigma M = 0$ , and thus need but one additional equation from the elastic-energy theory. One of the limiting conditions of the problem is that the supports are unyielding, that is, that the displacements of points  $A$ ,  $B$ , and  $C$  are zero. We may apply an auxiliary load  $F$  at  $B$ , and, on the basis of formula (5), derive the following:

$$EIF\Delta_B = \int_A^C mMdx = \int_A^B \frac{5}{9}FxMdx + \int_C^B \frac{4}{9}FxMdx.$$

Therefore

$$\begin{aligned} EI\Delta_B &= \frac{5}{9} \int_A^B xMdx + \frac{4}{9} \int_C^B xMdx \\ &= \frac{5}{9} \left( \text{Area } \bar{X} \right)_A^B + \frac{4}{9} \left( \text{Area } \bar{X} \right)_C^B. \end{aligned}$$

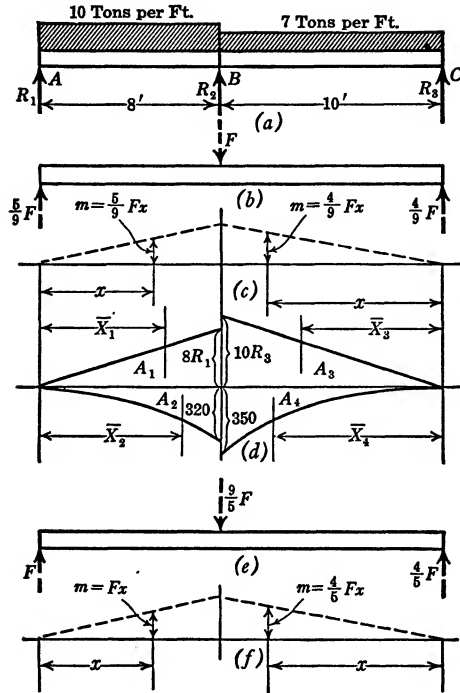

FIG. 37.

The equation is broken up into two parts: first, a summation between limits  $A$  and  $B$ ; second, a summation between limits  $C$  and  $B$ . We measure  $x$  from points  $A$  and  $C$ , and thus  $\bar{X}$ , the distance to the centroid of the  $M$  bending-moment area, will likewise be measured from  $A$  and  $C$ , that is, from the vertices of the  $m$  bending-moment diagram.

$$\begin{aligned} \Delta_B EI = 0 &= \frac{5}{9} (A_1 \bar{X}_1 - A_2 \bar{X}_2) + \frac{4}{9} (A_3 \bar{X}_3 - A_4 \bar{X}_4) \\ &= \frac{5}{9} (8R_1 \times \frac{8}{2} \times \frac{2}{3} \times 8 - 320 \times \frac{8}{3} \times \frac{3}{4} \times 8) + \frac{4}{9} (10R_3 \times \frac{10}{2} \\ &\quad \times \frac{2}{3} \times 10 - 350 \times \frac{10}{3} \times \frac{3}{4} \times 10) \\ &= 5 \left( \frac{8^3 R_1}{3} - 5120 \right) + 4 \left( \frac{10^3 R_3}{3} - 8750 \right) = 0. \end{aligned}$$

$$512R_1 - 15,360 + 800R_3 - 21,000 = 0. \quad (a)$$

$$\Sigma F_y = 0 \text{ gives us } R_1 + R_2 + R_3 = 80 + 70 = 150. \quad (b)$$

$$\Sigma M = 0 \text{ gives us } 10R_3 - 350 = 8R_1 - 320. \quad (c)$$

The simultaneous solution of equations (a), (b), and (c) gives  $R_1 = 29.5$ ,  $R_2 = 93.9$ , and  $R_3 = 26.6$ .

If we base our analysis on the limiting condition  $\Delta_a = 0$  (in place of  $\Delta_b = 0$ ), the auxiliary load  $F$  is applied at point  $A$  (Fig. 37e), and the expressions for  $m$  for the left and right halves of the beam are  $m = Fx$  and  $m = \frac{4}{5}Fx$ , respectively (Fig. 37f).

Under this condition the equation  $EIF\Delta_a = \int_A^c mMdx$  appears as  $0 = \int_A^B xMdx + \int_B^c \frac{4}{5}xMdx$ , which is identical with the equation we obtain for  $EIF\Delta_b = 0$ , except for the constant  $\frac{5}{9}$ .

Since any equation may be multiplied by a constant without altering its meaning, it follows that it is immaterial whether we use the equation  $\Delta_a = 0$  or  $\Delta_b = 0$ .

#### EXAMPLE 19

*Given:* A continuous beam of uniform cross section and uniform modulus of elasticity, spanning three successive openings, 3, 2, and 4 feet in length, respectively (Fig. 38a). The beam is loaded with a uniformly distributed load,  $w$  pounds per foot, and is supported at points  $A$ ,  $B$ ,  $C$ , and  $D$  by unyielding supports.\*

*To find:* The four reactions  $R_1$ ,  $R_2$ ,  $R_3$ , and  $R_4$ .

The equations of static equilibrium provide us with two of the four necessary equations, namely,  $\Sigma F_y = 0$  and  $\Sigma M = 0$ . The fact that the displacements of points  $A$ ,  $B$ ,  $C$ , and  $D$  are all zero enables us, by means of formula (5) to write four additional equations involving the four unknown quantities we are to find. Having the two equations of static equilibrium, however, we need apply formula (5) only twice to find the last two equations required. It is immaterial which of the points  $A$ ,  $B$ ,  $C$ , or  $D$  we select as a basis for our analysis. Let us select points  $B$  and  $C$ , and express, by means of formula (5), the fact that the vertical displacement of both these points is zero:

$$\Delta_B = \frac{\int_A^D mMdx}{FEI} = 0.$$

\* See also theorem of three moments, page 79.

Therefore

$$\frac{\int_A^D m M dx}{F} = 0.$$

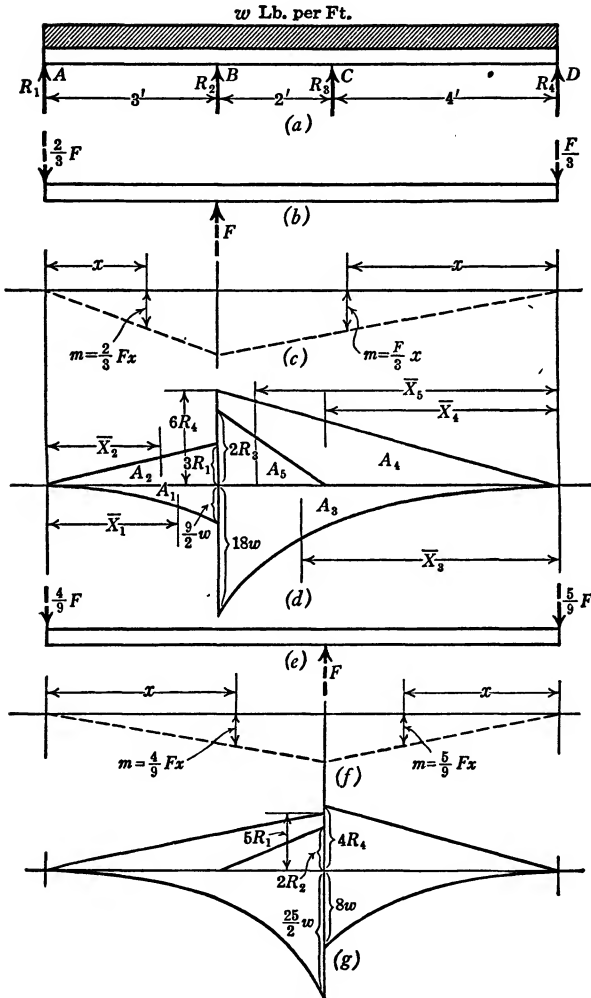

FIG. 38.

We apply an auxiliary load  $F$  at point  $B$  (Fig. 38b) and draw the corresponding  $m$  diagram (Fig. 38c).

The  $M$  bending-moment diagram is shown in Fig. 38d. Both the  $m$  and  $M$  curves being discontinuous at point  $B$ , the integration will

have to proceed in two steps: (1) over the region  $AB$ ; (2) over  $BD$ . The  $m$  diagram being a triangle,  $\int \frac{mMdx}{F}$  is equivalent to the moment of the area under the  $M$  bending-moment diagram. This moment is taken about the vertex of the  $m$  bending-moment diagram. (See page 60.) Thus:

$$\begin{aligned} \Delta_B = 0 &= \frac{\int_A^D mMdx}{F} = \frac{2F}{3} \frac{\int_A^B xMdx}{F} + \frac{F}{3} \frac{\int_B^D xMdx}{F} \\ &= \frac{2}{3} \text{Area } \bar{X} \Big]_A^B + \frac{1}{3} \text{Area } \bar{X} \Big]_B^D \\ &= \frac{2}{3}(A_1\bar{X}_1 - A_2\bar{X}_2) + \frac{1}{3}(A_3\bar{X}_3 - A_4\bar{X}_4 - A_5\bar{X}_5) \\ &= \frac{2}{3}\left(\frac{9}{2}w \times \frac{3}{3} \times \frac{3}{4} \times 3 - 3R_1 \times \frac{3}{2} \times \frac{2}{3} \times 3\right) \\ &\quad + \frac{1}{3}\left(18w \times \frac{6}{3} \times \frac{3}{4} \times 6 - 6R_4 \times \frac{6}{2} \times \frac{2}{3} \times 6 - 2R_3 \times \frac{2}{2} \times \frac{16}{3}\right) = 0. \end{aligned}$$

Simplifying this equation we obtain

$$2187w - 216R_1 - 128R_3 - 864R_4 = 0. \quad (a)$$

The second equation is based on the limiting condition that the linear displacement of point  $C$  equals zero.

$$\Delta_c = \int_A^D \frac{mMdx}{FEI} = 0.$$

We introduce an auxiliary load  $F$  at point  $C$  (Fig. 38e) and draw its bending-moment diagram (Fig. 38f). In connection with this development we should reconstruct the  $M$  moment diagram in the manner of Fig. 38g. If we use Fig. 38d in connection with Fig. 38f, though equally correct in theory, it would be necessary to express the moment of the trapezoidal and truncated parabolic bending-moment area lying between points  $B$  and  $C$  (Fig. 38d) about the point  $A$ . We can avoid this by using the equally valid and expressly constructed  $M$  bending-moment diagram of Fig. 38g. Thus:

$$\Delta_c = 0 = \int_A^D \frac{mMdx}{FEI}.$$



Therefore

$$\int_A^D \frac{mMdx}{F} = \frac{4}{9} \int_A^C \frac{FxMdx}{F} + \frac{5}{9} \int_C^D \frac{FxMdx}{F}$$

$$= \frac{4}{9} \text{Area } \bar{X} \Big|_A^C + \frac{5}{9} \text{Area } \bar{X} \Big|_C^D = 0.$$

$$\frac{4}{9} \left( \frac{2}{2} \cdot 5w \times \frac{5}{3} \times \frac{3}{4} \times 5 - 5R_1 \times \frac{5}{2} \times \frac{2}{3} \times 5 - 2R_2 \times \frac{2}{2} \times \frac{1}{3} \cdot 3 \right)$$

$$+ \frac{5}{9} (8w \times \frac{4}{3} \times \frac{3}{4} \times 4 - 4R_4 \times \frac{4}{2} \times \frac{2}{3} \times 4) = 0.$$

$$2835w - 1000R_1 - 208R_2 - 640R_4 = 0. \tag{b}$$

$$\Sigma F_y = 0.$$

Therefore

$$R_1 + R_2 + R_3 + R_4 - 9w = 0. \tag{c}$$

$$\Sigma M = 0.$$

Therefore

$$9R_1 + 6R_2 + 4R_3 - \frac{81w}{2} = 0. \tag{d}$$

Solving equations (a), (b), (c), and (d) simultaneously, we obtain

$$R_1 = 1.30w; R_2 = 2.30w; R_3 = 3.75w; R_4 = 1.65w.$$

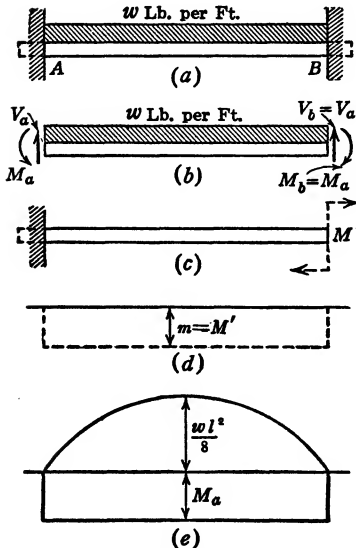

FIG. 39.

EXAMPLE 20

*Given:* A built-in beam, perfectly restrained at both ends (Fig. 39a) and loaded with a uniformly distributed load,  $w$  pounds per foot.

*To find:* The restraining moment at the end.

The free-body sketch of the beam (Fig. 39b) permits us to solve for a few unknowns by inspection. Since the beam is symmetrical with respect to a vertical through the center,  $V_a = V_b$  and  $M_a = M_b$ .

$$V_a + V_b = 2V_b = wl.$$

Therefore

$$V_b = \frac{wl}{2}.$$

Two limiting conditions suggest themselves as a means of solving for the remaining unknown  $M_a$ , the restraining moment at the wall. We may assume the vertical displacement of point  $B$ , namely  $\Delta_B$ , to be zero, and use formula (5), or we may assume the angular displacement of the beam at point  $B$ , namely  $\theta_B$ , to be zero, and use formula (6).

Let us use formula (6) in this case. If we apply an auxiliary moment  $M'$  at point  $B$  (Fig. 39c), the  $m$  diagram will be as shown in Fig. 39d,  $m = M'$ .

$$M'\theta_B = 0 = \int_A^B \frac{mMdx}{EI}.$$

Since  $m = M'$ ,

$$\int_A^B Mdx = 0.$$

This is equivalent to saying

$$\text{Area} \int_A^B = 0.$$

The  $M$  bending-moment diagram is shown in Fig. 39e. Therefore,

$$\frac{wl^2}{8} \times \frac{2}{3}l - M_al = 0 \quad \text{or} \quad M_a = \frac{wl^2}{12}.$$

#### EXAMPLE 21

*Given:* A built-in beam, restrained at both ends and loaded with a total load  $W$ , which varies uniformly from zero at the right end to a maximum at its left end (Fig. 40a).

*To find:* The reaction and bending moment at  $B$ .

If  $W$  is the total load, then  $\frac{w}{l}$ , or the load intensity at a distance unity, is  $\frac{2W}{l^2}$ , and the load intensity at any point  $x$  is  $\frac{2W}{l^2}x$  (Fig. 40b).

(The loading of the beam in example 21 lacks the symmetry of that in example 20. This is the essential difference between the two.)

We may still write  $\Sigma F_y = V_a + V_b - W = 0$ .

However, as we cannot tell by inspection what the relation is between  $V_a$  and  $V_b$ , we are as yet unable to solve for these two unknowns. It cannot be too much emphasized that  $V_a$  and  $V_b$  are *not* equal to the values of the reactions of a simple beam similarly loaded.

Again, as in the previous example, two limiting conditions exist, namely, that the vertical displacement of point  $B$  is zero,  $\Delta_B = 0$ , and

$A_r \bar{X}_r$  represents static moment of the positive bending-moment area over right span about the right end of the two consecutive spans.

One of the limiting conditions of the problem is that the supports are unyielding. We may say then that the displacement of the middle

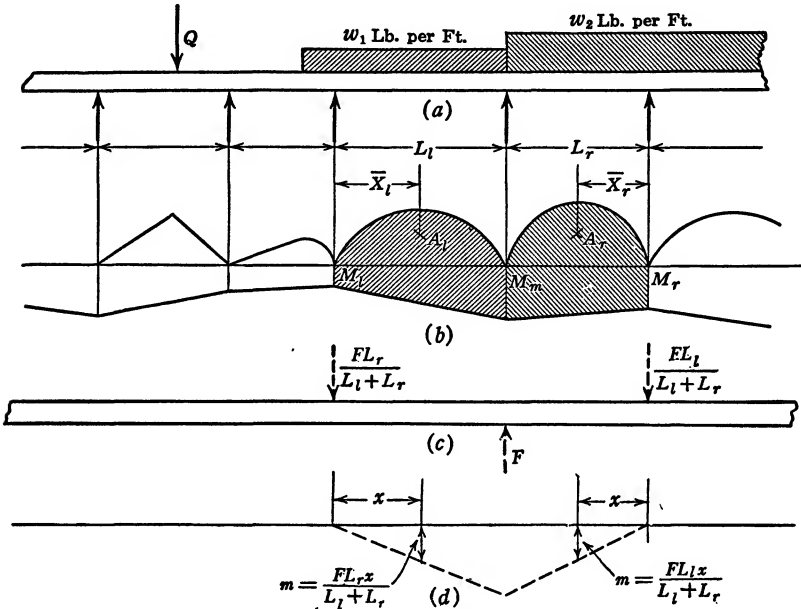

FIG. 41.

support of two consecutive spans,  $\Delta_m$ , is zero. The expression for  $\Delta_m$  is  $\int \frac{mMdx}{FEI}$ . We apply an auxiliary load  $F$  at the middle support of the two consecutive spans (Fig. 41c) and construct its moment diagram (Fig. 41d). On page 67 we have seen that, as the auxiliary load  $F$  is applied, sufficient restraints may be thought removed to reduce the beam to a statically determinate one.

$$\Delta_m = \int \frac{mMdx}{FEI} = 0.$$

The integration is to proceed only so far as the product  $mM$  gives real values. Since  $m$  extends only over two spans, the integration therefore extends only over two spans and is best performed in two steps. Thus:

$$\Delta_m = \int \frac{mMdx}{FEI} = \int_0^{L_l} \frac{FL_r x M dx}{(L_l + L_r) FEI} + \int_0^{L_r} \frac{FL_l x M dx}{(L_l + L_r) FEI} = 0.$$

Canceling  $F$  and multiplying through by  $(L_l + L_r)EI$  we obtain

$$\int_0^{L_l} L_r x M dx + \int_0^{L_r} L_l x M dx = L_r \text{Area } \bar{X} \Big|_0^{L_l} + L_l \text{Area } \bar{X} \Big|_0^{L_r} = 0;$$

$$L_r \left( M_l \times \frac{L_l}{2} \times \frac{L_l}{3} + M_m \times \frac{L_l}{2} \times \frac{2}{3} L_l \right)$$

$$+ L_l \left( M_m \times \frac{L_r}{2} \times \frac{2}{3} L_r + M_r \times \frac{L_r}{2} \times \frac{L_r}{3} \right) - L_r A_l \bar{X}_l - L_l A_r \bar{X}_r = 0.$$

Multiplying by  $\frac{6}{L_r L_l}$  and transposing we obtain

$$M_l L_l + 2M_m(L_l + L_r) + M_r L_r = 6 \left( \frac{A_l \bar{X}_l}{L_l} + \frac{A_r \bar{X}_r}{L_r} \right).$$

When, as in Fig. 41a, the loading is uniformly distributed,

$$A_l = \frac{w_1 L_l^2}{8} \times \frac{2L_l}{3} \quad \text{and} \quad \bar{X}_l = \frac{L_l}{2}.$$

$$\frac{A_l \bar{X}_l}{L_l} \text{ thus becomes } \frac{w_1 L_l^3}{24}; \quad \text{similarly } \frac{A_r \bar{X}_r}{L_r} = \frac{w_2 L_r^3}{24}.$$

The foregoing then becomes

$$M_l L_l + 2M_m(L_l + L_r) + M_r L_r = \frac{w_1 L_l^3}{4} + \frac{w_2 L_r^3}{4}.*$$

Repeating this process  $(n - 2)$  times and adding two equations from the theory of static equilibrium we obtain the  $n$  simultaneous equation necessary for the solution of the  $n$  unknowns.

The general equation just stated is called the theorem of three moments. This theorem is largely of historic interest. It would seem that, once the theory by which the theorem is derived is properly mastered, it is no more trouble to set up the necessary simultaneous equations for the analysis of redundant structures by the application of first principles than it is to do so by means of a special formula.

\* In our proof the bending moments over the supports are assumed to be of a sense opposite to that produced in the beam by the loads, the beams being considered as cut at the supports. A positive answer for moments over the support would mean, then, a bending moment of the same sense as that assumed in our proof. In proof of the three-moment theorem in American textbooks the bending moments over the support are frequently assumed as of the same sign as those produced by the loads on simply supported beams. This results in the same theorem except that the factors on the right-hand side of the equation have the negative sign.

BENTS

EXAMPLE 22

Given: A bent of a certain width  $l$ , with two equal legs of height  $h$ , pin-connected at bottom, and loaded with a concentrated load  $Q$  off center.  $I_1$  represents the moment of inertia for the legs;  $I_2$ , the moment

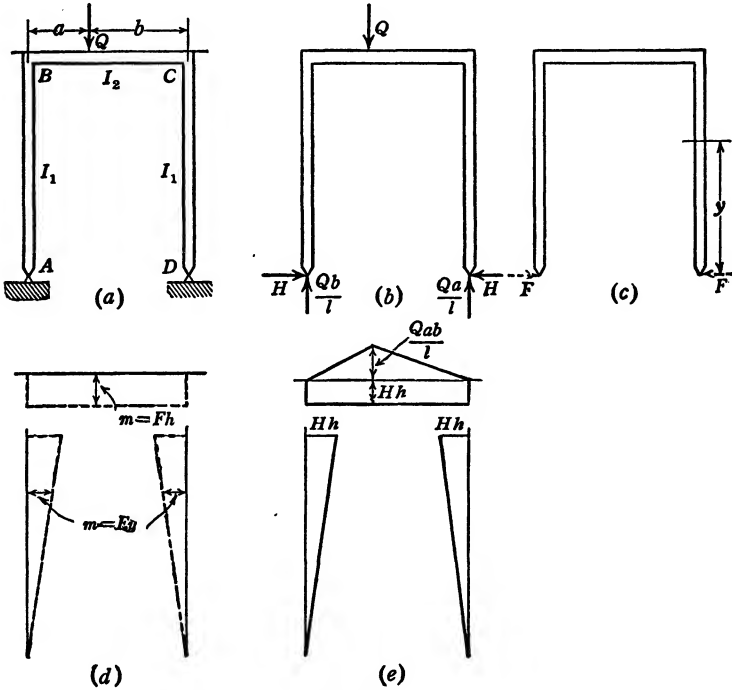

FIG. 42.

of inertia for the cross tie. The modulus of elasticity  $E$  is the same, both for legs and cross tie (Fig. 42a).

To find: The horizontal reaction  $H$ .

The pin-connection of the bent insures zero displacement and zero moment at points  $A$  and  $D$ . The horizontal reactions  $H$ , at points  $A$  and  $D$ , are necessarily the same, being the only horizontal forces acting on the bent (Fig. 42b). Taking the moments of all the forces about point  $A$  and equating them to zero gives us the vertical reactions

$$R_d = \frac{Qa}{l} \text{ and } R_a = \frac{Qb}{l}.$$

The horizontal reaction  $H$  is the only remaining unknown.  $H$  is the force necessary to keep the points  $A$  and  $D$  from

separating when the structure is loaded. The value of  $H$  will depend on the effectiveness with which this restraint is accomplished. If points  $A$  and  $D$  retain their original position,  $H$  will have a certain value. Its value decreases in the proportion to which this restraint yields. If by some mechanical device the supports could be moved more closely together,  $H$  would necessarily have to be larger. It is logical, therefore, to base our attempt to solve for the unknown  $H$  upon the displacement of point  $D$  relative to point  $A$ .

As stated at the outset, assuming  $A$  as a reference point, the horizontal displacement of  $D$  is zero and is expressed by the symbol  $\Delta_{dx}$ .

To obtain an expression for displacement according to formula (5), we introduce an auxiliary force  $F$  at the point in question and in the direction of the displacement (Fig. 42c). The resulting bending moment for this condition of loading is shown in Fig. 42d. The actual  $M$  bending moment is shown in Fig. 42e. The bending moment for the top strut  $BC$  is drawn after the manner of Fig. 32f, page 57.

$$F\Delta_{dx} = \int_A^D \frac{mMds}{EI} = 0.$$

This summation cannot be accomplished in one operation but must be performed in three steps, thus:

$$\int_A^D \frac{mMds}{EI} = \int_A^B \frac{mMdy}{EI_1} + \int_B^C \frac{mMdx}{EI_2} + \int_C^D \frac{mMdy}{EI_1} = 0.$$

For the explanation of these summations see Figs. 42d and 42e. The three summations taken together being equal to zero,  $E$  may be canceled. Note that in this example the summations from  $A$  to  $B$  and from  $C$  to  $D$  involve the factor  $I_1$ , while the summation from  $B$  to  $C$  involves a different moment of inertia, namely,  $I_2$ . The  $I$  factors, therefore, are not to be canceled in this case.

$$\begin{aligned} \int_A^B \frac{mMdy}{FI_1} &= \int_A^B \frac{FyMdy}{FI_1} = \int_A^B \frac{yMdy}{I_1} = \left[ \frac{\text{Area } \bar{Y}}{I_1} \right]_A^B \\ &= \frac{Hh}{I_1} \times \frac{h}{2} \times \frac{2}{3}h = \frac{Hh^3}{3I_1}. \end{aligned}$$

$$\begin{aligned} \int_B^C \frac{mMdx}{FI_2} &= \int_B^C \frac{FhMdx}{FI_2} = \int_B^C \frac{hMdx}{I_2} = \left[ \frac{h \text{ Area}}{I_2} \right]_B^C \\ &= \frac{h}{I_2} \left( Hh \times l - \frac{Qab}{l} \times \frac{l}{2} \right) = \frac{Hh^2l}{I_2} - \frac{Qabh}{2I_2}. \end{aligned}$$

Note that, in Figs. 42*b* and 42*c*,  $H$  and  $F$  are applied in the same sense. Therefore, the  $m$  and  $M$  bending-moment diagrams for the legs (Figs. 42*d* and 42*e*) are placed on the same side of the  $y$  axis. In the summation from  $A$  to  $B$  their product is positive.

In our evaluation of the summation from  $B$  to  $C$  we find, in the  $M$  diagram (Fig. 42*e*), the moment  $Hh$  drawn below the  $x$  axis and the triangular moment diagram above the  $x$  axis. The moment effect of  $F$  and the moment  $Hh$  therefore are positive and the triangular bending-moment diagram is negative.  $\int_C^D \frac{mMdy}{EI_1}$  (for the right leg) is identical with  $\int_A^B \frac{mMdy}{EI}$  (for the left leg) and may be expressed by the factor  $\frac{+Hh^3}{3I_1}$ . We thus obtain

$$\int_A^D \frac{mMdx}{FEI} = 0 = \frac{2Hh^3}{3I_1} + \frac{Hh^2l}{I_2} - \frac{Qabh}{2I_2}.$$

$$H = \frac{3QabI_1}{2(2I_2h^2 + 3I_1hl)}.$$

### EXAMPLE 23

*Given:* A bent with equal legs, built in at its extremities and unsymmetrically loaded. To simplify the process we shall assume  $I$  and  $E$  constant throughout.

*To find:* The moments at the corners of the bent (Figs. 43*a* and 43*c*).

Whereas in the preceding example we had only one degree of redundancy, in this case it is necessary to consider three superfluous restraints. The point  $D$ , with reference to point  $A$ , is restrained in its sidewise motion, and also in its vertical displacement; and the tangent to the elastic curve at  $D$  is restrained against rotation. We may express the three limiting conditions thus:

$$F_1\Delta_{d_x} = \int_A^D \frac{m_1Mds}{EI} = 0, \quad (a)$$

$$F_2\Delta_{d_y} = \int_A^D \frac{m_2Mds}{EI} = 0, \quad (b)$$

and

$$M'\theta_d = \int_A^D \frac{mMds}{EI} = 0. \quad (c)$$

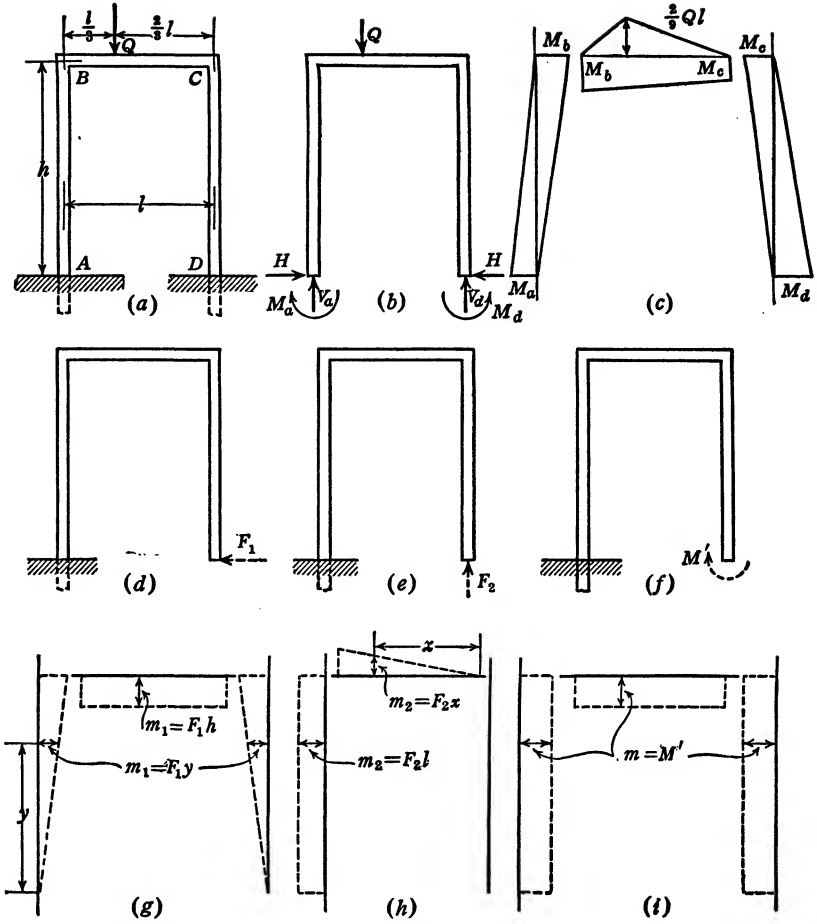

FIG. 43.

Figure 43b presents a free-body sketch of the bent showing a total of six unknown quantities. In addition to the foregoing equations the equations of static equilibrium give three more equations:

$$\Sigma F_x = 0 = H_a - H_d = 0, \tag{d}$$

$$\Sigma F_y = 0 = V_a + V_d - Q = 0, \tag{e}$$

$$\Sigma M = 0 = M_d + V_d l - M_a - Q \frac{l}{3} = 0,$$

or, since

$$V_d l - Q \frac{l}{3} = M_c - M_b \text{ (Fig. 43b),}$$

$$M_d - M_a - M_b + M_c = 0. \tag{f}$$



To write the first three equations in algebraic form we regard the bent as a statically determinate structure, with all three restraints at point  $D$  removed. Then we apply the auxiliary force  $F_1$  in the direction of  $\Delta_x$  (Fig. 43*d*),  $F_2$  in the direction of  $\Delta_y$  (Fig. 43*e*), and the auxiliary moment  $M'$  in the direction of  $\theta_d$  (Fig. 43*f*).

The corresponding moment diagrams are shown in Figs. 43*g*, 43*h*, and 43*i*. (In accordance with the general rule on page 67 we eliminate a sufficient number of restraints to simplify the structure to a statically determinate one before the auxiliary loading  $F_1$ ,  $F_2$ , or  $M'$  is applied.)

Figure 43*c* shows the  $M$  bending-moment diagram for the structure. (See also Figs. 32*f*, 32*g*, 32*h*, and 32*i*.)

To write the first equation,

$$F_1 \Delta_{d_x} = \int_A^D \frac{m_1 M ds}{EI} = 0 \quad \text{or} \quad \int_A^D \frac{m_1 M ds}{F_1} = 0,$$

in algebraic form we multiply the  $m_1$  ordinate at any point in Fig. 43*g* by the  $M ds$  of the  $M$  ordinate corresponding to the same point of Fig. 43*c*. For the leg  $CD$  we obtain

$$\begin{aligned} \int_C^D \frac{m_1 M dy}{F_1} &= \int_C^D \frac{F_1 y M dy}{F_1} = \int_C^D y M dy = \text{Area } \bar{Y} \Big]_C^D \\ &= \frac{M_c h}{2} \times \frac{2}{3} h - \frac{M_d h}{2} \times \frac{h}{3}. \end{aligned}$$

In the top strut  $BC$  we have

$$\begin{aligned} \int_B^C \frac{m_1 M dx}{F_1} &= \int_B^C \frac{F_1 h M dx}{F_1} = \int_B^C h M dx = h \text{Area} \Big]_B^C \\ &= h \left\{ \frac{(M_c + M_b)}{2} l - \frac{2}{9} Ql \times \frac{l}{2} \right\}. \end{aligned}$$

For the left leg  $AB$  we have

$$\begin{aligned} \int_A^B \frac{m_1 M dy}{F_1} &= \int_A^B \frac{F_1 y M dy}{F_1} \\ &= \int_A^B y M dy = \text{Area } \bar{Y} \Big]_A^B = \frac{M_b h}{2} \times \frac{2}{3} h - \frac{M_a h}{2} \times \frac{h}{3}. \end{aligned}$$

$$\int_A^D \frac{m_1 M ds}{F_1} = \int_A^B \frac{m_1 M dy}{F_1} + \int_B^C \frac{m_1 M dx}{F_1} + \int_C^D \frac{m_1 M dy}{F_1} = 0.$$

$$\frac{M_c h^2}{3} - \frac{M_d h^2}{6} + \frac{M_c h l}{2} + \frac{M_b h l}{2} - \frac{Ql^2 h}{9} + \frac{M_b h^2}{3} - \frac{M_a h^2}{6} = 0.$$

$$M_a h - M_b (3l + 2h) - M_c (3l + 2h) + M_d h + \frac{2}{3} Ql^2 = 0. \quad (a)$$

In a similar manner

$$EI\Delta_{dy} = \int_A^D \frac{m_2 M ds}{F_2} = l \left[ \text{Area} \right]_A^B + \left[ \text{Area } \bar{X} \right]_B^C = 0.$$

(For the right leg  $m_2 = 0$ . Therefore  $\int_C^D \frac{m_2 M dy}{F_2} = 0$ .)

$$l \left( \frac{M_a h}{2} - \frac{M_b h}{2} \right) + \frac{2}{9} Ql \times \frac{2l}{3} \times \frac{1}{2} \times \frac{2}{3} \times \frac{2l}{3} + \frac{2Ql}{9} \times \frac{1}{2} \times \frac{l}{3}$$

$$\times \left( \frac{2l}{3} + \frac{1}{3} \times \frac{l}{3} \right) - M_b \frac{l}{2} \times \frac{2}{3} l - \frac{M_c l}{2} \times \frac{l}{3} = 0.$$

$$3M_a h - M_b(3h + 2l) - M_c l + \frac{10Ql^2}{27} = 0. \quad (b)$$

Equation (c), expressed algebraically, is written thus:

$$M'\theta_d = \int_A^D \frac{m M ds}{EI} = 0.$$

It will be noted (Fig. 43*i*) that  $m$  for all members is equal to  $M'$ .

Therefore

$$M'\theta_d = \int_A^D \frac{M' M ds}{M' EI} = 0.$$

Therefore

$$\int_A^D M ds = \int_A^B M dy + \int_B^C M dx + \int_C^D M dy$$

$$= \text{Area} \left]_A^B + \text{Area} \left]_B^C + \text{Area} \left]_C^D = 0.$$

$$- \frac{M_a h}{2} + \frac{M_b h}{2} + \frac{M_b l}{2} + \frac{M_c l}{2} - \frac{2Ql}{9} \times \frac{l}{2} + \frac{M_c h}{2} - \frac{M_d h}{2} = 0.$$

$$M_a h - M_b(h + l) - M_c(h + l) + M_d h + \frac{2}{9} Ql^2 = 0. \quad (c)$$

Solving equations (a), (b), (c), and (f) simultaneously, we obtain the values for the moments  $M_a$ ,  $M_b$ ,  $M_c$ , and  $M_d$ .

$$M_b = \frac{Ql^2(37h + 8l)}{27(6h^2 + 13hl + 2l^2)}.$$

EXAMPLE 24

Vierendeel Truss

Given: A Vierendeel truss, consisting of two rectangular panels,  $h$  representing their height,  $l$  the length of one, and  $t$  the length of the other. The truss is unsymmetrically loaded with a load  $Q$  (Fig. 44a). Assume  $E$  and  $I$  constant throughout.

To find: The bending moments at the corners.

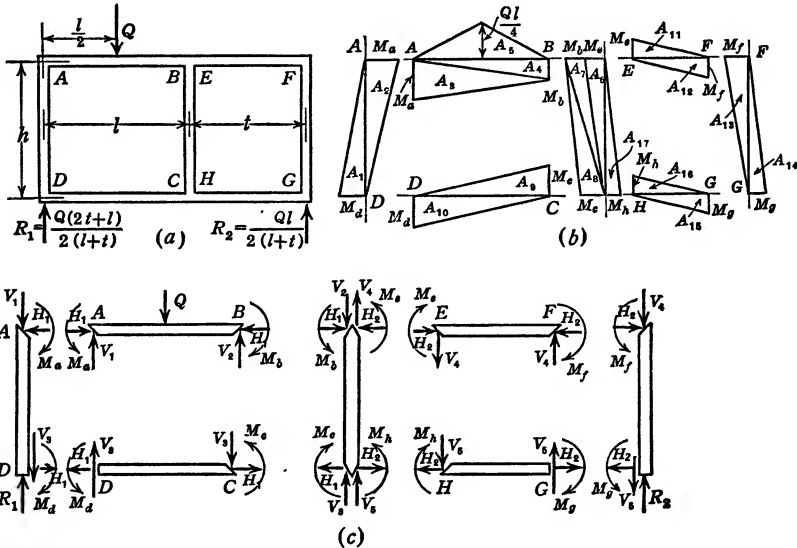

Fig. 44 (a-c). Vierendeel Truss.

Figure 44b shows the  $M$  bending-moment diagram for the entire structure. The  $M$  bending moment may be drawn in various ways. It is here drawn in accordance with the example demonstrated by Figs. 32f and 32i, page 57.

The free-body sketches of the various members, shown in Fig. 44c, are drawn as an aid in representing the moments. We must remember that at the outset we know nothing about any of the reactions at any section in the structure. All we know is that in coplanar structures any reaction at any section may be represented by a horizontal force, a vertical force, and a moment.

There is no way of determining in advance whether  $H_1$ , at left end of beam AB (Fig. 44c), acts to the right, and whether  $M_a$  acts counter-clockwise or not. It is immaterial, as long as Newton's third law of motion, that action and reaction at all points are always equal and

opposite, is kept in mind. Having shown  $H_1$  at point  $A$  in beam  $AB$  to be acting to the right, it must be shown at top of beam  $AD$  as operating to the left.

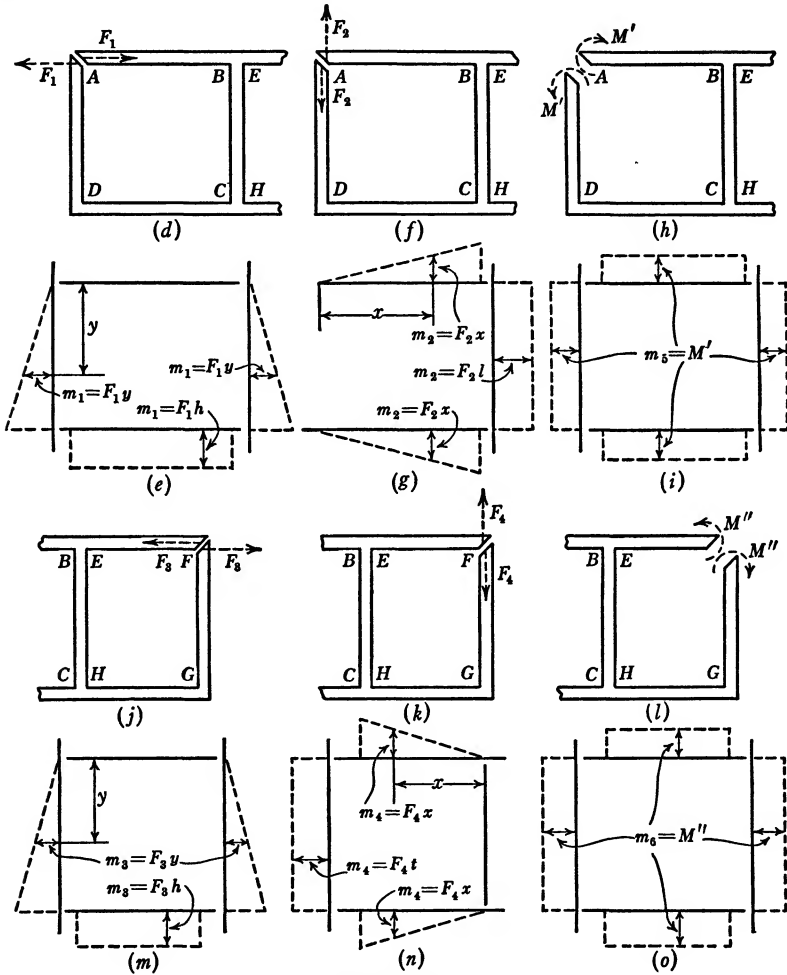

FIG. 44 (d-o).

Similarly, if  $M_a$  in the one case is shown as counterclockwise, it must be indicated in the other as clockwise. Furthermore, if  $M_a$ , at the left of beam  $AB$  (Fig. 44b), is negative, it must also be negative at top of beam  $AD$ .

If any one of the moments shown in Fig. 44c should be of a sense opposite to the one assumed, it will manifest itself by a negative value in the final answer.

There are eight unknowns, and thus eight independent equations are required. The first two equations we obtain from statics. Taking moments about  $B$  (Fig. 44c),

$$V_1 l = M_a + \frac{Ql}{2} - M_b.$$

Taking moments about  $C$ ,

$$V_3 l = M_d + M_c,$$

$$V_3 = R_1 - V_1.$$

Therefore

$$R_1 l = M_d + M_c + V_1 l.$$

$$R_1 l = M_a - M_b + M_d + M_c + \frac{Ql}{2}. \quad (a)$$

Taking moments about  $F$  (Fig. 44c),

$$V_4 t = M_e + M_f.$$

Taking moments about  $G$  (Fig. 44c),

$$V_5 t = M_h + M_g,$$

$$(V_4 + V_5)t = R_2 t = M_e + M_f + M_g + M_h. \quad (b)$$

To obtain the required additional six equations, the three conditions of restraint for each panel may be expressed in terms of elastic energy. For example, point  $A$  (Fig. 44a) will be displaced as a result of the loading of the truss. However, we may regard point  $A$ , at the left of beam  $AB$ , as the beginning, and point  $A$ , at the top of member  $AD$ , as the end of the structure. Since the two points are permanently adjacent, the horizontal displacement of the structure's beginning, relative to its end, is zero; or

$$\Delta_{A_x} = \int_A^A \frac{m_1 M ds}{F_1 EI} = 0.$$

By  $\int_A^A$  we mean a summation over all members of the structure wherever the product  $mM$  gives real values.

Similarly,

$$\Delta_{A_y} = \int_A^A \frac{m_2 M ds}{F_2 EI} = 0.$$

Since the vertical and horizontal tangents to the structure at point  $A$  permanently form a  $90^\circ$  angle, we may express it thus:

$$\theta_A = \int_A^A \frac{m_5 M ds}{M' EI} = 0.$$

To express  $\Delta_{A_x}$  algebraically we apply an auxiliary load  $F_1$  in a horizontal direction at point  $A$  (Fig. 44*d*). As nothing would be gained by leaving the structure statically indeterminate when  $F_1$  is applied, we follow the general rule (page 67) and cut the structure at  $A$  and  $F$ , thus making it statically determinate. Its  $m_1$  bending moment is shown in Fig. 44*e*. Note that  $m_1$ , for members  $AB$ ,  $EF$ ,  $FG$ , and  $GH$ , is zero.

$$\Delta_{A_x} = \int_A^A \frac{m_1 M dx}{F_1 EI} = 0$$

therefore becomes

$$\int_B^C \frac{m_1 M dy}{F_1 EI} + \int_C^D \frac{m_1 M ds}{F_1 EI} + \int_D^A \frac{m_1 M dy}{F_1 EI}$$

$EI$ , being constant, may be canceled, and the above expression may be written

$$\int_B^C \frac{F_1 y M dy}{F_1} + \int_C^D \frac{F_1 h M dx}{F_1} + \int_D^A \frac{F_1 y M dy}{F_1} = 0.$$

$$\text{Area } \bar{Y} \Big|_B^C + h \left[ \text{Area} \Big|_C^D + \text{Area } \bar{Y} \Big|_D^A \right] = 0.$$

$$\begin{aligned} & \left( + M_h \times \frac{h}{2} \times \frac{2}{3} h - \frac{M_e h}{2} \times \frac{h}{3} - \frac{M_b h}{2} \times \frac{h}{3} - \frac{M_c h}{2} \times \frac{2}{3} h \right) \\ & + \left( \frac{M_d l}{2} - \frac{M_c l}{2} \right) h + \left( \frac{M_d h}{2} \times \frac{2h}{3} - \frac{M_a h}{2} \times \frac{h}{3} \right) = 0. \end{aligned} \quad (c)$$

To express  $\Delta_{A_y}$  algebraically we apply an auxiliary vertical force  $F_2$  at  $A$  (Fig. 44*f*). Its  $m$  bending-moment diagram is shown in Fig. 44*g*. Note that it is zero for all members except  $AB$ ,  $BC$ , and  $CD$ .

$$\Delta_{A_y} = \int_A^A \frac{m_2 M ds}{F_2 EI} = 0,$$

then becomes

$$\int_A^B \frac{F_2 x M dx}{F_2} + \int_B^C \frac{F_2 l M dy}{F_2} + \int_C^D \frac{F_2 x M dx}{F_2} = 0,$$

or

$$\text{Area } \bar{X} \Big|_A^B + \left[ \text{Area} \Big|_B^C \right] l + \text{Area } \bar{X} \Big|_C^D = 0.$$

$$\begin{aligned}
 & \left( \frac{Ql}{4} \times \frac{l}{2} \times \frac{l}{2} - M_a \times \frac{l}{2} \times \frac{l}{3} - M_b \times \frac{l}{2} \times \frac{2l}{3} \right) \\
 & + \left( M_h \frac{h}{2} - \frac{M_e h}{2} - \frac{M_b h}{2} - \frac{M_c h}{2} \right) l \\
 & + \left( M_d \frac{l}{2} \times \frac{l}{3} - \frac{M_c l}{2} \times \frac{2l}{3} \right) = 0. \quad (d)
 \end{aligned}$$

To express algebraically the equation,

$$\theta_A = \int_A^A \frac{mMds}{M'EI} = 0,$$

we introduce an auxiliary moment  $M'$  at point  $A$  (Fig. 44*h*). Its  $m$  moment diagram is shown in Fig. 44*i* and for all four members of the left panel is expressed by the equation

$$m_5 = M'.$$

For three members of the right panel its value is zero.

$$\int_A^A \frac{m_5 M ds}{M'EI} = \int_A^A \frac{M' M ds}{M'EI} = \int_A^A \frac{M ds}{EI} = 0.$$

Therefore

$$\text{Area} \int_A^B + \text{Area} \int_B^C + \text{Area} \int_C^D + \text{Area} \int_D^A = 0.$$

$$\begin{aligned}
 & \left( \frac{Ql}{4} \times \frac{l}{2} - \frac{M_d l}{2} - \frac{M_b l}{2} \right) + \left( \frac{M_h h}{2} - \frac{M_b h}{2} - \frac{M_e h}{2} - \frac{M_c h}{2} \right) \\
 & + \left( \frac{M_d l}{2} - \frac{M_c l}{2} \right) + \left( \frac{M_d h}{2} - \frac{M_a h}{2} \right) = 0. \quad (e)
 \end{aligned}$$

In a manner similar to the analysis just completed we may write three conditions of restraint for the remaining right panel:

$$\Delta_{F_x} = 0, \quad \Delta_{F_y} = 0, \quad \text{and} \quad \theta_F = 0.$$

We cut the structure at  $A$  and  $F$  to simplify it and make it a statically determinate structure (general rule, page 67). We apply auxiliary forces  $F_3$  and  $F_4$  in the direction of  $x$  and  $y$  at point  $F$  (Figs. 44*j* and 44*k*) and draw their respective  $m$  moment diagrams (Figs. 44*m* and 44*n*). We apply an auxiliary moment,  $M''$  (Fig. 44*l*), and draw its  $m$  moment diagram (Fig. 44*o*).

$$\Delta_{F_x} = \int_F^F \frac{m_3 M ds}{F_3 EI} = 0; \left[ \text{Area } \bar{Y} \right]_F^G + h \left( \text{Area} \right)_G^H + \left[ \text{Area } \bar{Y} \right]_H^E = 0.$$

$$\left( \frac{M_g h}{2} \times \frac{2}{3} h - \frac{M_f h}{2} \times \frac{h}{3} \right) + h \left( \frac{M_g t}{2} - \frac{M_h t}{2} \right)$$

$$+ \left( \frac{M_c h}{2} \times \frac{2}{3} h + \frac{M_b h}{2} \times \frac{h}{3} + \frac{M_e h}{2} \times \frac{h}{3} - \frac{M_h h}{2} \times \frac{2h}{3} \right) = 0. \quad (f)$$

$$\Delta_{F_y} = \int_F^F \frac{m_4 M ds}{F_4 EI} = 0; \left[ \text{Area } \bar{X} \right]_G^H + t \left[ \text{Area} \right]_H^E + \left[ \text{Area } \bar{X} \right]_E^F = 0.$$

$$\left( \frac{M_g t}{2} \times \frac{t}{3} - \frac{M_h t}{2} \times \frac{2t}{3} \right) + t \left( \frac{M_c h}{2} + \frac{M_b h}{2} + \frac{M_e h}{2} - \frac{M_h h}{2} \right)$$

$$+ \left( \frac{M_e t}{2} \times \frac{2t}{3} - \frac{M_f t}{2} \times \frac{t}{3} \right) = 0. \quad (g)$$

$$\theta_F = \int_F^F \frac{m_6 M ds}{M'' EI} = 0.$$

For all four members  $m$  is equal to  $M''$  (Fig. 44o). Therefore

$$\int_F^F \frac{m_6 M ds}{M'' EI} = \int_F^F \frac{M'' M ds}{M'' EI} = \int_F^F \frac{M ds}{EI} = 0.$$

$EI$ , being constant, may be canceled, and

$$\int_F^F M ds = \int_F^G M dy + \int_G^H M dx + \int_H^E M dy + \int_E^F M dx = 0;$$

$$\text{Area} \left]_F^G + \text{Area} \left]_G^H + \text{Area} \left]_H^E + \text{Area} \left]_E^F = 0.$$

$$\frac{M_g h}{2} - \frac{M_f h}{2} + \frac{M_g t}{2} - \frac{M_h t}{2} + \frac{M_c h}{2} + \frac{M_b h}{2}$$

$$+ \frac{M_e h}{2} - \frac{M_h h}{2} + \frac{M_e t}{2} - \frac{M_f t}{2} = 0. \quad (h)$$

The simultaneous solution of the above eight equations will give values for the eight bending moments at the eight corners.

This foregoing example is typical. A Vierendeel truss of any number of panels and under any condition of loading may be analyzed similarly. The setting up of the required number of equations will be no more difficult than it was in this example. The simultaneous solution of more than eight equations, however, is disproportionately more bother-



some, and the advisability of seeking a solution based upon the theory of elasticity in more complicated problems may be questioned. (See the chapter on limitations of elastic energy theory, page 264.)

Since we are applying the theory of elasticity, the author feels that the elastic energy theory, in problems of this kind, offers a distinct advantage in that a great share of the work can be done by means of sketches.

With reference to the analysis of the foregoing type of problem a few important points may, for purposes of emphasis, be reiterated.

1. In the philosophy of elastic energy there can be no objection to the elimination of as many restraints as desired in order to make a structure statically determinate before any auxiliary forces are applied.

2. Only when there are real values of both  $m$  and  $M$  for any member do we have stored elastic energy of the kind in which we are interested. When either  $m$  or  $M$  is zero, the product  $mM$  will, of course, be zero.

3. The  $m$  diagram will always be either a triangle or a rectangle.

When the  $m$  diagram is a triangle the expression  $\int mMdx$  is equivalent to Area  $\bar{X}$ , the moment of the area under the  $M$  bending-moment diagram about the vertex of the  $m$  bending-moment diagram. When  $m$  is a rectangle the expression  $\int mMdx$  is always a constant, multiplied by the corresponding  $M$  bending-moment area.

4. Signs are of the greatest importance in writing the equations. As pointed out with reference to Fig. 44c, it does not matter in what direction the forces are shown to operate, but they must be shown in agreement with Newton's third law, action and reaction are equal and opposite.

The expressions "Area" and "Area  $\bar{X}$ " are positive when  $m$  and  $M$  are of the same sign, and negative when they are of opposite sign. Thus for the central member, for example, the area  $\frac{M_c h}{2}$  appears as negative in equations (c), (d), and (e) because it was of opposite sign from  $m$  in Figs. 44e, 44g, and 44i, and appears as positive in equations (f), (g), and (h), because it was of the same sign as  $m$  in Figs. 44m, 44n, and 44o.

NOTE. Attention is here called to *Bulletin* 108 of the University of Illinois Experimental Station, entitled "Analysis of Statically Indeterminate Structures," 1918, by Wilson, Richart, and Weiss. This bulletin is devoted to the analysis of bents and culverts by the slope deflection method. The authors develop the slope deflection method from the differential equation of curvature,  $\frac{d^2y}{dx^2} = \frac{M}{EI}$ . It might be equally well derived from the elastic energy equations used in this book. The author does not favor the development of special methods. In connection with

the analysis of bents and culverts, however, he cannot fail to call attention to the above bulletin, because it is outstanding in its scope and accuracy. In it one may find the answers to the analysis of statically indeterminate structures with straight members, composed of a great variety of shapes and subject to a great variety of loadings.

### SYMMETRY AND ANTI-SYMMETRY

In example 20 (page 76) we discussed the built-in beam subject to a uniformly distributed load. We found from symmetry considerations that the reactions at each end were identical and that therefore we needed only a single elasticity equation to effect a solution. In example 21 (page 77), in which we discussed the built-in beam subject to a uniformly varying load, we found that the reactions at each end of the beam were dissimilar and that therefore two elasticity equations were required, in addition to the equations of static equilibrium, to effect a solution.

Symmetry considerations are twofold. They apply to the loading as well as to the geometric relations of the structure. The structures as given in examples 20 and 21 are geometrically symmetrical. In example 20 the loading also is symmetrical, but in example 21 it is not.

**Rule for Symmetry.** *A structure subject to a certain loading condition is said to be symmetrical about an axis of symmetry when, on being turned about this axis through  $180^\circ$ , the resulting structure and loading are identical with the original.*

When symmetry conditions exist relative to the geometric proportions of the structure and not relative to the loading then advantage may be taken of what is called anti-symmetry.

**Rule for Anti-Symmetry.** *A structure subject to a certain loading condition is said to be anti-symmetrical about an axis of anti-symmetry when, on being turned about this axis of anti-symmetry through  $180^\circ$  and the sense of the loading reversed, the resulting structure and loading are identical with the original.*

Any loading on a geometrically symmetrical structure may be represented as the equivalent of two component loadings, one symmetrical, the other anti-symmetrical. Symmetry and anti-symmetry considerations are valid only when the principle of superposition applies, or when the load-deformation relationship is linear.

### EXAMPLE 25

Figure 45a presents the same problem that was discussed in example 21 (page 77). Figures 45b and 45c, combined, are identical with Fig. 45a.

REDUNDANT BEAMS

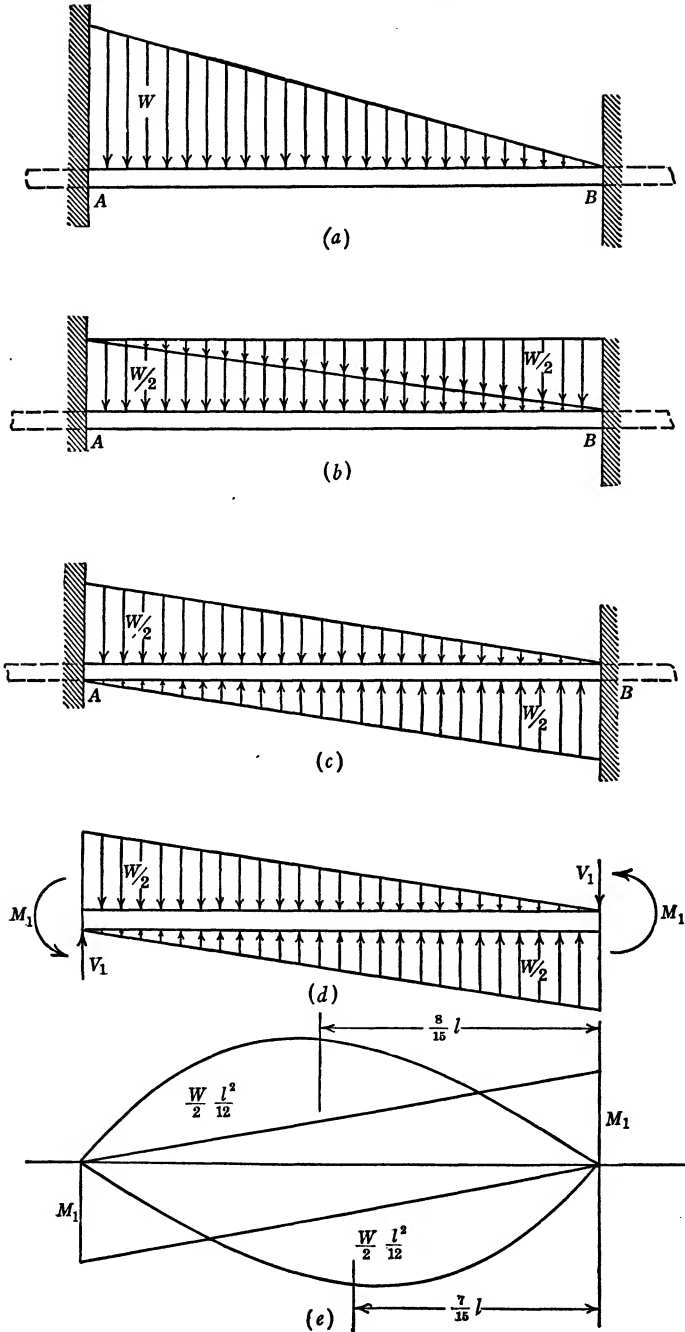

FIG. 45.

Figure 45*b* presents a built-in beam subject to a uniformly distributed load  $W$ . This problem was solved in example 20. There we found the moments at each wall to be  $\frac{wl^2}{12}$  or  $\frac{Wl}{12}$ , while the shear at each wall was found as  $\frac{wl}{2}$  or  $\frac{W}{2}$ .

Figure 45*d* is the free-body sketch for Fig. 45*c*. Both Figs. 45*d* and 45*c* are anti-symmetrical with respect to a vertical axis through the center of the structure. If Fig. 45*c* or 45*d* is rotated 180° about this axis and the sense of the loading reversed (the arrows on the figures reversed), then the resulting figures are identical with Fig. 45*c* or 45*d*.

Figure 45*e* represents the bending-moment diagram for the structure shown in Fig. 45*c* or 45*d*. The moment of these bending-moment areas about point  $B$  (see case V of Appendix I) is

$$\frac{W}{2} \cdot \frac{l^2}{12} \cdot \frac{8l}{15} + \frac{M_1 l}{2} \cdot \frac{l}{3} - \frac{W}{2} \cdot \frac{l^2}{12} \cdot \frac{7l}{15} - \frac{M_1 l}{2} \cdot \frac{2l}{3} = 0.$$

Therefore

$$M_1 = \frac{Wl}{60}.$$

If, for Fig. 45*d*, we write  $\Sigma M = 0$ , we obtain

$$2M_1 - V_1 l + \frac{W}{2} \cdot \frac{l}{3} = 0.$$

Therefore

$$V_1 = \frac{2W}{10}.$$

Combining these values for  $M_1$  and  $V_1$  with the values for the moment and shear at the ends of the beam as given in Fig. 45*b*, we obtain the values for the reactions of the beam shown in Fig. 45*a*. Thus:

$$M_a = \frac{Wl}{12} + \frac{Wl}{60} = \frac{Wl}{10}; \quad V_a = \frac{W}{2} + \frac{2W}{10} = \frac{7W}{10}.$$

$$M_b = \frac{Wl}{12} - \frac{Wl}{60} = \frac{Wl}{15}; \quad V_b = \frac{W}{2} - \frac{2W}{10} = \frac{3W}{10}.$$

### EXAMPLE 26

Figure 46(I) represents a culvert loaded with a uniformly distributed load  $w_2$  pounds per foot over the top, and with a hydrostatic pressure  $\frac{w_1 y}{l}$  against one of the sides. Since we are primarily concerned with

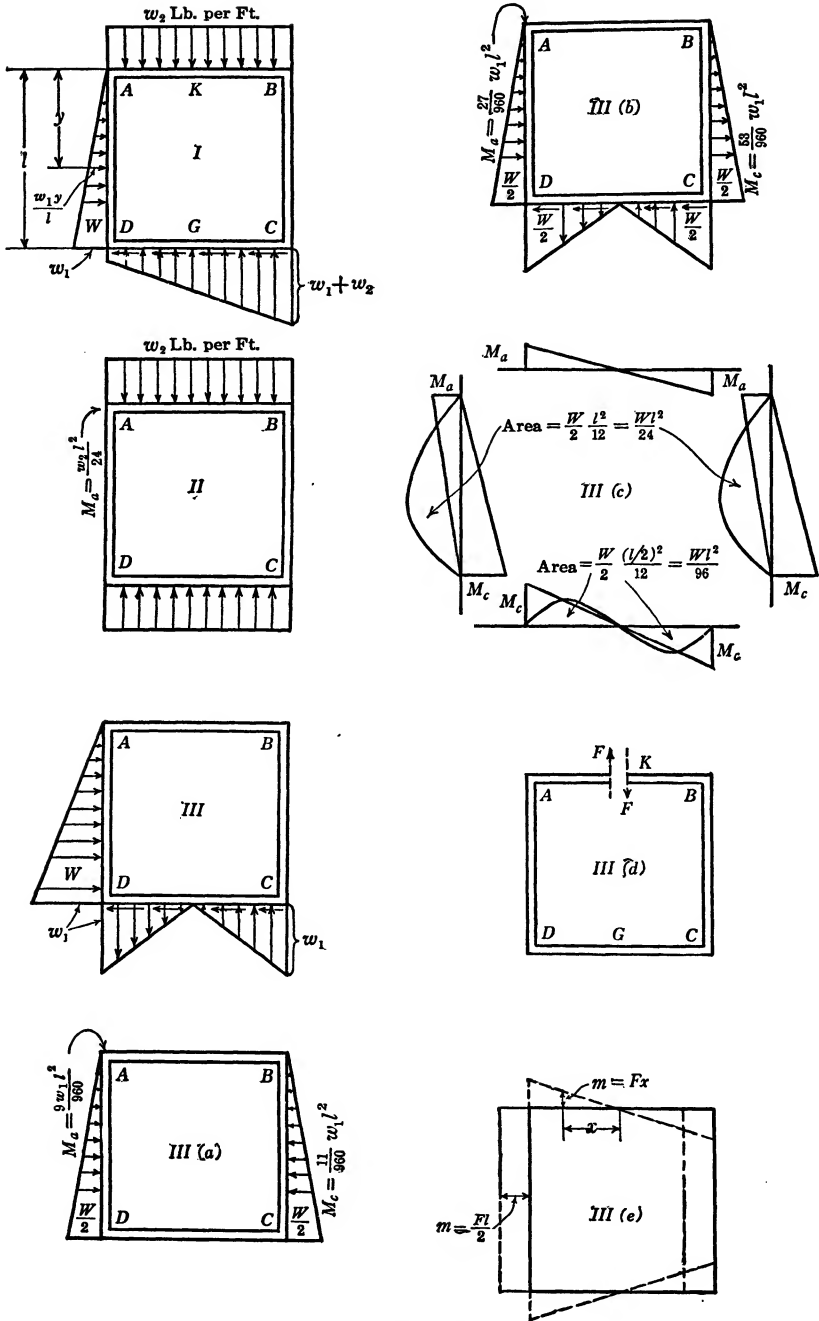

FIG. 46 (I-IIIe).

illustrating a method of solution we shall assume the length and width of the culvert to be equal as well as  $E$  and  $I$  to be constant. The method used would be equally applicable, even though the length differed from the height and  $E$  and  $I$  were not constant, so long as the culvert had a geometric axis of symmetry.

Figure I might be resolved into Figs. II and III. Figure III in turn might be resolved into Figs. IIIa and IIIb. The analysis of the problems presented by Figs. II and IIIa does not require special attention. The culvert as shown in Fig. IIIb is anti-symmetrical; and so is its bending-moment diagram (Fig. IIIc). The auxiliary loading represented by Fig. IIId and its bending-moment diagram, Fig. IIIe, are also anti-symmetrical. Anti-symmetry shows that no tension is transmitted through the member  $AB$  and that the bending moment at the midpoint between  $A$  and  $B$ , as well as the moment at the midpoint between  $C$  and  $D$ , is zero. Draw a free-body sketch of the right half of Fig. IIIb. Rotate this sketch about the axis of anti-symmetry, and then reverse all the arrows. This will show that the condition of zero moment and zero tension or compression at the midpoint is the only condition consistent with that of anti-symmetry as well as with Newton's third law. If we apply an  $F$  loading as shown in Fig. IIId, the  $m$  bending moments will appear as given in Fig. IIIe. Since the auxiliary loading is an internal loading its external work will be zero. Therefore:  $\int_A^A \frac{mMds}{EI}$

$= 0 = \int_A^A mMds$ . As the result of the anti-symmetry of both  $m$  and  $M$  bending moments, we have

$$\begin{aligned} \int_A^A mMds &= 2 \int_K^G mMds = 0. \\ \int_K^G mMds &= \text{Area } \bar{x} \Big]_K^B + \frac{l}{2} \text{Area} \Big]_B^C + \text{Area } \bar{x} \Big]_C^G \\ &= M_a \frac{l}{2} \cdot \frac{1}{2} \cdot \frac{2}{3} \cdot \frac{l}{2} + \frac{l}{2} \left( \frac{M_a l}{2} - \frac{M_c l}{2} + \frac{Wl^2}{24} \right) \\ &\quad - \frac{M_c l}{2} \cdot \frac{1}{2} \cdot \frac{2}{3} \cdot \frac{l}{2} - \frac{Wl^2}{96} \cdot \frac{8}{15} \cdot \frac{l}{2} = 0. \end{aligned}$$

Since there is no horizontal reaction at  $A$  we obtain from statics

$$M_a + M_c = \frac{W}{2} \cdot \frac{l}{3} = \frac{Wl}{6}.$$

Solving simultaneously, we obtain

$$M_a = M_b = \frac{27}{960} w_1 l^2,$$

$$M_c = M_d = \frac{53}{960} w_1 l^2.$$

In Fig. I,

$$M_a = \frac{w_2 l^2}{24} + \frac{9w_1 l^2}{960} - \frac{27}{960} w_1 l^2 = \frac{w_2 l^2}{24} - \frac{18}{960} w_1 l^2.$$

### CURVED BEAMS

#### EXAMPLE 27

*Given:* A semicircular ring, hinged at its extremities and loaded with a concentrated load  $Q$  at the center (Fig. 47a). The curvature of the beam is relatively small.  $E$  and  $I$  are assumed constant.

*To find:* The horizontal reaction  $H$ .

The hinges at points  $A$  and  $C$  insure zero moments and zero displacement at those points. We may say that

$$\Delta_{C-A} = 0,$$

or, since the structure is symmetrical about the center line, that

$$\Delta_{(C-B)_x} = 0.$$

The latter equation expresses the horizontal displacement of the point  $C$  relative to the point  $B$ .

The general expression for  $\Delta$ , in terms of elastic energy, is expressed by formula (5):

$$\Delta = \int \frac{mMds}{FEI}.$$

In this formula  $ds$  stands for the element of length much the same as  $dx$  and  $dy$  represent this element in the foregoing examples involving structures composed of straight beams.

In the proof of formula (5) we make use of the formula

$$\text{Stress} = \frac{Mv}{I}.$$

This flexure formula is not strictly applicable to curved beams. The stress analysis of curved beams is a rather complicated matter. However, in a large group of important engineering structures, varying in size from watch springs to arches, the curvature of the beam is relatively small (the thickness of the beam compared to the radius of curvature is small), and the formula

$$\text{Stress} = \frac{Mv}{I}$$

holds without appreciable error.

In evaluating the expression

$$\int mMds$$

we cannot apply the process of graphical summation used in examples 11 to 26. We may, however, conceive of our structure as divided in short segments,  $ds$ , evaluate  $mMds$  for each segment, and complete the summation by ordinary addition. The procedure is thus seen to be similar to the one we followed in analyzing trusses, and a tabular arrangement will also serve the purpose here.

The loaded semicircular beam of Fig. 47a is assumed divided in nine equal segments of length  $ds$  (Fig. 47c). With a radius  $R = 100$  in.,  $ds = 17.45$  in., the vertical and horizontal distances of the midpoints of the segments from the point  $C$  are partly shown in Fig. 47c, and may also be found in the table below.

In the column  $m$  are found the values of  $m$  for the midpoints of the segments caused by the auxiliary load  $F$  as applied in Fig. 47b. In the column  $M$  are found the values of  $M$  for the midpoints of the segments caused by the actual loads,  $H$  and  $\frac{Q}{2}$  (Fig. 47a).

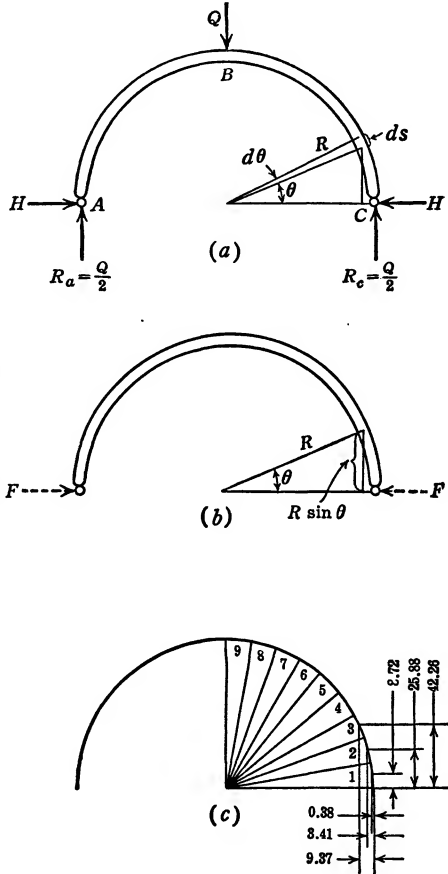

FIG. 47.



Segment	Horizontal Distance from C	$m = (\text{Vert. Distance from } C) \times F$	$M$	$mM$
1	0.38	8.72F	$8.72H - 0.38 \frac{Q}{2}$	$76.04FH - 3.31 \frac{FQ}{2}$
2	3.41	25.88F	$25.88H - 3.41 \frac{Q}{2}$	$669.77FH - 88.25 \frac{FQ}{2}$
3	9.37	42.26F	$42.26H - 9.37 \frac{Q}{2}$	$1,785.90FH - 395.97 \frac{FQ}{2}$
4	18.08	57.36F	$57.36H - 18.08 \frac{Q}{2}$	$3,290.16FH - 1,037.07 \frac{FQ}{2}$
5	29.29	70.71F	$70.71H - 29.29 \frac{Q}{2}$	$5,000.00FH - 2,071.10 \frac{FQ}{2}$
6	42.64	81.91F	$81.91H - 42.64 \frac{Q}{2}$	$6,709.24FH - 3,497.50 \frac{FQ}{2}$
7	57.74	90.63F	$90.63H - 57.74 \frac{Q}{2}$	$8,213.80FH - 5,233.00 \frac{FQ}{2}$
8	74.12	96.60F	$96.60H - 74.12 \frac{Q}{2}$	$9,301.56FH - 7,160.00 \frac{FQ}{2}$
9	91.30	99.62F	$99.62H - 91.30 \frac{Q}{2}$	$9,924.14FH - 9,095.31 \frac{FQ}{2}$
				$\Sigma mM =$
				$44,970.61FH - 28,581.51 \frac{FQ}{2}$

$$\Sigma mMs = \left( 44,970FH - 28,581 \frac{FQ}{2} \right) 17.45.$$

$E$  and  $I$  being constant, the expression

$$\Delta_{(C-B)_x} = \int \frac{mMs}{FEI} = 0$$

reduces to

$$44,970H = 28,581 \frac{Q}{2}.$$

Therefore

$$H = 0.3178Q.$$

In this computation the values for the horizontal and vertical distances from the midpoint of the segments to point  $C$  were found from a

trigonometric table instead of being scaled from a drawing. The computations are carried out to a greater degree of accuracy and the answer is given to a greater number of digits than would be warranted in good engineering practice. This is done to permit a comparison with the answer which we will presently obtain by means of analytic integration.

To accomplish the same analysis of our problem by means of integral calculus we let

$$ds = R d\theta,$$

$$m = FR \sin \theta,$$

$$M = HR \sin \theta - \frac{Q}{2} (R - R \cos \theta).$$

Then

$$\Delta_{(C-B)_x} = \int_C^B \frac{mM ds}{FEI} = 0$$

becomes

$$\int_0^{\pi/2} \frac{FR \sin \theta}{FEI} \left\{ HR \sin \theta - \frac{Q}{2} (R - R \cos \theta) \right\} R d\theta = 0.$$

$E$ ,  $I$ , and  $r$  being constant, this reduces to

$$\int_0^{\pi/2} \left( H \sin^2 \theta - \frac{Q}{2} \sin \theta + \frac{Q}{2} \sin \theta \cos \theta \right) d\theta = 0,$$

$$H \left( \frac{\theta}{2} - \frac{\sin 2\theta}{4} \right) + \frac{Q}{2} \cos \theta + \frac{Q \sin^2 \theta}{2} \Big|_0^{\pi/2} = 0,$$

$$\frac{H\pi}{4} - \frac{Q}{2} + \frac{Q}{4} = 0,$$

$$H = \frac{Q}{\pi} = \frac{1}{3.1416} Q = 0.3183Q.$$

In the analysis of straight beams we have freely resorted to graphic integration. In the analysis of structures of circular outline we may frequently resort to a similar procedure. For example, in the preceding problem we might say

$$m = Fy,$$

$$M = Hy - \frac{Q}{2} x,$$

and  $\int_0^{\pi/2} mM ds = 0$  becomes  $\int_0^{\pi/2} Fy \left( Hy - \frac{Q}{2} x \right) ds = 0.$

Therefore

$$H = \frac{Q}{2} \frac{\int_0^{\pi/2} xy ds}{\int_0^{\pi/2} y^2 ds}.$$

The values of  $\int_0^{\pi/2} xy ds$  and  $\int_0^{\pi/2} y^2 ds$  are obtained from the Appendix, page 270. Thus

$$H = \frac{Q0.5R^34}{2\pi R^3} = \frac{Q}{\pi}.$$

### EXAMPLE 28

#### Piston Ring Design

To find the shape of a piston ring which, when installed in a cylinder, will assume a perfectly circular outline and will bear against the cylinder wall with uniformly distributed radial pressure  $p$  pounds per square inch.

In Fig. 48a the solid black line represents a split ring of a perfectly circular outline of elastic material of a width  $b$  (measured radially) and a thickness  $t$ . When the ring is loaded with a radial pressure  $p$  pounds per square inch (the pressure per length  $ds$  will then be  $ptds$ ), it will deform and assume the shape indicated by the dash line (Fig. 48a).

Let us next consider Fig. 48b where the solid black line represents the outline of a non-circular split ring in an unstressed condition. The solid black line in Fig. 48b is identical with the dashed line in Fig. 48a. When this ring, represented by Fig. 48b, is loaded with a uniformly distributed radial pressure ( $pt$  pounds per linear inch) directed inwardly, its final elastic curve will be the perfect circle represented by the dashed line (Fig. 48b), which is identical with the perfect circle represented by the solid black line (Fig. 48a).

It would seem then that the only remaining step necessary for the solution of our problem is to obtain the elastic curve of a circular split ring loaded in the manner of Fig. 48a and manufacture a ring to that shape. Several procedures suggest themselves. Procedure one: Obtain the elastic curve of a circular ring, loaded in a manner of Fig. 48a, by means of the elastic energy equations. The point on the ring marked by the angle  $\theta$  moves radially a distance  $\Delta_r$  and tangentially a distance  $\Delta_t$ .

The bending moment  $M$  in the ring, at a point marked by the angle  $\phi$ , and caused by the actual loading  $pt$ , is

$$M = \int_0^\phi (pt ds) R \sin(\phi - \alpha) = ptR^2 \int_0^\phi \sin(\phi - \alpha) d\alpha$$

$$= ptR^2 (1 - \cos \phi)$$

$$\Delta_r = \frac{\int_\alpha^\pi mM ds}{FEI}$$

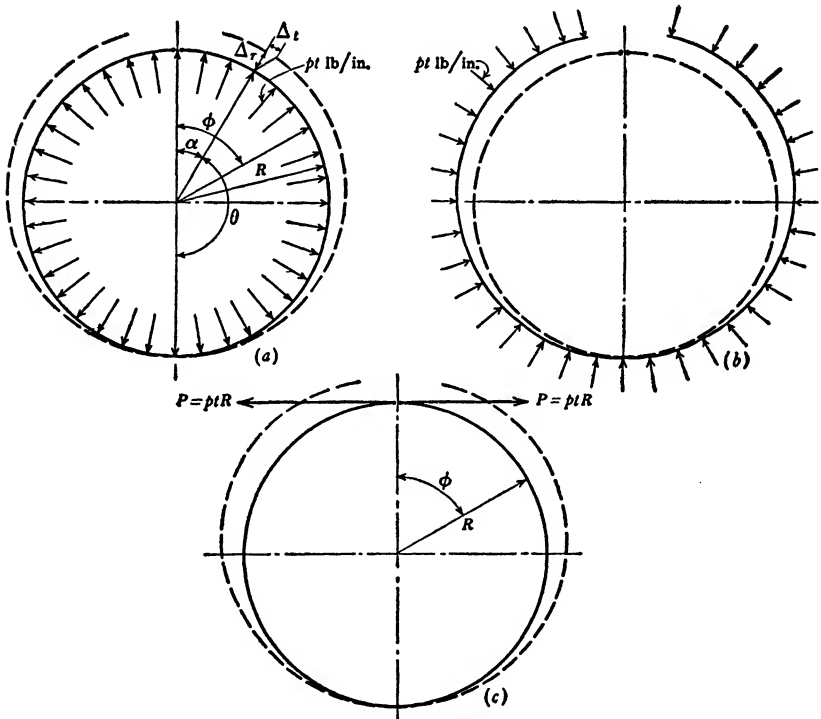

FIG. 48. The Piston Ring.

In order to obtain the algebraic expression for  $m$  we load the ring at the point marked by the angle  $\alpha$  with an auxiliary force  $F$ .

Thus,

$$m = FR \sin(\phi - \alpha)$$

Then

$$\frac{EI\Delta_r}{ptR^4} = \int_{\alpha}^{\pi} \sin(\phi - \alpha)(1 - \cos \phi) d\phi = 1 - \left(\frac{\pi - \alpha}{2}\right) \sin \alpha + \cos \alpha,$$

$$\Delta_r = \frac{ptR^4}{EI} \left(1 - \cos \theta + \frac{\theta}{2} \sin \theta\right).$$

The expression for the tangential displacement is

$$\Delta_t = \int_{\alpha}^{\pi} \frac{mMs}{FEI}$$

where

$$m = FR\{1 - \cos(\phi - \alpha)\}.$$

$$M = ptR^2(1 - \cos \phi).$$

Thus,

$$\begin{aligned} \frac{EI\Delta_t}{ptR^4} &= \int_{\alpha}^{\pi} \{1 - \cos(\phi - \alpha)\}(1 - \cos \phi) d\phi \\ &= (\pi - \alpha) + \frac{(\pi - \alpha)}{2} \cos \alpha - \frac{\sin \alpha}{2}. \end{aligned}$$

$$\Delta_t = \frac{ptR^4}{EI} \left(\theta - \frac{\theta}{2} \cos \theta - \frac{\sin \theta}{2}\right).$$

When  $\theta = \pi$ , then

$$\Delta_t = \frac{3\pi ptD^4}{32EI} = \frac{3\pi D^3 P}{16EI},$$

where  $P = ptR$ .

$$\text{Stress} = s = \frac{Mc}{I} = \frac{6PD}{tb^2};$$

therefore, when  $\theta = \pi$ , then  $\Delta_t$  may also be expressed as

$$\Delta_t = \frac{3\pi D^2 s}{8bE}.$$

The total gap is  $2\Delta_t$ .

Procedure two: Load a circular split ring with a uniformly distributed radial pressure and obtain the resultant elastic curve by direct measurement. This procedure, however, involves serious difficulties.

Procedure three: Consider Fig. 48c, which represents a perfectly circular split ring identical with the solid black line in Fig. 48a, except that it is loaded with two equal and opposite forces  $P$  at the ends of the ring. The bending-moment equation for a circular split ring loaded in this manner is

$$M = PR(1 - \cos \phi).$$

When  $P = ptR$ , this bending-moment equation for a ring loaded in the manner of Fig. 48c becomes

$$M = ptR^2(1 - \cos \phi),$$

which equation is identical with the one for the ring loaded in the manner of Fig. 48a. If the bending-moment equations for the two rings (Fig. 48a and Fig. 48c) are identical and both rings are otherwise identical, then their elastic curves also must be identical. (Not only are the bending moments under loading conditions represented by Fig. 48a and 48c identical, but the shears also are identical. The direct compression under the two types of loading differ. In Fig. 48a it is  $ptR [\cos \phi - 1]$ , while in Fig. 48c it is  $ptR \cos \phi$ . As compared with the bending effect on the elastic functioning of slender structures, the effect of direct compression is inconsequential. It is ignored in this analysis.)

Procedure two has its disadvantages because of the difficulty of obtaining a uniformly distributed radial pressure. It now appears that we can obtain identical results merely by loading a ring in the manner of Fig. 48c, which offers little difficulty.

Suppose that we take a ring of any shape, cast of a material which need not obey Hooke's law (stress proportional to strain), but which must be elastic in the sense that it returns to its original shape when the load is removed. A section of this ring is cut out and the ring is drawn together with two equal and opposite tangential forces acting in a sense opposite to that shown in Fig. 48c. When thus loaded this ring is machined to a true round shape. Neither the thickness  $t$  nor the radial depth  $b$  need be uniform.

When the force which closes the ring is removed the effect will be the same as if a force of equal magnitude but opposite sense (as shown in Fig. 48c) were superimposed. When next the ring is fitted in a cylinder of exactly the size to which the ring is machined the effect will be equivalent to a uniformly distributed radial loading as shown in Fig. 48a. Should an extra pressure at the gap be required to prevent flutter, it may be obtained in a similar manner.

If we followed the conventions of the guidebook publishers, we would mark this "procedure three" with four stars. From the point of view of engineering philosophy it is a nearly perfect solution. It is one problem in which, so far as the bending and the shear effects are concerned, the principle of superposition may be truly said to apply.

It is not to be inferred, however, that the foregoing is the final answer to piston-ring-design problems. We have discussed only the problem that applies to rings of circular shape combined with uniform

radial pressure. Various other problems are involved in piston-ring design.

### RINGS SUBJECTED TO VARIOUS LOADINGS

#### EXAMPLE 29

*Given:* A circular ring supported at one point and loaded by its own weight (Fig. 49c). The curvature of the ring is small compared to its thickness, so that the formula,  $\text{Stress} = \frac{Mv}{I}$ , may be assumed to apply. The material is homogeneous and elastic ( $E$  is constant), and the cross section of the ring is constant. Therefore,  $I$  is constant.

*To find:* The maximum bending moment in the ring.

We present two solutions: first, by means of tabular summation; second, or alternative solution, by means of analytic integration. (Throughout this text the semi-graphic solution is stressed, because it constitutes the most general as well as the simplest method. In problems such as this one, analysis by means of tabular summation is still the most general method. If, as in our example, the moment of inertia,  $I$ , varies, or if the shape of the ring deviates from a perfect circular shape, tabular summation is clearly the best method to use. [See Example 34, page 149.] However, when the shape of the ring is a perfect circle easily expressed in polar coordinates, and when the moment of inertia and the modulus of elasticity are constant, the analytic integration method is the simpler of the two.)

#### FIRST SOLUTION:

Let  $R$  = radius of ring (in Fig. 46a it is drawn as 100 units).

$$u_1 = \text{weight of one cubic inch of material (for steel } u_1 = \frac{490}{1728} \\ = 0.2835 \text{ lb. per cu. in.)}$$

$A$  = cross section of ring.

(If we have under consideration a section of a water pipe of length  $b$  [perpendicular to the plane of the sketch] and thickness  $t$ ,  $A = bt$ , and  $I = \frac{bt^3}{12}$ .)

Figure 49a represents one half of the ring. Since the ring is symmetrical about a vertical center line there can be no vertical force at  $B$ . From the equation  $\Sigma F_y = 0$ , we conclude that the total weight of the right half of the ring,  $u_1 A \pi R$ , is balanced by one-half the reaction at  $C$ , as shown in Fig. 49a. The horizontal forces  $H$  at  $B$  and  $C$  are the only horizontal forces acting on the free body. Their sum must be zero; therefore, they must be equal and opposite. At both top and bottom

we have an unknown bending moment, here indicated by  $M_1$  and  $M_2$ . We thus have three unknowns,  $H$ ,  $M_1$ , and  $M_2$ , requiring three simultaneous equations for their solution. In arguing that the forces  $H$ , at

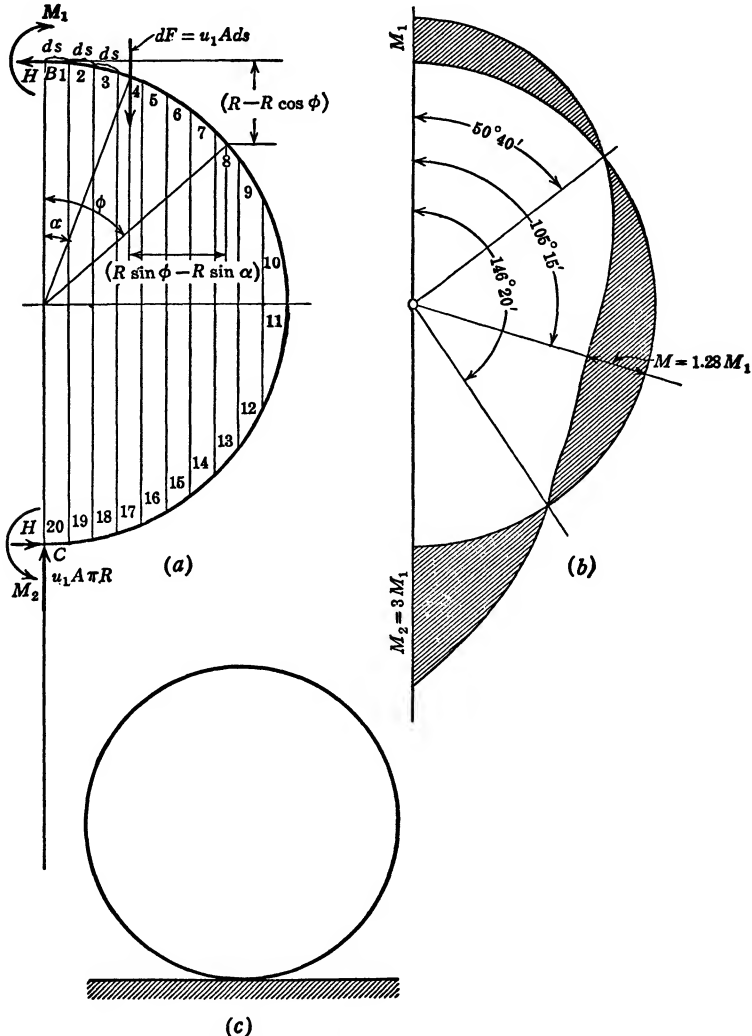

FIG. 49. Circular Ring Loaded by Its Own Weight.

points  $B$  and  $C$ , are equal and that there is no vertical force at  $B$ , we have used the equations  $\Sigma F_y = 0$  and  $\Sigma F_x = 0$ . These equations are taken from statics, leaving available for use the only remaining statics equation, namely,  $\Sigma M = 0$ . The centroid of a semicircular ring is  $\frac{2R}{\pi}$ .



Therefore

$$M_1 + u_1 A \pi R \left( \frac{2R}{\pi} \right) - M_2 - 2HR = 0. \quad (a)$$

From the theory of elastic energy we obtain two more equations. One of these is based upon the limiting condition that the tangents to the ring at points  $B$  and  $C$  always remain horizontal. The change of slope between  $B$  and  $C$  caused by the loading (not caused by the initial curvature of the beam) is zero. Therefore

$$\theta \Big|_B^C = 0. \quad (b)$$

The other equation is built upon the limiting condition that, as the ring is loaded and thus deformed, point  $B$  is displaced downward along the vertical center line. Therefore,  $\Delta_{(B-C)_x}$ , the horizontal displacement of point  $B$  relative to the point  $C$ , is zero.

$$\Delta_{(B-C)_x} = 0. \quad (c)$$

The general equation for change of slope is formula (6):

$$\theta \Big|_B^C = \int_B^C \frac{mM ds}{M' EI}.$$

If we imagine an auxiliary moment  $M'$  applied at  $B$ , then  $m$ , for all points of the structure, is equal to  $M'$ . Therefore

$$\theta \Big|_B^C = \int_B^C \frac{M' M ds}{M' EI} = 0$$

or

$$\int_B^C M ds = 0.$$

Let the right half of the ring be divided into twenty parts so that the horizontal projection of each element shall be a constant (Fig. 49a). This, of course, gives a variable length to the quantity  $ds$  for each part of the structure. We might have made  $ds$  constant and the horizontal projections variable. It is a matter of individual judgment how we divide the ring, provided that we make a relatively large number of divisions  $ds$ , compute  $Mds$  for each division, and add the products  $Mds$  for the entire length of the beam between  $B$  and  $C$ .

$$M = H(R - R \cos \phi) - M_1 + \sum_0^\phi (R \sin \phi - R \sin \alpha) dF.$$

Note that  $M$  consists of three factors. The first is  $H(R - R \cos \phi)$ . (Coefficient  $[R - R \cos \phi]$  is listed in table on page 113.) The second is  $M_1$ , and is a constant. The third factor,  $\sum_0^\phi (R \sin \phi - R \sin \alpha) dF$ , represents the moment at the point in the beam marked by  $\phi$  and is caused by the dead weight of the beam to the left of this point. The weight of each element is designated as,  $dF = u_1 A ds$ ; its moment is  $dF(R \sin \phi - R \sin \alpha)$ , and the total moment at the point marked by  $\phi$  is the sum of all expressions  $dF(R \sin \phi - R \sin \alpha)$  to the left of that point.

For the center of the eighth element  $ds$ , taking  $R$  as 100, the moment (element  $1 \times 70 +$  element  $2 \times 60 \dots$  etc.) is equal to

$$u_1 A (10 \times 70 + 10.2 \times 60 + 10.3 \times 50 + 10.65 \times 40 + 11.15 \times 30 \\ + 12 \times 20 + 13.2 \times 10) = + 2959 u_1 A \text{ (see table on page 113).}$$

For the center of the thirteenth element, the moment is the same as for the eighth element, except for the negative moment of elements 9, 10, 11, and 12. Thus

$$(+2959 - 2 \times 19.4 \times 10 - 2 \times 45 \times 20) u_1 A = + 771 u_1 A.$$

$$\sum_B^C M ds = \sum_B^C H(R - R \cos \phi) ds - \sum_B^C M_1 ds \\ + \sum_B^C \left\{ \sum_0^\phi (R \sin \phi - R \sin \alpha) dF \right\} ds = 0.$$

From the table:

$$\sum_B^C H(R - R \cos \phi) ds = 31,394 H.$$

$$\sum_B^C - M_1 ds = - M_1 \pi R = - 100 \pi M_1.$$

From the table:

$$\sum_B^C \left\{ \sum_0^\phi (R \sin \phi - R \sin \alpha) dF \right\} ds = - 296 A u_1.$$

Therefore

$$31,394 H - 100 \pi M_1 - 296 A u_1 = 0. \quad (b)$$

The general expression for equation (c) is

$$\Delta_{(B-C)_x} = \int_B^C \frac{m M ds}{F E I}.$$

To develop this equation we apply an auxiliary force  $F$  at  $B$  in the direction  $x$ . This force  $F$  acts similarly to  $H$ , and its moment is

$$F(R - R \cos \phi).$$

Therefore

$$\Delta_{(B-C)_x} = \int_B^C \frac{F(R - R \cos \phi)M ds}{FEI} = 0$$

or

$$\int_B^C (R - R \cos \phi)M ds = 0.$$

This may be written as

$$\sum_B^C (R - R \cos \phi)^2 H ds - \sum_B^C (R - R \cos \phi)M_1 ds + \sum_B^C (R - R \cos \phi) \left\{ \sum_0^\phi (R \sin \phi - R \sin \alpha) dF \right\} ds = 0.$$

The various factors are evaluated in the table on page 113.

$$\sum_B^C (R - R \cos \phi)^2 ds = 4,697,727.0.$$

$$\sum_B^C (R - R \cos \phi) ds = 31,394.2.$$

$$\sum_B^C (R - R \cos \phi) \left\{ \sum_0^\phi (R \sin \phi - R \sin \alpha) dF \right\} ds = -76,490,000 A u_1.$$

Thus:

$$4,697,700H - 31,394M_1 - 76,490,000Au_1 = 0 \quad (c)$$

Solving equations (a), (b), and (c) simultaneously, we obtain

$$H = 49.3Au_1.$$

$$M_1 = 4,930Au_1.$$

$$M_2 = 15,070Au_1.$$

**Alternative Solution.** From Fig. 49a it is seen that the bending moment at the point marked by the angle  $\phi$  is

$$M = M_1 - H(R - R \cos \phi) - \int_0^\phi (R \sin \phi - R \sin \alpha) dF.$$

$A$  = cross-sectional area of ring.

$ds = R d\alpha$ .

$dF = u_1 A ds$ .

Element	Angle in degrees	Arc	ds	$\phi$	Cos $\phi$	$\sum_0^\phi \frac{R(\sin \phi - \sin \alpha)dF}{Au_1}$	$\sum_0^\phi \frac{R(\sin \phi - \sin \alpha)dFds}{Au_1}$	$(R - R \cos \phi)$	$(R - R \cos \phi)ds$	$(R - R \cos \phi)^2$	$(R - R \cos \phi)^2 ds$	$(R - R \cos \phi) \sum_0^\phi \frac{R(\sin \phi - R \sin \alpha)dFs}{Au_1}$
1	6.74	10.0	10.0	2.87	0.9988	0	0	0.12	1.2	0.0	13	+
2	11.55	20.2	10.2	8.65	0.9886	100	1,020	1.14	11.6	1.3	102	+
3	17.47	30.5	10.3	14.51	0.9685	302	3,111	6.35	32.4	9.9	430	+
4	23.58	41.15	10.65	20.52	0.9385	607	6,465	6.35	67.6	40.3	1,286	+
5	30.00	52.30	11.15	26.79	0.8826	1,018	11,351	10.74	119.7	113.3	1,286	+
6	36.90	64.30	12.00	33.45	0.8336	1,541	18,492	16.64	199.7	278.9	3,323	+
7	44.43	77.50	13.2	40.66	0.7585	2,184	28,816	24.15	318.8	583.2	7,698	+
8	53.13	92.60	15.1	48.78	0.6590	2,959	44,681	34.10	515.0	1,162.8	17,568	+
9	64.16	112.00	19.4	58.63	0.5203	3,885	75,369	47.97	890.6	2,301.1	44,642	+
10	80.00	157.00	45.0	77.08	0.2235	5,005	122,525	77.65	3,484.2	6,029.5	271,327	+
11	.....	.....	45.0	.....	.....	5,005	225,225	122.35	6,505.7	14,969.5	673,627	+
12	.....	.....	19.4	.....	.....	2,985	57,909	152.03	2,943.8	23,105.0	448,237	+
13	.....	.....	15.1	.....	.....	1,694	11,642	165.90	2,505.1	27,522.8	415,694	+
14	.....	.....	13.2	.....	.....	771	4,091	175.85	2,321.2	30,923.2	370,500	+
15	.....	.....	12.00	.....	.....	4,708	7,4794	183.36	2,200.3	33,621.3	403,828	+
16	.....	.....	11.15	.....	.....	6,437	10,504	189.28	2,110.2	35,821.3	399,407	+
17	.....	.....	10.65	.....	.....	8,437	14,504	193.65	2,062.4	37,300.3	399,378	+
18	.....	.....	10.30	.....	.....	12,271	19,618	196.85	2,027.5	38,749.9	399,124	+
19	.....	.....	10.20	.....	.....	15,200	25,040	198.86	2,028.3	39,600.0	404,336	+
20	.....	.....	10.00	.....	.....	18,250	31,500	199.88	1,998.8	39,990.0	399,601	+
							296		31,384.2		4,697,727	-76,490,000

Thus

$$M = M_1 - H(R - R \cos \phi) - u_1 AR^2 \int_0^\phi (\sin \phi - \sin \alpha) d\alpha,$$

$$M = M_1 - H(R - R \cos \phi) - u_1 AR^2 \left[ \alpha \sin \phi + \cos \alpha \right]_0^\phi,$$

$$M = M_1 - H(R - R \cos \phi) - u_1 AR^2 (\phi \sin \phi + \cos \phi - 1).$$

Since the ring is symmetrical about the center line through the point of support, the tangents to the ring at points  $B$  and  $C$  always remain horizontal. The change of slope, therefore, between the limits of  $B$  and  $C$  is zero.  $\theta \Big|_B^C = 0$ . The general expression for  $\theta$  from formula (6) is

$$\theta = \int \frac{mMds}{M'EI}.$$

Thus

$$\theta \Big|_B^C = \int_B^C \frac{mMds}{M'EI} = 0.$$

We assumed at the outset that  $E$  and  $I$  are constant, that the curvature is slight as compared to the thickness of the ring, and that the law of superposition holds, that is, that the ring maintains essentially the shape of a circle throughout the loading. If we imagine an auxiliary moment  $M'$  applied at point  $B$ , then, for all points on the ring,  $m = M'$ ; and

$$\theta \Big|_B^C = \int_B^C \frac{mMds}{M'EI} = \int_B^C \frac{M'Mds}{M'EI} = 0.$$

Thus

$$\int_B^C Mds = \int_0^\pi Mds = 0.$$

In establishing the general expression for  $M$  we integrated between limits 0 and  $\phi$ , and  $ds$  was expressed as  $Rd\alpha$ . However, integrating between points  $B$  and  $C$ , or between limits 0 and  $\pi$ ,  $ds$  is expressed as  $Rd\phi$ . Thus

$$\begin{aligned} \int_0^\pi Mds &= \int_0^\pi MRd\phi \\ &= \int_0^\pi \{M_1 - H(R - R \cos \phi) - u_1 AR^2 (\phi \sin \phi + \cos \phi - 1)\} Rd\phi = 0. \end{aligned}$$

$$\int_0^\pi Mds = \left\{ M_1 \phi - HR\phi + HR \sin \phi - u_1 AR^2 (2 \sin \phi - \phi \cos \phi - \phi) \right\}_0^\pi = 0.$$

$$\int_0^\pi Mds = M_1 \pi - HR\pi - u_1 AR^2 (+\pi - \pi) = M_1 \pi - HR\pi = 0$$

or

$$M_1 = HR. \tag{d}$$

Since the ring is symmetrical about the center line through the point of support, point  $B$  will remain directly above point  $C$ . Thus the horizontal displacement of point  $B$ , relative to point  $C$ , is zero.

The general expression for linear displacement is obtained from formula (5):

$$\Delta = \int \frac{mMds}{FEI}.$$

Thus,

$$\Delta_{B-C} = \int_B^C \frac{mMds}{FEI} = \int_0^\pi \frac{mMds}{FEI} = 0.$$

If we imagine an auxiliary load  $F$  acting in the horizontal direction at point  $B$ , while the loading is applied, we have

$$m = F(R - R \cos \phi) \text{ (see Fig. 49a).}$$

$$\Delta_{B-C} = \int_0^\pi \frac{(R - R \cos \phi)Mds}{EI} = 0.$$

$$ds = Rd\phi; R^2 \text{ and } EI \text{ may be canceled.}$$

Thus,

$$\int_0^\pi M d\phi - \int_0^\pi \cos \phi M d\phi = 0.$$

When we established equation (d) we found that

$$\int_0^\pi M d\phi = 0.$$

Thus,

$$\begin{aligned} & \int_0^\pi \cos \phi M d\phi \\ &= \int_0^\pi \cos \phi \left\{ M_1 - H(R - R \cos \phi) - u_1 AR^2 (\phi \sin \phi + \cos \phi - 1) \right\} d\phi \\ & \left[ M_1 \sin \phi - HR \left( \sin \phi - \frac{\phi}{2} - \frac{\sin 2\phi}{4} \right) - u_1 AR^2 \left( \frac{\sin 2\phi}{8} - \frac{\phi \cos 2\phi}{4} + \frac{\phi}{2} \right. \right. \\ & \quad \left. \left. + \frac{\sin 2\phi}{4} - \sin \phi \right) \right]_0^\pi = HR \frac{\pi}{2} - u_1 AR^2 \left( \frac{\pi}{2} - \frac{\pi}{4} \right) \\ &= HR \frac{\pi}{2} - u_1 AR^2 \frac{\pi}{4} = 0. \end{aligned} \tag{e}$$

Solving equations (d) and (e) we obtain

$$H = \frac{u_1 AR}{2}; \quad M_1 = \frac{u_1 AR^2}{2}.$$

Substituting these values in equation (a) (page 110), we obtain

$$M_2 = M_1 - 2HR + 2u_1AR^2 = \frac{3}{2}u_1AR^2.$$

Substituting the values of  $M_1$ ,  $M_2$ , and  $H$  in the equation for  $M$  (page 114), we obtain the general equation for bending moment in its simplest form:

$$\begin{aligned} M &= \frac{u_1AR^2}{2} - \frac{u_1AR^2}{2} (1 - \cos \phi) - u_1AR^2(\phi \sin \phi + \cos \phi - 1) \\ &= u_1AR^2 \left( 1 - \phi \sin \phi - \frac{\cos \phi}{2} \right) = \frac{W_1R}{2\pi} \left( 1 - \phi \sin \phi - \frac{\cos \phi}{2} \right), \end{aligned}$$

where  $W_1$  is weight of entire ring.

To determine the maximum value of  $M$  we differentiate  $M$  with respect to  $\phi$  and equate to zero. Thus

$$\frac{2\pi}{W_1R} \frac{dM}{d\phi} = -\phi \cos \phi - \sin \phi + \frac{\sin \phi}{2} = -\phi \cos \phi - \frac{\sin \phi}{2} = 0.$$

$$\frac{\sin \phi}{2} = -\phi \cos \phi.$$

$$\tan \phi = -2\phi.$$

The value of  $\phi$ , other than zero, which satisfies the above equation is

$$\phi = 105^\circ 15' = 1.835 \text{ radians.}$$

To make sure whether the foregoing value of  $\phi$  gives a maximum or minimum, we differentiate a second time:

$$\frac{2\pi}{W_1R} \frac{d^2M}{d\phi^2} = \phi \sin \phi - \cos \phi - \frac{\cos \phi}{2} = \phi \sin \phi - \frac{3}{2} \cos \phi.$$

For the value  $\phi = 105^\circ 15'$ ,  $\frac{d^2M}{d\phi^2}$  is positive. Therefore,  $\phi = 105^\circ 15'$  gives a minimum value of the bending moment, which is

$$M = u_1AR^2 \left( 1 - 1.835 \sin 105^\circ 15' - \frac{\cos 105^\circ 15'}{2} \right) = -0.64u_1AR^2$$

The point of inflection of the elastic curve of the ring may be found by equating the bending moment to zero, which gives the positions of zero bending moment as  $\phi = 50^\circ 40'$  and  $\phi = 146^\circ 20'$ .

Figure 49b shows the bending-moment curve plotted in polar coordinates. The curve reveals that, although for a value of  $\phi = 105^\circ 15'$  we obtain a maximum bending moment, the numerically largest bending

moment occurs at point  $C$ , the point of support, and is equal to  $M_2$ , which is  $\frac{3}{2}u_1AR^2$ .

The maximum bending stress in a ring of a rectangular section, loaded by its own weight and supported at one point, may be expressed in terms of the dimensions of the ring as follows:

$$\text{Stress} = s = \frac{Mc}{I}.$$

If the length of the ring is  $b$ , the thickness  $t$ , and the diameter  $D$ , then

$$s = \frac{3u_1AR^2b}{2bt^2} = \frac{9u_1btR^2}{bt^2} = \frac{9u_1R^2}{t} = \frac{9u_1D^2}{4t}.$$

For steel,  $u_1$  is 0.2835 lb. per cu. in. For a steel pipe, then,

$$s = \frac{9}{4} \times 0.2835 \frac{D^2}{t} = \frac{0.638D^2}{t}.$$

In comparing the values derived by the two methods, we find that the difference in the two values of  $M_2$  is 0.5 per cent, and the difference in the two values of  $H$  is 1.5 per cent.

The tensile stress  $T$ , at any point in the ring, may be found by resolving all forces to the left of the point, marked by the angle  $\phi$ , in the direction tangent to the ring at that point.

Thus

$$\begin{aligned} T &= H \cos \phi - u_1AR\phi \sin \phi = \frac{u_1AR}{2} \cos \phi - u_1AR\phi \sin \phi \\ &= \frac{W_1}{4\pi} (\cos \phi - 2\phi \sin \phi). \end{aligned}$$

### EXAMPLE 30

#### Ring Subjected to Hydrostatic Pressure

*Given:* A ring supported at one point and filled to the top with a liquid.  $E$  and  $I$  are assumed constant (Fig. 50a).

*To find:* The maximum bending moment in the ring.

In this case we submit only a solution by means of analytic integration.

Let  $R$  = radius of ring.

$t$  = thickness of ring.

$u_2$  = weight of 1 cu. in. of liquid.



Assume section of ring analyzed to be of length unity, perpendicular to plane of sketch (Fig. 50b).

The ring being symmetrical about the center line through the point of support we may limit our attention to one half of the cross section (Fig. 50b). Because of symmetry there can be no vertical force acting

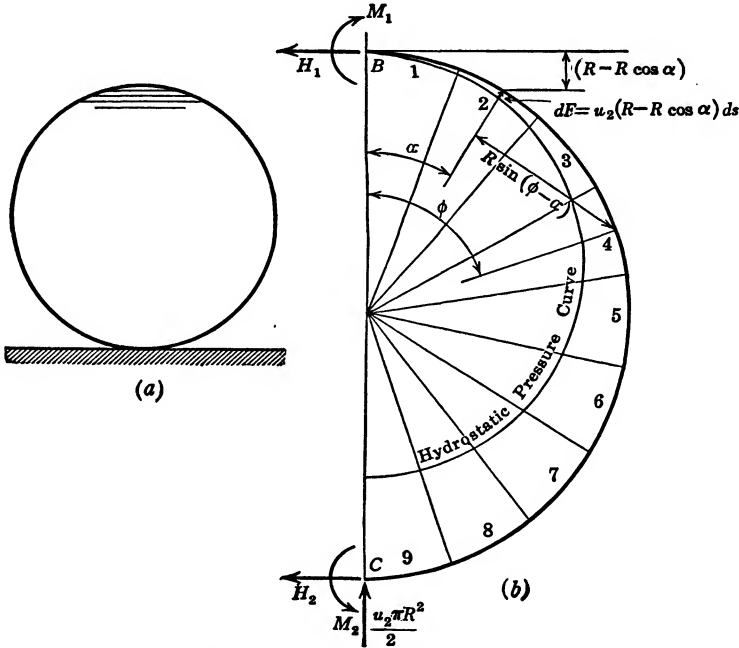

FIG. 50. Ring Flowing Full with a Liquid.

at point B. At point C, therefore, the vertical force is equal to all the liquid contained in the right half of the pipe. If the pipe is of unit length and if the weight of the liquid per cubic inch is  $u_2$ , then this vertical force at C is  $\frac{u_2\pi R^2}{2}$  (Fig. 50b). Horizontal forces  $H_1$  and  $H_2$  are acting at points B and C respectively.  $H_1$  and  $H_2$  together must equal the total hydrostatic pressure on the line BC. The head  $h$  at point C is  $2R$ . Therefore

$$H_1 + H_2 = \frac{u_2 h^2}{2} = 2u_2 R^2. \tag{a}$$

Taking moments about point C, not only must we include the factors  $M_1$ ,  $M_2$ , and  $H_1$ , shown in Fig. 50b, but the downward weight of the water in the semicircular ring to the right of the line BC and the hydrostatic pressure on the line BC must also be taken into consideration.

The centroid of a semicircular area is  $\frac{4R}{3\pi}$ .

The moment of the weight of the water, then, is

$$u_2 \times \frac{\pi R^2}{2} \times \frac{4R}{3\pi} = \frac{2}{3} u_2 R^3.$$

The hydrostatic pressure on the line  $BC$  is  $2u_2R^2$ . The moment of this hydrostatic pressure, therefore, is  $2u_2R^2 \times \frac{1}{3} \times 2R = \frac{4}{3}u_2R^3$ .

$$M_1 - H_1 \times 2R - M_2 + \frac{2}{3}u_2R^3 + \frac{4}{3}u_2R^3 = 0$$

or

$$M_1 - 2H_1R - M_2 + 2u_2R^3 = 0. \quad (b)$$

On a small length  $ds$  marked by the angle  $\alpha$  the hydrostatic pressure is  $u_2(R - R \cos \alpha)ds$ . The moment of this pressure about the point marked by angle  $\phi$  is  $u_2(R - R \cos \alpha)ds \times R \sin(\phi - \alpha)$ . The moment of the total hydrostatic pressure between point  $B$  and the point marked by the angle  $\phi$  is

$$\int_0^\phi u_2(R - R \cos \alpha)ds \times R \sin(\phi - \alpha).$$

Since  $ds = R d\alpha$ , this expression may be written

$$u_2R^3 \int_0^\phi (1 - \cos \alpha) \sin(\phi - \alpha) d\alpha.$$

(In this integration  $\phi$  is constant and  $\alpha$  is the only variable.)

The hydrostatic pressure moment about the point marked by  $\phi$  is

$$u_2R^3 \left( 1 - \cos \phi - \frac{\phi}{2} \sin \phi \right).$$

The total moment of all the forces to the left of the point marked by the angle  $\phi$ , therefore, is

$$M = M_1 - H_1(R - R \cos \phi) + u_2R^3 \left( 1 - \cos \phi - \frac{\phi}{2} \sin \phi \right).$$

Since the ring is symmetrical about the center line  $B-C$ , the tangents to the ring at points  $B$  and  $C$  will permanently remain horizontal. The change of slope, due to the loading, between points  $B$  and  $C$  will thus be zero.

$$\theta \Big|_B^C = 0 = \int_0^C \frac{mMds}{M'EI} = \int_0^\pi \frac{mMds}{M'EI}.$$

If an auxiliary load  $M'$  is assumed acting at point  $B$ , then  $m = M'$  for all points of the structure. Thus

$$\int_0^\pi M ds = 0 \quad ds = R d\phi.$$

$$\int_0^\pi M d\phi = \int_0^\pi \left\{ M_1 - H_1 R (1 - \cos \phi) + u_2 R^3 \left( 1 - \cos \phi - \frac{\phi}{2} \sin \phi \right) \right\} d\phi$$

$$= \left[ M_1 \phi - H_1 R (\phi - \sin \phi) + u_2 R^3 \left( \phi - \sin \phi - \frac{\sin \phi}{2} + \frac{\phi \cos \phi}{2} \right) \right]_0^\pi$$

$$= M_1 \pi - H_1 R \pi + u_2 R^3 \left( \pi - \frac{\pi}{2} \right) = 0.$$

$$M_1 - H_1 R + \frac{u_2 R^3}{2} = 0. \quad (c)$$

Since the ring is symmetrical about the center line  $B-C$ , point  $B$  will move only along the line  $BC$  relative to point  $C$ . The horizontal displacement of point  $B$  relative to point  $C$  is zero.  $\Delta_{(B-C)_x} = 0$ .

$$\Delta_{(B-C)_x} = \int_B^C \frac{m M ds}{FEI} = \int_0^\pi \frac{m M ds}{FEI} = 0.$$

If we assume an auxiliary load  $F$  applied at point  $B$  in the horizontal direction (similar to  $H_1$ , Fig. 50b), then  $m = F(R - R \cos \phi)$ , and

$$\Delta_{(B-C)_x} = \int_0^\pi \frac{FR(1 - \cos \phi) M ds}{FEI} = 0.$$

We have

$$ds = R d\phi.$$

Therefore

$$\int_0^\pi (1 - \cos \phi) M d\phi = \int_0^\pi M d\phi - \int_0^\pi \cos \phi M d\phi = 0.$$

We have seen that  $\int_0^\pi M d\phi = 0$ .

Therefore

$$\int_0^\pi \cos \phi M d\phi = 0.$$

$$\begin{aligned}
 \int_0^\pi \cos \phi M d\phi &= \int_0^\pi \left[ M_1 \cos \phi - H_1 R (\cos \phi - \cos^2 \phi) \right. \\
 &\quad \left. + u_2 R^3 \left( \cos \phi - \cos^2 \phi - \frac{\phi}{2} \sin \phi \cos \phi \right) \right] d\phi \\
 &= \left[ M_1 \sin \phi - H_1 R \left( \sin \phi - \frac{\phi}{2} - \frac{\sin 2\phi}{4} \right) \right. \\
 &\quad \left. + u_2 R^3 \left( \sin \phi - \frac{\phi}{2} - 5 \frac{\sin 2\phi}{16} + \frac{2\phi \cos 2\phi}{16} \right) \right]_0^\pi \\
 &= \frac{H_1 R \pi}{2} + u_2 R^3 \left( -\frac{\pi}{2} + \frac{2\pi}{16} \right) = \frac{H_1 R \pi}{2} - \frac{3}{8} u_2 R^3 \pi = 0. \quad (d)
 \end{aligned}$$

Solving equations (c) and (d) simultaneously, we obtain

$$M_1 = \frac{u_2 R^3}{4}; \quad H_1 = \frac{3}{4} u_2 R^2.$$

Substituting the value for  $H_1$  in equation (a) (page 118) of the first solution, we obtain

$$H_2 = \frac{5}{4} u_2 R^2.$$

Substituting the values for  $H_1$  and  $M_1$  in equation (b) (page 119) of the first solution, we obtain

$$M_2 = \frac{3}{4} u_2 R^3.$$

Substituting the values for  $M_1$  and  $H_1$  in the equation for  $M$  (page 119) we obtain the general equation for the bending moment in polar coordinates:

$$\begin{aligned}
 M &= \frac{u_2 R^3}{4} - \frac{3}{4} u_2 R^2 (R - R \cos \phi) + u_2 R^3 \left( 1 - \cos \phi - \frac{\phi}{2} \sin \phi \right) \\
 &= \frac{-u_2 R^3}{2} + \frac{3}{4} u_2 R^3 \cos \phi + u_2 R^3 - u_2 R^3 \cos \phi - \frac{u_2 R^3 \phi \sin \phi}{2} \\
 &= \frac{u_2 R^3}{2} - \frac{u_2 R^3 \cos \phi}{4} - \frac{u_2 R^3 \phi \sin \phi}{2} \\
 &= \frac{u_2 R^3}{2} \left( 1 - \frac{\cos \phi}{2} - \phi \sin \phi \right) = \frac{W_2 r}{2\pi} \left( 1 - \frac{\cos \phi}{2} - \phi \sin \phi \right),
 \end{aligned}$$

where  $W_2$  is the total weight of water.

It is interesting to note that this equation is identical with the general equation for the bending moment found in example 29.

Figure 49*b*, therefore, shows the bending moment in polar coordinates for the ring subjected to hydrostatic pressure from the inside out as well as the bending moment for the ring subjected to the effects of gravity.

The point of maximum stress is at *C*, where the force,  $H_2 = \frac{5}{4}u_2R^2$ , coincides with the maximum moment,  $M_2 = \frac{3}{4}u_2R^3$ . The maximum stress is  $s = \frac{P}{A} + \frac{Mc}{I}$ .

We assumed the ring to be of length unity and of thickness  $t$ .

Therefore

$$A = 1 \times t, \quad c = \frac{t}{2}, \quad I = \frac{1 \times t^3}{12}, \quad \text{and} \quad \frac{I}{c} = \frac{t^2}{6}.$$

Thus,

$$s = \frac{5u_2R^2}{4t} + \frac{3u_2R^3 \times 6}{4 \times t^2} = \frac{u_2R^2}{4t} \left( 5 + \frac{18R}{t} \right).$$

It may be seen that for ordinary values the effect of direct stress caused by  $H_2$  is negligible as compared to the bending stress caused by  $M_2$ . The above formula may, therefore, be simplified to read

$$s = \frac{9u_2R^3}{2t^2} = \frac{9}{16} \frac{u_2D^3}{t^2},$$

in which  $D$  is the diameter of ring. If the ring is full of water,  $u_2 = \frac{62.4}{1728} = 0.0361$  lb. per cu. in., and  $s = \frac{0.0203D^3}{t^2}$ .  $D$  and  $t$  are to be expressed in inches.

The tensile stress  $T$  at any point in the ring may be found by resolving all forces to the left of the point marked by the angle  $\phi$  in the direction tangent to the pipe at that point.

$$\begin{aligned} \text{Thus, } T &= + H_1 \cos \phi + \int_0^\phi u_2(R - R \cos \alpha) \sin(\phi - \alpha) ds \\ &= + H_1 \cos \phi + u_2R^2 \int_0^\phi (1 - \cos \alpha) \sin(\phi - \alpha) d\alpha \\ &= + H_1 \cos \phi + u_2R^2 \left( 1 - \cos \phi - \frac{\phi}{2} \sin \phi \right) \\ &= \frac{W_2}{\pi} \left( 1 - \frac{\cos \phi}{4} - \frac{\phi \sin \phi}{2} \right). \end{aligned}$$

## EXAMPLE 31

Derivation of Bending-Moment Equation for a Ring Subject to Shear Loading

$$s_s = \frac{W_2}{\pi R t} \sin \alpha^* \quad (\text{Case II, page 127})$$

A free-body sketch for one half of the ring is shown in the left half of diagram for Case II, page 127.

$$\begin{aligned} M &= M_1 - T_1 R(1 - \cos \phi) + \int_0^\phi \frac{W_2}{\pi R} \sin \alpha \, ds \{R - R \cos(\phi - \alpha)\} \\ &= M_1 - T_1 R(1 - \cos \phi) + \frac{W_2 R}{\pi} \left(1 - \cos \phi - \frac{\phi}{2} \sin \phi\right). \end{aligned} \quad (a)$$

Since the tangents to the ring at points *A* and *D* remain horizontal,

$$\int_0^\pi M d\phi = 0. \quad \text{Thus}$$

$$\int_0^\pi \left\{ M_1 - T_1 R + T_1 R \cos \phi + \frac{W_2 R}{\pi} \left(1 - \cos \phi - \frac{\phi}{2} \sin \phi\right) \right\} d\phi = 0,$$

or

$$M_1 \pi - T_1 R \pi + \frac{W_2 R}{2} = 0. \quad (b)$$

Since the horizontal displacement of point *A* relative to point *D* is zero,

$$\int_0^\pi (R - R \cos \phi) M d\phi = 0; \quad \text{and since, according to (b), } \int_0^\pi M d\phi = 0,$$

$$\int_0^\pi \cos \phi M d\phi = 0. \quad \text{Thus}$$

$$\begin{aligned} \int_0^\pi \left\{ M_1 \cos \phi - T_1 R \cos \phi + T_1 R \cos^2 \phi \right. \\ \left. + \frac{W_2 R}{\pi} \left( \cos \phi - \cos^2 \phi - \frac{2\phi \sin 2\phi}{8} \right) \right\} d\phi \\ = \frac{T_1 R \pi}{2} - \frac{3}{8} W_2 R = 0. \end{aligned} \quad (c)$$

Solving (b) and (c) simultaneously, we obtain

$$T_1 = \frac{3W_2}{4\pi}; \quad M_1 = \frac{W_2 R}{4\pi}.$$

\* For derivation of this formula see Appendix II.

Substituting these values in (a) we obtain

$$M = \frac{W_2 R}{2\pi} \left( 1 - \frac{\cos \phi}{2} - \phi \sin \phi \right).$$

$$T = T_1 \cos \phi - \int_0^\phi \frac{W_2 \sin \alpha}{\pi R} \cos(\phi - \alpha) R d\alpha$$

$$= \frac{W_2}{2\pi} \left( \frac{3}{2} \cos \phi - \phi \sin \phi \right).$$

### EXAMPLE 32

#### Ring Subjected to Concentrated Vertical Loads

*Given:* A ring loaded at the bottom point with a concentrated load acting coincident with the vertical diameter and supported by two symmetrically placed vertical reactions.

*To find:* The bending moment and thrust in the ring as a function of the loading.

A free-body sketch for one half of the ring is shown in the left half of diagram for Case VI, page 128.

The bending moment  $M$ , marked by the angle  $\phi$  between the values  $\phi = 0$  and  $\phi = \pi - \phi_1$ , is

$$M_{A-C} = M_1 - T_1 R (1 - \cos \phi). \quad (a)$$

Between the values  $\phi = \pi - \phi_1$  and  $\phi = \pi$  we have

$$M_{C-D} = M_1 - T_1 R (1 - \cos \phi) - \frac{Q_1 R}{2} (\sin \phi_1 - \sin \phi). \quad (b)$$

Since the tangents to the ring at points  $A$  and  $D$  remain horizontal,

$$\int_A^D M d\phi = 0. \quad (c)$$

Therefore

$$\int_0^{(\pi-\phi_1)} M d\phi + \int_{(\pi-\phi_1)}^\pi M d\phi = 0$$

or

$$\int_0^\pi \{M_1 - T_1 R (1 - \cos \phi)\} d\phi - \int_{(\pi-\phi_1)}^\pi \frac{Q_1 R}{2} (\sin \phi_1 - \sin \phi) d\phi = 0$$

or

$$M_1 - T_1 R = \frac{Q_1 R}{2\pi} (\phi_1 \sin \phi_1 - 1 + \cos \phi_1). \quad (d)$$

Since the horizontal displacement of point  $A$  relative to point  $D$  is zero,  $\int_0^\pi (R - R \cos \phi) M d\phi = 0$ ; and, according to (c),  $\int_0^\pi M d\phi = 0$ , therefore

$$\int_A^D \cos \phi M d\phi = 0.$$

Thus

$$\int_0^{(\pi-\phi_1)} \{M_1 - T_1 R(1 - \cos \phi)\} \cos \phi d\phi + \int_{(\pi-\phi_1)}^\pi \left\{M_1 - T_1 R(1 - \cos \phi) - \frac{Q_1 R}{2} (\sin \phi_1 - \sin \phi)\right\} \cos \phi d\phi = 0.$$

Therefore

$$\int_0^\pi \{M_1 - T_1 R(1 - \cos \phi)\} \cos \phi d\phi - \int_{(\pi-\phi_1)}^\pi \frac{Q_1 R}{2} (\sin \phi_1 - \sin \phi) \cos \phi d\phi = 0.$$

Thus

$$\frac{T_1 R \pi}{2} + \frac{Q_1 R}{4} \sin^2 \phi_1 = 0. \quad (e)$$

Solving (d) and (e) simultaneously, we obtain

$$T_1 = -\frac{Q_1}{2\pi} \sin^2 \phi_1 \quad \text{and} \quad M_1 = \frac{Q_1 R}{2\pi} (\phi_1 \sin \phi_1 - 1 + \cos \phi_1 - \sin^2 \phi_1).$$

Substituting these values in (a), we obtain for the moment between points  $A$  and  $C$ :

$$M \Big|_A^C = \frac{Q_1 R}{2\pi} (\phi_1 \sin \phi_1 + \cos \phi_1 - \sin^2 \phi_1 \cos \phi - 1).$$

Substituting them in (b) we obtain

$$M \Big|_C^D = M \Big|_A^C - \frac{Q_1 R}{2} (\sin \phi_1 - \sin \phi) = \frac{Q_1 R}{2\pi} [(\phi_1 - \pi) \sin \phi_1 + \cos \phi_1 - \sin^2 \phi_1 \cos \phi - 1 + \pi \sin \phi]$$

$$T \Big|_A^C = T_1 \cos \phi = -\frac{Q_1 \sin^2 \phi_1}{2\pi} \cos \phi.$$

$$T \Big|_C^D = -\frac{Q_1 \sin^2 \phi_1 \cos \phi}{2\pi} + \frac{Q_1}{2} \sin \phi.$$



The following diagrams, referred to as Cases I–IX, give expression to the bending moments,  $M$ , and the tangential forces,  $T$ , induced in circular rings by various loading conditions. The development of the equations for Cases I, II, V, and VI is given in detail in examples 29, 31, 30, and 32, respectively. The equations for Cases III, IV, VII, VIII, and IX are derived in similar manner. The derivation of these equations, however, is not reproduced.

Cases I to IX may be regarded as key diagrams. The development, by suitable superposition, of the resulting equations for the moment,  $M$ , and the tangential force,  $T$ , in problems involving complex loading is illustrated in the following seven problems.

### PIPE PROBLEMS

#### 1. Pipe Flowing Full and Supported along the Invert Line

Consider a pipe of indefinite length, of uniform thickness, full of water (with its ends closed to retain the water), and resting on a horizontal surface. We may then obtain the resulting bending-moment equation merely by adding the component equations obtained from Cases I and V.

$$M = (W_1 + W_5) \frac{R}{2\pi} \left( 1 - \phi \sin \phi - \frac{\cos \phi}{2} \right).$$

$W_1$  represents weight of pipe, and  $W_5$  represents weight of water which it contains.

#### 2. Pipe Subjected to Hydrostatic Head

Suppose that the water in this pipe were subjected to a surcharge, say, a head,  $h$ . In that event the hydrostatic loading would be increased by a constant factor  $u_5 h$  ( $u_5$  represents weight per unit volume of water). This would in no way affect the bending-moment equation and would merely increase the circumferential tension in the pipe at all points by a constant amount.

#### 3. Pipe Afloat with Top Surface Awash

Consider a pipe of uniform thickness, of indefinite length, with ends closed, and afloat in water with the top of the pipe awash, that is, the top of the pipe just breaking the surface of the water. Under these conditions the problem is identical with problem 1, except that the hydrostatic pressure is acting radially inward instead of radially out-

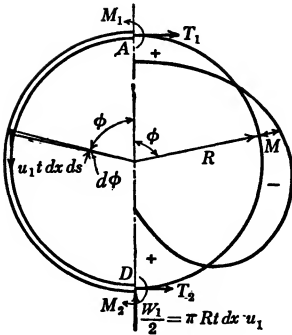

Case I. Shell, of length  $dx$ , loaded with its own dead weight  $u_1$  lb./in.<sup>3</sup>

$$M = \frac{W_1 R}{2\pi} \left( 1 - \phi \sin \phi - \frac{\cos \phi}{2} \right).$$

$$T = \frac{W_1}{2\pi} \left( \frac{\cos \phi}{2} - \phi \sin \phi \right).$$

For derivation of equations see page 108.

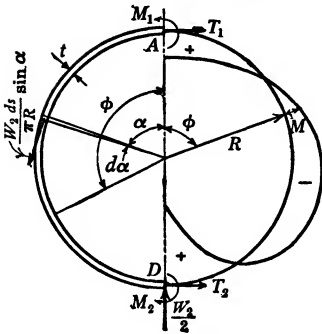

Case II. Shell, of length  $dx$ , loaded with shearing forces acting parallel to the circumference.

$$M = \frac{W_2 R}{2\pi} \left( 1 - \phi \sin \phi - \frac{\cos \phi}{2} \right).$$

$$T = \frac{W_2}{2\pi} \left( \frac{3}{2} \cos \phi - \phi \sin \phi \right).$$

For derivation of equations see page 123..

Case III. Shell partially filled with liquid, weighing  $u_2$  lb./in.<sup>3</sup>

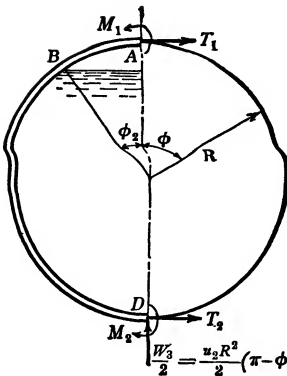

$$M \Big|_A^B = \frac{u_2 R^3}{\pi} \left[ \frac{\pi - \phi_2}{2} - (\pi - \phi_2) \cos \phi_2 - \sin \phi_2 + \frac{\sin 2\phi_2}{4} + \left( \frac{\pi}{4} - \frac{\phi_2}{2} + \frac{3}{8} \sin 2\phi_2 + \frac{\pi}{2} \cos^2 \phi_2 - \frac{\phi_2 \cos 2\phi_2}{4} \right) \cos \phi \right] dx.$$

$$M \Big|_B^D = M \Big|_A^B + \frac{u_2 R^3}{2} [2 \cos \phi_2 - \cos \phi_2 \cos (\phi - \phi_2) - (\phi - \phi_2) \sin \phi - \cos \phi] dx.$$

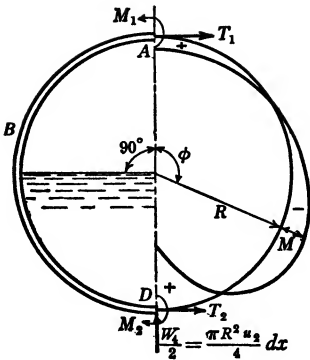

Case IV. Shell half filled with liquid.

$$M \Big|_A^B = \frac{u_2 R^3}{\pi} \left( \frac{\pi}{4} - 1 + \frac{\pi}{8} \cos \phi \right) dx$$

$$M \Big|_B^D = \frac{u_2 R^3}{\pi} \left[ \frac{\pi}{4} - 1 - \frac{3\pi}{8} \cos \phi + \frac{\pi}{2} \left( \frac{\pi}{2} - \phi \right) \sin \phi \right] dx.$$

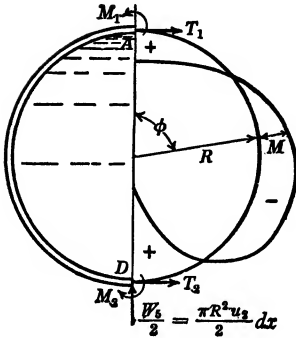

Case V. Shell completely filled with liquid.

$$M = \frac{W_5 R}{2\pi} \left( 1 - \phi \sin \phi - \frac{\cos \phi}{2} \right).$$

$$T = \frac{W_5}{\pi} \left( 1 - \frac{\phi \sin \phi}{2} - \frac{\cos \phi}{4} \right).$$

For derivation of equations see page 117.

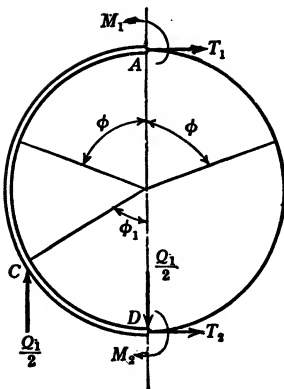

Case VI. Two symmetrical, vertical supports

$$M \Big|_A^C = \frac{Q_1 R}{2\pi} [\phi_1 \sin \phi_1 + \cos \phi_1 - \sin^2 \phi_1 \cos \phi - 1].$$

$$M \Big|_C^D = \frac{Q_1 R}{2\pi} [(\phi_1 - \pi) \sin \phi_1 + \cos \phi_1 - \sin^2 \phi_1 \cos \phi - 1 + \pi \sin \phi]$$

$$T \Big|_A^C = -\frac{Q_1 \sin^2 \phi_1}{2\pi} \cos \phi.$$

$$T \Big|_C^D = -\frac{Q_1 \sin^2 \phi_1}{2\pi} \cos \phi + \frac{Q_1}{2} \sin \phi.$$

For derivation of equations see page 124.

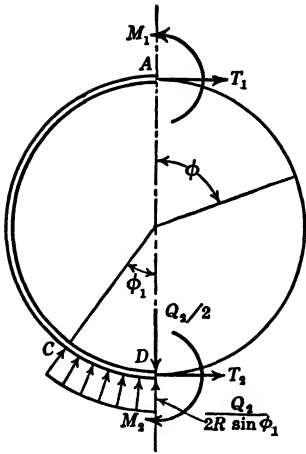

Case VII. Symmetrical uniform radial support.

$$M \Big|_A^C = \frac{Q_2 R}{2\pi \sin \phi_1} [\phi_1 - \sin \phi_1 + (\phi_1 \cos \phi_1 - \sin \phi_1) \cos \phi].$$

$$M \Big|_C^D = \frac{Q_2 R}{2\pi \sin \phi_1} [\phi_1 - \pi - \sin \phi_1 + (\phi_1 - \pi) \cos \phi_1 \cos \phi + \pi \sin \phi_1 \sin \phi - \sin \phi_1 \cos \phi].$$

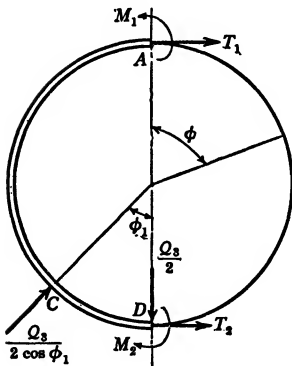

Case VIII. Two symmetrical radial supports.

$$M \Big|_A^C = \frac{Q_3 R}{2\pi} (\sec \phi_1 - 1 - \phi_1 \tan \phi_1 \cos \phi).$$

$$M \Big|_C^D = \frac{Q_3 R}{2\pi} (\sec \phi_1 - 1 - \phi_1 \tan \phi_1 \cos \phi) + \frac{Q_3 R}{2 \cos \phi_1} \sin (\phi + \phi_1).$$

$$T \Big|_A^C = -\frac{Q_3 \phi_1 \tan \phi_1}{2\pi} \cos \phi.$$

$$T \Big|_C^D = -\frac{Q_3 \phi_1 \tan \phi_1}{2\pi} \cos \phi + \frac{Q_3}{2 \cos \phi_1} \sin (\phi + \phi_1).$$

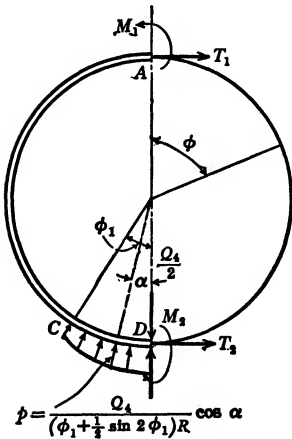

Case IX. Symmetrical, elastic radial support.

$$M \Big|_A^C = \frac{Q_4 R}{\pi (\phi_1 + \frac{1}{2} \sin 2\phi_1)} \left[ \sin \phi_1 - \frac{\phi_1}{2} - \frac{\sin 2\phi_1}{4} - \frac{\sin 2\phi_1}{8} \cos \phi + \frac{\phi_1 \cos 2\phi_1}{4} \cos \phi \right].$$

$$M \Big|_C^D = M \Big|_A^C + \frac{Q_4 R}{(\phi_1 + \frac{1}{2} \sin 2\phi_1)} \left[ \frac{\sin^2 \phi_1}{2} \cos \phi + \left( \frac{\phi_1 + \phi - \pi}{2} + \frac{\sin 2\phi_1}{4} \right) \sin \phi \right]$$

ward. Then the sign for the coefficient  $W_5$  will change, and the resulting bending-moment equation will be

$$M = (W_1 - W_5) \frac{R}{2\pi} \left( 1 - \phi \sin \phi - \frac{\cos \phi}{2} \right).$$

If next we consider that for any length of pipe, with the top of the pipe awash, the weight of the pipe is equal to the water displaced, then  $W_5 = W_1$  and the resulting bending moment is

$$M = 0.$$

#### 4. Pipe Suspended in a Liquid

Suppose a pipe of uniform thickness, indefinite length, and closed ends, is suspended, instead of floating, in water. Here problem 4 is the negative of problem 2, just as problem 3 is the negative of problem 1. The hydrostatic pressure is increased by a constant  $u_1 h$ , in which  $u_1$  represents the weight of unit volume of liquid and  $h$  the distance of top of pipe from surface of liquid. This constant surcharge of radial hydrostatic pressure does not affect the bending moment  $M$ . It merely increases the tangential compression in the pipe. The moment  $M$  thus remains zero.

#### 5. Pipe Suspended and Loaded along Center Line

Consider a pipe like the ones we have been discussing (problem 3 or 4), but loaded with a concentrated load  $W_6$  (Fig. 51a) uniformly distributed along the bottom of the pipe. The pipe is of uniform thickness, ends closed, and is suspended in water.  $W_1$  represents the weight of unit length of pipe,  $W_6$  the concentrated load applied to unit length of pipe, and  $W_5$  the weight of water displaced by unit length of pipe. The resulting bending moment is

$$M = (W_1 - W_5) \frac{R}{2\pi} \left( 1 - \phi \sin \phi - \frac{\cos \phi}{2} \right).$$

$W_1 + W_6 = W_5$ ; therefore

$$M = - \frac{W_6 R}{2\pi} \left( 1 - \phi \sin \phi - \frac{\cos \phi}{2} \right).$$

#### 6. Submarine or Dirigible

Consider a pipe like the one discussed in problem 5 except that the concentrated load  $W_7$ , instead of being applied at the bottom, is applied symmetrically to both sides of the center line. It is observed that the conditions of this problem may be obtained by superimposing the following three cases upon each other: Case I; the negative of Case V; and

the negative of Case VI. Figure 51b presents a composite picture of the figures representing the loading in Case I, the negative of Case V, and the negative of Case VI. Note that, since the weight of the shell  $W_1$  plus the concentrated loads  $W_7$  equals the liquid displaced  $W_5$ , the resultant

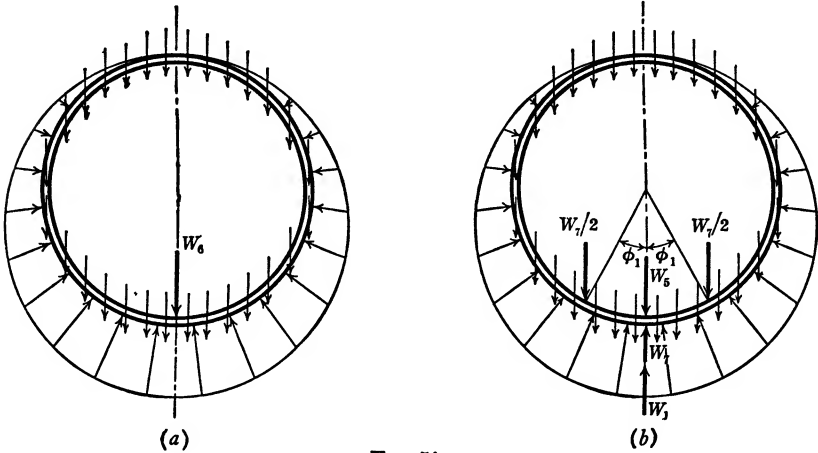

FIG. 51.

concentrated reaction at the bottom of Fig. 51b equals zero. The resultant moment for the top part of the shell, therefore, is

$$M = (W_1 - W_5) \frac{R}{2\pi} \left( 1 - \phi \sin \phi - \frac{\cos \phi}{2} \right) - W_7 \frac{R}{2\pi} (\phi_1 \sin \phi_1 + \cos \phi_1 - \sin^2 \phi_1 \cos \phi - 1).$$

Since  $W_1 + W_7 = W_5$ , or  $-W_7 = W_1 - W_5$ , we have

$$M = \frac{W_7 R}{2\pi} \left( \phi \sin \phi + \frac{\cos \phi}{2} + \sin^2 \phi_1 \cos \phi - \cos \phi_1 - \phi_1 \sin \phi_1 \right).$$

The midsection of a submarine, or a dirigible, of uniform shell thickness and circular outline, long enough to permit ignoring of end effects, and its loading symmetrically framed into its sides, constitutes an example of the problem we have just discussed.

Fitting into this general picture one more problem is worthy of special attention.

### 7. Circular Pipe Lines

In recent years steel pipe lines with diameters of the order of magnitude of 20 ft., stiffened and supported by rings placed at intervals, have become popular. Figure 52 represents such a pipe in a horizontal position and filled with water. (If the water is under an extra head  $h$ , this will affect our analysis only in that the tangential forces in the pipe will be increased, while the bending moments will not be affected.)

The pipe, obviously, constitutes a continuous beam loaded uniformly. This phase of the problem is too well known to require special discussion. However, the analysis of a transverse section of such a beam is of particular interest to us here.

Figures 52b and 52c represent a section of the pipe halfway between supports of length  $dx$ . A side view is shown in Fig. 52b, while 52c shows a cross-sectional view. The large arrow in Fig. 52b and the vertical

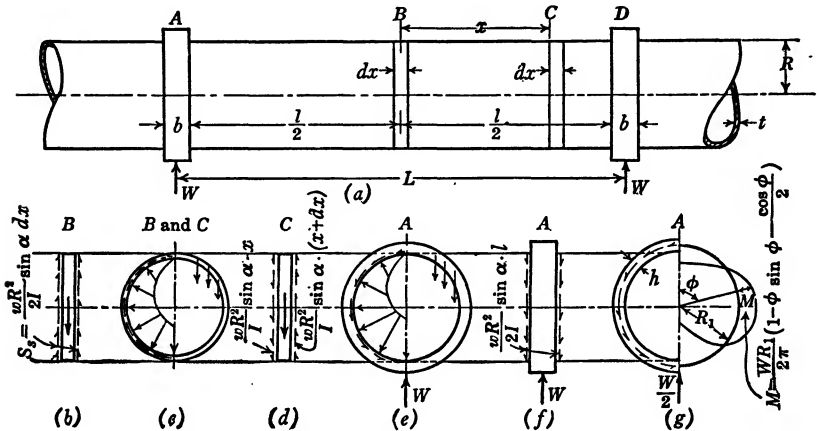

FIG. 52. Steel Pipe Line.

and radial arrows in 52c represent the dead-weight effect of the pipe as well as the radial pressure due to the water. The shear is represented by vertical arrows on the sides of Fig. 52b, and by arrows acting in the tangential direction on Fig. 52c. The value of the resulting shear stress on a section of the pipe of length  $dx$  is given by the expression  $s_s = \frac{wR^2 \sin \alpha dx}{I}$  or  $\frac{w \sin \alpha dx}{\pi Rt}$  ( $w$  is weight per unit length of pipe plus the weight of the water which it contains). If we replace  $w dx$  by  $W_2$ , then  $s_s = \frac{W_2 R^2 \sin \alpha}{I} = \frac{W_2 \sin \alpha}{\pi Rt}$  (see Appendix II).

The bending moment for a thin shell cylinder, subjected to a shear loading, is represented in Case II. Whether the section be taken halfway between supporting rings (section  $B$ ), or at any other point (section  $C$ ),  $W_2$  equals the weight of the ring plus the water which it contains. Therefore,  $W_2 = W_1 + W_5$ .

Figure 52c shows a section of a circular pipe subjected to the simultaneous loadings of its dead weight (Case I), of hydrostatic pressure (Case V), and of shear loading (the negative of Case II). If we super-

impose the bending moments of these three separate loadings, we obtain the resultant bending moment for any section of pipe:

$$M = (W_1 - W_2 + W_5) \frac{R}{2\pi} \left( 1 - \phi \sin \phi - \frac{\cos \phi}{2} \right).$$

$W_1 + W_5$  represents the weight of a section of pipe and the water it contains.  $W_2$  represents the difference of the total shear on either side of the section.  $W_1 + W_5$  must necessarily equal  $W_2$ . Therefore,  $W_1 - W_2 + W_5 = 0$ , and  $M = 0$ .

**Stiffening Ring.** An interesting problem is presented by the design and manner of support of the stiffening ring. Figure 52*f* represents a supporting ring. Note that in Fig. 52*b* the shears point upward and that in Fig. 52*d* the upward-pointing shear is larger than that pointing downward, thus causing the resultant shear to point upward. In Fig. 52*f*, however, we find that the shears transmitted to the ring on both sides point downward. If we consider the depth of the ring to be small relative to the diameter of the pipe, then the shear may be assumed acting through the neutral axis of the ring. If supported at the bottom point, the bending moment in the ring is represented by the expression

$$M = \frac{WR_1}{2\pi} \left( 1 - \phi \sin \phi - \frac{\cos \phi}{2} \right).$$

$W$  represents the total weight of water, pipe, and ring from center to center of span on both sides.

If the ring is considered as being of considerable depth compared with the diameter of the pipe, then it is not justifiable to assume the shear as acting along the center line of the ring, and a simple correction must be made for the shear loading which is tangential to the inner surface instead of acting along the center line.

**Saddle Support.** A pipe is not likely to be supported by a single reaction at its bottom point. A uniformly distributed radial support (Case VII), or an elastic support (Case IX), provided by some kind of saddle, is frequently considered feasible. When a thin-shell pipe is continuously supported in a rigid saddle, or when the pipe is intermittently supported in rigid saddles by means of stiffening rings, the pipe or the stiffening rings will draw away from the saddle as indicated by Fig. 53. When the angle  $\phi_1$ , through which the saddle extends, is less than  $37^\circ$ , then the pipe will ride on the corners of the saddle and the so-called saddle support will in reality be two radial supports (Case VIII, Figs. 56 and 57). For the limiting value,  $\phi_1 = 37^\circ$ , the elastic curve will just touch the saddle at the bottom. Figure 53 shows the elastic curve



of a pipe drawn to scale and supported in a saddle which extends through this limiting value of  $\phi_1 = 37^\circ$ .

A stiffening ring of a steel pipe imbedded in a concrete saddle would not constitute a saddle support in the same sense as we have used it here. It would rather approximate the problem of a fixed-ended arch. A solution of this problem does not lend itself readily to representation in a

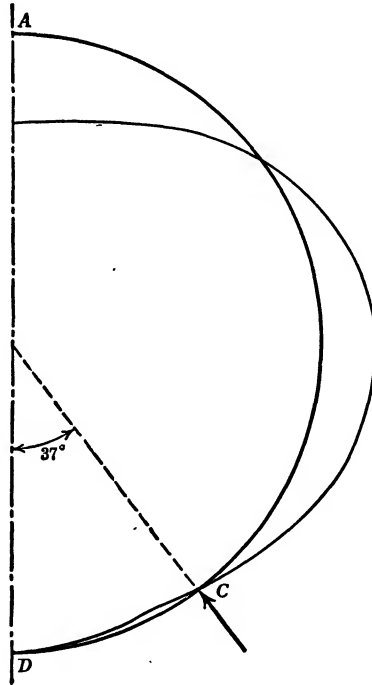

FIG. 53. Elastic Curve of Radially Supported Pipe Flowing Full.

generalized form. However, the analysis of such a special problem is so simple as hardly to require special attention.

**Vertical or Radial Supports of Stiffening Ring.** The common manner of supporting stiffening rings is similar to that given in Case VI. Figures 54 and 55 present four different analyses with a view to obtaining the value of  $\phi_1$ , marking the best location of the vertical support (Case VI). It would appear from these diagrams that when  $\phi_1 = 90^\circ$  the maximum moment anywhere in the ring is smaller than it is when  $\phi_1$  has values other than  $90^\circ$ . Figures 56 and 57 present four similar analyses made for the purpose of obtaining the most favorable value of  $\phi_1$ , the angle marking the position of the radial supports (Case VIII).

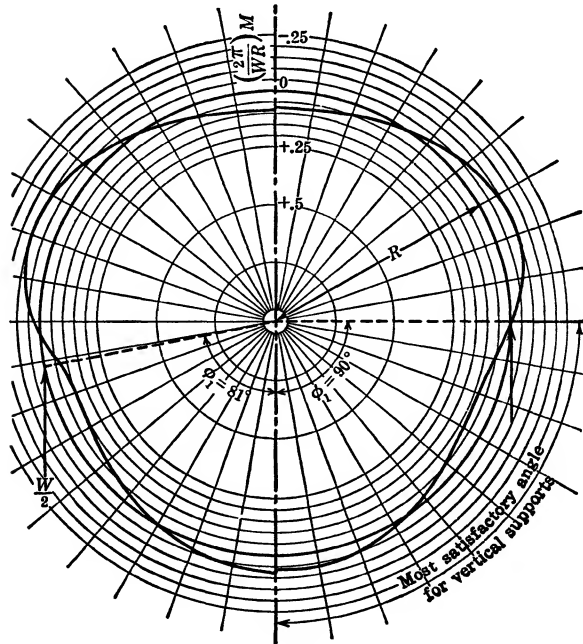
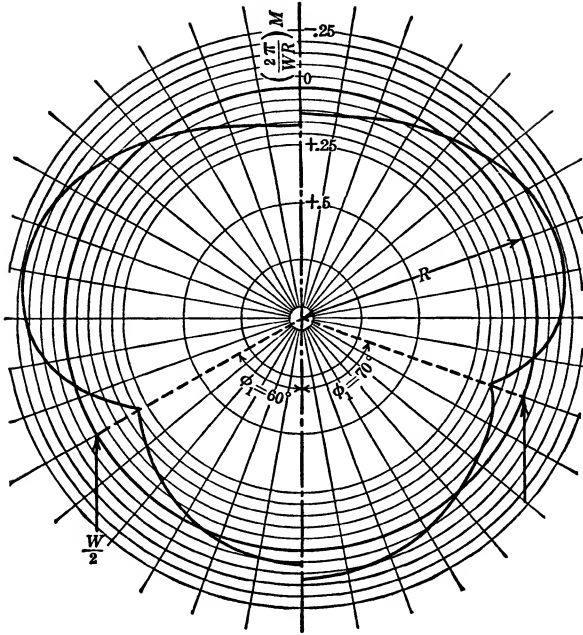

FIG. 54 (above) and FIG. 55 (below). Moment Diagrams, Symmetrical about Center Line, for Cylindrical Shell Flowing Full with Vertical Supports.

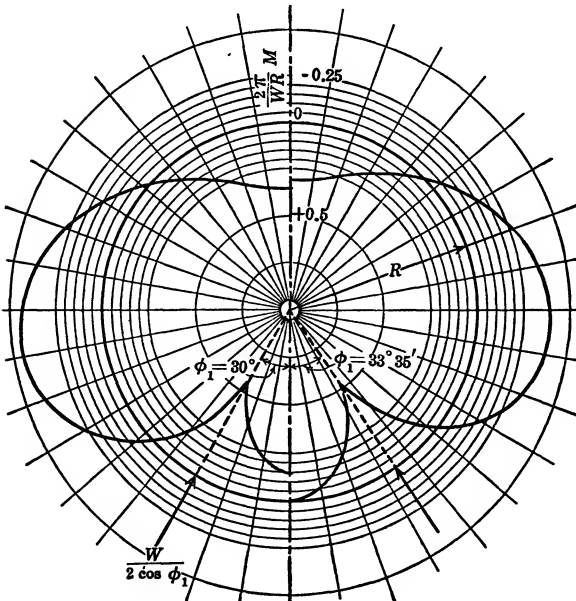
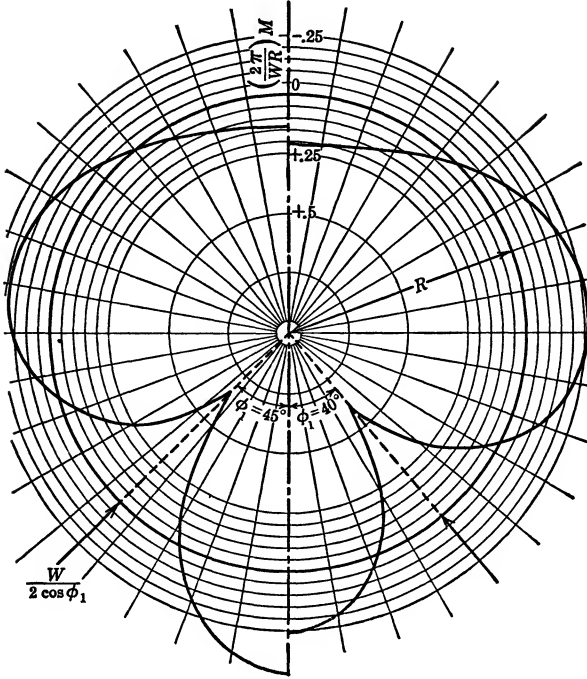

FIG. 56 (above) and FIG. 57 (below). Moment Diagrams, Symmetrical about Center Lines, for Cylindrical Shells Flowing Full with Radial Supports.

Figures 56 and 57 show a localized, acute, bending moment over the radial supports. These supports are assumed to be concentrated forces applied at a point or along a line. Although forces are commonly assumed as acting at a point or along a line, such application of forces is never realized. The reaction is bound to be distributed over an area. The acute point on the bending-moment curve (Figs. 56 and 57) is, therefore, likewise not realized. Thus the bending moment over the support will not be as severe as it appears in Figs. 56 and 57, while the rest of the bending-moment curve will not be materially affected by the fact that the reactions are distributed over an area instead of applied at a point. In view of these considerations it would appear from Figs. 56 and 57 that a saddle support, or radial supports, defined by the angle  $\phi_1 = 37^\circ$ , would result in bending moments of practically the same magnitude at the top, side, and bottom of the ring and would thus be most favorable.

In comparing the bending moments resulting from radial supports with those induced by vertical supports (comparing Figs. 55 and 56) it appears that for rings carried by vertical supports the absolute value of the maximum bending moment is less than 50 per cent of that found with the radial support.

In connection with an analysis of transverse bending moments in thin-shell pipes one more point should be mentioned. In considering pipes filled with liquid we must also consider the condition of the pipe in the process of being filled, even if this partially filled condition happened only once in the lifetime of a pipe line. Cases III and IV provide some data for a pipe partially filled with liquid. These data may be applied with confidence to pipes continuously supported. It is not immediately applicable to pipes supported by stiffening rings and only partially filled. For a discussion of this problem see "Design of Large Pipe Lines" by Herman Schorer, *Trans. Am. Soc. C. E.*, 1933, Vol. 98, p. 101.

## CHAPTER VII

### COMBINED BENDING AND DIRECT STRESS

In the preceding chapters we have successively analyzed frames and beams. In engineering practice structures occur which are simultaneously subjected to bending and direct stresses. When such structures are statically determinate the analysis is very simple. For the eccentrically loaded strut, for example, we compute the stresses due to the direct loading, and add to or subtract from them the stresses caused by the bending. When the structure simultaneously subjected to bending and direct stresses is redundant, the analysis is not so simple. However, no principles other than the ones already discussed are involved. The following three examples will illustrate how structures, acting simultaneously as frames and beams, may be analyzed.

#### EXAMPLE 33A

##### Braced Beam

*Given:* A wooden beam, braced by a steel truss and loaded with a uniformly distributed load  $w$  pounds per foot over the left half of its span (Fig. 58a).

The working stress for wood is 1200 lb. per sq. in.

The working stress for steel is 18,000 lb. per sq. in.

The modulus of elasticity for wood,  $E_w = 1,500,000$  lb. per sq. in.

The modulus of elasticity for steel,  $E_s = 30,000,000$  lb. per sq. in.

The beam is continuous from  $A$  to  $C$  and has a rectangular cross section 6 in. by 14 in. Its depth is 14 in.

Bars  $a$ ,  $d$  and  $e$  have a cross-sectional area of  $\frac{1}{4}$  sq. in.

Bars  $b$  and  $c$  have a cross-sectional area of 2 sq. in.

*To find:* The maximum load,  $w$  pounds per foot, which the structure can support, loaded as shown in Fig. 58a.

By applying the test as given on page 3 it is seen that the structure is once redundant. By assuming any one of the bars removed the structure is statically determinate. It is immaterial which one of the bars is regarded as the redundant one. We may also regard the moment in the beam at any point, say point  $B$ , as the redundant factor.

Let bar  $e$  be the redundant bar, and we solve for  $S_e$ , the final load in bar  $e$ . The same reasoning as that used in developing formula (2) (page 16) is here applied.

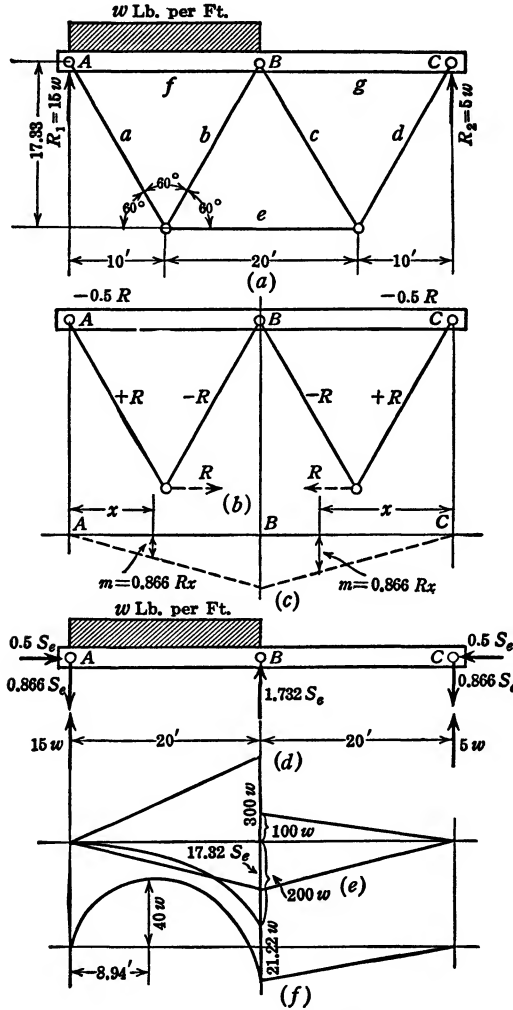

FIG. 58 (a-f). Braced Beam.

Suppose, for purposes of analysis, that a turnbuckle is built into bar  $e$ . This turnbuckle is slightly tightened so as to produce in bar  $e$  an auxiliary force  $RU_e$ . (Let  $U$  be a unit tensile force acting in the place of bar  $e$ , Fig. 58b.) The auxiliary forces in the members are as shown in Fig. 58b and as listed under column  $f$  in the table given with this example. Note

that the beam  $AC$  acts simultaneously as a beam and as a top chord of the truss. In other words, beam  $AC$  is subjected to compression by an auxiliary force  $f$  of  $0.5R$  lb. and to an auxiliary moment  $m = 0.866Rx$ , as shown in Fig. 58c.

When the load  $w$  pounds per foot is applied over the left half of the structure, bar  $e$  is loaded with a force  $S_e$ . The various bars are loaded with forces as shown in the table in column  $S$ . Beam  $AC$  is loaded with the load  $w$  pounds per foot and its reactions, plus the extra loading applied through the steel truss (Fig. 58d). The  $M$  bending moment, caused by the actual loading, therefore, will be as shown in Fig. 58e or 58f.

That portion of the total elastic energy in the entire structure, present because an auxiliary force  $R$  is acting in bar  $e$  while the actual load  $w$  pounds per foot is applied, is given by the expression

$$\Sigma Cfs + \int \frac{mMdx}{EI} + \iint \frac{fdaMvdx}{AIE} + \iint \frac{mvdaSdx}{IAE}.$$

The force  $R$  is an internal force and its external work is zero.

If the law of conservation of energy is assumed to hold, we have

$$\Sigma Cfs + \int \frac{mMdx}{EI} + \iint \frac{fdaMvdx}{AIE} + \iint \frac{mvdaSdx}{IAE} = 0.$$

Since the truss is assumed pin-connected, both  $m$  and  $M$  for the bars are zero, and the last three factors in the above equation, therefore, apply only to the beam  $AC$ . Since the auxiliary load  $R$  causes direct compression as well as an  $m$  moment in the beam  $AC$ , the expression

$\Sigma Cfs$  must include the beam as well as the bars.  $\iint \frac{fdaMvdx}{AIE}$  repre-

sents the elastic energy stored in the beam  $AC$  because an auxiliary force  $f$  is acting during the application of the actual bending moment  $M$ .

The force  $f$  causes stresses uniformly distributed over the cross section of the beam. The moment  $M$ , on the other hand, causes tensile stresses on one side of the neutral axis of the beam and compressive stresses on the other side. The elementary theory of strength of materials proves that the total tension on a cross section of a beam, due to bending,

is equal to the total compression.  $\iint \frac{fdaMvdx}{AIE}$  thus represents an equal amount of positive and negative energy the sum of which is zero.

Similarly,  $\iint \frac{mvdaSdx}{IAE}$  is equal to zero, and the equation reduces to

$$\Sigma Cfs + \int \frac{mMdx}{EI} = 0.$$

The elastic coefficient  $C = \frac{L}{AE}$  is not given in the accompanying table. The factor  $\frac{CE_w}{12}$  is listed instead. In the table, therefore, the lengths are given in foot units and the modulus of elasticity of steel is given as  $20E_w$ .

Bar	$\frac{CE_w}{12}$	$f$	$S$	$\frac{CE_{wf}S}{12}$
<i>a</i>	$20/0.25 \times 20$	$+R$	$+S_e$	$+4.000RS_e$
<i>b</i>	$20/2 \times 20$	$-R$	$-S_e$	$+0.500RS_e$
<i>c</i>	$20/2 \times 20$	$-R$	$-S_e$	$+0.500RS_e$
<i>d</i>	$20/0.25 \times 20$	$+R$	$+S_e$	$+4.000RS_e$
<i>e</i>	$20/0.25 \times 20$	$+R$	$+S_e$	$+4.000RS_e$
<i>f</i>	$20/84$	$-0.5R$	$-0.5S_e$	$+0.0595RS_e$
<i>g</i>	$20/84$	$-0.5R$	$-0.5S_e$	$+0.0595RS_e$
$\sum \frac{CE_{wf}S}{12} = +13.12RS_e$				

From the table we have

$$\begin{aligned} \Sigma C f S &= \frac{12 \times 13.12}{1,500,000} RS_e. \\ \int_A^C \frac{m M dx}{EI} &= \int_A^B \frac{0.866 R x M dx}{EI} + \int_B^C \frac{0.866 R x M dx}{EI} \\ &= \frac{0.866 R}{EI} \left\{ \left( \text{Area } \bar{X} \right)_A^B + \left( \text{Area } \bar{X} \right)_B^C \right\}. \end{aligned}$$

$\bar{X}$  and  $x$ , in both terms, are measured from the vertex of the  $m$  diagram (Fig. 58c). When  $m$  and  $M$  (Figs. 58c and 58e) are shown on the same side of the  $x$  axis, Area  $\bar{X}$  is positive; when they are shown on opposite sides of the  $x$  axis, Area  $\bar{X}$  is negative.

$$\begin{aligned} \left( \text{Area } \bar{X} \right)_A^B &= 200w \times \frac{20}{3} \times \frac{3}{4} \times 20 \times 12^3 + 17.32S_e \times \frac{20}{2} \times \frac{2}{3} \times 20 \\ &\quad \times 12^3 - 300w \times \frac{20}{2} \times \frac{2}{3} \times 20 \times 12^3 = 12^3(20,000w \\ &\quad + 2312S_e - 40,000w). \end{aligned}$$



$$\begin{aligned} \left( \text{Area } \bar{X} \right)_B^C &= 17.32S_e \times \frac{20}{2} \times \frac{2}{3} \times 20 \times 12^3 - 100w \times \frac{20}{2} \times \frac{2}{3} \times 20 \\ &\quad \times 12^3 = 12^3(2312S_e - 13,330w). \end{aligned}$$

(The factor  $12^3$  in the above expression is applied to change the foot units of Fig. 58e to inch units.)

$$\int_A^C \frac{mMdx}{EI} \text{ then is } \frac{0.866R \times 12 \times 12^3}{1,500,000 \times 6 \times 14^3} (4624S_e - 33,330w).$$

Adding  $\Sigma CfS$  and  $\int_A^C \frac{mMdx}{EI}$ , and simplifying and equating their sum to zero, we obtain

$$\begin{aligned} 13.12S_e + 0.091(4624S_e - 33,330w) &= 0. \\ 433.9S_e &= 3033w. \\ S_e &= 6.991w. \end{aligned}$$

The bending moment at  $B$  is

$$M_b = 100w - 17.32S_e = 100w - 121.224w = -21.224w.$$

The resultant bending-moment curve is shown in Fig. 58f.

The maximum bending moment over the portion  $AB$  occurs where the shear is zero.

$$\begin{aligned} \text{Shear} &= 15w - 0.866S_e - wx = 15w - 6.06w - wx = 0. \\ x &= 8.94 \text{ ft.} \end{aligned}$$

$$M_{\max.} = (15w)8.94 - (0.866S_e)8.94 - \frac{w(8.94)^2}{2} = 40w \text{ ft-lb.}$$

On the basis of maximum bending moment plus maximum direct compression in the beam,  $s = \frac{P}{A} + \frac{Mc}{I}$ .

$$1200 = \frac{0.5S_e}{84} + \frac{6M}{bd^2} = \frac{0.5(6.991)w}{84} + \frac{6 \times 40w \times 12}{6 \times 14^2}.$$

$$w = 482 \text{ lb. per ft.}$$

On the basis of the maximum stress in the truss,

$$s = \frac{P}{A}; \quad 18,000 = \frac{6.991w}{0.25};$$

$$w = 644 \text{ lb. per ft.}$$

The safe allowable load is 482 lb. per ft.

## EXAMPLE 33B

*Given:* The structure of example 33A loaded with a uniformly distributed load  $w'$  pounds per foot over its entire length.

*To find:* The maximum load  $w'$  pounds per foot the structure can carry.

In example 33A the loading of the beam  $AC$ , when loaded with  $w$  pounds per foot over half its length, is as shown in Fig. 58*g*. When the same beam, as part of the same structure, is loaded with  $w'$  pounds per foot over its entire length, its loading is as shown in Fig. 58*h*, and its bending moment as shown in Fig. 58*i*.

The maximum bending moment is at  $B$ .  $M_b = 42.4w'$  ft-lb.

The maximum force in bar  $e$  is twice the magnitude of that found in example 33A.

$$S_e = 13.982w'.$$

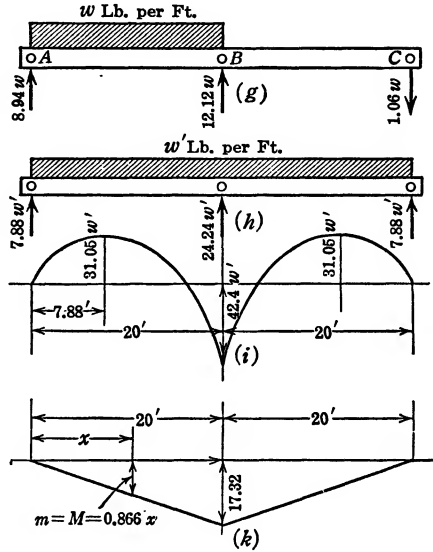

FIG. 58 (g-k).

On the basis of the maximum moment plus the maximum direct compression,

$$s = \frac{P}{A} + \frac{Mc}{I}.$$

$$1200 = \frac{0.5S_e}{84} + \frac{6 \times 42.4w' \times 12}{6 \times 14^2}.$$

$$w' = 448 \text{ lb. per ft.}$$

On the basis of the maximum stress in the truss,

$$s = \frac{P}{A} = \frac{S_e}{0.25}; \quad 18,000 = \frac{13.982w'}{0.25};$$

$$w' = 322 \text{ lb. per ft.}$$

The safe allowable load is 322 lb. per ft.

## EXAMPLE 33C

*Given:* The same structure used in example 33A loaded with a uniformly distributed load,  $w$  pounds per foot, over its entire length. A turn-buckle is built into bar  $e$  for the purpose of putting initial stresses in the structure so that, under the full load  $w$  pounds per foot, the points  $A$ ,  $B$ , and  $C$ , shall be on a straight line.

*To find:* The required initial force in bar  $e$ .

Beam  $AC$  is symmetrical about the center line through  $B$ . If points  $A$ ,  $B$ , and  $C$  are on a straight line, beam  $BC$  is identical with a beam fixed at its left end and freely supported at its right end. Under the condition of loading shown in example 14 (Fig. 34a), it was shown that the right reaction is  $\frac{3}{8}wl$  and the left reaction is  $\frac{5}{8}wl$ . The resultant vertical reaction at  $B$  is  $\frac{5}{8}wl$  for the span  $BC$  and the same for the span  $AB$ . Therefore,  $R_b = 1.25wl = 1.25 \times 20w = 25w$ .

In order that the vertical component of the forces in the truss at point  $B$  may be  $25w$  lb. the vertical component of the forces in the diagonal bars must be  $12.5w$  lb., and the forces in the diagonal bars are  $\frac{2}{\sqrt{3}} \times 12.5w = 14.43w$  lb. In bar  $e$  the force  $S_e$  also equals  $14.43w$  lb.

In example 33B it is shown that the force increment in bar  $e$ , due to a uniformly distributed load  $w'$  pounds per foot, is  $13.98w'$  lb. To keep points  $A$ ,  $B$ , and  $C$  on a straight line, under the action of  $w$  pounds per foot uniformly distributed, bar  $e$  must have an initial tensile force of  $(14.43 - 13.98)w = 0.45w$  lb.

## EXAMPLE 33D

*Given:* The structure for example 33A loaded with a uniformly distributed load  $w$  pounds per foot over its entire length. (Similar to example 33B and as shown in Fig. 58h.)

*To find:* The initial force in bar  $e$  necessary to insure maximum efficiency. Also, to consider the redesigning of the structure for the purpose of securing maximum efficiency.

In example 33B the truss was found to be the weakest part of the structure, that is, the stress in the steel reached its allowable maximum (18,000 lb. per sq. in.) before the maximum allowable stress for the wood (1200 lb. per sq. in.) was obtained. The condition of example 33C, in which an initial force was built into the truss so that points  $A$ ,  $B$ , and  $C$  would be on a straight line under a uniformly distributed load, was even more unfavorable. This would suggest, at first glance, an increase of

the cross-sectional area of the tension members of the truss. These considerations are typical of design of statically indeterminate structures. We assume dimensions, make our analysis, and if the results are not entirely satisfactory we make changes in accordance with the conclusions of our analysis and recompute stresses. We repeat this operation until we are satisfied with the results.

Before investigating the effect of a change in the size of the tension members of the truss, let us investigate another possible improvement.

In example 33C, with points  $A$ ,  $B$ , and  $C$  kept on a straight line, the moments in the beam are  $28.125w$  ft-lb. at a point 7.5 ft. from  $A$ , and  $50w$  ft-lb. at point  $B$ .

In example 33B the moments in the beam are  $31.05w'$  ft-lb. at a point 7.88 ft. from  $A$ , and  $42.4w'$  ft-lb. at point  $B$  (Fig. 58*i*).

Beam  $B$  will function most efficiently when the positive moment between points  $A$  and  $B$  is equal to the negative moment at  $B$ . To accomplish this, point  $B$  must be lowered, that is, the reaction of the truss against the beam must be decreased. This reaction is computed as follows:

Measuring  $x$  from point  $C$  to the left, the moment between  $B$  and  $C$  is  $R_c x - \frac{wx^2}{2}$ ; the moment at point  $B$  is  $20R_c - \frac{w20^2}{2}$ ; taking  $\Sigma F_y = 0$  for the entire beam, we have

$$R_a + R_b + R_c = 40w.$$

Because of the condition of symmetry  $R_a = R_c$ . Therefore

$$R_b + 2R_c = 40w.$$

Taking the two moments equal to each other (equal except that they have opposite signs), we have

$$R_c x - \frac{wx^2}{2} = \frac{w20^2}{2} - 20R_c.$$

$$R_c(x + 20) = \frac{w}{2}(x^2 + 20^2).$$

$$R_c = \frac{w(x^2 + 20^2)}{2(x + 20)}.$$

At the point of maximum moment between points  $B$  and  $C$  the shear must be zero. Therefore,  $R_c = wx$ . And

$$wx = \frac{w(x^2 + 20^2)}{2(x + 20)}.$$

$$2x^2 + 40x = x^2 + 400.$$

$$x^2 + 40x - 400 = 0.$$

$$x = 8.3 \text{ ft.}$$

Under these conditions  $R_c = 8.3w$ , and  $R_b = 40w - 16.6w = 23.4w$ .

In example 33C we find that the force  $S_e$ , necessary to insure a reaction of  $25w$  lb., is  $\frac{2}{\sqrt{3}} \times \frac{25}{2} w = 14.43 \text{ lb.}$  In this instance the force  $S_e$ , necessary to insure a reaction of  $23.4w$  lb., is  $\frac{2}{\sqrt{3}} \times \frac{23.4w}{2} = 13.51w \text{ lb.}$

In example 33B the increment of force in bar  $e$ , due to a uniformly distributed load  $w_1$  pounds per foot over the entire beam, is a tensile force of  $13.98w_1$  lb. For a most favorable distribution of stress the tensile force in bar  $e$ , as has been shown, should be  $13.51w_1$  lb. To accomplish this, bar  $e$  should be loaded with an initial compressive force of  $(13.98 - 13.51)w_1 = 0.47w_1$  lb.

Possibly the easiest way to impose an initial compressive force of  $0.47w_1$  lb. in bar  $e$  is as follows: A load  $w_1$  pounds per foot uniformly distributed from  $A$  to  $C$  would impose a tensile force of  $13.98w_1$  lb. on bar  $e$ .

Therefore, the load,  $\frac{0.47}{13.98} \times w_1 = 0.0336w_1$  lb. per ft., uniformly distributed over the entire length of the beam, would impose a tensile force of  $0.47w_1$  lb. on bar  $e$ .

A load of  $0.0336w_1$  is uniformly distributed over the beam before bar  $e$  is fitted and pin-connected to the truss. When the load  $0.0336w_1$  is removed bar  $e$  remains stressed with an initial compressive force of  $0.47w_1$  lb., or rather, it has a slack equivalent to a force of  $0.47w_1$  lb.

It is of course one thing to assume a uniformly distributed load of  $0.0336w_1$  lb. per ft. and quite another thing to accomplish the same in practice. However, the procedure as outlined may be followed with reference to a concentrated load  $Q$  placed at  $B$ . First, compute the stress in  $e$  as a function of a concentrated load  $Q$  at  $B$ . Next compute the magnitude that must be given to  $Q$  to produce a tensile force  $0.47w_1$  lb. in  $e$ . Then place such a load at  $B$ , fit bar  $e$  to the truss, and subsequently remove the concentrated load.

It should be realized that the present discussion is an academic one, presented solely for purposes of illustrating theory and method. It should also be realized that, if we are going to compute to a refinement of  $0.47w_1$  lb., we should likewise take the dead-load stresses into account. The action of the dead load of the beam, if it is allowed to be acting before the truss is fitted, will, in a measure, act similarly to the load of  $0.0336w_1$  lb. per ft. used in our problem. For this condition of maximum

efficiency the beam  $AC$  must resist a maximum moment of  $8.3w_1 \times 8.3 - \frac{8.3^2 w_1}{2} = 34.45w_1$  ft-lb. On the basis of the maximum moment in the beam plus the direct stress, we have

$$s = \frac{P}{A} + \frac{Mc}{I}.$$

$$1200 = \frac{13.51w_1}{6 \times 14} + \frac{6 \times 34.45 \times w_1 \times 12}{6 \times 14^2}.$$

$$w_1 = 516 \text{ lb. per ft.}$$

On the basis of the maximum stress in the truss, we have

$$s = \frac{P}{A} \quad 18,000 = \frac{13.51w}{0.25}.$$

$$w_1 = 333 \text{ lb. per ft.}$$

Comparing this with example 33B it is seen that the efficiency of the truss is increased 3 per cent, perhaps a negligible quantity. However, the discrepancy between the strength based on the beam and that based on the truss is more pronounced. This suggests that, to obtain maximum efficiency, we strengthen the truss by increasing the cross-sectional area of the tension members. This of course will depend on the available commercial sizes. Tension bars of approximately  $\frac{1}{2}$  sq. in. cross-sectional area may give the best results.

#### EXAMPLE 33E

*Given:* The structure described in example 33A loaded with a uniformly distributed load  $w$  pounds per foot over its entire length, similar to example 33B and as shown in Fig. 58h.

*To find:* The amount a turnbuckle in bar  $e$  must be tightened to maintain points  $A$ ,  $B$ , and  $C$  on a straight line.

In example 33C we compute the initial force necessary in bar  $e$  to maintain points  $A$ ,  $B$ , and  $C$  on a straight line; in this example we compute the amount bar  $e$  must be shortened, after being fitted, to accomplish the same purpose.

In shop assemblage it is quite feasible to put an initial force on the truss, but in field assemblage this may not be practicable. Since bar  $e$  is provided with a turnbuckle of which the thread is known, it may be more to the point to compute the number of turns that must be given to it, that is, find the amount bar  $e$  must be shortened, to obtain the desired result. If bar  $e$  were fitted to fixed pins, the problem would be

extremely simple. The formula  $E = \frac{\text{stress}}{\text{strain}}$  would give the answer directly. Bar  $e$ , however, is part of an elastic structure, and the elastic behavior of the entire structure must be taken into account. We assume bar  $e$  to be fitted to the truss at one extremity and disconnected at the other. A unit force is applied at the free end of bar  $e$ , and an equal and opposite one at the point from which bar  $e$  is assumed to be disconnected. By means of formulas (1) and (5) [formula (5) must be included because beam  $AC$  is subject to bending as well as compression, see example 33A], we compute the displacement  $\Delta_e$  of the free end of bar  $e$  relative to the point from which we assume it to be free. This displacement is a function of the unit load and the elastic coefficients of the structure.

$$1 \times \Delta_e = \Sigma Cfs + \int_A^C \frac{mMdx}{EI}.$$

Assuming an auxiliary force acting in the place of the actual force unity and also of magnitude unity, we obtain:

$$\begin{aligned} \Delta_e &= \sum_a^g CS^2 + \int_A^C \frac{0.866xMdx}{EI} = \sum_a^g CS^2 + \left. \frac{0.866 \text{ Area } \bar{X}}{EI} \right]_A^C \\ &= \sum_a^g CS^2 + \left. \frac{2 \times 0.866 \text{ Area } \bar{X}}{EI} \right]_A^B. \end{aligned}$$

$m$  and  $M$  both are shown by Fig. 58k.

Bar	$\frac{CE_w}{12}$	$S$	$S^2$	$\frac{CE_w S^2}{12}$
$a$	4.0	+1.0	+1.0	+4.0
$b$	0.5	-1.0	+1.0	+0.5
$c$	0.5	-1.0	+1.0	+0.5
$d$	4.0	+1.0	+1.0	+4.0
$e$	4.0	+1.0	+1.0	+4.0
$f$	0.238	-0.5	+0.25	+0.06
$g$	0.238	-0.5	+0.25	+0.06
				13.12

$$\sum_a^g CS^2 = \frac{12 \times 13.12}{1,500,000}.$$

$$\text{Area } \bar{X} \Big]_A^B = \frac{17.32 \times 20}{2} \times \frac{2}{3} \times 20 \times 12^3 = 2312 \times 12^3.$$

(The factor  $12^3$  is necessary to reduce foot units to inch units.)

$$\Delta_e = \frac{12 \times 13.12}{1,500,000} + \frac{2312 \times 12^3 \times 12 \times 2 \times 0.866}{1,500,000 \times 6 \times 14^3}$$

$$= \frac{12}{1,500,000} (13.12 + 420.3) = 0.003467 \text{ in.}$$

In example 33C it is seen that we need an initial tensile force of  $0.45w$  in bar  $e$  to keep points  $A$ ,  $B$ , and  $C$  on a horizontal line. By means of a turnbuckle bar  $e$  is shortened in the ratio of  $0.003467$  in. to every pound. The total required shortening of bar  $e$ , therefore, is

$$0.45w \times 0.003467 = 0.00156w \text{ in.}$$

EXAMPLE 34

The Arch

Given: A fixed arch rib in the shape of an arc of a circle which has a radius of 200 ft. The rib is of rectangular cross section, width  $b$ , and

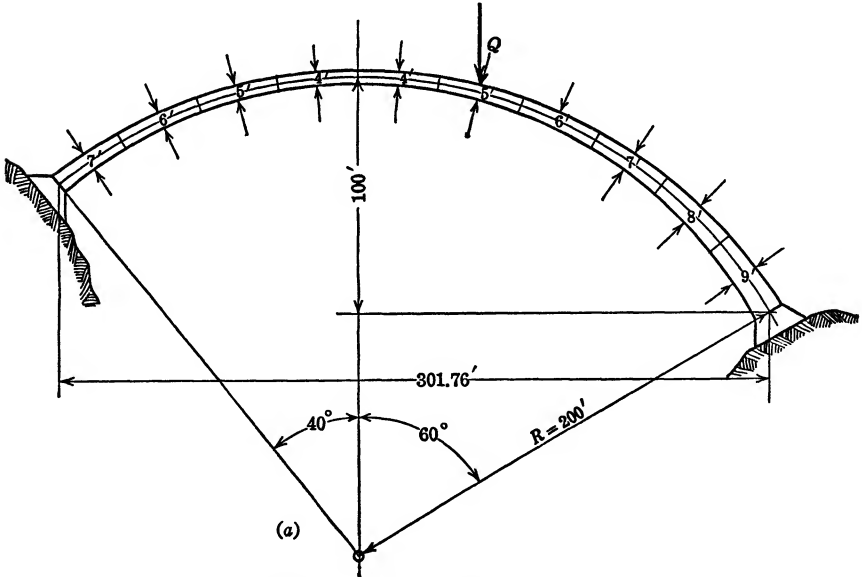

FIG. 59 (a). Unsymmetrical Fixed Arch.

depth as indicated in Fig. 59a. The supports are on different levels; the total vertical depth is 100 ft.; the horizontal span is 301.76 ft.

To find: The influence lines for horizontal reaction  $H$ , vertical reaction  $V_1$ , and moment  $M_1$  at the left end.



A large number of textbooks on arch design are available. Questions such as the relative merits of the hinged and fixed arches, steel and concrete arches, and the preliminary analysis for the purpose of deciding on the most suitable shape are left to the professional treatise. These questions disposed of, one still remains, namely, the stress analysis of the arch finally decided upon. The present example deals exclusively with this.

To make our analysis general we have selected a structure completely restrained at both supports, and unsymmetrical as to dimensions as well as to loading. To avoid unnecessarily involved figures we have chosen homogeneous material and even numerical values for the depth of the arch at different points, so that the moment of inertia will be merely  $\frac{bh^3}{12}$ . All dimensions throughout will be in foot units. In the analysis of an actual arch, of either reinforced concrete or steel, the moment of inertia of the arch at the various sections involves more elaborate computations. Likewise computations of the horizontal and vertical distances between center points of segments, if the shape of the arch is other than an arc of a circle, will be more involved. These, however, are only matters of minor detail. So far as the analysis on the basis of the theory of elasticity is concerned, methods of obtaining results advocated in various books may differ, but their results coincide and are in exact agreement with what we propose to accomplish in this analysis.

In the chapter on influence lines we show how the influence line in one graph gives a complete record of the effect of varying loads applied at different points. Here we solve in detail for the horizontal, vertical, and moment reactions at the left support under action of the load  $Q$  at the center of the sixth segment (Fig. 59*b*). This will give us one point on each of the three influence diagrams (Figs. 59*c*, *d*, and *e*). By repeating the same analysis for the load  $Q$  applied to the center of the other nine segments we obtain the other nine points on the influence diagram. With the influence lines completed we may obtain the effect upon the three left reactions of the dead weight of the arch, of the vertical component of the earth fill, and of any concentrated loads which may be placed upon the arch. The three left reactions determined, the stress condition on any other section of the arch may be obtained by means of the equations of static equilibrium. In fact, once the three influence lines are obtained, the influence line for the thrust, the shear, or the moment at any section may be constructed by making use of the equations of static equilibrium only.

Upon close analysis of the structure represented by Fig. 59b we find that it is threefold redundant. The three reactions,  $H$ ,  $V_1$ , and  $M_1$ , may be removed from the left support. The structure, provided that it is

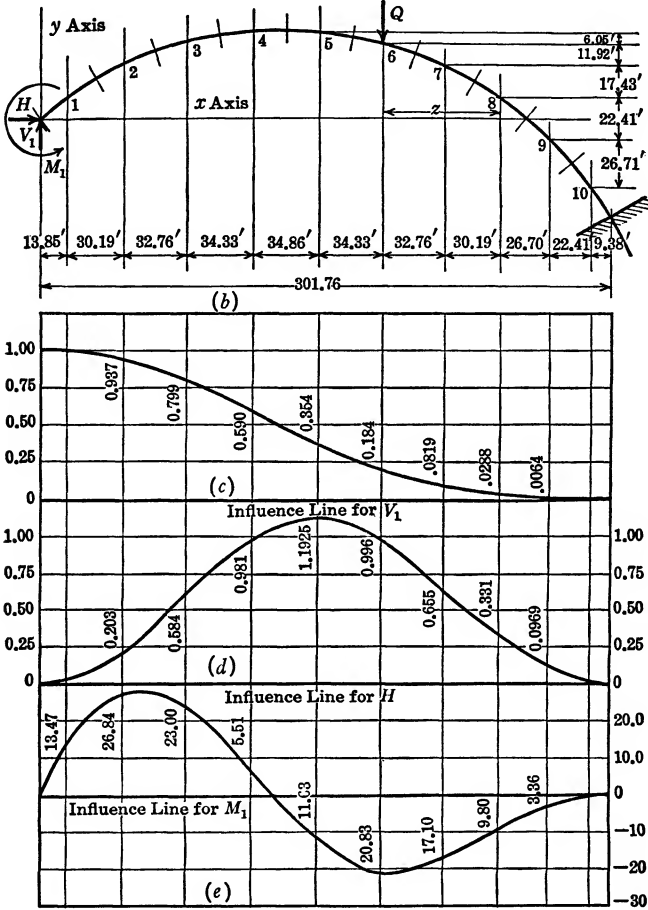

FIG. 59 (b-e). Influence Lines for Vertical, Horizontal, and Moment Reactions at Left End of Unsymmetrical Arch.

strong enough, will remain stable and becomes statically determinate. We may regard the three component reactions at the left support as the three redundants. Their function is to insure a zero value for the linear horizontal displacement  $\Delta_x$ , for the linear vertical displacement  $\Delta_y$ , and for the angular displacement  $\theta_1$  of the left end relative to the right end.

These three physical limitations enable us to use the elastic energy equations three times, namely:

$$\theta_1 = \int \frac{mMds}{M'EI} = 0, \quad (a)$$

$$\Delta_y = \int \frac{mMds}{FEI} = 0, \quad (b)$$

$$\Delta_x = \int \frac{mMds}{FEI} + \frac{\Sigma Cfs}{F} = 0. \quad (c)$$

We may evaluate the equations and solve them simultaneously as in numerous previous examples, particularly examples 27 and 29. We do not meet with anything unusual in the evaluations of the three equations given above except in one respect. When the auxiliary load  $F$  is applied to the left end, the arch is conceived as fixed at the right end and free at the left end, as we have it in a cantilever (Fig. 59b). In connection with equation (c) we assume an auxiliary load  $F$  applied at the left end in a horizontal direction, while in connection with equation (b) we assume an auxiliary load  $F$  applied in a vertical direction. By means of these equations we evaluate the elastic energy in the structure, stored therein because stresses induced by  $F$  are present while stresses induced by  $Q$  are being applied. It is readily seen that  $F$  causes three kinds of stresses, bending stresses, direct stresses, and shear stresses. All these should be separately considered. In other words, our structure acts both as a beam and as a strut. In example 33, page 140, in which we have a combination of truss and beam action, we discuss the same phenomenon in detail. In fact, the combination of shear and bending stresses occurred in practically all structures composed of beams which we analyzed.

It is well to realize the similarity between arches and cables. The one, in a measure, may be considered the negative of the other. A cable is subjected only to tensile stresses, and, when loaded with a load uniformly distributed in a horizontal direction, it will assume the shape of a parabola. An arch of parabolic shape and loaded in a similar manner will be subjected to compressive stresses only. Under circumstances in which the cable readily changes shape to adjust itself to locally applied concentrated loads, the load line of an arch will similarly change as concentrated loads are applied. Since the arch is rigid and does not change its shape, a load line in the arch other than one coinciding with the center line, or with the elastic curve of the arch, will induce both transverse stresses and moments. Transverse stresses in the arch are of relatively less importance than they are in the beams which we analyzed in all preceding examples. Since we did not discuss them in these previous

examples (see page 171), we may well ignore them here also. That is not true, however, of the direct stresses. It may be said that the ideal arch is one subjected to a direct stress only. It is obvious then that the direct stress must be taken into account. The direct stress is relatively more important in flat arches.

In the present instance the effect of the direct stress may prove to be insignificant compared with the effects due to bending. Since we are primarily concerned with theory, we shall include the direct stress effects for purposes of illustration.

In connection with equation (a) an auxiliary load  $M'$  is assumed acting at the left end, while the actual loading due to  $H$ ,  $V_1$ ,  $M_1$ , and  $Q$  is being applied. On page 140 it is shown that a direct stress, caused by  $H$ ,  $V_1$ , or  $Q$ , and superimposed upon existing bending stresses produced by  $M'$ , stores no elastic energy. This is true because the bending stresses caused by  $M'$  are tensile and compressive stresses on opposite sides of the beam and are of the same magnitude, therefore accounting for equal amounts of positive and negative elastic energy stored as the  $Q$  loading and its consequent reactions are being superimposed. In connection with equation (a), therefore, the effect of direct stress is zero, and the terms representing it will not be enumerated in the development of the equation.

In connection with equation (b) an auxiliary vertical force  $F$  is assumed to be acting at the left end, while the arch is fixed at the right end. We have already argued that the effects of direct stresses are important only in flat arches, arches with a relatively small rise. In a flat arch the component of the auxiliary force  $F$  at the left end, normal to the cross section of the arch, is very small. Furthermore, it is zero at the crown of the arch, positive on one side, and negative on the other side. If the arch were symmetrical, the stresses caused by the actual force  $H$  (the force causing the largest direct stresses), being of constant sign throughout and being of the same intensity in the left half of the arch as in the right half, would store equal amounts of positive and negative elastic energy and could thus be ignored. In our example, in which the arch is not symmetrical, we conclude that in connection with formula (2) (page 16) the effect of direct stresses is largely compensating and need not be taken into account. In terms of physics we may put it somewhat more tersely. In considering the vertical displacement of the left end of the arch relative to the right end, the effect of bending is paramount, whereas the effect of direct compression is negligible.

The same reason that leads us to ignore the effects of direct stress in equation (b) compels its inclusion in equation (c). The auxiliary force  $F$ , assumed acting at the left end while the actual forces are being

superimposed, causes compressive forces throughout the length of the arch. The major actual load, causing a direct stress  $H$ , also causes compressive forces throughout. The two being of the same sign, the elastic energy in the arch, stored therein because  $F$  is acting while  $H$  is being applied, is accumulative and, in flat arches, may be of appreciable magnitude. Again, in terms of physics, considering the horizontal displacement of the left end of the arch relative to the right end, we may say that the effect of direct stress may be appreciable and in flat arches it should be taken into account.

Formulas (1) and (5) express the elastic energy in the arch stored therein because a horizontal force  $F$  is assumed acting at the left end while the actual loading  $Q$  and its induced reactions are being superimposed. We have argued, in connection with equation (c), that we are to consider the structure acting simultaneously as a beam and as a strut. Both formulas,  $\int \frac{mMds}{EI}$  and  $\Sigma CfS$ , must thus be used to evaluate the two kinds of elastic energy—that due to beam action and that due to strut action. Equation (c) on page 152 is therefore written

$$\Delta_x = \int \frac{mMds}{FEI} + \frac{\Sigma CfS}{F} = 0.$$

The second expression,  $\frac{\Sigma CfS}{F}$ , in this equation is quite often approximately evaluated by considering it equal to  $\frac{HL}{AE}$ ,  $H$  representing the actual force  $S$ ,  $L$  representing the span length, and  $A$  being given an average value of the cross-sectional area of the arch. In our example, the arch being unsymmetrical, the factor  $\Sigma CfS$  is evaluated in Table III on page 159.

Letting  $H$ ,  $V_1$ , and  $M_1$  be the horizontal, vertical, and moment reactions, respectively, at the left end of the arch (Fig. 59b), the actual moment at any point in the arch is

$$M = V_1x - M_1 - Hy - Qz.$$

(The last term,  $-Qz$ , applies only to points in the arch to the right of the point of application of  $Q$ .) The signs in this expression merely indicate that the bending caused by  $V_1$  is of sense opposite to that caused by  $M_1$ .

For that part of the arch above the  $x$  axis the sense of the moment caused by  $H$  is the same as that caused by  $M_1$ ; for the extreme right end of the arch, that portion that lies below the  $x$  axis, the sense of the

moment caused by  $H$  is opposite to that caused by  $M_1$ . For this latter portion of the arch  $y$  becomes negative, and thus automatically takes care of the change in sense above referred to. In our solution this change of signs must be carefully watched. To evaluate equation (a) we assume an auxiliary moment  $M'$ , similar in every respect to  $M_1$ , to be acting at the left end of the arch before the actual loading  $Q$  and the reactions  $H$ ,  $V_1$ , and  $M_1$ , caused by  $Q$ , are applied.

The auxiliary moment  $m$  caused by  $M'$  is at all points equal to  $M'$ . Equation (a) therefore becomes

$$\theta_1 = \int \frac{mMds}{M'EI} = \int \frac{M'Mds}{M'EI} = \int \frac{Mds}{EI} = 0.$$

Since  $E$  is constant for the entire arch and since  $I = \frac{b \times h^3}{12}$ , we may

multiply through by  $\frac{bE}{12}$ . Then we have

$$\int \frac{Mds}{h^3} = 0.$$

Thus,

$$V_1 \int \frac{xds}{h^3} - M_1 \int \frac{ds}{h^3} - H \int \frac{yds}{h^3} - Q \int \frac{zds}{h^3} = 0. \quad (a)$$

The integration in the above expression is to proceed over the entire length of the arch.

The depth  $h$  of the beam being a variable, we shall evaluate the summations in the above expression by means of tabular arrangement and algebraic addition. The manner of dividing the arch in segments  $ds$  is subject to various interpretations. Some designers make  $ds$  variable in such manner that  $\frac{ds}{I}$  is a constant. Others make  $ds$  variable so as to make the horizontal projection of  $ds$  a constant. As a third alternative the arch may be divided in a number of segments  $ds$  of equal length. In the present instance we adopt the last named method. Ten segments, each 34.90 ft. long, are sufficient to exemplify our theory.

Because  $ds$  is constant it may be canceled. Thus we have

$$V_1 \int \frac{x}{h^3} - M_1 \int \frac{1}{h^3} - H \int \frac{y}{h^3} - Q \int \frac{z}{h^3} = 0. \quad (a)$$

The various terms under the summation signs are evaluated in Table I (page 157). The  $h$  is shown on Fig. 59a; and  $x$ ,  $y$ , and  $z$  may be obtained from Fig. 59b.

Substituting the summations obtained in Table I for the factors appearing under the integral signs in equation (a), we obtain

$$8.943V_1 - 0.06566M_1 - 2.3615H - 0.6640Q = 0. \quad (a)$$

To evaluate equation (b) (page 152) we assume an auxiliary load  $F$  acting at the left end of the arch in the direction and sense of  $V_1$ . The arch is conceived as a cantilever held at the right end and loaded with  $F$  only. The auxiliary moment caused by  $F$  is  $m = Fx$ .

$$\Delta_y = \int \frac{mMds}{FEI} = \int \frac{FxMds}{FEI} = \int \frac{xMds}{EI} = 0. \quad (b)$$

Substituting for  $I$  its value  $\frac{b \times h^3}{12}$  and multiplying the above equation through by  $\frac{bE}{12ds}$ , we obtain

$$\int \frac{xM}{h^3} = 0.$$

The expression for  $M$  is to be found on page 154. Thus,

$$V_1 \int \frac{x^2}{h^3} - M_1 \int \frac{x}{h^3} - H \int \frac{xy}{h^3} - Q \int \frac{xz}{h^3} = 0. \quad (b)$$

$\int \frac{x}{h^3}$  may be obtained from Table I. The other terms under the summation signs are evaluated in Table II.

$$1485.2V_1 - 8.943M_1 - 292.0H - 169.2Q = 0. \quad (b)$$

To evaluate equation (c) (page 152) we assume an auxiliary load  $F$  acting at the left end of the arch in the direction and sense of  $H$ . The arch is conceived as a cantilever held at the right end and loaded with  $F$  only. The auxiliary moment caused by  $F$  is  $m = -Fy$ . The auxiliary direct force caused by  $F$  is  $f = F \cos \theta$ . ( $\theta$  is the angle which the tangent to the arch at the center of the segments makes with the  $x$  axis.)

$$\Delta_x = \int \frac{mMds}{FEI} + \frac{\Sigma Cfs}{F} = - \int \frac{FyMds}{FEI} + \frac{\Sigma CSF \cos \theta}{F} = 0. \quad (c)$$

In this equation,

$$C = \frac{L}{AE} = \frac{ds}{bhE}$$

and

$$S = H \cos \theta.$$

TABLE I

Segment	$h$	$h^3$	$x$	$1/h^3$	$x/h^3$	$y$	$y/h^3$	$z$	$z/h^3$
1	7	343	13.85	0.00291545	0.040379	+11.20	0.032653		
2	6	216	44.04	0.00462963	0.203889	+28.63	0.132546		
3	5	125	76.80	0.00800000	0.614400	+40.55	0.324400		
4	4	64	111.13	0.0156250	1.736406	+46.60	0.728125		
5	4	64	145.99	0.0156250	2.281094	+46.60	0.728125		
6	5	125	180.32	0.00800000	1.44256	+40.55	0.324400		
7	6	216	213.08	0.00462963	0.986481	+28.63	0.132546	0	0.151667
8	7	343	243.27	0.00291545	0.709242	+11.20	0.032653	32.76	0.183528
9	8	512	269.97	0.00195312	0.527285	-11.21	-0.021894	62.95	0.175097
10	9	729	292.38	0.00137174	0.401069	-37.92	-0.052016	89.65	0.153717
				0.065665	8.9428		2.361538	112.06	
									0.6640

TABLE II

Segment	$h$	$h^3$	$x$	$x^2$	$x^2/h^3$	$y$	$xy$	$xy/h^3$	$z$	$zx$	$zx/h^3$
1	7	343	13.85	191.82	0.559242	+11.20	155.12	0.452245			
2	6	216	44.04	1939.52	8.979260	+28.63	1260.87	5.837362			
3	5	125	76.80	5898.24	47.185920	+40.55	3114.24	24.913920			
4	4	64	111.13	12349.88	192.96687	+46.60	5178.66	80.916562			
5	4	64	145.99	21313.08	333.01688	+46.60	6808.13	106.2989			
6	5	125	180.32	32513.30	260.1064	+40.55	7311.98	58.4958	0	0	
7	6	216	213.08	45403.09	210.1995	+28.63	6100.48	28.24297	32.76	6980.50	32.31713
8	7	343	243.27	59180.29	172.5372	+11.20	2724.62	7.94349	62.95	15313.85	44.6468
9	8	512	269.97	72883.80	142.3508	-11.21	-3026.36	-5.91084	89.65	24202.81	47.2710
10	9	729	292.38	85486.06	117.2646	-37.92	-11087.05	-15.2085	112.06	32764.10	44.9438
					1485.1667			291.9819			169.1787



Thus,

$$\Delta_x = - \int \frac{yMds}{EI} + \sum \frac{dsH \cos^2 \theta}{bhE} = 0.$$

Substituting for  $I$  its value  $\frac{bh^3}{12}$  and multiplying through by  $\frac{bE}{12ds}$ , we obtain

$$- \int \frac{yM}{h^3} + \frac{H}{12} \sum \frac{\cos^2 \theta}{h} = 0.$$

Substituting  $M$  as expressed on page 154, we have

$$-V_1 \int \frac{xy}{h^3} + M_1 \int \frac{y}{h^3} + H \int \frac{y^2}{h^3} + Q \int \frac{zy}{h^3} + \frac{H}{12} \sum \frac{\cos^2 \theta}{h} = 0.$$

$\int \frac{xy}{h^3}$  may be obtained from Table II, and  $\int \frac{y}{h^3}$  from Table I. The other terms under the summation signs are evaluated in Table III, (page 159). Equation (c) then becomes

$$-291.98V_1 + 2.3615M_1 + 104.71H - 1.3941Q + \frac{1.44}{12}H = 0.$$

The last term,  $\frac{1.44}{12}H$ , in the equation represents the effect of direct compression in the arch on the horizontal displacement of the left end relative to the right end. As compared with the third term,  $104.71H$ , which represents the effects of the bending caused by  $H$  on the same displacement, it constitutes only 0.1 per cent. In the arch under consideration the direct compression effect, as compared with the bending of the arch, is negligible. As a general rule the effect of direct compression need be considered only in very flat arches.

Solving equations (a), (b), and (c) simultaneously, we obtain

$$V_1 = + 0.1834Q.$$

$$H = + 1.0029Q.$$

$$M_1 = - 21.205Q.$$

To obtain influence lines for the reactions at the left end of the arch the load  $Q$  is placed in different positions and the foregoing analysis repeated. The various columns would then appear the same as those in Tables I, II, and III. In fact only the columns involving the variable  $z$  would be different for each new position of the load  $Q$ . Table IV gives the evaluation of the various terms in equations (a), (b), and (c) which

TABLE III

Segment	$h$	$h^2$	$y$	$y^2$	$y^2/h^3$	$z$	$zy$	$zy/h^3$	$\theta$	$\text{Cos } \theta$	$(\text{Cos } \theta)^2$	$(\text{Cos } \theta)^2 (\text{Cos } \theta)/h$
1	7	343	+11.20	125.44	0.365714				35°	.8191	.6709	.09584
2	6	216	+28.63	819.68	3.7948				25°	.9063	.8214	.13690
3	5	125	+40.55	1644.30	13.1544				15°	.9659	.9330	.1866
4	4	64	+46.60	2171.56	33.9306				5°	.9962	.9924	.2481
5	4	64	+46.60	2171.56	33.9306				- 5°	.9962	.9924	.2481
6	5	125	+40.55	1644.30	13.1544	0			-15°	.9659	.9330	.1866
7	6	216	+28.63	819.68	3.7948	32.76	937.92	4.3422	-25°	.9063	.8214	.1369
8	7	343	+11.20	125.44	0.3657	62.95	705.04	2.0555	-35°	.8191	.6709	.09584
9	8	512	-11.21	125.66	0.2454	89.65	-1004.98	-1.9628	-45°	.7071	.5000	.0625
10	9	729	-37.92	1437.93	1.9725	112.06	-4249.32	-5.8290	-55°	.5736	.3290	.03656
					104.7089			-1.3941				1.4359

TABLE IV

Segment	h	h <sup>3</sup>	z	y	Load Q Applied at Center of Segment 1					
					z	z/h <sup>3</sup>	zz	zz/h <sup>3</sup>	yz	yz/h <sup>3</sup>
1	7	343	13.85	+11.20	0	0	0	.....	0	
2	6	216	44.04	+28.63	30.19	.1398	1,329.57	6.1554	864.34	4.0016
3	5	125	76.80	+40.55	62.95	.5036	4,834.56	38.8765	2552.62	20.4210
4	4	64	111.13	+46.60	97.28	1.5200	10,810.73	168.9177	4533.25	70.8320
5	4	64	145.99	+46.60	132.14	2.0647	19,291.12	301.4237	6157.72	96.2144
6	5	125	180.32	+40.55	166.47	1.3318	30,017.87	240.1430	6750.36	54.0029
7	6	216	213.08	+28.63	199.23	.9224	42,451.93	196.5367	5703.95	26.4072
8	7	343	243.27	+11.20	229.42	.6689	55,811.00	162.7142	2569.50	7.4912
9	8	512	269.97	-11.21	256.12	.5002	69,144.72	135.0479	-2871.10	-5.6076
10	9	729	292.38	-37.92	278.53	.3821	81,436.60	111.7098	-10561.86	-14.4881
						8.0335		1361.3249		259.2746

Segment	h	h <sup>3</sup>	z	y	Load Q Applied at Center of Segment 4					
					z	z/h <sup>3</sup>	zz	zz/h <sup>3</sup>	yz	yz/h <sup>3</sup>
4	4	64	111.13	+46.60	0	.....	0	.....	0	
5	4	64	145.99	+46.60	34.86	0.5447	5,089.21	79.5189	1624.48	25.8925
6	5	125	180.32	+40.55	69.19	0.5535	12,476.34	99.8107	2805.65	22.4452
7	6	216	213.08	+28.63	101.95	0.4720	21,723.51	100.5718	2918.83	13.5131
8	7	343	243.27	+11.20	132.14	0.3852	32,145.70	93.7192	1479.97	4.3143
9	8	512	269.97	-11.21	158.84	0.3102	42,882.03	83.7538	-1780.60	-3.4777
10	9	729	292.38	-37.92	181.25	0.2486	52,993.88	72.6938	-6873.00	-9.4280
						2.5142		530.0682		52.7499

Segment	h	h <sup>3</sup>	z	y	Load Q Applied at Center of Segment 8					
					z	z/h <sup>3</sup>	zz	zz/h <sup>3</sup>	yz	yz/h <sup>3</sup>
8	7	343	243.27	+11.20	0		0		0	
9	8	512	269.97	-11.21	26.70	0.0521	7,208.20	14.0785	-299.31	- .5846
10	9	729	292.38	-37.92	49.11	0.0674	14,355.86	19.6925	-1861.87	-2.5540
						0.1195		33.7710		-3.1386

are different from those enumerated in Tables I, II, and III. With the load *Q* placed successively at the center of each of the ten segments, we obtain ten groups of three simultaneous equations each. The solution of these ten groups of simultaneous equations gives us ten answers for the values of *V*<sub>1</sub>, *H*, and *M*<sub>1</sub> corresponding to each of the ten positions of the load *Q*. The results are graphically represented in Figs. 59*c*, 59*d* and 59*e*.

The ordinate to the curves of Figs. 59*c*, 59*d*, and 59*e* measures the influence of the load *Q* (directly over the ordinate) upon the reactions at the left end of the arch, namely, *V*<sub>1</sub>, *H*, or *M*<sub>1</sub>. These curves then constitute influence lines. From them the effect of any vertical load, or any combination of vertical loads, upon the left end reactions may be found. With these reactions evaluated the stress condition at any point within the arch may readily be obtained with the aid of elementary strength of materials theory and the equations of static equilibrium.

TABLE IV

Load Q Applied to Center of Segment 2						Load Q Applied to Center of Segment 3					
<i>z</i>	<i>z/h</i> <sup>3</sup>	<i>zx</i>	<i>zx/h</i> <sup>3</sup>	<i>yz</i>	<i>yz/h</i> <sup>3</sup>	<i>z</i>	<i>z/h</i> <sup>3</sup>	<i>zx</i>	<i>zx/h</i> <sup>3</sup>	<i>yz</i>	<i>yz/h</i> <sup>3</sup>
0						0					
32.76	0.2621	2,515.97	20.1278	1328.42	10.6274	0	0	0	0	0	0
67.09	1.0483	7,455.71	116.4955	3126.39	48.8498	34.33	0.5364	3,815.09	59.6108	1599.78	24.9966
101.95	1.5930	14,883.68	232.5575	4750.87	74.2323	69.19	1.0811	10,101.05	157.8289	3224.25	50.3789
136.28	1.0902	24,574.01	196.5921	5526.15	44.2092	103.52	0.8282	18,666.73	149.3338	4197.74	33.5819
169.04	0.7826	36,019.04	166.7548	4839.62	22.4056	136.28	0.6309	29,038.54	134.4377	3901.70	18.0634
199.23	0.5808	48,466.68	141.3022	2231.38	6.5055	166.47	0.4853	40,497.16	118.0674	1864.46	5.4357
225.93	0.4413	60,994.32	119.1292	-2532.68	-4.9466	193.17	0.3773	52,150.10	101.8554	-2165.44	-4.2294
248.34	0.3407	72,809.65	99.6016	-9417.05	-12.9177	215.58	0.2957	63,031.28	86.4625	-8174.79	-11.2137
	6.1390		1092.5607		188.9655		4.2349		807.5965		117.0134

Load Q Applied at Center of Segment 5						Load Q Applied at Center of Segment 7					
<i>z</i>	<i>z/h</i> <sup>3</sup>	<i>zx</i>	<i>zx/h</i> <sup>3</sup>	<i>yz</i>	<i>yz/h</i> <sup>3</sup>	<i>z</i>	<i>z/h</i> <sup>3</sup>	<i>zx</i>	<i>zx/h</i> <sup>3</sup>	<i>yz</i>	<i>yz/h</i> <sup>3</sup>
0		0		0		0		0		0	
34.33	0.2746	6,190.39	49.5231	1392.08	11.1366	0		0		0	
67.09	0.3108	14,295.54	66.1831	1920.79	8.8925	30.19	0.0880	7,344.32	21.4120	338.13	.9858
97.28	0.2836	23,665.51	68.9950	1089.54	3.1765	56.89	0.1111	15,358.59	29.9972	-637.74	-1.2456
123.98	0.2421	35,470.88	65.3726	-1389.82	-2.7145	79.30	0.1088	23,185.73	31.8048	-3007.06	-4.1249
146.39	0.2008	42,801.51	58.7125	-5551.11	-7.6147						
	1.3117		308.7863		12.8764		0.3079		83.2140		-4.3847

Load Q Applied at Center of Segment 9					
<i>z</i>	<i>z/h</i> <sup>3</sup>	<i>zx</i>	<i>zx/h</i> <sup>3</sup>	<i>yz</i>	<i>yz/h</i> <sup>3</sup>
0		0		0	
22.41	0.0307	6,552.24	8.9880	-849.79	-1.1660
	0.0307		8.9880		-1.1660

**Temperature Stresses in Arch.** Let  $\lambda$  represent coefficient of expansion,  $t$  temperature change,  $L$  horizontal distance, and  $N$  vertical distance between the two ends of the arch.

If we assume one end of the arch to be unrestrained and the arch to undergo a temperature change of  $t$  degrees, then  $\lambda tL$  represents the horizontal displacement and  $\lambda tN$  the vertical displacement of one end of the arch relative to the other end. If the arch is completely restrained, not only will such horizontal and vertical displacement not occur, but the angular displacement of the tangents to the center line of the arch at the ends will likewise be prevented.

We may assume the left end of the arch (Fig. 59f) to have undergone horizontal and vertical displacements of  $\lambda tL$  and  $\lambda tN$ , respectively, under a change in temperature  $t$ , and subsequently forces  $H_2$ ,  $M_2$ , and  $V_2$  applied to return the end to its original position. The problem, then, is to find  $H_2$ ,  $M_2$ , and  $V_2$ , the forces necessary to give a horizontal linear

displacement,  $\lambda tL$ , accompanied by a vertical displacement,  $\lambda tN$ , and a zero angular displacement.

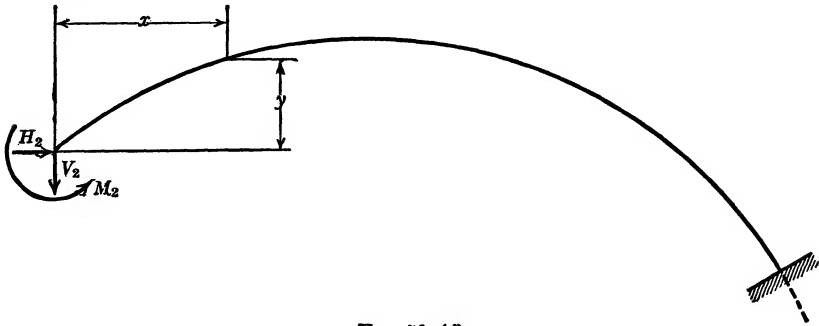

FIG. 59 (f).

The theory of elastic energy furnishes us with the following three equations:

$$\Delta'_x = \lambda tL = \int \frac{mMds}{FEI}, \quad (a)$$

$$\Delta'_y = \lambda tN = \int \frac{mMds}{FEI}, \quad (b)$$

and

$$\phi' = 0 = \int \frac{mMds}{M'EI}. \quad (c)$$

In all these three equations

$$M = M_2 + H_2y + V_2x \quad (\text{Fig. 59f})$$

$$\text{For equation (a), } m = Fy.$$

$$\text{For equation (b), } m = Fx.$$

$$\text{For equation (c), } m = M'.$$

The three equations thus become

$$\lambda tL = \int \frac{yMds}{EI}, \quad (a)$$

$$\lambda tN = \int \frac{xMds}{EI}, \quad (b)$$

and

$$0 = \int \frac{Mds}{EI}; \quad (c)$$

or

$$\frac{Eb}{12ds} \lambda t L = M_2 \int \frac{y}{h^3} + H_2 \int \frac{y^2}{h^3} + V_2 \int \frac{xy}{h^3}, \quad (a)$$

$$\frac{Eb \lambda t N}{12ds} = M_2 \int \frac{x}{h^3} + H_2 \int \frac{xy}{h^3} + V_2 \int \frac{x^2}{h^3}, \quad (b)$$

$$0 = M_2 \int \frac{1}{h^3} + H_2 \int \frac{y}{h^3} + V_2 \int \frac{x}{h^3}. \quad (c)$$

The various coefficients under the summation signs are obtained from Tables I, II, and III.

$$\frac{Eb}{12(ds)} \lambda t L = 2.36M_2 + 105H_2 + 292V_2. \quad (a)$$

$$\frac{Eb \lambda t N}{12ds} = 8.94M_2 + 292H_2 + 1485V_2. \quad (b)$$

$$0 = 0.0657M_2 + 2.36H_2 + 8.94V_2. \quad (c)$$

We assume the arch to be built of masonry with a coefficient of expansion  $\lambda = 0.0000065$ , a temperature change  $t = +100^\circ \text{ F.}$ , and a modulus of elasticity  $E = 2,000,000 \text{ lb. per sq. in.} = 288,000,000 \text{ lb. per sq. ft.}$

If we substitute these values in equations (a) and (b) in addition to substituting the values 301.7 for  $L$ , 53.2 for  $N$ , and 1 for  $b$ , and solve equations (a), (b), and (c) simultaneously, we obtain

$$H_2 = + 8036 \text{ lb.}$$

$$M_2 = - 417,870 \text{ ft.-lb.}$$

$$V_2 = + 949.7 \text{ lb.}$$

The values for  $H_2$  and  $V_2$  are positive while that for  $M_2$  is negative. For a positive temperature change, that is, for a rise in temperature of  $t$  degrees,  $H_2$  and  $V_2$  are in the sense and direction as indicated in Fig. 59f, while  $M_2$  will be of sense opposite to that indicated by the arrow representing  $M_2$  in Fig. 59f.

The depth of the crown is  $3\frac{1}{2}$  ft., the vertical distance from the line of action of  $H_2$  to the center line of the arch at the crown is 46.8 ft., the horizontal distance from the line of action of  $V_2$  to the crown of the arch

is 128.6 ft. The maximum compressive stress in the arch at the crown, due to a temperature change of 100° F., then is

$$\begin{aligned} s_c &= \frac{P}{A} + \frac{Mc}{I} = \frac{P}{bh} + \frac{M_2}{bh^2} = \frac{H_2}{bh} + \frac{(46.8H_2 + 128.6V_2 + M_2)6}{bh^2} \\ &= \frac{8036}{1 \times 3.5} + \frac{(46.8 \times 8036 + 128.6 \times 949.7 - 417,870)6}{1 \times 3.5^2} \\ &= 2296 + 39,361 = 41,657 \text{ lb. per sq. ft.} \\ &= 289.2 \text{ lb. per sq. in.} \end{aligned}$$

**Temperature Stresses in a Symmetrical Arch.** If the arch were symmetrical about a center line through the crown, the vertical reactions at the ends  $V_2$  would be equal in magnitude and of the same sense. (Since the vertical forces at the ends would be the only vertical forces acting on the arch, since symmetry insures their being of the same magnitude and sense, and since their sum equals zero,  $\Sigma F_y = 0$ , their numerical value must likewise be zero.) Since  $V_2$  is zero, there remain but two unknowns, namely,  $H_2$  and  $M_2$ . Therefore, we can dispense with equation (b) and the remaining equations simplify to

$$\frac{Eb\lambda tL}{12ds} = M_2 \int \frac{y}{h^3} + H_2 \int \frac{y^2}{h^3} \quad (a)$$

and

$$0 = M_2 \int \frac{1}{h^3} + H_2 \int \frac{y}{h^3} \quad (c)$$

If the lack of symmetry is not very pronounced, we may at the outset assume  $V_2$  to be zero and thus materially reduce our required computations. For purposes of establishing the extent of the error involved in this process, we shall solve for the forces  $M_2$  and  $H_2$  induced by a temperature change of 100° in the arch represented by Fig. 59a, assuming  $V_2$  to be zero.

$$\frac{Eb\lambda tL}{12ds} = 2.36M_2 + 105.0H_2. \quad (a)$$

$$0 = 0.0657M_2 + 2.36H_2. \quad (c)$$

Solving these two equations we obtain

$$M_2 = - \frac{2.36Eb\lambda tL}{12 \times 1.35 \times ds} = - 235,800 \text{ lb-ft.}$$

$$H_2 = + \frac{0.0657Eb\lambda tL}{12 \times 1.35ds} = 6532 \text{ lb.}$$

The maximum compressive stress in the arch at the crown, due to a temperature change of 100°, then is:

$$\begin{aligned}
 s_c &= \frac{P}{A} + \frac{Mc}{I} = \frac{H_2}{bh} + \frac{(46.8H_2 + M_2)6}{bh^2} \\
 &= \frac{6532}{3.5} + \frac{(46.8 \times 6532 - 235,800)6}{3.5^2} = 1866 + \frac{69,900 \times 6}{12.25} \\
 &= 1866 + 34,235 \\
 &= 36,100 \text{ lb. per sq. ft.} = 250.7 \text{ lb. per sq. in.}
 \end{aligned}$$

Comparing this value with the values previously obtained, our error, due to the assumption that  $V_2$  is zero, is 15.5 per cent.

**Temperature Stresses in a Symmetrical Two-Hinged Arch.** If the arch under consideration were symmetrical about a center line through the crown and hinged at both ends, both  $V_2$  and  $M_2$  would be zero. Equations (b) and (c) could then be dispensed with, and equation (a) would simplify and give the value directly:

$$\frac{Eb\lambda tL}{12ds} = H_2 \int \frac{y^2}{h^3} \tag{a}$$

$$H_2 = \frac{Eb\lambda tL}{12ds} \int \frac{y^2}{h^3}$$

NOTE: The following table gives a comparison of results obtained in an arch analysis for two conditions: Case I, direct stress effect ( $\Sigma cfs$ ) ignored; Case II, direct item effect ( $\Sigma cfs$ ) included in the equation  $\Delta_x = 0$ . The arch in question has the outline shown in Fig. 59(a), p. 149, but has a constant rectangular cross section of 6 ft. by 1 ft.

Unit Load at Point	Case I			Case II		
	$H_1$	$V_1$	$M_1$	$H_1$	$V_1$	$M_1$
1	0.03069	0.98846	0.05526 R	0.03057	0.98848	0.05529 R
2	.23848	.90218	.10193 R	.23744	.90235	.10217 R
3	.53970	.75168	.08355 R	.53736	.75207	.08408 R
4	.81103	.56823	.03107 R	.80752	.56881	.03188 R
5	.95581	.38408	-.02502 R	.95167	.38478	-.02407 R
6	.92821	.22577	-.06233 R	.92417	.22645	-.06140 R
7	.74094	.10966	-.07063 R	.73772	.11020	-.06988 R
8	.46267	.03938	-.05370 R	.46066	.03972	-.05324 R
9	.19034	.00776	-.02517 R	.18951	.00790	-.02498 R
10	.02243	.00021	-.00324 R	.02233	.00023	-.00321 R



## CHAPTER VIII

### COMBINED BENDING AND TORSION

We may find the angular displacement of shafts subjected to torsion by the same reasoning used in finding the angular displacements of beams subjected to bending (page 46).

If an auxiliary torque  $t$  is assumed acting before an actual torque  $T$  is applied, then each of the various particles in the shaft carries a load  $\frac{t v d a}{J}$ . If, subsequently, the shaft is subjected to a torque  $T$ , each

particle is strained an amount  $\frac{T v d s}{J G}$ . The elastic energy stored in the

particle, because  $t$  is acting while  $T$  is applied, is  $\frac{t T v^2 d a d s}{G J^2}$ , and for the

entire shaft this elastic energy is  $\int_L \int_A \frac{t T v^2 d a d s}{G J^2} = \int_L \frac{t T d s}{G J}$ . This elastic energy must equal the mechanical energy of the force, or torque, which is responsible for  $t$ .

Thus,

$$F \Delta \text{ or } T' \phi = \int \frac{t T d s}{G J}. \quad \text{Formula (8)}$$

#### EXAMPLE 35

*Given:* A round rod of radius  $r$  in the shape of a  $90^\circ$  arc of a circle which has a radius  $R$ . The rod is rigidly held at one end and loaded with a concentrated load  $Q$ , applied at the free end and acting perpendicularly to the plane of the circle (Fig. 60).

*To find:* The displacement  $\Delta_x$  of the free end of the rod in the direction of the load  $Q$ .

Any section of the beam is simultaneously loaded with a bending moment,  $M = QR \sin \phi$ , and with a torque,  $T = Q(R - R \cos \phi)$ . If we assume an auxiliary load  $F$  applied at the point at which we desire to evaluate  $\Delta_x$ , and assume this load operating in the direction of  $\Delta_x$ , then an auxiliary moment  $m = FR \sin \phi$ , and an auxiliary torque,

$t = F(R - R \cos \phi)$ , will be induced in the structure. The total elastic energy stored because  $F$  is assumed acting while  $Q$  is being applied, therefore, is

$$\int \frac{mMds}{EI} + \int \frac{tTds}{GJ}$$

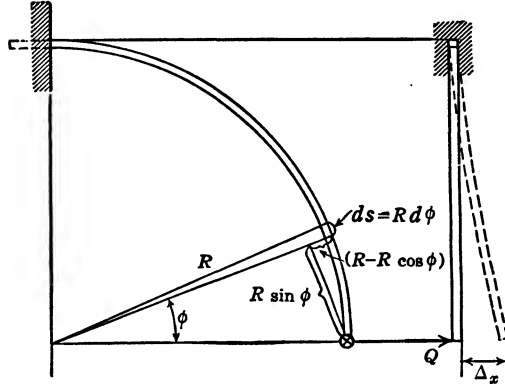

FIG. 60.

(See formula (5), page 45, and formula (8), page 166.)

If the law of conservation of energy applies, this elastic energy equals the mechanical energy involved in displacing  $F$  through the distance  $\Delta_x$ .

Thus

$$F\Delta_x = \int_0^{\pi/2} \frac{mMds}{EI} + \int_0^{\pi/2} \frac{tTds}{GJ}$$

$$\begin{aligned} \Delta_x &= \frac{QR^3}{EI} \int_0^{\pi/2} \sin^2 \phi d\phi + \frac{QR^3}{GJ} \int_0^{\pi/2} (1 - \cos \phi)^2 d\phi \\ &= \frac{QR^3}{EI} \left( \frac{\phi}{2} - \frac{\sin 2\phi}{4} \right)_0^{\pi/2} + \frac{QR^3}{GJ} \left( \phi - 2 \sin \phi + \frac{\phi}{2} + \frac{\sin 2\phi}{4} \right)_0^{\pi/2} \\ &= \frac{QR^3\pi}{EI4} + \frac{QR^3}{GJ} \left( \frac{3\pi - 8}{4} \right) \\ &= \frac{QR^3}{r^4} \left( \frac{1}{E} + \frac{1.425}{2\pi G} \right). \end{aligned}$$

Assuming that, for a steel rod,  $E = 28,000,000$  lb. per sq. in. and  $G = 11,000,000$  lb. per sq. in., then

$$\Delta_x = \frac{QR^3}{r^4} (0.0000000357 + 0.0000000203) = \frac{0.000000056 QR^3}{r^4}$$

## EXAMPLE 36

*Given:* A semicircular beam, rigidly supported at its extremities and loaded with a concentrated load  $Q$ , acting on its axis of symmetry and perpendicularly to the plane in which the beam lies (Fig. 61).

*To find:* The end reactions as well as  $\Delta_B$ , the vertical displacement of point  $B$ .

Figure 61 gives three views of the structure built into a wall, as well as three views of it ( $a$ ,  $b$ , and  $c$ ) drawn as a free body. At each end there are six unknowns, three linear reactions,  $R_x$ ,  $R_y$ , and  $R_z$ , and three moment reactions  $M_x$ ,  $M_y$ , and  $M_z$ . Three of these reactions may be determined from equilibrium and symmetry considerations, and two of them from considerations of anti-symmetry, leaving but one to be determined by means of an elasticity equation. Symmetry and equilibrium considerations prove that  $R_y = \frac{P}{2}$ ,  $R_z = 0$ , and  $M_x = \frac{PR}{2}$ ; considerations of anti-symmetry prove that  $R_x = 0$ , also that  $M_y = 0$ . To determine  $M_z$  we write:  $\theta_z = 0$ . The auxiliary loading is shown in Fig. 61d.

$$\theta_z = 0 = \int_A^C \frac{mMds}{M'EI} + \int_A^C \frac{tTds}{M'GJ} = 2 \int_A^B \frac{mMds}{M'EI} + 2 \int_A^B \frac{tTds}{M'GJ}.$$

$$m = M' \sin \phi; \quad t = M' \cos \phi.$$

$$M = M_z \sin \phi - \frac{PR}{2} \cos \phi + \frac{P}{2} R \sin \phi.$$

$$T = M_z \cos \phi + \frac{PR}{2} \sin \phi - \frac{P}{2} (R - R \cos \phi).$$

The cross at point  $B$  (Figs. 61a and c) indicates the force  $P$  directed perpendicular to the paper and downward, while the circle at points  $A$  and  $C$  indicates the forces  $\frac{P}{2}$  directed perpendicular to the paper and upward.

The signs in the foregoing expressions are determined as follows: The second term in the expression for  $M$  carries a negative sign because the component of  $M_x$ , or  $\frac{PR}{2}$ , is of opposite sense to the component of

$M'$ . On the other hand the torque component of  $M_x$ , or  $\frac{PR}{2}$ , has the same sense as the torque component of  $M'$ , and therefore the second term in the expression for  $T$  is written with a plus sign. The third term

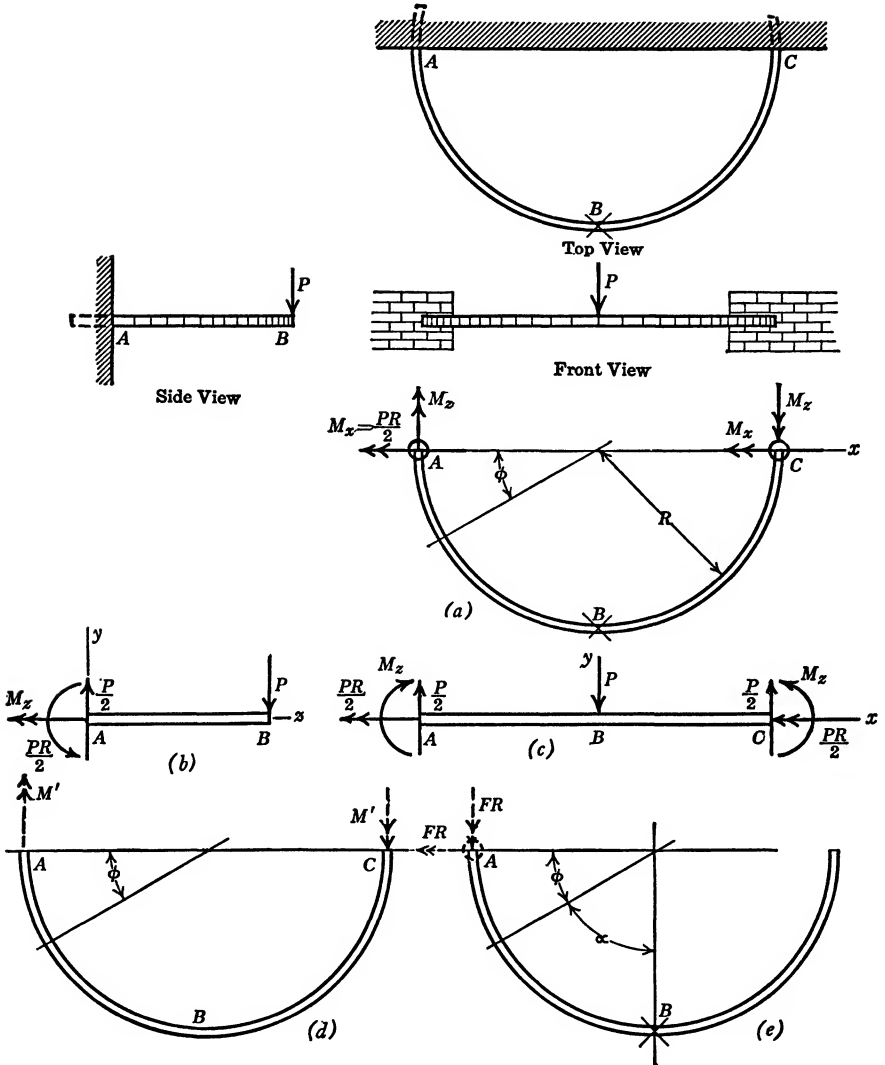

FIG. 61. The Semicircular Balcony.

in the expressions for  $M$  and  $T$  respectively represents the moment, or torque, effect of the reaction  $R_y$ , or  $\frac{P}{2}$ .

$$\theta_z = 0 = \int_0^{\pi/2} \frac{\sin \phi}{EI} \left( M_z \sin \phi - \frac{PR}{2} \cos \phi + \frac{P}{2} R \sin \phi \right) R d\phi$$

$$+ \int_0^{\pi/2} \frac{\cos \phi}{GJ} \left\{ M_z \cos \phi + \frac{PR}{2} \sin \phi - \frac{P}{2} (R - R \cos \phi) \right\} R d\phi.$$

Thus

$$M_z = \frac{PR}{2\pi} (2 - \pi) = -0.181PR.$$

The minus sign in the answer signifies that  $M_z$  is of a sense opposite to the one assumed in the free-body sketches.

In order to find  $\Delta_{B_y}$ , the vertical displacement of point  $B$ , we apply an auxiliary vertical load  $F$  at  $B$ . Under this load as many restraints as possible may be eliminated provided that equilibrium is maintained. The cross in Fig. 61e indicates the  $F$  load acting on the structure which is cut loose from the wall at  $C$ . Over the portion  $BC$  both  $m$  and  $t$  are zero. Between  $A$  and  $B$ ,  $m$  and  $t$  may be expressed either as a function of the reactions at  $A$ , or as a function of the loading at  $B$ . We choose the latter procedure as the simpler one. Thus

$$m = FR \sin \alpha, \quad \text{and} \quad t = F(R - R \cos \alpha).$$

The actual torque at  $B$  is zero.

The actual moment at  $B$  is  $\frac{P}{2}R + M_z = (0.5 - 0.181)PR = 0.319PR$ .

The shear at  $B$  is  $\frac{P}{2}$ .

Therefore,  $M$ , expressed in terms of the loading at  $B$ , is

$$M = \frac{P}{2} R \sin \alpha - 0.319PR \cos \alpha$$

while

$$\begin{aligned} T &= \frac{P}{2} (R - R \cos \alpha) - 0.319PR \sin \alpha. \\ \Delta_{B_y} &= \int_0^{\pi/2} \frac{mMds}{FEI} + \int_0^{\pi/2} \frac{tTds}{FGJ} \\ &= \int_0^{\pi/2} \frac{FR}{FEI} \sin \alpha \left( \frac{P}{2} R \sin \alpha - 0.319PR \cos \alpha \right) R d\alpha \\ &+ \int_0^{\pi/2} \frac{F(R - R \cos \alpha)}{FGJ} \left\{ \frac{P}{2} (R - R \cos \alpha) - 0.319PR \sin \alpha \right\} R d\alpha. \\ \Delta_{B_y} &= \frac{PR^3}{8} \left\{ \frac{(\pi - 1.276)}{EI} + \left( \frac{3\pi - 9.276}{GJ} \right) \right\}. \end{aligned}$$

## CHAPTER IX

### ELASTIC ENERGY AND DEFORMATIONS DUE TO SHEAR

#### I. BEAMS

Formula (1),  $\Delta = \frac{\Sigma Cfs}{F}$ , gives expression to deformations of structures in terms of elastic coefficients and concentric, axial loading stresses. Formulas (5), (6), and (7),

$$\Delta = \int \frac{mMds}{FEI}, \quad \theta = \int \frac{mMds}{M'EI}, \quad \text{and} \quad W = \int \frac{M^2ds}{2EI},$$

give expression to linear and angular deformations and to elastic energy stored in a beam as functions of bending-moment stresses. However, while a beam is being loaded, not only bending stresses but also shear stresses are present in the beam. It remains for us to consider these shear stresses.

Consider a cantilever beam loaded with a force  $Q$  at its end. The shear forces are proportional to  $Q$ , but independent of the length of the beam. If we assume the shear forces as uniformly distributed over the cross section of the beam, a particle of length  $dx$  and cross-sectional area  $da$  is loaded with a shear force across its surface equal to  $\frac{Q}{A} da$ . The shear deformation in the length  $dx$  is

$$\text{Strain} \times \text{length} = \frac{\text{stress}}{G} \times dx = \frac{Qdx}{AG}.$$

By analogy with the development of formula (7) the total energy in the particle is

$$\frac{1}{2} \frac{Qdx}{AG} \times \frac{Qda}{A}.$$

The total shear elastic energy stored in the beam is

$$\int_L \int_A \frac{Q^2 dadx}{2A^2G}.$$

The summation must include all the particles of the beam.  $\int_A$  means summation over the entire cross section of the beam, and  $\int_L$  means summation over the entire length of the beam.  $\int_A \frac{Qda}{A^2}$ , provided that  $\frac{Q}{A^2}$  is constant, is expressed as:  $\frac{QA}{A^2} = \frac{Q}{A}$ .  $\int_L \frac{Qdx}{2G} = \frac{QL}{2G}$ . Therefore, the total energy due to shear stresses is  $\frac{Q^2L}{2AG}$ . This energy is equal to the work done by  $Q$ , which is  $\frac{Q\Delta}{2}$ . Therefore,  $\frac{Q^2L}{2AG} = \frac{Q\Delta}{2}$ , or  $\Delta = \frac{QL}{AG}$ .

The shear stress, notwithstanding our assumption, is not uniformly distributed over the cross section of the beam. The shear stress is at its maximum at, or in the region of, the neutral axis, and is zero at the top and bottom of the beam. The expression  $\int_A \frac{Qda}{A^2}$  may be modified in agreement with the common formula for shear stress,  $s_s = \frac{V\bar{y}A}{bI}$ , and integrated over the cross section of the beam, in which case the value for  $\Delta$  is  $N$  times the value obtained on the assumption of uniform distribution of shear stress over the cross-sectional area of the beam. For rectangular beams  $N = \frac{6}{5}$ ; for circular beams  $N = \frac{10}{9}$ . This procedure, though not strictly accurate, is in somewhat closer agreement with facts. However, as we shall presently see in the type of problems discussed in this book, the deformations in beams caused by horizontal and vertical shear stresses are negligible compared with those caused by bending stresses.

For a cantilever steel beam (cross section 2 in. by 6 in. and length 60 in.,  $G = 11,000,000$  lb. per sq. in., and  $E = 30,000,000$  lb. per sq. in.) the displacement of its end, due to shear stresses under the action of a load  $Q$  applied at the end, is

$$\Delta = \frac{NQL}{AG} = \frac{1.2 \times 60Q}{12 \times 11,000,000} = 0.00000545Q \text{ in.}$$

This value remains the same whether the 6-in. side of the beam is placed vertically or horizontally.

The deflection of the same beam due to bending (see example 13, page 50) is

$$\Delta = \frac{QL^3}{3EI}$$

With the 6-in. side vertical,

$$\Delta = \frac{Q \times 60^3 \times 12}{3 \times 30,000,000 \times 2 \times 6^3} = 0.0000667Q \text{ in.}$$

With the 6-in. side horizontal,

$$\Delta = \frac{Q \times 60^3 \times 12}{3 \times 30,000,000 \times 6 \times 2^3} = 0.0006Q \text{ in.}$$

The displacement due to shear is less than 1 per cent of the displacement due to bending when the 6-in. side of the beam has a vertical position, and less than 0.1 per cent of the displacement due to bending when the 6-in. side has a horizontal position. To equalize the displacement due to shear with that due to bending we equate the two expressions for displacements to each other and solve for  $L$ .

Thus,

$$\frac{1.2QL}{AG} = \frac{QL^3}{3EI}$$

$$\frac{1.2QL}{12 \times 11,000,000} = \frac{QL^3 \times 12}{3 \times 30,000,000 \times 2 \times 6^3}$$

$$L = 5.43 \text{ in.}$$

The end of a rectangular cantilever beam is loaded with a load  $Q$ . To equalize the shear displacement of this end with the displacement caused by bending, the length of the beam must be made less than its depth. We are primarily concerned with structures composed of beams with a length-to-depth ratio much greater than unity. In the analysis of such structures the effects of shear may be ignored without causing appreciable errors.

In shafts subjected to twisting loads, shear stresses are the primary stresses, and shear elastic energy and deformations caused by shear stresses are of primary importance.



## II. SHAFTS

The development of the expression for elastic energy due to twisting is similar to that of formula (7) (page 47), which expresses the elastic energy due to bending.

If a torque  $T$  is applied to a shaft, any particle, of length  $dx$  (parallel to the axis of the shaft), cross-sectional area  $da$ , and a distance  $z$  from the axis, is stressed with a stress  $\frac{Tz}{J}$ . The shearing force on the face  $da$  of the particle is  $\frac{Tzda}{J}$ . The particle undergoes a shear deformation of strain  $\times$  length, or

$$\frac{\text{Stress}}{G} \times \text{length} = \frac{Tzdx}{JG}.$$

The elastic energy stored in the particle is one-half the force times the displacement, or

$$\frac{1}{2} \times \frac{Tzda}{J} \times \frac{Tzdx}{JG} = \frac{T^2 z^2 dadx}{2J^2 G}.$$

The elastic energy stored in the entire shaft will be obtained by summing the elastic energy of the particle, first, over the cross section of the shaft  $\int_A$ , and second, along the length of the shaft  $\int_L$ .

Thus

$$W = \int_L \int_A \frac{T^2 z^2 dadx}{2J^2 G}.$$

Considering  $dx$  as a constant, the summation of  $z^2 da$  over the cross-sectional area of the shaft gives  $\int_A z^2 da$ . This expresses the polar moment of inertia  $J$  of the cross-sectional area of the shaft with reference to its axis.

Summing over the entire length of the shaft,  $T$ ,  $J$ , and  $G$  being constant,

$$\int_L \frac{T^2 dx}{J^2 G} = \frac{T^2 L}{J^2 G}.$$

Therefore

$$W = \frac{T^2 L J}{2J^2 G} = \frac{T^2 L}{2JG}.$$

This total elastic energy is equal to the work done by  $T$  as it is gradually applied to the shaft and increased from zero to  $T$ . This mechanical work performed by  $T$  is  $\frac{T\phi}{2}$ , in which  $\phi$  is the angular displacement of the point of application of the torque  $T$ .

$$\frac{T\phi}{2} = \frac{T^2L}{2JG}$$

$$\phi = \frac{TL}{JG} \qquad \text{Formula (9)}$$

This value of  $\phi$  is also obtainable directly from formula (8), page 166.

## CHAPTER X

### RESILIENCE

Resilience is that property of a structure by which, under the application of a load, it stores within itself elastic energy which may be utilized as mechanical energy when the load is removed. A watch spring is an example of the property of resilience put to practical use. The degree of deformation is not a measure of resilience, although in most practical applications a large potential deformation is desirable along with the greatest possible capacity for storing energy.

Material contains its maximum amount of stored energy when all its fibers are stressed to their elastic limit. A unit volume of mild steel, subjected to tensile stresses in one direction, will store its maximum elastic energy when the tensile stress equals the elastic limit stress,  $s_1$ , and when the corresponding elongation is  $\frac{s_1}{E}$ . The maximum tensile elastic energy per unit volume, then, is  $\frac{s_1^2}{2E}$ .

The same unit volume, subjected to shear stresses (the shear elastic limit for mild steel is  $\frac{s_1}{2}$ ), would be deformed to the amount  $\frac{s_1}{2G}$ , and the maximum shear elastic energy would be  $\frac{1}{2} \times \frac{s_1}{2} \times \frac{s_1}{2G} = \frac{s_1^2}{8G}$ . Since, for mild steel,  $E$  and  $G$  have values of 30,000,000 and 11,000,000 lb. per sq. in., respectively, the ratio of the two quantities of stored elastic energy is

$$\frac{s_1^2}{2E} : \frac{s_1^2}{8G} = \frac{4G}{E} = \frac{44}{30}$$

Theoretically, therefore, when a material such as mild steel is subjected to either tensile or compressive stresses, it will store about 50 per cent more energy than it will when subjected to shear stresses. In practice a difficulty presents itself because the storing of elastic energy generally calls for relatively large deformations, as in shock absorbers.

The tensile and compressive stresses are commonly applied in the form of bending stresses, while shear stresses are usually most effectively applied by means of twisting. The following examples will make this clear.

#### EXAMPLE 37

*Given:* A cantilever beam of mild steel, cross section  $bh$  and length  $L$ . The beam is loaded with a concentrated load  $Q$  at the end, which will stress the material to its elastic limit stress  $s_1$ . The modulus of elasticity is  $E$  pounds per square inch.

*To find:* The elastic energy stored in the beam.

The maximum stress is at the support. The load  $Q$ , producing this elastic limit stress at the support, is obtained from the formula

$$s_1 = \frac{Mc}{I}, \quad s_1 = \frac{QLh}{2I}, \quad Q = \frac{2s_1I}{hL}.$$

In example 13, page 50, the displacement of the end of a cantilever beam under a concentrated load  $Q$  is  $\Delta = \frac{QL^3}{3EI}$ . The work done by  $Q$  in deflecting the beam, or the total elastic energy stored in the beam, is therefore  $\frac{Q\Delta}{2} = \frac{Q^2L^3}{6EI}$ . Substituting the value found for  $Q$ , this total elastic energy in the beam is

$$\frac{4s_1^2I^2L^3}{h^2L^26EI} = \frac{2s_1^2IL}{3h^2E} = \frac{2s_1^2bh^3L}{3 \times 12 \times h^2E} = \frac{s_1^2bhL}{18E} = \frac{s_1^2V}{18E}.$$

(In this equation  $V$  is volume of beam.)

The average elastic energy per unit of volume stored in the beam is  $\frac{s^2}{18E}$ . This is one-ninth of the potential elastic energy that the material is capable of storing when subjected to uniformly distributed tensile or compressive stresses throughout. Note in the foregoing development that it is immaterial whether the greatest cross-sectional dimension of the beam is placed vertically or horizontally.

#### EXAMPLE 38

*Given:* The same cantilever beam as in example 37, but loaded with a couple  $M_1$  applied to the free end.

*To find:* The total elastic energy stored in the beam.

The angular displacement of the free end of a cantilever loaded with a couple  $M_1$  at the free end is

$$\theta_1 = \int_L \frac{mMdx}{M'EI} = \int \frac{M'Mdx}{M'EI} = \int_L \frac{Mdx}{EI} = \int_L \frac{M_1dx}{EI} = \frac{\text{Area}}{EI}.$$

Thus

$$\theta_1 = \frac{M_1L}{EI}.$$

The work done by  $M_1$ , as it is displaced through the angular distance  $\theta_1$ , is  $\frac{M_1\theta_1}{2}$ . This is equal to the total elastic energy stored. Substituting, for  $\theta_1$ , its value  $\frac{M_1L}{EI}$ , we obtain:  $\frac{M_1^2L}{2EI}$ , which is the total elastic energy stored.

To produce the maximum elastic energy the beam should be stressed to its elastic limit,  $s_1 = \frac{M_1c}{I}$ , or  $M_1 = \frac{2s_1I}{h}$ . Substituting this value of  $M_1$ , we obtain the expression for maximum elastic energy stored in the beam, which is:

$$\frac{4s_1^2I^2}{h^2} \times \frac{L}{2EI} = \frac{2s_1^2IL}{h^2E} = \frac{2s_1^2bh^3L}{12h^2E} = \frac{s_1^2bhL}{6E} = \frac{s_1^2V}{6E}.$$

The average elastic energy per unit volume is  $\frac{s_1^2}{6E}$ . This value is three times the value obtained for the same beam loaded with a concentrated load at the free end, and is one-third of the maximum potential energy the material is capable of storing when subjected to direct tension or compression. In a beam of circular cross-sectional area similarly loaded, the total elastic energy stored per unit volume is  $\frac{s^2}{8E}$ .

## BEAMS OF CONSTANT STRENGTH AND MAXIMUM RESILIENCE

### The Leaf Spring

The maximum elastic energy stored in a structure is obtained when all the material is stressed to its elastic limit. Because of the small deformations in most materials this is usually not practicable except in rubber. To store the maximum elastic energy in structures subject to bending it is aimed to design these structures so as to make the bending stresses as large as possible over as large a portion of the structures as is practicable. This object may be attained in either of two ways: first,

make the bending moment constant over as large a portion of the structure as possible, leaving the dimensions of the structure constant also; second, make the bending moment a variable, but vary the dimensions of the structure in such a manner as to make the maximum bending stresses constant.

The common leaf spring (Fig. 62) is designed to satisfy the first condition. For the inner leaf, the portion  $A - B$  is subjected to con-

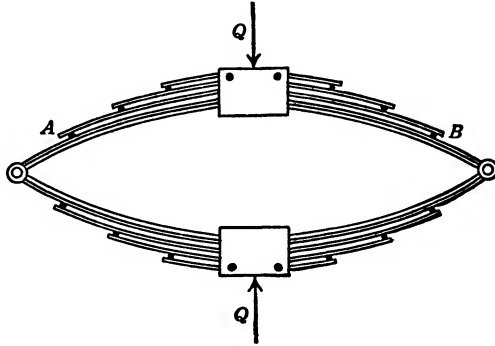

FIG. 62. Leaf Spring.

stant bending moments while the projections beyond the points  $A$  and  $B$  are cantilever beams. For leaves other than the inside ones similar conditions obtain.

In airplane design we aim primarily to obtain lightness consistent with strength. This, in turn, may be interpreted to mean that the largest possible percentage of the material used shall absorb the largest possible stress increments when the loads are applied. This is the same condition as for obtaining maximum resilience in a structure.

#### EXAMPLE 39

*Given:* A cantilever beam of rectangular cross section  $bd$ , with a constant force  $Q$  at the free end.

*To find:* The degree of variation in the cross section of the beam from point to point, so that the beam will store a maximum of elastic energy and will be of constant strength.

A cantilever beam loaded with a concentrated load  $Q$  at the free end has a bending moment  $M = Qx$  ( $x$  is measured from  $Q$  to the point of bending moment). Stress =  $s = \frac{Mc}{I}$ . For a rectangular section,

$$\frac{I}{c} = \frac{bd^2}{6}.$$

Therefore

$$s = \frac{6M}{bd^2} = \frac{6Qx}{bd^2}.$$

Assuming  $b$  as constant and  $d$  as variable,  $d^2 = \left(\frac{6Q}{bs}\right)x$ . This is the equation of a parabola.

Assuming the depth  $d$  as constant,  $b = \left(\frac{6Q}{sd^2}\right)x$ . This is the equation of a straight line.

A cantilever beam of constant strength, width  $b$  variable, and depth  $d$  constant, therefore, is wedge-shaped and tapers uniformly to a vertical line at the point of application of the load. A beam of rectangular cross section (example 38) subjected to a constant bending moment, that is, having the top and bottom fibers of the beam throughout its length stressed to the elastic limit, stores an amount of elastic energy per unit volume equal to  $\frac{s_1^2}{6E}$ . The stress condition of the wedge-shaped cantilever beam with a concentrated load at the end is the same as that of the beam in example 38. Its energy stored per unit volume also is  $\frac{s_1^2}{6E}$ . The total energy stored in the beam is therefore

$$\frac{s_1^2}{6E} \times \frac{L \times b_1 d_1}{2} = \frac{s_1^2 L b_1 d_1}{12E}$$

( $b_1$  and  $d_1$  are the width and depth, respectively, of the beam at the fixed end). This elastic energy is one-half the force  $Q$  times its displacement, or  $\frac{Q\Delta}{2}$ . The displacement of the end of the beam is therefore

$$\Delta = \frac{s_1^2 L b_1 d_1}{6EQ}.$$

$$s_1 = \frac{Mc}{I} = \frac{6M}{b_1 d_1^2} = \frac{6QL}{b_1 d_1^2}.$$

Therefore

$$\Delta = \frac{6QL^3}{b_1 d_1^3 E} \quad \text{or} \quad \frac{QL^3}{2EI_1}.$$

#### EXAMPLE 40

*Given:* A cantilever beam of rectangular cross section  $bd$ , with a uniformly distributed load  $w$  pounds per inch along its length.

*To find:* The variation in cross section of the beam from point to point so that the beam will store a maximum elastic energy and will be of constant strength.

A cantilever beam, loaded with a uniformly distributed load  $w$  pounds per inch, is subjected to a bending moment  $M = \frac{wx^2}{2}$ ,  $x$  being measured

from the free end of the beam.  $s = \frac{Mc}{I}$ , and, for a rectangular cross

section,  $s = \frac{6M}{bd^2}$ . If the beam is to be stressed to its maximum stress at the extreme fiber, and if the beam is of constant width  $b$  and variable depth  $d$ , then

$$s_1 = \frac{6M}{bd^2} = \frac{6wx^2}{2bd^2}.$$

$$d = x \sqrt{\frac{3w}{bs_1}}.$$

The above expression is the equation of a straight line.

A cantilever beam, designed to carry a uniformly distributed load  $w$  pounds per inch, of constant strength, constant maximum fiber stress at the top and bottom of the beam for any point on the beam, and of rectangular cross section, is, therefore, a wedge-shaped beam. It tapers from a depth  $d_1$  and width  $b_1$  at the fixed support to a horizontal line of width  $b_1$  at the extremity of the cantilever. On any cross section the conditions are again similar to the stress conditions of the preceding example and of example 38. The elastic energy per unit volume, therefore, again is  $\frac{s_1^2}{6E}$ , and the total elastic energy is

$$\frac{s_1^2}{6E} \times \frac{b_1 d_1 L}{2} = \frac{s_1^2 b_1 d_1 L}{12E}.$$

#### EXAMPLE 41

*Given:* A cantilever beam of rectangular cross section  $bd$ , with a uniformly varying load  $wx$  pounds per inch along its length ( $x$  is measured from the free end and  $b$  is in a fixed proportion to  $d$ ,  $b = nd$ ).

*To find:* The variation in cross section of the beam so that the beam will store a maximum elastic energy and will be of constant strength.



A cantilever beam loaded with a uniformly varying load  $wx$  pounds per inch (see Fig. 31, page 56) is subjected to a bending moment  $M = \frac{wx^3}{6}$ ;

$$s_1 = \frac{Mc}{I} = \frac{M6}{bd^2} = \frac{wx^3}{bd^2}.$$

If  $b$  is in a fixed proportion to  $d$ ,  $b = nd$ , then

$$bd^2 = nd^3 = \frac{w}{s_1}x^3.$$

$$d = x \sqrt[3]{\frac{w}{s_1 n}}.$$

This is again the equation of a straight line.

A vertical section, including the axis of the beam, will thus be a triangle. And since  $b$  is a fixed proportion of  $d$  throughout, a horizontal section through the beam including the beam's longitudinal axis will also be a triangle. The beam is thus wedge-shaped in elevation as well as in plan. If the ratio of  $b$  to  $d$  is unity, then the shape of the beam is a pyramid.

Another example of a cantilever beam of uniform strength is in the pine or fir tree as it grows undisturbed in nature. The outline of the tree is cone-shaped. If the vertical distance from the top of the tree is  $y$ , the width of the beam's branches is proportional to  $y$ . From this it follows that the wind pressure upon the branches is likewise proportional to  $y$ . The bending moment caused by the wind at any section of the beam, therefore, is

$$M = \frac{wy^2}{2} \times \frac{y}{3} = \frac{wy^3}{6}. \quad s = \frac{Mc}{I}.$$

Since

$$I = \frac{\pi r^4}{4}, \quad s = \frac{4Mr}{\pi r^4} = \frac{4wy^3}{6\pi r^3}.$$

In a beam of constant strength  $s$ , the maximum fiber stress, is constant. Therefore,

$$r = \sqrt[3]{\frac{2w}{3\pi s}} \times y.$$

This is the equation of a straight line. Since the tree has to resist wind pressure from all directions, the moment of inertia should be equal

about all possible axes. A pine tree, therefore, can resist wind loads to best advantage when its cross section is circular in shape. The ideal shape for the tree is that of a cone. The only way in which the design of a pine tree can be improved, to achieve a minimum expenditure of material, is to make the tree hollow. Nature has not seen fit to design trees in this manner. It has done so, however, in the design of reeds and grasses.

EXAMPLE 42

The Helical Spring

*Given:* A closely coiled helical spring (Fig. 63a). The diameter  $D$  of the coil extends from center to center of wire, radius of coil  $R$ , diameter of the wire  $d$ , radius of wire  $r$ . The spring is concentrically loaded with a force  $Q$ .

*To find:* (a) The elongation  $\Delta_y$  of the spring as a function of the load  $Q$ ; (b) the rotation about the axis of one end of the spring relative to its other end,  $\theta_y$ , as a function of the load  $Q$ .

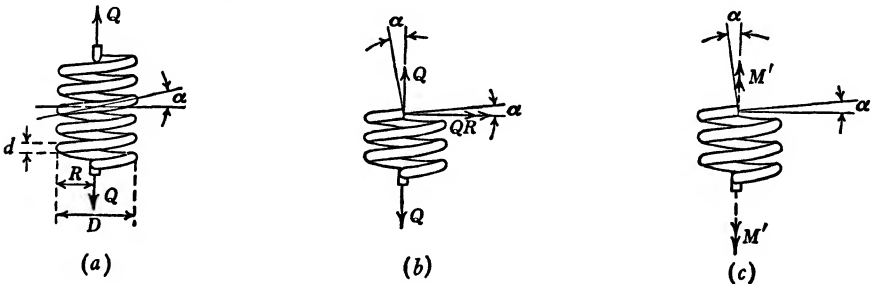

FIG. 63. Helical Spring.

Figure 63b represents a free-body sketch of a portion of the spring under the action of a load  $Q$  applied along the axis of the spring. At the point where the spring is cut the reactions consist of a force  $Q$ , represented by a single-headed vector, and a couple  $QR$ , represented by a double-headed vector. The same condition exists along the entire length of the spring except for the ends where the wire is bent in. In order to find the displacement  $\Delta_y$  we conceive of an auxiliary load  $F$  being applied along the  $y$  axis prior to the application of the  $Q$  loading. The  $F$  loading and the  $Q$  loading then will be qualitatively identical. Figure 63b would show a free-body sketch of part of the spring subject to the auxiliary loading merely by replacing  $Q$  by  $F$ .

The couple  $FR$  subjects the wire to an auxiliary torque  $t = FR \cos \alpha$ , and an auxiliary moment  $m = FR \sin \alpha$ , respectively, while

the couple  $QR$  subjects the wire to a torque  $T = QR \cos \alpha$ , and a moment  $M = QR \sin \alpha$ .

$$\Delta_y = \int \frac{mMds}{FEI} + \int \frac{tTds}{FGJ} = QR^2L \left( \frac{\sin^2 \alpha}{EI} + \frac{\cos^2 \alpha}{GJ} \right),$$

in which  $L$  represents the length of the wire.

$$\left( L = \frac{2\pi RN}{\cos \alpha}, \quad N \text{ representing the number of coils.} \right)$$

Therefore

$$\Delta_y = \frac{8QD^3N}{d^4} \left( \frac{2 \sin^2 \alpha}{E \cos \alpha} + \frac{\cos \alpha}{G} \right).$$

For a closely coiled spring  $\cos \alpha$  is nearly unity, and  $\sin \alpha$  is nearly zero. The expression for  $\Delta_y$  then reduces to

$$\Delta_y = \frac{8QD^3N}{d^4G} . *$$

To find the rotation about the  $y$  axis,  $\theta_y$ , we introduce an auxiliary couple  $M'$  acting about this axis prior to the application of the  $Q$  load. A free-body sketch of this auxiliary loading is shown in Fig. 63c. The auxiliary couple  $M'$  is resolved into an auxiliary torque  $t = M' \sin \alpha$ , and an auxiliary moment  $m = M' \cos \alpha$ .

$$\begin{aligned} \theta_y &= \int \frac{mMds}{M'EI} + \int \frac{tTds}{M'GJ} \\ &= - \int \frac{\cos \alpha QR \sin \alpha ds}{EI} + \int \frac{\sin \alpha QR \cos \alpha ds}{GJ} \\ &= QR \sin \alpha \cos \alpha L \left( \frac{1}{GJ} - \frac{1}{EI} \right) \\ &= \frac{16QD^2N \sin \alpha}{d^4} \left( \frac{1}{G} - \frac{2}{E} \right). \end{aligned}$$

Since both  $t$  and  $T$  have the same sense, the term  $tTds$  is positive; since  $m$  and  $M$  are opposite in sense (see Figs. 63b and c), the term  $mMds$  is given a negative sign. The expression  $\left( \frac{1}{G} - \frac{2}{E} \right)$  for a steel wire is positive. Therefore the rotation of the lower end of the spring relative

\* We have considered only the torsion and bending effects on the wire. The transverse shear effect would give an additional displacement  $4DNQ/d^2G \cos \alpha$ . This displacement, however, is so small that it is generally ignored.

to the upper end, under the action of the load  $Q$ , is of the same sense as that indicated by the auxiliary load  $M'$ , that is, it is counterclockwise as viewed from above.

### The Spiral Spring

The spiral spring is used for two distinct purposes: (1) storing mechanical energy for purposes of propelling a mechanism; (2) governing or regulating the rate of propulsion of a mechanism. Both these uses are exemplified in the modern watch. The power spring propels the mechanism, while the hairspring regulates the rate of propulsion of this mechanism. In this book only the power spring will be discussed.

**The Power Spring.** As we have seen on page 176, the maximum elastic energy that may be stored in a structure is represented by the expression  $\frac{s_1^2 V}{2E}$ , in which  $s_1$  is the elastic limit stress,  $V$  the volume, and  $E$  the modulus. To obtain this objective we strive to stress as large a portion of the structure as possible, to the value of this limiting stress  $s_1$ . Either we vary the cross-sectional dimensions of the structure so as to allow for variations in torque or bending moments, or (if the cross-sectional dimensions of the structure are constant) we direct our efforts to maintaining the torque or bending moments constant. The closely coiled helical spring is substantially a long slender shaft of constant cross section, compacted into a small space and subject to a constant torque from end to end. The spiral spring, on the other hand, properly designed, may be made to function as a long slender beam, subject to a constant bending moment from end to end.

A beam, initially straight and of constant  $E$  and  $I$ , when subjected to a constant bending moment would assume the shape of an arc of a circle. A beam, initially shaped as an arc of a circle and of constant  $E$  and  $I$ , when subjected to a constant bending moment would assume the shape of another arc of a circle with a radius of curvature differing from the initial radius of curvature.

We are privileged to represent the spring shown in Fig. 64 either by the equation of the involute of the circle or by the equation of the Archimedes spiral, or we may regard it merely as a series of arcs of circles having different radii. The three choices would come equally close to representing an actual spring. The one shown in Fig. 64 was actually drawn by fitting together a series of half circles. We select the last choice, a series of arcs of circles, which in this discussion fits our purpose best. If the arcs of circles of which the spring is composed are subjected to constant bending moments, these arcs will assume different radii of curvature.

Let the spring, Fig. 64, be considered mounted on an arbor at  $B$ , and loaded with a constant moment  $M_1$  from end to end. Each complete turn of the arbor would add one more loop to the spring. If we are justified in regarding the outline of the spring as being substantially equivalent to a number of concentric circles, then, upon loading, the outline of the spring would remain substantially equivalent to a number

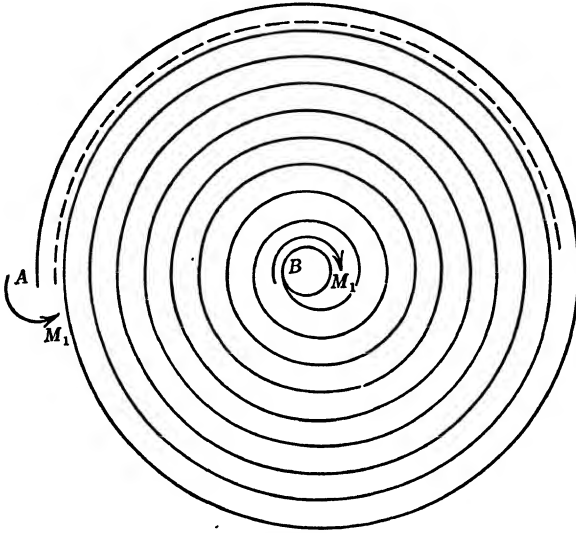

FIG. 64.

of concentric circles. This statement is contingent on permitting the outer loop to assume the shape indicated by the dash line, Fig. 64. In other words, the mounting of the extremity, point  $A$ , should be such as fully to restrain the tangent to the curve at  $A$  against rotation, while allowing complete freedom of linear motion of point  $A$  in a radial direction.

Traditionally, in coplanar structures we employ three types of restraints: rollers, which provide a restraint against linear displacement in only one direction, the direction normal to the plane upon which the roller rests; pins, which provide restraint against linear displacement in any direction; and so-called built-in or fixed-ended restraints, which prevent rotation as well as linear displacement in any direction. We employ these restraints either singly or in combination with each other. The restraint called for in this instance is the one which only prevents rotation of the tangent to the structure at point  $A$ .

The tangential displacement of point  $A$  affects the functioning of the spring only indirectly. Suppose that the arbor is rotated through a

clockwise angle  $\phi$  while point  $A$  moves in an arc of a circle through a clockwise angle  $\phi$ , and while the tangent to the structure at  $A$  turns through the same angle. Such a displacement would result in neither loading nor elastic deformations. The loading of the spring results only from the relative angular displacement of the tangents to the spring at the two extremities, points  $A$  and  $B$ . This may be accomplished as

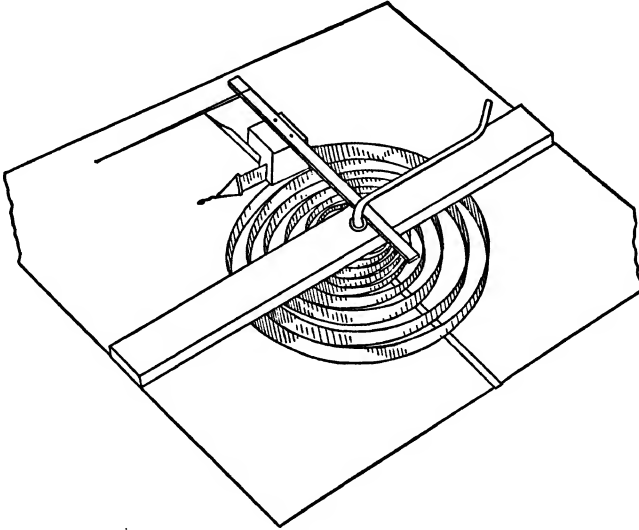

FIG. 65.

follows: (1) by restraining the tangent at  $A$  and displacing the tangent at  $B$  (rotating the arbor or winding the spring); (2) by fixing the tangent at  $B$  (clamping the arbor) and rotating the tangent at  $A$  (such a rotation of the tangent would involve a motion of point  $A$  along an arc of a curve); (3) by displacing the tangents to the structure at points  $A$  and  $B$  by different amounts. The manner in which this may be accomplished is illustrated by Figs. 65, 66, 67, and 68.\*

In Fig. 65 the outer extremity of the spring is fitted into a groove in a piece of wood. The wood is fastened to a bar which is loaded with two equal and opposite forces, one supplied through the string, the other by the bearing on the arbor. The bar travels freely in a radial direction. Upon winding the outer extremity moves in, and the coils remain concentric.

Figure 66 shows two similar springs connected through a link  $JK$ . Through a system of ratchets both springs are wound simultaneously

\* These figures are reproduced from the author's paper "Spiral Springs, A New Theory Regarding Their Stress, Strain and Energy Functions," *Trans. Am. Soc. Mech. Engrs.*, APM-53-18, 1931.

and at the same rate, but in opposite sense. Each spring provides the necessary reaction for the other. Upon winding, points *J* and *K* move radially and the coils remain open to the last.

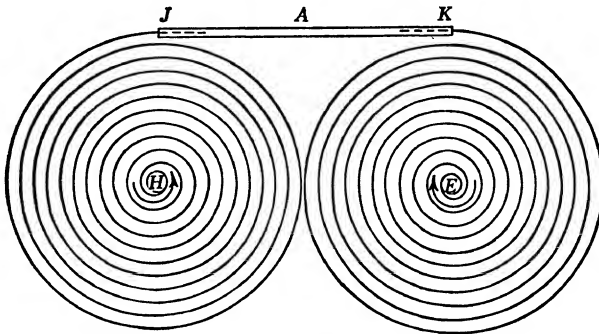
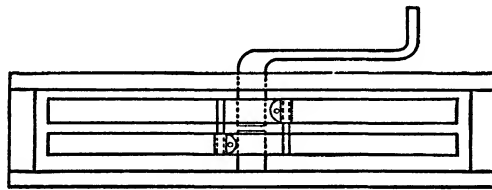
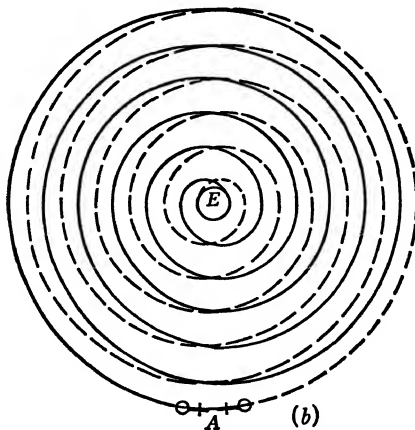

FIG. 66.

Figures 67 and 68 show an arrangement very similar to that shown in Fig. 66, except that the two springs are placed one above the other



(a)



(b)

FIG. 67.

instead of side by side. The clamp connecting the two springs might easily be dispensed with, if the entire spring is manufactured out of one

piece. If the top and bottom halves of the spring are wound at the same rate but in opposite sense, then the connecting link will move radially only. The same result may be obtained by clamping, say, the bottom spring and winding the top one, in which case the clamp will move radially as before but will make only one revolution for every two of the winding arbor.

Figure 67 shows a spacer placed between the two halves of the spring to prevent the leaves from fouling. This is sometimes necessary. As the spring is loaded a condition of instability is reached. The spring buckles. This buckling manifests itself by a tendency on part of the leaves to

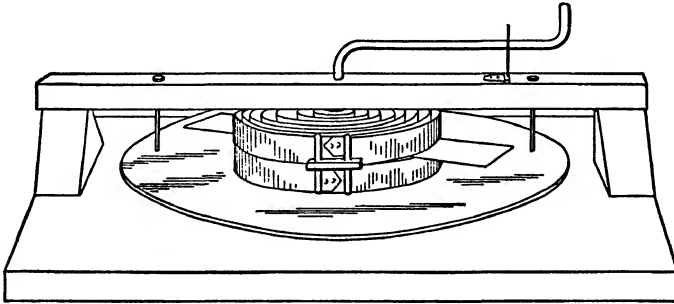

FIG. 68.

move suddenly out of their normal plane. The conventionally mounted spring does not exhibit this phenomenon because the friction between the leaves prevents it. In a spring mounted in the manner shown by Figs. 65 to 67 the container of the spring and the spacer, if there be one, generally are sufficient to control this tendency to buckle.

**Residual Stresses.** This treatise is devoted to the presentation of the elastic energy theory. However, this theory fails to explain what is possibly the most important aspect of the spiral-spring problem. The author would feel himself remiss if he failed to present those theoretical aspects of the problem which he regards as the most significant. To present these aspects he will draw on his notes on the theory of limit design (see footnote, page 267).

In the paper referred to in the footnote on page 187, he presented a new theory. However, it was not an ultimate one. In it he remarked: "The current theory of spiral springs appears to be one more case in which theory and practice disagree—with practice carrying off the honors." This statement was objected to by one of those who discussed the paper. In the author's opinion practice generally leads theory. Practice leads the way, and theory comes awkwardly and clumsily limping behind. The first failure of the Quebec Bridge had a far-reaching influence on the theory of bridge design. One hardly can doubt that ten



years hence the theory of suspension bridge will be far from perfect, but that, thanks to the Tacoma Bridge failure, it is likely to be a far better theory than the present one. In spite of our best intentions we are creatures of habits. We involuntarily get into ruts, and, much as we may fight dogmatism, we are all more or less dogmatic. To criticize anyone for "thinking in a rut" can hardly be taken as a reflection, since no one escapes it. What constituted the "newness" of the earlier spiral-spring theory (footnote, page 187) lay in our abandonment of the conventional habit of restricting the possibilities of restraining the outer end of the spring to either pinning or fixing it, and in our investigation and recommendation of the possibilities of a support against rotation without any linear restraint whatsoever. Further, any analysis based on an initial geometric configuration, which analysis became completely invalid as soon as the spring began materially to deform, was likewise abandoned. In spite of these possible advances the author remained in still another rut in that he assumed a perfectly elastic material free from any initial stresses. We have consistently made this assumption throughout this book, which is the general practice. Certain contradictions appeared which only recently, to the author's mind at least, have become clarified. These contradictions were forcibly expressed by Mr. Wadlow of Hayes End, England, in his discussion of the author's paper. Mr. Wadlow wrote: "The best way to appreciate the merits and conveniences of the spiral spring is to attempt to substitute for it a spring of another form." He further wrote: "The curves are calculated on the assumption that the elastic limit for the material is 375,000 lb. per sq. in., but judged by the material used in this country [England] this stress is much too high."

A few years back, the author, discussing spiral springs with his students, would say: "A spiral spring is substantially a long slender beam with a constant modulus and constant rectangular cross section." The elastic energy stored in such a beam is given by the expression  $W = \frac{s^2V}{6E}$  (see example 38, page 177). The maximum elastic energy to strive for is  $\frac{s^2V}{2E}$ . Apparently, then, there is room for a 200 per cent improvement.

At the present time the author holds that the elastic energy stored in a fully wound spiral spring is actually 100 per cent. The usable portion of this energy is 75 per cent rather than 33 per cent.

The criticism of the excessively high stress of 375,000 lb. per sq. in., coming from such an authority as Mr. Wadlow, might well have been accepted except for one thing. This stress was used in the computation of the outline which a spring must have in order that, when fully wound,

it may be stressed uniformly from end to end. The initial cross-sectional dimensions were taken from a spring conveniently at hand. Upon completion of the analysis the curve was plotted to scale and the outline of the commercial spring was then compared with this theoretical curve. A very close agreement between the commercial spring and the theoretical curve was observed. This close agreement seemed all the more remarkable when the extreme simplicity of manufacture is considered.

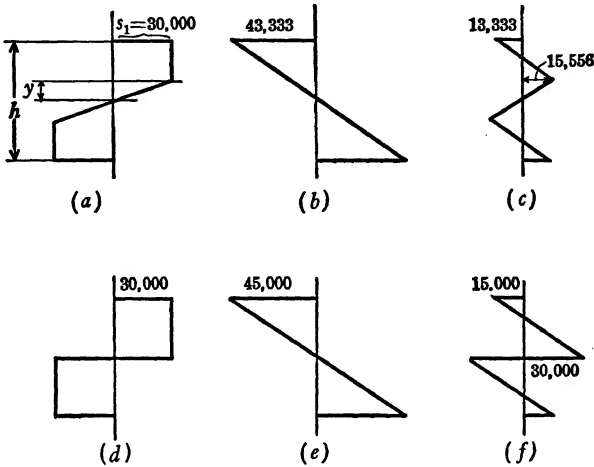

FIG. 69.

This manufacturing process, except for provision for end connections, is little more than taking a flat piece of spring steel, winding it on an arbor, slipping a clamp over it to prevent its release, wrapping it in tissue paper, and shipping it to a customer.

The high efficiency of spiral springs as well as the avoidance of error when using an exceptionally high elastic limit stress in design is explained by means of the following numerical example, which is taken from lecture notes on the theory of limit design:

Consider a solid rectangular beam. Cross section is  $bh = 2$  in. by 6 in., modulus  $E = 30,000,000$  lb. per sq. in., and elastic limit stress  $s_1 = 30,000$  lb. per sq. in. This beam is loaded with a moment  $M_1$  at each end until two-thirds of the beam is strained beyond the elastic limit.

(a) How large is  $M_1$ ?

The stress distribution over any cross section of the beam loaded in this manner is represented by Fig. 69a. The resisting moment corresponding to this stress distribution, readily developed from this sketch, is

$$M_1 = s_1 b \left( \frac{h^2}{4} - \frac{y^2}{3} \right) = 30,000 \times 2 \left( \frac{6^2}{4} - \frac{1^2}{3} \right) = 520,000 \text{ in-lb.}$$

(b) What is  $R_1$ , radius of curvature, when  $M_1$  is fully acting?

The radius of curvature is determined by the elastic core, the middle third portion of the beam, and is given by the expression

$$\frac{d^2y}{dx^2} = \frac{1}{R} = \frac{s_1}{yE} = \frac{30,000}{1 \times 30,000,000}$$

Therefore

$$R_1 = 1000 \text{ in.}$$

(c) What is  $R_2$ , radius of curvature, when  $M_1$  is removed?

When an elastic and ductile material is stressed and strained beyond the elastic limit and the stresses are subsequently removed, then the stress-strain relationship is again substantially linear. This holds true not only until the zero value for stress is again reached, but also when the process continues beyond the zero stress value and the stresses change sign. When  $M_1$  is removed the beam's behavior is again substantially elastic and the resulting  $R_2$  may be obtained from the formula

$$\frac{1}{R_2} - \frac{1}{R_1} = \frac{M}{EI} = \frac{-520,000 \times 12}{30,000,000 \times 2 \times 6^3} = \frac{1}{R_2} - \frac{1}{1000}$$

Therefore,  $R_2 = 1928 \text{ in.}$

(d) How are residual stresses distributed over the cross section of the beam after the removal of  $M_1$ ?

The negative stress pattern, as  $M_1$  is removed, is illustrated in Fig. 69b and is computed by the formula

$$s = \frac{Mc}{I} = \frac{520,000 \times 6}{2 \times 6^2} = 43,333 \text{ lb. per sq. in.}$$

The residual stress pattern is obtained by adding Figs. 69a and 69b, and is represented by Fig. 69c.

(e) Find the moment  $M_2$  necessary to stress all fibers in the beam beyond the elastic limit.

The stress pattern when all fibers are stressed beyond the elastic limit is represented by Fig. 69d. The moment corresponding to this stress pattern may be computed from the formula used in question (a) by letting  $y = 0$ , thus:

$$M = \frac{s_1 bh^2}{4} = \frac{30,000 \times 2 \times 6^2}{4} = 540,000 \text{ in-lb.}$$

(f) What is the residual stress pattern when  $M_2$  is removed?

The values belonging to the negative stress pattern (Fig. 69e) are

$$s = \frac{Mc}{I} = \frac{540,000 \times 6}{2 \times 6^2} = 45,000 \text{ lb. per sq. in.}$$

Superimposing Fig. 69e upon Fig. 69d, we obtain the residual stress pattern Fig. 69f.

(g) What is the residual elastic energy when  $M_2$  is removed?

We have seen from example 38 that, in a beam subject to a constant bending moment and to a linear stress variation, the strain energy is  $\frac{s^2V}{6E}$ . If we consider an element of the beam 1 in. long (12 cu. in.), we find that the middle two-thirds of the beam (8 cu. in.) contains

$$\frac{s^2V}{6E} = \frac{30,000^2}{6 \times 30,000,000} = 5 \text{ in.-lb. per cu. in.,}$$

or 40 in.-lb. of elastic energy. The other one-third of the beam (4 cu. in.) contains

$$\frac{s^2V}{6E} = \frac{15,000^2}{6 \times 30,000,000} = 1.25 \text{ in.-lb. per cu. in.,}$$

or 5 in.-lb. of elastic energy. The entire element of the beam (12 cu. in.) thus contains 45 in.-lb. of elastic energy. The residual elastic energy in the beam, therefore, is

$$\frac{45}{12} = 3.75 \text{ in.-lb. per cu. in.}$$

(h) What is the total elastic energy in the beam when  $M_2$  is fully acting?

When  $M_2$  is fully acting the stress pattern (Fig. 69d) prevails and the strain energy is given by the expression

$$\frac{s^2V}{2E} = \frac{30,000^2}{2 \times 30,000,000} = 15 \text{ in.-lb. per cu. in.}$$

(i) What is the usable elastic energy?

The available elastic energy is

$$15 - 3.75 = 11.25 \text{ in.-lb. per cu. in.}$$

(j) What is the elastic energy in a 2 in. by 6 in. rectangular beam if a moment  $M_3$  (elastic limit stress equal to 45,000 lb. per sq. in.) is applied elastically, when there are no residual stresses in the beam to begin with and no fibers are strained beyond the elastic limit?

The elastic energy under this condition is

$$\frac{s^2V}{6E} = \frac{45,000^2}{6 \times 30,000,000} = 11.25 \text{ in.-lb. per cu. in.}$$

Spring steel stock is alloy steel drawn quite hard. It is not to be too hard drawn lest it break when being coiled. If the steel submits to being coiled and takes on a permanent set, this is evidence of its being strained beyond the elastic limit. The routine manufacturing process thus leaves residual stresses in the spring closely resembling Fig. 69f. To quote from the author's paper on limit design (see first footnote, page 267), pages 645 and 646, "*This means that for an application of one type of limit loading, up to ductile capacity, the first application and removal of the load induce in the structure residual stresses of such a nature and magnitude that subsequent application of loads does not call forth additional ductile deformation. After the first application of the loads the behavior of the structure again becomes completely elastic.*" The ultimate stress distribution is that represented by Fig. 69d. The energy represented by this stress distribution  $\left(\frac{s^2 V}{2E}\right)$  does not all become

available upon releasing the spring. However, 11.25/15 or 75 per cent of it (see questions *h* and *i*) is available. It thus would seem that Mr. Wadlow was quite justified when he said: "The best way to appreciate the merits and conveniences of the spiral spring is to attempt to substitute for it a spring of another form."

In the operation of spiral power springs we are not bothered with either working stresses or factors of safety. The spring is a self-locking device. Upon being completely wound the elastic limit stresses will be reached. There is, however, no chance of exceeding these stresses. If the spring were subject to reversal of stress, then the residual stresses would prove to be detrimental. This, however, is not contemplated in regard to power springs.

The subject of aging and tempering cold-worked steel, which has a bearing on the functioning of spiral springs, will not be discussed here. This may be found treated fully in "Effects of Cold Working on Elastic Properties of Steel." \*

With the advent of electrically driven clocks and phonographs, the commercial interest in spiral springs is declining. The foregoing detailed discussion would seem justified, however, if for no reason other than that the purely academic aspects of the problem are interesting on several counts.

1. The applicability of the principle of superposition is sometimes made contingent on the displacements, or deformations, being relatively small. That this is not a sound criterion is illustrated, on the one hand, by the phenomenon of stability (column action) in which very small de-

\* "Effects of Cold Working on Elastic Properties of Steel," by J. A. Van den Broek, *Carnegie Scholarship Memoirs of the Iron and Steel Institute of Great Britain*, Vol. IX, 1918.

flections cause the principle of superposition to be violated, and, on the other hand, by the spiral-spring phenomenon, in which very large deformations may take place (the spring may be wound some ten to twenty complete turns) without violating the principle of superposition. The criterion by which we decide whether the principle of superposition applies or not is that any load-stress-deformation relationship which is formulated shall remain unchanged throughout the entire load-stress-deformation phenomenon, from the state of initial loading to that of final loading.

2. The residual stresses, which are automatically introduced in spiral-spring manufacture, account for a gain in efficiency of 33 to about 75 per cent. We may equally well take advantage of these residual stresses in other types of structures. In his paper, "Effects of Cold Working on Elastic Properties of Steel" (see footnote, page 194), the author recommended that shafts, subject to torsion in only one sense, be pre-cold-twisted before manufacture. Many helical springs are shafts which are loaded in this manner. The manufacturing process of inducing residual stresses in these springs is not automatic, as it is in spiral-spring manufacture, because of the requirement that the wire be twisted beyond the elastic limit before it is coiled. However, the suggestion has been acted upon in the manufacture of helical springs subject to one type of loading, either tension loading or compression loading, with very beneficial results. Manufacturers of leaf springs, so far as the author knows, do not take advantage of the possibilities of residual stresses. It would therefore appear that herein lies a distinct possibility for improvement. The theory of limit design teaches that residual stresses automatically introduced in many structures are generally very beneficial; in others they might well be consciously introduced.

3. The special mounting of the spiral spring (the double spring) appears to be advantageous not only because it eliminates friction, thus providing smoother performance, but also because it obviates the necessity of providing a lubricant. Since the elastic energy is proportional to the volume, any space occupied by lubricant instead of metal reduces efficiency.

**The Pin-Ended Spiral Spring.** Figure 70 represents a spiral spring consisting of a large number of substantially concentric rings, mounted upon an arbor at  $B$ , and pinned at its outer extremity  $A$ . The loading consists of a couple  $M_1$  applied at  $B$  and its induced reactions  $P$  at both  $A$  and  $B$ . So long as the configuration of Fig. 70 is maintained, the bending moment is  $Px$ . The elastic energy stored is

$$W = \int \frac{M^2 ds}{2EI} = \frac{P^2}{2EI} \int x^2 ds.$$

$\int x^2 ds$ , the moment of inertia of the outline of the spring about the  $y$  axis, may be written as  $Li^2$ , in which  $i$  is the radius of gyration. The radius of gyration of a number of closely spaced concentric rings is the same as that of a circular area. Therefore  $i^2 = \frac{5}{4} R^2$ . Thus

$$W = \frac{5P^2R^2L}{8EI}.$$

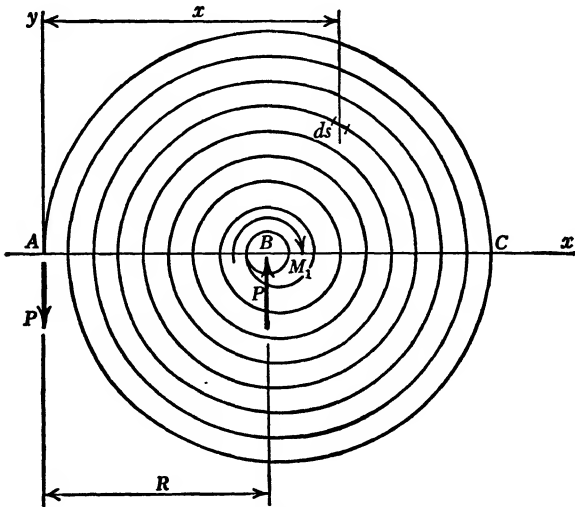

FIG. 70.

The maximum stress occurs at point  $C$  where the moment is  $2PR$ . For a spring leaf of rectangular cross section  $bt$ , this stress is

$$s = \frac{Mc}{I} = \frac{12PR}{bt^2} \quad \text{or} \quad PR = \frac{sb t^2}{12}.$$

The bending stress at  $C$  is the controlling stress, and the maximum elastic energy will be reached when this stress reaches the value of the elastic limit stress  $s_1$ . The expression for maximum elastic energy stored in the spring then becomes

$$W_{\max.} = \frac{5s_1^2 b^2 t^4 L \times 12}{8 \times 12^2 E b t^3} = \frac{5s_1^2 V}{96E}.$$

This value for energy is only  $\frac{5}{16}$ , or 31 per cent, of that obtained for the spring mounted in the manner of Fig. 64.

The foregoing analysis has no relation to watch, clock, or phonograph springs, the outer extremities of which are generally pinned. Even

though their outline initially may resemble Fig. 70, as soon as a small load is applied a pronounced shift takes place. The spring then comes to resemble a number of rings tangential to the arbor rather than a number of concentric rings. The efficiency of such a spring, except for the friction between the leaves as they slide over each other, may be proved to be as high as that of the double coiled spring represented by Fig. 64. The proof of this statement is as follows: In either case the fully wound springs would be identical. Two identical springs in identical states of strain would contain identical quantities of elastic energy. The exception referred to, however, the friction between the leaves, is a serious one. It makes the motion intermittent, and it requires lubrication, and this lubricant occupies space which otherwise might have been occupied by steel.

The analysis of the pin-ended spiral spring is included here because very stiff springs, to which this analysis applies, are manufactured and used.



## CHAPTER XI

### ELASTIC CURVES AS INFLUENCE LINES

The use of elastic curves as influence lines is predicated upon Maxwell's law of the reciprocity of displacement. On page 37 Maxwell's law as applied to trusses is developed. Three cases of Maxwell's law as applied to beams will be discussed in the present chapter preliminary to the discussion of the principle of reciprocity of displacement in connection with elastic curves as influence lines.

#### MAXWELL'S LAW OF RECIPROCITY OF DISPLACEMENT

##### CASE I.

*Given:* A beam loaded with a concentrated load  $Q$  applied, first, at point  $A$  (Fig. 71a), second, at point  $B$  (Fig. 71d).

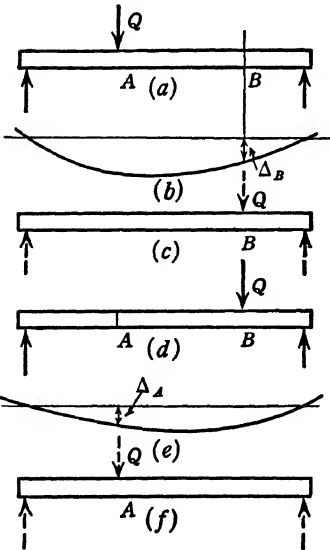

FIG. 71.

*To find:* The vertical linear displacement:

1.  $\Delta_B$  at point  $B$  when  $Q$  is applied at point  $A$  (Fig. 71b).
2.  $\Delta_A$  at point  $A$  when  $Q$  is applied at point  $B$  (Fig. 71e).

1. To find  $\Delta_B$  we apply an auxiliary force of any magnitude acting vertically at point  $B$ . Let this auxiliary force be of magnitude  $Q$  (Fig. 71c). From formula (5) we derive the equation

$$\Delta_B = \int \frac{mMdx}{QEI},$$

in which  $m$  is the bending moment corresponding to the loading shown in Fig. 71c and  $M$  is the bending moment corresponding to the loading shown in Fig. 71a.

2. To find  $\Delta_A$  with load  $Q$  acting at  $B$  (Fig. 71d) we apply an auxiliary vertical force of any magnitude at point  $A$ . Let this auxiliary force be of magnitude  $Q$  (Fig. 71f). Again applying formula (5) we have

$$\Delta_A = \int \frac{mMdx}{QEI}.$$

The factors  $dx$ ,  $Q$ ,  $E$ , and  $I$  are equal throughout both equations. In the first equation  $m$ , corresponding to the loading in Fig. 71c, is identical with  $M$  in the second equation corresponding to the loading in Fig. 71d.  $M$  of the first equation, corresponding to the loading in Fig. 71a, is identical with the  $m$  of the second equation corresponding to the loading in Fig. 71f. Therefore,  $mM$  of one equation is equal to  $mM$  of the other. Therefore,

$$\Delta_A = \Delta_B.$$

*If a force  $Q$  applied at point  $A$  in a beam causes a displacement  $\Delta_B$  at point  $B$ , then the same force  $Q$  applied at  $B$  will cause the same displacement  $\Delta_B$  at point  $A$ .*

Comparing this statement and its proof with Maxwell's law as given on pages 37 and 38, it is seen that both statement and proof are identical in principle and differ only in symbols.

The arguments here presented are based upon the simple sketches of Figs. 71a to 71f. To simplify the process the loads and displacements are taken to be vertical. The same reasoning as applied to redundant structures, with loads and displacements taken in any direction, is equally valid and gives identical results. Maxwell's law of reciprocity of displacement, therefore, is true, regardless of the shape or degree of redundancy of the structure, and regardless of the directions of loads and displacements. It is assumed, of course, that the directions remain invariable, that material is elastic and continuous, and that the law of superposition holds.

## CASE II.

In this case the actual couple  $M_1$  is substituted for the actual loading  $Q$  of Case I; auxiliary couple  $M_1$  for auxiliary load  $Q$ ; angular displacement  $\theta_A$  for linear displacement  $\Delta_A$ ; and angular displacement  $\theta_B$  for linear displacement  $\Delta_B$ . The reasoning is the same as in Case I, but the statement of Maxwell's law corresponds to the change of symbols.

*If a couple  $M_1$  applied at point  $A$  in a beam causes a displacement  $\theta_B$  at point  $B$ , then the same couple  $M_1$  applied at  $B$  will cause the same displacement  $\theta_B$  at  $A$ .*

CASE III.

(a) *Given:* A beam loaded with a concentrated load  $Q$  at point  $A$  (Fig. 72a).

*To find:* The angular displacement  $\theta_B$  at point  $B$ .

An auxiliary couple  $M'$  of any magnitude is applied at point  $B$  (Fig. 72c). Let  $M'$  be numerically equal to  $Q$ . By means of formula (6), page 46, we obtain

$$\theta_B = \int \frac{mMdx}{M'EI} = \int \frac{mMdx}{QEI}.$$

The bending moment  $m$  is caused by the loading shown in Fig. 72c, and  $M$  is the bending moment caused by the loading shown in Fig. 72a.

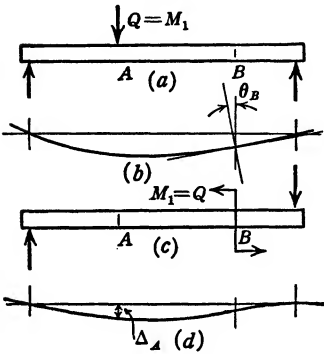

FIG. 72.

(b) *Given:* A beam loaded with a couple  $M_1$  applied at  $B$  (Fig. 72c).

*To find:* The linear displacement  $\Delta_A$  at point  $A$  (Fig. 72d).

An auxiliary force of any magnitude, say force  $Q$ , is applied at point  $A$  (Fig. 72a). By means of formula (5) we have

$$\Delta_A = \int \frac{mMdx}{QEI}.$$

In both expressions for  $\theta_B$  and  $\Delta_A$  the factors  $Q$ ,  $E$ , and  $I$  are equal throughout. The  $m$  in the first equation corresponds to the  $M$  in the second; the  $M$  in the first equation corresponds to the  $m$  in the second; and the product  $mM$  of the one is equal to the product  $mM$  of the other.

Therefore

$$\theta_B = \Delta_A.$$

*If a force  $Q$ , applied at point  $A$  in a beam, causes an angular displacement  $\theta_B$  at point  $B$ , then a couple  $M_1$  expressed in inch-pounds and numerically equal to the force  $Q$ , applied at point  $B$ , will cause a linear displacement  $\Delta_A$  at point  $A$ .  $\Delta_A$  expressed in inches is numerically equal to  $\theta_B$  expressed in radians.*

INFLUENCE DIAGRAMS

We are familiar with graphs, such as shear and bending-moment curves, the ordinate of which, at any point, gives the value of the function at that point.

An influence diagram is a curve the ordinate of which, at any point  $B$ , gives the value of function at a fixed point  $E$  while the load unity is being applied at  $B$ . For example, if a load unity is applied to a simply supported beam at point  $B$ , distance  $x$  from the left end (Fig. 73a), the reaction at  $A$  will be  $\frac{l-x}{l} = 1 - \frac{x}{l}$ ,

and the reaction at  $E$  will be  $\frac{x}{l}$ . The shear at point  $A$  is equal to the left reaction. Therefore, for any position of the load unity, or, for any value of  $x$ , the shear at point  $A$  is expressed by the equation

$$V_a = 1 - \frac{x}{l} \text{ (Fig. 73b).}$$

The shear at point  $E$  is numerically equal to the right reaction, but it carries a negative sign. For any value of  $x$ , therefore, the shear at point  $E$  is expressed by the equation

$$V_e = -\frac{x}{l} \text{ (Fig. 73b).}$$

The equations of the influence diagram for the shear at points  $A$  and  $E$  are

$$V_a = 1 - \frac{x}{l} \text{ and } V_e = -\frac{x}{l}, \text{ respectively.}$$

A load unity applied in the region from  $A$  to  $D$  will cause a negative shear at point  $D$ ; a load unity applied in the region from  $D$  to  $E$  will cause a positive shear at point  $D$ . The influence diagram for the shear at point  $D$  is shown in Fig. 73c.

The bending moment at point  $C$ , the middle of the beam, caused by a load unity applied at  $B$  in the region from  $A$  to  $C$ , is equal to the right reaction multiplied by  $\frac{l}{2}$ .

Therefore

$$M_c = \frac{x}{l} \times \frac{l}{2} = \frac{x}{2}.$$

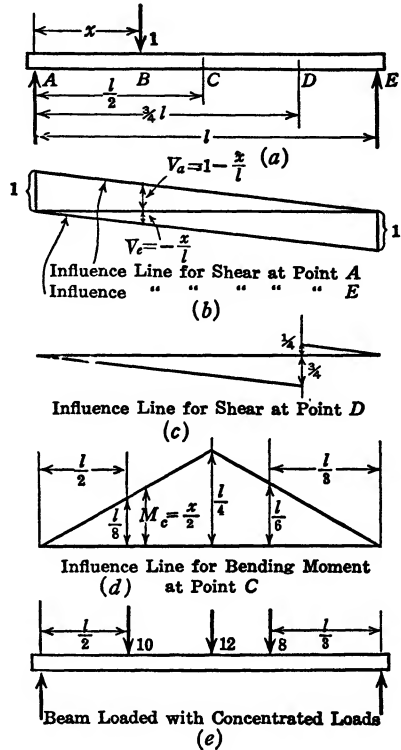

FIG. 73.

For the right half of the beam (the beam is symmetrical about the center line) the influence line for the bending moment at  $C$  will be a graph symmetrical to the one for the left half of the beam (Fig. 73d).

If a load unity, placed at the quarter position of the beam, causes a moment at  $C$  equal to  $\frac{l}{8}$  ft.-lb., then a load  $Q$  in that position will cause a moment,  $M_c = \frac{Ql}{8}$  ft.-lb.

A beam loaded with concentrated loads, 10, 12, and 8 lb. at the one-fourth, one-half, and two-thirds points, respectively (Fig. 73e), will cause a moment at  $C$ .

$$M_c = 10 \times \frac{l}{8} + 12 \times \frac{l}{4} + 8 \times \frac{l}{6} = \frac{67l}{12} \text{ ft.-lb. (Fig. 73d).}$$

If the beam is loaded with a uniformly distributed load  $w$  pounds per foot, the load on any short element of the beam  $dx$  will be equal to  $w dx$ . The influence of  $w dx$  on the function for which the influence diagram is drawn will be  $w y dx$ , if  $y$  is the ordinate to the influence diagram. Integrating over that portion of the beam on which the load  $w$  is applied (see page 59) we have

$$\int_{l_1}^{l_2} w y dx = w \int_{l_1}^{l_2} y dx = w \text{ Area} \Big]_{l_1}^{l_2} = w \text{ times the area under the}$$

influence diagram below the uniformly distributed load.

For example, if a uniformly distributed load  $w$  pounds per foot extends entirely across the simple beam (Fig. 73a), the value of the shear at points  $A$  and  $D$  is  $w$  times the area under the influence diagram for those points (Figs. 73b and 73c), namely:

$$V_a = w \times 1 \times \frac{l}{2} = + \frac{wl}{2}.$$

$$V_d = w \left( -\frac{3}{4} \times \frac{3l}{4} \times \frac{1}{2} + \frac{1}{4} \times \frac{l}{4} \times \frac{1}{2} \right) = - \frac{wl}{4}.$$

The bending moment at point  $C$ , when the beam is completely loaded with a uniformly distributed load  $w$  pounds per foot, is the area under the influence diagram (Fig. 73d) times  $w$ .

$$M_c = w \times \frac{l}{4} \times \frac{l}{2} = \frac{wl^2}{8} \text{ ft.-lb.}$$

Influence lines provide a condensed and convenient record; they give a general view of the effect of loads on certain important functions, when these loads are placed in different positions upon the structure. In the analysis of engineering structures it is common to draw influence lines for shear, bending moments, reactions, and stresses in principal members.

### ELASTIC CURVES AS INFLUENCE LINES

**Influence Line for  $R_a$ .** Consider a continuous beam over four supports with spans  $L_1$ ,  $L_2$ , and  $L_3$  (Fig. 74a). Let us assume that load  $Q$ , applied at point  $A$ , displaces point  $A$  a distance  $\Delta_1$ , point  $B$  a distance  $\Delta_2$ , and point  $C$  a distance  $\Delta_3$  (Fig. 74b). It follows, then, according to Maxwell's law of reciprocity of displacement, page 199, that load  $Q$  applied at point  $B$  (with the beam held at  $D$ ,  $E$ , and  $F$ , but free to move at  $A$ ) would displace point  $A$  a distance  $\Delta_2$ , and a load  $Q$  applied at point  $C$  would displace point  $A$  a distance  $-\Delta_3$ .

To hold point  $A$  in place with load  $Q$  applied at  $B$  requires a reaction  $R_a$  of sufficient magnitude to displace point  $A$  a distance  $\Delta_2$ .

Imagine a load  $Q$  applied at  $B$ , point  $A$  displaced a distance  $\Delta_2$ , and a reaction  $R_a$  subsequently applied for the purpose of returning point  $A$  to its original position.

Since force  $Q$  causes a displacement  $\Delta_1$  at point  $A$ , it will require the force  $R_a = \frac{\Delta_2}{\Delta_1} Q$  to hold point  $A$  in place under the action of the load  $Q$  at point  $B$ . Similarly, for a load  $Q$  applied at  $C$ , a reaction  $R_a = -\frac{\Delta_3}{\Delta_1} Q$  is required to hold point  $A$  in place.

Since the structure is elastic,  $\Delta_1$ ,  $\Delta_2$ , and  $\Delta_3$  will always be in a fixed ratio regardless of their numerical value (see note on page 205, and also General Comments, page 216).

For example, we may obtain the elastic properties of a steel I-beam of uniform cross section and supported at four points by means of a flexible spline. A steel straight-edge, or a T-square, is placed on edge and properly supported on a drawing board, the points of support for the spline on the drawing board being in the same relative positions as the supports of the steel beam. Furthermore,  $\Delta_1$  may be constructed as unity to any scale, in which case  $R_a = \Delta_2 Q$ , or  $R_a = -\Delta_3 Q$ . When load  $Q$  is applied at points  $B$  and  $C$  its influences upon the reaction at  $A$  are measured by  $\Delta_2$  and  $\Delta_3$ , respectively. What is true for points  $B$  and  $C$  is true for all points on the beam. Thus we may obtain the influence line for the reaction at  $A$  from a small model of the beam.

What is true of a beam on four supports is equally true for a beam on any number of supports. It is in fact applicable to any elastic

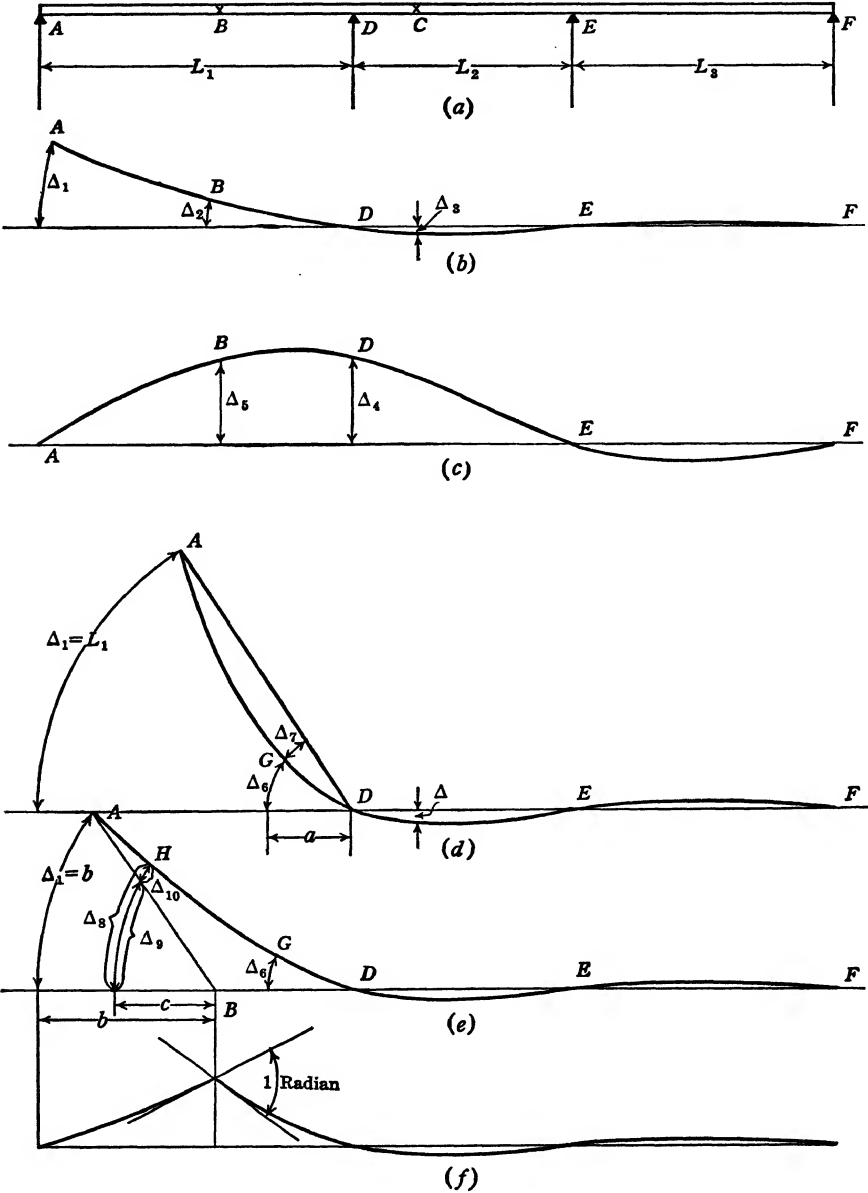

FIG. 74. Influence Lines for Reactions and Moments.

structure regardless of its shape and the number of statically indeterminate unknowns. The various examples worked out in the text show

that the theoretical analysis becomes disproportionately more difficult as the number of redundant restraints is increased. It was pointed out that Maxwell's law of reciprocity of displacement is true for statically determinate and indeterminate structures alike. Herein lies the great advantage of influence lines mechanically constructed. We know that a load on a span farthest removed from the left end has relatively little effect on the reaction at the left end. In a mathematical procedure that fact becomes clear only after a painstaking analysis. In an elastic curve mechanically constructed, however, it is at once apparent in its true significance. For a further discussion of the theoretical value of elastic curves as influence lines, mechanically obtained, see page 217.

**Influence Line for  $R_d$ .** The influence line for any of the other reactions, as  $R_d$ , may be obtained by the same process as the one used for finding the influence line for  $R_a$ . Give to the point at which  $R_d$  is applied a displacement  $\Delta_4$ , and measure the displacement at point  $B$  as  $\Delta_5$  (Fig. 74c). Since load  $Q$  at point  $D$  gives a displacement  $\Delta_5$  at point  $B$ , a load  $Q$  at  $B$  would cause a displacement  $\Delta_5$  at  $D$  (Maxwell's law). The reaction at  $D$ , necessary to prevent this displacement, is

$$R_d = \frac{\Delta_5}{\Delta_4} Q.$$

If  $\Delta_4$  is initially laid off as unity, we obtain

$$R_d = \Delta_5 Q.$$

What is true for point  $B$  is true for all other points on the beam.

Figure 74c, constructed as suggested, gives the influence line for the reaction at  $D$ .

**NOTE.** The use of elastic curves as influence lines is predicated upon Maxwell's law of reciprocity of displacement, and Maxwell's law in turn is proved by means of formulas (1), (5), and (6); that is, it is subject to the assumptions and limitations of the theory of elastic energy.

It is well to test our rules concerning the use of elastic curves as influence lines by the assumptions underlying the theory of elastic energy. Formulas (1), (5), and (6) are limited by the assumption of elastic material and the principle of superposition. The latter principle is contingent on the assumption that the structure does not materially change its shape under loading conditions. In influence lines we want measurable displacements, and this last assumption does not always strictly hold.

For example, suppose that the left end of the beam is given a vertical displacement, with the load constantly kept acting on a vertical line



through the original position of point  $A$ . As the beam is being deformed the point of application of the load will travel along the beam. In other words, the span length of the beam for the left span will be somewhat increased. This violates the theory involved in the proof of formula (5), and Maxwell's law for this condition of loading does not hold exactly true. Suppose, however, that the load, displacing point  $A$ , always acts vertically and is maintained at point  $A$ . The horizontal distance from point  $D$  decreases, and the moment of the load likewise decreases. If the deformations involved are appreciable, this decrease is also appreciable and is in conflict with our theory to the effect that the moment caused by the auxiliary load  $m$  remain constant while the moment caused by the actual load  $M$  is being applied. Very few authorities have taken the trouble to mention the error involved. In fact, one finds the rule not uncommonly given that the unit displacement should be in the line of operation of the reaction. The error involved may not be serious in individual cases, but if not considered at all it may, under certain conditions, lead to incorrect analysis and cause serious difficulty. (See page 210.)

Finally, suppose the load displacing point  $A$  to be always acting normally to the path it actually travels. Then the span length remains essentially constant, the moment of the auxiliary load  $F$  about point  $D$  also remains constant, and we avoid both disagreements with the elastic energy theory that are involved in the two preceding constructions. For this reason it is pointed out that  $\Delta_2$  is to be measured along the arc and not as a vertical ordinate from the base line (Fig. 74b).

Thus the error due to large deformations may easily and accurately be corrected in the drawing of the influence line for  $R_a$  and  $R_f$ . But a similar correction of the influence lines for  $R_d$  and  $R_e$  becomes more involved, and will not be taken up in this elementary discussion. The error, however, is not a serious one. In any mathematical analysis the assumptions of loads applied at points instead of distributed over areas and the neglect of thickness of members, brackets, and gusset plates are commonly far more serious than the errors involved in elastic curves as influence lines. Some devices for drawing influence lines anticipate the possible error, involved in large deformations, by giving very small deflections and employing a microscope to measure these deflections. (See General Comments, page 216.)

**Influence Line for Moment at  $D$ .** For any position between  $D$  and  $F$  the moment at point  $D$  is given by the expression  $M_d = R_a L_1$ . Therefore, the influence line for  $R_a$  between points  $D$  and  $F$  (Fig. 74b) will serve as influence line for the moment at point  $D$ . The ordinate to the influence line must be multiplied by  $L_1$  to give the value of the moment  $M_d$ . If the displacement of point  $A$  is made equal to  $L_1$  instead of unity

(Fig. 74d), the curve between  $D$  and  $F$  is the true influence line for  $M_d$  for the portion  $DF$  of the beam.

For a load  $Q$  in a position somewhere between points  $A$  and  $D$ , say at point  $G$ , the moment at  $D$  is

$$M_d = R_1 L_1 - Qa = Q \frac{\Delta_6}{\Delta_1} L_1 - Qa = \frac{QL_1}{\Delta_1} \left( \Delta_6 - \frac{a\Delta_1}{L_1} \right) = - \frac{QL_1}{\Delta_1} \Delta_7.$$

If  $\Delta_1 = \text{unity}$  (Fig. 74b),  $M_d = - QL_1 \Delta_7$ .

If  $\Delta_1 = L_1$  (Fig. 74d),  $M_d = - Q\Delta_7$ .

In either case (Fig. 74b or 74d) the elastic curve of the beam represents the influence diagram of  $M_d$  for the first span of the beam. But the ordinates must be measured along the arc and from the straight line connecting  $A$  and  $D$ , instead of being measured from the horizontal as a base line. However, measuring the ordinates at right angles to the connecting line  $A-D$  is for all practical purposes equivalent to measuring them along the arc. (See also Alternative Construction for Influence Line for Moment, page 208.)

**Influence Line for Moment at  $B$ .** Point  $B$  on the beam, for which the bending-moment influence line is constructed, is located a distance  $b$  to the right of point  $A$ . The diagram is constructed by giving point  $A$  a displacement equal to  $b$ ,  $\Delta_1 = b$  (Fig. 74e). For any point on the beam anywhere between  $B$  and  $F$ ,  $M_b = R_a b$ . For a load  $Q$ , in position  $G$ , for example,  $M_b = R_a b = \frac{Q\Delta_6}{\Delta_1} b$ , and when  $\Delta_1$  is equal to  $b$ ,  $M_b = Q\Delta_6$ .

For a load  $Q$  between  $A$  and  $B$ , say at point  $H$  (Fig. 74e), the moment at  $B$  is

$$M_b = R_a b - Qc \text{ (} c \text{ is the distance from } H \text{ to } B \text{)}.$$

$$M_b = \frac{\Delta_8}{\Delta_1} Qb - \frac{Q\Delta_1}{\Delta_1} c = \frac{Qb}{\Delta_1} \left( \Delta_8 - \frac{\Delta_1 c}{b} \right) = \frac{Qb}{\Delta_1} (\Delta_8 - \Delta_9) = \frac{Qb}{\Delta_1} \Delta_{10}.$$

$\left( \frac{\Delta_1}{b} c \text{ is only approximately equal to } \Delta_9. \right)$

When  $\Delta_1$  is laid off equal to  $b$ ,  $M_b = Q\Delta_{10}$ .

Figure 74e, obtained by giving point  $A$  a displacement equal to  $b$  and connecting point  $A$  with point  $B$  by a straight line, gives the influence line for the moment at point  $B$ . The ordinates must be measured between the elastic curve and the base line  $BF$ , or between the elastic curve and the connecting line  $AB$ , as the case may be. (See Alternative Construction of Influence Line for Moment on next page.)

**Alternative Construction of Influence Line for Moment.** The influence line for the moment at point  $B$  (Fig. 75a) is given by the elastic curve, the ordinates being measured at right angles from the straight lines  $AB$  and  $BC$  (Fig. 75b). If a force  $Q_a$  is required to produce this displacement of point  $A$ , it will require a force  $Q_c = \frac{Q_a L_1}{L_2}$  applied at point  $C$  (Fig. 75b) to keep the structure in equilibrium. Draw a tangent  $DBE$  to the elastic curve at point  $B$  (Fig. 75b), and assume the elastic curve to be displaced from the original position  $DBE$  to a final position  $ABC$ . The linear displacement, relative to this tangent, is

$$\Delta = \int \frac{mMdx}{FEI} = \frac{\text{Area } \bar{X}}{EI}.$$

Therefore

$$DA = \frac{Q_a L_1}{EI} \times \frac{L_1}{2} \times \frac{2}{3} L_1$$

and

$$\theta_1 = \frac{DA}{L_1} = \frac{Q_a L^2}{3EI}.$$

Also

$$EC = \frac{Q_a L_1 L_2}{L_2 EI} \times \frac{L_2}{2} \times \frac{2}{3} L_2$$

and

$$\theta_2 = \frac{EC}{L_2} = \frac{Q_a L_1 L_2}{3EI}.$$

If  $E$  and  $I$  are assumed constant,

$$\frac{\theta_1}{\theta_2} = \frac{L_1}{L_2}.$$

From Fig. 75b we have:

$$\theta_1 + \theta_2 = 1 \text{ radian.}$$

If, instead of giving point  $A$  a displacement equal to  $L_1$ , we cut the spline at  $B$ , and by a suitable device superimpose a unit angle at  $B$  keeping points  $A$ ,  $B$ , and  $C$  in their original position (Fig. 75c), it is seen that we obtain, in Fig. 75c, the same elastic curve, and thus the same influence line, as shown in Fig. 75b. This is in strict agreement with the third case of Maxwell's law of reciprocity of displacement as developed on page 198.

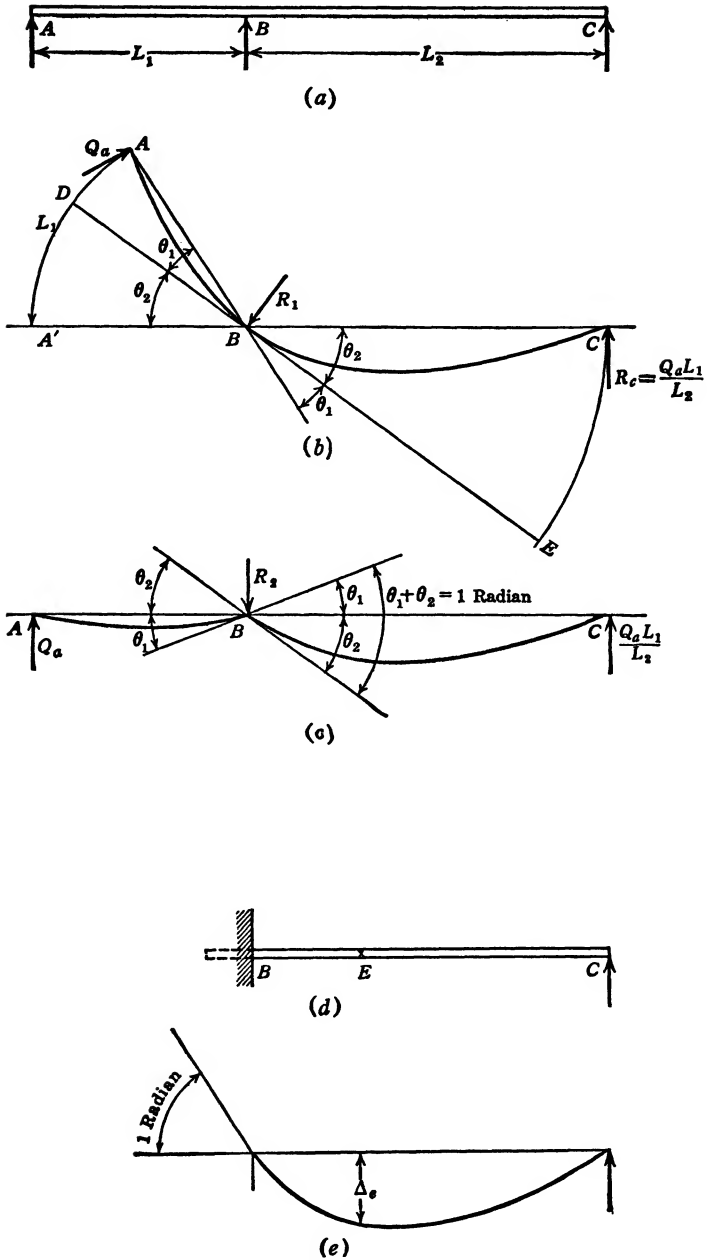

FIG. 75.

According to Maxwell's law of reciprocity of displacement, third case (page 200), the influence line for the bending moment at any point in a beam may be obtained by cutting the beam at the point in question, superimposing on the beam at this point an initial angle of magnitude one radian, and leaving unchanged the support of the beam at other points. Figures 75e and 75f give the influence line for the bending moment at point *B*.

In actual construction of an influence line for a moment it may not be practicable to impose a unit angle ( $57^\circ 18'$ ). An angle of magnitude one-fourth or one-half unity may be used, and the resulting ordinates multiplied accordingly by 4 or 2.

The foregoing argument with reference to the moment at point *B* (Fig. 75a) applies equally to the moment at point *D* (Figs. 74a and 74d).

**Influence Line for Moment at the Wall for a Built-in Beam.** Figure 75b represents the influence line for the moment at point *B* of the beam over three supports (Fig. 75a). If the left span  $L_1$  approaches zero as a limit, the point *A* approaches infinitely close to point *B*. Two adjacent points determine the direction of a tangent. *A* and *B* being on a horizontal line and infinitely close to each other, the tangent to the elastic curve of the beam under all conditions of loading must remain horizontal. This is the same limitation as that offered by the condition of complete restraint at a wall. Therefore, the limiting condition of  $L_1$  approaching zero (Fig. 75a) is identical with the condition of restraint shown in Fig. 75d. If  $L_1$  (Fig. 75a) approaches zero as a limit,  $\theta_1$  (Fig. 75b) also approaches zero as a limit and  $\theta_2$  (Fig. 75b) approaches unity as a limit. The influence line for  $M_b$  then becomes identical with Fig. 75e. This influence line in turn is in agreement with the third case of Maxwell's law of reciprocity of displacement.

The foregoing discussion is given as a check, to illustrate the fundamental reasoning involved. It should assist in avoiding a common, though serious, error. If the displacement  $A'-A$  (Fig. 75b) were vertical instead of extending along the arc, the limiting value of  $\theta_2$  (as  $\theta_1$  approaches zero) would be  $45^\circ$  instead of 1 radian. This in turn would cause the limiting shape for the influence line for  $M_b$  (as  $L_1$  approaches zero, Fig. 75b) to differ from the influence line (Fig. 75e) constructed by application of Maxwell's law (third case). There would thus be a contradiction. This discussion also corroborates the argument given on page 206 to the effect that "theoretically" the displacement of the point *A* (Figs. 74b and 75b) should be along the arc. Furthermore, it confirms the theory that, to obtain an influence line for a moment, we must impose an angular displacement of 1 radian.

**Units of Measurement.** In the influence line for the reaction  $R_a$  (Fig. 74b) the effect of a load  $Q$  at point  $C$  on the reaction at  $A$  is

$$R_a = Q \frac{\Delta_3}{\Delta_1}.$$

Only when  $\Delta_1$  is unity does this expression simplify to

$$R_a = Q\Delta_3.$$

$R_a$  is expressed by  $\frac{\text{pounds} \times \text{linear unit}}{\text{linear unit}} = \text{pounds}$ . It is thus seen that  $R_a$  is independent of the scale of the model. The only essential consideration is to make the dimensions of the model proportional to those of the structure it is to represent, and to measure  $\Delta_1$  and  $\Delta_3$  by the same scale. Thus, in Fig. 74b, if  $\Delta_1$  equals 1 in.,  $\Delta_3$  (measured in inches) will give the value of  $R_a$  in pounds provided load  $Q$  is given in pounds (in tons provided load  $Q$  is given in tons). If  $\Delta_1$  is measured with a centimeter rule,  $\Delta_3$  must be measured with the same rule regardless of the scale of  $L_1$ ,  $L_2$ , and  $L_3$ .

In regard to influence lines for moments the procedure differs in that  $\Delta$  is measured on the same scale as the model. According to Maxwell's law, the bending moment at point  $B$ , caused by the load at  $E$  (Fig. 75e), is given by the equation

$$M_b = \frac{Q\Delta_e}{\theta_b}.$$

The units are expressed in

$$\frac{\text{pounds} \times \text{linear unit}}{\text{abstract number}} = \text{pounds} \times \text{linear unit}.$$

The linear unit  $\Delta_e$  and  $L$  are measured on the same scale.

Let Fig. 75d represent a beam 10 ft. long, fixed at  $B$  and freely supported at  $C$ . Let Fig. 75e represent a model constructed to a scale,  $\frac{1}{4}$  in. = 1 ft. 0 in., that is,  $\frac{1}{48}$  actual size. If  $E$  is at the midpoint and  $\Delta_e$  is measured to be  $\frac{1}{3}\frac{5}{2}$  in., we have:

$$M_b = \frac{1}{3}\frac{5}{2} \times 48 \times Q = 22.5Q \text{ in-lb.}$$

Or  $\Delta_e$  may be measured on the scale of the model,  $\frac{1}{4}$  in. = 1 ft. 0 in.; in which case the answer is obtained directly:  $M_b = \Delta_e = 1.875Q$  ft-lb.

**Influence Lines for a Beam Built in at Both Ends.** The four curves in Figs. 76b, 76c, 76d, and 76e represent the influence lines for the shear at the wall, the bending moment at the wall, the shear at point  $C$  in the beam, and the bending moment at point  $C$ , respectively.

If an elastic curve is to serve as an influence line for a restraint, we impose a unit displacement at the point of application and in the direction of this restraint, leaving the other restraints unaltered (Maxwell's law).

As we impose a unit displacement at point  $B$  to obtain the influence line for the shear at point  $B$ , the question may arise whether we should

make such unit displacement with the tangent at  $B$  free to rotate (Fig. 76f), or retain the tangent at  $B$  continuously parallel to its original position.

We refer to the proof of Maxwell's law, page 198, which is applica-

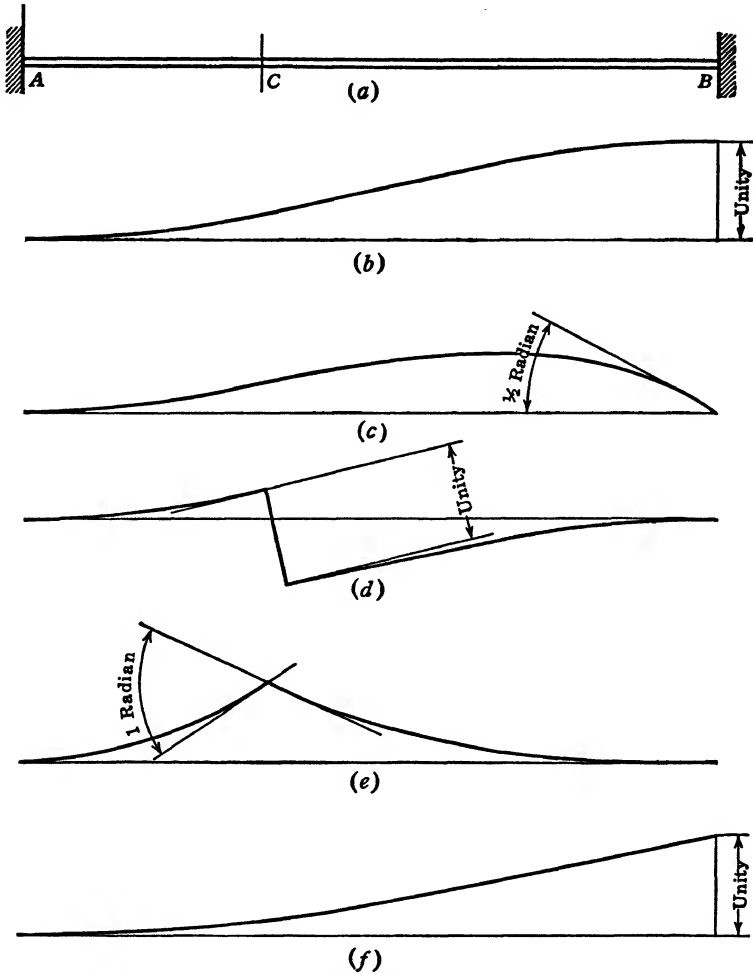

FIG. 76. Influence Lines for Shear and Moment at Points  $B$  and  $C$  of Fixed Beam.

ble to statically indeterminate as well as to statically determinate structures:

Figures 74a and 76a each represent a beam with four reactions. In each case we have two redundants. However, whereas in Fig. 74a all the reactions are vertical forces applied at different points, in Fig. 76a the reactions consist of a vertical force and a couple each at points  $A$  and  $B$ .

To obtain an influence line for any support, whether it is a vertical force or a moment, we superimpose a unit displacement, making sure that the other supports are acting in accordance with the original conditions of support. When we gave point  $A$  (Fig. 74b) a unit displacement, points  $D$ ,  $E$ , and  $F$  were kept in their original positions. In Fig. 76a we have at point  $B$  a restraint to prevent vertical displacement and another restraint to prevent angular displacement of the tangent to the elastic curve. If we impose a unit displacement (Fig. 76b) to obtain the influence line for the vertical reaction at point  $B$ , all other supports at points  $A$  and  $B$  (including the restraining effect at point  $B$  to insure a horizontal tangent) must be fully acting. The resultant curve is shown by Fig. 76b rather than 76f. The latter curve would be the influence line for the reaction at  $B$  when there is no restraining moment at  $B$  (Fig. 76f and Fig. 75d).

The beam  $AB$  (Fig. 76a) might be cut at any point, say point  $C$ , and still be stable. It would act as two independent cantilever beams. The shear and the bending moment at point  $C$  may be regarded as the two redundants instead of the reactions at either point  $A$  or point  $B$ . The influence line for either redundant, for the shear or the bending moment at  $C$ , may be obtained by imposing a unit linear displacement (Fig. 76d) for the shear and a unit angular displacement for the moment (Fig. 76e). As the spline is cut at  $C$  and both parts given a unit linear displacement relative to each other, the tangents to the elastic curves at both ends must not be displaced in relation to each other, that is, they must be kept parallel. Similarly, to obtain the influence line for the moment at point  $C$  the tangents are displaced through a unit angle, but the points must not undergo any vertical displacement relative to each other. They are, however, free to assume a vertical displacement relative to points  $A$  and  $B$ .

To obtain the influence line for the moment at  $B$  the tangent at  $B$  is rotated through a unit angle while point  $B$  is kept in its original position. Figure 76c gives the influence line for  $M_b$ . However, since in Fig. 76c the tangent at  $B$  was rotated through only one-half radian, the ordinates to the curve of Fig. 76c must be multiplied by 2.

**Check on Influence Line for Shear at One Extremity of a Beam Built in at Both Ends.** Influence lines can be obtained by three methods of procedure:

1. By deriving the equation for influence lines directly.
2. By computing mathematically the equation of the elastic curve under conditions outlined in this chapter on elastic curves as influence lines.
3. By means of a model.



*First Method:* Figure 77b is a free-body sketch of the restrained beam shown in Fig. 77a, loaded with a concentrated load  $Q$  at distance  $x$  from the left end. Figure 77c gives its bending-moment diagram. The angular displacement of point  $B$  is zero.

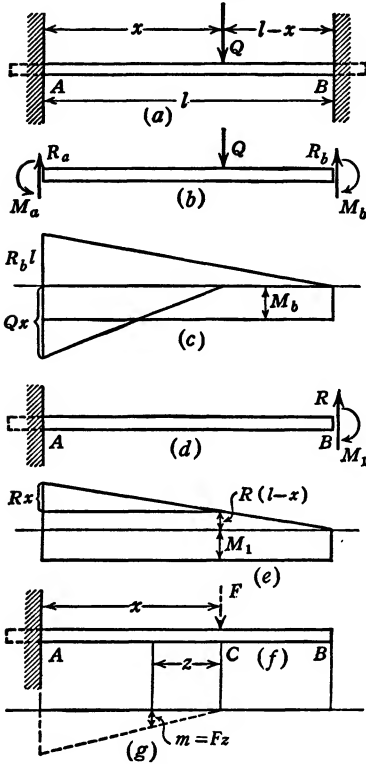

FIG. 77.

Therefore

$$\theta_b = \int \frac{mMdx}{M'EI} = 0.$$

In this case  $m$  equals  $M'$ .

Therefore

$$\theta_b = \int_A^B \frac{Mdx}{EI} = 0$$

or

$$\text{Area} \int_A^B = 0.$$

$$R_b l \times \frac{l}{2} - (Qx) \frac{x}{2} - M_b l = 0. \quad (a)$$

The vertical displacement of point  $B$  is zero.

Therefore

$$\Delta_b = \int_A^B \frac{mMds}{FEI} = 0.$$

$$\int_A^B \frac{F_s M ds}{FEI} = \int_A^B \frac{s M ds}{EI} = \frac{\text{Area } \bar{S}}{EI} \Big]_A^B = 0.$$

Therefore

$$\text{Area } \bar{S} \Big]_A^B = 0.$$

$s$  and  $\bar{S}$  in these equations are measured from point  $B$  to the left.

$$R_b l \times \frac{l}{2} \times \frac{2}{3} l - (Qx) \frac{x}{2} \left( l - \frac{x}{3} \right) - \frac{M_b l \times l}{2} = 0.$$

$$\frac{R_b l^3}{3} - \frac{Qx^2 l}{2} + \frac{Qx^3}{6} - \frac{M_b l^2}{2} = 0. \quad (b)$$

Solving for  $R_b$  between equations (a) and (b) gives

$$R_b = \frac{Q}{l^3} (3x^2l - 2x^3).$$

This is the equation of the influence line for  $R_b$ .

*Second Method:* To obtain the elastic curve to serve as the influence line for the shear at point  $B$  (pages 201 and 213) we displace the right end of the beam a unit distance, the tangent to the elastic curve at  $B$  remaining horizontal. The beam will thus be loaded as shown in Fig. 77d, and its bending moment will be as shown in Fig. 77e. To write the equation for the elastic curve of the beam, subjected to the loading of Fig. 77d, we introduce an auxiliary force  $F$  at point  $C$  a distance  $x$  from the left end (Fig. 77f; see page 41). The  $m$  bending moment will then be  $m = Fz$ .

The displacement of point  $C$ , which we will designate as  $y$  instead of  $\Delta_c$ , is, according to formula (5),

$$y = \int_A^C \frac{mMdz}{FEI} = \int_A^C \frac{FzMdz}{FEI} = \int_A^C \frac{zMdz}{EI} = \frac{\text{Area } \bar{Z}}{EI} \Big]_A^C.$$

From Fig. 77d we derive

$$EIy = (Rx) \left( \frac{x}{2} \right) \left( \frac{2x}{3} \right) + R(l-x)(x) \left( \frac{x}{2} \right) - (M_1x) \left( \frac{x}{2} \right).$$

$$EIy = \frac{Rx^2l}{2} - \frac{Rx^3}{6} - \frac{M_1x^2}{2}. \quad (a)$$

One of the limiting conditions is that the tangent to the elastic curve at  $B$  shall remain zero.

Therefore

$$\theta_b = \int_A^B \frac{mMdx}{M'EI} = 0.$$

In this case  $m = M'$ .

Therefore,

$$\int_A^B Mdx = \text{Area} \Big]_A^B = 0.$$

$$Rl \times \frac{l}{2} - M_1l = 0. \quad M_1 = \frac{Rl}{2}. \quad (b)$$

Substituting the value of  $M_1$  in equation (a) gives

$$EIy = \frac{Rx^2l}{4} - \frac{Rx^3}{6}. \quad (c)$$

One more limiting condition is that  $y = 1$  when  $x = l$ ; thus

$$EI = \frac{Rl^3}{12}.$$

From this we obtain

$$R = \frac{12EI}{l^3}. \quad (d)$$

Substituting the value of  $R$  in equation (c) we obtain

$$y = \frac{1}{l^3} (3x^2l - 2x^3).$$

Thus

$$Qy = \frac{Q}{l^3} (3x^2l - 2x^3).$$

The right side of the equation is identical with the equation of the influence line as obtained by Method 1. Therefore,  $R_b = Qy$ , or the shear at point  $B$  is  $Q$  times the ordinate to the elastic curve of the beam, provided that the elastic curve is obtained as outlined by Method 2.

*Third Method:* The elastic curve is obtained from a model instead of being obtained by means of mathematical logic.

#### GENERAL COMMENTS ON ELASTIC CURVES AS INFLUENCE LINES

Maxwell formulated his law of reciprocity of displacements in an article published in the *Philosophical Magazine* in the year 1864. The importance of it appears to have escaped notice at the time. It was not until Mohr independently discovered it and pointed out its possibilities (1875) that it received, to a degree, the attention it deserves. Not until in very recent years, however, has it claimed the serious consideration of engineers.

Various instruments designed to obtain elastic curves to be used as influence lines are at present obtainable. The author is familiar with three of these instruments. All have their strong as well as their weak points. Their common weakness is the insufficient explanation of their rules, though these rules may be mostly correct. However, the merit or lack of merit of individual instruments does not concern us here. The manufacturer and proponent may be relied upon to point out their merits. The student may easily find objections to them once he has properly familiarized himself with the fundamentals involved. It is held that not only may commercial instruments be employed to advantage, but that frequently it appears advantageous to construct models, or, as

in relatively small airplane structures, to use the structure itself, or part of it, to obtain the influence lines. It is one thing to theorize about obtaining an elastic curve on paper, but in practice it is a quite different matter to obtain a curve equal to those obtained by mathematical analysis.

The theoretical validity of elastic curves as influence lines, as well as a few obvious practical considerations, will be discussed here.

A scientific theory is a logical interpretation of facts. (See "Logic—A Challenge to Engineering Educators," *Engineering and Contracting*, January, 1929, Vol. 68, page 1.) A mathematical theory involves the use of mathematical logic. Such a theory is valuable, not in proportion to the amount of mathematics involved, but rather in proportion to the number of pertinent facts it includes. The mathematical theory of elasticity is extensively applied in the science of strength of materials. It sheds some light on the phenomena of strength and resistance of structures. The accuracy and reliability of the science of mathematics cannot be questioned. It should be self-evident, however, that the value of any mathematical theory is limited by the assumptions which it makes at the outset.

The theory involved in this book, although we have successfully avoided the compulsory use of integral calculus, is none the less a mathematical theory. Several limitations entered into the theory at successive stages. We started by assuming (1) that we have elastic material (stress is proportional to strain); (2) that the principle of superposition holds (deformations of the structures assumed to be of a relatively small order of magnitude); (3) that concentrated loads may be assumed as loads applied at points (a load applied at a point is equivalent to an infinite stress, which, of course, is impossible); and (4) that, in the analysis of Vierendeel trusses and bents, dimensions may be taken to the center line of members, and that irregularities at corners, such as fillets, brackets, or gusset plates, may be ignored. All the foregoing assumptions detract from the value of the theory. However, without these assumptions procedure is impracticable and often impossible. If our theory were 100 per cent correct, there would be no need of a safety factor. But in practice the highest attainment of accuracy possible must be discounted by applying a factor of safety ranging from 2 to 8.

Scientists, who have given thought to the subject, are agreed to measure dimensions to center lines of members and to ignore the irregularities at corners (as in the analysis of bents and Vierendeel trusses, for example). But this agreement of scientists does not make the resulting theory a correct one. It means that we do not know enough about the matter to do otherwise. However, much as we may regret it, our mathematical

theory is bound to be a limited one. Not infrequently we hear of theory conflicting with practice. If practice is based upon accurately observed facts, any disagreement between theory and such practice is evidence that the theory is faulty.

The theory of elastic curves as influence lines is predicated upon Maxwell's law of reciprocity of displacement, and Maxwell's law, in turn, is predicated upon the theories and limitations underlying this treatise.

**Elasticity.** When we apply our mathematical theory, we assume perfect elasticity and infinitely accurate dimensions. When we use a spline, or a model, we are bound by human imperfections, and we can attain neither infinite accuracy nor perfection in the elastic properties. Mathematical analysis, however, is not done for the fun of the thing. The essential object is to learn something about the probable distribution of stresses in an imperfect, humanly made structure.

Suppose, for example, that we wanted an influence line for the left reaction of a wooden beam, as shown in Fig. 75*a*. We may proceed in any one of three ways as mentioned on page 213. If we use our mathematical theory, we must assume perfect elasticity, because the elastic behavior of wood is too erratic to be included in formal mathematical logic. However, by placing a wooden T-square on edge on a drawing board we can obtain the influence line by practical means, namely, by supporting it at the proper points, displacing the left end a unit distance, and tracing the elastic curve. We shall probably find little disagreement between the two influence lines thus obtained.

Some engineers have admitted that the elastic curve so obtained checks quite nicely with the theory, the implication being that the results obtained mathematically should be regarded as the standard. To be sure, in our model the material is not perfectly elastic, nor are the supports finite loads applied at points. Neither of these conditions, however, is true for the beam. If we accept the definition of theory herein stated, we submit that the elastic curve obtained from a model exemplifies the better of the two theories. If the beam to be analyzed is a steel beam, a slender steel straight-edge placed on edge will serve the purpose better than a wooden T-square.

Sound judgment must be exercised at all times in selecting material for models and in deciding upon their proportion. For example, to obtain the influence line for a concrete bent it is inadvisable to construct the model from cardboard. The elastic properties of concrete may be far from ideal, but concrete is not likely to be as fibrous and directional as cardboard.

**The Principle of Superposition.** The principle of superposition underlies our mathematical theory of strength of materials. It states

that the resultant effects are equal to the sum of the component effects. In our theory we assumed that the stress increments, due to the actual loads  $Q$ , are independent of the stress increments caused by the auxiliary load  $F$ .

One instrument, designed for the purpose of obtaining influence lines by constructing elastic curves, specifies that the displacements at all times shall be very small, and that they shall always be of equal distance to each side of the neutral position. A microscope is used to measure the resulting displacements. This practice of obtaining elastic curves is no doubt well within the assumption of superposition of effects. It is undesirable on two counts. First, no continuous elastic curve can be obtained. The microscope must be moved from point to point, and the influence line must be constructed from readings thus obtained. Second, giving a displacement to both sides of the neutral position magnifies any error due to slack that may be present between the model and its supports.

To eliminate any danger of error due to slack at the supports, it is best to start from a base line obtained with an initial small displacement and subsequently superimpose a unit displacement in the same direction. In doing this, however, there must be no serious conflict with any of our assumptions.

On pages 206 and 210 we have shown how, in certain cases, the violation of the principle of superposition, due to large displacements, may be anticipated and mainly avoided. On page 210 it is suggested that the displacement should "theoretically" be measured on the path along which point  $A'$  travels from  $A'$  to  $A$ . The word "theoretically" was deliberately put in quotation marks. At this place the author wants to make one point clear. It is a difficult thing to measure displacement along an arc. Thirty years' experience with the mathematical theory of strength of materials has reconciled the author to inaccuracies, to violations of assumptions, to seeing the best theories discounted 50 per cent by applying a factor of safety. It is a subversion of our best theories to compute answers to more than three significant figures, or to quibble over methods of measuring distances along arcs. Errors are inevitable. At best, we can estimate their relative magnitude. Thus it may be left to the operator to decide how he may attain the desired end. However, it is important to realize clearly the manner of measuring displacements, if we would be in close agreement with the basic philosophy involved.

**Neglect of Fillets and Brackets.** As previously pointed out Maxwell's law of reciprocity of displacements is applicable to statically determinate and statically indeterminate structures alike. Herein lies the outstanding significance of the possibilities of elastic curves as influence lines. The mathematical theory of strength of materials is founded on simple

laws. If the behavior of material cannot actually be expressed in simple laws, we *assume* that it can be so expressed. We estimate the degree of error introduced by such assumption and discount the results proportionately. In complicated structures, as pointed out in the text, we require an independent equation for every redundant member or reaction. The required number of equations may easily become too large for practical solution. Further, in bents and Vierendeel trusses, for example, the dimensions of members are taken to the center line and the disturbing effects of corners are ignored. In practical cases fillets or gusset plates are found in the corners, since sharp corners should by all means be avoided. These brackets or gusset plates materially influence the behavior of the structure, but we must ignore them also because we do not know enough about the variation of stresses in fillets and gusset plates to include them accurately in our mathematical theory.

No such discrediting arguments apply to the use of models in the construction of influence lines. It may be difficult to find suitable material and difficult also to construct the model. Once it is constructed, however, no complexities due to the large number of redundants, to variable dimensions of members, to irregularities at corners, enter the problem to detract from the value of the result. The answer obtained from an elastic curve of a well-constructed model of a complicated structure is likely to be in much better agreement with the theory of elasticity than one obtained by mathematical process. In fact, the result obtained from the model would give expression to parts of the theory of elasticity which, as yet, we are unable to formulate mathematically.

**Conclusion.** The mathematical theory of elasticity, as applied to the theory of strength of materials, is employed to give expression to the elastic behavior of structures. This elastic behavior of structures may also be obtained directly from models. Maxwell's law of reciprocity of displacement, which is as sound as the theory of elasticity—in fact forms a part of it—provides a key to the interpretation of results. As to the relative merits of the two methods, the mathematical analysis is the easier one for the simpler problems and is generally accurate enough. In complicated problems the work involved in a mathematical analysis becomes very burdensome and the accuracy suffers because of successive assumptions that have to be made. The value of influence lines obtained from models depends on the quality of the model. Errors due to large displacement need not be feared; they should be kept in mind, however.

Even extreme degrees of redundancy do not detract from the value of the use of models in obtaining influence lines. In complex structures they often yield results more closely in agreement with the theory of elasticity than can be obtained by mathematical processes.

## CHAPTER XII

### THE THEORY OF LEAST WORK

Assume a beam to be loaded with any system of loads,  $Q_1, Q_2 \dots Q_n$  (Fig. 78a).

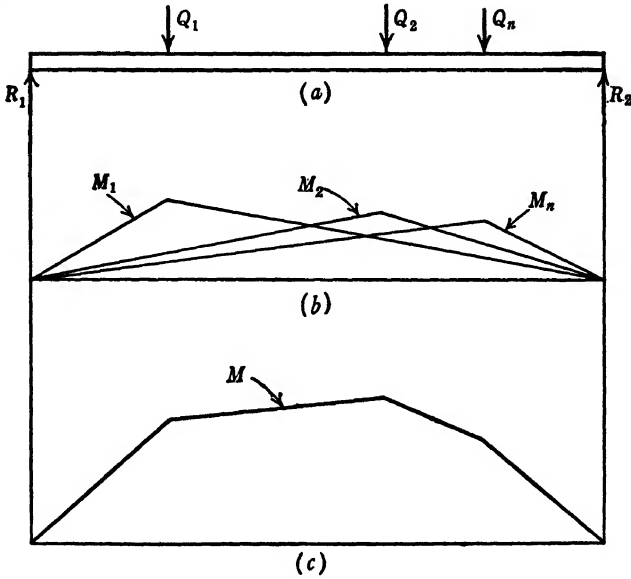

FIG. 78.

Let  $M_1$  be the bending moment at any point in the beam caused by  $Q_1$ .

$M_2$  be the bending moment at any point in the beam caused by  $Q_2$ .

$M_n$  be the bending moment at any point in the beam caused by  $Q_n$ .

$M$  be the bending moment at any point in the beam caused by  $(Q_1, Q_2 \dots Q_n)$ .

The total elastic energy stored in the beam because of the application of all the loads,  $Q_1, Q_2 \dots Q_n$  is given by formula (7) (page 47):

$$W = \int \frac{M^2 dx}{2EI}$$



If we differentiate this total elastic energy with respect to a single force, say  $Q_1$ ,

$$\frac{dW}{dQ_1} = \frac{d \int \frac{M^2 dx}{2EI}}{dQ_1} = \int \frac{2M}{2EI} \frac{dM}{dQ_1} dx.$$

(Note that we are not differentiating with respect to  $dx$ , in which case we would merely drop the integral sign.)

To evaluate  $\frac{dM}{dQ_1}$  we refer to Figs. 78*b* and 78*c*.  $M$  being the resultant moment of all the loads may be regarded as the algebraic sum of the component bending moments,  $M_1, M_2, M_n$ . If  $Q_1$  varies,  $Q_2 \cdots Q_n$  remaining constant,  $M_2$  will not be affected.  $\frac{dM}{dQ_1}$ , or the rate of change of the total bending moment with respect to  $Q_1$ , therefore, will be equal to  $\frac{dM_1}{dQ_1}$ .  $M_1$  being a linear function of  $Q_1$ ,

$$\frac{dM_1}{dQ_1} = \frac{M_1}{Q_1}.$$

Therefore

$$\frac{dW}{dQ_1} = \int \frac{M_1 M dx}{Q_1 EI}$$

Formula (5) (page 45) gives us:  $\Delta = \int \frac{mM dx}{FEI}$ , in which  $F$  was allowed to have any value. If, in formula (5), we let  $F = Q_1$ ,  $m$  will equal  $M_1$  and we obtain:  $\int \frac{M_1 M dx}{Q_1 EI} = \Delta_1$ , the displacement of the application of the load  $Q_1$  in the direction of  $Q$ .

Therefore

$$\frac{dW}{dQ_1} = \Delta_1.$$

Castigliano's law states that "The partial derivative of the total elastic energy, stored in a structure with respect to one of the loads, gives the displacement of the point of application of the load in the direction of the load."

For purposes of illustration we referred to the simple beam of Fig. 78*a*. The law holds for redundant structures and statically determinate struc-

tures alike. It holds regardless of shape and dimensions of the structure, as long as the material is elastic and the principle of superposition applies.

Throughout the work with redundant structures we have been interested in displacements  $\Delta$ , not for themselves but as a means to an end. Frequently the limiting conditions of the problem determined in advance a zero displacement of a point of the structure. In such a case the expression  $\int \frac{mMdx}{FEI} = 0$  constitutes a useful equation in our analysis. Cas-

tigliano's law interprets  $\int \frac{mMdx}{FEI}$  as a partial derivative. Further, the science of calculus teaches that, whenever a derivative of a function is zero, the function itself is either a maximum or a minimum. The question which of the two it is (maximum or minimum) in this particular instance needs further investigation. We are certain that such a thing as a minimum elastic energy in a structure exists. The equation  $\frac{dW}{dQ_1} = 0$ , being a first degree equation in  $Q_1$ , gives but a single solution. Since  $\frac{dW}{dQ_1} = 0$  gives but one answer, and since we know that a minimum elastic energy must exist, it follows that  $\frac{dW}{dQ_1} = 0$  gives *the* minimum elastic energy stored in the structure.

Three points in this connection are worthy of special emphasis:

1. In the theory of least work there is no question of an absolute minimum of elastic energy.
2. The term "least" applies only to the elastic energy stored in a structure in so far as it is affected by a single force applied at a particular point.
3. The theory of least work is not a general theory. We can speak of least work only when a single force applied at a particular point keeps that point from being displaced.

#### EXAMPLE 43

*Given:* A continuous beam 18 ft. long resting on three supports. Left span, 8 ft. long, loaded with 10 tons per ft.; right span, 10 ft. long, loaded with 7 tons per ft.  $E$  and  $I$  are assumed constant. (See example 18, page 71, Fig. 37.)

*To find:* The three reactions,  $R_1$ ,  $R_2$ , and  $R_3$  by means of the theory of least work.

The total elastic energy in the beam as shown in Fig. 37a, page 72, is found by applying formula (7) (page 47):

$$W = \int \frac{M^2 dx}{2EI}.$$

We evaluate this expression in two steps. First, we integrate between points *A* and *B*, and, second, between points *C* and *B*. The expressions for *M* will be simplest if we measure *x* for the first step from *A* to the right, and for the second step from *C* to the left. Thus:

$$W = \int_A^C \frac{M^2 dx}{2EI} = \int_A^B \frac{\left(R_1 x - \frac{10x^2}{2}\right)^2 dx}{2EI} + \int_C^B \frac{\left(R_3 x - \frac{7x^2}{2}\right)^2 dx}{2EI}.$$

$$2EIW = \left[ \frac{R_1^2 x^3}{3} + \frac{25x^5}{5} - \frac{10R_1 x^4}{4} \right]_0^8 + \left[ \frac{R_3^2 x^3}{3} + \frac{49x^5}{20} - \frac{7R_3 x^4}{4} \right]_0^{10}.$$

$$120EIW = 20 \times 8^3 \times R_1^2 + 300 \times 8^5 - 150 \times 8^4 R_1 + 20,000 R_3^2 + 14,700,000 - 1,050,000 R_3.$$

Taking moments about the point *A* (Fig. 37a) we have

$$R_3 = \frac{205}{3} - \frac{4}{9} R_2.$$

Taking moments about the point *C* (Fig. 37a) we have

$$R_1 = \frac{245}{3} - \frac{5}{9} R_2.$$

Substituting these values for *R*<sub>1</sub> and *R*<sub>3</sub> in the foregoing expression and differentiating with respect to *R*<sub>2</sub>, we obtain

$$120EI \frac{dW}{dR_2} = 20 \times 8^3 \left( \frac{50}{81} R_2 - \frac{2450}{27} \right) + 150 \times 8^4 \times \frac{5}{9} + 20,000 \left( \frac{32}{81} R_2 - \frac{1640}{27} \right) + \frac{4,200,000}{9}.$$

$$120EI \frac{dW}{dR_2} = \frac{512,000}{81} R_2 - \frac{10,240 \times 2450}{27} + \frac{3,072,000}{9} + \frac{640,000 R_2}{81} - \frac{32,800,000}{27} + \frac{4,200,000}{9}.$$

$$120EI \frac{dW}{dR_2} = \frac{1,152,000}{81} R_2 - \frac{108,200,000}{81}.$$

According to Castigliano's law,  $\frac{dW}{dR_2} = \Delta_2$ , which is the displacement of the point of application of  $R_2$ . In this instance  $\Delta_2 = 0$ . Therefore

$$1,152,000R_2 = 108,200,000.$$

$$R_2 = 93.9 \text{ tons.}$$

This value of  $R_2$  is the same as found in example 18, page 71.

Examples 18 and 43 represent two methods of solving a typical problem involving a statically indeterminate unknown. The one method is based upon the theory of conservation of energy, the other upon Castigliano's law. It may be argued that in the last analysis the two methods are the same. But in a practical sense they are not the same. First, to square the bending moment  $M$ , second, to integrate, and third, to differentiate, in order to arrive at the expression,  $\int \frac{mMdx}{FEI}$ , is indeed a very roundabout way compared with expressing  $m$  and  $M$  directly. The accuracy of Castigliano's law cannot be questioned.

In differential calculus, when a derivative is zero, we may look for a maximum or minimum. This frequently proves to be of great value, but this is no reason for applying Castigliano's law when it fails to clarify the procedure.

The theory of least work, although true, is a mathematical abstraction; and makes no essential contribution to the theory of elastic energy. Any problem known to the author, of the type we have been discussing, can be more effectively solved by the method developed in this text than by that of the theory of least work.

## CHAPTER XIII

### COLUMNS

#### CRITERIA OF STRENGTH

This book deals with certain phases of the theory of strength. We have grown familiar with formulas which express stress, or moment, as a function of either a concentrated load  $P$ , or a uniformly distributed load  $w$ . The implication is that any such relationship holds good independent of the magnitude of either  $P$  or  $w$ , provided that the elastic limit is not exceeded. Traditionally we specify a safe stress (working stress) as a fraction either of the elastic limit stress or of the ultimate stress. Then the problem of design consists of proportioning our structure so that, under a specified loading, the working stress is not exceeded. Having done so we conclude that we have designed our structure with a factor of safety proportional to the ratio between the elastic limit stress and the working stress, or to the ratio between ultimate stress and working stress, as the case may be. We have called this procedure a tradition—a tradition which obviously has a certain merit, else it would not have persisted to the present day. However, it would seem obvious that this tradition is valid only when the relationship between load and stress is linear, since only then does the principle of superposition apply.

#### THE PRINCIPLE OF SUPERPOSITION

In the stress analysis of trusses (for example, see problem 3) we either make free-body sketches of the joints and write equilibrium equations for each joint, or we draw a force diagram for the entire truss. In the analysis of problem 3 the angles introduced in the equilibrium equations, or the inclination of the lines in the force diagram, are all either  $45^\circ$  or  $0^\circ$ . When the truss is loaded it deflects, the various members of which it is composed change their lengths, and the inclination of these members in relation to the horizontal, which originally may have been  $45^\circ$  or  $0^\circ$ , no longer has these same values. A rigorous analysis would require that the angles introduced in the equilibrium equations or in the force diagram correspond to the final inclination of the members instead of to their

initial inclinations. Thus, in a rigorous analysis, we find that we must know at the outset the final inclinations of the members, but these inclinations cannot be determined until we know the stresses acting in the truss. This constitutes a vicious circle often very difficult to overcome. In the analysis of problem 3 we side-step the difficulty as follows: We say that the deformations are of relatively small order of magnitude. The inclusion of these deformations in either stress or deformation analyses would therefore affect the results only slightly. We say then that we assume the principle of superposition to apply: we assume the deformations to be zero for purposes of stress or deformation analyses.

A literal interpretation of the principle of superposition implies that we may, for example, make an analysis for dead loads, live loads, snow loads, wind loads, and impact, and that the resulting stress or deformation, when all five types of loading act simultaneously, may be obtained by merely adding algebraically (superimposing) the component stresses or deformations found in the component analyses.

The author does not know of a single instance where the principle of superposition applies rigorously. However, he is quite ready to agree that in a majority of problems we are justified in assuming that it does apply.

The expression "relatively small order of magnitude" was used advisedly. Occasionally we meet with the statement to the effect that small deformations are sufficient to insure the validity of the principle of superposition. This, however, is not true. We have seen on page 185 that a spiral spring, loaded with equal and opposite moments at each end, may be wound some ten to twenty complete turns—which certainly constitutes a displacement of very large order of magnitude—without violating the principle of superposition. That is, the moment-deformation, or the moment-stress, relationship is substantially linear over the entire range of loading, from zero stress to elastic limit stress. Note: We said "substantially linear" instead of "rigorously linear" for the following reason: The stresses across a curved beam of rectangular cross section vary parabolically, not linearly. As the curvature of the spiral spring leaf is increased the neutral axis shifts, and the equation of the parabolic stress distribution over the cross section changes. This, however, is a consideration of minor consequence, even as the deformation of the truss in problem 3 is of minor consequence in the stress analysis.

On the other hand, as we shall now show, deformations in the same structure which in one analysis appear to be of secondary importance may in another analysis assume primary importance. Consider, for example, Figs. 83*a* and 83*b*, page 237. First assume  $P$  to equal zero. Then Fig. 83*a* presents a simply supported beam subject to a uniformly dis-

tributed load  $kuA$ . The maximum stress at the midpoint is  $s = \frac{Mc}{I} = \frac{kuAl^2c}{8I}$ . We say so confidently, recognizing, however, that the formula

$s = \frac{Mc}{I}$  is not rigorously applicable to a curved beam. However, the curvature in a floor beam in a building, as the result of the load which it supports, is so slight as not to warrant its being considered as modifying the familiar formula  $s = \frac{Mc}{I}$ .

Next we consider the same beam represented by Fig. 83a. This time, however, the load  $P$  is acting alone and the transverse load  $kuA$  is removed. When the beam is loaded to capacity, with either the transverse load  $kuA$  or the direct load  $P$  acting singly, the deflection  $\Delta$  in both cases is of the same order of magnitude. When  $P$  is acting singly the maximum stress in the column is  $s = \frac{P}{A} + \frac{P\Delta c}{I}$ . Whereas in the one case we ignored the curvature, or the term  $\Delta$ , in the other the term  $\Delta$  is of primary importance. In the one case we found the deformations so small that the principle of superposition was not disturbed; in the other we found that these same deformations wholly invalidated the principle of superposition.

As another illustration consider problem 33. The ring is loaded with two equal and opposite loads acting along a diameter. When the loads compress the ring it changes into a somewhat elliptical shape with the major axis at right angles to the line of action of the loads. When the loads are reversed the structure changes again into a somewhat elliptical shape. In this circumstance the major axis is coincident with the line of action of the load. The answer given in the problem,  $M_b = \frac{QR}{\pi}$ , is quite accurate for small values of  $Q$ . However, since we are discussing strength, the load-stress relationships for small loads concern us but little, if at all. Our real interest lies in the load-stress relationship that exists when the load reaches its maximum value. This load-stress relationship is obviously a function of the somewhat elliptical shape of the ring that prevails when the maximum value of the load is reached, and not that of the circular outline which may have prevailed under initial loading conditions.

The difference in value of the loads that cause the elastic limit stress in the ring to be first reached—one pair of loads compressing the ring and the other acting in reversed sense—may easily be as great as 40 per cent.

Though the listed answers to problem 33 may be said to be accurate for small loads, they may be  $\pm 20$  per cent in error for large loads. The conclusion we reached on page 133, that the circumferential bending moments in large pipes is zero, is absolutely correct. The equations listed in connection with Cases I, II, and V, page 127, were based on the assumption that the principle of superposition applies. These answers, as applied to individual instances of loading flexible rings and corresponding to Cases I, II, and V, are somewhat in error because the principle of superposition does not apply rigorously. However, the results of Cases I, II, and V, predicated on the assumption that the outline is perfectly circular, may be applied collectively to a section of a large thin-shelled pipe. Here, since the theory assumes that the shape of the pipe under ultimate loading is the same as under initial loading, the principle of superposition rigorously applies, and the theoretical results may be accepted as fully trustworthy. We may state, as a test for the applicability of the principle of superposition:

*The principle of superposition is applicable when any load-stress or load-deformation relationship which we may formulate is valid for initial and intermediate loading as well as for capacity loading.*

#### STATEMENT OF THE PROBLEM OF COLUMN ANALYSIS

A column is a beam intended to carry a load substantially parallel to its axis. The structure is statically indeterminate, and the principle of superposition is inapplicable.

Consider a column loaded through frictionless hinges. Since it cannot possibly be perfectly straight, perfectly homogeneous, and perfectly elastic, and since the eccentricity cannot possibly be absolutely zero, the column deflects as the load is applied and gradually increased. The stress at point B in Fig. 80a, page 231, is accurately represented by the formula

$$s = \frac{P}{A} \pm \frac{Mc}{I} = \frac{P}{A} \pm \frac{P\Delta c}{I}$$

The bending moment of the deflected column is  $Px$ , and thus the bending-moment diagram (Fig. 80b), laid off to suitable scale, is identical with the elastic curve. In other words, the elastic curve is a function of the bending moment, and the bending moment in turn is a function of the elastic curve, presenting a vicious circle similar to the one discussed in connection with the ring analysis when deformations are so large as to make the principle of superposition inapplicable.

We referred earlier to the practice of predicating strength upon the concept of working stress as a tradition, acceptable in certain cases but



quite intolerable in others. We are creatures of habit, and traditions are valuable. If we have the firmly established habit of regarding working stress as a safe criterion of strength, then this habit requires careful scrutiny when we undertake to study the strength of columns. A new orientation and a new sense of value in regard to strength must then be developed.

In the study of beams subject to bending, we regard the elastic limit stress as the criterion of strength of the beam. Then we derive the working stress from this elastic limit stress by means of a safety factor introduced for that purpose. This procedure is acceptable although not strictly in agreement with fact. That is, after the elastic limit stress in a beam is reached, a certain increase in carrying capacity may still be anticipated. Nevertheless, even as the elastic limit stress in beams is conservatively regarded as a criterion of the strength of beams, so we propose to regard the elastic limit stress in columns as the criterion of the strength of columns. In slender columns the reaching of the elastic limit stress marks the absolute limiting strength of the columns, while in short struts a certain percentage of increase in strength of columns may be envisaged after the elastic limit stress is reached. This consideration may well be ignored as it is in beams subject to bending.

A general relationship between load and stress in columns is of no interest to the designer. As we show in detail in example 47 on page 259, a wide-flange 25 column, 16 ft. 0 in. long, loaded with a load of 100,000 lb., applied with an eccentricity of  $\frac{1}{8}$  in., is stressed with a maximum stress of 37,900 lb. per sq. in. The same column loaded with a load of 110,000 lb. applied with the same eccentricity of  $\frac{1}{8}$  in. is stressed to a maximum stress of 84,600 lb. per sq. in. The maximum stress of 37,900 lb. per sq. in. under the load of 100,000 lb. gives no indication of the true strength of the column, since an increase of only 10 per cent in the load results in an increase of more than 100 per cent in the stress. The designer is interested in the safe load which a column can carry, which safe load is a fraction of the ultimate, the critical, or the limit load. Our analysis then should be directed towards establishing a special load-stress relationship in which the load is the capacity load and the stress is the elastic limit stress. Any other load-stress relationship, since such a relationship is not linear, has no more than academic interest, and throws no light on the problem of strength of columns.

Euler's Column Formulas \*

When a slender, straight column with rounded ends, uniform cross section, and homogeneous material (constant  $E$  and  $I$ ) (Fig. 80) is concentrically loaded with two mutually opposing forces  $P$ , the column will remain substantially straight until  $P$  reaches a certain critical value. Then the column will suddenly bend sidewise and take on a curved shape. This phenomenon is called buckling of the column. In view of the fact

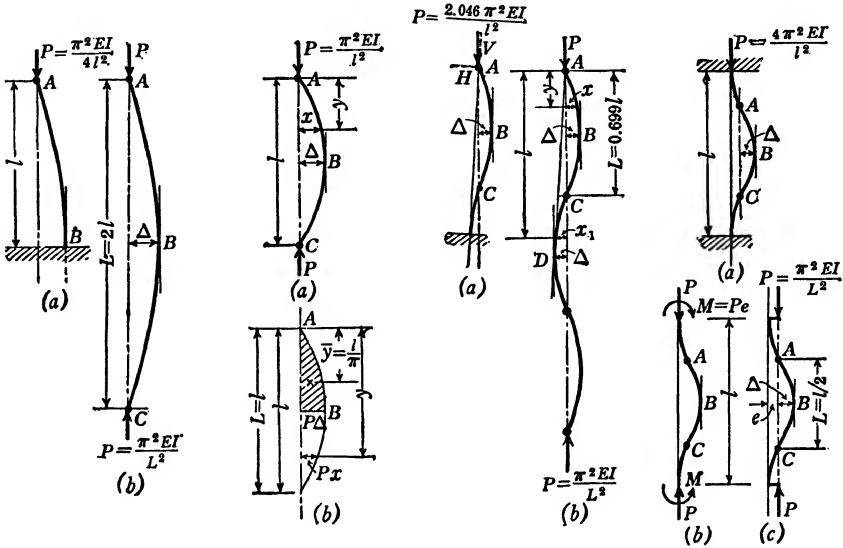

FIG. 79.

FIG. 80.

FIG. 81.

FIG. 82.

that the bent column is symmetrical relative to the midpoint, point  $B$ , we decide that the maximum deflection  $\Delta$  (Fig. 80) will occur at the midpoint of the column. While the column remains straight the stress therein is given by the equation  $s = \frac{P}{A}$ . Once the column buckles an eccentricity is created and the maximum stress at its midpoint becomes

$$s = \frac{P}{A} \pm \frac{Mc}{I} = \frac{P}{A} \pm \frac{P\Delta c}{I}$$

This formula is correct, but it has no practical value since  $\Delta$  is indeterminate and a function of the elastic curve. The elastic curve, in turn, is a function of the bending moment, while the bending moment is a function of  $\Delta$ , thus presenting a vicious circle.

\* This discussion of Euler's column formulas is reproduced from a paper, written by the author, which appeared in the *Michigan Technic* of April, 1939.

The analysis of the column will be materially simplified if we can make an intelligent guess as to the type of curve the column will assume once it buckles. In Figs. 81 and 82, which represent columns with restrained ends, we note that the elastic curves of these columns in the buckled state present reversed curves with one or more points of inflection, points of zero bending moment. For example: The center portion  $A-C$  (Fig. 82c) represents a column loaded in a manner identical with the one represented by Fig. 80a. This fact eliminates the possibility of the elastic curve of a buckled column assuming the form of a conic section. Any one of the conic sections, the circle, the parabola, or the hyperbola, could not possibly be expressed as a continuous function, as graphically shown in Figs. 81 and 82.

One equation which might express all of the various elastic curves which a column might assume when it buckles under the various conditions of loading represented by Figs. 79, 80, 81, and 82 is the equation of the sine curve. Let us then assume the equation of the elastic curve of a buckled column to be a sine curve, and on the basis of this assumption derive Euler's formula, a formula which is substantiated by a very large number of authenticated tests. This procedure is not so arbitrary as it might seem. For example: in the development of the formula  $s = \frac{Mc}{I}$ ,

it is assumed that a transverse plane before bending of the beam remains a plane after bending. Once developed, the formula is tested in the laboratory and found to be reliable. Throughout this procedure no one has ever looked inside a beam and seen a transverse plane in its entirety. The best that can be done is to see the intersection of such a plane with the outer surface of a beam. Similarly the process we propose to apply appears as follows: the assumption is made, the formula is developed, the formula is checked by every conceivable test and, if found reliable, this check in turn establishes the reasonableness of the assumption.

If, then, the elastic curve of a buckled column may be mathematically represented by the equation of a sine curve, the equation of Fig. 80a is  $x = \Delta \sin \frac{\pi y}{l}$ . The bending moment in this buckled column is given by the expression

$$M = Px = P\Delta \sin \frac{\pi y}{l} \quad (\text{Fig. 80b}).$$

The deflection is

$$\Delta = \frac{\text{Area } \bar{y} \Big|_A^B}{EI} \quad (\text{Fig. 80b}).$$

The area under one-quarter of a sine curve is  $\frac{2}{\pi}$  times the circumscribed rectangle. Thus the area in which we are interested, that between the limits of point *A* and point *B* (Fig. 80*b*), is

$$\frac{2}{\pi} \times P\Delta \times \frac{l}{2} = \frac{P\Delta l}{\pi}.$$

The  $\bar{y}$  for this area is  $\frac{2}{\pi}$  times the base of this circumscribed rectangle, thus:

$$\bar{y} = \frac{2}{\pi} \times \frac{l}{2} = \frac{l}{\pi}.$$

We thus obtain

$$\Delta = \frac{\text{Area } \bar{y}}{EI} = \frac{P\Delta l^2}{EI\pi^2}.$$

From the above expression it appears that  $\Delta$  is a function of  $\Delta$ . This is precisely what we discussed at the outset. If  $P$  is held constant after buckling has commenced, an increase in  $\Delta$  increases the bending moment, which in turn increases the deflection  $\Delta$ . If we cancel  $\Delta$  and solve for  $P$ , we obtain

$$P = \frac{\pi^2 EI}{l^2} \quad (\text{Euler's formula}).$$

The value of  $P$  obtained by this formula is the critical value which initiates the buckling of the column. Equilibrium would be obtained for any value of  $\Delta$ , provided that the column is not stressed beyond the elastic limit. With only a very slight increase in the value of  $P$ , equilibrium would be destroyed,  $\Delta$  would continue to increase until the elastic limit in the material of the column is passed, and the column would collapse completely and fail to return to its original form after removing the load  $P$ .

Figure 79*a* represents a column built in at the base but unrestrained at its top. When such a column is loaded with a critical load  $P$  the top will sway to one side and the column will assume a form as shown in Fig. 79*a*. If free-body sketches be made of Fig. 79*a* and of the top half (*A-B*) of Fig. 80*a*, it will appear that both sketches are qualitatively identical. Thus Fig. 79*a* is both qualitatively and quantitatively identical with the top half of Fig. 79*b*, which represents a column loaded similarly to Fig. 80*a*. However, this column has a length  $L = 2l$ . The critical load carried by the column (Fig. 79*b*) is

$$P = \frac{\pi^2 EI}{L^2} = \frac{\pi^2 EI}{4l^2},$$

which is identical with the critical load carried by the column shown in Fig. 79a.

Figure 82a represents a column with both ends built in. The free-body sketch for Fig. 82a appears as shown in Fig. 82b and this in turn is identical with Fig. 82c. Figure 82b may be divided in four equal parts which will show that all four parts are loaded identically. Thus the central portion ( $A-C$ ) of the elastic curve of the column, shown in Fig. 82, is of a length:  $L = \frac{l}{2}$ . This central portion  $A-C$  is loaded in a manner identical with that shown in Fig. 80a. The critical load  $P$  carried by this central portion  $A-C$  (Fig. 82c) is identical with the critical load carried by the column shown in Fig. 82a. Thus

$$P = \frac{\pi^2 EI}{L^2} = \frac{4\pi^2 EI}{l^2}.$$

Figure 81a represents a column built in at the bottom. The top is rounded and is restrained against side sway by friction, or by means of a pin. This column is prevented from assuming the form as shown in Fig. 79a, and its elastic curve, therefore, is as represented in Fig. 81a. The point of inflection at  $C$  is a distance  $L$  from the top. There is no bending moment at this point of inflection  $C$ . If a free-body sketch is made of portion  $A-C$  (Fig. 81a), it appears that portion  $A-C$  is in equilibrium under the action of two forces which, therefore, must be collinear. The force applied at  $A$  must then have a horizontal component in order that it may pass through point  $C$ . The loading of column 81 will thus consist of a vertical component  $V$  and a horizontal component  $H$  as shown in Fig. 81a, or it will consist of a single resultant  $P$  as shown in Fig. 81b. If we knew the relation between  $L$  and  $l$  (Fig. 81), the value of  $P$  would immediately be determined. The elastic curve of the buckled column (Fig. 81) will be qualitatively the same curve as those appearing in Figs. 79, 80, and 82. However, it will be a sine curve with respect to a  $y$  axis drawn through points  $A-C$  (shown by the dash line, Fig. 81b), but not with respect to the vertical through  $A$ . If we draw a line through point  $D$ , tangent to the sine curve and parallel to the dash line  $A-C$ , it appears that the distance  $A-C$  is two-thirds of the distance  $D-A$ . From this it follows that the distance  $A-C$ , or  $L$ , must be greater than  $\frac{2}{3}l$ . The exact value of this distance  $L$ , as a function of  $l$ , may be computed as follows:

The tangent to the elastic curve is given by the expression  $\frac{dx}{dy}$ . At the point where the column is built in, the tangent is  $\frac{x_1}{l}$ . Thus, the problem

resolves itself in finding  $L$  as a function of  $l$ , so that, at  $y = l$ ,  $\frac{dx}{dy} = \frac{x_1}{l}$ .

$$x = \Delta \sin \frac{\pi y}{L}.$$

$$\frac{dx}{dy} = \frac{d\Delta \sin(\pi y/L)}{dy} = \frac{\Delta \pi}{h} \frac{d \sin(\pi y/L)}{d(\pi y/L)} = \frac{\Delta \pi}{L} \cos \frac{\pi y}{L}.$$

For  $y = l$ ,  $x = x_1$ ; hence

$$\frac{dx}{dy} = \frac{\Delta \pi}{L} \cos \frac{\pi l}{L},$$

while  $x_1 = \Delta \sin \frac{\pi l}{L}$ .

Therefore

$$\frac{\Delta \pi}{L} \cos \frac{\pi l}{L} = \frac{x_1}{l} = \frac{\Delta}{l} \sin \frac{\pi l}{L}$$

or

$$\frac{\pi l}{L} = \tan \frac{\pi l}{L}.$$

The solution of this equation gives

$$\frac{\pi l}{L} = 4.4933$$

or

$$L = \frac{\pi l}{4.4933} = 0.6992l.$$

Thus, for a column built in at the base and hinged at the top, Fig. 81a,

$$P = \frac{\pi^2 EI}{L^2} = \frac{\pi^2 EI}{(0.6992l)^2} = \frac{2.046\pi^2 EI}{l^2}.$$

It appears from Figs. 81a and 81b that  $V$  is of necessity somewhat smaller than  $P$ , the former being only the vertical component of the latter. The relationship between  $V$  and  $P$  depends on the magnitude of the deflection when buckling occurs. From this it follows that, under a loading as represented by Fig. 81, the vertical component  $V$  being held constant, the load  $P$  would progressively increase as the deflection increases. Thus, once the process of buckling commences, the column will continue to deform until it is destroyed.

### The Beam Column \*

All columns which are placed in a horizontal position have to carry at least their own dead weight in addition to the axial column load  $P$ . If, as in a top chord of a bridge, the structure vibrates (the maximum acceleration of the particles of which the column is composed being greater than that of gravity), the transverse loading of the column will be proportionately greater than dead-weight loading.

When an airplane takes a nose dive and is subjected to an acceleration of  $kg$ , then the horizontal struts in the airplane are subjected to a transverse loading  $k$  times as great as the dead-weight loading.

Figure 83a represents a column ( $E$  and  $I$  constant) with a cross-sectional area that has at least one axis of symmetry, which is simultaneously loaded with axial loads  $P$  and transverse uniformly distributed loads  $kuA$  acting coincident with the axis of symmetry. Let  $u$  represent the weight per unit volume of the material of which the column is made. (For steel  $u = 0.2833$  lb. per cu. in.; for duralumin  $u = 0.101$  lb. per cu. in.; for magnesium alloy  $u = 0.065$  lb. per cu. in.)  $A$  represents the cross-sectional area of column. Thus  $Au = w$  is dead weight per unit length of column, and  $k$  represents the factor by which the dead weight per unit length must be multiplied to arrive at the value of the transverse loading. Thus, if the transverse load carried by a beam (including the weight of the beam) is 7500 lb. per ft. and the weight of the beam is 100 lb. per ft., then  $k = 75$ .

*The column, subject to uniformly distributed transverse loads* (Fig. 83), does not, strictly speaking, present a problem in stability. That is, instead of failing as the result of sudden buckling, the column will at all times suffer a deflection. The deflections and stresses will vary with changes either in the transverse loads  $kuA$  or in the axial load  $P$ . However, such variations will not be linear; they will not be proportional to the changes in the value of  $P$ . In other words, the principle of superposition does not apply. In the analysis of the beam-column, even though the principle of superposition is inapplicable, the elasticity equations may still be used with confidence within certain limits.

In the development of Euler's column formulas we surmounted the difficulty resulting from the fact that the principle of superposition was inapplicable by making an intelligent guess as to the type of elastic curve which the column would assume. Successfully deciding the type

\* Part of the following discussion is quoted from a paper by the author published in the *Engineering Journal* of the Engineering Institute of Canada, March, 1941, entitled "Columns Subject to Uniformly Distributed Transverse Loads—Illustrating a New Method of Column Analysis."

of elastic curve which the structure will assume is equivalent to eliminating one of the unknowns of our problem. With this unknown eliminated the problem presents no further difficulties. In this instance we propose to follow a procedure identical with that followed in the development of Euler's formulas.

If, in Fig. 83a,  $P$  is finite and  $kuA$  approaches zero as a limit, then the elastic curve of the column will approach the sine curve,  $y = -\Delta \sin$

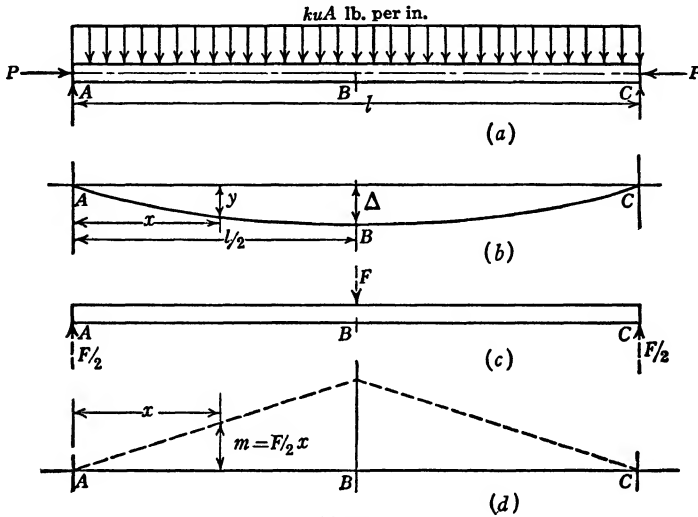

FIG. 83.

$\frac{\pi x}{l}$ , as a limiting curve. If, on the other hand,  $kuA$  is finite and  $P$  approaches zero as a limit, then the elastic curve will approach the fourth-degree parabola,  $y = -\frac{16\Delta}{5l^4}(l^3x - 2lx^3 + x^4)$ , as a limiting curve.

Figure 84 shows a number of curves plotted to scale. It may be observed that the sine curve and the fourth-degree parabola are so nearly alike as to be almost indistinguishable. The true elastic curve will be one which lies somewhere between these two curves. Since we know the limiting value of the elastic curve and since these limiting values are so close as to be nearly identical, we may assume the elastic curve to be either the fourth-degree parabola or the sine curve without introducing an appreciable error.

In formula (5)

$$F\Delta = \int \frac{mMds}{EI}$$

$F$  (Fig. 83c) represents an auxiliary load. It is of finite magnitude.



However, if we choose we may conceive it to be extremely small. The two expressions  $F\Delta$  and  $\int \frac{mMds}{EI}$  are identical. This identity is independent of the principle of superposition and is merely contingent on the assumption that  $m$  remains constant and that the material is elastic. Since the bending moment  $M$  is a function of the elastic curve, the use of formula (5) would be extremely involved if this elastic curve itself varied in type as well as in magnitude. If, on the other hand, we assume

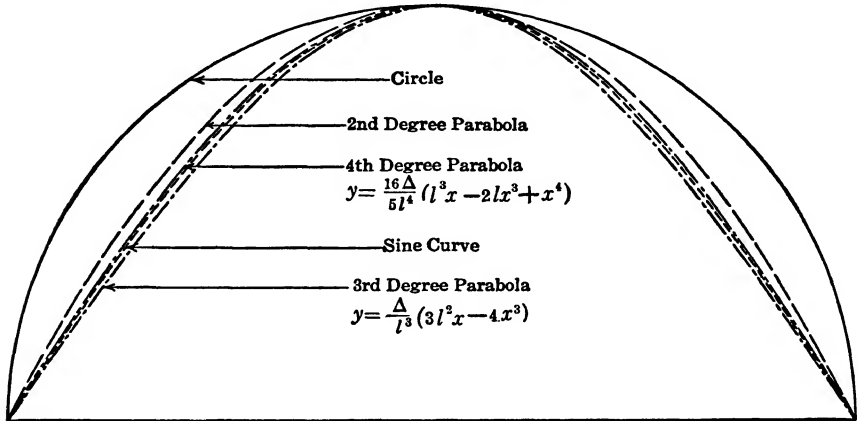

FIG. 84. Comparison of Various Curves.

this elastic curve for all values of  $kuA$  and  $P$  to be a sine curve, then formula (5) may be easily integrated:

$$\begin{aligned}
 M &= Py + \frac{kuAl}{2} x - \frac{kuAx^2}{2} \\
 &= P\Delta \sin \frac{\pi x}{l} + \frac{kuAlx}{2} - \frac{kuAx^2}{2}.
 \end{aligned}$$

$$m = \frac{F}{2} x.$$

$$F\Delta = \int_A^C \frac{mMds}{EI}.$$

However, owing to symmetry of both  $m$  and  $M$  about the center of the span, this equation can be expressed as

$$F\Delta = \frac{2}{EI} \int_A^B mMds.$$

If we here introduce the two assumptions which are commonly found to be acceptable, namely that  $l$  is constant and  $ds = dx$ , then we may write

$$\begin{aligned} EIF\Delta &= 2 \int_A^B mMds = 2 \int_0^{l/2} mMds \\ &= 2 \int_0^{l/2} \frac{Fx}{2} \left( P\Delta \sin \frac{\pi x}{l} + \frac{kuAl}{2} x - \frac{kuAx^2}{2} \right) dx \end{aligned}$$

and

$$EI\Delta = \frac{P\Delta l^2}{\pi^2} + \frac{5}{384} kuAl^4$$

or

$$\left( EI - \frac{Pl^2}{\pi^2} \right) \Delta = \frac{5}{384} kuAl^4. \tag{a}$$

In the case of a sine curve

$$\begin{aligned} y &= -\Delta \sin \frac{\pi x}{l}. \\ \frac{dy}{dx} &= -\frac{\pi\Delta}{l} \cos \frac{\pi x}{l}. \\ \frac{d^2y}{dx^2} &= +\frac{\pi^2\Delta}{l^2} \sin \frac{\pi x}{l}. \end{aligned}$$

The curvature, and therefore the stress in a column of constant  $E$  and  $I$ , is a maximum when  $x = \frac{l}{2}$ . The maximum curvature in the column then is

$$\left( \frac{d^2y}{dx^2} \right)_{\max.} = \frac{\pi^2\Delta}{l^2}.$$

The expression  $\frac{d^2y}{dx^2}$  at any point may be given as  $\frac{s}{Ec}$ , in which  $s$  is stress at the extreme fiber resulting from curvature and  $c$  is distance from the neutral axis to the extreme fiber. The stress in the extreme fiber of the midpoint of the column, expressed as a function of the curvature, or as a function of the maximum deflection  $\Delta$ , would then be

$$s = Ec \frac{d^2y}{dx^2} = \frac{Ec\pi^2\Delta}{l^2}. \tag{b}$$

As the load  $P$  is eccentrically applied, relative to a bent column, the stresses throughout the column are augmented by the factor  $\frac{P}{A}$ .

The expression for the controlling stress, the elastic limit stress  $s_1$  as a function of the curvature and of the load  $P$  therefore is

$$s_1 = \frac{\pi^2 \Delta E c}{l^2} + \frac{P}{A}$$

or

$$\Delta = \left( s_1 - \frac{P}{A} \right) \frac{l^2}{\pi^2 E c}. \quad (c)$$

Combining equations (a) and (c) we obtain

$$\left( EI - \frac{Pl^2}{\pi^2} \right) \left( s_1 - \frac{P}{A} \right) = \frac{5}{384} kuAl^2 \pi^2 E c \quad (d)$$

or

$$l^2 P^2 - (l^2 S_1 A + EI \pi^2) P - \left( \frac{5}{384} kuAl^2 \pi^2 E c - EI s_1 \right) \pi^2 A = 0.$$

Solving this quadratic equation we obtain

$$P = \frac{1}{2} \left( s_1 A + P_{cr} \pm \sqrt{(s_1 A - P_{cr})^2 + 5.0734 kuE c A^2} \right). \quad (e)$$

We select the minus sign in order to obtain the minimum value for  $P$ .

Thus

$$P = \frac{1}{2} \left( s_1 A + P_{cr} - \sqrt{(s_1 A - P_{cr})^2 + 5.0734 kuE c A^2} \right) \quad \text{Formula (10)}$$

$P$  = limiting load which induces elastic limit stress.

$s_1$  = elastic limit stress.

$A$  = cross-sectional area.

$u$  = weight per unit volume.

$k$  = constant by which  $uA$  is to be multiplied to arrive at uniformly distributed transverse load.

$c$  = distance from neutral axis to extreme fiber.

$$P_{cr} = \frac{\pi^2 EI}{l^2}.$$

At this point the accuracy of formula (10) may be checked against the known results which we should obtain in the two limiting cases: either when  $P$  is a maximum and  $kuA$  is zero, or when  $kuA$  is a maximum and  $P$  is zero. By making  $kuA = 0$  in equation (e), we obtain two limiting values for  $P$ , namely,  $P = s_1 A$  and  $P = P_{cr}$ . When on the other hand the length is such that the elastic limit stress would be reached as

the result of the transverse loading only, then  $P = 0$ , or, from equation (d),

$$kuA = \frac{7.78s_1I}{cl^2}. \quad (f)$$

In a simple beam subject to a uniformly distributed capacity load

$$M = \frac{kuAl^2}{8} = \frac{s_1I}{c} \quad \text{or} \quad kuA = \frac{8s_1I}{cl^2}. \quad (g)$$

The discrepancy between (f) and (g) is clearly the result of our assumption that the elastic curve is a sine curve, whereas, for this limiting case, when  $P = 0$ , it is a fourth-degree parabola.

If we divide formula (10) through by  $A$  we obtain

$$\frac{P}{A} = \frac{1}{2} \left[ s_1 + \frac{\pi^2 E}{(l/i)^2} - \sqrt{\left( s_1 - \frac{\pi^2 E}{(l/i)^2} \right)^2 + 5.0374kucE} \right]. \quad \text{Formula (11)}$$

We must not be misled and attempt to interpret the term  $\frac{P}{A}$  as stress.

The only symbol for stress in formula (11) is  $s_1$ , the elastic limit stress.

The term  $\frac{P}{A}$  in no sense represents a critical stress. It is a term which must be multiplied by  $A$  before it yields a value to which we can attach any real significance—the value of  $P$ , the load which spells collapse.

Had we predicated our analysis on the assumption that the elastic curve is the fourth-degree parabola,

$$y = -\frac{16\Delta}{5l^4} (l^3x - 2lx^3 + x^4),$$

then the resulting formula would have been

$$P = \frac{1}{2} \left[ s_1A + \frac{9.836EI}{l^2} - \sqrt{\left( s_1A - \frac{9.836EI}{l^2} \right)^2 + 4.918kucEA^2} \right] \quad \text{Formula (12)}$$

or

$$\frac{P}{A} = \frac{1}{2} \left[ s_1 + \frac{9.836E}{(l/i)^2} - \sqrt{\left( s_1 - \frac{9.836E}{(l/i)^2} \right)^2 + 4.918kucE} \right]. \quad \text{Formula (13)*}$$

The advantage of formulas (11) and (13) over formulas (10) and (12) lies in the fact that when they are plotted graphically the resulting curves

\* See footnote, page 245.

have a general application to all columns of the same material and the same elastic limit stress.

Figure 85 shows a graphical representation of formula (13), plotted for mild steel with a modulus of 29,500,000 lb. per sq. in. and an elastic limit stress of 36,000 lb. per sq. in.

Figure 86 shows similar curves for a steel of the same weight and

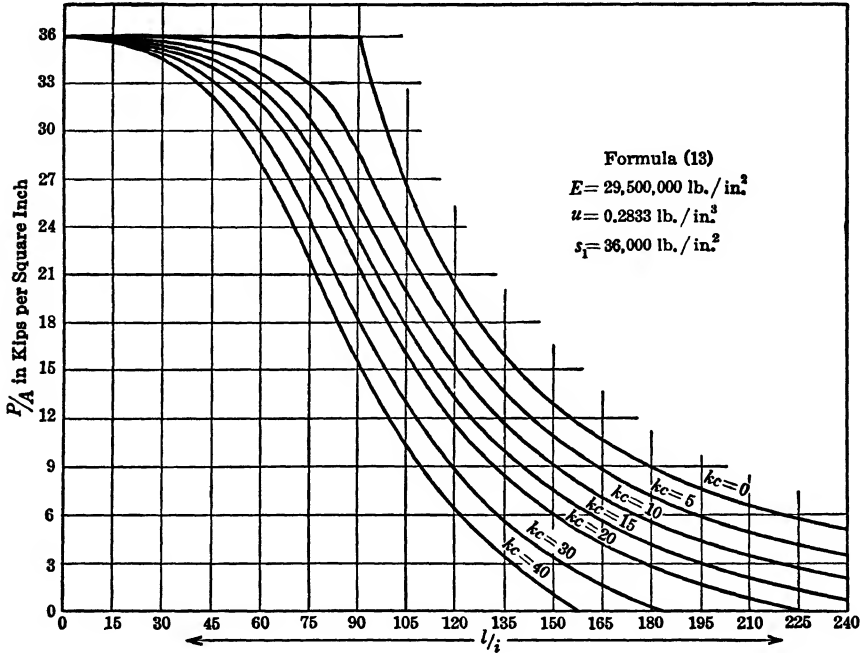

FIG. 85.

modulus, but differs from Fig. 85 in that the elastic limit stress is 54,000 instead of 36,000 lb. per sq. in.

Figure 87 shows curves similar to those of Figs. 85 and 86, except that in this instance the modulus  $E$ , the weight per unit volume  $u$ , and the elastic limit stress  $s_1$  correspond to the values for aluminum alloy 24S-T.

One very interesting feature of these curves is that either Euler's formula  $\frac{\pi^2 E}{(l/i)^2}$  (formula [11]) or  $\frac{9.836 E}{(l/i)^2}$  (formula [13]) appears as a limiting curve for the case when  $k = 0$ . Note that the graph for Euler's formula as expressed by formula (11) turns a sharp corner when the value  $\frac{l}{i}$  equals

critical, and is a level line corresponding to  $\frac{P}{A} = s_1$  for all values of  $\frac{l}{i}$  between zero and this critical value.

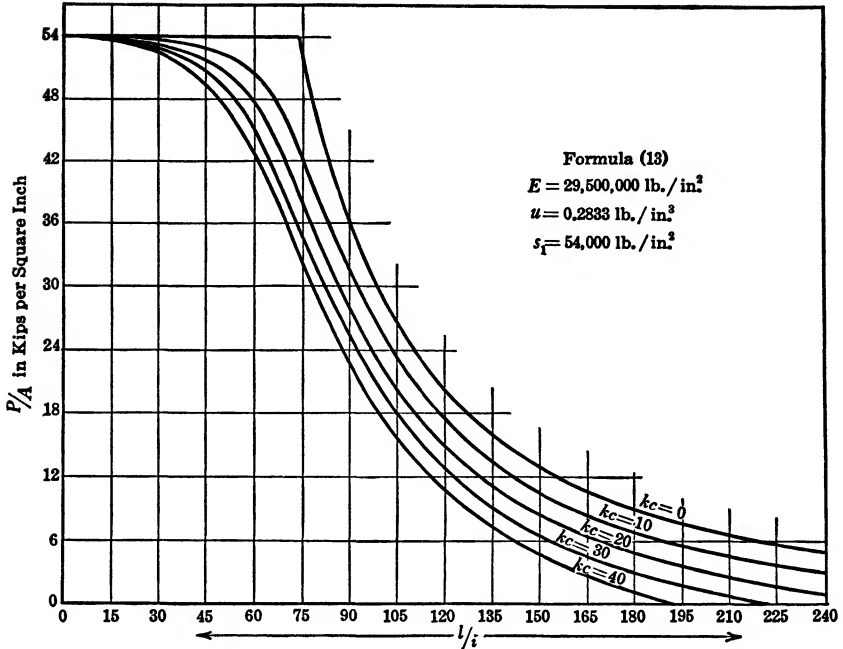

FIG. 86.

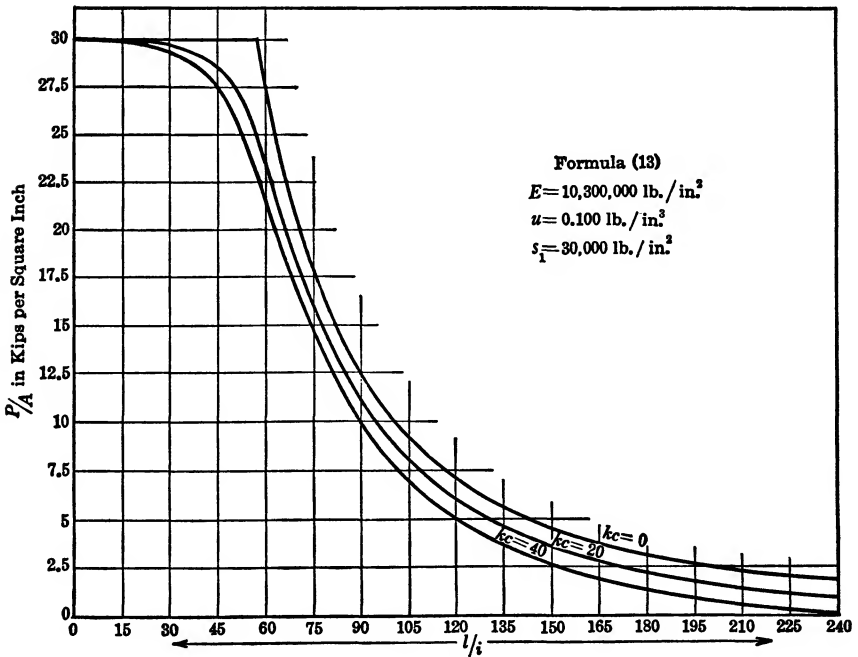

FIG. 87.

If in formula (11) we insert  $k = 0$  and a value  $\frac{l}{i}$  smaller than critical, then  $\frac{\pi^2 E}{(l/i)^2}$  will be larger than  $s_1$ , say  $(s_1 + B)$ . Thus formula (11) will appear as

$$\begin{aligned} \frac{P}{A} &= \frac{1}{2} [s_1 + s_1 + B - \sqrt{(s_1 - s_1 - B)^2}] \\ &= \frac{1}{2} (2s_1 + B - \sqrt{(-B)^2}) \\ &= \frac{1}{2} (2s_1 + B - \sqrt{B^2}) \\ &= \frac{1}{2} (2s_1 + B - B) = s_1. \end{aligned}$$

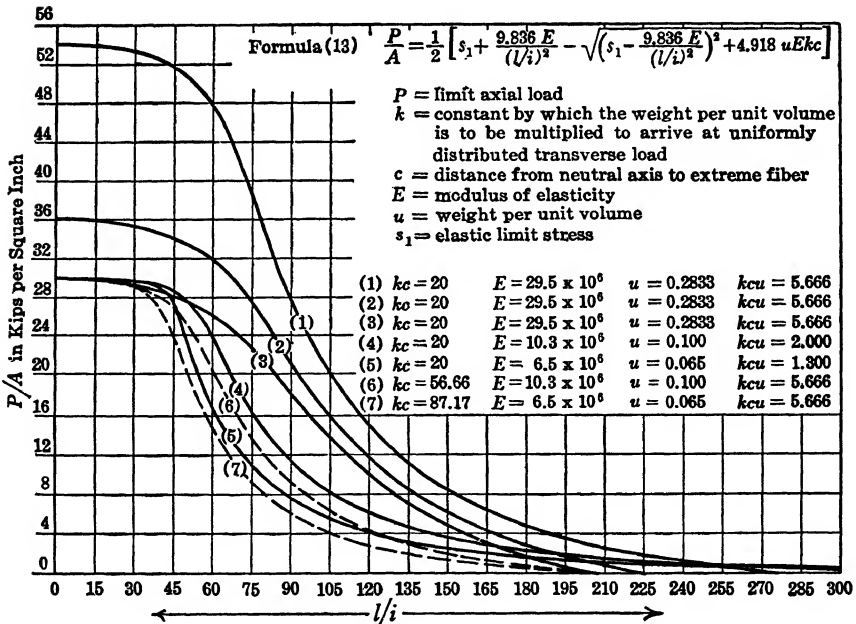

FIG. 88.

Figure 88 shows how the term  $\frac{P}{A}$  is affected by a change in the value of the elastic limit  $s_1$ , all other factors remaining constant. It also shows how the value of  $\frac{P}{A}$  is affected by a change in the modulus of elasticity  $E$ .

**Eccentrically Loaded or Partially Restrained Columns \***

The eccentrically loaded column is a special example of the concentrically loaded pin-ended column (Fig. 80a)—hence the phrase “or partially restrained” in the title of this discussion. Logically, this might well have been discussed as a fifth case under the heading “Euler’s Column Formulas.” We propose to discuss it separately because of its somewhat greater complexity.

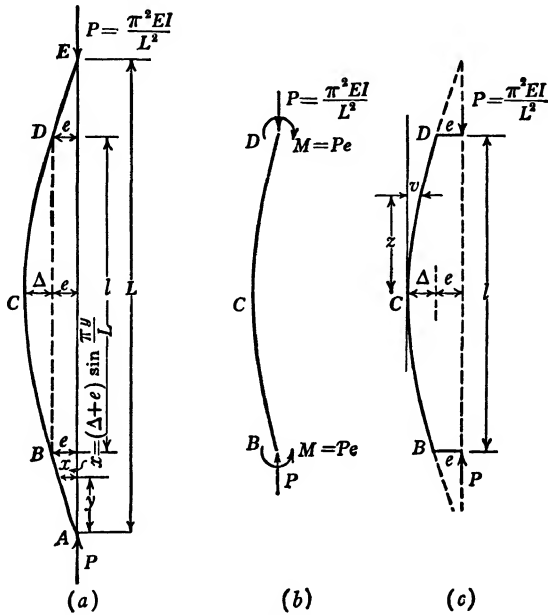

FIG. 89.

Figure 89a represents a pin-ended column of length  $L$ . This column in its buckled state assumes the shape of the sine curve, the equation for which is  $x = (\Delta + e) \sin \frac{\pi y}{L}$ . The central portion  $BD$  of this column, symmetrical about the horizontal center line through  $C$ , is represented by either the free-body sketch Fig. 89b or 89c. Figure 89c also truly represents an eccentrically loaded column. This then constitutes proof that an eccentrically loaded column is a special case of a concentrically loaded column.

Suppose that the eccentricity  $e$  in Fig. 89c approaches zero as a limit; then the elastic curve  $BCD$  approaches a full arch of a sine curve as a

\* See “Rational Column Analysis,” by J. A. Van den Broek, *Engineering Journal* of the Engineering Institute of Canada, December, 1941.



limit. If on the other hand the eccentricity  $e$  in Fig. 89c should approach infinity as a limit, then the elastic curve  $BCD$  would approach a circle as a limiting curve. Actually, for any normal value of eccentricity  $e$ , the curve  $BCD$  is an arc of an arch of a sine curve.

A strength formula for an eccentrically loaded column, Fig. 89c, may be derived as follows:

$$x = (\Delta + e) \sin \frac{\pi y}{L}.$$

$$e = (\Delta + e) \sin \frac{\pi(L - l)}{2L} = (\Delta + e) \cos \frac{\pi l}{2L}. \quad (h)$$

$$\frac{dx}{dy} = (\Delta + e) \frac{\pi}{L} \cos \frac{\pi y}{L}. \quad (i)$$

$$\frac{d^2x}{dy^2} = -(\Delta + e) \frac{\pi^2}{L^2} \sin \frac{\pi y}{L}.$$

The curvature, or  $\frac{1}{R}$ , equals  $\frac{d^2x/dy^2}{[1 + (dx/dy)^2]^{3/2}}$ .

This expression is a maximum for the value  $y = \frac{L}{2}$ . Thus

$$\left(\frac{1}{R}\right)_{\max.} = -\frac{d^2x}{dy^2} = (\Delta + e) \frac{\pi^2}{L^2} = \frac{s}{Ec},$$

in which  $s$  is stress due to curvature in the extreme fiber of column at point  $C$ .

$$s = \frac{\pi^2 Ec}{L^2} (\Delta + e).$$

This stress  $s$ , due to curvature, is augmented by a stress  $\frac{P}{A}$  due to the direct load. Thus the equation

$$s = \frac{\pi^2 Ec(\Delta + e)}{L^2} + \frac{P}{A} \quad (j)$$

gives a general, load-maximum-stress relationship for columns. But, since the principle of superposition does not apply, this relationship as discussed on page 230 throws no light on the strength of the column. An estimate of the column strength can be made only when we assign a definite maximum value for  $s$ , say the elastic limit stress  $s_1$ , and simultaneously define the corresponding load  $P$  as being equivalent to the limit

load, critical load, or maximum load, which the column can carry. With  $s_1$  and  $P$  so defined we may write

$$s_1 = \frac{\pi^2 Ec(\Delta + e)}{L^2} + \frac{P}{A},$$

or

$$(\Delta + e) = \frac{L^2}{\pi^2 Ec} \left( s_1 - \frac{P}{A} \right). \tag{k}$$

Eliminating  $(\Delta + e)$  between equations (h) and (k), we obtain

$$e = \frac{L^2[s_1 - (P/A)]}{\pi^2 Ec} \cos \frac{\pi l}{2L}. \tag{l}$$

From Fig. 89a we have  $L^2 = \frac{\pi^2 EI}{P}$  and  $\frac{l}{L} = \frac{l}{\pi} \sqrt{\frac{P}{EI}}$ . Substituting these values in (l) we obtain

$$e = \left( s_1 - \frac{P}{A} \right) \frac{I}{Pc} \cos \frac{l}{2} \sqrt{\frac{P}{EI}}.$$

$$s_1 - \frac{P}{A} = \frac{ecP}{I \cos l \sqrt{P/EI/2}}.$$

$$s_1 = \frac{P}{A} \left( 1 + \frac{ec}{i^2} \sec \frac{l}{2} \sqrt{\frac{P}{EI}} \right). \tag{Formula 14}$$

This formula (14) is theoretically perfect; that is, it cannot be criticized on the basis of sound logic. Nevertheless it contains two flaws, one minor and one major. Both these flaws pertain to the use of formula (14) as applied to the problem of column design.

The minor flaw in formula (14) lies in the fact that it does not lend itself to a direct solution for the limit load  $P$ . Formula (14) cannot be solved for  $P$  except by trial and error. We keep on substituting different values for  $P$  until we finally arrive at one which gives a value for  $s_1$  that comes close to being the true value of the elastic limit stress  $s_1$ . The exponents of "exact" formulas will have to acknowledge that we need an infinite number of lifetimes to accomplish an infinite number of trial-and-error solutions in order to arrive at an "exact" answer. Of course, we are going to be satisfied with an approximate solution of formula (14) obtained after a few trial-and-error solutions. An approximate solution being inevitable, we propose to develop a formula, avowedly approximate, but one which permits of a solution for  $\frac{P}{A}$  by direct substitution, one which in the hands of a designer is more usable.

## Development of Formula (15)

We shall in this instance follow a procedure similar to the one employed in the development of Euler's formulas and the formulas for columns subject to transverse loading, that is, we select a likely elastic curve and proceed to develop our formula upon this elastic curve as a basis. In the development of Euler's formula we selected a sine curve which is, so far as anyone knows, the correct curve, and which therefore gave us the correct result.

In the development of the column formula, which was to include the effect of the transverse loading, we concluded, from Fig. 84, that by basing our analysis upon either the fourth-degree parabola or upon the sine curve we could not go far wrong, since the two curves are nearly identical. A study of Fig. 84 bore out this truth so convincingly that we did not deem it necessary to compare our results with those obtainable from some other rational analysis.

In the analysis of eccentrically loaded columns we are not so fortunate in our selection of a likely compromise elastic curve upon which to base our analysis. We have concluded (page 245) that when  $e$  approaches zero the elastic curve approaches a full arch of a sine curve, and that when  $e$  approaches infinity the elastic curve approaches an arc of a circle as a limiting curve. These two curves differ greatly as shown in Fig. 84. Therefore in this instance it is well to have formula (14) available to serve as a standard. The true curve is an arc of an arch of a sine curve. The analysis based upon such a true curve results in formula (14). Of the several curves investigated for the purpose of obtaining an approximate formula which would not contain the minor flaw of formula (14), the author found the second-degree parabola to give the most satisfactory results.

Figure 90a represents an eccentrically loaded column, assumed to be curved in the shape of a second-degree parabola. The cross-hatched area represents the bending-moment area to which this column is subjected.

$$\Delta = \frac{\text{Area } \bar{y}}{EI}$$

The  $\bar{y}_1$  for the parabola bending-moment area is  $\frac{5}{8} \times \frac{l}{2}$  (see Appendix I).

The  $\bar{y}_2$  for the rectangular bending-moment area is  $\frac{l}{4}$ . Therefore

$$\Delta = \left( \frac{5\Delta l^2}{48} + \frac{el^2}{8} \right) \frac{P}{EI},$$

or

$$\left( EI - \frac{5}{48} l^2 P \right) \Delta = \frac{el^2}{8} P. \quad (m)$$

The equation of the parabola is  $z = \frac{4v^2}{l^2} \Delta$ .

$$\frac{dz}{dv} = \frac{8v\Delta}{l^2} \quad \text{and} \quad \frac{d^2z}{dv^2} = \frac{8\Delta}{l^2}.$$

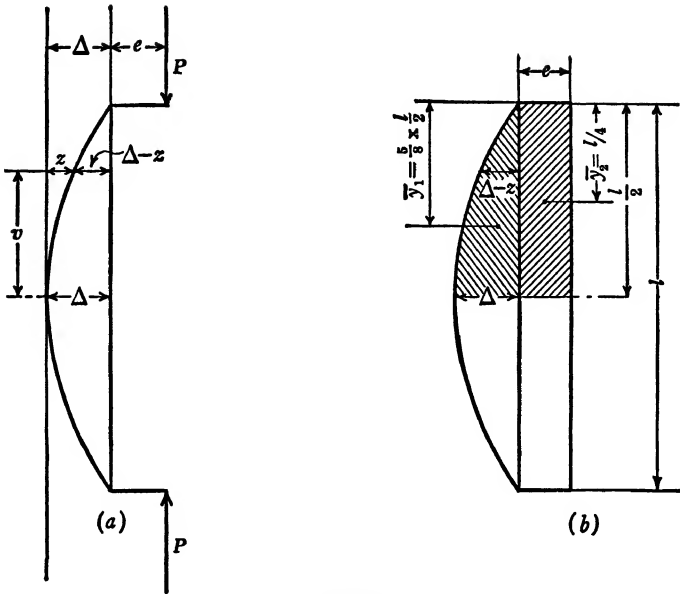

FIG. 90.

The maximum curvature

$$\left( \frac{1}{R} \right)_{\max.} = \frac{8\Delta}{l^2} = \frac{s}{Ec} \quad \text{or} \quad s = \frac{8Ec\Delta}{l^2}.$$

This stress due to curvature is augmented by a direct stress  $\frac{P}{A}$ . Thus the maximum stress as a function of  $P$  is

$$s = \frac{8Ec\Delta}{l^2} + \frac{P}{A}.$$

Defining  $P$  as limit load and  $s_1$  as elastic limit stress we have

$$s_1 = \frac{8Ec\Delta}{l^2} + \frac{P}{A},$$

or

$$\Delta = \left( s_1 - \frac{P}{A} \right) \frac{l^2}{8Ec} \quad (n)$$

Eliminating  $\Delta$  between (m) and (n), we obtain

$$\left( EI - \frac{5}{48} l^2 P \right) \left( s_1 - \frac{P}{A} \right) = cEeP,$$

or

$$P^2 - \left\{ s_1 A + 9.6 \left( \frac{EI}{l^2} + \frac{AceE}{l^2} \right) \right\} P + \frac{9.6EIs_1A}{l^2} = 0.$$

Solving this equation we obtain

$$\frac{P}{A} = \frac{1}{2} \left[ s_1 + \frac{9.6E}{(l/i)^2} \left( 1 + \frac{ce}{i^2} \right) - \sqrt{\left\{ s_1 + \frac{9.6E}{(l/i)^2} \left( 1 + \frac{ce}{i^2} \right) \right\}^2 - \frac{38.4s_1E}{(l/i)^2}} \right].$$

Formula (15)

Figure 91 shows graphs for both formulas (14) and (15), plotted for an elastic limit stress  $s_1 = 40,000$  lb. per sq. in., a modulus of elasticity  $E = 30,000,000$  lb. per sq. in., and for various values of eccentricity ratio  $\frac{ec}{i^2}$ . It appears from Fig. 91 that formula (15) gives results which are

not materially different from those obtained by formula (14). One interesting aspect of formula (15) lies in the fact that, when we replace the 9.6 by  $\pi^2$ , 38.4 by  $4\pi^2$ , and let  $e = 0$ , it appears identical with formula (11) when  $k$  in formula (11) equals zero. This suggests the possibility of a general formula which will include both transverse loading and eccentricity effects, a suggestion which will be discussed in more detail later.

*The major flaw in formula (14) is equally in evidence in formula (15).* This flaw lies in the difficulty, the impossibility in fact, of determining in advance of a solution the magnitude of the eccentricity  $e$ . Even in the most carefully controlled laboratory tests we find it impossible wholly to eliminate eccentricity when we seek to do so, and when we attempt to introduce it deliberately we have no satisfactory way of knowing the amount present at the instant of collapse. In a laboratory test, if anywhere, we may align a column so as to have a substantially zero eccentricity of the applied load, or else we may contrive to give to the initially applied load a definite, predetermined value. Neither of these procedures has any bearing on the problem of strength of columns. In this connection the initial loading conditions are of no consequence whatsoever; only the final conditions at the instant of collapse count in the reckoning.

By a positive eccentricity we mean an eccentricity which aggravates the curvature of a column (Fig. 89c or 90a). By a positive end restraint we mean one which reduces the effective length of a column. Thus a positive eccentricity is identical with a negative end restraint. Figures

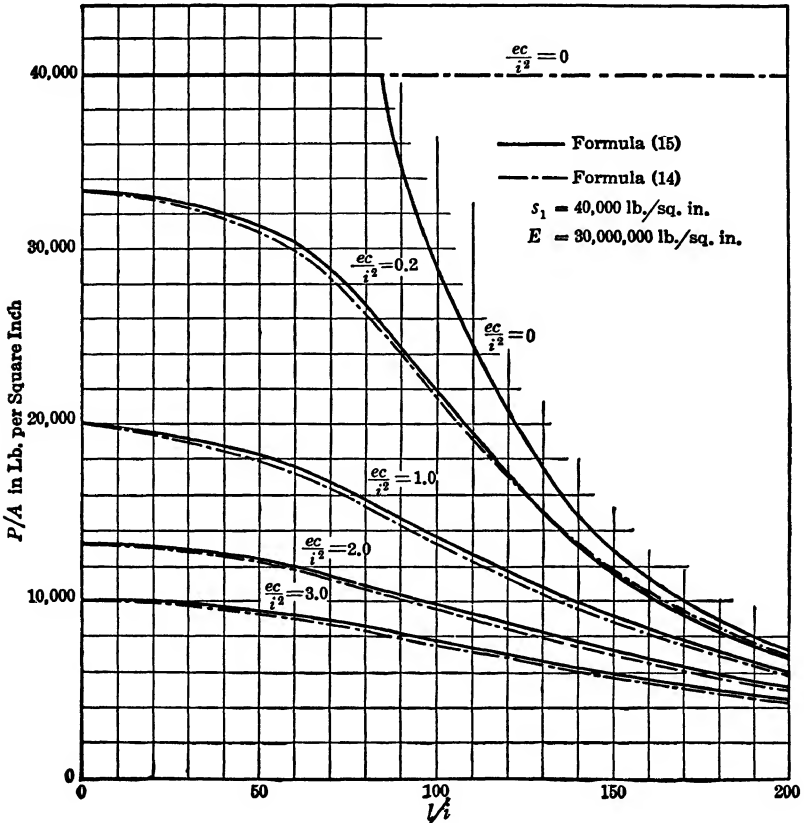

Fig. 91. Comparison between Approximate Eccentric Loading Formula (15) with Exact, Secant Formula (14).

82b and 82c represent two free-body sketches identical in meaning. We may speak of Fig. 82b as a column subject to a positive end restraint, while the same column, as shown in Fig. 82c, may be referred to as a column with a negative eccentricity.

Figure 92a represents one end of a column loaded through a pin, and Fig. 92b represents one end of a column having rounded ends. As the column deflects, the point of contact between load and column shifts in both columns. In both columns, provided that the pin is frictionless, the load passes through the center of curvature of either the pin or the

rounded end. The length  $l$  of these columns therefore should be measured between these centers of curvature at each end.

Figure 92*b* comes nearest to representing what we call the ideal pin-ended column. (A frictionless pin is inconceivable.) As a column is loaded as shown in Fig. 92*a*, friction will be induced as soon as the column starts bending. At the instant of failure, then, the column

would be loaded not concentrically but with a somewhat positive end restraint or, which is the same thing, with a somewhat negative eccentricity.

The only way, as the author conceives it, in which a column may be loaded so as to give a predetermined eccentricity at the instant of failure is that suggested by Fig. 92*c*. Here a string runs over an arc of a circle, and as the column bends the eccentricity remains constant and equal to the radius of this arc. The length of this column is to be measured from center to center of these arcs of the circles at each end of the column. The author has never heard of or seen any eccentric loading tests performed in this manner. All column tests he knows of involve variable loading conditions, due to change in value of eccentricity or to friction which is introduced as the loading progresses.

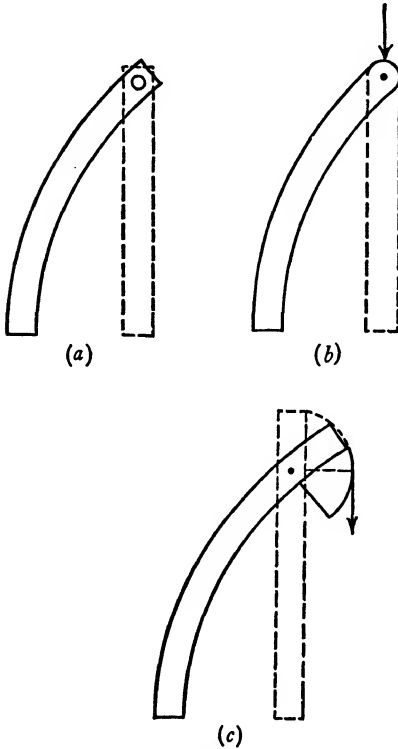

FIG. 92.

If it is difficult in laboratory tests to predetermine the amount of eccentricity that exists at the instant the column fails, it is equally difficult to determine this eccentricity with any degree of exactness in a column which functions as part of a complicated structure. Yet we are able to form a fairly clear picture of what eccentricity means in engineering construction.

#### EXAMPLE 44

Figure 93 represents a column  $AC$  fully restrained at both ends. If loaded the column bends to the left; this is evidence that there must have been an initial slight crookedness to the left, or an initial positive

eccentricity to the right. As the bending progresses and the restraints at the ends make themselves felt, the restraints become positive and the eccentricity passes through zero and becomes negative. One of the major theorems of the theory of static equilibrium says that a force  $P$  and a couple  $M$  may be represented by a single force equal and parallel to  $P$ , acting with an eccentricity  $e = \frac{M}{P}$ . Thus the loadings of the column,

shown differently for each end of the column (Fig. 93), nevertheless mean the same thing. As the loading increases both  $P$  and  $M$  increase but, since the principle of superposition is inapplicable, they do not increase at the same rate.

The conditions pictured at the top of the column (Fig. 93) give a fair representation of what takes place. As the loading increases the resultants of the moment  $M$  and the force  $P$  always pass through the points of inflection. That is, the application of each resultant assumes different positions as indicated by the arrows, 1, 2, 3, and 4 (Fig. 93). The eccentricity of the load is negative, that is, favorable, and changes progressively from 0 through  $e_2$  to  $e_3$ , and finally to  $e_4$ , which represents the maximum eccentricity. This maximum eccentricity, corresponding to the elastic limit stress being reached in the column, may be found as follows:

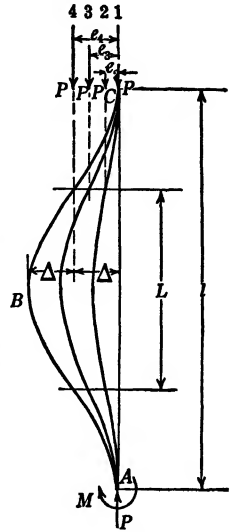

FIG. 93.

$$s_1 = \frac{P}{A} + \frac{Pec}{I} = \frac{P}{A} + \frac{Pec}{At^2}.$$

Therefore

$$\frac{ec}{i^2} = \frac{s_1 A}{P} - 1 = \frac{s_1 (L/i)^2}{\pi^2 E} - 1. \tag{o}$$

The fact that, in this example, we finally succeeded in evaluating the critical  $e$  at the instant of failure is small satisfaction. This critical  $e$  is a function of  $L^2$ , the length of a full arch of a sine curve corresponding to the distance between points of contraflexure. It is not, generally, the function of  $l$  which is the geometric length of the column and is the only initial datum as to length of columns that we have. We were able to determine  $e$  only after all other unknowns about the column were known.



## EXAMPLE 45

Figure 94 represents a 24 W.F. 74 beam 32 ft. 0 in. long freely supported at its ends, and supported at its midpoint on a 12 W.F. 25 column 16 ft. 0 in. long. This column, in turn, is supported on another 24 W.F. 74 beam, equal in length and similarly supported. Suppose, for the sake

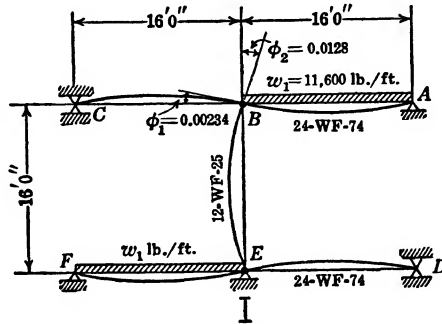

FIG. 94.

of argument, that the beams are continuous, but that the column is pinned. The limit load for the column is

$$\frac{\pi^2 EI}{l^2} = \frac{9.87 \times 30,000,000 \times 14.5}{16^2 \times 12^2} = 116,000 \text{ lb.}$$

Its  $\frac{l}{i}$  ratio is  $\frac{16 \times 12}{1.4} = 137$ . Suppose that both beams are loaded over only one span with a load  $w_1$  pounds per foot. The center reaction of this beam is  $\frac{5}{8}w_1l$ . In order that the limit strength of the column may be developed,  $\frac{5}{8}w_1l$  should be 116,000 lb., or  $w_1 = 11,600$  lb. per ft. The maximum moment in the beam is  $\frac{49w_1l^2}{512}$ . Thus the maximum bending stress in the beam would be

$$s = \frac{Mc}{I} = \frac{49}{512} \frac{11,600 \times 16^2 \times 12}{170.4} = 20,000 \text{ lb. per sq. in.}$$

The rotation of the tangent to the elastic curve of the beam at the midpoint, point B, is:

$$\phi_1 = \frac{wl^3 \times 12^2}{48EI} = \frac{11,600 \times 16^3 \times 12^2}{48 \times 30,000,000 \times 2034} = 0.00234 \text{ radian.}$$

The curvature and the deflection of the tangent to the elastic curve at

the top of the column, point  $B$ , is indeterminate, except that the limiting safe deflection is restricted by the elastic limit stress  $s_1$ .

From equation (k), page 247, we have

$$\Delta = \frac{L^2}{\pi^2 Ec} \left( s_1 - \frac{P}{A} \right).$$

From equation (i), page 246, we have

$$\frac{dx}{dy} = \frac{\Delta\pi}{L} \cos \frac{\pi y}{L}.$$

Thus the limiting angular displacement of the tangent to the elastic curve of the column at its end is

$$\phi = - \frac{\Delta\pi}{L} \cos \frac{\pi L}{L} = + \frac{\Delta\pi}{L}.$$

Eliminating  $\Delta$  between these two equations we obtain

$$\phi = \frac{[s_1 - (P/A)]L}{\pi Ec}. \quad \text{Formula (16)}$$

The letter  $L$  in formula (16) represents the complete arch of a sine curve, which in this instance is equal to the geometric length  $l$  of the column. Thus

$$\phi_2 = \frac{[36,000 - (116,000/7.39)] \times 192}{3.14 \times 30,000,000 \times 3.25} = 0.0128 \text{ radian.}$$

It appears that the rotation of the tangent to the hinged column at point  $B$ , at the time the elastic limit stress in the column is reached, is more than five times as great as the rotation of the tangent to the elastic curve of the beams at the same point. Therefore, if the column were rigidly connected to the beams, the rotation of the top of the column would be resisted by the beams; in other words, the column would be partially restrained.

If we visualize what takes place when the column is rigidly connected to the beams and the beams are loaded over only one span, we conclude that, under an initial small load, the beam, in addition to its reaction, transmits to the column a positive moment or a load with a positive eccentricity. As the load is gradually increased, the reaction on the column increases substantially in direct proportion to the load. The moment transmitted from the beam to the column, however, decreases, passes through zero, and changes sign. This means that the column is initially loaded with a positive eccentricity. During an intermediate

loading the eccentricity becomes zero, after which it becomes negative. At the time of critical loading, which is the only condition of loading we are interested in, it has become quite pronouncedly negative and the column is now partially restrained.

## EXAMPLE 46

Consider a 24 W.F. 74 simple beam supported by a 12 W.F. 25 hinged column, which in turn is supported on the free end of another simple beam like the first one (Fig. 95). The limit load for the column is

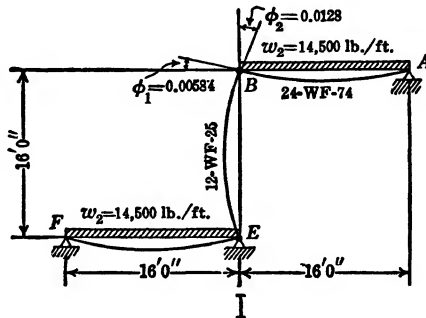

FIG. 95.

116,000 lb. To reach this limit load the beam must be loaded with  $w_2 = 14,500$  lb. per ft. The stress in the beam under this load is

$$s = \frac{Mc}{I} = \frac{wl^2 \times 12c}{8I} = \frac{14,500 \times 16^2 \times 12}{8 \times 170.4} = 32,800 \text{ lb. per sq. in.}$$

The deflection  $\phi_1$  of the tangent to the elastic curve of the simple beam at point B is

$$\phi_1 = \frac{wl^3 \times 12^2}{24EI} = \frac{14,500 \times 16^3 \times 12^2}{24 \times 30,000,000 \times 2034} = 0.00584 \text{ radian.}$$

This is only 45 per cent of the angular deflection  $\phi_2$  of the tangent to the elastic curve at the top of the column, a deflection which obtains when the column curvature is sufficiently acute to cause the stress due to curvature and to direct loading  $\frac{P}{A}$  to reach the value of the elastic limit stress. It

follows from this that the column would be partially restrained if it were rigidly connected to the beam, no matter how unfavorable an eccentricity might prevail under small-load conditions.

On the basis of the foregoing discussion we are able to draw some pertinent conclusions.

1. *The effect on columns of eccentricity or of partial restraint is identical.*

Partial restraint may be positive ( $n = \frac{L}{l} < 1$ , Fig. 93), or negative ( $n = \frac{L}{l} > 1$ , Fig. 89). The proof of this statement is given on page 245.

This proof involves only one simple equilibrium consideration. The validity of this proof, however, is not to be questioned because of its inherent simplicity. On the contrary, equilibrium considerations take precedence over elasticity or any other considerations. If eccentricity and partial restraint are identities, then we are privileged to confine our attention to one and exclude the other without in any way doing violence to the soundness of our logic. We have seen in example 44 (Fig. 93) how elusive is the eccentricity  $e$ , while the term  $n = \frac{L}{l} = \frac{1}{2}$  is constant for all stages of loading, including the critical loading. Furthermore, equation (o), page 253, shows that eccentricity  $e$  at the instant of collapse is a function of  $L^2$ . Thus, for two columns loaded in the manner shown in Fig. 93, identical in all their properties except that one is longer than the other, the eccentricity prevailing at the instant of collapse would be much the larger in the longer column. In both the  $\frac{L}{l}$  ratio or the constant  $n$  would be the same.

In examples 45 and 46 we have seen that, no matter how great it may be initially, the eccentricity becomes negative, that is favorable, before the condition of collapse is reached. This statement applies only to relatively long columns.

2. *As in aeronautical engineering, where a sharp distinction is made between velocities of a magnitude greater than the velocity of sound and those velocities smaller than that of sound, so in column analysis we make a sharp distinction between columns with an  $\frac{l}{i}$  ratio greater than critical and those with an  $\frac{l}{i}$  ratio smaller than critical.*

As may be seen from formula (16),  $\phi = \frac{[s_1 - (P/A)]L}{\pi Ec}$ , and  $\phi$  becomes zero for  $s_1 = \frac{P}{A}$ .

The critical  $\frac{l}{i}$  for the column specified in examples 45 and 46 is 90.8.

Therefore, since  $i$  for this column is 1.40, its critical length is 10 ft. 7 in. Had we specified a column length of 10 ft. 7 in. or less, in examples 45 and 46, then the deflection  $\phi_2$  (Figs. 94 and 95) would have been zero for the pin-ended column. Therefore such columns, if rigidly connected to the beam, would suffer a negative end restraint, positive eccentricity, or a ratio  $\frac{L}{l} = n > 1$ . The conclusion that columns eccentrically loaded are a special case of concentrically loaded columns is equally as valid for short as for long columns. (For a more detailed discussion of eccentrically loaded or partially restrained short columns, see footnote, page 245.)

*3. Eccentricity, end moments, partial restraint, and uniformly distributed transverse loads are subject to evaluation in one general formula.*

End moments, or eccentricities, derived by means of end-moment distribution methods or by other elasticity theories (when such arguments are predicated on the assumption that the principle of superposition applies), are meaningless, because they ignore the essential characteristics of column action. End moments, or eccentricities, may be most effectively incorporated in column analysis as partial restraints, or  $\frac{L}{l}$  ratio. In slightly modified form, then, formula (11) would incorporate both the transverse loading and the partial restraint effect, which partial restraint is another way of including either end moments or eccentricity. This formula appears as follows:

$$\frac{P}{A} = \frac{1}{2} \left[ s_1 + \frac{\pi^2 E}{(nl/i)^2} - \sqrt{\left\{ s_1 - \frac{\pi^2 E}{(nl/i)^2} \right\}^2 + 5.0734kuEc} \right].$$

Formula (17) \*

The minimum value for  $n$ , or  $\frac{L}{l}$ , is 0.5. For columns of a slenderness ratio  $\frac{l}{i}$ , 10 per cent or more above the critical value, the value for  $n$  is

\* If the distance from the neutral axis to the extreme fiber on the tension side of the column is called  $c_1$ , the distance to the compression side is called  $c$ ; furthermore, if  $c_1$  is materially greater than  $c$ , then the elastic limit stress in tension may be the determining factor in the strength of columns. (For example, consider the channel in problem 54 to be turned upside down.) In this case the formula for limit strength of the column will be

$$\frac{P}{A} = \frac{1}{2} \left[ \frac{\pi^2 E}{(nl/i)^2} - s_1 \pm \sqrt{\left\{ \frac{\pi^2 E}{(nl/i)^2} + s_1 \right\}^2 - 5.0734kuEc} \right].$$

Formula (17a)

$0.5 < n < 1$ . For columns of a slenderness ratio equal to or less than critical the value of  $n$  is greater than unity. When  $n = 1$  and  $k = 0$ , formula (17) reduces to a particular version of Euler's formula, which gives the value of  $\frac{P}{A} = s_1$  for all values of  $\frac{l}{i}$  smaller than critical.

Formula (17) is restricted to columns made of elastic material, of constant  $E$  and  $I$ , with at least one axis of symmetry, and loaded with a uniformly distributed transverse load  $kuA$  coincident with this axis of symmetry.

#### EXAMPLE 47

Consider a W.F. 25 column, 16 ft. 0 in. long and loaded with a load  $Q$  having an eccentricity of  $\frac{1}{8}$  in., offset from the axis of minor moment of inertia. If the loading is applied in the manner of Fig. 89c, the eccentricity will remain constant throughout the entire load range from zero load to limit load, and a modified form of formula (14) applies. This modified form of formula (14) reads

$$s = \frac{Q}{A} \left( 1 + \frac{ec}{i^2} \sec \frac{l}{2} \sqrt{\frac{Q}{EI}} \right).$$

In its original form  $s_1$  represented elastic limit stress and  $P$  represented buckling load. The formula is equally valid as written here with  $s$  representing any stress less than the elastic limit stress and  $Q$  representing any load short of the buckling load. We assume the elastic limit of the column to be 90,000 lb. per sq. in. The constants for this column are as follows:

$$A = 7.39; \quad e = \frac{1}{8}; \quad c = 3.25; \quad i = 1.40; \quad E = 30 \times 10^6; \quad I = 14.5;$$

$$l = 192; \quad \text{and} \quad \frac{ec}{i^2} = 0.207.$$

When  $Q = 100,000$  lb., then

$$s = \frac{100,000}{7.39} \left( 1 + 0.207 \sec 96 \sqrt{\frac{100,000}{30 \times 10^6 \times 14.5}} \right).$$

$$96 \sqrt{\frac{100,000}{30 \times 10^6 \times 14.5}} = 1.4555 \text{ radians.}$$

$$\sec 1.4555 = \frac{1}{0.1150}.$$

Therefore

$$s = \frac{100,000}{7.39} \left( 1 + \frac{0.207}{0.115} \right) = 37,900 \text{ lb. per sq. in.}$$

When  $Q = 110,000$  lb., then

$$\begin{aligned} s &= \frac{110,000}{7.39} \left( 1 + 0.207 \sec 96 \sqrt{\frac{110,000}{30 \times 10^6 \times 14.5}} \right) \\ &= 14,880 \left( 1 + \frac{0.207}{0.0442} \right) = 84,600 \text{ lb. per sq. in.} \end{aligned}$$

Thus, an increase of 10 per cent in the value of the load  $Q$  results in an increase of more than 100 per cent in the value of the maximum stress.

## CHAPTER XIV

### ESTIMATE OF ELASTIC ENERGY THEORY

Throughout this book we have applied one argument and one philosophy to the analysis of stresses in a large variety of problems. We have introduced an auxiliary force. We have given expression to the elastic energy which is stored in structures because this auxiliary force is acting while the actual loading is being applied, and, on the basis of the law of conservation of energy, we have equated this energy to the work done by the auxiliary force. Whenever this auxiliary force is an external force, its work done is  $F\Delta$ ; when it is an internal force, it occurs in pairs equal and opposite, and its work done is zero.

It remains for us to consider where this theory of elastic energy belongs in the general scheme of things. How does it compare with other theories? What are its outstanding merits or demerits? What are its possibilities and its limitations?

To avoid possible misunderstanding let us begin by defining a few commonplace terms:

- Theory:* (a) The logical correlation of facts.  
(b) The philosophical explanation of phenomena.
- Philosophy:* (a) The science of effects and their causes.  
(b) The knowledge of phenomena as explained by and resolved into laws.
- Science:* Ordered knowledge of the phenomena of nature.

#### ADVANTAGES OF THE ELASTIC ENERGY THEORY

The science of strength of materials as conventionally treated, or, to be more exact, all the treatises on strength of materials which have come to the author's attention, are predicated upon the assumption of the elastic behavior of material. They depart from the assumption of elasticity only in the theory of rivets, but there it is merely assumed that the stresses are uniformly distributed over the rivets. The most important part of the rivet theory, namely, that part which is meant to justify the assumption of uniform distribution of loads over all the rivets, is not, to the author's knowledge, discussed in treatises on strength of materials.



With reference to the analysis of redundant structures a large number of theories appear to be available. We mention only a few: theory of the elastic curve, theory of elastic energy, theory of least work, elastic weights, area moments, conjugate beams, slope deflection theory, kinetic theory of structures.

As a matter of fact, within the assumption of elastic behavior of material and the law of superposition but two theories are available, the theory of the elastic curve and the theory of elastic energy. All other so-called theories are the personal methods of their proponents, all of which may be developed from the theory of elastic energy, some of them from the theory of the elastic curve.

When simple redundant structures were first analyzed, it was natural that the differential equation of the elastic curve,  $\frac{d^2y}{dx^2} = \frac{1}{R} = \frac{M}{EI}$ , should be applied. The equation of the elastic curve is the basis of the analysis of redundant structures in practically all English and American textbooks on strength of materials. It still dominates to such an extent that structures which cannot be analyzed by the theory of the elastic curve are conveniently omitted. The theory of the elastic curve will serve our purpose well enough as long as we deal with relatively simple structures. In connection with bents and Vierendeel trusses it becomes very involved, especially as regards the plus and minus signs. In connection with trusses, or resilience, it fails us altogether.

The theory of elastic energy is the only alternative to the theory of the elastic curve. It is predicated, within the limiting condition of elastic behavior, upon the principle of conservation of energy. That fact has not always been stressed nor always made clear. One reason for this is that the theory of elastic energy antedates the general acceptance of the law of conservation of energy. Old treatises on the subject now appear to us involved and clothed in a more or less obscure terminology. Frequently the theory of elastic energy is regarded as synonymous with Castigliano's principle of least work. We have attempted to show in this book that the principle of least work, although true enough, constitutes only a part of the theory of elastic energy; that it appears to be essentially a mathematical abstraction in which it is difficult to recognize any physical law. Furthermore, the bibliography on the subject very often makes use of such terms as "virtual velocity," "kinetic theory of structures," terms which, fortunately, are not generally found in American engineering literature.

De la Grange, in his *Mécanique analytique*, 1788, page 11, says of virtual velocity: "Et en général je crois pouvoir avancer que tous les

principes généraux qu'on pourroit peut-être encore découvrir dans la science de l'équilibre, ne seront que le même principe des vitesses virtuelles, envisagé différemment, et dont ils ne différeront que dans l'expression." ("And in general I think I am able to maintain that all general principles which might conceivably yet be discovered in the science of equilibrium will be nothing more than this same principle of virtual velocities differently expressed, and from which they will not differ except in the mode of expression.")

With due feeling of admiration and indebtedness to pioneers in mechanics of a different age, it would seem justifiable in the present years to differ with certain conclusions made by De la Grange in 1788. The validity of De la Grange's statement is not here contested, but the advisability of continuing a terminology which would call displacement "velocities," and imaginary displacements "virtual velocities" is, however, seriously questioned.

In all fairness it should be recorded that some of the author's professional associates take sharp exception to his conclusions. On the other hand, he quotes the great authority, August Föppl, who in Vol. 1, page 74, of his classic six volume series, *Vorlesungen über die technische Mechanik*, says: "Dieser Satz wird ein Prinzip, auch ein grundlegender Satz genannt, obschon er bei unserer Darstellung nur eine einfache mathematische Folgerung aus dem Satze vom Kräfteparallelogramme bildet." ("This proposition is called a principle, a fundamental law, although on the basis of our statement it appears nothing more than an inference of the parallelogram law of forces.") Where Föppl argues that the principle of virtual velocities may well be dispensed with, we have gone a step farther and have effectively dispensed with it, without in any way detracting from the validity of our arguments.

It is frequently argued that the theory of elastic energy, although universally applicable, is undesirable because it is in such a large measure a mathematical abstraction and difficult to sense physically. We feel that this is true only when it is considered as synonymous with Castigliano's theory of least work. We have presented this theory of conservation of energy in terms of elastic energy stored in a structure because an auxiliary force is acting while the actual loading is being applied, in terms of  $m$  bending-moment diagrams which may be represented by dotted lines and  $M$  bending-moment diagrams which may be represented by solid lines. For this reason we believe that the theory may be more readily interpreted in physical terms than the theory of the elastic curve. The author confidently makes this statement after many years' experience in analyzing statically indeterminate structures with the aid of the theory of the elastic curve only.

We thus reach the conclusion that the theory of elastic energy, within the assumption of elasticity and the principle of superposition, is universally applicable. The same philosophy may be applied with equal success to trusses, straight beams, bents, and curved beams. As regards problems in resilience or problems involving redundant trusses, it reigns supreme. It thus serves to analyze all problems that may be analyzed by means of the theory of the elastic curve. It will generally do so much more effectively, even in cases where the elastic curve itself is to be obtained (see pages 49 and 215). Furthermore, by means of it we may analyze problems that cannot be analyzed by the theory of the elastic curve.

#### LIMITATIONS OF THE ELASTIC ENERGY THEORY

If the definition on page 261 is accepted, a true theory must take into account all facts relating to the particular problem at hand. A mathematical theory employs mathematical symbolism and mathematical logic. All this may sound commonplace, and it would not be mentioned here if it were not that the term "theory" is so frequently misused. A treatise that makes use of complicated mathematical symbolism is often regarded as very theoretical. The more mathematical, the more theoretical, seems to be the common interpretation. The use of the word "theoretical" as synonymous with "mathematical" is responsible for the common observation that theory and practice often conflict. Such a statement, on the face of it, would appear an absurdity. To be sure, alleged theories, utterly useless mathematical jugglings which gain recognition as theories, do often conflict with practice. As a general thing, however, any true conflict between an alleged theory and practice may be taken as *prima facie* evidence that the theory is unsound.

Few things are more inspiring than the marvelous accuracy with which the astronomer predicts an eclipse of the sun or discovers a planet. The mathematical logic which makes such predictions or discoveries possible commands our admiration. We must not, however, overlook the circumstance that all the factors entering into the astronomer's computations are known. Otherwise his mathematical deductions would be in error.

In the science of strength of materials we may but rarely expect results with a degree of accuracy comparable with that obtained by the astronomer. The author would say that the assumptions underlying a theory constitute 90 per cent of that theory. Assumptions may be grouped in two classes:

1. Assumptions dictated by the physically limiting conditions of the problem to be analyzed.

2. Assumptions dictated by the limited capacity of the human mind.

A few examples will serve to illustrate different analyses based upon the two different kinds of assumptions.

A steel frame for a high office building constitutes a highly redundant structure. What is known as "exact" analysis of stresses induced by wind loading on skyscrapers is more or less recognized by the structural engineering profession and, if not directly advocated, is alluded to as the ideal toward which we should strive, in specific cases being reluctantly abandoned only because of the insurmountable difficulties it presents. The author takes sharp issue with these conclusions. Writers on engineering science lend themselves to the perpetuation of many ambiguous terms, such as "equivalent loads" for bending-moment areas, "elastic weight" for  $\frac{ds}{I}$ , and "virtual velocities" for imaginary displacements.

But the qualification "exact" as applied to the analysis of wind stresses in a skyscraper and predicated upon the theory of elasticity and other assumptions that ordinarily are made is the most misleading and unfortunate ambiguity of all. Not only can such a theory not be called "exact," but we should not even call it a theory at all.

The assumptions underlying the "exact" method of analysis of wind stresses in skyscrapers are:

1. Material is elastic.
2. Structure is continuous.
3. Principle of superposition applies.
4. Dimensions may be taken to center line of members.
5. Gusset plates and bracing may be ignored.
6. The effect of shear may be ignored.
7. The effect of direct stress due to wind loading may be ignored.
8. The bracing effects of walls may be ignored.
9. Conditions of equilibrium apply.  $\Sigma F_x = 0$ ;  $\Sigma F_y = 0$ ;  $\Sigma M = 0$ .

Let us look more closely at some of these assumptions.

It is first assumed that material is elastic. Suppose that a structural engineer in charge of construction of a skyscraper is offered a very high-grade cast iron which obeys Hooke's law perfectly and which may have an elastic limit as high as 200,000 lb. per sq. in., but which is totally lacking in ductility. Can there be serious doubt as to what his answer would be? Every specification relating to skyscraper construction emphatically insists on a certain amount of ductility in the material of which the frame

is to be built. Yet by this first assumption we close our theory against this very important factor of ductility. By our definition this "exact" theory is limited to the extent determined by the exclusion of this one very important factor.

Again we assume that the structure is continuous. A building composed of thousands of pieces is assumed to act as a homogeneous and continuous structure! To be sure, it is difficult to allow, by any definite criterion, for the degree of discontinuity at the connections. However, to assume there is continuity only because we cannot estimate the degree of discontinuity would seem to be rather loose reasoning.

Assumptions 4 and 5 are the star assumptions. We propose to design for gusset plates and begin by assuming that they do not exist at all! Of course, we must, as previously defined, frequently make assumptions dictated by the limited capacity of the human mind, but we should not lose sight of the fact that any such assumption detracts from the validity of our theory. In the author's opinion the "exact" analysis of wind stresses, on the basis of the theory of elasticity and the assumptions that are usually associated with it, is completely invalidated by any one of the first five assumptions we have listed. The so-called "exact" method is saved from the discard only by the fact that the theory of elasticity is not an independent theory, but one that supplements the theory of equilibrium. As long as the material is ductile and the conditions of equilibrium (assumption 9) are applied, the "exact" method of analysis of wind stresses in skyscrapers fails to make a valid contribution. It merely befogs the issue. It does not, however, make the conclusions invalid.

In example 24, page 88, we analyzed the stresses in a Vierendeel truss. We ignored possible brackets, fillets, or gusset plates, in the corners. Furthermore, we ignored the thickness of members and measured the dimensions to center lines of the members. That analysis is included in this book because some reader may look for it in the index and because it is a more or less standard analysis.

A well-trained engineer should know the analysis of the Vierendeel truss. How often or to what extent he should apply such analysis is another question. Applying to the skyscraper frame the same reasoning as that presented in the analysis of the Vierendeel truss, one may, without great difficulty, set up hundreds of simultaneous equations. In a one-hour talk before his colleagues in the University of Michigan, the author accounted for the sixty simultaneous equations necessary for the solution of wind stresses in a ten-story, four-bent office building. He accounted for them, but did not solve them. He did not solve them for two reasons: first, because he does not possess the endurance to solve

sixty simultaneous equations; second, he is satisfied in advance that the result of the hypothetically "correct" solution is utterly valueless.

These remarks are not primarily directed against the validity of the elastic energy theory. Rather are they directed against the present conventional status of the science of strength of materials. If the author did not value the theory of elasticity in general and the theory of elastic energy in particular, he would not have written this treatise. The theory of elastic energy is exceedingly valuable, but it is restricted by all the limitations that circumscribe the theory of elasticity. As long as the theory of elasticity is to be used, the elastic energy theory is at once the simplest, the most comprehensive, and the easiest to apply. If one insists on making the nine assumptions enumerated above in the analysis of wind stresses, the method given in the solution of example 24 covers the ground adequately. In the author's opinion the theory of strength of materials is notoriously backward in recognizing the limitations of the theory of elasticity. Practice in designing offices is several laps ahead of textbooks on strength of materials.

When, in 1917, Mr. N. C. Kist was appointed to the chair of "Constructions in Iron and Steel" at the Technical University of Delft, Holland, one of the leading technical schools of Europe, he chose for his inaugural address the following topic: "Does a Stress Analysis, Which Assumes Elastic Behavior of Material, Lead to Economical Construction of Bridges and Buildings?" Kist's conclusions were that, so far as bridges are concerned, it does not. In this conclusion the author concurs.\*

Although the theory of elastic energy is shown to be deficient in the analysis of wind stresses in skyscrapers, it applies with a very high degree of exactness in the analysis of hairsprings in watches. In the analysis of rings loaded by their own weight and subject to hydrostatic pressure (examples 29 and 30) the theory may be some 20 per cent in error. The cause for this error lies in the assumption that the principle of superposition applies, whereas, as a matter of fact, flexible rings will materially deform before the elastic limit stress is reached. Yet the rings must be flexible, if the simple theory of bending stresses is to apply to curved beams. This same theory, however, as used in the analysis of a cylindrical shell suspended in a liquid without concentrated loading applies with a very high degree of exactness. This is true because the result shows a zero bending moment. This, in turn, gives us zero

\* See "Theory of Limit Design" by J. A. Van den Broek, *Transactions, Am. Soc. C.E.*, Vol. 105 (1940), page 638.

See also "Theory of Limit Design" by J. A. Van den Broek, *Journal of the Western Society of Engineers*, Vol. 44, No. 5, October, 1939, page 245.

changes from the original assumed shape, and thus we have agreement with the assumptions upon which the theory is based. The fact that a theory of stress analysis is correct during the initial stages of load application is of limited value in the theory of strength. To be entirely satisfactory, the theory must hold good for stress values nearly as great as the elastic limit stress.

# APPENDIX I

## BENDING-MOMENT AREAS AND THEIR PROPERTIES

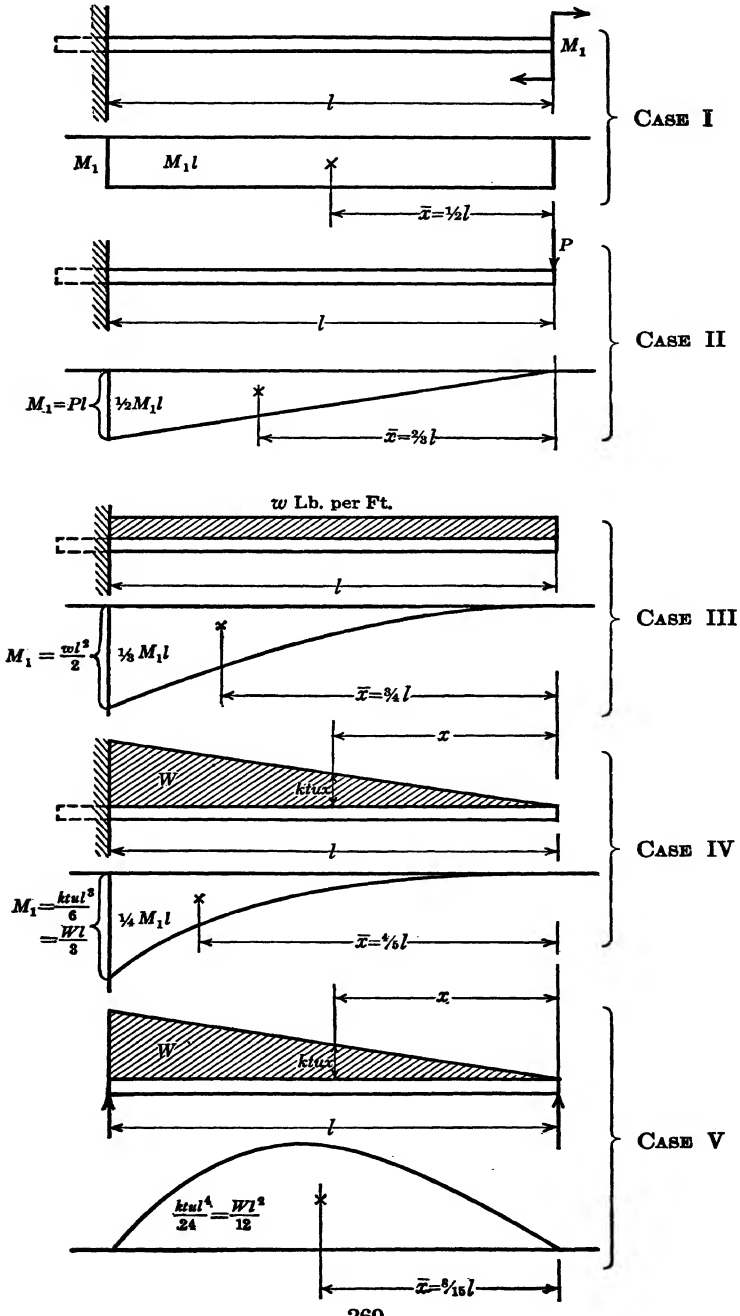



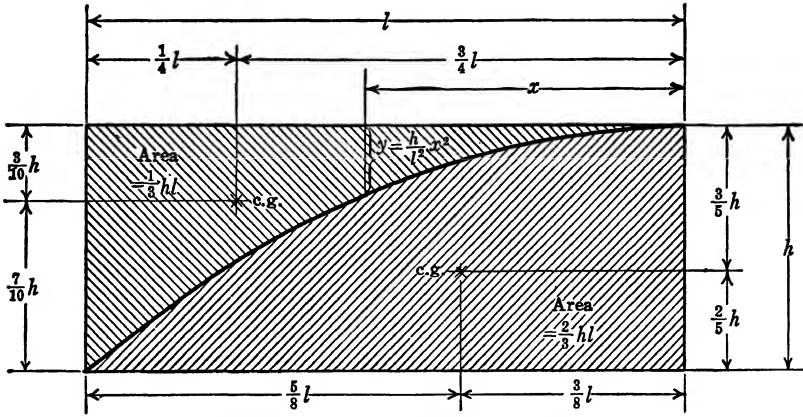

Parabolic Areas and Their Properties.

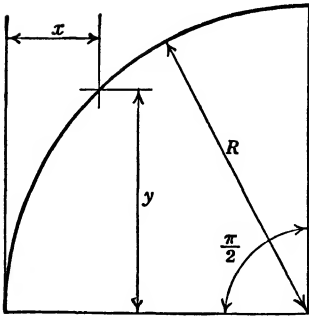

Circular Arc and Its Properties.

$$\int_0^{\pi/2} x ds = \frac{R^2}{2} (\pi - 2) = 0.5708R^2,$$

$$\int_0^{\pi/2} y ds = R^2,$$

$$\int_0^{\pi/2} x^2 ds = \frac{R^3}{4} (3\pi - 8) = 0.3562R^3,$$

$$\int_0^{\pi/2} y^2 ds = \frac{\pi}{4} R^3 = 0.7854R^3,$$

$$\int_0^{\pi/2} xy ds = 0.5 R^3,$$

$$\int_0^{\pi/2} yx^2 ds = 0.3333R^4,$$

$$\int_0^{\pi/2} xy^2 ds = \frac{R^4}{12} (3\pi - 4) = 0.4521R^4,$$

$$\int_0^{\pi/2} y^3 ds = 0.6667R^4,$$

$$\int_0^{\pi/2} x^3 ds = \frac{R^4}{12} (15\pi - 44) = 0.2603R^4.$$

## APPENDIX II

### LONGITUDINAL SHEAR STRESSES IN CIRCULAR PIPES

Figure *a* represents a hollow circular beam with a relatively thin wall, in which  $t$  represents thickness of wall,  $z_1$  inner radius, and  $z_2$  outer radius ( $z_2 - z_1 = t$ ). We assume that the formula  $s = \frac{Mc}{I}$ , and the assumptions upon which this formula is predicated, are applicable. The bending stresses will vary linearly and appear as shown in Fig. *c*. If we consider an element of the beam

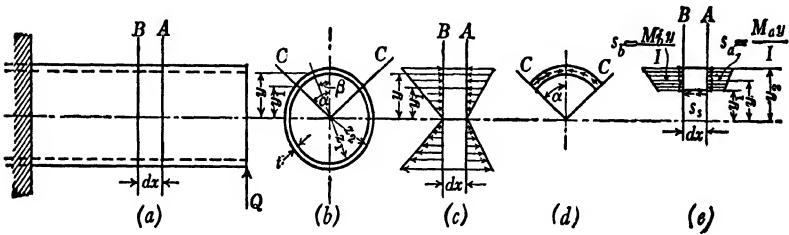

bounded by the planes *A*, *B*, and *C* as shown in Figs. *d* and *e* (planes *C* are defined by the angle  $\alpha$  measured from the vertical diameter), then the bending stresses on this element will appear as shown in Fig. *e*. The total normal force on plane *B* (Fig. *e*) is

$$F_b = \int_{y_1}^{y_2} \frac{M_b y da}{I}.$$

The corresponding force on plane *A* is

$$F_a = \int_{y_1}^{y_2} \frac{M_a y da}{I}.$$

The difference between these two forces must equal the sum of the shearing forces,  $F_c$ , acting on the planes *C*. Thus:

$$2F_c = \int_{y_1}^{y_2} \frac{(M_a - M_b)y da}{I} = \int_{y_1}^{y_2} \frac{M_b y da}{I} - \int_{y_1}^{y_2} \frac{M_a y da}{I} \quad (a)$$

In the foregoing equation the force  $F_c$  is multiplied by the factor 2 because it is bounded by the two planes *C*, each an angle  $\alpha$  removed from the vertical diameter.

A question arises about the direction and distribution of the shear stresses,  $s_s$ , that are involved in the building up of the shearing force  $F_c$ .

From the well-known principle that shearing stresses always occur in pairs, at right angles to each other, it follows that at the boundaries  $z_1$  and  $z_2$  the shear stresses can have no components normal to these boundaries and must therefore be acting in a direction normal to the radius (Fig. *d*). If  $z_2 - z_1$ , or  $t$ , though relatively small, is large enough to prevent secondary failure by buckling, we may assume the shear stress  $s_s$  to be uniformly distributed over the area cut by plane *C* and bounded by planes *A* and *B*. Thus

$$F_c = s_s t dx.$$

Therefore, from equation (a)

$$2s_s t dx = \int_{y_1}^{y_2} \frac{dM}{I} y da = 2 \int_0^\alpha \frac{dM}{I} z \cos \beta z t d\beta. \quad (b)$$

Therefore

$$s_s = \frac{V}{tI} z^2 t \sin \alpha. \quad (c)$$

Here  $z$  represents average radius;  $z d\beta = da$ , and  $\frac{dM}{dx} = V$ . Since, for small values of  $t$ ,  $I$  may be written  $\pi z^3 t$ ,

$$s_s = \frac{V \sin \alpha}{\pi z t}. \quad (d)$$

As previously argued, the shear stresses, on the longitudinal plane *C* and on the transverse plane *A* at the intersection of planes *A* and *C*, are equal in intensity. Therefore equation (d) which gives the value of the longitudinal shear stress on plane *C* also gives the value of the tangential shear stress on plane *A*.

## PROBLEMS

### ELASTIC DEFORMATIONS OF FRAMES

1. In the frame shown:

Bar  $a$  is 2 sq. in., cross-sectional area.

Bar  $b$  is 4 sq. in., cross-sectional area.

The modulus of elasticity  $E$  is 30,000,000 lb. per sq. in., or 15,000 tons per sq. in.

Find the displacement of point  $B$ .

*Ans.*  $\Delta_y = 0.048$  in.  
 $\Delta_x = 0.00925$  in.

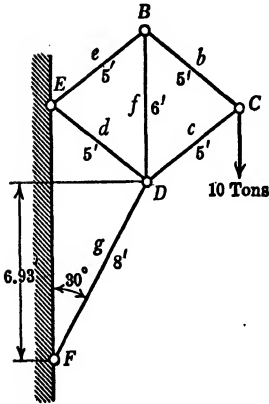
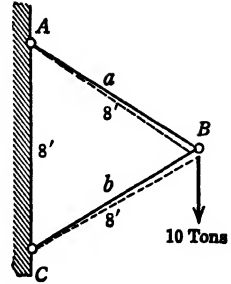

2. In the frame shown:

Bars  $b$ ,  $d$ , and  $e$  are 2 sq. in. each, cross-sectional area.

Bars  $c$ ,  $f$ , and  $g$  are 5 sq. in. each, cross-sectional area.

The modulus of elasticity  $E$  for all bars is 30,000,000 lb. per sq. in., or 15,000 tons per sq. in.

(a) Find the displacement of point  $C$ .

*Ans.*  $\Delta_x = 0.0261$  in.  
 $\Delta_y = 0.0768$  in.

(b) Find the displacement of point  $D$ .

*Ans.*  $\Delta_x = 0.0094$  in. to the left.  
 $\Delta_y = 0.0184$  in. downward.

3. In the truss shown:

The cross-sectional area of each bar is 2 sq. in.  $E$  is 30,000,000 lb. per sq. in., or 15,000 tons per sq. in.

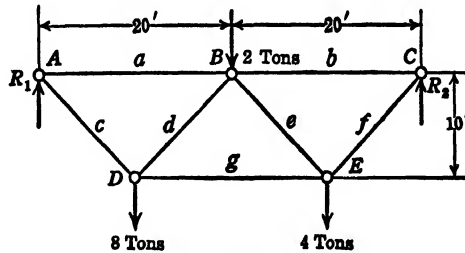

(a) Ignoring the loads at points *B* and *E*, find the vertical displacement of point *D*.

*Ans.*  $\Delta_y = 0.123$  in.

(b) Ignoring the load at point *D*, but with loads at *B* and *E* acting, find the vertical displacement of point *D*.

*Ans.*  $\Delta_y = 0.0582$  in.

(c) Assuming all loads to be acting as shown in sketch, find the vertical displacement of point *D*.

*Ans.*  $\Delta_y = 0.181$  in.

4. In the truss shown:

Bars *a*, *b*, *c*, and *h* are 20 sq. in. each cross-sectional area.

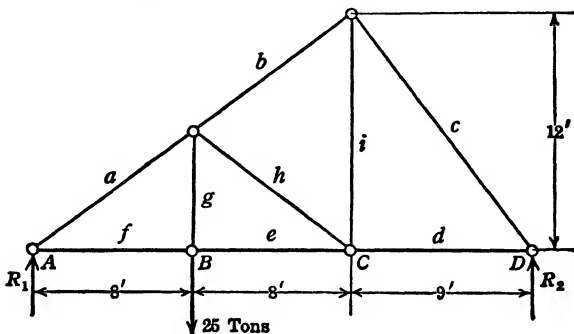

Bars *d*, *e*, *f*, *g*, and *i* are 2 sq. in. each cross-sectional area.

The modulus of elasticity *E* is 15,000 tons per sq. in.

Find the vertical displacement of point *C* and of point *B*.

*Ans.*  $\Delta_C = 0.153$  in.

$\Delta_B = 0.25$  in.

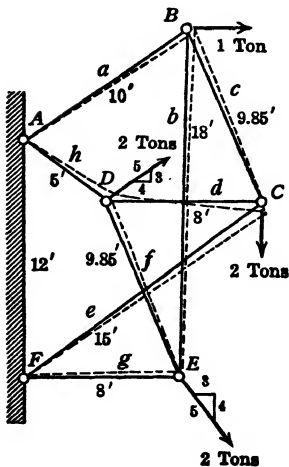

5. The frame shown in the accompanying sketch is statically determinate, pin-connected at points *A*, *B*, *C*, *D*, *E*, and *F*.

The modulus of elasticity *E* for all bars is 15,000 tons per sq. in.

The areas of bars *a*, *c*, *d*, *f*, and *h* are 2 sq. in. each.

The areas of bars *b*, *e*, and *g* are 4 sq. in. each.

Find the vertical and horizontal displacement of point *C* under the action of the loads applied at points *B*, *C*, *D*, and *E*.

*Ans.*  $\Delta_y = 0.0352$  in.

$\Delta_x = 0.022$  in.

REDUNDANT FRAMES

6. The frame shown in the sketch consists of five bars, pin-connected at points *A*, *B*, *C*, and *D*. A concentrated vertical load of 6 tons is applied at *C*.

(a) Assume the cross-sectional area of bar *d* to be very large and the cross-sectional areas of the remaining bars to be equal.

Find the force in bar *c*.

*Ans.*  $S_c = -5$  tons.

(b) Assume cross-sectional area of bars *a* and *b* to be 2 sq. in. each, and of bars *c*, *d*, and *e* to be 4 sq. in. each.

Find the force in bar *c*.

*Ans.*  $S_c = -5.285$  tons.

(c) Assume cross-sectional area of all bars to be equal.

Find the force in bar *c*.

*Ans.*  $S_c = -4.667$  tons.

(d) Assume cross-sectional area of all bars to be 2 sq. in. each. Assume, further, that bar *d* alone is heated  $100^\circ$  F.

Coefficient of expansion  $\lambda$  is 0.000005.

Find the increment of force in bar *c* due to the change in temperature of bar *d*.

*Ans.*  $S_c = +1.67$  tons.

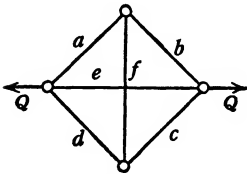
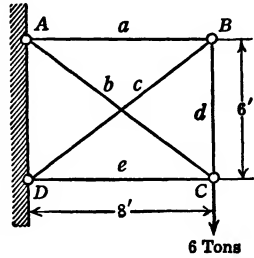

7. A square frame is pin-connected at the corners and braced by two diagonals.

The frame transmits a load *Q* acting in the direction of one of the diagonals.

The cross-sectional areas of all the bars are equal.

Find the force in the diagonal *e* and in the side bar *a*.

*Ans.*  $S_e = +0.707Q$ .

$S_a = +0.207Q$ .

8. A hexagonal frame is braced by six spokes, pinned at the center and at the corners of the frame. A load *Q* is applied in line with two of the spokes.

The cross-sectional areas of all the bars are equal.

Find the forces in the bars marked *a*, *b*, and *c*.

*Ans.*  $S_a = +\frac{Q}{6}$ ;

$S_b = -\frac{Q}{6}$ ;

$S_c = +\frac{5Q}{6}$ .

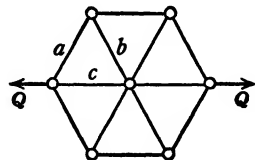

9. In the wheel shown in the sketch:

Assume the segments of the rim and the spokes to be pin-connected.

Assume the segments of the rim to be straight bars.

Assume the spokes to be able to carry tensile stresses only.

The wheel is loaded with two equal and opposite forces  $Q$ , acting in the direction of one of the spokes. One of the forces is applied at the center and the other at the periphery of the wheel.

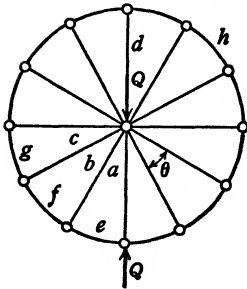

Find the forces in the wheel.

$$\text{Ans. } S_b = S_c = S_d = + Q;$$

$$S_a = 0;$$

$$S_e = S_f = S_g = S_h = \frac{-Q}{2 \sin \frac{\theta}{2}}.$$

10. In the wheel described in problem 9:

Assume the spokes as well as the rim to be capable of taking compression.

Let  $C_1$  represent the elasticity coefficient for the spokes.

Let  $C_2$  represent the elasticity coefficient for the rim segments.

Let  $n$  represent number of spokes.

Find the forces in the wheel.

$$\text{Ans. } S_a = - Q + \frac{4\pi^2 C_1 Q}{n(4\pi^2 C_1 + n^2 C_2)}.$$

$$S_c = S_d = \frac{+4\pi^2 C_1 Q}{n(4\pi^2 C_1 + n^2 C_2)}.$$

$$S_e = S_h = \frac{-2\pi C_1 Q}{4\pi^2 C_1 + n^2 C_2}.$$

11. The figure shown in the sketch represents the simplest kind of two-hinged arch. The structure consists of five bars, pin-connected at the points  $A$ ,  $B$ ,  $C$ , and  $D$ .

The cross-sectional areas of bar  $a$  and  $d$  are 25 sq. in. each, of bars  $b$  and  $e$ , 15 sq. in. each, and of bar  $c$ , 10 sq. in.

Find  $H$ , the horizontal component of the reaction at either point  $A$  or  $D$ .

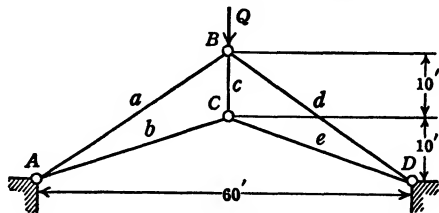

$$\text{Ans. } H = 0.88Q.$$





14. The figure represents one bay of an airplane fuselage. Planes  $A B C D$  and  $E F G H$  are assumed to be rigid.

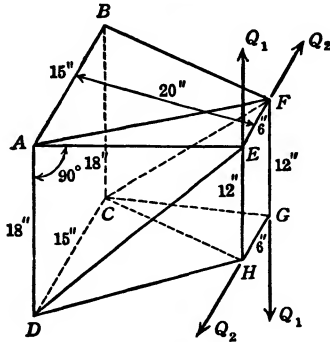

A total torque of 4500 in-lb. is applied to one end of the fuselage ( $6Q_1 + 12Q_2 = 4500$  in-lb.).

The dimensions of the members are given below:

	$AE$	$BF$	$CG$	$DH$	$DE$	$AF$	$CF$	$CH$
Length.....	20.55	20.55	21.35	21.35	27.22	22.55	27.22	23.35
Area.....	0.07862	0.07862	0.07862	0.07862	0.06487	0.05113	0.06487	0.05113

Find  $Q_1$  and  $Q_2$ .

*Ans.*  $Q_1 = 194$  lb.  
 $Q_2 = 278$  lb.

**RESTRAINED BEAMS, CULVERTS, AND BENTS**

In the following problems, unless otherwise stated, the reactions are assumed to be unyielding, the modulus of elasticity  $E$ , and the cross-sectional areas of the beams are assumed to be constant.

15. A beam  $A-C$  is 10 ft. clear length. At point  $A$  it is built into a wall so as to be completely restrained. (A support such as shown at  $A$  is called a "built-in," a "fixed," or a "restrained" support.) At the right end  $C$  the beam is freely supported, that is, the beam is restrained against vertical displacement, but is left free to rotate. At point  $B$ , 6 ft. from the wall, the beam is loaded with a concentrated load  $Q$ .

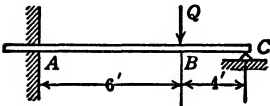

Find the reaction at  $C$ .

*Ans.*  $R_c = 0.432Q$ .

16. A round rod is bent L-shape with a clear vertical length of 10 ft. and a horizontal length of 3 ft. At its lower vertical end, point *A*, it is fixed, that is, it is restrained against all motion, angular as well as linear. At the free horizontal end, point *C*, the rod is loaded with a concentrated vertical load of 2 tons.

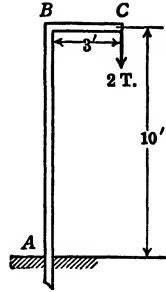

The modulus of elasticity  $E$  is 15,000 tons per sq. in.  
The moment of inertia of the cross-sectional area of the rod is 12 in.<sup>4</sup>

Find the vertical displacement  $\Delta_y$  and the horizontal displacement  $\Delta_x$  of point *C*.

*Ans.*  $\Delta_x = 2.88$  in.  
 $\Delta_y = 1.92$  in.

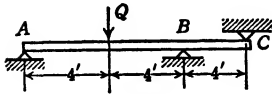

17. A beam is loaded and supported as shown in figure.

Find the reaction at *A*.

*Ans.*  $R_a = \frac{3}{8}Q$ .

18. A 16-ft. beam is built into a wall, point *A*, freely supported 12 ft. out from the wall, point *B*, and loaded over its entire length with a uniformly distributed load  $w$  pounds per foot.

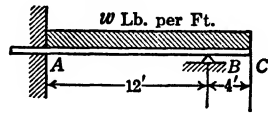

Find the reaction at *B*.

*Ans.*  $R_b = 9.5w$ .

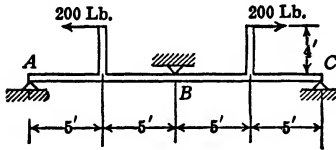

19. A beam is loaded and supported as shown in figure.

Find the reaction at *B*.

*Ans.*  $R_b = 180$  lb.

20. A horizontal beam 5 ft. long, built in at its left end, point *A*, freely supported at its other end, point *B*, is loaded with a horizontal load of 500 lb. through an offset 2 ft. long.

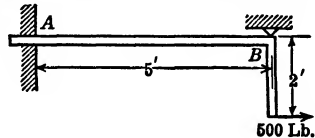

Find the bending moment in the beam at the wall support, point *A*.

*Ans.*  $M_a = 500$  ft.-lb.

21. An 8-in. I-beam 5 ft. long with a moment of inertia of 60 in.<sup>4</sup> and a 6 in. by 10 in. timber beam 4 ft. long are both built in at one end, and have their free ends just in contact. A concentrated load of 4000 lb. is placed at the mid-point of the wooded beam.

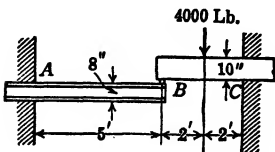

The modulus of elasticity for steel  $E_s$  is 30,000,000 lb. per sq. in.

The modulus of elasticity for wood  $E_w$  is 1,500,000 lb. per sq. in.

Find the load on the steel beam.

*Ans.*  $R_b = 688$  lb.

22. A cantilever beam of constant cross-section and constant modulus of elasticity is loaded with a uniformly varying load.

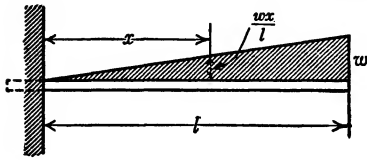

Find the vertical displacement of the free end.

$$Ans. \Delta_y = \frac{11wl^4}{120EI}$$

23. An 18-ft. beam is built in at its left end, point A, and supported on knife-edge supports at points B and C, 10 and 18 ft. from the wall. Over the span from A to B the beam is loaded with a uniformly distributed load of 100 lb. per ft. Over the span from B to C it is loaded with a load of 200 lb. per ft.

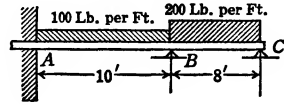

Find the reactions of the knife-edge supports.

$$Ans. R_b = 1510 \text{ lb.} \\ R_c = 646 \text{ lb.}$$

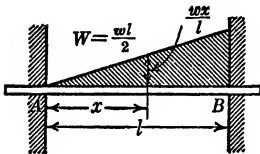

24. A beam of length  $l$  is built in at both ends and is loaded with a uniformly varying load.

Find the bending moment at the end of the beam, point A, at which the load intensity is zero.

$$Ans. M_a = \frac{wl^2}{30} = \frac{Wl}{15}$$

25. A culvert of length  $l$  and height  $h$  is loaded along one of its axes of symmetry with two equal and opposite forces  $Q$ . The cross-sectional areas and the moduli of elasticity of all the members are assumed to be constant throughout. Perfect continuity is assumed to exist at the corners.

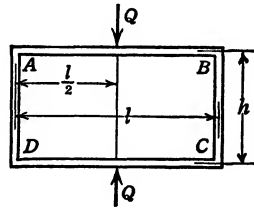

Find the bending moment at one of the corners of the culvert.

$$Ans. M_a = \frac{Ql^2}{8(h+l)}$$

26. A bent of length  $l$  and height  $h$  is pin-connected at the bottom. Across the top it is loaded with a uniformly distributed load  $w$  pounds per foot.

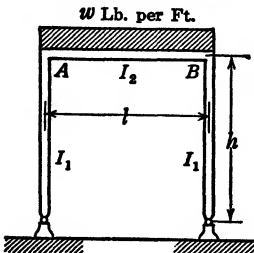

The moment of inertia for the top member is  $I_2$ , for the legs,  $I_1$ .

Find the bending moment at one of the corners.

$$Ans. M_a = \frac{I_1wl^3}{4(2hI_2 + 3lI_1)}$$

27. The culvert shown in this problem differs from that shown in problem 25 in that it has only one axis of symmetry. In problem 25 the moments at all four corners were equal. In this problem the moments at points *A* and *B* will be alike, but those at point *A* and point *D* will differ from each other. To solve problem 25 we require but one elastic energy equation. This problem, however, will require two simultaneous elastic energy equations for its solution.

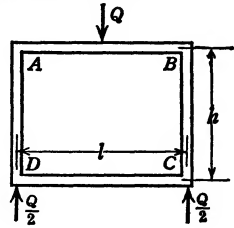

Find the moment at point *A*.

$$Ans. M_a = \frac{(2h + 3l)Ql^2}{8(h^2 + 4hl + 3l^2)}$$

28. A bent of height *h* and width *l* is pin-connected to the ground and loaded with a transverse horizontal force *Q* applied to one of the corners. The moments of inertia of the legs and of the horizontal member of the bent all differ from one another.

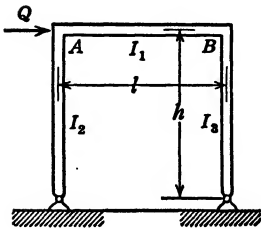

Find the bending moment in the bent at the corner at which the load *Q* is applied.

$$Ans. M_a = \frac{Qh}{2} \left( \frac{3I_2I_3 + 2hI_1I_2}{3I_2I_3 + hI_1I_3 + hI_1I_2} \right)$$

29. A beam is fully restrained at both its extremities and is loaded with a uniformly distributed load, *w* pounds per foot, over half its length.

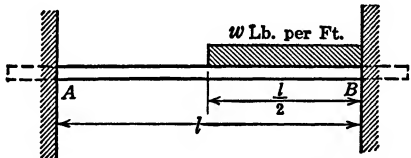

Find the bending moment at the support of the unloaded end of the beam.

$$Ans. M_a = \frac{5}{192} wl^2$$

30. A mill building, dimensions and properties as on sketch, is loaded with a

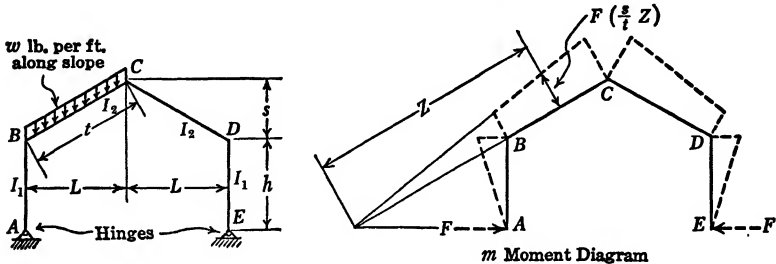

load of *w* pounds per foot along the slope of the roof. Find the horizontal reaction *H* at the hinges.

$$Ans. H = \frac{wt^2L(h + \frac{5}{8}s)I_1}{2h^3I_2 + 6h^2tI_1 + 6shtI_1 + 2s^2tI_1}$$

31. A 20-ft. beam is completely restrained at both ends. The beam has a constant width of 4 in., but its depth varies uniformly from 10 in. at the right end to 12 in. at the left end. The beam is loaded with a uniformly distributed load of 200 lb. per ft. over its entire length.

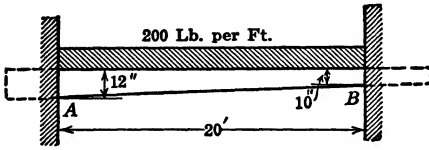

Find the maximum stress in the beam.

*Ans.* The maximum stress in the beam is 1430 lb. per sq. in. and occurs at point *B*.

32. *A-C* is a wooden beam 20 ft. long, of circular cross-sectional area 12 in. in diameter. *DE* is a wooden beam 10 ft. long, of circular cross-sectional area 10 in. in diameter. The two beams are pin-connected by a steel bar *B-E*, of 1 sq. in. cross-sectional area and 5 ft. in length. Both beams are loaded with an upward uniformly distributed pressure of 100 lb. per ft.

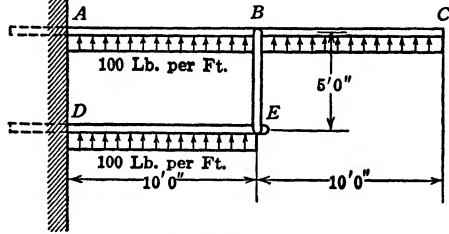

The modulus of elasticity for the wood is 1,000,000 lb. per sq. in.

The modulus of elasticity for the steel is 30,000,000 lb. per sq. in.

Find the force in the bar *B-E*.

*Ans.* 437 lb. tension.

### CURVED BEAMS

The theory of curved beams in this book is predicated upon two mutually contradictory assumptions. It is assumed on the one hand that the theory of curved beams is essentially the same as the theory of straight beams, provided that either the curvature of the beam or the thickness of the curved beam is relatively small. On the other hand it is assumed that the law of superposition holds. This is equivalent to saying that the ultimate deformations are relatively small, and that the structure maintains essentially its original shape throughout the loading process.

It is obvious that, the nearer we approach fulfilment of the first assumption, the more we violate the second. In problem 33, for example, we have a ring loaded with two equal and opposite forces acting along a diameter. In this circumstance, if the deformation of the circular ring that takes place during the loading process may be ignored, the values obtained for bending moments, displacements, or stresses would be the same, except for sign, regardless of whether the loading were directed towards the center or away from it. However, if the loads are vertical and acting towards the center, then the horizontal diameter will increase and the moment at *A* will be greater than the one obtained by means

of a theory which neglects to take this change of dimensions of the structure into account. Vice versa, if the vertical loads are acting away from the center, then the horizontal diameter will decrease and the moment at *A* will be smaller than that computed on the basis of a theory which neglects to take this change of dimensions into account.

For thin beams and small loads the law of superposition holds, and the stresses may be computed with a high degree of accuracy without any further adjustments. However, we are as a rule interested primarily in maximum loads and, therefore, in elastic limit stresses. In problems which involve relatively large distortions, an improved analysis may be made by first computing the approximate distortions under the action of loads of a value near the breaking load. Then, on the basis of the new shape of the structure thus obtained, recompute the values of moments and stresses desired.

The answers to the problems 33 to 44 are computed on the assumptions that the law of superposition holds and that the curvature of the beams is relatively small.

33. A circular ring is loaded with two equal and opposite loads *Q* acting along a diameter.

Find the moments at *A* and *B*, also the displacements of these points.

Ans.  $M_a = \left(\frac{\pi - 2}{2\pi}\right) QR = 0.182QR.$

$$M_b = \frac{QR}{\pi} = 0.318QR.$$

$$\Delta_x = \frac{(4 - \pi) QR^3}{4\pi EI} = 0.0683 \frac{QR^3}{EI}.$$

$$\Delta_y = \frac{(\pi^2 - 8) QR^3}{8\pi EI} = 0.0745 \frac{QR^3}{EI}.$$

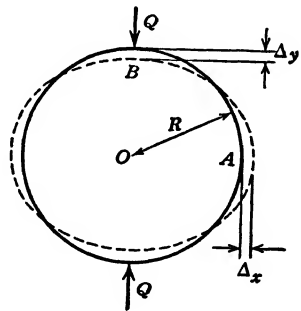

34. A circular ring is loaded along the top and bottom with a uniformly distributed load *w* lb. per horizontal ft.

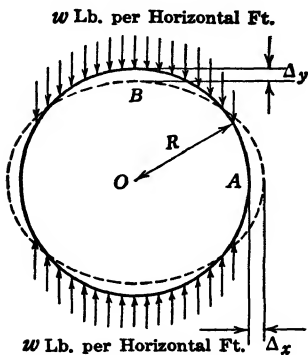

NOTE. The load is uniformly distributed relative to the diameter, not relative to the length of the ring.

Find the moments at *A* and *B*, also the displacements of these points.

$$\text{Ans. } M_a = \frac{wR^2}{4}. \quad M_b = \frac{wR^2}{4}.$$

$$\Delta_x = \frac{wR^4}{12EI}. \quad \Delta_y = \frac{wR^4}{12EI}.$$

35. A semicircular beam is hinged at both extremities and loaded along the axis of symmetry with a concentrated load  $Q$ .

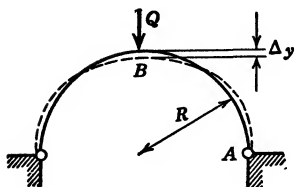

Find the horizontal component of one of the reactions. Also find the vertical displacement of the point of application of the load.

$$\text{Ans. } H = \frac{Q}{\pi}.$$

$$\Delta_y = \frac{(3\pi^2 - 8\pi - 4) QR^3}{8\pi EI} = 0.019 \frac{QR^3}{EI}.$$

36. Problem 36 differs from problem 35 in that the extremities of the beam are built in, fixed, instead of being pin-connected.

Whereas in problem 35 the moment at  $A$  is zero, in problem 36, at point  $A$ , there is an unknown moment  $M_a$  for which we have to solve. In problem 35 one elastic energy equation suffices for its solution, whereas here we have need of two elastic energy equations.

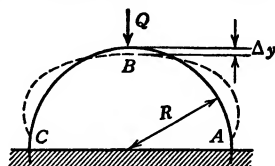

Find: the horizontal component of one of the reactions; the vertical displacement of point  $B$ ; the bending moment at one of the reactions.

$$\text{Ans. } H = 0.46Q; \quad \Delta_y = 0.0117 \frac{QR^3}{EI}; \quad M_a = 0.111QR.$$

37. A semicircular beam is built in at its extremities and loaded with a load uniformly distributed with respect to the plane of support.

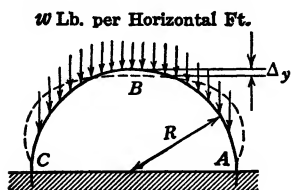

Find the horizontal component of the reaction at one end, the moment at one end, and the vertical displacement of point  $B$  the center of the beam.

$$\text{Ans. } H = \frac{\pi}{(\pi^2 - 8)} \frac{wR}{3} = 0.56wR.$$

$$M_a = 0.106wR^2.$$

$$\Delta_y = 0.0068 \frac{wR^4}{EI}.$$

38. A semicircular beam is built in at both its extremities, points  $A$  and  $C$ . The beam is eccentrically loaded with a concentrated load  $Q$ . The load acts along a line passing through the midpoint of the horizontal radius.

Find the horizontal component of the reaction; the bending moment at the right support.

$$\text{Ans. } H = 0.312Q.$$

$$M_a = 0.1127QR.$$

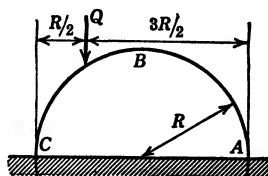

39. A two-hinged curved beam is supported at two points differing 20 ft. in elevation. The center line of the beam consists of two quarter circles, one of 40-ft. and the other of 60-ft. radius. A concentrated load  $Q$  is applied at the junction of the two curves.

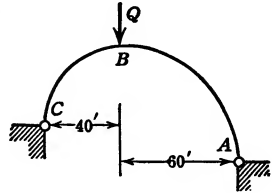

The beam is of uniform cross section and has a uniform modulus of elasticity throughout.  
 Find: the horizontal component of a reaction; the moment at the point of application of the load.

Ans.  $H = .304Q.$   
 $M_b = 9.41Q.$

40. A two-hinged curved beam with a span of 120 ft. and a rise of 20 ft. is loaded with a concentrated load of 3000 lb. applied at the midpoint.

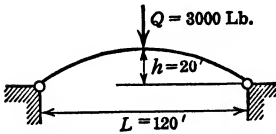

Find  $H$ , the horizontal component of a reaction.  
 Ans. Assuming the center line of a beam to be a parabola, and further assuming that  $ds$  may be replaced by  $dx$ , then  $H = \frac{25 QL}{128 h} = 3515.7$  lb.

Assuming the center line of the beam to be a parabola without making the simplifying assumption that  $ds = dx$ , then  $H = 3652.8$  lb. Assuming the center line of the beam to be an arc of a circle and further assuming that  $ds$  may be replaced by  $dx$ , then  $H = 3404.7$  lb. Assuming the center line of the beam to be an arc of a circle without making the assumption that  $ds = dx$ , then  $H = 3518.7$  lb.

41. A circular ring of radius  $r$  rotates with an angular velocity  $\omega$  about a vertical diameter.

The weight per unit volume of the ring is  $u$  pounds per cubic foot.

The cross-sectional area of the ring is  $A$ .

Find the bending moments in the ring at the top, point  $B$ , and at the side, point  $C$ . Also find the increase in length of the horizontal radius  $OC$ .

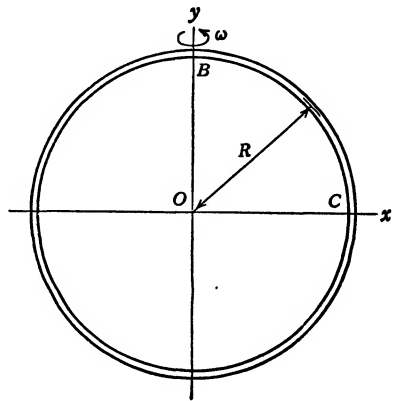

Ans.  $M_b = M_c = \frac{uA\omega^2 R^3}{4g}.$   
 $\Delta_{c_x} = \frac{uA\omega^2 R^5}{12gEI}.$



42. A ring is rotated about an axis perpendicular to its plane with an angular velocity  $\omega$ . It is completely restrained against radial motion by spokes. (The

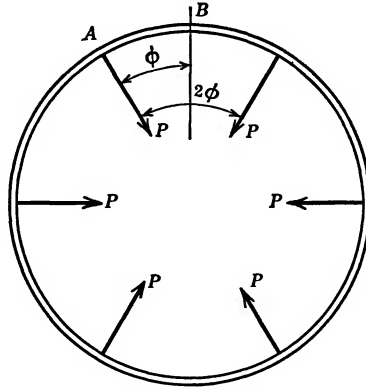

elongation of the spokes is to be ignored.) Find the tension,  $P$ , in the spokes and the moments  $M_a$  and  $M_b$  respectively, in the ring.

$$\text{Ans. } P = \frac{4A\omega^2 R^2}{g \left\{ \left( \frac{R}{i} \right)^2 \left( \frac{\phi}{\sin^2 \phi} + \cot \phi - \frac{2}{\phi} \right) + \left( \frac{\phi}{\sin^2 \phi} + \cot \phi \right) \right\}}$$

$$M_a = \frac{PR}{2} \left( \frac{1}{\phi} - \cot \phi \right).$$

$$M_b = \frac{PR}{2} \left( \frac{1}{\sin \phi} - \frac{1}{\phi} \right).$$

$i$  is the radius of gyration of the cross-sectional area of the ring about the neutral axis perpendicular to the paper.

### CYLINDERS SUPPORTED IN EARTH

The analysis of stresses in cylinders supported in earth is a complicated process. Such cylinders as large sewer sections are probably built of concrete, are of non-circular cross section, and have variable thickness. Stresses in concrete structures are generally computed on the assumption that the concrete is elastic, although in fact it is not. The difficulty arising from the facts that the cylinder does not have a circular cross section, and that its walls are of variable thickness, may be overcome by using the method of arithmetical summation as exemplified in examples 29 and 30. One serious obstacle remains in that earth loading on top of the cylinder and the earth reactions against the bottom of the cylinder may be difficult to determine with any degree of certainty.

43. In problem 43 we assume that the cylinder is of circular cross section and of constant thickness, and that it maintains essentially its circular shape while it is being loaded by being filled with a liquid. It is assumed that the cylinder is supported in earth up to half its height. Furthermore, it is assumed that the reaction developed by the earth is directly proportional to the compression to which the earth is subjected. Thus, as the cylinder moves downward a distance  $A-B$ , the earth at point  $A$  is compressed an amount  $D-B$ . The earth pressure  $p$ , then, at that point is given by the expression  $p = C \cos \theta$ , in which  $C$  is a constant that must be determined.

Let  $u$  represent the weight of a unit volume of liquid with which the cylinder is being filled. The diagrammatic sketch shows the hydrostatic pressure on the inside of the cylinder as well as the earth pressure on the outside. Furthermore, the bending moments at top and bottom and on the side of the cylinder, and other answers to the solution of the problem are marked on the sketch. The horizontal force at both top and bottom of cylinder is  $H_1 = \frac{uR^2}{2}$ .

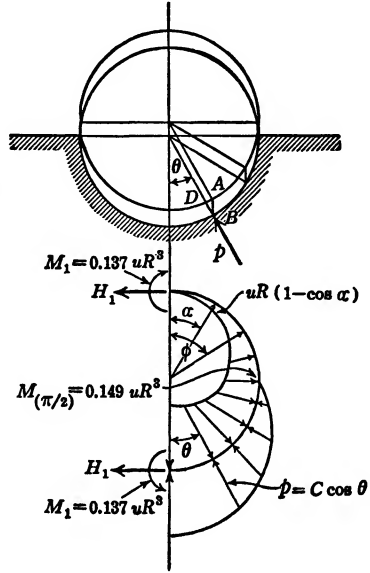

The student is to check the value for  $M_1$ ,  $M_{\frac{\pi}{2}}$ , and for  $H_1$ , and is to show that the bending moment and horizontal force at the top of the cylinder are equal to those at the bottom.

PIPE BENDS IN STEAM-PIPE LINES

As steam is injected into steel pipes, they tend to expand. With the modern tendency towards the use of superheated steam, high temperatures and large pipes, the expansion forces set up in steam-pipe lines may be of great magnitude. This expansion may be provided for in a variety of ways of which the pipe bend is one. Whereas in the majority of problems in this book we have evaluated deformations as caused by loads, in pipe bends the problem is reversed in that we compute the loads caused by the deformations to which the pipe bend is subjected. Suppose  $\lambda$  to be temperature coefficient,  $X_1$  the overall length of the pipe; then  $\lambda X_1$  represents the deformation in the pipe, provided that it is unrestrained. If the pipe is restrained, the expansion joint, or the pipe bend, must absorb this deformation  $\lambda X_1$ .

The problem, then, is to compute the forces induced in a pipe bend which is subjected to a deformation  $\lambda X_1$ .

44. The pipe bend shown in the sketch is symmetrical with reference to the vertical center line. The bending moments  $M_1$  are such as to prevent rotation

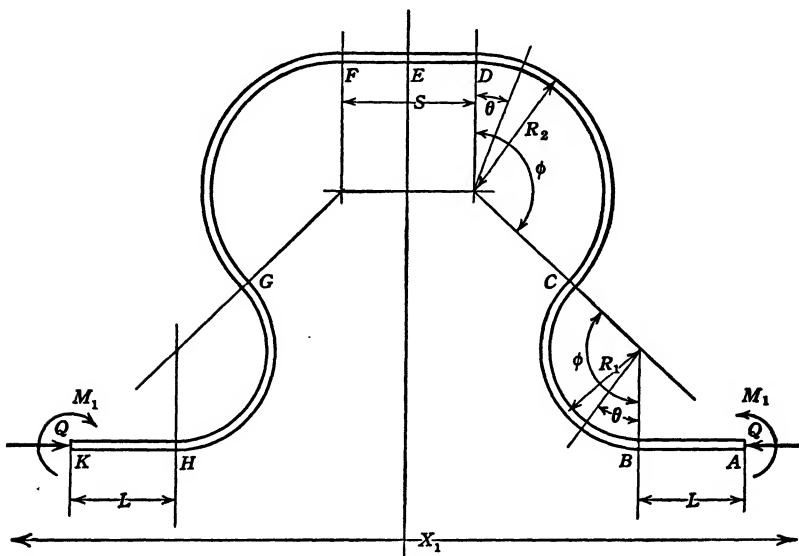

of the ends. The modulus of elasticity and moment of inertia for all sections of the pipe are constant.

Find the moment  $M_1$  and the force  $Q$ , induced at points  $A$  and  $K$ , as a function of the pipe constants and temperature change, ignoring the effects due to direct compression.

NOTE. The bend shown in the sketch represents a rather general case of a pipe bend. If  $M_1 = 0$ , then the ends may be said to be pin-connected. By varying the values for  $R_1$ ,  $R_2$ , and  $\phi$ , the solution for a variety of bends is obtained. This problem constitutes a part of a report on "The Elasticity of Pipe Bends," submitted by the author to the Detroit Edison Co.

$$\begin{aligned}
 \text{Ans. } \lambda t X_1 = \Delta_z = \frac{2Q}{EI} & \left[ R_1^3 \left( \frac{3}{2} \phi - 2 \sin \phi + \frac{\sin 2\phi}{4} \right) \right. \\
 & + R_1 R_2 \{ R_1 \phi - 2(R_1 + R_2)(\cos \phi) \phi + 2R_2 \sin \phi \} \\
 & + (R_1 + R_2)^2 \left\{ R_2 (\cos^2 \phi) \phi + (1 - 2 \cos \phi) \frac{S}{2} + (\cos^2 \phi) \frac{S}{2} \right\} \\
 & \left. + R_2^2 \left[ \frac{R_2 \phi}{2} - \frac{3}{4} R_2 \sin 2\phi - R_1 \sin 2\phi \right] \right] - \frac{2M_1}{EI} \left[ R_1^2 (\phi - \sin \phi) \right]
 \end{aligned}$$

$$+ R_2^2(\sin \phi - \phi \cos \phi) + R_1 R_2(\phi - \phi \cos \phi) + \frac{S}{2}(R_1 + R_2)(1 - \cos \phi) \Big].$$

$$M_1 = \frac{Q \left\{ \begin{aligned} &(R_1^2 + R_1 R_2)\phi + (R_2^2 - R_1^2) \sin \phi \\ &+ \frac{S}{2}(R_1 + R_2) - \left( R_2 \phi + \frac{S}{2} \right) (R_1 + R_2) \cos \phi \end{aligned} \right\}}{\left[ L + (R_1 + R_2)\phi + \frac{S}{2} \right]}$$

In case  $L = 0$ ,  $S = 0$ ,  $R_1 = R_2$  and  $\phi = \frac{\pi}{2}$ , then  $M_1 = QR$  and

$$\Delta_x = \frac{3Q\pi R^3}{EI} - \frac{2Q\pi R^3}{EI} = \frac{Q\pi R^3}{EI}$$

In case  $L = 0$ ,  $S = 0$ ,  $R_1 = R_2$  and  $\phi = \frac{3\pi}{4}$  then  $M_1 = 1.707QR$  and

$$\Delta_x = \frac{39.89QR^3}{EI} - \frac{27.46QR^3}{EI} = \frac{12.43QR^3}{EI}$$

BRACED BEAMS

45. A wooden frame braced by a steel tie rod is loaded with a concentrated load  $Q$  as shown.

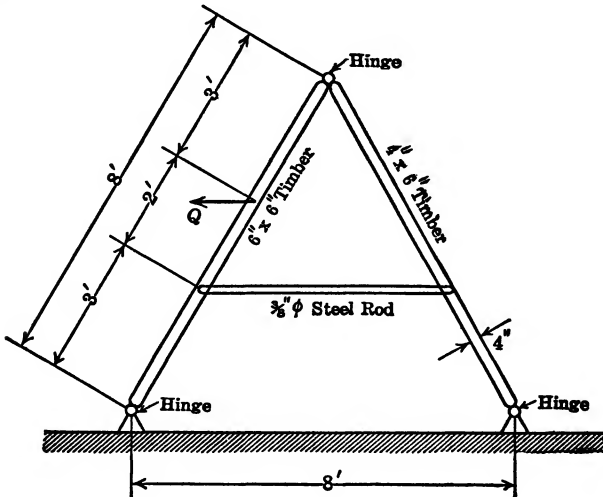

$E_s = 29,000,000$  lb. per sq. in.

$E_w = 1,600,000$  lb. per sq. in.

Find the force  $S$  acting in the tie rod.

Ans.  $S = 0.198Q$ .

46. A rectangular wooden beam 8 in. by 10 in., loaded with a uniformly distributed load  $w$  pounds per foot over half its length, is braced by a  $1\frac{1}{2}$ -in. round steel rod and a 3 in. by 8 in. by 4 ft. 0 in. wood post.

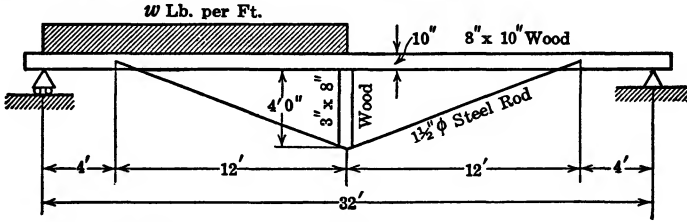

$E_s = 29,000,000$  lb. per sq. in. and

$E_w = 1,600,000$  lb. per sq. in.

Find the compression  $S$  in the wood post.

Ans.  $S = 13.9w$ .

47. A  $3\frac{1}{2}$ -in. standard pipe is braced by steel rods as shown.

$E$  is the same for pipe and rods.

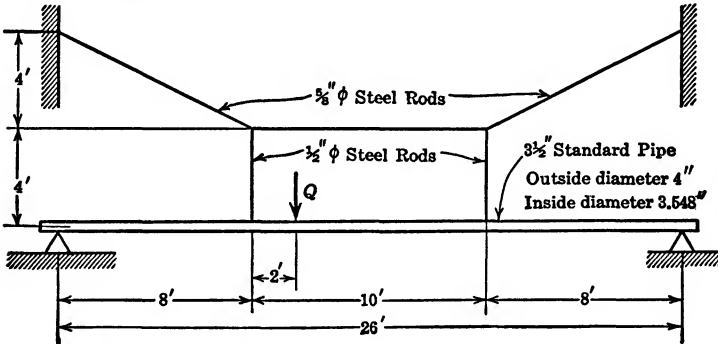

Find the tension in the vertical rod.

Ans.  $S = 0.557Q$ .

COMBINED TORSION AND BENDING

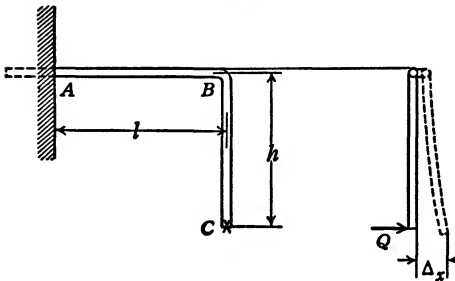

48. A rod is bent in a right angle, one end is fixed, and the other end is loaded with a concentrated load  $Q$  acting perpendicularly to the plane of the rod.

Find  $\Delta_x$ , the displacement of the point of application of the load  $Q$  in the direction of  $Q$ .

Ans.  $\Delta_x = Q \left( \frac{h^3}{3EI_x} + \frac{l^3}{3EI_y} + \frac{h^2l}{GJ} \right)$ .

49. A round rod of radius  $r$  in the shape of a  $360^\circ$  arc of a circle of radius  $R$ .  
 The rod is loaded with two equal and opposite forces  $Q$ , one applied to each of the two extremities and acting perpendicularly to the plane of the circle.

Find  $\Delta_x$ , the relative displacement of the two ends of the rod.

$$\text{Ans. } \Delta_x = \frac{2QR^3}{r^4} \left( \frac{2}{E} + \frac{3}{G} \right).$$

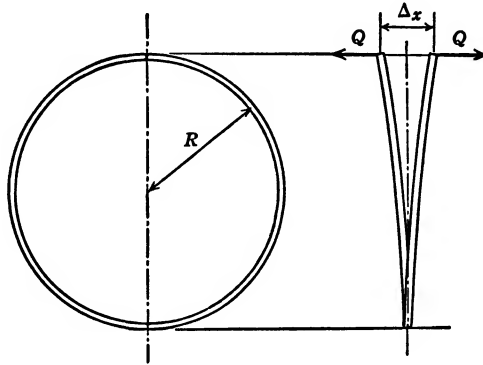

If  $E = 28,000,000$  and  $G = 11,000,000$  lb. per sq. in.

$$\Delta_x = \frac{2QR^3}{r^4} (0.000000714 + 0.00000273) = \frac{0.0000006888QR^3}{r^4}.$$

50. A rectangular frame is built in at both extremities and loaded with a concentrated load  $Q$  applied perpendicularly to the plane of the frame, on the axis of symmetry, at point  $E$ .

Find the torque  $T_A$ , acting at  $A$  in the plane of the wall, and the vertical displacement,  $\Delta_{Ez}$ , of point  $E$ .

$$\text{Ans. } T_A = \frac{Qb^2GJ}{8(bGJ + 2aEI_x)}.$$

$$\Delta_{Ez} = \frac{1}{48EI_x} (8Qa^3 + Qb^3 - 6T_A b^2).$$

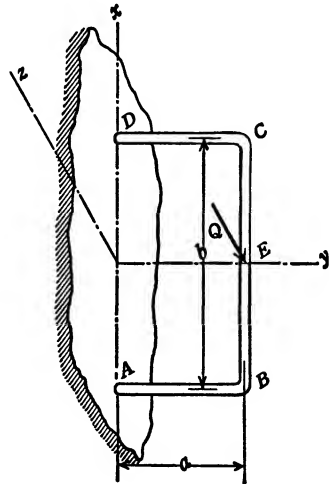

51. A rectangular frame, of constant  $E$  and  $I$ , is supported along one diagonal  $BD$ . The corner  $C$  is restrained against vertical displacement while the corner  $A$  is loaded with a load  $P$ . Find  $\Delta_A$ , the vertical displacement of point  $A$ .

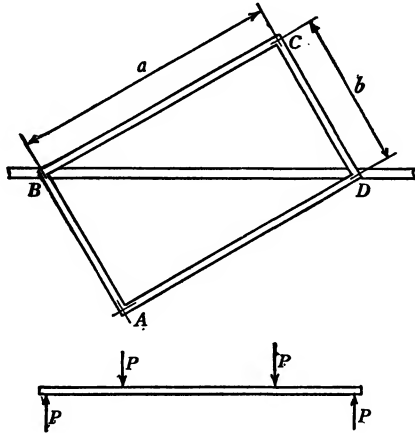

$$\text{Ans. } \Delta_A = \frac{Pa^2b^2(aGJ + 3bEI)(bGJ + 3aEI)}{6EIGJ(b^3GJ + 3ab^2EI + a^3GJ + 3ba^2EI)}$$

When  $a = b$ , then

$$\Delta_A = Pa^3 \left( \frac{1}{12EI} + \frac{1}{4GJ} \right).$$

52. A circular ring of diameter  $D$  is made of a solid round steel rod of diameter  $d$ . The ring is supported at points  $B$  and  $D$  which lie on one diameter. It is

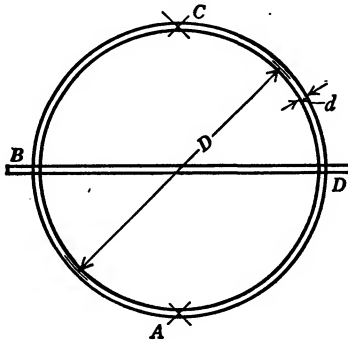

loaded with a load  $P$  at point  $A$  which lies on another diameter at right angles to the first one. The point  $C$ , opposite point  $A$ , is prevented from tipping up. Find  $\Delta_A$ , the deflection of point  $A$ .

$$\text{Ans. } \Delta_A = \frac{4PD^3}{\pi d^4} \left( \frac{\pi - 2}{E} + \frac{\pi - 3}{G} \right).$$

53. A solid, circular steel rod, radius  $r$ , is built in at  $G$ . It has a height  $H$  in the  $y$  direction. It is bent through an arc  $\frac{\pi}{2}$ , radius  $R_1$ , in the  $xy$  plane. Further, it has a length  $L$  in the  $x$  direction, and is bent through an arc  $\frac{\pi}{2}$ , radius  $R_2$ , in the  $xz$  plane. Finally, its length in the  $z$  direction is  $l$ . It is loaded at its extremity, point  $A$ , with a force  $P$  acting in the  $x$  direction.

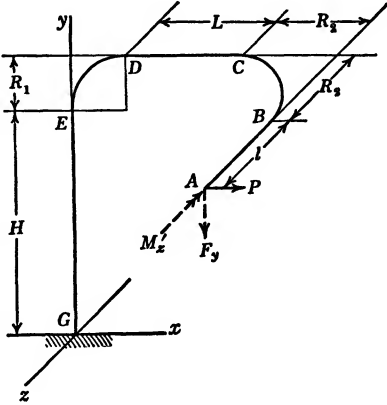

To find:  $\Delta_{Ay}$ , the linear displacement of point  $A$  in the  $y$  direction, and  $\theta_{Az}$ , the rotation of the rod at point  $A$  about the  $z$  axis.

The modulus of elasticity is  $E$ ; the shear modulus is  $G$ . The auxiliary forces and moment are indicated on the figure in order that the plus and minus signs in the answer may be properly interpreted in the light of the arrowheads on these auxiliaries.

$$\begin{aligned}
 \text{Ans. } \Delta_{Ay} &= \frac{PR_1^2}{2EI} [(\pi - 2)(L + R_2) + R_1] - \frac{P(l + R_2)^2 R_1}{2EI} + \frac{P(l + R_2)^2 R_1}{2GJ} \\
 &\quad + \frac{PH(L + R_1 + R_2)(R_1 + [H/2])}{EI} \\
 \theta_{Az} &= \frac{PR_1^2}{2EI} (\pi - 2) + \frac{PH(2R_1 + H)}{2EI}
 \end{aligned}$$

COLUMNS

54. A 12 in. by 3 in. 25-lb. channel ( $A = 7.32$  sq. in.,  $i = 0.79$  in.,  $s_1 = 36,000$  lb. per sq. in., and  $E = 29.5 \times 10^6$  lb. per sq. in.) is supported on a pin at its

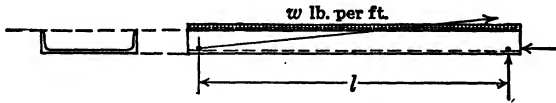

right end and by a cable having a slope of 1 : 10 at its other end. Find the limit transverse load which this beam column can carry when the lengths are respectively 47.4 in., 94.8 in., and 189.6 in.

Ans.  $w_1 = 2270$  lb. per ft.;  $w_2 = 560$  lb. per ft.;  $w_3 = 129$  lb. per ft.





## INDEX

### A

- Airplane fuselage, analysis of, 19-26
  - assumptions, 21-22
- Anti-symmetry, 95
  - rule, 95
- Arch, 149-165
  - assumptions in analysis of, 152-154
  - effect of direct compression on, 158
  - influence lines for reactions of, 151
  - similarity and difference between cable and, 152
  - temperature stresses in, 161-165
- Area  $\bar{X}$ , explanation of, 48, 59
- Assumptions, classified, 264-265
  - in analysis of airplane fuselage, 21-22
  - in analysis of curved beam, 101
  - in arch analysis, 152-154
  - in elastic energy theory, 5
  - relating to wind stress analysis of skyscrapers, 265
- Auxiliary load, general rule for application of, 65-67

### B

- Balcony, semicircular, 168-170
- Beam column, 236-244
- Beams, braced, 138-149
  - effect of initial force on, 144-147
  - effect of tightening turnbuckle on, 147-149
  - maximum efficiency of, 144-147
- curved, 100-137
  - assumptions in analysis of, 101
  - piston ring design, 104-108
  - ring, loaded by its own weight, 108-117
  - subjected to concentrated loads, 124-125
  - subjected to hydrostatic pressure, 117-122

- Beams, curved, ring, subjected to shear loading, 123-124
  - semicircular balcony, 168-170
- deformation of, due to bending, 41-46
  - due to shear, 171-173
  - due to torsion, 166
- rectilinear, 64-81
  - redundant, 64-137
- total elastic energy due to bending, 46-47
- Beams of constant strength, 178-197
  - leaf spring, 178-179
  - spiral spring, 185-197
    - available energy in, 193-194
    - residual stresses in, 191-193
- Bending and direct stress, combined, 138-165
- Bending and torsion, combined, 166-170
- Bending-moment areas and their properties, 269-270
- Bending-moment diagrams, hints about drawing, 57-58
- Bents, 82-95
  - Vierendeel truss, 88-95
- Braced beam, *see* Beams

### C

- Castigliano's law, 222
- Check on computed stresses in frames, 32-36
- Circular pipe, shear stresses in, 271-272
- Circular pipe lines, 131-137
- Column, 226-260
  - beam, 236-244
  - conclusions, 257-259
  - criteria of strength, 226
  - eccentrically loaded or partially restrained, 245-252
  - Euler's formulas, 231-235
  - failure in tension, 258
  - general formulas, 258

Column, problem of column analysis, 229-230  
 secant formula, 245-247  
 flaws in, 247, 250

Combined bending and direct stress, 138-165

Combined bending and torsion, 166-170

Comparison, of analytic integration with tabular summation, 100-104, 108-117  
 of arch and cable, 152  
 of formulas (1), (5), and (6), 46  
 of statically determinate and statically indeterminate structures, 1-3  
 of vertical and radial supports for stiffening ring of pipelines, 134, 137

Curved beams, *see* Beams

Cylinders supported in earth, 286-287

## D

Definition, of resilience, 176  
 of statically determinate structure, 1  
 of statically indeterminate structure, 1-2  
 of theory, 261

Deformation, of beams, due to bending, 41-46  
 due to shear, 171-173  
 due to torsion, 166  
 of frames or trusses, 8-10  
 of shafts, due to shear, 174-175

Dirigible, 130-131

Distinction between statically determinate and statically indeterminate structures, 2-3

## E

Eccentrically loaded or partially restrained columns, 245-252

Elastic curves as influence lines, beams, 198-216  
 frames, 38-40  
 units of measurement, 211

Elastic energy, due to bending, 46-47  
 due to shear, 171-175

Elastic energy theory, assumptions, 5  
 estimate of, 261-268  
 advantages, 261-264

Elastic energy theory, estimate of, limitations, 264-268  
 philosophy of, 94  
 rule of signs, 62

Elasticity, limitations of theory of, 4-5;  
*see also* Elastic energy theory

Euler's column formulas, 231-235

## F

Föppl, August, ix  
 quotation from, on virtual velocities, 263

Formulas:

$$(1) F\Delta = \Sigma Cfs, 9$$

$$(2) S_e = -\frac{\Sigma CTU}{\Sigma CU^2}, 16$$

$$(3) S_e = -\frac{\lambda L_e t}{\Sigma CU^2}, 32$$

$$(4) \Sigma Sl = \Sigma Qd, 34$$

$$(5) F\Delta = \int \frac{mMds}{EI}, 45$$

$$(6) M'\theta_1 = \int \frac{mMds}{EI}, 46$$

$$(7) W = \int \frac{M^2 ds}{2EI}, 47$$

$$(8) F\Delta \text{ or } T'\phi = \int \frac{tTds}{GJ}, 166$$

$$(9) \phi = \frac{TL}{JG}, 175$$

$$(10) \text{ (beam column formula), } 240$$

$$(11) \text{ (beam column formula), } 241$$

$$(12) \text{ (beam column formula), } 241$$

$$(13) \text{ (beam column formula), } 241$$

$$(14) \text{ (secant formula), } 247$$

$$(15) \text{ (approximate eccentricity column formula), } 250$$

$$(16) \phi = \frac{[s_1 - (P/A)]L}{\pi Ec}, 255$$

$$(17), (17a) \text{ (general column formulas), } 258$$

Frames, check on computed stresses in, 32-36  
 deformation of, 8-10  
 temperature stresses in, 30-32  
 with one redundant member, 14-19  
 with two or more redundant members, 26-30  
 Free-body sketches, 51-53  
 Fuselage, airplane, analysis of, 19-26  
 assumptions in, 21-22

## G

Graphic integration, 53-60, 269  
 discussion of  $\int mMdx$ , 60  
 four basic types of loading, 54-57, 269  
 hints about drawing bending-moment diagrams, 57-58  
 rules for, 54-58

## H

Helical spring, 183-185  
 Hydrostatic pressure, ring subjected to, 117-122

## I

Influence lines, by use of Maxwell's law, 38-40, 203-216  
 definition of, 201  
 for reactions of arch, 151  
*See also* Elastic curves as influence lines

## K

Kist, N. C., 267

## L

Leaf spring, 178-179  
 Least work, theory of, 221-225  
 comments on, 223, 225  
 Limitations, of elastic energy theory, 264-268  
 of Maxwell's law, 205  
 of theory of elasticity, 4

## M

Maxwell's law of reciprocity of displacement, for beam, 198-200  
 for truss, 36-38  
 for use in influence lines, 38-40, 203-216  
 advantage of, 40, 219-220  
 limitations of, 205

## P

Parabolic areas and their properties, 270  
 Pin-ended spiral spring, 195-197  
 Pipe, afloat with top surface awash, 126  
 flowing full and supported along invert line, 126  
 subjected to hydrostatic head, 126  
 submarine or dirigible analyzed as, 130-131  
 suspended and loaded along center line, 130  
 suspended in a liquid, 130  
 Pipe lines, circular, 131-137  
 saddle support of, 133-134  
 stiffening ring of, 133  
 Piston ring design, 104-108  
 Principle of superposition, 218-219, 226-229  
 rule for applicability of, 229

## R

Rectilinear beams, 64-81  
 Redundant beams, 64-137  
 Redundant frames, with one redundant member, 14-19  
 with two or more redundant members, 26-30  
 Residual stresses in spiral spring, 191-193  
 Resilience, 176-197  
 beams of constant strength and maximum, *see* Beams  
 definition of, 176  
 Rings, *see* Curved beams  
 Rule, of anti-symmetry, 95  
 of application of auxiliary load, 65-67  
 of signs for elastic energy theory, 62  
 of symmetry, 95

## S

- Saddle support of pipe lines, 133-134  
 Secant formula, 245-247  
   flaws in, 247, 250  
 Semi-graphic integration, *see* Graphic integration  
 Shafts, 174-175  
 Shear, deformation due to, 171-175  
   of beams, 171-173  
   of shafts, 174-175  
   elastic energy due to, 171-175  
   of beams, 171-173  
   of shafts, 174-175  
   stresses in circular pipes, 271-272  
 Signs, 60-63  
   rule for elastic energy theory, 62  
 Spiral spring, *see* Spring, spiral  
 Spring, helical, 183-185  
   leaf, 178-179  
   spiral, 185-197  
     available energy in, 193-194  
     pin-ended, 195-197  
     residual stresses in, 191-193  
 Statically determinate structures, *see* Structures  
 Statically indeterminate structures, *see* Structures  
 Steam pipe lines, pipe bends in, 287-289  
 Stiffening ring of pipe lines, 133  
   comparison of vertical and radial supports for, 134, 137  
 Stresses, temperature, in arch, 161-165  
   in frames, 30-32  
 Structures, distinction between statically determinate and indeterminate structures, 2-3

- Structures, statically determinate, 1-2  
   characteristics of, 2  
   definition of, 1  
   statically indeterminate, 2-4  
     characteristics of, 3  
     definition of, 1-2  
 Submarine, 130  
 Superposition, principle of, 218-219, 226-229  
   rule for applicability of, 229  
 Symmetry, 95  
   rule, 95

## T

- Temperature stresses, in arch, 161-165  
   in frames, 30-32  
   in steam pipe lines, 287-289  
 Theorem of three moments, 79-81  
 Theory, of elasticity, limitations of, 4  
   of least work, 221-225  
     comments on, 223, 225  
   of limit design, spiral spring, 191-194  
 Three moments theorem, 79-81  
 Tools of engineering mechanics, 51-63  
   free-body sketches, 51-53  
   semi-graphic integration, *see* Graphic integration  
   signs, 60-63  
     rule for elastic energy theory, 62  
 Torsion, combined bending and, 166-170  
 Truss, *see* Frames  
   Vierendeel, 88-94

## V

- Vierendeel truss, 88-94





**This book is issued for  
SEVEN DAYS ONLY.**